

**TABLE OF CONTENTS**

<b><u>Section</u></b>	<b><u>Title</u></b>	<b><u>Page</u></b>
<b>9.0</b>	<b>AUXILIARY SYSTEMS</b>	
<b>9.1</b>	<b>FUEL STORAGE AND HANDLING</b>	<b>9.1-1</b>
9.1.1	NEW FUEL STORAGE	9.1-1
9.1.1.1	DESIGN BASES	9.1-1
9.1.1.2	FACILITIES DESCRIPTION	9.1-1
9.1.1.3	SAFETY EVALUATION	9.1-1
9.1.2	SPENT FUEL STORAGE	9.1-2
9.1.2.1	DESIGN BASES	9.1-2
9.1.2.2	FACILITIES DESCRIPTION	9.1-2
9.1.2.3	SAFETY EVALUATION	9.1-3
9.1.2.4	MATERIALS	9.1-4
9.1.3	SPENT FUEL POOL COOLING AND CLEANUP SYSTEM (SFPCS)	9.1-4
9.1.3.1	DESIGN BASES	9.1-4
9.1.3.2	SYSTEM DESCRIPTION	9.1-5
9.1.3.3	SAFETY EVALUATION	9.1-8
9.1.3.4	TESTS AND INSPECTIONS	9.1-11
9.1.3.5	INSTRUMENT APPLICATION	9.1-11
9.1.4	FUEL HANDLING SYSTEM	9.1-12
9.1.4.1	DESIGN BASES	9.1-12
9.1.4.2	SYSTEM DESCRIPTION	9.1-13
9.1.4.3	DESIGN EVALUATION	9.1-20
9.1.4.4	TESTS AND INSPECTIONS	9.1-26
<b>9.2</b>	<b>WATER SYSTEMS</b>	<b>9.2-1</b>
9.2.1	ESSENTIAL RAW COOLING WATER (ERCW)	9.2-1
9.2.1.1	DESIGN BASES	9.2-1
9.2.1.2	SYSTEM DESCRIPTION	9.2-1
9.2.1.3	SAFETY EVALUATION	9.2-4
9.2.1.4	TESTS AND INSPECTIONS	9.2-8
9.2.1.5	INSTRUMENT APPLICATIONS	9.2-8
9.2.1.6	CORROSION, ORGANIC FOULING, AND ENVIRONMENTAL QUALIFICATION	9.2-10
9.2.1.7	DESIGN CODES	9.2-12

**TABLE OF CONTENTS**

<b><u>Section</u></b>	<b><u>Title</u></b>	<b><u>Page</u></b>
9.2.2	COMPONENT COOLING SYSTEM (CCS)	9.2-12
9.2.2.1	DESIGN BASES	9.2-12
9.2.2.2	SYSTEM DESCRIPTION	9.2-13
9.2.2.3	COMPONENTS	9.2-17
9.2.2.4	SAFETY EVALUATION	9.2-19
9.2.2.5	LEAKAGE PROVISIONS	9.2-21
9.2.2.6	INCIDENTAL CONTROL	9.2-21
9.2.2.7	INSTRUMENT APPLICATIONS	9.2-22
9.2.2.8	MALFUNCTION ANALYSIS	9.2-23
9.2.2.9	TESTS AND INSPECTIONS - HISTORICAL INFORMATION	9.2-24
9.2.2.10	CODES AND CLASSIFICATION	9.2-24
9.2.3	DEMINERALIZED WATER MAKEUP SYSTEM	9.2-24
9.2.3.1	DESIGN BASES	9.2-24
9.2.3.2	SYSTEM DESCRIPTION	9.2-25
9.2.3.3	SAFETY EVALUATION	9.2-25
9.2.3.4	TEST AND INSPECTION	9.2-26
9.2.3.5	INSTRUMENTATION APPLICATIONS	9.2-26
9.2.4	POTABLE AND SANITARY WATER SYSTEMS	9.2-26
9.2.4.1	POTABLE WATER SYSTEM	9.2-26
9.2.4.2	SANITARY WATER SYSTEM	9.2-27
9.2.5	ULTIMATE HEAT SINK	9.2-30
9.2.5.1	GENERAL DESCRIPTION	9.2-30
9.2.5.2	DESIGN BASES	9.2-31
9.2.5.3	SAFETY EVALUATION	9.2-31
9.2.5.4	INSTRUMENTATION APPLICATION	9.2-33
9.2.6	CONDENSATE STORAGE FACILITIES	9.2-33
9.2.6.1	DESIGN BASES	9.2-33
9.2.6.2	SYSTEM DESCRIPTION	9.2-34
9.2.6.3	SAFETY EVALUATION	9.2-34
9.2.6.4	TEST AND INSPECTIONS	9.2-35
9.2.6.5	INSTRUMENT APPLICATIONS	9.2-35
9.2.7	REFUELING WATER STORAGE TANK	9.2-36
9.2.7.1	ECCS PUMPS NET POSITIVE SUCTION HEAD (NPSH)	9.2-37
9.2.8	RAW COOLING WATER SYSTEM	9.2-39

**TABLE OF CONTENTS**

<b><u>Section</u></b>	<b><u>Title</u></b>	<b><u>Page</u></b>
9.2.8.1	DESIGN BASES	9.2-39
9.2.8.2	SYSTEM DESCRIPTION	9.2-40
9.2.8.3	SAFETY EVALUATION	9.2-42
9.2.8.4	TESTS AND INSPECTION	9.2-43
<b>9.3</b>	<b>PROCESS AUXILIARIES</b>	<b>9.3-1</b>
9.3.1	COMPRESSED AIR SYSTEM	9.3-1
9.3.1.1	DESIGN BASIS	9.3-1
9.3.1.2	SYSTEM DESCRIPTION	9.3-1
9.3.1.3	SAFETY EVALUATION	9.3-2
9.3.1.4	TESTS AND INSPECTIONS	9.3-5
9.3.1.5	INSTRUMENTATION APPLICATIONS	9.3-5
9.3.2	PROCESS SAMPLING SYSTEM	9.3-5
9.3.2.1	DESIGN BASIS	9.3-5
9.3.2.2	SYSTEM DESCRIPTION	9.3-5
9.3.2.3	SAFETY EVALUATION	9.3-8
9.3.2.4	TESTS AND INSPECTIONS	9.3-8
9.3.2.5	INSTRUMENTATION APPLICATIONS	9.3-8
9.3.2.6	POSTACCIDENT SAMPLING SUBSYSTEM - (UNIT 1 ONLY)	9.3-8
9.3.3	EQUIPMENT AND FLOOR DRAINAGE SYSTEM	9.3-12
9.3.3.1	DESIGN BASES	9.3-12
9.3.3.2	SYSTEM DESIGN	9.3-12
9.3.3.3	DRAINS - REACTOR BUILDING	9.3-15
9.3.3.4	DESIGN EVALUATION	9.3-15
9.3.3.5	TESTS AND INSPECTIONS	9.3-15
9.3.3.6	INSTRUMENTATION APPLICATION	9.3-15
9.3.3.7	DRAIN LIST	9.3-15
9.3.4	CHEMICAL AND VOLUME CONTROL SYSTEM	9.3-16
9.3.4.1	DESIGN BASES	9.3-16
9.3.4.2	SYSTEM DESCRIPTION	9.3-17
9.3.4.3	SAFETY EVALUATION	9.3-36
9.3.4.4	TESTS AND INSPECTIONS	9.3-38
9.3.4.5	INSTRUMENTATION APPLICATION	9.3-39
9.3.5	FAILED FUEL DETECTION SYSTEM	9.3-39
9.3.6	AUXILIARY CHARGING SYSTEM	9.3-39

**TABLE OF CONTENTS**

<b><u>Section</u></b>	<b><u>Title</u></b>	<b><u>Page</u></b>
9.3.6.1	DESIGN BASES	9.3-39
9.3.6.2	SYSTEM DESIGN DESCRIPTION	9.3-40
9.3.6.3	DESIGN EVALUATION	9.3-41
9.3.6.4	TESTS AND INSPECTION	9.3-41
9.3.6.5	INSTRUMENT APPLICATION	9.3-41
9.3.7	BORON RECYCLE SYSTEM	9.3-42
9.3.8	HEAT TRACING	9.3-42
<b>9.4</b>	<b>AIR CONDITIONING, HEATING, COOLING, AND VENTILATION SYSTEMS</b>	<b>9.4-1</b>
9.4.1	CONTROL ROOM AREA VENTILATION SYSTEM	9.4-1
9.4.1.1	DESIGN BASES	9.4-1
9.4.1.2	SYSTEM DESCRIPTION	9.4-3
9.4.1.3	SAFETY EVALUATION	9.4-7
9.4.1.4	TESTS AND INSPECTION	9.4-8
9.4.2	FUEL HANDLING AREA VENTILATION SYSTEM	9.4-9
9.4.2.1	DESIGN BASES	9.4-9
9.4.2.2	SYSTEM DESCRIPTION	9.4-10
9.4.2.3	SAFETY EVALUATION	9.4-11
9.4.2.4	INSPECTION AND TESTING	9.4-12
9.4.3	AUXILIARY BUILDING AND RADWASTE AREA VENTILATION SYSTEM	9.4-12
9.4.3.1	DESIGN BASES	9.4-12
9.4.3.2	SYSTEM DESCRIPTION	9.4-13
9.4.3.3	SAFETY EVALUATION	9.4-18
9.4.3.4	INSPECTION AND TESTING REQUIREMENTS	9.4-23
9.4.4	TURBINE BUILDING AREA VENTILATION SYSTEM	9.4-23
9.4.4.1	DESIGN BASES	9.4-23
9.4.4.2	SYSTEM DESCRIPTION	9.4-23
9.4.4.3	SAFETY EVALUATION	9.4-26
9.4.4.4	INSPECTION AND TESTING REQUIREMENTS	9.4-26
9.4.5	ENGINEERED SAFETY FEATURE VENTILATION SYSTEMS	9.4-26
9.4.5.1	ERCW INTAKE PUMPING STATION (IPS)	9.4-26
9.4.5.2	DIESEL GENERATOR BUILDINGS	9.4-28
9.4.5.3	AUXILIARY BUILDING ENGINEERED SAFETY FEATURES (ESF) EQUIPMENT COOLERS	9.4-33

**TABLE OF CONTENTS**

<b><u>Section</u></b>	<b><u>Title</u></b>	<b><u>Page</u></b>
9.4.6	REACTOR BUILDING PURGE VENTILATING SYSTEM (RBPVS)	9.4-37
9.4.6.1	DESIGN BASES	9.4-37
9.4.6.2	SYSTEM DESCRIPTION	9.4-40
9.4.6.3	SAFETY EVALUATION	9.4-41
9.4.6.4	INSPECTION AND TESTING REQUIREMENTS	9.4-43
9.4.7	CONTAINMENT AIR COOLING SYSTEM	9.4-43
9.4.7.1	DESIGN BASES	9.4-43
9.4.7.2	SYSTEM DESCRIPTION	9.4-44
9.4.7.3	SAFETY EVALUATION	9.4-47
9.4.7.4	TEST AND INSPECTION REQUIREMENTS	9.4-47
9.4.8	CONDENSATE DEMINERALIZER WASTE EVAPORATOR BUILDING ENVIRONMENTAL CONTROL SYSTEM	9.4-48
9.4.9	POSTACCIDENT SAMPLING FACILITY (PASF) ENVIRONMENTAL CONTROL SYSTEM (UNIT 1 ONLY)	9.4-48
<b>9.5</b>	<b>OTHER AUXILIARY SYSTEMS</b>	<b>9.5-1</b>
9.5.1	FIRE PROTECTION SYSTEM	9.5-1
9.5.1.1	DELETED BY AMENDMENT 87	9.5-1
9.5.1.2	DELETED BY AMENDMENT 87	9.5-1
9.5.1.3	DELETED BY AMENDMENT 87	9.5-1
9.5.1.4	DELETED BY AMENDMENT 87	9.5-1
9.5.1.5	DELETED BY AMENDMENT 87	9.5-1
9.5.2	PLANT COMMUNICATIONS SYSTEM	9.5-1
9.5.2.1	DESIGN BASES	9.5-1
9.5.2.2	GENERAL DESCRIPTION INTRAPLANT COMMUNICATIONS	9.5-1
9.5.2.3	GENERAL DESCRIPTION INTERPLANT SYSTEM	9.5-4
9.5.2.4	EVALUATION	9.5-5
9.5.2.5	INSPECTION AND TESTS	9.5-7
9.5.3	LIGHTING SYSTEMS	9.5-8
9.5.3.1	DESIGN BASES	9.5-8
9.5.3.2	DESCRIPTION OF THE PLANT LIGHTING SYSTEM	9.5-8
9.5.3.3	DIESEL GENERATOR BUILDING LIGHTING SYSTEM	9.5-9
9.5.3.4	SAFETY RELATED FUNCTIONS OF THE LIGHTING SYSTEMS	9.5-10
9.5.3.5	INSPECTION AND TESTING REQUIREMENTS	9.5-10

**TABLE OF CONTENTS**

<b><u>Section</u></b>	<b><u>Title</u></b>	<b><u>Page</u></b>
9.5.4	DIESEL GENERATOR FUEL OIL STORAGE AND TRANSFER SYSTEM	9.5-10
9.5.4.1	DESIGN BASIS	9.5-10
9.5.4.2	SYSTEM DESCRIPTION	9.5-11
9.5.4.3	SAFETY EVALUATION	9.5-14
9.5.4.4	TESTS AND INSPECTIONS	9.5-15
9.5.5	DIESEL GENERATOR COOLING WATER SYSTEM	9.5-15
9.5.5.1	DESIGN BASES	9.5-15
9.5.5.2	SYSTEM DESCRIPTION	9.5-15
9.5.5.3	SAFETY EVALUATION	9.5-16
9.5.5.4	TESTS AND INSPECTIONS	9.5-16
9.5.6	DIESEL GENERATOR STARTING SYSTEM	9.5-17
9.5.6.1	DESIGN BASES	9.5-17
9.5.6.2	SYSTEM DESCRIPTION	9.5-17
9.5.6.3	SAFETY EVALUATION	9.5-18
9.5.6.4	TESTS AND INSPECTIONS	9.5-18
9.5.7	DIESEL ENGINE LUBRICATION SYSTEM	9.5-18
9.5.7.1	DESIGN BASES	9.5-18
9.5.7.2	SYSTEM DESCRIPTION	9.5-19
9.5.7.3	SAFETY EVALUATION	9.5-20
9.5.7.4	TEST AND INSPECTIONS	9.5-21
9.5.8	DIESEL GENERATOR COMBUSTION AIR INTAKE AND EXHAUST SYSTEM	9.5-21
9.5.8.1	DESIGN BASES	9.5-21
9.5.8.2	SYSTEM DESCRIPTIONS	9.5-21
9.5.8.3	SAFETY EVALUATION	9.5-22
9.5.8.4	TESTS AND INSPECTION	9.5-22

# **WATTS BAR**

---

## **LIST OF TABLES**

<b><u>Section</u></b>	<b><u>Title</u></b>
TABLE 9.1-1	SPENT FUEL POOL COOLING AND CLEANUP SYSTEM DESIGN PARAMETERS
TABLE 9.1-2	SPENT FUEL POOL COOLING AND CLEANUP SYSTEM DESIGN AND OPERATING PARAMETERS
TABLE 9.1-3	BASIS FOR DESIGN CRITERIA OF THE WATTS BAR NUCLEAR PLANT SPENT FUEL RACKS
TABLE 9.2-1	ESSENTIAL RAW COOLING WATER SYSTEM PUMP DESIGN DATA
TABLE 9.2-2	ESSENTIAL RAW COOLING WATER SYSTEM FAILURE MODES AND EFFECTS ANALYSIS
TABLE 9.2-3	AVAILABLE NPSH DURING ECCS OPERATION
TABLE 9.2-4	DELETED BY AMENDMENT 66
TABLE 9.2-5	DELETED BY AMENDMENT 66
TABLE 9.2-6	DELETED BY AMENDMENT 66
TABLE 9.2-7	DELETED BY AMENDMENT 66
TABLE 9.2-8	COMPONENT COOLING SYSTEM COMPONENT DESIGN DATA
TABLE 9.2-9	COMPONENT COOLING SYSTEM FAILURE MODES AND EFFECTS ANALYSIS
TABLE 9.2-10	COMPONENT COOLING SYSTEM CODE REQUIREMENTS
TABLE 9.2-11	RAW COOLING WATER SYSTEM PUMP DESIGN DATA
TABLE 9.3-1	COMPRESSED AIR SYSTEM DESCRIPTIVE INFORMATION STATION CONTROL AND SERVICE AIR SYSTEMS
TABLE 9.3-2	PROCESS SAMPLING SYSTEM SAMPLE LOCATIONS AND DATA
TABLE 9.3-3	EQUIPMENT AND FLOOR DRAINAGE DATA REACTOR COOLANT SYSTEM
TABLE 9.3-4	CHEMICAL AND VOLUME CONTROL SYSTEM DESIGN PARAMETERS
TABLE 9.3-5	PRINCIPAL COMPONENT DATA SUMMARY
TABLE 9.3-6	DELETED BY AMENDMENT 95
TABLE 9.3-7	FAILURE MODE AND EFFECTS ANALYSIS AUXILIARY AIR SUPPLY EQUIPMENT
TABLE 9.3-8	EQUIPMENT SUPPLIED WITH AUXILIARY CONTROL SYSTEM AIR

**LIST OF TABLES**

<b><u>Section</u></b>	<b><u>Title</u></b>
TABLE 9.4-1	DELETED
TABLE 9.4-2	FAILURE MODES AND EFFECTS ANALYSIS INTAKE PUMPING STATION VENTILATION SYSTEM
TABLE 9.4-3	FAILURE MODES AND EFFECTS ANALYSIS FOR ACTIVE FAILURES SUBSYSTEM: SAFETY FEATURE EQUIPMENT COOLERS
TABLE 9.4-3A	FAILURE MODES AND EFFECTS ANALYSIS FOR ACTIVE FAILURES SUBSYSTEM: TURBINE DRIVEN AUXILIARY FEEDWATER PUMP ROOM VENTILATION
TABLE 9.4-4	FAILURE MODES AND EFFECTS ANALYSIS DIESEL GENERATOR VENTILATION SYSTEM
TABLE 9.4-4A	DELETED BY AMENDMENT 94
TABLE 9.4-5	FAILURE MODES AND EFFECTS ANALYSIS FOR ACTIVE FAILURES SUBSYSTEM: AUXILIARY BOARD ROOMS AIR CONDITIONING SYSTEM
TABLE 9.4-6	FAILURE MODES AND EFFECTS ANALYSIS FOR ACTIVE FAILURES SUBSYSTEM: 480 V SHUTDOWN TRANSFORMER ROOM VENTILATION
TABLE 9.4-7	FAILURE MODES AND EFFECTS ANALYSIS CONTROL BUILDING HVAC
TABLE 9.4-8	FAILURE MODES AND EFFECTS ANALYSIS FOR ACTIVE FAILURES SUBSYSTEM: AUXILIARY BUILDING GENERAL VENTILATION
TABLE 9.4-8A	FAILURE MODES AND EFFECTS ANALYSIS FOR ACTIVE FAILURES FOR COMPONENTS COMMON TO THE AUX BLDG HVAC SUBSYSTEM
TABLE 9.4-8B	FAILURE MODES AND EFFECTS ANALYSIS FOR AUXILIARY BUILDING HVAC SUBSYSTEM PASSIVE FAILURES
TABLE 9.4-9	FAILURE MODES AND EFFECTS ANALYSIS SUBSYSTEM: SHUTDOWN BOARD ROOM AIR CONDITIONING AND VENTILATION
TABLE 9.4-10	FAILURE MODES AND EFFECTS ANALYSIS FOR ACTIVE FAILURES SUBSYSTEM: MAIN STEAM VALVE VAULT VENTILATION SYSTEM (SHEET 1 OF 1)
TABLE 9.4-10A	FAILURE MODES AND EFFECTS ANALYSIS FOR ACTIVE FAILURES SUBSYSTEM: POST ACCIDENT SAMPLING SYSTEM (SHEET 1 OF 1)
TABLE 9.4-11	DELETED BY AMENDMENT 56



**LIST OF TABLES**

<b><u>Section</u></b>	<b><u>Title</u></b>
TABLE 9.5-1	DELETED BY AMENDMENT 52
TABLE 9.5-2	FAILURE MODES AND EFFECTS ANALYSIS OF THE STANDBY DIESEL GENERATOR AUXILIARY SYSTEMS

**LIST OF TABLES**

**Section**

**Title**

THIS PAGE INTENTIONALLY BLANK

**LIST OF FIGURES**

<b><u>Section</u></b>	<b><u>Title</u></b>
FIGURE 9.1-1	NEW FUEL STORAGE RACKS
FIGURE 9.1-2	DELETED BY AMENDMENT 44
FIGURE 9.1-3	POWERHOUSE, AUXILIARY, AND REACTOR BUILDINGS UNITS 1 & 2 MECHANICAL - FLOW DIAGRAM FOR FUEL POOL COOLING AND CLEANING SYSTEM
FIGURE 9.1-4	POWERHOUSE UNITS 1 & 2 ELECTRICAL CONTROL DIAGRAM FOR SPENT FUEL PIT COOLING SYSTEM
FIGURE 9.1-5	POWERHOUSE UNITS 1 & 2 ELECTRICAL LOGIC DIAGRAM FOR SPENT FUEL PIT COOLING SYSTEM
FIGURE 9.1-6	TYPICAL MANIPULATOR CRANE
FIGURE 9.1-7	TYPICAL SPENT FUEL PIT BRIDGE
FIGURE 9.1-8	NEW FUEL ELEVATOR
FIGURE 9.1-9	FUEL TRANSFER SYSTEM ASSEMBLY
FIGURE 9.1-10	ROD CLUSTER CONTROL CHANGING FIXTURE
FIGURE 9.1-11	TYPICAL SPENT FUEL HANDLING TOOL
FIGURE 9.1-12	TYPICAL NEW FUEL HANDLING TOOL
FIGURE 9.1-13	REACTOR BUILDING INTERNALS LIFTING RIG PLATFORM AND MECH. TOOLS ARRANGEMENT AND DETAILS
FIGURE 9.1-14	TYPICAL STUD TENSIONER
FIGURE 9.1-15	PLAN VIEW OF SPENT FUEL POOL
FIGURE 9.1-16	FLUX TRAP SPENT FUEL STORAGE RACK
FIGURE 9.2-1	IPS, YARD, DGB UNITS 1 & 2 FLOW DIAGRAM FOR ESSENTIAL RAW COOLING WATER SYSTEM POWERHOUSE AND AUXILIARY BUILDING FLOW DIAGRAM FOR ESSENTIAL RAW COOLING WATER SYSTEM
FIGURE 9.2-2	POWERHOUSE AUX BLDG UNITS 1 & 2 MECHANICAL FLOW DIAGRAM FOR ESSENTIAL RAW COOLING WATER SYSTEM (UNIT 1)
FIGURE 9.2-3	POWERHOUSE AUXILIARY AND CONTROL BUILDINGS FLOW DIAGRAM FOR ESSENTIAL RAW COOLING WATER SYSTEM (UNIT 1)
FIGURE 9.2-4	POWERHOUSE AUX & CONTROL BLDG UNIT 1 MECHANICAL FLOW DIAGRAM -ESSENTIAL RAW COOLING WATER
FIGURE 9.2-4A	POWERHOUSE TURBINE BUILDING UNITS 1 & 2 FLOW DIAGRAM FOR ESSENTIAL RAW COOLING WATER SYSTEM
FIGURE 9.2-4B	POWERHOUSE AUXILIARY BUILDING FLOW DIAGRAM FOR ESSENTIAL RAW COOLING WATER SYSTEM (UNIT 2)

**LIST OF FIGURES**

<b><u>Section</u></b>	<b><u>Title</u></b>
FIGURE 9.2-5	POWERHOUSE UNITS 1 & 2 ELECTRICAL LOGIC DIAGRAM FOR ESSENTIAL RAW COOLING WATER SYSTEM
FIGURE 9.2-6	POWERHOUSE UNITS 1 & 2 ELECTRICAL LOGIC DIAGRAM FOR ESSENTIAL RAW COOLING WATER SYSTEM
FIGURE 9.2-7	LOGIC DIAGRAM FOR ESSENTIAL RAW COOLING WATER SYSTEM
FIGURE 9.2-8	POWERHOUSE UNITS 1 & 2 ELECTRICAL LOGIC DIAGRAM FOR ESSENTIAL RAW COOLING WATER SYSTEM
FIGURE 9.2-9	POWERHOUSE UNITS 1 & 2 ELECTRICAL LOGIC DIAGRAM FOR ESSENTIAL RAW COOLING WATER SYSTEM
FIGURE 9.2-10	POWERHOUSE ELECTRICAL CONTROL DIAGRAM FOR ESSENTIAL RAW COOLING WATER SYSTEM (UNIT 1)
FIGURE 9.2-10A	POWERHOUSE ELECTRICAL CONTROL DIAGRAM FOR ESSENTIAL RAW COOLING WATER SYSTEM (UNIT 2)
FIGURE 9.2-11	POWERHOUSE ELECTRICAL CONTROL DIAGRAM FOR ESSENTIAL RAW COOLING WATER SYSTEM (UNIT 1)
FIGURE 9.2-11A	POWERHOUSE ELECTRICAL CONTROL DIAGRAM FOR ESSENTIAL RAW COOLING WATER SYSTEM (UNIT 2)
FIGURE 9.2-12	ELECTRICAL CONTROL DIAGRAM FOR ESSENTIAL RAW COOLING WATER SYSTEM (UNIT 1)
FIGURE 9.2-12	ELECTRICAL CONTROL DIAGRAM FOR ESSENTIAL RAW COOLING WATER SYSTEM (UNIT 2) (SHEET A)
FIGURE 9.2-13	POWERHOUSE ELECTRICAL CONTROL DIAGRAM FOR ESSENTIAL RAW COOLING WATER SYSTEM
FIGURE 9.2-14	POWERHOUSE ELECTRICAL CONTROL DIAGRAM FOR ESSENTIAL RAW COOLING WATER SYSTEM (UNIT 1)
FIGURE 9.2-14A	POWERHOUSE ELECTRICAL CONTROL DIAGRAM FOR ESSENTIAL RAW COOLING WATER SYSTEM (UNIT 2)
FIGURE 9.2-15	DELETED BY AMENDMENT 87
FIGURE 9.2-16	POWERHOUSE, AUXILIARY BUILDING FLOW DIAGRAM FOR COMPONENT COOLING WATER SYSTEM
FIGURE 9.2-17	POWERHOUSE, AUXILIARY AND REACTOR BUILDING FLOW DIAGRAM FOR COMPONENT COOLING SYSTEM (UNIT 2)
FIGURE 9.2-18	POWERHOUSE, AUXILIARY AND REACTOR BUILDING FLOW DIAGRAM FOR COMPONENT COOLING SYSTEM (UNIT 1)
FIGURE 9.2-19	POWERHOUSE, AUXILIARY BUILDING MECHANICAL FLOW DIAGRAM (UNITS 1 AND 2)

**LIST OF FIGURES**

<b><u>Section</u></b>	<b><u>Title</u></b>
FIGURE 9.2-20	POWERHOUSE ELECTRICAL CONTROL DIAGRAM FOR COMPONENT COOLING WATER SYSTEM
FIGURE 9.2-20A	POWERHOUSE UNIT 2 ELECTRICAL CONTROL DIAGRAM
FIGURE 9.2-21	POWERHOUSE ELECTRICAL CONTROL DIAGRAM FOR COMPONENT COOLING WATER S-YSTEM (UNIT 1)
FIGURE 9.2-21A	POWERHOUSE UNIT 2 ELECTRICAL CONTROL DIAGRAM
FIGURE 9.2-22	POWERHOUSE UNIT 1 ELECTRICAL CONTROL DIAGRAM
FIGURE 9.2-22A	POWERHOUSE UNIT 2 ELECTRICAL CONTROL DIAGRAM
FIGURE 9.2-23	POWERHOUSE UNITS 1 & 2 ELECTRICAL LOGIC DIAGRAM FOR COMPONENT COOLING SYSTEM
FIGURE 9.2-24	POWERHOUSE UNITS 1 & 2 ELECTRICAL LOGIC DIAGRAM FOR COMPONENT COOLING WATER SYSTEM
FIGURE 9.2-25	POWERHOUSE UNIT 1 ELECTRICAL LOGIC DIAGRAM
FIGURE 9.2-25A	POWERHOUSE UNITS 1 & 2 ELECTRICAL LOGIC DIAGRAM FOR COMPONENT COOLING SYSTEM
FIGURE 9.2-26	POWERHOUSE, TURBINE BUILDING UNITS 1 & 2 MECHANICAL FLOW DIAGRAM WATER HEATER AND DEMINERALIZERS
FIGURE 9.2-27	POWERHOUSE, TURBINE BUILDING UNITS 1 & 2 MECHANICAL-FLOW DIAGRAM FOR MAKEUP WATER TREATMENT AND DEMINERALIZERS
FIGURE 9.2-28	POWERHOUSE, SERVICE & OFFICE BUILDINGS UNITS 1 & 2 FLOW DIAGRAM FOR DEMINERALIZED WATER AND CASK DECON SYSTEM
FIGURE 9.2-29	DELETED BY AMENDMENT 62
FIGURE 9.2-29A	GENERAL FLOW DIAGRAM FOR POTABLE WATER DISTRIBUTION SYSTEM
FIGURE 9.2-29B	GENERAL FLOW DIAGRAM FOR POTABLE WATER DISTRIBUTION SYSTEM
FIGURE 9.2-29C	TURB, SERVICE & OFFICE BLDGS. UNITS 1 & 2 FLOW DIAGRAM FOR POTABLE WATER DISTRIBUTION SYSTEM
FIGURE 9.2-29D	GENERAL FLOW DIAGRAM FOR POTABLE WATER DISTRIBUTION SYSTEM
FIGURE 9.2-30	DELETED BY AMENDMENT 94
FIGURE 9.2-31	POWERHOUSE UNITS 1 & 2 FLOW DIAGRAM FOR CONDENSATE
FIGURE 9.2-32	POWERHOUSE FLOW DIAGRAM FOR RAW COOLING WATER

**LIST OF FIGURES**

<b><u>Section</u></b>	<b><u>Title</u></b>
FIGURE 9.2-33	POWERHOUSE FLOW DIAGRAM FOR RAW COOLING WATER
FIGURE 9.2-34	POWERHOUSE FLOW DIAGRAM FOR RAW COOLING WATER
FIGURE 9.2-35	POWERHOUSE UNITS 1 & 2 MECHANICAL FLOW DIAGRAM FOR RAW COOLING WATER
FIGURE 9.2-36	POWERHOUSE AND INTAKE PUMPING STATION ELECTRICAL CONTROL DIAGRAM FOR RAW COOLING WATER SYSTEM
FIGURE 9.2-37	POWERHOUSE UNITS 1 & 2 ELECTRICAL CONTROL DIAGRAM FOR RAW COOLING WATER SYSTEM
FIGURE 9.2-38	POWERHOUSE UNITS 1 & 2 ELECTRICAL CONTROL DIAGRAM FOR RAW COOLING WATER
FIGURE 9.2-39	POWERHOUSE POWERHOUSE UNITS 1 & 2 LOGIC DIAGRAM FOR RAW COOLING WATER
FIGURE 9.2-40	ESSENTIAL RAW COOLING WATER CONTROL AIR AND HPFP PIPING (UNIT 1)
FIGURE 9.2-41	DIVER PROTECTION BARRIERS
FIGURE 9.3-1	ELECTRICAL CONTROL DIAGRAM FOR CONTROL AIR SYSTEM
FIGURE 9.3-2	ELECTRICAL CONTROL DIAGRAM FOR CONTROL AIR SYSTEM
FIGURE 9.3-3	POWERHOUSE UNITS 1 & 2 ELECTRICAL LOGIC DIAGRAM FOR COMPRESSED AIR SYSTEM
FIGURE 9.3-4	POWERHOUSE UNITS 1 & 2 ELECTRICAL LOGIC DIAGRAM FOR CONTROL AIR SYSTEM
FIGURE 9.3-5	TURBINE BUILDING AND YARD UNITS 1 & 2 FLOW DIAGRAM FOR CONTROL AND SERVICE AIR SYSTEM
FIGURE 9.3-5A	CONTROL, AUXILIARY, REACTOR, TURBINE, OFFICE AND SERVICE BUILDING UNITS 1 & 2 FLOW DIAGRAM FOR CONTROL AND SERVICE AIR SYSTEM
FIGURE 9.3-6	POWERHOUSE UNITS 1 & 2 MECHANICAL FLOW DIAGRAM FOR CONTROL AIR SYSTEM
FIGURE 9.3-6A	POWERHOUSE UNITS 1 & 2 MECHANICAL FLOW DIAGRAM FOR CONTROL AIR SYSTEM
FIGURE 9.3-7	POWERHOUSE UNITS 1 & 2 MECHANICAL FLOW DIAGRAM - FLOOR AND EQUIPMENT DRAINS
FIGURE 9.3-8	POWERHOUSE UNITS 1 & 2 MECHANICAL FLOW DIAGRAM - FLOOR AND EQUIPMENT DRAINS

**LIST OF FIGURES**

<b><u>Section</u></b>	<b><u>Title</u></b>
FIGURE 9.3-9	POWERHOUSE, AUXILIARY BUILDING UNITS 1 & 2 MECHANICAL FLOW DIAGRAM -FLOOR AND EQUIPMENT DRAINS
FIGURE 9.3-10	POWERHOUSE, AUXILIARY BUILDING UNITS 1 & 2 FLOW DIAGRAM - FLOOR AND EQUIPMENT DRAINS
FIGURE 9.3-11	POWERHOUSE AUXILIARY BUILDING UNITS 1 & 2 FLOW DIAGRAM - FLOOR AND EQUIPMENT DRAINS
FIGURE 9.3-12	POWERHOUSE, AUXILIARY BUILDINGS UNIT 1 & 2 MECHANICAL FLOW DIAGRAM ROOF DRAINS AND FLOOR EQUIPMENT DRAINS
FIGURE 9.3-13	POWERHOUSE UNITS 1 & 2 ELECTRICAL LOGIC DIAGRAM FOR WASTE DISPOSAL SYSTEM
FIGURE 9.3-14	POWERHOUSE UNITS 1 & 2 ELECTRICAL LOGIC DIAGRAM FOR WASTE DISPOSAL SYSTEM
FIGURE 9.3-15	POWERHOUSE UNIT 1 CHEMICAL AND VOLUME CONTROL SYSTEM FLOW DIAGRAM (SHEET 1)
FIGURE 9.3-15	AUXILIARY BUILDING UNITS 1 & 2 FLOW DIAGRAM FOR CHEMICAL AND VOLUME CONTROL SYSTEM (BORON RECOVERY) (SHEET 2)
FIGURE 9.3-15	AUXILIARY BUILDING UNITS 1 & 2 FLOW DIAGRAM FOR CHEMICAL AND VOLUME CONTROL SYSTEM (BORON RECOVERY) (SHEET 3)
FIGURE 9.3-15	AUXILIARY BUILDING UNITS 1 & 2 FLOW DIAGRAM FOR CHEMICAL AND VOLUME CONTROL SYSTEM (BORON RECOVERY) (SHEET 4)
FIGURE 9.3-15	AUXILIARY BUILDING UNITS 1 & 2 FLOW DIAGRAM FOR CHEMICAL AND VOLUME CONTROL SYSTEM (BORIC ACID) (SHEET 5)
FIGURE 9.3-15	AUXILIARY BUILDING UNITS 1 & 2 FLOW DIAGRAM FOR CHEMICAL AND VOLUME CONTROL SYSTEM AND (BORON RECOVERY) (SHEET 6)
FIGURE 9.3-15	AUXILIARY BUILDING UNIT 2 FLOW DIAGRAM FOR CHEMICAL AND VOLUME CONTROL SYSTEM (BORON RECOVERY) (SHEET 6A)
FIGURE 9.3-15	POWERHOUSE UNIT 1 ELECTRICAL CONTROL DIAGRAM CHEMICAL & VOLUME CONTROL SYS (SHEET 7)

**LIST OF FIGURES**

<b><u>Section</u></b>	<b><u>Title</u></b>
FIGURE 9.3-15	POWERHOUSE UNIT 1 ELECTRICAL CONTROL DIAGRAM CHEMICAL & VOLUME CONTROL SYS (SHEET 8)
FIGURE 9.3-15	POWERHOUSE UNIT 1 ELECTRICAL CONTROL DIAGRAM CHEMICAL & VOLUME CONTROL SYS (SHEET 9)
FIGURE 9.3-15	POWERHOUSE UNIT 2 ELECTRICAL CONTROL DIAGRAM CHEMICAL & VOLUME CONTROL SYS (SHEET 9A)
FIGURE 9.3-15	POWERHOUSE UNITS 1 & 2 ELECTRICAL CONTROL DIAGRAM CHEMICAL & VOLUME CONTROL SYS (SHEET 10)
FIGURE 9.3-15	POWERHOUSE UNITS 1 & 2 ELECTRICAL CONTROL DIAGRAM CHEMICAL & VOLUME CONTROL SYS (SHEET 11)
FIGURE 9.3-15	POWERHOUSE UNITS 1 & 2 ELECTRICAL CONTROL DIAGRAM CHEMICAL & VOLUME CONTROL SYS (SHEET 12)
FIGURE 9.3-16	DELETED BY AMENDMENT 95
FIGURE 9.3-17	DELETED BY AMENDMENT 95
FIGURE 9.3-18	POWERHOUSE UNITS 1 & 2 FLOW DIAGRAM FOR FLOOD MODE BORATION
FIGURE 9.3-19	DELETED BY AMENDMENT 52 (SHEETS 1 THROUGH 3)
FIGURE 9.3-20	DELETED BY AMENDMENT 95
FIGURE 9.3-21	WATTS BAR NUCLEAR PLANT BORIC ACID TANK LIMITS
FIGURE 9.4-1	POWERHOUSE, CONTROL BUILDING UNITS 1 & 2 FLOW DIAGRAM FOR HEATING, VENTILATING, AND AIR CONDITIONING AIR FLOW
FIGURE 9.4-2	POWERHOUSE UNITS 1 & 2 FLOW DIAGRAM FOR AIR CONDITIONING CHILLED WATER
FIGURE 9.4-3	POWERHOUSE, CONTROL BUILDING UNITS 1 & 2 FLOW DIAGRAM FOR AIR CONDITIONING CHILLED WATER
FIGURE 9.4-4	POWERHOUSE, CONTROL BUILDING UNITS 1 & 2 ELECTRICAL CONTROL DIAGRAM AIR CONDITIONING
FIGURE 9.4-4A	CONTROL BUILDING UNITS 1 & 2 ELECTRICAL AIR CONDITIONING CONTROL DIAGRAM - CHILLED WATER
FIGURE 9.4-5	CONTROL BUILDING UNITS 1 & 2 ELECTRICAL AIR CONDITIONING CONTROL DIAGRAM - CHILLED WATER
FIGURE 9.4-6	CONTROL BUILDING UNITS 1 & 2 ELECTRICAL LOGIC DIAGRAM AIR CONDITIONING SYSTEM
FIGURE 9.4-7	CONTROL BUILDING UNITS 1 & 2 ELECTRICAL LOGIC DIAGRAM VENTILATION SYSTEM



**LIST OF FIGURES**

<b><u>Section</u></b>	<b><u>Title</u></b>
FIGURE 9.4-8	POWERHOUSE UNITS 1 & 2 AUXILIARY BUILDING FLOW DIAGRAM, HEATING, AND VENTILATING AIR FLOW
FIGURE 9.4-9	AUXILIARY BUILDING UNITS 1 & 2 ELECTRICAL LOGIC DIAGRAM FOR VENTILATION SYSTEM
FIGURE 9.4-10	AUXILIARY BUILDING UNITS 1 & 2 ELECTRICAL LOGIC DIAGRAM FOR VENTILATION SYSTEM
FIGURE 9.4-11	POWERHOUSE UNITS 1 & 2 FOR CONTAINMENT VENTILATION SYTEM CONTROL DIAGRAM
FIGURE 9.4-12	POWERHOUSE UNITS 1 & 2 ELECTRICAL CONTROL DIAGRAM FOR RADIATION MONITORING SYSTEM
FIGURE 9.4-13	POWERHOUSE UNITS 1 & 2 AUXILIARY BUILDING FLOW DIAGRAM FOR HEATING, COOLING, AND VENTILATING AIR FLOW
FIGURE 9.4-14	AUXILIARY BUILDING UNITS 1 & 2 FLOW DIAGRAM FOR HEATING, COOLING, AND VENTILATING AIR FLOW
FIGURE 9.4-15	POWERHOUSE UNITS 1 & 2 AUXILIARY BUILDING FLOW DIAGRAM FOR HEATING, VENTILATION AND AIR CONDITIONING AIR FLOW
FIGURE 9.4-16	POWERHOUSE UNITS 1 & 2 AUXILIARY BUILDING & ADDITIONAL EQPT BLDG FLOW DIAGRAM FOR HEATING, COOLING & VENTILATING AIR FLOW
FIGURE 9.4-17	POWERHOUSE UNITS 1 & 2 ELECTRICAL CONTROL DIAGRAM FOR CONTAINMENT VENTILATING SYSTEM
FIGURE 9.4-18	TURBINE BUILDING UNITS 1 & 2 AND CONTROL FLOW DIAGRAM FOR HEATING AND VENTILATING AIR FLOW
FIGURE 9.4-19	POWERHOUSE UNITS 1 & 2 FLOW DIAGRAM BUILDING HEATING
FIGURE 9.4-20	POWERHOUSE UNIT 2 FLOW DIAGRAM BUILDING HEATING
FIGURE 9.4-21	PUMPING STATIONS UNITS 1 & 2 MECHANICAL HEATING AND VENTILATING
FIGURE 9.4-22	DIESEL GENERATOR BUILDING UNITS 1 & 2 FLOW AND CONTROL DIAGRAM FOR HEATING, VENTILATING AIR FLOW
FIGURE 9.4-22A	ADDITIONAL DIESEL GENERATOR BUILDING UNITS 1 & 2 FLOW AND CONTROL DIAGRAM FOR HEATING AND VENTILATING AIR FLOW

**LIST OF FIGURES**

<b><u>Section</u></b>	<b><u>Title</u></b>
FIGURE 9.4-22B	ADDITIONAL DIESEL GENERATOR BUILDING UNITS 1 & 2 ELECTRICAL LOGIC DIAGRAM FOR 5TH DIESEL GENERATOR VENTILATOR SYSTEM
FIGURE 9.4-22C	ADDITIONAL DIESEL GENERATOR BUILDING MECHANICAL HEATING AND VENTILATING
FIGURE 9.4-23	DIESEL GENERATOR BUILDING MECHANICAL HEATING AND VENTILATING
FIGURE 9.4-24	DIESEL GENERATOR BUILDING MECHANICAL HEATING AND VENTILATING
FIGURE 9.4-24A	DIESEL GENERATOR BUILDING MECHANICAL HEATING AND VENTILATION
FIGURE 9.4-25	DIESEL BUILDING UNITS 1 & 2 ELECTRICAL LOGIC DIAGRAM FOR VENTILATION SYSTEM
FIGURE 9.4-26	POWERHOUSE UNIT 1 ELECTRICAL CONTROL DIAGRAM FOR CONTAINMENT VENTILATION SYSTEM
FIGURE 9.4-27	POWERHOUSE UNIT 1 ELECTRICAL CONTROL DIAGRAM FOR CONTAINMENT VENTILATION SYSTEM
FIGURE 9.4-28	REACTOR BUILDING UNITS 1 & 2 FLOW DIAGRAM FOR HEATING AND VENTILATION AIR FLOW
FIGURE 9.4-28A	POWERHOUSE REACTOR BUILDING UNIT 2 FLOW DIAGRAM HEATING & VENTILATION AIR FLOW
FIGURE 9.4-29	POWERHOUSE UNIT 1 ELECTRICAL LOGIC DIAGRAM FOR VENTILATION SYSTEM
FIGURE 9.4-30	POWERHOUSE UNIT 1 ELECTRICAL CONTROL DIAGRAM FOR CONTAINMENT VENTILATING SYSTEM
FIGURE 9.4-30	POWERHOUSE UNIT 2 ELECTRICAL CONTROL DIAGRAM CONTAINMENT VENTILATING SYSTEM (SHEET A)
FIGURE 9.4-30	POWERHOUSE UNIT 1 ELECTRICAL CONTROL DIAGRAM CONTAINMENT VENTILATING SYSTEM (SHEET B)
FIGURE 9.4-31	POWERHOUSE UNIT 1 ELECTRICAL CONTROL DIAGRAM FOR CONTAINMENT VENTILATING SYSTEM
FIGURE 9.4-32	POWERHOUSE UNIT 1 LOGIC DIAGRAM FOR VENTILATION SYSTEM
FIGURE 9.4-33	POWERHOUSE UNIT 1 ELECTRICAL LOGIC DIAGRAM FOR VENTILATION SYSTEM
FIGURE 9.4-34	POWERHOUSE UNIT 1 ELECTRICAL LOGIC DIAGRAM FOR VENTILATION SYSTEM

**LIST OF FIGURES**

<b><u>Section</u></b>	<b><u>Title</u></b>
FIGURE 9.4-35	POWERHOUSE POST-ACCIDENT SAMPLING SYSTEM UNIT 1 FLOW DIAGRAM FOR HEATING, VENTILATING AND AIR CONDITIONING AIR FLOW
FIGURE 9.4-36	AUXILIARY BUILDING UNITS 1 & 2 ELECTRICAL POST-ACCIDENT SAMPLING SYSTEM LOGIC DIAGRAM
FIGURE 9.4-37	AUXILIARY BUILDING UNITS 1 & 2 ELECTRICAL POST-ACCIDENT SAMPLING CONTROL DIAGRAM
FIGURE 9.5-1	DELETED BY AMENDMENT 87
FIGURE 9.5-2	DELETED BY AMENDMENT 87
FIGURE 9.5-3	DELETED BY AMENDMENT 87
FIGURE 9.5-4	DELETED BY AMENDMENT 87
FIGURE 9.5-5	DELETED BY AMENDMENT 87
FIGURE 9.5-6	DELETED BY AMENDMENT 87
FIGURE 9.5-7	DELETED BY AMENDMENT 87
FIGURE 9.5-8	DELETED BY AMENDMENT 87
FIGURE 9.5-9	DELETED BY AMENDMENT 87
FIGURE 9.5-10	DELETED BY AMENDMENT 87
FIGURE 9.5-11	DELETED BY AMENDMENT 87
FIGURE 9.5-12	DELETED BY AMENDMENT 87
FIGURE 9.5-13	DELETED BY AMENDMENT 87
FIGURE 9.5-14	DELETED BY AMENDMENT 87
FIGURE 9.5-15	DELETED BY AMENDMENT 87
FIGURE 9.5-16	DELETED BY AMENDMENT 95
FIGURE 9.5-17	DELETED BY AMENDMENT 95
FIGURE 9.5-18	DELETED BY AMENDMENT 90
FIGURE 9.5-19	WATTS BAR NUCLEAR PLANT-COMMUNICATIONS EQUIPMENT AVAILABILITY
FIGURE 9.5-20	YARD, POWERHOUSE, AND DIESEL GENERATOR BUILDING UNITS 1 & 2 FLOW DIAGRAM FUEL OIL ATOMIZING AIR & STEAM
FIGURE 9.5-20A	ADDITIONAL DSL GEN BLDG UNITS 1 & 2 FLOW DIAGRAM FUEL OIL ATOMIZING AIR & STEAM
FIGURE 9.5-20B	DIESEL GENERATOR BUILDING UNIT 2 FLOW DIAGRAM FUEL OIL ATOMIZING AIR & STEAM

**LIST OF FIGURES**

<b><u>Section</u></b>	<b><u>Title</u></b>
FIGURE 9.5-21	POWERHOUSE UNITS 1 & 2 ELECTRICAL CONTROL DIAGRAM FOR FUEL OIL SYSTEM
FIGURE 9.5-22	POWERHOUSE UNITS 1 & 2 ELECTRICAL LOGIC DIAGRAM FOR FUEL OIL SYSTEM
FIGURE 9.5-23	SCHEMATIC DIAGRAM -JACKET WATER SYSTEM WITH HEAT EXCHANGER
FIGURE 9.5-24	DIESEL GENERATOR BUILDING UNIT 1 FLOW DIAGRAM FOR DIESEL STARTING AIR SYSTEM
FIGURE 9.5-24A	ADDITIONAL DIESEL GEN BLDG UNIT 1 & 2 FLOW DIAGRAM DIESEL STARTING AIR SYSTEM
FIGURE 9.5-25	DELETED BY AMENDMENT 88
FIGURE 9.5-25A	DIESEL GENERATOR BUILDING UNIT 1 ELECTRICAL CONTROL DIAGRAM DSL STG AIR SYS DG 1B-B
FIGURE 9.5-25B	DIESEL GENERATOR BUILDING UNIT 1 ELECTRICAL CONTROL DIAGRAM DSL STG AIR SYS DG 2A-A
FIGURE 9.5-25C	DIESEL GENERATOR BUILDING UNIT 1 ELECTRICAL CONTROL DIAGRAM DSL STG AIR SYS DG 2B-B
FIGURE 9.5-25D	DIESEL GENERATOR BUILDING UNIT 1 ELECTRICAL CONTROL DIAGRAM DSL STG AIR SYS DG OC-S
FIGURE 9.5-26	SCHEMATIC DIAGRAM LUBE OIL SYSTEM
FIGURE 9.5-27	DIESEL ENGINE LUBRICATION SYSTEM
FIGURE 9.5-28	DELETED BY AMENDMENT 41
FIGURE 9.5-29	DIESEL AIR INTAKE PIPING SCHEMATIC
FIGURE 9.5-30	DIESEL EXHAUST SYSTEM PIPING SCHEMATIC
FIGURE 9.5-31	DELETED BY AMENDMENT 87

## 9.0 AUXILIARY SYSTEMS

### 9.1 FUEL STORAGE AND HANDLING

#### 9.1.1 New Fuel Storage

##### 9.1.1.1 Design Bases

New fuel is stored in racks (Figure 9.1-1). Each rack is composed of individual vertical cells which can be fastened together in any number to form a module that can be firmly bolted to anchors in the floor of the new fuel storage pit. The new fuel storage racks are designed to include storage for 1/3 core for each unit at a center to center spacing of 21 inches. This spacing provides a minimum separation between adjacent fuel assemblies of 12 inches which is sufficient to maintain a subcritical array even in the event the building is flooded with unborated water. Space between storage positions is blocked to prevent insertion of fuel. All surfaces that come into contact with the fuel assemblies are made of annealed austenitic stainless steel, whereas the supporting structure may be painted carbon steel. A three inch drain is provided in the new fuel storage vault.

The racks are designed to withstand nominal operating loads as well as SSE and OBE seismic loads in accordance with Regulatory Guides 1.29 and 1.13.

The new fuel storage racks are located in the new fuel pit area which has a cover that protects the racks from dropped objects. Administrative controls are utilized when a section of the protective cover is removed for handling of the new fuel assemblies.

##### 9.1.1.2 Facilities Description

The location of the new fuel storage vault is shown in Figures 1.2-3 and 1.2-8. The design of the new fuel storage racks is shown in Figure 9.1-1.

The new fuel storage vault is a reinforced concrete structure. This vault is a part of the Auxiliary Building, which is a Seismic Category I Structure (See Section 3.2)

The new fuel storage vault opens on to the elevation 757 floor, but is normally covered by a series of hatches which are designed to withstand the effects of an OBE or SSE. These hatches are removed as necessary during handling of the new fuel.

##### 9.1.1.3 Safety Evaluation

The center-to-center distance between new fuel assemblies is sufficient to assure  $k_{eff} \leq 0.98$  when the new fuel storage area is dry or fogged (optimally moderated). For the fully flooded condition assuming cold, clean, unborated water, the value of  $k_{eff}$  is less than or equal to 0.95.

The new fuel assemblies are stored dry, the 21 inch center to center spacing ensuring an ever safe geometric array. Under these conditions, a criticality accident during refueling and storage is not considered credible.

Design of the storage racks is in accordance with Regulatory Guide 1.13 and 1.29 and ensures adequate safety under normal and postulated accidents.

Consideration of criticality safety analysis is discussed in Section 4.3.2.7.

## 9.1.2 SPENT FUEL STORAGE

### 9.1.2.1 Design Bases

The spent fuel racks are designed in accordance with the following listed criteria:

- (1) The spent fuel storage racks were designed for storage of 1386 fuel assemblies. The design meets all the structural and seismic requirements of Category I equipment as defined by the NRC Position Paper dated April 14, 1978, on spent fuel storage and handling applications and the references listed in Table 9.1-3.
- (2) Burnup credit and fuel assembly placement controls are used to ensure the fuel array in the spent fuel racks is maintained subcritical assuming the array is fully flooded with nonborated water, the fuel is new with a maximum anticipated enrichment of 5.0 weight percent U-235, and the geometric array is the worst possible considering mechanical tolerances and abnormal conditions.
- (3) The spent fuel storage facility is designed to prevent severe natural phenomena, including missiles generated from high winds, from causing damage to the spent fuel. The spent fuel storage facility, including the spent fuel racks, is Seismic Category I.
- (4) The spent fuel storage racks are designed to withstand handling and normal operating loads and the maximum uplift forces generated by the fuel handling equipment.
- (5) A loss of pool cooling accident is not considered a credible accident because the pool cooling system is Seismic Category I and single failure proof.
- (6) The spent fuel storage racks are designed to withstand the impact of a dropped spent fuel assembly from the maximum lift height of the spent fuel pit bridge hoist.
- (7) The spent fuel storage facilities provide the capability for limiting the potential offsite exposures, in the event of significant release of radioactivity from the stored fuel, to well less than 10 CFR 100 guidelines.

### 9.1.2.2 Facilities Description

The spent fuel storage pool is a reinforced concrete structure with a stainless steel liner for leak tightness. This storage pool is a part of the Seismic Category I Auxiliary Building, and is shared between units one and two. Both the liner and pool walls are designed to withstand the effects of an OBE and SSE. The location of the spent fuel

storage pool is shown on Figures 1.2-3 and 1.2-8. The storage rack configuration in the pool is shown on Figure 9.1-15. Typical storage racks are shown on Figure 9.1-16.

The spent fuel storage pool opens onto the elevation 757 floor, and is protected by a guard rail which surrounds the pool. The depth of the pool is sufficient to allow some 26 feet of water shielding (nominally) above the spent fuel. This water depth ensures that the doses on the operating floor from stored spent fuel are negligibly small.

The spent fuel storage racks consist of stainless steel structures with cells or receptacles for nuclear fuel assemblies as they are used in a reactor. Twenty-four of these flux trap racks, provide 1386 storage positions in eighteen 7 x 8 cell array modules and six 7 x 9 cell array modules. Figure 9.1-15 shows the layout of the storage racks in the spent fuel pool. Each rack is supported by four pedestals (one rack has five pedestals) sitting on two-inch thick stainless steel bearing pads which spread the load on the pool floor.

### 9.1.2.3 Safety Evaluation

Design of these storage racks is in accordance with Regulatory Guide 1.13 and ensures a safe condition under normal and postulated accident conditions. The distance between spent fuel assemblies is maintained to ensure a  $k_{\text{eff}} \leq 0.95$  even if unborated water is used to fill the spent fuel storage pool. Consideration of criticality safety analysis is discussed in Section 4.3.2.7.

The spent fuel racks are designed as free standing and are qualified as seismic Category I structures. The seismic design considered fully loaded racks in water at less than boiling temperature undergoing a SSE. Composite, dynamic simulations which modeled all racks in the pool were utilized to determine limiting loads and displacements for each rack in the pool, to establish limiting relative motion between racks, and to evaluate the potential for and the consequences of inter-rack and rack-wall phenomena in the entire assemblage of racks. The racks were also checked for OBE loads and found to be satisfactory. See section 3.8.4 for related pool structure information.

The racks can withstand the drop of a fuel assembly from its maximum supported height and the drop of tools used in the pool. The racks are also capable of withstanding accidental drops of the gates which cover the slots between the spent fuel pool and the transfer canal and cask loading pit from a height of eight feet above the top of the racks. Electrical and mechanical stops prevent the movement of heavy objects over the spent fuel pool including the shipping casks. The movement of the casks is restricted to areas away from the pool. The wall which separates the fuel storage area from the cask loading area has been designed to restrict damage to the cask loading area if a cask were dropped even in a tipped position in the cask loading area.

Loss of pool cooling and pool water events are discussed in Section 9.1.3. Radiation sources and protection for the pool water are discussed in Sections 12.2.1 and 12.3.2.2. Although the number of stored fuel assemblies is increased, the capacity of

the pool water cleanup system is adequate to maintain radionuclide concentrations within design limits. Therefore no increase in personnel exposures is expected.

#### 9.1.2.4 Materials

The materials used in the construction of the spent fuel racks are 304 stainless, CF-3M stainless and 17-4 PH stainless. The neutron poison material is a commercial product known as Boral and contains  $B_4C$  powder in a matrix.

The flux trap racks contain the following proven materials:

- (1) Poison inner can and outer tubes: 304 stainless steel, ASTM A-666-72 Grade B
- (2) Top and bottom grid castings: CF-3M, ASTM A-296-77
- (3) Threaded pedestal foot: 17-4 PH, ASTM A-564-66

In addition to the stainless steel material, the racks employ Boral, a patented product of AAR Brooks and Perkins, as the thermal neutron absorber material. Boral is a thermal neutron absorbing material consisting of finely divided particles of boron carbide ( $B_4C$ ) uniformly distributed in type 1100 aluminum, pressed and sintered in a hot rolling process. Boron carbide is a compound having a high boron content in a physically stable and chemically inert form. The 1100 alloy aluminum is a light weight metal with high tensile strength which is protected from corrosion by a highly resistant oxide film. The two materials, boron carbide and aluminum, are chemically compatible and ideally suited for long term use in the radiation, thermal and chemical environment of a spent fuel pool.

### 9.1.3 Spent Fuel Pool Cooling and Cleanup System (SFPCCS)

The SFPCCS is designed to remove from the spent fuel pool water the decay heat generated by stored spent fuel assemblies. Additional functions of the SFPCCS are to clarify and purify the water in the spent fuel pool, transfer canal, and refueling water storage tanks (RWST). If a warning of flood above plant grade is received when one or both reactor vessels are open or vented to the containment atmosphere, the SFPCCS will be modified as indicated in Section 2.4.14 to accomplish cooling the reactor core(s).

#### 9.1.3.1 Design Bases

SFPCCS design parameters are given in Table 9.1-1.

##### 9.1.3.1.1 Spent Fuel Pool Cooling

The SFPCCS is designed to remove the decay heat from the spent fuel assemblies stored in the pool and maintain acceptable pool temperatures following a full core discharge. The temperatures listed in Table 9.1-1 can be maintained for the various full core offload scenarios assuming the SFPCCS heat exchangers are supplied with component cooling water at its design flow and temperature. If it is necessary to remove a complete core after a normal refueling, the system can maintain the spent



fuel pool water at or below 159.2°F in the worst case design basis single failure scenario.

The SFPCCS incorporates two trains of equipment (plus a spare pump capable of operation in either train). The flow through the pool provides sufficient mixing to ensure uniform water conditions throughout the pool. Under design basis Ultimate Heat Sink (UHS) temperatures and heat exchanger fouling conditions, the heat load in the spent fuel pool is limited to 28.1E+06 BTU/hr during refueling outages. Under more favorable conditions, up to 50.2E+06 BTU/hr may be accommodated. Cycle specific calculations may be performed prior to the start of a refueling outage to determine the exact heat removal capability of the SFPCCS using recent heat exchanger performance testing and anticipated UHS temperatures; otherwise, 28.1E+06 BTU/hr may not be exceeded. The rate of fuel transfer from the reactor to the SFP is controlled such that, with one (1) train of SFPCCS in service, the SFP temperature will remain below 151.2 °F. Operating procedures provide the controls to ensure these limitations are met. A decay heat calculation is routinely performed at the end of each operating cycle to produce heat decay vs time curves for the core and spent fuel pool. This calculation can be used to determine the time to begin core offload and the rate at which the core can be off loaded.

#### **9.1.3.1.2 Spent Fuel Pool Dewatering Protection**

System piping is arranged so that failure of any pipeline cannot drain the spent fuel pool below the water level required for radiation shielding. A water level of ten feet or more above the top of the stored spent fuel assemblies is maintained to limit direct gamma dose rate.

#### **9.1.3.1.3 Water Purification**

The system's demineralizer and filter are designed to provide adequate purification to permit unrestricted access to the spent fuel storage area for plant personnel and maintain optical clarity of the spent fuel pool water surface by use of the system's skimmers, strainer, and skimmer filter.

#### **9.1.3.1.4 Flood Mode Cooling**

Section 2.4.14 presents the design basis operation of the SFPCCS when it may be used for reactor core cooling during flooded plant conditions.

#### **9.1.3.2 System Description**

The SFPCCS, shown in Figure 9.1-3, consists of two cooling trains (plus a backup pump capable of operation in either train), a purification loop, and a separate skimmer loop. The electrical logic control diagrams for this system are shown in Figures 9.1-4 and 9.1-5.

The SFPCCS removes decay heat from fuel stored in the spent fuel pool. Spent fuel is placed in the pool during the refueling sequence and stored there until it is shipped offsite. The system normally handles the heat load from either a full core or 1/3 of a core freshly discharged from each reactor plus the decreasing heat load from

previously discharged fuel. Heat is transferred from the SFPCCS through the heat exchangers to the component cooling system.

When the SFPCCS is in operation, water flows from the spent fuel pool to both spent fuel pool pump suction, is pumped through the tube side of the heat exchangers, and is returned to the pool. Each pump's suction line, which is protected by a strainer, is located at an elevation four feet below the normal spent fuel pool water level, while the return line contains an anti-siphon hole near the surface of the water to prevent gravity drainage of the pool.

While the heat removal operation is in process, a portion of the spent fuel pool water may be diverted through a demineralizer and a filter to maintain spent fuel pool water clarity and purity. This purification loop is sufficient for removing fission products and other contaminants which may be introduced if a fuel assembly with defective cladding is transferred to the spent fuel pool.

The spent fuel pool demineralizer may be isolated, by manual valves, from the heat removal portion of the SFPCCS. By this means, the isolated demineralizer may be used in conjunction with a refueling water purification pump and filter to clean and purify the refueling water while spent fuel pool heat removal operations proceed. Connections are provided such that the refueling water may be pumped from either the RWST or the refueling cavity of either unit, through the demineralizer and filter, and discharged to the refueling cavity or RWST of either unit. Connections are also provided to allow cleanup of the water in the transfer canals. Water can be drawn from the canal, and is pumped by a refueling water purification pump through the spent fuel pool demineralizer and a refueling water purification filter before being returned to the transfer canal.

To further assist in maintaining spent fuel pool water clarity, the water surface is cleaned by a skimmer loop. Water is removed from the surface by the skimmers, pumped through a strainer and filter, and returned to the pool surface at three locations remote from the skimmers.

The spent fuel pool is filled with water that is at least 2000 ppm. Borated water may be supplied from the RWST via the refueling water purification pump connection, or by running a temporary line from the boric acid blender, located in the chemical and volume control system directly into the pool. Demineralized water can also be added for makeup purposes (i.e., to replace evaporative losses) through a connection in the recirculation return line.

The spent fuel pool water may be separated from the water in the transfer canal by a gate. The gate is installed so that the transfer canal may be drained to allow maintenance of the fuel transfer equipment. The water in the transfer canal is pumped via a refueling water purification pump (RWPP) to a RWST. The transfer canal will be refilled from the RWST by the RWPP when the maintenance is complete.

An alternate method when the transfer canal water is outside the chemistry limit for use in the RWST is to pump the transfer canal water to the chemical and volume control

system (CVCS) holdup tank via the RWPP. The water will be pumped back to the transfer canal via the CVCS holdup tank recirculation pumps.

A description of the operation of the SFPCCS during flood mode operation is given in Section 2.4.14.

### **9.1.3.2.1 Component Description**

Spent fuel pool cooling and cleanup system codes and classifications are given in Section 3.2. Equipment operating parameters are given in Table 9.1-2. System design parameters are given in Table 9.1-1.

#### **Spent Fuel Pool Pumps**

The two pumps are horizontal, centrifugal units. They circulate spent fuel pool water through the heat exchangers, demineralizer, and filter. The pumps are controlled manually from a local station. A third pump is installed to serve as a backup to either of the two pumps normally used for cooling the spent fuel pool water (refer to Section 2.4.14 and Section 9.1.3.3.1).

#### **Spent Fuel Pool Skimmer Pump**

This horizontal, centrifugal pump circulates surface water through a strainer and a filter and returns it to the pool.

#### **Refueling Water Purification Pumps**

These horizontal, centrifugal pumps are used to circulate water from the transfer canal, the refueling cavity and the RWST through the spent fuel pool demineralizer, and a refueling water purification filter. The pumps are operated manually from a local station.

#### **Spent Fuel Pool Heat Exchangers**

The spent fuel pool heat exchangers are of the shell and U-tube type with the tubes welded to the tube sheet. Component cooling water circulates through the shell, and spent fuel pool water circulates through the tubes.

#### **Spent Fuel Pool Demineralizer**

This flushable, mixed-bed demineralizer is designed to provide adequate fuel pool water purity for unrestricted access by plant personnel to the pool working area, and to maintain water visual clarity.

#### **Spent Fuel Pool Filter**

The spent fuel pool filter is designed to improve the pool water clarity by removing particles which obscure visibility.

### **Spent Fuel Pool Skimmer Filter**

The spent fuel pool skimmer filter is used to remove particles which are not removed by the strainer.

### **Refueling Water Purification Filters**

The refueling water purification filters are designed to improve the clarity of the refueling water in the refueling canal or in the RWST by removing particles which obscure visibility.

### **Spent Fuel Pool Strainer**

A strainer is located in each spent-fuel pool pump suction line for removal of relatively large particles which might otherwise clog the spent fuel pool demineralizer or damage the spent fuel pool pumps.

### **Spent Fuel Pool Skimmer Strainer**

The spent fuel pool skimmer strainer is designed to remove debris from the skimmer process stream.

### **Spent Fuel Pool Skimmers**

Two spent fuel pool skimmers are provided to remove water from the spent fuel pool water surface in order to remove floating debris.

### **Valves**

Manual stop valves are used to isolate equipment, and manual throttle valves provide flow control. Valves in contact with spent fuel pool water are of austenitic stainless steel or equivalent corrosion resistant material.

### **Piping**

All piping in contact with spent fuel pool water is austenitic stainless steel. The piping is welded except where flanged connections are used to facilitate maintenance and access to shadowed fuel storage cells.

## **9.1.3.3 Safety Evaluation**

### **9.1.3.3.1 Availability and Reliability**

The SFPCCS is located in a Seismic Category I structure that is tornado missile protected. Active components of the cooling portion of the system are located above the design basis flood level in the Auxiliary Building (Section 2.4.14). The SFPCCS heat removal equipment is designed to remain functional for the design basis earthquake and within the required stress limits for the operational basis earthquake.

Electrical power is supplied from emergency power buses to each of the spent fuel pool pumps. Each pump is connected to these emergency power buses so that it receives power from a separate diesel generator set should offsite power be lost. The use of emergency power buses assures the operation of these pumps for open reactor

cooling during plant flooding conditions. This manually controlled system may be shut down for limited periods of time for maintenance or replacement of malfunctioning components. The pool is sufficiently large that an extended period of time would be required for the water to heat up appreciably if cooling were interrupted (see Table 9.1-1). In the event of a failure of one spent fuel pool pump, the backup pump would be aligned and operated. In the event of loss of cooling to one spent fuel pool heat exchanger, cooling of the spent fuel pool water could be maintained by the remaining equipment; however, the reduced heat removal capacity would result in elevation of the spent fuel pool water equilibrium temperature to a higher, but acceptable, temperature.

In the event that cooling capability were lost for an extended period, the pool water temperature would approach boiling. At the maximum decay heat production rate, the water loss by vaporization would be about 102 gpm. A seismically qualified line is available from the common discharge of the refueling water purification pumps to the spent fuel pool cooling loop. All piping, valves, and pumps from the RWST to the common discharge of the refueling water purification pumps are seismically qualified. Other sources for makeup available are the demineralized water system and the fire protection system. A sufficient portion of the fire protection system is a Seismic Class I system. Fire hose stations located on seismic and non-seismic piping in the Fire Protection system are capable of supplying a sufficient quantity of makeup water.

#### **9.1.3.3.2 Spent Fuel Pool Dewatering**

The most serious failure of this system would be complete loss of water in the storage pool. To protect against this possibility, the spent fuel pool cooling suction connections enter near the normal water level such that it cannot be lowered appreciably by siphoning. The cooling water return line contains an anti-siphon hole to prevent draining of the pool. These design features assure that the pool cannot be drained below four feet of normal water level (normal water level in the spent fuel pool is approximately 26 feet above the top of the stored spent fuel).

The transfer canal has a drain connection in the bottom of the canal. The line runs upward, embedded in concrete, to a level about 13 feet below the normal pool surface. The line continues embedded, dropping below the bottom of the transfer canal. At the high point of the drain line, a siphon breaker line connects into the drain line, terminating in the canal above the normal pool surface. A valve in this line is locked open at all times except when the canal is to be drained. The transfer canal is isolated from the spent fuel pool with a sectionalizing gate during "Transfer Canal Dewatering", (draining operation). With this arrangement, if the transfer canal drain line ruptures, the pool level will not be affected. If the transfer canal drain line ruptures with the syphon valve open and the sectionalizing gate open, 13 feet of water will be above the fuel assemblies in the storage racks.

#### **9.1.3.3.3 Pool and Fuel Temperatures**

The cooling of the spent fuel assemblies stored within the storage racks has been analyzed for effective and adequate cooling under all postulated pool storage conditions.

Two discharge scenarios have been evaluated for both single and dual SFP cooling train operation. Case one considers a full core discharge while a second case considers a full core discharge following a normal refueling. Each case considers the accumulated decay heat of all previously discharged spent nuclear fuel assemblies stored in the SFP. Maximum bulk water temperatures for each core off load scenario are given in Table 9.1-1. Following unit shutdown, a decay time of approximately 33 days prior to the completion of core offload is required to maintain the total SFP decay heat below  $28.1\text{E}+06$  BTU/hr design basis limit.

For full core offload following a normal refueling outage (Emergency Offload), it is assumed that a unit is required to shutdown 36 days after a refueling outage on the opposite unit. Following shutdown, it is assumed that core offload will be completed after a 60 day decay time. Under these conditions, the maximum SFP decay heat will be less than  $25.61\text{E}+06$  BTU/hr, which is less than the normal refueling case. Specific guidance in the form of allowable spent fuel pool decay heat curves for better than design conditions of spent fuel pool heat exchanger fouling and shell side cooling temperatures has been developed. Decay heat curves are provided which allow outage specific variation in maximum spent fuel pool decay heat load based on known values of spent fuel pool heat exchanger fouling factors and component cooling system temperatures. Sufficient spent fuel pool cooling equipment is operated and the rate of fuel transfer is controlled to assure that the spent fuel pool temperature does not exceed  $150^{\circ}\text{F}$  during anticipated refueling activities. Operating procedures provide the controls to ensure these limitations are met. A decay heat calculation is routinely performed at the end of each operating cycle to produce heat decay vs time curves for the core and spent fuel pool. This calculation may be used to determine the time to begin core off load and the rate at which the core can be off loaded.

The maximum local water temperature and maximum local fuel temperature have been determined to evaluate the possibility of nucleate boiling on the surface of the fuel assemblies. Analysis has shown that for any scenario with at least one SFPCS train available, localized boiling does not occur within the fuel racks. The decay heat flux of the rods is greatest at the fuel mid-height. Mid height fuel cladding temperatures of  $208.2^{\circ}\text{F}$ ,  $217.1^{\circ}\text{F}$ , and  $208.9^{\circ}\text{F}$  have been calculated based on no blockage, partial blockage, and off-center placement of an assembly in a rack cell respectively. Local maximum water temperatures of  $193.7^{\circ}\text{F}$ ,  $204.1^{\circ}\text{F}$ , and  $195.2^{\circ}\text{F}$  have been calculated for the no blockage, partial blockage, and off-center placement cases respectively. The local saturation temperature at the top of the racks ( $240.7^{\circ}\text{F}$ ) is greater than any calculated local water temperature, which precludes the possibility of nucleate boiling. Additionally, the local saturation temperature is greater than any calculated fuel cladding temperature, which would preclude the possibility of film boiling at the surface of the fuel rods.

The approach to localized boiling within the racks has been evaluated for highest allowable spent fuel decay heat load ( $50.21$  Mbtu/hr) in Reference [1]. The conclusions of the evaluation indicate that greater than  $6^{\circ}\text{F}$  margin to localized boiling exist between the maximum calculated fuel clad temperature and the local saturation temperature even at the highest allowable heat load.

The total volume of water contained in the pool and cask pit area at the start of a loss of cooling scenario is 372,460 gallons. The expected water heat-up rates for a total loss of cooling capability accident for both a full core discharge and a full core discharge following a normal refueling are listed in Table 9.1-1.

#### **9.1.3.3.4 Water Quality**

Except for operation of this system in the flood mode of reactor cooling, only a very small amount of water is interchanged between the refueling canal and the spent fuel pool as fuel assemblies are transferred in the refueling process. Whenever a fuel assembly with defective cladding is transferred to the spent fuel pool, a small quantity of fission products may enter the spent fuel cooling water. The purification loop provided removes fission products and other contaminants from the water. Radioactivity concentrations in the spent fuel pool water are maintained at a level such that the dose rate at the surface of the pool is low enough to allow minimum-restricted access for plant personnel (refer to Section 12.3.2.2). With the use of high purity water, it is expected that the racks and pool walls will not see any significant crud buildup.

#### **9.1.3.3.5 Leakage Detection for the Spent Fuel Pool**

Leakage detection is provided for the spent fuel pool (SFP) by leakage channels located on the back side of each welded joint of the floor and walls of the SFP steel liner. Leakage into these channels will drain to the perimeter leakage channels located at the bottom of the SFP. The leakage will then flow into the SFP drain pipe to a normally open manual gate valve. Visual detection of the leakage from the SFP may be witnessed as the leakage exits the manual valve and drips into a funnel. The leakage is then routed to the tritiated drain collector tank (TDCT) of the waste disposal system. In the event of excessive leakage, the manual gate valve may be closed to prevent further leakage. Similar type design of leakage channels and visual display of leakage are also provided for the fuel transfer canal and the cask loading area. Non qualified instrumentation are provided in the SFP and the TDCT with MCR low and local high level alarms, respectively.

#### **9.1.3.4 Tests and Inspections**

Active components of the SFPCS are either in continuous or intermittent use during normal plant operation. Periodic visual inspection and preventive maintenance are conducted using normal industry practice.

#### **9.1.3.5 Instrument Application**

The instrumentation for the SFPCS is discussed below. Alarms and indicators are provided as noted.

##### **9.1.3.5.1 Temperature**

Instrumentation is provided to measure the temperature of the water in the spent fuel pool and give local indication as well as annunciation in the control room when normal temperatures are exceeded.

Instrumentation is also provided to give local indication of the temperature of the spent fuel pool water as it leaves the heat exchangers.

#### **9.1.3.5.2 Pressure**

Instrumentation is provided to give local indication of the pressure at points upstream and downstream of each pump and filter.

#### **9.1.3.5.3 Flow**

Instrumentation is provided to give local indication of the flow leaving the spent fuel pool filter and in the main cooling loops.

#### **9.1.3.5.4 Level**

Instrumentation is provided which gives an alarm in the control room when the water level in the spent fuel pool reaches either the high or low level condition.

### **9.1.4 FUEL HANDLING SYSTEM**

#### **9.1.4.1 Design Bases**

The fuel handling system (FHS) consists of equipment and structures utilized for safely implementing refueling operation in accordance with requirements of General Design Criteria 61 and 62 of 10 CFR 50, Appendix A.

The following design bases apply to the FHS.

- (1) Fuel handling devices have provisions to avoid dropping or jamming of fuel assemblies during transfer operation.
- (2) Handling equipment has provisions to avoid dropping of fuel handling devices during the fuel transfer operation.
- (3) Handling equipment used to raise and lower spent fuel has a limited maximum lift height so that the minimum required depth of water shielding is maintained. See New Fuel Elevator description for use with spent fuel.
- (4) The Fuel Transfer System (FTS), where it penetrates the containment, has provisions to preserve the integrity of the containment pressure boundary.
- (5) Criticality during fuel handling operations is prevented by geometrically safe configuration of the fuel handling equipment.
- (6) Handling equipment will not fail in such a manner as to damage Seismic Category I equipment in the event of a safe shutdown earthquake.
- (7) The inertial loads imparted to the fuel assemblies or core components during handling operations are less than the loads which could cause damage.



- (8) Physical safety features are provided for personnel operating handling equipment.

#### 9.1.4.2 System Description

The FHS consists of the equipment needed for the refueling operation on the reactor core. Basically this equipment is comprised of the reactor component hoisting equipment, fuel handling equipment and the FTS. The structures associated with the fuel handling equipment are the refueling cavity, the refueling canal, the transfer canal, the spent fuel storage pit, the cask loading area and the new fuel storage vault.

New fuel assemblies are received one or two per shipping container and moved one assembly at a time using the Auxiliary Building crane. The assemblies are temporarily stored in either the new fuel vault for dry storage or in the spent fuel pool as a staging area for the next refueling. When storage in the spent fuel pool is desired, assemblies are placed into the new fuel elevator and lowered into the transfer canal where normal spent fuel handling equipment is used to complete the movement into its storage location. New assemblies may be transferred directly from the shipping container or from the new fuel vault into the reactor core or spent fuel pool via the new fuel elevator and normal spent fuel handling equipment.

The fuel handling equipment is designed to handle the spent fuel under water from the time it leaves the reactor vessel until it is placed in a container for shipment from the site. Underwater transfer of spent fuel provides an effective, economic and transparent radiation shield, as well as a reliable cooling medium for removal of decay heat. The boric acid concentration in the water is sufficient to preclude criticality.

The associated fuel handling structures may be generally divided into three areas: the refueling cavity and refueling canal which are flooded only during plant shutdown for refueling, the spent fuel storage area which is kept full of water and is always accessible to operating personnel, and the new fuel storage vault which is separate and protected for dry storage. The refueling canal and the transfer canal are connected by a fuel transfer tube. This tube is fitted with a blind flange on the refueling canal end and a gate valve on the transfer canal end. The blind flange is in place except during refueling to ensure containment integrity. Fuel is carried through the tube on an underwater transfer car.

Fuel is moved between the reactor vessel and the refueling canal by the refueling machine. A rod cluster control changing fixture is located on the refueling canal wall and may be used for transferring control elements from one fuel assembly to another. The Rod Cluster Control Assembly (RCCA) change tool is used from the spent fuel pool bridge crane to transfer control elements from one assembly to another in the spent fuel pool.

The lifting arm at either end of the fuel transfer tube is used to pivot a fuel assembly. Before entering the transfer tube the lifting arm pivots a fuel assembly to the horizontal position for passage through the transfer tube. After the transfer car transports the fuel assembly through the transfer tube, the lifting arm at that end of the tube pivots the assembly to a vertical position so that it can be lifted out of the upender frame.

In the spent fuel storage area, spent fuel assemblies are moved about by the spent fuel pit bridge hoist. When lifting spent fuel assemblies, the hoist uses a long-handled tool to assure that sufficient radiation shielding is maintained. A shorter tool is used to handle new fuel assemblies with the Auxiliary Building crane, but the new fuel elevator must be used to lower the assembly to a depth at which the spent fuel pit bridge crane, using the long-handled tool, can place the new fuel assembly into the upending device.

The new fuel elevator may be used to raise or lower an irradiated fuel assembly to facilitate maintenance activities under administrative controls that ensure sufficient radiation shielding is maintained.

Decay heat, generated by the spent fuel assemblies in the spent fuel pit, is removed by the spent fuel pool cooling system.

#### 9.1.4.2.1 Refueling Procedure

The refueling operation follows a detailed procedure which provides a safe, efficient refueling operation. Reactor core alterations or handling of irradiated fuel are suspended during a tornado warning. Prior to initiating refueling operations the reactor coolant system is borated and cooled down to refueling shutdown conditions as specified in the Technical Specifications. Criticality protection for refueling operations, including a requirement for periodic checks of boron concentration, is specified in the Technical Specifications.

The following significant points are assured by the refueling procedure:

- (1) The refueling water and the reactor coolant contain the required concentration of boron. This concentration is sufficient to keep the core reactivity of  $k_{\text{eff}} \leq 0.95$  during the refueling operations with all control rods inserted, except the most reactive rod.
- (2) The water level in the refueling cavity is high enough to keep the radiation levels within acceptable limits when the fuel assemblies are being removed from the core.

The refueling operation is divided into four major phases. A general description of a typical refueling operation through the four phases is given below:

- (1) Phase I - Preparation

The reactor is shut down and cooled to refueling conditions with a final  $k_{\text{eff}} \leq 0.95$  (all rods in, except the most reactive rod). At this time, the coolant level in the reactor vessel is lowered to a point slightly below the vessel flange. Then the fuel transfer equipment is checked for proper operation. The refueling machine is checked for proper operation prior to or during Phase 1.

- (2) Phase II - Reactor Disassembly

Missile shields are removed from around the reactor head, allowing all piping, supports, cables, air ducts, and insulation to be removed from the vessel

head. The refueling cavity is then prepared for flooding by sealing off the reactor cavity, checking of the underwater lights, tools, and FTS, closing the refueling canal drain holes, and removing the blind flange from the fuel transfer tube. After the reactor vessel head has been detensioned, the vessel head is unseated and raised above the vessel flange. Water from the RWST is pumped into the reactor coolant system by the residual heat removal pumps. During reactor pressure vessel (RPV) head removal and lift, radiation levels are monitored and direct inspections are performed to detect potential rod cluster control assembly (RCCA) withdrawal. This inspection may be performed by monitoring the source range instrumentation for any unusual unexpected change during RPV head removal. The RPV head is raised to clear obstructions, and moved to the storage stand. The reactor cavity water level is raised to just above the vessel flange, leak inspections are initiated, and the level is increased to cover the upper internals guide tubes. The cavity water level is raised to normal refueling level. The control rod drive shafts are disconnected and, with the upper internals, are removed from the vessel. The fuel is now free from obstructions and the core is ready for refueling.

(3) Phase III - Fuel Handling

The general fuel handling sequence for a full core off load is:

- (a) The refueling machine is placed over the first assembly to be removed.
- (b) The fuel assembly is lifted and moved into the upender.
- (c) The upender is then pivoted to the horizontal position by the lifting arm.
- (d) The fuel is moved through the fuel transfer tube to the transfer canal area by the transfer car.
- (e) The fuel assembly is pivoted to the vertical position by the lifting arm. The fuel assembly is lifted and moved by the spent fuel handling tool attached to the spent fuel pit bridge crane.
- (f) The fuel assembly is then placed into a spent fuel rack storage cell.
- (g) This sequence is repeated until all 193 fuel assemblies are removed from the core and placed into the spent fuel pit.
- (h) Fuel related components are then shuffled/removed from assemblies and placed into their proper locations. After fuel related components shuffles are completed, the fuel is loaded back into the core in the prescribed sequence by reversing the above steps.

- (4) Phase IV - Spent Fuel Cask Loading. WBN currently does not, and has no immediate plans to, ship spent fuel off-site. The following discussion is provided for Historical Information only.
- (a) The fuel cask shipping conveyance is parked inside the Auxiliary Building with the hatch covers in the elevation 757 floor closed for ventilation control.
  - (b) When the outside door is closed, the hatch covers are opened.
  - (c) The shipping cask is picked up by the Auxiliary Building crane and is moved to an open area on the operating floor. If it is necessary to disengage the crane hook to free the crane for other uses, the cask is lowered to the cask decontamination facility or into the cask loading area of the spent fuel pool. In either of these locations, a seismic event would not overturn the cask.
  - (d) The gate is placed in the slot between the spent fuel pit and the cask loading area.
  - (e) The cask is picked up by the crane and is lowered onto the shelf in the loading area. The crane hook is disengaged from the cask, and an extension link is inserted between hook and cask. The cask then is lowered into the deep portion of the pit.
  - (f) The cask lid is removed and placed in the cask setdown area.
  - (g) The gate is removed from the slot.
  - (h) Using the spent fuel pit bridge crane, fuel assemblies are transferred, one at a time, from the spent fuel storage racks to the cask.
  - (i) The gate is placed in the slot and the cask lid is replaced.
  - (j) The cask is lifted onto the shelf, the extension link is removed, and the cask is removed from the loading areas. It is then placed in the cask decontamination room and tiedown devices are affixed.
  - (k) After decontamination the cask undergoes preshipment tests.
  - (l) The cask is placed on the shipping conveyance with the outer door closed.
  - (m) The hatch covers in the Elevation 757 floor are closed and the conveyance is moved out of the building.

### 9.1.4.2.2 Component Description

#### Refueling Machine

The refueling machine (Figure 9.1-6) is a rectilinear bridge and trolley crane with a vertical mast extending down into the refueling water. The bridge spans the refueling cavity and runs on rails set into the edge of the refueling cavity. The bridge and trolley motions are used to position the vertical mast over a fuel assembly. A long tube with a pneumatic gripper on the end is lowered down out of the mast to grip the fuel assembly. The gripper tube is long enough so that the upper end is still contained in the mast when the gripper end contacts the fuel. A winch mounted on the trolley raises the gripper tube and fuel assembly up into the mast tube. The fuel is transported while inside the mast tube to its new position.

The refueling machine uses three AC servo motors to control bridge, trolley, and hoist motions. Boundaries, interlocks, and speeds are controlled by an industrial programmable logic controller.

All major controls for the refueling machine are mounted in a console on the trolley. The bridge and trolley are positioned in relation to a grid pattern referenced to the core by a series of redundant digital encoder systems.

The drives for the bridge, trolley and hoist are variable speed. The maximum speed for the bridge is approximately 60 fpm and the maximum speed for the trolley is approximately 40 fpm. The maximum speed for the hoist is approximately 40 fpm.

The refueling machine has two auxiliary monorail hoists, one on each side of the bridge upper structure.

Electrical interlocks and limit switches on the bridge and trolley drives prevent damage to the fuel assemblies. The hoist is also provided with redundant limit switches to prevent a fuel assembly from being raised above a safe shielding depth should the limit switch fail. In an emergency, the bridge, trolley and hoist can be operated manually using a handwheel on the motor shaft to return the system to a safe configuration.

Portable underwater cameras are used, as required, during refueling operations and can permit viewing of all fuel assembly positions.

#### Spent Fuel Pit Bridge Crane

The spent fuel pit bridge crane (Figure 9.1-7) is a steel-mounted walkway spanning the spent fuel pit, which carries an electric monorail hoist on an overhead structure. The spent fuel pit bridge crane is used exclusively for handling fuel assemblies within the spent fuel pit and transfer canal by means of a long-handled tool suspended from the hoist. The hoist travel and tool length are designed to limit the maximum lift of a fuel assembly to a safe shielding depth.

The spent fuel bridge crane has two step magnetic controllers for the bridge and hoist. The bridge speeds are 11 and 33 fpm and the hoist speeds are 7 and 20 fpm. A hydraulic coupling is used in the bridge drive to limit starting acceleration.

The hoist pendent control is equipped with a load sensing device to indicate an overload in the up direction or an underload in the down direction to prevent damage to the fuel elements. The hoist trolley is hand operated by a chain drive.

### **New Fuel Elevator**

The new fuel elevator (Figure 9.1-8) consists of a box-shaped elevator assembly with its top end open and sized to house one fuel assembly.

The new fuel elevator is used primarily to lower a new fuel assembly to the bottom of the fuel transfer canal where it is transported to the fuel transfer system by the spent fuel pit bridge hoist.

The New Fuel Elevator may also be used to raise and lower an irradiated fuel assembly to facilitate maintenance activities. Prior to placing an irradiated fuel assembly in the elevator, safety precautions will be implemented to limit the maximum lift of the fuel assembly to a safe shielding depth.

### **Fuel Transfer System**

The fuel transfer system (Figure 9.1-9) includes a cable-driven transfer car that runs on tracks extending from the reactor cavity through the transfer tube into the transfer canal. At each end of the transfer tube are lifting arms. The upender in the refueling cavity receives a fuel assembly in the vertical position from the refueling machine. The fuel assembly is then pivoted to a horizontal position with the lifting arm for passage through the transfer tube. The transfer car is positively connected to the drive train in the transfer canal. After passing through the tube, the fuel assembly is pivoted to a vertical position for removal to the spent fuel pit storage location via the spent fuel pit bridge crane.

During reactor operation, the transfer car is stored in the transfer canal. A blind flange is bolted on the refueling canal end of the transfer tube to seal the reactor containment. The terminus of the tube in the transfer canal is closed by a gate valve.

### **Rod Cluster Control (RCC) Changing Fixture**

The RCC changing fixture is supplied for periodic RCC element inspections and for transfer of RCC elements from one fuel assembly to another in the event this operation is ever required (Figure 9.1-10). The major subassemblies which comprise the changing fixture are the frame and track structure, the carriage, the guide tube, the gripper, and the drive mechanism. The carriage is a moveable container supported by the frame and track structure. The tracks provide a guide for the four flanged carriage wheels and allows horizontal movement of the carriage during changing operation. The positioning stops on both the carriage and frame locate each of the three carriage compartments directly below the guide tube. Two of these compartments are designed to hold individual fuel assemblies while the third is made to support a single rod cluster control element. Situated above the carriage and mounted on the refueling canal wall is the guide tube. The guide tube provides for the guidance and proper orientation of the gripper and rod cluster control element as they are being raised and lowered. The gripper is a pneumatically actuated mechanism responsible for engaging the rod

cluster control element. It has two flexure fingers which can be inserted into the top of the rod cluster control element when air pressure is applied to the gripper piston. Normally the fingers are locked in a radially extended position. Mounted on the operating deck is the drive mechanism assembly which consists of the manual carriage drive mechanism, the operating handle, the pneumatic selector valve for actuating the gripper piston, and the electric hoist for elevation control of the gripper.

### **Spent Fuel Assembly Handling Tool**

The spent fuel assembly handling tool (Figure 9.1-11) is used to handle new and spent fuel assemblies in the spent fuel pit. It is a manually actuated tool, suspended from the spent fuel pit bridge crane, which uses four cam actuated latching fingers to grip the underside of the fuel assembly top nozzle. The operating handle to actuate the fingers is located at the top of the tool. When the fingers are latched, a pin is inserted into the operating handle which prevents the fingers from being accidentally unlatched during fuel handling operations.

### **New Fuel Assembly Handling Tool**

The new fuel assembly handling tool (Figure 9.1-12) is used to lift and transfer fuel assemblies between the new fuel shipping containers, the new fuel storage racks, and/or the new fuel elevator. It is a manually actuated tool suspended from the Auxiliary Building crane which uses four cam actuated latching fingers to grip the underside of the fuel assembly top nozzle. The operating handles to actuate the fingers are located on the side of tool. When the fingers are latched, the safety screw is turned in to prevent the accidental unlatching of the fingers.

### **Reactor Vessel Head Lifting Device**

The reactor vessel head lifting device consists of a welded and bolted structural steel frame with suitable rigging to enable lifting and storing the head during refueling operations. The lifting device is permanently attached to the reactor vessel head.

### **Reactor Internals Lifting Device**

The reactor internals lifting device (Figure 9.1-13) is a structural steel frame. The frame is lowered onto the guide tube support plate of the internals, and is mechanically connected to the support plate by three bolts. Bushings on the frame engage guide studs in the vessel flange to provide guidance during removal and replacement of the internals package.

### **Reactor Vessel Stud Tensioner**

The stud tensioners (Figure 9.1-14) are employed to secure the head closure joint at every refueling. The stud tensioner is a hydraulically operated device that uses oil as the working fluid. The device permits preloading and unloading of the reactor vessel closure studs at cold shutdown conditions. Stud tensioners minimize the time required for stud tensioning and detensioning operations. Three tensioners are provided and are applied simultaneously to three studs located 120 degrees apart. A single hydraulic pumping unit operates the tensioners, which are hydraulically connected. The studs are tensioned to their operational load in two steps to prevent high stresses

in the flange region and unequal loadings in the studs. Relief valves on each tensioner prevent overtensioning of the studs due to excessive pressure.

### 9.1.4.3 Design Evaluation

#### 9.1.4.3.1 Safe Handling

##### Design Criteria for the Refueling Machine

- (1) The primary design objective of the refueling machine is reliability. A conservative design approach is used for all load bearing parts. Throughout the design consideration is given to the fact that the machine spends long idle periods stored in an atmosphere of 80°F and high humidity. In general, the crane structure is considered in the Class A1, Standby Service, as defined by the Crane Manufacturers Association of American Specification No. 70.
- (2) Seismic design considerations are discussed in Section 9.1.4.3.2.
- (3) All components critical to the operation of the crane and parts which could fall into the reactor are positively restrained from loosening. Fasteners above water that cannot be lockwired or tack welded are coated with locking compound.

Industrial codes and standards used in the design of the fuel handling equipment are:

- (1) Refueling machine and fuel handling machine: Applicable sections of Crane Manufacturer Association of America Specification No. 70.
- (2) Structural: AISC, Part 5, 7th Edition
- (3) Electrical: Applicable standards and requirements of the IEEE Standard 279, National Electric Code, NFPA#70, and NEMA Standard MG 1 shall be used in the design of all electrical equipment.
- (4) Materials: Materials conform to the specifications of the ASTM standard.
- (5) Safety: OSHA Standards 29 CFR 1910 and 29 CFR 1926, including load testing requirements, the requirements of Regulatory Guide 1.29, and General Design Criteria 61 and 62.

##### Refueling Machine

The refueling machine design includes the following provisions to ensure safe handling of fuel assemblies:

- (1) Electrical Interlocks
  - (a) Bridge, Trolley and Hoist Drive Interlocks



Bridge, along with the trolley drives are interlocked with the hoist, using redundant interlocks to prevent simultaneous operation of the hoist with the bridge and/or trolley.

(b) Bridge Trolley Drive - Gripper Tube Up

Bridge and trolley drive operation is prevented except when the gripper tube up position switches are actuated or during indexing operation. The interlock is redundant.

(c) Gripper Interlock

An interlock is supplied which prevents the opening of a solenoid valve in the air line to the gripper except when zero suspended weight is indicated by a force gage. As backup protection for this interlock, the mechanical weight actuated lock in the gripper, prevents operation of the gripper under load even if air pressure is applied to the operating cylinder. This interlock is redundant.

(d) Excessive Suspended Weight

Two redundant excessive suspended weight switches open the hoist drive circuit in the up direction when the loading is excessive based on the vendor recommendations. The interlock is redundant.

The hoist is also provided with a low-load safety circuit, which prevents down-travel of the hoist if the load cell weight is sufficiently reduced. This minimizes the possibility of fuel assembly damage if one fuel assembly were to be lowered on top of another fuel assembly. The low load safety circuit setpoint is established using vendor recommendations.

(e) Hoist-Gripper Position Interlock

An interlock in the hoist drive circuit in the up direction permits the hoist to be operated only when either the open or closed indicating switch on the gripper is actuated. The hoist-gripper position interlock consists of two separate circuits that work in parallel so that one circuit must be closed for the hoist to operate. If one or both interlocking circuits fail in the closed position, an audible and visual alarm on the console is actuated.

(2) Bridge and Trolley Hold-Down Devices

Both refueling machine bridge and trolley are horizontally restrained on the rails by two pairs of guide rollers, one pair at each wheel location on one truck only. The rollers are attached to the bridge truck and contact the vertical faces on either side of the rail to prevent horizontal movement. Vertical restraint is accomplished by anti-rotation bars located at each of the four

wheels for both the bridge and trolley. The anti-rotation bars are bolted to the trucks and, for the bridge restraints, extended under the rail flange, while the trolley restraints extend beneath the top flange of the bridge girder which supports the trolley rail. Both horizontal and vertical restraints are adequately designed to withstand the forces and overturning moments resulting from the Safe Shutdown Earthquake.

(3) Design Load

The structure which supports the fuel assembly is designed for a static load of 5500 pounds. The refueling machine hoist has a manufacturer's rated capacity of 4000 pounds but is capable of supporting a static load of 5000 pounds with a safety factor of 5.0, and has been evaluated to be capable of a 5500 lb. static load in an emergency. Under normal conditions, the working load of the hoist is 2500 pounds (the weight of a fuel assembly, approximately 1600 pounds, plus gripper tube which weighs less than 1000 pounds). During normal hoist operation, the overload setpoint limits the hoist load to a value well below the rated capacity of the hoist. This value is based on vendor recommendations. The maximum allowable emergency pullout load (total maximum load which can be applied using the handwheel without danger of over stressing the hoist and supporting structure) is 5500 pounds. The 5500 pound load is a static load to be applied with the handwheel only, and only under emergency conditions. A load sensing device allows the load to be measured, so the operator knows the load being imposed on the hoist when using the handwheel.

(4) Main Hoist Braking System

The main hoist is equipped with two independent braking systems. A solenoid release, spring-set electric brake is mounted on the motor shaft.

This brake operates in the normal manner to release upon application of current to the motor and set when current is interrupted. The second brake is a mechanically actuated load brake internal to the hoist gear box that sets if the load starts to overhaul the hoist. It is necessary to apply torque from the motor to raise or lower the load. In raising, this motor cams to brake open; in lowering, the motor slips the brake allowing the load to lower. This brake actuates upon loss of torque from the motor for any reason and is not dependent on any electrical circuits. The motor brake capacity is 100% of the rated hoist capacity of 4000 pounds. The mechanical brake has a capacity of 150% of the rated hoist capacity.

(5) Fuel Assembly Support System

The main hoist system is supplied with redundant paths of load support such that failure of any one component will not result in free fall of the fuel assembly. Two wire ropes are anchored to the winch drum and carried over independent sheaves to a load equalizing mechanism on the top of the gripper tube. In addition, supports for the sheaves and equalizing

mechanism are backed up by passive restraints to pick up the load in the event of failure of this primary support. Each wire rope has a load rating 5 times the design load.

The gripper mechanism contains a spring actuated mechanical lock which prevents the gripper from opening unless the gripper is under a compressive load.

The gripper and hoist systems are routinely load tested to the requirements listed in plant Technical Requirements Manual.

### **Fuel Transfer System**

The following safety features are provided for in the fuel transfer system.

(1) Transfer Car Permissive Switch

The primary transfer car controls are located on the operating floor and conditions in the containment may, therefore, not be visible to the operator. The transfer car controls include an e-stop function on the containment side transfer control console allowing a second operator in the containment to exercise some control over car movement if conditions visible to him warrant such control. Transfer car operation is possible only when both lifting arms are in the down position as indicated by the underwater proximity switches. A second set of underwater proximity switches monitor the full up position of each of the upenders. Control logic provides a second permissive condition as a backup for the transfer car lifting arm interlock. Assuming the upender is in the upright position in the containment and the lifting arm interlock circuit fails in the permissive condition, the operator on the operating floor still cannot operate the car because the logic prevents car motion if either upender is indicated as being full up, or if either upender is indicated as being in motion.

(2) Lifting Arm - Transfer Car Position

Lifting arm operation is permitted only when the transfer car is at the respective end of its travel. Transfer car position indication, limit sensing, and braking controls are displayed on the control panel. The backup lifting arm interlock, a mechanical latch device which is opened by the weight of the fuel container when in the horizontal position, has been abandoned.

(3) Transfer Car - Valve Open

Interlocks on the transfer tube valve permit transfer car operation only when the transfer tube valve position switch indicates the valve is fully open.

(4) Transfer Car - Lifting Arm

The transfer car lifting arm interlock is primarily designed to protect the equipment from overload and possible damage if an attempt is made to move the car when the upender is not in the horizontal position. The basic interlock is a position limit switch in the control circuit made up from a 150 pound load, cart in position, and cart in zone.

(5) Lifting Arm - Refueling Machine

The refueling canal lifting arm is interlocked with the refueling machine. Whenever the transfer car is located in the refueling canal, the lifting arm cannot be operated unless the refueling machine mast is in the fully retracted position or the refueling machine is not over the upender.

(6) Lifting Arm - Spent Fuel Pit Bridge

The transfer canal lifting arm is interlocked with the spent fuel pit bridge position and hoist. The lifting arm cannot be operated when the spent fuel pit bridge is over the lifting arm area and the hoist is not in the full up position or when the spent fuel pit bridge crane is in bypass mode.

### **Spent Fuel Pit Bridge**

The spent fuel pit bridge includes the following safety features.

- (1) The spent fuel pit bridge controls are interlocked to prevent simultaneous operation of bridge drive and hoist.
- (2) Bridge drive operation is prevented except when the hoist is in the full up position unless in bypass mode which allows bridge slow speed when the hoist is not in the full up position.
- (3) An overload protection device is included on the load monitor to limit the uplift force. The overload is set and administratively controlled based on Westinghouse recommendations.
- (4) Restraining bars are provided on each track to prevent the bridge from overturning.

### **Fuel Handling Tools and Equipment**

All fuel handling tools and equipment handled over an open reactor vessel are designed to prevent inadvertent decoupling from machine hooks (i.e., lifting rigs are pinned to the machine hook and safety latches are provided on hooks supporting tools).

Tools required for handling internal reactor components are designed with fail safe features that prevent disengagement of the component in the event of operating

mechanism malfunction. These safety features apply to all tools which handle or service new or spent fuel or fuel related components.

#### **9.1.4.3.2 Seismic Considerations**

The safety classifications for all fuel handling and storage equipment are listed in Table 3.2-2. These safety classes provide criteria for the seismic design of the various components. Class 1 and Class 2 equipment is designed to withstand the forces of the OBE and SSE. For normal conditions plus OBE loadings, the resulting stresses are limited to allowable working stresses as defined in the ASME Code, Section III, Appendix XVII, Subarticle XVII-2200 for normal and upset conditions. For normal conditions plus SSE loadings, the stresses are limited to within the allowable values given by Subarticle XVII-2110 for critical parts of the equipment which are required to maintain the capability of the equipment to perform its safety function. Permanent deformation is allowed for the loading combination which includes the SSE to the extent that there is no loss of safety function.

The Class 3 fuel handling and storage equipment satisfies the Class 1 and Class 2 criteria given above for the SSE. Consideration is given to the OBE only insofar as failure of the Class 3 equipment might adversely affect Class 1 or 2 equipment.

For non-nuclear safety equipment, design for the SSE is considered if failure might adversely affect a Safety Class 1, 2 or 3 component. Design for the OBE is considered if failure of the non-nuclear safety component might adversely affect a Safety Class 1 or 2 component.

#### **9.1.4.3.3 Containment Pressure Boundary Integrity**

The fuel transfer tube which connects the refueling cavity (inside the reactor containment) and the operating floor (outside the containment) is closed on the refueling cavity side by a blind flange when containment integrity is required, except during refueling operations. Two seals are located around the periphery of the blind flange with leak-check provisions between them.

#### **9.1.4.3.4 Radiation Shielding**

During all phases of spent fuel transfer, the gamma dose rate at the refueling bridge is 2.5 mr/hr or less. This is accomplished by maintaining a minimum of 9.9 feet of water above the active fuel region which correlates to 8 feet and 10.875 inches above the top of the fuel assembly during all handling operations.

The two fuel handling devices used to lift spent fuel assemblies are the refueling machine and the spent fuel pit bridge. The refueling machine contains positive stops which prevent the active fuel region of a fuel assembly from being raised to within a minimum of 9.9 feet of the water level in the refueling cavity. The hoist on the spent fuel pit bridge moves spent fuel assemblies with a long handled tool. Hoist travel and tool length likewise limit the maximum lift of the active fuel region of a fuel assembly to within a minimum of 9.9 feet of the water level in the spent fuel pit and transfer canal.

**9.1.4.4 Tests and Inspections**

As part of normal plant operations, the fuel handling equipment is inspected for operating conditions prior to each refueling operation. During the operational testing of this equipment, procedures are followed that will affirm the correct performance of the fuel handling system interlocks.

**REFERENCES**

- (1) Holtec Report No. HI-2002607, R0, "LOCA Temperature Analysis of the Watts Bar Spent Fuel Pool."

**Table 9.1-1 SPENT FUEL POOL COOLING AND CLEANUP SYSTEM DESIGN PARAMETERS**

Spent Fuel Pool Storage Capacity	1386 Assemblies
Spent Fuel Pool Water Volume	372,460 <sup>(1)</sup> gallons
Nominal Boron Concentration of the Spent Fuel Pool Water	2,000 ppm

	Decay Heat <sup>(2)</sup> (MBTU/hr)	Maximum SFP Temperature (2-Train) (°F)	Maximum SFP Temperature (1-Train) (°F)	SFP Loss of Cooling Heatup Rate (°F/hr)	Boil-Off Time to 10ft Above Rack With no Makeup (hr)
Normal Full Core Discharge <sup>(3)</sup>	28.1	124.7	151.2	9.88	47.4
Emergency Offload <sup>(4)</sup>	25.6	129.3	159.2	8.40	55.1
Optimum (Better than Design) Conditions <sup>(5)</sup>	50.2	129.3	159.2	16.46	28.1

(1) Including Cask Pit Area Volume

(2) Decay Heat in accordance with ANS Standard 5.1, "Decay Heat Power in Light Water Reactors," and USNRC Regulatory Guide 3.54, "Spent Fuel Heat Generation in an Independent Spent Fuel Pool Storage Installation."

(3) Stored legacy fuel assemblies, plus an additional full core (193 assemblies) discharged after 33 days decay time at design basis heat exchanger fouling conditions and Technical Specification Ultimate Heat Sink (UHS) temperatures. The normal refueling interval for WBN is 18 months, with refueling outages typically scheduled in the spring and fall.

(4) Stored legacy fuel assemblies, plus 96 assemblies discharged the previous refueling outage, decayed 96 days, plus an additional full core (193 assemblies) discharged after 60 days decay time. The SFP has been analyzed for a maximum water temperature of 159.2 °F.

(5) Considers better than design heat exchanger fouling and better than design UHS temperature

**Table 9.1-2 SPENT FUEL POOL COOLING AND CLEANUP SYSTEM DESIGN AND OPERATING PARAMETERS**  
(Page 1 of 4)

<b>Spent Fuel Pool Pump</b>	
Number	3
Design pressure, psig	150
Design temperature, °F	200
Design flow, gpm	2300
Total developed head, ft	125
Material	Stainless Steel
<b>Spent Fuel Pool Skimmer Pump</b>	
Number	1
Design pressure, psig	150
Design temperature, °F	200
Design flow, gpm	100
Total developed head, ft	50
Material	Stainless Steel
<b>Refueling Water Purification Pump</b>	
Number	2
Design pressure, psig	150
Design temperature, °F	200
Design flow, gpm	200
Total developed head, ft	170
Material	Stainless Steel



**Table 9.1-2 SPENT FUEL POOL COOLING AND CLEANUP SYSTEM DESIGN AND OPERATING PARAMETERS (Continued)**  
(Page 2 of 4)

<b>Spent Fuel Pool Heat Exchanger</b>		
Number	2	
Design heat transfer, Btu/hr	11.94 x 10 <sup>6</sup>	
	Shell	Tube
Design pressure, psig	150	150
Design temperature, °F	200	200
Design flow lb/hr	1.49 x 10 <sup>6</sup>	1.14 x 10 <sup>6</sup>
Inlet temperature, °F	95	120
Outlet temperature, °F	103	109.5
Fluid circulated	Component Cooling Water	Spent Fuel Pool Water
Material	Carbon Steel	Stainless Steel
<b>Spent Fuel Pool Demineralizer</b>		
Number	1	
Design pressure, psig	300	
Design temperature, °F	250	
Design flow, gpm	100*	
Resin volume, ft <sup>1</sup>	30	
Material	Stainless Steel	
<b>Spent Fuel Pool Filter</b>		
Number		1
Design pressure, psig		300
Design temperature, °F		250
Design flow, gpm		150
Filtration requirement		98% retention of particles above 5 microns
Materials, vessel		Stainless Steel

\* Flow may be increased to 180 gpm for refueling cavity and RWST cleanup.

**Table 9.1-2 SPENT FUEL POOL COOLING AND CLEANUP SYSTEM DESIGN AND OPERATING PARAMETERS (Continued)**  
(Page 3 of 4)

<b>Spent Fuel Pool Skimmer Filter</b>	
Number	1
Design pressure, psig	300
Design temperature, °F	250
Design flow, gpm (Filter)	150
Rated flow, gpm (Pump)	100
Filtration requirement	98% retention of particles above 5 microns
Material, vessel	Stainless Steel
<b>Refueling Water Purification Filter</b>	
Number	2
Design pressure, psig	200
Design temperature, °F	250
Design flow, gpm	200
Filtration requirement	98% retention of particles above 5 microns
Material, vessel	Stainless Steel
<b>Spent Fuel Pool Strainer</b>	
Number	2
Rated flow, gpm	2300
Perforation, inches	Approximately 0.2
Material	Stainless Steel
<b>Spent Fuel Pool Skimmer Strainer</b>	
Number	1
Rated flow, gpm	100
Design pressure, psig	50
Design temperature, °F	200
Perforation, inches	1/8
Material	Stainless Steel

**Table 9.1-2 SPENT FUEL POOL COOLING AND CLEANUP SYSTEM DESIGN AND OPERATING PARAMETERS (Continued)**  
(Page 4 of 4)

<b>Spent Fuel Pool Skimmers</b>	
Number	2
Design flow, gpm	50
<b>Piping and Valves</b>	
Design pressure, psig	150
Design temperature, °F	200
Material	Stainless Steel

**Table 9.1-3 BASIS FOR DESIGN CRITERIA OF THE WATTS BAR NUCLEAR PLANT SPENT FUEL RACKS**

ASME B&PV Code, Section III, Subsection NF
AISC Manual of Steel Construction, Seventh Edition, 1970.
USNRC Standard Review Plan, Section 3.8.4, "Other Seismic Category I Structures".
USNRC Regulatory Guide 1.13, "Spent Fuel Storage Facility Design Basis."
USNRC Regulatory Guide 1.29, "Seismic Design Classification".
USNRC Regulatory Guide 1.92, "Combining Model Responses and Spatial Components in Seismic Response Analysis".
OT Position for Review and Acceptance of Spent Fuel Storage and Handling Applications, dated April 14, 1978.
10 CFR Part 50, Appendix B, "Quality Assurance Criteria For Nuclear Power Plants and Fuel Reprocessing Plants".

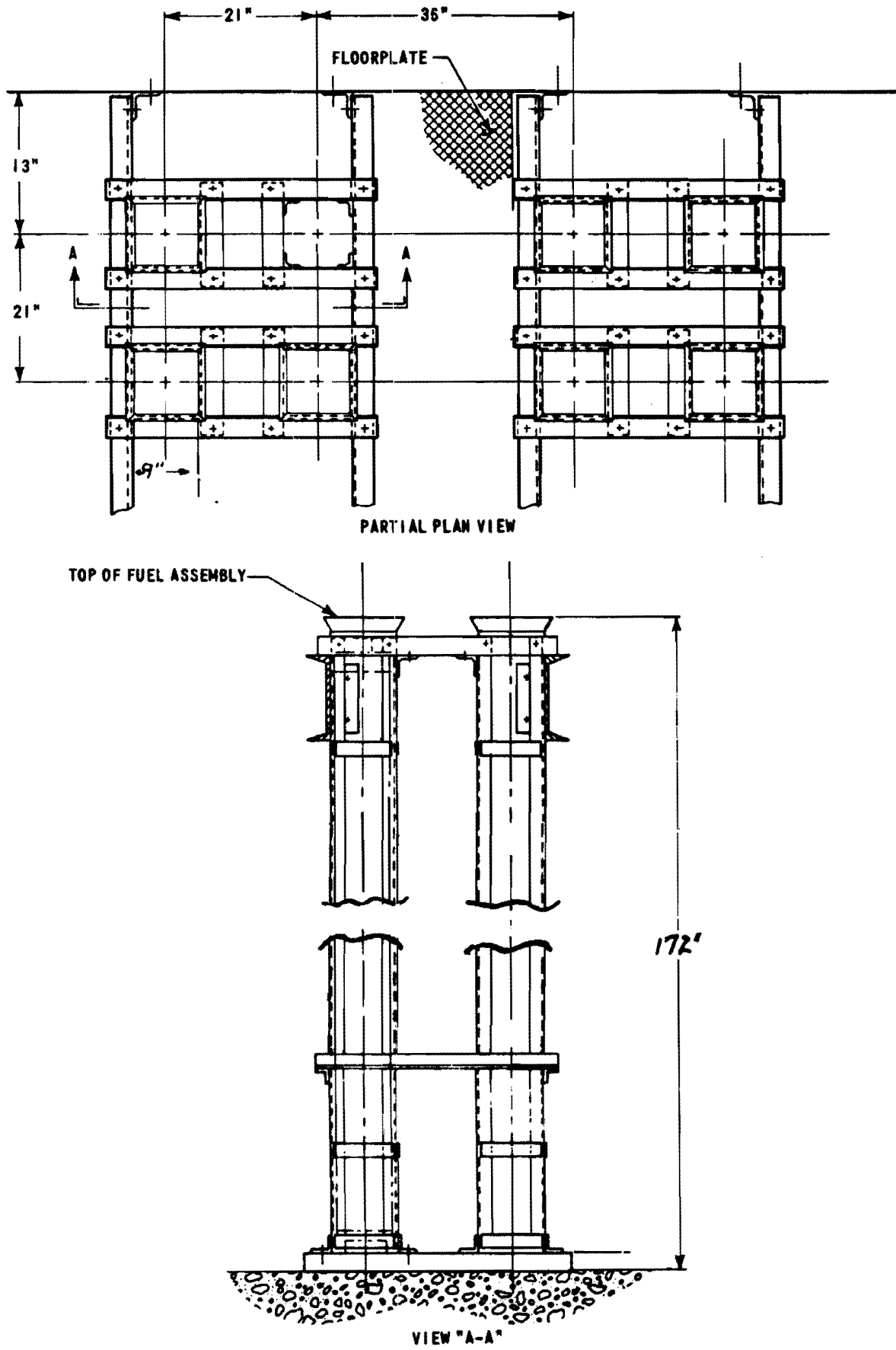

Figure 9.1-1. New Fuel Storage Racks

Figure 9.1-1 New Fuel Storage Racks

Figure 9.1-2 Deleted by Amendment 44

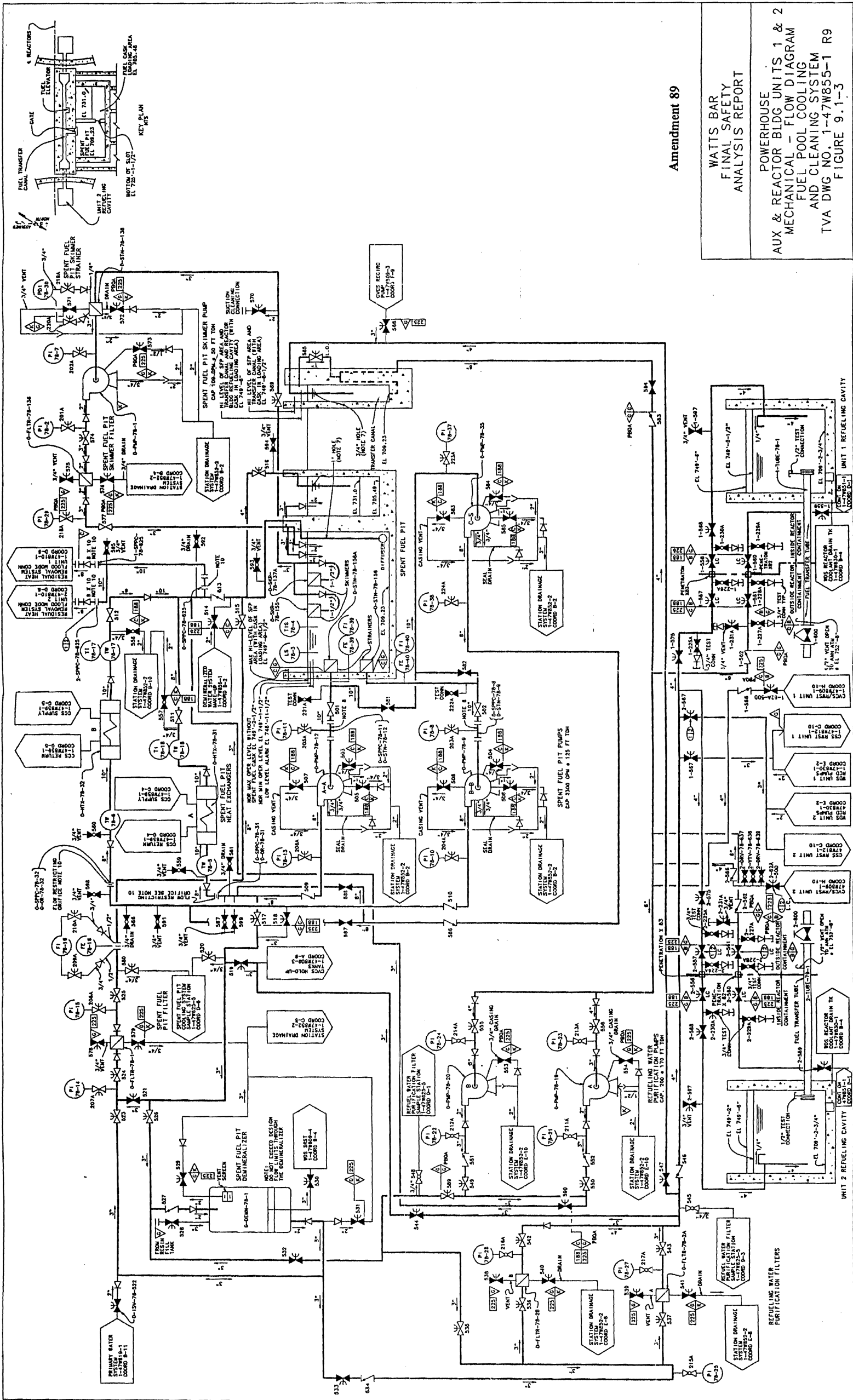
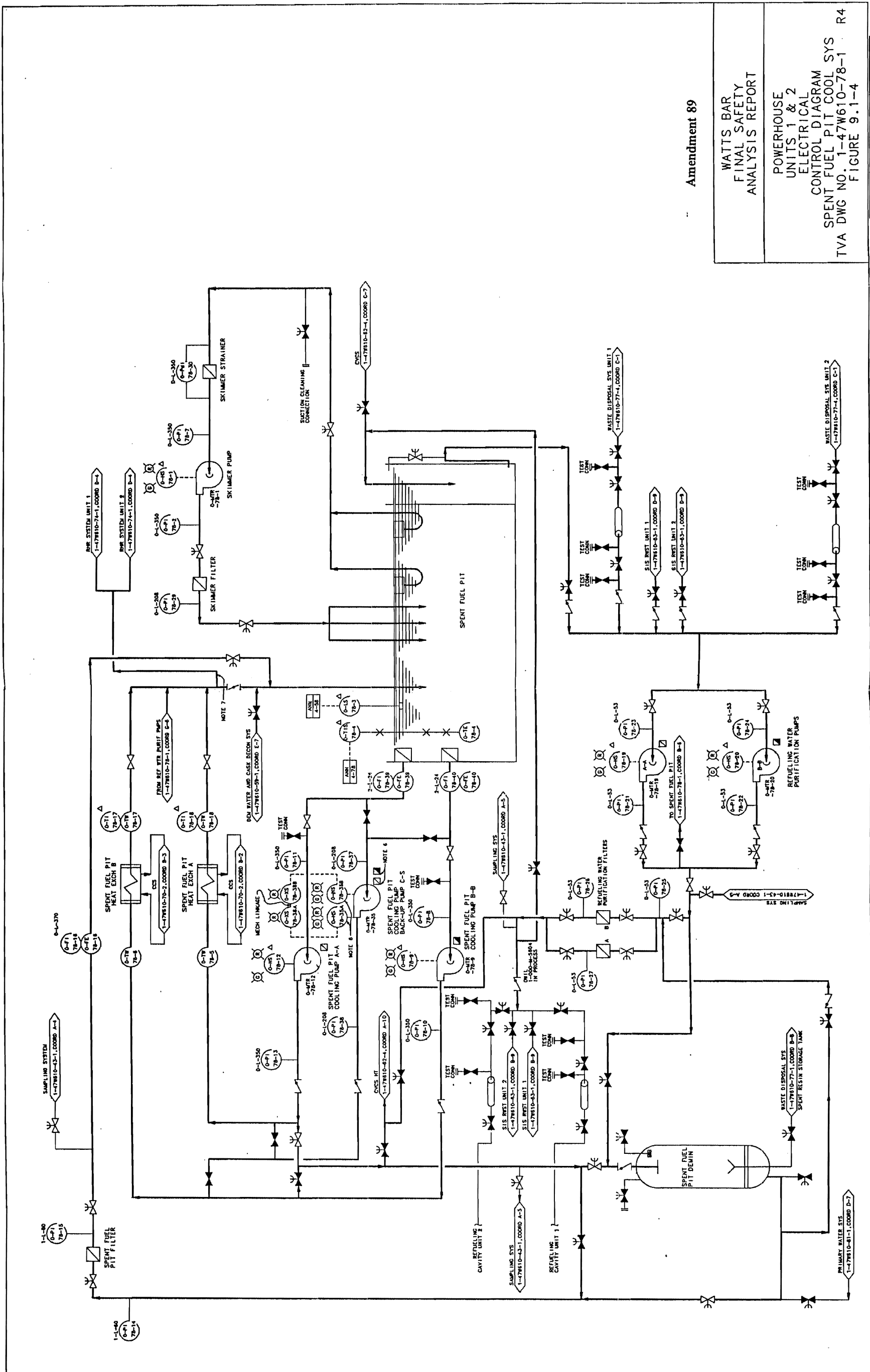

Figure 9.1-3 Powerhouse, Auxiliary, and Reactor Buildings Units 1 & 2 Mechanical - Flow Diagram for Fuel Pool Cooling and Cleaning System



Amendment 89

WATTS BAR  
FINAL SAFETY  
ANALYSIS REPORT

POWERHOUSE  
UNITS 1 & 2  
ELECTRICAL

CONTROL DIAGRAM  
SPENT FUEL PIT COOL SYS  
TVA DWG NO. 1-47W610-78-1 R4  
FIGURE 9.1-4

PROCADAM MAINTAINED DRAWING  
UNIT COOL SYSTEM CONTROL DIAGRAM FOR SPENT FUEL PIT  
FOR COOL UNIT AND TEST POINTS FOR PROCADAM PROJECT

Figure 9.1-4 Powerhouse Units 1 & 2 Electrical Control Diagram for Spent Fuel Pit Cooling System



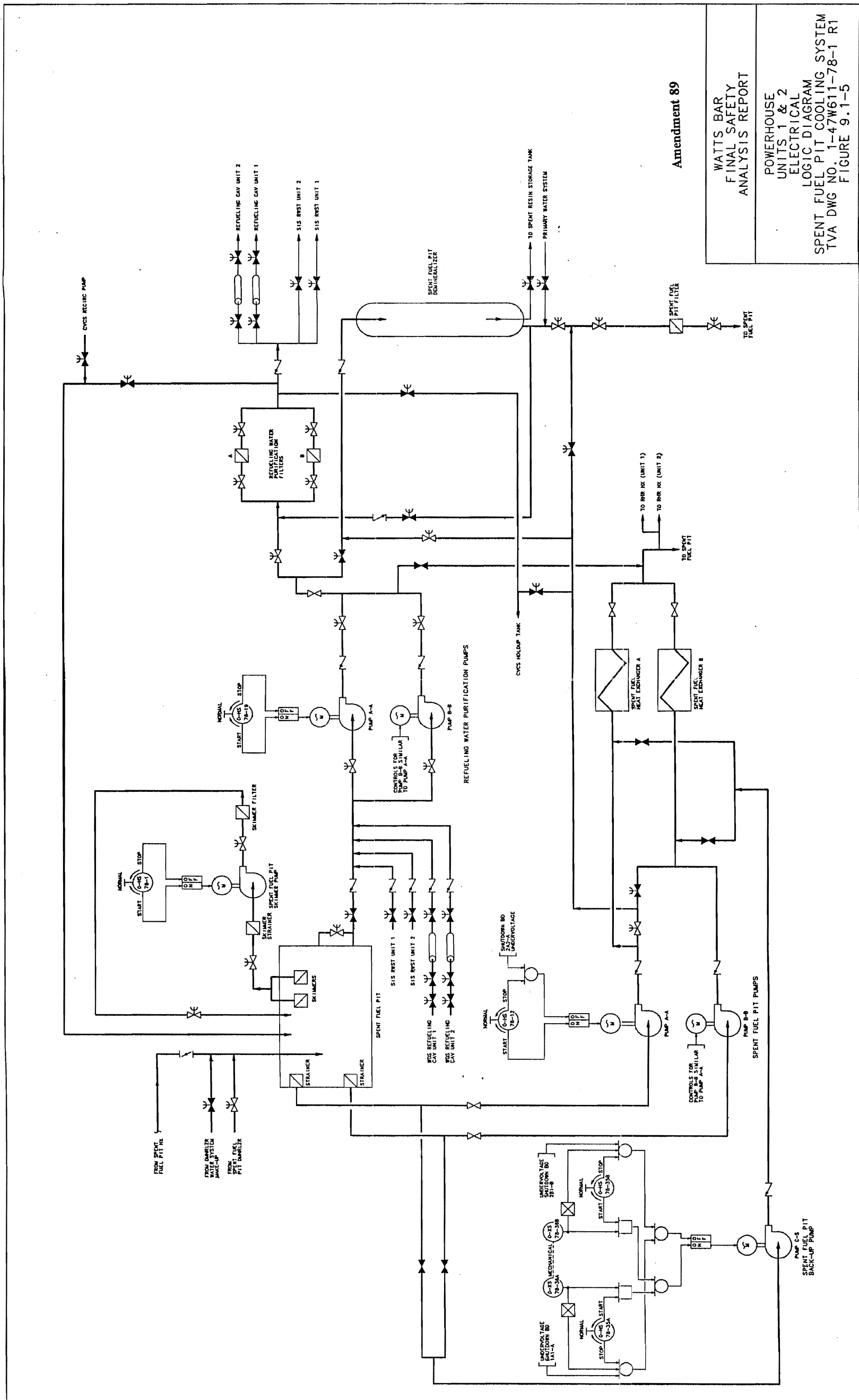

Amendment 89

WATTS BAR  
FINAL SAFETY  
ANALYSIS REPORT

POWERHOUSE  
UNITS 1 & 2  
ELECTRICAL  
LOGIC DIAGRAM  
SPENT FUEL PIT COOLING SYSTEM  
TVA DWG NO. 1-47W611-78-1 R1  
FIGURE 9.1-5

PROCADAM MAINTAINED DRAWING  
REV. 100 UNIT 1017 10 2004

Figure 9.1-5 Powerhouse Units 1 & 2 Electrical Logic Diagram for Spent Fuel Pit Cooling System

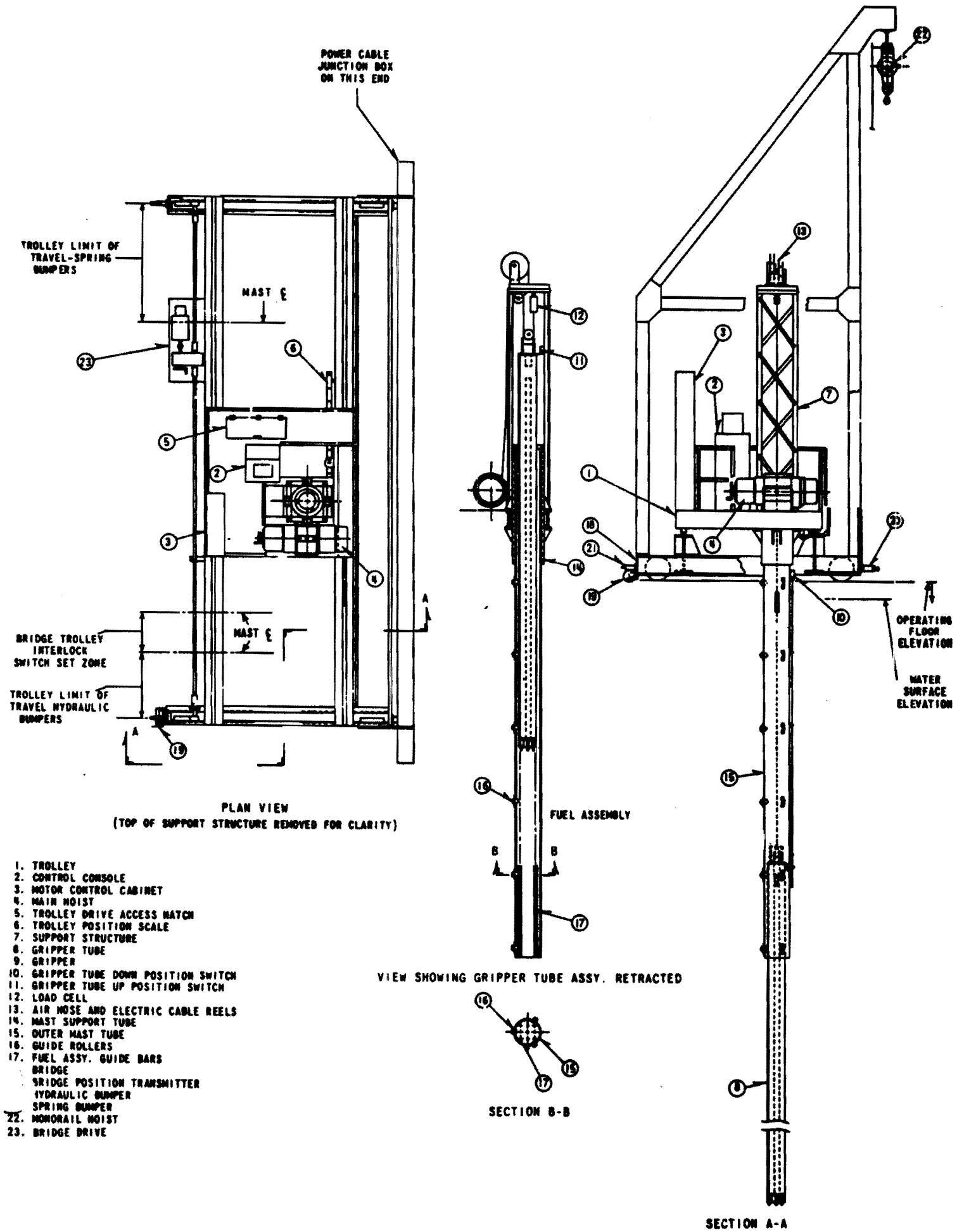

Figure 9.1-6 Typical Manipulator Crane

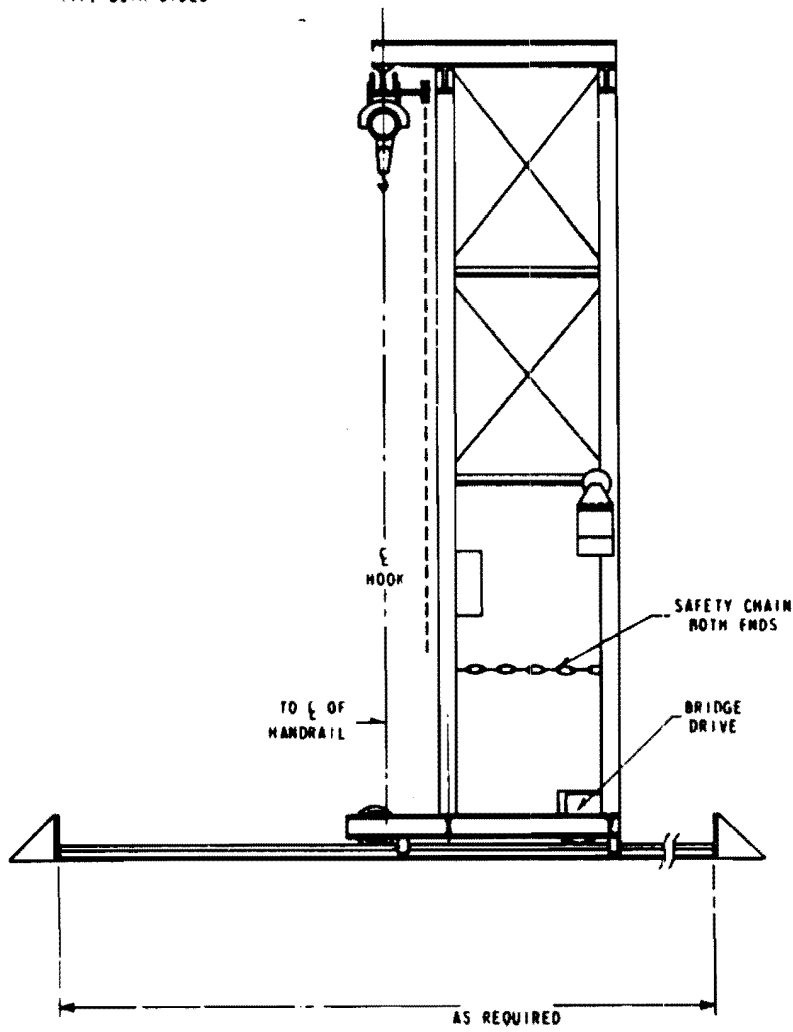
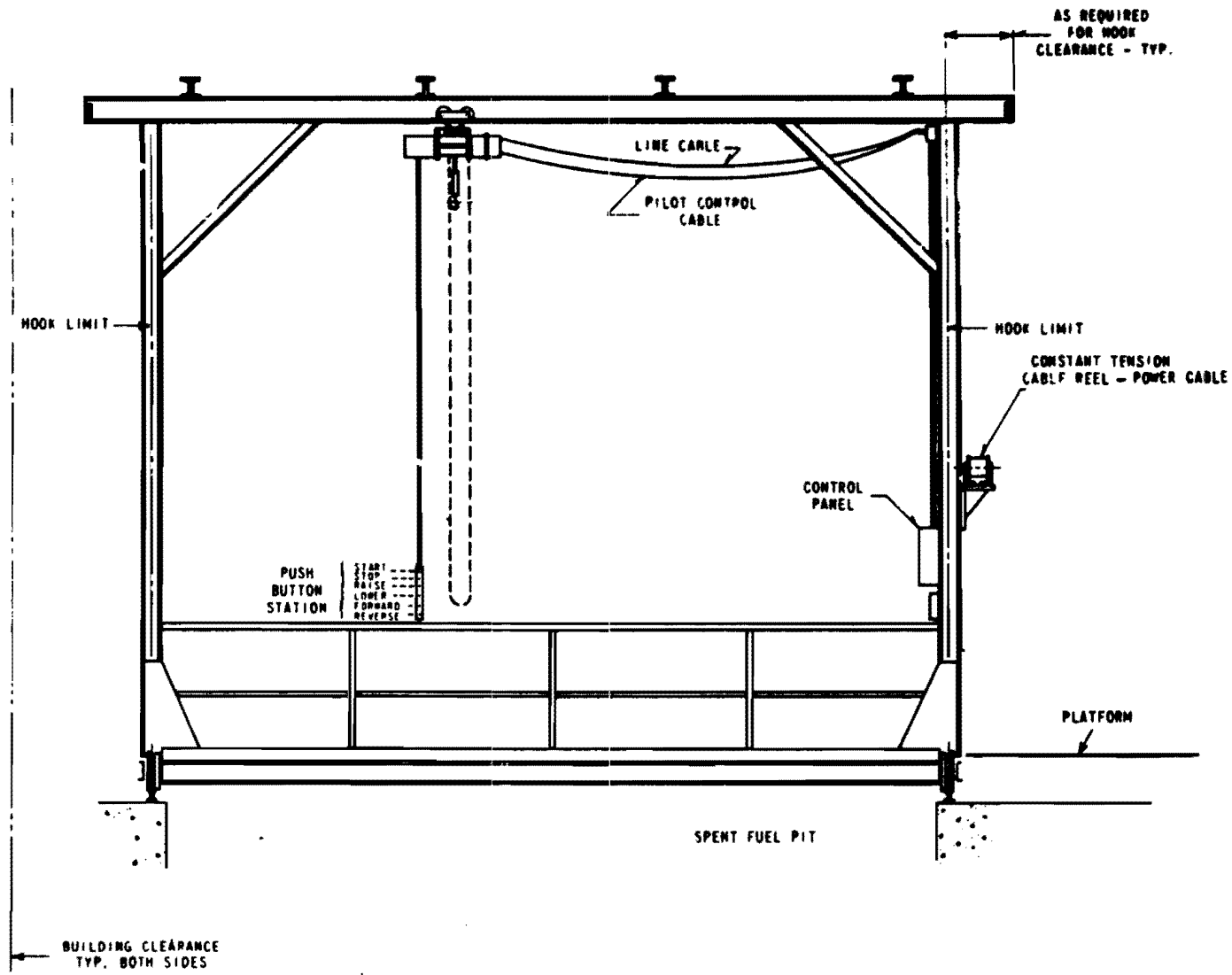

Figure 9.1-7 Typical Spent Fuel Pit Bridge

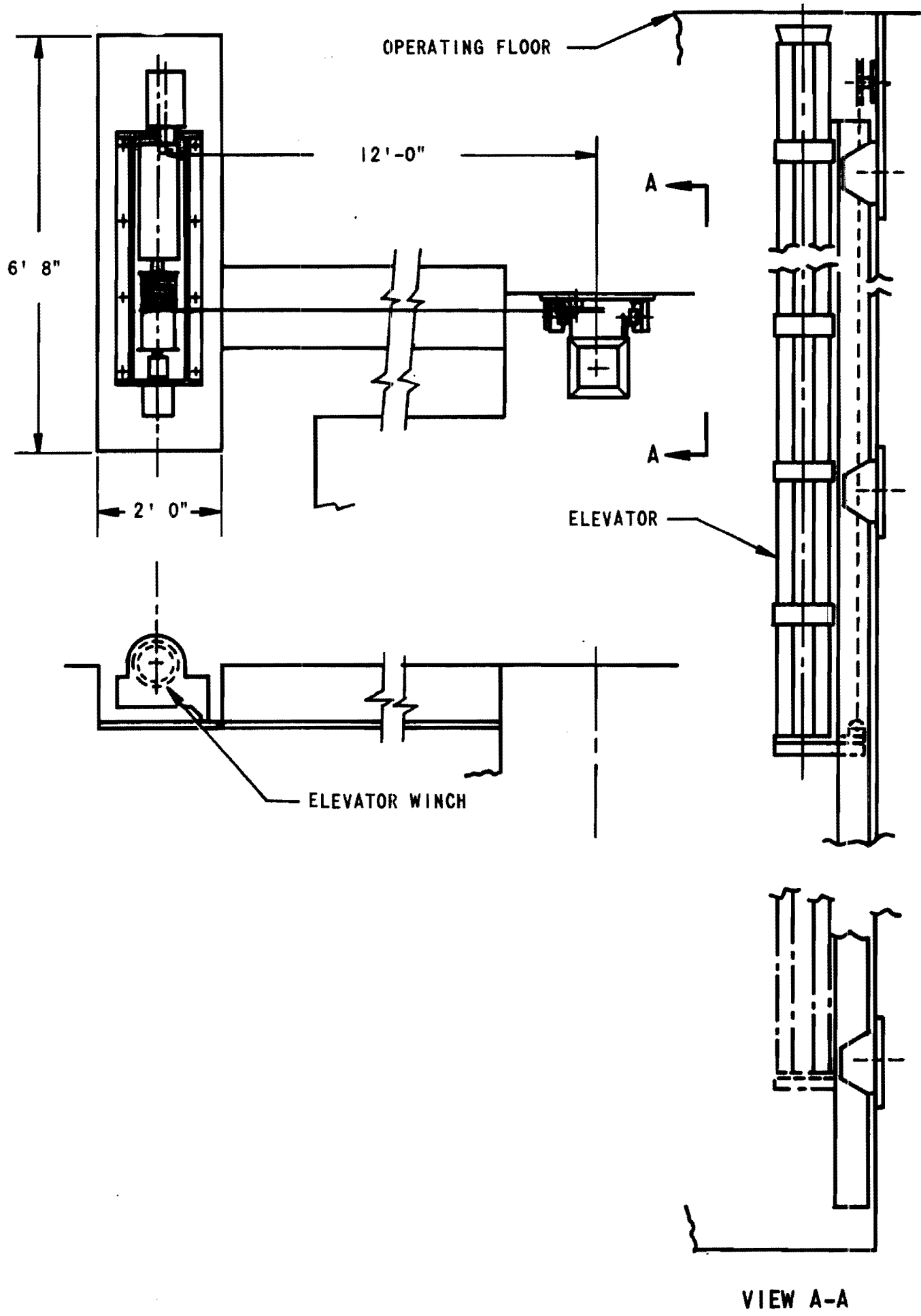

Figure 9.1-8 New Fuel Elevator

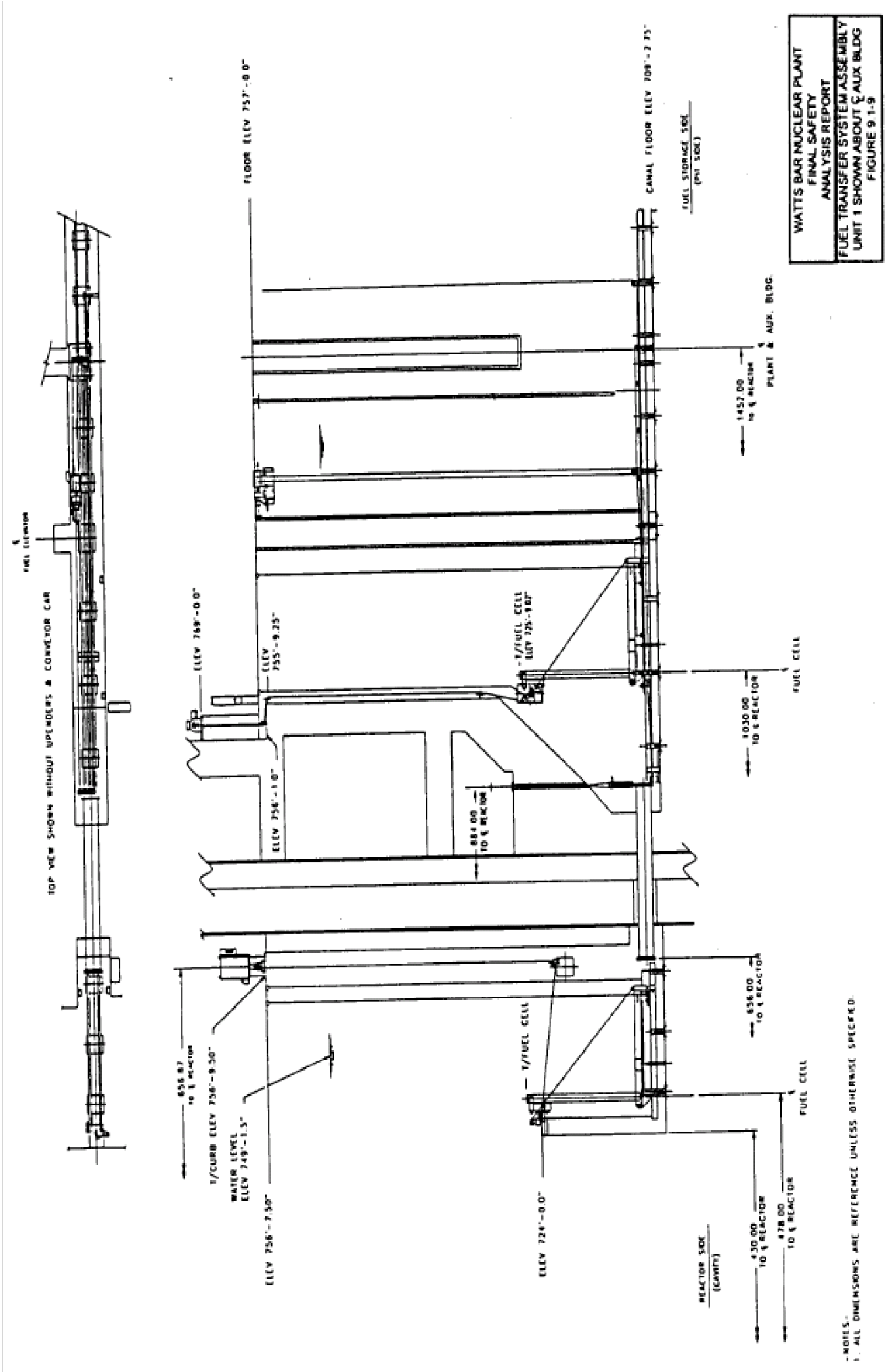

Figure 9.1-9 Fuel Transfer System Assembly

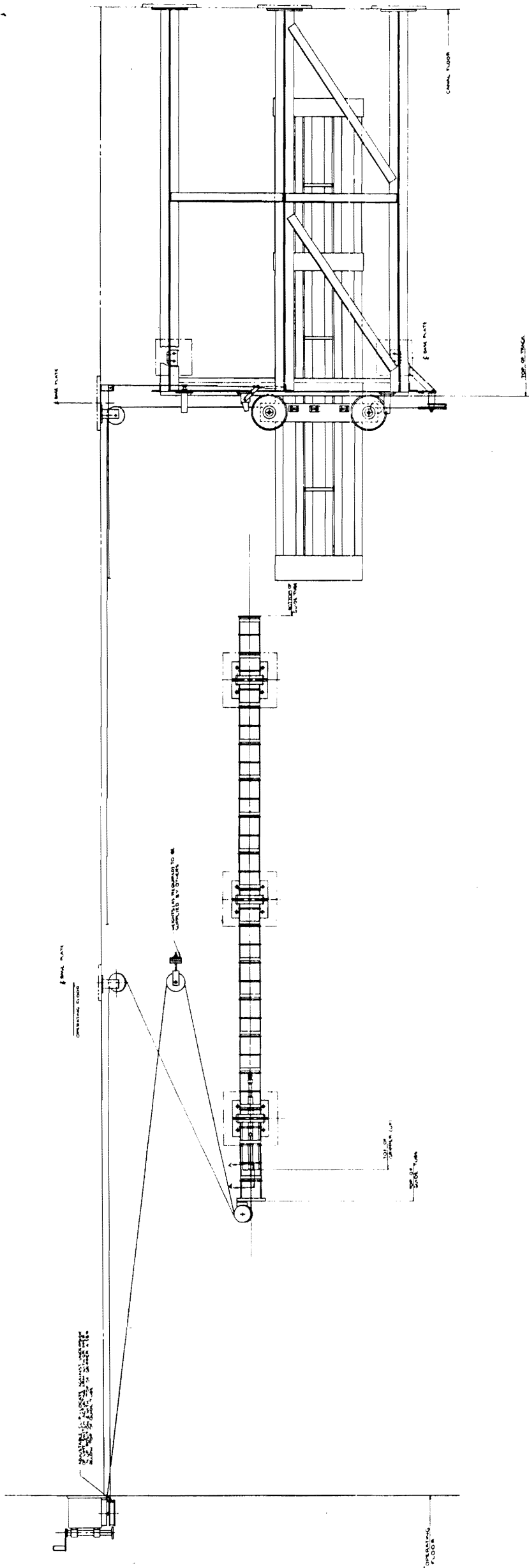

Figure 9.1-10 Rod Cluster Control Changing Fixture

Figure 9.1-10 Rod Cluster Control Changing Fixture

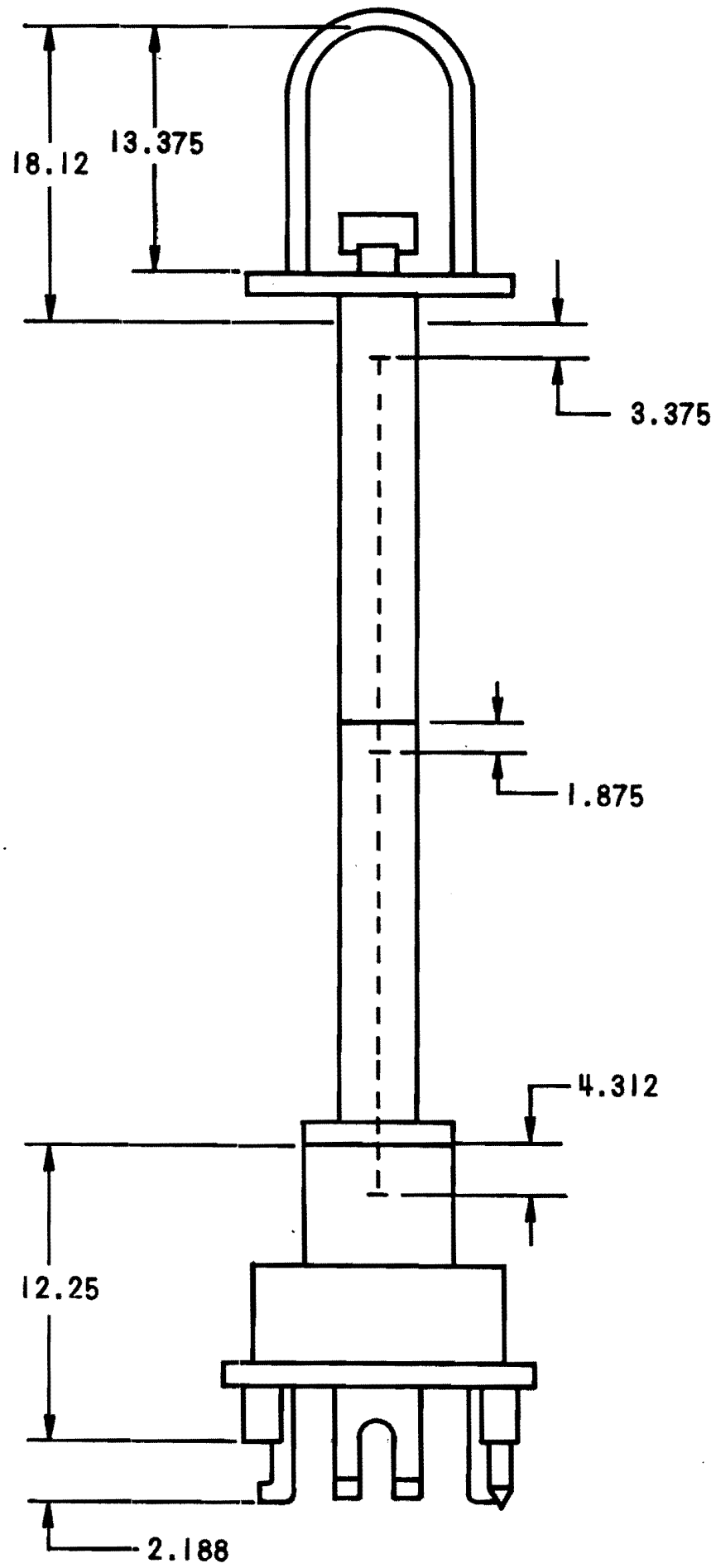

Figure 9.1-11 Typical Spent Fuel Handling Tool

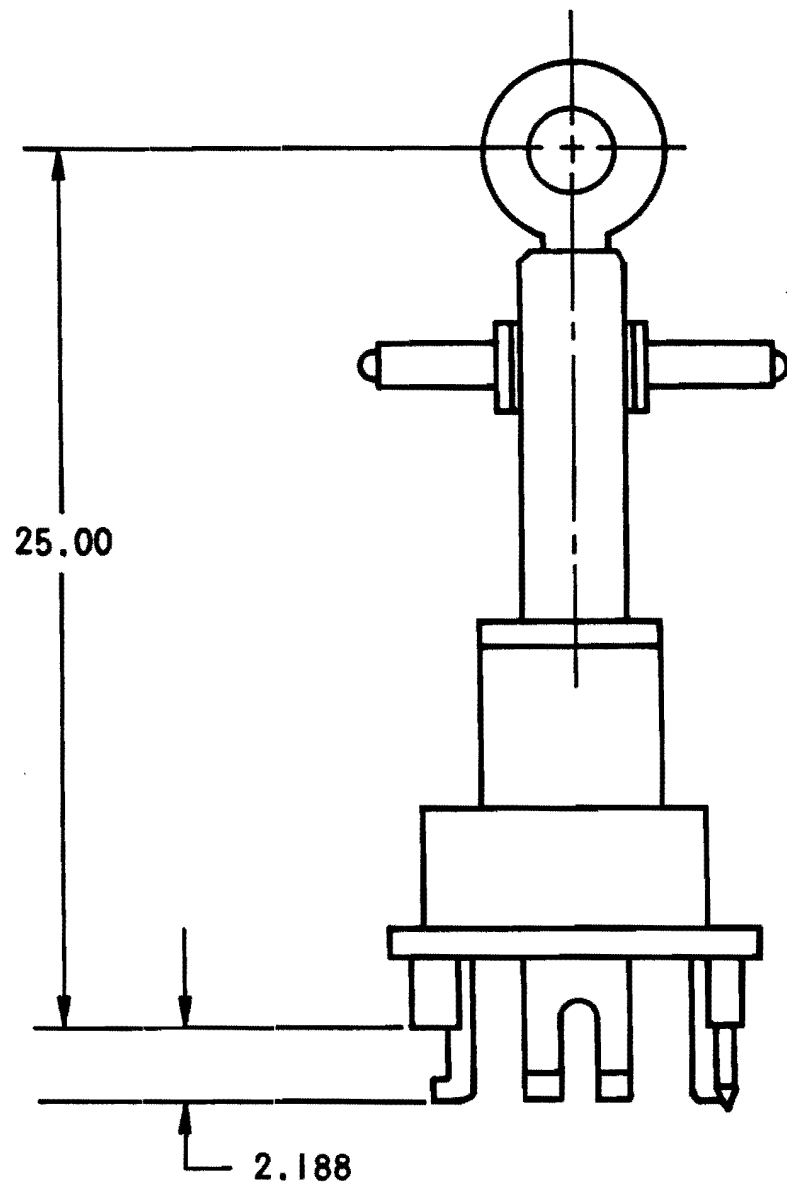

Figure 9.1-12 Typical New Fuel Handling Tool



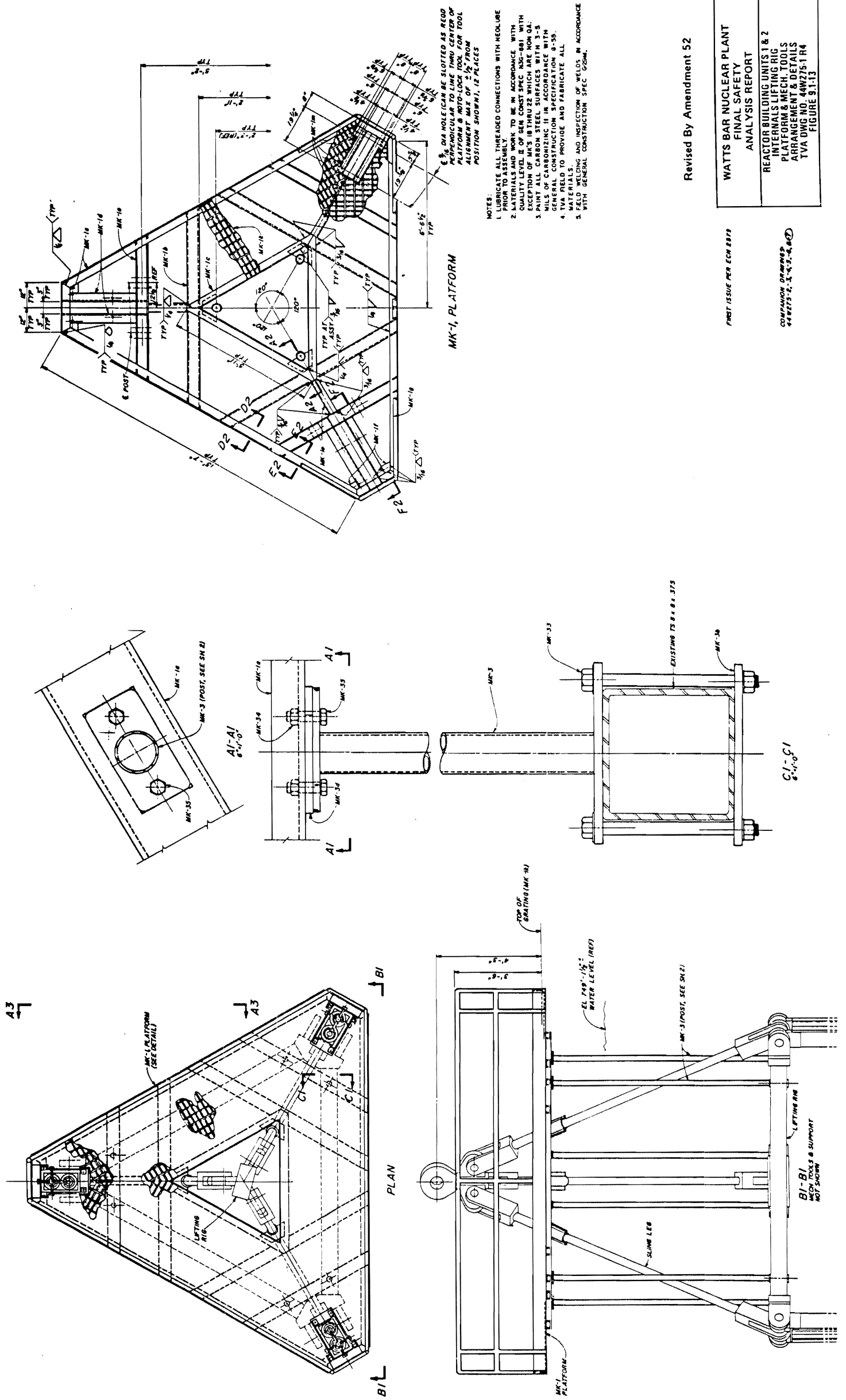

Figure 9.1-13 Reactor Building Internals Lifting Rig Platform and Mech. Tools Arrangement and Details

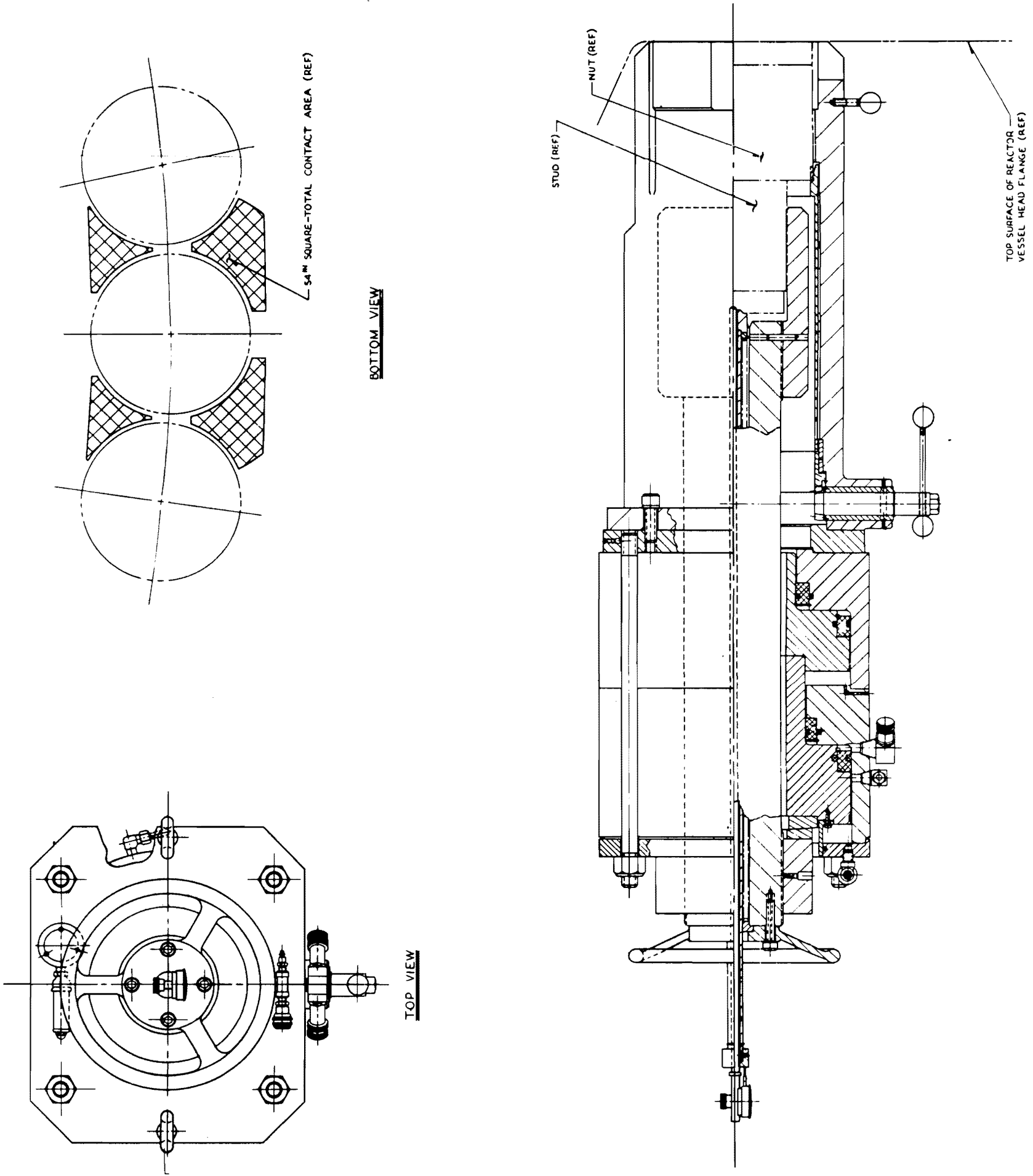

Figure 9.1-14 Typical Stud Tensioner

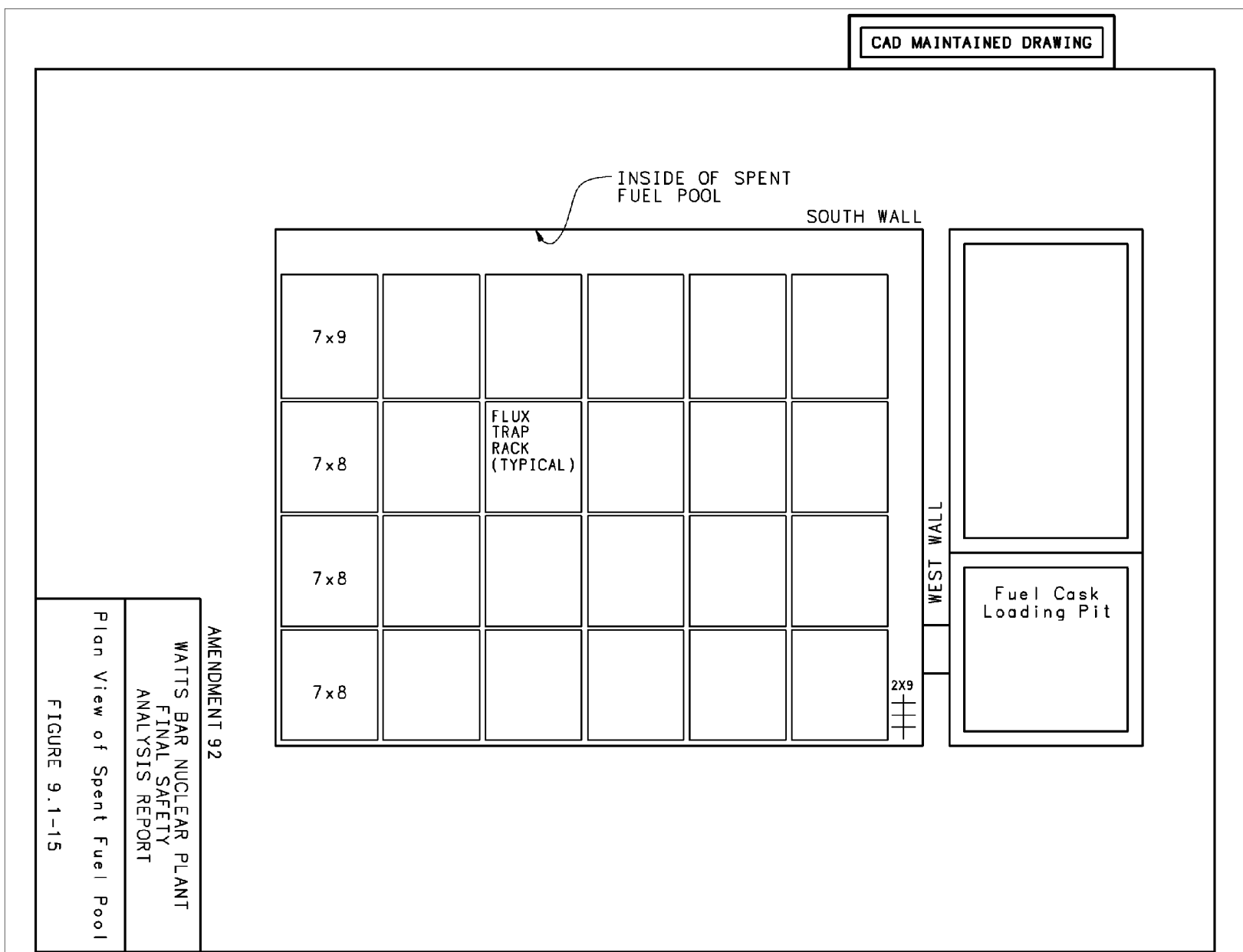

Figure 9.1-15 Plan View of Spent Fuel Pool

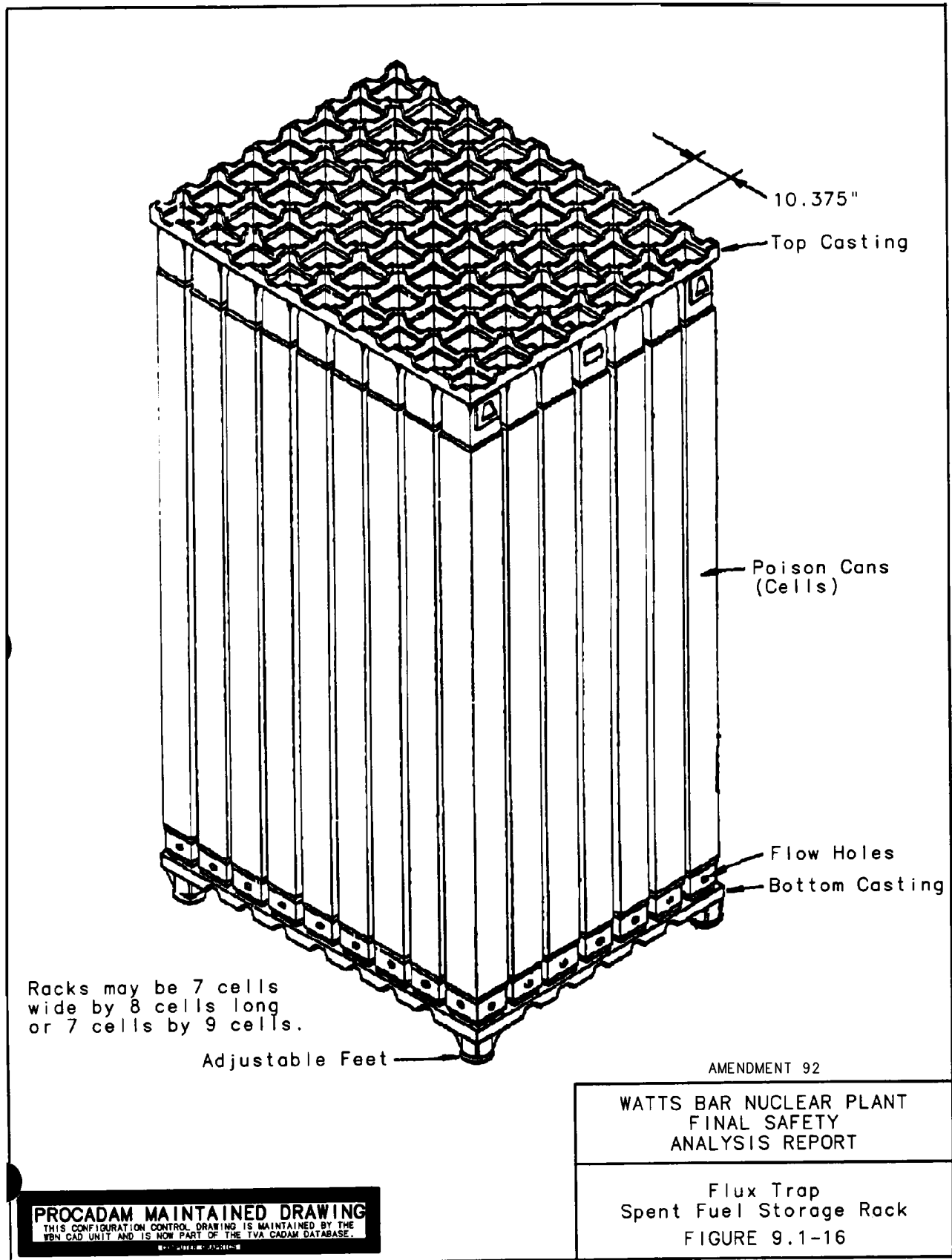

Figure 9.1-16 Flux Trap Spent Fuel Storage Rack

## 9.2 WATER SYSTEMS

### 9.2.1 Essential Raw Cooling Water (ERCW)

#### 9.2.1.1 Design Bases

The ERCW system is safety-related because it provides essential auxiliary support functions to the engineered safety features of the plant. The system is designed to supply cooling water to safety and non-safety related equipment. Provisions are made to ensure a continuous flow of cooling water to those systems and components necessary for plant safety either during normal operation or under accident conditions. Sufficient redundancy of piping and components is provided to ensure that cooling is maintained to vital loads at all times.

#### 9.2.1.2 System Description

The ERCW system consists of eight ERCW pumps, four traveling water screens, four screen wash pumps, four strainers located in the main intake pumping station, and associated piping and valves as shown in Figures 9.2-1 through 9.2-4B. The logic and control diagrams are presented in Figures 9.2-5 through 9.2-14A. The design data for pumps required for two-unit operation is shown in Table 9.2-1.

The eight ERCW pumps are mounted on the intake pumping station at Elevation 741.0 which is above the probable maximum flood level.

The ERCW system is designed to supply cooling water to the following components:

- (1) Component cooling heat exchangers\*\*\*
- (2) Containment spray heat exchangers
- (3) Emergency diesel generators
- (4) Emergency makeup for component cooling system
- (5) Control Building air conditioning water chillers\*\*\*
- (6) Auxiliary Building ventilation coolers (for ESF equipment)\*\*\*
- (7) Containment ventilation coolers\*\*\*
- (8) Air compressors\*\*\*
- (9) Reactor coolant pump (RCP) motor coolers\*\*\*
- (10) Control rod drive ventilation coolers\*\*\*
- (11) Residual heat removal heat exchangers \*
- (12) Shutdown Board Room Air Conditioning Water Chillers\*\*\*

- (13) Spent fuel pool heat exchangers\*
- (14) Reactor coolant pump thermal barrier\*
- (15) Ice machine refrigeration condenser\*
- (16) Instrument room chillers
- (17) Auxiliary feedwater\*\*
- (18) Sample system (SS) heat exchangers\*
- (19) Backup cooling water to the CCP 2A-A lube and gear oil cooler via the CCP 2A-A room cooler.

\*Provided with ERCW only during flood above Elevation 728.0.

\*\*Not a cooling load. ERCW discharge provides safety-related source for AFW only when preferred supply from the condensate storage tank is unavailable.

\*\*\*Loads on the system during normal operations.

The intake pumping station is located approximately 800 feet from the reservoir at the end of the plant intake channel which provides direct communication with the main river channel for reservoir levels including loss of downstream dam. The intake pumping station is so designed that ERCW related equipment located therein will remain operable during the probable maximum flood.

Water for the ERCW system enters two separate sump areas of the pumping station through four traveling water screens, two for each sump and two diver protection barriers, one for each sump (Figure 9.2-41). Four ERCW pumping units, on the same plant train, take suction from one of the sumps, and four more on the opposite plant train take suction from the other sump. One set of pumps and associated equipment is designated Train A, and the other Train B. These trains are redundant and are normally maintained separate and independent of each other. Each set of four pumps discharges into a common manifold, from which two separate headers (1A and 2A for Train A, 1B and 2B for Train B), each with its own automatic backwashing strainer, supply water to the various system users. Two ERCW Headers associated with the same ERCW train (i.e., 1A/2A or 1B/2B) may be cross-connected to provide greater flexibility (e.g., for strainer maintenance).

Two paths are available for water discharge from the ERCW system. The normal path is to the cooling tower basins of the condenser circulating water system for use as makeup for evaporative losses. The alternate path is to the yard holding pond through yard ERCW standpipes and an ERCW overflow box. The alternate path is seismically qualified up to and including the ERCW overflow box.

The alignment of ERCW headers and system users is as follows:

- (1) Containment spray heat exchangers 1A, 1B, 2A, and 2B are supplied from ERCW headers 1A, 1B, 2A and 2B, respectively.
- (2) The normal supply for both Train A diesel generators is from header 1A, although a backup source from header 2B is also provided. The normal supply for both Train B diesel generators is from header 1B with a backup supply from header 2A.
- (3) The normal supply for component cooling heat exchangers A, B, and C is from ERCW header 2A, 2A, and 2B, respectively. However, interconnections between headers 1B and 2A, and between 1A and 2B have been incorporated to permit alternate supplies.
- (4) Each header provides ERCW to its corresponding Main Control Room and Control Building electrical board room air-conditioning chillers, the Auxiliary Building ventilation coolers for ESF equipment, the containment ventilation coolers, the RCP motor coolers, the CRDM vent coolers, and the containment instrument room air conditioning water chillers (i.e., header 1A and 2A supply Train A equipment header 1B and 2B supply Train B equipment, etc.).
- (5) Headers 1A and 1B provide a normal and backup source of cooling water for the station air compressors. For the auxiliary control air compressors there is one compressor on header 1A and one on header 2B.
- (6) Under flood conditions, the ERCW system provides water to the spent fuel pool heat exchangers, reactor coolant pump thermal barrier, ice machine refrigeration condensers, and under certain conditions, residual heat removal heat exchangers and sample system heat exchangers (refer to Section 2.4.14) using spool piece inter-ties.
- (7) In the event of a need to supply ERCW to the auxiliary feedwater system, when the normal supply of water is not available from the condensate storage tank, discharge headers A and B automatically provide an emergency water supply to the motor-driven auxiliary feedwater pumps of the same train assignment as the header and to each unit's turbine driven auxiliary feedwater pump.
- (8) Connections are available in the A-train ERCW supply and return headers for the lower compartment coolers that will allow chilled water from a non-safety related chiller to be used to provide additional cooling of the Reactor Building during outages.
- (9) Two RCP motor coolers are supplied from ERCW Header 1A for Unit 1, 2A for Unit 2; and two are supplied from ERCW Header 1B for Unit 1 and 2B for Unit 2.

The supply headers are arranged and fitted with isolation valves such that a critical crack in either header can be isolated to ensure uninterrupted operation of the other

header. The operation of two pumps on the same plant train is sufficient to supply all cooling water requirements for the two-unit plant for unit cooldown, refueling or post-accident operation, and two pumps per plant train will operate during the hypothetical combined accident and loss of normal power if all four diesel generators are in operation. In an accident the safety injection signal automatically starts two pumps on each plant train, thus providing full redundancy.

Pump motors, traveling screen motors, screen wash pump motors, and backwashing strainer motors are supplied with power from normal and emergency sources, thereby ensuring a continuous flow of cooling water under all conditions. There are two independent power trains with two emergency diesel generators for each train, four of the eight ERCW pumps are assigned to Train A and four to Train B. Each diesel generator is aligned to supply power to either of two specific ERCW pumps; the generator capacity is such that only one pump per generator can be loaded automatically. Two traveling screens, two screen wash pumps, and two strainers are assigned to the power train corresponding to that of the ERCW pumps which this equipment serves. The motor-operated valves in the ERCW system are generally supplied with emergency power from the train of diesel generators which corresponds to the pump supplying the header in which the valve is located.

The component cooling system (CCS) heat exchanger discharge by-pass valves incorporate special trim to suppress cavitation. Flow is directed through the by-pass lines at low and intermediate heat exchanger flow rates by opening the by-pass line and closing the main 24-inch motor-operated butterfly valve at the heat exchanger outlet. For conditions which require flow rates beyond the capacity of the anti-cavitation valve, the 24-inch butterfly valve is opened and the anti-cavitation valve closed. To minimize cavitation of the butterfly valves, a multi-holed orifice is located in each of the two CCS heat exchanger vertical discharge headers to increase the back pressure at the valves.

### 9.2.1.3 Safety Evaluation

The ERCW system is designed to prevent any postulated failure from curtailing normal plant operation or limiting the ability of the engineered safety features to perform their functions in the event of natural disasters or plant accidents. Sufficient pump capacity is provided for design cooling water flows under all conditions and the system is arranged in such a way that even a complete header loss can be isolated in a manner that does not jeopardize plant safety.

The ERCW system has eight pumps (four pumps per train). However, minimum combined safety requirements for one 'accident' unit and one 'non-accident' unit, or two 'non-accident' units, are met by only two pumps on the same plant train. Sufficient redundancy, separation and independence of piping and components are provided to ensure that cooling is maintained to vital loads at all times despite the occurrence of a random single failure. A single active failure will not remove more than one supply train per unit (i.e., either headers 1A and 2A or headers 1B and 2B will always remain in service). The ERCW system is sufficiently independent so that a single active failure of any one component in one train will not preclude safe plant operations in either unit. A failure modes and effects analysis is presented in Table 9.2-2.



The safety-related portion of the ERCW system is designed such that total loss of either train, or the loss of offsite power and an entire plant shutdown power train will not prevent safe shutdown of either unit under any credible condition.

CCS Heat Exchanger C, which is shared between the two units, serves the train B engineered safety features for both units. During normal operation, the ERCW flow path to this heat exchanger will be through anti-cavitation bypass valve, FCV-67-144. A safety injection actuation signal in either unit or loss of offsite power signal causes valve FCV-67-152 to automatically open to assure ERCW flow from header 2B. Once the flow is established the operator determines which valve to close manually.

The Train A safeguards are capable of meeting the safety requirements independently of the Train B safeguards equipment. During a LOCA, it may be necessary to reduce flow to the component cooling heat exchanger prior to admitting flow to the containment spray heat exchanger. The earliest that this action is required is 15 minutes.

Under extreme flood conditions, the ERCW system provides a heat sink for required cooling systems, except the high pressure fire protection system water is used for steam generator feedwater for reactor cooling. The ERCW system is designed to continue operation during the postflood situation in which the loss of the downstream dam has also been assumed.

The ERCW system is designed to furnish a continuous supply of cooling water under normal conditions, as well as under the following extreme circumstances:

- (1) Tornado or other violent weather condition which might disrupt normal offsite power. The ERCW pumps are protected from tornadic winds and tornado-borne missiles, as described in Section 3.5, by a walled enclosure covered with a roof composed of structural steel wide-flanged I-beams. The walls and roof are designed to withstand the tornado wind loading and tornado-driven missile impact. In addition, the pumps on power train A are separated from those on train B by a wall on the pumping station deck. The traveling water screens and related screen wash pumps are also located within this protective structure. Yard piping (Class C) is protected by a minimum rock cover or concrete slabs where the minimum rock cover is not possible.
- (2) The ERCW pumps, intake pumping station traveling screens and screenwash pumps, and associated piping and structures remain operable during and after a safe shutdown earthquake which might destroy non-seismic structures and equipment and the main river dams upstream and downstream of the site. The components required for operation are designed either to Seismic Category I or I(L) - pressure boundary integrity requirements. The pumping station is designed to maintain direct communication with the main river channel at minimum possible water level resulting from loss of the downstream dams.

- (3) The design provides for the probable maximum flood with the coincident or subsequent loss of the upstream and/or downstream dams. To meet these conditions, the ERCW pumps, traveling screens, and screenwash pumps located in the intake pumping station are above the maximum possible flood level.
- (4) In the event of blockage of the non-qualified, normal discharge path, the alternative discharge path would be functional. In this event, the discharge water would flow through the ERCW standpipes and out of the ERCW overflow box. The ERCW overflow box is located in Area 2 which is described in Section 2.4.2.3. The flow from the overflow box will drain along the road, then across the perimeter road, flow west through a swale and across the low point in the access road. If the normal discharge path is blocked, no change in valve alignment or operator action is necessary to activate the alternate path. The alternate path is seismically qualified up to and including the ERCW overflow box. If the alternate path was in use and the non-qualified piping became blocked, the discharge water would flow out of the overflow box and drain away from the plant. Even with the maximum flow out of the overflow box, the water would not build up to reach the elevation of any of the entrances to safety-related buildings.

For purposes of maintenance to the cooling towers, a valve is provided in each of the normal discharge headers so that the ERCW flow can be terminated to the cooling towers and diverted to the holding pond via the alternate discharge path.

Cooling water is supplied in an open cycle cooling mode to the various heat exchangers served by the ERCW pumps during all modes of plant operation. With normal offsite power sources available, water is normally supplied to both units by operating up to two ERCW pumps per train. More than 2 pumps may be operated during pump changeover, etc. The ERCW system provides the required flow necessary to dissipate the heat loads imposed under the design basis operating mode combination, i.e., one unit in LOCA and the other unit in hot standby, based on a maximum river temperature. Maximum ERCW supply temperature is 85°F and is consistent with the recommendations in Regulatory Guide 1.27. Minimum river temperature is 35°F.

ERCW is a versatile system capable of providing sufficient flow and heat removal for a variety of conditions in each unit. As examples,

- (1) during normal operations, the ERCW system can supply the highest flow demand of one unit in startup and the other in hot shutdown with a flow requirement of approximately 26,400 gpm and remove the highest heat removal demand of one unit in hot shutdown and the other unit in cold shutdown with a heat load of approximately 238,800 kBTU/hr.

- (2) under design basis accident conditions with offsite power available, the ERCW system can supply the highest flow demand of one unit in startup and the other in LOCA Recirculation with a flow requirement of approximately 32,900 gpm and remove the highest heat removal demand of one unit in cold shutdown and the other unit in LOCA Recirculation with a heat load of approximately 473,400 kBTU/hr.
- (3) under design basis accident conditions with a LOOP coupled with a Loss of Train A, Train B of the ERCW system can supply the highest flow demand of one unit in either cold shutdown or refueling (equally demanding) and the other in LOCA Recirculation with a flow requirement of approximately 19,700 gpm and remove the highest heat removal demand of one unit in refueling and the other unit in LOCA Recirculation with a heat load of approximately 292,900 kBTU/hr.
- (4) under design basis accident conditions with a LOOP coupled with a Loss of Train B, Train A of the ERCW system can supply the highest flow demand of one unit in either cold shutdown or refueling and the other in LOCA Recirculation with a flow requirement of approximately 20,600 gpm and remove the highest heat removal demand of one unit in cold shutdown and the other unit in LOCA Recirculation with a heat load of approximately 296,700 kBTU/hr.

The availability of water for the design basis condition on the ERCW system is based on one unit being in a LOCA and the other unit in hot standby and the following events occurring simultaneously:

- (1) Loss of offsite power.
- (2) Loss of downstream dam.
- (3) Loss of an emergency power train.

Since emergency power is used to supply power for the pumps and valves in case of loss of offsite power, the loss of an emergency power train automatically dictates that cooling water must be supplied with two ERCW pumps operating through train headers.

Design basis safe shutdown for WBN is the hot standby mode. If one unit is in an accident condition, the other unit should be maintained at hot standby (if it can not be maintained in its operating mode) until the accident unit cooldown is accomplished.

A calculation has been performed that demonstrates there is sufficient ERCW and CCS capability to meet the GDC 5 requirement to bring the non-accident unit to cold shutdown. This calculation shows the non-accident unit can reach cold shutdown within 72 hours from entry into the Hot Standby mode. This cooldown analysis is performed with CCS carrying all required loads on both the accident and (later in the event) the non-accident unit, including the Spent Fuel Pool. The Core Decay Heat used in the calculation is consistent with the decay heat used in the normal cooldown

analysis. The analysis is conservative in that, once RHR is placed in service, credit for decay heat removal by the Steam Generators / Auxiliary Feedwater System is no longer taken.

In order to preclude leakage of radioactivity from the containment, the supply lines to the upper containment coolers are provided with double isolation by use of a check valve and motor-operated valve. The supply lines to the lower containment cooler groups and the discharge lines are doubly protected by use of two motor-operated valves operated on separate power trains as shown in Figure 9.2-11.

Radiation detectors are installed in each ERCW discharge header at a point downstream of the last equipment discharge point. If an abnormal radiation level is detected in either ERCW discharge header, the radiation source is located and isolated.

#### **9.2.1.4 Tests and Inspections**

All system components are hydrostatically tested in accordance with the applicable industry code before station startup. The yard piping is hydrostatically tested in accordance with Section III of the ASME Code. Subsequent to closing out Section III activities, the yard piping was opened at a number of locations and a cement-mortar lining was applied as a replacement under the provisions of Section XI of the ASME Code. Section XI defines a replacement as a design change to improve equipment service. Welds at pipe access points were examined visually and by magnetic particle test, and vacuum box leak tested before application of mortar to the weld area. After completion of cement-mortar lining, the piping was tested to the ASME Section III hydrostatic test requirements. The exposed welds were examined in accordance with the requirements of ASME Section III. ASME Section III examination pressure was maintained until the total time at pressure was one hour or greater. Following return of the system to service and before fuel load a visual examination (VT-2) will be performed in accordance with ASME Section XI IWA-5244 for buried components.

This alternative to visual examination during ASME Section III hydrostatic pressure testing was approved by NRC Inspection Report No. 50-390/89-04 and 50-391/89-04 for ERCW piping having inaccessible welds.

#### **9.2.1.5 Instrument Applications**

##### **9.2.1.5.1 General Description**

ERCW instrumentation and controls (see Figures 9.2-10 through 9.2-14A) for equipment supplied for a particular ERCW main supply header are powered from the same electrical power source as the pumps which normally supply the water to that header. Therefore, loss of one power train would result in the loss of only the instrumentation and controls associated with that particular ERCW header. Motor-operated containment isolation valves are arranged and powered such that isolation may be accomplished utilizing either one of the available power trains. Backup controls (see Section 7.4) are provided for devices which are required for operation in the event of a main control room evacuation.

#### **9.2.1.5.2 Pressure Instrumentation**

Pressure transmitters are provided on each ERCW pump discharge line and main supply header for displaying pressures locally and in the main control room, as well as actuating main control room annunciators when pressure drops below the setpoint. Each screenwash pump is provided with a local pressure gauge on the pump discharge line. Pressure differential switches are connected across each pair of traveling screens in a forebay. High differential pressure starts both screen wash pumps in a forebay and causes annunciation in the Main Control Room. Since this operation uses non-essential control air/service air, a nonqualified system, the screenwash system is put in continuous operation within three hours after an earthquake, tornado, flood, loop, loss of upstream or downstream dam, or within 12 hours of a LOCA. Screen wash pump discharge pressure switches are utilized to start the traveling screen motor when screen wash pressure has been established. Local pressure gauges and differential switches are provided on each ERCW strainer to monitor strainer pressures and indicate status. Local pressure test points are provided on the ERCW inlet and outlet of the water chillers of each electric board room air conditioner and each main control room air conditioner.

#### **9.2.1.5.3 Flow Instrumentation**

Flow elements and transmitters are provided for each ERCW main supply header to display the flow rates. The ERCW flow rate through each containment spray heat exchanger is also displayed in the main control room. The ERCW flow rate through each component cooling heat exchanger is also available in the main control room. Local flow indicators are provided for the flow rate through the emergency diesel engine heat exchangers, the flow rate inlet and discharge from each lower containment, RC pump motor, control rod drive ventilation cooler group each upper containment ventilation cooler, and ECCS pump room coolers. Flow elements are provided in the discharge lines of most other coolers and heat exchangers for use during testing and system balancing.

#### **9.2.1.5.4 Temperature Instrumentation**

ERCW pump motor winding and bearing temperatures are monitored by a plant computer system which provides recorded data capability. Local temperature indicators are provided for the discharge from each emergency diesel engine heat exchanger and for various other users. Temperature test wells are provided on the inlet of each air conditioner condensing unit and the discharge side of each component cooling system heat exchanger, containment spray heat exchanger, RC pump motor cooler, and control rod drive cooler. Temperature test wells are also provided in the inlet and discharge lines for most space coolers, room coolers, and in the main supply and return header.

#### **9.2.1.5.5 Deleted by Amendment 87**

#### **9.2.1.5.6 Control Valves**

The open and closed positions of the ERCW air operated and motor-operated valves are displayed in the main control room by means of lights incorporated either on the

controlling hand switch or on a valve status light subpanel. Air operated temperature and flow control valves are designed to fail open on loss of electrical power and/or operating air, thereby providing maximum ERCW cooling flow to the equipment being supplied.

ERCW is regulated to each upper and lower containment and control rod drive ventilation cooler through a throttling action type valve controlled by a temperature indicating controller. Manual and/or automatic override to fully close the control valve is provided by means of a hand switch and/or logic signal (Figures 9.2-5 through 9.2-9).

ERCW is supplied to each air conditioner condensing unit through an automatic water regulating valve controlled by condenser pressure.

Each CCS heat exchanger incorporates a motor-operated butterfly valve in its main ERCW discharge line. Each valve may be placed in either of two intermediate, throttled positions in addition to the full open or closed positions. The desired position is selected manually from the control room for the particular plant operating condition. In addition, the heat exchanger C valve has automatic controls to open the valve to the low-flow intermediate position in response to a loss of offsite power signal or a safety injection signal in either unit. Such automatic controls are not required for heat exchangers A or B since their bypass valves are normally open, whereas the heat exchanger C valve may be normally closed.

The by-pass lines at the CCS heat exchangers discharges have a special motor-operated, anti-cavitation modulating valve to control ERCW flow rate through the associated CCS heat exchanger at low and intermediate flow rates. These anti-cavitation valves may be manually adjusted to the open, closed, and/or intermediate position to achieve desired CCS heat exchanger performance for various operating modes. Control switches are provided in the main control room. The valves are designed to ASME Section III, Class 3, with Class 1E motor operators.

ERCW is supplied to each additional cooler or heat exchanger through an on-off action type valve controlled by either a hand switch, a temperature switch, a manual valve, a logic signal, or various combinations of these.

#### **9.2.1.6 Corrosion, Organic Fouling, and Environmental Qualification**

Watts Bar Nuclear Plant (WBN) has a comprehensive chemical treatment program for treating raw water systems. This treatment is a major part of WBN Raw Water Corrosion Program. The chemical treatment is used to control corrosion in carbon steel and yellow metals, to control organic fouling, including slime, to minimize the effect of microbiologically induced corrosion (MIC) and inhibit growth of Asiatic clams.

The water used in the Essential Raw Cooling Water (ERCW), High Pressure Fire Protection (HPFP) and Raw Cooling Water (RCW) system is chemically treated. The chemical treatment program injects chemicals to the ERCW, RCW, and HPFP raw water systems at the Intake Pumping Station (IPS) pits such that any pump taking suction from these pits will introduce the chemicals into the system. This treatment includes oxidizing biocide, non-oxidizing biocide, phosphate, and zinc. The phosphate

is used to sequester iron from existing corrosion products, the zinc is used to passivate the carbon steel surfaces, and the oxidizing and non-oxidizing biocide will control slime, clams, and MIC.

The dead legs to the containment spray system (CSS) heat exchangers (Hxs) and auxiliary feedwater (AFW) Pumps have biocide/chemical treatment lines which permit flow through those lines on a continuous basis when required by procedure. In addition, the CSS Hxs and piping between the motor-operated supply and discharge isolation valves are filled with demineralized water treated for corrosion control. Connections are provided on the biocide/chemical treatment lines feeding the Train A Auxiliary Feedwater Pump dead legs to permit chemical treatment with demineralized water and biocides.

The ERCW piping to the diesel generators is treated during periods of train specific biocide injection by opening the associated diesel generator ERCW supply valve.

For the ERCW line to the CCS surge tank, the blind flange at the spool piece connection is provided with a flushing connection to facilitate chemical treatment of the piping. Other lines used to connect to CCS piping during flood mode operation would be treated in a similar manner. These lines are not connected to the CCS during the flushing operation.

Control of organic fouling and Asiatic clams is further enhanced by the use of strainers in the supply headers. Each supply header is provided with a strainer (auto-backwash type) capable of removing particles and organic matter larger than 1/32-inch diameter. The strainers are located in the Intake Pumping Station downstream of the ERCW pumps.

Normal system operation and maintenance is considered adequate to disperse chemicals in the instrument lines, drains, and vents in the ERCW system.

Allowances for the effects of corrosion on the structural integrity of this system were made by increasing the wall thickness of the pump pressure boundary, pipe, heat exchanger shells and tubes, and other system pressure retaining components. Measures have also been taken to compensate for the effects of corrosion on the flow passing capability of the system. The normally wetted portion of the buried supply and discharge headers have been lined in situ with cement mortar, most of the 2-inch and smaller diameter piping is stainless steel, and selected runs of larger piping in the Auxiliary and Turbine Buildings are stainless steel, and almost all of the piping in the Reactor Building is stainless steel. Operator actions are taken, as needed, to provide surveillance and compensatory measures, to ensure the ERCW pumps auxiliary piping do not freeze during extreme weather conditions.

To the extent to which they are exposed to atmospheric conditions, all pumps and valves are designed to operate under the most extreme climatic conditions that are expected to prevail in the southeastern United States. Operator actions are taken, as needed, to provide surveillance and compensatory measures, to ensure the ERCW pumps auxiliary piping does not freeze during extreme weather conditions.

### 9.2.1.7 Design Codes

The ERCW system components are designed to the codes listed in Table 3.2-2a.

## 9.2.2 Component Cooling System (CCS)

### 9.2.2.1 Design Bases

The CCS is designed for operation during all phases of plant operation and shutdown. The system serves to remove residual and sensible heat from the reactor coolant system via the residual heat removal system during plant cooldown; cool the spent fuel pool water and the letdown flow of the chemical and volume control system; provide cooling to dissipate waste heat from various plant components; and provide cooling for safeguard loads after an accident.

The systems served by the CCS are:

- (1) Reactor coolant system (RCS), Section 5.5.1
  - Reactor coolant pumps (RCPs)
    - (a) RCP upper and lower oil coolers
    - (b) RCP thermal barrier heat exchangers.
- (2) Residual heat removal (RHR) system, Section 5.5.7
  - (a) RHR heat exchangers (Hxs)
  - (b) RHR pump seal water Hx
- (3) Safety injection system (SIS), Section 6.3
  - (a) Safety injection pump lube oil coolers
- (4) Chemical and volume control system (CVCS), Section 9.3.4
  - (a) Letdown Hx
  - (b) Excess letdown Hx
  - (c) Seal water Hx
  - (d) Centrifugal charging pump lube and gear oil coolers
- (5) Spent fuel pool cooling and cleanup system (SFPCS), Section 9.1.3
  - (a) SFPCS Hxs
- (6) Containment spray system (CSS), Section 6.2.2
  - (a) Containment spray pump oil Hx



- (7) Gaseous waste processing disposal system (GWPS), Section 11.3
  - (a) Waste gas compressor Hxs
- (8) Sampling system (SS), Section 11.4
  - (a) Sample Hxs
  - (b) Sample chiller package

The CCS serves as an intermediate loop between systems 1 through 8, listed above, and the ERCW system. Heat from the listed systems is transferred by the CCS through the component cooling heat exchangers to the ERCW system, which is the heat sink for these heat loads. The intermediate loop provides a double barrier to reduce the possibility of leakage of radioactive water to the environment.

The CCS design is based on a maximum ERCW inlet temperature of 85°F. The ERCW supply from the river is designed to be available under all conditions. The design temperature places no undue limitations on normal plant operation. It affects the time required for plant cooldown and the number of component cooling heat exchangers in use during the various plant operations.

Since the CCS is required for post-accident removal of heat from the reactor, the CCS is designed such that no single active or passive failure can interrupt cooling water to both A and B Engineered Safety Feature (ESF) trains. One ESF train is capable of providing sufficient heat removal capability for maintaining safe reactor shutdown.

The CCS pumps, thermal barrier booster pumps and required motor-operated valves will be automatically transferred to auxiliary onsite power upon loss of offsite power.

### 9.2.2.2 System Description

The CCS, shown in Figures 9.2-16, 9.2-17, 9.2-18, and 9.2-19, consists of five CCS pumps, two thermal barrier booster pumps per unit, three heat exchangers, two surge tanks, one CCS pump seal water collection unit, and associated valves, piping and instrumentation serving both units. The coolers associated with the systems served by CCS (see Section 9.2.2.1) are not part of CCS but rather are included in the serviced systems. Such coolers are discussed more fully in the references listed in Section 9.2.2.1.

The logic and control diagrams for this system are presented in Figures 9.2-20, 9.2-20A, 9.2-21, 9.2-21A, 9.2-22, 9.2-22A, 9.2-23, 9.2-24, 9.2-25, and 9.2-25A.

The CCS design pressure and temperature are 150 psig and 200°F, respectively, except as noted below:

- (i) The design pressure and temperature for piping from thermal barrier booster pumps (TBBPS) discharge to the first of redundant

check valves in each thermal barrier supply line are 200 psig and 200°F, respectively.

- (ii) From the first redundant check valve of each thermal barrier supply line to the outboard containment isolation valve on the thermal barrier return line, the design pressure and temperature are the same as the RCS design pressure and temperature which are 2485 psig and 650°F. This prevents overpressurization of this portion of the CCS piping in the event of thermal barrier leakage. A 3/4-inch check valve installed across the inboard containment isolation valve, incorporates a soft seat which is not designed for fluid temperatures above 300°F. In order for the temperature to exceed 300°F, reactor coolant must leak through the thermal barrier into the CCS. A thermal barrier tube rupture event will not degrade the soft seat since isolation would occur rapidly. In order to guard against leakage through the check valve, inspection and repair of the check valve seat will be performed whenever repairs for thermal barrier tube leakage are needed.
- (iii) In order to maintain containment integrity during and after a LOCA, CCS piping between and including the containment isolation valves is designed for 250°F.

CCS is a supporting system to other safe shutdown systems. Two redundant trains per unit are available. For each unit, Train A consists of two available CCS pumps and the associated valves, piping, instrumentation and heat exchanger (Heat Exchanger A for Unit 1 and Heat Exchanger B for Unit 2). Train B is common for both units and consists of one CCS pump and the associated valves, piping, instrumentation and heat exchanger (Heat Exchanger C).

Each unit has a CCS pump (1A-A for Unit 1 and 2A-A for Unit 2) which is aligned to that unit's Train A header and which receives electrical power from Train A. Each unit has another CCS pump (1B-B for Unit 1 and 2B-B for Unit 2) which can be aligned to that unit's Train A header but which receives electrical power from Train B. These pumps (1B-B and 2B-B) are normally aligned to the Train A piping system for that unit but can be aligned to the common Train B piping system. The C-S pump, which normally receives Train B electrical power while serving as the common Train B CCS pump, is capable of being powered from a Train A power source.

During normal full power operation, with all CCS equipment available, CCS pumps 1A-A and 1B-B and Heat Exchanger A are aligned with Unit 1, Train 1A ESF and miscellaneous equipment. CCS pumps 2A-A and 2B-B and Heat Exchanger B are aligned with Unit 2 Train 2A ESF and miscellaneous equipment. CCS pump C-S and Heat Exchanger C are aligned with both Unit 1, Train 1B and Unit 2, Train 2B.

CCS pump 1B-B can be used as additional capacity for Train 1A, as required, or as a replacement for CCS pumps 1A-A or C-S, if one should be out of service. CCS pump

2B-B can be used as additional capacity for Train 2A as required or as a replacement for CCS pumps 2A-A or C-S, if one should be out of service.

Train 1A and Train 2A equipment will provide all the cooling water necessary for the safe operation of Units 1 and 2, respectively. Train 1B/2B (common) supplies additional cooling capacity of both units during various operational modes. Train 1B/2B equipment has been sized to maintain plant safety in the event of Train A power loss.

Two surge tanks are located in the Auxiliary Building. Each surge tank is separated into two parts by a baffle, providing separate minimum surge volumes for each ESF cooling train.

Both units are served by two cooling system trains (A and B) serving ESF equipment, with train A also serving miscellaneous non-safety related components. Except for the RHR Hxs, excess letdown Hx, and PASS coolers (Unit 1 only), both trains of the safeguards equipment of both units served by the CCS are normally aligned and supplied with CCS water and will automatically continue to be supplied in a LOCA. In the event of an accident, nonsafety-related components are not required; therefore, CCS flow to these components may be manually isolated. The excess letdown heat exchanger is required only during startup and when normal letdown is lost, and is valved in at that time. Prior to switchover from injection to recirculation phase of safety injection it is necessary for the operator to open the CCS valves at the RHR heat exchangers of the accident unit in order to supply these heat exchangers with cooling water. This action is part of the switchover sequence specified in Section 6.3.2.2 and Table 6.3-3. The earliest time at which this operator action is required to be performed is 10 minutes. If an emergency power train is lost during an accident condition no additional operator action on the CCS is required for plant safety except for the following cases:

- (1) If the non-accident unit is utilizing RHR cooling it may be necessary to close the CCS supply to these heat exchangers. RHR cooling may be terminated when the non-accident unit is in RHR cooldown with the reactor coolant system not vented. If the reactor coolant system has been vented, RHR cooling of the non-accident unit will continue, but at a reduced rate.
- (2) If Train A electric power is lost, CCS pump 1B-B will supply cooling water to SFPCS heat exchanger A via CCS header 1A and CCS heat exchanger A during two unit operation.
- (3) During two unit operation, if Train B electrical power is lost, Pump C-S will be manually realigned to Train A power and valved into the Unit 1 Train A or Unit 2 Train A header to provide SFP cooling. The SFPCS heat exchanger shall be isolated until this realignment occurs.

In the event of a design basis flood at WBN, the CCS pumps will be submerged since the maximum flood level will be above the CCS pumps. Since cooling must be

maintained to certain CCS users during the flood, provisions have been made to interconnect the ERCW and CCS systems to supply ERCW to the following loads:

- (a) SFP heat exchangers,
- (b) RHR heat exchangers,
- (c) RCP thermal barriers,
- (d) Sample heat exchangers.

The interconnections are accomplished by installing spool pieces and opening normally-closed valves during flood mode preparation. The thermal barrier booster pumps are required to operate during flood mode and remain above the maximum flood. Some normally-open CCS valves will be closed during this phase to isolate nonessential equipment. The surge tanks shall be isolated upon ERCW interconnection to prevent potential overpressurization.

Provisions have been provided to reestablish CCS flow to the reactor coolant pump thermal barrier following a Phase B isolation signal. This action will protect the integrity of the seals in the event of passive failure of the chemical and volume control system seal injection flow to the reactor coolant pump seals.

The CCS water is circulated through the shell side of the CCS heat exchangers to the components using the cooling water and then back to the CCS pump suction. The surge tank for each unit is separated into two sections by a baffle. Each section is tied into the pump suction lines from safeguard trains. This tank accommodates expansion and contraction of the system water due to temperature changes or leakage, and provides a continuous water supply until a small leak from the system can be isolated. Because the surge tank is normally vented to the building atmosphere, a radiation monitor is provided in each component cooling water heat exchanger discharge line. These monitors actuate an alarm and close both surge tank vent valves when the radiation reaches a preset level above the normal background.

Cooling water is available to the components served by the system. The system is provided with adequate motor-operated-valves to permit realignment or isolation of equipment and cooling water headers by the control room operator. (Motor-operated valves are opened as necessary, to provide the RHR heat exchangers with cooling water during startup, cooldown, refueling, and LOCA.)

Normal system makeup is provided from the demineralized water system. Emergency makeup is provided from the ERCW system by installing a spool piece.

The component cooling water contains a corrosion inhibitor to protect the carbon steel piping. Corrosion inhibitor type is consistent with current water chemistry technology.

The design provides radiation monitors at each CCS heat exchanger outlet for the detection of radioactivity entering the system from the RCS and its associated auxiliary systems, and includes provisions for isolation of system components.

### 9.2.2.3 Components

The components for this system are located within the controlled environments of the Auxiliary Building and the Reactor Building and are designed to withstand the environmental occurrences within those structures such that the components will perform their design function(s). During flooding, connections are made to the ERCW system to maintain a cooling supply to the safeguard trains, since the CCS pumps will be inoperative.

The only safety-related CCS equipment subject to water spray damage includes the CCS pump motors, thermal barrier booster pump motors, and certain valve motors.

All motor-operated valves have totally enclosed, waterproof motors. The CCS pump motors have a NEMA weather-protected Type II enclosure. Drip-proof motors have been provided for the thermal barrier booster pumps.

CCS component design data is listed in Table 9.2-8.

#### 9.2.2.3.1 Component Cooling Heat Exchangers

The three component cooling water heat exchangers are of the shell and tube type. ERCW circulates through the tubes while component cooling water circulates through the shell side. The shell is of carbon steel and the tubes are ASME SB-676 stainless steel (AL-6X).

#### 9.2.2.3.2 Component Cooling Pumps

The five component cooling water pumps which circulate water through the component cooling loops are horizontal, centrifugal units of standard commercial construction. The pump motors receive electric power from normal or emergency sources. Each of the four normally assigned pumps (2 per unit) is connected to one of the four electric power trains. The fifth pump can be powered from either of two assigned electric power trains.

#### 9.2.2.3.3 Thermal Barrier Booster Pumps

The two booster pumps (per unit) circulate cooling water through the reactor coolant pump thermal barriers. The booster pumps provide the additional head necessary to overcome high head loss through the thermal barriers, and thereby allow the CCS pumps to operate at a lower total head, supplying the remaining component cooling loads at a lower operating pressure. One booster pump supplies the thermal barrier requirements (160 gpm) for each reactor unit. A second pump is assigned to provide 100% redundancy. The pumps are horizontal, centrifugal units of standard commercial construction. The pump motors receive electric power from Class 1E power systems, which are described in Chapter 8.

#### 9.2.2.3.4 Component Cooling Surge Tanks

The two component cooling water surge tanks accommodate changes in component cooling water volume. Each unit is provided with one tank for unit separation. Each tank has an internal baffle divider to provide two separate surge volumes for safeguard

train separation within each tank. This arrangement provides redundancy for a passive failure during recirculation following a loss-of-coolant accident.

#### 9.2.2.3.5 Seal Leakage Return Unit

The seal leakage return unit (SLRU) consists of a tank and two pumps. The tank serves as a collection point for seal leakage from the CCS pumps. The SLRU pumps return this water to the CCS surge tanks. This unit is not a safety class item, because its only function is the collection of pump seal leakage.

#### 9.2.2.3.6 Valves

Valves used in the component cooling system are standard commercial types of carbon steel construction, designed to minimize leakage. Self-actuated, spring-loaded relief valves are provided for lines and components that could be pressurized beyond their design pressure by improper operation or malfunction.

The relief valves protecting the reactor coolant pump thermal barriers and their associated piping are designed to relieve thermal expansion if the cooling line is isolated while the reactor coolant system is hot. The cooling water piping from the check valve upstream of the barrier to the last containment isolation valve downstream is designed for primary system pressure (see Section 9.2.2.2). If the thermal barrier tube ruptures, the cooling line is automatically isolated and the relief valve accommodates thermal expansion of the fluid in the isolated section (this condition will also exist after containment isolation). The valve set pressure equals the design pressure of that particular segment of piping as described below under piping. Discharged water is directed to the Reactor Building sump.

Cooling water to the RCP thermal barrier is made available to assure that there will be no mechanical damage to the pump. The cooling water supply and discharge lines to the RCP thermal barriers each contain two remote-operated valves in series: One valve operates on power train A, the other on train B. The redundant discharge valves assure the ability to isolate this circuit if a barrier leak is detected. Leak detection is accomplished by measuring thermal barrier supply and discharge cooling water flows.

The cooling water supply line to the excess letdown heat exchanger contains a motor-operated and a manual valve outside the containment wall. A pilot-operated, fail closed, pneumatic valve is provided in the return line outside containment. Both the motor-operated and pneumatic valves are normally closed except during startup, but also have automatic control signals to assure closure under containment isolation conditions. A relief valve is supplied on the cooling water line downstream of the excess letdown heat exchanger. It is sized for thermal expansion occurring when the CCS side is isolated and high temperature fluid continues to flow on the opposite side. If both sides of the heat exchanger are isolated, the relief valve is also sized to relieve any leakage through the high pressure letdown inlet isolation valve and into the cooling water piping via a heat exchanger tube leak.

Except for the normally closed makeup line and equipment vent and drain lines, there are no normal connections between the component cooling water and other systems.

The equipment vent and drain lines outside the containment have manual valves which are normally closed unless the equipment is being vented or drained for maintenance or repair.

Relief valves other than those on the CCS surge tank or excess letdown heat exchanger have been sized to relieve the volumetric expansion occurring if the exchanger CCS side is isolated and high temperature coolant flows through the opposite side. The set pressure equals the design pressure of the CCS side of the heat exchangers or the CCS piping whichever is less. Water from the relief valves is directed to the floor drains.

Relief valves on the component cooling surge tanks are sized to relieve the maximum flow rate of water which enters the surge tank following a tube rupture of the RHR heat exchanger, excess letdown heat exchanger, or letdown heat exchangers. The set pressure ensures the working pressure of the surge tank will not be exceeded. The discharge of those valves is directed to the floor drain collector tank.

The surge tank vent-overflow line, which is open to the Auxiliary Building atmosphere, is equipped with an air-operated valve that closes automatically if radiation is detected in the system. A vacuum breaker valve is also provided to prevent collapsing the tank in the event of a large loss of water in the system.

#### **9.2.2.3.7 Piping**

Component cooling water system piping is carbon steel, with welded joints and connections except flanges at components which might require removal for maintenance. CCS piping is standard weight except the portion of piping to reactor coolant pump thermal barriers which is Schedule 160 from the first of the redundant check valves to the last containment isolation valve or the return piping.

#### **9.2.2.4 Safety Evaluation**

The CCS is comprised of two independent trains (A&B) where the CCS Train B header and Heat Exchanger C serve both the Unit 1 and Unit 2 Train B engineered safeguards equipment. The Unit 1 Train A header and Heat Exchanger A serve Unit 1 miscellaneous equipment and Unit 1 Train A engineered safeguards equipment. The Unit 2 Train A header and Heat Exchanger B serve the Unit 2 miscellaneous equipment and Unit 2 Train A engineered safeguards equipment. Each train has the capability to provide the maximum cooling water requirement for the plant. These equipment trains are sufficiently independent to guarantee the availability of at least one train at any time. The system has been analyzed for "worst case" heat loads under combinations of maximum river water temperature, design basis accident conditions, normal cooldown requirements, power train failures. Design basis safe shutdown for WBN is the hot standby mode.

CCS is a versatile system capable of providing sufficient flow and heat removal for a variety of conditions in each unit. As examples,

- (1) during normal operations, the CCS system can supply the highest flow demand of both units in startup with a flow requirement of approximately 22,900 gpm and remove the highest heat removal demand of one unit in hot shutdown and the other unit in cold shutdown with a heat load of approximately 192,100 kBTU/hr.
- (2) under design basis accident conditions with offsite power available, the CCS system can supply the highest flow demand of one unit in startup and the other in LOCA Recirculation with a flow requirement of approximately 21,600 gpm and remove the highest heat removal demand of one unit in cold shutdown and the other unit in LOCA Recirculation with a heat load of approximately 154,500kBTU/hr.
- (3) under design basis accident conditions with a LOOP coupled with a Loss of Train A, Train B of the CCS system can supply the highest flow demand of one unit in either cold shutdown or initial refueling (equally demanding) and the other in LOCA Recirculation with a flow requirement of approximately 10,200 gpm and remove the highest heat removal demand of one unit in cold shutdown and the other unit in LOCA Recirculation with a heat load of approximately 128,700 kBTU/hr.
- (4) under design basis accident conditions with a LOOP coupled with a Loss of Train B, Train A of the CCS system can supply the highest flow demand of one unit in either cold shutdown or initial refueling (equally demanding) and the other in LOCA Recirculation with a flow requirement of approximately 15,800 gpm and remove the highest heat removal demand of one unit in cold shutdown and the other unit in LOCA Recirculation with a heat load of approximately 153,600 kBTU/hr.

Component cooling water pumps, heat exchangers, and most of the associated valves, piping, and instrumentation (except flow, pressure and temperature transmitters) are located outside the containment and are therefore available for maintenance and inspection during power operation. Maintenance on a pump or heat exchanger is practical while redundant equipment is in service, subject to limitations of the Technical Specifications.

Sufficient cooling capacity is provided to fulfill system requirements under normal and accident conditions. Adequate safety margins are included in the size and number of components to preclude the possibility of a component malfunction adversely affecting operation of safeguards equipment. Active system components considered vital to the cooling function are redundant; i.e., any single active or passive failure in the system will not prevent the system from performing its design function.

The component cooling water pumps are automatically placed on emergency power in the event of loss of offsite power; therefore, the minimum ESF requirements are met with regard to supply of component cooling water. Separate trains provide component cooling water to the engineered safety features. Each train services its safety related cooling loads associated with the same train. Should a single failure result in the loss



of a train of equipment (A or B) the other train is available for handling all required heat loads.

A calculation has been performed that demonstrates there is sufficient ERCW and CCS capability to meet the GDC 5 requirement to bring the non-accident unit to cold shutdown. This calculation shows the non-accident unit can reach cold shutdown within 72 hours from entry into the Hot Standby mode. This cooldown analysis is performed with CCS carrying all required loads on both the accident and (later in the event) the non-accident unit, including the Spent Fuel Pool. The Core Decay Heat used in the calculation is consistent with the decay heat used in the normal cooldown analysis. The analysis is conservative in that, once RHR is placed in-service, credit for decay heat removal by the Steam Generators / Auxiliary Feedwater System is no longer taken.

#### 9.2.2.5 Leakage Provisions

To minimize the possibility of leakage from piping, valves, and equipment, welded joints are used wherever possible. Flanged joints are used only in sections or connections to components which require inspection and/or maintenance on a periodic basis, and for butterfly valves.

A seal leakage return unit is provided to collect seal leakage from the component cooling pumps and return it to the system via the CCS surge tanks. The return unit consists of one collection tank and two seal leakage return pumps. The pumps alternate operation to return equal seal leakage volume to each unit surge tank and are not normally in service.

The component cooling water could become contaminated with radioactive water due to one of the following conditions:

- (1) A leak in any heat exchanger tube in the CVCS, RHR system, sampling system, or the SFPCS.
- (2) A leaking cooling coil for the thermal barrier cooler on a reactor coolant pump.
- (3) Seal leakage from the RHR pump.

#### 9.2.2.6 Incidental Control

If outleakage occurs anywhere in the system, detection is accomplished through a falling level in the surge tank, which will actuate a low level alarm in the control room. Leak detection and control is also provided for the sample heat exchanger and chiller package by the level alarms in the waste disposal system sump where any system leakage will be collected. Leak detection and control is also provided for the Train A side of either surge tank, which contains the Class G sample heat exchangers and chiller package, by both flow and level instrumentation as discussed in Sections 9.2.2.7.2 and 9.2.2.7.3. Inleakage is detected by a surge tank high level alarm. The leaking portion of the system is located by visual inspection, and is isolated. The backup train is then put into operation.

Since the system does not service any engineered safety feature component inside the containment following a LOCA, containment isolation valves on the component cooling lines entering and leaving the containment are automatically closed on high-high containment pressure signal (Phase B containment isolation) except isolation valves for the excess letdown heat exchanger which close on Phase A containment isolation signal.

### **9.2.2.7 Instrument Applications**

#### **9.2.2.7.1 General Description**

The CCS, being a water to water heat transfer system, uses inputs of flow rate, level, pressure, and temperature for instrumentation. Electric power to the essential or safety-related transducers in the instrument loops is from the same train as the equipment being served. Loss of a power train would result in loss of only instrumentation and control for equipment that is being served by that particular power train. Control of the system is through air and motor-operated valves. (See Figures 9.2-16, 9.2-17, 9.2-18, and 9.2-19.)

#### **9.2.2.7.2 Flow Instrumentation**

Maintaining ample flow rates is essential to proper heat transfer; therefore, flow measurements are taken at the outlet of virtually all heat exchangers and displayed in the control room. In addition, flows entering the power-trained headers are measured and displayed locally. Differential flow instrumentation is also provided for the sample heat exchangers and chiller package, but for a different reason. These coolers, as well as portions of the CCS piping, are designed to TVA Class G and therefore may break under seismic loading. Consequently, to preclude loss of water inventory, this flow instrumentation has been provided to detect outleakage and to provide control signals to isolate the Class G piping from the remainder of the system by automatic closure of valves FCV-70-183 and FCV-70-215. Main control room annunciation of this condition has also been provided. See Figures 9.2-18, 9.2-21, and 9.2-24.

The thermal barrier lines use differential flow to isolate a thermal barrier leak from the rest of the CCS. Flow rates are measured in both the supply and return headers. The two are compared, and should a mismatch occur due to in-leakage, the line is isolated. This comparison is done in each power train so the isolation function is completely redundant. Annunciation and flow rates on the individual thermal barriers give the operator the required data for proper control.

#### **9.2.2.7.3 Level Instrumentation**

Surge tank level measurements are used to monitor and control the total amount of water in the system. Should there be leakage into the system, the level will rise and activate a high-level switch for annunciation in the control room. Level is displayed in both the main and auxiliary control rooms.

Leakage out of the system is detected by a low level switch that activates a valve to provide demineralized water makeup to the system. Low-low level switches have also been provided on both the Train A side and the Train B side of both surge tanks. A

low-low level signal from the Train A side of either tank indicates a probable break or tube leak in the nonqualified sample cooler/chiller piping and causes automatic closure of valves to isolate the nonqualified portion of the piping system.

#### **9.2.2.7.4 Pressure Instrumentation**

Pressure measurement is essential for proper monitoring of pump performance. Local pressure indications are available for both suction and discharge of all essential pumps in the system. Local indication is also available for the main supply headers to various equipment. Pressure in the three discharge headers of the CCS pumps is displayed in the main control room and ACR. Discharge headers for trains 1A and 2A are annunciated in the MCR on low-pressure setting. Low header pressure in one unit will automatically start the standby pump in that unit. MCR annunciation is also given when an abnormally high pressure is sensed at the discharge of each CCS pump.

#### **9.2.2.7.5 Temperature Instrumentation**

Temperature can be monitored at the outlet of every heat exchanger or heat exchanger group. Temperature indication is provided in the main control room for the main return headers to the pumps and for the outlet of the CCS heat exchangers. Should temperatures at the outlet of the major heat exchangers become excessive, annunciation will occur in the MCR to alert the operator to take corrective action.

#### **9.2.2.7.6 Valves**

Most of the valves in the system are motor-operated, non-throttling, fail-as-is type valves. They are used mostly to isolate sections of the system. The motor-operated valves are power trained. Valve LCV-70-63 is an air operated, fail-closed, makeup water level control valve for the surge tank. Valve FCV-70-66 is an air-operated, fail-closed, vent valve for the surge tank. Valve FCV-70-85 is an air-operated, fail-closed, isolation valve on the return line from the excess letdown heat exchanger. Throttling valves are used for process control and are not actuated by safety systems.

#### **9.2.2.7.7 Conclusion**

Since the CCS is a safety buffer system between the radioactive primary water and the ERCW, appropriate instrumentation provides the necessary data and controls for the operator to ensure the functional safety of the system.

#### **9.2.2.8 Malfunction Analysis**

The CCS is sufficiently independent so that a single active failure of any one component will not preclude safe plant operations in either unit. A failure analysis is presented in Table 9.2-9.

This paragraph discusses the consequences of a loss of component cooling water to the RHR pump seal coolers and the indicators that are available to alert the operator of this loss. The RHR pumps were procured to be operable without cooling water being supplied to the seal coolers. A loss of component cooling water to the seal cooler, however, would result in higher seal unit temperature and consequently shorter seal

lifetime but would not cause or require a rapid shutdown of the pumps. Indication of a loss of component cooling water to an RHR seal cooler would be available from several sources. The component cooling lines serving the coolers are each provided with a flow element downstream of the cooler. Flow indication and alarm is provided in the main control room from each of the flow elements. The instrumentation discussed above is illustrated in Figures 9.2-21 and 9.2-22. Additionally, there is a temperature sensor in each RHR seal piping loop which will alarm in the MCR on high seal fluid temperature. A loss of component cooling water flow to one of the RHR seal coolers would not affect the redundant RHR pump.

### 9.2.2.9 Tests and Inspections - Historical Information

All systems piping and components were hydrostatically tested and CCS operability verified prior to station startup. Virtually all CCS components outside the containment are accessible for periodic inspection during operation. The position of system valves and automatic start of the CCS pumps on a safety injection signal are verified periodically.

### 9.2.2.10 Codes and Classification

Piping and components of the CCS are designed to the applicable codes and standards listed in Table 9.2-10.

The entire system is TVA Class C with the following exceptions:

- (1) Containment penetrations and associated containment isolation valves are TVA Class B.
- (2) The excess letdown heat exchanger piping inside containment is TVA Class B.
- (3) The sample cooler/chiller piping and valves between FCV-70-215 and FCV-70-183 is TVA Class G.
- (4) The CCS pump seal leakage collection tank is TVA Class L. The associated drain piping, valves, and seal leakage return pumps are TVA Class G from the collection point to the pumps outlet check valves 1-70-535 and 2-70-535.
- (5) The piping between valve 1-ISV-70-775, and the pipe cap and the piping between valve 1-ISV-70-777 and the pipe cap are TVA Class G.

## 9.2.3 Demineralized Water Makeup System

The demineralized water makeup system is a common system.

### 9.2.3.1 Design Bases

The system is designed to supply the requirements for high purity water for makeup to the steam generators, the primary water system, and the demineralized water system for cask decontamination, cleaning, flushing, and makeup for miscellaneous services.

A secondary function is to supply filtered water to the condenser circulating water pumps for bearing lubrication.

### 9.2.3.2 System Description

The system consists of the following two sub-systems: a vendor-supplied water purification system, and the demineralized water storage and distribution system.

Flow diagrams are shown in Figures 9.2-26, 9.2-27 and 9.2-28.

The vendor supplied water purification system has been designed to comply with the aspects of the plant. The system takes raw water from an existing header. The raw water is filtered for suspended solids removal. Water is then normally passed through a reverse osmosis (RO) system designed to remove dissolved solids and organics. RO effluent is then passed through a process designed to remove CO<sub>2</sub> from the water. Water from this process is then deoxygenated as necessary. Water from the deoxygenation system then flows through a demineralizer for final polishing.

Water not meeting the specification is automatically recycled either to the RO influent or the demineralizer influent, depending on the parameter that is out of specification. In-line analyzers continuously monitor the effluent quality. Once the effluent is in specification, it is pumped to the 500,000 gallon demineralized water storage tank to the plant demineralized water storage and distribution system.

The demineralized water storage and distribution system consists of a 10,000 gallon demineralized water head tank, a 15,000 gallon cask decontamination head tank, main piping loop and supply headers. The loop supplies water for various services as shown in Figure 9.2-28. The services include emergency showers, eye wash stations, water for cask washdown room, fuel transfer canals and makeup water for various system tanks and equipment.

The main piping loop is supplied from the demineralized water head tank. Makeup water for the condensate storage tanks (CST) is supplied from either the demineralized water storage or from the water purification system. Washdown water for the cask washdown room is supplied from the cask decontamination head tank. Makeup for the primary water storage tanks is supplied directly from the loop.

Storage tanks and system principal piping are aluminum except piping inside reactor containment which is stainless steel. Piping is TVA Class H except reactor containment isolation valves and connecting piping which are TVA Class B, and piping in the Reactor Building which is TVA Class G.

### 9.2.3.3 Safety Evaluation

The demineralized water makeup system is not required for maintenance of plant safety in the event of an accident and is not a part of the engineered safety systems; therefore, the reactor containment isolation valves and the piping connecting the valves are the only portions of this system which have a nuclear safety class designation in accordance with TVA Classification B.

Pipe hangers and supports in the Control Building, Auxiliary Building, and Reactor Buildings are designed for seismic loading to prevent damage to adjacent safety related equipment necessary for the safe shutdown of the plant.

#### **9.2.3.4 Test and Inspection**

Prior to startup piping and equipment were tested. After startup routine visual inspection of the system components and instrumentation is adequate to verify system operability.

#### **9.2.3.5 Instrumentation Applications**

Instrumentation is provided to maintain storage tank levels. The water purification system effluent is provided with a finished water monitor and alarm.

A flow control valve in the demineralized water supply line may be set to close when the demineralized water head tank level rises above the setpoint.

The cask decontamination head tank fills by gravity through a level seeking connection from the demineralized water system. Flow is controlled by a restrictive orifice and check valve.

High and low level switches annunciate both tank levels in the control room.

### **9.2.4 Potable and Sanitary Water Systems**

#### **9.2.4.1 Potable Water System**

##### **9.2.4.1.1 System Description**

Potable water for this project is purchased from a water supply system operated by Watts Bar Utility District.

Potable water from the supply system enters the plant site through a water meter and a backflow prevention valve and is routed to two storage tanks in the Turbine Building. Most potable water used on site is taken from the outlets of these tanks in order to keep the stored water fresh and maintain adequate chlorine residual. Some of the more remote facilities are supplied directly from the main supply line. Pressure reducing valves are used where required. The main supply line and the return lines from the storage tanks supply the yard distribution system which conveys potable water to the various buildings and to other points of usage. Concrete backing is poured where lines change direction or dead end. The materials used for pipelines of the potable water system are in compliance with the Standard Plumbing Code.

Plumbing fixtures, water coolers, water heaters, eyewash equipment, and emergency shower equipment are supplied with potable water. Some eyewash and emergency shower equipment are also supplied water from the demineralized water system. Applicable laboratory, hospital, kitchen, and laundry equipment are also supplied. Hose bibs and service outlets receive potable water where raw water is not readily

available or where water cleaner than raw water is needed. There are no potable water lines in the Reactor Building.

Hard-drawn copper tubing and solder joint fittings or galvanized steel pipe and galvanized malleable iron fittings are normally used on water lines in the buildings. Potable water lines are normally sized to limit fluid velocities to a maximum of seven to eight feet per second.

Flow diagrams are as shown on Figures 9.2-29A, 9.2-29B, 9.2-29C and 9.2-29D.

#### **9.2.4.1.2 Safety Evaluation**

Potable water is not essential for the normal operation or the safe shutdown of the nuclear reactors. An adequate supply is important, however, to operate emergency eyewash and shower equipment, to wash contaminated clothing, to provide drinking water, and to carry away human waste. Interruptions in supply are minimized by storage in the two tanks in the Turbine Building.

The potable water system is not cross-connected with any radioactive system. Contamination protection is by the air gap normal to plumbing fixtures. Backflow preventers and vacuum breakers are provided throughout the plant to protect the potable water system from contamination due to backflow from contaminating sources. A reduced pressure backflow preventer is also installed in the main supply line to the plant to prevent any possible onsite contamination of the system from spreading offsite.

#### **9.2.4.1.3 Tests and Inspections**

All parts of the potable water systems are tested and inspected for leaks. Fixtures are accessible for inspection during normal operation.

When repairs or additions are made, potable water quality and treatment is monitored in accordance with the requirements of the Tennessee Department of Public Health.

#### **9.2.4.1.4 Instrumentation Applications**

Water level in the two storage tanks is controlled by a flow control valve operated by level switches. Level switches also actuate a local alarm.

Potable water flow entering the nuclear plant site is recorded by a conventional water meter.

### **9.2.4.2 Sanitary Water System**

#### **9.2.4.2.1 Design Bases**

The maximum quantity of sanitary waste to be handled, treated, and disposed of is approximately 120,000 gallons per day. The average for normal operation is approximately 100,000 gallons per day. These quantities differ from potable water usage quantities because some potable water drains to other systems. See Sections 9.2.4.2.2 and 9.2.4.2.3.

Sanitary waste is pumped to the Spring City Sewage Treatment Facility under contract with Spring City Waterworks. The contractual agreement provides for processing waste at a capacity of up to 100,000 gallons per day. Processing is performed by the contractor in compliance with all current Local, State and Federal guidelines prior to waste water being discharge to the river. The contract allows TVA the right to access and structurally modify piping for the purpose of inspection or surveillance as needed for compliance with NRC requirements.

#### **9.2.4.2.2 System Description**

Sanitary waste is collected in individual sanitary waste systems for those buildings which have sanitary facilities and conveyed into the plant yard sewage system, except as noted below and in Section 9.2.4.2.3.

The environmental data station, located far from the main plant, has its own septic tank and drain field.

In general, for building sanitary waste systems, the embedded lines and fittings are extra heavy cast-iron soil pipe, bell and spigot with neoprene gaskets. Exposed lines are galvanized steel and the fittings are the black cast-iron drainage type. Vent lines are galvanized steel and fittings are galvanized malleable iron.

The sanitary waste from most buildings flows by gravity into the yard sewage system. Some buildings, which have sanitary facilities on the lower levels, also have sewage ejectors.

The Turbine Building sanitary waste lines are run to the lower floor, which is below grade, collected in a sewage basin system that contains duplex grinder pumps and pumped to the yard system.

The Service Building sanitary waste is collected and pumped by a similar system.

Control Building sanitary waste lines flow by gravity to the Service Building sewage basin system.

The yard sewage system consists of a number of buried gravity flow and pressurized sewers, a number of lift stations and a sewage treatment plant. Gravity flow sewers are provided with precast manholes.

Gravity flow sewers are normally of cast-iron soil pipe, vitrified clay, or polyvinyl chloride (PVC) construction. Pressurized sewers are PVC.

A lift station unit is provided in the yard at the Diesel Generator Building, consisting of a collection basin, two grinder pumps and associated controls.

Similar units are provided at the additional makeup water treatment plant and for the field services facility. These are duplex units with centrifugal sewage pumps located in a concrete basin. A lift station is also provided in the yard near the Office Building to deliver the sanitary waste to the treatment plant. The lift station has a concrete basin



and two sets of duplex pumps to send the waste to a connection in the construction sewer system and then offsite to the contracted waste processor.

#### 9.2.4.2.3 Safety Evaluation

The sanitary water system does not receive radioactive waste. Drainage from other plumbing equipment with the potential of receiving radioactive waste is as follows:

(a) AUXILIARY BUILDING:

Radiochemical Laboratory

- (1) Fume hood cup sink drains to the tritiated drain collector tank (TDCT).
- (2) Hospital-type sink and an eyewash drain to the laundry tank.
- (3) Fume hood cup sinks and one counter cup sink drain to the chemical drain tank.
- (4) Counter sinks drain to the floor drain collector tank (FDCT).

Titration Room

- (1) Fume hood cup sink drains to the chemical drain tank.
- (2) Counter sink drains to the FDCT.
- (3) Counter sinks drain to the Turbine Building station sump.

Hot Instrument Shop

- (1) Sink drains to the chemical drain tank.

125 V Vital Battery Rooms, 1-4

- (1) Sinks and eyewashes drain to the Turbine Building station sump.

(b) SERVICE BUILDING

Health Physics Laboratory

- (1) Counter sink drains to the laundry and hot shower tank.

Personnel Decontamination Room

- (1) The hot shower drains to the laundry and hot shower tank.

Instrument Shop

- (1) Counter sinks and one service sink drain to the laundry and hot shower tank.

Hot Shop Area

- (1) Emergency shower drains to the FDCT tank in the Auxiliary Building.
- (2) One decontamination shower and one sink drain to the laundry and hot shower tank.

Details of these drains and tanks are discussed in Section 9.3.3.

#### **9.2.4.2.4 Tests And Inspections**

Chlorinated effluent will be monitored in accordance with the requirements of the NPDES Permit.

#### **9.2.4.2.5 Instrumentation Applications**

A float-operated switch on each sewage pump in the plant will start the pump and force accumulated sewage into the yard sewer system.

The grinder pump lift stations in the yard have integral float or pressure switch control and alarm systems.

### **9.2.5 Ultimate Heat Sink**

#### **9.2.5.1 General Description**

The ultimate heat sink (subsequently referred to as 'sink') for a nuclear plant is that complex of water sources and associated retaining structures used to remove waste heat from the plant during all normal, shutdown, and accident plant conditions. The sink is designed to perform one principal safety function throughout the plant's life: dissipation of residual heat after an accident.

The sink is comprised of a single water source, the Tennessee River, including the complex of TVA-controlled dams upstream of the plant intake, TVA's Chickamauga Dam (the nearest downstream dam), and the plant intake channel.

In normal operation, cooling water (approximately 85°F maximum) will flow from Chickamauga Reservoir through the plant intake channel to the intake pumping station. The intake channel is located on the inside of a bend in the river about 2 miles downstream of Watts Bar Dam. The intake channel extends about 800 feet from the edge of the reservoir through the flood plain along a line approximately perpendicular to the river flow, with the bottom at sufficient depth to ensure direct flow from the main river channel to the pumping station during all low water levels. A floating pontoon type structure is provided across the channel to serve as a barrier and discourage direct approach to the pumping station from the reservoir. The barrier is designed to make it virtually impossible to sink; however, if it were to sink, it could not block the channel to the extent of preventing the required flow from reaching the station.

Water is pumped to the plant by the ERCW and raw cooling water pumps (described in Sections 9.2.1 and 9.2.8, respectively), and in certain events, the fire protection pumps housed in the Seismic Category I intake pumping station. The station design assures protection of the safety-related ERCW pumps and fire protection pumps from

the design basis flood. The ERCW pumps and fire protection pumps are capable of functioning under any plant design basis condition including a SSE plus loss of downstream dam and a LOCA. The ERCW system description and performance capabilities are discussed in detail in Section 9.2.1.

### 9.2.5.2 Design Bases

The sink for Watts Bar Nuclear Plant is designed to comply with the following regulatory positions in Regulatory Guide 1.27, Revision 1, March, 1974.

- (1) The ultimate heat sink is capable of providing sufficient cooling for at least 30 days (a) to permit simultaneous safe shutdown and cooldown of all nuclear reactor units and maintain them in a safe shutdown condition, and (b) in the event of an accident in one unit, to limit the effects of that accident safely, to permit simultaneous and safe shutdown of the remaining unit, and maintain them in a safe shutdown condition. Procedures for assuring a continued capability after 30 days are available.
- (2) The ultimate heat sink is capable of withstanding, without loss of the capability specified in regulatory position 1 above, the effects of (a) the most severe natural phenomena associated with this location taken individually, (b) the site related events that historically have occurred or that may occur during the plant lifetime, (c) reasonably probable combinations of less severe natural phenomena and/or site related events, and (d) a single failure of man-made structural features.
- (3) The ultimate heat sink consists of one source of water, with the capability to perform the safety functions specified in regulatory position 1, above. It can be demonstrated that there is an extremely low probability of losing the capability of the single source. There is one canal connecting the source with the intake structures of the nuclear power units. It can be demonstrated that there is an extremely low probability that the single canal can fail entirely as a result of natural phenomena. The water source and associated canal are highly reliable and can be protected such that a complete failure cannot happen.
- (4) The Technical Specifications for the plant include actions to be taken in the event that conditions threaten partial loss of the capability of the ultimate heat sink or it temporarily does not satisfy regulatory positions 1 and 3, above, during operation.

### 9.2.5.3 Safety Evaluation

This safety evaluation is sectionalized to correspond with the points of the preceding regulatory positions.

- (1) The cooling water requirements for the most demanding accident shutdown and cooldown of the plant's reactors are presented in Section 9.2.1. The adequacy of the Tennessee River to provide this amount of water, and therefore to satisfy regulatory position 1, is confirmed in Sections 2.4.11.1, 2.4.11.3, and 2.4.11.5.

- (2) Under the most adverse events expected at the site or a reasonable combination of less severe events and any single failure of a man-made feature, the sink is designed to retain its capability to perform the specified safety functions. The most severe natural phenomena (including flood, drought, tornado, wind, and earthquake) that might conceivably occur at this site are thoroughly discussed in Chapter 2.

As stated previously, the ERCW pumps are protected from the design basis flood including the effects of wind waves, and therefore will be capable of functioning in all flood conditions up to and including the design basis flood. The intake channel extends from the pumping station into the reservoir to the original river bed and is dredged down to Elevation 660 to provide free access to the river under low flow conditions described in Section 2.4.11. Both the normally exposed and submerged portions of the channel are dredged to sufficient width, riprapped on the sides, and seismically qualified (as discussed in Section 2.5) to eliminate the possibility of channel blockage due to an earth or mud slide. The channel will be monitored and dredged as required to maintain free access to the river. Therefore, adequate water will be available to the ERCW pumps at all times and for all events including the loss of downstream dam for any reason. Since the intake channel is seismically qualified, the unlikely occurrence of the SSE could significantly affect the sink only by causing failure of the non-Category I downstream dam and/or upstream dams. For the resulting low and/or high reservoir event, water will be available to the intake at all times. A seismically induced disturbance of the rock surfaces could only block a small percentage of the intake channel due to its high conservative width.

A tornado cannot disrupt the ERCW water supply to the intake station.

Protection of the intake channel and station against blockage or impact by river traffic is afforded by its location. For all conditions of river navigation (up to water level 698 which corresponds to the 40 year flood level in Watts Bar Dam tailwaters at which lock operation ceases), the grade elevation of the river flood plain through which the channel passes is such that even when the flood plain is submerged, sufficient depth will not exist for passage of any major river vessel. In addition, due to the close proximity of the upstream dam, the possibility of a barge being accidentally released upstream and reaching the plant site would be extremely remote. However, if such an incident does occur, the barge will be carried away from and past the intake channel and station by the high velocity water passing the plant on the outside of the river bend on the opposite side of the reservoir.

For lake levels which would provide sufficient water depth for a barge to approach the intake station, it is not considered credible that serious damage would be incurred. The intake station would be in relatively stagnant, shallow water approximately 800 feet from the main river channel, and would be a relatively small target.

TVA regulation of the Tennessee River is such that drought will not jeopardize the sink's capability required in regulatory position 1; this is historically confirmed by the data in Section 2.4.11.3.

The most severe combination of events considered credible to occur would be the simultaneous occurrence of a loss-of-coolant accident in one unit and hot standby of the other, loss of offsite power, and loss of upstream and/or downstream dams either individually or concurrently. Under this extreme situation, the sink retains the capability required by regulatory position 1.

Section 9.2.1.3 states that the ERCW system provides the required flow to remove the design basis heat load necessary to maintain the plant in a safe condition. As noted in Section 9.2.2.4, a calculation has been performed that shows there is sufficient ERCW and CCS capability to bring the non-accident unit to cold shutdown within 72 hours from entry into the Hot Standby mode to demonstrate compliance with GDC-5. Section 2.4.11.3 shows that the minimum available flow from the Tennessee River will be well in excess of this requirement.

- (3) The Tennessee River is the common supply for all plant cooling water requirements. Total interruption of this supply is incredible. Additionally, the integrity of the river's dams is not essential for safe reactor shutdown and cooldown. While only a single channel is provided to convey water from the river to the intake station, total failure is considered incredible due to the location, maintenance, and seismic qualification of the channel.
- (4) The limiting conditions and surveillance requirements for the ERCW system are given in the Technical Specifications. The limiting conditions for the plant's flood protection program are stated in the Technical Requirements Manual.

#### 9.2.5.4 Instrumentation Application

This requirement is not applicable to the ultimate heat sink at WBNP.

#### 9.2.6 Condensate Storage Facilities

The condensate storage facilities store and supply treated water for:

- (1) initial charging of the secondary system,
- (2) makeup water when the water treatment plant is being regenerated or is out of service,
- (3) replacement of water lost by safety valve or relief valve operation, and
- (4) the preferred source of an adequate quantity of feed quality water for emergency cooling (auxiliary feedwater system).

##### 9.2.6.1 Design Bases

The condensate storage facilities are designed to serve as a receiver of water from the main condenser high level dump and to provide treated water for makeup to the main

condenser while reserving a minimum amount for the auxiliary feedwater system. This amount is required to hold the plant for two hours after a Design Basis Event (DBE) and 5 hours to cool RCS from no-load hot standby at 50°F per hour to the point at which the residual heat removal system can take over.

The condensate storage tanks are not an engineered safety feature and are not seismically qualified. The storage tanks supply the preferred source of water to the auxiliary feedwater system, but the engineered safety feature source is the ERCW System (Safety Class 2b).

### 9.2.6.2 System Description

The condensate facility, shown in Figure 10.4-7, consists of one condensate transfer pump and two condensate storage tanks connected in parallel (one tank for each unit) and associated piping, controls, and instrumentation. The tanks are located in the plant yard adjacent to the east wall of the Turbine Building.

The auxiliary feedwater pumps take suction directly from the condensate storage tanks to supply treated water for cooldown of the reactor coolant system. A minimum of 200,000 gallons in each tank is reserved for the auxiliary feedwater system. This quantity is assured by means of standpipes through which other systems are supplied.

Makeup to the condenser is supplied by gravity flow from the tanks while reject water from the condenser flows to the tanks through the hotwell pumps. Makeup of deaerated and demineralized water to the condensate storage tanks can be from the water treatment plant or the 500,000 gallon demineralized water storage tank. The tanks are equipped with a level control system which will indicate the tank volumes.

The condensate storage tanks are constructed from ASTM A283 Grade C carbon steel plate to AWWA Standard D100. The inside has a coating of epoxy-phenolic resin to prevent corrosion. Each tank has a capacity of 385,000 gallons with an overflow at 395,000 gallons.

Air removal (nitrogen purging) connections have been added to each of the condensate storage tanks. Low pressure nitrogen is introduced into the bottom of each condensate storage tanks through a multi-nozzled distribution header. The nitrogen is bubbled through the stored condensate and then is released to the atmosphere. Through this process dissolved oxygen content of the condensate storage tank water is reduced to and maintained at acceptable levels during periods of time when water in the tank is not exchanged with water in the steam cycle.

The condensate transfer pump (CTP) is an electric motor driven pump designed to deliver 1000 gpm at 55 feet total head. The main purpose of the condensate transfer pump is for the transfer of water from one tank to the other.

### 9.2.6.3 Safety Evaluation

The condensate storage tanks are the preferred source of clean water supply for the auxiliary feedwater pumps and a storage reservoir for secondary system water. The tanks are not an engineered safety feature. The engineered safety feature water

source for the auxiliary feedwater system is the ERCW system (Safety Class 2b). Either tank is isolable, but auxiliary feedwater can be obtained from both tanks. This will be done only if necessary since each condensate storage tank normally contains auxiliary feedwater for just one unit.

The ERCW system pool quality feedwater will be used during an extreme emergency when safety is the prime consideration and steam generator cleanliness is of secondary importance.

Piping connected to the condensate storage tanks is routed through a heated tunnel under the tanks. Ice formation in the tanks during a period of prolonged low temperatures can be prevented, if necessary, by recirculation of water through the condensate transfer pump. The tank and its connecting piping can accommodate water whose temperature is in the range of 40°F to 120°F.

The water in the condensate storage tanks is not normally radioactive. However, in the event of primary-to-secondary leakage due to a steam generator tube leak, it is possible for the condensate and feedwater system to become radioactively contaminated. The water in the condensate storage tanks can become contaminated by rejected water from the main condenser in situations where the secondary system is contaminated. The maximum level of contamination in the tanks can be conservatively estimated to be comparable to that of the main condenser. (Section 10.4.1)

Each condensate storage tank has an overflow level at 395,000 gallons. The overflow lines terminate beside the tanks just above ground level. A tank overflow or rupture would allow the water to be drained to the Turbine Building sump or to the river by way of the holding pond. The radiological consequences of this are less than other postulated accidents discussed in Chapter 15.

Tank repairs necessitated by damage or leaks can be made after closing tank isolation valves in the interconnecting headers, and transferring water from the defective tank to the other storage tank using the condensate transfer pump. Excess water can be drained to waste through normally locked closed tank drain valves which lead to the yard drainage system.

#### **9.2.6.4 Test and Inspections**

The condensate storage tanks are tested during the preoperational test program for both the condensate system and the auxiliary feedwater system. Periodic visual inspections are performed in accordance with plant procedure to ensure integrity of the tank.

Preoperational test requirements are given in Chapter 14.

#### **9.2.6.5 Instrument Applications**

The level in each storage tank is indicated on the main control board and on a local panel in the area of the transfer pump. The level signal received from an electronic level transmitter provides the signal for the annunciation in the main control room of

low-low CST water level. Each tank is also equipped with side mounted displacement type level switches which provide signals for annunciation in the main control room of high-low CST water levels. The set points for these switches are set to alarm at points that are different from the low-low setpoint of the electronic level transmitter. Therefore, the electronic transmitter low-low setpoint is a backup for the displacement switch low level setpoint. Continuous tank level indication is provided locally and in the main control room for each tank.

### 9.2.7 Refueling Water Storage Tank

The refueling water storage tank (RWST) fulfills two basic requirements:

- (1) It provides an adequate supply of borated water (boron concentration of minimum 3100 ppm) for use during refueling operations.
- (2) It provides an adequate supply of borated water (boron concentration of minimum 3100 ppm) to the two charging pumps (CVCS), the two safety injection system (SIS) pumps, the two residual heat removal (RHR) pumps, and the two containment spray (CSS) pumps in the event of a loss-of-coolant accident (LOCA). During normal power operation, RWST water is valved to the suction of the SIS pumps, RHR pumps, and the CSS pumps. The suction of the CVCS pumps is automatically valved to the RWST by a safety injection signal.

The following criteria are used to fulfill the above requirements; the size of the RWST is sufficient to contain the largest of the following:

- (a) The amount of water required to fill the refueling cavity and fuel transfer tubes (350,000 gallons).
- (b) The amount of water, in addition to that in the SIS accumulator tanks, RCS inventory, and ice melt, necessary to establish the emergency cooling recirculation mode following a LOCA (i.e., the depth of water provided in the Reactor Building will be sufficient to provide free flow to the containment sump and to provide adequate suction head for the CVCS, SIS, RHR, and CSS pumps), including holdup or unavailable water (reactor cavity, containment atmosphere, water remaining in the RWST).
- (c) The amount of water necessary to supply the CVCS, SIS, RHR, and CSS for a period of time (10 minutes or more) sufficient to allow the operator to properly assess the situation and establish the recirculation mode following a LOCA.

The design parameters of the RWST are as follows:

Quantity	1
Design pressure	atmospheric
Normal operating pressure	atmospheric



Quantity	1
Tank design temperature	200°F
Operating temperature, (water-min)	60°F
Volume, gal (to overflow)	380,000
Minimum operating volume, gal	370,000
Boron concentration, ppm (nominal)	3,200
Outside diameter, ft	43-1/2
Straight Side height, ft	38
Material of construction	Austenitic stainless steel
Number of heaters	4
Capacity of each heater, kW	12

The RWST instrumentation is discussed in Chapter 7. Overflow routing is discussed in Section 11.2.

The vent is at the top of the RWST and covered by a rain hood. A protective screen having 3/4" openings and an effective area almost three times the cross sectional area of the 28-inch vent stack is fitted over windows near the top of the 28-inch stack but beneath and inside the rain hood. This screen guards against intrusion of foreign objects, yet is sufficiently open to minimize vent plugging by ice buildup. Additionally, to prevent freezing, the exterior surfaces of the vent stack and rain hood will be insulated with 3" of external grade insulation, suitably supported. Since the vent is located at the top of the RWST, and is approximately 44 feet from ground level, it is clear of normal debris (plastic sheets, paper, etc.), but further assurance is afforded by the shielding of the screen by the rain hood, and the large screen area.

The RWST's vortex nozzle assemblies were not radiographed. ASME Section III, Subsection NC, paragraph NC-5282.6 (1974 Edition, and Winter 1975 Addenda) requires butt joints in atmospheric storage tanks be fully radiographed.

TVA has issued CAQR's WBP890317 and WBP890318, for Units 1 & 2, respectively, for documentation of the problem. Calculation WBP-MTB-001 documents the basis for the acceptability of these welds.

#### 9.2.7.1 ECCS Pumps Net Positive Suction Head (NPSH)

The straight side height of the RWST is 38 feet, and the overflow pipe inlet is 411 inches above the bottom of the tank, which is at Elevation 729.17. The outside diameter is 43.5 feet, with a capacity of 925 gal/in of depth. The normal fill is 375,000 gallons. The minimum operating level is 370,000 gallons. Makeup will be made should the level drop to the minimum operating level. Further emergency condition data is tabulated below:

Pump Centerline		Minimum RWST Water
Pump	Elevation, ft	Level Used in NPSH Analysis
RHPP	679.7	731.8 (low-low)
CCP	695.92	731.8 (low-low)
SIP	695	731.8 (low-low)
CSP	679.00	731.8 (low-low)

Using the minimum RWST volume of 370,000 gallons at the start of ECCS pumping, sufficient water will have been pumped into the Reactor Building in just over 10 minutes (maximum flowrates), to cause the low level auto switchover alarm to be actuated signaling the switchover sequencing. The switchover sequence from injection to recirculation mode is completed in accordance with Table 6.3-3.

The RHR pumps are automatically aligned to the containment sump. The ECCS and CS pumps have injected approximately 224,000 gallons of water into the Reactor Building at this time. The low-low level alarm is actuated after approximately 320,000 gallons have been injected, signaling the operator to shut off the CSS pumps. These are the last pumps to be shut down after all pumps have been switched to recirculation modes.

See Sections 6.2.2.2, 6.3.2.14, and Table 9.2-3 for additional discussion of NPSH of ECCS pumps.

Analysis of RHR and containment spray pump NPSH considers the effects of the sump with its screens and all associated suction piping and valves. Assumptions made in the analysis are conservative and include:

- (1) water temperature, 190°F
- (2) normal containment atmospheric pressure
- (3) all pumps operating at maximum rated flow and
- (4) minimum sump water level

The total head loss across the screens includes losses associated with the screens, the plenum box and all possible debris loading combinations. Adequate NPSH margin ensures that the ECCS and CSS pumps will operate as designed in accordance with NRC Generic Letter 2004-02.

Note: The minimum sump water level is 5.78 ft, which is above the strainers. The total head loss through the strainer (2.218 ft at 120 °F) was used in NPSH analysis.

Based on the above, the ECCS and CSS pumps NPSH data is tabulated in Table 9.2-3.

All of the ECCS pumps will be preoperationally tested under conditions that simulate limiting design basis conditions. Where accident limits can be more extreme than test conditions, calculations and/or extrapolations are made from the test data to show that the system performance will be satisfactory under accident conditions. For instance, all ECCS pumps are to be started and operated at maximum possible flow from the RWST into an open reactor vessel. Suction pressure data is taken and then corrected to reflect any difference between the level in the RSWT at the point where data is taken and the lowest level to exist in the tank under accident conditions. This number is then compared to required NPSH conditions to assure that acceptable margin exists. The containment spray pumps are also run during this test to determine their effect on the NPSH conditions at the ECCS pumps.

To verify acceptable discharge piping losses, each ECCS pump will be run individually at its maximum flow into an open reactor vessel. The safety injection and centrifugal charging pump flows will be limited and balanced through the use of manual valves in the injection lines going to the separate reactor coolant loops. Hence, these discharge line losses are set during the preoperational tests. The RHR pump discharge line losses are determined entirely by the installed piping system. The ECCS pump flowrates achieved during preoperational testing were evaluated to determine actual system resistance and the system resistance was confirmed to be acceptable.

All of the ECCS pumps are determined to be running in conformance with manufacturers test curves for total developed head. Test points for total developed head are also compared and determined to exceed the performance curves assumed in the ECCS analysis.

Historical Information. A 1:4 scale model study which demonstrates the acceptability of the revised sump, sump screen, and trash rack design has been performed. The report of the model study, and an NPSH evaluation were submitted by letter from J. E. Gilleland to S. A. Varga, dated May 23, 1979.

## 9.2.8 Raw Cooling Water System

### 9.2.8.1 Design Bases

The raw cooling water (RCW) system is designed to achieve the following objectives:

- (1) Provide cooling water to the turbine-generator auxiliary equipment and miscellaneous cooling equipment within the Turbine Building.
- (2) Serve as primary nonqualified source of cooling water for the ice condenser system.
- (3) Provide cooling water to nonessential air conditioning equipment within the Auxiliary Building.
- (4) Serve as a source for filling and maintaining pressurization of the raw service water (RSW) system.

- (5) Serve as a source of makeup water to the condenser circulating water system.
- (6) Provide raw water makeup to water treatment plant.

### 9.2.8.2 System Description

The flow, logic and control diagrams for this system are shown on Figures 9.2-32 through 9.2-39.

The RCW system is a non-safety related, shared system. Water is supplied by seven electric motor driven pumps located in the plant intake pumping station. The design data for these pumps is given in Table 9.2-11. Six of the pumps are capable of meeting the maximum normal system flow requirements and the seventh serves as an installed spare.

Water is supplied to the Turbine Building through two sectional legs of a single loop header. In the Turbine Building, the water is filtered to 1/32-inch particle size by four automatic backwashing strainers common to both units. Each strainer is designed to handle 1/3 of the maximum normal flow of both units.

After being strained, the water is directed to two loop headers within the Turbine Building, one for each unit. Water is then distributed from each loop header to the following equipment within the Turbine Building:

- (1) Generator stator heat exchangers
- (2) Generator hydrogen heat exchangers
- (3) Generator exciter heat exchangers
- (4) Generator main bus heat exchangers
- (5) Generator seal oil heat exchanger
- (6) Main turbine oil heat exchanges
- (7) Turbine electro-hydraulic control fluid heat exchangers
- (8) Feedwater pump turbine oil heat exchanger
- (9) Condenser vacuum pump coolers
- (10) Condensate booster pump heat exchangers
- (11) No. 3 and No. 7 heater drain tank pump heat exchangers
- (12) Turbine Building ventilation coolers
- (13) Sample heat exchangers

- (14) Standby main feedwater pump heat exchanger
- (15) Heat exchangers 90-120 for radiation monitoring
- (16) Auxiliary Boiler System Blowdown Tank
- (17) Condensate Demineralizer Air Compressor

In addition, the system supplies raw water upon demand to the raw service water system and makeup to the water treatment plant from either unit.

The raw service water (RSW) system supplies water requirements for various air-conditioning loads and for maintenance, cleaning, and other miscellaneous, intermittent purposes throughout the Turbine, Service, and Office Buildings and plant yard.

The RCW discharge from the heat exchangers and coolers located in the Turbine Building, with the exception of the sample heat exchangers which discharge to plant drainage, is directed to the cold water outlet flume of the condenser circulating water (CCW) cooling tower corresponding to the same unit. However, the Unit 1 RCW flow can be discharged into either the Unit 1 CCW cold water outlet flume, or the Unit 2 CCW cold water outlet flume to allow work to be performed on the CCW system while still maintaining RCW flow. Similarly, the Unit 2 RCW flow can be discharged into either the Unit 2 CCW cold water outlet flume or the Unit 1 CCW cold water outlet flume to allow work to be performed on the CCW system while still maintaining RCW flow. As described in Section 10.4.5 this RCW discharge serves as a portion of the makeup water to the CCW system. A siphon break is provided on the RCW discharge of each unit to prevent flooding of the powerhouse by backflow of water from the CCW system in the event of a rupture of the RCW header within the buildings.

Since the flow through major components within the RCW system is varied by temperature control valves which monitor the process side temperature in order to maintain a constant temperature of the cooled systems, the total system flow is decreased in the winter when the river temperature decreases. Subsequently, fewer than six pumps operate and less flow is available for CCW cooling tower makeup water. Therefore, to enable the RCW system to be utilized to the fullest extent as a makeup source to the CCW system, a bypass line with modulating valve is provided from the RCW supply to RCW discharge headers. This line permits that portion of the RCW system flow in excess of the RCW component requirements to bypass the Turbine Building and serve as additional makeup water to the CCW system on demand.

A connection to the Turbine Building loop header of both units provides a nonessential source of water to various equipment within the Auxiliary and Additional Equipment Buildings. This equipment includes the following:

- (1) Auxiliary Building general ventilation system and coolers (nonsafety- related equipment)

- (2) Additional Equipment Building ventilation coolers (for nonsafety-related equipment)
- (3) Ice condenser system heat exchangers
- (4) Post-operational chemical cleaning equipment

Since the RCW system is not designed to remain operational for a flood level in excess of plant grade (Elevation 728.0), provisions are made in the Auxiliary Building for an intertie with the ERCW supply which is to be installed as part of the plant flood preparations (refer to Sections 2.4.14 and 9.2.1) in order to supply flow to the ice condenser system heat exchangers. The flow through the ice condenser system is always discharged to the holding pond, whether supplied from RCW or ERCW. The ERCW intertie is used in flood conditions to maintain a cooling water supply to the ice machine refrigeration condensers. Refer to Section 6.7 for a detailed description of the ice condenser system.

For control of organic fouling, including slime and Asiatic clam infestation, see Section 9.2.1.6. Strainers in the supply headers and periodic backflushing of the strainers curtail large clams from entering the plant. Chemical treatment of the RCW is necessary during the clam spawning season to control Asiatic clam growth, which is approximately May to October.

### 9.2.8.3 Safety Evaluation

Since this system has no safety-related functions, it is not required to be designed to remain operable through an earthquake, tornado, flood-above-plant-grade, or other such natural phenomena. The RCW system is designed such that none of its components can adversely affect the function of any safety-related system.

Within the intake pumping station, the RCW pumps and piping are located in a completely separate area from any safety-related equipment. The RCW piping in the electrical equipment room is supported to the extent required to prevent falling on safety-related cables and cable trays (pressure boundary integrity is not required).

The RCW system piping within the Auxiliary and Additional Equipment Buildings is seismically qualified (Seismic Category I(L)) to the extent required to ensure that a safe shutdown earthquake in combination with normal operating conditions will not cause flooding, water impingement, or damage due to falling on safety related equipment. This degree of seismic qualification is accomplished by supporting the piping in all areas so as to prevent its falling. In areas where safety-related equipment is located, either further support is provided to ensure the integrity of the RCW piping pressure boundary, or the safety-related equipment is sealed or shielded from water spray.

An isolation valve is provided in the seismically qualified portion of the RCW supply line from the Turbine Building to the Auxiliary Building. This prevents the loss of water from the ERCW system to the nonqualified portion of the RCW system whenever the flood mode intertie to the ERCW system is made.

**9.2.8.4 Tests and Inspection**

The RCW system is hydrostatically or in-service leak tested and performance tested prior to plant operation to ensure adequacy of the system to meet the operational requirements. Once the plant is operational, routine visual inspection of all the system components is sufficient to verify functionality. A diver protection barrier is installed in the pump bay to facilitate the inspection of the RCW pumps.

Table 9.2-1 ESSENTIAL RAW COOLING WATER SYSTEM PUMP DESIGN DATA

<b>Essential Raw Cooling Water Pumps</b>	
Quantity	8
Type	Vertical, wet pit centrifugal type
Rated capacity, gpm (each)	11,800
Rated head, ft	230
Motor horsepower, hp (each)	800
Submergence required, ft	5.25
Submergence available (minimum), ft	12.07
<b>Screen Wash Pumps</b>	
Quantity	4
Type	Vertical turbine
Rated capacity, gpm (each)	270
Rated head, ft	350
Motor horsepower, hp (each)	40
NPSH required, ft	10.35
NPSH available (minimum), ft	42.35
<b>Traveling Water Screens</b>	
Quantity	4
Motor Horsepower, hp (each)	3



Table 9.2-2 ESSENTIAL RAW COOLING WATER SYSTEM FAILURE MODES AND EFFECTS ANALYSIS (Page 1 of 79)

Item	Component	Function	Failure Mode	Potential Cause	Method of Detection	Effect on System	Effect on Plant	Remarks
1.	ERCW Pumps A-A B-A C-A D-A E-B F-B G-B H-B	Operate.	Any one pump either fails to start or stops operating.	Electrical or mechanical failure.	Status lights 0-HS-67-28A, 32A, 36A, 40A, 47A, 51A, 55A, 59A, respectively, and low header pressure alarms in MCR.	None. Any two of four pumps on either Train A or Train B are capable of providing full ERCW flow.	None.	
2.	Screen Wash Pumps 1A-A 2A-A 1B-B 2B-B	Operate.	Any one either fails to start or stops operating.	Electrical or mechanical failure.	Status lights 1-HS-67-431A, 2-HS-67-437A, 1-HS-67-440A, 2-HS-67-447A, respectively.	None. Any one of the two screens for either Train A or Train B intakes is capable of screening full ERCW flow.	None.	

**Table 9.2-2 ESSENTIAL RAW COOLING WATER SYSTEM  
FAILURE MODES AND EFFECTS ANALYSIS  
(Page 2 of 79)**

Item	Component	Function	Failure Mode	Potential Cause	Method of Detection	Effect on System	Effect on Plant	Remarks
3.	Traveling Water Screen 1A-A 1B-B 2A-A 2B-B	Operate. Start automatically on high pressure in wash line.	Any one either fails to start or stops operating.	Electrical or mechanical failure.	Motor indication 1-XI-67-434, 445, 2-XI-67-439, 451, respectively.	None. Any one of the two screens on either train A or Train B intake is capable of screening full ERCW flow.	None.	

**Table 9.2-2 ESSENTIAL RAW COOLING WATER SYSTEM  
FAILURE MODES AND EFFECTS ANALYSIS  
(Page 3 of 79)**

Item	Component	Function	Failure Mode	Potential Cause	Method of Detection	Effect on System	Effect on Plant	Remarks
4.	ERCW Pump Disch Check Valves 0-67-503A 0-67-503B 0-67-503C 0-67-503D 0-67-503E 0-67-503F 0-67-503G 0-67-503H	Open to provide flow path when respective pump starts.  Close to prevent backflow when respective pump stops.	Fails to open.  Fails to close.	Mechanically stuck closed.  Mechanically stuck open.	High pressure alarms in MCR.  Low flow and low pressure alarms in MCR	None. Any other two of the remaining three pumps in the affected train or any two of the four pumps in the other train can be started.  None. Respective pump train discharge valves 1,2-FCV-67-22 in Train A or 1,2-FCV-67-24 in Train B can be closed to isolate affected pump train from supply headers and supply ERCW from other pump train.	None.  None.	

**Table 9.2-2 ESSENTIAL RAW COOLING WATER SYSTEM  
FAILURE MODES AND EFFECTS ANALYSIS  
(Page 4 of 79)**

Item	Component	Function	Failure Mode	Potential Cause	Method of Detection	Effect on System	Effect on Plant	Remarks
5.	ERCW Pump Disch Hdr Butterfly Valves. 1-FCV-67-22 1-FCV-67-24 2-FCV-67-22 2-FCV-67-24	ERCW flow path to headers 1A, 1B, 2A, 2B, respectively.	Any one of four closes.	Inadvertent actuation or mechanical failure.	Low flow alarms in MCR.	None. Three of four headers are available to ensure either headers 1A and 2A or headers 1B and 2B will be in service to meet all plant requirements.	None.	Administratively locked in open position with breakers open.
6.	DG 1A-A Cir Inlet B'fly Valves 1-FCV-67-66	ERCW supply flow path from header 1A	Valve fails to fully open or recloses	Electrical or mechanical failure Inadvertent actuation or mechanical failure.	Status light 1-HS-67-66A	Inability to provide required cooling flow to diesel generator.	None. The remaining three diesel generators are available to supply required emergency power.	

Table 9.2-2 ESSENTIAL RAW COOLING WATER SYSTEM  
FAILURE MODES AND EFFECTS ANALYSIS  
(Page 5 of 79)

Item	Component	Function	Failure Mode	Potential Cause	Method of Detection	Effect on System	Effect on Plant	Remarks
7.	DG 2A-A Cir Inlet B'fly Valves 2-FCV-67-66	ERCW supply flow path from header 1A	Valve fails to fully open or recloses	Electrical or mechanical failure.  Inadvertent actuation or mechanical failure	Status light 2-HS-67-66A	Inability to provide required cooling flow to diesel generator.	None. The remaining three diesel generators are available to supply required emergency power.	
8.	DG 1B-B Cir Inlet B'fly Valves 1-FCV-67-67	ERCW supply flow path from header 1B	Valve fails to fully open or recloses	Electrical or mechanical failure  Inadvertent actuation or mechanical failure.	Status light 1-HS-67-67A	Inability to provide required cooling flow to diesel generator.	None. The remaining three diesel generators are available to supply required emergency power.	

Table 9.2-2 ESSENTIAL RAW COOLING WATER SYSTEM  
FAILURE MODES AND EFFECTS ANALYSIS  
(Page 6 of 79)

Item	Component	Function	Failure Mode	Potential Cause	Method of Detection	Effect on System	Effect on Plant	Remarks
9	DG 2B-B Cir Inlet B'fly Valves 2-FCV-67-67	ERCW supply flow path from header 1B	Valve fails to fully open or recloses	Electrical or mechanical failure. Inadvertent actuation or mechanical failure.	Status light 2-HS-67-67A	Inability to provide required cooling flow to diesel generator.	None. The remaining three diesel generators are available to supply required emergency power.	.
10.*	ADG Cir Inlet B'fly Valves 1-FCV-67-72-S 2-FCV-67-73-S	ERCW supply flow path from headers 2A/2B and 1A/1B re-spectively.	Either one of two fails to fully open or recloses.	Electrical or mechanical failure. Inadvertent actuation or mechanical failure.	Status lights 1-HS-67-72A, 2-HS-67-73A, respectively.	None. Each valve provides full flow capability..	None.	*The ADG is not operable, however this wording is retained for historical purposes.

Table 9.2-2 ESSENTIAL RAW COOLING WATER SYSTEM  
FAILURE MODES AND EFFECTS ANALYSIS  
(Page 7 of 79)

Item	Component	Function	Failure Mode	Potential Cause	Method of Detection	Effect on System	Effect on Plant	Remarks
11.	DG 1A-A Cir Inlet Check Valve 1-67-508A	ERCW supply flow path from header 1A backflow protection.	Fails to open	Mechanical failure or stuck closed.	No direct MCR indications available.	If the valve fails to open, flow to the DG jacket water heat exchangers would be isolated. If a failure occurred, the opposite train diesel would be available or flow from the opposite train ERCW supply Header 2B could be provided under the abnormal operating procedures.	None.	

**Table 9.2-2 ESSENTIAL RAW COOLING WATER SYSTEM  
FAILURE MODES AND EFFECTS ANALYSIS  
(Page 8 of 79)**

Item	Component	Function	Failure Mode	Potential Cause	Method of Detection	Effect on System	Effect on Plant	Remarks
11 Cont	1-67-508A Cont	ERCW supply flow path from header 1A, backflow protection.	Fails to close on reverse flow.	Mechanical failures or stuck open.	No direct MCR indications available.	None: Reverse flow would only occur on loss of ERCW supply Header 1A, if the opposite ERCW supply header had been placed in service. The loss of 1A would be the single failure in which case failure of this valve need not be postulated. Header realignment would be implemented by abnormal operating procedures.	None.	





Table 9.2-2 ESSENTIAL RAW COOLING WATER SYSTEM  
FAILURE MODES AND EFFECTS ANALYSIS  
(Page 10 of 79)

Item	Component	Function	Failure Mode	Potential Cause	Method of Detection	Effect on System	Effect on Plant	Remarks
11 cont	1-67-513A Cont	Alternate ERCW supply flow path from header 2B, backflow protection	Fails to close on reverse flow	Mechanical failure or stuck closed	No direct MCR indications available.	None, under normal plan operating conditions flow through this line is isolated by valve 1-FCV- 067-0068-A. Therefore, the failure of the check valve to close has no affect on the system.	None	

**Table 9.2-2 ESSENTIAL RAW COOLING WATER SYSTEM FAILURE MODES AND EFFECTS ANALYSIS (Page 11 of 79)**

Item	Component	Function	Failure Mode	Potential Cause	Method of Detection	Effect on System	Effect on Plant	Remarks
12.	DG 2A-A C/r Inlet Check Valve  2-67-508A	ERCW supply flow path from header 1A backflow protection.	<p>Fails to open</p> <p>or</p>	Mechanical failure or stuck closed.	No direct MCR indications available.	If the valve fails to open, flow to the DG jacket water heat exchangers would be isolated. If a failure occurred, the opposite train diesel would be available or flow from the opposite train ERCW supply Header 2B could be provided under the abnormal operating procedures.	None.	

Table 9.2-2 ESSENTIAL RAW COOLING WATER SYSTEM  
FAILURE MODES AND EFFECTS ANALYSIS  
(Page 12 of 79)

Item	Component	Function	Failure Mode	Potential Cause	Method of Detection	Effect on System	Effect on Plant	Remarks
12 Cont	2-67-508A Cont	ERCW supply flow path from header 1A, backflow protection.	Fails to close on reverse flow	Mechanical failures or stuck open	No direct MCR indications available.	None. Reverse flow would only occur on loss of ERCW supply Header 1A of the opposite ERCW supply Header 2B had been placed in service. The loss of 1A would be the single failure in which case failure of this valve need not be realignment would be implemented by abnormal operating procedures.	None.	

Table 9.2-2 ESSENTIAL RAW COOLING WATER SYSTEM  
FAILURE MODES AND EFFECTS ANALYSIS  
(Page 13 of 79)

Item	Component	Function	Failure Mode	Potential Cause	Method of Detection	Effect on System	Effect on Plant	Remarks
12 Cont	DG 2A-A Cir Inlet Check Valve  2-67-513A	Alternate ERCW supply flow path from header 2B, backflow prevention.	Fails to open   or	Mechanical failure or stuck closed.	No direct MCR indications available.	The back-up supply flow from ERCW supply header 2B would be unavailable. This supply is only placed in service under abnormal plant operating procedures when the normal supply from ERCW supply header 1A is unavailable.		

**Table 9.2-2 ESSENTIAL RAW COOLING WATER SYSTEM  
FAILURE MODES AND EFFECTS ANALYSIS  
(Page 14 of 79)**

Item	Component	Function	Failure Mode	Potential Cause	Method of Detection	Effect on System	Effect on Plant	Remarks
12 Cont	2-67-513A Cont	Alternate ERCW supply flow path from header 2B, backflow prevention.	Fails to close on reverse flow	Mechanical failure or stuck open.	No direct MCR indications available.	None, under normal plant operating conditions flow through this line is isolated by valve 2-FCV-067-0068-A. Therefore, the failure of the check valve to close has no affect on the ERCW system.	None.	

Table 9.2-2 ESSENTIAL RAW COOLING WATER SYSTEM  
FAILURE MODES AND EFFECTS ANALYSIS  
(Page 15 of 79)

Item	Component	Function	Failure Mode	Potential Cause	Method of Detection	Effect on System	Effect on Plant	Remarks
13.	DG 1B-B Clr Inlet Check Valve  1-67-508B	ERCW supply flow path from header 1B, backflow protection.	Fails to open    or	Mechanical failure or stuck closed	No direct MCR indications available.	If the valve fails to open, flow to the DG jacket water heat exchangers would be isolated. If a failure occurred, the opposite train diesel would be available or flow from the opposite train ERCW supply Header 2A could be provided under the abnormal operating procedures.	None.	

**Table 9.2-2 ESSENTIAL RAW COOLING WATER SYSTEM  
FAILURE MODES AND EFFECTS ANALYSIS  
(Page 16 of 79)**

Item	Component	Function	Failure Mode	Potential Cause	Method of Detection	Effect on System	Effect on Plant	Remarks
13 Cont	1-67-508B Cont	ERCW supply flow path from header 1B backflow protection.	Fails to close on reverse flow	Mechanical failures or stuck open.	No direct MCR indications available.	None. Reverse flow would only occur on loss of ERCW supply Header 1B, if the opposite ERCW supply Header 2A had been placed in service. The loss of 1B would be the single failure in which case failure of this valve need not be postulated. Header realignment would be implemented by abnormal operating procedures.	None.	



**Table 9.2-2 ESSENTIAL RAW COOLING WATER SYSTEM  
FAILURE MODES AND EFFECTS ANALYSIS  
(Page 17 of 79)**

Item	Component	Function	Failure Mode	Potential Cause	Method of Detection	Effect on System	Effect on Plant	Remarks
13 Cont	DG 1B-B Cir Inlet Check Valve 1-67-513B	Alternate ERCW supply flow path from header 2A, backflow protection.	Fails to open  or	Mechanical failure or stuck closed	No direct MCR indications available.	The back-up supply flow from ERCW supply header 2A would be unavailable. This supply is only placed in service under abnormal plant operating procedures when the normal supply from ERCW supply header 1B is unavailable.	None.	

**Table 9.2-2 ESSENTIAL RAW COOLING WATER SYSTEM  
FAILURE MODES AND EFFECTS ANALYSIS  
(Page 18 of 79)**

Item	Component	Function	Failure Mode	Potential Cause	Method of Detection	Effect on System	Effect on Plant	Remarks
13 Cont	1-67-513B Cont	Alternate ERCW supply flow path from header 2A, backflow protection.	Fails to close on reverse flow	Mechanical failures or stuck open.	No direct MCR indications available.	None, under normal plant operating conditions flow through this line is isolated by valve 1-FCV-067-0065-B. Therefore, the failure of the check valve to close has no affect on the system.	None.	

Table 9.2-2 ESSENTIAL RAW COOLING WATER SYSTEM  
FAILURE MODES AND EFFECTS ANALYSIS  
(Page 19 of 79)

Item	Component	Function	Failure Mode	Potential Cause	Method of Detection	Effect on System	Effect on Plant	Remarks
14.	DG 2B-B Cir Inlet Check Valve 2-67-508-B	ERCW supply flow path from header 1B, backflow protection.	<p>Fails to open</p> <p>or</p>	Mechanical failure or stuck closed.	No direct MCR indications available.	<p>If the valve fails to open, flow to the DG jacket water heat exchangers would be isolated. If a failure occurred, the opposite train diesel would be available or flow from the opposite train ERCW supply Header 2A could be provided under the abnormal operating procedures.</p>	None.	

**Table 9.2-2 ESSENTIAL RAW COOLING WATER SYSTEM  
FAILURE MODES AND EFFECTS ANALYSIS  
(Page 20 of 79)**

Item	Component	Function	Failure Mode	Potential Cause	Method of Detection	Effect on System	Effect on Plant	Remarks
14 Cont	2-67-508B Cont	ERCW supply flow path from header 1B backflow protection	Fails to close on reverse flow	Mechanical failures or stuck open.	No direct MCR indications available.	None. Reverse flow would only occur on loss of ERCW supply Header 1B, if the opposite ERCW supply Header 2A had been placed in service. The loss of Header 1B would be the single failure in which case failure of this valve need not be postulated. Header realignment would be implemented by abnormal operating procedures.	None.	

Table 9.2-2 ESSENTIAL RAW COOLING WATER SYSTEM  
FAILURE MODES AND EFFECTS ANALYSIS  
(Page 21 of 79)

Item	Component	Function	Failure Mode	Potential Cause	Method of Detection	Effect on System	Effect on Plant	Remarks
14 Cont	DG 1A-A Cir Inlet Check Valve  2-67-513B	Alternate ERCW supply flow path from header 2A, backflow protection.	Fails to open     or	Mechanical failure or stuck closed	No direct MCR indications available.	The back-up supply flow from ERCW supply header 2B would be unavailable. This supply is only placed in service under abnormal plant operating procedures when the normal supply from ERCW supply header 1A is unavailable.	None.	

**Table 9.2-2 ESSENTIAL RAW COOLING WATER SYSTEM  
FAILURE MODES AND EFFECTS ANALYSIS  
(Page 22 of 79)**

Item	Component	Function	Failure Mode	Potential Cause	Method of Detection	Effect on System	Effect on Plant	Remarks
14 Cont	2-67-513B Cont	Alternate ERCW supply flow path from header 2A, backflow protection.	Fails to close on reverse flow	Mechanical failures or stuck open.	No direct MCR indications available.	None, under normal plant operating conditions flow through this line is isolated by valve 1-FCV-067-0068-B. Therefore, the failure of the check valve to close has no affect on the system.		

**Table 9.2-2 ESSENTIAL RAW COOLING WATER SYSTEM  
FAILURE MODES AND EFFECTS ANALYSIS  
(Page 23 of 79)**

Item	Component	Function	Failure Mode	Potential Cause	Method of Detection	Effect on System	Effect on Plant	Remarks
15.	ADG Cir Check Supply Valves 0-67-508-A 0-67-508-B 0-67-513-A 0-67-513-B	ERCW supply flow path from header 2A, 2B, 1A and 1B, respectively, backflow protection.	Any one of four fails to open  or  Fails to close on reverse flow	Mechanical failure or stuck closed.  Mechanical failure or stuck open.	No direct MCR indications available	None. Each valve provides full flow capacity. ERCW supplied from any one of the unaffected valves.  None. Normally closed valves 1-FCV-67-72, 2-FCV-67-73 provide backup backflow protection for 508 and 513 check valves, respectively.	None.	

Table 9.2-2 ESSENTIAL RAW COOLING WATER SYSTEM  
FAILURE MODES AND EFFECTS ANALYSIS  
(Page 24 of 79)

Item	Component	Function	Failure Mode	Potential Cause	Method of Detection	Effect on System	Effect on Plant	Remarks
16.	ADG Cir Outlet Check Valves 0-67-517A 0-67-512A	ERCW return flow path to header A and B, respectively, back flow protection.	Either one of two fails to open.  or  Fails to close on reverse flow.	Mechanical failure or stuck closed.  Mechanical failure or stuck open.	No direct MCR indications available.	None. Each valve provides full flow capacity. ERCW return via unaffected valve.  None. Check valves 0-67-508A, B and 0-67-513A, B will stop backflow.	None.	



Table 9.2-2 ESSENTIAL RAW COOLING WATER SYSTEM  
FAILURE MODES AND EFFECTS ANALYSIS  
(Page 25 of 79)

Item	Component	Function	Failure Mode	Potential Cause	Method of Detection	Effect on System	Effect on Plant	Remarks
17.	Screen Wash Pump Disch Check Valves 1-67-940A 2-67-935B	Pump 1A-A and 2B-B discharge flow path to screens 1A-A and 2B-B, respectively, backflow protection when cross connect is open.	Either one of two fails to open.  or  Fails to close on reverse flow.	Mechanical failure or stuck closed.	Pump ON indicated by position of hand switch 1, 2-HS-67-431A, 447, respectively, and screen motors NOT ON by status indicating light 1, 2-XI-61-434, 451, respectively, indicates pressure switch 1, 2-PS-67-434, 451, respectively, did not reach setpoint and allow screen motor to run.	None. Pumps 2A-A and 1B-B and screens 2A-A and 1B-B, respectively, provide full capacity backup.	None.	

**Table 9.2-2 ESSENTIAL RAW COOLING WATER SYSTEM  
FAILURE MODES AND EFFECTS ANALYSIS  
(Page 26 of 79)**

Item	Component	Function	Failure Mode	Potential Cause	Method of Detection	Effect on System	Effect on Plant	Remarks
18.	Main Discharge Hdr A, B B'ly Valves FCV-67-360 FCV-67-362	ERCW to Cooling Tower 2 and 1 basin isolation, respectively.	Either one of two fails to close or reopens.	Electrical or mechanical failure. Inadvertent actuation or electrical failure.	Status Lights 0-HS-67-360A, 362A, respectively.	None. Alternate route to emergency pond thru overflow weir is always open without any obstruction for water discharge.	None.	
19.	ERCW Pump Discharge Strainers 1 A-A 1 B-B 2 A-A 2 B-B	Operate.	Any one of four fails to start or stops operating.	Electrical or mechanical failure.	High differential pressure alarms in MCR.	None. Both strainers on either Train A or B pump discharges are capable of full ERCW flow capacity. Shut down affected header and operate on other train.	None.	

**Table 9.2-2 ESSENTIAL RAW COOLING WATER SYSTEM  
FAILURE MODES AND EFFECTS ANALYSIS  
(Page 27 of 79)**

Item	Component	Function	Failure Mode	Potential Cause	Method of Detection	Effect on System	Effect on Plant	Remarks
20.	Screen Wash Pump 1 B-B, 2 B-B, 1A-A, 2 A-A Prelube Check Valves 1-67-934B 2-67-934B 1-67-938A 2-67-938A	Open to provide flow path to flush pump bearings.  Close to prevent backflow.	Any one of four fails to open.  or  Fails to close on reverse flow.	Mechanical failure or stuck closed.  Mechanical failure or stuck open.	No direct MCR indications available.	None. Either one of two pump in each train is capable of screening full ERCW flow.  None. Shut down pump with failed valve and operate other pump/screen set in train.	None.	
21.	Deleted by Amendment 89							

**Table 9.2-2 ESSENTIAL RAW COOLING WATER SYSTEM  
FAILURE MODES AND EFFECTS ANALYSIS  
(Page 28 of 79)**

Item	Component	Function	Failure Mode	Potential Cause	Method of Detection	Effect on System	Effect on Plant	Remarks
22.	ERCW Pump Prelube Check Valves  0-67-507A  0-67-507B  0-67-507C  0-67-507D  0-67-507E  0-67-507F  0-67-507G  0-67-507H	Open to provide flush path to flush bearings of pumps A-A, B-A, C-A, D-A, E-B, F- B, G-B, H-B, respectively, to prolong life of the bearings and stuffing box.	Any one of eight fails to open.          or          Any one of eight fails to close on reverse flow.	Mechanical failure or stuck closed.	High bearing temp logs T3110A and T3111A for A and C, T3112A and T3113A for B and D, T3114A and 3115A for E and G, T3116A and T3117A for F and H.          No direct MCR indications available.	None. Operate pumps on unaffected train.	None.	
				Mechanical failure or stuck open.		None. Operate pumps on unaffected train.	None.	

**Table 9.2-2 ESSENTIAL RAW COOLING WATER SYSTEM  
FAILURE MODES AND EFFECTS ANALYSIS  
(Page 29 of 79)**

Item	Component	Function	Failure Mode	Potential Cause	Method of Detection	Effect on System	Effect on Plant	Remarks
23.	ERCW Vac Brkr (Air Release Valves) 0-67-502A 0-67-502B 0-67-502C 0-67-502D 0-67-502E 0-67-502F 0-67-502G 0-67-502H	Close when Pumps A-A, B-A, C-A, D-A, E-B, F-B, G-B, H-B, respectively, are started and air is evacuated from pump discharge column.  Open when respective pump is stopped to break vacuum in column.	Any one of eight valves fails to close.  Any one of eight valves fails to open.	Mechanical failure or stuck open.  Mechanical failure or stuck closed.	No direct MCR indications available.	None. Two of four pumps on each Train A or B can furnish full ERCW flow.  None. Two of four pumps in each Train A or B can furnish full ERCW flow.	None.  None.	

**Table 9.2-2 ESSENTIAL RAW COOLING WATER SYSTEM  
FAILURE MODES AND EFFECTS ANALYSIS  
(Page 30 of 79)**

Item	Component	Function	Failure Mode	Potential Cause	Method of Detection	Effect on System	Effect on Plant	Remarks
24.	Strainer Flush Valves 1-FCV-67-9B 2-FCV-67-9B 1-FCV-67-10B 2-FCV-67-10B	Cycle intermittently to provide ERCW flow to flush strainer 1A-A, 2A-A, 1B-B, 2B-B, respectively.	Any one of four fails to operate correctly.	Electrical or mechanical failure.	High differential pressure alarms in MCR.	None. Respective strainer will clog reducing flow to Header 1A, 2A, 1B, 2B, respectively. Either one of two header sets of 1A and 2A or 1B and 2B above can furnish full ERCW flow.	None.	

**Table 9.2-2 ESSENTIAL RAW COOLING WATER SYSTEM  
FAILURE MODES AND EFFECTS ANALYSIS  
(Page 31 of 79)**

Item	Component	Function	Failure Mode	Potential Cause	Method of Detection	Effect on System	Effect on Plant	Remarks
25.	Strainer Backwash Valves 1-FCV-67-9A 2-FCV-67-9A 1-FCV-67-10A 2-FCV-67-10A	Cycle intermittently to provide ERCW flow to backwash strainer 1A-A, 2A-A, 1B-B, 2B-B, respectively.	Any one of four fails to operate correctly.	Electrical or mechanical failure.	High differential pressure alarms in MCR.	None. Respective strainer will clog reducing ERCW flow to Header 1A, 2A, 1B, 2B, respectively. Either one of two header sets of 1A and 2A or 1B and 2B alone can furnish full ERCW flow.	None.	
26.	Aux. Bldg. Supply Header Section Valves 1-FCV-67-81 1-FCV-67-82 2-FCV-67-81 2-FCV-67-82	ERCW supply flow path to Aux. Bldg. for headers 1A, 1B, 2A, 2B, respectively.	Any one of four fails closed.	Mechanical failure.	No direct MCR indication available. See remarks.	None. Interrupt ERCW supply to Aux. Bldg. via respective header. Either one of two header sets of 1A and 2A or 1B and 2B can furnish full ERCW flow.	None.	Administratively locked in open position with breaker open.

Table 9.2-2 ESSENTIAL RAW COOLING WATER SYSTEM  
FAILURE MODES AND EFFECTS ANALYSIS  
(Page 32 of 79)

Item	Component	Function	Failure Mode	Potential Cause	Method of Detection	Effect on System	Effect on Plant	Remarks
27.	Header 1B and 2A Section Valves 1-FCV-67-223 2-FCV-67-223	Both open to Supply CCS HX A from Header 2A.	Either FCV fails closed.	Mechanical failure.	High temperature alarm form 0-M-278.	Interrupts ERCW cooling to CCS HX A.	None. Train B CCS components , cooled by HX-C, provide backup for all safety-related loads.	Administratively locked open with breaker removed.
28.	CCS HX A Inlet B'fly 1-FCV-67-478	Remain open to supply CCS HX A from header 2A.	Fails closed.	Mechanical failure.	High temperature alarm form 0-M-278.	Interrupts ERCW cooling a CCS HX A. ERCW flow provided to redundant CCS HX C by Train B via Header 2B.	None. Train B CCS components , cooled by HX-C, provide backup for all safety-related loads.	Administratively locked in open position with breaker open.



**Table 9.2-2 ESSENTIAL RAW COOLING WATER SYSTEM  
FAILURE MODES AND EFFECTS ANALYSIS  
(Page 33 of 79)**

Item	Component	Function	Failure Mode	Potential Cause	Method of Detection	Effect on System	Effect on Plant	Remarks
29.	CCS HX A Outlet B'fly and Bypass 1-FCV-67-146 1-FCV-67-143	Remain closed, or open to control ERCW flow through HX.	Either one does not operate properly.	Electrical or mechanical failure.	Flow indicator 2-FI-67-222.	Depending on failure position of valves, disrupts system balance or interrupts proper flow to HX. ERCW flow provided to redundant CCS HX C by Train B via Header 2B.	None. CCS HX C provides 100% backup service.	
30.	CCS HX B Outlet B'fly and Bypass 2-FCV-67-146 2-FCV-67-143	Remain closed, or open to control ERCW flow through HX.	Either one does not operate properly.	Electrical or mechanical failure.	Flow indicator 2-FI-67-222.	Depending on failure position of valves, disrupts system balance or interrupts proper flow to HX. ERCW flow provided to redundant CCS HX C by Train B via Header 2B.	None. CCS HX C provides 100% backup service.	

Table 9.2-2 ESSENTIAL RAW COOLING WATER SYSTEM  
FAILURE MODES AND EFFECTS ANALYSIS  
(Page 34 of 79)

Item	Component	Function	Failure Mode	Potential Cause	Method of Detection	Effect on System	Effect on Plant	Remarks
31.	CCS HX C Inlet Bfly's 1-FCV-67-147 2-FCV-67-147	(1) isolates Header 1A from 2B. (2) provides ERCW flow path from Header B.	None for (1). See remarks.  (2) fails closed.	Not applicable.  Mechanical failure due to disc-stem slip.	Not applicable.  Flow indicator 0-FI-67-226.	Not applicable.  None.	Not applicable.  None. CCS HX A & B (Train A) provides 100% service.	Administratively locked in closed and open position, respectively, with breakers open.

Table 9.2-2 ESSENTIAL RAW COOLING WATER SYSTEM  
FAILURE MODES AND EFFECTS ANALYSIS  
(Page 35 of 79)

Item	Component	Function	Failure Mode	Potential Cause	Method of Detection	Effect on System	Effect on Plant	Remarks
32.	CCS HX C Outlet Bfily's and Bypass 0-FCV-67-152	Remain closed, or open to control flow through HX.	Either -152 or -144 does not operate properly.	Electrical or mechanical failure	Change in flow indication on O-FI-67-226	None.	None.	CCS HX C is back-up for CCS HX A and B. A failure related to HX A or B precludes a second failure related to HX C.
	0-FCV-67-151	Remain Closed Opens to provide ERCW discharge to discharge Header A.	None. See remarks.	Not applicable.	Not applicable.	None.	None.	Valve -151 is locked closed with breaker removed.
	0-FCV-67-144	Same as for 0-FCV-67-152				None.	None.	

Table 9.2-2 ESSENTIAL RAW COOLING WATER SYSTEM  
FAILURE MODES AND EFFECTS ANALYSIS  
(Page 36 of 79)

Item	Component	Function	Failure Mode	Potential Cause	Method of Detection	Effect on System	Effect on Plant	Remarks
33.	CSS HX 1A, 1B & 2A, 2B Inlet Bfly's  1-FCV-67-125 & 2-FCV-67-125  1-FCV-67-123 & 2-FCV-67-123	Open to provide ERCW flow.	Either one (for the affected unit) fails to open  or  Recloses.	Electrical or mechanical failure.  Mechanical failure or inadvertent actuation.	Status lights 1&2-HS-67-125A, 123A, respectively, and flow indicators 1&2-FI-67-136, 122, respectively.	None.	None. Only one of two HXs (each unit) required for safe shutdown.	

Table 9.2-2 ESSENTIAL RAW COOLING WATER SYSTEM  
FAILURE MODES AND EFFECTS ANALYSIS  
(Page 37 of 79)

Item	Component	Function	Failure Mode	Potential Cause	Method of Detection	Effect on System	Effect on Plant	Remarks
34.	CCS HX 1A, 1B & 2A, 2B Outlet Bfly's  1-FCV-67-126 & 2-FCV-67-126  1-FCV-67-124 & 2-FCV-67-124	Open to provide ERCW flow.	Either one fails (for the affected unit) to open  or  Recloses	Electrical or mechanical failure.  Electrical or mechanical failure or inadvertent actuation.	Status lights 1&2-HS-67-126A, 124A, respectively, and flow indicators 1&2 1-FI-67-136, 122, respectively.	None.	None. Only one of two HXs (each unit) required for safe shutdown.	
35.	Shutdown BD RM A/C Wtr Chiller A-A, B-B Outlet  1-TCV-67-158  2-TCV-67-158	Remain open to provide ERCW flow to Chillers A-A, B-B, respectively.	Either one of two fails closed.	Mechanical failure or inadvertent actuation.	No direct MCR indication available.	None.	None. Either one of two chillers provides 100% cooling.	
36.	Train 1A, 2A A/C Equip and Service Air Compressor Supply B'fly  1-FCV-67-127  2-FCV-67-127	Remain open to provide ERCW flow to Train 1A and 2A A/C equipment and SA compressor, respectively.	Either one of two fails closed.	Mechanical failure by disc stem slippage.	No direct MCR indication available.	None.	None. Either one of two trains 1A or 1B provides 100% cooling.	Administratively locked in open position with breaker open.

Table 9.2-2 ESSENTIAL RAW COOLING WATER SYSTEM  
FAILURE MODES AND EFFECTS ANALYSIS  
(Page 38 of 79)

Item	Component	Function	Failure Mode	Potential Cause	Method of Detection	Effect on System	Effect on Plant	Remarks
37.	Train 1B, 2B A/C Equip and Service Air Compressor Supply B'fly 1-FCV-67-128 2-FCV-67-128	Remain open to provide ERCW flow to Train 1B and 2B A/C equipment and SA compressor, respectively.	Either one of two fails closed.	Mechanical failure by disc stem slippage.	No direct MCR indication available.	None.	None. Either one of two trains 1A or 1B provides 100% cooling.	Administratively locked in open position with breaker open.
38.	Instr Rm Wtr Chlrs 1A, 1B, & 2A, 2B Inlet 1-TCV-67-115 & 2-TCV-67-115 1-TCV-67-118 & 2-TCV-67-118	Modulate to provide ERCW flow to Chillers 1A, 2A, 1B, 2B, respectively.	Either one of two (for the affected unit) fails to close.	Electrical or mechanical failure or inadvertent actuation.	No direct MCR indication available.	None. Either one of two coolers provides 100% service.	None.	Instr Rm coolers not required for safe shutdown

**Table 9.2-2 ESSENTIAL RAW COOLING WATER SYSTEM  
FAILURE MODES AND EFFECTS ANALYSIS  
(Page 39 of 79)**

Item	Component	Function	Failure Mode	Potential Cause	Method of Detection	Effect on System	Effect on Plant	Remarks
39.	Upper Containment Vent Clrs 1A, 1C, 1B, 1D, & 2A, 2C, 2B, 2D Supply Control Valves 1-TCV-67-129 1-TCV-67-132 1-TCV-67-137 1-TCV-67-140 2-TCV-67-129 2-TCV-67-132 2-TCV-67-137 2-TCV-67-140 respectively	Piping system integrity.	Not applicable. See remarks.	Not applicable.	Status lights 1-ZS-67-129, 132, 137, 140, & 2-ZS-67-129, 132, 137, 140, respectively.	None.	None.	ERCW flow to containment will be isolated.

Table 9.2-2 ESSENTIAL RAW COOLING WATER SYSTEM  
FAILURE MODES AND EFFECTS ANALYSIS  
(Page 40 of 79)

Item	Component	Function	Failure Mode	Potential Cause	Method of Detection	Effect on System	Effect on Plant	Remarks
40.	Upper Containment Vent Clrs 1A, 1C, 1B, 1D & 2A, 2C, 2B, 2D Supply Cont Isol Valves 1-FCV-67-130 (Penet X-69) 1-FCV-67-133 (Penet X-75) 1-FCV-67-138 (Penet X-74) 1-FCV-67-141 (Penet X-68) 2-FCV-67-130 (Penet X-69) 2-FCV-67-133 (Penet X-75)	Close for containment isolation.	Fails to close or Reopens	Mechanical or electrical failure. Mechanical failure or inadvertent actuation.	Status lights 1-HS-67-130, 133, 138, 141 & 2-HS-67-130, 133, 138, 141, respectively.	None. Check valves 580A, 580C, 580B, 580D, respectively, provide containment isolation backup.	None.	



Table 9.2-2 ESSENTIAL RAW COOLING WATER SYSTEM  
FAILURE MODES AND EFFECTS ANALYSIS  
(Page 41 of 79)

Item	Component	Function	Failure Mode	Potential Cause	Method of Detection	Effect on System	Effect on Plant	Remarks
40. Cont	2-FCV-67-138 (Penet X-74)  2-FCV-67-141 (Penet X-68)							

**Table 9.2-2 ESSENTIAL RAW COOLING WATER SYSTEM  
FAILURE MODES AND EFFECTS ANALYSIS  
(Page 42 of 79)**

Item	Component	Function	Failure Mode	Potential Cause	Method of Detection	Effect on System	Effect on Plant	Remarks
41.	Upper Containment Vent Clrs 1A, 1C, 1B & 1D & 2A, 2C, 2B, 2D Supply Cont Iso Check Valves 1-67-580A (Penet X-69) 1-67-580C (Penet X-75) 1-67-580B (Penet X-74) 1-67-580D (Penet X-68) 2-67-580A (Penet X-69) 2-67-580C (Penet X-75)	Close to provide containment isolation backup for valves 1-FCV-67-130, 133, 138, 141, 2-FCV-67-130, 133, 141 respectively.	Any one of four (for the affected unit) fails to close.	Mechanical failure or stuck open.	No direct MCR indication available.	None. Containment isolation valves fulfill containment isolation function.	None.	

**Table 9.2-2 ESSENTIAL RAW COOLING WATER SYSTEM  
FAILURE MODES AND EFFECTS ANALYSIS  
(Page 43 of 79)**

Item	Component	Function	Failure Mode	Potential Cause	Method of Detection	Effect on System	Effect on Plant	Remarks
41. Cont	2-67-580B (Penet X-74)  2-67-580D (Penet X-68)							

Table 9.2-2 ESSENTIAL RAW COOLING WATER SYSTEM  
FAILURE MODES AND EFFECTS ANALYSIS  
(Page 44 of 79)

Item	Component	Function	Failure Mode	Potential Cause	Method of Detection	Effect on System	Effect on Plant	Remarks
42.	Upper Containment Vent Coolers 1A, 1C, 1B, 1D & 2A, 2C, 2B, 2D Return Inboard Cont Iso Valves 1-FCV-67-295 (Penet X-73) 1-FCV-67-296 (Penet X-71) 1-FCV-67-297 (Penet X-70) 1-FCV-67-298 (Penet X-72) 2-FCV-67-295 (Penet X-73) 2-FCV-67-296 (Penet X-71)	Close for containment isolation.	Any one of four (for the affected unit) fails to close. or Reopens.	Electrical or mechanical failure.  Mechanical failure or inadvertent actuation.	Status lights 1-HS-67-295A, 296A, 297A, 298A & 2-HS-67-295A, 296A, 297A, 298A, respectively.	None. Outboard containment isolation valves 1-FCV-67-131, 134, 139, 142 & 2-FCV-67-131, 134, 139, 142, respectively, provide backup isolation.	None.	

**Table 9.2-2 ESSENTIAL RAW COOLING WATER SYSTEM  
FAILURE MODES AND EFFECTS ANALYSIS  
(Page 45 of 79)**

Item	Component	Function	Failure Mode	Potential Cause	Method of Detection	Effect on System	Effect on Plant	Remarks
42. Cont	2-FCV-67-297 (Penet X-70)  2-FCV-67-298 (Penet X-72)							

**Table 9.2-2 ESSENTIAL RAW COOLING WATER SYSTEM  
FAILURE MODES AND EFFECTS ANALYSIS  
(Page 46 of 79)**

Item	Component	Function	Failure Mode	Potential Cause	Method of Detection	Effect on System	Effect on Plant	Remarks
43.	Upper Containment Vent Clrs 1A, 1C, 1B & 1D & 2A, 2C, 2B, 2D Return Pressure Relief Cont Iso Check Valves 1-67-585A (Penet X-73) 1-67-585C (Penet X-71) 1-67-585B (Penet X-70) 1-67-585D (Penet X-72) 2-67-585A (Penet X-73) 2-67-585C (Penet X-71)	Close to provide containment isolation backup for valves 1-FCV-67-131, 134, 139, 142 & 2-FCV-67-131, 134, 139, 141 respectively.	Any one of four (for the affected unit) fails to close. See remarks.	Mechanical failure or stuck open.	No direct MCR indication available.	None. Respective containment isolation valves fulfill isolation function.	None.	Primary function is thermal pressure relief of liquid trapped between isolation valves. Failure to open is not considered credible.

**Table 9.2-2 ESSENTIAL RAW COOLING WATER SYSTEM  
FAILURE MODES AND EFFECTS ANALYSIS  
(Page 47 of 79)**

Item	Component	Function	Failure Mode	Potential Cause	Method of Detection	Effect on System	Effect on Plant	Remarks
43. Cont	2-67-585B (Penet X-70)  2-67-585D (Penet X-72)							

**Table 9.2-2 ESSENTIAL RAW COOLING WATER SYSTEM  
FAILURE MODES AND EFFECTS ANALYSIS  
(Page 48 of 79)**

Item	Component	Function	Failure Mode	Potential Cause	Method of Detection	Effect on System	Effect on Plant	Remarks
44.	Upper Containment Vent Clr 1A, 1C, 1B, 1D & 2A, 2C, 2B, 2D Return Outboard Cont Iso Valves 1-FCV-67-131 (Penet X-73) 1-FCV-67-134 (Penet X-71) 1-FCV-67-139 (Penet X-70) 1-FCV-67-142 (Penet X-72) 2-FCV-67-131 (Penet X-73) 2-FCV-67-134 (Penet X-71)	Close for containment isolation.	Any one of four (for the affected unit) fails to close. or reopens.	Electrical or mechanical failure.  Mechanical failure or inadvertent actuation.	Status lights 1-HS-67-131A, 134A, 139A, 142A & 2-HS-67-131A, 134A, 139A, 142A, respectively.	None. Inboard containment isolation valves 1&2-FCV-67-295, 296, 297, 298 and check valves 585A, 585C, 585B, 585D, respectively, provide backup isolation.	None.	



**Table 9.2-2 ESSENTIAL RAW COOLING WATER SYSTEM  
FAILURE MODES AND EFFECTS ANALYSIS  
(Page 49 of 79)**

Item	Component	Function	Failure Mode	Potential Cause	Method of Detection	Effect on System	Effect on Plant	Remarks
44. Cont	2-FCV-67-139 (Penet X-70)  2-FCV-67-142 (Penet X-72)							

**Table 9.2-2 ESSENTIAL RAW COOLING WATER SYSTEM  
FAILURE MODES AND EFFECTS ANALYSIS  
(Page 50 of 79)**

Item	Component	Function	Failure Mode	Potential Cause	Method of Detection	Effect on System	Effect on Plant	Remarks
45.	Lower Containment Vent Clr 1A, 1C, 1B, 1D & 2A, 2C, 2B, 2D Supply Outboard Cont Iso Valves 1-FCV-67-83 (Penet X-58A) 1-FCV-67-91 (Penet X-62A) 1-FCV-67-99 (Penet X-60A) 1-FCV-67-107 (Penet X-56A) 2-FCV-67-83 (Penet X-58A) 2-FCV-67-91 (Penet X-62A)	Close for containment isolation.	Any one of four (for the affected unit) fails to close.  or  reopens.	Electrical or mechanical failure.  Mechanical failure or inadvertent actuation.	Status lights 1-HS-67-83A, 91A, 99A, 107A, & 2-HS-67-83A, 91A, 99A, 107A, respectively.	None. Check Valves 562A, 562C, 562B, 562D, and isolation valve 1&2-FCV-113 respectively, provide isolation backup. Manual actions are required to isolate the line upstream of valve 1 & 2-FCV-67-107. See Remarks	None.	The line downstream of 1 & 2-FCV-67-113 and 1054D in containment is not protected from an HELB. With a single failure of 1 or 2-FCV-67-107, manual isolation using upstream valve 1 or 2-ISV-67-523B is required

**Table 9.2-2 ESSENTIAL RAW COOLING WATER SYSTEM  
FAILURE MODES AND EFFECTS ANALYSIS  
(Page 51 of 79)**

Item	Component	Function	Failure Mode	Potential Cause	Method of Detection	Effect on System	Effect on Plant	Remarks
45. Cont	2-FCV-67-99 (Penet X-60A)  2-FCV-67-107 (Penet X-56A)							

**Table 9.2-2 ESSENTIAL RAW COOLING WATER SYSTEM  
FAILURE MODES AND EFFECTS ANALYSIS  
(Page 52 of 79)**

Item	Component	Function	Failure Mode	Potential Cause	Method of Detection	Effect on System	Effect on Plant	Remarks
46.	Lower Containment Vent Clr 1A, 1C, 1B, 1D & 2A, 2C, 2B, 2D Supply Inboard Cont Iso Valves 1-FCV-67-89 (Penet X-58A) 1-FCV-67-97 (Penet X-62A) 1-FCV-67-105 (Penet X-60A) 1-FCV-67-113 (Penet X-56A) 2-FCV-67-89 (Penet X-58A) 2-FCV-67-97 (PenetX- 62A)	Close for containment isolation.	Any one of four (for the affected unit) fails to close. or reopens.	Electrical or mechanical failure.  Mechanical failure or inadvertent actuation.	Status lights 1-HS-67-89A, 97A, 105A, 113A & 2-HS-67-89A, 97A, 105A, 113A, respectively.	None. Valves 1&2-FCV-67-83, 91, 99, 107, respectively, provide backup isolation function.	None.	

**Table 9.2-2 ESSENTIAL RAW COOLING WATER SYSTEM  
FAILURE MODES AND EFFECTS ANALYSIS  
(Page 53 of 79)**

Item	Component	Function	Failure Mode	Potential Cause	Method of Detection	Effect on System	Effect on Plant	Remarks
46. Cont	2-FCV-67-105 (Penet X-60A)  2-FCV-67-113 (Penet X-56A)							

Table 9.2-2 ESSENTIAL RAW COOLING WATER SYSTEM  
FAILURE MODES AND EFFECTS ANALYSIS  
(Page 54 of 79)

Item	Component	Function	Failure Mode	Potential Cause	Method of Detection	Effect on System	Effect on Plant	Remarks
47.	Lower Containment Vent Clr 1A, 1C, 1B, 1D & 2A, 2C, 2B, 2D Supply Pressure Relief Cont Iso Valves 1-67-1054A 1-67-1054C 1-67-1054B 1-67-1054D  2-67-1054 A 2-67-1054 C 2-67-1054 B 2-67-1054 D	Close to provide backup containment isolation for valves 1&2-FCV-67-83, 91, 99, 107, respectively. See remarks.	Anyone of four (for the affected unit) fails to close.	Mechanical failure or stuck open.	No direct MCR indication available.	None. Respective containment isolation valve will fulfill isolation function.	None.	Primary function is thermal pressure relief of liquid trapped between isolation valves. Failure to open is not considered credible.

Table 9.2-2 ESSENTIAL RAW COOLING WATER SYSTEM  
FAILURE MODES AND EFFECTS ANALYSIS  
(Page 55 of 79)

Item	Component	Function	Failure Mode	Potential Cause	Method of Detection	Effect on System	Effect on Plant	Remarks
48.	Lower Containment Vent Clrs 1A, 1C, 1B, 1D & 2A, 2C, 2B, 2D Temperature Control Valves 1-TCV-67-84 1-TCV-67-92 1-TCV-67-100 1-TCV-67-108 2-TCV-67-84 2-TCV-67-92 2-TCV-67-100 2-TCV-67-108	None.	Not applicable.	Not applicable.	Not applicable.	None.	None.	These valves are isolated from ERCW flow by containment isolation valves.

Table 9.2-2 ESSENTIAL RAW COOLING WATER SYSTEM  
FAILURE MODES AND EFFECTS ANALYSIS  
(Page 56 of 79)

Item	Component	Function	Failure Mode	Potential Cause	Method of Detection	Effect on System	Effect on Plant	Remarks
49	Unit 1 RC Pump Motor 1, 3, 2, 4 Clr and Unit 2 RC Pump Motor 1, 3, 2, 4 Clrs Temperature Control Valves 1-TCV-67-86 1-TCV-67-94 1-TCV-67-102 1-TCV-67-110 2-TCV-67-86 2-TCV-67-94 2-TCV-67-102 2-TCV-67-110	None	Not applicable	Not applicable	Not applicable	None	None	These valves are isolated from ERCW flow by containment isolation valves.



Table 9.2-2 ESSENTIAL RAW COOLING WATER SYSTEM  
FAILURE MODES AND EFFECTS ANALYSIS  
(Page 57 of 79)

Item	Component	Function	Failure Mode	Potential Cause	Method of Detection	Effect on System	Effect on Plant	Remarks
50.	Control Rod Drive Units 1A, 1C, 1B, 1D 2A, 2C, 2B, 2D Temperature Control Valves 1-TCV-67-85 1-TCV-67-93 1-TCV-67-101 1-TCV-67-109 2-TCV-67-85 2-TCV-67-93 2-TCV-67-101 2-TCV-67-109	None.	Not applicable.	Not applicable.	Not applicable.	None.	None.	These valves are isolated from ERCW flow by containment isolation valves.

Table 9.2-2 ESSENTIAL RAW COOLING WATER SYSTEM  
FAILURE MODES AND EFFECTS ANALYSIS  
(Page 58 of 79)

Item	Component	Function	Failure Mode	Potential Cause	Method of Detection	Effect on System	Effect on Plant	Remarks
51.	Lower Containment Vent Clrs 1A, 1C, 1B, 1D, 2A, 2C, 2B, 2D Check Valves 1-67-565A 1-67-565C 1-67-565B 1-67-565D 2-67-565A 2-67-565C 2-67-565B 2-67-565D	None.	Not applicable.	Not applicable.	Not applicable.	None.	None.	These valves are isolated from ERCW flow by containment isolation valves.

Table 9.2-2 ESSENTIAL RAW COOLING WATER SYSTEM  
FAILURE MODES AND EFFECTS ANALYSIS  
(Page 59 of 79)

Item	Component	Function	Failure Mode	Potential Cause	Method of Detection	Effect on System	Effect on Plant	Remarks
52.	RC Pump Motor Unit 1 1, 3, 2, 4 & Unit 2 1, 3, 2, 4 Clrs Check Valves 1-67-571A 1-67-571C 1-67-571B 1-67-571D 2-67-571A 2-67-571C 2-67-571B 2-67-571D	None.	Not applicable.	Not applicable.	Not applicable.	None.	None.	These valves are isolated from ERCW flow by containment isolation valves.

Table 9.2-2 ESSENTIAL RAW COOLING WATER SYSTEM  
FAILURE MODES AND EFFECTS ANALYSIS  
(Page 60 of 79)

Item	Component	Function	Failure Mode	Potential Cause	Method of Detection	Effect on System	Effect on Plant	Remarks
53.	Control Rod Drive Vent Clrs 1A, 1C, 1B, 1D, 2A, 2C, 2B, 2D Check Valves 1-67-568A 1-67-568C 1-67-568B 1-67-568D  2-67-568A 2-67-568C 2-67-568B 2-67-568D	None.	Not applicable.	Not applicable.	Not applicable.	None.	None.	These valves are isolated from ERCW flow by containment isolation valves.

**Table 9.2-2 ESSENTIAL RAW COOLING WATER SYSTEM  
FAILURE MODES AND EFFECTS ANALYSIS  
(Page 61 of 79)**

Item	Component	Function	Failure Mode	Potential Cause	Method of Detection	Effect on System	Effect on Plant	Remarks
54.	Lower Containment Vent Clrs 1A, 1C, 1B, 1D, 2A, 2C, 2B, 2D Return Inboard Cont Iso Valves 1-FCV-67-87 (Penet X-59A) 1-FCV-67-95 (Penet X-63A) 1-FCV-67-103 (Penet X-61A) 1-FCV-67-111 (Penet X-57A) 2-FCV-67-87 (Penet X-59A) 2-FCV-67-95 (Penet X-63A)	Close for containment isolation.	Any one of four (for the affected unit) fails to close.  or  reopens.	Electrical or mechanical failure.  Mechanical failure or inadvertent actuation.	Status lights 1&2 -HS-67-87A, 95A, 103A, 111A, respectively.	None. Valves 1&2-FCV-67-88, 96, 104, 112, respectively, provide backup isolation function.	None.	

Table 9.2-2 ESSENTIAL RAW COOLING WATER SYSTEM  
FAILURE MODES AND EFFECTS ANALYSIS  
(Page 62 of 79)

Item	Component	Function	Failure Mode	Potential Cause	Method of Detection	Effect on System	Effect on Plant	Remarks
54. Cont	2-FCV-67-103 (Penet X-61A)  2-FCV-67-111 (Penet X-57A)							
55.	Lower Containment Vent Clrs 1A, 1C, 1B, 1D, 2A, 2C, 2B, 2D Return Pressure Relief Cont Iso Check Valves  575A (Penet X-59A)  575C (Penet X-63A)  575B (Penet X-61A)  575D (Penet X-57A)	Close for containment isolation backup for valves 1&2-FCV-67-88, 96, 104, 112, respectively.	Any one of four (for the affected unit) fails open.	Mechanical failure or stuck open.	No direct MCR indication available.	None. Containment isolation valves fulfill isolation function.	None.	

**Table 9.2-2 ESSENTIAL RAW COOLING WATER SYSTEM  
FAILURE MODES AND EFFECTS ANALYSIS  
(Page 63 of 79)**

Item	Component	Function	Failure Mode	Potential Cause	Method of Detection	Effect on System	Effect on Plant	Remarks
56.	Lower Containment Vent Clrs 1A, 1C, 1B, 1D, 2A, 2C, 2B, 2D Return Outboard Cont Iso Valves 1-FCV-67-88 (Penet X-59A) 1-FCV-67-96 (Penet X-63A) 1-FCV-67-104 (Penet X-61A) 1-FCV-67-112 (Penet X-57A) 2-FCV-67-88 (Penet X-59A) 2-FCV-67-96 (Penet X-63A)	Close for containment isolation.	Any one of four (for the affected unit) fails to close. or reopens.	Electrical or mechanical failure.  Mechanical failure or inadvertent actuation.	Status lights 1&2-HS-67-88A, 96A, 104A, 112A, respectively.	None. Inboard containment isolation valves 1&2-FCV-67-87, 95, 103, 111 and check valves 575A, 575C, 575B, 575D, respectively, provide backup isolation.	None.	

Table 9.2-2 ESSENTIAL RAW COOLING WATER SYSTEM  
FAILURE MODES AND EFFECTS ANALYSIS  
(Page 64 of 79)

Item	Component	Function	Failure Mode	Potential Cause	Method of Detection	Effect on System	Effect on Plant	Remarks
56. Cont	2-FCV-67-104 (Penet X-61A)  2-FCV-67-112 (Penet X-57A)							
57.	Spent Fuel Pit Pump & TB Booster Pump Space Cir 1A, 1B Supply Valves  1-FCV-67-213  1-FCV-67-215	Open for ERCW flow to Coolers 1A, 1B, respectively.	Either one of two fails to open.  or  either one of two recloses.	Electrical or mechanical failure.  Mechanical failure or inadvertent actuation.	Status lights 1-ZS-67-213A, 215A, respectively. No indication for disc-stem connection failure. None.	None	None. Either one of two coolers provides 100% service.	
58.	CCS Pump & Aux FW Pump Space Cir 1A, 1B Supply Valves  1-FCV-67-162  1-FCV-67-164	Open for ERCW flow to Coolers 1A, 1B, respectively.	Either one of two fails to open  or  either one of two recloses	Electrical or mechanical failure  Mechanical failure or inadvertent actuation	Status lights 1-ZS-67-162A, 164A, respectively. No indication for disc-stem connection failure.	None.	None. Either one of two coolers provides 100% service.	



Table 9.2-2 ESSENTIAL RAW COOLING WATER SYSTEM  
FAILURE MODES AND EFFECTS ANALYSIS  
(Page 65 of 79)

Item	Component	Function	Failure Mode	Potential Cause	Method of Detection	Effect on System	Effect on Plant	Remarks
59.	Centrif Charging Pump Rm Cir 1A, 1B, 2A, 2B Supply Valves 1-FCV-67-168 1-FCV-67-170 2-FCV-67-168 2-FCV-67-170	ERCW flow to Coolers 1A, 1B, 2A, 2B, respectively.	Either one of two (for the affected unit) closes.	Mechanical failure or inadvertent actuation.	Status lights 1&2-ZS-67-168A, 170A, respectively. No indication for disc-stem connection failure.	None.	None. Either one of two coolers provides 100% service.	Administratively locked open with power to their FSVs removed.
60.	Recip Charging Pump Rm Cir 1C, 2C Supply Valves 1-FCV-67-172 2-FCV-67-172	None.	None. See remarks.	Not applicable.	Not applicable.	None.	None.	During DBE does not effect ERCW safety function.

**Table 9.2-2 ESSENTIAL RAW COOLING WATER SYSTEM  
FAILURE MODES AND EFFECTS ANALYSIS  
(Page 66 of 79)**

Item	Component	Function	Failure Mode	Potential Cause	Method of Detection	Effect on System	Effect on Plant	Remarks
61.	SIS Pump RM	Open for ERCW flow to Coolers 1A, 1B, 2A, 2B, respectively.	Either one of two (for the affected unit) fails to open. or Either one of two recloses.	Electrical or mechanical failure.  Mechanical failure or inadvertent actuation.	Status lights 1&2-ZS-67-176A, 182A, respectively. No indication for disc-stem connection failure	None.	None. Either one of two (each unit) coolers provide 100% service.	
	2B Supply Valves							
	1-FCV-67-176							
	1-FCV-67-182							
	2-FCV-67-176							
62.	CS Pump Rm	Open for ERCW flow to Coolers 1A, 1B, 2A, 2B, respectively.	Either one of two (for the affected unit) fails to open. or Either one of two recloses.	Electrical or mechanical failure.  Mechanical failure or inadvertent actuation.	Status lights 1&2-ZS-67-184A, 186A, respectively. No indication for disc-stem connection failure	None.	None. Either one of two (each unit) coolers provide 100% service.	
	1B-B, 2A-A, 2B-B Supply Valves							
	1-FCV-67-184							
	1-FCV-67-186							
	2-FCV-67-184							
2-FCV-67-186								

**Table 9.2-2 ESSENTIAL RAW COOLING WATER SYSTEM  
FAILURE MODES AND EFFECTS ANALYSIS  
(Page 67 of 79)**

Item	Component	Function	Failure Mode	Potential Cause	Method of Detection	Effect on System	Effect on Plant	Remarks
63.	RHR Pump Rm Clr 1A-A, 1B-B, 2A-A, 2B-B Supply Valves	ERCW flow path to Coolers 1A-A, 1B- B, 2A-A, 2B-B, respectively.	Either one of two (for the affected Unit) closes.	Mechanical failure or inadvertent actuation.	Status lights 1&2-ZS-67-188A, 190A, respectively. No indication for disc-stem connection failure.	None.	None. Either one of two (each unit) coolers provide 100% service.	Administratively locked open with power to their FSVs removed.
	1-FCV-67-188							
	1-FCV-67-190							
	2-FCV-67-188							
64.	2-FCV-67-190							
	Penet Rm Elev 692 ft Crs 1A1, 1B1, 2A1, 2B1 Supply Valves	Open for ERCW flow to Coolers 1A1, 1B1,2A1, 2B1 respectively.	Either one of two (for the affected Unit) fails to open.  or  Either one of two recloses.	Electrical or mechanical failure.  Mechanical failure or inadvertent actuation.	Status lights 1&2-ZS-67-346A, 348A, respectively. No indication for disc-stem connection failure.	None.	None. Either one of two (each unit) coolers provide 100% service.	
	1-FCV-67-346							
	1-FCV-67-348							
	2-FCV-67-346 2-FCV-67-348							

**Table 9.2-2 ESSENTIAL RAW COOLING WATER SYSTEM  
FAILURE MODES AND EFFECTS ANALYSIS  
(Page 68 of 79)**

Item	Component	Function	Failure Mode	Potential Cause	Method of Detection	Effect on System	Effect on Plant	Remarks
65.	Penet Rm Elev 713 ft Clrs 1A2, 1B2, 2A2, 2B2 Supply Valves	Open for ERCW flow to Coolers 1A2, 1B2, 2A2, 2B2, respectively.	Either one of two (for the affected unit) fails to open.  or  Either one of two recloses.	Electrical or mechanical failure.  Mechanical failure or inadvertent actuation.	Status lights 1-ZS-67-350A, 352A, 2-Z5-67- 350A, 352A, respectively. No indication for disc-stem connection failure.	None.	None. Either one of two coolers provides 100% service.	
	1-FCV-67-350							
	1-FCV-67-352							
	2-FCV-67-350							
66.	2-FCV-67-352							
	Penet Rm Elev 737 ft Clrs 1A3, 1B3, 2A3, 2B3 Supply Valves	Open for ERCW flow to Coolers 1A3, 1B3, 2A3, 2B3, respectively.	Either one of four fails to open.  or  Either one of four recloses.	Electrical or mechanical failure.  Mechanical failure or inadvertent actuation.	Status lights 1-ZS-67-354A, 356A, 2-ZS-67-354A, 356A, respectively. No indication for disc-stem connection failure.	None.	None. Either pair of coolers 1A3 and 2A3 or 1B3 and 2B3 provide 100% service.	
	1-FCV-67-354							
	1-FCV-67-356							
2-FCV-67-354								
2-FCV-67-356								

**Table 9.2-2 ESSENTIAL RAW COOLING WATER SYSTEM  
FAILURE MODES AND EFFECTS ANALYSIS  
(Page 69 of 79)**

Item	Component	Function	Failure Mode	Potential Cause	Method of Detection	Effect on System	Effect on Plant	Remarks
67.	Pipe Chase Cir 1A, 1B, 2A, 2B Supply Valves 1-FCV-67-342 1-FCV-67-344 2-FCV-67-342 2-FCV-67-344	Open for ERCW flow to Coolers 1A, 1B, 2A, 2B, respectively.	Either one of two (for the affected unit) fails to open. or Either one of two recloses.	Electrical or mechanical failure  Mechanical failure or inadvertent actuation	Status lights 1&2-ZS-67-342A, 344A, respectively. No indication for disc-stem connection failure.	None.	None. Either one of two coolers provides 100% required capacity.	
68.	Emerg Gas treatment Rm Cir 2A, 2B Supply Valves 2-FCV-67-336 2-FCV-67-338	Open for ERCW flow to Coolers 2A, 2B, respectively.	Either one of two fails to open or Either one of two recloses.	Electrical or mechanical failure  Mechanical failure or inadvertent actuation	Status lights 1&2-ZS-67-336A, 338A, respectively. No indication for disc-stem connection failure.	None.	None. Either one of two coolers provides 100% required capacity.	

Table 9.2-2 ESSENTIAL RAW COOLING WATER SYSTEM FAILURE MODES AND EFFECTS ANALYSIS (Page 70 of 79)

Item	Component	Function	Failure Mode	Potential Cause	Method of Detection	Effect on System	Effect on Plant	Remarks
69.	BA Transf Pump & Aux FW Pump Space Cir 2A, 2B Supply Valves 2-FCV-67-217 2-FCV-67-219	Open for ERCW flow to Coolers 2A, 2B, respectively.	Either one of two fails to open. or Either one of two recloses.	Electrical or mechanical failure.  Mechanical failure or inadvertent actuation.	Status lights 1-ZS-67-217A, 219A, respectively. No indication for disc-stem connection failure.	None	None. Either one of two coolers provides 100% required capacity.	
70.	TB Supply Header 1A, 1B, Iso Bfly 0-FCV-67-205 0-FCV-67-208	Close on high flow and low pressure to isolate non-essential portion of ERCW system piping.	Either one of two fails to close or Either one of two reopens.	Electrical or mechanical failure.  Mechanical failure or inadvertent actuation.	Status lights 0-HS-67-205A, 208A, respectively.	None. Shut down train with failed valve. Operate other train.	None.	
71.	Header 1 B to CCS HX A Supply Bfly Valve 1-FCV-67-458-A	Remain closed	Fails open.	Electrical or Mechanical failure or inadvertent actuation.	1-FI-67-222 flow indication.	Interrupts flow to CCS HX A & B. ERCW flow provided to CCS HX C via Header 2B.	None. CCS HX C provides 100% backup service.	Locked closed with breaker removed.

**Table 9.2-2 ESSENTIAL RAW COOLING WATER SYSTEM  
FAILURE MODES AND EFFECTS ANALYSIS  
(Page 71 of 79)**

Item	Component	Function	Failure Mode	Potential Cause	Method of Detection	Effect on System	Effect on Plant	Remarks
72.	Emergency Power to Train A, B	Provide power to Train A, B ERCW system pumps, screens, strainer motors and valve actuators, respectively.	Either one of two fails.	Diesel generator mechanical failure or shutdown board failure.	MCR Indication.	Loss of ERCW system Train A or B, respectively.	None. Other train has 100% ERCW system capability.	Only one of two Trains A or B required to mitigate DBE.
73.	Passive failure of any one piping system pressure boundary component (i.e., valve body, disc, pump casing, HX tube or shell, etc.) in either train A or B.	Pressure boundary integrity.	Ruptures, leakage, component pressure boundary breaches, etc.	Mechanical failures.	No direct MCR indication available, however various process parameters such as temperature, pressure, flow, etc., will permit monitoring of system performance.	System capability for respective train diminished.	None. Other train has 100% ERCW system capability.	Only one of two Trains A or B required to mitigate DBE.

Table 9.2-2 ESSENTIAL RAW COOLING WATER SYSTEM  
FAILURE MODES AND EFFECTS ANALYSIS  
(Page 72 of 79)

Item	Component	Function	Failure Mode	Potential Cause	Method of Detection	Effect on System	Effect on Plant	Remarks
73a	Electrical failure of ERCW Train 1B and 2B		Cable Tray malfunction	Fire, missile electrical malfunction	High temperature alarm from 0-M-27B	Lose ERCW Train B	None. No cooling will be provided to CCS HX C, however both CCS HX A and B are available from ERCW header 2A for cooling Unit 1 and 2, respectively.	CCS HXs A and B are not affected. Thus, they are available and provide 100% cooling capacity.
	ERCW Train 1B	Normal supply to ESF equipment						
	ERCW Train 2B	Normal supply to CCS HX C						



Table 9.2-2 ESSENTIAL RAW COOLING WATER SYSTEM  
FAILURE MODES AND EFFECTS ANALYSIS  
(Page 73 of 79)

Item	Component	Function	Failure Mode	Potential Cause	Method of Detection	Effect on System	Effect on Plant	Remarks
74.	Electric Board Room A/C Condensers A-A and B-B discharge temperature control valves 0-TCV-67-1050-A 0-TCV-67-1052-B	Throttles ERCW flow to EBR Bd. Rm. A/C Condensers A-A & B-B	Either valve fails open or fails closed or fails to modulate.	Mechanical failure.	Local indication at EBR chiller skid on low refrigerant suction pressure or low compressor oil pressure. See Remark 1.  Local indication at EBR chiller skid on high refrigerant pressure. See Remark 1.  Possible local indication at EBR chiller skid dependent upon severity of condition. See Remark 2.	None for ERCW. For HVAC, loss of associated EBR chilled water train. Eventual shutdown of associated EBR AHUs upon switchover to redundant train.  None for ERCW. For HVAC, potential loss of associated EBR chilled water train.	None. Standby chilled water train is 100% redundant.	1) MCR annunciation of EBR Air conditioning safety train switchover to standby HVAC/chilled water train due to eventual temperature increase in conditioned EBR spaces.  (2) May behave similar to either fail open or fail closed.

Table 9.2-2 ESSENTIAL RAW COOLING WATER SYSTEM  
FAILURE MODES AND EFFECTS ANALYSIS  
(Page 74 of 79)

Item	Component	Function	Failure Mode	Potential Cause	Method of Detection	Effect on System	Effect on Plant	Remarks
75.	Main Control Room A/C condensers A-A & B-B discharge temperature control valves. 0-TCV-67-1051A 0-TCV-67-1053-B	Throttles ERCW flow to MCR A/C Condensers A-A & B-B	Either valve fails open or fails closed	Mechanical failure.	Local indication at MCR chiller skid on low refrigerant suction pressure or low compressor oil pressure. See Remark 1.  Local indication at MCR chiller skid on high refrigerant pressure. See Remark 1.  Possible local indication at MCR chiller skid dependent upon severity of condition. See Remark 2.	None for ERCW . For HVAC, loss of associated MCR chilled water train. Eventual shutdown of associated MCR AHUs upon switchover to redundant train.  None for ERCW. For HVAC potential loss of associated MCR chilled water train.	None. Standby chilled water train is 100% rredundant.	1) MCR annunciation of MCR Air conditioning safety train switchover to standby HVAC/chilled water train due to eventual temperature increase in conditioned MCR spaces. (2) May behave similar to either fail open or fail closed.

Table 9.2-2 ESSENTIAL RAW COOLING WATER SYSTEM  
FAILURE MODES AND EFFECTS ANALYSIS  
(Page 75 of 79)

Item	Component	Function	Failure Mode	Potential Cause	Method of Detection	Effect on System	Effect on Plant	Remarks
76.	Auxiliary Control Air Compressors A & B cooling water supply solenoid cutoff valves. 0-FSV-67-1221-A and 0-FSV-67-1223-B	Open for ERCW flow to the ACAC A & B cylinder jackets and aftercoolers. Valves close when compressors are not running	Either valve fails open or fails closed	Electrical or Mechanical failure. Mechanical failure or inadvertent operation.	None. Higher than normal discharge air temperature local indication on 0-TI-32-65 or -92 and high temperature alarm via 0-TS-32-64 or -91 if affected ACAC is running.	See Remarks. Potential loss of affected ACAC due to overheating.	None. Other train available to provide safe shutdown.	If idle for long periods, potential damage to internal components of affected ACAC due to rust condensation.

Table 9.2-2 ESSENTIAL RAW COOLING WATER SYSTEM  
FAILURE MODES AND EFFECTS ANALYSIS  
(Page 76 of 79)

Item	Component	Function	Failure Mode	Potential Cause	Method of Detection	Effect on System	Effect on Plant	Remarks
77.	Auxiliary Control Air Compressors A and B cooling water supply pressure control valves. 0-PCV-67-1222 and 0-PCV-67-1224	Reduces ERCW pressure to the ACAC A and B cylinder jackets and aftercoolers.	Either valve fails open or fails closed.	Mechanical failure.	Visible discharge flow from relief valve 0-RFV-67-971 or -672 if affected ACAC is running  Higher than normal discharge air temperature local indication on 0-TI-32-65 or -92 and high temperature alarm via 0-TS-32-64 or -91 if affected ACAC is running.	None.	None.	
						Potential loss of affected ACAC due to overheating.	None. Other train available to provide safe shutdown.	

Table 9.2-2 ESSENTIAL RAW COOLING WATER SYSTEM  
FAILURE MODES AND EFFECTS ANALYSIS  
(Page 77 of 79)

Item	Component	Function	Failure Mode	Potential Cause	Method of Detection	Effect on System	Effect on Plant	Remarks
78.	Auxiliary Control Air Compressors A and B cooling water supply temperature control valves. 0-TCV-67 -1222A and 0-TCV-67-1224A	Throttles ERCW flow to ACAC A and B cylinder jackets.	Either valve fails open or fails closed.	Mechanical failure.	Lower than normal local temperature indication on 0-TI-32-65 or -92 if affected ACAC is running.  Higher than normal discharge air temperature local indication on 0-TI-32-65- or -92 and high temperature alarm via 0-TS-32-64 or -91 if affected ACAC is running.	None  Potential loss of affected ACAC due to overheating	None.  None. Other train available to provide safe shutdown.	

Table 9.2-2 ESSENTIAL RAW COOLING WATER SYSTEM  
FAILURE MODES AND EFFECTS ANALYSIS  
(Page 78 of 79)

Item	Component	Function	Failure Mode	Potential Cause	Method of Detection	Effect on System	Effect on Plant	Remarks
79.	Auxiliary Control Air Compressors A and B cooling water supply temperature control valves.  0-TCV-67 -1222B & 0-TCV-67 -1224B	Throttles ERCW flow to ACAC A and B aftercoolers.	Either valve fails open  or  fails closed.	Mechanical failure.	Lower than normal discharge air temperature local indication on 0-TI-32-65 or -92 if affected ACAC is running.  Higher than normal discharge air temperature local indication on 0-TI-32-65 or -92 if affected ACAC is running.	None.  Potential overheating and loss of air dryers downstream of affected ACAC due to high discharge air temperature.	None.  None. Other train available to provide safe shutdown.	

Table 9.2-2 ESSENTIAL RAW COOLING WATER SYSTEM  
FAILURE MODES AND EFFECTS ANALYSIS  
(Page 79 of 79)

Item	Component	Function	Failure Mode	Potential Cause	Method of Detection	Effect on System	Effect on Plant	Remarks
80.	ERCW Header Cross-Tie Isolatin Valves  1-ISV-67-1117 2-ISV-67-1119 1-ISV-67-1118 2-ISV-67-1120	Manual butterfly valves normally closed.  Provides ERCW flow path in the event of a strainer malfunction or outage on a given train.	Fails to open.  One closes while crosstie is in operation.	Mechanically stuck closed.  Inadvertent closure or mechanical failure.	Low flow alarms 1-FA-67-61, 62 2-FA-67-61, 62 respectively.  Low flow alarms 1-FA-67-61, 62 2-FA-67-61, 62 respectively.	None. Three of four strainers are available to insure either headers 1A and 2A or headers 1B and 2B will be in service to meet plant requirements.  None. Three of four strainers are available to insure either headers 1A and 2A or headers 1B and 2B will be in service to meet plant requirements.	None  None	Closed with hand wheel attached.  Must put another ERCW train in service to serve isolated unit header.

**Table 9.2-3 AVAILABLE NPSH DURING ECCS OPERATION**

Pump	Flow (gpm)	Supply	NPSH <sub>R</sub> (ft)	NPSH <sub>A</sub> (ft)	Margin (ft)
<b>Injection Mode - two of each pump in operation (Note 1)</b>					
CCP A-A	560	RWST	25	43.9	18.9
CCP B-B	560	RWST	25	4.5	19.5
SIP A-A	675	RWST	32	35.2	3.2
SIP B-B	675	RWST	32	34.6	2.6
RHRP A-A	4550	RWST	17	31.2	14.2
RHRP B-B	4550	RWST	17	32.1	15.1
<b>Recirculation Mode - both trains operating</b>					
RHRP A-A	5000	Sump	19	29.5	10.5
RHRP B-B	5000	Sump	19	30.5	11.5

Note: 1: The following conservative design inputs were used to calculate the NPSHA for injection mode case:

1. The minimum water level (low-low) in RWST (731.8’).
2. Both trains of CSS with maximum calculated injection flow rate (4641 gpm) are in operation.
3. RWST fluid is at maximum temperature of 105°F.
4. The pressure in upper containment is 0 psig.

Note 2: The following conservative design inputs were used to calculate the NPSHA for Recirculation mode case.

1. The minimum sump water level above sump floor (120 gpm SBLOCA) is 5.78 ft.
2. Both trains of CCS with maximum calculated recirculation flow rate (4532 gpm) are in operation.
3. The containment sump fluid is at its design 190°F.
4. The pressure in upper containment is 0 psig.



**Table 9.2-4 Deleted by Amendment 66**

**Table 9.2-5 Deleted by Amendment 66**

**Table 9.2-6 Deleted by Amendment 66**

**Table 9.2-7 Deleted by Amendment 66**

Table 9.2-8 COMPONENT COOLING SYSTEM COMPONENT DESIGN DATA

<b>Component Cooling Pumps</b>	
Quantity	5
Type	Horizontal centrifugal
Rated capacity, gpm, each	6000 gpm*
Rated head, ft water	190*
Motor horsepower, hp	350
Casing material	Cast steel
Design pressure, psig	150
Design temperature, °F	200
<b>Thermal Barrier Booster Pumps</b>	
Quantity	2
Type	Horizontal centrifugal
Rated Capacity, gpm, each	160*
Rated head, ft water	130*
Motor horsepower, hp	10
Casing material	Cast steel (SS 316)
Design pressure, psig	200
Design temperature, °F	200
<b>Surge Tanks</b>	
Number	2
Design pressure	
Internal, psig	33 psig
External, psig	vacuum breaker provided
Design temperature, °F	200
Total volume, gal	12,000
Normal water volume, gal	6,900 (minimum)
Fluid	Component cooling water (Demineralized Water)
Material	Carbon steel
<b>Heat Exchangers</b>	
Quantity	3
Type	Shell and tube
Heat transferred, BTU/hr, each; normal operating condition	64.3 x 10 <sup>6</sup>
Shell side (component cooling water)	
Inlet temperature, °F	109.3
Outlet temperature, °F	95.0
Flow rate, lb/hr	4.5 x 10 <sup>6</sup>
Design temperature, °F	200
Design pressure, psig	150
Shell material	ASME SA 516 Grade 70
Tube side (essential raw cooling water)	
Inlet temperature, °F	85
Outlet temperature, °F	95.7

**Table 9.2-8 COMPONENT COOLING SYSTEM COMPONENT DESIGN DATA**

<b>Seal Leakage Collection Station</b>	
Quantity	1 Tank w/ 2 pumps
Pump type	Regenerative turbine (horizontal)
Rated capacity, gpm, each	10
Rated head, ft water	150
Motor horsepower, hp	1.5
Pump casing material	Cast iron
Tank capacity, gal	180
Tank material	Carbon steel
Design pressure, psig	150
Design temperature, °F	200

\* During preoperational testing of the component cooling system (CCS) pumps and thermal barrier booster pumps, the pumps did not meet vendor pump performance curves. This was due mainly to the instrument inaccuracies factored into both the flow and head measurements for the data points. A review of the CCS hydraulic losses calculation has determined that even with the instrument inaccuracies factored in, the CCS pumps will still exceed the CCS hydraulic performance requirements on the pumps.

Table 9.2-9 COMPONENT COOLING SYSTEM  
FAILURE MODES AND EFFECTS ANALYSIS  
(Page 1 of 28)

Item	Component	Function	Failure Mode	Potential Cause	Method of Detection	Effect on System	Effect on Plant	Remarks
<b>A CONTAINMENT ISOLATION</b>								
A-1	1-FCV-70-85	Containment Isolation Penetration No. X-35	Fails to Close	Mechanical Failure	1-HS-70-85A status lights	Single Failure	None, inside containment is a closed system.	Containment integrity is maintained. Valve is normally closed.
2A-1	2-FCV-70-85	Containment Isolation Penetration No. X-35	Fails to Close	Mechanical Failure	2-HS-70-85A status lights	Single Failure	None, inside containment is a closed system.	Containment integrity is maintained. Valve is normally closed.
A-2	1-FCV-70-143	Containment Isolation Penetration No. X-53	Fails to Close	Power Supply, Electrical, or Mechanical Failure	1-HS-70-143A status lights	Single Failure	None, inside containment is a closed system.	Containment integrity is maintained. Valve is normally closed.
2A-2	2-FCV-70-143	Containment Isolation Penetration No. X-53	Fails to Close	Power Supply, Electrical, or Mechanical Failure	2-HS-70-143A status lights	Single Failure	None, inside containment is a closed system.	Containment integrity is maintained. Valve is normally closed.

**Table 9.2-9 COMPONENT COOLING SYSTEM  
FAILURE MODES AND EFFECTS ANALYSIS (Continued)**  
(Page 2 of 28)

Item	Component	Function	Failure Mode	Potential Cause	Method of Detection	Effect on System	Effect on Plant	Remarks
A-3	1-RFV-70-703	Relieve high pressure in piping to and from Excess Letdown HX inside containment due to tube leakage or failure of CVCS isolation valves	See "Effect on System" Column.	Mechanical Failure	None	None, tube leakage or CVCS isolation valve failure constitutes the single failure. 1-RFV-70-703 will lift on overpressure.	None	None
2A-3	2-RFV-70-703	Relieve high pressure in piping to and from Excess Letdown HX inside containment due to tube leakage or failure of CVCS isolation valves	See "Effect on System" Column.	Mechanical Failure	None	None, tube leakage or CVCS isolation valve failure constitutes the single failure. 2-RFV-70-703 will lift on overpressure.	None	None



**Table 9.2-9 COMPONENT COOLING SYSTEM  
FAILURE MODES AND EFFECTS ANALYSIS (Continued)**  
(Page 3 of 28)

Item	Component	Function	Failure Mode	Potential Cause	Method of Detection	Effect on System	Effect on Plant	Remarks
A-4	1FCV-70-87	Containment Isolation Penetration No. X-50A	Fails to Close	Power Supply, Electrical, or Mechanical Failure	1-HS-70-87A status lights	Single failure	None, isolation will be achieved by redundant valve 1-FCV-70-90.	Containment integrity is maintained. Valve is normally closed.
2A-4	2FCV-70-87	Containment Isolation Penetration No. X-50A	Fails to Close	Power Supply, Electrical, or Mechanical Failure	2-HS-70-87A status lights	Single failure	None, isolation will be achieved by redundant valve 2-FCV-70-90.	Containment integrity is maintained. Valve is normally closed.
A-5	1-FCV-70-90	Containment Isolation Penetration No. X-50A	Fails to Close	Power Supply, Electrical, or Mechanical Failure	1-HS-70-90A status lights	Single failure	None, isolation will be achieved by redundant valve 1-FCV-70-87.	Containment integrity is maintained
2A-5	2-FCV-70-90	Containment Isolation Penetration No. X-50A	Fails to Close	Power Supply, Electrical, or Mechanical Failure	2-HS-70-90A status lights	Single failure	None, isolation will be achieved by redundant valve 2-FCV-70-87.	Containment integrity is maintained
A-6	1-CKV-70-687	Containment Isolation Penetration No. X-50A	Fails to Close	Mechanical Failure	None	Single Failure	None, isolation will be achieved by redundant valve 1-FCV-70-90.	Containment integrity is maintained (See Note 1)
2A-6	2-CKV-70-687	Containment Isolation Penetration No. X-50A	Fails to Close	Mechanical Failure	None	Single Failure	None, isolation will be achieved by redundant valve 2-FCV-70-90.	Containment integrity is maintained (See Note 1)

**Table 9.2-9 COMPONENT COOLING SYSTEM  
FAILURE MODES AND EFFECTS ANALYSIS (Continued)**  
(Page 4 of 28)

Item	Component	Function	Failure Mode	Potential Cause	Method of Detection	Effect on System	Effect on Plant	Remarks
A-7	1-FCV-70-89	Containment Isolation Penetration No. X-29	Fails to Close	Power Supply, Electrical, or Mechanical Failure	1-HS-70-89A status lights	Single Failure	None, isolation will be achieved by redundant valve 1-FCV-70-92.	Containment integrity is maintained.
2A-7	2-FCV-70-89	Containment Isolation Penetration No. X-29	Fails to Close	Power Supply, Electrical, or Mechanical Failure	2-HS-70-89A status lights	Single Failure	None, isolation will be achieved by redundant valve 2-FCV-70-92.	Containment integrity is maintained.
A-8	1-FCV-70-92	Containment Isolation Penetration No. X-29	Fails to Close	Power Supply, Electrical, or Mechanical Failure	1-HS-70-92A status lights	Single Failure	None, isolation will be achieved by redundant valve 1-FCV-70-89 and manual isolation of a downstream valve. See Remarks.	The line inside containment upstream of 1-FCV-70-89 is not protected from a HELB. Thermal relief check valve 1-CKV-70-698 around 1-FCV-70-89 will allow backflow into containment. Action is required to manually isolate valve 1-ISV-70-700 down stream of 1-FCV-70-92.

**Table 9.2-9 COMPONENT COOLING SYSTEM  
FAILURE MODES AND EFFECTS ANALYSIS (Continued)**  
(Page 5 of 28)

Item	Component	Function	Failure Mode	Potential Cause	Method of Detection	Effect on System	Effect on Plant	Remarks
2A-8	2-FCV-70-92	Containment Isolation Penetration No. X-29	Fails to Close	Power Supply, Electrical, or Mechanical Failure	2-HS-70-92A status lights	Single Failure	None, isolation will be achieved by redundant valve 2-FCV-70-89 and manual isolation of a downstream valve. See Remarks.	The line inside containment upstream of 2-FCV-70-89 is not protected from a HELB. Thermal relief check valve 2-CKV-70-698 around 2-FCV-70-89 will allow backflow into containment. Action is required to manually isolate valve 2-ISV-70-700 downstream of 2-FCV-70-92.
A-9	1-CKV-70-698	Containment Isolation Penetration No. X-29	Fails to Close	Mechanical Failure	None	Single Failure	None, isolation will be achieved by redundant valve 1-FCV-70-92.	Containment integrity is maintained (See Note 1).
2A-9	2-CKV-70-698	Containment Isolation Penetration No. X-29	Fails to Close	Mechanical Failure	None	Single Failure	None, isolation will be achieved by redundant valve 2-FCV-70-92.	Containment integrity is maintained (See Note 1).
A-10	1-FCV-70-100	Containment Isolation Penetration No. X-52	Fails to Close	Power Supply, Electrical, or Mechanical Failure	1-HS-70-100A status lights	Single Failure	None, isolation will be achieved by redundant valve 1-FCV-70-140.	Containment integrity is maintained.

Table 9.2-9 COMPONENT COOLING SYSTEM  
FAILURE MODES AND EFFECTS ANALYSIS (Continued)  
(Page 6 of 28)

Item	Component	Function	Failure Mode	Potential Cause	Method of Detection	Effect on System	Effect on Plant	Remarks
2A-10	2-FCV-70-100	Containment Isolation Penetration No. X-52	Fails to Close	Power Supply, Electrical, or Mechanical Failure	2-HS-70-100A status lights	Single Failure	None, isolation will be achieved by redundant valve 2-FCV-70-140.	Containment integrity is maintained.
A-11	1-FCV-70-140	Containment Isolation Penetration No. X-52	Fails to Close	Power Supply, Electrical, or Mechanical Failure	1-HS-70-140A status lights	Single Failure	None, isolation will be achieved by redundant valve 1-FCV-70-100 and manual isolation of an upstream valve. See Remarks.	The line inside containment downstream of 1-FCV-70-100 is not protected from a HELB. Thermal relief check valve 1-CKV-70-790 around 1-FCV-70-100 will allow flow to enter containment. Action is required to manually isolate valve 1-ISV-70-516 upstream of 1-FCV-70-140.

**Table 9.2-9 COMPONENT COOLING SYSTEM  
FAILURE MODES AND EFFECTS ANALYSIS (Continued)**  
(Page 7 of 28)

Item	Component	Function	Failure Mode	Potential Cause	Method of Detection	Effect on System	Effect on Plant	Remarks
2A-11	2-FCV-70-140	Containment Isolation Penetration No. X-52	Fails to Close	Power Supply, Electrical, or Mechanical Failure	2-HS-70-140A status lights	Single Failure	None, isolation will be achieved by redundant valve 2-FCV-70-100 and manual isolation of an upstream valve. See Remarks.	The line inside containment downstream of 2-FCV-70-100 is not protected from a HELB. Thermal relief check valve 2-CKV-70-790 around 2-FCV-70-100 will allow flow to enter containment. Action is required to manually isolate valve 2-ISV-70-516 upstream of 2-FCV-70-140.
A-12	1-CKV-70-790	Containment Isolation Penetration No. X-52	Fails to Close	Mechanical Failure	None	Single Failure	None, isolation will be achieved by redundant valve 1-FCV-70-140.	Containment integrity is maintained (See Note 1).
2A-12	2-CKV-70-790	Containment Isolation Penetration No. X-52	Fails to Close	Mechanical Failure	None	Single Failure	None, isolation will be achieved by redundant valve 2-FCV-70-140.	Containment integrity is maintained (See Note 1).

**Table 9.2-9 COMPONENT COOLING SYSTEM  
FAILURE MODES AND EFFECTS ANALYSIS (Continued)**  
(Page 8 of 28)

Item	Component	Function	Failure Mode	Potential Cause	Method of Detection	Effect on System	Effect on Plant	Remarks
A-13	1-FCV-70-133	Prevention of leakage of unborated CCS water into containment	Fails to Close	Power Supply, Electrical, or Mechanical Failure	1-HS-70-133A status lights	Single Failure	None, inleakage prevention will be achieved by redundant valve 1-FCV-70-134.	None
2A-13	2-FCV-70-133	Prevention of leakage of unborated CCS water into containment	Fails to Close	Power Supply, Electrical, or Mechanical Failure	2-HS-70-133A status lights	Single Failure	None, inleakage prevention will be achieved by redundant valve 2-FCV-70-134.	None
A-14	1-FCV-70-134	Containment Isolation Penetration No. X-50B and prevention of leakage of unborated CCS water into containment	Fails to Close	Power Supply, Electrical, or Mechanical Failure	1-HS-70-134A status lights	Single failure for both functions	None, isolation will be maintained by redundant valve 1-CKV-70-679 and inleakage prevention will be achieved by redundant valve 1-FCV-70-133.	Containment integrity is maintained

**Table 9.2-9 COMPONENT COOLING SYSTEM  
FAILURE MODES AND EFFECTS ANALYSIS (Continued)**  
(Page 9 of 28)

Item	Component	Function	Failure Mode	Potential Cause	Method of Detection	Effect on System	Effect on Plant	Remarks
2A-14	2-FCV-70-134	Containment Isolation Penetration No. X-50B and prevention of leakage of unborated CCS water into containment	Fails to Close	Power Supply, Electrical, or Mechanical Failure	2-HS-70-134A status lights	Single failure for both functions	None, isolation will be maintained by redundant valve 2-CKV-70-679 and inleakage prevention will be achieved by redundant valve 2-FCV-70-133.	Containment integrity is maintained.
A-15	1-CKV-70-679	Containment Isolation Penetration No. X-50B	Fails to Close	Mechanical Failure	None	Single Failure	None, isolation will be achieved by redundant valve 1-FCV-70-134.	Containment integrity is maintained.
2A-15	2-CKV-70-679	Containment Isolation Penetration No. X-50B	Fails to Close	Mechanical Failure	None	Single Failure	None, isolation will be achieved by redundant valve 2-FCV-70-134.	Containment integrity is maintained.







Table 9.2-9 COMPONENT COOLING SYSTEM  
FAILURE MODES AND EFFECTS ANALYSIS (Continued)  
(Page 12 of 28)

Item	Component	Function	Failure Mode	Potential Cause	Method of Detection	Effect on System	Effect on Plant	Remarks
<b>B COOLING WATER TO EQUIPMENT FOR SAFE SHUTDOWN</b>								
B-1	1-FCV-70-153	Supply water to RHR HX 1B-B	Fails Closed	Mechanical failure	Alarm with 1-HS-70-153A status lights or low flow alarm if stem or disc separation.	Supply to HX 1B-B is stopped	None, redundant RHR HX 1A-A will provide heat removal capability.	Safe shutdown function is achieved with one HX. Administratively locked open with breaker open.
2B-1	2-FCV-70-153	Supply water to RHR HX 2B-B	Fails to Open	Power Supply, Electrical, or Mechanical Failure	Alarm with 2-HS-70-153A status lights or low flow alarm if stem or disc separation.	Supply to HX 2B-B is stopped	None, redundant RHR HX 2A-A will provide heat removal capability.	Safe shutdown function is achieved with one HX.
B-2	1-FCV-70-156	Supply water to RHR HX 1A-A	Fails to Open	Power Supply, Electrical, or Mechanical Failure	Alarm with 1-HS-70-156A status lights or low flow alarm if stem or disc separation.	Supply to HX 1A-A is stopped	None, redundant RHR HX 1B-B will provide heat removal capability.	Safe shutdown function is achieved with one HX.
2B-2	2-FCV-70-156	Supply water to RHR HX 2A-A	Fails to Open	Power Supply, Electrical, or Mechanical Failure	Alarm with 2-HS-70-156A status lights or low flow alarm if stem or disc separation.	Supply to HX 2A-A is stopped	None, redundant RHR HX 2B-B will provide heat removal capability.	Safe shutdown function is achieved with one HX.

**Table 9.2-9 COMPONENT COOLING SYSTEM  
FAILURE MODES AND EFFECTS ANALYSIS (Continued)**  
(Page 13 of 28)

Item	Component	Function	Failure Mode	Potential Cause	Method of Detection	Effect on System	Effect on Plant	Remarks
B-3	0-FCV-70-194	Supply water to Spent Fuel Pit HX B	Fails to Open	Power Supply, Electrical, or Mechanical Failure	0-HS-70-194A status lights or low flow alarm if stem or disc separation.	Supply to HX B is stopped	None, 0-FCV-70-197 will supply water to redundant Spent Fuel Pit HX A.	Safe shutdown function is achieved with one HX.
B-4	0-FCV-70-197	Supply water to Spent Fuel Pit HX A	Fails to Open	Power Supply, Electrical, or Mechanical Failure	0-HS-70-197A status lights or low flow alarm if stem or disc separation	Supply to HX A is stopped	None, 0-FCV-70-194 will supply water to redundant Spent Fuel Pit HX B.	Safe shutdown function is achieved with one HX.
<b>C CCS PUMPS</b>								
C-1	CCS Pump 1A-A (1-PMP-70-46)	Supply water to Train 1A	Pump Fails to Operate	Power Supply, Electrical, or Mechanical Failure	1-HS-70-46A status lights low header pressure alarm	Flow from Pump 1A-A is lost	None, redundant CCS Pump 1B-B will start on low pressure.	Safe shutdown function is achieved from redundant pump.
C-2	CCS Pump 1B-B (1-PMP-70-38)	Supply water to Train 1A	Pump Fails to Operate	Power Supply, Electrical, or Mechanical Failure	1-HS-70-38A status lights low header pressure	Flow from Pump 1B-B is lost	None, redundant CCS Pump 1A-A will start on low pressure.	Safe shutdown function is achieved from redundant pump.
C-3	CCS Pump C-S (0-PMP-70-51)	Supply water to Train 1B/2B	Pump Fails to Operate	Power Supply, Electrical, or Mechanical Failure	1-HS-70-51A status lights	Flow from Pump C-S is lost	None, redundant CCS Pump 1B-Bor 2B-B can supply water to Train B.	Safe shutdown function is achieved from redundant pump.

**Table 9.2-9 COMPONENT COOLING SYSTEM  
FAILURE MODES AND EFFECTS ANALYSIS (Continued)**  
(Page 14 of 28)

Item	Component	Function	Failure Mode	Potential Cause	Method of Detection	Effect on System	Effect on Plant	Remarks
2C-3A	Pump 2B-B (2-PMP-70-33)	Supply water to Train 2A	Pump Fails to Operate	Power Supply, Electrical, or Mechanical Failure	2-HS-70-33A status lights, low header pressure alarm	Flow from 2B-B is lost	None, redundant CCS Pump 2A-A will start on low pressure.	Safe shutdown function is achieved from redundant pump.
2C-3B	Pump 2A-A (2-PMP-70-59)	Supply water to Train 2A	Pump Fails to Operate	Power Supply, Electrical, or Mechanical Failure	2-HS-70-59A status lights, low header pressure alarm	Flow from 2A-A is lost	None, redundant CCS Pump 2B-B will start on low pressure.	Safe shutdown function is achieved from redundant pump.
C-4	1-CKV-70-504A	Prevent backflow to CCS Pump 1A-A when pump is not operating	Fails to Close	Mechanical Failure	Low header pressure alarm	Train A header pressure may be low	None, manual isolation valve 1-ISV-70-505A will be closed. Pump 1B-B or C-S will continue to operate.	Safe shutdown function is not affected.
C-5	1-CKV-70-504B	Prevent backflow to CCS Pump 1B-B when pump is not operating	Fails to Close	Mechanical Failure	Low header pressure alarm	Train A header pressure may be low	None, manual isolation valve 1-ISV-70-505B will be closed. Pump 1A-A or C-S will continue to operate.	Shutdown function is not affected.

**Table 9.2-9 COMPONENT COOLING SYSTEM  
FAILURE MODES AND EFFECTS ANALYSIS (Continued)**  
(Page 15 of 28)

Item	Component	Function	Failure Mode	Potential Cause	Method of Detection	Effect on System	Effect on Plant	Remarks
C-6	0-CKV-70-504	Prevent backflow to CCS Pump C-S when pump is not operating	Fails to Close	Mechanical Failure	None	Train B header pressure may be low	None, manual isolation valve 0-ISV-70-505 will be closed. Pump 1A-A/2A-A or 1B-B/2B-B will continue to operate.	Shutdown function is not affected.
2C-6A	2-CKV-70-504A	Prevent backflow to CSS Pump 2A-A when pump is not operating	Fails to close	Mechanical Failure	Low header pressure alarm	Train A header pressure may be low	None, manual isolation valve 2-ISV-70-505A will be closed. Pump 2B-B or C-S will continue to operate.	Safe Shutdown Function is not affected.
2C-7	2-CKV-70-504B	Prevent backflow to CSS Pump 2B-B when pump is not operating	Fails to Close	Mechanical Failure	Low header pressure alarm	Train A header pressure may be low	None, manual isolation valve 2-ISV-70-505B will be closed. Pump 2A-A or C-S will continue to operate.	Safe Shutdown Function is not affected.

Table 9.2-9 COMPONENT COOLING SYSTEM  
FAILURE MODES AND EFFECTS ANALYSIS (Continued)  
(Page 16 of 28)

Item	Component	Function	Failure Mode	Potential Cause	Method of Detection	Effect on System	Effect on Plant	Remarks
<b>D SAFETY/NONSAFETY ISOLATION</b>								
D-1	1-FCV-70-183	Isolate break in Class G piping to Sample HXs and Chiller on high flow differential from 1-FE-70-215A and B and/or low Surge Tank level at 1-LT-70-63	Fails to Close	Power Supply, Electrical, or Mechanical Failure	1-HS-70-183A status lights, low level alarm	Loss of inventory from Train 1A portion of the Surge Tank	None, Train 1B portion of the Surge Tank is still intact, supporting Train B of CCS.	Safe shutdown is achieved by redundant Train B.
2D-1	2-FCV-70-183	Isolate break in Class G piping to Sample HXs and Chiller on high flow differential from 2-FE-70-215A and B and/or low Surge Tank level at 2-LT-70-63	Fails to Close	Power Supply, Electrical, or Mechanical Failure	2-HS-70-183A status lights, low level alarm	Loss of inventory from the Train 2A portion of the Surge Tank	None, Train 2B portion of the Surge Tank is still intact, supporting Train B of CCS.	Safe shutdown is achieved by redundant Train B.

**Table 9.2-9 COMPONENT COOLING SYSTEM  
FAILURE MODES AND EFFECTS ANALYSIS (Continued)**  
(Page 17 of 28)

Item	Component	Function	Failure Mode	Potential Cause	Method of Detection	Effect on System	Effect on Plant	Remarks
D-2	1-FCV-70-215	Isolate break in Class 'G' piping to Sample HXs and Chiller on signal that valve 1-FCV-70-183 has closed	Fails to Close	Power Supply, Electrical, or Mechanical Failure	Low level alarm	Potential loss of inventory from Train 1A portion of the Surge tank	None, Train 1B portion of the Surge Tank is still intact, supporting Train B of CCS.	Safe shutdown is achieved by redundant Train B.
2D-2	2-FCV-70-215	Isolate break in Class 'G' piping. to Sample HXs and Chiller on signal that valve 2-FCV-70-183 has closed	Fails to Close	Power Supply, Electrical, or Mechanical Failure	Low level alarm	Potential loss of inventory from Train 2A portion of the Surge tank	None, Train 2B portion of the Surge Tank is still intact, supporting Train B of CCS.	Safe shutdown is achieved by redundant Train B.
D-3	0-FCV-70-206	None	N/A	N/A	N/A	N/A	N/A	This valve is locked closed with a full face gasket and silicone casting installed.

**Table 9.2-9 COMPONENT COOLING SYSTEM  
FAILURE MODES AND EFFECTS ANALYSIS (Continued)**  
(Page 18 of 28)

Item	Component	Function	Failure Mode	Potential Cause	Method of Detection	Effect on System	Effect on Plant	Remarks
<b>E HIGH PRESSURE PIPING ISOLATION</b>								
E-1	1-CKV-70-681A	Prevent backflow of high pressure RCS fluid into low pressure CCS Piping (See Note 4.).	Fails to Close	Mechanical Failure	None	Single Failure	None, isolation will be achieved by redundant check valve 1-CKV-70-682A.	None
2E-1	2-CKV-70-681A	Prevent backflow of high pressure RCS fluid into low pressure CCS Piping (See Note 4.).	Fails to Close	Mechanical Failure	None	Single Failure	None, isolation will be achieved by redundant check valve 2-CKV-70-682A.	None
E-2	1-CKV-70-682A	Prevent backflow of high pressure RCS fluid into low pressure CCS Piping (See Note 4.).	Fails to Close	Mechanical Failure	None	Single Failure	None, isolation will be achieved by redundant check valve 1-CKV-70-681A.	None
2E-2	2-CKV-70-682A	Prevent backflow of high pressure RCS fluid into low pressure CCS Piping (See Note 4.).	Fails to Close	Mechanical Failure	None	Single Failure	None, isolation will be achieved by redundant check valve 2-CKV-70-681A.	None



**Table 9.2-9 COMPONENT COOLING SYSTEM  
FAILURE MODES AND EFFECTS ANALYSIS (Continued)**  
(Page 19 of 28)

Item	Component	Function	Failure Mode	Potential Cause	Method of Detection	Effect on System	Effect on Plant	Remarks
E-3	1-CKV-70-681B	Prevent backflow of high pressure RCS fluid into low pressure CCS Piping (See Note 4.).	Fails to Close	Mechanical Failure	None	Single Failure	None, isolation will be achieved by redundant check valve 1-CKV-70-682B.	None
2E-3	2-CKV-70-681B	Prevent backflow of high pressure RCS fluid into low pressure CCS Piping (See Note 4.).	Fails to Close	Mechanical Failure	None	Single Failure	None, isolation will be achieved by redundant check valve 2-CKV-70-682B.	None
E-4	1-CKV-70-682B	Prevent backflow of high pressure RCS fluid into low pressure CCS Piping (See Note 4.).	Fails to Close	Mechanical Failure	None	Single Failure	None, isolation will be achieved by redundant check valve 1-CKV-70-681B.	None
2E-4	2-CKV-70-682B	Prevent backflow of high pressure RCS fluid into low pressure CCS Piping (See Note 4.).	Fails to Close	Mechanical Failure	None	Single Failure	None, isolation will be achieved by redundant check valve 2-CKV-70-681B.	None

**Table 9.2-9 COMPONENT COOLING SYSTEM  
FAILURE MODES AND EFFECTS ANALYSIS (Continued)**  
(Page 20 of 28)

Item	Component	Function	Failure Mode	Potential Cause	Method of Detection	Effect on System	Effect on Plant	Remarks
E-5	1-CKV-70-681C	Prevent backflow of high pressure RCS fluid into low pressure CCS Piping (See Note 4.).	Fails to Close	Mechanical Failure	None	Single Failure	None, isolation will be achieved by redundant check valve 1-CKV-70-682C.	None
2E-5	2-CKV-70-681C	Prevent backflow of high pressure RCS fluid into low pressure CCS Piping (See Note 4.).	Fails to Close	Mechanical Failure	None	Single Failure	None, isolation will be achieved by redundant check valve 2-CKV-70-682C.	None
E-6	1-CKV-70-682C	Prevent backflow of high pressure RCS fluid into low pressure CCS Piping (See Note 4.).	Fails to Close	Mechanical Failure	None	Single Failure	None, isolation will be achieved by redundant check valve 1-CKV-70-681C.	None
2E-6	2-CKV-70-682C	Prevent backflow of high pressure RCS fluid into low pressure CCS Piping (See Note 4.).	Fails to Close	Mechanical Failure	None	Single Failure	None, isolation will be achieved by redundant check valve 2-CKV-70-681C.	None

**Table 9.2-9 COMPONENT COOLING SYSTEM  
FAILURE MODES AND EFFECTS ANALYSIS (Continued)**  
(Page 21 of 28)

Item	Component	Function	Failure Mode	Potential Cause	Method of Detection	Effect on System	Effect on Plant	Remarks
E-7	1-CKV-70-681D	Prevent backflow of high pressure RCS fluid into low pressure CCS Piping (See Note 4.).	Fails to Close	Mechanical Failure	None	Single Failure	None, isolation will be achieved by redundant check valve 1-CKV-70-682D.	None
2E-7	2-CKV-70-681D	Prevent backflow of high pressure RCS fluid into low pressure CCS Piping (See Note 4.).	Fails to Close	Mechanical Failure	None	Single Failure	None, isolation will be achieved by redundant check valve 2-CKV-70-682D.	None
E-8	1-CKV-70-682D	Prevent backflow of high pressure RCS fluid into low pressure CCS Piping (See Note 4.).	Fails to Close	Mechanical Failure	None	Single Failure	None, isolation will be achieved by redundant check valve 1-CKV-70-681D.	None
2E-8	2-CKV-70-682D	Prevent backflow of high pressure RCS fluid into low pressure CCS Piping (See Note 4.).	Fails to Close	Mechanical Failure	None	Single Failure	None, isolation will be achieved by redundant check valve 2-CKV-70-681D.	None

Table 9.2-9 COMPONENT COOLING SYSTEM  
FAILURE MODES AND EFFECTS ANALYSIS (Continued)  
(Page 22 of 28)

Item	Component	Function	Failure Mode	Potential Cause	Method of Detection	Effect on System	Effect on Plant	Remarks
<b>F SURGE TANK MAKE-UP</b>								
F-1	1-LCV-70-63	Isolate Surge Tank upon demineralized water line break Provide make-up to CCS Surge Tank	Fails to Close  Fails to Open	Mechanical Failure  Pneumatic or Mechanical Failure	1-HS-70-63A status lights high level alarm.  1-HS-70-63A status lights low level alarm	Single Failure  Make-up to Surge Tank is lost	None, backflow will be prevented by valve 1-CKV-70-541  None, CCS Pump C-S may take suction from Train 2B portion of Unit 2 Surge Tank.	Failure to close without a Demineralized Water line break occurring would result in tank overflow to LWDS which would not affect safe shutdown function.
2F-1	2-LCV-70-63	Isolate Surge Tank upon demineralized water line break. Provide make-up to CCS Surge Tank	Fails to Close  Fails to Open	Mechanical Failure  Pneumatic or mechanical failure	2-HS-70-63A status lights high level alarm  2-HS-70-63A status lights low level alarm	Single Failure  Make-up to Surge Tank is lost	None, backflow will be prevented by valve 2-CKV-70-541.  None, CCS Pump C-S may take suction from Train 1B portion of Unit 1 Surge Tank.	Failure to close without a Demineralized Water line break occurring would result in tank overflow to LWDS which would not affect safe shutdown function.
F-2	1-CKV-70-541	Prevent backflow of water from Surge Tank	Fails to Close	Mechanical Failure	None	Single Failure	None, backflow will be prevented by valve 1-LCV-70-63	None

**Table 9.2-9 COMPONENT COOLING SYSTEM  
FAILURE MODES AND EFFECTS ANALYSIS (Continued)**  
(Page 23 of 28)

Item	Component	Function	Failure Mode	Potential Cause	Method of Detection	Effect on System	Effect on Plant	Remarks
2F-2	2-CKV-70-541	Prevent backflow of water from Surge Tank	Fails to Close	Mechanical Failure	None	Single Failure	None, backflow will be prevented by valve 2-LCV-70-63	None
<b>G SURGE TANK RADIATION RELEASE</b>								
G-1	1-FCV-70-66	Surge Tank Vent to isolate tank when radiation detected in system	See 'Effect on System' column.	Mechanical Failure	1-HS-70-66A status lights	None, radiation detected in system caused by tube break constitutes the single failure 1-FCV-70-66 will close on detection of radiation.	None	None
		Surge Tank vent to atmosphere	Fails to Open	Pneumatic or Mechanical Failure	1-HS-70-66A status lights	Surge tank may be pressurized. However, Relief Valve 1-RFV-70-538 protects the CCS from overpressure.	None	

**Table 9.2-9 COMPONENT COOLING SYSTEM  
FAILURE MODES AND EFFECTS ANALYSIS (Continued)**  
(Page 24 of 28)

Item	Component	Function	Failure Mode	Potential Cause	Method of Detection	Effect on System	Effect on Plant	Remarks
2G-2	2-FCV-70-66	Surge Tank vent to isolate tank when radiation detected in system	See 'Effect on System' column.	Mechanical Failure	2-HS-70-66A status lights	None, radiation detected in system caused by tube break constitutes the single failure. 2-FCV-70-66 will close on detection of radiation.	None	None
		Surge Tank Vent to atmosphere	Fails to open	Pneumatic or mechanical failure	2-HS-70-66A status lights	Surge tank may be pressurized. However, Relief Valve 2-RFV-70-538 protects the CCS from overpressure.	None	

**Table 9.2-9 COMPONENT COOLING SYSTEM  
FAILURE MODES AND EFFECTS ANALYSIS (Continued)**  
(Page 25 of 28)

Item	Component	Function	Failure Mode	Potential Cause	Method of Detection	Effect on System	Effect on Plant	Remarks
G-3	1-RFV-70-538	Relieve over-pressure in the Suge Tank	See 'Effect on System' column.	Mechanical Failure	None	None, over-pressurization in system caused by tube break constitutes the single failure. 1-RFV-70-538 will relieve over-pressure in the Surge Tank.	None	None
2G-4	2-RFV-70-538	Relieve over-pressure in the Surge Tank	See 'Effect on System' column.	Mechanical Failure	None	None, over-pressurization in system caused by tube break constitutes the single failure. 2-RFV-70-538 will relieve over-pressure in the Surge Tank.	None	None

**Table 9.2-9 COMPONENT COOLING SYSTEM  
FAILURE MODES AND EFFECTS ANALYSIS (Continued)**  
(Page 26 of 28)

Item	Component	Function	Failure Mode	Potential Cause	Method of Detection	Effect on System	Effect on Plant	Remarks
G-5	CCS Equipment - Various coolers	Varies	Passive Failure Tube Leak	Mechanical Failure	High level alarm or high radiation alarm	Potential radiation present in the system and/or increase in system volume.	None, the Surge Tank Vent valve 1- FCV-70-66 will close, preventing radiation release to atmosphere.	None
2G-5	CCS Equipment - Various Coolers	Varies	Passive Failure Tube Leak	Mechanical Failure	High level alarm or high radiation alarm	Potential radiation present in the system and/or increase in system volume.	None, the Surge Tank Vent valve 2- FCV-70-66 will close, preventing radiation release to atmosphere.	None
G-6	1-RFV-70-539	Vacuum Relief for CCS Surge Tank A	Failure to Open	Mechanical Failure	Decrease in water level in Tank B (Unit 2).	None	None, reduced pressure in surge tank will result in water from Tank B being drawn into Tank A to equalize the pressure. If pressure in Tank B drops below the setpoint, 2-RFV- 70-539 will open.	Tanks A and B are interconnected between the 1B and 2B header with the isolation valves administratively locked open with the breakers open.



Table 9.2-9 COMPONENT COOLING SYSTEM  
FAILURE MODES AND EFFECTS ANALYSIS (Continued)  
(Page 27 of 28)

Item	Component	Function	Failure Mode	Potential Cause	Method of Detection	Effect on System	Effect on Plant	Remarks
2G-7	2-RFV-70-539	Vacuum Relief for CCS Surge Tank B	Failure to Open	Mechanical Failure	Decrease in water level in Tank A (Unit 1).	None	None, reduced pressure in surge tank will result in water from Tank A being drawn into Tank B to equalize the pressure. If pressure in Tank A drops below the setpoint, 1-RFV-70-539 will open.	Tanks A and B are interconnected between the 1B and 2B header with the isolation valves administratively locked open with the breakers open.
<b>H EMERGENCY FAILURE</b>								
H-1	Emergency Power to Train A	Provide power to pump A motor and all MOVs in Train A	Fails	Diesel Generator Shutdown Board 1A-A Failure	Control room indication	CCS Train A is lost	None, two 100% capacity trains are provided	Only one train is required to mitigate accident consequences. Equipment realignments are required.
H-2	Emergency Power to Train B	Provide power to pump B motor and all MOVs in Train B	Fails	Diesel Generator Shutdown Board 1B-B Failure	Control room indication	CCS Train B is lost	None, two 100% capacity trains are provided	Only one train is required to mitigate accident consequences. Equipment realignments are required.

Table 9.2-9 COMPONENT COOLING SYSTEM  
FAILURE MODES AND EFFECTS ANALYSIS (Continued)  
(Page 28 of 28)

Item	Component	Function	Failure Mode	Potential Cause	Method of Detection	Effect on System	Effect on Plant	Remarks
<b>I PASSIVE FAILURE</b>								
I-1	Piping System (Valve body, disc, pump casing, HX shell, etc.)	Varies	Ruptures, leakages disc separation, etc.	Mechanical Failure	Various process parameters (pressure, temperature, flow, etc.)	System capability diminished	None, two 100% capacity trains are provided.	Only one train is required to mitigate the accident consequences.
NOTE 1: Primary function of the valve is to relieve pressure generated by expanding liquid trapped between isolation valves. Failure of a check valve to open is not considered to be credible.								
NOTE 2: Not Used								
NOTE 3: Not Used								
NOTE 4: This evaluation is based on the assumption that RCP thermal barrier tube break has occurred causing the high pressure RCS to pressurize the low pressure CCS.								

**Table 9.2-10 COMPONENT COOLING SYSTEM CODE REQUIREMENTS**

	TVA Class <sup>(1)</sup>	Design Code
Heat exchangers	C	ASME III, Class 3
Surge Tanks	C	ASME III, Class 3
Pumps	C	ASME III, Class 3
System piping	B&C	ASME III, Class 2 and Class 3
Valves	B&C	ASME III, Class 2 and Class 3
Seal leakage return unit (Excluding Pumps)	L	Unclassified
Piping to sample heat exchangers and sample chiller package	C&G	ASME III, Class 3 and ANSI B31.1
Seal leakage return pumps	G	Manufacturer's Standards
Sample Cooler/Chiller piping and valves	G	ANSI B31.1

(1) TVA classes are defined in Section 3.2

**Table 9.2-11 RAW COOLING WATER SYSTEM PUMP DESIGN DATA**

Number of Pumps	7
Type	Vertical Turbine
Rated Capacity (gpm)	5135

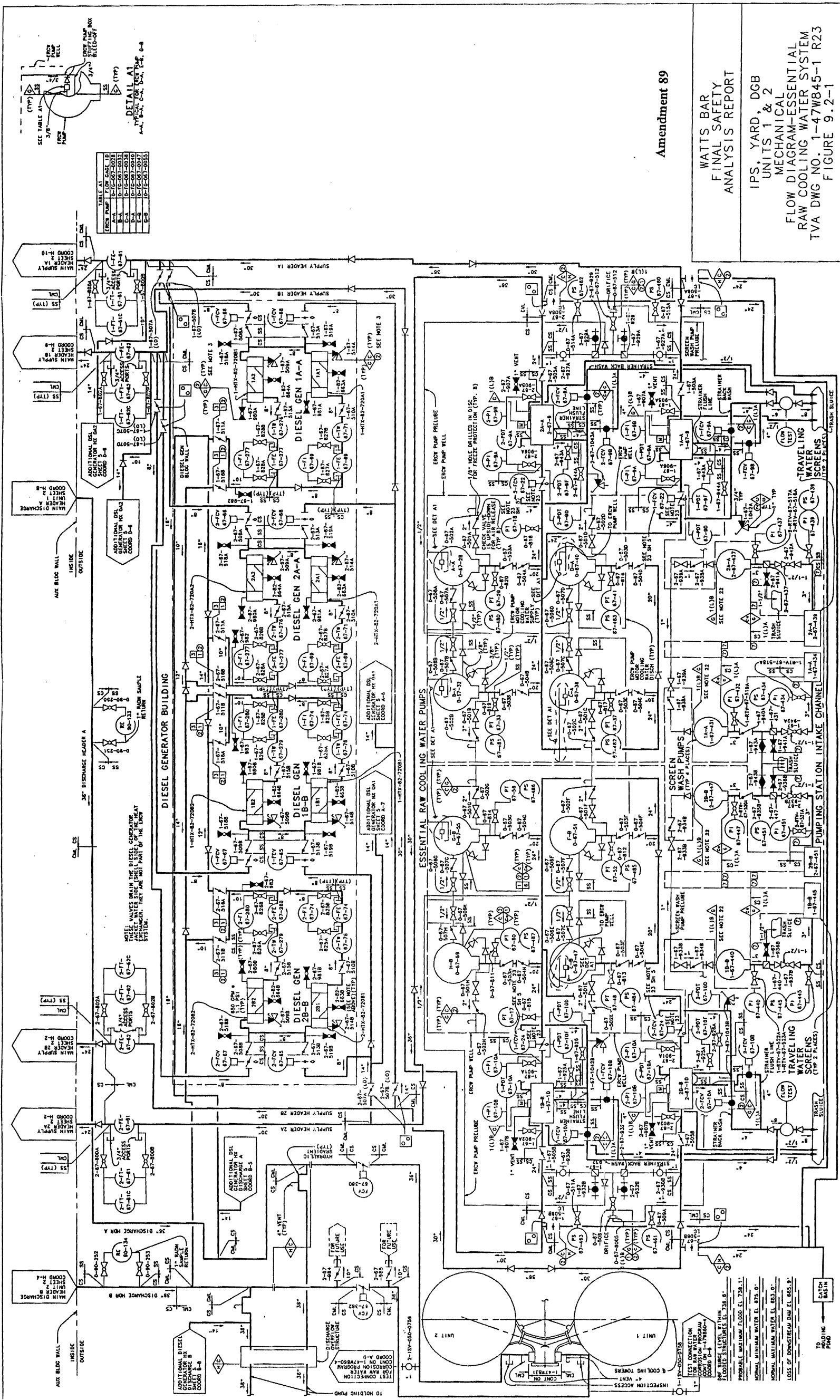
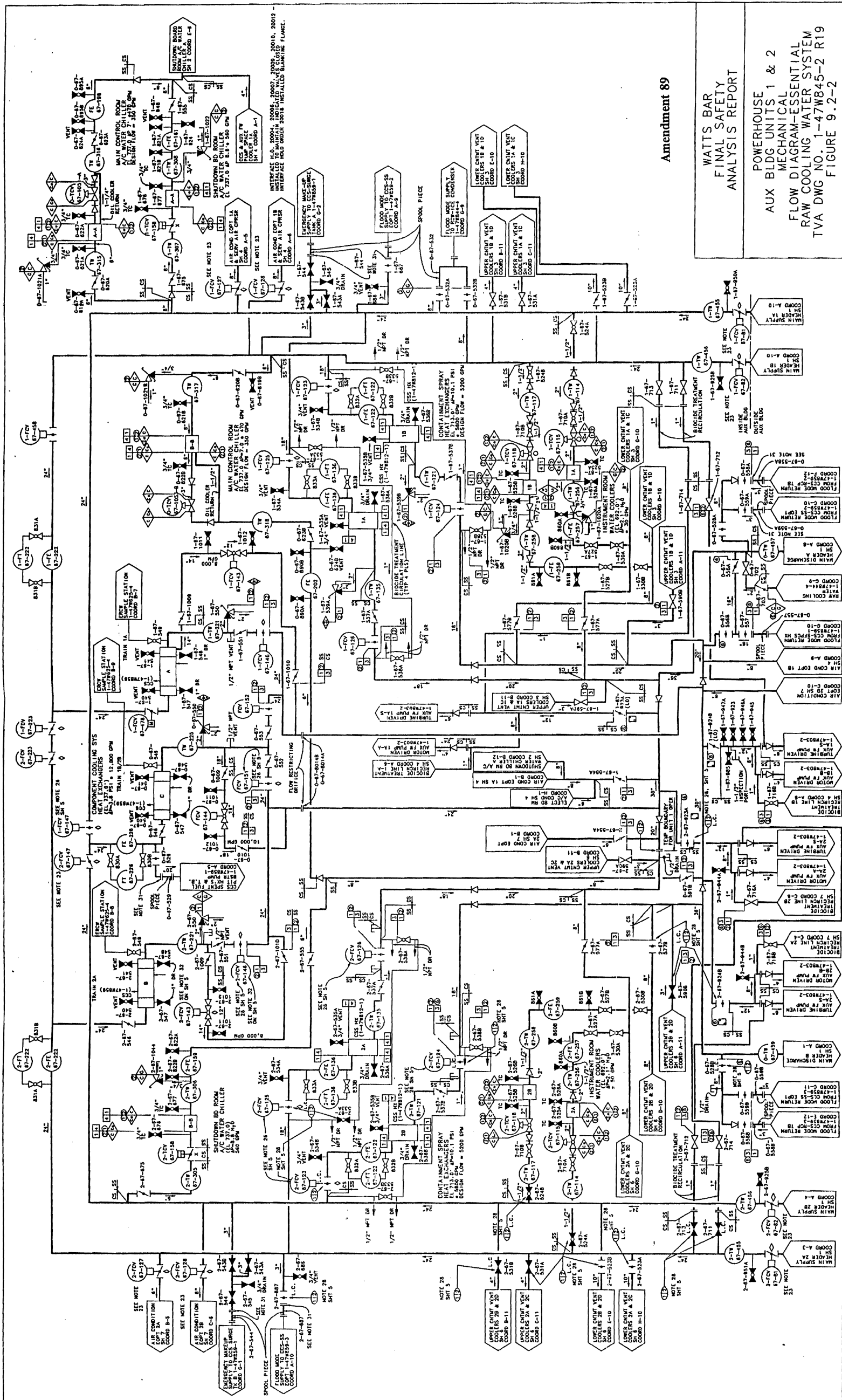

Figure 9.2-1 IPS, Yard, DGB Units 1 & 2 Flow Diagram for Essential Raw Cooling Water System Powerhouse and Auxiliary Building



Amendment 89

WATTS BAR  
FINAL SAFETY  
ANALYSIS REPORT

POWERHOUSE  
AUX BLDG UNITS 1 & 2  
MECHANICAL  
FLOW DIAGRAM-ESSENTIAL  
RAW COOLING WATER SYSTEM  
TVA DWG NO. 1-47WB45-2 R19  
FIGURE 9.2-2

PROCADAM MAINTAINED DRAWING  
THIS DRAWING IS THE PROPERTY OF THE U.S. NUCLEAR REGULATORY COMMISSION

Figure 9.2-2 Powerhouse Aux Bldg Units 1 & 2 Mechanical Flow Diagram for Essential Raw Cooling Water System (Unit 1)

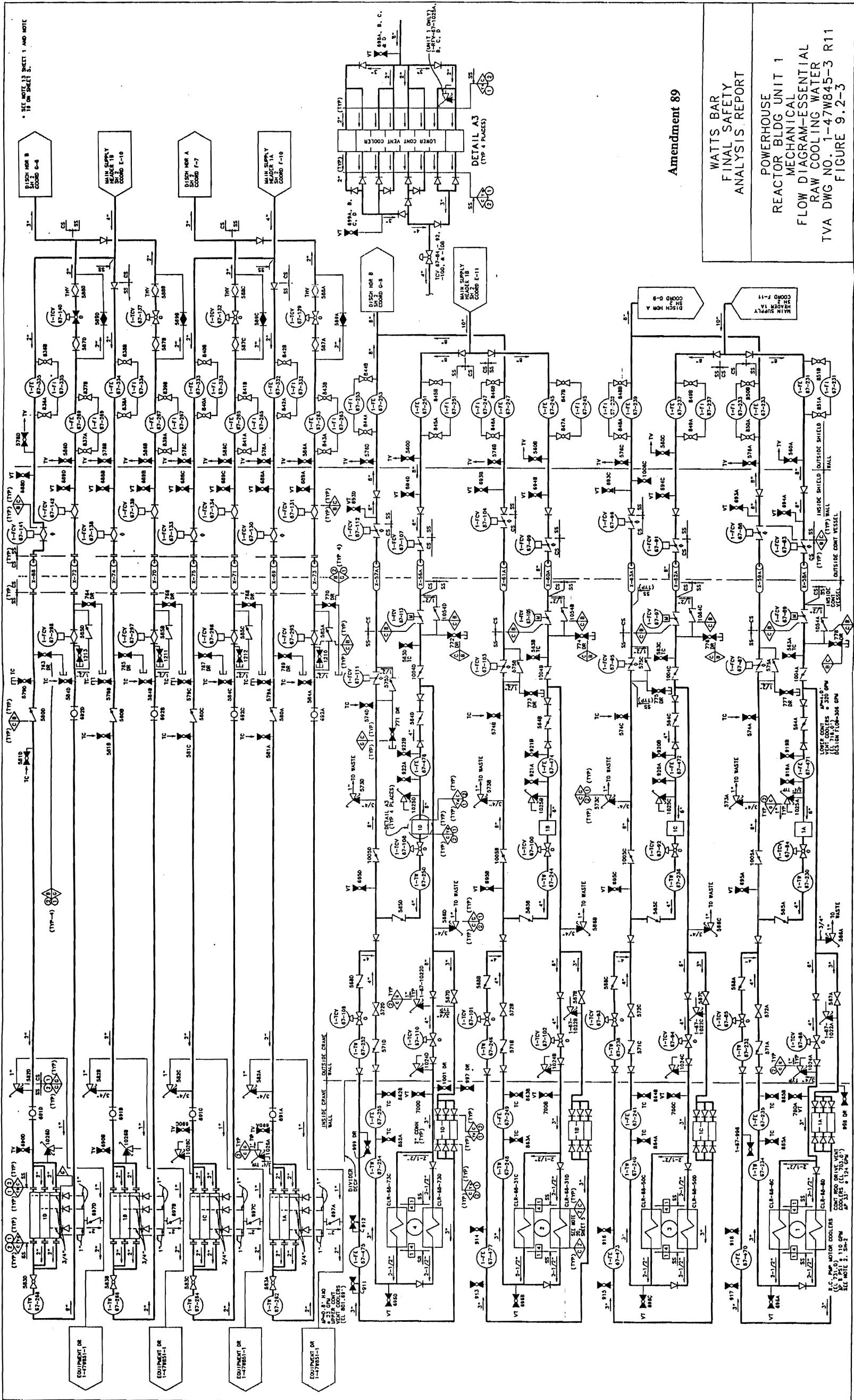
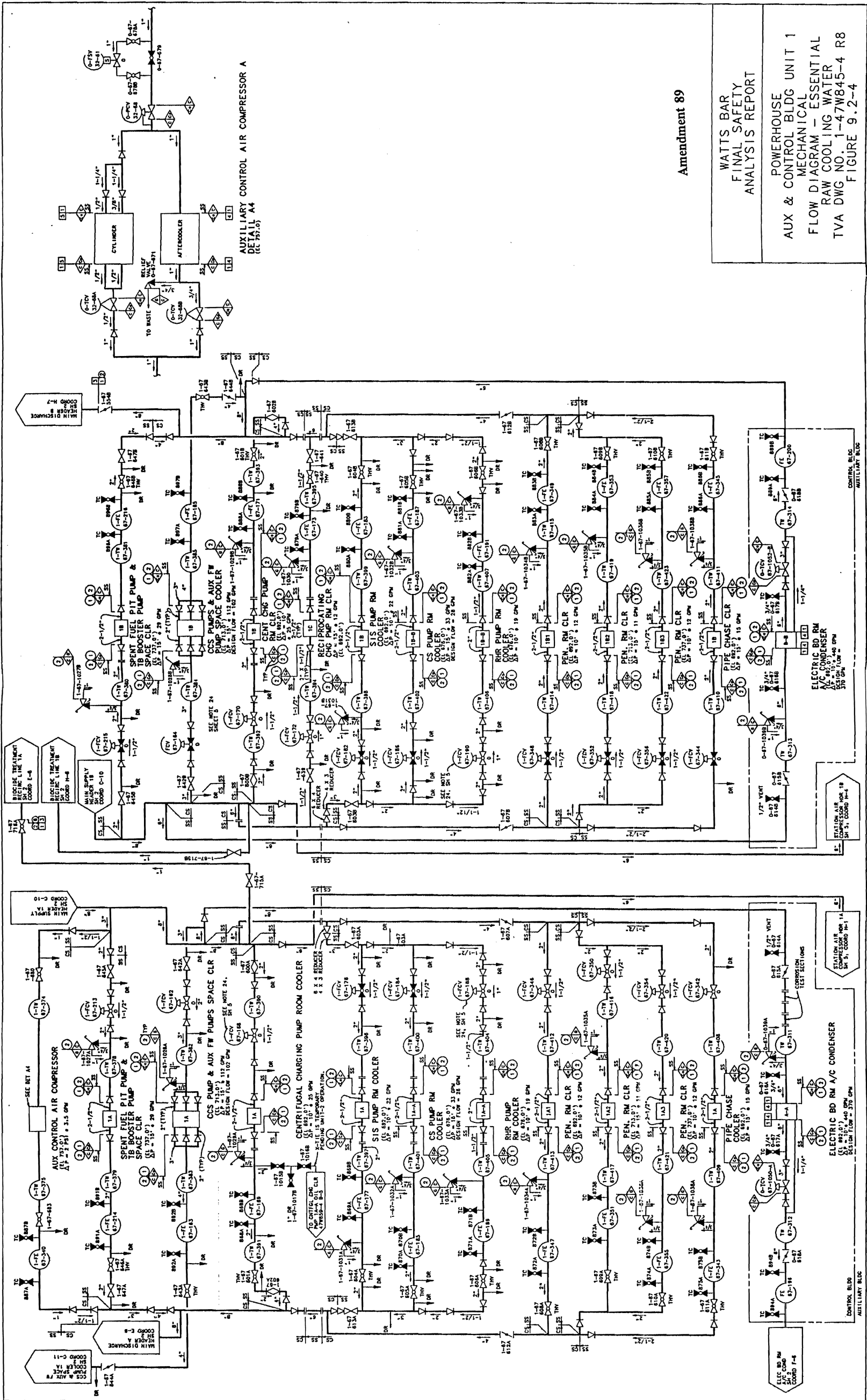

Figure 9.2-3 Powerhouse Auxiliary and Control Buildings Raw Cooling Water System (Unit 1)

PROCADAM MAINTAINED DRAWING  
THIS DRAWING IS A MAINTAINED DRAWING  
FOR THE WATTS BAR UNIT 1 PROJECT  
DATE: 08/21/89



Amendment 89

WATTS BAR  
FINAL SAFETY  
ANALYSIS REPORT

POWERHOUSE  
AUX & CONTROL BLDG UNIT 1  
MECHANICAL  
FLOW DIAGRAM - ESSENTIAL  
RAW COOLING WATER  
TVA DWG NO. 1-47W845-4 R8  
FIGURE 9.2-4

PROCEED AND MAINTAINED DRAWING  
THIS DRAWING IS THE PROPERTY OF THE  
U.S. GOVERNMENT AND IS TO BE REPRODUCED  
AND TRANSMITTED IN ANY FORM AND BY ANY  
MEANS, ELECTRONIC OR MECHANICAL, INCLUDING  
PHOTOCOPYING, RECORDING, OR BY ANY  
INFORMATION STORAGE AND RETRIEVAL SYSTEM.

Figure 9.2-4 Powerhouse Aux & Control Bldg Unit 1 Mechanical Flow Diagram - Essential Raw Cooling Water



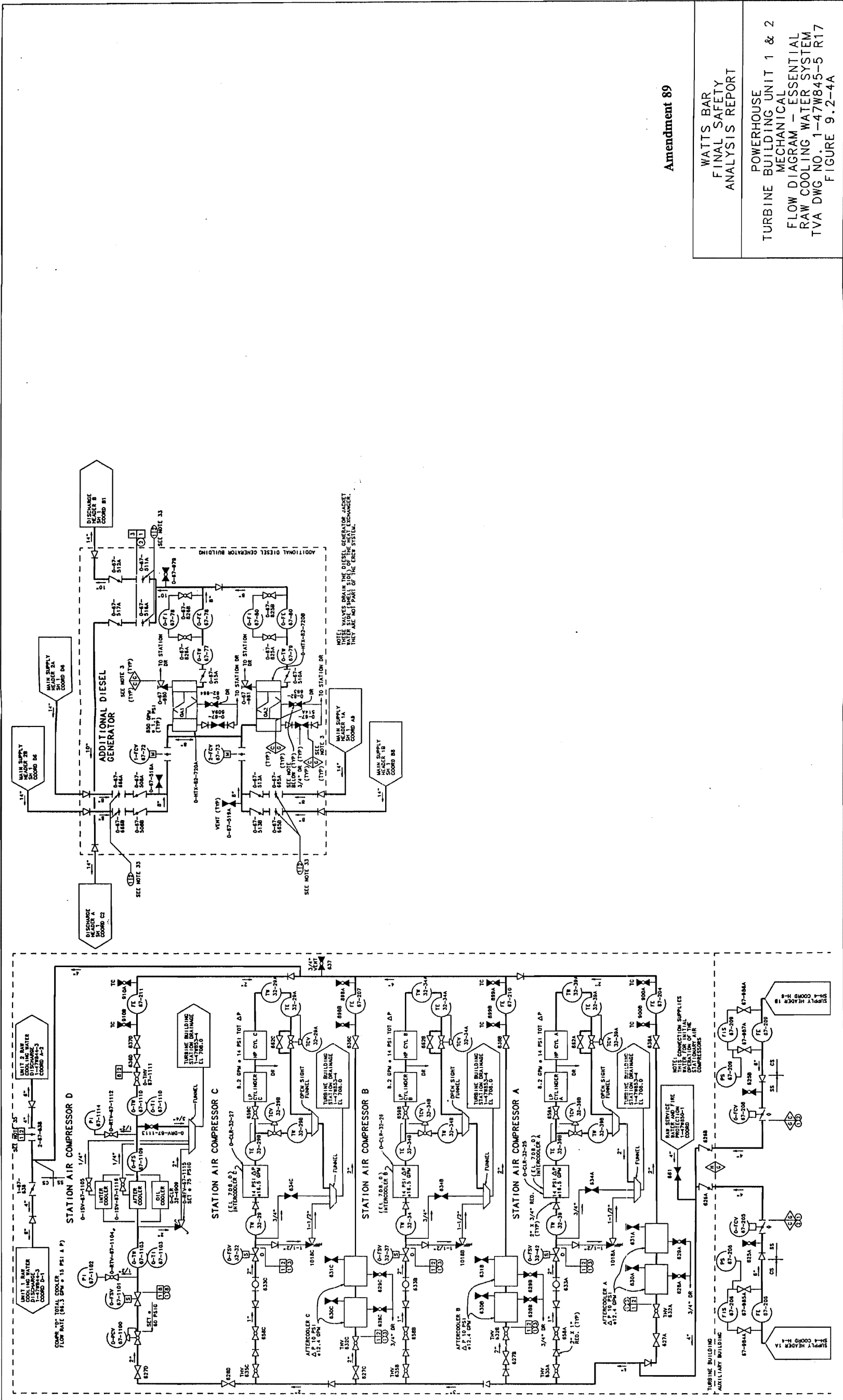

Amendment 89

WATTS BAR  
 FINAL SAFETY  
 ANALYSIS REPORT

POWERHOUSE  
 BUILDING UNIT 1 & 2  
 MECHANICAL  
 FLOW DIAGRAM - ESSENTIAL  
 RAW COOLING WATER SYSTEM  
 TVA DWG NO. 1-47W845-5 R17  
 FIGURE 9.2-4A

PROCADAM MAINTAINED DRAWING  
 THIS CONFIGURATION CONTROL DRAWING IS UNCONTROLLED BY THE  
 ORIGINAL DRAWING NUMBER AND DATE. FOR THE LATEST REVISIONS,  
 SEE THE DRAWING REVISIONS.

Figure 9.2-4a Powerhouse Turbine Building Units 1 & 2 Flow Diagram for Essential Raw Cooling Water System

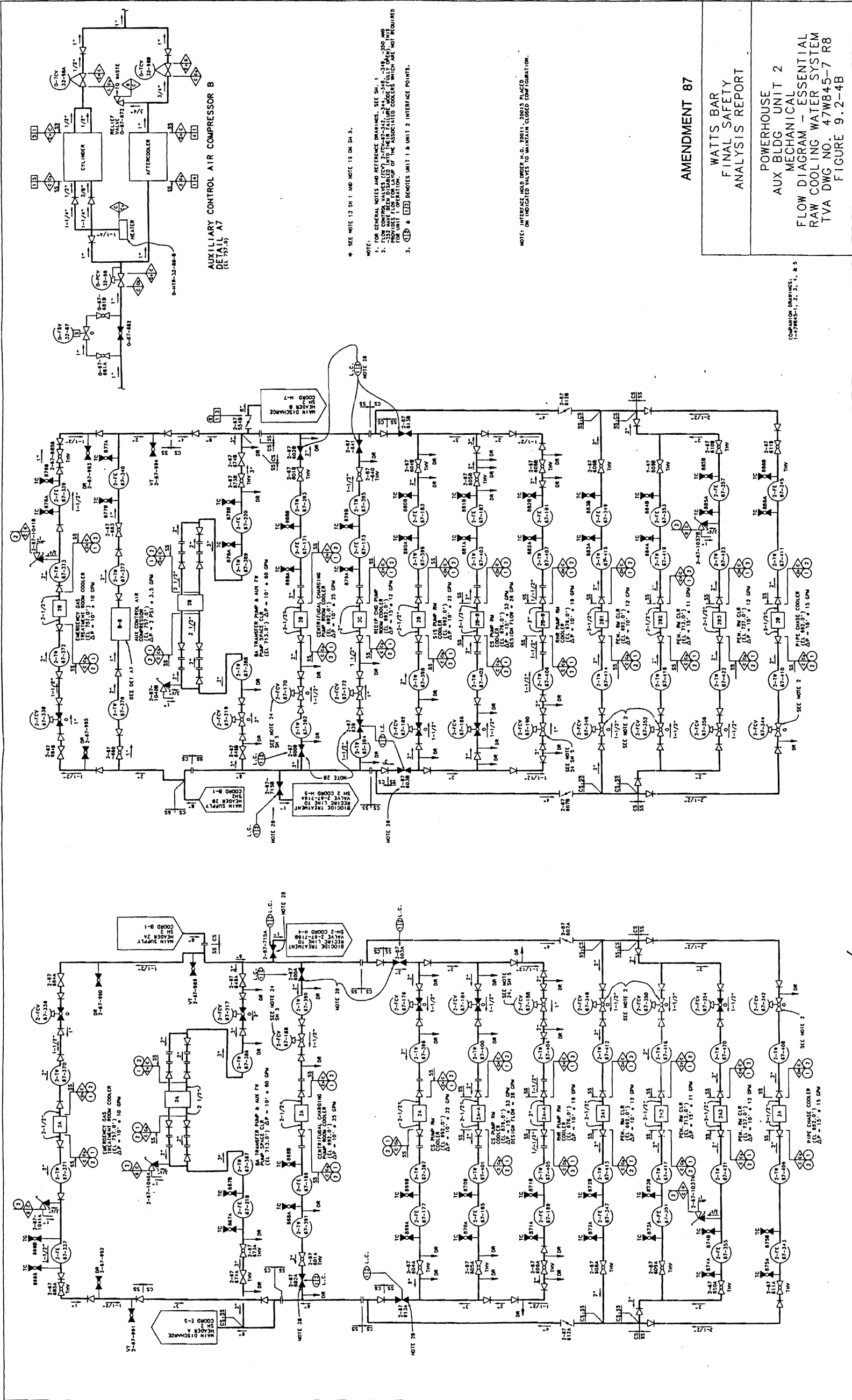

NOTE:  
 1. FOR GENERAL NOTES AND REFERENCE DRAWINGS, SEE SH. 1  
 2. ALL VALVES SHALL BE DISCLOSED TO THEIR FAILURE MODE. FAILURE MODE SHALL BE DETERMINED BY THE ASSOCIATED COOLERS WHICH ARE NOT REQUIRED FOR UNIT 1 OPERATION.  
 3. (C) & (D) DENOTES UNIT 1 & UNIT 2 INTERFACE POINTS.

NOTE: INTERFACED, HOLD OVER, O.C. 20011, 20012 PLACED ON INDICATED VALVES TO MAINTAIN CLOSED CONFIGURATION.

AMENDMENT 87

WATTS BAR  
 FINAL SAFETY  
 ANALYSIS REPORT

POWERHOUSE  
 AUX BLDG UNIT 2  
 MECHANICAL  
 FLOW DIAGRAM - ESSENTIAL  
 RAW COOLING WATER SYSTEM  
 TVA DWG NO. 47W845-7 R8  
 FIGURE 9.2-4B

1-27885-1, 2, 3, 4, & 5

PROCADAM MAINTAINED DRAWING  
 THIS DRAWING IS THE PROPERTY OF THE TVA AND IS NOT TO BE REPRODUCED OR TRANSMITTED IN ANY FORM OR BY ANY MEANS, ELECTRONIC OR MECHANICAL, INCLUDING PHOTOCOPYING, RECORDING, OR BY ANY INFORMATION STORAGE AND RETRIEVAL SYSTEM.

Figure 9.2-4b Powerhouse Auxiliary Building Flow Diagram for Essential Raw Cooling Water System (Unit 2)

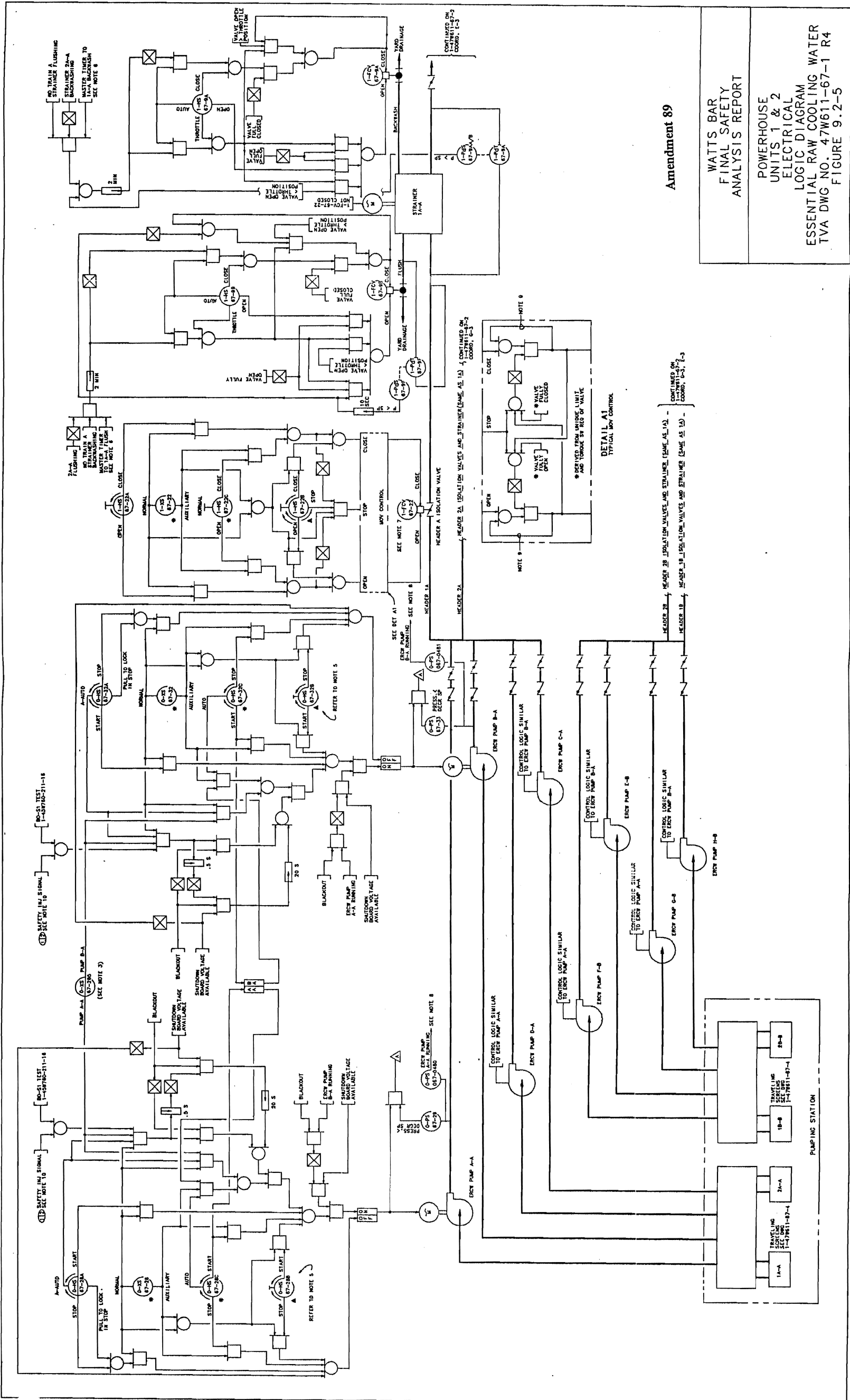

Figure 9.2-5 Powerhouse Units 1 & 2 Electrical Logic Diagram for Essential Raw Cooling Water System

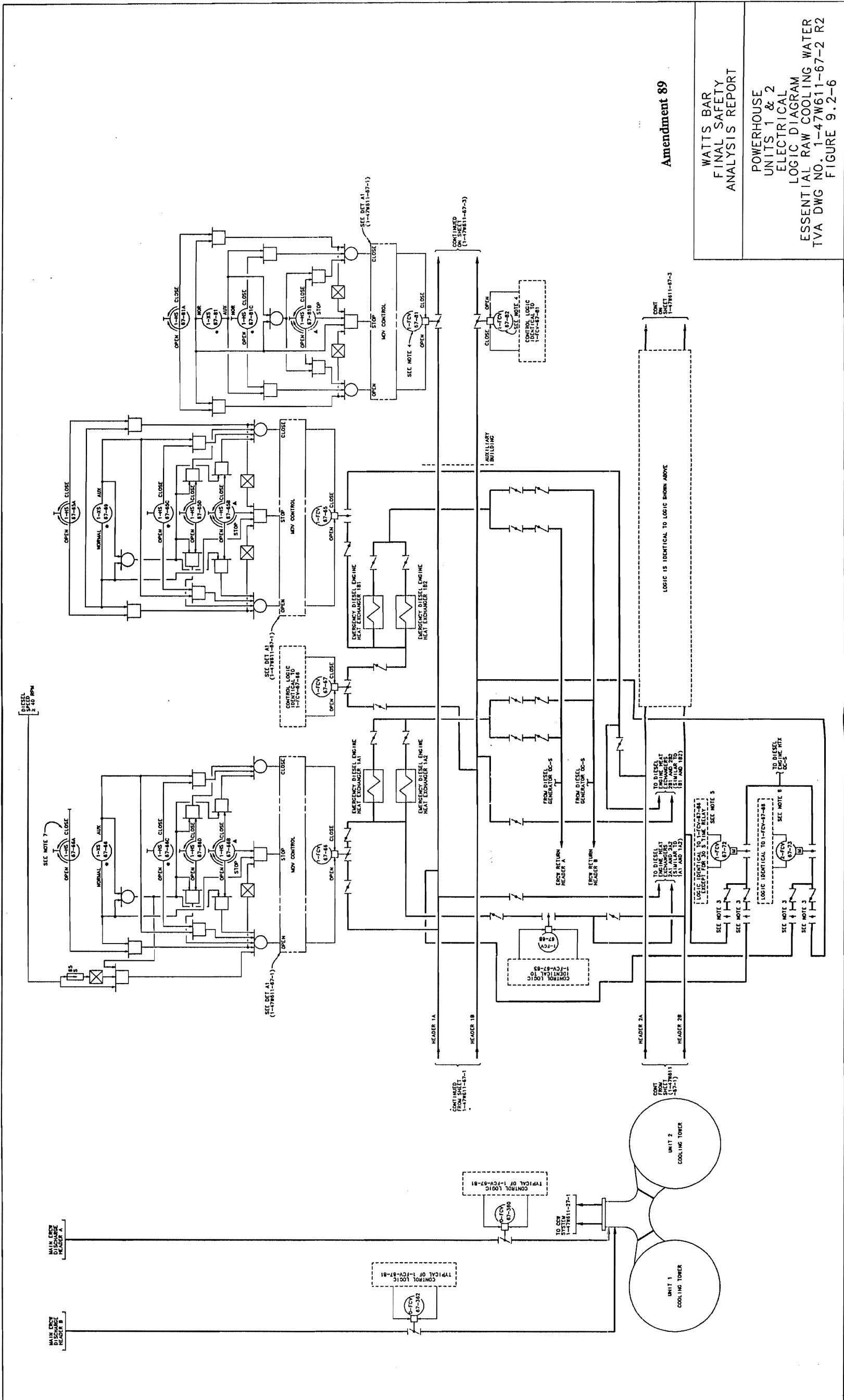

Figure 9.2-6 Powerhouse Units 1 & 2 Electrical Logic Diagram for Essential Raw Cooling Water System

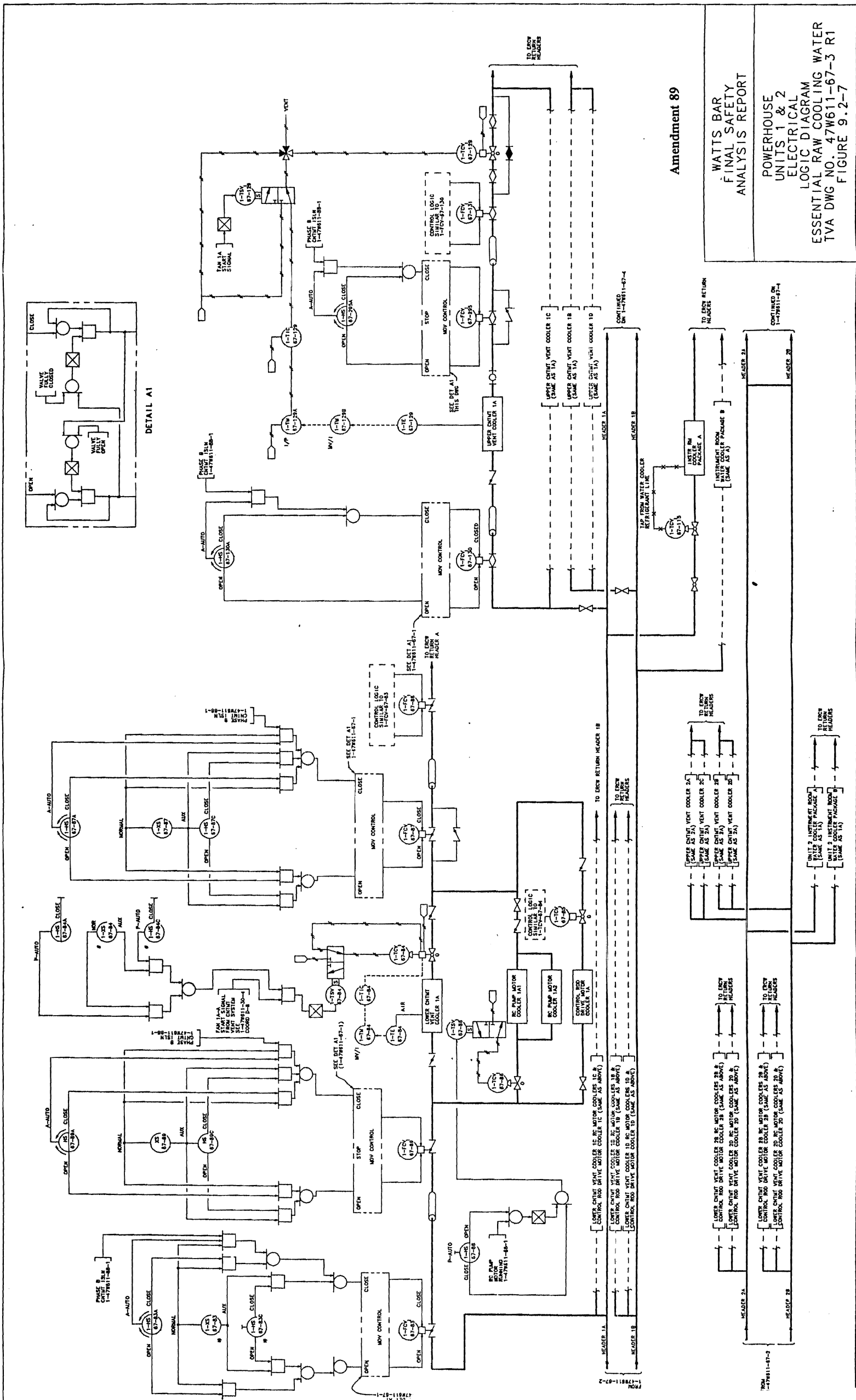

Figure 9.2-7 Logic Diagram for Essential Raw Cooling Water System

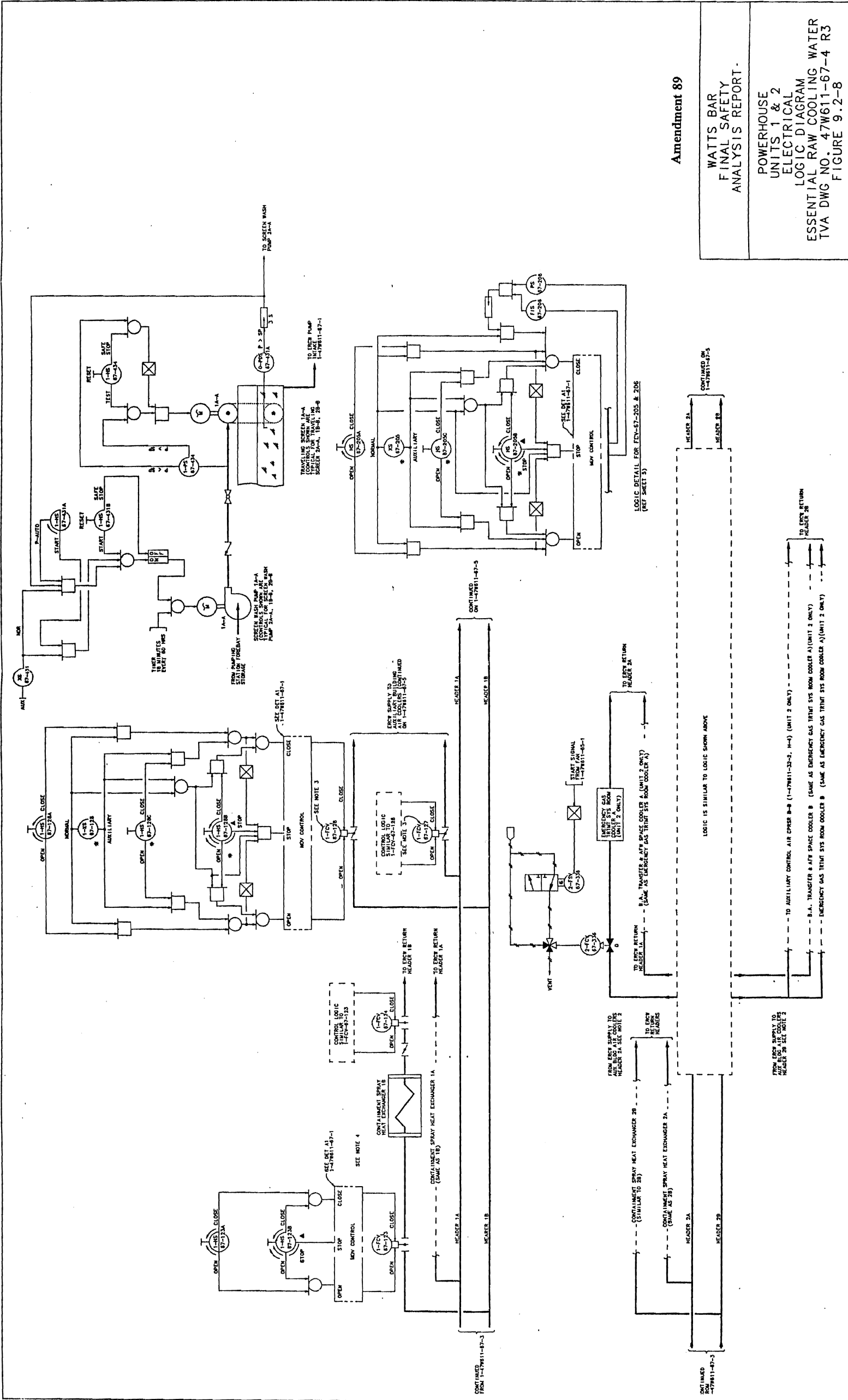
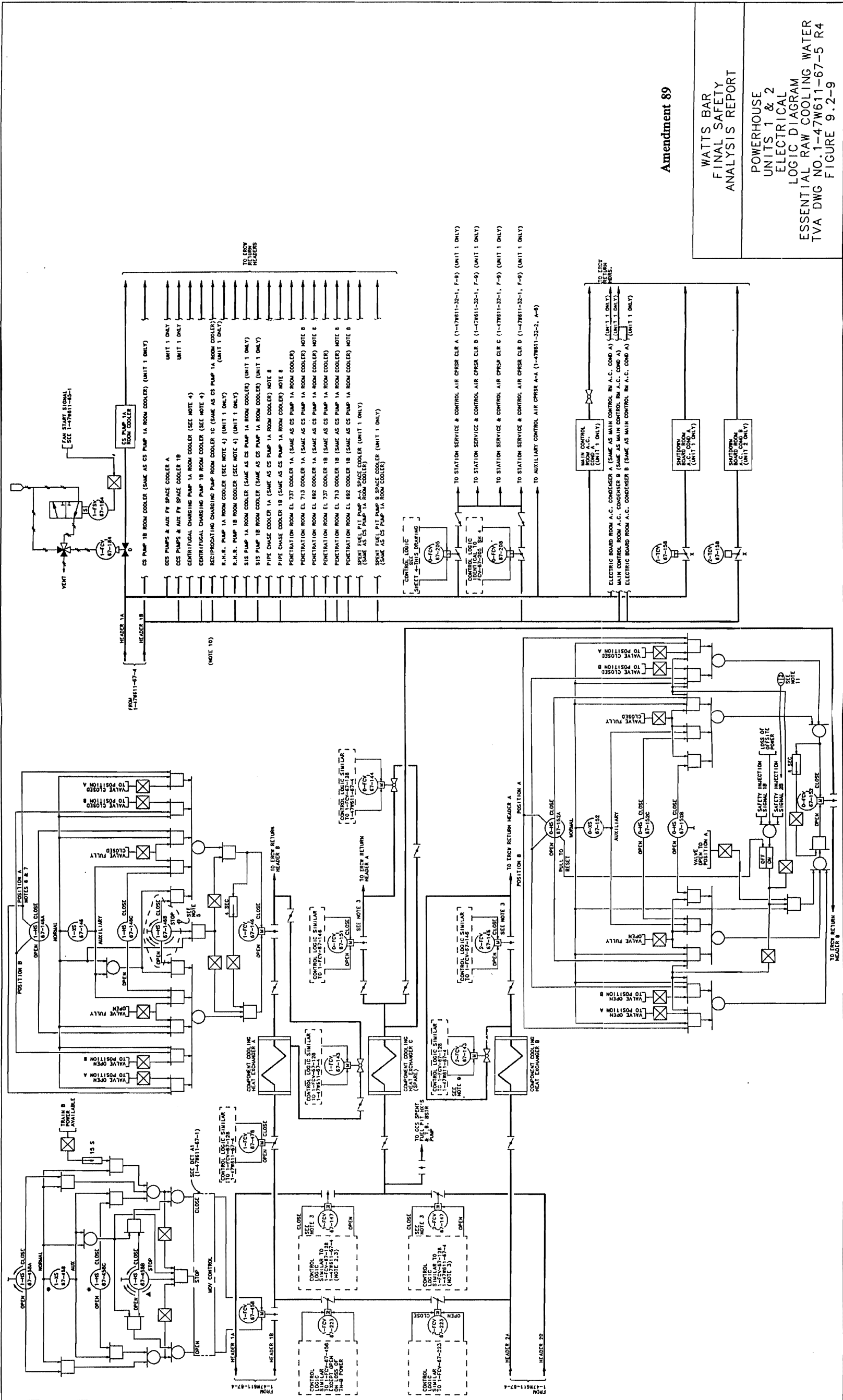

Figure 9.2-8 Powerhouse Units 1 & 2 Electrical Logic Diagram for Essential Raw Cooling Water System



Amendment 89

WATTS BAR  
FINAL SAFETY  
ANALYSIS REPORT

POWERHOUSE  
UNITS 1 & 2  
ELECTRICAL  
LOGIC DIAGRAM  
ESSENTIAL RAW COOLING WATER  
TVA DWG NO. 1-47W611-67-5 R4  
FIGURE 9.2-9

PROCADAM MAINTAINED DRAWING  
THIS DRAWING IS THE PROPERTY OF THE U.S. NUCLEAR REGULATORY COMMISSION  
IT IS TO BE KEPT IN THE ORIGINAL FILED COPY OF THE DRAWING

Figure 9.2-9 Powerhouse Units 1 & 2 Electrical Logic Diagram for Essential Raw Cooling Water System

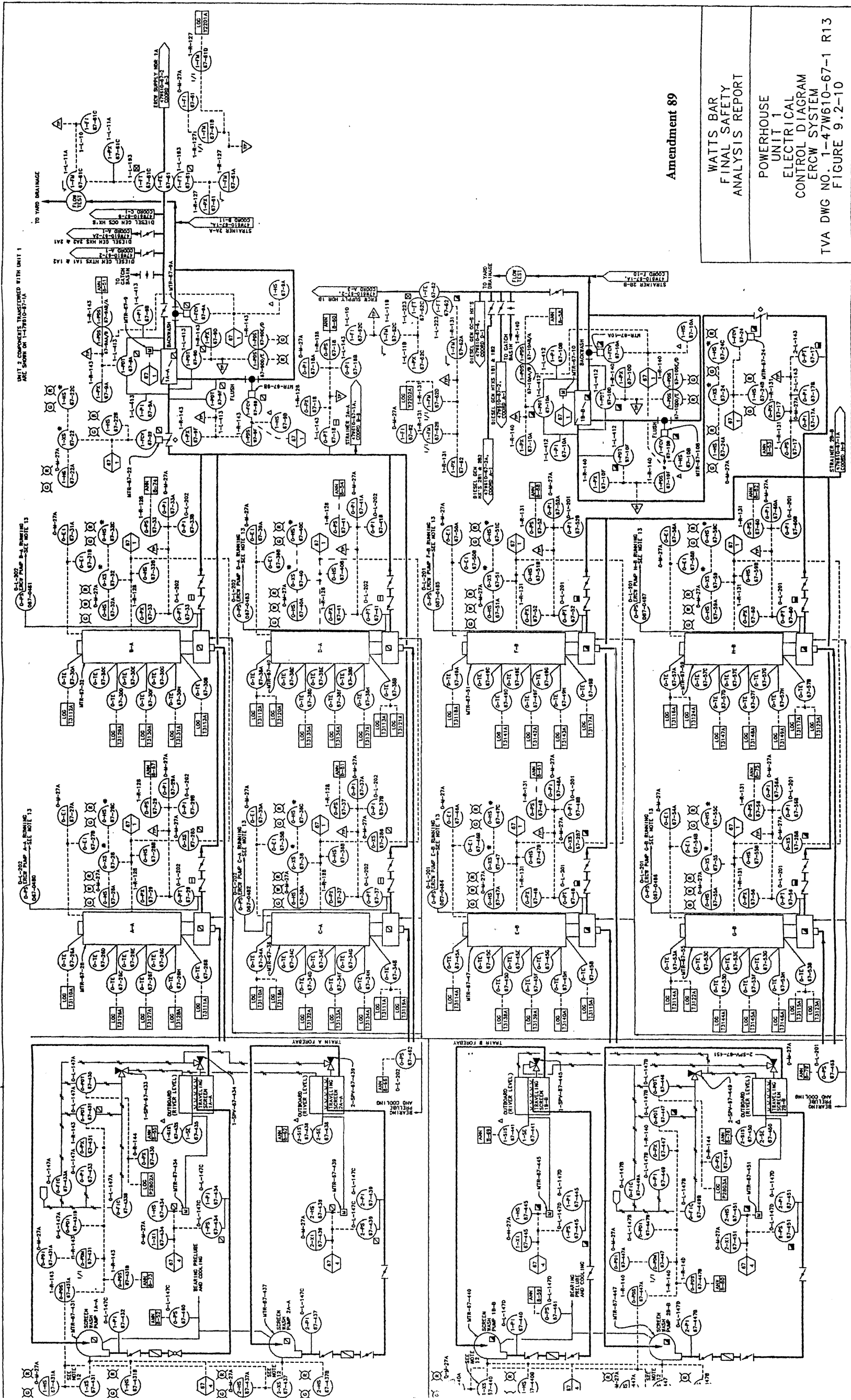
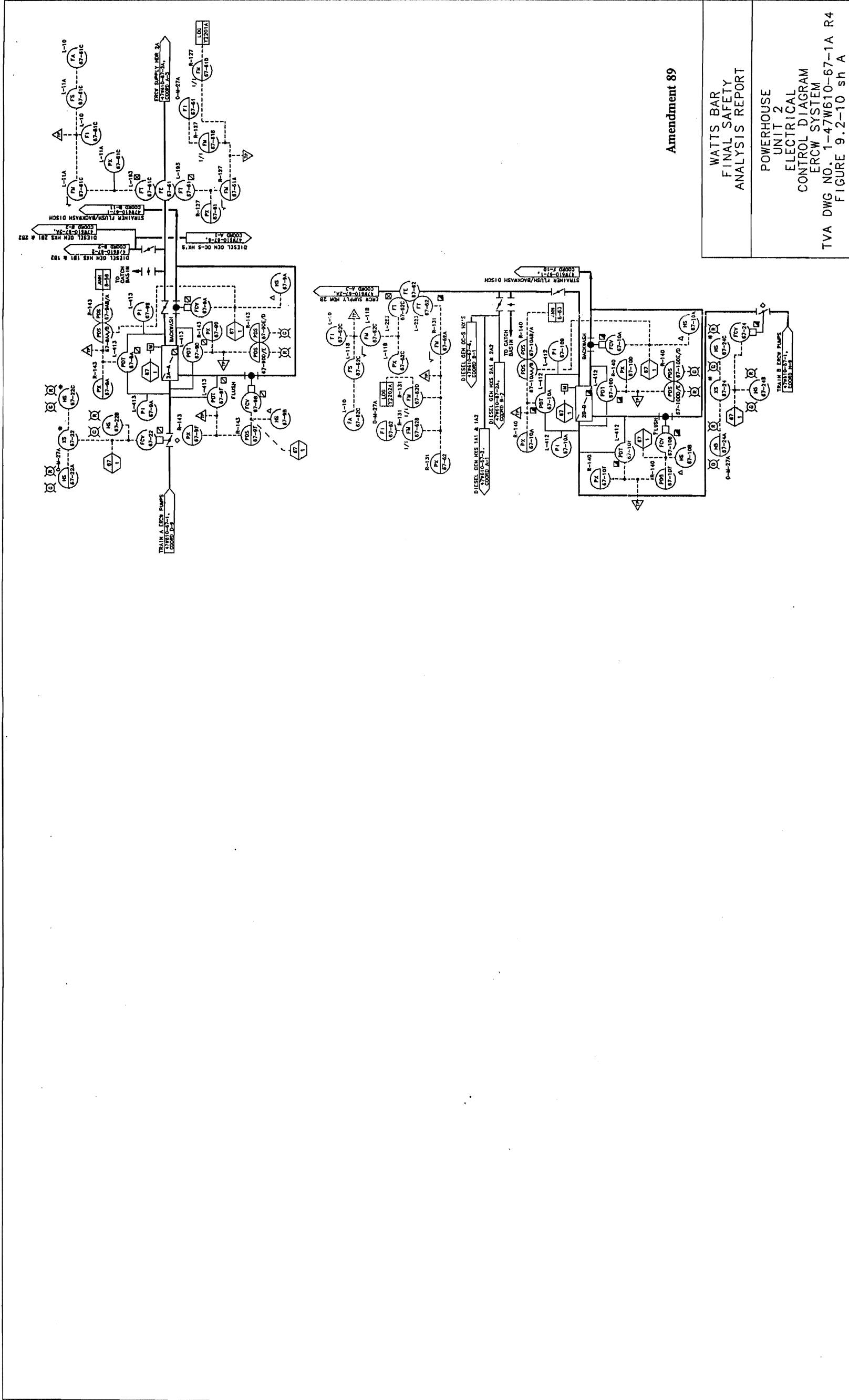

Figure 9.2-10 Powerhouse Electrical Control Diagram for Essential Raw Cooling Water System (Unit 1)





Amendment 89

WATTS BAR  
FINAL SAFETY  
ANALYSIS REPORT  
  
POWERHOUSE  
UNIT 2  
ELECTRICAL  
CONTROL DIAGRAM  
ERCW SYSTEM  
TVA DWG NO. 1-47W610-67-1A R4  
FIGURE 9.2-10 sh A

PROCADAM MAINTAINED DRAWING  
THIS DRAWING IS A COMPUTER-GENERATED DRAWING  
AND SHOULD NOT BE REPRODUCED OR TRANSMITTED IN ANY FORM OR BY ANY MEANS  
WITHOUT THE WRITTEN PERMISSION OF THE OWNER

Figure 9.2-10a Powerhouse Electrical Control Diagram for Essential Raw Cooling Water System (Unit 2)

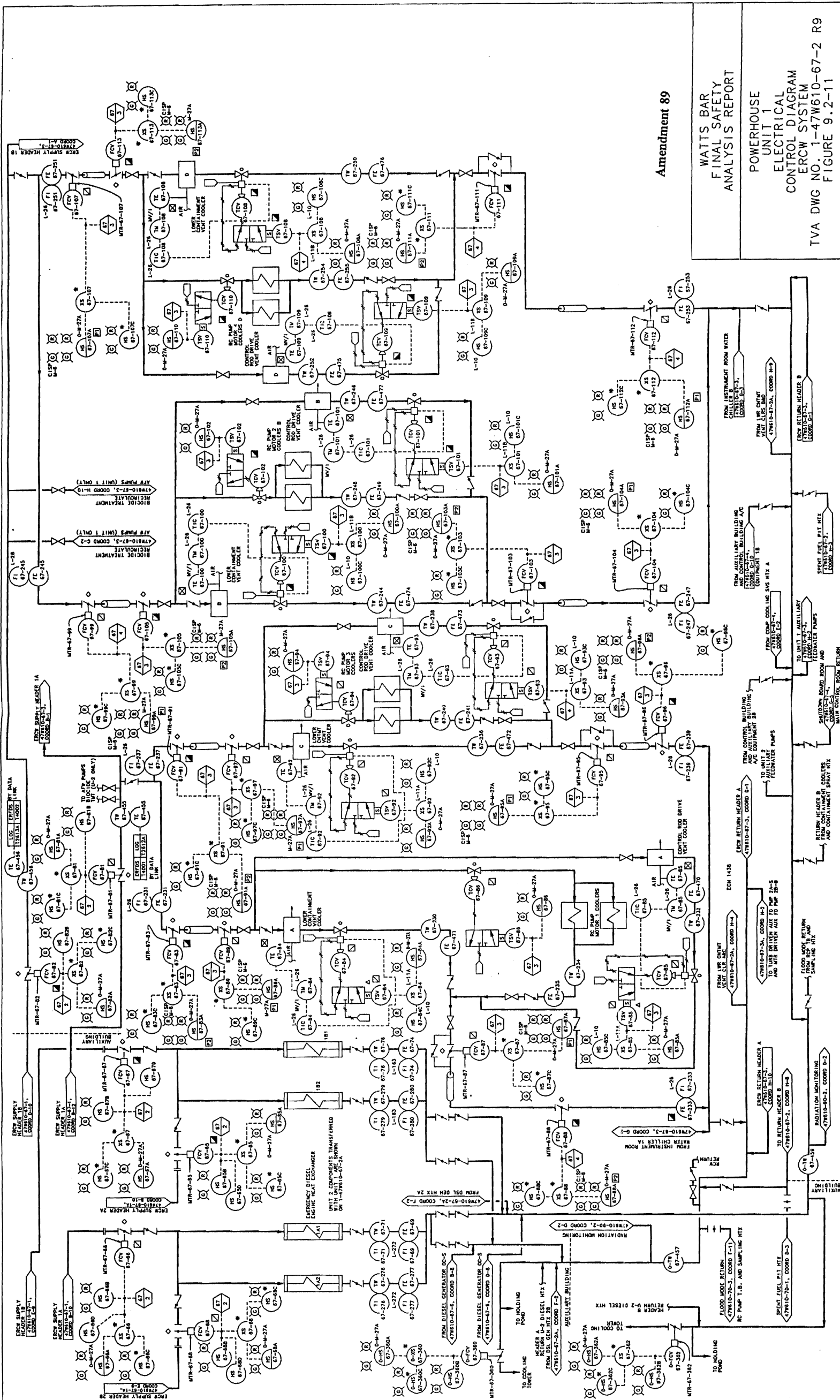

Amendment 89

WATTS BAR  
FINAL SAFETY  
ANALYSIS REPORT

POWERHOUSE  
UNIT 1  
ELECTRICAL  
CONTROL DIAGRAM  
ERCW SYSTEM  
TVA DWG NO. 1-47W610-67-2 R9  
FIGURE 9.2-11

PROCADAM MAINTAINED DRAWING  
THIS DRAWING IS THE PROPERTY OF THE TVA AND IS NOT TO BE REPRODUCED OR TRANSMITTED IN ANY FORM OR BY ANY MEANS, ELECTRONIC OR MECHANICAL, INCLUDING PHOTOCOPYING, RECORDING, OR BY ANY INFORMATION STORAGE AND RETRIEVAL SYSTEM.

Figure 9.2-11 Powerhouse Electrical Control Diagram for Essential Raw Cooling Water System (Unit 1)

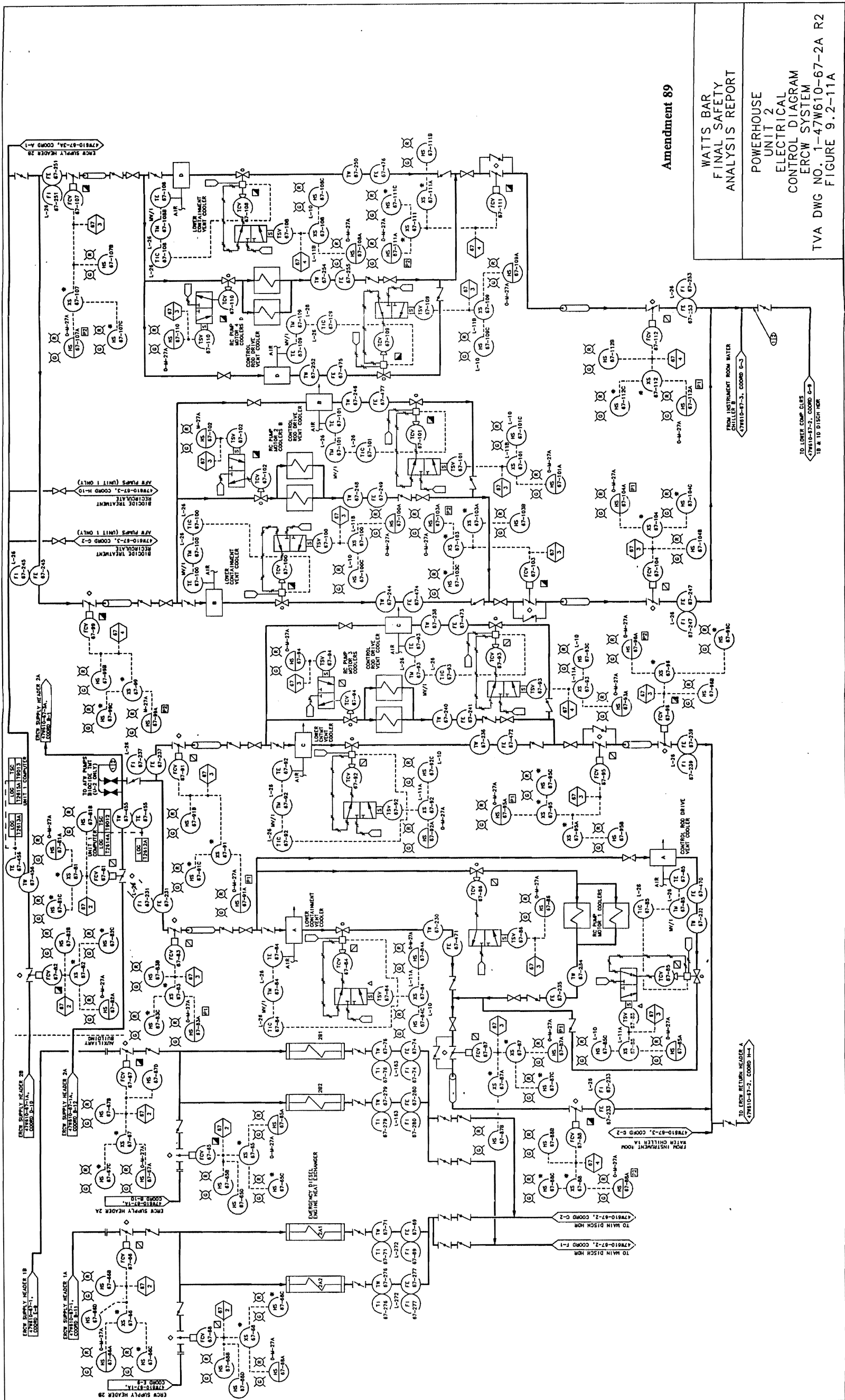

Amendment 89

WATTS BAR  
FINAL SAFETY  
ANALYSIS REPORT  
  
POWERHOUSE  
UNIT 2  
ELECTRICAL  
CONTROL DIAGRAM  
ERCW SYSTEM  
TVA DWG NO. 1-47W610-67-2A R2  
FIGURE 9.2-11A

PROVIDER MAINTAINED DRAWING  
THIS DRAWING IS NOT PART OF THE PROGRAM BIDDING  
AND SHOULD NOT BE USED FOR CONTRACTING PURPOSES

Figure 9.2-11a Powerhouse Electrical Control Diagram for Essential Raw Cooling Water System (Unit 2)

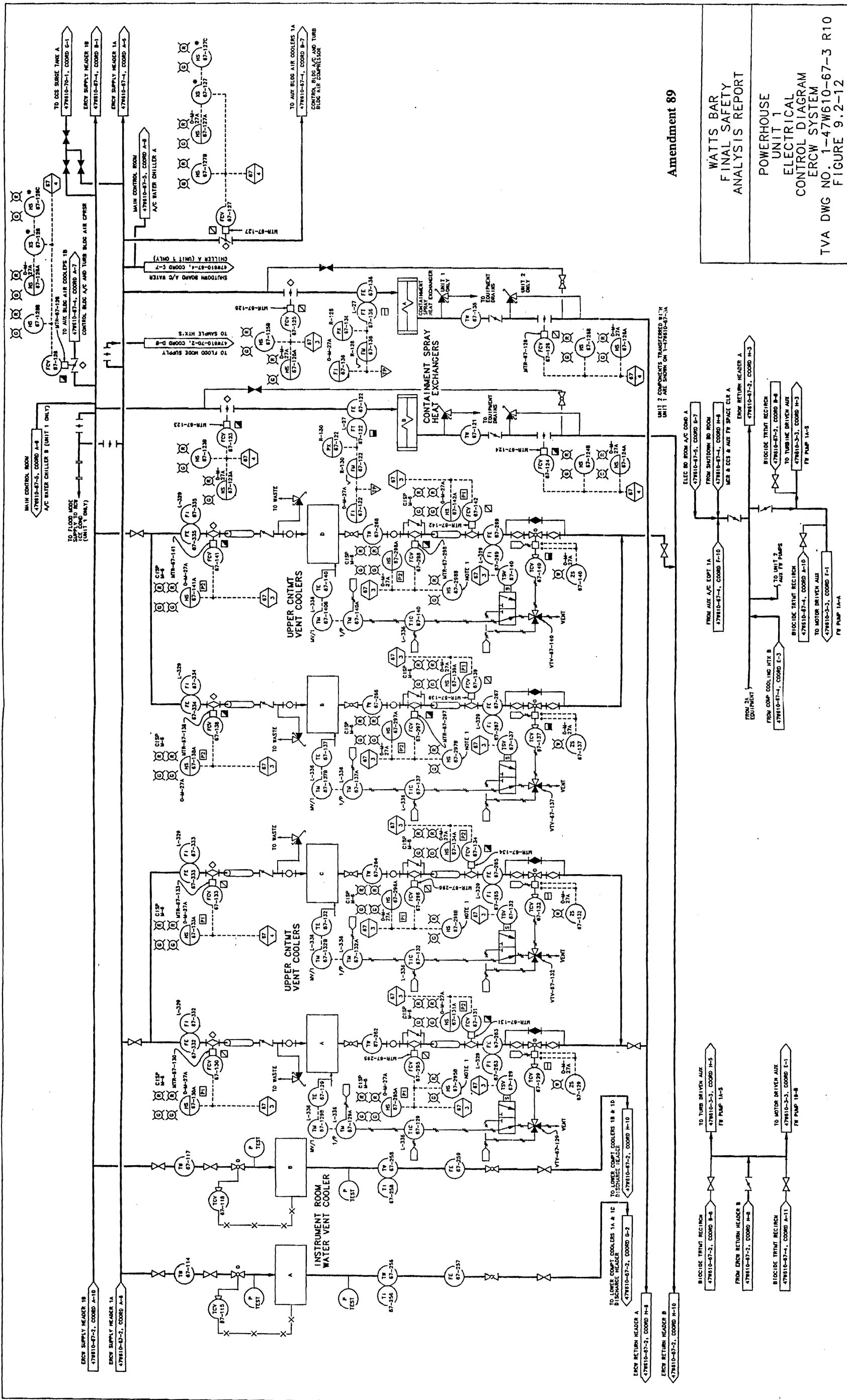

Figure 9.2-12 Electrical Control Diagram for Essential Raw Cooling Water System (Unit 1)

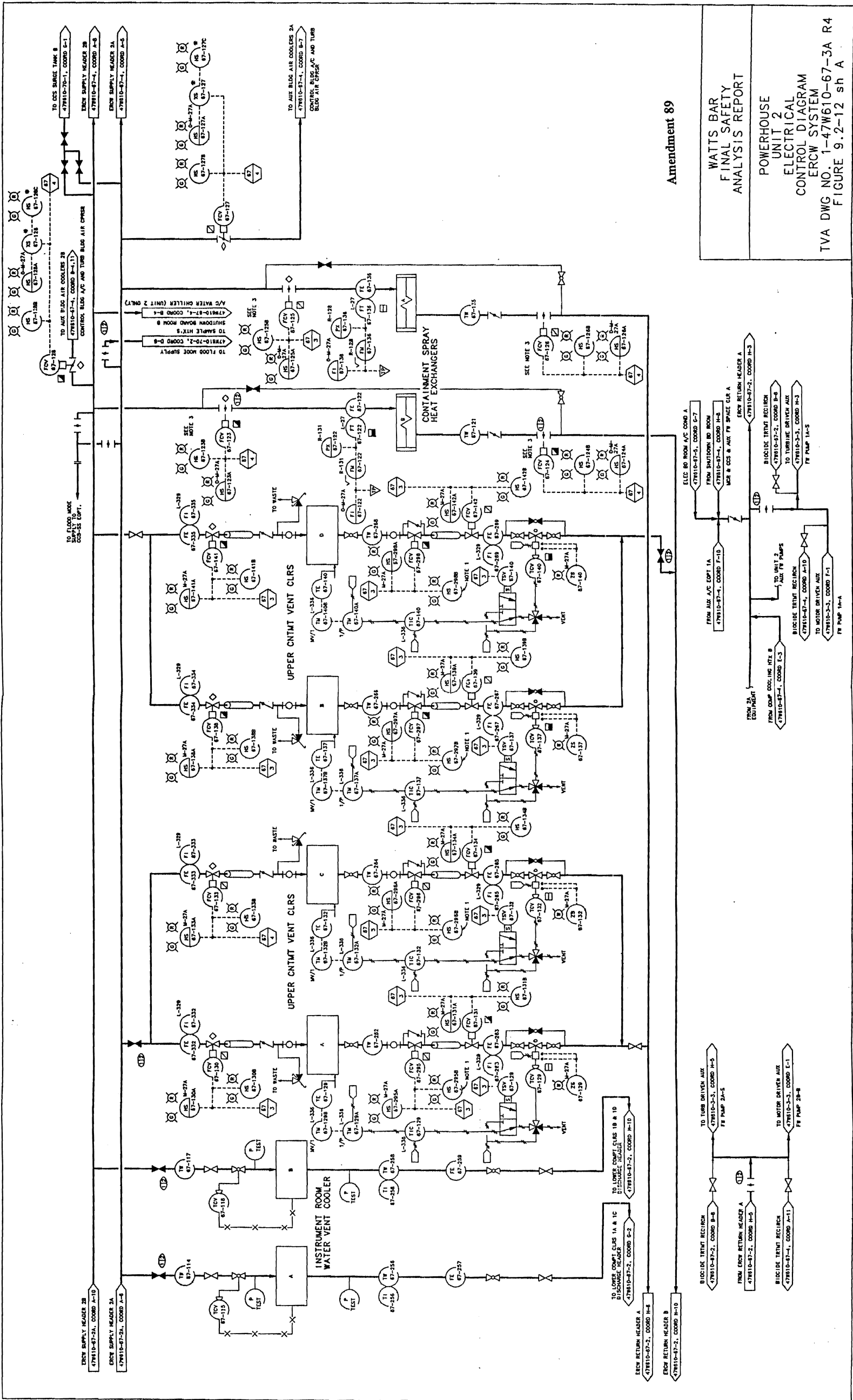

Figure 9.2-12 Electrical Control Diagram for Essential Raw Cooling Water System (Unit 2) (Sheet A)

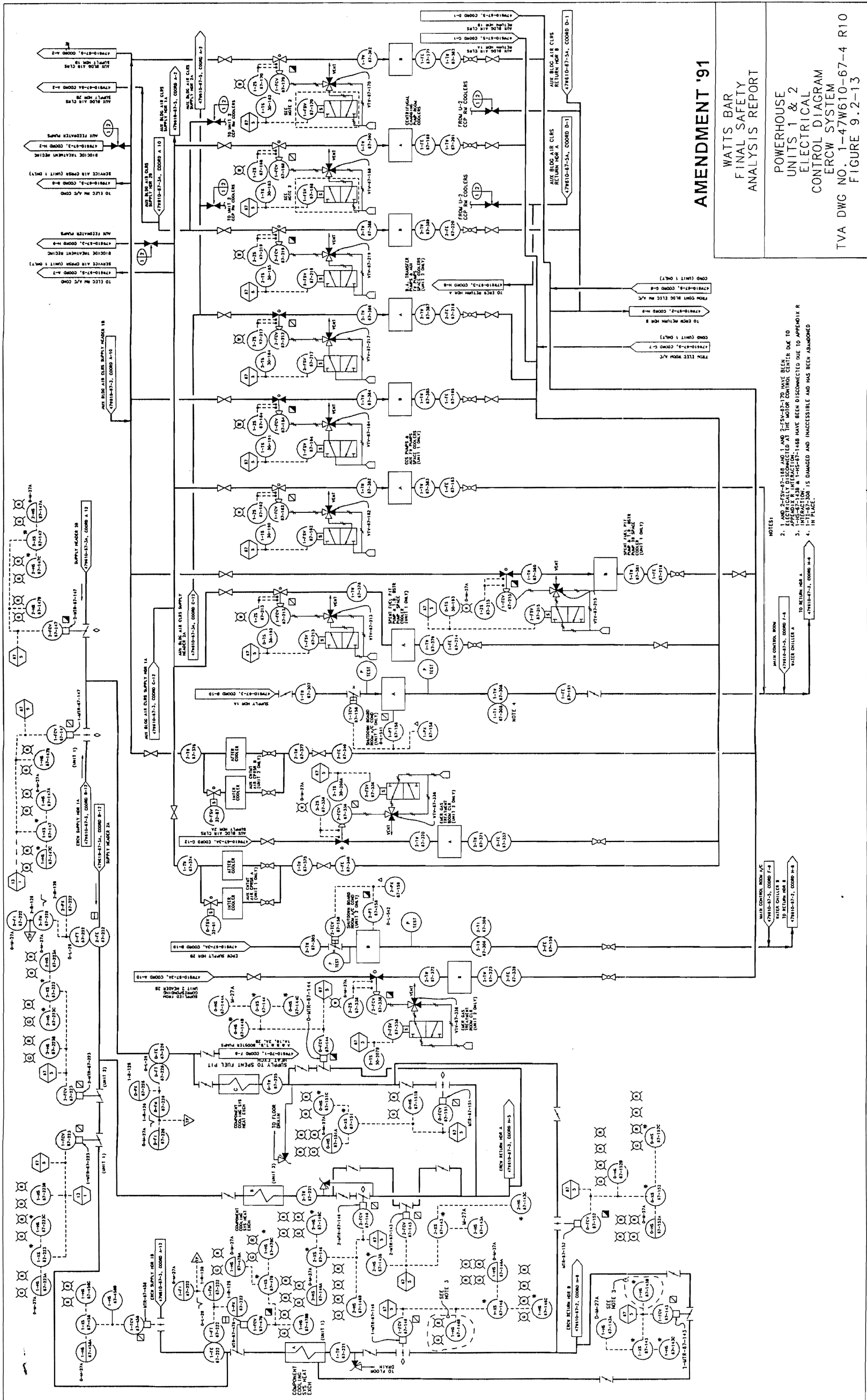
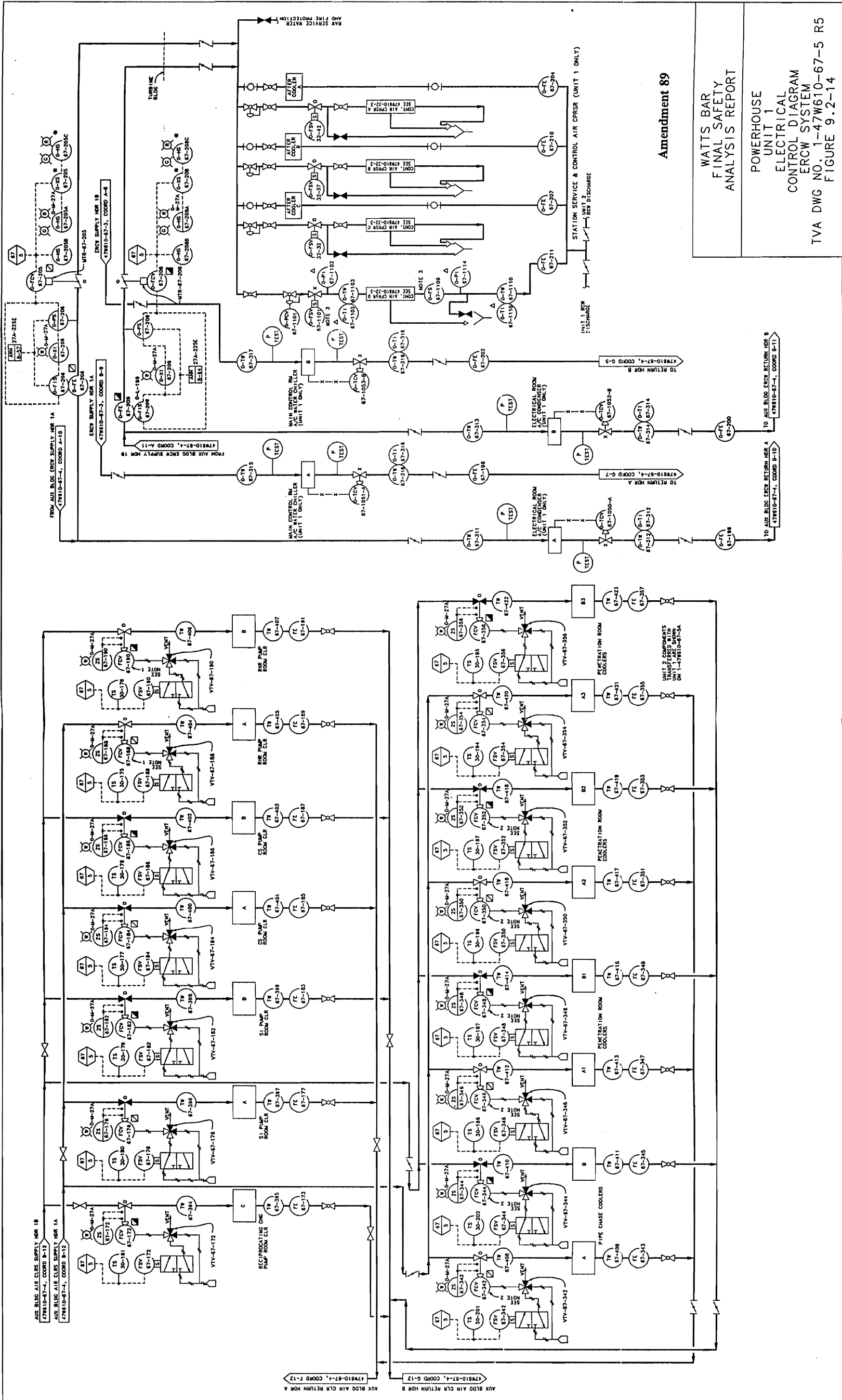

Figure 9.2-13 Powerhouse Electrical Control Diagram for Essential Raw Cooling Water System



Amendment 89

WATTS BAR  
FINAL SAFETY  
ANALYSIS REPORT

POWERHOUSE  
UNIT 1  
ELECTRICAL  
CONTROL DIAGRAM  
ERCW SYSTEM  
TVA DWG NO. 1-47W610-67-5 R5  
FIGURE 9.2-14

PROGRAM MAINTAINED DRAWING  
THIS CONTROL SYSTEM CONTROL DRAWING IS MAINTAINED BY THE  
RAW COOL UNIT AND IS NOT PART OF THE TYPICAL PROCESS DRAWING  
CONVENTION

Figure 9.2-14 Powerhouse Electrical Control Diagram for Essential Raw Cooling Water System (Unit 1)

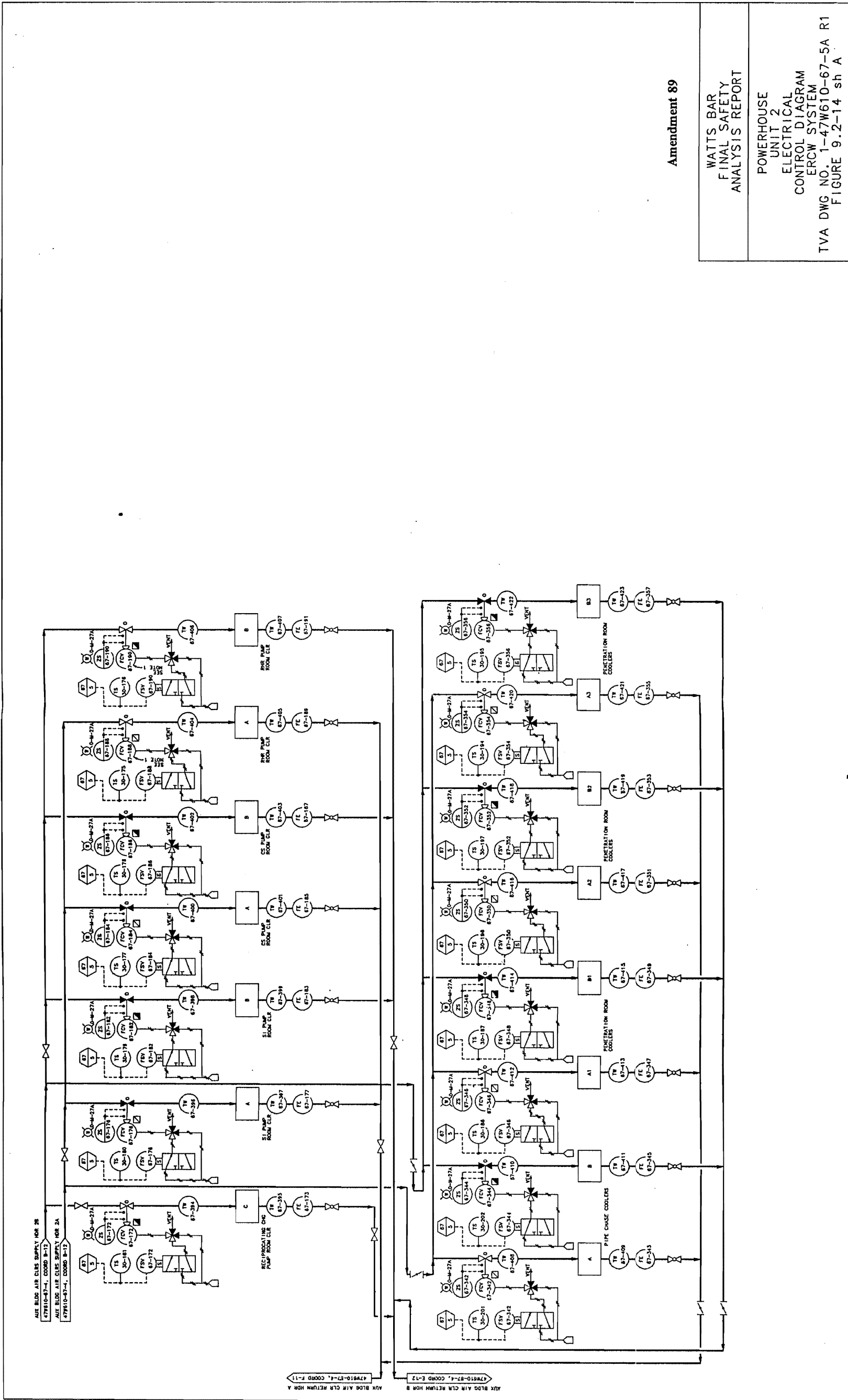

PROCAD MAINTAINED DRAWING  
 THIS DRAWING IS PART OF THE TVA RECORDS AT  
 THE WATTS BAR OFFICE, 2000 WATTS BAR, TENNESSEE  
 37864-0001

Figure 9.2-14a Powerhouse Electrical Control Diagram for Essential Raw Cooling Water System (Unit 2)



**Figure 9.2-15 Deleted by Amendment 87**

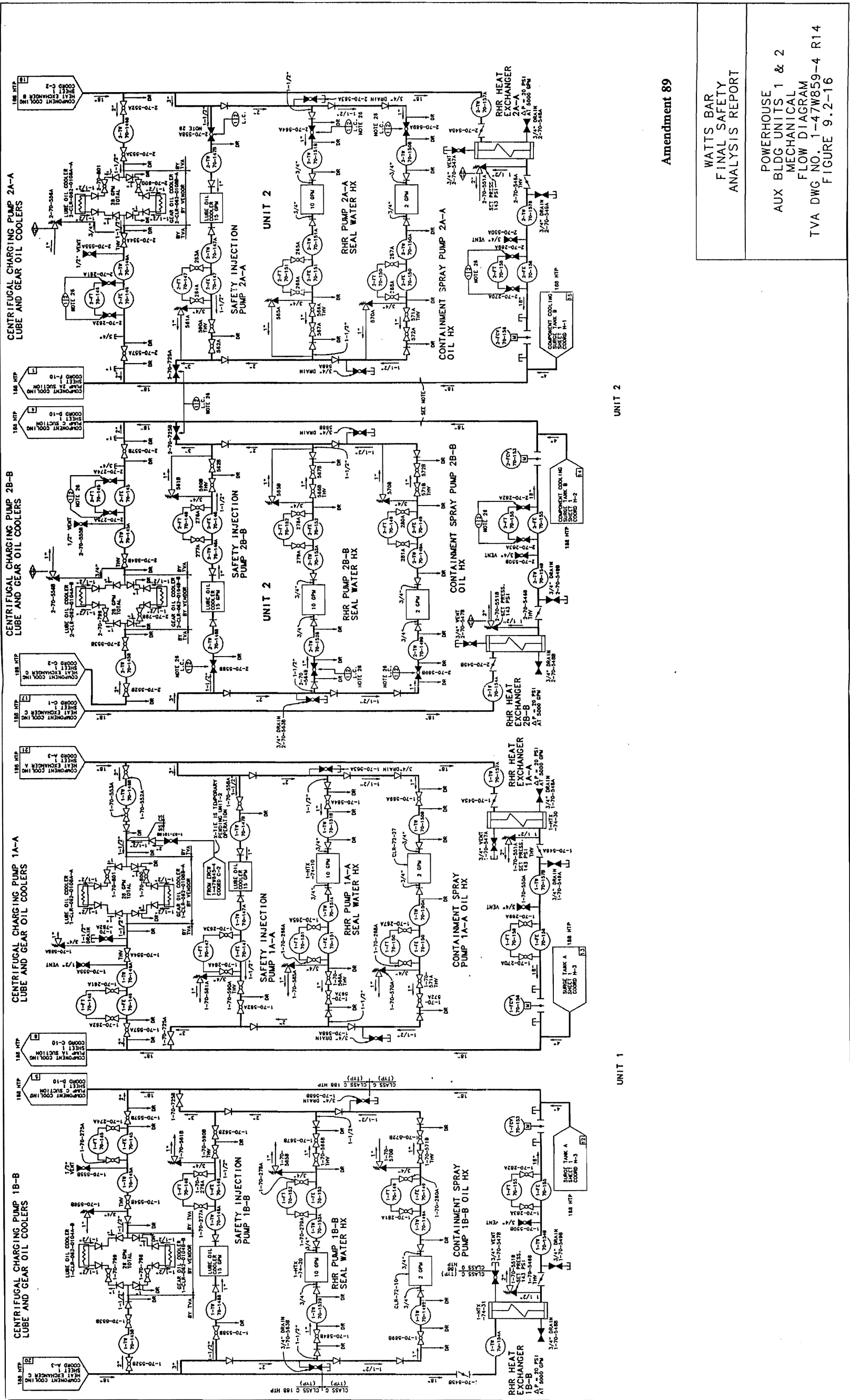
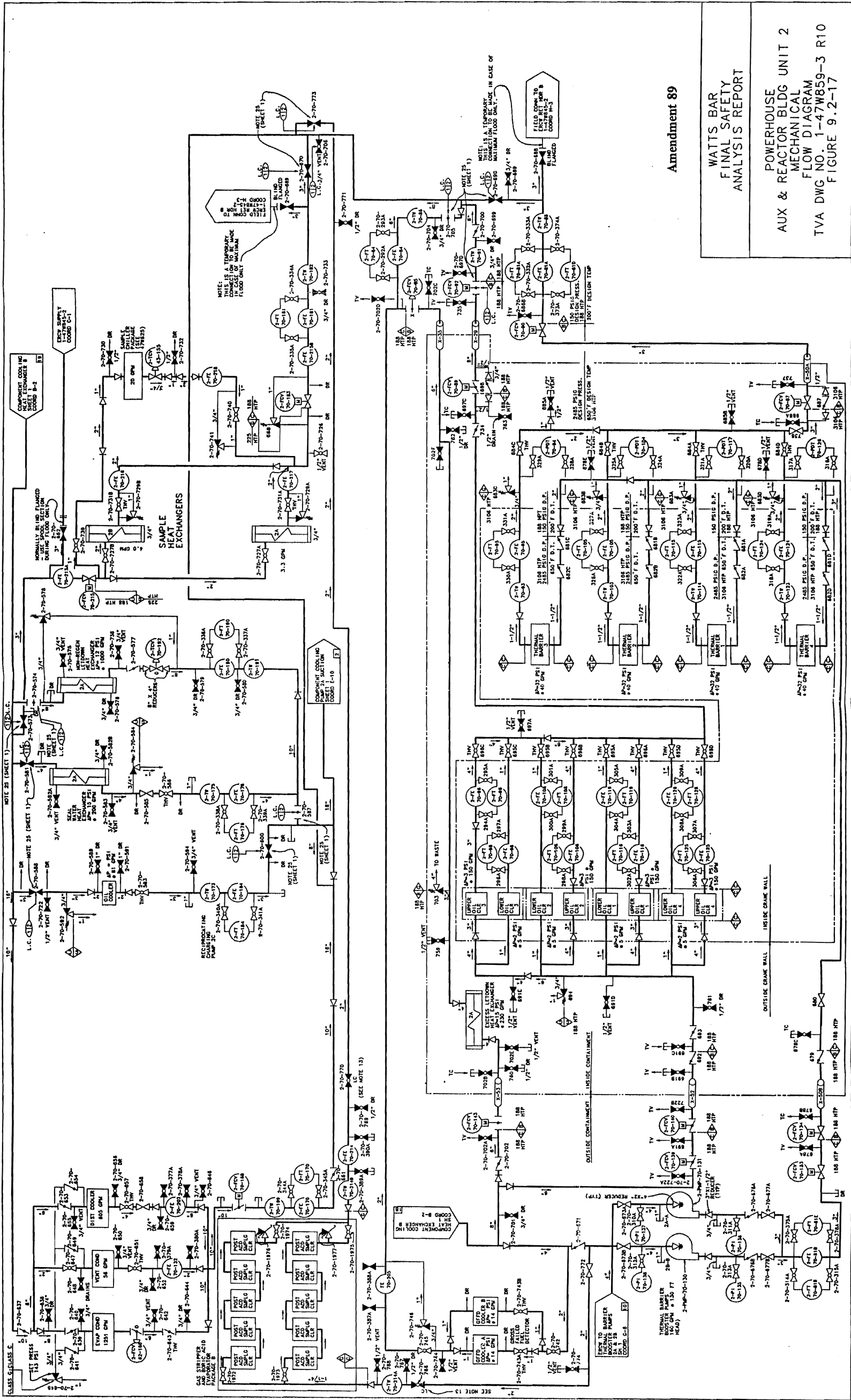

Figure 9.2-16 Powerhouse, Auxiliary Building Flow Diagram for Component Cooling Water System



Amendment 89

WATTS BAR  
FINAL SAFETY  
ANALYSIS REPORT

POWERHOUSE  
AUX & REACTOR BLDG UNIT 2  
MECHANICAL  
FLOW DIAGRAM  
TVA DWG NO. 1-47WB59-3 R10  
FIGURE 9.2-17

PROCADAM MAINTAINED DRAWING  
THIS IS A PART OF THE TYPING RECORD FOR THE  
WORKING DRAWING

Figure 9.2-17 Powerhouse, Auxiliary and Reactor Building Flow Diagram for Component Cooling System (Unit 2)

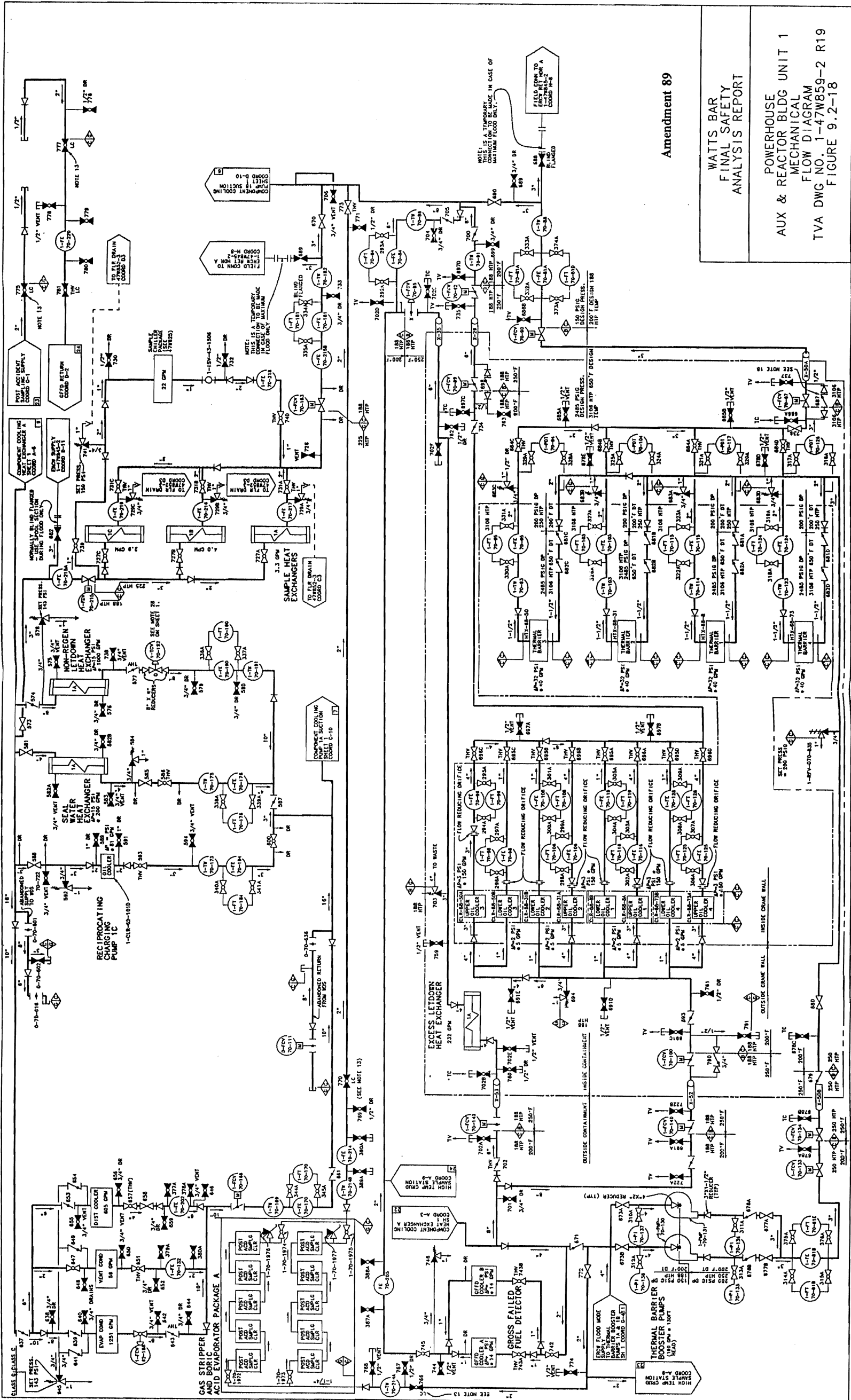
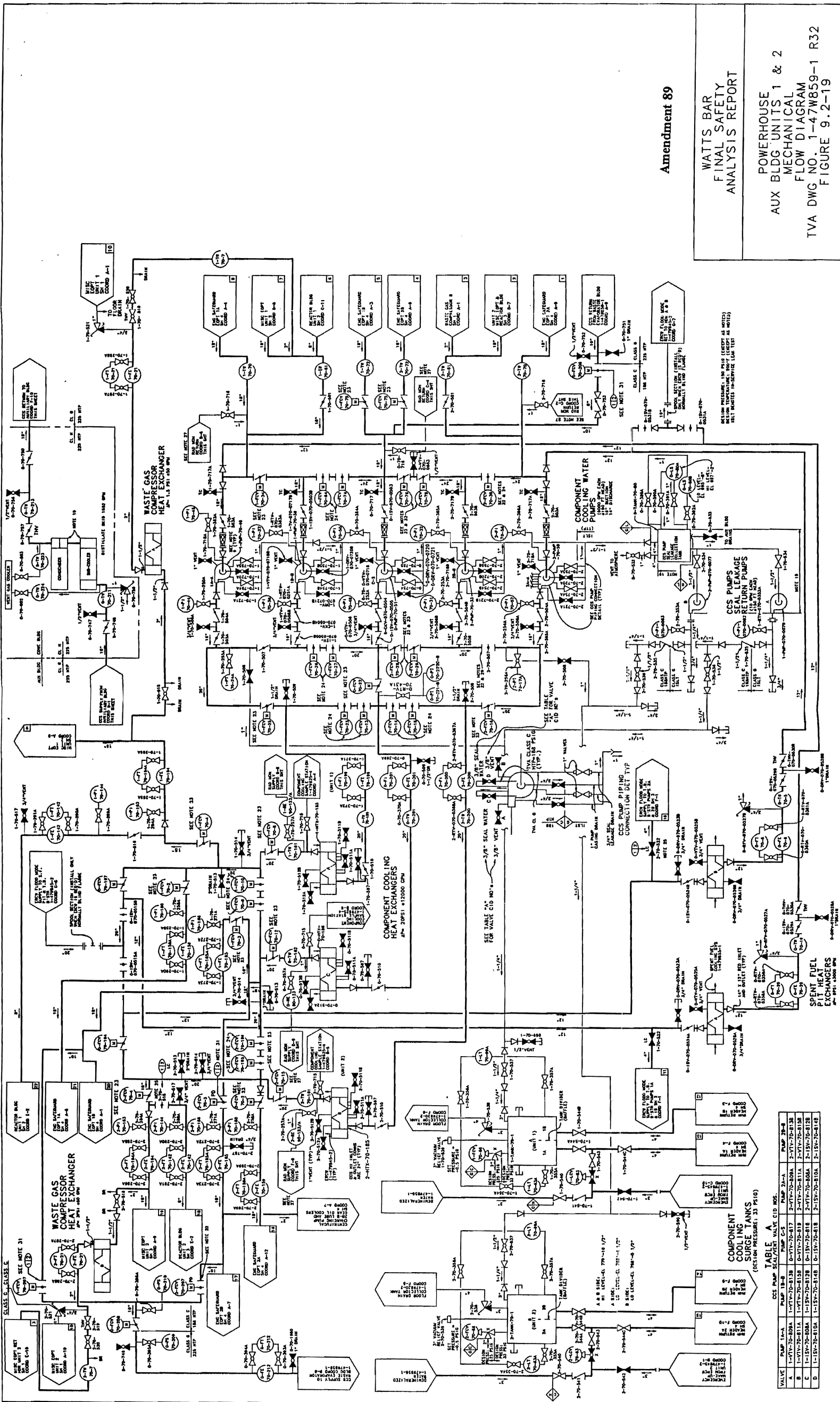

Figure 9.2-18 Powerhouse, Auxiliary and Reactor Building Flow Diagram for Component Cooling System (Unit 1)



Amendment 89

WATTS BAR  
FINAL SAFETY  
ANALYSIS REPORT

POWERHOUSE  
AUX BLDG UNITS 1 & 2  
MECHANICAL  
FLOW DIAGRAM  
TVA DWG NO. 1-47W859-1 R32  
FIGURE 9.2-19

PROCADAM MAINTAINED DRAWING  
DATE: 10/11/88 BY: J. W. HARRIS  
REVISED: 10/11/88 BY: J. W. HARRIS

Figure 9.2-19 Powerhouse, Auxiliary Building Mechanical Flow Diagram (Units 1 and 2)

TABLE A  
VALVE IDENTIFICATION

VALVE	PUMP	CLASS	TYPE	SIZE	LOCATION
A	1-15V-70-B00A	1-15V-70-B00A	1-15V-70-B00A	2-15V-70-B00A	2-15V-70-B00A
B	1-15V-70-B01A	1-15V-70-B01A	1-15V-70-B01A	2-15V-70-B01A	2-15V-70-B01A
C	1-15V-70-B02A	1-15V-70-B02A	1-15V-70-B02A	2-15V-70-B02A	2-15V-70-B02A
D	1-15V-70-B03A	1-15V-70-B03A	1-15V-70-B03A	2-15V-70-B03A	2-15V-70-B03A

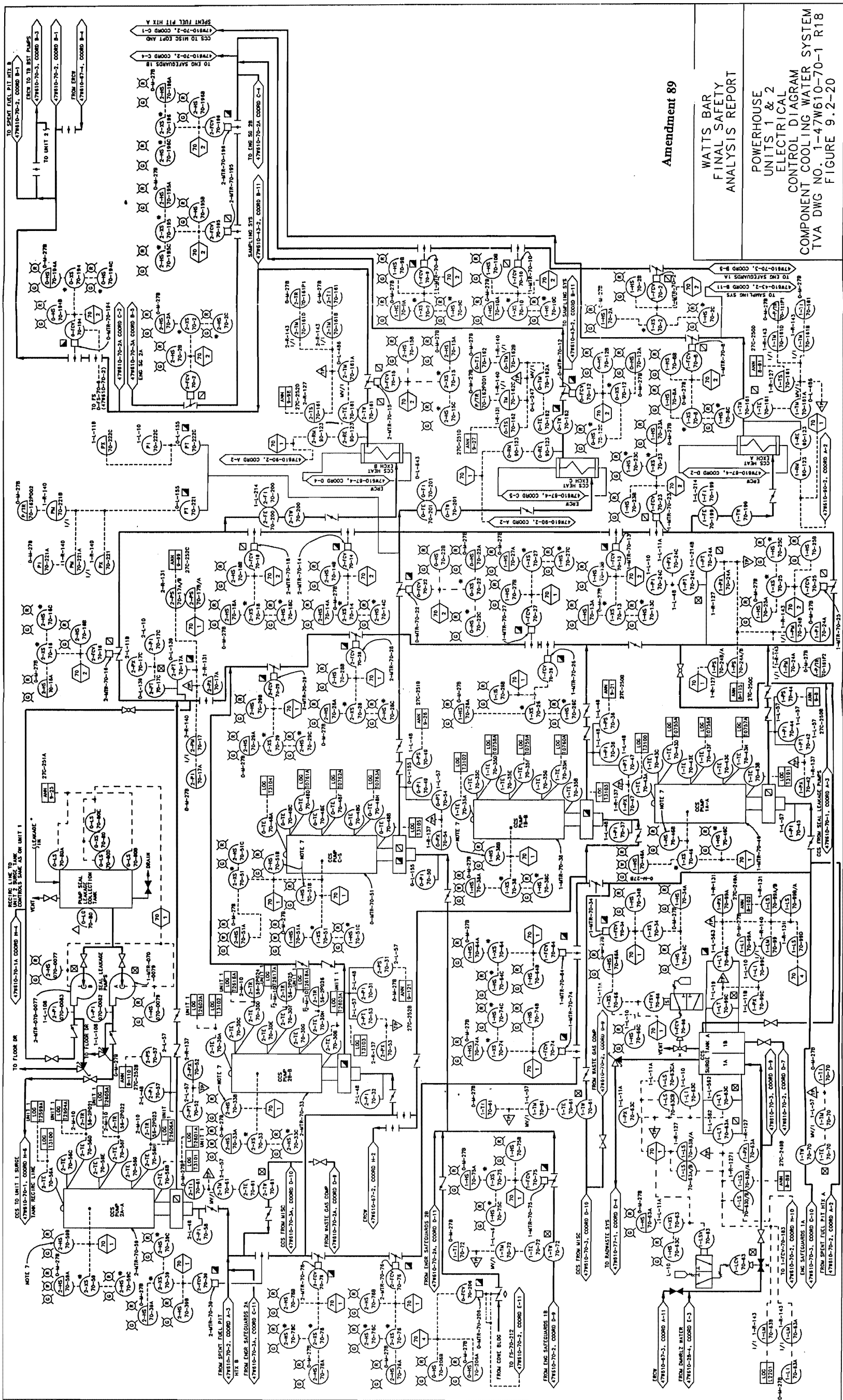

Amendment 89

WATTS BAR  
 FINAL SAFETY  
 ANALYSIS REPORT

POWERHOUSE  
 UNITS 1 & 2  
 ELECTRICAL  
 CONTROL DIAGRAM  
 COMPONENT COOLING WATER SYSTEM  
 TVA DWG NO. 1-47W610-70-1 R18  
 FIGURE 9.2-20

PROGRAM MAINTAINED DRAWING  
 THIS DRAWING IS NOT PART OF THE PROVISIONAL DESIGN  
 CONTRACT DOCUMENTS AND IS NOT TO BE USED FOR CONSTRUCTION

Figure 9.2-20 Powerhouse Electrical Control Diagram for Component Cooling Water System

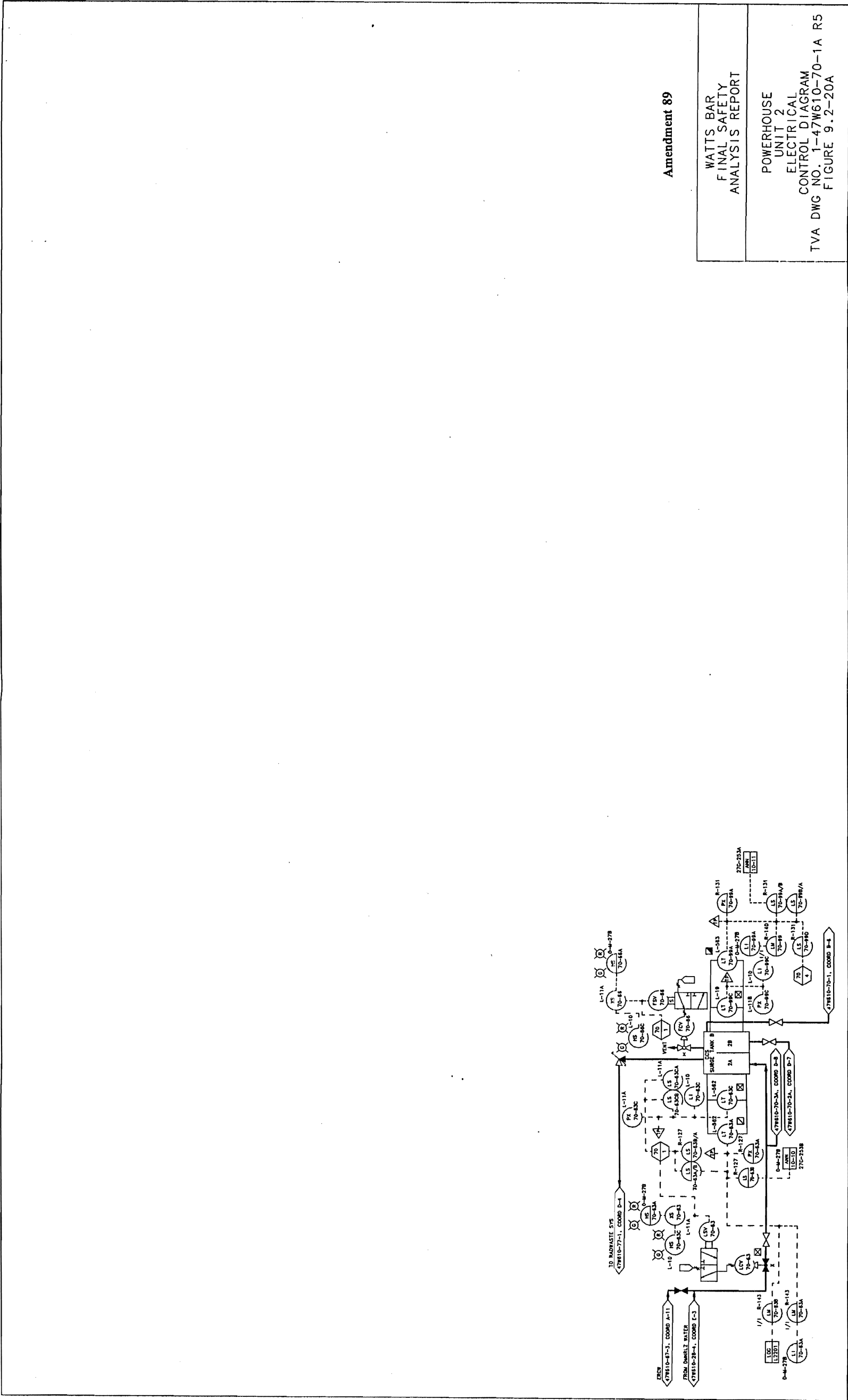

Amendment 89

WATTS BAR  
FINAL SAFETY  
ANALYSIS REPORT

POWERHOUSE  
UNIT 2  
ELECTRICAL  
CONTROL DIAGRAM  
TVA DWG NO. 1-47W610-70-1A R5  
FIGURE 9.2-20A

PROCADAM MAINTAINED DRAWINGS  
THIS DRAWING IS THE PROPERTY OF THE U.S. NUCLEAR REGULATORY COMMISSION  
AND IS LOANED TO YOU BY THE U.S. NUCLEAR REGULATORY COMMISSION  
IT IS TO BE RETURNED TO THE U.S. NUCLEAR REGULATORY COMMISSION  
UPON COMPLETION OF YOUR WORK

Figure 9.2-20a Powerhouse Unit 2 Electrical Control Diagram

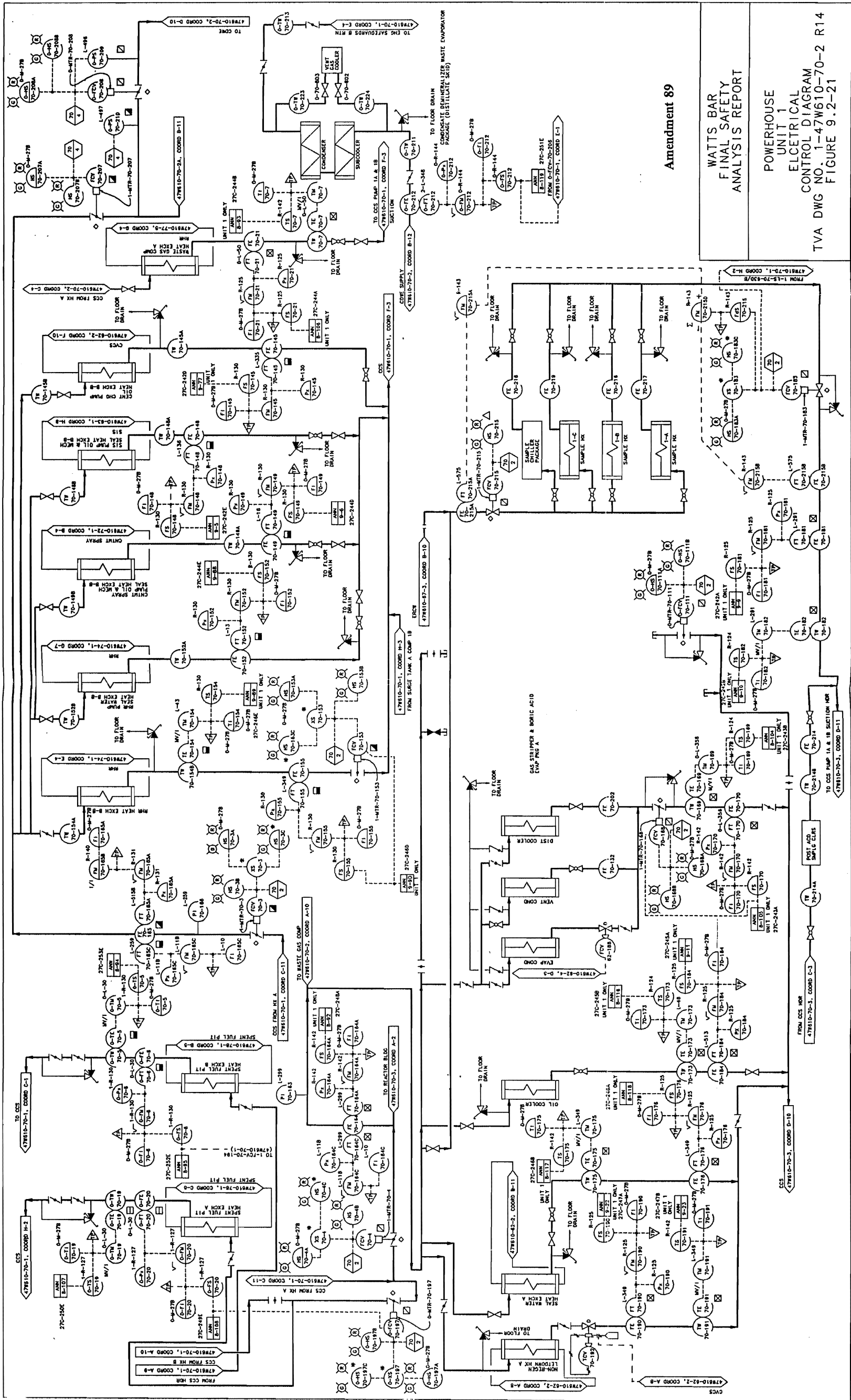

Figure 9.2-21 Powerhouse Electrical Control Diagram for Component Cooling Water System (Unit 1)



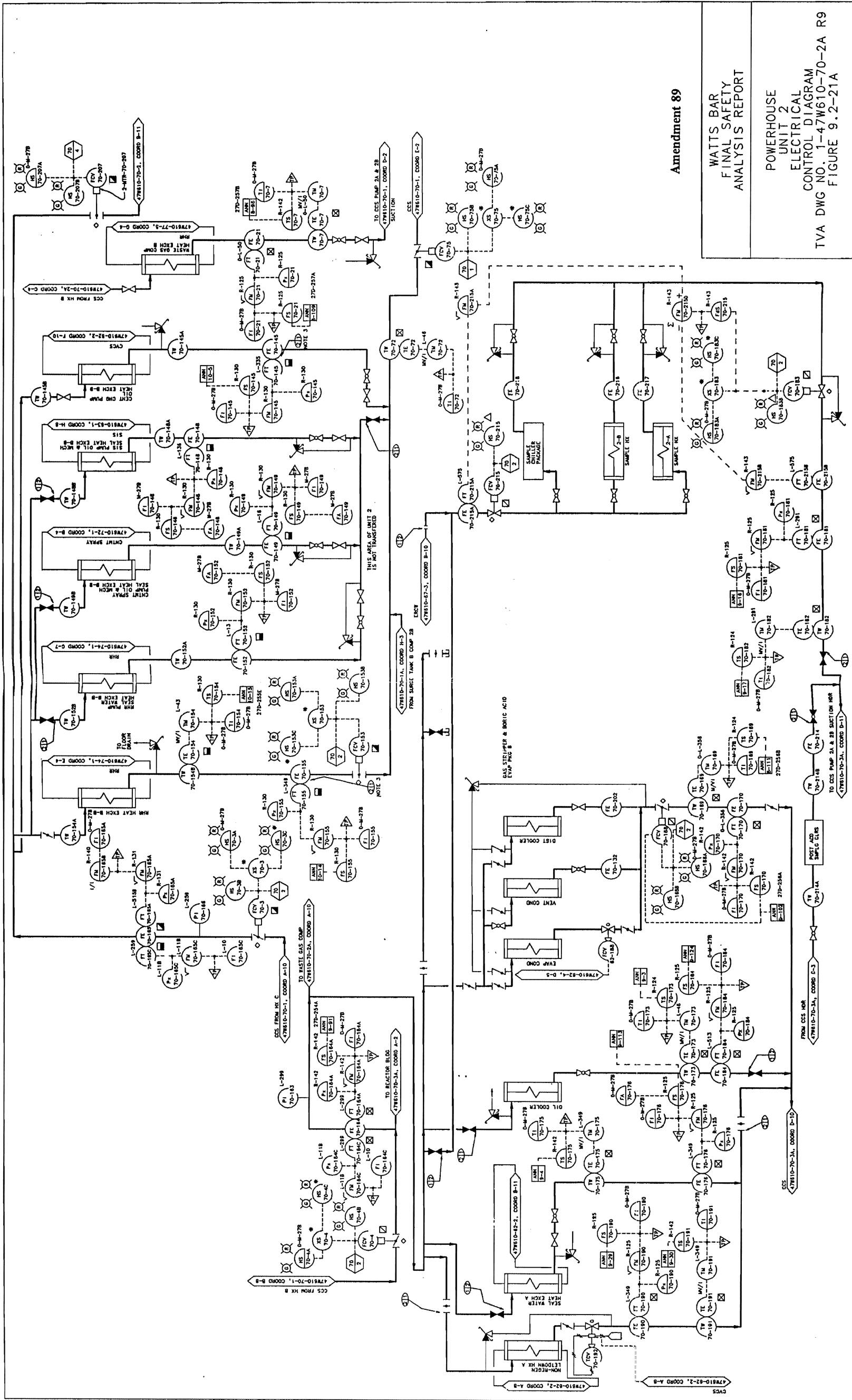
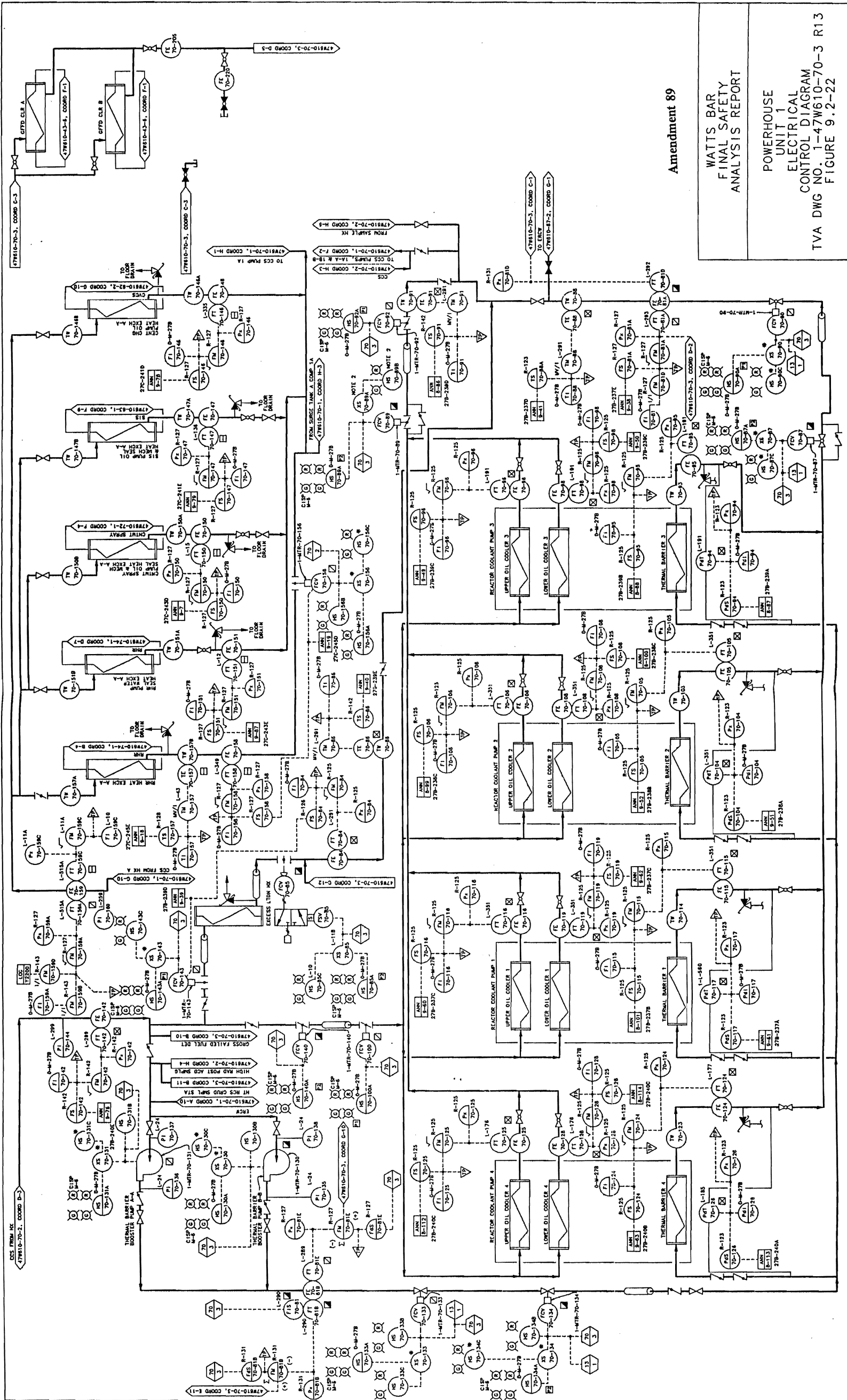

Figure 9.2-21a Powerhouse Unit 2 Electrical Control Diagram



Amendment 89

WATTS BAR  
FINAL SAFETY  
ANALYSIS REPORT

POWERHOUSE  
UNIT 1  
ELECTRICAL  
CONTROL DIAGRAM  
TVA DWG NO. 1-47W610-70-3 R13  
FIGURE 9.2-22

PROGRAM MAINTAINED DRAWING  
THIS COMPANION CONTROL DRAWING IS MAINTAINED BY THE  
DRAWING NUMBER AND THE PROJECT NUMBER.

Figure 9.2-22 Powerhouse Unit 1 Electrical Control Diagram

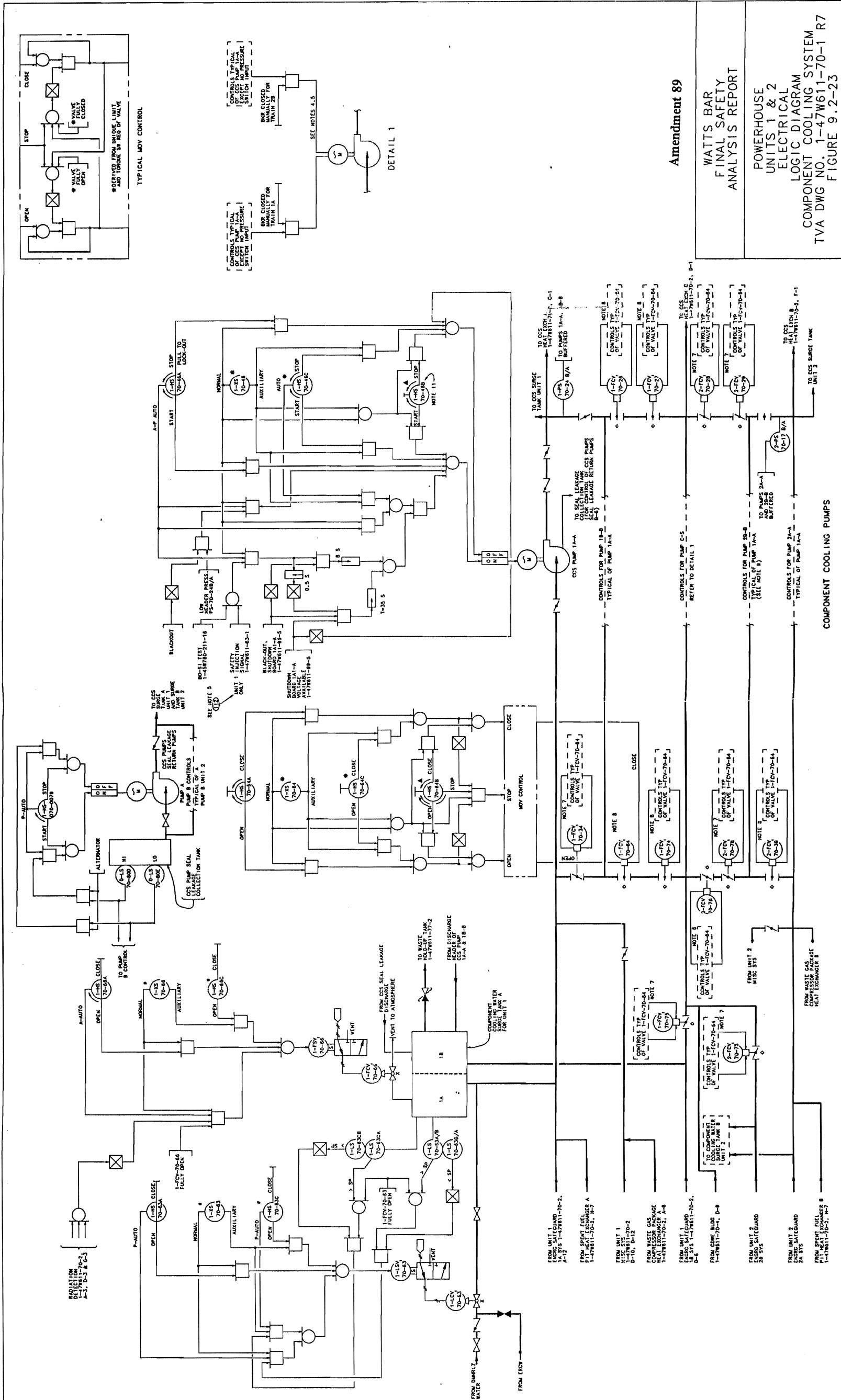

Amendment 89

WATTS BAR  
FINAL SAFETY  
ANALYSIS REPORT

POWERHOUSE  
UNITS 1 & 2  
ELECTRICAL  
LOGIC DIAGRAM  
COMPONENT COOLING SYSTEM  
TVA DWG NO. 1-47W611-70-1 R7  
FIGURE 9.2-23

PROCADAM MAINTAINED DRAWING  
THIS DRAWING IS THE PROPERTY OF THE TVA AND IS NOT TO BE REPRODUCED OR TRANSMITTED IN ANY FORM OR BY ANY MEANS, ELECTRONIC OR MECHANICAL, INCLUDING PHOTOCOPYING, RECORDING, OR BY ANY INFORMATION STORAGE AND RETRIEVAL SYSTEM.

Figure 9.2-22a Powerhouse Unit 2 Electrical Control Diagram

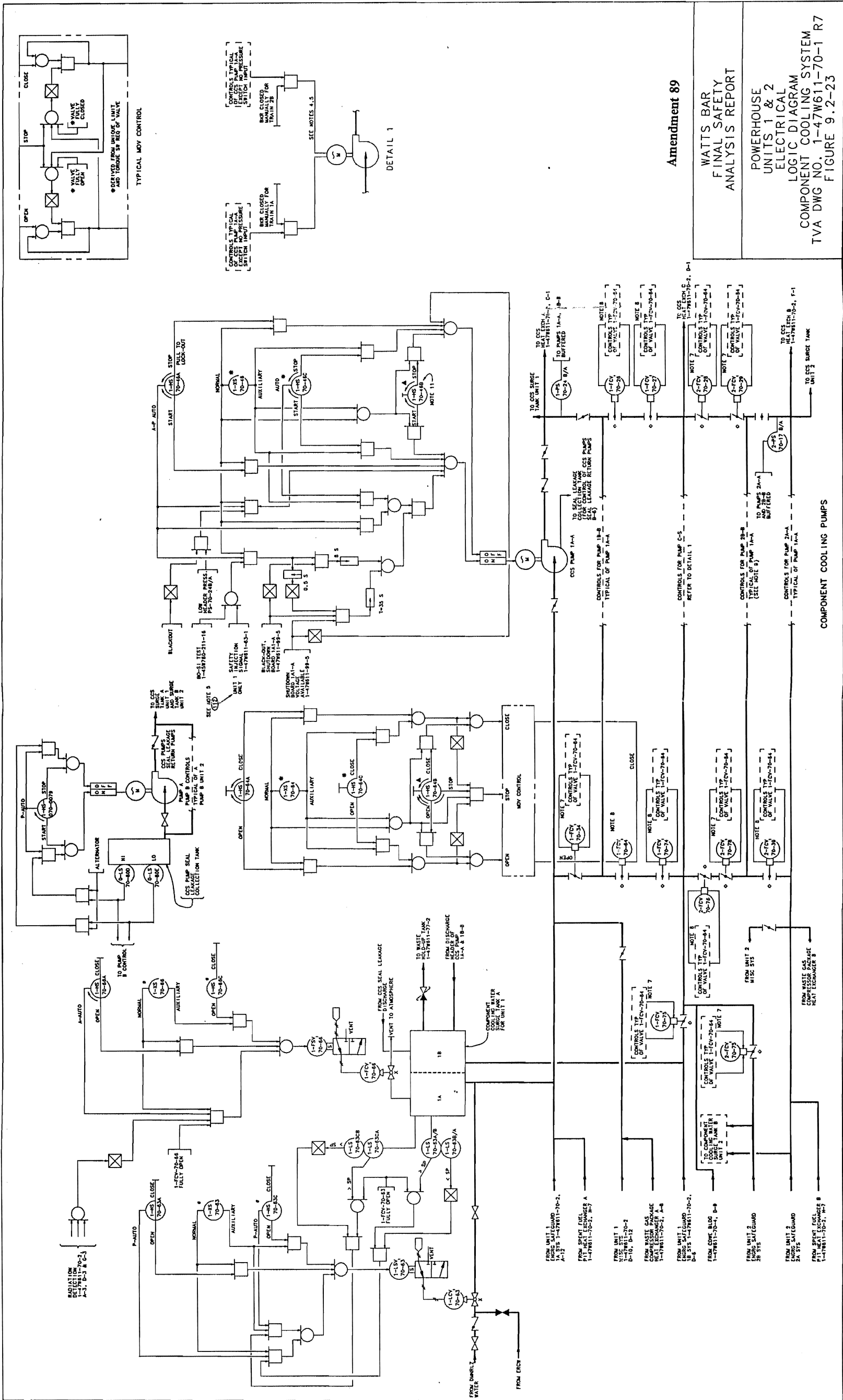

Figure 9.2-23 Powerhouse Units 1 & 2 Electrical Logic Diagram for Component Cooling System

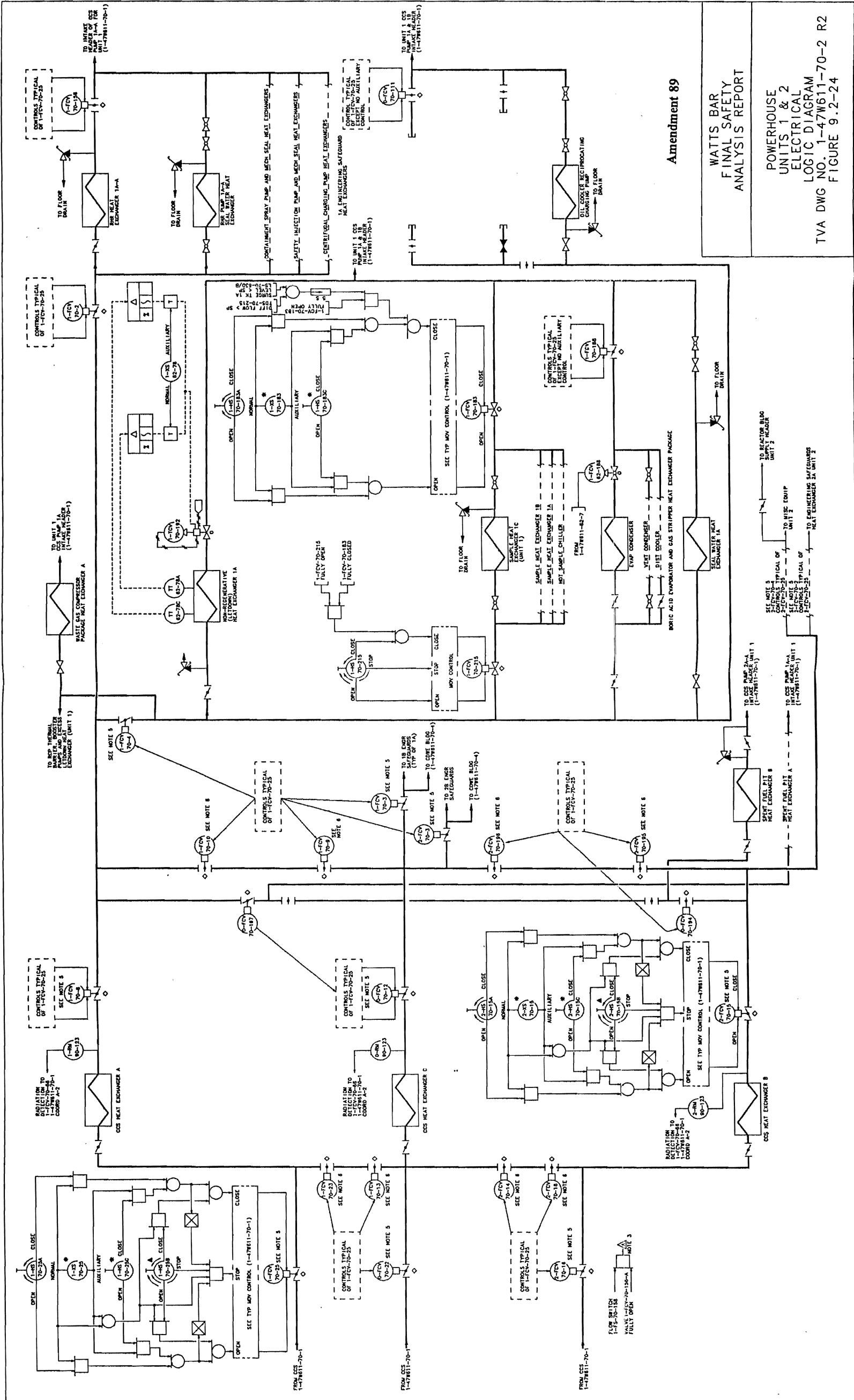
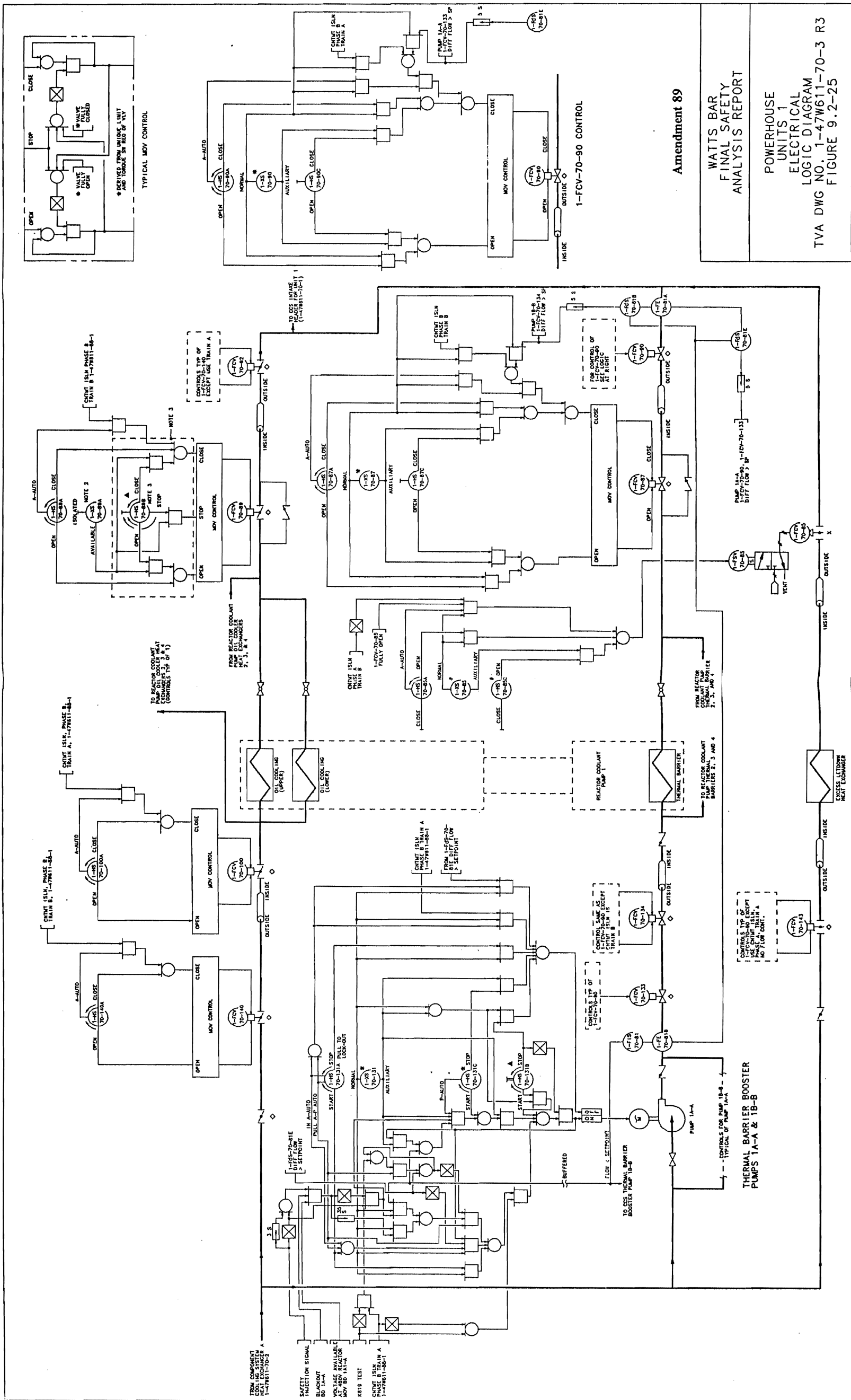

Figure 9.2-24 Powerhouse Units 1 & 2 Electrical Logic Diagram for Component Cooling Water System



Amendment 89

WATTS BAR  
FINAL SAFETY  
ANALYSIS REPORT

POWERHOUSE  
UNITS 1  
ELECTRICAL  
LOGIC DIAGRAM  
TVA DWG NO. 1-47W611-70-3 R3  
FIGURE 9.2-25

PROCADAM MAINTAINED DRAWING  
THIS DRAWING IS THE PROPERTY OF THE U.S. NUCLEAR REGULATORY COMMISSION  
IT IS LOANED TO YOU BY THE U.S. NUCLEAR REGULATORY COMMISSION  
IT IS NOT TO BE REPRODUCED OR TRANSMITTED IN ANY FORM OR BY ANY MEANS  
ELECTRONIC OR MECHANICAL, INCLUDING PHOTOCOPYING, RECORDING, OR BY ANY INFORMATION STORAGE AND RETRIEVAL SYSTEM

Figure 9.2-25 Powerhouse Unit 1 Electrical Logic Diagram

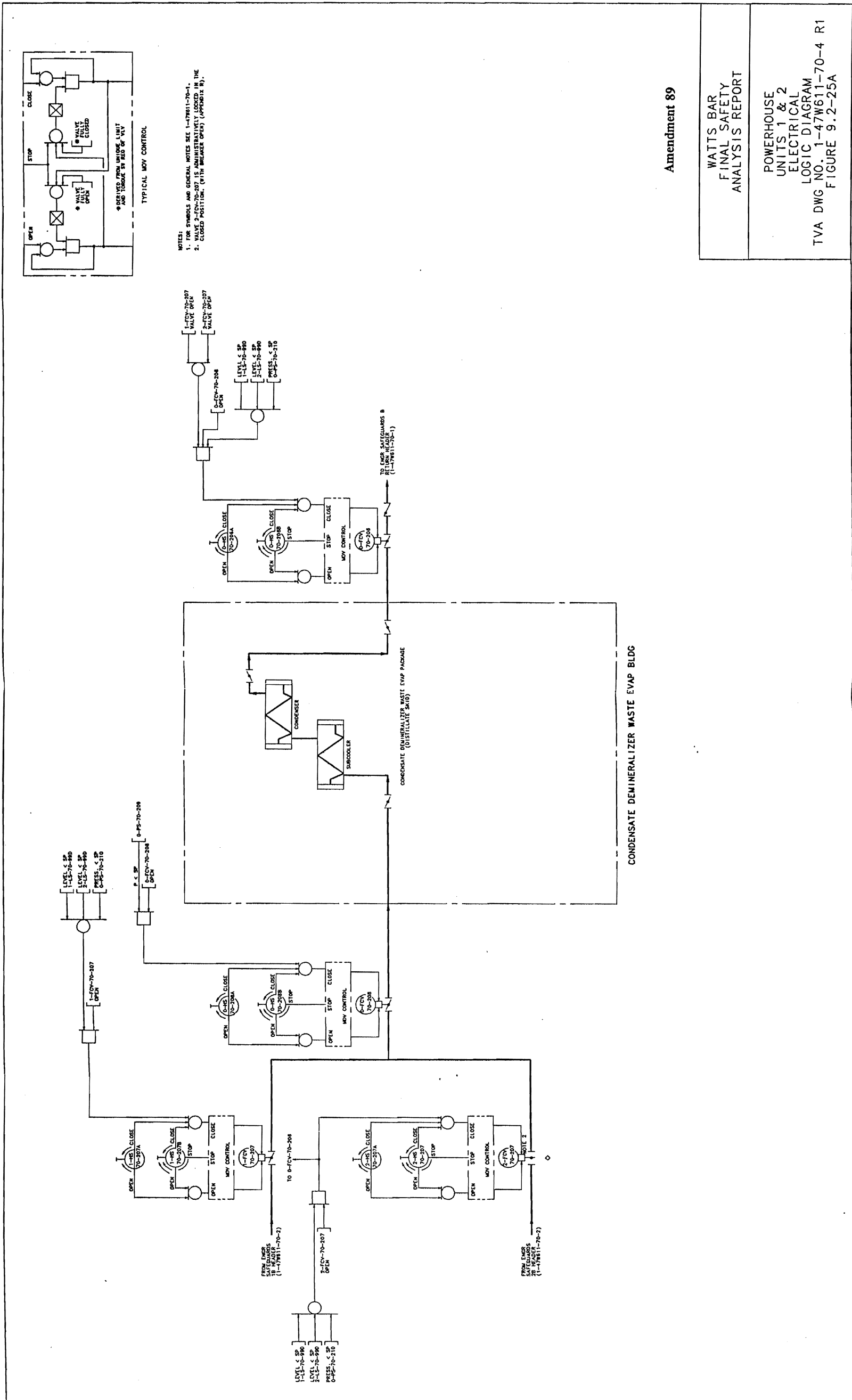

PROGRAM MAINTAINED BY THE  
CONTROL SYSTEMS GROUP AT THE  
TVA. THIS DOCUMENT IS THE PROPERTY OF THE  
TVA AND IS NOT TO BE REPRODUCED OR  
TRANSMITTED IN ANY FORM OR BY ANY  
MEANS, ELECTRONIC OR MECHANICAL,  
INCLUDING PHOTOCOPYING, RECORDING,  
OR BY ANY INFORMATION STORAGE  
RETRIEVAL SYSTEM.

Figure 9.2-25a Powerhouse Units 1 & 2 Electrical Logic Diagram for Component Cooling System

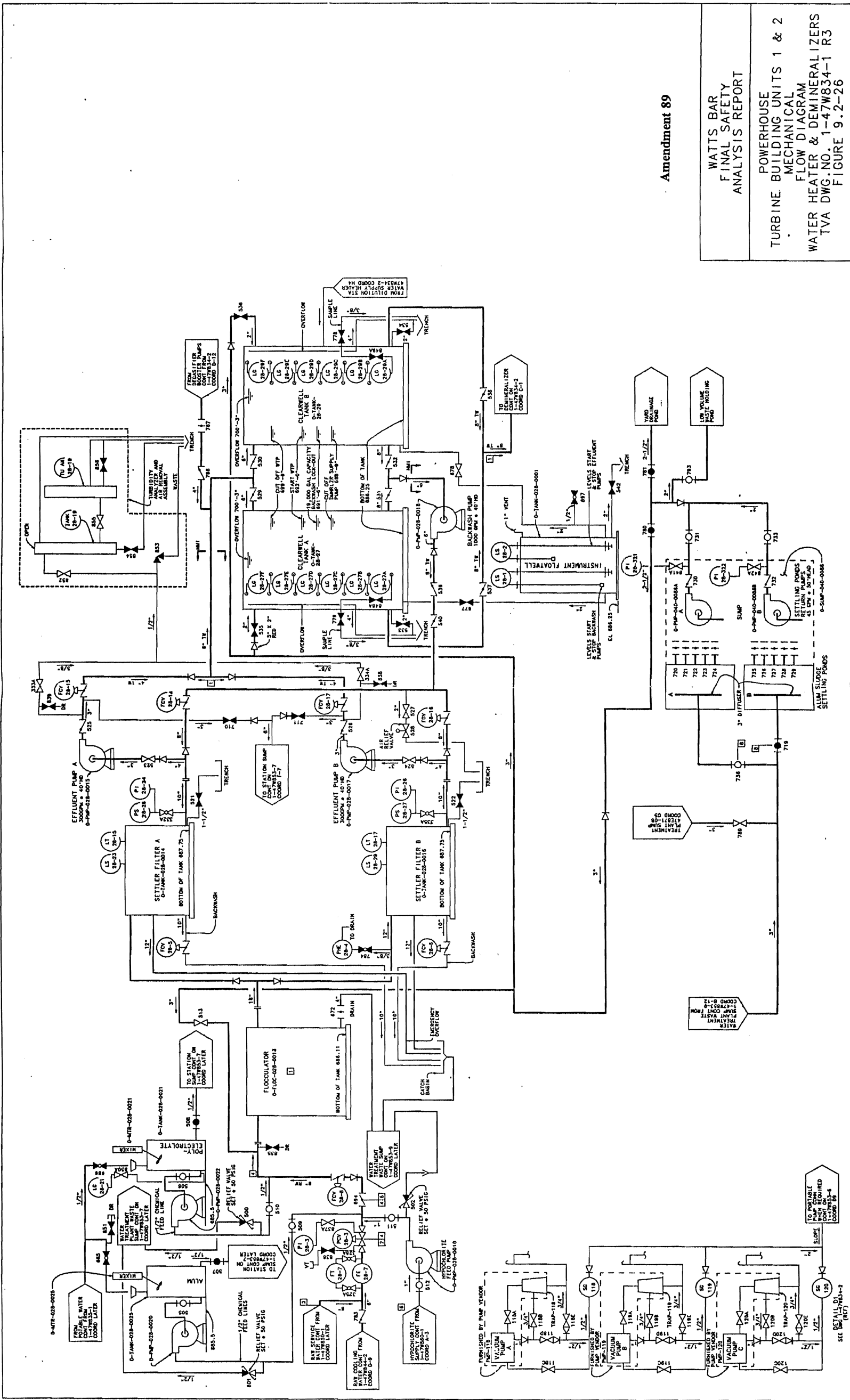

Amendment 89

WATTS BAR  
FINAL SAFETY  
ANALYSIS REPORT

POWERHOUSE  
BUILDING UNITS 1 & 2  
MECHANICAL  
FLOW DIAGRAM  
WATER HEATER & DEMINERALIZERS  
TVA DWG. NO. 1-47W834-1 R3  
FIGURE 9.2-26

PROCADAM MAINTAINED DRAWING  
THIS DRAWING IS THE PROPERTY OF THE TVA  
ENGINEERING CENTER

Figure 9.2-26 Powerhouse, Turbine Building Units 1 & 2 Mechanical Flow Diagram Water Heater and Demineralizers



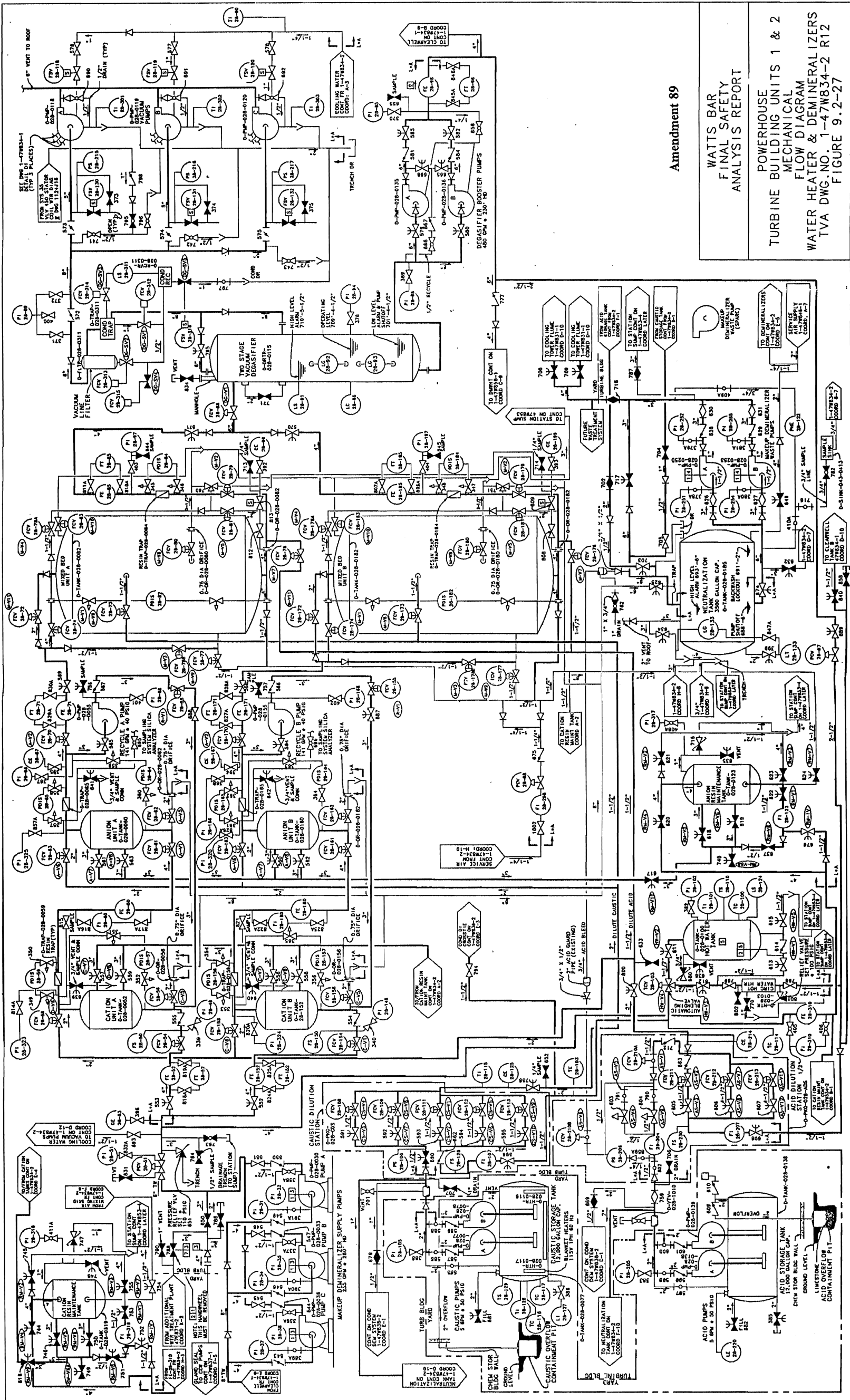

Amendment 89

WATTS BAR  
FINAL SAFETY  
ANALYSIS REPORT

POWERHOUSE  
BUILDING UNITS 1 & 2  
MECHANICAL  
FLOW DIAGRAM  
WATER HEATER & DEMINERALIZERS  
TVA DWG. NO. 1-47W834-2 R12  
FIGURE 9.2-27

PROCADAM MAINTAINED DRAWING  
DATE: 05/11/00  
BY: [REDACTED]  
CHECKED BY: [REDACTED]  
APPROVED BY: [REDACTED]

Figure 9.2-27 Powerhouse, Turbine Building Units 1 & 2 Mechanical-Flow Diagram for Makeup Water Treatment and Demineralizers

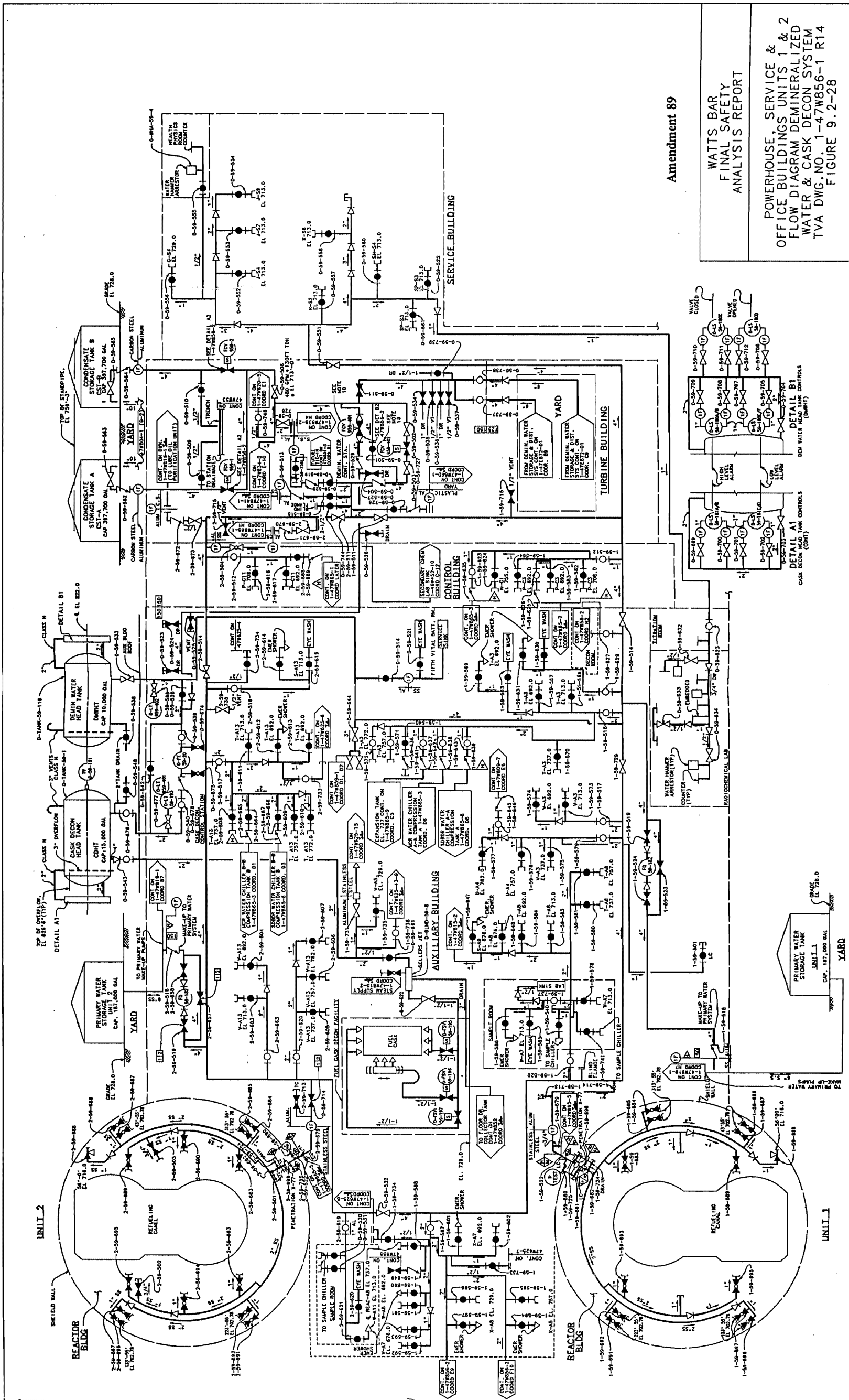

Amendment 89

WATTS BAR  
FINAL SAFETY  
ANALYSIS REPORT

POWERHOUSE, SERVICE &  
OFFICE BUILDINGS UNITS 1 & 2  
FLOW DIAGRAM DEMINERALIZED  
WATER & CASK DECON SYSTEM  
TVA DWG. NO. 1-47W856-1 R14  
FIGURE 9.2-28

PROCEDURAL MAINTAINED DRAWING  
THIS CAP UNIT WAS A PART OF THE 1st PROVISIONAL SAFETY  
ANALYSIS REPORT

Figure 9.2-28 Powerhouse, Service & Office Buildings Units 1 & 2 Flow Diagram for Demineralized Water and Cask Decon System

**Figure 9.2-29 Deleted by Amendment 62**

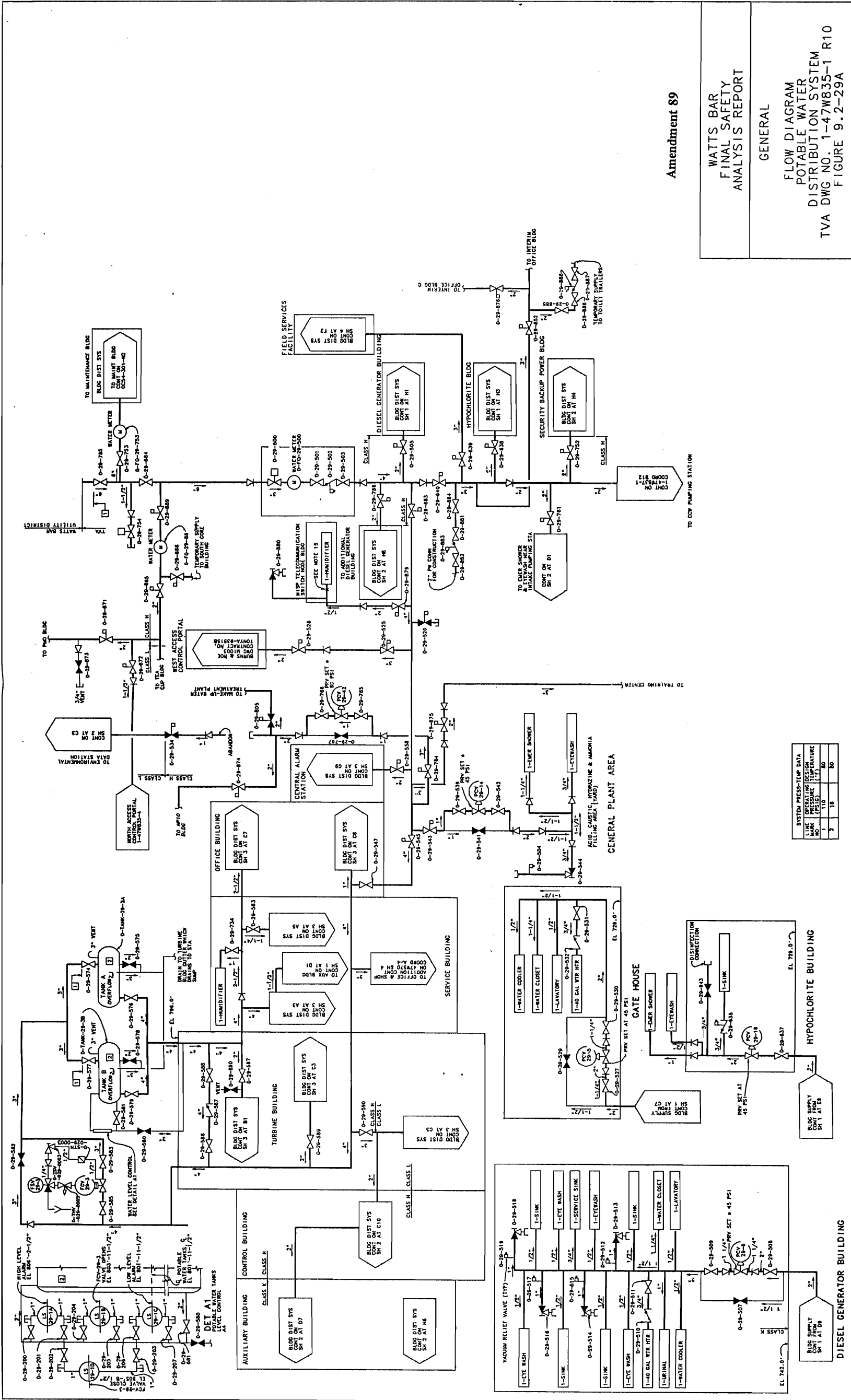

Amendment 89

WATTS BAR  
FINAL SAFETY  
ANALYSIS REPORT  
GENERAL  
FLOW DIAGRAM  
POTABLE WATER  
DISTRIBUTION SYSTEM  
TVA DWG NO. 1-47WB835-1 R10  
FIGURE 9.2-29A

SYSTEM PRESS-TEMP DATA			
LINE	OPERATING PRESSURE (PSI)	DESIGN PRESSURE (PSI)	TEMPERATURE (°F)
1	110	80	50
2	18	50	50

PROGRAM MAINTAINED DRAWING  
THIS DRAWING IS THE PROPERTY OF THE  
TVA AND IS NOT TO BE REPRODUCED OR  
TRANSMITTED IN ANY FORM OR BY ANY  
MEANS, ELECTRONIC OR MECHANICAL,  
INCLUDING PHOTOCOPYING, RECORDING,  
OR BY ANY INFORMATION STORAGE  
RETRIEVAL SYSTEM.

Figure 9.2-29a General Flow Diagram for Potable Water Distribution System

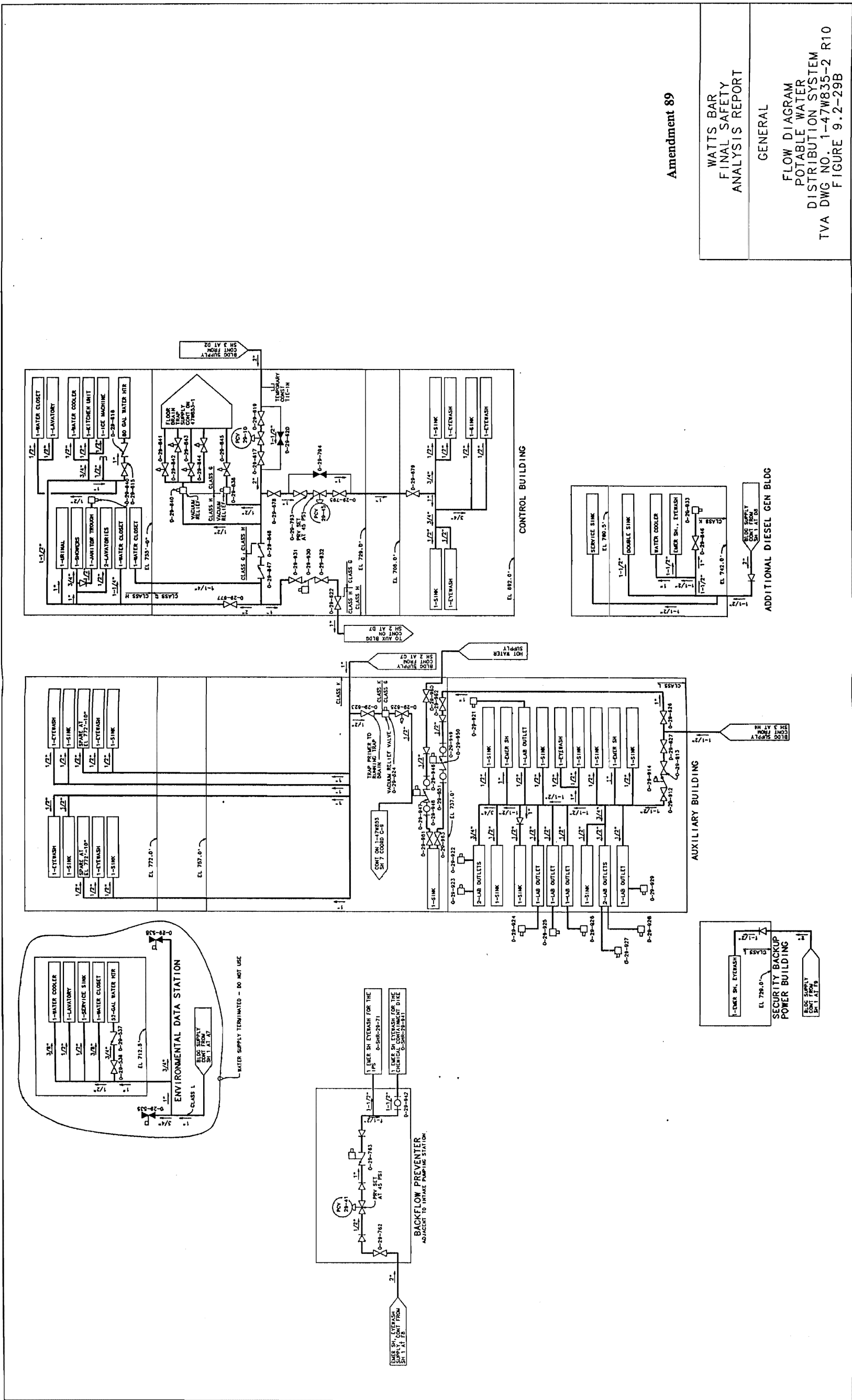

Amendment 89

WATTS BAR  
FINAL SAFETY  
ANALYSIS REPORT

GENERAL

FLOW DIAGRAM  
POTABLE WATER  
DISTRIBUTION SYSTEM  
TVA DWG NO. 1-47W835-2 R10  
FIGURE 9.2-29B

PROCADAM MAINTAINED DRAWING  
LIMITS AND MATERIALS SHOWN ARE THE PROPERTY OF THE  
DRAWING CONTRACTOR AND ARE NOT TO BE REPRODUCED OR  
COPIED WITHOUT THE WRITTEN CONSENT OF THE CONTRACTOR.

Figure 9.2-29b General Flow Diagram for Potable Water Distribution System

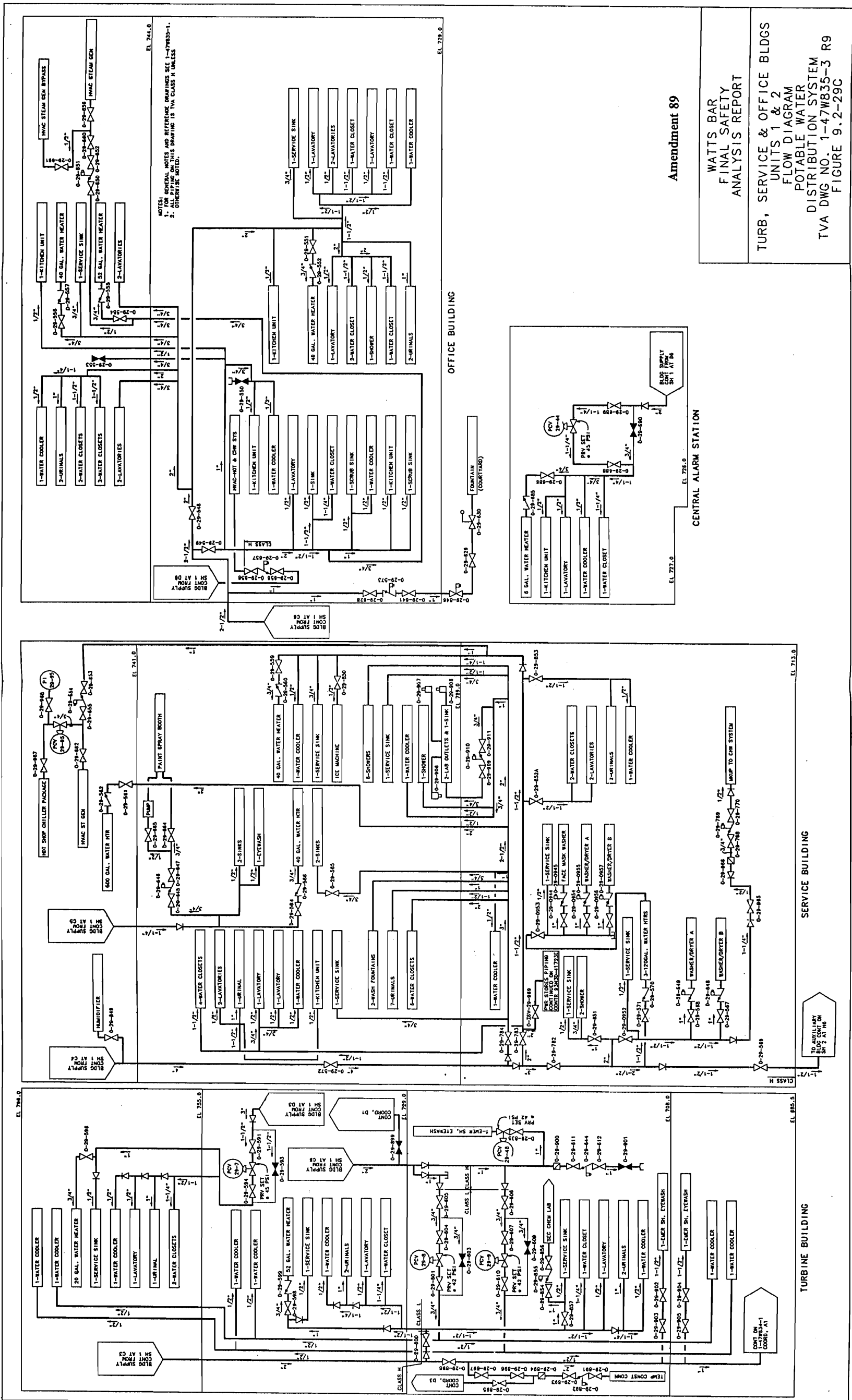
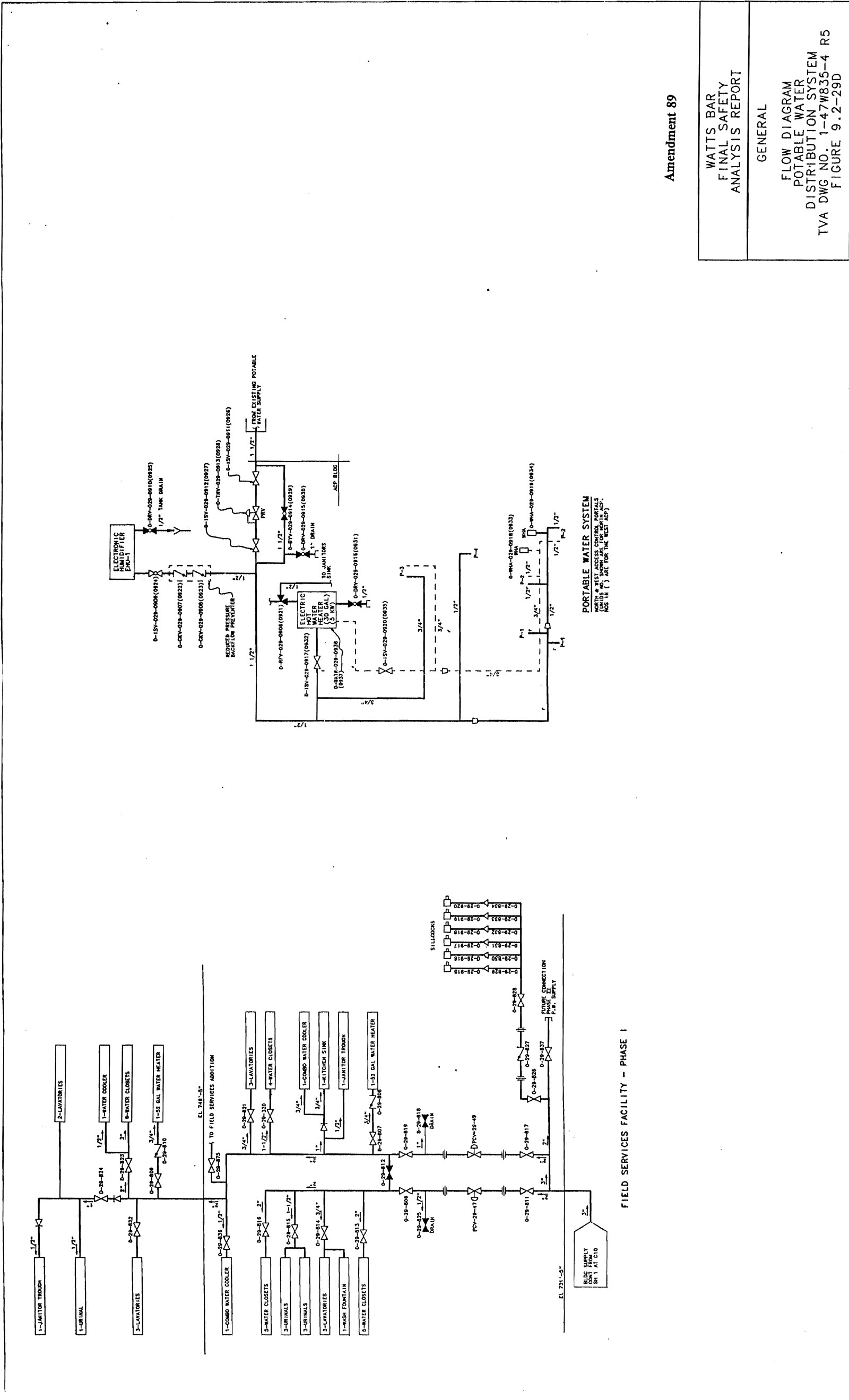

Figure 9.2-29c Turb, Service & Office Bldgs. Units 1 & 2 Flow Diagram for Potable Water Distribution System



Amendment 89

WATTS BAR  
FINAL SAFETY  
ANALYSIS REPORT

GENERAL

FLOW DIAGRAM  
POTABLE WATER  
DISTRIBUTION SYSTEM  
TVA DWG NO. 1-47W835-4 R5  
FIGURE 9.2-29D

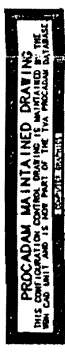
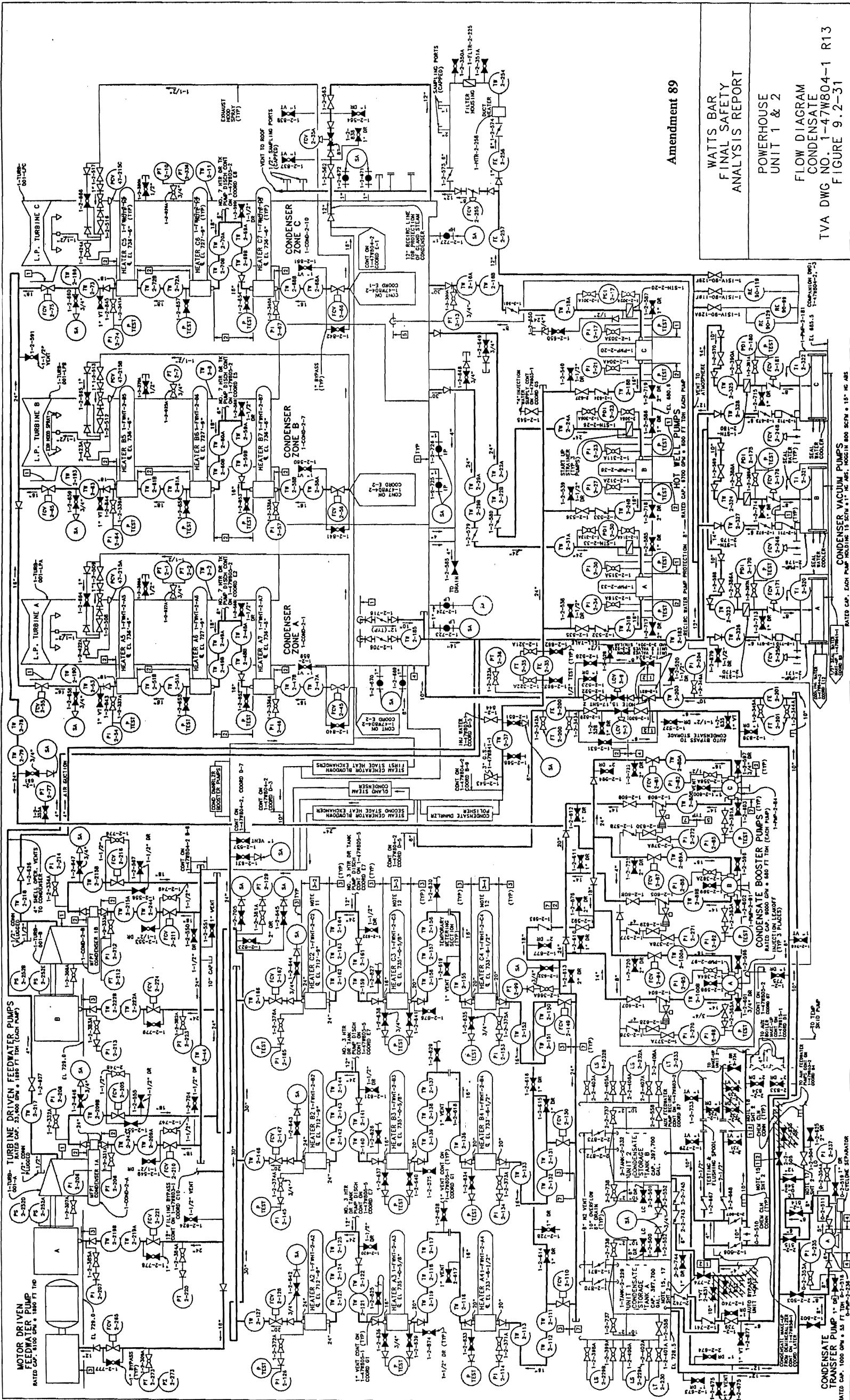

Figure 9.2-29d General Flow Diagram for Potable Water Distribution System

Figure 9.2-30 Deleted by Amendment 94





Amendment 89

WATTS BAR  
FINAL SAFETY  
ANALYSIS REPORT

POWERHOUSE  
UNIT 1 & 2

FLOW DIAGRAM  
CONDENSATE  
TRANSFER PUMPS  
TVA DWG NO. 1-47W804-1 R13  
FIGURE 9.2-31

PROCAD MANAGED DRAWING  
THIS DRAWING IS THE PROPERTY OF THE U.S. NUCLEAR REGULATORY COMMISSION  
IT IS LOANED TO YOU BY THE U.S. NUCLEAR REGULATORY COMMISSION  
IT IS NOT TO BE REPRODUCED OR TRANSMITTED IN ANY FORM OR BY ANY MEANS  
ELECTRONIC OR MECHANICAL, INCLUDING PHOTOCOPYING, RECORDING, OR BY ANY INFORMATION STORAGE AND RETRIEVAL SYSTEM

Figure 9.2-31 Powerhouse Units 1 & 2 Flow Diagram for Condensate

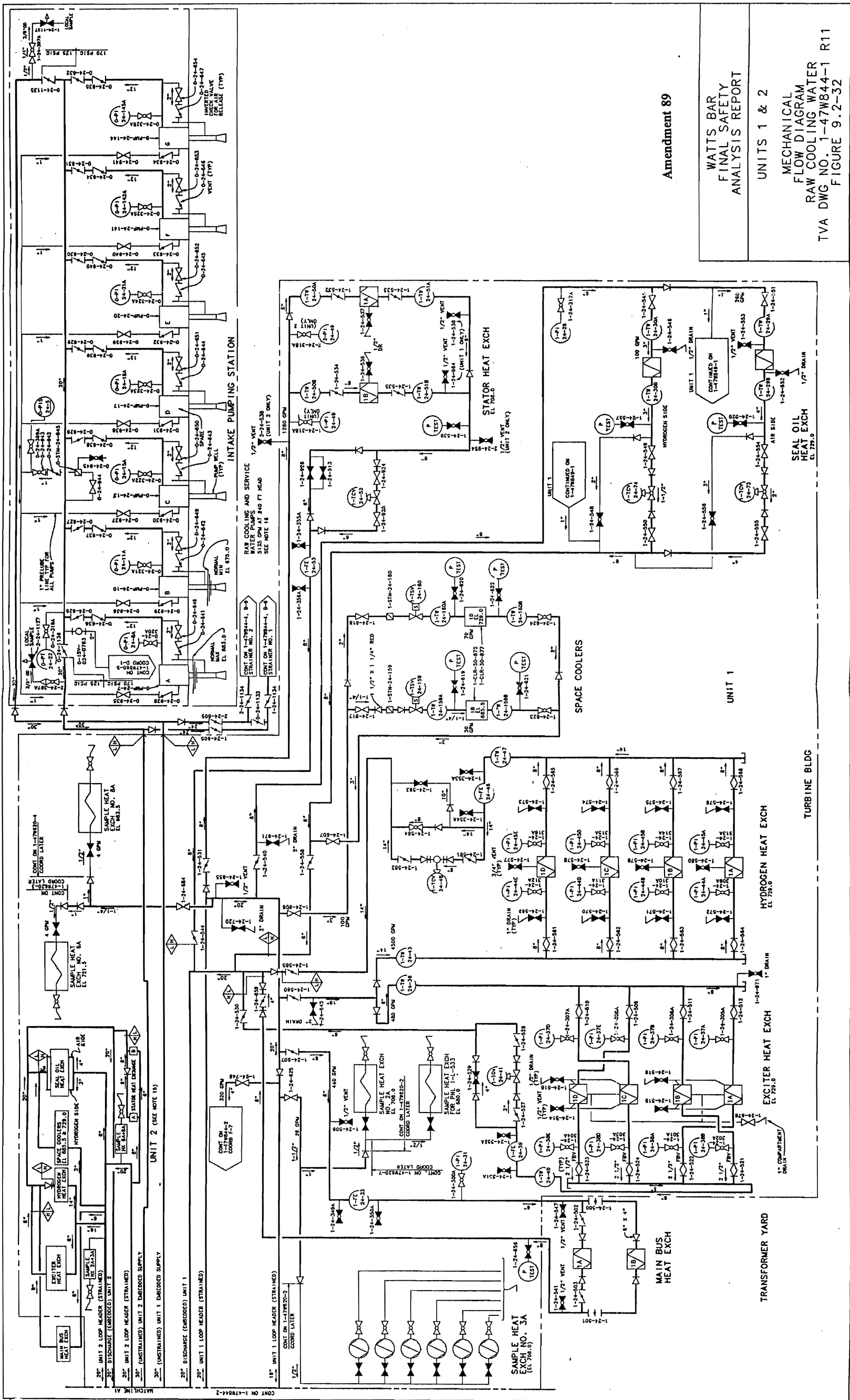

Amendment 89

WATTS BAR  
FINAL SAFETY  
ANALYSIS REPORT

UNITS 1 & 2

MECHANICAL  
FLOW DIAGRAM  
RAW COOLING WATER  
TVA DWG NO. 1-47W844-1 R11  
FIGURE 9.2-32

PROCAD MAINTAINED DRAWING  
THIS IS NOT PART OF THE FINAL SAFETY ANALYSIS REPORT  
DATE: 08/11/89

Figure 9.2-32 Powerhouse Flow Diagram for Raw Cooling Water

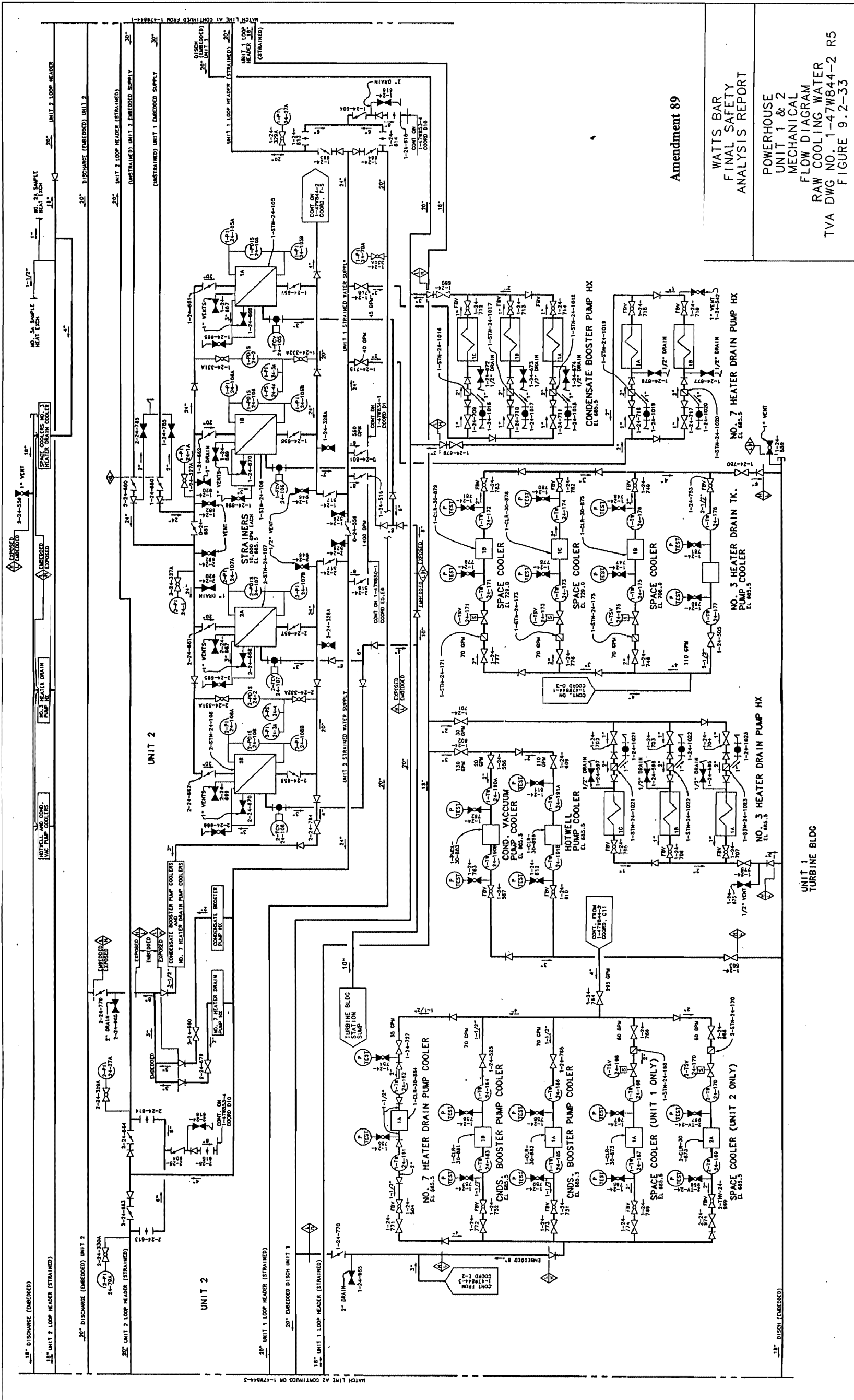
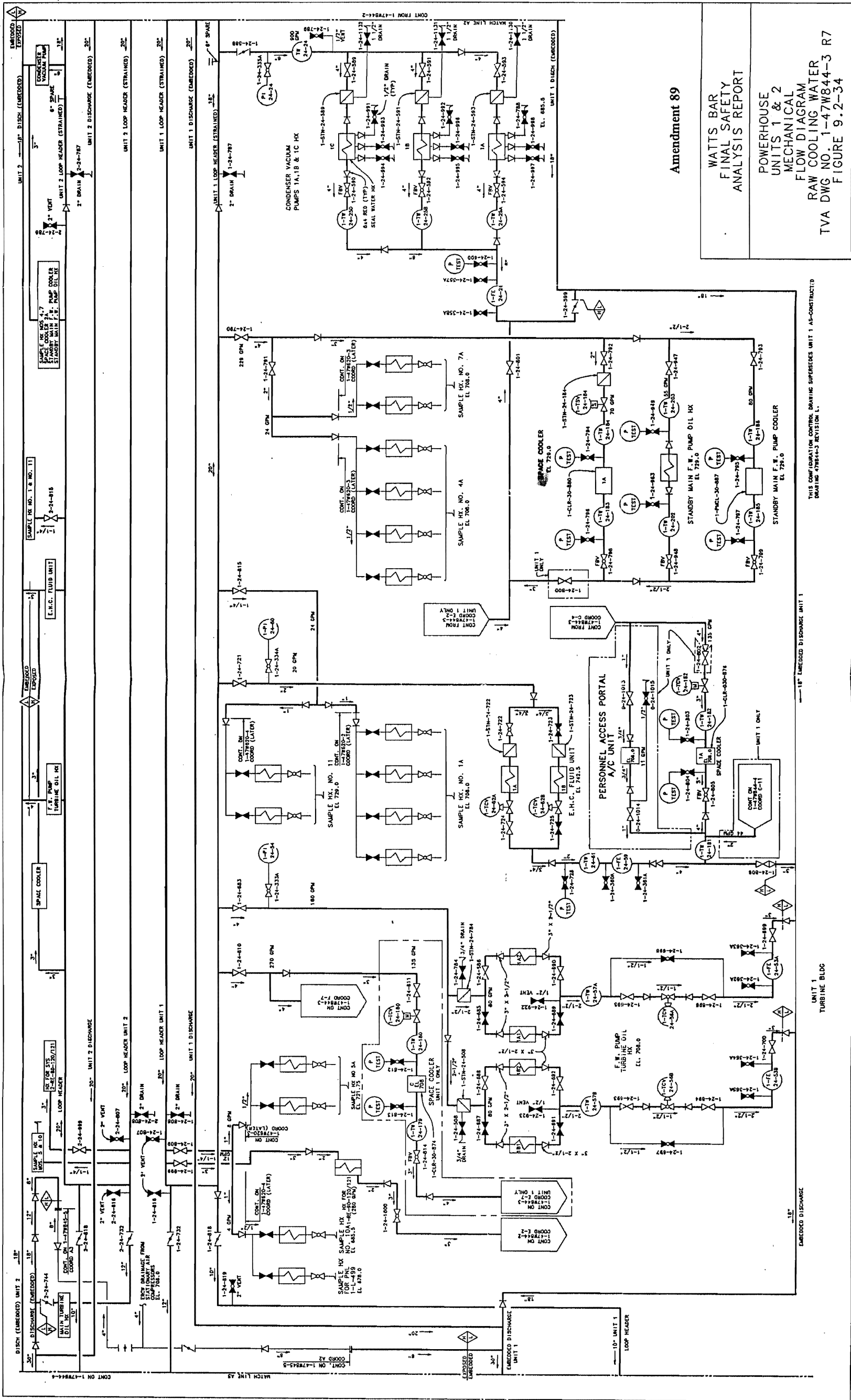

Figure 9.2-33 Powerhouse Flow Diagram for Raw Cooling Water



PROCADAM MAINTAINED DRAWING  
 THIS DRAWING IS PART OF THE 1A, 4A, 7A, 11, 12, 13, 14, 15, 16, 17, 18, 19, 20, 21, 22, 23, 24, 25, 26, 27, 28, 29, 30, 31, 32, 33, 34, 35, 36, 37, 38, 39, 40, 41, 42, 43, 44, 45, 46, 47, 48, 49, 50, 51, 52, 53, 54, 55, 56, 57, 58, 59, 60, 61, 62, 63, 64, 65, 66, 67, 68, 69, 70, 71, 72, 73, 74, 75, 76, 77, 78, 79, 80, 81, 82, 83, 84, 85, 86, 87, 88, 89, 90, 91, 92, 93, 94, 95, 96, 97, 98, 99, 100, 101, 102, 103, 104, 105, 106, 107, 108, 109, 110, 111, 112, 113, 114, 115, 116, 117, 118, 119, 120, 121, 122, 123, 124, 125, 126, 127, 128, 129, 130, 131, 132, 133, 134, 135, 136, 137, 138, 139, 140, 141, 142, 143, 144, 145, 146, 147, 148, 149, 150, 151, 152, 153, 154, 155, 156, 157, 158, 159, 160, 161, 162, 163, 164, 165, 166, 167, 168, 169, 170, 171, 172, 173, 174, 175, 176, 177, 178, 179, 180, 181, 182, 183, 184, 185, 186, 187, 188, 189, 190, 191, 192, 193, 194, 195, 196, 197, 198, 199, 200, 201, 202, 203, 204, 205, 206, 207, 208, 209, 210, 211, 212, 213, 214, 215, 216, 217, 218, 219, 220, 221, 222, 223, 224, 225, 226, 227, 228, 229, 230, 231, 232, 233, 234, 235, 236, 237, 238, 239, 240, 241, 242, 243, 244, 245, 246, 247, 248, 249, 250, 251, 252, 253, 254, 255, 256, 257, 258, 259, 260, 261, 262, 263, 264, 265, 266, 267, 268, 269, 270, 271, 272, 273, 274, 275, 276, 277, 278, 279, 280, 281, 282, 283, 284, 285, 286, 287, 288, 289, 290, 291, 292, 293, 294, 295, 296, 297, 298, 299, 300, 301, 302, 303, 304, 305, 306, 307, 308, 309, 310, 311, 312, 313, 314, 315, 316, 317, 318, 319, 320, 321, 322, 323, 324, 325, 326, 327, 328, 329, 330, 331, 332, 333, 334, 335, 336, 337, 338, 339, 340, 341, 342, 343, 344, 345, 346, 347, 348, 349, 350, 351, 352, 353, 354, 355, 356, 357, 358, 359, 360, 361, 362, 363, 364, 365, 366, 367, 368, 369, 370, 371, 372, 373, 374, 375, 376, 377, 378, 379, 380, 381, 382, 383, 384, 385, 386, 387, 388, 389, 390, 391, 392, 393, 394, 395, 396, 397, 398, 399, 400, 401, 402, 403, 404, 405, 406, 407, 408, 409, 410, 411, 412, 413, 414, 415, 416, 417, 418, 419, 420, 421, 422, 423, 424, 425, 426, 427, 428, 429, 430, 431, 432, 433, 434, 435, 436, 437, 438, 439, 440, 441, 442, 443, 444, 445, 446, 447, 448, 449, 450, 451, 452, 453, 454, 455, 456, 457, 458, 459, 460, 461, 462, 463, 464, 465, 466, 467, 468, 469, 470, 471, 472, 473, 474, 475, 476, 477, 478, 479, 480, 481, 482, 483, 484, 485, 486, 487, 488, 489, 490, 491, 492, 493, 494, 495, 496, 497, 498, 499, 500, 501, 502, 503, 504, 505, 506, 507, 508, 509, 510, 511, 512, 513, 514, 515, 516, 517, 518, 519, 520, 521, 522, 523, 524, 525, 526, 527, 528, 529, 530, 531, 532, 533, 534, 535, 536, 537, 538, 539, 540, 541, 542, 543, 544, 545, 546, 547, 548, 549, 550, 551, 552, 553, 554, 555, 556, 557, 558, 559, 560, 561, 562, 563, 564, 565, 566, 567, 568, 569, 570, 571, 572, 573, 574, 575, 576, 577, 578, 579, 580, 581, 582, 583, 584, 585, 586, 587, 588, 589, 590, 591, 592, 593, 594, 595, 596, 597, 598, 599, 600, 601, 602, 603, 604, 605, 606, 607, 608, 609, 610, 611, 612, 613, 614, 615, 616, 617, 618, 619, 620, 621, 622, 623, 624, 625, 626, 627, 628, 629, 630, 631, 632, 633, 634, 635, 636, 637, 638, 639, 640, 641, 642, 643, 644, 645, 646, 647, 648, 649, 650, 651, 652, 653, 654, 655, 656, 657, 658, 659, 660, 661, 662, 663, 664, 665, 666, 667, 668, 669, 670, 671, 672, 673, 674, 675, 676, 677, 678, 679, 680, 681, 682, 683, 684, 685, 686, 687, 688, 689, 690, 691, 692, 693, 694, 695, 696, 697, 698, 699, 700, 701, 702, 703, 704, 705, 706, 707, 708, 709, 710, 711, 712, 713, 714, 715, 716, 717, 718, 719, 720, 721, 722, 723, 724, 725, 726, 727, 728, 729, 730, 731, 732, 733, 734, 735, 736, 737, 738, 739, 740, 741, 742, 743, 744, 745, 746, 747, 748, 749, 750, 751, 752, 753, 754, 755, 756, 757, 758, 759, 760, 761, 762, 763, 764, 765, 766, 767, 768, 769, 770, 771, 772, 773, 774, 775, 776, 777, 778, 779, 780, 781, 782, 783, 784, 785, 786, 787, 788, 789, 790, 791, 792, 793, 794, 795, 796, 797, 798, 799, 800, 801, 802, 803, 804, 805, 806, 807, 808, 809, 810, 811, 812, 813, 814, 815, 816, 817, 818, 819, 820, 821, 822, 823, 824, 825, 826, 827, 828, 829, 830, 831, 832, 833, 834, 835, 836, 837, 838, 839, 840, 841, 842, 843, 844, 845, 846, 847, 848, 849, 850, 851, 852, 853, 854, 855, 856, 857, 858, 859, 860, 861, 862, 863, 864, 865, 866, 867, 868, 869, 870, 871, 872, 873, 874, 875, 876, 877, 878, 879, 880, 881, 882, 883, 884, 885, 886, 887, 888, 889, 890, 891, 892, 893, 894, 895, 896, 897, 898, 899, 900, 901, 902, 903, 904, 905, 906, 907, 908, 909, 910, 911, 912, 913, 914, 915, 916, 917, 918, 919, 920, 921, 922, 923, 924, 925, 926, 927, 928, 929, 930, 931, 932, 933, 934, 935, 936, 937, 938, 939, 940, 941, 942, 943, 944, 945, 946, 947, 948, 949, 950, 951, 952, 953, 954, 955, 956, 957, 958, 959, 960, 961, 962, 963, 964, 965, 966, 967, 968, 969, 970, 971, 972, 973, 974, 975, 976, 977, 978, 979, 980, 981, 982, 983, 984, 985, 986, 987, 988, 989, 990, 991, 992, 993, 994, 995, 996, 997, 998, 999, 1000.

Figure 9.2-34 Powerhouse Flow Diagram for Raw Cooling Water

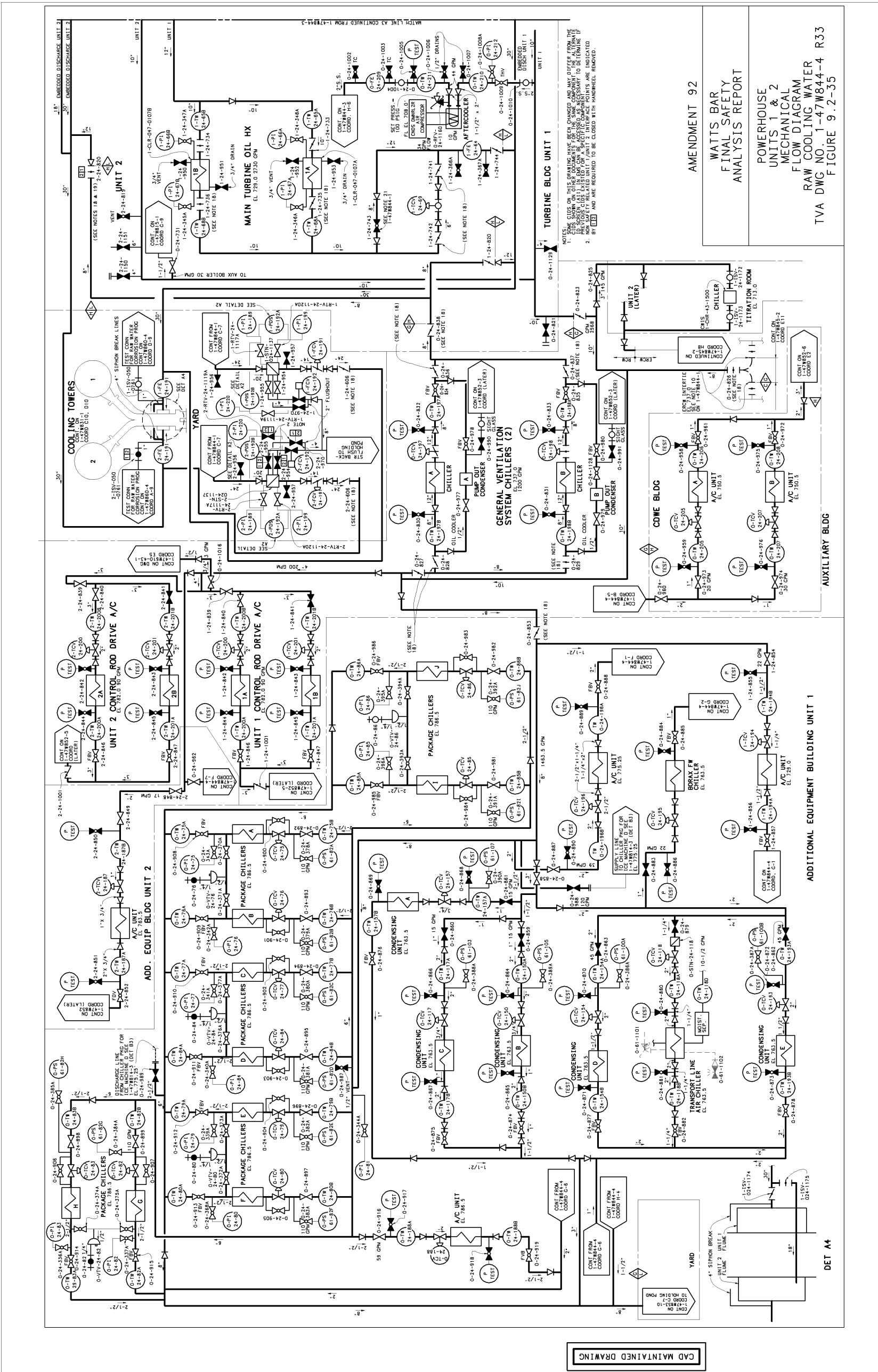

Figure 9.2-35 Powerhouse Units 1 & 2 Mechanical Flow Diagram for Raw Cooling Water

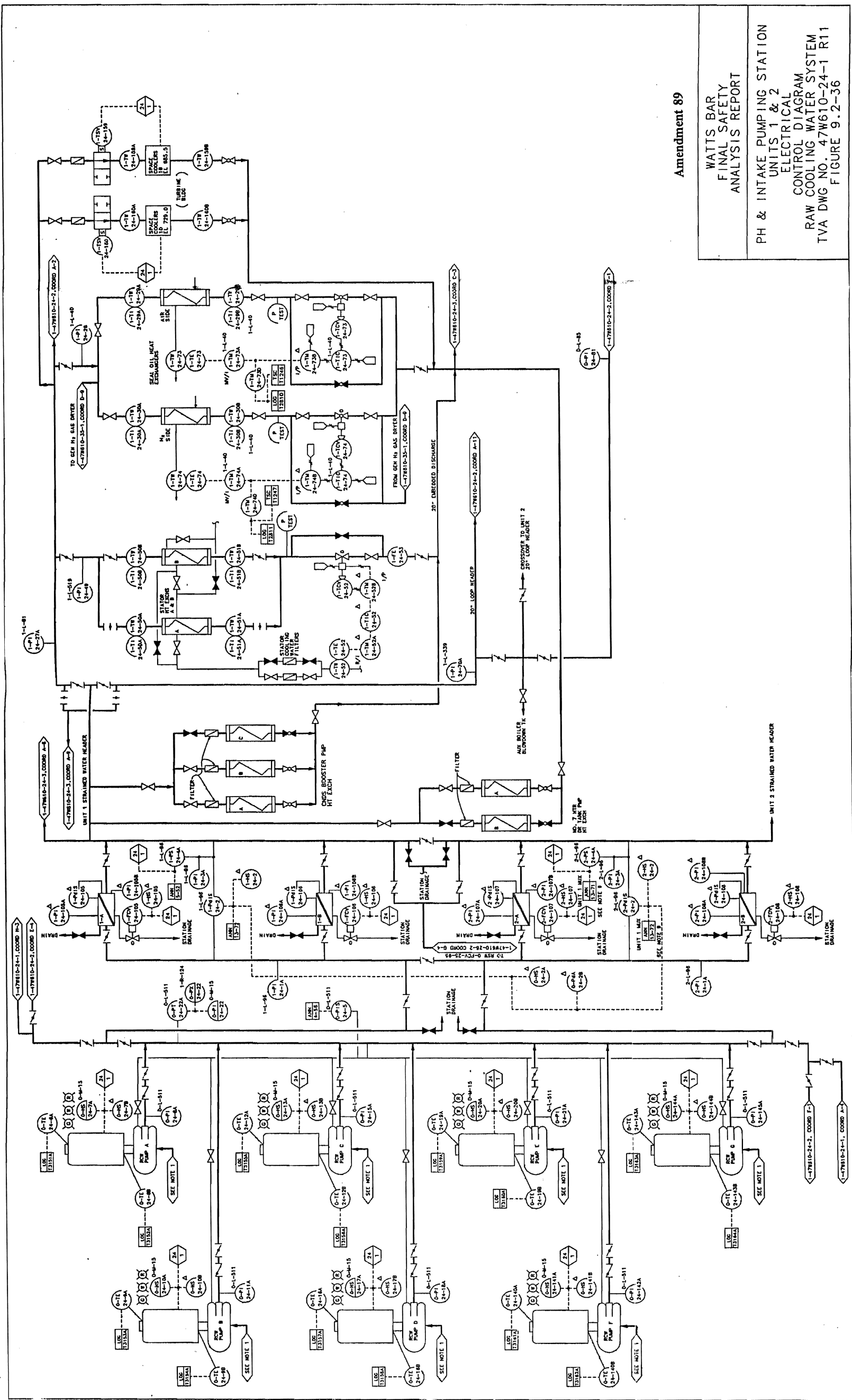
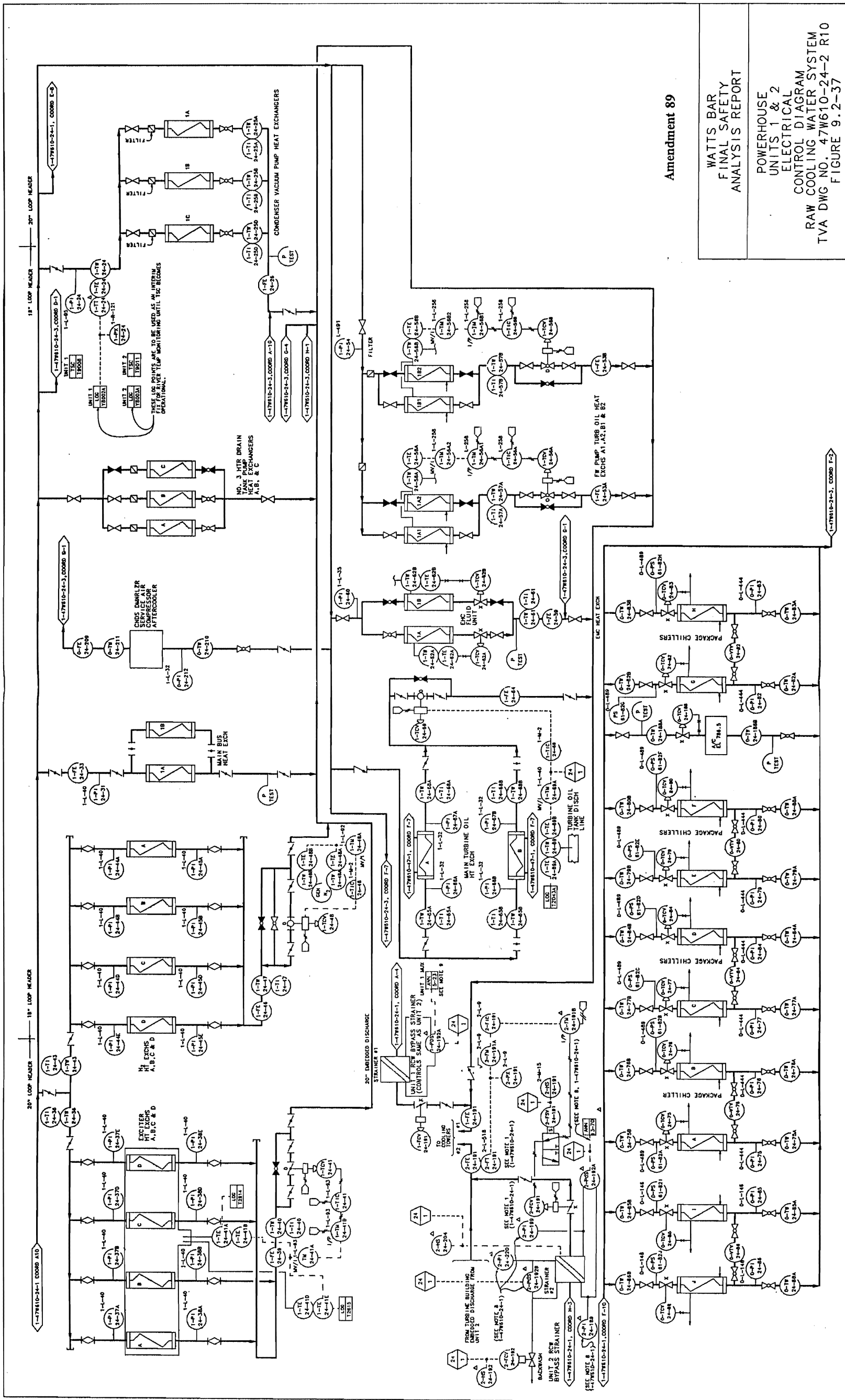

Figure 9.2-36 Overhouse and Intake Pumping Station Electrical Control Diagram for Raw Cooling Water System



Amendment 89

WATTS BAR  
FINAL SAFETY  
ANALYSIS REPORT

POWERHOUSE  
UNITS 1 & 2  
ELECTRICAL  
CONTROL DIAGRAM  
RAW COOLING WATER SYSTEM  
TVA DWG NO. 47W610-24-2 R10  
FIGURE 9.2-37

PROCEDURE MAINTAINED DRAWING  
THIS DRAWING IS THE PROPERTY OF THE UNITED STATES GOVERNMENT  
AND IS NOT TO BE REPRODUCED IN ANY MANNER WITHOUT PERMISSION

Figure 9.2-37 Powerhouse Units 1 & 2 Electrical Control Diagram for Raw Cooling Water System

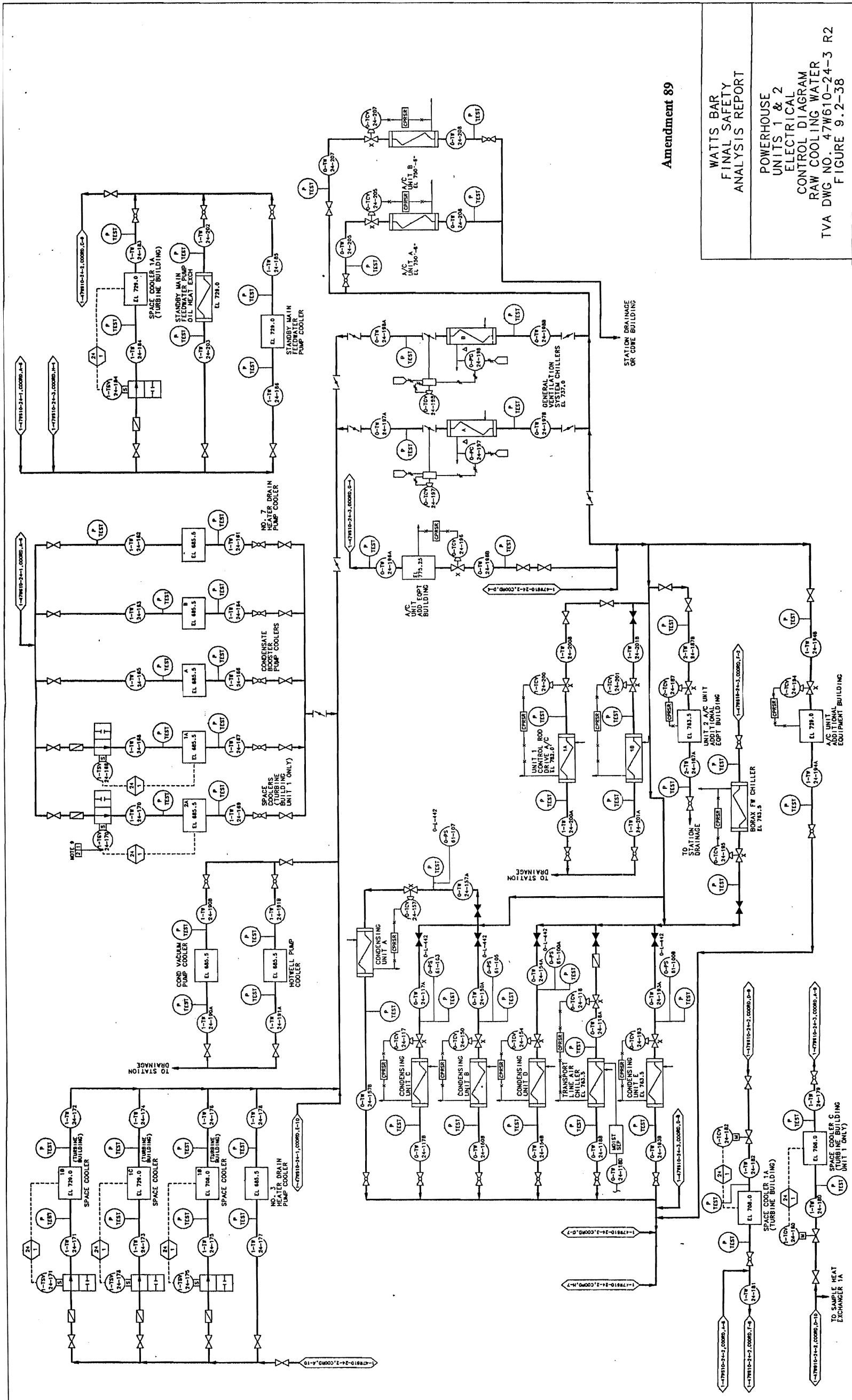

Amendment 89

WATTS BAR  
FINAL SAFETY  
ANALYSIS REPORT

POWERHOUSE  
UNITS 1 & 2  
ELECTRICAL  
CONTROL DIAGRAM  
RAW COOLING WATER  
TVA DWG NO. 47W610-24-3 R2  
FIGURE 9.2-38

PROCAD MAINTAINED DRAWING  
THIS DRAWING IS PART OF THE TWA RECORD SYSTEM  
DATE: 08/11/08

Figure 9.2-38 Powerhouse Units 1 & 2 Electrical Control Diagram for Raw Cooling Water



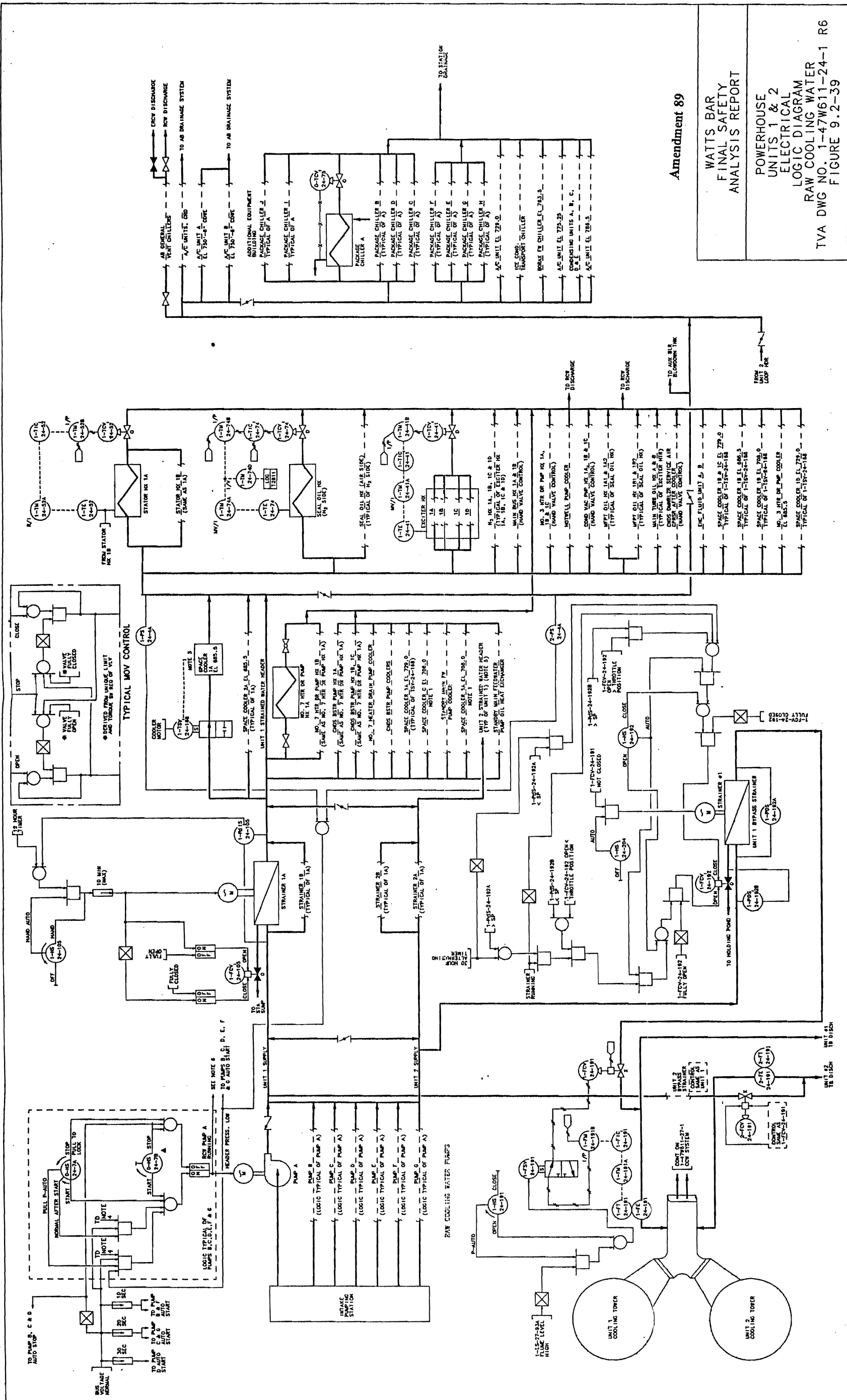

PROCEDURE MAINTAINED DURING THIS REVISION. THE ORIGINAL DRAWING IS NOT TO BE USED FOR CONSTRUCTION OF THE TWA PROCESSOR BUILDING EXCEPT AS SPECIFIED.

Figure 9.2-39 Powerhouse Powerhouse Units 1 & 2 Logic Diagram for Raw Cooling Water

Figure 9.2-40 Essential Raw Cooling Water Control Air and HPPFP Piping (Unit 1)

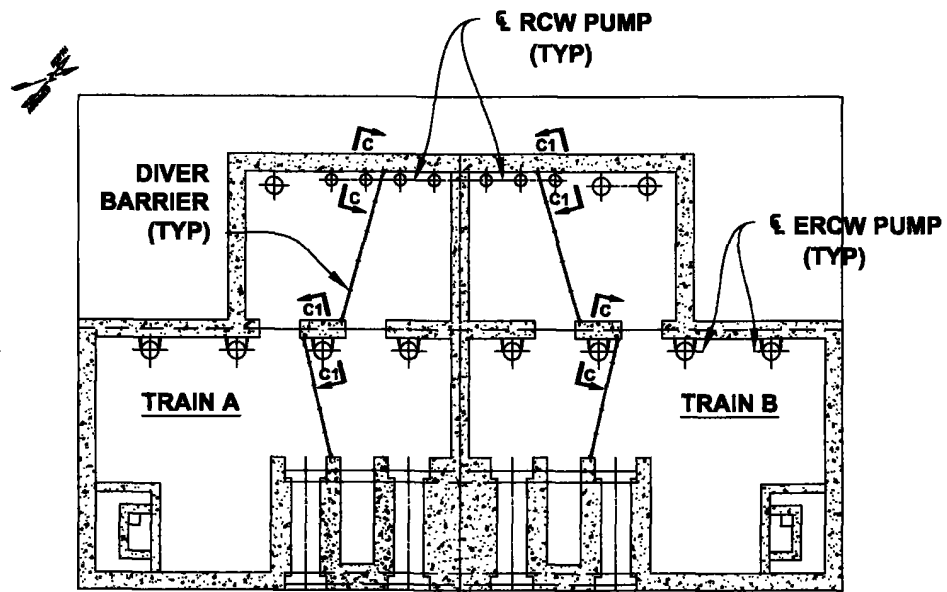

**INTAKE PUMPING STATION  
PLAN EL 652.0'**

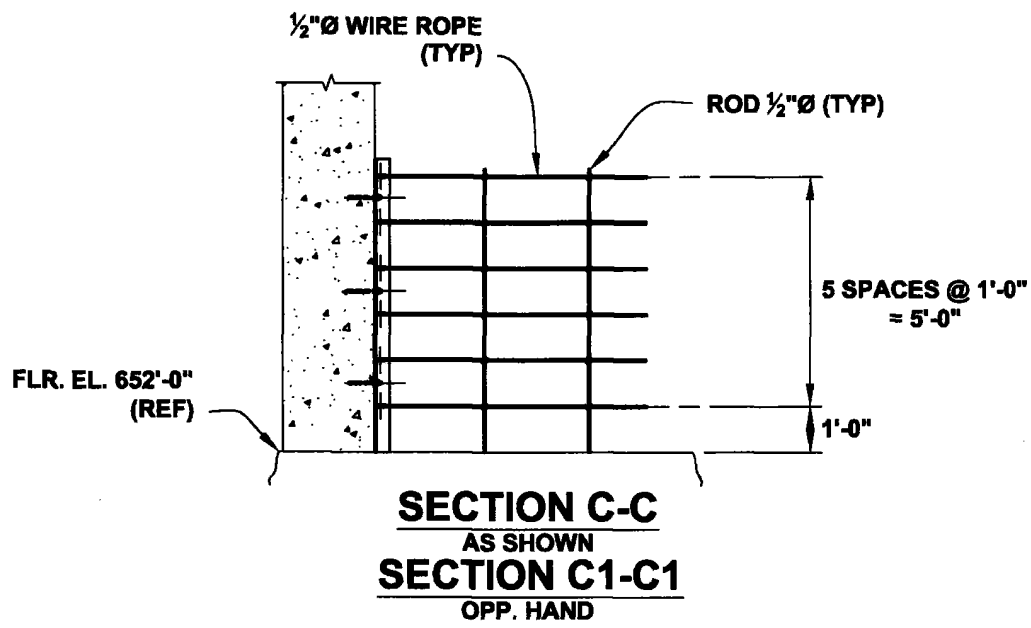

Figure 9.2-41 Diver Protection Barriers

THIS PAGE INTENTIONALLY BLANK

## 9.3 PROCESS AUXILIARIES

### 9.3.1 Compressed Air System

#### 9.3.1.1 Design Basis

The compressed air system is common to both units and is divided into two systems, the station control and service air system and the auxiliary control air systems for emergency use. The auxiliary control air system is comprised of two fully qualified and redundant trains or subsystems. The station control and service air system is designed to supply adequate compressed air capacity for general plant service, instrumentation, testing and control. Each subsystem of the auxiliary control air system supplies air to the auxiliary air distribution system of Unit 1 and Unit 2. The auxiliary air system ensures that all vital equipment will receive air from the appropriate assigned subsystem under all conditions, including safe shutdown earthquake and maximum possible flood.

#### 9.3.1.2 System Description

Station control and service air is supplied by three motor-driven, non-lubricated, two stage, reciprocating compressors and one centrifugal air compressor. Two of the three reciprocating compressors or the centrifugal compressor will handle the total plant control air requirements under normal conditions with sufficient additional capacity to handle minimal service air requirements. With three reciprocating station air compressors operational and the centrifugal compressor shutdown for maintenance, the total plant control air and peak service air requirements will still be met. Peak service air requirements will occur during unit outages and other periods of heavy usage of pneumatic operated tools and equipment. The compressed air system includes normal accessory equipment such as intake air filters, cylinder cooling equipment, after coolers, and safety relief valves.

All four air compressors are provided with intake air silencers to reduce noise and vibration levels due to the resonance characteristics of the intake pipes.

The station compressors discharge into two redundant headers which are provided with manual isolation valves. These headers feed the two control air receivers which in turn supply air through redundant headers to the control air station. The control air station contains three complete trains of prefilters, dryers, and after filters. Each dryer train is sized to fully handle plant control air requirements for one unit. Manual bypasses are provided around each element for abnormal or emergency operation. The control air is then piped through two independent headers to valves, controllers, instruments, etc., throughout the plant.

Service air is supplied to the service air receiver by a single header from the control air receivers. Service air is supplied through a back pressure valve which closes if control air pressure drops below 80 psig, thus assuring that control air requirements take precedence over service air requirements. Service air is piped from the receiver to service outlets and miscellaneous equipment throughout the plant.

Auxiliary control air is supplied by two motor-driven, nonlubricated, single-stage, reciprocating compressors. Each compressor is sized to supply the total safety-related control air requirements in the event of an accident, flood, or loss of the station control air system. The auxiliary control air system (ACAS) is separated into two independent subsystems each containing its own compressor, receiver, dryer, and filter. The auxiliary control air piping is arranged so that the auxiliary receivers are charged from the non-qualified station control air system during normal operation. Electric power for the auxiliary system is provided from both normal and emergency sources. The auxiliary control air system is located entirely within Category I structures and is designed to Category I seismic requirements. The auxiliary air system is automatically isolated from the station air system upon loss of air from the station system. Refer to the tabulation of descriptive information in Table 9.3-1.

The dryer and filter trains for both the station control and auxiliary control air systems are designed to give compressed air of high instrument quality. The auxiliary control air system inlet filters (from control air system) are designed to remove 100% liquid water entrainment and other foreign matter from the compressed airstream down to 0.9 micron size. The station control air prefilters are designed to remove 100% liquid water entrainment and other foreign matter from the compressed airstream down to 2 to 3 micron size. The air dryers dry the air to a dewpoint of 0°F or less at line pressure. The discharge of the auxiliary control air dryers is routed through an afterfilter which removes 100% of particles of desiccant and other foreign matter down to 0.9-micron size. The discharge of the station control air dryers is routed through three micron afterfilter elements which remove 100% of particles of desiccant and other foreign matter larger than 3 microns.

### 9.3.1.3 Safety Evaluation

The compressed air system meets General Design Criterion 5 and is designed to provide a highly reliable source of compressed air for all plant uses. The two independent auxiliary systems are powered from separate emergency electrical power sources to provide a single failure capability.

The station compressors are also powered from diverse electrical sources. One compressor is powered from the 480-volt Auxiliary Building common board, one from the 480-volt Turbine Building common board, and the other two from 480-volt shutdown boards. Two of the three reciprocating compressors or the centrifugal compressor will handle the total plant control air requirement. Thus two of the four station compressors can fail due to power loss, accident, or other cause, and system pressure will still be maintained. The compressed air system contains sufficient receiver capacity to supply air for several minutes. The loss of all four station compressors would result in the shutdown of both units after this reserve is expended. Loss of station control air pressure from an accident such as a pipe break would result in the shutdown of both units if the break was not manually isolated before system pressure fell below the point required to sustain plant operation. The auxiliary compressors will start automatically when the system pressure in its respective trained receiver falls below 83 psig.

The control air dryers are divided into three independent units each containing a prefilter, a dryer, and an afterfilter. The loss of a dryer unit would result in a high moisture content in the air. This would be alarmed by moisture sensors located in the discharge headers. The air supply would then be diverted to the spare dryer unit.

The station air compressor system is designed for 115 psig and arranged for parallel operation. The maximum system pressure is 105 psig. For reciprocating compressors A, B and C, further protection against system overpressure is provided by safety relief valves set at 115 psig placed between the reciprocating compressor and the aftercooler and on each receiver for the main air system. Safety relief valves are also placed on the auxiliary air compressors and auxiliary air receivers. These valves are also set at 115 psig. Station air compressor D has a relief valve located on its pulsation dampener.

The station air compressors and dryer units are located on Elevation 708.0 in the Turbine Building. The building at this elevation is not a Category I structure and is below plant grade. Therefore, the main air system must be considered inoperable during (or after) a seismic event and flooding above plant grade. The two independent auxiliary air systems are located on Elevation 757.0 of the Auxiliary Building. This is a Seismic Category I structure and above maximum possible flood elevation.

The auxiliary air systems are designed to Seismic Category I requirements; since they are completely separated, a single failure cannot render both systems inoperable. The auxiliary compressors start automatically upon loss of air from the main system for any reason. The auxiliary air system is automatically isolated from the main air system whenever the system pressure falls below 79.5 psig.

Each auxiliary air system is sized and equipped so that ample system capacity is provided for both units under all design basis accident conditions. Redundancy and train separation have been provided in the auxiliary compressed air system to the extent that no initial 'design basis event' followed by an arbitrarily selected 'single active failure' will prevent the system from performing its necessary safety functions. Total plant design is such that even total loss of all air will not prevent safe shutdown of both units, assuming no breaks in the primary or secondary piping.

The station control and service air system performs no safety related function. Containment penetration piping is installed to TVA Class B (Safety Class ANS-N-182) requirements and is an integral part of the containment isolation system. Also, station air system piping located inside Seismic I structures is installed to Seismic Category I(L) requirements (see Section 3.2.1). It normally supplies air to both trains of the auxiliary control air system, but is automatically isolated when the output pressure drops below an acceptable value.

A failure modes and effects analysis (FMEA) for the compressed air system has been performed and a summary of the result is presented in Table 9.3-7. Since the station control and service air is a non-essential system, the scope of the FMEA for the compressed air system will include only an analysis of the auxiliary control air system. The essential raw cooling water (ERCW) system, floor drainage, high pressure fire

protection, and the normal and emergency power systems define system interfaces with the auxiliary control air system. The redundant ERCW and emergency power trains are assigned to the appropriate redundant auxiliary control air system. All equipment receiving auxiliary control air is listed in Table 9.3-8.

The auxiliary compressor suction is taken from a nonfiltered area. Calculations were performed to verify that the amount of radioactivity introduced into the main control room (MCR) habitability area during an accident condition is not significant. Also, as an additional safety precaution, the air lines leading into the MCR are filtered by charcoal and HEPA filters.

A safety precaution was also provided to protect the MCR from airborne contaminants in the event of a pipe leak that may originate from the fire protection system, which was routed inside the MCR. The air supply to the fire protection system was provided with an orifice and a seismically qualified check valve.

The auxiliary control air systems are used to ensure plant safety, even if the station control and service air system fails for any reason.

Safety-related components and equipment which require instrument air to perform an active safety function are supplied from the auxiliary control air compressors. These safety-related items and their related safety functions are identified below and discussed in the indicated FSAR sections.

- (1) Auxiliary Feedwater (AFW) system steam generator level control and pressure control valves (Section 10.4.9) - These valves are required during all AFW operating conditions,
- (2) Main steam atmospheric relief valves (Section 10.1) - control of these valves are necessary during flood mode operation,
- (3) Auxiliary building gas treatment system (ABGTS) - flow control and isolation dampers (Section 6.2.3),
- (4) Emergency gas treatment system (EGTS) isolation and flow control dampers and valves (Section 6.2.3),
- (5) Control Building HVAC isolation and flow control valves, dampers, temperature controllers, transmitters, and other pneumatic instruments (Section 9.4.1),
- (6) Radiation monitoring system containment isolation valves,
- (7) Reactor coolant system (RCS) pressurizer spray line pressure control valves (Section 5.5.10)



- (8) Sample isolation valves for radiation monitoring equipment which are required to remain functional during and after a safe shutdown earthquake, as discussed in Section 5.2.7.6, will be supplied with essential control air from the ACAS.

#### 9.3.1.4 Tests and Inspections

Preoperational testing of the compressed air system and components is to be performed in compliance (see Section 14.2.7 for exceptions) with the requirements of Regulatory Guide 1.68.3, April 1982, 'Preoperational Testing of Instrument and Control Air Systems'. The compressed air system preoperational tests are discussed in more detail in Chapter 14.

Periodic tests will be performed after plant startup to ensure proper operation of the auxiliary system and isolation valves.

#### 9.3.1.5 Instrumentation Applications

The control air system is designed to operate automatically. The auxiliary systems are started automatically upon loss of air pressure from the primary system. Control room instrumentation monitors control air pressure. Position lights indicate closure of any isolation valve. Audible alarms are produced in the MCR for high compressor oil temperature, low oil pressure, high discharge air temperature, high dewpoint of auxiliary control air, and low auxiliary control air pressure. Local indication of air pressure at various points and air temperature, is also provided in addition to local trouble lights. See Figure 9.3-1 and 9.3-2 for detailed control application, Figures 9.3-3 and 9.3-4 for logic, and Figures 9.3-5, 9.3-5A, and 9.3-6 for the detailed flow diagrams.

### 9.3.2 Process Sampling System

#### 9.3.2.1 Design Basis

The process sampling system is composed of both the routine and post accident sampling subsystems. The routine sampling subsystem is designed to obtain samples from the various process systems in each of the two units. The samples are obtained in the titration room, hot sample room, or locally (grab samples) for laboratory analysis. This system has no primary safety-related function except for containment isolation valves. During a loss-of-coolant accident, this system is isolated at the containment boundary.

The postaccident sampling subsystem (PASS - for Unit 1 Only) is used to acquire samples of the reactor coolant and containment atmosphere during a loss of coolant accident (LOCA). This system has no primary safety-related function. However, the operation of this subsystem requires the operation of various closed containment isolation valves. The PASS is discussed in Section 9.3.2.6.

#### 9.3.2.2 System Description

The routine sampling subsystem consists of the following collection areas and equipment:

- (1) The titration room where secondary process system samples are routed for automatic analysis of several variables such as pH, conductivity, dissolved oxygen, and sodium. Typically these variables are indicated and recorded, and any variable exceeding established limits is annunciated.

In addition, nonradioactive grab samples are obtained in this room.

- (2) The hot sample room where primary and secondary samples are routed for automatic analysis of several variables such as pH, sodium and conductivity. These variables are indicated in the hot sample room and typically recorded in the titration room. Typically a variable exceeding established limits is annunciated. Most hot sample room samples are radioactive grab samples which are taken to the radiochemical laboratory for further analysis.
- (3) Local grab samples are taken throughout the plant for detailed chemical and radiochemical analysis. These samples are analyzed either onsite or offsite, depending upon the analyses required.
- (4) During full power operations, primary system sampling is conducted once every week to determine boron concentration. Periodic sampling can effectively measure boron concentration in RCS and is described below.
- (5) A gas analyzer system sequentially monitors points in the waste disposal and chemical volume and control systems for oxygen concentrations in either a hydrogen or a nitrogen atmosphere. The concentrations are displayed, and recorded, and an alarm is given at the analyzer when appropriate. See Section 11.3.2 for detailed description.
- (6) A zinc injection skid located in the hot sample room is connected to the sample return line to the VCT.

The routine sampling subsystem is operated manually throughout the full range of operations. Sample lines originating within containment have isolation valves near the sample point and inside and outside containment for automatic containment isolation. Sample lines outside containment normally have manual isolation valves. Sample line isolation valve hand switches are normally located on a wall panel in the hot sample room. Each sample line to the titration or hot sample room cubicles normally has indicators for pressure, temperature, and flow rate. Samples, whether local or to a sample room, normally have pressure throttling valves and/or heat exchangers (as required).

To ensure that representative samples are obtained, the sample points are normally located in a free-flowing stream and the sample takeoff points are normally on the side of the horizontal pipes. Prior to the collection of a sample, each sample line is normally purged of stagnant process fluid. The volume of fluid purged and the volume of sample collected are dependent on the stream being sampled, length of sample line, and analysis to be performed.

Sampling of the RCS is used to detect failed fuel. RCS sampling is used to determine gross specific activity and dose equivalent I-131 analyses. The gross specific activity is performed every seven days and the dose equivalent I-131 specific activity is performed every fourteen days, both during power operation. Operations is notified if a negative trend or significant change develops in the analysis.

Boron concentration measurement is performed once every week, during power operation. Operations is notified if a negative trend or significant change develops in the analysis.

Each sample is listed in Table 9.3-2 giving the sampled system, sample location, system design temperature and pressure, sample type (local, titration room, hot sample room, or gas analyzer). Sampling lines from systems covered by TVA Classes A, B, C and D from root valve through first valve in sampling lines, or through second containment isolation valve if sample lines are extensions of containment, are the same class or higher as the sampled systems. Also, sample lines which form a primary pressure boundary are TVA Class B. Each of these sample lines which interface with TVA Class A piping normally has a 3/8 inch O.D. The sample line itself serves as a flow restrictor. Sample lines in Seismic Category I structures are a minimum of TVA Class G.

Remaining sample lines are TVA Class H, except some sample piping is TVA Class C. The sample piping and equipment, where applicable, meets the following codes and standards:

- (1) NEMA SG-5 and IC-1
- (2) ASME Boiler and Pressure Vessel Code, Section III (applicable sections) and Section IX (applicable sections)
- (3) ANSI B31.1 and B16.5
- (4) IEEE
- (5) ASTM
- (6) SAMA PUB19 and PMC20-2-1970

The hot sample room cubicles are able to withstand a 1.0 g horizontal acceleration to ensure their stability during a seismic event. Also, the hot sample room cubicle entry block valves meet ASME Section III, Paragraph NC-3676, Code Class 2 with applicable 'N' stamp.

The routine sampling subsystem provides the capability for sampling the reactor coolant hotleg and steam generator blowdown, in an emergency sample area during a maximum flood condition. Portable sample analyzer equipment is used to measure the boron concentration in the RCS.

### 9.3.2.3 Safety Evaluation

Sample lines have the required indicators, pressure throttling valves, heat exchangers, etc., to ensure plant operator safety when collecting samples.

The hot sample room has the following special safety features (due to handling primary loop samples):

- (1) Sample lines from the RCS hot legs contain a delay coil to provide a 40-second sample transient time within containment, plus a 20-second transient time from containment to the hot sample cubicles to provide decay time for N-16.
- (2) Cubicles 1A and 2A are expected to contain the most highly radioactive samples. Sample lines to these sinks are equipped with stainless steel sample cylinders. Cubicles 1A and 2A have a 2-inch lead shield behind the front plate of the cubicles. Samples can be obtained during conditions approximating 1% failed fuel.
- (3) Cubicles are designed to permit collection of a sample behind a shatterproof window.
- (4) Cubicles have individual exhaust hoods and fans to ensure that leakage of any gas is exhausted from the cubicle. Airborne particulates are removed by HEPA filters, and liquids are drained through the cubicle sink.
- (5) Entry block valves meet the ASME Section III, Class 2 (described in Section 9.3.2.2).

The presence of high pressure and temperature sample lines outside reactor containment is not considered hazardous because of the limited flow capacity.

### 9.3.2.4 Tests and Inspections

System equipment is tested prior to plant operation under normal conditions. Periodic tests are performed after plant operation begins, to ensure proper operation of the routine sampling subsystem equipment.

### 9.3.2.5 Instrumentation Applications

The routine sampling subsystem is designed to be operated manually except for the gas analyzer, and the automatic analyzers (e.g., conductivity, pH, cation conductivity, sodium, hydrazine, dissolved oxygen).

### 9.3.2.6 Postaccident Sampling Subsystem - (Unit 1 Only)

The postaccident sampling subsystem (PASS) provides samples of the reactor coolant, containment atmosphere, and containment sump fluid during a LOCA. It is designed to meet the intent of and provide for sample acquisition, analysis, and disposal, as described in Section II.B.3 of NUREG-0737, and keep personnel exposures within GDC19 limits (see Section 3.1).

The existing Post Accident Sampling System (PASS) is being abandoned in place and disconnected for Unit 2.

#### 9.3.2.6.1 System Description

The PASS is composed of the following:

- (a) The postaccident sampling facility (PASF) which contains Sentry Equipment Corporation (SEC) high radiation sampling system (HRSS) or equivalent and associated control panels.
- (b) Sample connections to the reactor coolant, containment sump, and containment atmosphere.
- (c) Tubing, valving, and fittings as required to convey samples to the PASS.

#### 9.3.2.6.2 Postaccident Sampling Facility

The PASF is located in the Auxiliary Building on Elevation 729 between columns A5, W, and X (for Unit 1).

The PASF consists of piping, tubing, valves, components, and instrumentation necessary to obtain, do partial analysis, and dispose of the samples described in Section 9.3.2.6. Boron and isotopic analysis is performed. The major equipment used for these activities is the SEC HRSS. It is described in Section 9.3.2.6.3. The ventilation exhaust is filtered with charcoal adsorbers and high-efficiency particulate air (HEPA) filters. Liquid waste from the SEC HRSS, with the exception of the sampling panel drip pans, is routed to the waste holdup tank. From this tank the liquid is routed back to containment or the radwaste system for disposal. The liquid waste from the panels drip pans is routed to the floor drain system.

Gaseous waste is routed back to containment.

#### 9.3.2.6.3 Sampling Equipment

The major component used in the PASF for sampling acquisition and portions of the chemical analysis is the SEC HRSS. This system is composed of the liquid sampling panel (LSP), chemical analysis panel (CAP), containment air sampling panel (CASP), and their associated control panels. These components are discussed in the ensuing sections.

### 9.3.2.6.3.1 Liquid Sampling Panel

The following types of samples can be obtained from the LSP during accident conditions:

- (a) Undiluted and diluted (1,000:1) liquid grab samples of the reactor coolant.
- (b) An in-line sample of pressurized coolant.
- (c) A diluted (15,000:1) stripped gas sample from the reactor coolant pressurized liquid sample.

The LSP is able to purge sample lines before sampling to assure representative samples will be obtained and to flush the lines after sampling to reduce residual radioactivity.

The LSP uses shielded cart/casks for the removal of the reactor coolant samples. The cask is mounted on a cart, which allows the samples obtained to be mobile. A shielded syringe can be used to handle the aliquot to be analyzed. Isotopic analysis of reactor coolant (undiluted concentration 1  $\mu\text{Ci/g}$  to 10  $\text{Ci/g}$ ) can be performed.

### 9.3.2.6.3.2 Chemical Analysis Panel

The CAP can receive reactor coolant liquid and gas samples from LSP. The CAP has the capability to analyze for the following parameters: pH, specific conductivity, dissolved oxygen, chloride, hydrogen, temperature, and total dissolved gas. The ranges of the on-line equipment are listed below for their specific analyses:

- |                        |                            |
|------------------------|----------------------------|
| (a) pH                 | 1 - 14                     |
| (b) Conductivity       | 0.1-500 $\mu\text{mho/cm}$ |
| (c) Chlorides          | 0.1-20 ppm                 |
| (d) Dissolved Hydrogen | 10-2000 cc(STP)/kg         |
| (e) Dissolved Oxygen   | 0.1-20 ppm                 |

Lines carrying liquid and gaseous samples have the capability to be flushed to limit personnel radiation exposure and prepare for the acquisition of the next sample.

### 9.3.2.6.3.3 Containment Air Sampling Panel (CASP)

The CASP is used to obtain samples of the containment atmosphere. A particulate, iodine, and gas partitioning system is used to obtain these components in the containment atmosphere sample. As an alternate method, samples are located in shielded cart/casks. The shielded mobile assemblies can be used for sample transport to onsite analysis facilities. All CASP sample lines are purged with nitrogen following the sampling operations to remove radioactive gases and prepare for the next sample.

Also, the sample lines are heat traced to minimize plateout of radioactive material. Each of these components is then analyzed for radioactivity.

#### **9.3.2.6.3.4 HRSS Control Panels**

Operation of the HRSS is performed at various control panels. These panels give readouts of all in-line analysis performed by the CAP. The control panels are separated from the sample panels within the PASF. This separation makes possible a reduction in the operators' exposure to radiation from the sampling panels in the PASF.

#### **9.3.2.6.4 Sample Points**

The sample points chosen for use during postaccident conditions were selected to be representative of the required samples. The reactor coolant samples are obtained from the reactor vessel hot leg loops. Containment sump samples are acquired from the discharge of the residual heat removal system (RHR) pumps. Containment atmosphere samples are acquired from upper and lower containment from an opening at Elevations 815 (upper) and 750 (lower).

#### **9.3.2.6.5 Postaccident Counting Facilities**

Radiological analysis of liquids and gaseous samples is performed in plant counting room facilities. Analyses are performed within applicable Regulatory Guide 1.97 criteria. Appropriate radiation shielding is provided to reduce counting equipment background levels as necessary.

#### **9.3.2.6.6 Piping, Tubing, and Valves**

Sample piping, tubing, and valves are normally 304, 316, or 304L stainless steel designed to assure turbulent flow ( $RE \geq 4,000$ ). Sample lines between the containment isolation valves, and containment isolation valves, are ASME Section III, Class 2.

Sample lines outside containment are ANSI B31.1. The minimum tube size is 1/4 or 3/8 inch and root valves are 1/2 inch.

Sample lines are routed to be as short as practical, avoiding traps, dips, and deadlegs if possible to the PASF. Provisions have been incorporated to allow flushing of sample lines to reduce unnecessary radiation exposure to operating personnel. Also, consideration has been given to the routing of sample and waste return lines so that the radiation field of the pipe is consistent with the zone of the area it traverses. This is also accomplished by normally routing lines through shielded pipe tunnels, trenches, or chases.

All sample lines have been thermally evaluated to assure that pipe expansion caused by high operating temperatures does not impact the integrity of the sample piping or supports.

### 9.3.2.6.7 Safety Evaluation

The design life of all major components, equipment, and instrumentation is 40 years (100 days during accident conditions). The PASF does not serve a safety-related function.

### 9.3.2.6.8 Tests and Inspections

The postaccident sampling (PAS) equipment is preoperationally tested before startup. Instruments are calibrated and tested to verify equipment readiness. This equipment is used periodically to simulate actual sampling techniques for personnel training purposes.

## 9.3.3 Equipment and Floor Drainage System

### 9.3.3.1 Design Bases

Equipment drains and floor drains in the Auxiliary and Reactor Buildings are designed so that tritiated liquids (defined as liquids whose tritium concentration is 10% or more of the reactor water tritium concentration) are normally handled separately from nontritiated liquids, in so far as possible. Equipment drains and floor drains are routed to collector tanks in which the liquid can be held pending further treatment.

Except as specified below, Turbine Building drains are collected in the sump and periodically sampled as required by the NPDES permit for discharges.

Drainage in the condensate demineralizer area of the Turbine Building drains to the condensate polishing demineralizer sump. The sump contents are routed to the neutralization tank for processing and subsequent discharge. Drainage in the makeup water treatment plant area of the Turbine Building drains to the water treatment plant (WTP) waste sump. The WTP sump contents are routed to the alum sludge settling ponds. The supernatant from the alum sludge settling ponds is discharged to the yard Low Volume Waste Holding Pond.

### 9.3.3.2 System Design

The liquid drains are normally segregated into two basic systems. The first system collects all tritiated water. This system is further divided into aerated liquids, which are collected in the tritiated drain collector tank and deaerated liquids, which are collected in the reactor coolant drain tank or the CVCS holdup tank. This segregation promotes the recycling (if required) of radioactive tritiated liquids. The second system collects nontritiated water in the floor drain collector tank.

Detailed data for the various equipment and floor drains is presented in Table 9.3-3. Information contained in this table was generated from Attachment 2 of Westinghouse Letter, WAT-D-221. The flow and logic diagrams for the system are contained in Figures 9.3-7 to 9.3-14.

Critical exposed drain piping in the Control Building is supported per Seismic Category I(L) requirements.



Critical exposed drain piping in other areas where ESF equipment is located is supported per Seismic Category I(L) requirements.

Embedded drain piping in Category I structures is in seismically qualified concrete, and therefore meets seismic considerations in that the flow paths will remain inviolate during a safe shutdown earthquake.

#### **9.3.3.2.1 Drains from Lowest Floor Level in the Auxiliary Building**

In the Auxiliary Building, most equipment is located at an elevation which permits gravity feed into the desired drain collector tank. However, since the drain collector tanks are located on the lowest floor, the drains on this floor cannot be gravity fed to a drain collector tank. Therefore, there is an Auxiliary Building Floor and Equipment Drains (ABF & ED) sump and a tritiated sump. The drains on this floor are piped to the ABF & ED sump or to the tritiated sump. These sumps are then pumped to their respective drain tanks. There are sumps in the Additional Equipment Buildings that are normally pumped to the floor drain collector tank.

Excess fluid due to flooding would be collected in the ABF & ED passive sump. This passive sump is large enough to contain any postulated major rupture Watts Bar could experience with the exception of an unisolable break in the RWST discharge header. In the event this break occurs, flooding on Elevation 674.0 and 676.0 is minimized by transferring water to storage locations available inside the Auxiliary Building. Most equipment components sit on foundations high enough to keep them above most flood levels. Floor drains were provided in all areas where there is possibility of major rupture. Leak detectors are located where required in the Auxiliary Building and Reactor Building to alarm for a buildup of water on the floor.

#### **9.3.3.2.2 Residual Heat Removal Pump (RHR) and Containment Spray Pump (CSP) Compartments**

Each residual heat removal pump and containment spray pump is located in a separate curbed compartment designed to control any leakage. There is a small sump located in each compartment with a drain pipe extending above the bottom of the sump. There are 2 weep holes of 1/2 inch diameter in the drain pipe at the sump bottom to take care of small ordinary seepage. The drain pipe is designed to handle a leakage of 50 gpm and is piped to the Auxiliary Building floor and equipment drain sump. A water level detector is located in each RHR and CSP compartment sump to sound an alarm prior to overflowing in the drain pipe. An emergency drain is provided in each RHR and containment spray pump room, as shown in Figure 1.2-7, plan Elevation 676.0. These drains are provided to direct large breaks to the large, ABF & ED passive sump volume above Elevation 666.

The design basis for the emergency drains is to provide environmental isolation for each separately drained area unless needed for drainage purposes. These functions are assured by installing a breakaway plate in a 4-foot by 4-foot square hole in each room, which is held in place by breakaway bolts. If drainage into the room exceeds the capacity of the normal drain and flows over a small lip surrounding the breakaway emergency drain hole, the weight of approximately 2 feet 8 inches of water above the

emergency drain causes failure of the bolts and a large drain is established to remove water from the pump room. Water then released to the ABF & ED passive sump can be processed by opening the passive sump to the ABF & ED sump by means of a 6 inch valve.

#### **9.3.3.2.3 CVCS Holdup Tank Compartment and Tritiated Drain Collector Tank Room**

The CVCS holdup tanks are located in separate watertight rooms designed to contain the tank contents should a tank rupture. The tritiated drain collector tank is in a curbed room designed to contain the tank volume should there be a rupture. A drain with a normally closed valve is provided from each room to the building sump. In case of a rupture, the valve keeps the water within the room until the level of the drain collector tank is lowered to handle the additional volume of water.

Since these tanks are not essential, the rooms are not designed to exclude flood water. In case of flooding, the tanks are filled with a sufficient volume of water to prevent flotation and are sealed.

Both open and closed drains are provided in the tritiated system. The open drains are defined as being open to the atmosphere, and they usually empty into a funnel connected to the embedded drain header. The closed drains are connected directly to the drain header and are not open to the atmosphere. The embedded drain headers are normally routed to an 8 inch horizontal collection header at the tritiated drain collector tank. This header has a blind flange at each end to aid in cleaning. The various drain headers normally extend through the top of the 8 inch collection header to within 1-1/2 inches of the bottom of the header. The outlet from the 8 inch collection header to the tritiated drain collector tank is normally a 4 inch pipe welded to the upper half of the 8 inch pipe. This provides a 2 inch water seal in the 8 inch pipe at all times.

The floor drain collector tank, in addition to receiving the floor drains, also collects nontritiated open and closed equipment drains. These drains are normally piped to an 8 inch header at the floor drain collector tank where a water seal is maintained at all times. The 8 inch header normally has a 4 inch pipe welded to the top half which discharges to the floor drain collector tank. This ensures a 2 inch water seal. Some of the floor drains located in areas where a strong possibility exists for a tritium leak are provided with solid stainless steel cover plates to prevent tritium from entering the systems. The use of floor drains has been limited to areas where an emergency need for them exists. The floor drains are normally not used for regular maintenance washdown.

#### **9.3.3.2.4 Volume Control Tanks**

The volume control tanks are located in rooms with a curb to contain the liquid in case of a rupture. A floor drain is provided and piped separately to the floor drain collector tank to provide rapid room drainage.

#### 9.3.3.2.5 Boric Acid Tanks

The boric acid tanks are enclosed by a curb designed to contain the acid should there be a major tank leak. A number of floor drains are located within this area with a valve on the drain header to the floor drain collector tank. This valve permits the containment of the boric acid until it is pumped by a portable pump to other storage tanks. In case there are no storage tanks available, the acid can be diluted before being released to the floor drain collector tank.

#### 9.3.3.3 Drains - Reactor Building

Most equipment drains in the Reactor Building are for tritiated deaerated liquids which are piped to the reactor coolant drain tank. The reactor coolant drain pumps, pump this liquid to either the CVCS holdup tanks or to the tritiated drain collector tank in the Auxiliary Building.

The annulus floor drains are piped to the annulus sump which is emptied by gravity to the ABF & ED passive sump by opening a 10-inch butterfly valve in the Auxiliary Building.

The rest of the floor drains and equipment drains are piped to either the Reactor Building Floor and Equipment Drains (RBF&ED) sump or the RBF&ED pocket sump. The RBF & ED sump pumps automatically pump this liquid to the tritiated drain collector tank in the Auxiliary Building. If analysis shows the liquid is nontritiated it can be pumped to the floor drain collector tank.

#### 9.3.3.4 Design Evaluation

The drains are segregated and leakage is contained to ensure that there is no leakage of fluid or fumes to the atmosphere. This has been accomplished with the use of water seals or traps in drain lines where there is a possibility of cross-ventilation. See Chapter 11 for a more in-depth evaluation.

There is no mechanism for an inadvertent transfer of contaminated fluids to the non-contaminated drainage system. In the Auxiliary and Reactor Buildings only contaminated drain systems are provided.

#### 9.3.3.5 Tests and Inspections

Open equipment and floor drains are periodically monitored to ensure that there is no cross-ventilation. The water seals and traps are serviced by periodic addition of water through the drain and drains are inspected periodically for blockage.

#### 9.3.3.6 Instrumentation Application

Instrumentation related to this system is described in Chapter 11.

#### 9.3.3.7 Drain List

The following are the tanks used to collect drains from the NSSS:

- (1) Chemical Drain Tank (CDT) - collects radioactive sample waste from laboratory. (Described in Chapter 11, Radioactive Waste Management )
- (2) Component Cooling Surge Tank (CCST) - collects water from component cooling equipment drains.
- (3) Reactor Building Floor and Equipment Drain (RBF&ED) Sump and the RBF&ED Pocket Sump - collect water from floor drains and aerated equipment drains inside the containment, and the sump pumps can be directed to the FDCT or the TDCT.
- (4) Floor Drains Collector Tank (FDCT) - collects non-tritiated equipment and floor drains.
- (5) Laundry and Hot Shower Drain Tank (LHSDT) - collects water from laundry and hot showers (described in Chapter 11).
- (6) CVCS Holdup Tank (CVCS HUT) - collects deaerated tritiated water (reactor grade) inside the containment.
- (7) Tritiated Drain Collector Tank (TDCT) - collects aerated tritiated water in the Auxiliary Building, via the drain header (DH), from the RCDT and RBF&ED sump and RBF&ED pocket sump in containment and from the tritiated sump.
- (8) Component Cooling System (CCS) Pump Seal Leakage Collection Tank (SLCT) - collects seal leakage from CCS pumps and returns source to CCS, or to FDCT.

### 9.3.4 Chemical and Volume Control System

The chemical and volume control system (CVCS) is shown in Figure 9.3-15.

#### 9.3.4.1 Design Bases

The CVCS provides the following services to the RCS.

- A. Maintains the coolant inventory in the RCS within the allowable pressurizer level range for all normal modes of operation including startup from cold shutdown, full power operation and plant cooldown. This system also has sufficient makeup capacity to maintain the minimum required inventory in the event of minor RCS leaks.
- B. Supplies filtered water to each reactor coolant pump (RCP) seal, as required by the RCP design.
- C. Provides a means for adding chemicals to the RCS. These chemicals control the pH of the reactor coolant, scavenge oxygen from the reactor coolant during startup, counteract the production of oxygen in the RC due to radiolysis of water in the core region, chemically degas the RCS during the shutdown, and modify the primary system corrosion film layer. (The CVCS maintains the RCS water chemistry within the limits specified in Table 5.2-10.)

- D. Removes fission and activation products, and zinc in ionic form or as particulates, from the RC in order to provide limited access to those process lines carrying reactor coolant during operation and to reduce activity releases due to leaks.
- E. Collects and processes excess borated water and regulates the concentration of chemical neutron absorber (boron) in the RC to control reactivity changes resulting from the change in reactor coolant temperature between cold shutdown and hot full-power operation, burnup of fuel and burnable poisons, buildup of fission products in the fuel, and xenon transients. The CVCS is capable of borating the RCS through either one of two flow paths and from either one of two boric acid sources. The amount of boric acid retained and ready for injection always exceeds that amount required to borate the RCS to cold shutdown concentration assuming that the control assembly with the highest reactivity worth is stuck in its fully withdrawn position. This amount of boric acid also exceeds the amount required to bring the reactor to hot shutdown and to compensate for subsequent xenon decay.
- F. Provides reactor coolant makeup via the primary water makeup pumps to the VCT.
- G. Provides, via the centrifugal charging pumps, high-head safety injection for the emergency core cooling system. Other than the centrifugal charging pumps and associated piping and valves, the CVCS is not required to function during a loss-of-coolant accident (LOCA). During a LOCA, both centrifugal charging pumps serve as high head ECCS pumps by taking suction from the RWST and injecting borated water to the boron injection line and the RCP seals. The CVCS is isolated except for the centrifugal charging pumps and the piping in the safety injection path, and the supply to the RCP seals.

#### 9.3.4.2 System Description

The CVCS consists of several subsystems: the charging, letdown and seal water system; the reactor coolant purification and chemistry control system; and the reactor makeup control system.

- A. Charging, and Letdown (Inventory Control)

The CVCS maintains a programmed water level in the RCS pressurizer, thus maintaining proper reactor coolant inventory during all phases of plant operation. This is achieved by means of continuous feed and bleed process during which the feed rate is automatically controlled based on pressurizer water level. The bleed rate can be chosen to suit various plant operational requirements by selecting the proper combination of letdown orifices in the letdown flow path.

RC is discharged to the CVCS from a reactor coolant loop cold leg; it then flows through the shell side of the regenerative heat exchanger where its temperature is reduced by heat transfer to the charging flow passing through the tubes. The coolant then experiences a large pressure reduction as it passes through the letdown orifice(s) and flows through the tube side of the letdown heat exchanger where its temperature is further reduced. Downstream of the letdown heat exchanger a second pressure reduction occurs through the low pressure letdown valve. This second pressure

reduction maintains sufficient pressure upstream of the low pressure letdown valve to prevent flashing downstream of the letdown orifices.

The RC then normally flows through the mixed bed demineralizers. If additional purification of RC is required the flow can be directed to the cation bed demineralizer. (If the temperature of the coolant exceeds the temperature limit of the demineralizer a temperature control valve will bypass flow around the demineralizer).

The coolant then flows through the reactor coolant filter and into the VCT through a spray nozzle in the top of the tank. If the VCT is full, the excess RC is directed to the HUT for future use or disposal. The VCT is pressurized by hydrogen which is used for control of oxygen that is produced by radiolysis of water in the core. The partial pressure of hydrogen in the VCT determines the concentration of hydrogen dissolved in the reactor coolant. A remotely operated vent allows the removal of hydrogen and fission gases stripped from the reactor coolant. The contaminated hydrogen is vented back to the gaseous waste processing system.

Two centrifugal charging pumps take suction from the VCT and return the cooled, purified RC to the RCS. The charging flow splits into two paths. The bulk of the flow is pumped back to the RCS through the tube side of the regenerative heat exchanger. The second flow path provides the coolant to the RCP seals [see section 9.3.4.2(B)]. The letdown flow in the shell side of the regenerative heat exchanger raises the charging flow to a temperature approaching the RC temperature. The flow is then injected into a cold leg of the RCS. Two charging paths are provided from a point downstream of the regenerative heat exchanger. A flow path is also provided from the regenerative heat exchanger outlet to the pressurizer spray line. An air-operated valve in the spray line is employed to provide auxiliary spray to the vapor space of the pressurizer during plant cooldown.

The excess letdown path is provided as an alternate letdown path from the RCS in the event that the normal letdown path is inoperable. Reactor coolant can be discharged from a cold leg to flow through the tube side of the excess letdown heat exchanger where it is cooled by component cooling water. Downstream of the heat exchanger a remote-manual control valve controls the letdown flow. The flow path normally joins the number 1 seal discharge manifold and passes through the seal water return filter and heat exchanger to the suction side of the charging pumps. The excess letdown flow can also be directed to the reactor coolant drain tank. When the normal letdown line is not available, the normal purification path is also not in operation. Therefore this alternate condition would allow continued power operation for a limited period of time, dependent on RCS chemistry and activity. The excess letdown flow path is also available and can be used if needed to provide additional letdown capability during the final stages of plant heatup. This path removes some of the excess reactor coolant due to expansion of the system as a result of the RCS volume increase.

Surges in RCS volume due to load changes are accommodated for the most part in the pressurizer. The VCT provides additional surge capacity for reactor coolant expansion. If the water level in the VCT exceeds the normal operating range, a proportional controller modulates a three-way valve downstream of the reactor coolant

filter to divert a portion of the letdown to the HUT. If the high-level limit in the VCT is reached, an alarm is actuated in the control room and the letdown flow is completely diverted to the HUT.

Low level in the VCT initiates makeup from the reactor makeup control system. If the reactor makeup control system does not supply sufficient makeup to keep the VCT level from falling to a lower level, a low alarm is actuated. Manual action is taken to correct the situation. If the level continues to decrease, an emergency low level signal from both of the level channels causes the suction of the charging pumps to be transferred to the RWST.

#### B. Reactor Coolant Pump Seal Water Flow

A portion of the charging flow is directed to the reactor coolant pumps (nominally 8 gpm per pump) through a seal water injection filter. It is directed to a point between the pump shaft bearing and the thermal barrier cooling coil. Here the flow splits and a portion (nominally 5 gpm per pump) enters the RCS through the labyrinth seals and thermal barrier. The remainder of the flow is directed up the pump shaft, cooling the lower bearing, and to the number 1 seal. The number 1 seal leak-off flow discharges to a common manifold, exits from the containment, and then passes through the seal water return filter and the seal water heat exchanger to the suction side of the charging pumps, or by alternate path to the volume control tank. A very small portion of the seal flow leaks through to the number 2 seal. The number 3 seal provides a final barrier to leakage of reactor coolant to the containment atmosphere. The number 2 and 3 leak-off flow is discharged to the reactor coolant drain tank in the waste disposal system.

#### C. Reactor Coolant System Water Chemistry Control

Reactor coolant chemistry specifications are given in Table 5.2-10.

##### (1) pH Control

Lithium hydroxide is used to control the pH of the reactor coolant. This chemical is chosen for its compatibility with the materials and water chemistry of borated water/stainless steel/zirconium/inconel systems. Lithium-7 is produced in the core region due to irradiation of the dissolved boron in the coolant.

The concentration of Lithium-7 in the RCS is maintained for pH control. If needed, the cation bed demineralizer is employed to reduce lithium in the letdown line in series operation with a mixed bed demineralizer. If cation bed is unavailable, the mixed bed, with appropriate resins, may be utilized to reduce lithium. Since the amount of lithium to be removed is small and its buildup can be readily calculated, the flow through the cation bed demineralizer is not required to be full letdown flow. If the concentration of Lithium-7 is below the desired values lithium hydroxide can be introduced into the RCS via the charging flow. The solution is prepared in the laboratory and poured into the chemical mixing tank. Reactor makeup water is then used to flush the solution to the suction manifold of the charging pumps.

##### (2) Oxygen Control

During reactor startup from shutdown condition, hydrazine may be employed as an oxygen scavenging agent. The hydrazine solution is introduced into the RCS in the same manner as described above for the pH control agent. Dissolved hydrogen is employed to control and scavenge oxygen produced due to radiolysis of water in the core region. Sufficient partial pressure of hydrogen is maintained in the VCT such that the specified equilibrium concentration of hydrogen is maintained in the RC. A pressure control valve maintains a minimum pressure in the vapor space of the VCT. This valve can be adjusted to provide the correct equilibrium hydrogen concentration (See Table 5.2-10). Hydrogen is supplied from the hydrogen manifold in the waste disposal system.

### (3) Activity Level

Mixed bed demineralizers are provided in the letdown line to cleanup the letdown flow. The demineralizers remove ionic corrosion products and certain fission products. One demineralizer is normally in service and can be supplemented intermittently by the cation bed demineralizer, if necessary. The cation resin removes principally cesium and lithium isotopes from the purification flow. The second mixed bed demineralizer serves as a standby unit for use if the operating demineralizer becomes exhausted during operation. A further cleanup feature is provided for use during cold shutdown and RHR. A remotely operated valve admits a bypass flow from the RHR system into the letdown line upstream of the letdown heat exchanger. The flow passes through the heat exchanger, through a mixed bed demineralizer and the reactor coolant filter to the VCT. The fluid is then returned to the RCS via the normal charging route. To accelerate shutdown cleanup, letdown and associated charging flow may be increased beyond the normal flow rates. See Tables 9.3-4 and 9.3-5. Filters are provided at various locations to ensure filtration of particulate and resin fines and to protect the seals on the RCP.

### (4) Neutron Absorber (boron) Concentration Control

The reactor makeup control system consists of a group of instruments arranged to provide a manually preselected makeup composition to the charging pump suction header or the VCT. The makeup control function maintains the desired operating fluid inventory in the VCT and adjust RC boron concentration for reactivity control. For emergency boration and makeup, the capability exists to provide refueling water at 3100 to 3300 ppm boron directly to the suction of the charging pumps.

The boric acid is stored in three boric acid tanks. Four two-speed boric acid transfer pumps are provided with one or more pumps normally aligned with one or more boric acid tanks and continuously running at low speed to provide recirculation within the boric acid system and the boric acid tank. One or more pumps may be on stand-by. On a demand signal from the reactor makeup control system, the stand-by boric acid transfer pump may be started or the recirculation pump is shifted to high speed and delivers boric acid as required.



During reactor operation, changes are made in the reactor coolant boron concentration for the following conditions:

- (a) Reactor startup - boron concentration must be decreased from shutdown concentration to achieve criticality.
- (b) Load follow - boron concentration must be either increased or decreased to compensate for the xenon transient following a change in load.
- (c) Fuel burnup - boron concentration must be decreased to compensate for fuel burnup and the buildup of fission products in the fuel.
- (d) Cold shutdown - boron concentration must be increased to the cold shutdown concentration.

(5) Makeup

The primary makeup water pumps, taking suction from the primary water storage tank, are employed for various makeup and flushing operations throughout the systems. One of these pumps operates continuously and provides flow to the blender as needed.

The reactor makeup control system can be set up for the following modes of operation:

(a) Automatic Makeup

The "automatic makeup" mode of operation provides blended boric acid solution, preset to match the boron concentration in the RCS. Automatic makeup compensates for minor leakage of reactor coolant without causing significant changes in the reactor coolant boron concentration.

Under normal plant operating conditions, the mode selector switch is set in the "automatic makeup" position. This switch position establishes a preset control signal to the total makeup flow controller and establishes positions for the makeup stop valves for automatic makeup. The boric acid flow controller and primary water flow controller are set to blend to the same concentration of borated water as contained in the RCS. A preset low level signal from the VCT level controller initiates automatic makeup by shifting the operating boric acid transfer pump to high speed, opening the makeup stop valve to the charging pump suction, and positioning the boric acid flow control valve and the primary makeup water flow control valve. Since a primary makeup water pump runs continuously, automatic starting of this pump is not required. However, these pumps will be deenergized when the primary water storage tank is being bypassed. The primary makeup water will be supplied from the demineralized water and cask decontamination system. The flow controllers then blend the makeup stream according

to the preset concentration. Makeup addition to the charging pump suction header causes water level in the VCT to rise. At a preset high level point, the makeup is stopped. This operation may be terminated manually at any time.

If the automatic makeup fails or is not aligned for operation and the tank level continues to decrease, a low level alarm is actuated. Manual actions may correct the situation or, if the level continues to decrease, an emergency low level signal opens the stop valves in the refueling water supply line to the charging pumps, and closes the stop valves in the VCT outlet line.

(b) Dilution

The "dilute" mode of operation permits the addition of a preselected quantity of reactor makeup water at a preselected flow rate to the RCS. The operator sets the mode selector switch to "dilute," the total makeup flow controller set point to the desired flow rate, the total makeup batch integrator to the desired quantity and initiates system start. This opens the reactor makeup water flow control valve, and opens the makeup stop valve to the VCT inlet. Excessive rise of the VCT water level is prevented by automatic actuation (by the tank level controller) of a three-way diversion valve which routes the reactor coolant letdown flow to the HUT. When the preset quantity of water has been added, the batch integrator causes makeup to stop. The operation may be terminated manually at any time.

(c) Alternate Dilution

The "alternate dilute" mode of operation is similar to the dilute mode except a portion of the dilution water flows directly to the charging pump suction and a portion flows into the VCT via the spray nozzle and then flows to the charging pump suction. This decreases the delay in diluting the RCS caused by directing dilution water to the VCT.

(d) Boration

The "borate" mode of operation permits the addition of a preselected quantity of concentrated boric acid solution at a pre-selected flow rate to the RCS. The operator sets the mode selection switch to "borate", the concentrated boric acid flow controller setpoint to the desired flow rate, the concentrated boric acid batch integrator to the desired quantity, and initiates system start. This opens the makeup stop valve to the charging pump suction, positions the boric acid flow control valve, and transfers the selected boric acid transfer pump to hi-speed, which delivers 3.5 to 4.0% weight (wt) boric acid solution to the charging pump suction header. The total quantity added in most cases is so small that it has only a minor effect on the VCT level. When the preset quantity of concentrated boric acid solution is added, the batch integrator causes

makeup to stop. Also, the operation may be terminated manually at any time.

(e) Manual

The "manual" mode of operation permits the addition of a pre-selected quantity and blend of boric acid solution to the refueling water storage tank, VCT, HUT, or to some other location via a temporary connection. The discharge flow path to places other than the VCT must be aligned by opening manual valves in the desired path.

The operator sets the mode selector switch to "manual", the boric acid and total makeup flow controllers to the desired flow rates, the boric acid and total makeup batch integrators to the desired quantities, and actuates the makeup start switch.

The start switch actuates the boric acid flow control valve and the reactor makeup water flow control valve and transfers the pre-selected boric acid transfer pump to high-speed.

When the preset quantities of boric acid and reactor makeup water have been added, the batch integrators cause makeup to stop. This operation may be stopped manually by actuating the makeup stop switch. If either batch integrator is satisfied before the other has recorded its required total, the pump and valve associated with the integrator which has been satisfied will terminate flow. The flow controlled by the other integrator will continue until that integrator is satisfied.

The quantities of boric acid and reactor makeup water injected are totaled by the batch counters and the flow rates are monitored by the plant computer system which provides recorded data capability. Deviation alarms sound for both boric acid and reactor makeup water if flow rates deviate from setpoints.

### 9.3.4.2.1 Component Description

A summary of principal component design parameters is given in Table 9.3-5, and safety classifications and design codes are given in Section 3.2.

A. Pumps

(1) Charging Pumps

Two charging pumps are supplied to inject coolant into the RCS. The pumps are of the single speed, horizontal, centrifugal type. All parts in contact with the reactor coolant are fabricated of austenitic stainless steel or other material of adequate corrosion resistance. The CCS system provides normal cooling water to the CCP lube and gear oil coolers for pumps 2A-A and 2B-B. ERCW, via the CCP 2A-A room cooler,

provides backup cooling water to the CCP 2A-A lube and gear oil cooler. There is a minimum flow recirculation line to protect the centrifugal charging pumps from a closed discharge valve condition. Charging flow rate is determined from a pressurizer level signal. When operating a centrifugal charging pump, the flow paths remain the same but charging flow control is accomplished by a modulating valve on the discharge side of the centrifugal pumps. The centrifugal charging pumps also serve as high head safety injection pumps in the emergency core cooling system. A description of the charging pump function upon receipt of safety injection signal is given in Section 6.3.2.2.

#### (2) Boric Acid Transfer Pumps

Two horizontal, centrifugal, two speed pumps with mechanical seals are supplied for each unit. One pump of each pair is aligned with one boric acid tank and runs continuously at low speed to provide recirculation of the boric acid system and boric acid tank. The second pump of each pair is aligned with the third boric acid tank and is considered as a standby pump, with service being transferred as operation requires. These standby pumps also intermittently circulate fluid through the third tank. Manual or automatic initiation of the reactor makeup control system will activate the running pump for that unit to the higher speed to provide normal makeup of boric acid solution as required. For emergency boration, supplying of boric acid solution to the suction of the charging pump can be accomplished by manually actuating one or two pumps. The transfer pumps also function to transfer boric acid solution from the batching tank to the boric acid tanks. In addition to the automatic actuation by the makeup control system and manual actuation from the main control board, these pumps may also be controlled locally.

#### (3) Holdup Tank Recirculation Pump

The recirculation pump is used to mix the contents of a holdup tank for sampling or to transfer the contents of a holdup tank to another holdup tank. When one of the holdup tanks is used to store water from the fuel transfer canal, the recirculation pump is used to return the water to the transfer canal. The pump is the centrifugal type, manually actuated, with all wetted surfaces constructed of austenitic stainless steel.

#### (4) Gas Stripper Feed Pumps

Three centrifugal type gas stripper pumps are constructed of austenitic stainless steel. These pumps were originally part of the boric acid recovery system which is not used for unit operation. These pumps are used to provide a flow path from the HUT to the waste disposal system.

### B. Heat Exchanger

#### (1) Regenerative Heat Exchangers

The regenerative heat exchanger is designed to recover heat from the letdown flow by reheating the charging flow, which reduces thermal effects on the charging penetrations into the reactor coolant loop piping. The unit is constructed of austenitic

stainless steel, and is of all welded construction. The temperatures of both outlet streams from the heat exchanger are monitored with indication given in the control room. A high temperature alarm is actuated on the main control board if the temperature of the letdown stream exceeds desired limits.

### (2) Letdown Heat Exchanger

The letdown heat exchanger cools the letdown stream to the operating temperature of the mixed bed demineralizers. Reactor coolant flows through the tube side of the exchanger while component cooling water flows through the shell side. Surfaces in contact with the reactor coolant are austenitic stainless steel, and the shell is carbon steel.

The low pressure letdown valve, located downstream of the heat exchanger, maintains the pressure of the letdown flow upstream of the heat exchanger in a range sufficiently high to prevent two phase flow. Pressure indication and high pressure alarm are provided on the main control board.

The letdown temperature control indicates and controls the temperature of the letdown flow exiting from the letdown heat exchanger. A temperature sensor, which is part of the CVCS, provides input to the controller in the component cooling system. The exit temperature of the letdown stream is thus controlled by regulating the component cooling water flow through the letdown heat exchanger. Temperature indication is provided on the main control board. If the outlet temperature from the heat exchanger is excessive, a high temperature alarm is actuated and a temperature controlled valve diverts the letdown directly to the VCT. Valve failure mode also directs flow to the VCT.

The outlet temperature from the shell side of the heat exchanger is allowed to vary over an acceptable range compatible with the equipment design parameters and required performance of the heat exchanger in reducing letdown stream temperature.

### (3) Excess Letdown Heat Exchanger

The excess letdown heat exchanger cools reactor coolant letdown flow at a rate which is equivalent to the portion of the nominal seal injection flow which flows into the RCS through the RCP labyrinth seals.

The excess letdown heat exchanger can be employed either when normal letdown is temporarily out of service to maintain the reactor in operation or it can be used to supplement maximum letdown during the final stages of heatup. The letdown flows through the tube side of the unit and component cooling water is circulated through the shell. Surfaces in contact with reactor coolant are austenitic stainless steel and the shell is carbon steel. Tube joints are welded.

A temperature detector measures the temperature of the excess letdown flow downstream of the excess letdown heat exchanger. Temperature indication and high temperature alarm are provided on the main control board.

A pressure sensor indicates the pressure of the excess letdown flow downstream of the excess letdown heat exchanger and excess letdown control valve. Pressure indication is provided on the main control board.

#### (4) Seal Water Heat Exchanger

The seal water heat exchanger is designed to cool fluid from three sources: RCP number 1 seal leakage, reactor coolant discharged from the excess letdown heat exchanger, and miniflow from a centrifugal charging pump. Reactor coolant flows through the tube side of the heat exchanger and component cooling water is circulated through the shell. The design flow rate through the tube side is equal to the sum of the nominal excess letdown flow, maximum design RCP seal leakage, and miniflow from one centrifugal charging pump. The unit is designed to cool the above flow to the temperature normally maintained in the VCT. Surfaces in contact with reactor coolant are austenitic stainless steel and the shell is carbon steel.

### C. Tanks

#### (1) Volume Control Tank

The VCT provides surge capacity for part of the reactor coolant expansion volume not accommodated by the pressurizer. Overfilling of the VCT is prevented by automatic diversion of the letdown stream to the HUT. The VCT also provides a means for introducing hydrogen into the coolant to maintain the required equilibrium concentration and is used for degassing the reactor coolant. It also serves as a head tank for the charging pumps.

Venting of hydrogen gas which may come out of solution and collect in the charging pump suction lines is provided through three vent lines which are connected to piping high points between the VCT and the charging pumps. These vent lines are connected to a header which then connects to the VCT vent line upstream of the vent valve.

A spray nozzle located inside the tank on the letdown line provides liquid to gas contact between the incoming fluid and the hydrogen atmosphere in the tank.

Hydrogen (from the hydrogen manifold in the waste disposal system) is continuously available to the VCT while a remotely operated vent valve, discharging to the waste disposal system, permits removal of gaseous fission products which are stripped from the reactor coolant and collected in this tank. Relief protection, gas space sampling, and nitrogen purge connections are also provided. The tank can also accept the seal water return flow from the RCPs although this flow normally goes directly to the suction of the charging pumps.

VCT pressure and temperature are monitored with indication given in the control room. Alarm is actuated in the control room for high and low pressure conditions and for high temperature. The VCT pressure control valve is automatically closed by the low pressure signal.

Two level channels govern the water inventory in the VCT. These channels are input to a distributed control system (DCS) which provides signals for local and remote level indication, level alarms, level control, makeup control, and emergency makeup control. An average of the two level signals is provided for normal control. If a failed channel is detected by the DCS, the other channel will be used for control.

If the VCT level rises above the normal operating range, a proportional controller modulates the three-way valve downstream of the reactor coolant filter to maintain VCT level within the normal operating band. The three-way valve can split letdown flow so that a portion goes to the holdup tanks and a portion to the VCT. The controller would operate in this fashion during a dilution operation when reactor makeup water is being fed to the VCT from the reactor makeup control system.

If the modulating function of the control system fails and the VCT level continues to rise, the high level alarm will alert the operator to the malfunction and the full letdown flow will be automatically diverted by a high level interlock.

During normal power operation, a low level in the VCT initiates auto makeup which injects a pre-selected blend of boric acid solution and reactor makeup water into the charging pump suction header. When the VCT level is restored to normal, auto makeup stops.

If the automatic makeup fails or is not aligned for operation and the tank level continues to decrease, a low level alarm is actuated. If the level continues to decrease, a low-low signal from both of the level channels opens the isolation valves in the refueling water supply line. This signal also closes the isolation valves in the VCT outlet line which in turn closes the isolation valves of the hydrogen vent header for the charging pump suction side piping. Failure of the VCT level controller may require operator action to prevent damage to the charging pump. Following a low level alarm, the operator would have sufficient time to transfer the charging pump suction to the RWST, stop the pump or restore letdown to the VCT to prevent pump damage.

## (2) Chemical Mixing Tank

The primary use of the chemical mixing tank is in the preparation of caustic solutions for pH control and hydrazine solution for oxygen scavenging.

## (3) Batching Tank

The batching tank is used for mixing a makeup supply of boric acid solution for transfer to the boric acid tanks. A local sampling point is provided for verifying the solution concentration prior to transferring it out of the tank. The tank is provided with an agitator to improve mixing during batching operations and electric strip heaters to heat the tank contents to expedite dissolution of boric acid.

## (4) Holdup Tanks

Two holdup tanks hold radioactive liquid which enters from the letdown line or other sources. The liquid is released from the RCS during startup, shutdowns, load changes

and from boron dilution to compensate for burnup. When it is necessary to empty the fuel transfer canal, one of the tanks is emptied and is used to store the canal water.

#### (5) Boric Acid Tanks

Approximately two and one-half full tanks of 4% wt boric acid solution (based on 9,890 gallons usable volume per tank) are required for shutdown and refueling of one unit. This is normally the most limiting evolution that an operator must perform involving system boration, i.e., the addition of maximum amount of boron to the RCS. Two tanks, one for each unit, supply boric acid for each reactor coolant makeup system during normal operation, while the third tank serves as a spare.

The concentration of boric acid solution in storage is maintained between 3.5 and 4% by weight. Periodic manual sampling and corrective action, if necessary, ensure that these limits are maintained. As a consequence, measured boric acid solution can be delivered to the reactor coolant to control the chemical poison concentration. The combination overflow and breather vent connection has a water loop seal to minimize vapor discharge during storage of the solution.

Manually-operated electric immersion heaters in each boric acid tank can raise the temperature of boric acid solution to 100°F, if required. The heaters are sheathed in austenitic stainless steel.

One temperature detector provides temperature measurement of each tank's contents. Local temperature indication is provided and high and low temperature alarms are indicated on the main control board. A level detector indicates the level in each boric acid tank. Level indication with high and low level alarms is provided on the main control board. The low alarm is set to indicate the minimum level of boric acid in the tank to ensure sufficient boric acid to provide suction head to the boric acid transfer pumps.

### D. Demineralizers

#### (1) Mixed Bed Demineralizers

Two flushable mixed bed demineralizers assist in maintaining reactor coolant purity. A cation resin and anion resin are charged into the demineralizers. The anion resin is converted to the borate form in operation.

Both types of resin remove fission and corrosion products. The resin bed is designed to reduce the concentration of ionic isotopes in the purification stream, except for cesium, yttrium and molybdenum, by a minimum factor of 10. If cation bed is unavailable, the mixed bed with appropriate resin may be used to reduce lithium.

Each demineralizer has more than sufficient capacity for one core cycle with 1% of the rated core thermal power being generated by defective fuel rods. One demineralizer is normally in service with the other in standby.



## (2) Cation Bed Demineralizer

A flushable demineralizer with cation resin in the hydrogen form is located downstream of the mixed bed demineralizers and is used intermittently to control the concentration of Lithium-7 which builds up in the coolant from the  $B^{10} (N, \alpha)$  Lithium-7 reaction. The demineralizer also has sufficient capacity to maintain the Cesium-137 concentration in the coolant below  $1.0 \mu\text{Ci/cc}$  with 1% defective fuel. The resin bed is designed to reduce the concentration of ionic isotopes, particularly cesium and lithium.

The demineralizer has more than sufficient capacity for one core cycle with 1% of the rated core thermal power being generated by defective fuel rods.

## E. Filter

### (1) Reactor Coolant Filter

The reactor coolant filter is located in the letdown line downstream of the mixed bed and cation bed demineralizer. The filter collects resin fines and particulates from the letdown stream. The nominal flow capacity of the filter is equal to the maximum purification flow rate.

Two local pressure indicators are provided upstream and downstream of the reactor coolant filter to provide filter differential pressure.

### (2) Seal Water Injection Filters

Two seal water injection filters are located in parallel in a common line to the reactor coolant pump seals; they collect particulate matter that could be harmful to seal faces. Each filter is sized to accept flow in excess of the normal seal water flow requirements.

A differential pressure indicator monitors the pressure drop across each seal water injection filter and gives local indication with high differential pressure alarm on the main control board.

### (3) Seal Water Return Filter

This filter collects particulates from the reactor coolant pump seal water return and from the excess letdown flow. The filter is designed to pass the sum of the excess letdown flow and the maximum design leakage from all reactor coolant pumps.

Two local pressure indicators are provided to show the pressures upstream and downstream of the filter and thus provide indication of differential pressure across the filter.

### (4) Boric Acid Filter

The boric acid filter collects particulates from the boric acid solution being pumped from the boric acid tanks by the boric acid transfer pumps. The filter is designed to pass the design flow of two boric acid transfer pumps operating simultaneously. Local pressure

indicators indicate the pressure upstream and downstream of the boric acid filter and thus, can be used to provide filter differential pressure.

F. Boric Acid Blender

The boric acid blender promotes thorough mixing of boric acid solution and primary makeup water for the reactor coolant makeup circuit. The blender consists of a conventional pipe-tee. The blender decreases the pipe length required to homogenize the mixture for taking a representative local sample. A sample point is provided in the piping just downstream of the blender.

G. Orifices

(1) Letdown Orifices

Three letdown orifices are provided to reduce the letdown pressure from reactor conditions and to control the flow of reactor coolant leaving the RCS. The orifices are placed into or out of service by remote operation of their respective isolation valves. One orifice is designed for normal letdown flow with the other two serving as standby. One or both of the standby orifices may be used in parallel with the normally operating orifice for flow control when the RCS pressure is less than the maximum allowable during normal RHR operating conditions. Maximum purification letdown flow is limited to 120 gpm when RCS exceeds allowable RHR operating conditions. Each orifice consists of an assembly which provides for permanent pressure loss without recovery. In addition to the three letdown orifices noted above, another orifice has been provided to limit the rate of thermal change on the welds upstream of the Regenerative Heat Exchanger. All letdown orifice assemblies are made of austenitic stainless steel or other adequate corrosion resistant material.

A flow monitor provides indication in the control room of the letdown flow rate, and a high alarm to indicate unusually high flow.

A low pressure letdown controller located downstream of the letdown heat exchanger controls the pressure upstream of the letdown heat exchanger to prevent flashing of the letdown liquid. Pressure indication and high pressure alarm are provided on the main control board.

(2) Seal Water Return Bypass Orifice

An orifice in each reactor coolant pump number 1 seal bypass line can be in service during startup or shutdown when the RCS pressure is low. The bypass flow may be necessary to ensure adequate flow for cooling of the pump's lower radial bearing and to limit the temperature rise of the water cooling the number 1 seal. The orifice is constructed of austenitic stainless steel and designed to pass adequate flow for the differential pressure existing at the lowest allowable RCS pressure for reactor coolant pump operation.

(3) Chemical Mixing Tank Orifice

An orifice is provided in the piping upstream of the mixing tank. This orifice limits the flow rate through the tank to 2 gpm to avoid slugging the pump seals with concentrated chemicals.

#### (4) Reactor Coolant Pump Standpipe Orifice

A seal stand pipe which contains water applies a constant head to the reactor coolant pump No. 3 seal to minimize leakage along the reactor coolant pump shaft. An orifice is provided in the standpipe drain line to the reactor coolant drain tank to limit the rate of drainage from the standpipe to the design leakage rate for the No. 2 seal. An increase in the No. 2 seal leak rate would then result in an increase in standpipe level and an eventual high level alarm which would alert the operator of a possible reactor coolant pump seal failure.

#### (5) Charging Pump Bypass Orifices

A bypass orifice is provided for each centrifugal charging pump. The purpose of these orifices is to provide a minimum flow for pump protection.

#### (6) Boric Acid Tank Orifice

Each boric acid tank orifice is designed to pass the minimum flow required to provide sufficient recirculation through the piping and tanks with the transfer pumps. The orifice is constructed of austenitic stainless steel.

Alternatively, valves may have enhanced "live loads" packing allowing the lantern leak-off to be capped.

### H. Valves

Where pressure and temperature conditions permit, diaphragm type valves are used to essentially eliminate leakage to the atmosphere. All packed valves which are larger than 2 inches and which are designated for radioactive services are provided with stuffing box and lantern leak-off connections. Alternatively, valves may have enhanced "live load" packing allowing the lantern leak-off to be capped. All control (modulating) and three-way valves are either provided with stuffing box and leak-off connections or are totally enclosed. Leakage to the atmosphere is essentially zero for these valves. Basic material of construction is stainless steel for all valves which handle radioactive liquid or boric acid solutions.

Relief valves are provided for lines and components that might be pressurized above design pressure by improper operation or component malfunction.

#### (1) Check - Charging Line Downstream of Regenerative Heat Exchanger

If the charging side of the regenerative heat exchanger is isolated while the hot letdown flow continues at its maximum rate, the volumetric expansion of coolant on the charging side of the heat exchanger is relieved to the RCS through a spring-loaded check valve.

(2) Pressurizer Relief

(a) Letdown Line Downstream of Letdown Orifices

The pressure relief valve downstream of the letdown orifices protects the low pressure piping and the letdown heat exchanger from overpressure when the low pressure piping is isolated. The capacity of the relief valve is equal to the maximum flow rate through all letdown orifices. The valve set pressure is equal to the design pressure of the letdown heat exchanger tube side.

(b) Letdown Line Downstream of Low Pressure Letdown Valve

The pressure relief valve downstream of the low pressure letdown valve protects the low pressure piping and equipment from overpressure when this section of the system is isolated. The overpressure may result from leakage through the low pressure letdown valve. The capacity of the relief valve equals the maximum flow rate through all letdown orifices. The valve set pressure is equal to the design pressure of the demineralizers.

(3) Relief

(a) Volume Control Tank

The relief valve protects the VCT from over-pressurization when the tank normal outlet lines are closed and flow from several sources are still entering the tank. The valve set pressure is equal to the VCT design pressure minus valve inlet piping losses.

(b) Charging Pump Suction

A relief valve on the common charging pump suction header relieves pressure that may build up if the suction line isolation valves are closed or if the system is overpressurized. Also, each charging pump has a relief valve downstream of the suction isolation valve to provide overpressure protection of the suction piping in the event of check valve backleakage. Valve set pressure is equal to the design pressure of the associated piping and equipment.

(c) Seal Water Return Line (Inside Containment)

This relief valve is designed to relieve over-pressurization in the seal water return piping inside the containment if the motor-operated isolation valve is closed. The valve is designed to relieve the total leak-off flow from the No. 1 seals of the reactor coolant pumps plus the design excess letdown flow. The valve is set to relieve at the design pressure of the piping.

(d) Seal Water Return Line (Charging Pumps Bypass Flow)

This relief valve protects the seal water heat exchanger and its associated piping from over-pressurization. If either of the isolation valves for the heat exchanger are closed and if the bypass line is closed, the piping would be over-pressurized by the miniflow from the centrifugal charging pumps. The valve is sized to handle the miniflow from the centrifugal charging pumps. The valve is set to relieve at the design pressure of the heat exchanger.

*l.* Piping

All CVCS piping that handles radioactive liquid is austenitic stainless steel. All piping joints and connections are welded, except where flanged connections are required to facilitate equipment removal for maintenance and hydrostatic testing.

### 9.3.4.2.2 System Operation

A. Reactor Startup

- (1) Reactor startup is defined as the operations which bring the reactor from cold shutdown to normal operating temperature and pressure. It is assumed that:
  - (a) Normal residual heat removal is in progress.
  - (b) RCS boron concentration is at the cold shutdown concentration.
  - (c) Reactor makeup control system is set to provide makeup at the cold shutdown concentration.
  - (d) RCS is either water solid or drained to minimum level for the purpose of refueling or maintenance. If the RCS is water solid, system pressure is maintained by operation of a charging pump and controlled by the low pressure letdown valve in the letdown line (letdown is achieved via the residual heat removal system).
  - (e) The charging and letdown lines of the CVCS are filled with coolant at the cold shutdown boron concentration. The letdown orifice isolation valves are open.
- (2) If the RCS requires filling and venting, the procedure is as follows:
  - (a) One charging pump is started, which provides blended flow from the reactor makeup control system at the cold shutdown boron concentration.
  - (b) The vents on the head of the reactor vessel and pressurizer are opened.
  - (c) The RCS is filled and the vents closed.

- (3) The system pressure is raised by using the charging pump and controlled by the low pressure letdown valve. When the system pressure is adequate for operation of the reactor coolant pumps, seal water flow to the pumps is established and the pumps are operated and vented sequentially until the gases are cleared from the system. Final venting takes place at the pressurizer. RCS vacuum refill may be performed in lieu of, or in conjunction with, the conventional method of filling and venting the RCS. The RCS vacuum refill method is accomplished by applying a vacuum to the system and drawing out the gases as the reactor vessel, pressurizer, and steam generator tubes are filled.
- (4) After the filling and venting operations are completed, charging and letdown flows are established. Pressurizer heaters are energized to form a steam bubble in the pressurizer. At this point, steam formation in the pressurizer is accomplished by manual control of the charging flow and automatic pressure control of the letdown flow. When the pressurizer water level reaches the no-load programmed setpoint, the pressurizer level control is shifted to control the charging flow to maintain programmed level. The RHRS is then isolated from the RCS and the normal letdown path is established. The pressurizer heaters are now used to increase RCS pressure, and reactor coolant pumps are started to increase RCS temperature.
- (5) The reactor coolant boron concentration is now reduced by operating the reactor makeup control system in the "dilute" mode. The reactor coolant boron concentration is corrected to the point where the control rods may be withdrawn and criticality achieved. Power increase may then proceed with corresponding manual adjustment of the reactor coolant boron concentration to balance the temperature coefficient effects and maintain the control rods within their operating range.
- (6) Prior to or during this process, the CVCS is employed to obtain the correct chemical properties in the RCS. The reactor makeup control system is operated on a continuing basis to ensure correct control rod position. Chemicals are added through the chemical mixing tank as required to control reactor coolant chemistry such as pH and dissolved oxygen content. Hydrogen overpressure is established in the VCT to assure the appropriate hydrogen concentration in the reactor coolant.

#### B. Power Generation and Hot Standby Operation

##### (1) Base Load

At a constant power level, the rates of charging and letdown are dictated by the requirements for seal water to the reactor coolant pumps and the normal purification of the RCS. One charging pump is employed and charging flow is controlled automatically from pressurizer level. The only adjustments in boron concentration necessary are those to compensate for core burnup. These adjustments are made at infrequent intervals to maintain the control groups within their allowable limits. Rapid variations in power demand are accommodated automatically by control rod

movement. If variations in power level occur, and the new power level is sustained for long periods, some adjustment in boron concentration may be necessary to maintain the control groups within their maneuvering band.

During normal operation, normal letdown flow is maintained and one mixed bed demineralizer is in service. Reactor coolant samples are taken periodically to check zinc concentration, boron concentration, water quality, pH and activity level. The charging flow to the RCS is controlled automatically by the pressurizer level control signal through the discharge header flow control valve.

### (2) Load Follow

A power reduction will initially cause a xenon buildup followed by xenon decay to a new, lower equilibrium value. The reverse occurs if the power level increases; initially, the xenon level decreases and then it increases to a new and higher equilibrium value associated with the amount of the power level change.

The reactor makeup control system is used to vary the boron concentration in the reactor coolant to compensate for xenon transients occurring when reactor power level is changed.

Control rod position provides the operator with an indication of whether dilution or boration of the reactor coolant is necessary. If rod position is out of the desired range, proper manipulation of boron concentration will return the rods to the desired range.

During periods of plant loading, the reactor coolant expands as its temperature rises. The pressurizer absorbs this expansion as the level controller raises the level setpoint to the increased level associated with the new power level. Any excess coolant due to RCS expansion is let down and stored in the VCT. During this period, the flow through the letdown orifice remains constant and the charging flow is reduced by the pressurizer level control signal, resulting in an increased temperature at the regenerative heat exchanger outlet. The temperature controller downstream from the letdown heat exchanger increases the component cooling water flow to maintain the desired letdown temperature.

During periods of plant unloading, the charging flow is increased to make up for the coolant contraction not accommodated by the programmed reduction in pressurizer level.

### (3) Hot Shutdown

If required, for periods of maintenance, or following reactor trips, the reactor can be held subcritical, but with the capability to return to full power within the period of time it takes to withdraw control rods. During this hot shutdown period, temperature is maintained at no-load  $T_{avg}$  by dumping steam to remove core residual heat, by running reactor coolant pumps to maintain system temperature.

Following shutdown, xenon buildup occurs and increases the degree of shutdown ( $\Delta k/k$ ). The effect of xenon build-up is to increase the degree of shutdown ( $\Delta k/k$ ).

k/k) to a maximum at about eight hours following shutdown from equilibrium full power conditions. If hot shutdown is maintained past this point, xenon decay results in a decrease in degree of shutdown. Since the delta-k/k value of the initial xenon concentration is high (assuming that an equilibrium concentration had been reached during operation), boration of the reactor coolant is necessary to counteract the xenon decay and maintain shutdown.

If a rapid recovery is required, dilution of the system may be performed to counteract this xenon buildup. However, after the xenon concentration reaches a peak, boration must be performed to maintain the reactor subcritical as the xenon decays out.

#### (4) Cold Shutdown

Cold shutdown is the operation which takes the reactor from hot shutdown conditions to cold shutdown conditions (reactor is subcritical by at least 1%  $\Delta k/k$  and  $T_{avg} \leq 200^\circ\text{F}$ ).

Before initiating a cold shutdown, the RCS hydrogen concentration is lowered by reducing the volume control tank overpressure, by replacing the VCT hydrogen atmosphere with nitrogen, and by continuous purging to the waste disposal system.

During the plant cooldown, charging is provided to make up for coolant contraction. During the initial phase of the cooldown, the makeup is provided from the boric acid tanks. The boric acid tanks should be used until at least the technical specification minimum volume has been charged. At that point, operators can continue using the boric acid tanks if additional volume is available, or shift suction of the charging pumps to the refueling water storage tank. If the boric acid tanks are used, 3.5 to 4.0% boric acid solution should be charged until the RCS reaches the desired cold shutdownXe free concentration. The cooldown is completed by using blended makeup at the cold shutdown concentration.

Contraction of the coolant during cooldown of the RCS results in actuation of the pressurizer level control to maintain normal pressurizer water level. The charging flow is increased, relative to letdown flow, and results in a decreasing VCT level. The VCT level controller automatically initiates makeup to maintain the inventory.

After the RHRS is placed in service and the reactor coolant pumps are shutdown, further cooling of the pressurizer liquid is accomplished by charging through the auxiliary spray line. Coincident with plant cooldown, a portion of the reactor coolant flow is diverted from the RHRS to the CVCS for cleanup. Demineralization of ionic radioactive impurities and stripping of fission gases reduce the reactor coolant activity level sufficiently to permit personnel access for refueling or maintenance operations.

### 9.3.4.3 Safety Evaluation

#### A. Reactivity Control

Any time that the plant is at power, the quantity of boric acid retained and ready for injection always exceeds that quantity required for the normal cold shutdown assuming



that the control assembly of greatest worth is in its fully withdrawn position. This quantity always exceeds the quantity of boric acid required to bring the reactor to hot shutdown and to compensate for subsequent xenon decay.

When the reactor is subcritical, i.e., during cold or hot shutdown, refueling and approach to criticality, the neutron source multiplication is continuously monitored and indicated. Any appreciable increase in the neutron source multiplication, including that caused by the maximum physical boron dilution rate, is slow enough to give ample time to start a corrective action to prevent the core from becoming critical. The rate of boration, with a single boric acid transfer pump operating, is sufficient to take the reactor from full power operation to 1% shutdown in the hot condition, with no rods inserted, in less than 135 minutes. In less than 110 additional minutes, enough boric acid can be injected via the normal boron charging path to compensate for xenon decay, although xenon decay below the equilibrium operating level will not begin until approximately 25 hours after shutdown. Additional boric acid is employed if it is desired to bring the reactor to cold shutdown conditions.

Two separate and independent flow paths are available for reactor coolant boration, i.e., the charging line and the reactor coolant pump seal injection line. A single failure does not result in the inability to borate the RCS.

If the normal charging line is not available, charging to the RCS is continued via reactor coolant pump seal injection at the rate of approximately 5 gpm per pump. At the charging rate of 20 gpm (5 gpm per reactor coolant pump), approximately 6.5 hours are required to add enough boric acid solution to counteract xenon decay, although xenon decay below the full power equilibrium operating level will not begin until approximately 25 hours after the reactor is shutdown.

As backup to the normal boric acid supply, the operator can align the refueling water storage tank outlet to the suction of the charging pumps.

Since inoperability of a single component does not impair ability to meet boron injection requirements, plant operating procedures allow components to be temporarily out of service for repairs. However, with an inoperable component, the ability to tolerate additional component failure is limited. Therefore, Technical Specifications require immediate action to effect repairs of an inoperable component, restrict permissible repair time, and require demonstration of the operability of the redundant component.

#### B. Reactor Coolant Purification

The CVCS is capable of reducing the concentration of ionic isotopes in the purification stream as required in the design basis. This is accomplished by passing the letdown flow through one of the mixed bed demineralizers which removes ionic isotopes, (except those of cesium, molybdenum and yttrium, with a minimum decontamination factor of 10) and zinc. Through occasional use of the cation bed demineralizer the concentration of cesium can be maintained below 1.0  $\mu\text{Ci/cc}$ , assuming 1% of the rated core thermal power is being produced by fuel with defective cladding. The cation bed demineralizer is capable of passing the maximum purification letdown flow, though only a portion of this capacity is normally utilized. Each mixed bed demineralizer is

capable of processing the maximum purification letdown flow rate. If the normally operating mixed bed demineralizer resin has become exhausted, the second demineralizer can be placed in service. Each demineralizer is designed, however, to operate for one core cycle with 1% defective fuel.

There would be no safety problem associated with over-heating of the demineralizer resins. The only effect on reactor operating conditions would be the possibility of an increase in the reactor coolant activity level. If the activity level in the reactor coolant were to exceed the limit given in the Technical Specifications, reactor operation would be restricted as required by the Technical Specifications.

C. Seal Water Injection

Flow to the reactor coolant pumps' seals is assured by the fact that there are two charging pumps, any one of which is capable of supplying the normal charging line flow plus the nominal seal water flow.

D. Leakage Provisions

CVCS components, valves, and piping which see radioactive service are designed to limit leakage to the atmosphere. Leakage to the atmosphere is limited through:

- (1) Welding of all piping joints and connections except where flanged connections are provided to facilitate maintenance and hydrostatic testing,
- (2) Extensive use of leak-offs to collect leakage, and use of enhanced "live-load" packing
- (3) Use of diaphragm valves where conditions permit.

The VCT in the CVCS provides an inferential measurement of leakage from the CVCS as well as the RCS. Low level in the volume control tank actuates makeup at the prevailing reactor coolant boron concentration. The amount of leakage can be inferred from the amount of makeup added by the reactor makeup control system.

E. Ability to Meet the Safeguards Function

A failure analysis of the portion of the CVCS which is safety-related (used as part of the emergency core cooling system) is included as part of the emergency core cooling system failure analysis presented in Section 6.3.

#### 9.3.4.4 Tests and Inspections

As part of plant operation, periodic tests, surveillance inspections and instrument calibrations are made to monitor equipment condition and performance. Most components are in use regularly; therefore, assurance of the availability and performance of the systems and equipment is provided by control room and/or local indication.

### 9.3.4.5 Instrumentation Application

Process control instrumentation is provided to acquire data concerning key parameters about the CVCS. The location of the instrumentation is shown on Figure 9.3-15.

The instrumentation furnishes input signals for monitoring and/or alarming purposes. Indications and/or alarms are provided for the following parameters:

- 1 Temperature
- 2 Pressure
- 3 Flow
- 4 Water level

The instrumentation also supplies input signals for control purposes. Some specific control functions are:

- 1 Letdown flow is diverted to the VCT upon high temperature indication upstream of the mixed bed demineralizers.
- 2 Pressure upstream of the letdown heat exchanger is controlled to prevent flashing of the letdown liquid.
- 3 Charging flow rate is controlled during charging pump operation.
- 4 Water level is controlled in the VCT.
- 5 Reactor makeup is controlled.

### 9.3.5 Failed Fuel Detection System

The Gross Failed Fuel Detection System is not a safety-related system and is not used for Unit 1 or Unit 2 operations.

### 9.3.6 Auxiliary Charging System

#### 9.3.6.1 Design Bases

The auxiliary charging system is designed to provide makeup to the reactor coolant system (RCS) when the plant is operating in the "flood mode." For definition of "flood mode" see Section 2.4.14. This system is an essential part of the equipment used in flood protection provisions. This system is also designated as the flood mode boration makeup system (FMBMS).

The auxiliary charging system includes the following equipment:

- (1) 4 full-capacity auxiliary charging pumps (2 per unit).
- (2) 1 auxiliary boration makeup tank.

- (3) 2 filters.
- (4) 1 demineralizer.
- (5) 2 auxiliary charging booster pumps.
- (6) Associated instrumentation and control equipment.

Each auxiliary charging pump capacity is 100 gph and each auxiliary charging booster pump capacity is 300 gph. Both capacities are several times greater than the maximum postulated leakage loss from the primary system. Postulated total recoverable leakage is based on No. 2 and No. 3 seal leakage (approximately 576 gpd) with No. 1 seal injection and return lines isolated for each RCP of both units plus the total recoverable leakage of 225 gpd at an RCS pressure of 350 psig (maximum during 'flood mode'). Nonrecoverable leakage need not be considered during flood mode operation since any two of the four steam generators provide adequate cooling and a steam generator with primary to secondary leakage can be isolated. Also, any other system leakage will be insignificant since the operating pressure during flood mode is considerably less than during normal operation.

The auxiliary boration makeup tank has a usable capacity of 868 gallons to provide a minimum of 12 hours makeup (801 gallons) based on the above leakage loss from each unit.

The demineralizer is provided for cleanup of makeup water and the filters prevent the demineralizer resins from leaving the FMBMS. The filters are designed for a maximum flow rate of 10 gpm each, and the demineralizer is designed for a maximum flow rate of 27 gpm. Auxiliary charging system equipment is located above flood level on Elevation 757.0 of the Auxiliary Building.

### 9.3.6.2 System Design Description

The auxiliary charging system is shown on Figure 9.3-18. The initial fill of makeup water for the auxiliary boration makeup tank will come from the demineralized water tank. The majority of leakage, from RCS pump seals, etc., is collected in the reactor coolant drain tank (RCDDT) and is pumped by the reactor coolant drain tank pumps to the auxiliary boration makeup tank. This recoverable leakage is the main preferred source of makeup water. Additional makeup water is supplied from other preferred sources: (1) cold leg accumulator tanks via the RCDDT pumps, (2) pressurizer relief tank via the RCDDT pumps, and (3) demineralized water tanks.

The above preferred sources of makeup water are backed up by the pumps of the high pressure fire protection system which can pump river water to the auxiliary makeup tank. To prevent inadvertent injection of raw water into the primary system, this source requires manual addition, via fire hose, only if it is needed.

The makeup water is borated to the extent necessary to maintain refueling shutdown concentration in the RCS. Boric acid, lithium hydroxide, and hydrazine are added and mixed with the makeup water in the auxiliary boration makeup tank in a batch process.

The process system provides a means to be sampled periodically for water quality analysis. Sample outlets are provided that are accessible in the flood mode.

The makeup water is pumped from the auxiliary boration makeup tank to the primary system as required to maintain pressurizer level. One booster pump per plant and one charging pump per unit are sufficient to provide the required makeup; two booster pumps and four charging pumps are provided.

Spool pieces are used to connect the auxiliary charging system to the normal charging lines. These spool pieces are installed only in the event of a flood warning and after the RCS pressure has been reduced to less than 350 psig.

### 9.3.6.3 Design Evaluation

See Table 3.2-2a for classification of the auxiliary charging system components.

Sufficient separation and redundancy of components and circuits are provided so that no single failure can jeopardize system operation. The components are capable of being supplied with emergency power.

Refer to Sections 2.4.14.1.2 and 2.4.14.10 for the limitation on the coincidence of seismic events and a flood exceeding plant grade. As indicated in Table 3.2-2a, the auxiliary charging system piping essential for makeup and boration in the event of a flood above plant grade and portions of the system necessary for containment isolation are designed to Seismic Category I requirements. The balance of the system is designed to limited seismic Category I(L) requirements.

### 9.3.6.4 Tests and Inspection

Components of the auxiliary charging system are accessible for inspection. The system was tested during preoperational testing to assure its adequacy and is tested per the requirements of the ASME Augmented Inservice Testing Program for pumps and valves.

Inservice inspections of the Class C (ASME Class 3) for the tanks will be performed to the extent practical per the guidelines of the ASME Code, Section XI. Inservice inspections of the Class C (ASME Class 3) for the pumps and valves will be performed to the extent practical per the guidelines of the ASME OM Code as required by 10CFR50.55a.

### 9.3.6.5 Instrument Application

Manual control is employed to the maximum extent practicable.

The level of the RCDT is indicated continuously and alarmed on high and low level on a panel in the Auxiliary Building. The RCDT level is controlled between the high and low alarm setpoints by the actuation of start and stop signals to the RCDT pumps. Completely manual operation will be used to transfer water to the auxiliary boration makeup tank (ABMT). Levels in the ABMT can be visually checked (a level indicator is provided) since the tank has a 1/2-day supply under worst case conditions. The

redundant pressure and pressurizer level loops in the RCS serve as indications of the low pressure necessary for the activation of the auxiliary charging pumps.

### 9.3.7 Boron Recycle System

The boron recycle system (BRS) is not required for the operation of Unit 2. The portions of this system which are used for the operation of Unit 2 are discussed in Section 9.3.4. The components which make up the BRS are installed in the Auxiliary Building and were originally intended to recover boron from the excess RCS.

A summary of the principal components of the BRS is listed below:

Evaporator Feed Ion Exchanger  
Evaporator Condensate Demineralizer  
Condensate Filter  
Concentration Filter  
Ion-Exchanger Filter  
Gas Stripper and Boric Acid Evaporator Package

### 9.3.8 Heat Tracing

Electric heat tracing is used to supply heat to some of the insulated mechanical piping systems to prevent freezing of the fluid in the pipe or to provide process temperature control to maintain the media within its specified temperature range; and it is used on some instrument sense lines.

The following systems use heat tracing:

- (a) Condensate - System 002
- (b) Main and auxiliary feedwater - System 003<sup>(Note 1)</sup>
- (c) Raw cooling water - System 024
- (d) High pressure fire protection - System 026
- (e) Sampling and water quality - System 043 (UNIT 1 ONLY)
- (f) Safety injection - System 063
- (g) Essential raw cooling water - System 067
- (h) Radiation monitoring - System 090
- (i) Makeup water treatment plant - System 928
- (j) Main Steam - System 001<sup>(Note 1)</sup>
- (k) Ice Condenser - System 061

Note 1 - No main control room alarm for instrument sense lines in North and South valve vault rooms.

**Table 9.3-1 Compressed Air System Descriptive  
Information Station Control and Service Air Systems  
(Page 1 of 2)**

<b>Station Air Compressors</b>	
Number	4
Type	3 Reciprocating, 1 centrifugal
Discharge pressure, psig	100
Discharge Temperature, °F	110 (A, B, C)
Capacity, scfm, total	610 (A, B, C)
<b>Station Air Compressors A, B, C (reciprocating) Aftercoolers</b>	
Number	1 per compressor
Type	Shell and tube
Tube side flow, scfm (air)	610 (A, B, C)
Shell side flow, gpm (water)	12.4 (A, B, C)
Shell side design pressure, psig	150
Tube side design pressure, psig	150
Shell material	Carbon steel
Tube material	Admiralty
Design code	ASME VIII
Discharge Temperature, °F	110
Design Temperature, °F	340
<b>Station Air Compressor D Coolers</b>	
Intercooler/Aftercooler	Integral
Type	Shell & Tube
Tube Side Flow, SCFM (Air)	1166
Total Shell Side Water Flow, gpm	96.3 (Includes flow to external oil cooler)
Discharge Temperature, °F	105
Shell side design pressure, psig	75
Tube Side Design pressure, psig	150
Shell Material	Cast Iron
Tube Material	Copper (ASTM B111)
Tube FIN Material	Copper (ASTM B152)
Header	Muntz Metal (ASTM B111)
Design Code	Manufacturer's standard

**Table 9.3-1 Compressed Air System Descriptive  
Information Station Control and Service Air Systems  
(Page 2 of 2)**

<b>Station Air Receivers</b>	
Number	3 (two control and one service air)
Capacity, ft <sup>3</sup>	266
Design pressure, psig	150
Design temperature, °F	300
Operating pressure, psig	100
Operating temperature, °F	105
Material	Carbon steel
Design code	ASME VIII
<b>Auxiliary Air Compressors</b>	
Number	2
Type	Reciprocating
Discharge pressure, psig	100
Discharge temperature, °F	430 (to aftercooler)
Capacity, scfm	75 each (this value is the procurement capacity; actual tested capacity could be lower)
<b>Auxiliary Air Compressor Aftercooler</b>	
Number	1 per compressor
Type	Tube and shell
Tube side flow, scfm (air)	75
Shell side flow, gpm (water)	4.5
Discharge temperature, °F	100 (15°F above ERCW inlet temperature of 85°F)
<b>Auxiliary Air Receivers</b>	
Number	2
Capacity, ft <sup>3</sup>	34
Design pressure, psig	125
Operating pressure, psig	115
Design Code	ASME Section VIII



Table 9.3-2 Process Sampling System Sample Locations and Data  
(Page 1 of 11)

Sampled System	Sample Location	Design		Sample Type (See Note 1)
		Pressure: psig	Temperature, °F	
CVCS	Outlet Boric Acid Blender	P = 150 T = 250		Hot Sample Room
WDS	*Downstream Monitor Tank Pumps A and B (One Sample)	P = 150 T = 180		Local
CVCS	Upstream Evaporator Feed, Ion Exchanger No. 1A and 2A	P = ATM T = 150		Hot Sample Room
CVCS	Downstream Evaporator Feed, Ion Exchanger No. 1B and 2B	P = ATM T = 150		Hot Sample Room
CVCS	Volume Control Tank Vent	P = 75 T = 250		Hot Sample Room
CVCS	Inlet Mixed Bed Demineralizer	P = 200 T = 250		Hot Sample Room
CVCS	Outlet Mixed Bed Demineralizer	P = 200 T = 250		Hot Sample Room
CVCS	*CVCS Holdup Tank Recirc	P = 150 T = 200		Hot Sample Room
WDS	*Downstream Laundry Pump	P = 150 T = 180		Local
WDS	*Downstream Waste Condensate Pumps	P = 150 T = 180		Local
WDS	Waste Gas Decay Tanks Auto and Manual	P = 150 T = 180		Gas Analyzer
WDS	Spent Resin Storage Tank	P = 150 T = 180		Gas Analyzer

Table 9.3-2 Process Sampling System Sample Locations and Data  
(Page 2 of 11)

Sampled System	Sample Location	Design Pressure: psig Temperature, °F	Sample Type (See Note 1)
WDS	CVCS Holdup Tanks A & B	P = 150 T = 200	Gas Analyzer
WDS	RCS Pressurizer Relief Tank	P = 2485 T = 650	Gas Analyzer
WDS	CVCS Vol. Control Tank Vent	P = 75 T = 250	Gas Analyzer
WDS	Reactor Coolant Drain Tank	P = 150 T = 180	Gas Analyzer
WDS	*Chemical Drain Tank Recirculate	P = 150 T = 180	Local
WDS	*Cask Decontamination Collector Tank	P = 150 T = 180	Local
WDS	*Tritiated Drain Tank Recirculation	P = 150 T = 180	Hot Sample Room
WDS	*Floor Drain Collector Tank Recirculation	P = 150 T = 180	Hot Sample Room
RCS	Hot Leg Loop 1	P = 2485 T = 650	Hot Sample Room
RCS	Hot Leg Loop 3	P = 2485 T = 650	Hot Sample Room
RCS	Pressurizer Liquid	P = 2485 T = 680	Hot Sample Room
RCS	Pressurizer Gas	P = 2485 T = 650	Hot Sample Room

Table 9.3-2 Process Sampling System Sample Locations and Data  
(Page 3 of 11)

Sampled System	Sample Location	Design Pressure: psig Temperature, °F	Sample Type (See Note 1)
Main Steam	Steam Gen No. 1 to H.P. Turbine	P = 1185 T = 600	Titration Room
Main Steam	Steam Gen No. 1 to H.P. Turbine	P = 1185 T = 600	Local
Main Steam	Steam Gen No. 2 to H.P. Turbine	P = 1185 T = 600	Titration Room
Main Steam	Steam Gen No. 2 to H.P. Turbine	P = 1185 T = 600	Local
Main Steam	Steam Gen No. 3 to H.P. Turbine	P = 1185 T = 600	Titration Room
Main Steam	Steam Gen No. 3 to H.P. Turbine	P = 1185 T = 600	Local
Main Steam	Steam Gen No. 4 to H.P. Turbine	P = 1185 T = 600	Titration Room
Main Steam	Steam Gen No. 4 to H.P. Turbine	P = 1185 T = 600	Local
Main Steam	Steam Gen No. 1, 2, 3, & 4 Downcomers	P = 1185 T = 600	Hot Sample Room
Main Steam	Steam Gen Blowdown No. 1, 2, 3, & 4	P = 1185 T = 600	Hot Sample Room
Steam Generator Blowdown	Downstream of Steam Gen Blowdown Flash Tank	P = 450 T = 250	Local
Steam Generator Blowdown	Downstream of Steam Gen Blowdown Heat Exchanger	P = 1185 T = 150	Local

Table 9.3-2 Process Sampling System Sample Locations and Data  
(Page 4 of 11)

Sampled System	Sample Location	Design Pressure: psig Temperature, °F	Sample Type (See Note 1)
S.F.P.C.	*Upstream Spent Fuel Pool Demin	P = 150 T = 200	Local
S.F.P.C.	*Downstream Spent Fuel Pool Demin	P = 150 T = 200	Local
S.F.P.C.	*Refueling Water Purification Filter (Upstream)	P = 150 T = 200	Local
S.F.P.C.	*Refueling Water Purification Filter (Downstream)	P = 150 T = 200	Local
Htr Dr & V	No. 3 Htr Drain Tank	P = 250 T = 370	Local
Htr Dr & V	No. 7 Htr Drain Tank Pump A Discharge	P = 410 T = 180	Local
Htr Dr & V	No. 7 Htr Drain Tank Pump B Discharge	P = 410 T = 180	Local
Htr Dr & V	No. 7 Htr Drain Tank Pumps Discharge Common Discharge Header	P = 410 T = 180	Local
FW	Downstream Htr 2A-1	P = 1185 T = 465	Local
FW	Downstream Htr 2B-1	P = 1185 T = 465	Local
FW	Downstream Htr 2C-1	P = 1185 T = 465	Local
FW	Htrs 1 A-1, 1B-1, and 1C-1 Hdr	P = 1185 T = 465	Titration Room

Table 9.3-2 Process Sampling System Sample Locations and Data  
(Page 5 of 11)

Sampled System	Sample Location	Design Pressure: psig Temperature, °F	Sample Type (See Note 1)
FW	Htrs 2A-1, 2B-1, and 2C-1 Hdr	P = 1185 T = 465	Local
FW	Auxiliary FW Pump Hdr 2A-A	P = 1975 T = 120	Local
FW	Auxiliary FW Pump Hdr 2B-B	P = 1975 T = 120	Local
FW	Turbine Driven Auxiliary FW Pump 2A	P = 1975 T = 120	Local
Cnds	Hotwell Pumps Discharge Header	P = 350 T = 270	Titration Room
Cnds	Inlet Cond Booster Pump	P = 350 T = 270	Titration Room
Cnds	Outlet Heaters A-5, A-6, and A-7s	P = 350 T = 270	Local
Cnds	Outlet Heaters B-5, B-6, and B-7	P = 350 T = 270	Local
Cnds	Outlet Heaters C-5, C-6, and C-7	P = 350 T = 270	Local
Cnds	Inlet to Heaters A-4, B-4, and C-4	P = 650 T = 300	Local
Cnds	Downstream Heater A-2	P = 650 T = 410	Local
Cnds	Downstream Heater B-2	P = 650 T = 410	Local

Table 9.3-2 Process Sampling System Sample Locations and Data  
(Page 6 of 11)

Sampled System	Sample Location	Design Pressure: psig Temperature, °F	Sample Type (See Note 1)
Cnds	Downstream Heater C-2	P = 650 T = 410	Local
Cnds	Heaters A-2, B-2, and C-2 Downstream Hdr	P = 650 T = 410	Local
Cnds	Upstream MFP A and B	P = 650 T = 410	Local
Cnds	Hotwell Pump Discharge Header	P = 350 T = 270	Local
Cnds	Downstream MFPT Cond A	P = 350 T = 270	Local
Cnds	Downstream MFPT Cond B	P = 350 T = 270	Local
Cnds	Condenser Inlet Tube Sheet	P = 150/30" Hg & Total Vacuum T = 140	Local
Cnds	Condense Inlet Tube Sheet	P = 150/30" Hg & Total Vacuum T = 140	Local
Cnds	Condenser Zone A Low Pressure	P = 150/30" Hg & Total Vacuum T = 140	Local
Cnds	Condenser Zone A Low Pressure	P = 150/30" Hg & Total Vacuum T = 140	Local

Table 9.3-2 Process Sampling System Sample Locations and Data  
(Page 7 of 11)

Sampled System	Sample Location	Design Pressure: psig Temperature, °F	Sample Type (See Note 1)
Cnds	Condenser Outlet Tube Sheet	P = 150/30" Hg & Total Vacuum T = 140	Local
Cnds	Condenser Outlet Tube Sheet	P = 150/30" Hg & Total Vacuum T = 140	Local
Cnds	Condenser Zone B Intermediate Pressure Crossover	P = 150/30" Hg & Total Vacuum T = 140	Local
Cnds	Condenser Zone B Intermediate Pressure Crossover	P = 150/30" Hg & Total Vacuum T = 140	Local
Cnds	Condensate Demineralizer Influent Header	P = 350 T = 270	Local
Cnds	Condensate Demineralizer Effluent Header	P = 350 T = 270	Local
Cnds	Outlet of Each Polisher Vessel	P = 300 T = 140	Local
Cnds	Dilute Caustic	P = 60 T = 140	Local
Cnds	Dilute Acid	P = 60 T = Ambient	Local
Cnds	Downstream Anion Tank	P = 75 T = 140	Local

Table 9.3-2 Process Sampling System Sample Locations and Data  
(Page 8 of 11)

Sampled System	Sample Location	Design Pressure: psig Temperature, °F	Sample Type (See Note 1)
Cnds	Condenser Zone C Bottom (High Pressure)	P = 150/30" Hg & Total Vacuum	Local
Ext Steam	Inlet Htrs A-1, B-1, and C-1	T = 140 P = 475	Local
Ext Steam	Inlet Htrs A-2, B-2, and C-2	T = 460 P = 325	Local
Ext Steam	Inlet Htrs A-3, B-3, and C-3	T = 420 P = 250	Local
Ext Steam	Inlet MST SEP Reheaters A-1, B-1, and C-1	T = 375 P = 475	Local
Ext Steam	Inlet MST SEP Reheaters A-2, B-2, and C-2	T = 460 P = 475	Local
RCW	RCW Header	P = 125 T = 130	Local
Aux Blr	*Auxiliary Deareator Tank	P = 50 T = 75	Titration Room
Aux Blr	*Continuous Blowdown (Aux Blr A)	P = 200 T = 300	Titration Room
Aux Blr	*Continuous Blowdown (Aux Blr B)	P = 200 T = 300	Titration Room
Aux Blr	*Upper Drum Stm Sample (Aux Blr A)	P = 200 T = 300	Titration Room
Aux Blr	*Upper Drum Stm Sample (Aux Blr B)	P = 200 T = 300	Titration Room



Table 9.3-2 Process Sampling System Sample Locations and Data  
(Page 9 of 11)

Sampled System	Sample Location	Design Pressure: psig Temperature, °F	Sample Type (See Note 1)
Station Drainage	*Demin Waste Sump Turbine Bldg	P = ATM T = 100	Local
CCS	Downstream Component Cooling System Heat Exchanger A	P = 150 T = 200	Local
CCS	Downstream Component Cooling System Heat Exchanger B	P = 150 T = 200	Local
CCS	Downstream Component Cooling System Heat Exchanger C	P = 150 T = 200	Local
ERCW	*Downstream CCS Heat Exchanger A	P = 160 T = 130	Local
ERCW	*Downstream CCS Heat Exchanger B	P = 160 T = 130	Local
ERCW	*Downstream CCS Heat Exchanger C	P = 160 T = 130	Local
PMW	Primary Water Storage Tank	P = 150 T = 130	Local
RHR	RHR Pump 1A Minimum Flow Line	P = 600 T = 400	Hot Sample Room
RHR	RHR Pump 1B Minimum Flow Line	P = 600 T = 400	Hot Sample Room
RHR	RHR Pump 2A Minimum Flow Line	P = 600 T = 400	Hot Sample Room
RHR	RHR Pump 2B Minimum Flow Line	P = 600 T = 400	Hot Sample Room

Table 9.3-2 Process Sampling System Sample Locations and Data  
(Page 10 of 11)

Sampled System	Sample Location	Design Pressure: psig Temperature, °F	Sample Type (See Note 1)
RHR	Upstream RHR Exchanger 1A	P = 600 T = 400	Hot Sample Room
RHR	Upstream RHR Exchanger 1B	P = 600 T = 400	Hot Sample Room
RHR	Upstream RHR Exchanger 2A	P = 600 T = 400	Hot Sample Room
RHR	Upstream RHR Exchanger 2B	P = 600 T = 400	Hot Sample Room
SIS	Accumulator Tanks No. 1, 2, 3, and 4	P = 700 T = 300	Hot Sample Room
SIS	Accumulator tank Header Outlet	P = 2485 T = 650	Hot Sample Room
SIS	SIS Pump (Unit 1) Refueling Water/Minimum Flow Line	P = 1750 T = 200	Hot Sample Room
SIS	SIS Pump (Unit 2) Refueling Water	P = 1750 T = 200	Hot Sample Room
SIS	Refueling Water Storage Tank	P = 150 T = 200	Local at SFPC Refueling Water Purification Filter (upstream)
SIS	Downstream Boron Injection Tank (Unit 1)	P = 2735 T = 200	Hot Sample Room
SIS	Upstream Boron Injection Tank (Unit 1)	P = 2735 T = 200	Hot Sample Room
SIS	Downstream Boron Injection Tank (Unit 2)	P = 2800 T = 200	Hot Sample Room

**Table 9.3-2 Process Sampling System Sample Locations and Data**  
(Page 11 of 11)

Sampled System	Sample Location	Design Pressure: psig Temperature, °F	Sample Type (See Note 1)
SIS	Upstream Boron Injection Tank (Unit 2)	P = 2800 T = 200	Hot Sample Room
Flood Mode Boration Makeup System	Downstream Auxiliary Boration Makeup System	P = 70 T = 180	Local
WLRS	Wet Layout Recirculation	P = 150 T = 200	Local
Gland Seal	Gland Seal water at Demineralized Water Connection	P = 100 T = 150	Local
PMW	Primary Makeup Water Pump 2A Discharge	P = 150 T = 130	Local
PMW	Primary Makeup Water Pump 2B Discharge	P = 150 T = 130	Local

\*These are common plant samples.

Note 1: The sample type indicates sample collection area or sample equipment.

Note 2: All samples listed for Unit 2 unless noted as Unit 1 or common.

Table 9.3-3 Equipment and Floor Drainage Data Reactor Coolant System  
(Page 1 of 9)

Component	Drain Type	Fluid (water and)		Drain 7 Channel	Drain Tank 8	Comments
		Tritium	Air			
Reactor Vessel	Flange Leak-off	X		A	RCDT	
Pressurizer Relief Tank	Drain	X		A	RCDT Pump Suction	
Reactor Coolant Pump (Seals)	No. 2 Seal Leak-off	X <sup>1</sup>		A	RCDT	
	No. 3 Seal Leak-off	X	X	A	RCDT	
Reactor Coolant Pump (Cooling)	Thermal Barrier Relief	X <sup>2</sup>	X	B or A	FDCT or TDCT via Sump	
	Bearing oil cooler Pres. Relief	X	X	B or A	FDCT or TDCT via Sump	
Loop Drain	Drain	X	X <sup>4</sup>	A	RCDT	
Volume Control Tank	Drain	X		A	TDCT	
	Pres. Relief	X		A	CVCS HUT	
Boric Acid Tank	Overflow			A	TDCT	
	Drain			A	TDCT	
Batching Tank	Drain			A	TDCT	
	Overflow				TDCT	
Regenerative HX	Shell & Tube Drain	X	X <sup>4</sup>	A	(FDCT or TDCT) <sup>3</sup> via Sump	
Letdown HX	Shell Drain		X	B	FDCT	
	Tube Drain	X	X <sup>4</sup>	A	TDCT	

Table 9.3-3 Equipment and Floor Drainage Data Reactor Coolant System  
(Page 2 of 9)

Component	Drain Type	Fluid (water and)		Drain <sup>7</sup> Channel	Drain Tank <sup>8</sup>	Comments
		Tritium	Air			
Excess Let-down HX	Shell Drain		X	B	FDCT or TDCT via Sump	
	Tube Drain	X	X <sup>4</sup>	A	FDCT or TDCT via Sump	
Seal Water Hx	Shell Drain		X	B	FDCT	
	Tube Drain	X	X <sup>4</sup>	A	TDCT	
Charging Pump	Drain	X	X <sup>4</sup>	A	TDCT	
Boric Acid Transfer Pump	Drain		X <sup>4</sup>	B	TDCT	
All CVCS Filters	Drain	X <sup>9</sup>	X <sup>4</sup>	A	TDCT	
All CVCS Resin Columns	Drain	X	X <sup>4</sup>	A	TDCT	
Chemical Mixing Tank	Drain	X	X	A	TDCT	
CVCS Holdup Tank	Safety Valve Relief	X		A	TDCT	
	Drain	X		A	TDCT via Sump	
Gas Stripper Feed Pump	Drain	X	X <sup>4</sup>	A	TDCT via Sump	
Monitor Tank	Overflow	X		A	TDCT	
	Drain	X		A	TDCT	
Monitor Tank Pumps	Drain	X	X <sup>4</sup>	A	TDCT	

Table 9.3-3 Equipment and Floor Drainage Data Reactor Coolant System  
(Page 3 of 9)

Component	Drain Type	Fluid (water and)		Drain <sup>7</sup> Channel	Drain Tank <sup>8</sup>	Comments
		Tritium	Air			
CVCS Holdup Tank Recirculation Pump	Drain	X		A	TDCT via Sump	
Reactor Coolant Pump Seal Injection Line	Drain	X	X <sup>4</sup>	A	FDCT or TDCT via Sump	
Excess Letdown to Waste Disposal System	Drain	X		A	RCDT	
Tritiated Drain Collector Tank	Overflow	X	X	A	Sump	
	Drain	X	X	A	Sump	
Waste Condensate Tanks	Overflow	X		B	FDCT	
Waste Condensate Tank Pump	Drain		X <sup>4</sup>	B	FDCT	
Reactor Coolant Drain Tanks	Overflow (or Safety Valve)	X		A	TDCT or FDCT via Sump	
	Drain	X		A	TDCT or FDCT via RBF & ED Sump	
Floor Drain Collector Tank	Overflow		X	B	Sump	
	Drain		X	B	Sump	
Laundry and Hot Shower Tanks	Overflow		X	B	FDCT	

Table 9.3-3 Equipment and Floor Drainage Data Reactor Coolant System  
(Page 4 of 9)

Component	Drain Type	Fluid (water and)		Drain <sup>7</sup> Channel	Drain Tank <sup>8</sup>	Comments
		Tritium	Air			
Chemical Drain Tank	Drain & Over-flow	X <sup>10</sup>	X	B	FDCT	
CCS Pump Seal Leakage Collection Tank	Overflow		X	B	FDCT	This is a small tank to be used for return of pump seal leakage to system
	Drain		X	B	FDCT	
Spent Resin Storage Tank	Drain	X			TDCT	
Reagent Tanks	Drain		X	A	TDCT	
TDCT Pumps	Drain	X	X	A	Sump	
Chemical Drain Pump	Drain	X <sup>10</sup>	X	B	FDCT	
FDCT Pumps	Drain		X	B	Sump	
Laundry Pump	Drain		X	B	FDCT	
Reactor Coolant Drain Tank Pumps	Drain	X	X <sup>4</sup>	A	TDCT or FDCT via Sump	
Auxiliary Waste Evaporator Feed Pumps	Drain		X	B	Sump	
Waste Package Area	Drains	X		A	TDCT	
TDCT Discharge Filter	Drain	X	X <sup>4</sup>	A	TDCT via Sump	

Table 9.3-3 Equipment and Floor Drainage Data Reactor Coolant System  
(Page 5 of 9)

Component	Drain Type	Fluid (water and)		Drain <sup>7</sup> Channel	Drain Tank <sup>8</sup>	Comments
		Tritium	Air			
FDCT Discharge Filter	Drain	X	X <sup>4</sup>	B	FDCT via Sump	
Waste Condensate Tank Feed Filter	Drain			B	FDCT	
Waste Evap. Condensate Demineralizer	Drain	X	X	A	TDCT	
Waste Gas Compressor	Condensate	X		A	TDCT	Expected to be insignificant
	HX Drain			B	FDCT	
Gas Waste Vent Header(Power)	Drain	X		A	TDCT	
Gas Decay Tank (Shut-downs)	Drain	X		A	TDCT via Sump	
Accumulator	Drain	X		A	RCDT	Drain to RCDT
	Pressure Relief Drain	X		A	FDCT or TDCT via Sump	
Boron Injection Tank	Drain	X	X <sup>4</sup>	A	TDCT	
Safety Injection Pump	Drain	X	X <sup>4</sup>	A	TDCT	
Containment Spray Pump	Drain	X	X <sup>4</sup>	A	TDCT via Sump	
Residual HX	Shell Drain CCS		X	B	FDCT	
	Tube Drain RCS	X	X	A	TDCT	



Table 9.3-3 Equipment and Floor Drainage Data Reactor Coolant System  
(Page 6 of 9)

Component	Drain Type	Fluid (water and)		Drain <sup>7</sup> Channel	Drain Tank <sup>8</sup>	Comments
		Tritium	Air			
Residual Heat Removal Pumps	Drain	X	X	A	TDCT via Sump	
	Pres. Relief		X	B	FDCT	
	Overflow		X	B	FDCT	
Component Cooling Surge Tank	Drain		X	B	FDCT	
	Shell Drain		X	B	FDCT	
Component Cooling HX	Tube Drain (ERCW)			Special	Send overboard or to a floor drain	
	Drain		X	B	(CCST via CCS Pump SLCT) or FDCT	
Thermal Barrier Booster Pumps	Drain		X	B	Portable Container	
	Overflow		X	B	FDCT	
CCS Pump SLCT & Pump	Drain		X	B	FDCT	
	Overflow		X	B	FDCT	
Spent Fuel Pit HX	Shell Drain CCS		X	B	FDCT <sup>5</sup>	
	Tube Drain RCS	X	X	A	TDCT <sup>5</sup>	
Spent Fuel Pit Pump	Drain	X	X	A	TDCT <sup>5</sup>	
	Drain	X	X	A	TDCT <sup>5</sup>	
Spent Fuel Pit Skimmer Pump	Drain	X	X	A	TDCT <sup>5</sup>	
	Drain	X	X	A	TDCT	
Refueling Water Purification Pumps	Drain	X		A	TDCT	

Table 9.3-3 Equipment and Floor Drainage Data Reactor Coolant System  
(Page 7 of 9)

Component	Drain Type	Fluid (water and)		Drain <sup>7</sup> Channel	Drain Tank <sup>8</sup>	Comments
		Tritium	Air			
Refueling Water Purification Filter	Drain	X		A	TDCT	
Spent Fuel Pit Leakage	Drain	X		A	TDCT	
Spent Fuel Pit Skimmer Filter	Drain	X	X	A	TDCT	
Spent Fuel Pit Demineralizer	Drain	X	X	A	TDCT	
Radiochem. Laboratory	Spent or Treated Sample & Chem'ls	X			CDT	
	Radioactive Excess Tritiated Sample Sink Drain	X	X	A	TDCT	
Sample Heat Exchanger	Non-Tritium Sample & Rinse Sink Drains		X	B	FDCT	
	Shell Drain		X	B	FDCT <sup>5</sup>	
	Tube Drain	X	X	A	TDCT	
Sample Vessel	Non-Tritium Tube Drain		X		FDCT	
	Drain	X	X	A	VCT	

Table 9.3-3 Equipment and Floor Drainage Data Reactor Coolant System  
(Page 8 of 9)

Component	Drain Type	Fluid (water and)		Drain <sup>7</sup> Channel	Drain Tank <sup>8</sup>	Comments
		Tritium	Air			
Sample Room	Sample Sink Drain	X	X	A	TDCT	Liquid from secondary side must be re-turned to secondary side or discharged to FDCT.
	Non-Tritium		X	B	FDCT	
Floor Drain Inside Containment	Floor Drain	X	X	A	FDCT or TDCT via Sump	
Floor Drains Aux. Building	Floor Drain		X	B	FDCT	See 2.3.1 and 2.3.3.
Valve Leak-off Inside Containment	Leak-off	X		A	RCDT	
Valve Leak-off Outside Containment	Leak-off	X		A	TDCT	
	Leak-off	X	X	A	TDCT	
Hot Shower	Drain		X	B	LHSDT	
Laundry	Drain		X	B	LHSDT	
Containment Fan Coolers	Condensate Drain	X <sup>6</sup>	X	A	FDCT or TDCT via Sump	Essential Raw Cooling Water may be either (1) routed to a floor drain or (2) use portable container or (3) use procedure to force liquid into discharge header.
	Cooling Water Drain (ERCW)		X	Special	(Sent overboard) or (FDCT or TDCT via Sump)	

Table 9.3-3 Equipment and Floor Drainage Data Reactor Coolant System  
(Page 9 of 9)

Component	Drain Type	Fluid (water and)		Drain <sup>7</sup> Channel	Drain Tank <sup>8</sup>	Comments
		Tritium	Air			
Gas Analyzer Drain	Drain	X		A	TDCT	
Fuel Transfer Canal Leakage	Drain	X		A	TDCT	
Primary Water Makeup Pumps	Drain				TDCT	
Liner Leakage (Reactor Bldg)	Drain	X		A	FDCT or TDCT via Sump	
Cask Loading Area	Drain	X		A	TDCT	
Auxiliary Feedwater Pumps	Drain			B	FDCT	

## NOTES:

1. This liquid is aerated; however, because of the small amount it is directed to the RCDDT.
2. Only in abnormal case or thermal barrier leak.
3. Flush after drain if desired to reduce airborne activity levels.
4. Becomes aerated during drain.
5. Or drain to portable container and recycle to respective system.
6. If high concentration, flow can be directed to TDCT.
7. Channel A is for tritiated liquid. Channel B is for non-tritiated liquid. See Section 9.3.3.2.
8. See Section 9.3.3.7 for explanation of acronyms.
9. Drains do not contain tritium because the RCS liquid is not being recycled.
10. Only in abnormal case.

Table 9.3-4 Chemical and Volume Control System Design Parameters

<b>General</b>	
Seal water supply flow rate, for four reactor coolant pumps, nominal, gpm	32
Seal water return flow rate, for four reactor coolant pumps, nominal, gpm	12
Letdown flow:	
Normal, gpm (centrifugal pump operation)	75
Maximum, gpm	120*
Charging flow (excludes seal water):	
Normal, gpm (centrifugal pump operation)	55
Maximum, gpm	100*
Temperature of letdown reactor coolant entering system at full power, °F	557.3
Normal temperature of charging flow directed to Reactor Coolant System, °F	514
Temperature of effluent directed to Mixed Bed Demineralizer, °F	127
Centrifugal charging pump bypass flow (each), gpm	60
Amount of 3.5 to 4.0% boric acid solution required to meet cold shutdown requirements at the end of a core cycle with the most reactive control rod stuck out of the core, gallons	See Figure 9.3-21 for Requirements
Maximum pressurization required for hydrostatic testing of Reactor Coolant System, psig	3107
* During RHR Shutdown Cleanup, letdown flow is qualified for 180 gpm and charging flow is qualified to 200 gpm (including seal water).	
Reference: Westinghouse Summary Report on the Equipment Evaluation for the Effects of an Increased Shutdown Purification Flow Rate for Watts Bar Unit 1 (LTR-SEE-05-20).	
NOTE:	
The maximum allowable letdown and charging flows provide margin for volume expansion transient event mitigation. Letdown and charging piping qualified flows provide for accelerated shutdown cleanup operation only in Modes 5 & 6.	

**Table 9.3-5 Principal Component Data Summary  
(Page 1 of 7)**

<b>Centrifugal Charging Pumps</b>	
Number	2
Design pressure, psig	2800
Design temperature, °F	300
Design flow, gpm	150
Total Developed head, ft.	5800
Material	Austenitic stainless steel
<b>Boric Acid Transfer Pumps</b>	
Number	4
Design pressure, psig	150
Design temperature, °F	250
Design flow, gpm	75
Design head, ft.	235
Material	Austenitic stainless steel
<b>Gas Stripper Feed Pumps</b>	
Number	3
Design pressure, psig	150
Design temperature, °F	200
Design flow, gpm	500
Design head, ft.	320
Material	Austenitic stainless steel
<b>Holdup Tank Recirculation Pump</b>	
Number	1
Design pressure, psig	150
Design temperature, °F	200
Design flow, gpm	500
Design head, ft.	100
Material	Austenitic stainless steel
<b>Regenerative Heat Exchanger</b>	
Number	1
Heat transfer rate at design conditions, Btu/hr	$10.84 \times 10^6$
<b>Shell Side</b>	
Design pressure, psig	2485
Design temperature, °F	650
Fluid	Borated reactor coolant
Material	Austenitic stainless steel

**Table 9.3-5 Principal Component Data Summary  
(Page 2 of 7)**

<b>Tube Side</b>		
Design pressure, psig		2735
Design temperature, °F		650
Fluid		Borated reactor coolant
Material		Austenitic stainless steel
<b>Shell Side (Letdown)</b>		
Normal Flow, lb/hr		37,020
Inlet temperature, °F		557.3
Outlet temperature, °F		290
<b>Tube Side (Charging)</b>		
Normal Flow, lb/hr		27,148
Inlet temperature, °F		130
Outlet temperature, °F		514
<b>Letdown Heat Exchanger</b>		
Number		1
Heat transfer rate at design conditions, Btu/hr		15.27 x 10 <sup>6</sup>
<b>Shell Side</b>		
Design pressure, psig		150
Design temperature, °F		250
Fluid		Component cooling water
Material		Carbon steel
<b>Tube Side</b>		
Design pressure, psig		600
Design temperature, °F		400
Fluid		Borated reactor coolant
Material		Austenitic stainless steel
<b>Shell Side</b>		
	(Heat up)	(Normal)
Flow, lb/hr	498,000	203,000
Inlet temperature, °F	95	95
Outlet temperature, °F	126	126
<b>Tube Side (Letdown)</b>		
	(Heatup)	(Normal)
Flow, lb/hr	59,232	37,050
Inlet temperature, °F	380	290
Outlet temperature, °F	126	127



**Table 9.3-5 Principal Component Data Summary  
(Page 3 of 7)**

<b>Excess Letdown Heat Exchanger</b>		
Number	1	
Heat transfer rate at design conditions, Btu/hr	4.79 x 10 <sup>6</sup>	
	<u>Shell Side</u>	<u>Tube Side</u>
Design pressure, psig	150	2485
Design temperature, °f	250	650
Design flow, lb/hr	115,000	12,340
Inlet temperature, °F	95	557.3
Outlet temperature, °F	137	195
Fluid	Component	Borated reactor coolant
	cooling	
	water	
Material	Carbon	Austenitic stainless steel
	steel	
<b>Seal Water Heat Exchanger</b>		
Number	1	
Heat transfer rate at design conditions, Btu/hr	1.46 x 10 <sup>6</sup>	
	<u>Shell Side</u>	<u>Tube Side</u>
Design pressure, psig	150	200
Design temperature, °F	250	250
Design flow, lb/hr	99,500	47,879
Inlet temperature, °F	95	157.4
Outlet temperature, °F	109.7	127
Fluid	Component	Borated reactor coolant
	Cooling	
	water	
Material	Carbon	Austenitic stainless steel
	steel	
<b>Volume Control Tank</b>		
Number	1	
Volume, ft <sup>3</sup>	400	
Design pressure, psig	75	
Design temperature, °F	250	
Material	Austenitic stainless steel	

**Table 9.3-5 Principal Component Data Summary  
(Page 4 of 7)**

<b>Boric Acid Tanks</b>	
Number	3
Capacity, gal.	11,000
Design Pressure, psig	Atmospheric
Design Temperature, °F	200
Material	Austenitic stainless steel
<b>Boric Acid Batching Tank</b>	
Number	1
Capacity, gal.	800
Design Pressure, psig	Atmospheric
Design Temperature, °F	300
Material	Austenitic stainless steel
<b>Holdup Tanks</b>	
Number	2
Capacity, gal.	126,000 (per tank)
Design Pressure, psig	15
Design Temperature, °F	200
Material	Stainless Tank
<b>Chemical Mixing Tank</b>	
Number	1
Capacity, gal	5
Design pressure, psig	150
Design temperature, °F	200
Material	Austenitic stainless steel
<b>Mixed Bed Demineralizers</b>	
Number	2
Design pressure, psig	300
Design temperature, °F	250
Design flow, gpm	120*
Resin volume, each, ft. <sup>3</sup>	30
Material	Austenitic stainless steel

\* Flow may be increased to 180 gpm for shutdown cleanup.

**Table 9.3-5 Principal Component Data Summary  
(Page 5 of 7)**

<b>Cation Bed Demineralizer</b>	
Number	1
Design pressure, psig	300
Design temperature, °F	250
Design flow, gpm	75
Resin volume, ft. <sup>3</sup>	20
Material	Austenitic stainless steel
<b>Reactor Coolant Filter</b>	
Number	1
Design pressure, psig	300
Design temperature, °F	250
Design flow, gpm	150 (Flow may be increased to 180 gpm for shutdown cleanup.)
Particle retention	98% of 25 micron size
Material, (vessel)	Austenitic stainless steel
<b>Seal Water Injection Filters</b>	
Number	2
Design pressure, psig	3100
Design temperature, °F	250
Design flow, gpm	80
Particle retention	98% of 5 micron size
Material, (vessel)	Austenitic stainless steel
<b>Seal Water Return Filter</b>	
Number	1
Design pressure, psig	300
Design temperature, °F	250
Design flow, gpm	150 (max.)
Particle retention	98% of 25 micron size
Material (vessel)	Austenitic stainless steel
<b>Boric Acid Filters</b>	
Number	1
Design pressure, psig	300
Design temperature, °F	250
Design flow, gpm	150
Particle retention	98% of 25 micron size
Material (vessel)	Austenitic stainless steel

**Table 9.3-5 Principal Component Data Summary  
(Page 6 of 7)**

<b>Letdown Orifice</b>	Approx. 3 gpm	45 gpm (Note 1)	75 gpm (Note 2)
Number	1	1	2
Design flow, lb/hr	Approx. 1482	22,230	37,050
Differential pressure at design flow, psid	1900	1900	1900
Design pressure, psig	2485	2485	2485
Design temperature, °F	650	650	650
Material	Austenitic Stainless Steel	Austenitic Stainless Steel	Austenitic Stainless Steel
<b>Seal Water Return Bypass Orifice</b>			
Number			4
Design flow, gpm			1
Differential pressure at design flow, psid			300
Design pressure, psig			2485
Design temperature, °F			250
Material			Austenitic Stainless Steel
<b>Chemical Mixing Tank Orifice</b>			
Number			1
Design flow, gpm			2
Differential pressure at design flow, psid			50
Design pressure, psig			150
Design temperature, °F			200
Material			Austenitic Stainless Steel
<b>Reactor Coolant Pump Standpipe Orifice</b>			
Number			4
Design, flow, gpm			0.5
Differential pressure			9 inches of H2O
Design pressure, psig			150
Design temperature, °F			200
Material			Stainless Steel

**Table 9.3-5 Principal Component Data Summary  
(Page 7 of 7)**

<b>Charging Pump Bypass Orifice</b>	
Number	2
Design flow, gpm	60
Differential pressure at design flow, psid	6000
Design pressure, psig	2800
Design temperature, °F	300
Material	Stainless Steel
<b>Boric Acid Blender</b>	
Number	1
Design pressure, psig	150
Design temperature, °F	250
Material	Austenitic Stainless Steel
<b>Boric Acid Tank Orifice</b>	
Number	3
Design flow, gpm	3
Differential pressure at design flow, psid	100
Design pressure, psig	150
Design temperature, °F	200
Material	Austenitic Stainless Steel

**Table 9.3-6 Deleted by Amendment 95**

**Table 9.3-7  
(Sheet 1 of 45)  
FAILURE MODE AND EFFECTS ANALYSIS AUXILIARY AIR SUPPLY EQUIPMENT**

No.	COMPONENT IDENTIFICATION	FUNCTION	FAILURE MODE	POTENTIAL CAUSE	METHOD OF FAILURE DETECTION	EFFECT ON SYSTEM	EFFECT ON PLANT	REMARKS
<b>TRAIN A</b>								
1.	ACAS Compressor Intake Filter 0-FLTR-32-60	Filters Air Prior to compressor	None	None	None	None	None	No active failures for 0-FLTR-32-60
2.	Auxiliary Compressor 0-COMP-32-60	Provide required pressure and flow to essential loads due to loss of CAS supply	Fails to start	Control/Mechanical failure	Pressure indication via PI-32-62,-66 and/or -1000.	Loss of Train "A"	None. Train "B" available to provide for safe shutdown.	
			Unloader fails (FSV-32-62)	Control/Mechanical failure	Relief valves 0-32-366,-367, and/or -372 relieve at pressure >115 psig. If compressor fails to load low pressure indicated via PI-32-62,-66 and/or -1000	Loss of Train "A"	None. Train "B" available to provide for safe shutdown.	
			Cooling water failure	Control/Mechanical failure	High air temperature alarm via 0-TS-32-64	Loss of cooling water to compressor will cause failure of compressor due to high temperature	None. Train "B" available to provide for safe shutdown.	

**Table 9.3-7  
(Sheet 2 of 45)  
FAILURE MODE AND EFFECTS ANALYSIS AUXILIARY AIR SUPPLY EQUIPMENT**

No.	COMPONENT IDENTIFICATION	FUNCTION	FAILURE MODE	POTENTIAL CAUSE	METHOD OF FAILURE DETECTION	EFFECT ON SYSTEM	EFFECT ON PLANT	REMARKS
<b>TRAIN A</b>								
3.	After cooler 0-HTX-32-60	Remove the heat of compression from the auxiliary control air	Tube rupture  Cooling water failure	Mechanical failure  Control/Mechanical failure	High moisture alarm via ME-32-83  High temperature indication via 0-TI-32-65 if failure is just to After Cooler supply. Also, high temperature alarm via 0-TS-32-64 if entire cooling water supply disrupted.	High moisture would cause saturation of the air dryers and degradation loss of Train "A"  High system temperatures resulting in possible system degradation.	None. Train "B" available to provide for safe shutdown.  None. Train "B" available to provide for safe shutdown.	
4.	Compressor Accumulator 0-ACUM-32-60	Dampen compressor discharge pressure pulses and provide sufficient air volume (in conjunction with the receivers) to minimize compressor starts/stops and unloading/ loading cycles	None	None	None	None	None	No active failure for the accumulator



Table 9.3-7  
(Sheet 3 of 45)

FAILURE MODE AND EFFECTS ANALYSIS AUXILIARY AIR SUPPLY EQUIPMENT

No.	COMPONENT IDENTIFICATION	FUNCTION	FAILURE MODE	POTENTIAL CAUSE	METHOD OF FAILURE DETECTION	EFFECT ON SYSTEM	EFFECT ON PLANT	REMARKS
<b>TRAIN A</b>								
5.	Check valve 0-32-240	Prevents backflow of air from the receiver back to the compressor.	Fails open  Fails closed	Mechanical failure  Mechanical failure	Low receiver pressure indication via PI-32-66. Compressor running longer than normal.  Low receiver pressure indicated via PI-32-66 without any resultant pressure increase due to compressor operation.	Compressor will cycle more often in order to maintain receiver pressure.  Reduction of system pressure until too low for user operation. Loss of train "A".	None  None. Train "B" available to provide for safe shutdown.	
6.	Auxiliary Air Receiver 0-RCVR-32-62	Dampen compressor pressure pulses and provide a sufficient stored air volume to minimize startups and load/unload cycling of the ACAS compressors.	None	None	None	None	None	No active failures for receiver.
7.	Isolation valve 0-32-246	To isolate the CAS supply from the inlet to the ACAS air dryers.	None	None	None	None	None	No active failure failure for 0-32-246.

**Table 9.3-7  
(Sheet 4 of 45)  
FAILURE MODE AND EFFECTS ANALYSIS AUXILIARY AIR SUPPLY EQUIPMENT**

No.	COMPONENT IDENTIFICATION	FUNCTION	FAILURE MODE	POTENTIAL CAUSE	METHOD OF FAILURE DETECTION	EFFECT ON SYSTEM	EFFECT ON PLANT	REMARKS
<b>TRAIN A</b>								
8.	Flow control valve to air Dryer No. 1 0-FCV-32-71	To regulate inlet air flow to Dryer No. 1	Fails open	Control/Mechanical failure	No switching to Dryer No. 2 flow path as indicated by PI-32-74 and -75 along with possible high moisture alarm via Annunciator Window 136-C on 1- XA-55-6D.	Without switch over to the other dryer, the moisture will begin to carry over until the high moisture alarm sounds thus causing potential system high moisture levels and degradation	None. Train "B" available to provide for safe shutdown.	
			Fails closed	Control/Mechanical failure	Continual flow through dryer No. 2 flow path as indicated by PI-32-74 and -75 along with possible high moisture alarm via Annunciator Window 136-C on 1-XA-55-6D.	Without switch over to the other dryer, the moisture will begin to carry over until the high moisture alarm sounds thus causing potential system high moisture levels and degradation. Fail closed position will also result in low header pressure which will alarm in the MCR via 0- PS-32-0104.	None. Train "B" available to provide for safe shutdown.	



**Table 9.3-7  
(Sheet 6 of 45)  
FAILURE MODE AND EFFECTS ANALYSIS AUXILIARY AIR SUPPLY EQUIPMENT**

No.	COMPONENT IDENTIFICATION	FUNCTION	FAILURE MODE	POTENTIAL CAUSE	METHOD OF FAILURE DETECTION	EFFECT ON SYSTEM	EFFECT ON PLANT	REMARKS
<b>TRAIN A</b>								
10.	Flow Control Valve for Dryer No. 1 purge flow 0-FCV-32-72	Provides flow path for backflow of air for drying the desiccant in Dryer No. 1 when not in operation	Fails open	Control/Mechanical failure	Switchover will not occur due to electrical interlock which can be determined by pressure indications on PI-32-74 & -75 along with possible high moisture alarm via annunciator window 136-C on 1-XA-55-6D	Without switchover to Dryer No. 2 high moisture levels could occur as indicated via alarm at annunciator window 136-C on 1-XA-55-6D	None. Train "B" available to provide for safe shutdown	
			Fails closed	Control/Mechanical failure	No purge flow through Dryer No. 1 or switchover to Dryer No. 2 which can be determined by pressure indications on PI-32-74 & -75 along with possible high moisture alarm via annunciator window 136-C on 1-XA-55-6D	Without switchover to Dryer No. 2 high moisture levels could occur as indicated via alarm at annunciator window 136-C on 1-XA-55-6D	None. Train "B" available to provide for safe shutdown.	

**Table 9.3-7  
(Sheet 7 of 45)  
FAILURE MODE AND EFFECTS ANALYSIS AUXILIARY AIR SUPPLY EQUIPMENT**

No.	COMPONENT IDENTIFICATION	FUNCTION	FAILURE MODE	POTENTIAL CAUSE	METHOD OF FAILURE DETECTION	EFFECT ON SYSTEM	EFFECT ON PLANT	REMARKS
<b>TRAIN A</b>								
11.	Flow Control Valve for valve for Dryer No. 2 purge flow 0-FCV-32-73	Provides flow path for backflow of air for drying the desiccant in Dryer No. 2 when not in operation	Fails open	Control/Mechanical failure	Switchover will not occur due to electrical interlock which can be determined by pressure indications on PI-32-74 & -75 along with possible high moisture alarm via annunciator 136-C on 1-XA-55-6D	Without switchover to Dryer No. 1 high moisture levels could occur as indicated via alarm at annunciator window 136-C on 1-XA-55-6D	None. Train "B" available to provide for safe shutdown.	
			Fails closed	Control/Mechanical failure	No purge flow through Dryer No. 2 or switchover to Dryer No. 1 which can be determined by pressure indications on PI-32-74 & -75 along with possible high moisture alarm via annunciator window 136-C on 1-XA-55-6D	Without switchover to Dryer No. 1 high moisture levels could occur as indicated via alarm at annunciator window 136-C on 1-XA-55-6D	None. Train "B" available to provide for safe shutdown.	

**Table 9.3-7  
(Sheet 8 of 45)  
FAILURE MODE AND EFFECTS ANALYSIS AUXILIARY AIR SUPPLY EQUIPMENT**

No.	COMPONENT IDENTIFICATION	FUNCTION	FAILURE MODE	POTENTIAL CAUSE	METHOD OF FAILURE DETECTION	EFFECT ON SYSTEM	EFFECT ON PLANT	REMARKS
<b>TRAIN A</b>								
12.	Dryer No. 1 0-DRYR-32-75	Reduce the moisture content of the air to a dew point of -40°F at line pressure and design flow for air usage.	None	None	None	None	None	No active failures for 0-DRYR-32-75
13.	Dryer No. 2 0-DRYR-32-74	Reduce the moisture content of the air to a dew point of -40°F at the pressure and design flow for air usage.	None	None	None	None	None	No active failures for 0-DRYR-32-74

**Table 9.3-7  
(Sheet 9 of 45)  
FAILURE MODE AND EFFECTS ANALYSIS AUXILIARY AIR SUPPLY EQUIPMENT**

No.	COMPONENT IDENTIFICATION	FUNCTION	FAILURE MODE	POTENTIAL CAUSE	METHOD OF FAILURE DETECTION	EFFECT ON SYSTEM	EFFECT ON PLANT	REMARKS
<b>TRAIN A</b>								
14.	Dryer No. 1 purge check valve 0-CKV-32-70B	Prevent backflow through the dryer purge line when Dryer No. 1 is in service  Allow backflow through the dryer purge line when Dryer No. 2 is in service	Stuck open  Stuck closed	Mechanical failure  Mechanical failure	Reduced air header pressure as indicated by PT-32-104 due to loss of air through Dryer No. 2 purge when Dryer No. 1 is in service  No flow indicated via FI-32-76 for purge flow when Dryer No. 2 is in service. Also possible alarm via annunciator window 136-C on 1-XA-55-6D when Dryer No. 1 is in service.	Reduced header pressure resulting in more frequent cycling of ACAS compressor "A". Possible reduction of pressure below minimum operating.  Possible high moisture levels when Dryer No. 1 is in service due to no backflow when Dryer No. 2 is in operation. Potential for high moisture alarm via annunciator 136-C on 1-XA-55-6D.	None. Train "B" available to provide for safe shutdown.  None. Train "B" available to provide for safe shutdown.	

**Table 9.3-7  
(Sheet 10 of 45)  
FAILURE MODE AND EFFECTS ANALYSIS AUXILIARY AIR SUPPLY EQUIPMENT**

No.	COMPONENT IDENTIFICATION	FUNCTION	FAILURE MODE	POTENTIAL CAUSE	METHOD OF FAILURE DETECTION	EFFECT ON SYSTEM	EFFECT ON PLANT	REMARKS
<b>TRAIN A</b>								
15.	Dryer No. 2 Purge check valve 0-CKV-32-70A	Prevent backflow through the dryer purge line when Dryer No. 2 is in service  Allow backflow through the dryer purge line when Dryer No. 1 is in service	Stuck open  Stuck closed	Mechanical failure  Mechanical failure	Reduced air header pressure as indicated by PT-32-104 due to loss of air through Dryer No. 1 purge when Dryer No. 2 is in service  No flow indicated via FI-32-76 for purge flow when Dryer No. 1 is in service. Also possible alarm via annunciator window 136-C on 1-XA-55-6D when dryer No. 2 is in service.	Reduced header pressure resulting in more frequent cycling of ACAS compressor "A". Possible reduction of pressure below minimum operating.  Possible high moisture levels when Dryer No. 2 is in service due to no backflow when Dryer No. 1 is in operation. Potential for high moisture alarm via annunciator window 136-C on 1-XA-55-6D.	None. Train "B" available to provide for safe shutdown.  None. Train "B" available to provide for safe shutdown.	



**Table 9.3-7  
(Sheet 11 of 45)  
FAILURE MODE AND EFFECTS ANALYSIS AUXILIARY AIR SUPPLY EQUIPMENT**

No.	COMPONENT IDENTIFICATION	FUNCTION	FAILURE MODE	POTENTIAL CAUSE	METHOD OF FAILURE DETECTION	EFFECT ON SYSTEM	EFFECT ON PLANT	REMARKS
<b>TRAIN A</b>								
16.	Dryer No. 1 flow path check valve 0-CKV-32-70D	Prevents backflow through Dryer No. 1 flow path (except for the purge flow) when Dryer No. 2 is in service	Stuck open	Mechanical failure	When Dryer No. 2 is in service, air system pressure would drop as indicated via 0-PT-32-104 alarm and PI-32-75 indication.	Reduced system pressure resulting would cause more frequent compressor "A" cycling. Possible reduction of pressure below minimum operating.	None. Train "B" available to provide for safe shutdown.	
			Stuck closed	Mechanical failure	When Dryer No. 1 is in service, there would be no purge flow to Dryer No. 2 and no flow to the system; therefore, FI-32-76 and PT-32-104 would give indication of no purge flow and a drop in system pressure. Possible high moisture alarm via annunciator window 136-C on 1-XA-55-6D when Dryer No. 2 is in service.	Reduced system pressure and high moisture contents in Dryer No. 2 due to lack of purge flow.	None. Train "B" available to provide for safe shutdown.	

**Table 9.3-7  
(Sheet 12 of 45)  
FAILURE MODE AND EFFECTS ANALYSIS AUXILIARY AIR SUPPLY EQUIPMENT**

No.	COMPONENT IDENTIFICATION	FUNCTION	FAILURE MODE	POTENTIAL CAUSE	METHOD OF FAILURE DETECTION	EFFECT ON SYSTEM	EFFECT ON PLANT	REMARKS
<b>TRAIN A</b>								
17.	Dryer No. 2 flow path check valve 0-CKV-32-70C	Prevents backflow through Dryer No. 2 flow path (except for the purge flow) when Dryer No. 1 is in service	Stuck open	Mechanical failure	When Dryer No. 1 is in service, air system pressure would drop as indicated via 0-PT-32-104 alarm and PI-32-74 indication.	Reduced system pressure resulting would cause more frequent compressor "A" cycling. Possible reduction of pressure below minimum operating.	None. Train "B" available to provide for safe shutdown.	
			Stuck closed	Mechanical failure	When Dryer No. 2 is in service, there would be no purge flow to Dryer No. 1 and no flow to the system; therefore, FI-32-76 and PT-32-104 would give indication of no purge flow and a drop in system pressure. Possible high moisture alarm via annunciator window 136-C on 1-XA-55-6D when Dryer No. 1 is in service.	Reduced system pressure and high moisture contents in Dryer No. 1 due to lack of purge flow.	None. Train "B" available to provide for safe shutdown.	

**Table 9.3-7**  
**(Sheet 13 of 45)**  
**FAILURE MODE AND EFFECTS ANALYSIS AUXILIARY AIR SUPPLY EQUIPMENT**

No.	COMPONENT IDENTIFICATION	FUNCTION	FAILURE MODE	POTENTIAL CAUSE	METHOD OF FAILURE DETECTION	EFFECT ON SYSTEM	EFFECT ON PLANT	REMARKS
<b>TRAIN A</b>								
18.	Dryer after filter 0-FLTR-32-76	Filter out 100% of particles of desiccant and other foreign matter down to 0.9 micron size.	None	None	None	None	None	No active failure for 0-FLTR-32-76
19.	Dryer Isolation Valve 0-32-249	Isolates dryer unit from air header.	None	None	None	None	None	No active failure for 0-32-249
20.	ACAS Inlet filter 0-FLTR-32-82	Filter CAS air entering the ACAS during normal operation.	None	None	None	None	None	No active failure for 0-FLTR-32-82

**Table 9.3-7  
(Sheet 14 of 45)  
FAILURE MODE AND EFFECTS ANALYSIS AUXILIARY AIR SUPPLY EQUIPMENT**

No.	COMPONENT IDENTIFICATION	FUNCTION	FAILURE MODE	POTENTIAL CAUSE	METHOD OF FAILURE DETECTION	EFFECT ON SYSTEM	EFFECT ON PLANT	REMARKS
<b>TRAIN A</b>								
21.	ACAS Isolation Valve 0-FCV-32-82	Isolates ACAS from CAS supply on low control air pressure	Stuck open	Control/Mechanical failure	Valve position indication	ACAS compressor "A" will take control of ACAS in the case of low CAS pressure; therefore, with 0-FCV-32-82 stuckopen, check valve 0-32-256 will prevent back flow with no effect on train "A" operation.	None	
			Stuck closed	Control/Mechanical failure	Valve position indication	ACAS compressor "A" will take control of ACAS; therefore, train "A" will not be effected.	None	

**Table 9.3-7**  
**(Sheet 15 of 45)**  
**FAILURE MODE AND EFFECTS ANALYSIS AUXILIARY AIR SUPPLY EQUIPMENT**

No.	COMPONENT IDENTIFICATION	FUNCTION	FAILURE MODE	POTENTIAL CAUSE	METHOD OF FAILURE DETECTION	EFFECT ON SYSTEM	EFFECT ON PLANT	REMARKS
22.	ACAS Backflow Check Valve 0-32-256	Prevents flow from ACAS back to CAS	Stuck open	Mechanical failure	None	0-FCV-32-82 will cycle to maintain system pressure and isolate any backflow; therefore, train "A" will not be effected.	None	
			Stuck closed	Mechanical failure	None	ACAS compressor "A" will supply train "A"; therefore, no effect on train "A" operation	None	

**Table 9.3-7  
(Sheet 16 of 45)  
FAILURE MODE AND EFFECTS ANALYSIS AUXILIARY AIR SUPPLY EQUIPMENT**

No.	COMPONENT IDENTIFICATION	FUNCTION	FAILURE MODE	POTENTIAL CAUSE	METHOD OF FAILURE DETECTION	EFFECT ON SYSTEM	EFFECT ON PLANT	REMARKS
<b>TRAIN A</b>								
23.	CAS Isolation Valve 0-32-251	Bypasses CAS around ACAS air dryers	None	None	None	None	None	No active failure for 0-32-251
24.	Moisture Element (ME-32-83) Inlet Isolation Valve 0-32-252	Isolates inlet of ME-32-83 for maintenance	None	None	None	None	None	No active failure for 0-32-252
25.	Moisture element (ME-32-83) Outlet Isolation Valve 0-32-253	Isolates outlet of ME-32-83 for maintenance	None	None	None	None	None	No active failure for 0-32-253
26.	Moisture Element (ME-32-83) Bypass Valve 0-32-254	Isolate ME-32-83 bypass	None	None	None	None	None	No active failure for 0-32-254

**Table 9.3-7  
(Sheet 17 of 45)  
FAILURE MODE AND EFFECTS ANALYSIS AUXILIARY AIR SUPPLY EQUIPMENT**

No.	COMPONENT IDENTIFICATION	FUNCTION	FAILURE MODE	POTENTIAL CAUSE	METHOD OF FAILURE DETECTION	EFFECT ON SYSTEM	EFFECT ON PLANT	REMARKS
<b>TRAIN A</b>								
27.	Control Air Check Valve 0-32-380 for 1-LCV-3-172 and -175 Backflow	Prevents loss of air pressure in piping to ensure operation in the event of loss of air header pressure	Fails open          Fails closed	Mechanical failure    Mechanical failure	No position change indicated for 1-LCV-3-172 and -175 in control room via HS-3-172A and -175A.   Unable to cycle valves 1-LCV-3-172 and -175 as indicated on control room hand switches HS-3-172A and -175A.	Unable to operate SG level control valves 1-LCV-3-172 and -175 on loss of header pressure. No effect with full header pressure  Valves 1-LCV-3-172 and -175 inoperable.	None. Valves 1-LCV-3-173 and -174 operable in train "B"  None. Valves 1-LCV-3-173 and -174 operable in train "B"	

**Table 9.3-7  
(Sheet 18 of 45)  
FAILURE MODE AND EFFECTS ANALYSIS AUXILIARY AIR SUPPLY EQUIPMENT**

No.	COMPONENT IDENTIFICATION	FUNCTION	FAILURE MODE	POTENTIAL CAUSE	METHOD OF FAILURE DETECTION	EFFECT ON SYSTEM	EFFECT ON PLANT	REMARKS
<b>TRAIN A</b>								
28.	Train "A" Containment Isolation Valve 1-FCV-32-80	Isolate containment on low air pressure or containment isolation signal.	Fails open  Fails closed	Control/Mechanical failure  Control/Mechanical failure	Valve position indication via 1-HS-32-80A  Valve position indication via 1-HS-32-80A	None. Check valve 1-32-303 provides containment isolation backup.  Pressurizer spray valves not operable, however, these will not effect train "A" safety function.	None  None. While Train "A" spray valves will be inoperable, the Train "A" components required for safe shutdown are still available. Train "B" spray valves operable for plant operation.	
29.	Containment Isolation Valve (1-FCV-32-80) Inlet Isolation Valve 1-32-297	Isolates Inlet to 1-FCV-32-80 for maintenance	None	None	None	None	None	No active failure mode for 1-32-297
30.	Containment Isolation Valve (1-FCV-32-80) Outlet Isolation Valve 1-32-301	Isolates Outlet to 1-FCV-32-80 for maintenance	None	None	None	None	None	No active failure mode for 1-32-301



**Table 9.3-7  
(Sheet 19 of 45)  
FAILURE MODE AND EFFECTS ANALYSIS AUXILIARY AIR SUPPLY EQUIPMENT**

No.	COMPONENT IDENTIFICATION	FUNCTION	FAILURE MODE	POTENTIAL CAUSE	METHOD OF FAILURE DETECTION	EFFECT ON SYSTEM	EFFECT ON PLANT	REMARKS
<b>TRAIN A</b>								
31.	Containment Isolation Valve (1-FCV-32-80) bypass Valve 1-32-298	Isolates 1-FCV-32-80 bypass	None	None	None	None	None	No active failure mode for 1-32-298
32.	Containment Isolation Check Valve 1-32-303	Provide containment isolation as a backup for 1-FCV-32-80	Fails open  Failed closed	Mechanical failure  Mechanical failure	None  Pressurizer spray valve 1-PCV-68-340D position indication via 1-HS-340	None. 1-FCV-32-80 would provide containment isolation.  Safety function not effected; however, spray valve inoperable	None  None. Train "A" components required for safe shutdown are still available and train "B" spray valve 1-PCV-68-340B is operable	
33.	Isolation valve 0-32-385	Isolation air supply to system 65 dampers and valves	None	None	None	None	None	No active failure for 0-32-385

**Table 9.3-7  
(Sheet 20 of 45)  
FAILURE MODE AND EFFECTS ANALYSIS AUXILIARY AIR SUPPLY EQUIPMENT**

No.	COMPONENT IDENTIFICATION	FUNCTION	FAILURE MODE	POTENTIAL CAUSE	METHOD OF FAILURE DETECTION	EFFECT ON SYSTEM	EFFECT ON PLANT	REMARKS
<b>TRAIN B</b>								
34.	ACAS Compressor Intake Filter 0-FLTR-32-86	Filters air prior to compressor	None	None	None	None	None	No active failure for 0-FLTR-32-86
35.	Auxiliary Compressor 0-COMP-32-86	Provide required pressure and flow to essential loads due to loss of CAS supply	Fails to start	Control/ Mechanical failure	Pressure indication via PI-32-88, -89, and/or -1100	Loss of Train "B"	None. Train "A" available to provide for safe shutdown.	
			Unloader fails (FSV-32-88)	Control/ Mechanical failure	Relief valves 0-32, -368, -391, -369 relieve at pressure >115 psig. If compressor fails to load low pressure indicated via PI-32-88, -89 and/or -1100	Loss of Train "B"	None. Train "A" available to provide for safe shutdown.	
			Cooling Water Failure	Control/ Mechanical failure	High air temperature alarm via 0-TS-32-91	Loss of cooling water to compressor will cause failure of compressor due to high temperature.	None. Train "A" available to provide for safe shutdown.	

**Table 9.3-7  
(Sheet 21 of 45)  
FAILURE MODE AND EFFECTS ANALYSIS AUXILIARY AIR SUPPLY EQUIPMENT**

No.	COMPONENT IDENTIFICATION	FUNCTION	FAILURE MODE	POTENTIAL CAUSE	METHOD OF FAILURE DETECTION	EFFECT ON SYSTEM	EFFECT ON PLANT	REMARKS
<b>TRAIN B</b>								
36.	After cooler 0-HTX-32-86	Remove the heat of compression from the auxiliary control air.	Tube rupture  Cooling water failure	Mechanical failure  Control/ Mechanical failure	High moisture alarm via ME-32-84  High temperature indication via 0-TI-32-92 if failure is just to after cooler supply. Also, high temperature alarm via 0-TS-32-91 if entire cooling water supply disrupted.	High moisture would cause saturation of air dryers and degradation of train "B".  High system temperatures resulting in possible system degradation.	None. Train "A" available to provide for safe shutdown.  None. Train "A" available to provide for safe shutdown.	
37.	Compressor Accumulator 0-ACUM-32-86	Dampen compressor discharge pressure pulses and provide sufficient air volume (in conjunction with the receivers) to minimize compressor starts/stops and unloading/ loading cycles.	None	None	None	None	None	No active failures for the Accumulators

**Table 9.3-7  
(Sheet 22 of 45)  
FAILURE MODE AND EFFECTS ANALYSIS AUXILIARY AIR SUPPLY EQUIPMENT**

No.	COMPONENT IDENTIFICATION	FUNCTION	FAILURE MODE	POTENTIAL CAUSE	METHOD OF FAILURE DETECTION	EFFECT ON SYSTEM	EFFECT ON PLANT	REMARKS
<b>TRAIN B</b>								
38.	Check valve 0-32-279	Prevents backflow of air from the receiver back to the compressor.	Fails open  Fails closed	Mechanical failure  Mechanical failure	Low receiver pressure indication via PI-32-89. Compressor running longer than normal.  Low receiver pressure indicated via PI-32-89 without any resultant pressure increase due to compressor operation.	Compressor will cycle more often in order to maintain receiver pressure.  Reduction of system pressure until too low for user operation. Loss of train "B"	None  None. Train "A" capable of carrying entire system load.	
39.	Auxiliary Air Receiver 0-RCVR-32-88	Dampen compressor pressure pulses and provide a sufficient stored air volume to minimize startups and load/unload cycling of the ACAS compressors.	None	None	None	None	None	No active failures for the receiver.
40.	Isolation Valve 0-32-275.	To isolate the CAS supply from the inlet to the ACAS air dryers.	None	None	None	None	None	No active failure for 0-32-275



**Table 9.3-7  
(Sheet 24 of 45)  
FAILURE MODE AND EFFECTS ANALYSIS AUXILIARY AIR SUPPLY EQUIPMENT**

No.	COMPONENT IDENTIFICATION	FUNCTION	FAILURE MODE	POTENTIAL CAUSE	METHOD OF FAILURE DETECTION	EFFECT ON SYSTEM	EFFECT ON PLANT	REMARKS
<b>TRAIN B</b>								
42.	Flow control valve to air Dryer No. 2 0-FCV-32-94	To regulate inlet air flow to Dryer No. 2	Fails open	Control/Mechanical failure	No switchover to Dryer No. 1 flow path as indicated by PI-32-99 & -100 along with possible high moisture alarm via annunciator window 137-C on 1-XA-55-6D	Without switch over to the other dryer, the moisture will begin to carry over until the high moisture alarm sounds thus causing potential system high moisture levels and degradation.	None. Train "A" available to provide for safe shutdown.	
			Fails closed	Control/Mechanical failure	Continual flow through Dryer No. 1 flow path as indicated by PI-32-99 & -100 along with possible high moisture alarm via annunciator window 137-C on 1-XA-55-6D	Without switch-over to the other dryer, the moisture will begin to carry over until the high moisture alarm sounds thus causing potential system high moisture levels and degradation. Fail closed position will also result in low header pressure which will alarm in the MCR via 0-PS-032-0105.	None. Train "A" available to provide for safe shutdown.	



**Table 9.3-7  
(Sheet 26 of 45)  
FAILURE MODE AND EFFECTS ANALYSIS AUXILIARY AIR SUPPLY EQUIPMENT**

No.	COMPONENT IDENTIFICATION	FUNCTION	FAILURE MODE	POTENTIAL CAUSE	METHOD OF FAILURE DETECTION	EFFECT ON SYSTEM	EFFECT ON PLANT	REMARKS
<b>TRAIN B</b>								
44.	Flow control Valve for Dryer No. 2 purge flow 0-FCV-32-97,	Provides flow path for backflow of air for drying the desiccant in Dryer No. 2 when not in operation	Fails open	Control/Mechanical failure	Switch over will not occur due to electrical interlock which can be determined by pressure indications on PI-32-99 & -100 along with possible high moisture alarm via annunciator window 137-C on 1-XA-55-6D	Without switchover to Dryer No. 1 high moisture levels could occur as indicated via alarm at annunciator window 137-C on 1-XA-55-6D.	None. Train "A" available to provide for safe shutdown.	
			Fails closed	Control/Mechanical failure	No purge flow through Dryer No. 2 or switchover to Dryer No. 1 which can be determined by pressure indications on PI-32-99 and -100 and possible high moisture alarm via Annunciator Window 137-C on 1-XA-55-6D.	Without switch over to Dryer No. 1 high moisture levels could occur as indicated via alarm at Annunciator Window 137-C on 1-XA-55-6D.	None. Train "A" available to provide for safe shutdown	



**Table 9.3-7**  
**(Sheet 27 of 45)**  
**FAILURE MODE AND EFFECTS ANALYSIS AUXILIARY AIR SUPPLY EQUIPMENT**

No.	COMPONENT IDENTIFICATION	FUNCTION	FAILURE MODE	POTENTIAL CAUSE	METHOD OF FAILURE DETECTION	EFFECT ON SYSTEM	EFFECT ON PLANT	REMARKS
<b>TRAIN B</b>								
45.	Dryer No. 1 0-DRYR-32-100	Reduce the moisture content of the air to a dew point of -40°F at line pressure and design flow for air usage.	None	None	None	None	None	No active failure for 0-DRYR-32-100
46.	Dryer No. 2 0-DRYR-32-99	Reduce the moisture content of the air to a dew point of -40°F at line pressure and design flow for air usage.	None	None	None	None	None	No active failure for 0-DRYR-32-99

**Table 9.3-7  
(Sheet 28 of 45)  
FAILURE MODE AND EFFECTS ANALYSIS AUXILIARY AIR SUPPLY EQUIPMENT**

No.	COMPONENT IDENTIFICATION	FUNCTION	FAILURE MODE	POTENTIAL CAUSE	METHOD OF FAILURE DETECTION	EFFECT ON SYSTEM	EFFECT ON PLANT	REMARKS
<b>TRAIN B</b>								
47.	Dryer No. 1 Purge check valve 0-CKV-32-94B	Prevent backflow through the dryer purge line when Dryer No.1 is in service  Allow backflow through the dryer purge line when Dryer No. 2 is in operation.	Stuck open  Stuck closed	Mechanical failure  Mechanical failure	Reduced air header pressure as indicated by PT-32-105 due to loss of air through Dryer no. 2 purge when Dryer No. 1 is in service  No flow indicated via FI-32-101 for purge flow when Dryer No. 2 is in service. Also, possible alarm via Annunciator Window 137-C on 1-XA-55-6D when Dryer No. 1 is in service.	Reduced header pressure resulting in more frequent cycling of ACAS compressor "B". Possible reduction of pressure below minimum operating.  Possible high moisture levels when Dryer No. 1 is in service due to no backflow when Dryer No. 2 is in operation. Potential for high moisture alarm via Annunciator Window 137-C on 1-XA-55-6D.	None. Train "A" available to provide for safe shutdown.  None. Train "A" available to provide for safe shutdown.	

**Table 9.3-7  
(Sheet 29 of 45)  
FAILURE MODE AND EFFECTS ANALYSIS AUXILIARY AIR SUPPLY EQUIPMENT**

No.	COMPONENT IDENTIFICATION	FUNCTION	FAILURE MODE	POTENTIAL CAUSE	METHOD OF FAILURE DETECTION	EFFECT ON SYSTEM	EFFECT ON PLANT	REMARKS
<b>TRAIN B</b>								
48.	Dryer No. 2 Purge check valve 0-CKV-32-94A	<p>Prevent backflow through the Dryer purge line when Dryer No. 2 is in service</p> <p>Allow backflow through the dryer purge line when Dryer No. 1 is in service</p>	<p>Stuck open</p> <p>Stuck closed</p>	<p>Mechanical failure</p> <p>Mechanical failure</p>	<p>Reduced air header pressure as indicated by PT-32-105 due to loss of air through Dryer No. 1 purge when Dryer No. 2 is in service.</p> <p>No flow indicated via FI-32-101 for purge flow when Dryer No. 1 is in service. Also possible alarm via annunciator window 137-C on 1-XA-55-6D when Dryer No. 2 is in service.</p>	<p>Reduced header pressure resulting in more frequent cycling of ACAS compressor "B". Possible reduction of pressure below minimum operating.</p> <p>Possible high moisture levels when Dryer No. 2 is in service due to no backflow when Dryer No. 1 is in operation. Potential for high moisture alarm via annunciator window 137-C on 1-XA-55-6D.</p>	<p>None. Train "A" available to provide for safe shutdown.</p> <p>None. If Train "A" available to provide for safe shutdown.</p>	

**Table 9.3-7  
(Sheet 30 of 45)  
FAILURE MODE AND EFFECTS ANALYSIS AUXILIARY AIR SUPPLY EQUIPMENT**

No.	COMPONENT IDENTIFICATION	FUNCTION	FAILURE MODE	POTENTIAL CAUSE	METHOD OF FAILURE DETECTION	EFFECT ON SYSTEM	EFFECT ON PLANT	REMARKS
<b>TRAIN B</b>								
49.	Dryer No. 1 Flow path check valve 0-CKV-32-94D	Prevents backflow through dryer No. 1 flow path (except for the purge flow) when Dryer No. 2 is in service	Stuck open  Stuck closed	Mechanical failure  Mechanical failure	When Dryer No. 2 is in service, air system pressure would drop as indicated via 0-PT-32-105 alarm and PI-32-100  When Dryer No. 1 is in service, there would be no purge flow to Dryer No. 2 and no flow to the system; therefore, FI-32-101 and PT-32-105 would give indication of no purge flow and a drop in system pressure. Possible high moisture alarm via annunciator window 137-C on 1-XA-55-6D when Dryer No. 2 is in service.	Reduced system pressure resulting would casue more frequent compressor "B" cycling. Possible reduction of pressure below minimum operating.  Reduced system pressure and high moisture contents in Dryer No. 2 due to lack of purge flow.	None. Train "A" available to provide for safe shutdown.  None. Train "A" available to provide for safe shutdown.	

**Table 9.3-7**  
**(Sheet 31 of 45)**  
**FAILURE MODE AND EFFECTS ANALYSIS AUXILIARY AIR SUPPLY EQUIPMENT**

No.	COMPONENT IDENTIFICATION	FUNCTION	FAILURE MODE	POTENTIAL CAUSE	METHOD OF FAILURE DETECTION	EFFECT ON SYSTEM	EFFECT ON PLANT	REMARKS
<b>TRAIN B</b>								
50.	Dryer No. 2 Flow path check valve 0-CKV-32-94C	Prevents backflow through Dryer No. 2 flow path (except for the purge flow) when Dryer No. 1 is in service	Stuck open	Mechanical failure	When Dryer No. 1 is in service, air system pressure would drop as indicated via 0-PT-32-105 alarm and PI-32-99 indication.	Reduced system pressure resulting would cause more frequent compressor "B" cycling. Possible reduction of pressure below minimum operating.	None. Train "A" available to provide for safe shutdown.	
			Stuck closed	Mechanical failure	When Dryer No. 2 is in service, there would be no purge flow to Dryer No. 1 and no flow to the system; therefore, FI-32-101 and PT-32-105 would give indication of no purge flow and a drop in system pressure. Possible high moisture alarm via annunciator window 137-C on 1-XA-55-6D when Dryer No. 1 is in service.	Reduced system pressure and high moisture contents in Dryer No. 1 due to lack of purge flow.	None. Train "A" available to provide for safe shutdown.	

**Table 9.3-7  
(Sheet 32 of 45)  
FAILURE MODE AND EFFECTS ANALYSIS AUXILIARY AIR SUPPLY EQUIPMENT**

No.	COMPONENT IDENTIFICATION	FUNCTION	FAILURE MODE	POTENTIAL CAUSE	METHOD OF FAILURE DETECTION	EFFECT ON SYSTEM	EFFECT ON PLANT	REMARKS
<b>TRAIN B</b>								
51.	Dryer Afterfilter 0-FLTR-32-101	Filter out 100% of particles of desiccant and other foreign matter down to 0.9 micron size	None	None	None	None	None	No active failure for 0-FLTR-32-101
52.	Dryer Isolation Valve 0-32-270	Isolates dryer unit from air header.	None	None	None	None	None	No active failure for 0-32-270
53.	ACAS Inlet Filter 0-FLTR-32-85	Filter CAS air entering the ACAS during normal operation.	None	None	None	None	None	No active failure for 0-FLTR-32-85

**Table 9.3-7  
(Sheet 33 of 45)  
FAILURE MODE AND EFFECTS ANALYSIS AUXILIARY AIR SUPPLY EQUIPMENT**

No.	COMPONENT IDENTIFICATION	FUNCTION	FAILURE MODE	POTENTIAL CAUSE	METHOD OF FAILURE DETECTION	EFFECT ON SYSTEM	EFFECT ON PLANT	REMARKS
<b>TRAIN B</b>								
54.	ACAS Isolation Valve 0-FCV-32-85	Isolates ACAS from CAS supply on low control air pressure	Stuck open	Control/Mechanical failure	Valve position indication	ACAS compressor "B" will take control of ACAS in the case of low CAS pressure; therefore, with 0-FCV-32-85 stuck open, check valve 0-32-264 will prevent backflow with no effect on train "B" operation	None	
			Stuck closed	Control/Mechanical failure	Valve position indication	ACAS compressor "B" will take control of ACAS; therefore, train "B" will not be effected.	None	
55.	ACAS Backflow Check Valve 0-32-264	Prevents flow from ACAS back to CAS.	Stuck open	Mechanical failure	None	0-FCV-32-85 will cycle to maintain system pressure and isolate any backflow; therefore, train "B" will not be effected.	None	
			Stuck closed	Mechanical failure	None	ACAS compressor "B" will supply train "B"; therefore, no affect on train "B" operation.	None	

**Table 9.3-7  
(Sheet 34 of 45)  
FAILURE MODE AND EFFECTS ANALYSIS AUXILIARY AIR SUPPLY EQUIPMENT**

No.	COMPONENT IDENTIFICATION	FUNCTION	FAILURE MODE	POTENTIAL CAUSE	METHOD OF FAILURE DETECTION	EFFECT ON SYSTEM	EFFECT ON PLANT	REMARKS
<b>TRAIN B</b>								
56.	CAS Isolation Valve 0-32-265	Bypass CAS around ACAS air dryers.	None	None	None	None	None	No active failure for 0-32-265
57.	Moisture Element (ME-32-84) Inlet Isolation Valve 0-32-268	Isolates Inlet of ME-32-84 for maintenance	None	None	None	None	None	No active failure for 0-32-268
58.	Moisture Element (ME-32-84) Outlet Isolation Valve 0-32-269	Isolates Outlet of ME-32-84 for maintenance	None	None	None	None	None	No active failure for 0-32-269
59.	Moisture Element (ME-32-84) bypass Valve 0-32-266	Isolates ME-32-84 Bypass	None	None	None	None	None	No active failure for 0-32-266



**Table 9.3-7  
(Sheet 35 of 45)  
FAILURE MODE AND EFFECTS ANALYSIS AUXILIARY AIR SUPPLY EQUIPMENT**

No.	COMPONENT IDENTIFICATION	FUNCTION	FAILURE MODE	POTENTIAL CAUSE	METHOD OF FAILURE DETECTION	EFFECT ON SYSTEM	EFFECT ON PLANT	REMARKS
<b>TRAIN B</b>								
60.	Control Air Check Valve 0-32-407 for 1-LCV-3-173 and -174 Backflow Control Air Check Valve 0-32-407	Prevents loss of air pressure in piping to ensure operation in the event of loss of air header pressure.	Fails open  Fails closed	Mechanical failure  Mechanical failure	No position change indicated for 1-LCV-3-173 and -174 in control room via HS-3-173A and -174A  Unable to cycle valves 1-LCV-3-173 and -174 as indicated on control room hand switches HS-3-173A and -174A.	Unable to operate SG level control valves 1-LCV-3-173 and -174 on loss of header pressure. No effect with full header pressure.  Valves 1-LCV-3-173 and -174 inoperable.	None. Valves 1-LCV-3-172 and -175 operable in train "A".  None. Valves 1-LCV-3-172 and -175 operable in train "A".	
61.	Train "B" Containment Isolation Valve 1-FCV-32-102	Isolate containment on low air pressure or containment isolation signal.	Fails open  Fails closed	Control/ Mechanical failure  Control/ Mechanical failure	Valve position indication via 1-HS-32-102A.  Valve position indication via 1-HS-32-102A	None. Check valve 1-32-313 provides containment isolation as a backup.  Pressurizer spray valves not operable; however, these will not affect train "B" safety function.	None  None. While train "B" spray valves will be inoperable the train "B" safety functions are still available. Train "A" spray valves operable for plant operation.	

**Table 9.3-7  
(Sheet 36 of 45)  
FAILURE MODE AND EFFECTS ANALYSIS AUXILIARY AIR SUPPLY EQUIPMENT**

No.	COMPONENT IDENTIFICATION	FUNCTION	FAILURE MODE	POTENTIAL CAUSE	METHOD OF FAILURE DETECTION	EFFECT ON SYSTEM	EFFECT ON PLANT	REMARKS
<b>TRAIN B</b>								
62.	Containment Isolation Valve (1-FCV-32-102) Inlet isolation Valve 1-32-307	Isolate inlet to 1-FCV-32-102 for maintenance	None	None	None	None	None	No active failure mode for 1-32-307
63.	Containment Isolation Valve (1-FCV-32-102) Outlet Isolation Valve 1-32-311	Isolate outlet to 1-FCV-32-102 for maintenance	None	None	None	None	None	No active failure mode for 1-32-311
64.	Containment Isolation Valve (1-FCV-32-102) Bypass Valve 1-32-308	Isolate 1-FCV-32-102 bypass	None	None	None	None	None	No active failure mode for 1-32-308
65.	Containment Isolation Check Valve 1-32-313	Provide containment isolation as a backup for 1-FCV-32-102.	Fail open  Fail closed	Mechanical failure  Mechanical failure	None  Pressurizer spray valve 1-PCV-340B position indication via 1-HS-340.	None. 1-FCV-32-102 would provide containment isolation.  Safety function not effected; however, spray valve inoperable.	None  None. Train "B" safety functions operable and train "A" spray valve 1-PCV-68-340D operable.	

**Table 9.3-7  
(Sheet 37 of 45)  
FAILURE MODE AND EFFECTS ANALYSIS AUXILIARY AIR SUPPLY EQUIPMENT**

No.	COMPONENT IDENTIFICATION	FUNCTION	FAILURE MODE	POTENTIAL CAUSE	METHOD OF FAILURE DETECTION	EFFECT ON SYSTEM	EFFECT ON PLANT	REMARKS
<b>TRAIN B</b>								
66.	Isolation Valve 0-32-413	Isolates air supply to systems 65 dampers and valves	None	None	None	None	None	No active failure for 0-32-413

**Table 9.3-7  
(Sheet 38 of 45)  
FAILURE MODE AND EFFECTS ANALYSIS AUXILIARY AIR SUPPLY EQUIPMENT**

No.	COMPONENT IDENTIFICATION	FUNCTION	FAILURE MODE	POTENTIAL CAUSE	METHOD OF FAILURE DETECTION	EFFECT ON SYSTEM	EFFECT ON PLANT	REMARKS
<b>CAS</b>								
67.	Control Air System Containment Isolation Valve 1-FCV-32-110	Isolate Containment on the non-safety portion of control air on a low air pressure or containment isolation signal	Fails open	Control/ Mechanical failure	Valve position indication via 1-HS-32-110A	None. Check valve 1-32-293 provides containment isolation backup by manual isolation of an upstream valve or by turning off the non-safety related control air compressors by removing breakers. See Remarks.	None	The line inside containment downstream of check valve 1-32-293 is not protected from a HELB. The check valve will allow flow to enter containment with a single failure of 1-FCV-32-110. Action is required to manually isolate valve 0-ISV-32-1013. If manual action is unsuccessful, breakers shall be removed to stop the non-safety related compressors.
			Fails closed	Control/ Mechanical failure	Valve position indication via 1-HS-32-110A	Non-safety air loads inside containment not available	None	

**Table 9.3-7  
(Sheet 39 of 45)  
FAILURE MODE AND EFFECTS ANALYSIS AUXILIARY AIR SUPPLY EQUIPMENT**

No.	COMPONENT IDENTIFICATION	FUNCTION	FAILURE MODE	POTENTIAL CAUSE	METHOD OF FAILURE DETECTION	EFFECT ON SYSTEM	EFFECT ON PLANT	REMARKS
<b>TRAIN A (UNIT 2)</b>								
68.	Control Air check Valve 0-32-386 for 2-LCV-3-172 and -175 Backflow	Prevents loss of air pressure in piping to ensure operation in the event of loss of air header pressure	Fails open  Fails closed	Mechanical failure  Mechanical failure	No position change indicated for 2-LCV-3-172 and -175 in control room via 2-HS-3-172A and -175A  Unable to cycle valves 2-LCV-3-172 and -175 as indicated on control room hand switches 2-HS-3-172A and -175A	Unable to operate SG level control valves 2-LCV-3-172 and -175 on loss of header pressure. No effect with full header pressure  Valves 2-LCV-3-172 and -175 inoperable	None. Valves 2-LCV-3-173 and -174 operable in train "B"  None. Valves 2-LCV-3-173 and -174 operable in train "B"	

**Table 9.3-7  
(Sheet 40 of 45)  
FAILURE MODE AND EFFECTS ANALYSIS AUXILIARY AIR SUPPLY EQUIPMENT**

No.	COMPONENT IDENTIFICATION	FUNCTION	FAILURE MODE	POTENTIAL CAUSE	METHOD OF FAILURE DETECTION	EFFECT ON SYSTEM	EFFECT ON PLANT	REMARKS
<b>TRAIN A (UNIT 2)</b>								
69.	Train "A" Containment isolation valve 2-FCV-32-81	Isolate containment on low air pressure or containment isolation signal.	Fails open  Fails closed	Control/ Mechanical failure  Control/ Mechanical failure	Valve position indication via 2-HS-3-81A  Valve position indication via 2-HS-3-81A	None. Check valve 2-32-333 provides containment isolation backup  Pressurizer spray valves not operable; however these will not effect train "A" safety function	None  None. While train "2-A" spray valves will be inoperable the train "A" components required for safe shutdown are still available. Train "B" spray valves operable for plant operation	
70.	Containment Isolation Valve (2-FCV-32-81) Inlet Isolation Valve 2-32-327	Isolates Inlet to 2-FCV-32-81 for maintenance	None	None	None	None	None	No active failure mode for 2-32-327
71.	Containment Isolation Valve (2-FCV-32-81) Outlet Isolation Valve 2-32-331	Isolates Outlet to 2-FCV-32-81 for maintenance	None	None	None	None	None	No active failure mode for 2-32-331

**Table 9.3-7  
(Sheet 41 of 45)  
FAILURE MODE AND EFFECTS ANALYSIS AUXILIARY AIR SUPPLY EQUIPMENT**

No.	COMPONENT IDENTIFICATION	FUNCTION	FAILURE MODE	POTENTIAL CAUSE	METHOD OF FAILURE DETECTION	EFFECT ON SYSTEM	EFFECT ON PLANT	REMARKS
<b>TRAIN A (UNIT 2)</b>								
72.	Containment Isolation Valve (2-FCV-32-81) Bypass Valve 2-32-328	Isolates 2-FCV-32-81 bypass	None	None	None	None	None	No active failure mode for 2-32-328
73.	Containment Isolation Check Valve 2-32-333	Provide containment isolation as a backup for 2-FCV-32-81	Fails open  Fails closed	Mechanical failure  Mechanical failure	None  Pressurizer spray valve 2-PCV-68-340D position indication via 2-HS-68-340D	None. 2-FCV-32-81 would provide containment isolation  Safety function not effected; however, spray valve inoperable	None  None. Train "A" components required for safe shutdown are still available and train "B" spray valve 2-PCV-68-340B is operable	

**Table 9.3-7  
(Sheet 42 of 45)  
FAILURE MODE AND EFFECTS ANALYSIS AUXILIARY AIR SUPPLY EQUIPMENT**

No.	COMPONENT IDENTIFICATION	FUNCTION	FAILURE MODE	POTENTIAL CAUSE	METHOD OF FAILURE DETECTION	EFFECT ON SYSTEM	EFFECT ON PLANT	REMARKS
<b>TRAIN B (UNIT 2)</b>								
74.	Control Air Check Valve 0-32-414 for 2-LCV-3-173 and -174 Backflow	Prevents loss of air pressure in piping to ensure operation in the event of loss of air header pressure	Fails open  Fails closed	Mechanical failure  Mechanical failure	No position change indicated for 2-LCV-3-173 and -174 in control room via 2-HS-3-173A and -174A  Unable to cycle valves 2-LCV-3-173 and -174 as indicated on control room hand switches 2-HS-3-173A and -174A	Unable to operate SG level control valves 2-LCV-3-173 and -174 on loss of header pressure. No effect with full header pressure  Valves 2-LCV-3-173 and -174 inoperable	None. Valves 2-LCV-3-172 and -175 operable in train "A"  None. Valves 2-LCV-3-172 and -175 operable in train "A"	



**Table 9.3-7  
(Sheet 43 of 45)  
FAILURE MODE AND EFFECTS ANALYSIS AUXILIARY AIR SUPPLY EQUIPMENT**

No.	COMPONENT IDENTIFICATION	FUNCTION	FAILURE MODE	POTENTIAL CAUSE	METHOD OF FAILURE DETECTION	EFFECT ON SYSTEM	EFFECT ON PLANT	REMARKS
<b>TRAIN B (UNIT 2)</b>								
75.	Train "B" Containment Isolation Valve 2-FCV-32-103	Isolates containment on low air pressure or containment isolation signal.	Fails open  Fails closed	Control/ Mechanical failure  Control/ Mechanical failure	Valve position indication via 2-HS-3-103A  Valve position indication via 2-HS-3-103A	None. Check valve 2-32-323 provides containment isolation backup  Pressurizer spray valves not operable; however these will not effect train "B" safety function	None  None. While train "B" spray valves will be inoperable, the train "B" components required for safe shutdown are still available. Train "A" spray valves operable for plant operation	
76.	Containment Isolation Valve ( 2-FCV-32-103) Inlet Isolation Valve 2-32-317	Isolates Inlet to 2-FCV-32-103 for maintenance	None	None	None	None	None	No active failure mode for 2-32-317
77.	Containment Isolation Valve (2-FCV-32-103) Outlet Isolation Valve 2-32-321	Isolates Inlet to 2-FCV-32-103 for maintenance	None	None	None	None	None	No active failure mode for 2-32-321
78.	Containment Isolation Valve ( 2-FCV-32-103) Bypass Valve 2-32-318	Isolates Inlet 2-FCV-32-103 bypass	None	None	None	None	None	No active failure mode for 2-32-318

**Table 9.3-7  
(Sheet 44 of 45)  
FAILURE MODE AND EFFECTS ANALYSIS AUXILIARY AIR SUPPLY EQUIPMENT**

No.	COMPONENT IDENTIFICATION	FUNCTION	FAILURE MODE	POTENTIAL CAUSE	METHOD OF FAILURE DETECTION	EFFECT ON SYSTEM	EFFECT ON PLANT	REMARKS
<b>TRAIN B (UNIT 2)</b>								
79.	Containment Isolation Check Valve 2-32-323	Provide containment isolation as a backup for 2-FCV-32-103	Fails open  Fails closed	Mechanical failure  Mechanical failure	None  Pressurizer spray valve 2-PCV-68-340B position indication via 2-HS-68-340B	None. 2-FCV-103 would provide containment isolation  Safety function not effected; however, spray valve inoperable	None  None. Train "B" components required for safe shutdown are still available and train "A" spray valve 2-PCV-68-340D is operable	

**Table 9.3-7  
(Sheet 45 of 45)  
FAILURE MODE AND EFFECTS ANALYSIS AUXILIARY AIR SUPPLY EQUIPMENT**

No.	COMPONENT IDENTIFICATION	FUNCTION	FAILURE MODE	POTENTIAL CAUSE	METHOD OF FAILURE DETECTION	EFFECT ON SYSTEM	EFFECT ON PLANT	REMARKS
<b>TRAIN B (UNIT 2)</b>								
80.	Control Air System Containment Isolation Valve 2-FCV-32-111	Isolates containment on the non-safety portion of control air on a low air pressure or containment isolation signal	Fails open	Control/ Mechanical failure	Valve position indication via 2-HS-32-111A	None. Check valve 2-32-342 provides containment isolation backup by manual isolation of an upstream valve or by turning off the related control air compressors by removing breakers. See remarks	None	The line inside containment downstream of the check valve 2-32-343 is not protected from HELB. The check valve will allow flow to enter containment with a single failure of 2-FCV-32-111. Action is required to manually isolate valve 0-ISV-32-1013. If manual action is not successful, breakers shall be removed to stop the non-safety related compressors.
			Fails closed	Control/ Mechanical failure	Valve position indication via 2-HS-62-111A	Non-safety air loads inside containment not available.	None.	

THIS PAGE INTENTIONALLY BLANK

**Table 9.3-8 Equipment Supplied With Auxiliary Control System Air  
(Page 1 of 4)**

<b>Auxiliary Building Gas Treatment System Dampers</b>		
<b>Component ID</b>	<b>OP Mode - Failure Mode</b>	<b>Supplied From</b>
0-FCO-30-148	(N/A-FC)	Train B
0-FCO-30-149	(N/A-FC)	Train A
0-FCO-30-279	(NC-FC)	Train B
0-FCO-30-280	(NC-FC)	Train A
1-FCO-30-146B	(NC-FC)	Train A
1-FCO-30-146A	(NC-FC)	Train A
2-FCO-30-157B	(NC-FC)	Train B
2-FCO-30-157A	(NC-FC)	Train B
<b>Auxiliary Feedwater Control Valves</b>		
1,2-LCV-3-148	(NC-FO)	Train B
1,2-LCV-3-148A	(NC-FC)	Train B
1,2-LCV-3-156	(NC-FO)	Train A
1,2-LCV-3-156A	(NC-FC)	Train A
1,2-LCV-3-164	(NC-FO)	Train A
1,2-LCV-3-164A	(NC-FC)	Train A
1,2-LCV-3-171	(NC-FO)	Train B
1,2-LCV-3-171A	(NC-FC)	Train B
1,2-LCV-3-172	(NC-FC)	Train A
1,2-LCV-3-173	(NC-FC)	Train B
1,2-LCV-3-174	(NC-FC)	Train B
1,2-LCV-3-175	(NC-FC)	Train A
1-PCV-3-122	(NC-FC)	Train A
1-PCV-3-132	(NC-FC)	Train B
2-PCV-3-122	(NC-FC)	Train A
2-PCV-3-132	(NC-FC)	Train B
Panel 1-L-222B	NA	Train B
Panel 1-L-214B	NA	Train A
Panel 2-L-222B	NA	Train B
Panel 2-L-214B	NA	Train A
Panel 2-L-218A	NA	Train A
Panel 2-L-929	NA	Train B
<b>Main Steam Pressure Relief Valves</b>		
1,2-PCV-1-5	(NC-FC)	Train A
1,2-PCV-1-12	(NC-FC)	Train B
1,2-PCV-1-23	(NC-FC)	Train A
1,2-PCV-1-30	(NC-FC)	Train B

**Table 9.3-8 Equipment Supplied With Auxiliary Control System Air  
(Page 2 of 4)**

Component ID	OP Mode - Failure Mode	Supplied From
Panel 2-L-420*	NA	Train A
1-L-420	NA	Train A
2-L-423*	NA	Train A
1-L-423	NA	Train A
2-L-421*	NA	Train B
1-L-421	NA	Train B
2-L-422*	NA	Train B
1-L-422	NA	Train B
<b>Reactor Coolant System Valves</b>		
1,2-PCV-68-340B	(NC-FC)	Train B
1,2-PCV-68-340D	(NC-FC)	Train A
Panels 1-L-366	NA	Train A
Panels 1,2-L-180	NA	Train B
Panel 2-L-351B	NA	Train A
<b>Emergency Gas Treatment System Equipment</b>		
Train A		Train B
2-FCV-65-5	(NC-FC)	2-FCV-65-4
2-FCV-65-9	(NC-FC)	2-FCV-65-7
1-FCV-65-10	(NC-FC)	1-FCV-65-8
0-FCV-65-24	(NC-FC)	1-FCO-65-27
1-FCO-65-26	(NC-FC)	0-FCV-65-28A
2-FCO-65-46	(NC-FC)	0-FCV-65-28B
0-FCV-65-47A	(NC-FC)	2-FCV-65-29
0-FCV-65-47B	(NC-FC)	1-FCV-65-30
2-FCV-65-50	(NC-FC)	0-FCV-65-43
1-FCV-65-51	(NC-FC)	2-FCO-65-45
1-FCV-65-52	(NO-FC)	1-FCV-65-53
1,2-PCV-65-81	(NC-FC)	1,2-PCV-65-83
1,2-PCV-65-86	(NC-FC)	1,2-PCV-65-87
1,2-PCO-65-80**	(NC-FO)	1,2-PCO-65-82**
1,2-PCO-65-88**	(NO-FC)	1,2-PCO-65-89**
Panel 1-L-44	NA	
Panel 2-L-44	NA	Panel 1-L-45
	NA	Panel 2-L-45

**Table 9.3-8 Equipment Supplied With Auxiliary Control System Air  
(Page 3 of 4)**

<b>Control Building Heating, Ventilation, and Air Conditioning Equipment</b>		
Train A		Train B
FCO-31-335	(NC-FC)	FCO-31-337
FCO-31-336	(NC-FC)	FCO-31-338
TCV-31-108	NA	TCV-31-138
TCV-31-112	NA	TCV-31-142
FCV-31-3	(NO-FC)	FCV-31-4
FCV-31-6	(NC-FC)	FCV-31-5
FCO-31-8	(NC-FC)	FCO-31-7
FCO-31-30	(NO-FO)	FCO-31-31
0-FCO-31-12	(NO-FO)	0-FCO-31-11
0-FCO-31-82	(NA-FO)	0-FCO-31-91
0-MCV-31-176*	(NA-FO)	0-MCV-31-201*
0-MCV-31-231*	(NA-FO)	0-MCV-31-261*
0-MCV-31-232*	(NA-FO)	0-MCV-31-262*
<b>Equipment Supplied with Auxiliary Control System Air</b>		
Train A		Train B
TT-31-41	NA	TT-31-54
TT-31-47	NA	TT-31-59
TT-31-82	NA	TT-31-91
TT-31-335	NA	TT-31-337
TT-31-336	NA	TT-31-338
TC-31-82	NA	TC-31-91
TC-31-335	NA	TC-31-337
TC-31-336	NA	TC-31-338
0-MC-31-176	NA	0-MC-31-201
0-MC-31-231	NA	0-MC-31-261
Panel L-523	NA	Panel L-524
Panel L-529	NA	Panel L-530
<b>Radiation Monitoring Sample Isolation Valves</b>		
Train A		Train B
1,2-FCV-90-107	(NO-FC)	1,2-FCV-90-108
1,2-FCV-90-111	(NO-FC)	1,2-FCV-90-109
1,2-FCV-90-113	(NO-FC)	1,2-FCV-90-110
1,2-FCV-90-117	(NO-FC)	1,2-FCV-90-114
	(NO-FC)	1,2-FCV-90-115
	(NO-FC)	1,2-FCV-90-116

**Table 9.3-8 Equipment Supplied With Auxiliary Control System Air  
(Page 4 of 4)**

<b>Auxiliary Control Air System</b>		
Train A		Train B
1-FCV-32-80	(NO-FC)	1-FCV-32-102
2-FCV-32-81	(NO-FC)	2-FCV-32-103
Air Dryers A-A	NA	Air Dryers B-B

\*Valves 0-MCV-31-176, 0-MCV-31-201, 0-MCV-31-231, 0-MCV-31-232, 0-MCV-31-261 and 0-MCV-31-262 do not directly receive control air from ACAS but instead receive an input signal for position control from controllers 0-MC-31-176, 0-MC-31-201, 0-MC-31-231 and 0-MC-31-261 which are supplied with control air from ACAS.

\*\*Dampers 1-PCO-65-80 and 2-PCO-65-80 are mechanically linked to dampers 1-PCO-65-BB and 2-PCO-65-88, respectively. Dampers 1-PCO-65-82 and 2-PCO-65-82 are mechanically linked to dampers 1-PCO-65-89 and 2-PCO-65-89, respectively.



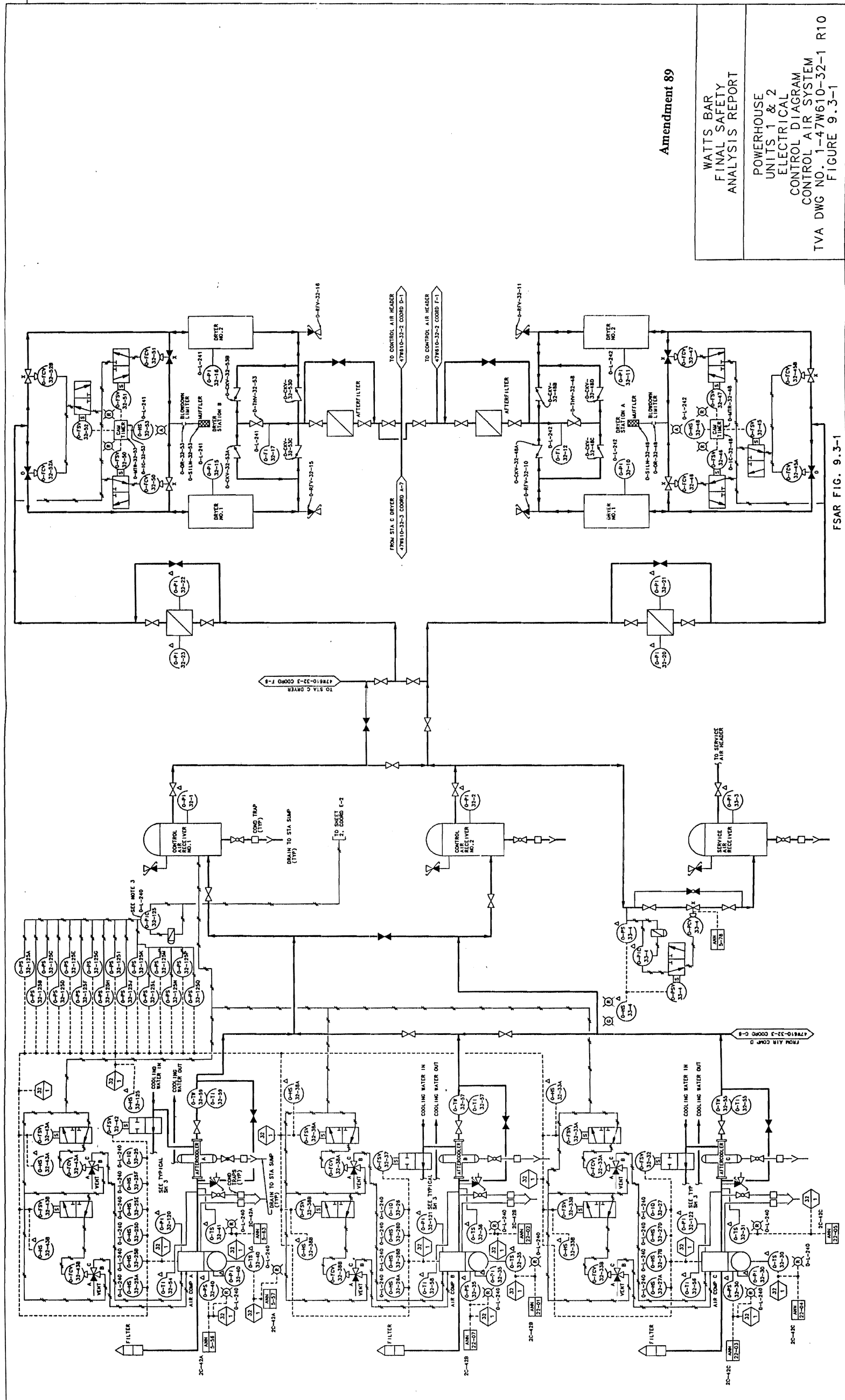

Amendment 89

WATTS BAR  
FINAL SAFETY  
ANALYSIS REPORT

POWERHOUSE  
UNITS 1 & 2  
ELECTRICAL  
CONTROL DIAGRAM  
CONTROL AIR SYSTEM  
TVA DWG NO. 1-47W610-32-1 R10  
FIGURE 9.3-1

FSAR FIG. 9.3-1

PROCADAM MAINTAINED DRAWING  
THIS DRAWING IS THE PROPERTY OF THE U.S. GOVERNMENT  
AND IS NOT TO BE REPRODUCED OR TRANSMITTED IN ANY FORM  
WITHOUT PERMISSION FROM THE U.S. GOVERNMENT

Figure 9.3-1 Electrical Control Diagram for Control Air System

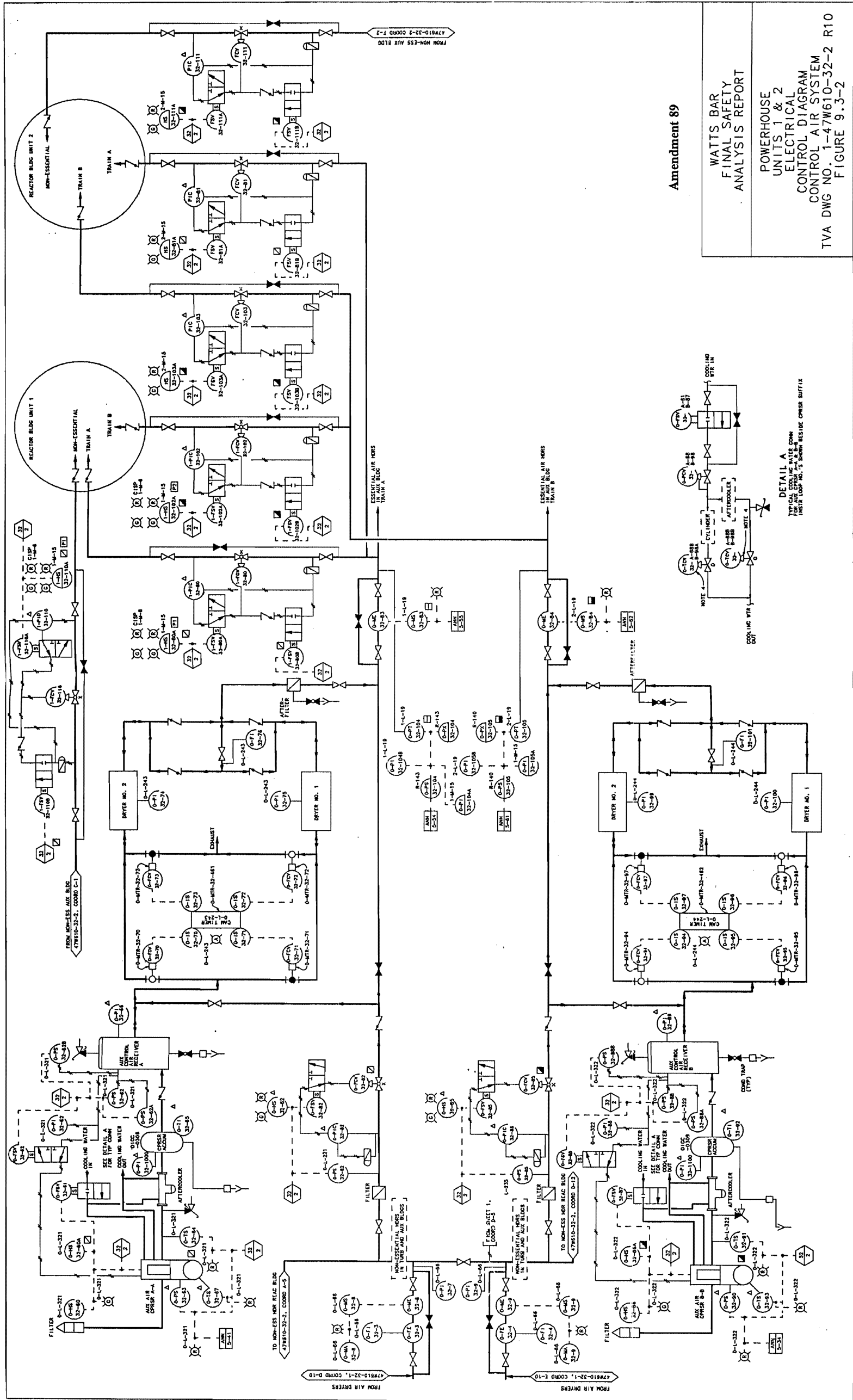

Amendment 89

WATTS BAR  
FINAL SAFETY  
ANALYSIS REPORT

POWERHOUSE  
UNITS 1 & 2  
ELECTRICAL  
CONTROL AIR SYSTEM  
TVA DWG NO. 1-47W610-32-2 R10  
FIGURE 9.3-2

DETAIL A  
TYPICAL COOLING WATER CONTROL LOOP  
NOTE: COOLING WATER CONTROL LOOP IS SHOWN RESERVE OPERATOR SUFFIX

PROCADAM MAINTAINED DRAWING  
THIS DRAWING AND ITS CONTENTS ARE THE PROPERTY OF THE LAWRENCE BERKELEY NATIONAL LABORATORY  
COPYRIGHT © 1994

Figure 9.3-2 Electrical Control Diagram for Control Air System

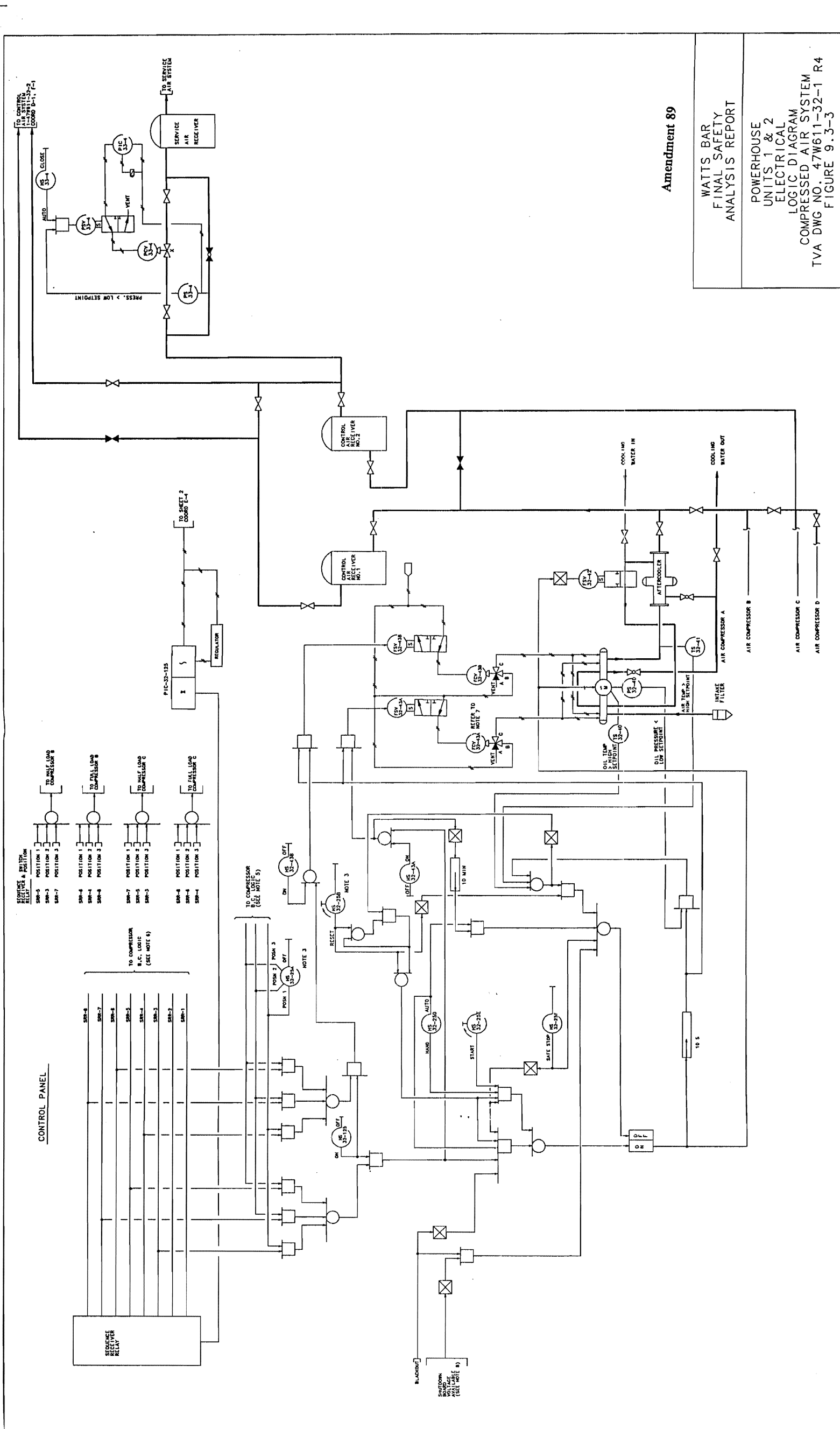

Amendment 89

WATTS BAR  
FINAL SAFETY  
ANALYSIS REPORT

POWERHOUSE  
UNITS 1 & 2  
ELECTRICAL  
LOGIC DIAGRAM  
COMPRESSED AIR SYSTEM  
TVA DWG. NO. 47W611-32-1 R4  
FIGURE 9.3-3

PROGRAM MAINTAINED DRAWING  
THIS DOCUMENT CONTAINS INFORMATION THAT IS UNCLASSIFIED  
AND FOR WHICH THERE IS NO RESTRICTION ON THE REVISIONS

Figure 9.3-3 Powerhouse Units 1 & 2 Electrical Logic Diagram for Compressed Air System

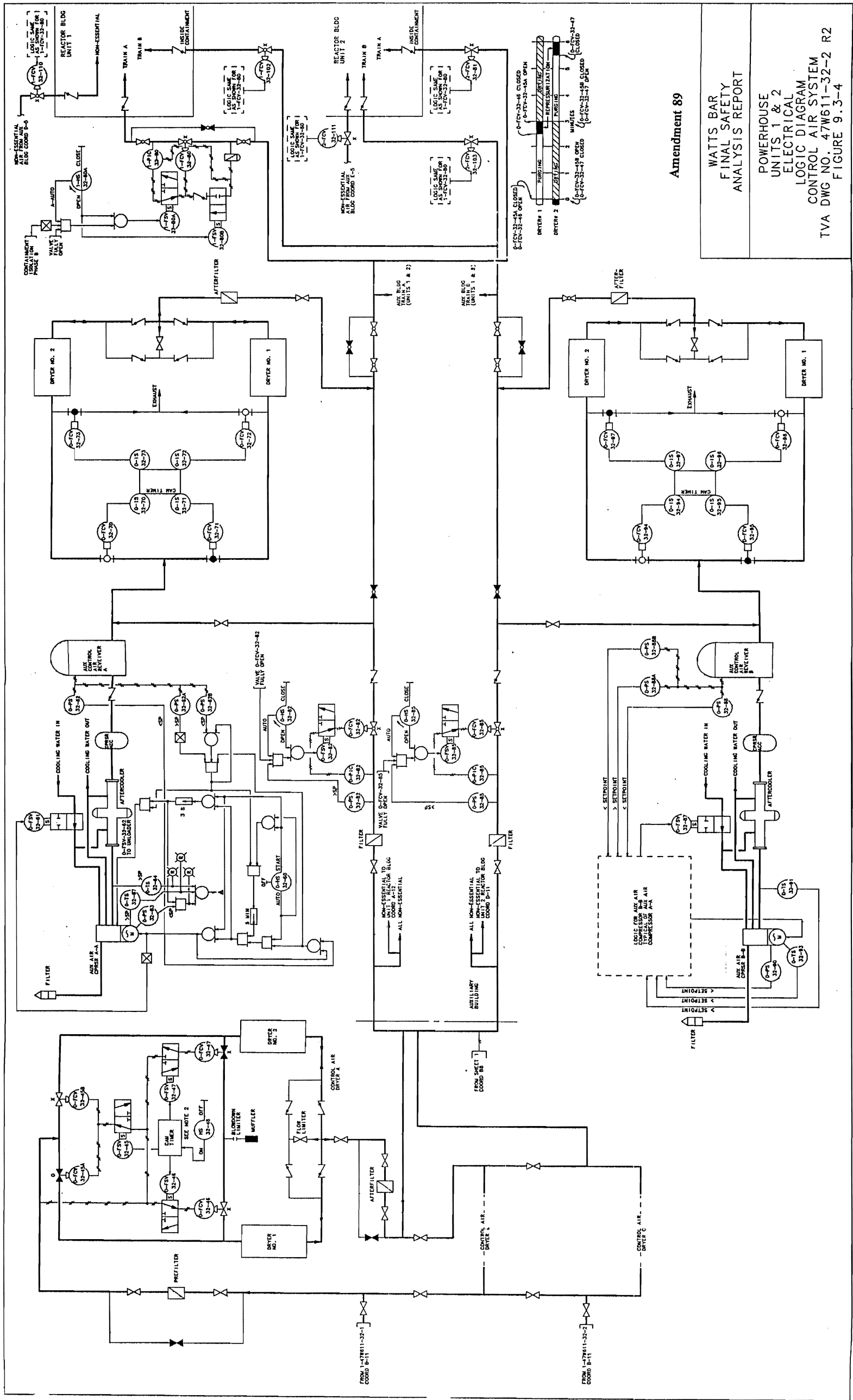

Amendment 89

WATTS BAR  
FINAL SAFETY  
ANALYSIS REPORT

POWERHOUSE  
UNITS 1 & 2  
ELECTRICAL  
LOGIC DIAGRAM  
CONTROL AIR SYSTEM  
TVA DWG NO. 47W611-32-2 R2  
FIGURE 9.3-4

PROCAD/M MAINTAINED DRAWING  
THIS DRAWING CONTAINS INFORMATION THAT IS UNCLASSIFIED BY THE  
DATE 01-22-2001 BY 60322/UC/STP/STP

Figure 9.3-4 Powerhouse Units 1 & 2 Electrical Logic Diagram for Control Air System

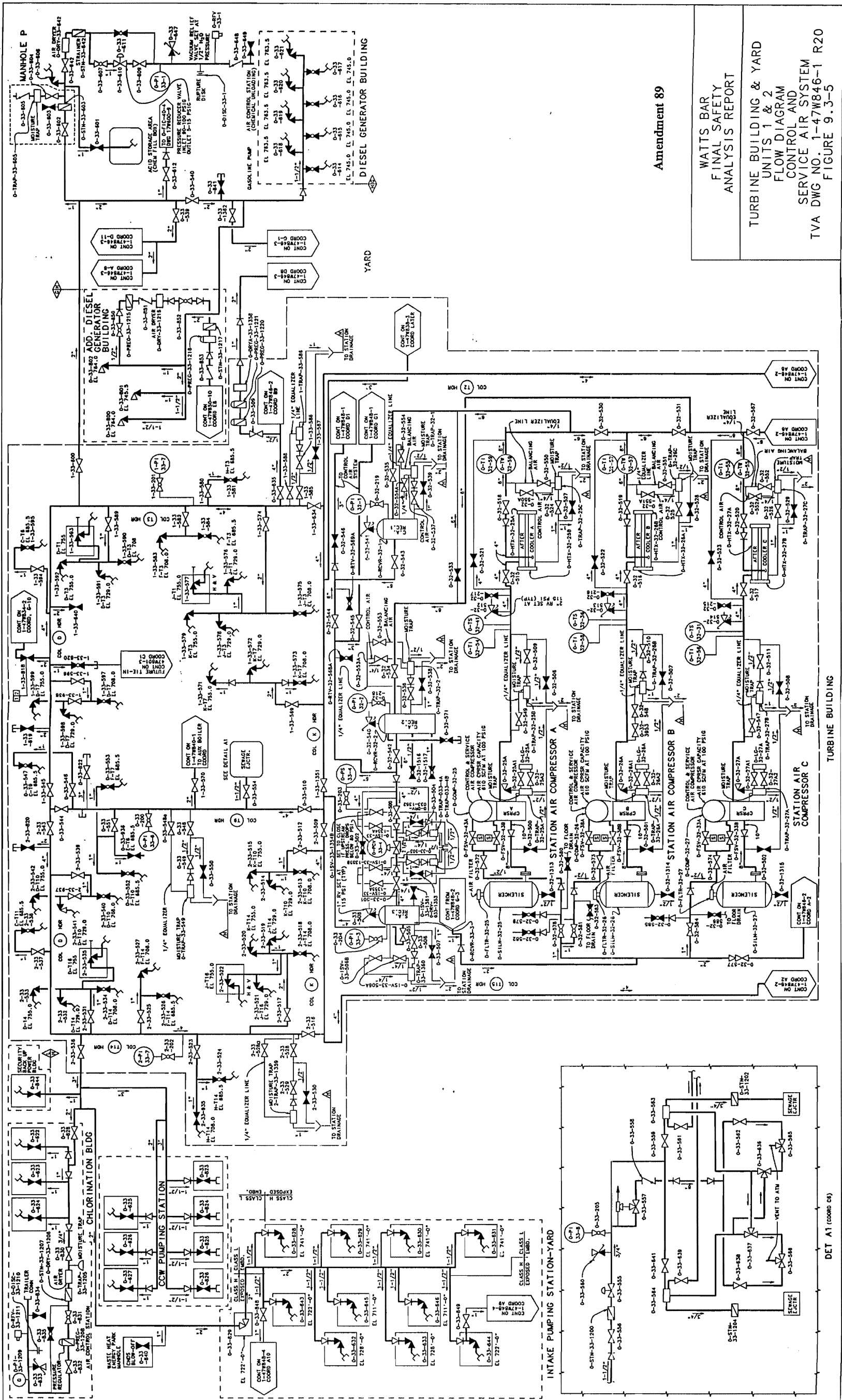

PROCADAM MAINTAINED DRAWING  
 THIS DRAWING IS THE PROPERTY OF THE U.S. NUCLEAR ENERGY RESEARCH & DEVELOPMENT ADMINISTRATION  
 U.S. GOVERNMENT PRINTING OFFICE: 1975 O 227018

Figure 9.3-5 Turbine Building and Yard Units 1 & 2 Flow Diagram for Control and Service Air System

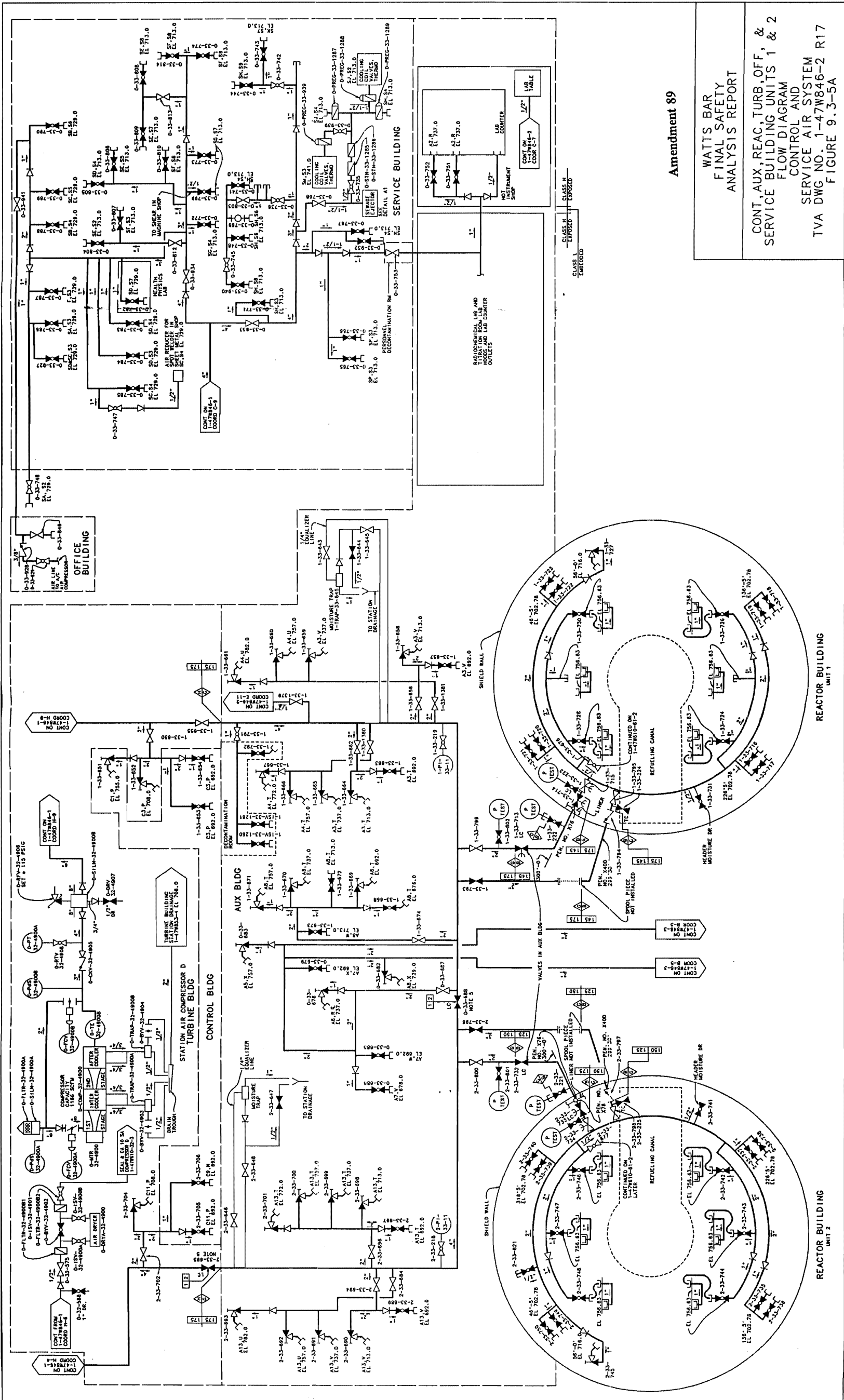

Amendment 89

WATTS BAR  
FINAL SAFETY  
ANALYSIS REPORT

CONT, AUX, REAC, TURB, OFF, &  
SERVICE BUILDING UNITS 1 & 2  
FLOW DIAGRAM  
CONTROL AND  
SERVICE AIR SYSTEM  
TVA DWG NO. 1-47W846-2 R17  
FIGURE 9.3-5A

PROCADAM MAINTAINED DRAWING  
UNIT 1 AND UNIT 2 CONTROL AND SERVICE AIR SYSTEM  
DATE: 11/15/88

Figure 9.3-5a Control, Auxiliary, Reactor, Turbine, Office and Service Building Units 1 & 2 Flow Diagram for Control and Service Air System

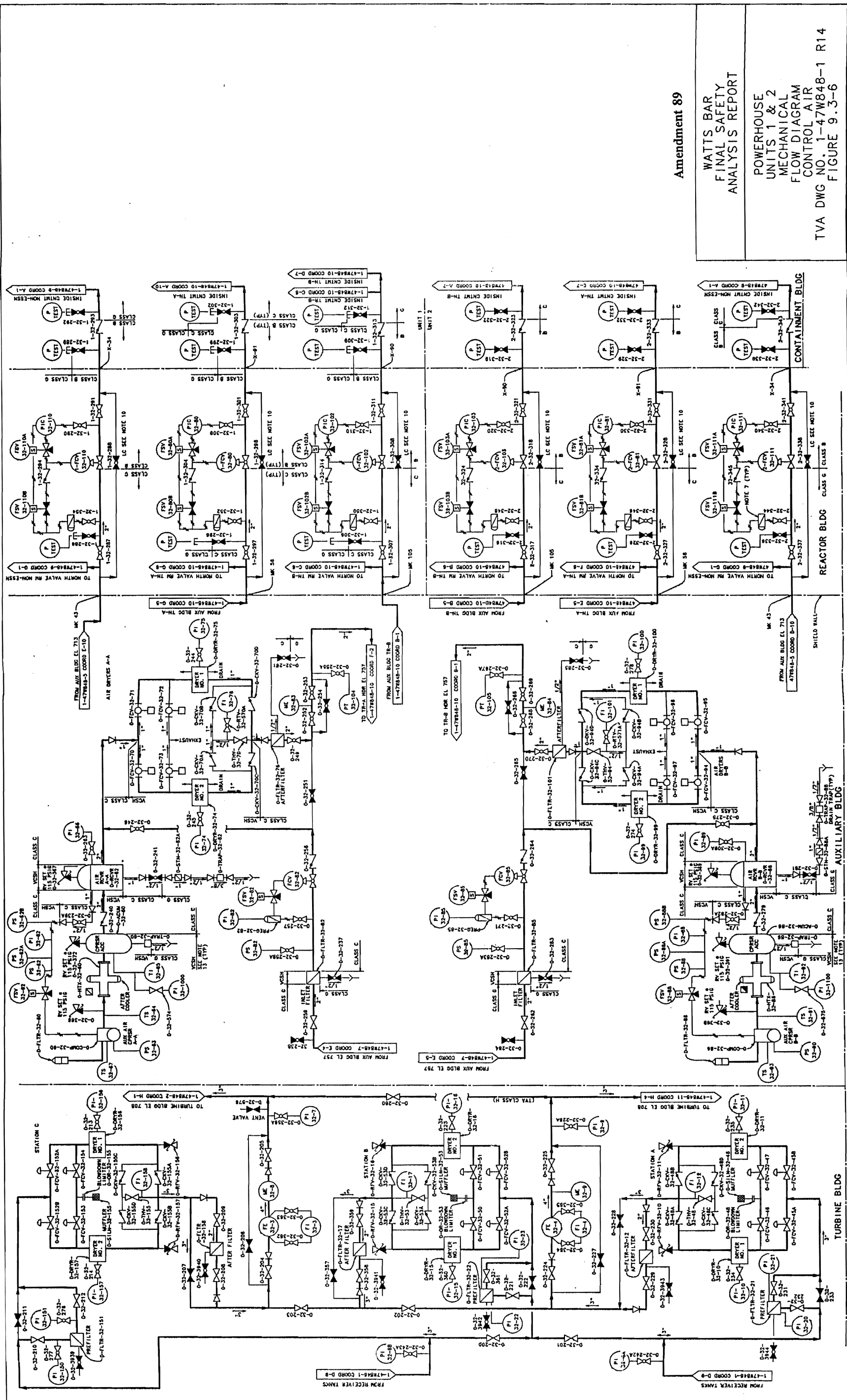

Amendment 89

WATTS BAR  
FINAL SAFETY  
ANALYSIS REPORT

POWERHOUSE  
UNITS 1 & 2  
MECHANICAL  
FLOW DIAGRAM  
CONTROL AIR

TVA DWG NO. 1-47WB48-1 R14  
FIGURE 9.3-6

PROCADAM MAINTAINED DRAWING  
THIS DRAWING IS THE PROPERTY OF THE U.S. GOVERNMENT  
AND IS NOT TO BE REPRODUCED OR TRANSMITTED IN ANY FORM  
WITHOUT PERMISSION FROM THE U.S. GOVERNMENT

Figure 9.3-6 Powerhouse Units 1 & 2 Mechanical Flow Diagram for Control Air System





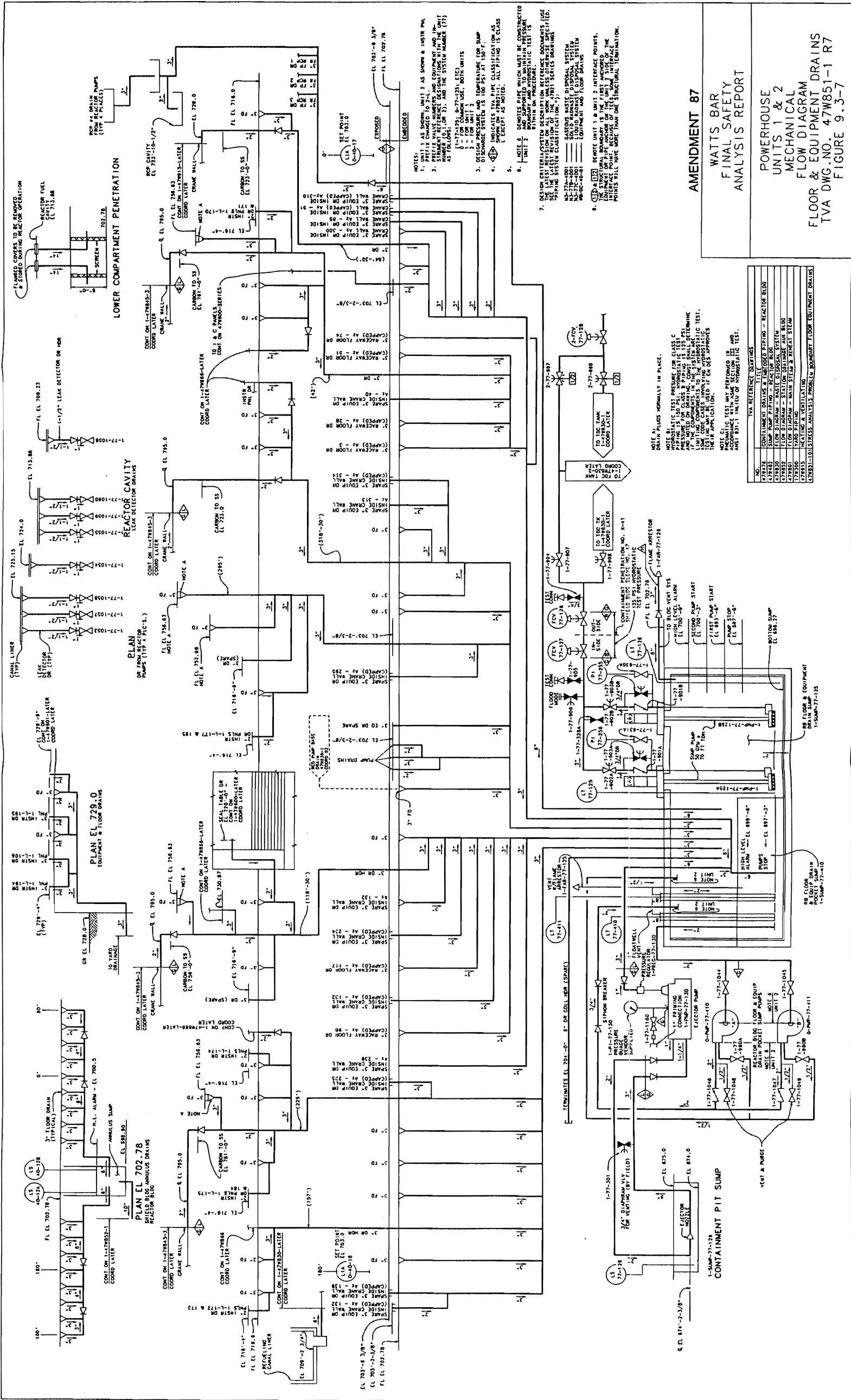

**AMENDMENT 87**

WATTS BAR  
FINAL SAFETY  
ANALYSIS REPORT

POWERHOUSE  
UNITS 1 & 2  
MECHANICAL  
FLOW DIAGRAM  
FLOOR & EQUIPMENT DRAINS  
TVA DWG. NO. 47W851-1 R7  
FIGURE 9.3-7

PROCADAM MAINTAINED DRAWING  
THIS DRAWING CONTAINS THE LATEST REVISIONS  
AND IS THE ONLY COPY TO BE USED FOR CONSTRUCTION

Figure 9.3-7 Powerhouse Units 1 & 2 Mechanical Flow Diagram - Floor and Equipment Drains

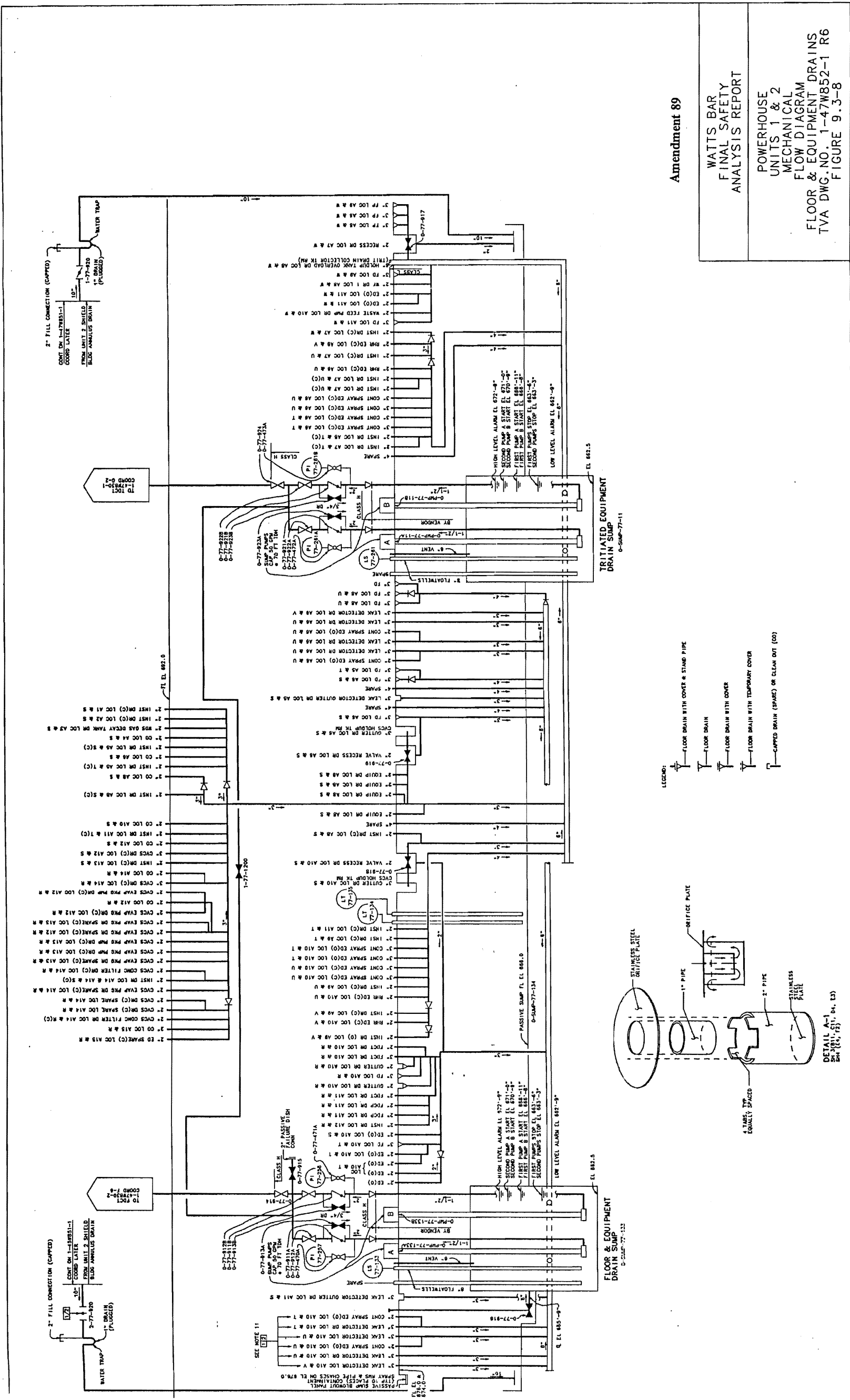

Amendment 89

WATTS BAR  
FINAL SAFETY  
ANALYSIS REPORT

POWERHOUSE  
UNITS 1 & 2  
MECHANICAL  
FLOW DIAGRAM  
FLOOR & EQUIPMENT DRAINS  
TVA DWG. NO. 1-47W852-1 R6  
FIGURE 9.3-8

PROCESS MAINTAINED DRAWING  
THIS DRAWING IS PART OF THE PROCESS MAINTAINED DRAWING  
SET FOR WATTS BAR. THE PROCESS MAINTAINED DRAWING  
SET IS LOCATED IN THE PROJECT ROOM AT THE  
END OF THE CORRIDOR.

Figure 9.3-8 Powerhouse Units 1 & 2 Mechanical Flow Diagram -Floor and Equipment Drains

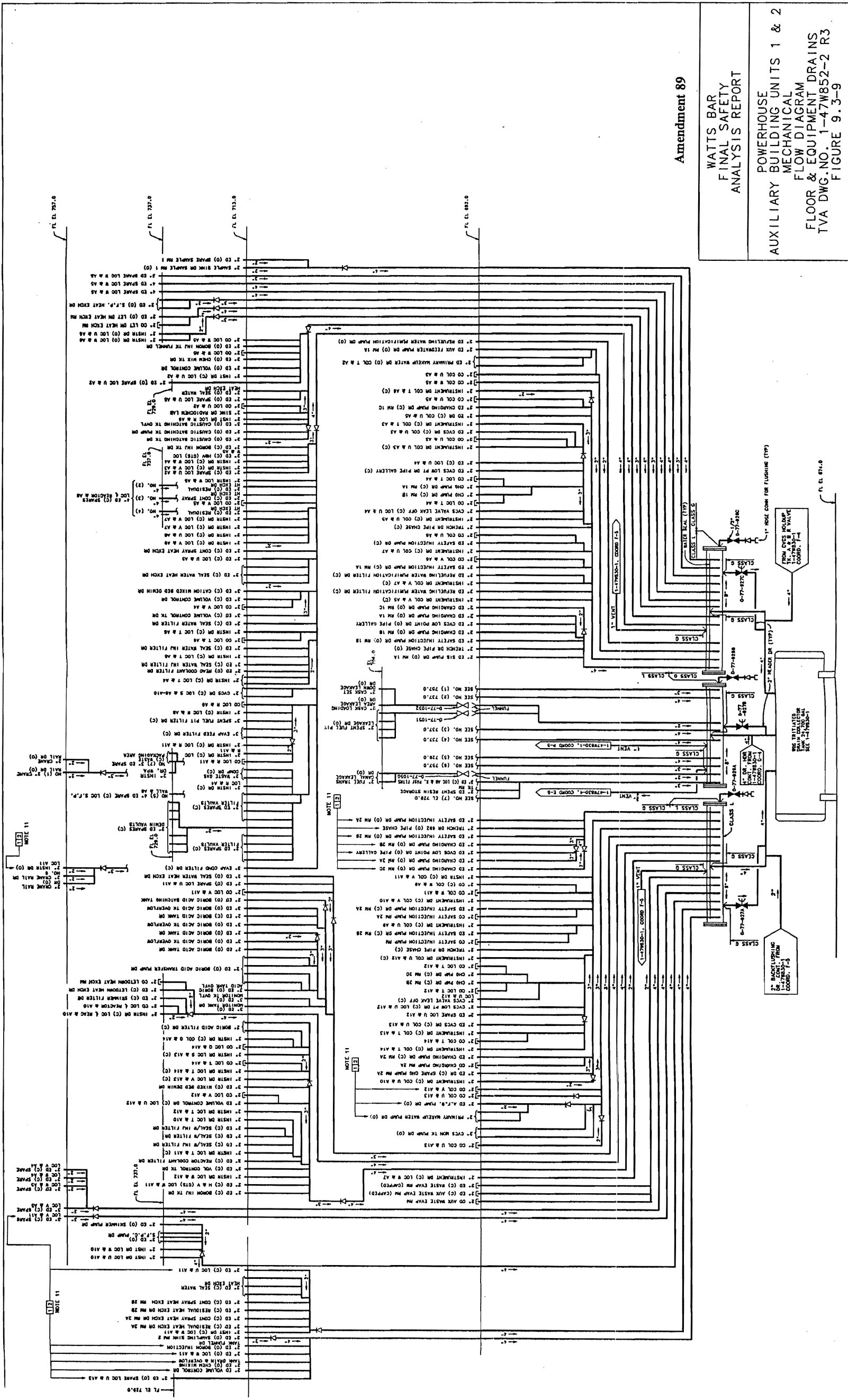

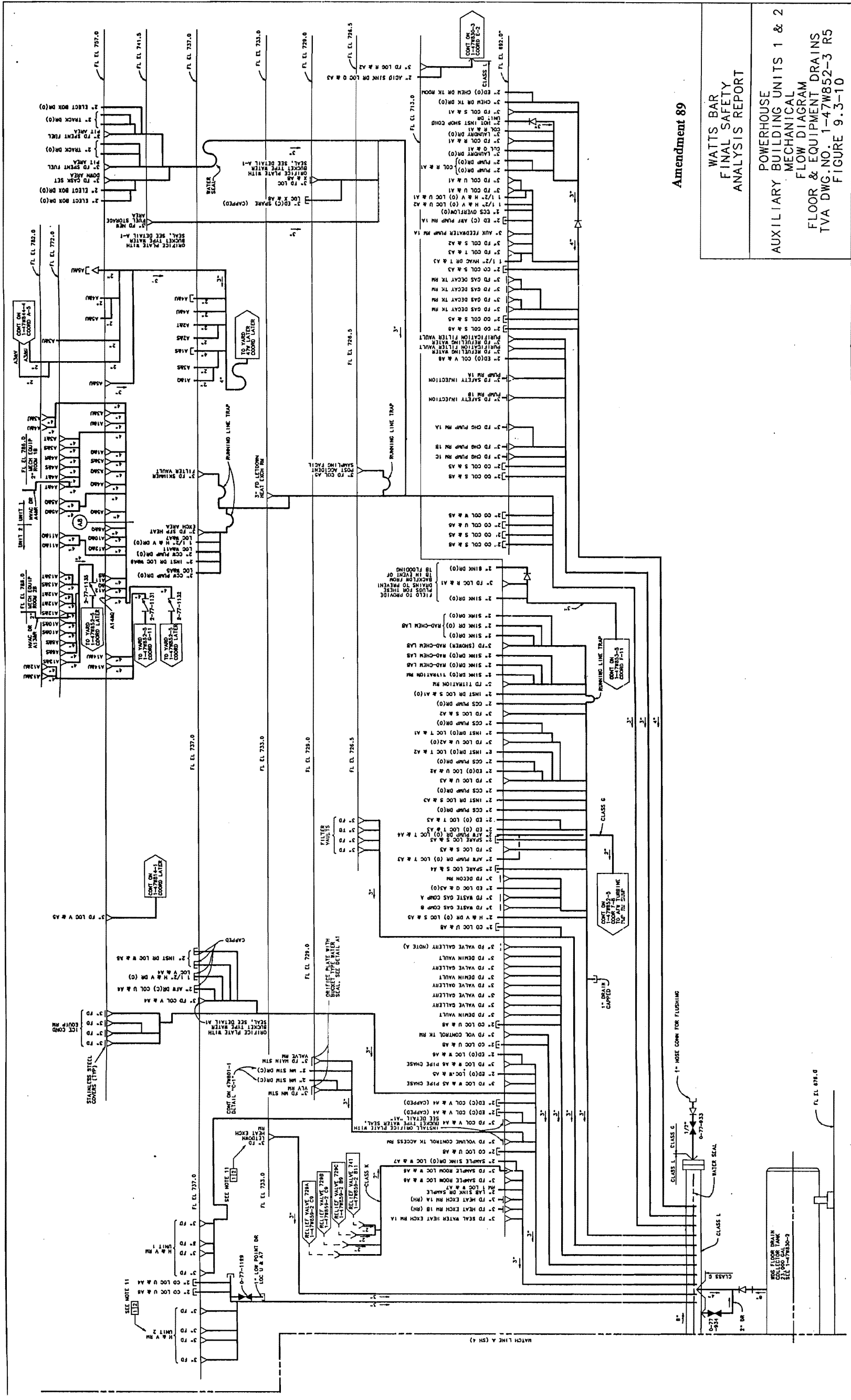

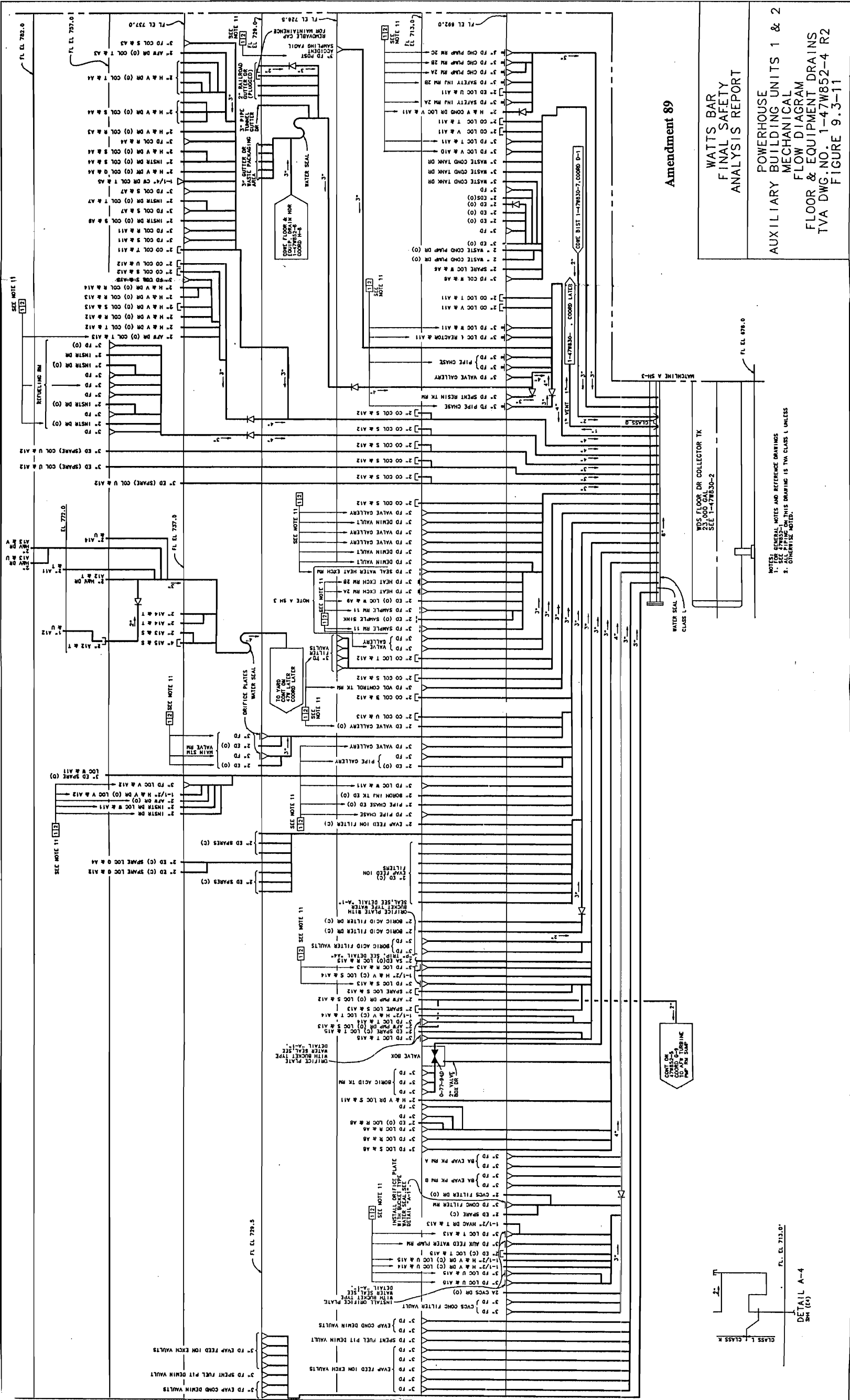

**Amendment 89**

WATTS BAR  
FINAL SAFETY  
ANALYSIS REPORT

POWERHOUSE  
BUILDING UNITS 1 & 2  
MECHANICAL  
FLOW DIAGRAM  
FLOOR & EQUIPMENT DRAINS  
TVA DWG. NO. 1-47WB52-4 R2  
FIGURE 9.3-11

PROCEEDING MAINTAINED DRAWING  
THIS DRAWING IS THE PROPERTY OF THE  
UNIT AND IS NOT TO BE REPRODUCED  
WITHOUT PERMISSION

NOTES:  
1. SEE GENERAL NOTES AND REFERENCE DRAWINGS  
2. SEE SPECIFICATIONS  
3. DIMENSIONS UNLESS OTHERWISE NOTED

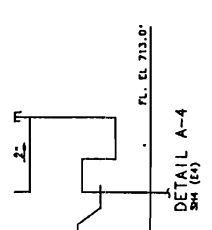
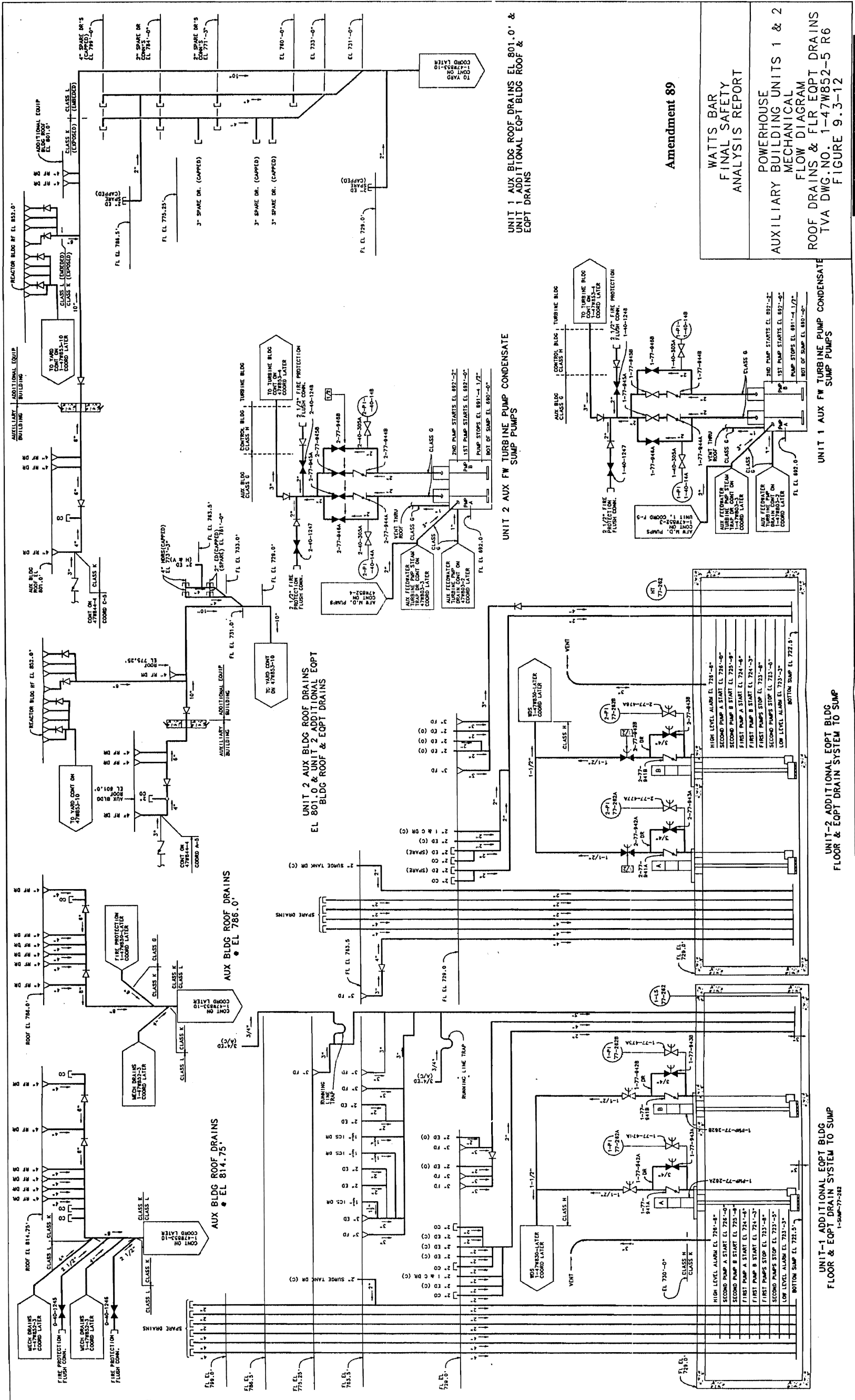

Figure 9.3-11 Powerhouse Auxiliary Building Units 1 & 2 Flow Diagram - Floor and Equipment Drains



Amendment 89

WATTS BAR  
FINAL SAFETY  
ANALYSIS REPORT

POWERHOUSE  
BUILDING UNITS 1 & 2  
MECHANICAL  
FLOW DIAGRAM  
ROOF DRAINS & FLR EQPT DRAINS  
TVA DWG. NO. 1-47WB52-5 R6  
FIGURE 9.3-12

PRO-CAD MAINTAINED DRAWING  
THIS COPY (FOR UNIT 1) IS CONTROLLED BY THE TVA PROCESS AUXILIARIES  
THIS COPY (FOR UNIT 2) IS CONTROLLED BY THE TVA PROCESS AUXILIARIES

Figure 9.3-12 Powerhouse, Auxiliary Buildings Unit 1 & 2 Mechanical Flow Diagram Roof Drains and Floor Equipment Drains



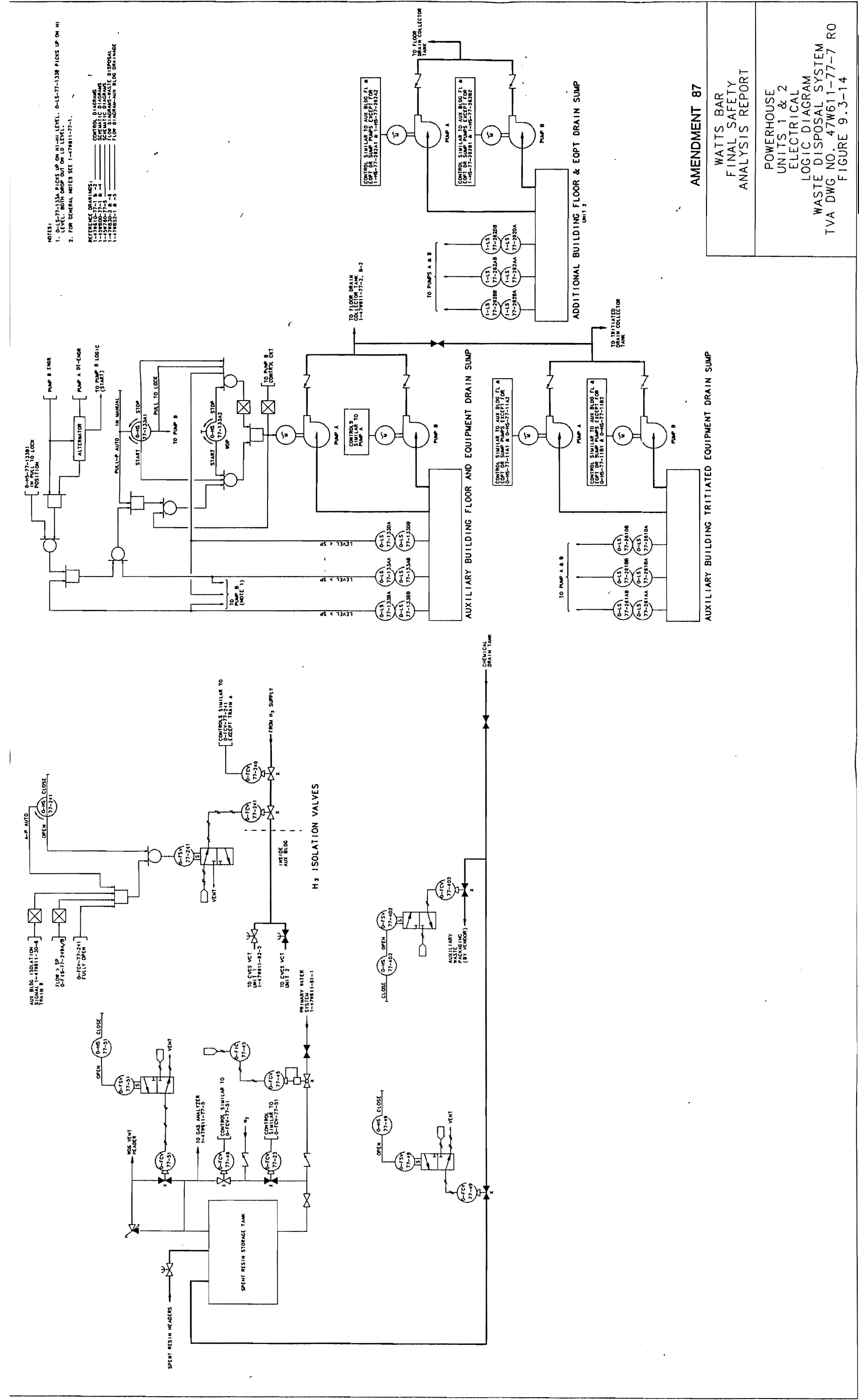

AMENDMENT 87

WATTS BAR  
FINAL SAFETY  
ANALYSIS REPORT

POWERHOUSE  
UNITS 1 & 2  
ELECTRICAL  
LOGIC DIAGRAM  
WASTE DISPOSAL SYSTEM  
TVA DWG NO. 47W611-77-7 RO  
FIGURE 9.3-14

PROCADAM MAINTAINED DRAWING  
DATE: 01/11/88 BY: J. L. HARRIS  
SCALE: AS SHOWN

Figure 9.3-14 Powerhouse Units 1 & 2 Electrical Logic Diagram for Waste Disposal System



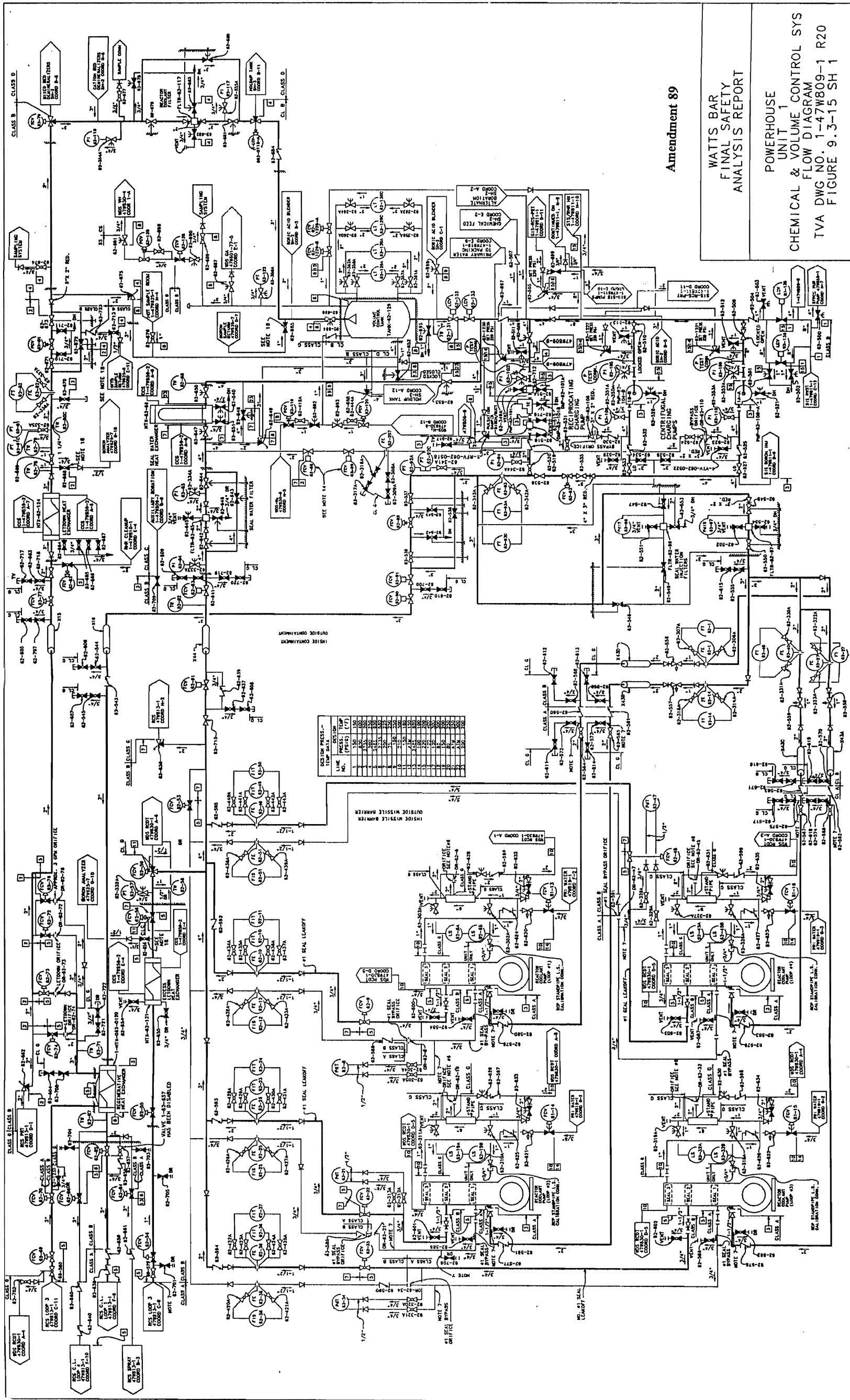

PROCEDURE MAINTAINED DRAWING  
THIS DRAWING IS CONTROLLED BY THE PROJECT MANAGER  
NO CHANGES SHALL BE MADE WITHOUT HIS APPROVAL

Amendment 89  
WATTS BAR  
FINAL SAFETY  
ANALYSIS REPORT  
POWERHOUSE  
UNIT 1  
CHEMICAL & VOLUME CONTROL SYS  
FLOW DIAGRAM  
TVA DWG NO. 1-47W809-1 R20  
FIGURE 9.3-15 SH 1

Figure 9.3-15 Powerhouse Unit 1 Chemical and Volume Control System Flow Diagram (Sheet 1)

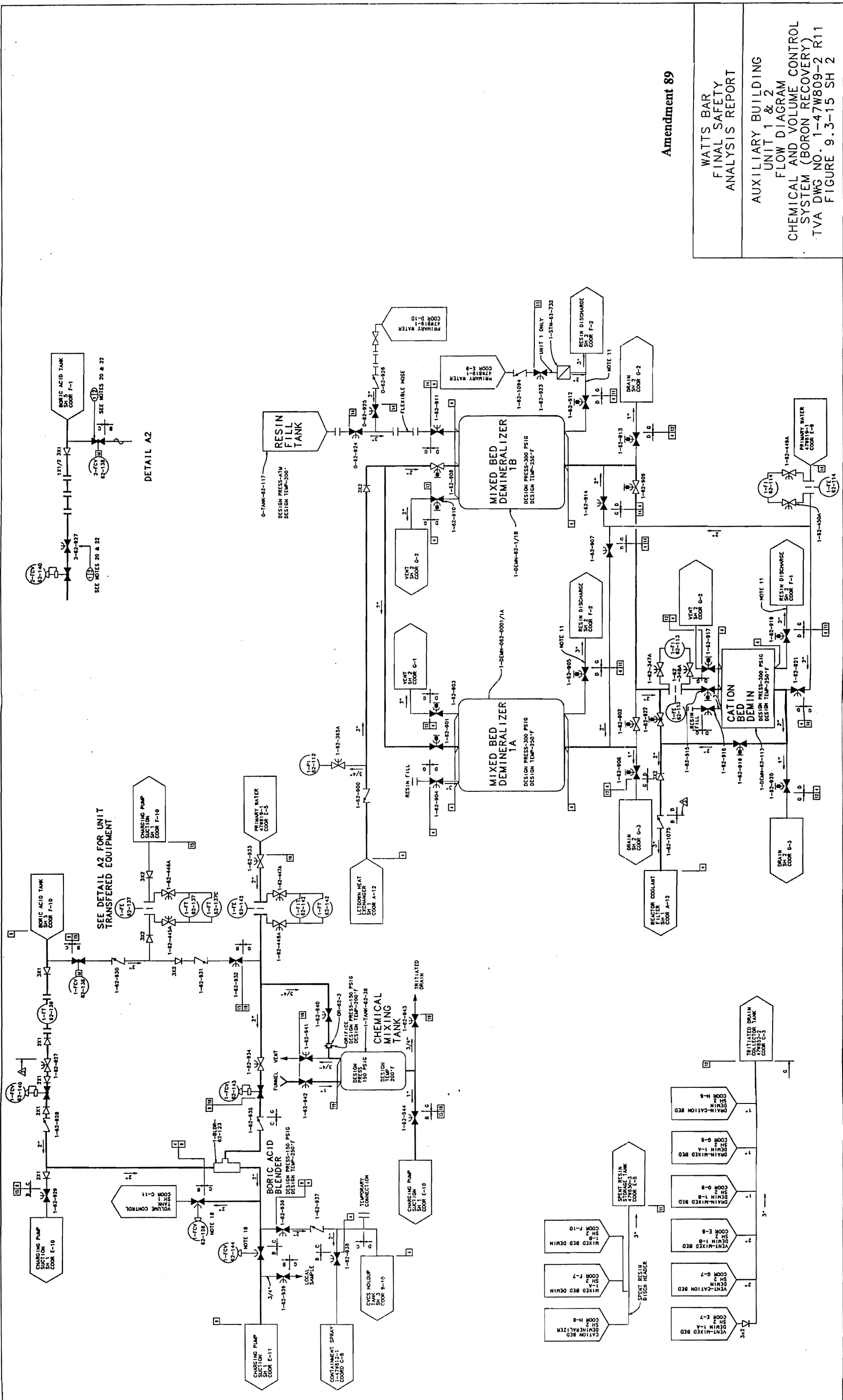

Amendment 89

WATTS BAR  
FINAL SAFETY  
ANALYSIS REPORT

AUXILIARY BUILDING  
UNIT 1 & 2  
FLOW DIAGRAM  
CHEMICAL AND VOLUME CONTROL  
SYSTEM (BORON RECOVERY)  
TVA DWG NO. 1-47W809-2 R11  
FIGURE 9.3-15 SH 2

PROGRAM MAINTAINED DRAWING  
THIS DRAWING IS PART OF THE TVA PROGRAM ON ADS  
NO. 1-47W809-2 R11

Figure 9.3-15 Auxiliary Building Units 1 & 2 Flow Diagram for Chemical and Volume Control System (Boron Recovery) (Sheet 2)

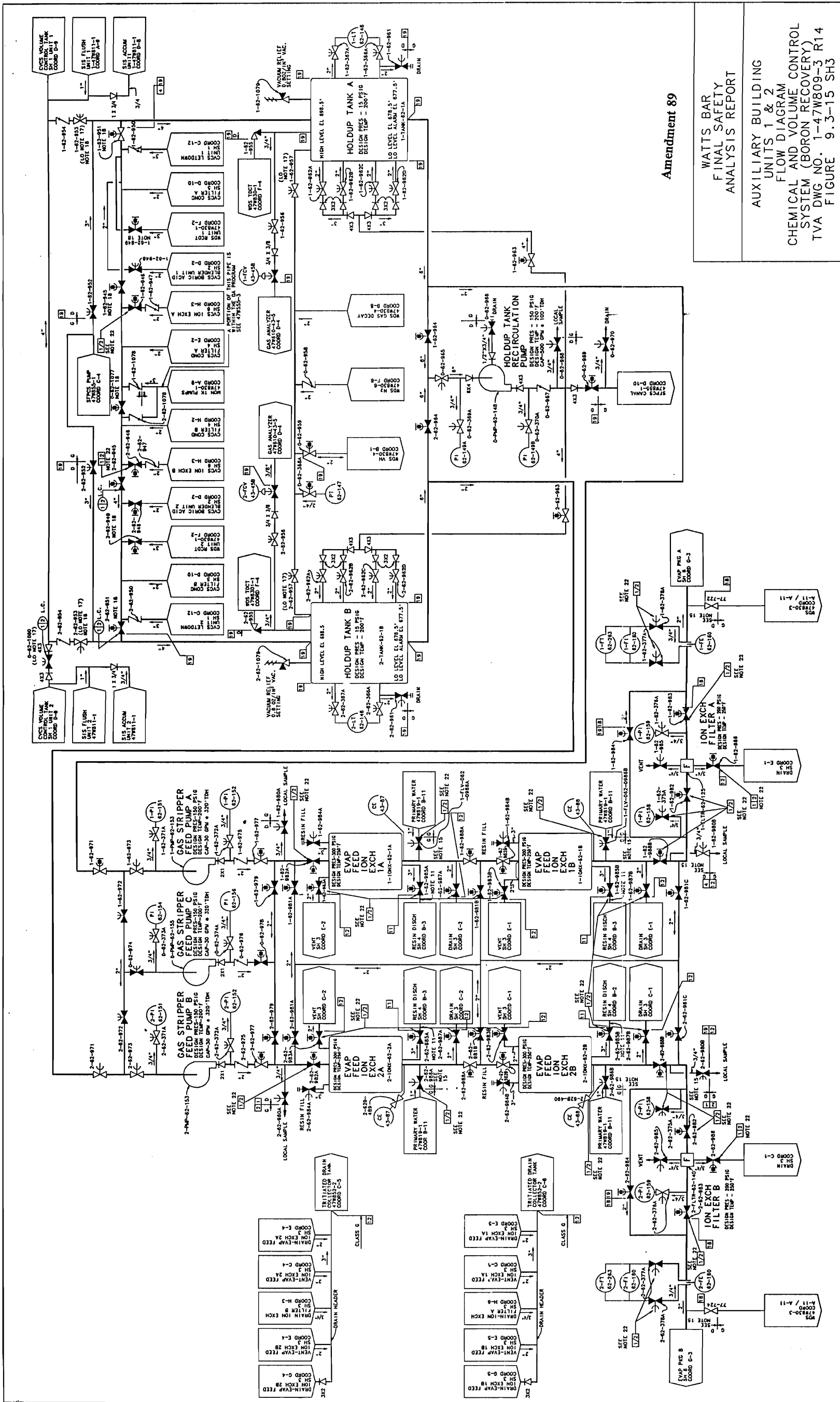

Amendment 89

WATTS BAR  
FINAL SAFETY  
ANALYSIS REPORT

AUXILIARY BUILDING  
UNITS 1 & 2  
FLOW DIAGRAM CONTROL  
SYSTEM (BORON RECOVERY)  
TVA DWG NO. 1-47W809-3 R14  
FIGURE 9.3-15 SH3

PROCADAM MAINTAINED DRAWING  
THIS DRAWING IS A PART OF THE 1, 2, 3, 4, 5, 6, 7, 8, 9, 10, 11, 12, 13, 14, 15, 16, 17, 18, 19, 20, 21, 22, 23, 24, 25, 26, 27, 28, 29, 30, 31, 32, 33, 34, 35, 36, 37, 38, 39, 40, 41, 42, 43, 44, 45, 46, 47, 48, 49, 50, 51, 52, 53, 54, 55, 56, 57, 58, 59, 60, 61, 62, 63, 64, 65, 66, 67, 68, 69, 70, 71, 72, 73, 74, 75, 76, 77, 78, 79, 80, 81, 82, 83, 84, 85, 86, 87, 88, 89, 90, 91, 92, 93, 94, 95, 96, 97, 98, 99, 100, 101, 102, 103, 104, 105, 106, 107, 108, 109, 110, 111, 112, 113, 114, 115, 116, 117, 118, 119, 120, 121, 122, 123, 124, 125, 126, 127, 128, 129, 130, 131, 132, 133, 134, 135, 136, 137, 138, 139, 140, 141, 142, 143, 144, 145, 146, 147, 148, 149, 150, 151, 152, 153, 154, 155, 156, 157, 158, 159, 160, 161, 162, 163, 164, 165, 166, 167, 168, 169, 170, 171, 172, 173, 174, 175, 176, 177, 178, 179, 180, 181, 182, 183, 184, 185, 186, 187, 188, 189, 190, 191, 192, 193, 194, 195, 196, 197, 198, 199, 200, 201, 202, 203, 204, 205, 206, 207, 208, 209, 210, 211, 212, 213, 214, 215, 216, 217, 218, 219, 220, 221, 222, 223, 224, 225, 226, 227, 228, 229, 230, 231, 232, 233, 234, 235, 236, 237, 238, 239, 240, 241, 242, 243, 244, 245, 246, 247, 248, 249, 250, 251, 252, 253, 254, 255, 256, 257, 258, 259, 260, 261, 262, 263, 264, 265, 266, 267, 268, 269, 270, 271, 272, 273, 274, 275, 276, 277, 278, 279, 280, 281, 282, 283, 284, 285, 286, 287, 288, 289, 290, 291, 292, 293, 294, 295, 296, 297, 298, 299, 300, 301, 302, 303, 304, 305, 306, 307, 308, 309, 310, 311, 312, 313, 314, 315, 316, 317, 318, 319, 320, 321, 322, 323, 324, 325, 326, 327, 328, 329, 330, 331, 332, 333, 334, 335, 336, 337, 338, 339, 340, 341, 342, 343, 344, 345, 346, 347, 348, 349, 350, 351, 352, 353, 354, 355, 356, 357, 358, 359, 360, 361, 362, 363, 364, 365, 366, 367, 368, 369, 370, 371, 372, 373, 374, 375, 376, 377, 378, 379, 380, 381, 382, 383, 384, 385, 386, 387, 388, 389, 390, 391, 392, 393, 394, 395, 396, 397, 398, 399, 400, 401, 402, 403, 404, 405, 406, 407, 408, 409, 410, 411, 412, 413, 414, 415, 416, 417, 418, 419, 420, 421, 422, 423, 424, 425, 426, 427, 428, 429, 430, 431, 432, 433, 434, 435, 436, 437, 438, 439, 440, 441, 442, 443, 444, 445, 446, 447, 448, 449, 450, 451, 452, 453, 454, 455, 456, 457, 458, 459, 460, 461, 462, 463, 464, 465, 466, 467, 468, 469, 470, 471, 472, 473, 474, 475, 476, 477, 478, 479, 480, 481, 482, 483, 484, 485, 486, 487, 488, 489, 490, 491, 492, 493, 494, 495, 496, 497, 498, 499, 500, 501, 502, 503, 504, 505, 506, 507, 508, 509, 510, 511, 512, 513, 514, 515, 516, 517, 518, 519, 520, 521, 522, 523, 524, 525, 526, 527, 528, 529, 530, 531, 532, 533, 534, 535, 536, 537, 538, 539, 540, 541, 542, 543, 544, 545, 546, 547, 548, 549, 550, 551, 552, 553, 554, 555, 556, 557, 558, 559, 560, 561, 562, 563, 564, 565, 566, 567, 568, 569, 570, 571, 572, 573, 574, 575, 576, 577, 578, 579, 580, 581, 582, 583, 584, 585, 586, 587, 588, 589, 590, 591, 592, 593, 594, 595, 596, 597, 598, 599, 600, 601, 602, 603, 604, 605, 606, 607, 608, 609, 610, 611, 612, 613, 614, 615, 616, 617, 618, 619, 620, 621, 622, 623, 624, 625, 626, 627, 628, 629, 630, 631, 632, 633, 634, 635, 636, 637, 638, 639, 640, 641, 642, 643, 644, 645, 646, 647, 648, 649, 650, 651, 652, 653, 654, 655, 656, 657, 658, 659, 660, 661, 662, 663, 664, 665, 666, 667, 668, 669, 670, 671, 672, 673, 674, 675, 676, 677, 678, 679, 680, 681, 682, 683, 684, 685, 686, 687, 688, 689, 690, 691, 692, 693, 694, 695, 696, 697, 698, 699, 700, 701, 702, 703, 704, 705, 706, 707, 708, 709, 710, 711, 712, 713, 714, 715, 716, 717, 718, 719, 720, 721, 722, 723, 724, 725, 726, 727, 728, 729, 730, 731, 732, 733, 734, 735, 736, 737, 738, 739, 740, 741, 742, 743, 744, 745, 746, 747, 748, 749, 750, 751, 752, 753, 754, 755, 756, 757, 758, 759, 760, 761, 762, 763, 764, 765, 766, 767, 768, 769, 770, 771, 772, 773, 774, 775, 776, 777, 778, 779, 780, 781, 782, 783, 784, 785, 786, 787, 788, 789, 790, 791, 792, 793, 794, 795, 796, 797, 798, 799, 800, 801, 802, 803, 804, 805, 806, 807, 808, 809, 810, 811, 812, 813, 814, 815, 816, 817, 818, 819, 820, 821, 822, 823, 824, 825, 826, 827, 828, 829, 830, 831, 832, 833, 834, 835, 836, 837, 838, 839, 840, 841, 842, 843, 844, 845, 846, 847, 848, 849, 850, 851, 852, 853, 854, 855, 856, 857, 858, 859, 860, 861, 862, 863, 864, 865, 866, 867, 868, 869, 870, 871, 872, 873, 874, 875, 876, 877, 878, 879, 880, 881, 882, 883, 884, 885, 886, 887, 888, 889, 890, 891, 892, 893, 894, 895, 896, 897, 898, 899, 900, 901, 902, 903, 904, 905, 906, 907, 908, 909, 910, 911, 912, 913, 914, 915, 916, 917, 918, 919, 920, 921, 922, 923, 924, 925, 926, 927, 928, 929, 930, 931, 932, 933, 934, 935, 936, 937, 938, 939, 940, 941, 942, 943, 944, 945, 946, 947, 948, 949, 950, 951, 952, 953, 954, 955, 956, 957, 958, 959, 960, 961, 962, 963, 964, 965, 966, 967, 968, 969, 970, 971, 972, 973, 974, 975, 976, 977, 978, 979, 980, 981, 982, 983, 984, 985, 986, 987, 988, 989, 990, 991, 992, 993, 994, 995, 996, 997, 998, 999, 1000.

Figure 9.3-15 Auxiliary Building Units 1 & 2 Flow Diagram for Chemical and Volume Control System (Boron Recovery) (Sheet 3)

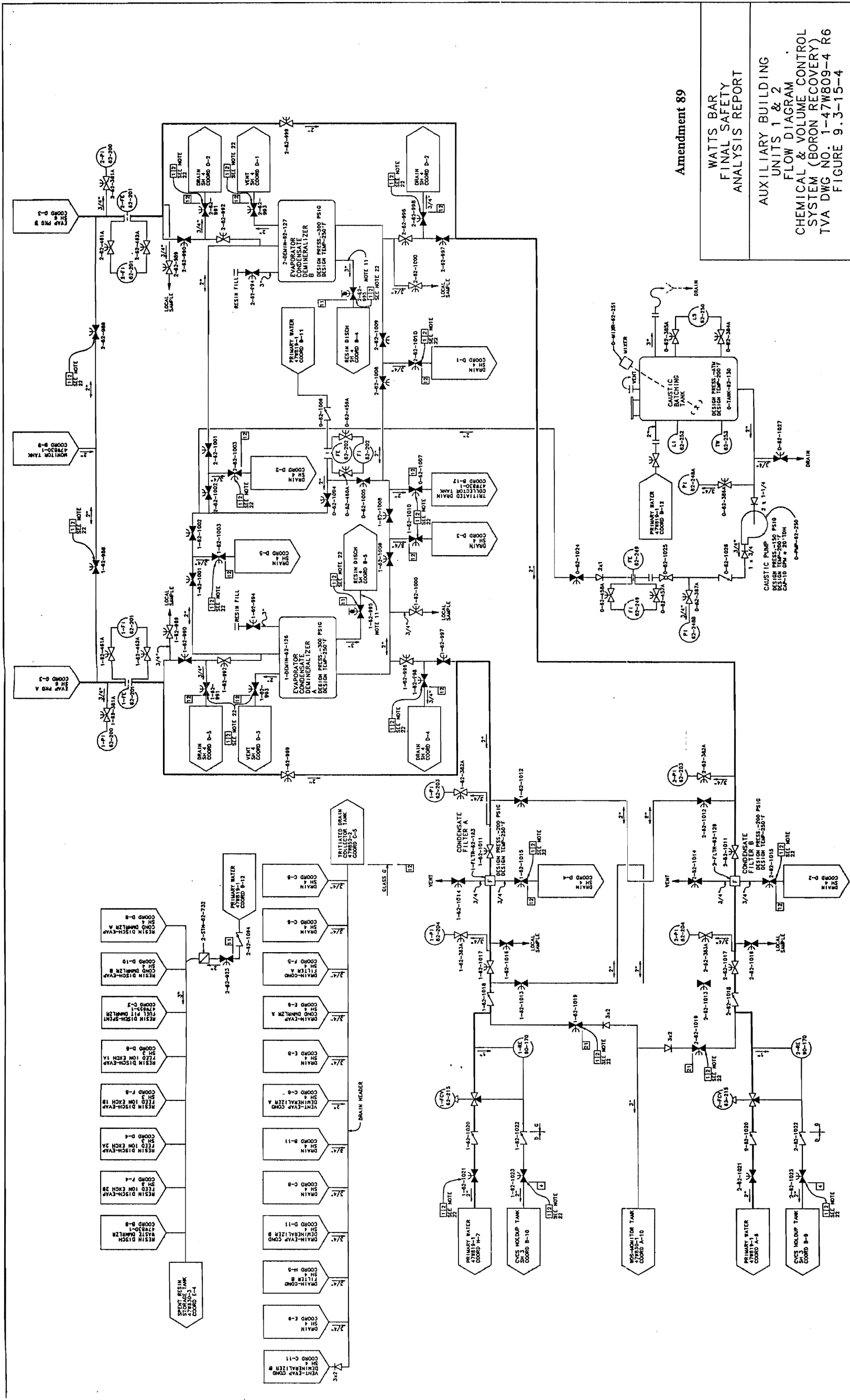

Amendment 89

WATTS BAR  
FINAL SAFETY  
ANALYSIS REPORT  
  
AUXILIARY BUILDING  
UNITS 1 & 2  
FLOW DIAGRAM  
CHEMICAL & VOLUME CONTROL  
SYSTEM (BORON RECOVERY)  
TVA DWG NO. 1-47W809-4 R6  
FIGURE 9.3-15-4

PROCESS MAINTAINED DRAWING  
THIS DRAWING IS THE PROPERTY OF THE U.S. NUCLEAR ENERGY  
CORPORATION AND IS NOT TO BE REPRODUCED OR  
TRANSMITTED IN ANY FORM OR BY ANY MEANS  
ELECTRONIC OR MECHANICAL, INCLUDING PHOTOCOPYING,  
RECORDING, OR BY ANY INFORMATION STORAGE AND  
RETRIEVAL SYSTEM.

Figure 9.3-15 Auxiliary Building Units 1 & 2 Flow Diagram for Chemical and Volume Control System (Boron Recovery) (Sheet 4)

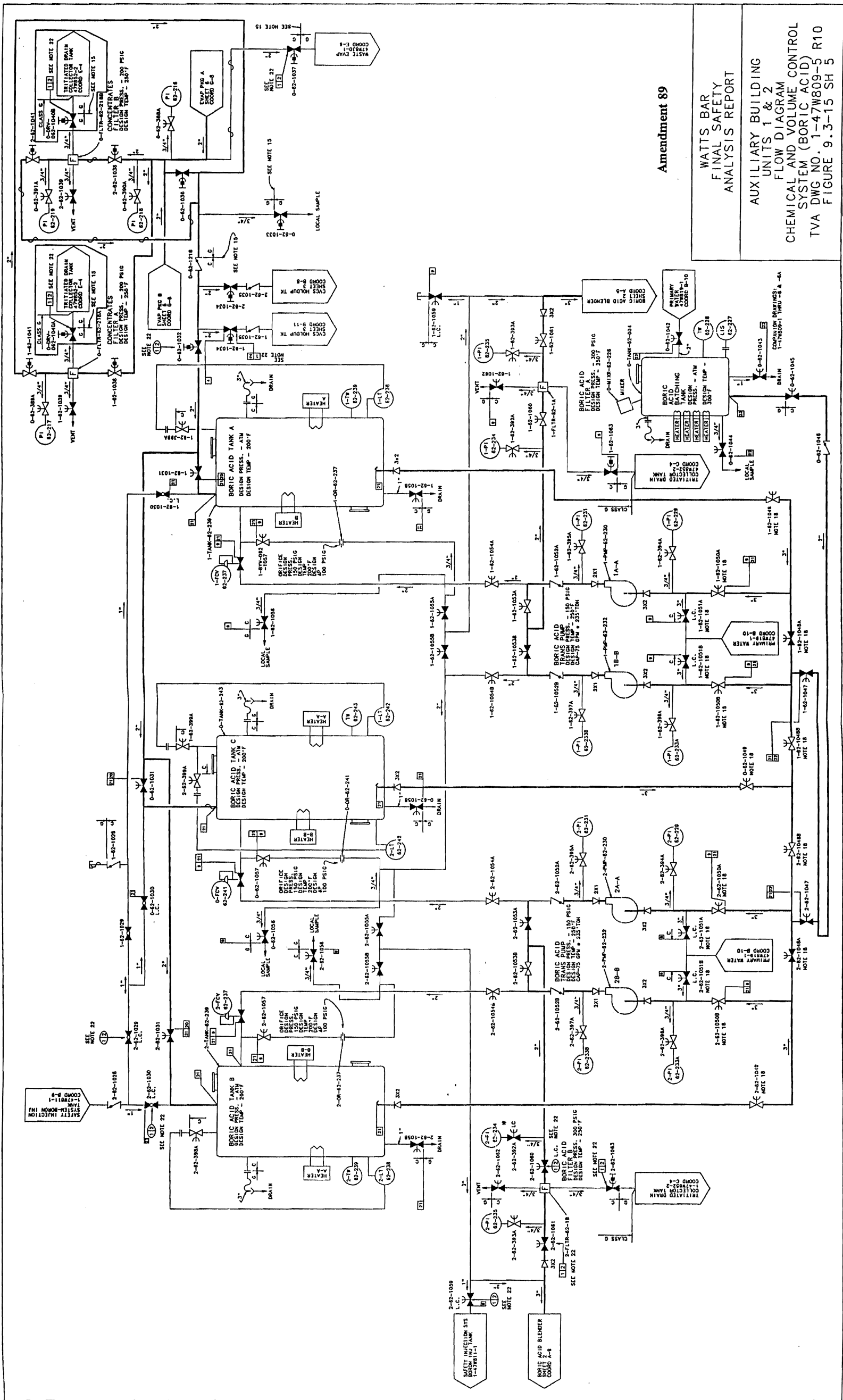

Amendment 89

WATTS BAR  
FINAL SAFETY  
ANALYSIS REPORT  
  
AUXILIARY BUILDING  
UNITS 1 & 2  
FLOW DIAGRAM  
CHEMICAL AND VOLUME CONTROL  
SYSTEM (BORIC ACID)  
TVA DWG NO. 1-47W809-5 R10  
FIGURE 9.3-15 SH 5

PROCEDURE MAINTAINED DRAWING  
THIS DOCUMENTATION CONTROL PART OF THE TVA PROCESS RELIABLE  
OPERATION PROGRAM

Figure 9.3-15 Auxiliary Building Units 1 & 2 Flow Diagram for Chemical and Volume Control System (Boric Acid) (Sheet 5)

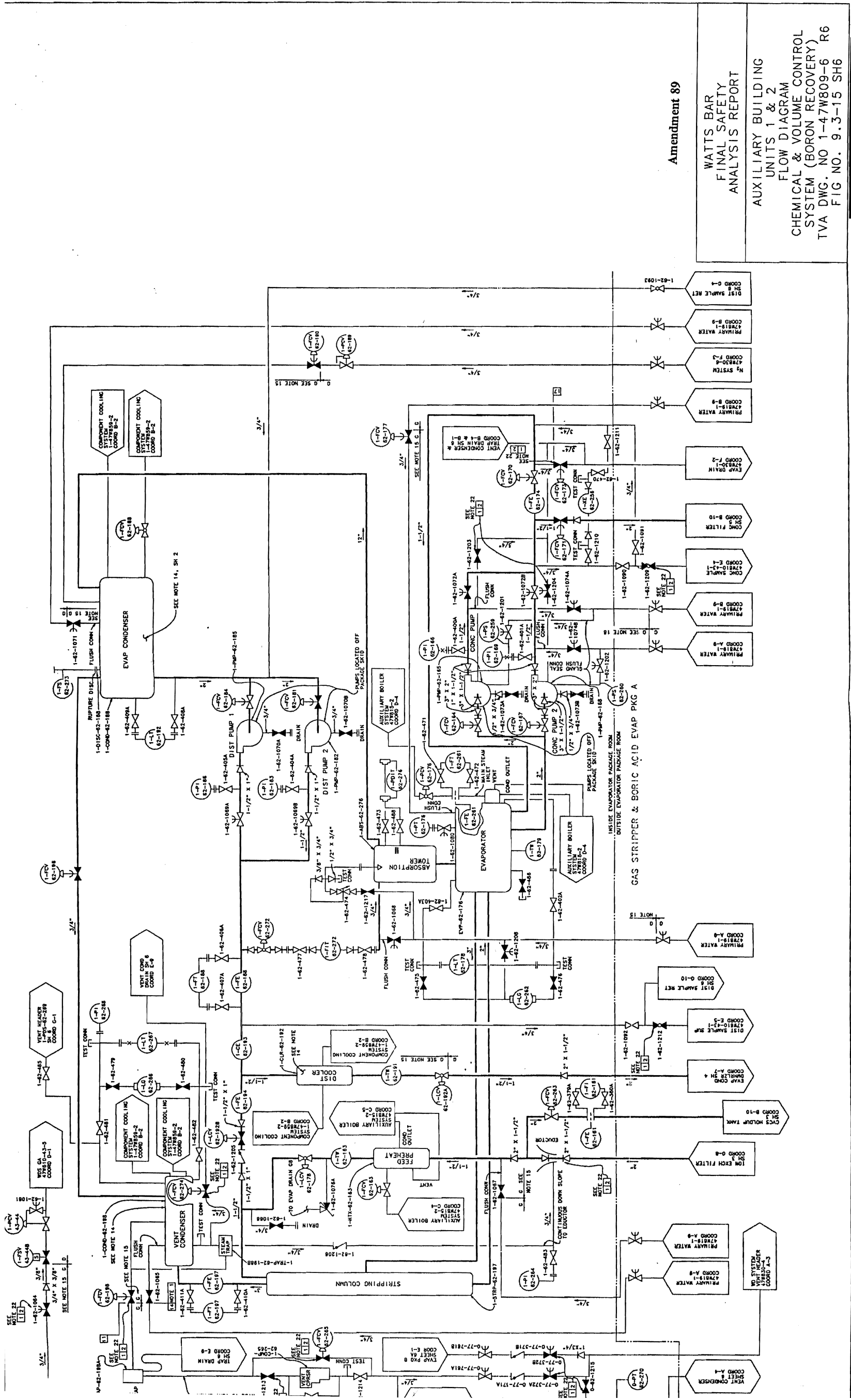

**Amendment 89**

WATTS BAR  
FINAL SAFETY  
ANALYSIS REPORT

AUXILIARY BUILDING  
UNITS 1 & 2  
FLOW DIAGRAM  
CHEMICAL & VOLUME CONTROL  
SYSTEM (BORON RECOVERY)  
TVA DWG. NO 1-47W809-6 R6  
FIG NO. 9.3-15 SH6

PROGRAM MAINTAINED DRAWING  
THIS CONFIGURATION CONTROL DRAWING IS MAINTAINED BY THE  
P&ID UNIT AND IS NOT PART OF THE P&ID PROCESS DRAWING  
REVISION HISTORY

Figure 9.3-15 Auxiliary Building Units 1 & 2 Flow Diagram for Chemical and Volume Control System and (Boron Recovery) (Sheet 6)

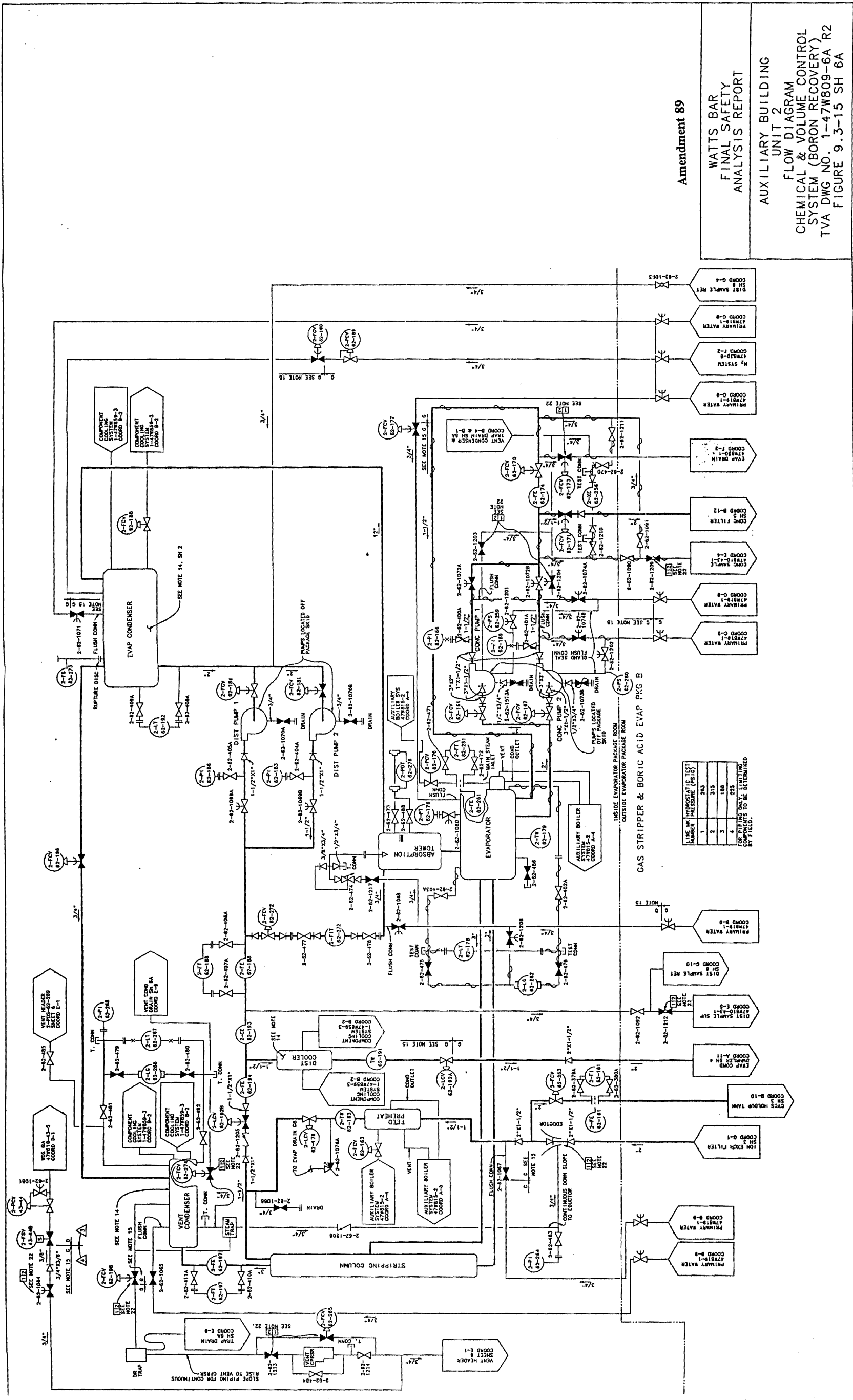
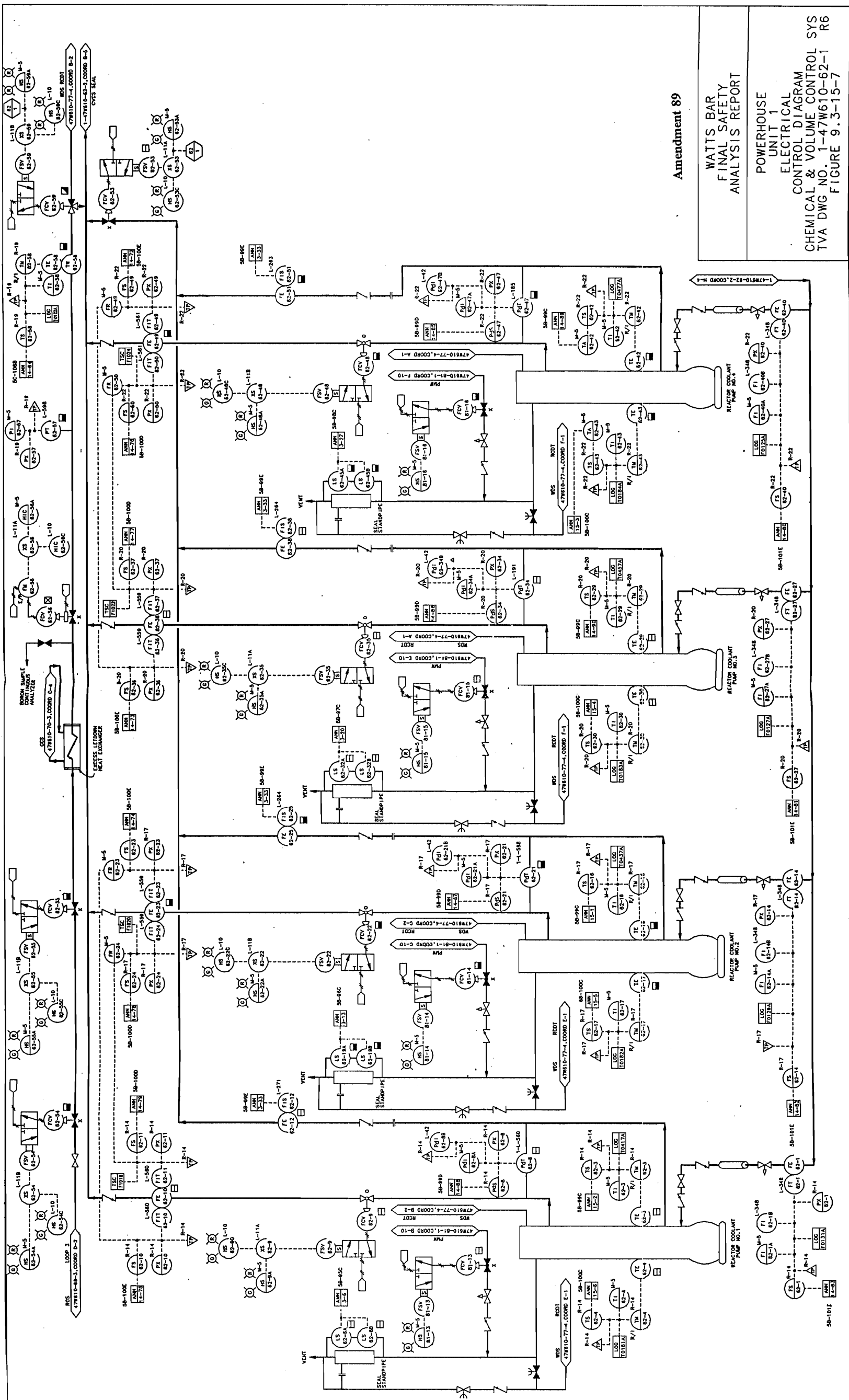

Figure 9.3-15 Auxiliary Building Unit 2 Flow Diagram for Chemical and Volume Control System (Boron Recovery) (Sheet 6a)



Amendment 89

WATTS BAR  
FINAL SAFETY  
ANALYSIS REPORT

POWERHOUSE  
UNIT 1  
ELECTRICAL  
CONTROL DIAGRAM  
CHEMICAL & VOLUME CONTROL SYS  
TVA DWG NO. 1-47W610-62-1 R6  
FIGURE 9.3-15-7

PROCADAM MAINTAINED DRAWING  
THIS DRAWING IS THE PROPERTY OF THE TVA  
REPRODUCED BY PERMIT  
8/27/88

Figure 9.3-15 Powerhouse Unit 1 Electrical Control Diagram Chemical & Volume Control Sys (Sheet 7)



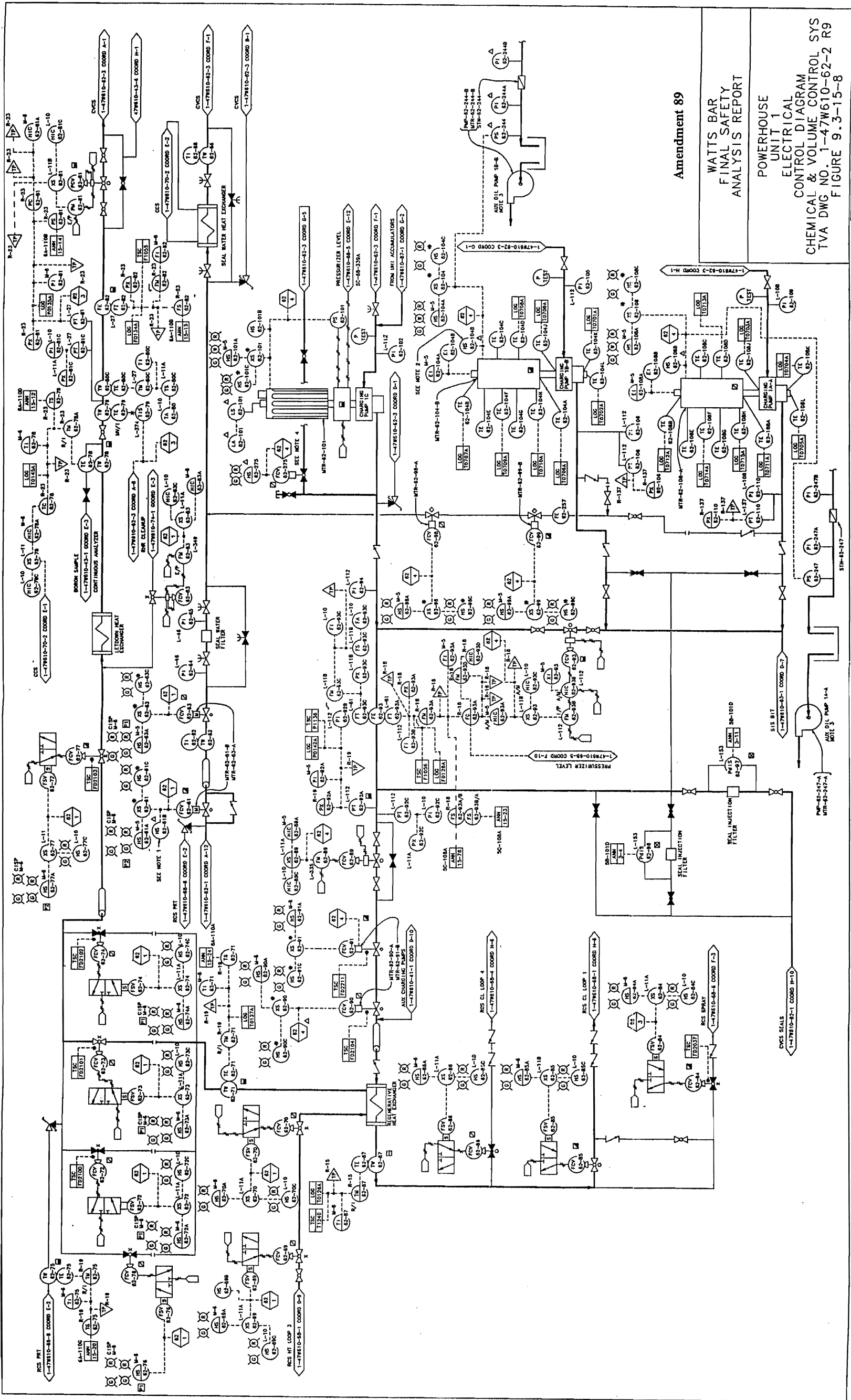
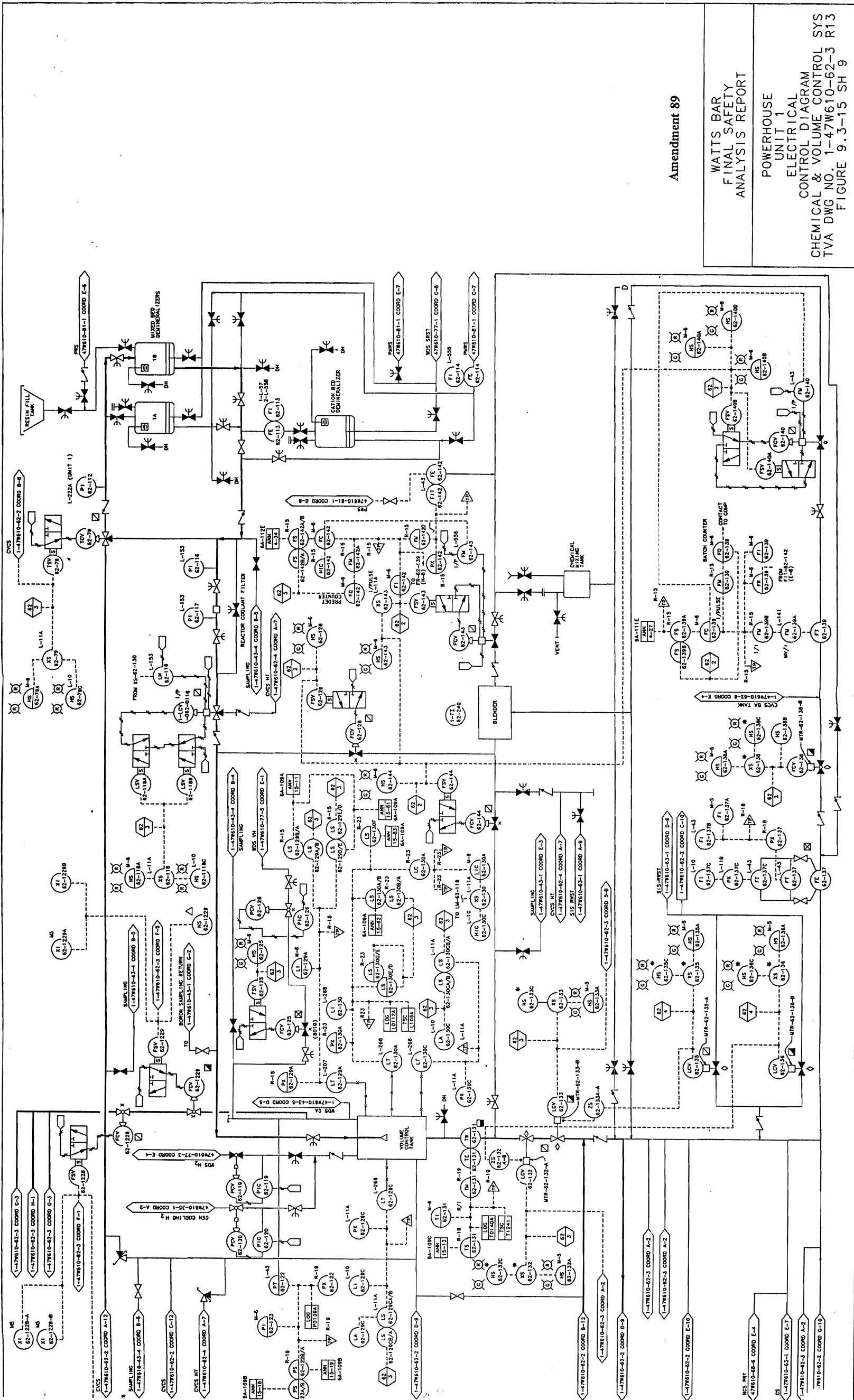

Figure 9.3-15 Powerhouse Unit 1 Electrical Control Diagram Chemical & Volume Control Sys (Sheet 8)



Amendment 89

WATTS BAR  
FINAL SAFETY  
ANALYSIS REPORT

POWERHOUSE  
UNIT 1  
ELECTRICAL  
CONTROL DIAGRAM  
CHEMICAL & VOLUME CONTROL SYS  
TVA DWG NO. 1-47W610-62-3 R13  
FIGURE 9.3-15 SH 9

PROCADAM MAINTAINED DRAWING  
THIS CAD UNIT AND THE TOOL DRAWING OF THE TOOL INCLUDES ALL PAGES  
OF THE DRAWING.

Figure 9.3-15 Powerhouse Unit 1 Electrical Control Diagram Chemical & Volume Control Sys (Sheet 9)

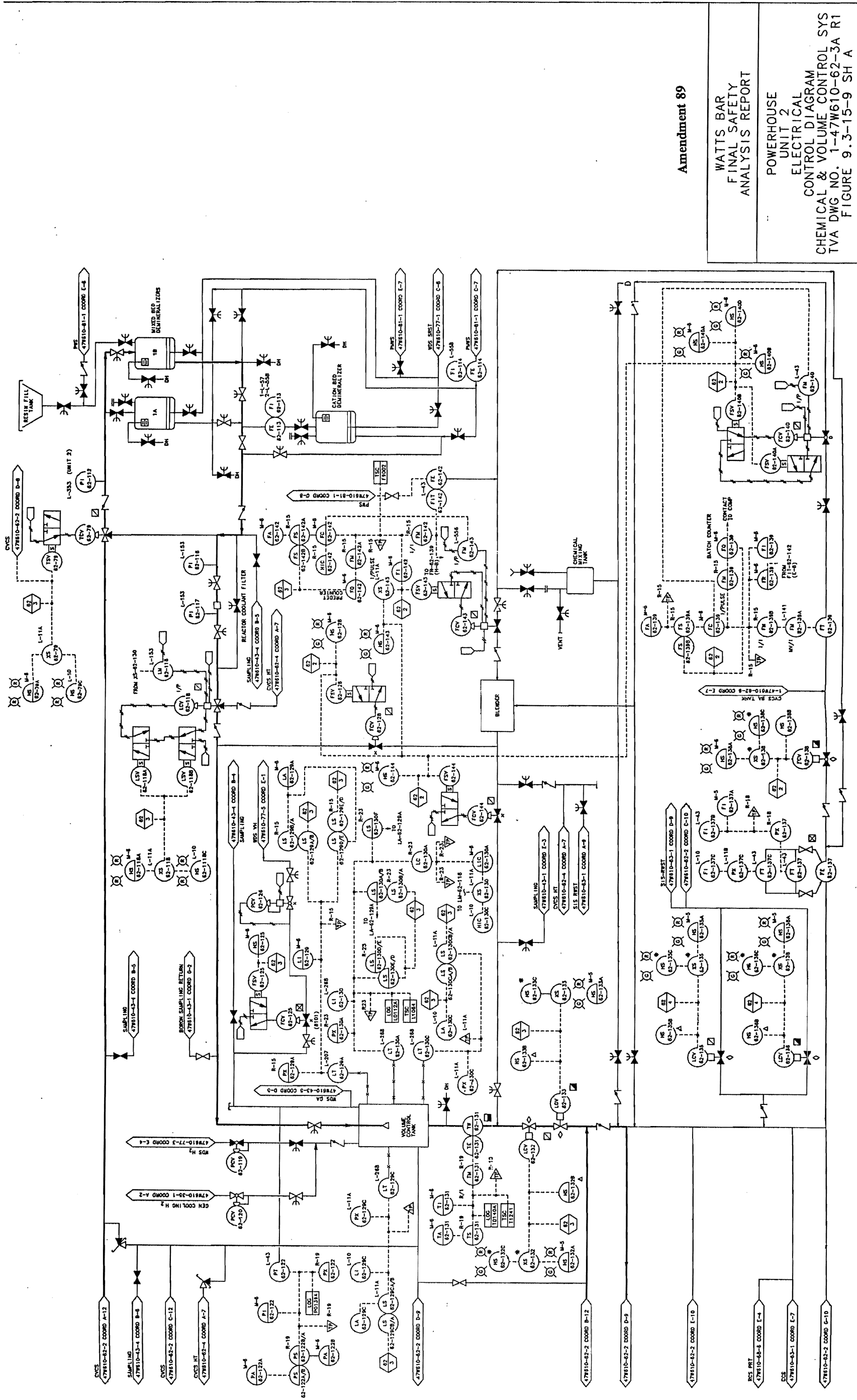

Amendment 89

WATTS BAR  
FINAL SAFETY  
ANALYSIS REPORT

POWERHOUSE  
UNIT 2  
ELECTRICAL  
CONTROL DIAGRAM  
CHEMICAL & VOLUME CONTROL SYS  
TVA DWG NO. 1-47W610-62-3A R1  
FIGURE 9.3-15-9 SH A

PROCAD MAINTAINED DRAWING  
THIS DRAWING AND ITS CONTENTS ARE THE PROPERTY OF THE U.S. NUCLEAR REGULATORY COMMISSION AND ARE NOT TO BE REPRODUCED OR TRANSMITTED IN ANY FORM OR BY ANY MEANS, ELECTRONIC OR MECHANICAL, INCLUDING PHOTOCOPYING, RECORDING, OR BY ANY INFORMATION STORAGE AND RETRIEVAL SYSTEM.

Figure 9.3-15 Powerhouse Unit 2 Electrical Control Diagram Chemical & Volume Control Sys (Sheet 9a)

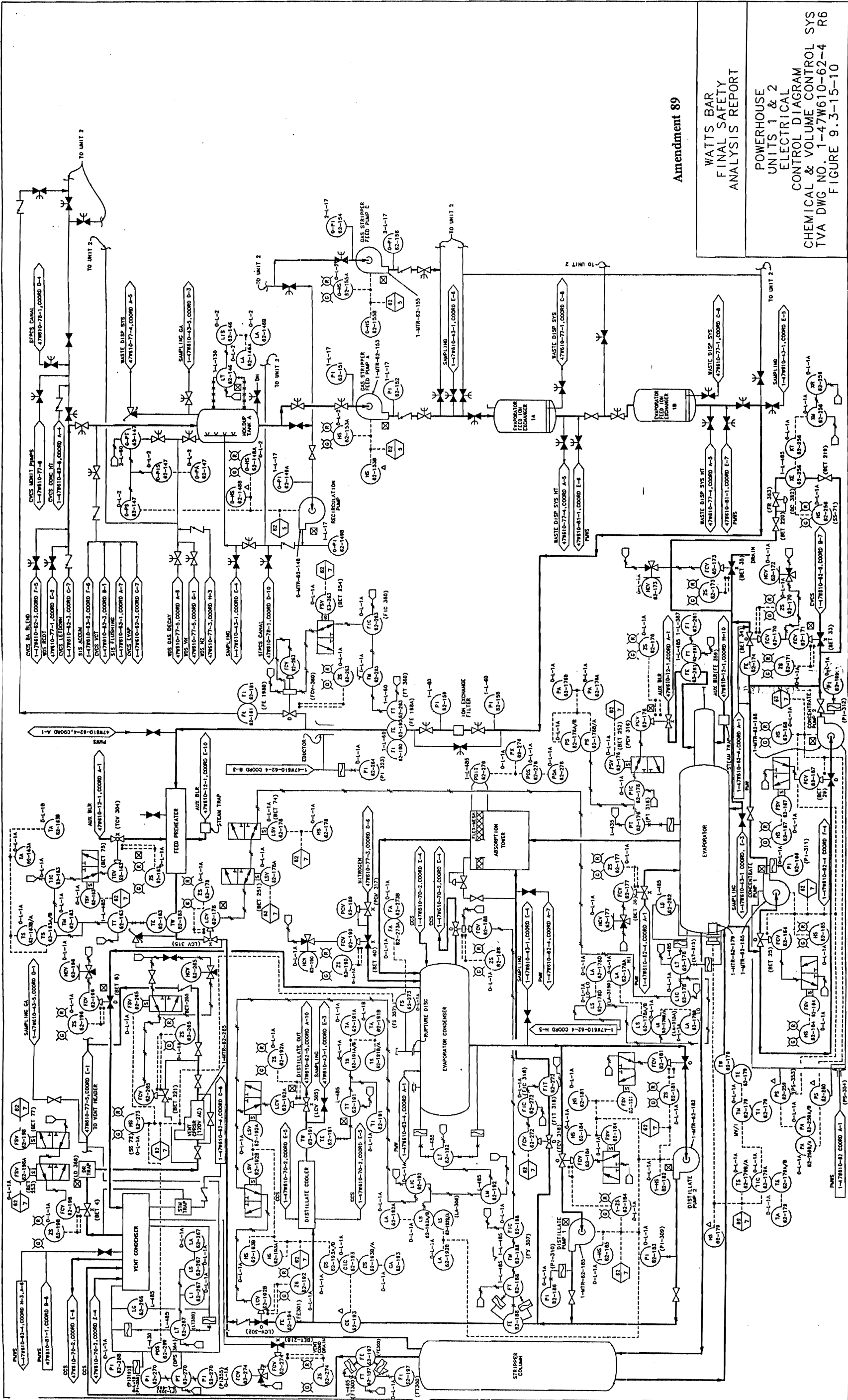

Amendment 89

WATTS BAR  
FINAL SAFETY  
ANALYSIS REPORT

POWERHOUSE  
UNITS 1 & 2  
ELECTRICAL  
CONTROL DIAGRAM  
CHEMICAL & VOLUME CONTROL SYS  
TVA DWG NO. 1-47W610-62-4 R6  
FIGURE 9.3-15-10

PROCADAM MAINTAINED DRAWING  
THIS DRAWING IS THE PROPERTY OF THE  
AT&T WORLDWIDE COMMUNICATIONS GROUP  
AND IS NOT TO BE REPRODUCED OR  
TRANSMITTED IN ANY FORM OR BY ANY  
MEANS, ELECTRONIC OR MECHANICAL,  
INCLUDING PHOTOCOPYING, RECORDING,  
OR BY ANY INFORMATION STORAGE AND  
RETRIEVAL SYSTEM.

Figure 9.3-15 Powerhouse Units 1 & 2 Electrical Control Diagram Chemical & Volume Control Sys (Sheet 10)



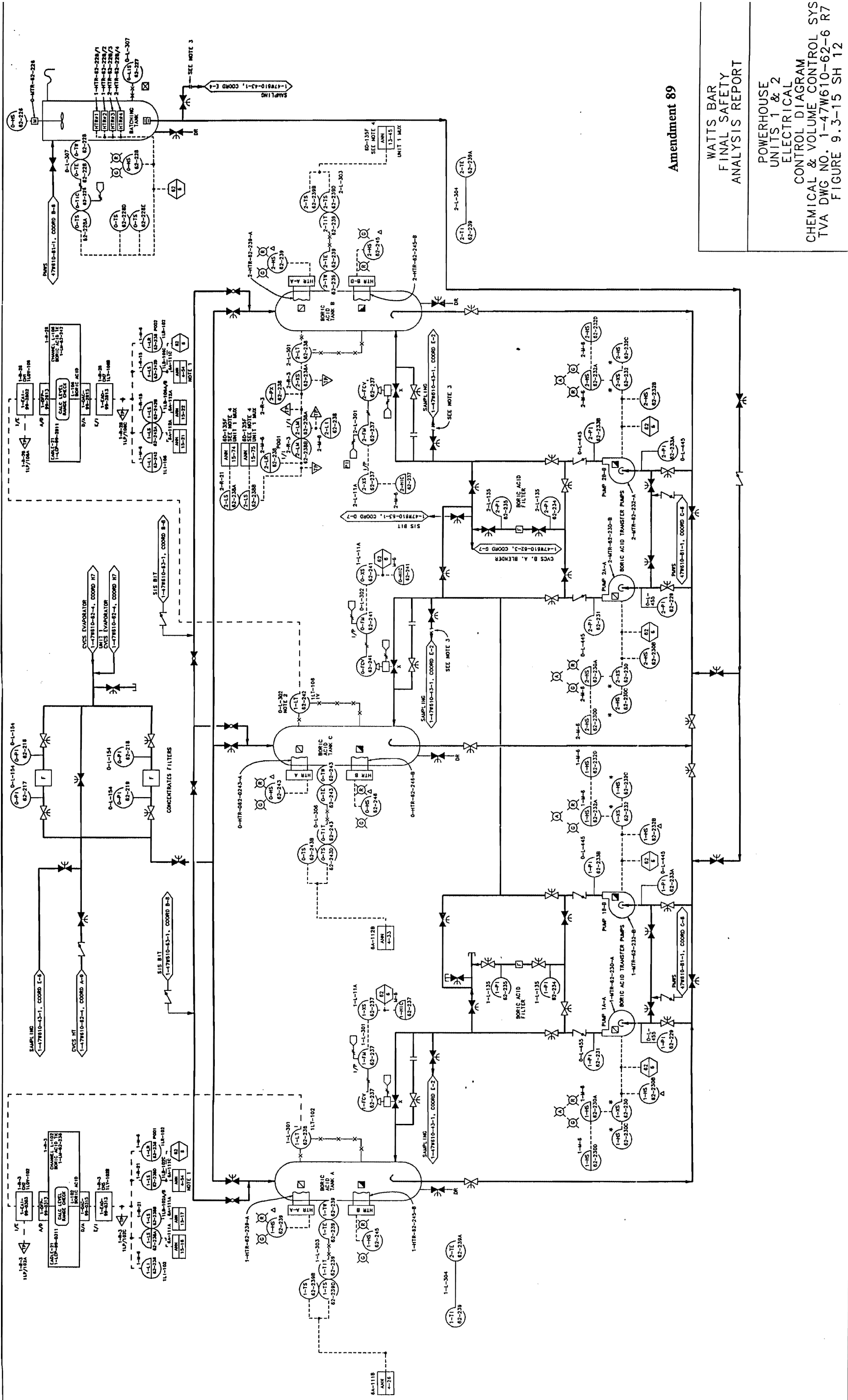

Amendment 89

WATTS BAR  
FINAL SAFETY  
ANALYSIS REPORT

POWERHOUSE  
UNITS 1 & 2  
ELECTRICAL  
CONTROL DIAGRAM

CHEMICAL & VOLUME CONTROL SYS  
TVA DWG NO. 1-47W610-62-6 R7  
FIGURE 9.3-15 SH 12

PROGRAM MAINTAINED, DRAWING  
THIS CONTROL SYSTEM CONTROL PANELS AND  
THEir CAP UNIT ARE NOT PART OF THE TVA PRODUCTION EXCHANGE  
PROGRAM (REVISED 8/2/87)

Figure 9.3-15 Powerhouse Units 1 & 2 Electrical Control Diagram Chemical & Volume Control Sys (Sheet 12)

Figure 9.3-16 Deleted by Amendment 95

**Figure 9.3-17 Deleted by Amendment 95**



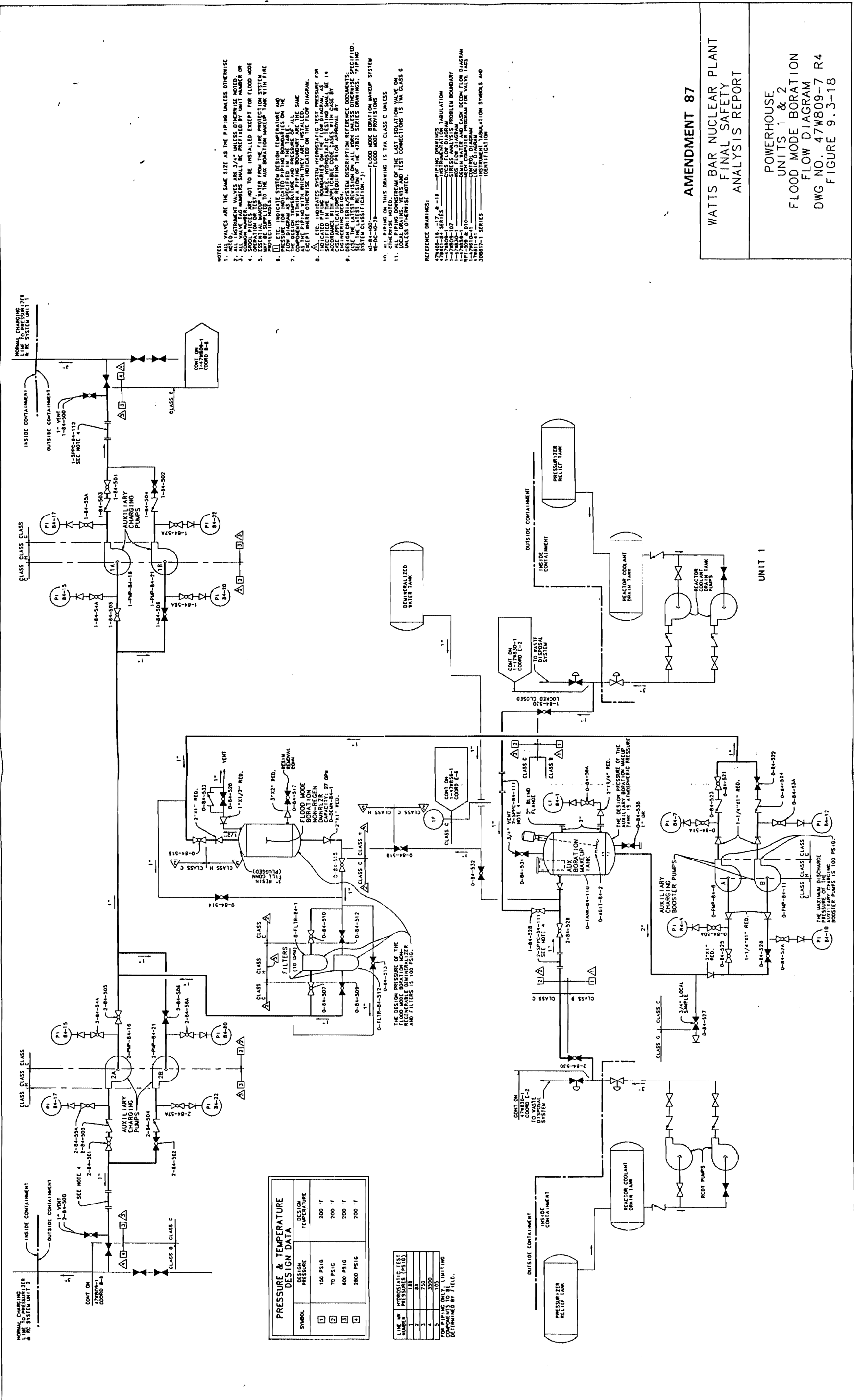

- NOTES: VALVES ARE THE SAME SIZE AS THE PIPING UNLESS OTHERWISE NOTED.
1. NOTED DIMENSION VALUES ARE 3/4" UNLESS OTHERWISE NOTED.
  2. ALL VALVE TAG NUMBERS SHALL BE PREFIXED BY UNIT NUMBER OR COMMON NUMBER ARE NOT TO BE INSTALLED EXCEPT FOR FLOOD MODE OPERATION OR TEST.
  3. OPERATION OR TEST WATER FROM THE FIRE PROTECTION SYSTEM MAY BE SUPPLIED TO THE AUXILIARY BORATION MAKEUP TANK WITH FIRE PROTECTION HOSES.
  4. ALL SIZE INDICATED IN THIS DRAWING IS THE NOMINAL SIZE UNLESS OTHERWISE SPECIFIED IN THE TABLE.
  5. COMPONENTS WITHIN A PIPING BOUNDARY ARE THE SAME EXCEPT WHERE OTHERWISE INDICATED ON THE FLOW DIAGRAM.
  6. INDICATED PIPING BOUNDARIES ON THE FLOW DIAGRAM, AS SHOWN IN THE APPLICABLE CODE CLASS WITHIN EACH CASE APPLICATIONS REQUIRING PRIOR APPROVAL BY THE DESIGNER.
  7. DESIGN CRITERIA/SYSTEM DESCRIPTION REFERENCE DOCUMENTS: USE THE LATEST REVISION OF ALL PERTAINING DOCUMENTS, SPECIFIED.
  8. SYSTEM CLASSIFICATION: "3" FLOOD MODE BORATION MAKEUP SYSTEM
  9. ALL PIPING ON THIS DRAWING IS TYPICAL CLASS C UNLESS OTHERWISE SPECIFIED.
  10. LOCAL VALVE TAGS AND TEST CONNECTIONS IS TYPICAL CLASS G UNLESS OTHERWISE SPECIFIED.

- REFERENCE DRAWINGS:
- 47800-18, -17, & -18 PIPING DRAWINGS TABULATION
  - 47800-19, -20, -21, -22, -23, -24, -25, -26, -27, -28, -29, -30, -31, -32, -33, -34, -35, -36, -37, -38, -39, -40, -41, -42, -43, -44, -45, -46, -47, -48, -49, -50, -51, -52, -53, -54, -55, -56, -57, -58, -59, -60, -61, -62, -63, -64, -65, -66, -67, -68, -69, -70, -71, -72, -73, -74, -75, -76, -77, -78, -79, -80, -81, -82, -83, -84, -85, -86, -87, -88, -89, -90, -91, -92, -93, -94, -95, -96, -97, -98, -99, -100, -101, -102, -103, -104, -105, -106, -107, -108, -109, -110, -111, -112, -113, -114, -115, -116, -117, -118, -119, -120, -121, -122, -123, -124, -125, -126, -127, -128, -129, -130, -131, -132, -133, -134, -135, -136, -137, -138, -139, -140, -141, -142, -143, -144, -145, -146, -147, -148, -149, -150, -151, -152, -153, -154, -155, -156, -157, -158, -159, -160, -161, -162, -163, -164, -165, -166, -167, -168, -169, -170, -171, -172, -173, -174, -175, -176, -177, -178, -179, -180, -181, -182, -183, -184, -185, -186, -187, -188, -189, -190, -191, -192, -193, -194, -195, -196, -197, -198, -199, -200, -201, -202, -203, -204, -205, -206, -207, -208, -209, -210, -211, -212, -213, -214, -215, -216, -217, -218, -219, -220, -221, -222, -223, -224, -225, -226, -227, -228, -229, -230, -231, -232, -233, -234, -235, -236, -237, -238, -239, -240, -241, -242, -243, -244, -245, -246, -247, -248, -249, -250, -251, -252, -253, -254, -255, -256, -257, -258, -259, -260, -261, -262, -263, -264, -265, -266, -267, -268, -269, -270, -271, -272, -273, -274, -275, -276, -277, -278, -279, -280, -281, -282, -283, -284, -285, -286, -287, -288, -289, -290, -291, -292, -293, -294, -295, -296, -297, -298, -299, -300, -301, -302, -303, -304, -305, -306, -307, -308, -309, -310, -311, -312, -313, -314, -315, -316, -317, -318, -319, -320, -321, -322, -323, -324, -325, -326, -327, -328, -329, -330, -331, -332, -333, -334, -335, -336, -337, -338, -339, -340, -341, -342, -343, -344, -345, -346, -347, -348, -349, -350, -351, -352, -353, -354, -355, -356, -357, -358, -359, -360, -361, -362, -363, -364, -365, -366, -367, -368, -369, -370, -371, -372, -373, -374, -375, -376, -377, -378, -379, -380, -381, -382, -383, -384, -385, -386, -387, -388, -389, -390, -391, -392, -393, -394, -395, -396, -397, -398, -399, -400, -401, -402, -403, -404, -405, -406, -407, -408, -409, -410, -411, -412, -413, -414, -415, -416, -417, -418, -419, -420, -421, -422, -423, -424, -425, -426, -427, -428, -429, -430, -431, -432, -433, -434, -435, -436, -437, -438, -439, -440, -441, -442, -443, -444, -445, -446, -447, -448, -449, -450, -451, -452, -453, -454, -455, -456, -457, -458, -459, -460, -461, -462, -463, -464, -465, -466, -467, -468, -469, -470, -471, -472, -473, -474, -475, -476, -477, -478, -479, -480, -481, -482, -483, -484, -485, -486, -487, -488, -489, -490, -491, -492, -493, -494, -495, -496, -497, -498, -499, -500, -501, -502, -503, -504, -505, -506, -507, -508, -509, -510, -511, -512, -513, -514, -515, -516, -517, -518, -519, -520, -521, -522, -523, -524, -525, -526, -527, -528, -529, -530, -531, -532, -533, -534, -535, -536, -537, -538, -539, -540, -541, -542, -543, -544, -545, -546, -547, -548, -549, -550, -551, -552, -553, -554, -555, -556, -557, -558, -559, -560, -561, -562, -563, -564, -565, -566, -567, -568, -569, -570, -571, -572, -573, -574, -575, -576, -577, -578, -579, -580, -581, -582, -583, -584, -585, -586, -587, -588, -589, -590, -591, -592, -593, -594, -595, -596, -597, -598, -599, -600, -601, -602, -603, -604, -605, -606, -607, -608, -609, -610, -611, -612, -613, -614, -615, -616, -617, -618, -619, -620, -621, -622, -623, -624, -625, -626, -627, -628, -629, -630, -631, -632, -633, -634, -635, -636, -637, -638, -639, -640, -641, -642, -643, -644, -645, -646, -647, -648, -649, -650, -651, -652, -653, -654, -655, -656, -657, -658, -659, -660, -661, -662, -663, -664, -665, -666, -667, -668, -669, -670, -671, -672, -673, -674, -675, -676, -677, -678, -679, -680, -681, -682, -683, -684, -685, -686, -687, -688, -689, -690, -691, -692, -693, -694, -695, -696, -697, -698, -699, -700, -701, -702, -703, -704, -705, -706, -707, -708, -709, -710, -711, -712, -713, -714, -715, -716, -717, -718, -719, -720, -721, -722, -723, -724, -725, -726, -727, -728, -729, -730, -731, -732, -733, -734, -735, -736, -737, -738, -739, -740, -741, -742, -743, -744, -745, -746, -747, -748, -749, -750, -751, -752, -753, -754, -755, -756, -757, -758, -759, -760, -761, -762, -763, -764, -765, -766, -767, -768, -769, -770, -771, -772, -773, -774, -775, -776, -777, -778, -779, -780, -781, -782, -783, -784, -785, -786, -787, -788, -789, -790, -791, -792, -793, -794, -795, -796, -797, -798, -799, -800, -801, -802, -803, -804, -805, -806, -807, -808, -809, -810, -811, -812, -813, -814, -815, -816, -817, -818, -819, -820, -821, -822, -823, -824, -825, -826, -827, -828, -829, -830, -831, -832, -833, -834, -835, -836, -837, -838, -839, -840, -841, -842, -843, -844, -845, -846, -847, -848, -849, -850, -851, -852, -853, -854, -855, -856, -857, -858, -859, -860, -861, -862, -863, -864, -865, -866, -867, -868, -869, -870, -871, -872, -873, -874, -875, -876, -877, -878, -879, -880, -881, -882, -883, -884, -885, -886, -887, -888, -889, -890, -891, -892, -893, -894, -895, -896, -897, -898, -899, -900, -901, -902, -903, -904, -905, -906, -907, -908, -909, -910, -911, -912, -913, -914, -915, -916, -917, -918, -919, -920, -921, -922, -923, -924, -925, -926, -927, -928, -929, -930, -931, -932, -933, -934, -935, -936, -937, -938, -939, -940, -941, -942, -943, -944, -945, -946, -947, -948, -949, -950, -951, -952, -953, -954, -955, -956, -957, -958, -959, -960, -961, -962, -963, -964, -965, -966, -967, -968, -969, -970, -971, -972, -973, -974, -975, -976, -977, -978, -979, -980, -981, -982, -983, -984, -985, -986, -987, -988, -989, -990, -991, -992, -993, -994, -995, -996, -997, -998, -999, -1000, -1001, -1002, -1003, -1004, -1005, -1006, -1007, -1008, -1009, -1010, -1011, -1012, -1013, -1014, -1015, -1016, -1017, -1018, -1019, -1020, -1021, -1022, -1023, -1024, -1025, -1026, -1027, -1028, -1029, -1030, -1031, -1032, -1033, -1034, -1035, -1036, -1037, -1038, -1039, -1040, -1041, -1042, -1043, -1044, -1045, -1046, -1047, -1048, -1049, -1050, -1051, -1052, -1053, -1054, -1055, -1056, -1057, -1058, -1059, -1060, -1061, -1062, -1063, -1064, -1065, -1066, -1067, -1068, -1069, -1070, -1071, -1072, -1073, -1074, -1075, -1076, -1077, -1078, -1079, -1080, -1081, -1082, -1083, -1084, -1085, -1086, -1087, -1088, -1089, -1090, -1091, -1092, -1093, -1094, -1095, -1096, -1097, -1098, -1099, -1100, -1101, -1102, -1103, -1104, -1105, -1106, -1107, -1108, -1109, -1110, -1111, -1112, -1113, -1114, -1115, -1116, -1117, -1118, -1119, -1120, -1121, -1122, -1123, -1124, -1125, -1126, -1127, -1128, -1129, -1130, -1131, -1132, -1133, -1134, -1135, -1136, -1137, -1138, -1139, -1140, -1141, -1142, -1143, -1144, -1145, -1146, -1147, -1148, -1149, -1150, -1151, -1152, -1153, -1154, -1155, -1156, -1157, -1158, -1159, -1160, -1161, -1162, -1163, -1164, -1165, -1166, -1167, -1168, -1169, -1170, -1171, -1172, -1173, -1174, -1175, -1176, -1177, -1178, -1179, -1180, -1181, -1182, -1183, -1184, -1185, -1186, -1187, -1188, -1189, -1190, -1191, -1192, -1193, -1194, -1195, -1196, -1197, -1198, -1199, -1200, -1201, -1202, -1203, -1204, -1205, -1206, -1207, -1208, -1209, -1210, -1211, -1212, -1213, -1214, -1215, -1216, -1217, -1218, -1219, -1220, -1221, -1222, -1223, -1224, -1225, -1226, -1227, -1228, -1229, -1230, -1231, -1232, -1233, -1234, -1235, -1236, -1237, -1238, -1239, -1240, -1241, -1242, -1243, -1244, -1245, -1246, -1247, -1248, -1249, -1250, -1251, -1252, -1253, -1254, -1255, -1256, -1257, -1258, -1259, -1260, -1261, -1262, -1263, -1264, -1265, -1266, -1267, -1268, -1269, -1270, -1271, -1272, -1273, -1274, -1275, -1276, -1277, -1278, -1279, -1280, -1281, -1282, -1283, -1284, -1285, -1286, -1287, -1288, -1289, -1290, -1291, -1292, -1293, -1294, -1295, -1296, -1297, -1298, -1299, -1300, -1301, -1302, -1303, -1304, -1305, -1306, -1307, -1308, -1309, -1310, -1311, -1312, -1313, -1314, -1315, -1316, -1317, -1318, -1319, -1320, -1321, -1322, -1323, -1324, -1325, -1326, -1327, -1328, -1329, -1330, -1331, -1332, -1333, -1334, -1335, -1336, -1337, -1338, -1339, -1340, -1341, -1342, -1343, -1344, -1345, -1346, -1347, -1348, -1349, -1350, -1351, -1352, -1353, -1354, -1355, -1356, -1357, -1358, -1359, -1360, -1361, -1362, -1363, -1364, -1365, -1366, -1367, -1368, -1369, -1370, -1371, -1372, -1373, -1374, -1375, -1376, -1377, -1378, -1379, -1380, -1381, -1382, -1383, -1384, -1385, -1386, -1387, -1388, -1389, -1390, -1391, -1392, -1393, -1394, -1395, -1396, -1397, -1398, -1399, -1400, -1401, -1402, -1403, -1404, -1405, -1406, -1407, -1408, -1409, -1410, -1411, -1412, -1413, -1414, -1415, -1416, -1417, -1418, -1419, -1420, -1421, -1422, -1423, -1424, -1425, -1426, -1427, -1428, -1429, -1430, -1431, -1432, -1433, -1434, -1435, -1436, -1437, -1438, -1439, -1440, -1441, -1442, -1443, -1444, -1445, -1446, -1447, -1448, -1449, -1450, -1451, -1452, -1453, -1454, -1455, -1456, -1457, -1458, -1459, -1460, -1461, -1462, -1463, -1464, -1465, -1466, -1467, -1468, -1469, -1470, -1471, -1472, -1473, -1474, -1475, -1476, -1477, -1478, -1479, -1480, -1481, -1482, -1483, -1484, -1485, -1486, -1487, -1488, -1489, -1490, -1491, -1492, -1493, -1494, -1495, -1496, -1497, -1498, -1499, -1500, -1501, -1502, -1503, -1504, -1505, -1506, -1507, -1508, -1509, -1510, -1511, -1512, -1513, -1514, -1515, -1516, -1517, -1518, -1519, -1520, -1521, -1522, -1523, -1524, -1525, -1526, -1527, -1528, -1529, -1530, -1531, -1532, -1533, -1534, -1535, -1536, -1537, -1538, -1539, -1540, -1541, -1542, -1543, -1544, -1545, -1546, -1547, -1548, -1549, -1550, -1551, -1552, -1553, -1554, -1555, -1556, -1557, -1558, -1559, -1560, -1561, -1562, -1563, -1564, -1565, -1566, -1567, -1568, -1569, -1570, -1571, -1572, -1573, -1574, -1575, -1576, -1577, -1578, -1579, -1580, -1581, -1582, -1583, -1584, -1585, -1586, -1587, -1588, -1589, -1590, -1591, -1592, -1593, -1594, -1595, -1596, -1597, -1598, -1599, -1600, -1601, -1602, -1603, -1604, -1605, -1606, -1607, -1608, -1609, -1610, -1611, -1612, -1613, -1614, -1615, -1616, -1617, -1618, -1619, -1620, -1621, -1622, -1623, -1624, -1625, -1626, -1627, -1628, -1629, -1630, -1631, -1632, -1633, -1634, -1635, -1636, -1637, -1638, -1639, -1640, -1641, -1642, -1643, -1644, -1645, -1646, -1647, -1648, -1649, -1650, -1651, -1652, -1653, -1654, -1655, -1656, -1657, -1658, -1659, -1660, -1661, -1662, -1663, -1664, -1665, -1666, -1667, -1668, -1669, -1670, -1671, -1672, -1673, -1674, -1675, -1676, -1677, -1678, -1679, -1680, -1681, -1682, -1683, -1684, -1685, -1686, -1687, -1688, -1689, -1690, -1691, -1692, -1693, -1694, -1695, -1696, -1697, -1698, -1699, -1700, -1701, -1702, -1703, -1704, -1705, -1706, -1707, -1708, -1709, -1710, -1711, -1712, -1713, -1714, -1715, -1716, -1717, -1718, -1719, -1720, -1721, -1722, -1723, -1724, -1725, -1726, -1727, -1728, -1729, -1730, -1731, -1732, -1733, -1734, -1735, -1736, -1737, -1738, -1739, -1740, -1741, -1742, -1743, -1744, -1745, -1746, -1747, -1748, -1749, -1750, -1751, -1752, -1753, -1754, -1755, -1756, -1757, -1758, -1759, -1760, -1761, -1762, -1763, -1764, -1765, -1766, -1767, -1768, -1769, -1770, -1771, -1772, -1773, -1774, -1775, -1776, -1777, -1778, -1779, -1780, -1781, -1782, -1783, -1784, -1785, -1786, -1787, -1788, -1789, -1790, -1791, -1792, -1793, -1794, -1795, -1796, -1797, -1798, -1799, -1800, -1801, -1802, -1803, -1804, -1805, -1806, -1807, -1808, -1809, -1810, -1811, -1812, -1813, -1814, -1815, -1816, -1817, -1818, -1819, -1820, -1821, -1822, -1823, -1824, -1825, -1826, -1827, -1828, -1829, -1830, -1831, -1832, -1833, -1834, -1835, -1836, -1837, -1838, -1839, -1840, -1841, -1842, -1843, -1844, -1845, -1846, -1847, -1848, -1849, -1850, -1851, -1852, -1853, -1854, -1855, -1856, -1857, -1858, -1859, -1860, -1861, -1862, -1863, -1864, -1865, -1866, -1867, -1868, -1869, -1870, -1871, -1872, -1873, -1874, -1875, -1876, -1877, -1878, -1879, -1880, -1881, -1882, -1883, -1884, -1885, -1886, -1887, -1888, -1889, -1890, -1891, -1892, -1893, -1894, -1895, -1896, -1897, -1898, -1899, -1900, -1901, -1902, -1903, -1904, -1905, -1906, -1907, -1908, -1909, -1910, -1911, -1912, -1913, -1914, -1915, -1916, -1917, -1918, -1919, -1920, -1921, -1922, -1923, -1924, -1925, -1926, -1927, -1928, -1929, -1930, -1931, -1932, -1933, -1934, -1935, -1936, -1937, -1938, -1939, -1940, -1941, -1942, -1943, -1944, -1945, -1946, -1947, -1948, -1949, -1950, -1951, -1952, -1953, -1954, -1955, -1956, -1957, -1958, -1959, -1960, -1961, -1962, -1963, -1964, -1965, -1966, -1967, -1968, -1969, -1970, -1971, -1972, -1973, -1974, -1975, -1976, -1977, -1978, -1979, -1980, -1981, -1982, -1983, -1984, -1985, -1986, -1987, -1988, -1989, -1990, -1991, -1992, -1993, -1994, -1995, -1996, -1997, -1998, -1999, -2000, -2001, -2002, -2003, -2004, -2005, -2006, -2007, -2008, -2009, -2010, -2011, -2012, -2013, -2014, -2015, -2016, -2017, -2018, -2019, -2020, -2021, -2022, -2023, -2024, -2025, -2026, -2027, -2028, -2029, -2030, -2031, -2032, -2033, -2034, -2035, -2036, -2037, -2038, -2039, -2040, -2041, -2042, -2043, -2044, -2045, -2046, -2047, -2048, -2049, -2050, -2051, -2052, -2053, -2054, -2055, -2056, -2057, -2058, -2059, -2060, -2061, -2062, -2063, -2064, -2065, -2066, -2067, -2068, -2069, -2070, -2071, -2072, -2073, -2074, -2075, -2076, -2077, -2078, -2079, -2080, -2081, -2082, -2083, -2084, -2085, -2086, -2087, -2088, -2089, -2090, -2091, -2092, -2093, -2094, -2095, -2096, -2097, -2098, -2099, -2100, -2101, -2102, -2103, -2104, -2105, -2106, -2107, -2108, -2109, -2110, -2111, -2112, -2113, -2114, -2115, -2116, -2117, -2118, -2119, -2120, -2121, -2122, -2123, -2124, -2125, -2126, -2127, -2128, -2129,

**Figure 9.3-19 Deleted by Amendment 52 (Sheets 1 through 3)**

Figure 9.3-20 Deleted by Amendment 95

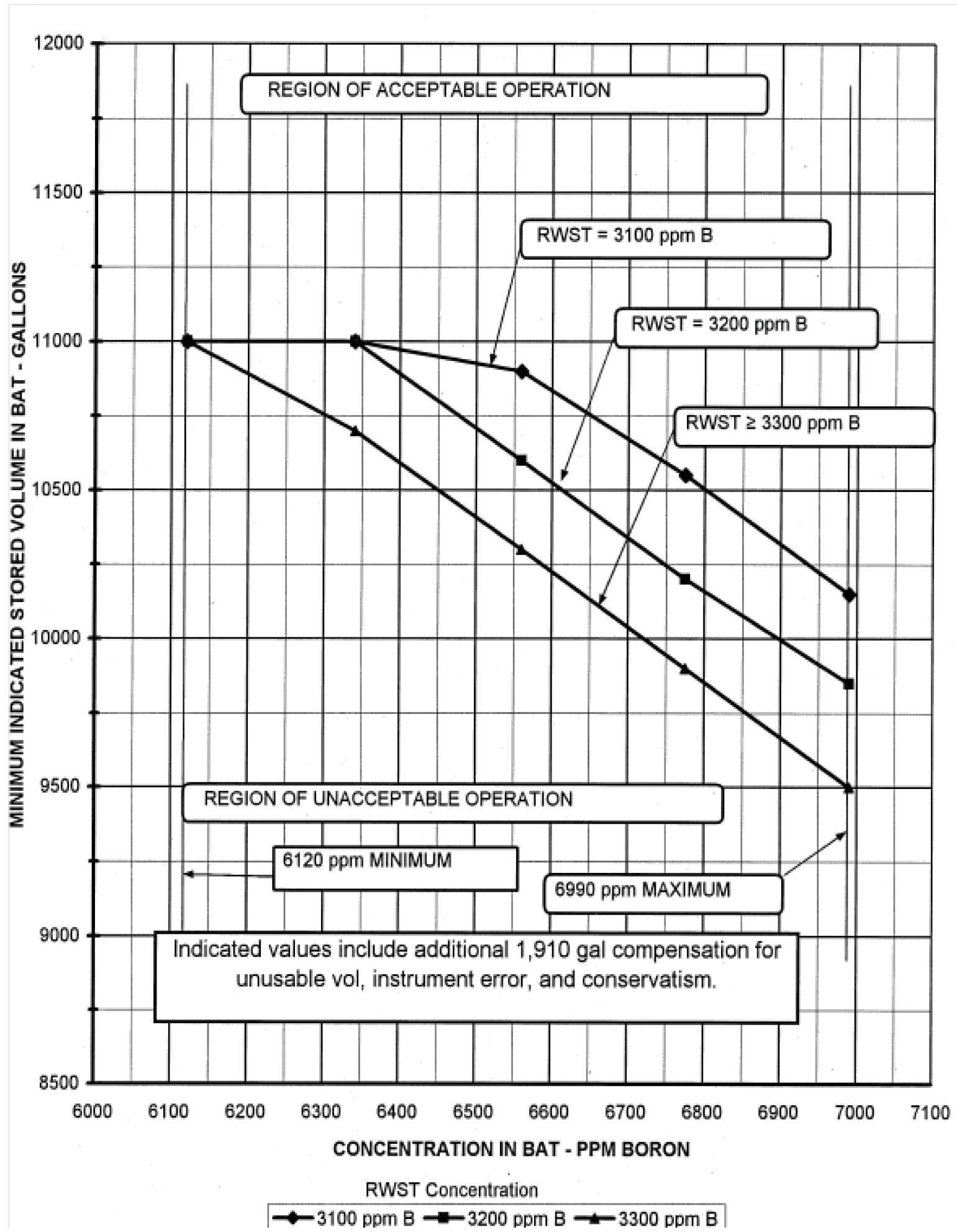

Figure 9.3-21 Watts Bar Nuclear Plant Boric Acid Tank Limits