

Revised by Amendment 33.

<b>WATTS BAR NUCLEAR PLANT FINAL SAFETY ANALYSIS REPORT</b>
INDEX MAP - EARTHQUAKES 6.3 RICHTER OR GREATER LATITUDE 30-37 NORTH LONGITUDE 78-92 WEST
Figure 2.5-181

Figure 2.5-181 Index Map -Earthquakes 6.3 Richter or Greater Latitude 30-37 North Longitude 78-92 West

SEISMIC HISTORY OF THE SOUTHEAST REGION OF THE UNITED STATES

THIS IS A CHRONOLOGICAL LISTING OF ALL EARTHQUAKES HAVING EPICENTERS IN THE RECTANGULAR PORTION OF THE SOUTH-EAST REGION BOUNDED BY THE FOLLOWING GEODETIC COORDINATE LINES --

- SOUTHERN BOUNDARY - 30.0 -DEGREE NORTH LATITUDE
- NORTHERN BOUNDARY - 37.0 -DEGREE NORTH LATITUDE
- EASTERN BOUNDARY - 78.0 -DEGREE WEST LONGITUDE
- WESTERN BOUNDARY - 92.0 -DEGREE WEST LONGITUDE

AND HAVING A RICHTER SCALE MAGNITUDE EQUAL TO OR GREATER THAN 6.3

YEAR	DATE	TIME-HR-MIN-SEC	LAT - LONG	LOCALITY AND NOTES	FELT-SQ.MI.	MAG/INT	REFERENCES
1811	DEC 16	8 0 0.0	(36.6 89.6)	NEW MADRID, MO-FELT EXTENSIVELY EASTWARD, PERHAPS THE STRONGEST EVER IN U.S., LIMITED DAMAGE BECAUSE POP. SPARCE, INTENSITY-XII	2000000		ABCD -5,6
1812	JAN 23	15 0 0.0	(36.6 89.6)	NEW MADRID, MO-SECOND MAIN SHOCK OF SERIES, INTENSITY-XII	2000000		ABCD-5,6
1812	FEB 7	9 45 0.0	(36.6 89.6)	NEW MADRID, MO-THIRD MAIN SHOCK OF SERIES, INTENSITY-XII			ABCD-5,6
1886	SEP 1	2 51 0.0	(32.9 80.0)	FIFTEEN MILES NW OF CHARLESTON, SC-ONE OF STRONGEST EVER TO OCCUR IN U.S., EXTENSIVE DAMAGE, INTENSITY X	2000000		ABCD-5,6,8
1886	SEP 1	2 59 0.0	(32.9 80.0)	CHARLESTON, SC-2ND MAIN SHOCK, INT-X	2000000		ABCD-5,6,8
1886	SEP 1	5 5 0.0	(32.9 80.0)	CHARLESTON-AFTERSHOCK			-14
1895	OCT 31	11 8 0.0	(37.0 89.4)	NEAR CHARLESTON, MO-4 ACRES OF GROUND SANK FORMING A LAKE, CONSIDERABLE DAMAGE AT CAIRO, ILL, FELT EXTENSIVELY EASTWARD	1000000	VIII-IX	ACD-6,5
1905	JAN 27	0 0 0.0	(34.0 86.0)	NEAR GADSDEN, ALA	250000	VIII	ACD-6,5
1905	JAN 28	0 0 0.0	(34.0 86.0)	GADSDEN-SECOND SHOCK	250000	VIII	ACD-6,5

Revised by Amendment 33.

<p><b>WATTS BAR NUCLEAR PLANT FINAL SAFETY ANALYSIS REPORT</b></p>
<p>EARTHQUAKE LISTING 6.3 RICHTER OR GREATER LATITUDE 30-37 NORTH LONGITUDE 78-92 WEST SHEET 1 OF 1 Figure 2.5-182</p>

Figure 2.5-182 Earthquakes Listing 6.3 Richter Or Greater Latitude 30-37 Longitude 78-92 West

LIST OF REFERENCES  
-----

1. US COAST AND GEODETIC SURVEY, UNITED STATES EARTHQUAKES 1928-1935 (COLLECTED ANNUAL REPORTS)
2. US COAST AND GEODETIC SURVEY, UNITED STATES EARTHQUAKES 1936-1940 (COLLECTED ANNUAL REPORTS)
3. US COAST AND GEODETIC SURVEY, UNITED STATES EARTHQUAKES 1941-1970 (INDIVIDUAL ANNUAL REPORTS)
4. US COAST AND GEODETIC SURVEY, SUMMARY OF PRELIMINARY DETERMINATION OF EPICENTERS 1968-1973 (MONTHLY SUMMARY OF SEISMIC EVENTS LISTED ON PDE CARDS)
5. US COAST AND GEODETIC SURVEY, EARTHQUAKE HISTORY OF THE UNITED STATES, PTI-STRONGER EARTHQUAKES OF THE UNITED STATES, ESSA BULL NO. 41-1 (1965)
6. MONEYSMAKER, BERLEN C., EARTHQUAKES IN TENNESSEE AND NEARBY SECTIONS OF NEIGHBORING STATES. J TENN ACAD SCI. PT1 (1699-1850)-V 29, N 3, JULY, 1954, P. 224-233. PT2 (1851-1900)-V 30, N 3, JULY, 1955, P. 222-233. PT3 (1901-1925)-V 32, N 2, APR, 1957, P. 91-105. PT4 (1926-1950)-V 33, N 3, JULY, 1958, P. 224-239.
7. WOOLLARD, GEORGE P., A CATALOGUE OF EARTHQUAKES IN THE UNITED STATES PRIOR TO 1925 - BASED ON UNPUBLISHED DATA COMPILED BY HARRY F RIED AND PUBLISHED SOURCES PRIOR TO 1930. DATA RPT N. 10, HIG-68-9, HAWAII INST GEOPHYSICS, UNIV. HAWAII, 1968.
8. CAMPBELL, R. B., EARTHQUAKES IN FLORIDA, PROC FLA ACAD SCI, V 6, N 1, P. 1-4, 1943.
9. BOLLINGER, G. A., SEISMICITY OF THE CENTRAL APPALACHIAN STATES OF VIRGINIA, WEST VIRGINIA, AND MARYLAND -1758 THROUGH 1968, BULL SEIS SOC AM, V 59, N 5, P. 2103-11, OCT 1969.
10. MACCARTHY, G. R., THREE FORGOTTEN EARTHQUAKES, BULL SEIS SOC AM, V 59, N 3, P 687-92, APRIL, 1963.
11. SEISMOLOGICAL NOTES SECTION OF BULL SEIS SOC AM FOR THE APPROPRIATE PERIOD.
12. STATION -ORT- SEISMOGRAPH RECORDS.
13. BOLLINGER, G. A., HISTORICAL AND RECENT SEISMIC ACTIVITY IN SOUTH CAROLINA, BULL SEIS SOC AM, V 62, N 3, P. 851-64, JUNE 1972.
14. TABER, STEPHEN, SEISMIC ACTIVITY IN THE ATLANTIC COASTAL PLAIN NEAR CHARLESTON, SOUTH CAROLINA, BULL SEIS SOC AM, V 4, N 3, P. 108-160, SEPT 1914.
15. BOLLINGER, G. A., SEISMICITY OF THE SOUTHEASTERN UNITED STATES, BULL SEIS SOC AM, V 63, N 5, P. 1785-1808, OCT 1973.
16. NATIONAL OCEANIC AND ATMOSPHERIC ADMINISTRATION, EARTHQUAKE HISTORY OF THE UNITED STATES, PUBLICATION 41-1 (REVISED), 1937.
17. USGS-NATIONAL EARTHQUAKE INFORMATION SERVICE PUBLICATIONS OF PRELIMINARY DETERMINATION OF EPICENTERS (PDE) AND EARTHQUAKE DATA REPORT (EDR) FOR THE APPROPRIATE PERIOD.

WATTS BAR NUCLEAR PLANT  
FINAL SAFETY  
ANALYSIS REPORT

EARTHQUAKE LISTING  
LIST OF REFERENCES

Figure 2.5-183

Figure 2.5-183 Earthquake Listing List of References

THE FOLLOWING NOTES APPLY TO VARIOUS SYMBOLS AND CODE LETTERS USED IN THE EARTHQUAKE LIST

---

ALL DATES AND TIMES ARE GIVEN IN GREENWICH MEAN TIME.

FOR THE EVENTS PRIOR TO 1928, ZEROS IN THE SEC, MIN, OR HOUR COLUMNS MEANS THAT THE TIME OF THE EVENT IS NOT ACCURATELY KNOWN.

PARENTHESIS AROUND THE COORDINATES OF THE EPICENTER INDICATES THE LOCATION OF AN ISOLATED FELT REPORT OR THE APPROXIMATE CENTER OF THE REPORTED FELT AREA AND THAT THE EVENT WAS NOT INSTRUMENTALLY LOCATED.

IN THE -MAG/INT- COLUMN, THE RICHTER MAGNITUDE OF THE EARTHQUAKE IS GIVEN IN ARABIC NUMBERS WITH A DECIMAL POINT. IF THE MAGNITUDE IS NOT AVAILABLE, THE ESTIMATED INTENSITY, ON THE MODIFIED MERCALLI SCALE, IS GIVEN IN ROMAN NUMERALS. IF NEITHER OF THESE MEASURES OF THE SIZE OF THE EARTHQUAKE ARE AVAILABLE, THIS COLUMN IS LEFT BLANK.

THE FIRST NUMBERED REFERENCE CITED IN THE REFERENCE LIST CONTAINS THE BEST DESCRIPTION AND MOST COMPLETE DISCUSSION OF THE VARIOUS EFFECTS OF THAT EARTHQUAKE. SOME OF THE EFFECTS AND CHARACTERISTICS ARE SUMMARIZED USING THE LETTER CODES BELOW.

- A- INDICATES THAT THIS EARTHQUAKE WAS FOLLOWED BY AN AFTERSHOCK SEQUENCE, THE INDIVIDUAL EVENTS OF WHICH ARE NOT INCLUDED IN THE LISTING UNLESS THEY ARE IDENTIFIED AS SUCH.
- B- INDICATES THAT VARIOUS RUMBLINGS, GROANS, AND OTHER EARTH NOISES WERE REPORTED ACCOMPANYING THE EARTHQUAKE.
- C- INDICATES THAT VISIBLE TOPOGRAPHIC CHANGES OCCURRED AS A RESULT OF THE EARTHQUAKE.
- D- INDICATES DAMAGE OR CHANGES TO STRUCTURES SUCH AS CHIMNEYS THROWN DOWN, CONCRETE OR PLASTER CRACKED, MOVEMENT OF FURNITURE OR FIXTURES, ETC.
- F- INDICATES A SHARPLY FELT LOCAL SHOCK.

<b>WATTS BAR NUCLEAR PLANT FINAL SAFETY ANALYSIS REPORT</b>
EARTHQUAKE LISTING NOTES  Figure 2.5-184

Figure 2.5-184 Earthquake Listing Notes

Figure 2.5-185 Yard Soil Borings Location Plan

Figure 2.5-185a Yard Soil Borings Location Plan

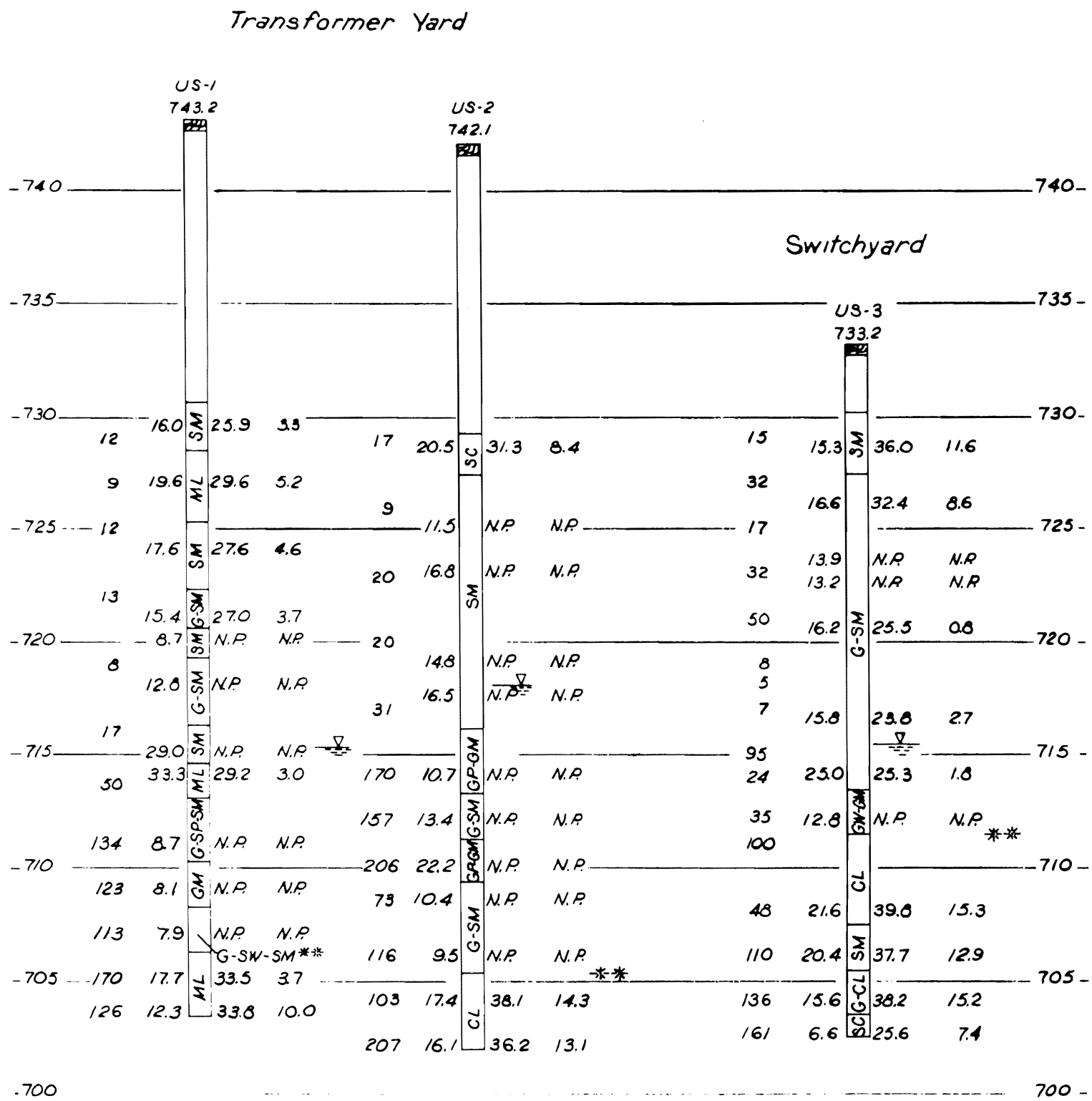

Symbols

- Watertable
- Topsoil

LEGEND

Hole No.	Elev.	* Blows	Natural Moisture Content	Liquid Limit	Plasticity Index	Classification
US-1	743.2					
US-2	742.1					
US-3	733.2					

Scale 1"=5' Before Reduction

\* Blows per foot with a 140lb. hammer and a 30 inch drop on a 2 inch OD splitspoon.  
 \*\* Top of weathered shale

WATTS BAR NUCLEAR PLANT  
 FINAL SAFETY  
 ANALYSIS REPORT

---

TRANSFORMER YARD & SWITCHYARD  
 SOIL INVESTIGATION

Figure 2.5-186

Figure 2.5-186 Transformer Yard & Switchyard Soil Investigation

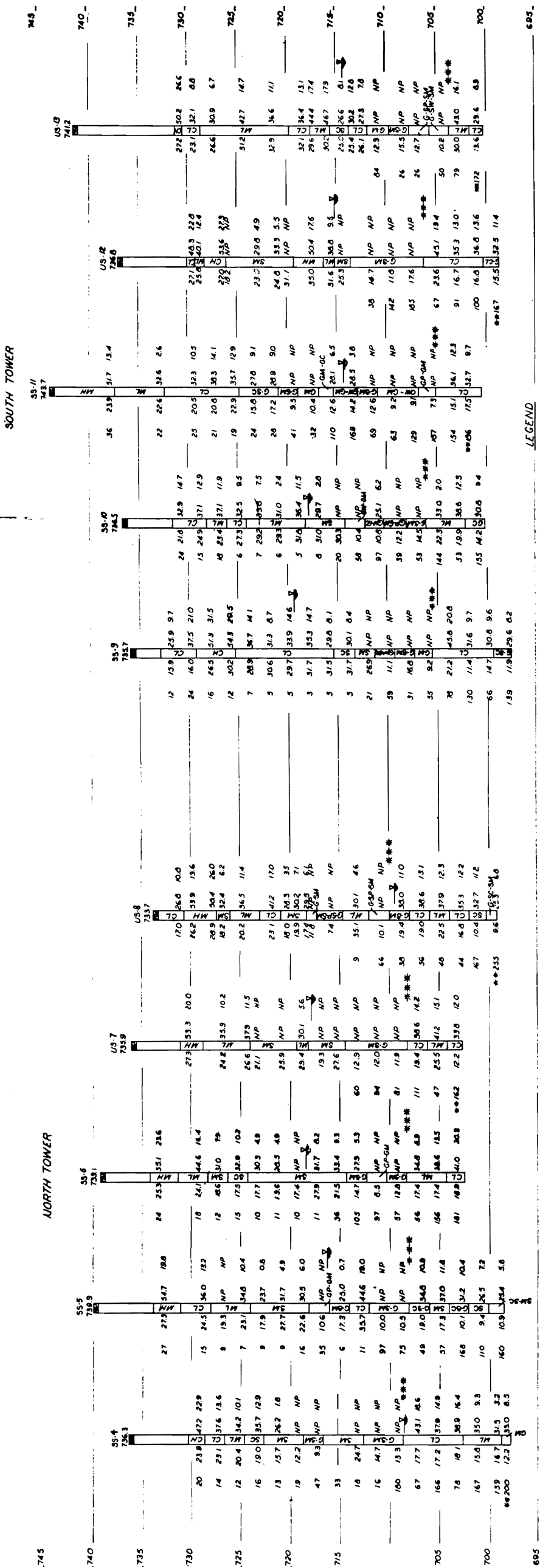

WATTS BAR NUCLEAR PLANT  
FINAL SAFETY  
ANALYSIS REPORT

COOLING TOWERS SOIL INVESTIGATION

Figure 2.5-187

**SYMBOLS**  
Topsoil  
Water table  
Blows  
Natural Moisture Content  
Clay Content  
Liquid Limit  
Plasticity Index

Moisture No.  
Blow No.  
Blows per foot with a MOIS hammer  
and a 30-inch drop on a 2-inch OD  
split/spoon.  
Blows with less than one foot penetration  
Top of undisturbed shale

Figure 2.5-187 Cooling Towers Soil Investigation



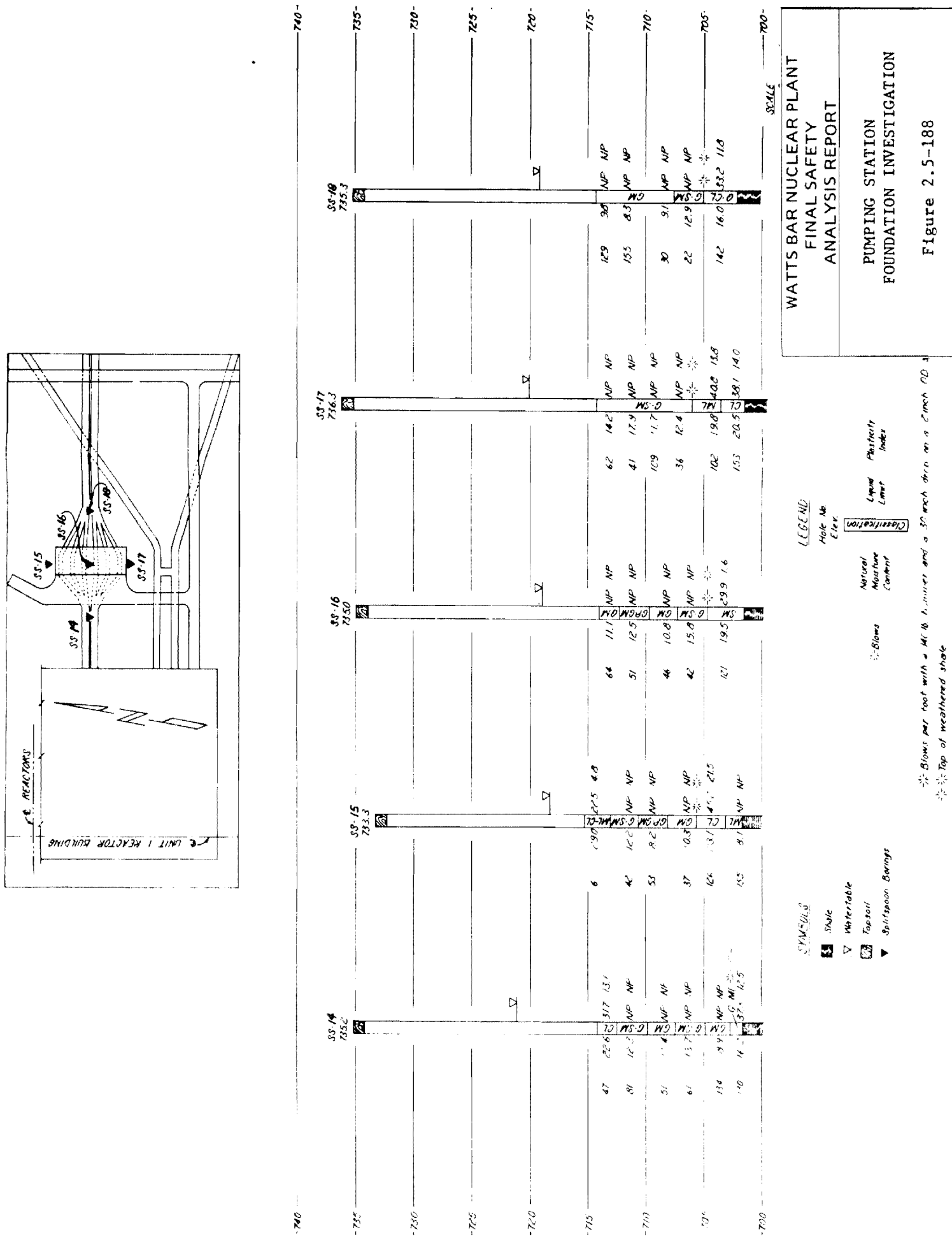

Figure 2.5-188 Pumping Station Foundation Investigation

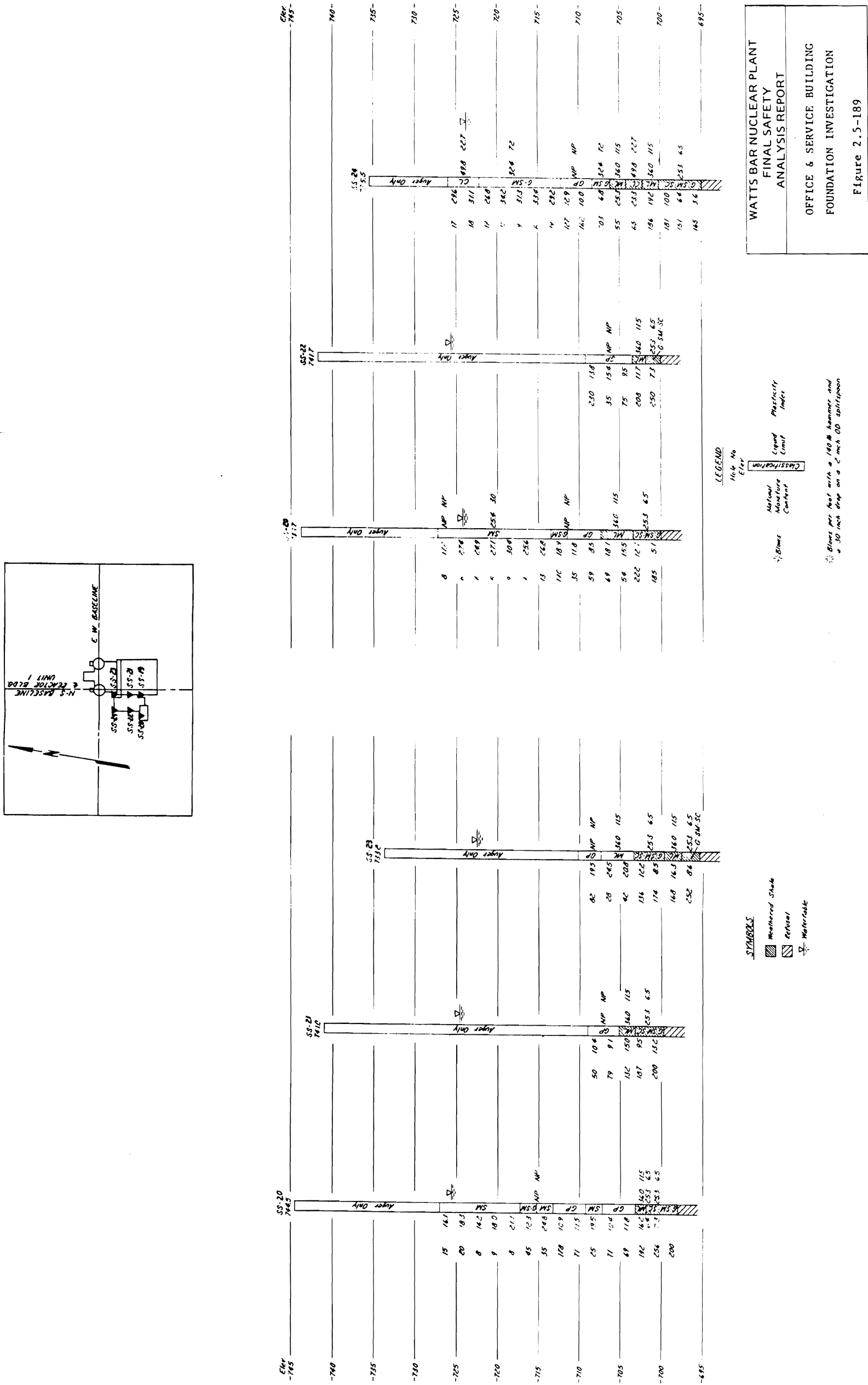
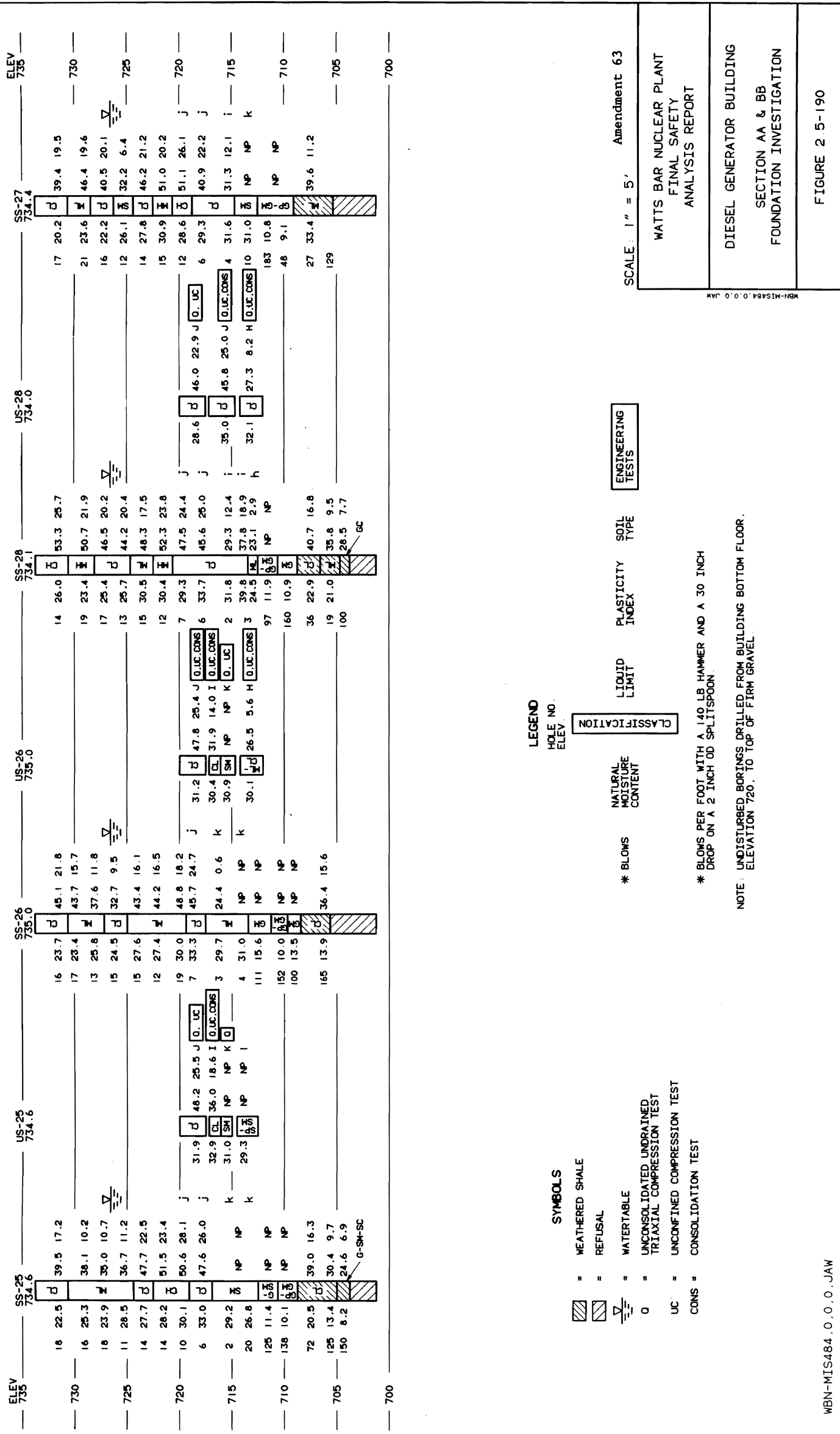

Figure 2.5-189 Office & Service Building Foundation Investigation



**SYMBOLS**

- = WEATHERED SHALE
- = REFUSAL
- = WATERTABLE
- = UNCONSOLIDATED UNDRAINED TRIAXIAL COMPRESSION TEST
- = UNCONFINED COMPRESSION TEST
- = CONSOLIDATION TEST

**LEGEND**

HOLE NO.  
ELEV.

**CLASSIFICATION**

**NATURAL MOISTURE CONTENT**

**LIQUID LIMIT**

**PLASTICITY INDEX**

**SOIL TYPE**

**ENGINEERING TESTS**

\* BLOWS

\* BLOWS PER FOOT WITH A 140 LB HAMMER AND A 30 INCH DROP ON A 2 INCH OD SPLITSPOON.

NOTE: UNDISTURBED BORINGS DRILLED FROM BUILDING BOTTOM FLOOR, ELEVATION 720, TO TOP OF FIRM GRAVEL.

SCALE: 1" = 5'

Amendment 63

WATTS BAR NUCLEAR PLANT  
FINAL SAFETY  
ANALYSIS REPORT

DIESEL GENERATOR BUILDING  
SECTION AA & BB  
FOUNDATION INVESTIGATION

FIGURE 2 5-190

WBN-MIS484.0.0.0.JAW

Figure 2.5-190 Diesel Generator Building Sections AA & BB Foundation Investigation

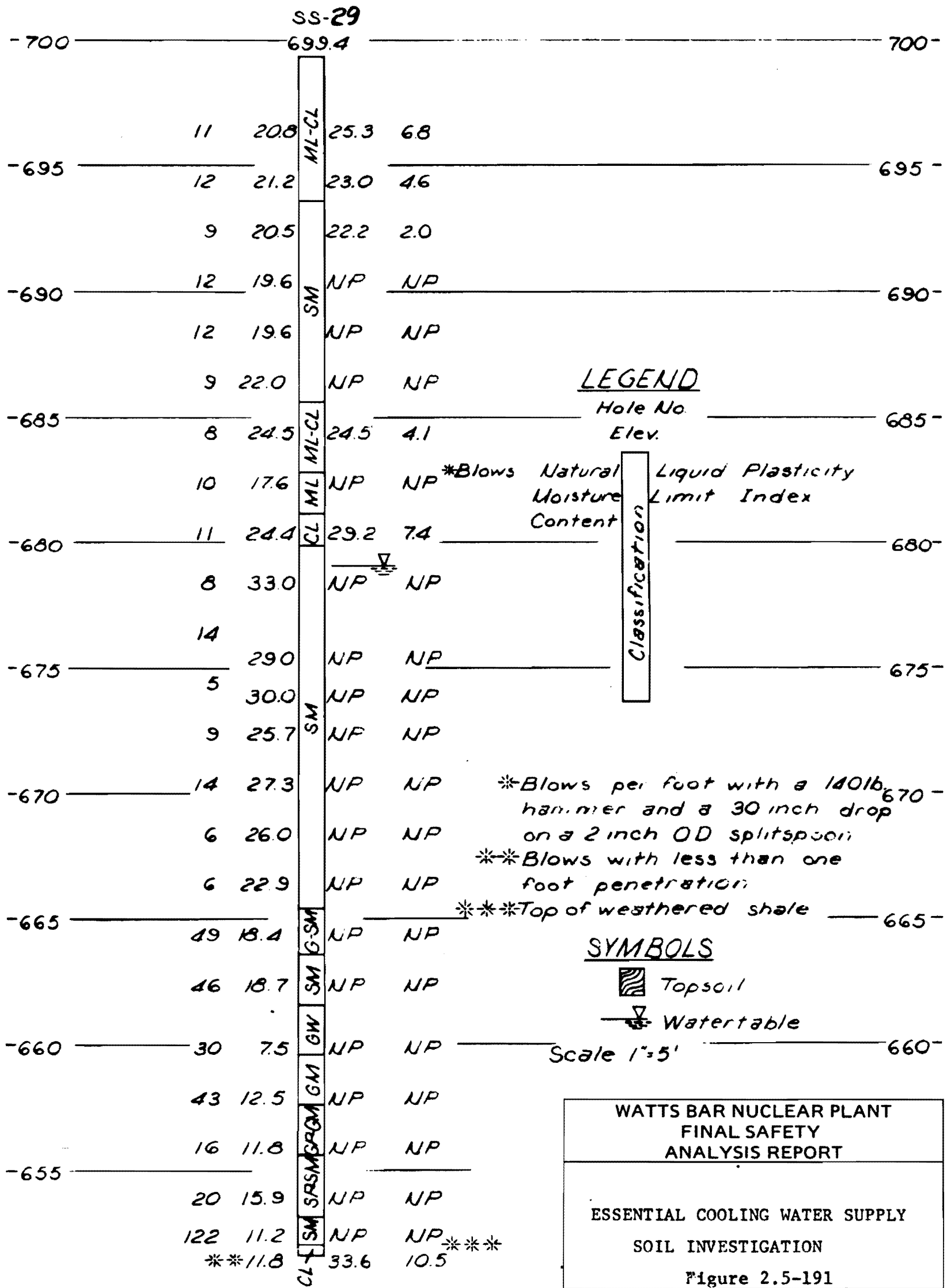
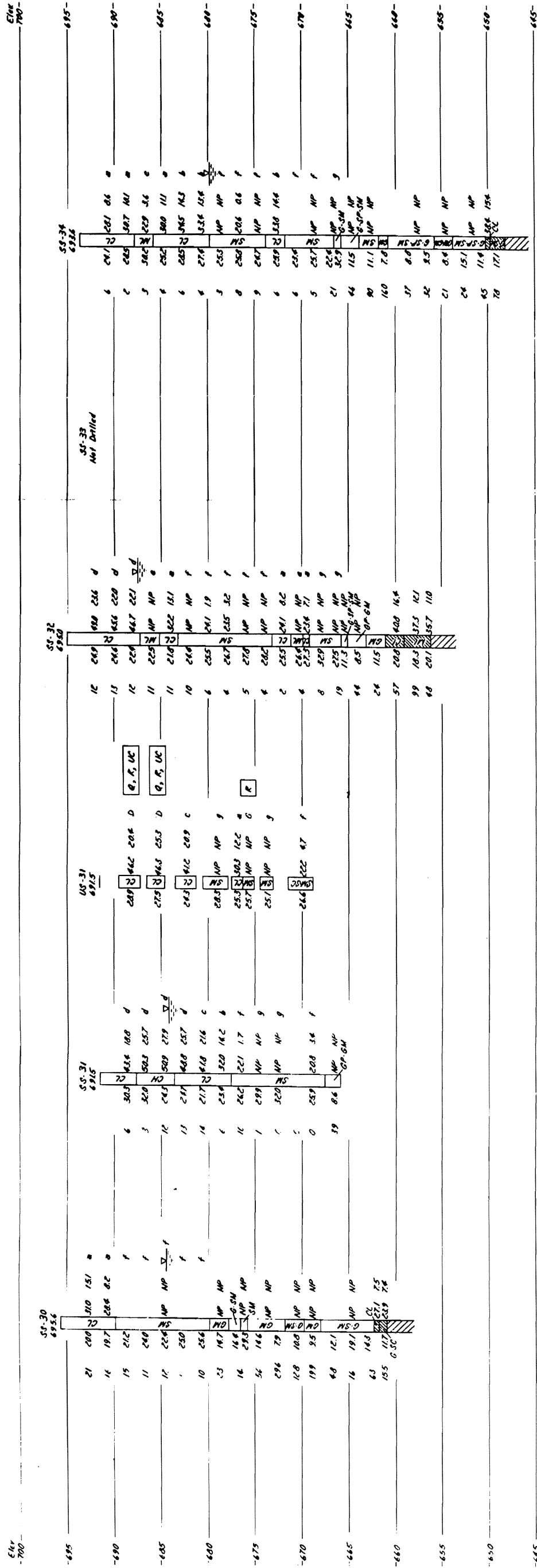

Figure 2.5-191 Essential Cooling Water Supply Soil Investigation



**SYMBOLS**

- Weathered shale
- Refusal
- Water table
- Unconsolidated undrained triaxial compression test
- Consolidated undrained triaxial compression test
- Unconfined compression test

**LEGEND**

- Hole No
- Elev
- Classification
- Natural Moisture Content
- Liquid Limit
- Plasticity Index
- Soil Type
- Engineering Tests

Blows per foot with a 140 lb hammer and a 30 inch drop on a 2 inch OD split spoon

NOTE: Undisturbed sample drilled to top of firm gravel

WATTS BAR NUCLEAR PLANT  
FINAL SAFETY  
ANALYSIS REPORT

INTAKE CHANNEL, SECTION DD  
FOUNDATION INVESTIGATION

Figure 2.5-192

Figure 2.5-192 Intake Channel, Section DD Foundation Investigation

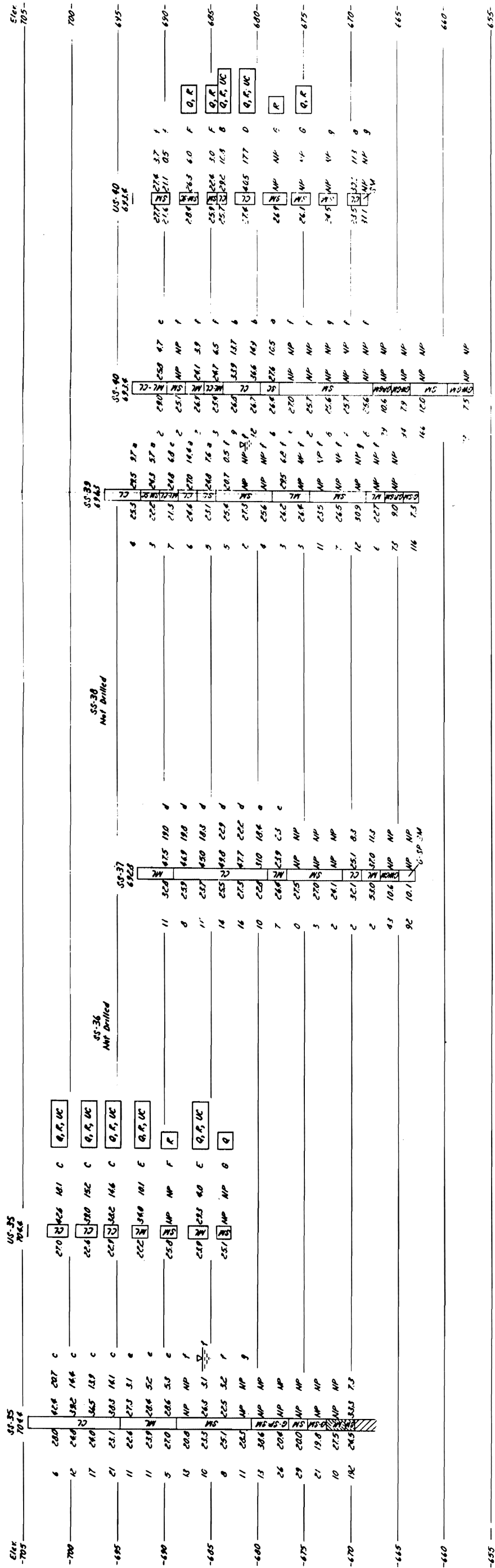

**SYMBOLS**

- Weathered shale
- Refusal
- Undrilled

**LEGEND**

- Blows per foot with a 140 lb hammer and a 30 inch drop on a 2 inch OD splitpen
- UC: Undisturbed brimms drilled to top of firm gravel
- Q: Unconsolidated undrained triaxial compression test
- C: Consolidated undrained triaxial compression test
- UC: Unconfined compression test

WATTS BAR NUCLEAR PLANT  
FINAL SAFETY  
ANALYSIS REPORT

INTAKE CHANNEL, SECTION EE  
FOUNDATION INVESTIGATION  
Figure 2.5-193

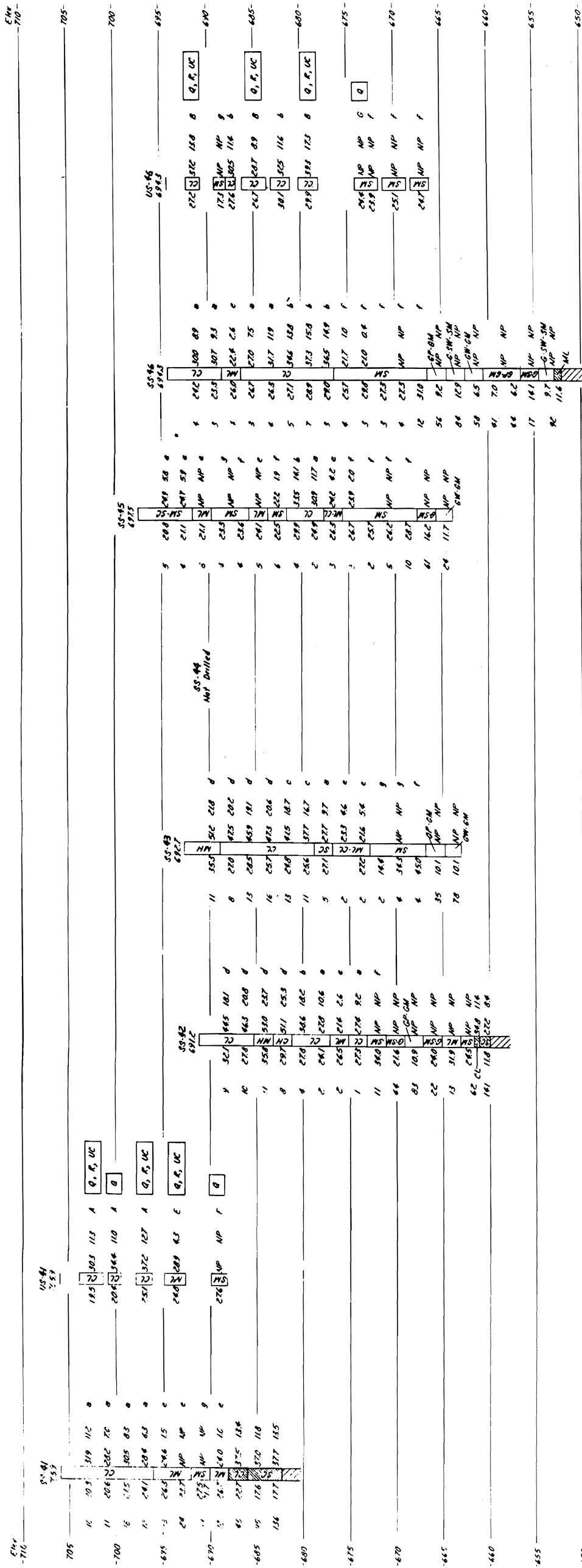

LEGEND

- Blows per foot with a 140 lb hammer and a 30 inch drop on a 2 inch OD splitpen
- Undrilled borings drilled to top of firm gravel

SYMBOLS

- Unconsolidated undrained frictional compression test
- Consolidated undrained frictional compression test
- Unconfined compression test
- Weathered shale
- Refusal

WATTS BAR NUCLEAR PLANT  
FINAL SAFETY  
ANALYSIS REPORT

INTAKE CHANNEL, SECTION CC  
FOUNDATION INVESTIGATION

Figure 2.5-194

Figure 2.5-194 Intake Channel, Section CC Foundation Investigation

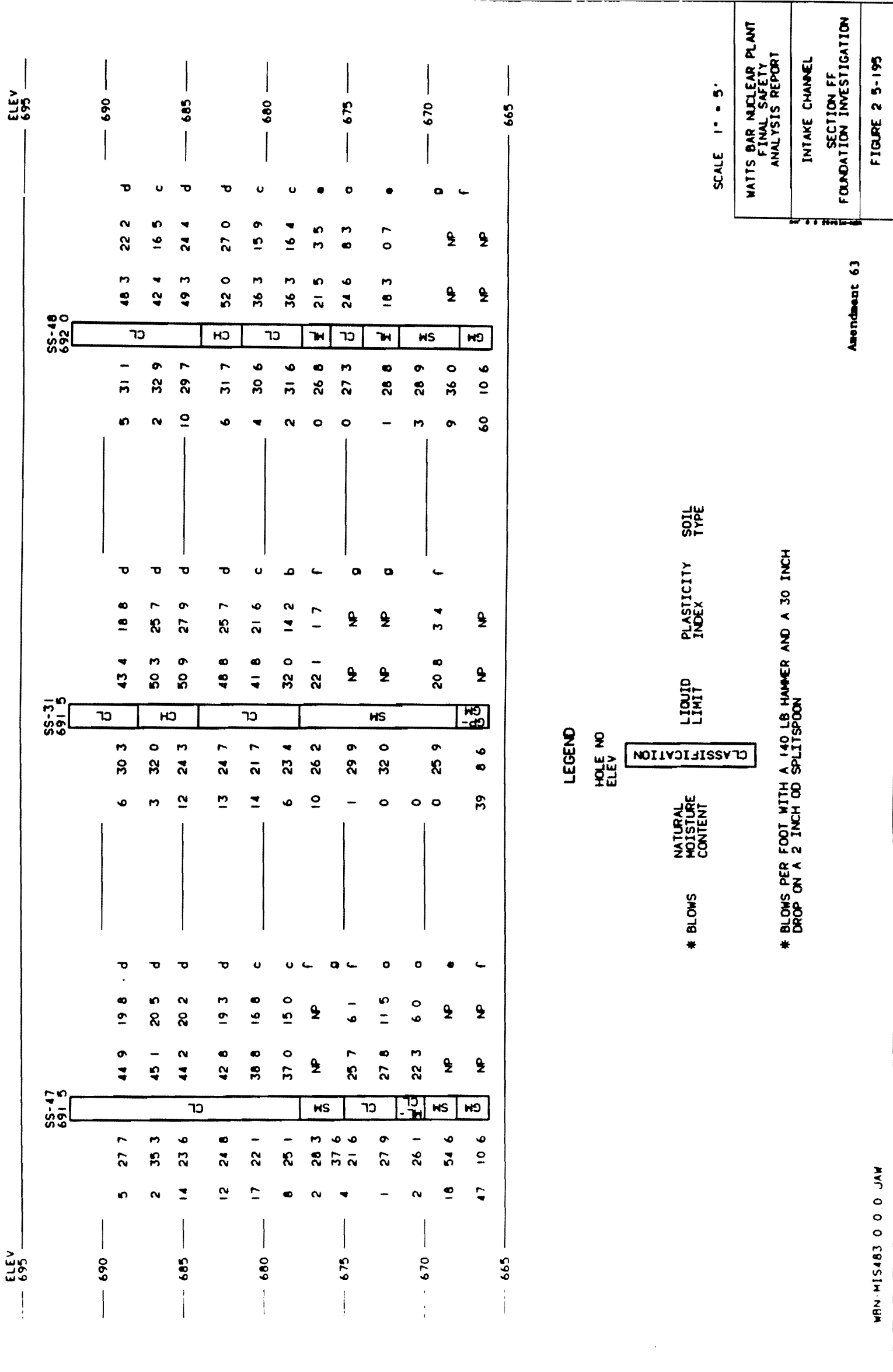

\* BLOWS PER FOOT WITH A 140 LB HAMMER AND A 30 INCH DROP ON A 2 INCH OD SPLITSPOON

LEGEND  
HOLE NO  
ELEV

SCALE 1" = 5'

WATTS BAR NUCLEAR PLANT  
FINAL SAFETY  
ANALYSIS REPORT  
INTAKE CHANNEL  
SECTION FF  
FOUNDATION INVESTIGATION  
FIGURE 2 5-195

Amendment 63

WBN-MIS483 0 0 0 JAW

Figure 2.5-195 Intake Channel, Section FF Foundation Investigation



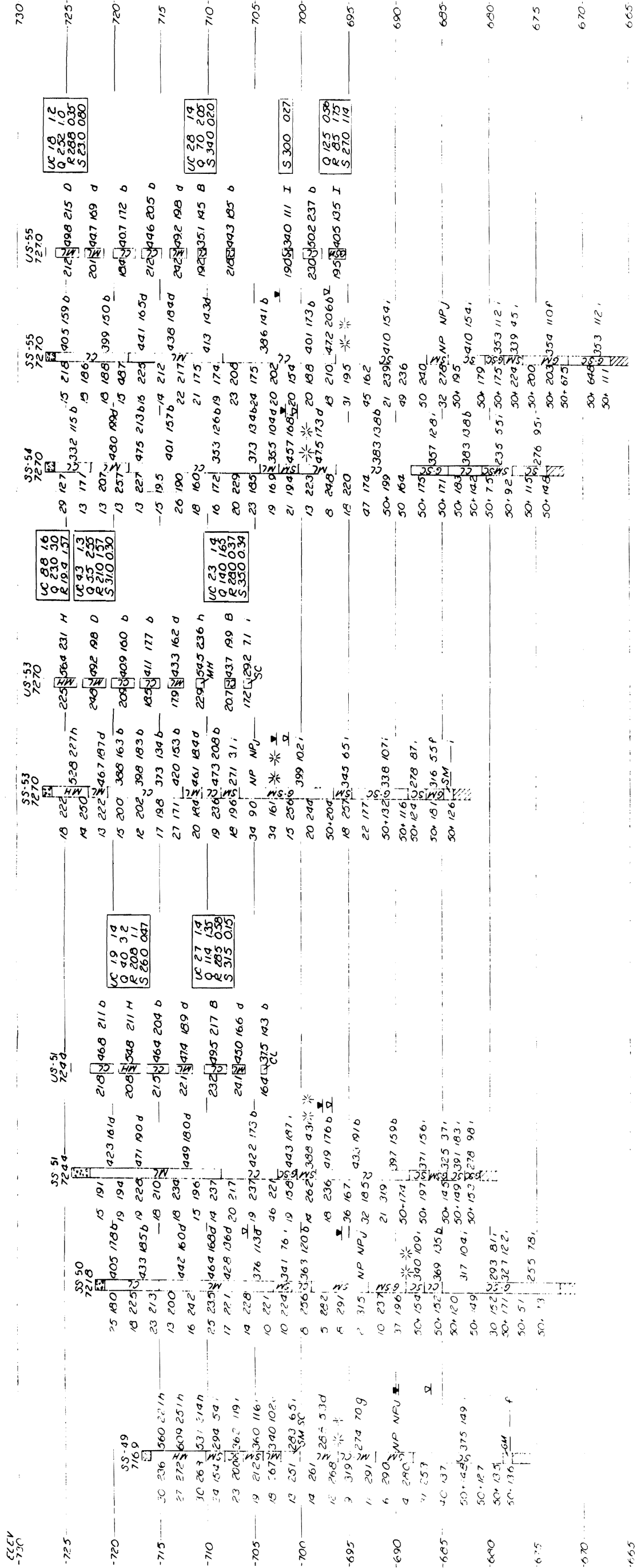

- SYMBOLS**
- ☐ Silty clay
  - ☐ Limestone gravel
  - ☐ Refusal

- LEGEND**
- ☐ Blows per foot with a 140 lb hammer and a 30 inch drop on a 2 inch OD split/spoon sampler.
  - ☐ Top of weathered shale

Friction Angle (degrees)	Cohesion (tsf)	Unconfined Compressive Strength (tsf)	Soil Type
30	111	353	112
50	64	353	112
50	111	353	112

WATTS BAR NUCLEAR PLANT  
FINAL SAFETY  
ANALYSIS REPORT

CLASS IE CONDUITS  
SOIL INVESTIGATION

Figure 2.5-196

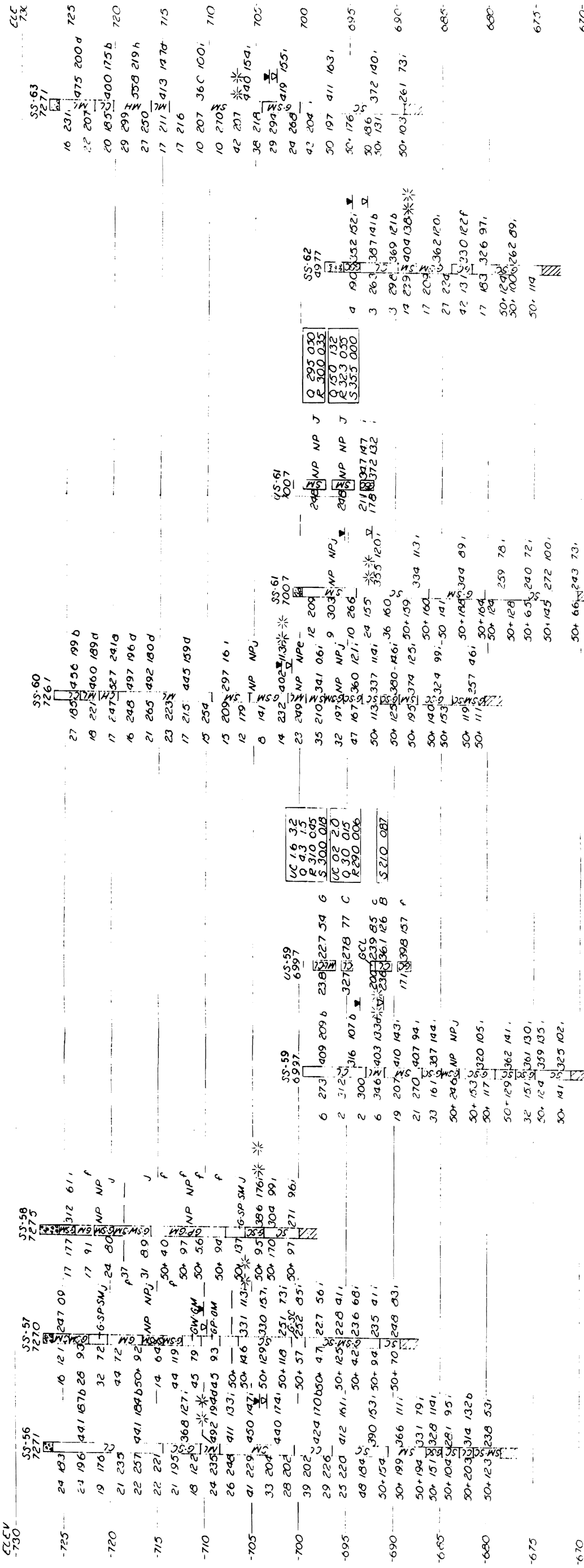

LEGEND

**SYMBOLS**

- Limestone gravel
- Refusal
- Unconsolidated undrained triaxial compression test
- Consolidated undrained triaxial compression test
- Consolidated drained direct shear test
- Unconfined compression test
- 1-hour water table reading
- 24-hour water table reading

**TEST TYPES**

- Friction Angle (degrees) or Unconfined Compressive Strength
- Cohesion (psf) or Sensitivity Ratio

\* Blows per foot with a 140 lb hammer and a 30 inch drop on a 2 inch OD split spoon sample.  
 \* \* Top of weathered shale

WATTS BAR NUCLEAR PLANT  
 FINAL SAFETY  
 ANALYSIS REPORT

---

CLASS IE CONDUITS  
 SOIL INVESTIGATION

Figure 2.5-197

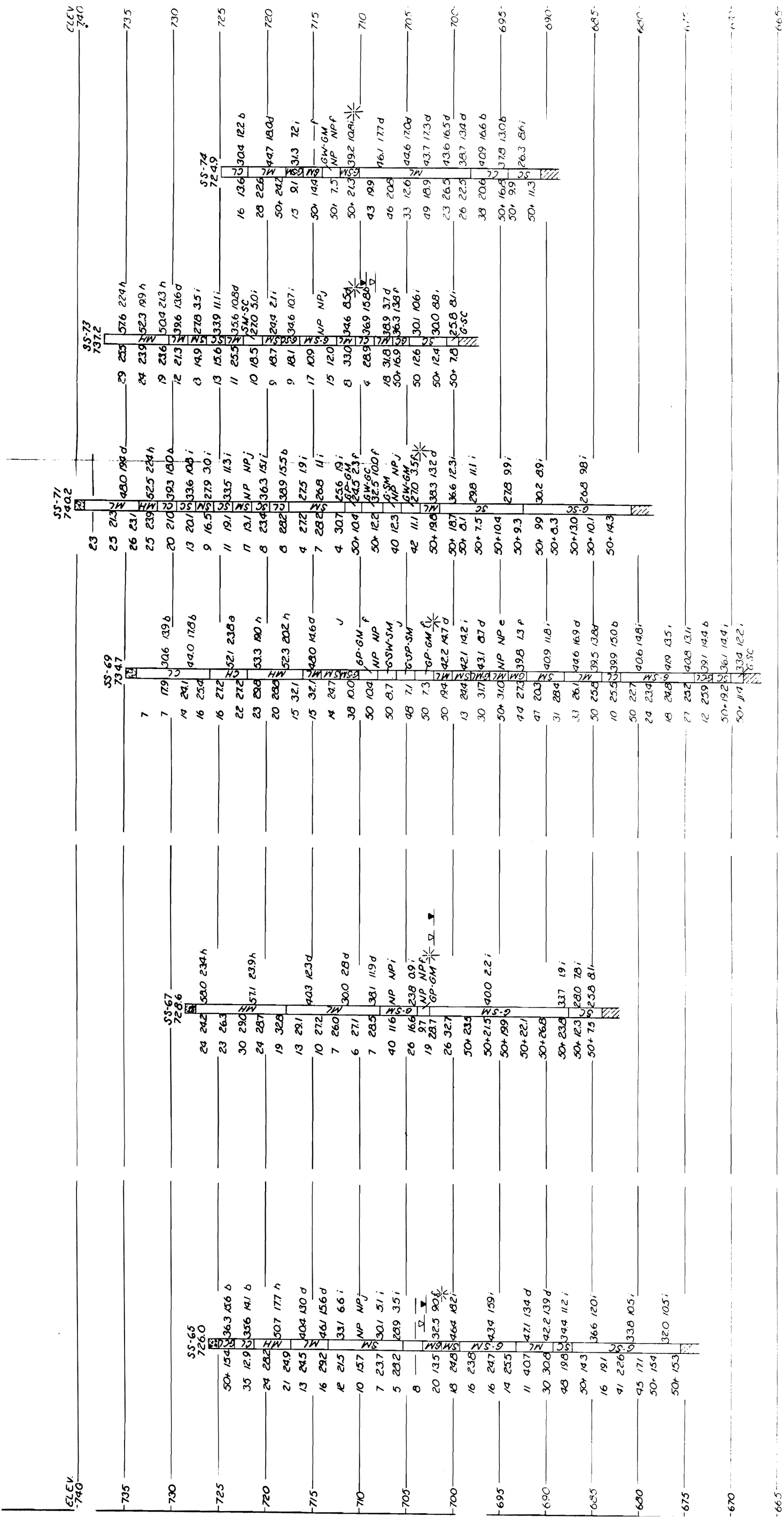

WATTS BAR NUCLEAR PLANT  
FINAL SAFETY  
ANALYSIS REPORT

SOIL INVESTIGATION BORINGS  
FOR ERCW AND HPFP SYSTEMS  
Figure 2.5-198  
Added by Amendment 24

LEGEND

Blows per foot with 140 lb hammer and 30 inch drop on a 2 inch O.O split spoon sampler  
 \* Top of weathered shale

SYMBOLS

Topsoil  
 Limestone gravel  
 Refusal  
 One hour water table reading  
 Twenty four hour water table reading

Note: Blows per foot with 140 lb hammer and 30 inch drop on a 2 inch O.O split spoon sampler.

\* Top of weathered shale

Figure 2.5-198 Soil Investigation Borings For ERCW & HPFP Systems

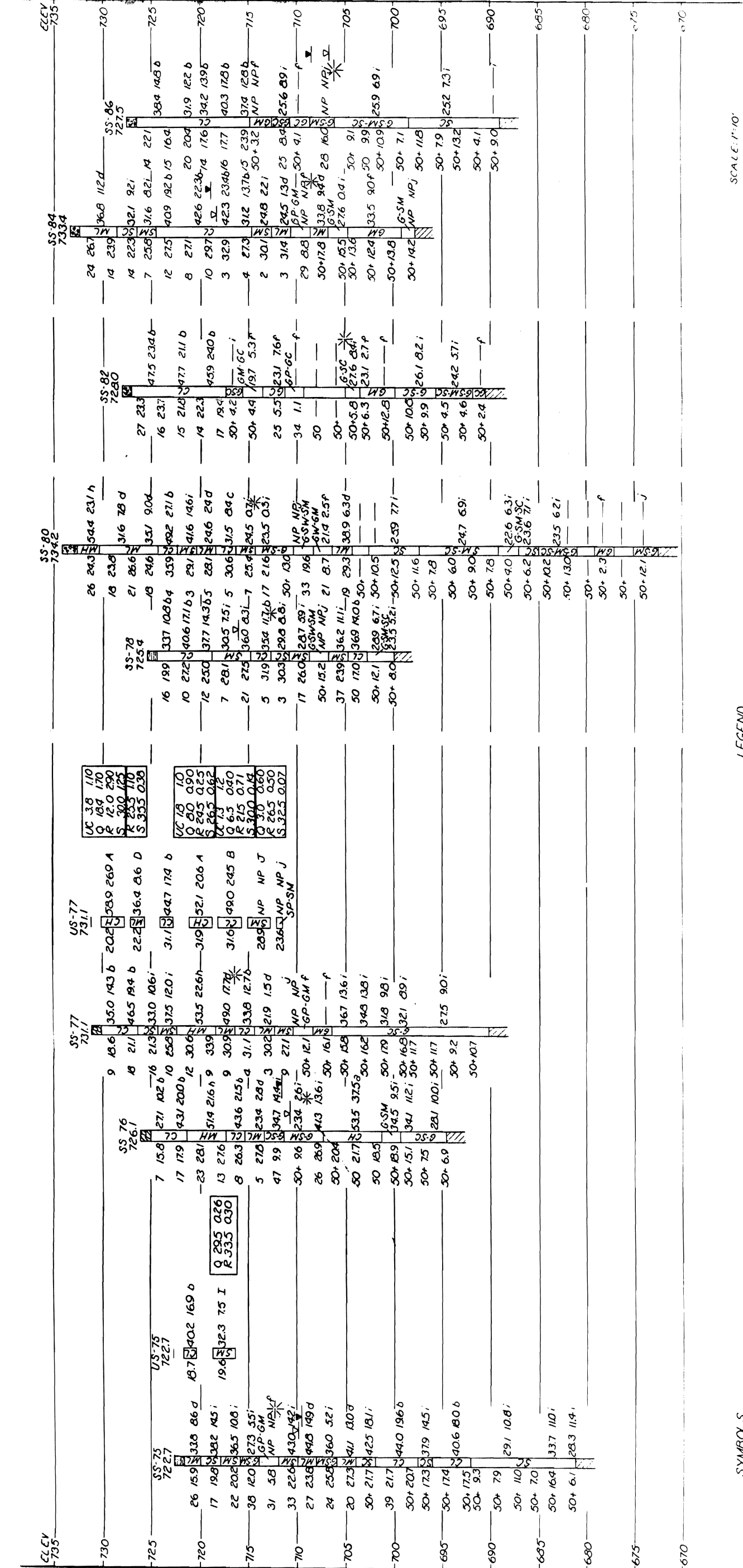

SCALE: 1"=10'

**WATTS BAR NUCLEAR PLANT  
FINAL SAFETY  
ANALYSIS REPORT**

**SOIL INVESTIGATION BORINGS  
FOR ERCW AND HPFP SYSTEMS**  
Figure 2.5-199  
Added by Amendment 24

**LEGEND**

Boring No  
Elevation

Blows

Natural  
Moisture  
Content

Liquid  
Limit

Plasticity  
Index

Soil  
Type

Type  
Test

Friction  
Angle  
(degrees)

or

Unconfined  
Compressive  
Strength  
( $\tau_{cu}$ )

Cohesion  
( $c$ )  
( $\tau_{cu}$ )

Sensitivity  
Ratio

**SYMBOLS**

- Topsoil
- Limestone, gravel
- Clayey silt
- Refusal

Q - Unconsolidated undrained triaxial compression test  
 R - Consolidated undrained triaxial compression test at natural moisture  
 S - Consolidated drained direct shear test  
 UC - Unconfined compression test  
 W - One hour water table reading  
 TW - Twenty-four hour water table reading

\* Top of weathered shale

Note: Blows per foot with a 140 lb hammer and a 30 inch drop on a 2 inch OD splitspoon sampler

Figure 2.5-199 Soil Investigation Borings For ERCW & HPFP Systems

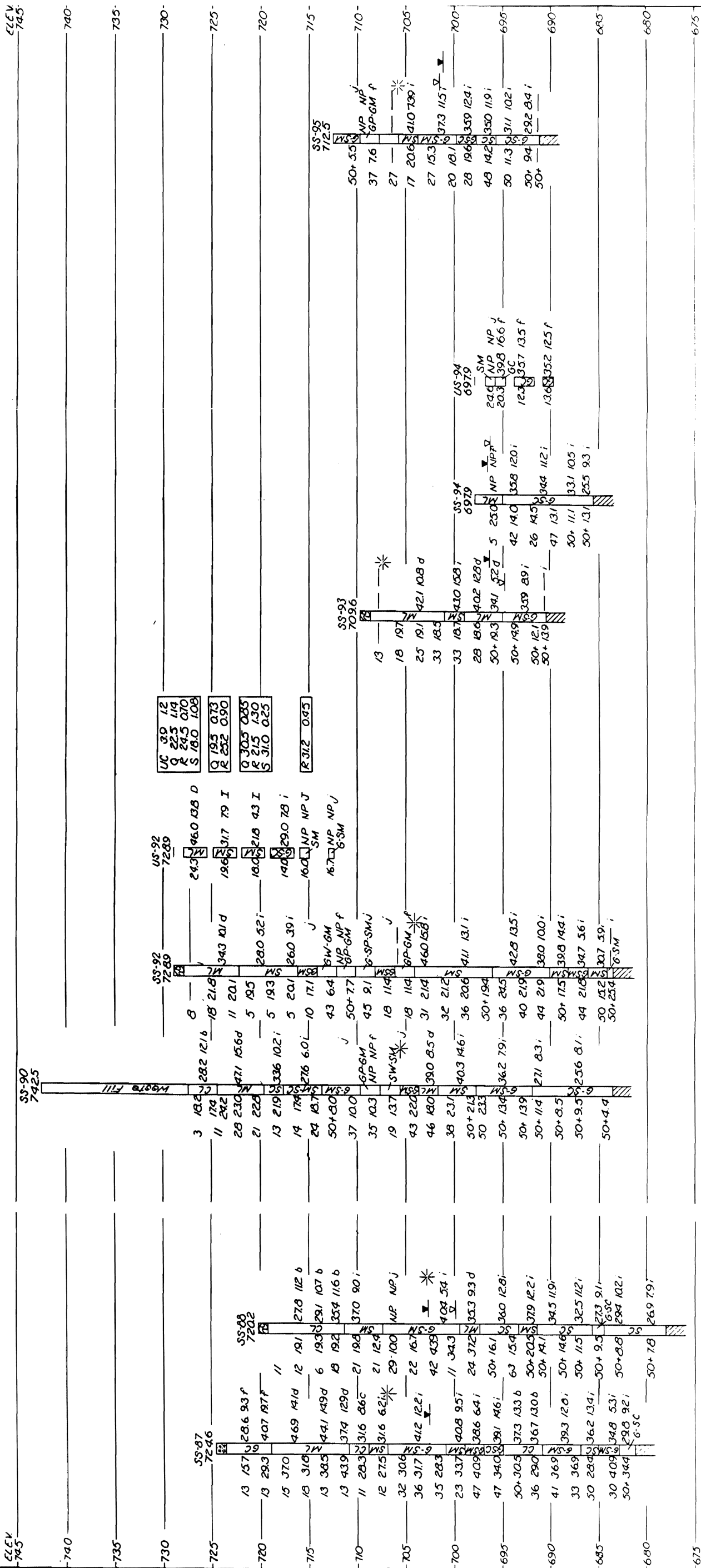

SCALE 1"=10'

WATTS BAR NUCLEAR PLANT  
FINAL SAFETY  
ANALYSIS REPORT

SOIL INVESTIGATION BORINGS  
FOR ERCW AND HPFP SYSTEMS  
Figure 2.5-200  
Added by Amendment 24

**LEGEND**

Boring No.  
Elevation

Blows

Natural Moisture Content

Liquid Limit

Plasticity Index

Soil Type

Type Test

Unconfined Compressive Strength (tsf)

or

Cohesion (tsf)

Sensitivity Ratio

**SYMBOLS**

Topsoil

Limestone, gravel

Refusal

Q - Unconsolidated undrained triaxial compression test

R - Consolidated undrained triaxial compression test at natural moisture

S - Consolidated drained direct shear test

UC - Unconsolidated compression test

SL - One hour water table reading

SW - Twenty four hour water table reading

Note: Blows per foot with a 140 lb. hammer and a 30 inch drop on a 2 inch OD split spoon sampler

\* Top of weathered shale

Figure 2.5-200 Soil Investigation Borings For ERCW & HPFP Systems

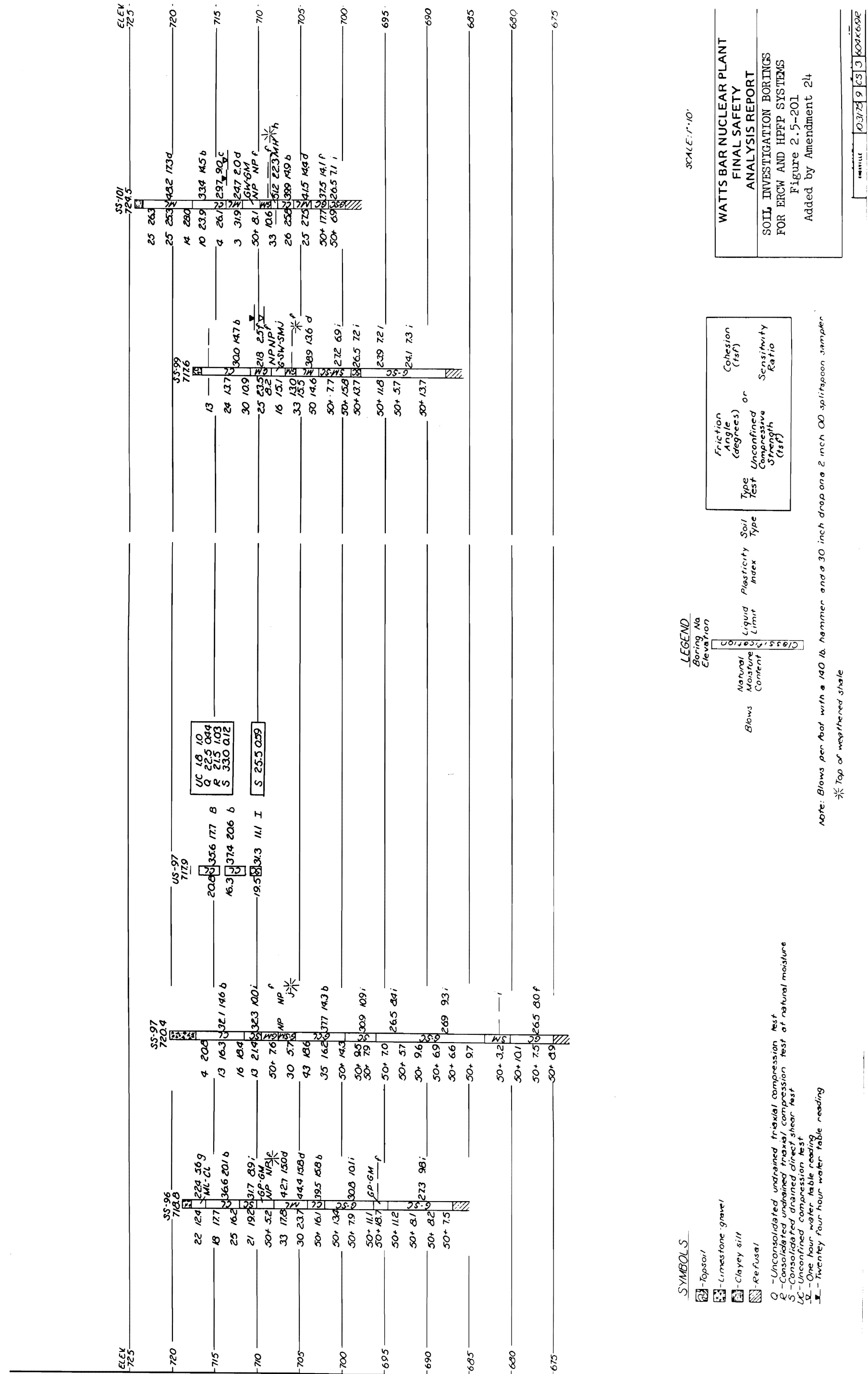

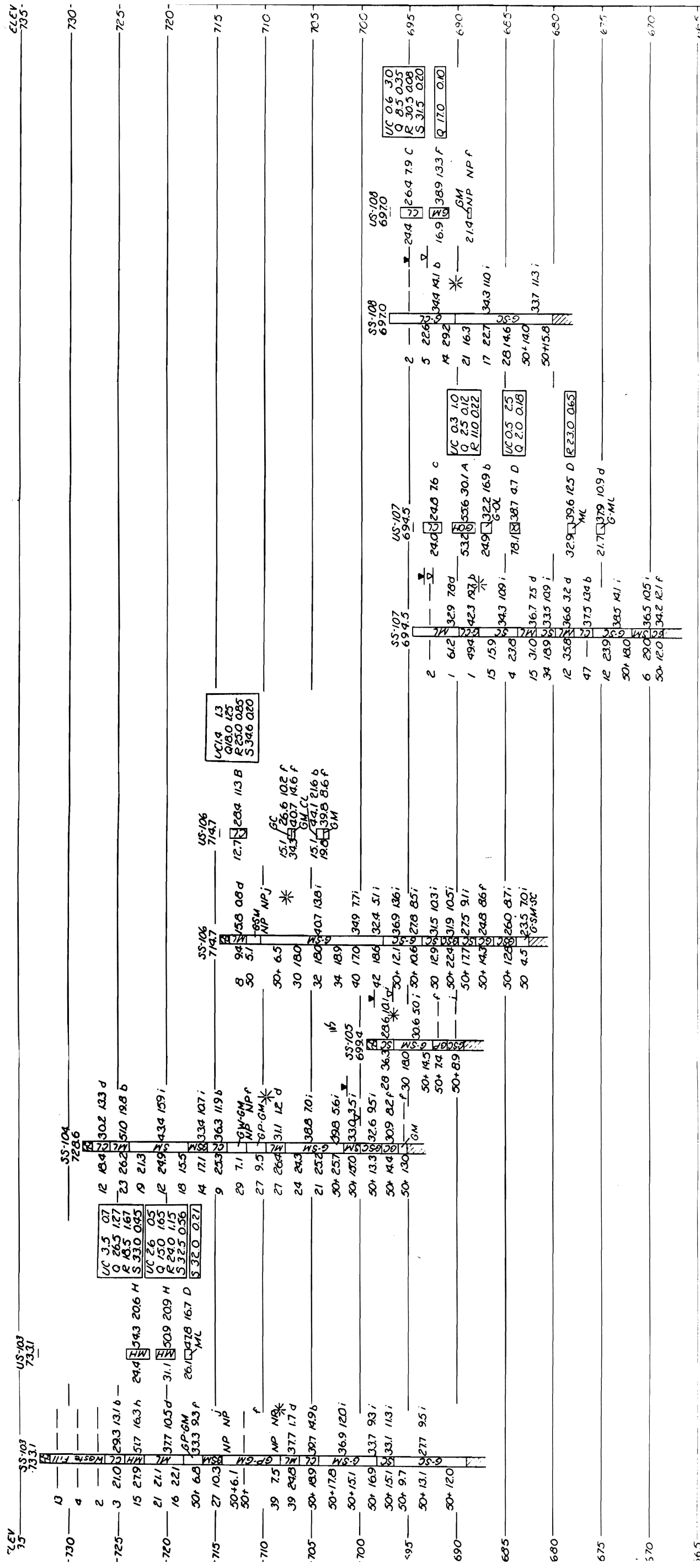

**WATTS BAR NUCLEAR PLANT  
FINAL SAFETY  
ANALYSIS REPORT**

**SOIL INVESTIGATION BORINGS  
FOR ERCW AND HFPF SYSTEMS**  
Figure 2.5-202  
Added by Amendment 24

SCALE: 1"=10'

**LEGEND**

Boring No.  
Elevation

Blows

Natural Moisture Content

Liquid Limit

Plasticity Index

Soil Type

Type Test

Friction Angle (degrees) or Unconfined Strength (tsf)

Cohesion (tsf)

Sensitivity Ratio

**SYMBOLS**

- Q - Unconsolidated undrained triaxial compression test
- R - Consolidated undrained triaxial compression test at natural moisture
- S - Consolidated drained triaxial compression test
- UC - Unconfined compression test
- G - One hour water table reading
- W - Twenty four hour water table reading

Note: Blows per foot with a 140 lb hammer and a 30 inch drop on a 2 inch OD split spoon sampler  
\* Top of weathered shale

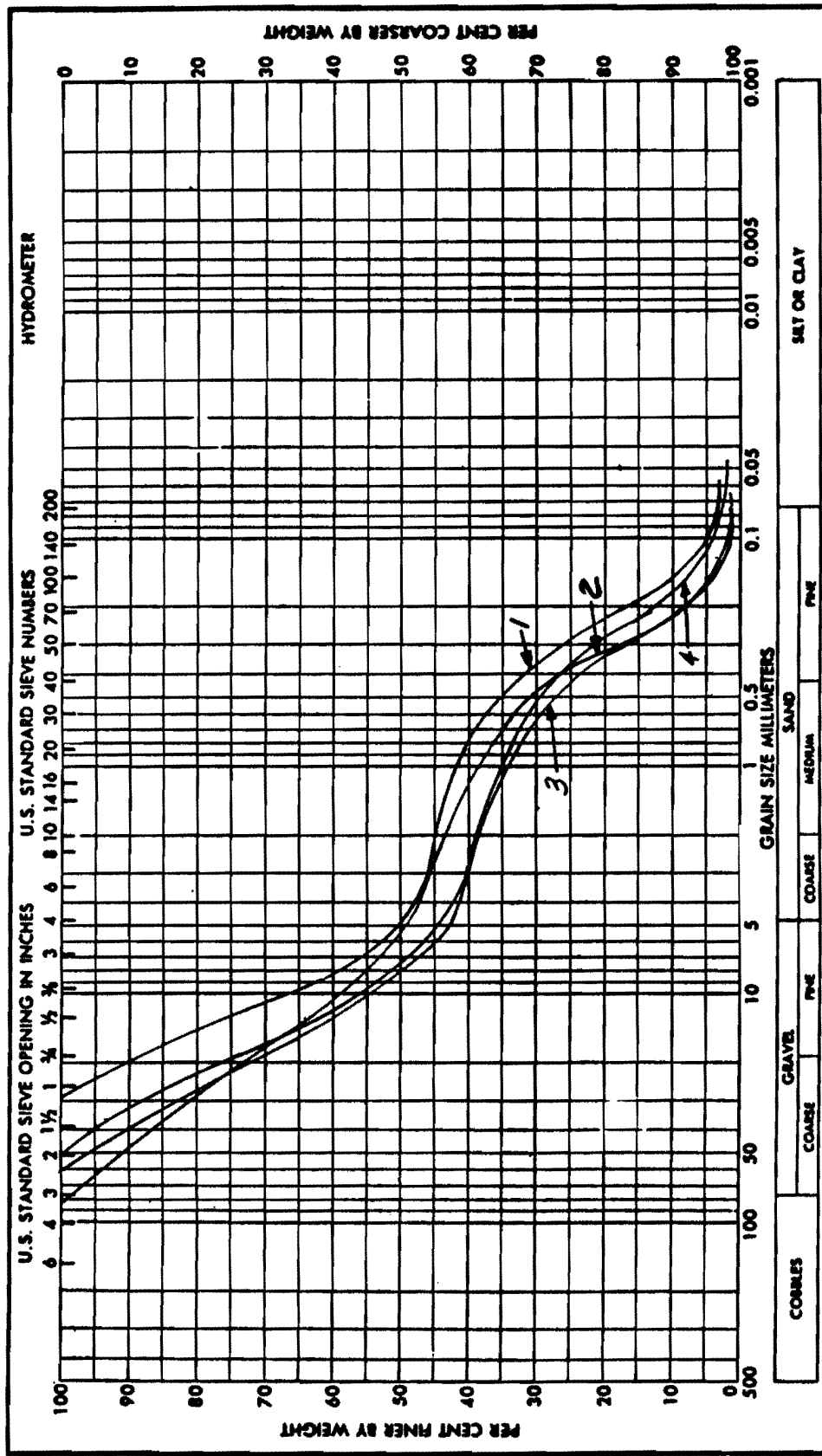

Soil Symbol	GP	Liquid Limit, %	
Moisture Content, %		Plastic Limit, %	
Specific Gravity		Plasticity Index, %	
		Shrinkage Limit, %	

Remarks:

WATTS BAR NUCLEAR PLANT FINAL SAFETY ANALYSIS REPORT
INTAKE CHANNEL TRENCH
Figure 2.5-203

Figure 2.5-203 Intake Channel Trench



WATTS BAR NUCLEAR PLANT - INTAKE CHANNEL

TEST 1

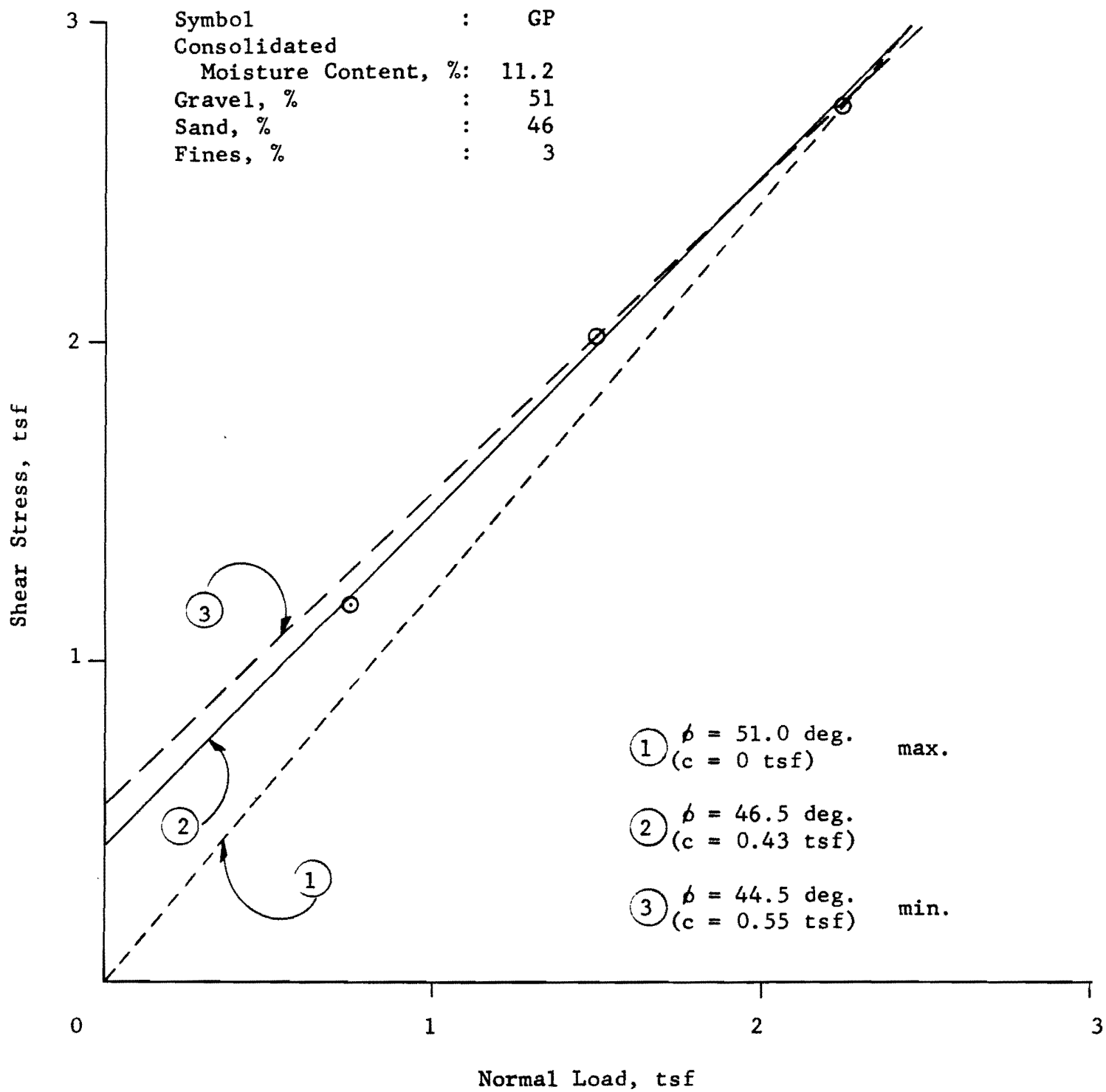

Normal Load tsf	Consolidated* Deformation in.	Shear Stress tsf	Consolidated* Dry Density pcf
0.75	0.1833	1.17	118.9
1.50	0.1543	2.02	120.5
2.25	0.2013	2.76	120.3

\*Under an overburden pressure of 3000 psf.

Figure 2.5-204

Figure 2.5-204 Intake Channel Test 1

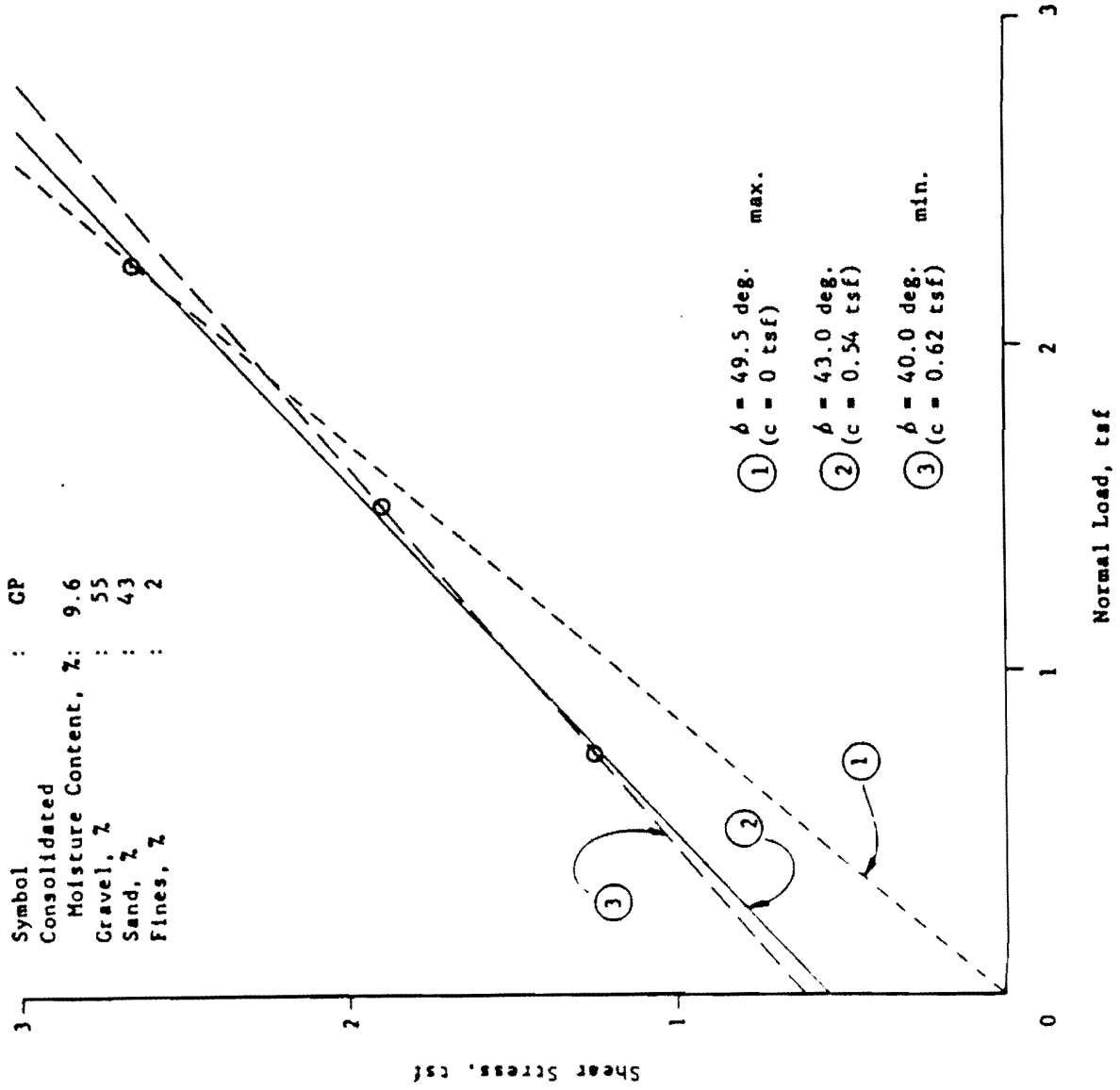

Normal Load (tsf)	Consolidated * Deformation (in)	Shear Stress (tsf)	Consolidated * Dry Density (psf)
0.75	0.0987	1.25	126.3
1.50	0.0987	1.89	126.3
2.25	0.0842	2.65	125.5

\*Under an overburden pressure of 3000 psf.

Amendment 63

WATTS BAR NUCLEAR PLANT FINAL SAFETY ANALYSIS REPORT
INTAKE CHANNEL STRENGTH EVALUATION TEST 2
Figure 2.5-205

Figure 2.5-205 Intake Channel Strength Evaluation Test 2

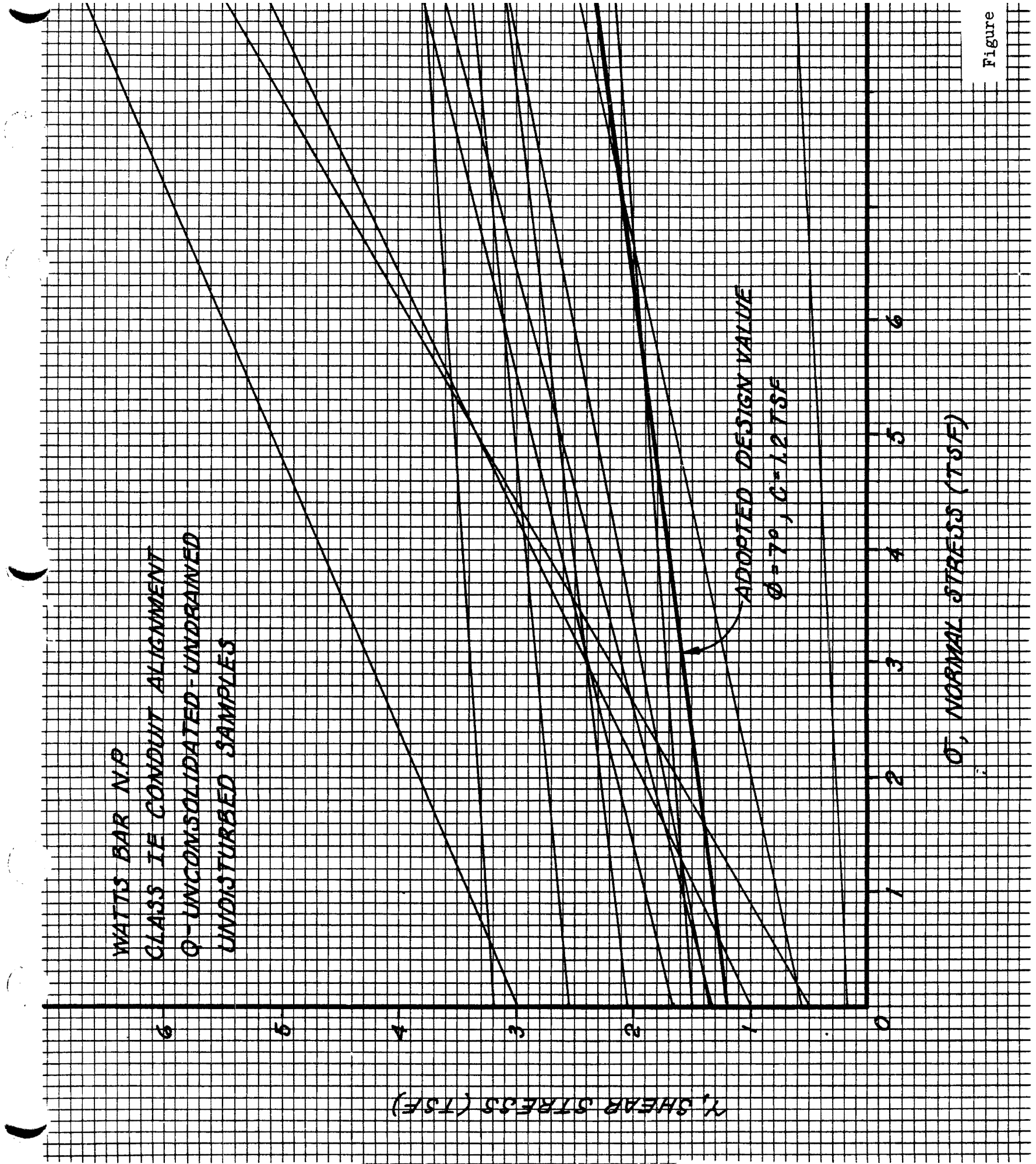

Figure 2.5-206 Class IE Conduit Alignment Q (Unconsolidated, Undrained, Undisturbed) Samples.

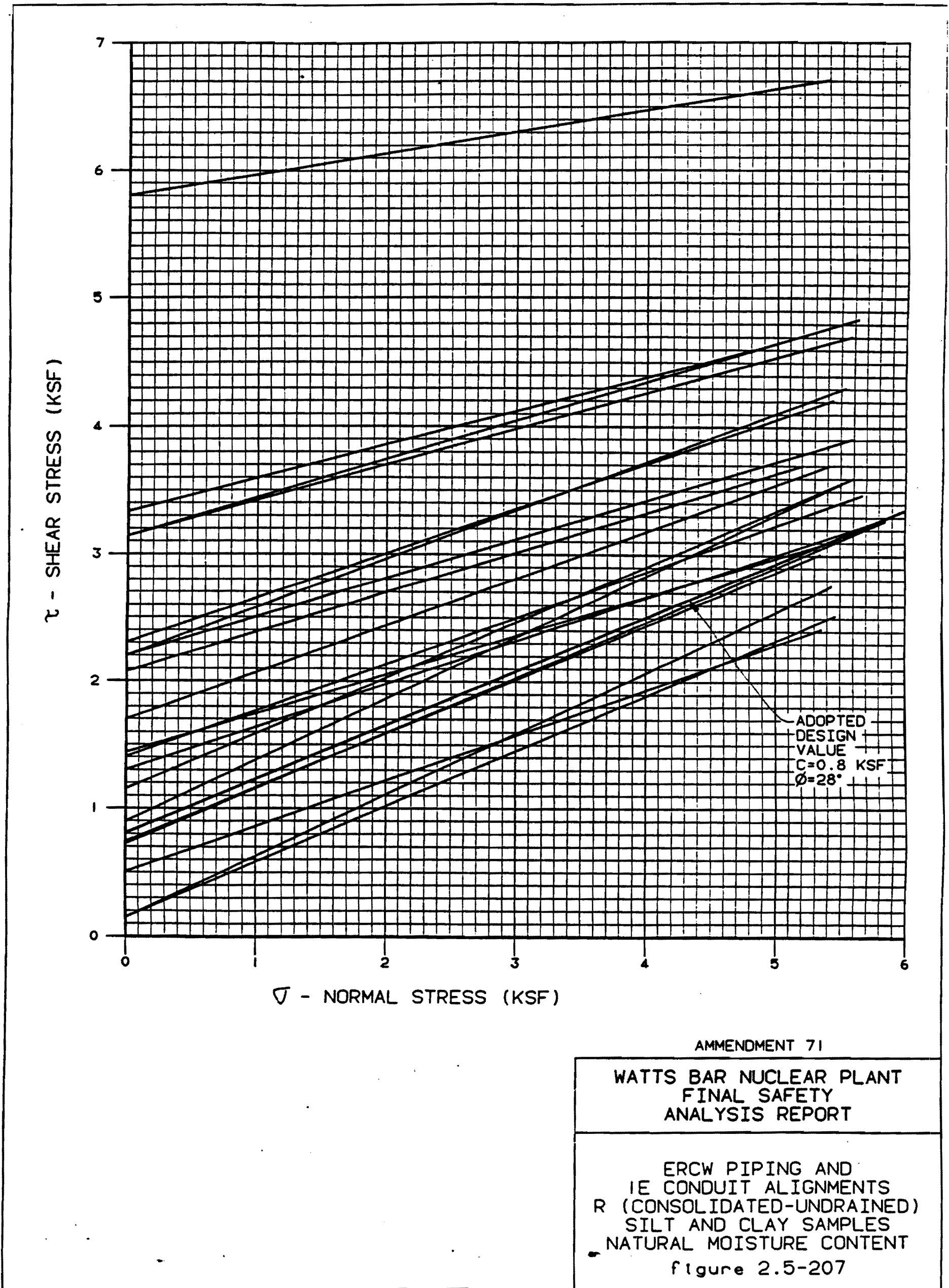

Figure 2.5-207 ERCW Piping and IE Conduit Alignments R (Consolidated - Undrained) Silt and Clay Samples Natural Moisture Content

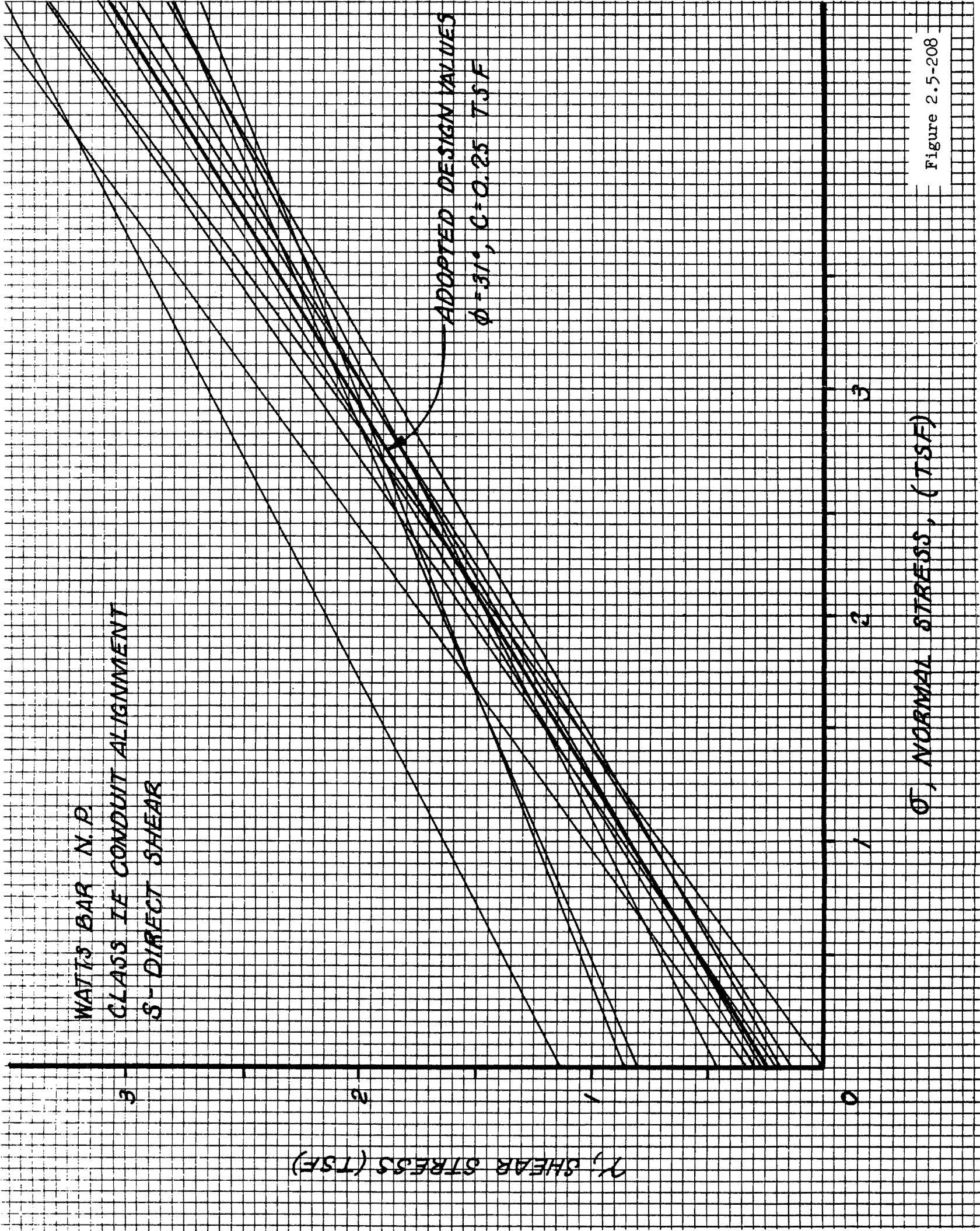
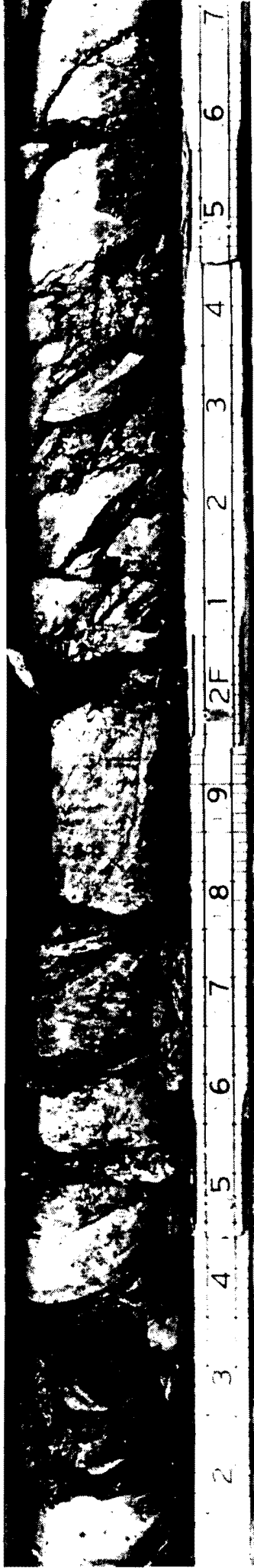

Figure 2.5-208 Class IE Conduit Alignment S-Direct Shear

TYPE 1 - SOFT SHALE



TYPE 2 - HARD SHALE



TYPE 3 - LIMESTONE



Figure 2.5-209

Figure 2.5-209 Type 1-Soft Shale Type 2-Hard Shale -Type 3 Limestone

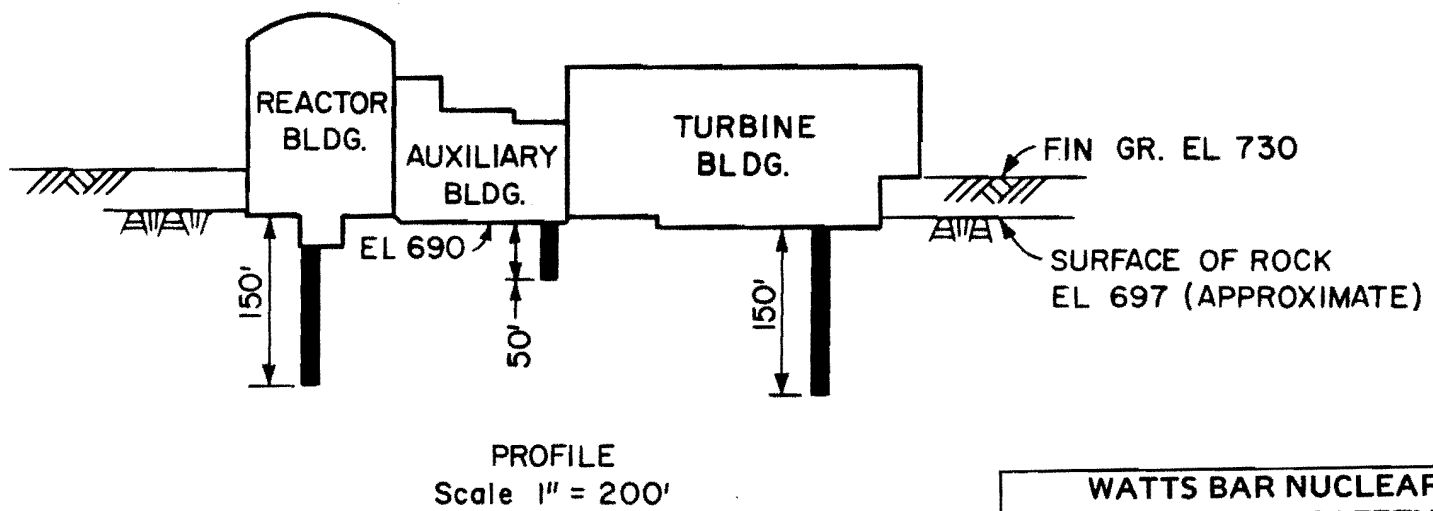
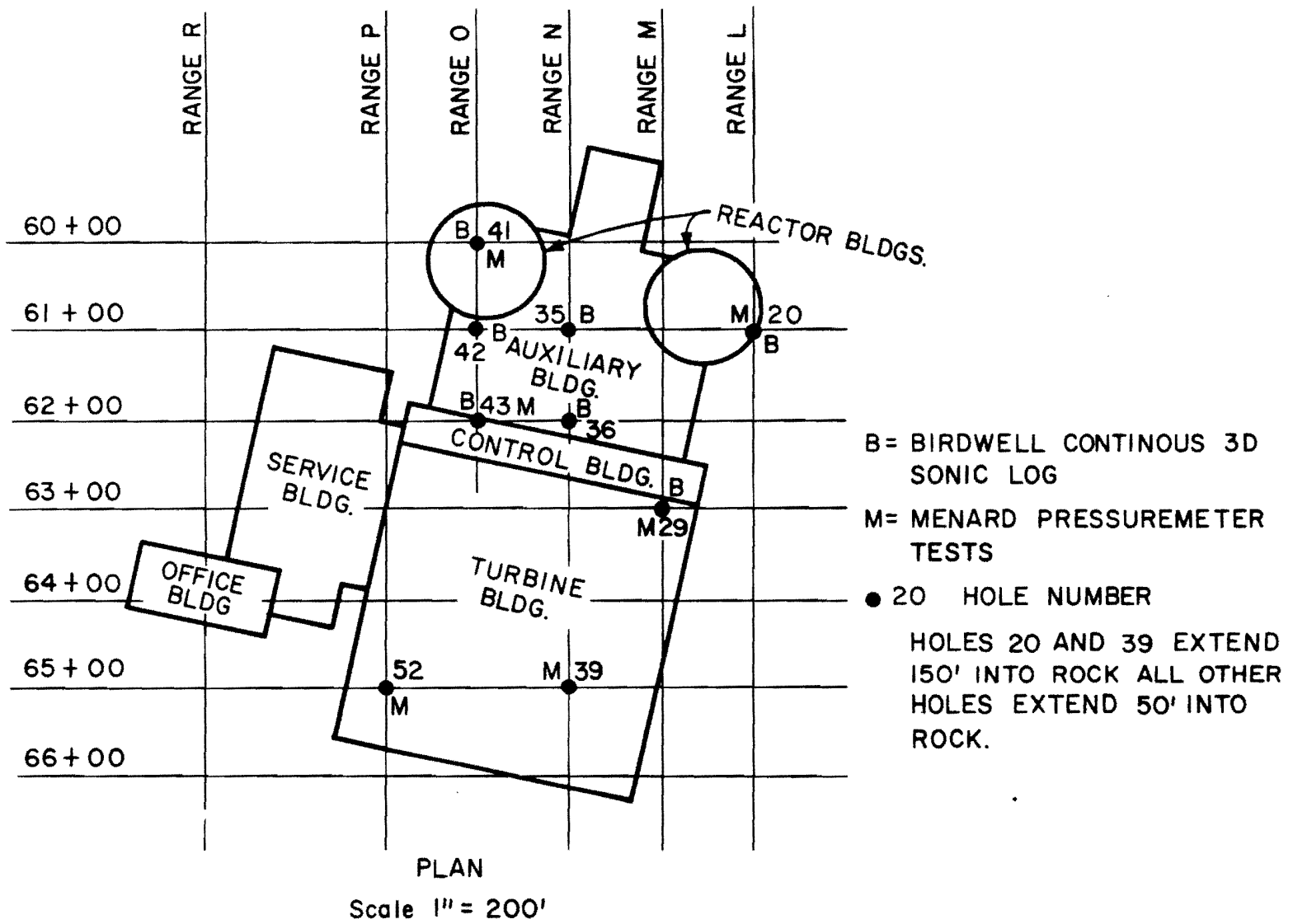

WATTS BAR NUCLEAR PLANT  
 FINAL SAFETY  
 ANALYSIS REPORT

---

LOCATION OF TEST HOLES  
 Figure 2.5-210

Figure 2.5-210 Location of Test Holes

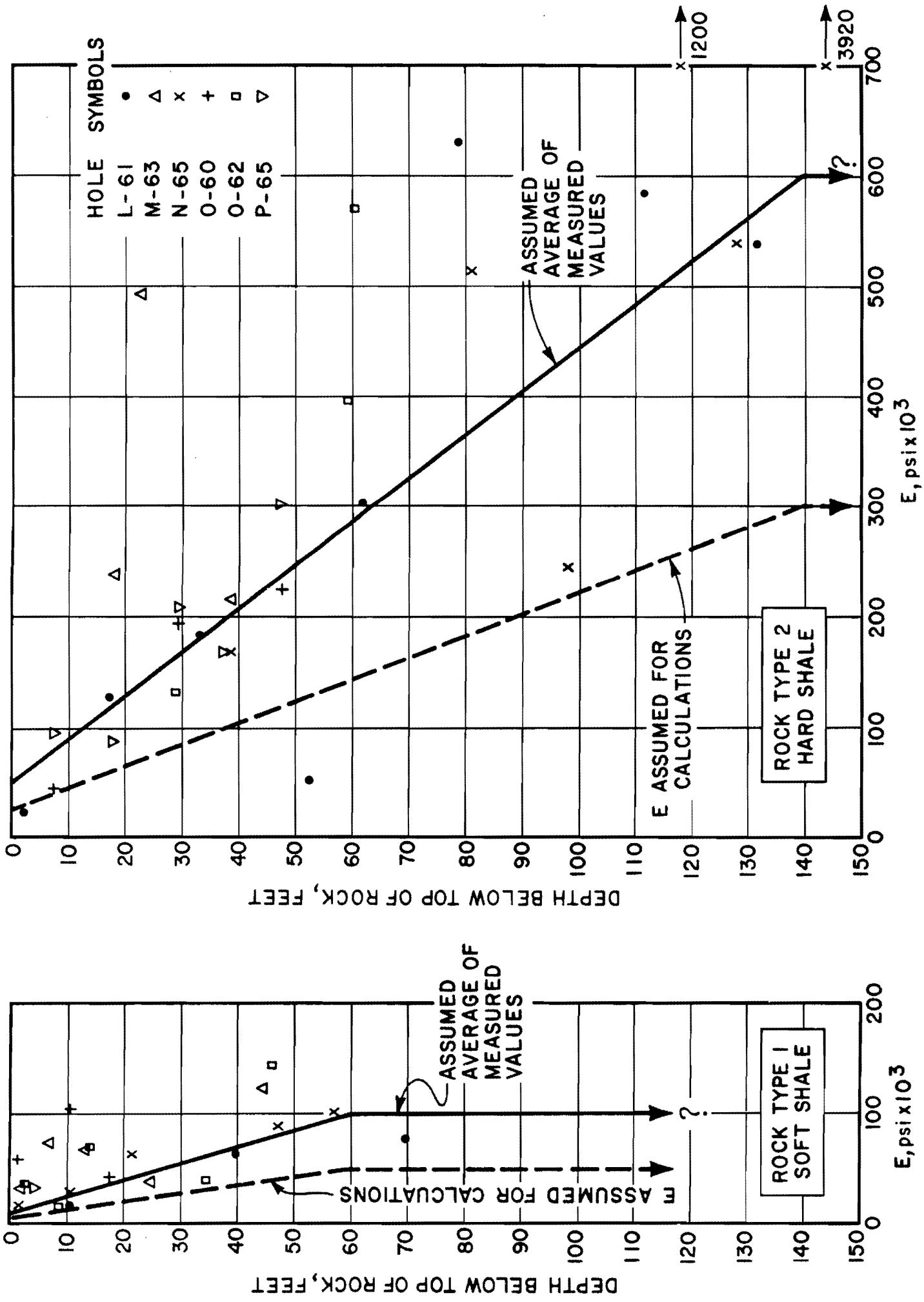

WATTS BAR NUCLEAR PLANT  
FINAL SAFETY  
ANALYSIS REPORT

DEFORMATION MODULI FROM MENARD  
PRESSUREMETER TESTS

Figure 2.5-211

Figure 2.5-211 Deformation Moduli From Menard Pressuremeter Tests



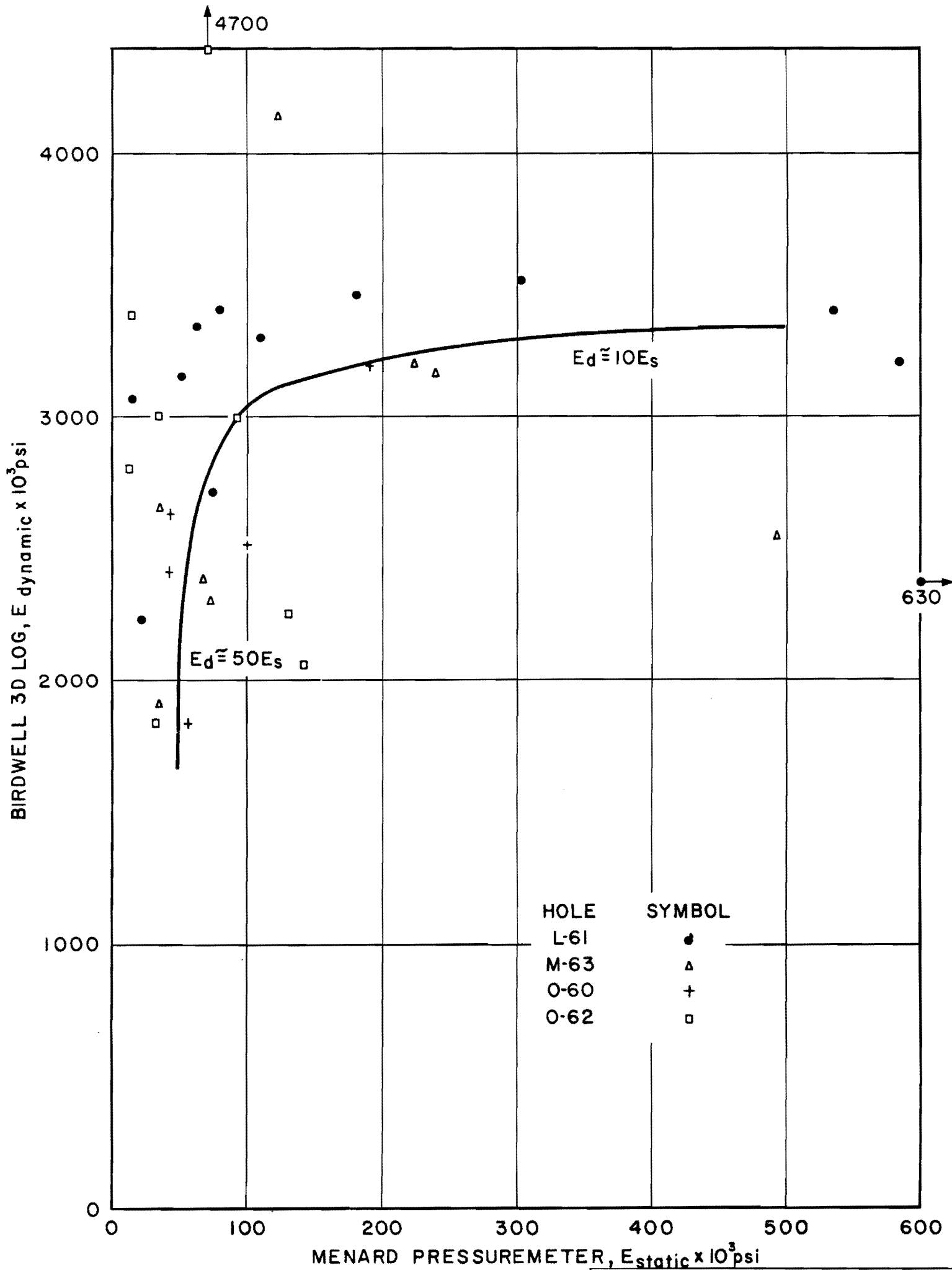

**WATTS BAR NUCLEAR PLANT  
 FINAL SAFETY  
 ANALYSIS REPORT**

---

**COMPARISON OF MODULI OBTAINED  
 WITH MENARD PRESSUREMETER AND  
 BIRDWELL 3D SONIC LOGGER**

**Figure 2.5-212**

Figure 2.5-212 Comparison of Moduli Obtained With Menard Pressuremeter and Birdwell 3D Sonic Logger

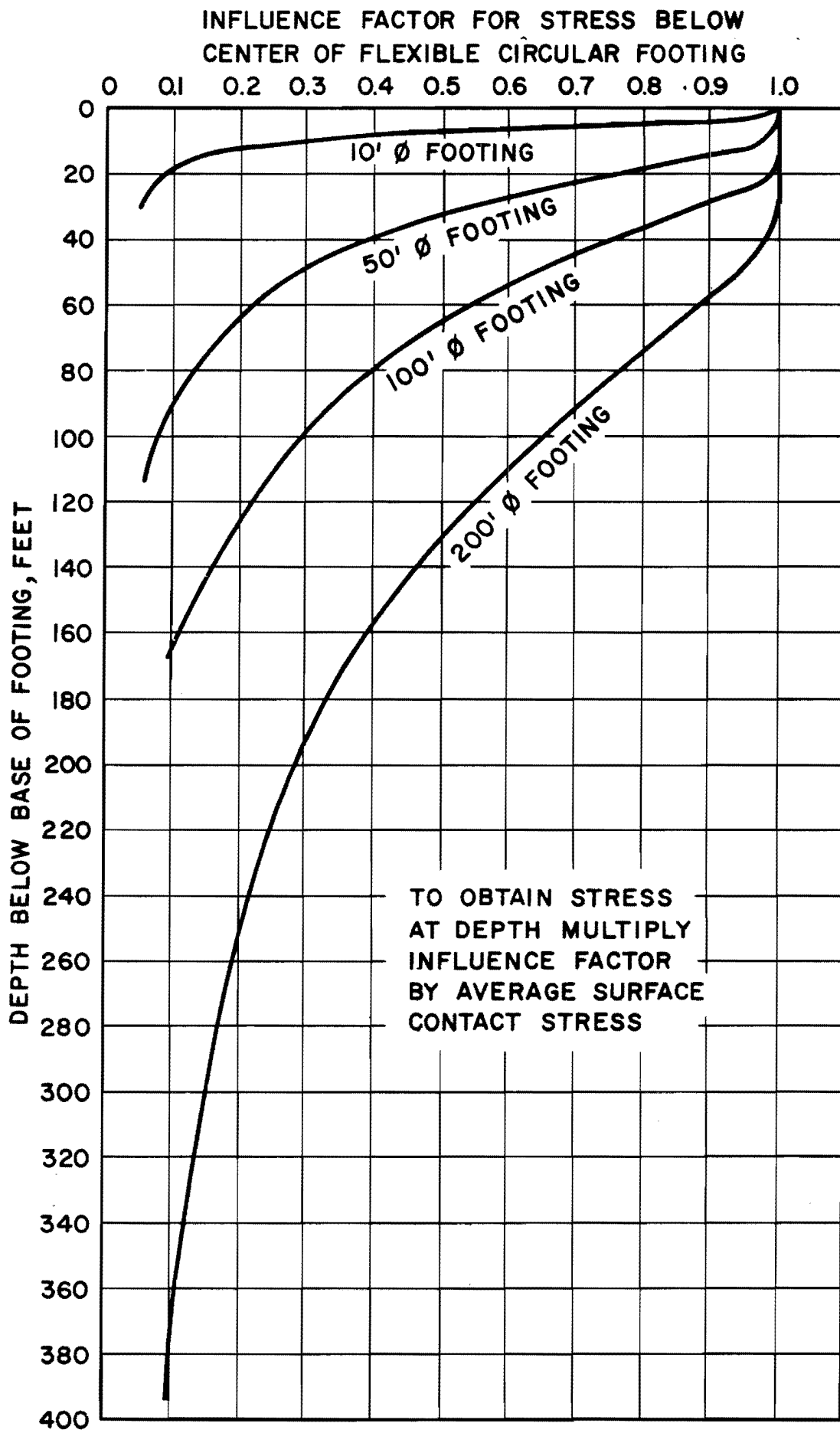

**WATTS BAR NUCLEAR PLANT  
FINAL SAFETY  
ANALYSIS REPORT**

INFLUENCE FACTORS FOR DETERMINING  
STRESSES BELOW THE CENTER OF FLEX-  
IBLE CIRCULAR FOOTING 10, 50, 100,  
AND 200 FT. IN DIAMETER

Figure 2.5-213

Figure 2.5-213 Influence Factors For Determining Stresses Below The Center of Flexible Circular Footing 10, 50, 100, and 200 Ft. in Diameter

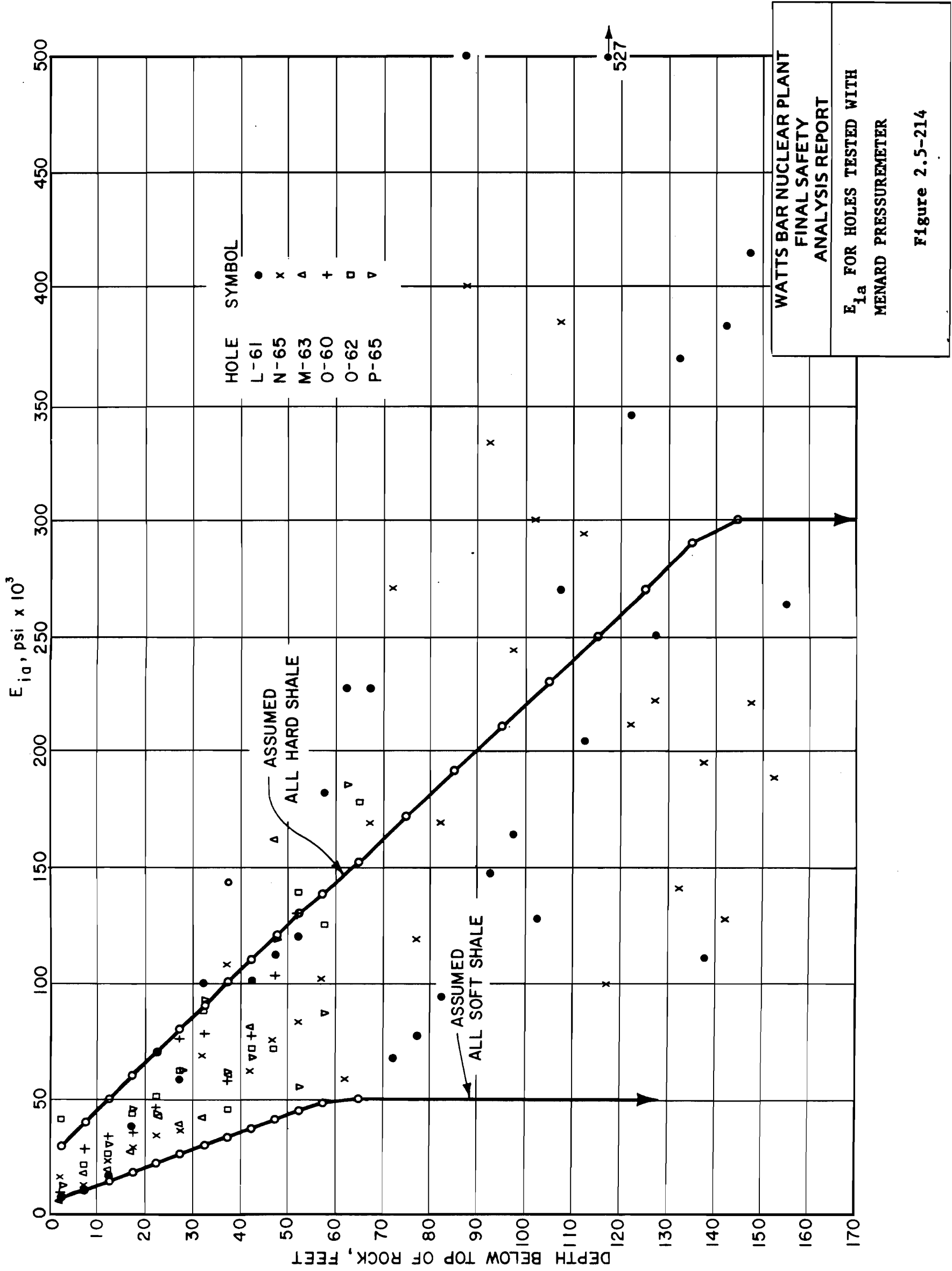

Figure 2.5-214  $E_{ia}$  For Holes Tested With Menard Pressuremeter

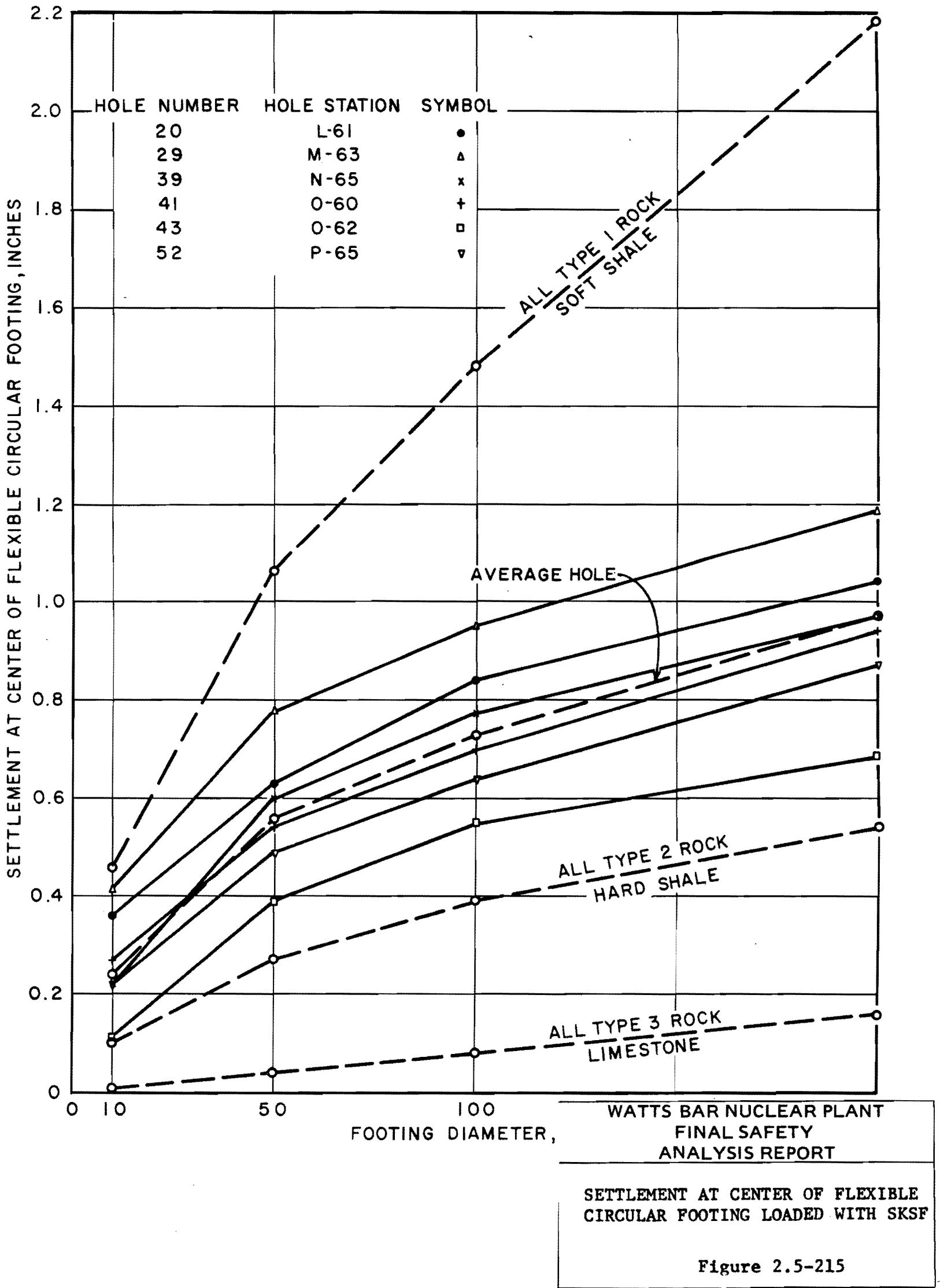
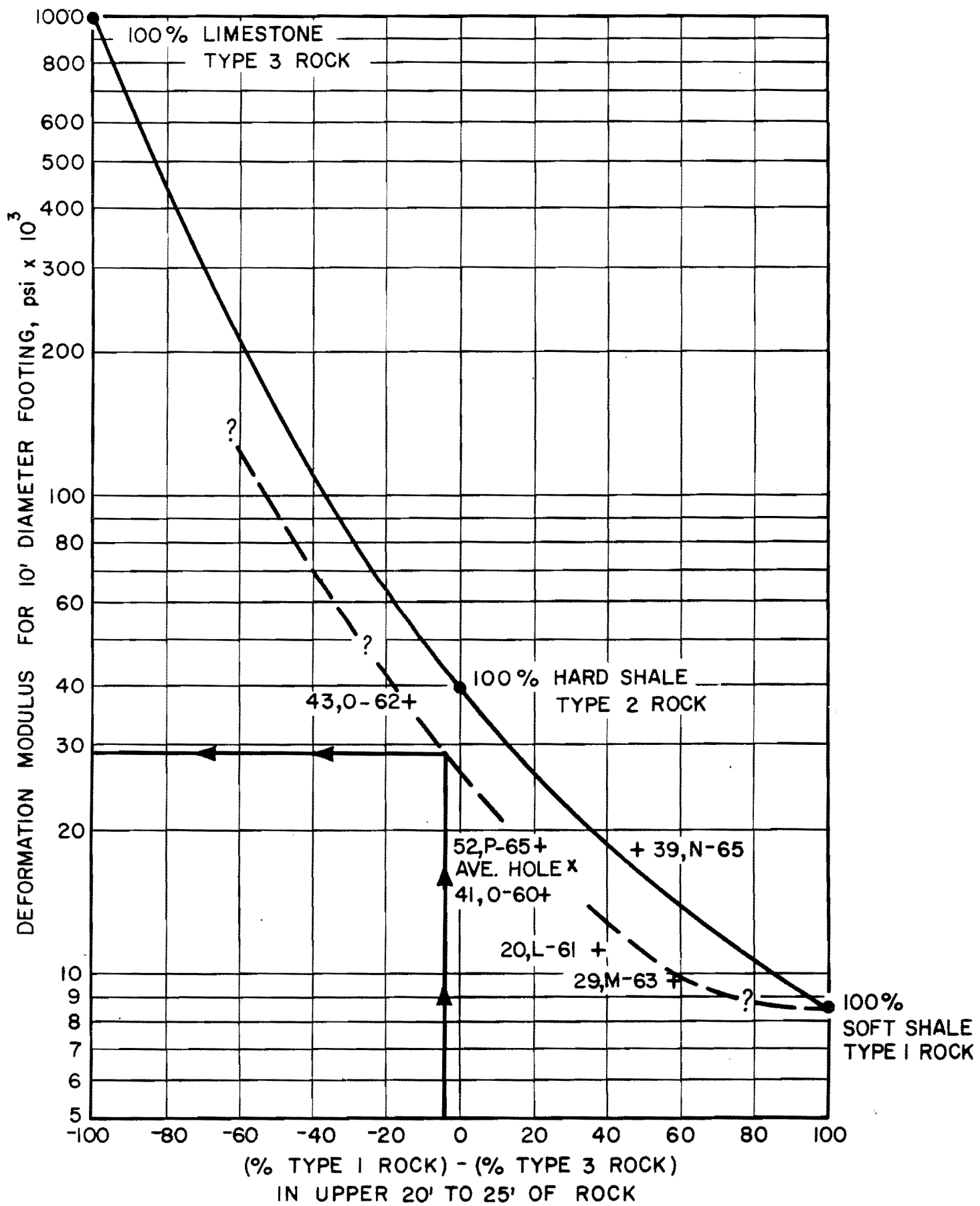

Figure 2.5-215 Settlement at Center of Flexible Circular Footing Loaded With SKSF



WATTS BAR NUCLEAR PLANT  
FINAL SAFETY  
ANALYSIS REPORT

---

CORRELATION USED TO ESTIMATE  
AVERAGE MODULI FOR HOLES WHERE  
DETAILED CALCULATIONS WERE NOT  
MADE  
Figure 2.5-216

Figure 2.5-216 Correlation Used To Estimate Average Moduli For Holes Where Detailed Calculations Were Not Made.

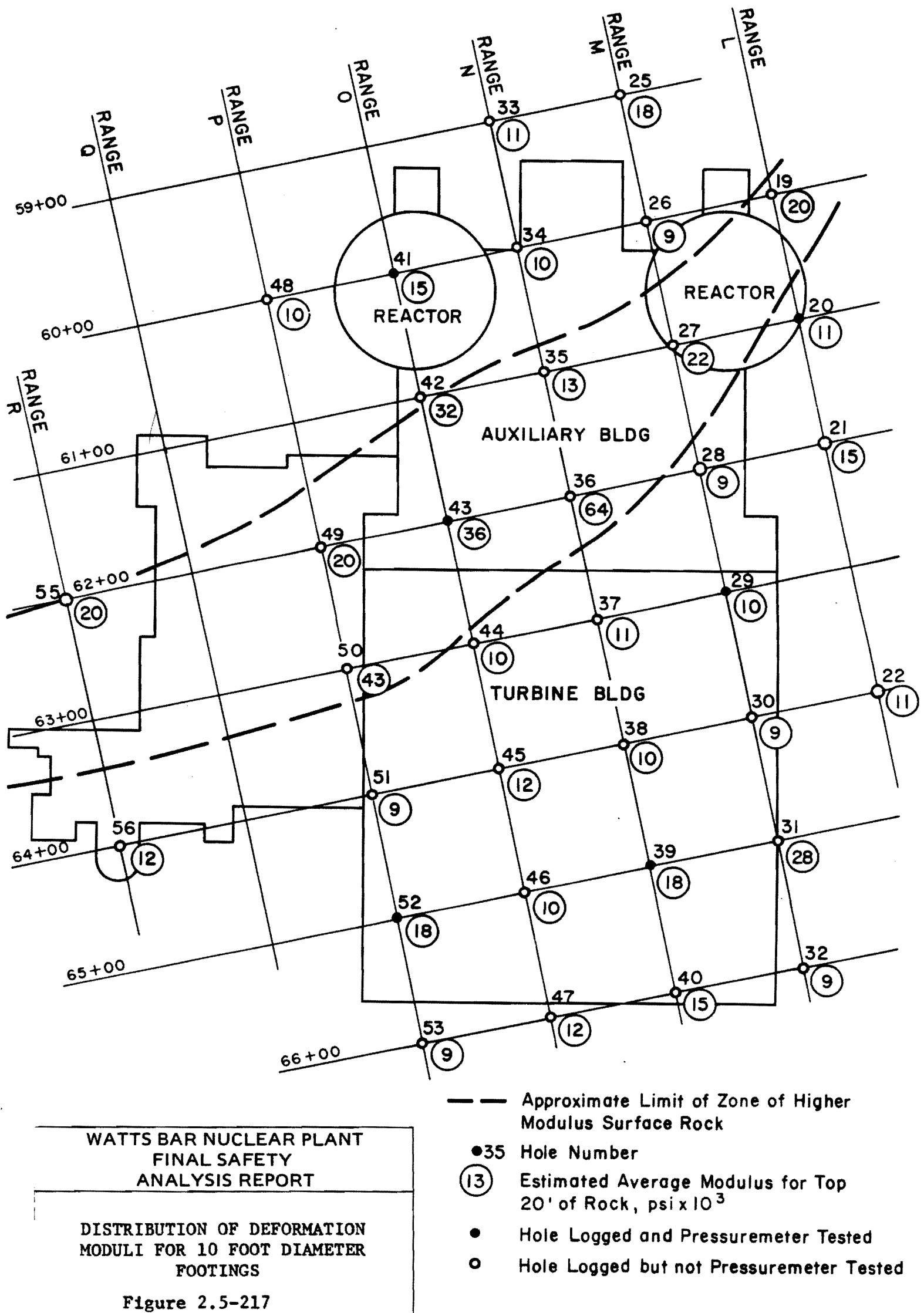
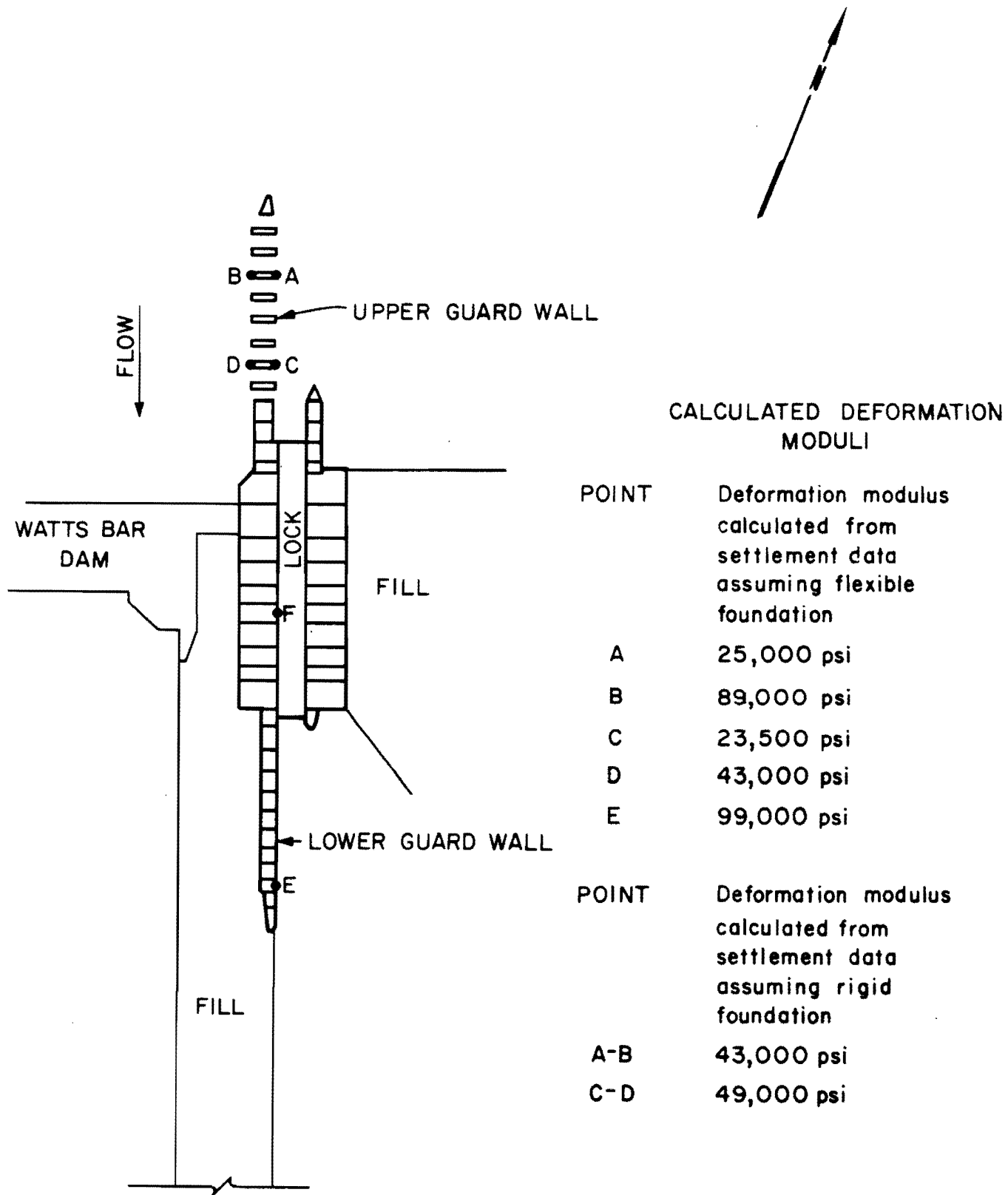

Figure 2.5-217 Distribution of Deformation Moduli For 10 Foot Diameter Footings



WATTS BAR NUCLEAR PLANT  
FINAL SAFETY  
ANALYSIS REPORT

---

SIMPLIFIED PLAN OF LOCK FOUNDATION  
SHOWING LOCATION OF MODULUS CALCULATIONS

Figure 2.5-218

Figure 2.5-218 Simplified Plan of Lock foundation Showing Location of Modulus Calculations

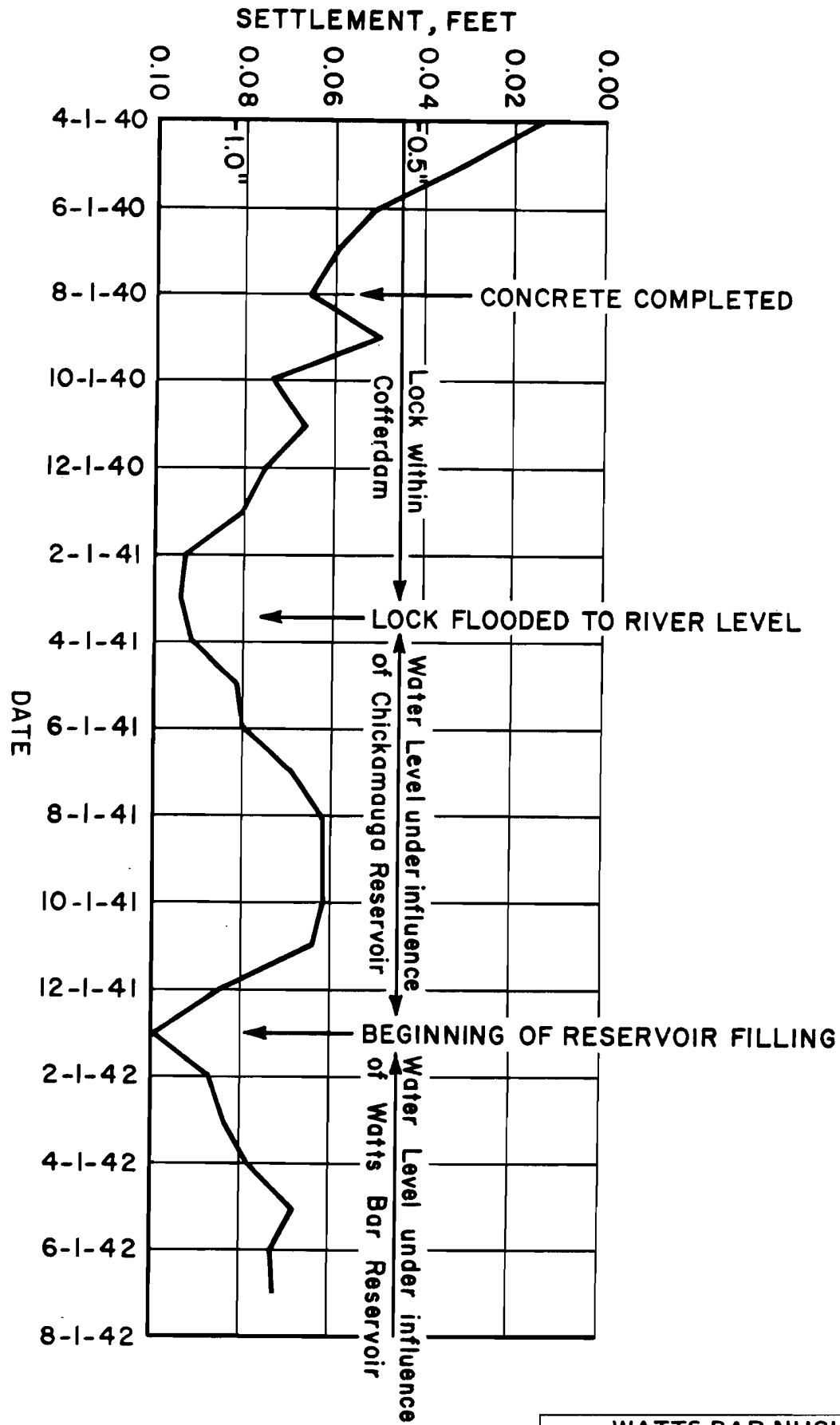

WATTS BAR NUCLEAR PLANT  
 FINAL SAFETY  
 ANALYSIS REPORT

SETTLEMENT OF FACE OF BLOCK R-10  
 (Point F, fig. 16)

Figure 2.5-219

Figure 2.5-219 Settlement of Face of Block R-10 (Point F, fig. 16)



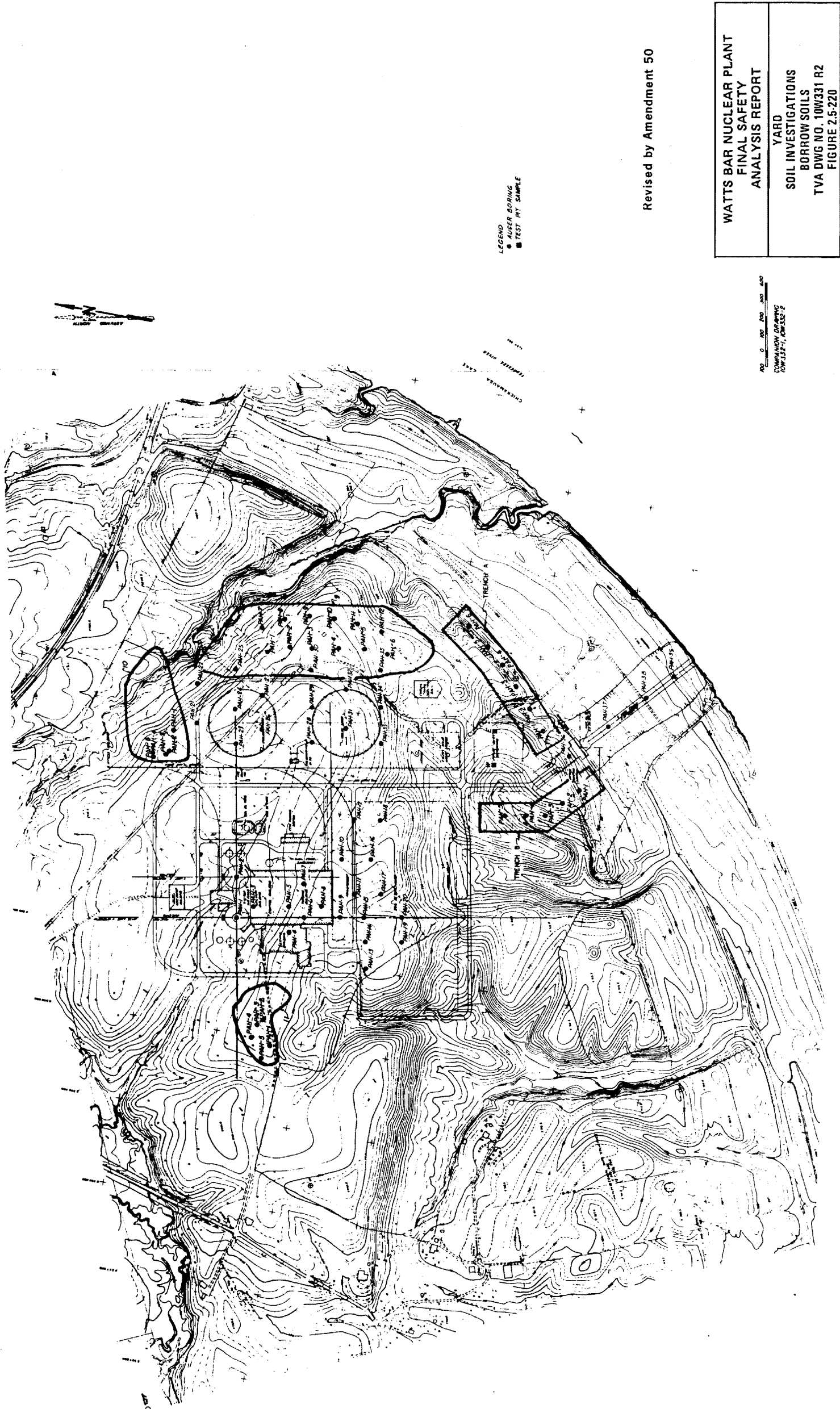

Figure 2.5-220 Yard Soil Investigations Borrow Soils

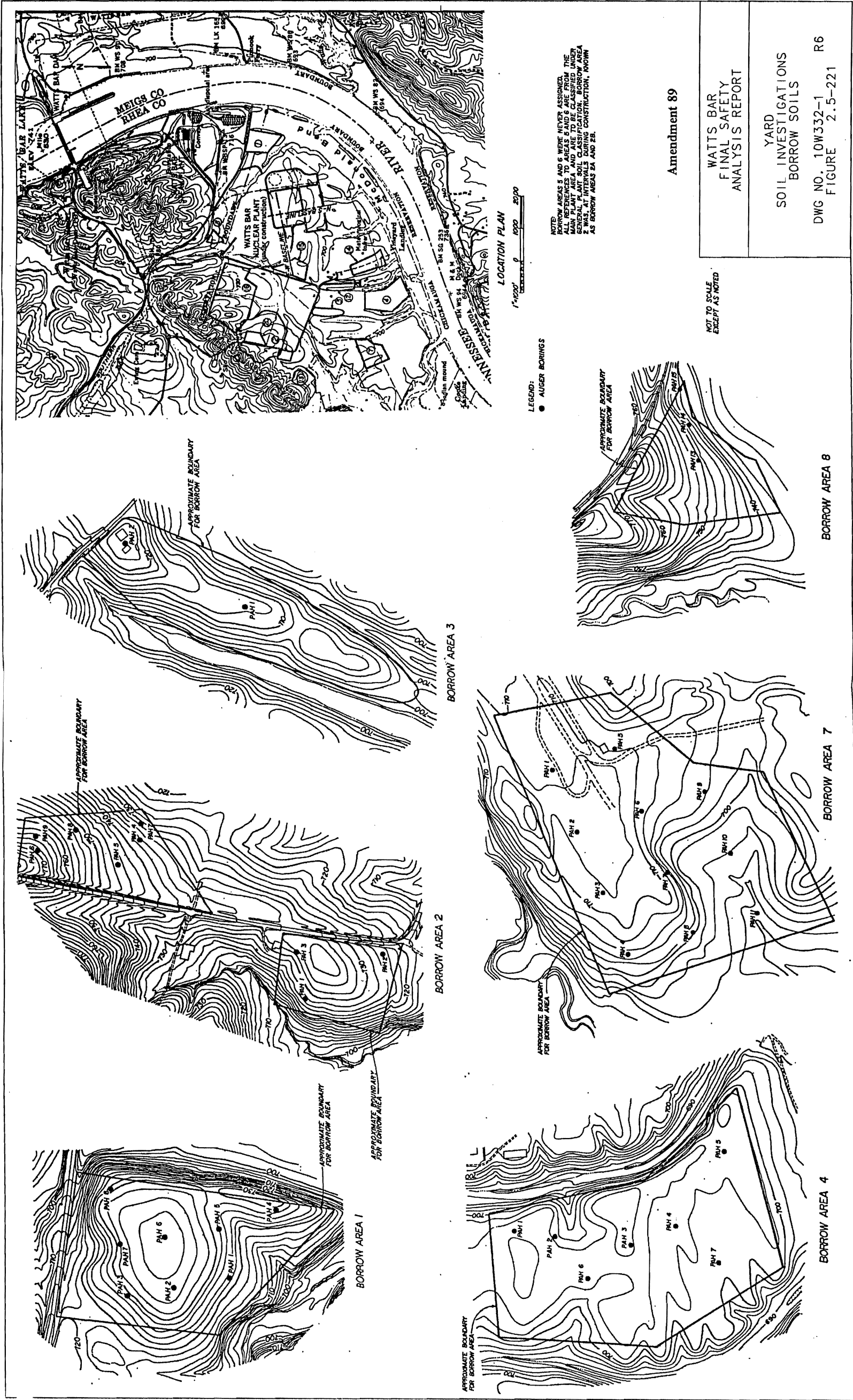
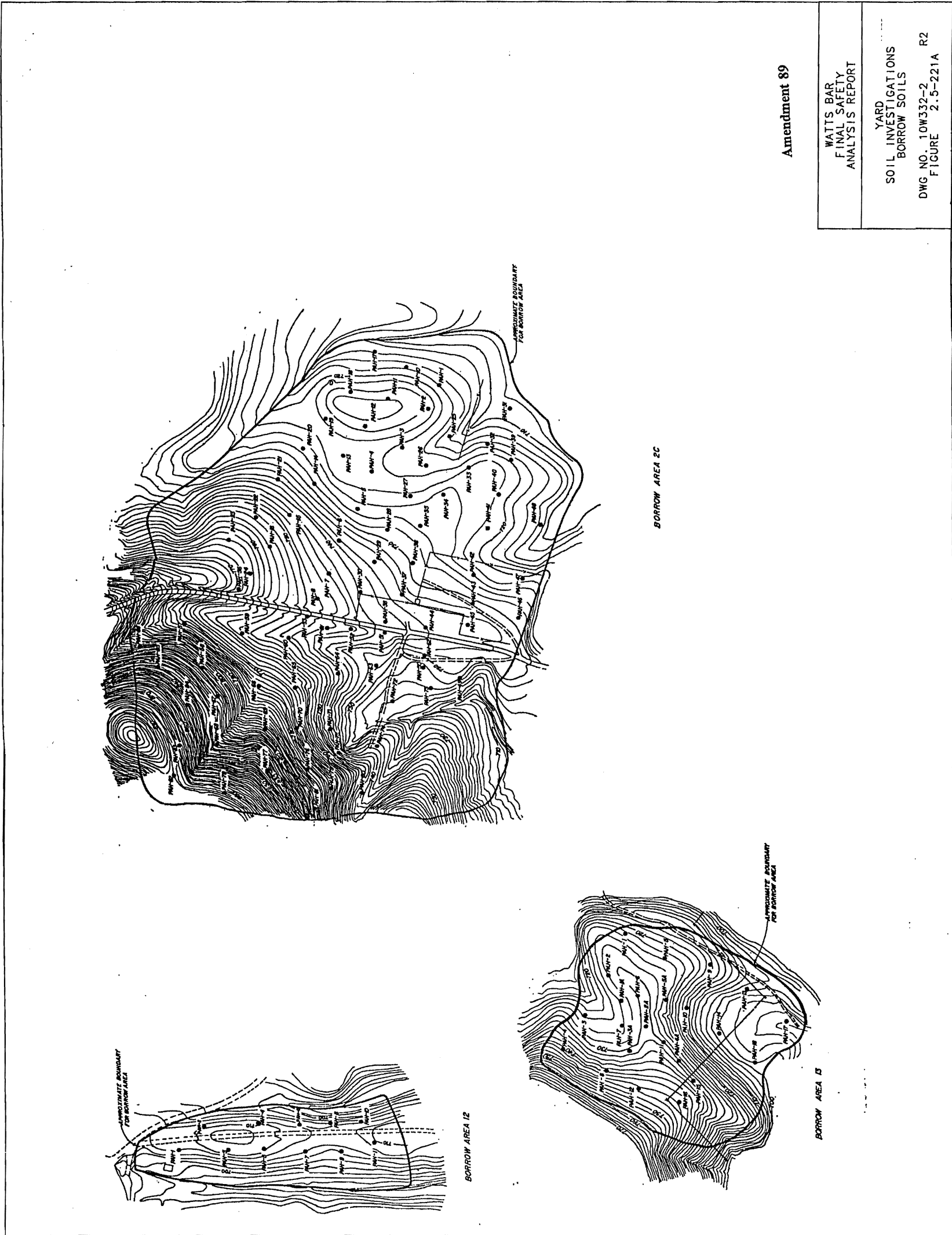

Figure 2.5-221 Yard Soil Investigations Borrow Soils



THIS DRAWING WAS PREPARED BY THE U.S. ARMY CORPS OF ENGINEERS, WATTS BAR, MISSISSIPPI. IT IS THE PROPERTY OF THE U.S. ARMY CORPS OF ENGINEERS AND IS LOANED TO YOU. IT AND ITS CONTENTS ARE NOT TO BE DISTRIBUTED OUTSIDE YOUR AGENCY.

Figure 2.5-221a Yard Soil Investigations Borrow Soils

Figure 2.5-222 Borrow Investigation (Actual Figure Located in Oversized Figures File)

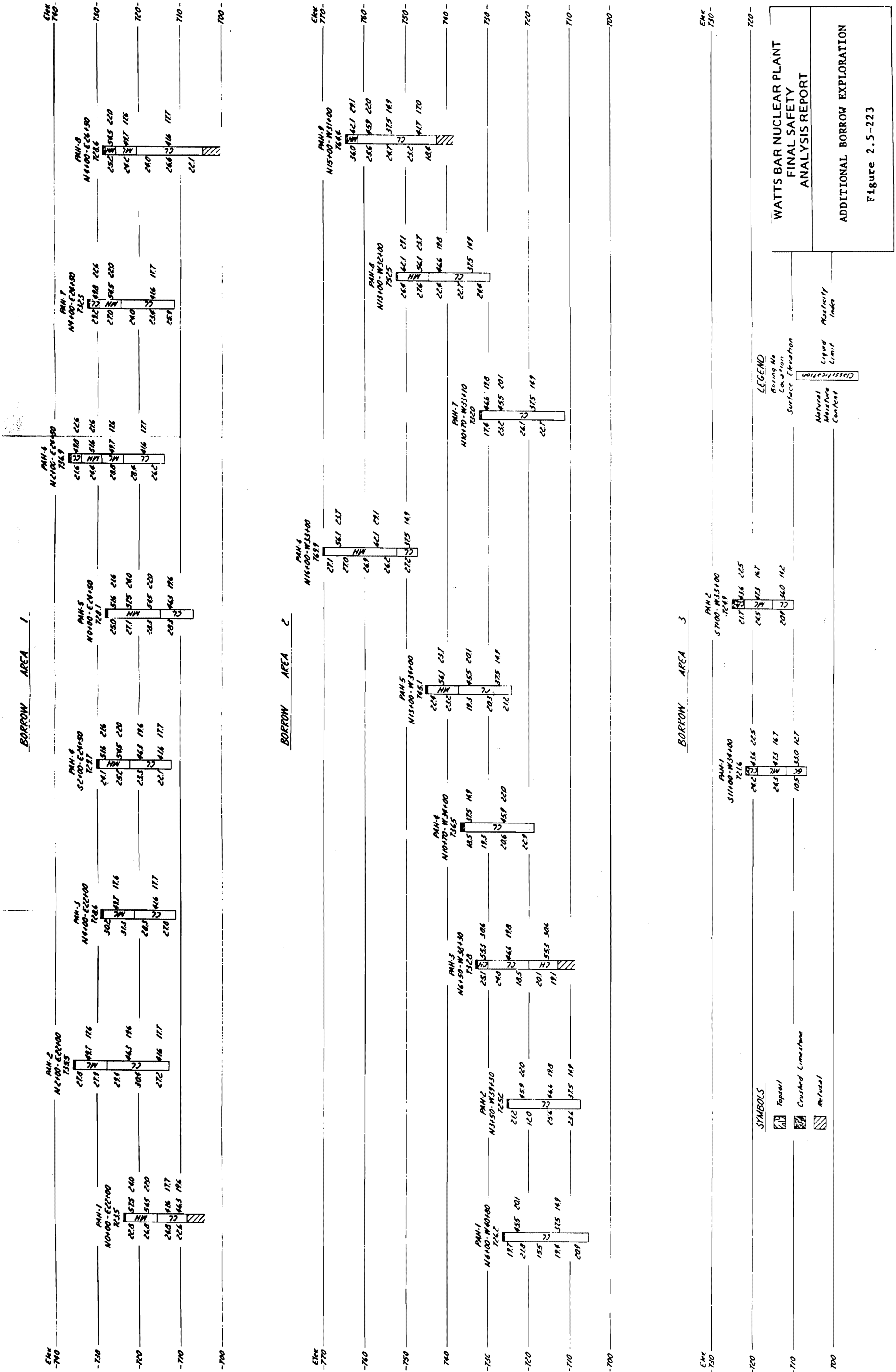

Figure 2.5-223 Additional Borrow Exploration

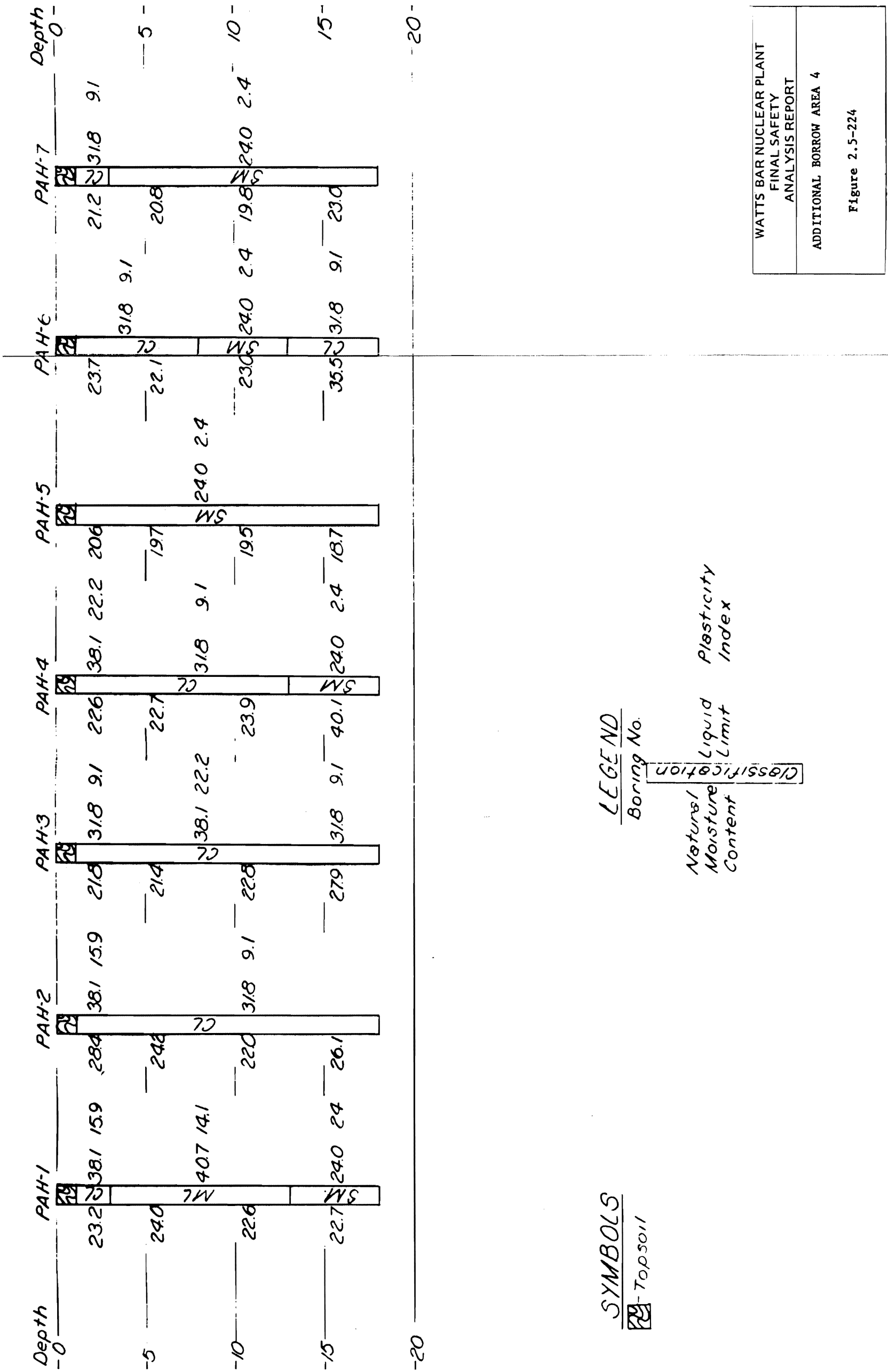

Figure 2.5-224 Additional Borrow Area 4

Figure 2.5-225 Main Plant Excavation & Backfill Category I Structures

Figure 2.5-226 Main Plant Excavation & Backfill Category I Structures



Figure 2.5-226a Excavation and Backfill Category I Structures

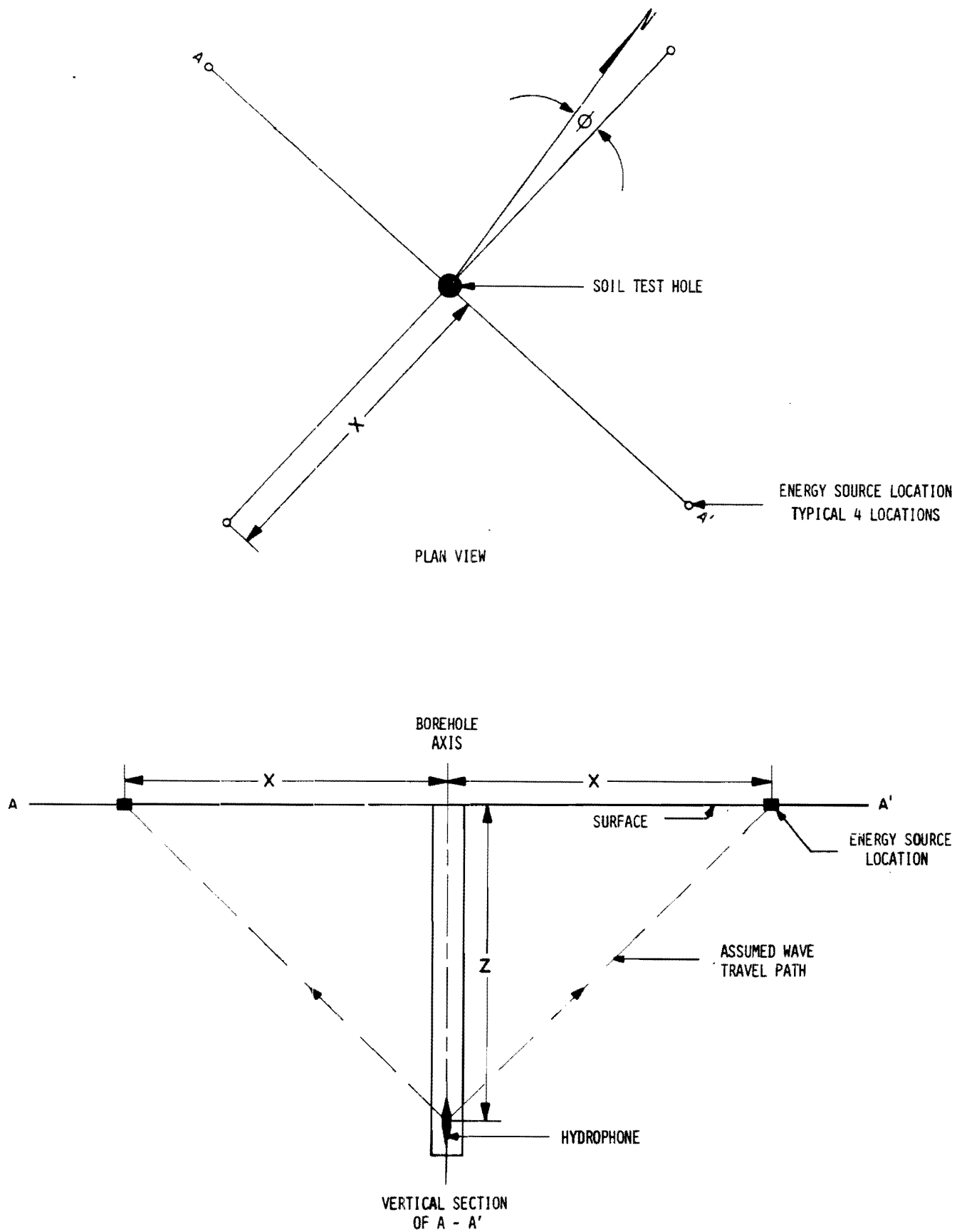

NOTES:

1. THIS DRAWING SHOWS A TYPICAL PLAN VIEW AND VERTICAL SECTION VIEW FOR ALL IN-SITU SOIL DYNAMIC MEASUREMENTS.
2. FOR DRILL HOLE LOCATIONS SEE FIGURE 2.5-185
3. COMPRESSIONAL AND SHEAR WAVES WERE EITHER OBTAINED BY STRIKING A STEEL PLATE WITH A SLEDGEHAMMER OR BY EXPLODING TWO FEET OF PRIMACORD ONE FOOT BELOW GROUND.
4. FOR EACH BOREHOLE EITHER EXPLOSIVES OR SLEDGEHAMMER WAS USED AS THE ENERGY SOURCE. A SINGLE TYPE OF SOURCE WAS USED FOR EACH HOLE, AS CONDITIONS REQUIRED.
5. WHERE POSSIBLE, ENERGY SOURCE LOCATIONS ARE PLACED IN A 90° ARRAY AT HORIZONTAL DISTANCE X FROM BOREHOLE AND ORIENTED NORTH, SOUTH, EAST, AND WEST. OTHERWISE, THE WHOLE ARRAY MAY BE ROTATED ABOUT THE BOREHOLE AXIS BY THE ANGLE  $\phi$  ABOVE.

**WATTS BAR NUCLEAR PLANT  
FINAL SAFETY  
ANALYSIS REPORT**

---

**TYPICAL IN-SITU SOIL DYNAMICS  
MEASUREMENT LAYOUT & SECTION  
Figure 2.5-227**

Figure 2.5-227 Typical In-Situ Soil Dynamics Measurements Layout & Section

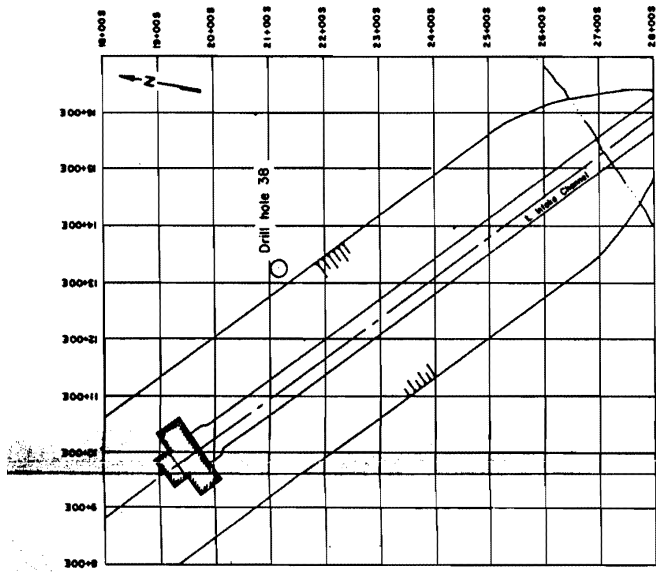

SEISMIC LINE NUMBER	SEISMIC PATH DISTANCE (FEET)	COMPRESSIONAL VELOCITY FT./SEC. MEASURED	SHEAR VELOCITY FT./SEC. CALCULATED	DENSITY LB./CU.FT. ASSUMED	POISSON'S RATIO ASSUMED	DYNAMIC SHEAR MODULUS PST. X 10 <sup>3</sup> CALCULATED	DYNAMIC YOUNG'S MODULUS PST. X 10 <sup>3</sup> CALCULATED
1 - A	40.31	3191	962	90	0.45	17.97	52.11
2 - A	40.31	3312	999	90	0.45	19.36	56.13
3 - A	40.31	3182	959	90	0.45	17.87	51.81
4 - A	40.31	3410	1028	90	0.45	20.52	59.50
AVERAGE	40.31	3274	987	90	0.45	18.28	54.85

NOTES:

1. THE LINES ON THE SECTIONS BETWEEN SHOT POINTS AND GEOPHONE LOCATIONS INDICATE ONLY THE TRAVEL DIRECTION OF COMPRESSIONAL WAVES.
2. THE TYPES OF SOILS ARE BASED ON GENERAL SOIL DATA OBTAINED FROM THE CONSTRUCTION SERVICES BRANCH.
4. THE EQUIPMENT USED IN MAKING THE TIME MEASUREMENTS CONSISTED OF A BILSON SEISMOGRAPH 1570B AND RECORDER 1540, AND A HALL SEARS GEOPHONE 1P-8.
5. USING ALL 4 SEISMIC LINES THE SHEAR MODULUS WITH A 67% CONFIDENCE INTERVAL IS 17,670 PSI TO 20,180 PSI AND WITH A 90% CONFIDENCE INTERVAL IT IS 16,410 PSI TO 21,440 PSI.



WATTS BAR NUCLEAR PLANT  
FINAL SAFETY  
ANALYSIS REPORT

SOIL DYNAMICS INTAKE CHANNEL  
STATION 13+ 26E, 21 + 12S

Figure 2.5-228

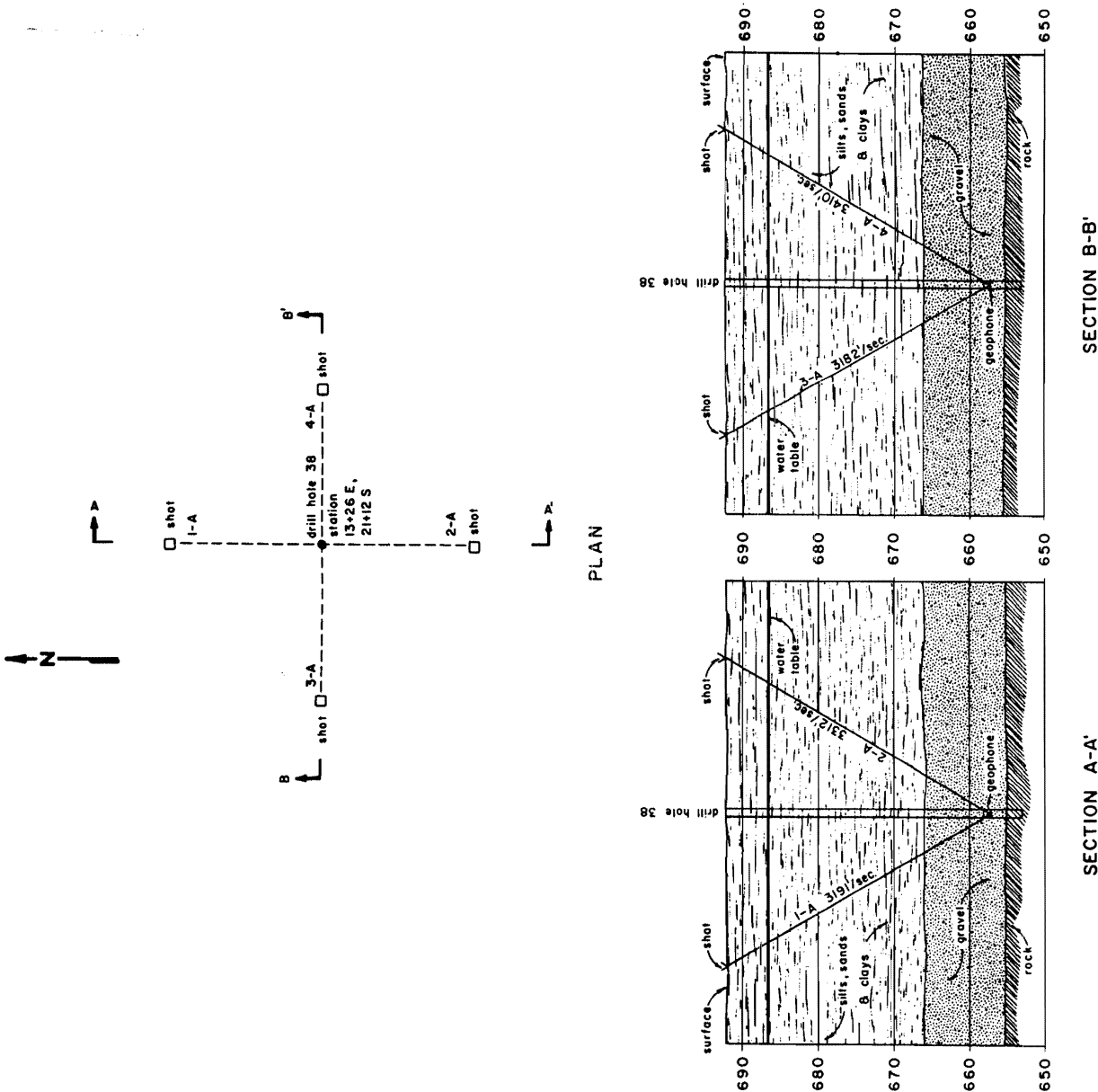

Figure 2.5-228 Soil Dynamics Intake Channel Station 13 + 26E, 21 + 12S

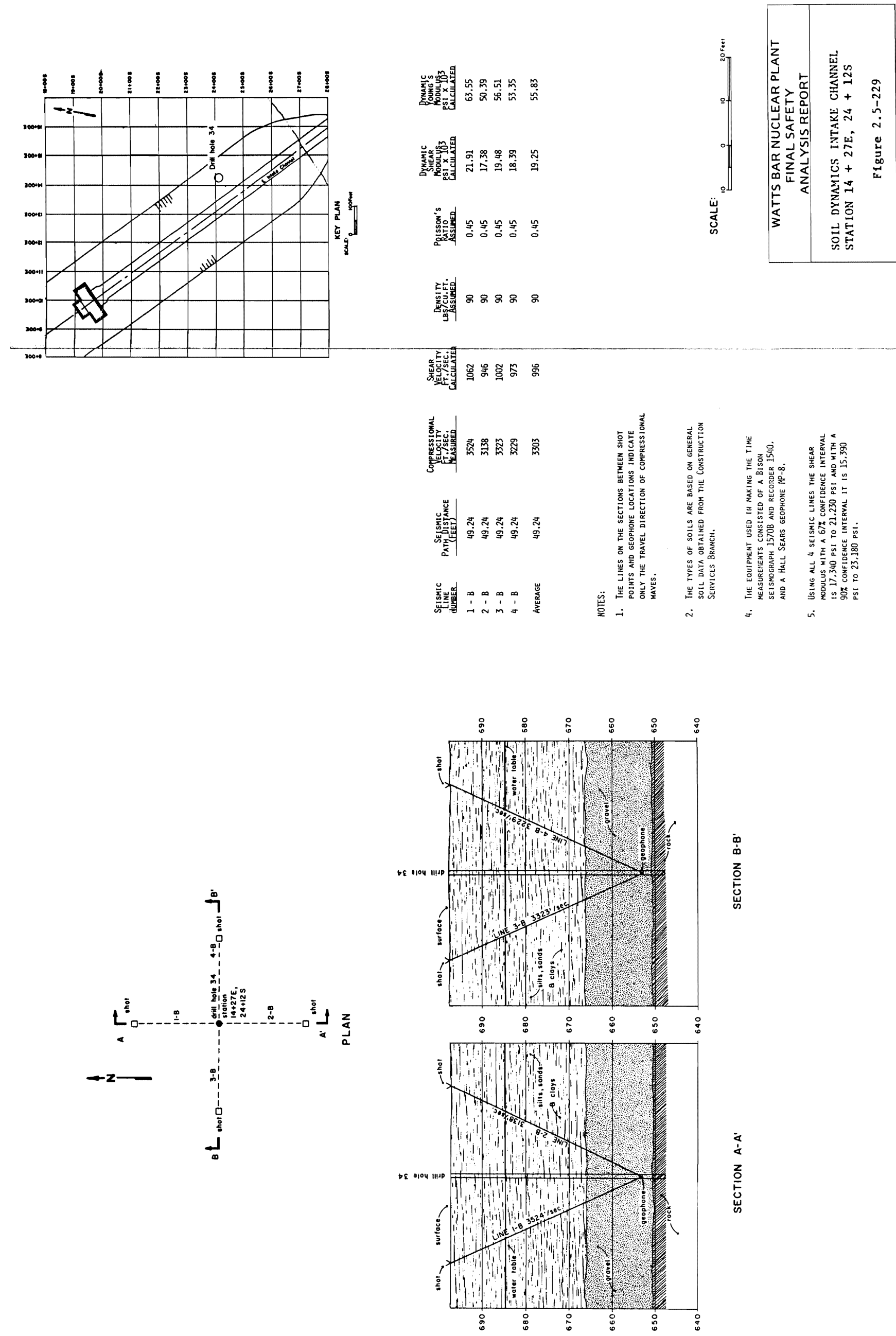
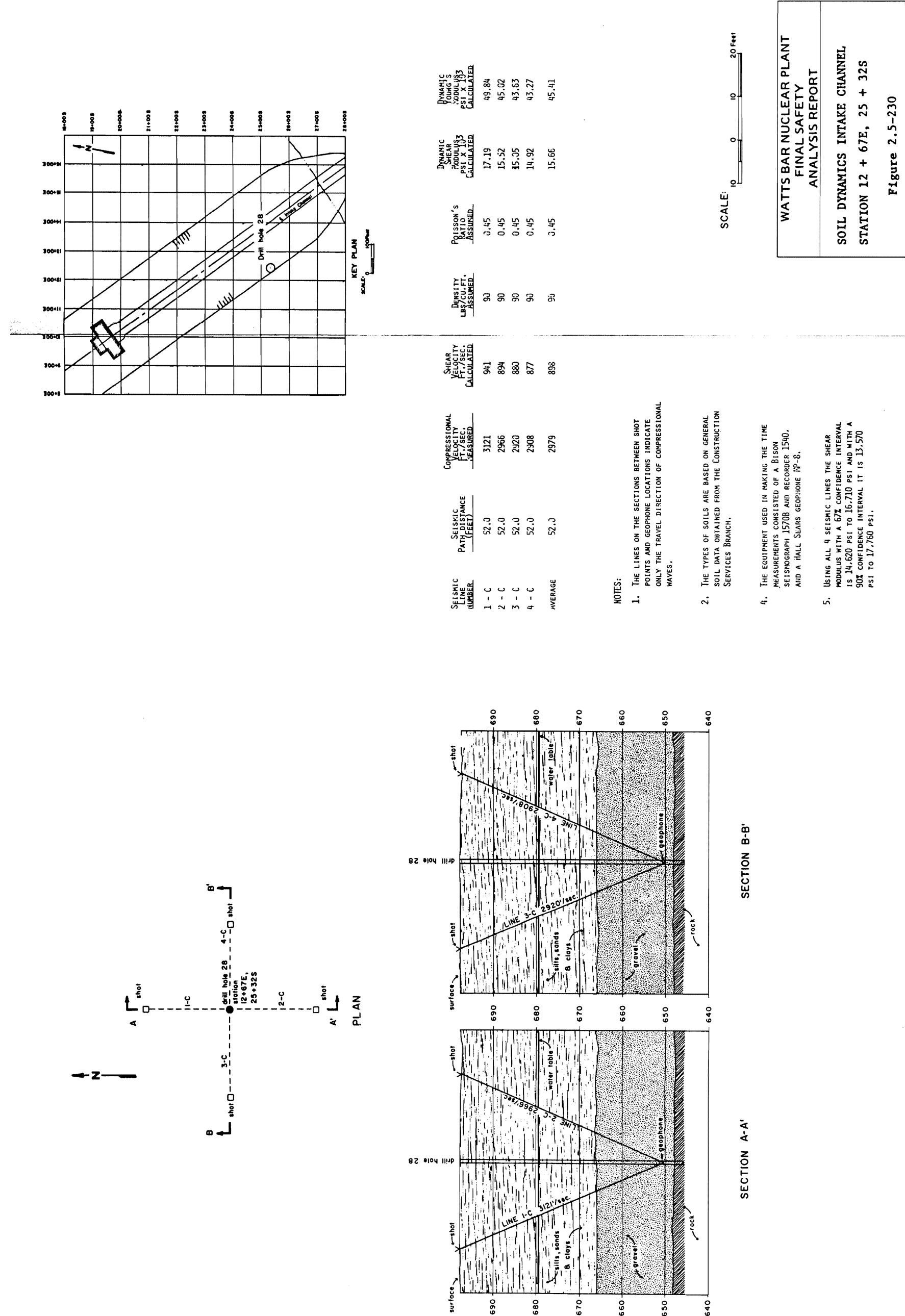

Figure 2.5-229 Soil Dynamics Intake Channel Station 14 + 27E, 24 + 12S



WATTS BAR NUCLEAR PLANT  
FINAL SAFETY  
ANALYSIS REPORT

SOIL DYNAMICS INTAKE CHANNEL  
STATION 12 + 67E, 25 + 32S

Figure 2.5-230

Figure 2.5-230 Soil Dynamics Intake Channel Station 12 + 67E, 25 + 32S

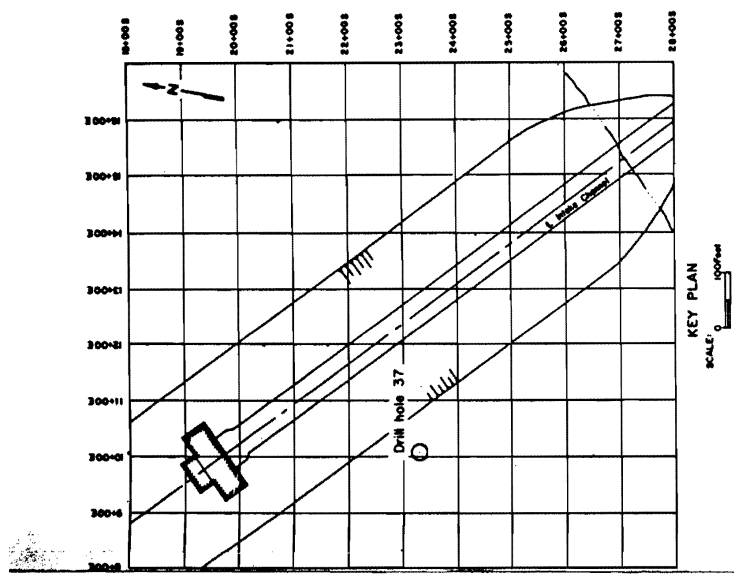

DENSITY LBS/CU.FT. ASSUMED	POISSON'S RATIO ASSUMED	DYNAMIC SHEAR MODULUS PSI X 10 <sup>3</sup> CALCULATED	DYNAMIC YOUNG'S MODULUS PSI X 10 <sup>3</sup> CALCULATED
90	0.45	15.35	47.42
90	0.45	15.17	43.99
90	0.45	15.83	45.90
90	0.45	13.56	39.32
90	0.45	15.21	44.11

SEISMIC LINE NUMBER	SEISMIC PATH DISTANCE (FEET)	COMPRESSIONAL VELOCITY FT./SEC. MEASURED	SHEAR VELOCITY FT./SEC. CALCULATED
1 - U	44.72	3044	918
2 - D	44.72	2932	884
3 - U	44.72	2995	903
4 - D	44.72	2772	836
AVERAGE	44.72	2936	885

NOTES:  
1. THE LINES ON THE SECTIONS BETWEEN SHOT POINTS AND GEOPHONE LOCATIONS INDICATE ONLY THE TRAVEL DIRECTION OF COMPRESSIONAL WAVES.

2. THE TYPES OF SOILS ARE BASED ON GENERAL SOIL DATA OBTAINED FROM THE CONSTRUCTION SERVICES BRANCH.

4. THE EQUIPMENT USED IN MAKING THE TIME MEASUREMENTS CONSISTED OF A BISON SEISMOGRAPH 1570B AND RECORDER 1540, AND A HALL SEARS GEOPHONE #8-8.

5. USING ALL 4 SEISMIC LINES THE SHEAR MODULUS WITH A 67% CONFIDENCE INTERVAL IS 14,010 PSI TO 16,450 PSI AND WITH A 90% CONFIDENCE INTERVAL IT IS 12,800 PSI TO 17,650 PSI.

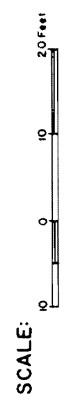

WATTS BAR NUCLEAR PLANT  
FINAL SAFETY  
ANALYSIS REPORT  
SOIL DYNAMICS INTAKE CHANNEL  
STATION 10 + 07E, 23 + 53S  
Figure 2.5-231

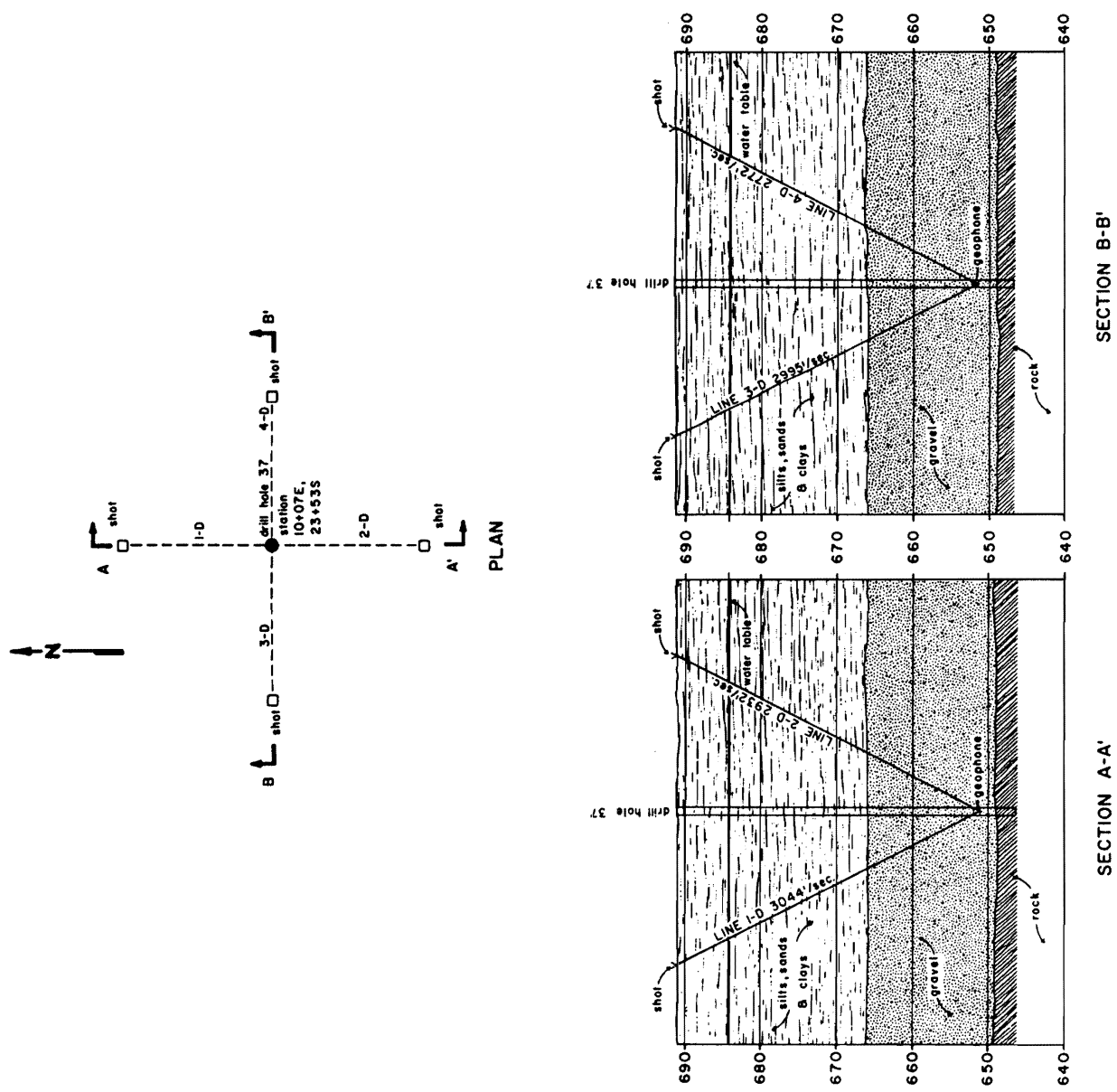
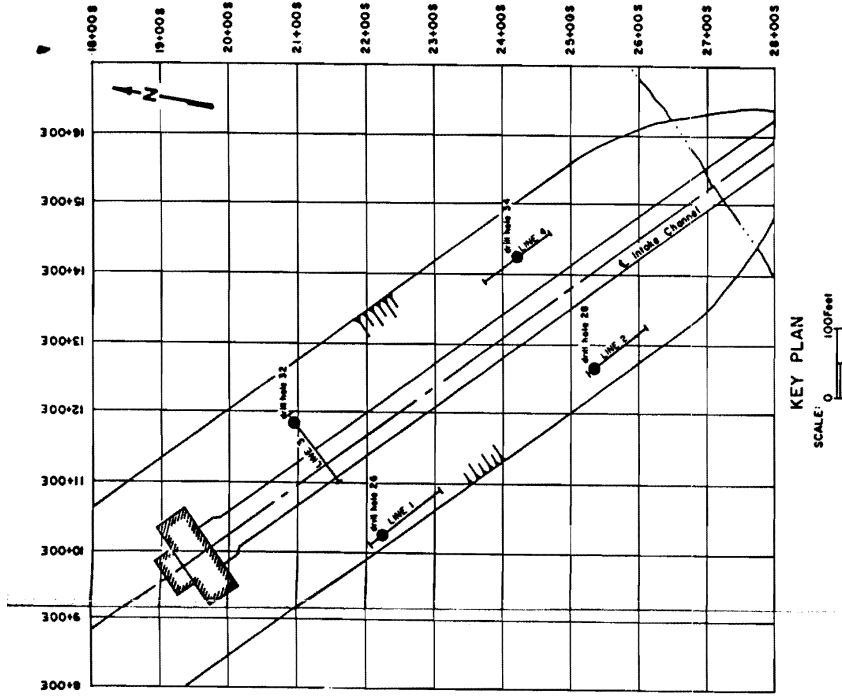

Figure 2.5-231 Soil Dynamics Intake Channel Station 10 + 07E, 23 + 53S



NOTES:

1. THE TYPES OF SOILS ARE BASED ON GENERAL SOIL DATA OBTAINED FROM THE CONSTRUCTION SERVICES BRANCH.
2. THE EQUIPMENT USED IN MAKING THE REFRACTION SURVEY CONSISTED OF A BISON SEISMOGRAPH 1570B AND RECORDER 1540.
3. THE REFRACTED COMPRESSIONAL VELOCITY OF FOR SATURATED GRAVELS. THIS VELOCITY IS NOT COMPATIBLE WITH THE UP-HOLE SEISMIC VELOCITY MEASUREMENTS AND DOES NOT COMPARE FAVORABLE WITH LINES 1, 3 AND 4.
4. THE SOIL VELOCITIES BELOW THE WATER TABLE DO NOT DIFFERENTIATE BETWEEN SILTS AND GRAVELS. THIS MAY BE THE RESULT OF THE GRADATIONAL NATURE OF THE SOIL.
5. REFRACTED SHEAR VELOCITIES FOR ZONES 1 AND 2 ALONG LINES 1, 3 AND 4 WERE OBTAINED. THE REFRACTION SEISMIC LINES WERE SURVEYED IN TWO DIRECTIONS WITH APPARENT VELOCITIES BEING AVERAGED FOR EACH LINE.

SEISMIC REFRACTION LINES SOIL DYNAMIC PROPERTIES

SEISMIC REFRACTION LINE	VELOCITY ZONES ELEVATIONS	COMPRESSIONAL VELOCITY FT./SEC. MEASURED	SHEAR VELOCITY FT./SEC.	DENSITY LBS./CU. FT. ASSUMED	POISSON'S RATIO CALCULATED	DYNAMIC SHEAR MODULUS PSI X 10 <sup>3</sup> CALCULATED	DYNAMIC YOUNG'S MODULUS PSI X 10 <sup>3</sup> CALCULATED
LINE 1	697 - 670 679 - 648	1200 4750	545 MEASURED 1130 MEASURED	90 90	0.37 0.46	5.77 32.44	15.80 94.72
LINE 2	691 - 682 682 - 666 666 - 640	1200 2950 8150	545 CALCULATED 803 CALCULATED 2218 CALCULATED	90 90 90	0.37 0.46 0.46	5.77 12.51 95.50	15.80 36.54 278.86
LINE 3	691 - 679 679 - 658	1150 5600	572 MEASURED 1574 MEASURED	90 90	0.37 0.46	5.29 45.09	14.51 131.66
LINE 4	697 - 685 685 - 654	1200 4400	545 MEASURED 1130 MEASURED	90 90	0.37 0.46	5.77 25.67	15.80 75.13

DYNAMIC SHEAR MODULUS SEISMIC LINES 1, 3 AND 4 STANDARD DEVIATION

ZONE	67% CONFIDENCE INTERVAL - PSI X 10 <sup>3</sup>	90% CONFIDENCE INTERVAL - PSI X 10 <sup>3</sup>	AVERAGE - PSI X 10 <sup>3</sup>
1	5.33 TO 5.88	5.05 TO 6.16	5.61
2	9.85 TO 24.54	14.68 TO 54.11	34.40

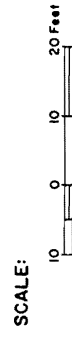

WATTS BAR NUCLEAR PLANT  
FINAL SAFETY  
ANALYSIS REPORT

SEISMIC REFRACTION DYNAMIC  
PROPERTIES INTAKE CHANNEL

Figure 2.5-232

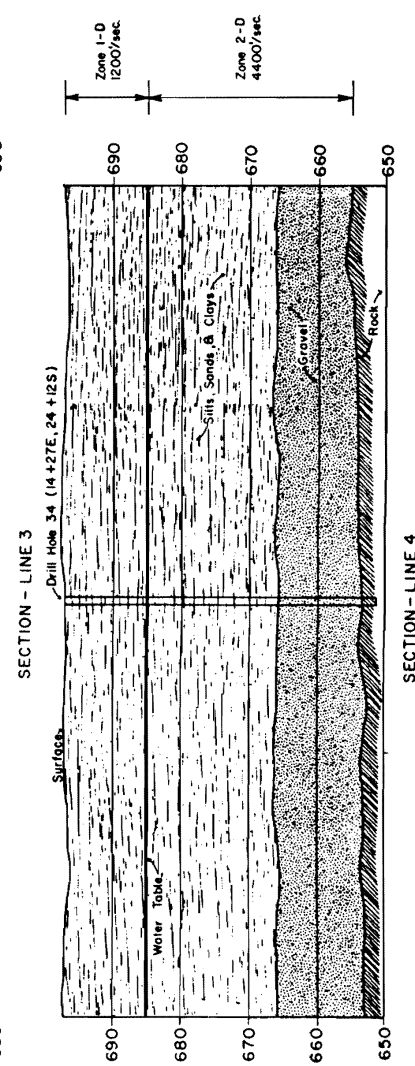
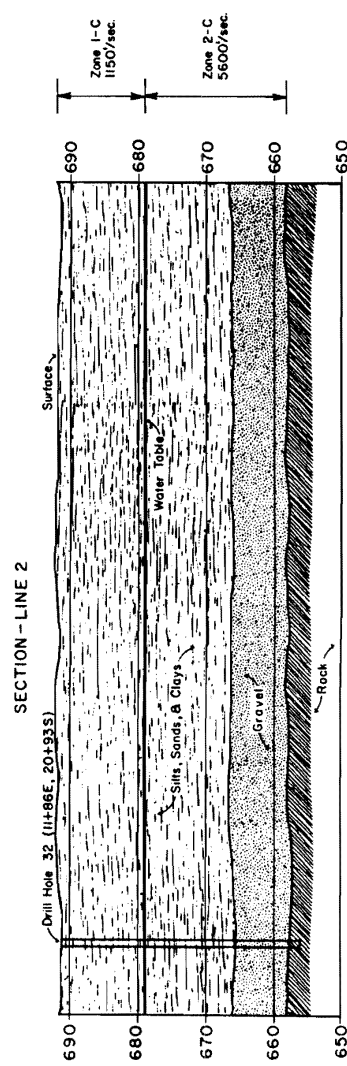
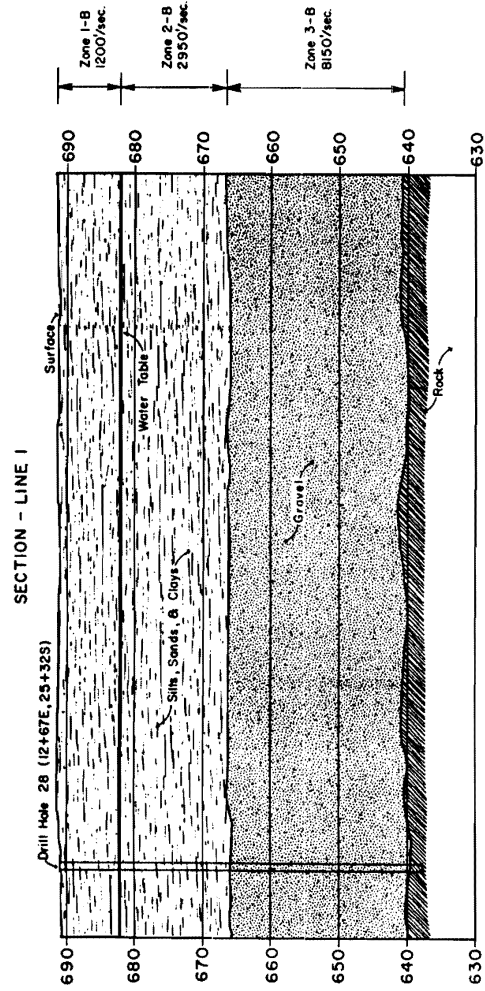
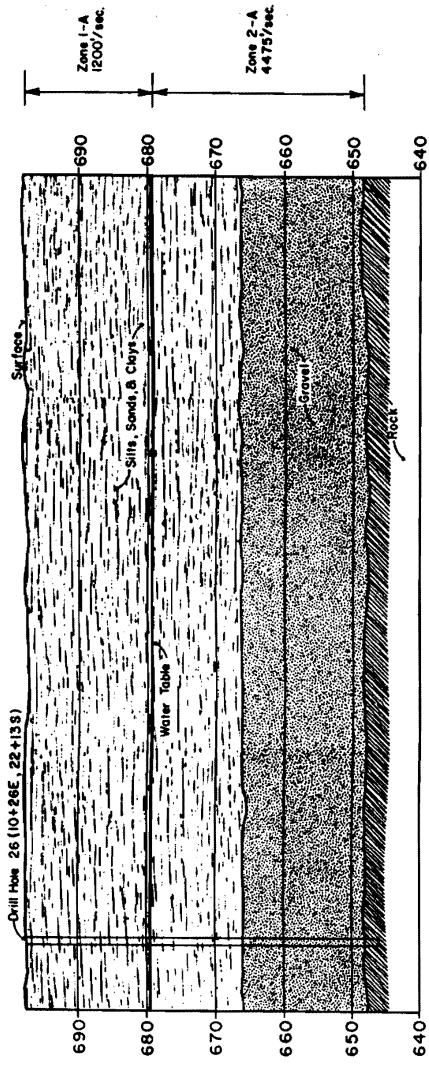

Figure 2.5-232 Seismic Refraction Dynamic Properties Intake Channel

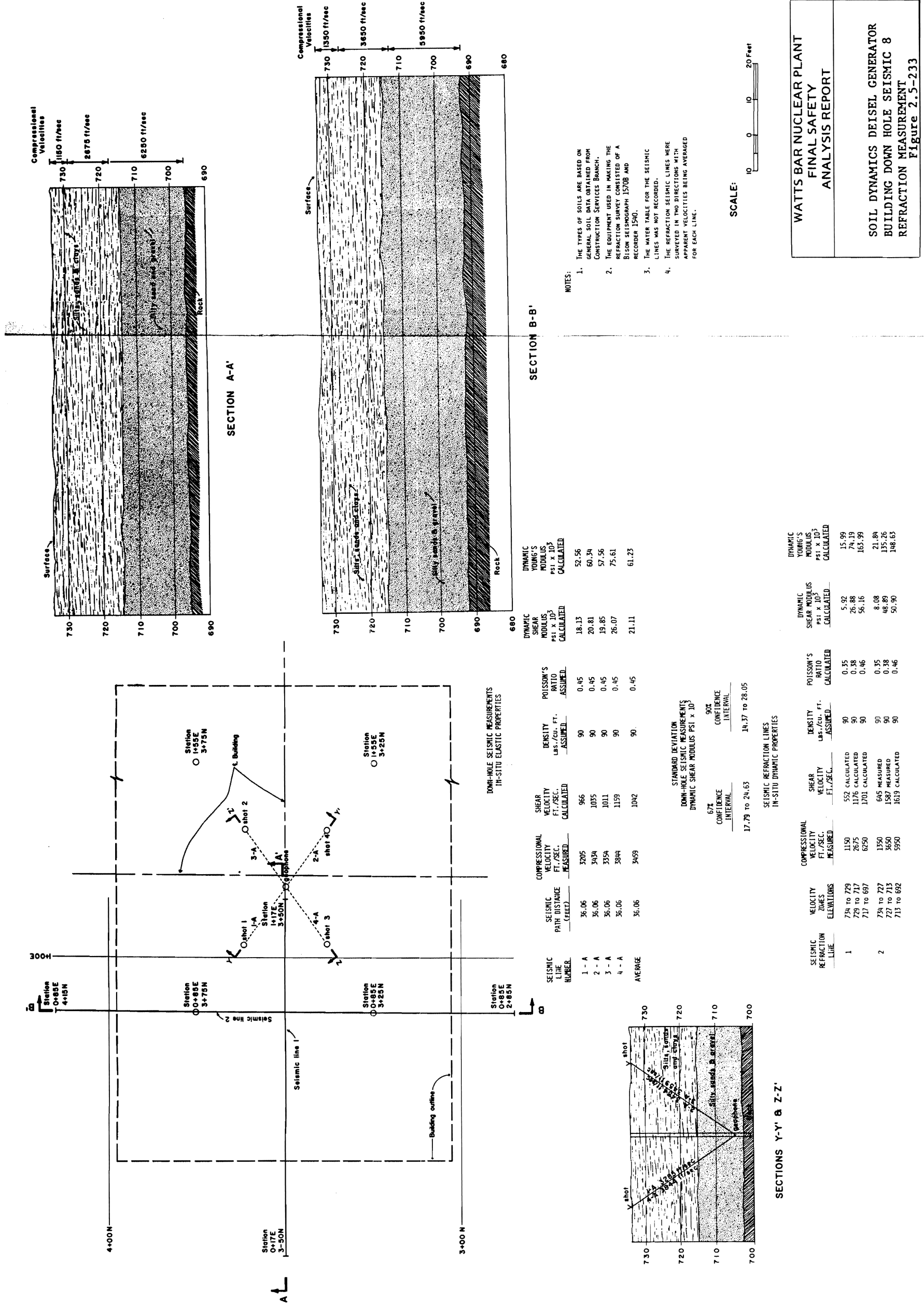
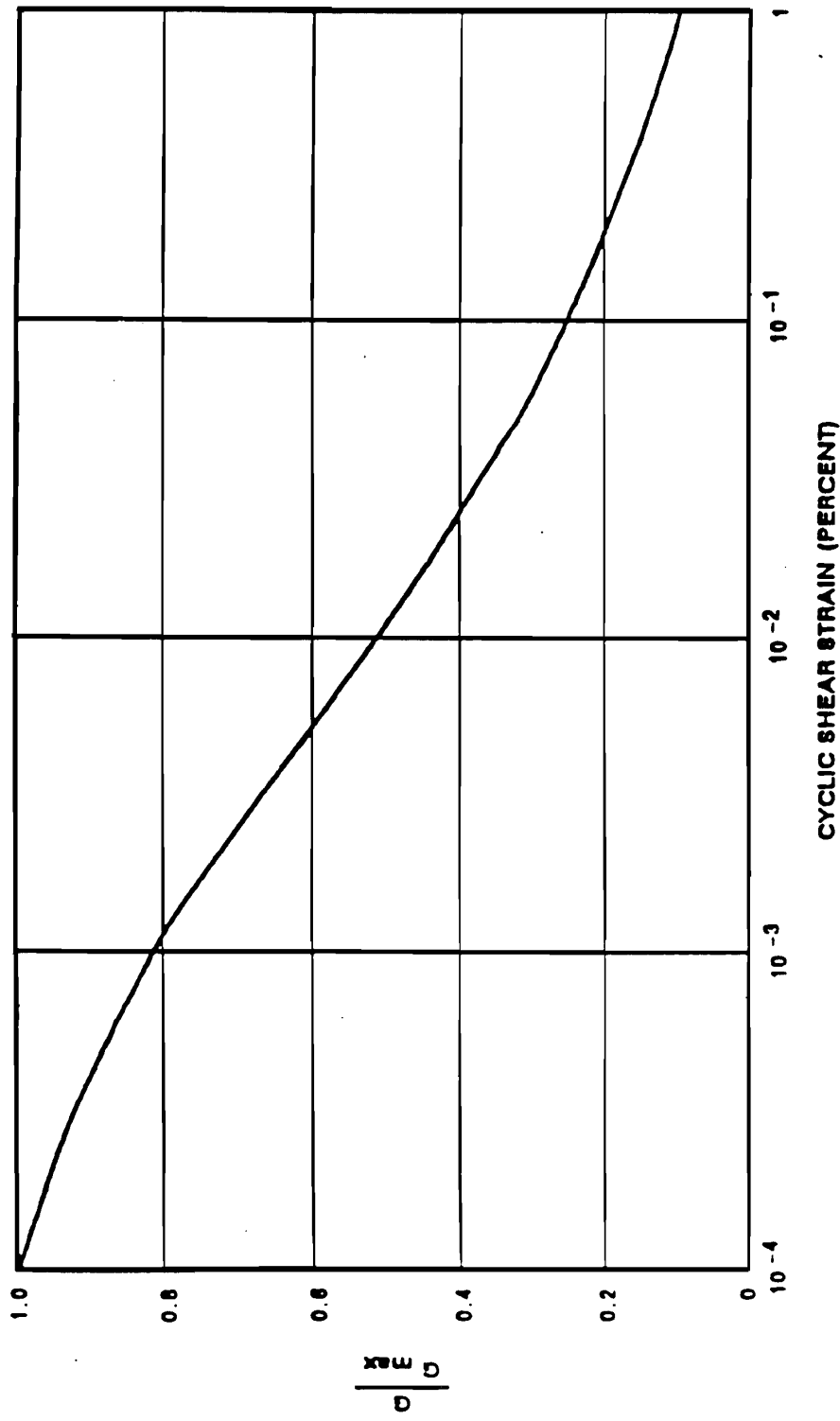

Figure 2.5-233 Soil Dynamics Diesel Generator Building Down Hole Seismic 8 Refraction Measurement





WATTS BAR NUCLEAR PLANT FINAL SAFETY ANALYSIS REPORT
CLASS A BACKFILL
SHEAR MODULUS REDUCTION WITH SHEAR STRAIN
Figure 2.5-233A

Amendment 63

Figure 2.5-233a Class A Backfill -Shear Modulus Reduction with Shear Strain

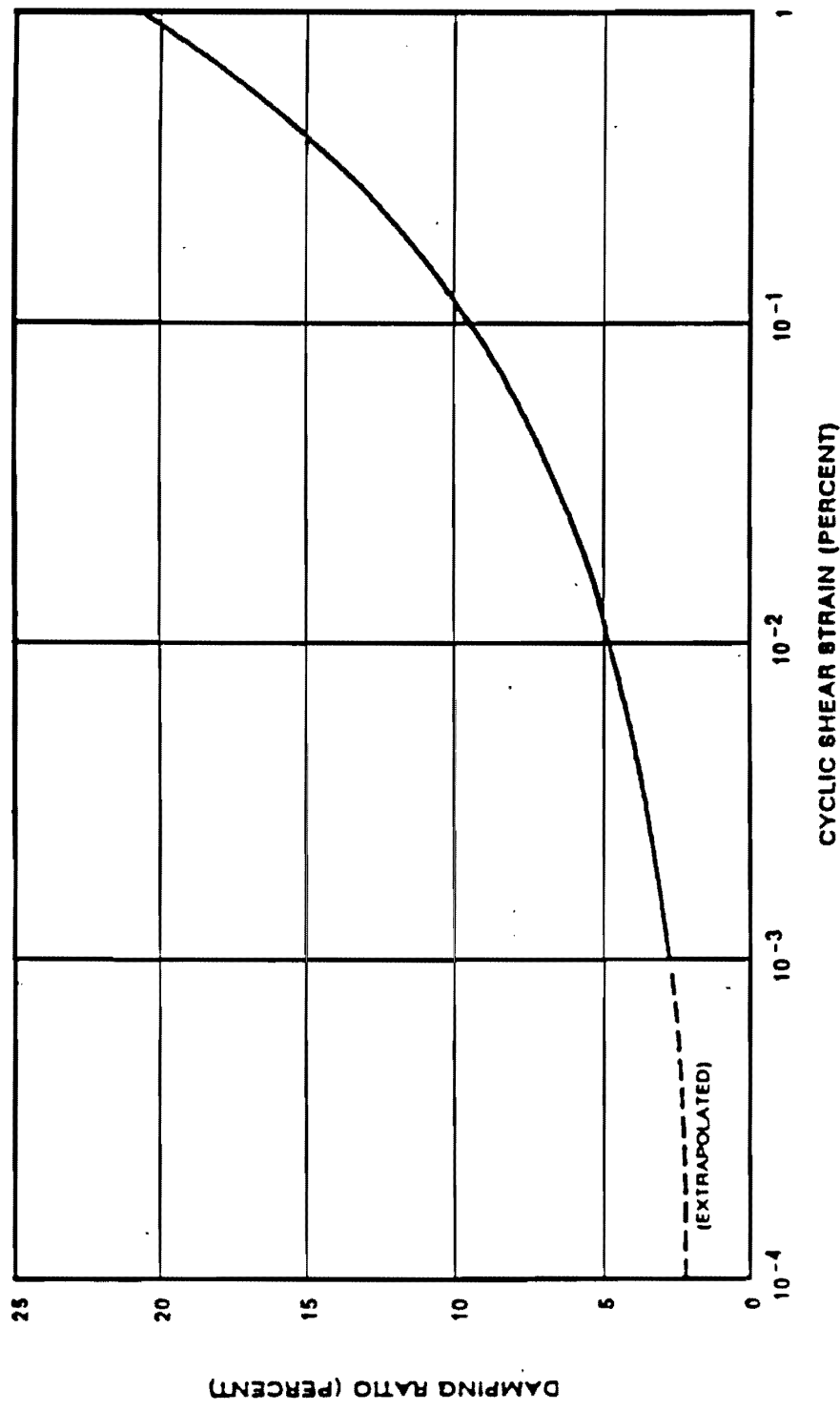

<b>WATTS BAR NUCLEAR PLANT FINAL SAFETY ANALYSIS REPORT</b>
<b>CLASS A BACKFILL</b>
<b>DAMPING RATIO VARIATION WITH SHEAR STRAIN</b>
<b>Figure 2.5-233B</b>

Amendment 63

Figure 2.5-233b Class A Backfill -Damping Ratio Variation with Shear Strain

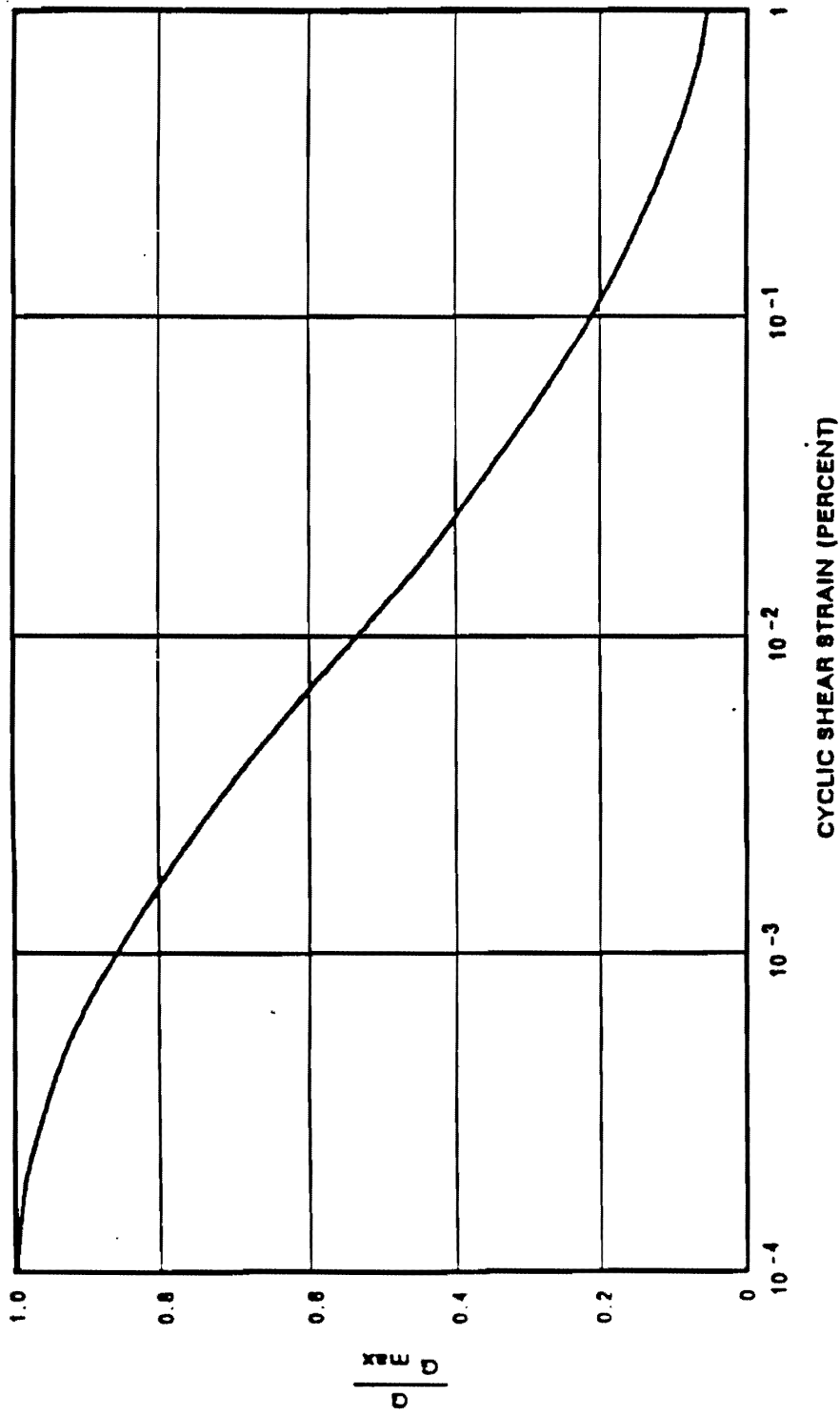

<b>WATTS BAR NUCLEAR PLANT FINAL SAFETY ANALYSIS REPORT</b>
<b>CRUSHED STONE BACKFILL SHEAR MODULUS REDUCTION WITH SHEAR STRAIN</b>
<b>Figure 2.5-233C</b>

Amendment 63

Figure 2.5-233c Crushed Stone Backfill - Shear Modulus Reduction with Shear Strain

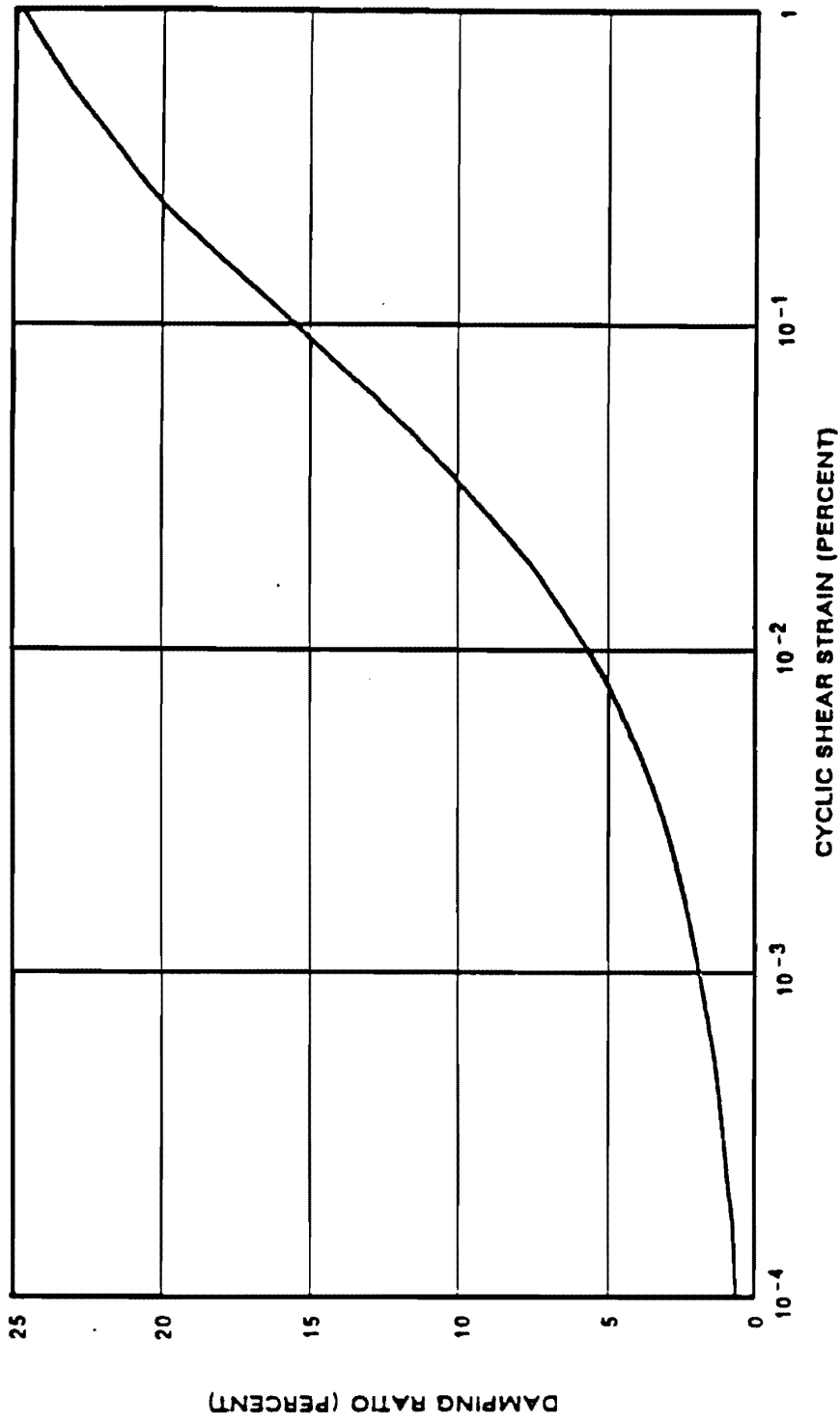

<b>WATTS BAR NUCLEAR PLANT FINAL SAFETY ANALYSIS REPORT</b>
<b>CRUSHED STONE BACKFILL DAMPING RATIO VARIATION WITH SHEAR STRAIN</b>
<b>Figure 2.5-233D</b>

Amendment 63

Figure 2.5-233d Crushed Stone Backfill - Damping Ratio Variation with Shear Strain

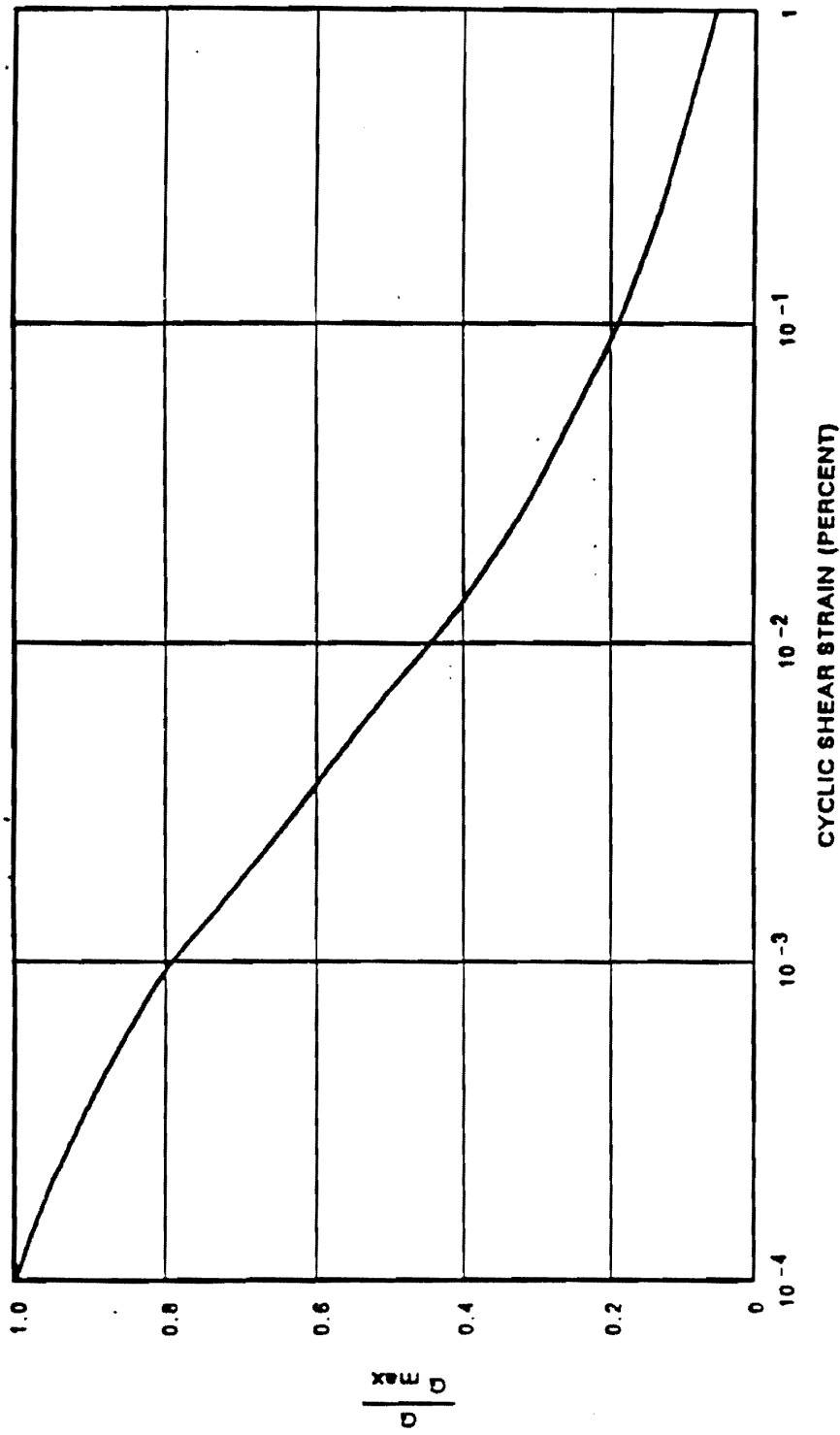

<p><b>WATTS BAR NUCLEAR PLANT FINAL SAFETY ANALYSIS REPORT</b></p>
<p><b>IN SITU COHESIVE SOILS SHEAR MODULUS REDUCTION WITH SHEAR STRAIN</b></p>
<p><b>Figure 2.5-233E</b></p>

Amendment 63

Figure 2.5-233e In Situ Cohesive Soils - Shear Modulus Reduction with Shear Strain

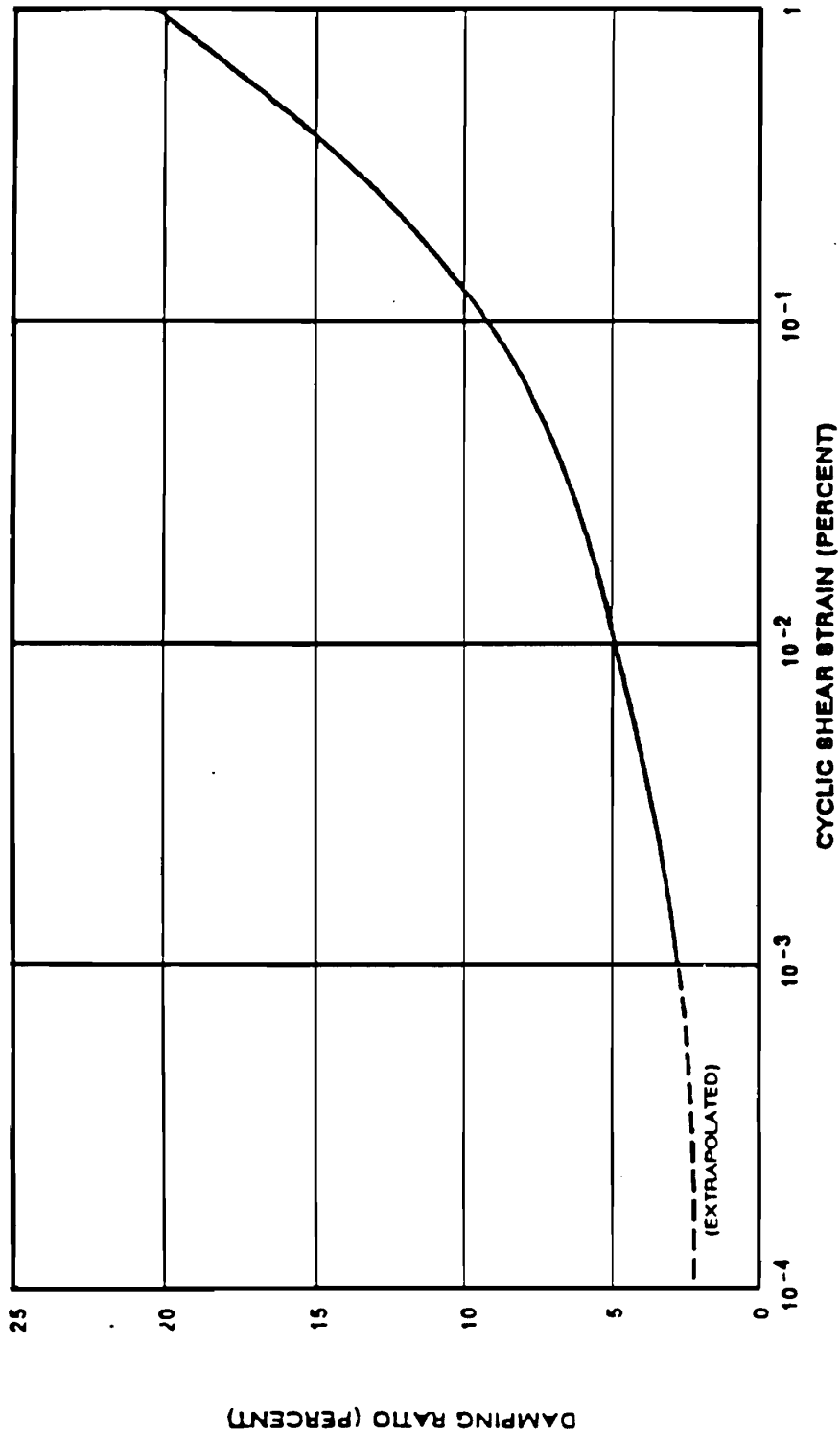

<p>WATTS BAR NUCLEAR PLANT FINAL SAFETY ANALYSIS REPORT</p>
<p>IN SITU COHESIVE SOILS DAMPING RATIO VARIATION WITH SHEAR STRAIN</p>
<p>Figure 2.5-233F</p>

Amendment 63

Figure 2.5-233f In Situ Cohesive Soils - Damping Ratio Variation with Shear Strain

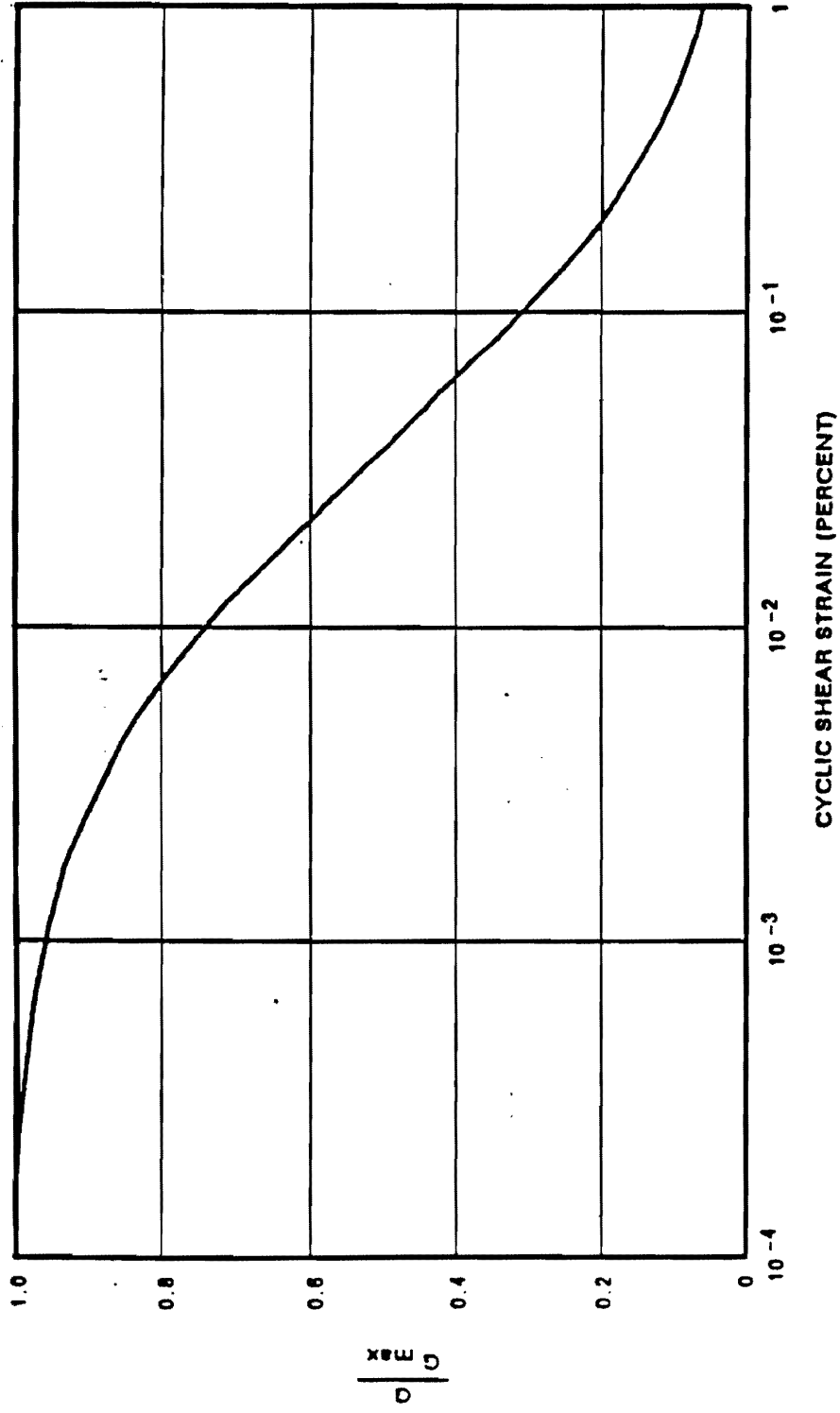

<b>WATTS BAR NUCLEAR PLANT FINAL SAFETY ANALYSIS REPORT</b>
<b>NON-PLASTIC IN SITU SOIL SHEAR MODULUS REDUCTION WITH SHEAR STRAIN</b>
<b>Figure 2.5-233G</b>

Amendment 63

Figure 2.5-233g Non-Plastic In Situ Soil - Shear Modulus Reduction with Shear Strain

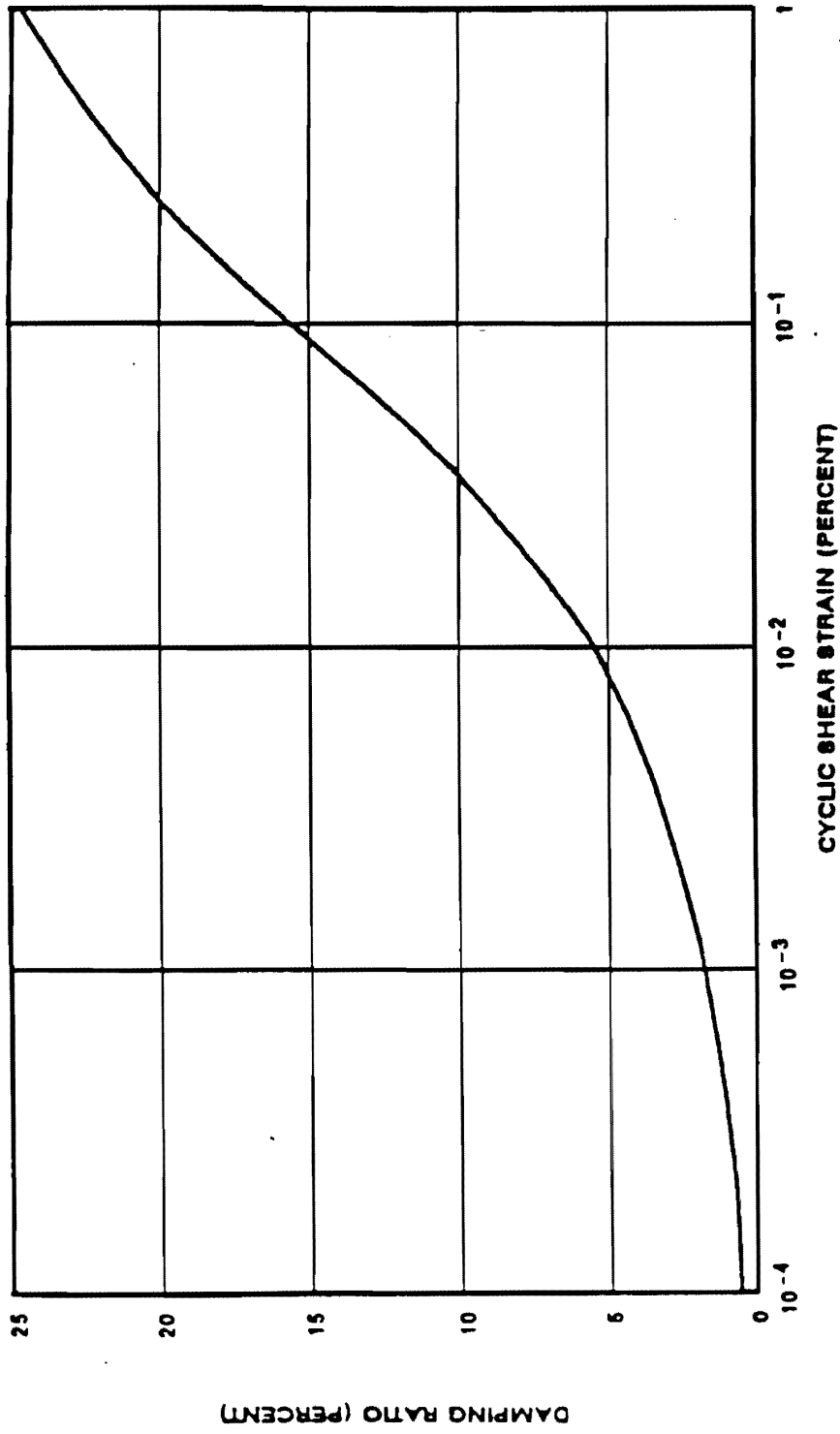

<p>WATTS BAR NUCLEAR PLANT FINAL SAFETY ANALYSIS REPORT</p>
<p>NON-PLASTIC IN SITU SOILS DAMPING RATIO VARIATION WITH SHEAR STRAIN</p>
<p>Figure 2.5-233H</p>

Amendment 63

Figure 2.5-233h Non-Plastic In Situ Soils - Damping Ratio Variation with Shear Strain



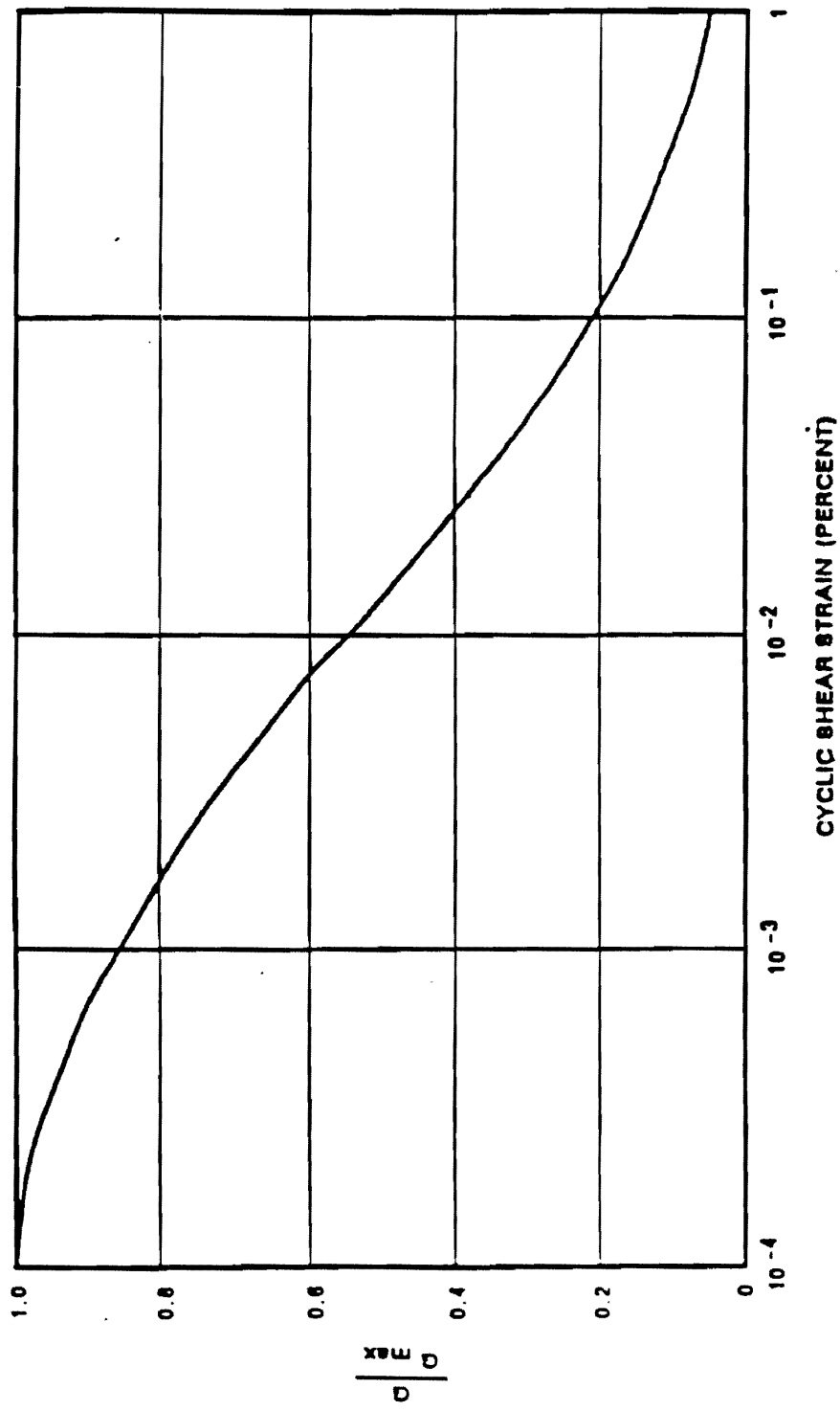

<b>WATTS BAR NUCLEAR PLANT FINAL SAFETY ANALYSIS REPORT</b>
<b>BASAL GRAVEL</b>
<b>SHEAR MODULUS REDUCTION WITH SHEAR STRAIN</b>
<b>Figure 2.5-233I</b>

Amendment 63

Figure 2.5-233i Basal Gravel - Shear Modulus Reduction with Shear Strain

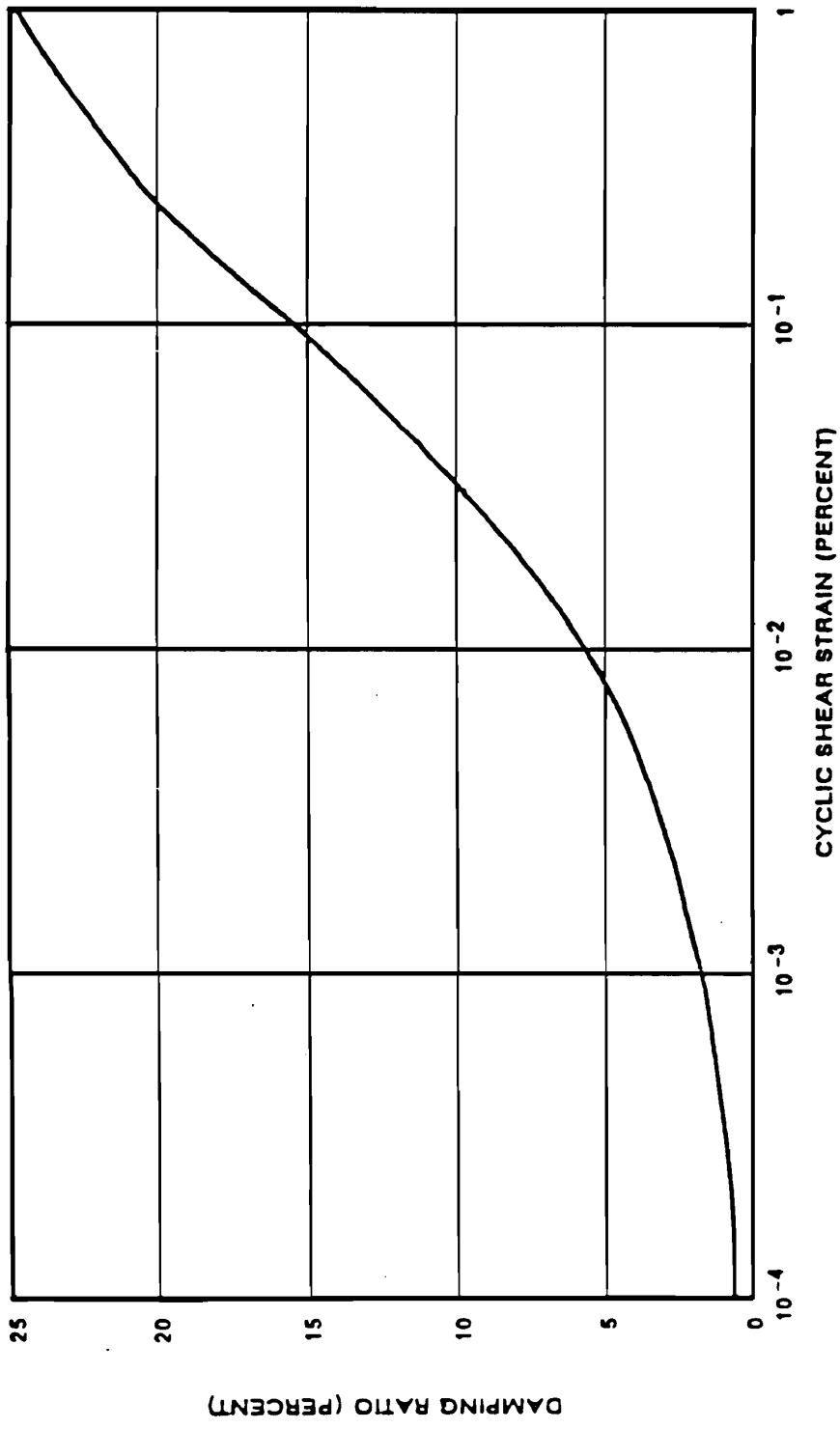

<b>WATTS BAR NUCLEAR PLANT FINAL SAFETY ANALYSIS REPORT</b>
<b>BASAL GRAVEL</b>
<b>DAMPING RATIO VARIATION WITH SHEAR STRAIN</b>
<b>Figure 2.5-233J</b>

Amendment 63

Figure 2.5-233j Basal Gravel - Damping Ratio Variation with Shear Strain

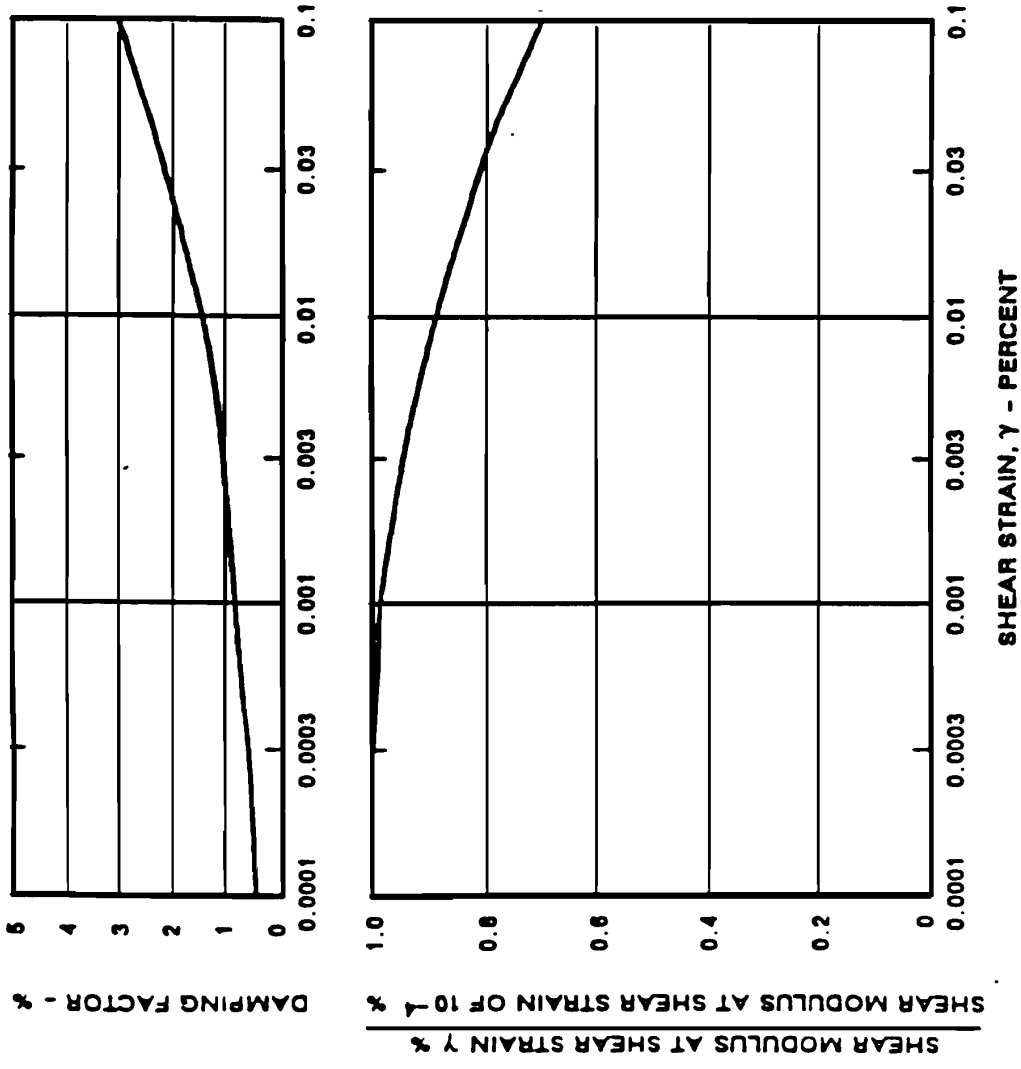

Amendment 63

<p>WATTS BAR NUCLEAR PLANT FINAL SAFETY ANALYSIS REPORT</p>
<p>WEATHERED SHALE</p>
<p>SHEAR MODULUS AND DAMPING VARIATION WITH SHEAR STRAIN</p>
<p>Figure 2.5-233K</p>

Figure 2.5-233k Weathered Shale - Shear Modulus and Damping Variation with Shear Strain

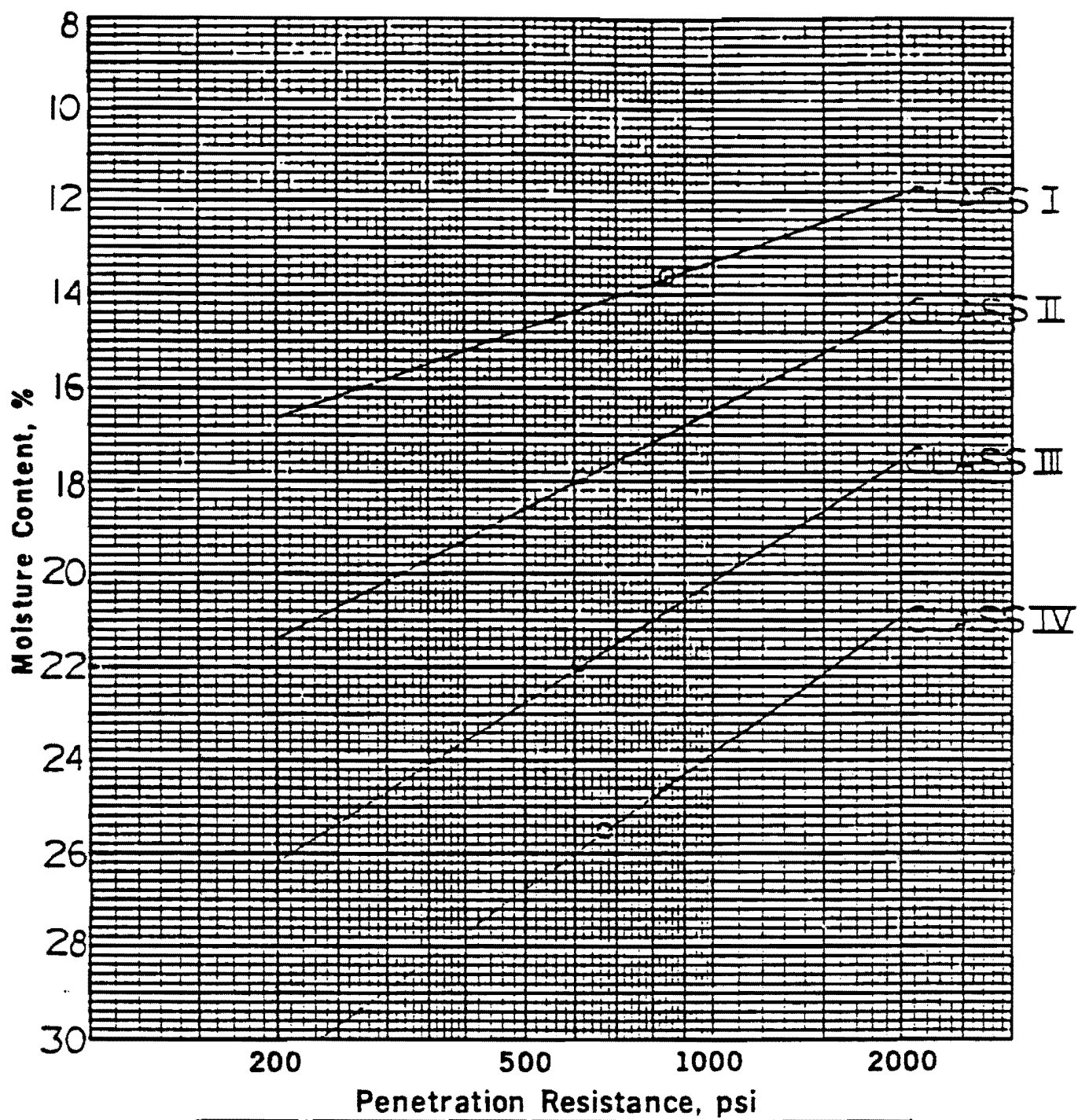

Soil Class	Optimum Moisture, %	Maximum Density, pcf	Penetration Resistance, psi
I-SC	13.6	116.3	850
II-CL	17.9	108.0	615
III-MH	21.8	101.1	615
IV-MH	25.5	94.2	680

Remarks:  
 REVISED 12-8-82

○ Denotes Optimum Moisture

WATTS BAR NUCLEAR PLANT  
 FINAL SAFETY  
 ANALYSIS REPORT

MAIN PLANT BORROW AREAS  
 MOISTURE-PENETRATION TEST

Figure 2.5-234

Amendment 63

Figure 2.5-234 Main Plant Borrow Areas, Moisture - Penetration Test

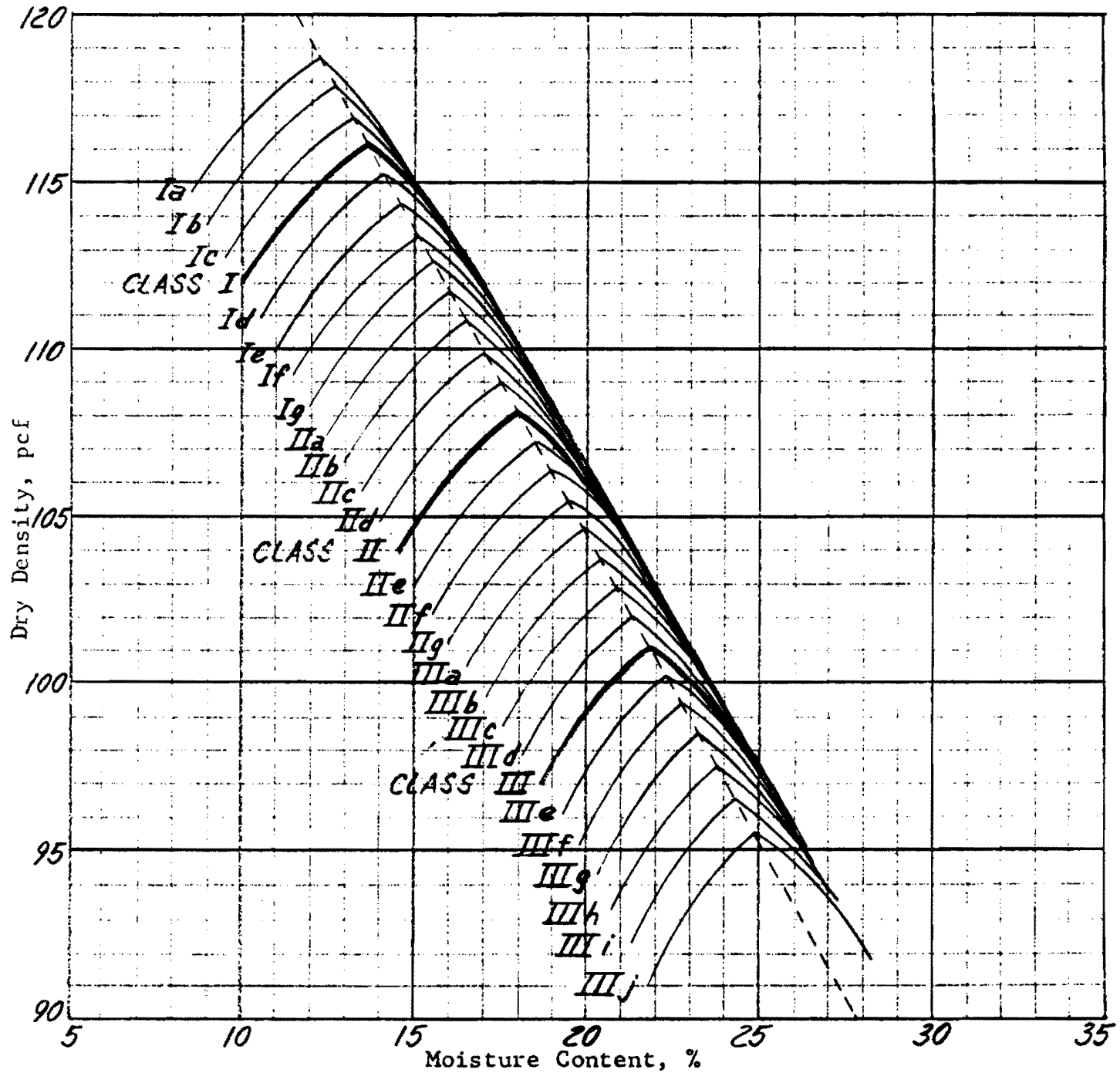

Soil Class	Gravel %	Sand %	Silt %	Clay %	Specific Gravity	LL %	PI %	Optimum Moisture, %	Maximum Density, pcf
I-SC	0	54	25	21	2.71	25.4	7.8	13.6	116.3
II-CL	0	35	29	36	2.73	41.9	18.6	17.9	108.0
III-MH	0	24	30	46	2.76	50.6	22.1	21.8	101.1

Plus No. 4 Specific Gravity, SSD	
Plus No. 4 Absorption, %	

Remarks:

---



---



---

**WATTS BAR NUCLEAR PLANT  
FINAL SAFETY  
ANALYSIS REPORT**

COMPACTION TEST  
BORROW AREAS (family of curves)  
date tested 1-5-73

Figure 2.5-235

Soil Form 14

Figure 2.5-235 Compaction Test Borrow Areas (Family Of Curves)

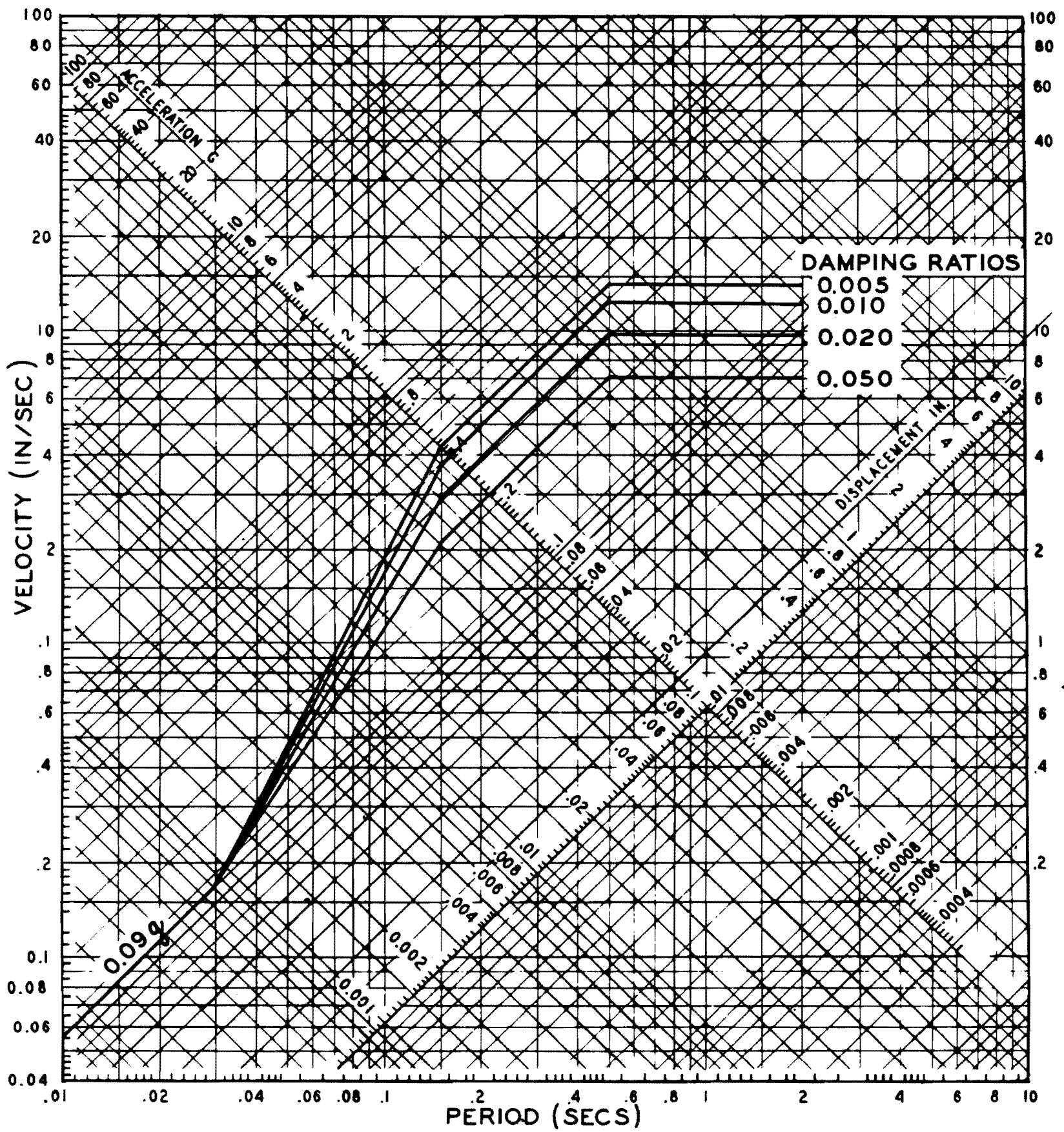

WATTS BAR NUCLEAR PLANT  
 FINAL SAFETY  
 ANALYSIS REPORT

OPERATING BASIS EARTHQUAKE  
 RESPONSE SPECTRA FOR ROCK SUPPORT  
 STRUCTURES

Figure 2.5-236a

Figure 2.5-236A Operating Basis Earthquake Response Spectra For Rock Support Structures

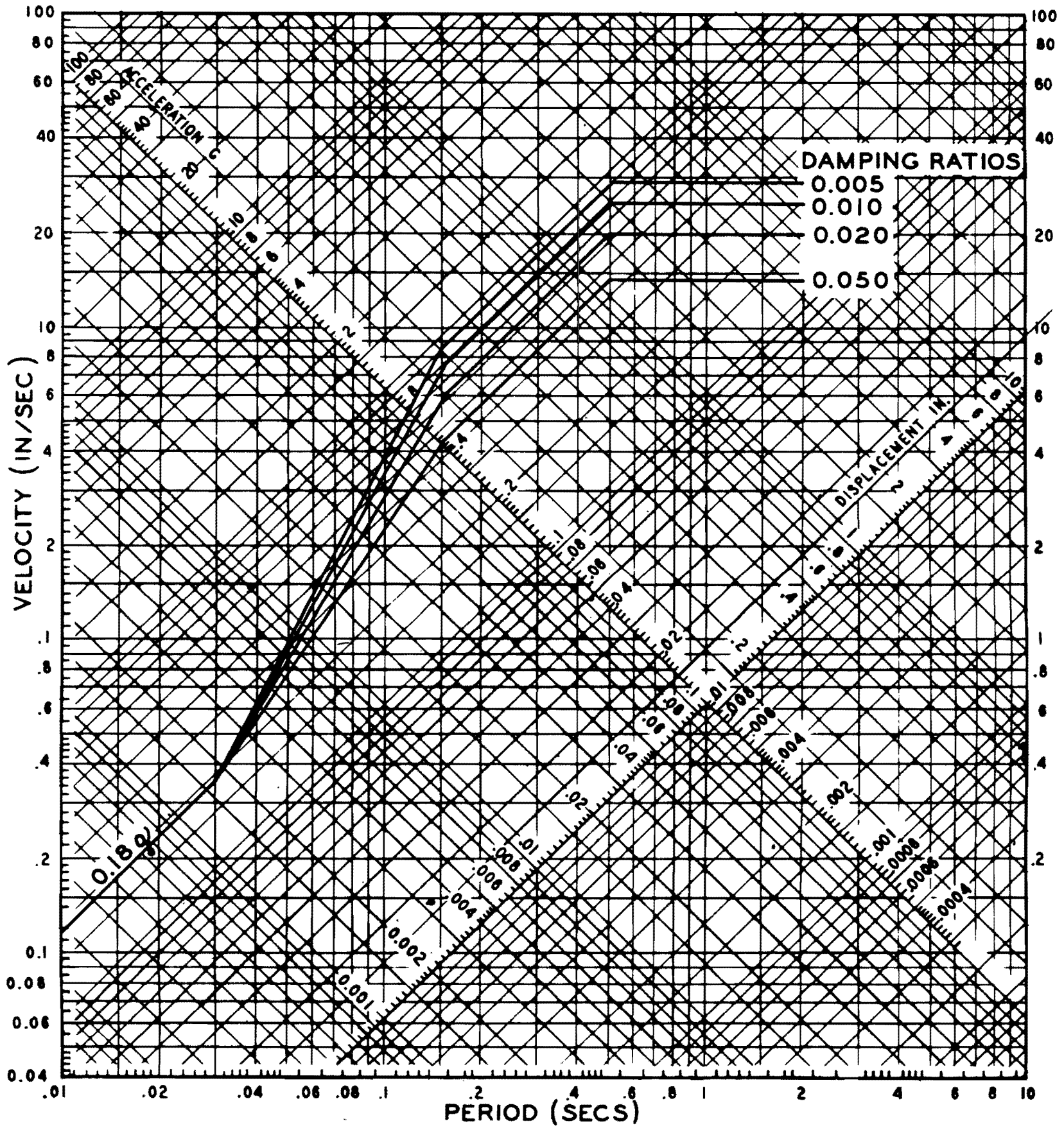

WATTS BAR NUCLEAR PLANT  
FINAL SAFETY  
ANALYSIS REPORT

SAFE SHUTDOWN EARTHQUAKE  
RESPONSE SPECTRA FOR ROCK SUPPORT  
STURCTURES

Figure 2.5-236b

Figure 2.5-236b Safe Shutdown Earthquake Response Spectra For Rock Support Structures

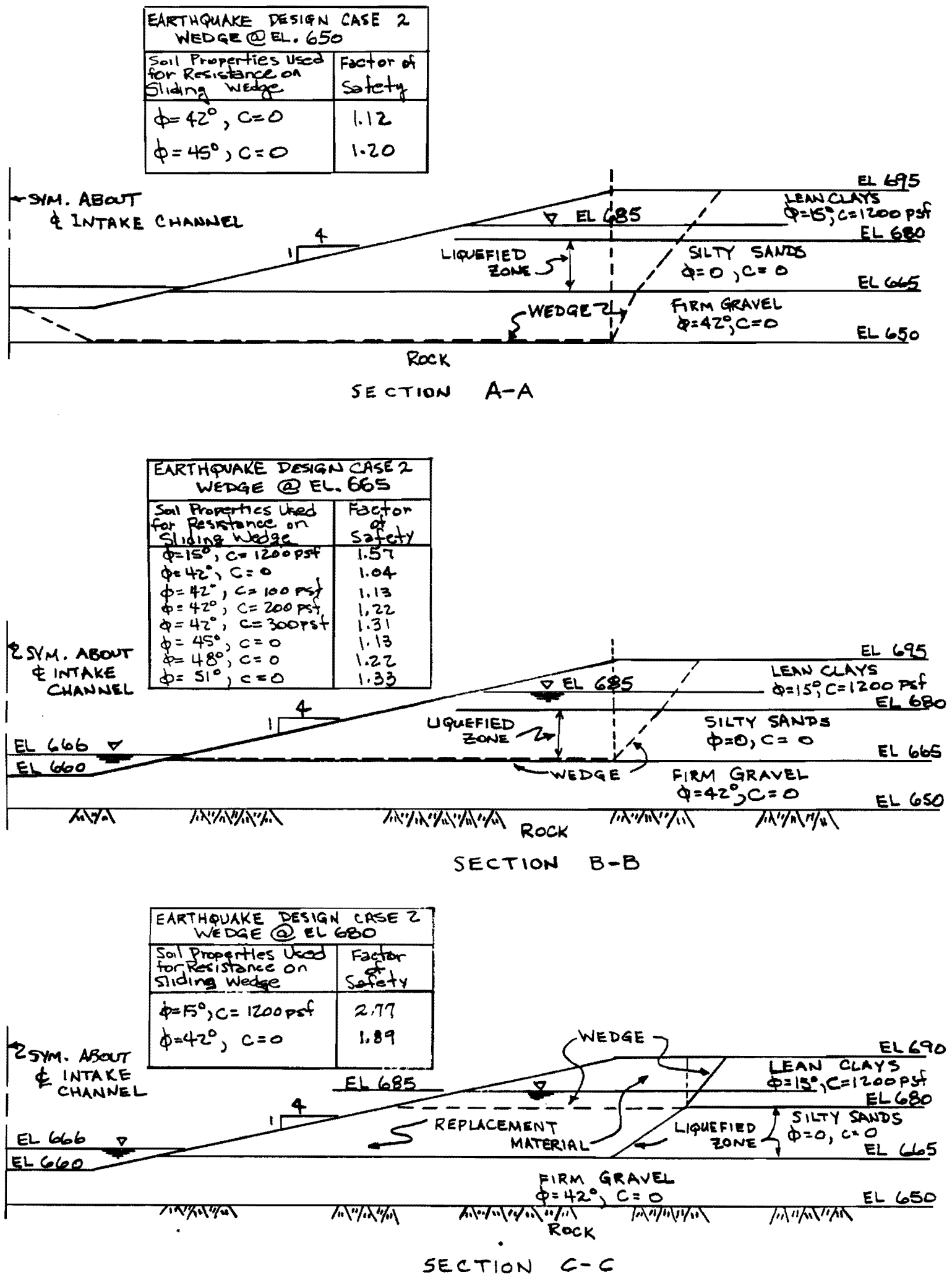
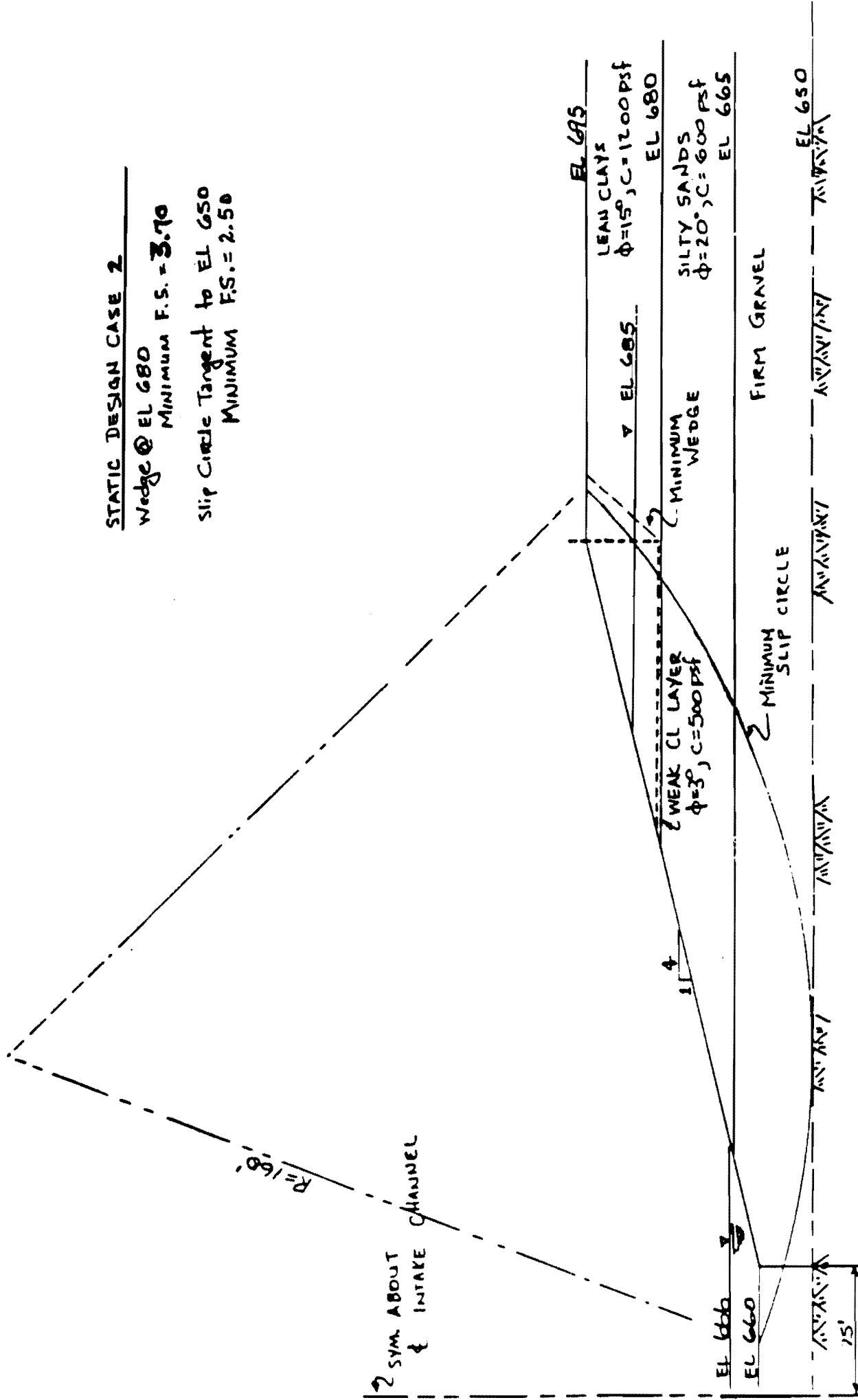

FIGURE 2.5-237  
INTAKE CHANNEL  
SEISMIC STABILITY ANALYSIS

NOTE:  
Soils above firm gravel will be removed and replaced as compacted fill with controlled compaction density and moisture content at least as far back as the critical wedges shown.  
See Figure 2.5-239

Figure 2.5-237 Intake Channel Seismic Stability Analysis





Amendment 63

FIGURE 2.5-238

Figure 2.5-238 Static Design Case 2

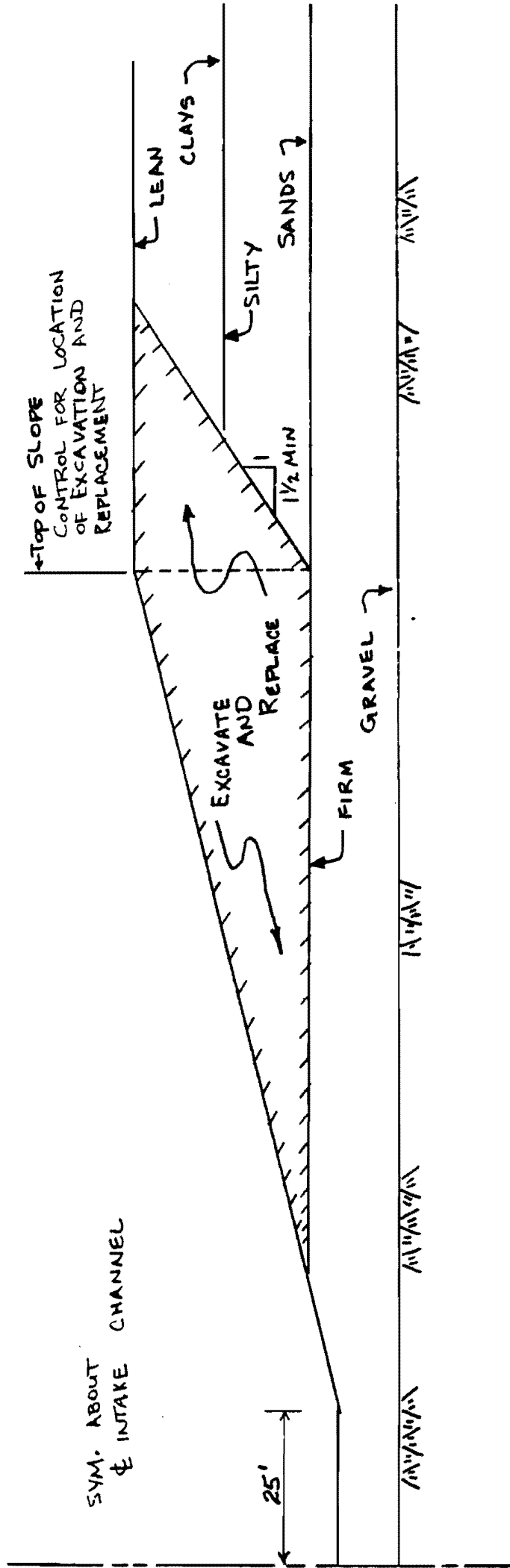
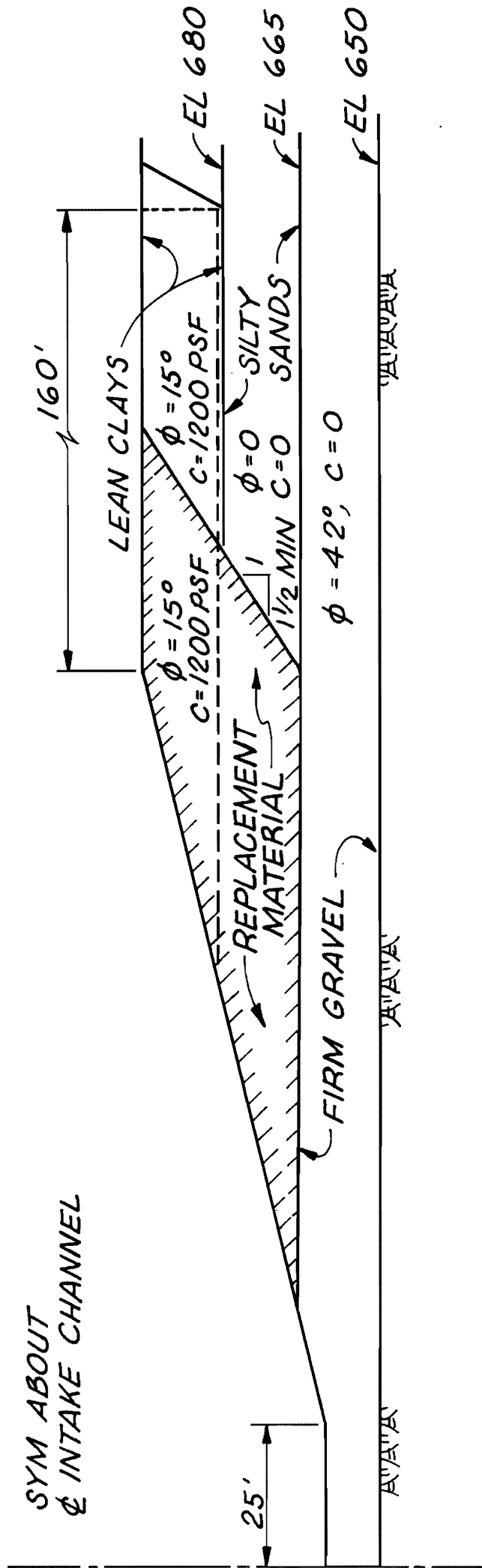

FIGURE 2.5-239  
INTAKE CHANNEL - LATERAL  
EXCAVATION & REPLACEMENT  
ADDED BY AMENDMENT 28

Figure 2.5-239 Intake Channel-Lateral Excavation & Replacement



WEDGE USED TO DETERMINE HORIZONTAL  
DISPLACEMENT OF THE INTAKE CHANNEL  
BY NEWMARK'S METHOD

FIGURE 2.5-240  
ADDED BY AMENDMENT 28

Figure 2.5-240 Wedge Used To Determine Horizontal Displacement of The Intake Channel By Newmark's Method

THIS PAGE INTENTIONALLY BLANK

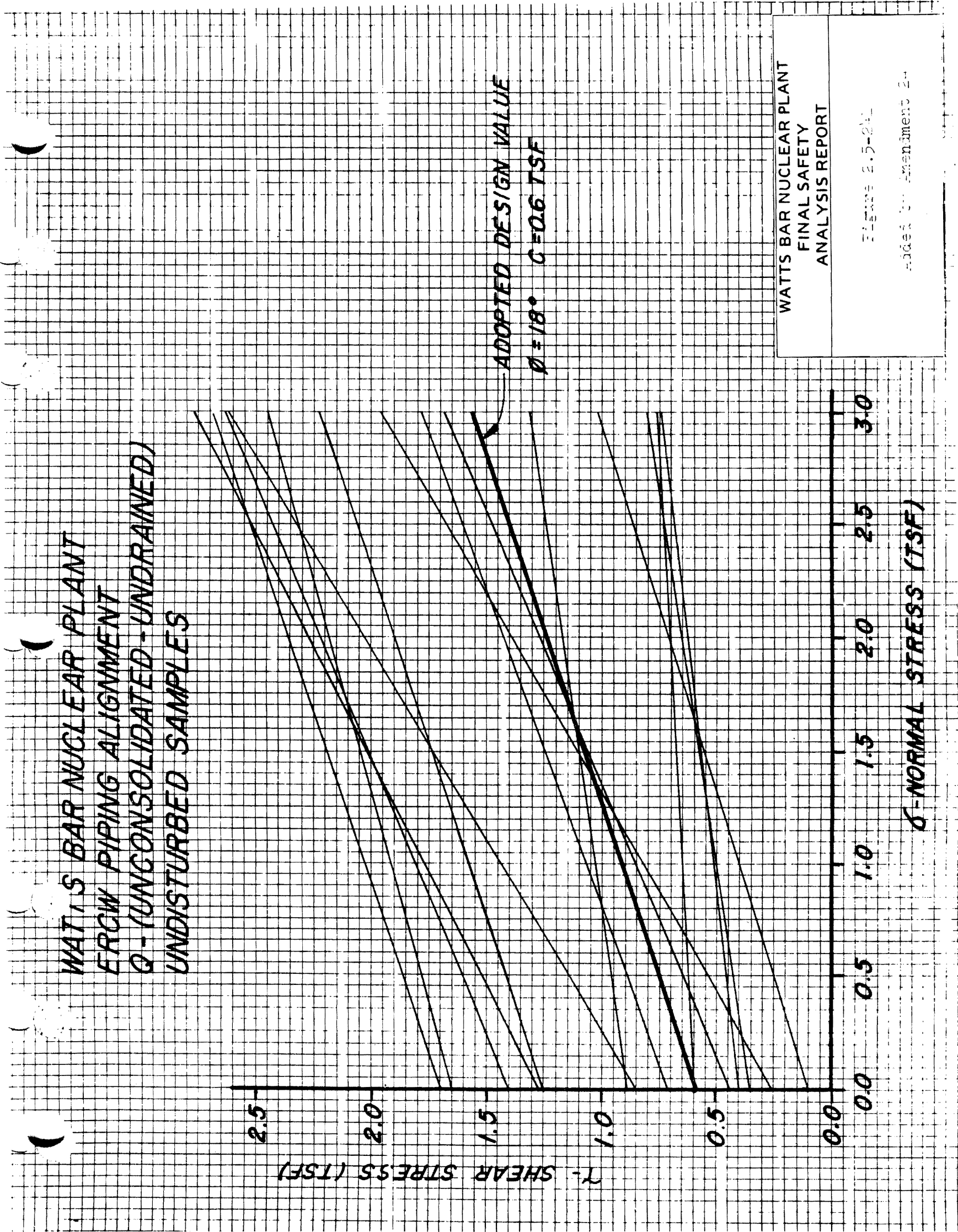

Figure 2.5-241 ERCW Piping Alignment Q (Unconsolidated Undrained - Undisturbed Samples)

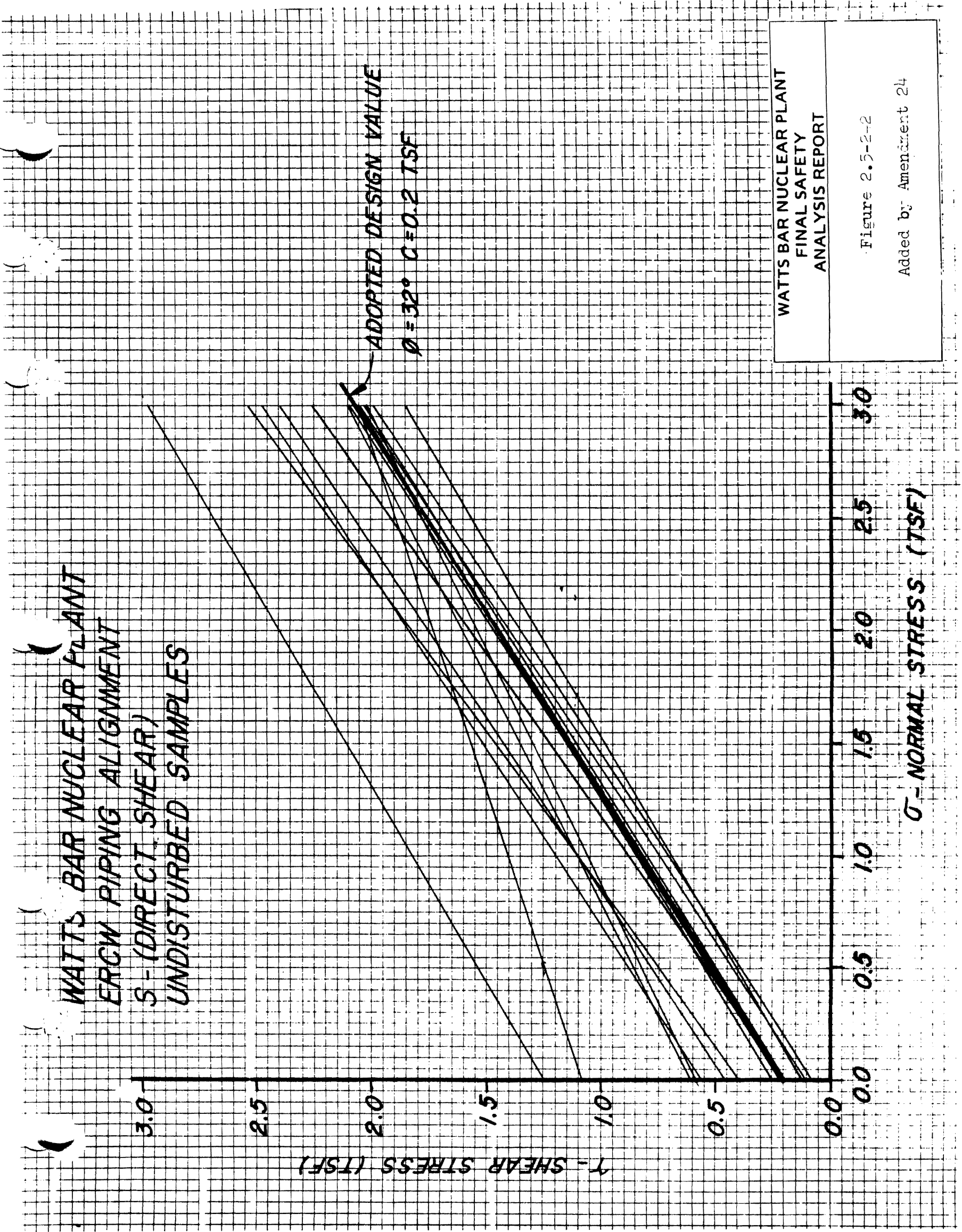
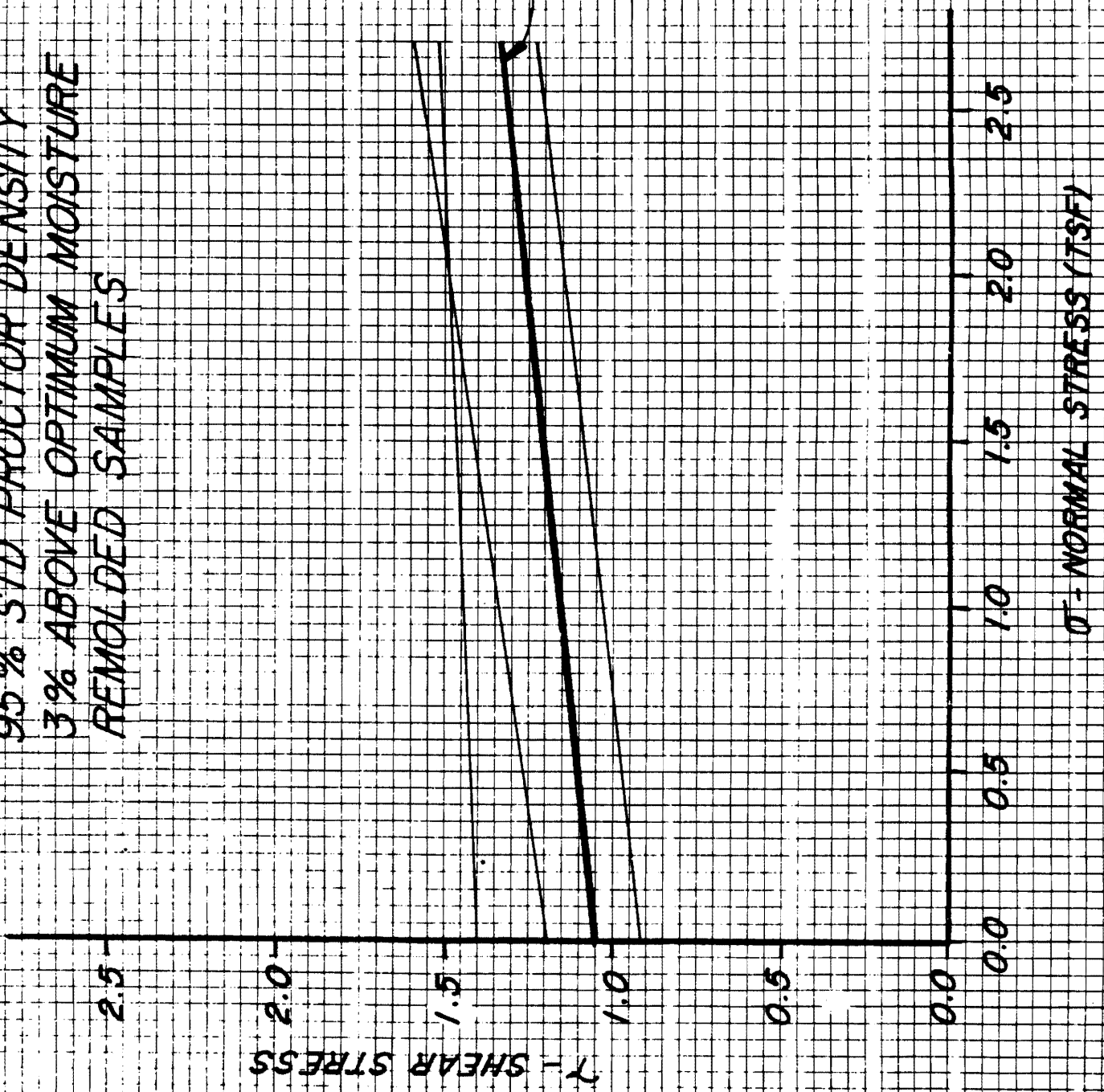

Figure 2.5-242 ERCW Piping Alignment S (Direct Shear) Undisturbed Samples

**Figure 2.5-243 Deleted by Amendment 71**

WATTS BAR NUCLEAR PLANT  
BORROW AREA 4

Q - (UNCONSOLIDATED - UNDRAINED)  
95% STD PROCTOR DENSITY  
3% ABOVE OPTIMUM MOISTURE  
REMOLDED SAMPLES



WATTS BAR NUCLEAR PLANT  
FINAL SAFETY  
ANALYSIS REPORT

Figure 2.5-244

Added by Amendment 24

Figure 2.5-244 Borrow Area 4 Q - (Unconsolidated - Undrained) 95% STD Proctor Density 3% Above Optimum Moisture Remolded Samples



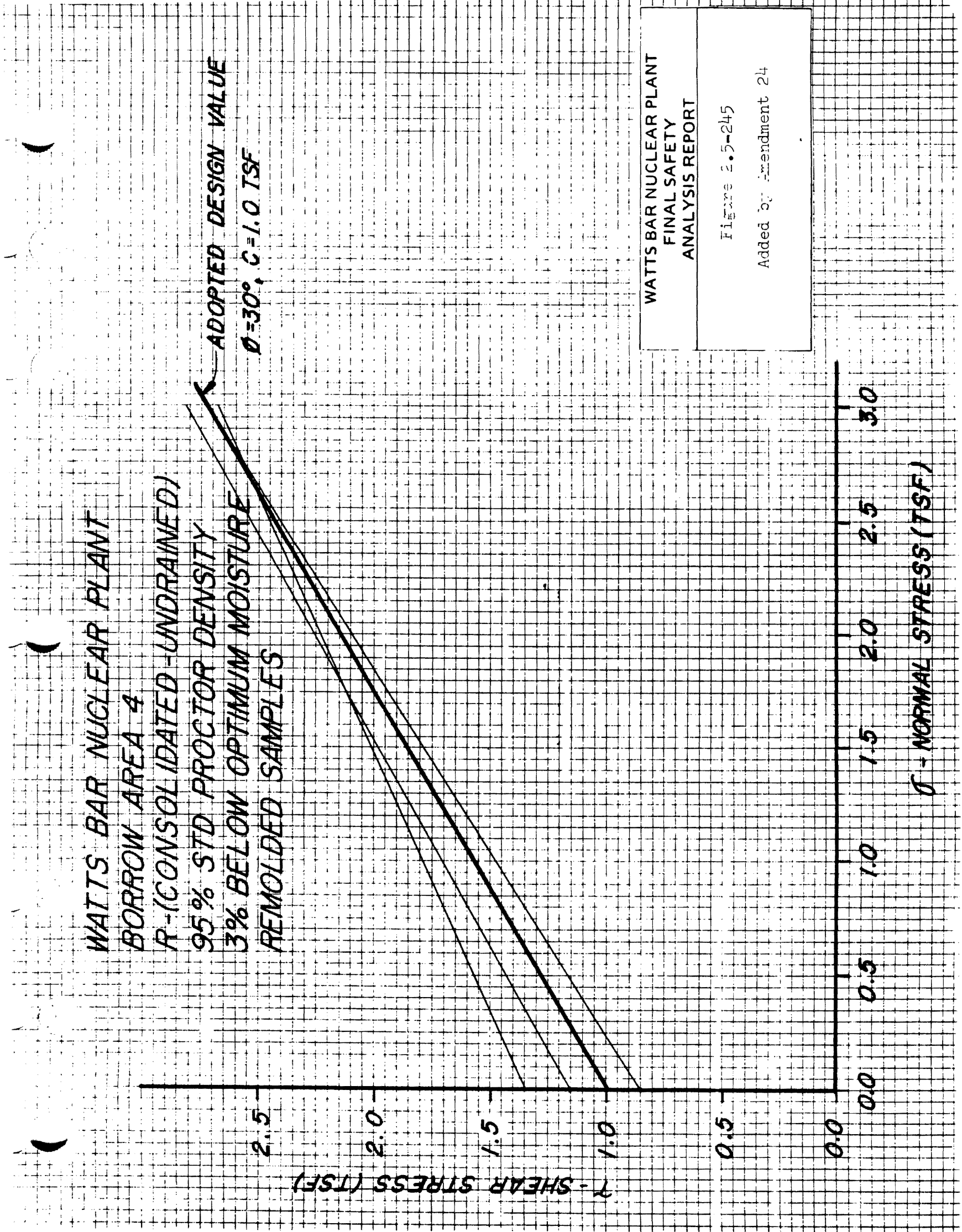
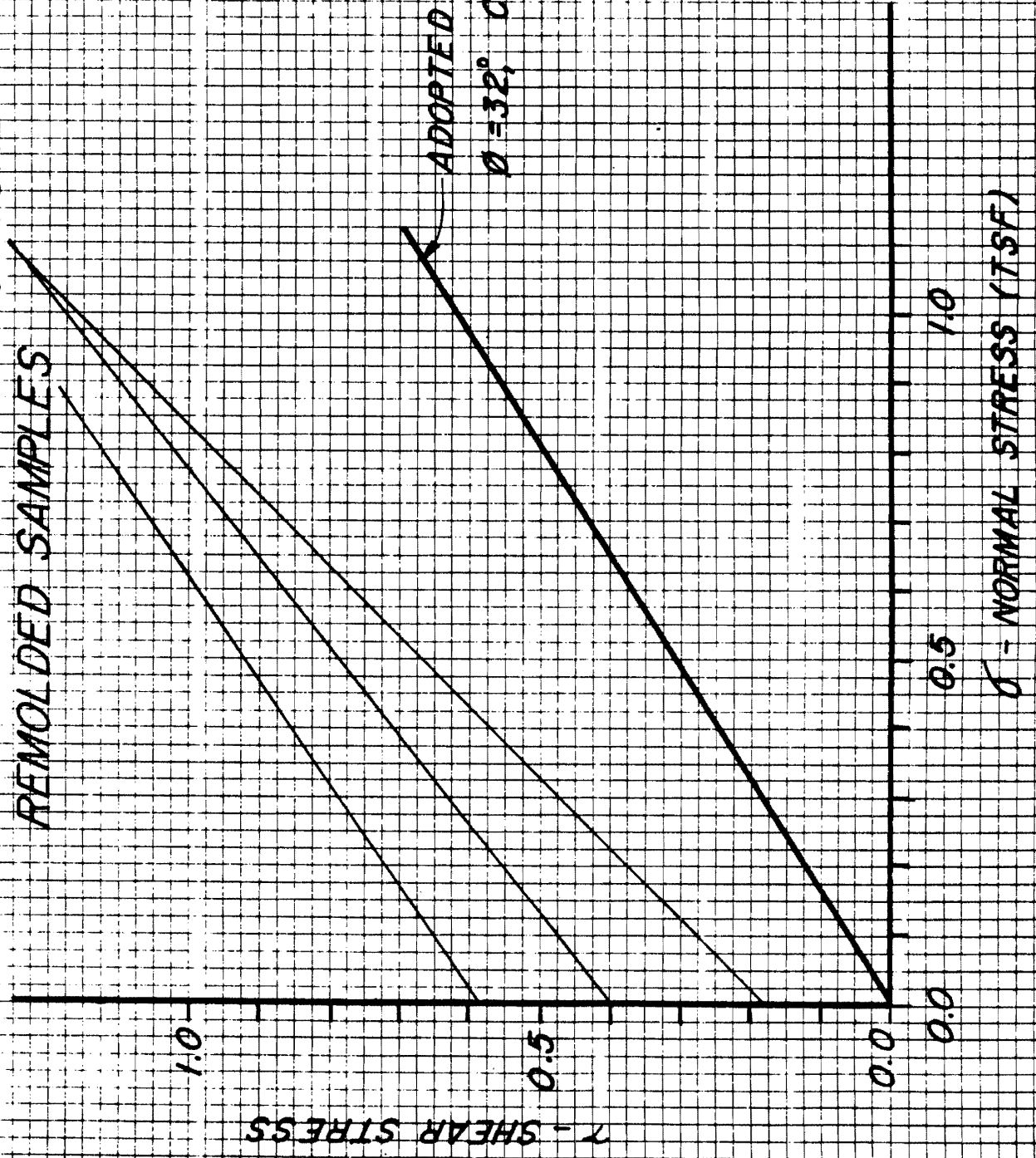

Figure 2.5-245 Watts Bar Nuclear Plant Borrow Area 4R - (Consolidate Undrained) 95% STD Proctor Density 3% Below Optimum Moisture Remolded Samples

WATTS BAR NUCLEAR PLANT  
 BORROW AREA 4  
 S - (DIRECT SHEAR)  
 95% STD PROCTOR DENSITY  
 3% BELOW OPTIMUM MOISTURE  
 REMOLDED SAMPLES



WATTS BAR NUCLEAR PLANT  
 FINAL SAFETY  
 ANALYSIS REPORT

Figure 2.5-246  
 Added by Amendment 24

Figure 2.5-246 Borrow Area 4 S - (Direct Shear) 95% STD Proctor Density 3% Below Optimum Moisture Remolded Samples

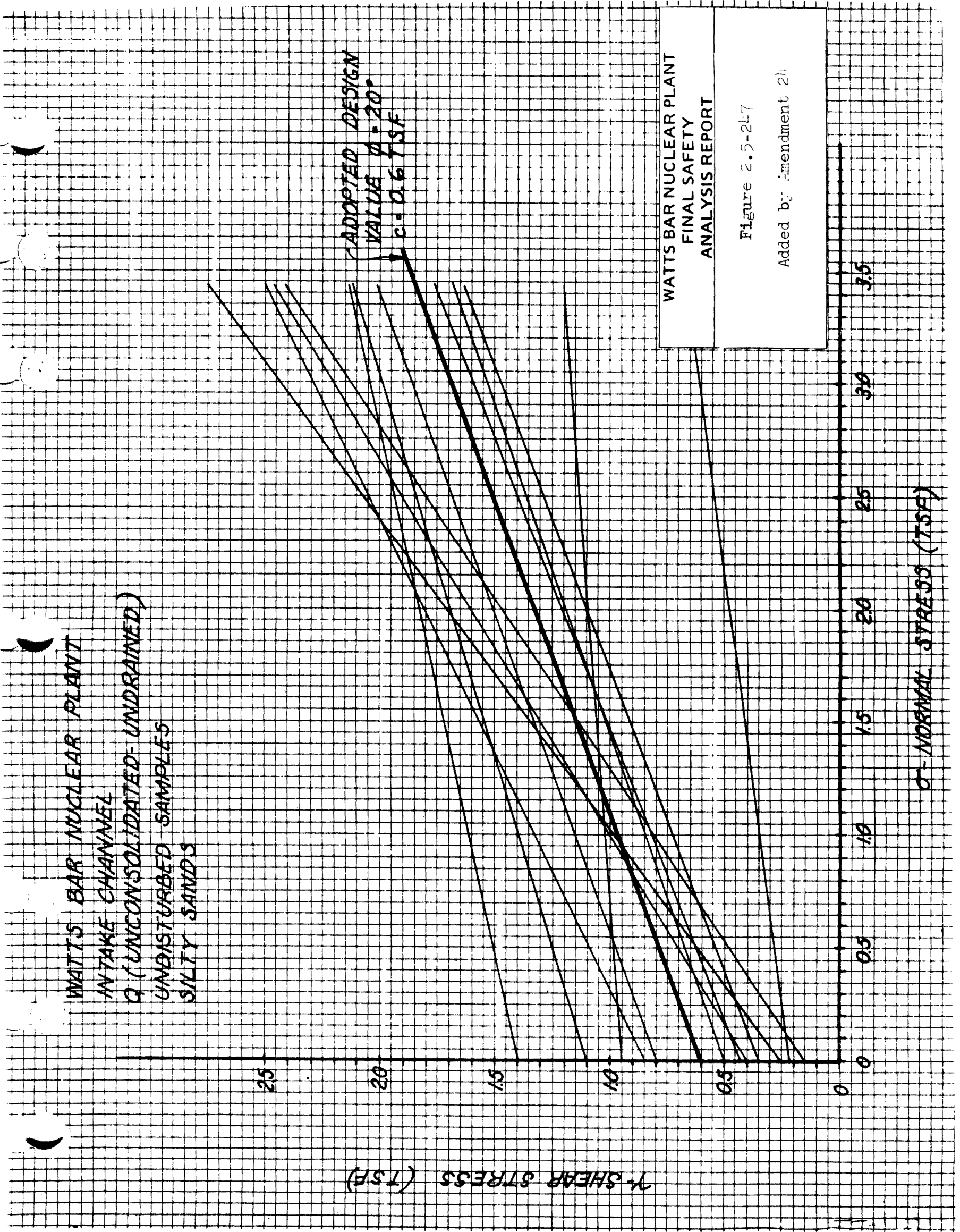

Figure 2.5-247 Intake Channel Q - (Unconsolidated - Undrained - Undisturbed Samples) Silty Sands

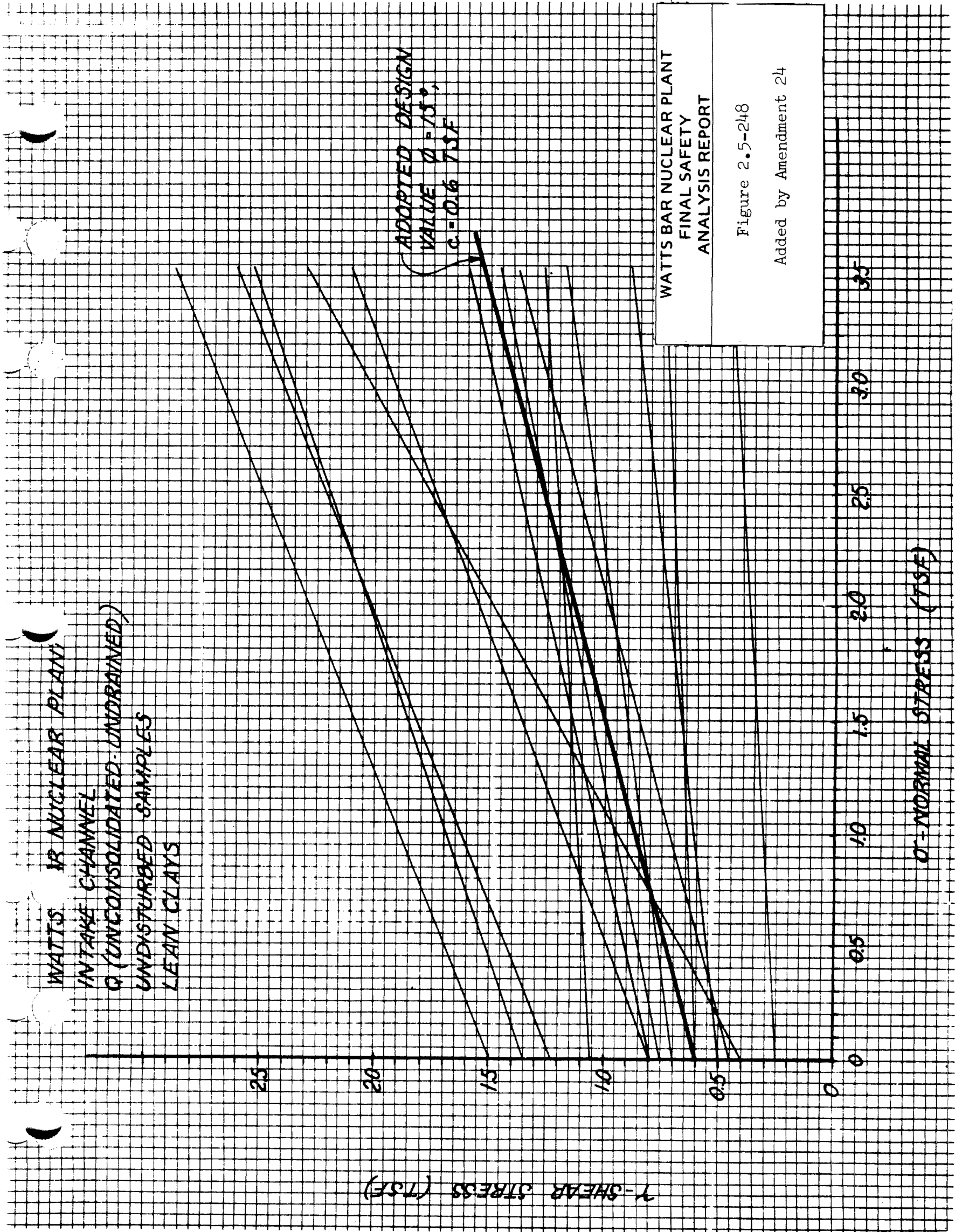

Figure 2.5-248 Intake Channel Q - (Unconsolidated-Undrained) Undisturbed Samples Lean Clays

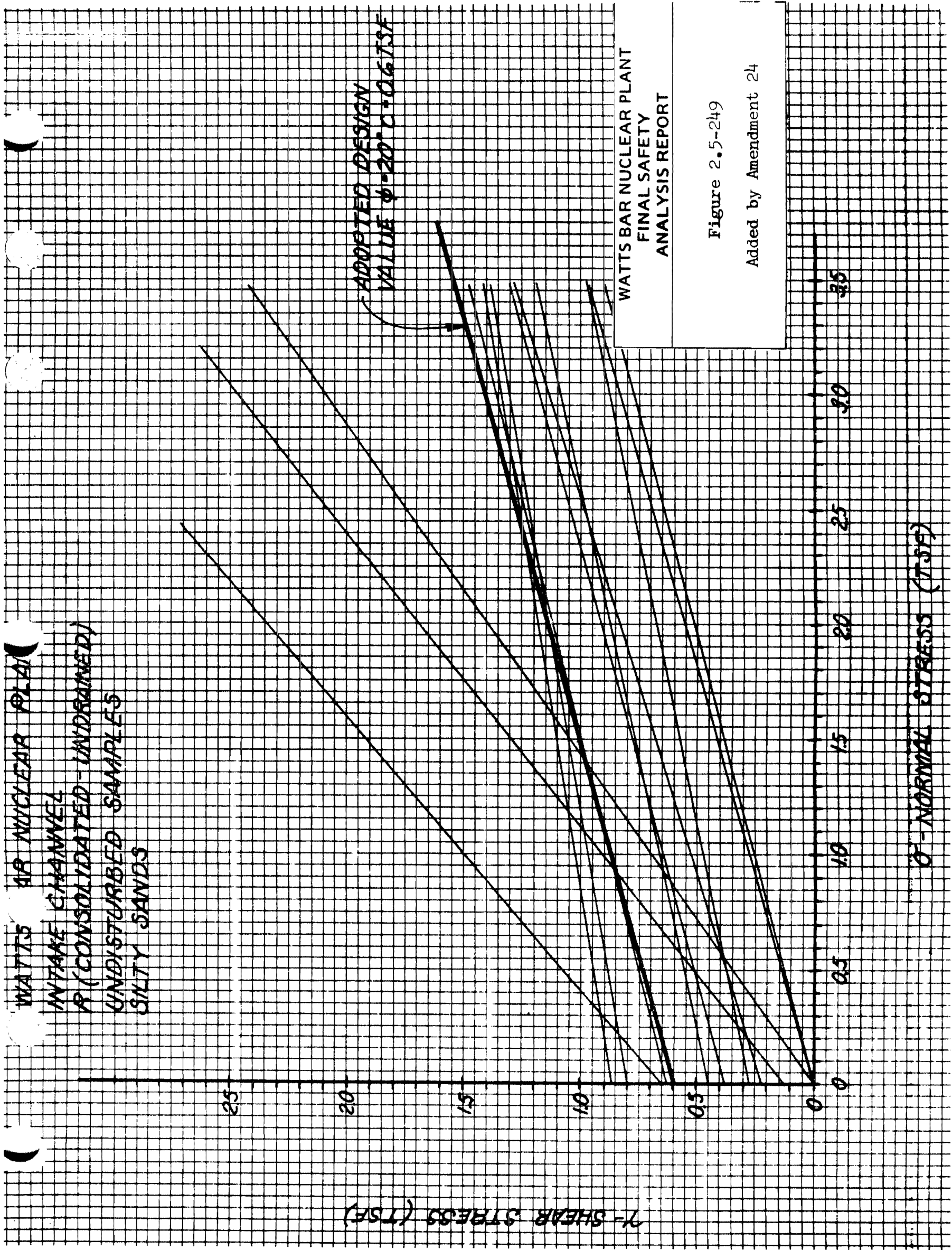

Figure 2.5-249 Intake Channel R - (Consolidated-Undrained) Undisturbed Samples Silty Sands

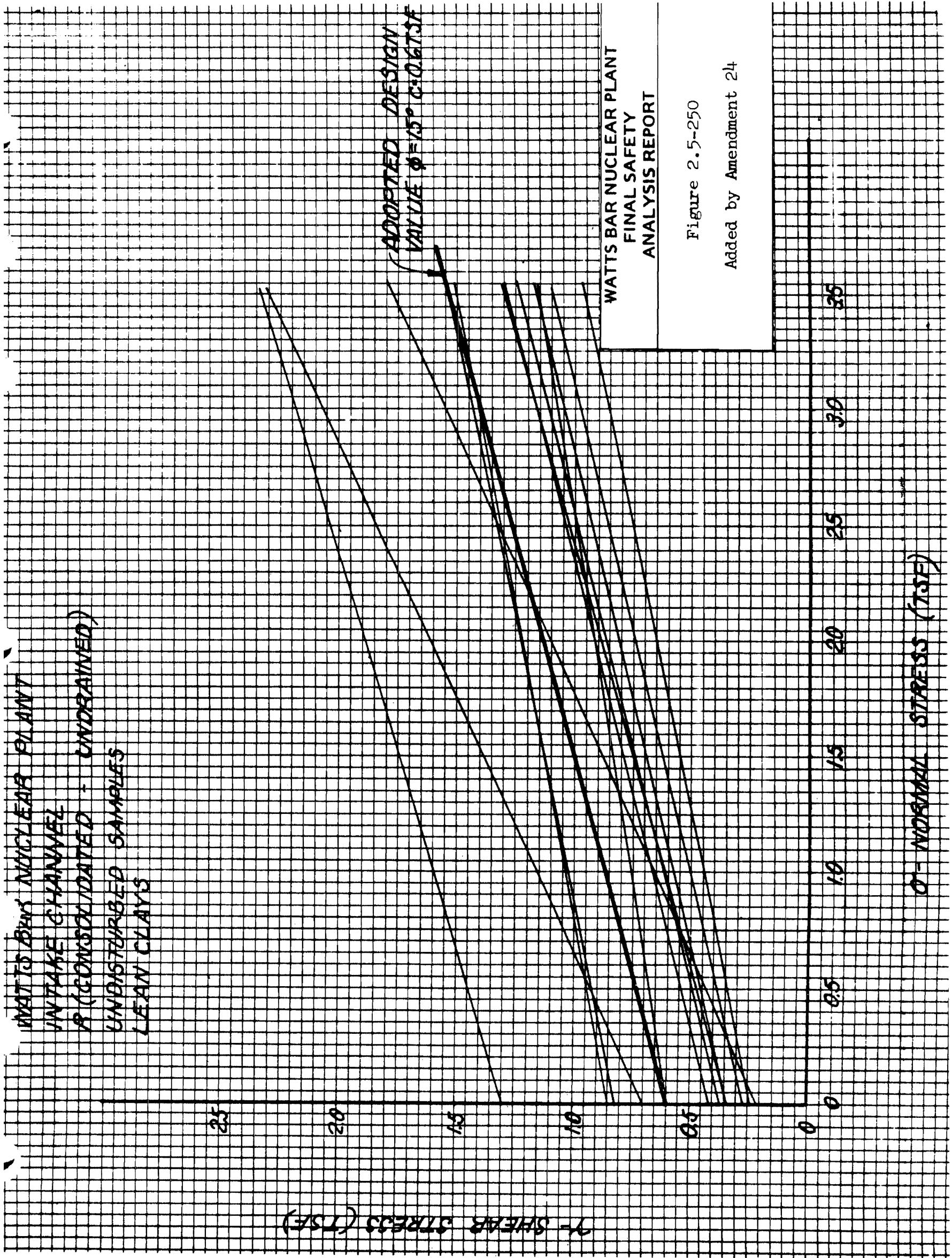

Figure 2.5-250 Intake Channel R - (Consolidated-Undrained) - Undisturbed Samples Lean Clays

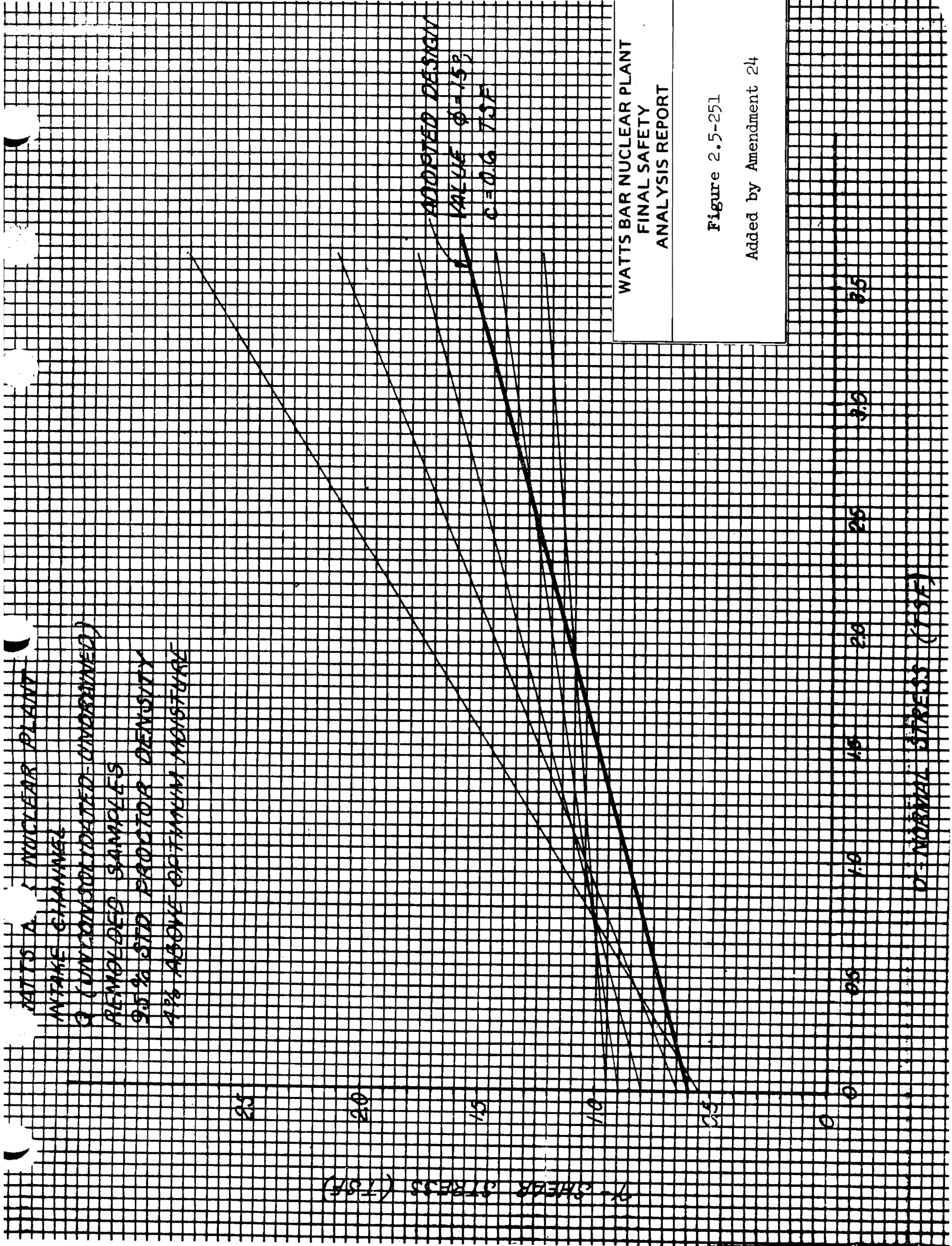
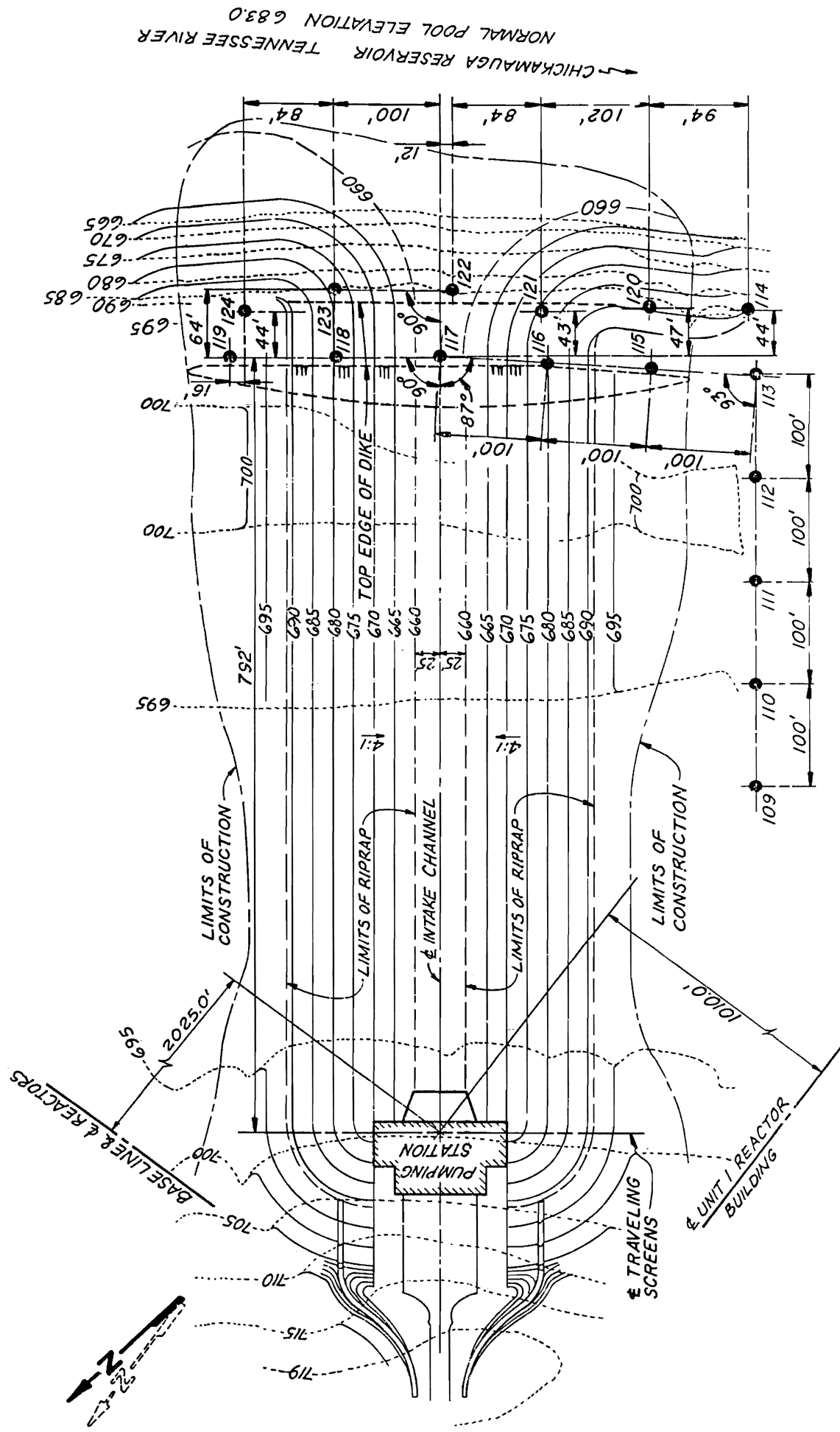

Figure 2.5-251 Intake Channel Q - (Unconsolidated Undrained) RemolDED Samples 95% SDT Proctor Density 4% Above Optimum Moisture



Revised by Amendment 44

WATTS BAR NUCLEAR PLANT FINAL SAFETY ANALYSIS REPORT	SITE STUDIES INTAKE CHANNEL ADDITIONAL SOILS INVESTIGATION TVA DWG NO. 10B333 R1 FIGURE 2.5-252
--	--

LEGEND:  
● SOIL BORING

Figure 2.5-252 Site Studies Intake Channel Additional Soils Investigation



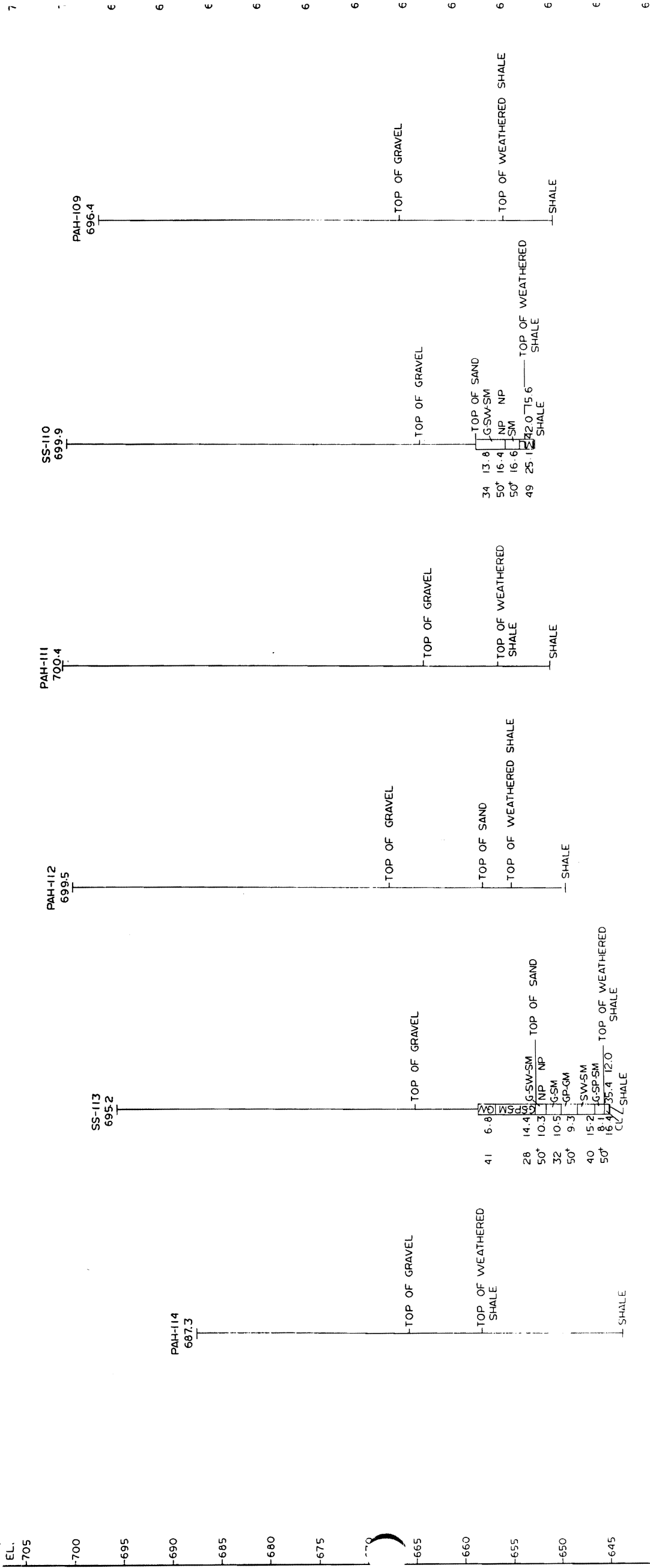

**LEGEND**

- BORING NO
- ELEVATION
- NATURAL MOISTURE CONTENT
- BLOWS PER FOOT WITH A 140 LB HAMMER AND A 30 INCH DROP ON A 2 INCH OD SPLITSPOON SAMPLER
- LIQUID PLASTICITY LIMIT INDEX
- CLASSIFICATION

SCALE 1" = 5'

NOTE: BLOWS PER FOOT WITH A 140 LB HAMMER AND A 30 INCH DROP ON A 2 INCH OD SPLITSPOON SAMPLER

WATTS BAR NUCLEAR PLANT FINAL SAFETY ANALYSIS REPORT
INTAKE CHANNEL ADDITIONAL SOIL INVESTIGATION SECTION AA FIGURE 2.5-253 ADDED BY AMENDMENT 28

DATE: 11-10-76 9 CS 3 804K78

Figure 2.5-253 Intake Channel Additional Soil Investigation Section AA

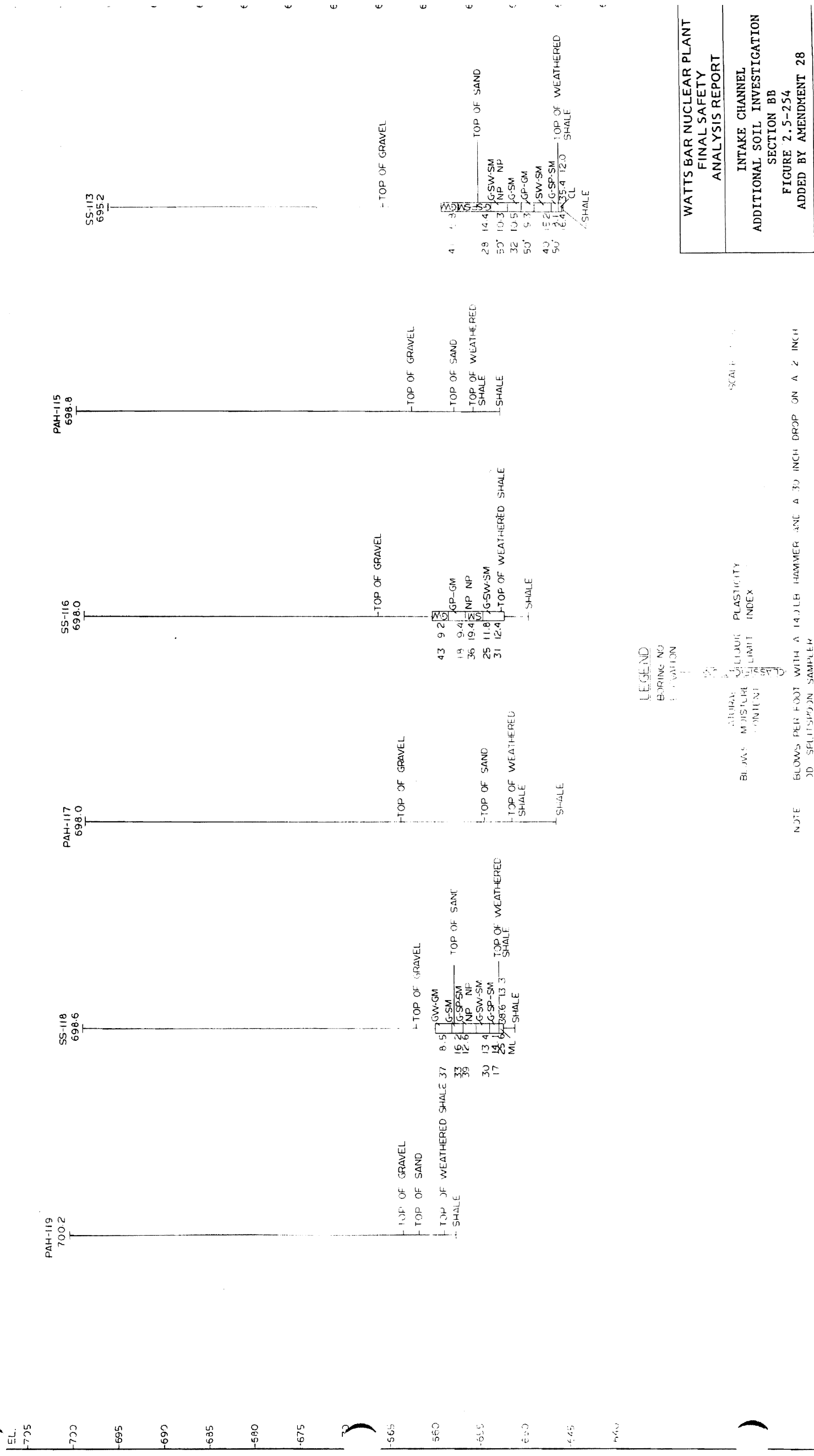
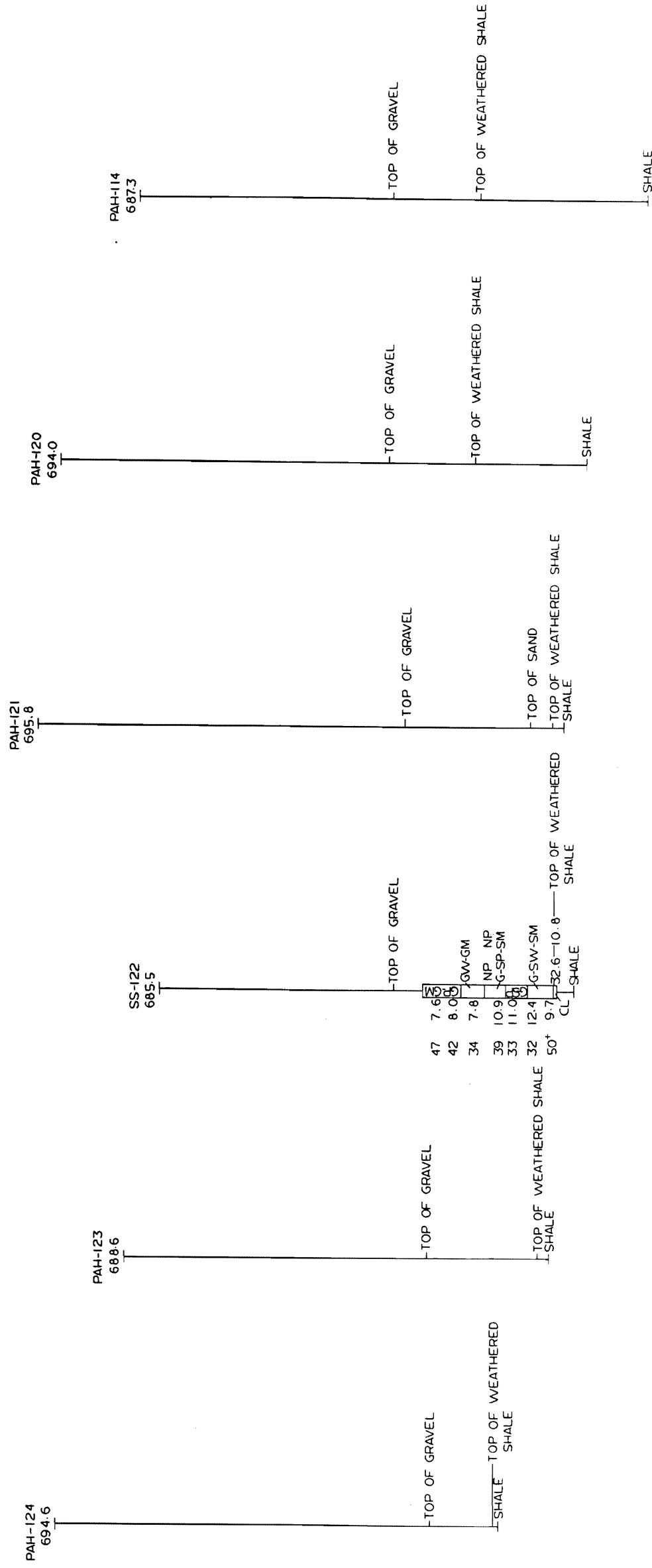

Figure 2.5-254 Intake Channel Additional Soil Investigation Section BB



SCALE: 1"=5'

WATTS BAR NUCLEAR PLANT FINAL SAFETY ANALYSIS REPORT
INTAKE CHANNEL ADDITIONAL SOIL INVESTIGATION SECTION CC FIGURE 2.5-255 ADDED BY AMENDMENT 28

LEGEND

BORING NO.  
ELEVATION

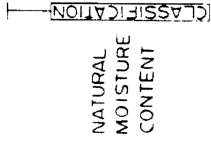

NOTE: BLOWS PER FOOT WITH A 140LB HAMMER AND A 30 INCH DROP ON A 2 INCH  
OD SPLITSPOON SAMPLER

Figure 2.5-255 Intake Channel Additional Soil Investigation Section CC

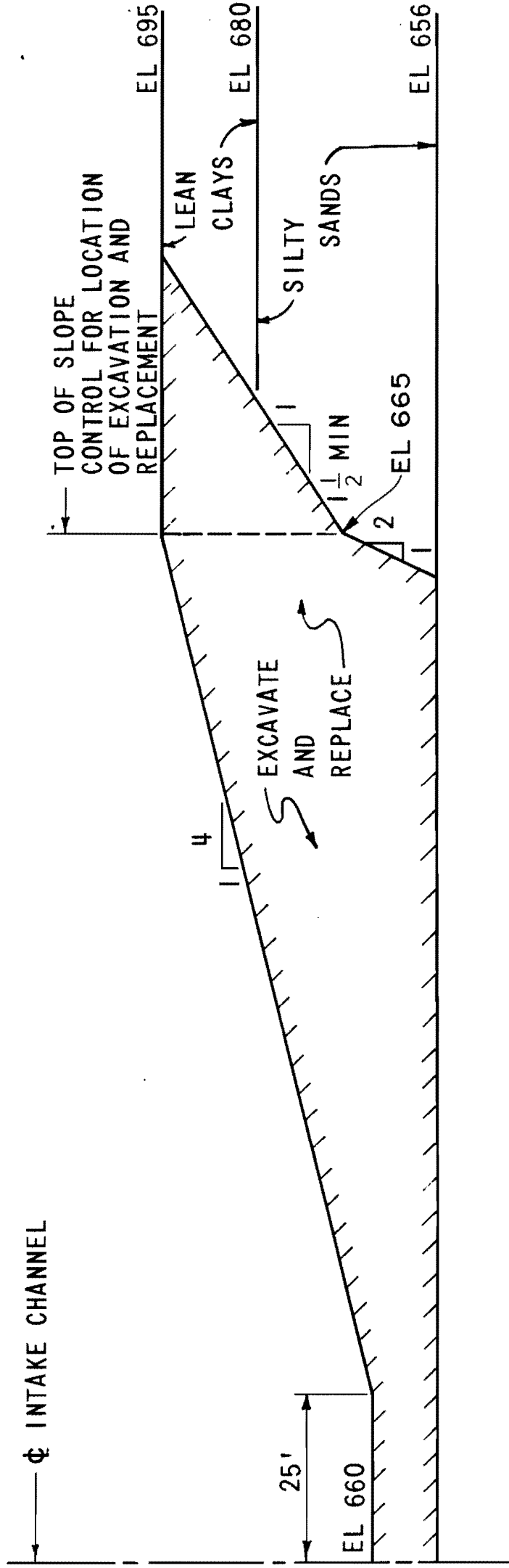

INTAKE CHANNEL - LATERAL EXCAVATION AND REPLACEMENT  
DOWNSTREAM SIDE OF INTAKE CHANNEL WITH BEDROCK AT 656

FIGURE 2.5-256  
ADDED BY AMENDMENT 28

Figure 2.5-256 Intake Channel - Lateral Excavation and Replacement Downstream Side of Intake Channel with Bedrock at 656

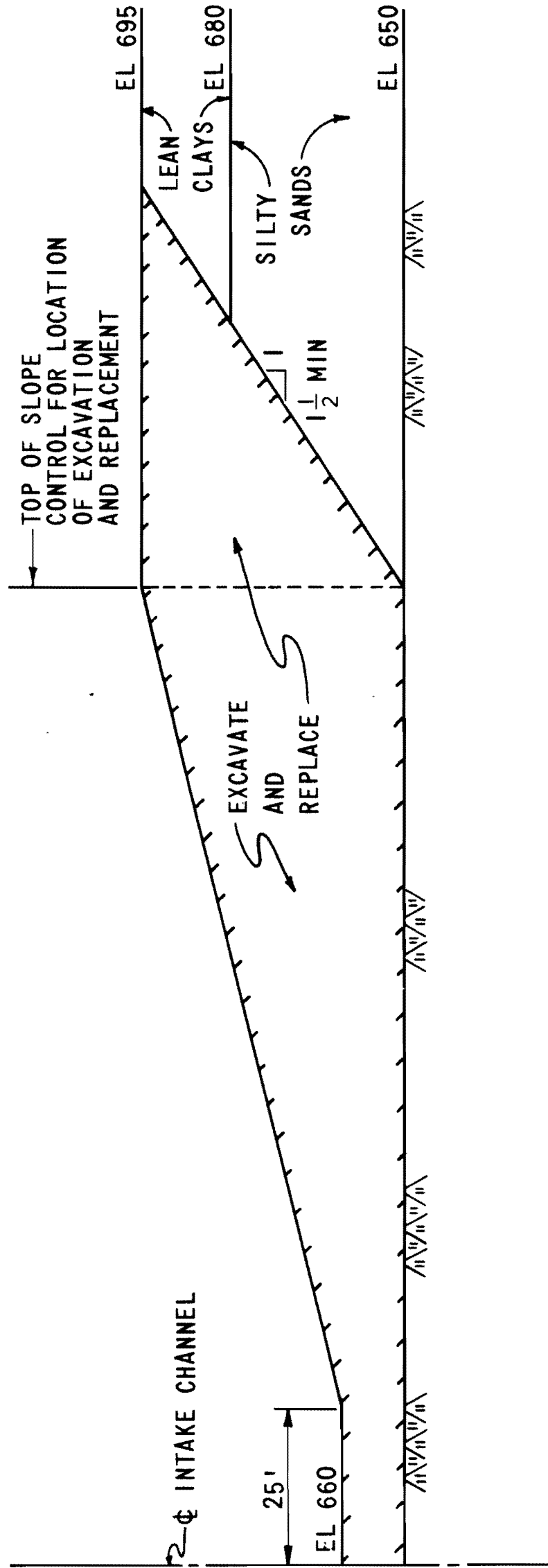

INTAKE CHANNEL - LATERAL EXCAVATION AND REPLACEMENT  
DOWNSTREAM SIDE OF INTAKE CHANNEL WITH BEDROCK AT 650

FIGURE 2.5-257  
ADDED BY AMENDMENT 28

Figure 2.5-257 Intake Channel - Lateral Excavation and Replacement Downstream Side of Intake Channel with Bedrock at 650

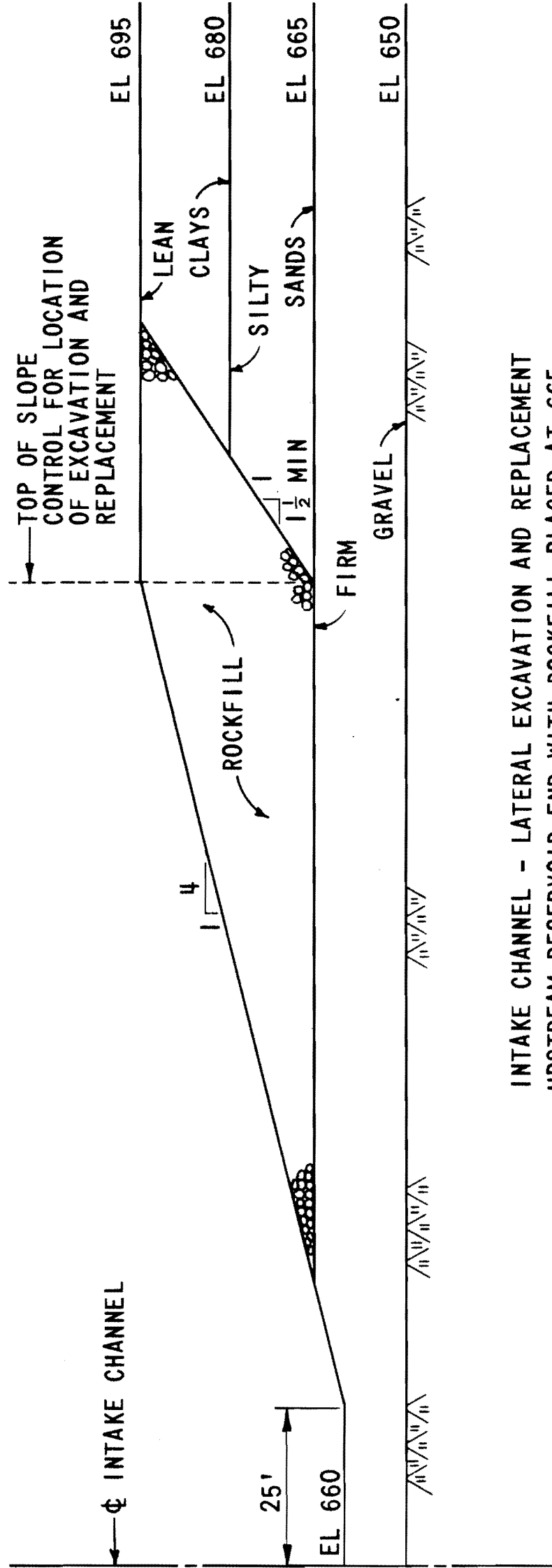

INTAKE CHANNEL - LATERAL EXCAVATION AND REPLACEMENT  
UPSTREAM RESERVOIR END WITH ROCKFILL PLACED AT 665

FIGURE 2.5-258  
ADDED BY AMENDMENT 28

Figure 2.5-258 Intake Channel - Lateral Excavation and Replacement Upstream Reservoir End with Rockfill Placed at 665

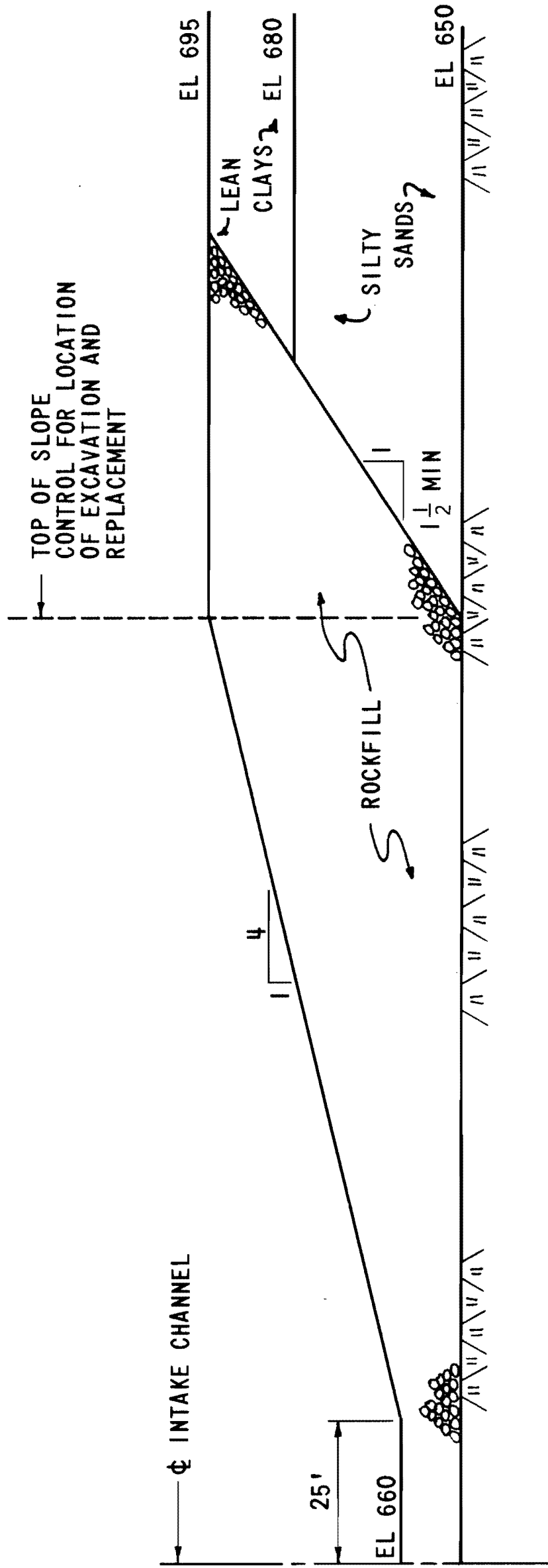

INTAKE CHANNEL - LATERAL EXCAVATION AND REPLACEMENT  
DOWNSTREAM RESERVOIR END WITH ROCKFILL PLACED AT EL 650

FIGURE 2.5-259  
ADDED BY AMENDMENT 28

Figure 2.5-259 Intake Channel - Lateral Excavation and Replacement Downstream Reservoir End With Rockfill Placed at El. 650

TENNESSEE VALLEY AUTHORITY  
 SINGLETON MATERIALS ENGINEERING LABORATORY  
 SOIL PROFILE (SS, PA, HA, TP BORING)

Sheet  
1 of 1

Project WATTS BAR N. P. Feature BORROW AREA 7  
 Boring PAH-1 Station 15+53S Range 43+82 W Surface EI 699.1  
 Date Drilled 10-6-80 To 10-6-80 Prepared By JLB Checked By JLB

Depth	EI	SPT (N)	Log	W	LL	PI	X	Remarks
0								
0			ML	23.4	42	14		
5	695		ML	21.2	33	4		
10	690		CL	23.1	35	13		
15	685		CL	24.2	30	9		
20	680							
25								
30								
35								

DISCONTINUED.

Added by Amendment 44

**WATTS BAR NUCLEAR PLANT  
 FINAL SAFETY  
 ANALYSIS REPORT**

**SOIL PROFILE-BORROW AREA 7-BORING PAH-1  
 FIGURE 2.5-260**

Figure 2.5-260 Soil Profile - Borrow Area 7, Boring PAH-1



**TENNESSEE VALLEY AUTHORITY**  
**SINGLETON MATERIALS ENGINEERING LABORATORY**  
**SOIL PROFILE (SS, PA, HA, TP BORING)**

Shee  
1 Of 1

Project WATTS BAR N. P. Feature BORROW AREA 7  
 Boring PAH-2 Station 15+92S Range 45+78W Surface El 693.3  
 Date Drilled 10-6-80 To 10-6-80 Prepared By JLB Checked By JLB

Depth	El	SPT (N)	Log	W	LL	PI	X	Remarks
0			CL-ML	20.4	41	15		
5	695		ML	20.8	33	12		
10	690			26.3	34	13		
15	685							DISCONTINUED
20	680							
25								
30								
35								

Added by Amendment 44

**WATTS BAR NUCLEAR PLANT**  
**FINAL SAFETY**  
**ANALYSIS REPORT**  
**SOIL PROFILE-BORROW AREA 7-BORING PAH-2**  
**FIGURE 2.5-261**

Figure 2.5-261 Soil Profile - Borrow Area 7, Boring PAH-2

**TENNESSEE VALLEY AUTHORITY**  
**SINGLETON MATERIALS ENGINEERING LABORATORY**  
**SOIL PROFILE (SS, PA, HA, TP BORING)**

Sheet  
1 of 1

Project WATTS BAR N. P. Feature BORROW AREA 7  
 Boring PAH-3 Station 16+31S Range 47+74W Surface El 695.2  
 Date Drilled 10-7-80 To 10-7-80 Prepared By JLB Checked By JLB

Depth	El	SPT (N)	Log	W	LL	PI	X	Remarks
0	695		CL-ML	21.9	36	12		
5	690			23.2	32	10		
10	685		CL	25.5	31	10		
15	680			26.2	32	12		
								DISCONTINUED
								Added by Amendment 44
								<div style="border: 1px solid black; padding: 5px;"> <p> <b>WATTS BAR NUCLEAR PLANT</b>  <b>FINAL SAFETY</b>  <b>ANALYSIS REPORT</b> </p> </div> <div style="border: 1px solid black; padding: 5px; margin-top: 5px;"> <p> <b>SOIL PROFILE-BORROW AREA 7-BORING PAH-3</b>  <b>FIGURE 2.5-262</b> </p> </div>
35								

Figure 2.5-262 Soil Profile - Borrow Area 7, Boring PAH-3

TENNESSEE VALLEY AUTHORITY  
 SINGLETON MATERIALS ENGINEERING LABORATORY  
 SOIL PROFILE, (SS, PA, HA, TP BORING)

Sheet  
1 of 1

Project WATTS BAR N. P. Feature BORROW AREA 7  
 Boring PAH-4 Station 16+715 Range 49+70 Surface El 695.5  
 Date Drilled 10-7-80 To 10-7-80 Prepared By JLB Checked By [Signature]

Depth	El	SPT (N)	Soil	W	LL	PI	X	Remarks
0	695		CL-ML	21.7	40	15		
5	690		ML	22.7	38	13		
10	685		ML	27.7	43	13		
15	680		CL	25.1	45	25		
20	675		CL	24.4	44	21		
20								DISCONTINUED
25								
30								
35								

Added by Amendment 44

WATTS BAR NUCLEAR PLANT  
 FINAL SAFETY  
 ANALYSIS REPORT  
 SOIL PROFILE-BORROW AREA 7-BORING PAH-4  
 FIGURE 2.5-263

Figure 2.5-263 Soil Profile - Borrow Area 7, Boring PAH-4

TENNESSEE VALLEY AUTHORITY  
 SINGLETON MATERIALS ENGINEERING LABORATORY  
 SOIL PROFILE (SS, PA, HA, TP BORING)

Sheet  
1 of 1

Project WATTS BAR N, P Feature BORROW AREA 7  
 Boring PAH-5 Station 17+51S Range 43+58W Surface El 700.7  
 Date Drilled 10-9-80 To 10-9-80 Prepared By JLB Checked By JEB

Depth	El	SPT (N)	Log	W	LL	PI	X	Remarks
0	700		ML	24.2	42	11		
5	695		CE-ML	20.7	28	5		
10	690			24.9	34	10		
15	685							NO RECOVERY - WET MATERIAL
20								DISCONTINUED
25								
30								
35								

Added by Amendment 44

**WATTS BAR NUCLEAR PLANT  
 FINAL SAFETY  
 ANALYSIS REPORT**  
**SOIL PROFILE-BORROW AREA 7-BORING PAH-5  
 FIGURE 2.5-264**

Figure 2.5-264 Soil Profile - Borrow Area 7, Boring PAH-5

TENNESSEE VALLEY AUTHORITY  
 SINGLETON MATERIALS ENGINEERING LABORATORY  
 SOIL PROFILE (SS, PA, HA, TP BORING)

Sheet  
1 of 1

Project WATTS BAR N. P. Feature BORROW AREA 7  
 Boring PAH-6 Station 17+91S Range 45+54W Surface El 693.  
 Date Drilled 10-7-80 To 10-7-80 Prepared By JLB Checked By [Signature]

Depth	El	SPT (N)	Log	W	LL	PI	X	Remarks
1"=5'								
0			ML	21.1	32	7		
	695							
5			CL	25.6	31	9		
	690							
10			CL-ML	24.1	27	6		
	685							DISCONTINUED
15								
	680							
20								
25								
30								
35								

Added by Amendment 44

**WATTS BAR NUCLEAR PLANT  
 FINAL SAFETY  
 ANALYSIS REPORT**  
**SOIL PROFILE-BORROW AREA 7-BORING PAH-6  
 FIGURE 2.5-265**

Figure 2.5-265 Soil Profile - Borrow Area 7, Boring PAH-6

TENNESSEE VALLEY AUTHORITY  
 SINGLETON MATERIALS ENGINEERING LABORATORY  
 SOIL PROFILE (SS, PA, HA, TP BORING)

Sheet  
1 of 1

Project WATTS BAR N. P. Feature BORROW AREA 7  
 Boring PAH-7 Station 18+30S Range 47+50W Surface El 697.1  
 Date Drilled 10-7-80 To 10-7-80 Prepared By JLB Checked By JLB

Depth	El	SPT (N)	LOG	W	LL	PI	X	Remarks
0	695		CL-ML	21.9	49	18		
5	690			23.1	40	15		
10	685			CU	25.7	34	12	
15	680							NO RECOVERY - WET MATERIAL
20								DISCONTINUED
25								
30								
35								

Added by Amendment 44

**WATTS BAR NUCLEAR PLANT  
 FINAL SAFETY  
 ANALYSIS REPORT**  
**SOIL PROFILE-BORROW AREA 7-BORING PAH-7  
 FIGURE 2.5-266**

Figure 2.5-266 Soil Profile - Borrow Area 7, Boring PAH-7

TENNESSEE VALLEY AUTHORITY  
SINGLETON MATERIALS ENGINEERING LABORATORY  
SOIL PROFILE (SS, PA, HA, TP BORING)

Sheet  
1 of 1

Project WATTS BAR N. P Feature BORROW AREA 7  
 Boring PAH-8 Station 18+69S Range 49+46W Surface El 697.1  
 Date Drilled 10-7-80 To 10-7-80 Prepared By JLB Checked By [Signature]

Depth	El	SPT (N)	Soil Type	W	LL	PI	X	Remarks
0	695		CL	22.7	43	18		
5	690		CL-ML	23.6	38	13		
10	685		MH	26.9	53	23		
15	680		CL	24.7	42	19		
20	675							DISCONTINUED
25								
30								
35								

Added by Amendment 44

WATTS BAR NUCLEAR PLANT  
FINAL SAFETY  
ANALYSIS REPORT

---

SOIL PROFILE-BORROW AREA 7-BORING PAH-8  
FIGURE 2.5-267

Figure 2.5-267 Soil Profile - Borrow Area 7, Boring PAH-8

**WATTS BAR NUCLEAR PLANT  
FINAL SAFETY  
ANALYSIS REPORT**

---

SOIL PROFILE  
(SS, PA, HA, TP BORING)  
FIGURE 2.5-268  
SHEET 1 OF 1

SINGLE  
SO

ATORY  
(NG)

Sheet  
1 of 1

Project WATTS BAR N. P. Feature BORROW AREA 7  
 Boring PAH-9 Station 19 + 89S Range 45 + 30W Surface El 699.0  
 Date Drilled 10-9-80 To 10-9-80 Prepared By CLB Checked By WBT

Depth	El	SPT (N)	Log	W	LL	PI	X	Remarks
0			CL	21.6	39	16		
5	695		CL-ML	23.6	41	16		
10	690		CL	22.5	39	16		
15	685		CL	24.9	33	12		
20	680							DISCONTINUED
25								
30								
35								

APR 13 1980

Added by Amendment 62

Figure 2.5-268 Soil Profile - Borrow Area 7, Boring PAH-9 (SS, PA, HA, TP, Boring)



TENNESSEE VALLEY AUTHORITY  
 SINGLETON MATERIALS ENGINEERING LABORATORY  
 SOIL PROFILE (SS, PA, HA, TP BORING)

Sheet  
1 of 1

Project WATTS BAR N. P. Feature BORROW AREA 7  
 Boring PAH-10 Station 20+28S Range 47+26W Surface El 698.2  
 Date Drilled 10-9-80 To 10-9-80 Prepared By JLB Checked By [Signature]

Depth	El	SPT (N)	gOL	W	LL	PI	X	Remarks
1"=5'								
0			CL	25.2	47	22		
	695							
5			CLML	25.1	46	18		
	690							
10			CHMH	26.5	52	23		
	685							
15			CL	25.7	48	23		
	680							DISCONTINUED
20								
	675							
25								
								Added by Amendment 44
30								<div style="border: 1px solid black; padding: 5px; text-align: center;"> <p>WATTS BAR NUCLEAR PLANT FINAL SAFETY ANALYSIS REPORT</p> </div> <div style="border: 1px solid black; padding: 5px; text-align: center;"> <p>SOIL PROFILE-BORROW AREA 7-BORING PAH-10 FIGURE 2.5-269</p> </div>
35								

Figure 2.5-269 Soil Profile - Borrow Area 7, Boring PAH-10

TENNESSEE VALLEY AUTHORITY  
 SINGLETON MATERIALS ENGINEERING LABORATORY  
 SOIL PROFILE (SS, PA, HA, TP BORING)

Sheet  
1 of 1

Project WATTS BAR N. P. Feature BORROW AREA 7

Boring PAH-11 Station 20 + 68S Range 49 + 26W Surface El 696.8

Date Drilled 10-9-80 To 10-9-80 Prepared By JLB Checked By [Signature]

Depth	El	SPT (N)	Log	W	LL	PI	X	Remarks
0	695			21.0	49	23		
5	690		CL	21.2	44	19		
10	685			25.2	46	22		
15	680		CH:MH	33.7	54	25		
20	675							DISCONTINUED
25								
30								
35								

Added by Amendment 44

WATTS BAR NUCLEAR PLANT  
 FINAL SAFETY  
 ANALYSIS REPORT  
 SOIL PROFILE-BORROW AREA 7-BORING PAH-11  
 FIGURE 2.5-270

Figure 2.5-270 Soil Profile - Borrow Area 7, Boring PAH-11

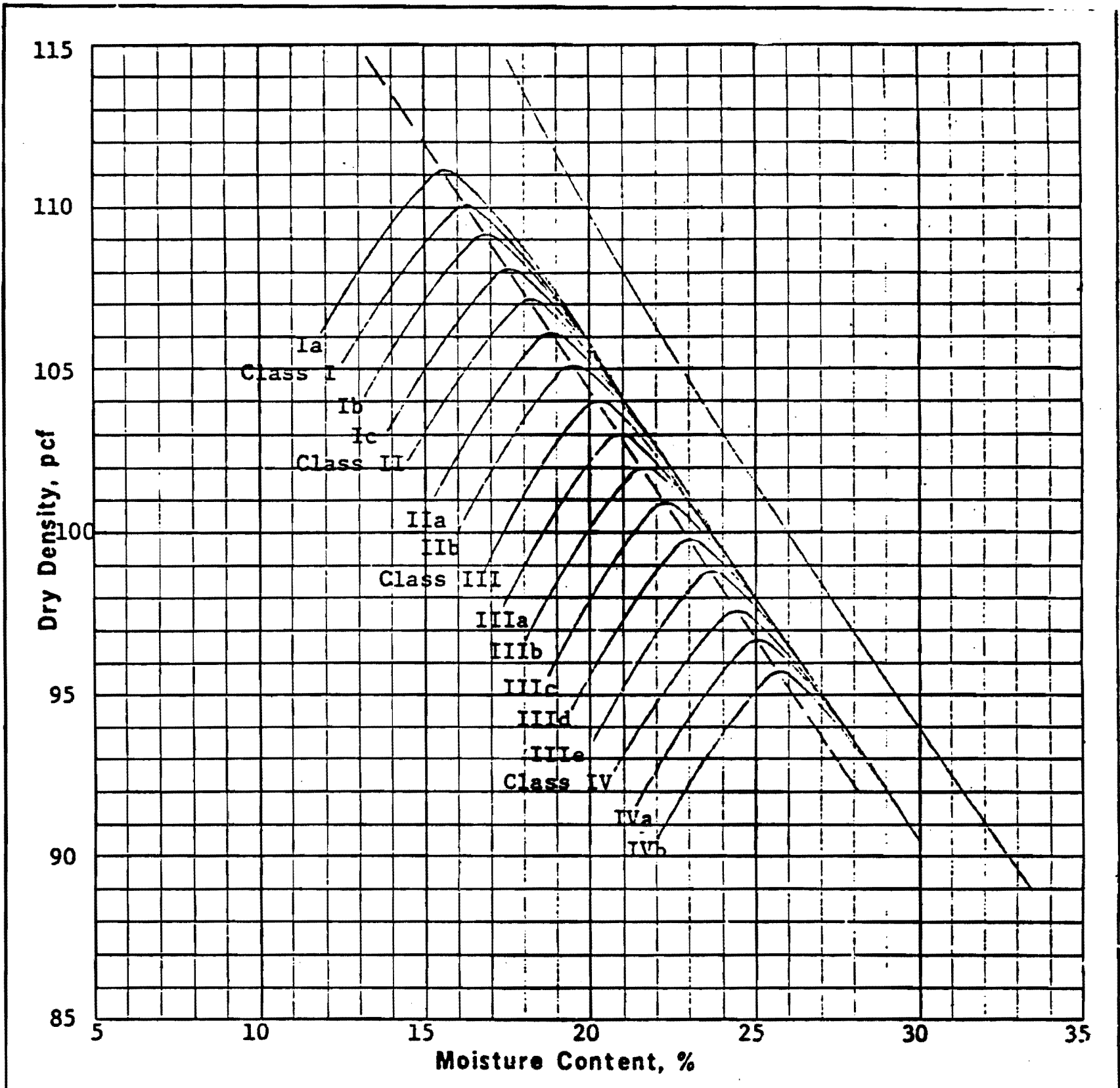

Soil Class	Gravel %	Sand %	Silt %	Clay %	Specific Gravity	LL %	PI %	Optimum Moisture, %	Maximum Density, pcf
I-CL	0	32	39	29	2.75	34	11	16.2	110.1
II-CL	0	34	35	31	2.72	34	12	18.2	107.2
III-CL	0	19	39	42	2.74	43	18	20.2	104.0
IV-CH-MH	0	6	42	52	2.74	54	25	24.4	97.7

Added by Amendment 44

Plus No. 4 Specific Gravity, S S D	
Plus No. 4 Absorption, %	
Remarks:	

**WATTS BAR NUCLEAR PLANT  
 FINAL SAFETY  
 ANALYSIS REPORT**

---

**COMPACTION TEST (FAMILY OF CURVES)  
 BORROW AREA 7  
 FIGURE 2.5-271**

TVA 10201 (CONST-12-76)      Tested by: CHF      Reviewed by: CLF      24

Figure 2.5-271 Compaction Test (Family of Curves) - Borrow Area 7

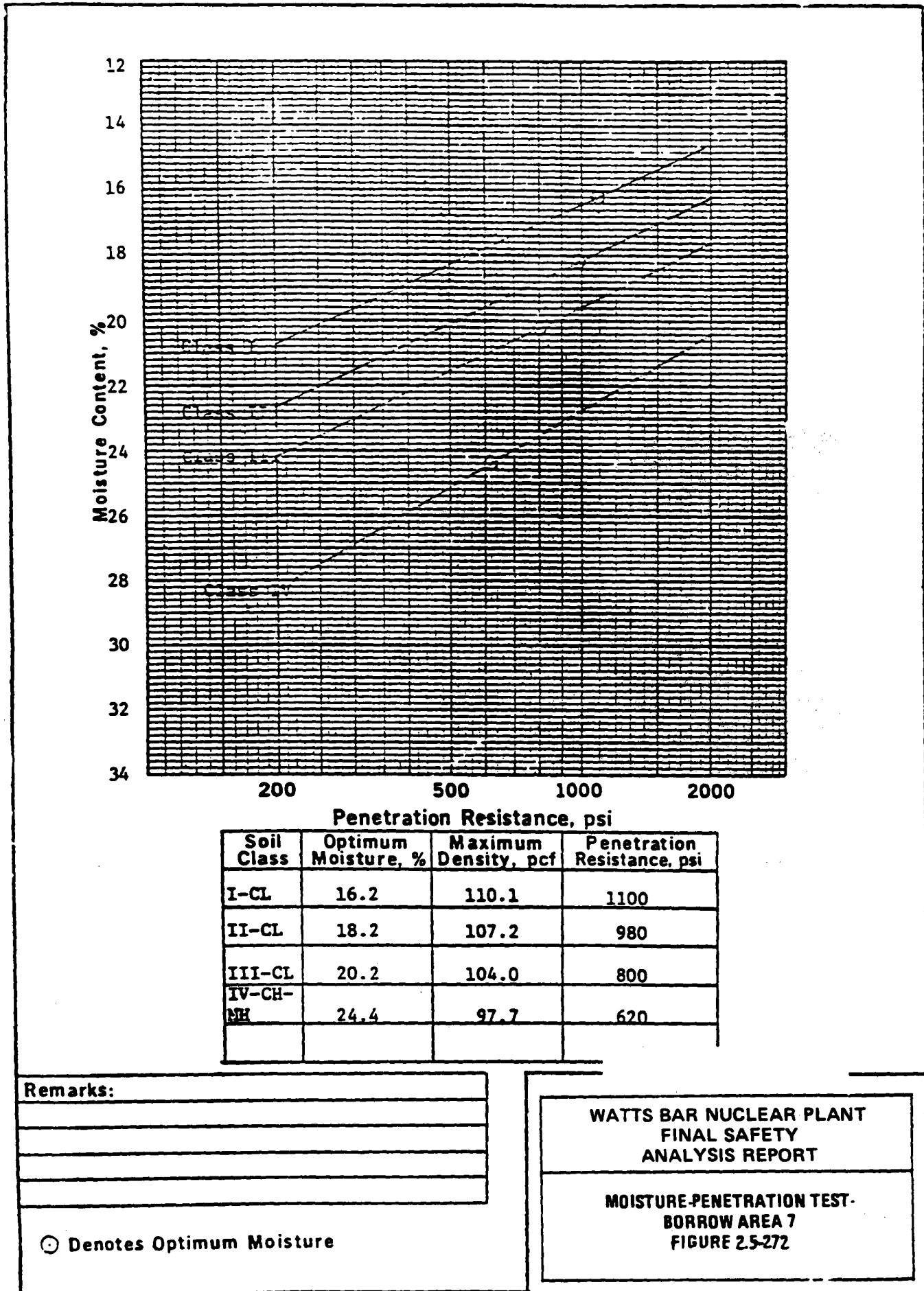

TVA 10200 (CONST-6-77)

Tested by: CHF

Reviewed by: PBF

Figure 2.5-272 Moisture - Penetration Test - Borrow Area 7

Figure 2.5-273 Yard Category I ERCW Piping and Conduits Plan

SOIL PROFILE (SS, PA, HA, TP BORING)

SHEET  
1 OF 1

PROJECT WATTS BAR N. P. FEATURE 1E CONDUIT BANKS  
 BORING SS-171 STATION 760:1E RANGE 1276.9 S SURFACE E1 721.2  
 DATE DRILLED 11-25-81 TO 12-1-81 PREPARED BY JLB CHECKED BY HPP

DEPTH	E1	SPT (N)	LOG	W	LL	PI	REMARKS
0	720						1032 - GRAVEL FILL
5	715						
10	710	20	SMSC	24.6	40	14	ALLUVIUM
		11	SM	26.4	42	15	
		6	SM	26.7			
15	705	9	SPSM	26.5	NP	NP	
		9	SPSM	24.1			
20	700	50	SM	19.7	37	11	WEATHERED SHALE
		50	ML	23.4	NP	NP	
25	695						BEDROCK
30							Added by Amendment 49
							WATTS BAR NUCLEAR PLANT FINAL SAFETY ANALYSIS REPORT
							SOIL PROFILE (SS, PA, HA, TP BORING) 1E CONDUIT BANKS FIGURE 2.5-274
35							

Figure 2.5-274 Soil Profile (SS, PA, HA, TP, Boring) 1E Conduit Banks

SINGLETON MATERIALS ENGINEERING LABORATORY  
SOIL PROFILE (SS, PA, HA, TP BORING)

SHEET  
1 OF

PROJECT WATTS BAR N.P. FEATURE 1E CONDUIT BANKS  
BORING SS-172 STATION 672.25E RANGE 1227.75S SURFACE ET 728.0  
DATE DRILLED 12-7-81 TO 12-7-81 PREPARED BY JLB CHECKED BY HPM

DEPTH	ET	SPT (N)	SOIL	w	LL	PI	REMARKS
1"=5'							
0							1032- GRAVEL FILL
	-725	17	CL	19.4	34	15	BACKFILL
5		14		20.9			
		8		23.3	36	16	
	-720		CL				ALLUVIUM
10		15		21.4	41	18	
		17		19.9	36	13	
	-715	34		19.2	38	15	
15		33	CL-ML	23.5	48	21	
		29		20.6	39	17	
	-710		CL	26.1	40	17	ALLUVIUM
20		15		23.7	42	18	
		30	GM	13.8	34	9	
25		43	SM	22.0	35	8	
		50		22.5	36	10	
	-700		SM-SC	21.2	35	11	WEATHERED SHALE Added by Amendment 49
30		50		21.9	36	12	WATTS BAR NUCLEAR PLANT FINAL SAFETY ANALYSIS REPORT
		41	SM	22.6	36	11	
	-695						SOIL PROFILE (SS, PA, HA, TP BORING) 1E CONDUIT BANKS FIGURE 2.5-275
35							

Figure 2.5-275 Soil Profile (SS, PA, HA, TP, Boring) 1E Conduit Banks

SOIL PROFILE (SS, PA, HA, TP BORING)

SHEET  
1 OF

PROJECT WATTS BAR N. P. FEATURE IE CONDUIT BANKS  
 BORING SS-173 STATION 583.3E RANGE 1177.8 S SURFACE E1 728.0  
 DATE DRILLED 12-2-81 TO 12-3-81 PREPARED BY JLB CHECKED BY H

DEPTH	E1	SPT (N)	GOL.	W	LL	PI	REMARKS
0							1032-GRAVEL FILL
725		18	CL	22.3	46	20	ALLUVIUM
720		20	CL-ML	21.9	41	14	
720		16	CL	19.3	40	16	
715		23	ML	20.4	39	13	
715		25	SC	17.8	30	9	
715		37	SC	18.8	33	12	
710		28	ML-MH	25.0	49	17	
710		25	SC	20.9	35	13	
705		20	SM-SC	20.6	37	12	
705		28	SM	24.6	55	20	
705		50	CHMH	22.9	42	14	WEATHERED SHALE Added by Amendment 49
700		21		36.6	41	9	
700		40	SM	23.5	48	11	
695		25		25.8	36	10	
695		34		24.9	39	13	
35		30	SM-SC	20.5	33	9	

**WATTS BAR NUCLEAR PLANT  
FINAL SAFETY  
ANALYSIS REPORT**

---

**SOIL PROFILE  
(SS, PA, HA, TP BORING)  
ID CONDUIT BANKS  
FIGURE 2.5-276 (SHEET 1 OF 2)**

Figure 2.5-276 Soil Profile (SS, PA, HA, TP, Boring) IE Conduit Banks Sheet 1 of 2



DEPTH	E1	SPI (N)	GOI	W	LL	PI	REMARKS
1"=5' 35		50+	SMSC	17.6	33	10	WEATHERED SHALE
	690	50		18.5	29	7	
40		50+	SC	17.0	30	9	
	685						BEDROCK
45							
50							
55							
60							
65							
70							
75							
80							

Added by Amendment 49

**WATTS BAR NUCLEAR PLANT  
FINAL SAFETY  
ANALYSIS REPORT**

**SOIL PROFILE  
(SS, PA, HA, TP BORING)  
ID CONDUIT BANKS  
FIGURE 2.5-276 (SHEET 2 OF 2)**

Figure 2.5-276 Soil Profile (SS, PA, HA, TP, Boring) ID Conduit Banks Sheet 2 of 2

SINGLETON MATERIALS ENGINEERING LABORATORY  
SOIL PROFILE (SS, PA, HA, TP BORING)

SHEET  
1 OF 1

PROJECT WATTS BAR N.P. FEATURE IE CONDUIT BANKS  
BORING SS-174 STATION 49Q.75E RANGE 1123.75S SURFACE E1 728.0  
DATE DRILLED 12-3-81 TO 12-4-81 PREPARED BY JLB CHECKED BY HPM

DEPTH	E1	SPT (N)	GOL	W	LL	PI	REMARKS
0							
							1032-GRAVEL FILL
40	725	40	ML	21.5	43	15	
5		18	CL	19.4	39	18	
		33	ML	21.9	44	15	
47	720	47	CL	19.1	40	18	BACKFILL
10		47	ML	25.4	44	15	
		45		21.3	38	12	
15	715	40	SC	15.5	32	13	
		41	CL ML	19.0	39	15	
20	710	50+	SM	18.3	NP	NP	ALLUVIUM
		50+	GC	14.2			
		50+	CL ML	21.3	44	16	
25	705	50+					
		50+	ML	21.6	40	13	WEATHERED SHALE
		50+	SM	21.6	38	12	
30	700	50+	SM-SC	18.8	32	8	Added by Amendment 49
							<b>WATTS BAR NUCLEAR PLANT FINAL SAFETY ANALYSIS REPORT</b>
							<b>SOIL PROFILE (SS, PA, HA, TP BORING) ID CONDUIT BANKS FIGURE 2.5-277</b>
35	695						

Figure 2.5-277 Soil Profile (SS, PA, HA, TP, Boring) ID Conduit Banks

TENNESSEE VALLEY AUTHORITY  
 SINGLETON MATERIALS ENGINEERING LABORATORY  
 SOIL PROFILE (SS, PA, HA, TP BORING)

SHEET  
 1 OF

PROJECT WATTS BAR N.P. FEATURE IE CONDUIT BANKS  
 BORING SS-175 STATION 405.75E RANGE 1072.85 SURFACE E1 728.0  
 DATE DRILLED 12-3-81 TO 12-4-81 PREPARED BY JLB CHECKED BY HPA

DEPTH	E1	SPT (N)	GOL	W	LL	PI	REMARKS
0							1032-GRAVEL FILL
5		14	SC	15.9	37	17	ALLUVIUM
		21	CL-ML	24.5	47	20	
10		19	SC	17.8	37	16	ALLUVIUM
		31	ML	20.8	40	13	
15		38	SC	15.5	32	12	ALLUVIUM
		22	CH	33.0	54	26	
20		33		25.0	38	10	WEATHERED SHALE
		47		23.6	39	12	
25		42	SM	23.1	43	15	WEATHERED SHALE
		30		31.4	NP	NP	
30		41		25.7			DISCONTINUED

Added by Amendment 49

WATTS BAR NUCLEAR PLANT  
 FINAL SAFETY  
 ANALYSIS REPORT

SOIL PROFILE  
 (SS, PA, HA, TP BORING)  
 ID CONDUIT BANKS  
 FIGURE 2.5-278

Figure 2.5-278 Soil Profile (SS, PA, HA, TP, Boring) ID Conduit Banks

TENNESSEE VALLEY AUTHORITY  
 SINGLETON MATERIALS ENGINEERING LABORATORY  
 SOIL PROFILE (SS, PA, HA, TP BORING)

SHEET  
 1 OF 1

PROJECT WATTS BAR N.P FEATURE IE CONDUIT BANKS  
 BORING SS-176 STATION 377.25E RANGE 968.75S SURFACE E1 728.0  
 DATE DRILLED 12-7-81 TO 12-8-81 PREPARED BY JLB CHECKED BY HFM

DEPTH	E1	SPT (N)	LOG	W	LL	PI	REMARKS
0							
							1032- GRAVEL FILL
0	725	35	SC	15.5	32	12	
5		29	SM	11.0	20	1	BACKFILL
		47	SP-SM	5.3	NP	NP	
10	720	50	SM	11.1			
		50	SM-SC	27.2	26	5	
		50	GP-GM	7.8			ALLUVIUM
15	715	50	GM	13.3	NP	NP	
		50	GM	11.5			
		50		13.0			
20	710	50	CL-ML	27.5	41	16	
		47	SM-SC	21.5	39	13	
25	705	50	SM-SC	19.6	36	12	WEATHERED SHALE
		50	CL-ML	23.8	40	13	
		50	SM-SC	20.6	36	11	
30	700						DISCONTINUED
							Added by Amendment 49
35							

**WATTS BAR NUCLEAR PLANT  
 FINAL SAFETY  
 ANALYSIS REPORT**

**SOIL PROFILE  
 (SS, PA, HA, TP BORING)  
 ID CONDUIT BANKS  
 FIGURE 2.5-279**

Figure 2.5-279 Soil Profile (SS, PA, HA, TP, Boring) ID Conduit Banks

TENNESSEE VALLEY AUTHORITY  
 SINGLETON MATERIALS ENGINEERING LABORATORY  
 SOIL PROFILE (SS,PA,HA,TP BORING)

SHEET  
 1 OF

PROJECT WATTS BAR N.P. FEATURE I.E. CONDUIT BANKS  
 BORING SS-177 STATION 353.25E RANGE 753.75S SURFACE E1 728.0  
 DATE DRILLED 12-10-81 TO 12-10-81 PREPARED BY JLB CHECKED BY HPN

DEPTH	E1	SPT (N)	LOG	W	LL	PI	REMARKS
1" = 5'							
0							1032-GRAVEL FILL
	725	50+	CL	16.7	34	15	BACKFILL
		50		8.5	NP	NP	
5		20		15.4	24	1	
	720	50+	SM	13.8			
10		50+		14.2			
	715	50+		SP-SM 9.2			ALLUVIUM
		50+		SW-SM 16.3	NP	NP	
15		50+	SM	11.2			
	710	50+		SP-SM 11.7			
20		50+	SM	13.1			
	705	50+		12.1 GP-GM			WEATHERED SHALE
25		50+		8.2 SM-SC	26	6	BEDROCK
	700						Added by Amendment 50
30							<b>WATTS BAR NUCLEAR PLANT                  FINAL SAFETY                  ANALYSIS REPORT</b>
							SOIL PROFILE (SS, PA, HA, TP BORING) ID CONDUIT BANKS FIGURE 2.5-280
35							

Figure 2.5-280 Soil Profile (SS, PA, HA, TP, Boring) ID Conduit Banks

**Figure 2.5-281 (Actual Figure Located in Oversized Figures File) (Sheet 1 of 2)**

**Figure 2.5-281 (Actual Figure Located in Oversized Figures File) (Sheet 2 of 2)**

WATTS BAR NUCLEAR PLANT ERCW  
SOIL PROFILE

Boring SS-49					Boring SS-49A					Prepared by JLB	
Station 1821.9S Range 868.7E					Station 1820.3S Range 871.93E					Checked by HPM	
Surface El 716.9					Surface El 711.7						
Date Drilled 7-7-75 to 7-7-75					Date Drilled 11-16-81 to 11-18-81						
El	SPT (N)	LOG	W	LL	PI	SPT (N)	LOG	W	LL	PI	REMARKS
715	30		23.6	56.0	22.1						
	27	MH	27.2	60.9	25.1						
	30		26.8	53.1	21.4						
710	24	SM	15.4	29.4	5.4	17	CL-ML	21.1	32	8	ROADBED GRAVEL
	23	SC	20.0	36.2	11.9	14		21.4	30	6	
705	19	SM	21.2	36.0	11.6	9		24.6	29	3	
	18		26.7	34.0	10.2	5		26.5 21.6	28	3	
	13	SM-SC	25.1	28.3	6.5	5	SM	26.5 29.0	NP	NP	ALLUVIUM
700	14	ML	26.1			6		29.9	23	1	
	12		26.8	28.8	5.3	5		31.8 32.4	NP	NP	
	9	ML-CL	31.9			6	ML	28.3 28.0	22	3	
695	11		29.1	27.4	7.0	5	CL	27.8	NP	NP	
	6	SM	29.0			6	SM	30.0	NP	NP	
690	4		28.0			17		31.2 21.2	NP	NP	
	31		25.3			50		18.9	37	13	WEATHERED SHALE DISCONTINUED
685	50		13.7								
	50	SC	14.8	37.5	14.9						
	50		12.7								
680	50		13.5								
	50	GM	13.5								
675											

WATTS BAR NUCLEAR PLANT  
FINAL SAFETY  
ANALYSIS REPORT

SOIL PROFILE  
FIGURE 2.5-282

Added by Amendment 50

Figure 2.5-282 Soil Profile



**WATTS BAR NUCLEAR PLANT  
FINAL SAFETY  
ANALYSIS REPORT**

---

**SOIL PROFILE  
FIGURE 2.5-283  
SHEET 1 OF 2**

Project WATTS BAR N.P. Feature ERCW ALIGNMENT  
 Boring SS-131 Station 1755.05 Range 805.0E Surface El 713.9  
 Date Drilled 6-1-79 To 6-4-79 Prepared By JLE Checked By [Signature]

Depth	El	SPT (N)	Color	W	LL	PI	X	Remarks
0								ASPHALT
25		25	ML	24.3	48.8	18.4		LEAN CLAY AND SILT FILL
710		25		19.5	39.0	14.7		
5		21	CL	19.3	35.2	11.5		ALLUVIAL LEAN CLAY AND SILT
705		18		20.7				
10		10		25.9	37.1	13.3		ALLUVIAL SAND
700		7	ML	22.2	28.5	5.2		
15		4		28.1	30.8	6.9	▽	ALLUVIAL SAND
		5		30.1	25.9	3.3	▽	
695		5	SM	29.7				
20		7		26.2				ALLUVIAL GRAVEL
		7		24.0	NP	NP		
690		50+	GSM	20.6				WEATHERED SHALE
25		50+	CL	17.2	38.0	14.9		
		50		15.8				
685		50+	SC	15.9	32.7	11.2		
30		50+		14.9				
680		16		14.1				Added by Amendment 50
35								

Figure 2.5-283 Soil Profile (Sheet 1 of 2)

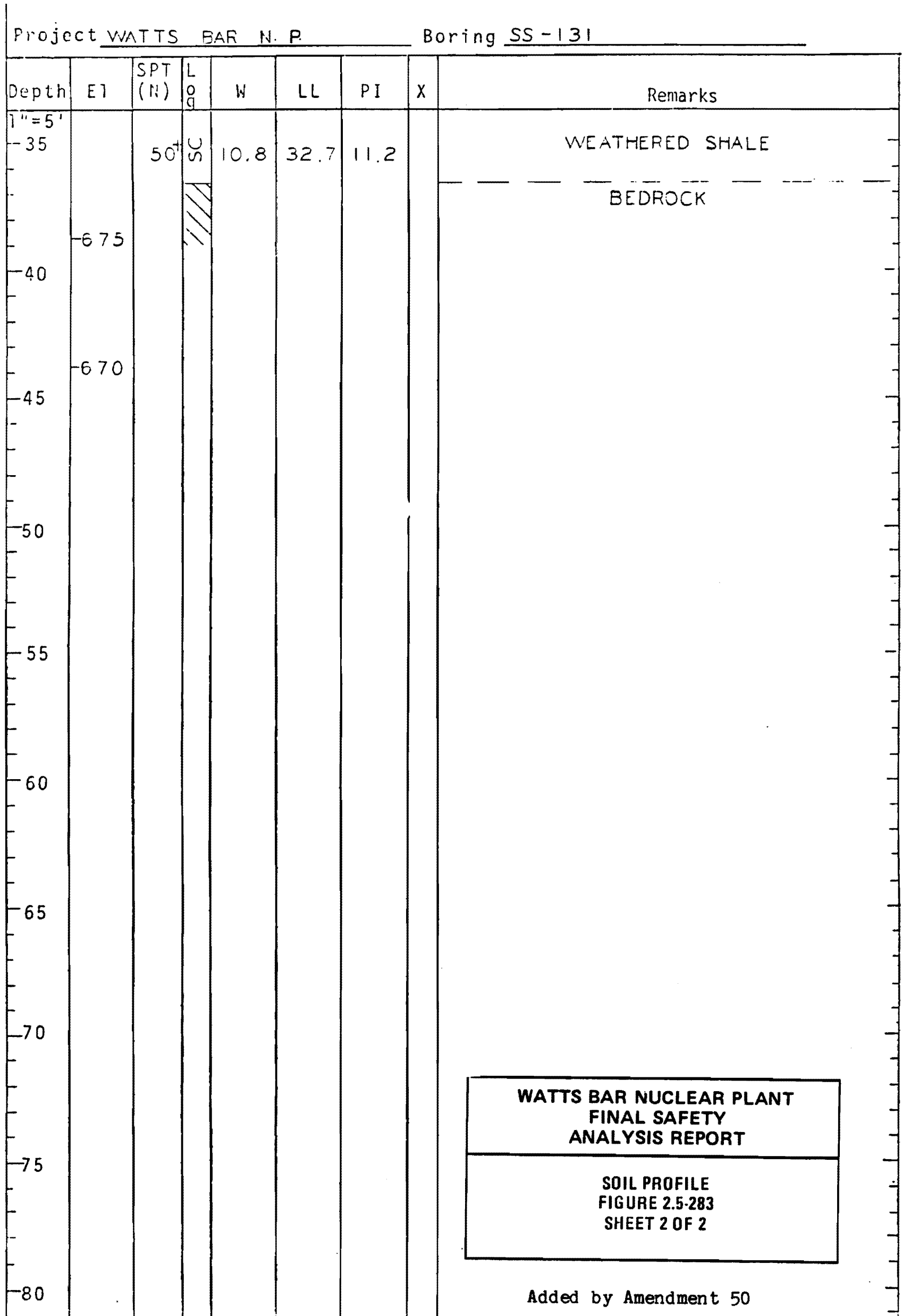
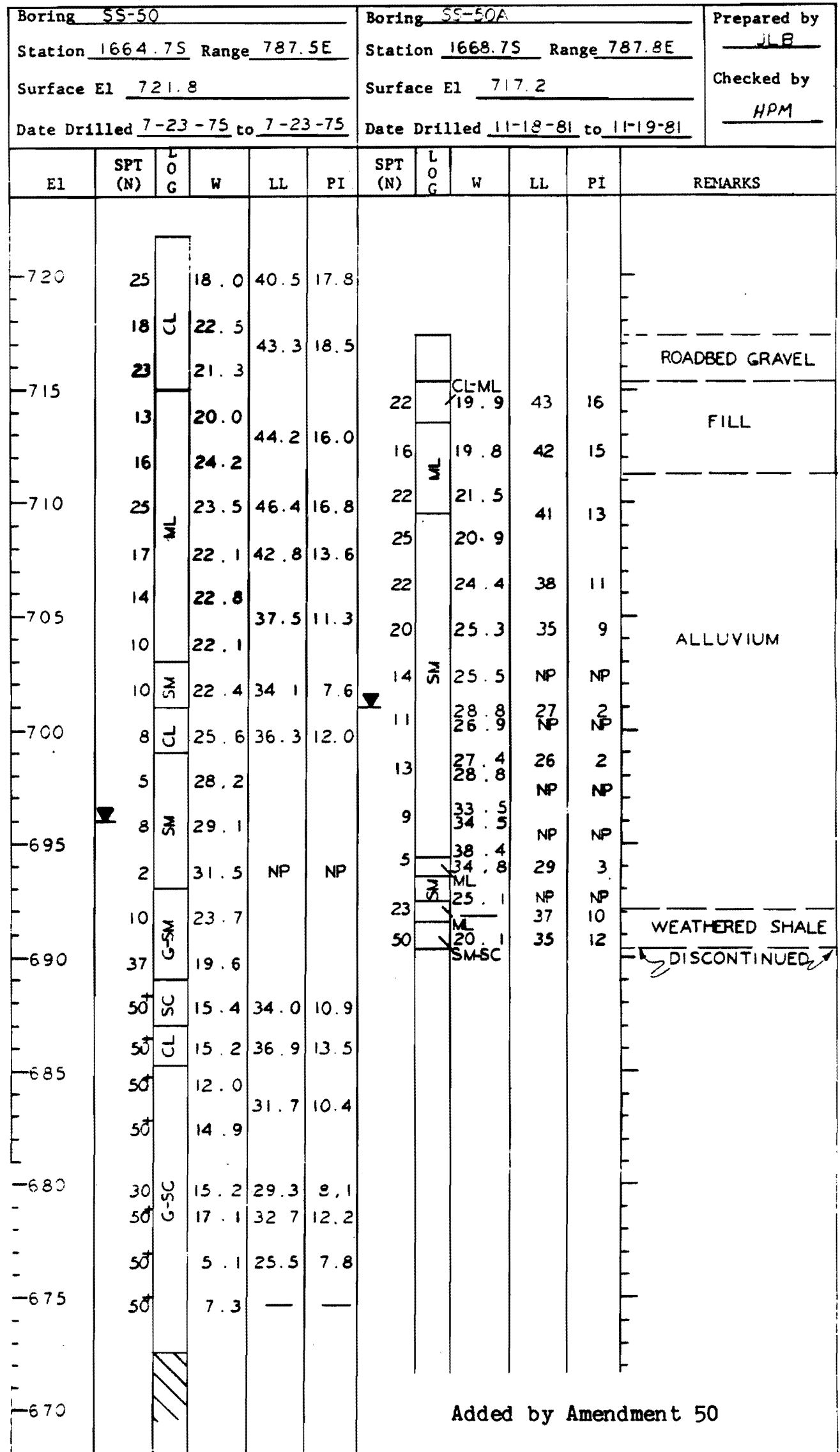

Figure 2.5-283 Soil Profile (Sheet 2 of 2)

WATTS BAR NUCLEAR PLANT ERCW  
SOIL PROFILE



WATTS BAR NUCLEAR PLANT  
 FINAL SAFETY  
 ANALYSIS REPORT  
  
 SOIL PROFILE  
 FIGURE 2.5-284

Figure 2.5-284 Soil Profile

**WATTS BAR NUCLEAR PLANT  
FINAL SAFETY  
ANALYSIS REPORT**

---

**SOIL PROFILE  
FIGURE 2.5-285  
SHEET 1 OF 2**

Project WATTS BAR N.P. Feature ERCW ALIGNMENT  
 Boring SS-132 Station 1560.0 S Range E 785.0 E Surface El 719.1  
 Date Drilled 6-4-79 To 6-5-79 Prepared By JLB Checked By QCL

Depth	El	SPT (N)	LOG	W	LL	PI	X	Remarks
1"=5								
0								
	715	22		19.6				
5		22		20.3				
		19		22.3	44.7	17.9		ALLUVIAL SANDY LEAN CLAY
10	710	14	CL	21.3				
		15		21.8				
		13		23.5				
15	705	14		23.6	42.0	17.8		
		13	ML	25.7	43.1	15.2		ALLUVIAL LEAN SILT
20	700	15		23.4	45.8	17.5		
		5	CL	25.9	40.4	16.8		
		50+		—	—	—		NO SAMPLE RECOVERY
25	695	18	CL	22.7	40.8	16.6		LAMINATED RESIDUAL CLAY
		29		19.3				
30	690	50+		20.2				
		50+	SC	16.5	37.1	12.9		WEATHERED SHALE
		50+		15.6				
35	685	48		16.6				Added by Amendment 50

Figure 2.5-285 Soil Profile (Sheet 1 of 2)

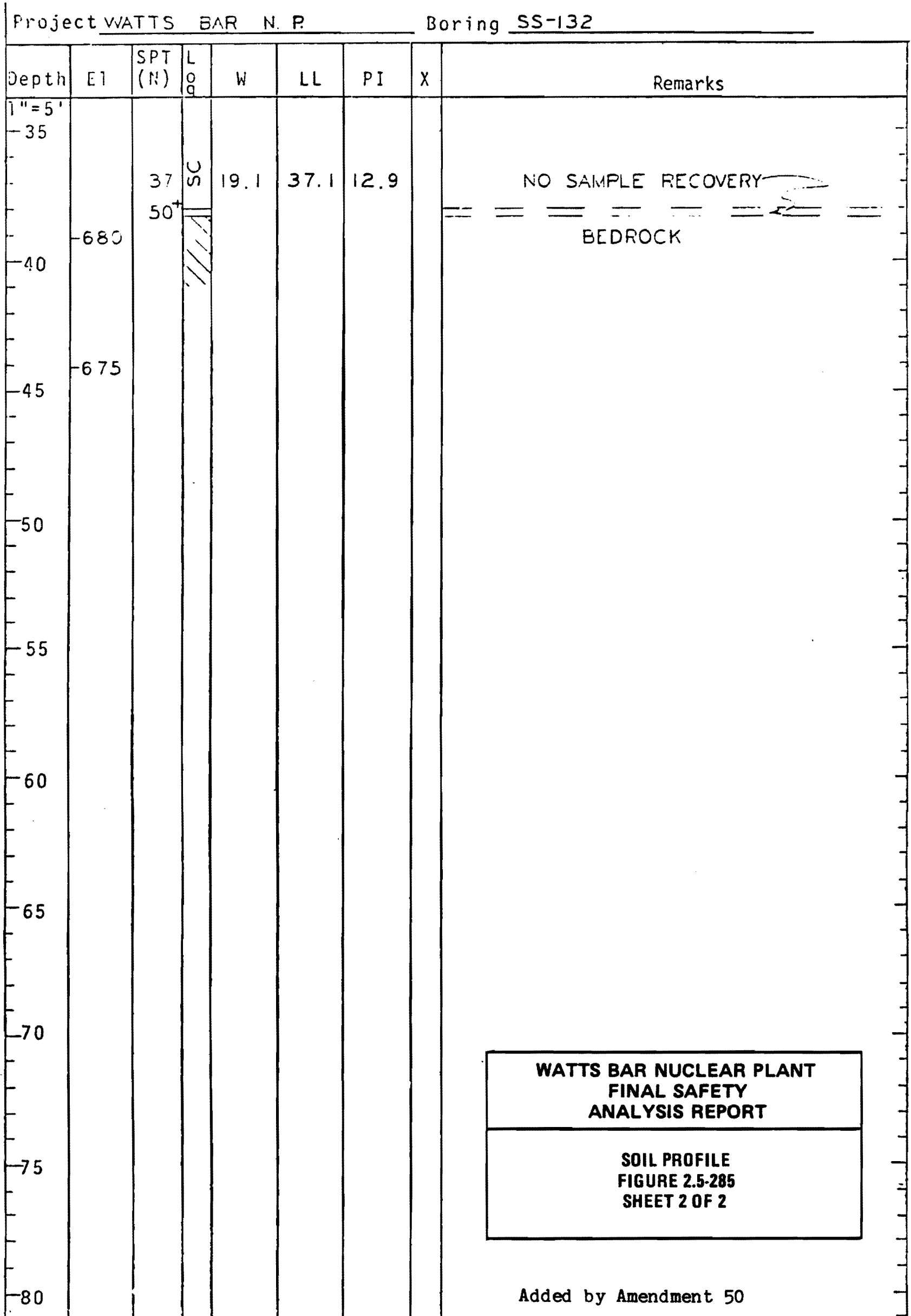

Figure 2.5-285 Soil Profile (Sheet 2 of 2)

<b>WATTS BAR NUCLEAR PLANT FINAL SAFETY ANALYSIS REPORT</b>
<b>SOIL PROFILE FIGURE 2.5-286 SHEET 1 OF 2</b>

Project WATTS BAR N. P. Feature ERCW ALIGNMENT  
 Boring SS-133 Station 1361.05 Range 785.0E Surface E1 725.0  
 Date Drilled 6-4-79 To 6-4-79 Prepared By JLB Checked By [Signature]

Depth	E1	SPT (N)	LOG	W	LL	PI	X	Remarks
1"=5'								
0	725							AUGER
		23		15.7				
5	720	18		16.6	39.9	20.5		
		16		18.9				
		12		19.7	42.6	17.4		LEAN CLAY TO SANDY LEAN CLAY, FILL
10	715	12	CL	22.9				
		11		21.7	43.9	19.2		
15	710	9		22.5				
		2		23.6	37.7	16.3		
		4		32.9	39.1	16.7		
20	705	19	GSM	17.3	NP	NP		ALLUVIAL GRAVEL
		48		20.1	42.8	13.8		
25	700	28	ML	28.3				
		40		24.0	35.1	1.5		WEATHERED SHALE
		50		20.8				
30	695	50	SM	18.0				
		50			32.3	8.1		
		50	CL	16.1				
35	690	50		12.7	31.7	11.0		Added by Amendment 50

Figure 2.5-286 Soil Profile (Sheet 1 of 2)

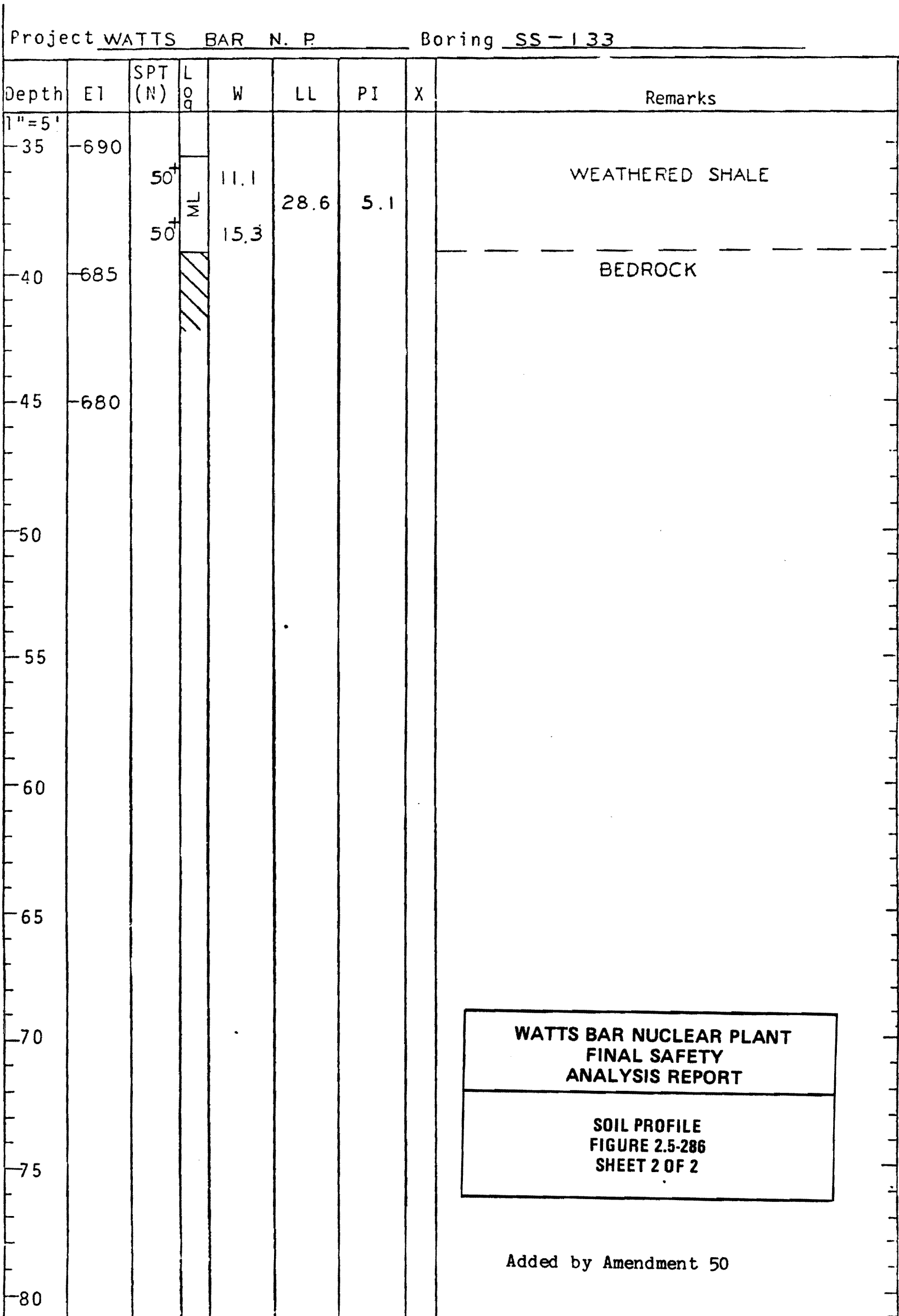

Figure 2.5-286 Soil Profile (Sheet 2 of 2)

**WATTS BAR NUCLEAR PLANT  
FINAL SAFETY  
ANALYSIS REPORT**

---

**SOIL PROFILE  
FIGURE 2.5-287  
SHEET 1 OF 2**

Project WATTS BAR N.P. Feature ERCW ALIGNMENT  
 Boring SS-134 Station 1373.0S Range 900.0 E Surface El 726.5  
 Date Drilled 6-6-79 To 6-7-79 Prepared By JLB Checked By [Signature]

Depth	El	SPT (N)	Log	W	LL	PI	X	Remarks
1"=5'								
0								
	-725	10		20.0				
		16		16.9	28.0	8.4		
5		14		18.9				
	-720	15	CL	18.7	36.2	17.1		ALLUVIAL SANDY LEAN CLAY
		8		21.7				
10		13		20.9	39.1	19.5		
	-715	2		23.8				
15		3	SM	29.3			▽	ALLUVIAL SAND
	-710	8		27.5	NP	NP		
20		27	GM	11.4				ALLUVIAL GRAVEL
	-705	50 <sup>+</sup>		10.0				
		50 <sup>+</sup>		18.1				
25		50 <sup>+</sup>		18.1	39.3	15.2		
	-700	50 <sup>+</sup>	CL	16.5				WEATHERED SHALE
		50 <sup>+</sup>		16.6				
30		50 <sup>+</sup>		16.6				
	-695	50 <sup>+</sup>	SC	20.4	36.7	13.5		
		42		16.2				Added by Amendment 50
35								

Figure 2.5-287 Soil Profile (Sheet 1 of 2)



Project WATTS BAR N.P Boring SS-134

Depth	E1	SPT (N)	Log	W	LL	PI	X	Remarks
1"=5'								
-35		50+	CL	15.2	35.6	13.3		WEATHERED SHALE
-690		50+		15.8	37.2	13.4		
-40		50+	SC	14.7	35.6	12.1		
-685		50+		15.1				
-45		50+	CL	18.7	33.4	11.4		NO SAMPLE RECOVERY BEDROCK
-680		50+						
-50								
-55								
-60								
-65								
-70								
-75								
-80								

**WATTS BAR NUCLEAR PLANT  
 FINAL SAFETY  
 ANALYSIS REPORT**

---

**SOIL PROFILE  
 FIGURE 2.5-287  
 SHEET 2 OF 2**

Added by Amendment 50

Figure 2.5-287 Soil Profile (Sheet 2 of 2)

WATTS BAR NUCLEAR PLANT ERCW  
SOIL PROFILE

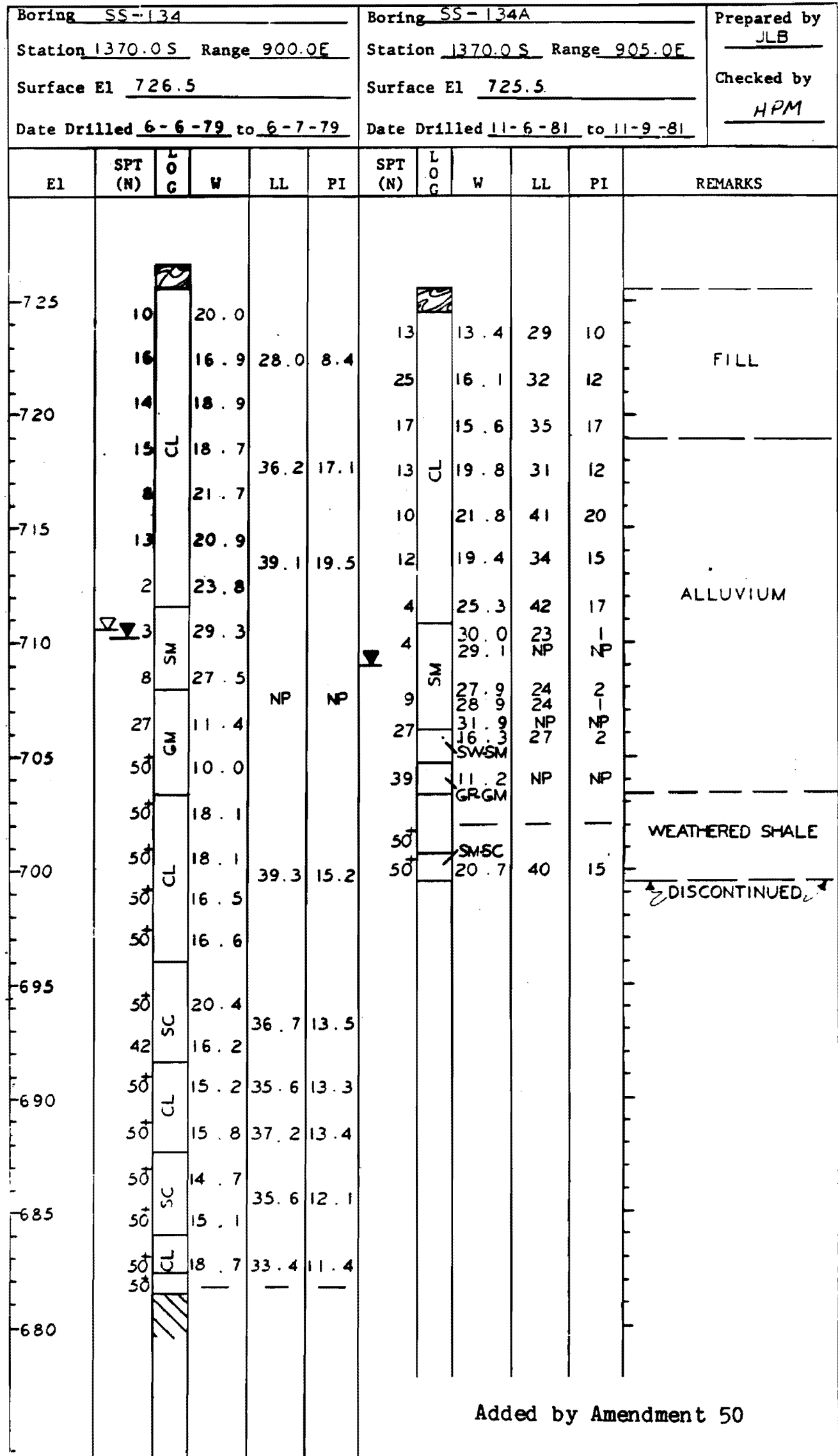

WATTS BAR NUCLEAR PLANT  
 FINAL SAFETY  
 ANALYSIS REPORT  
  
 SOIL PROFILE  
 FIGURE 2.5-288

Figure 2.5-288 Soil Profile

<b>WATTS BAR NUCLEAR PLANT FINAL SAFETY ANALYSIS REPORT</b>
<b>SOIL PROFILE FIGURE 2.5-289 SHEET 1 OF 2</b>

Project WATTS BAR N.P. Feature ERCW ALIGNMENT  
 Boring SS-135 Station 1370.0S Range 1000.0 E Surface El 726.9  
 Date Drilled 5-30-79 To 6-1-79 Prepared By JLB Checked By CBG

Depth	El	SPT (N)	COL	W	LL	PI	X	Remarks
1"=5'								
0								
	725	7	CL	—	30.9	12.2		SANDY LEAN CLAY FILL
		13	CL	19.4	32.7	9.7		
5		13		19.3	37.8	19.6		ALLUVIAL SANDY SILT
	720	21		—	48.0	19.6		
		14	ML	26.7	46.5	16.5		ALLUVIAL SAND
10		12		26.3	42.2	13.8		
	715	11		23.6	34.1	8.7		LAMINATED RESIDUAL CLAY
		12		20.1	30.0	4.4		
15								WEATHERED SHALE
	710	8	SM	—				
		8		—	NP	NP		Added by Amendment 50
20		8		25.3				
	705	8		—	32.3	11.8		
		8	CL	—				
25		22	GSM	28.9	44.5	15.8		
	700	26		25.7	43.5	16.7		
		50	SM	20.4	38.9	12.7		
30		48		21.3	38.6	12.4		
	695	43		23.3	37.9	10.5		
35								

Figure 2.5-289 Soil Profile (Sheet 1 of 2)

Project WATTS BAR N. P.				Boring SS-135					
Depth	E1	SPT (N)	Log	W	LL	PI	X	Remarks	
1"=5'									
35		50+	CL	17.9	34.3	11.3		WEATHERED SHALE	
	690	50+	CL	—	35.1	13.1			
		50+	SC	15.6	34.1	12.0			
40		50+	SC	12.3	30.7	10.7			
	685								
		50+	CL	20.6	36.1	16.1			
45		50+	CL	11.2	28.5	8.7			
	680								
									BEDROCK
50									
	675								
55									
60									
65									
70									
75									
80									

**WATTS BAR NUCLEAR PLANT  
 FINAL SAFETY  
 ANALYSIS REPORT**  
**SOIL PROFILE  
 FIGURE 2.5-289  
 SHEET 2 OF 2**

Added by Amendment 50

Figure 2.5-289 Soil Profile (Sheet 2 of 2)

WATTS BAR NUCLEAR PLANT ERCW  
SOIL PROFILE

Boring SS-135						Boring SS-135A						Prepared By JLB	
Station 1373.0S Range 1000.0E						Station 1363.3S Range 1004.5E						Checked By HPM	
Surface Elev 726.9						Surface Elev 726.5							
Date Drilled 5-30-79 To 6-1-79						Date Drilled 11-9-81 To 11-10-81							
E1	SPT (N)	L/G	W	LL	PI	SPT (N)	L/G	W	LL	PI	REMARKS		
725	7		—	30.9	12.2	19		16.1	28	7	FILL		
	13	CL	19.4	32.7	9.7	20	CL	16.6	33	13			
	13		19.3	37.8	19.6	21	CEML	19.8	40	15			
720	21		—	48.0	19.6	19	ML	24.7	41	13			
	14	ML	26.7	46.5	16.5	19	ML	26.7	41	12			
715	12		26.3	42.2	13.8	13		24.3	31	3	ALLUVIUM		
	11		23.6	34.1	8.7	7		22.8					
	12		20.1	30.0	4.4	7	SM	24.3	NP	NP			
710	8	SM	—	—	—	5		34.2					
	8		—	—	—	8		27.0	22	22			
	8		25.3	—	NP	8	ML	32.1	27	27			
705	8		—	—	—	7	SM	32.1	25	25			
	8		—	—	—	50	SM	30.9	NP	NP			
	22	CL	28.9	44.5	15.8	36	GM	16.7	—	—			
700	26	G-SM	25.7	43.5	16.7			30.1	46	14			DISCONTINUED
	50	SM	20.4	38.9	12.7						WEATHERED SHALE		
	48		21.3	38.6	12.4								
695	43		23.3	37.9	10.5								
	50	CL	17.9	34.3	11.3								
690	50		—	35.1	13.1								
	50	SC	15.6	34.1	12.0								
	50		12.3	30.7	10.7								
685	50	CL	20.6	36.1	16.1								
	50		11.2	28.5	8.7								
680													Added by Amendment 50

WATTS BAR NUCLEAR PLANT  
FINAL SAFETY  
ANALYSIS REPORT

SOIL PROFILE  
FIGURE 2.5-290

Figure 2.5-290 Soil Profile

WATTS BAR NUCLEAR PLANT ERCW  
SOIL PROFILE

Boring SS-65						Boring SS-65B						Prepared by JLB	
Station 1374.8S		Range 1097.5E				Station 1362.3S		Range 1091.0E				Checked by HPM	
Surface El 726.0						Surface El 727.2							
Date Drilled 7-25-75 to 7-25-75						Date Drilled 11-13-81 to 11-13-81							
EI	SPT (N)	LOG	W	LL	PI	SPT (N)	LOG	W	LL	PI	REMARKS		
725	50	CL	15.4	36.3	15.6	11	SC	14.1	28	8	FILL		
	35	CL	12.9	35.6	14.1	20	CL	12.5	32	14			
720	24	MH	28.2			25	MH	28.3	55	8			
	21	MH	24.9	50.7	17.7	18	MH	28.9	51	15			
	13	ML	24.5	40.4	13.0	12	ML	29.1	42	12			
715	16	ML	29.2	46.1	15.6	14	ML	26.7	35	6	ALLUVIUM		
	12		21.5	33.1	6.6	9		25.7	29	2			
710	10	SM	15.7	NP	NP	6		27.5	25	1			
	7	SM	23.7	30.1	5.1	3	SM	33.1	NP	NP			
	5		28.2	28.9	3.5	5		32.9	NP	NP			
705	8					7		32.5	25	1			
	20	GM	13.5	32.5	9.0	37		27.1	26	2			
	18	SM	24.8	46.4	18.2			30.8	25	1			
	16		23.8					21.9	44	14	WEATHERED SHALE		
	16	G-SM	24.7	43.4	15.9						DISCONTINUED		
695	14		25.5										
	11	ML	40.7	47.1	13.4								
690	30	ML	30.8	42.2	13.9								
	48	SC	19.8	34.4	11.2								
	50		14.3										
685	16		19.1	36.6	12.0								
	41	G-SC	22.6										
680	45	G-SC	17.1	33.8	10.5								
	50		15.4										
	50			32.0	10.5								
675	50		15.3										

Added by Amendment 50

WATTS BAR NUCLEAR PLANT  
FINAL SAFETY  
ANALYSIS REPORT

SOIL PROFILE  
FIGURE 2.5-291

Figure 2.5-291 Soil Profile

**WATTS BAR NUCLEAR PLANT  
FINAL SAFETY  
ANALYSIS REPORT**

---

**SOIL PROFILE  
FIGURE 2.5-292  
SHEET 1 OF 2**

Project WATTS BAR N.P. Feature ERCW ALIGNMENT  
 Boring SS-136 Station 1373.7 S Range 1215.0 E Surface E1 726.9  
 Date Drilled 6-22-79 To 6-22-79 Prepared By JLB Checked By gcl

Depth	E1	SPT (N)	Log	W	LL	PI	X	Remarks
0								TOPSOIL
	725	19	CL	19.2	38.8	20.3		LEAN CLAY FILL
		6		22.5	49.7	24.2		
5			MH	25.8	51.1	20.4		ALLUVIAL SANDY SILT
	720	14		26.5	40.7	11.4		
		17		25.8				
		14	ML	23.7	32.8	5.7		
15				25.0				ALLUVIAL SAND
	710	5		26.3				
		8	SM	28.5	NP	NP		
20				21.9				ALLUVIAL GRAVEL
	705	50+		15.1				
		50+	ML-CL	19.1	41.7	16.7		WEATHERED SHALE
25		50+		17.2				
	700	34	CL	20.3	37.2	13.4		
		31		21.6	36.3	11.7		
30				16.9				Added by Amendment 50
	695	50+	SM	17.4	34.0	7.0		
35		50+						

Figure 2.5-292 Soil Profile (Sheet 1 of 2)

Project WATTS BAR N. P.							Boring SS-136	
Depth	E1	SPT (N)	Log	W	LL	PI	X	Remarks
1"=5'								
35								
	690	50	SM	21.0	33.3	3.7		WEATHERED SHALE
		50+		20.3				
40		50+		12.6	35.3	13.2		
	685	50+	SC	12.8				
		50+			31.4	9.6		
45				14.9				BEDROCK
	680							
50								
55								
60								
65								
70								
75								
80								

**WATTS BAR NUCLEAR PLANT  
 FINAL SAFETY  
 ANALYSIS REPORT**

---

**SOIL PROFILE  
 FIGURE 2.5-292  
 SHEET 2 OF 2**

Added by Amendment 50

Figure 2.5-292 Soil Profile (Sheet 2 of 2)



**WATTS BAR NUCLEAR PLANT  
FINAL SAFETY  
ANALYSIS REPORT**

---

**SOIL PROFILE  
FIGURE 2.5-293  
SHEET 1 OF 1**

Project WATTS BAR N.P. Feature ERCW ALIGNMENT  
 Boring SS-137 Station 1375.0 S Range 1300.0 E Surface El 726.9  
 Date Drilled 6-7-79 To 6-8-79 Prepared By JLB Checked By JCB

Depth	El	SPT (N)	Soil Log	W	LL	PI	X	Remarks
0								TOPSOIL
0	725	20	ML	19.0	35.2	10.9		
5		7		21.2				ALLUVIAL SANDY LEAN CLAY OR SILT
5	720	11	CL	21.0	42.0	17.1		
		16		26.5				
10		14		25.1	43.9	14.1		ALLUVIAL SANDY SILT
10	715	11	ML	24.2	35.6	9.6		
		9	SM	20.7	25.9	1.8		ALLUVIAL SAND
15		7		25.0				
15	710	8	ML	25.3	31.7	5.6		ALLUVIAL LEAN CLAY OR SILT
		3	CL	33.9	34.7	10.7		
20		32	GM	9.6	NP	NP		ALLUVIAL GRAVEL
25		41		21.1	42.6	14.9		
25	700	50	ML	22.8				WEATHERED SHALE
		39		23.0	40.8	16.5		
30		50	CL	20.4				
30	695	50		16.9	36.5	13.0		
								BEDROCK
35								

Added by Amendment 50

Figure 2.5-293 Soil Profile

**WATTS BAR NUCLEAR PLANT  
FINAL SAFETY  
ANALYSIS REPORT**

---

**SOIL PROFILE  
FIGURE 2.5-294  
SHEET 1 OF 2**

Project WATTS BAR N.P. Feature ERCW ALIGNMENT  
 Boring SS-138 Station 1373.0 S Range 1400.0 E Surface El 727.2  
 Date Drilled 6-8-79 To 6-11-79 Prepared By JLB Checked By [Signature]

Depth	El	SPT (N)	Log	W	LL	PI	X	Remarks
1"=5'								
0								TOPSOIL
	725	18	CL	15.7	34.3	16.9		
		23	MH	28.5	55.0	24.1		ALLUVIAL LEAN CLAY TO FAT SILT
5		15		27.5				
	720	13	ML	30.1	48.0	19.7		ALLUVIAL SANDY SILT
10		10		25.6	40.2	14.5		
	715	9		22.3	31.6	7.8		
		6	SM	23.4	28.1	2.5		ALLUVIAL SAND
15		7		24.5				
	710	7	ML	28.4	32.7	5.9		ALLUVIAL SANDY SILT OR SANDY LEAN CLAY
20		5	ML-CL	29.6	27.0	5.1		
	705	13	SM	15.0	26.4	2.3		ALLUVIAL SAND
		16		26.8				
25		43	G-SM	26.7				
	700	32		29.3	NP	NP		WEATHERED SHALE
30		50+		20.4				
		50+	SM	14.6				
	695	50+						
		50+	SC	20.5	34.9	12.0		Added by Amendment 50
35								

Figure 2.5-294 Soil Profile (Sheet 1 of 2)

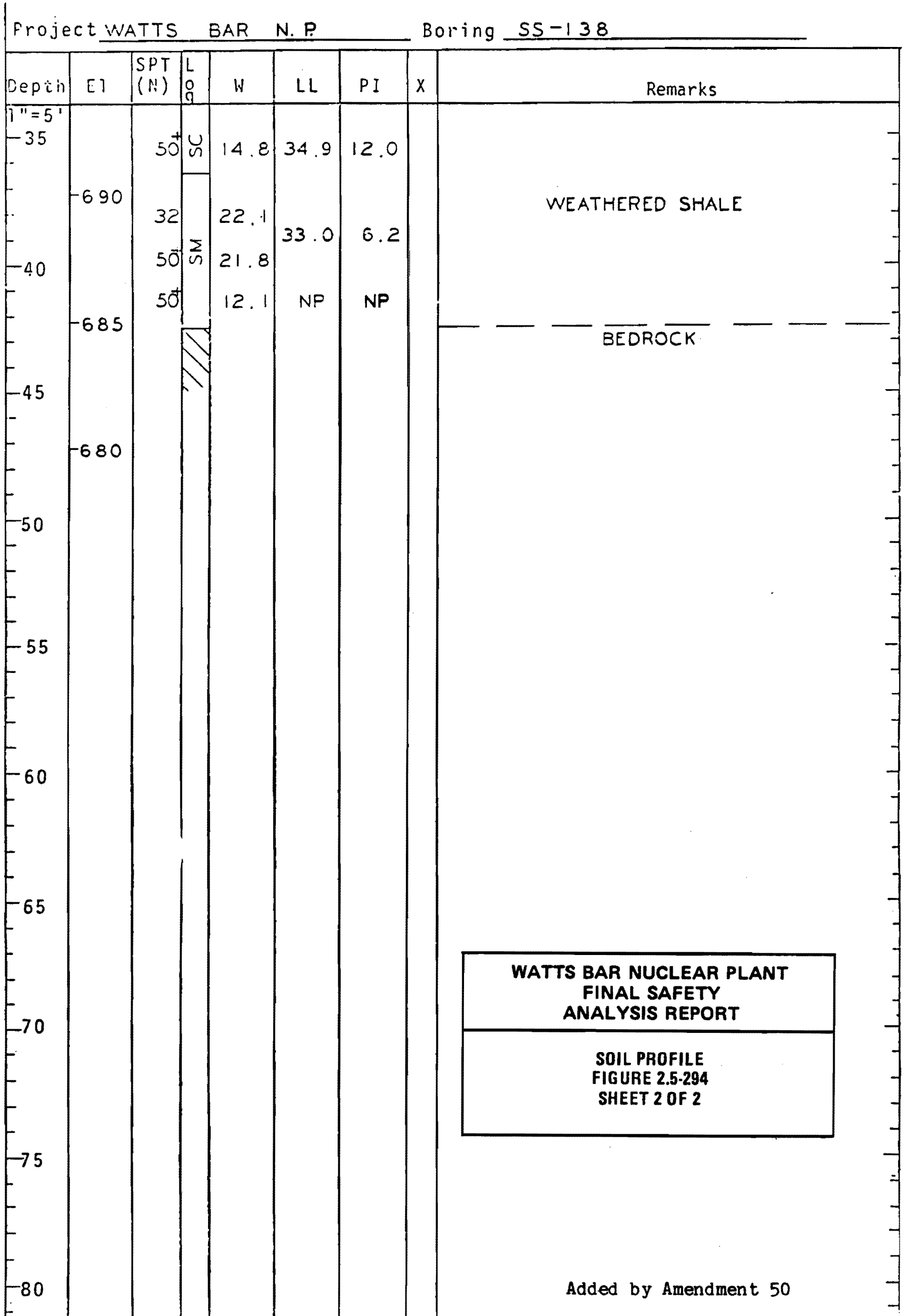

Figure 2.5-294 Soil Profile (Sheet 2 of 2)

WATTS BAR NUCLEAR PLANT ERCW  
SOIL PROFILE

Boring SS-138						Boring SS-138A						Prepared by JLB	
Station 1373.0S		Range 1400.0E				Station 1368.8S		Range 1406.5E				Checked by HPM	
Surface El 727.2						Surface El 726.7							
Date Drilled 6-8-79 to 6-11-79						Date Drilled 11-12-81 to 11-12-81							
El	SPT (N)	LOG	W	LL	PI	SPT (N)	LOG	W	LL	PI	REMARKS		
725	18	CL	15.7	34.3	16.9	50	GC	6.7	35	18	FILL		
	23	MP	28.5	55.0	24.1								
	15	MP	27.5			32	ML-MPT	27.3	50	19	ALLUVIUM		
720	13	ML	30.1	48.0	19.7	19	ML	30.9	48	18			
	10	ML	25.6	40.2	14.5	16	ML	27.1	39	13			
	9	ML	22.3	31.6	7.8	12	ML	25.1	33	6			
	6	SM	23.4	28.1	2.5	8	SM	25.1	29	3			
	7	SM	24.5			8	SM	22.1	NP	NP			
710	7	ML	28.4	32.7	5.9	12	SM	27.1	29	1	WEATHERED SHALE DISCONTINUED		
	5	ML-CL	29.6	27.0	5.1	4	SM	35.6	29	2			
	13	SM	15.0	26.4	2.3	9	SM	27.8	22	NP			
705	16	SM	26.8			22	SM	30.6	NP	NP			
	43	G-SM	26.7			50*	SM	38.4	NP	NP			
	32	G-SM	29.3	NP	NP								
	50*	SM	20.4										
	50*	SM	14.6										
695	50*	SC	20.5	34.9	12.0								
	50*	SC	14.8										
690	32	SM	22.1	33.0	6.2								
	50*	SM	21.8										
	50*	SM	12.1	NP	NP								
685													
680													

WATTS BAR NUCLEAR PLANT  
FINAL SAFETY  
ANALYSIS REPORT

SOIL PROFILE  
FIGURE 2.5-295

Added by Amendment 50

Figure 2.5-295 Soil Profile

**WATTS BAR NUCLEAR PLANT  
FINAL SAFETY  
ANALYSIS REPORT**

---

**SOIL PROFILE  
FIGURE 2.5-296  
SHEET 1 OF 2**

Project WATTS BAR N.P. Feature ERCW ALIGNMENT  
 Boring SS-139 Station 1375.0 S Range 1500.0E Surface El 727.5  
 Date Drilled 6-11-79 To 6-12-79 Prepared By JLB Checked By ecj

Depth	El	SPT (N)	Log	W	LL	PI	X	Remarks
1"=5'								
0			CL					TOPSOIL
	-725	16	CL	15.8	34.7	17.3		SANDY LEAN CLAY FILL
		11		14.4				
5		9	CL-CH	22.0	50.1	25.0		ALLUVIAL LEAN TO FAT CLAY
	-720	10		25.9				
10		15		26.4	47.2	17.7		ALLUVIAL SANDY SILT
	-715	13	ML	23.8	36.9	11.0		
		9		19.2				
15		8	SM	15.5	NP	NP		ALLUVIAL SANDY SILT AND SILTY SAND
	-710	9		18.2				
20		7	ML	32.8	31.0	3.9	▽	
	-705	14	SM	22.1	NP	NP		ALLUVIAL GRAVEL
		50+	GM	7.5				
25		49	CL	17.0	36.7	14.6		
	-700	50+		18.9	33.1	11.5		WEATHERED SHALE
		50+		13.7				
30		50+	SC	16.0	32.9	12.6		
	-695	50+		11.8				
35								Added by Amendment 50

Figure 2.5-296 Soil Profile (Sheet 1 of 2)

Project WATTS BAR N.P. Boring SS-139								
Depth	E1	SPT (N)	Log	W	LL	PI	X	Remarks
1"=5'								
-35		50+	SM	15.0	NP	NP		
-690		50+		12.2				
-40		50+	CL	13.1	30.6	10.0		
-685		50+		9.5	—	—		
-45		50+	G-SC	10.7	—	—		WEATHERED SHALE
-680		50+		18.0	—	—		
-50		50+	GSMSC	10.1	30.7	10.3		
-675		50+		16.6				
-55		50+	GSM	13.4	27.2	7.0		
-670		50+		9.4	NP	NP		
-60								BEDROCK
-65								
-70								
-75								
-80								

**WATTS BAR NUCLEAR PLANT  
 FINAL SAFETY  
 ANALYSIS REPORT**

---

**SOIL PROFILE  
 FIGURE 2.5-296  
 SHEET 2 OF 2**

Added by Amendment 50

Figure 2.5-296 Soil Profile (Sheet 2 of 2)

**WATTS BAR NUCLEAR PLANT  
FINAL SAFETY  
ANALYSIS REPORT**

---

**SOIL PROFILE  
FIGURE 2.5-297  
SHEET 1 OF 2**

Project WATTS BAR N.P. Feature ERCW ALIGNMENT  
 Boring SS-140 Station 1334.2S Range 1560.8 E Surface El 726.7  
 Date Drilled 6-11-79 To 6-11-79 Prepared By JLB Checked By OCJ

Depth	El	SPT (N)	Log	W	LL	PI	X	Remarks
0	-725	21	CL	12.7	35.0	17.4		ALLUVIAL SILT AND CLAY
		8	CL	13.9	—	—		
5	-720	9	CHMH	20.0	43.1	19.0		
		16	CHMH	27.4	60.9	30.0		
10	-715	11	ML	22.0	36.5	7.4		
		8	ML	24.3				
15	-710	7	ML	24.6	34.1	6.2		
		12	SM	25.0				
20	-705	3	SM	17.4	NP	NP		
		4	SM	38.7				
		29	CL	17.4	43.1	18.4		LAMINATED RESIDUUM
		44	MECL	18.3	44.2	18.7		WEATHERED SHALE
25	-700	40	ML	21.9	35.2	6.1		
		50	CL	16.8	36.9	14.0		
30	-695	41	SM	22.3	37.4	7.4		
		50+	CL-ML	20.0	36.3	13.2		
		50+	MECL	18.7	35.4	10.8		
35								Added by Amendment 50

Figure 2.5-297 Soil Profile (Sheet 1 of 2)

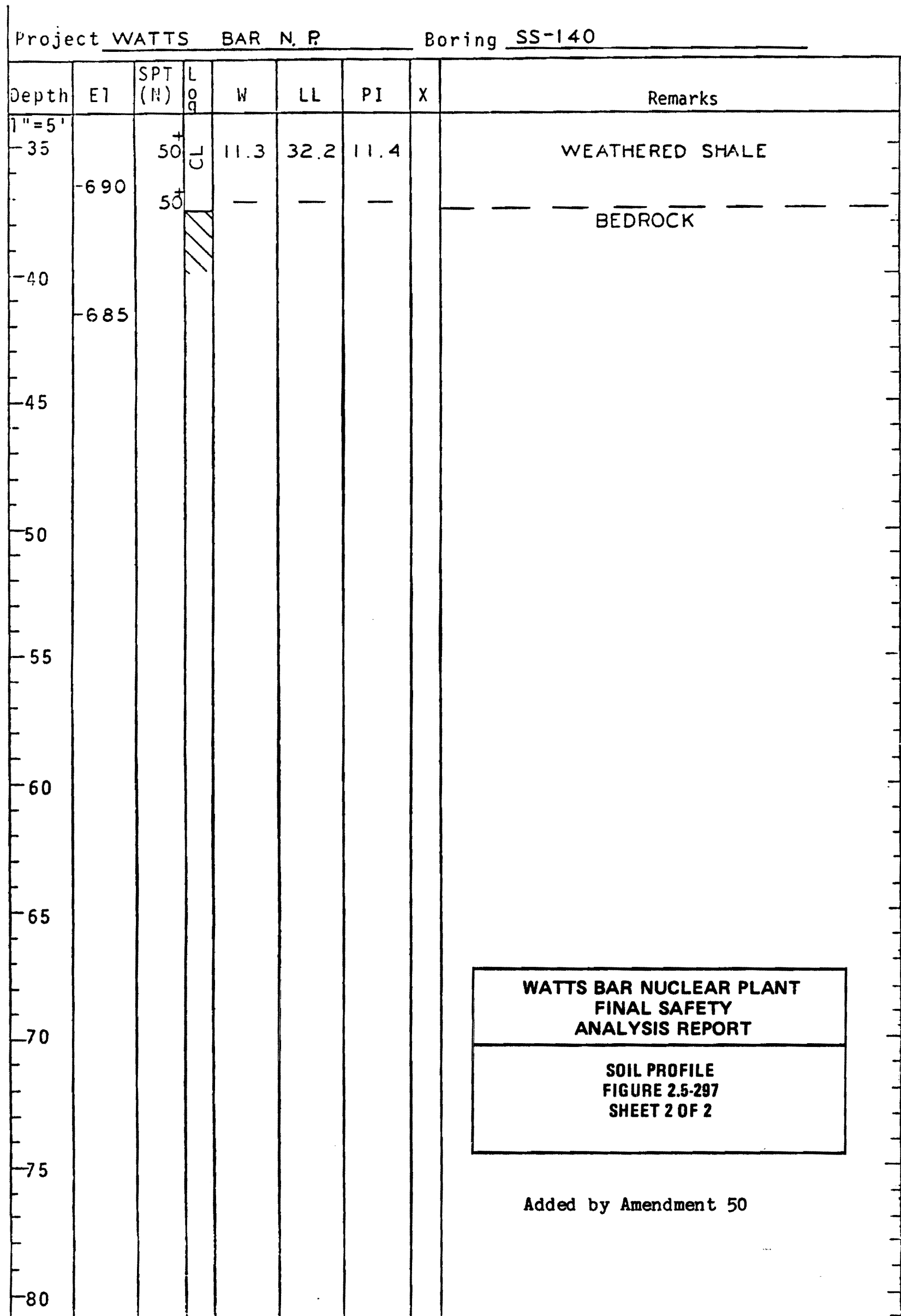

Figure 2.5-297 Soil Profile (Sheet 2 of 2)



**WATTS BAR NUCLEAR PLANT  
FINAL SAFETY  
ANALYSIS REPORT**

---

**SOIL PROFILE  
FIGURE 2.5-298  
SHEET 1 OF 2**

Project WATTS BAR N. P. Feature ERCW ALIGNMENT  
 Boring SS-141 Station 1187.5 S Range 1707.5 E Surface El 724.6  
 Date Drilled 6-11-79 To 6-12-79 Prepared By JLB Checked By CCG

Depth	El	SPT (N)	Log	W	LL	PI	X	Remarks
1"=5								
0								
			16	14.6	29.7	13.8		
			CL					
	-720		14	15.7	32.1	15.7		ALLUVIAL CLAY
5			16	9.9	35.1	18.6		
			GCL					
			16	11.8	34.5	18.0		
	-715		9	19.3	36.2	16.6		
			1	24.7				
			18	19.0	27.4	5.9		ALLUVIAL SAND
	-710		CL					
15			14	23.7	27.6	7.2		ALLUVIAL CLAY
			23	8.5				
			GSM		NP	NP		ALLUVIAL GRAVELLY SAND
20	-705		17	7.8				
			31	16.6	37.4	14.5		LAMINATED RESIDUUM
	-700		10	22.6				
25			21	20.7	36.7	6.8		
			50+	14.2	34.7	11.8		
	-695		50+	12.2	33.2	11.8		WEATHERED SHALE
			50+	17.2	36.9	11.7		
			50+	8.7	28.0	5.4		
	-690							Added by Amendment 50
35								

Figure 2.5-298 Soil Profile (Sheet 1 of 2)

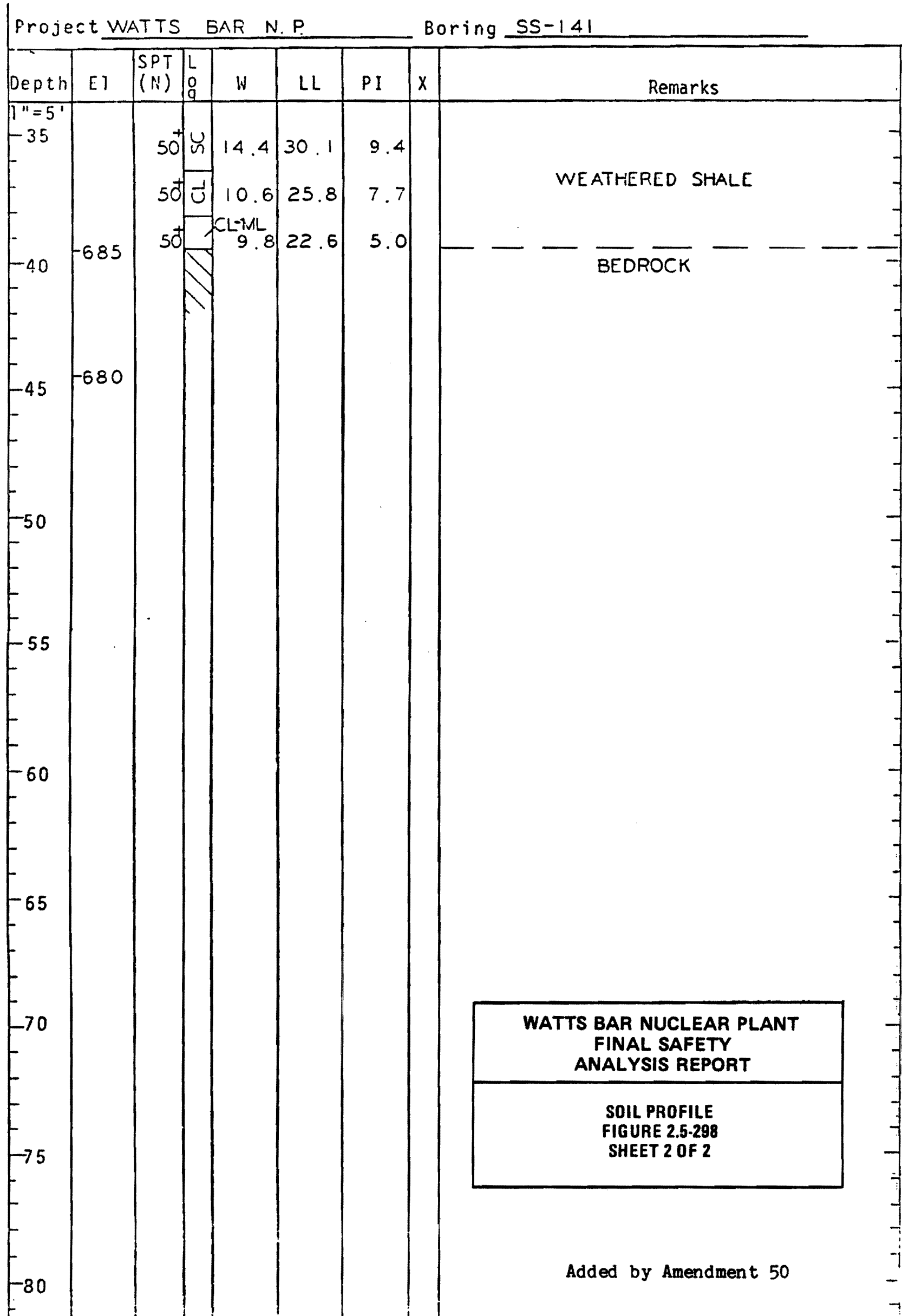

Figure 2.5-298 Soil Profile (Sheet 2 of 2)

**WATTS BAR NUCLEAR PLANT  
FINAL SAFETY  
ANALYSIS REPORT**

---

**SOIL PROFILE  
FIGURE 2.5-299  
SHEET 1 OF 2**

Project WATTS BAR N.P. Feature ERCW ALIGNMENT  
 Boring SS-142 Station 1012.5 S Range 1882.5 E Surface El 721.8  
 Date Drilled 6-12-79 To 6-13-79 Prepared By JLB Checked By gcl

Depth	El	SPT (N)	Soil	W	LL	PI	X	Remarks
0	-720	13	CL	14.1	33.9	19.0		ALLUVIAL CLAY
		24	CL	13.9	31.7	14.2		
5	-715	18	GCL	14.0	36.1	17.9		
		11	CL	14.8	37.9	19.2	▽	
10	-710	12	ML-CL	20.1	38.7	13.5		
		15	ML-CL	22.4				
15	-705	11	—	—	38.4	15.0		
		12	—	23.3				
20	-700	10	CL	21.9	36.7	16.4		
		16	CL	17.0				
25	-695	9	CL	24.1	41.3	17.6		LAMINATED RESIDUUM
		4	CL	26.2	42.0	20.2		
30	-690	11	GCL	19.0	48.4	26.6		WEATHERED SHALE Added by Amendment 50
		33	CL	15.1	35.4	13.7		
		24	ME-CL	17.9	35.8	12.3		
		50	CL	13.0	35.6	15.7		
		49	ME-CL	15.7	34.4	10.0		

Figure 2.5-299 Soil Profile (Sheet 1 of 2)

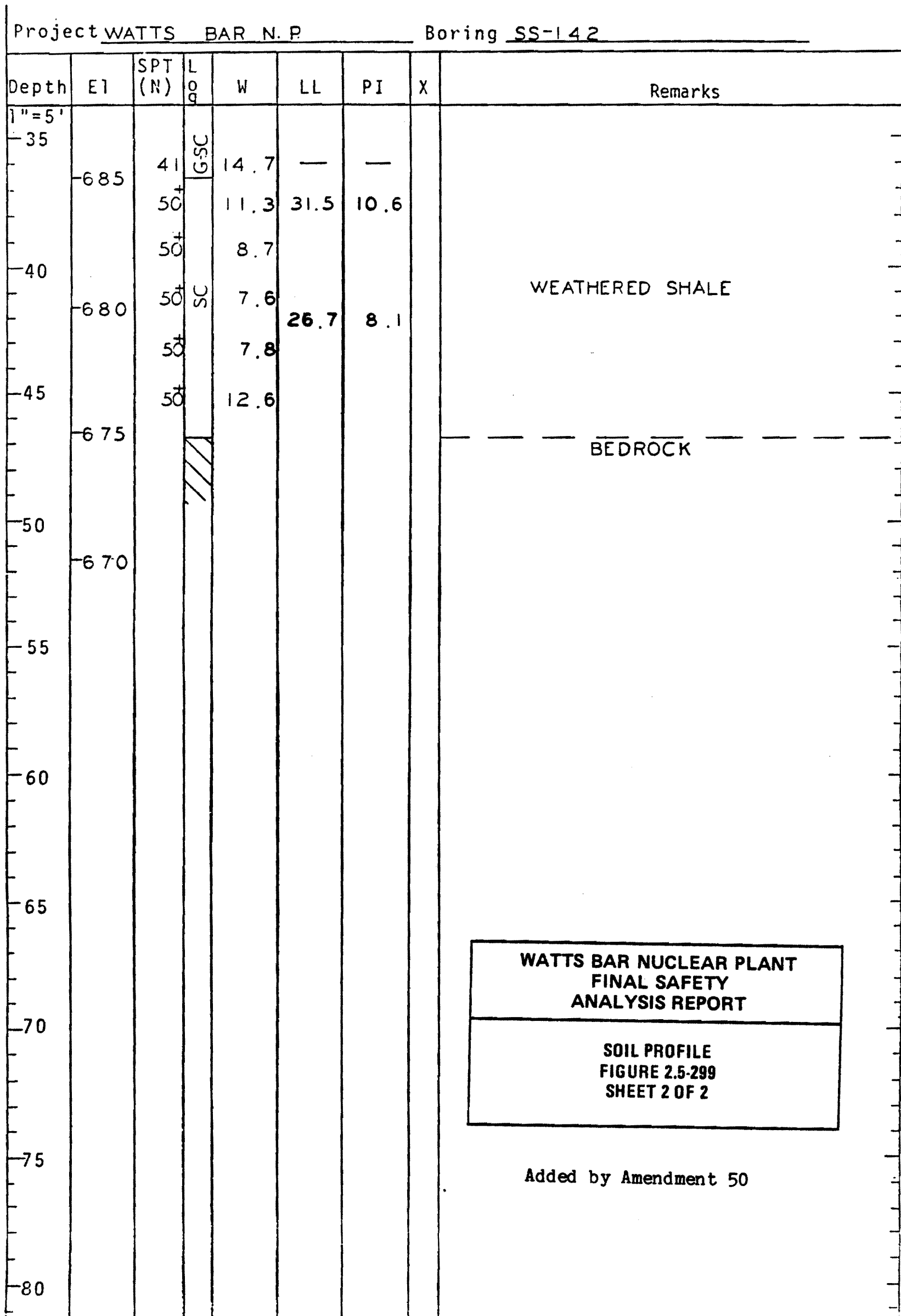

Figure 2.5-299 Soil Profile (Sheet 2 of 2)

**WATTS BAR NUCLEAR PLANT  
FINAL SAFETY  
ANALYSIS REPORT**

---

**SOIL PROFILE  
FIGURE 2.5-300  
SHEET 1 OF 2**

Project WATTS BAR N.P. Feature ERCW ALIGNMENT  
 Boring SS-143 Station 965.0 S Range 1923.2 E Surface El 723.1  
 Date Drilled 6-14-79 To 6-14-79 Prepared By JLB Checked By JCS

Depth	El	SPT (N)	Log	W	LL	PI	X	Remarks
1"=5								
0								
		10		16.3	31.9	16.8		
	-720	24		16.4	30.5	12.7		
5		13	U	15.9	35.3	17.0		
	-715	10		20.9	35.4	16.1		
10		9		19.4				
	-710	9	ML-CL	22.4	37.4	13.6		ALLUVIAL CLAY
15		9		22.9	38.9	13.3		
	-705	9		22.7	36.2	11.5		
20		6		21.8	39.3	18.2		
	-700	7		25.0				
25		3	CL	29.0	42.2	22.4		
	-695	4		25.6				
		4		29.0	35.2	16.2		
		7						NO SAMPLE RECOVERY
30		9	GSPSM	13.5	NP	NP		ALLUVIAL GRAVELLY SAND
	-690	2	CL	—	31.2	15.5		ALLUVIAL CLAY
35		17		11.4	—	—		Added by Amendment 50

Figure 2.5-300 Soil Profile (Sheet 1 of 2)

Project WATTS BAR N.P. Boring SS-143								
Depth	E1	SPT (N)	Log	W	LL	PI	X	Remarks
1"=5'								
-35		27	SM	21.2	28.9	2.6		LAMINATED RESIDUUM
-685		50	SC	16.3	30.8	9.7		WEATHERED SHALE
-40		50		11.1				
-680		50		13.9	29.8	10.9		
-45		34	G-SC	15.2	29.6	9.2		
-50		50	SC	14.0	28.0	7.6		BEDROCK
-675								
-50								
-55								
-60								
-65								
-70								
-75								
-80								

**WATTS BAR NUCLEAR PLANT  
 FINAL SAFETY  
 ANALYSIS REPORT**

---

**SOIL PROFILE  
 FIGURE 2.5-300  
 SHEET 2 OF 2**

Added by Amendment 50

Figure 2.5-300 Soil Profile (Sheet 2 of 2)

WATTS BAR NUCLEAR PLANT ERCW  
SOIL PROFILE

**ISSUED**  
JUN 25 1987

Boring SS-143						Boring SS-143A						Prepared by JLB	
Station 969.0S Range 1923.2E						Station 975.0S Range 1930.0E						Checked by HPM	
Surface El 723.1						Surface El 723.0							
Date Drilled 6-14-79 to 6-14-79						Date Drilled 11-19-81 to 11-20-81							
El	SPT (N)	LOG	W	LL	PI	SPT (N)	LOG	W	LL	PI	REMARKS		
720	13		16.3	31.9	16.9	12	SC	15.0	33	16	FILL		
	24		16.4	30.5	12.7	20	SC	13.3	31	13			
	13	CL	15.9	35.3	17.0	13	CL	19.6	35	16	ALLUVIUM		
715	10		20.9	35.4	16.1	12	CL-M	21.8	33	10			
	9		19.4			9	SC	22.4	29	10	ALLUVIUM		
	9		22.4	37.4	13.6	4	ML	36.5	43	20			
710	9	ME-CL	22.9	38.9	13.3	2	ML	21.6	39	11			
	9		22.7	36.2	11.5	8	CL	37.2	36	19			
	6		21.8			1	SC	29.1	38	18			
705	7		25.0	39.3	18.2	0	SC	41.4	39	20			
	3	CL	29.0	42.2	22.4	3	SM-SC	21.2	21	5			
700	4		25.6			4	CL	24.9	25	8			
	4		29.0	35.2	16.2	8	SC	43.1	37	11			
	7					16	SC	33.8	34	12			
695	9	G-SPSM	13.5	NP	NP	31	SM	25.9	NP	NP	WEATHERED SHALE		
	2			31.2	15.5						DISCONTINUED		
690	17	CL	11.4										
	27	SM	21.2	28.9	2.6								
685	50	SC	16.3	30.8	9.7								
	50	SC	11.1										
	50		13.9	29.8	10.9								
680	34	G-SC	15.2	29.6	9.2								
	50	SC	14.0	28.0	7.6								
675													

WATTS BAR NUCLEAR PLANT  
FINAL SAFETY  
ANALYSIS REPORT

SOIL PROFILE  
FIGURE 2.5-301

Added by Amendment 50

Figure 2.5-301 Soil Profile

SOIL PROFILE (SS, PA, HA, TP BORING)

Project WATTS BAR N.P. Feature ERCW ALIGNMENT  
 Boring SS-144 Station 865.15 Range 1923.2 E Surface El 729.0  
 Date Drilled 6-13-79 To 6-14-79 Prepared By JLB Checked By SCJ

Depth	El	SPT (N)	Log	W	LL	PI	X	Remarks
1"=5'								
0								
			CL	17.2	41.8	25.8		
	-725		CL	14.0	39.0	20.5		
5				20.8				
			ML-CL	20.2	36.6	12.8		
	-720			17.4				
10				19.9				
			CL	18.9	37.7	14.8		
15			CL	20.2				
				25.3	41.8	25.8		
	-710		ML-CL	24.7	43.5	16.7		
20				20.9				
			CL	24.4	42.6	16.7		
25			CL	27.0	38.0	15.8		
			CL-CH	21.1	50.6	24.6		
	-700		ML	22.6				
30			MECL	18.3	39.8	14.9		
				26.4	35.1	11.5		
	-695		SM-SC					
35								

ALLUVIAL CLAY

**WATTS BAR NUCLEAR PLANT  
FINAL SAFETY  
ANALYSIS REPORT**

---

**SOIL PROFILE  
FIGURE 2.5-302  
SHEET 1 OF 2**

LAMINATED RESIDUUM

Added by Amendment 50

Figure 2.5-302 Soil Profile (Sheet 1 of 2)



Project WATTS BAR N. P. Boring SS-144								
Depth	El	SPT (N)	Log	W	LL	PI	X	Remarks
1"=5'								
-35								LAMINATED RESIDUMM
		17	SM-SC	19.2	35.1	11.5		
		30	SM-SC	17.2				
-690								
-40		42	CL	18.8	36.7	13.9		WEATHERED SHALE
		50+	SC	19.8	36.0	13.7		
		50	SM-SC	17.5	31.7	9.0		
-685		50+	CL	5.7	26.6	7.5		
-45								BEDROCK
-680								
-50								
-55								
-60								
-65								
-70								
-75								
-80								

**WATTS BAR NUCLEAR PLANT  
 FINAL SAFETY  
 ANALYSIS REPORT**

---

**SOIL PROFILE  
 FIGURE 2.5-302  
 SHEET 2 OF 2**

Added by Amendment 50

Figure 2.5-302 Soil Profile (Sheet 2 of 2)

**WATTS BAR NUCLEAR PLANT  
FINAL SAFETY  
ANALYSIS REPORT**

---

**SOIL PROFILE  
FIGURE 2.5-303  
SHEET 1 OF 2**

Project WATTS BAR N.P. Feature ERCW ALIGNMENT  
 Boring SS-145 Station 665.0 S Range 1923.2 E Surface El 737.1  
 Date Drilled 6-14-79 To 6-19-79 Prepared By JLB Checked By ang

Depth	El	SPT (N)	Soil	W	LL	PI	X	Remarks
0	735	15	CL	17.3	41.6	23.2		CLAY FILL
5		21	ML-CL	19.0	39.1	14.3		
		25	ML	17.9				
10	730	23	ML	22.8	47.2	19.1		ALLUVIAL FILL
15	725	17	ML-CL	19.0	41.3	16.6		
20	720	10	SM	13.7	NP	NP		ALLUVIAL SILTY SAND
		14		9.3				
25	715	21	GSPSM	11.0				ALLUVIAL GRAVELLY SAND
		22	GSM	14.5	23.8	3.6		
		50		7.1				
30	710	37	GSPSM	8.7				ALLUVIAL GRAVEL
		50	GSPSM	8.5	NP	NP		
		35	GM	8.2				
35	705	33	GRGM	8.2				Added by Amendment 50

Figure 2.5-303 Soil Profile (Sheet 1 of 2)

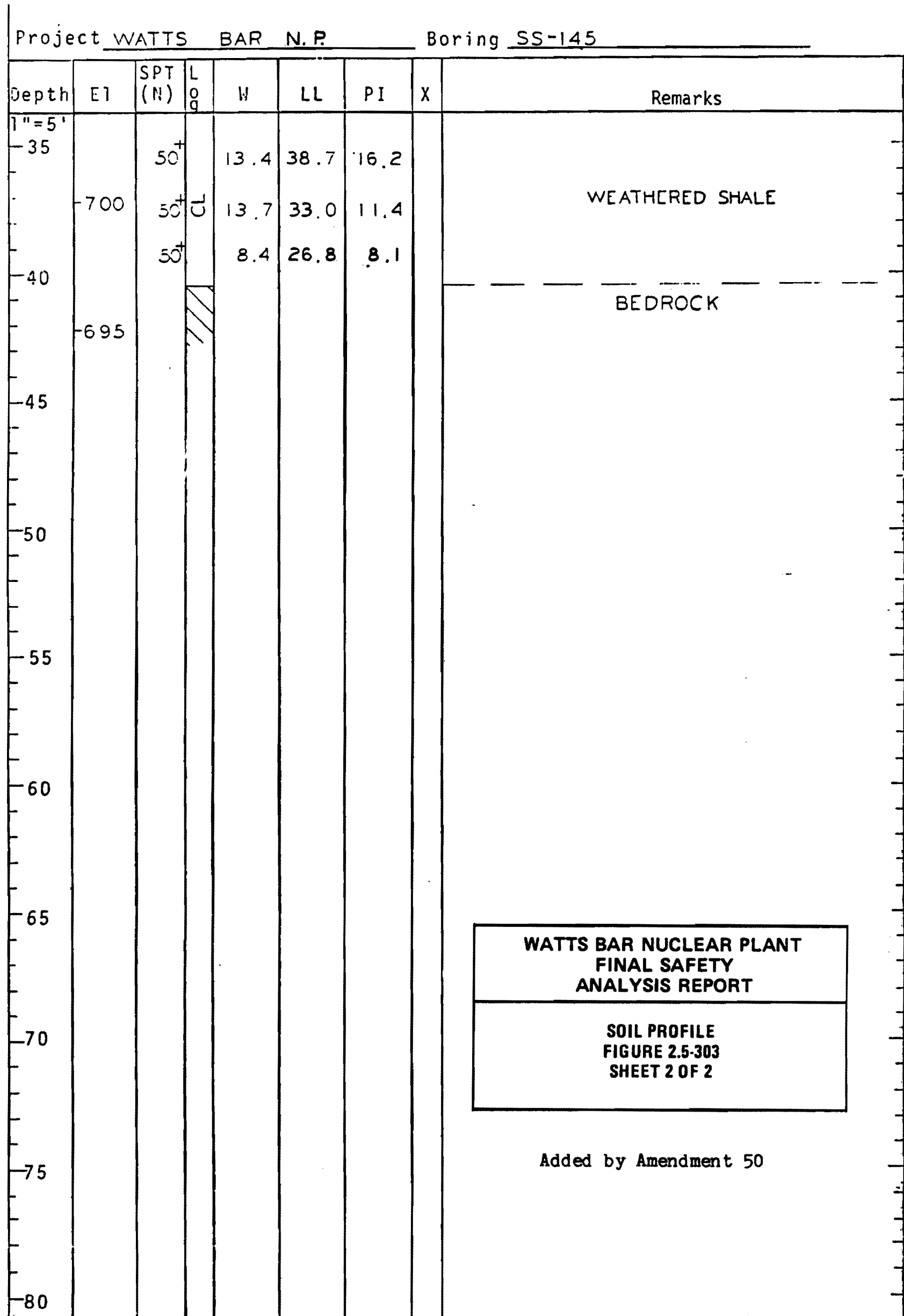

Figure 2.5-303 Soil Profile (Sheet 2 of 2)

**WATTS BAR NUCLEAR PLANT  
FINAL SAFETY  
ANALYSIS REPORT**

---

**SOIL PROFILE  
FIGURE 2.5-304  
SHEET 1 OF 2**

Project WATTS BAR N.P. Feature ERCW ALIGNMENT  
 Boring SS-146 Station 565.0 S Range 1923.2 E Surface El 741.4  
 Date Drilled 6-19-79 To 6-20-79 Prepared By JLB Checked By [Signature]

Depth	El	SPT (N)	LOG	W	LL	PI	X	Remarks
1"=5"								
0	-740	17	CL	10.0	29.3	12.8		CLAY FILL
		20		13.9	29.6	11.1		
5	-735	11		12.6	30.7	12.0		
		13		13.5	36.0	19.2		
-10	-730	14	CL-ML	14.2	47.7	21.2		
		22	ML	13.4	44.9	14.9		ALLUVIAL SILT & CLAY
		21		10.2				
-15	-725	20	CL-ML		39.2	13.7		
		13	SMSC	12.3	28.4	6.3		SILTY CLAYEY SAND
-20	-720	16	GSM	12.8				ALLUVIAL GRAVELLY SAND
		10	SM	11.2				
		16	GSM	7.1				
-25	-715	10		16.4	NP	NP		ALLUVIAL SAND
		10	SM	16.5				
-30	-710	14		8.4				
		39	GP	3.2				ALLUVIAL GRAVEL
		13	GSM	14.6	21.6	1.9		ALLUVIAL GRAVELLY SAND
-35								Added by Amendment 50

Figure 2.5-304 Soil Profile (Sheet 1 of 2)

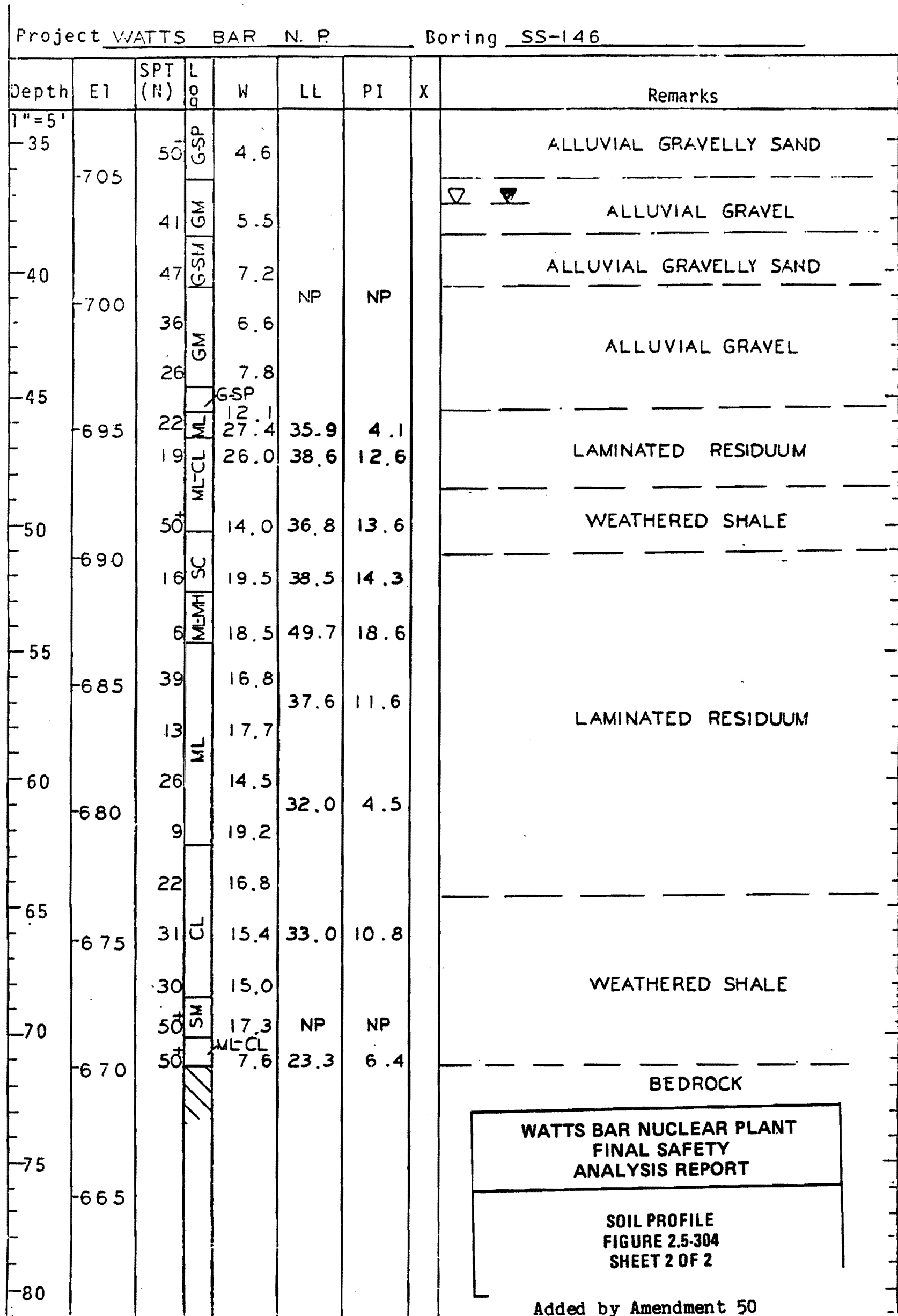

Figure 2.5-304 Soil Profile (Sheet 2 of 2)

<b>WATTS BAR NUCLEAR PLANT FINAL SAFETY ANALYSIS REPORT</b>
<b>SOIL PROFILE FIGURE 2.5-305 SHEET 1 OF 2</b>

Project WATTS BAR N.P. Feature ERCW ALIGNMENT  
 Boring SS-147 Station 464.15 Range 1866.4 E. Surface El 741.7  
 Date Drilled 6-20-79 To 6-21-79 Prepared By JLB Checked By gcl

Depth	El	SPT (N)	Log	W	LL	PI	X	Remarks
1"=5								
0	740	16		15.2				
		22	CL	16.3	30.4	12.0		CLAY FILL
5	735	16		17.1				
		38	CL	14.3	34.1	17.6		
10	730	31	CH	24.0	51.3	24.5		
		20		20.4	43.1	17.4		ALLUVIAL CLAY
		25	CL-ML	20.5	39.7	15.1		
15	725	15		17.4	—	—		
		10		14.4				ALLUVIAL SAND
20	720	11	SM	15.9				
		11		14.0	NP	NP		ALLUVIAL GRAVELLY SAND
		12	GSM	17.4				ALLUVIAL SAND
25	715	14	SM	11.0				
		15	GMGC	12.2	24.6	4.8		
30	710	28	GSPSM	5.8	NP	NP		ALLUVIAL GRAVEL
		40	GSMSC	11.7	23.4	4.3		
		50	GSPSM	7.6	NP	NP		Added by Amendment 50
35								

Figure 2.5-305 Soil Profile (Sheet 1 of 2)

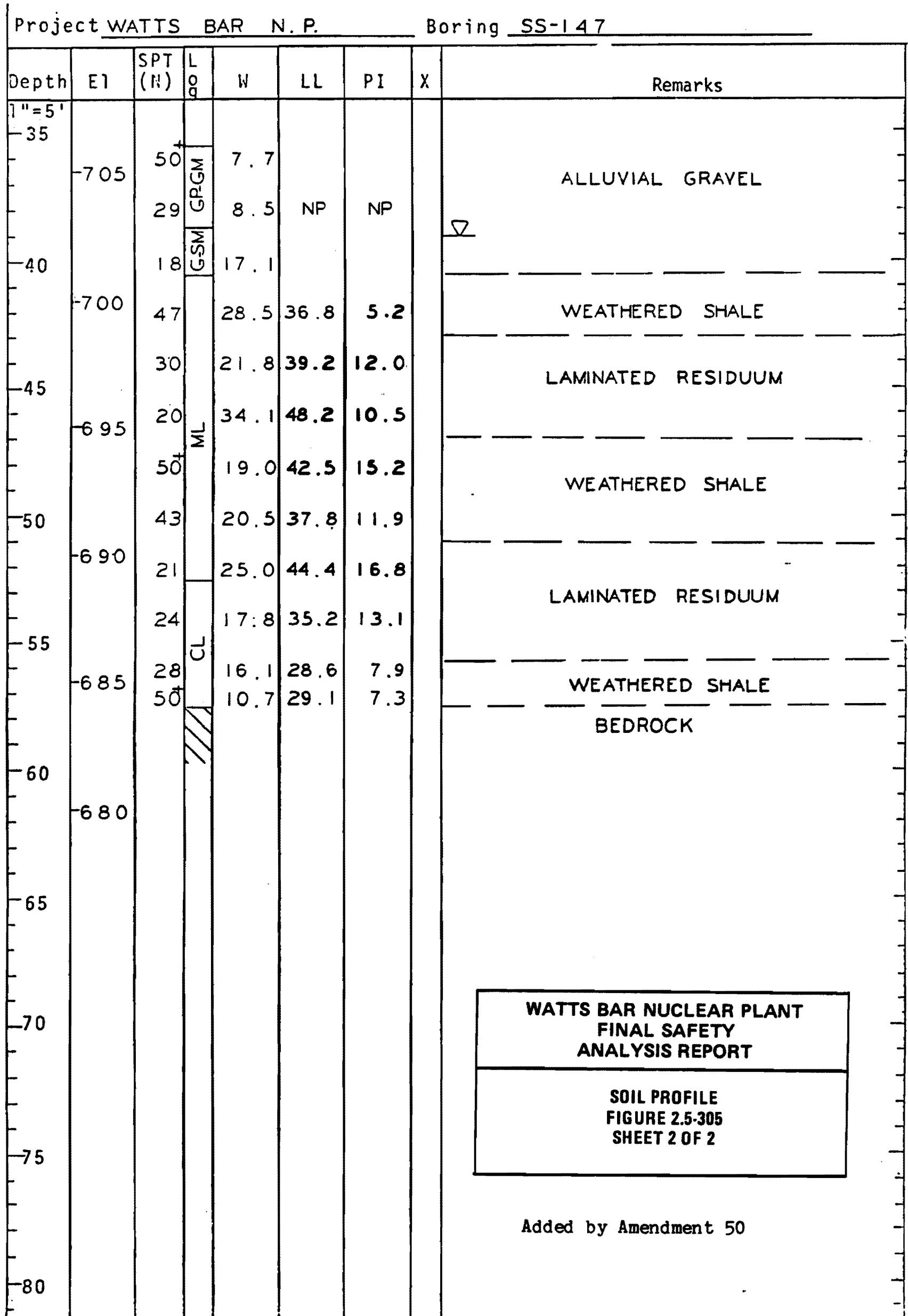

Figure 2.5-305 Soil Profile (Sheet 2 of 2)

**WATTS BAR NUCLEAR PLANT  
FINAL SAFETY  
ANALYSIS REPORT**

---

**SOIL PROFILE  
FIGURE 2.5-306  
SHEET 1 OF 1**

Project WATTS BAR N.P. Feature ERCW ALIGNMENT  
 Boring SS-148A Station 265.0 S Range 1923.0 E Surface El 715.4  
 Date Drilled 6-19-79 To 6-19-79 Prepared By JLB Checked By JCB

Depth	El	SPT (N)	Log	W	LL	PI	X	Remarks
1"=5								
0	715		79					
		10		12.3	27.2	10.9		
		16		15.3				
5	710				33.7	16.5		
		17		15.3				ALLUVIAL CLAY
		25	U	15.8	28.3	10.4		
10	705							
		19		12.5	29.4	14.3		
		30		11.9	30.2	12.7		
		50		16.6	31.4	13.4		
15	700							DISCONTINUED
20								
25								
30								
35								Added by Amendment 50

Figure 2.5-306 Soil Profile



<b>WATTS BAR NUCLEAR PLANT FINAL SAFETY ANALYSIS REPORT</b>
<b>SOIL PROFILE FIGURE 2.5-307 SHEET 1 OF 2</b>

Project WATTS BAR N.P. Feature ERCW ALIGNMENT  
 Boring SS-148B Station 259.0S Range 1865.5 E Surface El 736.6  
 Date Drilled 6-19-79 To 6-21-79 Prepared By JLB Checked By [Signature]

Depth	El	SPT (N)	Log	W	LL	PI	X	Remarks
0	735							NO SAMPLING ALLUVIAL CLAY
5	730							
10	725							
15	720	38	GSM	8.2				
		26		11.2	NP	NP		ALLUVIAL GRAVELLY SAND
20		23	GWGM	7.0				ALLUVIAL GRAVEL
		25		20.3	44.8	16.1		LAMINATED RESIDUUM
25	710	50 <sup>+</sup>	ML	17.1	45.9	18.9		WEATHERED SHALE
		50 <sup>+</sup>		19.4	36.3	10.2		
		50 <sup>+</sup>		19.4				
30		37		20.1	38.8	11.2		
	705	46	CL-ML	17.6	40.9	15.2		
		41	CL	14.8	34.9	12.3		Added by Amendment 50
35								

Figure 2.5-307 Soil Profile (Sheet 1 of 2)

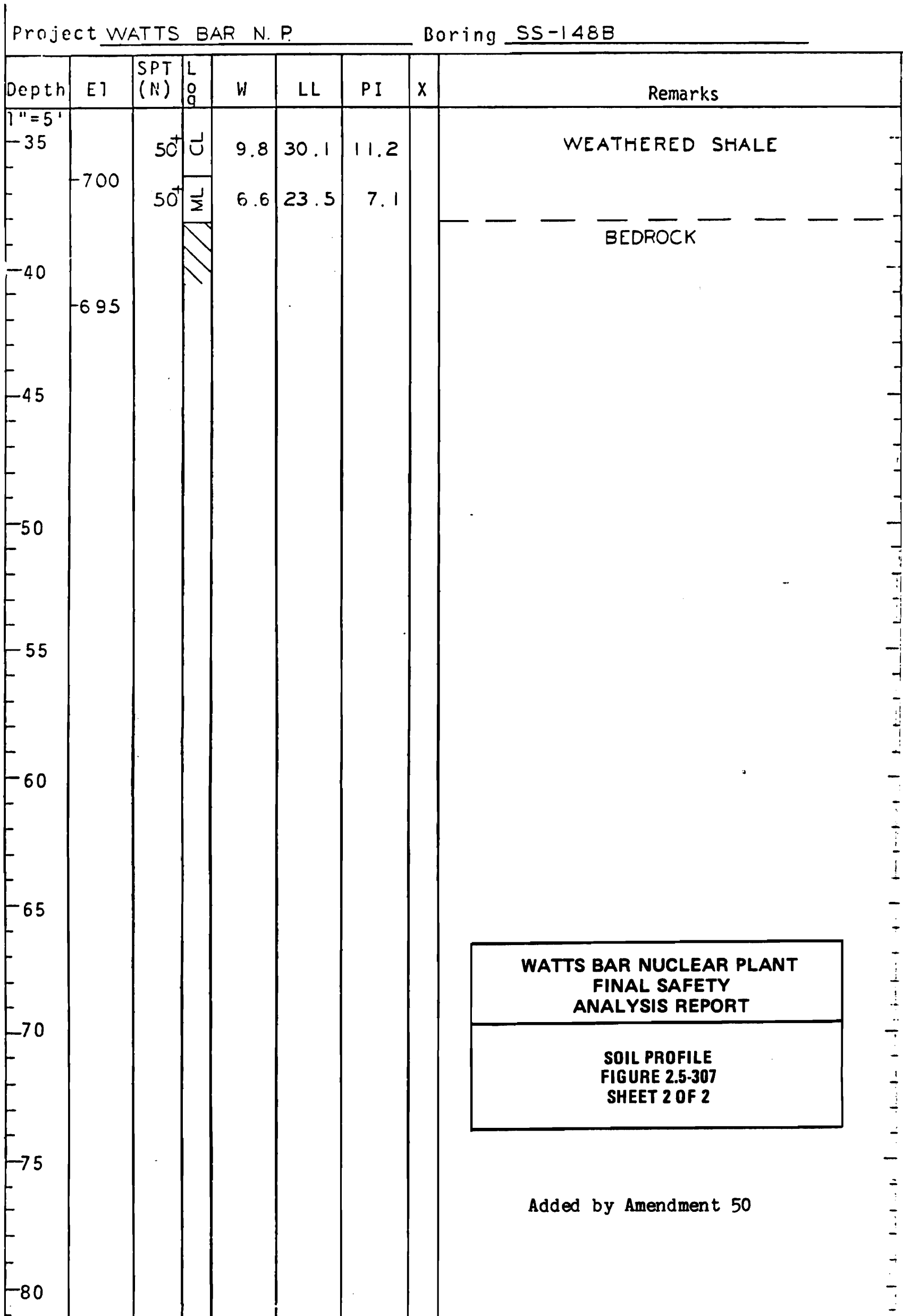

Figure 2.5-307 Soil Profile (Sheet 2 of 2)

TENNESSEE VALLEY AUTHORITY  
 SINGLETON MATERIALS ENGINEERING LABORATORY  
 SOIL PROFILE (SS, PA, HA, TP BORING)

Sheet  
 1 of 2

Project WATTS BAR NF Feature ERCW ALIGNMENT  
 Boring SS-149 Station 65 OS Range 1923.5 E Surface El 705.9  
 Date Drilled 6-20-79 To 6-21-79 Prepared By JLE Checked By [Signature]

Depth	El	SPT (N)	Log	W	LL	PI	X	Remarks
0	705							
		7		14.4	32.5	16.8		ALLUVIAL CLAY
		11	CL	18.2	31.9	11.0		
5	700	10		20.5	36.1	16.0		ALLUVIAL CLAYEY SAND
		13	SC	17.3	30.9	11.7		
10	695	23		23.7	43.4	15.0		LAMINATED RESIDUUM
		16	ML	25.8	36.4	4.9		
		29		21.9	38.6	8.1		
15	690	40	CL	19.3	45.0	19.3		WEATHERED SHALE
		25		22.9	36.2	8.5		
20	685	35	ML	20.5				
		30	CLML	17.4	32.4	8.8		
		43	SM	15.7	28.9	3.2		
25	680	50	GSMSC	12.7	29.1	6.1		
		50	ML	9.5	31.4	10.4		
30	675	50		14.9	27.8	3.6		
		50	SMSC	8.0	22.3	5.0		
		50		11.7				
35								

WATTS BAR NUCLEAR PLANT  
 FINAL SAFETY  
 ANALYSIS REPORT

---

SOIL PROFILE

---

Figure 2.5-308  
 SHEET 1 OF 2

Amendment 63

Figure 2.5-308 Soil Profile (Sheet 1 of 2)

Project WATTS BAR N. P. Boring SS-149								
Depth	E1	SPT (N)	L <sub>90</sub>	W	LL	PI	X	Remarks
1"=5'								
35	670	50	GSM	4.2	NP	NP		WEATHERED SHALE
								BEDROCK
40	665							
45								
50								
55								
60								
65								
70								
75								
80								

**WATTS BAR NUCLEAR PLANT  
 FINAL SAFETY  
 ANALYSIS REPORT**

---

**SOIL PROFILE  
 FIGURE 2.5-308  
 SHEET 2 OF 2**

Added by Amendment 50

Figure 2.5-308 Soil Profile (Sheet 2 of 2)

**WATTS BAR NUCLEAR PLANT  
FINAL SAFETY  
ANALYSIS REPORT**

---

**SOIL PROFILE  
FIGURE 2.5-309  
SHEET 1 OF 1**

Project WATTS BAR N. P. Feature ERCW ALIGNMENT  
 Boring SS-150 Station 135.0 N Range 1923.2 E Surface El 709.1  
 Date Drilled 6-22-79 To 6-22-79 Prepared By JLB Checked By [Signature]

Depth	El	SPT (N)	Log	W	LL	PI	X	Remarks
0								
0		22		14.8	27.3	8.9		ALLUVIAL CLAY
5	705	13	CL	17.5	33.0	13.7		
		16		17.8				
10	700	50	ML	20.7	30.5	4.5		WEATHERED SHALE
		50		17.3				
		34		14.9	33.2	11.4		
15	695	50	CL	16.2	37.2	13.5		BEDROCK
		50		12.8	29.4	9.0		
		50	SMSC	6.3	23.7	6.7		
20	690	50		8.3				
25	685							
30								
35								

Added by Amendment 50

Figure 2.5-309 Soil Profile

<b>WATTS BAR NUCLEAR PLANT FINAL SAFETY ANALYSIS REPORT</b>
<b>SOIL PROFILE FIGURE 2.5-310 SHEET 1 OF 1</b>

Project WATTS BAR N.P Feature ERCW ALIGNMENT  
 Boring SS-151 Station 285.8 ~~X~~N Range 1824.9E Surface E1 717.5  
 Date Drilled 6-25-79 To 6-25-79 Prepared By JLB Checked By [Signature]

Depth	E1	SPT (N)	Soil	W	LL	PI	X	Remarks
0								
15	715	15	CL	16.1	36.3	16.3		ALLUVIAL CLAY & SILT
10		10		17.4	30.3	11.0		
40		40	ML	11.5	NP	NP		
50	710	50	GSPSM	5.6	—	—		ALLUVIAL GRAVELLY SAND
50		50		4.9	NP	NP		
23	705	23	CL-ML	13.9	41.2	16.3		LAMINATED RESIDUUM
21		21	CL	19.0	39.2	15.4	▽	
25		25		19.9			▽	
32	700	32	SM	18.7	36.8	10.9		WEATHERED SHALE
50		50		16.4	37.3	15.0		
50		50	CL	6.9	28.1	9.5		
50	695	50		7.0	25.1	7.3		NO SAMPLE RECOVERY
50		50						
50	690	50		6.9				WEATHERED SHALE
50		50	SC	7.0	24.5	7.8		
50		50		5.7				
50	685	50	GML	3.9	—	—		
								BEDROCK

Added by Amendment 50

Figure 2.5-310 Soil Profile

<b>WATTS BAR NUCLEAR PLANT FINAL SAFETY ANALYSIS REPORT</b>
<b>SOIL PROFILE FIGURE 2.5-311 SHEET 1 OF 1</b>

Project WATTS BAR N.P. Feature ERCW ALIGNMENT  
 Boring SS-152 Station 465.1N Range 1693.1E Surface El 719.6  
 Date Drilled 6-25-79 To 6-25-79 Prepared By JLB Checked By ACD

Depth	El	SPT (N)	Log	W	LL	PI	X	Remarks
1"=5'								
0								
		23	CL	12.6	32.3	14.9		
	715	21	CL	17.8	27.9	10.6		ALLUVIAL CLAY
5		19	CL	17.5	34.8	18.7		
		22		15.6	30.1	11.1		
	710	50+	GSM	4.6	NP	NP		
10		23	GSPSM	13.9				ALLUVIAL GRAVELLY SAND
	705	24	ML	24.6	37.1	10.4		
15		19	ML-CL	22.4	41.3	16.0		LAMINATED RESIDUUM
		27		26.2	40.8	17.0		
	700	50+	CL	15.3	32.7	11.8		
20		50+	CL	14.5				WEATHERED SHALE
	695	50+		9.4	26.0	9.3		
25		50+	ML-CL	5.9	24.0	6.7		BEDROCK
30	690							
35								

Added by Amendment 50

Figure 2.5-311 Soil Profile

**WATTS BAR NUCLEAR PLANT  
FINAL SAFETY  
ANALYSIS REPORT**

---

**SOIL PROFILE  
FIGURE 2.5-312  
SHEET 1 OF 1**

Project WATTS BAR N.P. Feature ERCW ALIGNMENT  
 Boring SS-153 Station 585.0N Range 1540.0E Surface El 719.7  
 Date Drilled 6-26-79 To 6-26-79 Prepared By JLB Checked By [Signature]

Depth	El	SPT (N)	Soil	W	LL	PI	X	Remarks
0								FILL
4.9		49	CLCH GCL	14.8	31.3	15.9		
5.18	715	18	CLCH	19.4	49.1	28.6		
5.32		32	CL	13.5	23.5	7.5		ALLUVIAL CLAY
5.13		13	CL	14.7	28.3	11.8		
10.50	710	50	GSPSM					ALLUVIAL GRAVEL
10.15		15	GSWSM	10.8	NP	NP		
15.48	705	48	MECL	20.2	48.5	21.4		
15.50		50	CL-ML	16.3	38.1	13.3		
15.50		50		14.8				
20.50	700	50	CL	12.7	37.3	14.7		WEATHERED SHALE
20.50		50		8.3	28.9	9.4		
25.50	695	50	SC	5.7	24.2	7.5		
25.50		50		4.7				BEDROCK
30	690							
35								Added by Amendment 50

Figure 2.5-312 Soil Profile



<b>WATTS BAR NUCLEAR PLANT FINAL SAFETY ANALYSIS REPORT</b>
<b>SOIL PROFILE FIGURE 2.5-313 SHEET 1 OF 1</b>

Project WATTS BAR N.P. Feature ERCW ALIGNMENT  
 Boring SS-154 Station 633.5 N Range 1444.4E Surface El 719.7  
 Date Drilled 6-26-79 To 6-26-79 Prepared By JLB Checked By [Signature]

Depth	El	SPT (N)	Log	W	LL	PI	X	Remarks
0								
25				14.8	31.6	13.7		ALLUVIAL CLAY
50	715		CL	13.2	27.6	10.7		
75				14.1	23.0	9.2		
100	710			13.1				ALLUVIAL GRAVELLY SAND
125				GSM 8.8	NP	NP		
150				GSPSM 10.2				
175	705			17.4	38.2	15.6		LAMINATED RESIDUUM
200				17.6				
225	700			9.6				WEATHERED SHALE
250				8.0	29.4	10.8		
275				6.1				
300	695			5.5	26.0	8.5		
325			SC	5.3				
350				8.7	24.0	7.5		
375	690			5.4				
400				ML-CL 7.2	23.0	6.9		BEDROCK
425								
450	685							Added by Amendment 50

Figure 2.5-313 Soil Profile

**WATTS BAR NUCLEAR PLANT  
FINAL SAFETY  
ANALYSIS REPORT**

---

**SOIL PROFILE  
FIGURE 2.5-314  
SHEET 1 OF 1**

Project WATTS BAR N.P. Feature ERCW ALIGNMENT  
 Boring SS-155 Station 664.1 N Range 1410.0 E Surface El 719.5  
 Date Drilled 6-26-79 To 6-26-79 Prepared By JLB Checked By [Signature]

Depth	El	SPT (N)	LOG	W	LL	PI	X	Remarks
0								FILL
22				16.3	26.8	10.7		
35	715		CL	12.9				ALLUVIAL CLAY
20				14.9	35.9	20.5		
21			CL-ML	12.3	19.7	4.7		
32	710		GSM	17.5				ALLUVIAL GRAVELLY SAND
23				12.5	NP	NP		
36	705		GSPSM	11.7				LAMINATED RESIDUUM
28				16.0	38.0	16.0		
50+			CL	5.6				WEATHERED SHALE
50+	700			15.5	26.6	8.8		
50+			ML-CL	6.5	23.7	6.3		DISCONTINUED
25	695							
35								Added by Amendment 50

Figure 2.5-314 Soil Profile

**WATTS BAR NUCLEAR PLANT  
FINAL SAFETY  
ANALYSIS REPORT**

---

**SOIL PROFILE  
FIGURE 2.5-315  
SHEET 1 OF 1**

Project WATTS BAR N.P. Feature ERCW ALIGNMENT  
 Boring SS-156 Station 664.8 N Range 1210 0 E Surface El 720.4  
 Date Drilled 6-26-79 To 6-26-79 Prepared By JLB Checked By [Signature]

Depth	El	SPT (N)	Soil	W	LL	PI	X	Remarks
0	720		CL					ALLUVIAL SILT & CLAY
14		14	CL	13.0	30.8	14.3		
10		10	ML	17.7	32.4	15.0		
5	715	16	ML	29.1	37.2	2.9		
		15	M-CL	14.7	22.4	6.4		ALLUVIAL GRAVELLY SAND
10	710	13	ML	18.0	15.9	1.3		
		29	GSM	13.2	NP	NP		
		22	GSPSM	8.1				
15	705	34	M-CL	20.3	33.2	10.6		WEATHERED SHALE
		41	M-CL	15.0	30.3	6.5		
20	7.00	50	SC	13.7	32.6	11.2		
		50	SC	6.9				BEDROCK
25	6.95							
30								
35								

Added by Amendment 50

Figure 2.5-315 Soil Profile

**WATTS BAR NUCLEAR PLANT  
FINAL SAFETY  
ANALYSIS REPORT**

---

**SOIL PROFILE  
FIGURE 2.5-316  
SHEET 1 OF 1**

Project WATTS BAR N.P. Feature ERCW ALIGNMENT  
 Boring SS-157 Station 664.8 N Range 1110.0 E Surface El 723.5  
 Date Drilled 6-27-79 To 6-27-79 Prepared By JLB Checked By JCB

Depth	El	SPT (N)	LOG	W	LL	PI	X	Remarks
1"=5								
0								LIMESTONE-GRAVEL
								CLAY FILL
	720	10		15.4	29.3	13.1		
		20		12.4	24.0	8.1		
5		19	CL	18.6	38.7	17.7		
	715	17		17.9				ALLUVIAL CLAY
		20		18.3	33.2	16.3		
	710	13		22.6	37.6	17.2		
		39	GSM	13.3				ALLUVIAL GRAVELLY SAND
15		33		9.2				
	705	33	ML	23.2				
		43		21.8	NO	NP		WEATHERED SHALE
20		50		15.1				
	700	50	SM	16.4				
25		50		10.6				
								BEDROCK
	695							
30								
								Added by Amendment 50
35								

Figure 2.5-316 Soil Profile (Sheet 1 of 1)

**WATTS BAR NUCLEAR PLANT  
FINAL SAFETY  
ANALYSIS REPORT**

---

**SOIL PROFILE  
FIGURE 2.5-317  
SHEET 1 OF 1**

Project WATTS BAR N.P. Feature ERCW ALIGNMENT  
 Boring SS-158 Station 664.8 N Range 1010.0 E Surface El 727.5  
 Date Drilled 6-26-79 To 6-27-79 Prepared By JLB Checked By [Signature]

Depth	El	SPT (N)	Log	W	LL	PI	X	Remarks
0								
1"=5								
0								
	-725	8		13.6				CLAY FILL
		17		15.4	28.0	9.8		
5								
	-720	13		19.1				
		11	CL	17.3	26.9	11.0		ALLUVIAL CLAY
10								
	-715	9		18.4				
		7		23.0	34.0	12.2		
15								
	-710	3		27.6				
		2	SM	32.2	22.9	2.5	▽	ALLUVIAL SAND
	-710	39	GSM	9.7	NP	NP		ALLUVIAL GRAVELLY SAND
20								
	-705	49	ML	21.5	28.0	2.8		WEATHERED SHALE
		28		24.7				
		50 <sup>+</sup>	CL-ML	18.7	30.8	8.8		
25								
	-700	50 <sup>+</sup>	CL	11.3	26.6	5.4		
		50 <sup>+</sup>	CL	6.7	24.2	8.2		BEDROCK
30								
	-695							Added by Amendment 50
35								

Figure 2.5-317 Soil Profile

WATTS BAR NUCLEAR PLANT ERCW  
SOIL PROFILE

Boring SS-158						Boring SS-158A						Prepared by JLB		
Station 664.8N Range 1010.0E						Station 658.8N Range 1015.0E						Checked by HPM		
Surface El 727.5						Surface El 727.6								
Date Drilled 6-26-79 to 6-26-79						Date Drilled 11-20-81 to 11-20-81								
El	SPT (N)	LOG	W	LL	PI	SPT (N)	LOG	W	LL	PI	REMARKS			
725	8		13.6			20		16.1	26	9	GRAVEL ROADBED			
	17		15.4	28.0	9.8	15		21.2	43	23	FILL			
720	13		19.1			15	CL	21.0	36	15	ALLUVIUM			
	11	CL	17.3			19		23.2	41	18				
	9		18.4	26.9	11.0	15		24.8	19	7				
715	7		23.0	34.0	12.2	8	ML	25.2	32	8				
	3		27.6			4	CL	30.6	31	13				
	2	SM	32.2	22.9	2.5	3	SC	27.8	35	15				
710	39	GSM	9.7	NP	NP	50	GM	24.1	NP	NP				
	49	ML	21.5	28.0	2.8	23	SM	24.5	31	6			WEATHERED SHALE	
705	28		24.7										DISCONTINUED	
	50	CL-ML	18.7	30.8	8.8									
	50	CL	11.3	26.6	5.4									
700	50	CL	6.7	24.2	8.2									
695														

WATTS BAR NUCLEAR PLANT  
FINAL SAFETY  
ANALYSIS REPORT

SOIL PROFILE  
FIGURE 2.5-318

Added by Amendment 50

Figure 2.5-318 Soil Profile

**WATTS BAR NUCLEAR PLANT  
FINAL SAFETY  
ANALYSIS REPORT**

---

**SOIL PROFILE  
FIGURE 2.5-319  
SHEET 1 OF 1**

Added by Amendment 50

Project WATTS BAR N. P. Feature ERCW ALIGNMENT  
 Boring SS-159 Station 640.0 N Range 810.0 E Surface El 731.7  
 Date Drilled 6-27-79 To 6-27-79 Prepared By JLB Checked By JCB

Depth	El	SPT (N)	Log	W	LL	PI	X	Remarks
1"=5								
0	730	11		16.4	31.2	11.8		GRAVEL
		21	CL	25.6	—	—		
5	725	17		26.6	—	—		
		18	ML	23.8	39.5	13.2		ALLUVIAL CLAY
10	720	14		25.6				
		11	CL	25.8	32.8	13.4		
		6	CL-ML	29.4	26.8	4.2		
15	715	5		27.1	34.6	16.1	▽	
		3	CL	25.6	29.3	13.3		
20	710	20	GSM	13.7	NP	NP		ALLUVIAL GRAVEL
		50 <sup>+</sup>	GM	9.9				
		43	CL	20.2	38.7	16.4		
25	705	43	CL-ML	28.4	36.1	12.6		
		41		21.3	39.4	15.7		WEATHERED SHALE
30	700	50 <sup>+</sup>		18.4	37.0	14.3		
		43	CL	9.7	31.4	11.9		
		50 <sup>+</sup>		10.6				DISCONTINUED
35								

Figure 2.5-319 Soil Profile

**WATTS BAR NUCLEAR PLANT  
FINAL SAFETY  
ANALYSIS REPORT**

---

**SOIL PROFILE  
FIGURE 2.5-320  
SHEET 1 OF 1**

Project WATTS BAR N.P Feature ERCW ALIGNMENT  
 Boring SS-160 Station 566.0 N Range 740.0 E Surface El 732.9  
 Date Drilled 6-27-79 To 6-27-79 Prepared By JLB Checked By goc

Depth	El	SPT (N)	Log	W	LL	PI	X	Remarks
0								CLAY FILL
13	730	13		21.5	35.8	17.9		
21		21	CL	22.8	39.2	16.1		ALLUVIAL CLAY
21		21		21.4				
15	725	15		14.7	30.2	6.0		
13		13		24.0	30.0	6.0		
15	720	15	SM	22.5	NP	NP		ALLUVIAL SAND
7		7		23.8	24.2	1.7		
12		12		25.8	27.0	3.0		
5	715	5	SMSC	30.2	32.1	8.5		
21		21	GM	22.0	26.2	2.2		ALLUVIAL GRAVEL
5		5		24.3				
50+	710	50+	GRGM	9.6	NP	NP		
39		39	SMSC	16.8	29.5	7.5		
29	705	29	CL	21.1	38.7	16.3		WEATHERED SHALE
50+		50+	ML	16.9	30.6	6.7		
50+		50+	CEML	15.1	23.7	15.9		
50+	700	50+		10.1				
								DISCONTINUED
								Added by Amendment 50

Figure 2.5-320 Soil Profile



**WATTS BAR NUCLEAR PLANT  
FINAL SAFETY  
ANALYSIS REPORT**

---

**SOIL PROFILE  
FIGURE 2.5-321  
SHEET 1 OF 2**

Project WATTS BAR N. P. Feature ERCW ALIGNMENT  
 Boring SS-161 Station 488.0N Range 670.0 E Surface El 732.4  
 Date Drilled 6-28-79 To 6-28-79 Prepared By JLB Checked By gcl

Depth	El	SPT (N)	Soil	W	LL	PI	X	Remarks
0								
	-730	20	CH	26.2	57.6	30.0		ALLUVIAL SAND TO CLAY
		14	ML	21.1	41.2	14.4		
5		9	CEML	25.1	43.0	16.5		
	-725	8	SC	28.2	34.4	11.9		
10		5	CL	25.3	29.7	8.4		ALLUVIAL SILT & SAND
	-720	6	SC	25.3	30.8	9.4		
15		9	SM	18.4	NP	NP	▽	ALLUVIAL GRAVEL
		10		21.5				
	-715	3	CEML	35.8	36.8	13.2		
20		5	ML	30.9	25.7	2.3		WEATHERED SHALE
	-710	37	GM	11.1	NP	NP		
		19	GSM	12.7				
25		45		21.0				WEATHERED SHALE
	-705	50+	CEML	16.8	41.1	16.6		
30		50+		18.6				
	-700	25		19.8	38.9	14.3		
		50+	CL	22.2	46.1	20.4		Added by Amendment 50
		50+	SC	12.2	29.1	9.6		
35								

Figure 2.5-321 Soil Profile (Sheet 1 of 2)

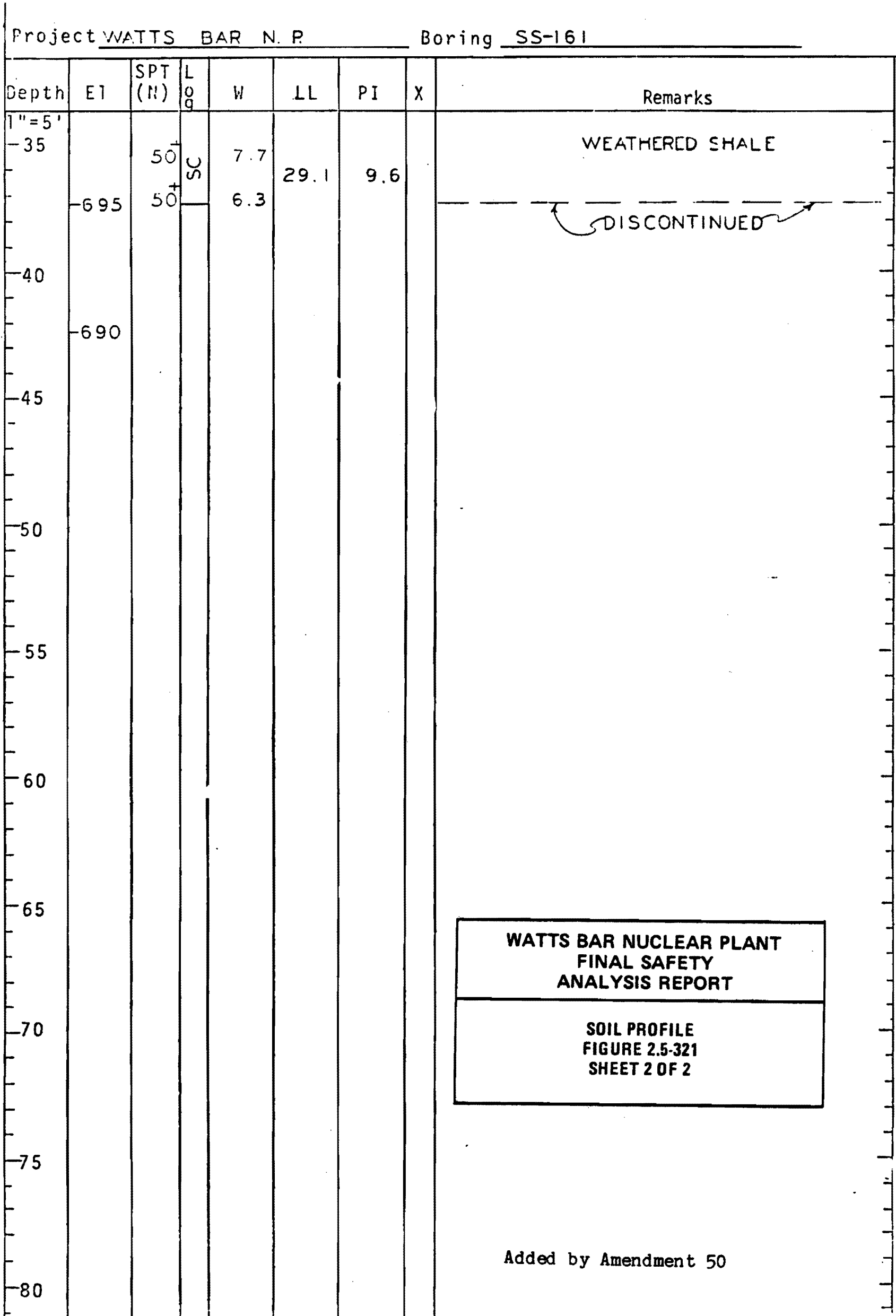

Figure 2.5-321 Soil Profile (Sheet 2 of 2)

WATTS BAR NUCLEAR PLANT ERCW  
SOIL PROFILE

Boring <u>SS-161</u>						Boring <u>SS-161A</u>						Prepared by <u>JLB</u>	
Station <u>488.0 N</u> Range <u>670.0 E</u>						Station <u>488.0 N</u> Range <u>675.0 E</u>						Checked by <u>HPM</u>	
Surface El <u>732.4</u>						Surface El <u>732.9</u>							
Date Drilled <u>6-28-79</u> to <u>6-28-79</u>						Date Drilled <u>11-23-81</u> to <u>11-23-91</u>							
El	SPT (N)	LOG	W	LL	PI	SPT (N)	LOG	W	LL	PI	REMARKS		
730	20	CH	26.2	57.6	30.0	33	CH	28.4	62	34	ALLUVIUM		
	14	ML	21.1	41.2	14.4	26	SM	19.2	39	12			
	9	CL-ML	25.1	43.0	16.5	13	CL	24.3	36	13			
725	8	SC	28.2	34.4	11.9	12	SMSC	21.8	32	8			
	5	CL	25.3	30.8	9.4	9	SC	22.4	28	8			
720	6	SC	25.3	29.7	8.4	10	SM	23.8	26	2			
	9	SM	18.4	NP	NP	13	SM	17.8	NP	NP			
	10	SM	21.5			23	SC	14.0	29	9			
715	3	CL-ML	35.8	36.8	13.2	5	ML	35.7	38	12			
	5	ML	30.9	25.7	2.3	5	CL	33.0 32.4	32 27	13 9			
710	37	GM	11.1	NP	NP	50	SM	15.4					
	19	G-SM	12.7			40	GP-GM	10.3	NP	NP			
	45	G-SM	21.0			16	SM	44.2					
705	50	CL-ML	16.8	41.1	16.6							WEATHERED SHALE	
	50	CL-ML	18.6									DISCONTINUED	
700	25	CL	19.8	38.9	14.3								
	50	CL	22.2	46.1	20.4								
	50	SC	7.7	29.1	9.6								
695	50	SC	6.3										
690													

WATTS BAR NUCLEAR PLANT  
FINAL SAFETY  
ANALYSIS REPORT

SOIL PROFILE  
FIGURE 2.5-322

Added by Amendment 50

Figure 2.5-322 Soil Profile

**WATTS BAR NUCLEAR PLANT  
FINAL SAFETY  
ANALYSIS REPORT**

---

**SOIL PROFILE  
FIGURE 2.5-323  
SHEET 1 OF 1**

Project WATTS BAR N. P. Feature ERCW ALIGNMENT  
 Boring SS-162 Station 488.0 N Range 560.0E Surface El 733.8  
 Date Drilled 6-28-79 To 6-28-79 Prepared By JLB Checked By JCB

Depth	El	SPT (N)	Log	W	LL	PI	X	Remarks
1"=5								
0								LIMESTONE GRAVEL
		13	CL	14.4	37.1	21.4		
	730							ALLUVIAL CLAY
		17	CH	21.6	67.1	41.7		
5		14		28.4				
		20	SM	16.4	31.6	7.1		
	725							ALLUVIAL SAND
		34	SM	22.7	31.0	6.6		
		27	GSM	20.7	29.1	3.8		
	720							
		36		23.0	31.6	4.9		
	715							
		20	SM	27.7	28.3	1.6		
		19		30.2	27.6	3.0		
	710							ALLUVIAL SAND & GRAVEL
		5		34.3				
		11	GSWSM	20.4	NP	NP		
		50+	GM	10.9				
	705							WEATHERED SHALE
		50+	SM	12.3				
		50+		18.6				
		50+	CL-ML		38.6	13.9		
		50+		14.3				
		50+	CL	12.0	32.0	10.8		
	700							DISCONTINUED
								Added by Amendment 50
	35							

Figure 2.5-323 Soil Profile

**WATTS BAR NUCLEAR PLANT  
FINAL SAFETY  
ANALYSIS REPORT**

---

**SOIL PROFILE  
FIGURE 2.5-324  
SHEET 1 OF 1**

Project WATTS BAR N. P. Feature ERCW ALIGNMENT  
 Boring SS-163 Station 488.0 N Range 450.0 E Surface El 737.0  
 Date Drilled 6-28-79 To 6-28-79 Prepared By JLB Checked By gco

Depth	El	SPT (N)	Log	W	LL	PI	X	Remarks
0								GRAVEL
	735	19	CL	18.3	31.7	13.3		ALLUVIAL CLAY
				GRGM 3.4	NP	NP		ALLUVIAL GRAVEL
5		18	MH	25.2	54.0	20.9		ALLUVIAL CLAY & SILT
	730	10	CL-ML	24.7	40.0	15.3		
		9	CL-ML	27.7				
	725	5	SM	19.7	NP	NP		
		5		27.1				
15		5	SM-SC	28.4	30.4	7.1		ALLUVIAL SAND
	720	6		26.9				
		3	SM	31.1	27.2	3.3		
	715	4	SM	33.5	29.7	4.7		
		17	GSM	27.3	28.7	3.8		
25		50+	GSM	7.8				ALLUVIAL GRAVEL
	710	50+		12.1 GRGM	NP	NP		
		50	ML	18.5	43.6	16.2		WEATHERED SHALE
	705	50	ML	21.2	37.3	9.0		
		50		2.7				DISCONTINUED
35								Added by Amendment 50

Figure 2.5-324 Soil Profile

WATTS BAR NUCLEAR PLANT ERCW  
SOIL PROFILE

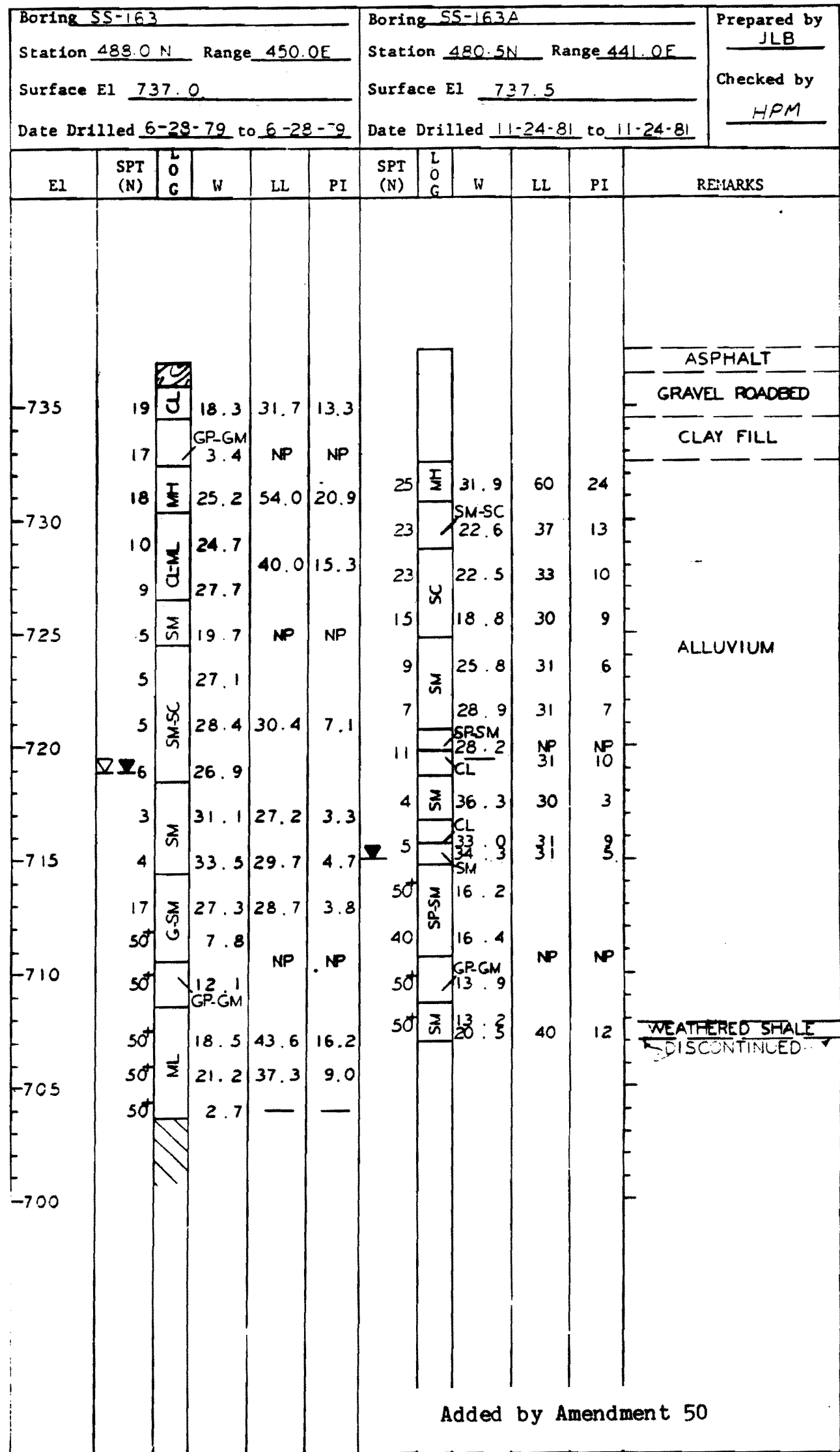

WATTS BAR NUCLEAR PLANT  
 FINAL SAFETY  
 ANALYSIS REPORT  
  
 SOIL PROFILE  
 FIGURE 2.5-325

Figure 2.5-325 Soil Profile

**WATTS BAR NUCLEAR PLANT  
FINAL SAFETY  
ANALYSIS REPORT**

---

**SOIL PROFILE  
FIGURE 2.5-326  
SHEET 1 OF 2**

Added by Amendment 50

Project WATTS BAR N.P. Feature LRV ALIGNMENT  
 Boring SS-164 Station 488.0 N Range 230.0 E Surface El 741.0  
 Date Drilled 6-28-79 To 6-29-79 Prepared By JLB Checked By JCB

Depth	El	SPT (N)	SOIL	W	LL	PI	X	Remarks
0	-740		G-CL	6.9	28.3	10.5		BACKFILL
		20	SMSC	16.7	27.0	5.4		ALLUVIAL SAND & GRAVEL
5	-735	50 <sup>+</sup>	G-SM	1.7	NP	NP		
		20	CHMHCL-M	24.7	48.7	21.3		ALLUVIAL CLAY & SILT
10	-730	31	CHMHCL-M	—	52.7	24.5		
		21	SMSC	20.8	38.6	12.7		ALLUVIAL SAND
15	-725	15	ML	22.3	39.4	13.1		
		16	ML	25.6				ALLUVIAL CLAY & SILT
20	-720	9	CH	26.2	60.3	36.3		
		6	CL-M	28.2	36.0	12.1		
		9	SMSC	27.4	31.5	8.6		
25	-715	15	G-SPSM	16.2				
		20	G-SPSM	20.9	NP	NP		
30	-710	11	SM	26.6	31.1	5.7		ALLUVIAL SAND & GRAVEL
		50 <sup>+</sup>	G-SPSM	11.0				
		50	G-SPSM	14.9	NP	NP		
35		26	CL	13.2	46.7	22.7		WEATHERED SHALE

Figure 2.5-326 Soil Profile (Sheet 1 of 2)

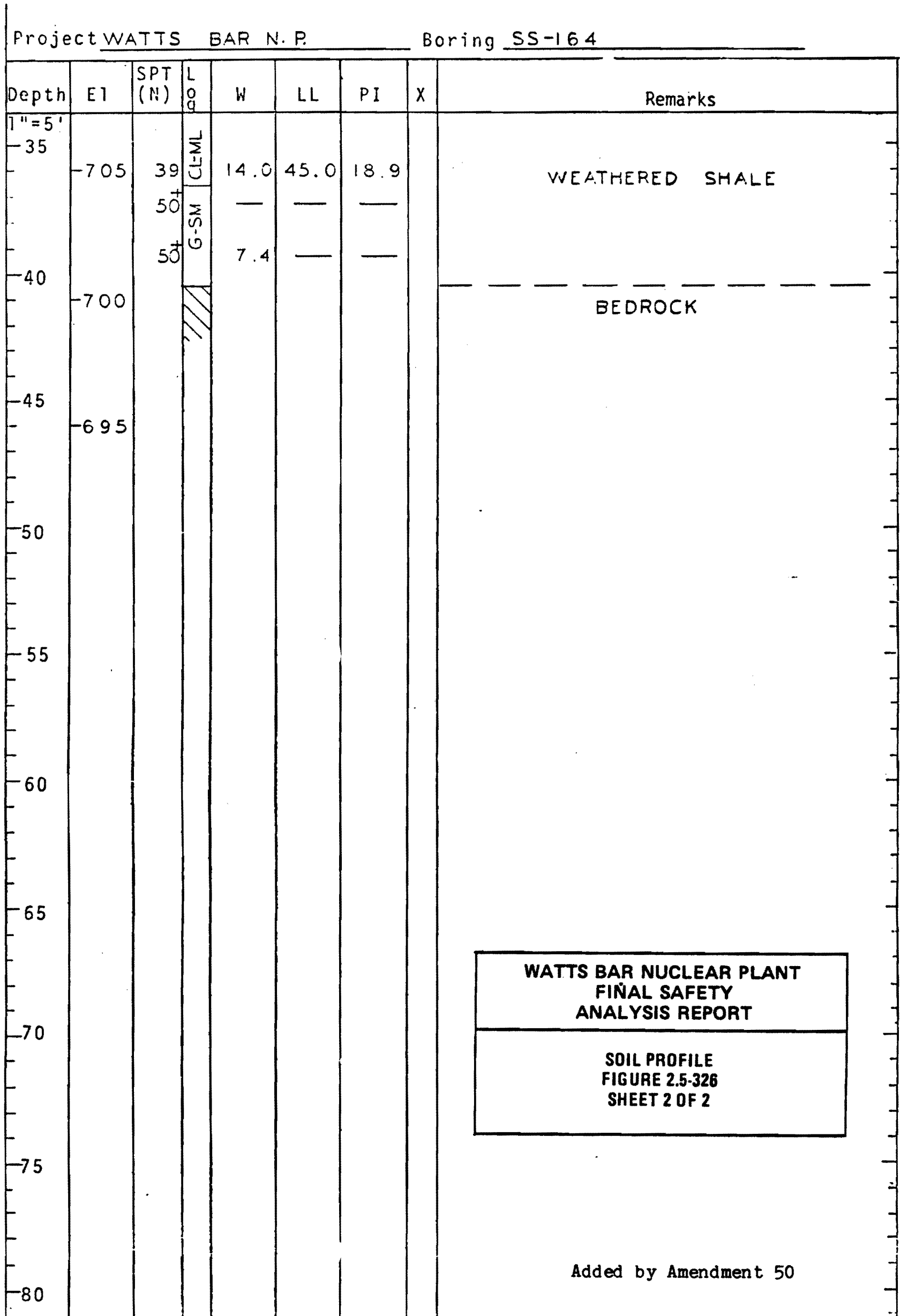

Figure 2.5-326 Soil Profile (Sheet 2 of 2)



**WATTS BAR NUCLEAR PLANT  
FINAL SAFETY  
ANALYSIS REPORT**

---

**SOIL PROFILE  
FIGURE 2.5-327  
SHEET 1 OF 2**

Project WATTS BAR N. P. Feature LRCW ALIGNMENT  
 Boring SS-165 Station 488.0 N Range 120.0 E Surface El 740.7  
 Date Drilled 6-29-79 To 6-29-79 Prepared By JLB Checked By [Signature]

Depth	El	SPT (N)	Log	W	LL	PI	X	Remarks
1"=5								
0	740	50						SANDY SILT
5	735	13	CL	19.8	31.2	13.0		ALLUVIAL CLAY & SILT
		20	CLCH	27.2	50.6	23.6		
10	730	18	ML	20.7	44.7	16.3		
		11	CLML	22.9	35.8	12.2		
		13	ML	28.5	44.5	16.6		
15	725	11	CL	26.7	36.7	14.4		
		12	SM	21.8	34.1	9.2		
20	720	5	ML	31.9	37.4	11.5		ALLUVIAL SAND & SILT
		6	CLML	31.2	39.0	14.2		
		3	SMSC	33.3	30.7	8.1		
25	715	2	SMSC	34.4				
		27	GSC	17.7				
30	710	50	GP-GM	10.5				ALLUVIAL GRAVEL
		47	GP-GM	10.5	NP	NP		
35		34	GWGM	11.6				Added by Amendment 50

Figure 2.5-327 Soil Profile (Sheet 1 of 2)

Project WATTS BAR N. P.		Boring SS-165						
Depth	E1	SPT (N)	L <sub>90</sub>	W	LL	PI	X	Remarks
1"=5'								
35	705	49	ML	19.0	37.1	11.6		LAMINATED RESIDUUM
		50+		7.9	27.6	7.7		
		50+	G-SC	—	—	—		NO SAMPLE RECOVERY
40	700	50+		8.7	27.6	7.7		LAMINATED RESIDUUM
								DISCONTINUED
45	695							
50								
55								
60								
65								
70								
75								
80								

**WATTS BAR NUCLEAR PLANT  
 FINAL SAFETY  
 ANALYSIS REPORT**

---

**SOIL PROFILE  
 FIGURE 2.5-327  
 SHEET 2 OF 2**

Added by Amendment 50

Figure 2.5-327 Soil Profile (Sheet 2 of 2)

<b>WATTS BAR NUCLEAR PLANT FINAL SAFETY ANALYSIS REPORT</b>
<b>SOIL PROFILE FIGURE 2.5-328 SHEET 1 OF 2</b>

Project WATTS BAR N. P. Feature ERCW ALIGNMENT  
 Boring SS-166 Station 488.0 N Range 10.0 E Surface El 740.5  
 Date Drilled 6-29-79 To 6-29-79 Prepared By JLB Checked By gcb

Depth	El	SPT (N)	Soil	W	LL	PI	X	Remarks
0	740							FILL
		12	CL	20.5	38.5	18.4		
		50	GSM	3.0	NP	NP		
5	735	24		0.7				ALLUVIAL SILT & CLAY
				GRGM				
		17	CL-ML	25.1	48.1	21.1		
10	730	17	CL-ML	24.0				
		21	CL	25.8	39.6	15.9		
		12	ML	24.2	30.0	5.6		
15	725	18	CL-ML	23.4	33.2	10.8		
		16	CL-ML	28.1	40.3	14.6		
20	720	13	ML	29.6	48.8	19.8		
		11	CL-ML	32.2				
		6	CL-ML	28.4	31.4	9.1		
25	715	5	CL	29.3	36.8	14.3		ALLUVIAL SAND OR GRAVEL
		5	SC	27.1	26.7	9.6		
30	710	50	GSPSM	12.6	NP	NP		
		50	GSPSM	10.1				
		50	CL-ML	15.2	34.1	10.7		
35								WEATHERED SHALE Added by Amendment 50

Figure 2.5-328 Soil Profile (Sheet 1 of 2)

Project WATTS BAR N. P.		Boring SS-166						
Depth	E1	SPT (N)	L LOG	W	LL	PI	X	Remarks
1"=5'								
35	705	50 <sup>+</sup>	ML	13.8	31.5	7.4		WEATHERED SHALE
		50 <sup>+</sup>		12.9	—	—		DISCONTINUED
40	700							
45								
50								
55								
60								
65								
70								
75								
80								

**WATTS BAR NUCLEAR PLANT  
 FINAL SAFETY  
 ANALYSIS REPORT**

---

**SOIL PROFILE  
 FIGURE 2.5-328  
 SHEET 2 OF 2**

Added by Amendment 50

Figure 2.5-328 Soil Profile (Sheet 2 of 2)

**WATTS BAR NUCLEAR PLANT  
FINAL SAFETY  
ANALYSIS REPORT**

---

**SOIL PROFILE  
FIGURE 2.5-329  
SHEET 1 OF 1**

Added by Amendment 50

Project WATTS BAR N. P. Feature ERCW ALIGNMENT  
 Boring SS-167 Station 420.0N Range 83.3 W Surface El 739.7  
 Date Drilled 7-2-79 To 7-2-79 Prepared By JLB Checked By COJ

Depth	El	SPT (N)	Log	W	LL	PI	X	Remarks
0								
18			CL-ML	17.0	27.7	6.2		FILL
12	735		CL	13.4	29.8	10.4		
13				21.8	43.2	25.0		
25			GSC	23.7	—	—		
23	730		CHMH	25.6	51.9	23.4		ALLUVIAL CLAY
21				22.6				
16	725		CL-ML	25.1	43.4	18.5		
14				27.4	46.0	19.4		
14				27.3				
13	720			28.8	46.5	21.6		
10			CL	30.2	44.7	19.5		
6	715			32.1				
5				31.8	32.7	12.1		
2				34.1	31.0	15.2		
50+	710		GSM	10.1	NP	NP		ALLUVIAL GRAVELLY SAND
50+			CL-ML	12.8	26.2	4.6		WEATHERED SHALE
50+				10.9	30.1	7.2		
	705							BEDROCK

Figure 2.5-329 Soil Profile

**WATTS BAR NUCLEAR PLANT  
FINAL SAFETY  
ANALYSIS REPORT**

---

**SOIL PROFILE  
FIGURE 2.5-330  
SHEET 1 OF 2**

Project WATTS BAR N. P. Feature ERCW ALIGNMENT  
 Boring SS-168 Station 319.8 N Range 65.3 W Surface El 739.6  
 Date Drilled 7-2-79 To 7-3-79 Prepared By JLB Checked By JOB

Depth	El	SPT (N)	Log	W	LL	PI	X	Remarks
0								
		17	CLML	15.5	28.9	6.2		CLAY FILL
		11		16.5				
5	-735	12		16.9	27.4	7.0		
		12	CL	17.3				
10	-730	8		16.6	29.6	9.5		ALLUVIAL CLAY
		14		20.1	43.6	22.8		
15	-725	18	CLCH	25.9	50.7	27.2		
		9		25.6	41.8	20.5		
20	-720	11		28.6	43.7	19.5	▼	
		7	CL	31.1				
25	-715	2		29.0	36.7	18.6	▼	ALLUVIAL GRAVEL
		1		28.4	25.5	9.0		
		50+	GRGM	9.5	NP	NP		
30	-710	50+	GWGM	8.9				WEATHERED SHALE
		50+	CL	17.2	36.2	13.7		
		50+		13.9	34.1	13.1		
35	-705							Added by Amendment 50

Figure 2.5-330 Soil Profile (Sheet 1 of 2)

Project WATTS BAR N.P. Boring SS-168

Depth	E1	SPT (N)	Log	W	LL	PI	X	Remarks
1"=5'								
35		50+	SC	8.5	27.3	8.0		WEATHERED SHALE
		50+		7.3				DISCONTINUED
40	700							
45								
50								
55								
60								
65								
70								
75								
80								

**WATTS BAR NUCLEAR PLANT  
FINAL SAFETY  
ANALYSIS REPORT**

---

**SOIL PROFILE  
FIGURE 2.5-330  
SHEET 2 OF 2**

Added by Amendment 50

Figure 2.5-330 Soil Profile (Sheet 2 of 2)

Figure 2.5-331 Blank Page



<b>WATTS BAR NUCLEAR PLANT FINAL SAFETY ANALYSIS REPORT</b>
<b>SOIL PROFILE FIGURE 2.5-332 SHEET 1 OF 2</b>

Project WATTS BAR N. P. Feature ERCW ALIGNMENT  
 Boring SS-169 Station 320.0 N Range 348.0 E Surface El 741.1  
 Date Drilled 7-2-79 To 7-2-79 Prepared By JLB Checked By gch

Depth	El	SPT (N)	Log	W	LL	PI	X	Remarks
0	740	17		16.7	31.2	11.8		ALLUVIAL CLAY
		18		14.9				
5	735	16	CL	18.4	32.6	13.6		
		13		17.9	33.3	15.3		
10	730	14		16.8				
		19	CH	24.5	51.5	29.3		
		15		21.0	44.6	24.7		
15	725	10	CL	26.9	43.3	20.1		
		10	MLCL	27.6	42.1	17.3		
20	720	13	ML	32.3	48.4	17.2		
		8	CLML	31.8	43.0	17.0		ALLUVIAL SILT
25	715	6	ML	34.3	41.4	13.7		
		6		32.3				
30	710	5		33.1	40.8	13.7		ALLUVIAL GRAVEL
		50	GSM	10.4	NP	NP		
		50	GRGM	9.7				
35		50	CL-ML	14.7	36.8	12.0		WEATHERED SHALE
								Added by Amendment 50

Figure 2.5-332 Soil Profile (Sheet 1 of 2)

Project WATTS BAR N.P				Boring SS-169				
Depth	El	SPT (N)	Log	W	LL	PI	X	Remarks
1"=5'								
35								
	705	50	CL	17.0	38.1	14.5		WEATHERED SHALE
		50 <sup>+</sup>	SC	11.0	29.0	9.8		
		50 <sup>+</sup>		6.3				
40	700							DISCONTINUED
45								
50								
55								
60								
65								
70								
75								
80								

**WATTS BAR NUCLEAR PLANT  
 FINAL SAFETY  
 ANALYSIS REPORT**

---

**SOIL PROFILE  
 FIGURE 2.5-332  
 SHEET 2 OF 2**

Added by Amendment 50

Figure 2.5-332 Soil Profile (Sheet 2 of 2)

<b>WATTS BAR NUCLEAR PLANT FINAL SAFETY ANALYSIS REPORT</b>
<b>SOIL PROFILE FIGURE 2.5-333 SHEET 1 OF 2</b>

Project WATTS BAR N. P. Feature ERCW ALIGNMENT  
 Boring SS-170 Station 420.0N Range 348.0 E Surface El 741.2  
 Date Drilled 7-2-79 To 7-2-79 Prepared By JLB Checked By [Signature]

Depth	El	SPT (N)	Log	W	LL	PI	X	Remarks
1"=5"								
0	740	18	CL-ML	15.6	30.1	8.5		SANDY SILT
		14		16.2	27.8	6.0		
5	7.35	15		15.8				
		24	CL	17.6	31.8	12.3		ALLUVIAL CLAY
10	730	21	CH	25.2	61.5	34.2		
		13	CL	19.3	44.0	21.2		
		7		23.5	33.4	13.7		
15	725	14	ML-CL	25.5	44.5	27.5		
		14		29.5				
20	720	12	SM	21.9	32.6	7.4		
		4	GSMSC	29.1	34.8	11.5		
		17		23.6				
25	715	18	GSWSM	19.2				ALLUVIAL SAND & GRAVEL
		31	GSM	12.1	NP	NP		
30	710	50	GSM	42.5				
		50	GSM	10.4				
		21	GM	17.8				
35								Added by Amendment 50

Figure 2.5-333 Soil Profile (Sheet 1 of 2)

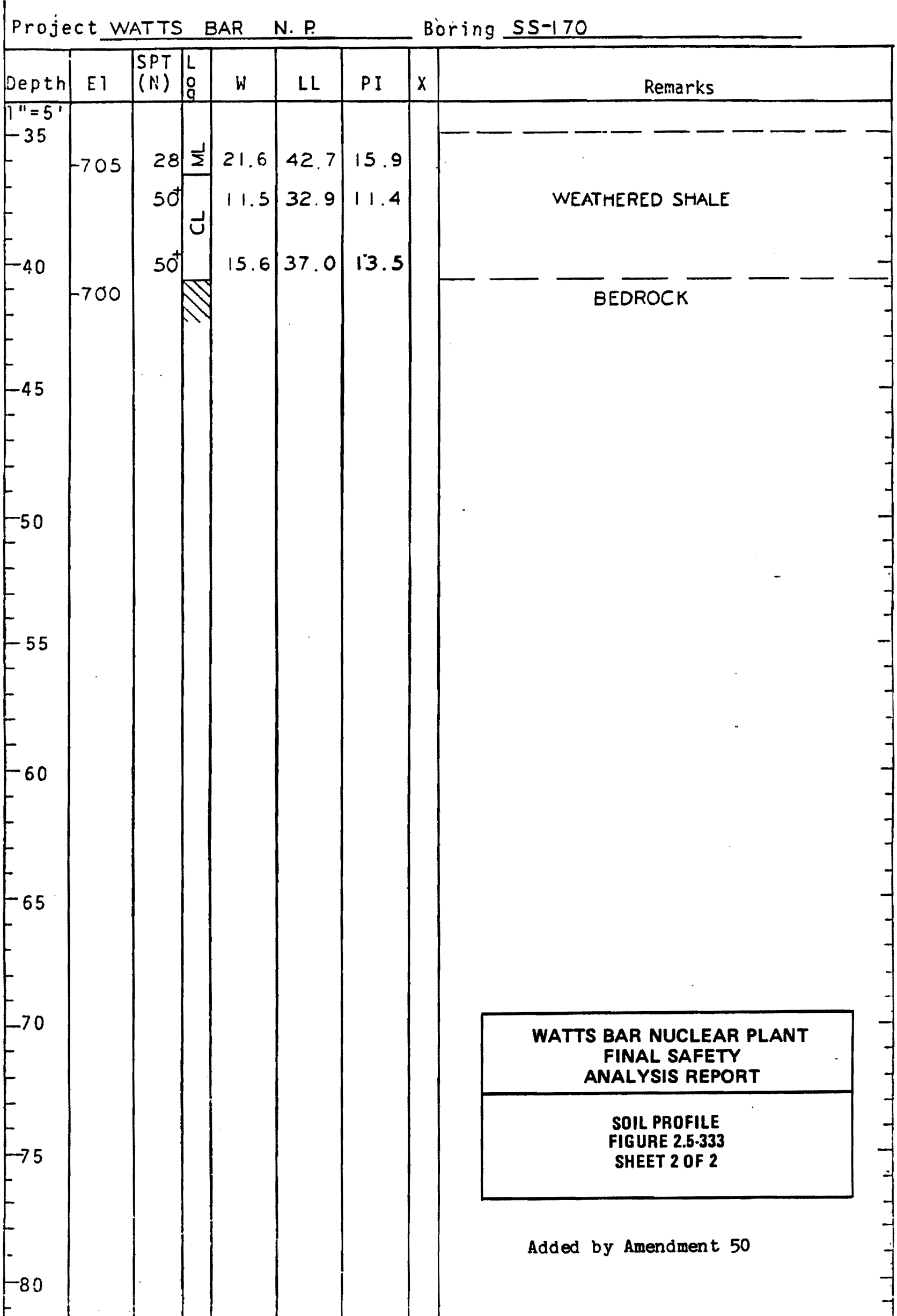

Figure 2.5-333 Soil Profile (Sheet 2 of 2)

<b>WATTS BAR NUCLEAR PLANT FINAL SAFETY ANALYSIS REPORT</b>
<b>SOIL PROFILE FIGURE 2.5-334 SHEET 1 OF 2</b>

PROJECT: WATTS BAR N.P.                      FEATURE: VOL REDUC & SOLID SYS BLDG  
 BORING: SS-1                      STATION: 1                      RANGE: G                      SURFACE EL: 741.7  
 DATE DRILLED: 6-14-82 TO 6-14-82                      PREPARED BY: MHD                      CHECKED BY:

DEPTH ft.	EL	SPT (N)	* LOG	W	LL	PI	FIELD DESCRIPTION
	740	26		13.3			TOPSOIL SI SD, DK BRN, MST, MIC, HOMO, (FL)
5		21	CL	15.6	29	12	CL SI SD, MD-DK BRN, MST, MIC, HOMO (FL)
	735	16		16.1			CL SI SD, DKBRN, MST, MIC, HOMO, (FL)
		50+		18.6			SD CL SI, DKBRN, MST, MIC, HOMO, (FL) 1032 GRAVEL - NO SAMPLE
10		24	CL	24.7			SI CL, MD-LT TN, MOTT, MST, HOMO, MIC (CALL.)
	730	22	CL	22.1	43	18	SI SD, MD TN-YEL TN, MOTT, MST, HOMO (CALL.)
15		14		24.2			CL SI, MD TN-YEL TN, MOTT, MST, HOMO (CALL.)
	725	18	CL Σ	29.1	39	14	CL SD SI, MD TN-YEL TN, MOTT, MST, HOMO (CALL.)
20							
	720	5	Σ	31.0	30	2	SD CL SI, MD TN, MST, HOMO, MIC, (CALL.)
25							
	715	10	Σ	25.2	25	3	SI SD, MD TN, V MST, HOMO, MIC, (CALL.)
30							
	710	50+	CL Σ	10.2	NP	NP	GV SD, MD TN-BLK BRN, W, STRAT. (CALL.)
35							
1''=5'			* Lab. Classif.				Added by Amendment 50

Figure 2.5-334 Soil Profile (Sheet 1 of 2)

<b>WATTS BAR NUCLEAR PLANT FINAL SAFETY ANALYSIS REPORT</b>
<b>SOIL PROFILE FIGURE 2.5-334 SHEET 2 OF 2</b>

PROJECT: WATTS BAR N.P.                      FEATURE: VOL REDUC & SOLID SYS BLDG  
 BORING: SS-1                      STATION: 1                      RANGE: G                      SURFACE EL: 741.7  
 DATE DRILLED: 6-14-82 TO 6-14-82                      PREPARED BY: MHD                      CHECKED BY:

DEPTH ft.	EL	SPT (N)	* LOG	W	LL	PI	FIELD DESCRIPTION
	705	37	Σ 10 (0) (0)	24.5	38	12	WTH SH, MD TN-BLK GY, MST, LAM-STRAT.
40							BEDROCK (EL. 704.0)
	700						
45							
	695						
50							
	690						
55							
	685						
60							
	680						
65							
	675						
70							
1''=5'							Added by Amendment 50
							* Lab. Classif.

Figure 2.5-334 Soil Profile (Sheet 2 of 2)

<b>WATTS BAR NUCLEAR PLANT FINAL SAFETY ANALYSIS REPORT</b>
<b>SOIL PROFILE FIGURE 2.5-335 SHEET 1 OF 2</b>

PROJECT: WATTS BAR N.P.                      FEATURE: VOL REDUC & SOLID SYS BLDG  
 BORING: SS-2                      STATION: 1                      RANGE: C                      SURFACE EL: 741.5  
 DATE DRILLED: 6-11-82 TO 6-11-82                      PREPARED BY: MHD                      CHECKED BY:

DEPTH ft.	EL	SPT (N)	* LOG	W	LL	PI	FIELD DESCRIPTION
5	740	34	CL	13.4	30	11	TOPSOIL DTY SD, MD-DKBRN, MST, MIC, HOMO (FL)
		20	CL	15.9			CL SI SD, MD-DKBRN, MST, MIC, HOMO (FL)
10	735	17	CL	17.1	31	12	CL SI SD, MD BRN, MST, MIC, HOMO (FL)
		53+	SM	17.6			CL SD SI, MD BRN, MST, MIC, HOMO (FL)
		20	SH	2.6			NP
15	730	20	SH	24.5	51	20	SD CL SI, MD-LT BRN, MST, MIC, HOMO (ALL.)
		22	SH	26.4			SD CL SI, MD BRN-TN, MST, MIC, HOMO (ALL.)
20	725	14	SH	23.0	43	14	SD CL SI, MD BRN-TN, MST, MIC, HOMO (ALL.)
		20	SH	31.5			CL SI, MD BRN-TN-WHT, MST, MIC, HOMO (ALL.)
25	720	6	US	26.3	29	6	DTY SD, MD BRN, W, MIC, HOMO, (ALL.)
		4					NO RECOVERY
30	710	50+	US	12.0	NP	NP	GV SD, MD BRN, W, HOMO, (±45% SB RD GV) (ALL.)
35							
1''=5'							Added by Amendment 50
* Lab. Classif.							

Figure 2.5-335 Soil Profile (Sheet 1 of 2)

<b>WATTS BAR NUCLEAR PLANT FINAL SAFETY ANALYSIS REPORT</b>
<b>SOIL PROFILE FIGURE 2.5-335 SHEET 2 OF 2</b>

PROJECT: WATTS BAR N.P.                      FEATURE: VOL REDUC & SOLID SYS BLDG  
 BORING: SS-2                      STATION: 1                      RANGE: C                      SURFACE EL: 741.5  
 DATE DRILLED: 6-11-82 TO 6-11-82                      PREPARED BY: MHD                      CHECKED BY:

DEPTH ft.	EL	SPT (N)	* LOG	W	LL	PI	FIELD DESCRIPTION
	705	30	$\frac{1}{\Sigma}$	26.5	28	20	MD CL, MD BRN-GRN, MST, STRAT-SHLY (RES.)
40							REFUSAL (EL. 704.3)
	700						
45							
	695						
50							
	690						
55							
	685						
60							
	680						
65							
	675						
70							
1"=5'							Added by Amendment 50
							* Lab. Classif.

Figure 2.5-335 Soil Profile (Sheet 2 of 2)



<b>WATTS BAR NUCLEAR PLANT FINAL SAFETY ANALYSIS REPORT</b>
<b>SOIL PROFILE FIGURE 2.5-336 SHEET 2 OF 2</b>

PROJECT: WATTS BAR N.P.                      FEATURE: VOL REDUC & SOLID SYS BLDG  
 BORING: SS-3                      STATION: 6                      RANGE: D                      SURFACE EL: 741.5  
 DATE DRILLED: 6-8-82                      TO 6-9-82                      PREPARED BY: MHD                      CHECKED BY:

DEPTH ft.	EL	SPT (N)	* LOG	W	LL	PI	FIELD DESCRIPTION
	705	20		58.4	43	9	FN SD SI, DK BRN-BLK, MOTT, MST (ALL.)
			Σ 0	22.8	34	8	CL SI, MD BRN-BLK, MOTT, MST, SHLY, (RES.)
40							REFUSAL-BEDROCK (EL. 702.8)
	700						
45							
	695						
50							
	690						
55							
	685						
60							
	680						
65							
	675						
70							
1''=5'							Added by Amendment 50
							* Lab. Classif.

Figure 2.5-336 Soil Profile (Sheet 1 of 2)

WATTS BAR NUCLEAR PLANT FINAL SAFETY ANALYSIS REPORT
SOIL PROFILE FIGURE 2.5-336 SHEET 2 OF 2

PROJECT: WATTS BAR N.P.                      FEATURE: VOL REDUC & SOLID SYS BLDG  
 BORING: SS-3                      STATION: 6                      RANGE: D                      SURFACE EL: 741.5  
 DATE DRILLED: 6-8-82                      TO 6-9-82                      PREPARED BY: MHD                      CHECKED BY:

DEPTH ft.	EL	SPT (N)	* LOG	W	LL	PI	FIELD DESCRIPTION
	705	20		58.4	43	9	FN SD SI, DK BRN-BLK, MOTT, MST (CALL.)
			Σ 0	22.8	34	8	CL SI, MD BRN-BLK, MOTT, MST, SHLY, (RES.)
40							REFUSAL-BEDROCK (EL. 702.8)
	700						
45							
	695						
50							
	690						
55							
	685						
60							
	680						
65							
	675						
70							
1"=5'			* Lab. Classif.				Added by Amendment 50

Figure 2.5-336 Soil Profile (Sheet 2 of 2)

<b>WATTS BAR NUCLEAR PLANT FINAL SAFETY ANALYSIS REPORT</b>
<b>SOIL PROFILE FIGURE 2.5-337 SHEET 1 OF 1</b>

PROJECT: WATTS BAR N.P.      FEATURE: VOL REDUC & SOLID SYS BLDG  
 BORING: SS-4      STATION: 9      RANGE: H      SURFACE EL: 740.7  
 DATE DRILLED: 6-15-82 TO 6-16-82      PREPARED BY: MHD      CHECKED BY:

DEPTH ft.	EL	SPT (N)	* LOG	W	LL	PI	FIELD DESCRIPTION
5	740	9	CL	19.2	35	14	TOPSOIL CL SI, MD BRN, MST, HOMO, MIC (FL)
		4	CL	23.0			FN SD CL SI, MD BRN, MST, HOMO, MIC (FL)
10	735	4	CL	19.9	32	12	SAME AS ABOVE
		4	CL	29.3			CL SI, DK BRN, V MST, HOMO, MIC (FL)
		50+	SM	11.7	NP	NP	DTY SD, DK GY, VMST, HOMO (PGD) (FL)
			GM	8.5	NP	NP	1032
15	730	25	CL	21.8	48	22	CL SD SI, MD TN-YEL TN-GY, MOTT, MST, HOMO (ALL.)
		22	CL	24.9			CL SI SD, MD TN-YEL TN-GY, MOTT, MST, MIC, HOMO (ALL.)
20	725	16	CL	28.4	39	14	SD CL SI, MD TN-YEL TN-GY, MOTT, MST, MIC, HOMO (ALL.)
			CL				
25	720	9	CL	30.8	41	21	SI CL, MD TN-GY-BLK, MOTT, MST, HOMO (ALL.)
			CL				
30	715	5		31.2	NP	NP	MD CL, MD TN-LT BRN, MOTT, V. MST, HOMO (W/TR MIC) (ALL.)
			SP				9.8
35	710	50+	SS	11.2	NP	NP	
			SS				
1' = 5'			* Lab. Classif.				REFUSAL (EL. 705.5)

Added by Amendment 50

Figure 2.5-337 Soil Profile

<b>WATTS BAR NUCLEAR PLANT FINAL SAFETY ANALYSIS REPORT</b>
<b>SOIL PROFILE FIGURE 2.5-338 SHEET 1 OF 1</b>

PROJECT: WATTS BAR N.P.                      FEATURE: VOL REDUC & SOLID SYS BLDG  
 BORING: SS-5                      STATION: 9                      RANGE: B                      SURFACE EL: 737.1  
 DATE DRILLED: 6-9-82                      TO 6-10-82                      PREPARED BY: MHD                      CHECKED BY:

DEPTH ft.	EL	SPT (N)	* LOG	W	LL	PI	FIELD DESCRIPTION
5	735	11	CL	17.7	28	11	GRAVELLY ROADBED
		6	CL	21.4			CL SI, DK BRN, MST, HOMO, MIC (W/TR LS GV)(FL)
		50+					CL SI, DK BRN, MST, HOMO, MIC(FL)
10	730	16	CL	22.8	38	19	1032 - NO SAMPLE RECOVERED
		15	CL	19.3			CL SD SI, BRN-GY, MST, STRAT, MIC (ALL.)
		18	CL	25.9			CL SI SD, LT BRN-GY, MST, STRAT (ALL.)
15	725	23	ML	26.8	35	12	CL SI SD, LT BRN-GY, MST (ALL.)
		18	ML	30.0			CL SI SD, MD BRN-CRM, MST, BLKY (ALL.)
		18	ML	30.0			SI CL, MD-LT BRN, MOTT, MST, HOMO (ALL.)
20	720	4	CL	30.7	32	15	CL SD SI, MD BRN-TN, W, HOMO, MIC (ALL.)
		50+	GP	20.2			NP
25	715	50+	GP	20.2	NP	NP	
		50+	GP	20.2			NP
30	710	50+	SM	15.9	34	10	WITH LS & CL, LT BLU-DK BRN-BLK, MST, LAM (3-IN. THK)(RES.)
		50+	SM	15.9			
35							REFUSAL (EL. 703.8)
1''=5'							
			* Lab. Classif.				

Added by Amendment 50

Figure 2.5-338 Soil Profile

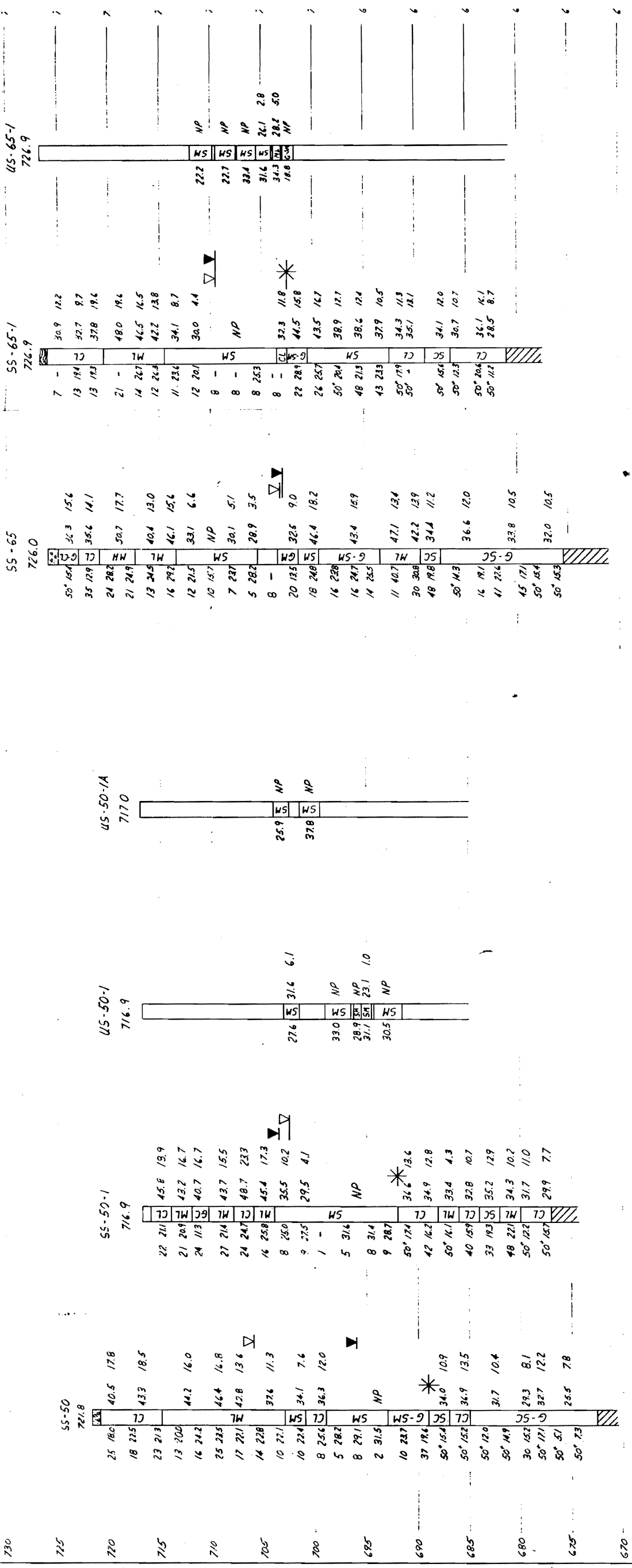

Added by Amendment 50

WATTS BAR NUCLEAR PLANT  
FINAL SAFETY  
ANALYSIS REPORT

ERCW ROUTE  
LIQUEFACTION EVALUATION  
GRAPHIC LOGS NO. 50 & 65  
FIGURE 2.5-339

SCALE: 1" = 5'

**LEGEND**

Boring No.  
Elevation

Blows  
Moisture Content  
Liquid Limit  
Plasticity Index  
Classification

Note: Blows per foot with a 140 lb hammer and  
a 30 inch drop on a 2 inch OD split-bar sampler

**SYMBOLS**

Topsoil  
Limestone gravel  
Refract  
One hour water table reading  
Twenty four hour water table reading  
Top of weathered shale

Figure 2.5-339 ERCW Route Liquefaction Evaluation Graphic Logs No. 50 & 65

**WATTS BAR NUCLEAR PLANT  
FINAL SAFETY  
ANALYSIS REPORT**

---

**ERCW LIQUEFACTION  
FIGURE 2.5-340**

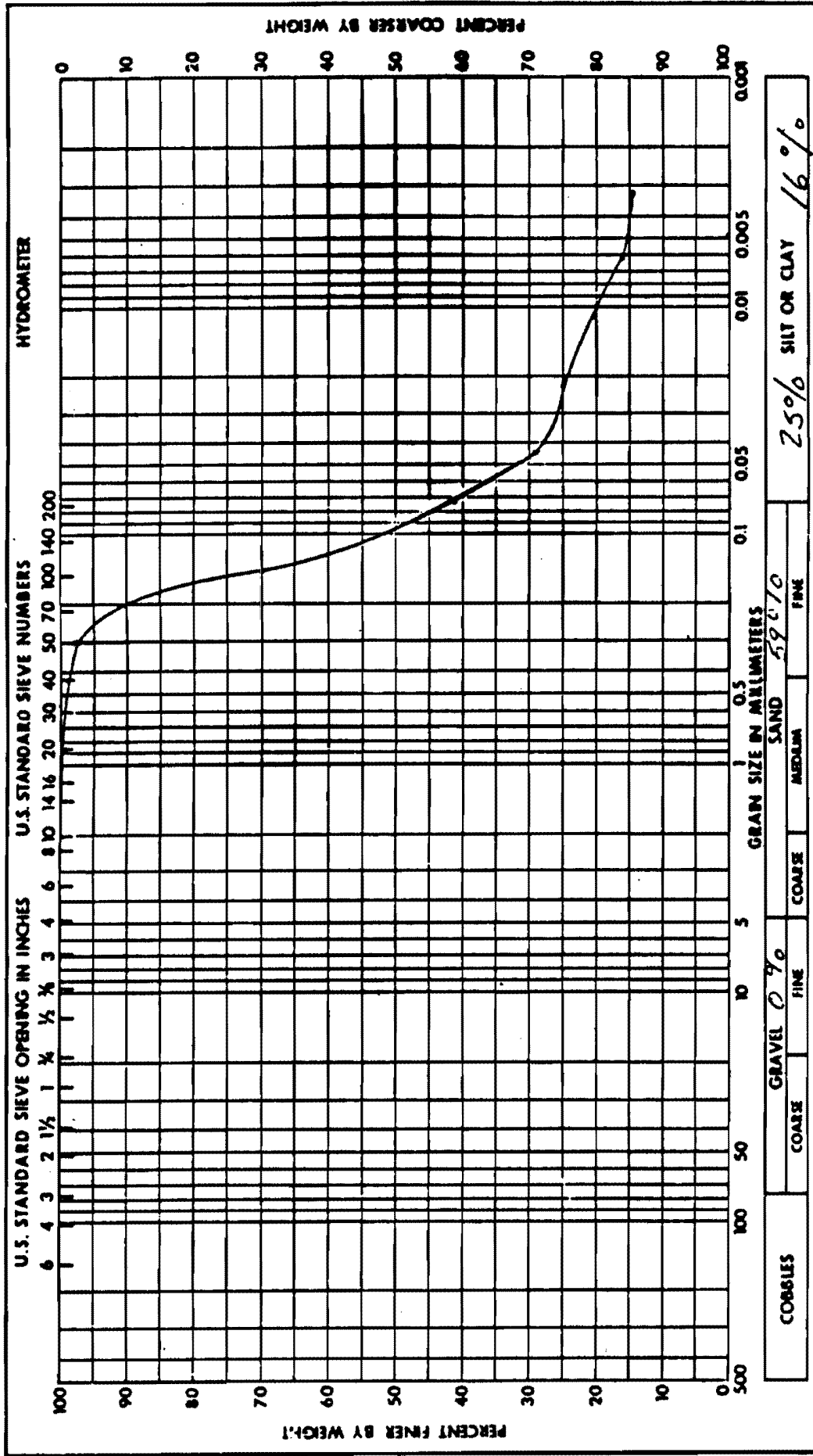

Added by Amendment 50

Project <i>WATTS BAR NP</i>
Feature <i>ERCW LIQUEFACTION</i>
Boring No. <i>11S-50-1</i> Sample No. <i>1</i>
Station <i>1650.05</i> Range <i>785.0E</i>
Date <i>8-1-79</i> Elevation <i>701.4-700.7</i>
<b>GRAIN SIZE ANALYSIS</b>

Remarks:

Soil Symbol	SM	Liquid Limit, %	31.6	
Moisture Content, %	27.6	Plastic Limit, %	25.5	
Specific Gravity	2.73	Plasticity Index, %	6.1	
		Shrinkage Limit, %		

Figure 2.5-340 ERCW Liquefaction

ATTACHMENT 6  
CONST-QCP 5.3

**WATTS BAR NUCLEAR PLANT  
FINAL SAFETY  
ANALYSIS REPORT**

---

**ERCW LIQUEFACTION  
FIGURE 2.5-341**

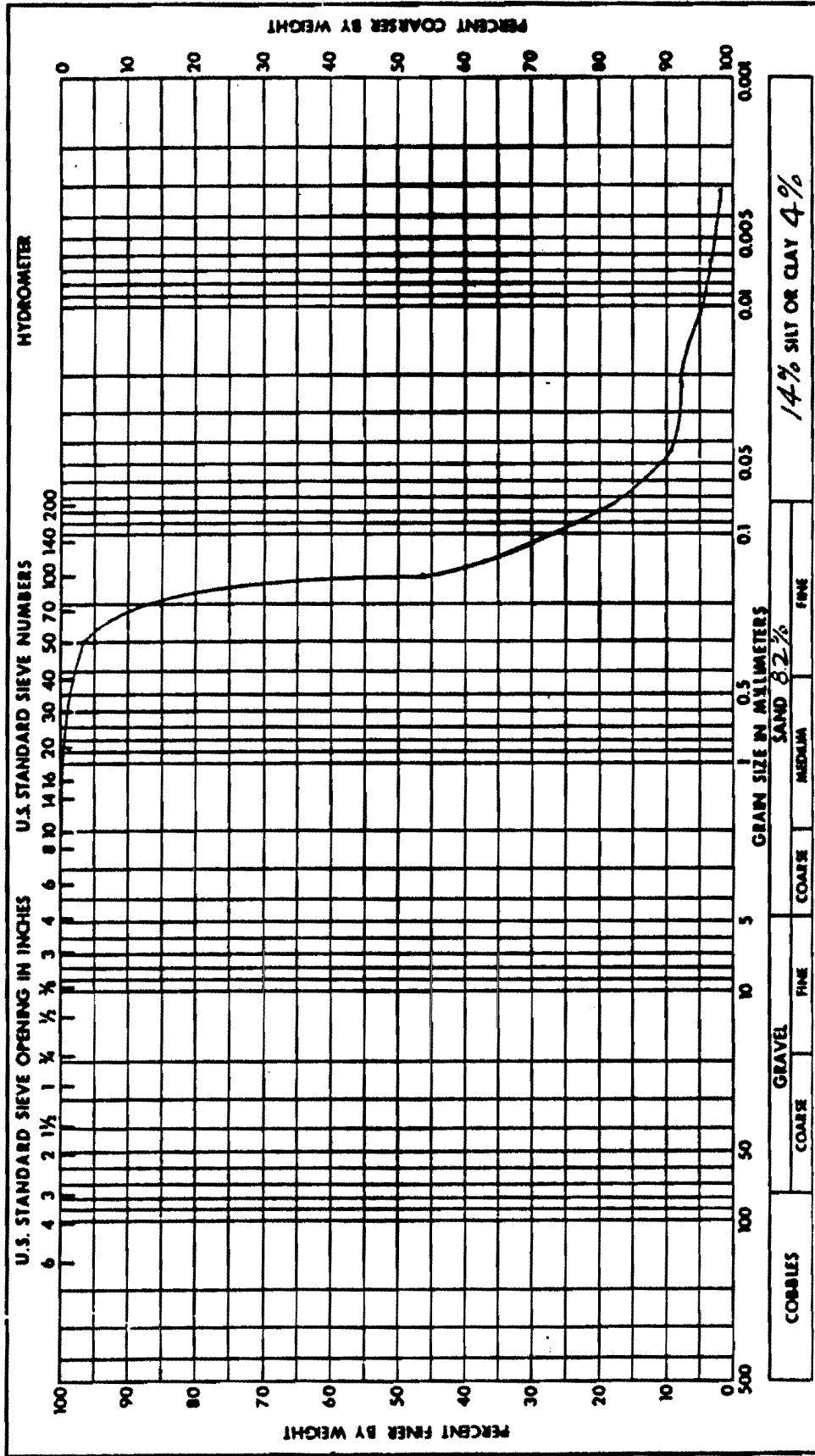

Added by Amendment 50

<b>Project</b> <i>WATTS BAR NP</i>	
<b>Feature</b> <i>ERCW LIQUEFACTION</i>	
<b>Boring No.</b> <i>LS-20-1</i>	<b>Sample No.</b> <i>2</i>
<b>Station</b> <i>1650.0 S</i>	<b>Range</b> <i>785.0 E</i>
<b>Date</b> <i>7-20-79</i>	<b>Elevation</b> <i>698.9-696.6</i>
<b>GRAIN SIZE ANALYSIS</b>	

**Remarks:**

<b>Soil Symbol</b>	<i>SM</i>	<b>Liquid Limit, %</b>	<i>NP</i>
<b>Moisture Content, %</b>	<i>33.0</i>	<b>Plastic Limit, %</b>	<i>NP</i>
<b>Specific Gravity</b>	<i>2.70</i>	<b>Plasticity Index, %</b>	<i>NP</i>
		<b>Shrinkage Limit, %</b>	

Figure 2.5-341 ERCW Liquefaction

**WATTS BAR NUCLEAR PLANT  
FINAL SAFETY  
ANALYSIS REPORT**

**LIQUEFACTION  
FIGURE 2.5-342**

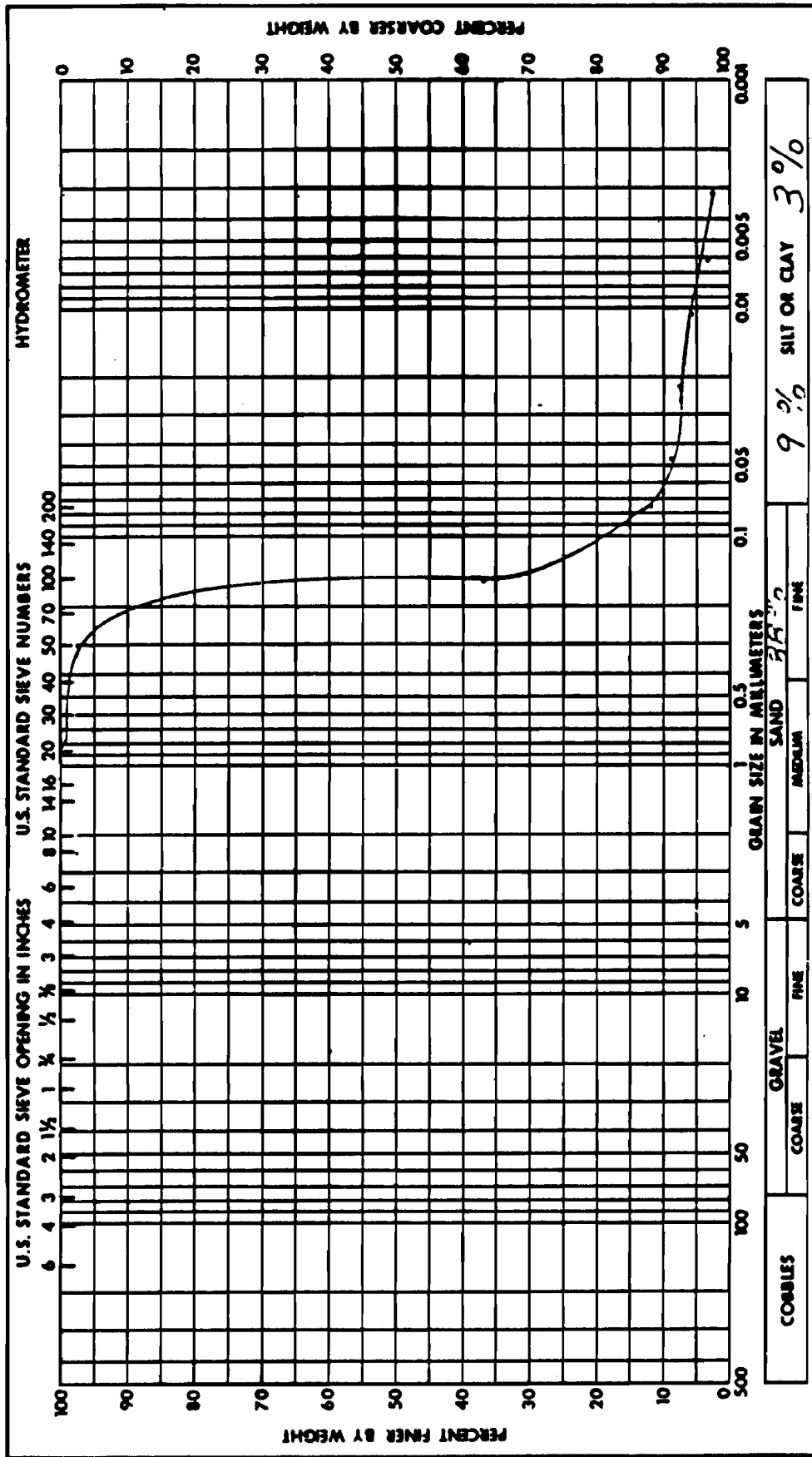

Added by Amendment 50

<b>Project</b> <i>Watts Bar N.P.</i>	
<b>Feature</b> <i>Liquefaction</i>	
<b>Boring No.</b> <i>W5-50-1</i>	<b>Sample No.</b> <i>3</i>
<b>Station</b> <i>1650.0S</i>	<b>Range</b> <i>785.0E</i>
<b>Date</b> <i>7-16-79</i>	<b>Elevation</b> <i>696.4-695.3</i>
<b>GRAIN SIZE ANALYSIS</b>	

<b>Remarks:</b>

<b>Soil Symbol</b>	<i>SM</i>	<b>Liquid Limit, %</b>	<i>N.P.</i>
<b>Moisture Content, %</b>	<i>28.9</i>	<b>Plastic Limit, %</b>	<i>N.P.</i>
<b>Specific Gravity</b>	<i>2.73</i>	<b>Plasticity Index, %</b>	<i>N.P.</i>
		<b>Shrinkage Limit, %</b>	

Figure 2.5-342 Liquefaction



**WATTS BAR NUCLEAR PLANT  
FINAL SAFETY  
ANALYSIS REPORT**

---

**LIQUEFACTION  
FIGURE 2.5-343**

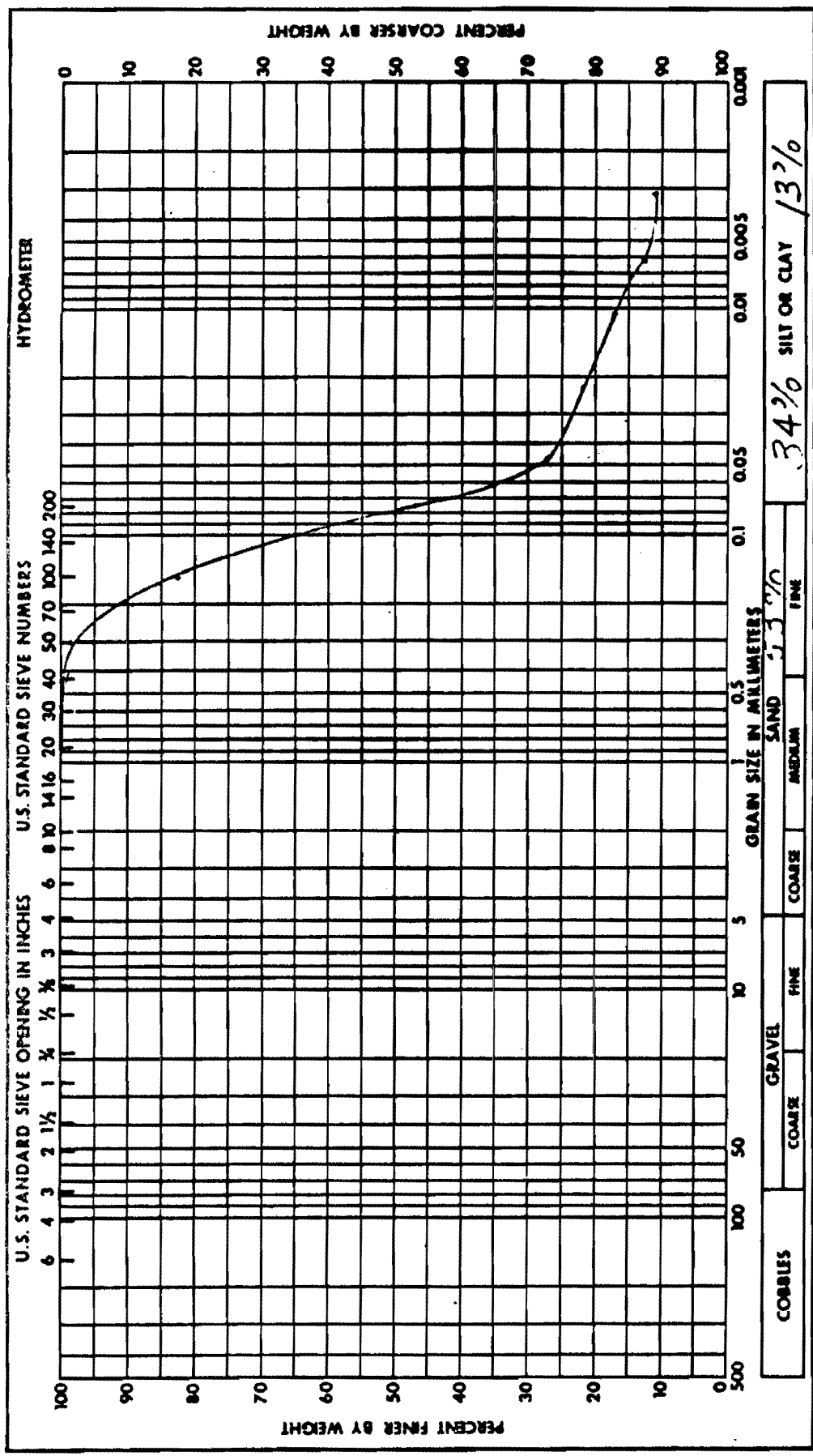

Added by Amendment 50

<b>Project</b>	<i>Watts Bar N.p.</i>
<b>Feature</b>	<i>Liquefaction</i>
<b>Boring No.</b>	<i>U.S. 50-1</i>
<b>Station</b>	<i>1650.0 S</i>
<b>Date</b>	<i>7-16-79</i>
<b>Sample No.</b>	<i>3</i>
<b>Range</b>	<i>785.0 E</i>
<b>Elevation</b>	<i>695.3-694.5</i>
<b>GRAIN SIZE ANALYSIS</b>	

<b>Remarks:</b>

<b>Soil Symbol</b>	<i>SM</i>	<b>Liquid Limit, %</b>	<i>23.1</i>
<b>Moisture Content, %</b>	<i>31.1</i>	<b>Plastic Limit, %</b>	<i>22.1</i>
<b>Specific Gravity</b>	<i>2.70</i>	<b>Plasticity Index, %</b>	<i>1.0</i>
		<b>Shrinkage Limit, %</b>	

Figure 2.5-343 Liquefaction

**WATTS BAR NUCLEAR PLANT  
FINAL SAFETY  
ANALYSIS REPORT**

**LIQUEFACTION  
FIGURE 2.5-344**

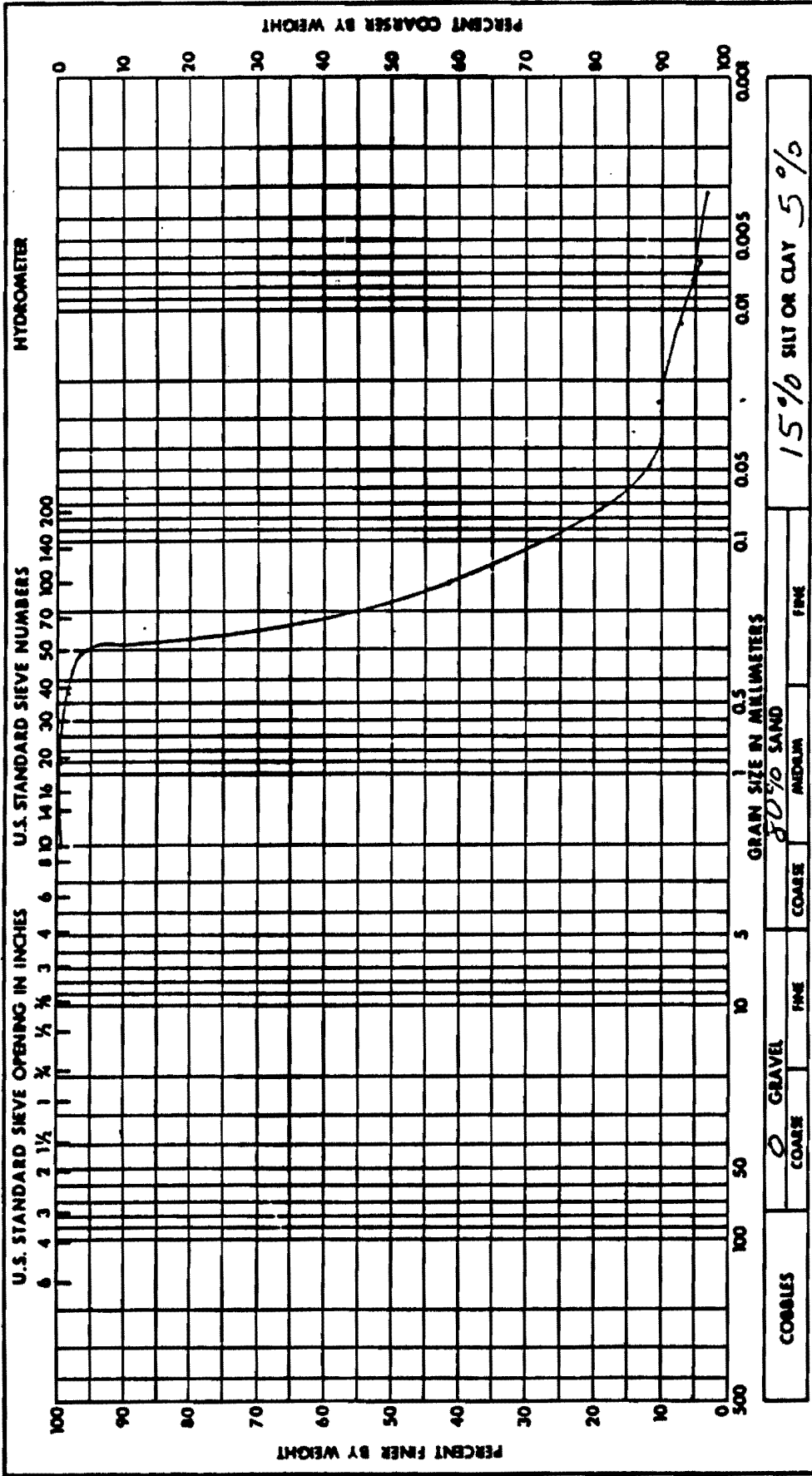

Added by Amendment 50

<b>Project</b> Watts Bar N.P.
<b>Feature</b> Liquefaction
<b>Boring No.</b> US-50-1
<b>Station</b> 1650.05
<b>Date</b> 7-13-79
<b>Sample No.</b> 4
<b>Range</b> 785.0E
<b>Elevation</b> 694.2-692.1
<b>GRAIN SIZE ANALYSIS</b>

<b>Remarks:</b>

<b>Soil Symbol</b>	SM	<b>Liquid Limit, %</b>	NP
<b>Moisture Content, %</b>	30.5	<b>Plastic Limit, %</b>	NP
<b>Specific Gravity</b>	2.74	<b>Plasticity Index, %</b>	NP
		<b>Shrinkage Limit, %</b>	

Figure 2.5-344 Liquefaction

WATTS BAR NUCLEAR PLANT  
FINAL SAFETY  
ANALYSIS REPORT

LIQUEFACTION  
FIGURE 2.5-345

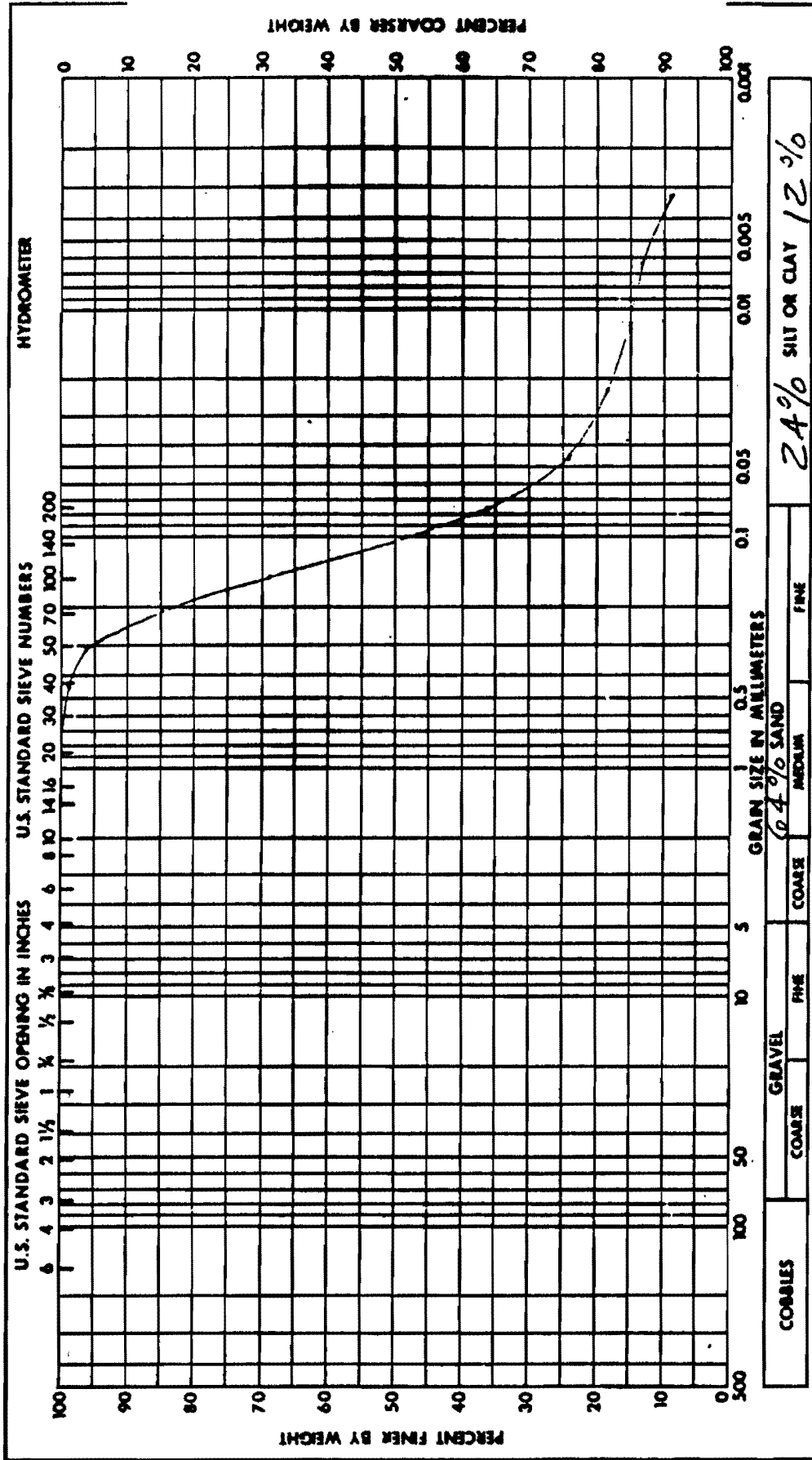

Added by Amendment 50

Project	Watts Bar N.P.
Feature	Liquefaction
Boring No.	US-50-1A
Sample No.	1
Station	1645.0E
Range	785.0E
Date	7-13-79
Elevation	703.9-702

GRAIN SIZE ANALYSIS

Remarks:	

Soil Symbol	SM	Liquid Limit, %	NP
Moisture Content, %	25.9	Plastic Limit, %	NP
Specific Gravity	2.73	Plasticity Index, %	NP
		Shrinkage Limit, %	

Figure 2.5-345 Liquefaction

**WATTS BAR NUCLEAR PLANT  
FINAL SAFETY  
ANALYSIS REPORT**

---

**LIQUEFACTION  
FIGURE 2.5-346**

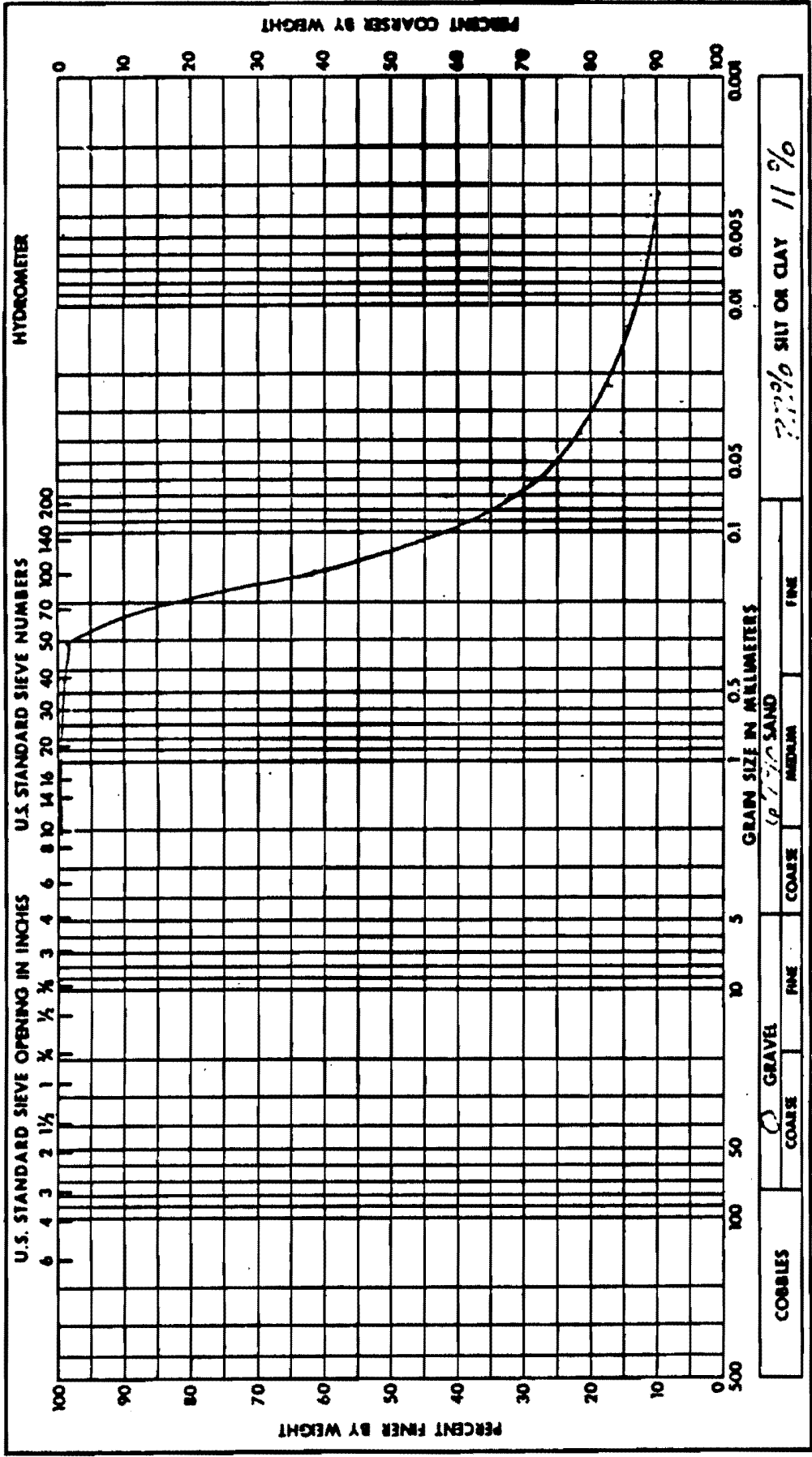

Added by Amendment 50

<b>Project</b> Watts Bar N.P.	
<b>Feature</b> Liquefaction	
<b>Boring No.</b> US-50-1A	<b>Sample No.</b> 2
<b>Station</b> 1645.05	<b>Range</b> 785.0 E
<b>Date</b> 7-13-79	<b>Elevation</b> 701.6-699.4
<b>GRAIN SIZE ANALYSIS</b>	

<b>Remarks:</b>

<b>Soil Symbol</b>	SM	<b>Liquid Limit, %</b>	NP
<b>Moisture Content, %</b>	37.8	<b>Plastic Limit, %</b>	NP
<b>Specific Gravity</b>	2.73	<b>Plasticity Index, %</b>	NP
		<b>Shrinkage Limit, %</b>	

Figure 2.5-346 Liquefaction

**WATTS BAR NUCLEAR PLANT  
FINAL SAFETY  
ANALYSIS REPORT**

---

**LIQUEFACTION  
FIGURE 2.5-347**

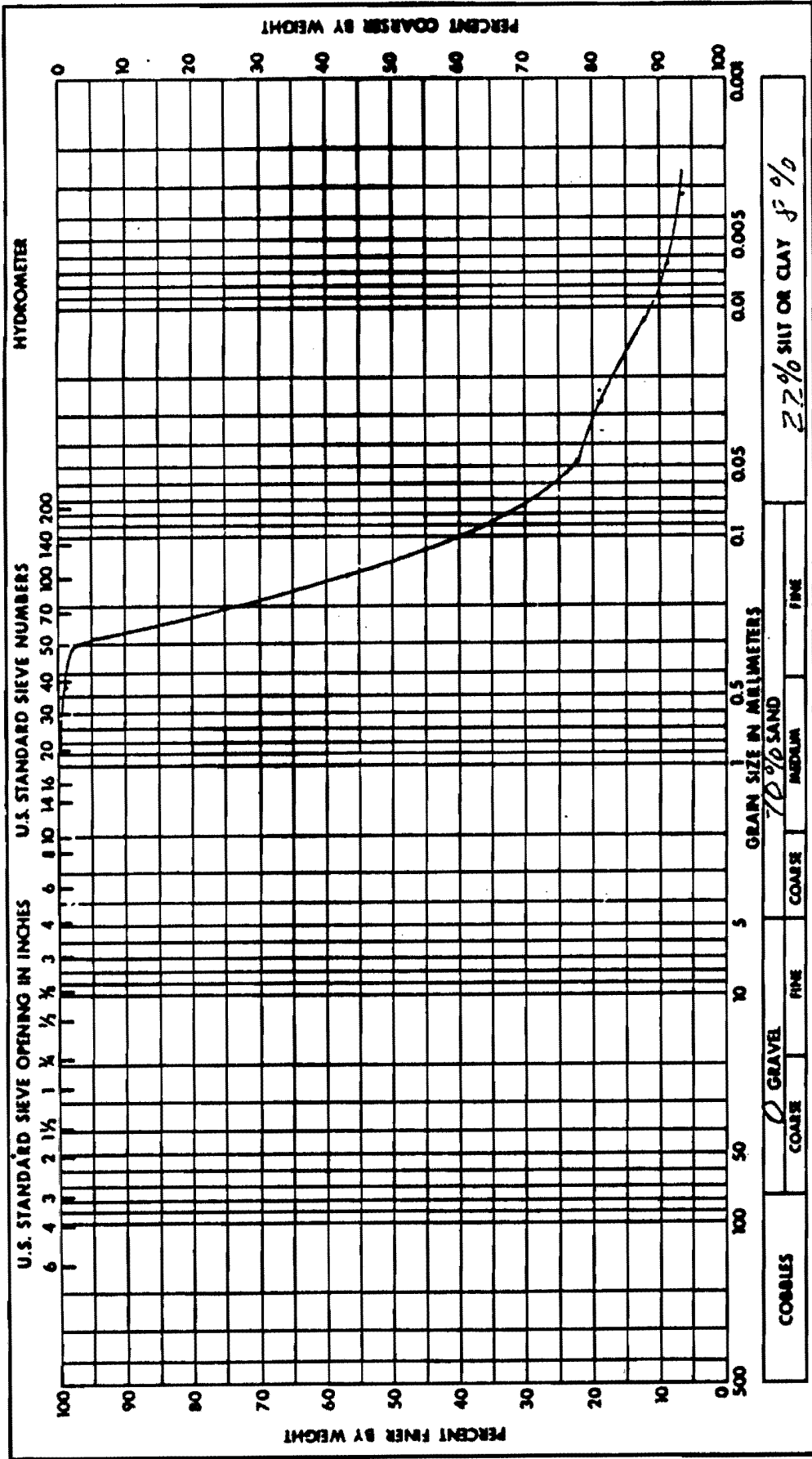

Added by Amendment 50

Project <i>Watts Bar N.P.</i>	
Feature <i>Liquefaction</i>	
Boring No. <i>15-65-1</i>	Sample No. <i>1</i>
Station <i>1367.0 S</i>	Range <i>1005.7 E</i>
Date <i>7-13-79</i>	Elevation <i>711.9-709.6</i>
<b>GRAIN SIZE ANALYSIS</b>	

Remarks:

Soil Symbol	<i>SM</i>	Liquid Limit, %	<i>NP</i>
Moisture Content, %	<i>22.2</i>	Plastic Limit, %	<i>NP</i>
Specific Gravity	<i>2.70</i>	Plasticity Index, %	<i>NP</i>
		Shrinkage Limit, %	

Figure 2.5-347 Liquefaction

**WATTS BAR NUCLEAR PLANT  
FINAL SAFETY  
ANALYSIS REPORT**

---

**LIQUEFACTION  
FIGURE 2.5-348**

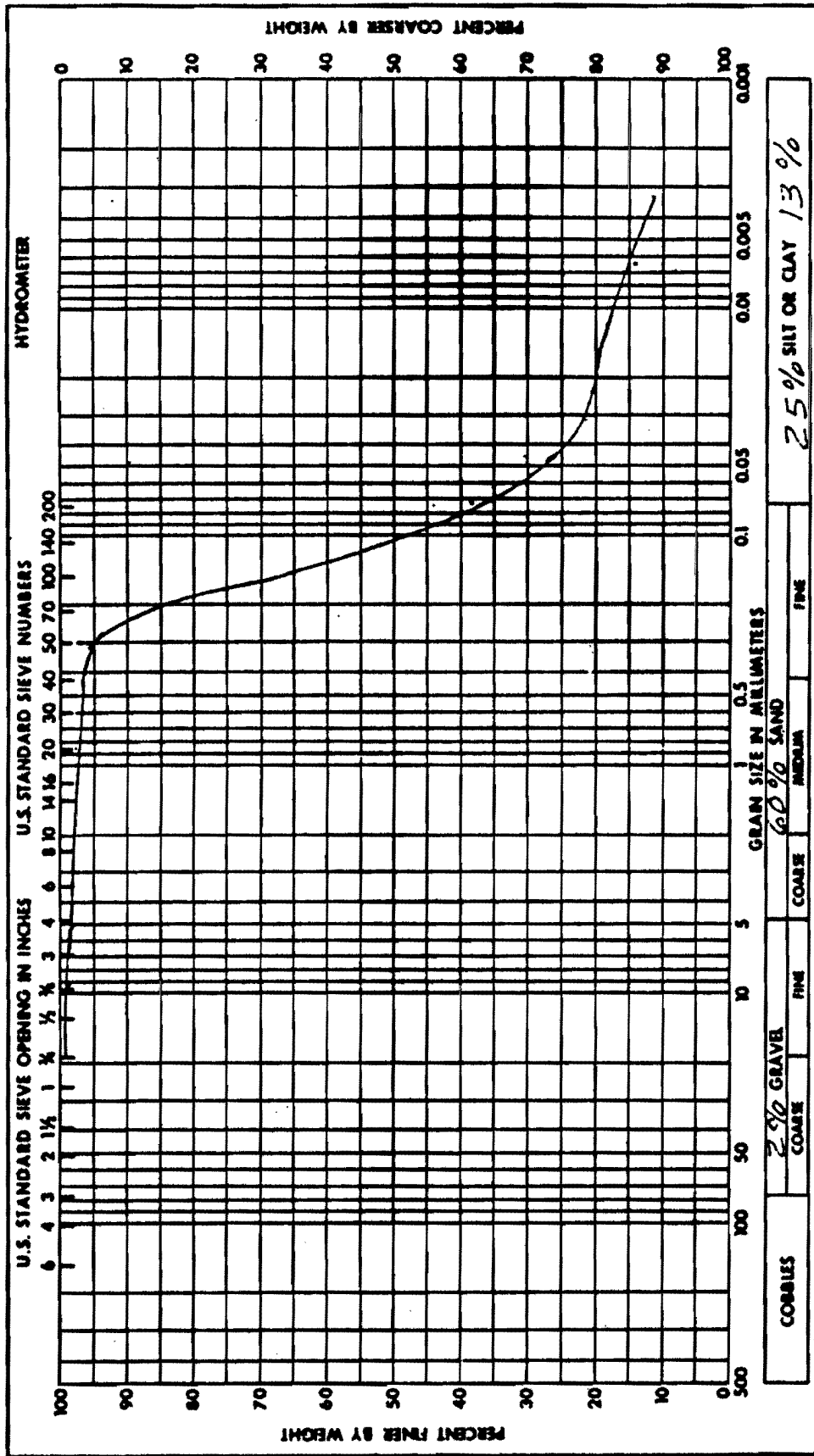

Added by Amendment 50

Project	Watts Bar N.P.
Feature	Liquefaction
Boring No.	05-65-1
Sample No.	2
Station	13670 S
Date	7-13-79
Range	1005.7 E
Elevation	709.4-707.3
<b>GRAIN SIZE ANALYSIS</b>	

Remarks:

Soil Symbol	SM	Liquid Limit, %	NP
Moisture Content, %	22.7	Plastic Limit, %	NP
Specific Gravity	2.72	Plasticity Index, %	NP
		Shrinkage Limit, %	

Figure 2.5-348 Liquefaction

**WATTS BAR NUCLEAR PLANT  
FINAL SAFETY  
ANALYSIS REPORT**

---

**LIQUEFACTION  
FIGURE 2.5-349**

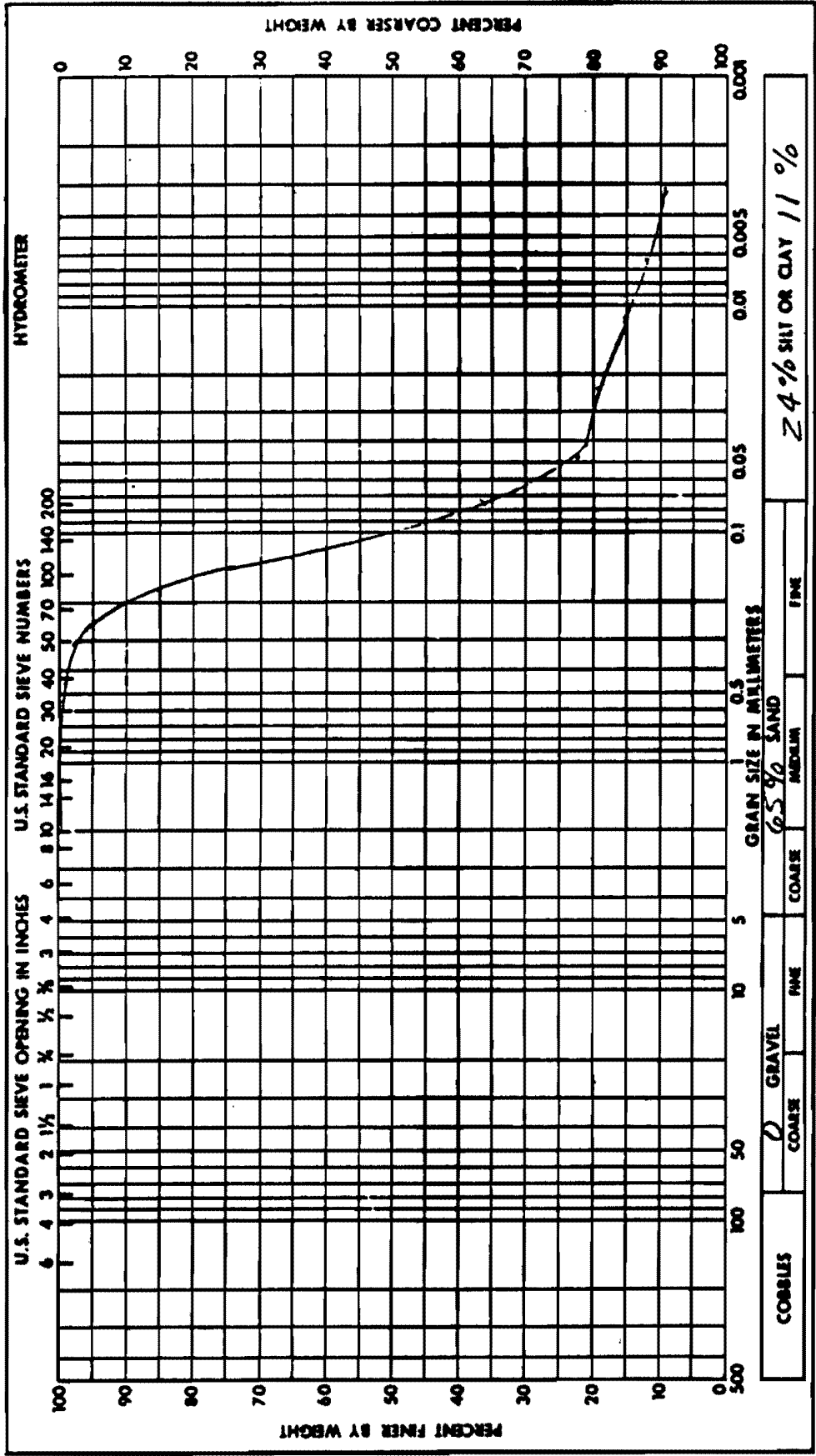

Project	WATTS Bar N.P.
Feature	Liquefaction
Boring No.	115-65-1
Sample No.	3
Station	1367.0 S
Range	1005.7 E
Date	7-13-79
Elevation	707.2-705.2

**GRAIN SIZE ANALYSIS**

Remarks:

Soil Symbol	SM	Liquid Limit, %	NP
Moisture Content, %	33.4	Plastic Limit, %	NP
Specific Gravity	2.72	Plasticity Index, %	NP
		Shrinkage Limit, %	

Added by Amendment 50

Figure 2.5-349 Liquefaction

**WATTS BAR NUCLEAR PLANT  
FINAL SAFETY  
ANALYSIS REPORT**

---

**LIQUEFACTION  
FIGURE 2.5-350**

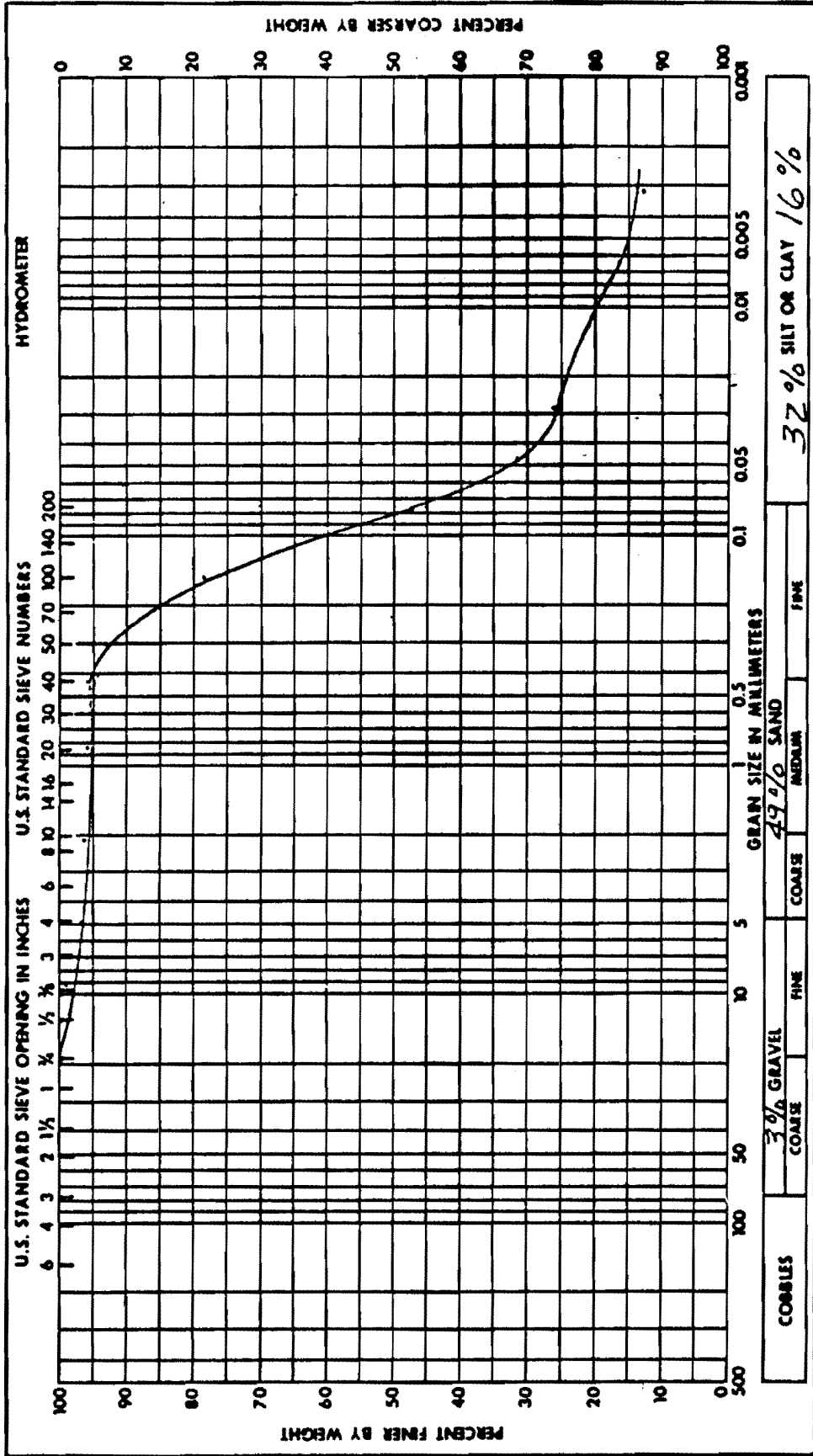

Added by Amendment 50

Project <i>Watts Bar N.P.</i>	
Feature <i>LIQUEFACTION</i>	
Boring No. <i>15-651</i>	Sample No. <i>4</i>
Station <i>1367.0 S</i>	Range <i>1005.7 E</i>
Date <i>1-13-71</i>	Elevation <i>705.2-704.0</i>
<b>GRAIN SIZE ANALYSIS</b>	

Remarks:

Soil Symbol	<i>SM</i>	Liquid Limit, %	<i>26.1</i>
Moisture Content, %	<i>31.6</i>	Plastic Limit, %	<i>23.3</i>
Specific Gravity	<i>2.71</i>	Plasticity Index, %	<i>2.8</i>
		Shrinkage Limit, %	

Figure 2.5-350 Liquefaction



**WATTS BAR NUCLEAR PLANT  
FINAL SAFETY  
ANALYSIS REPORT**

---

**LIQUEFACTION  
FIGURE 2.5-351**

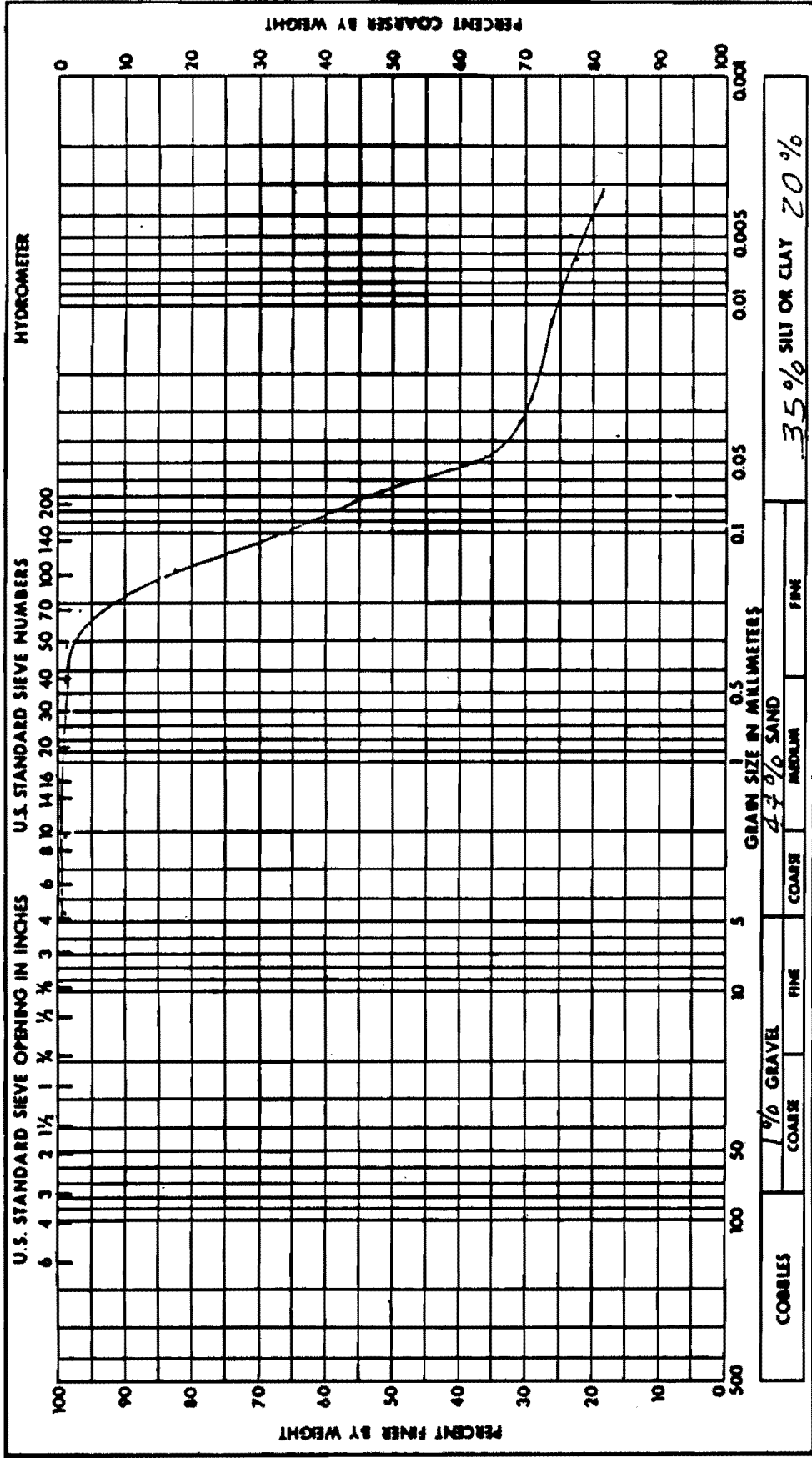

Added by Amendment 50

<b>Project</b> <i>Watts Bar N.P.</i>	
<b>Feature</b> <i>Liquefaction</i>	
<b>Boring No.</b> <i>US-65-1</i>	<b>Sample No.</b> <i>5</i>
<b>Station</b> <i>1367.0 S</i>	<b>Range</b> <i>1005.7 E</i>
<b>Date</b> <i>7-13-77</i>	<b>Elevation</b> <i>703.8-703.2</i>
<b>GRAIN SIZE ANALYSIS</b>	

<b>Remarks:</b>

<b>Soil Symbol</b>	<i>ML</i>	<b>Liquid Limit, %</b>	<i>28.2</i>
<b>Moisture Content, %</b>	<i>3.4.3</i>	<b>Plastic Limit, %</b>	<i>23.2</i>
<b>Specific Gravity</b>	<i>2.71</i>	<b>Plasticity Index, %</b>	<i>5.0</i>
		<b>Shrinkage Limit, %</b>	

Figure 2.5-351 Liquefaction

**WATTS BAR NUCLEAR PLANT  
FINAL SAFETY  
ANALYSIS REPORT**

---

**LIQUEFACTION  
FIGURE 2.5-352**

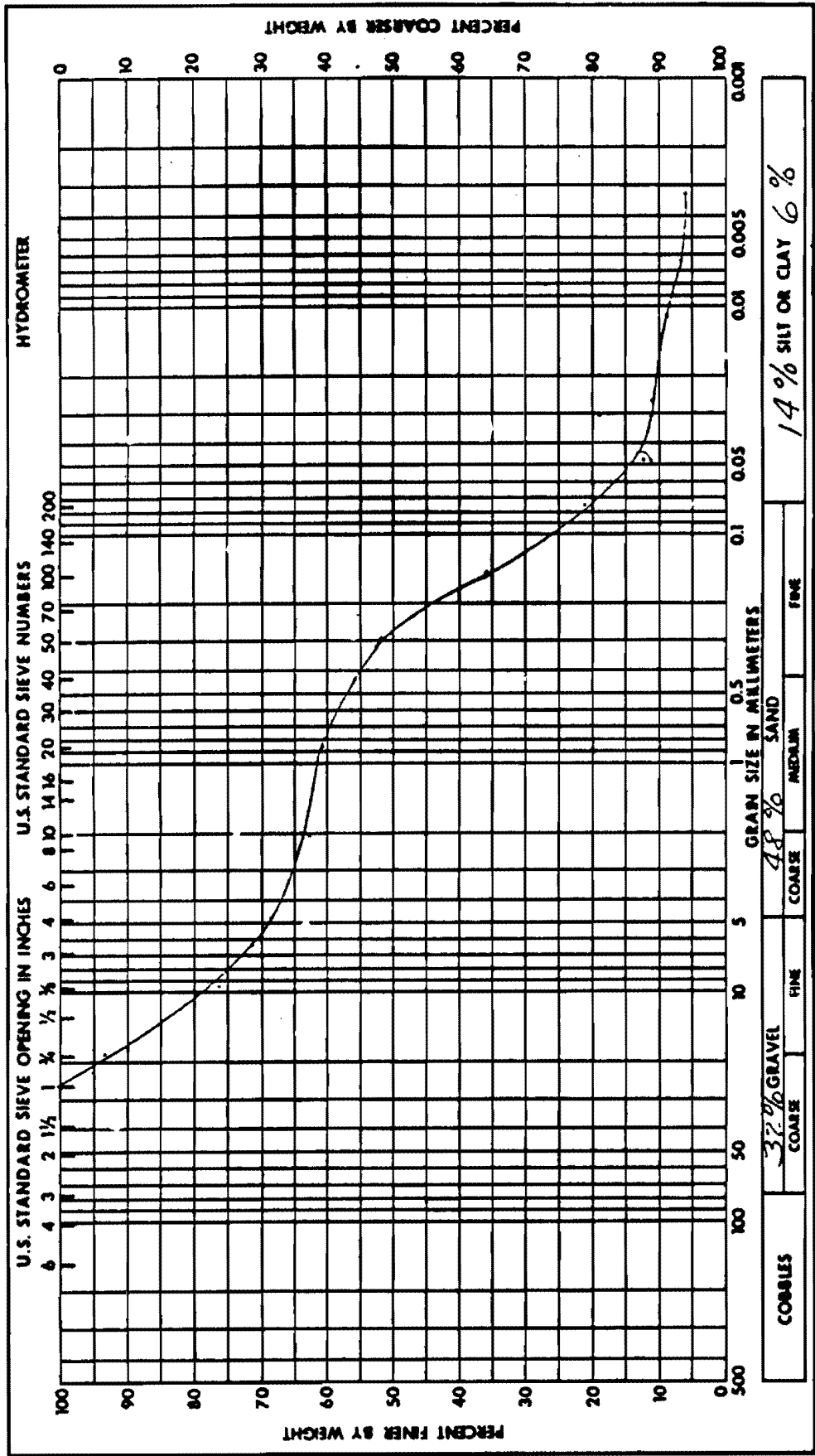

Added by Amendment 50

<b>Project</b> Watts Bar N.P.	
<b>Feature</b> Liquefaction	
<b>Boring No.</b> DS-65-1	<b>Sample No.</b> 6
<b>Station</b> 1367.0 S	<b>Range</b> 1005.7 E
<b>Date</b> 7-13-79	<b>Elevation</b> 703.0-701.8
<b>GRAIN SIZE ANALYSIS</b>	

<b>Remarks:</b>

<b>Soil Symbol</b>	G-SM	<b>Liquid Limit, %</b>	NP
<b>Moisture Content, %</b>	16.8	<b>Plastic Limit, %</b>	NP
<b>Specific Gravity</b>	2.70	<b>Plasticity Index, %</b>	NP
		<b>Shrinkage Limit, %</b>	

Figure 2.5-352 Liquefaction

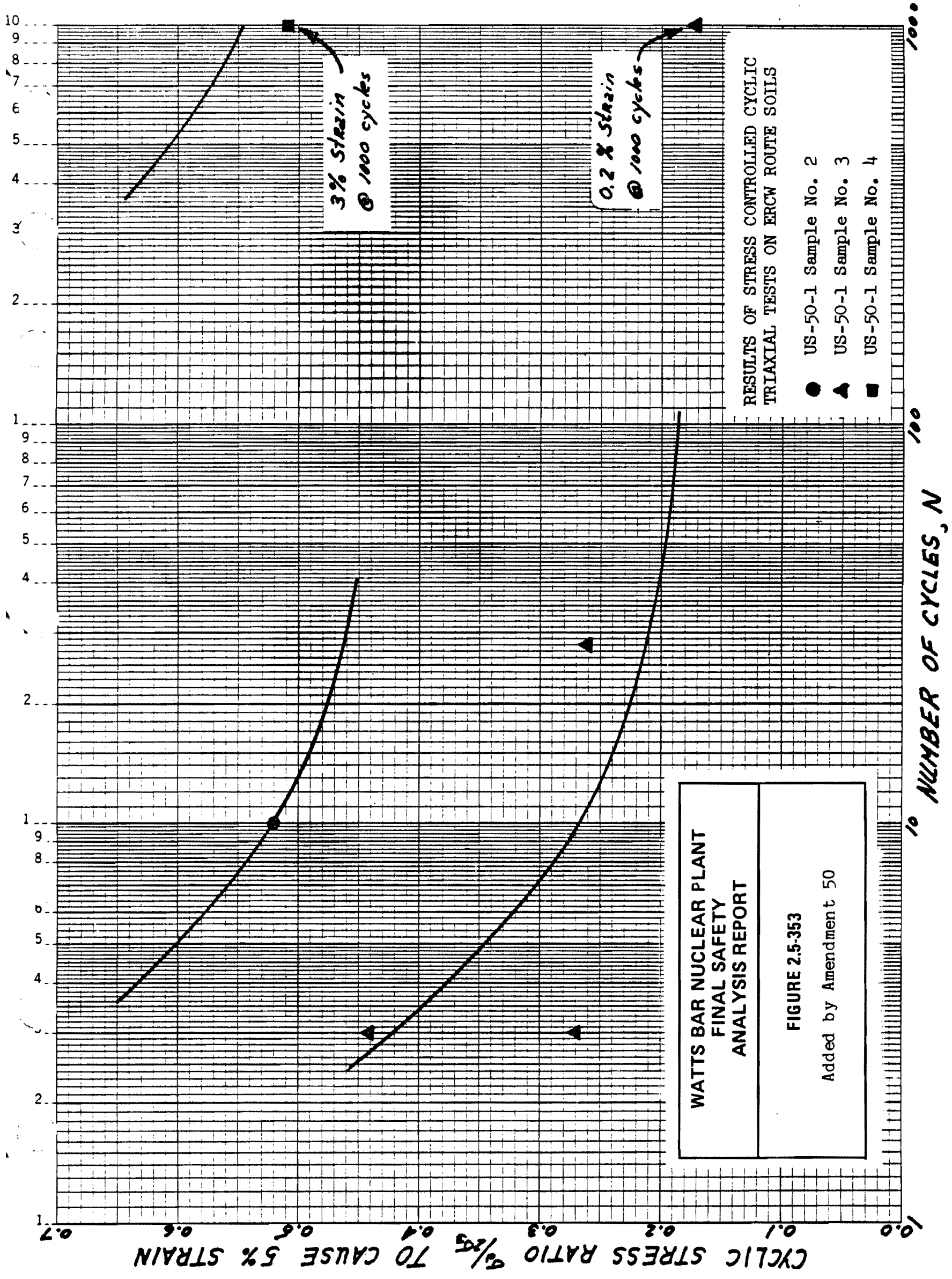
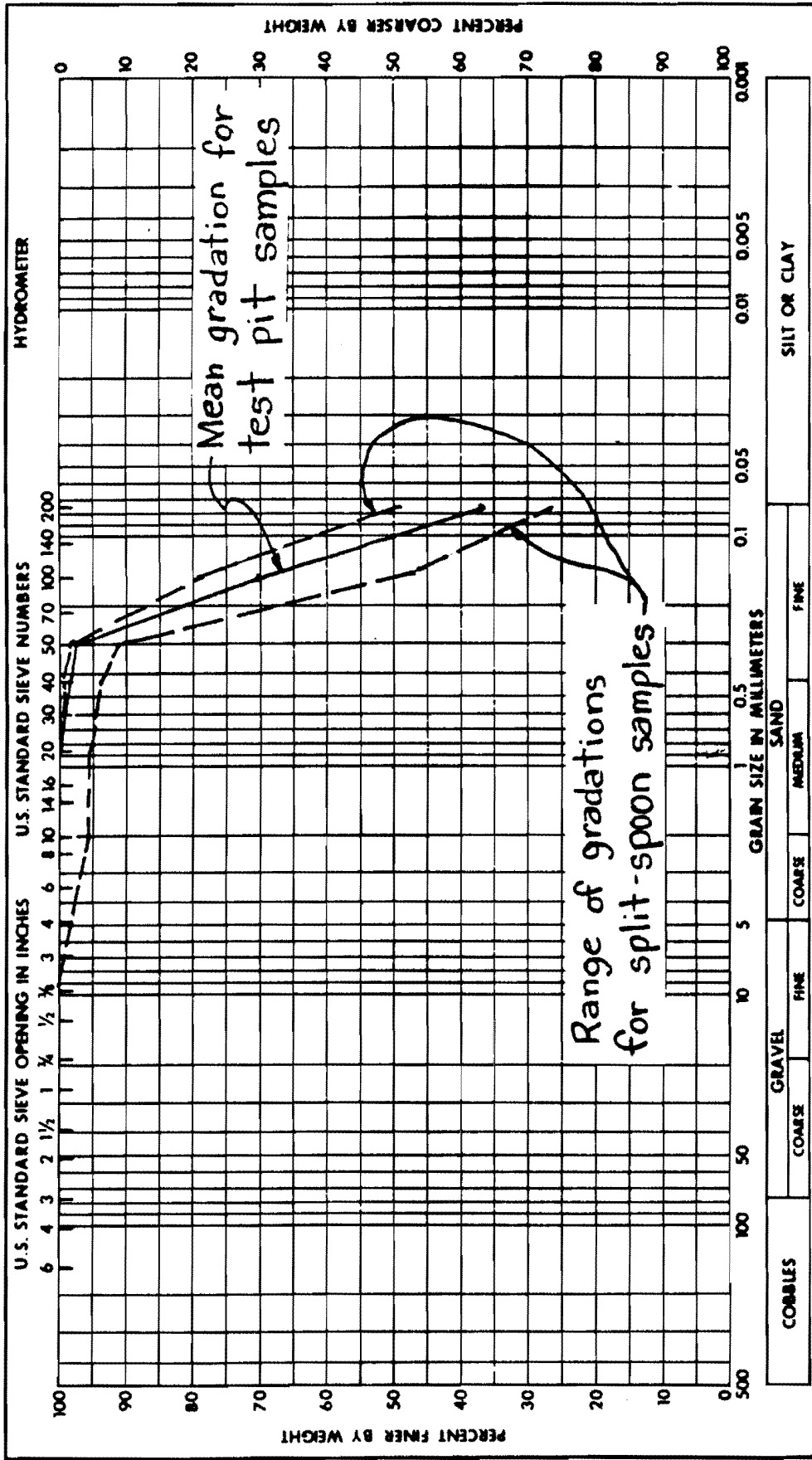

Figure 2.5-353 Results Of Stress Controlled Cyclic Triaxial Tests On ERCW Route Soils

**WATTS BAR NUCLEAR PLANT  
FINAL SAFETY  
ANALYSIS REPORT**

---

**LIQUEFACTION STUDY  
ERCW PIPELINE  
FIGURE 2.5-354**



Added by Amendment 50

Project Watts Bar Nuclear Plant
Liquefaction Study
Feature ERCW Pipeline
<i>Figure 1</i>
<b>GRAIN SIZE ANALYSIS</b>

*Remarks: Comparison of Test Pit #1 samples with SW samples from split-spoon borings 134, 134A, & 135A*

Soil Symbol	Liquid Limit, %
Moisture Content, %	Plastic Limit, %
Specific Gravity	Plasticity Index, %
	Shrinkage Limit, %

Figure 2.5-354 Liquefaction Study ERCW Pipeline

**WATTS BAR NUCLEAR PLANT  
FINAL SAFETY  
ANALYSIS REPORT**

**LIQUEFACTION STUDY  
ERCW PIPELINE  
FIGURE 2.5-355**

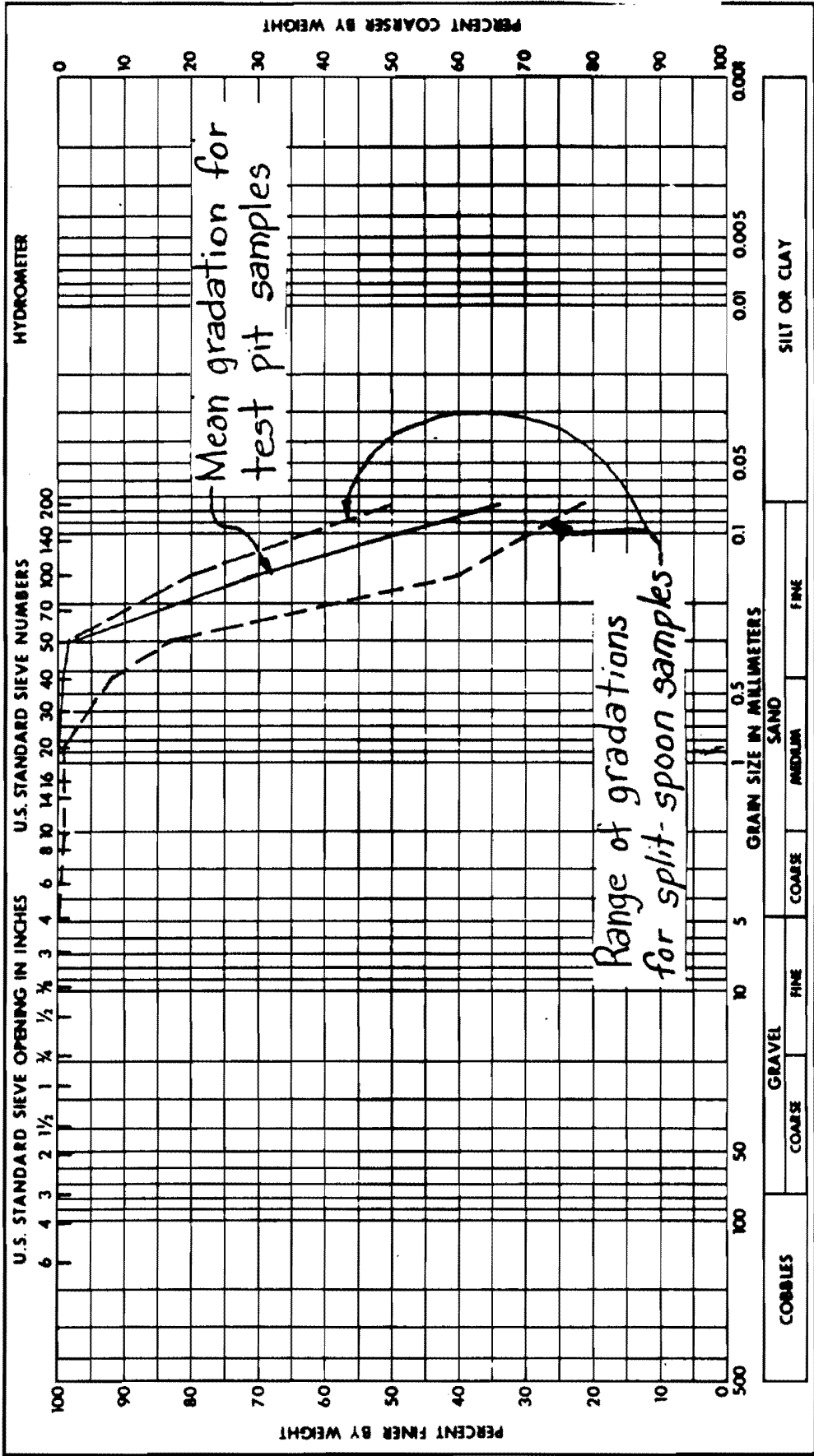

Added by Amendment 50

Remarks: Comparison of  
Test Pit #2 samples with  
SM (without gravel)  
samples from split-spoon  
borings 138, 138A, 138B,  
138C, & 139

Soil Symbol	
Moisture Content, %	Liquid Limit, %
Specific Gravity	Plastic Limit, %
	Plasticity Index, %
	Shrinkage Limit, %

Figure 2.5-355 Liquefaction Study ERCW Pipeline

**WATTS BAR NUCLEAR PLANT  
FINAL SAFETY  
ANALYSIS REPORT**

---

**LIQUEFACTION STUDY  
ERCW PIPELINE  
FIGURE 2.5-356**

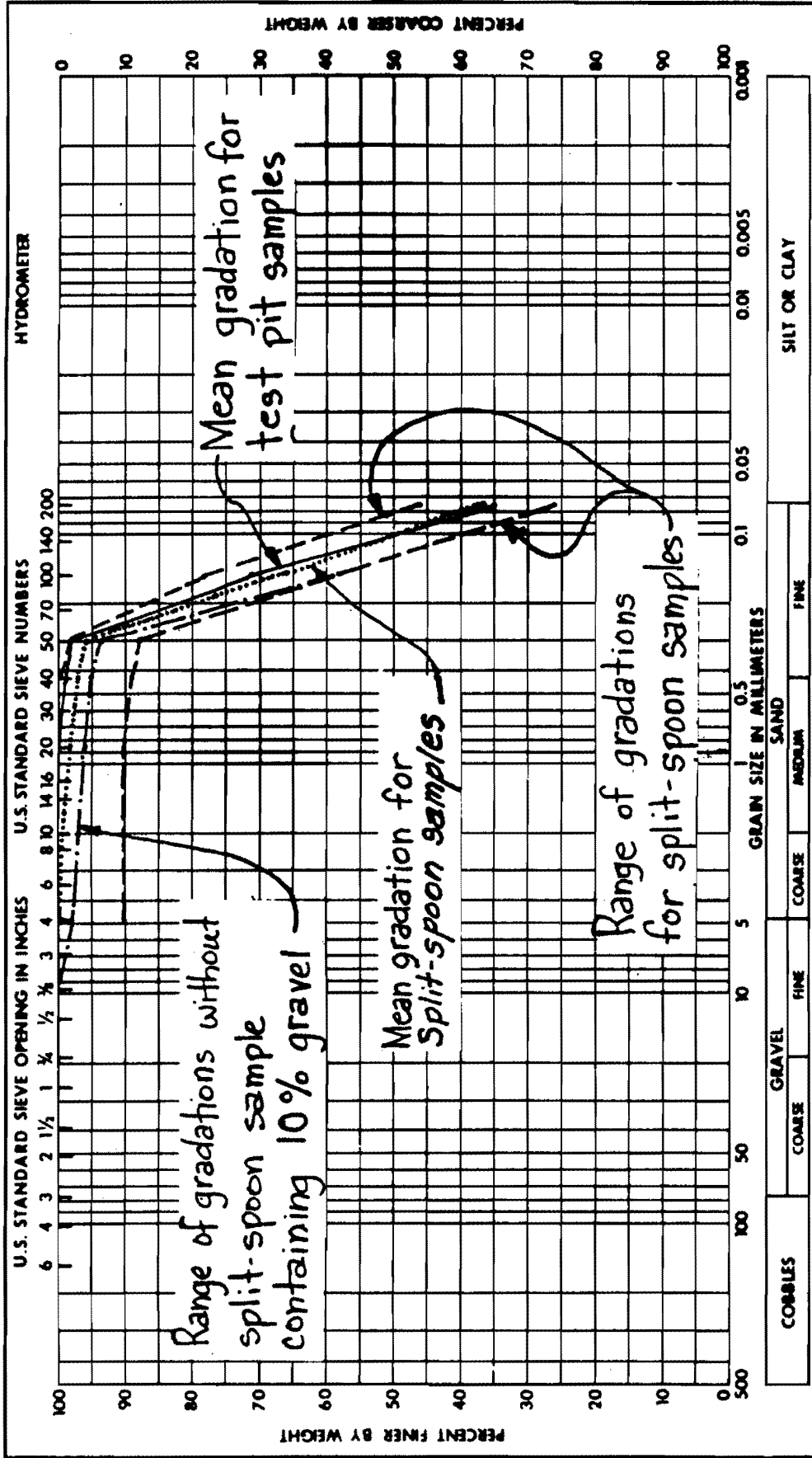

Added by Amendment 50

Project Watts Bar Nuclear Plant
Liquefaction Study
Feature ERCW Pipeline
Figure 3
<b>GRAIN SIZE ANALYSIS</b>

Remarks: Comparison of test pit samples with split-spoon samples from south of the cooling towers

Soil Symbol	
Moisture Content, %	
Liquid Limit, %	
Plastic Limit, %	
Specific Gravity	
Plasticity Index, %	
Shrinkage Limit, %	

Figure 2.5-356 Liquefaction Study ERCW Pipeline

**WATTS BAR NUCLEAR PLANT  
FINAL SAFETY  
ANALYSIS REPORT**

---

**LIQUEFACTION STUDY  
ERCW PIPELINE  
FIGURE 2.5-357**

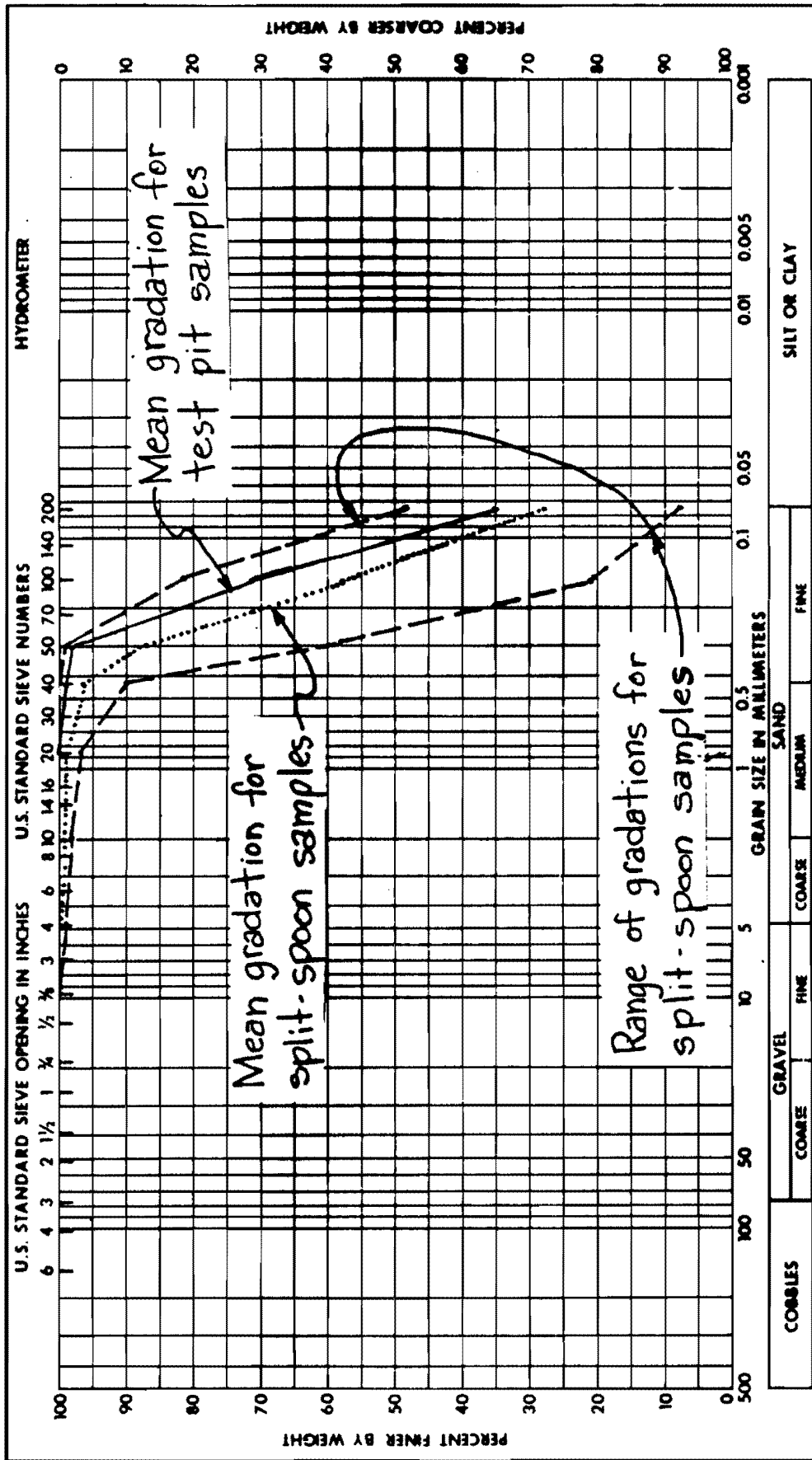

Added by Amendment 50

Remarks: Comparison of test pit samples with split-spoon samples from the main plant area

Soil Symbol	Liquid Limit, %
Moisture Content, %	Plastic Limit, %
Specific Gravity	Plasticity Index, %
	Shrinkage Limit, %

Figure 2.5-357 Liquefaction Study ERCW Pipeline

Figure 2.5-358 Additional Soil Investigations Category I Soil Supported Structures



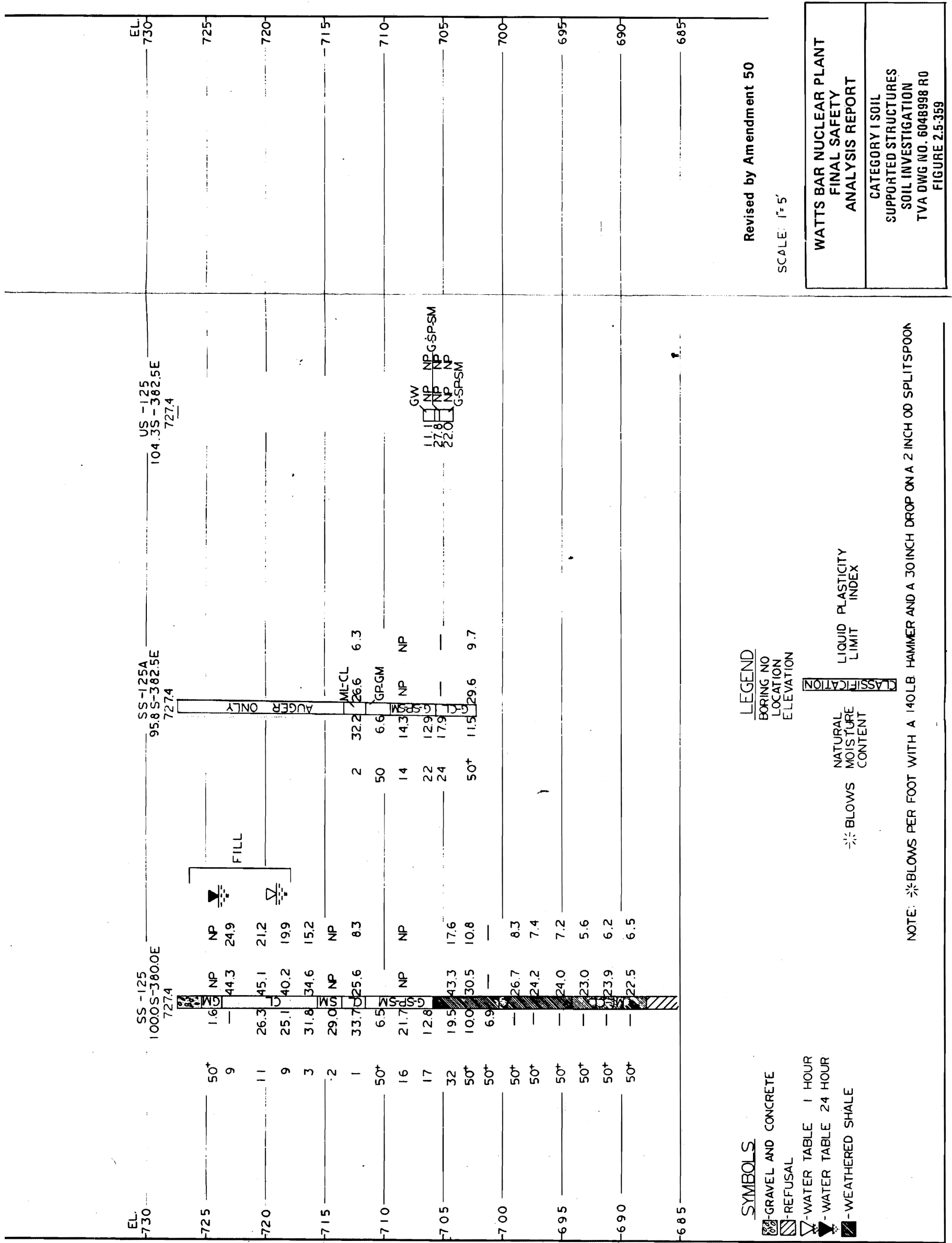

Revised by Amendment 50

SCALE: 1"=5'

WATTS BAR NUCLEAR PLANT  
FINAL SAFETY  
ANALYSIS REPORT

CATEGORY I SOIL  
SUPPORTED STRUCTURES  
SOIL INVESTIGATION  
TVA DWG NO. 6048998 R0  
FIGURE 2.5-359

LEGEND

- ☐ - GRAVEL AND CONCRETE
- ☐ - REFUSAL
- ▽ - WATER TABLE 1 HOUR
- ▽ - WATER TABLE 24 HOUR
- ☐ - WEATHERED SHALE
- ☐ - BLOWS PER FOOT WITH A 140LB HAMMER AND A 30 INCH DROP ON A 2 INCH OD SPLITSPOON
- ☐ - NATURAL MOISTURE CONTENT
- ☐ - LIQUID PLASTICITY INDEX

NOTE: \*BLOWS PER FOOT WITH A 140LB HAMMER AND A 30 INCH DROP ON A 2 INCH OD SPLITSPOON

Figure 2.5-359 Category I Soil Supported Structures Soil Investigation

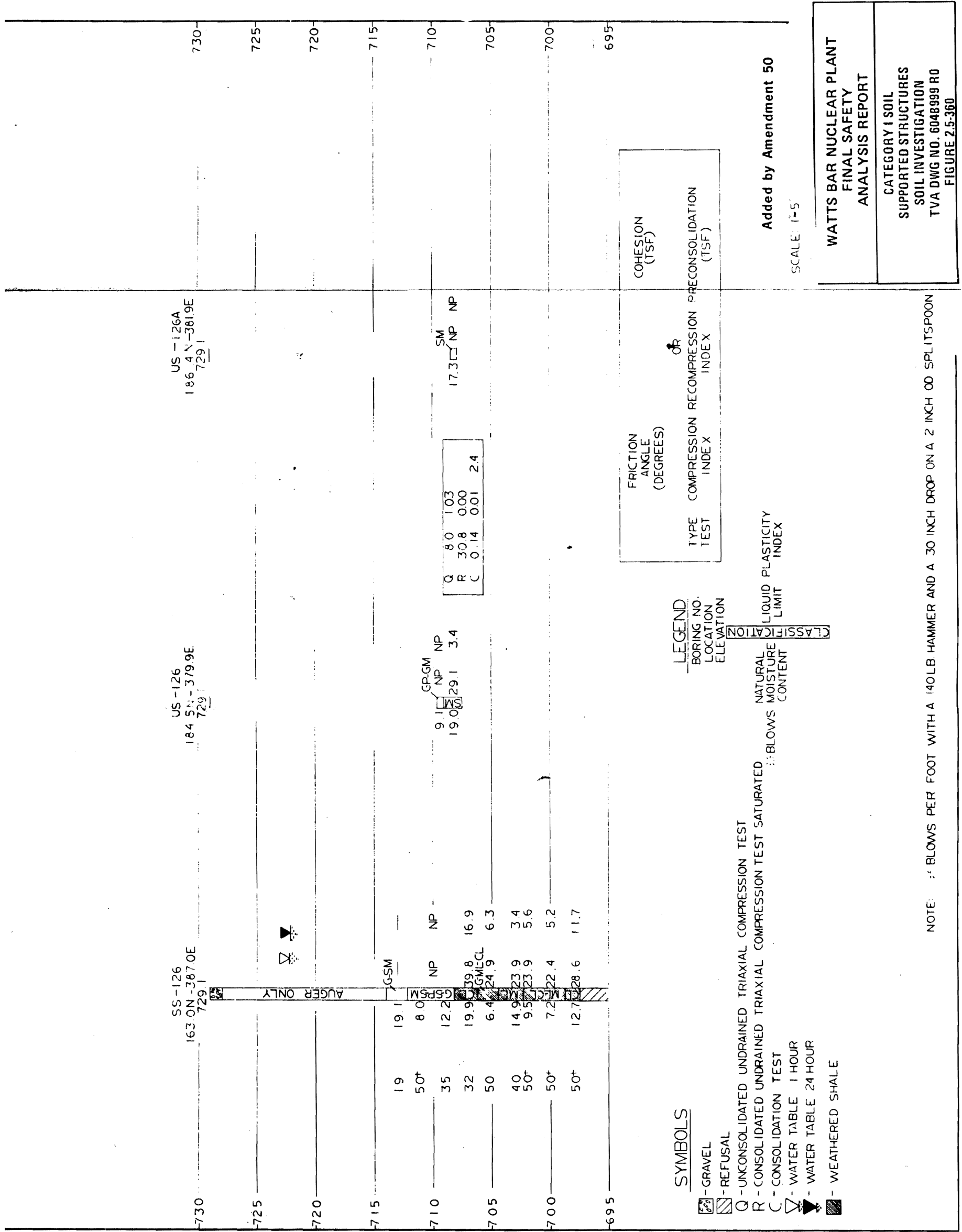

NOTE: # BLOWS PER FOOT WITH A 140LB HAMMER AND A 30 INCH DROP ON A 2 INCH OD SPLITSPOON

Figure 2.5-360 Category I Soil Supported Structures Soil Investigation

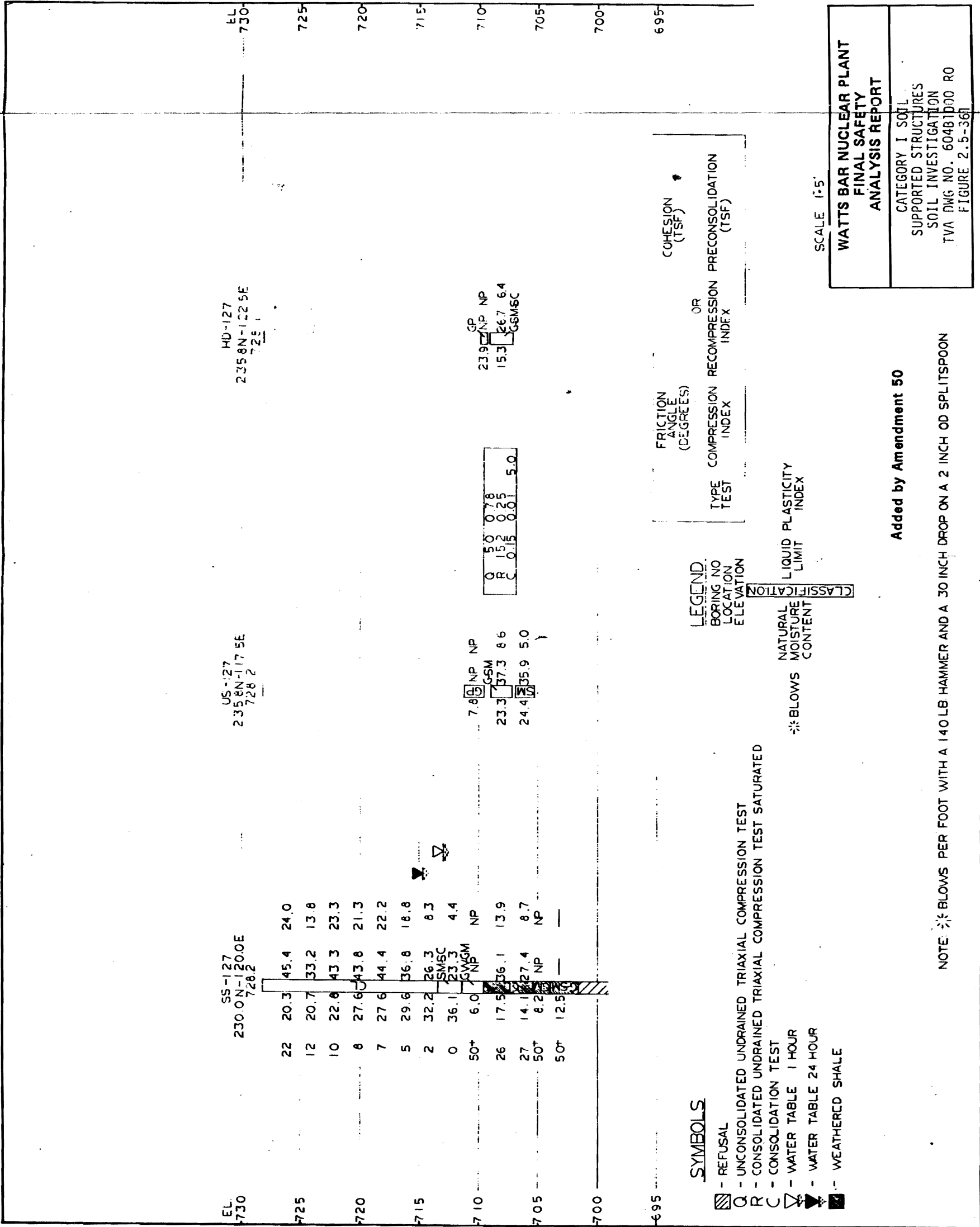

Figure 2.5-361 Category I Soil Supported Structures Soil Investigation

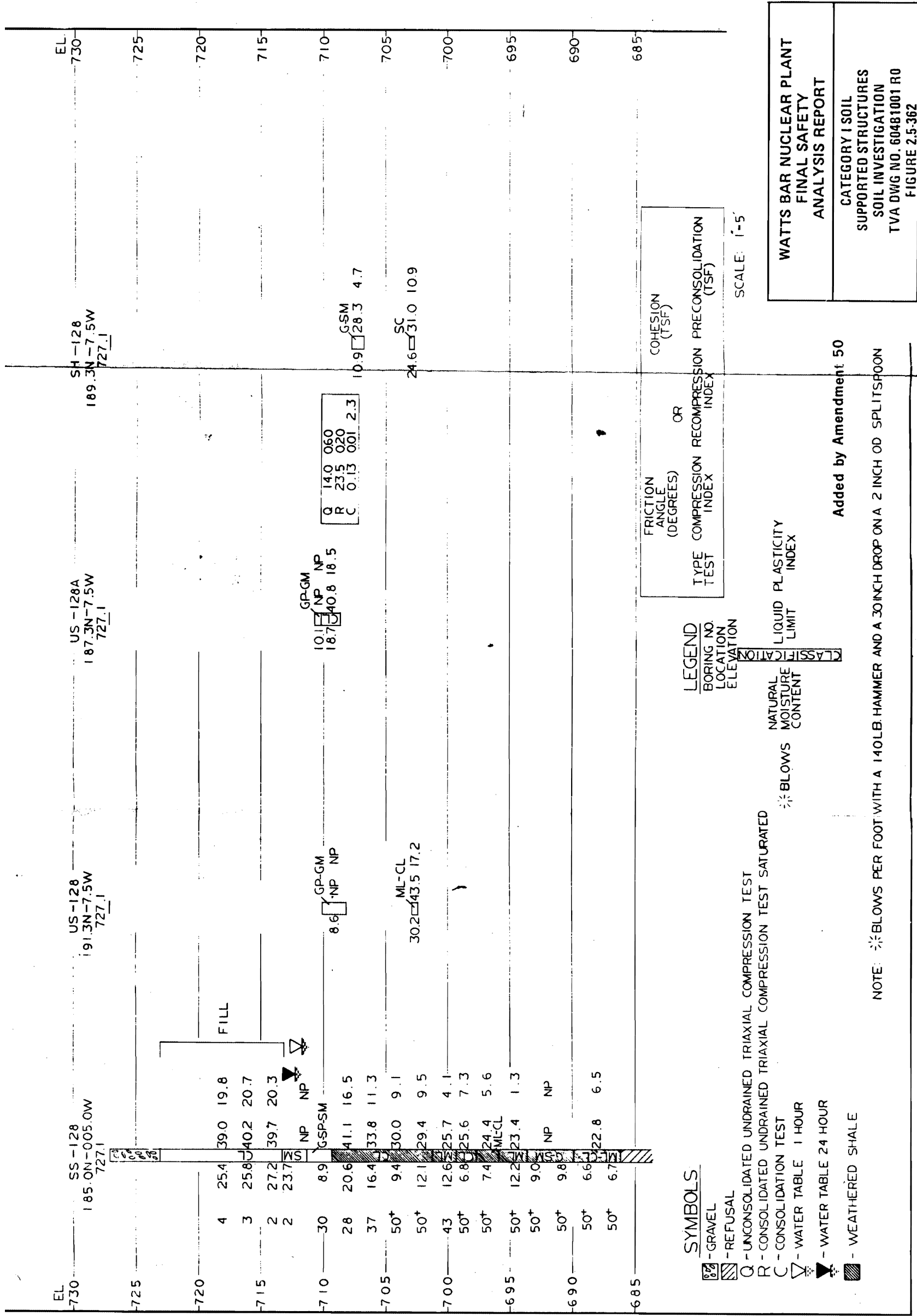

Figure 2.5-362 Category I Soil Supported Structures Soil Investigation

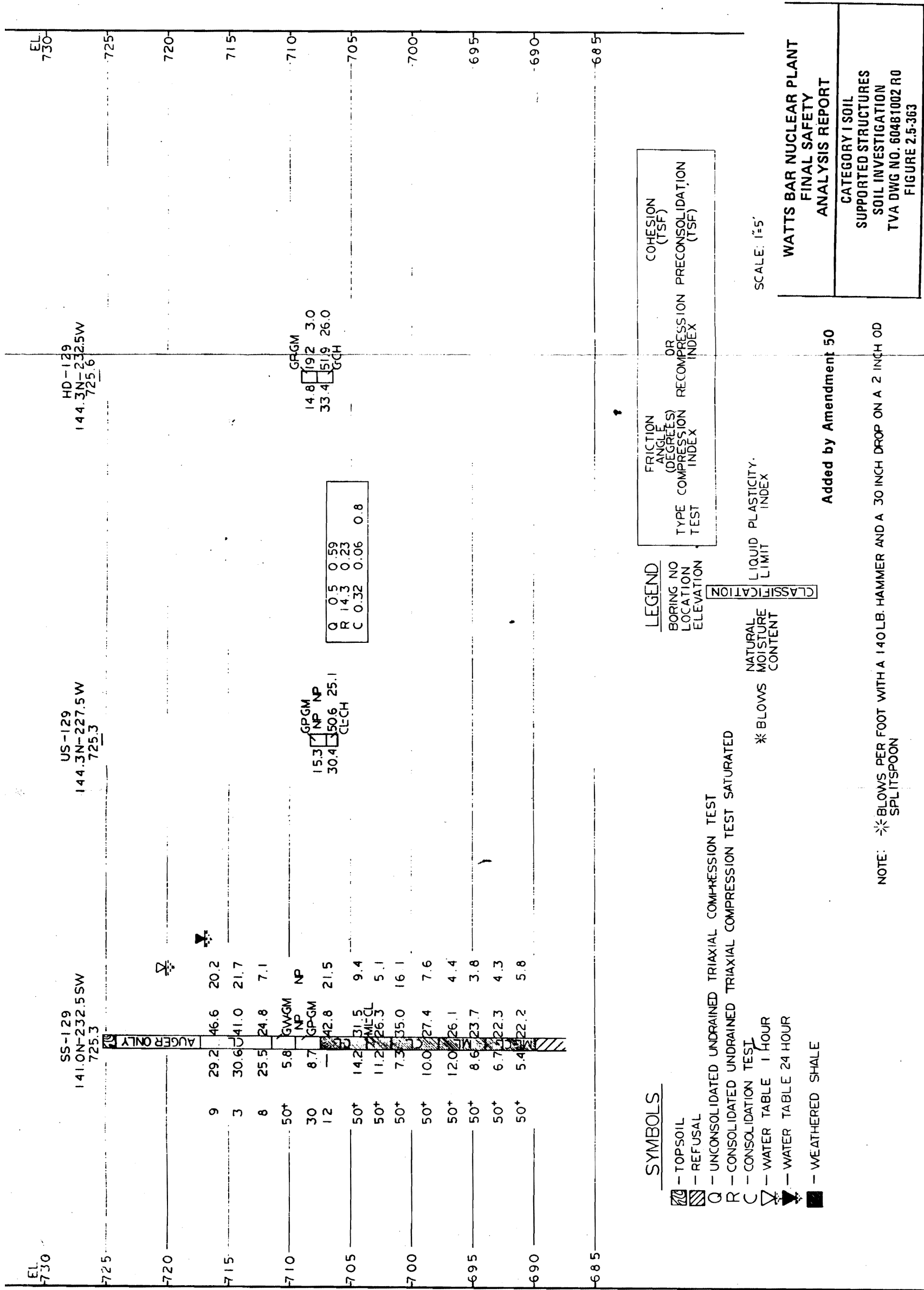

Figure 2.5-363 Category I Soil Supported Structures Soil Investigation

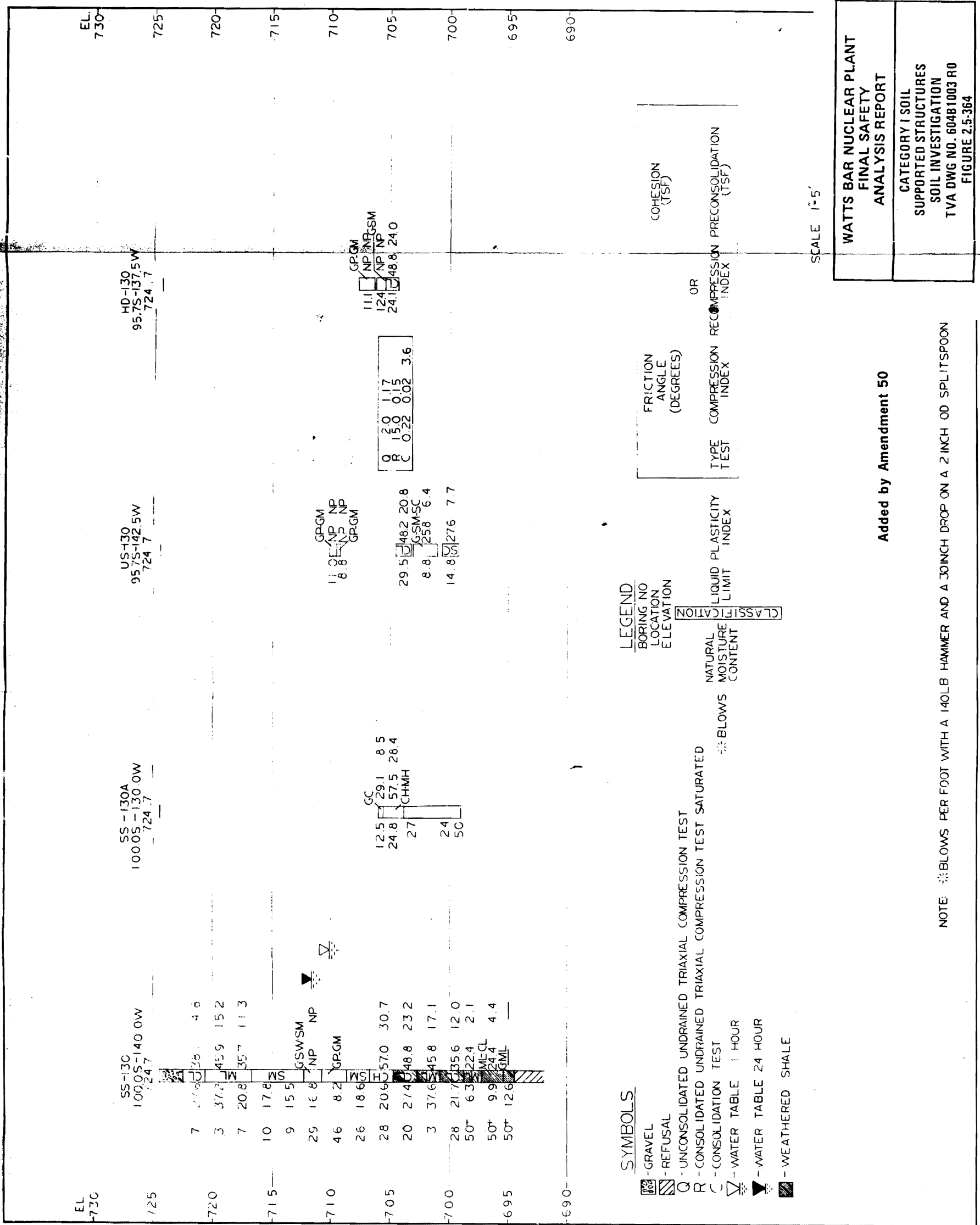

Figure 2.5-364 Category I Soil Supported Structures Soil Investigation

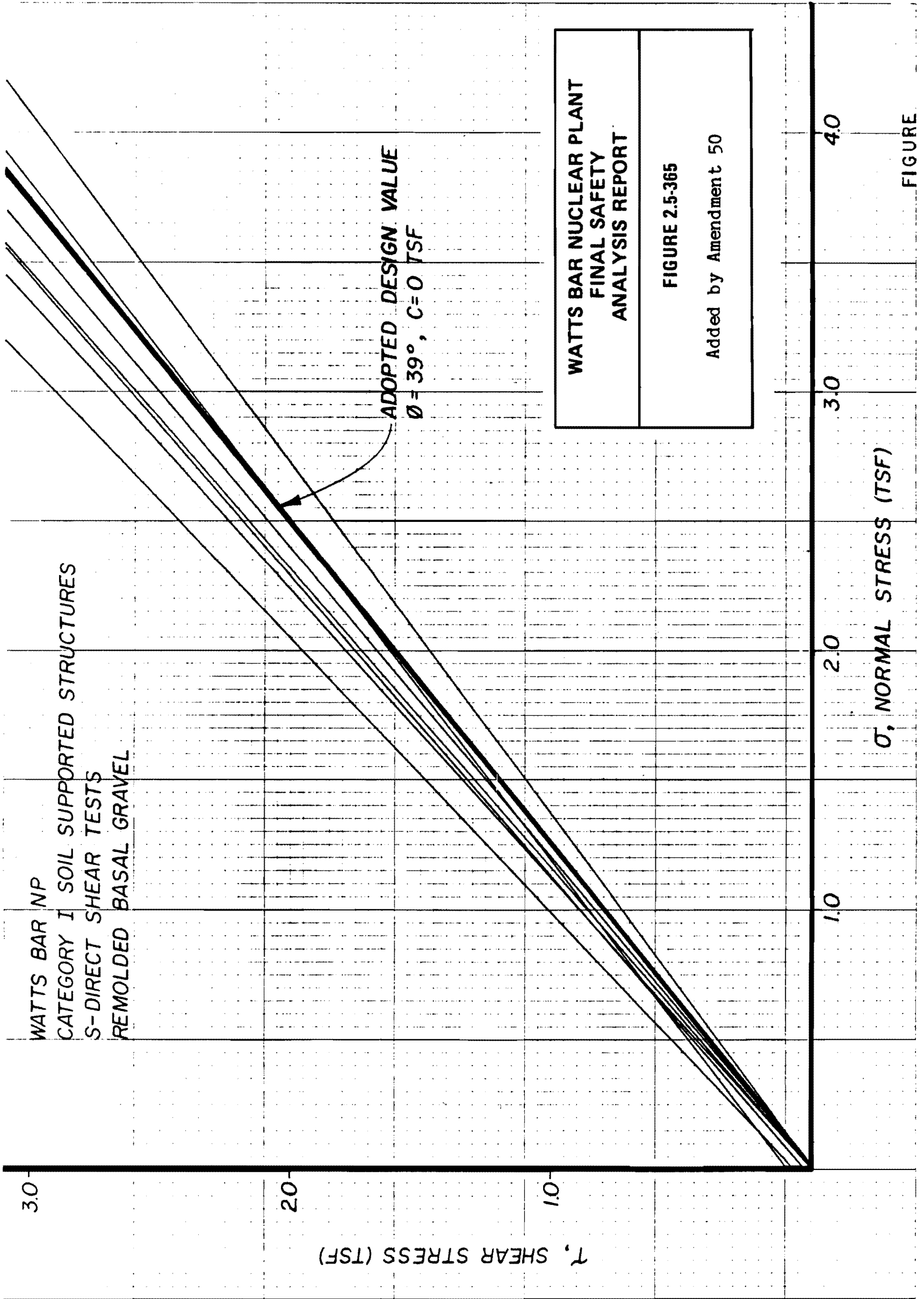
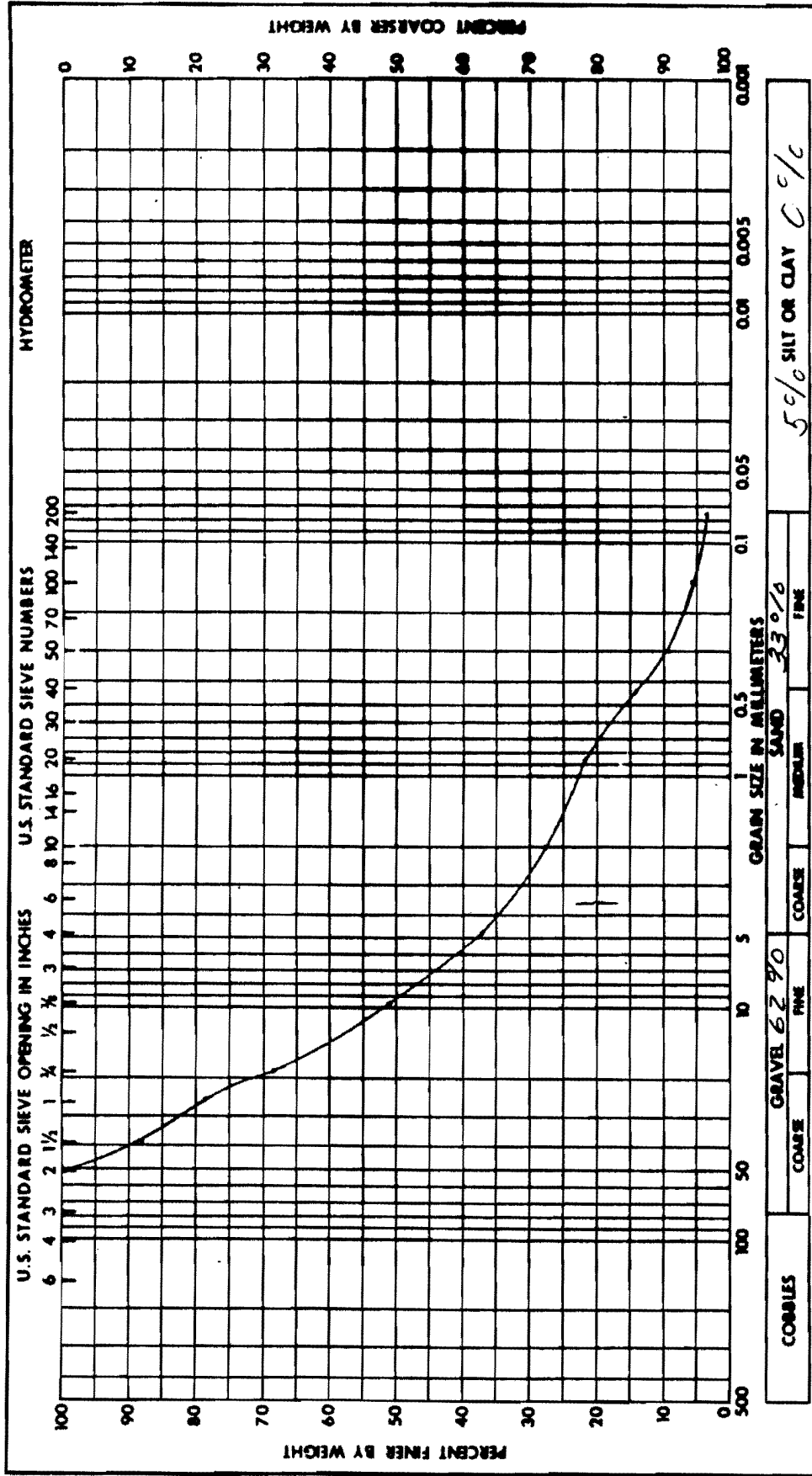

Figure 2.5-365 Category I Supported Structures S-Direct Shear Test Remolded Basal Gravel

**WATTS BAR NUCLEAR PLANT  
FINAL SAFETY  
ANALYSIS REPORT**

**SOIL SUPPORTED STRUCTURES  
FIGURE 2.5-366**



Added by Amendment 50

<b>Project</b>	WATTS BAR N.P.
<b>Feature</b>	Soil Supported Structures
<b>Boring No.</b>	U5-125
<b>Sample No.</b>	3 P. 2
<b>Station</b>	104.35
<b>Date</b>	8-3-73
<b>Range</b>	382.5 E
<b>Elevation</b>	706.8-705.8
<b>GRAIN SIZE ANALYSIS</b>	

**Remarks:**

<b>Soil Symbol</b>	GW	<b>Liquid Limit, %</b>	NP
<b>Moisture Content, %</b>	11.1	<b>Plastic Limit, %</b>	NP
<b>Specific Gravity</b>	2.58	<b>Plasticity Index, %</b>	NP
		<b>Shrinkage Limit, %</b>	

Figure 2.5-366 Soil Supported Structures



**WATTS BAR NUCLEAR PLANT  
FINAL SAFETY  
ANALYSIS REPORT**

---

**SOIL SUPPORTED STRUCTURES  
FIGURE 2.5-367**

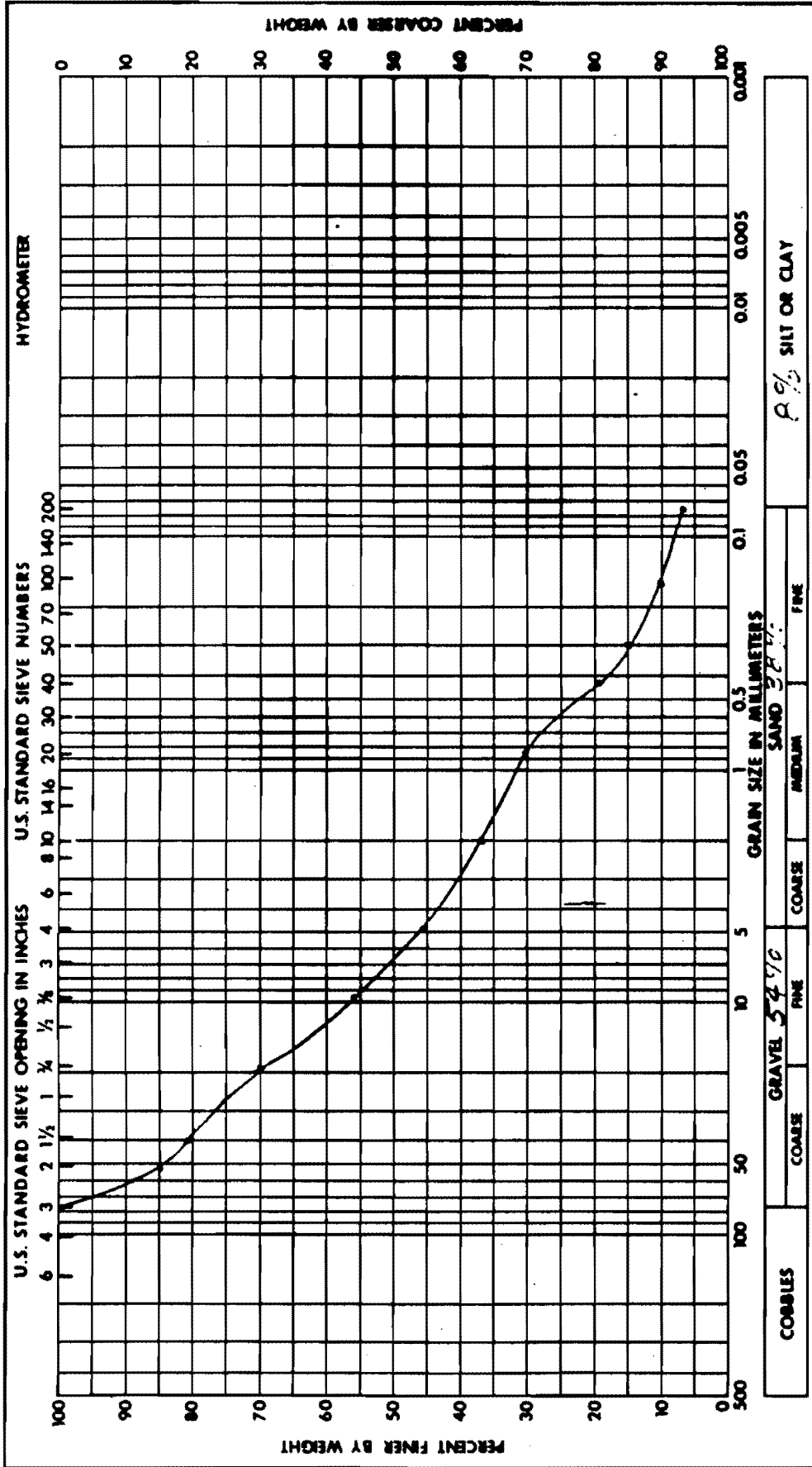

Added by Amendment 50

<b>Project</b>	WATTS BAR LP
<b>Feature</b>	Soils Supported Structure
<b>Boring No.</b>	US-126
<b>Sample No.</b>	4 RI
<b>Station</b>	184.5N
<b>Date</b>	8-31-79
	Range 379.9E
	Elevation 709.6-708.7
<b>GRAIN SIZE ANALYSIS</b>	

<b>Remarks:</b>	

<b>Soil Symbol</b>	GP-GM	<b>Liquid Limit, %</b>	NP
<b>Moisture Content, %</b>	9.1	<b>Plastic Limit, %</b>	NP
<b>Specific Gravity</b>	2.61	<b>Plasticity Index, %</b>	NP
		<b>Shrinkage Limit, %</b>	

Figure 2.5-367 Soil Supported Structures

**WATTS BAR NUCLEAR PLANT  
FINAL SAFETY  
ANALYSIS REPORT**

---

**SOIL SUPPORTED STRUCTURES  
FIGURE 2.5-368**

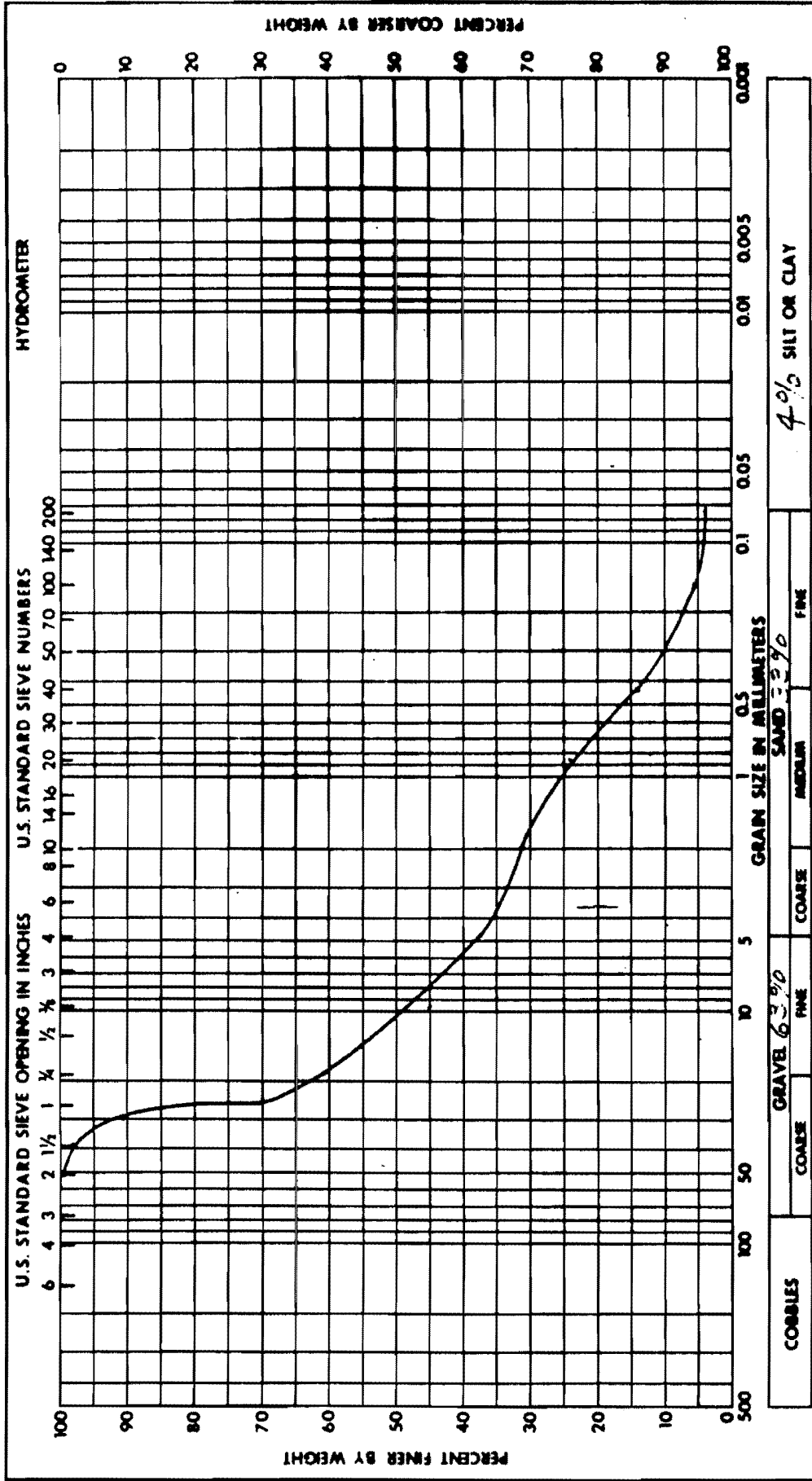

Added by Amendment 50

<b>Project</b> <i>WATTS BAR N.P.</i>	
<b>Feature</b> <i>SOIL SUPPORTED STRUCTURES</i>	
<b>Boring No.</b> <i>US-127</i>	<b>Sample No.</b> <i>1</i>
<b>Station</b> <i>225-BN</i>	<b>Range</b> <i>117.5E</i>
<b>Date</b> <i>8-6-79</i>	<b>Elevation</b> <i>742.709.6</i>

**Remarks:**

<b>Soil Symbol</b>	<i>GP</i>	<b>Liquid Limit, %</b>	<i>NP</i>
<b>Moisture Content, %</b>	<i>7.8</i>	<b>Plastic Limit, %</b>	<i>NP</i>
<b>Specific Gravity</b>	<i>2.58</i>	<b>Plasticity Index, %</b>	<i>NP</i>
		<b>Shrinkage Limit, %</b>	

Figure 2.5-368 Soil Supported Structures

**WATTS BAR NUCLEAR PLANT  
FINAL SAFETY  
ANALYSIS REPORT**

---

**SOIL SUPPORTED STRUCTURES  
FIGURE 2.5-369**

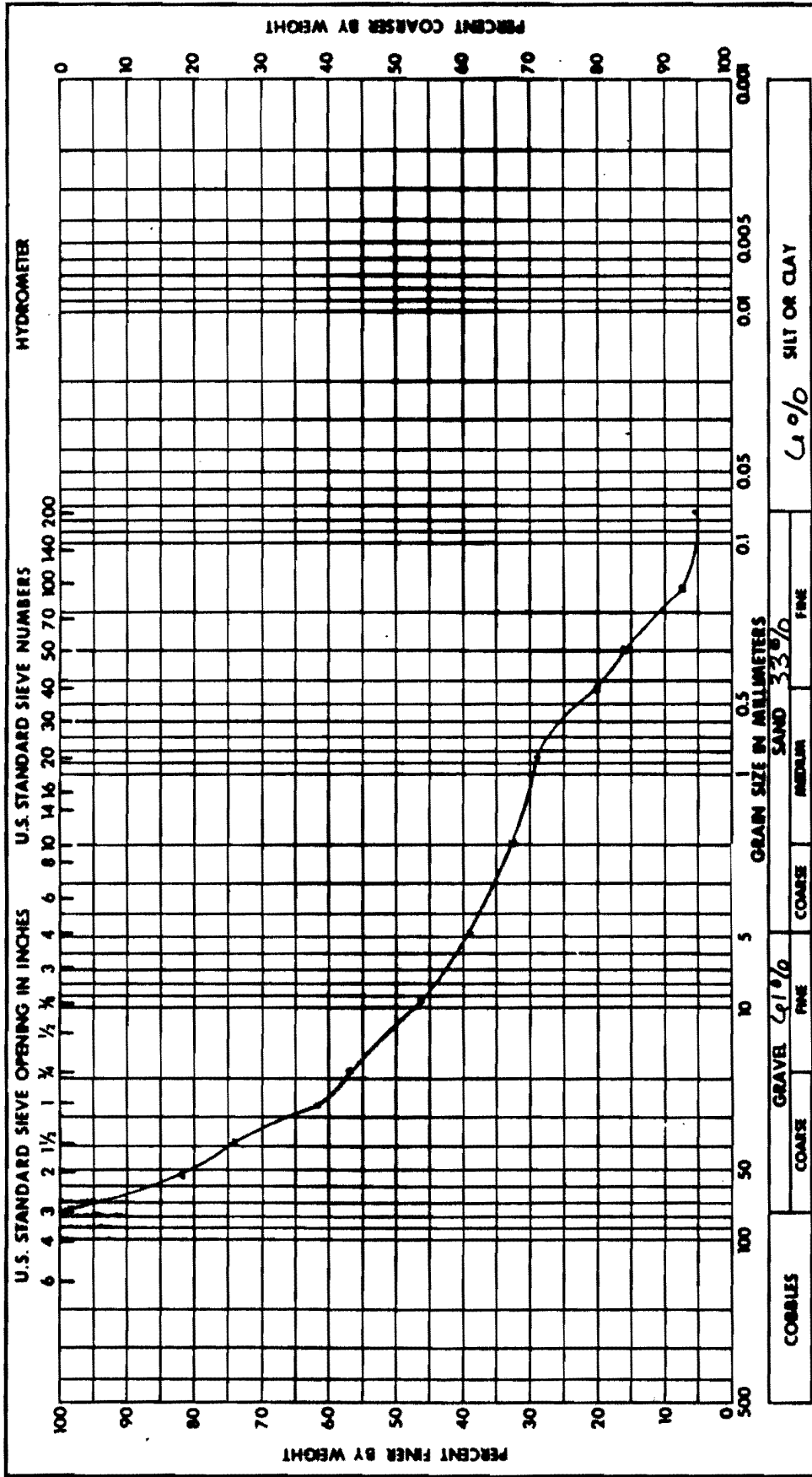

**WATTS BAR NUCLEAR PLANT  
FINAL SAFETY  
ANALYSIS REPORT**

**SOIL SUPPORTED STRUCTURES  
FIGURE 2.5-370**

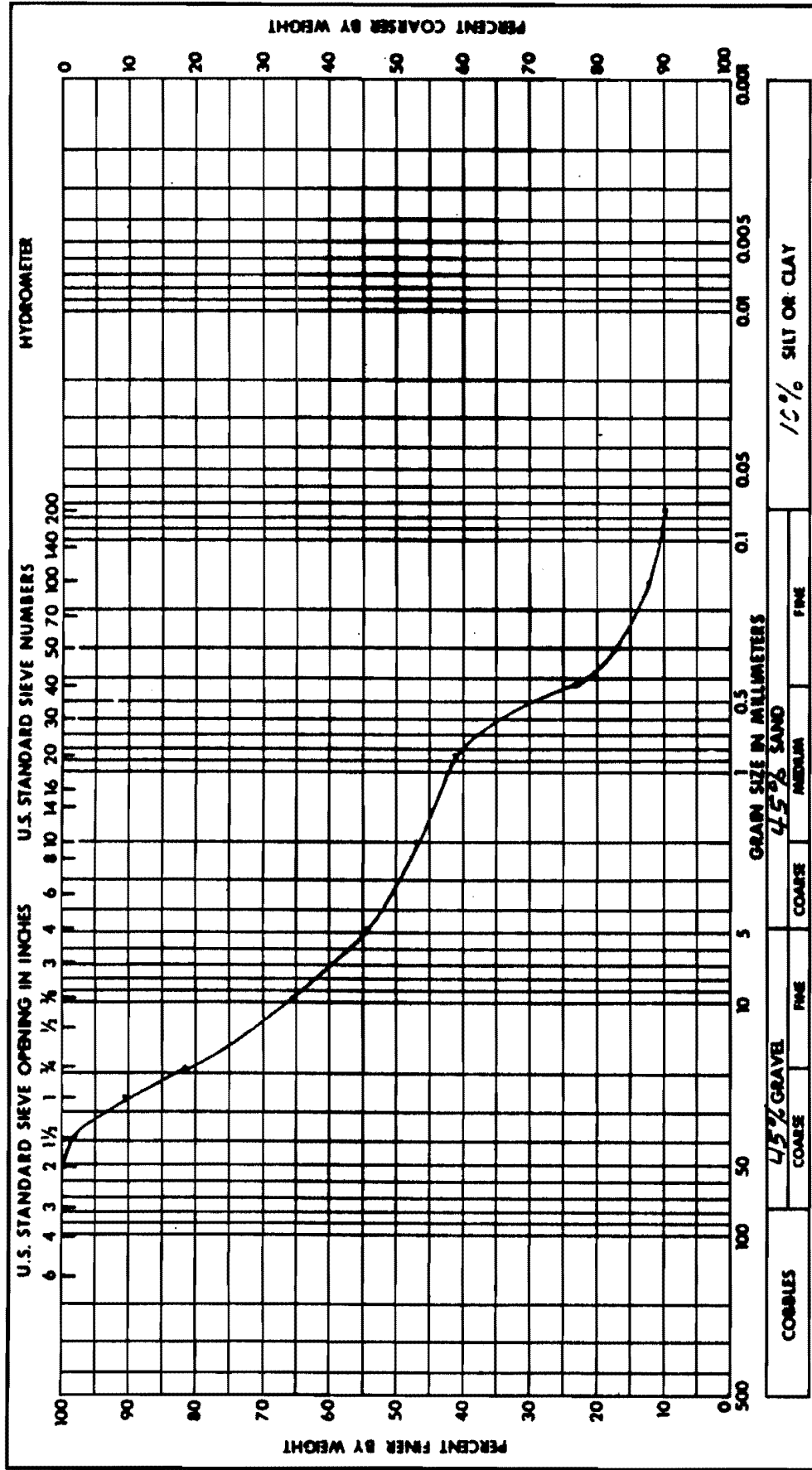

Added by Amendment 50

Project Watts Bar N.P.	
Feature Soil Support Structures	
Boring No. 45-129	Sample No. 3, P-2
Station H4-3N	Range 227.5 W
Date 9-4-79	Elevation 708.3-707.0
<b>GRAIN SIZE ANALYSIS</b>	

Remarks:

Soil Symbol	GP-611	Liquid Limit, %	NP
Moisture Content, %	15.3	Plastic Limit, %	NP
Specific Gravity	2.62	Plasticity Index, %	NP
		Shrinkage Limit, %	

Figure 2.5-370 Soil Supported Structures

**WATTS BAR NUCLEAR PLANT  
FINAL SAFETY  
ANALYSIS REPORT**

---

**SOIL SUPPORTED STRUCTURES  
FIGURE 2.5-371**

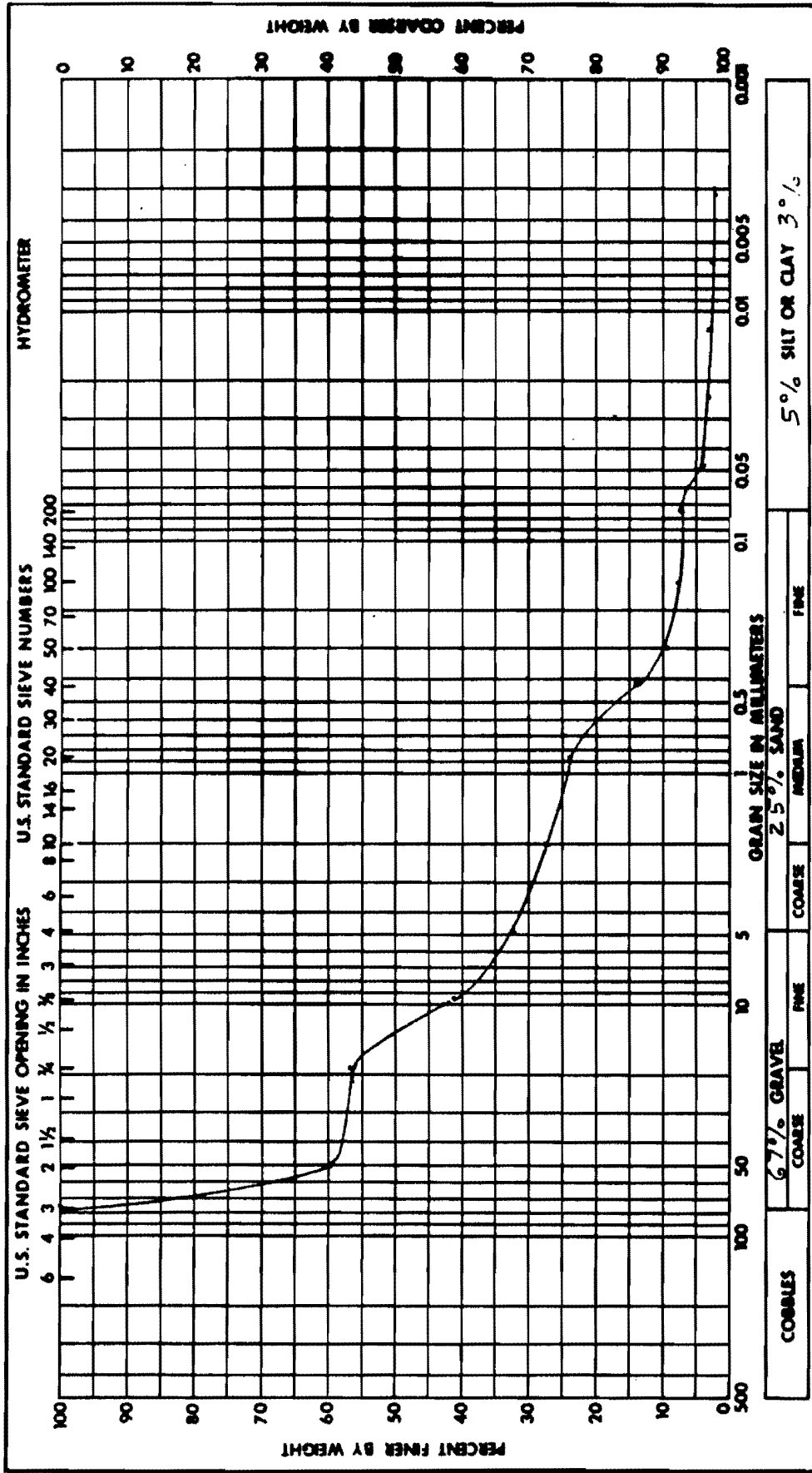

Added by Amendment 50

<b>Project</b> WATTS BLE VIF	
<b>Feature</b> Soil Supported Structure	
<b>Boring No.</b> US-130	<b>Sample No.</b> Z, P-2
<b>Station</b> 95.75	<b>Range</b> 142.5' W
<b>Date</b> 9-4-79	<b>Elevation</b> 709.7-709.4
<b>GRAIN SIZE ANALYSIS</b>	

**Remarks:**

<b>Soil Symbol</b>	GR.6M	<b>Liquid Limit, %</b>	NP
<b>Moisture Content, %</b>	8.8	<b>Plastic Limit, %</b>	NP
<b>Specific Gravity</b>	2.59	<b>Plasticity Index, %</b>	NP
		<b>Shrinkage Limit, %</b>	--

Figure 2.5-371 Soil Supported Structures



<p>WATTS BAR NUCLEAR PLANT FINAL SAFETY ANALYSIS REPORT</p>
<p>GRAVEL BORING NO. 125 FIGURE 2.5-372</p>

Added by Amendment 50

Figure 2.5-372 Gravel Boring No. 125



<p>WATTS BAR NUCLEAR PLANT FINAL SAFETY ANALYSIS REPORT</p>
<p>GRAVEL BORING NO. 129 FIGURE 2.5-373</p>

Added by Amendment 50

Figure 2.5-373 Gravel Boring No. 129

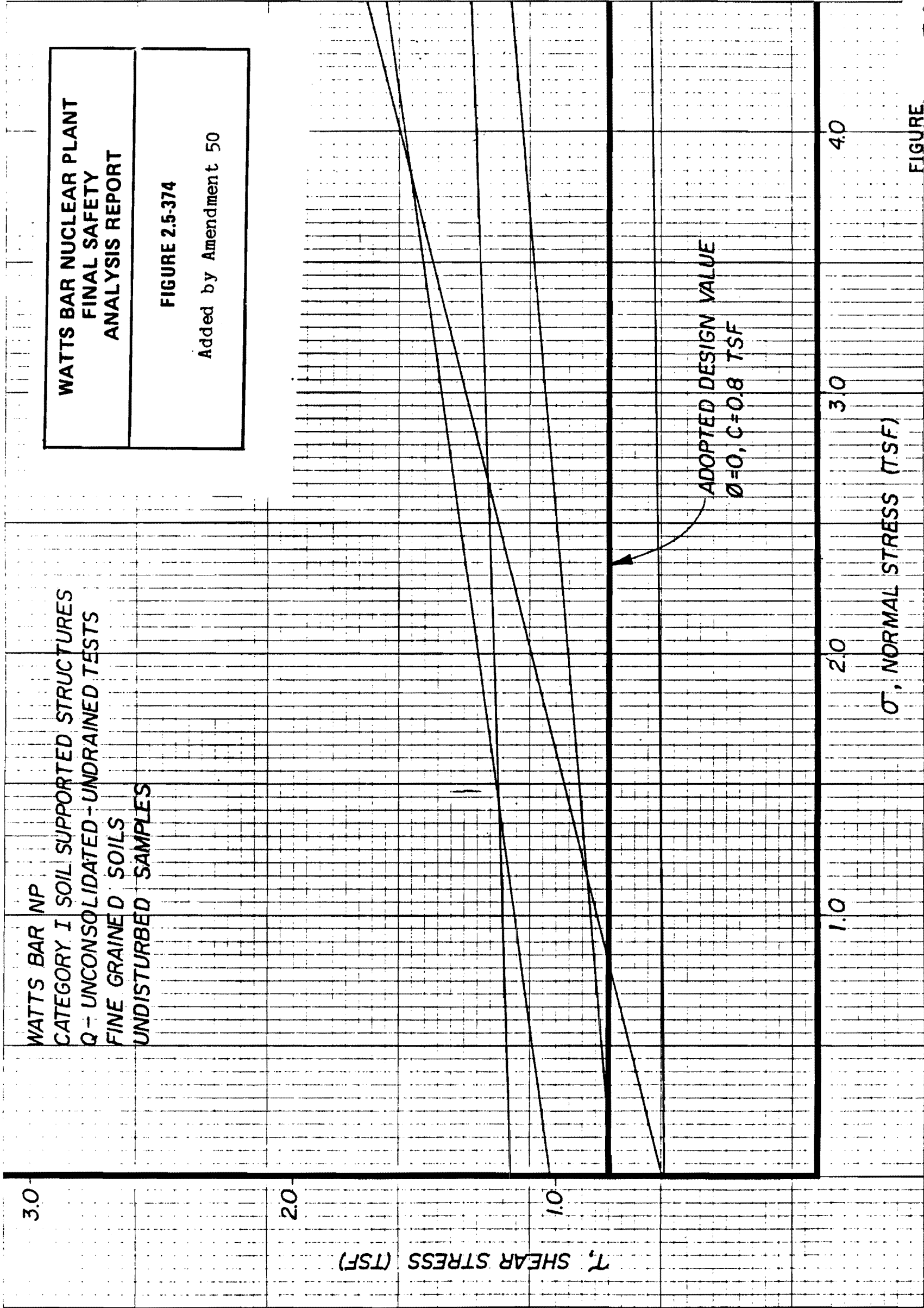

Figure 2.5-374 Watts Bar Nuclear Plant Category I Soil Supported Structures Q - (Unconsolidated - Undrained) Test Fine Grained Soils (Undisturbed Samples)



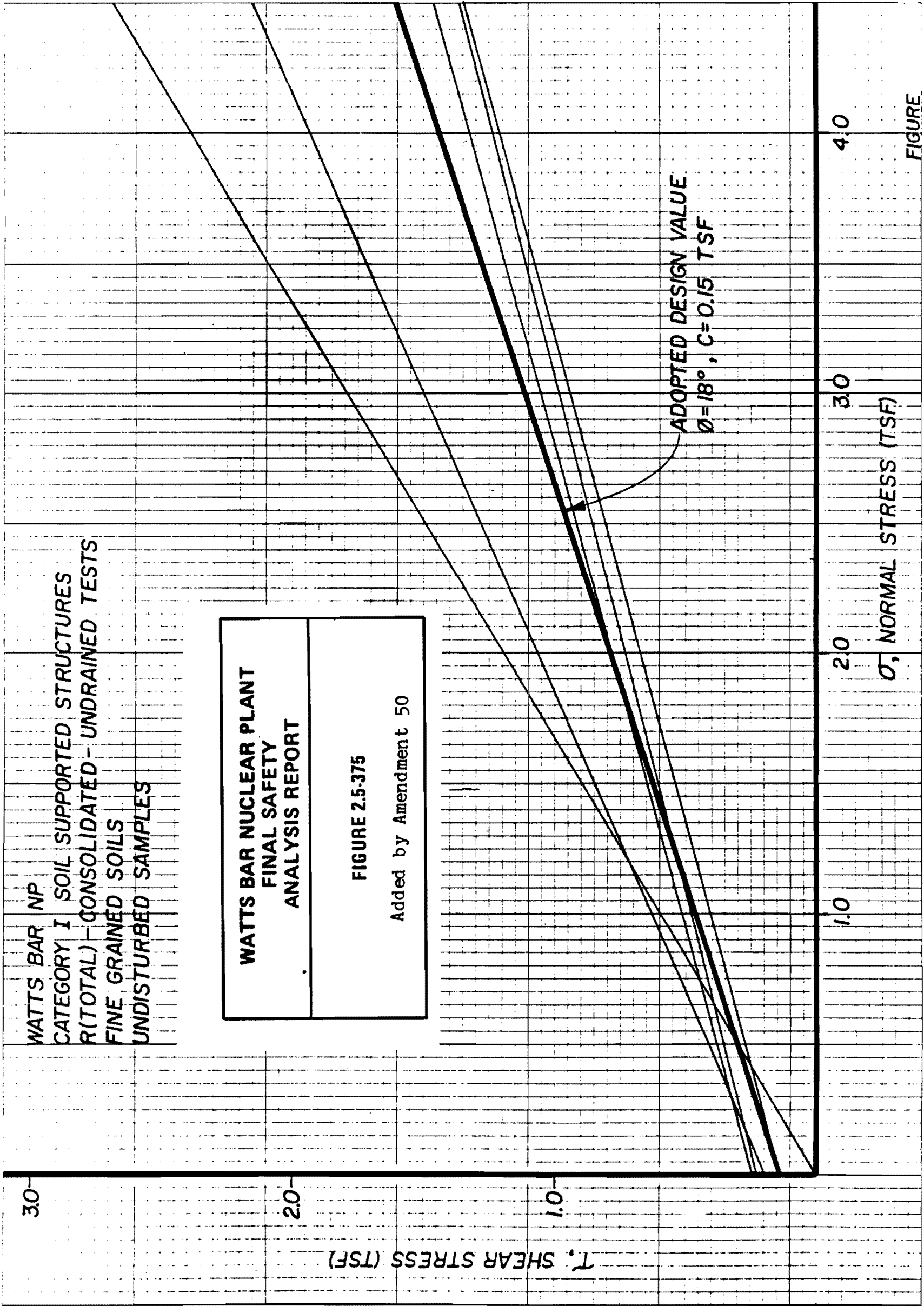

Figure 2.5-375 Watts Bar Nuclear Plant Category I Soil Supported Structures R (Total) - (Consolidated - Undrained) Test Fine Grained Soils (Undisturbed Samples)

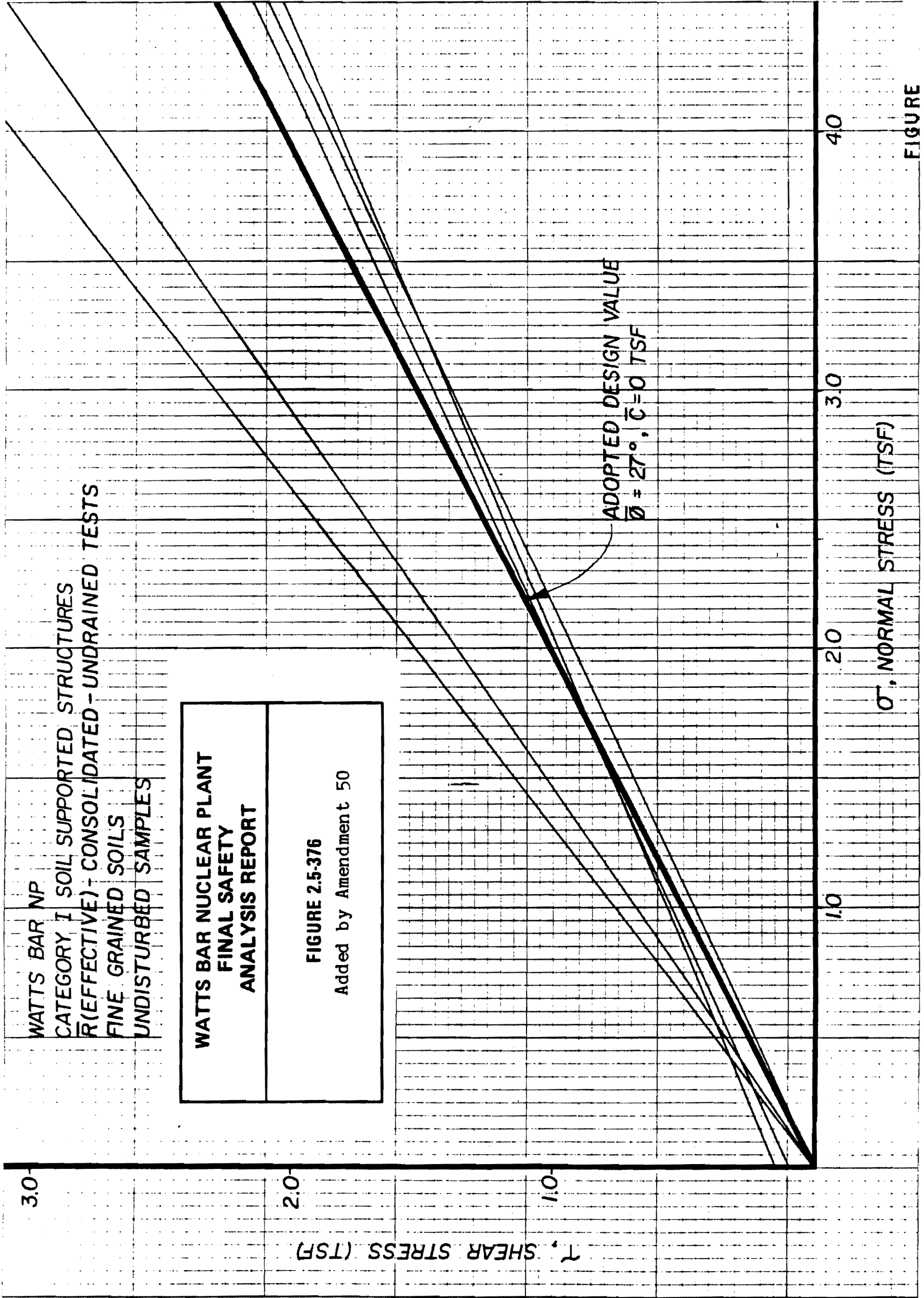

Figure 2.5-376 Watts Bar Nuclear Plant Category I Soil Supported Structure R (Effective) - (Consolidated -Undrained) Test Fine Grained Soils (Undisturbed Samples)

WATTS BAR NUCLEAR PLANT FINAL SAFETY ANALYSIS REPORT
SOIL PROFILE FIGURE 2.5-377 SHEET 1 OF 1

PROJECT: WATTS BAR N.P.                      FEATURE: ERCW TRENCH A  
 BORING: PAH-1                      STATION: 8+85.2                      RANGE:                      SURFACE EL: 730.2  
 DATE DRILLED: 5/30/83 TO                      PREPARED BY: MHD                      CHECKED BY: BA

DEPTH ft.	EL	SPT (N)	* LOG	W	LL	PI	FIELD DESCRIPTION
	730						TOPSOIL
5			US	12.2	29	12	GV CL, BRN, MST, SP FL
	725		US	13.0	29	12	GV CL, BRN, V MST, SP FL
10				8.8			(SHALE SHOTROCK) CL GV, GY, MST, SP FL
	720						
15				7.3			(SHALE SHOTROCK) CL GV, GY, MST, SP FL
	715						
20			US	25.8	29	7	SD SI, R-BRN, MST, MIC, ALL ORIG SOIL
	710						
25			US	16.5	NP	NP	SI SD, R-BRN, V MST, ALL
	705		US	10.6	33	14	SI SD, ±20% GV, R-BRN, W, ALL
							ROU AUGG - GV
30				26.3			WEATHERED SHALE
	700						DISCONTINUED. EL 700.7
35							
1''=5'			* Lab. Classif.				Added by Amendment 50

Figure 2.5-377 Soil Profile

**WATTS BAR NUCLEAR PLANT  
FINAL SAFETY  
ANALYSIS REPORT**

---

**SOIL PROFILE  
FIGURE 2.5-378  
SHEET 1 OF 1**

Added by Amendment 50

PROJECT: WATTS BAR N.P.  
BORING: PAH-2 STATION: 7+00  
DATE DRILLED: 5/27/83 TO

FEATURE: ERCW TRENCH A  
RANGE: SURFACE EL: 733.4  
PREPARED BY: MHD CHECKED BY: BA

DEPTH ft.	EL	SPT (N)	* LOG	W	LL	PI	FIELD DESCRIPTION
5	730		US	11.8	30	13	SD GV, BRN-GY, WOOD, MST, SP FL
10	725		US	10.3	30	13	SD GV, BRN; WOOD, WIRE & PLASTIC DBR, MST, SP FL
15	720		US	12.1	30	13	GV SI CL, BRN, MST, SP FL
20	715		US	20.3	30	13	SI CL, TR GV, BRN, V MST, SP FL
20			SC	16.2	30	13	GV CL, BRN, MST, SP FL
25	710		US	22.0	30	13	SI CL, BRN, MST, ALL, ORIG SOIL
30	705		Σ US	32.5	27	5	SD SI, R-BRN, V MST, ALL, MIC
35	700		Σ US	32.3	27	5	SD SI, R BRN, V MST, ALL, MIC
1''=5'				18'			WEATHERED SHALE
			* Lab. Classif.				DISCONTINUED FL 697.2

Figure 2.5-378 Soil Profile

<b>WATTS BAR NUCLEAR PLANT FINAL SAFETY ANALYSIS REPORT</b>
<b>SOIL PROFILE FIGURE 2.5-379 SHEET 1 OF 1</b>

Added by Amendment 50

PROJECT: WATTS BAR N.P.      FEATURE: ERCW TRENCH A  
 BORING: PAH-3      STATION: 5+50      RANGE:      SURFACE EL: 728.9  
 DATE DRILLED: 5/27/83 TO      PREPARED BY: MHD      CHECKED BY: BA

DEPTH ft.	EL	SPT (N)	* LOG	W	LL	PI	FIELD DESCRIPTION
5	725		SC	12.0	30	13	SPOIL FILL GV CL, BRN-GY, MST, WOOD, SP FL
			CL	15.5	33	14	SI CL, BRN, MST, SP FL
10	720		SC	22.6	30	13	SI CL - FT CL MIX, BRN-GY, V MST, SP FL
15	715		SC	18.9	30	13	SI CL, BRN, MST, ALL, ORIG SOIL
20	710		SC	20.0	30	13	SI CL, BRN, MST, ALL
25	705		SC	18.8	30	13	SI CL, BRN, V MST, ALL
30	700		Σ SC SC	24.5	29	7	CL SI SD, BRN, W, ALL
35	695		CH	34.9	54	35	FT CL, GY, V MST, MIC, ALL WEATHERED SHALE
				17.6			DISCONTINUED. EL 696.5
1''=5'			* Lab. Classif.				

Figure 2.5-379 Soil Profile

<b>WATTS BAR NUCLEAR PLANT FINAL SAFETY ANALYSIS REPORT</b>
<b>SOIL PROFILE FIGURE 2.5-380 SHEET 1 OF 1</b>

Added by Amendment 50

PROJECT: WATTS BAR N.P.                      FEATURE: ERCW TRENCH A  
 BORING: PAH-4      STATION: 4+00      RANGE:                      SURFACE EL: 720.5  
 DATE DRILLED: 5/27/83 TO                      PREPARED BY: MHD CHECKED BY: BA

DEPTH ft.	EL	SPT (N)	* LOG	W	LL	PI	FIELD DESCRIPTION
	720						SOD - TOPSOIL
5			US	10.4	25	8	GV CL SD, GY-R, MST, SP FL
	715		US	11.2	25	8	GV CL SD, GY-R, MST, SP FL
10			UL	17.7	27	11	SI SD, GY, V MST, ALL
	710		UL	20.1	27	11	SI SD CL, BRN, W, ALL
15			UL	20.5	27	11	SD CL, TR GY, BRN, V MST, ALL
	705		UL	20.5	27	11	SD CL, TR GY, BRN, V MST, ALL
20			UL	20.5	27	11	SD CL, TR GY, BRN, V MST, ALL
	700		SP-SM	28.3	NP	NP	SI SD, BRN, W, ALL
25							REFUSAL - SHALE. EL 698.5
	695						
30							
	690						
35							
1''=5'			* Lab. Classif.				

Figure 2.5-380 Soil Profile

<b>WATTS BAR NUCLEAR PLANT FINAL SAFETY ANALYSIS REPORT</b>
<b>SOIL PROFILE FIGURE 2.5-381 SHEET 1 OF 1</b>

Added by Amendment 50

PROJECT: WATTS BAR N.P.      FEATURE: ERCW TRENCH A  
 BORING: PAH-5      STATION: 2+50      RANGE:      SURFACE EL: 712.3  
 DATE DRILLED: 5/31/83 TO      PREPARED BY: MHD      CHECKED BY: BA

DEPTH ft.	EL	SPT (N)	* LOG	W	LL	PI	FIELD DESCRIPTION
							TOPSOIL
5	710		U	21.1	36	16	SI CL, BRN, MST, ALL
	705		U	23.0	36	16	SI CL, BRN, MST, ALL
10			U	22.7	36	16	SI CL, BRN, MST, ALL
	700		U	22.9	36	16	SI CL, TR RD GV, BRN, MST, ALL
15			U	20.0	36	16	SI CL, TR RD GV, BRN, V MST, ALL
	695		U	20.8	27	11	SI CL, DK BRN, V MST, ALL
20			U	26.2	27	11	CL SI, DK BRN, W, ALL
	690		U	17.9			WEATHERED SHALE
25							DISCONTINUED. EL 685.8
	685						
30							
	680						
35							
1"=5'							*Lab. Classif.

Figure 2.5-381 Soil Profile

<b>WATTS BAR NUCLEAR PLANT FINAL SAFETY ANALYSIS REPORT</b>
<b>SOIL PROFILE FIGURE 2.5-382 SHEET 1 OF 1</b>

PROJECT: WATTS BAR N.P.  
BORING: PAH-6 STATION: 1+00  
DATE DRILLED: 5/31/83 TO

FEATURE: ERCW TRENCH A  
RANGE: SURFACE EL: 707.1  
PREPARED BY: MHD CHECKED BY: BA

DEPTH ft.	EL	SPT (N)	* LOG	W	LL	PI	FIELD DESCRIPTION
5	705		CL	17.7	33	14	GV CL, BRN, MST, SP FL
10	700		Σ S I S	22.4	29	7	SD CL, TN, MST, ALL (ORIG SOIL)
15	695		Σ S I S	23.7	29	7	SD CL, TN V MST, ALL
20	690		Σ S I S	35.8	27	5	CL SD, TR RD FN GV, TN, W, ALL
25	685			17.8			WEATHERED SHALE
30	680						DISCONTINUED. EL 688.1
35	675						
1''=5'			* Lab. Classif.				Added by Amendment 50

Figure 2.5-382 Soil Profile



<b>WATTS BAR NUCLEAR PLANT FINAL SAFETY ANALYSIS REPORT</b>
<b>SOIL PROFILE FIGURE 2.5-383 SHEET 1 OF 2</b>

PROJECT: WATTS BAR N.P.                      FEATURE: ERCW TRENCH B  
 BORING: PAH-1      STATION: 1+00 ±      RANGE:                      SURFACE EL: 712.0  
 DATE DRILLED: 5/31/83 TO                      PREPARED BY: MHD      CHECKED BY: BA

DEPTH ft.	EL	SPT (N)	* LOG	W	LL	PI	FIELD DESCRIPTION
5	710		CL	18.4	26	8	SD SI CL, BRN, MST, FL
			CL	14.7	35	13	SI CL, BRN, MST, TR GV, FL
10	705		CL	17.2	35	13	SD CL, BRN, MST, ALL (ORIG SOIL)
			CL	20.6	26	8	SD CL, BRN, MST, ALL
15	700		CL	25.0	26	8	SI CL, BRN, MST, ALL
			SM	25.1	27	3	ALT STRATA - SI SD & CL SI, TN-BRN, V MST, ALL
20	695		CL	30.2	NP	NP	ALT STRATA - SI SD & CL SI, TN-BRN, W, ALL
			SM	26.7	NP	NP	SI SD, GY-TN, V MST, ALL
25	690		SM	21.0	NP	NP	SI SD, TN, V MST, ALL
			SM				
30	685		SM				
			SM				
35	680		SM				
			SM				
1''=5'			* Lab. Classif.				Added by Amendment 50

Figure 2.5-383 Soil Profile  
(Sheet 1 of 2)

<b>WATTS BAR NUCLEAR PLANT FINAL SAFETY ANALYSIS REPORT</b>
<b>SOIL PROFILE FIGURE 2.5-383 SHEET 1 OF 2</b>

PROJECT: WATTS BAR N.P.                      FEATURE: ERCW TRENCH B  
 BORING: PAH-1      STATION: 1+00 ±      RANGE:                      SURFACE EL: 712.0  
 DATE DRILLED: 5/31/83 TO                      PREPARED BY: MHD      CHECKED BY: BA

DEPTH ft.	EL	SPT (N)	* LOG	W	LL	PI	FIELD DESCRIPTION
5	710		CL	18.4	26	8	SD SI CL, BRN, MST, FL
			CL	14.7	35	13	SI CL, BRN, MST, TR GV, FL
10	705		CL	17.2	35	13	SD CL, BRN, MST, ALL (ORIG SOIL)
	700		CL	20.6	26	8	SD CL, BRN, MST, ALL
20	695		CL	25.0	26	8	SI CL, BRN, MST, ALL
	690		SM	25.1	27	3	ALT STRATA - SI SD & CL SI, TN-BRN, V MST, ALL
30	685		SM	30.2	NP	NP	ALT STRATA - SI SD & CL SI, TN-BRN, W, ALL
			SM	26.7	NP	NP	SI SD, GY-TN, V MST, ALL
35	680		SM	21.0	NP	NP	SI SD, TN, V MST, ALL
1''=5'			* Lab. Classif.				Added by Amendment 50

Figure 2.5-383 Soil Profile  
(Sheet 2 of 2)

<b>WATTS BAR NUCLEAR PLANT FINAL SAFETY ANALYSIS REPORT</b>
<b>SOIL PROFILE FIGURE 2.5-384 SHEET 1 OF 2</b>

PROJECT: WATTS BAR N.P.                      FEATURE: ERCW TRENCH B  
 BORING: PAH-2      STATION: 2+25 ±      RANGE:                      SURFACE EL: 713  
 DATE DRILLED: 6/1/83      TO                      PREPARED BY: MHD      CHECKED BY: BA

DEPTH ft.	EL	SPT (N)	* LOG	W	LL	PI	FIELD DESCRIPTION
5	710		CL	19.2	35	13	SI CL, TR GV, BRN, MST, FL
10	705		CL	21.3	35	13	SI CL, BRN, MST, ALL
15	700		CL	24	35	13	SI CL, BRN, MST, ALL
20	695		Σ S S	27.4	31	8	CL SD, BRN, W, ALL
25	690		Σ S	27.5	NP	NP	ALT STRATA - SI SD & CL SI, TN-BRN, V MST, ALL
30	685		Σ S	26.7	NP	NP	ALT STRATA - SI SD & CL SI, TN-BRN, V MST, ALL
35	680		SP S Σ S	17.3	NP	NP	GV SD, BRN-TN, W, ALL
1''=5'			* Lab. Classif.				Added by Amendment 50

Figure 2.5-384 Soil Profile  
(Sheet 1 of 2)

<b>WATTS BAR NUCLEAR PLANT FINAL SAFETY ANALYSIS REPORT</b>
<b>SOIL PROFILE FIGURE 2.5-384 SHEET 2 OF 2</b>

PROJECT: WATTS BAR N.P.                      FEATURE: ERCW TRENCH B  
 BORING: PAH-2      STATION: 2+25              RANGE:                      SURFACE EL: 713  
 DATE DRILLED: 6/1/83      TO                      PREPARED BY: MHD      CHECKED BY: BA

DEPTH ft.	EL	SPT (N)	* LOG	W	LL	PI	FIELD DESCRIPTION
40	675		12.8				WEATHERED SHALE
							DISCONTINUED. EL 674.0
45	670						
50	665						
55	660						
60	655						
65	650						
70	645						
1''=5'							Added by Amendment 50
							* Lab. Classif.

Figure 2.5-384 Soil Profile  
(Sheet 2 of 2)

<b>WATTS BAR NUCLEAR PLANT FINAL SAFETY ANALYSIS REPORT</b>
<b>SOIL PROFILE FIGURE 2.5-385 SHEET 1 OF 1</b>

PROJECT: WATTS BAR N.P.                      FEATURE: ERCW TRENCH B  
 BORING: PAH-3      STATION: 3+50              RANGE:                      SURFACE EL: 701.3  
 DATE DRILLED: 6/1/83      TO                      PREPARED BY: MHD      CHECKED BY: BA

DEPTH ft.	EL	SPT (N)	* LOG	W	LL	PI	FIELD DESCRIPTION
5	700		Σ U U	24.2	31	8	SD SI CL, BRN, MST, ALL
10	695		Σ U	37.0	28	4	SD SI, BRN, V MST, ALL
15	690		Σ U U	26.4	31	8	SD SI, TN, V MST, ALL
			SM	29.2	28	4	SI SD, R-TN, V MST, ALL
	685			20.3			WEATHERED SHALE _____
20							DISCONTINUED. EL 684.8
25	680						
30	675						
35	670						
1''=5'			* Lab. Classif.				Added by Amendment 50

Figure 2.5-385 Soil Profile

<b>WATTS BAR NUCLEAR PLANT FINAL SAFETY ANALYSIS REPORT</b>
<b>SOIL PROFILE FIGURE 2.5-386 SHEET 1 OF 1</b>

PROJECT: WATTS BAR N.P.  
BORING: PAH-4 STATION: 4+75  
DATE DRILLED: 6/2/83 TO

FEATURE: ERCW TRENCH B  
RANGE: SURFACE EL: 700.4  
PREPARED BY: MHD CHECKED BY: BA

DEPTH ft.	EL	SPT (N)	* LOG	W	LL	PI	FIELD DESCRIPTION
	700						
5	695		U	28.2	26	8	SD SI CL, GY, W, ALL
			Σ	18.0	NP	NP	SD SI, GY, W, ALL
10	690		CL-M	26.7	23	5	SD SI, GY, W, ALL
				24.9			WEATHERED SHALE
							DISCONTINUED. EL 688.9
15	685						
20	680						
25	675						
30	670						
35							
1''=5'			* Lab. Classif.				Added by Amendment 50

Figure 2.5-386 Soil Profile

<b>WATTS BAR NUCLEAR PLANT FINAL SAFETY ANALYSIS REPORT</b>
<b>SOIL PROFILE FIGURE 2.5-387 SHEET 1 OF 1</b>

PROJECT: WATTS BAR N.P.  
BORING: PAH-5 STATION: 6+00  
DATE DRILLED: 6/2/83 TO

FEATURE: ERCW TRENCH B  
RANGE: SURFACE EL: 702.7  
PREPARED BY: MHD CHECKED BY: BA

DEPTH ft.	EL	SPT (N)	* LOG	W	LL	PI	FIELD DESCRIPTION
5	700		CL	20.6	26	8	SD SI CL, TN-GY, MST, ALL
			CL	30	26	8	SL SD SI, TN-GY, V MST, ALL
10			CL	22.9 15.3	30	13	LAM RESD CL, MST WEATHERED SHALE
15	690						DISCONTINUED. EL 691.2
20	685						
25	680						
30	675						
35	670						
1''=5'			* Lab. Classif.				Added by Amendment 50

Figure 2.5-387 Soil Profile





<b>WATTS BAR NUCLEAR PLANT FINAL SAFETY ANALYSIS REPORT</b>
<b>SOIL PROFILE FIGURE 2.5-389 SHEET 1 OF 1</b>

PROJECT: WATTS BAR N.P.                      FEATURE: ERCW BORROW AREA 9  
 BORING: PAH-2      STATION: 1618.7E      RANGE: 323.5S      SURFACE EL: 740.4  
 DATE DRILLED: 6/2/83      TO                      PREPARED BY: MHD      CHECKED BY: BA

DEPTH ft.	EL	SPT (N)	* LOG	W	LL	PI	FIELD DESCRIPTION
	740						TOPSOIL
5			Σ	18.8	43	14	SI CL, GY-TN, MOTT, MST, ALL
	735		Σ	24.6	41	14	SI CL, R, MST, ALL
10			Σ	23.2	41	14	SD CL, R, MST, ALL
	725						-----
							DISCONTINUED. EL 725.4
20	720						
25	715						
30	710						
35							
1''=5'							Added by Amendment 50
							* Lab. Classif.

Figure 2.5-389 Soil Profile

<b>WATTS BAR NUCLEAR PLANT FINAL SAFETY ANALYSIS REPORT</b>
<b>SOIL PROFILE FIGURE 2.5-390 SHEET 1 OF 1</b>

PROJECT: WATTS BAR N.P.                      FEATURE: ERCW BORROW AREA 9  
 BORING: PAH-3      STATION: 1605.2E      RANGE: 465.2S      SURFACE EL: 742.1  
 DATE DRILLED: 6/2/83      TO                      PREPARED BY: MHD      CHECKED BY: BA

DEPTH ft.	EL	SPT (N)	* LOG	W	LL	PI	FIELD DESCRIPTION
	740						TOPSOIL
5			Σ	21.4	43	14	SD SI CL, R, MST, ALL
	735						
10			Σ	24.4	41	14	SD SI CL, R, MST, ALL
	730						
15			Σ	18.4	41	14	SD CL, R-BRN, MST, ALL
	725						DISCONTINUED. EL 727.1
20							
	720						
25							
	715						
30							
	710						
35							
1''=5'							Added by Amendment 50
							* Lab. Classif.

Figure 2.5-390 Soil Profile

<b>WATTS BAR NUCLEAR PLANT FINAL SAFETY ANALYSIS REPORT</b>
<b>SOIL PROFILE FIGURE 2.5-391A SHEET 1 OF 1</b>

PROJECT: WATTS BAR N.P.                      FEATURE: ERCW BORROW AREA 9  
 BORING: PAH-4      STATION: 1606.0E      RANGE: 616.6S      SURFACE EL: 743.3  
 DATE DRILLED: 6/2/83      TO                      PREPARED BY: MHD      CHECKED BY: BA

DEPTH ft.	EL	SPT (N)	* LOG	W	LL	PI	FIELD DESCRIPTION
							TOPSOIL - MIXED W/GRAVEL
5	740		Σ	20.3	43	14	SD SI, R, MST, ALL
10	735		Σ	23.2	41	14	SD SI CL, R, MST, ALL
15	730		Σ	21.0	41	14	SD SI CL, R, MST, ALL
							-----
							DISCONTINUED. EL 728.3
20	725						
25	720						
30	715						
35	710						
1''=5'							Added by Amendment 50
							* Lab. Classif.

Figure 2.5-391a Soil Profile

<b>WATTS BAR NUCLEAR PLANT FINAL SAFETY ANALYSIS REPORT</b>
<b>SOIL PROFILE FIGURE 2.5-392 SHEET 1 OF 1</b>

PROJECT: WATTS BAR N.P.      FEATURE: ERCW BORROW AREA 9  
 BORING: PAH-5      STATION: 1604.9E      RANGE: 767.3S      SURFACE EL: 737.8  
 DATE DRILLED: 6/2/83      TO      PREPARED BY: MHD      CHECKED BY: BA

DEPTH ft.	EL	SPT (N)	* LOG	W	LL	PI	FIELD DESCRIPTION
5	735		CL	18.5	33	17	TOPSOIL SI CL, BRN, MST, ALL
	730		CL	20.8	33	17	SI CL, BRN, MST, ALL
	725		ML	22.9	43	14	SD CL SI, R, MST, ALL
15							-----
20	720						DISCONTINUED. EL 723.8
25	715						
30	710						
35	705						
1''=5'							Added by Amendment 50
			* Lab. Classif.				

Figure 2.5-392 Soil Profile

<b>WATTS BAR NUCLEAR PLANT FINAL SAFETY ANALYSIS REPORT</b>
<b>SOIL PROFILE FIGURE 2.5-393 SHEET 1 OF 1</b>

PROJECT: WATTS BAR N.P.                      FEATURE: ERCW BORROW AREA 9  
 BORING: PAH-6      STATION: 1576.3E      RANGE: 902.2S      SURFACE EL: 735.6  
 DATE DRILLED: 6/2/83      TO                      PREPARED BY: MHD      CHECKED BY: BA

DEPTH ft.	EL	SPT (N)	* LOG	W	LL	PI	FIELD DESCRIPTION
	735						TOPSOIL
5			┌ └ 0	15.4	29	14	SI CL, TN-BRN, MST, FL
	730						
10			┌ └ 0	20.4	33	17	(BURIED TOPSOIL) SI TO SI CL, TN-BRN, MST-V MST, ALL
	725						
15			┌ └ Σ	24.0	43	14	SI CL, BRN, MST, ALL
	720						DISCONTINUED. EL 720.6
20	715						
25	710						
30	705						
35							
1"=5'							Added by Amendment 50
							* Lab. Classif.

Figure 2.5-393 Soil Profile

<b>WATTS BAR NUCLEAR PLANT FINAL SAFETY ANALYSIS REPORT</b>
<b>SOIL PROFILE FIGURE 2.5-394 SHEET 1 OF 1</b>

PROJECT: WATTS BAR N.P.                      FEATURE: ERCW BORROW AREA 9  
 BORING: PAH-7      STATION: 1730.2E      RANGE: 160.1S      SURFACE EL: 735.7  
 DATE DRILLED: 6/3/83      TO                      PREPARED BY: MHD      CHECKED BY: BA

DEPTH ft.	EL	SPT (N)	* LOG	W	LL	PI	FIELD DESCRIPTION
5  10  15	735		U	16.3	29	14	TOPSOIL SI CL, BRN, MST, ALL
	730		U	17.8	33	17	SI CL, GY, MST, ALL
	725		U	20.4	33	17	SI CL, GY, MST, ALL
	720		Σ	14.6	41	14	SD SI, GY, MST, ALL
20	715						DISCONTINUED. EL 720.7
25	710						
30	705						
35							
1''=5'							Added by Amendment 50
			* Lab. Classif.				

Figure 2.5-394 Soil Profile

WATTS BAR NUCLEAR PLANT FINAL SAFETY ANALYSIS REPORT
SOIL PROFILE FIGURE 2.5-395 SHEET 1 OF 1

PROJECT: WATTS BAR N.P.                      FEATURE: ERCW BORROW AREA 9  
 BORING: PAH-8      STATION: 1785.7E      RANGE: 290.0S      SURFACE EL: 737.3  
 DATE DRILLED: 6/3/83      TO                      PREPARED BY: MHD      CHECKED BY: BA

DEPTH ft.	EL	SPT (N)	* LOG	W	LL	PI	FIELD DESCRIPTION
5	735		U	20.3	28	13	TOPSOIL SI CL, TN, MST, ALL
	730		U	18.8	35	17	SI CL, BRN, MST, ALL
	725		Σ	20.5	41	14	SI CL, R, MST, ALL
15							DISCONTINUED. 723.3
20	720						
25	715						
30	710						
35	705						
1''=5'							Added by Amendment 50
			* Lab. Classif.				

Figure 2.5-395 Soil Profile

<b>WATTS BAR NUCLEAR PLANT FINAL SAFETY ANALYSIS REPORT</b>
<b>SOIL PROFILE FIGURE 2.5-396 SHEET 1 OF 1</b>

PROJECT: WATTS BAR N.P.                      FEATURE: ERCW BORROW AREA 9  
 BORING: PAH-9      STATION: 1802.0E      RANGE: 439.7S      SURFACE EL: 740.0  
 DATE DRILLED: 6/3/83      TO                      PREPARED BY: MHD      CHECKED BY: BA

DEPTH ft.	EL	SPT (N)	* LOG	W	LL	PI	FIELD DESCRIPTION
	740						
5	735		CL	13.6	28	13	SI CL, BRN, MST, ALL
10	730		CL	23.0	43	14	SI CL, R, MST, ALL
15	725		ML	20.9	41	14	SD SI CL, R, MST, ALL
20	720						DISCONTINUED. EL 726.0
25	715						
30	710						
35	705						
1''=5'			* Lab. Classif.				Added by Amendment 50

Figure 2.5-396 Soil Profile



WATTS BAR NUCLEAR PLANT FINAL SAFETY ANALYSIS REPORT
SOIL PROFILE FIGURE 2.5-397 SHEET 1 OF 1

PROJECT: WATTS BAR N.P.      FEATURE: ERCW BORROW AREA 9  
 BORING: PAH-10      STATION: 1787.1E      RANGE: 584.7S      SURFACE EL: 744.2  
 DATE DRILLED: 6/3/83      TO      PREPARED BY: MHD      CHECKED BY: BA

DEPTH ft.	EL	SPT (N)	* LOG	W	LL	PI	FIELD DESCRIPTION
5	740		┌ O	13.2	28	13	TOPSOIL SI CL, TR GV, BRN, MST, FL
10	735		┌ O	17.7	29	14	SI CL, BRN, MST, ALL (ORIG SOIL)
15	730		┌ Σ	22.8	43	14	SI CL, R, MST, ALL
20	725						----- DISCONTINUED. EL 730.2
25	720						
30	715						
35	710						
1"=5'							Added by Amendment 50
							* Lab. Classif.

Figure 2.5-397 Soil Profile

<b>WATTS BAR NUCLEAR PLANT FINAL SAFETY ANALYSIS REPORT</b>
<b>SOIL PROFILE FIGURE 2.5-398 SHEET 1 OF 1</b>

PROJECT: WATTS BAR N.P.                      FEATURE: ERCW BORROW AREA 9  
 BORING: PAH-11      STATION: 1750.5E      RANGE: 726.7S      SURFACE EL: 740.9  
 DATE DRILLED: 6/3/83      TO                      PREPARED BY: MHD      CHECKED BY: BA

DEPTH ft.	EL	SPT (N)	* LOG	W	LL	PI	FIELD DESCRIPTION
5  10  15	740		CL	16.8	29	14	TOPSOIL SI CL, BRN, MST, ALL
	735		CL	18.1	33	17	SI CL, BRN, MST, ALL
	730		CL	19.8	35	17	SI CL, BRN, V MST, ALL
	725		ML	22.3	43	14	SD SI, BRN, V MST, ALL
20	720						DISCONTINUED. EL 725.9
25	715						
30	710						
35							
1''=5'			* Lab. Classif.				Added by Amendment 50

Figure 2.5-398 Soil Profile

<b>WATTS BAR NUCLEAR PLANT FINAL SAFETY ANALYSIS REPORT</b>
<b>SOIL PROFILE FIGURE 2.5-399 SHEET 1 OF 1</b>

PROJECT: WATTS BAR N.P.                      FEATURE: ERCW BORROW AREA 9  
 BORING: PAH-12    STATION: 1708.3E    RANGE: 866.6S    SURFACE EL: 739.1  
 DATE DRILLED: 6/3/83    TO                      PREPARED BY: MHD    CHECKED BY: BA

DEPTH ft.	EL	SPT (N)	* LOG	W	LL	PI	FIELD DESCRIPTION
5	735		J O	13.7	28	13	TOPSOIL SI CL, BRN, MST, ALL
10	730		J O	25.1	35	17	SI CL, BRN, V MST, ALL
15	725		J O	22.4	35	17	SI CL, BRN, V MST, ALL
20	720						DISCONTINUED. EL 725.1
25	715						
30	710						
35	705						
1''=5'							Added by Amendment 50
			* Lab. Classif.				

Figure 2.5-399 Soil Profile

<b>WATTS BAR NUCLEAR PLANT FINAL SAFETY ANALYSIS REPORT</b>
SOIL PROFILE FIGURE 2.5-400 SHEET 1 OF 1

PROJECT: WATTS BAR N. P.                      FEATURE: BORROW AREA 10  
 BORING: PAH-1                      STATION: 11+23.2E RANGE: 3+68.2N SURFACE EL: 733.8  
 DATE DRILLED: 6/6/83 TO                      PREPARED BY: MHD CHECKED BY: BA

DEPTH ft.	EL	SPT (N)	* LOG	W	LL	PI	FIELD DESCRIPTION
							TOPSOIL
5	730		U O Σ	25.2	41	15	SI CL, R-BRN, MS <sub>1</sub> , ALL
10	725		U O Σ	24.0	41	15	SI CL, R-BRN, MST, ALL
15	720		U O Σ	23.9	41	15	SI CL, R-BRN, MST, ALL
20	715						
25	710						
30	705						
35	700						
1''=5'							APR 13 1988
			* Lab. Classif.				

Revised by Amendment 62

Figure 2.5-400 Soil Profile

<b>WATTS BAR NUCLEAR PLANT FINAL SAFETY ANALYSIS REPORT</b>
SOIL PROFILE FIGURE 2.5-401 SHEET 1 OF 1

PROJECT: WATTS BAR N.P.                      FEATURE: BORROW AREA 10  
 BORING: CH-2                      STATION: 9+72.1E    RANGE: 4+08.5N    SURFACE EL: 737.2  
 DATE DRILLED: 6/7/83    TO                      PREPARED BY: MHD    CHECKED BY: JA

DEPTH ft.	EL	SPT (N)	* LOG	W	LL	PI	FIELD DESCRIPTION
	735		┌──┐ U Σ └──┘	26.1	41	15	TOPSOIL SI CL, R, MST, ALL
5							
	730		┌──┐ U Σ └──┘	21.5	41	15	SI CL, R, MST, ALL
10							
	725						
15							
	720						
20							
	715						
25							
	710						
30							
	705						
35							
1''=5'							APR 13 1988
							* Lab. Classif.

Revised by Amendment 62

Figure 2.5-401 Soil Profile

<b>WATTS BAR NUCLEAR PLANT FINAL SAFETY ANALYSIS REPORT</b>
SOIL PROFILE FIGURE 2.5-402 SHEET 1 OF 1

PROJECT: WATTS BAR N.P.                      FEATURE: BORROW AREA 10  
 BORING: CH-3                      STATION: 9+84.6E    RANGE: 4+91.1N    SURFACE EL: 734.5  
 DATE DRILLED: 6/7/83    TO                      PREPARED BY: MHD    CHECKED BY: *BAL*

DEPTH ft.	EL	SPT (N)	* LOG	W	LL	PI	FIELD DESCRIPTION
5	730		U O   I Σ	22.7	41	15	SI CL, BRN, MST, ALL
			U O   I Σ	27.6	45	19	FT CL, BRN, MST, ALL
10	725						
15	720						
20	715						
25	710						
30	705						
35	700						APR 18 1988
1''=5'							* Lab. Classif.

Added by Amendment 62

Figure 2.5-402 Soil Profile

<b>WATTS BAR NUCLEAR PLANT FINAL SAFETY ANALYSIS REPORT</b>
<b>SOIL PROFILE FIGURE 2.5-403 SHEET 1 OF 1</b>

PROJECT: WATTS BAR N.P.                      FEATURE: BORROW AREA 11  
 BORING: PAH-1      STATION: 6+06.9W      RANGE: 1+48.4S      SURFACE EL: 736.1  
 DATE DRILLED: 6/6/83      TO                      PREPARED BY: MHD      CHECKED BY: BA

DEPTH ft.	EL	SPT (N)	* LOG	W	LL	PI	FIELD DESCRIPTION
5	735		Σ	28.1	44	16	CL SI, R, MST, ALL
10	730		Σ	30.4	45	16	CI SI, R, MST, ALL
15	725		Σ	28.7	45	16	CL SI, BRN, V MST, ALL
20	720						
25	715						
30	710						
35	705						
1''=5'			* Lab. Classif.				Added by Amendment 50

Figure 2.5-403 Soil Profile

WATTS BAR NUCLEAR PLANT FINAL SAFETY ANALYSIS REPORT
SOIL PROFILE FIGURE 2.5-404 SHEET 1 OF 1

PROJECT: WATTS BAR N.P.                      FEATURE: BORROW AREA 11  
 BORING: PAH-2      STATION: 7+60.1W      RANGE: 1+89.0S      SURFACE EL: 742.0  
 DATE DRILLED: 6/6/83      TO                      PREPARED BY: MHD      CHECKED BY: BA

DEPTH ft.	EL	SPT (N)	* LOG	W	LL	PI	FIELD DESCRIPTION
	740						GRAVEL
5			Σ	27.1	44	16	SI CL, R, MST, ALL
	735						
10			Σ	33.7	45	16	CL SI, R-BRN, MST, ALL
	730						
15			Σ	27.9	45	16	CL SI, R-BRN, MST, ALL
	725						
20							
	720						
25							
	715						
30							
	710						
35							
1''=5'							Added by Amendment 50
							* Lab. Classif.

Figure 2.5-404 Soil Profile



<b>WATTS BAR NUCLEAR PLANT FINAL SAFETY ANALYSIS REPORT</b>
<b>SOIL PROFILE FIGURE 2.5-405 SHEET 1 OF 1</b>

PROJECT: WATTS BAR N.P.                      FEATURE: BORROW AREA 11  
 BORING: PAH-3      STATION: 6+93.1W      RANGE: 1+15.2S      SURFACE EL: 741.9  
 DATE DRILLED: 6/6/83      TO                      PREPARED BY: MHD      CHECKED BY: BA

DEPTH ft.	EL	SPT (N)	* LOG	W	LL	PI	FIELD DESCRIPTION
	740						GRAVEL
5			Σ	23.4	44	16	SI CL, R-BRN, MST, ALL
	735						
10			Σ	26.7	44	16	SI CL, R-BRN, MST, ALL
	730						
15			Σ	23.2	44	16	SI CL, BRN, MST, ALL
	725						
20							
	720						
25							
	715						
30							
	710						
35							
1''=5'							Added by Amendment 50
			* Lab. Classif.				

Figure 2.5-405 Soil Profile

<b>WATTS BAR NUCLEAR PLANT FINAL SAFETY ANALYSIS REPORT</b>
<b>SOIL PROFILE FIGURE 2.5-406 SHEET 1 OF 1</b>

PROJECT: WATTS BAR N.P.                      FEATURE: BORROW AREA 11  
 BORING: PAH-4      STATION: 7+16.8W      RANGE: 0+83.0S      SURFACE EL: 741.1  
 DATE DRILLED: 6/6/83      TO                      PREPARED BY: MHD      CHECKED BY: EA

DEPTH ft.	EL	SPT (N)	* LOG	W	LL	PI	FIELD DESCRIPTION
	740						GRAVEL
5	735		ΣL	26.8	44	16	CL SI, R-BRN, MST, ALL
10	730		ΣL	27.8	44	16	CL SI, R-BRN, MST, ALL
15	725		ΣL	27.0	44	16	CL SI, R-BRN, MST, ALL
20	720						
25	715						
30	710						
35							
1''=5'			* Lab. Classif.				Added by Amendment 50

Figure 2.5-406 Soil Profile

WATTS BAR NUCLEAR PLANT FINAL SAFETY ANALYSIS REPORT
SOIL PROFILE FIGURE 2.5-407 SHEET 1 OF 1

PROJECT: WATTS BAR N.P.                      FEATURE: BORROW AREA 11  
 BORING: PAH-5      STATION: 8+39.7W      RANGE: 1+40.2S      SURFACE EL: 738.7  
 DATE DRILLED: 6/6/83      TO                      PREPARED BY: MHD      CHECKED BY: BA

DEPTH ft.	EL	SPT (N)	* LOG	W	LL	PI	FIELD DESCRIPTION
							GRAVEL
5	735		Σ	22.6	45	16	SI CL, R-BRN, MST, ALL
10	730		Σ	26.8	49	15	SI CL, R-BRN, MST, ALL
15	725		Σ	22.8	45	16	SD SI CL, BRN, MST, ALL
20	720						
25	715						
30	710						
35	705						
1''=5'			* Lab. Classif.				Added by Amendment 50

Figure 2.5-407 Soil Profile

<b>WATTS BAR NUCLEAR PLANT FINAL SAFETY ANALYSIS REPORT</b>
<b>SOIL PROFILE FIGURE 2.5-408 SHEET 1 OF 1</b>

PROJECT: WATTS BAR N.P.  
BORING: PAH-1 STATION:  
DATE DRILLED: 6/3/83 TO

FEATURE: BORROW AREA 12  
RANGE: SURFACE EL: 709.6  
PREPARED BY: MHD CHECKED BY: BA

DEPTH ft.	EL	SPT (N)	* LOG	W	LL	PI	FIELD DESCRIPTION
							TOPSOIL
5	705		┌ └ 0	25.7	40	17	SI CL, BRN, MST, ALL
10	700		┌ └ 0	27.1	40	17	SI CL, BRN, MST, ALL
15	695		┌ └ 0	26.6	40	17	SI CL, BRN, V MST, ALL
							-----
							DISCONTINUED.
20	690						
25	685						
30	680						
35	675						
1''=5'							Added by Amendment 50
							* Lab. Classif.

Figure 2.5-408 Soil Profile

<b>WATTS BAR NUCLEAR PLANT FINAL SAFETY ANALYSIS REPORT</b>
<b>SOIL PROFILE FIGURE 2.5-409 SHEET 1 OF 1</b>

PROJECT: WATTS BAR N.P.  
BORING: PAH-2 STATION:  
DATE DRILLED: 6/3/83 TO

FEATURE: BORROW AREA 12  
RANGE: SURFACE EL: 708.3  
PREPARED BY: MHD CHECKED BY: BA

DEPTH ft.	EL	SPT (N)	* LOG Σ	W	LL	PI	FIELD DESCRIPTION
5	705		Σ	24.7	40	13	SI CL, R-BRN, MST, ALL
10	700		Σ	27.4	40	13	SI CL, R-BRN, MST, ALL
15	695		Σ	25.6	40	13	SI CL, R-BRN, V MST, ALL
20	690						DISCONTINUED.
25	685						
30	680						
35	675						
1''=5'							Added by Amendment 50

\* Lab. Classif.

Figure 2.5-409 Soil Profile

<b>WATTS BAR NUCLEAR PLANT FINAL SAFETY ANALYSIS REPORT</b>
<b>SOIL PROFILE FIGURE 2.5-410 SHEET 1 OF 1</b>

PROJECT: WATTS BAR N.P.  
BORING: PAH-3 STATION:  
DATE DRILLED: 6/6/83 TO

FEATURE: BORROW AREA 12  
RANGE: SURFACE EL: 711.5  
PREPARED BY: MHD CHECKED BY: BA

DEPTH ft.	EL	SPT (N)	* LOG	W	LL	PI	FIELD DESCRIPTION
5	710		┌ └ 0	25.1	40	17	FT CL, R, MST, ALL
10	705		┌ └ Σ	23.7	40	13	FT CL, R, MST, ALL
15	700		┌ └ 0	25.7	40	17	SI CL, R-BRN, MST, ALL
20	695						DISCONTINUED.
25	690						
30	685						
35	680						
1''=5'							Added by Amendment 50
			* Lab. Classif.				

Figure 2.5-410 Soil Profile

<b>WATTS BAR NUCLEAR PLANT FINAL SAFETY ANALYSIS REPORT</b>
<b>SOIL PROFILE FIGURE 2.5-411 SHEET 1 OF 1</b>

PROJECT: WATTS BAR N.P.  
BORING: PAH-4 STATION:  
DATE DRILLED: 6/6/83 TO

FEATURE: BORROW AREA 12  
RANGE: SURFACE EL: 707.7  
PREPARED BY: MHD CHECKED BY: BA

DEPTH ft.	EL	SPT (N)	* LOG	W	LL	PI	FIELD DESCRIPTION
							TOPSOIL
5	705		Σ	23.2	40	13	SI CL, R-BRN, MST, ALL
10	700		Σ	24.1	40	13	SI CL, R-BRN, MST, ALL
15	695		Σ	25.9	40	13	SI CL, BRN, V MST, ALL
20	690						DISCONTINUED.
25	685						
30	680						
35	675						
1''=5'			* Lab. Classif.				Added by Amendment 50

Figure 2.5-411 Soil Profile

<b>WATTS BAR NUCLEAR PLANT FINAL SAFETY ANALYSIS REPORT</b>
<b>SOIL PROFILE FIGURE 2.5-412 SHEET 1 OF 1</b>

PROJECT: WATTS BAR N.P.  
BORING: PAH-5 STATION:  
DATE DRILLED: 6/6/83 TO

FEATURE: BORROW AREA 12  
RANGE: SURFACE EL: 709.7  
PREPARED BY: MHD CHECKED BY: EA

DEPTH ft.	EL	SPT (N)	* LOG	W	LL	PI	FIELD DESCRIPTION
							TOPSOIL
5	705		Σ	26.7	40	13	FT CL, R, MST, ALL
10	700		Σ	23.8	40	13	SI CL, R-BRN, MST, ALL
15	695		Σ	25.2	40	13	SI CL, R-BRN, MST, ALL
							-----
							DISCONTINUED.
20	690						
25	685						
30	680						
35	675						
1''=5'			* Lab. Classif.				Added by Amendment 50

Figure 2.5-412 Soil Profile



<b>WATTS BAR NUCLEAR PLANT FINAL SAFETY ANALYSIS REPORT</b>
<b>SOIL PROFILE FIGURE 2.5-413 SHEET 1 OF 1</b>

PROJECT: WATTS BAR N.P.  
BORING: PAH-6 STATION:  
DATE DRILLED: 6/6/83 TO

FEATURE: BORROW AREA 12  
RANGE: SURFACE EL: 705.7  
PREPARED BY: MHD CHECKED BY: BA

DEPTH ft.	EL	SPT (N)	* LOG	W	LL	PI	FIELD DESCRIPTION
	705						TOPSOIL
5			U O	26.2	40	17	FT CL, BRN, MST, ALL
	700						
10			U O	26.1	40	17	FT CL, BRN, MST, ALL
	695						
15			U O	23.7	40	17	SI CL, BRN, MST, ALL
	690						-----
20							DISCONTINUED.
	685						
25							
	680						
30							
	675						
35							
1"=5'							Added by Amendment 50
			* Lab. Classif.				

Figure 2.5-413 Soil Profile

<b>WATTS BAR NUCLEAR PLANT FINAL SAFETY ANALYSIS REPORT</b>
<b>SOIL PROFILE FIGURE 2.5-414 SHEET 1 OF 1</b>

PROJECT: WATTS BAR N.P.  
BORING: PAH-7 STATION:  
DATE DRILLED: 6/6/83 TO

FEATURE: BORROW AREA 12  
RANGE: SURFACE EL: 706.0  
PREPARED BY: MHD CHECKED BY: BA

DEPTH ft.	EL	SPT (N)	* LOG	W	LL	PI	FIELD DESCRIPTION
5	705		U	25.7	40	17	FT CL, R-BRN, MST, ALL
10	700		Σ	25.8	40	13	SI CL, R-BRN, MST, ALL
15	695		Σ	23.6	40	13	SI CL, BRN, MST, ALL
20	690						DISCONTINUED.
25	685						
30	680						
35	675						
1''=5'			* Lab. Classif.				Added by Amendment 50

Figure 2.5-414 Soil Profile

<b>WATTS BAR NUCLEAR PLANT FINAL SAFETY ANALYSIS REPORT</b>
<b>SOIL PROFILE FIGURE 2.5-415 SHEET 1 OF 1</b>

PROJECT: WATTS BAR N.P.  
BORING: PAH-7 STATION:  
DATE DRILLED: 6/8/83 TO

FEATURE: BORROW AREA 2C  
RANGE: SURFACE EL: 744.0 est.  
PREPARED BY: MHD CHECKED BY: EA

DEPTH ft.	EL	SPT (N)	* LOG	W	LL	PI	FIELD DESCRIPTION
5	740		┌ └ U	22.5	42	18	FT CL, R, MST, ALL
			┌ └ U	24.9	42	18	SI CL, R, MST, ALL
10	735		┌ └ U	20.1	35	14	CL SI, TN, MST, RESD
15	730		┌ └ U	22.0	35	14	CL SI, TN, MST, RESD
20	725						DISCONTINUED.
25	720						
30	715						
35	710						Added by Amendment 50
1''=5'							* Lab. Classif.

Figure 2.5-415 Soil Profile

<b>WATTS BAR NUCLEAR PLANT FINAL SAFETY ANALYSIS REPORT</b>
<b>SOIL PROFILE FIGURE 2.5-416 SHEET 1 OF 1</b>

PROJECT: WATTS BAR N.P.  
BORING: PAH-8 STATION:  
DATE DRILLED: 6/6/83 TO

FEATURE: BORROW AREA 12  
RANGE: SURFACE EL: 706.3  
PREPARED BY: MHD CHECKED BY: BA

DEPTH ft.	EL	SPT (N)	* LOG	W	LL	PI	FIELD DESCRIPTION
	705						TOPSOIL
5			Σ	23.7	40	13	FT CL, R, MST, ALL
	700		Σ	23.3	40	13	SI CL, BRN, MST, ALL
10							
	695		U	23.5	40	17	SI CL, BRN, MST, ALL
15							
	690						DISCONTINUED.
20							
	685						
25							
	680						
30							
	675						
35							
1''=5'							Added by Amendment 50
							* Lab. Classif.

Figure 2.5-416 Soil Profile

<b>WATTS BAR NUCLEAR PLANT FINAL SAFETY ANALYSIS REPORT</b>
<b>SOIL PROFILE FIGURE 2.5-417 SHEET 1 OF 1</b>

PROJECT: WATTS BAR N.P.  
BORING: PAH-9 STATION:  
DATE DRILLED: 6/6/83 TO

FEATURE: BORROW AREA 12  
RANGE: SURFACE EL: 703.7  
PREPARED BY: MHD CHECKED BY: PA

DEPTH ft.	EL	SPT (N)	* LOG	W	LL	PI	FIELD DESCRIPTION
5	700		U	22.3	40	17	SI CL, R-BRN, MST, ALL
10	695		Σ	25.6	40	13	MD CL, R-BRN, MST, ALL
15	690		Σ	24.6	40	13	SI CL, BRN, V MST, ALL
20	685						DISCONTINUED.
25	680						
30	675						
35	670						
1''=5'							Added by Amendment 50
							* Lab. Classif.

Figure 2.5-417 Soil Profile

<b>WATTS BAR NUCLEAR PLANT FINAL SAFETY ANALYSIS REPORT</b>
<b>SOIL PROFILE FIGURE 2.5-418 SHEET 1 OF 1</b>

PROJECT: WATTS BAR N.P.  
BORING: PAH-10 STATION:  
DATE DRILLED: 6/6/83 TO

FEATURE: BORROW AREA 12  
RANGE: SURFACE EL: 706.0  
PREPARED BY: MHD CHECKED BY: BA

DEPTH ft.	EL	SPT (N)	* LOG	W	LL	PI	FIELD DESCRIPTION
5	705		Σ	25.7	40	13	FT CL, R-BRN, MST, ALL
10	700		Σ S U S S	25.1	30	8	SI CL, R-BRN, MST, ALL
15	695		Σ S U S S	20.2	29	6	SI CL, BRN, MST, ALL
20	690						DISCONTINUED.
25	685						
30	680						
35	675						
1''=5'			* Lab. Classif.				Added by Amendment 50

Figure 2.5-418 Soil Profile

<b>WATTS BAR NUCLEAR PLANT FINAL SAFETY ANALYSIS REPORT</b>
<b>SOIL PROFILE FIGURE 2.5-419 SHEET 1 OF 1</b>

PROJECT: WATTS BAR N.P.  
BORING: PAH-11 STATION:  
DATE DRILLED: 6/6/83 TO

FEATURE: BORROW AREA 12  
RANGE: SURFACE EL: 710.4  
PREPARED BY: MHD CHECKED BY: BA

DEPTH ft.	EL	SPT (N)	* LOG	W	LL	PI	FIELD DESCRIPTION
	710						
5			Σ L	24.9	40	13	SI CL, R-BRN, MST, ALL
	705						
10			Σ U S	21.6	29	6	SD SI CL, R-BRN, MST, ALL
	700						
15			Σ U S	19.5	29	6	SI SD, R-BRN, MST, ALL
	695						-----
							DISCONTINUED.
20	690						
25	685						
30	680						
35							
1''=5'							Added by Amendment 50
			* Lab. Classif.				

Figure 2.5-419 Soil Profile

<b>WATTS BAR NUCLEAR PLANT FINAL SAFETY ANALYSIS REPORT</b>
<b>SOIL PROFILE FIGURE 2.5-420 SHEET 1 OF 1</b>

PROJECT: WATTS BAR N.P.  
BORING: PAH-1 STATION:  
DATE DRILLED: 8/26/83 TO

FEATURE: BORROW AREA 13  
RANGE: SURFACE EL: 723.1  
PREPARED BY: MHD CHECKED BY: *MB*

DEPTH ft.	EL	SPT (N)	* LOG	W	LL	PI	FIELD DESCRIPTION
5  10  15  20  25  30  35 1''=5'	720		U O   Σ	21.3	35	11	TOPSOIL SI CL, BRN, MST, RESD
	715		U O	23.0	43	20	SI CL, BRN, MST, RESD
	710		U O	22.3	43	20	SI CL, BRN, MST, RESD
	705		U O	20.4	43	20	SI CL, BRN, MST, RESD
							----- DISCONTINUED.
	700						
	695						
	690						
			* Lab. Classif.				Added by Amendment 50

Figure 2.5-420 Soil Profile



<b>WATTS BAR NUCLEAR PLANT FINAL SAFETY ANALYSIS REPORT</b>
<b>SOIL PROFILE FIGURE 2.5-421 SHEET 1 OF 1</b>

PROJECT: WATTS BAR N.P.  
BORING: PAH-2 STATION:  
DATE DRILLED: 8/26/83 TO

FEATURE: BORROW AREA 13  
RANGE: SURFACE EL: 728.6  
PREPARED BY: MHD CHECKED BY: *MBG*

DEPTH ft.	EL	SPT (N)	* LOG	W	LL	PI	FIELD DESCRIPTION
							TOPSOIL, SPOIL GRAVEL
5	725		CL	27.6	36	13	SI CL, PURP, MST, RESD
10	720		CL	23.9	36	13	SI CL, PURP, MST, RESD
15	715		CL	20.2	36	13	SI CL, PURP, MST, RESD
20	710						DISCONTINUED.
25	705						
30	700						
35	695						
1''=5'			* Lab. Classif.				Added by Amendment 50

Figure 2.5-421 Soil Profile

<b>WATTS BAR NUCLEAR PLANT FINAL SAFETY ANALYSIS REPORT</b>
<b>SOIL PROFILE FIGURE 2.5-422 SHEET 1 OF 1</b>

PROJECT: WATTS BAR N.P.  
BORING: PAH-3 STATION:  
DATE DRILLED: 8/26/83 TO

FEATURE: BORROW AREA 13  
RANGE: SURFACE EL: 723.4  
PREPARED BY: MHD CHECKED BY: *CKG*

DEPTH ft.	EL	SPT (N)	* LOG	W	LL	PI	FIELD DESCRIPTION
5	720		U O   I   Σ	14.9	35	11	SI CL, BRN, MST, RESD
10	715		U O   Σ	31.9	43	20	SI CL, BRN, SAT, RESD
15	710						DISCONTINUED (WET).
20	705						
25	700						
30	695						
35	690						
1''=5'			* Lab. Classif.				Added by Amendment 50

Figure 2.5-422 Soil Profile

<b>WATTS BAR NUCLEAR PLANT FINAL SAFETY ANALYSIS REPORT</b>
<b>SOIL PROFILE FIGURE 2.5-423 SHEET 1 OF 1</b>

PROJECT: WATTS BAR N.P.  
BORING: PAH-4 STATION:  
DATE DRILLED: 8/26/83 TO

FEATURE: BORROW AREA 13  
RANGE: SURFACE EL: 742.1  
PREPARED BY: MHD CHECKED BY: *OB*

DEPTH ft.	EL	SPT (N)	* LOG	W	LL	PI	FIELD DESCRIPTION
	740		J U Σ	14.9	35	11	TOPSOIL CL SI, BRN, MST, RESD
5							
	735		J U Σ	22.5	35	11	CL SI, BRN, MST, RESD
10							
	730		J U Σ	25.7	45	17	CL SI, BRN, MST, RESD
15							
	725		J U Σ	28.3	45	17	CL SI, BRN, MST, RESD
20							
	720						DISCONTINUED.
25							
	715						
30							
	710						
35							
1''=5'							Added by Amendment 50

Figure 2.5-423 Soil Profile

<b>WATTS BAR NUCLEAR PLANT FINAL SAFETY ANALYSIS REPORT</b>
<b>SOIL PROFILE FIGURE 2.5-424 SHEET 1 OF 1</b>

PROJECT: WATTS BAR N.P.  
BORING: PAH-5 STATION:  
DATE DRILLED: TO

FEATURE: BORROW AREA 13  
RANGE: SURFACE EL: 723.5  
PREPARED BY: MHD CHECKED BY: *CRG*

DEPTH ft.	EL	SPT (N)	* LOG	W	LL	PI	FIELD DESCRIPTION
							TOPSOIL
5	720		Σ	22.2	42	14	CL SI, BRN, MST, RESD
10	715		Σ	23.1	42	14	CL SI, BRN, MST, RESD
15	710		Σ	20.9	42	14	CL SI, BRN, MST, RESD
20	705		Σ	22.1	42	14	CL SI, BRN, MST, RESD
25	700						DISCONTINUED.
30	695						
35	690						
1''=5'							Added by Amendment 50

\* Lab. Classif.

Figure 2.5-424 Soil Profile

<b>WATTS BAR NUCLEAR PLANT FINAL SAFETY ANALYSIS REPORT</b>
<b>SOIL PROFILE FIGURE 2.5-425 SHEET 1 OF 1</b>

PROJECT: WATTS BAR N.P.  
BORING: PAH-6 STATION:  
DATE DRILLED: 8/26/83 TO

FEATURE: BORROW AREA 13  
RANGE: SURFACE EL: 730.5  
PREPARED BY: MHD CHECKED BY: *CBG*

DEPTH ft.	EL	SPT (N)	* LOG	W	LL	PI	FIELD DESCRIPTION
	730						TOPSOIL
5	725		Σ	22.3	42	14	CL SI, BRN, MST, RESD
10	720		Σ	15.3	42	14	CL SI, BRN, MST, RESD
15	715		U	17.2	36	13	CL SI, PUR-BRN, MST, RESD
15	715		U	13.7	36	13	CL SI, PUR-BRN, MST, RESD
20	710						DISCONTINUED.
25	705						
30	700						
35							
1''=5'			* Lab. Classif.				Added by Amendment 50

Figure 2.5-425 Soil Profile

<b>WATTS BAR NUCLEAR PLANT FINAL SAFETY ANALYSIS REPORT</b>
<b>SOIL PROFILE FIGURE 2.5-426 SHEET 1 OF 1</b>

PROJECT: WATTS BAR N.P.  
BORING: PAH-7 STATION:  
DATE DRILLED: 8/26/83 TO

FEATURE: BORROW AREA 13  
RANGE: SURFACE EL: 728.8  
PREPARED BY: MHD CHECKED BY: *CRF*

DEPTH ft.	EL	SPT (N)	* LOG	W	LL	PI	FIELD DESCRIPTION
							TOPSOIL
5	725		U Σ	18.1	35	11	CL SI, BRN, MST, RESD
10	720		Σ	19.9	42	14	CL SI, LT BRN, MST, RESD
15	715		U	21.5	36	13	CL SI, PUR-BRN, MST, RESD
20	710		U	18.0	36	13	CL SI, PUR-BRN, MST, RESD
25	705						DISCONTINUED.
30	700						
35	695						
1''=5'			* Lab. Classif.				Added by Amendment 50

Figure 2.5-426 Soil Profile

<b>WATTS BAR NUCLEAR PLANT FINAL SAFETY ANALYSIS REPORT</b>
<b>SOIL PROFILE FIGURE 2.5-427 SHEET 1 OF 1</b>

PROJECT: WATTS BAR N.P.  
BORING: PAH-8 STATION:  
DATE DRILLED: 8/26/83 TO

FEATURE: BORROW AREA 13  
RANGE: SURFACE EL: 740.1  
PREPARED BY: MHD CHECKED BY: *CBG*

DEPTH ft.	EL	SPT (N)	* LOG	W	LL	PI	FIELD DESCRIPTION
	740						TOPSOIL
5	735		U	22.6	36	13	CL SI, BRN, MST, RESD
10	730		U	24.8	36	13	CL SI, BRN, MST, RESD
15	725		U	24.2	36	13	CL SI, BRN, MST, RESD
20	720		U Σ	21.5	45	17	CL SI, BRN, V MST, RESD
25	715						DISCONTINUED.
30	710						
35							
1"=5'							Added by Amendment 50
							* Lab. Classif.

Figure 2.5-427 Soil Profile

<b>WATTS BAR NUCLEAR PLANT FINAL SAFETY ANALYSIS REPORT</b>
<b>SOIL PROFILE FIGURE 2.5-428 SHEET 1 OF 1</b>

PROJECT: WATTS BAR N.P.  
BORING: PAH-9 STATION:  
DATE DRILLED: 8/26/83 TO

FEATURE: BORROW AREA 13  
RANGE: SURFACE EL: 714.2  
PREPARED BY: MHD CHECKED BY: *CPG*

DEPTH ft.	EL	SPT (N)	* LOG	W	LL	PI	FIELD DESCRIPTION
							TOPSOIL
5	710		CL	18.9	43	20	CL SI, LT BRN, MST, RESD
10	705		CL	20.9	43	20	CL SI, LT BRN, MST, RESD
15	700		CL Σ	17.7	37	12	CL SI, LT BRN, MST, RESD
20	695		CL Σ	18.0	37	12	CL SI, LT BRN, MST, RESD
25	690						DISCONTINUED.
30	685						
35	680						
1"=5'			*Lab. Classif.				Added by Amendment 50

Figure 2.5-428 Soil Profile



<b>WATTS BAR NUCLEAR PLANT FINAL SAFETY ANALYSIS REPORT</b>
<b>SOIL PROFILE FIGURE 2.5-429 SHEET 1 OF 1</b>

PROJECT: WATTS BAR N.P.  
BORING: PAH-10 STATION:  
DATE DRILLED: 8/26/83 TO

FEATURE: BORROW AREA 13  
RANGE: SURFACE EL: 713.0  
PREPARED BY: MHD CHECKED BY: *CBG*

DEPTH ft.	EL	SPT (N)	* LOG	W	LL	PI	FIELD DESCRIPTION
							SPOIL FILL
5	710		CL   ML	21.0	37	12	CL SI, LT BRN, MST, RESD
10	705		CL   ML	20.8	37	12	CL SI, LT BRN, MST, RESD
15	700		CL   ML	16.3	37	12	CL SI, LT BRN, MST, RESD
20	695		CL   ML	18.5	37	12	CL SI, LT BRN, MST, RESD
25	690						DISCONTINUED.
30	685						
35	680						
1''=5'			* Lab. Classif.				Added by Amendment 50

Figure 2.5-429 Soil Profile

<b>WATTS BAR NUCLEAR PLANT FINAL SAFETY ANALYSIS REPORT</b>
<b>SOIL PROFILE FIGURE 2.5-430 SHEET 1 OF 1</b>

PROJECT: WATTS BAR N.P.  
BORING: PAH-11 STATION:  
DATE DRILLED: 8/26/83 TO

FEATURE: BORROW AREA 13  
RANGE: SURFACE EL: 730.5  
PREPARED BY: MHD CHECKED BY: *CLC*

DEPTH ft.	EL	SPT (N)	* LOG	W	LL	PI	FIELD DESCRIPTION
	730						TOPSOIL
5	725		CL SI	21.0	35	11	CL SI, BRN, MST, RESD
10	720		CL SI	18.4	35	11	CL SI, TR GV, BRN, MST, RESD
15	715		CL SI	17.4	35	11	CL SI, BRN, MST, RESD
20	710						DISCONTINUED
25	705						
30	700						
35							
1"=5'			* Lab. Classif.				Added by Amendment 50

Figure 2.5-430 Soil Profile

<b>WATTS BAR NUCLEAR PLANT FINAL SAFETY ANALYSIS REPORT</b>
<b>SOIL PROFILE FIGURE 2.5-431 SHEET 1 OF 1</b>

PROJECT: WATTS BAR N.P.  
BORING: PAH-12 STATION:  
DATE DRILLED: 8/26/83 TO

FEATURE: BORROW AREA 13  
RANGE: SURFACE EL: 745.8  
PREPARED BY: MHD CHECKED BY: *RLG*

DEPTH ft.	EL	SPT (N)	* LOG	W	LL	PI	FIELD DESCRIPTION
5  10  15  20  25  30  35 1''=5'	745		U O Σ	18.2	35	11	TOPSOIL CL SI, BRN, MST, RESD
	740		I Σ	25.6	52	17	CL SI, BRN, MST, RESD
	735		I Σ	27.4	52	17	CL SI, TR BENT, BRN, MST, RESD
	730		I Σ	29.7	52	17	CL SI, BRN, MST, RESD
	725						
	720						
	715						
							Added by Amendment 50
			* Lab. Classif.				

Figure 2.5-431 Soil Profile

<b>WATTS BAR NUCLEAR PLANT FINAL SAFETY ANALYSIS REPORT</b>
<b>SOIL PROFILE FIGURE 2.5-432 SHEET 1 OF 1</b>

PROJECT: WATTS BAR N.P.  
BORING: PAH-13 STATION:  
DATE DRILLED: 8/26/83 TO

FEATURE: BORROW AREA 13  
RANGE: SURFACE EL: 701.0  
PREPARED BY: MHD CHECKED BY: *UBG*

DEPTH ft.	EL	SPT (N)	* LOG	W	LL	PI	FIELD DESCRIPTION
	700						TOPSOIL, SPOIL
5			Σ	23.1	44	16	CL SI, BRN, MST, RESD
	695		Σ	19.1	44	16	CL SI, BRN, MST, RESD
10			ML	16.4	44	16	SI CL, IR BENT, BRN, MST, RESD
	690						DISCONTINUED.
15	685						
20	680						
25	675						
30	670						
35							
1''=5'			* Lab. Classif.				Added by Amendment 50

Figure 2.5-432 Soil Profile

<b>WATTS BAR NUCLEAR PLANT FINAL SAFETY ANALYSIS REPORT</b>
<b>SOIL PROFILE FIGURE 2.5-433 SHEET 1 OF 1</b>

PROJECT: WATTS BAR N.P.  
BORING: PAH-14 STATION:  
DATE DRILLED: 8/26/83 TO

FEATURE: BORROW AREA 13  
RANGE: SURFACE EL: 698.9  
PREPARED BY: MHD CHECKED BY: *UBG*

DEPTH ft.	EL	SPT (N)	* LOG	W	LL	PI	FIELD DESCRIPTION
5	695		U I Σ	16.6	35	11	TOPSOIL CL SI, BRN, MST, RESD
10	690		CL	21.3	40	18	SI CL, TR BENT, BRN, MST, RESD
15	685		CL	22.1	40	18	SI CL, TR BENT, BRN, MST, RESD
20	680		CL	20.4	40	18	SI CL, TR BENT, BRN, MST, RESD
25	675						DISCONTINUED.
30	670						
35	665						
1"=5'		* Lab. Classif.		Added by Amendment 50			

Figure 2.5-433 Soil Profile

<b>WATTS BAR NUCLEAR PLANT FINAL SAFETY ANALYSIS REPORT</b>
<b>SOIL PROFILE FIGURE 2.5-434 SHEET 1 OF 1</b>

PROJECT: WATTS BAR N.P.  
BORING: PAH-15 STATION:  
DATE DRILLED: 8/26/83 TO

FEATURE: BORROW AREA 13  
RANGE: SURFACE EL: 733.1  
PREPARED BY: MHD CHECKED BY: *MLG*

DEPTH ft.	EL	SPT (N)	* LOG	W	LL	PI	FIELD DESCRIPTION
5  10  15  20  25  30  35 1''=5'	730		Σ	26.4	44	16	CUT SURFACE, TOPSOIL SI CL, TR BENT, BRN, MST, RESD
	725		0	28.6	40	18	SI CL, TR BENT, BRN, MST, RESD
	720		0 Σ	18.6	35	11	CL SI, BRN, MST, RESD
	715		0 Σ	20.0	35	11	CL SI, BRN, MST, RESD
	710						DISCONTINUED.
	705						
	700						
							Added by Amendment 50

\* Lab. Classif.

Figure 2.5-434 Soil Profile

<b>WATTS BAR NUCLEAR PLANT FINAL SAFETY ANALYSIS REPORT</b>
<b>SOIL PROFILE FIGURE 2.5-435 SHEET 1 OF 1</b>

PROJECT: WATTS BAR N.P.  
BORING: PAH-16 STATION:  
DATE DRILLED: 8/26/83 TO

FEATURE: BORROW AREA 13  
RANGE: SURFACE EL: 745.3  
PREPARED BY: MHD CHECKED BY: *DBG*

DEPTH ft.	EL	SPT (N)	* LOG	W	LL	PI	FIELD DESCRIPTION
	745						TOPSOIL
5			U O I Σ	17.3	35	11	CL SI, BRN, MST, RESD
	740						
10			U O I Σ	24.1	35	11	CL SI, BRN, MST, RESD
	735						
15			Σ	27.1	44	16	CL SI, BRN, MST, RESD
	730						
20			Σ	28.6	44	16	CL SI, BRN, MST, RESD
	725						DISCONTINUED.
25							
	720						
30							
	715						
35							
1"=5'							Added by Amendment 50
							* Lab. Classif.

Figure 2.5-435 Soil Profile

<b>WATTS BAR NUCLEAR PLANT FINAL SAFETY ANALYSIS REPORT</b>
<b>SOIL PROFILE FIGURE 2.5-436 SHEET 1 OF 1</b>

PROJECT: WATTS BAR N.P.  
BORING: PAH-17 STATION:  
DATE DRILLED: 8/26/83 TO

FEATURE: BORROW AREA 13  
RANGE: SURFACE EL: 693.0  
PREPARED BY: MHD CHECKED BY: *llc*

DEPTH ft.	EL	SPT (N)	* LOG	W	LL	PI	FIELD DESCRIPTION
							TOPSOIL
5	690		Σ	23.5	44	16	SI CL, BRN, MST, RESD
10	685		Σ	25.7	44	16	SI CL, BRN-GY, MST, RESD
15	680		U	18.6	40	18	SI CL, BRN-GY, MST, RESD
20	675						DISCONTINUED (GV).
25	670						
30	665						
35	660						
1''=5'							Added by Amendment 50
							* Lab. Classif.

Figure 2.5-436 Soil Profile



<b>WATTS BAR NUCLEAR PLANT FINAL SAFETY ANALYSIS REPORT</b>
<b>SOIL PROFILE FIGURE 2.5-437 SHEET 1 OF 1</b>

PROJECT: WATTS BAR N.P.  
BORING: PAH-18 STATION:  
DATE DRILLED: 8/26/83 TO

FEATURE: BORROW AREA 13  
RANGE: SURFACE EL: 697.9  
PREPARED BY: MHD CHECKED BY: *CRG*

DEPTH ft.	EL	SPT (N)	* LOG	W	LL	PI	FIELD DESCRIPTION
							TOPSOIL
5	695		Σ	19.7	44	16	CL SI, BRN, MST, RESD
10	690		Σ	26.7	44	16	CL SI, TN, MST, RESD
15	685		Σ	22.3	44	16	CL SI, TN, MST, RESD
20	680		Σ	20.3	44	16	CL SI, TN, MST, RESD
25	675						DISCONTINUED.
30	670						
35	665						
1''=5'							Added by Amendment 50
							* Lab. Classif.

Figure 2.5-437 Soil Profile

<b>WATTS BAR NUCLEAR PLANT FINAL SAFETY ANALYSIS REPORT</b>
<b>SOIL PROFILE FIGURE 2.5-438 SHEET 1 OF 1</b>

PROJECT: WATTS BAR N.P.  
BORING: FAH-1 STATION:  
DATE DRILLED: 6/7/83 TO

FEATURE: BORROW AREA 2C  
RANGE: SURFACE EL: 714.2  
PREPARED BY: MHD CHECKED BY: BA

DEPTH ft.	EL	SPT (N)	* LOG	W	LL	PI	FIELD DESCRIPTION
5	710		C U	18.2	29	12	SI CL, TN-BRN, MST, ALL
			Σ C U U	20.5	26	7	CL SD, ±20% FN RD GV, TN, V MST, ALL
10	705						SD GV, ±40% FN RD GV, ALL
			C U	19.5	29	12	FT SI, GRN-GY, MST, RESD
15	700						WITH GY SHL _____
							DISCONTINUED.
20	695						
25	690						
30	685						
35	680						
1''=5'			* Lab. Classif.				Added by Amendment 50

Figure 2.5-438 Soil Profile

<b>WATTS BAR NUCLEAR PLANT FINAL SAFETY ANALYSIS REPORT</b>
<b>SOIL PROFILE FIGURE 2.5-439 SHEET 1 OF 1</b>

PROJECT: WATTS BAR N.P.  
BORING: PAH-2 STATION:  
DATE DRILLED: 6/7/83 TO

FEATURE: BORROW AREA 2C  
RANGE: SURFACE EL: 722.1  
PREPARED BY: MHD CHECKED BY: BA

DEPTH ft.	EL	SPT (N)	* LOG	W	LL	PI	FIELD DESCRIPTION
							TOPSOIL
5	720		CL	27.5	38	13	SI CL, R, MST, ALL
10	715		CL	29.6	38	13	SI CL, R-BRN, MST, ALL
15	710		SO	27.2	34	14	SI CL, R-TN, V MST, ALL
20	705		SO	27.9	34	14	CL SI SD, BRN, V MST, ALL
25	700						W SI SD
30	695						DISCONTINUED.
35	690						
1"=5'			* Lab. Classif.				Added by Amendment 50

Figure 2.5-439 Soil Profile

<b>WATTS BAR NUCLEAR PLANT FINAL SAFETY ANALYSIS REPORT</b>
<b>SOIL PROFILE FIGURE 2.5-440 SHEET 1 OF 1</b>

PROJECT: WATTS BAR N.P.  
BORING: PAH-3 STATION:  
DATE DRILLED: 6/7/83 TO

FEATURE: BORROW AREA 2C  
RANGE: SURFACE EL: 717.2  
PREPARED BY: MHD CHECKED BY: BA

DEPTH ft.	EL	SPT (N)	* LOG	W	LL	PI	FIELD DESCRIPTION
5	715		CL	20.6	38	13	SI CL, TN, MST, ALL
	710		CS	24.3	34	14	SI CL, TN, MST, ALL
10			CS	26.1	34	14	SD SI CL, TN, V MST, ALL
	705						W SD SI CL
15							DISCONTINUED.
	700						
20							
	695						
25							
	690						
30							
	685						
35							
1''=5'			* Lab. Classif.				Added by Amendment 50

Figure 2.5-440 Soil Profile

WATTS BAR NUCLEAR PLANT FINAL SAFETY ANALYSIS REPORT
SOIL PROFILE FIGURE 2.5-441 SHEET 1 OF 1

PROJECT: WATTS BAR N.P.  
 BORING: PAH-4 STATION:  
 DATE DRILLED: 6/7/83 TO

FEATURE: BORROW AREA 2C  
 RANGE: SURFACE EL: 718  
 PREPARED BY: MHD CHECKED BY: BA

DEPTH ft.	EL	SPT (N)	* LOG	W	LL	PI	FIELD DESCRIPTION
							TOPSOIL
5	715		J 0	21.1	29	12	SI CL, TN-BRN, V MST, ALL
							-----
10	710						DISCONTINUED.
15	705						
20	700						
25	695						
30	690						
35	685						
1''=5'							Added by Amendment 50
							* Lab. Classif.

Figure 2.5-441 Soil Profile

<b>WATTS BAR NUCLEAR PLANT FINAL SAFETY ANALYSIS REPORT</b>
<b>SOIL PROFILE FIGURE 2.5-442 SHEET 1 OF 1</b>

PROJECT: WATTS BAR N.P.  
BORING: PAH-5 STATION:  
DATE DRILLED: 6/8/83 TO

FEATURE: BORROW AREA 2C  
RANGE: SURFACE EL: 723.1  
PREPARED BY: MHD CHECKED BY: BA

DEPTH ft.	EL	SPT (N)	* LOG	W	LL	PI	FIELD DESCRIPTION
							TOPSOIL
5	720		1 0 1 Σ	19.6	42	16	CL SI, TN, MST, ALL
10	715		1 0	24.8	42	18	CL SI, TN, MST, ALL
15	710						W CL SI
							DISCONTINUED.
20	705						
25	700						
30	695						
35	690						
1''=5'			* Lab. Classif.				Added by Amendment 50

Figure 2.5-442 Soil Profile

<b>WATTS BAR NUCLEAR PLANT FINAL SAFETY ANALYSIS REPORT</b>
<b>SOIL PROFILE FIGURE 2.5-443 SHEET 1 OF 1</b>

PROJECT: WATTS BAR N.P.  
BORING: PAH-6 STATION:  
DATE DRILLED: 6/8/83 TO

FEATURE: BORROW AREA 2C  
RANGE: SURFACE EL: 735.6  
PREPARED BY: MHD CHECKED BY: BA

DEPTH ft.	EL	SPT (N)	* LOG	W	LL	PI	FIELD DESCRIPTION
	735						TOPSOIL
5			U U Σ	28.4	42	16	FT CL, R, MST, ALL
	730		U U	23.3	35	14	SI CL, TN, MST, ALL
10			U U	22.7	35	14	SI CL, TN, MST, ALL
	725		U U	22.7	35	14	SI CL, TN, MST, ALL
15			U U	22.9	31	11	CL SI, TN, V MST, ALL
	720		U U	22.9	31	11	CL SI, TN, V MST, ALL
20							DISCONTINUED.
	715						
25							
	710						
30							
	705						
35							
1''=5'							Added by Amendment 50
			* Lab. Classif.				

Figure 2.5-443 Soil Profile

<b>WATTS BAR NUCLEAR PLANT FINAL SAFETY ANALYSIS REPORT</b>
<b>SOIL PROFILE FIGURE 2.5-444 SHEET 1 OF 1</b>

PROJECT: WATTS BAR N.P.  
BORING: PAH-8 STATION:  
DATE DRILLED: 6/8/83 TO

FEATURE: BORROW AREA 2C  
RANGE: SURFACE EL: 749.1  
PREPARED BY: MHD CHECKED BY: BA

DEPTH ft.	EL	SPT (N)	* LOG	W	LL	PI	FIELD DESCRIPTION
5	745		LO	20.8	33	13	SI CL, BRN, MST, ALL
10	740		LO   Σ	23.7	42	16	SI CL, R, MST, ALL
15	735		LO   Σ	25.6	42	16	FT CL, R, MST, RESD
20	730		LO	20.8	39	16	FT SI, DK R, MST, RESD (SL AUGG)
25	725						DISCONTINUED.
30	720						
35	715						
1''=5'			* Lab. Classif.				Added by Amendment 50

Figure 2.5-444 Soil Profile



<b>WATTS BAR NUCLEAR PLANT FINAL SAFETY ANALYSIS REPORT</b>
<b>SOIL PROFILE FIGURE 2.5-445 SHEET 1 OF 1</b>

PROJECT: WATTS BAR N.P.  
BORING: PAH-10 STATION:  
DATE DRILLED: 6/7/83 TO

FEATURE: BORROW AREA 2C  
RANGE: SURFACE EL: 713.4  
PREPARED BY: MHD CHECKED BY: BA

DEPTH ft.	EL	SPT (N)	* LOG	W	LL	PI	FIELD DESCRIPTION
							TOPSOIL
5	710		U	17.4	29	12	CL SI, TN, MST, RESD
10	705		U	14.3	29	12	CL SI, GRN-TN, MST, RESD
15	700						DISCONTINUED.
20	695						
25	690						
30	685						
35	680						
1''=5'			* Lab. Classif.				Added by Amendment 50

Figure 2.5-445 Soil Profile

<b>WATTS BAR NUCLEAR PLANT FINAL SAFETY ANALYSIS REPORT</b>
<b>SOIL PROFILE FIGURE 2.5-446 SHEET 1 OF 1</b>

PROJECT: WATTS BAR N.P.  
BORING: PAH-11 STATION:  
DATE DRILLED: 6/7/83 TO

FEATURE: BORROW AREA 2C  
RANGE: SURFACE EL: 723.4  
PREPARED BY: MHD CHECKED BY: BA

DEPTH ft.	EL	SPT (N)	* LOG	W	LL	PI	FIELD DESCRIPTION
5	720		U   O   Σ	25.3	38	13	SI CL, R-BRN, MST, ALL
10	715		U   O   Σ	24.3	38	13	CL SI SD, BRN, MST, ALL
15	710						SI CL SD, W
20	705						DISCONTINUED.
25	700						
30	695						
35	690						
1''=5'			* Lab. Classif.				Added by Amendment 50

Figure 2.5-446 Soil Profile

<b>WATTS BAR NUCLEAR PLANT FINAL SAFETY ANALYSIS REPORT</b>
<b>SOIL PROFILE FIGURE 2.5-447 SHEET 1 OF 1</b>

PROJECT: WATTS BAR N.P.  
BORING: PAH-12 STATION:  
DATE DRILLED: 6/7/83 TO

FEATURE: BORROW AREA 2C  
RANGE: SURFACE EL: 724.3  
PREPARED BY: MHD CHECKED BY: BA

DEPTH ft.	EL	SPT (N)	* LOG	W	LL	PI	FIELD DESCRIPTION
							TOPSOIL
5	720		U Σ	26.2	38	13	SI CL, R-BRN, MST, ALL
10	715		U Σ	26.4	38	13	CL SI SD, R-BRN, V MST, ALL
15	710						W CL SI SD
20	705						DISCONTINUED.
25	700						
30	695						
35	690						
1''=5'			* Lab. Classif.				Added by Amendment 50

Figure 2.5-447 Soil Profile

<b>WATTS BAR NUCLEAR PLANT FINAL SAFETY ANALYSIS REPORT</b>
<b>SOIL PROFILE FIGURE 2.5-448 SHEET 1 OF 1</b>

PROJECT: WATTS BAR N.P.  
BORING: PAH-13 STATION:  
DATE DRILLED: 6/8/83 TO

FEATURE: BORROW AREA 2C  
RANGE: SURFACE EL: 718.7  
PREPARED BY: MHD CHECKED BY: *BT*

DEPTH ft.	EL	SPT (N)	* LOG	W	LL	PI	FIELD DESCRIPTION
5	715		J O	19.3	34	14	SI CL, BRN, V MST, ALL
10	710						SI CL, W DISCONTINUED.
15	705						
20	700						
25	695						
30	690						
35	685						
1' '=5'							Added by Amendment 50
			* Lab. Classif.				

Figure 2.5-448 Soil Profile

<b>WATTS BAR NUCLEAR PLANT FINAL SAFETY ANALYSIS REPORT</b>
<b>SOIL PROFILE FIGURE 2.5-449 SHEET 1 OF 1</b>

PROJECT: WATTS BAR N.P.  
BORING: PAH-14 STATION:  
DATE DRILLED: 6/8/83 TO

FEATURE: BORROW AREA 2C  
RANGE: SURFACE EL: 730.0  
PREPARED BY: MHD CHECKED BY: BA

DEPTH ft.	EL	SPT (N)	* LOG	W	LL	PI	FIELD DESCRIPTION
	730						SPOIL FILL & BURIED TOPSOIL
5	725						
			┌ └	20.3	39	18	SI CL, TN-BRN, MST, ALL
10	720						
			┌ └	26.5	39	18	FT CL, R-BRN, MST, ALL
15	715						
			┌ └	25.9	42	16	SI CL, R-BRN, MST, ALL
20	710						-----
							DISCONTINUED.
25	705						
30	700						
35	695						
1"=5'							Added by Amendment 50
							* Lab. Classif.

Figure 2.5-449 Soil Profile

<b>WATTS BAR NUCLEAR PLANT FINAL SAFETY ANALYSIS REPORT</b>
<b>SOIL PROFILE FIGURE 2.5-450 SHEET 1 OF 1</b>

PROJECT: WATTS BAR N.P.  
BORING: PAH-15 STATION:  
DATE DRILLED: 6/7/83 TO

FEATURE: BORROW AREA 2C  
RANGE: SURFACE EL: 739.7  
PREPARED BY: MHD CHECKED BY: BA

DEPTH ft.	EL	SPT (N)	* LOG	W	LL	PI	FIELD DESCRIPTION
5	735		J O   Σ	25.0	42	16	FT CL, R, MST, RESD
10	730		J O	23.6	39	18	FT CL, R, MST, RESD
15	725		J O	23.0	42	18	FT SI, TN, MST, RESD
20	720		J O	22.8	39	18	FT SI, TN, MST, RESD
25	715						DISCONTINUED.
30	710						
35	705						
1''=5'			* Lab. Classif.				Added by Amendment 50

Figure 2.5-450 Soil Profile

WATTS BAR NUCLEAR PLANT FINAL SAFETY ANALYSIS REPORT
SOIL PROFILE FIGURE 2.5-451 SHEET 1 OF 1

PROJECT: WATTS BAR N.P.  
 BORING: PAH-16 STATION:  
 DATE DRILLED: 6/7/83 TO

FEATURE: BORROW AREA 2C  
 RANGE: SURFACE EL: 749.8  
 PREPARED BY: MHD CHECKED BY: BA

DEPTH ft.	EL	SPT (N)	* LOG	W	LL	PI	FIELD DESCRIPTION
5	745		I U I Σ	30.5	64	31	FT SI, DK R, MST, RESD
10	740		U	27.1	39	16	FT SI, DK R, MST, RESD
15	735		U	27.6	39	16	FT SI, DK R, MST, RESD
20	730		U	25.0	39	16	FT SI, DK R, MST, RESD
25	725						DISCONTINUED.
30	720						
35	715						
1''=5'			* Lab. Classif.				Added by Amendment 50

Figure 2.5-451 Soil Profile

<b>WATTS BAR NUCLEAR PLANT FINAL SAFETY ANALYSIS REPORT</b>
<b>SOIL PROFILE FIGURE 2.5-452 SHEET 1 OF 1</b>

PROJECT: WATTS BAR N.P.  
BORING: PAH-17 STATION:  
DATE DRILLED: 6/7/83 TO

FEATURE: BORROW AREA 2C  
RANGE: SURFACE EL: 713.7  
PREPARED BY: MHD CHECKED BY: SA

DEPTH ft.	EL	SPT (N)	* LOG	W	LL	PI	FIELD DESCRIPTION
							TOPSOIL - V MST
5	710		∫ Σ	17.1	NP	NP	SD SI, LT TN, V MST, ALL
							-----
							DISCONTINUED.
10	705						
15	700						
20	695						
25	690						
30	685						
35	680						
1''=5'							Added by Amendment 50
							* Lab. Classif.

Figure 2.5-452 Soil Profile



<b>WATTS BAR NUCLEAR PLANT FINAL SAFETY ANALYSIS REPORT</b>
<b>SOIL PROFILE FIGURE 2.5-453 SHEET 1 OF 1</b>

PROJECT: WATTS BAR N.P.  
BORING: PAH-18 STATION:  
DATE DRILLED: 6/7/83 TO

FEATURE: BORROW AREA 2C  
RANGE: SURFACE EL: 722.9  
PREPARED BY: MHD CHECKED BY: PA

DEPTH ft.	EL	SPT (N)	* LOG	W	LL	PI	FIELD DESCRIPTION
5	720		U O   Σ	25.7	38	13	SD SI CL, R-BRN, MST, ALL
10	715		U O   Σ	26.8	38	13	CL SD SI, R-BRN, V MST, ALL
15	710						DISCONTINUED.
20	705						
25	700						
30	695						
35	690						
1''=5'			* Lab. Classif.				Added by Amendment 50

Figure 2.5-453 Soil Profile

<b>WATTS BAR NUCLEAR PLANT FINAL SAFETY ANALYSIS REPORT</b>
<b>SOIL PROFILE FIGURE 2.5-454 SHEET 1 OF 1</b>

PROJECT: WATTS BAR N.P.  
BORING: PAH-19 STATION:  
DATE DRILLED: 6/7/83 TO

FEATURE: BORROW AREA 2C  
RANGE: SURFACE EL: 721.8  
PREPARED BY: MHD CHECKED BY: BA

DEPTH ft.	EL	SPT (N)	* LOG	W	LL	PI	FIELD DESCRIPTION
	720						
5			CL	21.8	34	14	SI CL, R-TN, MST, ALL
	715						
10			CL	25.6	34	14	SI CL, R-TN, V MST, ALL
	710						
15							W CL SD
	705						DISCONTINUED.
20							
	700						
25							
	695						
30							
	690						
35							
1"=5'			* Lab. Classif.				Added by Amendment 50

Figure 2.5-454 Soil Profile

<b>WATTS BAR NUCLEAR PLANT FINAL SAFETY ANALYSIS REPORT</b>
<b>SOIL PROFILE FIGURE 2.5-455 SHEET 1 OF 1</b>

PROJECT: WATTS BAR N.P.  
BORING: PAH-20 STATION:  
DATE DRILLED: 6/8/83 TO

FEATURE: BORROW AREA 2C  
RANGE: SURFACE EL: 722.5  
PREPARED BY: MHD CHECKED BY: *BA*

DEPTH ft.	EL	SPT (N)	* LOG	W	LL	PI	FIELD DESCRIPTION
	720						
5			┌ └ O	18.6	34	14	CL SI, BRN, MST, ALL
	715						
10			┌ └ O	23.2	34	14	SI CL, BRN, V MST, ALL
	710						
15							DISCONTINUED.
	705						
20							
	700						
25							
	695						
30							
	690						
35							
1"=5'							Added by Amendment 50
							* Lab. Classif.

Figure 2.5-455 Soil Profile

<b>WATTS BAR NUCLEAR PLANT FINAL SAFETY ANALYSIS REPORT</b>
<b>SOIL PROFILE FIGURE 2.5-456 SHEET 1 OF 1</b>

PROJECT: WATTS BAR N.P.  
BORING: PAH-21 STATION:  
DATE DRILLED: 6/8/83 TO

FEATURE: BORROW AREA 2C  
RANGE: SURFACE EL: 733.2  
PREPARED BY: MHD CHECKED BY: BA

DEPTH ft.	EL	SPT (N)	* LOG	W	LL	PI	FIELD DESCRIPTION
							TOPSOIL
5	730		┌ └	23.3	39	18	SI CL, R-BRN, MST, ALL
10	725		┌ └	28.5	33	13	CL SI, DK R, MST, RESD
15	720		┌ └	26.2	42	16	SI CL, TN-BRN, MST, RESD
20	715						----- DISCONTINUED.
25	710						
30	705						
35	700						
1''=5'							Added by Amendment 50
							* Lab. Classif.

Figure 2.5-456 Soil Profile

<b>WATTS BAR NUCLEAR PLANT FINAL SAFETY ANALYSIS REPORT</b>
<b>SOIL PROFILE FIGURE 2.5-457 SHEET 1 OF 1</b>

PROJECT: WATTS BAR N.P.  
BORING: PAH-22 STATION:  
DATE DRILLED: 6/7/83 TO

FEATURE: BORROW AREA 2C  
RANGE: SURFACE EL: 747.8  
PREPARED BY: MHD CHECKED BY: BA

DEPTH ft.	EL	SPT (N)	* LOG	W	LL	PI	FIELD DESCRIPTION
5	745		UII U I Σ	32.6	64	31	FT SI, DK R, MST, RESD
10	740		CL	31.2	39	16	FT SI, DK R, MST, RESD
15	735		CL	26.9	39	16	FT SI, DK R, MST, RESD
20	730		CL	24.3	39	16	FT SI, DK R, MST, RESD
25	725						DISCONTINUED.
30	720						
35	715						
1''=5'			* Lab. Classif.				Added by Amendment 50

Figure 2.5-457 Soil Profile

<b>WATTS BAR NUCLEAR PLANT FINAL SAFETY ANALYSIS REPORT</b>
<b>SOIL PROFILE FIGURE 2.5-458 SHEET 1 OF 1</b>

PROJECT: WATTS BAR N.P.  
BORING: PAH-23 STATION:  
DATE DRILLED: 6/7/83 TO

FEATURE: BORROW AREA 2C  
RANGE: SURFACE EL: 759.9  
PREPARED BY: MHD CHECKED BY: BA

DEPTH ft.	EL	SPT (N)	* LOG	W	LL	PI	FIELD DESCRIPTION
5	755		┌─┐ ├─┤ └─┘ Σ	22.8	42	16	SI CL, R, MST, ALL
10	750		┌─┐ ├─┤ └─┘ Σ	27.5	42	16	FT CL, R, MST, ALL
15	745		┌─┐ ├─┤ └─┘ Σ	29.4	42	16	FT CL, R, MST, ALL
20	740		┌─┐ └─┘	23.2	39	16	FT SI, DK R, MST, RESD
25	735						----- DISCONTINUED.
30	730						
35	725						
1''=5'			* Lab. Classif.				Added by Amendment 50

Figure 2.5-458 Soil Profile

<b>WATTS BAR NUCLEAR PLANT FINAL SAFETY ANALYSIS REPORT</b>
<b>SOIL PROFILE FIGURE 2.5-459 SHEET 1 OF 1</b>

PROJECT: WATTS BAR N.P.  
BORING: PAH-24 STATION:  
DATE DRILLED: 6/7/83 TO

FEATURE: BORROW AREA 2C  
RANGE: SURFACE EL: 757.3  
PREPARED BY: MHD CHECKED BY: EA

DEPTH ft.	EL	SPT (N)	* LOG	W	LL	PI	FIELD DESCRIPTION
5	755		CL	24.3	42	18	FT SI, R-BRN, MST, ALL
10	750		CL	28.4	42	18	FT SI, R-BRN, MST, ALL
15	745		CL	29.2	35	14	SI CL, R, V MST, ALL
20	740		CL	28.7	39	18	CL SI, GY-TN, MST, RESD
25	735						DISCONTINUED.
30	730						
35	725						
1''=5'			* Lab. Classif.				Added by Amendment 50

Figure 2.5-459 Soil Profile

<b>WATTS BAR NUCLEAR PLANT FINAL SAFETY ANALYSIS REPORT</b>
<b>SOIL PROFILE FIGURE 2.5-460 SHEET 1 OF 1</b>

PROJECT: WATTS BAR N.P.  
BORING: PAH-25 STATION:  
DATE DRILLED: 6/9/83 TO

FEATURE: BORROW AREA 2C  
RANGE: SURFACE EL: 714.2  
PREPARED BY: MHD CHECKED BY: *BA*

DEPTH ft.	EL	SPT (N)	* LOG	W	LL	PI	FIELD DESCRIPTION
5	710		*	26.2	18	1	TOPSOIL
			Σ				SD SI, GY, W, ALL
10	705						DISCONTINUED.
15	700						
20	695						
25	690						
30	685						
35	680						
1''=5'							Added by Amendment 50
							* Lab. Classif.

Figure 2.5-460 Soil Profile



<b>WATTS BAR NUCLEAR PLANT FINAL SAFETY ANALYSIS REPORT</b>
<b>SOIL PROFILE FIGURE 2.5-461 SHEET 1 OF 1</b>

PROJECT: WATTS BAR N.P.  
BORING: PAH-26 STATION:  
DATE DRILLED: 6/9/83 TO

FEATURE: BORROW AREA 2C  
RANGE: SURFACE EL: 716.0  
PREPARED BY: MHD CHECKED BY: *PA*

DEPTH ft.	EL	SPT (N)	* LOG	W	LL	PI	FIELD DESCRIPTION
	715						TOPSOIL
5			J 0	18.8	29	12	SI SD CL, BRN, V MST, ALL
	710						W GY-IN SI SD
10							DISCONTINUED.
	705						
15							
	700						
20							
	695						
25							
	690						
30							
	685						
35							
1''=5'							Added by Amendment 50
							* Lab. Classif.

Figure 2.5-461 Soil Profile

<b>WATTS BAR NUCLEAR PLANT FINAL SAFETY ANALYSIS REPORT</b>
<b>SOIL PROFILE FIGURE 2.5-462 SHEET 1 OF 1</b>

PROJECT: WATTS BAR N.P.  
BORING: PAH-27 STATION:  
DATE DRILLED: 6/9/83 TO

FEATURE: BORROW AREA 2C  
RANGE: SURFACE EL: 720.7  
PREPARED BY: MHD CHECKED BY: BA

DEPTH ft.	EL	SPT (N)	* LOG	W	LL	PI	FIELD DESCRIPTION
	720						TOPSOIL
5			CL	19.9	29	12	SI CL, BRN, V MST, ALL
	715						
10			CL	23.2	38	13	SI CL, BRN, V MST, ALL
	710						W SD CL
15							DISCONTINUED.
	705						
20							
	700						
25							
	695						
30							
	690						
35							
1''=5'							Added by Amendment 50
			* Lab. Classif.				

Figure 2.5-462 Soil Profile

<b>WATTS BAR NUCLEAR PLANT FINAL SAFETY ANALYSIS REPORT</b>
<b>SOIL PROFILE FIGURE 2.5-463 SHEET 1 OF 1</b>

PROJECT: WATTS BAR N.P.  
BORING: PAH-28 STATION:  
DATE DRILLED: 6/8/83 TO

FEATURE: BORROW AREA 2C  
RANGE: SURFACE EL: 727.0  
PREPARED BY: MHD CHECKED BY: BA

DEPTH ft.	EL	SPT (N)	* LOG	W	LL	PI	FIELD DESCRIPTION
	725						TOPSOIL
5			┌ └	20.5	39	18	SI CL, TN-BRN, MST, ALL
	720						
10			┌ └	20.9	35	14	SI CL, TN-BRN, MST, ALL
	715						
15			┌ └	25.0	35	14	CL SI, TN, V MST, ALL
	710						W CL SI
20							DISCONTINUED.
	705						
25							
	700						
30							
	695						
35							
1''=5'							Added by Amendment 50
							* Lab. Classif.

Figure 2.5-463 Soil Profile

<b>WATTS BAR NUCLEAR PLANT FINAL SAFETY ANALYSIS REPORT</b>
<b>SOIL PROFILE FIGURE 2.5-464 SHEET 1 OF 1</b>

SHEET 1 OF 1

PROJECT: WATTS BAR N.P.  
BORING: PAH-29 STATION:  
DATE DRILLED: 6/8/83 TO

FEATURE: BORROW AREA 2C  
RANGE: SURFACE EL: 733.1  
PREPARED BY: MHD CHECKED BY: BA

DEPTH ft.	EL	SPT (N)	* LOG	W	LL	PI	FIELD DESCRIPTION
5	730		0	21.4	42	18	SI CL, TN, MST, ALL
			0	28.3	39	18	FT CL, TN, MST, RESD
10	725		0	30.0	42	18	FT SI, TN, MST, RESD
15	720		0	25.9	42	18	FT SI, TN, MST, RESD
20	715						----- DISCONTINUED.
25	710						
30	705						
35	700						
1''=5'							Added by Amendment 50
							* Lab. Classif.

Figure 2.5-464 Soil Profile

<b>WATTS BAR NUCLEAR PLANT FINAL SAFETY ANALYSIS REPORT</b>
<b>SOIL PROFILE FIGURE 2.5-465 SHEET 1 OF 1</b>

PROJECT: WATTS BAR N.P.  
BORING: PAH-30 STATION:  
DATE DRILLED: 6/8/83 TO

FEATURE: BORROW AREA 2C  
RANGE: SURFACE EL: 740.5  
PREPARED BY: MHD CHECKED BY: BA

DEPTH ft.	EL	SPT (N)	* LOG	W	LL	PI	FIELD DESCRIPTION
	740						TOPSOIL
5	735		0	20.9	39	18	SI CL, TN, MST, ALL
10	730		0	19.1	39	18	CL SI, TN, MST, RESD
15	725		0	22.6	35	14	SI CL, TN, MST, RESD
20	720		0	21.5	42	18	SI CL, TN, MST, RESD
25	715						DISCONTINUED.
30	710						
35							
1''=5'							Added by Amendment 50
							* Lab. Classif.

Figure 2.5-465 Soil Profile

<b>WATTS BAR NUCLEAR PLANT FINAL SAFETY ANALYSIS REPORT</b>
<b>SOIL PROFILE FIGURE 2.5-466 SHEET 1 OF 1</b>

PROJECT: WATTS BAR N.P.  
BORING: PAH-31 STATION:  
DATE DRILLED: 6/8/83 TO

FEATURE: BORROW AREA 2C  
RANGE: SURFACE EL: 743.0 est.  
PREPARED BY: MHD CHECKED BY: *BT*

DEPTH ft.	EL	SPT (N)	* LOG	W	LL	PI	FIELD DESCRIPTION
5	740		U O   Σ	22.2	42	16	SI CL, R, MST, ALL
10	735		U O   Σ	21.7	42	16	SI CL, R, MST, ALL
15	730		U O	21.2	39	18	SI CL, BRN, MST, RESD
20	725		U O	20.1	43	20	SI CL, BRN, MST, RESD
25	720						DISCONTINUED.
30	715						
35	710						
1''=5'							Added by Amendment 50

\* Lab. Classif.

Figure 2.5-466 Soil Profile

<b>WATTS BAR NUCLEAR PLANT FINAL SAFETY ANALYSIS REPORT</b>
<b>SOIL PROFILE FIGURE 2.5-467 SHEET 1 OF 1</b>

PROJECT: WATTS BAR N.P.  
BORING: PAH-32 STATION:  
DATE DRILLED: 6/9/83 TO

FEATURE: BORROW AREA 2C  
RANGE: SURFACE EL: 713.7  
PREPARED BY: MHD CHECKED BY: BA

DEPTH ft.	EL	SPT (N)	* LOG	W	LL	PI	FIELD DESCRIPTION
							TOPSOIL
5	710		J U	20.6	29	12	CL SI, TN, V MST, ALL
10	705						W CL ST
							DISCONTINUED.
15	700						
20	695						
25	690						
30	685						
35	680						
1''=5'							Added by Amendment 50
							* Lab. Classif.

Figure 2.5-467 Soil Profile

<b>WATTS BAR NUCLEAR PLANT FINAL SAFETY ANALYSIS REPORT</b>
<b>SOIL PROFILE FIGURE 2.5-468 SHEET 1 OF 1</b>

PROJECT: WATTS BAR N.P.  
BORING: PAH-33 STATION:  
DATE DRILLED: 6/9/83 TO

FEATURE: BORROW AREA 2C  
RANGE: SURFACE EL: 721.1  
PREPARED BY: MHD CHECKED BY: BA

DEPTH ft.	EL	SPT (N)	* LOG	W	LL	PI	FIELD DESCRIPTION
	720						TOPSOIL
5			U Σ	23.5	38	13	SI CL, R-BRN, MST, ALL
	715						
10			U Σ	26.1	38	13	SD SI CL, R, MST, ALL
	710						
15			U	27.6	34	14	SD CL SI, TN, V MST, ALL
	705						W SD ST
20							DISCONTINUED.
	700						
25							
	695						
30							
	690						
35							
1''=5'							Added by Amendment 50
							* Lab. Classif.

Figure 2.5-468 Soil Profile



<b>WATTS BAR NUCLEAR PLANT FINAL SAFETY ANALYSIS REPORT</b>
<b>SOIL PROFILE FIGURE 2.5-469 SHEET 1 OF 1</b>

PROJECT: WATTS BAR N.P.  
BORING: PAH-34 STATION:  
DATE DRILLED: 6/9/83 TO

FEATURE: BORROW AREA 2C  
RANGE: SURFACE EL: 722.7  
PREPARED BY: MHD CHECKED BY: BA

DEPTH ft.	EL	SPT (N)	* LOG	W	LL	PI	FIELD DESCRIPTION
							TOPSOIL
5	720		U O I Σ	23.1	38	13	SI CL, R-BRN, MST, ALL
10	715		U O I Σ	26.0	38	13	SI CL, R-BRN, MST, ALL
15	710		U O	27.3	34	14	SI CL, R-TN, V MST, ALL
							W ST CL
20	705						DISCONTINUED.
25	700						
30	695						
35	690						
1''=5'			* Lab. Classif.				Added by Amendment 50

Figure 2.5-469 Soil Profile

<b>WATTS BAR NUCLEAR PLANT FINAL SAFETY ANALYSIS REPORT</b>
<b>SOIL PROFILE FIGURE 2.5-470 SHEET 1 OF 1</b>

PROJECT: WATTS BAR N.P.  
BORING: PAH-35 STATION:  
DATE DRILLED: 6/8/83 TO

FEATURE: BORROW AREA 2C  
RANGE: SURFACE EL: 724.6  
PREPARED BY: MHD CHECKED BY: BA

DEPTH ft.	EL	SPT (N)	* LOG	W	LL	PI	FIELD DESCRIPTION
							TOPSOIL
5	720		U <sub>1</sub> Σ	19.9	38	13	SI CL, BRN, MST, ALL
10	715		U <sub>1</sub> Σ	26.1	38	13	SI CL, BRN-TN, MST, ALL
			U <sub>0</sub>	26.3	34	14	SI CL, TN, V MST, ALL
15	710						W CL SD _____
							DISCONTINUED.
20	705						
25	700						
30	695						
35	690						
1''=5'			* Lab. Classif.				Added by Amendment 50

Figure 2.5-470 Soil Profile

<b>WATTS BAR NUCLEAR PLANT FINAL SAFETY ANALYSIS REPORT</b>
<b>SOIL PROFILE FIGURE 2.5-471 SHEET 1 OF 1</b>

PROJECT: WATTS BAR N.P.  
BORING: PAH-36 STATION:  
DATE DRILLED: 6/8/83 TO

FEATURE: BORROW AREA 2C  
RANGE: SURFACE EL: 728.2  
PREPARED BY: MHD CHECKED BY: BA

DEPTH ft.	EL	SPT (N)	* LOG	W	LL	PI	FIELD DESCRIPTION
							TOPSOIL
5	725		CL	20.2	35	14	SI CL, TN-BRN, MST, ALL
10	720		CL	22.0	42	18	CL SI, R-BRN, MST, RESD
15	715		CL	21.5	42	18	CL SI, R-BRN, MST, RESD
20	710		CL	21.7	35	14	CL SD SI, TN, MST, RESD
25	705						DISCONTINUED.
30	700						
35	695						
1''=5'			* Lab. Classif.				Added by Amendment 50

Figure 2.5-471 Soil Profile

<b>WATTS BAR NUCLEAR PLANT FINAL SAFETY ANALYSIS REPORT</b>
<b>SOIL PROFILE FIGURE 2.5-472 SHEET 1 OF 1</b>

PROJECT: WATTS BAR N.P.  
BORING: PAH-37 STATION:  
DATE DRILLED: 6/9/83 TO

FEATURE: BORROW AREA 2C  
RANGE: SURFACE EL: 733.3  
PREPARED BY: MHD CHECKED BY: BA

DEPTH ft.	EL	SPT (N)	* LOG	W	LL	PI	FIELD DESCRIPTION
							TOPSOIL
5	730		CL	21.0	35	14	SI CL, TN, MST, ALL
10	725		CL	23.0	42	18	SI CL, TN, MST, ALL
15	720		CL	23.7	39	18	CL SI, TN, MST, RESD
20	715						----- DISCONTINUED.
25	710						
30	705						
35	700						
1''=5'			* Lab. Classif.				Added by Amendment 50

Figure 2.5-472 Soil Profile

<b>WATTS BAR NUCLEAR PLANT FINAL SAFETY ANALYSIS REPORT</b>
<b>SOIL PROFILE FIGURE 2.5-473 SHEET 1 OF 1</b>

PROJECT: WATTS BAR N.P.  
BORING: PAH-38 STATION:  
DATE DRILLED: 6/8/83 TO

FEATURE: BORROW AREA 2C  
RANGE: SURFACE EL: 738.4  
PREPARED BY: MHD CHECKED BY: BA

DEPTH ft.	EL	SPT (N)	* LOG	W	LL	PI	FIELD DESCRIPTION
							GV DBR & TOPSOIL
5	735		J O   J	22.1	42	16	SI CL, TN, MST, ALL
10	730		J O	21.9	42	18	CL SI, TN, MST, RESD
15	725		J O	23.0	42	18	CL SI, TN, MST, RESD
20	720						DISCONTINUED.
25	715						
30	710						
35	705						
1''=5'			* Lab. Classif.				Added by Amendment 50

Figure 2.5-473 Soil Profile

<b>WATTS BAR NUCLEAR PLANT FINAL SAFETY ANALYSIS REPORT</b>
<b>SOIL PROFILE FIGURE 2.5-474 SHEET 1 OF 1</b>

PROJECT: WATTS BAR N.P.  
BORING: PAH-39 STATION:  
DATE DRILLED: 6/9/83 TO

FEATURE: BORROW AREA 2C  
RANGE: SURFACE EL: 716.5  
PREPARED BY: MHD CHECKED BY: BA

DEPTH ft.	EL	SPT (N)	* LOG	W	LL	PI	FIELD DESCRIPTION
	715						TOPSOIL
5			┌─┐ └─┘ U I Σ	20.7	38	13	SD SI CL, R-BRN, V MST, ALL
	710						
10			┌─┐ └─┘ U I Σ	19.2	38	13	SD SI CL, TR GV, R-BRN, V MST, ALL
	705						
15							W CL SD
	700						DISCONTINUED.
20							
	695						
25							
	690						
30							
	685						
35							
1''=5'							Added by Amendment 50
							* Lab. Classif.

Figure 2.5-474 Soil Profile

<b>WATTS BAR NUCLEAR PLANT FINAL SAFETY ANALYSIS REPORT</b>
<b>SOIL PROFILE FIGURE 2.5-475 SHEET 1 OF 1</b>

PROJECT: WATTS BAR N.P.  
BORING: PAH-40 STATION:  
DATE DRILLED: 6/9/83 TO

FEATURE: BORROW AREA 2C  
RANGE: SURFACE EL: 721.1  
PREPARED BY: MHD CHECKED BY: BA

DEPTH ft.	EL	SPT (CN)	* LOG	W	LL	PI	FIELD DESCRIPTION
	720						TOPSOIL
5			U O   Σ	24.6	38	13	SI CL, R-BRN, MST, ALL
	715		U O   Σ	24.8	38	13	SI CL, R-BRN, MST, ALL
10							W ST CL
	710						DISCONTINUED.
15							
	705						
20							
	700						
25							
	695						
30							
	690						
35							
1''=5'							Added by Amendment 50
							* Lab. Classif.

Figure 2.5-475 Soil Profile

<b>WATTS BAR NUCLEAR PLANT FINAL SAFETY ANALYSIS REPORT</b>
<b>SOIL PROFILE FIGURE 2.5-476 SHEET 1 OF 1</b>

PROJECT: WATTS BAR N.P.  
BORING: PAH-41 STATION:  
DATE DRILLED: 6/9/83 TO

FEATURE: BORROW AREA 2C  
RANGE: SURFACE EL: 720.6  
PREPARED BY: MHD CHECKED BY: BA

DEPTH ft.	EL	SPT (N)	* LOG	W	LL	PI	FIELD DESCRIPTION
	720						TOPSOIL
5			U <sub>1</sub> Σ	25.4	38	13	SI CL, R-BRN, MST, ALL
	715		U <sub>1</sub> Σ	27.4	38	13	SI CL, R-BRN, V MST, ALL
10							W ST CL
	710						DISCONTINUED.
15							
	705						
20							
	700						
25							
	695						
30							
	690						
35							
1''=5'							Added by Amendment 50
							* Lab. Classif.

Figure 2.5-476 Soil Profile



<b>WATTS BAR NUCLEAR PLANT FINAL SAFETY ANALYSIS REPORT</b>
<b>SOIL PROFILE FIGURE 2.5-477 SHEET 1 OF 1</b>

PROJECT: WATTS BAR N.P.  
BORING: PAH-42 STATION:  
DATE DRILLED: 6/9/83 TO

FEATURE: BORROW AREA 2C  
RANGE: SURFACE EL: 723.0  
PREPARED BY: MHD CHECKED BY: EA

DEPTH ft.	EL	SPT (N)	* LOG	W	LL	PI	FIELD DESCRIPTION
5	720		U O   Σ	22.3	42	16	SI CL, BRN, MST, ALL
10	715		U O	19.7	42	18	CL SI, R-TN, MST, ALL
15	710		U O	24.7	42	18	CL SI, TN, V MST, ALL
20	705						W CL ST
25	700						DISCONTINUED.
30	695						
35	690						
1''=5'			* Lab. Classif.				Added by Amendment 50

Figure 2.5-477 Soil Profile

<b>WATTS BAR NUCLEAR PLANT FINAL SAFETY ANALYSIS REPORT</b>
<b>SOIL PROFILE FIGURE 2.5-478 SHEET 1 OF 1</b>

PROJECT: WATTS BAR N.P.  
BORING: PAH-43 STATION:  
DATE DRILLED: 6/9/83 TO

FEATURE: BORROW AREA 2C  
RANGE: SURFACE EL: 730.6  
PREPARED BY: MHD CHECKED BY: PA

DEPTH ft.	EL	SPT (N)	* LOG	W	LL	PI	FIELD DESCRIPTION
	730						
5	725		0 1 1 Σ	21.8	42	16	SI CL, R-BRN, MST, ALL
10	720		0 1 1 Σ	21.4	42	16	CL SI, TN-BRN, MST, RESD
15	715		0	20.0	33	13	CL SI, DK R, MST, RESD
20	710						DISCONTINUED.
25	705						
30	700						
35							
1''=5'			* Lab. Classif.				Added by Amendment 50

Figure 2.5-478 Soil Profile

<b>WATTS BAR NUCLEAR PLANT FINAL SAFETY ANALYSIS REPORT</b>
<b>SOIL PROFILE FIGURE 2.5-479 SHEET 1 OF 1</b>

PROJECT: WATTS BAR N.P.  
BORING: PAH-44 STATION:  
DATE DRILLED: 6/8/83 TO

FEATURE: BORROW AREA 2C  
RANGE: SURFACE EL: 736.1  
PREPARED BY: MHD CHECKED BY: PA

DEPTH ft.	EL	SPT (N)	* LOG	W	LL	PI	FIELD DESCRIPTION
	735						ROADBED GRAVEL
5			┌┐ └┘	18.3	39	18	SI CL, TN-BRN, MST, ALL
	730		┌┐┌┐ └┘└┘	26.5	42	16	SI CL, R, MST, ALL
10			┌┐ └┘	23.6	42	18	CL SI, TN, MST, ALL
	725						
15			┌┐┌┐ └┘└┘	22.8	42	16	CL SI, TN, MST, ALL
	720						
20							SD & GV _____
	715						DISCONTINUED.
25							
	710						
30							
	705						
35							
1''=5'							Added by Amendment 50
							* Lab. Classif.

Figure 2.5-479 Soil Profile

<b>WATTS BAR NUCLEAR PLANT FINAL SAFETY ANALYSIS REPORT</b>
<b>SOIL PROFILE FIGURE 2.5-480 SHEET 1 OF 1</b>

PROJECT: WATTS BAR N.P.  
BORING: PAH-45 STATION:  
DATE DRILLED: 6/8/83 TO

FEATURE: BORROW AREA 2C  
RANGE: SURFACE EL: 736.4  
PREPARED BY: MHD CHECKED BY: BA

DEPTH ft.	EL	SPT (N)	* LOG	W	LL	PI	FIELD DESCRIPTION
	735						GRAVEL - SPOILED SOILS
5			0	23.4	42	18	SI CL, R, MST, ALL
	730		0				
10			0	21.4	42	18	CL SI, R, MST, ALL
	725		0				
15			0	24.1	42	18	CL SI, TN, MST, RESD
	720		0				
20			0	22.7	42	18	CL SI, TN, MST, RESD
	715						DISCONTINUED.
25							
	710						
30							
	705						
35							
1''=5'							Added by Amendment 50
							* Lab. Classif.

Figure 2.5-480 Soil Profile

<b>WATTS BAR NUCLEAR PLANT FINAL SAFETY ANALYSIS REPORT</b>
<b>SOIL PROFILE FIGURE 2.5-481 SHEET 1 OF 1</b>

PROJECT: WATTS BAR N.P.  
BORING: PAH-46 STATION:  
DATE DRILLED: 6/9/83 TO

FEATURE: BORROW AREA 2C  
RANGE: SURFACE EL: 729.0 est  
PREPARED BY: MHD CHECKED BY: PA

DEPTH ft.	EL	SPT (N)	* LOG	W	LL	PI	FIELD DESCRIPTION
5	725		U	22.5	33	13	SI CL, BRN, MST, ALL
10	720		U	23.2	42	18	CL SI, R-BRN, MST, ALL
15	715		U	25.0	42	18	CL SI, R-BRN, MST, ALL
20	710		U	24.0	42	18	CL SI, R-BRN, MST, ALL
25	705						DISCONTINUED.
30	700						
35	695						
1''=5'			* Lab. Classif.				Added by Amendment 50

Figure 2.5-481 Soil Profile

<b>WATTS BAR NUCLEAR PLANT FINAL SAFETY ANALYSIS REPORT</b>
<b>SOIL PROFILE FIGURE 2.5-482 SHEET 1 OF 1</b>

SHEET 1 OF 1

PROJECT: WATTS BAR N.P.  
BORING: PAH-47 STATION:  
DATE DRILLED: 6/10/83 TO

FEATURE: BORROW AREA 2C  
RANGE: SURFACE EL: 721.0 est.  
PREPARED BY: MHD CHECKED BY: BA

DEPTH ft.	EL	SPT (N)	* LOG	W	LL	PI	FIELD DESCRIPTION
	720						TOPSOIL
5			U Σ	21.2	38	13	SI CL, R-BRN, MST, ALL
	715		U U				
10				28.0	29	12	SI CL, R-BRN, MST, ALL
	710						W SI CL (NO SAMPLE)
15							DISCONTINUED.
	705						
20							
	700						
25							
	695						
30							
	690						
35							
1''=5'							
			* Lab. Classif.				Added by Amendment 50

Figure 2.5-482 Soil Profile

<b>WATTS BAR NUCLEAR PLANT FINAL SAFETY ANALYSIS REPORT</b>
<b>SOIL PROFILE FIGURE 2.5-483 SHEET 1 OF 1</b>

PROJECT: WATTS BAR N.P.  
BORING: PAH-48 STATION:  
DATE DRILLED: 6/9/83 TO

FEATURE: BORROW AREA 2C  
RANGE: SURFACE EL: 713.7  
PREPARED BY: MHD CHECKED BY: BA

DEPTH ft.	EL	SPT (N)	* LOG	W	LL	PI	FIELD DESCRIPTION
							TOPSOIL
5	710		J 0	19.4	29	12	SI CL, BRN-TN, MST, ALL SD SI CL, TN, W
10	705						DISCONTINUED.
15	700						
20	695						
25	690						
30	685						
35	680						
1"=5'			* Lab. Classif.				Added by Amendment 50

Figure 2.5-483 Soil Profile

**WATTS BAR NUCLEAR PLANT  
FINAL SAFETY  
ANALYSIS REPORT**

---

**SOIL PROFILE  
FIGURE 2.5-484  
SHEET 1 OF 1**

PROJECT: WATTS BAR N.P.  
BORING: PAH-49 STATION:  
DATE DRILLED: 6/9/83 TO

FEATURE: BORROW AREA 2C  
RANGE: SURFACE EL: 729.7  
PREPARED BY: MHD CHECKED BY: BA

DEPTH ft.	EL	SPT (N)	* LOG	W	LL	PI	FIELD DESCRIPTION
5	725		CL	19.6	43	20	SI CL, BRN, MST, ALL
10	720		CL	23.4	33	13	SI CL, DK BRN-TN, MST, ALL
15	715		UI	22.9	42	16	SI CL, R, MST, ALL
20	710		CL	22.7	42	18	CL SI, TN-BRN, MST, ALL
25	705						W CL ST
30	700						DISCONTINUED.
35	695						
1''=5'			* Lab. Classif.				Added by Amendment 50

Figure 2.5-484 Soil Profile



<b>WATTS BAR NUCLEAR PLANT FINAL SAFETY ANALYSIS REPORT</b>
<b>SOIL PROFILE FIGURE 2.5-485 SHEET 1 OF 1</b>

PROJECT: WATTS BAR N.P.  
BORING: PAH-50 STATION:  
DATE DRILLED: 6/9/83 TO

FEATURE: BORROW AREA 2C  
RANGE: SURFACE EL: 730.0  
PREPARED BY: MHD CHECKED BY: BA

DEPTH ft.	EL	SPT (N)	* LOG	W	LL	PI	FIELD DESCRIPTION
	730						
5	725		CL	18.4	43	20	SI CL, TR FN GV, TN-BRN, MST, ALL
10	720		CL	18.6	39	18	CL SI, TN, MST, RESD
15	715		CL	19.2	35	14	CL SI, TN, V MST, RESD
							W SI
20	710						DISCONTINUED.
25	705						
30	700						
35	695						Added by Amendment 50
1''=5'			* Lab. Classif.				

Figure 2.5-485 Soil Profile

<b>WATTS BAR NUCLEAR PLANT FINAL SAFETY ANALYSIS REPORT</b>
<b>SOIL PROFILE FIGURE 2.5-486 SHEET 1 OF 1</b>

PROJECT: WATTS BAR N.P.  
BORING: PAH-51 STATION:  
DATE DRILLED: 6/9/83 TO

FEATURE: BORROW AREA 2C  
RANGE: SURFACE EL: 739.8  
PREPARED BY: MHD CHECKED BY: RA

DEPTH ft.	EL	SPT (N)	* LOG	W	LL	PI	FIELD DESCRIPTION
							ROADFILL
5	735		J U	21.3	39	18	SI CL, R-BRN, MST, ALL
10	730		J U Σ	22.9	42	16	SI CL, R, MST, ALL
15	725		J U Σ	24.2	42	16	SI CL, R, MST, ALL
20	720						DISCONTINUED.
25	715						
30	710						
35	705						
1''=5'							Added by Amendment 50
			* Lab. Classif.				

Figure 2.5-486 Soil Profile

<b>WATTS BAR NUCLEAR PLANT FINAL SAFETY ANALYSIS REPORT</b>
<b>SOIL PROFILE FIGURE 2.5-487 SHEET 1 OF 1</b>

PROJECT: WATTS BAR N.P.  
BORING: PAH-52 STATION:  
DATE DRILLED: 6/9/83 TO

FEATURE: BORROW AREA 2C  
RANGE: SURFACE EL: 743.7  
PREPARED BY: MHD CHECKED BY: BA

DEPTH ft.	EL	SPT (N)	* LOG	W	LL	PI	FIELD DESCRIPTION
							RANDOM ROADFILL
5	740		U Σ	23.1	42	16	SI CL, R-BRN, MST, ALL
10	735		U Σ	22.7	42	16	SI CL, R-BRN, MST, ALL
15	730		U	21.9	39	18	SI CL, R-BRN, MST, ALL
20	725						DISCONTINUED.
25	720						
30	715						
35	710						
1''=5'			* Lab. Classif.				Added by Amendment 50

Figure 2.5-487 Soil Profile

<b>WATTS BAR NUCLEAR PLANT FINAL SAFETY ANALYSIS REPORT</b>
<b>SOIL PROFILE FIGURE 2.5-488 SHEET 1 OF 1</b>

PROJECT: WATTS BAR N.P.  
BORING: PAH-53 STATION:  
DATE DRILLED: 6/9/83 TO

FEATURE: BORROW AREA 2C  
RANGE: SURFACE EL: 750.6  
PREPARED BY: MHD CHECKED BY: FA

DEPTH ft.	EL	SPT (N)	* LOG	W	LL	PI	FIELD DESCRIPTION
	750						RANDOM ROADFILL
5	745		┌┐┐ └┘└	23.5	42	16	SI CL, R-BRN, MST, ALL
10	740		┌┐┐ └┘└	23.6	42	16	SI CL, R, MST, ALL
15	735		┌┐┐ └┘└	37.1	42	16	SI CL, R V MST, ALL
20	730						W ST CL
							DISCONTINUED.
25	725						
30	720						
35							
1''=5'							Added by Amendment 50
							* Lab. Classif.

Figure 2.5-488 Soil Profile

WATTS BAR NUCLEAR PLANT FINAL SAFETY ANALYSIS REPORT
SOIL PROFILE FIGURE 2.5-489 SHEET 1 OF 1

PROJECT: WATTS BAR N.P.  
 BORING: PAH-56 STATION:  
 DATE DRILLED: 8/24/83 TO

FEATURE: BORROW AREA EXT 2C  
 RANGE: SURFACE EL: 769.0 est  
 PREPARED BY: MHD CHECKED BY: *BBE*

DEPTH ft.	EL	SPT (N)	* LOG	W	LL	PI	FIELD DESCRIPTION
							CUT SURFACE; SP FL
5	765		U	23.2	44	19	FT CL, BRN, MST, RESD
10	760		U Σ	24.2	42	16	FT CL, BRN, MST, RESD
15	755		U	26.7	48	21	FT CL, BRN, MST, RESD
20	750						
25	745						
30	740						
35	735						
1''=5'			* Lab. Classif.				Added by Amendment 50

Figure 2.5-489 Soil Profile

<b>WATTS BAR NUCLEAR PLANT FINAL SAFETY ANALYSIS REPORT</b>
<b>SOIL PROFILE FIGURE 2.5-490 SHEET 1 OF 1</b>

PROJECT: WATTS BAR N.P.  
BORING: PAH-57 STATION:  
DATE DRILLED: 8/25/83 TO

FEATURE: BORROW AREA EXT 2C  
RANGE: SURFACE EL: 774.1  
PREPARED BY: MHD CHECKED BY: *CBG*

DEPTH ft.	EL	SPT (N)	* LOG	W	LL	PI	FIELD DESCRIPTION
5	770		U	11.5	33	11	CUT SURFACE CL SI, BRN, MST, RESD
10	765		U	20.4	44	19	CL SI, BRN, MST, RESD
15	760		U I Σ	20.6	40	14	CL SI, BRN, MST, RESD
20	755		U I Σ	24.9	36	12	CL SI, BRN, V MST, RESD
25	750						DISCONTINUED.
30	745						
35	740						
1"=5'			* Lab. Classif.				Added by Amendment 50

Figure 2.5-490 Soil Profile

WATTS BAR NUCLEAR PLANT FINAL SAFETY ANALYSIS REPORT
SOIL PROFILE FIGURE 2.5-491 SHEET 1 OF 1

PROJECT: WATTS BAR N.P.  
 BORING: PAH-58 STATION:  
 DATE DRILLED: 8/25/83 TO

FEATURE: BORROW AREA EXT 2C  
 RANGE: SURFACE EL: 798.0  
 PREPARED BY: MHD CHECKED BY: *DEG*

DEPTH ft.	EL	SPT (N)	* LOG	W	LL	PI	FIELD DESCRIPTION
5	795		I I U Σ	26.6	53	24	CUT SURFACE CL SI, BRN, MST, RESD
	790		J J U Σ	21.3	36	12	CL SI, BRN, MST, RESD
	785		J J U Σ	26.3	40	14	CL SI, BRN, MST, RESD
	780		J U	22.6	39	17	CL SI, TN-BRN, MST, RESD
20						-----	
775							
25							
770							
30							
765							
35							Added by Amendment 50
1"=5'			* Lab. Classif.				

Figure 2.5-491 Soil Profile

<b>WATTS BAR NUCLEAR PLANT FINAL SAFETY ANALYSIS REPORT</b>
<b>SOIL PROFILE FIGURE 2.5-492 SHEET 1 OF 1</b>

PROJECT: WATTS BAR N.P.  
BORING: PAH-59 STATION:  
DATE DRILLED: 8/24/83 TO

FEATURE: BORROW AREA EXT 2C  
RANGE: SURFACE EL: 755.0  
PREPARED BY: MHD CHECKED BY: *CRF*

DEPTH ft.	EL	SPT (N)	* LOG	W	LL	PI	FIELD DESCRIPTION
	755						
5	750		CL	12.7	33	11	SI CL, BRN, MST, RESD
10	745		CL	21.4	45	22	SI CL, BRN, MST, RESD -
15	740		CL	18.8	48	21	SI CL, TN, TR LS GV, MST, RESD
20	735		CL	22.2	42	16	CL SI, GRN-TN, MST, RESD
25	730						DISCONTINUED.
30	725						
35	720						Added by Amendment 50
1''=5'			* Lab. Classif.				

Figure 2.5-492 Soil Profile



<b>WATTS BAR NUCLEAR PLANT FINAL SAFETY ANALYSIS REPORT</b>
<b>SOIL PROFILE FIGURE 2.5-493 SHEET 1 OF 1</b>

PROJECT: WATTS BAR N.P.  
BORING: PAH-60 STATION:  
DATE DRILLED: 8/24/83 TO

FEATURE: BORROW AREA EXT 2C  
RANGE: SURFACE EL: 748.2  
PREPARED BY: MHD CHECKED BY: *DBG*

DEPTH ft.	EL	SPT (N)	* LOG	W	LL	PI	FIELD DESCRIPTION
							(PREVIOUSLY CUT SURFACE)
5	745		CU	17.5	44	20	SI CL, TN, MST, TERRACE ALL
			ML	16.1	37	11	GV SI, DK BRN, MST, TERRACE ALL
10	740						
			Σ SU S	17.9	35	11	SI CL, BRN, TR GV
15	735						
			CU Σ	20.1	40	14	CL SI, R-BRN, MST, RESD
20	730						-----
							DISCONTINUED.
25	725						
30	720						
35	715						
1''=5'							Added by Amendment 50

\* Lab. Classif.

Figure 2.5-493 Soil Profile

WATTS BAR NUCLEAR PLANT FINAL SAFETY ANALYSIS REPORT
SOIL PROFILE FIGURE 2.5-494 SHEET 1 OF 1

PROJECT: WATTS BAR N.P.  
 BORING: PAH-61 STATION:  
 DATE DRILLED: 8/24/83 TO

FEATURE: BORROW AREA EXT 2C  
 RANGE: SURFACE EL: 745.0 est  
 PREPARED BY: MHD CHECKED BY: *[Signature]*

DEPTH ft.	EL	SPT (CN)	* LOG	W	LL	PI	FIELD DESCRIPTION
	745						CUT SURFACE
5			Σ 0 0	15.5	35	11	GV CL, DK BRN, MST, TERRACE ALL
	740						
			J 0 Σ	20.3	40	14	GV CL, DK BRN, MST, TERRACE ALL
10	735						-----
							DISCONTINUED.
15	730						
20	725						
25	720						
30	715						
35	710						
1''=5'							Added by Amendment 50
							* Lab. Classif.

Figure 2.5-494 Soil Profile

<b>WATTS BAR NUCLEAR PLANT FINAL SAFETY ANALYSIS REPORT</b>
SOIL PROFILE FIGURE 2.5-495 SHEET 1 OF 1

Added by Amendment 50

PROJECT: WATTS BAR N.P.  
 BORING: PAH-62 STATION:  
 DATE DRILLED: 8/25/83 TO

FEATURE: BORROW AREA EXT 2C  
 RANGE: SURFACE EL: 731.0 es  
 PREPARED BY: MHD CHECKED BY: *[Signature]*

DEPTH ft.	EL	SPT (N)	* LOG	W	LL	PI	FIELD DESCRIPTION	
	730						CUT SURFACE	
5			I O   I Σ	23.1	53	24	SI CL, BRN, MST, RESD	
	725		I O   I Σ	23.3	53	24	CL SI, BRN, MST, RESD	
10			I O   I Σ	22.2	53	24	CL SI, BRN, MST, RESD	
	720						REFUSAL. BEDROCK.	
15								
	715							
20								
	710							
25								
	705							
30								
	700							
35								
1''=5'			* Lab. Classif.					

Figure 2.5-495 Soil Profile

<b>WATTS BAR NUCLEAR PLANT FINAL SAFETY ANALYSIS REPORT</b>
<b>SOIL PROFILE FIGURE 2.5-496 SHEET 1 OF 1</b>

PROJECT: WATTS BAR N.P.  
BORING: PAH-63 STATION:  
DATE DRILLED: 8/25/83 TO

FEATURE: BORROW AREA EXT 2C  
RANGE: SURFACE EL: 730.8  
PREPARED BY: MHD CHECKED BY: *[Signature]*

DEPTH ft.	EL	SPT (CN)	* LOG	W	LL	PI	FIELD DESCRIPTION
	730		Σ U 0 0	16.4	35	11	CUT SURFACE CL SI, BRN, MST, RESD
5	725		I I 0 Σ	24.6	53	24	FT CL, LT BRN, MST, RESD
10	720		Σ	18.0	37	11	CL SI, R-BRN, MST, RESD
15	715		Σ	16.7	37	11	CL SI, R-BRN, MST, RESD
20	710						DISCONTINUED.
25	705						
30	700						
35							Added by Amendment 50
1"=5'			* Lab. Classif.				

Figure 2.5-496 Soil Profile

WATTS BAR NUCLEAR PLANT FINAL SAFETY ANALYSIS REPORT
SOIL PROFILE FIGURE 2.5-497 SHEET 1 OF 1

PROJECT: WATTS BAR N.P.  
 BORING: PAH-64 STATION:  
 DATE DRILLED: 8/24/83 TO

FEATURE: BORROW AREA EXT 2C  
 RANGE: SURFACE EL: 744.1  
 PREPARED BY: MHD CHECKED BY: *CBP*

DEPTH ft.	EL	SPT (N)	* LOG	W	LL	PI	FIELD DESCRIPTION
							TOPSOIL
5	740		ML	19.0	37	11	SI CL, BRN, D, RESD
10	735		ML	23.6	37	11	SI CL, BRN, MST, RESD
15	730		ML	23.3	37	11	SI CL, BRN, MST, RESD
							V MST W/SH & W/BENTANITE
							DISCONTINUED.
20	725						
25	720						
30	715						
35	710						
1"=5'			* Lab. Classif.				Added by Amendment 50

Figure 2.5-497 Soil Profile

<b>WATTS BAR NUCLEAR PLANT FINAL SAFETY ANALYSIS REPORT</b>
<b>SOIL PROFILE FIGURE 2.5-498 SHEET 1 OF 1</b>

PROJECT: WATTS BAR N.P.  
BORING: PAH-65 STATION:  
DATE DRILLED: 8/24/83 TO

FEATURE: BORROW AREA EXT 2C  
RANGE: SURFACE EL: 766.0  
PREPARED BY: MHD CHECKED BY: *[Signature]*

DEPTH ft.	EL	SPT (CN)	* LOG	W	LL	PI	FIELD DESCRIPTION
5	765		CL Σ	14.3	40	14	SI CL, R-BRN, MST, RESD
	760		HI Σ	19.8	67	29	SI CL, R-BRN, MST, RESD
10	755		CL Σ	15.8	40	14	SI CL, R-BRN, MST, RESD, TR GV
15	750		CL	15.7	44	19	SI CL, TR GV, R-BRN, MST, RESD
20	745						DISCONTINUED.
25	740						
30	735						
35							
1''=5'			* Lab. Classif.				Added by Amendment 50

Figure 2.5-498 Soil Profile

WATTS BAR NUCLEAR PLANT FINAL SAFETY ANALYSIS REPORT
SOIL PROFILE FIGURE 2.5-499 SHEET 1 OF 1

PROJECT: WATTS BAR N.P.  
 BORING: PAH-66 STATION:  
 DATE DRILLED: 8/24/83 TO

FEATURE: BORROW AREA EXT 2C  
 RANGE: SURFACE EL: 776.9  
 PREPARED BY: MHD CHECKED BY: *UBG*

DEPTH ft.	EL	SPT (N)	* LOG	W	LL	PI	FIELD DESCRIPTION
5  10  15	775		┌─┐ ├─┤ └─┘ 0 1 Σ	13.6	40	14	CUT SURFACE SI CL, R-BRN, MST, RESD
	770		┌─┐ ├─┤ └─┘ 0 1 Σ	19.1	40	14	SI CL, R-BRN, MST, RESD
	765		┌─┐ ├─┤ └─┘ 0 1 Σ	16.1	37	12	CL SI, TR GV, BRN, MST, RESD
	760		┌─┐ ├─┤ └─┘ 0 1 Σ	17.5	37	12	CL SI, TR GV, BRN, MST, RESD
20							DISCONTINUED.
25	755						
30	750						
35	745						
1' = 5'							Added by Amendment 50
			* Lab. Classif.				

Figure 2.5-499 Soil Profile

<b>WATTS BAR NUCLEAR PLANT FINAL SAFETY ANALYSIS REPORT</b>
<b>SOIL PROFILE FIGURE 2.5-500 SHEET 1 OF 1</b>

PROJECT: WATTS BAR N.P.  
BORING: PAH-67 STATION:  
DATE DRILLED: 8/25/83 TO

FEATURE: BORROW AREA EXT 2C  
RANGE: SURFACE EL: 815.0  
PREPARED BY: MHD CHECKED BY: *MBE*

DEPTH ft.	EL	SPT (N)	* LOG	W	LL	PI	FIELD DESCRIPTION
	815						
5	810		I Σ	29.2	67	29	FT CL, R, MST, RESD
10	805		I Σ	32.7	67	29	FT CL, R, MST, RESD
15	800		U	24.7	44	20	CL SI, TN, MST, RESD
20	795		U	22.1	44	20	CL SI, TN, MST, RESD
25	790						DISCONTINUED.
30	785						
35	780						
1''=5'			* Lab. Classif.				Added by Amendment 50

Figure 2.5-500 Soil Profile



<b>WATTS BAR NUCLEAR PLANT FINAL SAFETY ANALYSIS REPORT</b>
SOIL PROFILE FIGURE 2.5-501 SHEET 1 OF 1

PROJECT: WATTS BAR N.P.  
 BORING: PAH-68 STATION:  
 DATE DRILLED: 8/25/83 TO

FEATURE: BORROW AREA EXT 2C  
 RANGE: SURFACE EL: 824.0  
 PREPARED BY: MHD CHECKED BY: *WEG*

DEPTH ft.	EL	SPT (N)	* LOG	W	LL	PI	FIELD DESCRIPTION
5	820		U	12.9	35	15	CUT SURFACE CL SI, TN, MST, RESD
10	815		UII U Σ	19.5	53	24	CL SI, YEL-TN, MST, RESD
15	810		U	20.6	39	17	CL SI, TN, MST, RESD
20	805		UII U Σ	14.5	36	12	CL SI, TN, MST, RESD
25	800						----- DISCONTINUED.
30	795						
35	790						
1''=5'			* Lab. Classif.				Added by Amendment 50

Figure 2.5-501 Soil Profile

WATTS BAR NUCLEAR PLANT FINAL SAFETY ANALYSIS REPORT
SOIL PROFILE FIGURE 2.5-502 SHEET 1 OF 1

PROJECT: WATTS BAR N.P.  
 BORING: PAH-69 STATION:  
 DATE DRILLED: 8/24/83 TO

FEATURE: BORROW AREA EXT 2C  
 RANGE: SURFACE EL: 802.2  
 PREPARED BY: MHD CHECKED BY: *[Signature]*

DEPTH ft.	EL	SPT (N)	* LOG	W	LL	PI	FIELD DESCRIPTION
	800		J U	11.2	35	15	CUT SURFACE SI CL, R-BRN, D, RESD
5			J U	21.3	44	19	SI CL, TR GV, D, RESD
	795						
10			I O I Σ	20.1	53	24	CL SI, MST, RESD
	790						
15			J O I Σ	18.3	36	12	CL SI, MST, RESD
	785						
20							DISCONTINUED.
	780						
25							
	775						
30							
	770						
35							
1''=5'							Added by Amendment 50
							* Lab. Classif.

Figure 2.5-502 Soil Profile

WATTS BAR NUCLEAR PLANT FINAL SAFETY ANALYSIS REPORT
SOIL PROFILE FIGURE 2.5-503 SHEET 1 OF 1

PROJECT: WATTS BAR N.P.  
 BORING: PAH-70 STATION:  
 DATE DRILLED: 8/24/83 TO

FEATURE: BORROW AREA EXT 2C  
 RANGE: SURFACE EL: 772.0  
 PREPARED BY: MHD CHECKED BY: *MB*

DEPTH ft.	EL	SPT (N)	* LOG	W	LL	PI	FIELD DESCRIPTION
	770		U	17.3	33	11	CUT SURFACE SI CL, R-BRN, MST, RESD
5							
	765		U I U	24.7	53	24	SI CL, R-BRN, MST, RESD
10							
	760		U	24.8	44	20	SI CL, R-BRN-WHT, MST, RESD
15							
	755		U	24.4	44	20	SI CL, R-BRN-WHT, MST, RESD
20							
	750						DISCONTINUED.
25							
	745						
30							
	740						
35							
1"=5'							Added by Amendment 50
							* Lab. Classif.

Figure 2.5-503 Soil Profile

WATTS BAR NUCLEAR PLANT FINAL SAFETY ANALYSIS REPORT
SOIL PROFILE FIGURE 2.5-504 SHEET 1 OF 1

PROJECT: WATTS BAR N.P.  
 BORING: PAH-71 STATION:  
 DATE DRILLED: 8/25/83 TO

FEATURE: BORROW AREA EXT 2C  
 RANGE: SURFACE EL: 742.0  
 PREPARED BY: MHD CHECKED BY: *ML*

DEPTH ft.	EL	SPT (N)	* LOG	W	LL	PI	FIELD DESCRIPTION
5	740		U	8.9	33	11	CUT SURFACE CL SI, BRN, D, RESD
10	735		U	13.4	35	15	CL SI, BRN, MST, RESD
15	730		U 1 Σ	17.2	37	12	CL SI, BRN, MST, RESD
20	725		U	20.3	45	22	SI CL, BRN, MST, RESD
25	720						DISCONTINUED.
30	715						
35	710						
1' = 5'			* Lab. Classif.				Added by Amendment 50

Figure 2.5-504 Soil Profile

WATTS BAR NUCLEAR PLANT FINAL SAFETY ANALYSIS REPORT
SOIL PROFILE FIGURE 2.5-505 SHEET 1 OF 1

PROJECT: WATTS BAR N.P.  
 BORING: PAH-72 STATION:  
 DATE DRILLED: 8/25/83 TO

FEATURE: BORROW AREA EXT 2C  
 RANGE: SURFACE EL: 725.8  
 PREPARED BY: MHD CHECKED BY: *[Signature]*

DEPTH ft.	EL	SPT (N)	* LOG	W	LL	PI	FIELD DESCRIPTION
	725						FL SP
5			U	15.8	39	17	CL SI, BRN, MST, RESD
			U	16.9	39	17	CL SI, LT BRN-BRN, MST, RESD
	720		U	26.4	45	22	CL SI, BRN, MST,
10	715						DISCONTINUED.
15	710						
20	705						
25	700						
30	695						
35							
1"=5'			*				Lab. Classif.
							Added by Amendment 50

Figure 2.5-505 Soil Profile

WATTS BAR NUCLEAR PLANT FINAL SAFETY ANALYSIS REPORT
SOIL PROFILE FIGURE 2.5-506 SHEET 1 OF 1

PROJECT: WATTS BAR N.P.  
 BORING: PAH-73 STATION:  
 DATE DRILLED: 8/25/83 TO

FEATURE: BORROW AREA EXT 2C  
 RANGE: SURFACE EL: 721.0  
 PREPARED BY: MHD CHECKED BY: *MB*

DEPTH ft.	EL	SPT (N)	* LOG	W	LL	PI	FIELD DESCRIPTION
	720		O   Σ	23.0	40	14	CUT SURFACE CL SI, BRN, MST, RESD
5			M   Σ	19.0	22	2	CL SI, GY, V MST, RESD
	715		Σ	18.7	22	2	SI CL, BRN, MST, RESD
10			O   Σ	17.4	37	12	SI CL, DK BRN, MST, RESD
	710						----- DISCONTINUED.
15							
	705						
20							
	700						
25							
	695						
30							
	690						
35							
1"=5'			* Lab. Classif.				Added by Amendment 50

Figure 2.5-506 Soil Profile

WATTS BAR NUCLEAR PLANT FINAL SAFETY ANALYSIS REPORT
SOIL PROFILE FIGURE 2.5-507 SHEET 1 OF 1

PROJECT: WATTS BAR N.P.  
 BORING: PAH-74 STATION:  
 DATE DRILLED: 8/25/83 TO

FEATURE: BORROW AREA EXT 2C  
 RANGE: SURFACE EL: 736.5  
 PREPARED BY: MHD CHECKED BY: *[Signature]*

DEPTH ft.	EL	SPT (N)	* LOG	W	LL	PI	FIELD DESCRIPTION
5	735		I O I Σ	34.4	53	24	CUT SURFACE CL SI, TN, V MST, RESD
	730		O I	39.6	48	21	CL SI, TN, V MST, RESD
	725		O I	40.4	48	21	CL SI, TN, V MST, RESD
	720		O I	26.8	22	2	SI CL, (BENT), GRN-TN, V MST, RESD
20						DISCONTINUED.	
25	715						
30	710						
35	705						
1''=5'			* Lab. Classif.				Added by Amendment 50

Figure 2.5-507 Soil Profile

WATTS BAR NUCLEAR PLANT FINAL SAFETY ANALYSIS REPORT
SOIL PROFILE FIGURE 2.5-508 SHEET 1 OF 1

PROJECT: WATTS BAR N.P.  
 BORING: PAH-75 STATION:  
 DATE DRILLED: 8/25/83 TO

FEATURE: BORKUW AREA EXT 2C  
 RANGE: SURFACE EL: 742.3  
 PREPARED BY: MHD CHECKED BY: *[Signature]*

DEPTH ft.	EL	SPT (N)	* LOG	W	LL	PI	FIELD DESCRIPTION
	740		┌ └─┘ 0	8.7	34	13	CUT SURFACE SL CI, TN, D, RESD
5							
	735		┌ └─┘ 0   ┌ Σ	14.5	37	12	CL SI, TN, MST, RESD
10							
	730		┌ └─┘ 0   ┌ Σ	24.2	37	12	CL SI, TN, MST, RESD
15							
	725		┌ └─┘ 0   ┌ Σ	24.3	42	16	
20							
	720						DISCONTINUED.
25							
	715						
30							
	710						
35							
1"=5'							Added by Amendment 50
							* Lab. Classif.

Figure 2.5-508 Soil Profile



<b>WATTS BAR NUCLEAR PLANT FINAL SAFETY ANALYSIS REPORT</b>
<b>SOIL PROFILE FIGURE 2.5-509 SHEET 1 OF 1</b>

PROJECT: WATTS BAR N.P.  
BORING: PAH-76 STATION:  
DATE DRILLED: 8/24/83 TO

FEATURE: BORROW AREA EXT 2C  
RANGE: SURFACE EL: 787.0  
PREPARED BY: MHD CHECKED BY: *lcl*

DEPTH ft.	EL	SPT (N)	* LOG	W	LL	PI	FIELD DESCRIPTION
	785		U	16.6	34	13	CUT SURFACE SI CL, TR GV, D, RESD
5							
	780		U Σ	16.2	36	12	CL SI, MST, RESD
10							
	775		U	17.8	30	11	CL SI, MST, BRN, RESD
15							
	770		U	16.8	30	11	CL SI, MST, BRN, RESD
20							DISCONTINUED.
	765						
25							
	760						
30							
	755						
35							
1"=5'							Added by Amendment 50

\* Lab. Classif.

Figure 2.5-509 Soil Profile

<b>WATTS BAR NUCLEAR PLANT FINAL SAFETY ANALYSIS REPORT</b>
SOIL PROFILE FIGURE 2.5-510 SHEET 1 OF 1

PROJECT: WATTS BAR N.P.  
BORING: PAH-77 STATION:  
DATE DRILLED: 8/24/83 TO

FEATURE: BORROW AREA EXT 2C  
RANGE: SURFACE EL: 836.0  
PREPARED BY: MHD CHECKED BY: *MBG*

DEPTH ft.	EL	SPT (N)	* LOG	W	LL	PI	FIELD DESCRIPTION
5  10  15  20	835		CL	20.1	34	13	CUT SURFACE SI CL, TN, MST, RESD
	830		CL	16.9	33	12	SI CL, PK-TN, MST, RESD
	825		U I Σ	12.1	36	12	SI CL, TN, MST, RESD, TR GV
	820		U I Σ	14.6	36	12	SI CL, TN, MST, RESD
815						DISCONTINUED.	
810							
805							
35							Added by Amendment 50
1"=5'			* Lab. Classif.				

Figure 2.5-510 Soil Profile

WATTS BAR NUCLEAR PLANT FINAL SAFETY ANALYSIS REPORT
SOIL PROFILE FIGURE 2.5-511 SHEET 1 OF 1

PROJECT: WATTS BAR N.P.  
 BORING: PAH-78 STATION:  
 DATE DRILLED: 8/24/83 TO

FEATURE: BORROW AREA EXT 2C  
 RANGE: SURFACE EL: 882.3  
 PREPARED BY: MHD CHECKED BY: *CB*

DEPTH ft.	EL	SPT (N)	* LOG	W	LL	PI	FIELD DESCRIPTION
	880		SO	12.4	40	16	CUT SURFACE CL SI, TN, MST, RESD
5			SO				
	875		SO	10.3	40	16	CL SI, TN, MST, RESD
10			SO				
	870		CL SI	9.9	36	12	CL SI, TN, TR GV, MST, RESD
15			CL SI				
	865		CL SI	8.6	36	12	CL SI, TN, TR GV, MST, RESD
20			CL SI				
	860						DISCONTINUED.
25							
	855						
30							
	850						
35							
1"=5'			* Lab. Classif.				Added by Amendment 50

Figure 2.5-511 Soil Profile

<b>WATTS BAR NUCLEAR PLANT FINAL SAFETY ANALYSIS REPORT</b>
SOIL PROFILE FIGURE 2.5-512 SHEET 1 OF 1

PROJECT: WATTS BAR N.P.  
 BORING: PAH-79 STATION:  
 DATE DRILLED: 8/25/83 TO

FEATURE: BORROW AREA EXT 2C  
 RANGE: SURFACE EL: 777.0  
 PREPARED BY: MHD CHECKED BY: *CEK*

DEPTH ft.	EL	SPT (N)	* LOG	W	LL	PI	FIELD DESCRIPTION
							TOPSOIL
5	775		CL	15.5	33	12	CL SI, BRN, MST, RESD
10	770		CL	14.6	34	12	CL SI, TR GV, BRN, MST, RESD
15	765		CL	16.5	34	12	CL SI, TR GV, R-BRN, MST, RESD
20	760		CL	16.7	34	12	CL SI, BRN, MST, RESD
25	755						DISCONTINUED.
30	750						
35	745						
1''=5'			* Lab. Classif.				Added by Amendment 50

Figure 2.5-512 Soil Profile

<b>WATTS BAR NUCLEAR PLANT FINAL SAFETY ANALYSIS REPORT</b>
<b>SOIL PROFILE FIGURE 2.5-513 SHEET 1 OF 1</b>

PROJECT: WATTS BAR N.P.  
BORING: PAH-80 STATION:  
DATE DRILLED: 8/25/83 TO

FEATURE: BORROW AREA EXT 2C  
RANGE: SURFACE EL: 744.0  
PREPARED BY: MHD CHECKED BY: *MB*

DEPTH ft.	EL	SPT (N)	* LOG	W	LL	PI	FIELD DESCRIPTION
5	740		CL	13.8	34	13	CUT SURFACE CL SI, TN, MST, RESD
10	735		CL	22.6	39	17	CL SI, TN, MST, RESD
15	730		CL	21.9	44	20	CL SI, TN, MST, RESD
20	725		CL	21.4	44	20	CL SI, TN, MST, RESD
25	720						DISCONTINUED.
30	715						
35	710						
1"=5'			* Lab. Classif.				Added by Amendment 50

Figure 2.5-513 Soil Profile

WATTS BAR NUCLEAR PLANT FINAL SAFETY ANALYSIS REPORT
SOIL PROFILE FIGURE 2.5-514 SHEET 1 OF 1

PROJECT: WATTS BAR N.P.  
 BORING: PAH-81 STATION:  
 DATE DRILLED: 8/24/83 TO

FEATURE: BORROW AREA EXT 2C  
 RANGE: SURFACE EL: 802.0  
 PREPARED BY: MHD CHECKED BY: *BBG*

DEPTH ft.	EL	SPT (CN)	* LOG	W	LL	PI	FIELD DESCRIPTION
5	800		CL	7.8	33	12	CUT SURFACE CL SI, TR GV, TN, MST, RESD
10	795		CL	11.1	30	11	CL SI, TR GV, TN, MST, RESD
15	790		CL	14.2	30	11	CL SI, TR LS GV, R-BRN, MST, RESD
20	785		CL	12.3	30	11	CL SI, TR LS GV, R-BRN, MST, RESD
25	780						DISCONTINUED.
30	775						
35	770						
1''=5'							Added by Amendment 50

\* Lab. Classif.

Figure 2.5-514 Soil Profile

<b>WATTS BAR NUCLEAR PLANT FINAL SAFETY ANALYSIS REPORT</b>
<b>SOIL PROFILE FIGURE 2.5-515 SHEET 1 OF 1</b>

PROJECT: WATTS BAR N.P.  
BORING: PAH-82 STATION:  
DATE DRILLED: 8/25/83 TO

FEATURE: BORROW AREA EXT 2C  
RANGE: SURFACE EL: 884.0  
PREPARED BY: MHD CHECKED BY: *J.Biz*

DEPTH ft.	EL	SPT (N)	* LOG	W	LL	PI	FIELD DESCRIPTION
5	880		U S	11.4	40	16	CUT SURFACE CL SI, D, RESD
			U S	11.6	40	16	CL SI, D, RESD
10	875		U S	12.8	40	16	CL SI, TR GV, D, RESD
15	870		U S	12.4	40	16	CL SI, D, RESD
20	865						----- DISCONTINUED.
25	860						
30	855						
35	850						
1''=5'			* Lab. Classif.				Added by Amendment 50

Figure 2.5-515 Soil Profile

<b>WATTS BAR NUCLEAR PLANT FINAL SAFETY ANALYSIS REPORT</b>
<b>SOIL PROFILE FIGURE 2.5-516 SHEET 1 OF 1</b>

PROJECT: WATTS BAR N.P.                      FEATURE: BORROW AREA EXT 2C  
 BORING: PAH-83      STATION:                      RANGE:                      SURFACE EL: 872.0  
 DATE DRILLED:                      TO 8/25/83      PREPARED BY: MHD      CHECKED BY: *UB*

DEPTH ft.	EL	SPT (N)	* LOG	W	LL	PI	FIELD DESCRIPTION
	870		CL	16.7	35	15	CUT SURFACE CL SI, R-BRN, D, RESD
5			MS	10.1	22	1	CL SI, TR GV, TN, MST, RESD
	865						
10			CL	10.2	33	12	CL SI, TR GV, BRN, MST, RESD
	860						
15			CL	8.1	30	11	CL SI, GV, BRN
	855						
20							DISCONTINUED.
	850						
25							
	845						
30							
	840						
35							
1"=5'							
			* Lab. Classif.				Added by Amendment 50

Figure 2.5-516 Soil Profile



<b>WATTS BAR NUCLEAR PLANT FINAL SAFETY ANALYSIS REPORT</b>
<b>SOIL PROFILE FIGURE 2.5-517 SHEET 1 OF 1</b>

PROJECT: WATTS BAR N.P.                      FEATURE: BORROW AREA EXT 2C  
 BORING: PAH-84      STATION:                      RANGE:                      SURFACE EL: 846.0  
 DATE DRILLED:                      TO 8/25/83      PREPARED BY: MHD      CHECKED BY: *OB*

DEPTH ft.	EL	SPT (N)	* LOG	W	LL	PI	FIELD DESCRIPTION
	845						CUT SURFACE
5			U I Σ	20.3	36	12	CL SI, BRN, MST, RESD
	840		CL	21.4	33	11	CL SI, R-BRN, MST, RESD
10			CL	22.5	34	12	SI CL, BRN, MST, RESD
	835		CL	21.0	44	19	SI CL, BRN, MST, RESD
15							
	830		CL	19.7	34	12	SI CL, R-BRN, MST, RESD
20							
	825						DISCONTINUED.
25							
	820						
30							
	815						
35							
1"=5'			* Lab. Classif.				Added by Amendment 50

Figure 2.5-517 Soil Profile

<b>WATTS BAR NUCLEAR PLANT FINAL SAFETY ANALYSIS REPORT</b>
<b>SOIL PROFILE FIGURE 2.5-518 SHEET 1 OF 1</b>

PROJECT: WATTS BAR N.P.                      FEATURE: BORROW AREA EXT 2C  
 BORING: PAH-85      STATION:                      RANGE:                      SURFACE EL: 834.0  
 DATE DRILLED:                      TO 8/25/83      PREPARED BY: M.      CHECKED BY: *WBE*

DEPTH ft.	EL	SPT (N)	* LOG	W	LL	PI	FIELD DESCRIPTION
5	830		CL	18.8	34	13	CUT SURFACE CL SI, TN, MST, RESD
10	825		CL Σ	12.3	36	12	CL SI, TN, MST, RESD
15	820		CL Σ	13.0	36	12	CL SI, TN, MST, RESD
20	815		CL	13.4	33	12	CL SI, YEL-TN, MST, RESD
25	810						----- DISCONTINUED.
30	805						
35	800						
1''=5'			* Lab. Classif.				Added by Amendment 50

Figure 2.5-518 Soil Profile

WATTS BAR NUCLEAR PLANT FINAL SAFETY ANALYSIS REPORT
SOIL PROFILE FIGURE 2.5-519 SHEET 1 OF 1

PROJECT: WATTS BAR N.P.  
 BORING: PAH-86 STATION:  
 DATE DRILLED: 8/25/83 TO

FEATURE: BORROW AREA EXT 2C  
 RANGE: SURFACE EL: 802.0  
 PREPARED BY: MHD CHECKED BY: *llg*

DEPTH ft.	EL	SPT (N)	* LOG	W	LL	PI	FIELD DESCRIPTION
5	800		CL	13.6	34	13	CUT SURFACE CL SI, TN, MST, RESD
10	795		CL Σ	18.5	36	12	CL SI, TN, MST, RESD
15	790		CL Σ	18.7	36	12	CL SI, TN, MST, RESD
20	785		CL Σ	16.4	36	12	CL SI, TN, MST, RESD
25	780						DISCONTINUED.
30	775						
35	770						
1''=5'			* Lab. Classif.				Added by Amendment 50

Figure 2.5-519 Soil Profile

WATTS BAR NUCLEAR PLANT  
FINAL SAFETY  
ANALYSIS REPORT

FIGURE 2.5-520  
Added by Amendment 50

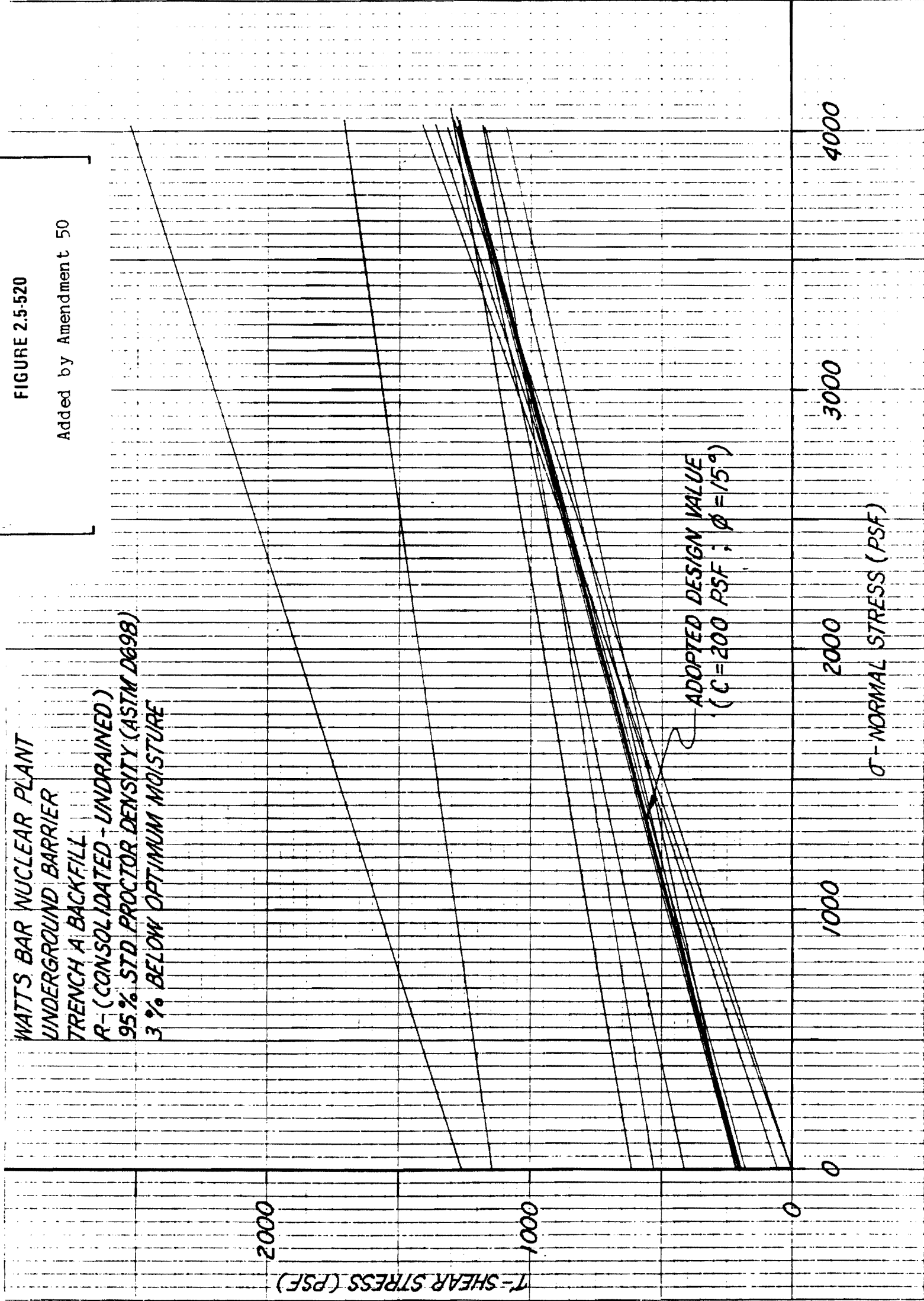

Figure 2.5-520 Watts Bar Nuclear Plant Underground Barrier Trench A Backfill R - (Consolidated -Undrained) 95% STD Proctor Density (ASTM D698) 3% Below Optimum Moisture

WATTS BAR NUCLEAR PLANT  
FINAL SAFETY  
ANALYSIS REPORT

FIGURE 2.5-521

Added by Amendment 50

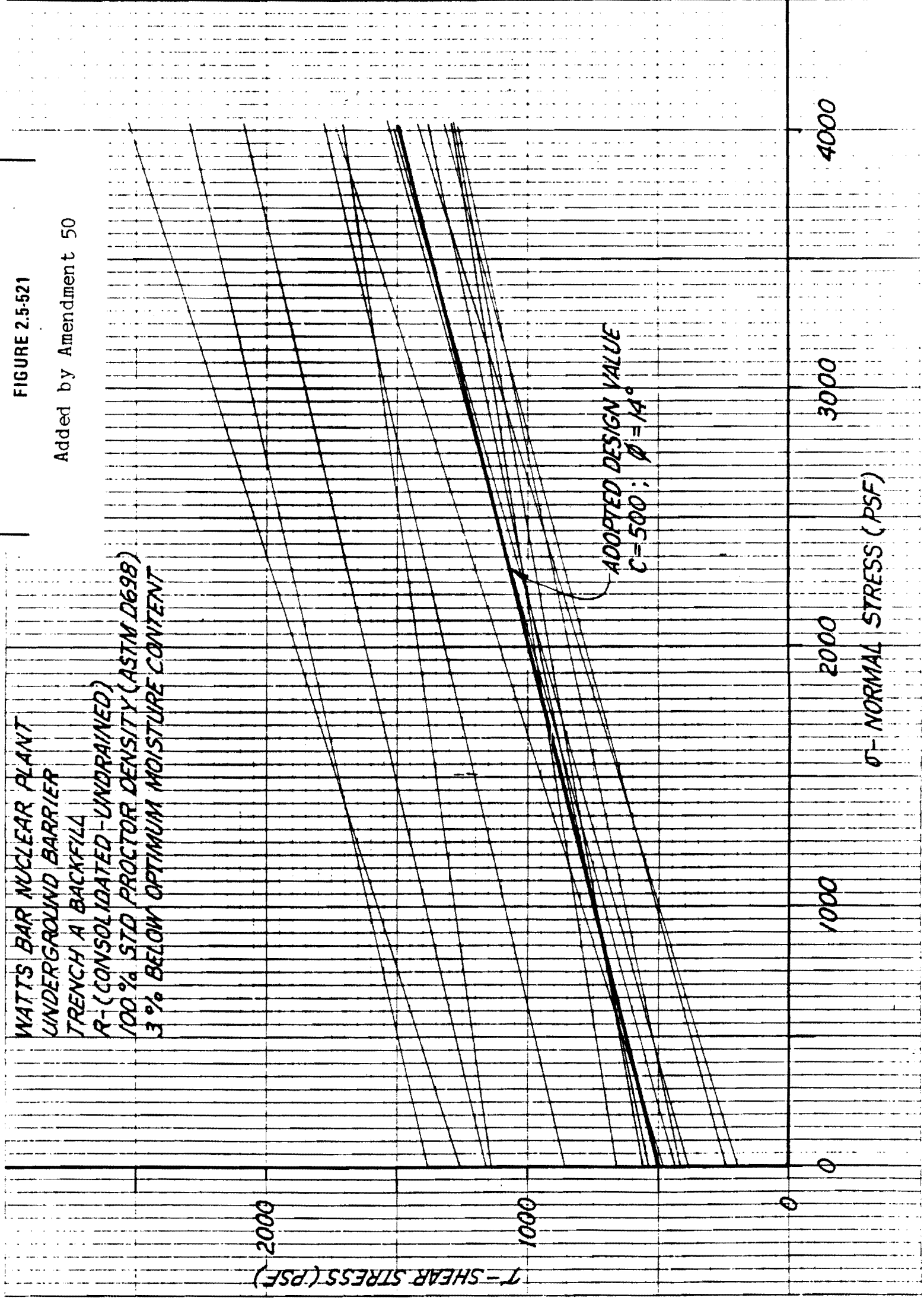

Figure 2.5-521 Watts Bar Nuclear Plant Underground Barrier Trench A Backfill R ( Consolidated - Undrained) 100% STD Proctor Density (ASTM D698) 3% Below Optimum Moisture Content

WATTS BAR NUCLEAR PLANT  
FINAL SAFETY  
ANALYSIS REPORT

FIGURE 2.5-522

Added by Amendment 50

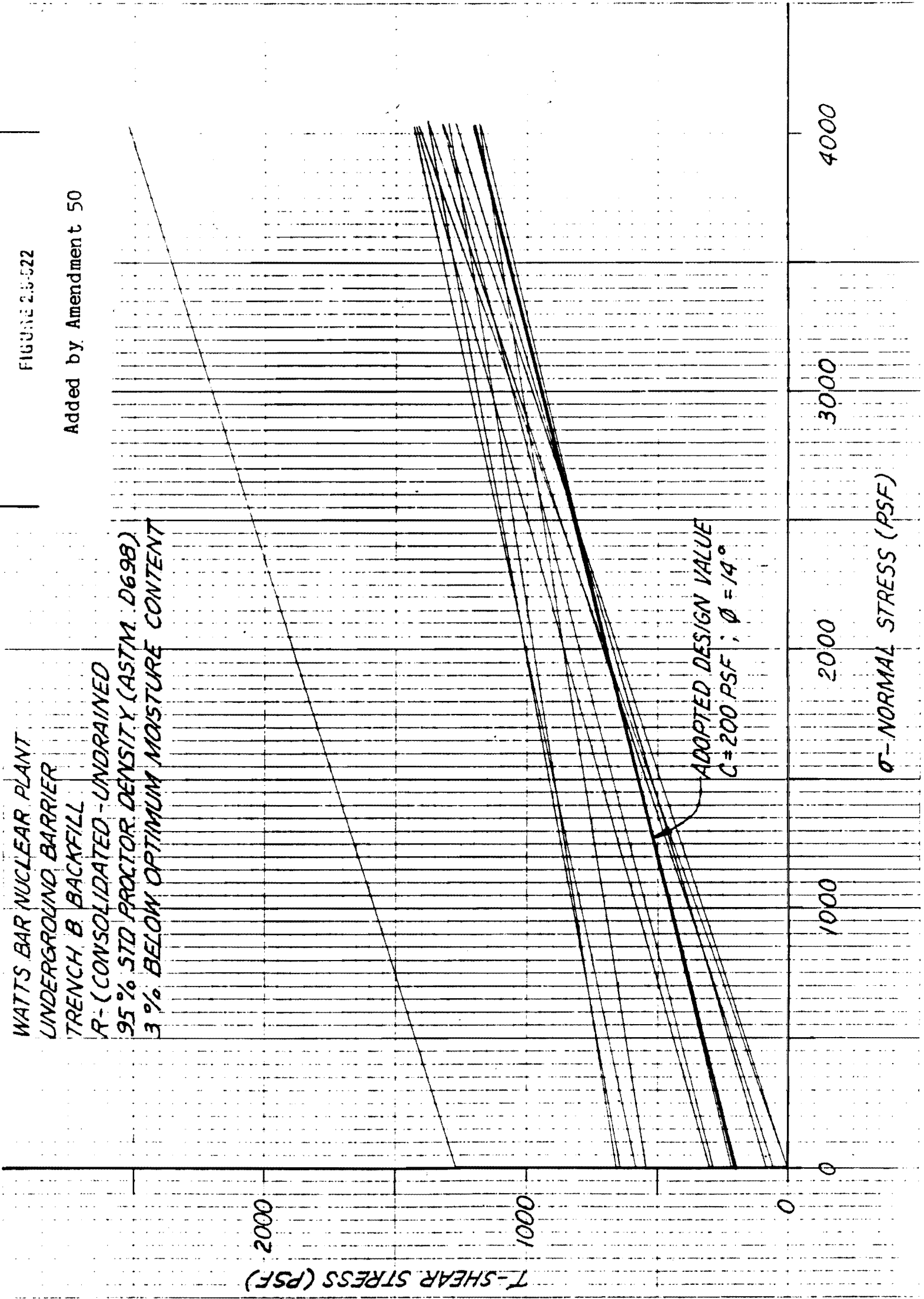
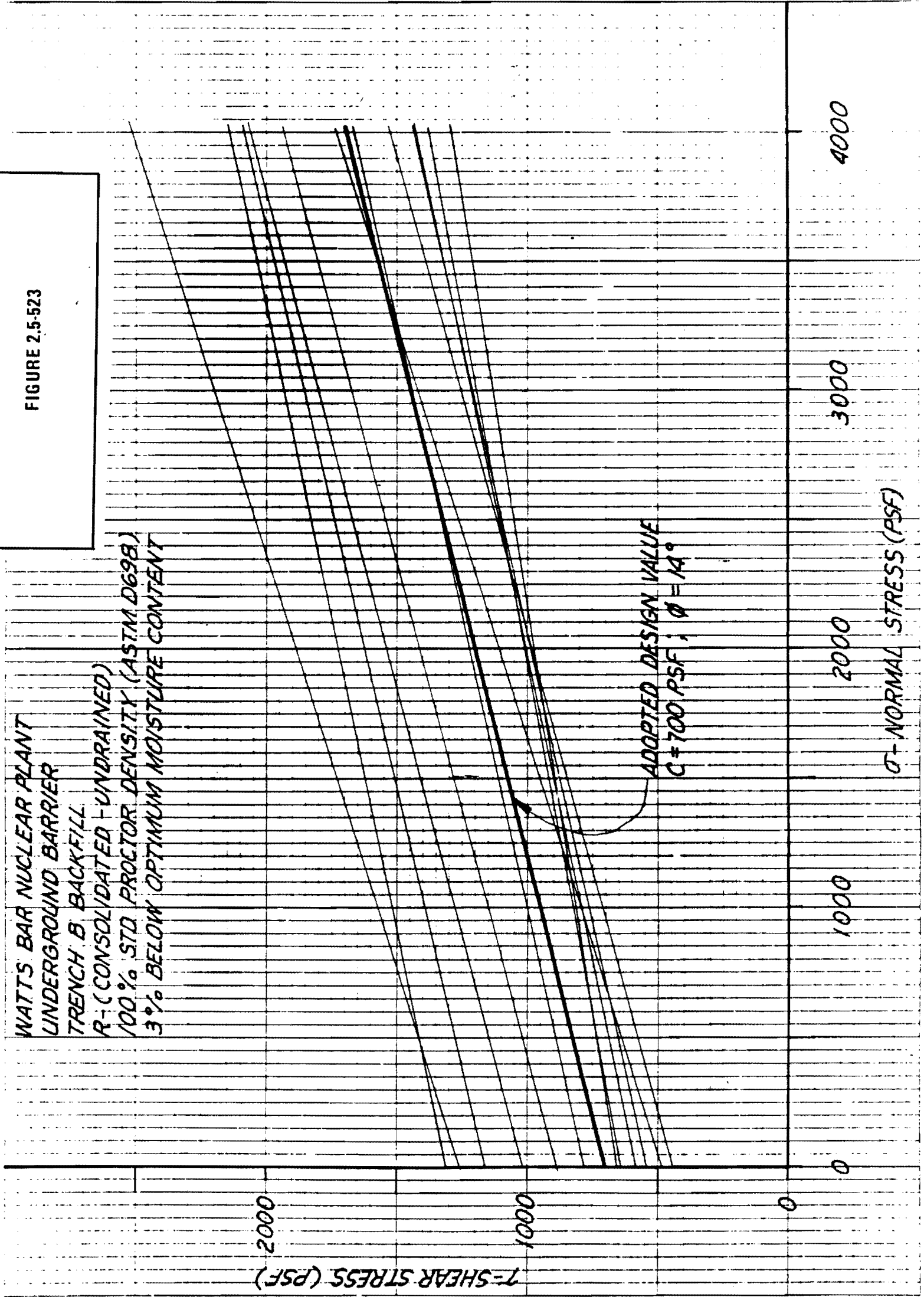

Figure 2.5-522 Watts Bar Nuclear Plant Underground Barrier Trench B Backfill R ( Consolidated - Undrained) 95% STD Proctor Density (ASTM D698) 3% Below Optimum Moisture Content

WATTS BAR NUCLEAR PLANT  
FINAL SAFETY  
ANALYSIS REPORT

FIGURE 2.5-523



Added by Amendment 50

Figure 2.5-523 Watts Bar Nuclear Plant Underground Barrier Trench B Backfill R ( Consolidated -Undrained) 100% STD Proctor Density (ASTM D698) 3% Below Optimum Moisture Content

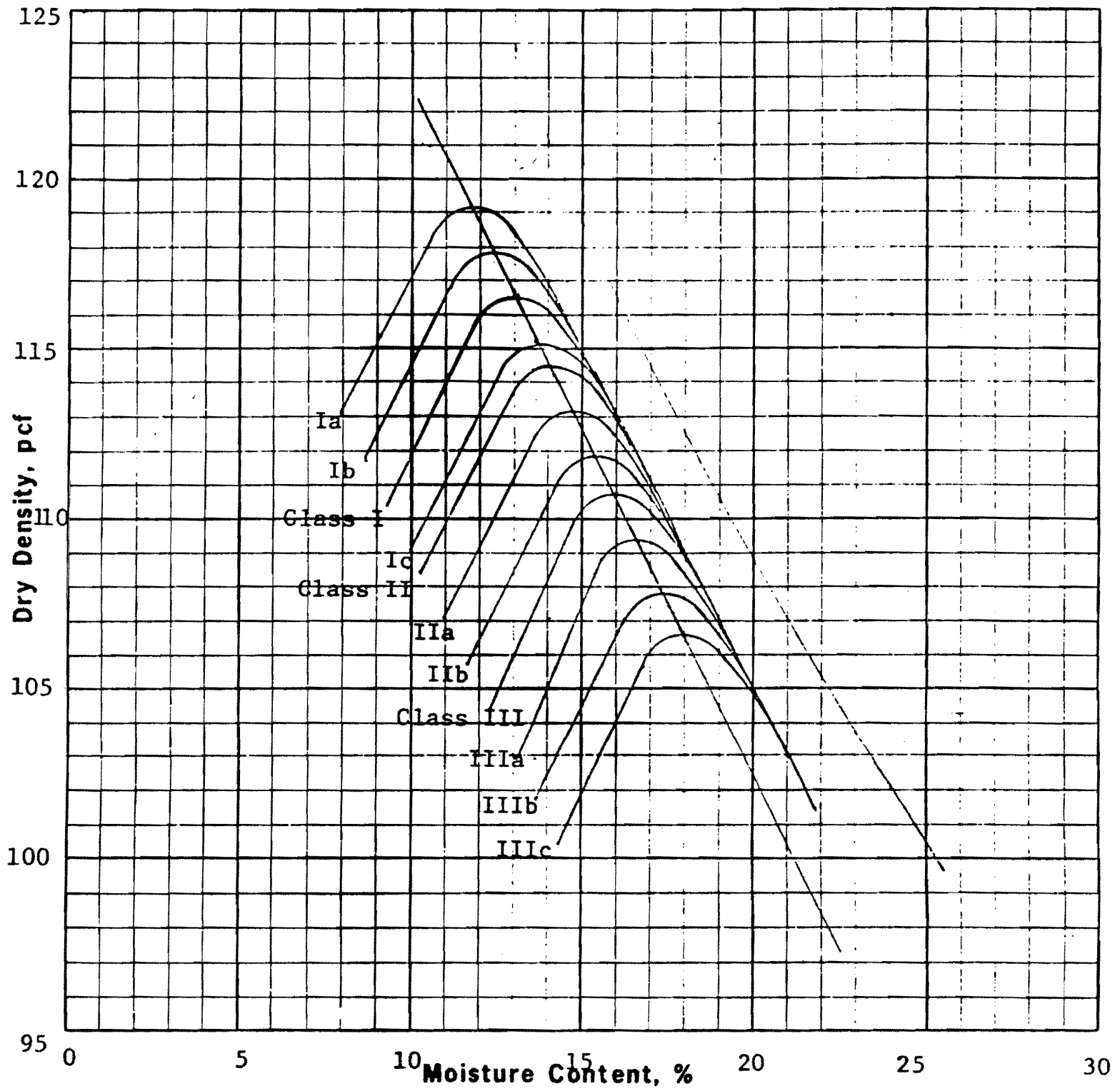

Soil Class	Gravel %	Sand %	Silt %	Clay %	Specific Gravity	LL %	PI %	Optimum Moisture, %	Maximum Density, pcf
I-SM-SC	0	70	15	15	2.66	24	5	13.1	116.6
II-SC	0	51	24	25	2.69	28	11	14.1	114.4
III-CL	0	40	29	31	2.69	34	15	15.9	110.8

Plus No. 4 Specific Gravity, S S D	---
Plus No. 4 Absorption, %	--

Remarks:

---



---



---

Added by Amendment 50

**WATTS BAR NUCLEAR PLANT  
FINAL SAFETY  
ANALYSIS REPORT**

---

**ERCW LIQUEFACTION  
TRENCH A, BORROW  
FIGURE 2.5-524**

Figure 2.5-524 ERCW Liquefaction Trench A Borrow



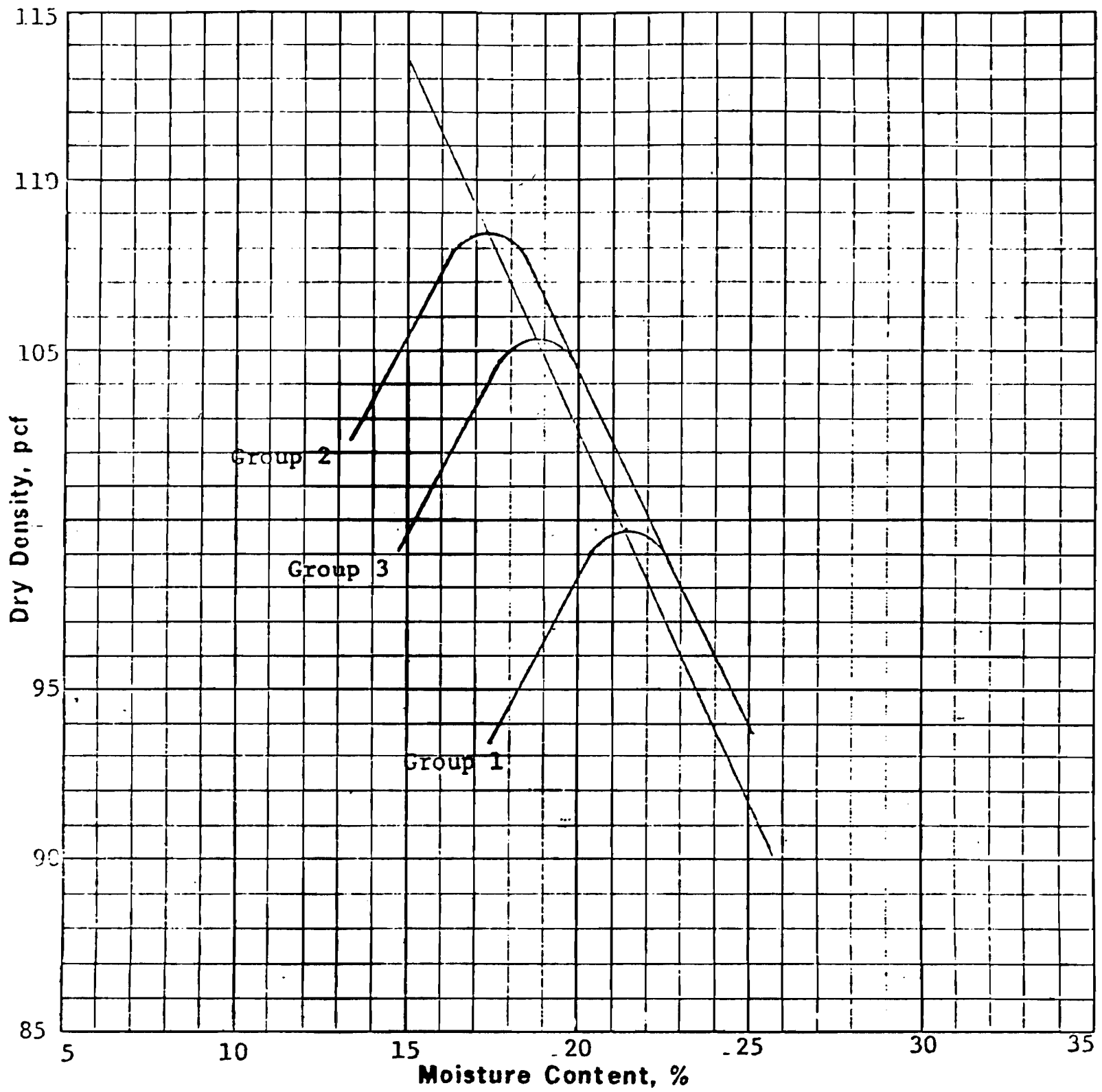

Soil Group	Gravel %	Sand %	Silt %	Clay %	Specific Gravity	LL %	PI %	Optimum Moisture, %	Maximum Density, pcf
1-ML	0	16	44	.40	2.73	47	18	21.4	99.7
2-SM	0	54	31	15	2.72	26	1	17.3	108.4
3-ML	0	43	35	22	2.73	34	8	18.8	105.3

Plus No. 4 Specific Gravity, S S D	--
Plus No. 4 Absorption, %	--

<b>Remarks:</b>	
Group 1	Silty sand fraction, upper
Group 2	Sand fraction, lower
Group 3	Composite, stockpile

**WATTS BAR NUCLEAR PLANT  
 FINAL SAFETY  
 ANALYSIS REPORT**

---

**ERCW LIQUEFACTION, TRENCH A  
 SUPPLEMENTAL BORROW  
 FIGURE 2.5-525**  
 Added by Amendment 50

Figure 2.5-525 ERCW Liquefaction Trench A Supplemental Borrow

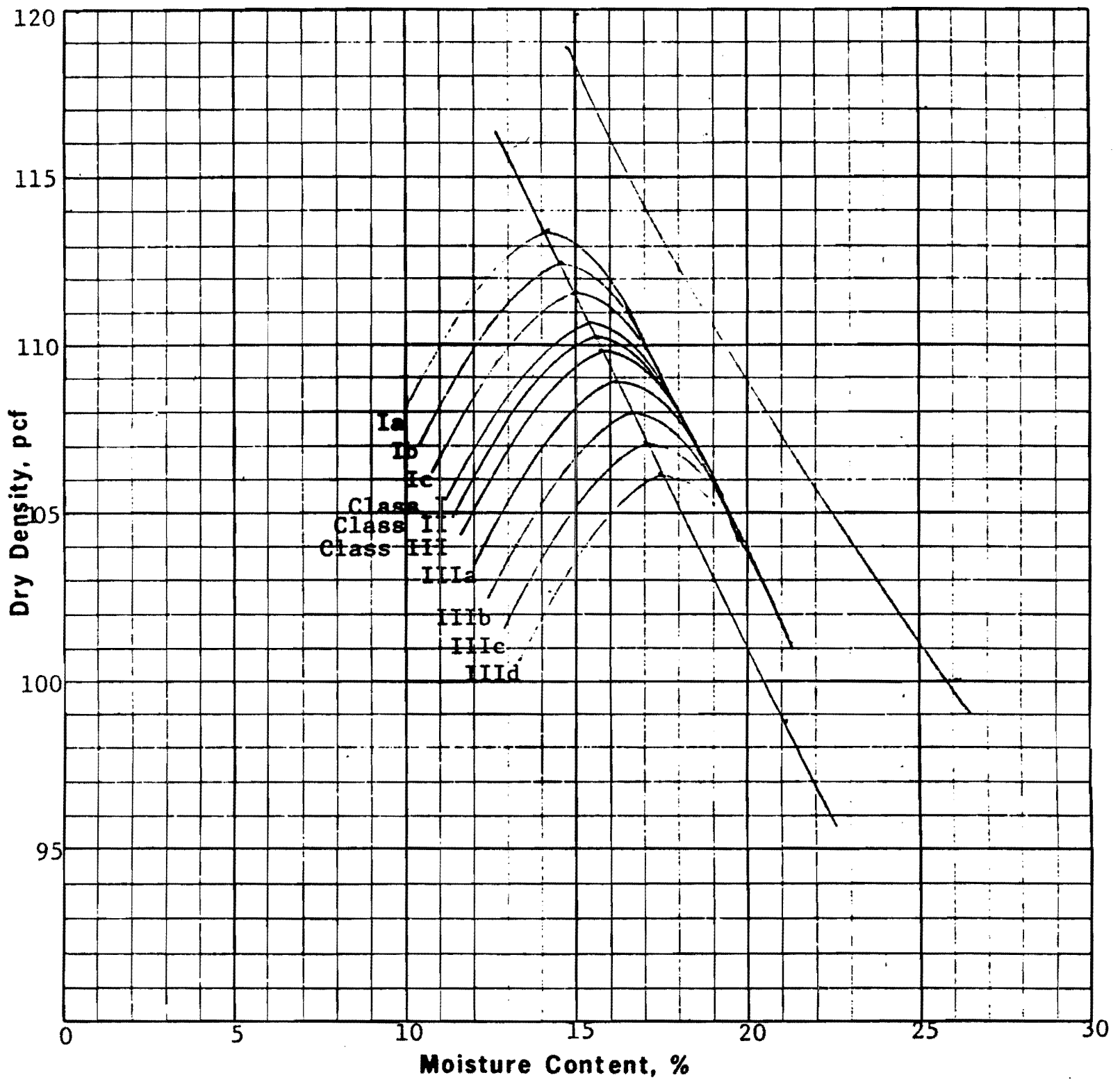

Soil Class	Gravel %	Sand %	Silt %	Clay %	Specific Gravity	LL %	PI %	Optimum Moisture, %	Maximum Density, pcf
I-SM	0	66	22	12	2.65	NP	NP	15.3	110.7
II-SM-SC	0	55	24	21	2.67	28	6	15.6	110.3
III-CL	0	43	28	29	2.69	30	11	15.8	109.8

Plus No. 4 Specific Gravity, S S D	--
Plus No. 4 Absorption, %	--

Remarks:

---

Added by Amendment 50

**WATTS BAR NUCLEAR PLANT  
FINAL SAFETY  
ANALYSIS REPORT**

---

**ERCW LIQUEFACTION  
TRENCH B  
FIGURE 2.5-526**

Figure 2.5-526 ERCW Liquefaction Trench B

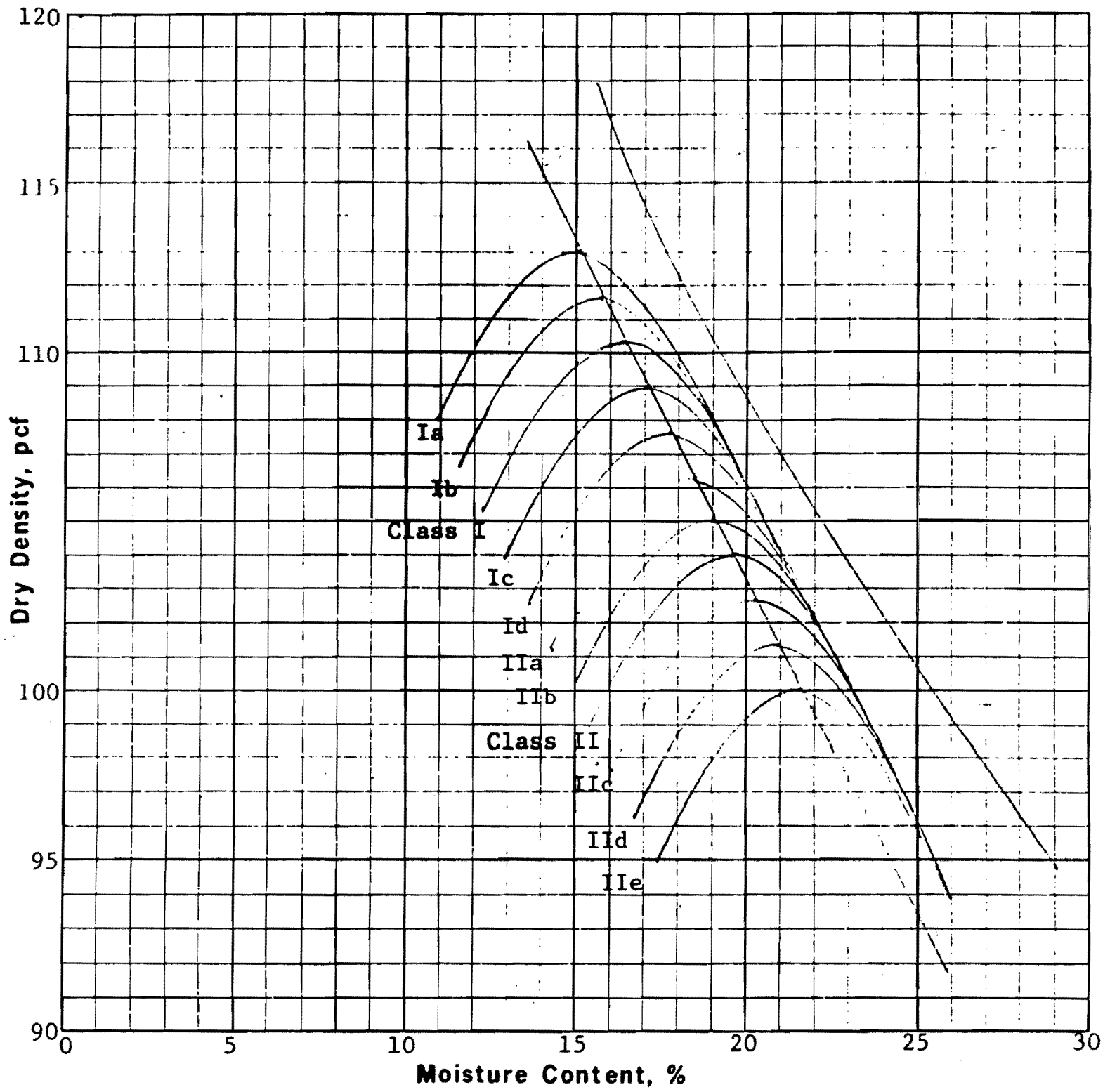

Soil Class	Gravel %	Sand %	Silt %	Clay %	Specific Gravity	LL %	PI %	Optimum Moisture, %	Maximum Density, pcf
I-CL	0	24	40	.36	2.66	31	16	16.4	110.3
II-CL-ML	0	32	27	41	2.70	40	15	19.6	104.0

Plus No. 4 Specific Gravity, S S D	--
Plus No. 4 Absorption, %	--

Remarks:

Added by Amendment 50

WATTS BAR NUCLEAR PLANT  
FINAL SAFETY  
ANALYSIS REPORT

---

ERCW LIQUEFACTION  
BORROW AREA 9  
FIGURE 2.5-527

Figure 2.5-527 ERCW Liquefaction Borrow Area 9

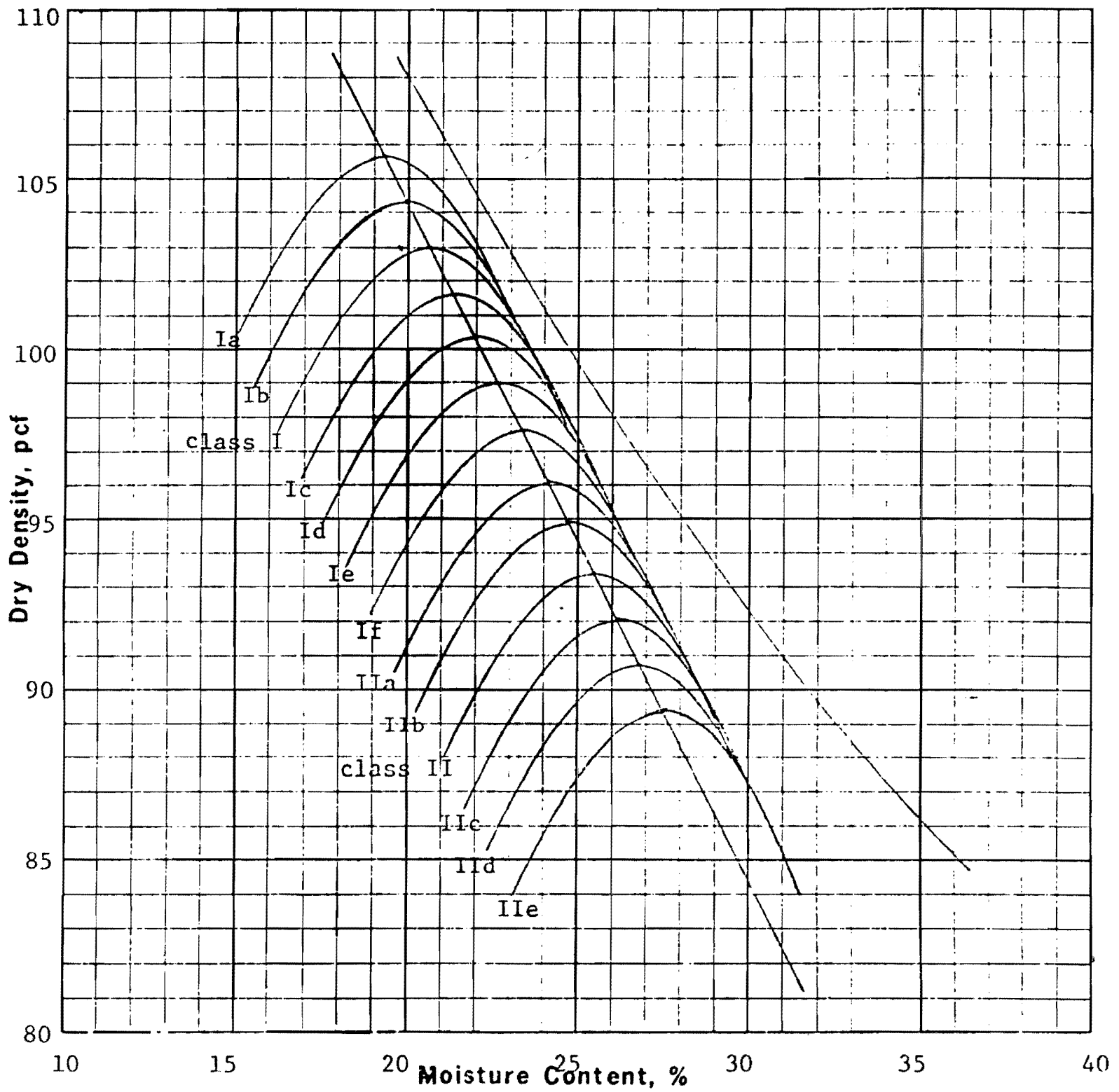

Soil Class	Gravel %	Sand %	Silt %	Clay %	Specific Gravity	LL %	PI %	Optimum Moisture, %	Maximum Density, pcf
I-CL	0	33	31	36	2.65	39	16	20.6	103.0
II-CL-ML	0	19	33	48	2.65	45	19	25.4	93.3

Plus No. 4 Specific Gravity, S S D	--
Plus No. 4 Absorption, %	--

Remarks:

---



---



---

Added by Amendment 50

**WATTS BAR NUCLEAR PLANT  
FINAL SAFETY  
ANALYSIS REPORT**

---

**ERCW LIQUEFACTION  
BORROW AREA 10  
FIGURE 2.5-528**

TVA 10001 (CONST. 6-77)

Figure 2.5-528 ERCW Liquefaction Borrow Area 10

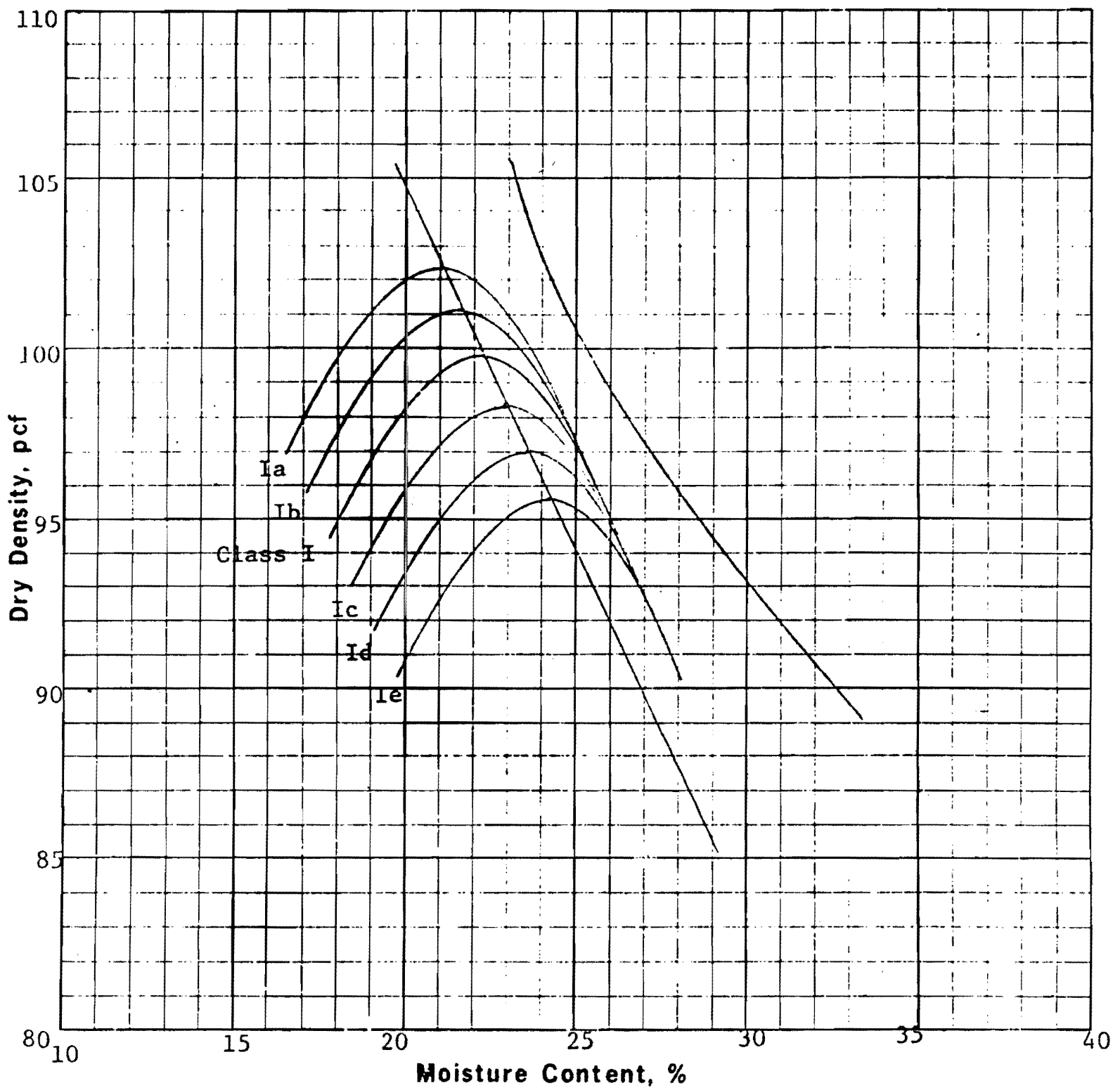

Soil Class	Gravel %	Sand %	Silt %	Clay %	Specific Gravity	LL %	PI %	Optimum Moisture, %	Maximum Density, pcf
I-ML	0	21	35	44	2.71	44	15	22.2	99.8

Plus No. 4 Specific Gravity, S S D	--
Plus No. 4 Absorption, %	--

Remarks:

---



---



---

Added by Amendment 50

**WATTS BAR NUCLEAR PLANT  
FINAL SAFETY  
ANALYSIS REPORT**

---

**ERCW LIQUEFACTION  
BORROW AREA 11  
FIGURE 2.5-529**

Figure 2.5-529 ERCW Liquefaction Borrow Area 11

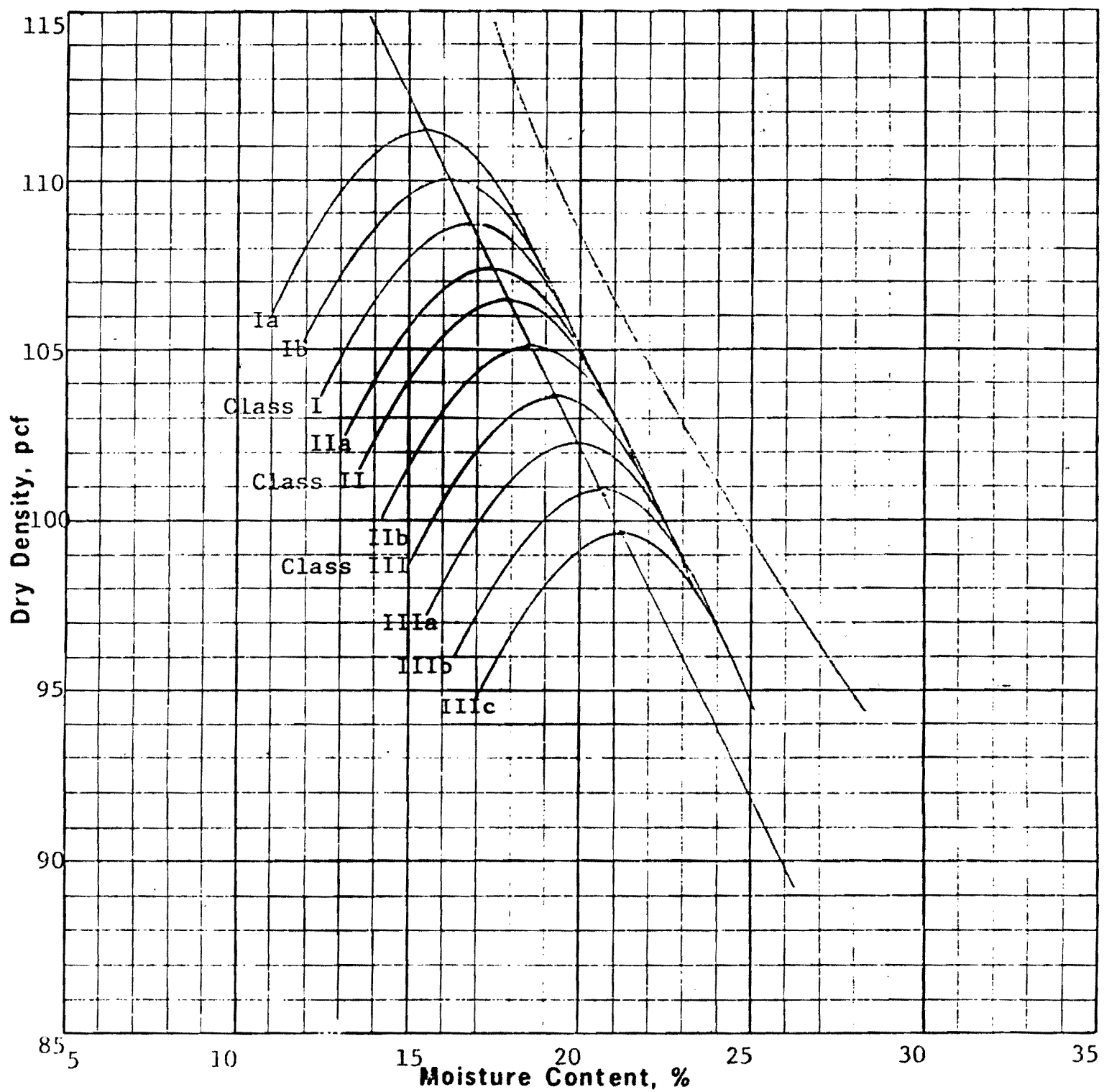

Soil Class	Gravel %	Sand %	Silt %	Clay %	Specific Gravity	LL %	PI %	Optimum Moisture, %	Maximum Density, pcf
I-SM	0	50	26	24	2.69	32	7	16.8	108.8
II-CL- ML	0	22	39	39	2.70	40	15	17.8	106.5
III-CL- ML	0	22	40	38	2.66	42	16	19.2	103.7

Plus No. 4 Specific Gravity, S S D	--
Plus No. 4 Absorption, %	--
Remarks:	

Added by Amendment 50

**WATTS BAR NUCLEAR PLANT  
FINAL SAFETY  
ANALYSIS REPORT**

---

**ERCW LIQUEFACTION  
BORROW AREA 12  
FIGURE 2.5-530**

Figure 2.5-530 ERCW Liquefaction Borrow Area 12

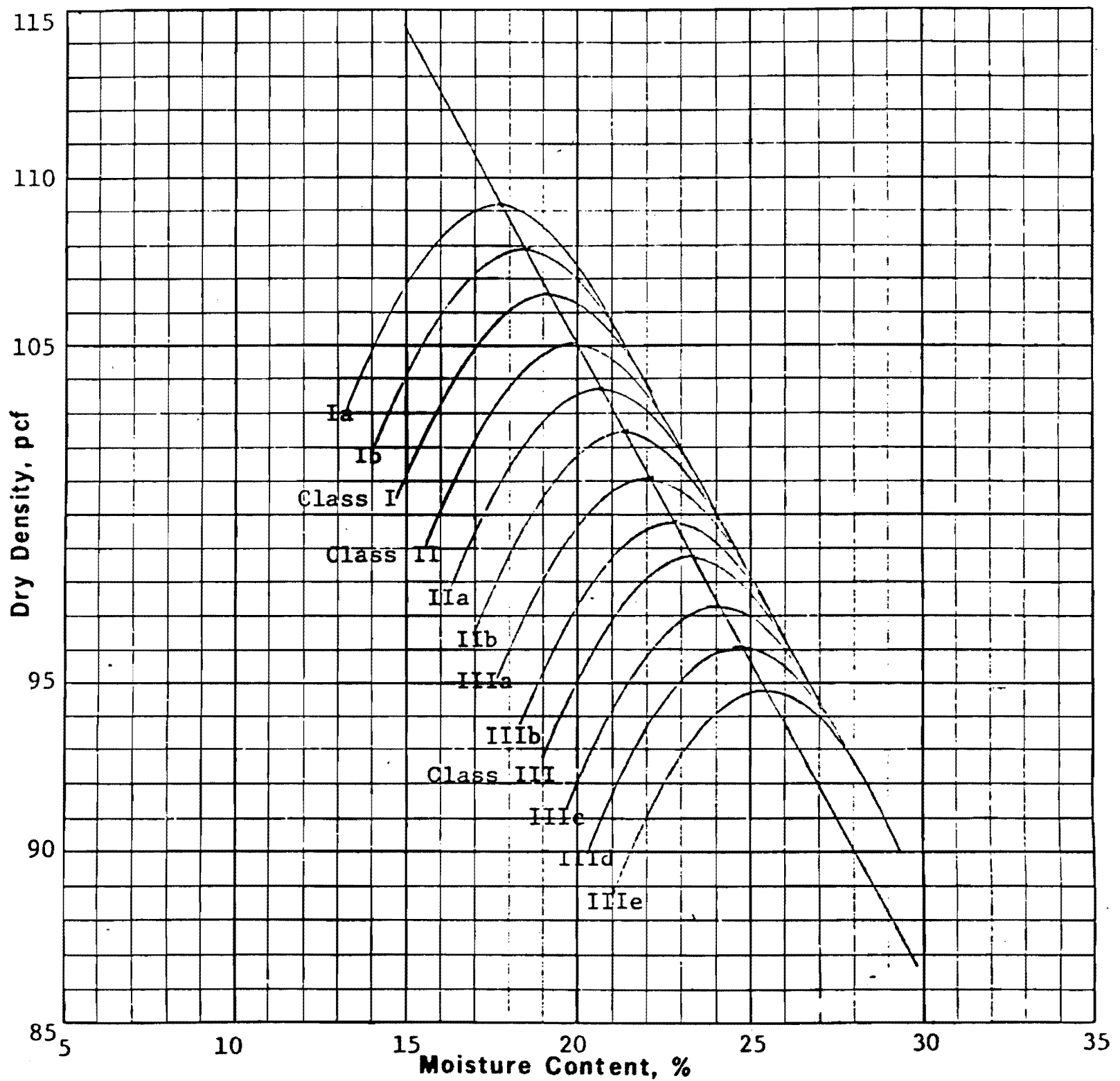

Soil Class	Gravel %	Sand %	Silt %	Clay %	Specific Gravity	LL %	PI %	Optimum Moisture, %	Maximum Density, pcf
I-ML	0	24	42	34	2.71	37	11	19.2	106.6
II-ML	0	23	39	38	2.73	41	14	20.0	105.1
III-MH	0	12	41	47	2.74	52	17	23.3	98.8

Plus No. 4 Specific Gravity, S S D	--
Plus No. 4 Absorption, %	--

Remarks:

---



---

Added by Amendment 50

WATTS BAR NUCLEAR PLANT  
FINAL SAFETY  
ANALYSIS REPORT

---

ERCW LIQUEFACTION  
BORROW AREA 13  
FIGURE 2.5-531

Figure 2.5-531 ERCW Liquefaction Borrow Area 13

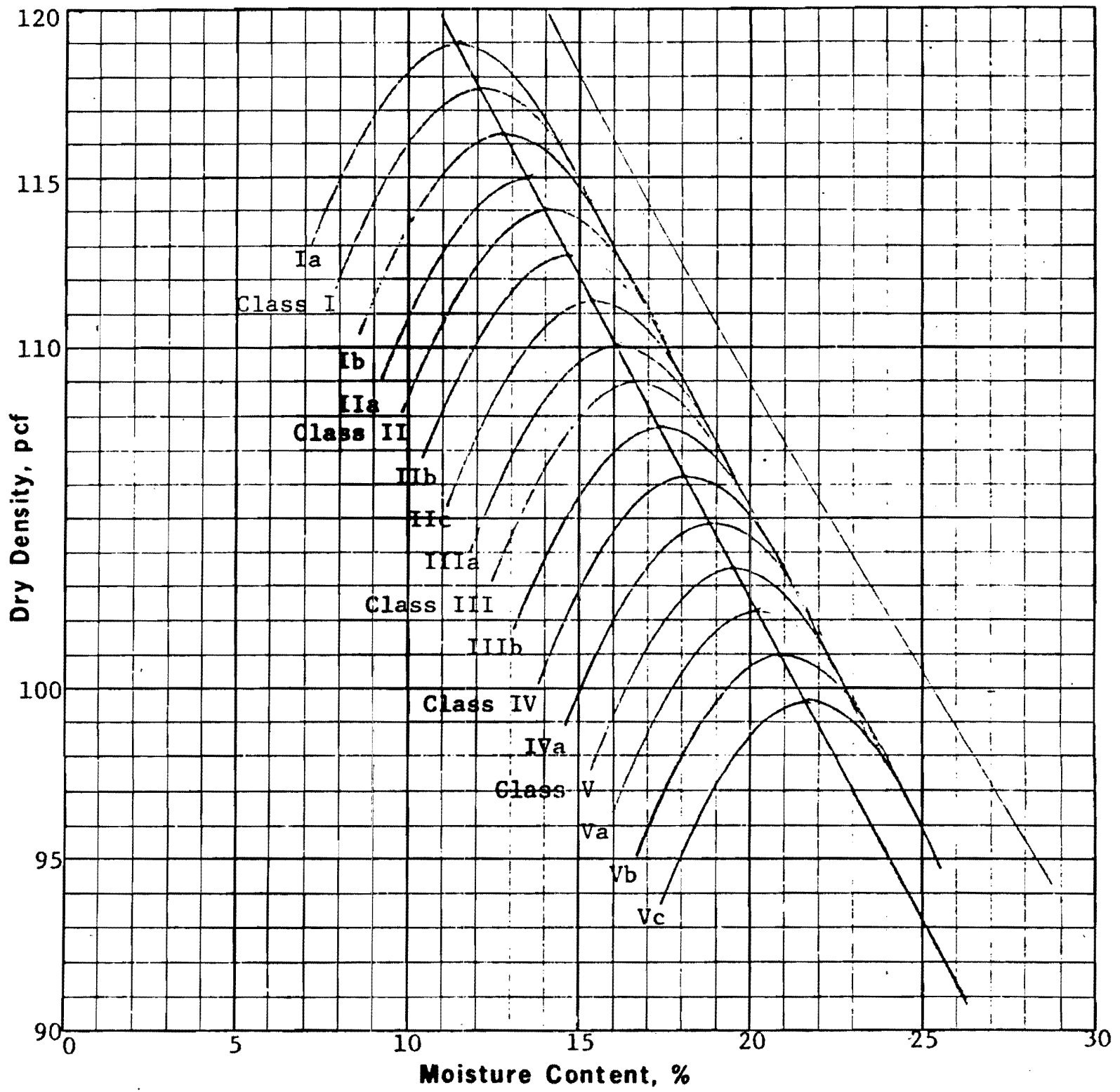

Soil Class	Gravel %	Sand %	Silt %	Clay %	Specific Gravity	LL %	PI %	Optimum Moisture, %	Maximum Density, pcf
I-ML	0	48	40	12	2.63	NP	NP	12.1	117.7
II-SM-SC	0	65	16	19	2.68	25	6	13.9	114.0
III-CL	0	48	23	29	2.67	36	14	16.6	109.0
IV-CL	0	30	34	36	2.68	41	17	18.1	106.2
V-CL-ML	0	23	39	38	2.70	44	17	19.5	103.5

Plus No. 4 Specific Gravity, S S D	--
Plus No. 4 Absorption, %	--

Remarks:

---

Added by Amendment 50

**WATTS BAR NUCLEAR PLANT  
FINAL SAFETY  
ANALYSIS REPORT**

---

**ERCW LIQUEFACTION  
BORROW AREA 2C  
FIGURE 2.5-532**

Figure 2.5-532 ERCW Liquefaction Borrow Area 2C



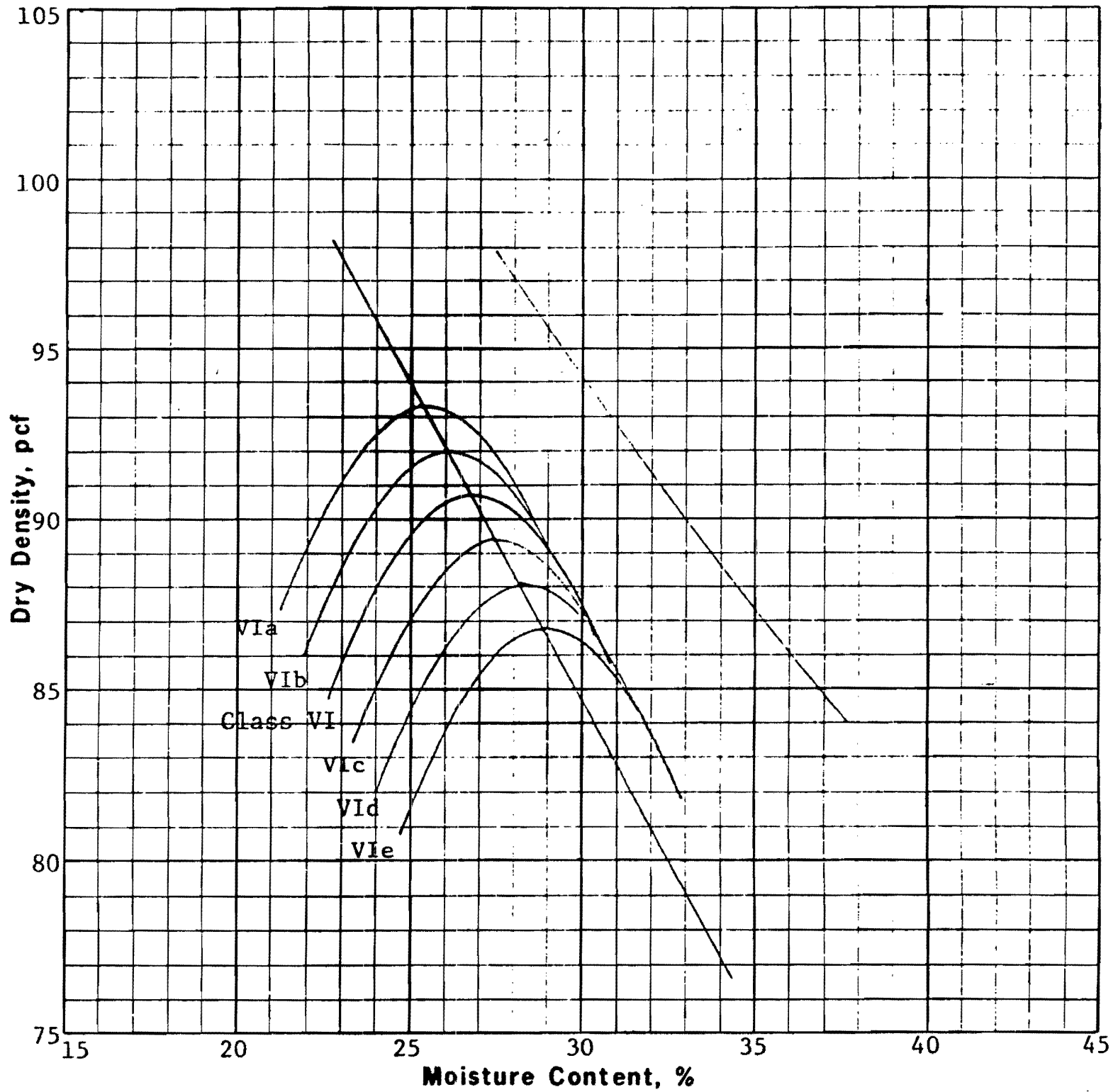

Soil Class	Gravel %	Sand %	Silt %	Clay %	Specific Gravity	LL %	PI %	Optimum Moisture, %	Maximum Density, pcf
VI-MH	0	5	40	55	2.74	62	27	26.8	90.8

Plus No. 4 Specific Gravity, S S D	--
Plus No. 4 Absorption, %	--

Remarks:

---



---

Added by Amendment 50

**WATTS BAR NUCLEAR PLANT  
FINAL SAFETY  
ANALYSIS REPORT**

---

**ERCW LIQUEFACTION  
BORROW AREA 2C  
FIGURE 2.5-533**

Figure 2.5-533 ERCW Liquefaction Borrow Area 2C

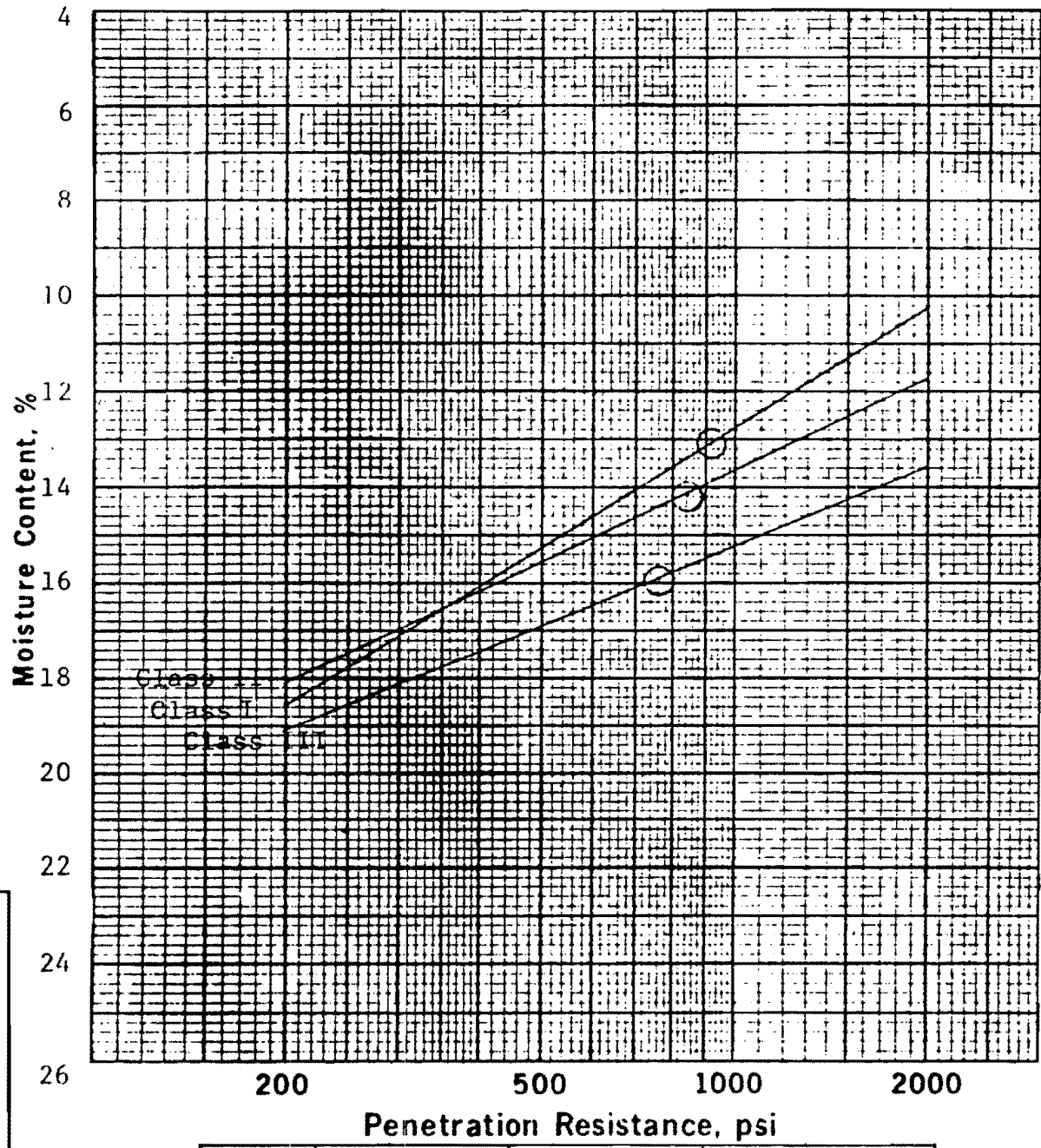

WATTS BAR NUCLEAR PLANT  
 FINAL SAFETY  
 ANALYSIS REPORT

ERGW LIQUEFACTION  
 TRENCH A  
 FIGURE 2.5-534

Soil Class	Optimum Moisture, %	Maximum Density, pcf	Penetration Resistance, psi
I-SM-SC	13.1	116.6	910
II-SC	14.1	114.4	840
III-CL	15.9	110.8	760

**Remarks:**

---



---



---



---

Project Watts Bar Nuclear Plant	
ERCW Liquefaction	
Feature Trench A	
ASTM Designation	D 698A
Date Tested	6-6-83
<b>MOISTURE - PENETRATION TEST</b>	

○ Denotes Optimum Moisture

Added by Amendment 50

Figure 2.5-534 ERCW Liquefaction Trench A

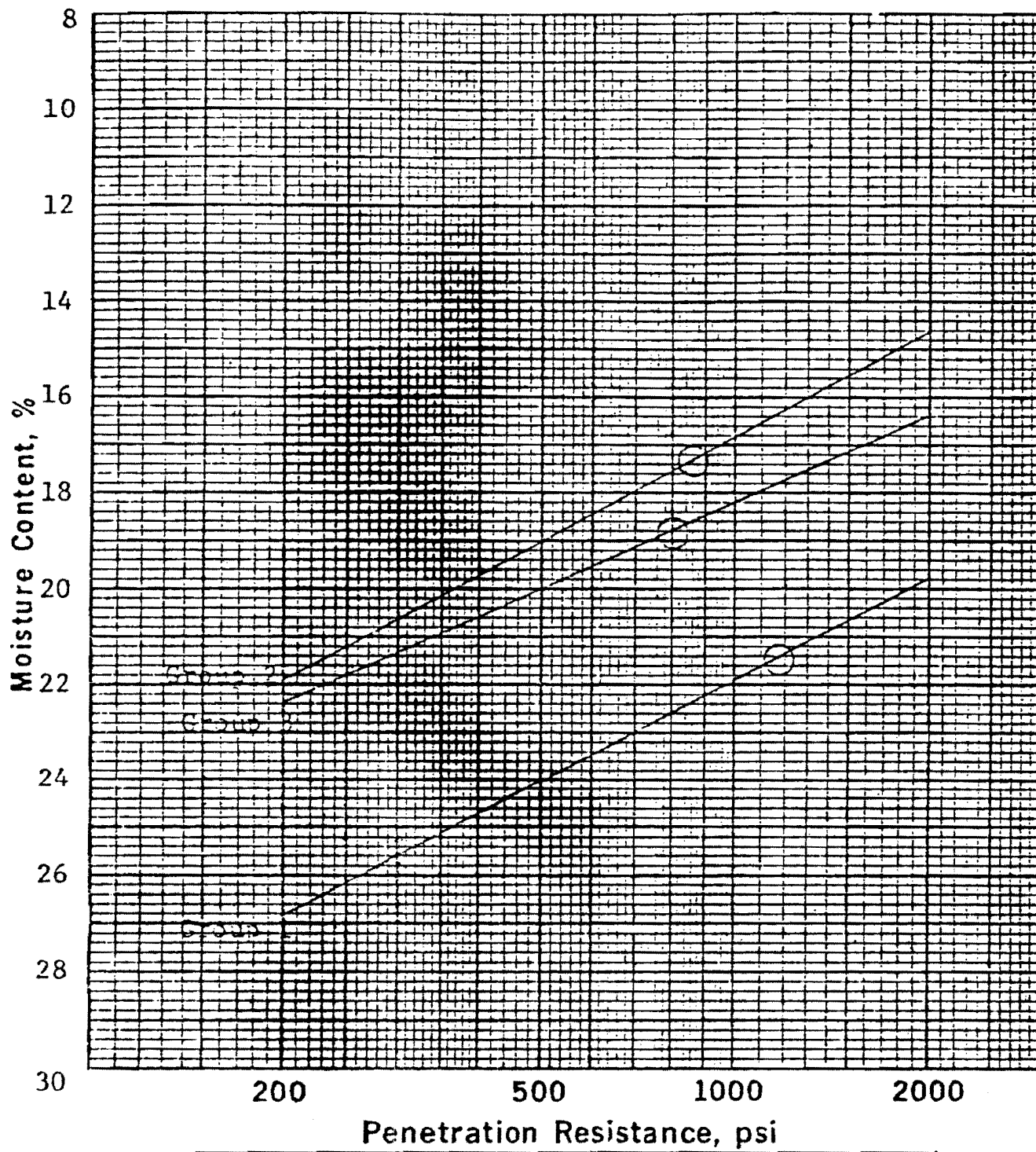

Soil Group	Optimum Moisture, %	Maximum Density, pcf	Penetration Resistance, psi
1-ML	21.4	99.7	1180
2-SM	17.3	108.4	860
3-ML	18.8	105.3	800

Added by Amendment t 50

Remarks:

○ Denotes Optimum Moisture

<p><b>WATTS BAR NUCLEAR PLANT FINAL SAFETY ANALYSIS REPORT</b></p>
<p><b>ERCW LIQUEFACTION, TRENCH A SUPPLEMENTAL BORROW FIGURE 2.5-535</b></p>

Figure 2.5-535 ERCW Liquefaction Trench A Supplemental Borrow

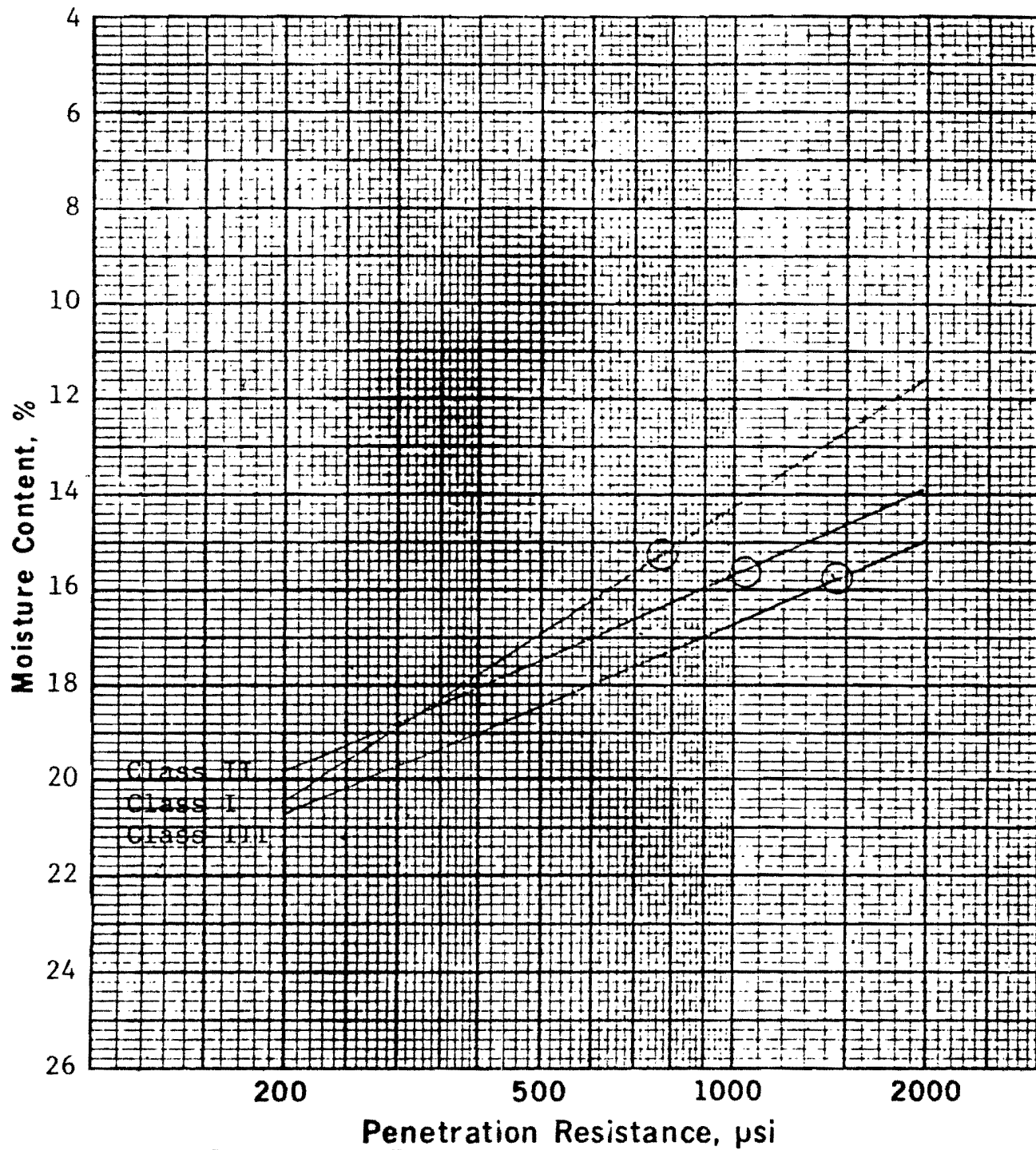

Soil Class	Optimum Moisture, %	Maximum Density, pcf	Penetration Resistance, psi
I-SM	15.3	110.7	770
II-SM-SC	15.6	110.3	1025
III-CL	15.8	109.8	1425

Remarks:

---



---



---



---

Added by Amendment 50

○ Denotes Optimum Moisture

WATTS BAR NUCLEAR PLANT  
FINAL SAFETY  
ANALYSIS REPORT

---

ERCW LIQUEFACTION  
TRENCH B  
FIGURE 2.5-536

Figure 2.5-536 ERCW Liquefaction Trench B

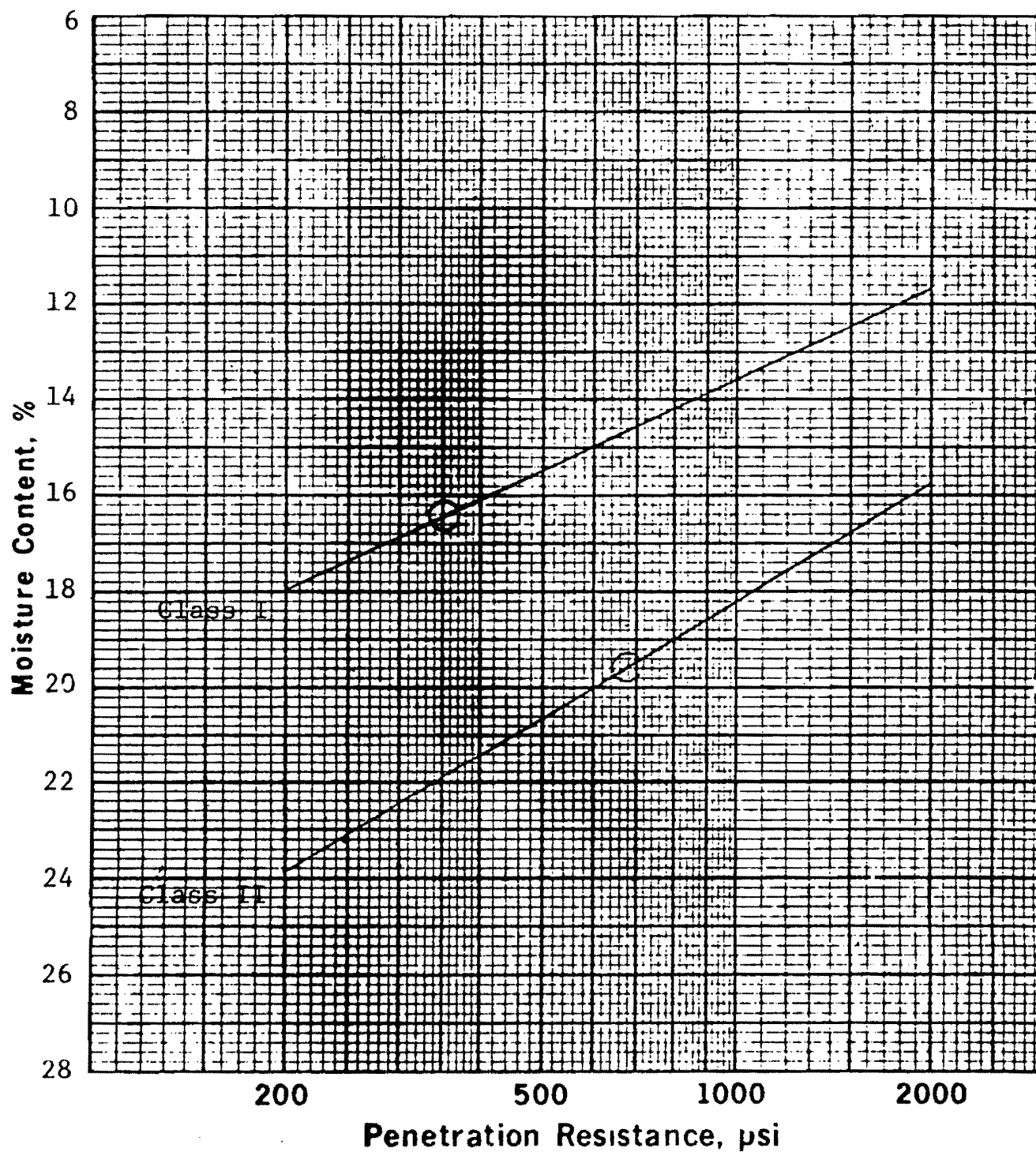

Soil Class	Optimum Moisture, %	Maximum Density, pcf	Penetration Resistance, psi
I-CL	16.4	110.3	350
II-CL-ML	19.6	104.0	680

Added by Amendment 50

**Remarks:**

<b>WATTS BAR NUCLEAR PLANT FINAL SAFETY ANALYSIS REPORT</b>
<b>ERCW LIQUEFACTION BORROW AREA 9 FIGURE 2.5-537</b>

○ Denotes Optimum Moisture

Figure 2.5-537 ERCW Liquefaction Borrow Area 9

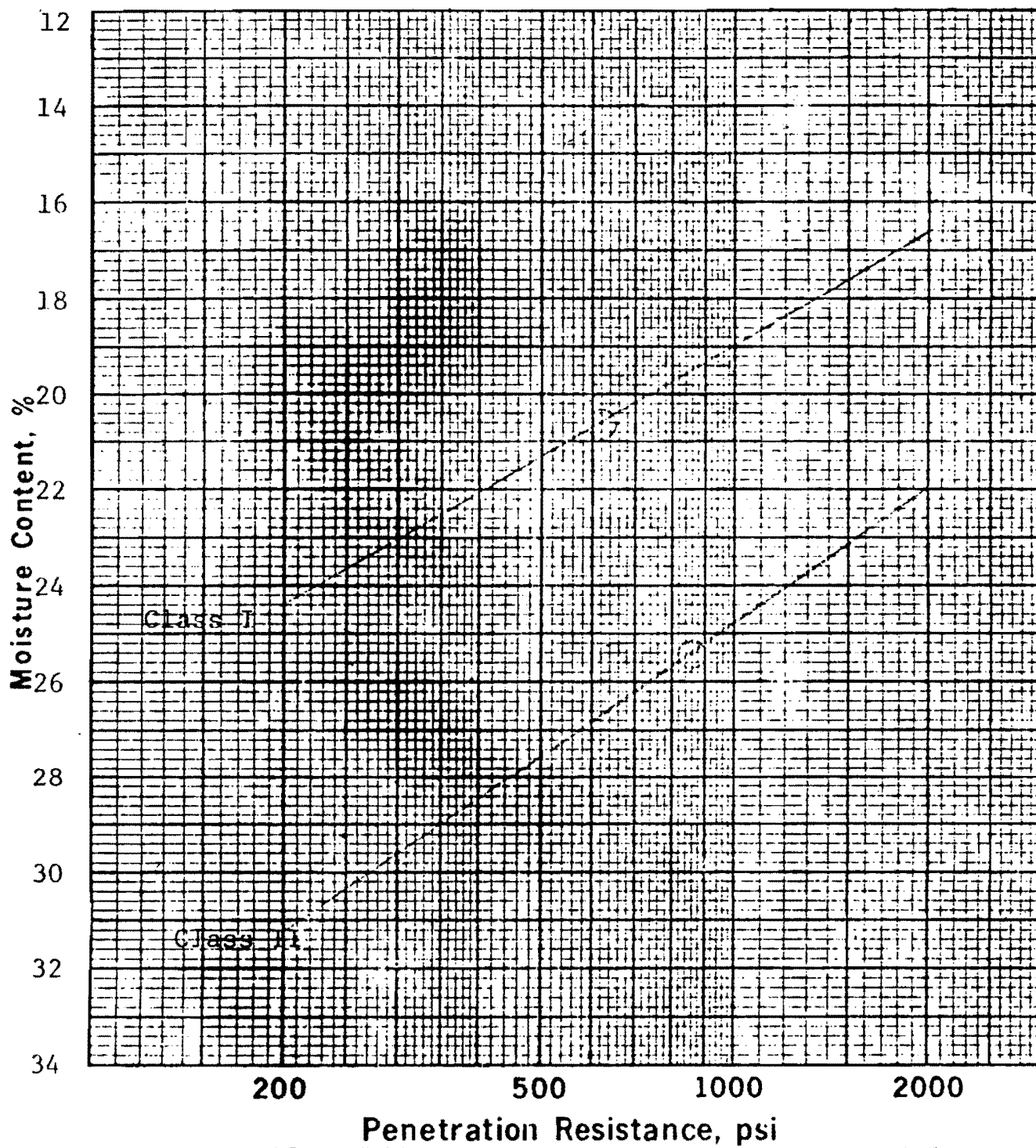

Soil Class	Optimum Moisture, %	Maximum Density, pcf	Penetration Resistance, psi
I-CL	20.6	103.0	620
II-CL-ML	25.4	93.3	860

Added by Amendment 50

Remarks:

○ Denotes Optimum Moisture

<b>WATTS BAR NUCLEAR PLANT FINAL SAFETY ANALYSIS REPORT</b>
<b>ERCW LIQUEFACTION BORROW AREA 10 FIGURE 2.5-538</b>

Figure 2.5-538 ERCW Liquefaction Borrow Area 10

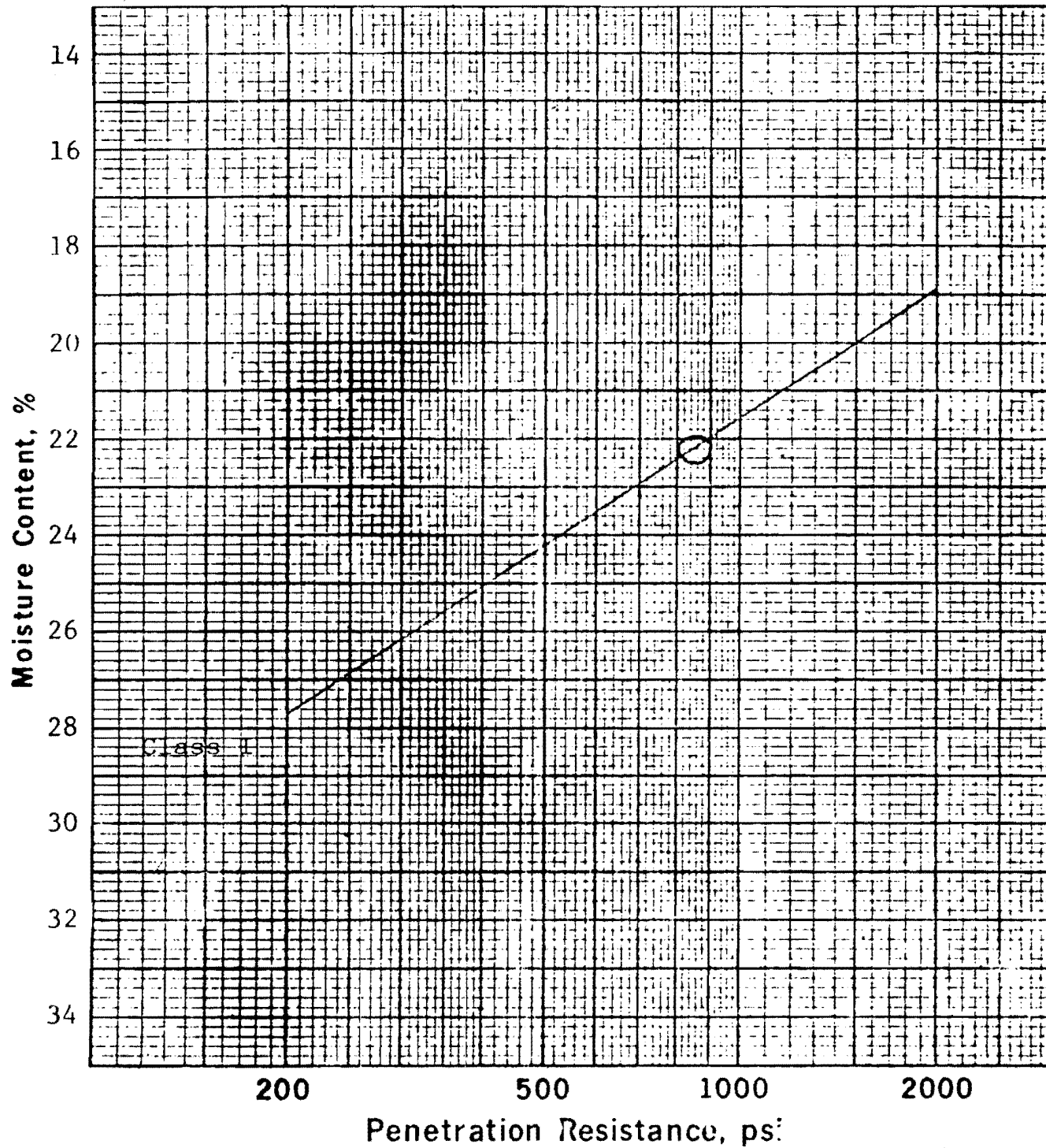

Soil Class	Optimum Moisture, %	Maximum Density, pcf	Penetration Resistance, psi
I-ML	22.2	99.8	850

Added by Amendment 50

Remarks:

---



---



---



---

**WATTS BAR NUCLEAR PLANT  
FINAL SAFETY  
ANALYSIS REPORT**

---

**ERCW LIQUEFACTION  
BORROW AREA 11  
FIGURE 2.5-539**

○ Denotes Optimum Moisture

Figure 2.5-539 ERCW Liquefaction Borrow Area 11

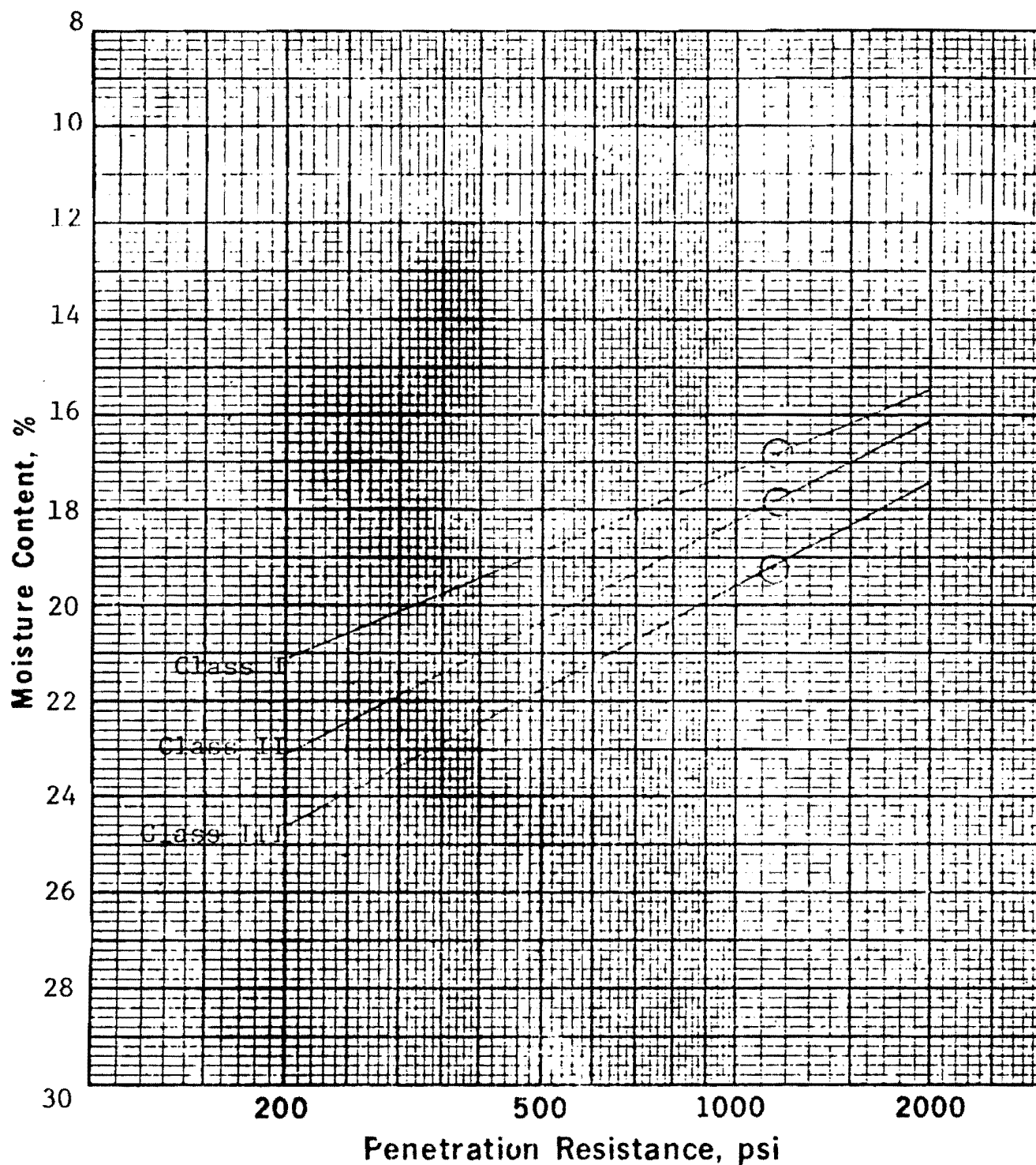

Soil Class	Optimum Moisture, %	Maximum Density, pcf	Penetration Resistance, psi
I-ML	16.8	108.8	1165
CL- II-ML	17.8	106.5	1150
CL- III-ML	19.2	103.7	1145

Added by Amendment 50

Remarks:

---



---



---



---

○ Denotes Optimum Moisture

**WATTS BAR NUCLEAR PLANT  
FINAL SAFETY  
ANALYSIS REPORT**

---

**ERCW LIQUEFACTION  
BORROW AREA 12  
FIGURE 2.5-540**

Figure 2.5-540 ERCW Liquefaction Borrow Area 12



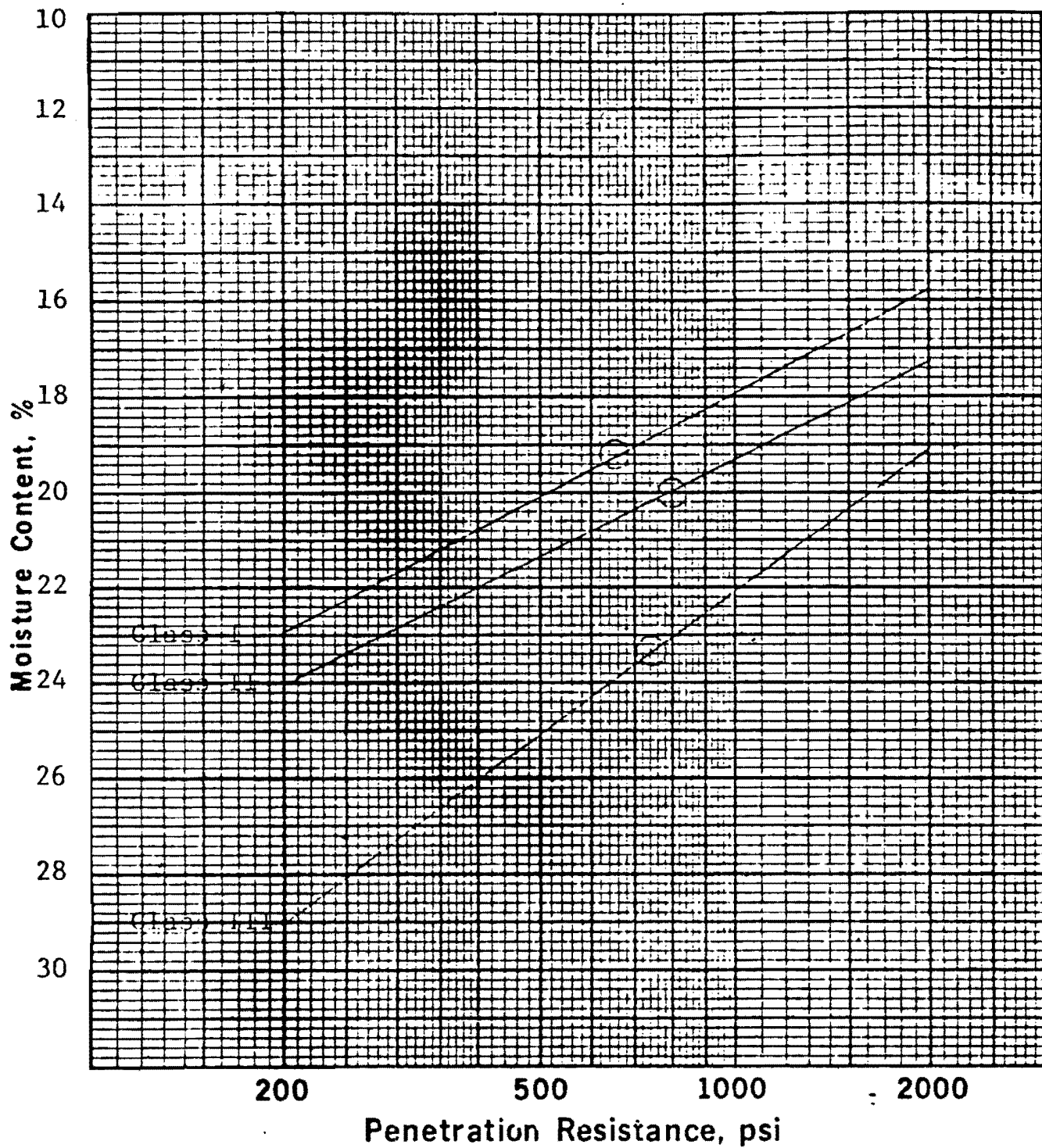

Soil Class	Optimum Moisture, %	Maximum Density, pcf	Penetration Resistance, psi
I-ML	19.2	106.6	650
II-ML	20.0	105.1	800
III-MH	23.3	98.8	740

Added by Amendment 50

Remarks:

○ Denotes Optimum Moisture

<b>WATTS BAR NUCLEAR PLANT FINAL SAFETY ANALYSIS REPORT</b>
<b>ERCW LIQUEFACTION BORROW AREA 13 FIGURE 2.5-541</b>

Figure 2.5-541 ERCW Liquefaction Borrow Area 13

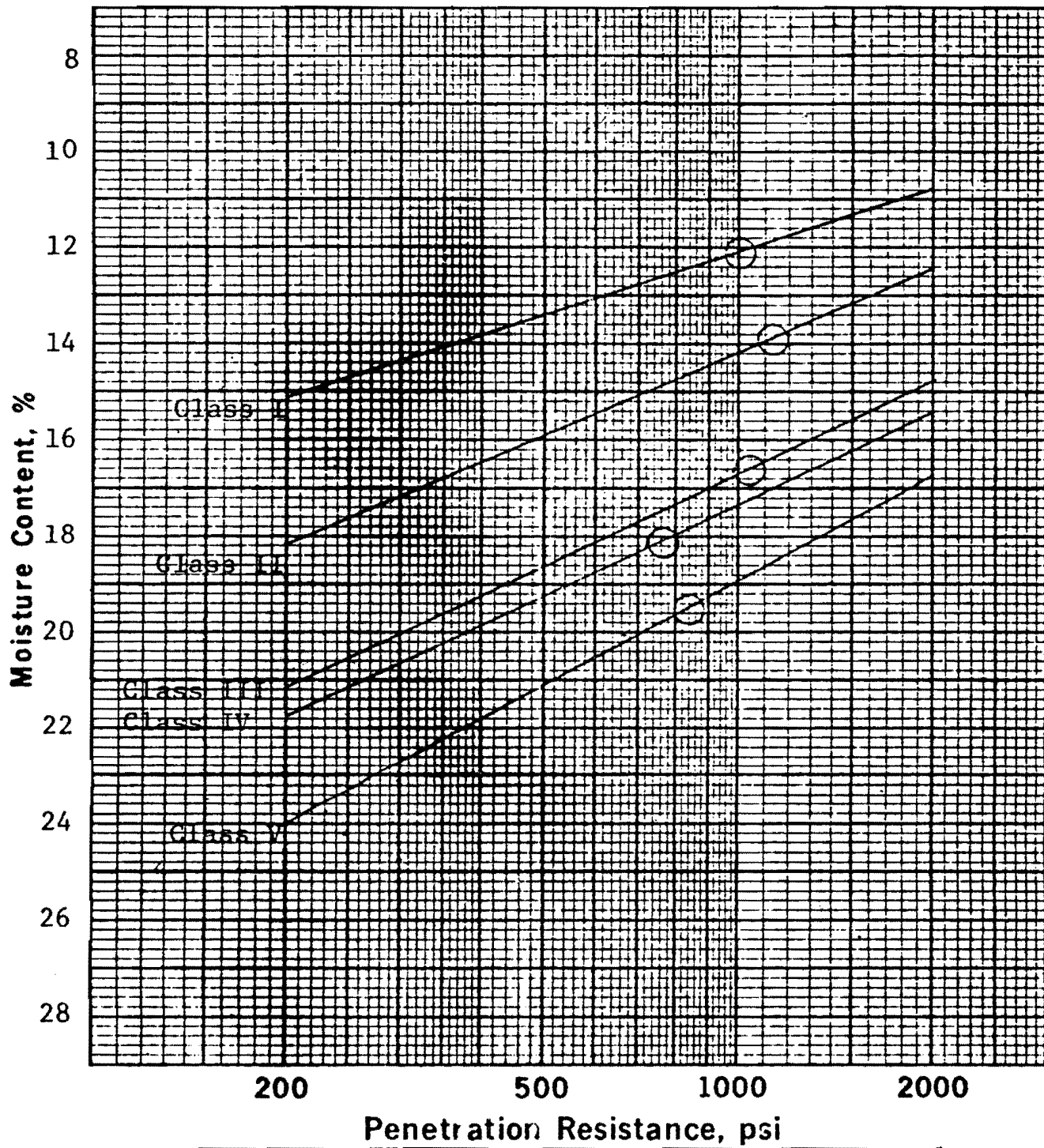

Soil Class	Optimum Moisture, %	Maximum Density, pcf	Penetration Resistance, psi
I-ML	12.1	117.7	1000
II-SM-SC	13.9	114.0	1125
III-CL	16.6	109.0	1050
IV-CL	18.1	106.2	760
V-CL-ML	19.5	103.5	840

Remarks:

○ Denotes Optimum Moisture

**WATTS BAR NUCLEAR PLANT  
FINAL SAFETY  
ANALYSIS REPORT**

---

**ERCW LIQUEFACTION  
BORROW AREA 2C  
FIGURE 2.5-542**

Added by Amendment 50

Figure 2.5-542 ERCW Liquefaction Borrow Area 2C

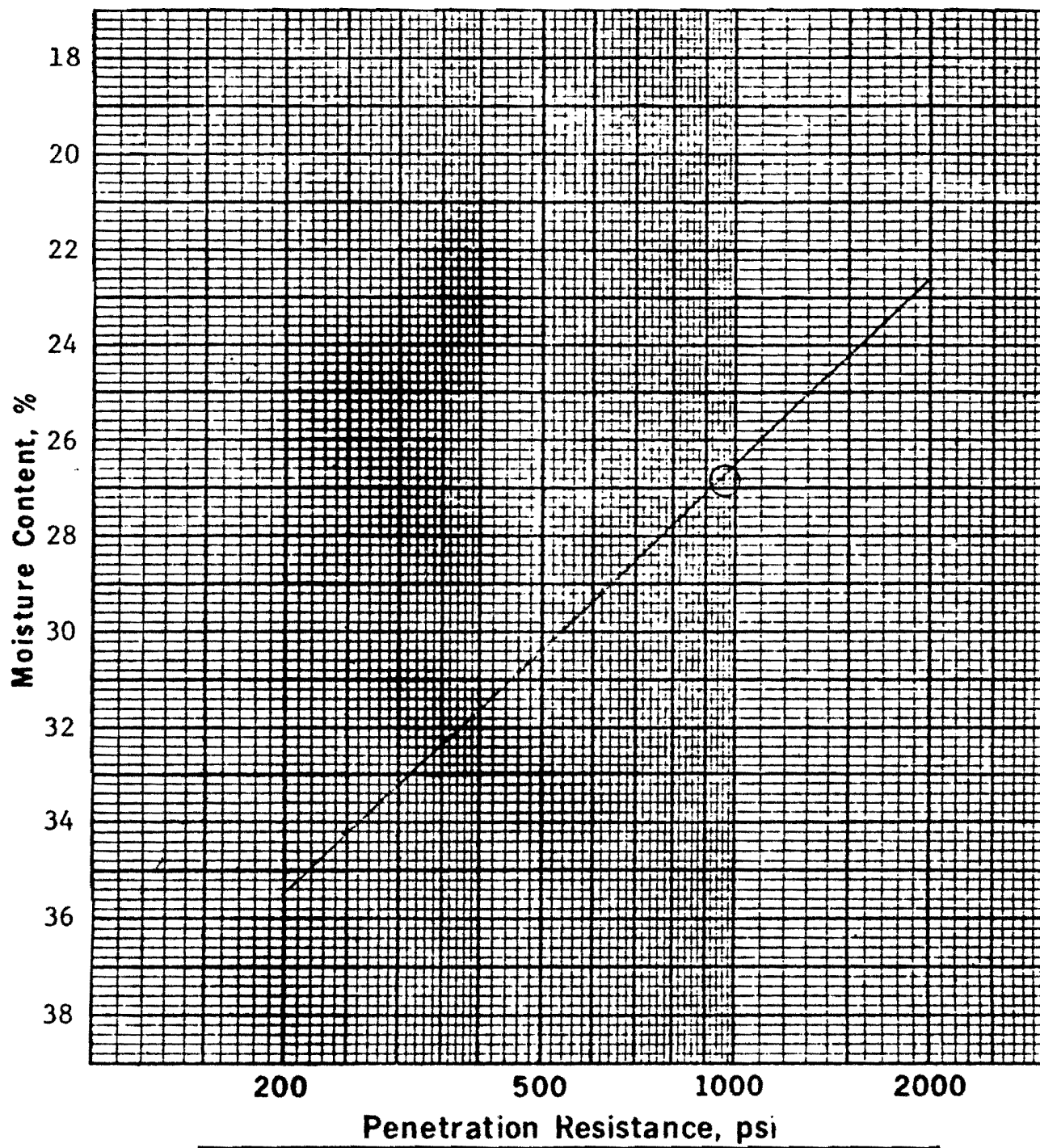

Soil Class	Optimum Moisture, %	Maximum Density, pcf	Penetration Resistance, psi
VI-MH	26.8	90.8	950

Added by Amendment 50

Remarks:

<b>WATTS BAR NUCLEAR PLANT FINAL SAFETY ANALYSIS REPORT</b>
<b>ERCW LIQUEFACTION BORROW AREA 2C FIGURE 2.5-543</b>

○ Denotes Optimum Moisture

Figure 2.5-543 ERCW Liquefaction Borrow Area 2C

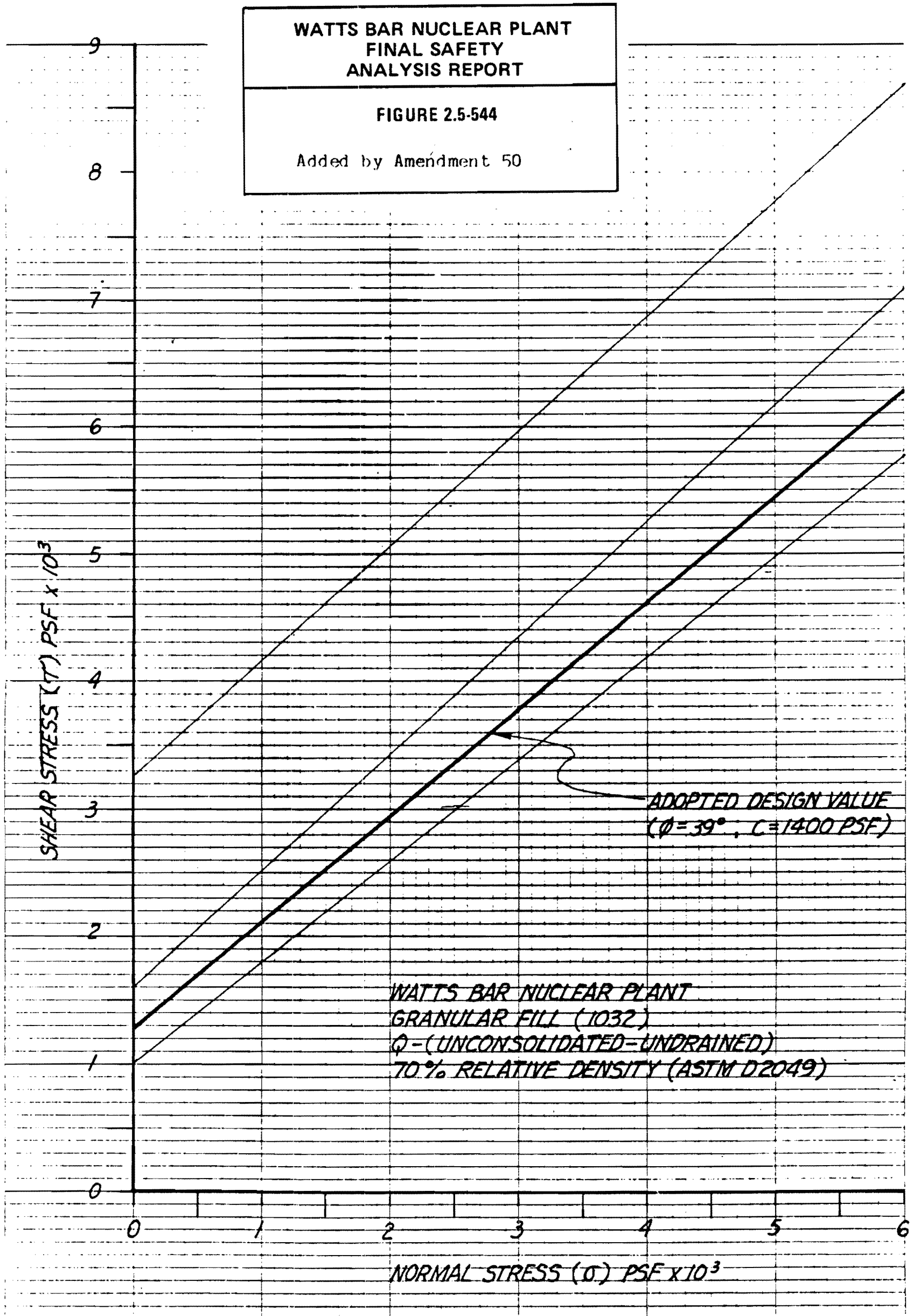

Figure 2.5-544 Watts Bar Nuclear Plant Granular Fill (1032) Q-(Unconsolidated-Undrained) 70% Relative Density (ASTM D2049)

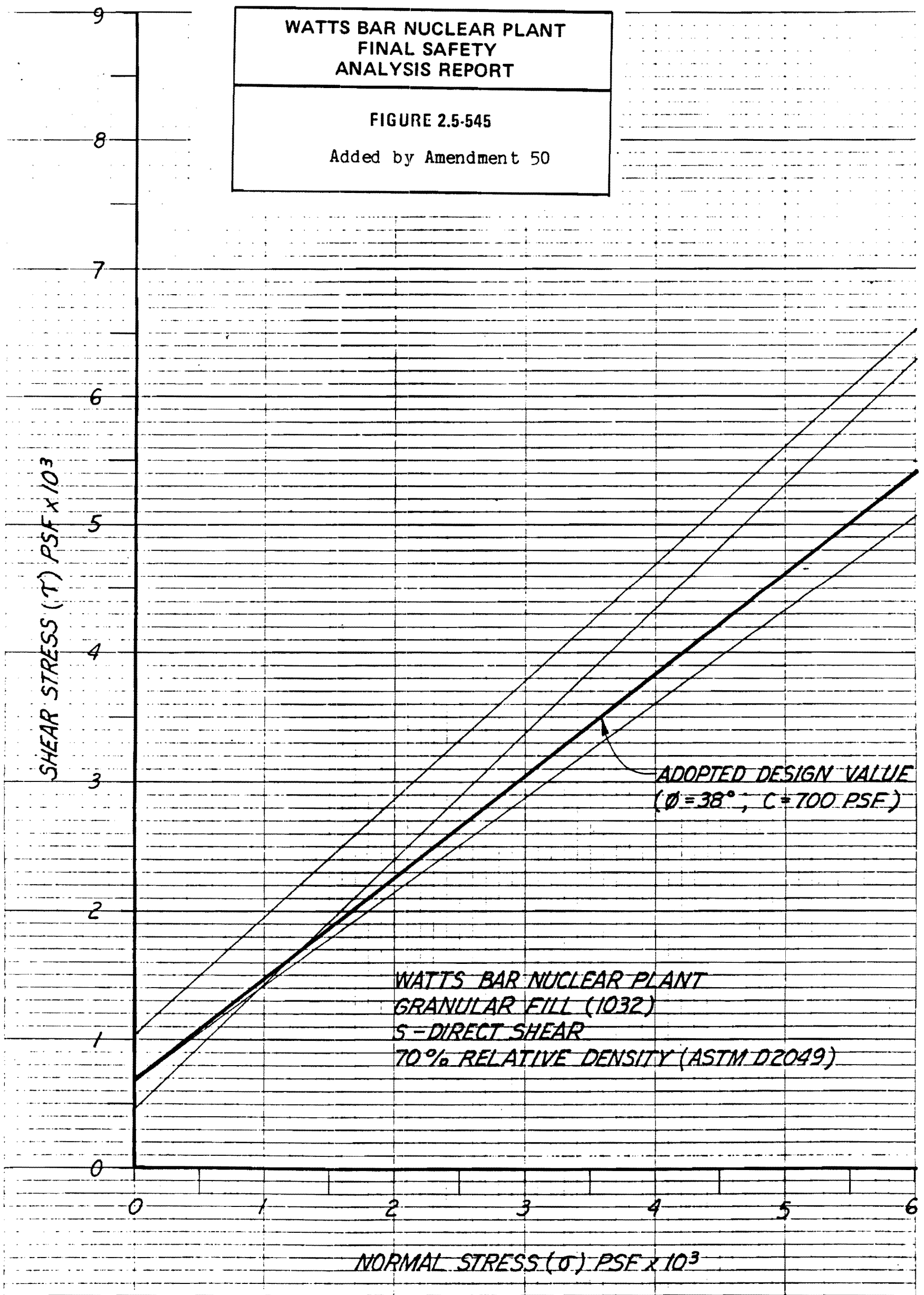

Figure 2.5-545 Watts Bar Nuclear Plant Granular Fill (1032) S-Direct Shear 70% Relative Density (ASTM 02049)

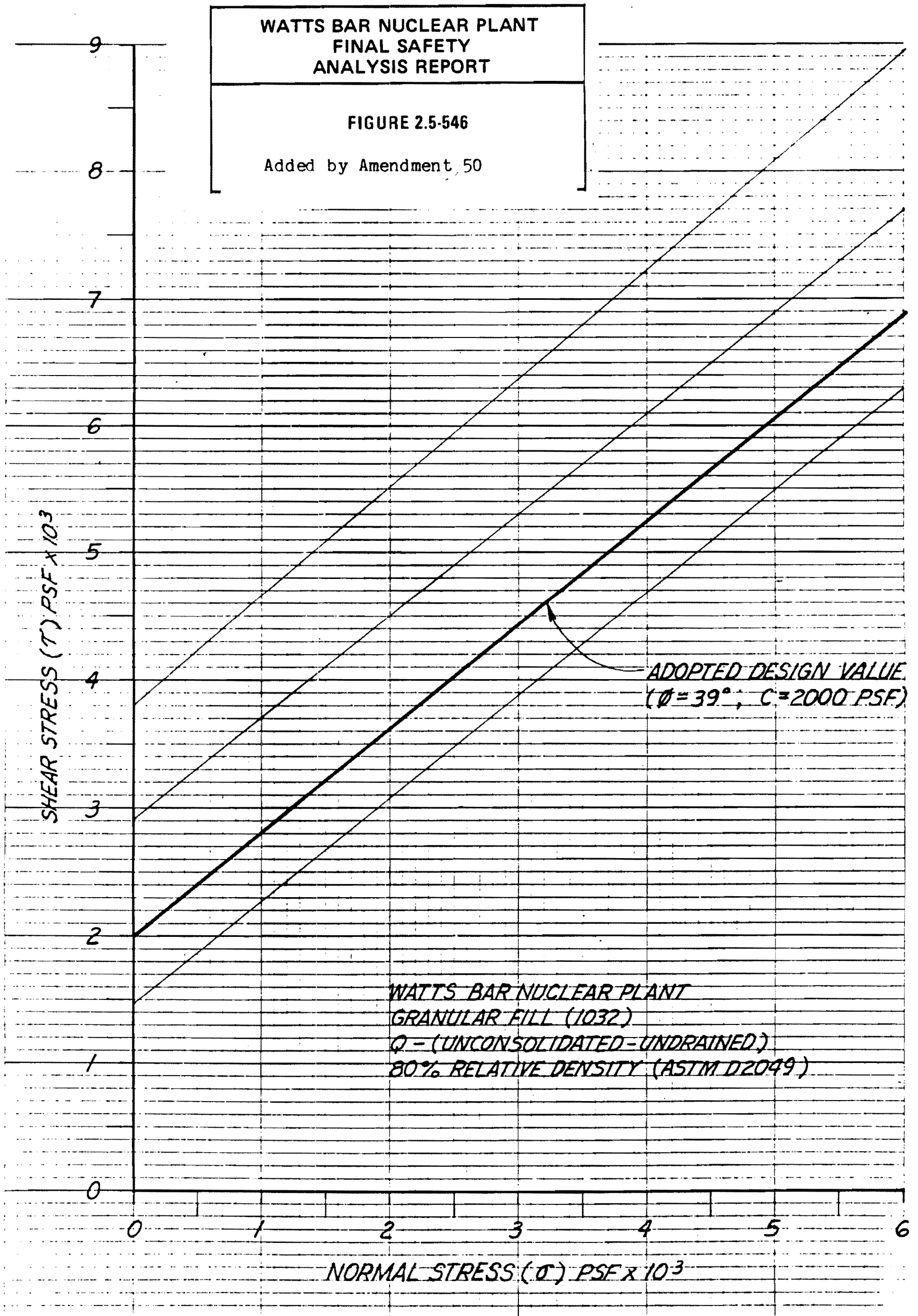

Figure 2.5-546 Watts Bar Nuclear Plant Granular Fill (1032) Q- (Unconsolidated - Undrained) 80% Relative Density (ASTM D2049)

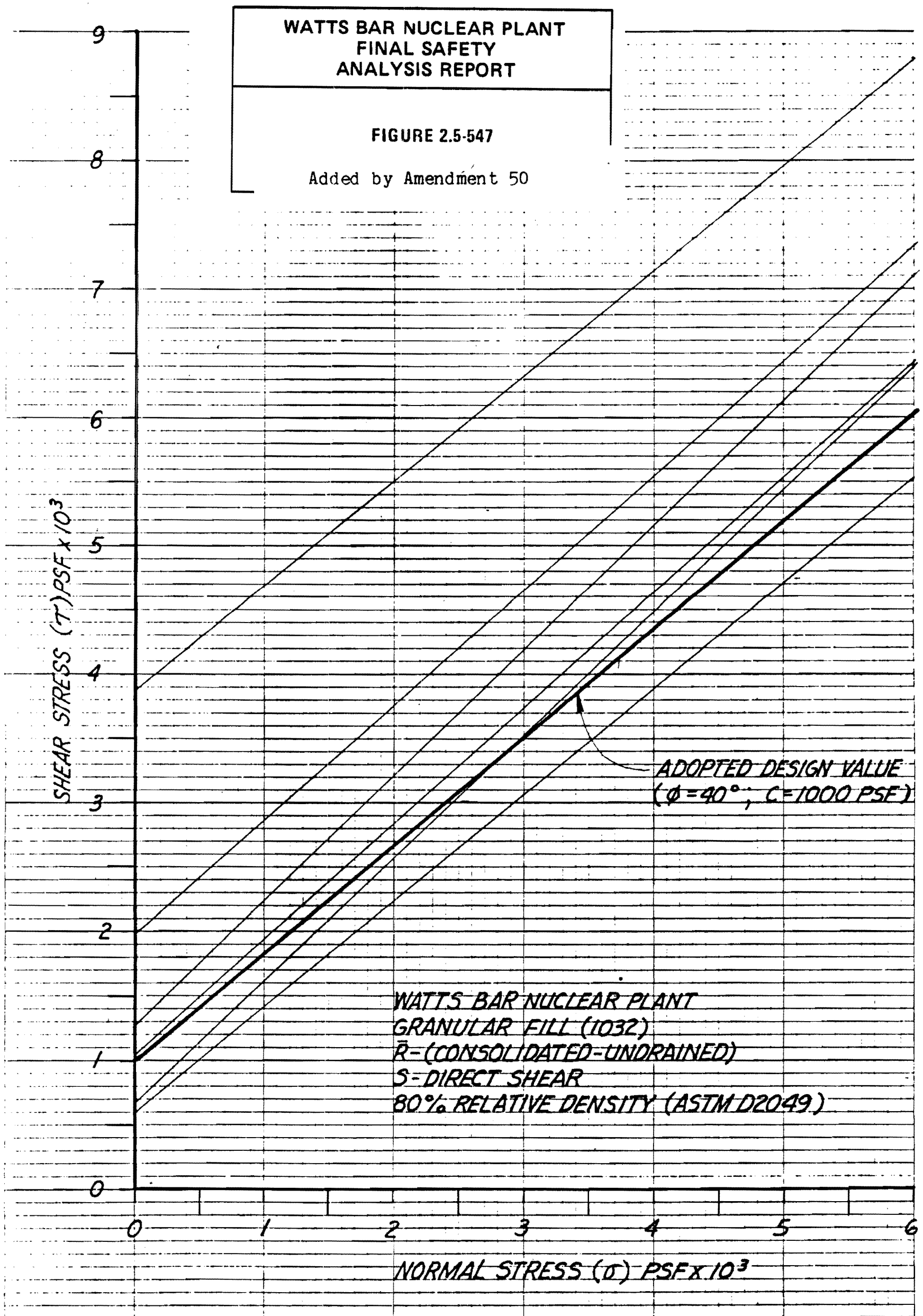

Figure 2.5-547 Watts Bar Nuclear Plant Granular Fill (1032) R- (Consolidated-Undrained) S-Direct: Shear 80% Relative Density (ASTM D2049)

**WATTS BAR NUCLEAR PLANT  
FINAL SAFETY  
ANALYSIS REPORT**

---

**FIGURE 2.5-548**

Summary of granular fill test data - relative density

Feature: DIESEL GENERATOR BUILDING

Period: 3-28-75 to 4-24-75 Test No. \_\_\_\_\_ to \_\_\_\_\_

Part II Section \_\_\_\_\_ Prepared by \_\_\_\_\_

RELATIVE DENSITY, %

	PLOT THIS COLUMN	PREV. CUM. F	THIS PERIOD				TO DATE		
			FREQUENCY (F)	F	CUM F	CUM %	F	CUM F	CUM %
55.0	59.9								
60.0	64.9								
65.0	69.9		1	1	1	2.7			
70.0	74.9		1111	4	5	13.5			
75.0	79.9		<del>1111</del> 11	12	17	45.9			
80.0	84.9		<del>1111</del> 1	6	23	62.2			
85.0	89.9		<del>1111</del> 11	10	33	89.2			
90.0	94.9		111	3	36	97.2			
95.0	99.9		1	1	37	100.0			
100.0	104.9								
105.0	109.9								
TOTALS			--	--	37	--	--	--	--

Specification Source 1032 MATERIAL

	PREV.	THIS PERIOD	TO DATE
Avg. Relative Density			81.0%

Specified Min. 70 % AS DETERMINED BY ASTM D2049

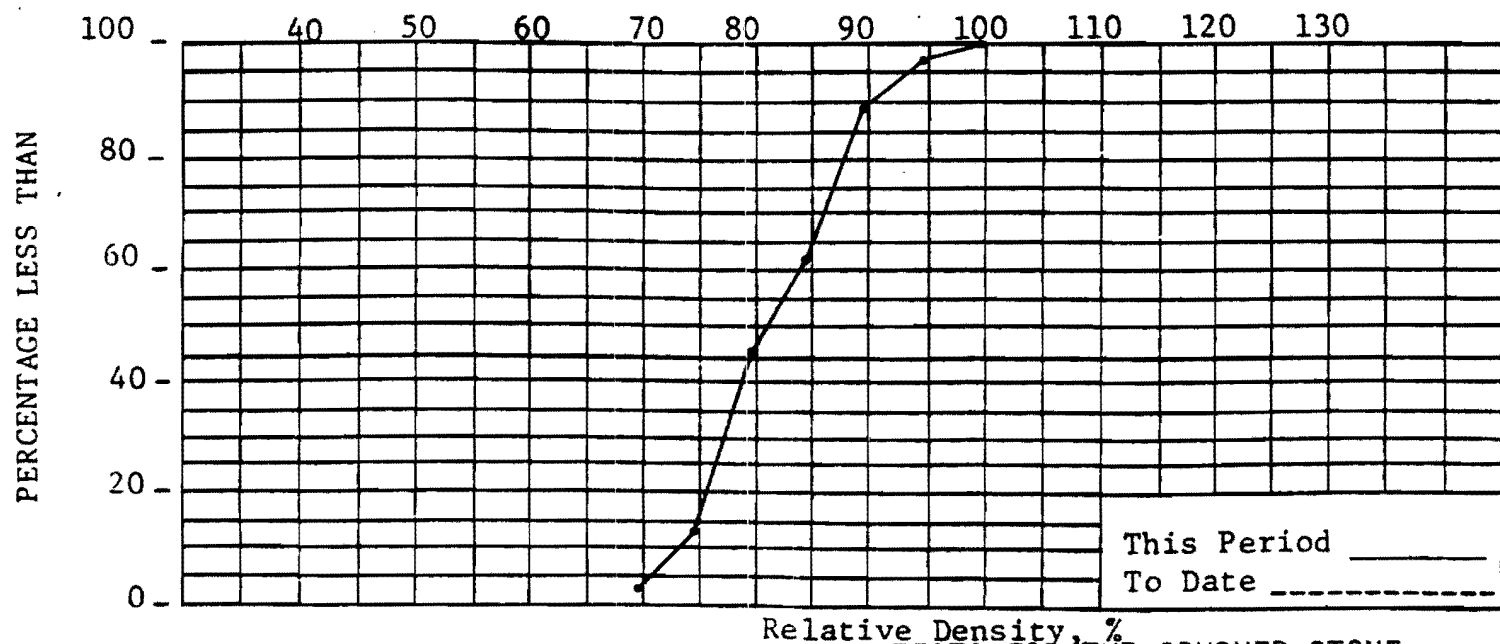

Remarks THESE TESTS COVER ALL DENSITY TESTS FOR THE CRUSHED STONE PLACED BELOW THE DIESEL GENERATOR BUILDING AT WATTS BAR NUCLEAR PLANT.

Added by Amendment 50

Figure 2.5-548 Summary of Granular Fill Test Data -Relative Density Diesel Generator Building



**Figure 2.5-549 ERCW Pipeline Section A-A (Actual Figure Located in Oversized Figures File) (Sheet 1 of 4)**

**Figure 2.5-549 ERCW Pipeline Section A-A (Actual Figure Located in Oversized Figures File) (Sheet 2 of 4)**

**Figure 2.5-549 ERCW Pipeline Section A-A (Actual Figure Located in Oversized Figures File) (Sheet 3 of 4)**

**Figure 2.5-549 ERCW Pipeline Section A-A (Actual Figure Located in Oversized Figures File) (Sheet 4 of 4)**

**Figure 2.5-550 ERCU Pipeline Section B-B (Actual Figure Located in Oversized Figures File)**

**Figure 2.5-551 ERCU Pipeline Section C-C (Actual Figure Located in Oversized Figures File)**

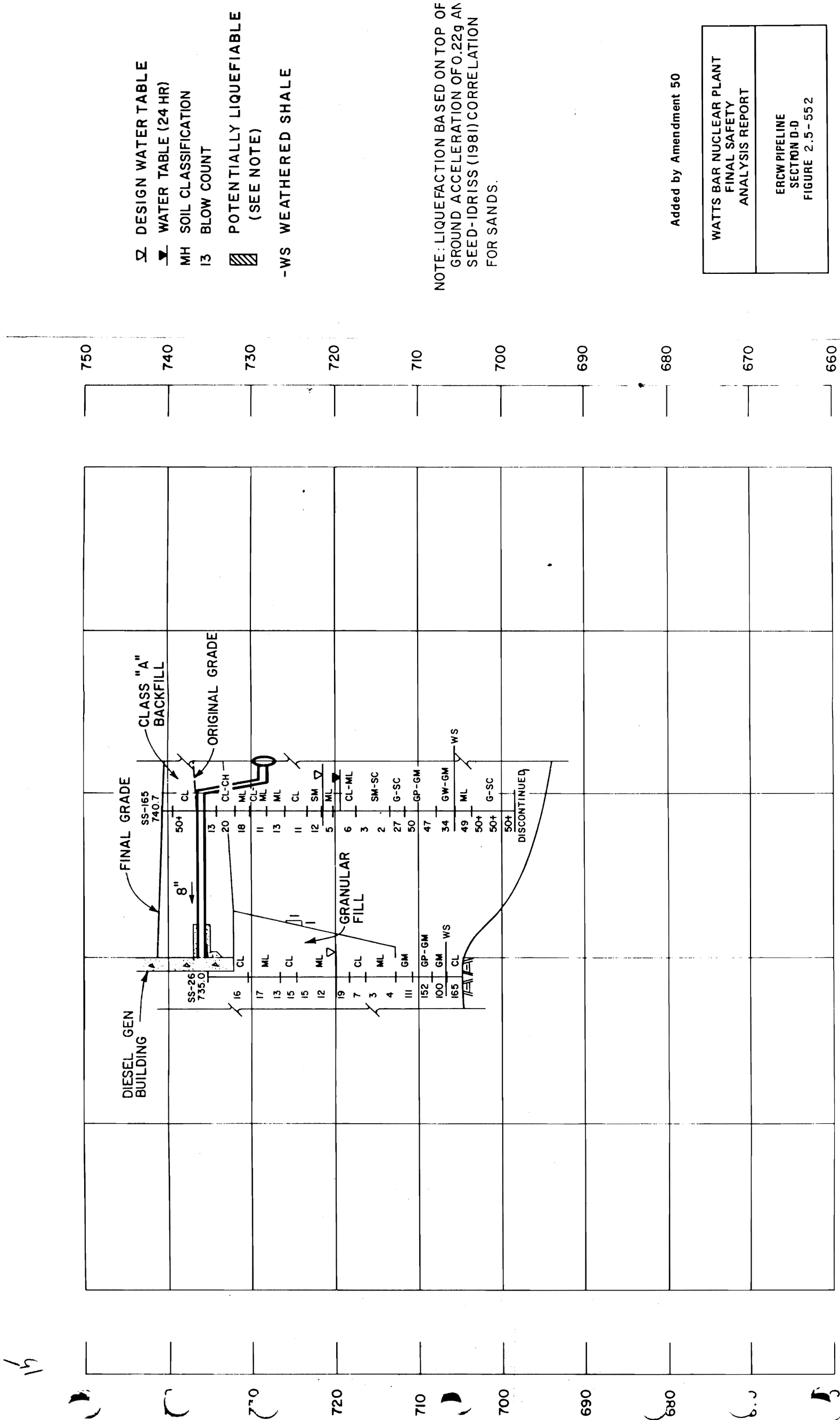

Figure 2.5-552 ERCW Pipeline Section D-D

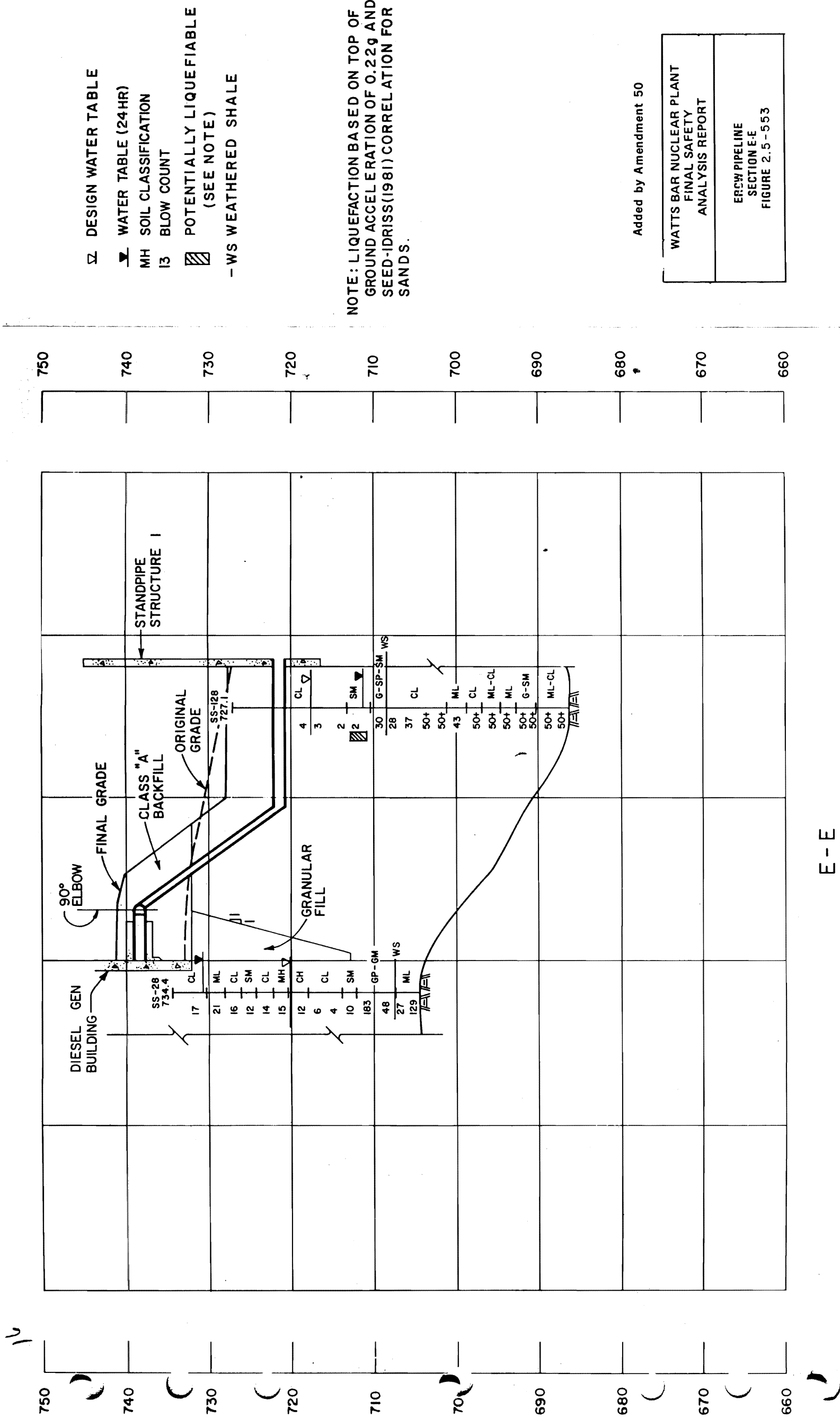

Figure 2.5-553 ERCW Pipeline Section E-E



**Figure 2.5-554 Category I Electrical Conduits Section F-F (Actual Figure Located in Oversized Figures File)(Sheet 1 of 2)**

**Figure 2.5-554 Category I Electrical Conduits Section F-F (Actual Figure Located in Oversized Figures File)(Sheet 2 of 2)**

**Figure 2.5-555 Category I Electrical Conduits Section G-G (Actual Figure Located in Oversized Figures File)**

**Figure 2.5-556 Category I Electrical Conduits Section H-H (Actual Figure Located in Oversized Figures File)**

**WATTS BAR NUCLEAR PLANT  
FINAL SAFETY  
ANALYSIS REPORT**

---

**CLASS IE CONDUIT  
FIGURE 2.5-557**

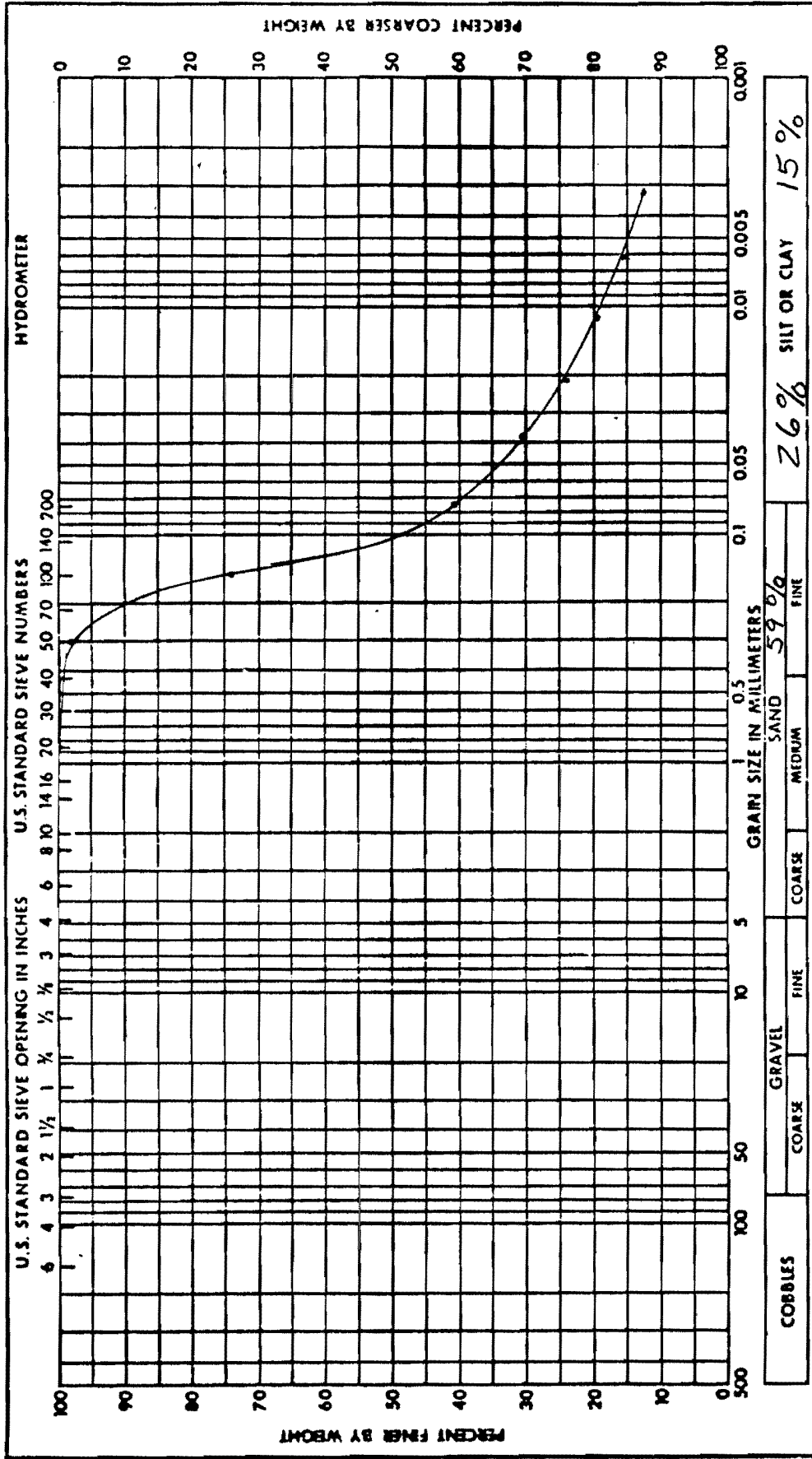



**WATTS BAR NUCLEAR PLANT  
FINAL SAFETY  
ANALYSIS REPORT**

---

**CLASS IE CONDUIT  
FIGURE 2.5-559**

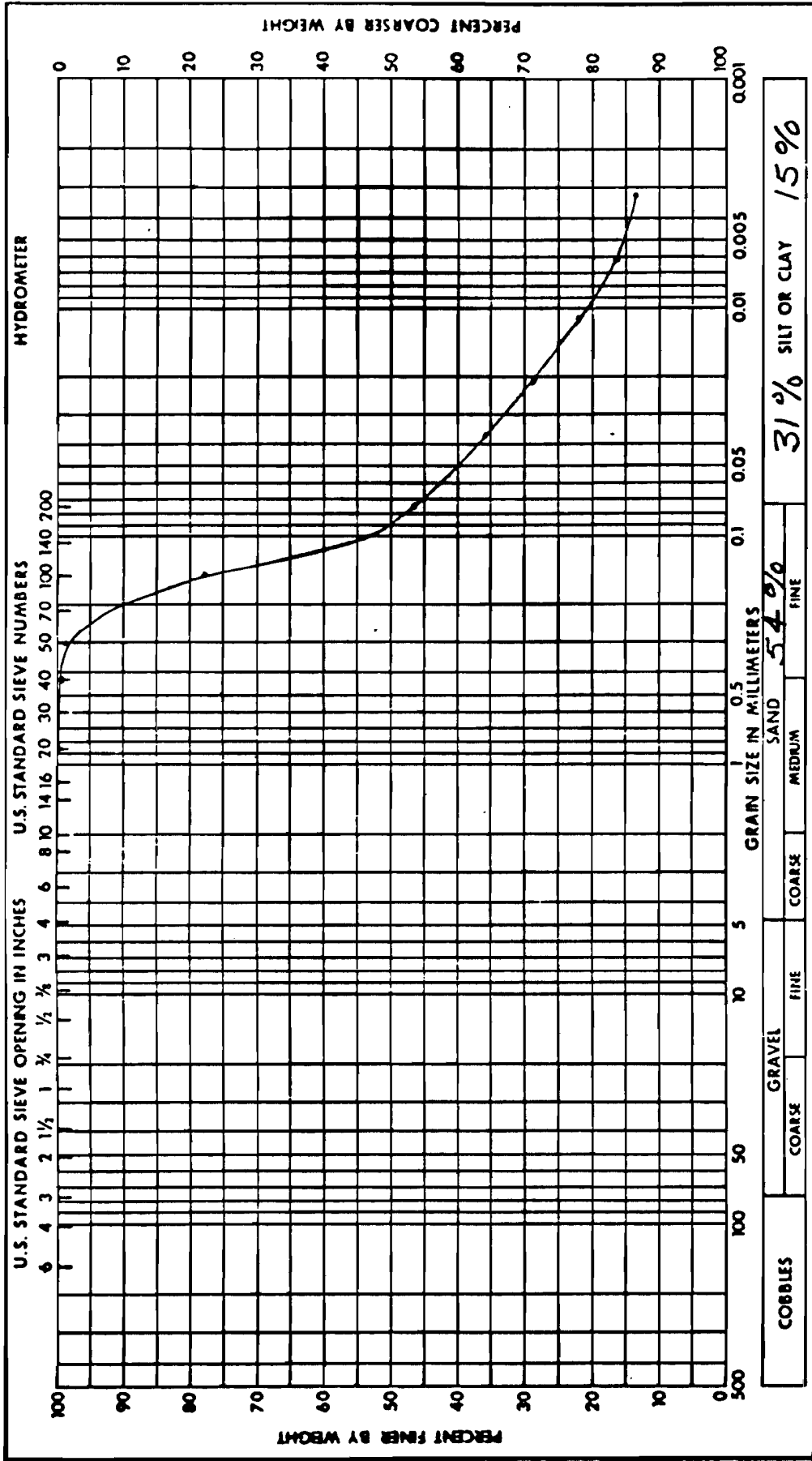

Added by Amendment 50

Project WATTS BAR N.P.	
Feature CLASS IE CONDUIT	
Boring No. SS-50	Sample No. GP.11
Station	Offset
Date 10-7-75	Elevation
<b>GRAIN SIZE ANALYSIS</b>	

Remarks:
N=2
w=31.5

Soil Symbol	SM	Liquid Limit, %	NP
Moisture Content, %		Plastic Limit, %	NP
Specific Gravity		Plasticity Index, %	NP
		Shrinkage Limit, %	

Figure 2.5-559 Class IE Conduit





**WATTS BAR NUCLEAR PLANT  
FINAL SAFETY  
ANALYSIS REPORT**

**IE CONDUIT  
FIGURE 2.5-561**

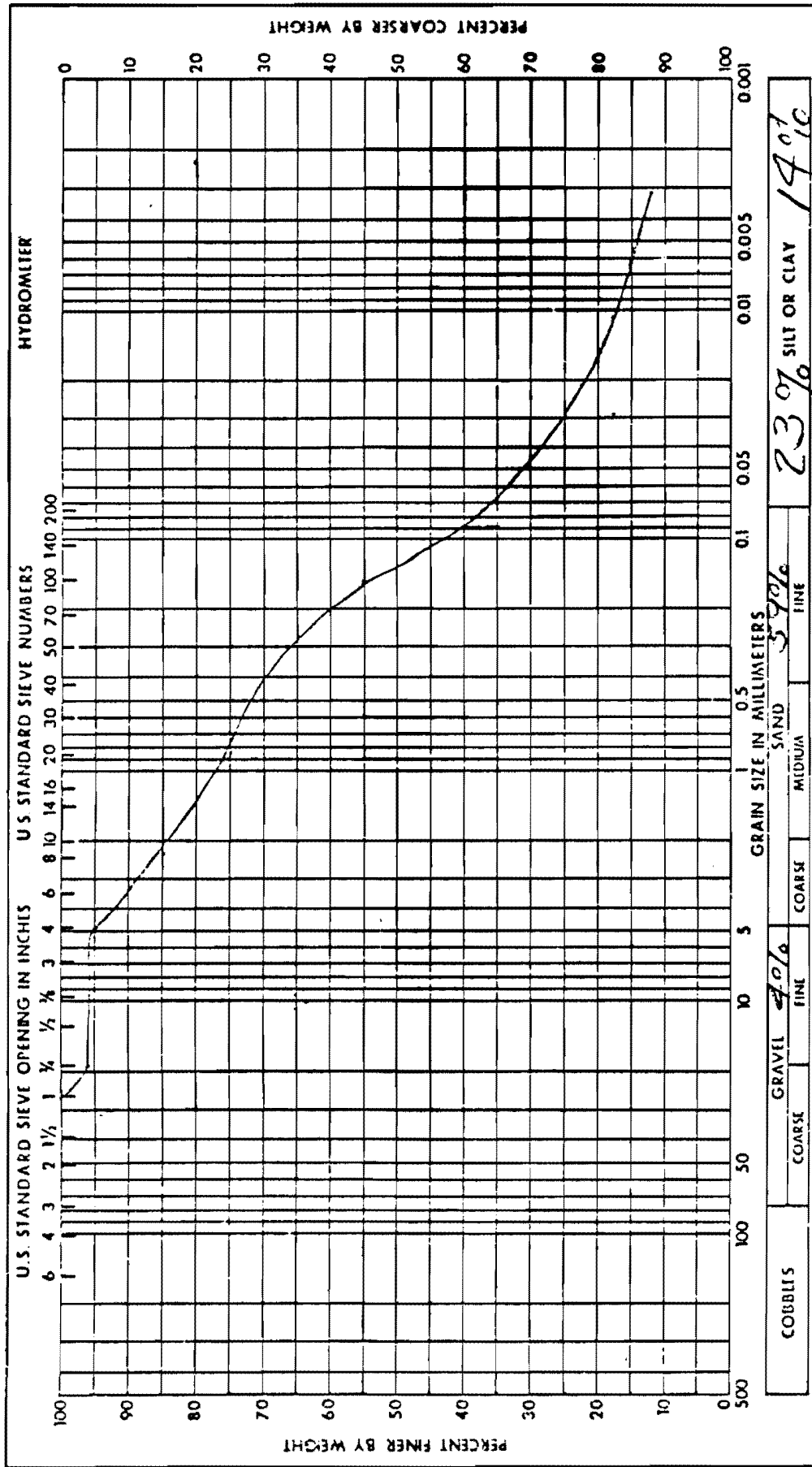

Added by Amendment 50

Project	Watts Bar N.P.	
Feature	IE CONDUIT	
Boring No.	GS-66	Sample No. 10A
Station		Offset
Date	1-16-76	Elevation
<b>GRAIN SIZE ANALYSIS</b>		

Remarks:	
	N=1%
	w=16.9

Soil Symbol	SAA	Liquid Limit, %	NP
Moisture Content, %		Plastic Limit, %	NP
Specific Gravity		Plasticity Index, %	NP
		Shrinkage Limit, %	

Figure 2.5-561 Class IE Conduit

**WATTS BAR NUCLEAR PLANT  
FINAL SAFETY  
ANALYSIS REPORT**

**FIGURE 2.5-562**

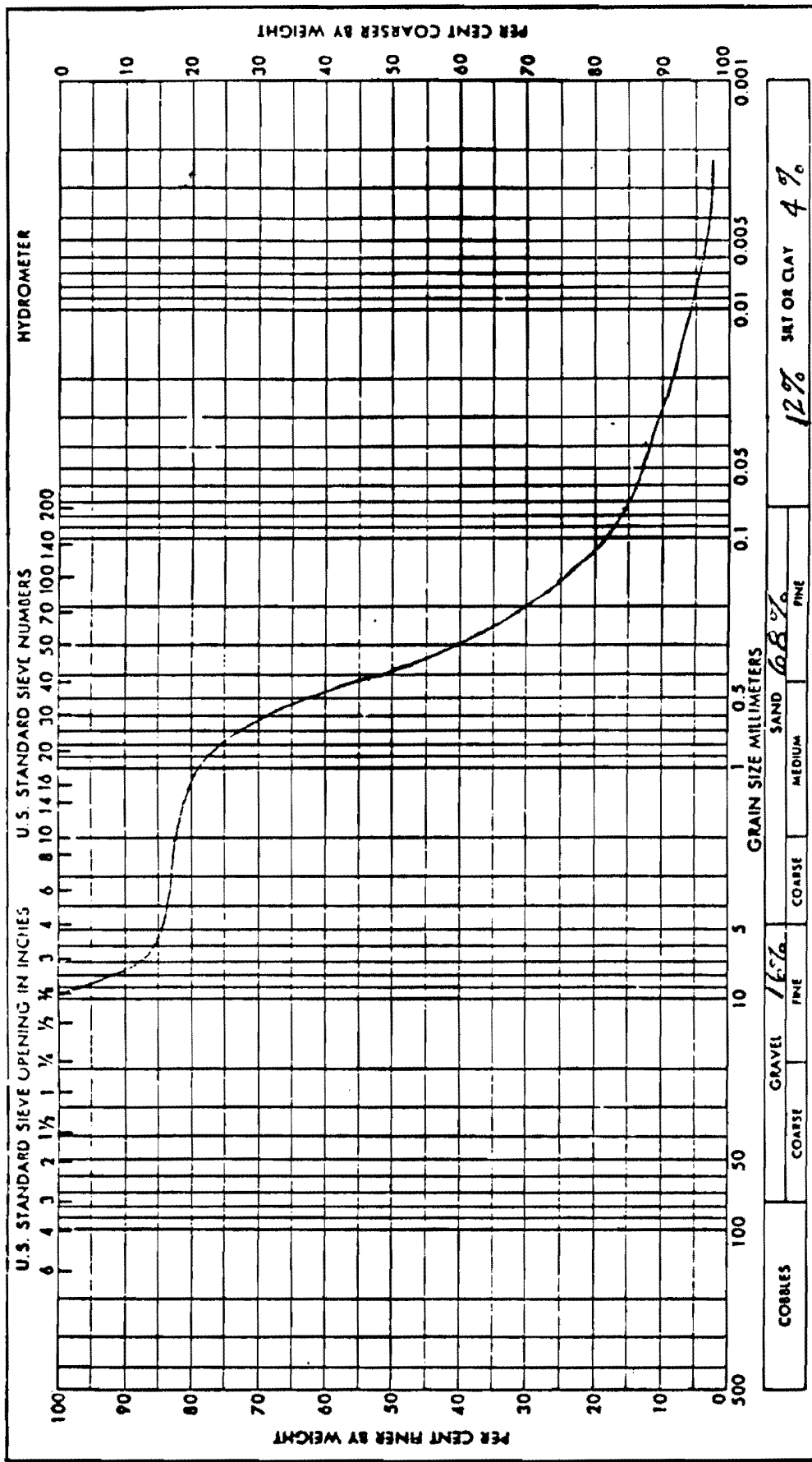

Added by Amendment 50

Project	WATTS BAR NP		
Feature			
Boring No.	SS-66	Sample No.	11A
Station	0 Feet		
Date	8-7-76	Element	
<b>GRAIN SIZE ANALYSIS</b>			

Remarks:	
	N = 8
	w = 14.1

Soil Symbol	1-5M	Liquid Limit, %	NP
Moisture Content, %		Plastic Limit, %	NP
Specific Gravity		Plasticity Index, %	NP
		Shrinkage Limit, %	

Figure 2.5-562 Class IE Conduit

**WATTS BAR NUCLEAR PLANT  
FINAL SAFETY  
ANALYSIS REPORT**

---

**CLASS IE CONDUIT  
FIGURE 2.5-563**

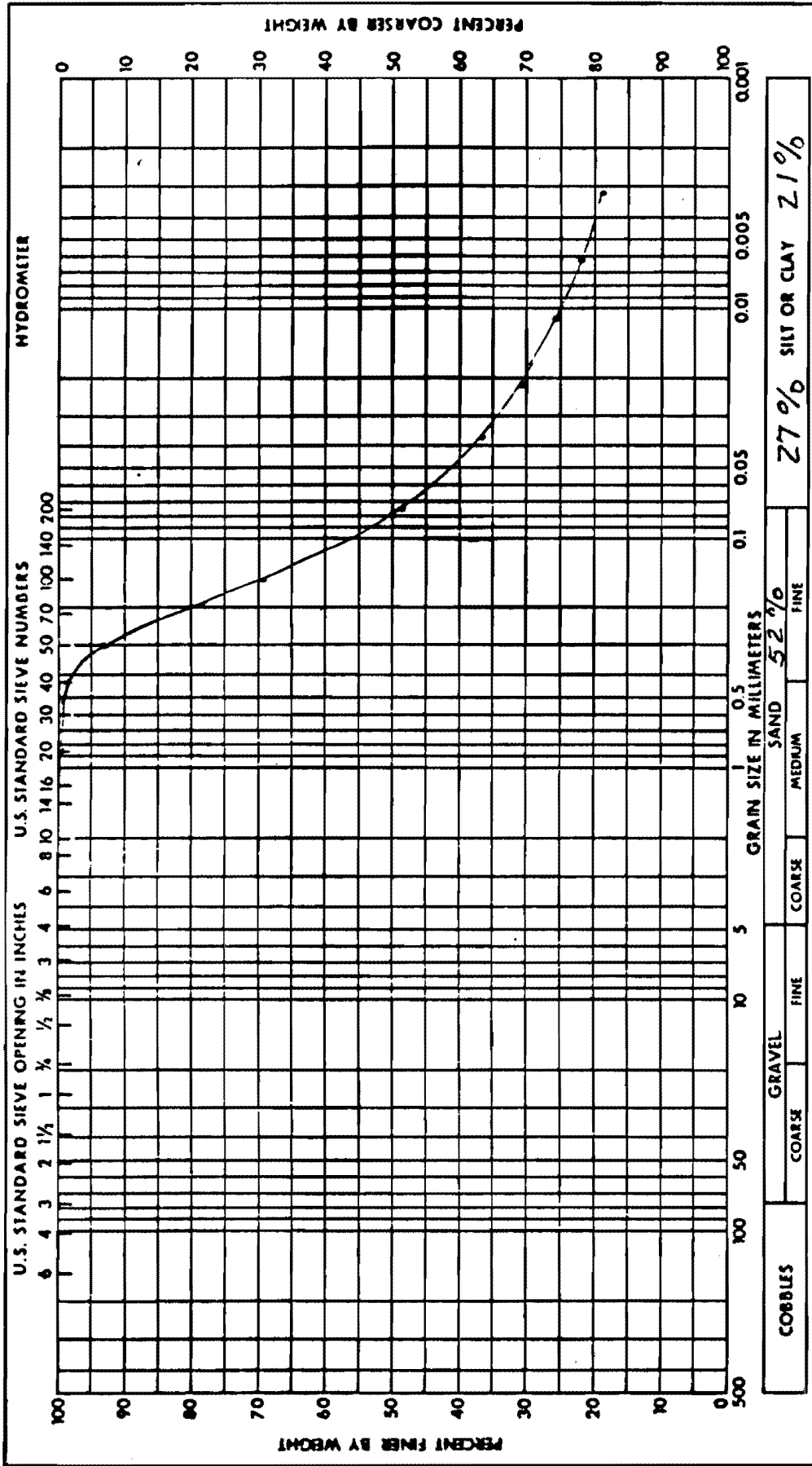

Added by Amendment 50

Project	WATTS BAR N.P.
Feature	CLASS IE CONDUIT
Boring No.	SS-63
Station	Offset
Date	10-1-75
	Elevation
<b>GRAIN SIZE ANALYSIS</b>	

Remarks:
N = 10
w = 20.7

Soil Symbol	SM	Liquid Limit, %	36.0
Moisture Content, %		Plastic Limit, %	26.0
Specific Gravity		Plasticity Index, %	10.0
		Shrinkage Limit, %	

Figure 2.5-563 Class IE Conduit

**WATTS BAR NUCLEAR PLANT  
FINAL SAFETY  
ANALYSIS REPORT**

---

**ERCW & HPFP SYSTEM  
FIGURE 2.5-564**

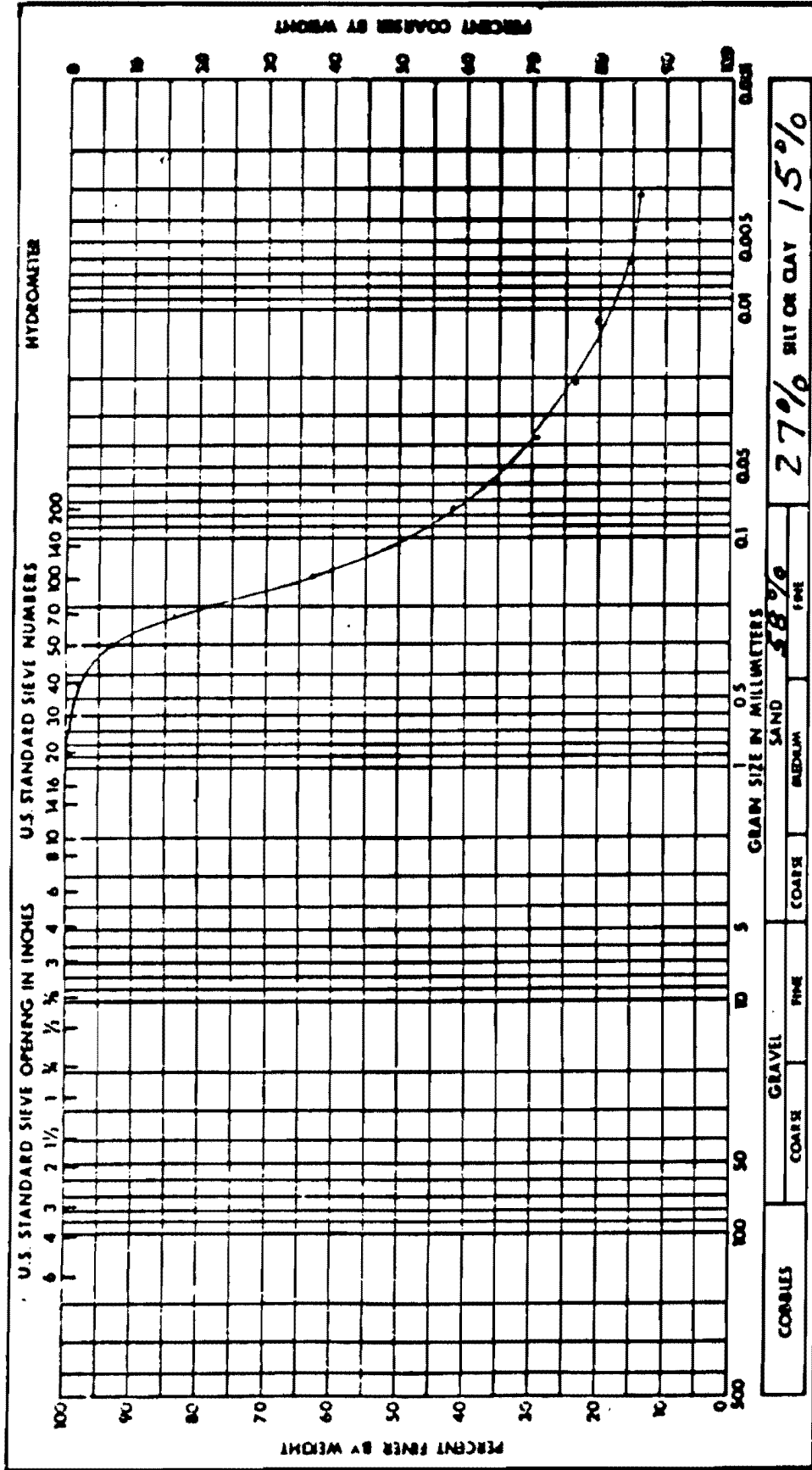

Project	WATTS BAR N.P.
Feature	ERCW & HPFP SYSTEM
Boring No.	SS-92
Sample No.	3A, 4A
Station	Offset
Date	11-26-75
Elevation	719.720.5

Remarks:	N=5

Soil Symbol	SM	Liquid Limit, %	28.0
Moisture Content, %		Plastic Limit, %	22.8
Specific Gravity		Plasticity Index, %	5.2
		Shrinkage Limit, %	

Added by Amendment 50

Figure 2.5-564 ERCU & HPFP System

**WATTS BAR NUCLEAR PLANT  
FINAL SAFETY  
ANALYSIS REPORT**

---

**ERCW & HPFP SYSTEM  
FIGURE 2.5-565**

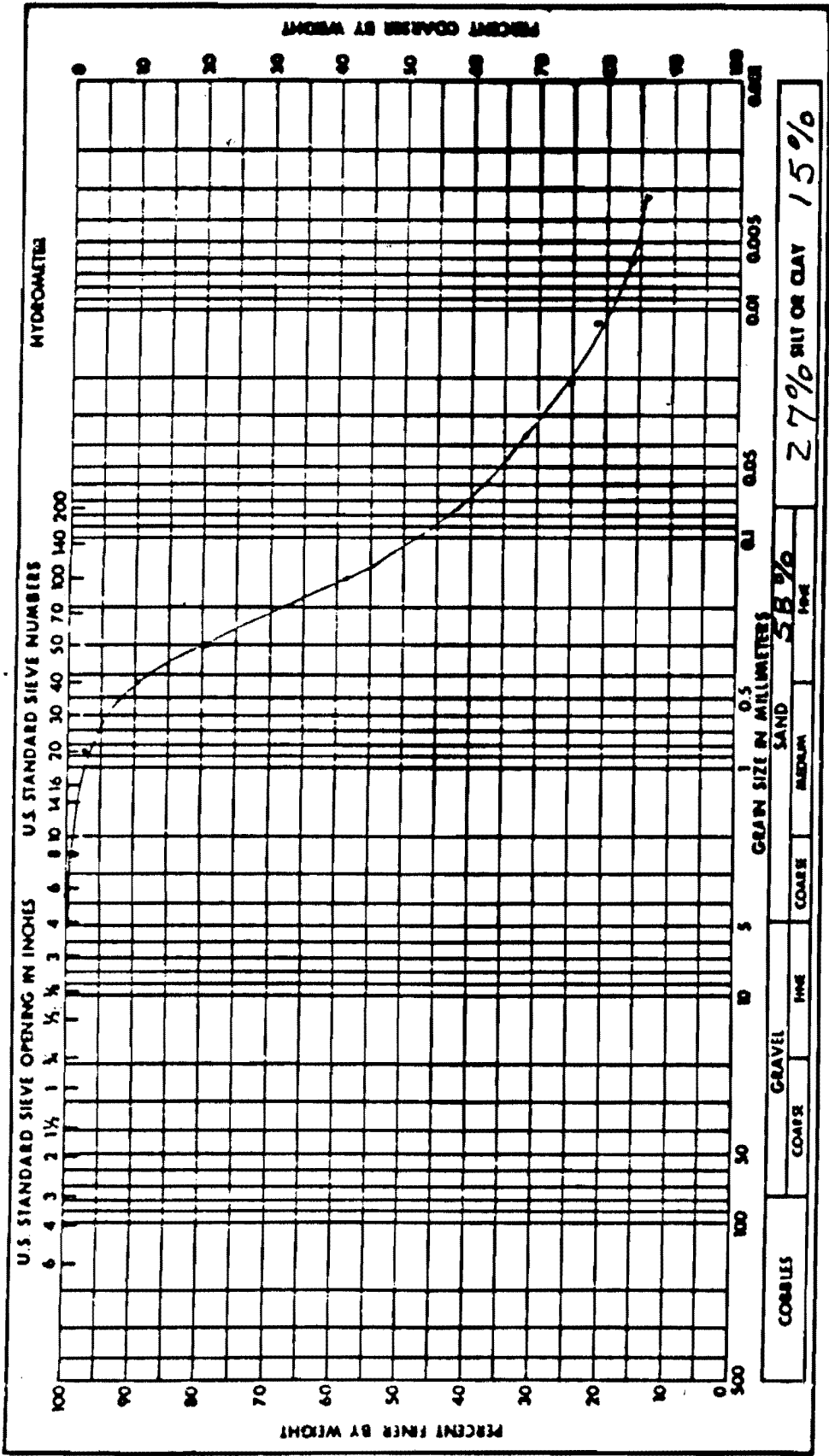

Added by Amendment 50

<b>Project</b> WATTS BAR N.P.	
<b>Feature</b> ERCW & HPFP SYSTEM	
<b>Boring No.</b> SS-92	<b>Sample No.</b> SA
<b>Station</b>	<b>Offset</b>
<b>Date</b> 11-26-75	<b>Elevation</b> 716.9
<b>GRAIN SIZE ANALYSIS</b>	

**Remarks:**

<b>Soil Symbol</b>	SM	<b>Liquid Limit, %</b>	26.0
<b>Moisture Content, %</b>	20.1	<b>Plastic Limit, %</b>	22.1
<b>Specific Gravity</b>		<b>Plasticity Index, %</b>	3.9
		<b>Shrinkage Limit, %</b>	

Figure 2.5-565 ERCU & HPFP System

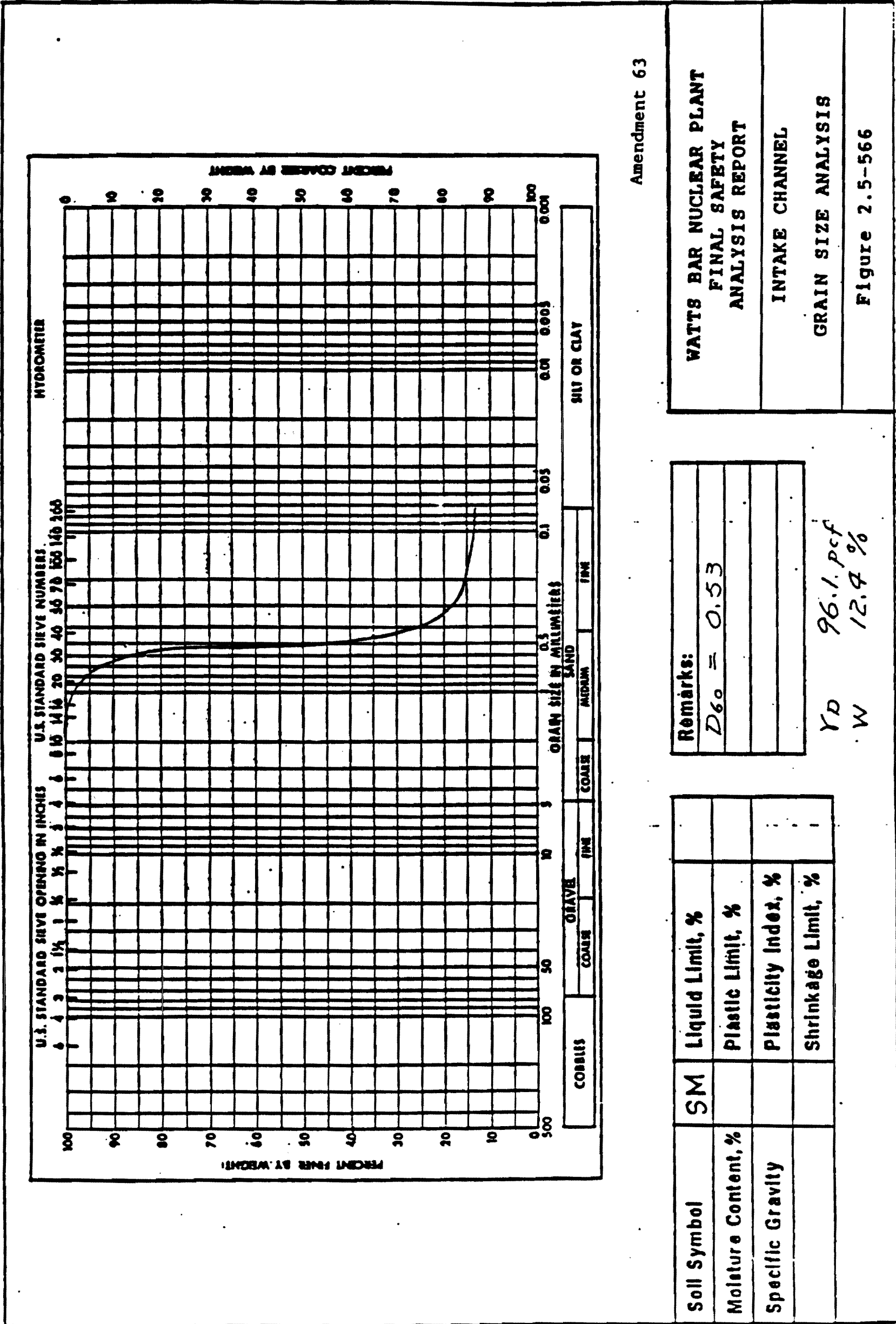

Amendment 63

Figure 2.5-566 Intake Channel Grain Size Analysis

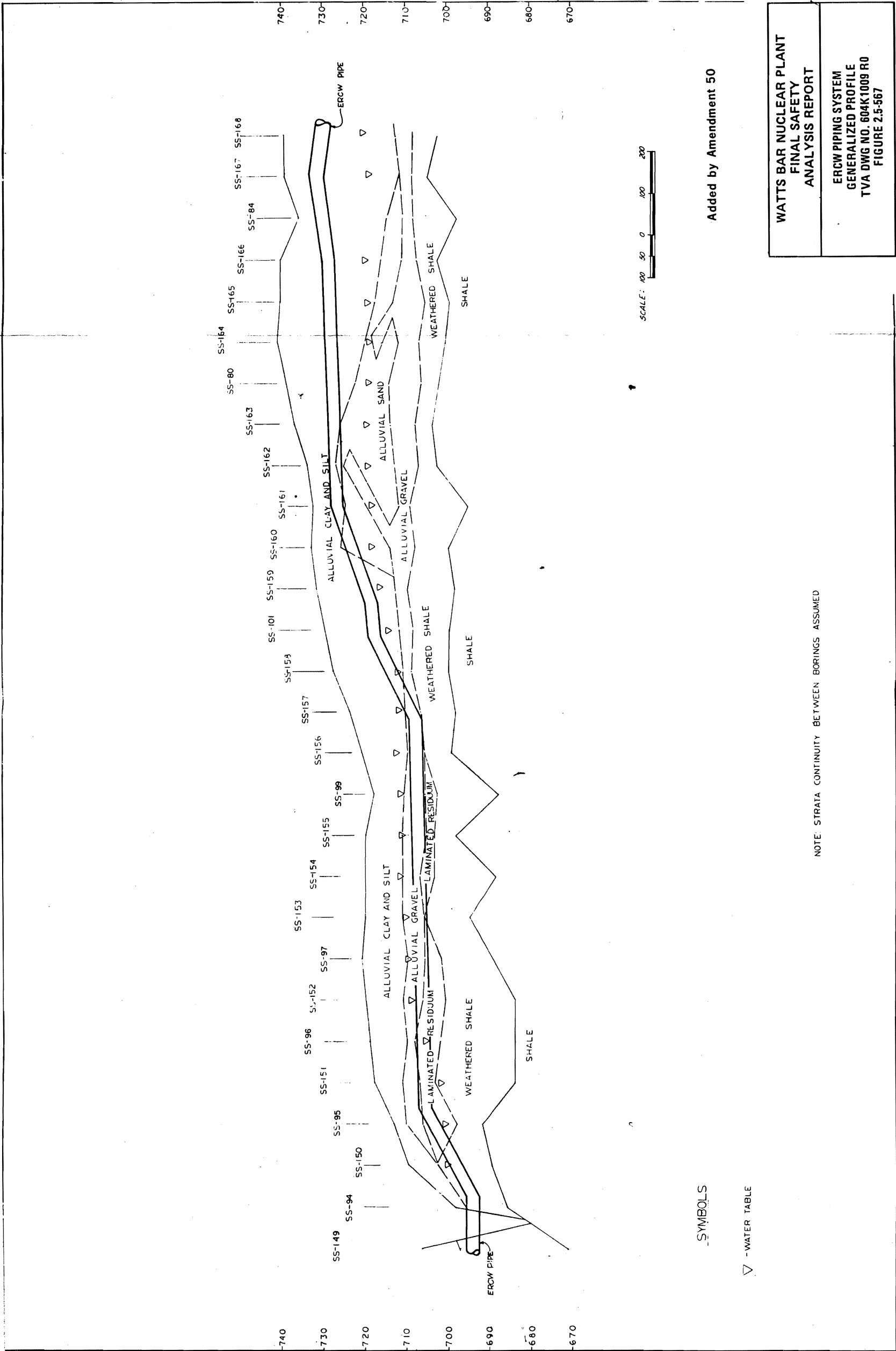

Figure 2.5-567 ERCW Piping System - Generalized Profile TVA DWG NO. 604K1009 RO

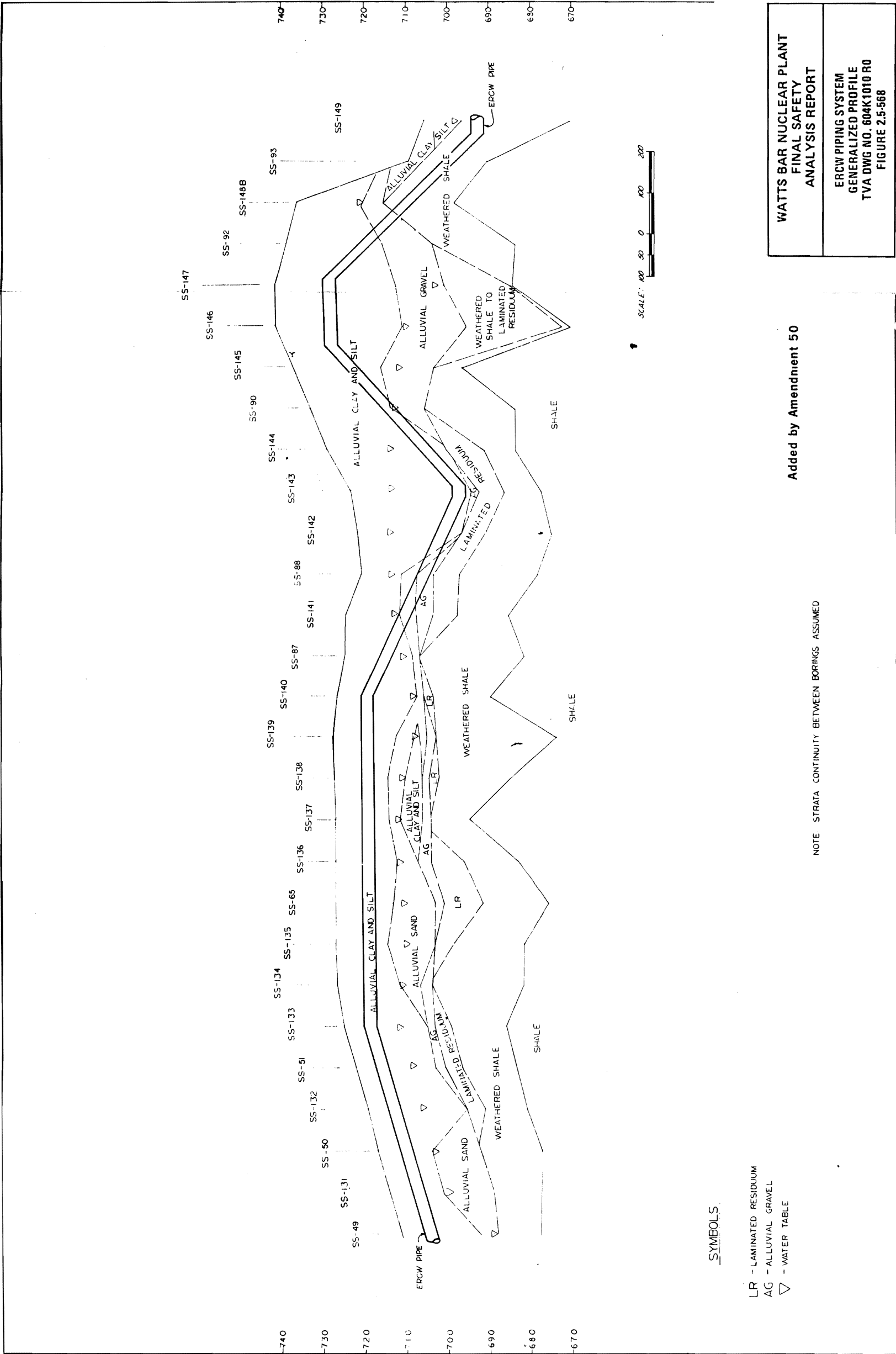
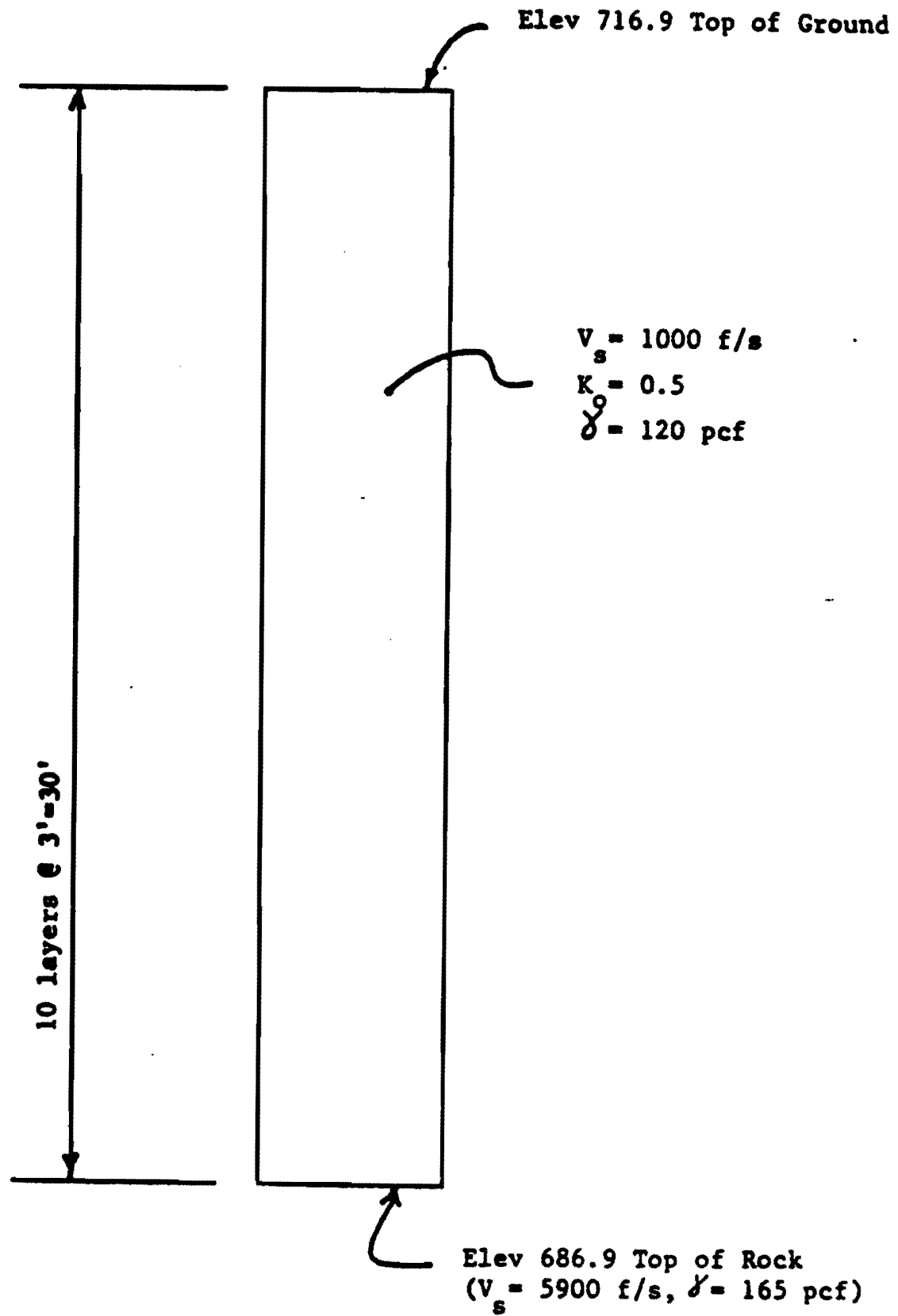

Figure 2.5-568 ERCW Piping System - Generalized Profile TVA DWG NO. 604K1010 RO





One-Dimensional Soil Profile Used for Liquefaction Evaluation

Added by Amendment 50

WATTS BAR NUCLEAR PLANT FINAL SAFETY ANALYSIS REPORT
FIGURE 2.5-569

Figure 2.5-569 One-Dimensional Soil Profile Used for Liquefaction Evaluation

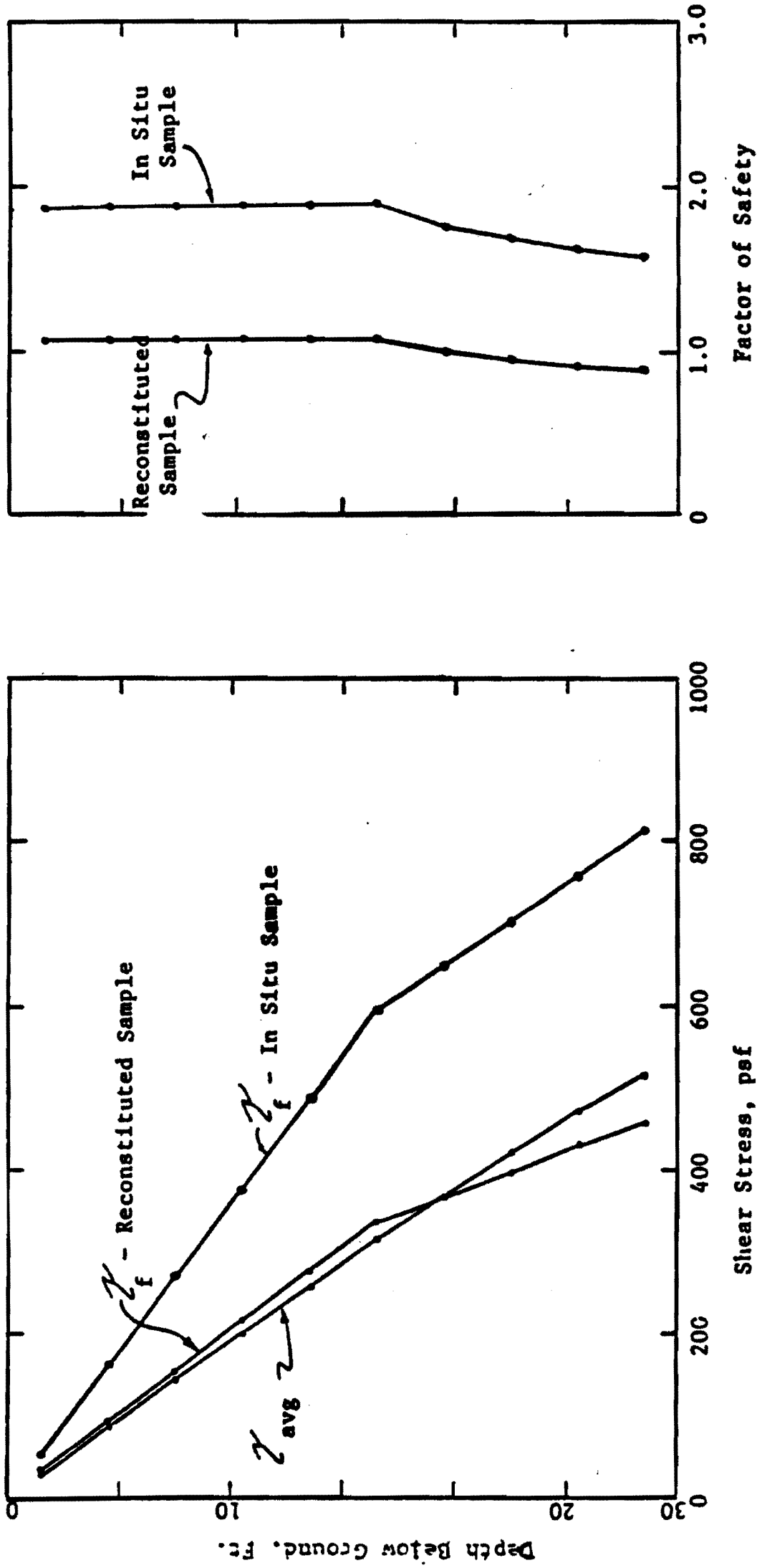

Comparison of Induced Shear Stress ( $\tau_{avg}$ ) and Shear Stress Required to cause 5% strain ( $\tau_f$ ) and Resulting Factors of Safety with Depth Below Ground Surface.

WATTS BAR NUCLEAR PLANT FINAL SAFETY ANALYSIS REPORT
FIGURE 2.5-570

Added by Amendment 50

Figure 2.5-570 Comparison of Induced Shear Stress and Shear Stress Required to Cause 5% Strain and Resulting Factors Of Safety With Depth Below Ground Surface

**Figure 2.5-571 ERCW Pipeline Section A-A  
(Actual Figure Located in Oversized Figures File)(Sheet 1 of 4)**

**Figure 2.5-571 ERCW Pipeline Section A-A  
(Actual Figure Located in Oversized Figures File)(Sheet 2 of 4)**

**Figure 2.5-571 ERCW Pipeline Section A-A  
(Actual Figure Located in Oversized Figures File)(Sheet 3 of 4)**

Figure 2.5-571 ERCW Pipeline Section A-A  
(Actual Figure Located in Oversized Figures File)(Sheet 4 of 4)

Figure 2.5-572 ERCW Pipeline Section B-B

**Figure 2.5-573 (Actual Figure Located in Oversized Figures File)**



(1.1)  
(2.7)  
POTENTIAL SETTLEMENT BASED ON 1.5%  $\epsilon$  CRITERIA (INCHES)  
POTENTIAL SETTLEMENT BASED ON 6%  $\epsilon$  CRITERIA (INCHES)

- ▽ DESIGN WATER TABLE
- ▽ WATER TABLE (24 HR)
- MH SOIL CLASSIFICATION
- 13 BLOW COUNT
- ▨ POTENTIALLY LIQUEFIABLE SOIL (SEE NOTE)
- WS WEATHERED SHALE

NOTE:  
I. LIQUEFACTION BASED ON TOP OF GROUND ACCELERATION OF 0.4g AND SEED - IDRIS (1971) CORRELATION FOR SANDS.

Added by Amendment 50

WATTS BAR NUCLEAR PLANT FINAL SAFETY ANALYSIS REPORT
ERCW PIPELINE SECTION D-D FIGURE 2.5-574

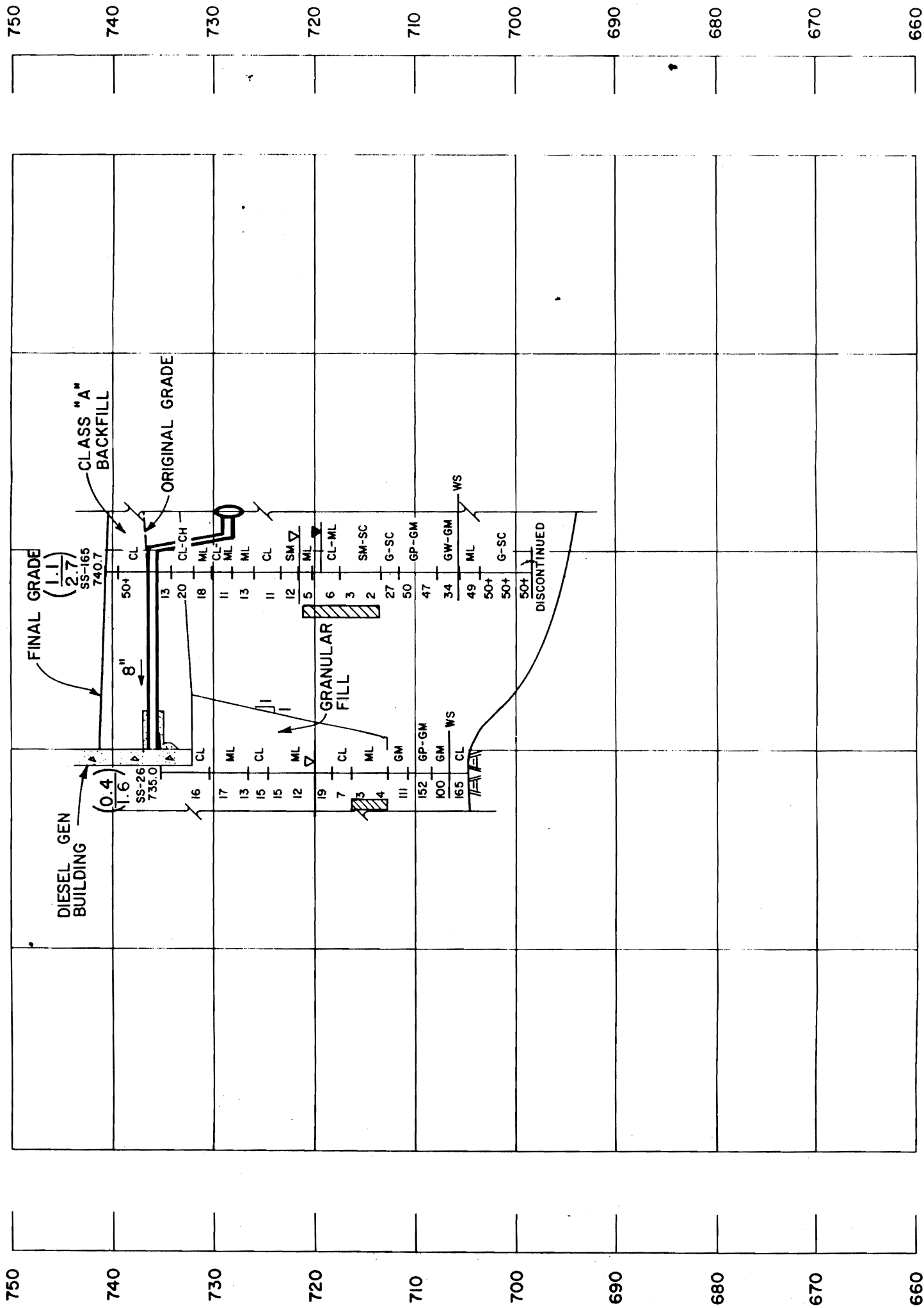

D-D

Figure 2.5-574 ERCW Pipeline Section D-D

POTENTIAL SETTLEMENT BASED ON  
1.5%  $\epsilon$  CRITERIA (INCHES)  
(0.4)  
POTENTIAL SETTLEMENT BASED ON  
6%  $\epsilon$  CRITERIA (INCHES)  
(1.0)

- ▽ DESIGN WATER TABLE
- ▽ WATER TABLE (24HR)
- MH SOIL CLASSIFICATION
- 13 BLOW COUNT
- ▨ POTENTIALLY LIQUEFIABLE SOIL (SEE NOTE)
- WS WEATHERED SHALE

NOTE:  
1 LIQUEFACTION BASED ON TOP OF  
GROUND ACCELERATION OF 0.4g  
AND SEED - IDRIS (1971)  
CORRELATION FOR SANDS.

Added by Amendment 50

WATTS BAR NUCLEAR PLANT FINAL SAFETY ANALYSIS REPORT
ERCW PIPELINE SECTION E-E FIGURE 2.5-575

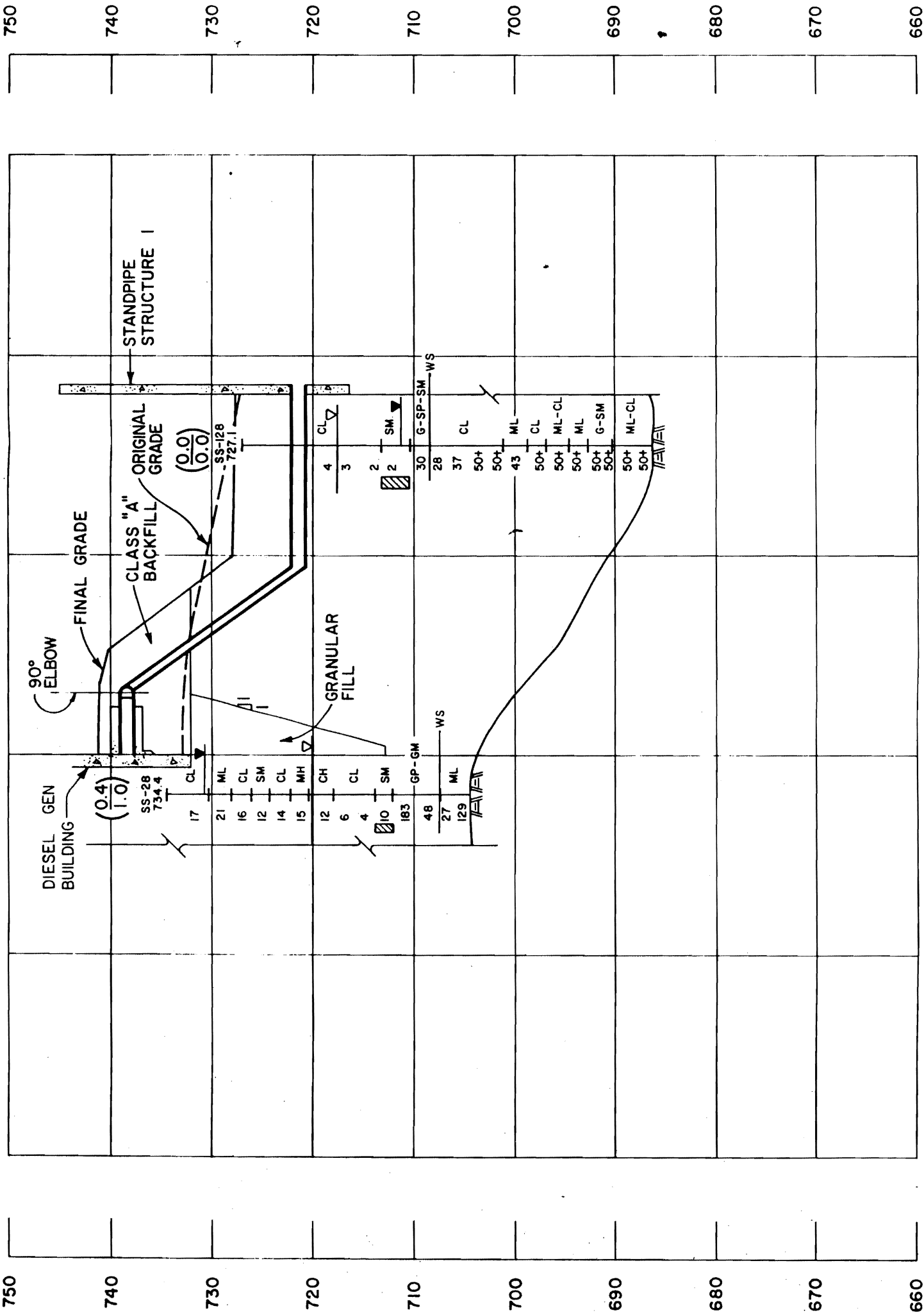

E - E

Figure 2.5-575 ERCW Pipeline Section E-E

**Figure 2.5-576 Category I Electrical Conduits Section F-F  
(Actual Figure Located in Oversized Figures File)(Sheet 1 of 2)**

**Figure 2.5-576 Category I Electrical Conduits Section F-F  
(Actual Figure Located in Oversized Figures File)(Sheet 2 of 2)**

**Figure 2.5-577 Category I Electrical Conduits Section G-G  
(Actual Figure Located in Oversized Figures File)**

**Figure 2.5-578 Category I Electrical Conduits Section H-H  
(Actual Figure Located in Oversized Figures File)**

**Figure 2.5-579 Miscellaneous ERCW Piping and IE Conduit Soil Borings  
(Actual Figure Located in Oversized Figures File)**

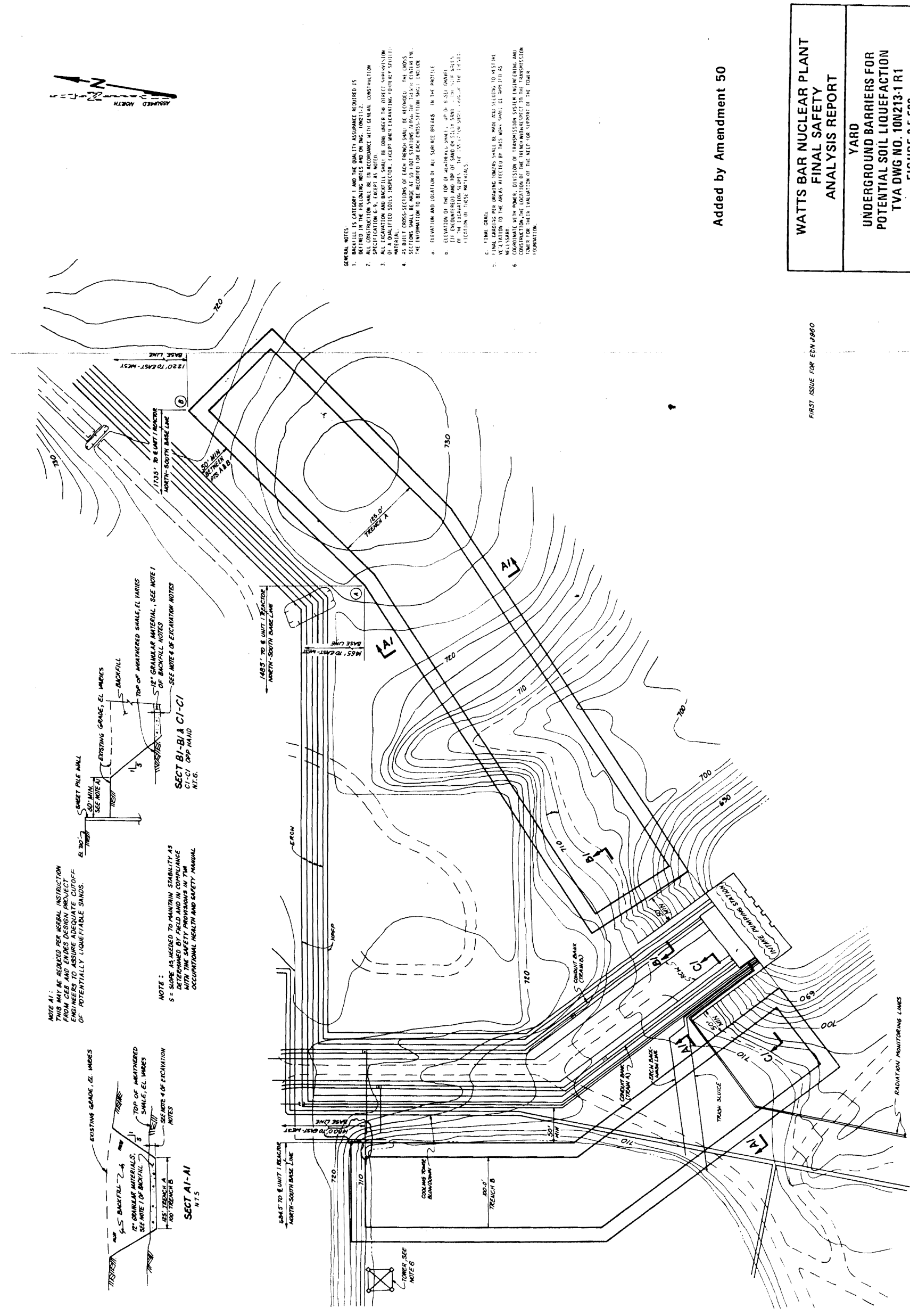

NOTE A1:  
THIS MAY BE REDUCED PER VERBAL INSTRUCTION FROM CEE AND ENRS DESIGN PROJECT ENGINEERS TO ASSURE ADEQUATE CUTOFF OF POTENTIALLY LIQUEFIABLE SANDS.

NOTE:  
S = SLOPE AS NEEDED TO MAINTAIN STABILITY AS DETERMINED BY THE DESIGNER IN ACCORDANCE WITH THE SAFETY PROVISIONS IN THE OCCUPATIONAL HEALTH AND SAFETY MANUAL

EXISTING GRADE, EL. MARKS  
TOP OF WEATHERED SHALE, EL. VARIES  
SEE NOTE 4 OF EXCAVATION NOTES

SECT A1-A1  
170.0' TRENCH B  
SEE NOTE 4 OF EXCAVATION NOTES

EXISTING GRADE, EL. MARKS  
TOP OF WEATHERED SHALE, EL. VARIES  
SEE NOTE 4 OF EXCAVATION NOTES

SECT B1-B1 & C1-C1  
140.0' OR 120.0' TRENCH  
SEE NOTE 4 OF EXCAVATION NOTES

- GENERAL NOTES:
1. BACKFILL IS CATEGORY 1 AND THE QUALITY ASSURANCE REQUIRED IS DEFINED IN THE FOLLOWING NOTES AND ON Dwg. 10N213-2.
  2. ALL CONSTRUCTION SHALL BE IN ACCORDANCE WITH GENERAL CONSTRUCTION SPECIFICATION C-9, EXCEPT AS NOTED.
  3. ALL EXCAVATIONS SHALL BE UNDER THE DIRECT SUPERVISION OF A QUALIFIED SOILS INSPECTOR, EXCEPT WHEN EXCAVATING TO EXISTING SOIL MATERIAL.
  4. AS BUILT CROSS-SECTIONS OF EACH TRENCH SHALL BE RECORDED. THE CROSS SECTIONS SHALL BE MADE AT 50' INTERVALS ALONG THE TRENCH LENGTH. THE INFORMATION TO BE RECORDED FOR EACH CROSS-SECTION SHALL INCLUDE:
    - a. ELEVATION AND LOCATION OF ALL SURFACE BREAKS IN THE PROFILE
    - b. ELEVATION OF THE TOP OF WEATHERED SHALE, AND OF ALL SOIL CORRECTION ENCOUNTERED AND TOP OF SAND ON SLOPE SIDE OF THE TRENCH
    - c. LOCATION OF THE EXCAVATION LUMPS, THE LOCATION OF ALL SURFACE BREAKS IN THE PROFILE
  5. FINAL GRADE:
    - a. FINAL GRADING PER DRAWING DIMENSIONS SHALL BE MADE AND SLOPING TO MATCH THE ELEVATION TO THE AREA ADJACENT TO THIS WORK, WHILE BE APPLICABLE.
    - b. COORDINATE WITH POWER, DIVISION OF TRANSMISSION SYSTEM ENGINEERING AND CONSTRUCTION THE LOCATION OF THE TRENCH WITH RESPECT TO THE TRANSMISSION TOWER FOR THEIR EVALUATION OF THE NEED FOR SUPPORT OF THE TOWER FOUNDATION.

Added by Amendment 50

WATTS BAR NUCLEAR PLANT FINAL SAFETY ANALYSIS REPORT
YARD UNDERGROUND BARRIERS FOR POTENTIAL SOIL LIQUEFACTION TVA DWG NO. 10N213-1 R1 FIGURE 2.5-580

FIRST ISSUE FOR ECH 4960

Figure 2.5-580 Yard Underground Barriers for Potential Soil Liquefaction  
TVA DWGNO. 10N213-1 R1





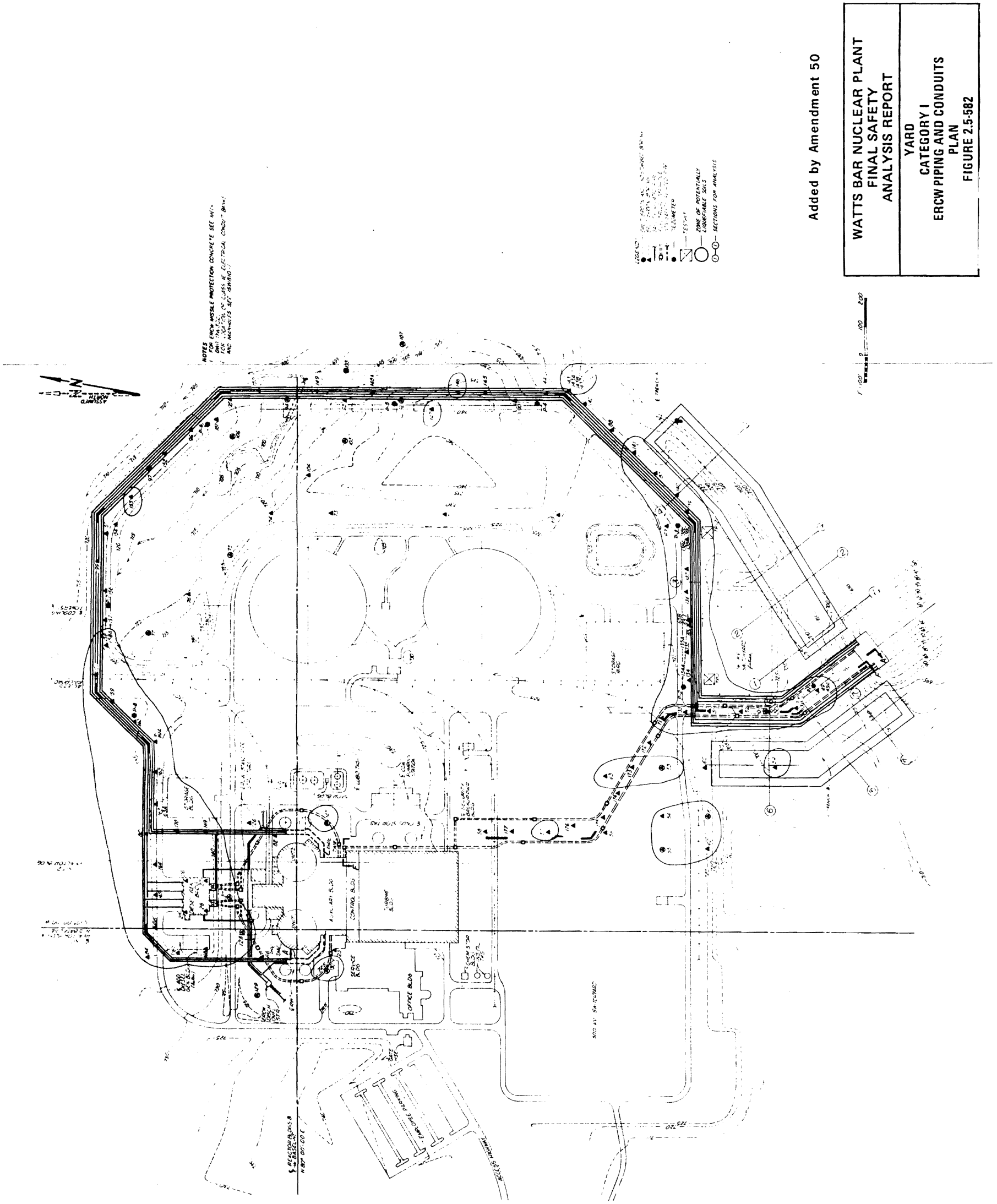

Figure 2.5-582 Yard Category I ERCW Piping and Conduits - Plan

**Figure 2.5-583 Remedial Treatment for Potential Soil Liquefaction -Stability Analysis Summary  
(Actual Figure Located in Oversized Figures File)**

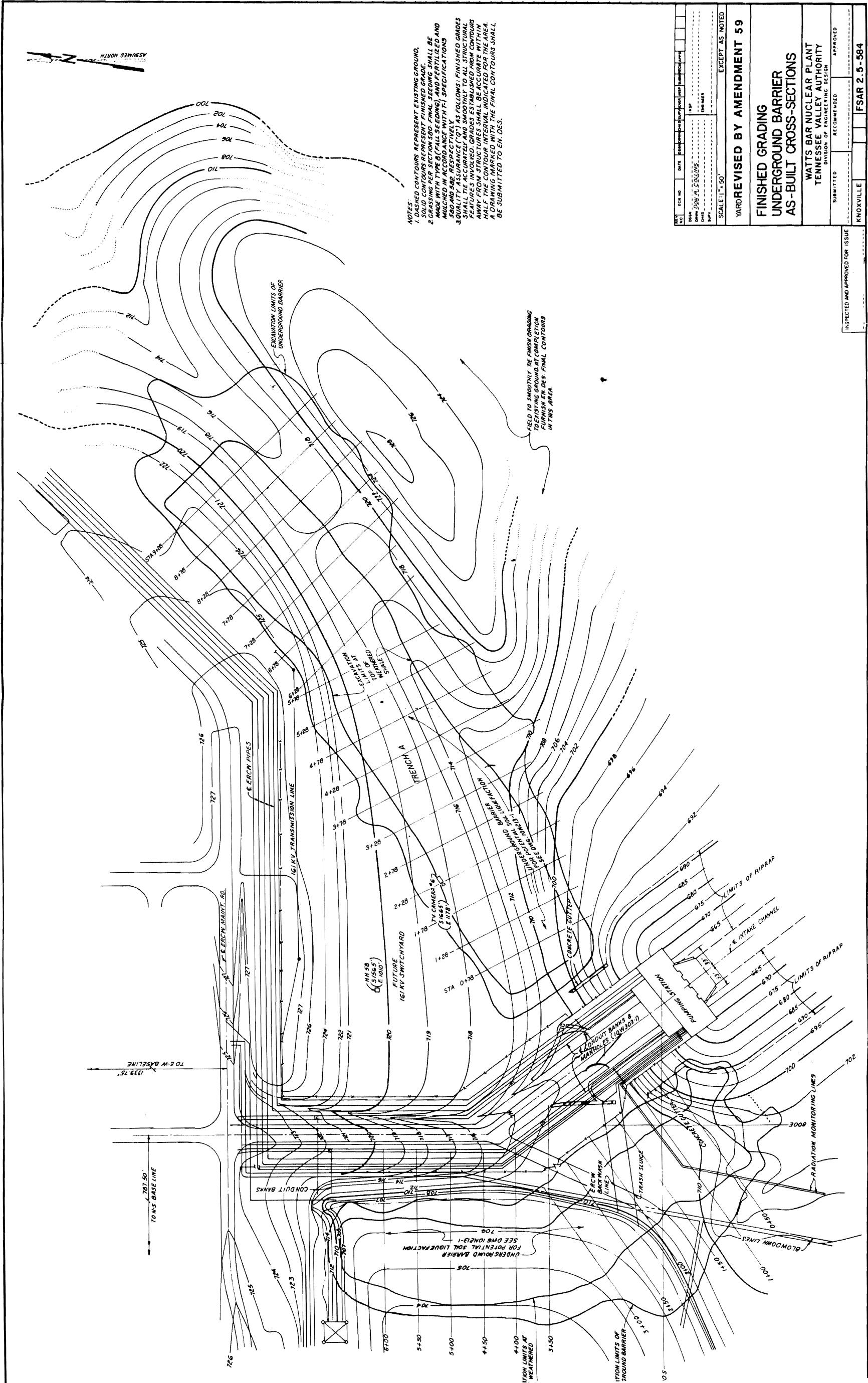

Figure 2.5-584 Finished Grading - Underground Barrier As-Built Cross-Sections

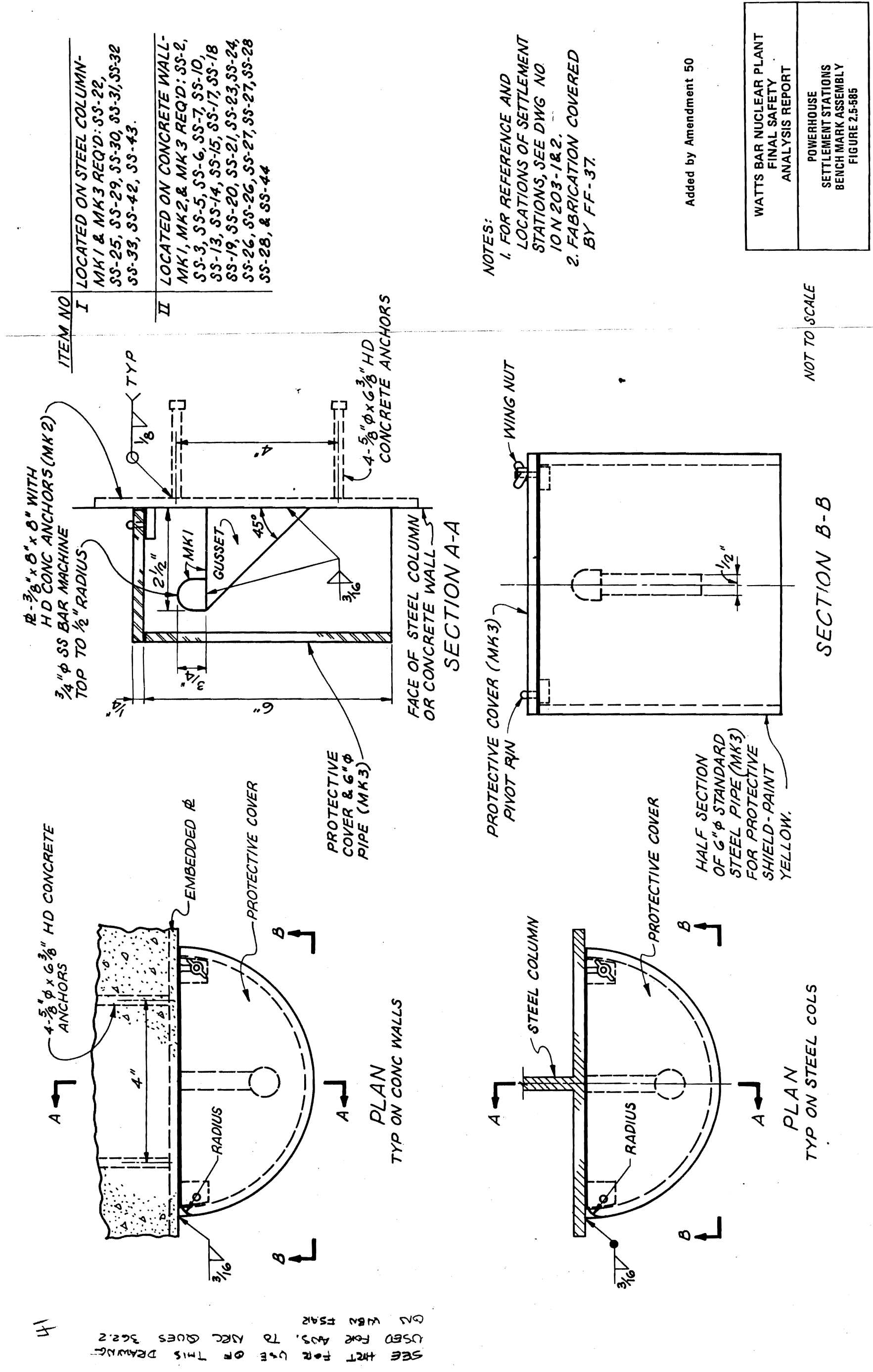
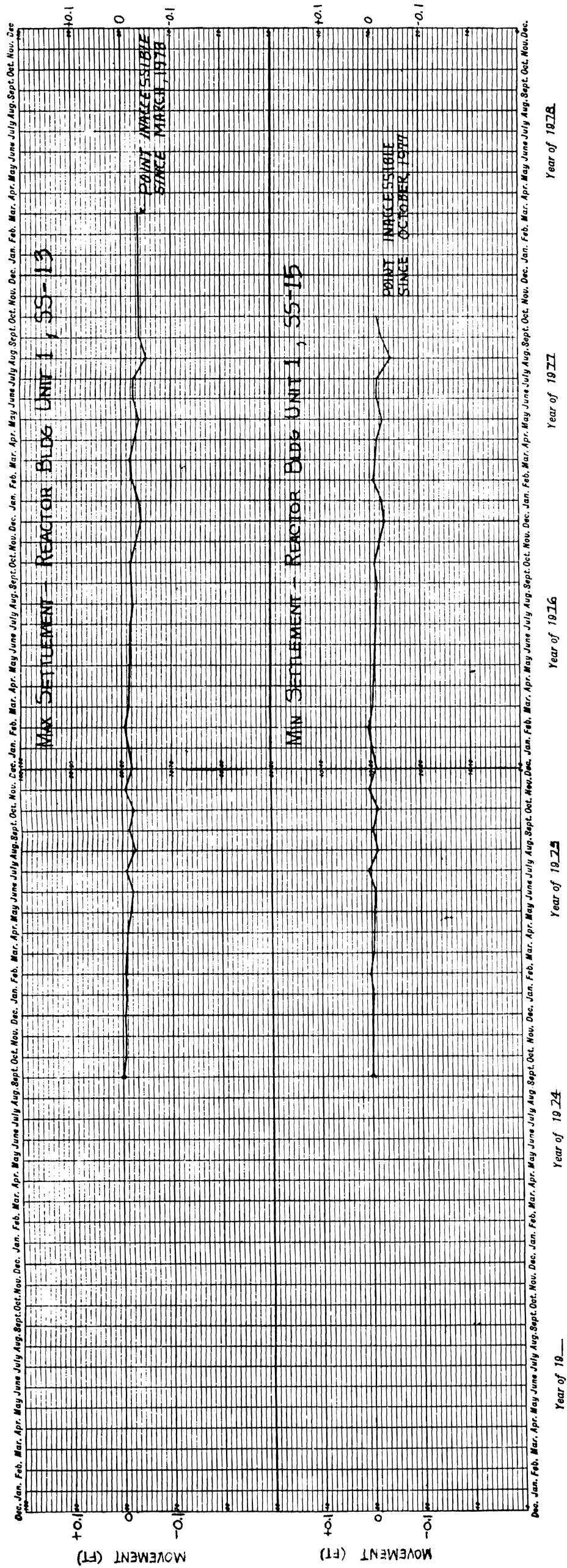

Figure 2.5-585 Powerhouse -Settlement Stations -Bench Mark Assembly



Added by Amendment 50

WATTS BAR NUCLEAR PLANT FINAL SAFETY ANALYSIS REPORT
SETTLEMENT VS. TIME FOR UNIT 1 REACTOR BUILDING FIGURE 2.5-586

Figure 2.5-586 Settlement VS. Time For Unit 1 Reactor Building

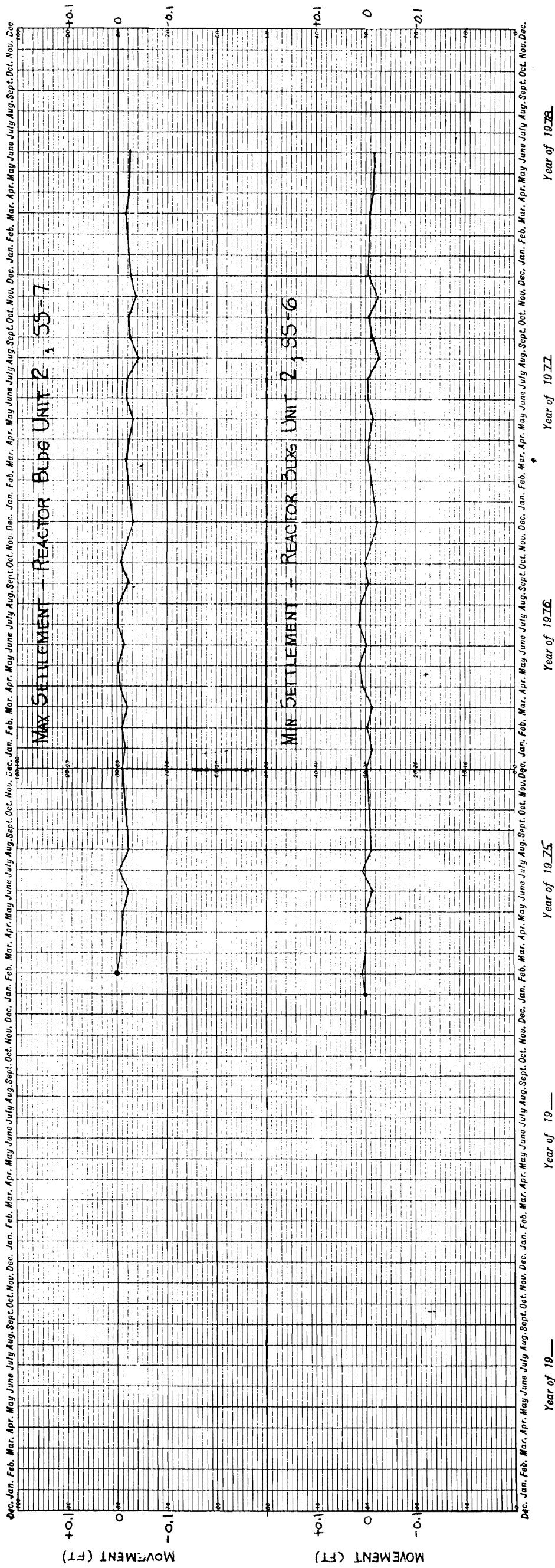

Added by Amendment 50

WATTS BAR NUCLEAR PLANT FINAL SAFETY ANALYSIS REPORT
SETTLEMENT VS. TIME FOR UNIT 2 REACTOR BUILDING FIGURE 2.5-587

Figure 2.5-587 Settlement Vs. Time For Unit 2 Reactor Building

**Figure 2.5-588 Maximum Settlement -Auxiliary Building Settlement Station 10; Minimum Settlement -Auxiliary Building Settlement Station 20 (1973-1982)  
(Actual Figure Located in Oversized Figures File)**



**Figure 2.5-589 Maximum Settlement - Diesel Generator Building Settlement Station 1 & Intake Pumping Station Settlement Station 3A;  
Minimum Settlement Diesel Generator Building Settlement Station 4 & Intake Pumping Station Settlement Station 4 (1975-1982)  
(Actual Figure Located in Oversized Figures File)**

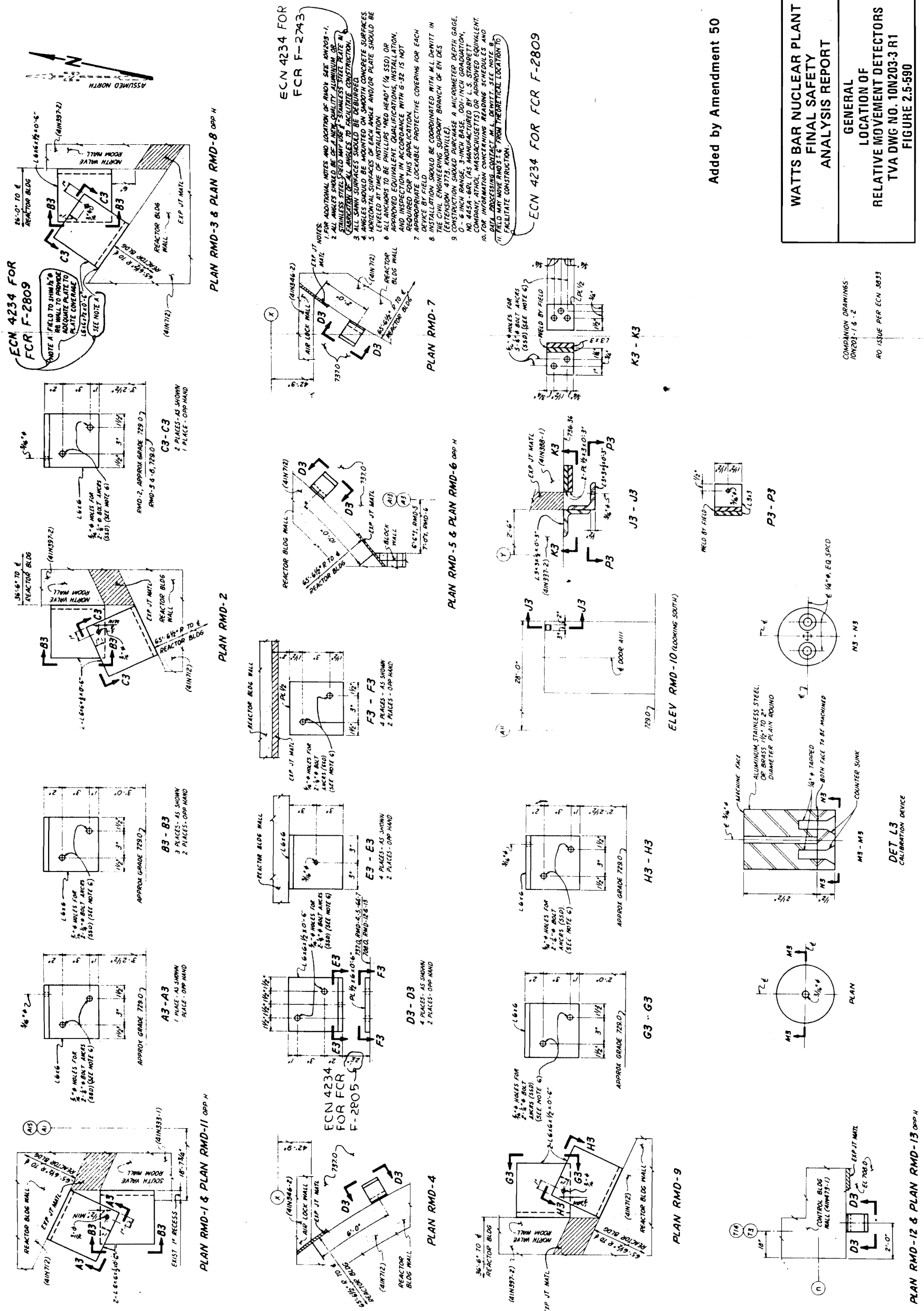

Figure 2.5-590 General Location of Relative Movement Detectors  
TVA DWG NO. 10N203-3 R1

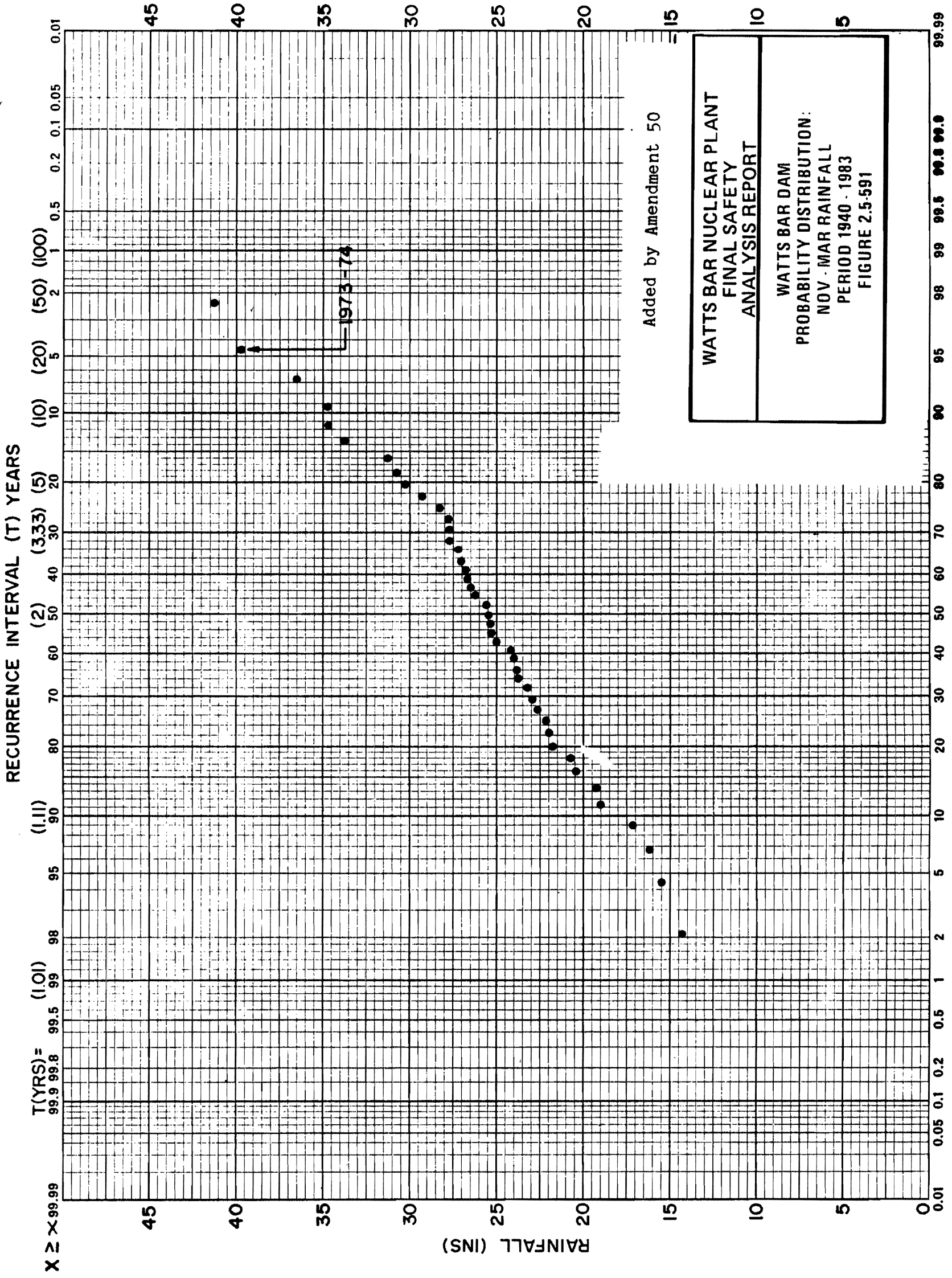

Figure 2.5-591 Watts Bar Dam Probability Distribution: November - March Rainfall Period 1940 - 1983

Figure 2.5-592 Yard ERCW Pipeline EST. 25-YR High Water Table

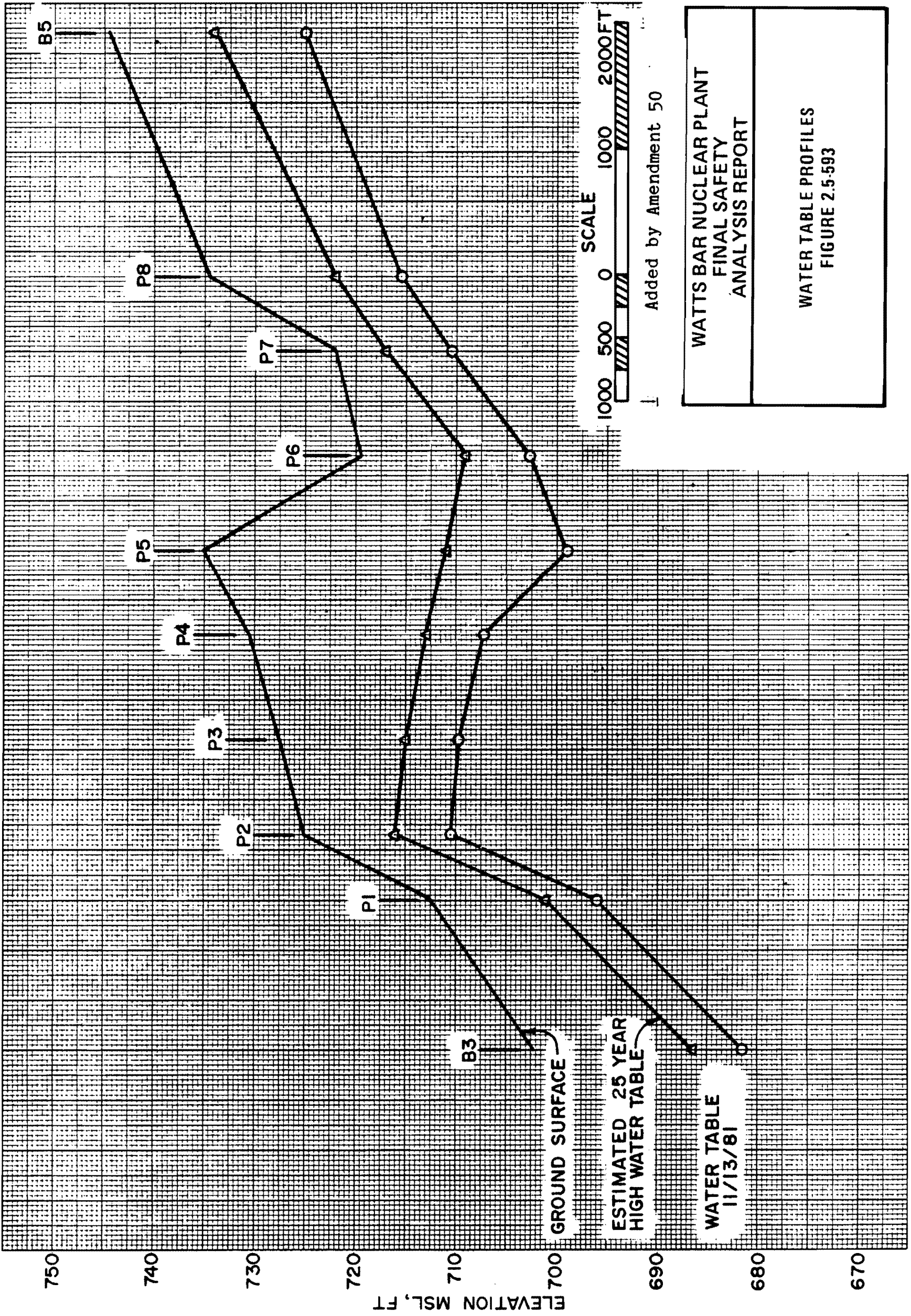

Figure 2.5-593 Water Table Profiles

**Figure 2.5-594 Yard Underground Barrier Trench A STA 1 + 78  
(Actual Figure Located in Oversized Figures File)**

**Figure 2.5-595 Yard Underground Barrier Trench A STA 3 + 78  
(Actual Figure Located in Oversized Figures File)**

**Figure 2.5-596 Yard Underground Barrier Trench A STA 5 + 78  
(Actual Figure Located in Oversized Figures File)**



**Figure 2.5-597 Yard Underground Barrier Trench A STA 7 + 78  
(Actual Figure Located in Oversized Figures File)**

**WATTS BAR NUCLEAR PLANT  
FINAL SAFETY  
ANALYSIS REPORT**

---

**SUMMARY OF EARTHFILL  
TEST DATA - DENSITY  
FIGURE 2.5-598**

DP-2.01 ~~RT~~ *SW*  
 cont F *R4 11-5-83*

2 of 2

FEATURE: UNDERGROUND BARRIER - TRENCH A-95%  $\gamma_{DMAX}$  FILL  
 DATE: 9-30-83 TO: 10-22-83 TEST NO.: 1351 TO: 1390  
 PART: I SECTION: 52A (A) PREPARED BY: W.S. WOODLEE

	PLOT THIS COI	PREV CUM F	THIS PERIOD				TO DATE			
			FREQUENCY (F)	F	CUM F	CUM %	F	CUM F	CUM %	
	90.0	91.9								
	92.0	92.9								
	93.0	93.9								
	94.0	94.9								
	95.0	95.9	3				3	3	4.5	
	96.0	96.9	4				1	4	6.0	
	97.0	97.9	8	II	2	2	7.4	6	10	14.9
	98.0	98.9	10				2	12	17.9	
	99.0	99.9	13	II	2	4	14.8	5	17	25.4
	100.0	100.9	14	I	1	5	18.5	2	19	28.4
	101.0	101.9	19	II	2	7	25.9	7	26	38.8
	102.0	102.9	27	III	5	12	44.4	13	39	58.2
	103.0	103.9	31	II	2	14	51.9	6	45	67.2
	104.0	104.9	35	III-I	6	20	74.1	10	55	82.1
	105.0	108.9	40	III-II	7	27	100.0	12	67	100.0
TOTALS		40				27		67		

PERCENT COMPACTION ( $\gamma_{df} - \gamma_{dl}$ ) x 100

SPECIFICATION SOURCE: DWG #10N213-2 R2

	PREV	THIS PERIOD	TO DATE
AVG FILL DRY DENSITY, $\gamma_{df}$ , pcf	105.5	105.8	105.6
AVG MAXIMUM DRY DENSITY, $\gamma_{dl}$ , pcf	104.0	102.6	103.4
MEAN VARIATION $\gamma_{df} - \gamma_{dl}$ , pcf	+1.5	+3.2	+2.2

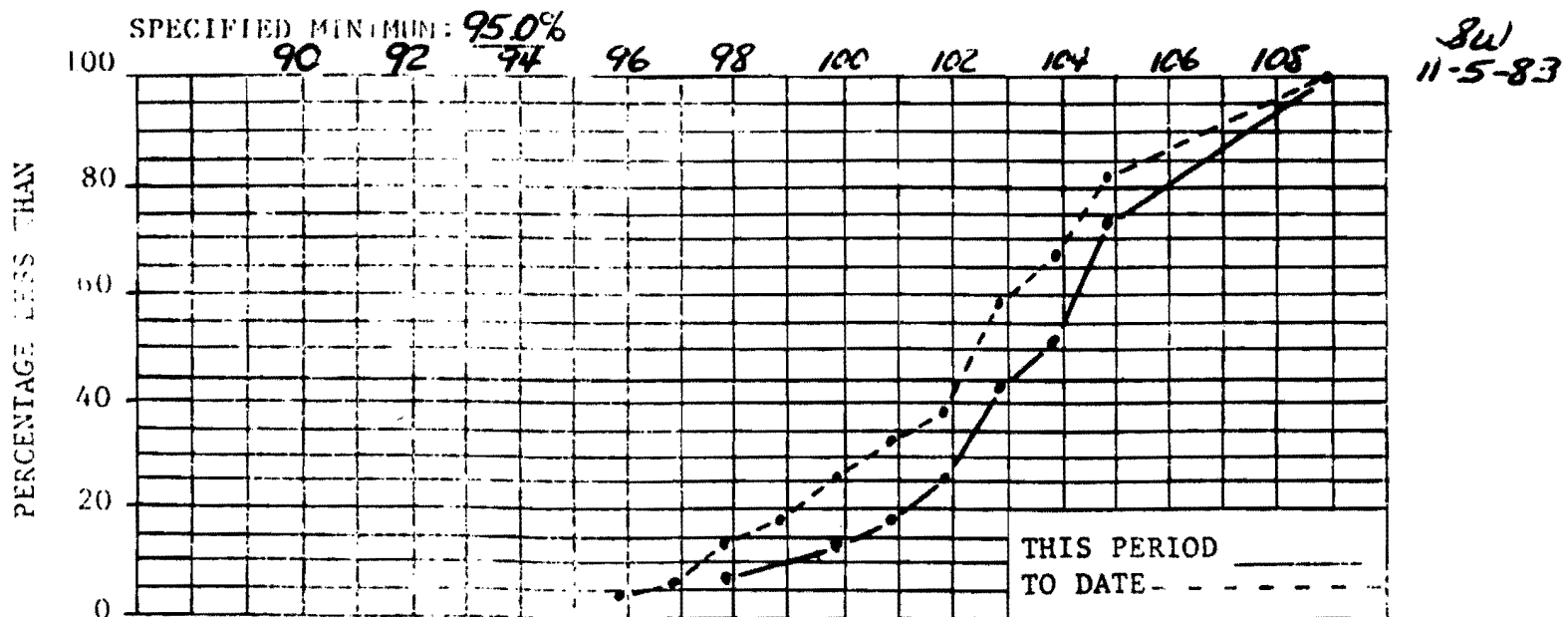

REMARKS: THIS IS THE FINAL ANALYSIS FOR TYPE A FILL COMPACTION.  
 INSPECTED/CHECKED/VERIFIED IN ACCORDANCE WITH REV 4 OF WBNP-QCP-2.01. *SW*  
W. Scott Woodlee 11-5-83  
 INSPECTOR Date

**ADDED BY AMENDMENT 59**

Figure 2.5-598 Summary of Earthfill Test Data - Density

**WATTS BAR NUCLEAR PLANT  
FINAL SAFETY  
ANALYSIS REPORT**

---

**SUMMARY OF EARTHFILL  
TEST DATA - MOISTURE CONTENT  
FIGURE 2.5-599**

BNP-QCP-2.01 #3 SW  
Attachment C R4 11-5-83  
DP

SUM

Sheet 2 of 2

FEATURE: UNDERGROUND BARRIER - TRENCH A - 95%  $\sigma_{DMAX}$  Fill  
 DATE: 9-30-83 TO: 10-22-83 TEST NO.: 1351 TO: 1390  
 PART: I SECTION: 52A (A) PREPARED BY: W.S. WOODLEE

	PLOT THIS COL.	PREV CUM F	THIS PERIOD				TO DATE				
			FREQUENCY (F)	F	CUM F	CUM %	F	CUM F	CUM %		
W <sub>F</sub> ABOVE OPT	+4.6	5.2									
	3.9	4.5									
	3.1	3.8									
	2.5	3.0	2	I	1	1	3.7	3	3	4.5	
	1.8	2.4	3	II	2	3	11.1	3	6	9.0	
	1.1	1.7	7	I	1	4	14.8	5	11	16.4	
	0.4	1.0	13	II	2	6	22.2	8	19	28.4	
	+0.3	-0.3	20	III-II	7	13	48.1	14	33	49.3	
	0.4	1.0	23	III-III	8	21	77.8	11	44	65.7	
	1.1	1.7	32	III	3	24	88.9	12	56	83.6	
W <sub>F</sub> BELOW OPT	1.8	2.4	38	III	3	27	100.0	9	65	97.0	
	2.5	3.0	40					2	67	100.0	
	3.1	3.8									
	3.9	4.5									
	-4.6	5.2									
	TOTALS	NA	40	--	--	27	--	--	67	--	

SPECIFICATION SOURCE: DWG. #10N213-2 R2

	PREV	THIS PERIOD	TO DATE
AVG FILL MOISTURE CONTENT, W <sub>F</sub> , %	18.9	19.8	19.3
AVG OPTIMUM MOISTURE CONTENT, W <sub>0</sub> , %	19.4	20.0	19.6
MEAN VARIATION (W <sub>F</sub> - W <sub>0</sub> ), %	-0.5	-0.2	-0.3

SPECIFIED MINIMUM -30 to +30%

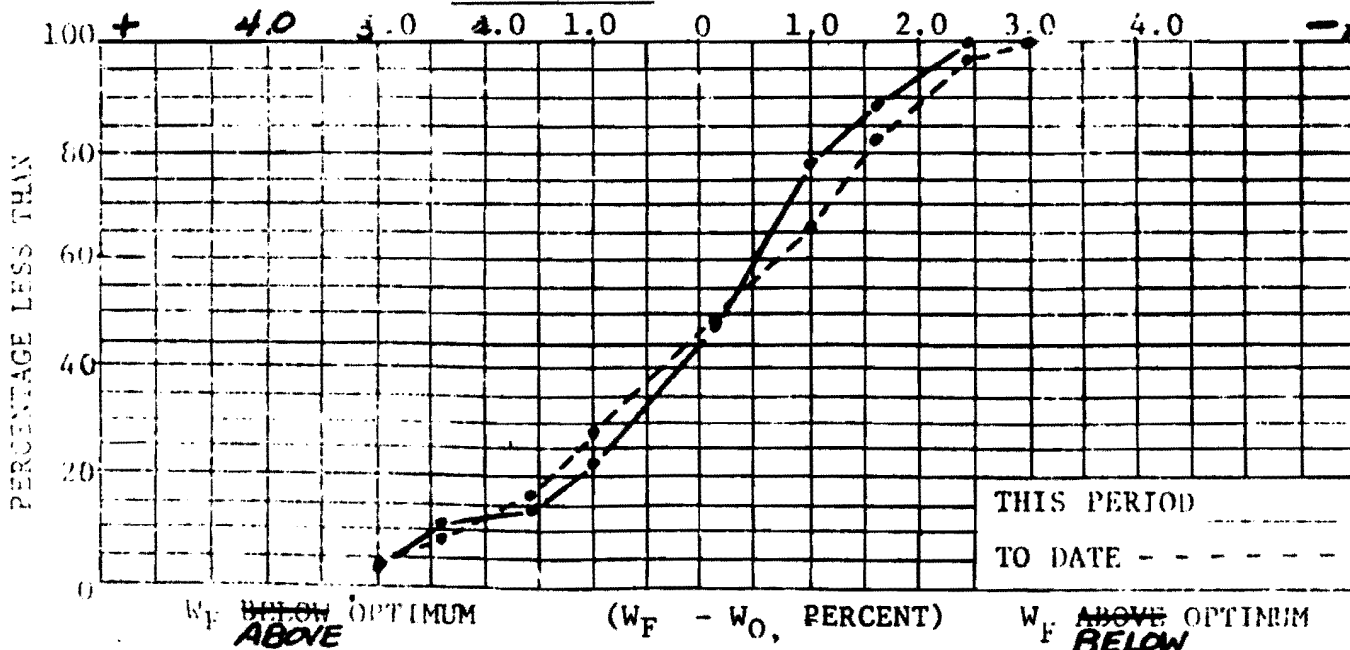

REMARKS: THIS IS THE FINAL ANALYSIS FOR TYPE A FILL COMPACTION.  
 INSPECTED/CHECKED/VERIFIED IN ACCORDANCE WITH R 4 OF WBNP-QCP-2.01. SW

W. Scott Woodlee  
 Inspector

11-5-83  
 ADDED BY AMENDMENT 59

Figure 2.5-599 Summary Of Earthfill Test Data -Moisture Content

**WATTS BAR NUCLEAR PLANT  
FINAL SAFETY  
ANALYSIS REPORT**

---

**SUMMARY OF EARTHFILL  
TEST DATA - DENSITY  
FIGURE 2.5-600**

BNP-QCP-2.01 R4 *SW*  
Attachment F R4 *11-5-83*  
OP

Sheet 4 of 4

FEATURE: UNDERGROUND BARRIER - TRENCH A - 100%  $\delta_{max}$  FILL  
 DATE: 9-30-83 TO: 10-9-83 TEST NO.: 1347 TO: 1364  
 PART: I SECTION: 52A (A1) PREPARED BY: W.S. WOODLEE

PLOT THIS COL.	PREV CUM F	THIS PERIOD				TO DATE		
		FREQUENCY (F)	F	CUM F	CUM %	F	CUM F	CUM %
95.0	95.9							
96.0	96.9							
97.0	97.9							
98.0	98.9							
99.0	99.9							
100.0	100.9	16				16	16	20.0
101.0	101.9	32	I		1	17	33	41.3
102.0	102.9	46	II		5	19	52	65.0
103.0	103.9	55	III		4	13	65	81.3
104.0	104.9	61	II		2	8	73	91.3
105.0	105.9	64	I		1	4	77	96.3
106.0	106.9							
107.0	107.9	65	I		1	2	79	98.8
108.0	108.9							
109.0	110.9		I		1	1	80	100.0
TOTALS		65			15		80	

SPECIFICATION SOURCE: DWG. \*10N213-2 R2

	PREV	THIS PERIOD	TO DATE
AVG FILL DRY DENSITY, $\gamma_{df}$ , pcf	104.4	105.2	104.6
AVG MAXIMUM DRY DENSITY, $\gamma_{dL}$ , pcf	102.1	101.2	101.9
MEAN VARIATION $\gamma_{df} - \gamma_{dL}$ , pcf	+2.3	+4.0	+2.7

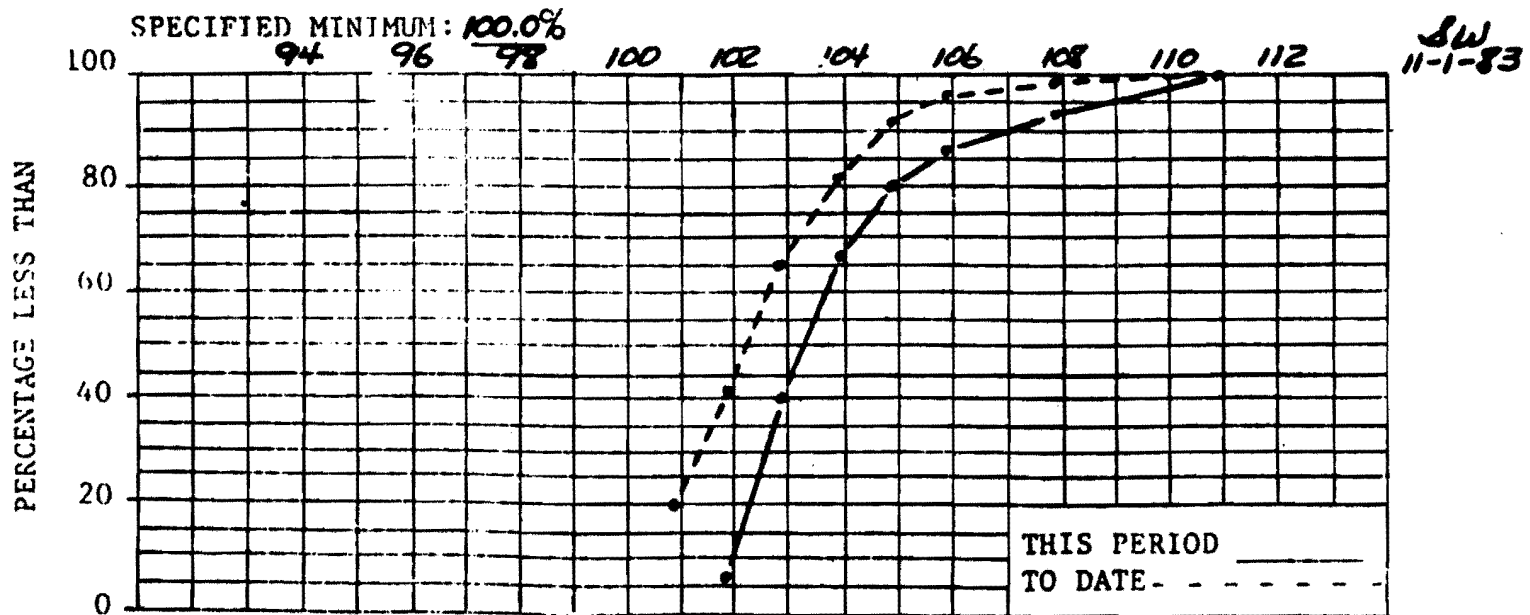

REMARKS: THIS IS THE FINAL ANALYSIS FOR TYPE A1 FILL COMPACTION. SW  
 INSPECTED/CHECKED/VERIFIED IN ACCORDANCE WITH REV 4 OF WBNP-QCP-2.01.

W. Scott Woodlee 11-5-83  
 INSPECTOR Date

ADDED BY AMENDMENT 59

Figure 2.5-600 Summary Of Earthfill Test Data -Density

**WATTS BAR NUCLEAR PLANT  
FINAL SAFETY  
ANALYSIS REPORT**

---

**SUMMARY OF EARTHFILL  
TEST DATA - MOISTURE CONTENT  
FIGURE 2.5-601**

WBNP-QCP-2.01 ~~++~~ *SW*  
Attachment G ~~R4~~ *R4* 11-5-83  
LOP  
Sheet 4 of 4

FEATURE: UNDERGROUND BARRIER - TRENCH A - 100%  $\gamma_{Dmax}$  FILL  
DATE: 9-30-83 TO: 10-9-83 TEST NO.: 1347 TO: 1364  
PART: I SECTION: 52A (A1) PREPARED BY: W.S. WOODLEE

	PLOT THIS COL.	PREV CUM F	THIS PERIOD				TO DATE			
			FREQUENCY (F)	F	CUM F	CUM %	F	CUM F	CUM %	
W <sub>F</sub> ABOVE OPT	+4.6	5.2								
	3.9	4.5								
	3.1	3.8								
	2.5	3.0								
	1.8	2.4	1					1	1	1.3
PLOT	1.1	1.7	6					5	6	7.5
	0.4	1.0	13	II	2	2	13.3	9	15	18.8
	+0.3	-0.3	25	II	2	4	26.7	14	29	36.3
	0.4	1.0	38	III	5	9	60.0	18	47	58.8
	1.1	1.7	52	III	4	13	86.7	18	65	81.3
W <sub>F</sub> BELOW OPT	1.8	2.4	61					9	74	92.5
	2.5	3.0	65	II	2	15	100.0	6	80	100.0
	3.1	3.8								
	3.9	4.5								
	-4.6	5.2								
TOTALS	NA	65	--	--	15	--	--	80	--	--

SPECIFICATION SOURCE: DWG. #10N213-2 R2

	PREV	THIS PERIOD	TO DATE
AVG FILL MOISTURE CONTENT, W <sub>F</sub> , %	19.7	19.9	19.7
AVG OPTIMUM MOISTURE CONTENT, W <sub>0</sub> , %	20.4	20.8	20.5
MEAN VARIATION (W <sub>F</sub> - W <sub>0</sub> ), %	-0.7	-0.9	-0.8

SPECIFIED MINIMUM -3.0 TO +3.0%

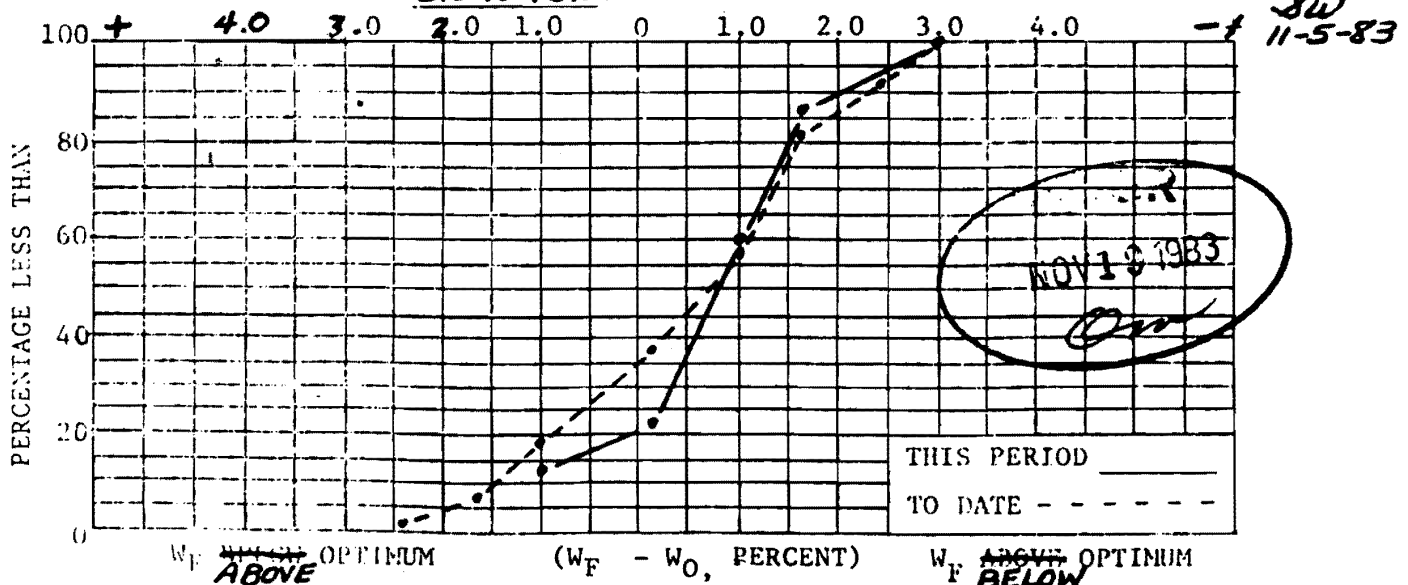

REMARKS: THIS IS THE FINAL ANALYSIS FOR TYPE A1 FILL COMPACTION. *SW*  
INSPECTED/CHECKED/VERIFIED IN ACCORDANCE WITH R 4 OF WBNP-QCP-2.01.

ADDED BY AMENDMENT 59 W. Scott Woodlee 11-5-83  
INSPECTOR

Figure 2.5-601 Summary Of Earthfill Test Data -Moisture Content

**Figure 2.5-602 Yard Underground Barrier Trench B STA 1 + 100  
(Actual Figure Located in Oversized Figures File)**

**Figure 2.5-603 Yard Underground Barrier Trench B STA 2 + 50  
(Actual Figure Located in Oversized Figures File)**

**Figure 2.5-604 Yard Underground Barrier Trench B STA 3 + 00  
(Actual Figure Located in Oversized Figures File)**



**Figure 2.5-605 Yard Underground Barrier Trench B STA 4 + 50  
(Actual Figure Located in Oversized Figures File)**

**WATTS BAR NUCLEAR PLANT  
FINAL SAFETY  
ANALYSIS REPORT**

---

**SUMMARY OF FILL TEST  
DATA - DENSITY  
FIGURE 2.5-606**

NP-QCP-2.01 R6  
Attachment F  
Sheet 1 of     

FEATURE: UNDERGROUND BARRIER - TRENCH B-95%  $\gamma_{Dmax}$  FILL  
 DATE: 11-2-83 TO: 6-28-84 TEST NO.: 1397 TO: 1475  
 PART: I SECTION: 52B (A) PREPARED BY: W.S. WOODLEE

	PLOT THIS COL	PREV CUM F	THIS PERIOD				TO DATE		
			FREQUENCY (F)	F	CUM F	CUM %	F	CUM F	CUM %
95.0	95.9		I	1	1	2.7			
96.0	96.9		I	1	2	5.4			
97.0	97.9		II	2	4	10.8			
98.0	98.9		I	1	5	13.5			
99.0	99.9		III-II	7	12	32.4			
100.0	100.9		III	3	15	40.5			
101.0	101.9		III-II	7	22	59.5			
102.0	102.9	NA	III	3	25	67.6	NA	NA	NA
103.0	103.9		III	3	28	75.7			
104.0	104.9		III	4	32	86.5			
105.0	105.9		III	3	35	94.6			
106.0	106.9		I	1	36	97.3			
107.0	107.9								
108.0	108.9		I	1	37	100.0			
109.0	110.9								
TOTALS			--	--	37	--	--	--	--

SPECIFICATION SOURCE: DWG. #10N213-2 B4

	PREV	THIS PERIOD	TO DATE
AVG FILL DRY DENSITY, $\gamma_{df}$ , pcf	NA	107.0	107.0
AVG MAXIMUM DRY DENSITY, $\gamma_{dl}$ , pcf	NA	105.3	105.3
MEAN VARIATION $\gamma_{df} - \gamma_{dl}$ , pcf	NA	+1.7	+1.7

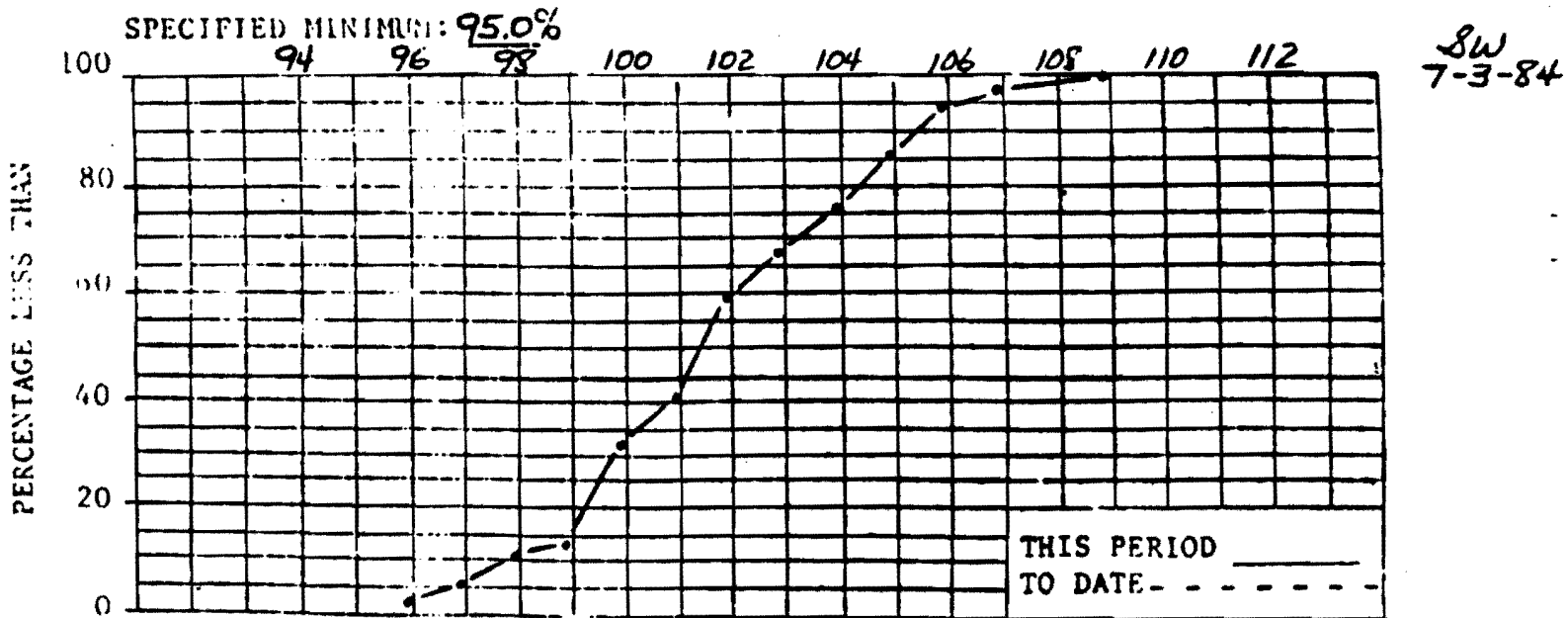

REMARKS: FAILED TESTS NOT INCLUDED IN THIS ANALYSIS. SW  
 INSPECTED/CHECKED/VERIFIED IN ACCORDANCE WITH REV 6 OF WBNP-QCP-2.01.

ADDED BY AMENDMENT 59 W. Scott Woodlee 7-3-84  
 INSPECTOR Date

Figure 2.5-606 Summary of Fill Test Data -Density

**WATTS BAR NUCLEAR PLANT  
FINAL SAFETY  
ANALYSIS REPORT**

---

**SUMMARY OF EARTHFILL  
TEST DATA - MOISTURE CONTENT  
FIGURE 2.5-607**

WP-QCP-2.01 R6  
Attachment C

Page 1 of 1

FEATURE: UNDERGROUND BARRIER - TRENCH B - 95%  $\gamma_{max}$  FILL  
 DATE: 11-2-83 TO: 6-28-84 TEST NO.: 1397 TO: 1475  
 PART: I SECTION: 52B (A) PREPARED BY: W.S. WOODLEE

	PLOT THIS COL.	PREV CUM F	THIS PERIOD				TO DATE			
			FREQUENCY (F)	F	CUM F	CUM %	F	CUM F	CUM %	
W <sub>F</sub> ABOVE OPT	+4.6	5.2								
	3.9	4.5								
	3.1	3.8								
	2.5	3.0								
	1.8	2.4		III	3	3	8.1			
PLOT	1.1	1.7		III-	5	8	21.6			
	0.4	1.0		III	3	11	29.7			
	+0.3	-0.3	NA	II	2	13	35.1	NA	NA	NA
	0.4	1.0		III-III	9	22	59.5			
	1.1	1.7		III	4	26	70.3			
W <sub>F</sub> BELOW OPT	1.8	2.4		III	4	30	81.1			
	2.5	3.0		III-II	7	37	100.0			
	3.1	3.8								
	3.9	4.5								
	-4.6	5.2								
TOTALS	NA		--	--	37	--	--			

SPECIFICATION SOURCE: DWG #10N213-2 R4

	PREV	THIS PERIOD	TO DATE
AVG FILL MOISTURE CONTENT, W <sub>F</sub> , %	NA	18.4	18.4
AVG OPTIMUM MOISTURE CONTENT, W <sub>O</sub> , %	NA	19.0	19.0
MEAN VARIATION (W <sub>F</sub> - W <sub>O</sub> ), %	NA	-0.6	-0.6

SPECIFIED MINIMUM -3.0 TO +3.0%

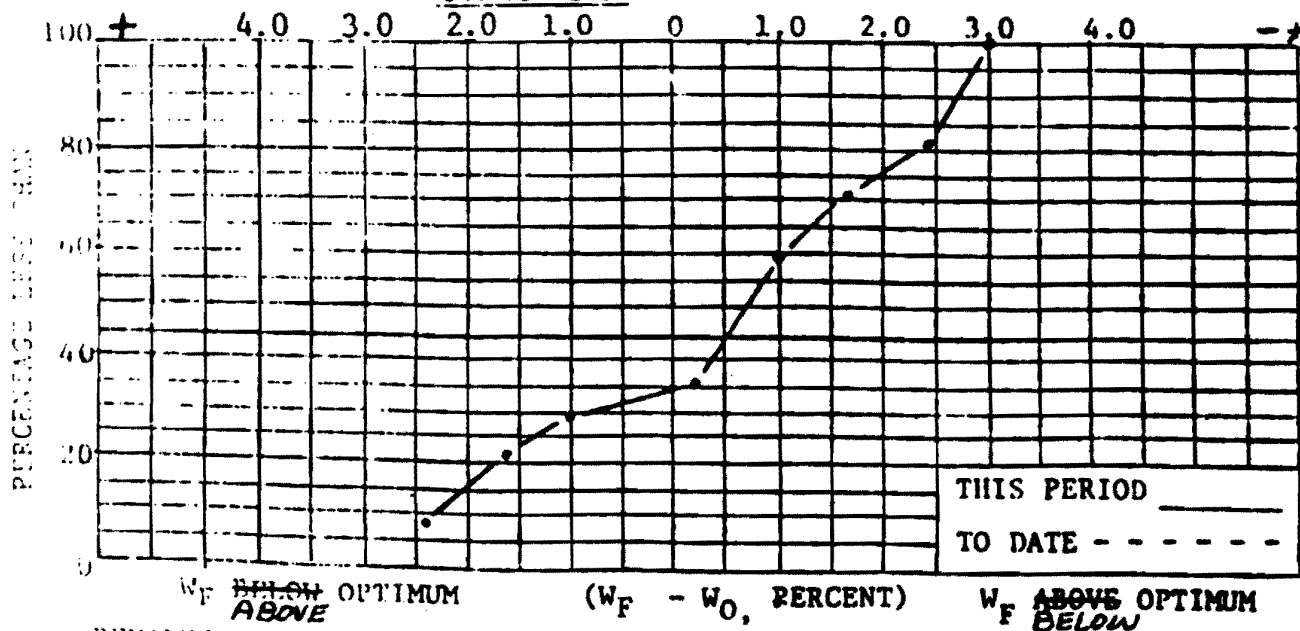

REMARKS: FAILED TESTS NOT INCLUDED IN THIS ANALYSIS. SW  
 INSPECTED/CHECKED/VERIFIED IN ACCORDANCE WITH R 6 OF WBNP-QCP-2.01

ADDED BY AMENDMENT 59 W. Scott Woodlee 7-3-84  
 INSPECTOR

Figure 2.5-607 Summary of Earthfill Test Data - Moisture Content

WBNP-QCP-2.01 B6  
Attachment F  
LOF

TENNESSEE VALLEY AUTHORITY  
WATTS BAR NUCLEAR PLANT  
SUMMARY OF FILL TEST DATA - DENSITY

Sheet 2 of 2

FEATURE: UNDERGROUND BARRIER - TRENCH B-100% Lower-Fill.  
DATE: 11-25-83 TO: 5-31-84 TEST NO.: 1408 TO: 1438  
PART: I SECTION: 52B (A1) PREPARED BY: N.S. WOODLEE

PLOT THIS COL	PREV CUM F	THIS PERIOD				TO DATE			
		FREQUENCY (F)	F	CUM F	CUM %	F	CUM F	CUM %	
95.0	95.9								
96.0	96.9								
97.0	97.9								
98.0	98.9		1	1	8.3	1	1	3.4	
99.0	99.9								
100.0	100.9	2		2	3	25.0	4	5	17.2
101.0	101.9	7		7	7	58.3	9	14	48.3
102.0	102.9	10		10	11	91.7	7	21	72.4
103.0	103.9	11					1	22	75.9
104.0	104.9	12					2	24	82.8
105.0	105.9	14					1	25	86.2
106.0	106.9		1	1	12	100.0	1	26	89.7
107.0	107.9	15					1	27	93.1
108.0	108.9	16					1	28	96.6
109.0	110.9	17					1	29	100.0
TOTALS		17			12			29	

SPECIFICATION SOURCE: DWG # 10N213-2 R4

	PREV	THIS PERIOD	TO DATE
AVG FILL DRY DENSITY, $\gamma_{df}$ , pcf	104.7	105.6	105.1
AVG MAXIMUM DRY DENSITY, $\gamma_{dl}$ , pcf	101.0	103.6	102.1
MEAN VARIATION $\gamma_{df} - \gamma_{dl}$ , pcf	+3.7	+2.0	+3.0

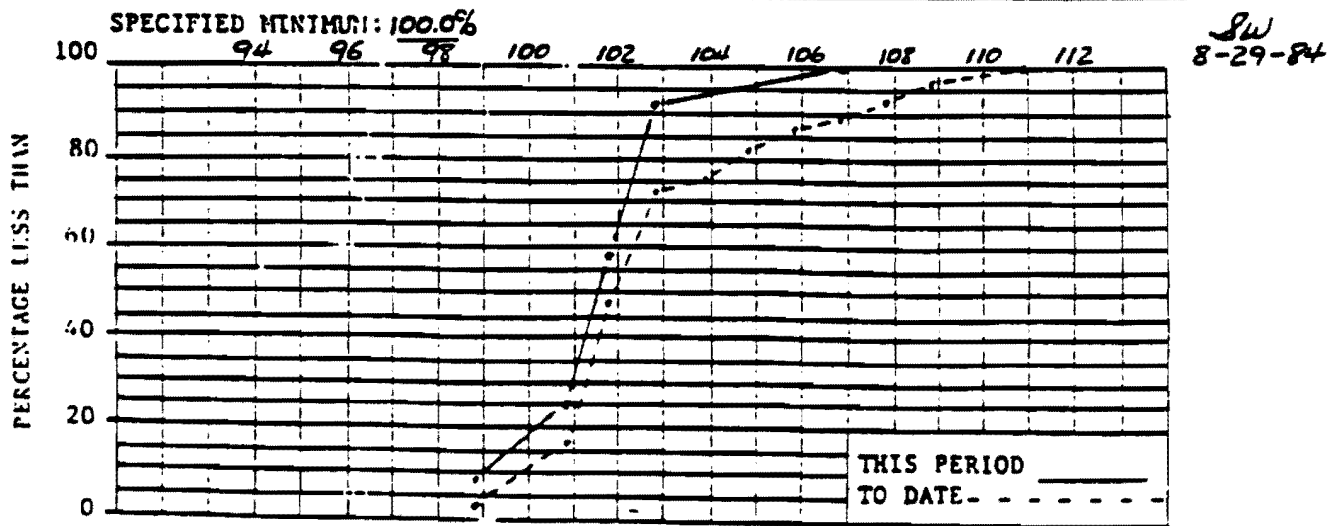

REMARKS: ANALYSIS ISSUED TO REFLECT CHANGE DUE TO MISTAKE ON SAND CONE INSPECTED/CHECKED/VERIFIED IN ACCORDANCE WITH REV 6 OF WBNP-QCP-2.01. TEST #1426.  
W. Scott Woodlee 8-29-84 ICR #5804  
INSPECTOR Date

WATTS BAR NUCLEAR PLANT  
FINAL SAFETY  
ANALYSIS REPORT

---

SUMMARY OF FILL TEST DATA  
DENSITY

---

Amendment 63

---

Figure 2.5-608

Figure 2.5-608 Summary of Earthfill Test Data -Density

TENNESSEE VALLEY AUTHORITY  
WATTS BAR NUCLEAR PLANT  
SUMMARY OF EARTHFILL TEST DATA - MOISTURE CONTENT Sheet 2 of 2

WBNP-OCP-2.01 R6  
Attachment C  
LOP

FEATURE: UNDERGROUND BARRIER - TRENCH B - 100% T<sub>max</sub> FILL  
DATE: 11-25-83 TO: 5-31-84 TEST NO.: 1408 TO: 1438  
PART: I SECTION: 52B (A) PREPARED BY: W.S. WOODLEE

	PLOT THIS (M)	PREV CUM F	THIS PERIOD				TO DATE		
			FREQUENCY (F)	F	CUM F	CUM %	F	CUM	CUM %
W <sub>F</sub> ABOVE OPT	+4.6	5.2							
	3.9	4.5							
	3.1	3.8							
	2.5	3.0							
	1.8	2.4	2	1	1	8.3	3	3	10.3
PIQT	1.1	1.7							
	0.4	1.0	4	1	2	16.7	3	6	20.7
	+0.3	-0.3	7	2	4	33.3	5	11	37.9
	0.4	1.0	10	2	6	50.0	5	16	55.2
	1.1	1.7	11				1	17	58.6
W <sub>F</sub> BELOW OPT	1.8	2.4	15	2	8	66.7	6	23	79.3
	2.5	3.0	17	3	11	91.7	5	28	96.6
	3.1	3.8		1	12	100.0	1	29	100.0
	3.9	4.5							
	-4.6	5.2							
TOTALS	NA	17	--	--	12	--	--	29	--

SPECIFICATION SOURCE: DWG #10N213-2 R4

	PREV	THIS PERIOD	TO DATE
AVG FILL MOISTURE CONTENT, W <sub>F</sub> , %	20.2	18.7	19.6
AVG OPTIMUM MOISTURE CONTENT, W <sub>0</sub> , %	21.1	20.2	20.7
MEAN VARIATION (W <sub>F</sub> - W <sub>0</sub> ), %	-0.9	-1.5	-1.1

SPECIFIED MINIMUM -3.0 TO +3.0%

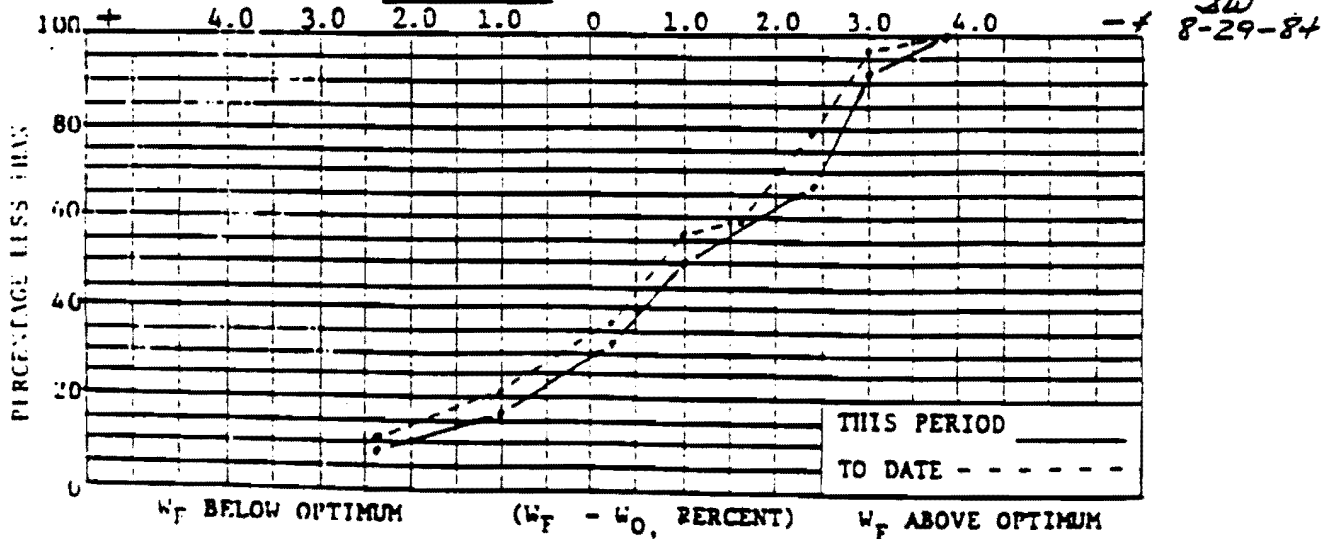

REVISION: ANALYSIS ISSUED TO REFLECT CHANGE, DUE TO MISTAKE ON SAND CONE INSPECTION/CHECKED/VERIFIED IN ACCORDANCE WITH R 6 OF WBNP-OCP-2.01. TEST #1426.  
W. Scott Woodlee 8-29-84 NCR#5604

WATTS BAR NUCLEAR PLANT FINAL SAFETY ANALYSIS REPORT
SUMMARY OF EARTHILL TEST DATA MOISTURE CONTENT
Figure 2.5-609

Amendment 63

Figure 2.5-609 Summary of Earthfill Test Data - Moisture Content

