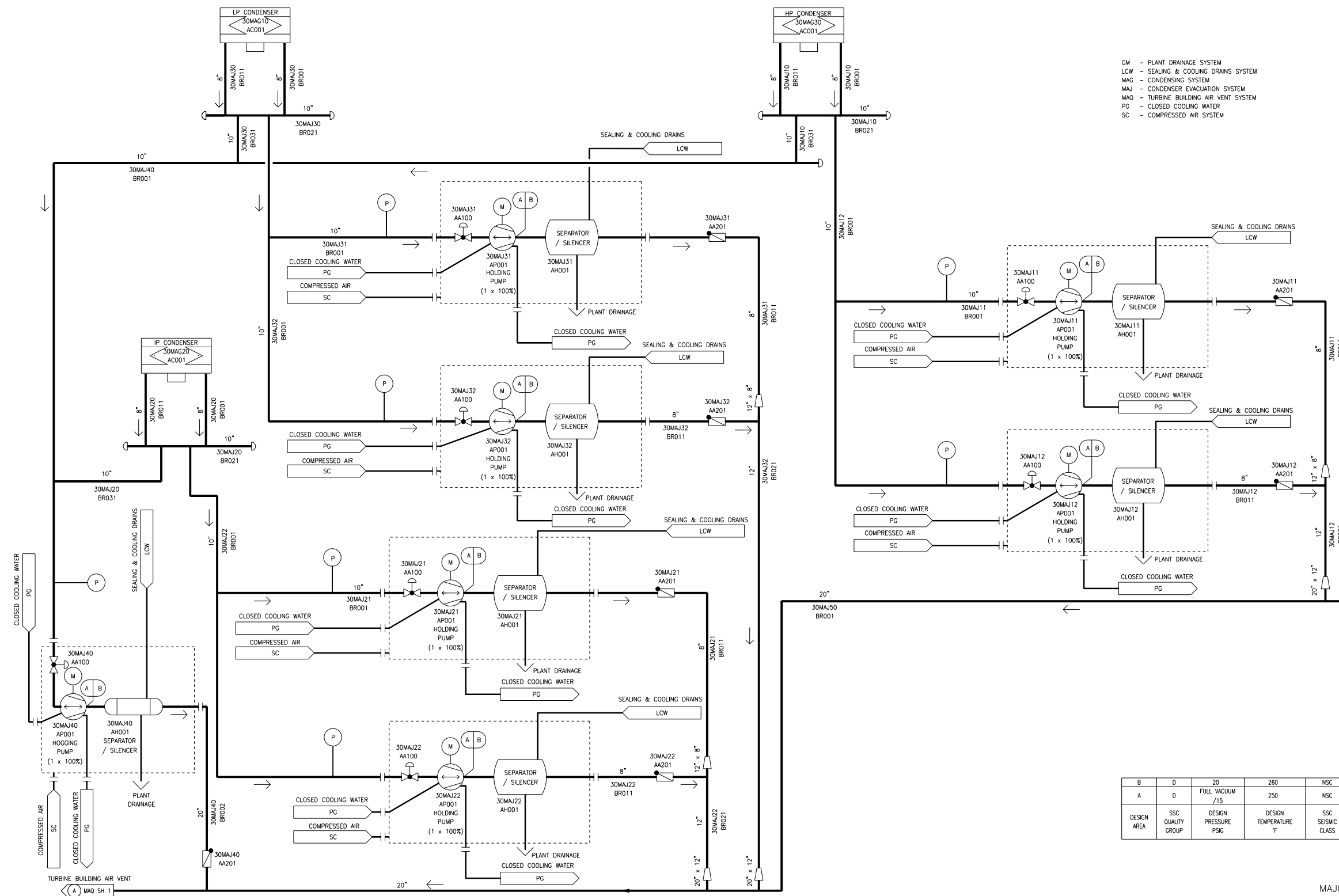
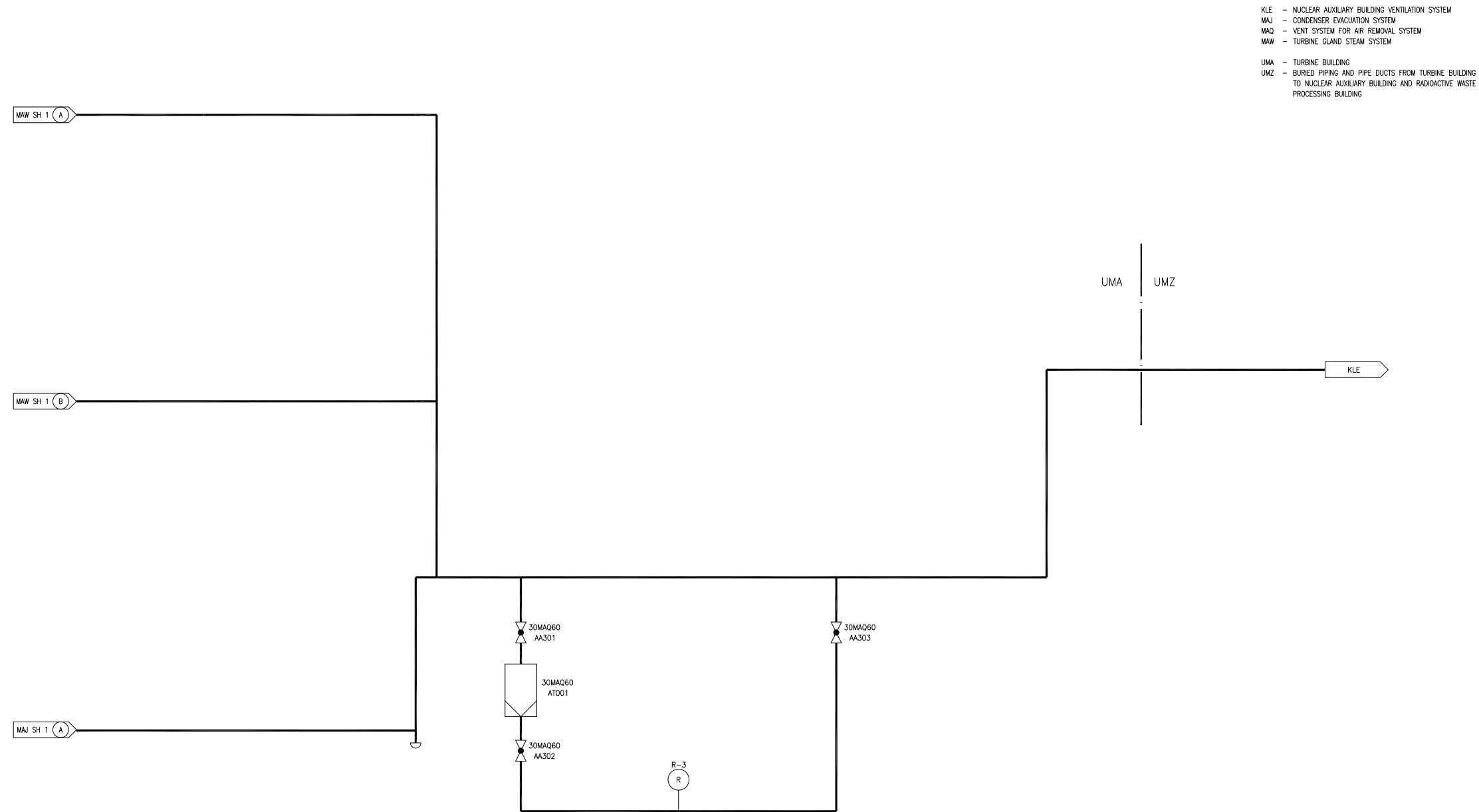

Figure 10.4.2-1—Main Condenser Evacuation System



MAJ01T2

Figure 10.4.2-2—Vent System for Air Removal



A	D	8	175	NSC
DESIGN AREA	SSC QUALITY GROUP	DESIGN PRESSURE PSIG	DESIGN TEMPERATURE °F	SSC SEISMIC CLASS

REV 003
MAQ01T2