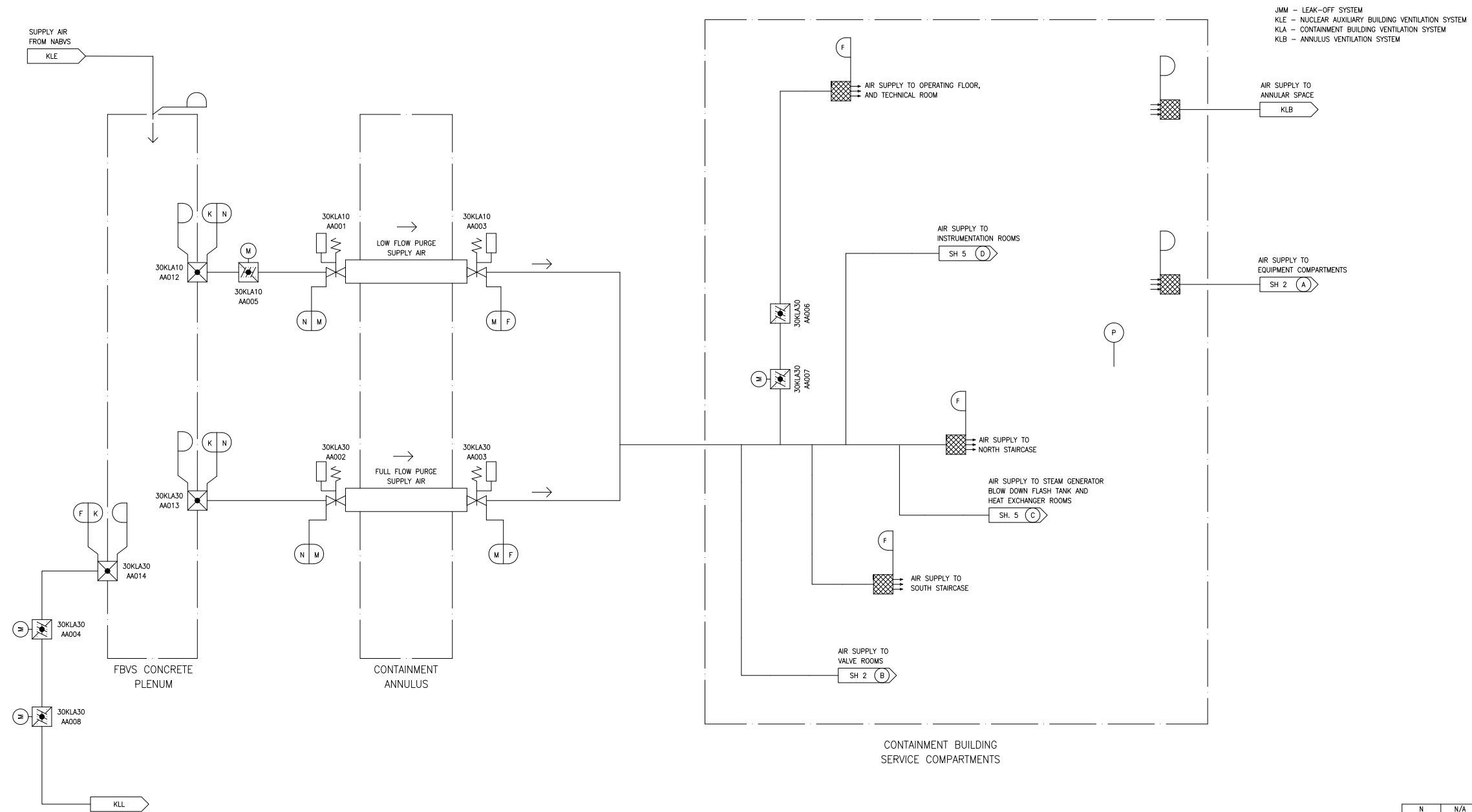

Figure 9.4.7-1—Containment Building Low Flow and Full Flow Purge Supply Subsystem



N	N/A	NSC
M	B	I
K	N/A	II
F	N/A	II
DESIGN AREA	SSC QUALITY GROUP	SSC SEISMIC CLASS

REV 005
KLA01T2

Figure 9.4.7-2—Containment Building Low Flow and Full Flow Purge Exhaust Subsystem

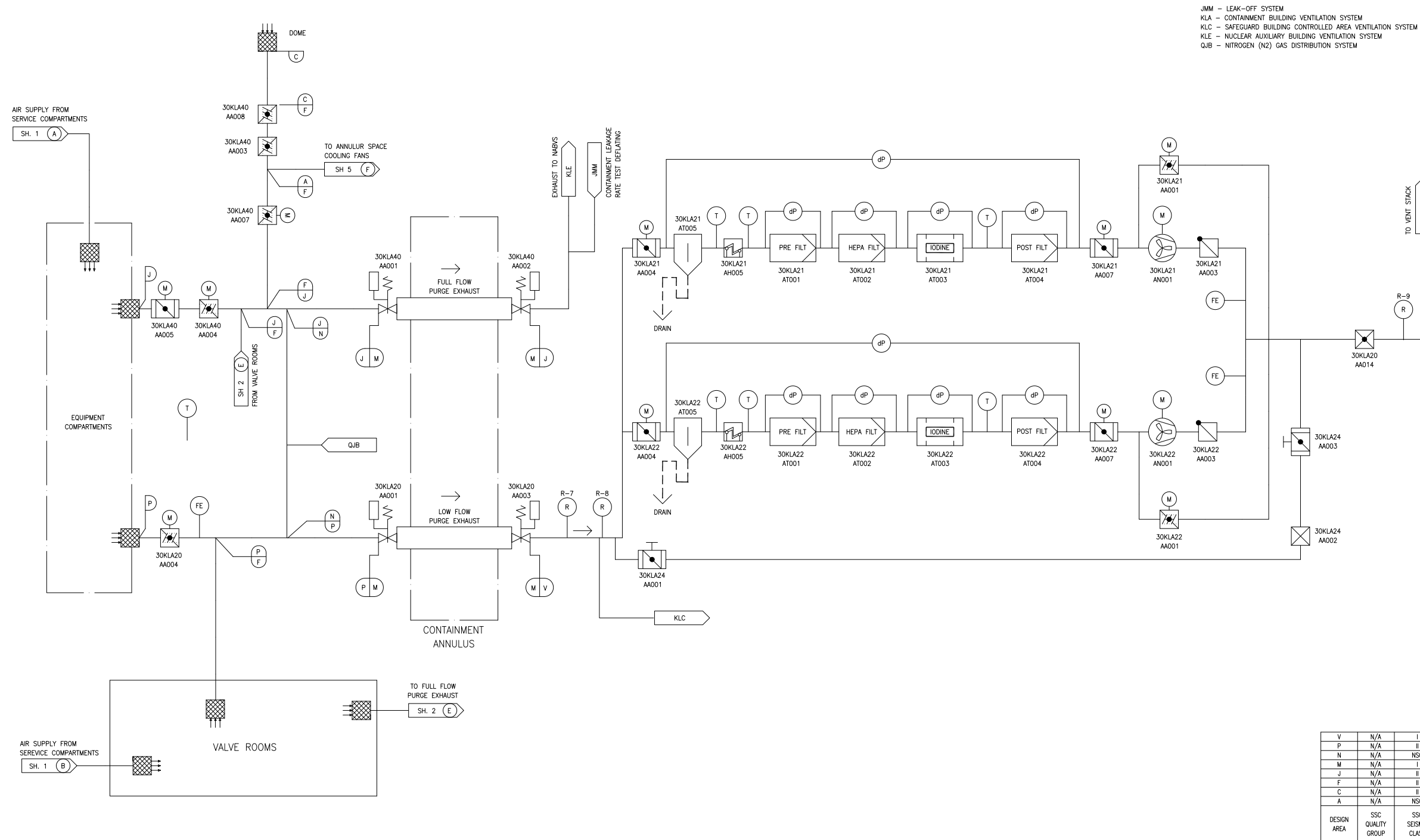

REV 005
KLA02T2

Figure 9.4.7-3—Containment Building Internal Filtration Subsystem

KLE – NUCLEAR AUXILIARY BUILDING VENTILATION SYSTEM
 KLA – CONTAINMENT BUILDING VENTILATION SYSTEM

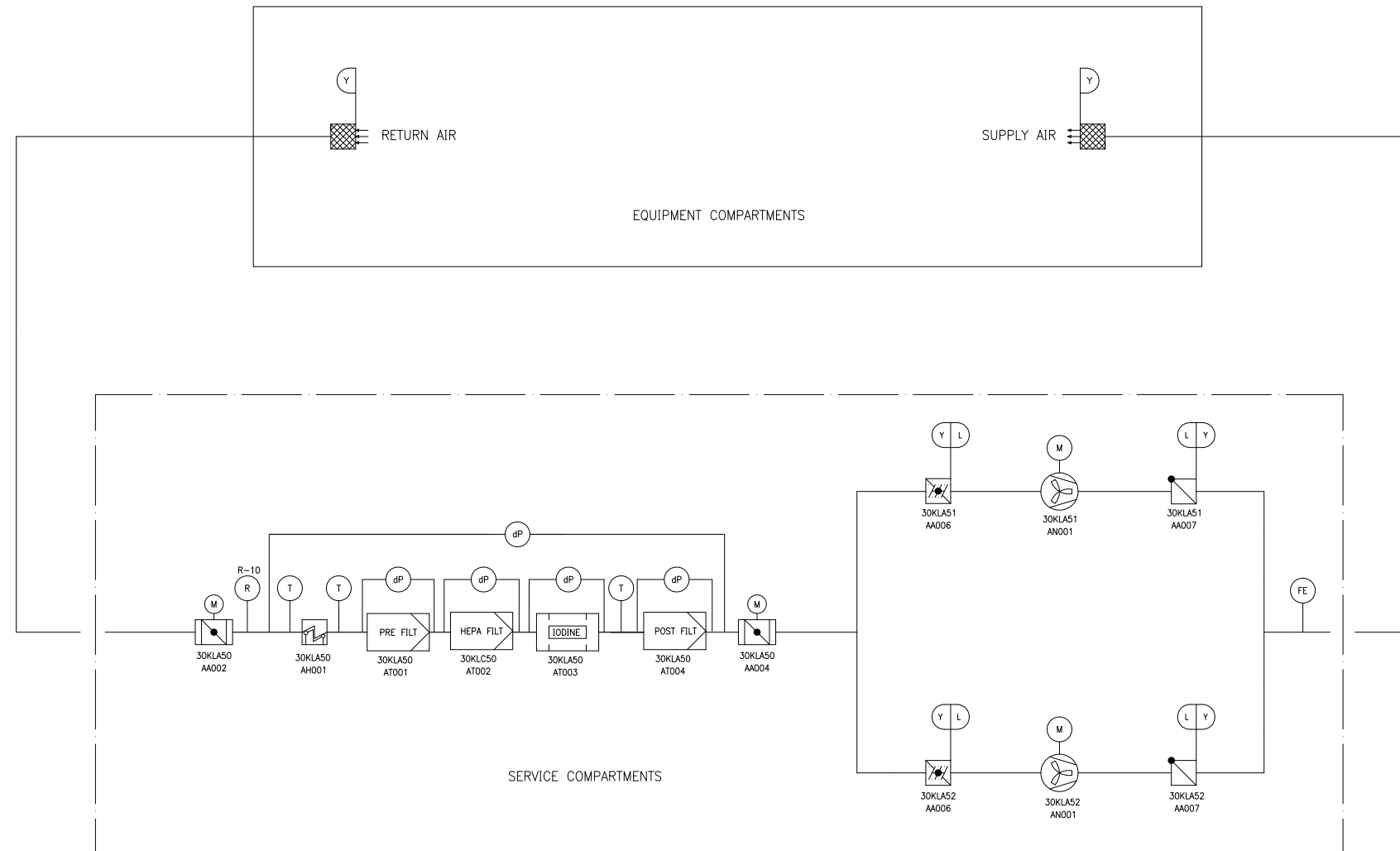

Y	N/A	I
L	N/A	I
DESIGN AREA	SSC QUALITY GROUP	SSC SEISMIC CLASS

REV 005
 KLA03T2

Figure 9.4.7-4—Containment Building Cooling Subsystem

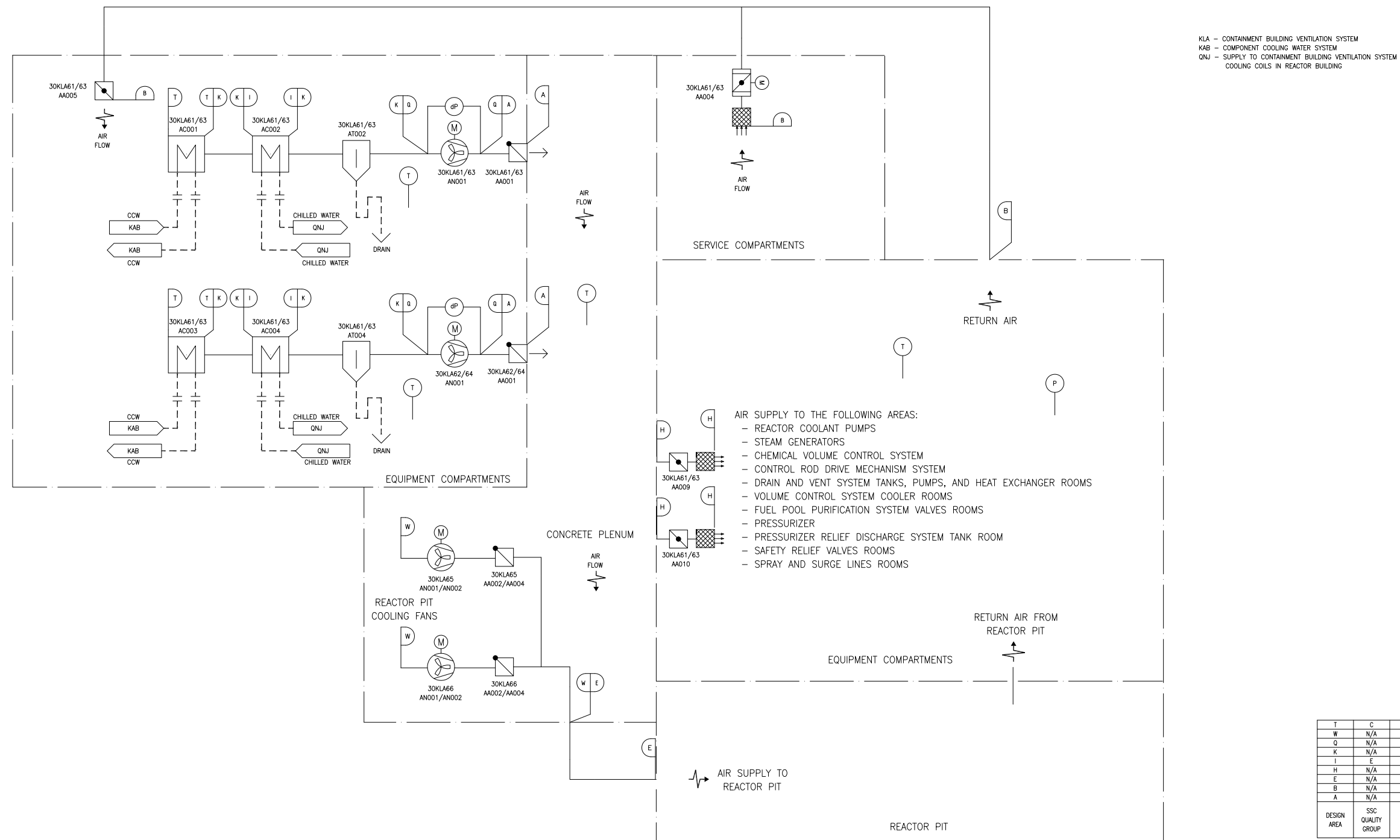

REV 005
KLA04T2

Figure 9.4.7-5—Containment Building Service Compartments Cooling Subsystem

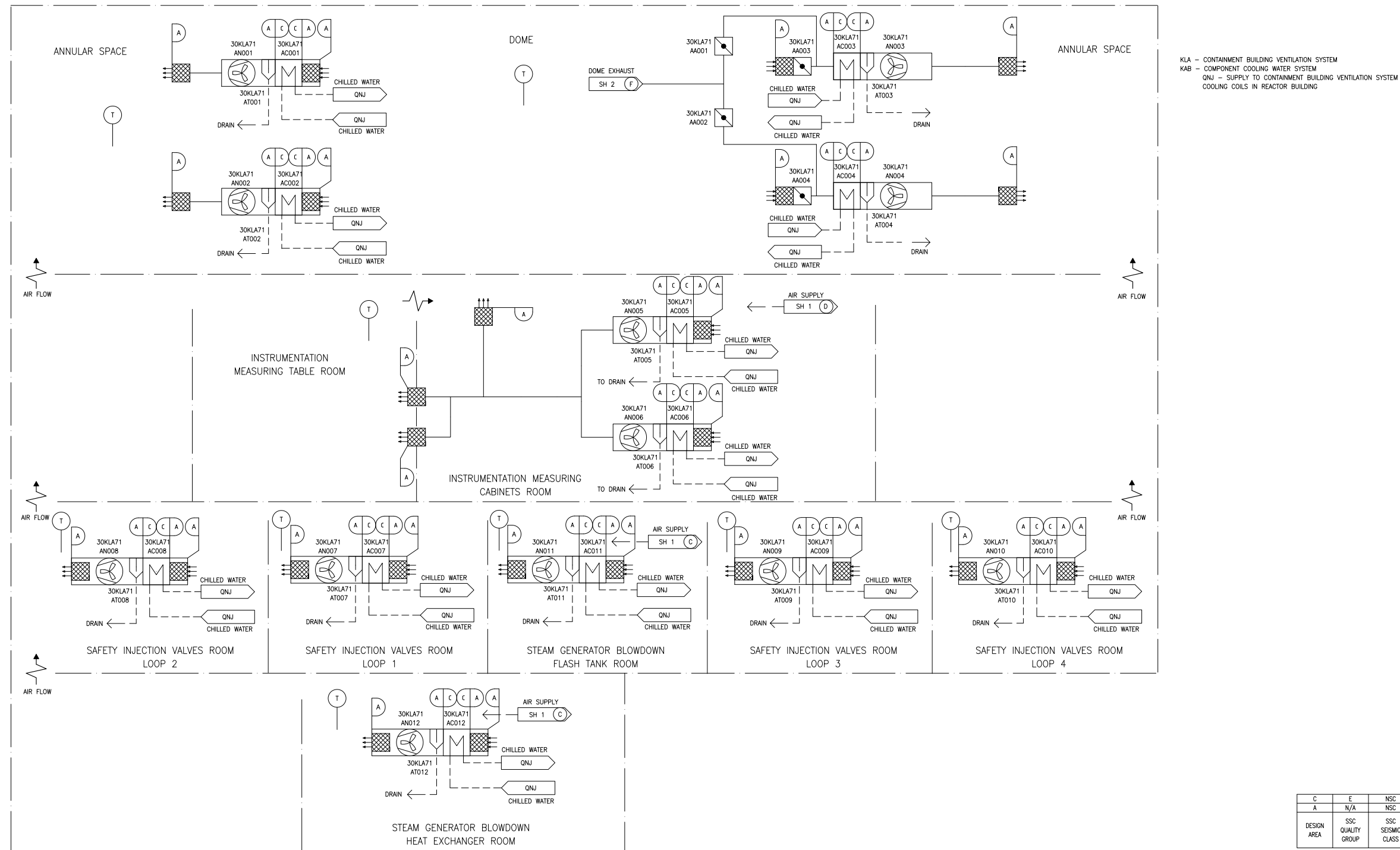

REV 005
KLA05T2