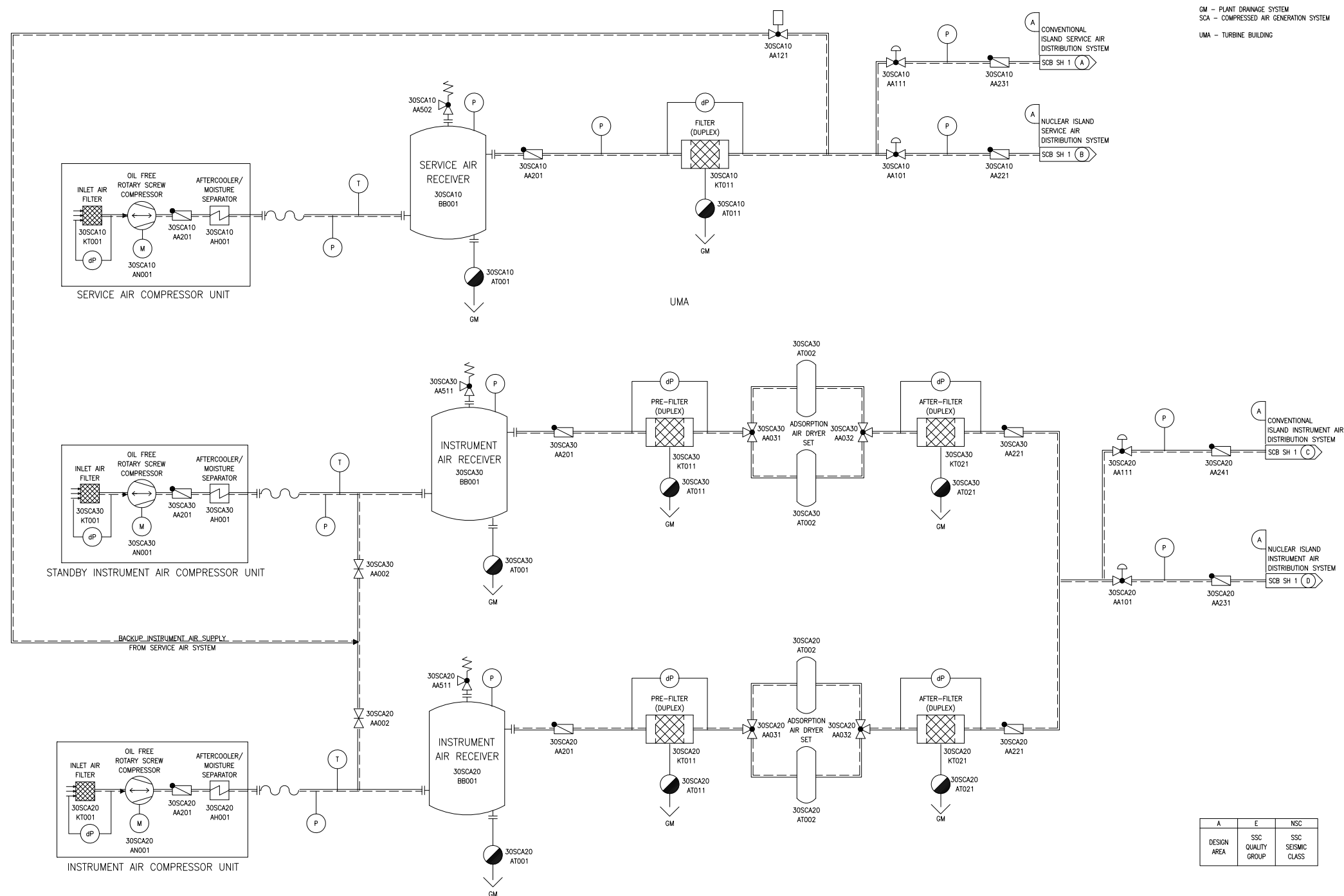

Figure 9.3.1-1—Compressed Air Generation System



GM - PLANT DRAINAGE SYSTEM
 SCA - COMPRESSED AIR GENERATION SYSTEM
 UMA - TURBINE BUILDING

A	E	NSC
DESIGN AREA	SSC QUALITY GROUP	SSC SEISMIC CLASS

REV 001
 SCA01T2

Figure 9.3.1-2—Compressed Air Distribution System

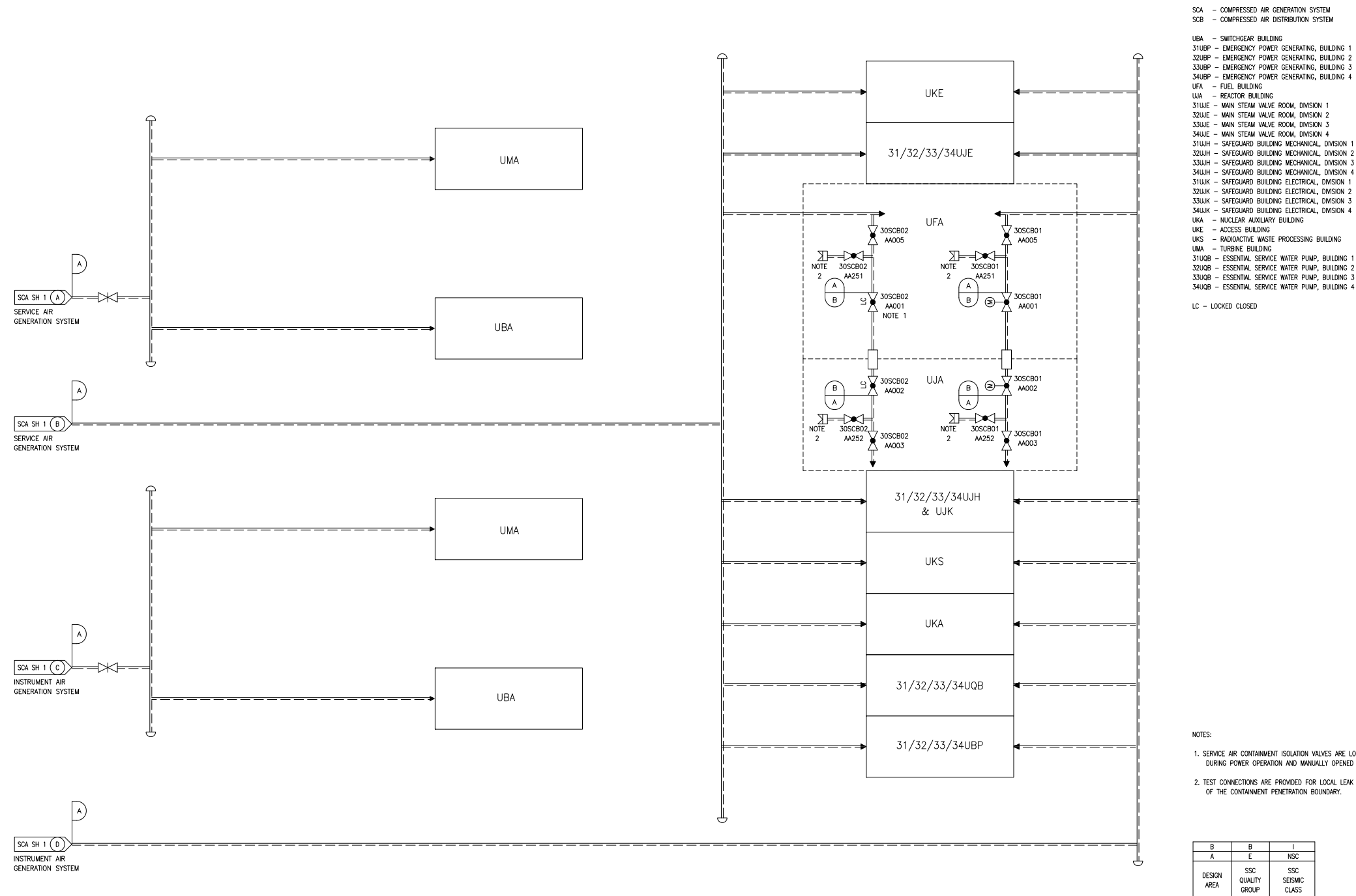

REV 001
SCB01T2