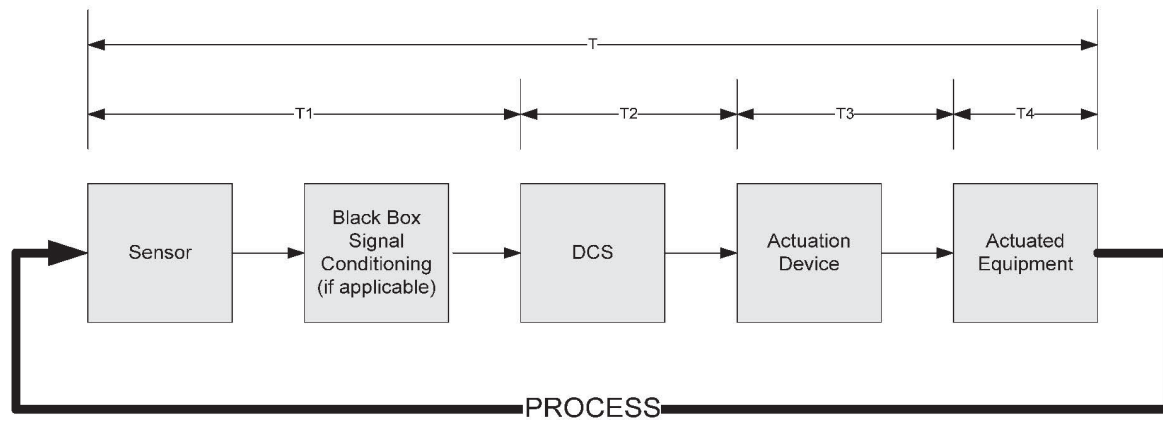
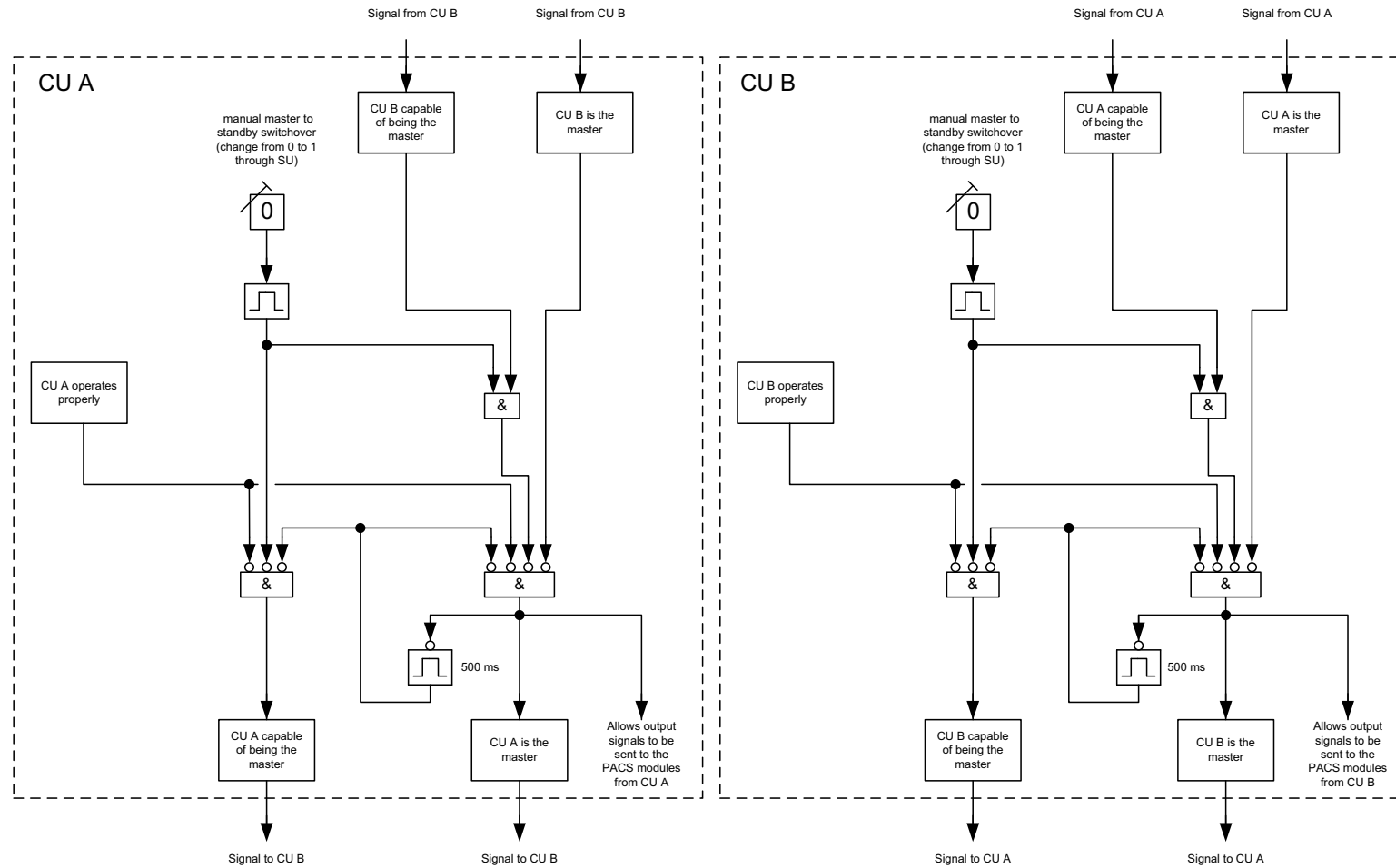

Figure 7.1-28—Definition and Allocation of Response Times



EPR3429 T2

Figure 7.1-29—SAS Switchover Configuration



NOTE: The terms CU A and CU B do not correspond to specific CUs. These terms are used to facilitate the understanding of a CU pair in the general master/standby configuration. If a CU operates properly, then the "CU operates properly" block sends out a "0" signal to denote that no errors were detected.

REV 005
EPR3096 T2

Figure 7.1-30—Operational I&C Disable Switch Configuration

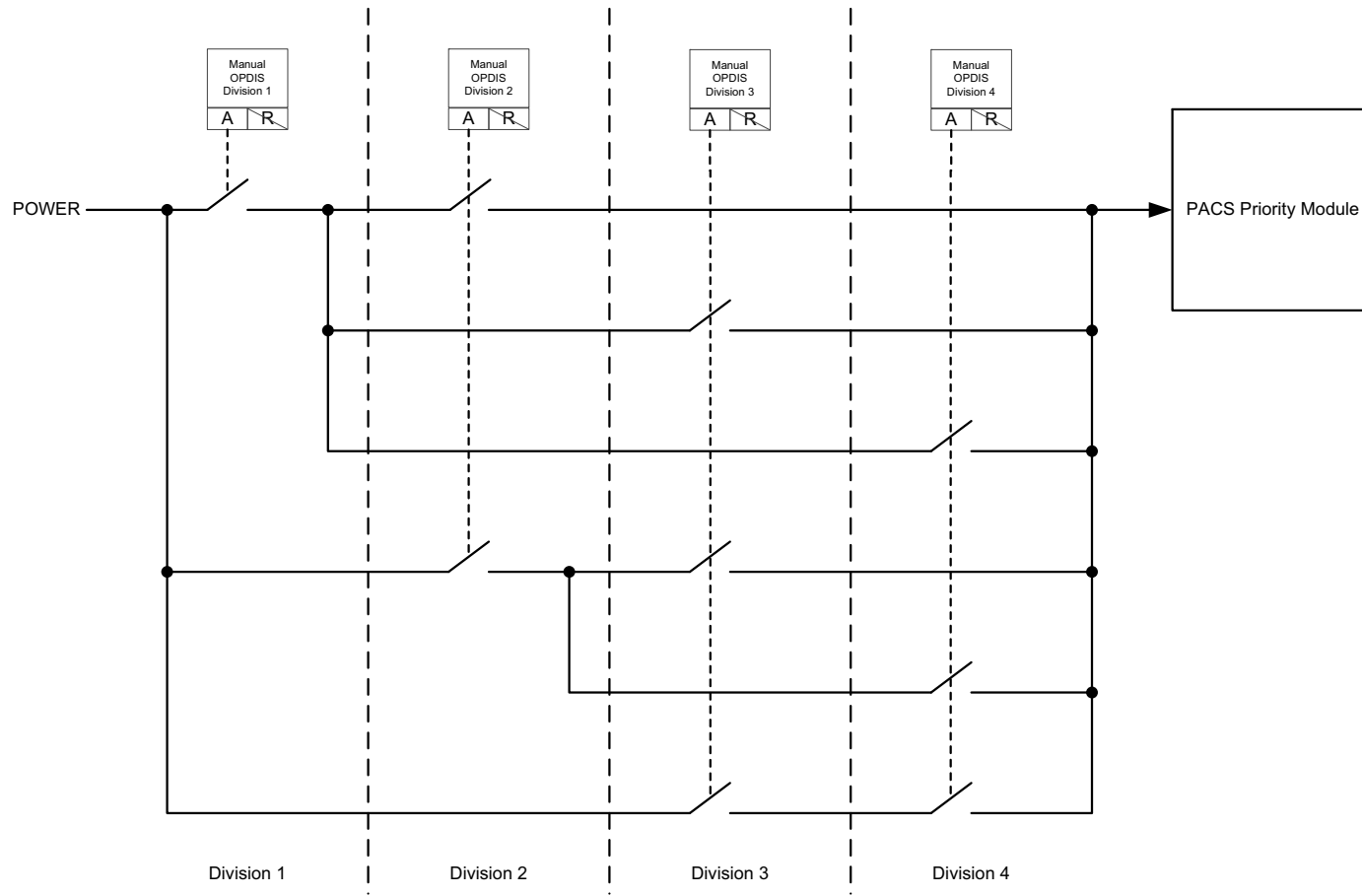

Note: The connections in this figure are “make”, not “break”

EPR3097 T2

[Next File](#)