

## 5.3 Reactor Vessel

The reactor pressure vessel (RPV) and closure head form what is the enclosure that contains the reactor core. The RPV holds the internals that support the fuel assemblies and that direct the reactor coolant flow through the reactor core. Eight nozzles provide inlet and outlet connections to the four reactor coolant system (RCS) loops. The general design of the RPV is described in Section 5.3.3.1.

### 5.3.1 Reactor Vessel Materials

The RPV is part of the reactor coolant pressure boundary (RCPB) and is designed and constructed to meet the requirements for ASME Boiler and Pressure Vessel Code Section III (ASME Section III (ASME Section III, Reference 1), Class 1 components, in accordance with 10 CIII, Reference 1), Class 1 components, in accordance with 10 CFR 50.55(a). The RPV materials are selected, designed and constructed to minimize the probability of significant degradation or rapidly propagating fractures in the RPV (GDC 1, GDC 14 and GDC 30).

As addressed in Section 5.3.3.1, the RPV provides support for internal reactor components and is designed to accommodate the effects of environmental conditions associated with normal operations, maintenance, testing, postulated accidents and anticipated operational occurrences (AOO) as defined by GDC 4. Section 3.9 identifies the design transients for which the RPV is designed.

The RPV meets the fracture toughness requirements of 10 CFR Part 50, Appendix G and those associated with ASME Section III, Class 1 components (10 CFR 50.60). The ferritic materials provide sufficient margin to account for uncertainties associated with flaws and the effects of service and operating conditions, while allowing the vessel to behave in a non-brittle manner and minimizing the probability of rapidly propagating fracture (GDC 31).

An RPV material surveillance program monitors the RPV beltline materials for changes in fracture toughness resulting from exposure to neutron irradiation and the thermal environment (GDC 32). The program complies with 10 CFR Part 50, Appendix H, as described in Section 5.3.1.6 (10 CFR 50.60).

Material cleaning control for the RPV conforms to RG 1.37 and meets the quality assurance requirements of 10 CFR Part 50, Appendix B, Criterion XIII.

#### 5.3.1.1 Material Specifications

The RPV is made of low-alloy steel due to its mechanical and physical properties, toughness, availability in the required sizes and thicknesses, satisfactory prior service in neutron fields, fabricability, and weldability. The low-alloy steel is also compatible with the stainless steel and Ni-Cr-Fe alloy cladding used for corrosion resistance. The

austenitic stainless steels and non-ferrous materials used for RPV appurtenances are used for their corrosion resistance, acceptable mechanical properties, and fabricability. The RPV surfaces normally in contact with the reactor coolant are either austenitic stainless steel or Ni-Cr-Fe alloy. A listing of material specifications for the RPV and its appurtenances is provided in Table 5.3-1—Reactor Pressure Vessel Material Specifications and Table 5.3-2—Reactor Pressure Vessel Weld Material Specifications. The RPV materials meet the requirements of the ASME Section III and comply with fracture toughness requirements of 10 CFR Part 50, Appendix G as addressed in Section 5.3.1.5.

The weld filler materials used for the reactor vessel conform to ASME Section II Part C material specifications SFA 5.4, 5.9, 5.11, 5.14, 5.22, 5.23, 5.28, 5.29, and 5.30.

The shell forgings of the RPV beltline are restricted to the maximum composition limits shown in Table 5.3-3—Maximum Limits for RPV and Appurtenances Material Composition. The phosphorous, nickel, and copper content is limited to reduce sensitivity to radiation embrittlement of the vessel. The weld filler metals used in the beltline region of the RPV are restricted to the limits shown in Table 5.3-3.

Stainless steel normally in contact with the reactor coolant has a maximum cobalt content of 0.05 wt percent. Stainless steel base and weld filler materials have a limited carbon content not exceeding 0.03 wt percent and are supplied in accordance with RG 1.44. Stainless steel base and weld filler metal in contact with the reactor coolant has a limited sulfur content, as shown in Table 5.3-3.

The Ni-Cr-Fe Alloy 600 base metal and Alloy 82/182 weld filler metal are not used in Ni-Cr-Fe applications. Alloy 690 base metal and Alloy 52/52M/152 weld filler metal are used in Ni-Cr-Fe applications. The Ni-Cr-Fe base metal in contact with the reactor coolant has a limited sulfur content not exceeding 0.02 percent.

### **5.3.1.2 Special Processes Used for Manufacturing and Fabrication**

The RPV is a vertically mounted cylindrical vessel consisting of forged shells, heads, and nozzles joined by circumferential welds. The design of the RPV is addressed in Section 5.3.3.

The RPV is fabricated in accordance with ASME Section III, NB-4000 and RPV materials comply with the requirements of ASME Section III, NB-2000.

The internal surfaces of the RPV low alloy steel that could come into contact with the reactor coolant are clad using weld metal overlay primarily with stainless steel, with the exception of the areas where Alloy 690 radial keys are to be welded, as shown on Figure 5.3-4. For these areas, Ni-Cr-Fe weld filler materials are used to clad the low alloy steel to minimize dissimilar materials in the overall RPV pressure boundary, clad,

attachment configuration. The cladding at all interfaces between the stainless steel and Ni-Cr-Fe cladding is deposited with Ni-Cr-Fe weld filler material.

As the radial keys perform a structural function in support of the reactor vessel internals, the Ni-Cr-Fe cladding directly below the radial key attachment is qualified as part of the radial key full penetration structural weld in accordance with ASME Sections III and IX. Where the radial keys are welded to the cladding without subsequent post-weld heat treatment, the cladding is qualified as weld buttering in accordance with ASME Sections III and IX. Deposited weld metal performing a cladding function, whether qualified as cladding, structural weld, or weld buttering, meets the cladding thickness specified in Table 5.3-7.

### 5.3.1.3 Special Methods for Nondestructive Examination

The non-destructive examination (NDE) of the RPV and its appurtenances is conducted in accordance with ASME Section III requirements. Full penetration weld preparations for pressure retaining materials are examined in accordance with ASME Section III, NB-5130, prior to welding.

The cladding on the sealing surfaces and load-bearing surfaces of the RPV flange and the closure head flange are ultrasonically examined for the complete volume for both bond and defects. All cladding is ultrasonically examined for bond. Surfaces to be clad are examined using magnetic particle or liquid penetrant techniques in accordance with ASME Section III NB-2545 or NB-2546, respectively, prior to cladding.

### 5.3.1.4 Special Controls for Ferritic and Austenitic Stainless Steels

Welding of ferritic and austenitic stainless steels is addressed in Section 5.2.3, which addresses conformance to the guidance of RG 1.31, RG 1.34, RG 1.37, RG 1.43, RG 1.44, RG 1.50, and RG 1.71 regarding welding, composition, heat treatments, and similar processes. In addition, RG 1.99 is addressed in Section 5.3.1.5 and RG 1.190 is addressed in Section 5.3.1.6.

### 5.3.1.5 Fracture Toughness

RCPB ferritic materials provide adequate fracture toughness in accordance with ASME Section III, NB-2300 and 10 CFR Part 50, Appendix G.

The initial Charpy V-notch minimum upper-shelf fracture energy levels for the RPV beltline materials (in the transverse direction for base materials), including welds (along the weld), is 75 ft-lbs, as required by 10 CFR Part 50, Appendix G. The maximum initial nil-ductility reference temperature,  $RT_{NDT}$ , of the RPV is  $-4^{\circ}\text{F}$ . Materials are evaluated with regard to the effects of chemistry (copper content), initial upper shelf energy, and neutron fluence to assure that 50 ft-lbs upper-shelf energy, as required by 10 CFR Part 50, Appendix G, is maintained throughout the life of the

vessel. The vessel fracture toughness data is calculated in accordance with RG 1.99, Revision 2, and is provided in Table 5.3-4—60 EFPY RPV Fluence, Upper Shelf Energy, ART, and  $RT_{NDT}$  Projections.

### 5.3.1.6 Material Surveillance

The U.S. EPR RPV material surveillance program monitors changes in the mechanical properties of the ferritic steel in the beltline region of the RPV due to the thermal and irradiation environment. The material surveillance program complies with 10 CFR Part 50, Appendix H and ASTM E185-82 (Reference 2) and is fully described, as that term is defined in SRM-SECY-04-0032 (Reference 3), in this section. A COL applicant that references the U.S. EPR design certification will identify the implementation milestones for the material surveillance program.

The RPV surveillance program uses four specimen capsules, which meets the minimum requirements of both ASTM E185-02 (Reference 4) and ASTM E185-82, containing RPV material samples, neutron dosimeters and temperature monitors. All four irradiated capsules contain the same type and number of mechanical test specimens, neutron dosimeter, and temperature monitors.

The specimen capsules are confined in rigid specimen guide baskets. The specimen guide baskets are attached with austenitic stainless steel bolts to the outside of the core barrel in the down-comer region at the mid elevation of the core, as shown in Figure 5.3-3—Major Weld Locations on the RPV. The specimen guide baskets are fabricated from ASME SA-240 Type 304 steel carbon <0.03% and are located at 7 and 187 degrees from the main axis of the vessel. Each of the two guide baskets provides two capsule irradiation positions, one on either side of the 7 and 187 degree locations, for a total of four capsule irradiation locations. A plug in the RPV upper internals provides the ability to remove the capsules when the vessel closure head is removed.

The specimen capsules are fabricated from a corrosion resistant material. The specimens are placed in the capsules with spacers to promote heat transfer to the surrounding coolant and backfilled with an inert gas to protect against specimen oxidation. The projected capsule lead factors are as follows and are the same for all irradiation locations:

- Ferritic/clad interface - 1.6.
- 1/4T RV location - 2.9.

The RPV material samples experience higher neutron fluence than the RPV because of their closer proximity to the reactor core. Thus, changes in the material properties of the samples will precede changes in the RPV material properties. Periodically, these capsules are withdrawn and the material samples are tested to measure the mechanical property changes. Data from the tested material samples are used to predict the

material property changes to the RPV. The specimen evaluations include pre-irradiation and post-irradiation testing of Charpy V-notch, tensile and 1/2t (thickness) compact tension (CT) fracture mechanics specimens.

The materials selected for the reactor vessel surveillance program are those that are adjacent to the active height of the core. Using the maximum initial nil-ductility reference temperature ( $RT_{NDT}$ ) values, maximum nickel and copper contents allowed in the RPV and a 60 effective full power year (EFPY) fluence, the limiting RPV beltline material for the U.S. EPR is predicted to be Weld #2, as shown in Figure 5.3-3. This prediction was made in accordance with 10 CFR 50.61. Based on the predictions of the most susceptible materials and on the requirements of ASTM E-185-82 and ASTM E185-02, these materials are included in the reactor vessel surveillance program:

- Weld #2 (RPV specimen welds are made of the same weld wire heat, flux, and procedure as the respective RPV weld).
- Weld #3.
- Upper core shell forging.
- Lower core shell forging.
- Heat affected zone (HAZ) from a core shell forging and RPV Weld #2.

For each of the beltline materials selected, Charpy V-notch, tension and compact fracture (CT) specimens are included, except for the HAZ for which only Charpy V-notch specimens are required. The Charpy V-notch specimens are the standard full size Type A as described in ASTM A370 (Reference 5) and ASTM E23 (Reference 6). The tension specimens have a 1.0 inch gage length and 0.25 inch diameter and meet ASTM A370 and ASTM E08 (Reference 7) requirements. The compact fracture specimens are the standard 1/2T CT type per ASTM E1921 (Reference 8). The specimen inventory is provided in Table 5.3-5—Surveillance Specimen Inventory Per Capsule.

In addition to the four capsules that are assembled for irradiation, surplus material sufficient to fabricate four additional capsules is archived. The total material quantity complies with the minimum requirements of both ASTM E185-82 (Reference 2) and ASTM E185-02 (Reference 4).

The base metal specimens are taken from prolongations of the forgings used in the associated RPV core shells. This material receives the same heat treatment as the RPV. The base metal and HAZ specimens are located at either the 1/4T or 3/4T locations. The CT specimens and Charpy V-notch specimens from the base metal forgings are oriented so that the major axis of the specimen (axis normal to the crack plane for CT specimens) is parallel to the RV inside surface and normal to the major working

direction. The tension specimens are oriented the same as the Charpy V-notch specimens; i.e. major axis of the specimen is parallel to the surface and normal to the major working direction (the transverse direction). The CT specimens and Charpy V-notch specimens from the weld metal are oriented so that the major axis of the specimen (axis normal to the crack plane for CT specimens) is parallel to the RV inside surface and normal to the weld bead direction. Weld metal tension specimens are oriented in the same direction as the Charpy V-notch specimens with the gage length consisting entirely of weld metal (the transverse direction). The Charpy V-notch specimens from the HAZ are oriented so that the major axis of the specimen is parallel to the RPV inside surface and normal to the weld bead direction. The Charpy V-notch root is in the HAZ about 1/32 inch from the fusion line.

#### **5.3.1.6.1 Fluence Monitoring**

The neutron fluence on the vessel material test specimens and the vessel itself is determined based on core-follow calculations of the cycle-by-cycle operation. The fluence and uncertainty methodologies, described in BAW-2241P-A, “Fluence and Uncertainty Methodologies” (Reference 9), explain how the calculations are performed. The calculations conform to RG 1.190 and thus meet the requirements of 10 CFR Part 50, Appendix H.

As noted in RG 1.190, the bases for the bias and random uncertainties in the calculations are:

- Database of dosimetry measurements.
- Benchmark database comparing calculations to measurements.
- Sensitivity evaluation with fabrication and operational tolerances.

#### **5.3.1.6.2 Plant Specific Monitoring**

The uncertainty evaluations noted in BAW-2241P-A provide calculations, with well-defined uncertainties, for RPV fluence in operating light water reactors. While it is expected that the calculations for the U.S. EPR will have similar accuracy and random uncertainties, measured data from the material surveillance program will supplement the calculated predictions. A COL applicant that references the U.S. EPR design certification will provide plant-specific surveillance capsule data to benchmark BAW-2241P-A and demonstrate applicability to the specific plant. The capsule withdrawal and reporting requirements will follow 10 CFR Part 50, Appendix H. The recommended withdrawal schedule is outlined in Table 5.3-6—Surveillance Specimen Withdrawal Schedule Per ASTM E185-82.

Calculations are used to estimate the initial fluence to the vessel materials. Once operation has commenced, plant specific dosimetry measurements are evaluated to

demonstrate that fluence uncertainties are consistent with historical data. Showing consistency with historical data confirms that the initial plant-specific calculations of fluence are valid.

### 5.3.1.7 Reactor Vessel Fasteners

The RPV studs are manufactured of high-strength bolting steel. The closure studs are the necked-down type and are screwed into tapped blind holes in the RPV flange.

Refueling procedures require that studs, nuts, and washers be removed from the RPV with a stud tensioning device. The reactor closure studs are never exposed to the borated refueling water. The stud holes in the reactor flange are sealed using special plugs before removing the reactor closure head to prevent leakage of borated refueling water into their cavities. In addition, closure studs are lubricated in accordance with the guidance provided in NUREG-1339 (Reference 10).

The RPV studs, nuts and washers are manufactured using ASME SA-540 grade B24V (4340V Mod), Class 3 steel as shown in Table 5.3-1. The RPV studs, nuts and washers are constructed in accordance with ASME Section III requirements and are tested in accordance with ASME Section III, NB-2580, including additional recommendations identified in RG 1.65. The closure stud material meets the fracture toughness requirements of the ASME Section III and 10 CFR Part 50, Appendix G and shall have an ultimate tensile strength less than or equal to 170 ksi. Conformance with RG 1.65 guidance is addressed in Section 3.13.

### 5.3.2 Pressure-Temperature Limits, Pressurized Thermal Shock, and Charpy Upper-Shelf Energy Data and Analyses

Section 5.3.1 identifies the regulations with which the RPV design complies, including GDC 1, GDC 14, GDC 31, GDC 32, 10 CFR 50.55a, 10 CFR 50.60, and 10 CFR Part 50, Appendix G. The RPV is designed and fabricated to meet these requirements and the fracture toughness requirements of 10 CFR 50.61 for protection against pressurized thermal shock events.

#### 5.3.2.1 Pressure-Temperature Limit Curves

Radiation embrittlement causes a reduction in the ductility of the RPV beltline materials. This reduction is measured in terms of the adjusted reference nil ductility temperature  $RT_{NDT}$ . The presence of elements such as copper, nickel and phosphorus is controlled to limit reductions in ductility and fracture toughness in the steel that forms the RPV, in accordance with Section 5.3.1.1. Pressure-temperature (P-T) limits, derived using linear-elastic fracture mechanics principles, provide margins of safety to prevent nonductile fracture during normal operation, heat-up, cooldown, AOOs, system hydrostatic, preservice and inservice leakage tests. The analysis of RPV beltline material properties satisfies the requirements of GDC 31 and complies with

the requirements of 10 CFR Part 50, Appendix G. The analysis follows the guidance provided in RG 1.99 and the methodology of ASME Section XI (Reference 11), Appendix G. From the analyses, curves are developed that specify pressure-temperature limits to envelop plant operation for 60 years (conservatively considering 60 EFPY).

ANP-10283P, Revision 2, “US EPR Pressure-Temperature Limits Methodology for RCS Heat-Up and Cool-Down” (Reference 12), contains the detailed methodology for developing the P-T limit curves. The P-T limits are revised as necessary, for various reasons including refined end of life (EOL) fluence estimations obtained from the material surveillance program, in accordance with the recommendations of RG 1.190. Testing of each surveillance capsule will be performed in accordance with 10 CFR 50, Appendix H. The material data will be evaluated using the guidance of RG 1.99. The P/T limits will be recalculated or the applicable EFPY will be adjusted, as necessary, to confirm that the 1/4T and 3/4T adjusted  $RT_{NDT}$  of the RPV based P/T limits is not exceeded. The initial  $RT_{NDT}$ , final predicted  $RT_{NDT}$  or adjusted reference temperature (ART), and the copper and nickel contents for materials in the RPV beltline are provided in Table 5.3-3 and Table 5.3-4. The fluence attenuation to the 1/4T and 3/4T locations and the ART values are calculated per RG 1.99, Revision 2.

Generic heatup and cooldown curves for the U.S. EPR RPV design are provided in Figure 5.3-1—Reactor Coolant System Heatup Pressure-Temperature Curve and Figure 5.3-2—Reactor Coolant System Cooldown Pressure-Temperature Curve, and are based on limiting vessel material properties. A COL applicant that references the U.S. EPR design certification will provide a plant-specific pressure and temperature limits report (PTLR), consistent with an approved methodology.

### 5.3.2.2 Operating Procedures

Plant operating procedures provide reasonable assurance that the P-T limits identified in Section 5.3.2.1 will not be exceeded during conditions of normal operation, AOOs and system hydrostatic tests. The transient conditions considered in the design of the RPV, as presented in Section 3.9.1.1, are representative of the operating conditions considered to occur during plant operation. The selected transients form a conservative basis for evaluation of the RCS and do not result in pressure-temperature changes that exceed the heatup and cooldown rate limits used in the development of the Pressure-Temperature Limit curves of Section 5.3.2.1.

### 5.3.2.3 Pressurized Thermal Shock

The RPV design provides protection against unstable crack growth under faulted conditions. A safety injection actuation following an emergency or faulted event produces relatively high thermal stresses in regions of the RPV contacting the cooler water from the safety injection system. Consideration is given to these areas,



including the beltline region and the RPV nozzles, which provide reasonable assurance of RPV integrity under these postulated transients.

An analysis was performed to determine the RPV pressurized thermal shock reference temperatures ( $RT_{PTS}$ ) applicable to 60 EFPY. The  $RT_{PTS}$  values were conservatively calculated for various RPV materials over 60 EFPY with the most limiting core design. These values, calculated in accordance with 10 CFR 50.61 and presented in Table 5.3-4, do not exceed the screening criteria. A COL applicant that references the U.S. EPR design certification will provide plant-specific  $RT_{PTS}$  values in accordance with 10 CFR 50.61 for vessel beltline materials.

#### **5.3.2.4 Upper-Shelf Energy**

The minimum Charpy upper-shelf energy values for RPV beltline materials, which meet the requirement of paragraph IV.A.1.a of Appendix G, are specified in Section 5.3.1.5.

### **5.3.3 Reactor Vessel Integrity**

#### **5.3.3.1 Design**

The RPV and closure head form the enclosure which contains the reactor core. The vessel holds the internals that support the fuel assemblies and that direct the reactor coolant flow through the reactor core. Eight nozzles provide inlet and outlet connections to the four reactor coolant system (RCS) loops. The RPV design data is given in Table 5.3-7—Reactor Pressure Vessel Design Data.

The closure head is attached to the RPV with a stud-nut-washer set. The joint between the RPV and the closure head is sealed by two seals located in concentric, circular recesses on the head flange. The closure head can be removed for refueling and vessel maintenance.

The control rod drive mechanisms (CRDM) are installed on top of the closure head. They are affixed to adaptors welded to the RPV head. Instrumentation adaptors are mounted to the vessel head via welded adapter penetrations to monitor the core temperature and neutron flux.

Section 5.3.1 identifies the regulations with which the RPV design complies, including GDC 1, GDC 14, GDC 30, GDC 31, GDC 32, 10 CFR 50.55a, 10 CFR 50.60 and 10 CFR Part 50, Appendix G. Component classifications are identified in Section 3.2.

The RPV consists of the following forged components, as shown in Figure 5.3-4—Reactor Pressure Vessel:

- Closure Head Assembly:

- One Upper Head Dome.
- One Closure Head Flange.
- Upper Assembly:
  - One Nozzle/Flange Integrated Shell.
  - Eight Inlet/Outlet Nozzles.
- Lower Assembly:
  - One Upper Core Shell.
  - One Lower Core Shell.
  - One Transition Ring.
  - One Lower Head.

Details regarding the manufacturing and fabrication of these components are addressed in Section 5.3.3.1.1 through Section 5.3.3.1.4.

#### **5.3.3.1.1 Closure Head Assembly**

The RPV closure head assembly consists of a forged upper head and flange welded together by a circumferential weld.

The semi-hemispherical upper head contains penetrations to accommodate the adapters for the CRDMs, in-core instrumentation, thermocouple tube and vent piping. The adapters are welded to the inside surface of the upper head using partial penetration welds.

The closure head flange contains holes to accommodate the closure studs. The lower face of the closure head flange contains two grooves that accommodate metallic spring energized seals.

#### **5.3.3.1.2 Upper Assembly**

The RPV upper assembly consists of a forged nozzle/flange integrated shell and eight nozzles used for inlet and outlet RCS flow. The nozzles are welded to the vessel by circumferential welds.

The inside top surface of the integrated shell flange contains a core support ledge from which the core barrel and reactor core are supported. The top surface of the integrated shell flange also contains threaded holes to accommodate the closure studs and a machined sealing surface for the metallic spring energized seals. A seal leak-off line drains from the space between the two head flange seals.

The eight inlet and outlet nozzles are welded to the integrated shell symmetrically about the RPV axis. This facilitates the welding and the nondestructive examination of nozzle welds. The inlet and outlet nozzles contain support pads located on the bottom of the nozzles. The support pads are an integral part of the nozzle forgings. These pads rest on the support ring which is part of the RPV support structure.

#### **5.3.3.1.3 Lower Assembly**

The RPV lower assembly consists of two core shells, one transition ring, and one lower head which are all forged. These forgings are welded to each other by circumferential welds. The radial keys are used to center the lower internals and provide a secondary core support function. Section 3.9.5 provides a description of the RPV internals.

The semi-hemispherical lower head does not contain any penetrations. The required penetrations for the RPV are contained in the upper head.

#### **5.3.3.1.4 Reactor Vessel Supports**

The RPV is positioned and supported in the containment by a steel structure ring embedded in the concrete of the reactor pit. The RPV inlet and outlet nozzles lie in specifically designed gaps of the ring. Each nozzle has its own support pad constructed from machined forgings.

#### **5.3.3.2 Materials of Construction**

The materials used in the fabrication of the RPV, including weld materials, are addressed in Section 5.2.3 and Section 5.3.1.

#### **5.3.3.3 Fabrication Methods**

The fabrication methods used in the construction of the RPV, including the processes of forming, welding, cladding, and machining, are addressed in Section 5.3.1.

#### **5.3.3.4 Inspection Requirements**

The non-destructive examination methods performed on the RPV are described in Section 5.3.1.

#### **5.3.3.5 Shipment and Installation**

Protective measures taken during shipment of the reactor vessel and its installation at the site verify that the as-built characteristics of the reactor vessel are not degraded by improper handling. Vessel openings are sealed to prevent the entrance of moisture and debris. External surfaces are painted with a strippable coating before shipment. Coatings are removed during installation of the components.

The closure head is coated and covered for shipment like the RPV.

### 5.3.3.6 Operating Conditions

Section 5.3.2 addresses pressure-temperature limits for the RPV, as well as pressurized thermal shock events. RCS design transients are addressed in Section 3.9.

### 5.3.3.7 Inservice Surveillance

The internal and external surfaces of the RPV are accessible for periodic inspection using visual and NDE techniques. During refueling, the vessel cladding can be inspected in certain areas between the closure flange and the primary coolant inlet nozzles. If required, the core barrel can be removed to examine the entire inside vessel surface.

The closure head is examined visually during each refueling as described in Section 5.2.4. Optical devices permit a selective inspection of the cladding, CRDM nozzles and the gasket seating surface. The knuckle transition piece, which is the area of highest stress on the closure head, is accessible on the outer surface for visual surface and volumetric examination. The closure studs and nuts can be inspected periodically using visual, surface and volumetric examination techniques in accordance with RG 1.65.

The closure studs, nuts, washers, and the vessel flange seal surface, as well as the full penetration welds in the following areas of the installed RPV are available for non-destructive examination:

- Vessel shell from the inside and outside surfaces.
- Primary coolant nozzles from the inside and outside surfaces.
- Closure head from the inside and outside surfaces.
- Bottom head from the inside and outside surfaces.
- RPV nozzle to nozzle safe end welds from the inside and outside surfaces.

The design considerations which have been incorporated into the component design to permit these inspections are:

- Reactor internals are completely removable. The tools and storage space required to permit these inspections are provided.
- The closure head is stored dry on the reactor operating deck during refueling to facilitate direct visual inspection.
- RPV studs, nuts, and washers can be removed to dry storage during refueling.
- Access is provided to the RPV nozzle safe ends. The insulation covering the nozzle-to-pipe welds can be removed.

- Reactor cavity and thermal insulation allows access to the outside surface of the vessel. Tracks are installed to allow the use of mechanical equipment for vessel surface inspection.

The RPV presents access problems because of the radiation levels and remote underwater accessibility to this component. Because of the limited access to the RPV, steps have been incorporated into the design and manufacturing procedures in preparation for the ASME Code required inservice inspection. These steps include the following:

- Shop ultrasonic examinations are performed on internally clad surfaces to an acceptance and repair standard to confirm an adequate cladding bond to allow later volumetric testing of the base metal from the inside surface.
- The RPV shell is designed as an uncluttered cylindrical surface to permit future positioning of the test equipment without obstruction.
- The weld deposited clad surface on both sides of the welds to be inspected is specifically prepared for volumetric examinations.

The material surveillance program supports the requirements of 10 CFR Part 50, Appendix H as described in Section 5.3.1.6. The vessel design and construction enables inspection in accordance with ASME Section XI. The ASME Class I inservice inspection program is described in Section 5.2.4.

Fracture toughness evaluations performed to date for thermal and radiation aging indicate that a thermal annealing of the vessel will not be necessary to maintain the required material properties over the life of the plant or even into a license extension. Any instance arising during plant operation that would necessitate this action will be addressed by the licensee in accordance with 10 CFR 50.66.

#### **5.3.3.8 Threaded Fasteners**

The program provided for ensuring the integrity of bolting and threaded fasteners is described in Section 3.13.

#### **5.3.4 References**

1. ASME Boiler and Pressure Vessel Code, Section III, "Rules for Construction of Nuclear Facility Components," The American Society of Mechanical Engineers, 2004.
2. ASTM E-185-82, "Standard Practice for Conducting Surveillance Tests for Light-Water Cooled Nuclear Power Reactor Vessels," American Society for Testing and Materials, 1982.

3. SRM-SECY-04-0032, "Programmatic Information Needed For Approval of Combined License Without Inspections, Test, Analyses and Acceptance Criteria," Secretary of the Commission, U.S. Nuclear Regulatory Commission, 2004.
4. ASTM E185-02, "Standard Practice for Design of Surveillance Programs for Light-Water Moderated Nuclear Power Reactor Vessels," American Society for Testing and Materials, 2002.
5. ASTM A370-07a, "Standard Test Methods and Definitions for Mechanical Testing of Steel Products," American Society for Testing and Materials, June 2007.
6. ASTM E23-07ae1, "Standard Test Methods for Notched Bar Impact Testing of Metallic Materials," American Society for Testing and Materials, 2007.
7. ASTM E08-04, "Standard Test Methods for Tension Testing of Metallic Materials," American Society for Testing and Materials.
8. ASTM E1921-05, "Standard Test Method for Determination of Reference Temperature, To', for Ferritic Steels in the Transition Range," American Society for Testing and Materials, 2005.
9. BAW-2241P-A-002, "Fluence and Uncertainty Methodologies," AREVA NP Inc., April 2006.
10. NUREG-1339, "Resolution of Generic Safety Issue 29: Bolting Degradation of Failure in Nuclear Power Plants," U.S. Nuclear Regulatory Commission, June 1990.
11. ASME Boiler and Pressure Vessel Code, Section XI, "Rules for Inservice Inspection of Nuclear Power Plant Components," The American Society of Mechanical Engineers, 2004.
12. ANP-10283P, Revision 2, "U.S. EPR Pressure-Temperature Limits Methodology for RCS Heat-Up and Cool-Down," AREVA NP Inc., April 2012.

**Table 5.3-1—Reactor Pressure Vessel Material Specifications**

<b>Component</b>	<b>Material Specification</b>
Lower head	ASME SA-508 Grade 3 Class 1
Transition ring	ASME SA-508 Grade 3 Class 1
Upper/lower core shells	ASME SA-508 Grade 3 Class 1
Nozzle/Flange integrated shell	ASME SA-508 Grade 3 Class 1
Radial Keys	ASME SB-564 Alloy 690 (UNS N06690)
Safe ends for inlet and outlet nozzles	ASME SA-182 Grade F316 (See Notes 1 & 2) or ASME SA-336 Grade F316 (See Notes 1 & 2)
Upper head	ASME SA-508 Grade 3 Class 1
Closure head flange	ASME SA-508 Grade 3 Class 1
Head studs/nuts/washers	ASME SA-540 Grade B24V (4340V Mod) Class 3
CRDM adaptor tubes	ASME SB-167 Alloy 690 (UNS N06690)
CRDM adaptor flanges	ASME SA-182 Grade F304 (See Notes 1 & 2) or ASME SA-336 Grade F304 (See Notes 1 & 2)
Instrument adapter tubes	ASME SB-167 Alloy 690 (UNS N06690)
Instrument adapter flanges	ASME SA-182 Grade F304 (See Notes 1 & 2) or ASME SA-336 Grade F304 (See Notes 1 & 2)

Notes:

1. Solution annealed and rapidly cooled.
2. Carbon content not exceeding 0.03 wt%.

**Table 5.3-2—Reactor Pressure Vessel Weld Material Specifications**

<b>Material A</b>	<b>Material B</b>	<b>Filler Material</b>
Type 304 or Type 316/316L stainless steel	Type 304 or Type 316/316L stainless steel	Type 308L/309L/316L austenitic stainless steel
ASME SA-508 or ASME SA-533	Type 304 or Type 316/316L stainless steel	Alloy 52/52M/152
ASME SA-508 or ASME SA-533	ASME SA-508 or ASME SA-533	Alloy steel
ASME SA-508 or ASME SA-533	Carbon steel	Alloy steel
Alloy 690	ASME SA-508	Alloy 52/52M/152
Primary surface cladding alloy or carbon steel in contact with primary coolant	N/A	Type 308L/309L austenitic stainless steel, or Alloy 52/52M/152



**Table 5.3-3—Maximum Limits for RPV and Appurtenances Material Composition**

Element	RPV Forgings	Weld Filler Metal
Low Alloy Steel Adjacent to the Core		
Copper	0.06%	0.06%
Nickel	0.80%	1.20%
Phosphorus	0.008%	0.012%
Sulfur	0.005%	0.015%
Cobalt	0.03%	0.03%
Carbon	0.20%	0.1%
Chromium	---	0.3%
Stainless Steel		
Carbon	0.03%	0.03%
Cobalt <sup>1</sup>	0.05%	0.05%
Sulfur <sup>1</sup>	0.02%	---
Ni-Cr-Fe Alloys		
Cobalt <sup>1</sup>	0.05%	0.05%
Sulfur <sup>1</sup>	0.02%	---

**Notes:**

1. For materials in contact with reactor coolant.

Table 5.3-4—60 EFPY RPV Fluence, Upper Shelf Energy, ART, and RT<sub>NDT</sub> Projections

Material	Inner Wetted Surface Fluence (n/cm <sup>2</sup> ) E>1MeV	1/4T Fluence (n/cm <sup>2</sup> ) E>1MeV	3/4T Fluence (n/cm <sup>2</sup> ) E>1MeV	Initial CV USE (ft-lbs)	Predicted EOL CV USE <sup>1</sup> (ft-lbs)	Initial RT <sub>NDT</sub> (°F)	1/4T Adjusted RT <sub>NDT</sub> <sup>1</sup> (°F)	3/4T Adjusted RT <sub>NDT</sub> <sup>1</sup> (°F)	RT <sub>PTS</sub> <sup>1</sup> (°F)	Screening Criteria (°F)
Nozzle shell	2.1E+17	1.1E+17	3.4E+16	75	66	-4	8.0	1.2	14.0	270
Upper core shell	1.4E+19	7.3E+18	2.2E+18	75	64	-4	63.4	40.2	70.3	270
Lower core shell	1.4E+19	7.3E+18	2.2E+18	75	64	-4	63.4	40.2	70.3	270
Transition ring	4.4E+18	2.3E+18	7.1E+17	75	66	-4	57.8	32.0	69.4	270
Weld #1	2.1E+17	1.1E+17	3.4E+16	75	66	-4	15.4	4.2	24.8	300
Weld #2	1.4E+19	7.2E+18	2.2E+18	75	61	-4	126.5	93.4	141.1	300
Weld #3	4.4E+18	2.3E+18	7.1E+17	75	64	-4	95.4	53.8	115.3	300

**Notes:**

1. These values are conservatively estimated at 60 EFPY.

**Table 5.3-5—Surveillance Specimen Inventory Per Capsule**

<b>Specimens</b>	<b>Limiting Core Shell</b>	<b>Next Limiting Core Shell</b>	<b>Weld #2</b>	<b>Next Limiting Material</b>	<b>HAZ</b>	<b>Total</b>
Charpy	18	24	18	18	18	96
Tension	3	3	3	3	-	12
1/2T CT	10	-	10	10	-	30

**Table 5.3-6—Surveillance Specimen Withdrawal Schedule Per ASTM E185-82**

<b>Capsule</b>	<b>EFPY</b>	<b>Target Capsule Fluence (n/cm<sup>2</sup>)</b>	<b>ASTM E185-82 Requirement</b>
1	6	$2.1 \times 10^{18}$	6 EFPY or $5 \times 10^{18}$ n/cm <sup>2</sup> , whichever is first
2	15	$5.2 \times 10^{18}$	15 EFPY or EOL inside surface fluence, whichever is first
-	20	$7.3 \times 10^{18}$	Not required
-	40	$1.3 \times 10^{19}$	Not required
3	60	$2.1 \times 10^{19}$	EOL, but between 1 and 2 times EOL inside surface fluence
4	Supplemental	To be determined	Not required

**Table 5.3-7—Reactor Pressure Vessel Design Data**

<b>Parameter</b>	<b>Value</b>
Design Pressure	2535 psig
Design Temperature	664°F
Vessel Overall Height (in)	500.69
Vessel Inside Diameter (in)	192.32
Vessel Shell Thickness (in)	9.84
Cladding Thickness Nominal (in)	0.295

Figure 5.3-1—Reactor Coolant System Heatup Pressure-Temperature Curve

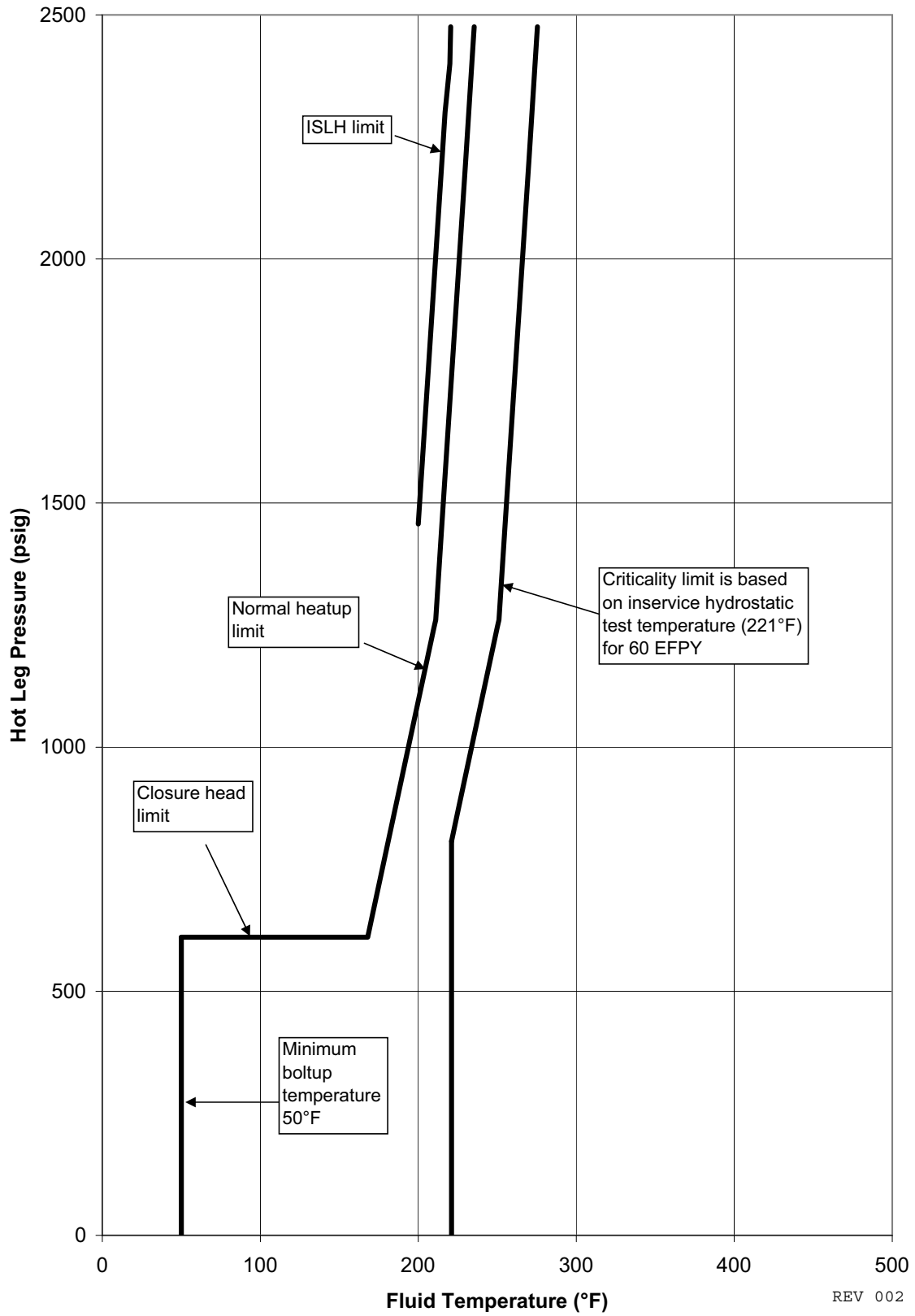

Figure 5.3-2—Reactor Coolant System Cooldown Pressure-Temperature Curve

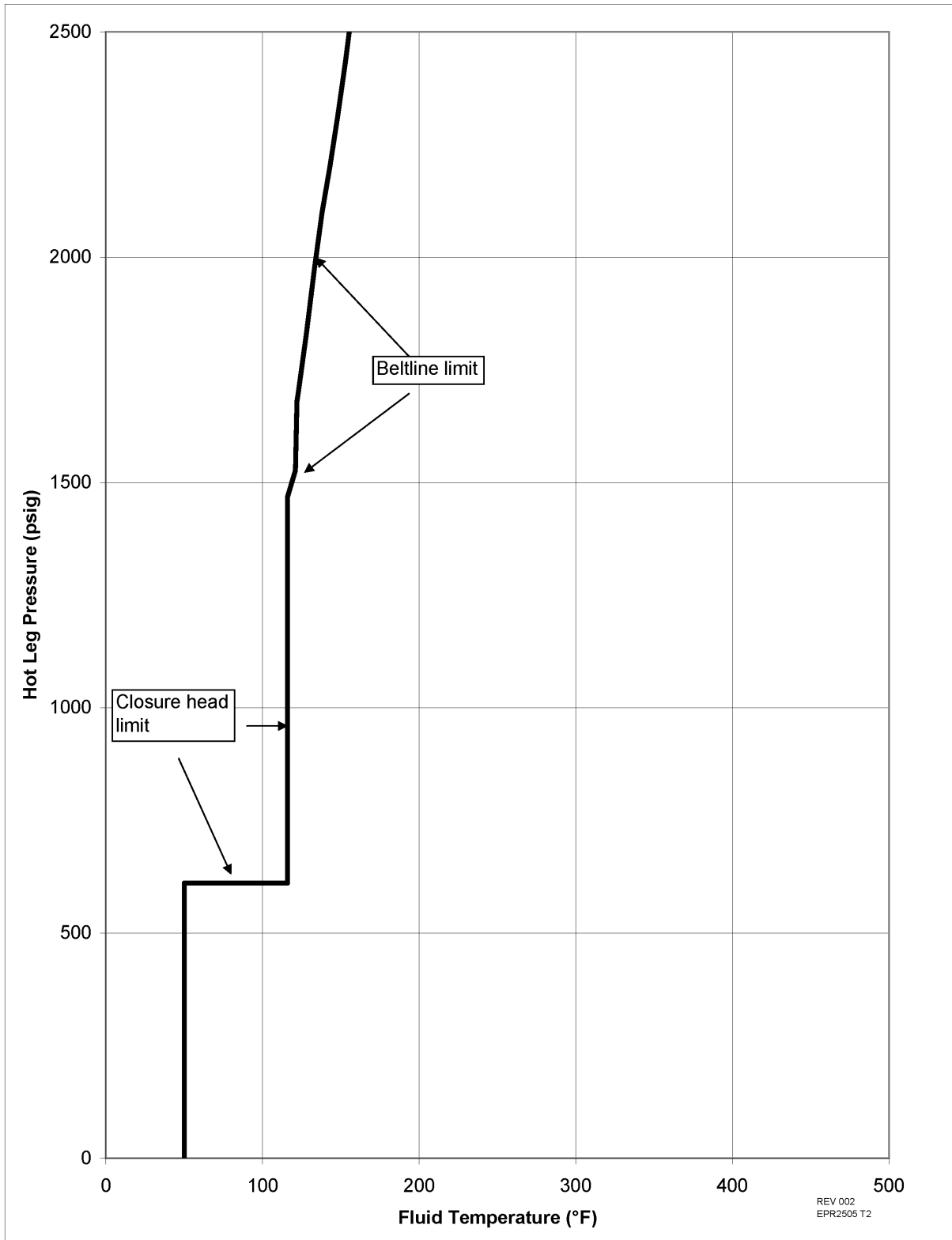
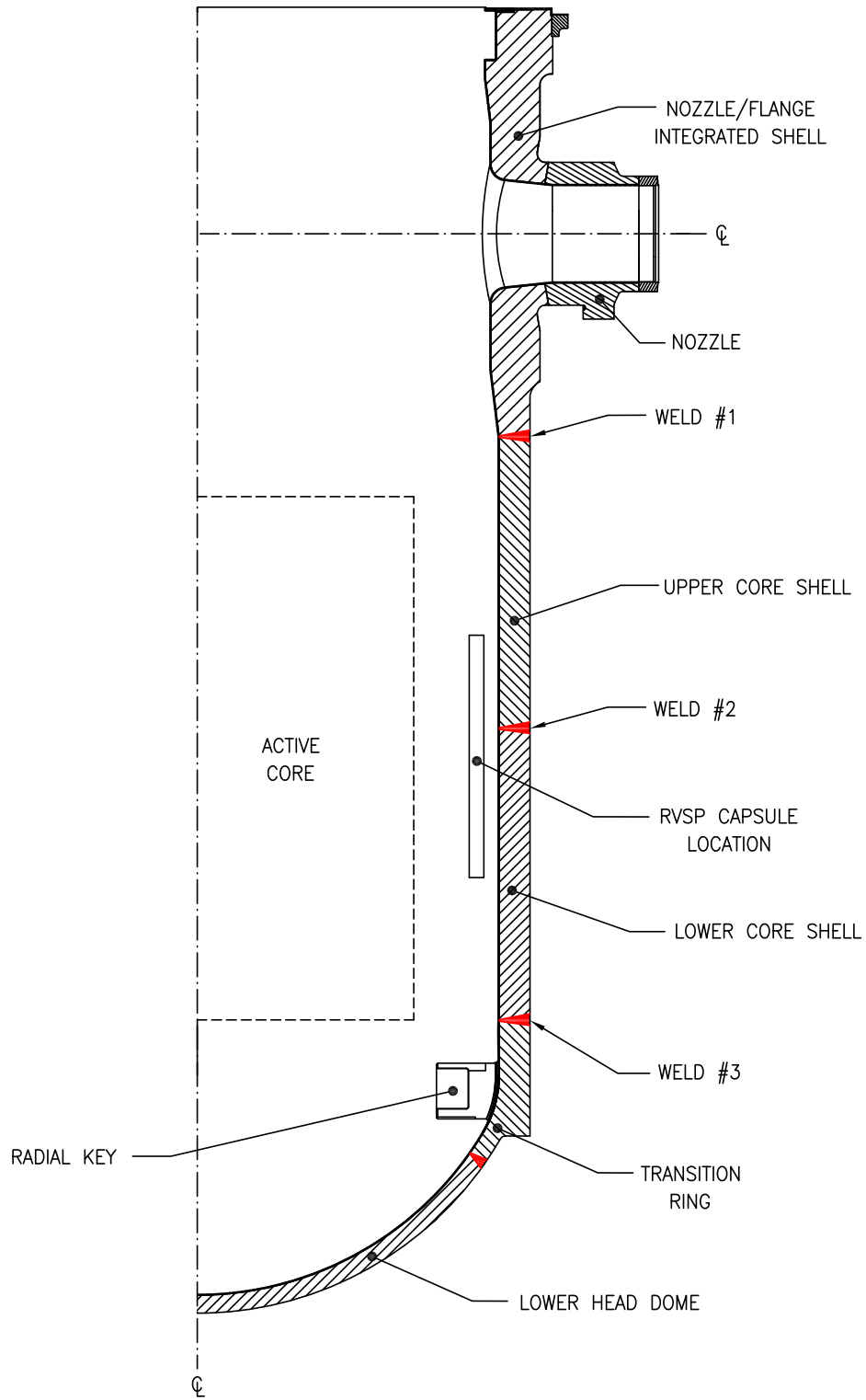

Figure 5.3-3—Major Weld Locations on the RPV



REV 001  
JAA03 T2



Figure 5.3-4—Reactor Pressure Vessel

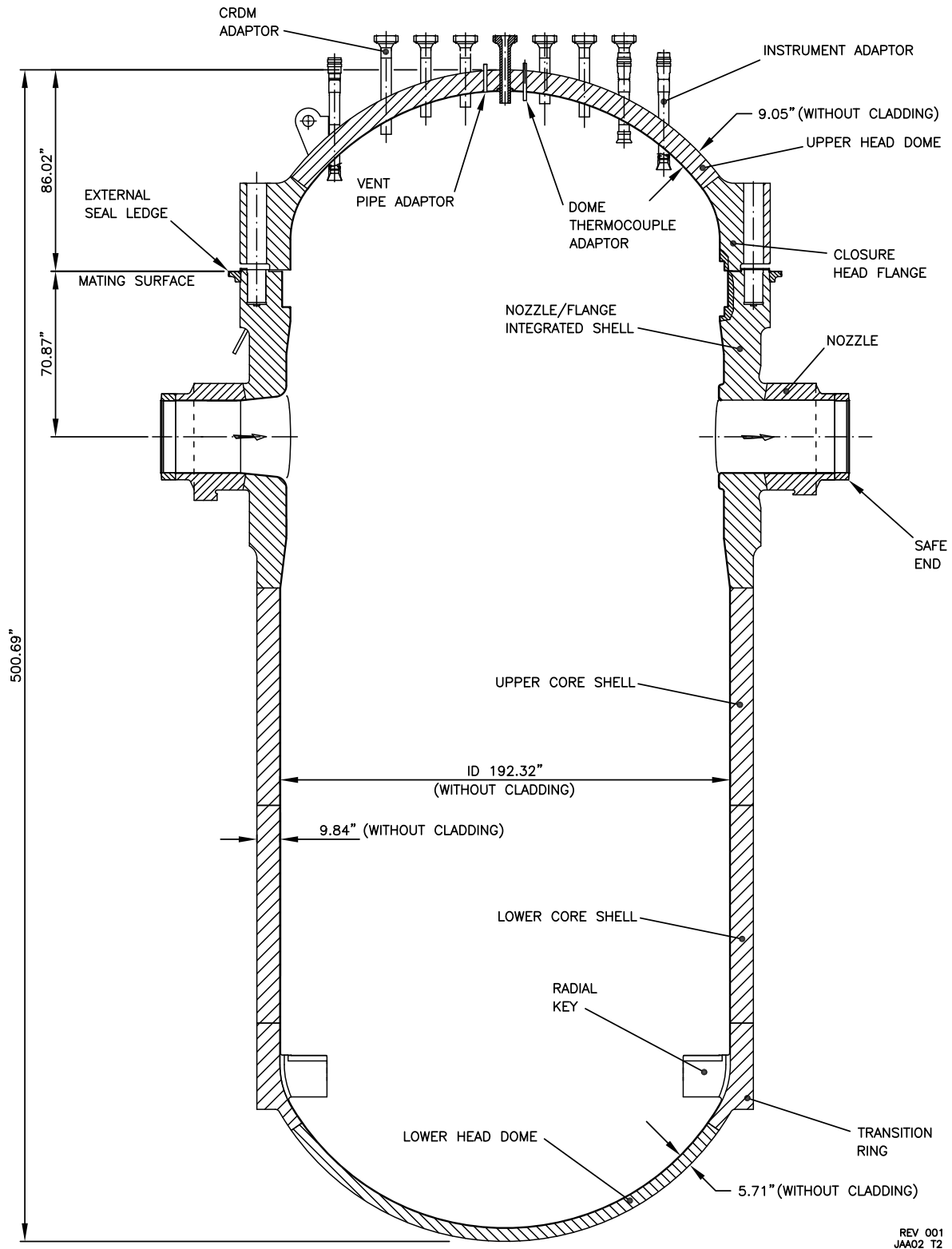

REV 001  
JAA02 T2

[Next File](#)