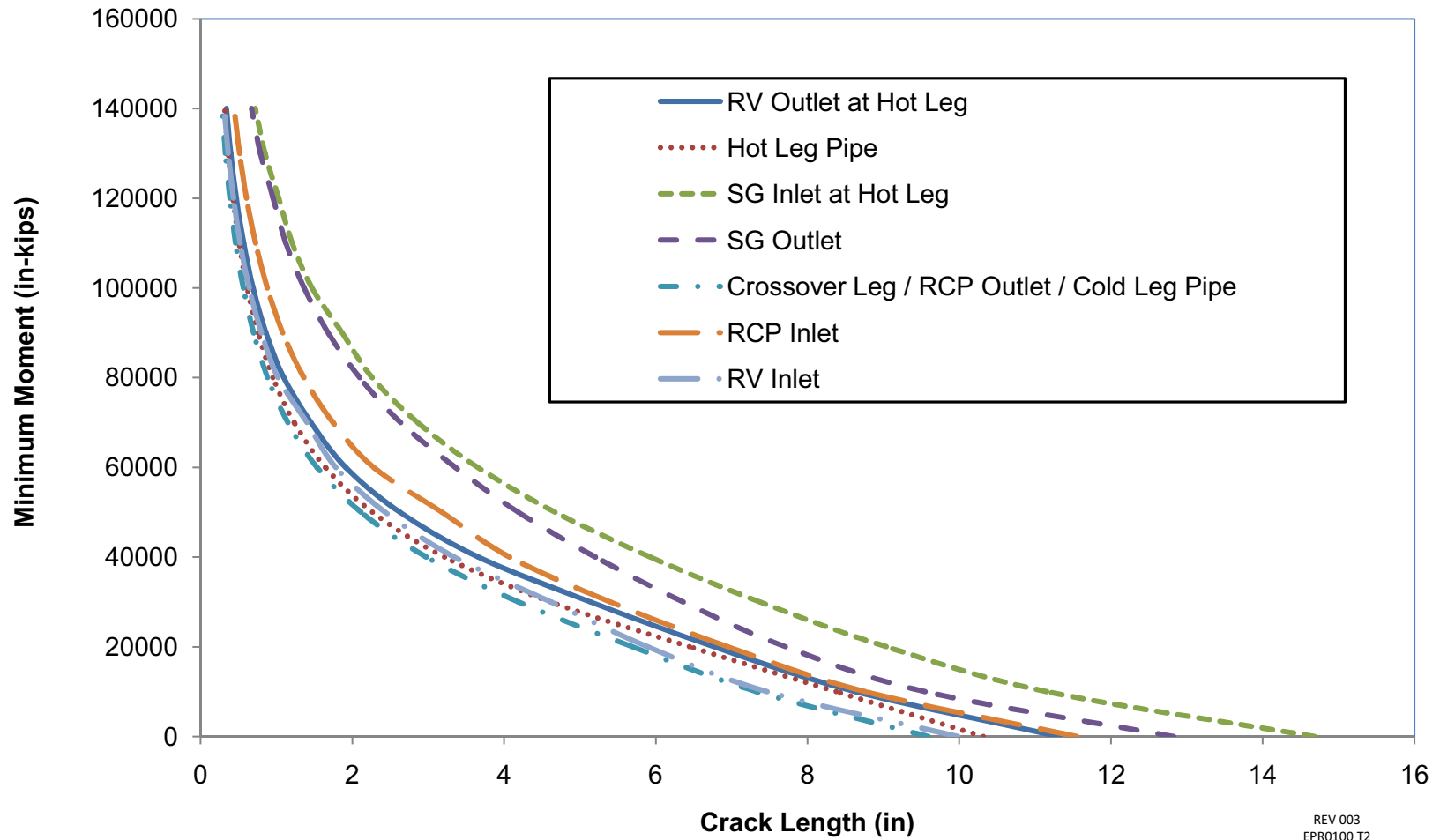

Figure 3.6.3-5—Minimum Moment versus Circumferential Leakage Crack Sizes for 5 gpm at Various Main Coolant Loop Locations



REV 003  
EPRO100 T2

Figure 3.6.3-6—Minimum Moment versus Circumferential Leakage Crack Sizes for 5 gpm at Three Surge Line Locations

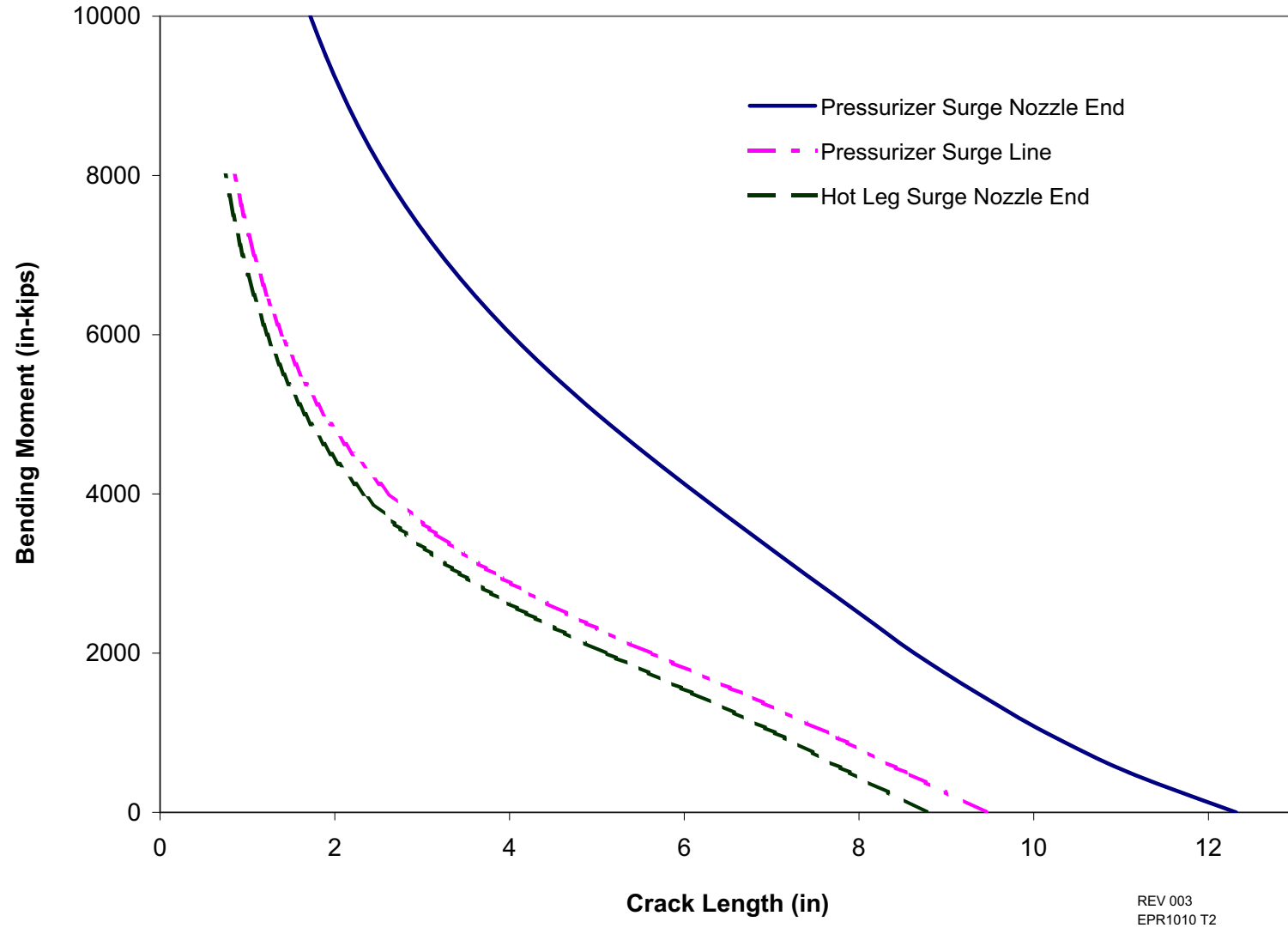

Figure 3.6.3-7—Pressure Only Leakage Rate versus Crack Length for Both Axial and Circumferential Crack Morphologies in Main Steam Line

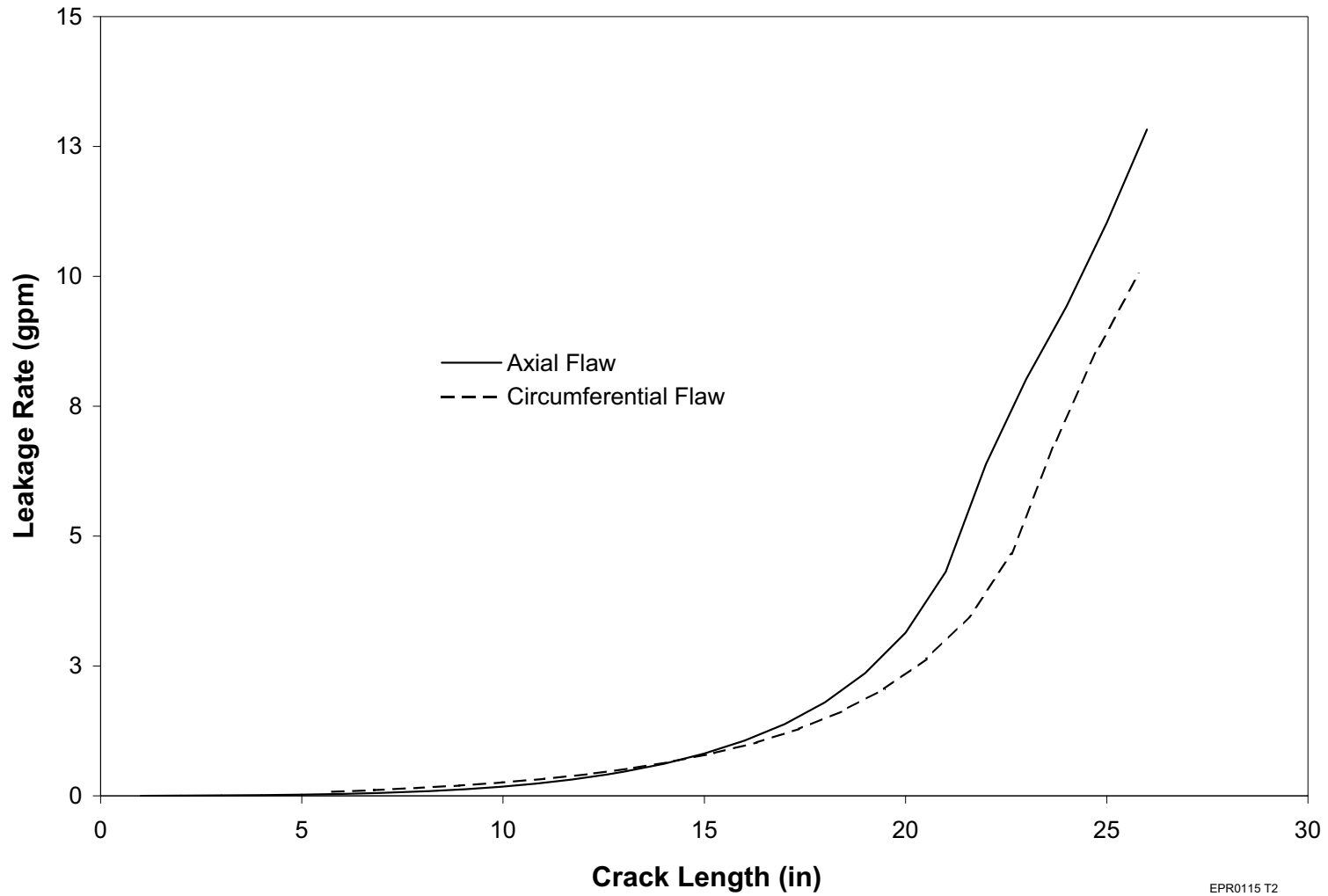
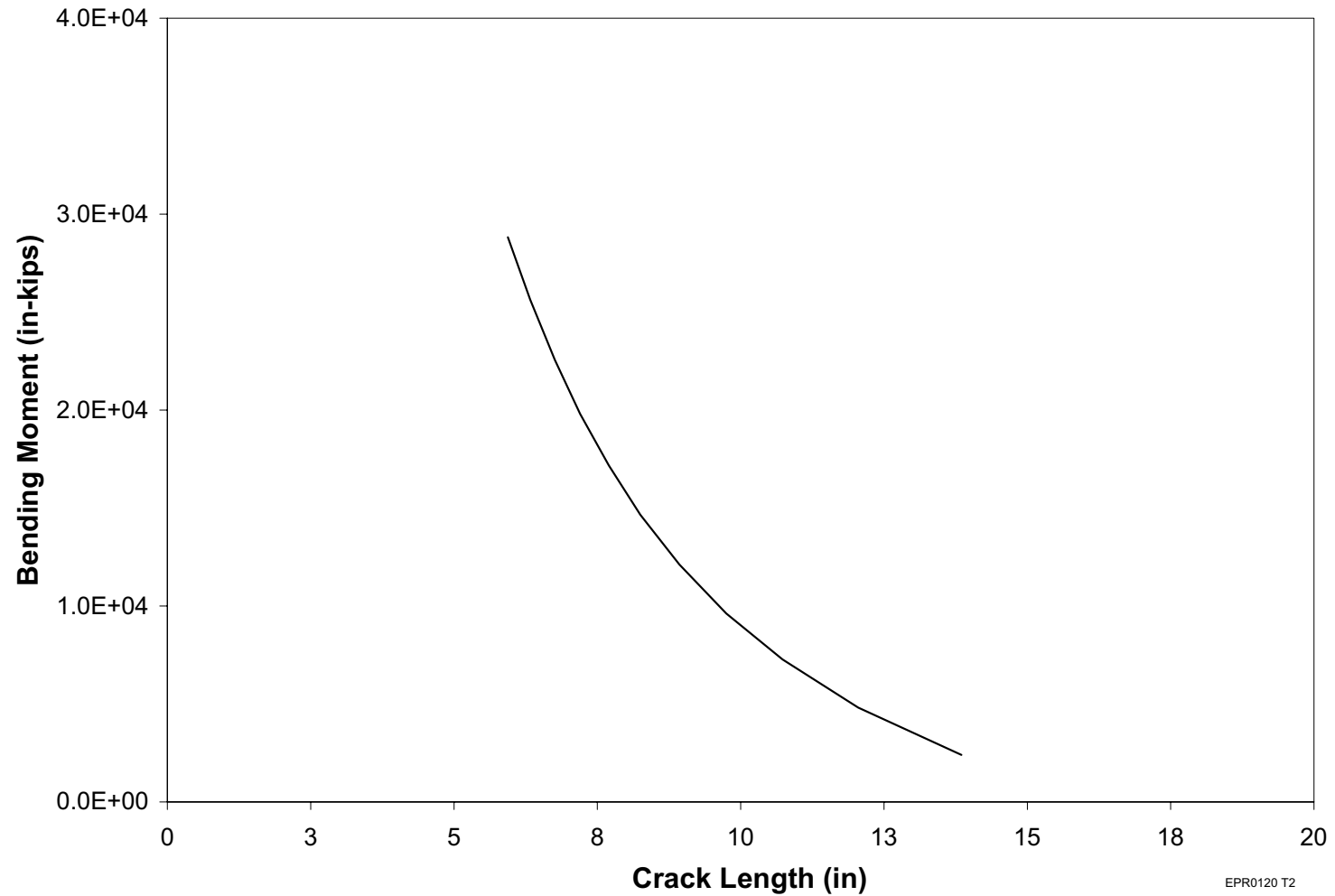
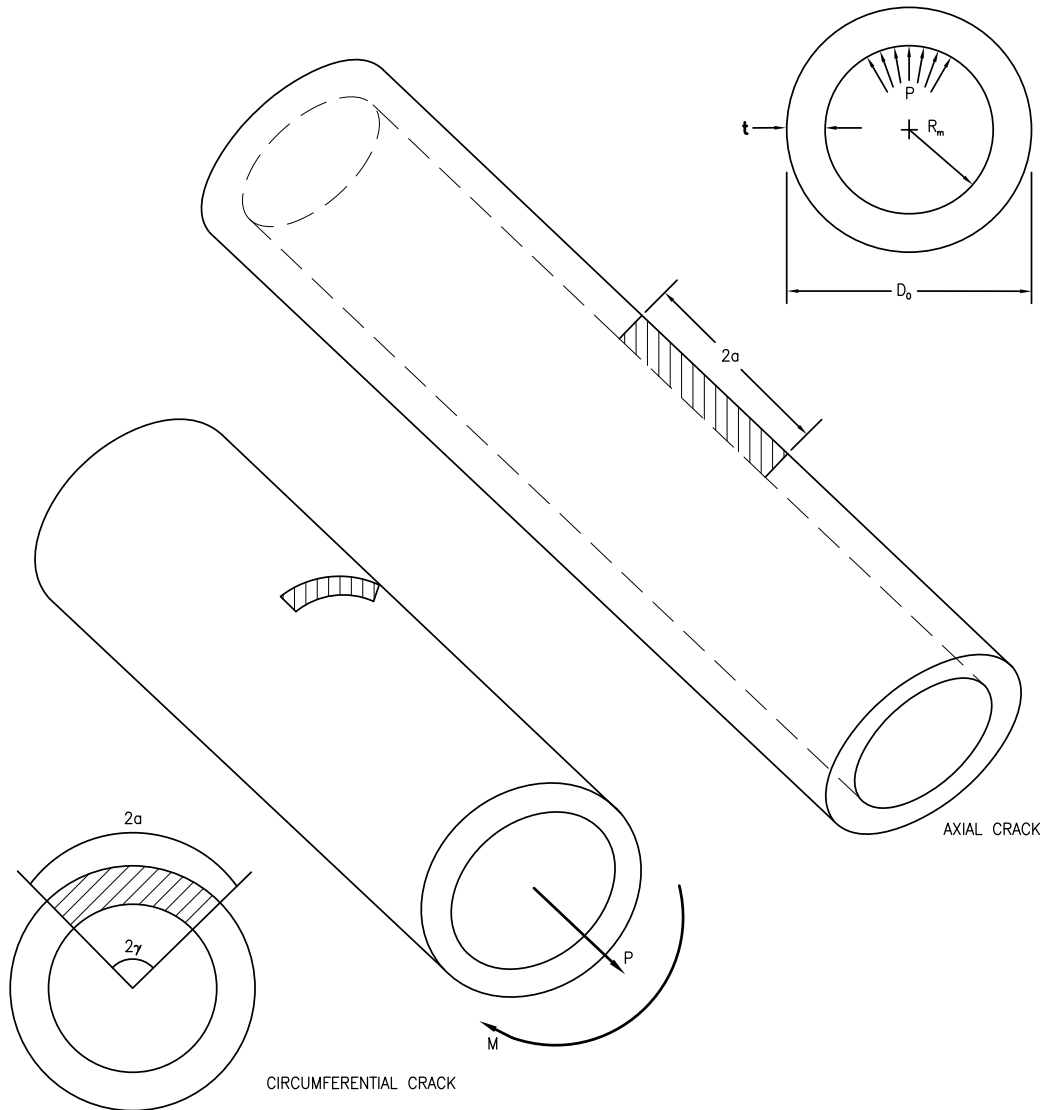

Figure 3.6.3-8—Minimum Moment versus Circumferential Crack Leakage Sizes for 1 gpm in Main Steam Line Piping

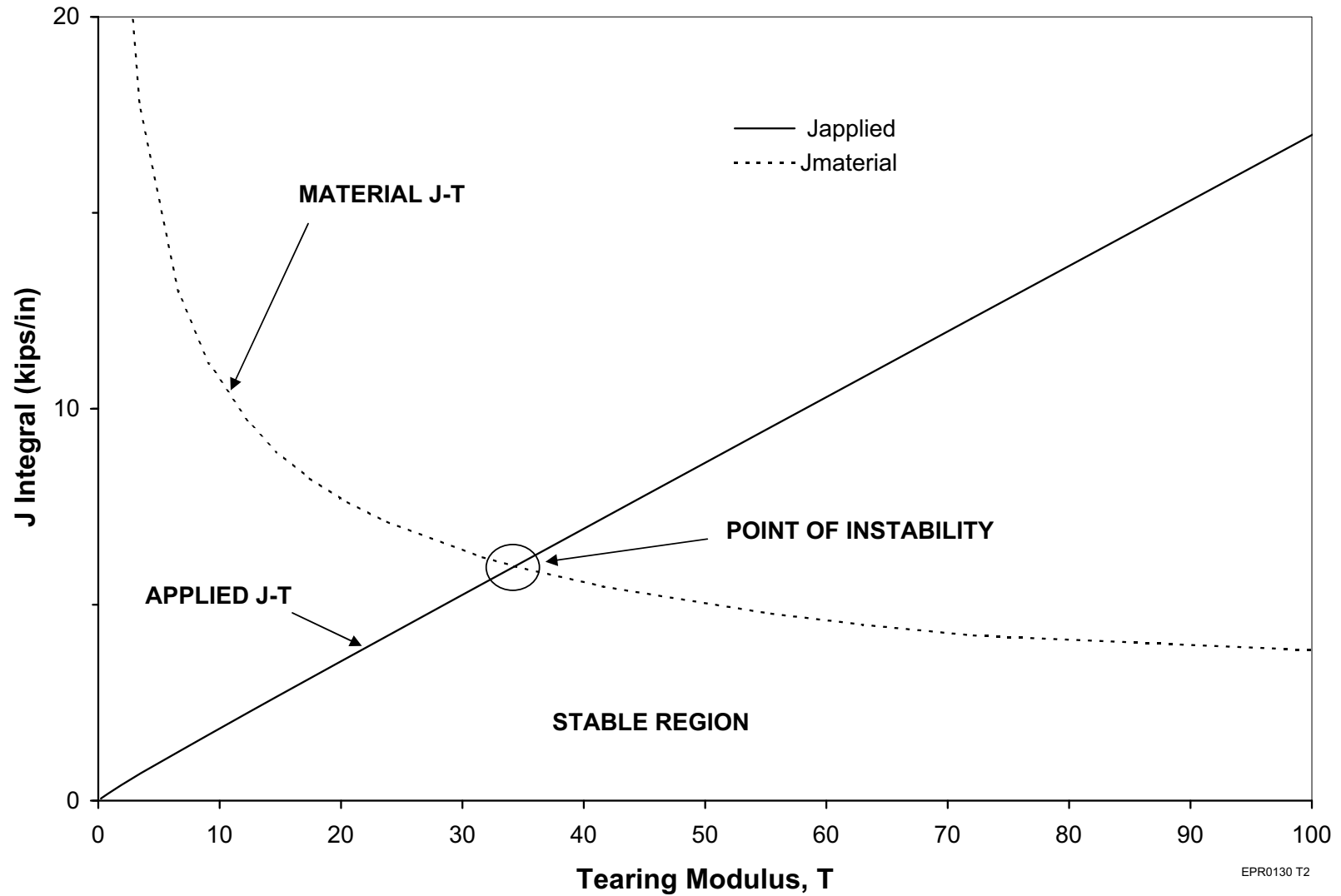

**Figure 3.6.3-9—Schematics of Analyzed Crack Geometries Considered for Straight Pipe Section**



EPR0125 T2

Figure 3.6.3-10—Schematic of J-Tearing Instability Diagram



EPR0130 T2

Figure 3.6.3-11—Typical Allowable Load Limit (ALL) Diagram Considering Various Axial Loadings

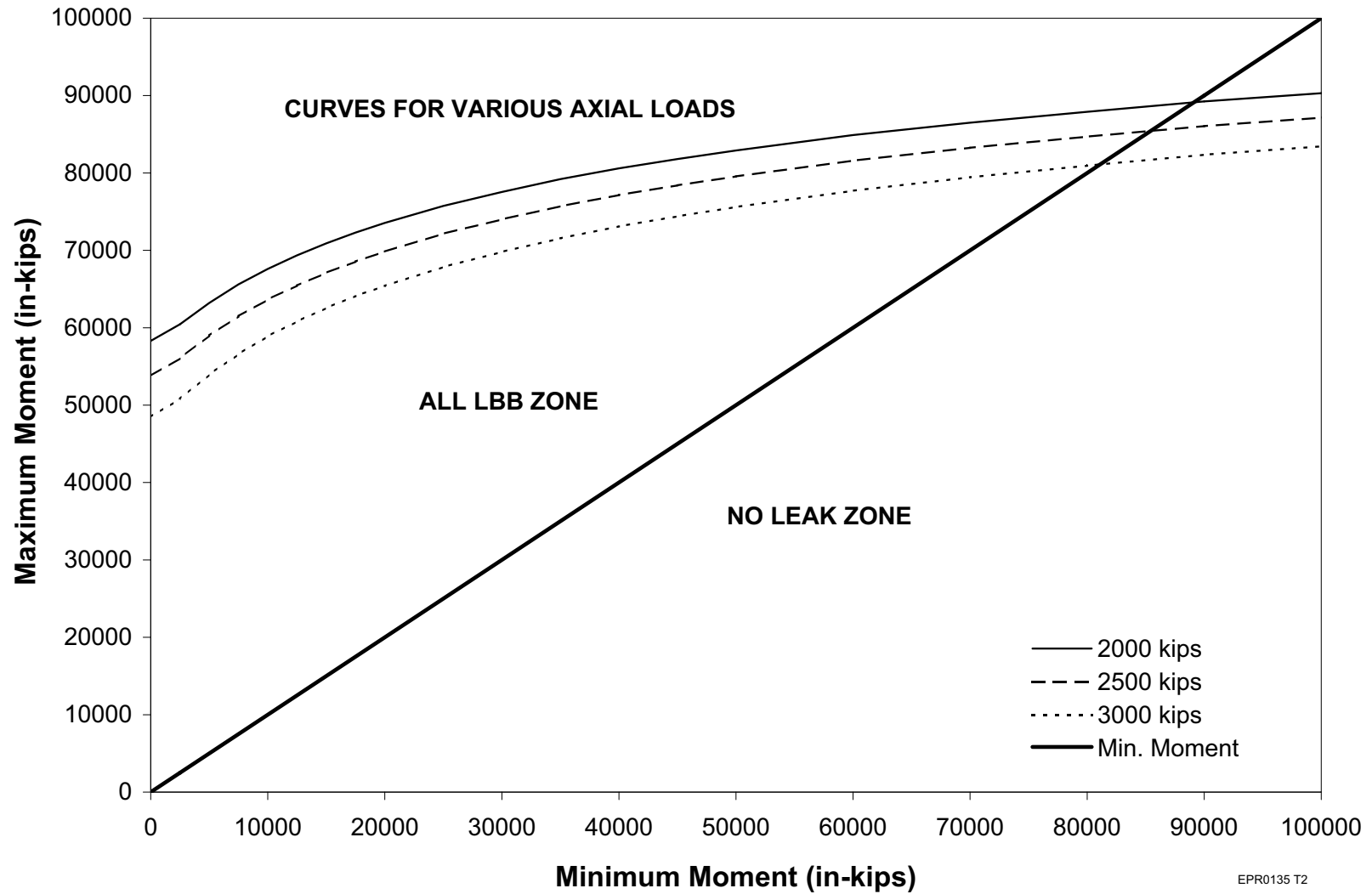

EPR0135 T2

Figure 3.6.3-12—ALL for Reactor Vessel Outlet Nozzle Region at Hot Leg (Location 1)

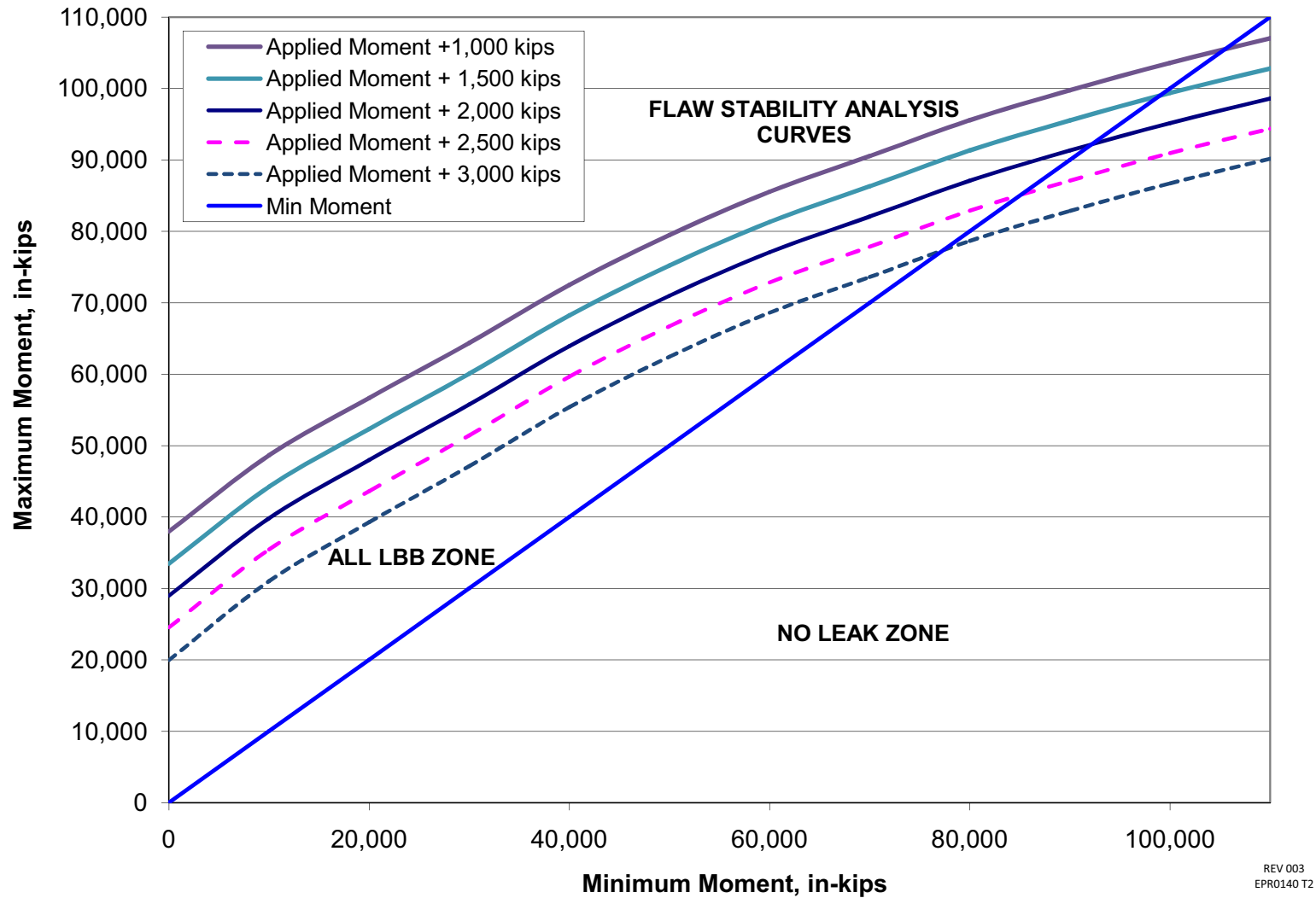

REV 003  
EPR0140 T2



Figure 3.6.3-13—ALL for Hot Leg Pipe (Location 2)

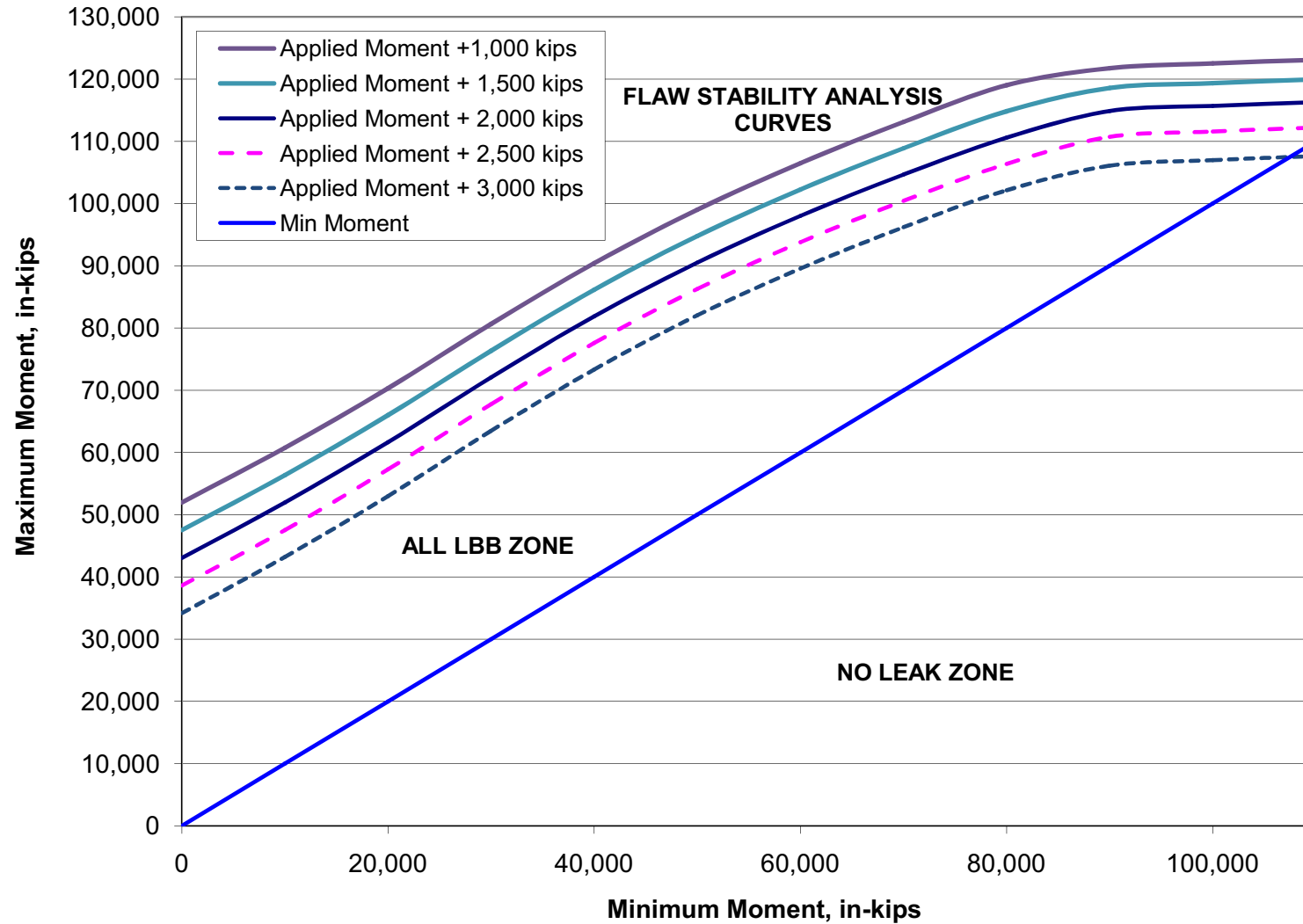

REV 003  
EPR0145 T2

Figure 3.6.3-14—ALL for Steam Generator Inlet Nozzle at Hot Leg (Location 3)

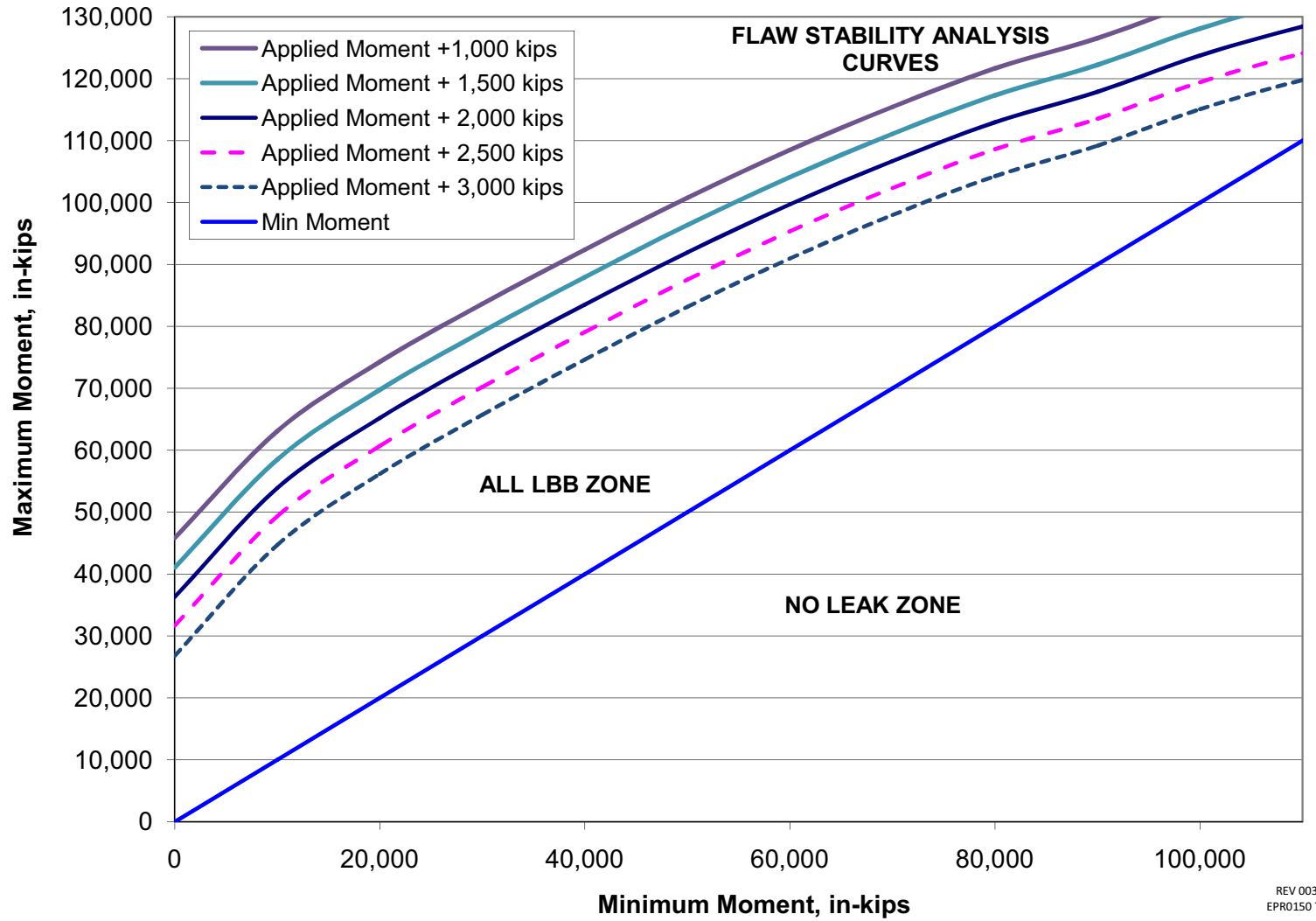

Figure 3.6.3-15—ALL for Steam Generator Outlet Nozzle (Location 4)

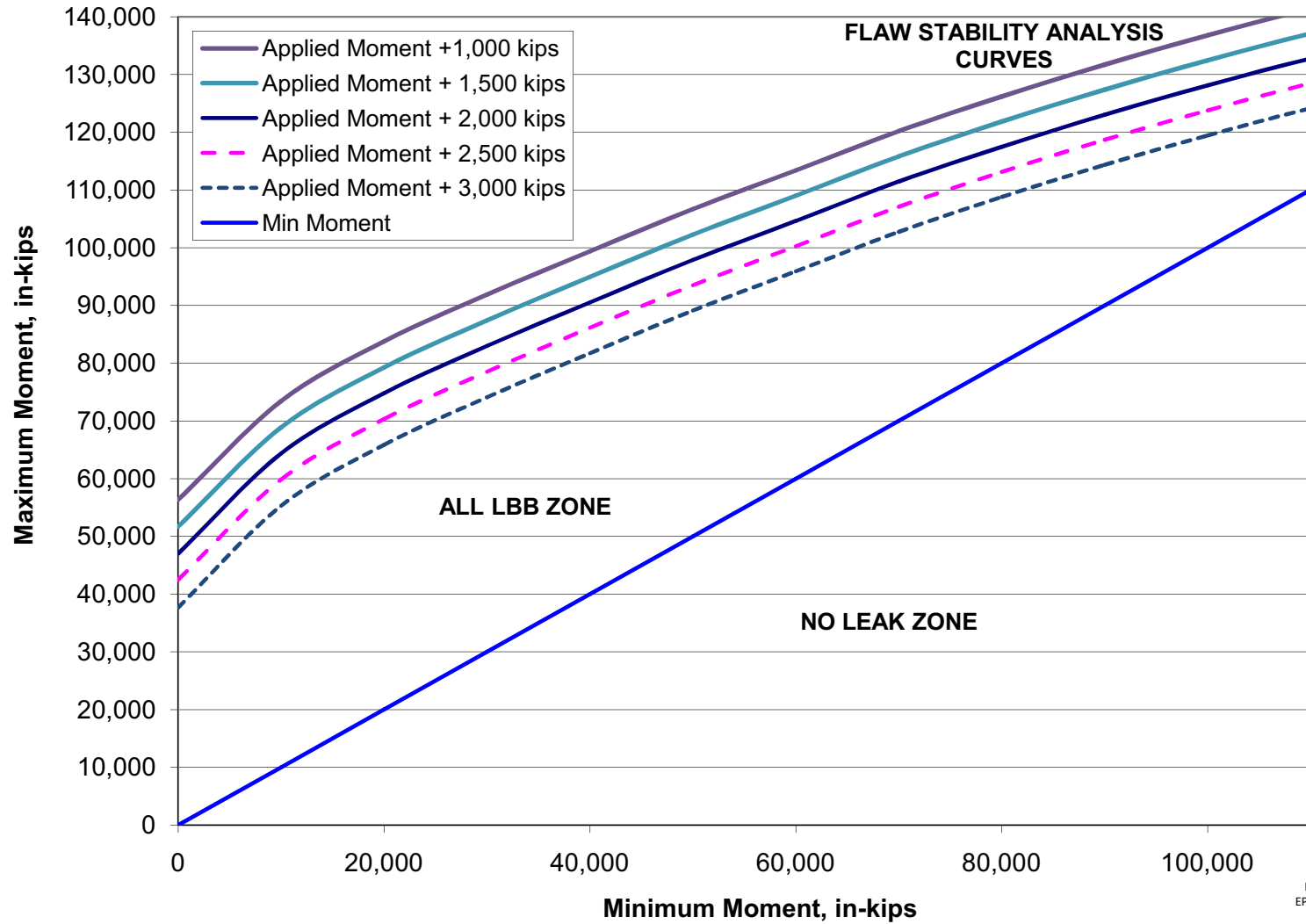

Figure 3.6.3-16—ALL for Crossover & Cold Leg Pipe (Locations 5 & 8)

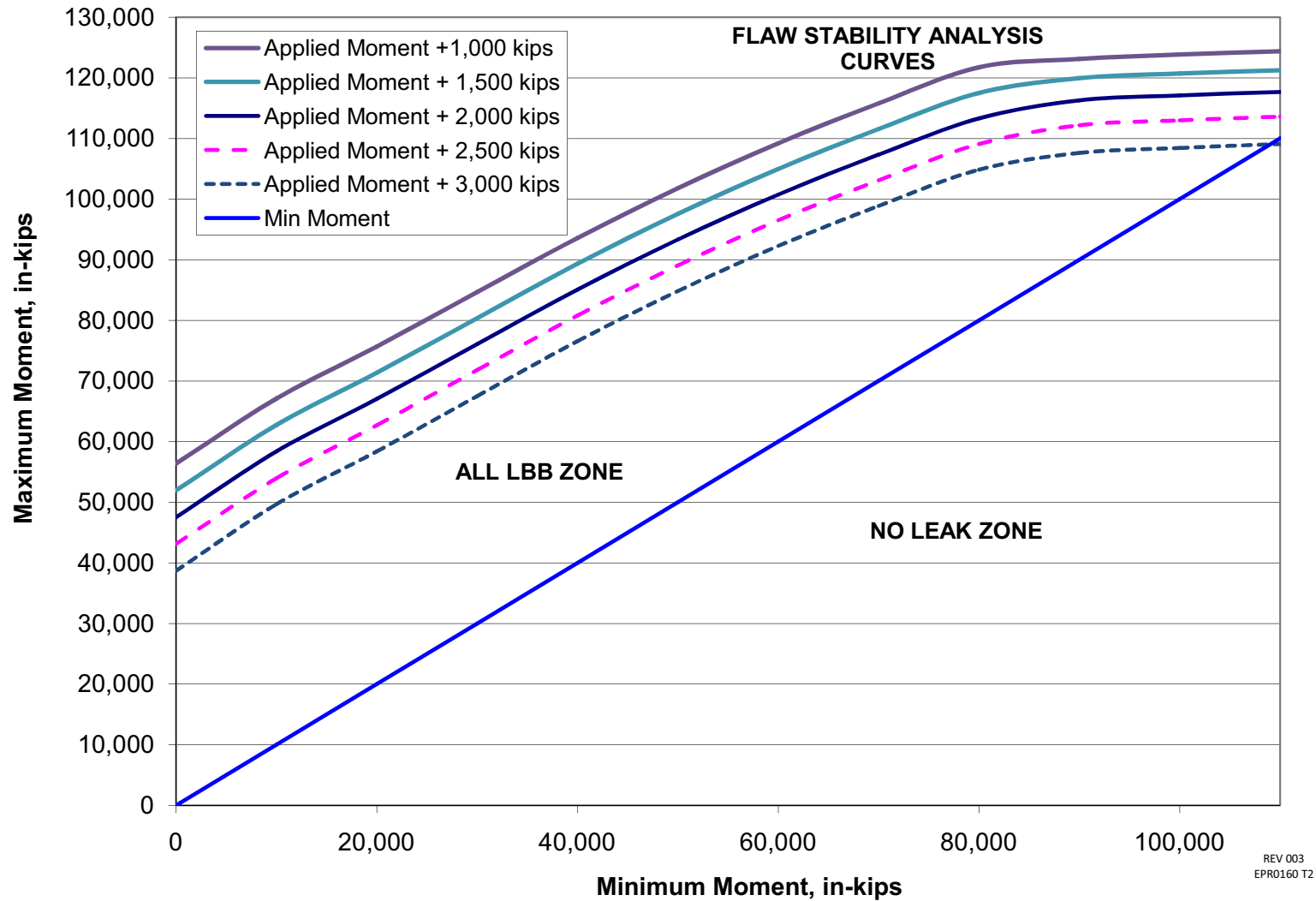
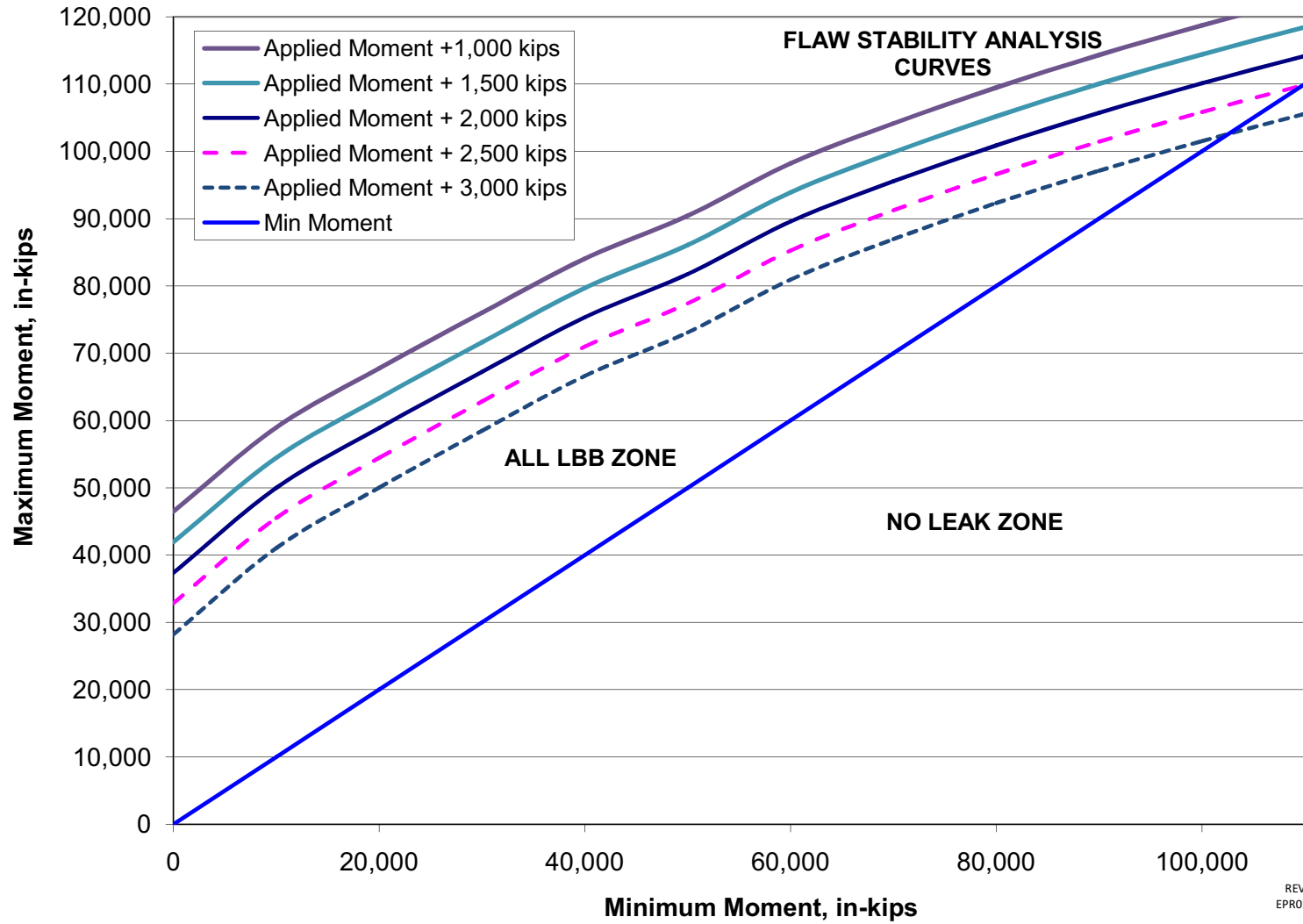
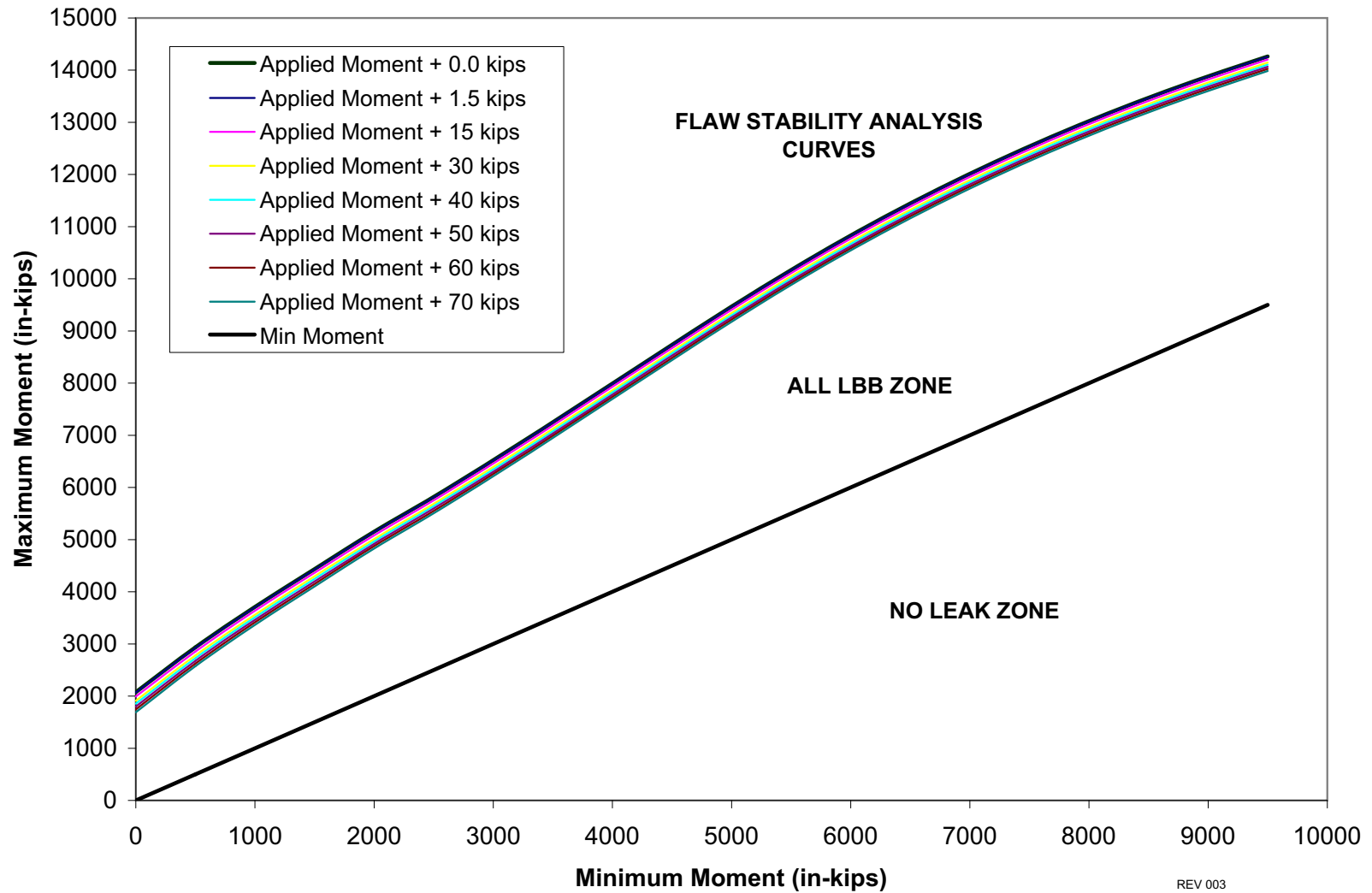

Figure 3.6.3-17—ALL for RCP Inlet Nozzle (Location 6)



REV 003  
EPR0165 T2

Figure 3.6.3-18—ALL for Pressurizer Surge Nozzle at Alloy 52 Weld



REV 003  
EPR0170 T2

Figure 3.6.3-19—ALL for Surge Line Piping

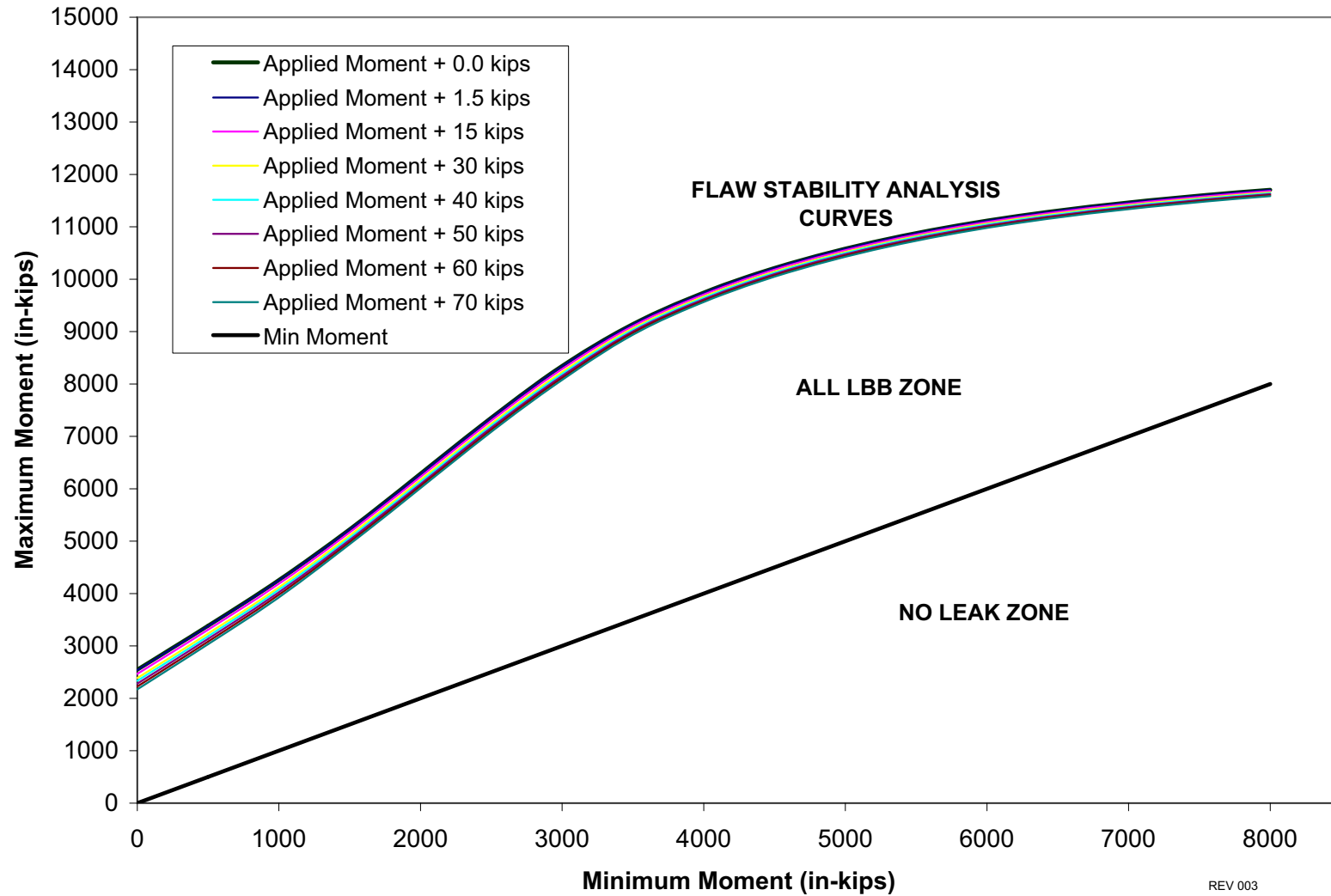

REV 003  
EPR0175 T2

Figure 3.6.3-20—ALL for Hot Leg Nozzle

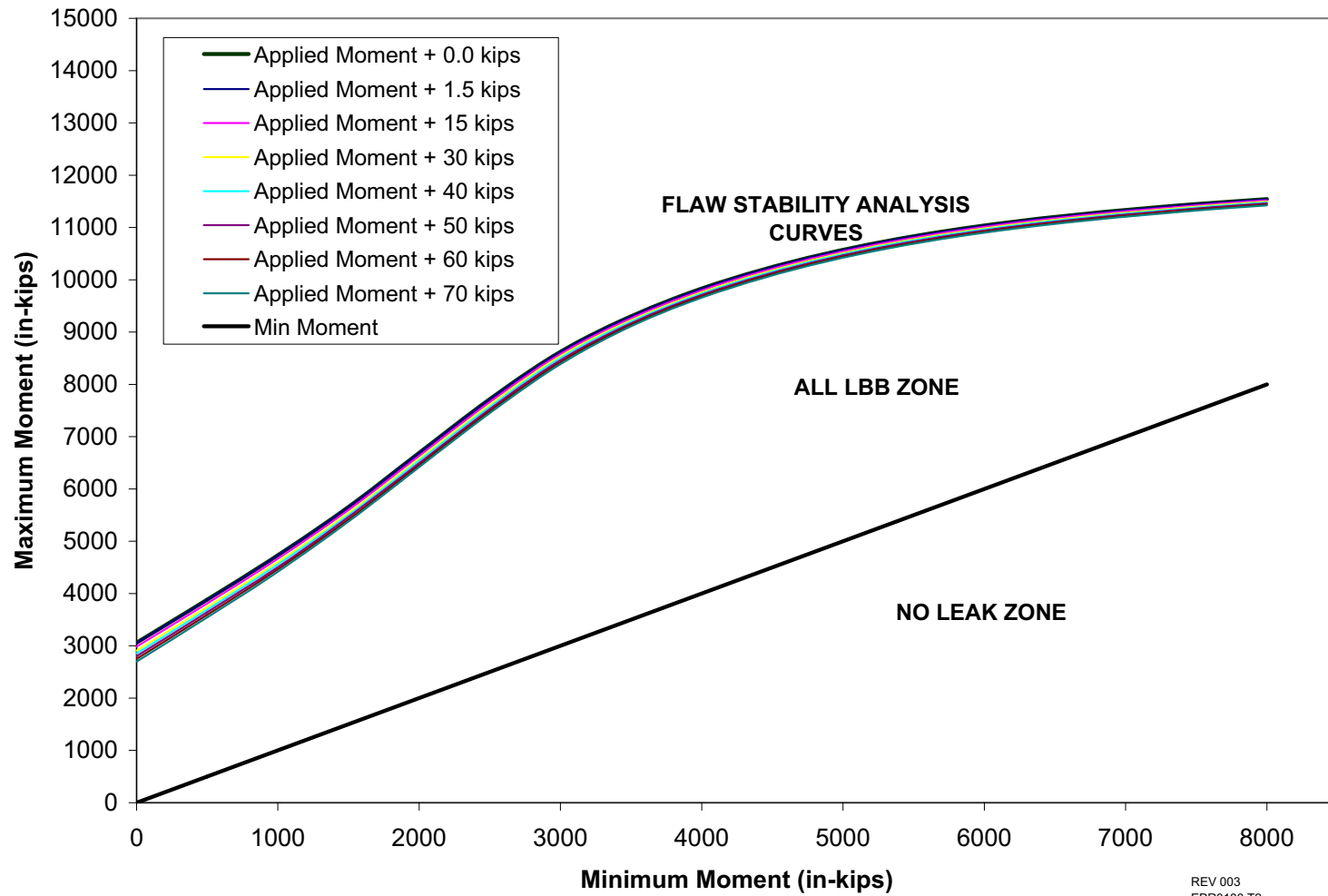



Figure 3.6.3-21—Comparison of Base and Weld Metal ALL in Main Steam Line Piping

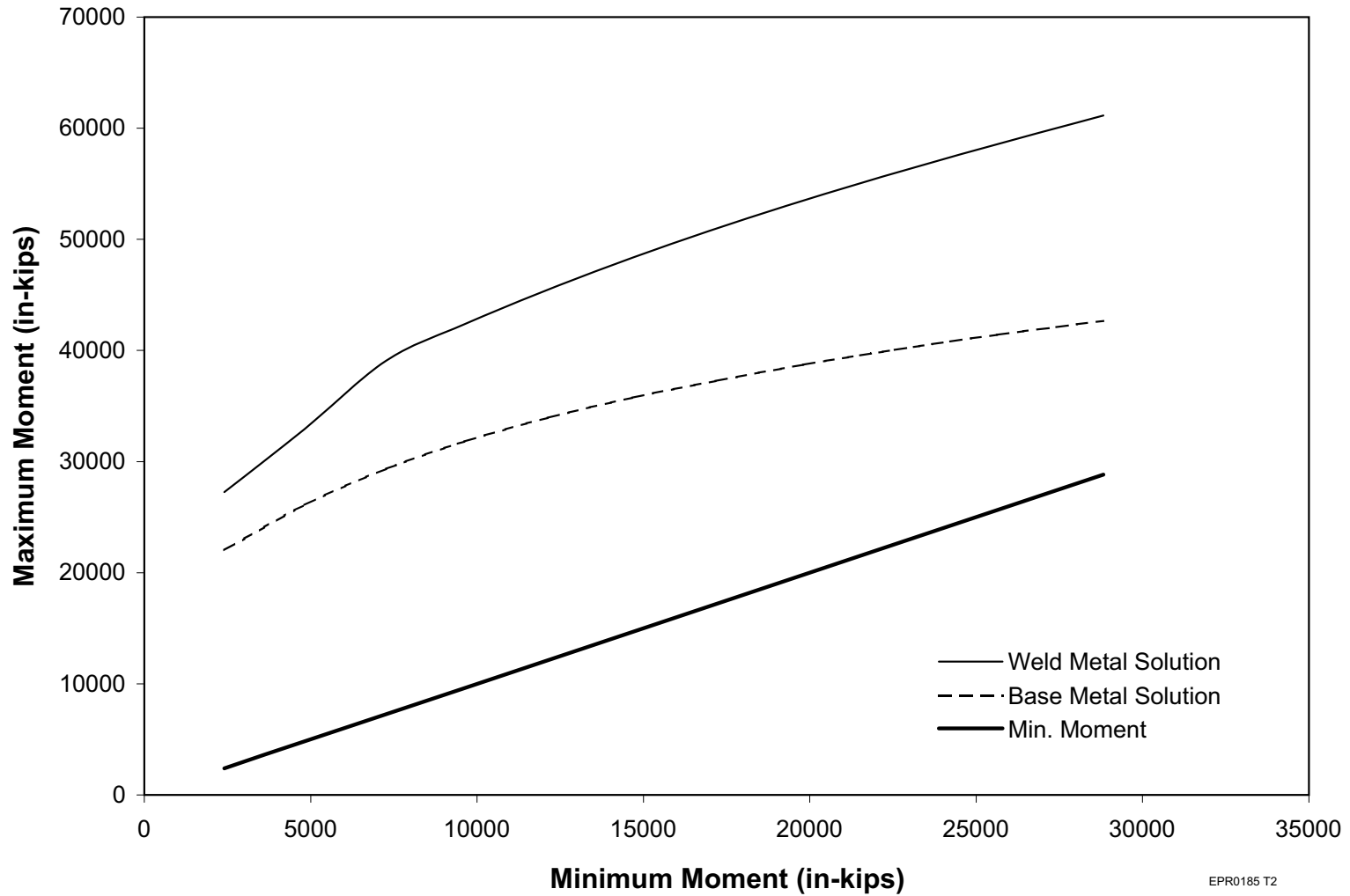

Figure 3.6.3-22—ALL for Main Steam Line Piping with Safety Factor of 2 on Flaw Size (Base Metal)

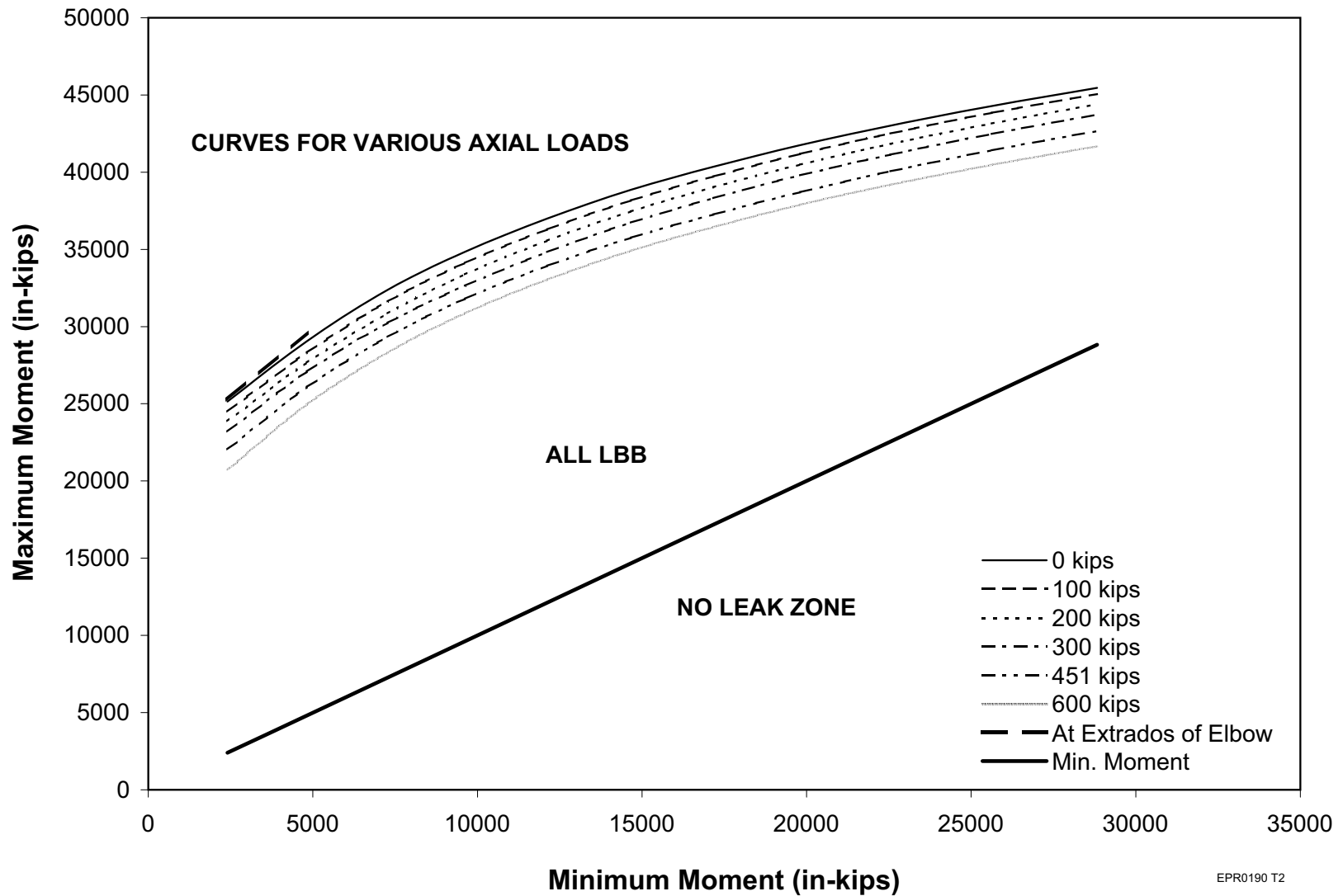
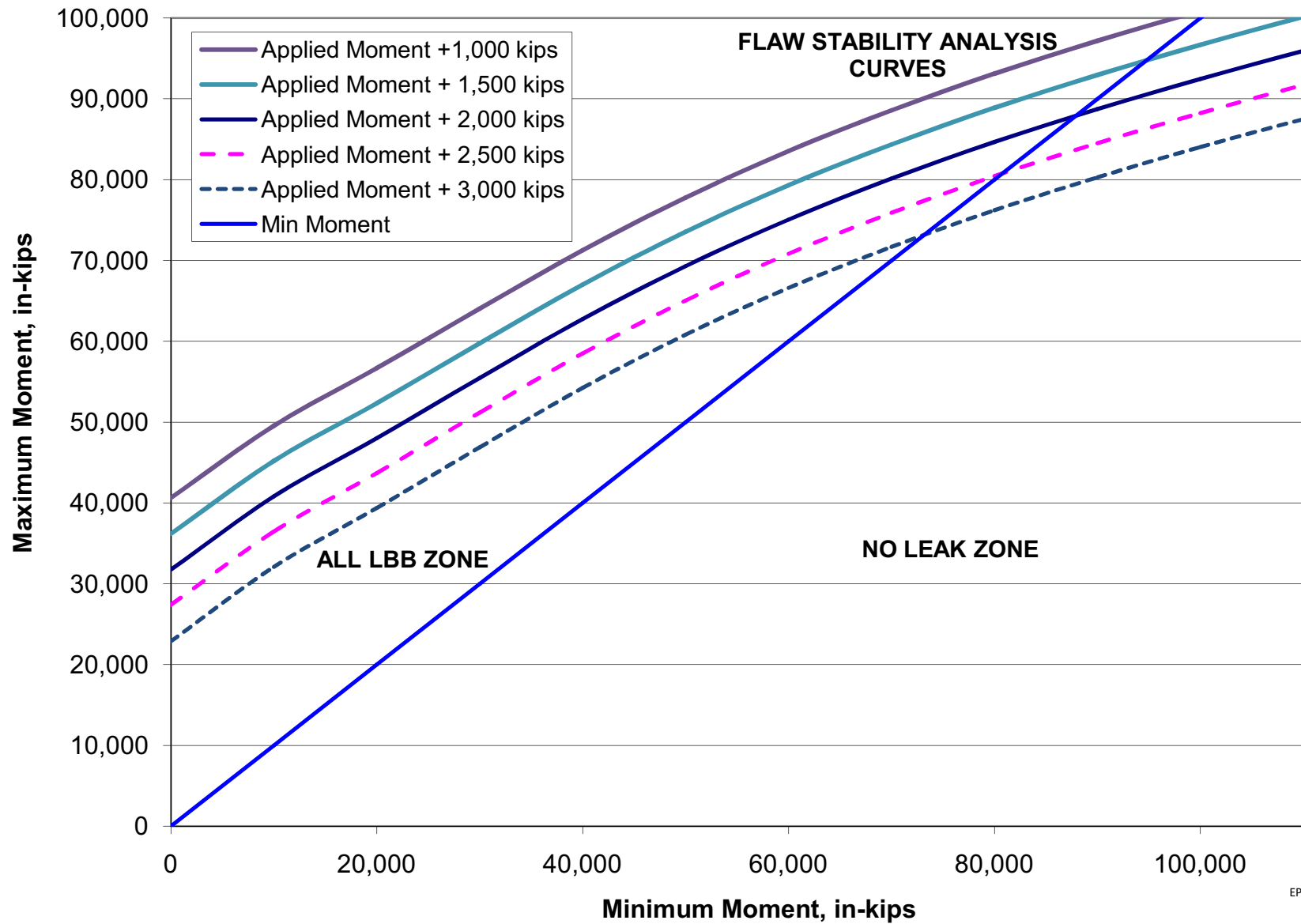

Figure 3.6.3-23—Deleted

Figure 3.6.3-24—ALL for RCP Outlet Nozzle (Location 7)



EPR0166 T2

Figure 3.6.3-25—ALL for RV Inlet Nozzle (Location 9)

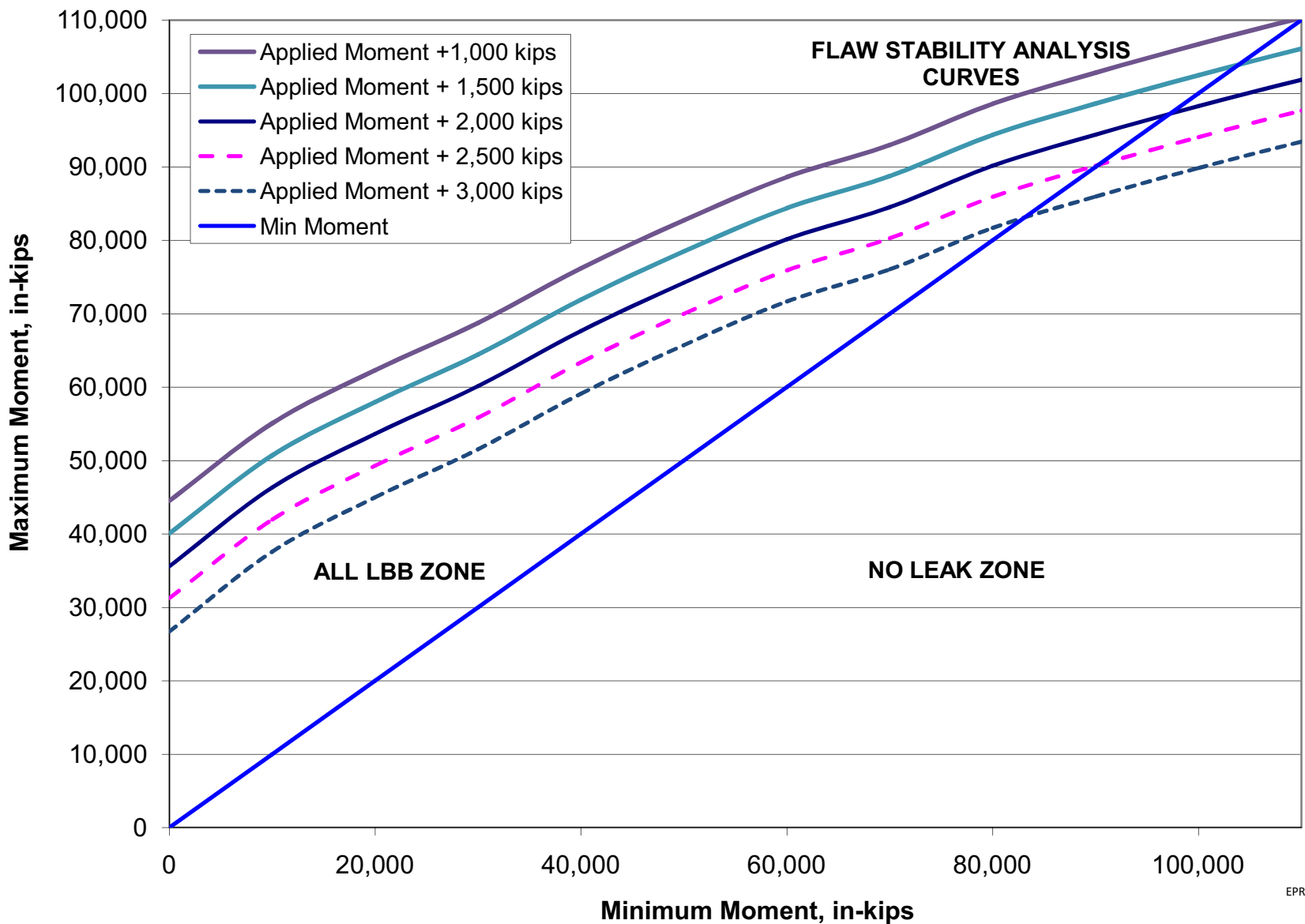

EPR0167 T2

[Next File](#)