

# **US-APWR Instrument Setpoint Methodology**

**Non-Proprietary Version**

**July 2013**

**© 2013 Mitsubishi Heavy Industries, Ltd.  
All Rights Reserved**

## Revision History

Revision	Date	Page or Section	Description
0	December 2009	All	Original issue.
1	April 2010	General	Revised to reflect the meeting result between NRC and MHI on 3/16/2010 (ML100570084). The setpoint methodologies for NTSP and AV determination are revised.
		General	Deleted the descriptions for Limiting Trip Setpoint (LTSP).
		General	Revised the descriptions related to LTSP in the previous revision.
		General	Made grammatical and typo corrections.
		List of Acronyms	Revised the acronyms.
		Sec.2.0 (P.8)	Revised the definition of Margin.
		Sec.2.0 (P.11)	Updated the revisions of MHI's reference documents.
		Sec.3.4 (P.12)	Revised the assumption of Safety Margin.
		Sec.5.1 (P.17,18)	Added the definition of Unmeasurable / measurable uncertainties.
		Sec.5.3 (P.21,22)	Added the description and Figure 5-3 for the general relationship between AL, NTSP, and AV.
		Sec.5.3.1 (P.22,23)	Revised the descriptions and figures for setpoint determination and surveillance of analog bistable functions.
		Sec.5.3.2 (P.24-26)	Revised the descriptions and figures for setpoint determination and surveillance of digital bistable functions.
		Sec.5.5.1 (P.30,31)	Revised the figure and table for DAS setpoint.
		Sec.5.5.2 (P.31)	Added the description for DAS allowable value.
		Table6-3, 6-8, 6-10, 6-13, 6-14, 6-21	Revised the CU calculations or setpoints to be consistent to the revised setpoint methodology in this revision.
		Table7-1 (P.64-67)	Revised CUs, Avs, PTACs and NTSPs, and added the UMUs to be consistent to the revised setpoint methodology in this revision.
		Table7-2 (P.68)	Deleted the LTSP terms.
2	May 2011	General	Editorial correction.
		Sec. 5.3.1 (P.22) Sec. 5.3.2 (P.24) Sec. 5.3.2.2 (P.28,29)	Revised to follow the response to RAI 590-4753 Question 16-301 item 9. <ul style="list-style-type: none"> <li>▪ Revised Section 5.3.1, 5.3.2.</li> <li>▪ Added Section 5.3.2.2.</li> </ul>
		Sec 6.3 (P.37), Table 5-1, 6-23, 7-2	Added ECCS Actuation on Low-Low Pressurizer Pressure for DAS.

Revision	Date	Page or Section	Description
3	July 2013	General  General  General  List of Acronyms (viii)  Sec. 2.0 (P.6, 7) Sec. 5.3.1 (P.22, 23) Sec. 5.3.2 (P.24, 26) Sec. 5.3.2.2 (P.27, 28) Sec. 5.4 (P.29)  Sec. 3.3.1 (P.12) Sec. 4.1 (P.13)	Editorial correction.  Use of terminology and typical descriptions are revised or removed to make consistency and to clarify specific application for the US-APWR to follow the responses to RAI 722-5597 Question 07.01-29 and Question 07.01-30.  Updated reference document to latest version.  Corrected word for COT. Added MIC.  Revised the definition and description to follow the amended response to RAI 590-4753 Question 16-301.  Corrected reference of ANSI/ISA-S67.04.

© 2013  
**MITSUBISHI HEAVY INDUSTRIES, LTD.**  
All Rights Reserved

This document has been prepared by Mitsubishi Heavy Industries, Ltd. ("MHI") in connection with the U.S. Nuclear Regulatory Commission ("NRC") licensing review of MHI's US-APWR nuclear power plant design. None of the information in this document, may be disclosed, used or copied without written permission of MHI, other than by the NRC and its contractors in support of the licensing review of the US-APWR.

This document contains technological information and intellectual property relating to the US-APWR and it is delivered to the NRC on the express condition that it not be disclosed, copied or reproduced in whole or in part, or used for the benefit of anyone other than MHI without the express written permission of MHI, except as set forth in the previous paragraph.

This document is protected by the laws of Japan, U.S. copyright law, international treaties and conventions, and the applicable laws of any country where it is being used.

Mitsubishi Heavy Industries, Ltd.  
16-5, Konan 2-chome, Minato-ku  
Tokyo 108-8215 Japan

## Abstract

This Technical Report describes the instrument setpoint methodology used for the US-APWR.

This document provides the methodology for deriving channel uncertainties and setpoints for reactor trip (RT) and engineered safety feature (ESF) actuation functions listed in the US-APWR Design Control Document (DCD) Chapter 7, Instrumentation and Controls, and Chapter 16, Technical Specifications Section 3.3. These setpoints are based on numerous factors, including uncertainties. This document also establishes the methodology for periodic surveillance related to these setpoints, to confirm that the instrumentation and control (I&C) system is in compliance with the plant Technical Specifications. Channel uncertainties, setpoints and limits associated with periodic surveillance are provided in Sections 6 and 7 of this report.

This setpoint methodology will also be used for calculating uncertainties and determining or verifying the acceptability of setpoints associated with 1) procedural actions that are important to safety, and 2) control system functions directly related to a) initial conditions assumed in the safety analysis, b) interlocks credited in the analysis of anticipated operational occurrences (AOOs), and c) Technical Specifications limiting conditions for operation (LCOs).

This setpoint methodology is referenced by the setpoint control program (SCP) described in the US-APWR DCD Chapter 16, Technical Specifications, Specification 5.5.21.

## Table of Contents

List of Tables .....	vi
List of Figures .....	vii
List of Acronyms .....	viii
1.0 INTRODUCTION .....	1
1.1 Purpose .....	2
1.2 Scope .....	2
2.0 DEFINITIONS .....	5
3.0 APPLICABLE CODES AND STANDARDS .....	12
3.1 U.S. Regulations .....	12
3.2 U.S. Nuclear Regulatory Guidance .....	12
3.3 U.S. Industry Guidance .....	12
3.4 Other References .....	12
4.0 BACKGROUND .....	13
4.1 Regulatory Basis for the Methodology .....	13
4.2 Industry Issues .....	13
4.3 Statistics .....	14
4.4 Assumptions .....	15
5.0 METHODOLOGY DESCRIPTION .....	17
5.1 Methodology for Overall Channel Uncertainty .....	17
5.2 Uncertainty of Digital I&C System (MELTAC Platform) .....	18
5.3 Establishment of Setpoints and Allowable Values .....	21
5.3.1 Protection Functions via Analog Bistables .....	22
5.3.2 Protection Functions via Digital Bistables .....	24
5.3.2.1 Calculated Functions .....	25
5.3.2.2 Binary Sensors .....	27
5.4 Performance Test Acceptance Criteria for Digital Channels .....	28
5.5 Diverse Actuation System .....	29
5.5.1 DAS vs. PSMS Setpoints .....	31
5.5.2 DAS Allowable Value .....	33
5.6 Uncertainty of Differential Pressure Flow Channel .....	34
5.7 Guidelines for Graded Approach .....	34
6.0 US-APWR PROTECTION SYSTEM SAFETY FUNCTIONS .....	35
6.1 Reactor Trip Functions .....	35
6.2 Engineered Safety Feature Functions .....	35
6.3 Diverse Actuation System Functions .....	36
7.0 SUMMARY OF RT AND ESF CHANNEL UNCERTAINTIES .....	65

## List of Tables

Table 5-1 DAS Setpoints vs PSMS Setpoints .....	33
Table 6-1 Source Range Neutron Flux – High .....	37
Table 6-2 Intermediate Range Neutron Flux – High.....	38
Table 6-3 Power Range Neutron Flux - High .....	39
Table 6-4 Power Range Neutron Flux.....	40
Table 6-5 Over Temperature $\Delta T$ - DNB Protection .....	41
Table 6-6 Over Temperature $\Delta T$ – Exit Boiling Limiting .....	43
Table 6-7 Over Power $\Delta T$ .....	45
Table 6-8 Reactor Coolant Flow – Low .....	47
Table 6-9 Reactor Coolant Pump Speed – Low.....	48
Table 6-10 Pressurizer Pressure – Low (including Accident Operation).....	49
Table 6-11 Pressurizer Pressure – High .....	50
Table 6-12 Pressurizer Water Level – High .....	51
Table 6-13 Steam Generator Water Level – Low (including Accident Operation).....	52
Table 6-14 Steam Generator Water Level – High, High-High .....	53
Table 6-15 Main Steam Line Pressure – Low .....	54
Table 6-16 Main Steam Line Pressure – High Negative Rate.....	55
Table 6-17 Containment Pressure – High, High-High and High-3 .....	56
Table 6-18 Main Control Room (MCR) Outside Air Intake Radiation – High .....	57
Table 6-19 Containment High Range Area Radiation – High.....	58
Table 6-20 Reactor Coolant Temperature Tavg – Low, Low-Low.....	59
Table 6-21 Turbine Emergency Trip Oil Pressure – Low .....	61
Table 6-22 LOOP Signal - Undervoltage (UV) .....	62
Table 6-23 Pressurizer Pressure – (DAS).....	63
Table 6-24 Steam Generator Water Level – Low (DAS).....	64
Table 7-1 Summary – RT/ESF Functions .....	66
Table 7-2 Summary – DAS Functions.....	70

## List of Figures

Figure 5-1 Signal Processing Path in MELTAC Platform .....	19
Figure 5-2 Signal Processing Path in NIS/RMS with MELTAC Platform.....	20
Figure 5-3 Relationship between AL and NTSP, AL and AV .....	21
Figure 5-4 Channel Calibration on Analog Measurements .....	22
Figure 5-5 Periodic Surveillance of Protection Function Implemented via Analog Bistables (Increasing Process) .....	23
Figure 5-6 Periodic Surveillance of Protection Functions Implemented via Digital Bistables...	26
Figure 5-7 Periodic Surveillance of Protection Functions Implemented via Binary Sensors Connected to PSMS (Increasing Process).....	28
Figure 5-8 Signal Path of DAS with PSMS.....	30
Figure 5-9 DAS vs PSMS Setpoints Relationship (Increasing Process).....	32
Figure 5-10 Example of PSMS vs DAS Margin Analysis (Worst Case) .....	32
Figure 6-1 Schematic of Over Temperature $\Delta T$ (DNB) Reactor Trip .....	41
Figure 6-2 Schematic of Over Temperature $\Delta T$ (Exit Boiling Limiting) Reactor Trip.....	43
Figure 6-3 Schematic of Over Power $\Delta T$ Reactor Trip.....	45
Figure 6-4 Schematic of Tavg Low (TBV Block and MFW Isolation) .....	59



## List of Acronyms

A/D	analog / digital
AL	analytical limit
ALARA	as low as reasonably achievable
ANS	American Nuclear Society
ANSI	American National Standards Institute
AOO	anticipated operational occurrence
AV	Allowable Value
BA	bias allowance
BTP	Branch Technical Position
CCF	common cause failure
COL	Combined License
COT	channel operational test
CPS	counts per second
CT	calibration tolerance
CU	channel uncertainty
CVCS	chemical and volume control system
D3	defense in depth and diversity
DAS	diverse actuation system
DCD	Design Control Document
DBE	design basis event
DNB	departure from nucleate boiling
DR	drift
EA	environmental allowance
ECCS	emergency core cooling system
EFW	emergency feedwater
EOP	emergency operating procedure
ESF	engineered safety feature
ESFAS	engineered safety features actuation system
FS	full span
GDC	General Design Criteria
HVAC	heating, ventilation and air-conditioning
LCO	limiting condition for operation
IR	intermediate range
IRE	insulation resistance effect
ITAAC	inspections, tests, analyses, and acceptance criteria
I&C	instrumentation and control
ISA	Instrument Society of America
LOCA	loss-of-coolant accident
LOOP	loss of off-site power
LSSS	limiting safety system setting
MCR	main control room
M&TE	measurement and test equipment
MFW	main feedwater
MHI	Mitsubishi Heavy Industries, Ltd.
MIC	memory integrity check
MS	main steam
NIS	nuclear instrumentation system
NRC	U.S. Nuclear Regulatory Commission

---

NTSP	nominal trip setpoint
OP	over power
OT	over temperature
PA	postulated accident
PAM	post accident monitoring
PEA	primary element accuracy
PMA	process measurement accuracy
PR	power range
PSMS	protection and safety monitoring system
PTAC	performance test acceptance criteria
RA	reference accuracy
RCA	rack calibration accuracy
RCP	reactor coolant pump
RD	rack drift
RG	Regulatory Guide
RMS	radiation monitoring system
RMTE	rack measurement & test equipment
RRA	rack reference accuracy
RT	reactor trip
RTD	resistance temperature detector
RTE	rack temperature effect
RTP	rated thermal power
RTS	reactor trip system
SCA	sensor calibration accuracy
SCP	setpoint control program
SD	sensor drift
SG	steam generator
SL	safety limit
SMTE	sensor measurement & test equipment
SPE	static pressure effect
SPS	sensor power supply effect
SR	source range
SRA	sensor reference accuracy
SREA	sensor accident radiation effect
SRP	Standard Review Plan
SRSS	square root of the sum of the squares
SSE	sensor seismic effect
STE	sensor temperature effect
STE A	sensor accident temperature effect
TADOT	trip actuating device operational test
TT	turbine trip
UV	under voltage
UMU	unmeasurable uncertainty
VDU	visual display unit

## 1.0 INTRODUCTION

This Technical Report provides the instrument setpoint methodology for the US-APWR. This report provides the methodology for deriving channel uncertainties (CUs) and setpoints for reactor trip (RT) and engineered safety features (ESF) actuation functions listed in the US-APWR Design Control Document (DCD) Chapter 7, Instrumentation and Controls, and Chapter 16, Technical Specifications Section 3.3. This report also establishes the methodology for periodic surveillance related to these setpoints, to confirm that the instrumentation and control (I&C) system is in compliance with the plant Technical Specifications.

Details concerning channel uncertainties, setpoints and limits associated with periodic surveillance are provided in Sections 6 and 7 of this report. The final setpoint analysis for each specific plant will be performed when the specific design for the plant and the specification of instruments are finalized.

This report includes typical industry uncertainty values and assumptions that reflect the US-APWR I&C design, to the extent required to support the DCD and Combined License (COL) application. Setpoints are established in DCD Tier 2 (Ref. 3.4.1) documents. Plant-specific setpoints will be determined against the final design (i.e., as-built I&C system) for each plant, as required by the US-APWR inspections, tests, analyses, and acceptance criteria (ITAAC) described in DCD Tier 1.

The methodology described herein will also be used to calculate uncertainties and determine or verify the acceptability of setpoints in applications for important to safety functions including post accident monitoring (PAM) Type A instrumentation used to support manual actions credited in the safety analysis, the diverse actuation system (DAS) functions, and control system functions directly related to 1) initial conditions assumed in the safety analysis, 2) interlocks credited in the analysis of anticipated operational occurrences (AOOs), and 3) Technical Specifications limiting conditions for operation (LCOs). Setpoint values and calculations for RT and ESF actuation functions listed in the DCD Chapter 7 and Chapter 16 Section 3.3 are provided in this report. Other important to safety functions and non-safety functions are not provided in this document with the exception of DAS setpoints, which are provided in this document to demonstrate the setpoint relationship between the DAS and the protection and safety monitoring system (PSMS).

Section 2.0 of this report defines the terminology for the setpoint methodology contained in this report. Section 3.0 lists the appropriate references to codes, regulatory guidance, industry standards, and the US-APWR documents used in the preparation of this report. Section 4.0 addresses the regulatory basis and the assumptions that were employed during the preparation of this report for the statistical analysis of various protection CUs. Section 5.0 addresses the methodology used to determine the overall instrument uncertainties. The nominal trip setpoint (NTSP) is the limiting safety system setting (LSSS), since it accounts for all known errors appropriately combined in the total loop uncertainty calculation. The NTSP which is the actual setpoint within the protection system, is derived from the analytical limit (AL). Section 5.0 also provides the relationship between AL, NTSP, and CU. This section also addresses how the AL and safety limit (SL) are protected by periodically confirming the allowable value (AV) at the time of surveillance testing. Maintaining measured parameters within the AV ensures the AL is not exceeded. The NTSP includes additional safety margin, beyond the total loop uncertainties, to reduce the potential for exceeding the AV. In addition, a

performance test acceptance criteria (PTAC) is established to identify a degrading instrument before it exceeds its AV limit.

Section 6.0 of this report identifies the various inputs to the US-APWR PSMS, and the details of the statistical method of error combination for the safety functions. This section includes tables of the uncertainty terms and values for each RT and ESF actuation channel uncertainty calculation. Each table includes the function specific uncertainty algorithm, which notes the appropriate combination of instrument uncertainties used in determining the CU.

A summary table "Table 7-1, Summary – RT/ESF Functions" is provided which lists AL, NTSP, CU, Safety Margin, PTAC, and AV for various protection functions. In all cases, it was concluded that safety margin exists between the AL and the NTSP after considering the channel instrument uncertainties. The methodology to derive the NTSP values is based on the uncertainties in the channels plus safety margin so that the NTSP is farther away from the AL. The ALs listed in Tables 7-1 and 7-2 are the values used in various plant analyses to demonstrate that safety limits are protected.

## 1.1 Purpose

The purpose of this document is to establish the instrument setpoint methodology for the US-APWR and to establish the requirements and methodologies for determining and maintaining setpoints for the RT and ESF actuation functions listed in the US-APWR DCD Chapter 7 and Chapter 16 Section 3.3.

For the purpose of this document the protection system is defined as the reactor trip system (RTS) and the engineered safety features actuation system (ESFAS), including analog and digital processing functions, implemented for the US-APWR plant. The primary purpose of RTS and ESFAS is to detect plant conditions that indicate the occurrence of an anticipated operational occurrence (AOO) or postulated accident (PA) and initiate the plant safety features required to mitigate the event. These safety features consist primarily of the automatic actuation of RTs and ESF actuations as appropriate.

A secondary purpose of this document is to establish the requirements and methodologies for calculating uncertainties and determining or verifying the acceptability of setpoints associated with 1) procedural actions that are important to safety, and 2) control system functions directly related to a) initial conditions assumed in the safety analysis, b) interlocks credited in the analysis of AOOs, and c) Technical Specifications LCOs.

The US-APWR implements Option 3 of DC/COL-ISG-8 (Ref 3.2.5) for Technical Specifications setpoints and allowable values as described in DCD Chapter 16 (Specification 5.5.21) and plant-specific Technical Specifications for COL applications. This setpoint methodology is referenced by the setpoint control program (SCP).

## 1.2 Scope

### Protection system

Protection system setpoints are determined by the methodology defined in this document, which establishes the applicable contributors to instrument loop errors, the method in which

they are combined, and the method in which the resulting uncertainties are applied to ALs used in various plant analyses to demonstrate that safety limits are protected.

The methodology applicable to the US-APWR protection system setpoints, as described in Section 5.0, is consistent with American National Standards Institute (ANSI)/ Instrument Society of America (ISA)-S67.04.01-2000, Setpoints for Nuclear Safety-Related Instrumentation (Ref. 3.3.1). The basic algorithm used to derive the total uncertainty applied to the setpoint determination is the square-root of the sum-of-the-squares (SRSS) of all the individual applicable uncertainty terms as endorsed by the ISA standard. This methodology was developed in accordance with Regulatory Guide (RG) 1.105 (Ref. 3.2.1). The latest version of U.S. Nuclear Regulatory Commission (NRC) RG 1.105 Revision 3, endorses the 1994 version of ANSI/ISA-S67.04, Part I (Ref. 3.3.1) and is consistent with uncertainty combinations guidance established by ISA-RP67.04.02-2000 (Ref. 3.3.2). The appropriate individual uncertainties have been included in each RT and ESF actuation channel uncertainty calculation provided in Section 6.0, which are consistent with the guidance provided in RG 1.105.

Instrument uncertainties are categorized as random, and it is acceptable to combine these uncertainties by the SRSS method which has a 95% probability with a high degree of confidence. See Section 4.3 for more details.

#### Post Accident Monitoring

Branch Technical Position (BTP) 7-12 (Ref. 3.2.2), Section B.3, calls for review of "...setpoints that trigger procedural actions that are important to safety." The PAM Type A, B, and C variables listed in DCD Table 7.5-3 will be analyzed using the calculation methodology described in Section 5.1. This analysis will be used to establish setpoints for related alarms and emergency operating procedure (EOP) actions.

#### Control Systems

References 3.2.1, 3.2.4, 3.3.1 and 3.3.2 were derived for situations where an automatic function is provided for protecting a limit, where uncertainties must be accounted for to ensure that the limit is not exceeded. Most non-safety control system setpoints are provided for maintaining the plant at preferred operating ranges. These preferred operating ranges are not directly associated with safety limits. Therefore, the setpoint methodologies endorsed and approved by the NRC do not apply to most control system setpoints.

However, the safety analysis assumes certain initial plant conditions that depend on plant control and monitoring system functions, and some control system interlocks are credited in the analysis of certain AOOs to ensure single failures within the control systems cannot cause conditions that are outside the boundaries of the safety analysis. Also, the US-APWR Technical Specifications contain LCOs that may require manual action based on certain indicated or calculated plant parameters (e.g., thermal power). Therefore, the channel uncertainties associated with control system functions directly related to 1) initial conditions assumed in the safety analysis, 2) interlocks credited in the analysis of AOOs, and 3) Technical Specifications LCOs, will be analyzed using the calculation methodology described in Section 5.1. This analysis will be limited to error contributors that arise from normal operating conditions only, as described in Section 4.4.11.

The design basis described above, for application of the calculation methodology described in Section 5.1 to a limited set of non-safety control system setpoints, is consistent with the guidance in BTP 7-12, Section B.3, which calls for review of ...”non-safety setpoints for functions providing protective functions important to safety or that are relevant to compliance with technical specification limiting conditions for operation.”

## 2.0 DEFINITIONS

The following definitions are derived from ANSI/ISA-S67.04.01-2000 (Ref. 3.3.1) and its references, MHI Topical Reports, and as developed in this report for simplicity of presentation.

### **Allowable Value (AV):**

A limiting value that the trip setpoint or calibration setting may have when tested periodically, beyond which appropriate action shall be taken (ANSI/ISA-S67.04.01-2000). The allowable value defines the maximum and/or minimum limits of operability. It is the limiting value of the measured variable at which the trip setpoint or calibration setting may be found during instrument surveillance to provide adequate assurance that the AL remains protected. The allowable value is an LSSS specified in plant Technical Specifications. It is used by the plant to verify performance at prescribed surveillance intervals.

For the US-APWR, where trip setpoints are implemented in analog bistables, the AV is applied to those trip setpoints. Where trip setpoints are implemented in digital bistables, the AV is applied to calibration settings for the associated channel. This approach is described in more detail in Section 5.3.

### **Analog Bistable**

Instrument channels where bistable functions on analog measurements are implemented with analog technology, prior to or independent of the MELTAC platform. Analog channels can experience setpoint drift.

### **Analytical Limit (AL):**

Limit of a measured or calculated variable established by the safety analysis for the actuation of protective actions. Actuating protective actions at or before the AL ensures that the SL is not exceeded and/or design conditions of equipment/systems assumed in other analyses are not exceeded. Performance of the safety analyses with conservative ALs demonstrates that the established SLs and other acceptance criteria are not exceeded during AOOs and PAs.

### **As-found:**

The condition in which a channel, or a portion of channel, is found after a period of operation and before recalibration (if necessary) (ANSI/ISA-S67.04.01-2000). The as-found value is compared to the AV to determine channel operability.

### **Bias Allowance (BA):**

Bias allowance is an uncertainty component that consistently has the same algebraic sign and is expressed as an estimated limit of error. Bias is defined in ISA-RP67.04.02-2000. Bias terms are the fixed or systematic uncertainty components within a measurement and are not generally eligible for SRSS combinations. They can be sometimes removed, in which case they are not accounted for in the uncertainty calculation since they can be compensated for in the scaling of the instrumentation. Any bias effects that cannot be calibrated out are accounted for in the uncertainty calculation.

### **Calibration Setting**

The five points check is performed during channel calibration (0%, 25%, 50%, 75% and 100% of span). For channels where protection functions are implemented with digital bistables, an AV is defined for the calibration setting (i.e., the AV is a two-sided limit applied to each of the

five points). The AV for each of the five points is a component of the LSSS defined in the Technical Specifications.

**Calibration Tolerance (CT):**

The limit(s) within which a channel or a portion of channel is allowed to be left after channel calibration or final setpoint device adjustment. Typically, CT is a tolerance provided on both sides of a specified value. CT may be equal to sensor calibration accuracy (SCA), rack calibration accuracy (RCA) or a combination of both as determined by engineering judgment. This term is synonymous with “setting tolerance” as used in Reference 3.2.4 (RIS 2006-17) and “as-left tolerance” as used in Reference 3.3.1 (ANSI/ISA–S67.04.01–2000).

**Channel Calibration**

A channel calibration is the adjustment, as necessary, of the channel measurement devices such that it responds within the necessary range and accuracy to known values of the parameter that the channel monitors.

The performance of a CHANNEL CALIBRATION shall be consistent with DCD Chapter 16, Specification 5.5.21 “Setpoint Control Program”.

**Analog Processing Functions:**

For analog processing functions, channel calibration confirms the accuracy of the channel from sensor to designated test points (typically at the rack).

For analog measurements by way of analog processing functions, channel calibration confirms the channel accuracy at five calibration settings corresponding to 0%, 25%, 50%, 75% and 100% of the instrument range. For binary measurements by way of analog processing functions, the channel calibration confirms the accuracy of the channel’s state change at the nominal trip setpoint. For analog or binary measurements shared between analog processing functions and digital processing functions, channel calibration is conducted, using the method for the digital processing function described below.

**Digital Processing Functions:**

For digital processing functions, the channel calibration confirms the accuracy of the channel, encompassing the sensor and all devices in the channel required for channel operability, with the exception of output devices. Channel calibration encompasses devices that are subject to drift between surveillance intervals and all input and function processing devices that are tested through continuous automated self-testing. Refer to trip actuating device operational test (TADOT) for output devices.

For analog measurements by way of digital processing functions, channel calibration confirms the channel accuracy at five calibration settings corresponding to 0%, 25%, 50%, 75% and 100% of the instrument range. For binary measurements by way of digital processing functions, the channel calibration confirms the accuracy of the channel’s state change, at the nominal trip setpoint. For analog or binary measurements the confirmed settings are monitored on digital visual display unit (VDU) readouts, as described in Technical Report, “Safety I&C System Description and Design Process”, MUAP-07004 Section 4.4.1.

**RTDs and Thermocouples:**

Channel calibration of instrument channels with resistance temperature detector (RTD) or thermocouple sensors consists of an in-place qualitative assessment of sensor behavior at



designated test points. The remainder of the channel is calibrated, by signal injection, with overlap at those same test points, using the methods described above for analog measurements. For analog processing functions, the remainder of the channel may be calibrated during the channel operational test (COT).

**Channel Operational Test (COT)**

For analog processing functions, the COT shall be the injection of a simulated or actual signal into the channel as close to the sensor as practicable, at a point of overlap with channel calibration (typically at the rack), to verify operability of all devices in the channel required for channel operability.

For analog processing functions, the COT shall include adjustments, as necessary, of the required alarm, interlock, and trip setpoints required for channel operability such that the setpoints are within the necessary range and accuracy. For indicators the accuracy is confirmed at five calibration settings corresponding to 0%, 25%, 50%, 75% and 100% of the instrument range. For bistables the accuracy is confirmed at the NTSP. The COT may be performed by means of any series of sequential, overlapping, or total channel steps.

The performance of a COT shall be consistent with DCD Chapter 16, Specification 5.5.21 "Setpoint Control Program".

**Memory Integrity Check (MIC)**

For digital processing functions, the MIC is a check of the PSMS software memory integrity to ensure there is no change to the software that controls the processing algorithms, setpoints, time constants, time delays and continuous automatic self-test functions.

The PSMS is self-tested on a continuous basis from the digital side of all input modules to the digital side of all output modules. Self-testing also encompasses all data communications within a PSMS train, between PSMS trains and between the PSMS and PCMS. For the PSMS the self-testing is described in Technical Report, "Safety I&C System Description and Design Process," MUAP-07004 Section 4.3 and Technical Report, "Safety System Digital Platform - MELTAC-," MUAP-07005 Section 4.1.5. The software memory integrity test is described in Technical Report, "Safety I&C System Description and Design Process," MUAP-07004 Section 4.4.1 and Technical Report, "Safety System Digital Platform -MELTAC-," MUAP-07005 Section 4.1.4.1.c.

The performance of a MIC shall be consistent with DCD Chapter 16, Specification 5.5.21 "Setpoint Control Program".

**Channel Uncertainty (CU):**

The combined uncertainties of an instrument loop due to possible errors, either random or systematic, including process, sensing equipment, and digital conversion of the signal. It includes instrument and process rack uncertainties and non-instrument related effects which is process measurement accuracy (PMA). The uncertainty is generally identified in terms of percentage of span.

**Digital Bistable**

Instrument channels where bistable functions on analog measurements are implemented within the digital MELTAC platform. Bistable functions in the MELTAC platform experience no (zero) setpoint drift.

**Drift (DR):**

An undesired change in output over a period of time where change is unrelated to the input, environment, or load (ANSI/ISA-S67.04.01-2000).

**Environmental Allowance (EA):**

The worst case environment conditions expected during or after a design basis event (DBE) in which the harsh environment may cause degradation to the plant instruments (e.g., elevated temperature effects, seismic effects, radiations effects). The EA is the change in a process signal due to adverse environmental conditions from a limiting accident condition or seismic event. The environmental allowances on the sensor are defined below as sensor seismic effect (SSE), sensor accident radiation effect (SREA) and sensor accident temperature effect (STEA). These effects must be considered for the CU of the instruments which are expected to be operational during and/or after the DBE conditions.

**Error:**

The algebraic difference between the indication and the ideal value of the measured signal (ANSI/ISA-S67.04.01-2000).

**Insulation Resistance Effect (IRE):**

It is the insulation resistance degradation effect. The IRE accounts for biases imposed in a loop due an increase in leakage current between the conductors of instrument signal transmission components such as signal cables, connectors, splices, terminal block, containment penetration, etc. The increased leakage is caused by the decrease of component insulation resistance due to extreme changes in environmental (e.g., elevated temperature and humidity) conditions and is treated as bias. Leakage currents are negligibly small under normal, non-accident conditions. Therefore, IRE effect is only considered credible during an accident environment. This term is used only in determining instrument channel uncertainty under high-energy line break or loss-of-coolant accident (LOCA) conditions. Additional guidance is provided in ISA-RP67.04.02-2000 (Ref. 3.3.2) for determination of insulation resistance.

**Limiting Safety System Setting (LSSS):**

LSSSs for nuclear reactors are settings for automatic protective devices related to those variables having significant safety functions (ANSI/ISA-S67.04.01-2000). Where a LSSS is specified for a variable on which a safety limit has been placed, the setting must be so chosen that automatic protective action will correct the abnormal situation before a safety limit is exceeded. The LSSS are values defined in the plant Technical Specifications, which determine equipment operability.

**Margin:**

There are two types of margin – safety margin and operating margin. Safety margin is a value determined by engineering judgment that is used to establish an NTSP value that is conservative with respect to the AL (less CU). The minimum safety margin prevents expected channel drift from exceeding the AV. Additional safety margin provides increased assurance of avoiding spurious trips and actuations. Safety margin moves the NTSP farther away from the AL and must assure that  $NTSP + PTAC$  (or  $NTSP - PTAC$  on a decreasing process) does not exceed the AV. The calculations developed during detailed design will determine the plant specific values for safety margin, and the resulting NTSP. The resulting operating margin varies for each parameter.

**Measurement and Test Equipment Effect (M&TE):**

Uncertainties of the measurement and test equipment utilized during the calibration of a device or multiple devices in an instrument loop.

**Nominal Trip Setpoint (NTSP):**

A predetermined value for actuation of a bistable (either analog or digital) to initiate a protective action (ANSI/ISA–S67.04.01–2006, Ref. 3.3.3). This protective action could be a trip or other mitigating function. This is the actual setting value within the protection system. The NTSP accounts for the various instrumentation loop uncertainties including safety margin for conservatism to ensure that the AL is not exceeded.

**Performance Test Acceptance Criteria (PTAC):**

The as-found limits used to identify degraded instruments for values that are actually measured during periodic performance tests. PTAC reflects expected drift between performance test intervals and known calibration uncertainties at performance test conditions. Therefore, it is used to provide early warning of instrument degradation, prior to exceeding the AV, which is unlikely to be exceeded unless the degradation is severe.

**Primary Element Accuracy (PEA):**

The accuracy of the device installed in the process being measured. It is the measurement error of a primary element (excluding associated transmitter) that is in contact with a process resulting in some form of interaction (e.g., this parameter is generally limited to use in orifice plates, flow element, elbow tap, venturi, etc.).

**Process Measurement Accuracy (PMA):**

Allowance for non-instrument related effects which are caused by the characteristic of the changing process signal received by the sensor (e.g., temperature changes or stratification, fluid density changes on level measurement, velocity effects, etc.).

**Rack Calibration Accuracy (RCA):**

RCA is defined as the two-sided calibration tolerance of the process racks as reflected in the plant calibration procedures. All rack accuracies except for the temperature effects are included in RCA in the case of the digital MELTAC platform. Because of the self-calibrating feature of digital MELTAC platform, the rack reference accuracy (RRA) is implicitly included with the RCA term (see Section 5.2).

**Rack Reference Accuracy (RRA):**

The reference accuracy (RA) or accuracy rating that is achievable by the instrument as specified in the manufacturer's specification sheets. Inherent in this definition is the verification of the following under a reference set of conditions; 1) conformity 2) hysteresis and 3) repeatability.

**Rack Temperature Effect (RTE):**

The input-output relationship for the process rack may be affected due to changes in the ambient environment conditions.

**Safety Limit (SL):**

A performance limit on the physical barriers that guard against the uncontrolled release of radioactivity. Actuation of the protective actions at the AL, protects the SL.

**Sensor:**

The portion of a channel that responds to changes in a process variable and converts the measured variable into an instrument signal (ANSI/ISA–S67.04.01–2006), e.g., electric or pneumatic output.

**Sensor Accident Radiation Effect (SREA):**

The error introduced due to degradation of the instrument as a result of radiation exposure during postulated accident conditions. Most instruments (excluding post accident monitoring) are designed to perform their trip functions before harsh radiation conditions are established. However, the environmental data must be evaluated and it must be shown in the calculation that the radiation level for trip conditions is below the threshold for radiation induced error. It is a random error obtained from vendor's functional specifications or qualification data.

**Sensor Accident Temperature Effect (STE):**

The error introduced due to change in the ambient temperature from the normal operating conditions to the postulated accident conditions.

**Sensor Calibration Accuracy (SCA):**

The calibration accuracy for sensor or transmitter as defined by the plant calibration procedures, typically equal to sensor reference accuracy.

**Sensor Power Supply Effect (SPS):**

This effect must be evaluated for the transmitter. It is usually negligible because the normal voltage source maintains a tight tolerance and the error is relative to the variation in voltage.

**Sensor Pressure Effect (SPE):**

The error induced due to the process static pressure differences between calibration and operating conditions or the accuracy to which a correction factor is introduced for the difference between calibration and operating conditions of a differential transmitter.

**Sensor Reference Accuracy (SRA):**

A number or quantity that defines a limit that errors will not exceed when a device is used under specified operating conditions. It is defined as reference accuracy in ANSI/ISA–S67.04.01–2000 (Ref. 3.3.1). It is the manufacturer's reference accuracy that is achievable by the device. This term for analog devices typically includes linearity, repeatability, and hysteresis effects when performing only a single pass calibration, i.e., one up and one down.

**Sensor Seismic Effect (SSE):**

The uncertainties caused by the vibration associated with an earthquake. This effect is only considered, if the device must function after a seismic event and its value is based on instrument qualification data by the vendor. This is generally a random independent error.

**Sensor Temperature Effect (STE):**

The temperature error accounts for the uncertainties due to change in ambient temperature from the calibration base temperature to the operating conditions of the same device or for variations in the operating temperature environment of the device.

**Setpoint:**

A predetermined value at which a device (analog bistable or digital bistable) changes state to indicate that the parameter under surveillance has reached the selected value.

**Span:**

The term “span” is defined as the algebraic difference between minimum and maximum range value of the instrument in service.

**Uncertainty:**

The amount to which an instrument channel’s output is in doubt (or allowance made therefore) due to possible errors, either random or systematic. The term is generally identified within a probability and confidence level (ANSI/ISA–S67.04.01–2006) and is generally identified in terms of a percentage of the span of the instrument.

**UnMeasurable Uncertainty (UMU):**

The SRSS combination of unmeasurable uncertainties for a given channel or parameter. Unmeasurable uncertainties are described in Section 5.1.

### 3.0 APPLICABLE CODES AND STANDARDS

#### 3.1 U.S. Regulations

- 3.1.1 Technical Specifications, 10 CFR 50.36.
- 3.1.2 General Design Criteria for Nuclear Power Plants, 10 CFR 50, Appendix A. General Design Criteria (GDC) 13, "Instrumentation and Controls", GDC 20, "Protection System Functions"

#### 3.2 U.S. Nuclear Regulatory Guidance

- 3.2.1 Setpoints for Safety Related Instrumentation, RG 1.105, Rev.3, December 1999.
- 3.2.2 Guidance on Establishing and Maintaining Instrument Setpoints, NUREG-0800, Standard Review Plan (SRP), BTP 7-12, Rev.5, March 2007.
- 3.2.3 Acceptance Criteria and Guidelines on Instrumentation and Control Systems Important to Safety, NUREG-0800, SRP, Appendix 7.1-A, Rev.5, March 2007.
- 3.2.4 NRC Staff Position on the Requirements of 10 CFR 50.36, "Technical Specifications", regarding Limiting Safety System Settings during Periodic Testing and Calibration of Instrument Channels, Regulatory Issue summary RIS 2006-17, August 2006.
- 3.2.5 Final Interim Staff Guidance - Necessary Content of Plant-Specific Technical Specifications When a Combined License Is Issued, DC/COL-ISG-8, December 2008.

#### 3.3 U.S. Industry Guidance

- 3.3.1 Setpoints for Nuclear Safety-Related Instrumentation, ANSI/ISA-S67.04.01-2000, February 2000 (Reaffirmation of ANSI/ISA-S67.04, Part I-1994).
- 3.3.2 Methodologies for the Determination of Setpoints for Nuclear Safety-Related Instrumentation, ISA-RP67.04.02-2000, January 2000.
- 3.3.3 Setpoints for Nuclear Safety-Related Instrumentation, ANSI/ISA-S67.04.01-2006, May 2006.
- 3.3.4 Graded Approaches to Setpoints Determination, ISA-TR67.04.09-2005, October 2005.

#### 3.4 Other References

- 3.4.1 Design Control Document for the US-APWR, Rev. 3, March 2011.
- 3.4.2 Safety I&C System Description and Design Process, MUAP-07004-P Rev.7 (Proprietary) and MUAP-07004-NP Rev.7 (Non-Proprietary), May 2011.
- 3.4.3 Safety System Digital Platform – MELTAC, MUAP-07005-P Rev.8 (Proprietary) and MUAP-07005-NP Rev.8 (Non-Proprietary), July 2011.
- 3.4.4 Defense-in-Depth and Diversity, MUAP-07006-P-A Rev.2 (Proprietary) and MUAP-07006-NP-A Rev.2 (Non-Proprietary), September 2009.
- 3.4.5 Defense-in-Depth and Diversity Coping Analysis, MUAP-07014-P Rev.5 (Proprietary) and MUAP-07014-NP Rev.5 (Non-Proprietary), September 2011.

---

## 4.0 BACKGROUND

### 4.1 Regulatory Basis for the Methodology

10 CFR 50.36(c)(1)(ii)(A) (Ref. 3.1.1) and GDC 13 and 20 of 10 CFR 50, Appendix A (Ref. 3.1.2) apply to instrument setpoints.

10 CFR 50.36(c)(1)(ii)(A) requires that, where an LSSS is specified for a variable on which a SL has been placed, the setting must be chosen so that automatic protective action will correct the most severe abnormal situation anticipated without exceeding a safety limit. LSSSs are settings for automatic protective devices related to those variables having significant safety functions. A setpoint found to exceed technical specification limits is considered a malfunction of an automatic safety system. Such an occurrence can challenge the integrity of the reactor core, reactor coolant pressure boundary, containment, and associated systems.

10 CFR 50, Appendix A, GDC 13, "Instrumentation and Control," requires in part that instrumentation be provided to monitor variables and systems, and that controls be provided to maintain these variables and systems within prescribed operating ranges. The calculation of safety-related instrument setpoints for the US-APWR is based on RG 1.105 (Ref. 3.2.1) which describes a method acceptable to the NRC for complying with the applicable regulation, i.e., 10CFR50, Appendix A, GDC 13. RG 1.105 endorses the use of ISA 67.04-1994 part I. The US-APWR uses the latest industry guidance provided by ANSI/ISA 67.04.01-2000 (Reaffirmation of ANSI/ISA-S67.04, Part I-1994), and ISA RP67.04.02-2000 as described in DCD Chapter 7.

10 CFR 50, Appendix A, GDC 20, "Protection System Functions," requires in part that the protection system be designed to initiate operation of appropriate systems to assure that specified acceptable fuel design limits are not exceeded.

To meet 10 CFR 50.36(c)(1)(ii)(A), GDC 13 and GDC 20 requirements, SRP Appendix 7.1-A (Ref. 3.2.3) provides a reference to BTP 7-12 (Ref. 3.2.2) and RG 1.105 (Ref. 3.2.1) for guidance on establishing and maintaining instrument setpoints. ISA S67.04-1994 provides the nuclear industry with a standard for addressing instrument uncertainties and their associated impact on plant setpoints.

BTP 7-12 (Ref. 3.2.2) provides guidelines for reviewing the process that an applicant or licensee follows to establish and maintain instrument setpoints for the following objectives:

- To verify that setpoint calculation methods are adequate to ensure that protective actions are initiated before the associated plant process parameters exceed their analytical limits.
- To verify that setpoint calculation methods are adequate to ensure that control and monitoring setpoints are consistent with their requirements.
- To confirm that calibration intervals and methods established are consistent with safety analysis assumptions.

### 4.2 Industry Issues

The NTSP is calculated with consideration of all applicable instrument uncertainties, so that the trip or actuation will occur before the AL is reached, under all applicable adverse plant conditions. The AV is calculated based on normal drift expected in the instrument between

periodic surveillances and normal plant conditions expected during testing. NTSP also includes additional safety margin between the AL and the setpoint to allow degraded instruments to be identified before the AV is exceeded. To allow this early identification of degraded instruments even though AV is not exceeded, predefined as-found (i.e., PTAC) and as-left (i.e., CT) tolerances for surveillance testing are established with reference to the more conservative NTSP. The CT and PTAC terms are based on realistic values that provide reasonable assurance that the plant protection system instrumentation is performing as expected between the surveillance intervals. Therefore, instrument degradation would not be masked. The US-APWR setpoint methodology adopts the use of an assessment of as-found values based on the specific conditions stated in RIS 2006-17. Those conditions are:

- The setting tolerance band is less than or equal to the SRSS of reference accuracy, M&TE, and readability uncertainties.
- The setting tolerance is included in the total loop uncertainty.
- The pre-defined test acceptance criteria band for the as-found value includes either the setting tolerance or the uncertainties associated with the setting tolerance band, but not both of these.

The US-APWR plant as-found acceptance criteria for determining instrument degradation utilizes no more than the SRSS combination of the reference accuracy, M&TE error, and drift. Where calibration accuracy is equal to reference accuracy, either term may be used in the SRSS combination.

### 4.3 Statistics

Instrument uncertainties are categorized as random, bias, or abnormally distributed bias. It is assumed that the errors resulting from the inherent accuracy of the component instruments and errors resulting from the calibration of the instruments are independent and follow a Gaussian (normal) error distribution curve. A random uncertainty is a normally distributed variable that will fall between  $\pm 2\sigma$  95.6 % ( $\approx 95\%$ ) of the time. It is, therefore, acceptable to combine these errors at  $2\sigma$  (2 times standard deviation) value by the SRSS method which has a 95 % probability with a high confidence level. These independent uncertainties are errors whose value cannot be predicted with precision but can only be estimated by a probability distribution function. In calculation of the uncertainties for determining a trip setpoint and its allowable values, MHI uses 95/95 tolerance limits as an acceptable criterion, i.e., a 95% probability and 95% confidence level. Typical manufacturer's published accuracy figures are at  $2\sigma$  level with a 95.6 % probability on a normal error distribution curve.

RG 1.105 states that:

"The 95/95 tolerance limit is an acceptable criterion for uncertainties. That is, there is a 95 percent probability that the constructed limits contain 95 percent of the population of interest for the surveillance interval selected."

Although the 95/95 tolerance limit has an actual confidence level of  $1.96\sigma$ ,  $2\sigma$  is used to simplify calculations.

The independent uncertainties are errors whose value at a particular future instant cannot be predicted with precision but can only be estimated by a probability distribution function. The algebraic sign of a random uncertainty is equally likely to be positive or negative with respect to a given median value. Therefore, random uncertainties are eligible for the SRSS



combination propagated from the process measurement module through the signal conditioning module of the instrument channel to the device that initiates the actuation. Some uncertainties possess a significant correlation and are classified as dependent uncertainties. These dependent uncertainties are combined algebraically to create an independent uncertainty that is eligible for SRSS combination.

Bias uncertainties are those that consistently have the same algebraic sign. If they are predictable for a given set of conditions because of a known positive or negative direction, they are classified as bias with a known sign. If they do not have a known sign, they are treated conservatively by algebraically adding the bias in the worst direction. These are classified as bias with an unknown sign.

Abnormally distributed uncertainties are not eligible for SRSS combination since they do not have a normal distribution. Even if they are as likely to be positive or negative with respect to a given value, they are treated as a bias since they are non-normal.

#### 4.4 Assumptions

The guideline and assumptions listed below apply to this report. For plant specific guideline/assumptions, plant specific design documents will be provided.

- 4.4.1 Where bias terms have opposite effects on instrument accuracy, (positive vs. negative), and are both of known magnitude, the two uncertainties may be used to offset each other. If both magnitude and direction of a bias is known, (e.g., transmitter static pressure span effects), this effect can be calibrated out of an instrument and thus eliminated from the uncertainty calculation.
- 4.4.2 Any random independent term whose value is less than 1/10 of any of the other associated device random uncertainties can be statistically neglected.
- 4.4.3 Uncertainty terms of devices are calculated in terms of percent calibrated span.
- 4.4.4 For the purposes of the setpoint analyses, the instrumentation will be assumed to be calibrated at 70°F nominal ambient temperature. STE for the instrumentation will then be based on the temperature deviation between this assumed calibration temperature and the maximum and minimum ambient temperature of the specific location of the actual instrumentation.
- 4.4.5 RTE for the rack will then be based on the temperature deviation between the assumed calibration temperature (70°F) and the maximum and minimum ambient temperatures at the specific location of the actual rack.
- 4.4.6 The site specific procedures will be written to comply with the M&TE requirements and testing requirements for this methodology, and to specify trending requirements.
- 4.4.7 The random terms are assumed to have approximately normal probability distribution functions for the purposes of this document. Common industry practice is to assume that published vendor specifications are  $2\sigma$  values unless specific information is available to indicate otherwise.

- 4.4.8 M&TE is required to have accuracies equal to or better than the equipment setting tolerance. For the calibration of pressure or differential pressure devices, the accuracy of the sensor measurement & test equipment (SMTE) error is assumed to be at least the same as the accuracy of the device being calibrated (i.e., 1:1) which is readily achievable. This conservative assumption is to allow the technicians the flexibility of choosing the measurement and test equipment. Therefore, the SMTE will be assumed to be same value as SCA. All M&TE are assumed to have digital readout. Therefore, the readability error is not considered.
- 4.4.9 For the calibration of the process rack, it is assumed that the rack measurement & test equipment (RMTE) accuracy ratio is at least 4:1. All rack accuracies except for the temperature effects are included in RCA in case of the MELTAC platform.
- 4.4.10 A minimum safety margin is included to assure that NTSP + PTAC does not exceed AV (or NTSP – PTAC for a decreasing process). Additional safety margin is discretionary. The total safety margin and resulting operating margin varies for each parameter.
- 4.4.11 Operating environment:
- Normal plant operation: The parameters being monitored are assumed to be maintained within specified limits during normal plant operations. The setpoint calculations conservatively assume the worst case normal environmental effect based on the maximum environmental change for the specific sensor location.
  - Adverse environment: The channel uncertainty is calculated considering normal operating conditions and DBEs, if the system has to operate during and/or after a DBE condition. In calculating instrument uncertainties caused by a DBE, only uncertainties specific to the event, the installed equipment's environment, and required period of service need to be considered.

## 5.0 METHODOLOGY DESCRIPTION

This section describes the MHI setpoint methodology used to combine the US-APWR uncertainty components to determine the overall CU for the RT/ESF functions listed in Section 6.0 or other functions important to safety.

### 5.1 Methodology for Overall Channel Uncertainty

The methodology used to combine instrument loop uncertainties is an appropriate combination of those groups which are statistically and functionally independent. Those uncertainties which are not independent are conservatively treated by arithmetic summation and then systematically combined with other independent terms. Random and independent instrument loop uncertainties are combined using the statistical SRSS approach with abnormally distributed and non-random or bias uncertainties combined algebraically in accordance with ISA-RP67.04.02-2000. The calculation methodology for the US-APWR follows the intent of the procedure established in the ISA standard ANSI/ISA-S67.04.01-2000 and additional guidance on combining instrumentation uncertainties provided in ISA-RP67.04.02-2000. Also, various standards, such as ANSI, American Nuclear Society (ANS), and ISA approve the use of probabilistic and statistical techniques in determining safety-related setpoints.

The basic SRSS methodology is used in this report with minor changes to the nomenclature to facilitate presentation. All the error terms are combined together using the SRSS method to get maximum expected error. However, the error terms that are known to be non-random or are independent of other error terms included in the SRSS may be algebraically combined outside of the SRSS.

Instrument channel uncertainty for most of the protection system loops is determined by the following equation:

$$CU = \pm \sqrt{(PMA)^2 + (PEA)^2 + (SRA)^2 + (SCA)^2 + (SMTE)^2 + (SPE)^2 + (STE)^2 + (SD)^2 + (SPS)^2 + (SSE)^2 + (SREA)^2 + (STEA)^2 + (RCA)^2 + (RTE)^2 + (RD)^2 + (RMTE)^2} + IRE + BA$$

Where,

CU = Channel Uncertainty

The specific terms used in the calculation of CU are listed separately here for later use in the calculation of AV and PTAC, described in Sections 5.3 and 5.4, respectively.

#### **Measurable Uncertainties**

SCA = Sensor Calibration Accuracy

SD = Sensor Drift

SMTE = Sensor Measurement & Test Equipment Accuracy

RCA = Rack Calibration Accuracy

RD = Rack Drift (Analog Channels Only)

RMTE = Rack Measurement & Test Equipment Accuracy

#### **Unmeasurable Uncertainties**

PMA = Process Measurement Accuracy

PEA = Primary Element Accuracy

SRA = Sensor Reference Accuracy

SPE = Sensor Pressure Effect  
STE = Sensor Temperature Effect  
SPS = Sensor Power Supply Effect  
SSE = Sensor Seismic Effect  
SREA = Sensor Accident Radiation Effect  
STEA = Sensor Accident Temperature Effect  
RTE = Rack Temperature Effect  
IRE = Insulation Resistance Effect  
BA = Bias Allowance

The above mentioned error terms are defined in Section 2.0, Definitions. Note that the preceding equation is an example and may not be all inclusive. It is valid for protection loops that have only one input. If the measured parameter is calculated from several inputs, a specific approach may be necessary. All parameters contributing to the total CU are expressed in terms of % of span and "2 $\sigma$ ". Any input data that is not expressed in "2 $\sigma$ " and percent of span shall be converted to "2 $\sigma$ " and percent of span prior to inclusion in the total CU calculation.

The equation accounts for worst case conditions resulting from a harsh environment such as SREA and STEA, and PMA uncertainties. Since, the error caused by STEA bounds the normal STE, only the STEA error would be applied.

The PMA and PEA parameters are assumed to be independent of both sensor and rack parameters. The PMA term provides allowances for the non-instrument related effects; e.g., neutron flux, fluid density changes, and temperature changes. Where multiple, independent and random PMA terms apply, they can be combined using the SRSS methodology. The PMA does not include the PEA. The PEA term is a calculated or measured accuracy for the device and accounts for the accuracy of the device being installed in the process; e.g., elbows, nozzles, venturis, and orifice plates.

The error associated with the instrument is usually defined as the SRA. SRA is based on the capability of the instrument to repeat an output given an identical input for multiple tests. Depending on the number of samples in the test, this term is considered random approaching a normal distribution.

The parameters SCA, SPE, STE, SMTE, and SD are considered to be sensor allowances. These parameters are assumed to be independent terms supplied by the vendor. Based on vendor supplied data, product data sheets and qualification reports, these parameters are treated as 95/95 values unless otherwise specified by the vendor. The terms SCA and SMTE may be modified by the licensee as a result of the plant calibration and drift determination process. The SCA is treated as a 95/95 value based on the calibration and drift data evaluation. The SMTE term is treated as a 95/95 value based on vendor product data sheet.

## 5.2 Uncertainty of Digital I&C System (MELTAC Platform)

MHI uses the digital MELTAC platform for signal processing in the US-APWR safety I&C systems. The design and configuration of the MELTAC platform is described in more detail in the MELTAC platform Technical Report, MUAP-07005.

The parameters RCA, RTE, RD, and RMTE are assumed to be digital protection rack allowances. For MELTAC platform based digital racks, these terms are considered to be independent vendor supplied terms. Based on vendor data, these parameters satisfy 95/95 value.

A typical signal processing functional block diagram for the safety function with MELTAC platform is shown in Figure 5-1.

A signal processing path for safety functions via the MELTAC platform consists of a distribution module, an input module and a digital processing module. The distribution module is a completely passive device that adds no uncertainty and is therefore not included in any uncertainty calculations or shown in Figure 5-1. The input module (analog input module) processes a sensor signal through its signal conditioning and analog signal conversion or analog / digital (A/D) conversion. The uncertainty of the digital processing module is approximately 1E-3% of full scale (based on the rounding error of 16 bit sampling, Reference MUAP-07005, Section A.5), which is considered negligible. Only the uncertainty of the analog portion of the input module in the MELTAC platform needs to be considered.



**Figure 5-1 Typical Signal Processing Path in MELTAC Platform**



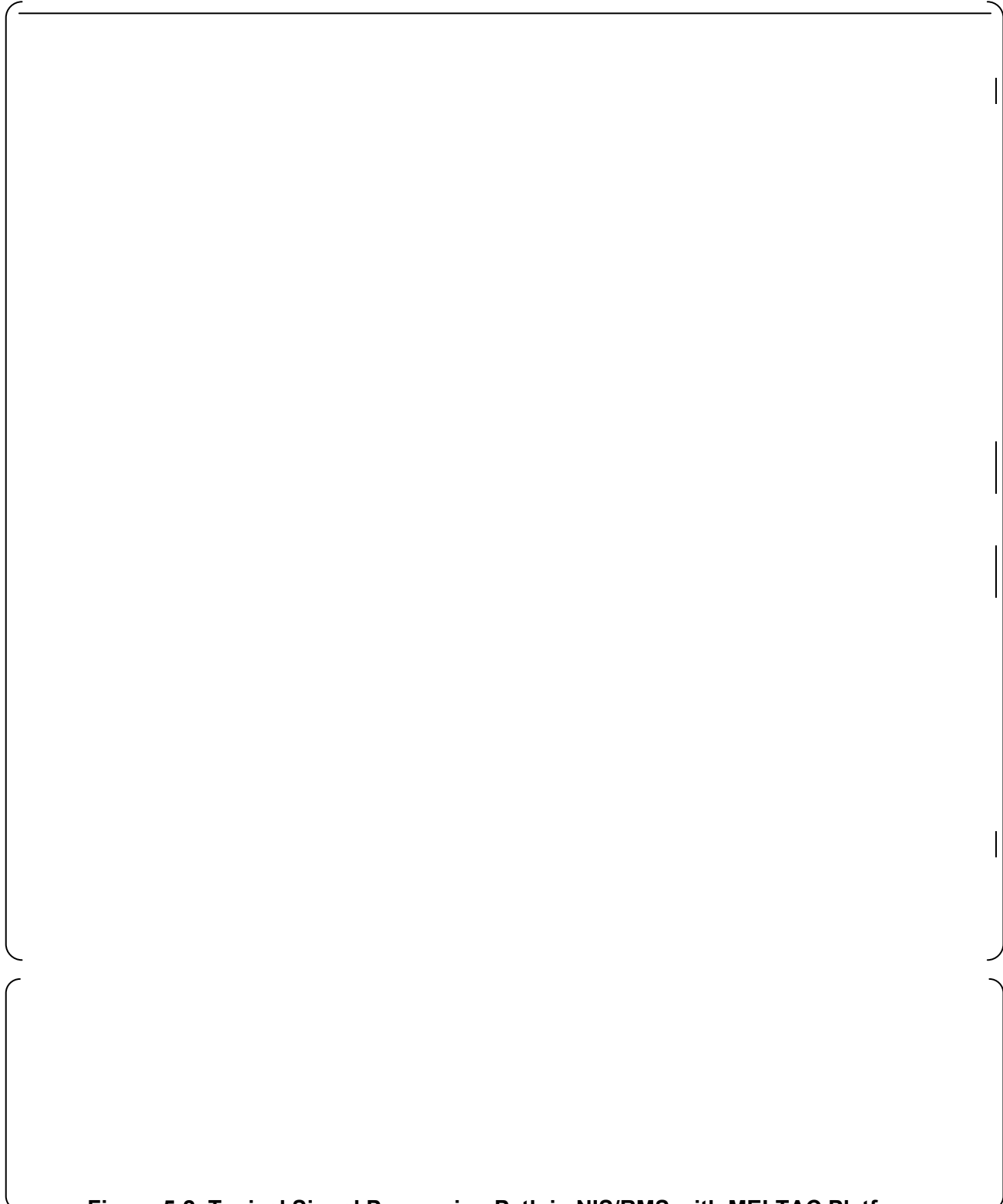

**Figure 5-2 Typical Signal Processing Path in NIS/RMS with MELTAC Platform**

### 5.3 Establishment of Setpoints and Allowable Values

For AOOs or PAs, protective actions by the RTS or ESFAS will occur at or prior to the AL, and will correct the monitored condition or mitigate the consequences of the monitored condition before a plant SL is reached. The NTSP is selected to assure that a trip or safety actuation occurs before the actual process value reaches the AL under all conditions. The NTSP accounts for all instrument uncertainties unless they were included in the determination of the AL. The NTSP is an LSSS managed by the plant Technical Specifications. The NTSP is the value at which the actual setpoint device is set to actuate. The NTSP also includes safety margin to allow instrument degradation to be detected and corrected before the AV is violated. The safety margin to the NTSP is chosen to be not too excessive to assure that the plant can operate and experience expected operational transients without unnecessary trips or safeguards challenges. The margin between normal plant operating limits and the NTSP is operating margin.

Uncertainties included in the determination of NTSP include instrument drift normally expected between calibration intervals. This drift, plus the uncertainties associated with the calibration effort itself, are referred to as the PTAC. Periodic recalibration to within the CT limits, ensures the expected drift is contained to within the value assumed during the NTSP determination.

Figure 5-3 illustrates the relationship between AL and NTSP and the relationship between AL and AV. The methods for calculating NTSP and AV are the same for analog and digital processing functions.

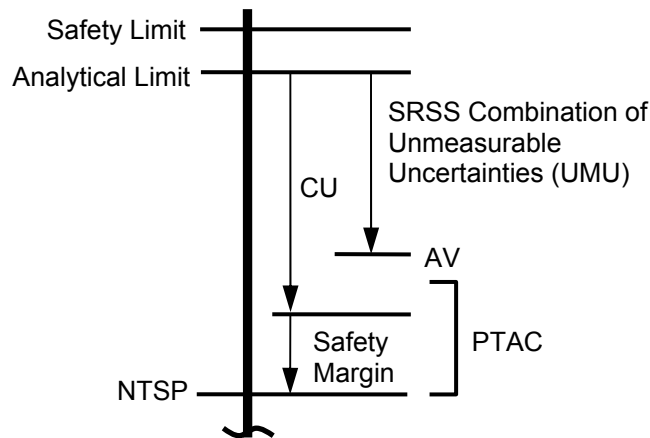

**Figure 5-3 Relationship between AL and NTSP, AL and AV**

$$\text{NTSP} = \text{AL} - \text{CU} - \text{Safety Margin}$$

$$\text{AV} = \text{AL} - \text{SRSS of Unmeasurable Uncertainties (UMU)}$$

CU is calculated using the equation described in Section 5.1. The CU represents the expected performance of the instrumentation under normal operating and accident (as applicable) conditions and it is calculated in Section 6 for each protection function.

A safety margin is included to accommodate normal expected conditions between surveillance intervals (e.g., drift). Safety margin is always greater than or equal to 0% of calibrated span, and must assure that NTSP + PTAC (increasing process) does not exceed AV. The minimum safety margin prevents expected channel drift from exceeding the AV. Additional safety margin provides increased assurance of avoiding spurious trips and actuations. Note that multiple safety margins could be determined for channels that perform multiple protection functions. See Sections 5.3.2 and 5.3.3 for a detailed discussion of surveillance test methods.

The SRSS of unmeasurable uncertainties is calculated using the same equation in Section 5.1, except the terms are limited to the terms listed under “Unmeasurable Uncertainties.” The total allowance between AL and NTSP can be defined as AL minus NTSP equal to CU plus safety margin (Total Allowance = AL – NTSP = CU + Safety Margin).

**5.3.1 Protection Functions via Analog Bistables**

Figure 5-5 illustrates the relationships between the trip setpoints and other parameters for protection functions implemented via conventional analog bistables. This figure illustrates how NTSP is derived, and how PTAC and AV are related to the trip setpoints. The protection functions implemented via analog bistables are associated with the DAS.

Surveillance testing and calibration of analog bistable channels is performed in two overlapping steps (i.e., Step 1 – Channel Calibration, Step 2 - COT)

Channel Calibration (Step 1)

Channel calibration confirms the instrument accuracy over its entire span. PTAC and CT limits are applied to the calibration settings (i.e., the five points checked during channel calibration - 0%, 25%, 50%, 75% and 100% of span). CT limits are applied to the as-left value of each calibration setting. The CT is a two-sided limit controlled by plant procedures, and is a function of SCA, RCA or a combination of both. Leaving the instrument calibrated within its CT limits gives the instrument room to drift as expected in the determination of NTSP. Channel calibration on analog measurements is illustrated in Figure 5-4.

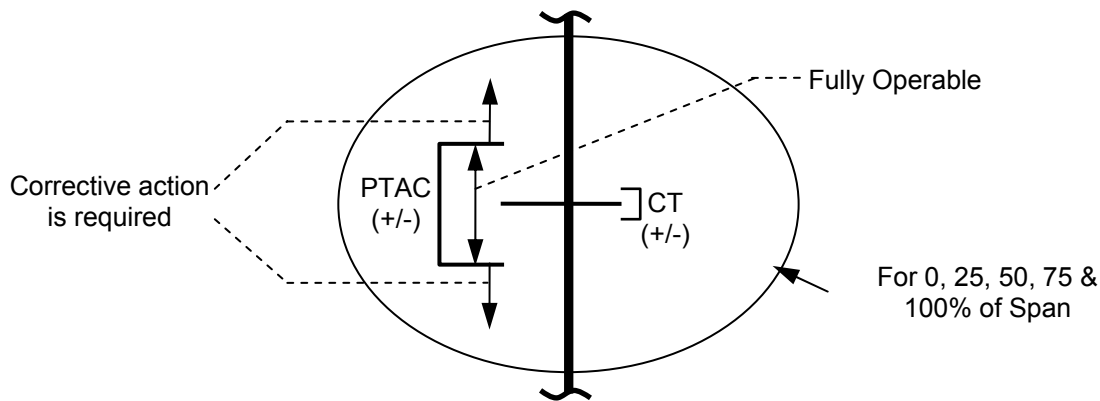

**Figure 5-4 Channel Calibration on Analog Measurements**



COT (Step 2)

COT confirms bistable accuracy. CT limits are applied to NTSP. Leaving the NTSP within its CT limits gives the analog bistable room to drift as expected in the determination of NTSP. COT for an increasing process trip function is illustrated in Figure 5-5. The Figure 5-5 illustrates the relationships between the NTSP and other parameters for protection functions implemented via conventional analog bistables. This figure illustrates how NTSP is derived, and how PTAC and AV are related to the NTSP.

The AV is used during periodic surveillance of analog bistables to determine operability. PTAC is used (relative to NTSP) to determine degradation, thus avoiding the use of excessive tolerances in as-found assessments as required by Reference 3.2.4 (RIS 2006-17). Plant procedures will reflect this approach:

- If the as-found trip value is less than NTSP + PTAC, then the channel is fully operable.
- If the as-found trip value is greater than NTSP + PTAC and less than AV, corrective action is required to restore the channel to within specifications.
- If the as-found trip value is greater than AV, then the channel is inoperable, and corrective action is required, including those actions required by 10 CFR 50.36 when automatic protective devices do not function as required.

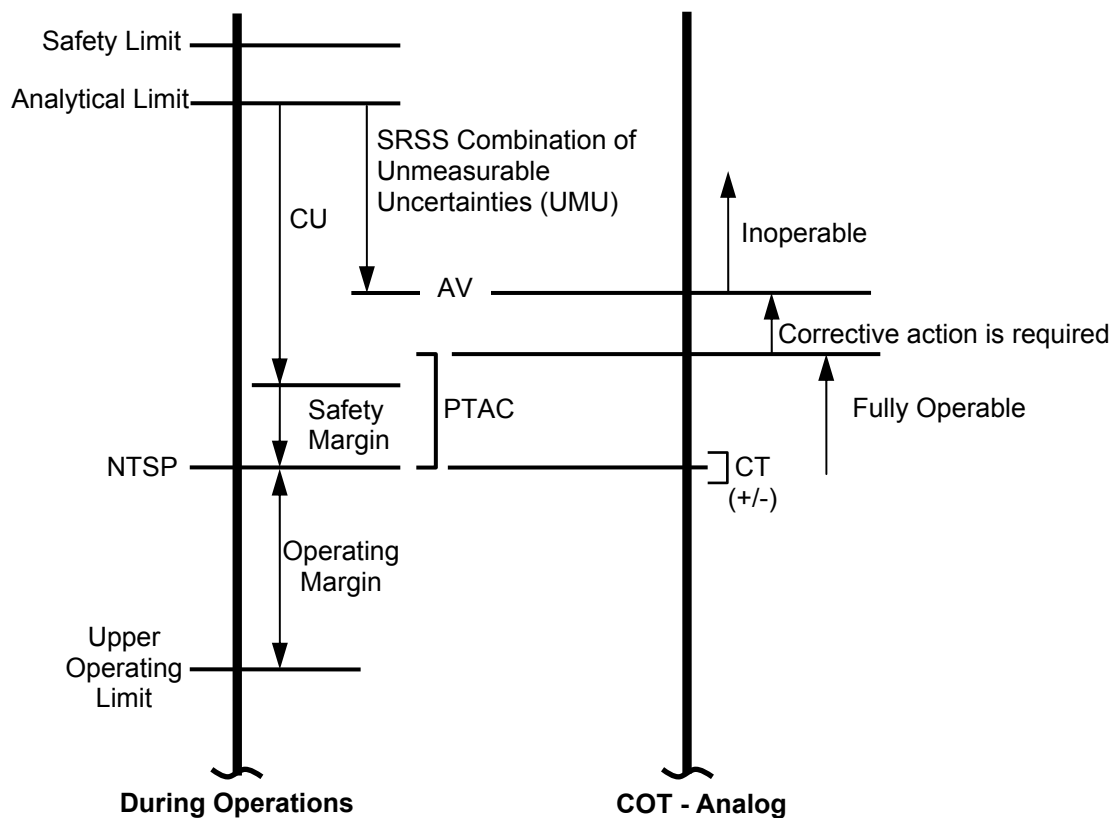

**Figure 5-5 Periodic Surveillance of Protection Function Implemented via Analog Bistables (Increasing Process)**

### 5.3.2 Protection Functions via Digital Bistables

Figure 5-6 illustrates the relationships between the trip setpoint and other parameters for protection functions implemented via digital bistables. This figure illustrates how the NTSP is derived, and how PTAC and AV are related to the calibration setting. The protection functions implemented via digital bistables in the US-APWR are all those that are implemented via analog bistables (identified above) and those originating as binary measurements (identified below).

Unlike protection functions implemented via analog bistables, which require two overlapping steps for periodic surveillance, protection functions implemented via digital bistables require only one step for periodic surveillance, channel calibration

Channel calibration confirms the complete channel accuracy over its entire span. AV, PTAC and CT limits are applied to the calibration settings (i.e., the five points checked during channel calibration - 0%, 25%, 50%, 75% and 100% of span).

The AV is a two-sided limit determined by selecting the most limiting difference between NTSP and AV from the setpoint calculation for the protection functions for a given channel. The most limiting AV is applied to each side of each calibration setting (0%, 25%, 50%, 75% and 100% of span). Referring to Figure 5-6:

$$\Delta 1 = | AV1 - NTSP1 |$$

$$\Delta 2 = | AV2 - NTSP2 |$$

To determine AVs for a given channel, select the lower of  $\Delta 1$  or  $\Delta 2$  (or  $\Delta n$  for channels with more than two protection functions), and add/subtract that value to/from each calibration setting.

The AV (relative to calibration settings) is used during channel calibration to determine operability. The PTAC term is described in Section 5.4. PTAC is used (relative to calibration settings) to determine degradation, thus avoiding the use of excessive tolerances as required by Reference 3.2.4 (RIS 2006-17). Plant procedures will reflect this approach:

- If all as-found calibration setting values are inside the two-sided limits of (Calibration Setting  $\pm$  PTAC), then the channel is fully operable.
- If any as-found calibration setting value is outside the two-sided limits of (Calibration Setting  $\pm$  PTAC), but inside the limits of (Calibration Setting  $\pm$  AV), corrective action is required to restore the channel to within specifications.
- If any as-found calibration setting value is outside the two-sided limits of (Calibration Setting  $\pm$  AV), then the channel is inoperable, and corrective action is required, including those actions required by 10 CFR 50.36 when automatic protective devices do not function as required.

Only one surveillance/calibration activity is required for digital channels as shown in Figure 5-6, as opposed to the two activities for analog channels shown in Figures 5-4 and 5-5, because there is no potential for drift in the digital bistable, and no bistable setting adjustments. Therefore, the only drift that can affect the NTSP is in the analog portion of the channel. By reading calibration settings on a VDU that is driven by the digital value converted from the

analog sensor signal (by the A/D converter in the input module), all potential drift in the analog portion of the channel can be checked in one surveillance/calibration activity.

Since there is only one surveillance/calibration activity, which confirms the calibration settings, the AV is applied to the calibration settings as shown on the right side of Figure 5-6. Therefore, an AV defined in reference to the calibration setting for a digital channel corresponds to an AV defined in reference to the NTSP for an analog channel. If the calibration settings are found within the applied AV, the NTSP will be accurate, the channel is operable, and the AL remains protected. Furthermore, if the calibration settings are found within the PTAC, the channel is operable with no degradation. Sensor CT is applied at the calibration settings for as-left limits.

This one-step surveillance/calibration approach for digital channels reduces the potential for human error because it is simpler and easier to implement than the traditional analog approach. It also reduces equipment out-of-service time, requires less M&TE, and reduces stay times in containment resulting in lower personnel dose (good for as low as reasonably achievable [ALARA]).

### 5.3.2.1 Calculated Functions

CUs for calculated functions, where two (2) or more signals are combined, are calculated using the methods described in Reference 3.3.2 (ISA-RP 67.04.02-2000, Appendix K). For calculated functions, the most limiting safety margin assigned to each input parameter shall be converted to the appropriate engineering units then summed together. The resulting total safety margin shall then be used to determine NTSP.

Total Safety Margin = (Safety Margin A x KA) + (Safety Margin B x KB) +....

Where:

A, B.... are process measurement inputs to the calculated function.

KA, KB.... are constants used to normalize each parameter to the engineering units of the function setpoints.

NTSP = AL - CU - Total Safety Margin

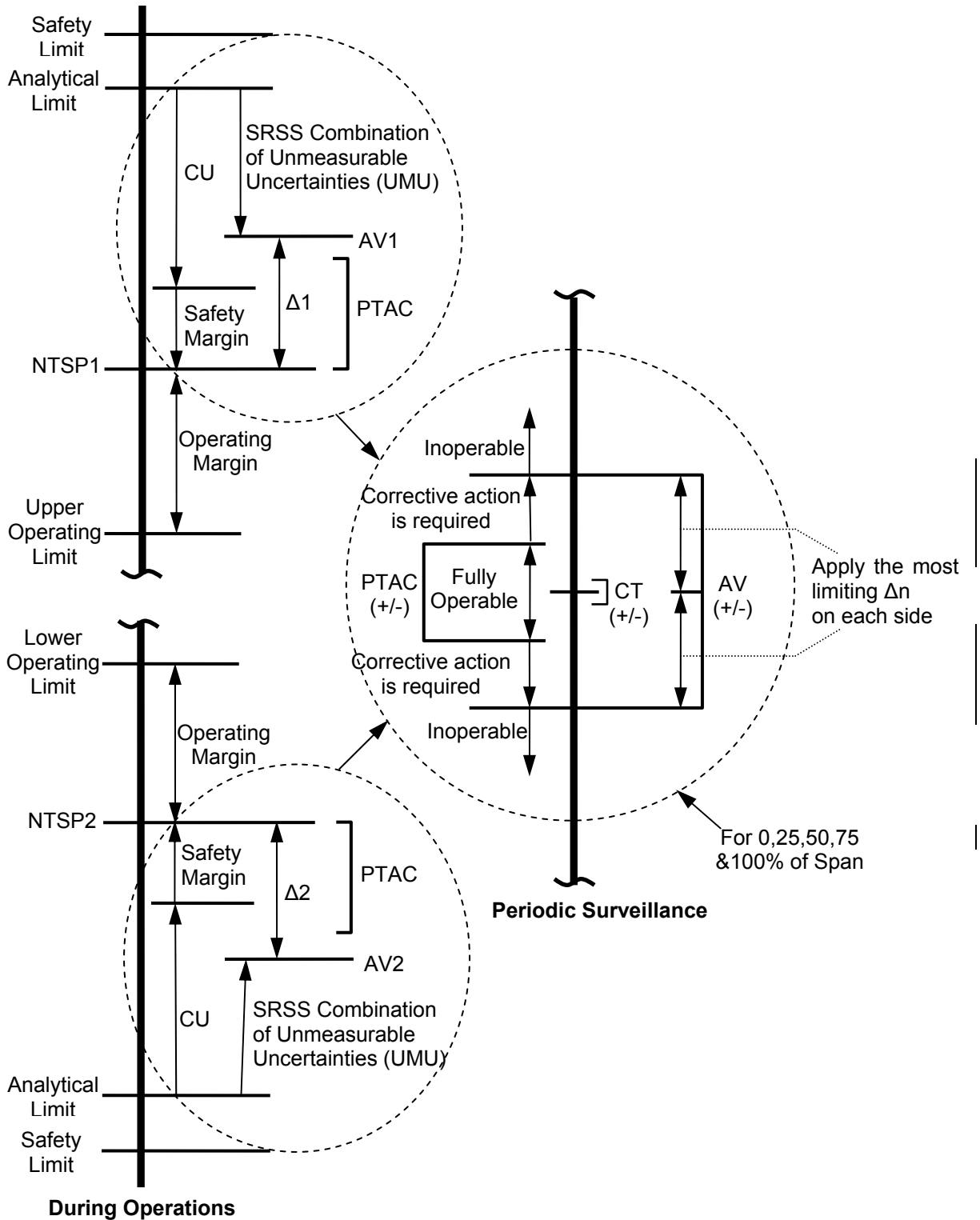

Figure 5-6 Periodic Surveillance of Protection Functions Implemented via Digital Bistables

### 5.3.2.2 Binary Sensors

Figure 5-7 illustrates the relationships between the trip setpoint and other parameters for protection functions implemented via binary sensors with drift potential connected to digital PSMS channels. These functions are 1) reactor trip (RT) on turbine trip (TT) via low turbine oil pressure (pressure switch) and 2) Loss of Power (LOP) signal (UV relay).

It is noted that the binary sensors used for actuation of Emergency Feedwater actuation due to a trip of all Main Feedwater Pumps have no drift potential.

Binary sensors connected to PSMS are surveyed in the same way as analog sensors connected to PSMS, whereby channel calibration confirms the complete channel accuracy in one step for periodic surveillance, with the exception that channel accuracy is checked at the binary sensor trip setting. AV, PTAC and CT limits are therefore applied to the NTSP.

The AV is used during channel calibration to determine operability. The PTAC term is described in Section 5.4. PTAC is used (relative to NTSP) to determine degradation, thus avoiding the use of excessive tolerances as required by Reference 3.2.4 (RIS 2006-17). Plant procedures will reflect this approach (increasing process; invert for decreasing process):

- If the as-found trip value is less than  $NTSP + PTAC$ , then the channel is fully operable
- If the as-found trip value is greater than  $NTSP + PTAC$  and less than AV, corrective action is required to restore the channel to within specifications.
- If the as-found trip value is greater than AV, then the channel is inoperable, and corrective action is required, including those actions required by 10 CFR 50.36 when automatic protective devices do not function as required.

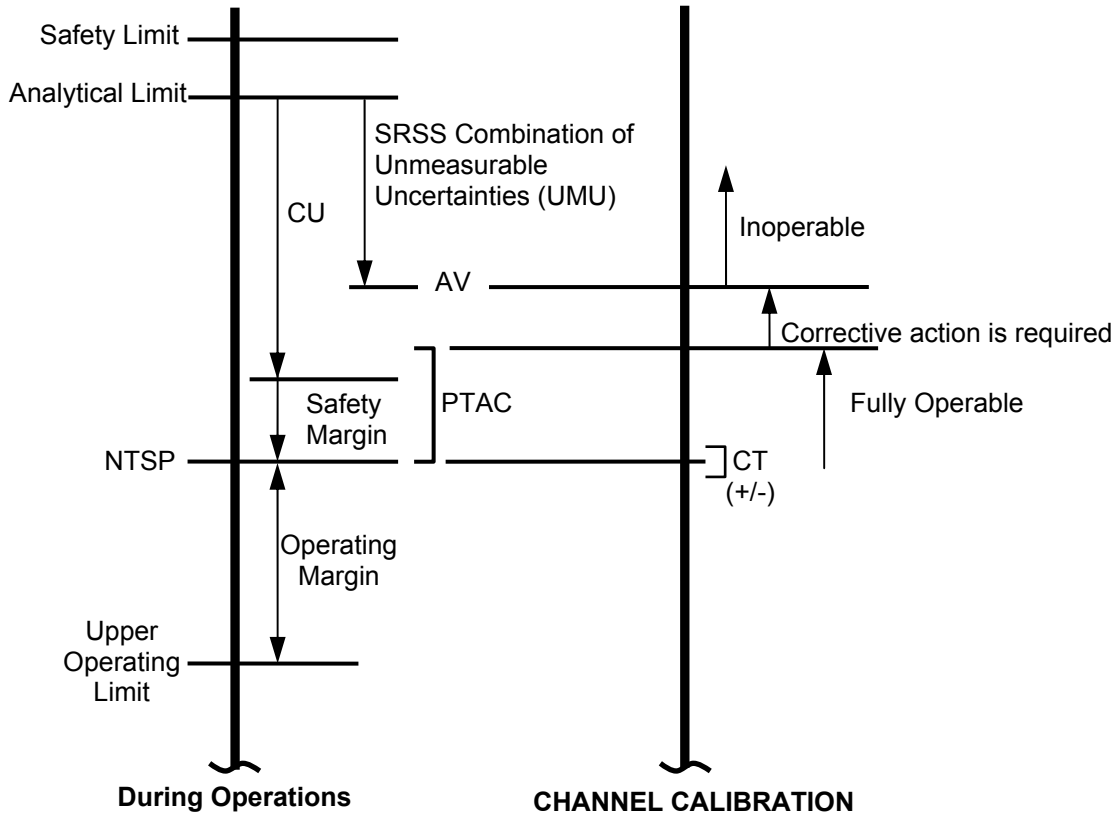

**Figure 5-7 Periodic Surveillance of Protection Functions Implemented via Binary Sensors Connected to PSMS (Increasing Process)**

**5.4 Performance Test Acceptance Criteria for Digital Channels**

Performance tests are designed to verify that the equipment being tested performs as expected. The instruments are periodically tested to verify that they perform their intended function within the expected accuracy. The acceptance criterion for a performance test is based on a calculation of the expected performance of the tested equipment. The expected uncertainty of the equipment being tested includes those uncertainty contributors expected to be present during the test and the expected uncertainty of the M&TE used in the test. A case by case determination of acceptance criteria is necessary.

PTAC is determined by the allowed calibration accuracy established by the calibration procedure, the anticipated drift for the instrument, and the M&TE accuracy. The drift term used would only account for the interval between successive surveillance periods.

For sensors, PTAC is calculated as follows:

$$PTAC_{SENSOR} = (SCA^2 + SD^2 + SMTE^2)^{1/2}$$

The MELTAC equipment is self-checking and cannot be calibrated. RD is not an expected error for the equipment racks and RMTE is included in RCA, so for digital racks PTAC is calculated as follows:

$$PTAC_{RACK (digital)} = (RCA^2)^{1/2}$$

For channel calibration settings which consider the total loop (sensor to VDU) PTAC is calculated as follows:

$$PTAC_{LOOP} = (SCA^2 + SD^2 + SMTE^2 + RCA^2)^{1/2}$$

For loops with additional components prior to the MELTAC racks, the additional components are each treated like an individual component calibration, or, if a loop calibration is performed, the SCA and SD of the extra components (or RCA and RD if rack mounted) are included in the PTAC equation as follows:

$$PTAC_{LOOP} = (SCA_1^2 + SD_1^2 + SMTE_1^2 + SCA_2^2 + SD_2^2 + \dots + RCA^2)^{1/2}$$

For calculated functions (Over Temperature  $\Delta T$ , Over Power  $\Delta T$ , and Tavg function, illustrated in Tables 6-5, 6-6, 6-7 and 6-20), PTAC is applied to each input signal used in the setpoint calculation using the  $PTAC_{LOOP}$  equations described above. PTAC is not applied to the internal digital calculations, as it is for conventional analog function processing, since there is no uncertainty in these digital calculations. This approach is acceptable because the channel calibration test confirms loop accuracy, and the MIC confirms the integrity of the digital setpoints, constants and calculations used in the calculated function, in the same manner as for all other digital protection functions. PTAC for DAS functions is described in Section 5.5.2.

## 5.5 Diverse Actuation System

DAS setpoints are established in the Defense-in-Depth and Diversity (D3) Coping Analysis, MUAP-07014 (Ref 3.4.5). BTP7-19, "Guidance for Evaluation of Diversity and Defense-in-Depth in Digital Computer-Based Instrumentation and Control Systems", allows best estimate methods for analysis that demonstrate adequate coping with common cause failure (CCF). Therefore, for DAS setpoints the basic assumption is that no errors or degradation are present when the function is required to perform. Therefore, the DAS bistable setpoints are established at the same value as the DAS analytical limit, with no channel uncertainty and no safety margin. Therefore, Channel Uncertainty and Safety Margin = 0, effectively making NTSP = AL. The DAS setpoints are defined in the Technical Specifications as NTSP. The DAS is described in DCD Chapter 7 and MUAP-07006 (Ref 3.4.4).

The sensor signal for DAS inputs is common to the PSMS. Therefore, this portion of the loop is tested through the PSMS channel calibration, described in Section 5.3.2. An additional COT is conducted for the remainder of the channel, which is uniquely applicable to DAS. The COT is conducted by injecting an analog test signal prior to the PSMS/DAS signal split. Therefore, this injected signal overlaps with the PSMS channel calibration. The injected signal is used to check the accuracy of the DAS bistable (at the NTSP as described in Section 5.3.1).



**Figure 5-8 Typical Signal Path of DAS with PSMS**



### 5.5.1 DAS vs. PSMS Setpoints

One of the design criteria of the US-APWR is to ensure PSMS actuations occur before DAS actuations occur. To accommodate fast transients, DAS actuations are delayed by 10 seconds, allowing PSMS to actuate first. PSMS and DAS setpoints must be enough apart to account for the instrument errors associated with each function.

The method used to determine adequate separation between DAS and PSMS setpoints evaluates the credible, worst case errors for each function as follows:

Error (DAS) = Error (Sensor) + Error (Isolator) + Error (Bistable), where

Error (Isolator) = Error (Isolator RCA\* + Isolator RD\* + Isolator RTE\* Isolator RMTE\*), and  
Error (Bistable) = Error (Bistable RCA\* + Bistable RD\* + Bistable RTE\* + Bistable RMTE\*)

Error (PSMS) = Error (Sensor) + Error (RCA) + Error (RTE)

Because this method postulates worst case credible errors for each function, but in opposite directions, the sensor errors can be ignored because DAS and PSMS share the same sensor, and sensor error cannot be positive and negative at the same time. Therefore,

Error (DAS) = Error (Bistable) + Error (Isolator), and  
Error (PSMS) = Error (RCA) + Error (RTE)

For an increasing process, the application of these terms is as follows:

$$\text{NTSP (DAS)} - \text{Error (Bistable)} - \text{Error (Isolator)} > \text{NTSP (PSMS)} + \text{Error (RCA)} + \text{Error (RTE)}$$

Rearranging terms:

$$\text{NTSP (DAS)} - \text{NTSP (PSMS)} > \text{Error (Bistable)} + \text{Error (Isolator)} + \text{Error (RCA)} + \text{Error (RTE)}$$

In other words, the difference between DAS and PSMS setpoints must be greater than the sum of the errors introduced by the DAS bistable, DAS isolator, and PSMS rack terms.

Substituting worst case errors:

$$(\text{NTSP (DAS)} - \text{NTSP (PSMS)}) \text{ must be greater than } 3.4\% \text{ of span}$$

Figures 5-9 and 5-10 illustrate how the credible worst case DAS and PSMS equipment errors compare using the equations above. Figure 5-9 is a generic diagram illustrating an increasing process. Figure 5-10 shows the Pressurizer Pressure Low (Reactor Trip) function (decreasing process), which is the worst case in terms of margin between the two setpoints (after accounting for credible errors).

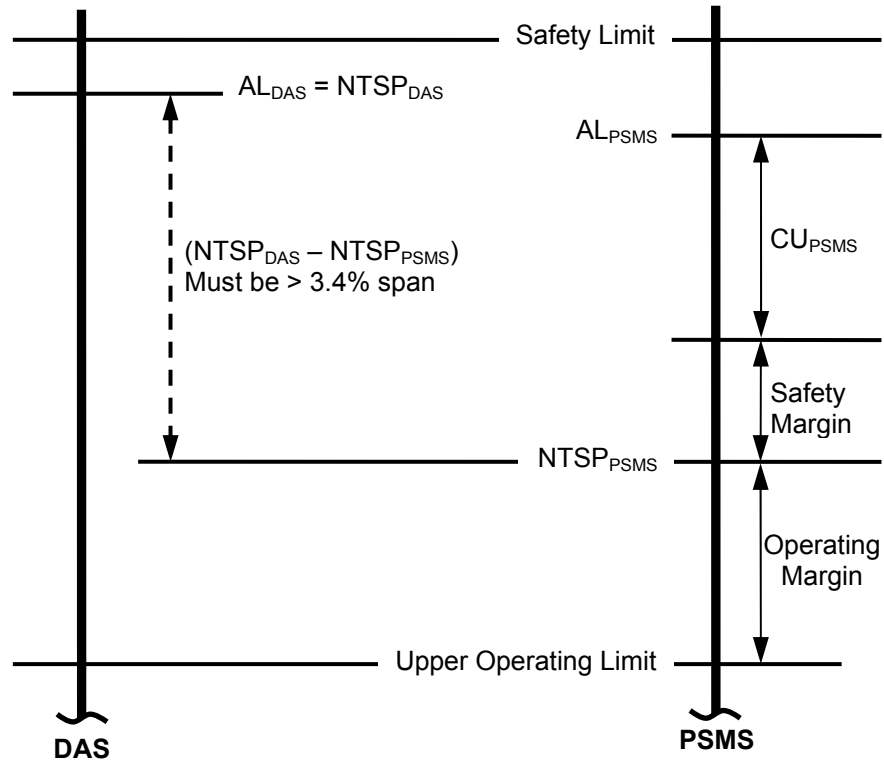

Figure 5-9 DAS vs PSMS Setpoints Relationship (Increasing Process)



Figure 5-10 Example of PSMS vs DAS Margin Analysis (Worst Case)

As listed in Table 5-1, the difference between DAS NTSP and PSMS NTSP is greater than 3.4% of span in all functions (i.e., 7.5% for Hi Pressurizer Pressure, 6.25% for Low Pressurizer Pressure, 7% for Low Steam Generator (SG) Water Level). Therefore, the design criterion to ensure PSMS functions occur before DAS functions occur on increasing or decreasing process transients is met. The PSMS and DAS setpoints are enough apart to account for the credible worst case instrument errors associated with each function.

**Table 5-1 DAS Setpoints vs PSMS Setpoints**

Process	Functions Common to DAS & PSMS	NTSP (PSMS)	NTSP (DAS)	Difference	Margin <sup>(1)</sup>
Hi Pressurizer Pressure (Increasing)	RT	2385 psig	2425 psig	60 psig (7.5% span)	4.1%
Low Pressurizer Pressure (Decreasing)	RT	1875 psig	1825 psig	50 psig (6.25% span)	2.85%
Low-Low Pressurizer Pressure (Decreasing)	Emergency Core Cooling Systems (ECCS) Actuation	1775 psig	1725 psig	50 psig (6.25% span)	2.85%
Low SG Level (Decreasing)	RT, Emergency Feedwater (EFW) Actuation	14%	7%	7%	3.6%

Note (1) Margin is: (DAS NTSP - PSMS NTSP) compared to 3.4%, for increasing process.

**5.5.2 DAS Allowable Value**

DAS is required for beyond-design-basis events due to CCF of PSMS concurrent with AOOs and PAs. Per BTP 7-19, best estimate methods are allowed for analyzing these events, whereby uncertainties can be ignored in the analysis. Therefore, the analysis assumes zero CU and “sets” NTSP at the AL. However, an AV is still necessary for surveillance testing of DAS channels, and PTAC is a suitable term for detecting measureable uncertainties above or below the setpoint. Therefore, for DAS, the AV applicable to the bistable COT is calculated as follows:

$$AV = NTSP + PTAC \text{ (increasing), or } AV = NTSP - PTAC \text{ (decreasing)}$$

where:

$$PTAC_{Bistable} = (SCA^2 + SD^2 + SMTE^2 + RCA_{Bistable}^2 + RD_{Bistable}^2 + RMTE_{Bistable}^2 + RCA_{Isolator}^2 + RD_{Isolator}^2 + RMTE_{Isolator}^2)^{1/2}$$

## 5.6 Uncertainty of Differential Pressure Flow Channel

This section describes the uncertainty conversion methodology for differential pressure ( $\Delta P$ ) flow channels. When  $\Delta P$  flow meters are applied to the instrument loop, the  $\Delta P$  is measured and converted to flow units through a square root extractor. The uncertainty of  $\Delta P$  is provided as a constant value against the  $\Delta P$  full span, while the uncertainty of flow converted from  $\Delta P$  cannot be provided as a constant value against the full span of flow.

The relationship between flow and measured differential pressure is represented as follows:

$$F^2 = \alpha \Delta P$$

where:

F: flow in flow channel,

$\Delta P$ : differential pressure in flow channel,

$\alpha$ : constant

The method used to calculate the uncertainty of differential pressure flow channels is described by transformation from the formula above, as follows:

$$\delta F (\% \text{ rated flow}) = (\delta \Delta P / 2) \times (F_{\max} / F)^2$$

where:

$\delta F$ : Flow uncertainty of flow channel (% rated flow),

$\delta \Delta P$ : Differential pressure uncertainty of flow channel (% full span)

$F_{\max}$ : Full span flow of flow channel (flow unit or % flow)

F: Flow of flow channel (flow unit or % flow)

## 5.7 Guidelines for Graded Approach

The statistical method presented in this report is the most common approach in use and is primarily focused on calculating a setpoint for a single instrument channel using acceptable statistical methods, where use of these methods is important to assuring the plant operates within the envelope of the accident analyses.

It is recognized that some setpoints are credited in various analyses for other functions that do not initiate reactor shutdown or actuate the engineered safety features. These functions do not have AVs managed by the Technical Specifications. Therefore, a graded approach is applied for these functions in accordance with ISA-TR67.04.09, Graded Approaches to Setpoints Determination (Ref. 3.3.4). This graded approach entails the use of engineering judgment to determine which uncertainty terms would apply to a given function (e.g., accident terms could be set to zero where an analysis assumes a control function maintains a controlled process state as an initial condition). The setpoints for these functions are established with consideration of the applicable uncertainties to ensure functions are maintained within the limits assumed in the applicable plant analysis. Safety margin is not added to these setpoints, since these setpoints are not managed by the Technical Specifications. However, PTAC is applied to these setpoints to allow detection of degraded equipment.

## 6.0 US-APWR PROTECTION SYSTEM SAFETY FUNCTIONS

To demonstrate the application of the setpoint methodology, the US-APWR automatic RT and ESF actuation functions are analyzed in this report. In addition, the automated DAS functions are analyzed in this report. This section includes detailed tables and a summary table of the uncertainty values for each calculation. Tables 6-1 through 6-24 provide individual component uncertainties and CU calculations for the RT and ESF actuation functions and DAS functions noted in Sections 6.1, 6.2, and 6.3 below. All uncertainties are generally expressed in % of span, unless specifically noted otherwise. All uncertainty values shown in Tables 6-1 through 6-24 are assumed values. An uncertainty value presented as "0" indicates that no specific uncertainty value is identified. The final computation of CUs must consider actual equipment specifications and plant conditions per the plant specific design. COL applicants may replace Tables 6-1 thru 6-24 with references to plant-specific uncertainty calculations that comply with the setpoint control program (SCP).

The following is a list of the US-APWR protection system functions and DAS functions used to demonstrate the setpoint methodology.

### 6.1 Reactor Trip Functions

- High Source Range (SR) Neutron Flux
- High Intermediate Range (IR) Neutron Flux
- High Power Range (PR) Neutron Flux (Low Setpoint)
- High Power Range Neutron Flux (High Setpoint)
- High Power Range Neutron Flux Positive Rate
- High Power Range Neutron Flux Negative Rate
- Over Temperature (OT)  $\Delta T$  Departure from Nuclear Boiling (DNB) Protection
- Over Temperature (OT)  $\Delta T$  Exit Boiling Limiting
- Over Power (OP)  $\Delta T$
- Low Reactor Coolant Flow
- Low Reactor Coolant Pump (RCP) Speed
- Low Pressurizer Pressure
- High Pressurizer Pressure
- High Pressurizer Water Level
- Low Steam Generator (SG) Water Level
- High-High SG Water Level
- Low Turbine Emergency Trip Oil Pressure

### 6.2 Engineered Safety Feature Functions

#### Emergency Core Cooling Systems (ECCS):

- Low Pressurizer Pressure
- Low Main Steam (MS) Line Pressure
- High Containment Pressure
- Loss of offsite power (LOOP) Signal – Undervoltage

#### Containment Spray:

- High-3 Containment Pressure

Main Control Room (MCR) Isolation:

- High MCR Outside Air Intake Radiation

Containment Purge Isolation:

- High Containment High Range Area Radiation

Main Feedwater (MFW) Isolation:

- High-High SG Water Level
- Low  $T_{avg}$

Main Steam Line Isolation:

- Low MS Line Pressure
- High MS Line Pressure Negative Rate
- High-High Containment Pressure

Emergency Feedwater Actuation:

- Low SG Water Level
- LOOP Signal

Emergency Feedwater Isolation:

- High Steam Generator Water Level
- Low Main Steam Line Pressure

Chemical Volume Control System (CVCS) Isolation:

- High Pressurizer Water Level

Turbine Bypass and Cooldown Valves Block:

- Low-Low  $T_{avg}$

### 6.3 Diverse Actuation System Functions

Reactor Trip, Turbine Trip (TT), MFW Isolation:

- Low Pressurizer Pressure
- High Pressurizer Pressure
- Low SG Water Level

EFW Actuation:

- Low SG Water Level

ECCS Actuation:

- Low-Low Pressurizer Pressure

**Table 6-1 Source Range Neutron Flux – High**  
 (Nominal Trip Setpoint  $1 \times 10^5$  cps\* - Reactor Trip)

Uncertainty Terms	Uncertainty (% of Span at Setpoint)
PMA	
PEA	
SRA	
SCA	
SPE	
STE	
SMTE	
SD	
RCA	
RTE	
RD	
RMTE	
BA	

\* DCD Table 7.2-3, Instrument Range =  $1 \times 10^6$  cps

( )

**Channel Uncertainty (CU):**

( )

**= ± 9.9 % of Span (± 0.59 decades) at trip setpoint**

**Table 6-2 Intermediate Range Neutron Flux – High**  
 (Nominal Trip Setpoint 25.0% RTP\* - Reactor Trip)

Uncertainty Terms	Uncertainty (% of RTP at Setpoint)
PMA	
PEA	
SRA	
SCA	
SPE	
STE	
SMTE	
SD	
RCA	
RTE	
RD	
RMTE	
BA	

\* DCD Table 7.2-3, Instrument Range = Approximately 8 decades of neutron flux overlapping source range by approximately 2 decades and including 100% Rated Thermal Power (RTP)

( )

**Channel Uncertainty (CU):**

( )

**= ± 12.5 % RTP at trip setpoint**



**Table 6-3 Power Range Neutron Flux - High**  
 (Low setpoint: Nominal Trip Setpoint 25.0% RTP\* - Reactor Trip)  
 (High setpoint: Nominal Trip Setpoint 109.0% RTP\* - Reactor Trip)

Uncertainty Terms	Uncertainty (% of RTP at Setpoint)
PMA	
PEA	
SRA	
SCA	
SPE	
STE	
SMTE	
SD	
RCA	
RTE	
RD	
RMTE	
BA	

\* DCD Table 7.2-3, Instrument Range = 1 to 120% RTP

[ ]

**Channel Uncertainty (CU):**

[ ]

**= ± 8.1 % RTP at low trip setpoint / ± 6.0 % RTP at high trip setpoint**

**Table 6-4 Power Range Neutron Flux**  
 (High Positive Rate: Nominal Trip Setpoint 10% RTP/sec\* - Reactor Trip)  
 (High Negative Rate: Nominal Trip Setpoint 7% RTP/sec\* - Reactor Trip)

Uncertainty Terms	Uncertainty (% of RTP)
PMA	
PEA	
SRA	
SCA	
SPE	
STE	
SMTE	
SD	
RCA	
RTE	
RD	
RMTE	
BA	

\* DCD Table 7.2-3, Instrument Range = 1 to 120% RTP

( )

**Channel Uncertainty (CU):**

( )

**= ± 1.8 % RTP/sec**

**Table 6-5 Over Temperature  $\Delta T$  - DNB Protection**  
 (Nominal Trip Setpoint Variable% RTP\* - Reactor Trip)

Uncertainty Terms	Uncertainty (% of Span)
PMA	See below
PEA	
SRA	
SCA	
SPE	
STE	
SMTE	
SD	
RCA	
RTE	
RD	
RMTE	
BA	

\* DCD Table 7.2-3

**Note:** (1) The range of the Over Temperature  $\Delta T$  function is 0 to 150% RTP. The following variables are monitored to derive the Over Temperature  $\Delta T$  value for DNB protection:

- (a) Reactor Coolant Cold Leg Temperature ( $T_{cold}$ ) 510 to 630°F
- (b) Reactor Coolant Hot Leg Temperature ( $T_{hot}$ ) 530 to 650°F
- (c) Pressurizer Pressure 1700 to 2500 psig
- (c) Neutron Flux (difference between top and bottom power range neutron flux detectors) -60 to 60% ( $\Delta I$ )

**Channel Uncertainty (CU):**

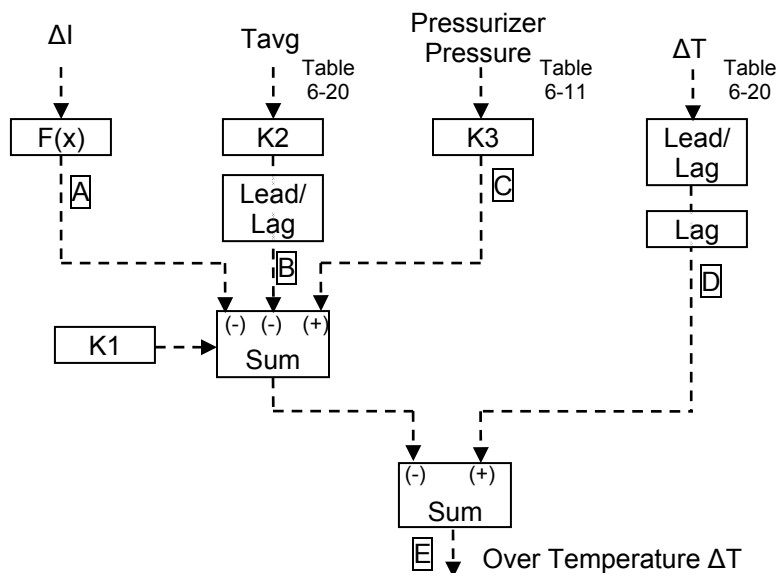

**Figure 6-1 Schematic of Over Temperature  $\Delta T$  (DNB) Reactor Trip**

As shown in Figure 6-1, above, four signals are used in the OT  $\Delta T$  (DNB) calculation.

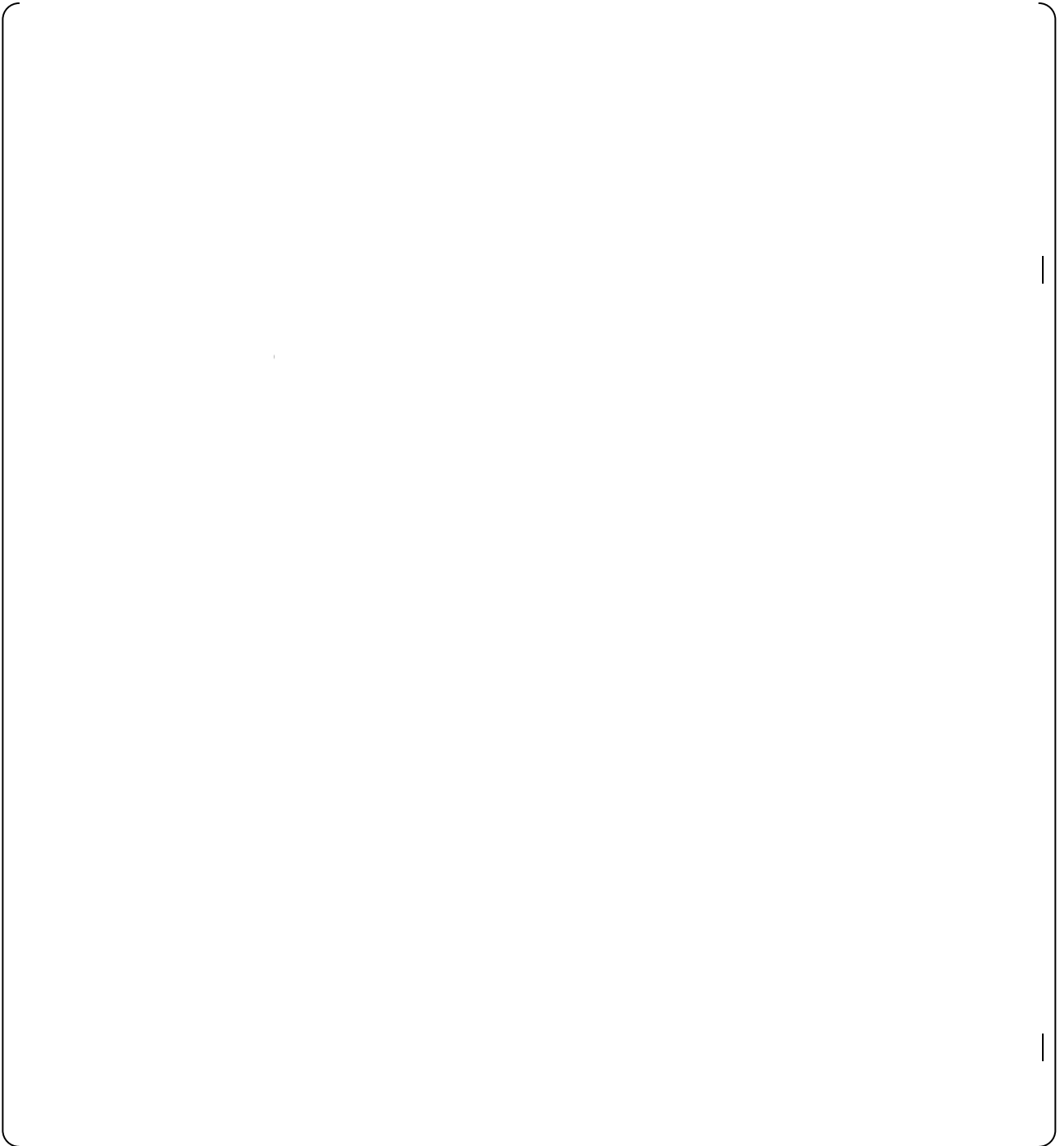

**CU = ± 3.7 % RTP**

**Table 6-6 Over Temperature  $\Delta T$  – Exit Boiling Limiting**  
(Nominal Trip Setpoint Variable% RTP\* - Reactor Trip)

Uncertainty Terms	Uncertainty (% of Span)
PMA	See below
PEA	
SRA	
SCA	
SPE	
STE	
SMTE	
SD	
RCA	
RTE	
RD	
RMTE	
BA	

\* DCD Table 7.2-3

**Note:** (1) The range of the Over Temperature  $\Delta T$  function is 0 to 150% RTP. The following variables are monitored to derive the Over Temperature  $\Delta T$  value for Exit Boiling Limiting protection:

- (a) Reactor Coolant Cold Leg Temperature ( $T_{cold}$ )      510 to 630°F
- (b) Reactor Coolant Hot Leg Temperature ( $T_{hot}$ )      530 to 650°F
- (c) Pressurizer Pressure      1700 to 2500 psig

**Channel Uncertainty (CU):**

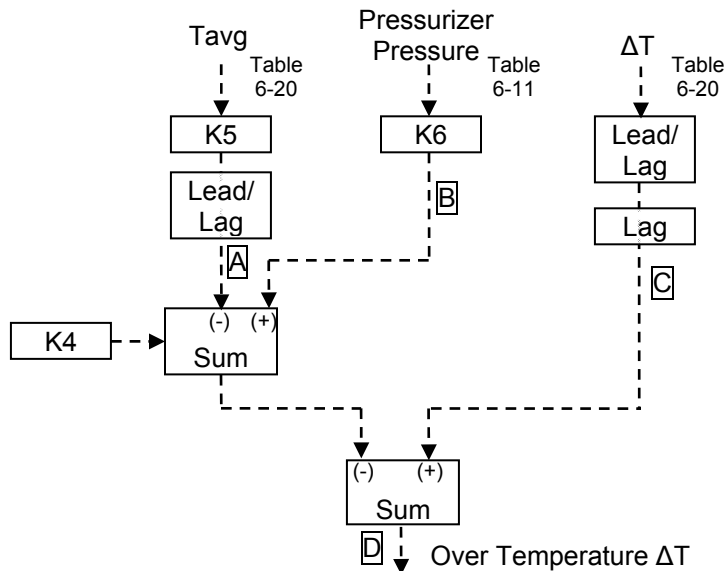

**Figure 6-2 Schematic of Over Temperature  $\Delta T$  (Exit Boiling Limiting) Reactor Trip**

As shown in Figure 6-2, above, three signals are used in the OT  $\Delta T$  (Exit Boiling Limiting) calculation.



**CU =  $\pm 7.5$  % RTP**

**Table 6-7 Over Power  $\Delta T$**   
(Nominal Trip Setpoint Variable RTP\* - Reactor Trip)

Uncertainty Terms	Uncertainty (% of Span)
PMA	See below
PEA	
SRA	
SCA	
SPE	
STE	
SMTE	
SD	
RCA	
RTE	
RD	
RMTE	
BA	

\* DCD Table 7.2-3

**Note:** (1) The range of the Over Power  $\Delta T$  function is 0 to 150% RTP. The following variables are monitored to derive Over Power  $\Delta T$  value:

- (a) Reactor Coolant Cold Leg Temperature ( $T_{cold}$ ) 510 to 630°F
- (b) Reactor Coolant Hot Leg Temperature ( $T_{hot}$ ) 530 to 650°F
- (c) Neutron Flux (difference between top and bottom power range neutron flux detectors) -60 to 60% ( $\Delta I$ )

**Channel Uncertainty (CU):**

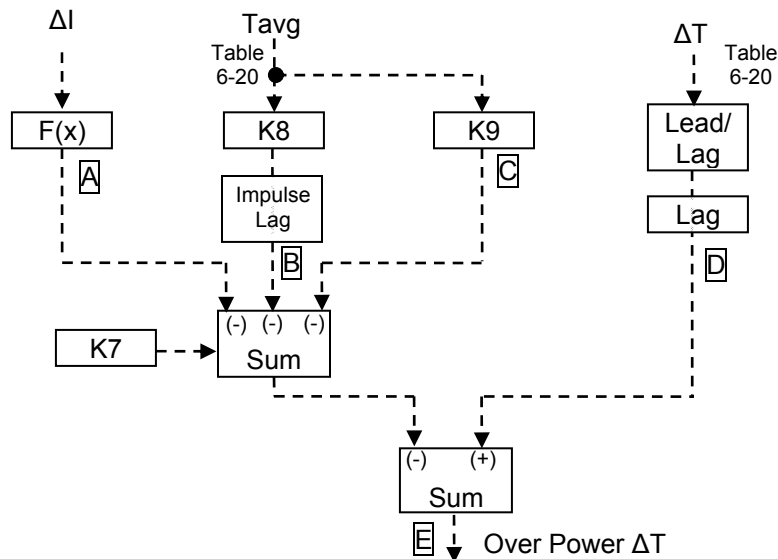

**Figure 6-3 Schematic of Over Power  $\Delta T$  Reactor Trip**

As shown in Figure 6-3, above, three signals are used in the OPΔT calculation.

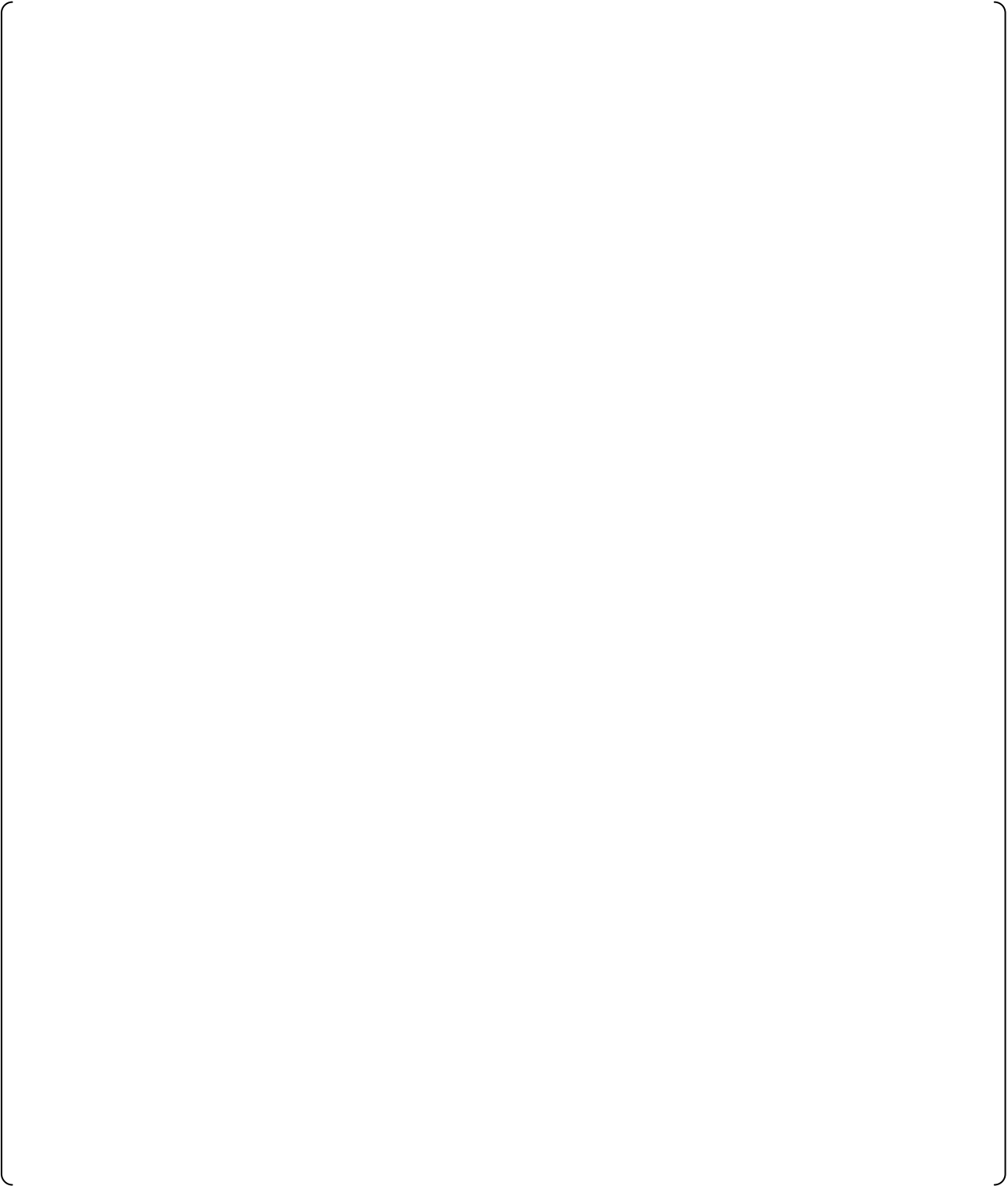

**CU = ± 3.5 % RTP**



**Table 6-8 Reactor Coolant Flow – Low**  
 (Nominal Trip Setpoint 91% of rated flow\* - Reactor Trip)

Uncertainty Terms	Uncertainty (% at 91%flow)
PMA	
PEA	
SRA	
SCA	
SPE	
STE	
SMTE	
SD	
RCA	
RTE	
RD	
RMTE	
BA	

\* DCD Table 7.2-3, Instrument Range = 0 to 120% of rated flow

[ ]

**Channel Uncertainty (CU):**

[ ]

**= ± 3.1% at 91% flow (2.9 % of Rated Flow)**

**Table 6-9 Reactor Coolant Pump Speed – Low**  
 (Nominal Trip Setpoint 95.5% of rated pump speed\* - Reactor Trip)

Uncertainty Terms	Uncertainty (% of Rated Seed)
PMA	
PEA	
SCA	
SPE	
STE	
SMTE	
SD	
RCA	
RTE	
RD	
RMTE	
BA	

\* DCD Table 7.2-3, Instrument Range = 0 to 120% of rated pump speed

[ ]

**Channel Uncertainty (CU):**

[ ]

**=± 0.1 % Rated Pump Speed**

**Table 6-10 Pressurizer Pressure – Low (including Accident Operation)**  
 (Nominal Trip Setpoint 1875 psig\* - Reactor Trip & 1775 psig\*\* - ECCS Actuation)

Uncertainty Terms	Uncertainty (% of Span)
PMA	
PEA	
SRA	
SCA	
SPE	
STE	
SMTE	
SD	
RCA	
RTE	
RD	
RMTE	
BA	

\* DCD Table 7.2-3, \*\* DCD Table 7.3-4, Instrument Range = 1700 to 2500 psig

**Channel Uncertainty (CU):**

[  
 = **±3.0 % of span (24 psi)**  
 ]

**Table 6-11 Pressurizer Pressure – High**  
 (Nominal Trip Setpoint 2385 psig\* - Reactor Trip)

Uncertainty Terms	Uncertainty (% of Span)
PMA	
PEA	
SRA	
SCA	
SPE	
STE	
SMTE	
SD	
RCA	
RTE	
RD	
RMTE	
BA	

\* DCD Table 7.2-3, Instrument Range = 1700 to 2500 psig

**Channel Uncertainty (CU):**

{ } (bracketed)

**= ± 2.1 % of Span (17 psi)**

**Table 6-12 Pressurizer Water Level – High**  
 (Nominal Trip Setpoint 92% of span\* - Reactor Trip and CVCS Isolation)

Uncertainty Terms	Uncertainty (% of Span)
PMA	
PEA	
SRA	
SCA	
SPE	
STE	
SMTE	
SD	
RCA	
RTE	
RD	
RMTE	
BA	

\* DCD Tables 7.2-3 and 7.3-4, Instrument Range = 0 to 100% of span

**Channel Uncertainty (CU):**

{ } (Large empty brackets for content)

**= ± 2.5 % of Span**

**Table 6-13 Steam Generator Water Level – Low (including Accident Operation)**  
 (Nominal Trip Setpoint 14% of span\* - Reactor Trip and EFW Actuation)

Uncertainty Terms	Uncertainty (% of Span)
PMA	
PEA	
SRA	
SCA	
SPE	
STE	
SMTE	
SD	
RCA	
RTE	
RD	
RMTE	
BA	

\* DCD Tables 7.2-3 and 7.3-4, Instrument Range = 0 to 100% of narrow range span

**Channel Uncertainty (CU):**

{ } (bracketed empty space)

**= ±13% of span**

**Table 6-14 Steam Generator Water Level – High, High-High**  
 (Nominal Trip Setpoint 54%of span\* - EFW Isolation,  
 69%of span - Reactor Trip, Turbine Trip and MFW Isolation)

Uncertainty Terms	Uncertainty (% of Span)
PMA	
PEA	
SRA	
SCA	
SPE	
STE	
SMTE	
SD	
RCA	
RTE	
RD	
RMTE	
BA	

\* DCD Table 7.3-4, Instrument Range = 0 to 100% of narrow range span

**Channel Uncertainty (CU):**

{ } (bracketed empty space)

**= ±5.0% of Span**

**Table 6-15 Main Steam Line Pressure – Low**  
 (Nominal Trip Setpoint 525 psig\* - ECCS Actuation, MS Line Isolation, and EFW Isolation)

Uncertainty Terms	Uncertainty (% of Span)
PMA	
PEA	
SRA	
SCA	
SPE	
STE	
SMTE	
SD	
RCA	
RTE	
RD	
RMTE	
BA	

\* DCD Table 7.3-4, Instrument Range = 0 to 1400psig

**Channel Uncertainty (CU):**

{

**= ± 1.7% of Span (24psi)**



**Table 6-16 Main Steam Line Pressure – High Negative Rate**  
 (Nominal Trip Setpoint 100 psig/sec\* - Main Steam Line Isolation)

Uncertainty Terms	Uncertainty (% of Span)
PMA	
PEA	
SRA	
SCA	
SPE	
STE	
SMTE	
SD	
RCA	
RTE	
RD	
RMTE	
BA	

\* DCD Table 7.3-4, Instrument Range = 0 to 1400 psig

**Channel Uncertainty (CU):**

{ } (Large empty brackets for content)

**= ± 0.6% of Span (8.4 psi)**

**Table 6-17 Containment Pressure – High, High-High and High-3**  
 (Nominal Trip Setpoint 6.8 psig\* - ECCS Actuation, 22.7 psig\* - MS Line Isolation,  
 34.0 psig\* - Containment Spray Actuation)

Uncertainty Terms	Uncertainty (% of Span)
PMA	
PEA	
SRA	
SCA	
SPE	
STE	
SMTE	
SD	
RCA	
RTE	
RD	
RMTE	
BA	

\* DCD Table 7.3-4, Instrument Range = -7 to 80 psig

**Channel Uncertainty (CU):**

{ } (bracketed empty space)

**= ± 2.0% of Span (1.8 psi)**

**Table 6-18 Main Control Room (MCR) Outside Air Intake Radiation – High**  
 (Nominal Trip Setpoint <sup>(1)\*</sup> - MCR Isolation)

Uncertainty Terms	Uncertainty (% of Span at Setpoint)
PMA	
PEA	
SRA	
SCA	
SPE	
STE	
SMTE	
SD	
RCA	
RTE	
RD	
RMTE	
BA	

\* DCD Table 7.3-4, Instrument Range (see below)

**Note:** (1) See below for specific setpoint value and instrument range for MCR Isolation signals.

<u>Signal</u>	<u>Inst. Range</u>	<u>Setpoint</u>
MCR Gas Radiation - High	1E -7 to 1E -2 µCi/cc	2E -6 µCi/cc
MCR Iodine Radiation – High	1E -11 to 1E -5 µCi/cc	8E -10 µCi/cc
MCR Particulate Radiation – High	1E -12 to 1E -7 µCi/cc	8E -10 µCi/cc

Measurement Range on Radiation Monitors is 1E+1 to 1E+7 cpm (6 decades).

(2) This value includes RCA, RRA, RTE, RMTE, and RD.

**Channel Uncertainty (CU):**

[ ]

**= ± 5.7 % of Span (0.34 decades) at trip setpoint**

**Table 6-19 Containment High Range Area Radiation – High**  
 (Nominal Trip Setpoint 100 R/h\* - Containment Purge Isolation)

Uncertainty Terms	Uncertainty (% of Span at Setpoint)
PMA	
PEA	
SRA	
SCA	
SPE	
STE	
SMTE	
SD	
RCA	
RTE	
RD	
RMTE	
BA	

\* DCD Table 7.3-4, Instrument Range = 1E+0 to 1E+7 R/h

[ ]

**Channel Uncertainty (CU):**

[ ]

**= ± 5.5% of span (0.38 decades) at trip setpoint**

**Table 6-20 Reactor Coolant Temperature Tavg – Low, Low-Low**  
 (Nominal Trip Setpoint 553°F\* - Block Turbine Bypass and Cooldown Valves,  
 564°F\* - MFW Control Valve Closure)

Uncertainty Terms	Uncertainty (% of Span)
PMA	
PEA	
SRA	
SCA	
SPE	
STE	
SMTE	
SD	
RCA	
RTE	
RD	
RMTE	
BA	

\* DCD Table 7.3-4, Instrument Range = 530 to 630°F,  
 (Tcold: 510 to 630°F, Thot: 530 to 650°F)

**Channel Uncertainty (CU):**

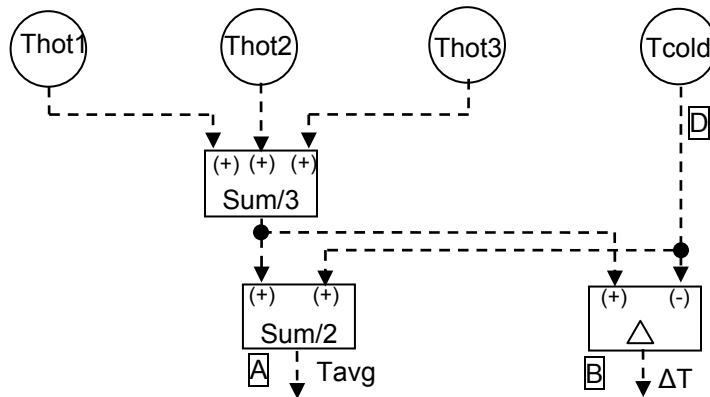

**Figure 6-4 Schematic of Tavg Low (TBV Block and MFW Isolation)**

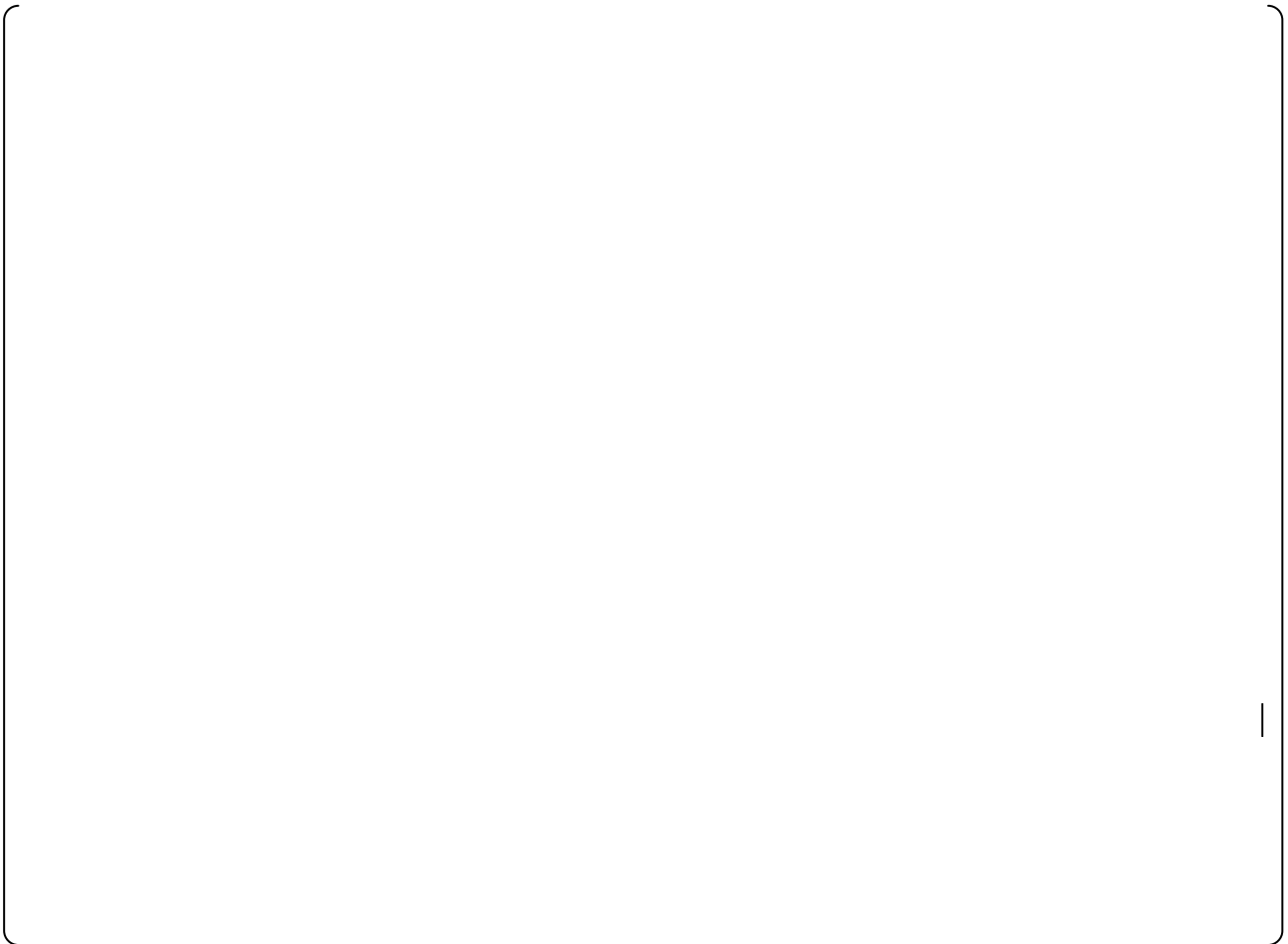

**CU = ± 1.5% span (1.8°F)**

**Table 6-21 Turbine Emergency Trip Oil Pressure – Low**  
 (Nominal Trip Setpoint 1000 psig\* – Reactor Trip)

Uncertainty Terms	Uncertainty (% of Span)
PMA	
PEA	
SRA	
SCA	
SPE	
STE	
SMTE	
SD	
RCA	
RTE	
RD	
RMTE	
BA	

\* DCD Table 7.2-3, Instrument Range = 0 to 3500 psig

[ ]

**Channel Uncertainty (CU):**

[ ]

**= ± 1.4% of Span (49 psi)**

**Table 6-22 LOOP Signal - Undervoltage (UV)**  
 Nominal Trip Setpoint (4934 V - Loss of Voltage, 6314 V - Degraded Voltage)

Uncertainty Terms	Uncertainty (% of Span)
PMA	
PEA	
SRA	
SCA	
SPE	
STE	
SPS	
SMTE	
SD	
RCA	
RTE	
RD	
RMTE	
BA	

\* Instrument Range = 0 to 6900V

**Channel Uncertainty (CU):**

( )

**= ±2.33 % of Line Volts AC (161 V)**



**Table 6-23 Pressurizer Pressure – (DAS)**  
 (Low Nominal Trip Setpoint 1825 psig - Reactor Trip, Turbine Trip, MFW Isolation)  
 (High Nominal Trip Setpoint 2425 psig - Reactor Trip, Turbine Trip, MFW Isolation)  
 (Low-Low Nominal Trip Setpoint 1725 psig – ECCS Actuation)

Uncertainty Terms	Uncertainty (% of Span)
PMA	
PEA	
SRA	
SCA	
SPE	
STE	
SMTE	
SD	
RCA	
RTE	
RD	
RMTE	
BA	

\* DCD Table 7.8-6, Instrument Range = 1700 to 2500 psig

**Channel Uncertainty (CU):**

[ ]

**= ± 2.3 % of Span (19 psi) for High Pressurizer Pressure**

[ ]

**= ±3.2 % of span (26 psi) for Low and Low-Low Pressurizer Pressure**

Because the CCF analysis uses best estimate methods, CU is provided here for reference only. See Section 5.5.

**Table 6-24 Steam Generator Water Level – Low (DAS)**  
 (Nominal Trip Setpoint 7.0% of span - Reactor Trip, Turbine Trip, MFW Isolation, EFW Actuation)

Uncertainty Terms	Uncertainty (% of Span)
PMA	
PEA	
SRA	
SCA	
SPE	
STE	
SMTE	
SD	
RCA	
RTE	
RD	
RMTE	
BA	

\* DCD Table 7.8-6, Instrument Range = 0 to 100% of span (narrow range taps)

**Channel Uncertainty (CU):**

[ ]

**= ±13.2 % of span**

Because the CCF analysis uses best estimate methods, CU is provided here for reference only. See Section 5.5.

## 7.0 SUMMARY OF RT AND ESF CHANNEL UNCERTAINTIES

A summary table, "Table 7-1", lists AL, CU, AV, Safety Margin, PTAC, and NTSP for RT and ESF actuation functions described in Section 6. Also a summary table "Table 7-2" lists AL, CU, AV, Safety Margin, PTAC, and NTSP for DAS functions. As noted in Section 6.0 the values provided in the tables are assumed for purposes of this evaluation. The final setpoint analysis for each specific plant must be performed with equipment specification and plant condition per plant specific design.

Table 7-1 Summary – RT/ESF Functions

No	Input Parameter	Protection Function	AL <sup>(1)</sup>	CU <sup>(2)</sup>	Safety Margin	AV <sup>(3)</sup>	UMU	PTAC <sup>(4)</sup>	NTSP <sup>(5)</sup>
1	SR Neutron Flux	RT on Hi Flux	---	±9.9% span					1 X 10 <sup>5</sup> cps (84% span)
2	IR Neutron Flux	RT on Hi Flux	---	±12.5% RTP					25% RTP
3	PR Neutron Flux	RT on Hi Flux (Low Setpoint)	35% RTP	±8.1% RTP					25% RTP
		RT on Hi Flux (Hi Setpoint)	118% RTP	±6.0% RTP					109% RTP
		RT on Hi Flux Positive Rate	---	±1.8% RTP/sec					10% RTP/sec <sup>(6)</sup>
4	OT ΔT	RT on Hi Flux Negative Rate	---	±1.8% RTP/sec					7% RTP/sec <sup>(6)</sup>
		RT on OTΔT (DNB Protection)	115.4% RTP	±3.7% RTP					109.8% RTP
5	OP ΔT	RT on OTΔT (Exit Boiling Limiting)	205.5% RTP	±7.5% RTP					195% RTP
6	Reactor Coolant Flow	RT on OPΔT	116.2% RTP	±3.5% RTP					110.6% RTP
7	RCP Speed	RT on Low Flow	87% rated flow	±2.9% rated flow					91% rated flow
8	Pressurizer Pressure	RT on Low Pump Speed	95% rated pump speed	±0.1% rated pump speed					95.5% rated pump speed
		RT on Low Pressure (Accident)	1860 psia (1845 psig)	±24 psi (3.0% span)					1875 psig
		ECCS on Low Pressure (Accident)	1760 psia (1745 psig)	±24 psi (3.0% span)					1775 psig
		RT on Hi Pressure	2425 psia (2410 psig)	±17psi (2.1% span)					2385 psig

No	Input Parameter	Protection Function	AL <sup>(1)</sup>	CU <sup>(2)</sup>	Safety Margin	AV <sup>(3)</sup>	UMU	PTAC <sup>(4)</sup>	NTSP <sup>(5)</sup>
9	Pressurizer Water Level	RT on Hi Level	100% span	±2.5% span					92% span
		CVCS Isolation on Hi Level	---	±2.5% span					92% span
10	SG Water Level (Narrow Range)	RT on Low Level (Accident)	0% span	±13% span					14% span
		RT on Hi-Hi Level	75% span	±5% span					69% span
		MFWS Isolation on Hi-Hi Level	75% span	±5% span					69% span
		EFW Actuation on Low Level (Accident)	0% span	±13% span					14% span
		EFW Isolation on Hi Level	60% span	±5% span					54% span
		Turbine Trip on Hi-Hi Level	---	±5.0% span					69% span
11	MS Line Pressure	ECCS on Low Pressure	500 psia (485 psig)	±24 psi (1.7% span)					525 psig
		MS Line Isolation on Low Pressure	500 psia (485 psig)	±24 psi (1.7% span)					525 psig
		MS Line Isolation on Hi Negative Rate	---	±8.4 psi (0.6% span)					100 psi/sec <sup>(6)</sup>
		EFW Isolation on Low Pressure	500 psia (485 psig)	±24 psi (1.7% span)					525 psig
12	Containment Pressure	ECCS on Hi Pressure	24.0 psia (9.3 psig)	±1.8 psi (2.0% span)					6.8 psig
		MS Line Isolation on Hi-Hi Pressure	39.9 psia (25.2 psig)	±1.8 psi (2.0% span)					22.7 psig
		Containment Spray Actuation on Hi-3 Pressure	51.2 psia (36.5 psig)	±1.8 psi (2.0% span)					34.0 psig

No	Input Parameter	Protection Function	AL <sup>(1)</sup>	CU <sup>(2)</sup>	Safety Margin	AV <sup>(3)</sup>	UMU	PTAC <sup>(4)</sup>	NTSP <sup>(5)</sup>
13	MCR Outside Air Intake Radiation	MCR Isolation on Hi Gas Radiation	---	±0.34 decades (5.7% span)	Safety Margin				2X10 <sup>-6</sup> µCi/cc
		MCR Isolation on Hi Iodine Radiation	---	±0.34 decades (5.7% span)					8X10 <sup>-10</sup> µCi/cc
		MCR Isolation on Hi Particulate Radiation	---	±0.34 decades (5.7% span)					8X10 <sup>-10</sup> µCi/cc
14	Containment Radiation	Containment Purge Isolation on Hi Radiation	---	±0.38 decades (5.5% span)					100 R/h
		Block Turbine Bypass and Cooldown Valves on Low-Low Tavg	---	±1.8°F (1.5% span) T <sub>hot</sub> : 1.7% T <sub>cold</sub> : 1.2%					553°F
15	Reactor Coolant Temperature	MFW Cont Valve Closure on Low Tavg	---	±1.8°F (1.5% span) T <sub>hot</sub> : 1.7% T <sub>cold</sub> : 1.2%					564°F
		Turbine Emergency Trip Oil Pressure	---	±49 psi (1.4% span)					1000 psig
17	LOOP Signal - Under voltage	Loss of Voltage	---	±161V					4934V
		Degraded Voltage	---	±161V					6314V

Note: (1)ALs in this table are the values credited in the DCD Chapter 15 safety analysis (Ref 3.4.1 - DCD Chapter 15, Table 15.0-4). Other ALs, which are currently not included, are the values used in various plant analyses to demonstrate that safety limits are protected. Therefore these ALs are not included in this table, and the NTSP values included in this table are typical. The final ALs and resulting NTSP will be documented in the plant specific setpoint analysis.

(2)CU is the calculated value. See Tables 6-1 through 6-22 of this report for CU values. These values are derived using assumed values. The final computation must consider actual equipment specification and plant conditions per plant specific design.

- 
- (3) With the exception of Turbine Emergency Trip Oil Pressure and LOOP signal, the functions in Table 7-1 are implemented via digital processing functions. Therefore, the Allowable Value for each of these digital functions is calculated using the method described in Section 5.3.2 of this report. When transcribing Allowable Values, apply the most limiting (lowest) Allowable Value for all functions associated with a given input parameter.
  - (4) See Section 5.4 for a description of how PTAC is calculated for input parameters for calculated functions.
  - (5) Actual NTSP values set in the digital equipment will be adjusted to the nearest settable value in the conservative direction (away from AL).
  - (6) These protection functions are rate based, calculating the change in signal value over a 1 second interval. The actual signal error will not vary significantly in this interval.

Table 7-2 Summary – DAS Functions

No	Input Parameter	Protection Function	AL <sup>(1)</sup>	CU <sup>(2)</sup>	Safety Margin	AV	UMU	PTAC	NTSP <sup>(1)</sup>
1	Pressurizer Pressure	DAS RT, TT, MFW Isolation on Hi Pressure	2440 psia (2425 psig)	±19 psi (2.3% span)					2425 psig
		DAS RT, TT, MFW Isolation on Low Pressure	1840 psia (1825 psig)	±26 psi (3.2% span)					1825 psig
2	SG Level (Narrow Range)	DAS ECCS on Low-Low Pressure	1740 psia (1725 psig)	±26 psi (3.2% span)					1725 psig
		DAS RT, TT, MFW Isolation, EFW Actuation on Low Level	7.0% span	±13.2% span					7.0% span

**Note:** (1) For AL and NTSP values refer to MUAP-07014-P (Ref 3.4.5). Because the CCF analysis uses best estimate methods, CU and Safety Margin are assumed equal to zero % of span. Therefore, NTSP is set equal to AL as described in MUAP-07014-P.  
 (2) CU is the value calculated in Tables 6-23 and 6-24, provided here for reference only. The values are derived using assumed values. The final computation must consider actual equipment with specification and plant condition per plant specific design.  
 (3) DAS is implemented with analog bistable devices; therefore, the AV for DAS functions is calculated using the method described in Section 5.3.1 of this report.