

Enclosure B
L-13-138

Offsite Dose Calculation Manual, Revision 20

PERRY OPERATIONS MANUAL

TITLE: OFFSITE DOSE CALCULATION MANUAL

REVISION: 20 EFFECTIVE DATE: 3-13-13

PREPARER: Jeff Burnett 2-19-13
/ Date

APPROVER: Joe Oelbracht 3-7-13
/ Date

Offsite Dose Calculation Manual

Table of Contents

<u>Section</u>	<u>Title</u>	<u>Page</u>
1.0	<u>INTRODUCTION</u>	1
2.0	<u>LIQUID EFFLUENTS</u>	2
2.1	Batch Releases	2
2.1.1	Monitor Alarm Setpoint Determination	3
2.1.1.1	Minimum Acceptable Dilution Factor Determination	3
2.1.1.2	Maximum Allowable Radwaste Tank Discharge Flow Rate Determination	4
2.1.1.3	Liquid Radwaste Discharge Flow Monitor Alarm Setpoint	4
2.1.1.4	Liquid Radwaste Discharge Radiation Monitor Alarm/Trip Setpoint	5
2.1.2	10CFR20 Compliance - Liquid Effluent Concentration	6
2.1.2.1	Concentration of Radionuclides in Prerelease	7
2.1.2.2	Post Release	7
2.2	Continuous Releases	8
2.2.1	Monitor Alarm Setpoint Determination	9
2.2.1.1	Monitor Alarm Setpoint	9
2.2.1.2	Minimum Allowable Background	10
2.2.1.3	Determination of the Expected Monitor Response Based on the Reactor Water Source Term	10
2.2.1.4	Minimum Allowable Setpoint Based on Monitor Background	11
2.3	10CFR50, Appendix I Compliance - Liquid Effluent Dose	11
2.3.1	Dose Calculations	12
2.3.2	Cumulation of Doses	14
2.3.3	Projection of Doses	14
2.3.4	Population Dose	15
3.0	<u>GASEOUS EFFLUENTS</u>	32
3.0.1	Batch Releases	32
3.0.2	Continuous Releases	32
3.1	Monitor Alarm Setpoint Determination	34
3.1.1	Determination of the "Mix" (Noble Gas Radionuclide Composition) of the Gaseous Effluent	35
3.1.2	Determination of the Maximum Acceptable Total Activity Release Rate of Noble Gas Radionuclides in Gaseous Effluent Based on Whole Body Dose Rate Limit	35
3.1.3	Determination of the Maximum Acceptable Total Activity Release Rate of Noble Gas Radionuclides in Gaseous Effluent Based on Skin Dose Rate Limit	36
3.1.4	Determination of the Maximum Acceptable Total Radioactivity Concentration of all Noble Gas Radionuclides in Gaseous Effluent	37
3.1.5	Determination of the Maximum Acceptable Monitor Count Rate Above Background Attributed to Noble Gas Radionuclides	38

Offsite Dose Calculation Manual

Table of Contents (Cont.)

<u>Section</u>	<u>Title</u>	<u>Page</u>
3.1.5.1	Determination of the Monitor High Alarm Setpoint	38
3.1.5.2	Determination of the Monitor Alert Setpoint	39
3.2	Compliance with 10CFR20 - Gaseous Effluent Dose Rate	39
3.2.1	Noble Gases	39
3.2.2	Radionuclides, Particulates, and Other Radionuclides	40
3.2.3	Dose Rate Calculations	40
3.3	10CFR50, Appendix I Compliance - Gaseous Effluent Dose	68
3.3.1	Noble Gases	68
3.3.2	Radioiodines, Particulates, and Other Radionuclides	68
3.3.3	Dose Calculations	69
3.3.4	Cumulation of Doses	70
3.3.5	Projection of Doses	71
3.4	Population Dose	71
4.0	<u>TOTAL DOSE</u>	72
4.1	40CFR190 Compliance - Uranium Fuel Cycle Dose	72
4.2	Direct Radiation Dose from PNPP	73
4.3	Dose to Members of the Public While Onsite	74
5.0	<u>RADIOLOGICAL ENVIRONMENTAL MONITORING PROGRAM</u>	74
5.1	Monitoring Program	74
5.2	Land Use Census Program	75
5.3	Inter-Laboratory Comparison Program	76
APPENDIX A	Atmospheric Dispersion and Deposition Parameters	81
APPENDIX B	Lower Limit of Detection	95
APPENDIX C	Controls	99
REFERENCES		181

List of Tables

<u>Table</u>	<u>Title</u>	<u>Page</u>
2.3-1	Organs Used for Liquid Effluent Dose Calculations	15
2.3-2	Age Groups Used for Liquid Effluent Dose Calculations	15
2.3-3	Liquid Effluent Dose Pathways	15
2.3-4	Bio-Accumulation Factors (B_p) (pCi/kg per pCi/liter)	16
2.3-5	Ingestion Dose Factors for Adult (mrem/pCi ingested)	17
2.3-6	Ingestion Dose Factors for Teenager (mrem/pCi ingested)	19
2.3-7	Ingestion Dose Factors for Child (mrem/pCi ingested)	21
2.3-8	Ingestion Dose Factors for Infant (mrem/pCi ingested)	23
2.3-9	External Dose Factors for Standing on Contaminated Ground	25
2.3-10	Liquid Effluent Dilution Factors (M_p)	27
2.3-11	Transit Times Required for Nuclides to Reach the Point of Exposure (t_p)	27
2.3-12	Usage Factors (U_{ap})	28
2.3-13	Dilution Factors for Each of the Potable Water Intakes within 50 Miles of PNPP	29
2.3-14	Dilution Factors for the Fish Ingestion Pathway Individual Grid Locations	30
2.3-15	Dilution Factors for the Shore Exposure Pathway	31
3.1-1	Whole Body and Skin Dose Factors	37
3.2-1	Organs Used for Gaseous Effluent Dose Calculations	46
3.2-2	Age Groups Used for Gaseous Effluent Dose Calculations	46
3.2-3	Gaseous Effluent Dose Pathways	46
3.2-4	Dose Factors for Exposure to a Semi-Infinite Cloud of Noble Gases	47
3.2-5	External Dose Factors for Standing on Contaminated Ground	48
3.2-6	Inhalation Dose Factors for Adult (mrem/pCi inhaled)	50

List of Tables (Cont.)

<u>Table</u>	<u>Title</u>	<u>Page</u>
3.2-7	Inhalation Dose Factors for Teenager (mrem/pCi inhaled)	52
3.2-8	Inhalation Dose Factors for Child (mrem/pCi inhaled)	54
3.2-9	Inhalation Dose Factors for Infant (mrem/pCi inhaled)	56
3.2-10	Ingestion Dose Factors for Adult (mrem/pCi ingested)	58
3.2-11	Ingestion Dose Factors for Teenager (mrem/pCi ingested)	60
3.2-12	Ingestion Dose Factors for Child (mrem/pCi ingested)	62
3.2-13	Ingestion Dose Factors for Infant (mrem/pCi ingested)	64
3.2-14	Annual Usage Factors for the Maximum Exposed Individual	66
3.2-15	Annual Usage Factors for the Average Individual	66
3.3-1	Gamma and Beta Air Dose Factors for Semi-Infinite Plume	71
5.1-1	ODCM REMP Sample Locations	77
A-1	Atmospheric Depletion and Deposition Factors	83
A-2	Site Boundary Atmospheric Dispersion (χ/Q) and Deposition Parameters (D/Q) for PNPP Unit 1	84
A-3	Atmospheric Dispersion (χ/Q) as a Function of Distance (s/m^3)	85
A-4	Atmospheric Dispersion (D/Q) as a Function of Distance (m^{-2})	91

List of Figures

<u>Figures</u>	<u>Title</u>	<u>Page</u>
2.1-1	Liquid Radioactive Waste (LRW) Discharge System	2
3.0-1	Gaseous Effluent System Flow Diagram	33
3.2-1	PNPP Site Boundary and Unrestricted Area	67
5.1-1	Technical Specification Required REMP Sampling Locations Within Two Miles of the Plant Site	78
5.1-2	Technical Specification Required REMP Sampling Locations Between Two and Eight Miles from the Plant Site	79
5.1-3	Technical Specification Required REMP Sampling Locations Greater Than Eight Miles from the Plant Site	80

SCOPE OF REVISION:

Rev. 20

1. Added potential release pathway due to leakage from the new ADHR system to Section 2.2, Continuous Release.
2. Modified description of releases from M35 Drains.
3. Clarified formulas in Section 2.2 used for determining ESW and Service Water (ADHR) alarm setpoints.
4. Corrected conversion factor typographical error in Section 3.1.4.
5. Deleted duplicate tables 5.1-1, 5.1-2 and 5.1-3.
6. Removed references to Tables 5.1-1 and 5.1-3 from Section 5.1. Section now refers to Tables 3.12.1-1 and 4.12.1-1.
7. Added milk as a sample media for location 18 on Table 5.1.1, ODCM REMP Sample Locations.
8. Added Service Water Radiation Monitor (ADHR) to Table 3.3.7.9-1, Radioactive Liquid Effluent Monitoring Instrumentation.
9. Added Service Water Radiation Monitor (ADHR) to Table 4.3.7.9-1, Radioactive Liquid Effluent Monitoring Instrumentation Surveillance Requirements.
10. Added footnote to Table 4.3.7.9-1 to state that the surveillance requirements for the Service Water (ADHR) are in effect only when the system is in service.
11. Added Service Water to Table 4.11.1.1.1-1, Radioactive Liquid Waste Sampling and Analysis Program.
12. Added table notation "h" to Table 4.11.1.1.1-1, Radioactive Liquid Waste Sampling and Analysis Program.
13. Modified Table 3.12.1-1, Radiological Environmental Monitoring Program. Table now requires two or more samples of commercially and/or recreationally important species of fish to be collected.

1.0 INTRODUCTION

This Offsite Dose Calculation Manual (ODCM) contains information and methodologies to be used by the Perry Nuclear Power Plant (PNPP), Unit 1, to ensure compliance with PNPP Radiological Effluent Technical Specifications. The Technical Specifications and this ODCM are written to satisfy 10CFR20, 10CFR50.36 and Appendix I, 40CFR190 and 10CFR72.104 requirements. This ODCM applies to doses from radioactivity and radiation from the Perry Nuclear Power Plant, which is considered to include the onsite Independent Spent Fuel Storage Installation (ISFSI).

Sections 2 and 3 of this manual deal with liquid and gaseous radiological effluents, respectively. Each of these sections contain alarm setpoint determination, radiation dose and dose rate calculation methodologies, as well as limits and requirements. Section 4 covers uranium fuel cycle related radiation dose limits including direct dose from the Perry Nuclear Power Plant, including the ISFSI.

Also included in this manual, in Section 5, is information relating to the Radiological Environmental Monitoring Program (REMP). The figures and tables contained therein designate specific sample types and locations currently used to satisfy the Technical Specification requirements for the REMP as well as sampling reporting and detection capability limits. The sample types and locations are subject to change based on factors including the results of the annual Land Use Census.

The ODCM has been prepared, as generally as possible, in order to minimize future revisions. However, any such changes will be reviewed and approved as per the Administrative Control Section of the PNPP Technical Specifications.

Supplemental information needed to support calculations is contained in the appendices at the end of this manual. Appendix A contains atmospheric dispersion and deposition parameters and Appendix B presents the methodology for determining the lower limit of detection (LLD).

Appendix C of the ODCM was prepared based on guidance of NUREG-1302, "Offsite Dose Calculation Manual Guidance: Standard Radiological Effluent Controls for Boiling Water Reactors," Generic Letter 89-01, Supplement No. 1. This appendix along with plant procedures will be used by plant personnel to demonstrate compliance with Specification 5.5.4 (Radioactive Effluent Controls Program) of the PNPP Technical Specifications. <L02211>

2.0 LIQUID EFFLUENTS

2.1 Batch Releases

A batch release is the discharge liquid radioactive waste of a discrete volume. Batch releases from the liquid radwaste system may occur from any of the following tanks: waste sample tank, floor drain sample tank, chemical waste distillate tank, and detergent drain tank (see Figure 2.1-1). The maximum release rate possible, due to pump capacity, is 200 gallons per minute from all release tanks except the detergent drain tanks, which have a maximum release rate of 50 gallons per minute. All of the above liquid radwaste releases go to the Emergency Service Water discharge which is then released through the discharge tunnel after mixing with Service Water effluent and/or and blowdown from Circulating Water system, if present.

Figure 2.1-1

Liquid Radioactive Waste (LRW) Discharge System

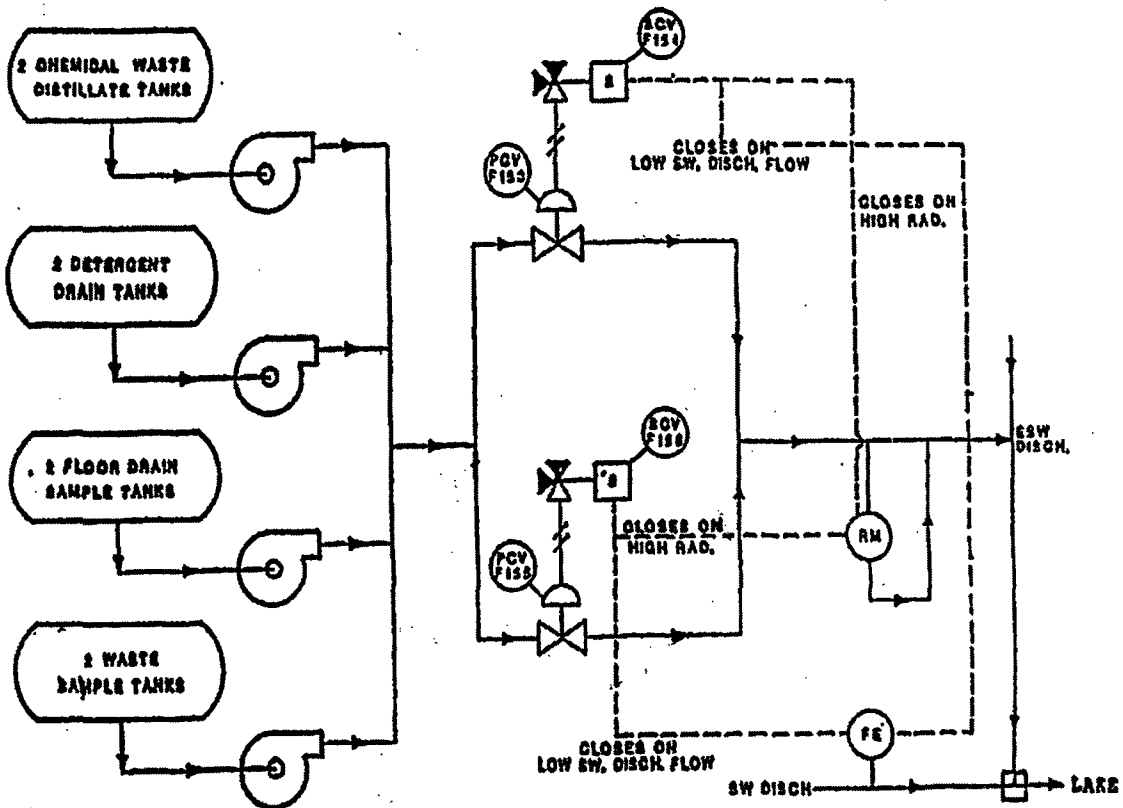

The type and frequency of sampling and analysis required by the ODCM is given in Appendix C, Table 4.11.1.1.1-1. Prior to sampling for analysis, each batch should be isolated, and thoroughly mixed to assure representative sampling. For mixing, the contents of the tank are recirculated by isolating the tank and turning on equipment that takes suction from and discharges back into the tank. Recycle lines are provided with one or more mixing eductors located near the bottom of the tanks to promote better mixing as well as reducing recirculation time. This ensures that the water in the tank will be mixed and will be representative of the activity in the tank. The minimum recirculation performed is the equivalent of two volumes of the tank contents.

Monitor alarm setpoints will be determined in order to ensure compliance with 10CFR20. The radioactive content of each batch release will be determined prior to release in accordance with ODCM, Appendix C, Table 4.11.1.1.1-1. Concentrations for tritium and other non-gamma emitting isotopes will be those most recently determined in the previous month/quarter. If there are no tritium results from the most recent month the most recent steam cycle value may be used as this will be a conservative number used for calculating batch releases. If there is sufficient time prior to a planned release, a composite of samples that are expected to be representative of the release may be analyzed for the tritium and other non-gamma emitting isotope values.

2.1.1 Monitor Alarm Setpoint Determination

The following methodology is used to calculate the setpoints for the Radwaste Discharge Radiation Monitor - ESW Discharge and Liquid Radwaste Adjustable High Flow Trip Unit to ensure that liquid radwaste effluent releases from the site to unrestricted areas are below the limiting effluent concentrations (EC) specified in 10CFR20, Appendix B, Table 2, Column 2 for radionuclides other than noble gases. An EC of 2.0E-4 $\mu\text{Ci}/\text{ml}$ has been established for dissolved and entrained noble gases. The Radwaste Discharge Radiation Monitor - ESW Discharge provides alarm and automatic termination of releases prior to exceeding these limits.

NOTE: Liquid radwaste discharge flow rate shall be verified at least once per four hours, whenever the flow rate measuring device(s) is inoperable during actual releases.

2.1.1.1 Minimum Acceptable Dilution Factor Determination:

$$DF_{\text{O}} = \sum \frac{C_i}{EC_i} \quad (2.1-1)$$

Where:

DF_{O} = the minimum acceptable dilution factor determined from analysis of the liquid effluent to be released;

C_i = the concentration of radionuclide "i" in the batch to be released, $\mu\text{Ci/ml}$. If the concentration of a radionuclide is below the lower limit of detection, the radionuclide shall not be included as a source term in the setpoint calculation.

EC_i = the limiting effluent concentration of radionuclide "i", from 10CFR20, Appendix B, Table 2, Column 2, in $\mu\text{Ci/ml}$ and ($2.0\text{E-}4$ $\mu\text{Ci/ml}$ for noble gases).

$$DF = 10DF_0 \quad (2.1-2)$$

Where:

DF = the conservative dilution factor used by PNPP to calculate the maximum release rate prior to release in order to ensure compliance with 10CFR20;

DF_0 = the minimum acceptable dilution factor, as per equation 2.1-1;

10 = a factor of ten less than 10CFR20, Appendix B, Table 2, Column 2, limits; which represents an order of magnitude of conservatism for liquid radwaste releases from PNPP.

2.1.1.2 Maximum Allowable Radwaste Tank Discharge Flow Rate Determination

$$f_{\max} = \frac{(0.64)(\text{mdf})}{DF} \quad (2.1-3)$$

Where:

f_{\max} = the maximum allowable radwaste tank discharge flow rate for the batch to be released, gpm;

DF = the conservative dilution factor, per equation 2.1-2;

mdf = the minimum dilution flow - supplied by the Service Water system, Emergency Service Water system, or Circulating Water system blowdown, gpm;

0.64 = an engineering factor to prevent spurious alarms.

2.1.1.3 Liquid Radwaste Discharge Flow Monitor Alarm Setpoint <L00434>

Monitor alarm setpoints are determined to ensure that the concentration of radionuclides in the liquid radwaste effluent released from PNPP to unrestricted areas does not exceed the limits specified in 10CFR20, Appendix B, Table 2, Column 2, for radionuclides other than dissolved and entrained noble gases. A limiting effluent concentration of $2.0\text{E-}4$ $\mu\text{Ci/ml}$ has been established for dissolved and entrained noble gases in liquid effluents.

$$SP_f = (1.25)(f_{act}) \quad (2.1-4)$$

Where:

SP_f = liquid radwaste adjustable high flow trip Unit (G50-K805A/B or G50-K926/7) alarm setpoint, gpm;

f_{act} = actual allowable radwaste tank discharge flow rate for the batch to be released, not to exceed the maximum allowable radwaste discharge flow rate f_{max} as defined in equation 2.1-3, gpm;

1.25 = engineering safety factor to prevent spurious alarms.

The liquid radwaste tank discharge flow should be maintained at or below this f_{act} value by proper regulation of the high or low volume discharge throttle valves (G50-F153 or G50-F155, respectively).

2.1.1.4 Liquid Radwaste Discharge Radiation Monitor Alarm/Trip Setpoint

Monitor alarm/trip setpoints are determined to ensure that the concentration of radionuclides in the liquid radwaste effluent released from PNPP to unrestricted areas does not exceed the limits specified in 10CFR20, Appendix B, Table 2, Column 2 for radionuclides other than dissolved or entrained noble gases. A limiting effluent concentration of $2.0E-4 \mu\text{Ci/ml}$ has been established for dissolved and entrained noble gases in liquid effluents.

$$CR_C = \sum (C_i)(E_i) \quad (2.1-5)$$

Where:

CR_C = the calculated monitor count rate above background, cpm;

C_i = the concentration of radionuclide "i" in the batch to be released, $\mu\text{Ci/ml}$;

E_i = the detector efficiency of the monitor for radionuclide "i", $\text{cpm}/(\mu\text{Ci/ml})$.

OR

$$CR_x = (R_s)(F_x)(\sum C_i) \quad (2.1-6)$$

Where:

CR_x = the cross-calibrated monitor count rate above background, cpm;

F_x = the cross-calibration factor is used to ratio the liquid radwaste discharge radiation monitor actual response to the Cs-137 calibrated response;

R_S = the response of the Liquid Radwaste Discharge Radiation Monitor to a Cs-137 calibrated standard, cpm/(μ Ci/ml).

$$SP_T = (1.25) \left(\frac{f_{max}}{f_{act}} \right) (CR_N) + BG \quad (2.1-7)$$

Where:

SP_T = the Radwaste Discharge Radiation Monitor - ESW Discharge alarm/trip setpoint, in cpm;

BG = background count rate due to internal contamination and radiation levels in the area of the monitor, cpm;

CR_N = monitor net count rate, either CR_C or CR_x , as per equation 2.1-5 or 2.1-6, cpm;

1.25 = engineering safety factor to prevent spurious alarms;

f_{max}/f_{act} = an adjustment factor (to account for the difference between an actual radwaste discharge flow rate to be used for the discharge and maximum allowable radwaste discharge flow rate) to allow operational flexibility and to minimize spurious alarms;

Where:

f_{act} = the actual radwaste discharge flow rate, this value must always be less than or equal to f_{max} , gpm;

f_{max} = the maximum allowable radwaste discharge flow rate, per equation 2.1-3, gpm.

2.1.2 10CFR20 Compliance - Liquid Effluent Concentration

In order to show compliance with 10CFR20, the concentrations of radionuclides in liquid effluents will be determined and compared with the limiting effluent concentrations as defined in 10CFR20, Appendix B, Table 2, Column 2, ($2.0E-4$ μ Ci/ml for dissolved and entrained noble gases). Concentrations of radioactivity in effluents prior to dilution will be determined. Concentration in diluted effluent will be calculated using these results prior to each batch release, and following each batch release.

2.1.2.1 Concentration of Radionuclides in Prerelease

The radioactivity content of each batch release will be determined prior to release. PNPP will show compliance with 10CFR20 in the following manner:

The concentration of the various radionuclides in batch releases prior to dilution is divided by the minimum dilution flow to obtain the concentration at the unrestricted area. This calculation is shown in the following equation:

$$\text{Conc}_i = \frac{(C_i)(f)}{\text{mdf}} \quad (2.1-8)$$

Where:

- Conc_i = the concentration of radionuclide "i" at the unrestricted area, $\mu\text{Ci/ml}$;
- C_i = the concentration of radionuclide "i" in the batch to be released, $\mu\text{Ci/ml}$;
- f = the radwaste tank discharge flow rate for the batch to be released, gpm;
- mdf = the minimum dilution flow, per equation 2.1-3, gpm.

The projected radionuclide concentrations in the unrestricted area are compared to the limiting effluent concentrations in 10CFR20, Appendix B, Table 2, Column 2 ($2.0\text{E-}4 \mu\text{Ci/ml}$ for dissolved and entrained noble gases) in order to give a final 10CFR20 compliance check, i.e., the following equation must be met:

$$\sum \frac{\text{Conc}_i}{\text{EC}_i} \leq 1 \quad (2.1-9)$$

Where:

- Conc_i = the concentration of radionuclide "i" at the unrestricted area, $\mu\text{Ci/ml}$;
- EC_i = the limiting effluent concentration of radionuclide "i", from 10CFR20, Appendix B, Table 2, Column 2 ($2.0\text{E-}4 \mu\text{Ci/ml}$ for dissolved and entrained noble gases), $\mu\text{Ci/ml}$.

2.1.2.2 Post Release

The actual radioactivity content of each batch release will be determined following release to show final compliance with 10CFR20.

The concentration of the various radionuclides in batch releases prior to dilution is divided by the actual dilution to obtain the concentration at the unrestricted area. This calculation is shown in the following equation:

$$\text{Conc}_i = \frac{(C_i)(V_{lrt})}{V_{dil}} \quad (2.1-10)$$

Where:

Conc_i = the actual concentration of radionuclide "i" at the unrestricted area for the release, $\mu\text{Ci/ml}$;

C_i = the concentration of radionuclide "i" in the batch released, $\mu\text{Ci/ml}$;

V_{dil} = the actual volume of dilution water during the release (total plant discharge flow, including Service Water, Emergency Service Water, and cooling tower blowdown), in gallons;

V_{lrt} = the actual volume of the liquid radwaste tank discharged for the batch, gal.

The concentrations in the unrestricted area are compared to the limiting effluent concentrations in 10CFR20, Appendix B, Table 2, Column 2 ($2.0\text{E-}4 \mu\text{Ci/ml}$ for dissolved and entrained noble gases). In order to demonstrate final compliance with 10CFR20, the following equation must be met:

$$\sum \frac{\text{Conc}_i}{\text{EC}_i} \leq 1 \quad (2.1-11)$$

Where:

Conc_i = concentration of radionuclide "i" at the unrestricted area, $\mu\text{Ci/ml}$;

EC_i = limiting effluent concentration of radionuclide "i", from 10CFR20, Appendix B, Table 2, Column 2, $\mu\text{Ci/ml}$.

2.2 Continuous Releases

A continuous release is the discharge of fluid wastes of a non-discrete volume, i.e., from a volume or system that has an input flow during the continuous release. Potential sources for a continuous release at Perry are RHR heat exchanger leakage into the Emergency Service Water system, tritium activity in the M35 Supply Plenum drain into storm drains and Alternate Decay Heat Removal (ADHR) heat exchanger leakage into Service Water.

Potentially contaminated discharges from the ESW are monitored by an installed radiation monitoring system. This system consists of two channels, one for monitoring downstream of equipment in Emergency Service Water System Loop A and the other for Emergency Service Water Loop B. If radiation is detected, the affected Emergency Service Water line can be manually isolated. The decision of whether to isolate or not is dependent upon other conditions. The PNPP staff will take appropriate action to limit release.

The Emergency Service Water discharged will be sampled and analyzed in accordance with ODCM Appendix C, Table 4.11.1.1.1-1. To show compliance with 10CFR20, the sum of the concentrations of radionuclide "i" in unrestricted areas due to both continuous and batch releases divided by that isotope's limiting effluent concentration must be less than 1.

During the summer months, the Turbine Building Supply Plenums (1M35B0001A,B,C) are used as a cooling source; condensation from the cooling coils is collected in the M35 plenum drain pans. Moisture from the outside air is condensed and flows into the drain pan. The potential exists for the outside air to contain tritium from the plant vents, thus the M35 Turbine Building Supply Plenums could also contain tritium. During the summer months the M35 drains are routed to storm drains due to the large quantity of condensation. Grab samples are obtained in accordance with ODCM Appendix C Table 4.11.1.1.1-1.

The ADHR system has an installed radiation monitor on the Service Water line that provides cooling to the AHDR heat exchanger. The Service Water (ADHR) system will be sampled and analyzed in accordance with ODCM Appendix C, Table 4.11.1.1.1-1. If radiation is detected, the ADHR system can be isolated. The decision of whether to isolate or not is dependent upon other conditions. The PNPP staff will take appropriate action to limit release.

2.2.1 Monitor Alarm Setpoint Determination

The following methodology is used to calculate the alarm setpoints for the Emergency Service Water loops A & B and Service Water (ADHR) Radiation Monitors. This methodology ensures an alarm will be received prior to exceeding the limiting effluent concentration listed in 10CFR20, Appendix B, Table 2, Column 2.

1. Alarm Setpoint

$$CR_C = (BG + MR) (0.75)$$

Where:

- CR_C = the calculated monitor count rate in cpm;
- BG = the background count rate due to internal contamination and radiation levels in the area of the monitor in cpm;
- MR = expected monitor response due to 1.0 EC of a typical reactor water isotopic mix;
- 0.75 = engineering safety factor

2. Minimum Allowable Backgrounds

$$BG_{\min} = CR_C - MR$$

Where:

BG_{\min} = minimum allowable background to ensure monitor will alarm prior to exceeding 1.0 EC;

CR_C = the calculated monitor count rate in cpm;

MR = expected monitor response due to 1.0 EC of a typical reactor water isotopic mix;

NOTE: If calculated value is negative, then 0 cpm will be used as the minimum allowable background.

3. Determination of the Expected Monitor Response Based on the Reactor Water Source Term

$$MR = \sum (EC_i \times \%_i \times Eff_i)$$

Where:

MR = expected monitor response due to 1.0 EC of a typical reactor water isotopic mix;

$\%_i$ = percent of isotope (i) in a typical reactor water isotopic mixture;

Eff_i = radiation monitor detector efficiency for isotope (i);

EC_i = Effluent concentration value for isotope (i), Appendix B, Table 2, Column 2, 10CFR20

4. Minimum Allowable Setpoint Based on Monitor Background

$$CR_{min} = BG + \left(\sqrt[2]{BG / 2TC} \right)$$

Where:

- CR_{min} = Minimum allowable setpoint for a given monitor background (BG);
- BG = the background count rate due to internal contamination and radiation levels in the area of the monitor in cpm;
- 2 = 95% confidence level;
- 2TC = two times the instrument time constant where

$$TC = \frac{(\log_{10}BG - \log_{10}Locpm)(TC_{Hicpm} - TC_{Locpm})}{(\log_{10}Hicpm - \log_{10}Locpm)} + TC_{Locpm}$$

Time Constants:

Hi/Lo cpm	TC Hi/Lo cpm
10 cpm	1.25 min
100 cpm	1.25 min
1,000 cpm	1.25 min
10,000 cpm	0.2 min
100,000 cpm	0.042 min
1,000,000 cpm	0.0033 min

For Backgrounds less than 400 cpm, the following values will be used:

- Locpm = 100 cpm $TC_{Locpm} = 1.25$ min
- Hicpm = 1000 cpm $TC_{Hicpm} = 1.25$ min

For Backgrounds \geq 400 cpm and less than 1,000 cpm, the following values will be used:

- Locpm = 1,000 cpm $TC_{Locpm} = 1.25$ min
- Hicpm = 10,000 cpm $TC_{Hicpm} = .2$ min

2.3 10CFR50, Appendix I Compliance - Liquid Effluent Dose

Doses resulting from liquid effluents will be calculated at least monthly to show compliance with 10CFR50, Appendix I. A cumulative summation of whole body and organ doses for the current quarter and current year will be maintained. Additionally, doses due to liquid releases are projected monthly.

2.3.1 Dose Calculations

Radiation doses due to liquid radioactive effluents from PNPP are calculated based on three main dose pathways: potable water, aquatic foods (namely fresh water fish ingestion), and exposure to shoreline deposits. Irrigated food pathways, as discussed in Regulatory Guide 1.109, will not be of concern at PNPP as little or no water from Lake Erie is used for irrigation in the nearby Ohio counties of Lake, Ashtabula, Cuyahoga and Lorain. Nursery businesses and other agricultural activities that require supplemental water generally rely on water drawn from small ponds and streams.

Radiation dose to members of the public for liquid radioactive releases from PNPP will be calculated for the potable water, aquatic food, and shoreline deposit pathways using the following equations:

Potable Water

$$R_{ajp} = 1100 \frac{U_{ap}}{(M_p)(F)} \sum (Q_i) (D_{aipj}) \exp(-\lambda_i t_p) \quad (2.3-1)$$

Aquatic Foods

$$R_{ajp} = 1100 \frac{U_{ap}}{(M_p)(F)} \sum (Q_i) (B_{ip}) (D_{aipj}) \exp(-\lambda_i t_p) \quad (2.3-2)$$

Shoreline Deposits

$$R_{ajp} = 110,000 \frac{(U_{ap})^{(W)}}{(M_p)(F)} \sum (Q_i) (T_i) (D_{aipj}) \left[\exp(-\lambda_i t_p) \right] \left[1 - \exp(-\lambda_i t_b) \right] \quad (2.3-3)$$

Where:

R_{ajp} = the dose to individuals of age group "a" to organ "j" from all the radionuclides in pathway "p", in mrem;

B_{ip} = the equilibrium bioaccumulation factor for radionuclide "i" in pathway "p", expressed as the ratio of the concentration in biota (pCi/kg) to the radionuclide concentration in water (pCi/l), from Table 2.3-4, l/kg;

D_{aipj} = the dose factor, specific to a given age group "a", radionuclide "i", pathway "p", and organ "j", which can be used to calculate the radiation dose from an intake of a radionuclide (mrem/pCi); or from exposure to a given concentration of a radionuclide in sediment, expressed as a ratio of the dose rate (mrem/h), and the areal radionuclide concentration, (pCi/m²), from Tables 2.3-5 through 2.3-9;

- F = the flow rate of the liquid effluent, ft³/sec;
- NOTE:** The normal minimum dilution flow will be 30,000 gpm (USAR 11.2.3.2).
- M_p = the dilution factor at the midpoint of exposure (or the point of withdrawal of drinking water, point of harvest of aquatic food or shoreline), from Table 2.3-10, dimensionless;
- Q_i = the release of radionuclide "i", Ci;
- T_b = the period of time for which the sediment or soil is exposed to the contaminated water, 1.75×10^5 hr (20 yrs);
- $T_{1/2}$ = the half-life of radionuclide "i", days;
- t_p = the average transit time required for radionuclides to reach the point of exposure, from Table 2.3-11; for internal dose, t_p is the total time elapsed between release of the radionuclides and the ingestion of food or water, hr;
- U_{ap} = the usage factor that specifies the exposure time or intake rate for an individual of age group a associated with pathway "p", from Table 2.3-12, hr/yr, 1/yr, or kg/yr;
- W = the shoreline width factor, 0.3 (from Regulatory Guide 1.109);
- λ_i = radioactive decay constant of radionuclide "i", h⁻¹;
- 1100 = a factor to convert from (Ci/yr)/(ft³/s) to pCi/l;
- 110,000 = a factor to convert from (Ci/yr)/(ft³/s) to pCi/l and to account for the proportionality constant used in the sediment radioactivity model.

2.3.2 Cumulation of Doses

The dose contribution from liquid effluents will be calculated at least monthly. Calculations will be performed to determine the maximum whole body as well as the maximum organ dose to an individual. These dose calculations will be summed for comparison with quarterly and annual limits. These results will be summed with the doses cumulated from the other months in the quarter of interest and in the year of interest. To assure compliance with the dose limits of 10CFR50, Appendix I the following relationships shall hold:

for the quarter:

Dose ≤ 1.5 mrems whole body;

Dose ≤ 5 mrems any organ;

for the year:

Dose ≤ 3 mrems whole body;

Dose ≤ 10 mrems any organ.

The quarterly limits given above represent one-half of the annual design objective. If these quarterly or annual limits are exceeded, a special report will be submitted to the NRC, in accordance with ODCM Appendix C controls, stating the reason and corrective action to be taken.

2.3.3 Projection of Doses

Anticipated doses resulting from the release of liquid effluents will be projected monthly. The doses calculated for the present month will be used as the projected doses unless information exists indicating that actual releases could differ significantly in the next month.

If the projected dose, when averaged over 31 days, exceeds 0.06 mrem to the whole body or 0.2 mrem to any organ, the liquid radwaste system will be used to process waste. The values for the projected dose impact levels correspond to approximately one forty-eighth of the 10CFR50, Appendix I design objective. If continued at this rate for one year, the projected impact would correspond to less than one-fourth of the 10CFR50, Appendix I limit. The projected doses will be calculated using equations 2.3-1, 2.3-2, and 2.3-3.

In this case, the source term will be adjusted to reflect this information and the justification for the adjustment noted. This adjustment should account for any radwaste equipment which was operated during the previous month that could be out of service in the coming month.

2.3.4 Population Dose

PNPP's Annual Radioactive Effluent Release Reports, as required by Regulatory Guide 1.21, will include total population dose and average individual doses calculated for radioactive effluent releases. The total population dose and average individual doses will be calculated using average individual transit times and usage factors, Table 2.3-12, (as compared to maximum exposed individual factors used for individual doses). The total population dose will be calculated by dose pathway and organ, with pathway doses being corrected for the fraction of the population assumed to be in each age group (adult, teen, child and infant: 0.71, 0.11, 0.18, 0.0 respectively).

Table 2.3-1

Organs Used for Liquid Effluent Dose Calculations

1. Bone
2. GI Tract
3. Kidney
4. Liver
5. Lung
6. Thyroid
7. Whole Body
8. Skin

Table 2.3-2

Age Groups Used for Liquid Effluent Dose Calculations

1. Adult (17 yrs. and older)
2. Teen (11 - 17 yrs)
3. Child (1 - 11 yrs)
4. Infant (0 - 1 yr)

Table 2.3-3

Liquid Effluent Dose Pathways

1. Water Ingestion
2. Shore Exposure
3. Fresh Water Fish Ingestion

Table 2.3-4

Bio-Accumulation Factors (B_{ip}) (pCi/kg per pCi/liter)

<u>Element</u>	<u>Fish</u>
H	9.0E-01
C	4.6E+03
Na	1.0E+02
P	1.0E+05
Cr	2.0E+02
Mn	4.0E+02
Fe	1.0E+02
Co	5.0E+01
Ni	1.0E+02
Cu	5.0E+01
Zn	2.0E+03
Br	4.2E+02
Rb	2.0E+03
Sr	3.0E+01
Y	2.5E+01
Zr	3.3E+00
Nb	3.0E+04
Mo	1.0E+01
Tc	1.5E+01
Ru	1.0E+01
Rh	1.0E+01
Sb	1.0E+00
Te	4.0E+02
I	1.5E+01
Cs	2.0E+03
Ba	4.0E+00
La	2.5E+01
Ce	1.0E+00
Pr	2.5E+01
Nd	2.5E+01
Ta	1.0E+00
W	1.2E+03
Re	1.0E+00
Au	1.0E+00
Np	1.0E+01

Table 2.3-5

Ingestion Dose Factors for Adult (mrem/pCi ingested)

ISOTOPE	BONE	LIVER	WHOLE BODY	THYROID	KIDNEY	LUNG	GI-LLI
H3	0.00E+00	1.05E-07	1.05E-07	1.05E-07	1.05E-07	1.05E-07	1.05E-07
C14	2.84E-06	5.68E-07	5.68E-07	5.68E-07	5.68E-07	5.68E-07	5.68E-07
NA24	1.70E-06	1.70E-06	1.70E-06	1.70E-06	1.70E-06	1.70E-06	1.70E-06
P32	1.93E-04	1.20E-05	7.46E-06	0.00E+00	0.00E+00	0.00E+00	2.17E-05
CR51	0.00E+00	0.00E+00	2.66E-09	1.59E-09	5.86E-10	3.53E-09	6.69E-07
MN54	0.00E+00	4.57E-06	8.72E-07	0.00E+00	1.36E-06	0.00E+00	1.40E-05
MN56	0.00E+00	1.15E-07	2.04E-08	0.00E+00	1.46E-07	0.00E+00	3.67E-06
FE55	2.75E-06	1.90E-06	4.43E-07	0.00E+00	0.00E+00	1.06E-06	1.09E-06
FE59	4.34E-06	1.02E-05	3.91E-06	0.00E+00	0.00E+00	2.85E-06	3.40E-05
CO58	0.00E+00	7.45E-07	1.67E-06	0.00E+00	0.00E+00	0.00E+00	1.51E-05
CO60	0.00E+00	2.14E-06	4.72E-06	0.00E+00	0.00E+00	0.00E+00	4.02E-05
NI63	1.30E-04	9.01E-06	4.36E-06	0.00E+00	0.00E+00	0.00E+00	1.88E-06
NI65	5.28E-07	6.86E-08	3.13E-08	0.00E+00	0.00E+00	0.00E+00	1.74E-06
CU64	0.00E+00	8.33E-08	3.91E-08	0.00E+00	2.10E-07	0.00E+00	7.10E-06
CU67	2.95E-07	8.41E-07	0.00E+00	2.24E-07	2.62E-07	2.27E-07	1.07E-05
ZN65	4.84E-06	1.54E-05	6.96E-06	0.00E+00	1.03E-05	0.00E+00	9.70E-06
ZN69	1.03E-08	1.97E-08	1.37E-09	0.00E+00	1.28E-08	0.00E+00	2.96E-09
BR83	0.00E+00	0.00E+00	4.02E-08	0.00E+00	0.00E+00	0.00E+00	5.79E-08
BR84	0.00E+00	0.00E+00	5.21E-08	0.00E+00	0.00E+00	0.00E+00	4.09E-13
BR85	0.00E+00	0.00E+00	2.14E-09	0.00E+00	0.00E+00	0.00E+00	0.00E+00
RB86	0.00E+00	2.11E-05	9.83E-06	0.00E+00	0.00E+00	0.00E+00	4.16E-06
RB88	0.00E+00	6.05E-08	3.21E-08	0.00E+00	0.00E+00	0.00E+00	8.36E-19
RB89	0.00E+00	4.01E-08	2.82E-08	0.00E+00	0.00E+00	0.00E+00	2.33E-21
SR87M	1.52E-08	1.77E-08	0.00E+00	2.96E-09	2.58E-08	6.92E-09	2.15E-07
SR89	3.08E-04	0.00E+00	8.84E-06	0.00E+00	0.00E+00	0.00E+00	4.94E-05
SR90	7.58E-03	0.00E+00	1.86E-03	0.00E+00	0.00E+00	0.00E+00	2.19E-04
SR91	5.67E-06	0.00E+00	2.29E-07	0.00E+00	0.00E+00	0.00E+00	2.70E-05
SR92	2.15E-06	0.00E+00	9.30E-08	0.00E+00	0.00E+00	0.00E+00	4.26E-05
Y90	9.62E-09	0.00E+00	2.58E-10	0.00E+00	0.00E+00	0.00E+00	1.02E-04
Y91M	9.09E-11	0.00E+00	3.52E-12	0.00E+00	0.00E+00	0.00E+00	2.67E-10
Y91	1.41E-07	0.00E+00	3.77E-09	0.00E+00	0.00E+00	0.00E+00	7.67E-05
Y92	8.45E-10	0.00E+00	2.47E-11	0.00E+00	0.00E+00	0.00E+00	1.48E-05
Y93	2.68E-09	0.00E+00	7.40E-11	0.00E+00	0.00E+00	0.00E+00	8.50E-05
ZR95	3.04E-08	9.75E-09	6.60E-09	0.00E+00	1.53E-08	0.00E+00	3.09E-05
ZR97	1.68E-09	3.39E-10	1.55E-10	0.00E+00	5.12E-10	0.00E+00	1.05E-04
NB95	6.22E-09	3.46E-09	1.86E-09	0.00E+00	3.42E-09	0.00E+00	2.10E-05
MO99	0.00E+00	4.31E-06	8.20E-07	0.00E+00	9.76E-06	0.00E+00	9.99E-06
TC99M	2.47E-10	6.98E-10	8.89E-09	0.00E+00	1.06E-08	3.42E-10	4.13E-07

Table 2.3-5 (Cont.)

Ingestion Dose Factors for Adult (mrem/pCi ingested)

ISOTOPE	BONE	LIVER	WHOLE BODY	THYROID	KIDNEY	LUNG	GI-LLI
TC101	2.54E-10	3.66E-10	3.59E-09	0.00E+00	6.59E-09	1.87E-10	1.10E-21
RU103	1.85E-07	0.00E+00	7.97E-08	0.00E+00	7.06E-07	0.00E+00	2.16E-05
RU105	1.54E-08	0.00E+00	6.08E-09	0.00E+00	1.99E-07	0.00E+00	9.42E-06
RU106	2.75E-06	0.00E+00	3.48E-07	0.00E+00	5.31E-06	0.00E+00	1.78E-04
AG110M	1.60E-07	1.48E-07	8.79E-08	0.00E+00	2.91E-07	0.00E+00	6.04E-05
TE125M	2.68E-06	9.17E-07	3.59E-07	8.06E-07	1.09E-05	0.00E+00	1.07E-05
TE127M	6.77E-06	2.42E-06	8.25E-07	1.73E-06	2.75E-05	0.00E+00	2.27E-05
TE127	1.10E-07	3.95E-08	2.38E-08	8.15E-08	4.48E-07	0.00E+00	8.68E-06
TE129M	1.15E-05	4.29E-06	1.82E-06	3.95E-06	4.80E-05	0.00E+00	5.79E-05
TE129	3.14E-08	1.18E-08	7.65E-09	2.41E-08	1.32E-07	0.00E+00	2.37E-08
TE131M	1.73E-06	8.46E-07	7.05E-07	1.34E-06	8.57E-06	0.00E+00	8.40E-05
TE131	1.97E-08	8.23E-09	6.22E-09	1.62E-08	8.63E-08	0.00E+00	2.79E-09
TE132	2.52E-06	1.63E-06	1.53E-06	1.80E-06	1.57E-05	0.00E+00	7.71E-05
I130	7.56E-07	2.23E-06	8.80E-07	1.89E-04	3.48E-06	0.00E+00	1.92E-06
I131	4.16E-06	5.95E-06	3.41E-06	1.95E-03	1.02E-05	0.00E+00	1.57E-06
I132	2.03E-07	5.43E-07	1.90E-07	1.90E-05	8.65E-07	0.00E+00	1.02E-07
I133	1.42E-06	2.47E-06	7.53E-07	3.63E-04	4.31E-06	0.00E+00	2.22E-06
I134	1.06E-07	2.88E-07	1.03E-07	4.99E-06	4.58E-07	0.00E+00	2.51E-10
I135	4.43E-07	1.16E-06	4.28E-07	7.65E-05	1.86E-06	0.00E+00	1.31E-06
CS134	6.22E-05	1.48E-04	1.21E-04	0.00E+00	4.79E-05	1.59E-05	2.59E-06
CS136	6.51E-06	2.57E-05	1.85E-05	0.00E+00	1.43E-05	1.96E-06	2.92E-06
CS137	7.97E-05	1.09E-04	7.14E-05	0.00E+00	3.70E-05	1.23E-05	2.11E-06
CS138	5.52E-08	1.09E-07	5.40E-08	0.00E+00	8.01E-08	7.91E-09	4.65E-13
BA139	9.70E-08	6.91E-11	2.84E-09	0.00E+00	6.46E-11	3.92E-11	1.72E-07
BA140	2.03E-05	2.55E-08	1.33E-06	0.00E+00	8.67E-09	1.46E-08	4.18E-05
BA141	4.71E-08	3.56E-11	1.59E-09	0.00E+00	3.31E-11	2.02E-11	2.22E-17
BA142	2.13E-08	2.19E-11	1.34E-09	0.00E+00	1.85E-11	1.24E-11	3.00E-26
LA140	2.50E-09	1.26E-09	3.33E-10	0.00E+00	0.00E+00	0.00E+00	9.25E-05
LA142	1.28E-10	5.82E-11	1.45E-11	0.00E+00	0.00E+00	0.00E+00	4.25E-07
CE141	9.36E-09	6.33E-09	7.18E-10	0.00E+00	2.94E-09	0.00E+00	2.42E-05
CE143	1.65E-09	1.22E-06	1.35E-10	0.00E+00	5.37E-10	0.00E+00	4.56E-05
CE144	4.88E-07	2.04E-07	2.62E-08	0.00E+00	1.21E-07	0.00E+00	1.65E-04
PR143	9.20E-09	3.69E-09	4.56E-10	0.00E+00	2.13E-09	0.00E+00	4.03E-05
PR144	3.01E-11	1.25E-11	1.53E-12	0.00E+00	7.05E-12	0.00E+00	4.33E-18
ND147	6.29E-09	7.27E-09	4.35E-10	0.00E+00	4.25E-09	0.00E+00	3.49E-05
TA183	4.77E-11	2.92E-10	2.39E-11	0.00E+00	1.66E-10	0.00E+00	1.76E-04
W187	1.03E-07	8.61E-08	3.01E-08	0.00E+00	0.00E+00	0.00E+00	2.82E-05
RE188	2.42E-07	1.90E-07	5.37E-07	1.26E-05	0.00E+00	0.00E+00	1.56E-05
AU198	0.00E+00	1.12E-08	1.90E-08	0.00E+00	3.42E-08	0.00E+00	8.67E-06
AU199	0.00E+00	7.00E-08	5.89E-08	0.00E+00	2.74E-07	0.00E+00	1.13E-05
NP239	1.19E-09	1.17E-10	6.45E-11	0.00E+00	3.65E-10	0.00E+00	2.40E-05
SB124	2.80E-06	5.29E-08	1.11E-06	6.79E-09	0.00E+00	2.18E-06	7.95E-05
SB125	1.79E-06	2.00E-08	4.26E-07	1.82E-09	0.00E+00	1.38E-06	1.97E-05

Table 2.3-6

Ingestion Dose Factors for Teenager (mrem/pCi ingested)

ISOTOPE	BONE	LIVER	WHOLE BODY	THYROID	KIDNEY	LUNG	GI-LLI
H3	0.00E+00	1.06E-07	1.06E-07	1.06E-07	1.06E-07	1.06E-07	1.06E-07
C14	4.06E-06	8.12E-07	8.12E-07	8.12E-07	8.12E-07	8.12E-07	8.12E-07
NA24	2.30E-06	2.30E-06	2.30E-06	2.30E-06	2.30E-06	2.30E-06	2.30E-06
P32	2.76E-04	1.71E-05	1.07E-05	0.00E+00	0.00E+00	0.00E+00	2.32E-05
CR51	0.00E+00	0.00E+00	3.60E-09	2.00E-09	7.89E-10	5.14E-09	6.05E-07
MN54	0.00E+00	5.90E-06	1.17E-06	0.00E+00	1.76E-06	0.00E+00	1.21E-05
MN56	0.00E+00	1.58E-07	2.81E-08	0.00E+00	2.00E-07	0.00E+00	1.04E-05
FE55	3.78E-06	2.68E-06	6.25E-07	0.00E+00	0.00E+00	1.70E-06	1.16E-06
FE59	5.87E-06	1.37E-05	5.29E-06	0.00E+00	0.00E+00	4.32E-06	3.24E-05
CO58	0.00E+00	9.72E-07	2.24E-06	0.00E+00	0.00E+00	0.00E+00	1.34E-05
CO60	0.00E+00	2.81E-06	6.33E-06	0.00E+00	0.00E+00	0.00E+00	3.66E-05
NI63	1.77E-04	1.25E-05	6.00E-06	0.00E+00	0.00E+00	0.00E+00	1.99E-06
NI65	7.49E-07	9.57E-08	4.36E-08	0.00E+00	0.00E+00	0.00E+00	5.19E-06
CU67	3.54E-07	1.07E-06	0.00E+00	2.74E-07	3.19E-7	2.81E-07	1.32E-05
CU64	0.00E+00	1.15E-07	5.41E-08	0.00E+00	2.91E-07	0.00E+00	8.92E-06
ZN65	5.76E-06	2.00E-05	9.33E-06	0.00E+00	1.28E-05	0.00E+00	8.47E-06
ZN69	1.47E-08	2.80E-08	1.96E-09	0.00E+00	1.83E-08	0.00E+00	5.16E-08
BR83	0.00E+00	0.00E+00	5.74E-08	0.00E+00	0.00E+00	0.00E+00	0.00E+00
BR84	0.00E+00	0.00E+00	7.22E-08	0.00E+00	0.00E+00	0.00E+00	0.00E+00
BR85	0.00E+00	0.00E+00	3.05E-09	0.00E+00	0.00E+00	0.00E+00	0.00E+00
RB86	0.00E+00	2.98E-05	1.40E-05	0.00E+00	0.00E+00	0.00E+00	4.41E-06
RB88	0.00E+00	8.52E-08	4.54E-08	0.00E+00	0.00E+00	0.00E+00	7.30E-15
RB89	0.00E+00	5.50E-08	3.89E-08	0.00E+00	0.00E+00	0.00E+00	8.43E-17
SR87M	2.81E-8	2.18E-08	0.00E+00	4.40E-9	3.00E-08	9.91E-09	2.42E-07
SR89	4.40E-04	0.00E+00	1.26E-05	0.00E+00	0.00E+00	0.00E+00	5.24E-05
SR90	8.30E-03	0.00E+00	2.05E-03	0.00E+00	0.00E+00	0.00E+00	2.33E-04
SR91	8.07E-06	0.00E+00	3.21E-07	0.00E+00	0.00E+00	0.00E+00	3.66E-05
SR92	3.05E-06	0.00E+00	1.30E-07	0.00E+00	0.00E+00	0.00E+00	7.77E-05
Y90	1.37E-08	0.00E+00	3.69E-10	0.00E+00	0.00E+00	0.00E+00	1.13E-04
Y91M	1.29E-10	0.00E+00	4.93E-12	0.00E+00	0.00E+00	0.00E+00	6.09E-09
Y91	2.01E-07	0.00E+00	5.39E-09	0.00E+00	0.00E+00	0.00E+00	8.24E-05
Y92	1.21E-09	0.00E+00	3.50E-11	0.00E+00	0.00E+00	0.00E+00	3.32E-05
Y93	3.83E-09	0.00E+00	1.05E-10	0.00E+00	0.00E+00	0.00E+00	1.17E-04
ZR95	4.12E-08	1.30E-08	8.94E-09	0.00E+00	1.91E-08	0.00E+00	3.00E-05
ZR97	2.37E-09	4.69E-10	2.16E-10	0.00E+00	7.11E-10	0.00E+00	1.27E-04
NB95	8.22E-09	4.56E-09	2.51E-09	0.00E+00	4.42E-09	0.00E+00	1.95E-05
MO99	0.00E+00	6.03E-06	1.15E-06	0.00E+00	1.38E-05	0.00E+00	1.08E-05
TC99M	3.32E-10	9.26E-10	1.20E-08	0.00E+00	1.38E-08	5.14E-10	6.08E-07

Table 2.3-6 (Cont.)

Ingestion Dose Factors for Teenager (mrem/pCi ingested)

ISOTOPE	BONE	LIVER	WHOLE BODY	THYROID	KIDNEY	LUNG	GI-LLI
TC101	3.60E-10	5.12E-10	5.03E-09	0.00E+00	9.26E-09	3.12E-10	8.75E-17
RU103	2.55E-07	0.00E+00	1.09E-07	0.00E+00	8.99E-07	0.00E+00	2.13E-05
RU105	2.18E-08	0.00E+00	8.46E-09	0.00E+00	2.75E-07	0.00E+00	1.76E-05
RU106	3.92E-06	0.00E+00	4.94E-07	0.00E+00	7.56E-06	0.00E+00	1.88E-04
AG110M	2.05E-07	1.94E-07	1.18E-07	0.00E+00	3.70E-07	0.00E+00	5.45E-05
TE125M	3.83E-06	1.38E-06	5.12E-07	1.07E-06	0.00E+00	0.00E+00	1.13E-05
TE127M	9.67E-06	3.43E-06	1.15E-06	2.30E-06	3.92E-05	0.00E+00	2.41E-05
TE127	1.58E-07	5.60E-08	3.40E-08	1.09E-07	6.40E-07	0.00E+00	1.22E-05
TE129M	1.63E-05	6.05E-06	2.58E-06	5.26E-06	6.82E-05	0.00E+00	6.12E-05
TE129	4.48E-08	1.67E-08	1.09E-08	3.20E-08	1.88E-07	0.00E+00	2.45E-07
TE131M	2.44E-06	1.17E-06	9.76E-07	1.76E-06	1.22E-05	0.00E+00	9.39E-05
TE131	2.79E-08	1.15E-08	8.72E-09	2.15E-08	1.22E-07	0.00E+00	2.29E-09
TE132	3.49E-06	2.21E-06	2.08E-06	2.33E-06	2.12E-05	0.00E+00	7.00E-05
I130	1.03E-06	2.98E-06	1.19E-06	2.43E-04	4.59E-06	0.00E+00	2.29E-06
I131	5.85E-06	8.19E-06	4.40E-06	2.39E-03	1.41E-05	0.00E+00	1.62E-06
I132	2.79E-07	7.30E-07	2.62E-07	2.46E-05	1.15E-06	0.00E+00	3.18E-07
I133	2.01E-06	3.41E-06	1.04E-06	4.76E-04	5.98E-06	0.00E+00	2.58E-06
I134	1.46E-07	3.87E-07	1.39E-07	6.45E-06	6.10E-07	0.00E+00	5.10E-09
I135	6.10E-07	1.57E-06	5.82E-07	1.01E-04	2.48E-06	0.00E+00	1.74E-06
CS134	8.37E-05	1.97E-04	9.14E-05	0.00E+00	6.26E-05	2.39E-05	2.45E-06
CS136	8.59E-06	3.38E-05	2.27E-05	0.00E+00	1.84E-05	2.90E-06	2.72E-06
CS137	1.12E-04	1.49E-04	5.19E-05	0.00E+00	5.07E-05	1.97E-05	2.12E-06
CS138	7.76E-08	1.49E-07	7.45E-08	0.00E+00	1.10E-07	1.28E-08	6.76E-11
BA139	1.39E-07	9.78E-11	4.05E-09	0.00E+00	9.22E-11	6.74E-11	1.24E-06
BA140	2.84E-05	3.48E-08	1.83E-06	0.00E+00	1.18E-08	2.34E-08	4.38E-05
BA141	6.71E-08	5.01E-11	2.24E-09	0.00E+00	4.65E-11	3.43E-11	1.43E-13
BA142	2.99E-08	2.99E-11	1.84E-09	0.00E+00	2.53E-11	1.99E-11	9.18E-20
LA140	3.48E-09	1.71E-09	4.55E-10	0.00E+00	0.00E+00	0.00E+00	9.82E-05
LA142	1.79E-10	7.95E-11	1.98E-11	0.00E+00	0.00E+00	0.00E+00	2.42E-06
CE141	1.33E-08	8.88E-09	1.02E-09	0.00E+00	4.18E-09	0.00E+00	2.54E-05
CE143	2.35E-09	1.71E-06	1.91E-10	0.00E+00	7.67E-10	0.00E+00	5.14E-05
CE144	6.96E-07	2.88E-07	3.74E-08	0.00E+00	1.72E-07	0.00E+00	1.75E-04
PR143	1.31E-08	5.23E-09	6.52E-10	0.00E+00	3.04E-09	0.00E+00	4.31E-05
PR144	4.30E-11	1.76E-11	2.18E-12	0.00E+00	1.01E-11	0.00E+00	4.74E-14
ND147	9.38E-09	1.02E-08	6.11E-10	0.00E+00	5.99E-09	0.00E+00	3.68E-05
TA183	6.81E-11	4.15E-10	3.42E-11	0.00E+00	2.37E-10	0.00E+00	1.86E-04
W187	1.46E-07	1.19E-07	4.17E-08	0.00E+00	0.00E+00	0.00E+00	3.22E-05
RE188	3.45E-07	2.70E-07	7.66E-07	1.68E-05	0.00E+00	0.00E+00	2.33E-05
AU198	0.00E+00	1.60E-08	2.72E-08	0.00E+00	4.88E-08	0.00E+00	9.84E-06
AU199	0.00E+00	9.92E-08	8.41E-08	0.00E+00	3.92E-07	0.00E+00	1.17E-05
NP239	1.76E-09	1.66E-10	9.22E-11	0.00E+00	5.21E-10	0.00E+00	2.67E-05
SB124	3.87E-06	7.13E-08	1.51E-06	8.78E-09	0.00E+00	3.38E-06	7.80E-05
SB125	2.48E-06	2.71E-08	5.80E-07	2.37E-09	0.00E+00	2.18E-06	1.93E-05

Table 2.3-7

Ingestion Dose Factors for Child (mrem/pCi ingested)

ISOTOPE	BONE	LIVER	WHOLE BODY	THYROID	KIDNEY	LUNG	GI-LLI
H3	0.00E+00	2.03E-07	2.03E-07	2.03E-07	2.03E-07	2.03E-07	2.03E-07
C14	1.21E-05	2.42E-06	2.42E-06	2.42E-06	2.42E-06	2.42E-06	2.42E-06
NA24	5.80E-06	5.80E-06	5.80E-06	5.80E-06	5.80E-06	5.80E-06	5.80E-06
P32	8.25E-04	3.86E-05	3.18E-05	0.00E+00	0.00E+00	0.00E+00	2.28E-05
CR51	0.00E+00	0.00E+00	8.90E-09	4.94E-09	1.35E-09	9.02E-09	4.72E-07
MN54	0.00E+00	1.07E-05	2.85E-06	0.00E+00	3.00E-06	0.00E+00	8.98E-06
MN56	0.00E+00	3.34E-07	7.54E-08	0.00E+00	4.04E-07	0.00E+00	4.84E-05
FE55	1.15E-05	6.10E-06	1.89E-06	0.00E+00	0.00E+00	3.45E-06	1.13E-06
FE59	1.65E-05	2.67E-05	1.33E-05	0.00E+00	0.00E+00	7.74E-06	2.78E-05
CO58	0.00E+00	1.80E-06	5.51E-06	0.00E+00	0.00E+00	0.00E+00	1.05E-05
CO60	0.00E+00	5.29E-06	1.56E-05	0.00E+00	0.00E+00	0.00E+00	2.93E-05
NI63	5.38E-04	2.88E-05	1.83E-05	0.00E+00	0.00E+00	0.00E+00	1.94E-06
NI65	2.22E-06	2.09E-07	1.22E-07	0.00E+00	0.00E+00	0.00E+00	2.56E-05
CU67	9.21E-07	2.52E-06	0.00E+00	7.83E-07	8.74E-07	7.81E-07	3.89E-05
CU64	0.00E+00	2.45E-07	1.48E-07	0.00E+00	5.92E-07	0.00E+00	1.15E-05
ZN65	1.37E-05	3.65E-05	2.27E-05	0.00E+00	2.30E-05	0.00E+00	6.41E-06
ZN69	4.38E-08	6.33E-08	5.85E-09	0.00E+00	3.84E-08	0.00E+00	3.99E-06
BR83	0.00E+00	0.00E+00	1.71E-07	0.00E+00	0.00E+00	0.00E+00	0.00E+00
BR84	0.00E+00	0.00E+00	1.98E-07	0.00E+00	0.00E+00	0.00E+00	0.00E+00
BR85	0.00E+00	0.00E+00	9.12E-09	0.00E+00	0.00E+00	0.00E+00	0.00E+00
RB86	0.00E+00	6.70E-05	4.12E-05	0.00E+00	0.00E+00	0.00E+00	4.31E-06
RB88	0.00E+00	1.90E-07	1.32E-07	0.00E+00	0.00E+00	0.00E+00	9.32E-09
RB89	0.00E+00	1.17E-07	1.04E-07	0.00E+00	0.00E+00	0.00E+00	1.02E-09
SR87M	5.47E-08	6.78E-08	0.00E+00	1.34E-08	6.65E-08	2.57E-08	6.66E-07
SR89	1.32E-03	0.00E+00	3.77E-05	0.00E+00	0.00E+00	0.00E+00	5.11E-05
SR90	1.70E-02	0.00E+00	4.31E-03	0.00E+00	0.00E+00	0.00E+00	2.29E-04
SR91	2.40E-05	0.00E+00	9.06E-07	0.00E+00	0.00E+00	0.00E+00	5.30E-05
SR92	9.03E-06	0.00E+00	3.62E-07	0.00E+00	0.00E+00	0.00E+00	1.71E-04
Y90	4.11E-08	0.00E+00	1.10E-09	0.00E+00	0.00E+00	0.00E+00	1.17E-04
Y91M	3.82E-10	0.00E+00	1.39E-11	0.00E+00	0.00E+00	0.00E+00	7.48E-07
Y91	6.02E-07	0.00E+00	1.61E-08	0.00E+00	0.00E+00	0.00E+00	8.02E-05
Y92	3.60E-09	0.00E+00	1.03E-10	0.00E+00	0.00E+00	0.00E+00	1.04E-04
Y93	1.14E-08	0.00E+00	3.13E-10	0.00E+00	0.00E+00	0.00E+00	1.70E-04
ZR95	1.16E-07	2.55E-08	2.27E-08	0.00E+00	3.65E-08	0.00E+00	2.66E-05
ZR97	6.99E-09	1.01E-09	5.96E-10	0.00E+00	1.45E-09	0.00E+00	1.53E-04
NB95	2.25E-08	8.76E-09	6.26E-09	0.00E+00	8.23E-09	0.00E+00	1.62E-05
MO99	0.00E+00	1.33E-05	3.29E-06	0.00E+00	2.84E-05	0.00E+00	1.10E-05
TC99M	9.23E-10	1.81E-09	3.00E-08	0.00E+00	2.63E-08	9.19E-10	1.03E-06

Table 2.3-7 (Cont.)

Ingestion Dose Factors for Child (mrem/pCi ingested)

ISOTOPE	BONE	LIVER	WHOLE BODY	THYROID	KIDNEY	LUNG	GI-LLI
TC101	1.07E-09	1.12E-09	1.42E-08	0.00E+00	1.91E-08	5.92E-10	3.56E-09
RU103	7.31E-07	0.00E+00	2.81E-07	0.00E+00	1.84E-06	0.00E+00	1.89E-05
RU105	6.45E-08	0.00E+00	2.34E-08	0.00E+00	5.67E-07	0.00E+00	4.21E-05
RU106	1.17E-05	0.00E+00	1.46E-06	0.00E+00	1.58E-05	0.00E+00	1.82E-04
AG110M	5.39E-07	3.64E-07	2.91E-07	0.00E+00	6.78E-07	0.00E+00	4.33E-05
TE125M	1.14E-05	3.09E-06	1.52E-06	3.20E-06	0.00E+00	0.00E+00	1.10E-05
TE127M	2.89E-05	7.78E-06	3.43E-06	6.91E-06	8.24E-05	0.00E+00	2.34E-05
TE127	4.71E-07	1.27E-07	1.01E-07	3.26E-07	1.34E-06	0.00E+00	1.84E-05
TE129M	4.87E-05	1.36E-05	7.56E-06	1.57E-05	1.43E-04	0.00E+00	5.94E-05
TE129	1.34E-07	3.74E-08	3.18E-08	9.56E-08	3.92E-07	0.00E+00	8.34E-06
TE131M	7.20E-06	2.49E-06	2.65E-06	5.12E-06	2.41E-05	0.00E+00	1.01E-04
TE131	8.30E-08	2.53E-08	2.47E-08	6.35E-08	2.51E-07	0.00E+00	4.36E-07
TE132	1.01E-05	4.47E-06	5.40E-06	6.51E-06	4.15E-05	0.00E+00	4.50E-05
I130	2.92E-06	5.90E-06	3.04E-06	6.50E-04	8.82E-06	0.00E+00	2.76E-06
I131	1.72E-05	1.73E-05	9.83E-06	5.72E-03	2.84E-05	0.00E+00	1.54E-06
I132	8.00E-07	1.47E-06	6.76E-07	6.82E-05	2.25E-06	0.00E+00	1.73E-06
I133	5.92E-06	7.32E-06	2.77E-06	1.36E-03	1.22E-05	0.00E+00	2.95E-06
I134	4.19E-07	7.78E-07	3.58E-07	1.79E-05	1.19E-06	0.00E+00	5.16E-07
I135	1.75E-06	3.15E-06	1.49E-06	2.79E-04	4.83E-06	0.00E+00	2.40E-06
CS134	2.34E-04	3.84E-04	8.10E-05	0.00E+00	1.19E-04	4.27E-05	2.07E-06
CS136	2.35E-05	6.46E-05	4.18E-05	0.00E+00	3.44E-05	5.13E-06	2.27E-06
CS137	3.27E-04	3.13E-04	4.62E-05	0.00E+00	1.02E-04	3.67E-05	1.96E-06
CS138	2.28E-07	3.17E-07	2.01E-07	0.00E+00	2.23E-07	2.40E-08	1.46E-07
BA139	4.14E-07	2.21E-10	1.20E-08	0.00E+00	1.93E-10	1.30E-10	2.39E-05
BA140	8.31E-05	7.28E-08	4.85E-06	0.00E+00	2.37E-08	4.34E-08	4.21E-05
BA141	2.00E-07	1.12E-10	6.51E-09	0.00E+00	9.69E-11	6.58E-10	1.14E-07
BA142	8.74E-08	6.29E-11	4.88E-09	0.00E+00	5.09E-11	3.70E-11	1.14E-09
LA140	1.01E-08	3.53E-09	1.19E-09	0.00E+00	0.00E+00	0.00E+00	9.84E-05
LA142	5.24E-10	1.67E-10	5.23E-11	0.00E+00	0.00E+00	0.00E+00	3.31E-05
CE141	3.97E-08	1.98E-08	2.94E-09	0.00E+00	8.68E-09	0.00E+00	2.47E-05
CE143	6.99E-09	3.79E-06	5.49E-10	0.00E+00	1.59E-09	0.00E+00	5.55E-05
CE144	2.08E-06	6.52E-07	1.11E-07	0.00E+00	3.61E-07	0.00E+00	1.70E-04
PR143	3.93E-08	1.18E-08	1.95E-09	0.00E+00	6.39E-09	0.00E+00	4.24E-05
PR144	1.29E-10	3.99E-11	6.49E-12	0.00E+00	2.11E-11	0.00E+00	8.59E-08
ND147	2.79E-08	2.26E-08	1.75E-09	0.00E+00	1.24E-08	0.00E+00	3.58E-05
TA183	2.04E-10	9.40E-10	1.02E-10	0.00E+00	4.98E-10	0.00E+00	2.07E-04
W187	4.29E-07	2.54E-07	1.14E-07	0.00E+00	0.00E+00	0.00E+00	3.57E-05
RE188	1.03E-06	6.12E-07	2.29E-06	5.03E-05	0.00E+00	0.00E+00	4.12E-05
AU198	0.00E+00	3.61E-08	8.12E-08	0.00E+00	1.02E-07	0.00E+00	1.20E-05
AU199	0.00E+00	2.25E-07	2.51E-07	0.00E+00	8.23E-07	0.00E+00	1.27E-05
NP239	5.25E-09	3.77E-10	2.65E-10	0.00E+00	1.09E-09	0.00E+00	2.79E-05
SB124	1.11E-05	1.44E-07	3.89E-06	2.45E-08	0.00E+00	6.16E-06	6.94E-05
SB125	7.16E-06	5.52E-08	1.50E-06	6.63E-09	0.00E+00	3.99E-06	1.71E-05

Table 2.3-8

Ingestion Dose Factors for Infant (mrem/pCi ingested)

ISOTOPE	BONE	LIVER	WHOLE BODY	THYROID	KIDNEY	LUNG	GI-LLI
H3	0.00E+00	3.08E-07	3.08E-07	3.08E-07	3.08E-07	3.08E-07	3.08E-07
C14	2.37E-05	5.06E-06	5.06E-06	5.06E-06	5.06E-06	5.06E-06	5.06E-06
NA24	1.01E-05	1.01E-05	1.01E-05	1.01E-05	1.01E-05	1.01E-05	1.01E-05
P32	1.70E-03	1.00E-04	6.59E-05	0.00E+00	0.00E+00	0.00E+00	2.30E-05
CR51	0.00E+00	0.00E+00	1.41E-08	9.20E-09	2.01E-09	1.79E-08	4.11E-07
MN54	0.00E+00	1.99E-05	4.51E-06	0.00E+00	4.41E-06	0.00E+00	7.31E-06
MN56	0.00E+00	8.18E-07	1.41E-07	0.00E+00	7.03E-07	0.00E+00	7.43E-05
FE55	1.39E-05	8.98E-06	2.40E-06	0.00E+00	0.00E+00	4.39E-06	1.14E-06
FE59	3.08E-05	5.38E-05	2.12E-05	0.00E+00	0.00E+00	1.59E-05	2.57E-05
CO58	0.00E+00	3.60E-06	8.98E-06	0.00E+00	0.00E+00	0.00E+00	8.97E-06
CO60	0.00E+00	1.08E-05	2.55E-05	0.00E+00	0.00E+00	0.00E+00	2.57E-05
NI63	6.34E-04	3.92E-05	2.20E-05	0.00E+00	0.00E+00	0.00E+00	1.95E-06
NI65	4.70E-06	5.32E-07	2.42E-07	0.00E+00	0.00E+00	0.00E+00	4.05E-05
CU67	5.26E-06	1.42E-05	0.00E+00	4.93E-06	4.98E-06	4.87E-06	1.36E-05
CU64	0.00E+00	6.09E-07	2.82E-07	0.00E+00	1.03E-06	0.00E+00	1.25E-05
ZN65	1.84E-05	6.31E-05	2.91E-05	0.00E+00	3.06E-05	0.00E+00	5.33E-05
ZN69	9.33E-08	1.68E-07	1.25E-08	0.00E+00	6.98E-08	0.00E+00	1.37E-05
BR83	0.00E+00	0.00E+00	3.63E-07	0.00E+00	0.00E+00	0.00E+00	0.00E+00
BR84	0.00E+00	0.00E+00	3.82E-07	0.00E+00	0.00E+00	0.00E+00	0.00E+00
BR85	0.00E+00	0.00E+00	1.94E-08	0.00E+00	0.00E+00	0.00E+00	0.00E+00
RB86	0.00E+00	1.70E-04	8.40E-05	0.00E+00	0.00E+00	0.00E+00	4.35E-06
RB88	0.00E+00	4.98E-07	2.73E-07	0.00E+00	0.00E+00	0.00E+00	4.85E-07
RB89	0.00E+00	2.86E-07	1.97E-07	0.00E+00	0.00E+00	0.00E+00	9.74E-08
SR87M	2.22E-07	1.56E-07	0.00E+00	4.70E-08	1.37E-07	7.71E-08	1.49E-06
SR89	2.51E-03	0.00E+00	7.20E-05	0.00E+00	0.00E+00	0.00E+00	5.16E-05
SR90	1.85E-02	0.00E+00	4.71E-03	0.00E+00	0.00E+00	0.00E+00	2.31E-04
SR91	5.00E-05	0.00E+00	1.81E-06	0.00E+00	0.00E+00	0.00E+00	5.92E-05
SR92	1.92E-05	0.00E+00	7.13E-07	0.00E+00	0.00E+00	0.00E+00	2.07E-04
Y90	8.69E-08	0.00E+00	2.33E-09	0.00E+00	0.00E+00	0.00E+00	1.20E-04
Y91M	8.10E-10	0.00E+00	2.76E-11	0.00E+00	0.00E+00	0.00E+00	2.70E-06
Y91	1.13E-06	0.00E+00	3.01E-08	0.00E+00	0.00E+00	0.00E+00	8.10E-05
Y92	7.65E-09	0.00E+00	2.15E-10	0.00E+00	0.00E+00	0.00E+00	1.46E-04
Y93	2.43E-08	0.00E+00	6.62E-10	0.00E+00	0.00E+00	0.00E+00	1.92E-04
ZR95	2.06E-07	5.02E-08	3.56E-08	0.00E+00	5.41E-08	0.00E+00	2.50E-05
ZR97	1.48E-08	2.54E-09	1.16E-09	0.00E+00	2.56E-09	0.00E+00	1.62E-04
NB95	4.20E-08	1.73E-08	1.00E-08	0.00E+00	1.24E-08	0.00E+00	1.46E-05
MO99	0.00E+00	3.40E-05	6.63E-06	0.00E+00	5.08E-05	0.00E+00	1.12E-05
TC99M	1.92E-09	3.96E-09	5.10E-08	0.00E+00	4.26E-08	2.07E-09	1.15E-06

Table 2.3-8 (Cont.)

Ingestion Dose Factors for Infant (mrem/pCi ingested)

ISOTOPE	BONE	LIVER	WHOLE BODY	THYROID	KIDNEY	LUNG	GI-LLI
TC101	2.27E-09	2.86E-09	2.83E-08	0.00E+00	3.40E-08	1.56E-09	4.86E-07
RU103	1.48E-06	0.00E+00	4.95E-07	0.00E+00	3.08E-06	0.00E+00	1.80E-05
RU105	1.36E-07	0.00E+00	4.58E-08	0.00E+00	1.00E-06	0.00E+00	5.41E-05
RU106	2.41E-05	0.00E+00	3.01E-06	0.00E+00	2.85E-05	0.00E+00	1.83E-04
AG110M	9.96E-07	7.27E-07	4.81E-07	0.00E+00	1.04E-06	0.00E+00	3.77E-05
TE125M	2.33E-05	7.79E-06	3.15E-06	7.84E-06	0.00E+00	0.00E+00	1.11E-05
TE127M	5.85E-05	1.94E-05	7.08E-06	1.69E-05	1.44E-04	0.00E+00	2.36E-05
TE127	1.00E-06	3.35E-07	2.15E-07	8.14E-07	2.44E-06	0.00E+00	2.10E-05
TE129M	1.00E-04	3.43E-05	1.54E-05	3.84E-05	2.50E-04	0.00E+00	5.97E-05
TE129	2.84E-07	9.79E-08	6.63E-08	2.38E-07	7.07E-07	0.00E+00	2.27E-05
TE131M	1.52E-05	6.12E-06	5.05E-06	1.24E-05	4.21E-05	0.00E+00	1.03E-04
TE131	1.76E-07	6.50E-08	4.94E-08	1.57E-07	4.50E-07	0.00E+00	7.11E-06
TE132	2.08E-05	1.03E-05	9.61E-06	1.52E-05	6.44E-05	0.00E+00	3.81E-05
I130	6.00E-06	1.32E-05	5.30E-06	1.48E-03	1.45E-05	0.00E+00	2.83E-06
I131	3.59E-05	4.23E-05	1.86E-05	1.39E-02	4.94E-05	0.00E+00	1.51E-06
I132	1.66E-06	3.37E-06	1.20E-06	1.58E-04	3.76E-06	0.00E+00	2.73E-06
I133	1.25E-05	1.82E-05	5.33E-06	3.31E-03	2.14E-05	0.00E+00	3.08E-06
I134	8.69E-07	1.78E-06	6.33E-07	4.15E-05	1.99E-06	0.00E+00	1.84E-06
I135	3.64E-06	7.24E-06	2.64E-06	6.49E-04	8.07E-06	0.00E+00	2.62E-06
CS134	3.77E-04	7.03E-04	7.10E-05	0.00E+00	1.81E-04	7.42E-05	1.91E-06
CS136	4.59E-05	1.35E-04	5.04E-05	0.00E+00	5.38E-05	1.10E-05	2.05E-06
CS137	5.22E-04	6.11E-04	4.33E-05	0.00E+00	1.64E-04	6.64E-05	1.91E-06
CS138	4.81E-07	7.82E-07	3.79E-07	0.00E+00	3.90E-07	6.09E-08	1.25E-06
BA139	8.81E-07	5.84E-10	2.55E-08	0.00E+00	3.51E-10	3.54E-10	5.58E-05
BA140	1.71E-04	1.71E-07	8.81E-06	0.00E+00	4.06E-08	1.05E-07	4.20E-05
BA141	4.25E-07	2.91E-10	1.34E-08	0.00E+00	1.75E-10	1.77E-10	5.19E-06
BA142	1.84E-07	1.53E-10	9.06E-09	0.00E+00	8.81E-11	9.26E-11	7.59E-07
LA140	2.11E-08	8.32E-09	2.14E-09	0.00E+00	0.00E+00	0.00E+00	9.77E-05
LA142	1.10E-09	4.04E-10	9.67E-11	0.00E+00	0.00E+00	0.00E+00	6.86E-05
CE141	7.87E-08	4.80E-08	5.65E-09	0.00E+00	1.48E-08	0.00E+00	2.48E-05
CE143	1.48E-08	9.82E-06	1.12E-09	0.00E+00	2.86E-09	0.00E+00	5.73E-05
CE144	2.98E-06	1.22E-06	1.67E-07	0.00E+00	4.93E-07	0.00E+00	1.71E-04
PR143	8.13E-08	3.04E-08	4.03E-09	0.00E+00	1.13E-08	0.00E+00	4.29E-05
PR144	2.74E-10	1.06E-10	1.38E-11	0.00E+00	3.84E-11	0.00E+00	4.93E-06
ND147	5.53E-08	5.68E-08	3.48E-09	0.00E+00	2.19E-08	0.00E+00	3.60E-05
TA183	4.33E-10	2.49E-09	2.17E-10	0.00E+00	9.05E-10	0.00E+00	2.10E-04
W187	9.03E-07	6.28E-07	2.17E-07	0.00E+00	0.00E+00	0.00E+00	3.69E-05
RE188	2.20E-06	1.62E-06	4.86E-06	1.25E-04	0.00E+00	0.00E+00	4.72E-05
AU198	0.00E+00	9.56E-08	1.73E-07	0.00E+00	1.86E-07	0.00E+00	1.25E-05
AU199	0.00E+00	5.91E-07	5.32E-07	0.00E+00	1.49E-06	0.00E+00	1.28E-05
NP239	1.11E-08	9.93E-10	5.61E-10	0.00E+00	1.98E-09	0.00E+00	2.87E-05
SB124	2.14E-05	3.15E-07	6.63E-06	5.08E-08	0.00E+00	1.34E-05	6.60E-05
SB125	1.23E-05	1.19E-07	2.53E-06	1.54E-08	0.00E+00	7.72E-06	1.64E-05

Table 2.3-9

External Dose Factors for Standing on Contaminated Ground

(mrem/h per pCi/m²)

<u>Element</u>	<u>Whole Body</u>	<u>Skin</u>
H-3	0.0	0.0
C-14	0.0	0.0
NA-24	2.50E-08	2.90E-08
P-32	0.0	0.0
Cr-51	2.20E-10	2.60E-10
Mn-54	5.80E-09	6.80E-09
Mn-56	1.10E-08	1.30E-08
Fe-55	0.0	0.0
Fe-59	8.00E-09	9.40E-09
Co-58	7.00E-09	8.20E-09
Co-60	1.70E-08	2.00E-08
Ni-63	0.0	0.0
Nr-65	3.70E-09	4.30E-09
Cu-64	1.50E-09	1.70E-09
Cu-67	1.40E-09	2.14E-9
Zn-65	4.00E-09	4.60E-09
Zn-69	0.0	0.0
Br-83	6.40E-11	9.30E-11
Br-84	1.20E-08	1.40E-08
Br-85	0.0	0.0
Rb-86	6.30E-10	7.20E-10
Rb-88	3.50E-09	4.00E-09
Rb-89	1.50E-08	1.80E-08
Sr-87M	4.05E-09	5.36E-09
Sr-89	5.60E-13	6.50E-13
Sr-91	7.10E-09	8.30E-09
Sr-92	9.00E-09	1.00E-08
Y-90	2.20E-12	2.60E-12
Y-91M	3.80E-09	4.40E-09
Y-91	2.40E-11	2.70E-11
Y-92	1.60E-09	1.90E-09
Y-93	5.70E-10	7.80E-10
Zr-95	5.00E-09	5.80E-09
Zr-97	5.50E-09	6.40E-09
Mo-95	5.10E-09	6.00E-09
Mo-99	1.90E-09	2.20E-09
Tc-99M	9.60E-10	1.10E-09
Tc-101	2.70E-09	3.00E-09
Ru-103	3.60E-09	4.20E-09
Ru-105	4.50E-09	5.10E-09
Ru-106	1.50E-09	1.80E-09

Table 2.3-9 (Cont.)

External Dose Factors for Standing on Contaminated Ground

(mrem/h per pCi/m²)

<u>Element</u>	<u>Whole Body</u>	<u>Skin</u>
Ag-110M	1.80E-08	2.10E-08
Te-125M	3.50E-11	4.80E-11
Te-127M	1.10E-12	1.30E-12
Te-127	1.00E-11	1.10E-11
Te-129M	7.70E-10	9.00E-10
Te-129	7.10E-10	8.40E-10
Te-131M	8.40E-09	9.90E-09
Te-131	2.20E-09	2.60E-06
Te-132	1.70E-09	2.00E-09
Sb-124	2.28E-08	6.93E-08
Sb-125	5.67E-09	7.96E-09
I-130	1.40E-08	1.70E-08
I-131	2.80E-09	3.40E-09
I-132	1.70E-08	2.00E-08
I-133	3.70E-09	4.50E-09
I-134	1.60E-08	1.90E-08
I-135	1.20E-08	1.40E-08
Cs-134	1.20E-08	1.40E-08
Cs-136	1.50E-08	1.70E-08
Cs-137	4.20E-09	4.90E-09
Cs-138	2.10E-08	2.40E-08
Ba-139	2.40E-09	2.70E-09
Ba-140	2.10E-09	2.40E-09
Ba-141	4.30E-09	4.90E-09
Ba-142	7.90E-09	9.00E-09
La-140	1.50E-08	1.70E-08
La-142	1.50E-08	1.80E-08
Ce-141	5.50E-10	6.20E-10
Ce-143	2.20E-09	2.50E-09
Ce-144	3.20E-10	3.70E-10
Pr-143	0.0	0.0
Pr-144	2.00E-10	2.30E-10
Nd-147	1.00E-09	1.20E-09
Ta-183	3.76E-09	7.30E-09
W-187	3.10E-09	3.60E-09
Re-188	7.86E-10	1.18E-07
Au-198	5.33E-09	3.36E-08
Au-199	1.13E-9	1.39E-09
Np-239	9.50E-10	1.10E-09

Table 2.3-10

Liquid Effluent Dilution Factors (M_p)

Maximum Individual Dilution Factors

<u>Pathway</u>	<u>Location</u>	<u>M_p</u>
Potable Water Ingestion	3.9 mile WSW of site	32.2
Fresh Water Fish Ingestion	Near Discharge Structure	10.9
Shoreline Exposure	0.7 mile ENE of Site	14.5

Population Dose Dilution Factors *

<u>Pathway</u>	<u>Location</u>	<u>M_p</u>
Potable Water Ingestion	Population Weighted Average	314
Fresh Water Fish Ingestion	Catch Weighted Average	77.4
Shoreline Exposure	7.7 mile WSW of site	162

Table 2.3-11

Transit Times Required for Nuclides to Reach the Point of Exposure (t_p)

	<u>Maximum Exposed Individual</u>	<u>Average Exposed Individual*</u>
Eventual transit time for water ingestion	12 h	24 h
Eventual transit time for fish ingestion	24 h	168 h
Eventual transit time for shore exposure	0 h	0 h

* for total population and average individual dose calculations

Table 2.3-12

Usage Factors (U_{ap})

	<u>Maximum Exposed Individual</u>	<u>Average Exposed Individual*</u>
Water ingestion (L/yr) Adult	730	370
Water ingestion (L/yr) Teen	510	260
Water ingestion (L/yr) Child	510	260
Water ingestion (L/yr) Infant	330	--
Fresh water fish ingestion (kg/yr) Adult	21	6.9
Fresh water fish ingestion (kg/yr) Teen	16	5.2
Fresh water fish ingestion (kg/yr) Child	6.9	2.2
Fresh water fish ingestion (kg/yr) Infant	--	--
Shore exposure (h/yr) Adult	12	8.3
Shore exposure (h/yr) Teen	67	47
Shore exposure (h/yr) Child	14	9.5
Shore exposure (h/yr) Infant	--	--

* for total population and average individual dose calculations

Table 2.3-13

Dilution Factors for Each of the Potable Water Intakes
within 50 Miles of PNPP

The total population dilution factor of 314 is population weighted using dilution factors for each of the potable water intakes within 50 miles of PNPP.

<u>Intake</u>	<u>Dist. (Mi)</u>	<u>Dir</u>	<u>Population</u>	<u>Fraction of Population</u>	<u>Dilution Factor</u>	<u>Weighted Dilution Factor</u>
Ohio American Water Serv. Co.	20	ENE	38,500	2.12E-2	187.7	3.98E+00
Conneaut	33	ENE	13,500	7.43E-03	238.2	1.77E+00
Avon Lake	50	WSW	99,500	5.48E-02	388.5	2.13E+01
Cleveland	35	SW	1,437,000	7.92E-01	326.7	2.59E+02
Fairport Harbor	7	WSW	3,200	1.76E-03	154.2	2.71E-01
Lake County East	3.5	WSW	10,258	5.65E-03	107.4	6.07E-01
Lake County West	15	WSW	85,000	4.68E-02	220.0	1.03E+01
Ohio Water Serv.	10	WSW	60,000	3.30E-02	181.9	6.00E+00
Painesville	7.5	WSW	27,000	1.49E-02	159.3	2.37E+00
Kent County Water Supply	50	NW	<u>42,000</u>	<u>2.31E-2102</u>	388.5	<u>8.97E+00</u>
TOTALS			1,815,958	1.00E+0	TOTAL DF	3.14E+02

Dist, Dir Population = distance, direction, and population values obtained from the 1989 Engineering Report "Lake Erie Potable Water Facilities and Intakes within 50 Miles of PNPP" (Ref. SO-11552 "E").

Fraction of Population = The ratio of the population receiving drinking water from that intake to the total population number for all drinking water intakes located within 50 miles of PNPP.

Dilution Factor = Values obtained from the Perry Environmental Report - Operating License Stage, Table 5.1-10 "Annual Average Dilution Factors for Lake Water Intakes within 50 Miles of PNPP" and Q&R Page 2.1-2. Lake County West dilution factor per interpolation. Kent County Water Supply dilution factor was estimated.

The Weighted Dilution Factor = (Fraction of Population) x (Dilution Factor), based on the population for each drinking water intake; the sum of which is to be used as the potable water total population dilution factor for radioactive liquid effluent releases from PNPP.

Table 2.3-14

Dilution Factors for the Fish Ingestion Pathway Individual
Grid Locations

The total population dilution factor of 77.4 is catch distance and volume weighted using dilution factors at those locations. Fish harvest is based on Ohio Department of Natural Resources the total angler catch (1987 annual) values for Lake Erie within 50 mile of PNPP.

<u>Grid</u>	<u>No. of Fish</u>	<u>Fraction of Fish</u>	<u>Distance (mi)</u>	<u>Dilution Factor</u>	<u>(Frac Fish)x (Dil Factor)</u>
617	52823	3.91E-02	29	92	3.60E+00
618	76004	5.63E-02	36	100	5.63E+00
714	102522	7.59E-02	9	52	3.96E+00
715	10743	7.95E-03	9	52	4.13E-01
716	19817	1.47E-02	11	56	8.21E-01
717	73401	5.43E-02	24	83	4.51E+00
718	118676	8.78E-02	33	95	8.34E+00
809	0	0.00E+00	48	115	0.00E+00
810	3953	2.93E-03	39	105	3.07E-01
811	13648	1.01E-02	30	92	9.29E-01
812	33923	2.51E-02	22	78	1.96E+00
813	182663	1.35E-01	13	61	8.25E+00
814	164369	1.22E-01	4	34	4.14E+00
909	80753	5.98E-02	50	116	6.93E+00
910	43800	3.24E-02	42	110	3.57E+00
911	117430	8.69E-02	33	95	8.26E+00
912	<u>256529</u>	<u>1.90E-01</u>	24	83	<u>1.58E+01</u>
TOTAL	1351054	1.00E+00		TOTAL D.F.	7.74E+01

Grid No. and No. of Fish = Total angler catch (1987 annual) for each grid location; per letter from Michael R. Rawson, Fairport Fisheries Research Station, Ohio Department of Natural Resources to Richard Cochnar (6/20/88). Commercial harvest data were not used as they were differentiated by harbor location only, not by geographical grid location.

Fraction of Fish = The ratio of the fish caught in that grid to the total number of fish caught in all grids located within 50 miles of PNPP.

Distance = Distance to the center of that grid from PNPP, in miles.

Dilution Factor = Derived, for the appropriate distance (center of each grid), from annual average dilution factor data (non-adjusted), per Perry Environmental Report - Operating License Stage, Table 5.1-10 "Annual Average Dilution Factors for Lake Water Intakes within 50 Miles of PNPP."

(Fraction of Fish) x (Dilution Factor) = The weighted dilution factor, based on catch, for each grid; the sum of which is to be used as the fish ingestion total population dilution factor for radioactive liquid effluent releases from PNPP.

Table 2.3-15

Dilution Factors for the Shore Exposure Pathway

MAXIMUM EXPOSED INDIVIDUAL DILUTION FACTOR

The point of exposure assumed for this pathway is the shoreline at the PNPP site boundary 0.7 miles down shore from the plant discharge structure. Interpolation of the data presented in the Perry Environmental Report - Operating License Stage, Table 5.1-10, "Annual Average Dilution Factors for Lake Water Intakes within 50 Miles of PNPP" yields a maximum individual dose dilution factor of 14.5 (dilution factor unadjusted for current frequency).

TOTAL POPULATION DILUTION FACTOR

The total population dilution factor of 162 is that of the Headlands Beach State Park, 7.7 miles WSW of PNPP (interpolated, adjusted WSW dilution factor). This location was selected because of its lake site location and it has, by far, the highest attendance of any park located in vicinity of PNPP (Perry Environmental Report - Operating License State, Table 2.1-2 "Major Camps and Parks within 10 Miles of the PNPP").

(INTENTIONALLY BLANK)

3.0 GASEOUS EFFLUENTS

3.0.1 Batch Releases

A batch release is the discontinuous discharge of gaseous radioactive effluents of known radionuclide concentration(s) and flowrate taking place over a finite period of time, usually hours or days. A batch release to the environment may occur as a result of an effluent flowpath that bypasses treatment or monitoring. Since radioactive releases approaching 10CFR20 limits are not anticipated, an ODCM Control is not entered for batch releases. Every reasonable effort will be made to maintain the levels of radioactive material in the gaseous effluents ALARA.

The radioactive gaseous effluent release flowpath is monitored for principal gamma emitters (noble gases, particulates, and halogens) as if the inoperable radioactive effluent monitor requirements of Table 3.3.7.10-1 had been entered. This action ensures the dose to a member of the general public is within the limits of Controls 3.11.2.2 and 3.11.2.3. If radioactivity is detected, the radionuclide concentration(s) is added to the dose calculations for the appropriate radioactive gaseous effluent continuous release point. Administrative instructions are employed to establish minimum monitoring requirements for these batch releases to ensure compliance with all regulatory requirements. The administrative instructions shall also ensure that the specific activity that will cause a batch release has been reviewed for the requirements of 10 CFR 50.59.

3.0.2 Continuous Releases

There are four environmental release points for gaseous effluents used for Unit 1 operation of the Perry Nuclear Power Plant: Turbine Bldg/Heater Bay Vent, Off-Gas Vent, Unit 1 Vent, and Unit 2 Vent (see Figure 3.0-1). The Unit 1 and Unit 2 Vents are located on the top of the Intermediate Building, Elevation 753'9". The Turbine Bldg/Heater Bay Vent is located on the top of the Heater Bay Building, Elevation 722'0". The Off-Gas Vent is located on the top of the Off-Gas Building, Elevation 723'0". Site ground level elevation is 620'0". Radiological releases from each vent are monitored by a noble gas radiation monitor.

All gaseous effluent releases from PNPP via these vents will be continuous releases, and are considered to be long-term (i.e., greater than 500 hours per year) and ground level. Containment/drywell purges and vents will be considered periods of increased radiological release as they are vented through the Unit 1 Vent, concurrent with normal, continuous releases.

Figure 3.0-1

Gaseous Effluent System Flow Diagram

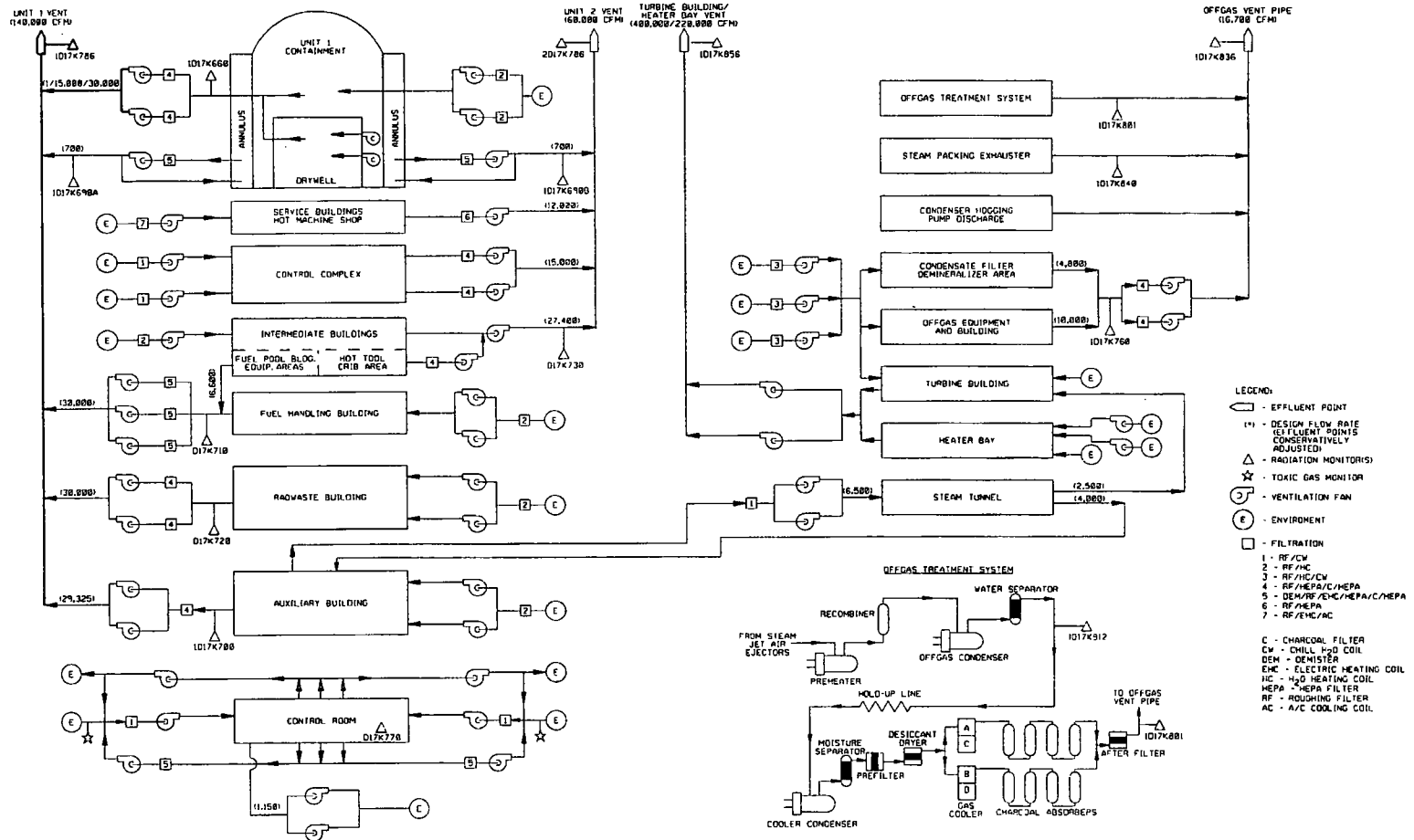

- LEGEND:
- - EFFLUENT POINT
 - (*) - DESIGN FLOW RATE (EFFLUENT POINTS CONSERVATIVELY ADJUSTED)
 - △ - RADIATION MONITOR(S)
 - ★ - TOXIC GAS MONITOR
 - ⊙ - VENTILATION FAN
 - ⊖ - ENVIRONMENT
 - - FILTRATION
 - 1 - RF/CW
 - 2 - RF/HC
 - 3 - RF/HC/CW
 - 4 - RF/HEPA/C/HEPA
 - 5 - DEM/RF/HC/HEPA/C/HEPA
 - 6 - RF/HEPA
 - 7 - RF/HC/HC
- C - CHARCOAL FILTER
 CW - CHILL H₂O COIL
 DEM - DEMISTER
 EHC - ELECTRIC HEATING COIL
 HC - H₂O HEATING COIL
 HEPA - HEPA FILTER
 RF - ROUGHING FILTER
 AC - A/C COOLING COIL

3.1 Monitor Alarm Setpoint Determination

The following calculation methods provide a means of determining the High Alarm Setpoint (HSP) and the Alert Setpoint (ASP) to ensure compliance with the regulatory dose rate limit to areas at or beyond the site boundary of 500 mrem/yr for the following noble gas monitors:

1. Unit 1 Vent radiation monitor (1D17K0786)
2. Unit 2 Vent radiation monitor (2D17K0786)
3. Off-Gas Vent radiation monitor (1D17K0836)
4. Turbine Building/Heater Bay Vent radiation monitor (1D17K0856)

The Unit 2 Vent radiation monitor is included for the operation of Unit 1 of the Perry Nuclear Power Plant because the second train of the Unit 1 Annulus Exhaust and the Control Complex and Intermediate Building ventilations are exhausted through the Unit 2 Vent.

The High Alarm Setpoint (HSP) for each release point radiation monitor will be set at 70% of the annual dose rate limit (350 mrem/yr) and the Alert Setpoint (ASP) will be at 10% of the annual dose rate limit (50 mrem/yr).

NOTE: These values are set as a small fraction of the total activity that may be released via the monitored pathways to ensure that the site boundary dose rate limits are not exceeded. Any single ASP can be exceeded without exceeding the 500 mrem/yr dose rate limit.

- a. Upon receipt of an alert alarm, a sample from the alarming effluent path will be obtained and analyzed. If two or more effluent monitors exceed the ASP, or if any one effluent monitor exceeds the HSP, the potential exists that the 500 mrem/yr dose rate limit may be exceeded. In this case, all four effluent paths will be sampled and analyzed, with the appropriate actions initiated to limit gaseous releases to below the annual dose rate limit.
- b. If a single HSP, or two or more ASPs continue to be exceeded, verification shall be made at least once per 4 hours, via the gaseous effluent radiation monitors, that plant releases are below the ODCM Appendix C 3.11.2.1 dose rate limits. Sampling and analysis shall be performed on the four gaseous effluent release points at least once per 12 hours.

This procedure determines the monitor alarm setpoints that indicate if the dose rate beyond the site boundary due to noble gas radionuclides in gaseous effluent released from the site exceeds 500 mrem/year to the whole body, or 3000 mrem/year to the skin.

3.1.1 Determination of the "Mix" (Noble Gas Radionuclide Composition) of the Gaseous Effluent

- a. The gaseous source terms that are representative of the "mix" of the gaseous effluent are determined. Gaseous source terms are the concentrations of the noble gas radionuclides in the effluent as determined by analysis of the various sources of gaseous effluents. During the early period of plant operation, before a sufficient operational effluent source term data base has been obtained, source terms will be those generated by the GALE code, Revision 0 for PNPP (FSAR Tables 11.3-9 and 11.3-10).
- b. Determination of the fraction of the total radioactivity in the gaseous effluent for each noble gas radionuclide in the gaseous effluent.

$$S_i = \frac{A_i}{\sum A_i} \quad (3.1-1)$$

Where:

S_i = the fraction of the total for radionuclide "i" in the effluent;

A_i = the activity of radionuclide "i" in the gaseous effluent.

NOTE: If the activity of a noble gas radionuclide is below the lower limit of detection the noble gas radionuclide is not included as a source term in this setpoint calculation.

3.1.2 Determination of the Maximum Acceptable Total Activity Release Rate of Noble Gas Radionuclides in Gaseous Effluent Based on Whole Body Dose Rate Limit

$$Q_b = \frac{500}{\left(\frac{\lambda}{Q}\right) \sum (K_i)(S_i)} \quad (3.1-2)$$

Where:

Q_b = the maximum acceptable total activity release rate of all noble gas radionuclides in the effluent (for whole body exposure), $\mu\text{Ci/s}$;

K_i = the whole body dose factor for a semi-infinite cloud of radionuclide "i" (includes 5g/cm^2 tissue attenuation) from Table 3.1-1, $(\text{mrem/yr})/(\mu\text{Ci/m}^3)$;

S_i = the fraction of the total for radionuclide "i", as per equation 3.1.1;

χ/Q = the annual average dispersion factor in s/m^3 (see Appendix A);

NOTE: The dispersion parameters (χ/Q) used in these calculations are the highest calculated site boundary values for any of the land-based sectors only. At PNPP the site boundary locations in the following sectors are totally over water: N, NNE, NNW, NW, W, WNW.

500 = the whole body dose rate limit, in mrem/yr.

3.1.3 Determination of the Maximum Acceptable Total Activity Release Rate of Noble Gas Radionuclides in Gaseous Effluent Based on Skin Dose Rate Limit

$$Q_s = \frac{3000}{\left(\frac{\chi}{Q}\right) \sum (L_i + 1.11 M_i) (S_i)} \quad (3.1-3)$$

Where:

Q_s = the maximum acceptable total activity release rate of all noble gas radionuclides in the effluent (for skin exposure), in $\mu\text{Ci/s}$;

L_i = the beta skin dose factor for a semi-infinite cloud of radionuclide "i" (includes attenuation by the outer "dead" layer of skin), in $(\text{mrem/yr})/(\mu\text{Ci}/\text{m}^3)$;

M_i = the gamma air dose factor for a uniform semi-infinite cloud of radionuclide "i", in $(\text{mrad/yr})/(\mu\text{Ci}/\text{m}^3)$;

S_i = the fraction of the total for radionuclide "i", per equation 3.1.1;

χ/Q = the annual average dispersion factor in s/m^3 (see Appendix A);

1.11 = the air dose to tissue dose equivalent conversion factor, in mrem/mrad;

3000 = the skin dose rate limit, in mrem/yr.

$(L_i + 1.11 M_i)$ values are shown in Table 3.1-1.

Table 3.1-1

Whole Body and Skin Dose Factors

Radionuclide	Whole Body Dose Factor (K _i) (mrem/yr/μCi/m ³)	Skin Dose Factor (L _i +1.11 M _i) mrem/yr/μCi/m ³
Kr-83m	7.56E-02	2.14E+01
Kr-85m	1.17E+03	2.83E+03
Kr-85	1.61E+01	1.36E+03
Kr-87	5.92E+03	1.66E+04
Kr-88	1.47E+04	1.92E+04
Kr-89	1.66E+04	2.93E+04
Xe-131m	9.15E+01	6.49E+02
Xe-133m	2.51E+02	1.36E+03
Xe-133	2.94E+02	6.97E+02
Xe-135	1.81E+03	3.99E+03
Xe-135m	3.12E+03	4.44E+03
Xe-137	1.42E+03	1.39E+04
Xe-138	8.83E+03	1.44E+04
Ar-41	8.84E+03	1.30E+04

3.1.4 Determination of the Maximum Acceptable Total Radioactivity Concentration of all Noble Gas Radionuclides in the Gaseous Effluent

$$C_t = \frac{(2.12 \times 10^{-3})(Q_t)}{f} \quad (3.1-4)$$

Where:

- C_t = the maximum acceptable total radioactivity concentration of all noble gas radionuclides in the effluent, in μCi/cc;
- f = the flow rate for the release point from the respective flow rate recorders, in ft³/min;

NOTE: Design flow rates, which incorporate a 10% flow rate inaccuracy correction, may be used in lieu of actual flow rates.

<u>Effluent Release Path</u>	<u>Flow Rate (cfm)</u>
Unit 1 Vent	140,000
Unit 2 Vent	60,000
Off-Gas Vent	16,700
Turbine Building/Heater Bay Vent	400,000 (summer) 220,000 (winter)

Q_t = the smaller of Q_b and Q_s , calculated in equations 3.1-2 and 3.1-3, respectively, $\mu\text{Ci/s}$;

$2.12\text{E-}03$ = the conversion factor to convert $(\mu\text{Ci/s})(\text{ft}^3/\text{min})$, $\mu\text{Ci/cc}$.

3.1.5 Determination of the Maximum Acceptable Monitor Count Rate Above Background Attributed to Noble Gas Radionuclides

$$CR_C = (0.8)(C_t)(E_m) \quad (3.1-5)$$

Where:

CR_C = the calculated monitor count rate above background attributed to noble gas radionuclides, in cpm;

C_t = the maximum acceptable radioactivity concentration, per equation 3.1-4, $\mu\text{Ci/cc}$;

E_m = the detector efficiency of the monitor for the "mix" of noble gas radionuclides in the effluent, in $\text{cpm}/(\mu\text{Ci/cc})$;

= the total $\mu\text{Ci/cc}$ concentration divided into the net monitor count rate taken at the time the sample was taken; during the early period of operation, before a sufficient operational effluent source term data base has been obtained, the value will be calculated using monitor calibration data;

0.8 = an engineering safety factor.

3.1.5.1 Determination of the Monitor High Alarm Setpoint

$$\text{HSP} = (0.70)(CR_C) + \text{BG} \quad (3.1-6)$$

Where:

HSP = the high alarm setpoint (including background), in cpm;

BG = the background count rate due to internal contamination and radiation levels in the area in which the monitor is installed when the monitor chamber is filled with uncontaminated air, in cpm;

CR_C = the calculated monitor net count rate, per equation 3.1-5, in cpm;

0.70 = the fraction of the maximum acceptable activity that may be released from the vent to ensure that the site boundary dose rate limits are not exceeded during concurrent releases from several pathways.

3.1.5.2 Determination of the Monitor Alert Setpoint

$$ASP = (0.10)(CR_C) + BG \quad (3.1-7)$$

Where:

ASP = the alert setpoint (including background), in cpm;

BG = the background count rate due to internal contamination and radiation levels in the area in which the monitor is installed when the monitor chamber is filled with uncontaminated air, in cpm;

CR_C = the calculated monitor net count rate, per equation 3.1-5, cpm;

0.10 = the fraction of the maximum acceptable activity that may be released from the vent to ensure that the site boundary dose rate limits are not exceeded during concurrent releases from several pathways.

3.2 10CFR20 Compliance - Gaseous Effluent Dose Rate

Dose rates resulting from the release of noble gases, radioiodines, tritium, and radionuclides in particulate form must be calculated to show compliance with 10CFR20. The limits of 10CFR20 are conservatively applied for the release period at the controlling location.

3.2.1 Noble Gases

The dose rate in unrestricted areas resulting from noble gas effluents is limited, by ODCM Appendix C controls, to 500 mrem/yr to the whole body and 3000 mrem/yr to the skin. Only the external dose pathway will be considered for noble gases. Because all gaseous effluent releases from PNPP are considered ground level, the controlling location for these dose rate limits is the site boundary location (see Figure 3.2-1) with the highest relative dispersion factor (χ/Q). (See Appendix A for elaboration on atmospheric dispersion.)

The alarm setpoint determinations discussed in the previous section should ensure compliance with these dose rate limits. However, if any one high alarm or two or more alert alarms occur, the dose rates in unrestricted areas resulting from the release of noble gas radionuclides from all vents will be calculated. The calculations will be based on the results of analyses obtained pursuant to the ODCM, Appendix C, CONTROLS.

3.2.2 Radioiodines, Particulates, and Other Radionuclides

The dose rate in unrestricted areas resulting from the release of iodine-131, iodine-133, tritium, and all radionuclides in particulate form with half-lives greater than eight days is limited, by ODCM Appendix C controls, to 1500 mrem/yr to any organ. The calculation of dose rate from these radionuclides will be performed based on results of analyses obtained pursuant to those Appendix C controls. The controlling location for this limit is the location of the highest relative deposition (D/Q) for the period of release as well as the actual receptor pathway. The receptor pathway locations will be reviewed once per year following the performance of the Land Use Census to include consideration of nearest residences, garden, and farm animal locations in each sector.

3.2.3 Dose Rate Calculations

The following is the equation used to calculate the dose rate resultant from the release of radioactive materials in gaseous effluents to areas at or beyond the site boundary for the purpose of showing compliance with ODCM Appendix C controls as related to 10CFR20.

$$D_{ajp} = \left(3.15 \times 10^1\right) \left(\chi/Q \text{ or } D/Q\right) \sum \left(D_{F_{aijp}}\right) \left(Q_i\right) \quad (3.2-1)$$

Where:

D_{ajp} = the organ "j" dose rate as a function of age group "a" and pathway "p", mrem/yr;

$D_{F_{aijp}}$ = the dose factor for organ type "j", age group "a", pathway "p" for isotope "i" (see Tables 3.2-1 through 3.2-3); units and equations used (equations 3.2-2 through 3.2-6) are provided later in this section;

χ/Q or D/Q = the normal or depleted relative dispersion factor (χ/Q) in s/m^3 , or relative deposition (D/Q) in m^{-2} , at the receptor distance (see Appendix A);

3.15×10^1 = conversion factor to convert $(mrem \cdot \mu Ci) / (Ci \cdot s)$ to mrem/yr;

$$Q_i = \text{release rate of isotope "i" (annualized) , } \mu\text{Ci/s}$$

$$= (472) (C_i) (f)$$

Where:

C_i = the concentration of radionuclide "i" in the gaseous effluent, in $\mu\text{Ci/cc}$;

f = the gaseous effluent flow rate during the release, ft^3/min ;

472 = conversion factor, $(\text{cc}/\text{ft}^3)/(\text{s}/\text{min})$.

The following relationships are used to derive the dose factors (Df_{aipp}) for noble gases, tritium, radioiodines and particulates used in equation 3.2-1.

a. Whole Body Dose Factors from Exposure to a Semi-Infinite Plume

$$DF_i^T = (S_F) (\chi_i) (DFB_i) \quad (3.2-2)$$

Where:

DF_i^T = the whole body factor due to immersion in a semi-infinite cloud of radionuclide "i", $(\text{mrem} \cdot \text{m}^3)/(\text{Ci} \cdot \text{s})$;

DFB_i = the whole body gamma dose factor for a semi-infinite cloud of radionuclide "i" which includes the attenuation of $5\text{g}/\text{cm}^2$ of tissue from Table 3.2-4, mrem/yr per pCi/m^3 ;

S_F = the attenuation factor that accounts for the dose reduction due to the shielding provided by residential structures, optional, dimensionless:

= maximum exposed individual = 0.7, population dose 0.5 (Regulatory Guide 1.109), if calculating dose rate = 1.0;

χ_i = the annual average concentration of radionuclide "i" in air (pCi/m^3), for a unit release rate (Ci/yr) and a unit χ/Q (s/m^3), $(\text{pCi}/\text{m}^3)/(\text{Ci}/\text{yr})(\text{s}/\text{m}^3)$.

b. Skin Dose Factors for Exposure to a Semi-Infinite Plume

$$DF_i^S = (\chi_i) \left[(1.11) (S_F) (DF_i^Y) + (DFS_i) \right] \quad (3.2-3)$$

Where:

DF_i^S = the skin dose factor due to immersion in a semi-infinite cloud of radionuclide "i", (mrem * m³)/(Ci * s);

DF_i^Y = the gamma air dose factor for a uniform semi-infinite cloud of radionuclide "i", from Table 3.2-4, mrad/yr per pCi/m³;

DSF_i = the beta skin dose factor for a semi-infinite cloud of radionuclide "i" (includes attenuation by the outer "dead" layer of skin), from Table 3.2-4, mrem/yr per pCi/m³;

S_F = the attenuation factor that accounts for the dose reduction due to the shielding provided by residential structures, optional, dimensionless:
= maximum exposed individual = 0.7, population dose 0.5 (Regulatory Guide 1.109), if calculating dose rate = 1.0;

χ_i = the annual average concentration of radionuclide "i" in air (pCi/m³), for a unit release rate (Ci/yr) and a unit χ/Q (s/m³), (pCi/m³)/(Ci/yr)(s/m³);

1.11 = the air dose to tissue dose equivalent conversion factor, mrem/mrad.

c. Dose Factors from External Irradiation from Radionuclides Deposited onto the Ground Surface

$$DF_{ij}^G = (8760) \left(C_i^G \right) \left(DF_{ij}^G \right) \left(S_F \right) \quad (3.2-4)$$

Where:

DF_{ij}^G = the dose factor for radionuclide "i" to organ "j" resulting from exposure to radionuclides deposited onto the ground surface, (mrem * m²)/Ci;

C_i^G = the ground plane concentration (pCi/m²) of radionuclide "i" for a unit release rate (Ci/yr) and a unit D/Q, relative ground deposition (m⁻²), (pCi/m²)/(Ci/yr)(m⁻²);

$DF_{G_{ij}}$ = the open field ground plane dose conversion factor for organ "j" from radionuclide "i", from Table 3.2-5, mrem/yr per pCi/m²;

S_F = the attenuation factor that accounts for the dose reduction due to the shielding provided by residential structures, optional, dimensionless:
= maximum exposed individual = 0.7, population dose 0.5 (Regulatory Guide 1.109), if calculating dose rate = 1.0;

8760 = the number of hours per year.

d. Dose Factors from Inhalation of Radionuclides in Air

$$DF_{aij}^A = (DFA_{aij}) (R_a) (\chi_i) \quad (3.2-5)$$

Where:

DF_{aij}^A = the dose factor for radionuclide "i" to organ "j" of an individual in age group "a" due to inhalation, (mrem m³)/(Ci s) [equivalent to (mrem/yr)(yr/Ci)(m³/s)];

DFA_{aij} = the inhalation dose factor for radionuclide "i", organ "j", and age group "a" (the value for skin is assumed to be 0), from Tables 3.2-6 through 3.2-9, mrem/pCi;

R_a = the annual air intake for individuals in age group "a", from Table 3.2-14, m³/yr;

χ_i = the annual average concentration of radionuclide "i" in air (pCi/m³), for a unit release rate (Ci/yr) and a unit χ/Q (s/m³), (pCi/m³)/(Ci/yr)(s/m³).

e. Dose Factors from the Ingestion of Atmospherically Released Radionuclides in Food

$$DF_{aij}^D = DFI_{aij} \left[\left(U_A^F \right) \left(C_i^F \right) + \left(U_A^L \right) \left(f_L \right) \left(C_i^L \right) + \left(U_a^M \right) \left(C_i^M \right) + \left(U_a^V \right) \left(f_V \right) \left(C_i^V \right) \right] \quad (3.2-6)$$

Where:

DF_{aij}^D = the dose factor for radionuclide "i" to organ "j" of an individual in age group "a" from the ingestion of meat, leafy vegetables, milk, and produce (non-leafy vegetables, fruits, and grains) in (mrem * m²)/Ci, or in the cases of H-3 and C-14 in (mrem * m³)/(Ci * s);

$C_i^F, C_i^L, C_i^M, C_i^V$ = the concentrations of radionuclide "i" in meat, leafy vegetables, milk, and produce, respectively (pCi/kg or pCi/L) for a unit release rate (Ci/yr) and a unit D/Q, relative ground deposition (m⁻²), or in cases of H⁻³ and C⁻¹⁴, a unit χ/Q , relative ground-level concentration (s/m³), in (pCi/kg)(Ci/yr)(m⁻²) or (pCi/kg)/(Ci/yr)(s/m³) or (pCi/L)/(Ci/yr)(m⁻²) or (pCi/L)(yr/Ci)(s/m³);

DFI_{aij} = the ingestion dose factor for radionuclide "i", organ "j", and age group "a", from Tables 3.2-10 through 3.2-13, mrem/pCi;

f_L, f_V = the respective fractions of the ingestion rates of leafy vegetables and produce that are produced in the garden of interest, 1.0 and 0.76 respectively (Regulatory Guide 1.109);

$U_a^F, U_a^L, U_a^M, U_a^V$ = the annual intake (usage) of meat, leafy vegetables, milk, and produce respectively, for individuals in age group "a", from Table 3.2-14, kg/yr or l/yr.

f. Dose rate example problem:

- 1) For the purpose of this sample problem, the following assumptions are utilized: a release of Xe133 at 1.0E-5uCi/cc, a flow rate of 1.0E5ft³/min, and a whole body dose factor of 2.94E-4 mrem/yr per pCi/m³. Dose rate and 1 hour cumulative dose are calculated.

2) Whole Body Dose Factor per ODCM equation 3.2-2.

For final dose calculation

$$DF_i^T = (0.7) \left(2.94E - 04 \frac{\text{mrem/yr}}{\text{pCi/m}^3} \right) \left(\frac{1E + 12 \text{ pCi/m}^3}{(\text{Ci/yr})(3.15E + 07 \text{ sec/m}^3)} \right) = 6.52 \frac{\text{mrem m}^3}{\text{Ci sec}}$$

For dose rate

$$DF_i^T = (1.0) \left(2.94E - 04 \frac{\text{mrem/yr}}{\text{pCi/m}^3} \right) \left(\frac{1E + 12 \text{ pCi/m}^3}{(\text{Ci/yr})(3.15E + 07 \text{ sec/m}^3)} \right) = 9.33 \frac{\text{mrem m}^3}{\text{Ci sec}}$$

3) Dose Rate per ODCM equation 3.2-1.

For final dose calculation

$$(3.15E1) \left(5.8E - 6 \frac{\text{sec}}{\text{m}^3} \right) \left(6.52 \frac{\text{mrem m}^3}{\text{Ci sec}} \right) \left(472 \frac{\text{cc min}}{\text{ft}^3 \text{ sec}} \right) \left(1.05E - 5 \frac{\mu\text{Ci}}{\text{cc}} \right) \left(1E5 \frac{\text{ft}^3}{\text{min}} \right) = 0.590 \frac{\text{mrem}}{\text{yr}}$$

For dose rate

$$(3.15E1) \left(5.8E - 6 \frac{\text{sec}}{\text{m}^3} \right) \left(9.33 \frac{\text{mrem m}^3}{\text{Ci sec}} \right) \left(472 \frac{\text{cc min}}{\text{ft}^3 \text{ sec}} \right) \left(1.05E - 5 \frac{\mu\text{Ci}}{\text{cc}} \right) \left(1E5 \frac{\text{ft}^3}{\text{min}} \right) = 0.845 \frac{\text{mrem}}{\text{yr}}$$

Final dose calculation

$$\left(0.590 \frac{\text{mrem}}{\text{yr}} \right) (1 \text{ hr}) \left(\frac{1 \text{ yr}}{8760 \text{ hr}} \right) = 6.74E - 5 \text{ mrem}$$

Table 3.2-1
Organ Used for Gaseous Effluent Dose Calculations

1. Bone
2. GI Tract
3. Kidney
4. Liver
5. Lung
6. Thyroid
7. Whole Body
8. Skin

Table 3.2-2
Age Groups Used for Gaseous Effluent Dose Calculations

1. Adult (17 yr and older)
2. Teen (11-17 yr)
3. Child (1-11 yr)
4. Infant (0-1 yr)

Table 3.2-3
Gaseous Effluent Dose Pathways

1. Plume
2. Ground Shine
3. Vegetables
4. Meat
5. Cow Milk
6. Goat Milk
7. Inhalation

Table 3.2-4
Dose Factors for Exposure to a Semi-Infinite
Cloud of Noble Gases

<u>Nuclide</u>	<u>Whole Body* Gamma Dose Factor (DFB)</u>	<u>Beta Skin* Dose Factor (DFS)</u>	<u>Gamma Air** Dose Factor γ (DF)</u>
Kr-83m	7.56E-08	---	1.93E-05
Kr-85m	1.17E-03	1.46E-03	1.23E-03
Kr-85	1.61E-05	1.34E-03	1.72E-05
Kr-87	5.92E-03	9.73E-03	6.17E-03
Kr-88	1.47E-02	2.37E-03	1.52E-02
Kr-89	1.66E-02	1.01E-02	1.73E-02
Kr-90	1.56E-02	7.29E-03	1.63E-02
Xe-131m	9.15E-05	4.76E-04	1.56E-04
Xe-133m	2.51E-04	9.94E-04	3.27E-04
Xe-133	2.94E-04	3.06E-04	3.53E-04
Xe-135m	3.12E-03	7.11E-04	3.36E-03
Xe-135	1.81E-03	1.86E-03	1.92E-03
Xe-137	1.42E-03	1.22E-02	1.51E-03
Xe-138	8.83E-03	4.13E-03	9.21E-03
Ar-41	8.84E-03	2.69E-03	9.30E-03

* mrem/yr per pCi/m³
** mrad/yr per pCi/m³

Table 3.2-5
External Dose Factors for Standing on Contaminated
Ground
(mrem/h per pCi/m²)

<u>Element</u>	<u>Whole Body</u>	<u>Skin</u>
H-3	0.0	0.0
C-14	0.0	0.0
NA-24	2.50E-08	2.90E-08
P-32	0.0	0.0
Cr-51	2.20E-10	2.60E-10
Mn-54	5.80E-09	6.80E-09
Mn-56	1.10E-08	1.30E-08
Fe-55	0.0	0.0
Fe-59	8.00E-09	9.40E-09
Co-58	7.00E-09	8.20E-09
Co-60	1.70E-08	2.00E-08
Ni-63	0.0	0.0
Nr-65	3.70E-09	4.30E-09
Cu-64	1.50E-09	1.70E-09
Zn-65	4.00E-09	4.60E-09
Zn-69	0.0	0.0
Br-83	6.40E-11	9.30E-11
Br-84	1.20E-08	1.40E-08
Br-85	0.0	0.0
Rb-86	6.30E-10	7.20E-10
Rb-88	3.50E-09	4.00E-09
Rb-89	1.50E-08	1.80E-08
Sr-89	5.60E-13	6.50E-13
Sr-91	7.10E-09	8.30E-09
Sr-92	9.00E-09	1.00E-08
Y-90	2.20E-12	2.60E-12
Y-91M	3.80E-09	4.40E-09
Y-91	2.40E-11	2.70E-11
Y-92	1.60E-09	1.90E-09
Y-93	5.70E-10	7.80E-10
Zr-95	5.00E-09	5.80E-09
Zr-97	5.50E-09	6.40E-09
Mo-95	5.10E-09	6.00E-09
Mo-99	1.90E-09	2.20E-09
Tc-99M	9.60E-10	1.10E-09
Tc-101	2.70E-09	3.00E-09
Ru-103	3.60E-09	4.20E-09
Ru-105	4.50E-09	5.10E-09
Ru-106	1.50E-09	1.80E-09
Ag-110N	1.80E-08	2.10E-08

Table 3.2-5 (Cont.)
External Dose Factors for Standing on Contaminated
Ground
(mrem/h per pCi/m²)

<u>Element</u>	<u>Whole Body</u>	<u>Skin</u>
Te-125M	3.50E-11	4.80E-11
Te-127M	1.10E-12	1.30E-12
Te-127	1.00E-11	1.10E-11
Te-129M	7.70E-10	9.00E-10
Te-129	7.10E-10	8.40E-10
Te-131M	8.40E-09	9.90E-09
Te-131	2.20E-09	2.60E-06
Te-132	1.70E-09	2.00E-09
I-130	1.40E-08	1.70E-08
I-131	2.80E-09	3.40E-09
I-132	1.70E-08	2.00E-08
I-133	3.70E-09	4.50E-09
I-134	1.60E-08	1.90E-08
I-135	1.20E-08	1.40E-08
Cs-134	1.20E-08	1.40E-08
Cs-136	1.50E-08	1.70E-08
Cs-137	4.20E-09	4.90E-09
Cs-138	2.10E-08	2.40E-08
Ba-139	2.40E-09	2.70E-09
Ba-140	2.10E-09	2.40E-09
Ba-141	4.30E-09	4.90E-09
Ba-142	7.90E-09	9.00E-09
La-140	1.50E-08	1.70E-08
La-142	1.50E-08	1.80E-08
Ce-141	5.50E-10	6.20E-10
Ce-143	2.20E-09	2.50E-09
Ce-144	3.20E-10	3.70E-10
Pr-143	0.0	0.0
Pr-144	2.00E-10	2.30E-10
Nd-147	1.00E-09	1.20E-09
W-187	3.10E-09	3.60E-09
Np-239	9.50E-10	1.10E-09

Table 3.2-6
Inhalation Dose Factors for Adult (mrem/pCi inhaled)

NUCLIDE	BONE	LIVER	WHOLE BODY	THYROID	KIDNEY	LUNG	GI-LLI
H 3	NO DATA	1.58E-07	1.58E-07	1.58E-07	1.58E-07	1.58E-07	1.58E-07
C 14	2.27E-06	4.26E-07	4.26E-07	4.26E-07	4.26E-07	4.26E-07	4.26E-07
NA 24	1.28E-06	1.28E-06	1.28E-06	1.28E-06	1.28E-06	1.28E-06	1.28E-06
P 32	1.65E-04	9.64E-06	6.26E-06	NO DATA	NO DATA	NO DATA	1.08E-05
CR 51	NO DATA	NO DATA	1.25E-08	7.44E-09	2.85E-09	1.80E-06	4.15E-07
MN 54	NO DATA	4.95E-06	7.87E-07	NO DATA	1.23E-06	1.75E-04	9.67E-06
MN 56	NO DATA	1.55E-10	2.29E-11	NO DATA	1.63E-10	1.18E-06	2.53E-06
FE 55	3.07E-06	2.12E-06	4.23E-07	NO DATA	NO DATA	9.01E-06	7.54E-07
FE 59	1.47E-06	3.47E-06	1.32E-06	NO DATA	NO DATA	1.27E-04	2.35E-05
CO 58	NO DATA	1.98E-07	2.59E-07	NO DATA	NO DATA	1.16E-04	1.33E-05
CO 60	NO DATA	1.44E-06	1.85E-06	NO DATA	NO DATA	7.46E-05	3.56E-05
NI 63	5.40E-05	3.93E-06	1.81E-06	NO DATA	NO DATA	2.23E-05	1.67E-06
NI 65	1.92E-10	2.62E-11	1.14E-11	NO DATA	NO DATA	7.00E-07	1.54E-06
CU 64	NO DATA	1.83E-10	7.69E-11	NO DATA	5.78E-10	8.48E-07	6.12E-06
ZN 65	4.05E-06	1.29E-05	5.82E-06	NO DATA	8.62E-06	1.08E-04	6.68E-06
ZN 69	4.23E-12	8.14E-12	5.65E-13	NO DATA	5.27E-12	1.15E-07	2.04E-09
BR 83	NO DATA	NO DATA	3.01E-08	NO DATA	NO DATA	NO DATA	2.90E-08
BR 84	NO DATA	NO DATA	3.91E-08	NO DATA	NO DATA	NO DATA	2.05E-13
BR 85	NO DATA	NO DATA	1.60E-09	NO DATA	NO DATA	NO DATA	LT E-24
RB 86	NO DATA	1.69E-05	7.37E-06	NO DATA	NO DATA	NO DATA	2.08E-06
RB 88	NO DATA	4.84E-08	2.41E-08	NO DATA	NO DATA	NO DATA	4.18E-19
RB 89	NO DATA	3.20E-08	2.12E-08	NO DATA	NO DATA	NO DATA	1.16E-21
SR 89	3.80E-05	NO DATA	1.09E-06	NO DATA	NO DATA	1.75E-04	4.37E-05
SR 90	1.24E-02	NO DATA	7.62E-04	NO DATA	NO DATA	1.20E-03	9.02E-05
SR 91	7.74E-09	NO DATA	3.13E-10	NO DATA	NO DATA	4.56E-06	2.39E-05
SR 92	8.43E-10	NO DATA	3.64E-11	NO DATA	NO DATA	2.06E-06	5.38E-06
Y 90	2.61E-07	NO DATA	7.01E-09	NO DATA	NO DATA	2.12E-05	6.32E-05
Y 91M	3.26E-11	NO DATA	1.27E-12	NO DATA	NO DATA	2.40E-07	1.66E-10
Y 91	5.78E-05	NO DATA	1.55E-06	NO DATA	NO DATA	2.13E-04	4.81E-05
Y 92	1.29E-09	NO DATA	3.77E-11	NO DATA	NO DATA	1.96E-06	9.19E-06
Y 93	1.18E-08	NO DATA	3.26E-10	NO DATA	NO DATA	6.06E-06	5.27E-05
ZR 95	1.34E-05	4.30E-06	2.91E-06	NO DATA	6.77E-06	2.21E-04	1.88E-05
ZR 97	1.21E-08	2.45E-09	1.13E-09	NO DATA	3.71E-09	9.84E-06	6.54E-05
NB 95	1.76E-06	9.77E-07	5.26E-07	NO DATA	9.67E-07	6.31E-05	1.30E-05
MO 99	NO DATA	1.51E-08	2.87E-09	NO DATA	3.64E-08	1.14E-05	3.10E-05
TC 99M	1.29E-13	3.64E-13	4.63E-12	NO DATA	5.52E-12	9.55E-08	5.20E-07

Table 3.2-6 (Cont.)
Inhalation Dose Factors for Adult (mrem/pCi inhaled)

NUCLIDE	BONE	LIVER	WHOLE BODY	THYROID	KIDNEY	LUNG	GI-LLI
TC101	5.22E-15	7.52E-15	7.38E-14	NO DATA	1.35E-13	4.99E-08	1.36E-21
RU103	1.91E-07	NO DATA	8.23E-08	NO DATA	7.29E-07	6.31E-05	1.38E-05
RU105	9.88E-11	NO DATA	3.89E-11	NO DATA	1.27E-10	1.37E-06	6.02E-06
RU106	8.64E-06	NO DATA	1.00E-06	NO DATA	1.67E-05	1.17E-03	1.14E-04
AG110M	1.35E-06	1.25E-06	7.43E-07	NO DATA	2.46E-06	5.79E-04	3.78E-05
TE125M	4.27E-07	1.98E-07	5.84E-08	1.31E-07	1.55E-06	3.92E-05	8.83E-05
TE127M	1.58E-06	7.21E-07	1.96E-07	4.11E-07	5.72E-06	1.20E-04	1.87E-05
TE127	1.75E-10	8.00E-11	3.87E-11	1.32E-10	6.37E-10	8.14E-07	7.17E-06
TE129M	1.22E-06	5.84E-07	1.98E-07	4.30E-07	4.57E-06	1.45E-04	4.79E-05
TE129	6.22E-12	2.99E-12	1.55E-12	4.87E-12	2.34E-11	2.42E-07	1.96E-08
TE131M	8.74E-09	5.45E-09	3.63E-09	6.88E-09	3.86E-08	1.82E-05	6.95E-05
TE131	1.39E-12	7.44E-13	4.49E-13	1.17E-12	5.46E-12	1.74E-07	2.30E-09
TE132	3.25E-08	2.69E-08	2.02E-08	2.37E-08	1.82E-07	3.60E-05	6.37E-05
I 130	5.72E-07	1.68E-06	6.60E-07	1.42E-04	2.61E-06	NO DATA	9.61E-07
I 131	3.15E-06	4.47E-06	2.56E-06	1.49E-03	7.66E-06	NO DATA	7.85E-07
I 132	1.45E-07	4.07E-07	1.45E-07	1.43E-05	6.48E-07	NO DATA	5.08E-08
I 133	1.08E-06	1.85E-06	5.65E-07	2.69E-04	3.23E-06	NO DATA	1.11E-06
I 134	8.05E-08	2.16E-07	7.69E-08	3.73E-06	3.44E-07	NO DATA	1.26E-10
I 135	3.35E-07	8.73E-07	3.21E-07	5.60E-05	1.39E-06	NO DATA	6.56E-07
CS134	4.66E-05	1.06E-04	9.10E-05	NO DATA	3.59E-05	1.22E-05	1.30E-06
CS136	4.88E-06	1.83E-05	1.38E-05	NO DATA	1.07E-05	1.50E-06	1.46E-06
CS137	5.98E-05	7.76E-05	5.35E-05	NO DATA	2.78E-05	9.40E-06	1.05E-06
CS138	4.14E-08	7.76E-08	4.05E-08	NO DATA	6.00E-08	6.07E-09	2.33E-13
BA139	1.17E-10	8.32E-14	3.42E-12	NO DATA	7.78E-14	4.70E-07	1.12E-07
BA140	4.88E-06	6.13E-09	3.21E-07	NO DATA	2.09E-09	1.59E-04	2.73E-05
BA141	1.25E-11	9.41E-15	4.20E-13	NO DATA	8.75E-15	2.42E-07	1.45E-17
BA142	3.29E-12	3.38E-15	2.07E-13	NO DATA	2.86E-15	1.49E-07	1.96E-26
LA140	4.30E-08	2.17E-08	5.73E-09	NO DATA	NO DATA	1.70E-05	5.73E-05
LA142	8.54E-11	3.88E-11	9.65E-12	NO DATA	NO DATA	7.91E-07	2.64E-07
CE141	2.49E-06	1.69E-06	1.91E-07	NO DATA	7.83E-07	4.52E-05	1.50E-05
CE143	2.33E-08	1.72E-08	1.91E-09	NO DATA	7.60E-09	9.97E-06	2.83E-05
CE144	4.29E-04	1.79E-04	2.30E-05	NO DATA	1.06E-04	9.72E-04	1.02E-04
PR143	1.17E-06	4.69E-07	5.80E-08	NO DATA	2.70E-07	3.51E-05	2.50E-05
PR144	3.76E-12	1.56E-12	1.91E-13	NO DATA	8.81E-13	1.27E-07	2.69E-18
ND147	6.59E-07	7.62E-07	4.56E-08	NO DATA	4.45E-07	2.76E-05	2.16E-05
W 187	1.06E-09	8.85E-10	3.10E-10	NO DATA	NO DATA	3.63E-06	1.94E-05
NP239	2.37E-08	2.82E-09	1.55E-09	NO DATA	8.75E-09	4.70E-06	1.49E-05

Table 3.2-7
Inhalation Dose Factors for Teenager (mrem/pCi inhaled)

NUCLIDE	BONE	LIVER	WHOLE BODY	THYROID	KIDNEY	LUNG	GI-LLI
H 3	NO DATA	1.59E-07	1.59E-07	1.59E-07	1.59E-07	1.59E-07	1.59E-07
C 14	3.25E-06	6.09E-07	6.09E-07	6.09E-07	6.09E-07	6.09E-07	6.09E-07
NA 24	1.72E-06	1.72E-06	1.72E-06	1.72E-06	1.72E-06	1.72E-06	1.72E-06
P 32	2.36E-04	1.37E-05	8.95E-06	NO DATA	NO DATA	NO DATA	1.16E-05
CR 51	NO DATA	NO DATA	1.69E-08	9.37E-09	3.84E-09	2.62E-06	3.75E-07
MN 54	NO DATA	6.32E-06	1.05E-06	NO DATA	1.59E-06	2.48E-04	8.35E-06
MN 56	NO DATA	2.12E-10	3.15E-11	NO DATA	2.24E-10	1.90E-06	7.18E-06
FE 55	4.18E-06	2.98E-06	6.93E-07	NO DATA	NO DATA	1.55E-05	7.99E-07
FE 59	1.29E-06	4.62E-06	1.79E-06	NO DATA	NO DATA	1.91E-04	2.23E-05
CO 58	NO DATA	2.59E-07	3.47E-07	NO DATA	NO DATA	1.68E-04	1.19E-05
CO 60	NO DATA	1.89E-06	2.48E-06	NO DATA	NO DATA	1.09E-03	3.24E-05
NI 63	7.25E-05	5.43E-06	2.47E-06	NO DATA	NO DATA	3.84E-05	1.77E-06
NI 65	2.73E-10	3.66E-11	1.59E-11	NO DATA	NO DATA	1.17E-06	4.59E-06
CU 64	NO DATA	2.54E-10	1.06E-10	NO DATA	8.01E-10	1.39E-06	7.68E-06
ZN 65	4.82E-06	1.67E-05	7.80E-06	NO DATA	1.08E-05	1.55E-04	5.83E-06
ZN 69	6.04E-12	1.15E-11	8.07E-13	NO DATA	7.53E-12	1.98E-07	3.56E-08
BR 83	NO DATA	NO DATA	4.30E-08	NO DATA	NO DATA	NO DATA	LT E-24
BR 84	NO DATA	NO DATA	5.41E-08	NO DATA	NO DATA	NO DATA	LT E-24
BR 85	NO DATA	NO DATA	2.29E-09	NO DATA	NO DATA	NO DATA	LT E-24
RB 86	NO DATA	2.38E-05	1.05E-05	NO DATA	NO DATA	NO DATA	2.21E-06
RB 88	NO DATA	6.82E-08	3.40E-08	NO DATA	NO DATA	NO DATA	3.65E-15
RB 89	NO DATA	4.40E-08	2.91E-08	NO DATA	NO DATA	NO DATA	4.22E-17
SR 89	5.43E-05	NO DATA	1.56E-06	NO DATA	NO DATA	3.02E-04	4.64E-05
SR 90	1.35E-02	NO DATA	8.35E-04	NO DATA	NO DATA	2.06E-03	9.56E-05
SR 91	1.10E-08	NO DATA	4.39E-10	NO DATA	NO DATA	7.59E-06	3.24E-05
SR 92	1.19E-09	NO DATA	5.08E-11	NO DATA	NO DATA	3.43E-06	1.49E-05
Y 90	3.73E-07	NO DATA	1.00E-08	NO DATA	NO DATA	3.66E-05	6.99E-05
Y 91M	4.63E-11	NO DATA	1.77E-12	NO DATA	NO DATA	4.00E-07	3.77E-09
Y 91	8.26E-05	NO DATA	2.21E-06	NO DATA	NO DATA	3.67E-04	5.11E-05
Y 92	1.84E-09	NO DATA	5.36E-11	NO DATA	NO DATA	3.35E-06	2.06E-05
Y 93	1.69E-08	NO DATA	4.65E-10	NO DATA	NO DATA	1.04E-05	7.24E-05
ZR 95	1.82E-05	5.73E-06	3.94E-06	NO DATA	8.42E-06	3.36E-04	1.86E-05
ZR 97	1.72E-08	3.40E-09	1.57E-09	NO DATA	5.15E-09	1.62E-05	7.88E-05
NB 95	2.32E-06	1.29E-06	7.08E-07	NO DATA	1.25E-06	8.39E-05	1.21E-05
MO 99	NO DATA	2.11E-08	4.03E-09	NO DATA	5.14E-08	1.92E-05	3.36E-05
TC 99M	1.73E-13	4.83E-13	6.24E-12	NO DATA	7.20E-12	1.44E-07	7.66E-07

Table 3.2-7 (Cont.)
Inhalation Dose Factors for Teenager (mrem/pCi inhaled)

NUCLIDE	BONE	LIVER	WHOLE BODY	THYROID	KIDNEY	LUNG	GI-LLI
TC101	7.40E-15	1.05E-14	1.03E-13	NO DATA	1.90E-13	8.34E-08	1.09E-16
RU103	2.63E-07	NO DATA	1.12E-07	NO DATA	9.29E-07	9.79E-05	1.36E-05
RU105	1.40E-10	NO DATA	5.42E-11	NO DATA	1.76E-10	2.27E-06	1.13E-05
RU106	1.23E-05	NO DATA	1.55E-06	NO DATA	2.38E-05	2.01E-03	1.20E-04
AG110M	1.73E-06	1.64E-06	9.99E-07	NO DATA	3.13E-06	8.44E-04	3.41E-05
TE125M	6.10E-07	2.80E-07	8.34E-08	1.75E-07	NO DATA	6.70E-05	9.38E-06
TE127M	2.25E-06	1.02E-06	2.73E-07	5.48E-07	8.17E-06	2.07E-04	1.99E-05
TE127	2.51E-10	1.14E-10	5.52E-11	1.77E-10	9.10E-10	1.40E-06	1.01E-05
TE129M	1.74E-06	8.23E-07	2.81E-07	5.72E-07	6.49E-06	2.47E-04	5.06E-05
TE129	8.87E-12	4.22E-12	2.20E-12	6.48E-12	3.32E-11	4.12E-07	2.02E-07
TE131M	1.23E-08	7.51E-09	5.03E-09	9.06E-09	5.49E-08	2.97E-05	7.76E-05
TE131	1.97E-12	1.04E-12	6.30E-13	1.55E-12	7.72E-12	2.97E-07	1.89E-09
TE132	4.50E-08	3.63E-08	2.74E-08	3.07E-08	2.44E-07	5.61E-05	5.79E-05
I 130	7.80E-07	2.24E-06	8.96E-07	1.86E-04	3.44E-06	NO DATA	1.14E-06
I 131	4.43E-06	6.14E-06	3.30E-06	1.83E-03	1.05E-05	NO DATA	8.11E-07
I 132	1.99E-07	5.47E-07	1.97E-07	1.89E-05	8.65E-07	NO DATA	1.59E-07
I 133	1.52E-06	2.56E-06	7.78E-07	3.65E-04	4.49E-06	NO DATA	1.29E-06
I 134	1.11E-07	2.90E-07	1.05E-07	4.94E-06	4.58E-07	NO DATA	2.55E-09
I 135	4.62E-07	1.18E-06	4.36E-07	7.76E-05	1.86E-06	NO DATA	8.69E-07
CS134	6.28E-05	1.41E-04	6.86E-05	NO DATA	4.69E-05	1.83E-05	1.22E-06
CS136	6.44E-06	2.42E-05	1.71E-05	NO DATA	1.38E-05	2.22E-06	1.36E-06
CS137	8.38E-05	1.06E-04	3.89E-05	NO DATA	3.80E-05	1.51E-05	1.06E-06
CS138	5.82E-08	1.07E-07	5.58E-08	NO DATA	8.28E-08	9.84E-09	3.38E-11
BA139	1.67E-10	1.18E-13	4.87E-12	NO DATA	1.11E-13	8.08E-07	8.06E-07
BA140	6.84E-06	8.38E-09	4.40E-07	NO DATA	2.85E-09	2.54E-04	2.86E-05
BA141	1.78E-11	1.32E-14	5.93E-13	NO DATA	1.23E-14	4.11E-07	9.33E-14
BA142	4.62E-12	4.63E-15	2.84E-13	NO DATA	3.92E-15	2.39E-07	5.99E-20
LA140	5.99E-08	2.95E-08	7.82E-09	NO DATA	NO DATA	2.68E-05	6.09E-05
LA142	1.20E-10	5.31E-11	1.32E-11	NO DATA	NO DATA	1.27E-06	1.50E-06
CE141	3.55E-06	2.37E-06	2.71E-07	NO DATA	1.11E-06	7.67E-05	1.58E-05
CE143	3.32E-08	2.42E-08	2.70E-09	NO DATA	1.08E-08	1.63E-05	3.19E-05
CE144	6.11E-04	2.53E-04	3.28E-05	NO DATA	1.51E-04	1.67E-03	1.08E-04
PR143	1.67E-06	6.64E-07	8.28E-08	NO DATA	3.86E-07	6.04E-05	2.67E-05
PR144	5.37E-12	2.20E-12	2.72E-13	NO DATA	1.26E-12	2.19E-07	2.94E-14
ND147	9.83E-07	1.07E-06	6.41E-08	NO DATA	6.28E-07	4.65E-05	2.28E-05
W 187	1.50E-09	1.22E-09	4.29E-10	NO DATA	NO DATA	5.92E-06	2.21E-05
NP239	4.23E-08	3.99E-09	2.21E-09	NO DATA	1.75E-08	8.11E-06	1.65E-05

Table 3.2-8
Inhalation Dose Factors for Child (mrem/pCi inhaled)

NUCLIDE	BONE	LIVER	WHOLE BODY	THYROID	KIDNEY	LUNG	GI-LLI
H 3	NO DATA	3.04E-07	3.04E-07	3.04E-07	3.04E-07	3.04E-07	3.04E-07
C 14	9.70E-06	1.82E-06	1.82E-06	1.82E-06	1.82E-06	1.82E-06	1.82E-06
NA 24	4.35E-06	4.35E-06	4.35E-06	4.35E-06	4.35E-06	4.35E-06	4.35E-06
P 32	7.04E-04	3.09E-05	2.67E-05	NO DATA	NO DATA	NO DATA	1.14E-05
CR 51	NO DATA	NO DATA	4.17E-08	2.31E-08	6.57E-09	4.59E-06	2.93E-07
MN 54	NO DATA	1.16E-05	2.57E-06	NO DATA	2.71E-06	4.26E-04	6.19E-06
MN 56	NO DATA	4.48E-10	8.43E-11	NO DATA	4.52E-10	3.55E-06	3.33E-05
FE 55	1.28E-05	6.80E-06	2.10E-06	NO DATA	NO DATA	3.00E-05	7.75E-07
FE 59	5.59E-06	9.04E-06	4.51E-06	NO DATA	NO DATA	3.43E-04	1.91E-05
CO 58	NO DATA	4.70E-07	8.55E-07	NO DATA	NO DATA	2.99E-04	9.29E-06
CO 60	NO DATA	3.55E-06	6.12E-06	NO DATA	NO DATA	1.91E-03	2.60E-05
NI 63	2.22E-04	1.25E-05	7.56E-06	NO DATA	NO DATA	7.43E-05	1.71E-06
NI 65	8.08E-10	7.99E-11	4.44E-11	NO DATA	NO DATA	2.21E-06	2.27E-05
CU 64	NO DATA	5.39E-10	2.90E-10	NO DATA	1.63E-09	2.59E-06	9.92E-06
ZN 65	1.15E-05	3.06E-05	1.90E-05	NO DATA	1.93E-05	2.69E-04	4.41E-06
ZN 69	1.81E-11	2.61E-11	2.41E-12	NO DATA	1.58E-11	3.84E-07	2.75E-06
BR 83	NO DATA	NO DATA	1.28E-07	NO DATA	NO DATA	NO DATA	LT E-24
BR 84	NO DATA	NO DATA	1.48E-07	NO DATA	NO DATA	NO DATA	LT E-24
BR 85	NO DATA	NO DATA	6.84E-09	NO DATA	NO DATA	NO DATA	LT E-24
RB 86	NO DATA	5.36E-05	3.09E-05	NO DATA	NO DATA	NO DATA	2.16E-06
RB 88	NO DATA	1.52E-07	9.90E-08	NO DATA	NO DATA	NO DATA	4.66E-09
RB 89	NO DATA	9.33E-08	7.83E-08	NO DATA	NO DATA	NO DATA	5.11E-10
SR 89	1.62E-04	NO DATA	4.66E-06	NO DATA	NO DATA	5.83E-04	4.52E-05
SR 90	2.73E-02	NO DATA	1.74E-03	NO DATA	NO DATA	3.99E-03	9.28E-05
SR 91	3.28E-08	NO DATA	1.24E-09	NO DATA	NO DATA	1.44E-05	4.70E-05
SR 92	3.54E-09	NO DATA	1.42E-10	NO DATA	NO DATA	6.49E-06	6.55E-05
Y 90	1.11E-06	NO DATA	2.99E-08	NO DATA	NO DATA	7.07E-05	7.24E-05
Y 91M	1.37E-10	NO DATA	4.98E-12	NO DATA	NO DATA	7.60E-07	4.64E-07
Y 91	2.47E-04	NO DATA	6.59E-06	NO DATA	NO DATA	7.10E-04	4.97E-05
Y 92	5.50E-09	NO DATA	1.57E-10	NO DATA	NO DATA	6.46E-06	6.46E-05
Y 93	5.04E-08	NO DATA	1.38E-09	NO DATA	NO DATA	2.01E-05	1.05E-04
ZR 95	5.13E-05	1.13E-05	1.00E-05	NO DATA	1.61E-05	6.03E-04	1.65E-05
ZR 97	5.07E-08	7.34E-09	4.32E-09	NO DATA	1.05E-08	3.06E-05	9.49E-05
NB 95	6.35E-06	2.48E-06	1.77E-06	NO DATA	2.33E-06	1.66E-04	1.00E-05
MO 99	NO DATA	4.66E-08	1.15E-08	NO DATA	1.06E-07	3.66E-05	3.42E-05
TC 99M	4.81E-13	9.41E-13	1.56E-11	NO DATA	1.37E-11	2.57E-07	1.30E-06

Table 3.2-8 (Cont.)
Inhalation Dose Factors for Child (mrem/pCi inhaled)

NUCLIDE	BONE	LIVER	WHOLE BODY	THYROID	KIDNEY	LUNG	GI-LLI
TC101	2.19E-14	2.30E-14	2.91E-13	NO DATA	3.92E-13	1.58E-07	4.41E-09
RU103	7.55E-07	NO DATA	2.90E-07	NO DATA	1.90E-06	1.79E-04	1.21E-05
RU105	4.13E-10	NO DATA	1.50E-10	NO DATA	3.63E-10	4.30E-06	2.69E-05
RU106	3.68E-05	NO DATA	4.57E-06	NO DATA	4.97E-05	3.87E-03	1.16E-04
AG110M	4.56E-06	3.08E-06	2.47E-06	NO DATA	5.74E-06	1.48E-03	2.71E-05
TE125M	1.82E-06	6.29E-07	2.47E-07	5.20E-07	NO DATA	1.29E-04	9.13E-06
TE127M	6.72E-06	2.31E-06	8.18E-07	1.64E-06	1.72E-05	4.00E-04	1.93E-05
TE127	7.49E-10	2.57E-10	1.65E-10	5.30E-10	1.91E-09	2.71E-06	1.52E-05
TE129M	5.19E-06	1.85E-06	8.22E-07	1.71E-06	1.36E-05	4.76E-04	4.91E-05
TE129	2.64E-11	9.45E-12	6.44E-12	1.93E-11	6.94E-11	7.93E-07	6.89E-06
TE131M	3.63E-08	1.60E-08	1.37E-08	2.64E-08	1.08E-07	5.56E-05	8.32E-05
TE131	5.87E-12	2.28E-12	1.78E-12	4.59E-12	1.59E-11	5.55E-07	3.60E-07
TE132	1.30E-07	7.36E-08	7.12E-08	8.58E-08	4.79E-07	1.02E-04	3.72E-05
I 130	2.21E-06	4.43E-06	2.28E-06	4.99E-04	6.61E-06	NO DATA	1.38E-06
I 131	1.30E-05	1.30E-05	7.37E-06	4.39E-03	2.13E-05	NO DATA	7.68E-07
I 132	5.72E-07	1.10E-06	5.07E-07	5.23E-05	1.69E-06	NO DATA	8.65E-07
I 133	4.48E-06	5.49E-06	2.08E-06	1.04E-03	9.13E-06	NO DATA	1.48E-06
I 134	3.17E-07	5.84E-07	2.09E-07	1.37E-05	8.92E-07	NO DATA	2.58E-07
I 135	1.33E-06	2.36E-06	1.12E-06	2.14E-04	3.62E-06	NO DATA	1.20E-06
CS134	1.76E-04	2.74E-04	6.07E-05	NO DATA	8.93E-05	3.27E-05	1.04E-06
CS136	1.76E-05	4.62E-05	3.14E-05	NO DATA	2.58E-05	3.93E-06	1.13E-06
CS137	2.45E-04	2.23E-04	3.47E-05	NO DATA	7.63E-05	2.81E-05	9.78E-07
CS138	1.71E-07	2.27E-07	1.50E-07	NO DATA	1.68E-07	1.84E-08	7.29E-08
BA139	4.98E-10	2.66E-13	1.45E-11	NO DATA	2.33E-13	1.56E-06	1.56E-05
BA140	2.00E-05	1.75E-08	1.17E-06	NO DATA	5.71E-09	4.71E-04	2.75E-05
BA141	5.29E-11	2.95E-14	1.72E-12	NO DATA	2.56E-14	7.89E-07	7.44E-08
BA142	1.35E-11	2.73E-15	7.54E-13	NO DATA	7.87E-15	4.44E-07	7.41E-10
LA140	1.74E-07	6.08E-08	2.04E-08	NO DATA	NO DATA	4.94E-05	6.10E-05
LA142	3.50E-10	1.11E-10	3.49E-11	NO DATA	NO DATA	2.35E-06	2.05E-05
CE141	1.06E-05	5.28E-06	7.83E-07	NO DATA	2.31E-06	1.47E-05	1.53E-05
CE143	9.89E-08	5.37E-08	7.77E-09	NO DATA	2.26E-08	3.12E-05	3.44E-05
CE144	1.83E-03	5.72E-04	9.77E-05	NO DATA	3.17E-04	3.23E-03	1.05E-04
PR143	4.99E-06	1.50E-06	2.47E-07	NO DATA	8.11E-07	1.17E-04	2.63E-05
PR144	1.61E-11	4.99E-12	8.10E-13	NO DATA	2.64E-12	4.23E-07	5.32E-08
ND147	2.92E-06	2.36E-06	1.84E-07	NO DATA	1.30E-06	8.87E-05	2.22E-05
W 187	4.41E-09	2.61E-09	1.17E-09	NO DATA	NO DATA	1.11E-05	2.46E-05
NP239	1.26E-07	9.04E-09	6.35E-09	NO DATA	2.63E-08	1.57E-05	1.73E-05

Table 3.2-9
Inhalation Dose Factors for Infant (mrem/pCi inhaled)

NUCLIDE	BONE	LIVER	WHOLE BODY	THYROID	KIDNEY	LUNG	GI-LLI
H 3	NO DATA	4.62E-07	4.62E-07	4.62E-07	4.62E-07	4.62E-07	4.62E-07
C 14	1.89E-05	3.79E-06	3.79E-06	3.79E-06	3.79E-06	3.79E-06	3.79E-06
NA 24	7.54E-06	7.54E-06	7.54E-06	7.54E-06	7.54E-06	7.54E-06	7.54E-06
P 32	1.45E-03	8.03E-05	5.53E-05	NO DATA	NO DATA	NO DATA	1.15E-05
CR 51	NO DATA	NO DATA	6.37E-08	4.11E-08	9.45E-09	9.17E-06	2.55E-07
MN 54	NO DATA	1.81E-05	3.56E-06	NO DATA	3.56E-06	7.14E-04	5.04E-06
MN 56	NO DATA	1.10E-09	1.58E-10	NO DATA	7.86E-10	8.95E-06	5.12E-05
FE 55	1.41E-05	8.39E-06	2.38E-06	NO DATA	NO DATA	6.21E-05	7.82E-07
FE 59	9.69E-06	1.68E-05	6.77E-06	NO DATA	NO DATA	7.25E-04	1.77E-05
CO 58	NO DATA	8.71E-07	1.30E-06	NO DATA	NO DATA	5.55E-04	7.95E-06
CO 60	NO DATA	5.73E-06	8.41E-06	NO DATA	NO DATA	3.22E-03	2.28E-05
NI 63	2.42E-04	1.46E-05	8.29E-06	NO DATA	NO DATA	1.49E-04	1.73E-06
NI 65	1.71E-09	2.03E-10	8.79E-11	NO DATA	NO DATA	5.80E-06	3.58E-05
CU 64	NO DATA	1.34E-09	5.53E-10	NO DATA	2.84E-09	6.64E-06	1.07E-05
ZN 65	1.38E-05	4.47E-05	2.22E-05	NO DATA	2.32E-05	4.62E-04	3.67E-05
ZN 69	3.85E-11	6.91E-11	5.13E-12	NO DATA	2.87E-11	1.05E-06	9.44E-06
BR 83	NO DATA	NO DATA	2.72E-07	NO DATA	NO DATA	NO DATA	LT E-24
BR 84	NO DATA	NO DATA	2.86E-07	NO DATA	NO DATA	NO DATA	LT E-24
BR 85	NO DATA	NO DATA	1.46E-08	NO DATA	NO DATA	NO DATA	LT E-24
RB 86	NO DATA	1.36E-04	6.30E-05	NO DATA	NO DATA	NO DATA	2.17E-06
RB 88	NO DATA	3.98E-07	2.03E-07	NO DATA	NO DATA	NO DATA	2.42E-07
RB 89	NO DATA	2.29E-07	1.47E-07	NO DATA	NO DATA	NO DATA	4.87E-08
SR 89	2.84E-04	NO DATA	8.15E-06	NO DATA	NO DATA	1.45E-03	4.57E-05
SR 90	2.92E-02	NO DATA	1.85E-03	NO DATA	NO DATA	8.03E-03	9.36E-05
SR 91	6.83E-08	NO DATA	2.47E-09	NO DATA	NO DATA	3.76E-05	5.24E-05
SR 92	7.50E-09	NO DATA	2.79E-10	NO DATA	NO DATA	1.70E-05	1.00E-04
Y 90	2.35E-06	NO DATA	6.30E-08	NO DATA	NO DATA	1.92E-04	7.43E-05
Y 91M	2.91E-10	NO DATA	9.90E-12	NO DATA	NO DATA	1.99E-06	1.68E-06
Y 91	4.20E-04	NO DATA	1.12E-05	NO DATA	NO DATA	1.75E-03	5.02E-05
Y 92	1.17E-08	NO DATA	3.29E-10	NO DATA	NO DATA	1.75E-05	9.04E-05
Y 93	1.07E-07	NO DATA	2.91E-09	NO DATA	NO DATA	5.46E-05	1.19E-04
ZR 95	8.24E-05	1.99E-05	1.45E-06	NO DATA	2.22E-05	1.25E-03	1.55E-05
ZR 97	1.07E-07	1.83E-08	8.36E-09	NO DATA	1.85E-08	7.88E-05	1.00E-04
NB 95	1.12E-05	4.59E-06	2.70E-06	NO DATA	3.37E-06	3.42E-04	9.05E-06
MO 99	NO DATA	1.18E-07	2.31E-08	NO DATA	1.89E-07	9.63E-05	3.48E-05
TC 99M	9.98E-13	2.06E-12	2.66E-11	NO DATA	2.22E-11	5.79E-07	1.45E-06

Table 3.2-9 (Cont.)
Inhalation Dose Factors for Infant (mrem/pCi inhaled)

NUCLIDE	BONE	LIVER	WHOLE BODY	THYROID	KIDNEY	LUNG	GI-LLI
TC101	4.65E-14	5.58E-14	5.80E-13	NO DATA	6.99E-13	4.17E-07	6.03E-07
RU103	1.44E-06	NO DATA	4.85E-07	NO DATA	3.03E-06	3.94E-04	1.15E-05
RU105	8.74E-10	NO DATA	2.93E-10	NO DATA	6.42E-10	1.12E-05	3.46E-05
RU106	6.20E-05	NO DATA	7.77E-06	NO DATA	7.61E-05	8.26E-03	1.17E-04
AG110M	7.13E-06	5.16E-06	3.57E-06	NO DATA	7.80E-06	2.62E-03	2.36E-05
TE125M	3.40E-06	1.42E-06	4.70E-07	1.16E-06	NO DATA	3.19E-04	9.22E-06
TE127M	1.19E-05	4.93E-06	1.48E-06	3.48E-06	2.68E-05	9.37E-04	1.95E-05
TE127	1.59E-09	6.81E-10	3.49E-10	1.32E-09	3.47E-09	7.39E-06	1.74E-05
TE129M	1.01E-05	4.35E-06	1.59E-06	3.91E-06	2.27E-05	1.20E-03	4.93E-05
TE129	5.63E-11	2.48E-11	1.34E-11	4.82E-11	1.25E-10	2.14E-06	1.88E-05
TE131M	7.62E-08	3.93E-08	2.59E-08	6.38E-08	1.89E-07	1.42E-04	8.51E-05
TE131	1.24E-11	5.87E-12	3.57E-12	1.13E-11	2.85E-11	1.47E-06	5.87E-06
TE132	2.66E-07	1.69E-07	1.26E-07	1.99E-07	7.39E-07	2.43E-04	3.15E-05
I 130	4.54E-06	9.91E-06	3.98E-06	1.14E-03	1.09E-05	NO DATA	1.42E-06
I 131	1.71E-05	3.17E-05	1.40E-05	1.06E-02	3.70E-05	NO DATA	7.56E-07
I 132	1.21E-06	2.53E-06	8.99E-07	1.21E-04	2.82E-06	NO DATA	1.36E-06
I 133	9.46E-06	1.37E-05	4.00E-06	2.54E-03	1.60E-05	NO DATA	1.54E-06
I 134	6.58E-07	1.34E-06	4.75E-07	3.18E-05	1.49E-06	NO DATA	9.21E-07
I 135	2.76E-06	5.43E-06	1.98E-06	4.97E-04	6.05E-06	NO DATA	1.31E-06
CS134	2.83E-04	5.02E-04	5.32E-05	NO DATA	1.36E-04	5.69E-05	9.53E-07
CS136	3.45E-05	9.61E-05	3.78E-05	NO DATA	4.03E-05	8.40E-06	1.02E-06
CS137	3.92E-04	4.37E-04	3.25E-05	NO DATA	1.23E-04	5.09E-05	9.53E-07
CS138	3.61E-07	5.58E-07	2.84E-07	NO DATA	2.93E-07	4.67E-08	6.26E-07
BA139	1.06E-09	7.03E-13	3.07E-11	NO DATA	4.23E-13	4.25E-06	3.64E-05
BA140	4.00E-05	4.00E-08	2.07E-06	NO DATA	9.59E-09	1.14E-03	2.74E-05
BA141	1.12E-10	7.70E-14	3.55E-12	NO DATA	4.64E-14	2.12E-06	3.39E-06
BA142	2.84E-11	2.36E-14	1.40E-12	NO DATA	1.36E-14	1.11E-06	4.95E-07
LA140	3.61E-07	1.43E-07	3.68E-08	NO DATA	NO DATA	1.20E-04	6.06E-05
LA142	7.36E-10	2.69E-10	3.46E-11	NO DATA	NO DATA	5.87E-06	4.25E-05
CE141	1.98E-05	1.19E-05	1.42E-06	NO DATA	3.75E-06	3.69E-04	1.54E-05
CE143	2.09E-07	1.38E-07	1.58E-08	NO DATA	4.03E-08	8.30E-05	3.55E-05
CE144	2.28E-03	8.65E-04	1.26E-04	NO DATA	3.84E-04	7.03E-03	1.06E-04
PR143	1.00E-05	3.74E-06	4.99E-07	NO DATA	1.41E-06	3.09E-04	2.66E-05
PR144	3.42E-11	1.32E-11	1.72E-12	NO DATA	4.80E-12	1.15E-06	3.06E-06
ND147	5.67E-06	5.81E-06	3.57E-07	NO DATA	2.25E-06	2.30E-04	2.23E-05
W 187	9.26E-09	6.44E-09	2.23E-09	NO DATA	NO DATA	2.83E-05	2.54E-05
NP239	2.65E-07	2.37E-08	1.34E-08	NO DATA	4.73E-08	4.25E-05	1.78E-05

Table 3.2-10
Ingestion Dose Factors for Adult (mrem/pCi ingested)

ISOTOPE	BONE	LIVER	WHOLE BODY	THYROID	KIDNEY	LUNG	GI-LLI
H3	0.00E+00	1.05E-07	1.05E-07	1.05E-07	1.05E-07	1.05E-07	1.05E-07
C14	2.84E-06	5.68E-07	5.68E-07	5.68E-07	5.68E-07	5.68E-07	5.68E-07
NA24	1.70E-06	1.70E-06	1.70E-06	1.70E-06	1.70E-06	1.70E-06	1.70E-06
P32	1.93E-04	1.20E-05	7.46E-06	0.00E+00	0.00E+00	0.00E+00	2.17E-05
CR51	0.00E+00	0.00E+00	2.66E-09	1.59E-09	5.86E-10	3.53E-09	6.69E-07
MN54	0.00E+00	4.57E-06	8.72E-07	0.00E+00	1.36E-06	0.00E+00	1.40E-05
MN56	0.00E+00	1.15E-07	2.04E-08	0.00E+00	1.46E-07	0.00E+00	3.67E-06
FE55	2.75E-06	1.90E-06	4.43E-07	0.00E+00	0.00E+00	1.06E-06	1.09E-06
FE59	4.34E-06	1.02E-05	3.91E-06	0.00E+00	0.00E+00	2.85E-06	3.40E-05
CO58	0.00E+00	7.45E-07	1.67E-06	0.00E+00	0.00E+00	0.00E+00	1.51E-05
CO60	0.00E+00	2.14E-06	4.72E-06	0.00E+00	0.00E+00	0.00E+00	4.02E-05
NI63	1.30E-04	9.01E-06	4.36E-06	0.00E+00	0.00E+00	0.00E+00	1.88E-06
NI65	5.28E-07	6.86E-08	3.13E-08	0.00E+00	0.00E+00	0.00E+00	1.74E-06
CU64	0.00E+00	8.33E-08	3.91E-08	0.00E+00	2.10E-07	0.00E+00	7.10E-06
ZN65	4.84E-06	1.54E-05	6.96E-06	0.00E+00	1.03E-05	0.00E+00	9.70E-06
ZN69	1.03E-08	1.97E-08	1.37E-09	0.00E+00	1.28E-08	0.00E+00	2.96E-09
BR83	0.00E+00	0.00E+00	4.02E-08	0.00E+00	0.00E+00	0.00E+00	5.79E-08
BR84	0.00E+00	0.00E+00	5.21E-08	0.00E+00	0.00E+00	0.00E+00	4.09E-13
BR85	0.00E+00	0.00E+00	2.14E-09	0.00E+00	0.00E+00	0.00E+00	0.00E+00
RB86	0.00E+00	2.11E-05	9.83E-06	0.00E+00	0.00E+00	0.00E+00	4.16E-06
RB88	0.00E+00	6.05E-08	3.21E-08	0.00E+00	0.00E+00	0.00E+00	8.36E-19
RB89	0.00E+00	4.01E-08	2.82E-08	0.00E+00	0.00E+00	0.00E+00	2.33E-21
SR89	3.08E-04	0.00E+00	8.84E-06	0.00E+00	0.00E+00	0.00E+00	4.94E-05
SR90	7.58E-03	0.00E+00	1.86E-03	0.00E+00	0.00E+00	0.00E+00	2.19E-04
SR91	5.67E-06	0.00E+00	2.29E-07	0.00E+00	0.00E+00	0.00E+00	2.70E-05
SR92	2.15E-06	0.00E+00	9.30E-08	0.00E+00	0.00E+00	0.00E+00	4.26E-05
Y90	9.62E-09	0.00E+00	2.58E-10	0.00E+00	0.00E+00	0.00E+00	1.02E-04
Y91M	9.09E-11	0.00E+00	3.52E-12	0.00E+00	0.00E+00	0.00E+00	2.67E-10
Y91	1.41E-07	0.00E+00	3.77E-09	0.00E+00	0.00E+00	0.00E+00	7.67E-05
Y92	8.45E-10	0.00E+00	2.47E-11	0.00E+00	0.00E+00	0.00E+00	1.48E-05
Y93	2.68E-09	0.00E+00	7.40E-11	0.00E+00	0.00E+00	0.00E+00	8.50E-05
ZR95	3.04E-08	9.75E-09	6.60E-09	0.00E+00	1.53E-08	0.00E+00	3.09E-05
ZR97	1.68E-09	3.39E-10	1.55E-10	0.00E+00	5.12E-10	0.00E+00	1.05E-04
NB95	6.22E-09	3.46E-09	1.86E-09	0.00E+00	3.42E-09	0.00E+00	2.10E-05
MO99	0.00E+00	4.31E-06	8.20E-07	0.00E+00	9.76E-06	0.00E+00	9.99E-06
TC99M	2.47E-10	6.98E-10	8.89E-09	0.00E+00	1.06E-08	3.42E-10	4.13E-07

Table 3.2-10 (Cont.)
Ingestion Dose Factors for Adult (mrem/pCi ingested)

ISOTOPE	BONE	LIVER	WHOLE BODY	THYROID	KIDNEY	LUNG	GI-LLI
TC101	2.54E-10	3.66E-10	3.59E-09	0.00E+00	6.59E-09	1.87E-10	1.10E-21
RU103	1.85E-07	0.00E+00	7.97E-08	0.00E+00	7.06E-07	0.00E+00	2.16E-05
RU105	1.54E-08	0.00E+00	6.08E-09	0.00E+00	1.99E-07	0.00E+00	9.42E-06
RU106	2.75E-06	0.00E+00	3.48E-07	0.00E+00	5.31E-06	0.00E+00	1.78E-04
AG110M	1.60E-07	1.48E-07	8.79E-08	0.00E+00	2.91E-07	0.00E+00	6.04E-05
TE125M	2.68E-06	9.17E-07	3.59E-07	8.06E-07	1.09E-05	0.00E+00	1.07E-05
TE127M	6.77E-06	2.42E-06	8.25E-07	1.73E-06	2.75E-05	0.00E+00	2.27E-05
TE127	1.10E-07	3.95E-08	2.38E-08	8.15E-08	4.48E-07	0.00E+00	8.68E-06
TE129M	1.15E-05	4.29E-06	1.82E-06	3.95E-06	4.80E-05	0.00E+00	5.79E-05
TE129	3.14E-08	1.18E-08	7.65E-09	2.41E-08	1.32E-07	0.00E+00	2.37E-08
TE131M	1.73E-06	8.46E-07	7.05E-07	1.34E-06	8.57E-06	0.00E+00	8.40E-05
TE131	1.97E-08	8.23E-09	6.22E-09	1.62E-08	8.63E-08	0.00E+00	2.79E-09
TE132	2.52E-06	1.63E-06	1.53E-06	1.80E-06	1.57E-05	0.00E+00	7.71E-05
I130	7.56E-07	2.23E-06	8.80E-07	1.89E-04	3.48E-06	0.00E+00	1.92E-06
I131	4.16E-06	5.95E-06	3.41E-06	1.95E-03	1.02E-05	0.00E+00	1.57E-06
I132	2.03E-07	5.43E-07	1.90E-07	1.90E-05	8.65E-07	0.00E+00	1.02E-07
I133	1.42E-06	2.47E-06	7.53E-07	3.63E-04	4.31E-06	0.00E+00	2.22E-06
I134	1.06E-07	2.88E-07	1.03E-07	4.99E-06	4.58E-07	0.00E+00	2.51E-10
I135	4.43E-07	1.16E-06	4.28E-07	7.65E-05	1.86E-06	0.00E+00	1.31E-06
CS134	6.22E-05	1.48E-04	1.21E-04	0.00E+00	4.79E-05	1.59E-05	2.59E-06
CS136	6.51E-06	2.57E-05	1.85E-05	0.00E+00	1.43E-05	1.96E-06	2.92E-06
CS137	7.97E-05	1.09E-04	7.14E-05	0.00E+00	3.70E-05	1.23E-05	2.11E-06
CS138	5.52E-08	1.09E-07	5.40E-08	0.00E+00	8.01E-08	7.91E-09	4.65E-13
BA139	9.70E-08	6.91E-11	2.84E-09	0.00E+00	6.46E-11	3.92E-11	1.72E-07
BA140	2.03E-05	2.55E-08	1.33E-06	0.00E+00	8.67E-09	1.46E-08	4.18E-05
BA141	4.71E-08	3.56E-11	1.59E-09	0.00E+00	3.31E-11	2.02E-11	2.22E-17
BA142	2.13E-08	2.19E-11	1.34E-09	0.00E+00	1.85E-11	1.24E-11	3.00E-26
LA140	2.50E-09	1.26E-09	3.33E-10	0.00E+00	0.00E+00	0.00E+00	9.25E-05
LA142	1.28E-10	5.82E-11	1.45E-11	0.00E+00	0.00E+00	0.00E+00	4.25E-07
CE141	9.36E-09	6.33E-09	7.18E-10	0.00E+00	2.94E-09	0.00E+00	2.42E-05
CE143	1.65E-09	1.22E-06	1.35E-10	0.00E+00	5.37E-10	0.00E+00	4.56E-05
CE144	4.88E-07	2.04E-07	2.62E-08	0.00E+00	1.21E-07	0.00E+00	1.65E-04
PR143	9.20E-09	3.69E-09	4.56E-10	0.00E+00	2.13E-09	0.00E+00	4.03E-05
PR144	3.01E-11	1.25E-11	1.53E-12	0.00E+00	7.05E-12	0.00E+00	4.33E-18
ND147	6.29E-09	7.27E-09	4.35E-10	0.00E+00	4.25E-09	0.00E+00	3.49E-05
W187	1.03E-07	8.61E-08	3.01E-08	0.00E+00	0.00E+00	0.00E+00	2.82E-05
NP239	1.19E-09	1.17E-10	6.45E-11	0.00E+00	3.65E-10	0.00E+00	2.40E-05

Table 3.2-11
Ingestion Dose Factors for Teenager (mrem/pCi ingested)

ISOTOPE	BONE	LIVER	WHOLE BODY	THYROID	KIDNEY	LUNG	GI-LLI
H3	0.00E+00	1.06E-07	1.06E-07	1.06E-07	1.06E-07	1.06E-07	1.06E-07
C14	4.06E-06	8.12E-07	8.12E-07	8.12E-07	8.12E-07	8.12E-07	8.12E-07
NA24	2.30E-06	2.30E-06	2.30E-06	2.30E-06	2.30E-06	2.30E-06	2.30E-06
P32	2.76E-04	1.71E-05	1.07E-05	0.00E+00	0.00E+00	0.00E+00	2.32E-05
CR51	0.00E+00	0.00E+00	3.60E-09	2.00E-09	7.89E-10	5.14E-09	6.05E-07
MN54	0.00E+00	5.90E-06	1.17E-06	0.00E+00	1.76E-06	0.00E+00	1.21E-05
MN56	0.00E+00	1.58E-07	2.81E-08	0.00E+00	2.00E-07	0.00E+00	1.04E-05
FE55	3.78E-06	2.68E-06	6.25E-07	0.00E+00	0.00E+00	1.70E-06	1.16E-06
FE59	5.87E-06	1.37E-05	5.29E-06	0.00E+00	0.00E+00	4.32E-06	3.24E-05
CO58	0.00E+00	9.72E-07	2.24E-06	0.00E+00	0.00E+00	0.00E+00	1.34E-05
CO60	0.00E+00	2.81E-06	6.33E-06	0.00E+00	0.00E+00	0.00E+00	3.66E-05
NI63	1.77E-04	1.25E-05	6.00E-06	0.00E+00	0.00E+00	0.00E+00	1.99E-06
NI65	7.49E-07	9.57E-08	4.36E-08	0.00E+00	0.00E+00	0.00E+00	5.19E-06
CU64	0.00E+00	1.15E-07	5.41E-08	0.00E+00	2.91E-07	0.00E+00	8.92E-06
ZN65	5.76E-06	2.00E-05	9.33E-06	0.00E+00	1.28E-05	0.00E+00	8.47E-06
ZN69	1.47E-08	2.80E-08	1.96E-09	0.00E+00	1.83E-08	0.00E+00	5.16E-08
BR83	0.00E+00	0.00E+00	5.74E-08	0.00E+00	0.00E+00	0.00E+00	0.00E+00
BR84	0.00E+00	0.00E+00	7.22E-08	0.00E+00	0.00E+00	0.00E+00	0.00E+00
BR85	0.00E+00	0.00E+00	3.05E-09	0.00E+00	0.00E+00	0.00E+00	0.00E+00
RB86	0.00E+00	2.98E-05	1.40E-05	0.00E+00	0.00E+00	0.00E+00	4.41E-06
RB88	0.00E+00	8.52E-08	4.54E-08	0.00E+00	0.00E+00	0.00E+00	7.30E-15
RB89	0.00E+00	5.50E-08	3.89E-08	0.00E+00	0.00E+00	0.00E+00	8.43E-17
SR89	4.40E-04	0.00E+00	1.26E-05	0.00E+00	0.00E+00	0.00E+00	5.24E-05
SR90	8.30E-03	0.00E+00	2.05E-03	0.00E+00	0.00E+00	0.00E+00	2.33E-04
SR91	8.07E-06	0.00E+00	3.21E-07	0.00E+00	0.00E+00	0.00E+00	3.66E-05
SR92	3.05E-06	0.00E+00	1.30E-07	0.00E+00	0.00E+00	0.00E+00	7.77E-05
Y90	1.37E-08	0.00E+00	3.69E-10	0.00E+00	0.00E+00	0.00E+00	1.13E-04
Y91M	1.29E-10	0.00E+00	4.93E-12	0.00E+00	0.00E+00	0.00E+00	6.09E-09
Y91	2.01E-07	0.00E+00	5.39E-09	0.00E+00	0.00E+00	0.00E+00	8.24E-05
Y92	1.21E-09	0.00E+00	3.50E-11	0.00E+00	0.00E+00	0.00E+00	3.32E-05
Y93	3.83E-09	0.00E+00	1.05E-10	0.00E+00	0.00E+00	0.00E+00	1.17E-04
ZR95	4.12E-08	1.30E-08	8.94E-09	0.00E+00	1.91E-08	0.00E+00	3.00E-05
ZR97	2.37E-09	4.69E-10	2.16E-10	0.00E+00	7.11E-10	0.00E+00	1.27E-04
NB95	8.22E-09	4.56E-09	2.51E-09	0.00E+00	4.42E-09	0.00E+00	1.95E-05
MO99	0.00E+00	6.03E-06	1.15E-06	0.00E+00	1.38E-05	0.00E+00	1.08E-05
TC99M	3.32E-10	9.26E-10	1.20E-08	0.00E+00	1.38E-08	5.14E-10	6.08E-07

Table 3.2-11 (Cont.)
Ingestion Dose Factor for Teenager (mrem/pCi ingested)

ISOTOPE	BONE	LIVER	WHOLE BODY	THYROID	KIDNEY	LUNG	GI-LLI
TC101	3.60E-10	5.12E-10	5.03E-09	0.00E+00	9.26E-09	3.12E-10	8.75E-17
RU103	2.55E-07	0.00E+00	1.09E-07	0.00E+00	8.99E-07	0.00E+00	2.13E-05
RU105	2.18E-08	0.00E+00	8.46E-09	0.00E+00	2.75E-07	0.00E+00	1.76E-05
RU106	3.92E-06	0.00E+00	4.94E-07	0.00E+00	7.56E-06	0.00E+00	1.88E-04
AG110M	2.05E-07	1.94E-07	1.18E-07	0.00E+00	3.70E-07	0.00E+00	5.45E-05
TE125M	3.83E-06	1.38E-06	5.12E-07	1.07E-06	0.00E+00	0.00E+00	1.13E-05
TE127M	9.67E-06	3.43E-06	1.15E-06	2.30E-06	3.92E-05	0.00E+00	2.41E-05
TE127	1.58E-07	5.60E-08	3.40E-08	1.09E-07	6.40E-07	0.00E+00	1.22E-05
TE129M	1.63E-05	6.05E-06	2.58E-06	5.26E-06	6.82E-05	0.00E+00	6.12E-05
TE129	4.48E-08	1.67E-08	1.09E-08	3.20E-08	1.88E-07	0.00E+00	2.45E-07
TE131M	2.44E-06	1.17E-06	9.76E-07	1.76E-06	1.22E-05	0.00E+00	9.39E-05
TE131	2.79E-08	1.15E-08	8.72E-09	2.15E-08	1.22E-07	0.00E+00	2.29E-09
TE132	3.49E-06	2.21E-06	2.08E-06	2.33E-06	2.12E-05	0.00E+00	7.00E-05
I130	1.03E-06	2.98E-06	1.19E-06	2.43E-04	4.59E-06	0.00E+00	2.29E-06
I131	5.85E-06	8.19E-06	4.40E-06	2.39E-03	1.41E-05	0.00E+00	1.62E-06
I132	2.79E-07	7.30E-07	2.62E-07	2.46E-05	1.15E-06	0.00E+00	3.18E-07
I133	2.01E-06	3.41E-06	1.04E-06	4.76E-04	5.98E-06	0.00E+00	2.58E-06
I134	1.46E-07	3.87E-07	1.39E-07	6.45E-06	6.10E-07	0.00E+00	5.10E-09
I135	6.10E-07	1.57E-06	5.82E-07	1.01E-04	2.48E-06	0.00E+00	1.74E-06
CS134	8.37E-05	1.97E-04	9.14E-05	0.00E+00	6.26E-05	2.39E-05	2.45E-06
CS136	8.59E-06	3.38E-05	2.27E-05	0.00E+00	1.84E-05	2.90E-06	2.72E-06
CS137	1.12E-04	1.49E-04	5.19E-05	0.00E+00	5.07E-05	1.97E-05	2.12E-06
CS138	7.76E-08	1.49E-07	7.45E-08	0.00E+00	1.10E-07	1.28E-08	6.76E-11
BA139	1.39E-07	9.78E-11	4.05E-09	0.00E+00	9.22E-11	6.74E-11	1.24E-06
BA140	2.84E-05	3.48E-08	1.83E-06	0.00E+00	1.18E-08	2.34E-08	4.38E-05
BA141	6.71E-08	5.01E-11	2.24E-09	0.00E+00	4.65E-11	3.43E-11	1.43E-13
BA142	2.99E-08	2.99E-11	1.84E-09	0.00E+00	2.53E-11	1.99E-11	9.18E-20
LA140	3.48E-09	1.71E-09	4.55E-10	0.00E+00	0.00E+00	0.00E+00	9.82E-05
LA142	1.79E-10	7.95E-11	1.98E-11	0.00E+00	0.00E+00	0.00E+00	2.42E-06
CE141	1.33E-08	8.88E-09	1.02E-09	0.00E+00	4.18E-09	0.00E+00	2.54E-05
CE143	2.35E-09	1.71E-06	1.91E-10	0.00E+00	7.67E-10	0.00E+00	5.14E-05
CE144	6.96E-07	2.88E-07	3.74E-08	0.00E+00	1.72E-07	0.00E+00	1.75E-04
PR143	1.31E-08	5.23E-09	6.52E-10	0.00E+00	3.04E-09	0.00E+00	4.31E-05
PR144	4.30E-11	1.76E-11	2.18E-12	0.00E+00	1.01E-11	0.00E+00	4.74E-14
ND147	9.38E-09	1.02E-08	6.11E-10	0.00E+00	5.99E-09	0.00E+00	3.68E-05
W187	1.46E-07	1.19E-07	4.17E-08	0.00E+00	0.00E+00	0.00E+00	3.22E-05
NP239	1.76E-09	1.66E-10	9.22E-11	0.00E+00	5.21E-10	0.00E+00	2.67E-05

Table 3.2-12
Ingestion Dose Factors for Child (mrem/pCi ingested)

ISOTOPE	BONE	LIVER	WHOLE BODY	THYROID	KIDNEY	LUNG	GI-LLI
H3	0.00E+00	2.03E-07	2.03E-07	2.03E-07	2.03E-07	2.03E-07	2.03E-07
C14	1.21E-05	2.42E-06	2.42E-06	2.42E-06	2.42E-06	2.42E-06	2.42E-06
NA24	5.80E-06	5.80E-06	5.80E-06	5.80E-06	5.80E-06	5.80E-06	5.80E-06
P32	8.25E-04	3.86E-05	3.18E-05	0.00E+00	0.00E+00	0.00E+00	2.28E-05
CR51	0.00E+00	0.00E+00	8.90E-09	4.94E-09	1.35E-09	9.02E-09	4.72E-07
MN54	0.00E+00	1.07E-05	2.85E-06	0.00E+00	3.00E-06	0.00E+00	8.98E-06
MN56	0.00E+00	3.34E-07	7.54E-08	0.00E+00	4.04E-07	0.00E+00	4.84E-05
FE55	1.15E-05	6.10E-06	1.89E-06	0.00E+00	0.00E+00	3.45E-06	1.13E-06
FE59	1.65E-05	2.67E-05	1.33E-05	0.00E+00	0.00E+00	7.74E-06	2.78E-05
CO58	0.00E+00	1.80E-06	5.51E-06	0.00E+00	0.00E+00	0.00E+00	1.05E-05
CO60	0.00E+00	5.29E-06	1.56E-05	0.00E+00	0.00E+00	0.00E+00	2.93E-05
NI63	5.38E-04	2.88E-05	1.83E-05	0.00E+00	0.00E+00	0.00E+00	1.94E-06
NI65	2.22E-06	2.09E-07	1.22E-07	0.00E+00	0.00E+00	0.00E+00	2.56E-05
CU64	0.00E+00	2.45E-07	1.48E-07	0.00E+00	5.92E-07	0.00E+00	1.15E-05
ZN65	1.37E-05	3.65E-05	2.27E-05	0.00E+00	2.30E-05	0.00E+00	6.41E-06
ZN69	4.38E-08	6.33E-08	5.85E-09	0.00E+00	3.84E-08	0.00E+00	3.99E-06
BR83	0.00E+00	0.00E+00	1.71E-07	0.00E+00	0.00E+00	0.00E+00	0.00E+00
BR84	0.00E+00	0.00E+00	1.98E-07	0.00E+00	0.00E+00	0.00E+00	0.00E+00
BR85	0.00E+00	0.00E+00	9.12E-09	0.00E+00	0.00E+00	0.00E+00	0.00E+00
RB86	0.00E+00	6.70E-05	4.12E-05	0.00E+00	0.00E+00	0.00E+00	4.31E-06
RB88	0.00E+00	1.90E-07	1.32E-07	0.00E+00	0.00E+00	0.00E+00	9.32E-09
RB89	0.00E+00	1.17E-07	1.04E-07	0.00E+00	0.00E+00	0.00E+00	1.02E-09
SR89	1.32E-03	0.00E+00	3.77E-05	0.00E+00	0.00E+00	0.00E+00	5.11E-05
SR90	1.70E-02	0.00E+00	4.31E-03	0.00E+00	0.00E+00	0.00E+00	2.29E-04
SR91	2.40E-05	0.00E+00	9.06E-07	0.00E+00	0.00E+00	0.00E+00	5.30E-05
SR92	9.03E-06	0.00E+00	3.62E-07	0.00E+00	0.00E+00	0.00E+00	1.71E-04
Y90	4.11E-08	0.00E+00	1.10E-09	0.00E+00	0.00E+00	0.00E+00	1.17E-04
Y91M	3.82E-10	0.00E+00	1.39E-11	0.00E+00	0.00E+00	0.00E+00	7.48E-07
Y91	6.02E-07	0.00E+00	1.61E-08	0.00E+00	0.00E+00	0.00E+00	8.02E-05
Y92	3.60E-09	0.00E+00	1.03E-10	0.00E+00	0.00E+00	0.00E+00	1.04E-04
Y93	1.14E-08	0.00E+00	3.13E-10	0.00E+00	0.00E+00	0.00E+00	1.70E-04
ZR95	1.16E-07	2.55E-08	2.27E-08	0.00E+00	3.65E-08	0.00E+00	2.66E-05
ZR97	6.99E-09	1.01E-09	5.96E-10	0.00E+00	1.45E-09	0.00E+00	1.53E-04
NB95	2.25E-08	8.76E-09	6.26E-09	0.00E+00	8.23E-09	0.00E+00	1.62E-05
MO99	0.00E+00	1.33E-05	3.29E-06	0.00E+00	2.84E-05	0.00E+00	1.10E-05
TC99M	9.23E-10	1.81E-09	3.00E-08	0.00E+00	2.63E-08	9.19E-10	1.03E-06

Table 3.2-12 (Cont.)
Ingestion Dose Factors for Child (mrem/pCi ingested)

ISOTOPE	BONE	LIVER	WHOLE BODY	THYROID	KIDNEY	LUNG	GI-LLI
TC101	1.07E-09	1.12E-09	1.42E-08	0.00E+00	1.91E-08	5.92E-10	3.56E-09
RU103	7.31E-07	0.00E+00	2.81E-07	0.00E+00	1.84E-06	0.00E+00	1.89E-05
RU105	6.45E-08	0.00E+00	2.34E-08	0.00E+00	5.67E-07	0.00E+00	4.21E-05
RU106	1.17E-05	0.00E+00	1.46E-06	0.00E+00	1.58E-05	0.00E+00	1.82E-04
AG110M	5.39E-07	3.64E-07	2.91E-07	0.00E+00	6.78E-07	0.00E+00	4.33E-05
TE125M	1.14E-05	3.09E-06	1.52E-06	3.20E-06	0.00E+00	0.00E+00	1.10E-05
TE127M	2.89E-05	7.78E-06	3.43E-06	6.91E-06	8.24E-05	0.00E+00	2.34E-05
TE127	4.71E-07	1.27E-07	1.01E-07	3.26E-07	1.34E-06	0.00E+00	1.84E-05
TE129M	4.87E-05	1.36E-05	7.56E-06	1.57E-05	1.43E-04	0.00E+00	5.94E-05
TE129	1.34E-07	3.74E-08	3.18E-08	9.56E-08	3.92E-07	0.00E+00	8.34E-06
TE131M	7.20E-06	2.49E-06	2.65E-06	5.12E-06	2.41E-05	0.00E+00	1.01E-04
TE131	8.30E-08	2.53E-08	2.47E-08	6.35E-08	2.51E-07	0.00E+00	4.36E-07
TE132	1.01E-05	4.47E-06	5.40E-06	6.51E-06	4.15E-05	0.00E+00	4.50E-05
I130	2.92E-06	5.90E-06	3.04E-06	6.50E-04	8.82E-06	0.00E+00	2.76E-06
I131	1.72E-05	1.73E-05	9.83E-06	5.72E-03	2.84E-05	0.00E+00	1.54E-06
I132	8.00E-07	1.47E-06	6.76E-07	6.82E-05	2.25E-06	0.00E+00	1.73E-06
I133	5.92E-06	7.32E-06	2.77E-06	1.36E-03	1.22E-05	0.00E+00	2.95E-06
I134	4.19E-07	7.78E-07	3.58E-07	1.79E-05	1.19E-06	0.00E+00	5.16E-07
I135	1.75E-06	3.15E-06	1.49E-06	2.79E-04	4.83E-06	0.00E+00	2.40E-06
CS134	2.34E-04	3.84E-04	8.10E-05	0.00E+00	1.19E-04	4.27E-05	2.07E-06
CS136	2.35E-05	6.46E-05	4.18E-05	0.00E+00	3.44E-05	5.13E-06	2.27E-06
CS137	3.27E-04	3.13E-04	4.62E-05	0.00E+00	1.02E-04	3.67E-05	1.96E-06
CS138	2.28E-07	3.17E-07	2.01E-07	0.00E+00	2.23E-07	2.40E-08	1.46E-07
BA139	4.14E-07	2.21E-10	1.20E-08	0.00E+00	1.93E-10	1.30E-10	2.39E-05
BA140	8.31E-05	7.28E-08	4.85E-06	0.00E+00	2.37E-08	4.34E-08	4.21E-05
BA141	2.00E-07	1.12E-10	6.51E-09	0.00E+00	9.69E-11	6.58E-10	1.14E-07
BA142	8.74E-08	6.29E-11	4.88E-09	0.00E+00	5.09E-11	3.70E-11	1.14E-09
LA140	1.01E-08	3.53E-09	1.19E-09	0.00E+00	0.00E+00	0.00E+00	9.84E-05
LA142	5.24E-10	1.67E-10	5.23E-11	0.00E+00	0.00E+00	0.00E+00	3.31E-05
CE141	3.97E-08	1.98E-08	2.94E-09	0.00E+00	8.68E-09	0.00E+00	2.47E-05
CE143	6.99E-09	3.79E-06	5.49E-10	0.00E+00	1.59E-09	0.00E+00	5.55E-05
CE144	2.08E-06	6.52E-07	1.11E-07	0.00E+00	3.61E-07	0.00E+00	1.70E-04
PR143	3.93E-08	1.18E-08	1.95E-09	0.00E+00	6.39E-09	0.00E+00	4.24E-05
PR144	1.29E-10	3.99E-11	6.49E-12	0.00E+00	2.11E-11	0.00E+00	8.59E-08
ND147	2.79E-08	2.26E-08	1.75E-09	0.00E+00	1.24E-08	0.00E+00	3.58E-05
W187	4.29E-07	2.54E-07	1.14E-07	0.00E+00	0.00E+00	0.00E+00	3.57E-05
NP239	5.25E-09	3.77E-10	2.65E-10	0.00E+00	1.09E-09	0.00E+00	2.79E-05

Table 3.2-13
Ingestion Dose Factors for Infant (mrem/pCi ingested)

ISOTOPE	BONE	LIVER	WHOLE BODY	THYROID	KIDNEY	LUNG	GI-LLI
H3	0.00E+00	3.08E-07	3.08E-07	3.08E-07	3.08E-07	3.08E-07	3.08E-07
C14	2.37E-05	5.06E-06	5.06E-06	5.06E-06	5.06E-06	5.06E-06	5.06E-06
NA24	1.01E-05	1.01E-05	1.01E-05	1.01E-05	1.01E-05	1.01E-05	1.01E-05
P32	1.70E-03	1.00E-04	6.59E-05	0.00E+00	0.00E+00	0.00E+00	2.30E-05
CR51	0.00E+00	0.00E+00	1.41E-08	9.20E-09	2.01E-09	1.79E-08	4.11E-07
MN54	0.00E+00	1.99E-05	4.51E-06	0.00E+00	4.41E-06	0.00E+00	7.31E-06
MN56	0.00E+00	8.18E-07	1.41E-07	0.00E+00	7.03E-07	0.00E+00	7.43E-05
FE55	1.39E-05	8.98E-06	2.40E-06	0.00E+00	0.00E+00	4.39E-06	1.14E-06
FE59	3.08E-05	5.38E-05	2.12E-05	0.00E+00	0.00E+00	1.59E-05	2.57E-05
CO58	0.00E+00	3.60E-06	8.98E-06	0.00E+00	0.00E+00	0.00E+00	8.97E-06
CO60	0.00E+00	1.08E-05	2.55E-05	0.00E+00	0.00E+00	0.00E+00	2.57E-05
NI63	6.34E-04	3.92E-05	2.20E-05	0.00E+00	0.00E+00	0.00E+00	1.95E-06
NI65	4.70E-06	5.32E-07	2.42E-07	0.00E+00	0.00E+00	0.00E+00	4.05E-05
CU64	0.00E+00	6.09E-07	2.82E-07	0.00E+00	1.03E-06	0.00E+00	1.25E-05
ZN65	1.84E-05	6.31E-05	2.91E-05	0.00E+00	3.06E-05	0.00E+00	5.33E-05
ZN69	9.33E-08	1.68E-07	1.25E-08	0.00E+00	6.98E-08	0.00E+00	1.37E-05
BR83	0.00E+00	0.00E+00	3.63E-07	0.00E+00	0.00E+00	0.00E+00	0.00E+00
BR84	0.00E+00	0.00E+00	3.82E-07	0.00E+00	0.00E+00	0.00E+00	0.00E+00
BR85	0.00E+00	0.00E+00	1.94E-08	0.00E+00	0.00E+00	0.00E+00	0.00E+00
RB86	0.00E+00	1.70E-04	8.40E-05	0.00E+00	0.00E+00	0.00E+00	4.35E-06
RB88	0.00E+00	4.98E-07	2.73E-07	0.00E+00	0.00E+00	0.00E+00	4.85E-07
RB89	0.00E+00	2.86E-07	1.97E-07	0.00E+00	0.00E+00	0.00E+00	9.74E-08
SR89	2.51E-03	0.00E+00	7.20E-05	0.00E+00	0.00E+00	0.00E+00	5.16E-05
SR90	1.85E-02	0.00E+00	4.71E-03	0.00E+00	0.00E+00	0.00E+00	2.31E-04
SR91	5.00E-05	0.00E+00	1.81E-06	0.00E+00	0.00E+00	0.00E+00	5.92E-05
SR92	1.92E-05	0.00E+00	7.13E-07	0.00E+00	0.00E+00	0.00E+00	2.07E-04
Y90	8.69E-08	0.00E+00	2.33E-09	0.00E+00	0.00E+00	0.00E+00	1.20E-04
Y91M	8.10E-10	0.00E+00	2.76E-11	0.00E+00	0.00E+00	0.00E+00	2.70E-06
Y91	1.13E-06	0.00E+00	3.01E-08	0.00E+00	0.00E+00	0.00E+00	8.10E-05
Y92	7.65E-09	0.00E+00	2.15E-10	0.00E+00	0.00E+00	0.00E+00	1.46E-04
Y93	2.43E-08	0.00E+00	6.62E-10	0.00E+00	0.00E+00	0.00E+00	1.92E-04
ZR95	2.06E-07	5.02E-08	3.56E-08	0.00E+00	5.41E-08	0.00E+00	2.50E-05
ZR97	1.48E-08	2.54E-09	1.16E-09	0.00E+00	2.56E-09	0.00E+00	1.62E-04
NB95	4.20E-08	1.73E-08	1.00E-08	0.00E+00	1.24E-08	0.00E+00	1.46E-05
MO99	0.00E+00	3.40E-05	6.63E-06	0.00E+00	5.08E-05	0.00E+00	1.12E-05
TC99M	1.92E-09	3.96E-09	5.10E-08	0.00E+00	4.26E-08	2.07E-09	1.15E-06

Table 3.2-13 (Cont.)
Ingestion Dose Factors for Infant

ISOTOPE	BONE	LIVER	WHOLE BODY	THYROID	KIDNEY	LUNG	GI-LLI
TC101	2.27E-09	2.86E-09	2.83E-08	0.00E+00	3.40E-08	1.56E-09	4.86E-07
RU103	1.48E-06	0.00E+00	4.95E-07	0.00E+00	3.08E-06	0.00E+00	1.80E-05
RU105	1.36E-07	0.00E+00	4.58E-08	0.00E+00	1.00E-06	0.00E+00	5.41E-05
RU106	2.41E-05	0.00E+00	3.01E-06	0.00E+00	2.85E-05	0.00E+00	1.83E-04
AG110M	9.96E-07	7.27E-07	4.81E-07	0.00E+00	1.04E-06	0.00E+00	3.77E-05
TE125M	2.33E-05	7.79E-06	3.15E-06	7.84E-06	0.00E+00	0.00E+00	1.11E-05
TE127M	5.85E-05	1.94E-05	7.08E-06	1.69E-05	1.44E-04	0.00E+00	2.36E-05
TE127	1.00E-06	3.35E-07	2.15E-07	8.14E-07	2.44E-06	0.00E+00	2.10E-05
TE129M	1.00E-04	3.43E-05	1.54E-05	3.84E-05	2.50E-04	0.00E+00	5.97E-05
TE129	2.84E-07	9.79E-08	6.63E-08	2.38E-07	7.07E-07	0.00E+00	2.27E-05
TE131M	1.52E-05	6.12E-06	5.05E-06	1.24E-05	4.21E-05	0.00E+00	1.03E-04
TE131	1.76E-07	6.50E-08	4.94E-08	1.57E-07	4.50E-07	0.00E+00	7.11E-06
TE132	2.08E-05	1.03E-05	9.61E-06	1.52E-05	6.44E-05	0.00E+00	3.81E-05
I130	6.00E-06	1.32E-05	5.30E-06	1.48E-03	1.45E-05	0.00E+00	2.83E-06
I131	3.59E-05	4.23E-05	1.86E-05	1.39E-02	4.94E-05	0.00E+00	1.51E-06
I132	1.66E-06	3.37E-06	1.20E-06	1.58E-04	3.76E-06	0.00E+00	2.73E-06
I133	1.25E-05	1.82E-05	5.33E-06	3.31E-03	2.14E-05	0.00E+00	3.08E-06
I134	8.69E-07	1.78E-06	6.33E-07	4.15E-05	1.99E-06	0.00E+00	1.84E-06
I135	3.64E-06	7.24E-06	2.64E-06	6.49E-04	8.07E-06	0.00E+00	2.62E-06
CS134	3.77E-04	7.03E-04	7.10E-05	0.00E+00	1.81E-04	7.42E-05	1.91E-06
CS136	4.59E-05	1.35E-04	5.04E-05	0.00E+00	5.38E-05	1.10E-05	2.05E-06
CS137	5.22E-04	6.11E-04	4.33E-05	0.00E+00	1.64E-04	6.64E-05	1.91E-06
CS138	4.81E-07	7.82E-07	3.79E-07	0.00E+00	3.90E-07	6.09E-08	1.25E-06
BA139	8.81E-07	5.84E-10	2.55E-08	0.00E+00	3.51E-10	3.54E-10	5.58E-05
BA140	1.71E-04	1.71E-07	8.81E-06	0.00E+00	4.06E-08	1.05E-07	4.20E-05
BA141	4.25E-07	2.91E-10	1.34E-08	0.00E+00	1.75E-10	1.77E-10	5.19E-06
BA142	1.84E-07	1.53E-10	9.06E-09	0.00E+00	8.81E-11	9.26E-11	7.59E-07
LA140	2.11E-08	8.32E-09	2.14E-09	0.00E+00	0.00E+00	0.00E+00	9.77E-05
LA142	1.10E-09	4.04E-10	9.67E-11	0.00E+00	0.00E+00	0.00E+00	6.86E-05
CE141	7.87E-08	4.80E-08	5.65E-09	0.00E+00	1.48E-08	0.00E+00	2.48E-05
CE143	1.48E-08	9.82E-06	1.12E-09	0.00E+00	2.86E-09	0.00E+00	5.73E-05
CE144	2.98E-06	1.22E-06	1.67E-07	0.00E+00	4.93E-07	0.00E+00	1.71E-04
PR143	8.13E-08	3.04E-08	4.03E-09	0.00E+00	1.13E-08	0.00E+00	4.29E-05
PR144	2.74E-10	1.06E-10	1.38E-11	0.00E+00	3.84E-11	0.00E+00	4.93E-06
ND147	5.53E-08	5.68E-08	3.48E-09	0.00E+00	2.19E-08	0.00E+00	3.60E-05
W187	9.03E-07	6.28E-07	2.17E-07	0.00E+00	0.00E+00	0.00E+00	3.69E-05
NP239	1.11E-08	9.93E-10	5.61E-10	0.00E+00	1.98E-09	0.00E+00	2.87E-05

Table 3.2-14
Annual Usage Factors for the Maximum Exposed Individual

<u>Pathway</u>	<u>Infant</u>	<u>Child</u>	<u>Teen</u>	<u>Adult</u>
Fruits, vegetables & grain (kg/yr)*	--	520	630	520
Leafy vegetables(kg/yr)	--	26	42	64
Milk (L/yr)	330	330	400	310
Meat & poultry (kg/yr)	--	41	65	110
Inhalation (m ³ /yr)	1400	3700	8000	8000

* Consists of the following (on a mass basis): 22% fruit, 54% vegetables (including leafy vegetables), and 24% grain.

Table 3.2-15
Annual Usage Factors for the Average Individual**

<u>Pathway</u>	<u>Infant</u>	<u>Child</u>	<u>Teen</u>	<u>Adult</u>
Fruits, vegetables & grain (kg/yr)*	--	200	240	190
Milk (L/yr)	--	170	200	110
Meat & poultry (kg/yr)	--	37	59	95
Inhalation (m ³ /yr)	--	3700	8000	8000

* Consists of the following (on a mass basis): 22% fruit, 54% vegetables (including leafy vegetables), and 24% grain.

** For total population and average individual dose calculations.

Figure 3.2-1
 PNPP Site Boundary and Unrestricted Area

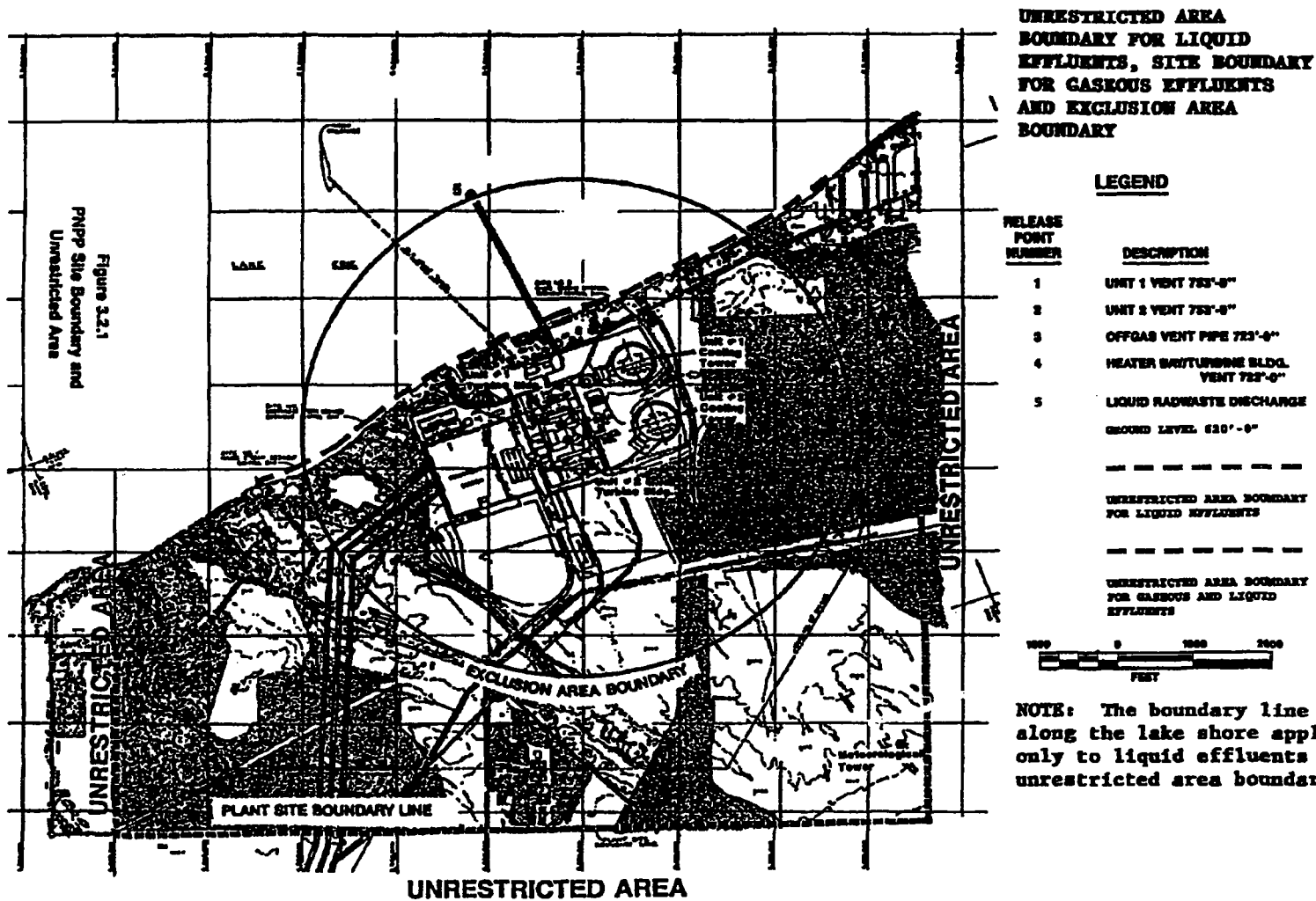

UNRESTRICTED AREA BOUNDARY FOR LIQUID EFFLUENTS, SITE BOUNDARY FOR GASEOUS EFFLUENTS AND EXCLUSION AREA BOUNDARY

LEGEND

RELEASE POINT NUMBER	DESCRIPTION
1	UNIT 1 VENT 723'-0"
2	UNIT 2 VENT 723'-0"
3	OFFGAS VENT PIPE 723'-0"
4	HEATER BUILDING BLDG. VENT 723'-0"
5	LIQUID RADWASTE DISCHARGE GROUND LEVEL 630'-0"

--- --
 UNRESTRICTED AREA BOUNDARY FOR LIQUID EFFLUENTS

--- --
 UNRESTRICTED AREA BOUNDARY FOR GASEOUS AND LIQUID EFFLUENTS



NOTE: The boundary line along the lake shore applies only to liquid effluents unrestricted area boundary.

3.3 10CFR50, Appendix I Compliance - Gaseous Effluent Dose

Doses resulting from the release of noble gases, radioiodines, tritium and radionuclides in particulate form must be calculated to show compliance with 10CFR50, Appendix I. The calculations will be performed at least monthly for all gaseous effluents.

3.3.1 Noble Gases

10CFR50, Appendix I, Section II.B.1, limits the releases of gaseous effluents from each reactor to unrestricted areas such that the estimated annual gamma air dose is limited to 10 millirads and the beta air dose is limited to 20 millirads. The external dose pathway only will be considered for noble gases. The controlling location for the above stated dose limits is the nearest site boundary location for the period of release.

ODCM Appendix C controls limit the dose resulting from the release of noble gas radionuclides in gaseous effluents to the following:

- a. For gamma radiation, during the current quarter:

$$D_{\text{air}} \leq 5 \text{ mrad},$$

- b. For beta radiation, during the current quarter:

$$D_{\text{air}} \leq 10 \text{ mrad},$$

- c. For gamma radiation, during the current year:

$$D_{\text{air}} \leq 10 \text{ mrad},$$

- d. For beta radiation, during the current year:

$$D_{\text{air}} \leq 20 \text{ mrad}.$$

3.3.2 Radioiodines, Particulates, and Other Radionuclides

10CFR50, Appendix I, Section II.C, limits the annual release of radioiodines and radioactive materials in particulate form from each reactor such that estimated dose or dose commitment to an individual in an unrestricted area from all pathways of exposure is not in excess of 15 mrem to any organ. The controlling location for this organ dose limit is the nearest site boundary, the deposition (D/Q) for the period of release, and the receptor pathway. Receptor pathway locations will be reviewed once per year following the performance of the Land Use Census to include consideration of nearest residences, garden, and farm animal locations in each sector.

ODCM, Appendix C, CONTROLS limit the dose resultant from the release of iodine-131, iodine-133, tritium, and all radionuclides in particulate form with half-lives greater than eight days to the following:

- a. During the current quarter:
Dose to Any Organ \leq 7.5 mrems
- b. During the current year:
Dose to Any Organ \leq 15 mrems.

3.3.3 Dose Calculations

The following calculations are used to determine gamma and beta air doses resultant from noble gas release to areas at or beyond the site boundary for purpose of showing compliance with 10CFR50, Appendix I. The equations used to calculate organ doses resultant from the release of iodine-131, iodine-133, tritium, and radionuclides in particulate form with half-lives greater than eight days are those found in Section 3.2.3.

Dose values are obtained by applying the dose rates over the appropriate surveillance or sampling time period.

- a. Gamma Air Dose from Noble Gas Releases

$$D_{\text{air}}^Y = \left(3.15 \times 10^1\right) \left(\frac{\chi}{Q}\right) \sum (Q_i) \left(DF_i^Y\right)$$

Where:

D_{air}^Y = the annual gamma air dose due to noble gas radionuclides, mrad/yr;

DF_i^Y = the gamma air dose factor for a uniform semi-infinite cloud of radionuclide "i", from Table 3.3-1, (mrad m³)/(s Ci);

Q_i = the release rate of radionuclide "i", $\mu\text{Ci/s}$;

χ/Q = the annual average dispersion factor (see Appendix A), s/m³;

3.15×10^1 = the conversion factor to convert (mrad* μCi)/(Ci*s) to mrad/yr.

b. Beta Air dose from Noble Gas Releases

$$D_{\text{air}}^{\beta} = \left(3.15 \times 10^1\right) \left(\chi/Q\right) \sum (Q_i) \left(DF_i^{\beta}\right)$$

Where:

D_{air}^{β} = the annual beta air dose due to noble gas radionuclides, mrad/yr;

DF_i^{β} = the beta air dose factor for a uniform semi-infinite cloud of radionuclide "i", from Table 3.3-1, (mrad m³)/(Ci s);

Q_i = the release rate of radionuclide "i", $\mu\text{Ci/s}$;

χ/Q = the annual average dispersion factor (see Appendix A), s/m³;

3.15×10^1 = the conversion factor to convert (mrad* μCi)/(Ci*s) to mrad/yr.

3.3.4 Cumulation of Doses

The dose contribution from gaseous effluents will be calculated at least monthly. Calculations will be performed to determine the maximum air dose as well as the maximum organ dose to an individual. These dose calculations will be summed for comparison with quarterly and annual limits. To assure compliance with 10CFR50, Appendix I, the dose limits for air dose and organ dose are those found in Sections 3.3.1 and 3.3.2, respectively. The quarterly limits specified in those sections represent one half of the annual design objectives. If these limits are exceeded, a special report will be submitted to the NRC in accordance with ODCM Appendix C controls.

Table 3.3-1
Gamma and Beta Air Dose Factors for Semi-Infinite Plume
(mrad/s per Ci/m³)

	Gamma Air Dose Factor $\left(DF_i^\gamma\right)$	Beta Air Dose Factor $\left(DF_i^\beta\right)$
Ar-41	2.95+02	1.04+02
Kr-83m	6.12-01	9.13+00
Kr-85m	3.90+01	6.24+01
Kr-85	5.45-01	6.18+01
Kr-87	1.96+02	3.27+02
Kr-88	4.82+02	9.29+01
Kr-89	5.48+02	3.36+02
Kr-90	5.14+02	2.48+02
Xe-131m	4.95+00	3.53+01
Xe-133m	1.04+01	4.69+01
Xe-133	1.12+01	3.33+01
Xe-135m	1.07+02	2.34+01
Xe-135	6.09+01	7.80+01
Xe-137	4.79+01	4.03+02
Xe-138	2.92+02	1.51+02

3.3.5 Projection of Doses

Anticipated doses resulting from the release of gaseous effluents will be projected monthly. The doses calculated for the present month will be used as the projected doses unless information exists indicating that actual releases could differ significantly in the next month. In this case the source term will be adjusted to reflect this information and the justification for the adjustment noted.

If the sum of the projected doses for the 31-day period exceeds 0.3 mrem to any organ, appropriate portions of the ventilation exhaust treatment system will be operated to reduce releases. The values for the projected dose impact levels correspond to about one forty-eighth of the 10CFR50, Appendix I dose limits. If continued for a year, these values would correspond to less than one-fourth of the 10CFR50, Appendix I dose limits.

3.4 Population Dose

PNPP's Annual Radioactive Effluent Release Reports, as required by Regulatory Guide 1.21, will include total population dose and average individual doses calculated for all radioactive gaseous effluent releases. The total population dose and average individual dose will be computed, taking into account geographical population distribution and pathway(s) using the equations in Section 3.2. However, the dose factors, DF_{ajp} , differ; total population and average individual doses are

calculated in a manner similar to that used for maximum individuals except that Regulatory Guide 1.109, Revision 1, assumptions for average individuals are used rather than for maximum exposed individuals and they are averaged over all age groups after weighting by the fraction of population in each age group.

4.0 TOTAL DOSE

4.1 40CFR190 and 10CFR72.104 Compliance - Uranium Fuel Cycle Dose

Annual dose contributions from liquid and gaseous effluent releases, as discussed in Sections 2.3.2 and 3.3.4, are summed to evaluate compliance with the 40CFR190 and 10CFR72.104 annual limit of 25 mrem whole body or any organ (except the thyroid, which is 75 mrem).

PNPP does not intend to exceed 40CFR190 or 10CFR72.104 limits during normal operation. However, if such a situation should occur, violations would be handled as per ODCM Appendix C Control 3/4.11.4a. which requires the following:

With the calculated doses from the release of radioactive materials in liquid or gaseous effluents exceeding twice the limits of Control 3.11.1.2a., 3.11.1.2b., 3.11.2.2a., 3.11.2.2b., 3.11.2.3a. or 3.11.2.3b., calculations shall be made including direct radiation contributions from the reactor units, from the ISFSI and from outside storage tanks to determine whether the above limits of Control 3.11.4 have been exceeded. If such is the case, prepare and submit to the Commission within 30 days, pursuant to Control 6.9.2, a Special Report that defines the corrective action to be taken to reduce subsequent releases to prevent recurrence of exceeding the above limits and includes the schedule for achieving conformance with the above limits. This Special Report, as defined in 10CFR20.405c, shall include an analysis that estimates the radiation exposure (dose) to a MEMBER OF THE PUBLIC from uranium fuel cycle sources, including all effluent pathways and direct radiation, for the calendar year that includes the release(s) covered by this report. It shall also describe levels of radiation and concentrations of radioactive material involved, and the cause of the exposure levels or concentrations. If the estimated dose(s) exceeds the above limits, and if the release condition resulting in violation of 40CFR190 has not already been corrected, the Special Report shall include a request for a variance in accordance with the provisions of 40CFR190. Submittal of the report is considered a timely request, and a variance is granted until staff action on the request is complete.

This Special Report shall contain:

1. A determination of which fuel cycle facilities or operations, in addition to the nuclear power reactor unit(s) at the site, contribute to the annual dose to the maximum exposed individual. Nuclear fuel facilities over five miles from PNPP need not be considered in this determination.

2. A determination of the maximum exposed individual.
3. A determination of the total annual dose to this person from all existing pathways and sources of radioactive effluents and direct radiation using the methodologies described in this ODCM. Where additional information on pathways and nuclides is needed, the best available information will be used and documented.
4. A determination of the dose resulting from direct radiation from the plant and storage facilities, including the ISFSI.

The whole body and organ doses resulting from liquid effluents from the PNPP will be summed with the doses resulting from gaseous releases of noble gases, radioiodines, tritium, and particulates with half-lives greater than eight days when any of the dose limits outlined in Sections 2.3.2, 3.3.1 or 3.3.2 are exceeded by a factor of two. The doses from the PNPP will be summed with the dose to the maximum exposed individual contributed from other operations of the uranium fuel cycle.

4.2 Direct Radiation Dose from PNPP(including the ISFSI)

Potential direct radiation dose to individuals outside PNPP will arise from (a) skyshine and direct dose from the turbines, (b) direct dose from the external surfaces of buildings, and (c) direct dose from stored radwaste.

Coolant activation by high energy neutrons, the $^{16}\text{O}(n,p)\text{N}^{16}$ reaction, is of interest in boiling water reactors, like PNPP, because it can result in turbine skyshine and direct dose. The N-16 present in the steam of a direct cycle BWR is carried with the steam into the turbine moisture separators, and associated equipment. Although N-16 has a half-life of 7.13 seconds, its gamma emission can present a radiation dose problem to the site boundary as a result of the high energy gamma scatter from structures and the atmosphere.

All external walls of buildings at PNPP have been designed to attenuate radiation sources from within the plant to maximum of 0.5 mrem/h outside, with an expected radiation dose not to exceed 0.25 mrem/h.

Projected direct radiation dose assessment for normal operations was performed, based on 80% load factor and 100% occupancy, for the closest site boundary location (WSW sector). Direct dose from turbine skyshine was calculated to be 1.3 mrem/yr and direct dose from the surface of buildings was calculated to be 2.2 E-3 mrem/yr.

Direct radiation doses at PNPP will be measured by self-contained dosimeters encircling the site located in the general area of the site boundary. These self-contained dosimeters will be of the thermoluminescent variety (TLDs) with analyses performed quarterly and annually.

4.3 Dose to Members of the Public While Onsite

ODCM Appendix C Control 6.9.1.7 requires "assessment of the radiation doses from radioactive liquid and gaseous effluents to members of the public due to their activities inside the site boundary." This assessment is included in Annual Radioactive Effluent Release Reporting.

A member of the public is defined in ODCM Appendix C to include anyone who is not occupationally associated with the plant, i.e., not a utility employee, contractor or vendor. Also excluded from this category is any person who enters the site to service equipment or make deliveries.

Maximum dose to member of the public while onsite is conservatively assessed relative to offsite dose values. The assessment methodology incorporates use of appropriate dilution, dispersion, and occupancy factors for onsite activities.

The only liquid effluent dose pathway affecting members of the public while onsite is shore exposure, which is assumed to be fishing on the Lake Erie shoreline. Onsite dose assessment is made via ratio to the maximum calculated offsite shore exposure dose, using adjustments for occupancy factor and liquid effluent dilution.

Several cases are considered for gaseous effluent dose assessment to member of the public while onsite including: traversing a public road within the site boundary, lakeshore fishing, non-PNPP related training sessions at the Training and Education Center, car pooling to the Primary Access Control Point (PACP) parking lot, and job applicant interviews. This evaluation is made using "relative χ/Q " (atmospheric dispersion) values. "Relative χ/Q " values are the product of the highest annual average χ/Q for the point of concern, and occupancy factor for the case. The ratio of the highest onsite "relative χ/Q " to the highest site boundary "relative χ/Q " is used as an adjustment factor. (A unity occupancy factor is used in the determination of the highest site boundary "relative χ/Q "). A conservative onsite dose determination is made by applying the "relative χ/Q " adjustment factor for the highest potential onsite dose activity to the highest calculated gaseous effluent offsite dose.

5.0 RADIOLOGICAL ENVIRONMENTAL MONITORING PROGRAM

5.1 Monitoring Program

Environmental samples shall be collected and analyzed according to Table 3.12.1-1 at locations shown in Figures 5.1-1, 5.1-2 and 5.1-3. The Radiological Environmental Monitoring Program (REMP) sample locations are controlled by REMP-0013. A list and figures of the specific locations are contained in the Master List of Sampling Locations in the REMP file. Analytical techniques used shall ensure that the detection capabilities in Table 4.12.1-1 are achieved.

Ground water sampling will not be conducted as part of PNPP's REMP because this source is not tapped for drinking or irrigation purposes in the area of the plant. The position of the plant and the underdrain system with respect to the hydraulic gradient is such that any leakage or overflow from the underdrain system will flow north towards Lake Erie. Local domestic wells outside the exclusion area boundary are up-gradient from the plant. As part of the REMP, samples will be routinely collected from the closest potable water intakes on Lake Erie.

The results of the radiological environmental monitoring program are intended to supplement the results of the radiological effluent monitoring by verifying that the measurable concentrations of radioactive materials and levels of radiation are not higher than expected on the basis of the effluent measurements and modeling of the environmental exposure pathways. Thus, the specified environmental monitoring program provides measurements of radiation and of radioactive materials in those exposure pathways and for those radionuclides which lead to the highest potential radiation exposures of individuals resulting from the station operation. The initial radiological environmental monitoring program was conducted for the first three years of commercial operation; program changes may now be proposed based on operational experience.

5.2 Land Use Census Program

A Land Use Census shall be conducted annually to identify, within a distance of 8 km (5 miles), the location in each of the meteorological sectors of the nearest residence, the nearest garden greater than 50m² (500 ft²) and the nearest milk-producing animal.

If a Land Use Census identifies a location(s) that yields a calculated dose or dose commitment (via the same exposure pathway) 20% greater than at the location from which samples are currently being obtained the new location(s) will be added to the radiological environmental monitoring program within 30 days. The sampling location(s), excluding the control station location, having the lowest calculated dose or dose commitment(s), via the same exposure pathway, may be deleted from this monitoring program after October 31 of the year in which this Land Use Census was conducted.

The Land Use Census shall be conducted during the growing season at least once per 12 months using that information that will provide the best results, such as by a door-to-door survey, aerial survey, general observations, or by consulting local agriculture authorities. The results of the Land Use Census shall be included in the Annual Radiological Environmental Operating Report.

- * Broad leaf vegetation sampling of at least three different types of vegetation may be performed at the site boundary in each of two different sectors with the highest predicted D/Qs in lieu of the garden census. Specifications for broad leaf vegetation sampling in Table 3.12.1-1 shall be followed, including analysis of control samples.

5.3 Inter-Laboratory Comparison Program

The laboratories of the licensee and/or licensee's contractors which perform analyses shall participate in an Interlaboratory Comparison Program which has been approved by the Commission. This participation shall include all of the determinations (sample medium-radionuclide combinations) that are included in the monitoring program. The results of analysis of these comparison samples shall be included in the Annual Radiological Environmental Operating Report.

If the results of a determination in the comparison crosscheck program are outside the specified control limits, the laboratory shall investigate the cause of the problem and take steps to correct it. The results of this investigation and corrective action shall be included in the Annual Radiological Environmental Operating Report.

Rev. 19
DEC 2012

Table 5.1-1
ODCM REMP Sample Locations⁽¹⁾ Identified on Figures 5.1-1, 5.1-2 and 5.1-3

Location #	Description	Miles	Direction	Media ⁽²⁾
1	Chapel Road	3.4	ENE	TLD, AIP
2	Kanda Garden	1.9	ENE	Food Products
3	Meteorological Tower	1.0	SE	TLD
4	Site Boundary	0.7	S	TLD, AIP
5	Quincy Substation	0.6	SW	TLD
6	Concord Service Center	11.0	SSW	TLD, AIP
7	Site Boundary	0.6	NE	TLD, AIP
8	Site Boundary	0.8	E	TLD
9	Site Boundary	0.7	ESE	TLD
10	Site Boundary	0.8	SSE	TLD
11	Pamly Rd.	0.6	SSW	TLD
12	Site Boundary	0.6	WSW	TLD
13	Madison-on-the-Lake	4.7	ENE	TLD
14	Hubbard Rd.	4.9	E	TLD
15	Eagle St. Substation	5.1	ESE	TLD
18	Kijauskas Farm	2.5	E	Food Products, Milk
21	Hardy Rd.	5.1	WSW	TLD
23	High St. Substation	7.9	WSW	TLD
24	St. Clair Ave.	15.1	SW	TLD
25	Offshore - PNPP discharge	0.6	NNW	Fish
28	CEI Ashtabula Plant Intake	22.0	ENE	Water
29	River Rd.	4.3	SSE	TLD
30	Lane Rd.	4.8	SSW	TLD
31	Wood and River Rd.	4.8	SE	TLD
32	Offshore - Mentor	15.8	WSW	Fish
33	River Rd.	4.5	S	TLD
35	Site Boundary	0.6	E	TLD, AIP
36	Lake County Water Plant	3.9	WSW	TLD, Water
37	Gerlica Farm	1.5	ENE	Food Products
53	Neff Perkins	0.5	WSW	TLD
54	Hale Rd. School	4.6	SW	TLD
55	Center Rd.	2.5	S	TLD
56	Madison High School	4.0	ESE	TLD
58	Antioch Rd.	0.8	ENE	TLD
59	Lake Shoreline at Green Rd.	4.0	ENE	Water
60	Lake Shoreline at Perry Park	1.0	WSW	Water
65	Major Stream Mouth	0.18	W	Sediment
70	H&H Farm Stand	16.2	SSW	Food Products

- (1) Missing location numbers denote deleted, retired or non-ODCM required sampling locations.
(2) AIP = Air, Iodine and Particulate
Veg = Vegetation
TLD = Thermoluminescent Dosimeter

Rev. 19
DEC 2012

Figure 5.1-1

ODCM required REMP sample locations within two miles of PNPP

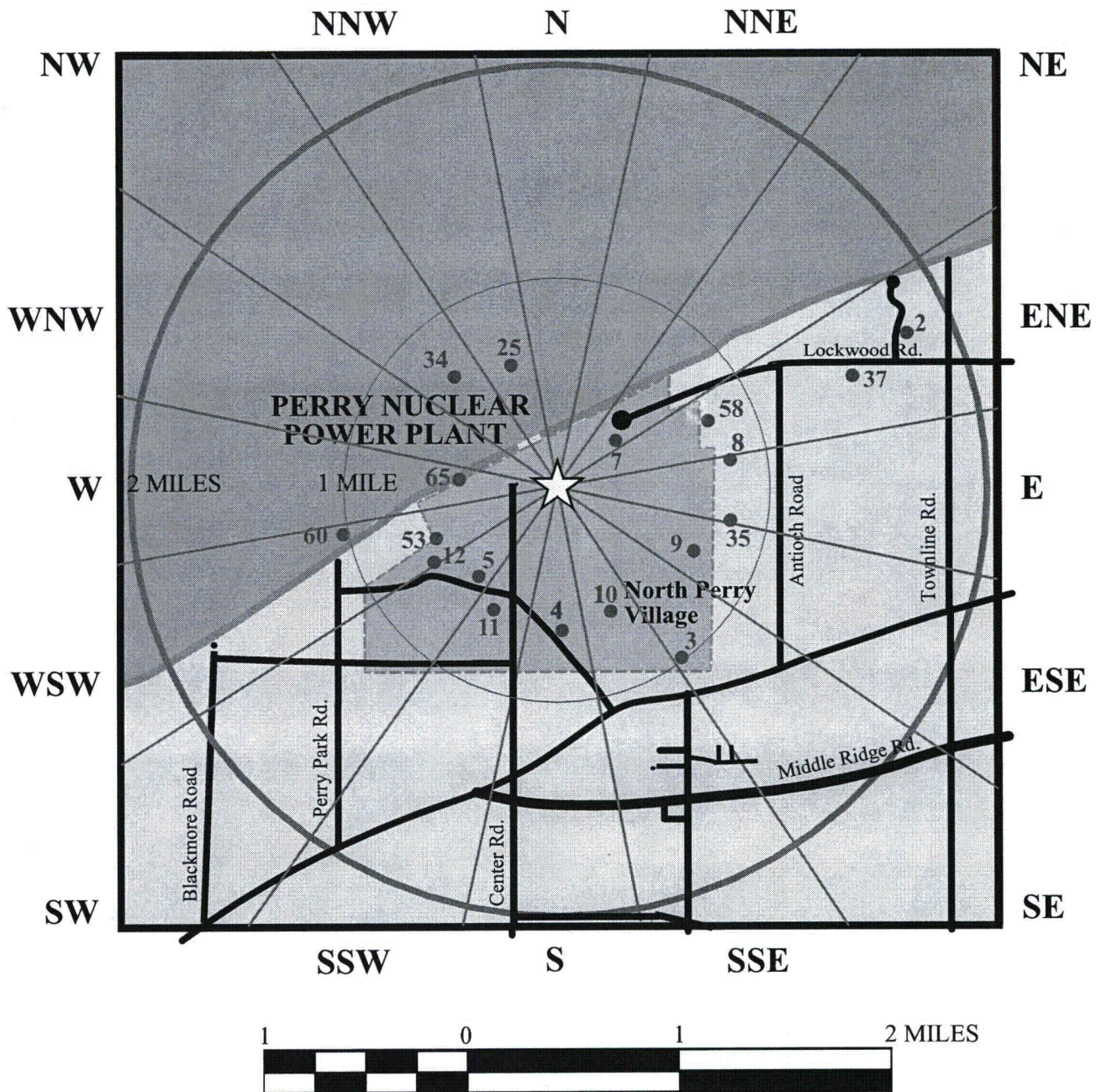

Figure 5.1-2

ODCM required REMP sample locations between two and eight miles of PNPP

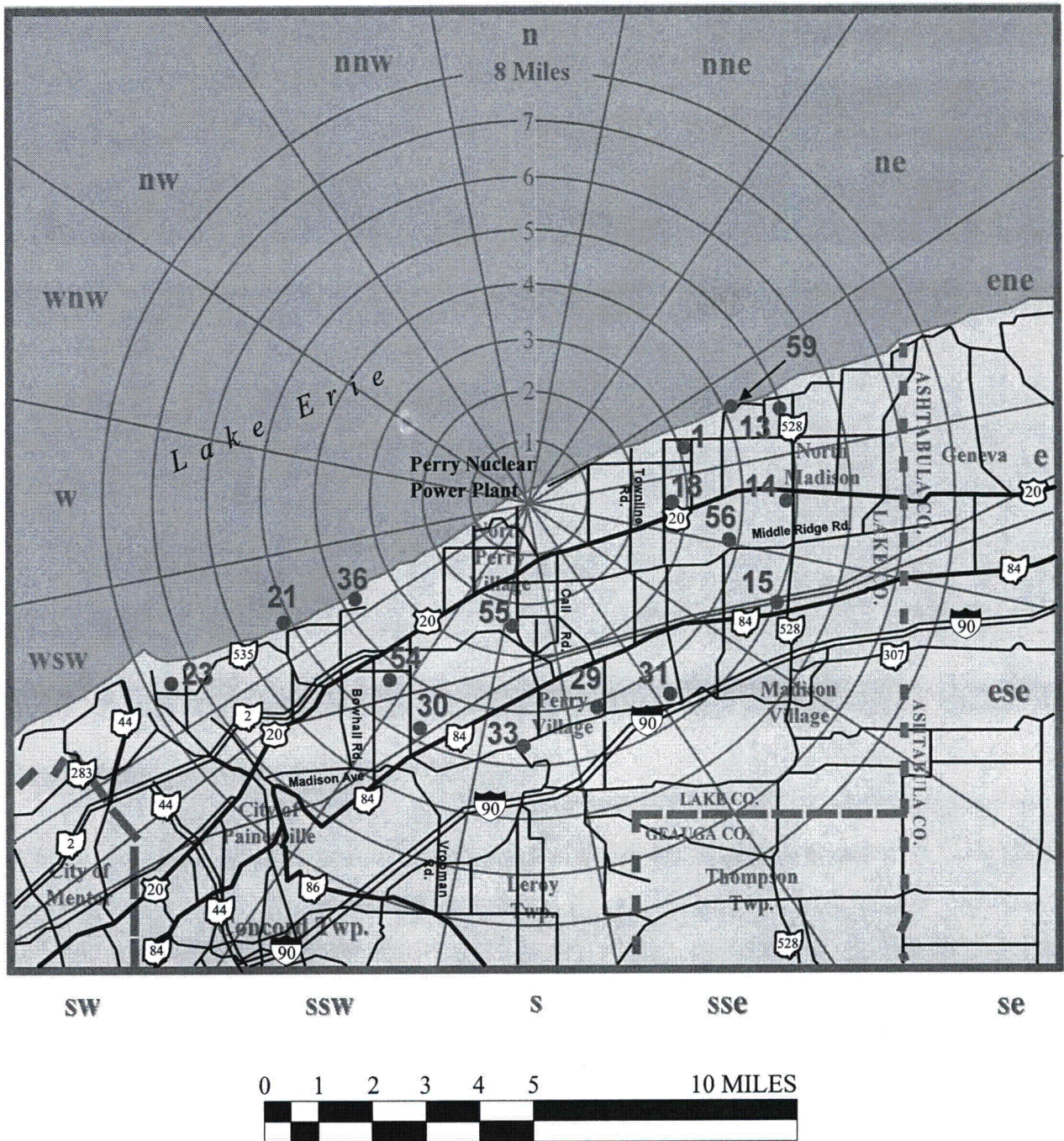
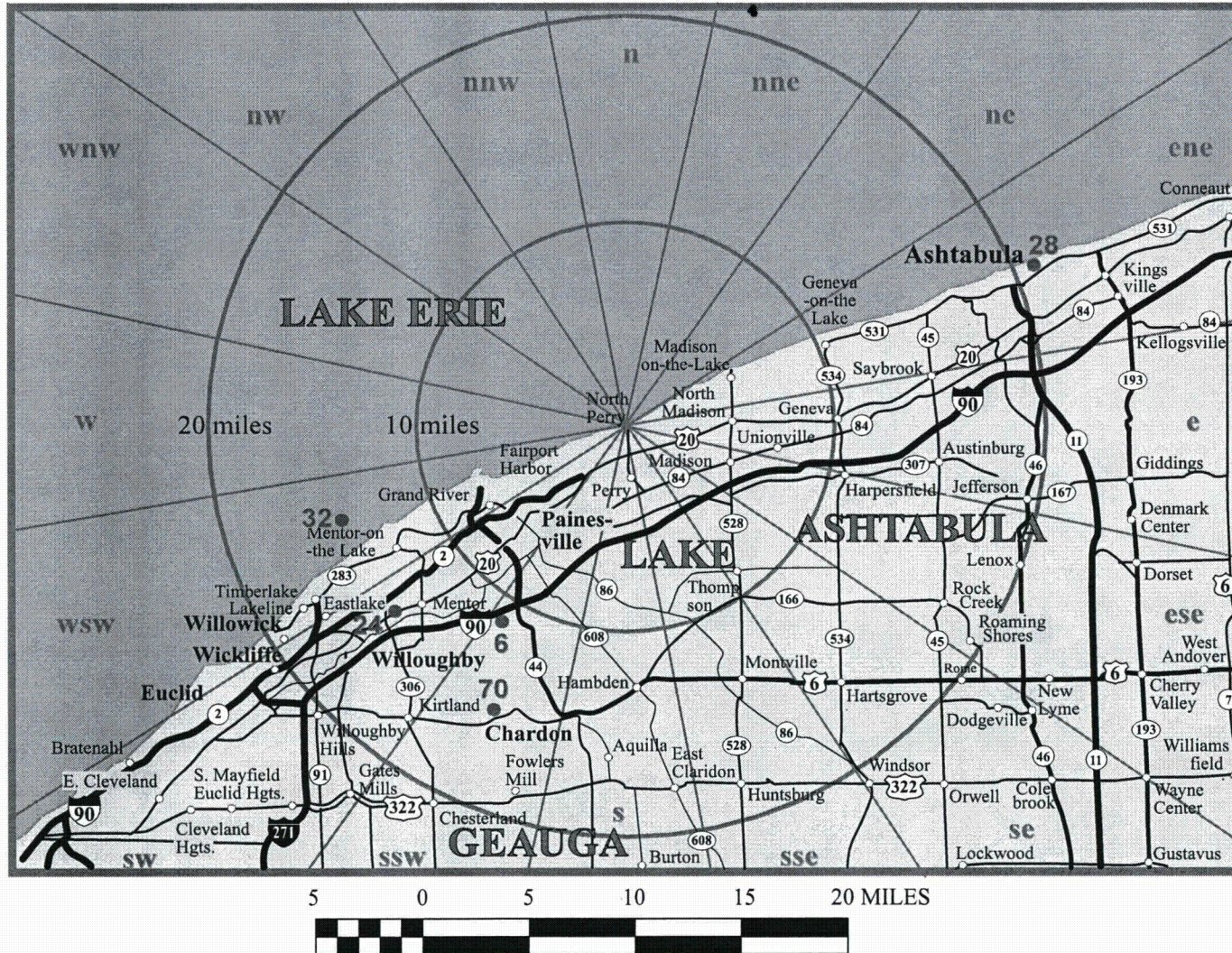

Figure 5.1-3

ODCM required REMP sample locations greater than eight miles from PNPP



Appendix A
Atmospheric Dispersion and Deposition Parameters

The atmospheric dispersion and deposition parameters used to calculate gaseous effluent doses will be calculated using the following equations. Dose calculations will be performed using meteorological conditions concurrent with the time of release of radioactive materials in gaseous effluents or using historical average atmospheric conditions. All atmospheric releases at PNPP are considered to be ground-level releases.

a. Constant Mean Wind Direction Relative Dispersion Factor

$$\chi/Q = \frac{(2.032)(T_f)}{(\bar{u})(x)(\sigma)} \quad (A-1)$$

Where:

- χ/Q = the annual average dispersion factor, s/m^3 ;
- T_f = the terrain correction factor, from FSAR Table 2.3-26, dimensionless;
- \bar{u} = the wind speed (measured at 10m), in m/s;
- X = the distance of calculation, in m;
- 2.032 = $(2/\pi)^{1/2}$ divided by the width in radians of a 22.5° sector

$$\sigma = \text{the lesser of } \left(\sigma_z^2 + \frac{H_C^2}{2\pi} \right)^{1/2} \text{ or } (\sigma_z)(3^{1/2})$$

Where:

- H_C = the building height (44.8m);
- σ_z = the vertical dispersion coefficient, per Regulatory Guide 1.111, in m.

b. Depleted Relative Dispersion Factor

$$\chi/Q_d = (\chi/Q)(DPL_j) \quad (A-2)$$

Where:

- χ/Q_d = the depleted relative dispersion factor (for airborne halogens and particulates), in s/m^3 ;
- DPL_j = the ground depletion factor for the "j"th distance, interpolated from Table A-1, dimensionless;
- χ/Q = the annual average dispersion factor per equation A-1, s/m^3 .

c. Ground Deposition

$$D/Q = \frac{(DEP_j)(T_f)}{(0.3927)(x)} \quad (A-3)$$

Where:

- D/Q = the relative deposition per unit area (for halogens and particulates), m⁻²;
- DEP_j = the ground deposition factor for the "j"th distance, interpolated from Table A-1, m⁻¹;
- T_f = terrain correction factor, from FSAR Table 2.3-26, dimensionless;
- x = the "j"th distance, m;
- 0.3927 = radians per 22.5° sector

Table A-1
Atmospheric Depletion and Deposition Factors

		Depletion Factors (DPL _j)	Deposition Factors (DEP _j , m ⁻¹)
Pasquill Stability	Class	All	All
Distance (meters)	200	0.970	1.25E-04
	500	0.936	8.0E-05
	1,000	0.900	5.4E-05
	2,000	0.860	3.2E-05
	3,000	0.832	2.6E-05
	6,000	0.770	1.5E-05
	10,000	0.714	9.9E-06
	30,000	0.590	4.5E-06
	50,000	0.517	3.0E-06
	80,000	0.440	2.0E-06

The following tables contain annual average atmospheric dispersion and deposition parameters for long-term releases at PNPP. Long-term releases are those that occur greater than 500 hours per year. The highest annual average relative concentration (χ/Q) value at the site boundary for sectors over land shall be used for radioactive gaseous effluent monitor setpoint calculations. The dispersion model used was XOQDOQ, with PNPP FSAR site-specific terrain adjustment factors included. Dispersion values are based on seven years of meteorological data (May 1, 1972 through April 30, 1974 and September 1, 1977 through August 31, 1982), ground-level releases, sector spread for purge calculations, and twelve wind speed classes.

Table A-2
Site Boundary Atmospheric Dispersion (χ/Q) and Deposition
Parameters (D/Q) for PNPP Unit 1

SECTOR	DISTANCE MILES)	χ/Q (SEC./CUB. METER)	D/Q (PER SQ. METER)
N	0.18	5.7E-05*	1.6E-07
NNE	0.25	1.8E-05*	7.9E-08
NE	0.42	5.8E-06*	3.1E-08
ENE	0.67	2.1E-06*	1.6E-08
E	0.67	2.2E-06	1.8E-08
ESE	0.67	1.6E-06	1.3E-08
SE	0.79	1.4E-06	1.1E-08
SSE	0.82	2.2E-06	1.4E-08
S	0.81	2.7E-06	1.6E-08
SSW	0.80	1.3E-06	6.8E-09
SW	0.65	2.3E-06*	1.1E-08
WSW	0.56	4.2E-06*	1.5E-08
W	0.27	2.5E-05*	4.6E-08
WNW	0.18	5.9E-05*	8.4E-08
NW	0.17	6.6E-05*	1.1E-07
NNW	0.17	5.9E-05*	1.2E-07

NOTE: All χ/Q values are taken from the Updated Safety Analysis Report (USAR) Table 2.3-27. All marked values (*) are from Unit 1 USAR values, and the balance are Unit 2 values. In each case, the most conservative χ/Q value is utilized.

Table A-3
Atmospheric Dispersion (γ/Q) as a Function of Distance (s/m³)

SECTOR	0.2 (MILES)	0.3 (MILES)	0.4 (MILES)	0.5 (MILES)	0.6 (MILES)
N	4.904E-05	2.453E-05	1.525E-05	1.057E-05	7.918E-06
NNE	2.656E-05	1.360E-05	8.640E-06	6.082E-06	4.612E-06
NE	1.859E-05	9.760E-06	6.293E-06	4.460E-06	3.383E-06
ENE	1.327E-05	7.129E-06	4.636E-06	3.293E-06	2.490E-06
E	1.363E-05	7.362E-06	4.760E-06	3.367E-06	2.538E-06
ESE	1.025E-05	5.566E-06	3.602E-06	2.547E-06	1.916E-06
SE	1.113E-05	6.061E-06	3.935E-06	2.788E-06	2.100E-06
SSE	1.894E-05	1.022E-05	6.647E-06	4.718E-06	3.560E-06
S	2.283E-05	1.227E-05	7.932E-06	5.615E-05	4.238E-06
SSW	1.142E-05	6.079E-06	3.925E-06	2.777E-06	2.097E-06
SW	1.449E-05	7.663E-06	4.928E-06	3.479E-06	2.622E-06
WSW	2.151E-05	1.111E-05	7.031E-06	4.934E-06	3.733E-06
W	4.184E-05	2.081E-05	1.281E-05	8.833E-06	6.606E-06
WNW	4.669E-05	2.298E-05	1.401E-05	9.573E-06	7.093E-06
NW	4.908E-05	2.423E-05	1.482E-05	1.015E-05	7.521E-06
NNW	4.580E-05	2.266E-05	1.390E-05	9.541E-06	7.083E-06
SECTOR	0.7 (MILES)	0.8 (MILES)	0.9 (MILES)	1.0 (MILES)	1.1 (MILES)
N	6.138E-06	4.968E-06	4.203E-06	3.636E-06	1.949E-06
NNE	3.622E-06	2.947E-06	2.481E-06	2.132E-06	1.278E-06
NE	2.662E-06	2.165E-06	1.815E-06	1.552E-06	9.269E-07
ENE	1.957E-06	1.588E-06	1.325E-06	1.129E-06	6.710E-07
E	1.991E-06	1.613E-06	1.343E-06	1.141E-06	6.768E-07
ESE	1.501E-06	1.215E-06	1.010E-06	8.571E-07	5.080E-07
SE	1.647E-06	1.334E-06	1.108E-06	9.402E-07	4.456E-07
SSE	2.796E-06	2.266E-06	1.885E-06	1.601E-06	5.524E-07
S	3.327E-06	2.697E-06	2.247E-06	1.911E-06	7.340E-07
SSW	1.646E-06	1.335E-06	1.114E-06	9.486E-07	5.223E-07
SW	2.053E-06	1.664E-06	1.391E-06	1.188E-06	5.667E-07
WSW	2.927E-06	2.380E-06	2.002E-06	1.719E-06	8.671E-07
W	5.110E-06	4.135E-06	3.504E-06	3.036E-06	1.630E-06
WNW	5.434E-06	4.378E-06	3.719E-06	3.235E-06	1.845E-06
NW	5.764E-06	4.643E-06	3.941E-06	3.425E-06	1.952E-06
NNW	5.439E-06	4.385E-06	3.720E-06	3.230E-06	1.839E-06

Table A-3 (Cont.)
Atmospheric Dispersion (γ/Q) as a Function of Distance (s/m^3)

SECTOR	1.2 (MILES)	1.3 (MILES)	1.4 (MILES)	1.5 (MILES)	1.6 (MILES)
N	1.729E-06	1.549E-06	1.399E-06	1.273E-06	1.166E-06
NNE	1.128E-06	1.006E-06	9.050E-07	8.202E-07	7.485E-07
NE	8.150E-07	7.243E-07	6.494E-07	5.867E-07	5.340E-07
ENE	5.878E-07	5.205E-07	4.652E-07	4.190E-07	3.803E-07
E	5.917E-07	5.230E-07	4.667E-07	4.197E-07	3.804E-07
ESE	4.437E-07	3.919E-07	3.494E-07	3.140E-07	2.843E-07
SE	3.891E-07	3.436E-07	3.062E-07	2.751E-07	2.491E-07
SSE	4.829E-07	4.267E-07	3.807E-07	3.423E-07	3.102E-07
S	6.424E-07	5.684E-07	5.076E-07	4.569E-07	4.145E-07
SSW	4.576E-07	4.054E-07	3.624E-07	3.266E-07	2.965E-07
SW	4.976E-07	4.417E-07	3.955E-07	3.570E-07	3.246E-07
WSW	7.648E-07	6.814E-07	6.125E-07	5.547E-07	5.060E-07
W	1.448E-06	1.299E-06	1.175E-06	1.070E-06	9.809E-07
WNW	1.644E-06	1.479E-06	1.341E-06	1.224E-06	1.124E-06
NW	1.733E-06	1.563E-06	1.416E-06	1.292E-06	1.186E-06
NNW	1.637E-06	1.471E-06	1.332E-06	1.214E-06	1.115E-06
SECTOR	1.7 (MILES)	1.8 (MILES)	1.9 (MILES)	2.0 (MILES)	2.1 (MILES)
N	1.074E-06	9.931E-07	9.226E-07	8.604E-07	8.052E-07
NNE	6.867E-07	6.331E-07	5.864E-07	5.453E-07	5.090E-07
NE	4.886E-07	4.494E-07	4.153E-07	3.854E-07	3.263E-07
ENE	3.471E-07	3.184E-07	2.936E-07	2.718E-07	2.526E-07
E	3.467E-07	3.177E-07	2.925E-07	2.705E-07	2.283E-07
ESE	2.590E-07	2.371E-07	2.182E-07	2.017E-07	1.871E-07
SE	2.268E-07	2.076E-07	1.910E-07	1.765E-07	1.637E-07
SSE	2.827E-07	2.590E-07	2.384E-07	2.205E-07	1.407E-07
S	3.780E-07	3.466E-07	3.194E-07	2.955E-07	1.373E-07
SSW	2.706E-07	2.484E-07	2.290E-07	2.121E-07	1.409E-07
SW	2.968E-07	2.727E-07	2.518E-07	2.335E-07	2.173E-07
WSW	4.639E-07	4.275E-07	3.957E-07	3.678E-07	5.303E-07
W	9.037E-07	8.365E-07	7.777E-07	7.258E-07	1.050E-06
WNW	1.038E-06	9.622E-07	8.960E-07	8.375E-07	1.142E-06
NW	1.095E-06	1.015E-06	9.445E-07	8.826E-07	8.275E-07
NNW	1.028E-06	9.527E-07	8.865E-07	8.281E-07	7.761E-07

Table A-3 (Cont.)
Atmospheric Dispersion (χ/Q) as a Function of Distance (s/m^3)

SECTOR	2.2 (MILES)	2.3 (MILES)	2.4 (MILES)	2.5 (MILES)	2.6 (MILES)
N	7.560E-07	7.118E-07	6.720E-07	6.359E-07	6.033E-07
NNE	4.766E-07	4.477E-07	4.217E-07	3.982E-07	3.770E-07
NE	3.050E-07	2.859E-07	2.688E-07	2.534E-07	2.395E-07
ENE	2.356E-07	2.205E-07	2.069E-07	1.947E-07	1.837E-07
E	2.127E-07	1.988E-07	1.864E-07	1.752E-07	1.652E-07
ESE	1.743E-07	1.628E-07	1.525E-07	1.433E-07	1.351E-07
SE	1.524E-07	1.424E-07	1.334E-07	1.253E-07	1.181E-07
SSE	1.311E-07	1.225E-07	1.149E-07	1.080E-07	1.018E-07
S	1.280E-07	1.197E-07	1.123E-07	1.056E-07	9.963E-08
SSW	1.314E-07	1.230E-07	1.154E-07	1.087E-07	1.025E-07
SW	2.030E-07	1.902E-07	1.787E-07	1.683E-07	1.590E-07
WSW	4.964E-07	4.661E-07	4.388E-07	4.142E-07	3.920E-07
W	9.867E-07	9.296E-07	8.780E-07	8.313E-07	7.891E-07
WNW	1.075E-06	1.014E-06	9.587E-07	9.088E-07	8.636E-07
NW	7.782E-07	7.339E-07	6.939E-07	6.576E-07	6.247E-07
NNW	7.297E-07	6.879E-07	6.502E-07	6.161E-07	5.852E-07
SECTOR	2.7 (MILES)	2.8 (MILES)	2.9 (MILES)	3.0 (MILES)	3.1 (MILES)
N	5.734E-07	5.460E-07	5.208E-07	4.976E-07	4.762E-07
NNE	3.576E-07	3.398E-07	3.235E-07	3.086E-07	2.948E-07
NE	2.268E-07	2.152E-07	2.046E-07	1.949E-07	1.859E-07
ENE	1.737E-07	1.645E-07	1.562E-07	1.485E-07	1.415E-07
E	1.560E-07	1.477E-07	1.401E-07	1.331E-07	1.267E-07
ESE	1.275E-07	1.207E-07	1.144E-07	1.087E-07	9.399E-08
SE	1.115E-07	1.054E-07	9.996E-08	9.493E-08	9.031E-08
SSE	9.613E-08	9.099E-08	8.630E-08	8.200E-08	7.805E-08
S	9.415E-08	8.917E-08	8.462E-08	8.044E-08	7.661E-08
SSW	9.697E-08	9.189E-08	8.725E-08	8.299E-08	7.907E-08
SW	1.505E-07	1.428E-07	1.357E-07	1.291E-07	1.231E-07
WSW	3.716E-07	3.531E-07	3.360E-07	3.204E-07	2.520E-07
W	7.503E-07	7.147E-07	6.820E-07	6.519E-07	5.874E-07
WNW	8.220E-07	7.838E-07	7.487E-07	7.164E-07	7.722E-07
NW	5.945E-07	5.668E-07	5.413E-07	5.178E-07	5.412E-07
NNW	5.567E-07	5.307E-07	5.067E-07	4.846E-07	4.642E-07

Table A-3 (Cont.)
Atmospheric Dispersion (γ/Q) as a Function of Distance (s/m³)

SECTOR	3.2 (MILES)	3.3 (MILES)	3.4 (MILES)	3.5 (MILES)	3.6 (MILES)
N	4.563E-07	4.379E-07	4.208E-07	4.047E-07	3.899E-07
NNE	2.820E-07	2.702E-07	2.592E-07	2.489E-07	2.395E-07
NE	1.777E-07	1.700E-07	1.629E-07	1.562E-07	1.501E-07
ENE	1.350E-07	1.290E-07	1.234E-07	1.182E-07	1.135E-07
E	1.208E-07	1.154E-07	1.103E-07	1.056E-07	1.013E-07
ESE	8.958E-08	8.550E-08	8.173E-08	7.821E-08	7.499E-08
SE	8.606E-08	8.213E-08	7.849E-08	7.510E-08	7.200E-08
SSE	7.441E-08	7.105E-08	6.794E-08	6.503E-08	6.237E-08
S	7.307E-08	6.980E-08	6.678E-08	6.395E-08	6.136E-08
SSW	7.546E-08	7.212E-08	6.902E-08	6.613E-08	6.348E-08
SW	1.176E-07	1.125E-07	1.077E-07	1.033E-07	9.922E-08
WSW	2.410E-07	2.308E-07	2.214E-07	2.125E-07	2.044E-07
W	5.631E-07	5.406E-07	5.196E-07	4.999E-07	4.818E-07
WNW	7.409E-07	7.118E-07	6.848E-07	6.593E-07	6.359E-07
NW	5.192E-07	4.987E-07	4.797E-07	4.618E-07	4.454E-07
NNW	4.452E-07	4.276E-07	4.112E-07	3.958E-07	3.817E-07
SECTOR	3.7 (MILES)	3.8 (MILES)	3.9 (MILES)	4.0 (MILES)	4.1 (MILES)
N	3.759E-07	3.628E-07	3.504E-07	3.388E-07	2.981E-07
NNE	2.306E-07	2.222E-07	2.144E-07	2.070E-07	1.819E-07
NE	1.444E-07	1.390E-07	1.339E-07	1.292E-07	1.247E-07
ENE	1.090E-07	1.048E-07	1.009E-07	9.718E-08	9.373E-08
E	9.722E-08	9.342E-08	8.987E-08	8.653E-08	8.341E-08
ESE	7.196E-08	6.912E-08	6.647E-08	6.399E-08	6.166E-08
SE	6.908E-08	6.635E-08	6.380E-08	6.140E-08	5.378E-08
SSE	5.987E-08	5.753E-08	5.533E-08	5.328E-08	5.135E-08
S	5.892E-08	5.664E-08	5.451E-08	5.251E-08	5.063E-08
SSW	6.098E-08	5.865E-08	5.646E-08	5.441E-08	5.248E-08
SW	9.537E-08	9.178E-08	8.841E-08	8.525E-08	8.228E-08
WSW	1.967E-07	1.896E-07	1.828E-07	1.765E-07	1.462E-07
W	4.646E-07	4.485E-07	4.334E-07	4.191E-07	3.043E-07
WNW	6.137E-07	6.929E-07	5.733E-07	5.548E-07	4.180E-07
NW	4.298E-07	4.151E-07	4.013E-07	3.883E-07	3.761E-07
NNW	3.682E-07	3.556E-07	3.438E-07	3.326E-07	2.928E-07

Table A-3 (Cont.)
Atmospheric Dispersion (γ/Q) as a Function of Distance (s/m^3)

SECTOR	4.2 (MILES)	4.3 (MILES)	4.4 (MILES)	4.5 (MILES)	4.6 (MILES)
N	2.887E-07	2.798E-07	2.714E-07	2.634E-07	2.559E-07
NNE	1.759E-07	1.703E-07	1.650E-07	1.599E-07	1.552E-07
NE	1.205E-07	1.166E-07	1.128E-07	1.093E-07	1.059E-07
ENE	9.047E-08	8.740E-08	8.451E-08	8.176E-08	7.921E-08
E	8.046E-08	7.769E-08	7.508E-08	7.260E-08	7.030E-08
ESE	5.946E-08	5.740E-08	5.545E-08	5.361E-08	5.189E-08
SE	5.186E-08	5.005E-08	4.835E-08	4.673E-08	4.523E-08
SSE	4.954E-08	4.783E-08	4.622E-08	4.469E-08	4.327E-08
S	4.886E-08	4.719E-08	4.562E-08	4.413E-08	4.274E-08
SSW	5.067E-08	4.896E-08	4.735E-08	4.581E-08	4.439E-08
SW	7.948E-08	7.684E-08	7.435E-08	7.198E-08	6.978E-08
WSW	1.413E-07	1.368E-07	1.325E-07	1.284E-07	1.246E-07
W	2.948E-07	2.858E-07	2.773E-07	2.691E-07	2.616E-07
WNW	4.051E-07	3.930E-07	3.815E-07	3.706E-07	3.603E-07
NW	3.645E-07	3.536E-07	3.432E-07	3.333E-07	3.241E-07
NNW	2.837E-07	2.752E-07	2.671E-07	2.593E-07	2.521E-07
SECTOR	4.7 (MILES)	4.8 (MILES)	4.9 (MILES)	5.0 (MILES)	
N	2.487E-07	2.419E-07	2.354E-07	2.292E-07	
NNE	1.507E-07	1.464E-07	1.423E-07	1.384E-07	
NE	1.028E-07	9.975E-08	9.689E-08	9.416E-08	
ENE	7.676E-08	7.443E-08	7.223E-08	7.014E-08	
E	6.809E-08	6.600E-08	6.402E-08	6.214E-08	
ESE	5.025E-08	4.869E-08	4.722E-08	4.582E-08	
SE	4.379E-08	4.244E-08	4.115E-08	3.992E-08	
SSE	4.191E-08	4.063E-08	3.941E-08	3.825E-08	
S	4.141E-08	4.015E-08	3.896E-08	3.782E-08	
SSW	4.302E-08	4.173E-08	4.050E-08	3.934E-08	
SW	6.767E-08	6.567E-08	6.377E-08	6.196E-08	
WSW	1.210E-07	1.175E-07	1.142E-07	1.110E-07	
W	2.543E-07	2.474E-07	2.408E-07	2.345E-07	
WNW	3.505E-07	3.411E-07	3.322E-07	3.237E-07	
NW	3.152E-07	3.068E-07	2.987E-07	2.910E-07	
NNW	2.452E-07	2.336E-07	2.323E-07	2.263E-07	

Table A-4
Atmospheric Dispersion (D/Q) as a Function of Distance (m⁻²)

SECTOR	0.2 (MILES)	0.3 (MILES)	0.4 (MILES)	0.5 (MILES)	0.6 (MILES)
N	1.396E-07	7.578E-08	4.836E-08	3.383E-08	2.516E-08
NNE	1.107E-07	6.008E-08	3.834E-08	2.682E-08	1.995E-08
NE	9.733E-08	5.284E-08	3.372E-08	2.359E-08	1.755E-08
ENE	1.067E-07	5.795E-08	3.698E-08	2.587E-08	1.924E-08
E	1.184E-07	6.429E-08	4.103E-08	2.870E-08	2.135E-08
ESE	8.865E-08	4.813E-08	3.071E-08	2.149E-08	1.598E-08
SE	9.402E-08	5.105E-08	3.258E-08	2.279E-08	1.695E-08
SSE	1.338E-07	7.266E-08	4.637E-08	3.244E-08	2.413E-08
S	1.429E-07	7.757E-08	4.951E-08	3.463E-08	2.576E-08
SSW	6.094E-08	3.309E-08	2.111E-08	1.477E-08	1.099E-08
SW	7.267E-08	3.945E-08	2.518E-08	1.761E-08	1.310E-08
WSW	7.117E-08	3.864E-08	2.466E-08	1.725E-08	1.283E-08
W	7.129E-08	3.870E-08	2.470E-08	1.728E-08	1.285E-08
WNW	6.970E-08	3.784E-08	2.415E-08	1.689E-08	1.256E-08
NW	8.904E-08	4.834E-08	3.085E-08	2.158E-08	1.605E-08
NNW	9.623E-08	5.225E-08	3.334E-08	2.332E-08	1.735E-08
SECTOR	0.7 (MILES)	0.8 (MILES)	0.9 (MILES)	1.0 (MILES)	1.1 (MILES)
N	1.954E-08	1.560E-08	1.277E-08	1.068E-08	5.545E-09
NNE	1.549E-08	1.237E-08	1.013E-08	8.465E-09	4.945E-09
NE	1.362E-08	1.088E-08	8.907E-09	7.445E-09	4.350E-09
ENE	1.494E-08	1.193E-08	9.768E-09	8.164E-09	4.770E-09
E	1.658E-08	1.323E-08	1.084E-08	9.058E-09	5.292E-09
ESE	1.241E-08	9.905E-09	8.112E-09	6.781E-09	3.961E-09
SE	1.316E-08	1.051E-08	8.605E-09	7.192E-09	3.361E-09
SSE	1.874E-08	1.496E-08	1.225E-08	1.024E-08	3.480E-09
S	2.000E-08	1.597E-08	1.308E-08	1.093E-08	4.128E-09
SSW	8.531E-09	6.810E-09	5.577E-09	4.662E-09	2.521E-09
SW	1.017E-08	8.120E-09	6.651E-09	5.559E-09	2.598E-09
WSW	9.963E-09	7.953E-09	6.513E-09	5.444E-09	2.678E-09
W	9.980E-09	7.966E-09	6.524E-09	5.453E-09	2.832E-09
WNW	9.757E-09	7.788E-09	6.379E-09	5.332E-09	2.932E-09
NW	1.246E-08	9.949E-09	8.148E-09	6.811E-09	3.745E-09
NNW	1.347E-08	1.075E-08	8.807E-09	7.361E-09	4.047E-09

Table A-4 (Cont.)
Atmospheric Deposition (D/Q) as a Function of Distance (m⁻²)

SECTOR	1.2 (MILES)	1.3 (MILES)	1.4 (MILES)	1.5 (MILES)	1.6 (MILES)
N	4.777E-09	4.163E-09	3.664E-09	3.252E-09	2.910E-09
NNE	4.260E-09	3.713E-09	3.268E-09	2.900E-09	2.595E-09
NE	3.747E-09	3.265E-09	2.874E-09	2.551E-09	2.283E-09
ENE	4.109E-09	3.581E-09	3.151E-09	2.797E-09	2.503E-09
E	4.559E-09	3.973E-09	3.497E-09	3.104E-09	2.777E-09
ESE	3.413E-09	2.974E-09	2.617E-09	2.323E-09	2.079E-09
SE	2.896E-09	2.524E-09	2.221E-09	1.971E-09	1.764E-09
SSE	2.998E-09	2.612E-09	2.299E-09	2.041E-09	1.826E-09
S	3.556E-09	3.099E-09	2.727E-09	2.421E-09	2.166E-09
SSW	2.172E-09	1.892E-09	1.666E-09	1.478E-09	1.323E-09
SW	2.238E-09	1.950E-09	1.717E-09	1.524E-09	1.363E-09
WSW	2.307E-09	2.011E-09	1.770E-09	1.571E-09	1.406E-09
W	2.440E-09	2.126E-09	1.871E-09	1.661E-09	1.486E-09
WNW	2.525E-09	2.201E-09	1.937E-09	1.719E-09	1.538E-09
NW	3.226E-09	2.811E-09	2.474E-09	2.196E-09	1.965E-09
NNW	3.487E-09	3.039E-09	2.674E-09	2.374E-09	2.124E-09
SECTOR	1.7 (MILES)	1.8 (MILES)	1.9 (MILES)	2.0 (MILES)	2.1 (MILES)
N	2.619E-09	2.371E-09	2.158E-09	1.973E-09	1.812E-09
NNE	2.336E-09	2.115E-09	1.925E-09	1.760E-09	1.616E-09
NE	2.055E-09	1.860E-09	1.693E-09	1.548E-09	1.292E-09
ENE	2.253E-09	2.040E-09	1.856E-09	1.697E-09	1.558E-09
E	2.500E-09	2.263E-09	2.059E-09	1.883E-09	1.572E-09
ESE	1.871E-09	1.694E-09	1.542E-09	1.410E-09	1.294E-09
SE	1.583E-09	1.437E-09	1.308E-09	1.196E-09	1.098E-09
SSE	1.644E-09	1.488E-09	1.354E-09	1.238E-09	7.816E-10
S	1.950E-09	1.765E-09	1.606E-09	1.469E-09	6.743E-10
SSW	1.191E-09	1.078E-09	9.810E-10	8.969E-10	5.883E-10
SW	1.227E-09	1.111E-09	1.011E-09	9.244E-10	8.488E-10
WSW	1.265E-09	1.145E-09	1.042E-09	9.530E-10	1.352E-09
W	1.338E-09	1.211E-09	1.102E-09	1.008E-09	1.430E-09
WNW	1.385E-09	1.254E-09	1.141E-09	1.043E-09	1.393E-09
NW	1.769E-09	1.601E-09	1.457E-09	1.333E-09	1.223E-09
NNW	1.912E-09	1.731E-09	1.575E-09	1.440E-09	1.322E-09

Table A-4 (Cont.)
Atmospheric Deposition (D/Q) as a Function of Distance (m⁻²)

SECTOR	2.2 (MILES)	2.3 (MILES)	2.4 (MILES)	2.5 (MILES)	2.6 (MILES)
N	1.670E-09	1.544E-09	1.433E-09	1.334E-09	1.245E-09
NNE	1.489E-09	1.377E-09	1.278E-09	1.189E-09	1.110E-09
NE	1.191E-09	1.101E-09	1.022E-09	9.511E-10	8.879E-10
ENE	1.436E-09	1.328E-09	1.233E-09	1.147E-09	1.071E-09
E	1.449E-09	1.340E-09	1.243E-09	1.157E-09	1.080E-09
ESE	1.193E-09	1.103E-09	1.024E-09	9.528E-10	8.895E-10
SE	1.012E-09	9.362E-10	8.687E-10	8.085E-10	7.548E-10
SSE	7.204E-10	6.663E-10	6.183E-10	5.754E-10	5.372E-10
S	6.215E-10	5.749E-10	5.334E-10	4.964E-10	4.634E-10
SSW	5.422E-10	5.015E-10	4.653E-10	4.331E-10	4.043E-10
SW	7.823E-10	7.236E-10	6.714E-10	6.249E-10	5.834E-10
WSW	1.246E-09	1.153E-09	1.070E-09	9.956E-10	9.294E-10
W	1.318E-09	1.219E-09	1.131E-09	1.053E-09	9.827E-10
WNW	1.284E-09	1.188E-09	1.102E-09	1.026E-09	9.575E-10
NW	1.128E-09	1.043E-09	9.678E-10	9.007E-10	8.409E-10
NNW	1.219E-09	1.127E-09	1.046E-09	9.735E-10	9.089E-10
SECTOR	2.7 (MILES)	2.8 (MILES)	2.9 (MILES)	3.0 (MILES)	3.1 (MILES)
N	1.165E-09	1.092E-09	1.026E-09	9.666E-10	9.120E-10
NNE	1.039E-09	9.742E-10	9.155E-10	8.621E-10	8.134E-10
NE	8.307E-10	7.789E-10	7.320E-10	6.893E-10	6.504E-10
ENE	1.002E-09	9.396E-10	8.830E-10	8.315E-10	7.845E-10
E	1.011E-09	9.477E-10	8.906E-10	8.387E-10	7.913E-10
ESE	8.322E-10	7.804E-10	7.334E-10	6.906E-10	5.923E-10
SE	7.061E-10	6.622E-10	6.223E-10	5.860E-10	5.529E-10
SSE	5.026E-10	4.713E-10	4.429E-10	4.171E-10	3.935E-10
S	4.336E-10	4.066E-10	3.821E-10	3.598E-10	3.395E-10
SSW	3.782E-10	3.547E-10	3.333E-10	3.139E-10	2.961E-10
SW	5.458E-10	5.118E-10	4.810E-10	4.529E-10	4.273E-10
WSW	8.695E-10	8.154E-10	7.663E-10	7.216E-10	5.607E-10
W	9.194E-10	8.621E-10	8.102E-10	7.630E-10	6.775E-10
WNW	8.958E-10	8.400E-10	7.894E-10	7.434E-10	7.890E-10
NW	7.867E-10	7.377E-10	6.933E-10	6.528E-10	6.719E-10
NNW	8.503E-10	7.973E-10	7.493E-10	7.056E-10	6.657E-10

Table A-4 (Cont.)
Atmospheric Deposition (D/Q) as a Function of Distance (m⁻²)

SECTOR	3.2 (MILES)	3.3 (MILES)	3.4 (MILES)	3.5 (MILES)	3.6 (MILES)
N	8.620E-10	8.161E-10	7.739E-10	7.347E-10	6.991E-10
NNE	7.688E-10	7.279E-10	6.902E-10	6.552E-10	6.235E-10
NE	6.147E-10	5.820E-10	5.518E-10	5.239E-10	4.985E-10
ENE	7.415E-10	7.020E-10	6.657E-10	6.320E-10	6.014E-10
E	7.479E-10	7.081E-10	6.714E-10	6.374E-10	6.066E-10
ESE	5.598E-10	5.300E-10	5.026E-10	4.771E-10	4.541E-10
SE	5.225E-10	4.947E-10	4.691E-10	4.454E-10	4.238E-10
SSE	3.719E-10	3.521E-10	3.339E-10	3.170E-10	3.016E-10
S	3.209E-10	3.038E-10	2.880E-10	2.735E-10	2.602E-10
SSW	2.799E-10	2.650E-10	2.513E-10	2.386E-10	2.270E-10
SW	4.039E-10	3.824E-10	3.626E-10	3.442E-10	3.276E-10
WSW	5.299E-10	5.017E-10	4.757E-10	4.516E-10	4.298E-10
W	6.403E-10	6.062E-10	5.749E-10	5.458E-10	5.193E-10
WNW	7.457E-10	7.060E-10	6.695E-10	6.356E-10	6.048E-10
NW	6.351E-10	6.013E-10	5.702E-10	5.413E-10	5.151E-10
NNW	6.292E-10	5.957E-10	5.649E-10	5.363E-10	5.103E-10
SECTOR	3.7 (MILES)	3.8 (MILES)	3.9 (MILES)	4.0 (MILES)	4.1 (MILES)
N	6.657E-10	6.347E-10	6.059E-10	5.791E-10	5.036E-10
NNE	5.937E-10	5.661E-10	5.404E-10	5.165E-10	4.492E-10
NE	4.747E-10	4.526E-10	4.321E-10	4.129E-10	3.951E-10
ENE	5.727E-10	5.460E-10	5.212E-10	4.981E-10	4.766E-10
E	5.776E-10	5.507E-10	5.257E-10	5.024E-10	4.807E-10
ESE	4.324E-10	4.122E-10	3.935E-10	3.761E-10	3.598E-10
SE	4.036E-10	3.848E-10	3.673E-10	3.510E-10	3.053E-10
SSE	2.872E-10	2.739E-10	2.614E-10	2.498E-10	2.390E-10
S	2.478E-10	2.363E-10	2.255E-10	2.155E-10	2.062E-10
SSW	2.162E-10	2.061E-10	1.968E-10	1.880E-10	1.799E-10
SW	3.119E-10	2.974E-10	2.839E-10	2.713E-10	2.596E-10
WSW	4.093E-10	3.902E-10	3.725E-10	3.560E-10	2.919E-10
W	4.945E-10	4.715E-10	4.501E-10	4.302E-10	3.087E-10
WNW	5.759E-10	5.491E-10	5.242E-10	5.010E-10	3.728E-10
NW	4.905E-10	4.677E-10	4.464E-10	4.266E-10	4.082E-10
NNW	4.895E-10	4.633E-10	4.423E-10	4.227E-10	3.676E-10

Table A-4 (Cont.)
Atmospheric Deposition (D/Q) as a Function of Distance (m⁻²)

SECTOR	4.2 (MILES)	4.3 (MILES)	4.4 (MILES)	4.5 (MILES)	4.6 (MILES)
N	4.823E-10	4.624E-10	4.437E-10	4.260E-10	4.097E-10
NNE	4.302E-10	4.124E-10	3.957E-10	3.800E-10	3.654E-10
NE	3.784E-10	3.627E-10	3.480E-10	3.342E-10	3.214E-10
ENE	4.564E-10	4.375E-10	4.198E-10	4.031E-10	3.877E-10
E	4.603E-10	4.413E-10	4.234E-10	4.066E-10	3.910E-10
ESE	3.446E-10	3.303E-10	3.170E-10	3.044E-10	2.927E-10
SE	2.924E-10	2.803E-10	2.690E-10	2.583E-10	2.484E-10
SSE	2.289E-10	2.195E-10	2.106E-10	2.022E-10	1.944E-10
S	1.975E-10	1.893E-10	1.817E-10	1.744E-10	1.677E-10
SSW	1.723E-10	1.652E-10	1.585E-10	1.522E-10	1.463E-10
SW	2.486E-10	2.383E-10	2.287E-10	2.196E-10	2.112E-10
WSW	2.796E-10	2.680E-10	2.572E-10	2.469E-10	2.375E-10
W	2.956E-10	2.834E-10	2.719E-10	2.611E-10	2.511E-10
WNW	3.570E-10	3.422E-10	3.284E-10	3.153E-10	3.032E-10
NW	3.909E-10	3.747E-10	3.596E-10	3.453E-10	3.320E-10
NNW	3.521E-10	3.375E-10	3.239E-10	3.110E-10	2.991E-10
SECTOR	4.7 (MILES)	4.8 (MILES)	4.9 (MILES)	5.0 (MILES)	
N	3.941E-10	3.795E-10	3.656E-10	3.525E-10	
NNE	3.515E-10	3.384E-10	3.261E-10	3.144E-10	
NE	3.092E-10	2.977E-10	2.868E-10	2.765E-10	
ENE	3.729E-10	3.591E-10	3.460E-10	3.336E-10	
E	3.762E-10	3.622E-10	3.489E-10	3.364E-10	
ESE	2.816E-10	2.711E-10	2.612E-10	2.519E-10	
SE	2.389E-10	2.300E-10	2.216E-10	2.137E-10	
SSE	1.871E-10	1.801E-10	1.735E-10	1.673E-10	
S	1.614E-10	1.554E-10	1.497E-10	1.443E-10	
SSW	1.408E-10	1.355E-10	1.306E-10	1.259E-10	
SW	2.031E-10	1.956E-10	1.884E-10	1.817E-10	
WSW	2.285E-10	2.199E-10	2.119E-10	2.043E-10	
W	2.415E-10	2.326E-10	2.241E-10	2.160E-10	
WNW	2.917E-10	2.809E-10	2.706E-10	2.609E-10	
NW	3.194E-10	3.075E-10	2.963E-10	2.857E-10	
NNW	2.877E-10	2.770E-10	2.669E-10	2.573E-10	

Appendix B
LOWER LIMIT OF DETECTION

The lower limit of detection (LLD) is the smallest concentration of radioactive material in a sample that will be detected with a 95 percent probability with a 5 percent probability of falsely concluding that a blank observation represents a "real" signal.

The LLD is defined as an "a priori" (before the fact) limit representing the capability of a measurement system and not as an "a posteriori" (after the fact) limit for a particular measurement.

For a measurement system (which may include radiochemical separation) based on gross beta, gross alpha, liquid scintillation, or other analyses where a background count determined by a separate measurement with no sample (or blank sample) is subtracted from the gross sample count to obtain a net count due to sample activity:

$$LLD = \frac{3.3 \left(\frac{n_b}{t_s} + \frac{n_b}{t_b} \right)^{1/2}}{(C)(E)(V)(Y_C) \exp(-\lambda \Delta t)} \quad (B-1)$$

Where:

- LLD = the "a priori" lower limit of detection, as defined above;
- C = the conversion factor of transformations per unit time per μCi or pCi ;
- E = the detector efficiency;
- n_b = the background count rate in units of transformations per unit time;
- t_b = the counting time of background;
- t_s = the counting time of the sample;
- V = the sample size, in units of mass or volume;
- Y_C = the fractional radiochemical sample collection or concentration yield (when applicable);
- Δt = for plant effluents, the elapsed time between the midpoint of sample collection and time of counting; for environmental samples, the elapsed time between sample collection (or end of the sample collection period) and time of counting;
- λ = the radioactive decay constant for the radionuclide in question.

For the purpose of routine analyses, count times for both the sample(s) and background(s) are equal. This satisfies the given ODCM Appendix C control for lower limit of detection definition, as the numerator of equation B-1 simplifies to 4.66 S_b , where S_b is the standard deviation of the background count rate or the count rate of a blank sample, as appropriate.

For gamma ray spectroscopy analyses:

$$LLD = \frac{L_D \exp\left(0.693 \frac{\Delta t}{t^{1/2}}\right)}{(C)(E)(t)(V)(Y_C)(Y_\gamma)} \quad (B-2)$$

Where:

- LLD = the lower limit of detection, in μCi or pCi per unit mass or volume;
- C = the conversion factor of transformations per unit time per μCi or pCi ;
- E = the detector efficiency for the energy in question;
- t = the data collection (counting) time of sample;
- $t^{1/2}$ = the half-life of the radionuclide in question;
- V = the sample size, in units of mass or volume;
- Y_C = the fractional radiochemical, sample collection, or concentration yield (when applicable);
- Y_λ = the yield of the gamma ray in question;
- Δt = for plant effluents the elapsed time between midpoint of sample collection and time of counting; for environmental samples, the elapsed time between sample collection (or end of the sample collection period) and the time of counting;
- L_d = the detection limit

$$= \left(k^2 + 2k \left(\frac{N}{2n} \left(1 + \frac{N}{2n} \right) (B_1 + B_2) + I + \sigma_I^2 \right) \right)^{1/2} \quad (B-3)$$

Where:

- B_1 = the number of counts in "n" background channels below the peak due to Compton scattering, etc., determined at the same time a photopeak is measured;

- B_2 = the number of counts in the "n" background channels above the peak;
- k = an abscissa of the normal distribution corresponding to confidence level,
= 1.645 at a confidence level of 95%;
- I = the measured value of interference in the photopeak of interest due to environmental background, detector contamination, etc., determined by a separate measurement with no sample;
- N = the number of channels in the photopeak of interest;
- n = the number of background channels on each side of the photopeak of interest;
- σ_I = the standard deviation of I.

Typical values of E, V, Y, and Δt shall be used in the calculation.

In calculating the LLD for a radionuclide determined by gamma-ray spectrometry, the background shall include the typical contributions of other radionuclides normally present in the samples (e.g., potassium-40 in milk samples).

Analyses shall be performed in such a manner that the LLD's listed in Tables 4.11.1.1.1-1, 4.11.2.1.2-1, and 4.12.1-1 of the ODCM Appendix C controls for the Perry Nuclear Power Plant will be achieved under routine conditions. Occasionally, background fluctuations, unavoidably small sample sizes, the presence of interfering nuclides, or other uncontrollable circumstances may render these LLDs unachievable. In such cases, the contributing factors will be identified and described in the Annual Radiological Environmental Operating Report.

Appendix C
Controls

INDEX

DEFINITIONS

SECTION

<u>1.0 DEFINITIONS</u>	<u>PAGE</u>
ACTIONS	1-1
CHANNEL CALIBRATION	1-1
CHANNEL CHECK	1-1
CHANNEL FUNCTIONAL TEST	1-1
DOSE EQUIVALENT I-131	1-1
FREQUENCY NOTATION	1-2
GASEOUS RADWASTE TREATMENT (OFF-GAS) SYSTEM	1-2
LIQUID RADWASTE TREATMENT SYSTEM	1-2
MEMBER(S) OF THE PUBLIC	1-2
MODE	1-2
OFFSITE DOSE CALCULATION MANUAL	1-2
OPERABLE - OPERABILITY	1-3
PURGE - PURGING	1-3
RATED THERMAL POWER	1-3
REPORTABLE EVENT	1-3
SITE BOUNDARY	1-3
SOURCE CHECK	1-3
THERMAL POWER	1-3
UNRESTRICTED AREA	1-3
VENTILATION EXHAUST TREATMENT SYSTEMS	1-4
VENTING	1-4
Table 1.1, Surveillance Frequency Notation	1-5
Table 1.2, MODES	1-6

CONTROLS AND SURVEILLANCE REQUIREMENTS

<u>SECTION</u>		<u>PAGE</u>
<u>3/4.0 APPLICABILITY</u>		3/4 0-1
<u>3/4.3 INSTRUMENTATION</u>		
Radioactive Liquid Effluent Monitoring Instrumentation		3/4 1-1
Table 3.3.7.9-1	Radioactive Liquid Effluent Monitoring Instrumentation	3/4 1-2
Table 4.3.7.9-1	Radioactive Liquid Effluent Monitoring Instrumentation Surveillance Requirements	3/4 1-4
Radioactive Gaseous Effluent Monitoring Instrumentation		3/4 1-6
Table 3.3.7.10-1	Radioactive Gaseous Effluent Monitoring Instrumentation	3/4 1-7
Table 4.3.7.10-1	Radioactive Gaseous Effluent Monitoring Instrumentation Surveillance Requirements	3/4 1-10
<u>3/4.11 RADIOACTIVE EFFLUENTS</u>		
<u>3/4.11.1 LIQUID EFFLUENTS</u>		
Concentration		3/4 2-1
Table 4.11.1.1.1-1	Radioactive Liquid Waste Sampling and Analysis Program	3/4 2-2
Dose		3/4 2-5
Liquid Radwaste Treatment System		3/4 2-6
<u>3/4.11.2 GASEOUS EFFLUENTS</u>		
Dose Rate		3/4 2-7
Table 4.11.2.1.2-1	Radioactive Gaseous Waste Sampling and Analysis Program	3/4 2-8
Dose - Noble Gases		3/4 2-11
Dose - Iodine-131, Iodine-133, Tritium and Radionuclides in Particulate Form		3/4 2-12

CONTROLS AND SURVEILLANCE REQUIREMENTS

<u>SECTION</u>	<u>PAGE</u>
<u>RADIOACTIVE EFFLUENTS (Continued)</u>	
Gaseous Radwaste (Off-Gas) Treatment.....	3/4 2-13
Ventilation Exhaust Treatment Systems.....	3/4 2-14
3/4.11.4 TOTAL DOSE.....	3/4 2-15
<u>3/4.12 RADIOLOGICAL ENVIRONMENTAL MONITORING</u>	
3/4.12.1 MONITORING PROGRAM.....	3/4 3-1
Table 3.12.1-1 Radiological Environmental Monitoring Program.....	3/4 3-3
Table 3.12.1-2 Reporting Levels for Radioactivity Concentrations In Environmental Samples.....	3/4 3-9
Table 4.12.1-1 Maximum Values for the Lower Limits of Detection (LLD) In Environmental Samples.....	3/4 3-10
3/4.12.2 LAND USE CENSUS.....	3/4 3-13
3/4.12.3 INTERLABORATORY COMPARISON PROGRAM.....	3/4 3-14

BASES

<u>SECTION</u>	<u>PAGE</u>
<u>3/4.0 APPLICABILITY</u>	B 3/4 0-1
<u>3/4.3 INSTRUMENTATION</u>	
Radioactive Liquid Effluent Monitoring Instrumentation.....	B 3/4 1-1
Radioactive Gaseous Effluent Monitoring Instrumentation.....	B 3/4 1-1
<u>3/4.11 RADIOACTIVE EFFLUENTS</u>	
3/4.11.1 LIQUID EFFLUENTS	
Concentration.....	B 3/4 2-1
Dose.....	B 3/4 2-1
Liquid Radwaste Treatment System.....	B 3/4 2-2

BASES

<u>SECTION</u>	<u>PAGE</u>
<u>3/4.11 RADIOACTIVE EFFLUENTS (Continued)</u>	
<u>3/4.11.2 GASEOUS EFFLUENTS</u>	
Dose Rate.....	B 3/4 2-3
Dose - Noble Gases.....	B 3/4 2-3
Dose - Iodine-131, Iodine-133, Tritium and Radionuclides in Particulate Form.....	B 3/4 2-4
Gaseous Radwaste Treatment (Offgas) System and Ventilation Exhaust Treatment Systems.....	B 3/4 2-5
<u>3/4.11.4 TOTAL DOSE.....</u>	<u>B 3/4 2-6</u>
<u>3/4.12 RADIOLOGICAL ENVIRONMENTAL MONITORING</u>	
<u>3/4.12.1 MONITORING PROGRAM.....</u>	<u>B 3/4 3-1</u>
<u>3/4.12.2 LAND USE CENSUS.....</u>	<u>B 3/4 3-1</u>
<u>3/4.12.3 INTERLABORATORY COMPARISON PROGRAM.....</u>	<u>B 3/4 3-2</u>

ADMINISTRATIVE CONTROLS

<u>SECTION</u>	<u>PAGE</u>
<u>6.9 REPORTING REQUIREMENTS</u>	
6.9.1.6 Annual Radiological Environmental Operating Report.....	4-1
6.9.1.7 Annual Radioactive Effluent Release Report.....	4-2
6.9.2 SPECIAL REPORTS.....	4-3
<u>6.10 RECORD RETENTION.....</u>	<u>4-3</u>
<u>6.15 MAJOR CHANGES TO RADIOACTIVE WASTE TREATMENT SYSTEMS.....</u>	<u>4-3</u>

SECTION 1.0
DEFINITIONS

1.0 DEFINITIONS

The following terms are defined so that uniform interpretation of these Controls may be achieved. The defined terms appear in capitalized type and shall be applicable throughout these Controls.

ACTIONS

ACTIONS shall be that part of a Control that prescribes remedial measures to be taken under designated conditions.

CHANNEL CALIBRATION

A CHANNEL CALIBRATION shall be the adjustment, as necessary, of the channel output such that it responds within the necessary range and accuracy to known values of the parameter which the channel monitors. The CHANNEL CALIBRATION shall encompass the entire channel, including the required sensor, alarm, display and trip functions, and shall include the CHANNEL FUNCTIONAL TEST. The CHANNEL CALIBRATION may be performed by means of any series of sequential, overlapping or total channel steps so that the entire channel is calibrated.

CHANNEL CHECK

A CHANNEL CHECK shall be the qualitative assessment, by observation of channel behavior during operation. This determination shall include, where possible, comparison of the channel indication and status to other indications or status derived from independent instrument channels measuring the same parameter.

CHANNEL FUNCTIONAL TEST

A CHANNEL FUNCTIONAL TEST shall be the injection of a simulated or actual signal into the channel as close to the sensor as practicable to verify OPERABILITY, including required alarm, interlock, display, and trip functions and channel failure trips. The CHANNEL FUNCTIONAL TEST may be performed by means of any series of sequential, overlapping, or total channel steps so that the entire channel is tested.

DOSE EQUIVALENT I-131

DOSE EQUIVALENT I-131 shall be that concentration of I-131 (microcuries per gram) that alone would produce the same thyroid dose as the quantity and isotopic mixture of I-131, I-132, I-133, I-134, and I-135 actually present. The thyroid dose conversion factors used for this calculation shall be those listed in Table III of TID-14844, AEC, 1962, "Calculation of Distance Factors for Power and Test Reactor Sites."

DEFINITIONS

FREQUENCY NOTATION

The FREQUENCY NOTATION specified for the performance of Surveillance Requirements shall correspond to the intervals defined in Table 1.1.

GASEOUS RADWASTE TREATMENT (OFF-GAS) SYSTEM

THE GASEOUS RADWASTE TREATMENT (OFF-GAS) SYSTEM is the system designed and installed to reduce radioactive gaseous effluents by collecting primary coolant system off-gasses from the main condenser evacuation system and providing for delay or holdup for the purpose of reducing the total radioactivity prior to release to the environment.

LIQUID RADWASTE TREATMENT SYSTEM

The LIQUID RADWASTE TREATMENT SYSTEM is any process or control equipment used to reduce the amount or concentration of liquid radioactive materials prior to their discharge to UNRESTRICTED AREAS. It involves all the installed and available liquid radwaste management system equipment, as well as their controls, power instrumentation, and services that make the system functional.

MEMBER OF THE PUBLIC

MEMBER OF THE PUBLIC means any individual except when that individual is receiving an OCCUPATIONAL DOSE.

MODE

A MODE shall correspond to any one inclusive combination of mode switch position, average reactor coolant temperature, and reactor vessel head closure bolt tensioning specified in Table 1.2 with fuel in the reactor vessel.

OCCUPATIONAL DOSE

OCCUPATIONAL DOSE means the dose received by an individual in the course of employment in which the individual's assigned duties involve exposure to radiation or to radioactive material from licensed and unlicensed sources of radiation, whether in the possession of the licensee or other person. Occupational dose does not include doses received from background radiation, from any medical administration the individual has received, from exposure to individuals administered radioactive material and released under § 35.75, from voluntary participation in medical research programs, or as a member of the public.

DEFINITIONS

OFFSITE DOSE CALCULATION MANUAL (ODCM)

The OFFSITE DOSE CALCULATION MANUAL shall contain the methodology and parameters used in the calculation of offsite doses resulting from radioactive gaseous and liquid effluents, in the calculation of gaseous and liquid effluent monitoring alarm/trip setpoints, and in the conduct of the radiological environmental monitoring program. The ODCM shall also contain the Radioactive Effluent Controls Program required by Technical Specification 5.5.4, the Radiological Environmental Monitoring Programs and descriptions of the information that should be included in the Annual Radioactive Effluent Release Report required by Technical Specifications 5.6.2 and 5.6.3.

OPERABLE - OPERABILITY

A system, subsystem, division, component or device shall be OPERABLE or have OPERABILITY when it is capable of performing its specified function(s) and when all necessary attendant instrumentation, controls, normal or emergency electrical power, cooling and seal water, lubrication and other auxiliary equipment that are required for the system, subsystem, division, component or device to perform its specified safety function(s) are also capable of performing their related support function(s).

PURGE - PURGING

PURGE OR PURGING is the controlled process of discharging air or gas from a confinement to maintain temperature, pressure, humidity, concentration or other operating condition, in such a manner that replacement air or gas is required to purify the confinement.

RATED THERMAL POWER

RATED THERMAL POWER shall be a total reactor core heat transfer rate to the reactor coolant of 3758 MWT.

REPORTABLE EVENT

A REPORTABLE EVENT shall be any of those conditions specified in 10CFR50.73.

SITE BOUNDARY

The SITE BOUNDARY shall be that line beyond which the land is neither owned, nor leased, nor otherwise controlled by the licensee.

SOURCE CHECK

A SOURCE CHECK shall be the qualitative assessment of channel response when the channel sensor is exposed to a source of increased radioactivity.

DEFINITIONS

THERMAL POWER

THERMAL POWER shall be the total reactor core heat transfer rate to the reactor coolant.

UNRESTRICTED AREA

An UNRESTRICTED AREA shall be any area at or beyond the SITE BOUNDARY access to which is not controlled by the licensee for purposes of protection of MEMBERS OF THE PUBLIC from exposure to radiation and radioactive materials, or any area within the SITE BOUNDARY used for residential quarters or for industrial, commercial, institutional, and/or recreational purposes.

VENTILATION EXHAUST TREATMENT SYSTEMS

A VENTILATION EXHAUST TREATMENT SYSTEM is any system designed and installed to reduce gaseous radioiodine or radioactive material in particulate form in effluents by passing ventilation or vent exhaust gases through charcoal adsorbers and/or HEPA filters for the purpose of removing iodines or particulates from the gaseous exhaust stream prior to the release to the environment (such a system is not considered to have any effect on noble gas effluents). Engineered Safety Feature (ESF) atmospheric cleanup systems are not considered to be VENTILATION EXHAUST TREATMENT SYSTEM components provided the ESF system is not utilized to treat normal releases.

VENTING

VENTING is the controlled process of discharging air or gas from a confinement to maintain temperature, pressure, humidity, concentration or other operating condition, in such a manner that replacement air or gas is not provided or required during VENTING. Vent, used in system names, does not imply a VENTING process.

TABLE 1.1
SURVEILLANCE FREQUENCY NOTATION

<u>NOTATION</u>	<u>FREQUENCY</u>
S	At least once per 12 hours.
D	At least once per 24 hours.
W	At least once per 7 days.
M	At least once per 31 days.
Q	At least once per 92 days.
SA	At least once per 184 days.
A	At least once per 366 days.
R	At least once per 24 months.
S/U	Prior to each reactor startup.
P	Completed prior to each release.
4H	Every 4 hours when required.
N.A.	Not applicable.

TABLE 1.2

MODES

<u>MODE</u>	<u>TITLE</u>	<u>REACTOR MODE SWITCH POSITION</u>	<u>AVERAGE REACTOR COOLANT TEMPERATURE</u>
1	POWER OPERATION	Run	NA
2	STARTUP	Refuel(a) or Startup/Hot Standby	NA
3	HOT SHUTDOWN(a)	Shutdown	> 200°F
4	COLD SHUTDOWN(a)	Shutdown	≤ 200°F
5	REFUELING(b)	Shutdown or Refuel	NA

(a) All reactor vessel head closure bolts fully tensioned.

(b) One or more reactor vessel head closure bolts less than fully tensioned.

SECTIONS 3.0 and 4.0
CONTROLS
AND
SURVEILLANCE REQUIREMENTS

3/4.0 APPLICABILITY

CONTROLS

3.0.1 Controls shall be met during the MODES or other conditions specified in the Applicability except as provided in Control 3.0.2.

3.0.2 Upon discovery of a failure to meet a Control, the requirements of the Actions shall be met except as provided in Control 3.0.5. If the Control is met or is no longer applicable prior to expiration of the specified time interval(s), completion of the Action(s) is not required, unless otherwise stated.

3.0.3 When a Control is not met and the associated ACTIONS are not met, an associated ACTION is not provided, or if directed by the associated ACTIONS, the unit shall be placed in a MODE or other specified condition in which the Control is not applicable. Action shall be initiated within 1 hour to place the unit, as applicable, in:

- a. MODE 2 within 7 hours;
- b. MODE 3 within 13 hours; and
- c. MODE 4 within 37 hours.

Exceptions to this Control are stated in the individual Controls.

Where corrective measures are completed that permit operation in accordance with the Control or ACTIONS, completion of the actions required by Control 3.0.3 is not required.

Control 3.0.3 is only applicable in MODES 1, 2, and 3.

3.0.4 When a Control is not met, entry into a MODE or other specified condition in the Applicability shall only be made:

- a. When the associated ACTIONS to be entered permit continued operation in the MODE or other specified condition in the Applicability for an unlimited period of time;
- b. After performance of a risk assessment addressing inoperable systems and components, consideration of the results, determination of the acceptability of entering the MODE or other specified condition in the Applicability, and establishment of risk management actions, if appropriate; exceptions to this Control are stated in the individual Controls, or
- c. When an allowance is stated in the individual value, parameter, or other Control.

This Control shall not prevent changes in MODES or other specified conditions in the Applicability that are required to comply with ACTIONS, or that are part of a shutdown of the unit.

3/4.0 APPLICABILITY

CONTROLS (Continued)

3.0.5 Equipment removed from service or declared inoperable to comply with ACTIONS may be returned to service under administrative control solely to perform testing required to demonstrate its OPERABILITY or the OPERABILITY of other equipment. This is an exception to Control 3.0.2 for the system returned to service under administrative control to perform the testing required to demonstrate OPERABILITY.

SURVEILLANCE REQUIREMENT (SR)

4.0.1 SRs shall be met during the MODES or other specified conditions in the Applicability for individual Controls, unless otherwise stated in the SR. Failure to meet a Surveillance, whether such failure is experienced during the performance of the surveillance or between performances of the Surveillance, shall be failure to meet the Control. Failure to perform a Surveillance within the specified Frequency shall be failure to meet the Control except as provided in SR 4.0.3. Surveillances do not have to be performed on inoperable equipment or variables outside specified limits.

4.0.2 The specified frequency for each SR is met if the Surveillance is performed within 1.25 times the interval specified in the frequency, as measured from the previous performance or as measured from the time a specified condition of the frequency is met.

If a completion time for an action requires periodic performance on a "once per ..." basis, the above frequency extension applies to each performance after the initial performance.

Exceptions to this SR are stated in the individual SR's.

4.0.3 If it is discovered that a Surveillance was not performed within its specified frequency, then compliance with the requirement to declare the Control not met may be delayed, from the time of discovery, up to 24 hours or up to the limit of the specified frequency, whichever is less. This delay period is permitted to allow performance of the Surveillance.

If the Surveillance is not performed within the delay period, the Control must immediately be declared not met, and the applicable ACTION(s) must be entered. When the Surveillance is performed within the delay period and the Surveillance is not met, the Control must immediately be declared not met, and the applicable ACTION(s) must be entered.

4.0.4 Entry into a MODE or other specified condition in the Applicability of a Control shall only be made when the Control's Surveillances have been met within their specified frequency, except as provided by Surveillance Requirement 4.0.3. When a control is not met due to Surveillances not having been met, entry into a MODE or other specified Condition in the Applicability shall only be made in accordance with Control 3.0.4.

This provision shall not prevent entry into MODES or other specified conditions in the Applicability that are required to comply with ACTIONS or that are part of a shutdown of the unit.

3/4.3 INSTRUMENTATION

RADIOACTIVE LIQUID EFFLUENT MONITORING INSTRUMENTATION

CONTROLS

3.3.7.9 In accordance with Perry Nuclear Power Plant Unit 1 TS 5.5.4.a, the radioactive liquid effluent monitoring instrumentation channels shown in Table 3.3.7.9-1 shall be OPERABLE with their alarm/trip setpoints set to ensure that the limits of Control 3.11.1.1 are not exceeded. The alarm/trip setpoints of these channels shall be determined and adjusted in accordance with the OFFSITE DOSE CALCULATION MANUAL (ODCM).

APPLICABILITY: At all times.

ACTION:

- a. With a radioactive liquid effluent monitoring instrumentation channel alarm/trip setpoint less conservative than required by the above Control, immediately suspend the release of radioactive liquid effluents monitored by the affected channel or declare the channel inoperable, or change the setpoint so it is acceptably conservative.
- b. With less than the minimum number of radioactive liquid effluent monitoring instrumentation channels OPERABLE, take the ACTION shown in Table 3.3.7.9-1. Restore the inoperable instrumentation to OPERABLE status within 30 days and, if unsuccessful, explain why this inoperability was not corrected in a timely manner in the next Annual Radioactive Effluent Release Report.
- c. The provisions of Control 3.0.3 are not applicable.

SURVEILLANCE REQUIREMENTS

4.3.7.9 Each radioactive liquid effluent monitoring instrumentation channel shall be demonstrated OPERABLE by performance of the CHANNEL CHECK, SOURCE CHECK, CHANNEL CALIBRATION and CHANNEL FUNCTIONAL TEST operations at the frequencies shown in Table 4.3.7.9-1.

TABLE 3.3.7.9-1RADIOACTIVE LIQUID EFFLUENT MONITORING INSTRUMENTATION

<u>INSTRUMENT</u>	<u>MINIMUM CHANNELS OPERABLE</u>	<u>ACTION</u>
1. GROSS RADIOACTIVITY MONITORS PROVIDING ALARM AND AUTOMATIC TERMINATION OF RELEASE		
a. Liquid Radwaste Discharge Radiation Monitor – ESW Discharge	1	110
2. GROSS BETA OR GAMMA RADIOACTIVITY MONITORS PROVIDING ALARM BUT NOT PROVIDING AUTOMATIC TERMINATION OF RELEASE		
a. Emergency Service Water Loop A Radiation Monitor	1	111
b. Emergency Service Water Loop B Radiation Monitor	1	111
c. Service Water Radiation Monitor (ADHR)	1	111
3. FLOW RATE MEASUREMENT DEVICES		
a. Radwaste High-Flow Discharge Header Flow	1	112
b. Service Water Discharge Header Flow Monitor	1	113
c. Unit 1 Emergency Service Water Header Flow Monitor or individual ESW HX Monitors	1	113
1) Emergency Service Water Flow Monitor, or		
2) Individual RHR, ECC and DG HX Flow Monitors <L02211>		

TABLE 3.3.7.9-1 (Continued)

RADIOACTIVE LIQUID EFFLUENT MONITORING INSTRUMENTATION

ACTION STATEMENTS

- ACTION 110 - With the number of channels OPERABLE less than required by the Minimum Channels OPERABLE requirement, effluent releases from this pathway may continue provided that prior to initiating a release:
- a. At least two independent samples are analyzed in accordance with Control 4.11.1.1.1, and
 - b. At least two technically qualified members of the Facility Staff independently verify the release rate calculations and discharge line valve lineup;
- Otherwise, suspend release of radioactive effluents via this pathway.
- ACTION 111 - With the number of channels OPERABLE less than required by the Minimum Channels OPERABLE requirement, effluent releases via this pathway may continue provided that, at least once per 12 hours, grab samples are collected and analyzed for gross radioactivity (beta or gamma) at a limit of detection of at least 10^{-7} microcuries/ml.
- ACTION 112 - With the number of channels OPERABLE less than required by the Minimum Channels OPERABLE requirement, effluent releases via this pathway may continue provided the discharge valve position is verified to be consistent with the flow rate provisions of the release permit at least once per 4 hours during actual releases. Prior to initiating another release, at least two technically qualified members of the Facility Staff shall independently verify the discharge line valve lineup and that the discharge valve position corresponds to the desired flow rate. Otherwise, suspend release of radioactive effluents via this pathway.
- ACTION 113 - With the number of channels OPERABLE less than required by the Minimum Channels OPERABLE requirement, effluent releases via this pathway may continue provided the flow rate is estimated at least once per 4 hours during actual releases. Pump performance curves generated in place as well as other curves generated using pump performance may be used to estimate flow.

TABLE 4.3.7.9-1RADIOACTIVE LIQUID EFFLUENT MONITORING INSTRUMENTATION SURVEILLANCE REQUIREMENTS

<u>INSTRUMENT</u>	<u>CHANNEL CHECK</u>	<u>FLOW CHECK</u>	<u>SOURCE CHECK</u>	<u>CHANNEL CALIBRATION</u>	<u>CHANNEL FUNCTIONAL TEST</u>
1. GROSS RADIOACTIVITY MONITORS PROVIDING ALARM AND AUTOMATIC TERMINATION OF RELEASE					
a. Liquid Radwaste Discharge Radiation Monitor - ESW Discharge	D	N/A	P	R(3)	Q(1)
2. GROSS BETA OR GAMMA RADIOACTIVITY MONITORS PROVIDING ALARM BUT NOT PROVIDING AUTOMATIC TERMINATION OF RELEASE					
a. Emergency Service Water Loop A Radiation Monitor	D	N/A	M	R(3)	Q(2)
b. Emergency Service Water Loop B Radiation Monitor	D	N/A	M	R(3)	Q(2)
c. Service Water Radiation Monitor (ADHR)(6)	D	N/A	M	R(3)	Q(2)
3. FLOW RATE MEASUREMENT DEVICES					
a. Radwaste High-Flow Discharge Header Flow	D(4)	N/A	N/A	R	Q
b. Service Water Discharge Header Flow	D(4)	N/A	N/A	R	Q
c. Unit 1 Emergency Service Water Header Flow					
1) Emergency Service Water Flow, or	D(4)	N/A	N/A	R	Q
2) Combination of Individual RHR, ECC & DG HX Flows	D(4)	4H(5)	N/A	N/A	N/A
3) Individual RHR, ECC, & DG HX Flows	N/A	N/A	N/A	R	Q

TABLE 4.3.7.9-1 (Continued)

RADIOACTIVE LIQUID EFFLUENT MONITORING
INSTRUMENTATION SURVEILLANCE REQUIREMENTS

TABLE NOTATION

- (1) The CHANNEL FUNCTIONAL TEST shall also demonstrate that automatic isolation of this pathway and control room alarm annunciation occur if any of the following conditions exists:
 1. Instrument indicates measured levels above the alarm/trip setpoint.
 2. Instrument indicates a downscale failure.
 3. Instrument controls not set in operate mode except in high voltage position.
- (2) The CHANNEL FUNCTIONAL TEST shall also demonstrate that control room alarm annunciation occurs if any of the following conditions exists:
 1. Instrument indicates measured levels above the alarm setpoint.
 2. Instrument indicates a downscale failure.
 3. Instrument controls not set in operate mode, except in high voltage position.
- (3) The initial CHANNEL CALIBRATION shall be performed using one or more of the reference standards certified by the National Bureau of Standards or using standards that have been obtained from suppliers that participate in measurement assurance activities with NBS. These standards shall permit calibrating the system over its intended range of energy and measurement range. For subsequent CHANNEL CALIBRATION, sources that have been related to the initial calibration shall be used.
- (4) CHANNEL CHECK shall consist of verifying indication of flow. A CHANNEL CHECK shall be made initially and at least once per 24 hours on days when continuous, periodic or batch releases occurs. Pump performance curves may be used to verify the indication of flow from flow instrumentation.
- (5) FLOW CHECK shall consist of verifying indication of flow by summing the individual RHR, ECC and DG heat exchanger flows. A FLOW CHECK shall be made initially, prior to securing ESW pumps, at least once per 4 hours during a Liquid Radwaste discharge, and at least once per 12 hours during operation of ESW pumps.
- (6) Surveillance requirements are in effect only when the system is in service.

INSTRUMENTATION

RADIOACTIVE GASEOUS EFFLUENT MONITORING INSTRUMENTATION

CONTROLS

3.3.7.10 In accordance with Perry Nuclear Power Plant Unit 1 TS 5.5.4.a, the radioactive gaseous effluent monitoring instrumentation channels shown in Table 3.3.7.10-1 shall be OPERABLE with their alarm/trip setpoints set to ensure that the limits of Control 3.11.2.1 are not exceeded. The alarm/trip setpoints of applicable channels shall be determined and adjusted in accordance with the methodology and parameters in the ODCM.

APPLICABILITY: As shown in Table 3.3.7.10-1

ACTION:

- a. With a radioactive gaseous effluent monitoring instrumentation channel alarm/trip setpoint less conservative than required by the above specification, declare the channel inoperable, or change the setpoint so it is acceptably conservative.
- b. With less than the minimum number of radioactive gaseous effluent monitoring instrumentation channels OPERABLE, take the ACTION shown in Table 3.3.7.10-1. Restore the inoperable instrumentation to OPERABLE status within 30 days and, if unsuccessful, explain why this inoperability was not corrected in a timely manner in the next Annual Radioactive Effluent Release Report.
- c. The provisions of Control 3.0.3 are not applicable.

SURVEILLANCE REQUIREMENTS

4.3.7.10 Each radioactive gaseous effluent monitoring instrumentation channel shall be demonstrated OPERABLE by performance of the CHANNEL CHECK, SOURCE CHECK, CHANNEL CALIBRATION and CHANNEL FUNCTIONAL TEST operations at the frequencies shown in Table 4.3.7.10-1.

TABLE 3.3.7.10-1RADIOACTIVE GASEOUS EFFLUENT MONITORING INSTRUMENTATION

<u>INSTRUMENT</u>	<u>MINIMUM CHANNELS OPERABLE</u>	<u>APPLICABILITY</u>	<u>ACTION</u>
1. OFF-GAS VENT RADIATION MONITOR			
a. Noble Gas Activity Monitor	1	*	121, 124
b. Iodine Sampler (1)	1	*	122
c. Particulate Sampler (1)	1	*	122
d. Effluent System Flow Rate Monitor	1	*	123
e. Sampler Flow Rate Monitor (Victoreen Flow Monitor)	1	*	123
2. UNIT 1 VENT RADIATION MONITOR			
a. Noble Gas Activity Monitor <L02211>	1	1, 2, 3 4, 5	121, 124, 125 121
b. Iodine Sampler (1)	1	*	122
c. Particulate Sampler (1)	1	*	122
d. Effluent System Flow Rate Monitor	1	*	123
e. Sampler Flow Rate Monitor (Victoreen Flow Monitor)	1	*	123

(1) This encompasses the isokinetic and Victoreen photohelics.

TABLE 3.3.7.10-1 (Continued)RADIOACTIVE GASEOUS EFFLUENT MONITORING INSTRUMENTATION

<u>INSTRUMENT</u>	<u>MINIMUM CHANNELS OPERABLE</u>	<u>APPLICABILITY</u>	<u>ACTION</u>
3. UNIT 2 VENT RADIATION MONITOR			
a. Noble Gas Activity Monitor	1	*	121, 124
b. Iodine Sampler (1)	1	*	122
c. Particulate Sampler (1)	1	*	122
d. Effluent System Flow Rate Monitor	1	*	123
e. Sampler Flow Rate Monitor (Victoreen Flow Monitor)	1	*	123
4. TURBINE BUILDING/HEATER BAY VENT RADIATION MONITOR			
a. Noble Gas Activity Monitor <L02211>	1	*	121, 124
b. Iodine Sampler (1)	1	*	122
c. Particulate Sampler (1)	1	*	122
d. Effluent System Flow Rate Monitor	1	*	123
e. Sampler Flow Rate Monitor (Victoreen Flow Monitor)	1	*	123

(1) This encompasses the isokinetic and Victoreen photohelics.

TABLE 3.3.7.10-1 (Continued)

RADIOACTIVE GASEOUS EFFLUENT MONITORING INSTRUMENTATION

TABLE NOTATION

* At all times.

** During main condenser offgas treatment system operation.

ACTION 121 - With the number of channels OPERABLE less than required by the Minimum Channels OPERABLE requirement, effluent releases via this pathway may continue provided grab samples are taken at least once per 12 hours and these samples are analyzed for principal gamma emitters as required by Table 4.11.2.1.2-1.

ACTION 122 - With the number of channels OPERABLE less than required by the Minimum Channels OPERABLE requirement, effluent releases via this pathway may continue provided samples are continuously collected within 4 hours with auxiliary sampling equipment as required by Table 4.11.2.1.2-1. If the inoperability is due to failure of the AMC skid, the Victoreen skid alone can be used as the auxiliary sampling equipment for a maximum of 30 consecutive days. <L02211> Loss of the isokinetic flow monitor constitutes inoperability of particulate and iodine channels (b, c).

ACTION 123 - With the number of channels OPERABLE less than required by the Minimum Channels OPERABLE requirement, effluent release via this pathway may continue provided the flow rate is estimated at least once per 4 hours. This action applies to both the effluent system flow and victoreen sample flow (d, e).

ACTION 124 - With the 1H13-P680 panel annunciator for noble gas channels locked in due to a downscale condition on the radiation monitoring panel, the affected noble gas monitor channels shall be verified in the Control Room at least once per 12 hours to ensure that no unmonitored high or alert level alarms are present.

ACTION 125 - With the number of channels OPERABLE less than required by the Minimum Channels OPERABLE requirement, except as a result of a non-conservative setpoint or within the criteria specified in Action 126, immediately suspend operation of the Containment Vessel and Drywell Purge (M14) system. Prior to resuming M14 System operation, ensure compliance with Control 3.11.2.1 requirements. If Control 3.11.2.1 compliance is met, operation of the M14 System may continue provided grab samples are taken at least once per 12 hours and analyzed for principal gamma emitters, as required by Table 4.11.2.1.2-1.

TABLE 3.3.7.10-1 (Continued)

RADIOACTIVE GASEOUS EFFLUENT MONITORING INSTRUMENTATION

TABLE NOTATION

* At all times.

** During main condenser offgas treatment system operation.

ACTION 126 - For periods of planned maintenance or performance of surveillance requirements in support of the requirements listed in Table 4.3.7.10-1, which will reduce the number of OPERABLE channels less than the Minimum Channels OPERABLE requirement, compliance with Control 3.11.2.1 may be verified prior to reducing the number of OPERABLE channels below the requirement. If Control 3.11.2.1 compliance is met, operation of the M14 System need not be suspended for the channel provided grab samples are taken at least once per 12 hours and analyzed for principal gamma emitters, as required by Table 4.11.2.1.2-1.

TABLE 4.3.7.10-1RADIOACTIVE GASEOUS EFFLUENT MONITORING INSTRUMENTATION SURVEILLANCE REQUIREMENTS

<u>INSTRUMENT</u>	<u>CHANNEL CHECK</u>	<u>SOURCE CHECK</u>	<u>CHANNEL CALIBRATION</u>	<u>CHANNEL FUNCTIONAL TEST</u>	<u>MODES IN WHICH SURVEILLANCE REQUIRED</u>
1. OFFGAS VENT RADIATION MONITOR					
a. Noble Gas Activity Monitor	D	M	R(2)	Q(1)	*
b. Iodine Sampler	W(4)	N.A.	N.A.	N.A.	*
c. Particulate Sampler	W(4)	N.A.	N.A.	N.A.	*
d. Effluent System Flow Rate Monitor	D	N.A.	R	Q	*
e. Sampler Flow Rate Monitor	D	N.A.	R	Q	*
2. UNIT 1 VENT RADIATION MONITOR					
a. Noble Gas Activity Monitor	D	M	R(2)	Q(1)	*
b. Iodine Sampler	W(4)	N.A.	N.A.	N.A.	*
c. Particulate Sampler	W(4)	N.A.	N.A.	N.A.	*
d. Effluent System Flow Rate Monitor	D	N.A.	R	Q	*
e. Sampler Flow Rate Monitor	D	N.A.	R	Q	*

TABLE 4.3.7.10-1 (Continued)RADIOACTIVE GASEOUS EFFLUENT MONITORING INSTRUMENTATION SURVEILLANCE REQUIREMENTS

<u>INSTRUMENT</u>	<u>CHANNEL CHECK</u>	<u>SOURCE CHECK</u>	<u>CHANNEL CALIBRATION</u>	<u>CHANNEL FUNCTIONAL TEST</u>	<u>MODES IN WHICH SURVEILLANCE REQUIRED</u>
3. UNIT 2 VENT RADIATION MONITOR					
a. Noble Gas Activity Monitor	D	M	R(2)	Q(1)	*
b. Iodine Sampler	W(4)	N.A.	N.A.	N.A.	*
c. Particulate Sampler	W(4)	N.A.	N.A.	N.A.	*
d. Effluent System Flow Rate Monitor	D	N.A.	R	Q	*
e. Sampler Flow Rate Monitor	D	N.A.	R	Q	*
4. TURBINE BUILDING/HEATER BAY VENT RADIATION MONITOR					
a. Noble Gas Activity Monitor	D	M	R(2)	Q(1)	*
b. Iodine Sampler	W(4)	N.A.	N.A.	N.A.	*
c. Particulate Sampler	W(4)	N.A.	N.A.	N.A.	*
d. Effluent System Flow Rate Monitor	D	N.A.	R	Q	*
e. Sampler Flow Rate Monitor	D	N.A.	R	Q	*

TABLE 4.3.7.10-1 (Continued)

RADIOACTIVE GASEOUS EFFLUENT MONITORING
INSTRUMENTATION SURVEILLANCE REQUIREMENTS

TABLE NOTATION

- * At all times.
- ** During main condenser offgas treatment system operation.
- (1) The CHANNEL FUNCTIONAL TEST shall also demonstrate that control room alarm annunciation occurs if any of the following conditions exists:
 - 1. Instrument indicates measured levels above the alarm setpoint.
 - 2. Instrument indicates a downscale failure.
 - 3. Instrument controls not set in operate mode.
- (2) The initial CHANNEL CALIBRATION shall be performed using one or more of the reference standards certified by the National Institute of Standards and Technology (NIST) or using standards that have been obtained from suppliers that participate in measurement assurance activities with NIST. These standards shall permit calibrating the system over its intended energy and measurement range. For subsequent CHANNEL CALIBRATION, sources that have been related to the initial calibration shall be used.
- (3) NOT USED
- (4) The iodine cartridges and particulate filters will be changed at least once per 7 days. Performance of this CHANNEL CHECK does not render the system inoperable, and the applicable ACTION statements need not be entered.

3/4.11 RADIOACTIVE EFFLUENTS

3/4.11.1 LIQUID EFFLUENTS

CONCENTRATION

CONTROLS

3.11.1.1 In accordance with Perry Nuclear Power Plant TS 5.5.4.b and c, the concentration of radioactive material released in liquid effluents to UNRESTRICTED AREAS (see Figure 3.2-1) shall be limited to the concentrations specified in 10CFR20, Appendix B, Table 2, Column 2, for radionuclides other than dissolved or entrained noble gases. For dissolved and entrained noble gases, the concentration shall be limited to 2×10^{-4} microcuries/ml total activity.

APPLICABILITY: At all times.

ACTION:

With the concentration of radioactive material released in liquid effluents to UNRESTRICTED AREAS exceeding the above limits, immediately restore the concentration to within the above limits.

SURVEILLANCE REQUIREMENTS

4.11.1.1.1 The radioactivity content of each batch of radioactive liquid waste shall be determined prior to release by sampling and analysis in accordance with Table 4.11.1.1.1-1. The results of pre-release analyses shall be used with the calculational methods in the ODCM to assure that the concentration at the point of release is maintained within the limits of Control 3.11.1.1.

4.11.1.1.2 Post-release analyses of samples composited from batch releases shall be performed in accordance with Table 4.11.1.1.1-1. The results of the radioactivity analysis shall be used in accordance with the methodology and parameters in the ODCM to assure that the concentrations at the point of release are maintained within the limits of Control 3.11.1.1.

4.11.1.1.3 Continuous releases of radioactive liquid effluents shall be sampled and analyzed in accordance with Table 4.11.1.1.1-1. The results of the radioactivity analyses shall be used in accordance with the methodology and parameters in the ODCM to assure that the concentrations at the point of release are maintained within the limits of Control 3.11.1.1.

**TABLE 4.11.1.1.1-1
RADIOACTIVE LIQUID WASTE SAMPLING AND ANALYSIS PROGRAM**

Liquid Release Type	Sampling Frequency	Minimum Analysis Frequency	Type of Activity Analysis	Lower Limit of Detection (LLD) ($\mu\text{Ci/ml}$) ^a	
A. Batch Waste Release Tanks ^c	P Each batch	P Each batch	Principal Gamma Emitters ^d	5×10^{-7}	
			I-131	1×10^{-6}	
	P One Batch/M	M	Dissolved and Entrained Gases (Gamma emitters)	1×10^{-5}	
			P Each Batch	M Composite ^b	H-3
	Gross Alpha	1×10^{-7}			
	P Each Batch	Q Composite ^b	Sr-89, Sr-90	5×10^{-8}	
			Fe-55	1×10^{-6}	
	B. Continuous Releases ^e RHR Heat Exchanger ESW Outlet M35 Drains ^g or Service Water ^h	D Grab Sample ^{f,g,h}	W Composite ^{b,f,g,h}	Principal Gamma Emitters ^d	5×10^{-7}
				I-131	1×10^{-6}
		M ^{g,h} Grab Sample	M	Dissolved and Entrained Gases (Gamma emitters)	1×10^{-5}
D Grab Sample ^{g,h}				M Composite ^{b,g,h}	H-3
		Gross Alpha	1×10^{-7}		
D Grab Sample ^{g,h}		Q Composite ^{b,g,h} <R00449>	Sr-89, Sr-90	5×10^{-8}	
			Fe-55	1×10^{-6}	

TABLE 4.11.1.1.1-1 (Continued)

RADIOACTIVE LIQUID WASTE SAMPLING AND ANALYSIS PROGRAM

TABLE NOTATION

- a. The LLD is the smallest concentration of radioactive material in a sample that will yield a net count (above system background) that will be detected with 95% probability with only 5% probability of falsely concluding that a blank observation represents a "real" signal.

It should be recognized that the LLD is defined as an "a priori" (before the fact) limit representing the capability of a measurement system and not as an "a posteriori" (after the fact) limit for a particular measurement.

For a particular measurement system (which may include radiochemical separation):

$$LLD = \frac{4.66S_b}{(E)(V)(2.22 \times 10^6)(Y) \exp(-\lambda \Delta t)}$$

where

LLD is the "a priori" lower limit of detection as defined above (as μCi per unit mass or volume).

S_b is the standard deviation of the background counting rate or of the counting rate of a blank sample as appropriate (as counts per minute)

E is the counting efficiency (as counts per disintegration)

V is the sample size (in units of mass or volume)

2.22×10^6 is the number of disintegrations per minute per microcurie

Y is the fractional radiochemical yield (when applicable)

λ is the radioactive decay constant for the particular radionuclide (sec^{-1})

Δt is the elapsed time between sample collection (or end of the sample collection period) and time of counting (sec)

Typical values of E, V, Y and Δt should be used in the calculation.

TABLE 4.11.1.1.1-1 (Continued)

RADIOACTIVE LIQUID WASTE SAMPLING AND ANALYSIS PROGRAM

TABLE NOTATION (Continued)

- b. A composite sample is one in which the quantity of liquid sampled is proportional to the quantity of liquid waste discharged and in which the method of sampling employed results in a specimen which is representative of the liquids released. A composite sample may also be obtained from liquid batches of similar origin that are not discharged as these liquid batches are expected to be representative of samples that could be discharged. Composite samples for batch liquids that were not released is performed to provide non-gamma emitting isotopic values to verify other batches are within limits prior to release when recent non-gamma emitting isotopic values for discharged liquids are not available.
- c. A batch release is the discharge of liquid wastes of a discrete volume. Prior to sampling for analyses, each batch shall be isolated, and then thoroughly mixed to assure representative sampling.
- d. The principal gamma emitters for which the LLD specification applies exclusively are the following radionuclides: Mn-54, Fe-59, Co-58, Co-60, Zn-65, Mo-99, Cs-134, Cs-137, and Ce-141. Ce-144 shall also be measured, but with an LLD of 5×10^{-6} . This list does not mean that only these nuclides are to be detected and reported. Other peaks which are measurable and identifiable, together with the above nuclides, shall also be identified and reported in the Annual Radioactive Effluent Release Report pursuant to Control 6.9.1.7 in the format outlined in Regulatory Guide 1.21, Appendix B, Revision 1, June 1974.
- e. A continuous release is the discharge of liquid wastes of a non-discrete volume, e.g., from a volume of a system that has an input flow during the continuous release. Sampling/Analysis of RHR Heat Exchanger is only applicable when there is ESW flow thru the RHR Heat Exchanger.
- f. Sampling and analysis is required of the RHR heat exchanger ESW outlet every 12 hours when the samples indicate levels greater than LLD.
- g. Sampling is only required for M35 drains, when the M35 drains have been lined up to storm drains. If activity other than tritium or naturally occurring isotopes is detected in the M35 drains, then these drains shall be lined up to radwaste.
- h. Sampling/Analysis of Service Water is only applicable when there is Service Water flow through the ADHR Heat Exchanger.

RADIOACTIVE EFFLUENTS

DOSE

CONTROLS

3.11.1.2 In accordance with Perry Nuclear Power Plant Unit 1 TS 5.5.4.d and e, the dose or dose commitment to a MEMBER OF THE PUBLIC from radioactive materials in liquid effluents released, from each reactor unit, to UNRESTRICTED AREAS (see Figure 3.2-1) shall be limited:

- a. During the current quarter to less than or equal to 1.5 mremS to the whole body and to less than or equal to 5 mremS to any organ; and
- b. During the current year to less than or equal to 3 mremS to the whole body and to less than or equal to 10 mremS to any organ.

APPLICABILITY: At all times.

ACTION:

- a. With the calculated dose from the release of radioactive materials in liquid effluents exceeding any of the above limits, prepare and submit to the Commission within 30 days, pursuant to Control 6.9.2, a Special Report which identifies the cause(s) for exceeding the limit(s) and defines the corrective actions that have been taken to reduce the releases and the corrective actions to be taken to ensure that future releases will be in compliance with the above limits.
- b. The provisions of Control 3.0.3 are not applicable.

SURVEILLANCE REQUIREMENTS

4.11.1.2 Dose Calculations. Cumulative dose contributions from liquid effluents for the current quarter and the current year shall be determined in accordance with the methodology and parameters of the ODCM at least once per 31 days.

RADIOACTIVE EFFLUENTS

LIQUID RADWASTE TREATMENT SYSTEM

CONTROLS

3.11.1.3 In accordance with Perry Nuclear Power Plant Unit 1 TS 5.5.4.f, the LIQUID RADWASTE TREATMENT SYSTEM shall be OPERABLE and appropriate portions of the system shall be used to reduce the release of radioactivity when the projected doses due to the liquid effluent from each reactor unit to UNRESTRICTED AREAS (see Figure 3.2-1) would exceed 0.06 mrem to the whole body or 0.2 mrem to any organ, in a 31-day period.

APPLICABILITY: At all times.

ACTION:

- a. With radioactive liquid waste being discharged without treatment and in excess of the above limits, and any portion of the liquid radwaste treatment system not in operation, prepare and submit to the Commission, within 30 days pursuant to Control 6.9.2, a Special Report which includes the following information:
 1. Explanation of why liquid radwaste was being discharged without treatment, identification of any inoperable equipment or subsystems, and the reason for the inoperability, and
 2. Action(s) taken to restore the inoperable equipment to OPERABLE status, and
 3. Summary description of action(s) taken to prevent a recurrence.
- b. The provisions of Control 3.0.3 are not applicable.

SURVEILLANCE REQUIREMENTS

4.11.1.3.1 Doses due to liquid releases from each reactor unit to UNRESTRICTED AREAS shall be projected at least once per 31 days, in accordance with methodology and parameters in the ODCM.

4.11.1.3.2 The installed LIQUID RADWASTE TREATMENT SYSTEM shall be demonstrated OPERABLE by meeting Controls 3.11.1.1 and 3.11.1.2.

RADIOACTIVE EFFLUENTS

3/4.11.2 GASEOUS EFFLUENTS

DOSE RATE

CONTROLS

3.11.2.1 In accordance with Perry Nuclear Power Plant Unit 1 TS 5.5.4.c and g, the dose rate due to radioactive materials released in gaseous effluents from the site to areas at and beyond the SITE BOUNDARY (see Figure 3.2-1) shall be limited to the following:

- a. For noble gases: Less than or equal to 500 mrem/yr to the whole body and less than or equal to 3000 mrem/yr to the skin, and
- b. For all iodine-131, iodine-133, tritium and all radionuclides in particulate form with half lives greater than 8 days: Less than or equal to 1500 mrem/yr to any organ.

APPLICABILITY: At all times.

ACTION:

With the dose rate(s) exceeding the above limits, immediately decrease the release rate(s) to within the above limit(s).

SURVEILLANCE REQUIREMENTS

4.11.2.1.1 The dose rate due to noble gases in gaseous effluents shall be determined to be within the above limits in accordance with the methodology and parameters of the ODCM.

4.11.2.1.2 The dose rate due to iodine-131, iodine-133, tritium and to radionuclides in particulate form with half lives greater than 8 days in gaseous effluents shall be determined to be within the above limits in accordance with the methodology and parameters of the ODCM by obtaining representative samples and performing analyses in accordance with the sampling and analysis program specified in Table 4.11.2.1.2-1.

TABLE 4.11.2.1.2-1
RADIOACTIVE GASEOUS WASTE SAMPLING AND ANALYSIS PROGRAM

GASEOUS RELEASE PATH	SAMPLING FREQUENCY	MINIMUM ANALYSIS FREQUENCY	TYPE OF ACTIVITY ANALYSIS	LOWER LIMIT OF DETECTION (LLD) ^(a) ($\mu\text{Ci/mL}$)
A. Containment Vessel and Drywell Purge (M14) System, and Combustible Gas Control (M51) System	Each PURGE ^(b) and VENT Grab Sample	Each PURGE ^(b) and VENT	Principal Gamma Emitters ^(e)	1×10^{-4}
	M Grab Sample	M	H-3	1×10^{-6}
B. Offgas Vent, Unit 1 Vent, Unit 2 Vent, and Turbine Bldg/Heater Bay Vent	M ^(b) Grab Sample	M ^(b)	Principal Gamma Emitters ^(b,e)	1×10^{-4}
			H-3	1×10^{-6}
C. All Release Paths as listed in B above	Continuous ^(d)	W ^(c)	I-131	1×10^{-12}
		Charcoal Sample	I-133	1×10^{-10}
	Continuous ^(d)	W ^(c) Particulate Sample	Principal Gamma Emitters ^(e)	1×10^{-11}
	Continuous ^(d)	M Composite Par-ticulate Filter	Gross Alpha	1×10^{-11}
	Continuous ^(d)	Q Composite Par-ticulate Filter	Sr-89, Sr-90	1×10^{-11}
	Continuous ^(d)	Noble Gas Monitor(f)	Noble Gases Gross Beta or Gamma	1×10^{-6} (Xe-133 equivalent)

TABLE 4.11.2.1.2-1 (Continued)

RADIOACTIVE GASEOUS WASTE SAMPLING AND ANALYSIS PROGRAM

TABLE NOTATION

- a. The LLD is the smallest concentration of radioactive material in a sample that will yield a net count (above system background) that will be detected with 95% probability with only 5% probability of falsely concluding that a blank observation represents a "real" signal.

It should be recognized that the LLD is defined as an "a priori" (before the fact) limit representing the capability of a measurement system and not as an "a posteriori" (after the fact) limit for a particular measurement.

For a particular measurement system (which may include radiochemical separation):

$$LLD = \frac{4.66 S_b}{(E) (V) (2.22 \times 10^6) (Y) \exp(-\lambda \Delta t)}$$

where

LLD is the "a priori" lower limit of detection as defined above (as μCi per unit mass or volume).

S_b is the standard deviation of the background counting rate or of the counting rate of a blank sample as appropriate (as counts per minute)

E is the counting efficiency (as counts per disintegration)

V is the sample size (in units of mass or volume)

2.22×10^6 is the number of disintegrations per minute per microcurie

Y is the fractional radiochemical yield (when applicable)

λ is the radioactive decay constant for the particular radionuclide (sec^{-1})

Δt is the elapsed time between sample collection (or end of the sample collection period) and time of counting (sec)

Typical values of E, V, Y and Δt should be used in the calculation.

TABLE 4.11.2.1.2-1 (Continued)

RADIOACTIVE GASEOUS WASTE SAMPLING AND ANALYSIS PROGRAM

TABLE NOTATION (Continued)

- b. Analyses shall also be performed following startup, shutdown, or a THERMAL POWER change exceeding 15 percent of the RATED THERMAL POWER within a one hour period. This requirement does not apply if (1) analysis shows that the DOSE EQUIVALENT I-131 concentration in the primary coolant has not increased more than a factor of 3; and (2) the noble gas monitor shows that effluent activity has not increased more than a factor of 3.
- c. Samples shall be changed at least once per 7 days and analyses shall be completed within 48 hours after changing or after removal from sampler. Sampling and analyses shall also be performed at least daily (≥ 24 hours) for at least 7 days following each shutdown, startup or THERMAL POWER change exceeding 15 percent of RATED THERMAL POWER in one hour. When samples collected for 24 hours are analyzed, the corresponding LLD's may be increased by a factor of 10. This requirement does not apply if:
 - (1) Analysis shows that the DOSE EQUIVALENT I-131 concentration in the primary coolant has not increased more than a factor of 3; and
 - (2) The noble gas monitor shows that effluent activity has not increased more than a factor of 3. If the noble gas monitor is not operable, then a grab sample may be used to demonstrate that activity has not increased by a factor of 3.
- d. The ratio of the sample flow rate to the sampled stream flow rate shall be known for the time period covered by each dose or dose rate calculation made in accordance with Control 3.11.2.1, 3.11.2.2 and 3.11.2.3.
- e. The principal gamma emitters for which the LLD specification applies exclusively are the following radionuclides: Kr-87, Kr-88, Xe-133, Xe-133m, Xe-135, and Xe-138 for gaseous emissions and Mn-54, Fe-59, Co-58, Co-60, Zn-65, Mo-99, I-131, Cs-134, Cs-137, Ce-141 and Ce-144 for particulate emissions. This list does not mean that only these nuclides are to be detected and reported. Other peaks which are measurable and identifiable, together with the above nuclides, shall also be identified and reported in the Annual Radioactive Effluent Release Report pursuant to Control 6.9.1.7 in the format outlined in Regulatory Guide 1.21, Appendix B, Revision 1, June 1974.
- f. Sampling and analysis of gaseous release points shall be performed initially whenever a high alarm setpoint is exceeded or whenever two or more of the alert setpoints are exceeded. If the high alarm setpoint or two or more of the alert setpoints continue to be exceeded, verify at least once per 4 hours via the radiation monitors that plant releases are below the Control 3.11.2.1 dose rate limits and sampling and analysis shall be performed at least once per 12 hours.

RADIOACTIVE EFFLUENTS

DOSE - NOBLE GASES

CONTROLS

3.11.2.2 In accordance with Perry Nuclear Power Plant Unit 1 TS 5.5.4.e and h, the air dose due to noble gases released in gaseous effluents, from each reactor unit, from the site to areas at and beyond the SITE BOUNDARY (see Figure 3.2-1) shall be limited to the following:

- a. During the current quarter: Less than or equal to 5 mrad for gamma radiation and less than or equal to 10 mrad for beta radiation; and
- b. During the current year: Less than or equal to 10 mrad for gamma radiation and less than or equal to 20 mrad for beta radiation.

APPLICABILITY: At all times.

ACTION:

- a. With the calculated air dose from the radioactive noble gases in gaseous effluents exceeding any of the above limits, prepare and submit to the Commission within 30 days, pursuant to Control 6.9.2, a Special Report which identifies the cause(s) for exceeding the limit(s) and defines the corrective actions to be taken to ensure that future releases will be in compliance with Control 3.11.2.2.
- b. The provisions of Control 3.0.3 are not applicable.

SURVEILLANCE REQUIREMENTS

4.11.2.2 Dose Calculations. Cumulative dose contributions for noble gases for the current quarter and current year shall be determined in accordance with the methodology and parameters in the ODCM at least once per 31 days.

RADIOACTIVE EFFLUENTS

DOSE - IODINE-131, IODINE-133, TRITIUM AND RADIONUCLIDES IN PARTICULATE FORM

CONTROLS

3.11.2.3 In accordance with Perry Nuclear Power Plant Unit 1 TS 5.5.4.e and i, the dose to a MEMBER OF THE PUBLIC from iodine-131, iodine-133, tritium and radionuclides in particulate form with half-lives greater than 8 days in gaseous effluents released, from each reactor unit, from the site to areas at and beyond the SITE BOUNDARY (see Figure 3.2-1) shall be limited to the following:

- a. During the current quarter: Less than or equal to 7.5 mrem to any organ; and
- b. During the current year: Less than or equal to 15 mrem to any organ.

APPLICABILITY: At all times.

ACTION:

- a. With the calculated dose from the release of iodine-131, iodine-133, tritium and radionuclides in particulate form, with half-lives greater than 8 days, in gaseous effluents exceeding any of the above limits, prepare and submit to the Commission within 30 days, pursuant to Control 6.9.2, a Special Report which identifies the cause(s) for exceeding the limit and defines the corrective actions that have been taken to reduce releases and the proposed corrective actions to be taken to ensure that future releases will be in compliance with Control 3.11.2.3.
- b. The provisions of Control 3.0.3 are not applicable.

SURVEILLANCE REQUIREMENTS

4.11.2.3 Dose Calculations. Cumulative dose contributions from iodine-131, iodine-133, tritium and radionuclides in particulate form with half-lives greater than 8 days for the current quarter and current year shall be determined in accordance with the methodology and parameters in the ODCM at least once per 31 days.

RADIOACTIVE EFFLUENTS

GASEOUS RADWASTE (OFF-GAS) TREATMENT

CONTROLS

3.11.2.4 The GASEOUS RADWASTE TREATMENT (OFFGAS) SYSTEM shall be in operation*. <L02211> The Charcoal bypass mode shall not be used unless the off-gas post-treatment radiation monitor is OPERABLE.

APPLICABILITY: Whenever the main condenser air ejector evacuation system is in operation.

ACTION:

- a. With gaseous radwaste from the main condenser air ejector system being discharged without treatment for more than 7 consecutive days, prepare and submit to the Commission within 30 days, pursuant to Control 6.9.2, a Special Report which includes the following information:
 1. Explanation of why gaseous radwaste was being discharged without treatment, identification of the inoperable equipment or subsystems which resulted in gaseous radwaste being discharged without treatment, and the reason for inoperability.
 2. Action(s) taken to restore the inoperable equipment to OPERABLE status, and
 3. Summary description of action(s) taken to prevent a recurrence.
- b. The provisions of Control 3.0.3 are not applicable.

SURVEILLANCE REQUIREMENTS

4.11.2.4 The readings of relevant instrumentation shall be checked at least once per 12 hours when the main condenser air ejector is in use to ensure that the gaseous radwaste treatment system is functioning.

* - Flow directed through the adsorber beds. <L02211>

RADIOACTIVE EFFLUENTS

VENTILATION EXHAUST TREATMENT SYSTEMS

CONTROLS

3.11.2.5 The VENTILATION EXHAUST TREATMENT SYSTEMS shall be OPERABLE and appropriate portions of the system shall be used to reduce releases of radioactivity when the projected dose due to gaseous effluent releases from each reactor unit to areas at and beyond the SITE BOUNDARY (see Figure 3.2-1) in a 31 day period would exceed 0.3 mrem to any organ of a MEMBER OF THE PUBLIC.

APPLICABILITY: At all times.

ACTION:

- a. With radioactive gaseous waste being discharged without treatment and in excess of the above limits, prepare and submit to the Commission within 30 days, pursuant to Control 6.9.2, a Special Report which includes the following information:
 1. Explanation of why gaseous radwaste was being discharged without treatment, identification of any inoperable equipment or subsystems which resulted in gaseous radwaste being discharged without treatment, and the reason for the inoperability,
 2. Action(s) taken to restore the inoperable equipment to OPERABLE status, and
 3. Summary description of action(s) taken to prevent a recurrence.
- b. The provisions of Control 3.0.3 are not applicable.

SURVEILLANCE REQUIREMENTS

4.11.2.5.1 Doses due to gaseous releases from each reactor unit to areas at and beyond the SITE BOUNDARY shall be projected at least once per 31 days in accordance with the methodology and parameters in the ODCM.

4.11.2.5.2 The installed VENTILATION EXHAUST TREATMENT SYSTEMS shall be demonstrated OPERABLE by meeting Controls 3.11.2.1 and 3.11.2.3.

RADIOACTIVE EFFLUENTS

3/4.11.4 TOTAL DOSE

CONTROLS

3.11.4 In accordance with Perry Nuclear Power Plant Unit 1 TS 5.5.4.j, the current year dose or dose commitment to any MEMBER of THE PUBLIC, due to releases of radioactivity and radiation, from uranium fuel cycle sources shall be limited to less than or equal to 25 mrem to the whole body or any organ, except the thyroid, which shall be limited to less than or equal to 75 mrem.

APPLICABILITY: At all times.

ACTION:

- a. With the calculated doses from the release of radioactive materials in liquid or gaseous effluents exceeding twice the limits of Control 3.11.1.2a., 3.11.1.2b., 3.11.2.2a., 3.11.2.2b., 3.11.2.3a, or 3.11.2.3b., calculations shall be made including direct radiation contributions from the reactor units, from the ISFSI and from outside storage tanks to determine whether the above limits of Control 3.11.4 have been exceeded.
 1. If such is the case, prepare and submit to the Commission within 30 days, pursuant to Control 6.9.2, a Special Report that defines the corrective action to be taken to reduce subsequent releases to prevent recurrence of exceeding the above limits and includes the schedule for achieving conformance with the above limits.
 2. This Special Report, as defined in 10CFR20.405c, shall include an analysis that estimates the radiation exposure (dose) to a MEMBER OF THE PUBLIC from uranium fuel cycle sources, including all effluent pathways and direct radiation, for the current year that includes the release(s) covered by this report. It shall also describe levels of radiation and concentrations of radioactive material involved, and the cause of the exposure levels or concentrations.
 3. If the estimated dose(s) exceeds the above limits, and if the release condition resulting in violation of 40CFR190 has not already been corrected, the Special Report shall include a request for a variance in accordance with the provisions of 40CFR190. Submittal of the report is considered a timely request, and a variance is granted until staff action on the request is complete.
- b. The provisions of Control 3.0.3 are not applicable.

SURVEILLANCE REQUIREMENTS

4.11.4.1 Cumulative dose contributions from liquid and gaseous effluents shall be determined in accordance with Controls 4.11.1.2, 4.11.2.2, and 4.11.2.3, and in accordance with the methodology and parameters in the ODCM.

4.11.4.2 If the cumulative dose contributions exceed the limits defined in 3.11.4, ACTION a, cumulative dose contributions from direct radiation from unit operation including from the ISFSI and outside storage tanks shall be determined in accordance with the methodology and parameters in the ODCM.

3/4.12 RADIOLOGICAL ENVIRONMENTAL MONITORING

3/4.12.1 MONITORING PROGRAM

CONTROLS

3.12.1 The radiological environmental monitoring program shall be conducted as specified in Table 3.12.1-1.

APPLICABILITY: At all times.

ACTION:

- a. With the radiological environmental monitoring program not being conducted as specified in Table 3.12.1-1, prepare and submit to the Commission, in the Annual Environmental and Effluent Release Report per Control 6.9.1.6, a description of the reasons for not conducting the program as required and the plans for preventing a recurrence.
- b. With the level of radioactivity as the result of plant effluents in an environmental sampling medium at a specified location exceeding the reporting levels of Table 3.12.1-2 when averaged over the current quarter, prepare and submit to the Commission within 30 days pursuant to Control 6.9.2 a Special Report that identifies the cause(s) for exceeding the limit(s) and defines the corrective actions to be taken to reduce radioactive effluents so that the potential annual dose to a MEMBER OF THE PUBLIC is less than the current year limits of Control 3.11.1.2, 3.11.2.2 and 3.11.2.3. When more than one of the radionuclides in Table 3.12.1-2 are detected in the sampling medium, this report shall be submitted if:

$$\frac{\text{concentration (1)}}{\text{reporting level (1)}} + \frac{\text{concentration (2)}}{\text{reporting level (2)}} + \dots \geq 1.0$$

When radionuclides other than those in Table 3.12.1-2 are detected and are the result of plant effluents, this report shall be submitted if the potential annual dose* to a MEMBER OF THE PUBLIC is equal to or greater than the current year limits of Control 3.11.1.2, 3.11.2.2 and 3.11.2.3. This report is not required if the measured level of radioactivity was not the result of plant effluents; however, in such an event, the condition shall be reported and described in the annual Radiological Environmental Operating Report required by Control 6.9.1.6.

* The methodology and parameters used to estimate the potential annual dose to a MEMBER OF THE PUBLIC shall be indicated in this report.

RADIOLOGICAL ENVIRONMENTAL MONITORING

CONTROLS

- c. With milk or broad leaf vegetation samples unavailable from one or more of the sample locations required by Table 3.12.1-1, identify specific locations for obtaining replacement samples and add them within 30 days to the Radiological Environmental Monitoring Program given in the ODCM. The specific locations from which samples were unavailable may then be deleted from the monitoring program. Pursuant to Control 6.9.1.7, submit in the next Annual Radiological Effluent Release Report documentation for a change in the ODCM including a revised figure(s) and table for the ODCM reflecting the new location(s) with supporting information identifying the cause of the unavailability of samples and justifying the selection of the new location(s) for obtaining samples.

- d. The provisions of Control 3.0.3 are not applicable.

SURVEILLANCE REQUIREMENTS

4.12.1 The radiological environmental monitoring samples shall be collected pursuant to Table 3.12.1-1 from the specific locations given in the table and figures in the ODCM and shall be analyzed pursuant to the requirements of Table 3.12.1-1 and the detection capabilities required by Table 4.12.1-1.

TABLE 3.12.1-1

RADIOLOGICAL ENVIRONMENTAL MONITORING PROGRAM*

<u>Exposure Pathway and/or Sample</u>	<u>Number of Samples and (1) Sample Locations</u>	<u>Sampling and Collection Frequency</u>	<u>Type and Frequency of Analysis</u>
1. Direction Radiation(2)	<p>Twenty-eight routine monitoring stations either with two or more dosimeters or with one instrument for measuring and recording dose rate continuously, placed as follows:</p> <p>An inner ring of stations, one in each meteorological sector, other than those sectors entirely over water (N, NNE, NNW, NW, W, WNW), in the general area of the SITE BOUNDARY;</p> <p>An outer ring of stations, one in each meteorological sector, other than those sectors entirely over water (N, NE, NNE, NNW, NW, W, WNW), in the 6- to 8-km range from the site; and</p> <p>The balance of the stations to be placed in special interest areas such as population centers, nearby residences, schools, and in one or two areas to serve as control stations.</p>	Quarterly.	Gamma dose quarterly.

TABLE 3.12.1-1 (Continued)

RADIOLOGICAL ENVIRONMENTAL MONITORING PROGRAM

<u>Exposure Pathway and/or Sample</u>	<u>Number of Samples and (1) Sample Locations</u>	<u>Sampling and Collection Frequency</u>	<u>Type and Frequency of Analysis</u>
<p>2. Airborne</p> <p>Radioiodine and Particulate</p>	<p>Samples from five locations:</p> <p>Three samples from close to the three SITE BOUNDARY locations, in different sectors, of the highest calculated annual average ground-level D/Q.</p> <p>One sample from the vicinity of a community having the highest calculated annual average ground-level D/Q; and</p> <p>One sample from a control location, as for example 15 to 30 km distant and in the least prevalent wind direction.</p>	<p>Continuous sampler operation with sample collection weekly, or more frequently if required by dust loading.</p>	<p><u>Radioiodine Canister:</u> I-131 analysis weekly.</p> <p><u>Particulate Sampler:</u> Gross beta radioactivity analysis following filter change;⁽³⁾ and gamma isotopic analysis⁽⁴⁾ of composite (by location) quarterly.</p>
<p>3. Waterborne</p> <p>a. Surface</p>	<p>Two samples</p>	<p>Composite sample over a 1-month period.⁽⁵⁾</p>	<p>Gamma isotopic analysis⁽⁴⁾ monthly. Composite for tritium analysis quarterly.</p>

TABLE 3.12.1-1 (Continued)RADIOLOGICAL ENVIRONMENTAL MONITORING PROGRAM

<u>Exposure Pathway and/or Sample</u>	<u>Number of Samples and (1) Sample Locations</u>	<u>Sampling and Collection Frequency</u>	<u>Type and Frequency of Analysis</u>
3. Waterborne (Continued)			
b. Drinking	One sample of each of one to three of the nearest water supplies that could be affected by its discharge. One sample from a control location.	Composite sample over 2-week period ⁽⁵⁾ when I-131 analysis is performed; monthly composite otherwise.	I-131 analysis on each composite when the dose calculated from the consumption of the water is greater than 1 mrem per year. ⁽⁶⁾ Composite for gross beta and gamma isotopic analyses ⁽⁴⁾ monthly. Composite for tritium analysis quarterly.
c. Sediment from shoreline	One sample from area with existing or potential recreational value.	Semi-annually.	Gamma isotopic analysis ⁽⁴⁾ semi-annually.
4. Ingestion			
a. Milk	Samples from milking animals in three locations within 5km distance having the highest dose potential. If there are none, then one sample from milking animals in each of between 5 to 8 km distant where doses are three areas calculated to be greater than 1 mrem per yr. ⁽⁶⁾ One sample from milking animals at a control location 15 to 30 km distant and in the least prevalent wind direction.	Semi-monthly when animals are on pasture; monthly at other times.	Gamma isotopic analysis ⁽⁴⁾ and I-131 analysis semi-monthly, when animals are on pasture; monthly at other times.

TABLE 3.12.1-1 (Continued)

RADIOLOGICAL ENVIRONMENTAL MONITORING PROGRAM

<u>Exposure Pathway and/or Sample</u>	<u>Number of Samples and (1) Sample Locations</u>	<u>Sampling and Collection Frequency</u>	<u>Type and Frequency of Analysis</u>
4. Ingestion (Continued)			
b. Fish and Invertebrates	Two or more samples of commercially and/or recreationally important species in vicinity of plant discharge area.	One sample in season.	Gamma isotopic analysis ⁽⁴⁾ on edible portions.
	Two or more samples of same species in areas not influenced by plant discharge.		
c. Food Products	Sample of three different kinds of broad leaf vegetation grown nearest each of two different offsite locations of highest predicted annual average ground level D/Q if milk sampling is not performed.0	Monthly during growing season.	Gamma isotopic analysis ⁽⁴⁾ and I-131 analysis.
	One sample of each of the similar broad leaf vegetation grown 15 to 30 km distant in the least prevalent wind direction if milk sampling is not performed.	Monthly during growing season.	Gamma isotopic analysis ⁽⁴⁾ and I-131 analysis.

TABLE 3.12.1-1 (Continued)

RADIOLOGICAL ENVIRONMENTAL MONITORING PROGRAM

TABLE NOTATIONS

- * Sample locations are given on the figure and the table in the ODCM.
- (1) Specific parameters of distance and direction sector from the centerline of one reactor, and additional description where pertinent, shall be provided for each and every sample location in Table 3.12-1 in a table and figure(s) in the ODCM. Refer to NUREG-0133, "Preparation of Radiological Effluent Technical Specifications for Nuclear Power Plants," October 1978, and to Radiological Assessment Branch Technical Position, Revision 1, November 1979. Deviations are permitted from the required sampling schedule if specimens are unobtainable due to circumstances such as hazardous conditions, seasonal unavailability, and malfunction of automatic sampling equipment. If specimens are unobtainable due to sampling equipment malfunction, effort shall be made to complete corrective action prior to the end of the next sampling period. All deviations from the sampling schedule shall be documented in the annual Radiological Environmental Operating Report pursuant to Control 6.9.1.6. It is recognized that, at times, it may not be possible or practicable to continue to obtain samples of the media of choice at the most desired location or time. In these instances suitable specific alternative media and locations may be chosen for the particular pathway in question and appropriate substitutions made with 30 days in the Radiological Environmental Monitoring Program given in the ODCM. Pursuant to Control 6.9.1.7, submit in the next annual Radioactive Effluent Release Report documentation for a change in the ODCM, including a revised figure(s) and table for the ODCM reflecting the new location(s) with supporting information identifying the cause of the unavailability of samples for that pathway and justifying the selection of the new location(s) for obtaining samples.
- (2) One or more instruments, such as a pressurized ion chamber, for measuring and recording dose rate continuously may be used in place of, or in addition to, integrating dosimeters. For the purposes of this table, a thermoluminescent dosimeter (TLD) is considered to be one phosphor; two or more phosphors in a packet are considered as two or more dosimeters. Film badges shall not be used as dosimeters for measuring direct radiation. (The frequency of analysis or readout for TLD systems will depend upon the characteristics of the specific system used and should be selected to obtain optimum dose information with minimal fading.)
- (3) Airborne particulate sample filters shall be analyzed for gross beta radioactivity 24 hours or more after sampling to allow for radon and thoron daughter decay. If gross beta activity in air particulate samples is greater than 10 times the yearly mean of control samples, gamma isotopic analysis shall be performed on the individual samples.

TABLE 3.12.1-1 (Continued)

TABLE NOTATIONS (Continued)

- (4) Gamma isotopic analysis means the identification and quantification of gamma-emitting radionuclides that may be attributable to the effluents from the facility.
- (5) A composite sample is one in which the quantity (aliquot) of liquid sampled is proportional to the quantity of flowing liquid and in which the method of sampling employed results in a specimen that is representative of the liquid flow. In this program composite sample aliquots shall be collected at time intervals that are very short (e.g., hourly) relative to the compositing period (e.g., monthly) in order to assure obtaining a representative sample.
- (6) The dose shall be calculated for the maximum organ and age group, using the methodology and parameters in the ODCM.

TABLE 3.12.1-2

REPORTING LEVELS FOR RADIOACTIVITY CONCENTRATIONS IN ENVIRONMENTAL SAMPLES

Reporting Levels

Analysis	Water (pCi/L)	Airborne Particulate or Gases (pCi/m ³)	Fish (pCi/Kg, wet)	Milk (pCi/L)	Food Products (pCi/kg, wet)
H-3	2 x 10 ⁴ ^a	NA	NA	NA	NA
Mn-54	1 x 10 ³	NA	3 x 10 ⁴	NA	NA
Fe-59	4 x 10 ²	NA	1 x 10 ⁴	NA	NA
Co-58	1 x 10 ³	NA	3 x 10 ⁴	NA	NA
Co-60	3 x 10 ²	NA	1 x 10 ⁴	NA	NA
Zn-65	3 x 10 ²	NA	2 x 10 ⁴	NA	NA
Zr-Nb-95	4 x 10 ²	NA	NA	NA	NA
I-131	2 ^b	0.9	NA	3	1 x 10 ²
Cs-134	30	10	1 x 10 ³	60	1 x 10 ³
Cs-137	50	20	2 x 10 ³	70	2 x 10 ³
Ba-La-140	2 x 10 ²	NA	NA	3 x 10 ²	NA

^aFor drinking water samples. This is a 40CFR141 value. If no drinking water pathway exists, a value of 30,000 pCi/L may be used.

^bIf no drinking water pathway exists, a value of 20 pCi/L may be used.

Rev. 19
DEC 2012

Rev. 19
DEC 2012

TABLE 4.12.1-1

(a),(b),(c)

MAXIMUM VALUES FOR THE LOWER LIMITS OF DETECTION (LLD)
IN ENVIRONMENTAL SAMPLES

Analysis	Water (pCi/l)	Airborne Particulate or Gases (pCi/m ³)	Fish (pCi/Kg, wet)	Milk (pCi/l)	Broad Leaf Vegetation (pCi/kg,wet)	Sediment (pCi/kg,wet)
Gross beta	4	1×10^{-2}	NA	NA	NA	NA
H-3	2000*	NA	NA	NA	NA	NA
Mn-54	15	NA	130	NA	NA	NA
Fe-59	30	NA	260	NA	NA	NA
Co-58,60	15	NA	130	NA	NA	NA
Zn-65	30	NA	260	NA	NA	NA
Zr-95	30	NA	NA	NA	NA	NA
Nb-95	15	NA	NA	NA	NA	NA
I-131	1**	7×10^{-2}	NA	1	60	NA
Cs-134	15	5×10^{-2}	130	15	60	150
Cs-137	18	6×10^{-2}	150	18	80	180
Ba-140	60	NA	NA	60	NA	NA
La-140	15	NA	NA	15	NA	NA

*If no drinking water pathway exists, a value of 3000 pCi/l may be used.

**If no drinking water pathway exists, a value of 15 pCi/l may be used.

TABLE 4.12.1-1 (Continued)

MAXIMUM VALUES FOR THE LOWER LIMITS OF DETECTION (LLD)

TABLE NOTATION

^aAcceptable detection capabilities for thermoluminescent dosimeters used for environmental measurements are given in Regulatory Guide 4.13.

^bTable 4.12-1 indicates acceptable detection capabilities for radioactive materials in environmental samples. These detection capabilities are tabulated in terms of the lower limits of detection (LLDs). The LLD is defined, for purposes of this guide, as the smallest concentration of radioactive material in a sample that will yield a net count (above system background) that will be detected with 95% probability with only 5% probability of falsely concluding that a blank observation represents a "real" signal.

For a particular measurement system (which may include radiochemical separation):

$$LLD = \frac{4.66 S_b}{(E) (V) (2.22 \times 10^6) (Y) \exp(-\lambda \Delta t)}$$

Where

LLD is the "a priori" lower limit of detection as defined above (as μCi per unit mass or volume).

S_b is the standard deviation of the background counting rate or of the counting rate of a blank sample as appropriate (as counts per minute)

E is the counting efficiency (as counts per disintegration)

V is the sample size (in units of mass or volume)

2.22×10^6 is the number of disintegrations per minute per microcurie

Y is the fractional radiochemical yield (when applicable)

λ is the radioactive decay constant for the particular radionuclide (sec^{-1})

Δt is the elapsed time between sample collection (or end of the sample collection period) and time of counting (sec)

Typical values of E, V, Y and Δt should be used in the calculation.

TABLE 4.12.1-1 (Continued)

MAXIMUM VALUES FOR THE LOWER LIMITS OF DETECTION (LLD)

TABLE NOTATION (continued)

It should be recognized that the LLD is defined as an "a priori" (before the fact) limit representing the capability of a measurement system and not as an "a posteriori" (after the fact) limit for a particular measurement.

Occasionally background fluctuations, unavoidable small sample size, the presence of interfering nuclides, or other uncontrollable circumstances may render these LLDs unachievable. In such cases, the contributing factors should be identified and described in the annual Radiological Environmental Operating Report pursuant to Control 6.9.1.6.

The value of s_b used in the calculation of the LLD for a particular measurement system should be based on the actual observed variance of the background counting rate or of the counting rate of the blank samples (as appropriate) rather than on an unverified theoretically predicated variance.

^cThis list does not mean that only these nuclides are to be considered. Other peaks that are identifiable, together with those of the above nuclides, shall also be analyzed and reported in the Annual Radiological Environmental Operating Report pursuant to Control 6.9.16.

RADIOLOGICAL ENVIRONMENTAL MONITORING

3/4.12.2 LAND USE CENSUS

CONTROLS

3.12.2 A land use census shall be conducted and shall identify within a distance of 8 km (5 miles) the location in each of the 16 meteorological sectors of the nearest milk animal, the nearest residence and the nearest garden* of greater than 50 m² (500 ft²) producing broad leaf vegetation.

APPLICABILITY: At all times.

ACTION:

- a. With a land use census identifying a location(s) which yields a calculated dose or dose commitment greater than the values currently being calculated in Control 4.11.2.3, identify the new location(s)* in the next Annual Radioactive Effluent Release Report, pursuant to Control 6.9.1.7.
- b. With a land use census identifying a location(s) which yields a calculated dose or dose commitment (via the same exposure pathway) 20 percent greater than at a location from which milk and/or broad leaf vegetation samples are currently being obtained in accordance with Control 3.12.1, add the new location(s) to the radiological environmental monitoring program within 30 days. If no milk and/or broad leaf vegetation samples are identified in the new sector with the highest D/Q value, then the next sector with the highest D/Q value will be considered and so on until a sampling location can be established. The sampling location(s), excluding the control station location, having the lowest calculated dose or dose commitment(s), via the same exposure pathway may be deleted from this monitoring program after October 31 of the year in which this land use census was conducted.* Identify the new location(s) in the next annual Radioactive Effluent Release Report and also include in the report a revised figure(s) and table(s) for the ODCM reflecting the new location(s).
- c. The provisions of Control 3.0.3 are not applicable.

SURVEILLANCE REQUIREMENTS

4.12.2 The land use census shall be conducted during the growing season at least once per 12 months using that information that will provide the best results, such as by a door-to-door survey, aerial survey, or by consulting local agriculture authorities. The results of the land use census shall be included in the annual Radiological Environmental Operating Report pursuant to Control 6.9.1.6.

*Broad leaf vegetation sampling of at least three different kinds of vegetation may be performed at the site boundary in each of two different direction sectors with the highest predicted D/Qs in lieu of the garden census. Controls for broad leaf vegetation sampling in Table 3.12.1-1 shall be followed, including analysis of control samples.

RADIOLOGICAL ENVIRONMENTAL MONITORING

3/4.12.3 INTERLABORATORY COMPARISON PROGRAM

CONTROLS

3.12.3 Analyses shall be performed on radioactive materials that correspond to samples required by Table 3.12.1-1. These materials are supplied as part of an Inter-laboratory Comparison Program.

APPLICABILITY: At all times.

ACTION:

- a. With analyses not being performed as required above, report the corrective actions taken to prevent a recurrence to the Commission in the Annual Environmental and Effluent Release Report pursuant to Control 6.9.1.6.
- b. The provisions of Control 3.0.3 are not applicable.

SURVEILLANCE REQUIREMENTS

4.12.3 A summary of the results obtained as part of the above required Inter-Laboratory Comparison Program shall be included in the annual Radiological Environmental Operating Report pursuant to Control 6.9.1.6.

BASES FOR
SECTIONS 3.0 AND 4.0
CONTROLS
AND
SURVEILLANCE REQUIREMENTS

NOTE

The BASES contained in succeeding pages summarize the reasons for the Controls in Section 3.0 and 4.0, but are not part of these Controls.

3/4 CONTROLS AND SURVEILLANCE REQUIREMENTS

3/4.0 APPLICABILITY

BASES

Controls 3.0.1 through 3.0.5 establish the general requirements applicable to Appendix C Controls and apply at all times, unless otherwise stated.

Control 3.0.1 establishes the Applicability statement within each individual control as the requirement for when the Control is required to be met (i.e., when the unit is in the MODES or other specified conditions of the Applicability statement of each Control).

Control 3.0.2 establishes that upon discovery of a failure to meet a Control, the associated ACTIONS shall be met. The Completion Time of each ACTION condition is applicable from the point in time that an ACTIONS condition is entered. The ACTIONS establish those remedial measures that must be taken within specified times when the requirements of a Control are not met. This Control establishes that:

- a. Completion of the ACTIONS within the specified times constitutes compliance with a Control; and
- b. Completion of the ACTIONS is not required when a Control is met within the specified time, unless otherwise specified.

There are two basic types of ACTION requirements. The first type of ACTIONS specifies a time limit in which the Control must be met. This time limit is the time to restore an inoperable system or component to OPERABLE status or to restore variables to within specified limits. If this type of ACTION is not completed within the specified completion time, a shutdown may be required to place the unit in a MODE or condition in which the Control is not applicable. (Whether stated as an ACTION or not, correction of the entered condition is an action that may always be considered upon entering ACTIONS.) The second type of ACTION specifies the remedial measures that permit continued operation of the unit that is not further restricted by the completion time. In this case, compliance with the ACTIONS provides an acceptable level of safety for continued operation.

Completing the ACTIONS is not required when a Control is met or is no longer applicable, unless otherwise stated in the individual Control.

The nature of some ACTIONS of some conditions necessitates that, once the condition is entered, the ACTIONS must be completed even though the associated condition no longer exists. The individual Control's ACTIONS specify where this is the case.

3/4.0 APPLICABILITY

BASES (Continued)

The completion times of the ACTIONS are also applicable when a system or component is removed from service intentionally. The reasons for intentionally relying on the ACTIONS include, but are not limited to, performance of Surveillances, preventive maintenance, corrective maintenance, or investigation of operational problems. Entering ACTIONS for these reasons must be done in a manner that does not compromise safety. Intentional entry into ACTIONS should not be made for operational convenience. Alternatives that would not result in redundant equipment being inoperable should be used instead. Doing so limits the time both subsystems/divisions of a safety function are inoperable and limits the time other conditions exist which result in Control 3.0.3 being entered. Individual Controls may specify a time limit for performing an SR when equipment is removed from service or bypassed for testing. In this case, the completion times of ACTIONS are applicable when this time limit expires, if the equipment remains removed from service or bypassed.

When a change in MODE or other specified condition is required to comply with an ACTION, the unit may enter a MODE or other specified condition in which another Control becomes applicable. In this case, the completion times of the associated ACTIONS would apply from the point in time that the new Control becomes applicable and the ACTIONS condition(s) are entered.

Control 3.0.3 establishes the actions that must be implemented when a Control is not met and:

- a. An associated ACTION and completion time is not met and no other condition applies; or
- b. The condition of the unit is not specifically addressed by the associated ACTIONS. This means that no combination of conditions stated in the ACTIONS can be made that exactly corresponds to the actual condition of the unit. Sometimes, possible combinations of conditions are such that entering Control 3.0.3 is warranted; in such cases, the ACTIONS specifically state a condition corresponding to such combinations and also that Control 3.0.3 be entered immediately.

This Control delineates the time limits for placing the unit in a safe MODE or other specified condition when operation cannot be maintained within the limits for safe operation as defined by the Control and its ACTIONS. It is not intended to be used as an operational convenience that permits routine voluntary removal of redundant systems or components from service in lieu of other alternatives that would not result in redundant systems or components being inoperable.

3/4.0 APPLICABILITY

BASES (Continued)

Upon entering Control 3.0.3, 1 hour is allowed to prepare for an orderly shutdown before initiating a change in unit operation. This includes time to permit the operator to coordinate the reduction in electrical generation with the load dispatcher to ensure the stability and availability of the electrical grid. The time limits specified to reach lower MODES of operation permit the shutdown to proceed in a controlled and orderly manner that is well within the specified maximum cooldown rate and within the capabilities of the unit, assuming that only the minimum required equipment is OPERABLE. This reduces thermal stresses on components of the Reactor Coolant System and the potential for a plant upset that could challenge safety systems under conditions to which this Control applies.

A unit shutdown required in accordance with Control 3.0.3 may be terminated and Control 3.0.3 exited if any of the following occurs:

- a. The Control is met.
- b. A condition exists for which the ACTIONS have now been performed.
- c. ACTIONS exist that do not have expired completion times. These completion times are applicable from the point in time that the condition is initially entered and not from the time Control 3.0.3 is exited.

The time limits of Control 3.0.3 allow 37 hours for the unit to be in MODE 4 when a shutdown is required during MODE 1 operation. If the unit is in a lower MODE of operation when a shutdown is required, the time limit for reaching the next lower MODE applies. If a lower MODE of operation is reached in less time than allowed, however, the total allowable time to reach MODE 4, or other applicable MODE, is not reduced. For example, if MODE 2 is reached in 2 hours, then the time allowed for reaching MODE 3 is the next 11 hours, because the total time for reaching MODE 3 is not reduced from the allowable limit of 13 hours. Therefore, if remedial measures are completed that would permit a return to MODE 1, a penalty is not incurred by having to reach a lower MODE of operation in less than the total time allowed.

In MODES 1, 2, and 3, Control 3.0.3 provides actions for conditions not covered in other Controls. The requirements of Control 3.0.3 do not apply in MODES 4 and 5 because the unit is already in the most restrictive condition required by Control 3.0.3. The requirements of Control 3.0.3 do not apply in other specified conditions of the Applicability (unless in MODE 1, 2, or 3) because the ACTIONS of individual Controls sufficiently define the remedial measures to be taken.

Exceptions to Control 3.0.3 are provided in instances where requiring a unit shutdown, in accordance with Control 3.0.3, would not provide appropriate remedial measures for the associated condition of the unit. These exceptions are addressed in the individual Controls.

3/4.0 APPLICABILITY

BASES (Continued)

Control 3.0.4 establishes limitations on changes in MODES or other specified conditions in the Applicability when a Control is not met. It allows placing the Unit in a MODE or other specified condition stated in that Applicability (e.g., Applicability desired to be entered) when unit conditions are such that the requirements of the LCO would not be met, in accordance with Control 3.0.4.a, 3.0.4.b, or 3.0.4.c.

Per Control 3.0.4.a, compliance with ACTION requirements that permit continued operation of the facility for an unlimited period of time in a MODE or other specified condition provides an acceptable level of safety for continued operation. This is without regard to the status of the plant before or after the MODE change. Therefore, in such cases, entry into a MODE or other specified condition in the Applicability may be made in accordance with the provisions of the ACTION requirements.

Per Control 3.0.4.b, changes in MODE may be made even if the ACTION requirements include a requirement to exit the Applicability, PROVIDED a risk assessment is performed (and is determined to be acceptable) which addresses the inoperable systems/components, and any appropriate risk management actions are put in place.

The provisions of this control should not be interpreted as endorsing the failure to exercise the good practice of restoring systems or components to OPERABLE status before Unit startup.

The provisions of Control 3.0.4 shall not prevent changes in MODES or other specified conditions in the Applicability that are required to comply with ACTIONS. In addition, the provisions of Control 3.0.4 shall not prevent changes in MODES or other specified conditions in the Applicability that result from any unit shutdown. In this context, a unit shutdown is defined as a change in MODE associated with transitioning from MODE 1 to MODE 2 or 3, MODE 2 to 3, and MODE 3 to 4.

Surveillances do not have to be performed on the associated inoperable equipment (or on variables outside the specified limits), as permitted by SR 3.0.1. Therefore, utilizing Control 3.0.4 is not a violation of SR 4.0.1 or SR 4.0.4 for any Surveillances that have not been performed on inoperable equipment. However, SRs must be met to ensure OPERABILITY prior to declaring the associated equipment OPERABLE (or variable within limits) and restoring compliance with the affected Control.

3/4.0 APPLICABILITY

BASES (Continued)

Control 3.0.5 establishes the allowance for restoring equipment to service under administrative controls when it has been removed from service or declared inoperable to comply with ACTIONS. The sole purpose of this Control is to provide an exception to Control 3.0.2 (e.g., to not comply with the applicable ACTION(s)) to allow the performance of SRs to demonstrate:

- a. The OPERABILITY of the equipment being returned to service; or
- b. The OPERABILITY of other equipment.

The administrative controls ensure the time the equipment is returned to service in conflict with the requirements of the ACTIONS is limited to the time absolutely necessary to perform the allows SRs. This Control does not provide time to perform any other preventative or corrective maintenance.

SR 4.0.1 through 4.0.5 establish the general requirements applicable to all Controls and apply at all times, unless otherwise stated.

SR 4.0.1 establishes the requirement that SRs must be met during the MODES or other specified conditions in the Applicability for which the requirements of the Control apply, unless otherwise specified in the individual SRs. This Control is to ensure that Surveillances are performed to verify the OPERABILITY of systems and components, and that variables are within specified limits. Failure to meet a Surveillance within the specified frequency, in accordance with SR 4.0.2, constitutes a failure to meet a Control.

Systems and components are assumed to be OPERABLE when the associated SRs have been met. Nothing in this Control, however, is to be construed as implying that systems or components are OPERABLE when:

- a. The systems or components are known to be inoperable, although still meeting the SRs; or
- b. The requirements of the Surveillance(s) are known to be not met between required Surveillance performances.

Surveillances do not have to be performed when the unit is in a MODE or other specified condition for which the requirements of the associated Control are not applicable, unless otherwise specified. The SRs associated with a Special Operations Control are only applicable when the Special Operations Control is used as an allowable exception to the requirements of a Control.

Surveillances, including Surveillances invoked by ACTIONS, do not have to be performed on inoperable equipment because the ACTIONS define the remedial measures that apply. Surveillances have to be met and performed in accordance with SR 4.0.2, prior to returning equipment to OPERABLE status.

3/4.0 APPLICABILITY

BASES (Continued)

Upon completion of maintenance, appropriate post maintenance testing is required to declare equipment OPERABLE. This includes ensuring applicable Surveillances are not failed and their most recent performance is in accordance with SR 4.0.2. Post maintenance testing may not be possible in the current MODE or other specified conditions in the Applicability due to the necessary unit parameters not having been established. In these situations, the equipment may be considered OPERABLE provided testing has been satisfactorily completed to the extent possible and the equipment is not otherwise believed to be incapable of performing its function. This will allow operation to proceed to a MODE or other specified condition where other necessary post maintenance tests can be completed.

SR 4.0.2 establishes the requirements for meeting the specified frequency for Surveillances and any ACTIONS with a completion time that requires the periodic performance of the ACTION on a "once per ..." interval.

SR 4.0.2 permits a 25% extension of the interval specified in the frequency. This extension facilitates Surveillance scheduling and considers plant operating conditions that may not be suitable for conducting the Surveillance (e.g., transient conditions or other ongoing Surveillance or maintenance activities).

The 25% extension does not significantly degrade the reliability that results from performing the Surveillance at its specified frequency. This is based on the recognition that the most probable result of any particular Surveillance being performed is the verification of conformance with the SRs. The exceptions to SR 4.0.2 are those Surveillances for which the 25% extension of the interval specified in the frequency does not apply. These exceptions are stated in the individual Controls.

As stated in SR 4.0.2, the 25% extension also does not apply to the initial portion of a periodic completion time that requires performance on a "once per ..." basis. The 25% extension applies to each performance after the initial performance. The initial performance of the ACTION, whether it is a particular Surveillance or some other remedial action, is considered a single action with a single completion time. One reason for not allowing the 25% extension to this completion time is that such an action usually verifies that no loss of function has occurred by checking the status of redundant or diverse components or accomplishes the function of the inoperable equipment in an alternative manner.

The provisions of SR 4.0.2 are not intended to be used repeatedly merely as an operational convenience to extend Surveillance intervals (other than those consistent with refueling intervals) or periodic completion time intervals beyond those specified.

3/4.0 APPLICABILITY

BASES (Continued)

SR 4.0.3 establishes the flexibility to defer declaring affected equipment inoperable or an affected variable outside the specified limits when a Surveillance has not been completed within the specified frequency. A delay period of up to 24 hours or up to the limit of the specified frequency, whichever is less, applies from the point in time that it is discovered that the Surveillance has not been performed in accordance with SR 4.0.2, and not at the time that the specified frequency was not met. This delay period provides adequate time to complete Surveillances that have been missed. This delay period permits the completion of a Surveillance before complying with ACTIONS or other remedial measures that might preclude completion of the Surveillance.

The basis for this delay period includes consideration of unit conditions, adequate planning, availability of personnel, the time required to perform the Surveillance, the safety significance of the delay in completing the required Surveillance, and the recognition that the most probable result of any particular Surveillance being performed is the verification of conformance with the requirements.

When a Surveillance with a frequency based not on time intervals, but upon specified unit conditions or operational situations, is discovered not to have been performed when specified, SR 4.0.3 allows the full delay period of 24 hours to perform the Surveillance.

SR 4.0.3 also provides a time limit for completion of Surveillances that become applicable as a consequence of MODE changes imposed by ACTIONS.

Failure to comply with specified frequencies for Surveillance Requirements is expected to be an infrequent occurrence. Use of the delay period established by SR 4.0.3 is a flexibility which is not intended to be used as an operational convenience to extend Surveillance intervals.

If a Surveillance is not completed within the allowed delay period, then the equipment is considered inoperable or the variable then is considered outside the specified limits and the completion times of the ACTIONS for the applicable Control conditions begin immediately upon expiration of the delay period. If a Surveillance is failed within the delay period, then the equipment is inoperable, or the variable is outside the specified limits and the completion times of the required ACTIONS for the applicable Control conditions begin immediately upon failure of the Surveillance.

Completion of the Surveillance within the delay period allowed by this Control, or within the completion time of the ACTIONS, restores compliance with SR 4.0.1.

SR 4.0.4 establishes the requirement that all applicable SRs must be met before entry into a MODE or other specified condition in the Applicability, with two exceptions as described in SR 4.0.4.

3/4.0 APPLICABILITY

BASES (Continued)

This Control ensures that system and component OPERABILITY requirements and variable limits are met before entry into MODES or other specified conditions in the Applicability for which these systems and components ensure safe operation of the unit.

However, in certain circumstances, failing to meet an SR will not result in SR 4.0.4 restricting a MODE change or other specified condition change. When a system, subsystem, division, component, device, or variable is inoperable or outside its specified limits, the associated SR(s) are not required to be performed, per SR 4.0.1, which states that surveillances do not have to be performed on inoperable equipment or variables outside specified limits. When equipment is inoperable, or variables are outside their specified limits, SR 4.0.4 does not apply to the associated SR(s) since the requirement for the SR(s) to be performed is removed. Therefore, failing to perform the Surveillance(s) within the specified frequency, on equipment that is inoperable, or on variables that are outside specified limits, does not result in an SR 4.0.4 restriction to changing MODES or other specified conditions in the Applicability. However, since the Control is not met in this instance, Control 3.0.4 will govern any restrictions that may (or may not) apply to MODE or other specified condition changes.

The provisions of this Control should not be interpreted as endorsing the failure to exercise the good practice of restoring systems or components to OPERABLE status before entering an associated MODE or other specified condition in the Applicability.

The provisions of SR 4.0.4 shall not prevent changes in MODES or other specified conditions in the Applicability that are required to comply with ACTIONS. In addition, the provisions of SR 4.0.4 shall not prevent changes in MODES or other specified conditions in the Applicability that result from any unit shutdown. In this context, a unit shutdown is defined as a change in MODE associated with transitioning from MODE 1 to MODE 2 or 3, MODE 2 to 3, and MODE 3 to 4.

The precise requirements for performance of SRs are specified such that exceptions to SR 4.0.4 are not necessary. The specific time frames and conditions necessary for meeting the SRs are specified in the frequency, in the Surveillance, or both. This allows performance of Surveillances when the prerequisite condition(s) specified in a Surveillance procedure require entry into the MODE or other specified condition in the Applicability of the associated Control prior to the performance or completion of a Surveillance. A Surveillance that could not be performed until after entering the Control's Applicability would have its frequency specified such that it is not "due" until the specific conditions needed are met. Alternately, the Surveillance may be stated in the form of a note as not required (to be met or performed) until a particular event, condition, or time has been reached.

3/4.3 INSTRUMENTATION

BASES

3/4.3.7 MONITORING INSTRUMENTATION

3/4.3.7.9 RADIOACTIVE LIQUID EFFLUENT MONITORING INSTRUMENTATION

The radioactive liquid effluent instrumentation is provided to monitor and control, as applicable, the releases of radioactive materials in liquid effluents during actual or potential releases of liquid effluents. The alarm/trip setpoints for these instruments shall be calculated in accordance with the procedures in the ODCM to ensure that the alarm/trip will occur prior to exceeding the limits of 10CFR20. The OPERABILITY and use of this instrumentation is consistent with the requirements of 10CFR50, Appendix A, General Design Criteria 60, 63, and 64.

3/4.3.7.10 RADIOACTIVE GASEOUS EFFLUENT MONITORING INSTRUMENTATION

The radioactive gaseous effluent instrumentation is provided to monitor and control, as applicable, the releases of radioactive materials in gaseous effluents during actual or potential releases of gaseous effluents. The alarm setpoints for these instruments shall be calculated in accordance with the procedures in the ODCM to ensure that the alarm will occur prior to exceeding the limits of 10CFR20. The OPERABILITY and use of this instrumentation is consistent with the requirements of 10CFR50, Appendix A, General Design Criteria 60, 63, and 64.

3/4.11 RADIOACTIVE EFFLUENTS

BASES

3/4.11.1 LIQUID EFFLUENTS

3/4.11.1.1 CONCENTRATION

This Control is provided to ensure that the concentration of radioactive materials released in liquid waste effluents to UNRESTRICTED AREAS will be less than the concentration levels specified in 10CFR20, Appendix B, Table 2, Column 2. This limitation provides additional assurance that the levels of radioactive materials in bodies of water in UNRESTRICTED AREAS will result in exposures within (1) the Section II.A. design objectives of 10CFR50, Appendix I, to a MEMBER OF THE PUBLIC, and (2) the limits of 10CFR20 to the population. The concentration limit for dissolved and entrained noble gases is based upon the assumption that Xe-135 is the controlling radioisotope and its limiting effluent concentration in air (submersion) was converted to an equivalent concentration in water using the methods described in International Commission on Radiological Protection (ICRP) Publication 2.

This Control applies to the release of radioactive materials in liquid effluents from all units at the site.

The required detection capabilities for radioactive materials in liquid waste samples are tabulated in terms of the lower limits of detection (LLDs). Detailed discussion of the LLD, and other detection limits, can be found in:

- (1) Currie, L. A., "Lower Limit of Detection: Definition and Elaboration of a Proposed Position for Radiological Effluent and Environmental Measurements," NUREG/CR-4007 (September, 1984).
- (2) HASL Procedures Manual, HASL-300 (revised annually).

3/4.11.1.2 DOSE

This Control is provided to implement the requirements of 10CFR50, Appendix I, Sections II.A, III.A and IV.A. The Control implements the guides set forth in of 10CFR50, Appendix I, Section II.A. The ACTION statements provide the required operating flexibility and at the same time implement the guides set forth in of 10CFR50, Appendix I, Section IV.A which assure that the releases of radioactive material in liquid effluents to UNRESTRICTED AREAS will be kept "as low as is reasonably achievable." Also, for fresh water sites with drinking water supplies which can be potentially affected by plant operations, there is reasonable assurance that the operation of the facility will not result in radionuclide concentrations in the finished drinking water that are in excess of the requirements of 40CFR141. The dose calculations in the ODCM implement the requirements in 10CFR50, Appendix I, Section III.A that conformance with the guides of 10CFR50, Appendix I be shown by calculational procedures based on models and data, such that the actual exposure of a MEMBER OF THE PUBLIC through appropriate pathways is unlikely to be substantially underestimated. The equations specified in the ODCM for calculating the doses due to the actual release rates of radioactive

RADIOACTIVE EFFLUENTS

BASES

3/4.11.1.2 DOSE (Continued)

materials in liquid effluents are consistent with the methodology provided in Regulatory Guide 1.109, "Calculation of Annual Doses to Man from Routine Releases of Reactor Effluents for the Purpose of Evaluating Compliance with 10 CFR Part 50, Appendix I, Revision 1", October 1977, and Regulatory Guide 1.113, "Estimating Aquatic Dispersion of Effluent from Accidental and Routine Reactor Releases for the Purpose of Implementing Appendix I," April 1977.

This Control applies to the release of liquid effluents from each reactor at the site. For units with shared radwaste treatment systems, the liquid effluents from the shared system are proportioned among the units sharing that system.

3/4.11.1.3 LIQUID RADWASTE TREATMENT SYSTEM

The OPERABILITY of the liquid radwaste treatment system ensures that this system will be available for use whenever liquid effluents require treatment prior to release to the environment.

The requirement that the appropriate portions of this system be used when specified provides assurance that the releases of radioactive materials in liquid effluents will be kept "as low as is reasonably achievable." This Control implements the requirements of 10CFR50.36a; 10CFR50, Appendix A, General Design Criterion 60; and the design objective given in 10CFR50, Appendix I, Section II.D. The specified limit governing the use of appropriate portions of the liquid radwaste treatment system were specified as a suitable fraction of the dose design objectives set forth in 10CFR50, Appendix I, Section II.A, for liquid effluents.

This Control applies to the release of liquid effluents from each reactor at the site. For units with shared radwaste treatment systems, the liquid effluents from the shared system are proportioned among the units sharing the system.

RADIOACTIVE EFFLUENTS

BASES

3/4.11.2 GASEOUS EFFLUENTS

3/4.11.2.1 DOSE RATE

This Control is provided to ensure that the dose any time at and beyond the SITE BOUNDARY from gaseous effluents from all units on the site will be within the annual dose limits of 10CFR20 for UNRESTRICTED AREAS. The annual dose rate limits are those associated with the concentrations of those limiting effluent concentrations, as described in Regulatory Guide 1.109. These limits provide reasonable assurance that radioactive material discharged in gaseous effluents will not result in the exposure of a MEMBER OF THE PUBLIC in an UNRESTRICTED AREA, either within or outside the SITE BOUNDARY, to annual average concentrations exceeding the limits specified in 10CFR20, Appendix B, Table II. For MEMBERS OF THE PUBLIC who may at times be within the SITE BOUNDARY, the occupancy of the MEMBER OF THE PUBLIC will be sufficiently low to compensate for any increase in the atmospheric diffusion factor above that for the SITE BOUNDARY. Examples of calculations for such MEMBERS OF THE PUBLIC, with appropriate occupancy factors, shall be given in the ODCM. The specified release rate limits restrict, at all times, the corresponding gamma and beta dose rates above background to a MEMBER OF THE PUBLIC at or beyond the SITE BOUNDARY to less than or equal to 500 mrem/year to the whole body or to less than or equal to 3000 mrem/year to the skin. These release rate limits also restrict, at all times, the corresponding thyroid dose rate above background to a child via the inhalation pathway to less than or equal to 1500 mrem/year.

This Control applies to the release of radioactive materials in gaseous effluents from all reactors at the site. The required detection capabilities for radioactive material in gaseous waste samples are tabulated in terms of the lower limit of detection (LLDs). Detailed discussion of the LLD and other detection limits can be found in:

- (1) Currie, L. A., "Lower Limit of Detection: Definition and Elaboration of a Proposed Position for Radiological Effluent and Environmental Measurements," NUREG/CR-4007 (September 1984).
- (2) HASL Procedures Manual, HASL-300 (revised annually).

3/4.11.2.2 DOSE - NOBLE GASES

This Control is provided to implement the requirements of 10CFR50, Appendix I, Sections II.B, III.A and IV.A. The Control implements the guides set forth in 10CFR50, Appendix I, Section II.B. The ACTION statements provide the required operating flexibility and at the same time implement the guides set forth in 10CFR50, Appendix I, Section IV.A to assure that the releases of radioactive material in gaseous effluents to UNRESTRICTED AREAS will be kept "as low as is reasonably achievable." The Surveillance Requirements implement the requirements in 10CFR50, Appendix I, Section III.A that conformance with the guides of 10CFR50, Appendix I, be shown by calculational procedures based on models and data such that the actual

RADIOACTIVE EFFLUENTS

BASES

3/4.11.2.2 DOSE - NOBLE GASES (Continued)

exposure of a MEMBER OF THE PUBLIC through appropriate pathways is unlikely to be substantially underestimated. The dose calculations established in the ODCM for calculating the doses due to the actual release rates of radioactive noble gases in gaseous effluents are consistent with the methodology provided in Regulatory Guide 1.109, "Calculation of Annual Doses to Man from Routine Releases of Reactor Effluents for the Purpose of Evaluating Compliance with 10CFR50, Appendix I, Revision 1", October 1977, and Regulatory Guide 1.111, "Methods for Estimating Atmospheric Transport and Dispersion of Gaseous Effluents in Routine Releases from Light-Water Cooled Reactors," Revision 1, July 1977. The ODCM equations provided for determining the air doses at and beyond the SITE BOUNDARY are made using meteorological conditions concurrent with the time of release of radioactive materials in gaseous effluents or are based upon the historical average atmospheric conditions.

This Control applies to the release of radioactive materials in gaseous effluents from each reactor at the site. For units with shared radwaste treatment systems, the gaseous effluents from the shared system are proportioned among the units sharing that system.

3/4.11.2.3 DOSE - IODINE-131, IODINE-133, TRITIUM AND RADIONUCLIDES IN PARTICULATE FORM

This Control is provided to implement the requirements of 10CFR50, Appendix I, Sections II.C, III.A and IV.A. The Controls are the guides set forth in 10CFR50, Appendix I, Section II.C. The ACTION statements provide the required operating flexibility and at the same time implement the guides set forth in 10CFR50, Appendix I, Section IV.A, to assure that the releases of radioactive materials in gaseous effluents to UNRESTRICTED AREAS will be kept "as low as is reasonably achievable." The ODCM calculational methods specified in the Surveillance Requirements implement the requirements in 10CFR50, Appendix I, Section III.A, that conformance with the guides of 10CFR50, Appendix I be shown by calculational procedures based on models and data, such that the actual exposure of a MEMBER OF THE PUBLIC through appropriate pathways is unlikely to be substantially underestimated. The ODCM calculational methods for calculating the doses due to the actual release rates of the subject materials are consistent with the methodology provided in Regulatory Guide 1.109, "Calculation of Annual Doses to Man from Routine Releases of Reactor Effluents for the Purpose of Evaluating Compliance with 10CFR50, Appendix I," Revision 1, October 1977, and Regulatory Guide 1.111, "Methods for Estimating Atmospheric Transport and Dispersion of Gaseous Effluents in Routine Releases from Light-Water-Cooled Reactors," Revision 1, July 1977. These equations also provide for determining the actual doses using meteorological conditions concurrent with the time of release of radioactive materials in gaseous effluents or are based upon the historical average atmospheric conditions. The release rate specifications for iodine-131, iodine-133, tritium and radionuclides in particulate form are dependent on the existing radionuclide pathway to man in

RADIOACTIVE EFFLUENTS

BASES

3/4.11.2.3 DOSE - IODINE-131, IODINE-133, TRITIUM AND RADIONUCLIDES IN PARTICULATE FORM (Continued)

the areas at and beyond the SITE BOUNDARY. The pathways which were examined in the development of these calculations were: (1) individual inhalation of airborne radionuclides, (2) deposition of radionuclides onto green leafy vegetation with subsequent consumption by man, (3) deposition onto grassy areas where milk animals and meat-producing animals graze with consumption of the milk and meat by man, and (4) deposition on the ground with subsequent exposure of man.

This Control applies to the release of radioactive materials in gaseous effluents from each reactor at the site. For units with shared radwaste treatment systems, the gaseous effluents from the shared system are proportioned among the units sharing that system.

3/4.11.2.4 AND 3/4.11.2.5 GASEOUS RADWASTE TREATMENT (OFFGAS) SYSTEM AND VENTILATION EXHAUST TREATMENT SYSTEMS

The OPERABILITY of the GASEOUS RADWASTE TREATMENT (OFFGAS) SYSTEM and the VENTILATION EXHAUST TREATMENT SYSTEMS ensures that the systems will be available for use whenever gaseous effluents require treatment prior to release to the environment. The requirement that the appropriate portions of the systems be used, when specified, provides reasonable assurance that the releases of radioactive materials in gaseous effluents will be kept "as low as is reasonably achievable." This Control implements the requirements of 10CFR50.36a; 10CFR50, Appendix A, General Design Criterion; and the design objectives given in 10CFR50, Appendix I, Section II.D. The specified limits governing the use of appropriate portions of the systems were specified as a suitable fraction of the dose design objectives set forth in 10CFR50, Appendix I, Sections II.B and II.C, for gaseous effluents.

This Control applies to the release of radioactive materials in gaseous effluents from each reactor at the site. For units with shared radwaste treatment systems, the gaseous effluents from the shared system are proportional among the units sharing that system.

RADIOACTIVE EFFLUENTS

BASES

3/4.11.4 TOTAL DOSE

This Control is provided to meet the dose limitations of 40CFR190 that have been incorporated into 10CFR20 by 46 FR 18525 and the dose limitations of 10CFR72.104. The Control requires the preparation and submittal of a Special Report whenever the calculated doses due to releases of radioactivity and to radiation from uranium fuel cycle sources exceed 25 mremS to the whole body or any organ, except the thyroid, which shall be limited to less than or equal to 75 mremS. For sites containing up to four reactors, it is highly unlikely that the resultant dose to a MEMBER OF THE PUBLIC will exceed the dose limits of 40CFR190, if the individual reactors remain within twice the dose design objectives of 10CFR50, Appendix I, and if direct radiation doses from the units including outside storage tanks, etc. are kept small. The Special Report will describe a course of action that should result in the limitation of the annual dose to a MEMBER OF THE PUBLIC to within the 40CFR190 limits. For the purposes of the Special Report, it may be assumed that the dose commitment to the MEMBER OF THE PUBLIC from other uranium fuel cycle sources is negligible, with the exception that dose contributions from other nuclear fuel cycle facilities at the same site or within a radius of 8 km must be considered. If the dose to any MEMBER OF THE PUBLIC is estimated to exceed the requirements of 40CFR190, the Special Report with a request for a variance (provided the release conditions resulting in violation of 40CFR190 have not already been corrected), in accordance with the provisions of 40CFR190.11 and 10CFR20.405c, is considered to be a timely request and fulfills the requirements of 40CFR190 until NRC staff action is completed. The variance only relates to the limits of 40CFR190, and does not apply in any way to the other requirements for dose limitation of 10CFR20, as addressed in ODCM Controls 3.11.1.1 and 3.11.2.1. An individual is not considered a MEMBER OF THE PUBLIC during any period in which he/she is engaged in carrying out any operation that is part of the nuclear fuel cycle.

3/4.12 RADIOLOGICAL ENVIRONMENTAL MONITORING

BASES

3/4.12.1 MONITORING PROGRAM

The Radiological Environmental Monitoring Program required by this Control provides representative measurements of radiation and of radioactive materials in those exposure pathways and for those radionuclides that lead to the highest potential radiation exposures of MEMBERS OF THE PUBLIC resulting from the plant operation. This monitoring program implements 10CFR50, Appendix I, Section IV.B.2, and thereby supplements the Radiological Effluent Monitoring Program by verifying that the measurable concentrations of radioactive materials and levels of radiation are not higher than expected on the basis of the effluent measurements and the modeling of the environmental exposure pathways. Guidance for this monitoring program is provided by the Radiological Assessment Branch Technical Position on Environmental Monitoring, Revision 1, November 1979. The initially specified monitoring program will be effective for at least the first 3 years of commercial operation. Following this period, program changes may be initiated based on operational experience.

The required detection capabilities for environmental sample analyses are tabulated in terms of the lower limits of detection (LLDs). The LLDs required by ODCM Table 4.12-1 are considered optimum for routine environmental measurements in industrial laboratories. It should be recognized that the LLD is defined as an *a priori* (before the fact) limit representing the capability of a measurement system and not as an *a posteriori* (after the fact) limit for a particular measurement.

Detailed discussion of the LLD, and other detection limits, can be found in:

- (1) Currie, L. A. "Lower Limit of Detection: Definition and Elaboration of a Proposed Position for Radiological Effluent and Environmental Measurements," NUREG/CR-4007 (September 1984).
- (2) HASL Procedure Manual, HASL-300 (revised annually).

3/4.12.2 LAND USE CENSUS

This Control is provided to ensure that changes in the use of areas at and beyond the SITE BOUNDARY are identified and that modifications to the radiological environmental monitoring program given in the ODCM are made if required by the results of the census. The best information from door-to-door survey, visual or aerial survey or from consulting with local agricultural authorities shall be used. This census satisfies the requirements of 10CFR50, Appendix I, Section IV.B.3. Restricting the census to gardens of greater than 50 m² provides assurance that significant exposure pathways via leafy vegetables will be identified and monitored since a garden of this size is the minimum required to produce the quantity (26 kg/year) of leafy vegetables assumed in Regulatory Guide 1.109 for consumption by a child. To determine this minimum garden size, the following assumptions were made: (1) 20% of the garden was used for growing broad leaf vegetation (i.e., similar to lettuce and cabbage), and (2) a vegetation yield of 2 kg/m².

RADIOLOGICAL ENVIRONMENTAL MONITORING

BASES

3/4.12.3 INTERLABORATORY COMPARISON PROGRAM

The requirement for participation in an approved Interlaboratory Comparison Program is provided to ensure that independent checks on the precision and accuracy of the measurements of radioactive material in environmental sample matrices are performed as part of the quality assurance program for environmental monitoring in order to demonstrate that the results are valid for the purposes of 10CFR50, Appendix I, Section IV.B.2.

6.0

ADMINISTRATIVE CONTROLS

ADMINISTRATIVE CONTROLS

ANNUAL REPORTS

ANNUAL RADIOLOGICAL ENVIRONMENTAL OPERATING REPORT

6.9.1.6 Routine radiological environmental operating reports covering the operation of the unit during the previous year shall be submitted by May 1 of each year.

Rev. 19
DEC 2012

The annual Radiological Environmental Operating Report shall include:

- a. Summaries, interpretations, and an analysis of trends of the results of the radiological environmental surveillance activities for the report period, including a comparison with pre-operational studies, operational controls (as appropriate), and previous environmental surveillance reports and an assessment of the observed impacts of the plant operation on the environment;
- b. The results of land use censuses required by Control 3.12.2;
- c. The results of analysis of all radiological environmental samples and of all locations specified in the table and figures in the Offsite Dose Calculation Manual, as well as summarized and tabulated results of these analyses and measurements in the format of the table in the Radiological Assessment Branch Technical Position, Revision 1, November 1979. In the event that some individual results are not available for inclusion with the report, the report shall be submitted noting and explaining the reasons for the missing results. The missing data shall be submitted as soon as possible in a supplementary report;
- d. A summary description of the Radiological Environmental Monitoring Program; at least two legible maps* covering all sampling locations keyed to a table giving distances and directions from the centerline of one reactor; the results of licensee participation in the Inter-laboratory Comparison Program and the corrective action taken if the specified program is not being performed as required by Control 3.12.3; reasons for not conducting the Radiological Environmental Monitoring Program as required by Control 3.12.1, and discussion of all deviations from the sampling schedule of Table 3.12.1-1; discussion of environmental sample measurements that exceed the reporting levels of Table 3.12.1-2 but are not the result of plant effluents, pursuant to ACTION b of Control 3.12.1; and discussion of all analyses in which the LLD required by Table 4.12.1-1 was not achievable.

* One map shall cover stations near the SITE BOUNDARY; a second shall include the more distant stations.

ADMINISTRATIVE CONTROLS

ANNUAL RADIOACTIVE EFFLUENT RELEASE REPORT

6.9.1.7 Routine radioactive release reports covering the operation of the unit during the previous year shall be submitted annually. The Report shall be submitted by May 1 of each year.

Rev. 19
DEC 2012

The annual Radioactive Effluent Release Report shall include:

- a. A summary of the quantities of radioactive liquid and gaseous effluents released from the unit as outlined in Regulatory Guide 1.21, "Measuring, Evaluating, and Reporting Radioactivity in Solid Wastes and Releases of Radioactive Materials in Liquid and Gaseous Effluents from Light-Water-Cooled Nuclear Power Plants," Revision 1, June 1974, with data summarized on a quarterly basis following the format of Appendix B thereof.
- b. A summary of hourly meteorological data collected over the previous year. This annual summary may be either in the form of an hour-by-hour listing on magnetic tape of wind speed, wind direction, atmospheric stability, and precipitation (if measured), or in the form of joint frequency distributions of wind speed, wind direction, and atmospheric stability.* This report shall include an assessment of the radiation doses due to the radioactive liquid and gaseous effluents released from the unit or station during the previous year. This report shall also include an assessment of the radiation doses from radioactive liquid and gaseous effluents to MEMBERS OF THE PUBLIC due to their activities inside the SITE BOUNDARY (see Figure 3.2-1) during the report period. All assumptions used in making these assessments, i.e., specific activity, exposure time, and location, shall be included in these reports. The assessment of radiation doses shall be performed in accordance with the methodology and parameters in the OFFSITE DOSE CALCULATION MANUAL (ODCM).
- c. An assessment of radiation doses to the likely most exposed MEMBER OF THE PUBLIC from reactor releases and other nearby uranium fuel cycle sources, including doses from primary effluent pathways and direct radiation, for the previous calendar year to show conformance with 40CFR190, "Environmental Radiation Protection Standards for Nuclear Power Operation." Acceptable methods for calculating the dose contribution from liquid and gaseous effluents are given in Regulatory Guide 1.109, Rev. 1, October 1977.

* In lieu of submission with the annual Radioactive Effluent Release Report, the licensee has the option of retaining this summary of required meteorological data on site in a file that shall be provided to the NRC upon request.

ADMINISTRATIVE CONTROLS

ANNUAL RADIOACTIVE EFFLUENT RELEASE REPORT (Continued)

- d. A list and description of unplanned releases from the site to UNRESTRICTED AREAS (see Figure 3.2-1) of radioactive materials in gaseous and liquid effluents made during the reporting period.
- e. Any changes made during the reporting period to the OFFSITE DOSE CALCULATION MANUAL (ODCM), pursuant to PNPP Technical Specification 5.5.1 as well as any major change to Liquid or Gaseous Treatment Systems pursuant to Control 6.15. It shall also include a listing of new locations for dose calculations and/or environmental monitoring identified by the Land Use Census pursuant to Control 3.12.2.
- f. The report shall also include the following: an explanation as to why the inoperability of liquid or gaseous effluent monitoring instrumentation was not corrected within the time specified in Control 3.3.7.9 or 3.3.7.10, respectively; and description of the events leading to liquid holdup tanks exceeding total curie limits.

SPECIAL REPORTS

6.9.2 Special reports shall be submitted in accordance with 10CFR50.4 within the time period specified for each report.

6.10 RECORD RETENTION

- 6.10.1 In addition to the applicable record retention requirements of Title 10 Code of Federal Regulations, the following records shall be retained for at least the minimum period indicated.
- 6.10.2 Records of surveillance activities, inspections, and calibrations required by these Controls shall be retained for at least 5 years:

* Licensee may choose to submit the information called for in this Control as part of the annual USAR update.

ADMINISTRATIVE CONTROLS

6.15 MAJOR CHANGES TO RADIOACTIVE WASTE TREATMENT SYSTEMS*

- 6.15.1 Licensee initiated major changes to the radioactive waste systems, liquid, gaseous and solid:
1. Shall be reported to the Commission in the annual Radioactive Effluent Release Report for the period in which the evaluation was reviewed by the PORC. The discussion of each change shall contain:
 - a. A summary of the evaluation that led to the determination that the change could be made in accordance with 10CFR50.59;
 - b. Sufficient detailed information to totally support the reason for the change without benefit of additional or supplemental information;
 - c. A detailed description of the equipment, components and processes involved and the interfaces with other plant systems
 - d. An evaluation of the change which shows the predicted releases of radioactive materials in liquid and gaseous effluents and/or quantity of solid waste that differ from those previously predicted in the license application and amendments thereto;
 - e. An evaluation of the change which shows the expected maximum exposures to MEMBERS OF THE PUBLIC in the UNRESTRICTED AREA and to the general population that differ from those previously estimated in the license application and amendments thereto;
 - f. A comparison of the predicted releases of radioactive materials, in liquid and gaseous effluents and in solid waste, to the actual releases for the period prior to when the changes are to be made;
 - g. An estimate of the exposure to plant operating personnel as a result of the change; and
 2. Shall become effective upon review and approval by the Plant Manager.

* Licensee may choose to submit the information called for in this Control as part of the annual USAR update.

Records

The following records are completed/generated by this document:

Quality Records

Annual Radioactive Effluent Release Report

Non-Quality Records

None

REFERENCES

1. Title 10, "Energy," Chapter 1, Code of Federal Regulations; Part 20, U.S. Government Printing Office, Washington, D.C. 20402, May 21, 1991.
2. Title 10, "Energy," Chapter 1, Code of Federal Regulations; Part 50; U.S. Government Printing Office, Washington, D.C. 20402, January 1, 1984.
3. Title 40, "Protection of Environment," Chapter 1, Code of Federal Regulations, Part 190, Federal Register, Vol. 42, Washington, D.C. 20402, January 13, 1977.
4. U.S. Nuclear Regulatory Commission, "Preparation of Radiological Effluent Technical Specifications for Nuclear Power Plants," USNRC NUREG-0133, Washington, D.C. 20555, October, 1981.
5. U.S. Nuclear Regulatory Commission, "Draft Radiological Effluent Technical Specifications for PWR's," USNRC NUREG-0473, Revision 2, Washington, D.C. 20555, February, 1980.
6. Regulatory Guide 1.21, "Measuring, Evaluating, and Reporting Radioactivity in Solid Wastes and Releases of Radioactive Materials in Liquid and Gaseous Effluents from Light-Water-Cooled Nuclear Power Plants," Revision 1, U.S. Nuclear Regulatory Commission, Washington, D.C. 20555, June 1974.
7. Regulatory Guide 1.109, "Calculation of Annual Doses to Man from Routine Releases of Reactor Effluents for the Purpose of Evaluating Compliance with 10CFR 50, Appendix I," Revision 0, U.S. Nuclear Regulatory Commission, Washington, D.C. 20555, March 1976.
8. Regulatory Guide 1.109, "Calculation of Annual Doses to Man from Routine Releases of Reactor Effluents for the Purpose of Evaluating Compliance with 10CFR Part 50, Appendix I," Revision 1, U.S. Nuclear Regulatory Commission, Washington, D.C. 20555, October 1977.
9. Regulatory Guide 1.111, "Methods for Estimating Atmospheric Transport and Dispersion of Gaseous Effluents in Routine Releases from Light-Water-Cooled Reactors," Revision 1, U.S. Nuclear Regulatory Commission, Washington, D.C. 20555, July 1977.
10. Regulatory Guide 1.113, "Estimating Aquatic Dispersion of Effluents from Accidental and Routine Reactor Releases for the Purpose of Implementing Appendix I," Revision 1, U.S. Nuclear Regulatory Commission, Washington, D.C. 20555, April 1977.

REFERENCES (Cont.)

11. Regulatory Guide 4.15, "Quality Assurance for Radiological Monitoring Programs (Normal Operation) - Effluent Streams and the Environment," U.S. Nuclear Regulatory Commission, Washington, D.C. 20555, February 1979.
12. U.S. Nuclear Regulatory Commission, "Branch Technical Position," Revision 1, Washington, D.C. 20555, November 1979.
13. Perry Nuclear Power Plant, Unit 1 and 2, "Final Safety Analysis Report," Amendment 14, The Cleveland Electric Illuminating Company, Perry, Ohio 44081, August 1984.
14. Perry Nuclear Power Plant, Units 1 and 2, "Environmental Report, Operating License Stage," Supplement 3, The Cleveland Electric Illuminating Company, Perry, Ohio 44081, November 1981.
15. Perry Nuclear Power Plant, Units 1 and 2, "Radiological Environmental Monitoring Program Manual," The Cleveland Electric Illuminating Company, Perry, Ohio 44081, February 1985.
16. "Midas User's Manual, for the Cleveland Electric Illuminating Company, Perry Nuclear Power Plant," Pickard, Lowe and Garrick, Washington, D.C. 20036, July 1983.
17. Kocher, D.C., "Radioactive Decay Data Tables," Technical Information Center, U.S. Department of Energy, Springfield, Virginia 22161, September 1985.
18. 1989 Engineering Report "Lake Erie Potable Water Facilities and Intakes within 50 Miles of PNPP, (Ref. SO-11552 "E").
19. Perry Environmental Report Operating License Stage, Table 5.1-10 "Annual Average Dilution Factors for Lake Water Intakes within 50 Miles of PNPP and Q&R Page 2.1-2.
20. PNPP Ohio Power Siting Commission application of August 1974, Appendix 1304-C-2, Table IV-A-2.
21. Total Angler Catch (1987 annual) for Each Grid Location; per letter from Michael R. Rawson, Fairport Fisheries Research Station, Ohio Department of Natural Resources (6-20-88).
22. Offsite Dose Calculation Manual Guidance: Standard Radiological Effluent Controls for Boiling Water Reactors; Generic Letter 89-01, Supplement No. 1.
23. Federal Guidance Report 13 CD Supplement: Cancer Risk Coefficients for Environmental Exposure to Radionuclides.

Enclosure C
L-13-138

Process Control Program, Revision 12

PERRY OPERATIONS MANUAL

Process Control Program

TITLE: PROCESS CONTROL PROGRAM (PCP)

REVISION: 12 EFFECTIVE DATE: 12-19-11

PREPARER: Mark R. Wolph 9-20-11
/ Date

APPROVER: Alan K. Schwenk 12-12-11
/ Date

PROCESS CONTROL PROGRAM (PCP)

Table of Contents

<u>Section</u>	<u>Title</u>	<u>Page</u>
1.0	<u>INTRODUCTION</u>	1
1.1	Definitions	1
2.0	<u>WASTE TYPES</u>	2
2.1	Deleted	2
2.2	Bead Resins (SRT)	2
2.3	Filter Demineralizer Media Sludge Powdered Resin Waste Stream	3
2.4	Irradiated Hardware	3
2.5	Filter Cartridges	3
2.6	Dry Active Waste (DAW)	4
2.7	Other Materials	4
3.0	<u>PROCESS DESCRIPTION</u>	4
3.1	Batch Tank Processing	4
3.1.1	Filling of Tanks	4
3.1.2	Sampling/Analysis	4
3.1.3	Preconditioning	5
3.1.4	Deleted	5
3.1.5	Dewatering	5
3.2	Dewatering Process	5
3.3	Cartridge Filters	11
3.4	Dry Active Waste	11
3.5	Other Waste Forms and Processes	11
4.0	<u>PRODUCT CONTROL</u>	12
4.1	Deleted	12
4.2	Product Quality	12
4.3	Acceptability	12
5.0	<u>WASTE CLASSIFICATION, CHARACTERIZATION AND MANIFEST REQUIREMENTS</u>	13
5.1	Waste Classification	13
5.2	Waste Characteristics and Manifest Requirements	13
6.0	<u>ADMINISTRATIVE CONTROLS</u>	14
7.0	<u>QUALITY ASSURANCE</u>	14
8.0	<u>RECORDS</u>	17
9.0	<u>ATTACHMENTS</u>	17
10.0	<u>REFERENCES</u>	17
10.1	Commitments	17
APPENDIX A	Controls	18
REFERENCES		38

SCOPE OF REVISION:

- Rev. 12 - 1. Changed 3.1.1 to permit the use of uniquely numbered seals as a replacement for the clearance program for isolating tanks for processing.

PROCESS CONTROL PROGRAM (PCP)

1.0 INTRODUCTION

The Process Control Program (PCP) is designed to provide administrative control and guidance for the dewatering and other processing of applicable forms of radwaste for ultimate disposal. The PCP contains information pertaining to the current processes and determinations to be made to ensure that the processing and packaging of radioactive wastes, based on demonstrated processing of actual or simulated wet solid wastes, will be accomplished in such a way as to ensure compliance with 10CFR20, 10CFR61, 10CFR71, Federal and State regulations, burial ground requirements and other requirements governing the disposal of radioactive waste.

The PCP is applicable to the plant installed and Energy Solutions and Chem--Nuclear Systems Inc. and their successors or assigns supplied mobile radwaste systems for dewatering of applicable waste forms. Waste packaged for intermediary processing at offsite vendors shall be prepared for shipment in accordance with the specific vendor's instructions and waste acceptance criteria, or approved operations manual instructions. All dewatering at Perry will be performed by a vendor dewatering system with a Topical Report that is accepted by the NRC and destination burial site(s) as meeting all necessary requirements. <B00797>

Features have been incorporated into the design of the solid radioactive waste system and the building housing this system to insure that exposures of operating personnel to radiation will be kept within ALARA guidelines.

Appendix A of the PCP was prepared based on guidance of NUREG-1302 "Offsite Dose Calculation Manual Guidance: Standard Radiological Effluent Controls for Boiling Water Reactors," Generic Letter 89-01, Supplement No. 1. This appendix along with plant procedures will be used by plant personnel to demonstrate compliance with Operational Requirements Manual (ORM) Section 7.9. (Process Control Program).

1.1 Definitions

The following definitions are applicable to the sections that follow:

ACCEPTABLE ENVELOPE: (of dewatering): specific properties of wastes that fall within the limits of the parameters required for dewatering. These parameters are established within the vendor waste acceptance criteria or Topical Report for each applicable waste type. <B00797>

BATCH: the volume of isolated waste contained in a tank that will be processed for dewatering.

CONTAINER: the physical container in which the final waste product is deposited.

HIGH INTEGRITY CONTAINER (HIC): a burial site licensing department approved container for burial having an expected life of 300 years and provides the stability to meet burial requirements. All HIC's must have an approved Certificate of Compliance.

Deleted

2.0 WASTE TYPES

There are numerous types of radioactive waste expected to be generated at the Perry Plant that will require processing, including dewatering or burial site approved intermediary offsite vendor process prior to their disposal. These radwaste types can be categorized based on their chemical and physical properties. The waste types expected at PNPP are bead resins, filter demineralizer media sludge, traveling belt filter cake, filter cartridges, oily waste, and dry active waste (DAW).

The following waste types (other than DAW) may be dewatered individually or in combination, with the provision that the chemistry of the waste falls within the acceptable envelope for dewatering.

2.1 Deleted

2.2 Bead Resins (SRT)

Bead resins are collected from the condensate, liquid radwaste, and suppression pool demineralizers and stored in the spent resin tank. Bead resins are also collected from chemical decontamination processes. Bead resin from the liquid radwaste and suppression pool demineralizers may contain activated carbon.

2.3 Filter Demineralizer Media Sludge Powdered Resin Waste Stream

Sludge is the waste product generated by the backwash of the condensate filters, the radwaste traveling belt filters, the reactor water cleanup filter/demineralizers, and the fuel pool filter/demineralizers. Sludge may consist of powdered ion exchange resin at varying degrees of exhaustion, fibrous filter media, and small concentrations of various solids and corrosion products. The media are normally decanted in the appropriate settling tank prior to dewatering or preparation for offsite processing.

The waste in this category is normally separated into two waste streams. The Condensate, Fuel Pool and Radwaste Filter media is collected into and processed from one of four Settling Tanks as a single waste stream.

The Reactor Water Cleanup filter/demineralizer waste is processed separately from the other powdered resin waste due to its higher activity levels. This waste stream is collected into and processed from one of two smaller settling tanks.

2.4 Irradiated Hardware

- a. Irradiated hardware removed from the internal area of the reactor pressure vessel is processed and packaged in the spent fuel pool(s)/cask storage pit. This waste stream is considered Irradiated Hardware.
- b. The constituents of this waste stream may include control rod blades, LRPMSs, IRMs, TIPS and components expended during hardware processing and packaging activities. Startup sources may also be processed as part of this waste stream.
- c. Irradiated hardware is packaged in steel liners or other suitable disposal containers for disposal.
- d. Liquid shall be drained to ensure the burial site free liquid Acceptance Criteria is met.
- e. Irradiated hardware should not be mixed with any other waste type in final processing due to differences in stability requirements. Mixing of this waste stream with other wastes can only occur with approval from the disposal site or the waste processor.

2.5 Filter Cartridges

Filter cartridges from the CRD pump suction and discharge filters, non-precoat condensate filter septa and any other disposable-type filter cartridge, or non metallic filter septa, that may be used in permanent or temporary, plant or vendor systems are included in this category.

2.6 Dry Active Waste (DAW)

Contaminated air filters, paper, rags, clothing, tools, trash, equipment and parts, that cannot be effectively decontaminated are contained in this category. Also included are laboratory wastes.

Oily waste is that oil collected in liquid radwaste systems resulting from leakage and maintenance on various lubrication and hydraulic systems. Oily waste is considered part of the DAW waste stream because it is contaminated with the same types of corrosion products. However, oily waste does require special processing prior to disposal.

2.7 Other Materials

Various other materials not specifically identified above, will be evaluated for dewatering, or other process on a case-by-case basis.

3.0 PROCESS DESCRIPTION

The following process descriptions apply to both plant and vendor supplied systems. Any differences between the two have been noted.

3.1 Batch Tank Processing

3.1.1 Filling of Tanks

Once it is determined that a liquid radwaste system batch tank is to be processed, it will be recirculated to ensure a homogeneous mixture. Eductors inside the tanks enhance the mixing capabilities. To ensure that no additional waste is added to the tank, the tank inlet valve control switch will be isolated using uniquely numbered seal devices that must be destroyed to permit operation of the switch.

3.1.2 Sampling/Analysis

Samples will be obtained and analyzed for each batch of waste in accordance with appropriate site chemistry instructions for the plant system, or vendor procedures and PCP for vendor supplied sampling systems. Prior to sampling, tanks will undergo sufficient mixing and/or recirculation to ensure representative sampling. At a minimum analysis will be performed for radionuclide content, pH, oil content, and settled solids (oil and concentrates only). At a minimum, for dewatering, analyses will be performed for radionuclide and oil content. These analyses are necessary to ensure that the waste falls within the acceptable envelopes for dewatering. Samples of waste destined for off site processing shall be analyzed as required to ensure the waste processor's 'Waste Acceptance Criteria' or topical report requirements are satisfied.

3.1.3 Preconditioning

Waste preconditioning may be performed on waste streams which are or will be dewatered or processed offsite to eliminate or reduce bacterial activity in the waste. Preconditioning of waste streams for this purpose will be conducted in accordance with approved site and/or vendor procedures.

Oily wastes may require special preconditioning. Handling of oily wastes will be conducted in accordance with burial site requirements.

3.1.4 Deleted.

3.1.5 Dewatering

Dewatering is the removal of water from solid material to a concentration of less than 0.5% or 1.0% by volume, as applicable to containers used and burial site limits. Dewatering of radioactive spent resins and filter sludges shall be performed in accordance with approved operating procedures which are based upon documented test data demonstrating the ability to achieve drainable water limits as specified in applicable regulations.

3.2 Dewatering Process

3.2.1 Description of Plant Processing System

Dewatering of wet solid radioactive waste will be processed by Energy Solutions Rapid Dewatering System or Energy Solutions Resin Drying System. These systems are discussed in Section 3.2.2. The following description applies to the plant installed solid radwaste system that will interface with the vendor equipment (See Figure 1).

Solid Radioactive Waste Processing System

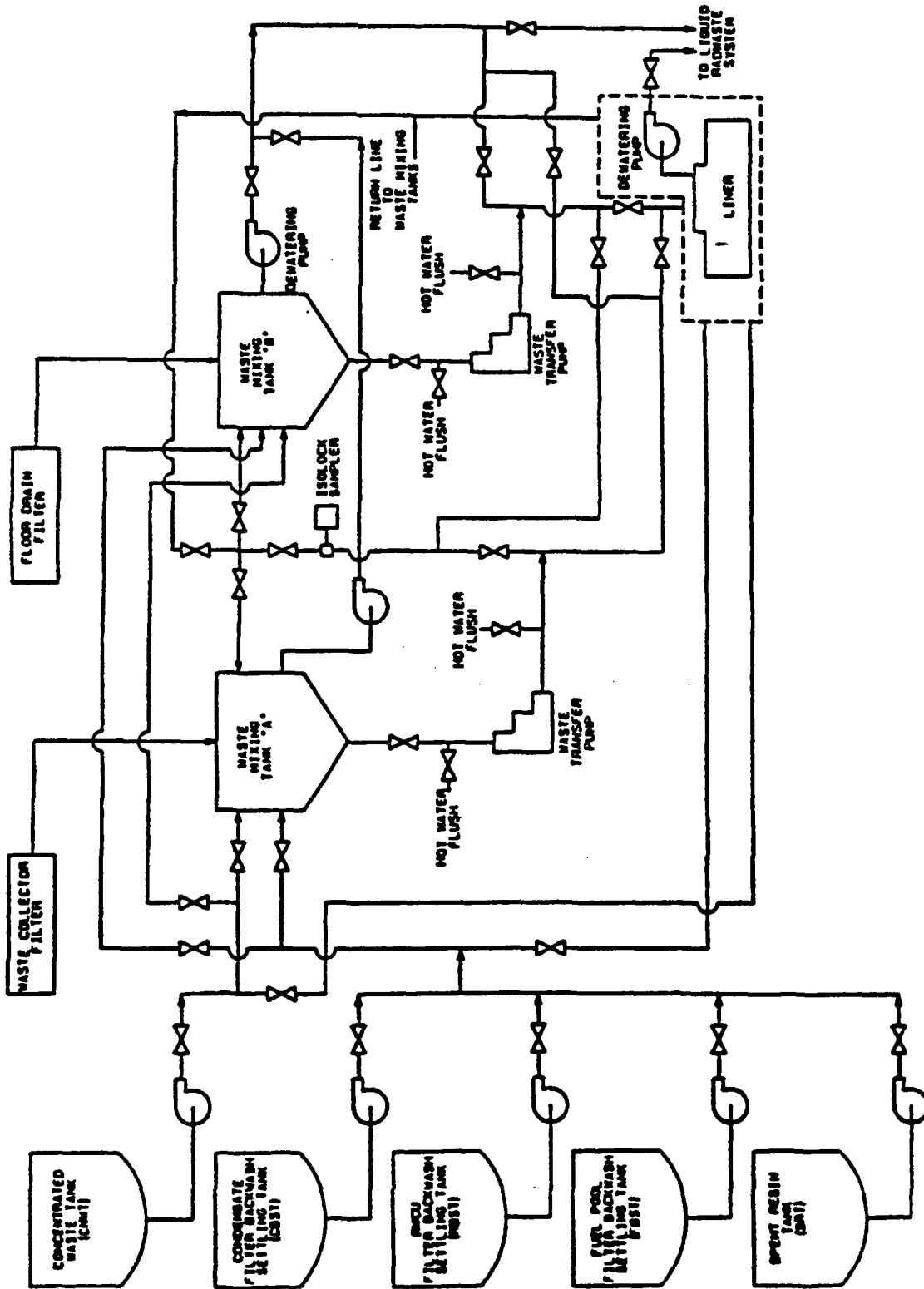

Figure 1

After the proper amount of waste has been accumulated in a settling or waste tank or has been transferred to the waste mixing tank, the tank is decanted to remove excess free water (except when the waste being handled is traveling belt filter cake, in which case a predetermined amount of water or other approved aqueous solution is added to the tank for slurry transfer of the contents). The waste slurry is transferred to the vendor's equipment, in accordance with RWI-G51 (SRW), where it is dewatered. The waste mixing tanks and settling tanks have recirculation capabilities where a representative sample can be drawn. A dewatering connection is routed to the liquid radwaste system. Flush water connections are provided to thoroughly flush the plant and the vendor equipment into the liner used for processing. The waste transfer line and dewatering return lines are located behind a two foot thick shield wall to reduce exposure to the operator during processing.

3.2.2 Description of the Vendor's Waste Processing System

The wet solid radioactive waste will be transferred to the vendor's equipment to be dewatered in accordance with site approved procedures. Table 1 lists the Topical Reports, procedures and any comments for each vendor.

The vendor's equipment is located in the Radwaste Building in the fill aisle, storage area, and truck bay (see Figure 2). Normal processing of radioactive waste will be performed in the fill aisle with the dewatering equipment located in the truck bay. Periodically, when determined prudent, waste will be processed in the truck bay. When this is performed several restrictions will be imposed to minimize the potential for radioactive spill and ensure the principles of ALARA are maintained. These include; all processing to be performed in a High Integrity Container (HIC) placed inside a shipping package, all hosing and associated connections to be placed in hose bags, truck bay access doors to have temporary curbing placed in front of them, and locking all access areas to the truck bay. The areas where the processing takes place are specifically designed to handle the movement, storage, and processing of radioactive waste. Concrete walls and floors in these areas have protective coatings and shield/ cask walls are provided between the vendors equipment and potential radioactive sources to keep personnel exposures ALARA. The storage area is large enough to contain approximately 15 liners. This provides adequate storage before it is shipped to a burial site, or transferred to the On Site Storage Area.

Vendor Procedures for Radwaste Processing

<u>Vendor</u>	<u>Topical Report</u>	<u>Operating Procedures</u>	<u>Comments</u>
Energy Solutions	Radioactive Waste Dewatering System, RDS-25506-01-P-A	Setup and Operating Procedure for the RDS-1000 Unit, FO-OP-032	
	Deleted.		
Energy Solutions	Vectra Dewatering System, TP-02-P-A	Resin Drying (Dewatering) System, OM-42-WS	
	Deleted		

Table 1

Vendor Mobile Dewatering Equipment Layout

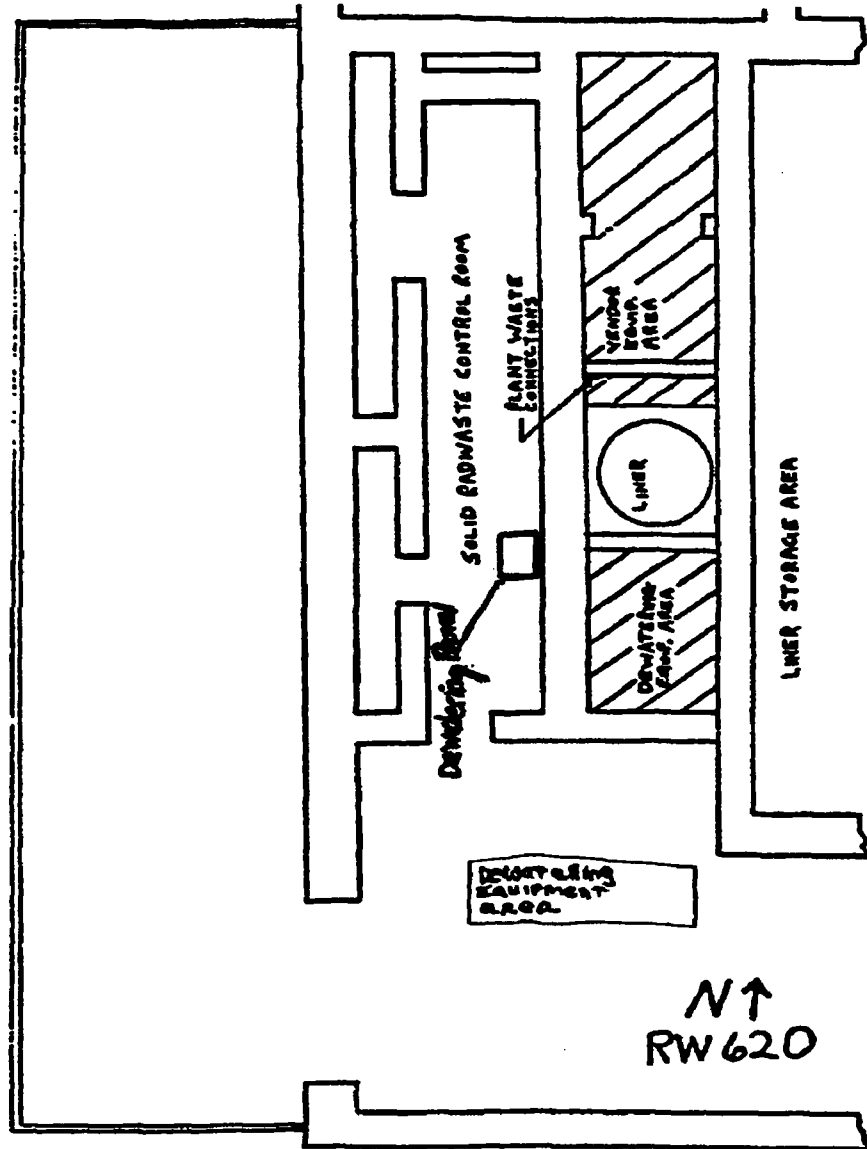

Figure 2

3.2.3 Radiological Effluent Controls and Monitoring

All processing with the vendor's equipment will be performed in a room with a volume sufficient to contain any postulated spill. A floor drain, routed to the liquid radwaste system, provides drainage in this area. All liquid radwaste discharges are sampled and monitored prior to their release to the environment.

Gaseous discharges from liners are processed through the vendor's off-gas blower system as described in the vendor's Topical Report. Ventilation from the areas housing the radwaste treatment and processing equipment, including the vendor's off-gas blower system, is routed through HEPA filters and charcoal beds prior to release to the environment via the Unit 1 Vent. Radiological monitoring is provided for Regulatory Guide 1.21 compliance to meet applicable Federal Code requirements.

3.2.4 Radiation Protection Support

Radiation Protection personnel will provide radiological control during the dewatering process. All work will be conducted under a Radiation Work Permit to keep personnel exposures ALARA.

3.2.5 Plant Utility Support

1. Fire Protection

Fire suppression is provided above the processing and storage area to protect against fires. A fire hose is available in the truck bay for miscellaneous uses.

2. Two-Way Communication

A two-way communication system will be used for communication between the plant operator and the vendor equipment operator. This will facilitate smooth coordination between the different segments of the waste processing system.

3. Heating and Ventilation

The Radwaste Building Ventilation System will maintain a negative pressure in the processing and storage area. Heating is provided by the building heating system.

4. Overhead Crane

An overhead crane will be used to transfer equipment between the storage and processing area and the truck bay. The crane has a 15 ton capacity which is fully capable of handling dewatered liners.

5. Closed Circuit Television

Closed Circuit Television will be used, where applicable, for remote viewing of the processing and storage areas. The overhead crane has an independent camera system for viewing all lifting and placing operations.

3.3 Cartridge Filters

Cartridge filters may be disposed of by encapsulation in a cement matrix in steel drums or liners. The encapsulation of cartridge filters shall be performed using approved procedures that provide reasonable assurance that the final waste form will meet the stability criteria of the Branch Technical Position on Waste Form. Cartridge filters may also be disposed of by placement in HIC's that are certified by the land disposal facility's State Agency. Additionally, cartridge filters may be sent to an offsite processor for processing if the filters meet the requirements of the processors waste acceptance criteria.

3.4 Dry Active Waste

Potentially contaminated dry wastes will be collected in containers located throughout the radiologically controlled areas within the plant. The waste will be periodically collected and transported to a temporary storage area prior to waste segregation onsite or offsite. Waste segregation will be performed to reduce waste volume and to recover reusable materials.

In order to reduce the waste volume, compressible waste will be compacted into shipping containers in accordance with applicable PNPP instructions, or sent to an offsite processor for volume reduction and/or final waste form packaging prior to disposal. Caution will be taken to avoid items that would cause free water formation as well as other compressibility hazards. Noncompressible waste will be loaded manually into suitable shipping containers.

The Waste Abatement and Reclamation Facility (WARF) is utilized (as an alternative to the Radwaste Building) for rad-material/Dry Active Waste (DAW) processing and storage areas. The WARF is used as a staging and processing area for items such as radioactive material and radioactive waste. It also houses a 96 ft 3 box compactor that can be utilized to supplement or as an alternative to the drum compactor located in the Radwaste Building.

3.5 Other Waste Forms and Processes

Waste forms and/or processes not previously discussed shall have an approved PNPP or vendor procedure to govern the process. The final waste product at PNPP must meet either: the disposal site waste acceptance criteria, the offsite waste processor's waste acceptance criteria, or be specifically waived in writing from the waste acceptance criteria by the disposal site or offsite waste processor prior to shipment of the material from PNPP.

4.0 PRODUCT CONTROL

Dewatering processes will be conducted by qualified PNPP or vendor personnel in accordance with approved plant and/or vendor operating instructions and procedures.

Waste processed for on site storage will be processed to meet final disposal site criteria.

Waste processed for off site processing will be gross dewatered or processed to meet the off site processor's specification.

PAP-0525, Solid Radwaste Administration will ensure appropriate documentation and compliance with this program.

4.1 Deleted

4.2 Product Quality

Dewatering process product quality shall be ensured by compliance with approved plant or vendor instructions.

4.3 Acceptability

The acceptability of the dewatered product shall be verified by ensuring that less than 0.5% free standing water exists.

Gross dewatered waste shall have no visible free standing water or will meet off site processor's specifications.

Adherence to approved dewatering operating procedures ensure the final product will meet or exceed the standing water requirements of 10CFR61.

Dewatering of radioactive bead resin, filter demineralizer media sludge, and traveling belt filter cake shall be performed in accordance with approved operating procedures which are based upon documented test data demonstrating the ability to remove free water volumes below the applicable regulatory limits.

5.0 WASTE CLASSIFICATION, CHARACTERIZATION AND MANIFEST REQUIREMENTS

5.1 Waste Classification

All wastes shall be classified in accordance with the requirements of 10CFR61 as implemented by applicable plant instructions and procedures. Waste classifications may be performed by radwaste shipping computer codes. Analyses shall be performed on the waste streams at least annually (biennially for Class A waste), to determine the isotopic abundance of non-gamma emitting isotopes in the streams. Scaling factors, for the non-gamma emitting and transuranic constituents, will be developed from these analyses. Prior to the establishment of an acceptable data, estimated isotopic concentrations will be those obtained from the "Data Base Analysis Report, August 1985" prepared by Waste Management Group, Inc. (WMG, Inc.).

The activity of each radionuclide in the radioactive waste shall be determined by a calculational method employing the isotopic analysis of the waste and scaling factors or a dose-to-curie conversion. For DAW, a dose-to-curie conversion factor, percent fraction of the radionuclides and scaling factors will be used to determine activity.

5.2 Waste Characteristics and Manifest Requirements

All wastes shall meet the characteristic requirements of 10CFR61.56 (a) and (b), as applicable, and waste packages shall be marked to identify the waste class. The manifesting requirements of 10CFR20.2006 shall be implemented by PNPP shipping instructions, and radwaste shipping computer codes may be utilized. Records are maintained in accordance with 10CFR71.91.

6.0 ADMINISTRATIVE CONTROLS

Compliance with applicable state and federal regulations, and with burial site criteria is ensured by compliance with the solid radioactive waste operating instruction RWI-G51 (SRW).

The implementing instructions and procedures for radioactive waste dewatering and segregation describe the requirements which must be met prior to processing radioactive waste, as well as the expected condition of the resultant waste form. Plant staff personnel shall provide Radiation Protection and Quality Assurance coverage, operate plant radioactive waste systems, collect waste stream samples, and perform isotopic analyses. Copies of all referenced documents are available onsite for use by personnel engaged in waste processing activities.

Any changes to the Process Control Program shall be reviewed by the Plant Operations Review Committee (PORC) and shall be detailed in the Annual Radioactive Effluent Release Report covering that period. The PROCESS CONTROL PROGRAM shall be modified as required, as provided in Perry Nuclear Power Plant Unit 1 ORM.

7.0 QUALITY ASSURANCE

Training and qualification of operators will be performed per Regulatory Guide 1.8 and ANSI N18.1 - 1971.

Quality of the end product of dewatered waste for final disposal shall be assured by processing per approved plant or vendor procedures.

Quality of gross dewatered waste shall be assured by processing per approved plant or vendor procedures.

For accountability of filled waste containers, a clearly legible storage diagram will be permanently displayed near the radwaste control panel. It will show the position of containers holding wastes, and may contain additional information (i.e., the date the wastes were processed, and their dose rate(s)). The storage diagram will be updated to reflect any changes, additions, or deletions to storage.

Radwaste Process Flow Chart

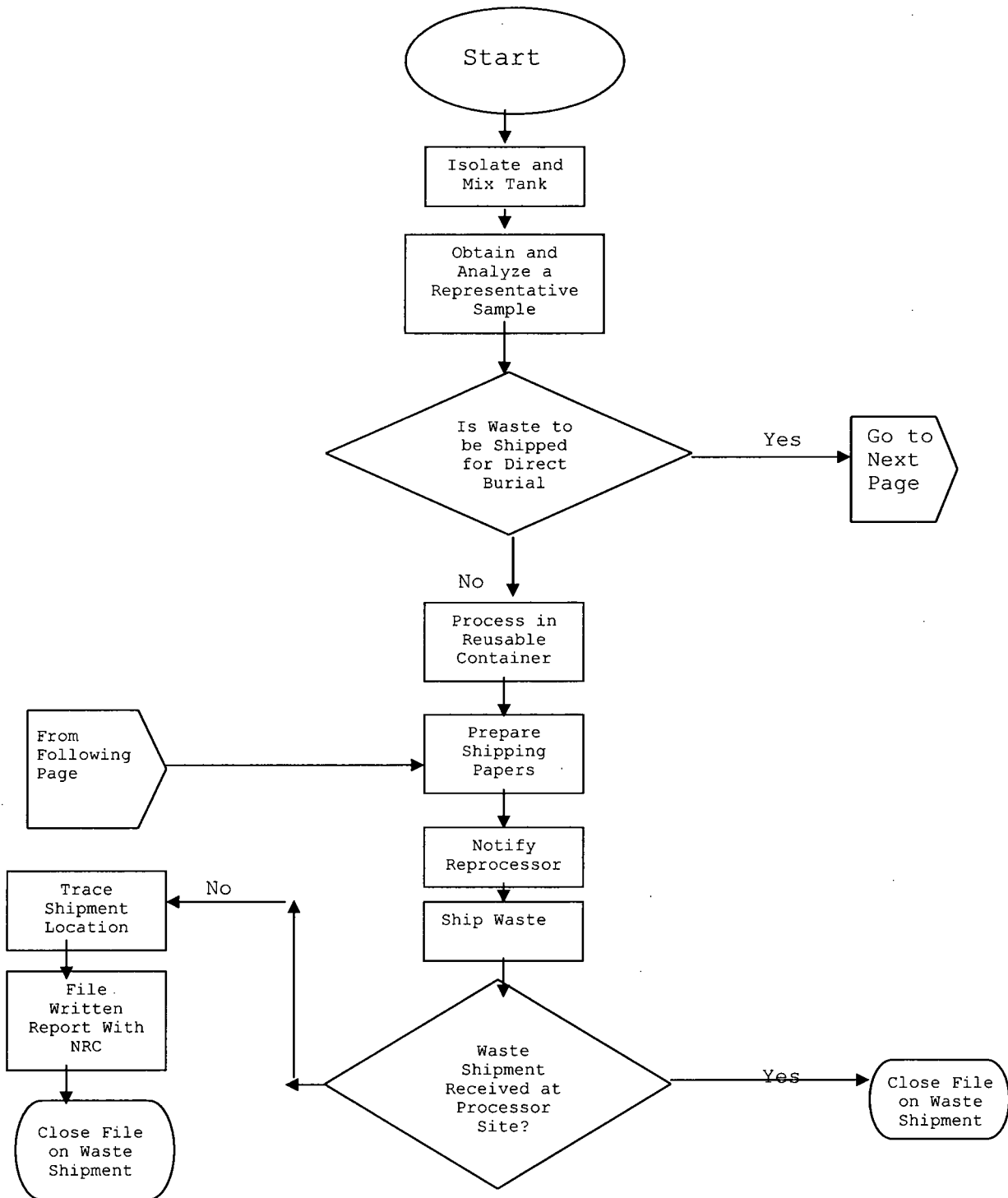

Figure 3

Radwaste Process Flow Chart

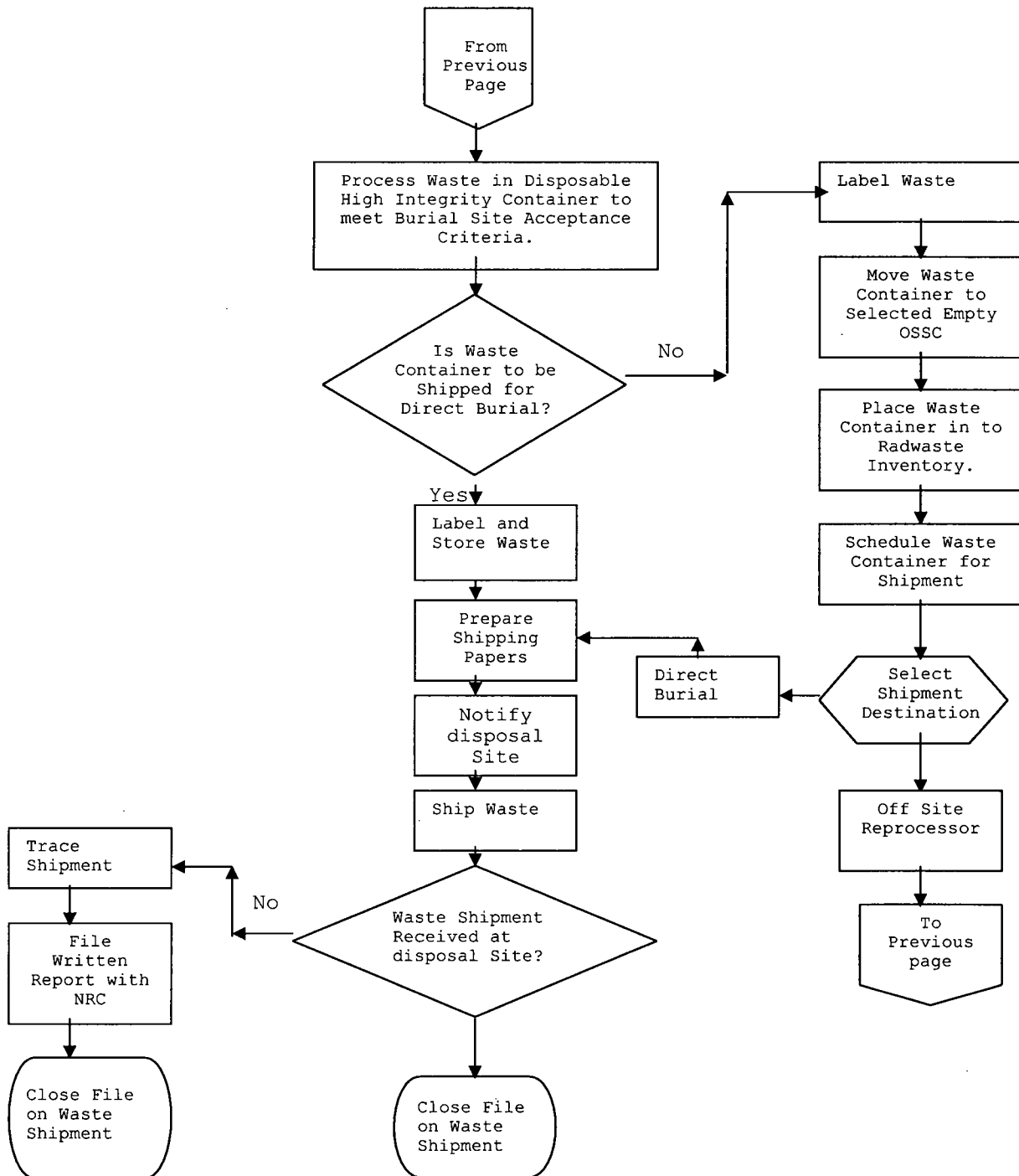

Figure 3

8.0 RECORDS

The following records are completed/generated by this program:

Quality Records

None

Non-Quality Records

None

9.0 ATTACHMENTS

None

10.0 REFERENCES

10.1 Commitments

The following commitments are wholly or in part met by this document:

B00301 B00797 F01412

APPENDIX A

Controls

INDEX

DEFINITIONS

SECTION

<u>1.0 DEFINITIONS</u>	<u>PAGE</u>
1.1 ACTION.....	1-1
1.26 MEMBER(S) OF THE PUBLIC.....	1-1
1.28 OFFSITE DOSE CALCULATION MANUAL.....	1-1
1.29 OPERABLE - OPERABILITY.....	1-1
1.30 OPERATIONAL CONDITION - CONDITION.....	1-1
1.34 PROCESS CONTROL PROGRAM.....	1-2
1.42 SITE BOUNDARY.....	1-2
1.49 UNRESTRICTED AREA.....	1-2

CONTROLS AND SURVEILLANCE REQUIREMENTS

3/4.0 APPLICABILITY.....	3/4 0-1
<u>3/4.11 RADIOACTIVE EFFLUENTS</u>	
3/4.11.3 SOLID RADWASTE TREATMENT.....	3/4 2-1

BASES

3/4.0 APPLICABILITY.....	B 3/4 0-1
<u>3/4.11.3 SOLID RADIOACTIVE WASTE</u>	B 3/4 3-1

ADMINISTRATIVE CONTROLS

6.9.1.7 ANNUAL RADIOACTIVE EFFLUENT RELEASE REPORT.....	4-1
6.15 MAJOR CHANGES TO RADIOACTIVE WASTE TREATMENT SYSTEMS.....	4-2

DEFINITIONS

The following terms are defined so that uniform interpretation of these Control may be achieved. The defined terms appear in capitalized type and be applicable throughout these Controls.

ACTION

1.1 ACTION shall be that part of a Control which prescribes remedial measures required under designated conditions.

MEMBER(S) OF THE PUBLIC

1.26 MEMBER(S) OF THE PUBLIC shall include all persons who are not occupationally associated with the plant. This category does not include employees of the utility, its contractors, or vendors. Also excluded from this category are persons who enter the site to service equipment or to make deliveries. This category does include persons who use portions of the site for recreational, occupational, or other purposes not associated with the plant.

OFFSITE DOSE CALCULATION MANUAL (ODCM)

1.28 The OFFSITE DOSE CALCULATION MANUAL shall contain the methodology and parameters used in the calculation of offsite doses due to radioactive gaseous and liquid effluents, in the calculation of gaseous and liquid effluent monitoring alarm/trip setpoints, and in the conduct of the radiological environmental monitoring program.

The ODCM shall also contain (1) the Radioactive Effluent Controls and Radiological Environmental Monitoring Programs required by Specification 5.5.1 and (2) descriptions of the information that should be included in the Annual Radiological Environmental Operating and Annual Radioactive Effluent Release Reports required by Specifications 5.6.2 and 5.6.3.

OPERABLE - OPERABILITY

1.29 A system, subsystem, train, component or device shall be OPERABLE or have OPERABILITY when it is capable of performing its specified function(s) and when all necessary attendant instrumentation, controls, electrical power, cooling or seal water, lubrication or other auxiliary equipment that are required for the system, subsystem, train, component or device to perform its function(s) are also capable of performing their related support function(s).

OPERATIONAL CONDITION - CONDITION

1.30 An OPERATIONAL CONDITION, i.e., CONDITION, shall be any one inclusive combination of mode switch position and average reactor coolant temperature as specified in Table 1.2.

PROCESS CONTROL PROGRAM (PCP)

1.34 The PROCESS CONTROL PROGRAM shall contain the current formulas (reference vendor topical reports; Energy Solutions Radwaste dewatering System, TP-02-P-A), sampling, analyses, and determinations to be made to ensure that the processing and packaging of solid radioactive wastes based on demonstrated processing will be accomplished in such a way as to assure compliance with 10 CFR Part 20, 10 CFR Part 61, 10 CFR Part 71 and Federal and State regulations, burial ground requirements and other requirements governing the disposal of the radioactive waste.

SITE BOUNDARY

1.42 The SITE BOUNDARY shall be that line beyond which the land is neither owned, nor leased, nor otherwise controlled by the licensee.

DELETED

UNRESTRICTED AREA

1.49 An UNRESTRICTED AREA shall be any area at or beyond the SITE BOUNDARY access to which is not controlled by the licensee for purposes of protection of MEMBERS OF THE PUBLIC from exposure to radiation and radioactive materials, or any area within the SITE BOUNDARY used for residential quarters or for industrial, commercial, institutional, and/or recreational purposes.

PCP
Page: 22
Rev.: 12

Deleted.

TABLE 1.2

OPERATIONAL CONDITIONS

<u>CONDITION</u>	<u>MODE SWITCH POSITION</u>	<u>AVERAGE REACTOR COOLANT TEMPERATURE</u>
1. POWER OPERATION	RUN	N/A
2. STARTUP	Refuel ^(a) or Startup/Hot Standby	N/A
3. HOT SHUTDOWN ^(a)	Shutdown	> 200 °F
4. COLD SHUTDOWN ^(a)	Shutdown	≤ 200 °F
5. REFUELING ^(b)	Shutdown or Refuel	N/A

(a) All reactor vessel head closure bolts fully tensioned.

(b) One or more reactor vessel head closure bolts less than fully tensioned.

3/4.0 APPLICABILITY

CONTROLS

3.0.1 Compliance with the Controls contained in the succeeding controls is required during the OPERATIONAL CONDITIONS or other conditions specified therein; except that upon failure to meet the Control, the associated ACTION requirements shall be met.

3.0.2 Noncompliance with a control shall exist when the requirements of the Control and associated ACTION requirements are not met within the specified time intervals. If the Control is restored prior to expiration of the specified time intervals, completion of the Action requirements is not required.

3.0.3 When a Control is not met, except as provided in the associated ACTION requirements, within one hour action shall be initiated to place the unit in an OPERATIONAL CONDITION in which the control does not apply by placing it, as applicable, in:

1. At least STARTUP within the next 6 hours,
2. At least HOT SHUTDOWN within the following 6 hours, and
3. At least COLD SHUTDOWN within the subsequent 24 hours.

Where corrective measures are completed that permit operation under the ACTION requirements, the ACTION may be taken in accordance with the specified time limits as measured from the time of failure to meet the Control. Exceptions to these requirements are stated in the individual controls.

This control is not applicable in OPERATIONAL CONDITIONS 4 or 5.

3.0.4 When a Control is not met, entry into an OPERATIONAL CONDITION or other specified condition in the Applicability shall only be made:

- a. When the associated ACTIONS to be entered permit continued operation in the OPERATIONAL CONDITION or other specified condition in the Applicability for an unlimited period of time;
- b. After performance of a risk assessment addressing inoperable systems and components, consideration of the results, determination of the acceptability of entering the OPERATIONAL CONDITION or other specified condition in the Applicability, and establishment of risk management actions, if appropriate; exceptions to this Control are stated in the individual Controls, or
- c. When an allowance is stated in the individual value, parameter, or other Control.

This Control shall not prevent changes in OPERATIONAL CONDITIONS or other specified conditions in the Applicability that are required to comply with ACTIONS.

APPLICABILITY

SURVEILLANCE REQUIREMENTS

4.0.1 Surveillance Requirements shall be met during the OPERATIONAL CONDITIONS or other conditions specified for individual Controls unless otherwise stated in an individual Surveillance Requirement.

4.0.2 Each Surveillance Requirement shall be performed within the specified surveillance interval with a maximum allowable extension not to exceed 25 percent of the specified surveillance interval.

4.0.3 Failure to perform a Surveillance Requirement within the allowed surveillance interval, defined by control 4.0.2, shall constitute noncompliance with the OPERABILITY requirements for a Control. The time limits of the ACTION requirements are applicable at the time it is identified that a Surveillance Requirement has not been performed. The ACTION requirements may be delayed for up to 24 hours to permit the completion of the surveillance when the allowable outage time limits of the ACTION requirements are less than 24 hours. Surveillance Requirements do not have to be performed on inoperable equipment.

4.0.4 Entry into an OPERATIONAL CONDITION or other specified applicable condition shall only be made when the Surveillance Requirement(s) associated with the Control have been met within the applicable surveillance interval or as otherwise specified, except as provided by Surveillance Requirement 4.0.3. When a Control is not met due to Surveillances not having been met, entry into an OPERATIONAL CONDITION or other specified condition in the Applicability shall only be made in accordance with Control 3.0.4.

This provision shall not prevent passage through or to OPERATIONAL CONDITIONS as required to comply with ACTION requirements or that are part of a shutdown of the unit.

RADIOACTIVE EFFLUENTS

3/4.11.3 SOLID RADWASTE TREATMENT

CONTROLS

3.11.3 In accordance with PCP Sect.1.34, radioactive wastes shall be dewatered in accordance with the PROCESS CONTROL PROGRAM to meet shipping and transportation requirements during transit, and disposal or vendor processing site requirements when received at the disposal site or vendor processing site.

APPLICABILITY: At all times.

ACTION:

- a. With not meeting disposal site and shipping and transportation requirements, suspend shipment of the inadequately processed wastes and correct the PROCESS CONTROL PROGRAM, the procedures and/or the solid waste system as necessary to prevent recurrence.
- b. With the dewatering was not performed in accordance with the PROCESS CONTROL PROGRAM, (1) test the improperly processed waste in each container to ensure that it meets burial ground reprocessing site and shipping requirements and (2) take appropriate administrative action to prevent recurrence.
- c. The provisions of Control 3.0.3 are not applicable.

SURVEILLANCE REQUIREMENTS

4.11.3.1 With the installed equipment incapable of meeting Control 3.11.3 or declared inoperable, restore the equipment to OPERABLE status or provide the contract capability to process wastes as necessary to satisfy all applicable transportation and disposal requirements.

- a. Deleted

RADIOACTIVE EFFLUENTS

SURVEILLANCE REQUIREMENTS (Continued)

- b. Deleted

- c. With the installed equipment incapable of meeting Control 3.11.3 or declared inoperable, restore the equipment to OPERABLE status or provide the contract capability to process wastes as necessary to satisfy all applicable transportation and disposal requirements.

- d. Dew point of the end product of dewatered waste for final disposal shall be performed by processing per approved plant or vendor procedures. If the dew point hygrometer becomes inoperable processing of waste for final disposal shall be suspended until the dew point hygrometer is restored to operability.

- e. Gross dewatered waste shall be performed by processing per approved plant or vendor procedures. If waste can not be processed to meet off site processor's acceptance criteria processing for off site disposal shall be suspended until waste can be processed to meet vendor's criteria.

BASES FOR
SECTIONS 3.0 AND 4.0
CONTROLS
AND
SURVEILLANCE REQUIREMENTS

NOTE

The BASES contained in succeeding pages summarize the reasons for the Controls in Section 3.0 and 4.0, but are not part of these Controls.

3/4 CONTROLS AND SURVEILLANCE REQUIREMENTS

3/4.0 APPLICABILITY

BASES

Controls 3.0.1 through 3.0.4 establish the general requirements applicable to the Appendix C Controls. These requirements are derived from the requirements for Limiting Conditions for Operation stated in the Code of Federal Regulations, 10 CFR 50.36(c)(2) for plant Technical Specifications.

Control 3.0.1 establishes the Applicability statement within each individual control as the requirement for when (i.e., in which OPERATIONAL CONDITIONS or other specified conditions) conformance to the Control is required for safe operation of the facility. The ACTION requirements establish those remedial measures that must be taken within specified time limits when the requirements of a Control are not met. It is not intended that the shutdown ACTION requirements be used as an operational convenience which permits (routine) voluntary removal of a system(s) or component(s) from service in lieu of other alternatives that would not result in redundant systems or components being inoperable.

There are two basic types of ACTION requirements. The first specifies the remedial measures that permit continued operation of the facility which is not further restricted by the time limits of the ACTION requirements. In this case, conformance to the ACTION requirements provides an acceptable level of safety for unlimited continued operation as long as the ACTION requirements continue to be met. The second type of ACTION requirement specifies a time limit in which conformance to the conditions of the Control must be met. This time limit is the allowable outage time to restore an inoperable system or component to OPERABLE status or for restoring parameters within specified limits. If these actions are not completed within the allowable outage time limits, a shutdown is required to place the facility in an OPERATIONAL CONDITION or other specified condition in which the control no longer applies.

The specified time limits of the ACTION requirements are applicable from the point in time it is identified that a Control is not met. The time limits of the ACTION requirements are also applicable when a system or component is removed from service for surveillance testing or investigation of operational problems. Individual controls may include a specified time limit for the completion of a Surveillance Requirement when equipment is removed from service. In this case, the allowable outage time limits of the ACTION requirements are applicable when this limit expires if the surveillance has not been completed. When a shutdown is required to comply with ACTION requirements, the plant may have entered an OPERATIONAL CONDITION in which a new control becomes applicable. In this case, the time limits of the ACTION requirements would apply from the point in time that the new control becomes applicable if the requirements of the Control are not met.

3/4.0 APPLICABILITY

BASES (Continued)

Control 3.0.2 establishes that noncompliance with a control exists when the requirements of the Control are not met and the associated ACTION requirements have not been implemented within the specified time interval. The purpose of this control is to clarify that (1) implementation of the ACTION requirement within the specified time interval constitutes compliance with a control, and (2) completion of the remedial measures of the ACTION requirements is not required when compliance with a Control is restored within the time interval specified in the associated ACTION requirements.

Control 3.0.3 establishes the shutdown ACTION requirements that must be implemented when a Control is not met and the condition is not specifically addressed by the associated ACTION requirements. The purpose of this control is to delineate the time limits for placing the unit in a safe shutdown CONDITION when plant operation cannot be maintained within the limits for safe operation defined by the Control and its ACTION requirements. It is not intended to be used as an operational convenience which permits (routine) voluntary removal of redundant systems or components from service in lieu of other alternatives that would not result in redundant systems or components being inoperable. One hour is allowed to prepare for an orderly shutdown before initiating a change in plant operation. This time permits the operator to coordinate the reduction in electrical generation with the load dispatcher to ensure the stability and availability of the electrical grid. The time limits specified to reach lower CONDITIONS of operation permit the shutdown to proceed in a controlled and orderly manner that is well within the specified maximum cooldown rate and within the cooldown capabilities of the facility assuming only the minimum required equipment is OPERABLE. This reduces thermal stresses on components of the primary coolant system and the potential for a plant upset that could challenge safety systems under conditions for which this control applies.

If remedial measures permitting limited continued operation of the facility under the provisions of the ACTION requirement are completed, the shutdown may be terminated. The time limits of the ACTION requirements are applicable from the point in time there was a failure to meet a Control. Therefore, the shutdown may be terminated if the ACTION requirements have been met or the time limits of the ACTION requirements have not expired, thus providing an allowance for the completion of the required actions.

3/4.0 APPLICABILITY

BASES (Continued)

The time limits of Control 3.0.3 allow 37 hours for the plant to be in COLD SHUTDOWN when a shutdown is required during POWER operation. If the plant is in a lower CONDITION of operation when a shutdown is required, the time limit for reaching the next lower CONDITION of operation applies. However, if a lower CONDITION of operation is reached in less time than allowed, the total allowable time to reach COLD SHUTDOWN, or other OPERATIONAL CONDITION, is not reduced. For example, if STARTUP is reached in 2 hours, the time allowed to reach HOT SHUTDOWN is the next 11 hours because the total time to reach HOT SHUTDOWN is not reduced from the allowable limit of 13 hours. Therefore, if remedial measures are completed that would permit a return to POWER operation; a penalty is not incurred by having to reach a lower CONDITION of operation in less than the total time allowed.

The same principle applies with regard to the allowable outage time limits of the ACTION requirements, if compliance with the ACTION requirements for one control results in entry into an OPERATIONAL CONDITION or condition of operation for another control in which the requirements of the Control are not met. If the new control becomes applicable in less time than specified, the difference may be added to the allowable outage time limits of the second control. However, the allowable outage time limits of ACTION requirements for a higher CONDITION of operation may not be used to extend the allowable outage time that is applicable when a Control is not met in a lower CONDITION of operation.

The shutdown requirements of Control 3.0.3 do not apply in CONDITIONS 4 and 5, because the ACTION requirements of individual controls define the remedial measures to be taken.

Control 3.0.4 establishes limitations on a change in OPERATIONAL CONDITIONS when a Control is not met. It allows placing the facility in a higher CONDITION of operation when the requirements for a Control are not met, in accordance with Control 3.0.4.a, 3.0.4.b, or 3.0.4.c. The purpose of this control is to ensure that facility operation is only initiated when corrective action is being taken to obtain compliance with a control by restoring equipment to OPERABLE status or parameters to specified limits.

Per Control 3.0.4.a, compliance with ACTION requirements that permit continued operation of the facility for an unlimited period of time provides an acceptable level of safety for continued operation. This is without regard to the status of the plant before or after a change in OPERATIONAL CONDITION or other specified condition.

Per Control 3.0.4.b, changes in Operational Conditions may be made even if the ACTION requirements include a requirement to exit the Applicability, PROVIDED a risk assessment is performed (and is determined to be acceptable) which addresses the inoperable systems/components, and any appropriate risk management actions are put in place.

3/4.0 APPLICABILITY

BASES (Continued)

The provisions of this control should not, however, be interpreted as endorsing the failure to exercise good practice in restoring systems or components to OPERABLE status before plant startup.

The provisions of Control 3.0.4 shall not prevent changes in OPERATIONAL CONDITIONS that are required to comply with ACTION requirements or that result from any unit shutdown. In this context, a unit shutdown is defined as a change in OPERATIONAL CONDITION associated with transitioning from OPERATIONAL CONDITION 1 to OPERATIONAL CONDITION 2 or 3, OPERATIONAL CONDITION 2 to 3, and OPERATIONAL CONDITION 3 to OPERATIONAL CONDITION 4.

Controls 4.0.1 through 4.0.4 establish the general requirements applicable to Surveillance Requirements. These requirements are derived from those for Surveillance Requirements stated in the Code of Federal Regulations, 10 CFR 50.36(c)(3) for plant Technical Specifications.

Control 4.0.1 establishes the requirement that surveillances must be performed during the OPERATIONAL CONDITIONS or other conditions for which the requirements of the Controls apply unless otherwise stated in an individual Surveillance Requirement. The purpose of this control is to ensure that surveillances are performed to verify the operational status of systems and components and that parameters are within specified limits to ensure safe operation of the facility when the plant is in an OPERATIONAL CONDITION or other specified condition for which the individual Controls are applicable.

Surveillance Requirements do not have to be performed when the facility is in an OPERATIONAL CONDITION for which the requirements of the associated Control do not apply unless otherwise specified. The Surveillance Requirements associated with a Special Test Exception are only applicable when the Special Test Exception is used as an allowable exception to the requirements of a control.

Control 4.0.2 establishes the limit for which the specified time interval for Surveillance Requirements may be extended. It permits an allowable extension of the specified surveillance interval to facilitate surveillance scheduling and consideration of plant operating conditions that may not be suitable for conducting the surveillance; e.g., transient conditions or other ongoing surveillance or maintenance activities. It also provides flexibility to accommodate the length of a fuel cycle for surveillances that are performed at each refueling outage and are specified with a 24 month surveillance interval.

3/4.0 APPLICABILITY

BASES (Continued)

It is not intended that this provision be used repeatedly as a convenience to extend surveillance intervals beyond that specified for surveillances that are not performed during refueling outages. The limitation of Control 4.0.2 is based on engineering judgment and the recognition that the most probable result of any particular surveillance being performed is the verification of conformance with the Surveillance Requirements. This provision is sufficient to ensure that the reliability ensured through surveillance activities is not significantly degraded beyond that obtained from the specified surveillance interval.

Control 4.0.3 establishes that the failure to perform a Surveillance Requirement within the allowed surveillance interval, defined by the provisions of Control 4.0.2, is a condition that constitutes a failure to meet the OPERABILITY requirements for a Control. Under the provisions of this control, systems and components are assumed to be OPERABLE when Surveillance Requirements have been satisfactorily performed within the specified time interval. However, nothing in this provision is to be construed as implying that systems or components are OPERABLE when they are found or known to be inoperable although still meeting the Surveillance Requirements. This control also clarifies that the ACTION requirements are applicable when Surveillance Requirements have not been completed within the allowed surveillance interval and that the time limits of the ACTION requirements apply from the point in time it is identified that a surveillance has not been performed and not at the time that the allowed surveillance interval was exceeded. Completion of the Surveillance Requirement within the allowable outage time limits of the ACTION requirements restores compliance with the requirements of Control 4.0.3. However, this does not negate the fact that the failure to have performed the surveillance within the allowed surveillance interval, defined by the provisions of Control 4.0.2., constitutes a failure to meet the OPERABILITY requirements for a Control and any reports required by 10 CFR 50.73 shall be determined based on the length of time the surveillance interval has been exceeded, and the corresponding Control ACTION time requirements, similar to those discussed in NUREG-1022, Supplement 1.

3/4.0 APPLICABILITY

BASES (Continued)

If the allowable outage time limits of the ACTION requirements are less than 24 hours or a shutdown is required to comply with ACTION requirements, e.g., Control 3.0.3, a 24-hour allowance is provided to permit a delay in implementing the ACTION requirements. This provides an adequate time limit to complete Surveillance Requirements that have not been performed. The purpose of this allowance is to permit the completion of a surveillance before a shutdown would be required to comply with ACTION requirements or before other remedial measures would be required that may preclude the completion of a surveillance. The basis for this allowance includes consideration for plant conditions, adequate planning, availability of personnel, the time required to perform the surveillance, and the safety significance of the delay in completing the required surveillance. This provision also provides a time limit for the completion of Surveillance Requirements that become applicable as a consequence of CONDITION changes imposed by ACTION requirements and for completing Surveillance Requirements that are applicable when an exception to the requirements of Control 4.0.4 is allowed. If a surveillance is not completed within the 24-hour allowance, the time limits of the ACTION requirements are applicable at that time. When a surveillance is performed within the 24-hour allowance and the Surveillance requirements are not met, the time limits of the ACTION requirements are applicable at the time that the surveillance is terminated.

Surveillance Requirements do not have to be performed on inoperable equipment because the ACTION requirements define the remedial measures that apply. However, the Surveillance Requirements have to be met to demonstrate that inoperable equipment has been restored to OPERABLE status.

Control 4.0.4 establishes the requirement that all applicable surveillances must be met before entry into an OPERATIONAL CONDITION or other condition of operation specified in the Applicability statement, with two exceptions as described in Surveillance Requirement 4.0.4. The purpose of this control is to ensure that system and component OPERABILITY requirements or parameter limits are met before entry into an OPERATIONAL CONDITION or other specified condition for which these systems and components ensure safe operation of the facility. This provision shall not prevent changes in OPERATIONAL CONDITIONS or other specified conditions that are required to comply with ACTION requirements or that result from any plant shutdown. In this context, a unit shutdown is defined as a change in OPERATIONAL CONDITION associated with transitioning from OPERATIONAL CONDITION 1 to 2 or 3, OPERATIONAL CONDITION 2 to 3, and OPERATIONAL CONDITION 3 to 4.

RADIOACTIVE EFFLUENTS

BASES

3/4.11.3 SOLID RADIOACTIVE WASTE

This Control implements the requirements of 10 CFR Part 50.36a and General Design Criterion 60 of Appendix A to 10 CFR Part 50. The process parameters included in establishing the PROCESS CONTROL PROGRAM may include, but are not limited to waste type, waste pH, waste/liquid, waste oil content and waste principal chemical constituents.

ADMINISTRATIVE CONTROLS

ANNUAL RADIOACTIVE EFFLUENT RELEASE REPORT

6.9.1.7 The Annual Radioactive Effluent Release Report shall include a summary of the quantities of radioactive solid waste released from the unit as outlined in Regulatory Guide 1.21, "Measuring, Evaluating, and Reporting Radioactivity in Solid Wastes and Releases of Radioactive Materials in Liquid and Gaseous Effluents from Light-Water-Cooled Nuclear Power Plants, : Revision 1, June 1974, with data summarized on a quarterly basis following the format of Appendix B thereof. For solid wastes, the format for Table 3 in Appendix B shall be supplemented with three additional categories: class of solid wastes (as defined by 10 CFR Part 61), type of container (e.g., LSA, Type A, Type B Large Quantity). This report shall also include any changes made during the reporting period to the PROCESS CONTROL PROGRAM (PCP) pursuant to PNPP ORM Section 7.9, as well as any major changes to Solid Radwaste Treatment Systems pursuant to Control 6.15.

ADMINISTRATIVE CONTROLS

6.15 MAJOR CHANGES TO RADIOACTIVE WASTE TREATMENT SYSTEMS*

6.15.1 Licensee initiated major changes to the radioactive waste systems, liquid, gaseous and solid:

1. Shall be reported to the Commission in the Annual Radioactive Effluent Release Report for the period in which the evaluation was reviewed by the PORC. The discussion of each change shall contain:
 - a. A summary of the evaluation that led to the determination that the change could be made in accordance with 10 CFR 50.59;
 - b. Sufficient detailed information to totally support the reason for the change without benefit of additional or supplemental information;
 - c. A detailed description of the equipment, components and processes involved and the interfaces with other plant systems;
 - d. An evaluation of the change which shows the predicted releases of radioactive materials in liquid and gaseous effluents and/or quantity of solid waste that differ from those previously predicted in the license application and amendments thereto;
 - e. An evaluation of the change which shows the expected maximum exposures to MEMBERS OF THE PUBLIC in the UNRESTRICTED AREA and to the general population that differ from those previously estimated in the license application and amendments thereto;
 - f. A comparison of the predicted releases of radioactive materials, in liquid and gaseous effluents and in solid waste, to the actual releases for the period prior to when the changes are to be made;
 - g. An estimate of the exposure to plant operating personnel as a result of the change; and
 - h. Documentation of the fact that the change was reviewed and found acceptable by the PORC.
2. Shall become effective upon review and acceptance by the PORC.

*Licensee may choose to submit the information called for in this CONTROL as part of the annual USAR update.

REFERENCES

1. Title 10, "Energy", Chapter 1, Code of Federal Regulations, Parts 20, 50, 61, and 71, U.S. Government Printing Office, Washington, D.C. 20402, January 1, 1984.
2. Title 49, "Transportation", Chapter 1, Code of Federal Regulations, Parts 170-178, U.S. Government Printing Office, Washington, D.C. 20402, November 1, 1983.
3. U.S. Nuclear Regulatory Commission, "Standard Radiological Effluent Technical Specifications for Boiling Water Reactors", USNRC NUREG-0473, Revision 3, Washington, D.C. 20555, September 1982.
4. U.S. Nuclear Regulatory Commission, "Low-Level Waste Licensing Branch Technical Position on Radioactive Waste Classification," Revision 0, May 1983.
5. U.S. Nuclear Regulatory Commission, "Branch Technical Position on Waste Form", Revision 0, May 1983.
6. "Standard Test Method for Compressive Strength of Cylindrical Concrete Specimens" ASTM C39-84, American Society for Testing and Materials, Philadelphia, Pennsylvania 19103, 1984.
7. Regulatory Guide 1.8, "Personnel Selection and Training", U.S. Nuclear Regulatory Commission, Washington D.C. 20555, September, 1975.
8. "Selection and Training of Nuclear Power Plant Personnel", ANSI-N18.1-1971, American National Standards Institute, New York, New York 10018, 1971.
9. "Radman - A Computer Code to Classify and Document Packaged LLW in Accordance with 10CFR Part 61 Regulations", WMG-NP-A, Waste Management Group, Inc. Croton-on-the-Hudson, New York 10521, May 1983.
10. "Data Base Analysis Report - Perry Nuclear Power Station", Waste Management Group, Inc., Croton-on-the-Hudson, New York, New York 10521, May 1983.
11. Deleted
12. Deleted
13. Deleted
14. Deleted

REFERENCES

15. "Perry Nuclear Power Plant Unit 1 Technical Specifications," The FENOC, Perry, Ohio 44081.
16. "Perry Nuclear Power Plant Units 1 and 2, Updated Safety Analysis Report", FENOC, Perry, Ohio 44081.
17. Perry Nuclear Power Plant Operations Manual "SHIPMENT OF RADIOACTIVE MATERIAL/WASTE", NOP-OP-5201, FENOC, Perry, Ohio 44081.
18. Deleted.
19. Perry Nuclear Power Plant Operations Manual, "Dry Radioactive Waste Volume Reduction Program", PAP-1901, FENOC, Perry, Ohio 44081.
20. Perry Nuclear Power Plant Operations Manual, "Plant Chemistry Control Program", PAP-1102, FENOC, Perry, Ohio 44081.
21. Deleted.
22. Perry Nuclear Power Plant Operations Manual, "Miscellaneous Sampling Systems", CHI-5, FENOC, Perry, Ohio 44081.
23. Deleted.
24. Perry Nuclear Power Plant Operations Manual, "Solid Radwaste Solidification System", RWI-G51(SRW), FENOC, Perry, Ohio 44081.
25. Perry Nuclear Power Plant Operations Manual, "Solid Radwaste Compaction System", RWI-G51(SRWC), FENOC, Perry, Ohio 44081.
26. Deleted.
27. Deleted.

REFERENCES

28. Deleted.
29. FENOC Quality Assurance Program Manual.
31. Operating Procedure for the Pacific Nuclear Resin Drying (Dewatering) Systems, OM-43-WS.
32. Topical Report Covering Nuclear Packaging, Inc. Dewatering System, TP-02-P-A.
33. Chem-Nuclear Systems Inc Topical Report for Radioactive Waste Dewatering System, RDS-25506-1-A.
34. Deleted.
35. Setup and Operating Procedure for the RDS-1000 Unit, FO-OP-032.
36. Deleted.
37. Topical Report covering Pacific Nuclear Systems Radwaste Solidification System, TP-05.
38. Deleted.
39. System Description of Pacific Nuclear Systems' Radioactive Waste Volume Reduction System, RVR-800.
40. Deleted.
41. Deleted
42. Waste Control Specialists LLC, Three Lincoln Centre, 5430 LBJ Freeway, Ste. 1700, Dallas, Texas 75240
43. Energy Solutions, Interstate 80, Exit 49, Grantsville, Utah 84029
44. Energy Solutions, 1560 Bear Creek Road, Oak Ridge, TN 37830