

From: [RILEY, Jim](#)
To: [Miller, Ed](#); [Cook, Christopher](#)
Cc: [RILEY, Jim](#)
Subject: FW: dam failure white paper
Date: Tuesday, January 15, 2013 12:44:39 PM
Attachments: [Dam Failure Rev F DRAFT \(3\).docx](#)

Ed, Chris;

The latest version of the dam failure white paper is attached. You will note that this is a work in progress. Joe spent his time carving out the attributes information and including information from your slides, but not all of your comments have yet to be addressed. I told Ed just a little while ago that we would like to do a detailed review tomorrow and decide on specific changes, but after looking at the attached I am not sure the document is ready for that yet. Take a look. I think it might be useful if the three of us talk tomorrow morning to decide how to be most productive at our webinar.

Jim Riley

NEI

(o) 202-739-8137

(c) 202-439-2459

From: Bellini, Joe V [<mailto:joe.bellini@amec.com>]
Sent: Monday, January 14, 2013 11:21 PM
To: RILEY, Jim
Subject: RE: dam failure white paper

From: RILEY, Jim [<mailto:jhr@nei.org>]
Sent: Monday, January 14, 2013 5:44 PM
To: Bellini, Joe V
Cc: RILEY, Jim
Subject: dam failure white paper

Joe,

Do you have a revised version of the dam failure white paper that we can send to the NRC? We promised it to them today.

Thanks,

Jim Riley

NEI

(o) 202-739-8137

(c) 202-439-2459



FOLLOW US ON



This electronic message transmission contains information from the Nuclear Energy Institute, Inc. The information is intended solely for the use of the addressee and its use by any other person is not authorized. If you are not the intended recipient, you have received this communication in error, and any review, use, disclosure, copying or distribution of the contents of this communication is strictly prohibited. If you have received this electronic transmission in error, please notify the sender immediately by telephone or by electronic mail and permanently delete the original message. IRS Circular 230 disclosure: To ensure compliance with requirements imposed by the IRS and other taxing authorities, we inform you that any tax advice contained in this communication (including any attachments) is not intended or written to be used, and cannot be used, for the purpose of (i) avoiding penalties that may be imposed on any taxpayer or (ii) promoting, marketing or recommending to another party any transaction or matter addressed herein.

Sent through mail.messaging.microsoft.com

The information contained in this e-mail is intended only for the individual or entity to whom it is addressed. Its contents (including any attachments) may contain confidential and/or privileged information. If you are not an intended recipient you must not use, disclose, disseminate, copy or print its contents. If you receive this e-mail in error, please notify the sender by reply e-mail and delete and destroy the message.



FOLLOW US ON



This electronic message transmission contains information from the Nuclear Energy Institute, Inc. The information is intended solely for the use of the addressee and its use by any other person is not authorized. If you are not the intended recipient, you have received this communication in error, and any review, use, disclosure, copying or distribution of the contents of this communication is strictly prohibited. If you have received this electronic transmission in error, please notify the sender immediately by telephone or by electronic mail and permanently delete the original message. IRS Circular 230 disclosure: To ensure compliance with requirements imposed by the IRS and other taxing authorities, we inform you that any tax advice contained in this communication (including any attachments) is not intended or written to be used, and cannot be used, for the purpose of (i) avoiding penalties that may be imposed on any taxpayer or (ii) promoting, marketing or recommending to another party any transaction or matter addressed herein.

Sent through mail.messaging.microsoft.com

POST-FUKUSHIMA NEAR-TERM TASK FORCE RECOMMENDATION 2.1
Supplemental Guidance for the Evaluation of Dam Failures

Contents

Contents.....	1
1 Introduction.....	3
1.1 Purpose.....	3
1.2 Background.....	4
2 Overview of Dam Failure Mechanisms.....	7
2.1 Hydrologically Induced Failures.....	7
2.2 Seismically Induced Failures.....	9
2.3 Sunny-Day Failures.....	12
2.4 Individual and Cascading Failures.....	13
3 Overview of HHA Approach for Dam Failure.....	14
4 Use of Existing Information.....	15
5 Dam Failure Flood Modeling.....	16
5.1 Simplified Modeling Approaches for Large Watersheds and Number of Dams.....	16
5.2 Refined Dam Failure Analysis.....	18
5.2.1 Hydrologic.....	18
5.2.2 Seismic.....	18
5.2.3 Sunny-Day.....	18
5.3 Dam Breach Modeling.....	19
5.3.1 Embankment Dams.....	19
5.3.2 Concrete Dams.....	20
5.3.3 Uncertainty.....	20
5.4 Flood Routing.....	20
5.4.1 1-Dimensional.....	20
5.4.2 2-Dimensional.....	22
6 Definitions and References.....	23
6.1 Definitions.....	23
6.2 References.....	26
6.2.1 Regulatory and Overall Dam Breach Analysis Guidelines.....	26
6.2.2 Hydrology and Hydraulics.....	27
6.2.3 Dam Design.....	27

Post-Fukushima Near-Term Task Force Recommendation 2.1
Supplemental Guidance for the Evaluation of Dam Failures
January 14, 2013, Revision F

6.2.4	Empirically-Based Breach Parameter and Outflow Estimation.....	28
6.2.5	Physically-Based Breach Methods	30
6.2.6	Other Dam Failure Research	31

Appendices

- A. Screening Upstream Dams with Negligible effect of Failure at the Site
- B. Example Dam Failure Evaluation Approaches
- C. Additional Details on Breach Parameters
- D. Additional Details on Modeling

DRAFT

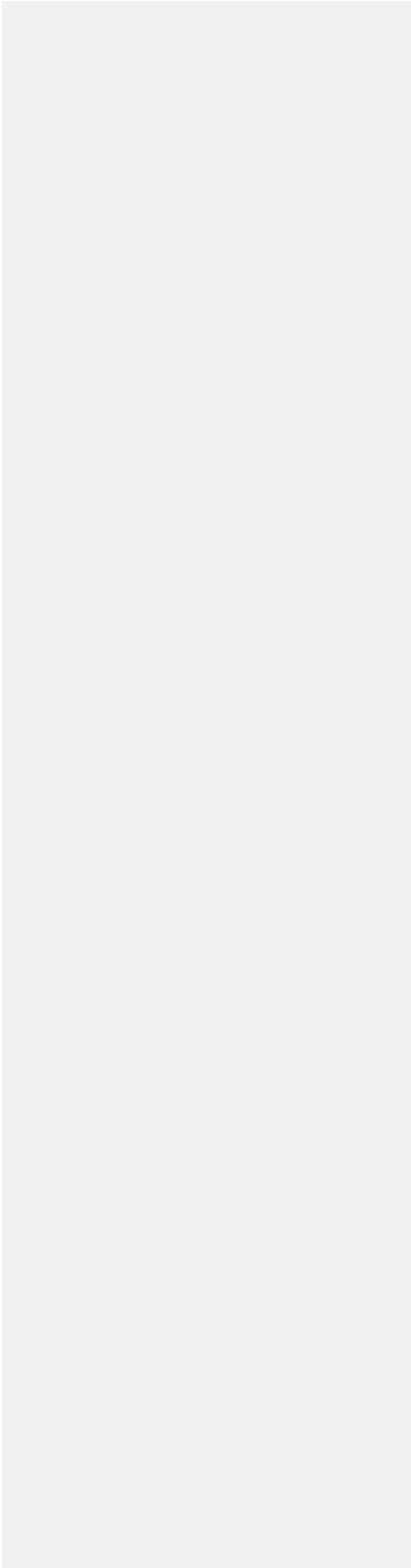

1 Introduction

1.1 Purpose

This paper is intended to clarify how dam failure should be considered when reevaluating the bounding PMF in response to Enclosure 2 (Recommendation 2.1: Flooding) of the March 12, 2012 50.54(f) letter. This paper provides added guidance to supplement the NUREG/CR-7046, Sections 3.4 and 3.9 and Appendix H.2, related to dam failure considerations. Dam failure is considered a factor when developing combined-effect floods. The goal is to achieve a realistic, physics-based, but conservative analysis of flooding. Per NUREG/CR-7046, when dams are present upslope of the site or within the watershed of an adjacent stream/river, three failure mechanisms should be evaluated independently:

1. **Hydrologic Failure:** Dam failure induced by an extreme precipitation/snowmelt event within the dam's upstream watershed.
2. **Seismic-Induced Failure:** Dam failure induced by an earthquake that causes weakening of the dam's structural components, embankment, foundation, and/or abutments.
3. **Sunny-Day Failure:** A 'sunny-day' dam failure is not associated or concurrent with an initiating event (such as an extreme flood or earthquake) and may result from a, for example, structural, geotechnical, or operational deficiency. Sunny-day failures are typically associated with short warning times. Assumptions for initial water levels and failure modes should be provided.

The resulting scenario for each failure mechanism is considered independently because each may produce bounding parameters at the site. For example, the 'hydrologic' failure mechanism may produce the highest volume, peak flow rate, and peak flood level. The 'seismically-induced' failure mechanism may produce high flows from simultaneous failures and rainfall events, and short warning times. The 'sunny-day' failure mechanism may produce the shortest warning time and highest dynamic loading condition.

Additional Considerations (from ANS 2.8, Section 5.5.4.2):

- **Concrete Sections:** *Concrete gravity dams shall be analyzed against overturning and sliding. With some blocks judged likely to fail and others not, the mode and degree of probable failure can be judged as well as the likely position and amount of downstream debris. From this analysis, the water path and the likely elevation-discharge relationship applying to the failed section can be estimated with reasonable accuracy. Rise of tailwater should be considered in the stability analysis.*
- **Arch Dams:** *Arch dams can usually sustain considerable overtopping with failure most likely from foundation and abutment failure. However, unless structural safety can be documented, failure should be postulated. Failure of an arch dam might approach instantaneous disappearance with minimum residual downstream debris.*
- **Earth and Rockfill:** *Earth and rock embankments shall be evaluated for breaching from overtopping. If there are two or more independent embankments, it may be necessary to fail only one if it produces the most critical flood wave. Potential for overtopping may be investigated for these two conditions:*
 - (i) *Probable maximum flood surcharge level plus maximum (1%) wave height resulting from sustained 2-yr wind speed applied in the critical direction.*
 - (ii) *Normal operating level plus maximum (1%) wave height based on the probable maximum gradient wind.*

Comment [JFK1]: Address debris more globally

If no overtopping is demonstrated, the evaluation may be terminated and the embankment may be declared safe from hydrologic failure. If overtopping and failure are likely, the breached section should be identified or postulated. Subsequent computations to determine the time and rate of failure may ignore wave-induced additive levels.

Other items worth noting:

- **Loss of Ultimate Heat Sink due to Flooding-Induced Downstream Dam Failure:** The NRC is requesting that the Recommendation 2.1: Flood Hazard Reevaluations include an evaluation of the effects of flooding on downstream dams that are used to impound the ultimate heat sink (UHS). Guidance contained herein for the hydrologic failure mechanism can be used to evaluate the potential flooding-induced loss of UHS.
- **Security Threats:** Failures caused by security events are not within the scope of Recommendation 2.1, Flooding Reevaluations.

Comment [g2]: Check wording against 10 CFR 50 and 50.54(f) letter wording.

1.2 Background

In response to the nuclear fuel damage at the Fukushima-Daiichi power plant due to the March 11, 2011 earthquake and subsequent tsunami, the United States Nuclear Regulatory Commission (NRC) is requesting information pursuant to Title 10 of the Code of Federal Regulations, Section 50.54 (f) (10 CFR 50.54(f) or 50.54(f)). As part of this request, licensees will be required to reevaluate flooding hazards, per present-day guidance and methodologies for early site permits and combined license reviews, to assess margin at safety-related structures, systems, components (SSCs) and effectiveness of current licensing basis (CLB) protection and mitigation measures. The request is associated with the NRC's Post-Fukushima Near-Term Task Force (NTTF) Recommendation 2.1 for flooding, approved by the Commission in SECY 11-0137, *Prioritization of Recommended Actions to be Taken in Response to Fukushima Lessons Learned*, dated December 15, 2011.

- **Requests in the March 12, 2012 50.54(f) Letter**

Requested Action:

Addressees are requested to perform a reevaluation of all appropriate external flooding sources, including the effects from local intense precipitation on the site, probable maximum flood (PMF) on stream and rivers, storm surges, seiches, tsunami, and dam failures. It is requested that the reevaluation apply present-day regulatory guidance and methodologies being used for ESP and COL reviews including current techniques, software, and methods used in present-day standard engineering practice to develop the flood hazard. The requested information will be gathered in Phase 1 of the NRC staffs two phase process to implement Recommendation 2.1, and will be used to identify potential vulnerabilities.

For the sites where the reevaluated flood exceeds the design basis, addressees are requested to submit an interim action plan that documents actions planned or taken to address the reevaluated hazard with the hazard evaluation.

Subsequently, addressees should perform an integrated assessment of the plant to identify vulnerabilities and actions to address them. The scope of the integrated assessment report will include full power operations and other plant configurations that could be susceptible due to the status of the flood protection features. The scope also includes those features of the ultimate heat sinks (UHS) that could be adversely affected by the flood conditions and lead to degradation of the

flood protection (the loss of UHS from non-flood associated causes are not included). It is also requested that the integrated assessment address the entire duration of the flood conditions.

Requested Information:

The NRC staff requests that each addressee provide the following information. Attachment 1 provides additional information regarding present-day methodologies and guidance used by the NRC staff performing ESP and COL reviews. The attachment also provides a stepwise approach for assessing the flood hazard that should be applied to evaluate the potential hazard from flood causing mechanisms at each licensed reactor site.

1. Hazard Reevaluation Report

Perform a flood hazard reevaluation. Provide a final report documenting results, as well as pertinent site information and detailed analysis. The final report should contain the following:

- a. Site information related to the flood hazard. Relevant SSCs important to safety and the UHS are included in the scope of this reevaluation, and pertinent data concerning these SSCs should be included. Other relevant site data includes the following:*
 - i. detailed site information (both designed and as-built), including present-day site layout, elevation of pertinent SSCs important to safety, site topography, as well as pertinent spatial and temporal data sets*
 - ii. current design basis flood elevations for all flood causing mechanisms*
 - iii. flood-related changes to the licensing basis and any flood protection changes (including mitigation) since license issuance*
 - iv. changes to the watershed and local area since license issuance*
 - v. current licensing basis flood protection and pertinent flood mitigation features at the site*
 - vi. additional site details, as necessary, to assess the flood hazard (i.e., bathymetry, walkdown results, etc.)*
- b. Evaluation of the flood hazard for each flood causing mechanism, based on present-day methodologies and regulatory guidance. Provide an analysis of each flood causing mechanism that may impact the site including local intense precipitation and site drainage, flooding in streams and rivers, dam breaches and failures, storm surge and seiche, tsunami, channel migration or diversion, and combined effects. Mechanisms that are not applicable at the site may be screened-out; however, a justification should be provided. Provide a basis for inputs and assumptions, methodologies and models used including input and output files, and other pertinent data.*
- c. Comparison of current and reevaluated flood causing mechanisms at the site. Provide an assessment of the current design basis flood elevation to the reevaluated flood elevation for each flood causing mechanism. Include how the findings from Enclosure 4 of this letter (i.e., Recommendation 2.3 flooding walkdowns) support this determination. If the current design basis flood bounds the reevaluated hazard for all flood causing mechanisms, include how this finding was determined.*

- d. *Interim evaluation and actions taken or planned to address any higher flooding hazards relative to the design basis, prior to completion of the integrated assessment described below, if necessary.*
- e. *Additional actions beyond Requested Information item 1.d taken or planned to address flooding hazards, if any.*

2. *Integrated Assessment Report*

For the plants where the current design basis floods do not bound the reevaluated hazard for all flood causing mechanisms, provide the following:

- a. *Description of the integrated procedure used to evaluate integrity of the plant for the entire duration of flood conditions at the site.*
- b. *Results of the plant evaluations describing the controlling flood mechanisms and its effects, and how the available or planned measures will provide effective protection and mitigation. Discuss whether there is margin beyond the postulated scenarios.*
- c. *Description of any additional protection and/or mitigation features that were installed or are planned, including those installed during course of reevaluating the hazard. The description should include the specific features and their functions.*
- d. *Identify other actions that have been taken or are planned to address plant-specific vulnerabilities.*

• **Flooding Evaluation**

The NRC standard for flood estimation is the 1977 version of Regulatory Guide (RG) 1.59, and its appendices, and Chapter 2.0 of the Standard Review Plan (NUREG-0800).

In the 50.54(f) letter, the NRC is requesting updated flooding hazard information using 'present-day regulatory guidance and methodologies to review early site permits (ESPs) and combined license (COL) applications'. Although the update to RG 1.59 is not complete, the NRC is considering NUREG/CR-7046, "Design Basis Flood Estimation for Site Characterization at Nuclear Power Plants in the United States of America", November 2011, as representing present-day methodologies for flooding evaluations. Other useful information may be found in completed Safety Evaluation Reports for COLs and ESPs.

NUREG/CR-7046 describes present-day methodologies and technologies that can be used to estimate design-basis floods at nuclear power plants for a range of flooding mechanisms, including rivers/streams, dam failures, local intense precipitation (local/site runoff), storm surge, seiche, ice-induced flooding, channel migration/diversion, and combined-effects floods (for dependent or correlated events).

NUREG/CR-6966 ("Tsunami Hazard Assessment at Nuclear Power Plant Sites in the United States of America") is referenced as a guide for the evaluation of tsunamis.

• **Dam Failures**

Modes of dam failure include overtopping of an unprotected portion of the dam during a significant hydrologic event, piping, and liquefaction of foundation from seismic activity, slope/stability issues, uncontrolled seepage, and other modes of failure. The resulting flood waves, including those from domino-type or cascading dam failures, should be evaluated for each site as applicable. Dams of interest to a nuclear site are those located within the upstream watershed of an adjacent stream/river

or from downstream dams that impound the station's UHS or dams that are in the watershed of a downstream tributary and could cause backwater effects at the site. Water storage and water control structures (such as onsite cooling or auxiliary water reservoirs and onsite levees) that may be located at or above SSCs important to safety should also be evaluated.

Models and methods used to evaluate the dam failure and the resulting effects should be appropriate to the type of failure mechanism. References herein provide guidance for developing dam break hydrographs. Unsteady-flow 1D or 2D hydraulic models are frequently used to route dam breach hydrographs to the site. Recent analyses completed by entities with appropriate jurisdiction for dams may be incorporated into the analysis. Overtopping dam breach/failure scenarios should include coincidental failure with the peak Probable Maximum Flood (PMF). Domino-type or cascading dam failures should be considered unless an engineering justification is provided showing that this scenario is not credible as part of the refined site specific hazard analysis. Part of the Hierarchical Hazard Assessment HHA approach may include an assumption that all dams fail, regardless of the cause; timed to produce the worse possible flooding conditions at the site (including compounding flows from cascading failures of dams in series).

2 Overview of Dam Failure Mechanisms

2.1 Hydrologically Induced Failures

Hydrologic dam failures are induced by an extreme precipitation/snowmelt event within the dam's upstream watershed. The licensee and its vendor have the option to bypass selected steps in the HHA process or assume all potentially-critical dams fail. See the 'Definitions' section for differentiating 'critical' and 'non-critical' dams and developing a final hydrologic failure scenario, which may include (with proper justification) non-failure of some or all critical dams. A description of non-failure justification is provided below:

Do Unprotected Portions of a Critical Dam Overtop during the Site's or Dam's Bounding PMF?

Section 5.5.1 of ANS 2.8, under 'Hydrologic Dam Failures', states that "critical dams should be subjected analytically to the probable maximum flood from their contributing watershed. If a dam can sustain this flood, no further hydrologic analysis shall be required." Therefore, answering this question requires the establishment of two hydrologic scenarios: 1) the bounding PMF scenario for the entire watershed at the site and 2) the bounding PMF for the specific watershed of the critical dam in question. In lieu of developing a dam-specific bounding PMP, documentation from the dam owner can be used to demonstrate that a critical dam can safely pass the dam's bounding PMF; as long as the documentation was developed or approved by a state or federal government agency using criteria/methodologies developed or bounded by USBR, USACE, or FERC. In situations where a critical dam does not overtop during the site's bounding PMF but does overtop during the dam's PMF, the licensee has the option to develop an alternative hydrologic scenario for the site that includes the bounding PMP for an individual, critical dam and failure of this dam. It is unreasonable to assume that multiple, individual, critical dams would be subjected to dam-specific bounding PMFs simultaneously. Cascading failures of dams in series should be considered in this alternative hydrologic scenario per Appendix D (Section D.1) of NUREG/CR-7046.

Per ANS 2.8, Section 5.5.4, "if no overtopping is demonstrated, the evaluation may be terminated and the embankment may be declared safe from hydrologic failure". Overtopping may be investigated for either of these two conditions:

Comment [F3]: I think this is not in line with our last NEI/NRC meeting where the SRP section on hazard screening was invoked.
FFTF -- please clarify
Public meeting --

Comment [A4]: Add sufficient free board capacity, spillway capacity, operating and maintenance procedures; Does the hydrologic failure section reflect all of these considerations (e.g., condition of the spillway in addition to its capacity; consideration of the availability of operating procedures so that gates will be opened when required?)

Comment [JFK5]: This seems to imply that design spillway capacity is all that matters. Some investigation of the condition and maintenance history of the dam would be prudent to assure that there is a reasonable expectation that it will perform as designed.
FFTF -- this comes directly from ANS 2.8. Should be able to assume that the dam's outlet system will perform as designed. It should be sufficient to assume that dams are maintained by their owner/operators as required by the governing authority.
Public Meeting -- Agree, use ANS 2.8

Comment [MB6]: Should this text appear earlier as well?
FFTF -- need to discuss. Development of a dam specific PMF should not be necessary until you r...

Comment [g7]: Clarify this discussion on how to use
FFTF -- this clarification will depend upon how the ICODS meetings proceed and under what circumstances we can take credit for the work of...

Comment [MB8]: Is there any thought given to the vintage of the PMF value for which the dam was designed?
FFTF -- add a statement that the vintage of the evaluation be considered

Comment [JFK9]: I don't understand this. Elaborate?
FFTF -- we will discuss and clarify
Public Meeting -- Recommend delete

Comment [JFK10]: It may actually be reasonable (or at least not clearly unreasonable) in some instances. The size and the duration of the PMP that is used to generate the PMF would speak to this question.

Comment [MB11]: So what event would be assumed to be happening at the site when the dam is having its PMF (e.g., to establish that antecedent water level at the site upon which the water from the dam failure would be added.)

Comment [MB12]: Is this optional
FFTF -- these words are a quote from ANS 2.8' We will modify to make it an exact quote.
We need to discuss the use of the word "or"

2. I think that comment 1 applies to screening methods 3 and 4.

FFTF -- see answer to comment 1

3. Do we need Figure 1 and 2? If comment 1 is true, then would Figures 1

- Probable maximum flood surcharge level plus maximum (1%) average height resulting from sustained 2-year wind speed applied in the critical direction; or
- Normal operating level plus maximum (1%) wave height based on the probable maximum gradient wind.

For the purpose of this paper, ‘overtopping’ is defined as the point at which an unprotected portion of the dam, or portion of the dam structure not designed to convey floodwater, is subject to flow during a postulated flood. ‘Overtopping’ could also apply if the design capacity of outlet component is exceeded by the postulated flood. Even without overtopping, additional information, discussed in the next step, may be required to demonstrate safety under PMF loading conditions.

Justifying Non-Failure of a Critical Dam during the Site’s or Dam’s Bounding PMF

For critical dams, where non-failure justification is sought, develop information in Section 5.5.4 of ANS 2.8, demonstrating safety from failure due to instability, erosion, sliding, or overturning during site’s or dam’s bounding PMF. A valid stability analyses of dams that meets the standards established by the dam’s regulator should be used requiring documentation of structural dimensions and composition from design plans; construction records; records from installed instrumentation; field surveys, on-site inspections; and special strength testing, coring, and instrumentation. Justification should also include sufficient freeboard capacity, capacity and condition of spillway system, and consideration of the availability of operating procedures so that gates will be opened when required. Information from the dam owner, developed or approved by a state or federal agency, can be used to justify non-failure. In situations where a critical dam does not overtop during the site’s bounding PMF but does overtop during the dam’s bounding PMF, the licensee has the option to develop an alternative hydrologic scenario for the site that includes the bounding PMP for an individual, critical dam and failure of this dam. If justification is sufficient, the dam can be credited as not failing during the site’s bounding PMF in the final hydrologic dam failure scenario. If not, this dam should be included as failing in the final hydrologic failure scenario.

Final Hydrologic Failure Scenario

The final hydrologic failure scenario includes:

- Site’s bounding PMF;
- Failure of non-critical dams;
- Failure of critical dams with insufficient non-failure justification;
- Wind-waves from 2-year wind speed; and
- Enhanced modeling techniques (e.g. 1D unsteady flow and/or 2D/3D hydrodynamic models) to refine flood level at site (optional).

Trigger failures in the site’s bounding PMF model at the peak water surface elevation for individual failures. For dams in series, failure should be triggered to maximize the affect of compounding flows from cascading failures.

Comment [JFK13]: This is the language about critical direction that I was looking for earlier. Use it everywhere.
 FFFF -OK

Comment [g14]: How does this affect spillways
 FFFF – as long as the outlet flow is within the design capacity of the spillway, its failure does not have to be assumed.

Comment [JFK15]: ANS-2.8 talks about use of engineering computations. This level of rigor seems to be missing here.
 FFFF – intent was to describe the ANS 2.8 requirement, not to repeat it. ANS 2.8 governs
 PM - OK

Comment [MB16]: Note that previous text focuses only on overtopping, not this more extensive list.
 FFFF – that is the intent of the process described (overtopping is not a concern)
 PM - Comment is that the referenced list is good and should be used consistently throughout.

Comment [g17]: Ensure this is using current methods
 FFFF – this item is subject to the resolution to the ICODS discussion
 FFFF – Should be able to use existing analyses as long as they meet the standards of the dam’s regulator

Comment [JFK18]: We need to think about the consequences of this. Are we going to have multiple standards and criteria? I would think that, to the extent possible, a uniform set of standards and criteria applied to all licensees furthers NRC’s safety goals.
 FFFF - We could reference specific federal agency standards as a minimum standard for comparison to other agencies. this item is subject to the outcome of the ICODS discussion.

Comment [MB19]: This needs to be discussed. This is a global comment.
 FFFF – this item is subject to the resolution to the ICODS discussion

Comment [JFK20]: Same comment as above. I don’t fully understand this.
 FFFF – We will discuss
 PM - Delete

Comment [JFK21]: Critical direction
 FFFF -OK

2.2 Seismically Induced Failures

The discussion below describes the approach to conducting an evaluation of upstream dam failures induced by a seismic event. NUREG/CR-7046 (Appendix H.2) and ANS-2.8 (Section 9.2.1.2) provide the following two (2) alternative combinations for seismically-induced dam failure:

1. 25-year flood, dam failure caused by the safe shutdown earthquake (SSE) coincident with the peak flood, and 2-year wind speed applied in the critical direction.
2. ½ PMF or 500-year flood, whichever is less, dam failure caused by the operating basis earthquake (OBE) coincident with the peak flood, and 2-year wind speed applied in the critical direction.

The best available interpretation of the above requirements is that seismically-induced dam failure occurs coincident with the peak pool levels for the 25-year flood, 500-year flood, or ½ PMF entering the dam; implying that runoff downstream of the dam to the site is not included.

This approach is reasonable for a single upstream dam but seems inappropriate for multiple dams. It may not be reasonable to assume that peak flood pool levels for all upstream dams would occur coincident with an earthquake. As an alternative approach, developing floods for multiple upstream dams can be accomplished by using watershed-wide precipitation events, not upstream flood-flow, to represent the above combinations. Therefore, seismically-induced dam failure analysis should be based on the following precipitation-based combinations:

1. 25-year precipitation throughout the site's watershed, dam failure caused by the safe shutdown earthquake (SSE), and 2-year wind speed applied in the critical direction.
2. ½ PMP or 500-year precipitation, whichever is less, throughout the site's watershed, dam failure caused by the operating basis earthquake (OBE), and 2-year wind speed applied in the critical direction.

This would be consistent with NRC expectations that, as stated in NUREG/CR-7046 and ANS-2.8, combinations are thought to have a probability-of-exceedance of less than 1×10^{-6} . Also, using watershed-wide precipitation events would be conservative because it would include runoff downstream of the dams to the site.

Note that all dams are assumed to fail when the earthquake occurs (the timing of which is established based on optimal impact to the site) which may not result in a particular dam failing at its peak water level.

Does the Critical Dam in Question remain Stable during a Seismic Event?

Information should be developed to assess a dam's ability to withstand a design earthquake. Regulation 10 CFR 100.23 (d)(3) states "the size of seismically induced floods and water waves that could affect a site from either locally or distantly generated seismic activity must be determined". Based on existing guidance in RG 1.59 and ANS 2.8, the earthquake centering shall be evaluated in a location(s) that produce the worst flooding at the nuclear power plant site from a seismically induced dam failure. In regions where two or more dams are located close together, a single seismic event shall be evaluated to determine if multiple dam failures could occur.

The evaluation of the dam's structural stability shall include the concrete and earth sections. The methods for evaluation should be those described by the dam's regulator. The existing evaluations completed by the dam owner may be used if the review determines that the current standards as prescribed by dam's regulator are used and the required factors of safety per those standards are satisfied. In addition, the

Comment [MB22]: Ensure consistency with use of PSHA.
FFTF – Need to clarify

Comment [MB23]: Needs discussion.
FFTF – agree, this is an ICODS issue

combined annual exceedance probability for design earthquake loading, seismic failure, and the hydrologic event, shall be 1×10^{-6} or less.

Design Earthquake Loading:

- Ground Motion Hazard Curves – The Recommendation 2.1 Seismic Hazard Reevaluations are ongoing and will be based, in part, on the Central and Eastern United States (CEUS) Source Characterization and new attenuation model; expected to be completed in February 2013. The Recommendation 2.1 Flood Hazard Reevaluations at some sites are scheduled for completion before the CEUS source characterization is available. Therefore, licensees with Flood Hazard Reevaluation Reports due by March 2013 are provided with three options for developing the ground motion hazard curves.
 1. Use USGS (2008) to determine the mean seismic hazard curves for 1 Hz, 5 Hz, 10 Hz, and PGA. Apply one of five EPRI mean amplification functions to the mean rock seismic hazard curves based on the known geologic conditions at the site. EPRI mean amplification functions can be found in EPRI (1993).
 2. Submit the Flood Hazard Reevaluation Reports assuming all critical (and non-critical) dams fail during a seismic event, combined with the lesser of the ½ PMP and 500-year precipitation.
 3. Use the CEUS seismic source term and associated attenuation model. If this results in not being able to submit the reevaluation in accordance with the committed schedule, submit all elements of the flooding reevaluation that are completed on the scheduled date. Establish a new completion date at the time of this submittal for completion of the upstream dam failure and overall conclusions.
- From the site-adjusted mean hazard curves, develop the 10^{-4} Uniform Hazard Response Spectrum (UHRs) and hazard curves for 1 Hz, 5 Hz, 10 Hz, and PGA.

The probability of seismic failure of a dam can be estimated using procedures as described in McCann et al, 1985. A brief summary of the procedures is described in the following steps:

- Develop failure criteria for each seismic failure mechanism. The criteria should be based on dam type (concrete sections, arch dams, earthfill and rockfill), construction details (slope protection, filters and drains, core width, past performance, etc), and overall construction quality. Examples of failure criteria could be maximum crest settlement, factor of safety against sliding, and fault offset at the foundation elevation. It is noted that not all potential seismic failure modes will need to be addresses at each site. For instance, potential failure due to surface fault rupture can be screened out for sites where no known faulting is present.
- If existing evaluations have been completed by the dam owner using current standards prescribed by the USACE, USBR, or FERC, summarize analyses results including ground motion parameters used, factors of safety for each failure mode, performance results (i.e. settlement or crest deformation).
- If the existing analyses include High Consequence of a Low Probability of Failure (HCLPF) results, and the results are enveloped by the ground motions from Step 1 above, the dam can be considered to have a probability of failure of less than one percent. If the HCLPF capacity is greater than the ground motions in Step 1, use the results of the HCLPF analyses to estimate the probability of failure for the ground motions in Step 1.

Comment [g24]: This assumption may require additional interaction.
FFTF – Discuss at meeting. ICODS issue
 This includes hazard and fragility

Comment [JFK25]: Does this timing issue need to be discussed in what is otherwise a technical document?
FFTF – at present one of the options is to submit a partial evaluation

Comment [initials26]: FFTF – This option must stand until the next flooding evaluation update is required, in order for it to be viable.

Comment [initials27]: FFTF – see comment above concerning combination of events

Comment [F28]: available?
FFTF – change word to “possible”

Comment [F29]: This assumes NRC will grant an extension a priori; and its highly problematic. Although this may be the case, it should be considered individually per NRC licensee provided a sufficient basis exists for such an extension. This needs to be removed and, if need be, a reference needs to be made to the NRC statements regarding potential delays in submitting a 50.54(f) letter response.
FFTF – we will discuss

Comment [initials30]: FFTF – one of the options we have been discussing

Comment [JFK31]: Not in reference list.
FFTF – OK, will add

Comment [MB32]: Why was this reference chosen? What about the vintage of the references within this document?
FFTF – need to discuss with our seismic resources to determine validity

- If the existing analyses are deterministic and do not include fragility evaluations, the deterministic evaluations should be updated to estimate the median ground parameter (A_m) for each failure criteria.
- Use the median ground motion parameter corresponding to failure and an assumed uncertainty values (β_R and β_U) to develop lognormal fragility curves for each failure mode.
- Estimate the probability of failure at the ground motion level from Step 1.

Data needed for the seismic evaluation include:

- Design or as-built drawings;
- Existing seismic stability evaluation reports containing:
 - Description of dam materials (zones, filters, surface protection);
 - Description of geologic setting;
 - Description of foundation conditions;
 - Description of cut-off trenches or foundation grouting; and
 - Description of previous analyses (ground motion inputs, methods, results).
- Instrumentation Data;
- Summary of past performance;
- Shear and compression wave velocity data within foundation; and
- Description of spillway and low-level outlet facilities.

If justification is sufficient, the dam can be credited as not failing during the site's bounding PMF in the final hydrologic dam failure scenario. If not, this dam should be included as failing in the final hydrologic failure scenario.

Final Seismically-Induced Failure Scenario

The final seismically-induced failure scenario includes:

- $\frac{1}{2}$ PMP or 500-year precipitation (whichever is less);
- Failure of non-critical dams;
- Failure of critical dams with insufficient non-failure justification;
- Wind-waves from 2-year wind speed; and
- Enhanced modeling techniques (e.g. 1D unsteady flow and/or 2D/3D hydrodynamic models) to refine flood level at site (optional).

Trigger individual failures in the final model at the same time, determined by optimizing the effects of the earthquake. For dams in series, failure should be triggered to maximize the affect of compounding flows from cascading failures. See Section **Error! Reference source not found.**

Comment [MB33]: Could use some additional discussion and clarification.
FFTF – trying to simplify a complicated process.

Comment [MB34]: Does this imply an “acceptable” probability of failure? Does this include all failure modes? What about the probability of failure under lower ground motion intensities?
FFTF – discuss at meeting

Comment [initials35]: FFTF – need to define event combinations

Comment [MB36]: Clarify.
FFTF – discuss at the meeting

2.3 Sunny-Day Failures

A sunny-day failure is a failure that is not induced by a precipitation event. (For the purposes of this paper, a seismically-induced failure is being considered separately.) Sunny-day failures are typically attributed to structural weakness or deficiency in the dam embankment, foundation, and/or abutments. Potential causes of failure (from Section 6.3.2 of ANS 2.8) include:

- Deterioration of concrete due to cracking, weathering, or chemical growth;
- Deterioration of embankment protection such as riprap or grass cover;
- Excessive saturation of downstream face or toe of embankment;
- Excessive embankment settlement;
- Cracking of embankment due to uneven settlement;
- Erosion or cavitation in waterways and channels, including spillways;
- Excessive pore pressure in structure, foundation, or abutment;
- Failure of spillway gates to operate during flood because of mechanical or electrical breakdown or clogging with debris;
- Buildup of silt load against dam;
- Excessive leakage through foundation;
- Leakage along conduit in embankment;
- Channels from tree roots or burrowing;
- Excessive reservoir rim leakage; and/or
- Landslide in reservoir.

While generally expected not to produce flood discharges and water levels that exceed the hydrologic or seismically-induced failure scenarios, discussed above, it can be associated with the shortest warning times. Some licensees may consider applying sunny-day failure warning times to the seismically-induced failure scenarios; in which case, sunny-day failure may not need to be a consideration at the site with proper justification. The following describes the steps in a sunny-day failure evaluation:

Iterations in Rainfall-Runoff-Routing Model

Perform iterations in rainfall-runoff model (e.g. HEC-HMS) to identify critical dam(s) whose individual or cascading sunny-day failures have an effect at the site. (Other than cascading failures for dams in series, simultaneous individual failures are not being considered.) Add wind-waves from 2-year wind speed. Use conservative breach parameters. If results are below grade of safety-related SSCs, proceed with completing flooding reevaluation without further dam failure considerations. If results exceed grade of safety-related SSCs, proceed to next step.

Does Information show that Critical Dam(s) are Unlikely to Fail?

Develop information, discussed below, to appraise likelihood of failure for the worst-case critical dam or series of dams. Information from the dam owner, developed or approved by a state or federal agency, can be used to justify non-failure. If justification adequately shows that the worst-case critical dam is unlikely to

Comment [JFK37]: This isn't straightforward because the landslide could be initiated by seismic or hydrologic event.
FFTF – just a list. Causes would be considered in developing your sunny day breach. Causes selected need to be justified.

Comment [MB38]: Could be related to a seismic event.
FFTF – just a list. Causes would be considered in developing your sunny day breach. Causes selected need to be justified.

Comment [MB39]: Depending on the outcomes of previous evaluations, the failure scenarios under these other mechanisms may not include failure of all dams. However sunny day may still be a viable mechanism for dams assumed not to fail under other mechanisms.
FFTF – OK. All dams need to be evaluated for sunny day. We will clarify this.

Comment [MB40]: Is it always true that the seismic failure bounds the sunny day? Wouldn't this depend on the seismic failure modes considered or deemed credible?
FFTF – sunny day failures are not believed to cause more limiting conditions than seismic in any way other than warning time., therefore seismic conditions with sunny day warning times is conservative.

Comment [JFK41]: Direction
FFTF – OK

Comment [MB42]: Does this imply a risk assessment?
FFTF – yes, comparison to the criteria listed in KSEE147

Comment [MB43]: Is this defined? Is it based on only water level or also on other factors (e.g., warning time or dynamic loads). Could consideration of multiple "worst-case" failures be necessary to capture the differences in these "associated effects"?
FFTF – It may be necessary to evaluate several dams to define "worst case" for different effects. They do not need to be considered simultaneously. We will add this explanation to the paper.

fail, proceed to Step SD7. If not, this represents the worst-case critical dam or series of dams for the sunny-day failure scenario (Step SD8).

For each critical dam the licensee intends to credit as unlikely to experience sunny-day failure, the information below may be required to demonstrate safety under 'sunny-day' conditions:

- Structural dimensions;
- Construction records;
- Records from installed monitoring instrumentation and/or piezometer wells;
- Field surveys
- On-site inspection reports;
- Maintenance records;
- Risk tolerance of operating agency; and
- Durable operation, inspection, monitoring, maintenance, and corrective action procedures and agreement.

Information from the dam owner, developed or approved by a state or federal agency, can be used to demonstrate that sunny-day failure is unlikely. If non-failure justification is adequate (such as concrete dam with rock abutments to eliminate the possibility of a piping failure), the next worst-case critical sunny-day dam failure (if applicable) should be evaluated.

Step SD8 – Final Sunny-Day Failure Scenario

The final sunny-day failure scenario includes:

- Failure of worse-case critical dam or series of dams (cascading failures);
- No precipitation;
- Wind-waves from 2-year wind speed ; and
- Enhanced modeling techniques (e.g. 1D unsteady flow and/or 2D/3D hydrodynamic models) to refine flood level at site (optional)

Assume failure occurs at full normal pool level. Given the nature of a sunny-day failure, it would be unreasonable to assume simultaneous individual failures.

2.4 Individual and Cascading Failures

Section 3.4 of NUREG/CR-7046 states that "dam failure scenarios, particularly those related to cascading dam failures, should be carefully analyzed and documented to establish that the most severe of the possible combinations has been accounted for". Typically, two scenarios of upstream dam failure should be considered:

1. **Failure of Individual Dams:** One or more dams may be located upstream of the site but on different tributaries so the flood generated from the failure of an individual dam would not flow into the reservoir impounded by another dam. Reasons for failing individual dams depends on the failure mechanism:

Comment [MB44]: Clarify and expand on this.
 FTF – see above comment KSEE147

Comment [g45]: Additional interactions will be necessary on this point.
 FTF – see above comment KSEE147

Comment [KSEE46]: I agree
 FTF – OK

Comment [F47]: The risk tolerance used needs to be that of the NRC. Different federal agencies may have different risk frameworks and criteria and this should not be used to obfuscate the ultimate goal of the guidance which is to address NPP applications.
 FTF – since the 10-7 criteria applies, this bullet will be removed. Note that ICODS discussions may affect this conclusion.

Comment [MB48]: Has this been decided?
 FTF – depends on ICODS discussion

Comment [JFK49]: Same comment about consisten or uniform standards/criteria
 FTF – depends on ICODS discussion

Comment [F50]: This entire section is problematic. It is unclear what 'unlikely' is in this context or how this may be used to meet the SRP hazard screening threshold. There is the potential that 'unlikely' may be translated into 'non-critical' or 'insignificant'.
 FTF – the terms critical and insignificant relate to effect of failure on the site. The work "unlikely" here refers to the probability of failure itself

Comment [MB51]: Based on risk?
 FTF – yes

Comment [MB52]: Is this defined?
 FTF – we will clarify, This is related to the possibility that you may have more than one worst case dam to account for all the limiting effects

Comment [JFK53]: Backwater again...
 FTF – see above

Comment [JFK54]: Justification based upon timing estimates should be provided.
 FTF –OK

- a. **Hydrologic Failure:** It is likely that a large flood on one tributary would coincide with similar large floods in adjoining tributaries.
 - b. **Seismically-Induced Failure:** It is possible that simultaneous failure of individual dams could occur during an earthquake. As discussed further below, individual seismic failure scenarios should consider the location and attenuation of the earthquake.
 - c. **Sunny-Day Failure:** Failure of multiple individual dams on separate tributaries is not applicable to the sunny-day failure mechanism since it is unreasonable to assume that individual dams on separate tributaries would simultaneously fail without an initiating external natural hazard event.
2. **Cascading or Domino-Like Failures of Dams:** Failure of an upstream dam may generate a flood that would become an inflow into the reservoir impounded by a downstream dam and may result in failure by **overtopping of the downstream dam**. If several such dams exist in a river basin, each sequence of dams within the river basin could fail in a cascade. Each of these cascading failure sequences should be investigated to determine one or more sequences of dam failures that may generate the most severe flood at the site. Simplified estimates of the total volume of storage in each of the potential cascades should provide a good indication of the most severe combination. In multiple cascades that cannot be separated by simple hydrologic reasoning, all of the candidate cascades that are comparable in terms of their potential to generate the most severe flood at the site should be simulated using the methods described in this appendix. The most severe flood at the site resulting from these cascades should be used to determine the governing flood.

Appendix D, Part D.1, of NUREG/CR-7046 provides additional guidance and examples for developing reasonable individual and cascading failure scenarios.

3 Overview of HHA Approach for Dam Failure

NUREG/CR-7046 describes the Hierarchical Hazard Assessment (HHA) approach as:

“a progressively refined, stepwise estimation of site-specific hazards that evaluates the safety of SSCs with the most conservative plausible assumptions consistent with available data. The HHA process starts with the most conservative simplifying assumptions that maximize the hazards from the probable maximum event for each natural flood-causing phenomenon expected to occur in the vicinity of a proposed site. The focus of this report is on flood hazards. If the site is not inundated by floods from any of the phenomena to an elevation critical for safe operation of the SSCs, a conclusion that the SSCs are not susceptible to flooding would be valid, and no further flood-hazard assessment would be needed.”

The HHA process allows licensees the option to conduct simplified flooding evaluations, based on varying degrees of conservativeness, to assess susceptibility to flooding. The evaluation is refined using site-specific parameters to achieve a realistic, physics based, but conservative analysis of flooding, particularly when resulting hazard levels exceed acceptance criteria for safety-related SSCs. NUREG/CR-7046 describes the key steps in the process as follows:

1. Identify flood-causing phenomena or mechanisms by reviewing historical data and assessing the geohydrological, geoseismic, and structural failure phenomena in the vicinity of the site and region.

Comment [MB55]: A little more explanation may be helpful here.
FFTF –OK
Public Meeting – Add additional details as given in (b) and (c) below.

Comment [MB56]: What about stability? Note that Step HY8 addresses stability issues. Consider doing a full document consistency check.
FFTF –OK

Comment [JFK57]: Consider moving this section closer to the beginning of the document.
FFTF –OK

2. For each flood-causing phenomenon, develop a conservative estimate of the flood from the corresponding probable maximum event using conservative simplifying assumptions.
3. If any safety-related SSC is adversely affected by flood hazards, use site-specific data to provide more realistic conditions in the flood analyses. Repeat Step 2; if all safety-related SSCs are unaffected by the estimated flood, or if all site-specific data have been used, specify design bases for each using the most severe hazards from the set of floods corresponding to the flood-causing phenomena.

According to Section 3.4.1 of NUREG/CR-7046, 'the simplest and most conservative dam-breach induced flood may be expected to occur under the assumption that (1) all dams upstream of the site are assumed to fail during the PMF event regardless of their design capacity to safely pass a PMF and (2) the peak discharge from individual dam failures reach the site at the same time.' This general approach was applied to all three failure mechanisms (hydrologic, seismic, and sunny-day).

4 Use of Existing Information

- EAPs and other studies (if available) should be considered if:
 - Have the appropriate attributes as described in the white paper
 - Reflect current state of practice and information
 - Assumptions used are still valid (e.g., condition of the dam, inspection frequency)
 - Reflect appropriate level of conservatism depending on the application (e.g., screening versus detailed analysis) and the characteristics of the available information

Overall

1. Original design memorandums for each of the main stem dams.
2. As-built plans and O&M manuals for each main stem dam.
3. Operating rules of gates and releases for each main stem dam.
4. Emergency operation procedures for the main stem dams.
5. Spillway design hydrographs for each main stem dam.
6. Spillway and gate rating curves for each main stem dam.
7. Most recent reservoir elevation-capacity data for each main stem reservoir.
8. Original HEC-2 and or HEC-RAS models.
9. Recent extreme Precipitation Meteorological Studies.
10. Available documentation and electronic models developed flood-frequency studies.
11. All available documentation and electronic models for upstream dam break studies.
12. HEC-HMS models watershed of adjacent waterway.
13. LiDAR data.
14. 2011 Flooding high-water data.

15. Historic hydrology information or flooding reports.
16. Annual inspection reports for critical upstream dams.
17. Historic aerial/topography/navigation mapping.
18. Any additional information (e.g. in-process, planned, proposed) that may be relevant to the hazard reevaluation efforts.

Seismic

1. Location of Dam.
2. Design and/or as-built drawings.
3. Type of soil (material) used to construct the dam.
4. Characteristics of the foundation soils (or rock).
5. Is the dam a rock fill dam or zoned?
6. What are the slopes of the outer embankment and slopes of any zones within the dam?
7. Are there any filter drains in the dam construction?
8. Type of wave protection provided upstream and is the dam grassed or riprapped on the downstream side?
9. The degree of compaction was used for the earth construction. How thick were the lifts when constructed?
10. What are the design water levels (both upstream and downstream)?
11. Is there a concrete or other spillway through the dam?
12. Is there an overflow (emergency spillway and at what elevation)?
13. Height and length of dam.
14. How is the dam integrated into the abutments?
15. Is there a key trench for seepage control?
16. Is there a slurry wall or other seepage cutoff through the dam (most likely in the center)?
17. Was any slope stability performed and for what conditions?
18. Soil properties of the material(s) used to construct the dam.
19. Specifications for the construction of the dam.

5 Dam Failure Flood Modeling

5.1 Simplified Modeling Approaches for Large Watersheds and Number of Dams

Address attributes such as:

- Use of a simplified and conservative approach for dealing with large watersheds with many dams

- Use of conservative assumptions with respect to routing, timing, etc.
- Use of conservative models (e.g., regression equations)
- Conservation of mass/volume
- Inclusion of multiple models and methods
- Inclusion of sensitivity studies
- Assurance that clustering has a defensible engineering basis based on timing, watersheds, etc. (e.g., use of HUCs)

Section 5.5 of ANS 2.8 states “All dams above the plant site shall be considered for potential failure, but some may be eliminated from further consideration because of low differential head, small volume, distance from plant site, and major intervening natural or reservoir detention capacity”. Note that dams along a tributary downstream of the plant may also need to be considered if failure of this dam creates backwater at the site. The purpose of this section is to provide guidance for assessing which dams can be screened as having negligible effect of failure at the site and eliminated from further consideration. All other dams should be considered potentially critical dams and subjected to further evaluation.

National and state dam inventories and classification systems can be used to identify dams within the watershed of an adjacent stream/river and obtain critical characteristics for each dam (location, height, and volume). Most states use a system to classify the size and hazard potential of each dam that can assist in the screening process as well. In most cases, dams immediately upslope from the site (not in line with an adjacent stream/river) and very large dams within the watershed should not be screened.

A justification for screening upstream dams should be developed on a site-specific basis and included in the Flood Hazard Reevaluation report. Several optional methods discussed below, and in more detail in Appendix A, provide a quantitative basis for screening upstream dams. The methods are presented in a HHA-type gradation of conservatism and applicable to the hydrologic and seismically-induced failure modes. The process for evaluating sunny-day failure does not require screening since it only involves identifying the worst-case individual or cascading failure scenario. Note that other methods can be used and will be reviewed on a case-by-case basis.

One method may include creating hypothetical dams in the flood hydrograph model (e.g. HEC-HMS) at existing subbasin outlet points to represent the affects of the small/remote dams within the subbasin. The screening work can still be used to differentiate which dams are lumped into the hypothetical dam and which are treated individually. Guidance on how to model failure of the hypothetical dam may include:

- The volume should equal the total of the upstream small/remote dams; computed from the national dam inventory (highest volume in the inventory for each dam).
- The height of the dam could either be the maximum height of the small/remote dams or a weighted average (weighted by volume).
- Breach parameters (particularly formation time) should not produce artificially high peak outflow rates, knowing that the actual small/remote dams are scattered and the representative release would be more gradual than if it were an actual dam.

It may also be reasonable to add the volume of the small/remote dams to an actual dam being modeled at the outlet of a subbasin.

Comment [JFK58]: It seems problematic to neglect the water. What about determining the cumulative effect of these “negligible” dams, and then simply carry this volume or discharge along in the rest of the analysis. Add it in when you want to estimate a water level.
FFTF –see previous response

Comment [MB59]: Does this mean they will be completely ignored?
FFTF –see previous response

Comment [JFK60]: It would be useful to include (maybe as a box or appendix) a description of how dam (and levee?) regulation actually works in the US. Include mention of the NID? NLD?
FFTF –will add a reference to the description in the Nations Dam Safety Act of 2006 Public Meeting - NID can have multiple levels. Clarify which one to use.

Comment [F61]: I’m concerned this statement may confuse the difference between the dam classification system and the potential impact at the site. Guidance should include a description of the criteria used in the dam hazard classification to make it clear that this relates to potential damage and fatalities, not necessarily due to the impact at the NPP. This is an important distinction that needs to be communicated in a guidance document.
FFTF –we will delete the sentence

Comment [MB62]: Is there guidance for defining “very large”? Is this related to volume or height? Figure 1 might suggest it is only based on height, but what about dams that retain a large volume but are not necessarily “very tall”?
FFTF –add a reference to the USBR/USACE definition of large dam we will also state that justification is required

Comment [JFK63]: HHA not defined
FFTF – OK

5.2 Refined Dam Failure Analysis

5.2.1 Hydrologic

Address attributes such as:

- Defensible engineering evaluation of credibility of mechanism, including
 - Inflow model and assumptions (e.g., design storm, rainfall run-off model)
 - Capacity of dam to pass PMF (as defined in NRC guidance)
 - Considerations other than spillway capacity
 - Condition and characteristics of dam and spillway (including capability to withstand volume and duration of flood event)
 - Potential failure of spillway gates during flood

5.2.2 Seismic

Address attributes such as:

- Defensible engineering evaluation of credibility of mechanism, including
 - Develop ground motions at 1E-4 level at the dam site using present day methods
 - Evaluation of capacity of dam under appropriate load combinations:
 - 1E-4 ground motion with a 25-year flood
 - ½ the ground motion associated with the 1E-4 level with lesser of 1/2PMF or 500-year flood
 - Consideration of dam failure coincident with appropriate flood if dam cannot withstand ground motion
 - Consideration of multiple dams

5.2.3 Sunny-Day

Address attributes such as:

- Discussion and analysis of credible failures modes

Note: Should refer to present day criteria for man-related hazards per 10 CFR 100.20(b). Other hazards have numerical criteria in SRP 2.2.1-2.2.2. However, with appropriate justification, other failure mechanisms may be considered in lieu of calculating the breach parameters under a sunny day failure. Differences in associated effects (e.g., warning time, duration, debris loads) must be considered.

- Description of condition of dam
- Dam operational characteristics (e.g., monitoring and surveillance) *Note: These characteristics may be used to assess warning time with respect to recognition that dam failure is likely or imminent*

5.3 Dam Breach Modeling

An essential part of the dam failure modeling process is formulating and characterizing the breach. Breach determination should be based on realistic but conservative assumptions. Key parameters, such as formation time and final bottom width, have a significant affect on outflow from a breach. Two methods for estimating breach parameters, empirically and physically-based, are discussed further below.

5.3.1 Embankment Dams

5.3.1.1 Empirically-Based (Regression) Peak Outflow Estimation

Empirically-based methods for estimating peak outflow from a dam failure include relatively simple regression equations, generated using observed flows from actual breach events. Wahl (1998) and Pierce (2010) identified and evaluated regression equations for peak outflow as a function of dam and/or reservoir properties. Original technical papers or documentation should be reviewed prior to using these equations to understand their limitations and applicability. The most credible and appropriate technical papers include validation of the breach parameter assumptions and equations with documented dam failure data for dams of similar design, materials, and construction to the dam being evaluated. As part of the HHA process, attenuation of the peak discharge can be ignored to conservatively account for the effect of the breach at the site.

5.3.1.2 Empirically-Based (Regression) Breach Parameter Estimation

Similar to peak outflow, empirically-based methods for estimating breach parameters (i.e. bottom width, bottom elevation, side slopes, formation time, etc.) include relatively simple regression equations, generated using observed data from actual breach events. Wahl (1998) provides a relatively comprehensive review of methods for predicting breach parameters. Simple regression equations that rely on an assumed hydrograph shape with a known volume of water can be useful as a screening tool or for sensitivity analysis to check the reasonability of other methods. The most realistic breach equations include multiple parameters, such as the primary geometric parameters and control variables (e.g. dam type, failure mode, and dam erodibility). Since estimates of breach parameters vary significantly, Wahl suggested using several methods to establish a range of breach parameters, giving due consideration to the dam's design characteristics. Other notable and more recent reviews of breach parameter prediction methods (and peak-flow prediction equations and related dam-failure modeling guidance) include Washington State (2007), Gee (2008), Wahl (2010), and Colorado Department of Natural Resources (2010).

5.3.1.3 Physically-Based Breach Methods

The use of a physically-based breach model requires significantly greater effort by the analyst, since dam and reservoir details must be specified, alternatives for erosion calculations selected, and soil erodibility properties estimated or measured. Sensitivity analyses should be conducted to investigate the effects of variation of input parameters. The use of physically-based models is appropriate when more accurate results are needed and soil erodibility can be reasonably estimated. A technical justification will be required to provide the basis for the assumptions made using physically-based breach models.

5.3.1.4 Breach Formation Time

The breach formation time is a variable that affects peak discharge and warning time for failure responses. Input data for breach formation time is typically described as follows:

- **Overtopping Failure:** The time from when the breach has eroded back to the upstream side of the top of the dam to when the breach is fully formed (i.e., significant erosion has stopped, not the time when the reservoir pool is emptied).

- **Piping Failure:** The time from when a significant amount of flow and material are moving through the piping failure to when the breach is fully formed (i.e., significant erosion has stopped, not the time until the reservoir pool is emptied).

The ultimate bottom elevation is the point at which erosion stops; usually either bedrock, or the bottom of the reservoir pool taking into consideration tailwater effects from a downstream reservoir.

5.3.2 Concrete Dams

In general, the current approach to concrete dams is instantaneous failure. The analysis does not necessarily need to include failure of the entire dam based on the dam design and failure initiation event. For example, for a dam with large gates on the top, it may be reasonable to analyze a failure mode where only the gates fail, but that the concrete portion of the dam beneath and adjacent to the gates remains intact. For dams with distinct structural segments (e.g., buttress dams), limiting failure to one or more segments that are most prone to a deficiency may be justifiable. A technical justification will be required to provide the basis for a determination of partial failure.

5.3.3 Uncertainty

In general, uncertainty in formulating a dam failure should be evaluated by applying multiple methods and evaluating sensitivity to reasonable variations in input parameters. Methods and assumptions should be realistic but conservative. Justification for use of a particular method should be established based on an understanding of how the method was developed and its applicability to the dam in question. Examples of uncertainty information can be found in Froehlich (2008), Wahl (2004), and Xu and Zhang (2009).

5.4 Flood Routing

Address attributes such as:

- Choice of models and methods
 - Type of model chosen (e.g., 1D vs. 2D, hydrologic vs. hydraulic, steady vs. unsteady flow), including justification
 - Performance of sensitivity studies for parameters in model (e.g., roughness)
 - Use of site-specific values (if known) over generic value

5.4.1 1-Dimensional

Flood hydrograph routing in a 1-dimensional model is a procedure to determine the time and magnitude of flow passing through a hydrologic system, such as reservoirs, ponds, channels, floodplains, etc. Flood routing accounts for changes in the time distribution of flood flows caused by storage and attenuation. The effect of storage is to re-distribute the hydrograph by shifting the centroid of the inflow hydrograph by the time of re-distribution to form the outflow hydrograph. The time of re-distribution occurs for level pool or reservoir routing situations. For very long channels, the entire flood wave travels a considerable distance and the centroid of its hydrograph may then be shifted by a time period longer than the time of re-distribution; called time of translation. The total shift in centroid can be called the time of flood movement, equal to the combined effect of the time of re-distribution and time of translation. See Figure 1.

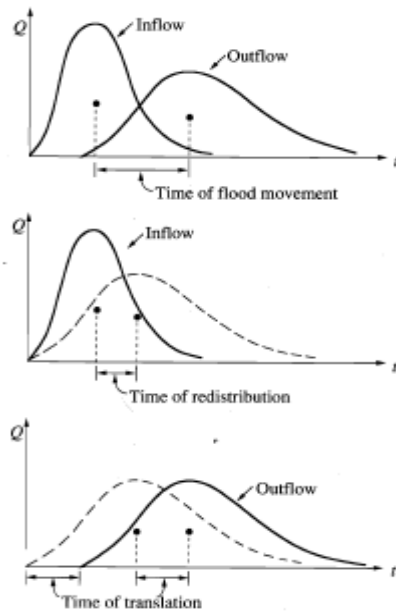

Figure 1 – Hydrograph Attenuation and Redistribution

The process for reservoir (level pool) routing can be expressed using the Continuity Equation (below). The inflow hydrograph, $I(t)$, is typically known. The outflow hydrograph, $Q(t)$, can be solved with another relationship, called a storage function, to relate S , I , and Q .

Equation 1 - Continuity

Other routing computations, including channel/floodplain routing, can vary in complexity; this paper will focus on the two typically used for dam breach routing. Both are based on the St. Venant equation, derived from the combination of the continuity and momentum equations, as illustrated below. As indicated in Equation 2, the St. Venant equation can be applied in 1-dimensional models for:

- **Kinematic (Simplified) Wave Routing** – The kinematic wave routing is based on a finite difference estimation of the continuity equation and simplification of the momentum equation (assume $S_f = S_0$). As indicated in Equation 2, the solution assumes steady-state and uniform flow conditions. The kinematic wave routing method is used in the USACE HEC-HMS model.
- **Dynamic (Time-Dependent or Unsteady) Wave Routing** – The dynamic wave method is a more accurate routing procedure that solves the entire St. Venant equation (Equation 2) and considers changes in flow rates with respect to time, a factor that can be significant with a dam breach wave. The dynamic wave routing method is used in the USACE HEC-RAS (unsteady-flow) model, MIKE 11,

the NWS FLDWAV model, and others. Developing a model using dynamic wave routing techniques involves much greater effort than the kinematic wave solution but produces more accurate results. After the initial setup, a dynamic wave model frequently requires refinements to cross-section spacing and computational time increments to reach and maintain model stability.

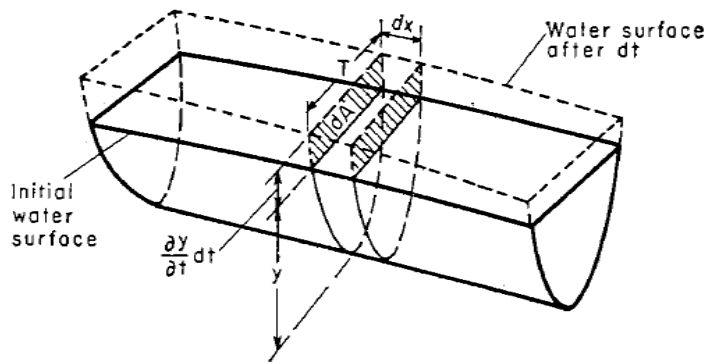
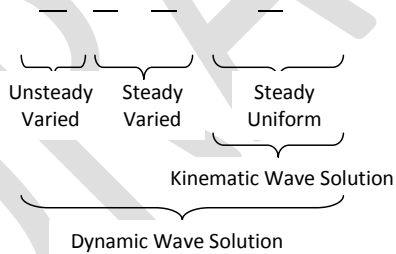

Figure 2 – Definition Sketch for St. Venant Equation

Equation 2 - St. Venant Equation



5.4.2 2-Dimensional

In some cases, flow pattern complexities, unusual dam failure configurations, and/or a desire for increased accuracy warrants the use of Two Dimensional (2D) (finite-element or finite-difference) hydrodynamic modeling to simulate the affects of dam failure. 2D models have the added advantage of producing velocity vectors (direction and magnitude) at the site to better assess hydrodynamic and debris loading conditions at the site due to dam failure. Some 2D models use finite-element solutions of continuity and momentum functions based on a triangular mesh, representing the surface terrain, developed from a series of points/nodes with X, Y, Z attributes. Other 2D models use finite-difference solution methods based on a surface terrain represented by grid elements. Some 2D models can be used to generate and route breach hydrographs; others can only perform the hydrodynamic routing of a user defined breach hydrograph. Example models include:

Comment [initials64]: FFTF – add one more model: RMA-2

- HEC-RAS 4.2 (currently being beta-tested but is expected to include a 2D component)
- RiverFLO-2D
- FLO-2D
- River-2D
- MIKE-21
- SRH-2-D Model (USBR)

6 Definitions and References

6.1 Definitions

Breach Parameters:

Breach Depth/Height – The vertical extent of the breach, measured from the dam crest to the invert of the breach. Some publications cite the reservoir head on the breach, measured from the reservoir water surface to the breach invert. (Adapted from Wahl (1998))

Breach Width – The ultimate width of the breach, reported either as the average breach width or breach width at the top or bottom of the breach opening. (Adapted from Wahl (1998))

Breach Side Slope Factor – The side slope, typically expressed in terms of ‘per unit height’ (Z units horizontal to 1 unit vertical or Z:1), of an idealized trapezoidal-shaped breach. (Adapted from Wahl 1998))

Breach Initiation Time – The breach initiation time begins with the first flow over or through a dam that will initiate warning, evacuation, or heightened awareness of the potential for dam failure. The breach initiation time ends at the start of the breach formulation phase. (Adapted from Wahl (1998))

Breach Formation Time (Time of Failure or Failure Time) – Breach formation time (or time to failure) has been defined in various ways. Below are the definitions included in the NWS DAMBRK and HEC-RAS models:

- *NWS DAMBRK: The duration of time between the first breaching of the upstream face of the dam until the breach is fully formed (i.e., significant erosion has stopped, not the time until the reservoir pool is emptied). For overtopping failures, the beginning of breach formulation is after the downstream face of the dam has eroded away and the resulting crevasse has progressed back across the width of the dam crest to reach the upstream face. For piping failures, it is the the time from when a significant amount of flow and material are moving through the piping failure to when the breach is fully formed.*
- *USACE HEC-RAS: [Full formulation time is] the breach development time in hours. This time represents the duration from when the breach begins to have some significant erosion, to the full development of the breach.*

Final Bottom Width – Bottom width of the breach at its maximum size (USACE, 2008a)

Combined Effect Flood – A combined effect is a plausible combination of flooding mechanisms occurring simultaneously.

Critical and Non-Critical Dams – A ‘critical’ dam is an upstream dam whose failure is shown, through an engineering evaluation, to have a significant affect at the site. Conversely, a ‘non-critical’ dam is an upstream dam whose failure is shown to not significantly affect the site. The critical (significant affect) – non-critical (insignificant affect) distinction is only used to assist the licensee in focusing refinement efforts on a ‘critical’ sub-set of dams and differs from the screening process. The final failure scenario would include failure of ‘non-critical’ dams using conservative breach parameters.

Dam – A dam is an artificial barrier used to impound or redirect water for multiple possible functions, including, but not limited to, flood control (attenuation), recreation, water supply, hydroelectric, sediment storage, aquatic habitat, stormwater (quantity/quality) management, or a combination thereof. Water-storage or water-control structures (such as onsite cooling or auxiliary water reservoirs and onsite levees) that may be located at or above the safety-related site grade should also be evaluated.

Dam Breaches/Failures – A breach/failure, which can be caused by several possible mechanisms including overtopping, seismic activity, slope failures, etc., can produce a floodwave with high flow rates, velocities, and depths. The flood wave may constitute a hazard that threatens life and property (generally downstream of the breached barrier). Floodwaves from dam failures of (or other upstream structures) are distinct from wind-generated waves. The flood wave attenuates as it moves downstream causing the peak flow rates, velocities, and flood elevations/stage to decrease. Failure of a dam could cause the formation of a floodwave that could threaten lives and property downstream of the barrier.

Design Basis Flood – A design-basis flood is a plant-specific phenomenon (water elevation, velocity, etc.) caused by one or an appropriate combination of several hydrometeorological, geoseismic, or structural-failure phenomena, which results in the most severe hazards to structures, systems, and components (SSCs) important to the safety of a nuclear power plant.

Failure Mechanism – The initiating conditions under which a dam fails. For the purpose of this paper, three failure mechanisms are being considered: hydrologic (induced by an extreme precipitation event), seismic (induced by an earthquake), and ‘sunny-day’ (no initiating event external to the dam).

Failure Mode – The means by which a dam fails, such as piping, slope failure, breach due to overtopping, spillway failure, sliding, overtopping, etc.

Flood Warning – Alert systems notifying people and/or facilities along low-lying areas that flooding is possible, likely, and/or imminent. Flood warning time is the time between the alert and arrival of floods and is dependent on the flooding characteristics. Flash floods are typically associated with fast-moving, short-duration, highly-intense storms affecting streams and drainage systems with relatively small watersheds, and generally have short warning times. Warning time for dam failure flooding can be very short and unpredictable, depending on the velocity of the flood wave, the dam’s distance from the point of interest, type of dam, and the time taken by the dam owner to notify emergency officials.

Negligible Effects of Dam Failure – Screening upstream dams from consideration in the dam failure scenario development process involves establishing a ‘negligible’ threshold for increase in stage, discharge, and/or volume at the site. ‘Negligible’ threshold should be developed on a site-specific basis and may include such considerations as margin of error in the hydraulic analysis.

Probable Maximum Flood (PMF) – The PMF is a hypothetical flood (peak discharge, volume, and hydrograph shape) considered to be the most severe reasonably possible, based on comprehensive hydrometeorological application of Probable Maximum Precipitation (PMP) and other hydrologic factors favorable for maximum flood runoff, such as sequential storms, and snowmelt.

Comment [MB65]: Will the specification of a critical dam account for effects of cascading failures?
FFTF – expand definition to capture. Include an example

Comment [MB66]: This language may cause some confusion and a little more explanation may help. Not having a significant effect may be confused with the definition of negligible. Failure of a non-critical dam may cause a large amount of water at the site, however the site characteristics are such that this amount of water can be accommodated.
FFTF – define significant, non-significant, and negligible

Comment [KSEE67]: Volumes should be conserved and considered in any analysis
FFTF – Account for dams that are screened out by possible including a hypothetical dam that includes the volumes of all the dams that are screened out
Public Meeting – Address Passim

Comment [JFK68]: mention spillway failure
FFTF – OK. Vulnerabilities include exceeding design capacity
Public Meeting – Need to provide reasonable assurance that spillway will operate as designed. Will be addressed later in document. Suggest tie to monitoring and surveillance programs.

Comment [JFK69]: prefer water elevation or stage
FFTF - OK

Comment [JFK70]: Include the idea that there can be more than one DBF (e.g. water level, hydrodynamic forces, warning time)
FFTF - OK

Comment [MB71]: Very minor comment: this addresses the system not the concept of “flood warning” or warning time, which is the goal of the next sentence. ...

Comment [JFK72]: Flash floods are also associated with collapse of ice or debris jams.
FFTF – OK

Comment [JFK73]: Not really. You get more precipitation at a given location if an intense storm moves slowly or stops. For example, consider the 1976 Big Thompson Flood. The flooding was inter... ..

Comment [MB74]: Is there or will there be guidance for specifying this threshold? ...

Comment [JFK75]: Uncertainty would be better choice. The idea presented in this section does not get carried through to Section 4 discussions.
FFTF – OK

Comment [KSEE76]: Red Flag. “Negligible” threshold is arbitrary. Also while each individual dam may only contribute a small amount to the flood level, when combined with other dams, it r... ..

Probable Maximum Precipitation (PMP) – The estimated depth of precipitation for a given duration, drainage area, and time of year for which there is virtually no risk of exceedance. The probable maximum precipitation for a given duration and drainage area approximates the maximum that is physically possible within the limits of contemporary hydrometeorological knowledge and techniques

Riverine Flooding – A watershed’s response to a rainfall-runoff event that produces overbank flow at a given location. Riverine flooding adjoining the site, associated with the PMF, is determined by applying the PMP and other hydrologic factors to the watershed draining to the site location.

Screening – Screening is the process in developing dam failure scenarios in which the licensee can eliminate upstream dams from further consideration, because of low differential head, small volume, distance from plant site, and major intervening natural or reservoir detention capacity. Screening dams is different than process for distinguishing ‘critical’ and ‘non-critical’ dams. See associated definition above.

Overtopping – The point at which an unprotected portion of the dam, or portion of the dam structure not designed to convey floodwater, is subject to flow during a postulated flood. ‘Overtopping’ could also apply if the design capacity of outlet component is exceeded by the postulated flood.

Comment [JFK77]: There is really no basis for this claim. In some instances, maximum probable precipitation or flood values have been exceeded shortly after or before publication.
FFTF - this is the definition from (ANS 2.8?). Stay with this definition as it is the current regulatory guidance
Public Meeting - Agree, match ANS 2.8

Comment [JFK78]: The ‘probable maximum’ concept began as ‘maximum possible’ because it was considered that maximum limits exist for all the elements that act together to produce rainfall, and that these limits could be defined by a study of the natural processes. This was found to be impossible to accomplish.
FFTF - this is the definition from (ANS 2.8?)
Public Meeting - Agree, match ANS 2.8

Comment [JFK79]: Backwater effects!
FFTF – OK

Comment [MB80]: This should consider conservation of volume (not just “ignore” dams)
FFTF – same answer as above for screened out dams

Comment [JFK81]: What about things like gate failure or clogging by debris?
FFTF – will mention in section 4.4 that this has to be demonstrated. Also add the concept of design duration to the definition of overtopping.

Comment [MB82]: What about damage to the outlet? Or the consideration of the outlet condition?
FFTF – unless there is a problem with the outlet system caused by the flood (like exceeding design capacity), we do not have to consider that it will not perform as designed
Public Meeting – Make consistent with previous discussions

Comment [JFK83]: How about collecting all the various definitions of negligible, potentially critical, critical, etc. in one place? Consider adding a figure to clarify?
FFTF – OK
Public Meeting – Concept good. Figure itself will need to be reworked.

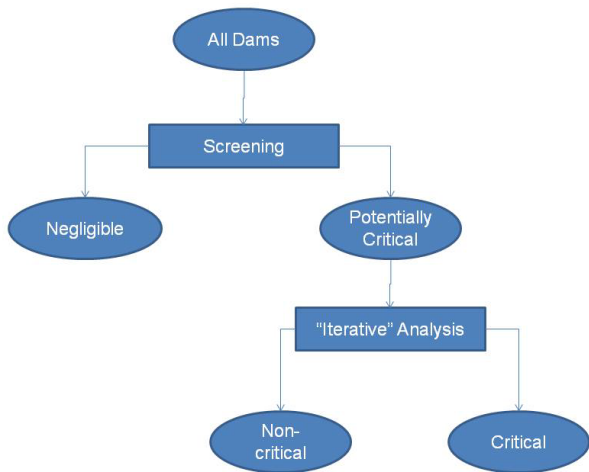

6.2 References

6.2.1 Regulatory and Overall Dam Breach Analysis Guidelines

American Nuclear Society (ANS). 1992. *American National Standard for Determining Design Basis Flooding at Power Reactor Sites*. Prepared by the American Nuclear Society Standards Committee Working Group ANS-2.8, La Grange Park, Illinois.

Colorado Department of Natural Resources, Office of the State Engineer, Division of Water Resources, Dam Safety Branch. 2010. "Guidelines for Dam Breach Analysis", State of Colorado, Department of Natural Resources, February 10.

Federal Emergency Management Agency. 2010. "Numerical Models Meeting the Minimum Requirement of National Flood Insurance Program." Available at http://www.fema.gov/plan/prevent/fhm/en_coast.shtm. Accessed December 20, 2010.

Federal Energy Regulatory Commission, 1987, Engineering Guidelines for the Evaluation of Hydropower Projects, FERC 0119-1, Office of Hydropower Licensing, July 1987, 9 p.

Federal Energy Regulatory Commission. 2001. *Engineering Guidelines for the Evaluation of Hydropower Projects*. Chapter 8 – "Determination of the Probable Maximum Flood." Washington, D.C.

U.S. Nuclear Regulatory Commission, NUREG/CR-7046, PNNL-20091, "Design-Basis Flood Estimation for Site Characterization at Nuclear Power Plants in the United States of America." ML11321A195, November 2011.

U.S. Nuclear Regulatory Commission, NUREG-0800, "Standard Review Plan for the Review of Safety Analysis Reports for Nuclear Power Plants: LWR Edition – Site Characteristics and Site Parameters (Chapter 2)," ML070400364, March 2007.

U.S. Nuclear Regulatory Commission. 1976. *Flood Protection for Nuclear Power Plants*. Regulatory Guide 1.102, Rev. 1, Washington, D.C.

U.S. Nuclear Regulatory Commission. 1977. *Design Basis Flood for Nuclear Power Plants*. Regulatory Guide 1.59, Rev. 2, Washington, D.C.

U.S. Nuclear Regulatory Commission. 2011. *Recommendations for Enhancing Reactor Safety in the 21st Century: The Near-term Task Force Review of Insights from the Fukushima Dai-ichi Accident*, ML111861807, July 12.

U.S. Nuclear Regulatory Commission, Reg Guide 1.127, Inspection of Water-Control Structures associated with Nuclear Power Plants.

U.S. Nuclear Regulatory Commission, SECY 11-0124, "Recommended Actions To Be Taken Without Delay from the Near-Term Task Force Report," ML11245A158, September 9, 2011.

U.S. Nuclear Regulatory Commission, SRM SECY 11-0124, "Recommended Actions To Be Taken Without Delay from the Near-Term Task Force Report," ML112911571, October 18, 2011.

U.S. Nuclear Regulatory Commission, SECY 11-0137, "Prioritization of Recommended Actions to Be Taken in Response to Fukushima Lessons Learned," ML11272A111, October 3, 2011.

U.S. Nuclear Regulatory Commission, SRM SECY 11-0137, "Prioritization of Recommended Actions to Be Taken in Response to Fukushima Lessons Learned," ML113490055, dated December 15, 2011.

Washington State Dept. of Ecology (2007), *Dam Break Inundation Analysis and Downstream Hazard Classification*, Dam Safety Guidelines, Technical Note 1.

Comment [g84]: Separate cited and non-cited references

Comment [F85]: Include USNRC Information Notice 2012-02: "POTENTIALLY NONCONSERVATIVE SCREENING VALUE FOR DAM FAILURE FREQUENCY IN PROBABILISTIC RISK ASSESSMENTS."

FFTF - OK

6.2.2 Hydrology and Hydraulics

- Chow V.T. 1959. *Open-Channel Hydraulics*. McGraw-Hill Book Company, New York.
- Chow V.T., D.R. Maidment, and L.W. Mays. 1988. "Applied Hydrology." McGraw-Hill Book Company, New York.
- U.S. Army Corps of Engineers (USACE), *River Hydraulics*, Engineer Manual (EM) 1110-2-1416
- U.S. Army Corps of Engineers (USACE), *Standard Project Flood Determinations*, Engineer Manual (EM) 1110-2-1411
- U.S. Army Corps of Engineers (USACE). 1997. *Hydrologic Engineering Requirements for Reservoirs*. Engineer Manual 1110-2-1420, Washington, D.C.
- U.S. Army Corps of Engineers (USACE). 2008a. *HEC-RAS River Analysis System User's Manual*. Version 4.1. U.S. Army Corps of Engineers Hydrologic Engineering Center, Davis, California. Available at <http://www.hec.usace.army.mil/software/hec-ras/>.
- U.S. Army Corps of Engineers (USACE). 2008b. "Hydrologic Modeling System HEC-HMS User's Manual. Version 3.3." U.S. Army Corps of Engineers Hydrologic Engineering Center, Davis, California. Available at <http://www.hec.usace.army.mil/software/hechms/>.
- U.S. Army Corps of Engineers (USACE). 2008c. *Inflow Flood Hydrographs*. USACE Dam Safety Program Portfolio Risk Assessment Draft Report, Washington D.C.

6.2.3 Dam Design

- Dewey, Robert L., and David R. Gillette, 1993, "Prediction of Embankment Dam Breaching for Hazard Assessment," *Proceedings*, ASCE Specialty Conference on Geotechnical Practice in Dam Rehabilitation, Raleigh, North Carolina, April 25-28, 1993.
- Hartung, F., and H. Scheuerlein, 1970, "Design of Overflow Rock Dams," in *Proceedings*, International Commission on Large Dams, Tenth International Congress on Large Dams, Q.36, R.35, Montreal, Canada, June 1-5, 1970, p. 587-598.
- Hunt, S., Hanson, G.J., Temple, D.M., Kadavy, K.C. 2005b. Embankment Overtopping and RCC Stepped Spillway Research. In: American Society of Agricultural Engineers Annual International Meeting, July 17-20, 2005, Tampa, Florida. Paper No. 05-2204. CD-ROM.
- Ko, H.Y., Dunn, R.J., and Hollingsworth, T., 1985. Study of embankment performance during overtopping-prototype modeling and dimensional verification. U.S. Army Corps of Engineers, Waterways Experiment Stations, Vicksburg, Mississippi.
- Ko, H.Y., Dunn, R.J., and Simantob, E., 1984. Study of embankment performance during overtopping and throughflow. U.S. Army Corps of Engineers, Waterways Experiment Stations, Vicksburg, Mississippi.
- Martins R. (1981), *Hydraulics of Overflow Rockfill Dams*, LNEC – Me 559, Lisboa.
- Martins R. (1996), *Design Criteria for Rockfill Structures Subjected to Flow*, LNEC – Me 807, Lisboa.

Post-Fukushima Near-Term Task Force Recommendation 2.1
Supplemental Guidance for the Evaluation of Dam Failures
January 14, 2013, Revision F

- U.S. Army Corps of Engineers (USACE). 1991. "Inflow design floods for dams and reservoirs." Engineer Regulation 1110-8-2(FR), Washington, D.C.
- U.S. Department of Agriculture, Natural Resources Conservation Service (NRCS), Technical Release 60 (TR-60), "Earth Dams and Reservoirs", July 2005
- U.S. Department of Interior, Bureau of Reclamation (Reclamation). 1987. *Design of Small Dams*. Third Edition. A Water Resources Technical Publication, Washington, D.C.
- U.S. Department of Interior, Bureau of Reclamation (Reclamation). 2010. *Best Practices in Dam Safety Risk Analysis, Version 2.1*. Denver, Colorado.
- U.S. Department of Interior, Bureau of Reclamation (Reclamation). 2003. *Guidelines for Achieving Public Protection in Dam Safety Decision-Making*. Denver, Colorado.
- U.S. Department of Interior, Bureau of Reclamation (Reclamation). 1977. *Design of Arch Dams*. A Water Resources Technical Publication, Denver, Colorado.
- U.S. Department of Interior, Bureau of Reclamation (Reclamation). 1976. *Design of Gravity Dams*. A Water Resources Technical Publication, Denver, Colorado.

6.2.4 Empirically-Based Breach Parameter and Outflow Estimation

- Froehlich, D.C. 1995a. Embankment dam breach parameters revisited. Proceedings of the 1995 ASCE Conference on Water Resources Engineering, San Antonio, Texas. August. p. 887-891.
- Froehlich, D.C. 1995b. Peak Outflow from Breached Embankment Dam. Journal of Water Resources Planning and Management, vol. 121, no. 1, p. 90-97.
- Froehlich, D.C. 1995b. Embankment dam breach parameters revisited. Proceedings of the 1995 ASCE Conference on Water Resources Engineering, San Antonio, Texas. August. p. 887-891.
- Froehlich, D.C. 1995a. Peak Outflow from Breached Embankment Dam. Journal of Water Resources Planning and Management, vol. 121, no. 1, p. 90-97.
- Froehlich, David C., and Tufail, M., 2004. Evaluation and use of embankment dam breach parameters and their uncertainties. Annual Conference of Association of State Dam Safety Officials, September, Phoenix, Arizona.
- Froehlich, 2008. Embankment dam breach parameters and their uncertainties. *Journal of Hydraulic Engineering*, 134(12):1708-1721.
- Gee, D. Michael, 2008. "Comparison of Dam Breach Parameter Estimators", Corps of Engineers Hydrologic Engineering Center, Davis, CA.
- Knauss, J., 1979, "Computation of Maximum Discharge at Overflow Rockfill Dams," *Proceedings*, International Commission on Large Dams, Thirteenth International Congress on Large Dams, Q.50, R.9, New Delhi, India, 1979, p. 143-160.
- Lecoite, G., 1998. "Breaching mechanisms of embankments an overview of previous studies and the models produced." CADAM Meeting, Munich, Germany. 8-9 October 1998.
- Lou W. C. (1981), *Mathematical Modeling of Earth Dam Breaches*, PhD Dissertation, Colorado State University – Fort Collins.

Post-Fukushima Near-Term Task Force Recommendation 2.1
Supplemental Guidance for the Evaluation of Dam Failures
January 14, 2013, Revision F

- MacDonald, T. C., and Langridge-Monopolis, J. (1984), "Breaching Characteristics of Dam Failures," *ASCE J. Hydraulic Engineering*, 110(5), 567-586.
- Pierce, M.W., Thornton, C.I., and S.R. Abt. 2010. "Predicting Peak Outflow from Breached Embankment Dams", Colorado State University. Prepared for: National Dam Safety Review Board Steering Committee on Dam Breach Equations. June 2010.
- Pierce, M.W., Thornton, C.I., and S.R. Abt. 2011, Enhanced Predictions for Peak Outflow from Breached Embankment Dams, *Journal of Hydrologic Engineering*, 16(1):81-88.
- Reed, S., J. Halgren. 2011. "Validation of a New GIS Tool to Rapidly Develop Simplified Dam Break Models", Proceedings of Association of Dam Safety Officials Dam Safety 2011, Sept. 25 - 29, Washington, D.C.
- U.S. Bureau of Reclamation (USBR). 1982. "Guidelines for defining inundated areas downstream from Bureau of Reclamation dams." *Reclamation Planning Instruction No. 82-11*, June 15.
- U.S. Department of Agriculture (USDA). 1985. Soil Conservation Service. Technical Release No. 66. *Simplified Dam Breach Routing Procedure*. September 30.
- Wahl T. L. (1997), Predicting Embankment Dam Breach Parameters – A Needs Assessment, 27th IAHR Congress, International Association for Hydraulic Research, San Francisco, California, August 10-15, 1997.
- Wahl, Tony L. (1988), "Prediction of Embankment Dam Breach Parameters – A Literature Review and Needs Assessment," DSO-98-004, Dam Safety Research Report, U.S. Department of the Interior, Bureau of Reclamation, Dam Safety Office, July 1998.
http://www.usbr.gov/pmts/hydraulics_lab/twahl/breach/breach_links.html
- Wahl, Tony L., 1998. "Prediction of Embankment Dam Breach Parameters – A Literature Review and Needs Assessment," DSO-98-004, Dam Safety Research Report, U.S. Department of the Interior, Bureau of Reclamation, Denver, CO, . http://www.usbr.gov/pmts/hydraulics_lab/pubs/DSO/DSO-98-004.pdf
- Wahl, Tony L., 2004. "Uncertainty of predictions of embankment dam breach parameters". *Journal of Hydraulic Engineering*, Vol. 130, No. 5, pp. 389-397.
- Wahl, Tony L., et al. 2008. "Development of Next-Generation Embankment Dam Breach Models," United States Society on Dams, 28th Annual USSD Conference, Portland, OR, April 28-May 2, 2008, pp. 767-779.
- Wahl, Tony L., 2009. "Evaluation of New Models for Simulating Embankment Dam Breach," in *Dam Safety 2009*, Annual Meeting of the Association of State Dam Safety Officials (ASDSO), Sept. 27-Oct. 1, 2009, Hollywood, FL.
- Wahl, Tony L. 2010. "Dam Breach Modeling – An Overview of Analysis Methods", Joint Federal Interagency Conference on Sedimentation and Hydrologic Modeling, Las Vegas, NV, June 27-July 1, 2010.
- Walder, Joseph S., and Jim E. O'Conner. 1997. "Methods for Predicting Peak Discharge of Floods Caused by Failure of Natural and Constructed Earth Dams," *Water Resources Research*, vol. 33, no. 10, October 1997.
- Whetmore, J.N., Fread, D.L., Lewis, J.M., Wiele, S.M., 1991. "The NWS Simplified Dam-break Flood Forecasting Model".
- Xu, Y. and Zhang, L. M. (2009), "Breaching Parameters for Earth and Rockfill Dams," *ASCE J. Geotechnical and Geoenvironmental Engineering*, 135(12), December 1, 1957-1970.

6.2.5 Physically-Based Breach Methods

Bechteler W., Broich K. (1993), Computational Analysis of the Dam Erosion Problem, Proceedings of the International Conference on Hydrosience and Engineering, Washington DC, Junho.

Cristofano E. A. (1965), Method of Computing Erosion Rate for Failure of Earthfill Dams, U. S. Bureau of Reclamation, Denver.

Franca, M.J., and Almeida, A.B., 2004. A computational model of rockfill dam breaching caused by overtopping (RoDaB). *Journal of Hydraulic Research*, Vol. 42, No. 2, pp. 197-206.

Loukola E. e Huokuna M. (1998), A Numerical Erosion Model for Embankment Dams Failure and It's Use for Risk Assessment, Proceedings of the 2nd CADAM Workshop, Munich.

Macchione, F., 2008a. Model for Predicting Floods due to Earthen Dam Breaching I: Formulation and Evaluation. *ASCE Journal of Hydraulic Engineering*, Vol. 134, pp. 1688-1696.

Macchione, F., Rino, A., 2008b. Model for Predicting Floods due to Earthen Dam Breaching II: Comparison with Other Methods and Predictive Use. *ASCE Journal of Hydraulic Engineering*, Vol. 134, pp. 1697-1707.

Morris, M.W., M.A.A.M Hassan, T.L. Wahl, R.D. Tejral, G.J. Hanson, and D.M. Temple, 2012. Evaluation and development of physically-based embankment breach models. The 2nd European Conference on FLOODrisk Management. 20-22 November 2012, Rotterdam, The Netherlands.

O'Brien, J.S., President, FLO-2D Software Inc. 2012. Dam Breach Mechanisms, Breach Growth and the Effect on Downstream Flooding.

Visser, K., G. Hanson, D. Temple, and M. Neilsen, 2012. Earthen Embankment Overtopping Analysis using the WinDAM B Software. *Dam Safety 2012*, Annual Meeting of the Association of State Dam Safety Officials (ASDSO), Sept. 17-19, 2012, Denver, CO.

Wang, Z. 2005. "A numerical three dimensional noncohesive earthen dam breach model". Ph.D. dissertation, 222 pp., Utah State Univ., Logan, UT.

Wang, Z. and Bowles, D. 2006a. "Three dimensional noncohesive earthen dam breach model". Part 1, Theory and methodology, *Advances in Water Resources*; in press, doi:10.1016/j.advwatres.2005.11.009.

Wang, Z. and Bowles, D. 2006b. "Three dimensional noncohesive earthen dam breach model". Part 2, Validation and applications, *Advances in Water Resources*; in press, doi:10.1016/j.advwatres.2005.11.010.

Wang, Z. and Bowles, D. 2006c. "Dam breach simulations with multiple breach locations under wind and wave actions", *Advances in Water Resources*; in press, doi:10.1016/j.advwatres.2005.10.008.

Wang, Z., Bowles, D. 2007. Overtopping Breaches for a Long Dam Estimated Using a Three Dimensional Model.

WinDAM B: USDA-ARS, USDA-NRCS and Kansas State University (2011), <http://go.usa.gov/8Og>

Wu, W., Wang, S. 2007. One-Dimensional Modeling of Dam-Break Flow over Movable Beds. *Journal of Hydraulic Engineering*, ASCE, 133(1):48-58.

6.2.6 Other Dam Failure Research

AlQaser, G., and Ruff, J.F., 1993. Progressive failure of an overtopped embankment. In *Hydraulic Engineering*, Proceedings of the 1993 ASCE Hydraulic Specialty Conference, San Francisco, California, July 25-30, 1993.

Andrews, D.P., Coleman, S.E., Webby, M.G., and Melville, B.W., 1999. Noncohesive embankment failure due to overtopping flow. Proceedings, 28th Congress of the International Association for Hydraulic Research, Graz, Austria.

Coleman, S.E., R.C. Jack, and B.W. Melville, 1997. Overtopping Breaching of Noncohesive Embankment Dams. 27th IAHR Congress, San Francisco, California, August 10-15, 1997. p. 42-47.

Coleman, Stephen E., Darryl P. Andrews, and M. Grant Webby, 2002. "Overtopping Breaching of Noncohesive Homogeneous Embankments," *Journal of Hydraulic Engineering*, vol. 128, no. 9, Sept. 2002, p. 829-838.

Coleman, Stephen E., Darryl P. Andrews, and M. Grant Webby, 2004. Closure to "Overtopping Breaching of Noncohesive Homogeneous Embankments," *Journal of Hydraulic Engineering*, vol. 130, no. 4, April 2004, p. 374-376.

Dewey, Robert L., and Ronald A. Oaks, 1990, *The Determination of Failure of an Embankment Dam During Overtopping*, draft Technical Memorandum No. MISG620-1, Bureau of Reclamation, Denver, Colorado, May 1989, revised April 1990.

Evans, Steven G., 1986, "The Maximum Discharge of Outburst Floods Caused by the Breaching of Man-Made and Natural Dams," *Canadian Geotechnical Journal*, vol. 23, August 1986.

Franca, M.J., and Almeida, A.B., 2002. Experimental tests on rockfill dam breaching process. International Symposium on Hydraulic and Hydrological Aspects of Reliability and Safety Assessment of Hydraulic Structures, St. Petersburg, Russia. May 29-June 2 2002.

Gerodetti, M., 1981, "Model Studies of an Overtopped Rockfill Dam," *International Water Power & Dam Construction*, September 1981, p. 25-31.

Hanson, G.J., D.M. Temple, S.L. Hunt, and R.D. Tejral, 2011. Development and characterization of soil material parameters for embankment breach. *Applied Engineering in Agriculture*, 27(4):587-595.

Hassan, Mohamed, and Morris, M.W., 2008. IMPACT Project Field Tests Data Analysis. FLOODsite Report No. T04-08-04, Revision 3_2_P01.

Mohamed A. A., Samuels P. G. e Morris M. W. (1998), A New Methodology to Model the Breaching of Non-Cohesive Homogeneous Embankments, Proceedings of the 4th CADAM Workshop, Zaragoza, Spain.

Ponce V. M. e Tsvoglou A. J. (1981), Modeling Gradual Dam Breaches, *Journal of Hydraulics Division*, Vol. 107, N. HY7, 829-838.

Powledge G. R., Ralston D. C., Miller P., Chen Y. H., Clopper P. E. e Temple D. M. (1989), Mechanics of Overflow Erosion on Embankments. II: Hydraulic and Design Considerations, *Journal of Hydraulic Engineering* Vol. 115, N° 8 Agosto. - Quintela A. C. (1981), *Hidráulica*, Fundação Calouste Gulbenkian, Lisboa.

Stephenson D. (1979), *Rockfill in Hydraulic Engineering*, Elsevier Scientific Publishing Company, Amsterdam.

Post-Fukushima Near-Term Task Force Recommendation 2.1
Supplemental Guidance for the Evaluation of Dam Failures
January 14, 2013, Revision F

Vaskinn, K.A., Løvoll, A., and Höeg, K., undated. WP2.1 BREACH FORMATION- LARGE SCALE EMBANKMENT FAILURE.
http://www.impact-project.net/AnnexII_DetailedTechnicalReports/AnnexII_PartA_WP2/Impact_kav.pdf

DRAFT

Appendix A

Screening Upstream Dams with Negligible effect of Failure at the Site

DRAFT

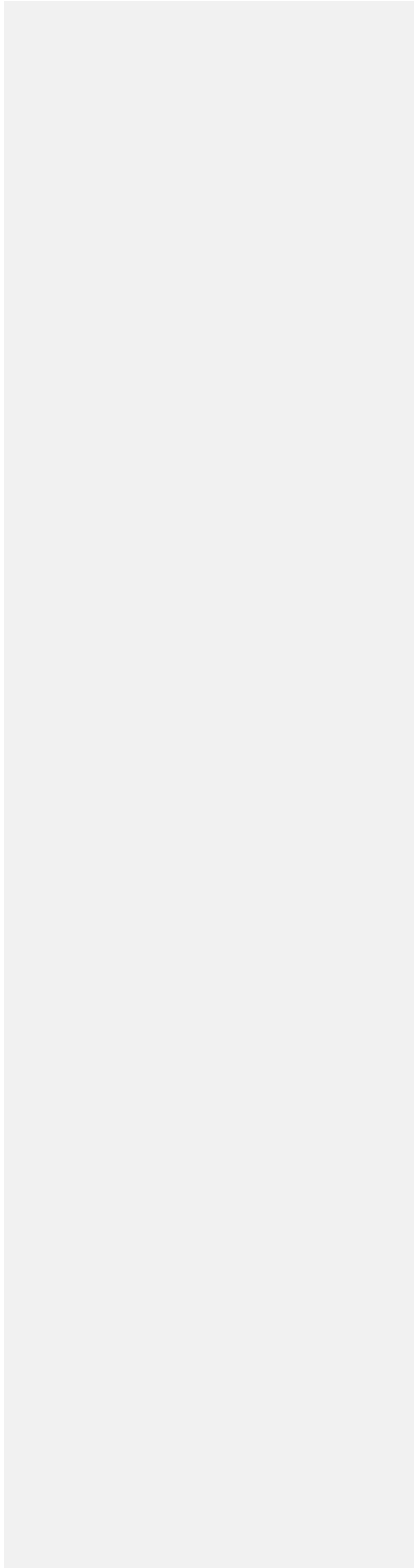

Screening Upstream Dams with Negligible effect of Failure at the Site

Section 5.5 of ANS 2.8 states “All dams above the plant site shall be considered for potential failure, but some may be eliminated from further consideration because of low differential head, small volume, distance from plant site, and major intervening natural or reservoir detention capacity”. The purpose of this section is to provide additional guidance for assessing which dams can be screened as having negligible effect of failure at the site and eliminated from further consideration. All other dams should be considered potentially critical dams and subjected to further evaluation.

National and state dam inventories and classification systems can be used to identify dams within the watershed of an adjacent stream/river and obtain critical characteristics for each dam (location, height, and volume). Most states use a system to classify the size and hazard potential of each dam that can assist in the screening process as well. In most cases, dams immediately upslope from the site (not in line with an adjacent stream/river) and very large dams within the watershed should not be screened.

A justification for screening upstream dams should be developed on a site-specific basis and included in the Flood Hazard Reevaluation report. Several optional methods discussed below, and in more detail in Appendix A, provide a quantitative basis for screening upstream dams. The methods are presented in a HHA-type gradation of conservatism and applicable to the hydrologic and seismically-induced failure mechanisms. The process for evaluating sunny-day failure does not require screening since it only involves identifying the worst-case individual or cascading failure scenario. Note that other methods can be used and will be reviewed on a case-by-case basis. The screening process involves establishing a ‘negligible increase’ threshold at the site. See Section 6 for definition of ‘negligible effects of dam failure’.

1. Volume Method: Estimate and sum the storage volume for all upstream dams in the watershed, assuming pool levels are at the top of each dam. Develop a stage-storage function for the river/floodplain system at the site assuming floodwaters have already reached plant grade. That is, do not credit volume in the channel and/or floodplain below plant grade. With available LiDAR datasets or USGS digital elevation models (DEM), GIS tools can be used to develop the stage-storage function at the site. Developing the stage-storage function should exclude remote floodplain storage areas that could not be accessed by overbank floodwaters. Compute the difference in elevation, starting at plant grade, by applying the total storage volume for all upstream dams to the stage-storage function. This calculation is representative of having the total upstream storage volume instantaneously and simultaneously transferred to the site. If the resulting elevation difference exceeds a negligible threshold, iteratively repeat the process, removing volumes from largest dams, to segregate potentially critical dams from dams with negligible incremental and cumulative effect of failure at the site. As an alternative to the iterative process, sequence and plot the dams by volume (smallest to largest) and segregate dams with incremental and cumulative affects above and below the threshold.
2. Peak Outflow without Attenuation Method: Estimate and sum the peak failure outflows for all upstream dams. Assume failure of all dams reach the site instantaneously and simultaneously, ignoring attenuation. Compare the peak outflow sum to the established discharge increase threshold. Or, using an available stage-discharge function (from available hydraulic models or USGS streamflow rating curves to identify a conservative determination of incremental and cumulative effects for screening purposes), estimate the increase in flood stage, above plant grade, corresponding to the peak failure outflow sum and compare this stage increase to the established threshold value. If the resulting discharge or stage difference exceeds the threshold value, iteratively repeat the process, removing discharges from largest dams, to segregate potentially

Comment [JFK86]: Same comment about backwater effects!
FFTF – see previous response

Comment [KSEE87]: Needs work. Further face to face discussions needed. Methods discussed are ok, but their application raises concerns. Overall comment / concern regarding how the “negligible effect” concept is applied.
FFTF –OK, will discuss
Public Meeting – Concern will be addressed by rework to document.

Comment [JFK88]: What about levees? Are they considered dams for our purposes? Or are they excluded from considerations?
FFTF –OK, onsite levees will be considered per 7046

Comment [JFK89]: Backwater yet again.
FFTF –see previous response

Comment [JFK90]: It seems problematic to neglect the water. What about determining the cumulative effect of these “negligible” dams, and then simply carry this volume or discharge along in the rest of the analysis. Add it in when you want to estimate a water level. ...

Comment [MB91]: Does this mean they will be completely ignored? ...

Comment [JFK92]: It would be useful to include (maybe as a box or appendix) a description of how ...

Comment [F93]: I’m concerned this statement may confuse the difference between the dam ...

Comment [MB94]: Is there guidance for defining “very large”? Is this related to volume of ...

Comment [JFK95]: HHA not defined
FFTF – OK

Comment [F96]: A comment needs to link this section with the next section on cascading dam ...

Comment [MB97]: What is the “top”? Is it normal full pool? The very top of the dam? Is this ...

Comment [MB98]: This doesn’t capture the effect of a dam failure occurring combined a severe ...

Comment [JFK99]: Referenc sources of information for these? ...

Comment [JFK100]: 1)Where to put the “dam”? ...

Comment [JFK101]: Not clear what this means.. ...

Comment [JFK102]: Point to section that discuss these estimates. ...

Comment [JFK103]: How to get this threshold? ...

Comment [JFK104]: Need to realize that the stage-discharge function may be pretty speculati ...

Comment [MB105]: How is this established?
FFTF –see above

critical dams from dams with negligible incremental and cumulative effect of failure at the site. As an alternative to the iterative process, sequence and plot the dams by discharge (smallest to largest) and segregate dams with incremental and cumulative affects above and below the threshold.

3. Peak Outflow with Attenuation Method: Using the established threshold value for increase in peak discharge at the site, develop a relationship between the size of dam (e.g. height and/or volume) and distance to site based on applicable regression equations for peak flow and attenuation, assuming failure occurs at each dam at full pool. (Section 0 and Appendix D.) The resulting curve can be used to judge upstream dams having negligible effect of failure at the site. (See example illustration in Figure 3.) Regression equations for attenuation (e.g. USBR (1982) or NWS (1991)) should be tested against available models and/or studies to justify their applicability to the adjacent river/floodplain system. This approach would be applicable to one upstream dam or multiple upstream dams that are remote from each other, with breach outflows that clearly reach the site at different times.

If multiple upstream dams exist, the dams can be grouped into zones or clusters with comparable size and proximity to the site. The above process for a single dam could be applied to each cluster using the total peak outflow for each cluster.

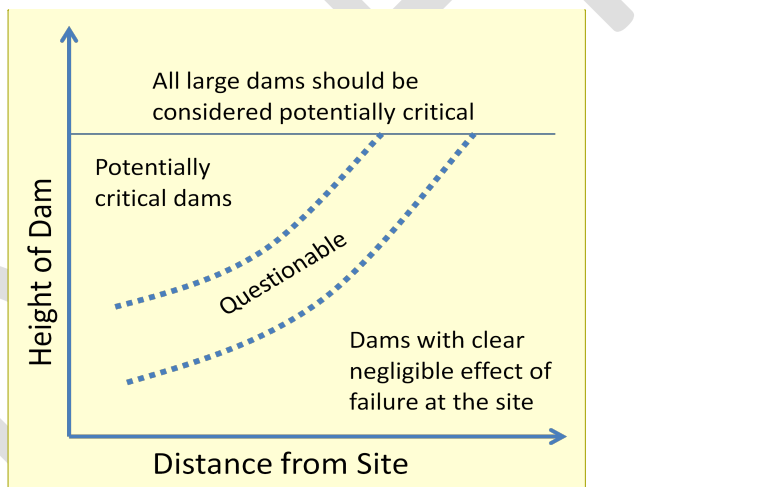

Figure 3 – Example Illustration of Dam Failure Evaluation Screening Approach (Method 3)

4. Rainflow Runoff Method: Use an available rainfall-runoff-routing model (e.g. HEC-HMS) to develop multiple failure scenarios and combinations for hypothetical dams, representative of the number, size, and proximity of the actual upstream dams in the watershed. (Setting up hypothetical dam simple dam models dams in a rainfall-runoff-routing model involves much less effort than coding in actual dams.) The hypothetical scenarios should include representative situations of dams in series and cascading failures. Iteratively remove hypothetical dams, larger to smaller, to the point where the incremental difference in discharge is negligible and cumulative affects at the site is less than the established threshold value. Size and distance plots, differentiating between dams

Comment [JFK106]: Not sure what this means.
 FFTF –we will discuss

Comment [JFK107]: How to establish peak outflow from cluster? Add individual peak outflows? With or without attenuation?
 FFTF –add individual flows at site with attenuation as described in method 3

Comment [MB108]: It is still not clear how the “large dams” threshold will be drawn.

In addition, it is necessary to compare this relationship (which is chosen here because it facilitates plotting in 2D) with other available relationships. Only considering height and distance may not be enough (as noted in ANS-2.8, “some [dams] may be eliminated from further consideration because of low differential head, small volume, distance from plant site, and major intervening natural or reservoir detention capacity.” Height and distance doesn’t capture all those factors.)

FFTF –the figure will be deleted. The additional explanation and the appendices make the figure unnecessary.

Comment [JFK109]: Software!
 There is a difference between a software package and a model. The model includes our specifications of the problem, assumptions, etc.
 This may be a nit to some, but it drives me batty how these terms get misused.
 FFTF –OK will change to software

Comment [JFK110]: the dams are real, but their properties are assumed.
 FFTF –the approach assumes hypothetical dams to take the place of the volume and height of multiple small dams

Comment [JFK111]: The dams are not hypothetical, but their properties are.
 FFTF –see above. This approach uses hypothetical or representative dams.

Comment [JFK112]: Cumulative effect seems more reasonable than incremental discharge. How does one develop criteria for acceptable incremental discharge?
 FFTF –we will discuss

removed and remaining in the model, could provide a basis for screening dams having a negligible effect at the site. The advantage to this approach is it better represents the affects of multiple upstream dam failures and attenuation to the site. See example illustration in Figure 4.

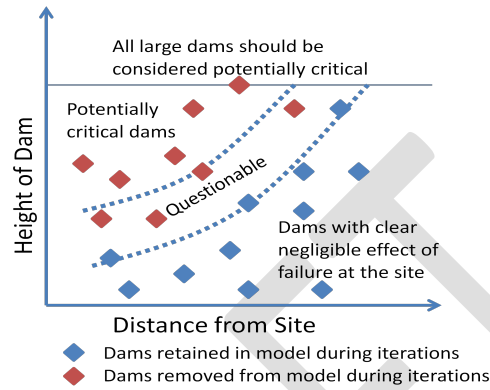

Figure 4 – Example Illustration of Dam Failure Evaluation Screening Approach (Method 4)

Discuss the use of the DSS-Wise tool developed by NCCHE for screening.

Comment [initials113]: FTF – OK, later

Appendix B

Example Dam Failure Evaluation Approaches

DRAFT

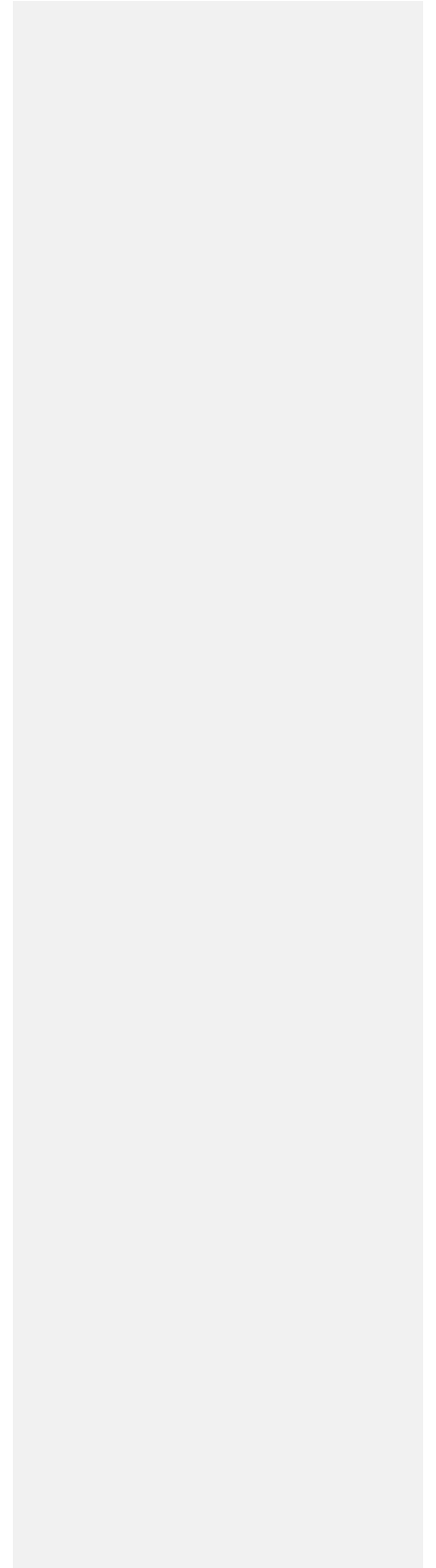

Hydrologic-Induced Failure

Figure 5 - Approach to Hydrologic Failure Evaluation

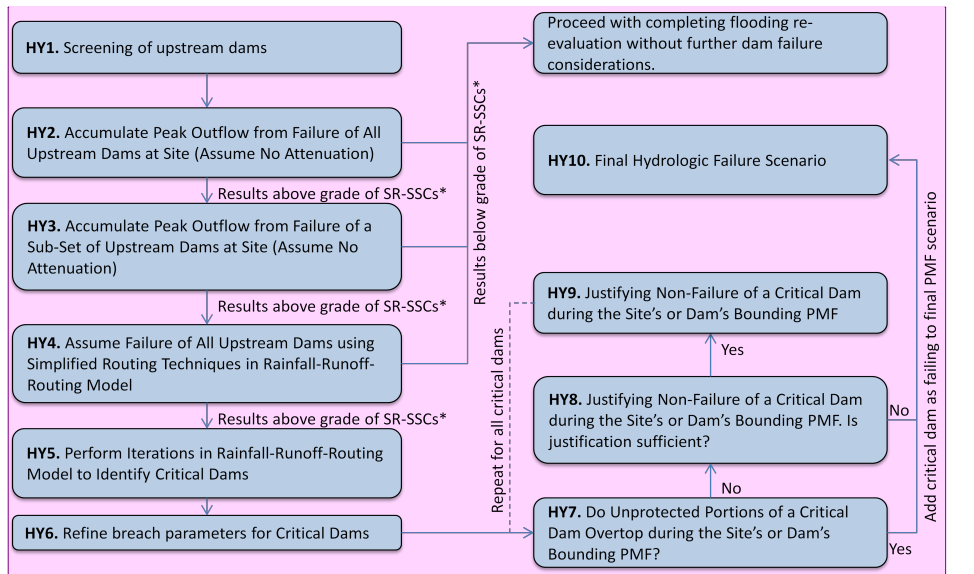

* SR-SSCs: Safety-Related Systems, Structures, and Components.

Figure 5 and the discussion below describe the approach to conducting an evaluation of upstream dam failures induced by a hydrologic (precipitation/snowmelt) event. The licensee and its vendor have the option to bypass selected steps in the HHA approach or go directly to Step HY10 and assume all potentially-critical dams fail). This section describes the process for differentiating 'critical' and 'non-critical' dams and developing a final hydrologic failure scenario, which may include (with proper justification) non-failure of some or all critical dams.

Step HY1 – Screening of Upstream Dams

Refer to Section 0.

Step HY2 – Accumulate Peak Outflow from Failure of All Upstream Dams at Site (Assume No Attenuation)

Assume all potentially critical dams fail during the PMF and all reach the site coincidental to the peak. Add wind-waves from 2-year wind speed. Use applicable regression equation(s), or other appropriate methods, to calculate peak outflow. Assume pool levels are at the top of dam. If results are below grade of safety-related SSCs, proceed with completing flooding reevaluation without further dam failure considerations. If results exceed grade of safety-related SSCs, proceed to next step.

Comment [MB114]: Section may need to be updated to reflect changes based on conservation of volume of dams that have been screened out.
FFTF –we will change this description to be consistent with the resolution f the screening comment.

Comment [JFK115]: HY8 Text could be simplified to this question: Does engineering evaluation demonstrate dam safety?
 HY9 can the say "Do not model dam failure"
FFTF –OK

Comment [KSEE116]: In HY-3 volume is not conserved?
FFTF –we are using peak outflow. Volume does not necessarily enter into concern when you are below grade

Comment [MB117]: Is this the dam's PMF or the site's PMF? Moreover, as noted above "It is likely that a large flood on one tributary would coincide with similar large floods in adjoining tributaries" ... Moreover, this may apply to dams on the same tributary.
FFTF – site's PMF. Need to discuss.

Comment [JFK118]: Assuming critical direction??
FFTF –yes, this is implied. We will add this

Comment [MB119]: Or important-to-safety?
FFTF –OK

Step HY3 – Accumulate Peak Outflow from Failure of a Sub-Set of Upstream Dams at Site (Assume No Attenuation)

Assume all potentially critical dams fail during the PMF but **only a sub-set** reach the site at the same time at the PMF peak. Add wind-waves from 2-year wind speed. Use applicable regression equation(s), or other appropriate methods, to calculate peak outflow. Assume pool levels are at the top of dam. If results are below grade of safety-related SSCs, proceed with completing flooding reevaluation without further dam failure considerations. If results exceed grade of safety-related SSCs, proceed to next step.

Comment [JFK120]: Based on timing. Need to provide justification
FFTF –assuming a subset is allowed NUREG/CR 7046. We will offer some ideas about how to define the subset.

Comment [MB121]: How is this subset chosen?
This is a global comment.
FFTF –see above

Step HY4 – Assume Failure of All Dams using Simplified Routing Techniques in Rainfall-Runoff-Routing Model

Fail all potentially critical dams in rainfall-runoff-routing model (e.g. HEC-HMS) during the PMF, with the trigger being the peak water level, and route hydrographs to site using simplified techniques in model. Add wind-waves from 2-year wind speed. Use conservative breach parameters. Dam failure scenarios should include combinations of individual and/or cascading failures per Section **Error! Reference source not found.** and Appendix D (Section D.1) of NUREG/CR-7046. If results are below grade of safety-related SSCs, proceed with completing flooding reevaluation without further dam failure considerations. If results exceed grade of safety-related SSCs, proceed to next step.

Step HY5 – Perform Iterations in Rainfall-Runoff-Routing Model to Identify Critical Dams

Perform iterations in rainfall-runoff-routing model (e.g. HEC-HMS) to identify critical dam(s) whose failures have a significant impact at site; **assume all non-critical dams fail.** Proceed to next step.

Comment [MB122]: Just to clarify, does this mean their volume would be conserved?
FFTF –see above response on the need to consider volume

Step HY6 – Refine Breach Parameters for Critical Dam

Refine breach parameters for each critical dam. (See Section 0.) Breach parameters should be specific to the type of dam (earthen, rock fill, concrete/arch, etc.) and type of failure (overtopping or piping) using realistic but conservative physics -based assumptions.

Comment [JFK123]: This seems to imply that design spillway capacity is all that matters. Some investigation of the condition and maintenance history of the dam would be prudent to assure that there is a reasonable expectation that it will perform as designed.
FFTF –this comes directly from ANS 2.8. Should be able to assume that the dam's outlet system will perform as designed. It should be sufficient to assume that dams are maintained by their owner/operators as required by the governing authority.
Public Meeting – Agree, use ANS 2.8

THE SUBSEQUENT STEPS ARE REPEATED FOR EACH CRITICAL DAM. The objective is to provide the licensee with the option to, with proper justification, credit a particular critical dam as not failing in the final hydrologic failure scenario.

Comment [MB124]: Should this text appear earlier as well?
FFTF – need to discuss. Development of a dam specific PMF should not be necessary until you no longer assume that the dam has failed. Up to HY6 that is the assumption.
Public Meeting – Will be addressed based upon previous discussion.

Step HY7 – Do Unprotected Portions of a Critical Dam Overtop during the Site's or Dam's Bounding PMF?

Section 5.5.1 of ANS 2.8, under 'Hydrologic Dam Failures', states that *"critical dams should be subjected analytically to the probable maximum flood from their contributing watershed. If a dam can sustain this flood, no further hydrologic analysis shall be required."* Therefore, answering this question requires the establishment of two hydrologic scenarios: 1) the bounding PMF scenario for the entire watershed at the site and 2) the bounding PMF for the specific watershed of the critical dam in question. In lieu of developing a dam-specific bounding PMP, documentation from the dam owner can be used to demonstrate that a critical dam can safely pass the dam's bounding PMF; as long as the documentation was developed or approved by a state or federal government agency using criteria/methodologies developed or bounded by

Comment [g125]: Clarify this discussion on how to use
FFTF – this clarification will depend upon how the ICODS meetings proceed and under what circumstances we can take credit for the work of other entities. Will incorporate a final change later.
Public Meeting – Agree that ICODS interaction will be germane to this. Also use info from NRC staff slides on EAPs presented earlier

USBR, USACE, or FERC. In situations where a critical dam does not overtop during the site's bounding PMF but does overtop during the dam's PMF, the licensee has the option to develop an alternative hydrologic scenario for the site that includes the bounding PMP for an individual, critical dam and failure of this dam. It is unreasonable to assume that multiple, individual, critical dams would be subjected to dam-specific bounding PMFs simultaneously. Cascading failures of dams in series should be considered in this alternative hydrologic scenario per Section Error! Reference source not found. and Appendix D (Section D.1) of NUREG/CR-7046.

Per ANS 2.8, Section 5.5.4, "if no overtopping is demonstrated, the evaluation may be terminated and the embankment may be declared safe from hydrologic failure". Overtopping may be investigated for either of these two conditions:

- Probable maximum flood surcharge level plus maximum (1%) average height resulting from sustained 2-year wind speed applied in the critical direction; or
- Normal operating level plus maximum (1%) wave height based on the probable maximum gradient wind.

For the purpose of this paper, 'overtopping' is defined as the point at which an unprotected portion of the dam, or portion of the dam structure not designed to convey floodwater, is subject to flow during a postulated flood. 'Overtopping' could also apply if the design capacity of outlet component is exceeded by the postulated flood. Even without overtopping, additional information, discussed in the next step, may be required to demonstrate safety under PMF loading conditions.

Step HY8 – Justifying Non-Failure of a Critical Dam during the Site's or Dam's Bounding PMF

For critical dams, where non-failure justification is sought, develop information in Section 5.5.4 of ANS 2.8, demonstrating safety from failure due to instability, erosion, sliding, or overturning during site's or dam's bounding PMF. A valid stability analyses of dams that meets the standards established by the dam's regulator should be used requiring documentation of structural dimensions and composition from design plans; construction records; records from installed instrumentation; field surveys, on-site inspections; and special strength testing, coring, and instrumentation. Information from the dam owner, developed or approved by a state or federal agency, can be used to justify non-failure. In situations where a critical dam does not overtop during the site's bounding PMF but does overtop during the dam's bounding PMF, the licensee has the option to develop an alternative hydrologic scenario for the site that includes the bounding PMP for an individual, critical dam and failure of this dam. If justification is sufficient, go the next step. If not, this dam should be included as failing in the final hydrologic failure scenario.

Step HY9 – Credit Critical Dam as Not Failing in the Final Hydrologic Failure Scenario

The critical dam can be credited as not failing during the site's bounding PMF in the final hydrologic dam failure scenario. Repeat HY7 through HY9 for the next critical dam.

Step HY10 – Final Hydrologic Failure Scenario

The final hydrologic failure scenario includes:

- Site's bounding PMF;

Marie Pohida - I am confused about the characterization of non-critical dams based on the definition below and the four screening methods starting on page 15 of the NEI white paper. I remember discussing these comments with NEI at the

Comment [MB126]: Is there any thought given to the vintage of the PMF value for which the dam was designed?
FFTF – add a statement that the vintage of the evaluation be considered

Comment [JFK127]: I don't understand this. Elaborate?
FFTF – we will discuss and clarify
Public Meeting – Recommend delete

Comment [JFK128]: It may actually be reasonable (or at least not clearly unreasonable) in some instances. The size and the duration of the PMP that is used to generate the PMF would speak to this question.
FFTF – we will discuss. You should not have to assume simultaneous dam specific PMFs
Public Meeting – Resolved in discussion at meeting.

Comment [MB129]: So what event would be assumed to be happening at the site when the dam is having its PMF (e.g., to establish that antecedent water level at the site upon which the water from the dam failure would be added.)

Comment [MB130]: Is this optional
FFTF – these words are a quote from ANS 2.8' We will modify to make it an exact quote.

Comment [JFK131]: This is the language about critical direction that I was looking for earlier. Use it everywhere.
FFTF -OK

Comment [g132]: How does this affect spillways

Comment [JFK133]: ANS-2.8 talks about use of engineering computations. This level of rigor seems to be missing here.

Comment [MB134]: Note that previous text focuses only on overtopping, not this more extensive list.

Comment [g135]: Ensure this is using current methods
FFTF – this item is subject to the resolution to the ICODS discussion

Comment [JFK136]: We need to think about the consequences of this. Are we going to have multiple standards and criteria? I would think that, to the extent possible, a uniform set of standards

Comment [MB137]: This needs to be discussed. This is a global comment.
FFTF – this item is subject to the resolution to the ICODS discussion

Comment [JFK138]: Same comment as above. I don't fully understand this.
FFTF – We will discuss
PM - Delete

- Failure of non-critical dams;
- Failure of critical dams with insufficient non-failure justification;
- Wind-waves from 2-year wind speed; and
- Enhanced modeling techniques (e.g. 1D unsteady flow and/or 2D/3D hydrodynamic models) to refine flood level at site (optional).

Comment [JFK139]: Critical direction
 FFTF –OK

Trigger failures in the site’s bounding PMF model at the peak water surface elevation for individual failures. For dams in series, failure should be triggered to maximize the affect of compounding flows from cascading failures. See Section Error! Reference source not found.

Seismically-Induced Failure

Figure 6 - Approach to Seismically-Induced Failure Evaluation

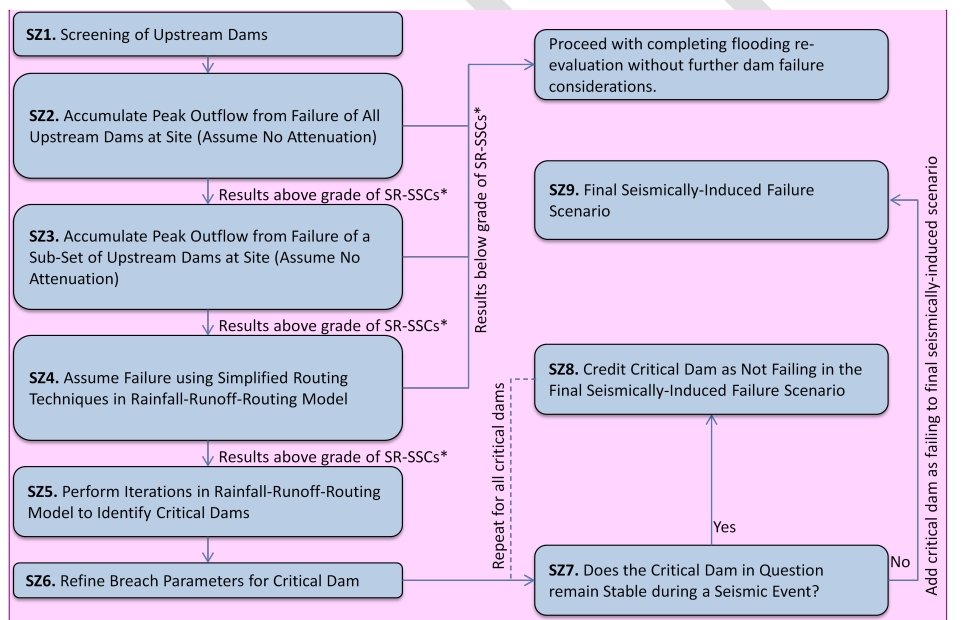

Comment [KSEE140]: In SZ-3 volume is not conserved.
 FFTF –need to discuss the comment, not sure of the intent

* SR-SSCs: Safety-Related Systems, Structures, and Components.

Figure 6 and the discussion below describe the approach to conducting an evaluation of upstream dam failures induced by a seismic event. The licensee and its vendor have the option to bypass selected steps in the HHA approach or go directly to Step SZ9 and assume all potentially-critical dams fail.

NUREG/CR-7046 (Appendix H.2) and ANS-2.8 (Section 9.2.1.2) provide the following two (2) alternative combinations for seismically-induced dam failure:

3. 25-year flood, dam failure caused by the safe shutdown earthquake (SSE) coincident with the peak flood, and 2-year wind speed applied in the critical direction.
4. $\frac{1}{2}$ PMF or 500-year flood, whichever is less, dam failure caused by the operating basis earthquake (OBE) coincident with the peak flood, and 2-year wind speed applied in the critical direction.

The best available interpretation of the above requirements is that seismically-induced dam failure occurs coincident with the peak pool levels for the 25-year flood, 500-year flood, or $\frac{1}{2}$ PMF entering the dam; implying that runoff downstream of the dam to the site is not included.

This approach is reasonable for a single upstream dam but seems inappropriate for multiple dams. It may not be reasonable to assume that peak flood pool levels for all upstream dams would occur coincident with an earthquake. As an alternative approach, developing floods for multiple upstream dams can be accomplished by using watershed-wide precipitation events, not upstream flood-flow, to represent the above combinations. Therefore, seismically-induced dam failure analysis should be based on the following precipitation-based combinations:

3. 25-year precipitation throughout the site's watershed, dam failure caused by the safe shutdown earthquake (SSE), and 2-year wind speed applied in the critical direction.
4. $\frac{1}{2}$ PMP or 500-year precipitation, whichever is less, throughout the site's watershed, dam failure caused by the operating basis earthquake (OBE), and 2-year wind speed applied in the critical direction.

This would be consistent with NRC expectations that, as stated in NUREG/CR-7046 and ANS-2.8, combinations are thought to have a probability-of-exceedance of less than 1×10^{-6} . Also, using watershed-wide precipitation events would be conservative because it would include runoff downstream of the dams to the site.

Note that all dams are assumed to fail when the earthquake occurs (the timing of which is established based on optimal impact to the site) which may not result in a particular dam failing at its peak water level.

Step SZ1 – Screening of Upstream Dams

Refer to Section 0.

Step SZ2 – Accumulate Peak Outflow from Failure of All Upstream Dams at Site (Assume No Attenuation)

Assume all potentially critical dams fail during the $\frac{1}{2}$ PMP or 500-year precipitation (whichever is less) and all reach the site coincidental to the peak. Add wind-waves from 2-year wind speed. Use applicable regression equation(s), or other appropriate methods, to calculate peak outflow. Assume pool levels are at the top of dam. If results are below grade of safety-related SSCs, proceed with completing flooding reevaluation without further dam failure considerations. If results exceed grade of safety-related SSCs, proceed to next step.

Step SZ3 – Accumulate Peak Outflow from Failure of a Sub-Set of Upstream Dams at Site (Assume No Attenuation)

Discussed accepting the combinations defined in ANS 2.8

Comment [MB142]: Perhaps clarify this text. I think this means to say the evaluation is complete rather than "don't need to consider the failure" when in fact the failure was considered and the site can accommodate it. Correct?

FFTF –OK, we will revise

Assume all potentially critical dams fail during the ½ PMP or 500-year precipitation (whichever is less) but only a sub-set reach the site coincidental to the peak; add wind-waves from 2-year wind speed. Use applicable regression equation(s), or other appropriate methods, to calculate peak outflow. Assume pool levels are at the top of dam. If results are below grade of safety-related SSCs, proceed with completing flooding reevaluation without further dam failure considerations. If results exceed grade of safety-related SSCs, proceed to next step.

Comment [MB143]: How is this determined?
FFTF – same idea as the cluster concept, namely that only those dams whose outflow arrives at the site simultaneously need be considered together.

Comment [JFK144]: Provide justification via estimates of timing.
FFTF – OK justification is appropriate

Step SZ4 – Assume Failure using Simplified Routing Techniques in Rainfall-Runoff-Routing Model

Fail all potentially critical dams in rainfall-runoff model (e.g. HEC-HMS) during the ½ PMP or 500-year precipitation (whichever is less), with the trigger being the critical time of the earthquake, and route hydrographs to site using simplified techniques in model. Add wind-waves from 2-year wind speed. Use conservative breach parameters and assume pool levels are at the top of dam. Dam failure scenarios should include combinations of individual and/or cascading failures per Section Error! Reference source not found. and Appendix D (Section D.1) of NUREG/CR-7046. If results are below grade of safety-related SSCs, proceed with completing flooding reevaluation without further dam failure considerations. If results exceed grade of safety-related SSCs, proceed to next step.

Comment [MB145]: Clarify.
FFTF – “critical” means maximizing the flood at the site taking into consideration the extent of the flooding at each dam at the time of the earthquake (the time of the flood conditions at each dam arising from one storm varies). This will be explained further.

Step SZ5 – Perform Iterations in Rainfall-Runoff-Routing Model to Identify Critical Dams

Perform iterations in rainfall-runoff-routing model (e.g. HEC-HMS) to identify critical dam(s) whose failures have a significant impact at site; assume all non-critical dams fail. Proceed to next step.

Comment [MB146]: Clarify.
FFTF – judgment call by the utility. Could change to “are the primary contributors to flooding at the site”. The failure of the dams that are not critical or primary contributors is assumed.

Step SZ6 – Refine Breach Parameters for Critical Dam

Refine breach parameters for each critical dam. Breach parameters should be specific to the type of dam (earthen, rock fill, concrete/arch, etc.) and type of failure (overtopping or piping) using realistic but conservative physics-based assumptions.

Comment [MB147]: Singular vs. plural?
FFTF – plural

Comment [MB148]: ???
Breach parameters should be based on seismic failure modes.
FFTF – change commented words to “seismic failure mode”

THE SUBSEQUENT STEPS ARE REPEATED FOR EACH CRITICAL DAM. The objective is to provide the licensee with the option to, with proper justification, credit a particular critical dam as not failing in the final seismically-induced failure scenario.

Step SZ7 – Does the Critical Dam in Question remain Stable during a Seismic Event?

Information should be developed to assess a dam’s ability to withstand a design earthquake. Regulation 10 CFR 100.23 (d)(3) states “the size of seismically induced floods and water waves that could affect a site from either locally or distantly generated seismic activity must be determined”. Based on existing guidance in RG 1.59 and ANS 2.8, the earthquake centering shall be evaluated in a location(s) that produce the worst flooding at the nuclear power plant site from a seismically induced dam failure at the nuclear power plant site. In regions where two or more dams are located close together, a single seismic event shall be evaluated to determine if multiple dam failures could occur.

Comment [MB149]: Ensure consistency with use of PSHA.
FFTF – Need to clarify

The evaluation of the dam’s structural stability shall include the concrete and earth sections. The methods for evaluation should be those described by the dam’s regulator. The existing evaluations completed by the

Comment [MB150]: Needs discussion.
FFTF – agree, this is an ICODS issue

dam owner may be used if the review determines that the current standards as prescribed by dam's regulator are used and the required factors of safety per those standards are satisfied. In addition, the combined annual exceedance probability for design earthquake loading, seismic failure, and the hydrologic event, shall be 1×10^{-6} or less.

Design Earthquake Loading:

- Ground Motion Hazard Curves – The Recommendation 2.1 Seismic Hazard Reevaluations are ongoing and will be based, in part, on the Central and Eastern United States (CEUS) Source Characterization and new attenuation model; expected to be completed in February 2013. The Recommendation 2.1 Flood Hazard Reevaluations at some sites are scheduled for completion before the CEUS source characterization is available. Therefore, licensees with Flood Hazard Reevaluation Reports due by March 2013 are provided with three options for developing the ground motion hazard curves.

1. Use USGS (2008) to determine the mean seismic hazard curves for 1 Hz, 5 Hz, 10 Hz, and PGA. Apply one of five EPRI mean amplification functions to the mean rock seismic hazard curves based on the known geologic conditions at the site. EPRI mean amplification functions can be found in EPRI (1993).

2. Submit the Flood Hazard Reevaluation Reports assuming all critical (and non-critical) dams fail during a seismic event, combined with the lesser of the ½ PMP and 500-year precipitation (Step SZ4).

3. Use the CEUS seismic source term and associated attenuation model. If this results in not being able to submit the reevaluation in accordance with the committed schedule, submit all elements of the flooding reevaluation that are completed on the scheduled date. Establish a new completion date at the time of this submittal for completion of the upstream dam failure and overall conclusions.

- From the site-adjusted mean hazard curves, develop the 10^{-4} Uniform Hazard Response Spectrum (UHRS) and hazard curves for 1 Hz, 5 Hz, 10 Hz, and PGA.

The probability of seismic failure of a dam can be estimated using procedures as described in McCann et al, 1985. A brief summary of the procedures is described in the following steps:

- Develop failure criteria for each seismic failure mode. The criteria should be based on dam type (concrete sections, arch dams, earthfill and rockfill), construction details (slope protection, filters and drains, core width, past performance, etc), and overall construction quality. Examples of failure criteria could be maximum crest settlement, factor of safety against sliding, and fault offset at the foundation elevation. It is noted that not all potential seismic failure modes will need to be addresses at each site. For instance, potential failure due to surface fault rupture can be screened out for sites where no known faulting is present.

- If existing evaluations have been completed by the dam owner using current standards prescribed by the USACE, USBR, or FERC, summarize analyses results including ground motion parameters used, factors of safety for each failure mode, performance results (i.e. settlement or crest deformation).

- If the existing analyses include High Consequence of a Low Probability of Failure (HCLPF) results, and the results are enveloped by the ground motions from Step 1 above, the dam can be considered to have a probability of failure of less than one percent. If the HCLPF capacity is greater

Comment [g151]: This assumption may require additional interaction.
 FTFF – Discuss at meeting. ICODS issue

This includes hazard and fragility

Comment [JFK152]: Does this timing issue need to be discussed in what is otherwise a technical document?
 FTFF – at present one of the options is to submit a partial evaluation

Comment [initials153]: FTFF – This option must stand until the next flooding evaluation update is required, in order for it to be viable.

Comment [initials154]: FTFF – see comment above concerning combination of events

Comment [F155]: available?
 FTFF – change word to "possible"

Comment [F156]: This assumes NRC will grant an extension a priori; and its highly problematic. Although this may be the case, it should be considered individually per NRC licensee provided a sufficient basis exists for such an extension. This needs to be removed and, if need be, a reference needs to be made to the NRC statements regarding potential delays in submitting a 50.54(f) letter response.
 FTFF – we will discuss

Comment [initials157]: FTFF – one of the options we have been discussing

Comment [JFK158]: Not in reference list.
 FTFF – OK, will add

Comment [MB159]: Why was this reference chosen? What about the vintage of the references within this document?
 FTFF – need to discuss with our seismic resources to determine validity

than the ground motions in Step 1, use the results of the HCLPF analyses to estimate the probability of failure for the ground motions in Step 1.

- If the existing analyses are deterministic and do not include fragility evaluations, the deterministic evaluations should be updated to estimate the median ground parameter (A_m) for each failure criteria.
- Use the median ground motion parameter corresponding to failure and an assumed uncertainty values (β_R and β_U) to develop lognormal fragility curves for each failure mode.
- Estimate the probability of failure at the ground motion level from Step 1.

Data needed for the seismic evaluation include:

- Design or as-built drawings;
- Existing seismic stability evaluation reports containing:
 - Description of dam materials (zones, filters, surface protection);
 - Description of geologic setting;
 - Description of foundation conditions;
 - Description of cut-off trenches or foundation grouting; and
 - Description of previous analyses (ground motion inputs, methods, results).
- Instrumentation Data;
- Summary of past performance;
- Shear and compression wave velocity data within foundation; and
- Description of spillway and low-level outlet facilities.

If justification is sufficient, go the next step. If not, this dam should be included as failing in the final seismically-induced failure scenario.

Step SZ8 – Credit Critical Dam as Not Failing in the Final Seismically-Induced Failure Scenario

The critical dam can be credited as not failing in the final seismically-induced dam failure scenario. Repeat SZ7 for the next critical dam.

Step SZ9 – Final Seismically-Induced Failure Scenario

The final seismically-induced failure scenario includes:

- $\frac{1}{2}$ PMP or 500-year precipitation (whichever is less);
- Failure of non-critical dams;
- Failure of critical dams with insufficient non-failure justification;
- Wind-waves from 2-year wind speed; and

Comment [MB160]: Could use some additional discussion and clarification.
FFTF – trying to simplify a complicated process.

Comment [MB161]: Does this imply an “acceptable” probability of failure? Does this include all failure modes? What about the probability of failure under lower ground motion intensities?
FFTF – discuss at meeting

Comment [MB162]: What constitutes sufficient justification?
FFTF – deterministic – factor of safety (TBD) – probabilistic – 10-6 failure probability

Comment [initials163]: **FFTF – need to define event combinations**

- Enhanced modeling techniques (e.g. 1D unsteady flow and/or 2D/3D hydrodynamic models) to refine flood level at site (optional).

Trigger individual failures in the final model at the same time, determined by optimizing the effects of the earthquake. For dams in series, failure should be triggered to maximize the affect of compounding flows from cascading failures. See Section **Error! Reference source not found.**

Comment [MB164]: Clarify.
FFTF –discuss at the meeting

Example Seismic Evaluation

Take the case of a 100ft tall earthfill dam. This dam is a well constructed zoned earthfill dam with a wide crest, compacted clay core and well-designed filters and drains. The freeboard at the normal operating level is 15 feet. Because of the overall construction, the failure criteria for crest settlement was established to be 10% of the dam height, or about 10 feet.

Comment [MB165]: Is this example finished?
FFTF –No. Need to finalize the related section first.

Previous analysis was done for a PGA of 0.15g, based on the median deterministic ground motions estimated at the time of the previous work. The results of the previous analysis showed that the expected seismically induced permanent crest settlement was about 4 feet. The analysis would then be revised by simply increasing the PGA (or scaling the input time history) until the estimated seismic crest settlement is 10 feet. This PGA value would then be considered the median PGA causing failure, and a lognormal fragility curve could be constructed about this median value using an assumed uncertainty $\sqrt{I_{in-PGA}}$ of about 0.55.

Comment [A166]: More to it than crest settlement; liquefaction and finite element analysis
FFTF – agree, will be addressed when the seismic evaluation guidance is completed.

The probabilities of failure at each discreet ground motion level are then multiplied by the annual probabilities of exceedance for that ground motion level, as determined from the simplified PSHA in Step 1, to estimate the annual probability of failure due to seismically induced crest settlement. If fault offset were considered a potential failure mode, the above process would be repeated using the existing analyses for fault offset and the annual probability of failure from fault offset would be added to the annual probability of failure due to crest settlement.

As for the white paper, the primary issue I have with Appendix C is that the example assumes a lot of work has already been done, and that all a dam owner has to do is change the parameters to assess the margin and exceedance probability. For many/most of the dams, I suspect that the type of analysis that is referenced in Appendix C has never been done so we don't know the baseline results much less the margins. Only a minority of TVA dams have been analyzed for seismic deformations. There is a very substantial effort required just to be in a position to do the Appendix C margin analysis. The scope of the effort needs to be recognized by all interests so we can have a realistic set of expectations about what can be done and on what schedule.

Formatted: Highlight

Sunny-Day Failure

Figure 7 - Approach to Sunny-Day Failure Evaluation

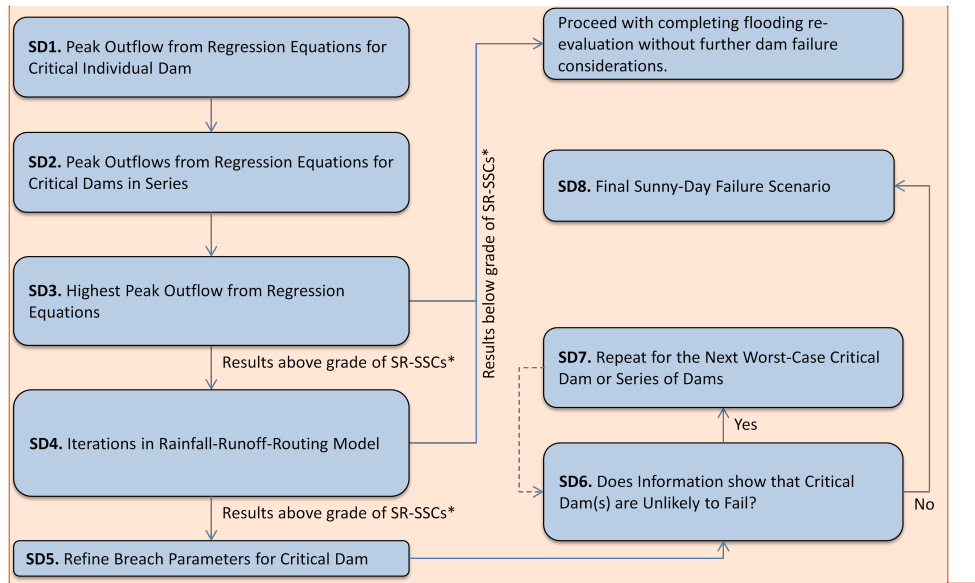

Comment [JFK167]: SD4 could be split into two pieces:
 SD4.1 – apply attenuation to dams from SD3
 SD4. Do the iterations if SD4.1 resulted in flooding above grade of SR-SSCs.
FFTF –OK will add a step between 3 and 4 to consider attenuation

* SR-SSCs: Safety-Related Systems, Structures, and Components.

A sunny-day failure is a failure that is not induced by a precipitation event. (For the purposes of this paper, a seismically-induced failure is being considered separately.) Sunny-day failures are typically attributed to structural weakness or deficiency in the dam embankment, foundation, and/or abutments. Potential causes of failure (from Section 6.3.2 of ANS 2.8) include:

- Deterioration of concrete due to cracking, weathering, or chemical growth;
- Deterioration of embankment protection such as riprap or grass cover;
- Excessive saturation of downstream face or toe of embankment;
- Excessive embankment settlement;
- Cracking of embankment due to uneven settlement;
- Erosion or cavitation in waterways and channels, including spillways;
- Excessive pore pressure in structure, foundation, or abutment;
- Failure of spillway gates to operate during flood because of mechanical or electrical breakdown or clogging with debris;
- Buildup of silt load against dam;
- Excessive leakage through foundation;

- Leakage along conduit in embankment;
- Channels from tree roots or burrowing;
- Excessive reservoir rim leakage; and/or
- Landslide in reservoir.

While generally expected not to produce flood discharges and water levels that exceed the hydrologic or seismically-induced failure scenarios, discussed above, it can be associated with the shortest warning times. Some licensees may consider applying sunny-day failure warning times to the seismically-induced failure scenarios; in which case, sunny-day failure may not need to be a consideration at the site with proper justification. The following describes the steps in a sunny-day failure evaluation:

Step SD1 – Peak Outflow from Regression Equations for Critical Individual Dam

Use applicable regression equation(s) and/or other appropriate methods to calculate the peak outflow at individual upstream dams, largest and closest to the site. Iterations may be required to identify the critical individual dam. Assume pool levels are at the top of dam.

Step SD2 – Peak Outflows from Regression Equations for Critical Dams in Series

Use applicable regression equation(s) and/or other appropriate methods to calculate and add the peak outflows for upstream dams in series (if relevant), largest and closest to the site. Iterations may be required to identify the critical series of dams. Assume pool levels are at the top of dam.

Step SD3 – Highest Peak Outflow from Regression Equations

Use the highest peak outflow from individual failure (SD1) or highest cascading peak outflow from dams in series (SD2), whichever is greater, and transpose directly to site (no attenuation). Add wind-waves from 2-year wind speed. If results are below grade of safety-related SSCs, proceed with completing flooding reevaluation without further sunny-day dam failure considerations. If results exceed grade of safety-related SSCs, proceed to next step.

Step SD4 – Iterations in Rainfall-Runoff-Routing Model

Perform iterations in rainfall-runoff model (e.g. HEC-HMS) to identify critical dam(s) whose individual or cascading sunny-day failures have an effect at the site. (Other than cascading failures for dams in series, simultaneous individual failures are not being considered.) Add wind-waves from 2-year wind speed. Use conservative breach parameters. If results are below grade of safety-related SSCs, proceed with completing flooding reevaluation without further dam failure considerations. If results exceed grade of safety-related SSCs, proceed to next step.

Step SD5 – Refine Breach Parameters for Critical Dam

Comment [JFK168]: This isn't straightforward because the landslide could be initiated by seismic or hydrologic event.
FFTF – just a list. Causes would be considered in developing your sunny day breach. Causes selected need to be justified.

FFTF – just a list. Causes would be considered in developing your sunny day breach. Causes selected need to be justified.

Comment [MB170]: Depending on the outcomes of previous evaluations, the failure scenarios under these other mechanisms may not include failure of all dams. However sunny day may still be a viable mechanism for dams assumed not to fail under other mechanisms.
FFTF – OK. All dams need to be evaluated for sunny day. We will clarify this.

Comment [MB171]: Is it always true that the seismic failure bounds the sunny day? Wouldn't this depend on the seismic failure modes considered or deemed credible?
FFTF – sunny day failures are not believed to cause more limiting conditions than seismic in any way other than warning time., therefore seismic conditions with sunny day warning times is conservative.

Comment [MB172]: Clarify and expand on this text.
FFTF – need to clarify what is requested here. The intent is to obtain the peak outflow from the most critical individual dams

Comment [JFK173]: Direction
FFTF – OK

Refine breach parameters for the critical dam. Breach parameters should be specific to the type of dam (earthen, rock fill, concrete/arch, etc.) and type of failure (overtopping or piping) using realistic but conservative physics-based assumptions.

THE SUBSEQUENT STEPS ARE REPEATED TO IDENTIFY THE WORST-CASE CRITICAL DAM. The objective is to identify the worst-case critical dam or provide the licensee with the option to, with proper justification, credit all critical dams as not failing in the sunny-day failure scenario.

Step SD6 – Does Information show that Critical Dam(s) are Unlikely to Fail?

Develop information, discussed below, to appraise likelihood of failure for the worst-case critical dam or series of dams. Information from the dam owner, developed or approved by a state or federal agency, can be used to justify non-failure. If justification adequately shows that the worst-case critical dam is unlikely to fail, proceed to Step SD7. If not, this represents the worst-case critical dam or series of dams for the sunny-day failure scenario (Step SD8).

For each critical dam the licensee intends to credit as unlikely to experience sunny-day failure, the information below may be required to demonstrate safety under 'sunny-day' conditions:

- Structural dimensions;
- Construction records;
- Records from installed monitoring instrumentation and/or piezometer wells;
- Field surveys
- On-site inspection reports;
- Maintenance records;
- Risk tolerance of operating agency; and
- Durable operation, inspection, monitoring, maintenance, and corrective action procedures and agreement.

Information from the dam owner, developed or approved by a state or federal agency, can be used to demonstrate that sunny-day failure is unlikely. If non-failure justification is adequate (such as concrete dam with rock abutments to eliminate the possibility of a piping failure), the next worst-case critical sunny-day dam failure (if applicable) should be evaluated.

Step SD7 – Repeat for the Next Worst-Case Critical Dam or Series of Dams

Sunny-day dam failure does not need to be considered for this dam or series of dams. Repeat for next worst-case critical dam or series of dams (cascading failures) until all critical dams or series of dams have been considered.

Step SD8 – Final Sunny-Day Failure Scenario

The final sunny-day failure scenario includes:

Comment [KSEE174]: This will be very difficult. FTF – understand. We will insert the criteria discussed at the November meeting (10-7 probability of failure or 10-6 with justification, ref 10CFR100.20(b))

Comment [MB175]: Does this imply a risk assessment? FTF – yes, comparison to the criteria listed in KSEE147

Comment [MB176]: Is this defined? Is it based on only water level or also on other factors (e.g., warning time or dynamic loads). Could consideration of multiple "worst-case" failures be necessary to capture the differences in these "associated effects"? FTF – It may be necessary to evaluate several dams to define "worst case" for different effects. They do not need to be considered simultaneously. We will add this explanation to the paper.

Comment [MB177]: Clarify and expand on this. FTF – see above comment KSEE147

Comment [g178]: Additional interactions will be necessary on this point. FTF – see above comment KSEE147

Comment [KSEE179]: I agree FTF – OK

Comment [F180]: The risk tolerance used needs to be that of the NRC. Different federal agencies may have different risk frameworks and criteria and this should not be used to obfuscate the ultimate goal of the guidance which is to address NPP applications. FTF – since the 10-7 criteria applies, this bullet will be removed. Note that ICODS discussions may affect this conclusion.

Comment [MB181]: Has this been decided? FTF – depends on ICODS discussion

Comment [JFK182]: Same comment about consistent or uniform standards/criteria FTF – depends on ICODS discussion

Comment [F183]: This entire section is problematic. It is unclear what 'unlikely' is in this context or how this may be used to meet the SRP hazard screening threshold. There is the potential that 'unlikely' may be translated into 'non-critical' or 'insignificant'. ...

Comment [MB184]: Based on risk? FTF – yes

Comment [MB185]: Is this defined? FTF – we will clarify. This is related to the possibility that you may have more than one worst case dam to account for all the limiting effects

Comment [MB186]: This reads a little strange. It sounds at first like the "next" dam is the one for which it is not necessary to consider sunny-day failures. ...

- Failure of worse-case critical dam or series of dams (cascading failures);
- No precipitation;
- Wind-waves from 2-year wind speed ; and
- Enhanced modeling techniques (e.g. 1D unsteady flow and/or 2D/3D hydrodynamic models) to refine flood level at site (optional)

Assume failure occurs at full normal pool level. Given the nature of a sunny-day failure, it would be unreasonable to assume simultaneous individual failures.

Formatted: Highlight

DRAFT

Appendix C
Additional Details on Breach Parameters

DRAFT

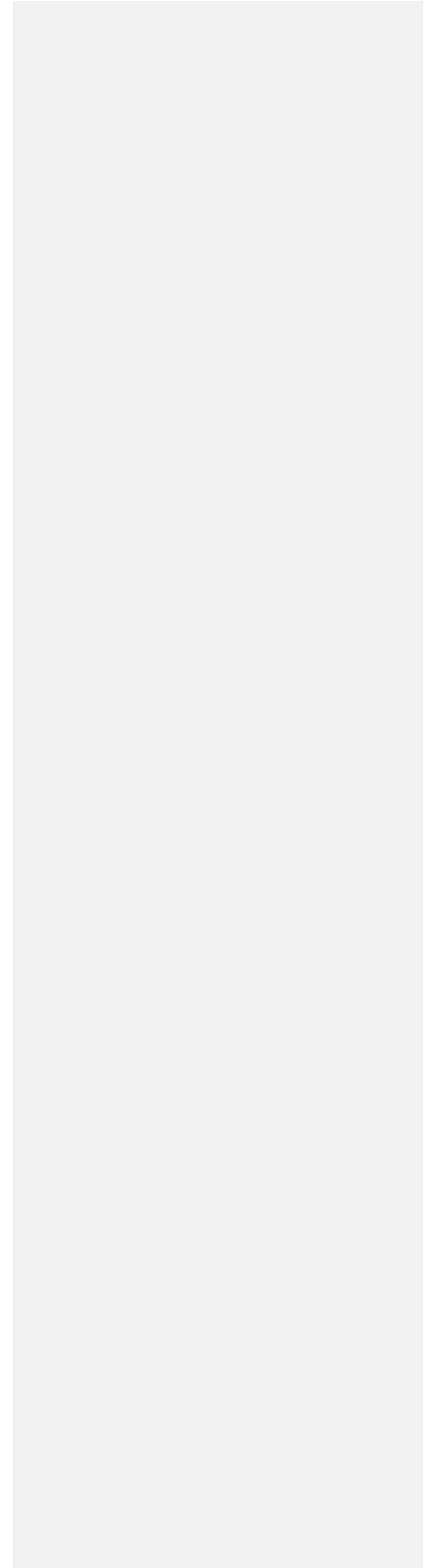

Breach Parameters and Development

Empirically-Based (Regression) Peak Outflow Estimation

These methods include relatively simple regression equations to estimate the peak outflow and attenuation resulting from a dam failure. Wahl (1998) identified regression equations that estimate the peak outflow as a function of dam and/or reservoir properties based on real dam failure data. Five peak outflow discharge estimation methods are listed below and presented in more detail in Appendix D. Note, original technical papers or documentation should be reviewed prior to using these equations to understand their limitations. As part of the HHA process, attenuation of the peak discharge can be ignored to conservatively account for the effect of the breach at the site. However, the USBR (1982) provides a simplified, conservative method for estimating the peak flow reduction as a function of distance to the site (miles). (See Figure 2 in USBR (1982).)

- USBR (1982) Peak Outflow
- Froehlich (1995a) Peak Outflow
- National Weather Service (NWS) Simplified Dam Break Model (Whetmore, 1991; Reed, 2011)
- Natural Resources Conservation Service (NRCS) Technical Release (TR) 60 (2005) (formerly the Soil Conservation Service (SCS))
- Walder and O'Connor 1997

Wahl (2004) indicates that the Froehlich (1995a) method has the lowest uncertainty of the dam breach peak discharges equations available at the time. Using 43 dam failure data points from Wahl (1998), Pierce (2010) developed comparisons between Kirkpatrick (1977), SCS (1981), USBR (1982), and Singh and Snorrason (1984) relations; single-variable (height of water behind the dam) regression peak outflow equations. Pierce (2010) concluded that 'the USBR (1982) equation provides the largest estimate of the peak outflow, while the Kirkpatrick equation represents the smallest peak-discharge estimate'. In the conclusions, Pierce (2010) further states that the USBR (1982) and Froehlich (1995a) equations 'remain valid for conservative peak-outflow predictions' for embankment dams. The figures below depict Pierce's (2010) comparisons of various single-variable (Figure 8 and Figure 9) and multi-variable (Figure 10) peak outflow regression equations to the Wahl (1998) data points.

Comment [KSEE187]: This section is ok.

Comment [JFK188]: There is a USBR memo (Planning Instruction 83-05, April 1983) that recommends a correction to the peak outflow equation in USBR (1982) that should be used when the storage capacity vs height is significantly different from the range used to develop the 1982 guidelines. This needs to be referenced when talking about the UBSAR (1982) peak outflow method. My copy of USBR (1982) has this memo attached, but I don't know if that is always the case.
FFTF –OK we will add the reference. Please provide the memo.

Comment [JFK189]: Including correction in 1983 memo?
FFTF –OK we will add the reference.

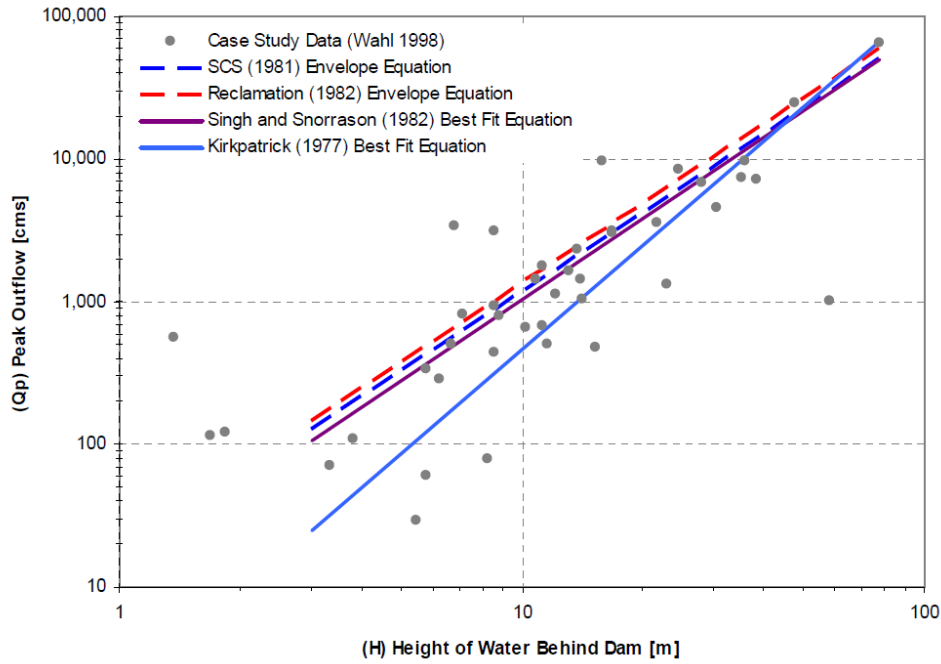

Figure 8 - Peak Outflow as a Function of Height of Water behind Dam (Pierce 2010)

Comment [JFK190]: Not sure this figure is needed. It's not really discussed much.
FFTF – this is illustrative and was added to address comments from T Wahl. This should be kept in.

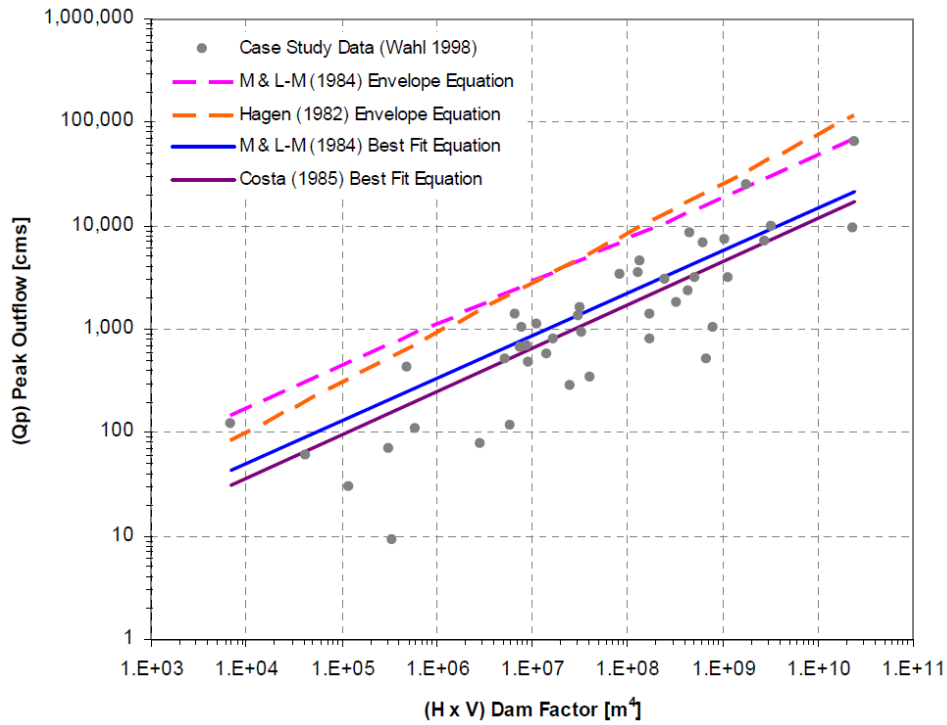

Figure 9 - Peak Outflow as a Function of Dam Factor (Pierce 2010)

Comment [JFK191]: Consider removing figure. FTF – this is illustrative and was added to address comments from T Wahl. This should be kept in.

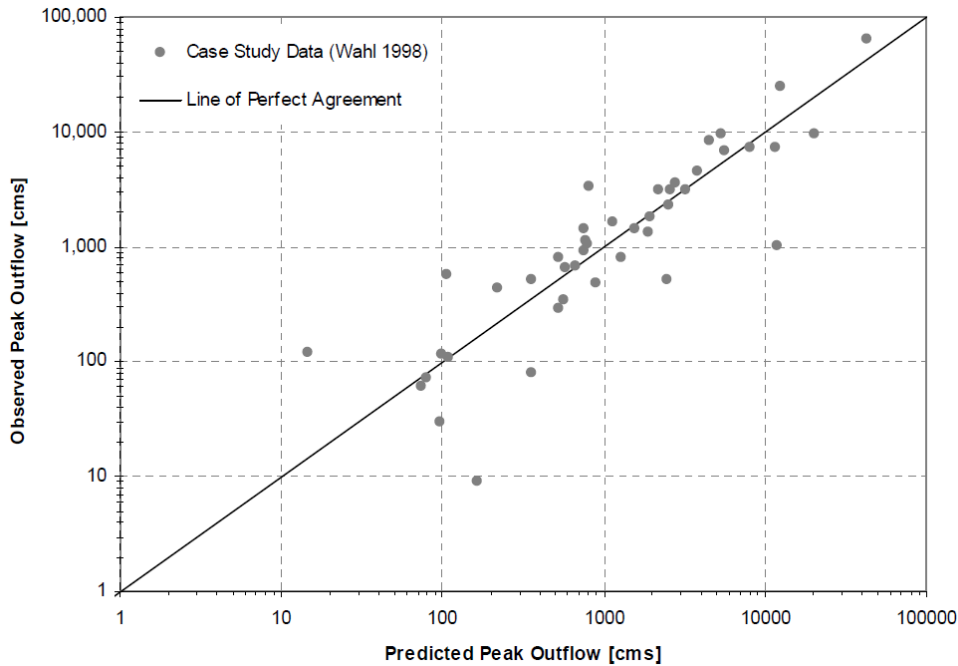

Figure 10 - Observed and Predicted Peak Outflow using Froehlich (1995a) Relationship (Pierce 2010)

Empirically-Based (Regression) Breach Parameter Estimation

The Bureau of Reclamation (Wahl, 1998) provides a relatively comprehensive review of methods for predicting breach parameters. Since estimates of breach parameters vary significantly, Wahl suggested using several methods to establish a range of breach parameters, giving due consideration to the dam’s design characteristics. Other notable and more recent reviews of breach parameter prediction methods (and peak-flow prediction equations and related dam-failure modeling guidance) include Washington State (2007) and Colorado Department of Natural Resources (2010).

The USACE (Gee, 2008) provided a review of three (3) regression models for breach parameter development:

- Froehlich (1995b) (updated in 2008) – Based on 63 earthen, zoned earthen, earthen with a core wall (i.e. clay), and rockfill dams to establish methods to estimate average breach width, side slopes, and failure time.
- MacDonald and Langridge-Monopolis (MacDonald, 1984) – Based on 42 predominately earthfill, earthfill with a clay core, and rockfill dams to establish a ‘Breach Formulation Factor’ (product of the volume of water released from the dam and the height of the water above the dam).

Comment [g192]: Describe the use of breach regression equations, their applicability, and uncertainty.

- Von Thun and Gillette (1990) – Based on 57 dams from both Froehlich (1987) and MacDonald and Langridge-Monopolis (1984) papers to estimate side slopes and breach development time.

Gee (2008) indicated that the above parameter estimation methods were applied to five (5) breach situations for comparison and provided the results of these comparisons to two (2) of the five (5) in the 2008 paper. The comparison for the Oros Dam, which failed by an overtopping event in March 1960 in Brazil, is provided in Figure 11. Gee (2008) concluded that “the methods predict a wide range of breach parameters and therefore, a large difference in outflow hydrographs. The MacDonald method routinely produced the largest peak outflows”. Gee (2008) also discusses physically-based breach formulation models that use sediment transport functions; this is addressed in the next section. As noted previously, original technical papers or documentation should be reviewed prior to using these equations to understand their limitations. Justification should be developed for the selected method(s). More than one method should be used provide higher confidence in the results.

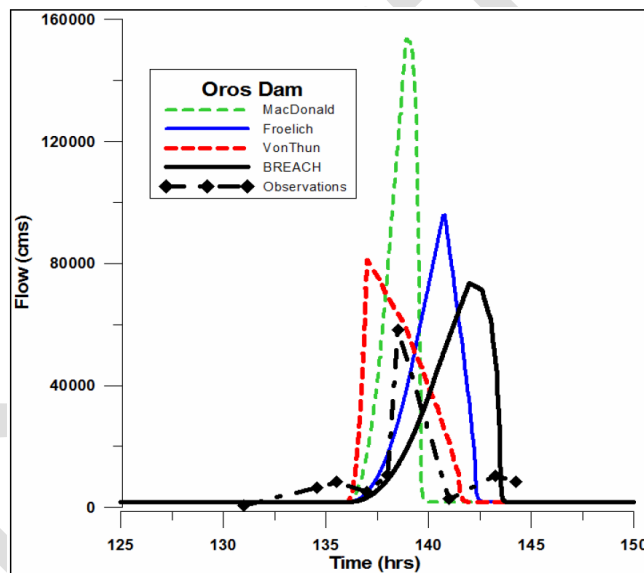

Figure 11 - Breach Hydrographs for Oros Dam (Gee, 2008)

Following a recommendation by Wahl (2008), Xu and Zhang (2009) developed new equations to estimate breach parameters for earth and rockfill dams. The new equations are based on an analysis that includes case study data from China and more recent failures not previously analyzed by the earlier investigators. From a database of 182 failures, they were able to utilize 75 for development of the new equations. A key difference from earlier works was the incorporation of soil erodibility into the method, which proved to be the most influential of all those examined. Xu and Zhang subdivided breaching parameters into two groups, geometric and hydrographic, and included:

- Geometric
 - Breach Depth (H_b)
 - Breach Top Width (B_t)

Post-Fukushima Near-Term Task Force Recommendation 2.1
 Supplemental Guidance for the Evaluation of Dam Failures
 January 14, 2013, Revision F

- Average Breach Width (B_{ave})
- Breach Bottom Width (B_b)
- Breach Side Slope Factor (Z)
- Hydrographic
 - Peak Outflow (Q_p) (see also previous section)
 - Failure Time (T_f)

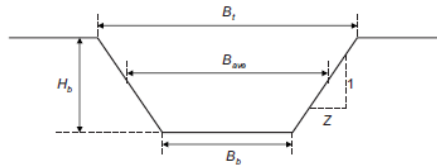

Figure 12 - Geometric Parameters of an Idealized Dam Breach (Xu and Zhang, 2009)

It is important to note the failure times predicted by Xu and Zhang are longer than those predicted by most other methods. Many other well-known case studies show longer failure times than those reported by other investigators. For the Teton Dam failure, as an example, Xu and Zhang (2009) used a 4-hour failure time in developing their regression equation, whereas Froehlich (1995a and 2008) used a 1.25-hour failure time.

Physically-Based Breach Methods

Comment [g193]: Similar to comment on 4.7.2

In 2004, the Centre for Energy Advancement through Technological Innovation (CEATI) formed a Dam Erosion and Breaching working group within their Dam Safety Interest Group (DSIG). The objective of this group was to collaborate on the development of improved methods for simulating embankment erosion and breach processes. The focus of the group's work was on physically-based computer models. The DSIG group comprised members from the USACE, USBR, USDA-ARS, Hydro Quebec, BC Hydro, HR Wallingford, Elforsk (Scandinavian Utility), and EDF (French Electrical Utility). Tasks undertaken by the CEATI-DSIG group included:

- International review of currently available breach models and new models under development;
- Selection of 3 most promising models for closer evaluation;
- Assembly of high quality case study data and large-scale laboratory test data (for model validation purposes);
- Evaluation of model performance against seven selected data sets;
 - Two large-scale lab tests conducted by USDA-ARS (Stillwater, OK);
 - Three large-scale tests conducted in Norway in connection with the European IMPACT project; and
 - Two actual dam failures (Oros, Banqiao).

The DSIG Project concluded (Wahl 2009; Morris et al. 2012) that the HR-BREACH and SIMBA/WinDAM models were both very capable, with many similarities and some differences. The two models continue to be separately under development at this time. The most significant differences between the models at this time are:

- HR-BREACH analyzes overtopping and piping failure modes and allows definition of zoned embankment geometry;
- WinDAM analyzes only homogeneous embankments and the overtopping failure mode;
- HR-BREACH includes an energy-based headcut erosion model and several alternative surficial erosion models (sediment transport equations);

- WinDAM offers both stress-based and energy-based headcut erosion models, but no surficial erosion of the body of the embankment;
- HR-BREACH is not publicly available, but is available via consultation with its developer, HR Wallingford, and is also being incorporated into commercial dam-break flood routing models used in Europe.
- WinDAM is publicly available from the USDA-NRCS. The technology contained in WinDAM was first developed in the SIMBA model (a research tool never made available to the public) by the Agricultural Research Service (USDA-ARS). WinDAM also contains earthen spillway headcut erosion analysis capabilities that are similar to the SITES model, also distributed by USDA-NRCS. A version of WinDAM that will analyze the piping failure mode is under development and may be available in late 2013.
- Both models allow simulation of the erosion and failure of grass or riprap armoring on the exterior of an embankment, although they use different algorithms.

CEATI-DSIG project (Morris 2012) provides a subjective comparison of the properties and capabilities of the models.

The use of a physically-based breach model requires significantly greater effort by the analyst, since dam and reservoir details must be specified, alternatives for erosion calculations must be selected, and soil erodibility properties must be estimated or measured. Sensitivity analyses must also be carried out to investigate the effects of variation of input parameters. The use of physically-based models may be justified when more accurate results are needed and soil erodibility can be reasonably estimated.

Other physically-based models have appeared in recent years: Macchione (2008a and 2008b); Wang and Bowles (2005, 2006a, 2006b, 2006c, and 2007); and Weiming Wu (2007). Furthermore, NWS-BREACH and currently being integrated into a commercially available 2D computer-flood routing model (O'Brien 2012), along with improvements to the code.

Uncertainty

In general, uncertainty in formulating a dam failure should be evaluated by applying multiple methods, applicable to the dam in question, and evaluating sensitivity to reasonable variations in input parameters. Additional uncertainty information developed by Froehlich (2008), Wahl (2004), and Xu and Zhang (2009) are summarized below.

In Froehlich (2008), data was collected from 74 embankment dam failures to develop empirical equations for breach width, trapezoidal side slope, and formation time. The findings of the statistical analysis were applied in a Monte Carlo simulation to estimate the degree of uncertainty of predicted peak flows.

Wahl (2004) evaluated uncertainty of various regression-based methods for predicting embankment dam breach parameters and peak breach outflows. Wahl's work considers the relations by Kirkpatrick (1977), SCS (1981), Hagen (1982), USBR (1982), MacDonald and Langridge-Monopolis (1984), Singh and Snorrason (1984), Costa (1985), Evans (1986), and Froehlich (1995b), and Walder and O'Connor (1997), and concluded the following:

- The uncertainties of predictions of breach width, failure time, and peak outflow are large for all methods, and thus it may be worthwhile to incorporate uncertainty analysis results into future risk assessment studies when predicting breach parameters using these methods.

Comment [JFK194]: This paper seems to rehash material from a paper that was published many years ago. The point being that the models in question have changed since then, so the comparison appears to be dated.
FFTF – the reference has value and is one of the few papers that provides a comparison.

Comment [g195]: Incorporate this concept into the previous three sections.

Post-Fukushima Near-Term Task Force Recommendation 2.1
Supplemental Guidance for the Evaluation of Dam Failures
January 14, 2013, Revision F

- Predictions of breach width generally have an uncertainty of about $\pm 1/3$ order of magnitude, predictions of failure time have uncertainties approaching ± 1 order of magnitude, and predictions of peak flow have uncertainties of about ± 0.5 to ± 1 order of magnitude, except the Froehlich peak flow equation, which has an uncertainty of about $\pm 1/3$ order of magnitude.
- The case study showed that significant engineering judgment must be exercised in the interpretation of predictions of breach parameters. The results from use of the physically based NWS-BREACH model were reassuring because they fell within the range of values obtained from the regression-based methods. However, at the same time, they also helped to show that even physically based methods can be highly sensitive to the assumptions of the analyst regarding breach morphology and the location of initial breach development.
- The NWS-BREACH simulations demonstrated the possibility for limiting failure mechanics that were not revealed by the regression-based methods.

Comment [JFK196]: Begs for elaboration.
FFTF – we will review

DRAFT

Post-Fukushima Near-Term Task Force Recommendation 2.1
 Supplemental Guidance for the Evaluation of Dam Failures
 January 14, 2013, Revision F

Table 1 - Uncertainty Estimates for Breach Parameter and Peak Flow Prediction Equations (Wahl, 2004)

Reference	Equation	Number of case studies		Mean prediction error (log cycles)	Width of uncertainty band, $\pm 2S_p$ (log cycles)	Prediction interval around hypothetical predicted value of 1.0
		Before outlier exclusion	After outlier exclusion			
Breach width equations						
Bureau of Reclamation (1988)	$B_{avg} = 3 h_w$	80	70	-0.09	± 0.43	0.45-3.3
MacDonald and Langridge-Monopolis (1984)	$V_{er} = 0.0261(V_w h_w)^{0.769}$ earthfill $V_{er} = 0.00348(V_w h_w)^{0.852}$ nonearthfills (e.g., rockfills)	60	58	-0.01	± 0.82	0.15-6.8
Von Thun and Gillette (1990)	$B_{avg} = 2.5 h_w + C_b$	78	70	+0.09	± 0.35	0.37-1.8
Froehlich (1995a)	$B_{avg} = 0.1803 K_o V_w^{0.32} h_b^{0.19}$	77	75	+0.01	± 0.39	0.40-2.4
Failure time equations						
MacDonald and Langridge-Monopolis (1984)	$t_f = 0.0179 V_{er}^{0.364}$	37	35	-0.21	± 0.83	0.24-11
Von Thun and Gillette (1990)	$t_f = 0.015 h_w$ highly erodible $t_f = 0.020 h_w + 0.25$ erosion resistant	36	34	-0.64	± 0.95	0.49-40
Von Thun and Gillette (1990)	$t_f = B_{avg} / (4 h_w)$ erosion resistant $t_f = B_{avg} (4 h_w + 61)$ highly erodible	36	35	-0.38	± 0.84	0.35-17
Froehlich (1995a)	$t_f = 0.00254 (V_w)^{0.53} h_b^{-0.9}$	34	33	-0.22	± 0.64	0.38-7.3
Bureau of Reclamation (1988)	$t_f = 0.011 (B_{avg})$	40	39	-0.40	± 1.02	0.24-27
Peak flow equations						
Kirkpatrick (1977)	$Q_p = 1.268(h_w + 0.3)^{2.5}$	38	34	-0.14	± 0.69	0.28-6.8
SCS (1981)	$Q_p = 16.6(h_w)^{1.85}$	38	32	+0.13	± 0.50	0.23-2.4
Hagen (1982)	$Q_p = 0.54(S \cdot h_d)^{0.5}$	31	30	+0.43	± 0.75	0.07-2.1
Bureau of Reclamation (1982)	$Q_p = 19.1(h_w)^{1.85}$ envelope eq.	38	32	+0.19	± 0.50	0.20-2.1
Singh and Snorrason (1984)	$Q_p = 13.4(h_d)^{1.89}$	38	28	+0.19	± 0.46	0.23-1.9
Singh and Snorrason (1984)	$Q_p = 1.776(S)^{0.47}$	35	34	+0.17	± 0.90	0.08-5.4
MacDonald and Langridge-Monopolis (1984)	$Q_p = 1.154(V_w h_w)^{0.412}$	37	36	+0.13	± 0.70	0.15-3.7
MacDonald and Langridge-Monopolis (1984)	$Q_p = 3.85(V_w h_w)^{0.411}$ envelope eq.	37	36	+0.64	± 0.70	0.05-1.1
Costa (1985)	$Q_p = 1.122(S)^{0.57}$	35	35	+0.69	± 1.02	0.02-2.1
Costa (1985)	$Q_p = 0.981(S \cdot h_d)^{0.42}$	31	30	+0.05	± 0.72	0.17-4.7
Costa (1985)	$Q_p = 2.634(S \cdot h_d)^{0.44}$	31	30	+0.64	± 0.72	0.04-1.22
Evans (1986)	$Q_p = 0.72(V_w)^{0.53}$	39	39	+0.29	± 0.93	0.06-4.4
Froehlich (1995b)	$Q_p = 0.607(V_w^{0.295} h_w^{1.24})$	32	31	-0.04	± 0.32	0.53-2.3
Walder and O'Connor (1997)	Q_p estimated by computational and graphical method using relative erodibility of dam and volume of reservoir	22	21	+0.13	± 0.68	0.16-3.6

Note: All equations use metric units (m, m³, m³/s). Failure times are computed in hours. Where multiple equations are shown for application to different types of dams (e.g., earthfill versus rockfill), a single prediction uncertainty was determined, with the set of equations considered as a single algorithm.

Xu and Zhang (2009) developed a comparison in empirical prediction equations using the case studies in their research, which will produce bias towards the Xu and Zhang results. Nevertheless, the Xu and Zhang method appears to offer the least variability and seems to accommodate a wider range of situations.

Post-Fukushima Near-Term Task Force Recommendation 2.1
 Supplemental Guidance for the Evaluation of Dam Failures
 January 14, 2013, Revision F

Table 2 - Comparison of Different Parameter Prediction Equations Xu and Zhang (2009) ('this paper' refers to equations developed by Xu and Zhang (2009))

Parameter	Best prediction models in this paper			Best-simplified prediction models in this paper			Bureau of Reclamation (1982, 1988)			Froehlich (1995a,b)		
	Number of cases ^a	Mean	SD	Number of cases ^a	Mean	SD	Number of cases ^a	Mean	SD	Number of cases ^a	Mean	SD
H_b	62	1.01	0.08	66	1.01	0.08	—	—	—	—	—	—
B_t	52	1.03	0.32	59	1.03	0.32	—	—	—	—	—	—
B_{ave}	43	1.02	0.32	52	1.03	0.33	51	1.31	0.94	51	1.07	0.43
Q_p	33	1.01	0.34	38	1.03	0.39	36	0.95	0.80	36	1.30	0.84
T_f	27	1.02	0.43	28	1.02	0.44	27	3.08	4.00	27	2.30	2.05

^aThe number of cases after using the objective outlier-exclusion algorithm (Rousseeuw 1998) at the 95% probability level.

DRAFT

DRAFT

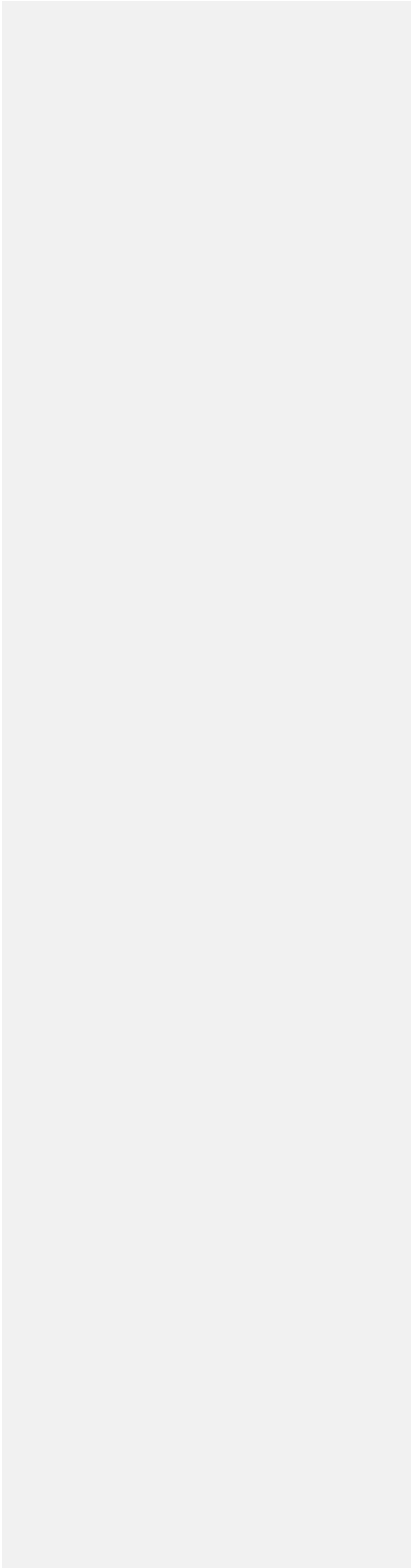

Appendix D

Additional Details on Modeling

Modeling Dam Failure in Rainfall-Runoff Models

Riverine systems with upstream dams will, ordinarily, require the development of a rainfall-runoff-routing model (e.g. HEC-HMS, TR-20, etc.) to estimate a watershed's response to the Probable Maximum Precipitation (PMP). Potentially critical upstream dams would normally be included in the model. The final steps of the HHA approach include using this rainfall-runoff-routing model to simulate dam failure and perform hydrologic routing to the site.

While using HEC-HMS for river reach hydrograph routing has advantages, namely numerical stability and minimal data requirements, its ability to accurately route breach hydrographs is limited. It uses a simplified hydrologic (kinematic wave) routing method, compared to hydraulic (dynamic wave) routing method (such as that used in the HEC-RAS unsteady flow model), to estimate the effect of channel/floodplain storage on hydrograph attenuation and peak flow rates. See Section **Error! Reference source not found.** for additional discussion on flood hydrograph routing.

HEC-HMS has the ability to, not only perform river reach routing, but also generate breach hydrograph at the dam given specific breach parameters. Similar to HEC-RAS, HEC-HMS uses forms of the weir and orifice equations to compute breach discharge values for overtopping and piping failure modes, respectively, at each time step to generate the breach hydrograph. As shown in **Error! Reference source not found.**, the dam breach parameters in HEC-HMS include:

- Final Bottom Width (B_b)
- Final Bottom Elevation
- Left/Right Side Slope (Z)
- Breach Weir Coefficient (for Overtopping Breaches)
- Breach Formation Time
- Piping/Orifice Coefficient (for Piping Breaches)
- Initial Piping Elevation
- Failure Trigger

Additional information on developing breach parameters is provided in Section **Error! Reference source not found.**. Alternatively, the dam breach hydrograph can be developed outside the rainfall-runoff-routing model and entered as a user-defined hydrograph.

Regardless of the methodology, the HHA approach warrants the use of conservative breach parameters and peak outflow and attenuation estimates. As discussed further in Section **Error! Reference source not found.**, the HHA approach should also consider combinations of individual and cascading failures and make conservative assumptions regarding the trigger-settings for these combinations.

Modeling Dam Failure in 1D Unsteady Flow Models

Frequently, a refined site-specific analysis is desired to predict dam failure hazard conditions at a nuclear site, accounting for time-progression of the breach and flood attenuation storage along the riverine/floodplain system between the dam and nuclear site. The computer modeling tool frequently used for this analysis is the USACE HEC-RAS Unsteady-Flow model.

Comment [initials197]: FTF – fix this

Comment [initials198]: FTF – fix this

Comment [JFK199]: Suggest discussing hydrologic vs hydraulic model approaches first. Provide some basic criteria for choosing one vs the other (e.g. slope, Then discuss software packages, saying what modeling approach they implement. FTF – this section is not intended to provide a lot of background or provide a tutorial for an inexperienced user. The user should check the source if more background is needed.

HEC-RAS generates a breach hydrograph by calculating discharge values in discrete time-steps as the breach progresses. At each time-step, HEC-RAS calculates a discharge (with a known head) using the weir equation (for an overtopping breach) or orifice equation (for a piping breach). The average discharge is used to estimate the volume released, corresponding drop in pool elevation, and discharge for the subsequent time-step to construct the breach hydrograph. The breach parameters needed for the USACE HEC-RAS Unsteady-Flow model will be the focus of this section. **Error! Reference source not found.** shows the HEC-RAS window view that receives the dam breach parameters. The parameters affecting outflow include:

- Final Bottom Width (B_b)
- Final Bottom Elevation
- Left/Right Side Slope (Z)
- Breach Weir Coefficient (for Overtopping Breaches)
- Full Formulation Time
- Piping/Orifice Coefficient (for Piping Breaches)
- Initial Piping Elevation
- Failure Trigger
(Water surface elevation, water surface elevation + duration, or user-defined time)
- Starting Water Surface Elevation

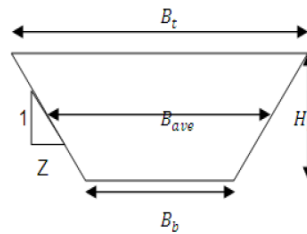

Modeling Dam Failure in 2D Models

With advancements in computational power, 2D (and 3D) computer models provide a viable alternative to conventional 1D unsteady-flow model to simulate dam failure and develop downstream inundation areas. Physically-based breach models (e.g. NWS-BREACH) are currently being integrated into 2D hydrodynamic models to combine 1D breach erosion and 2D unconfined flood routing models. O'Brien (2012) provides the following observations for applying 2D hydrodynamic models to dam breach simulations:

1. Using a 2D flood routing that conserves volume will result in an accurate prediction of the area of inundation if the reservoir volume is known with some certainty. The prediction of the breach hydrograph shape or peak discharge is not as critical as the reservoir volume because of rapid floodwave attenuation downstream of the breach.
2. Knowing the breach mechanism or initial duration to crest breaching is inconsequential to the predicted area of inundation or the floodwave travel time beyond the immediate vicinity of the dam. For the purpose of mapping the flood hazard, accurate assessment of the rate of breach growth (rate of vertical and horizontal breach failure in feet or meters per hour) will be sufficient.
3. The sediment transport capacity prediction in breach erosion models adds complexity to the logical next step of developing more elaborate breach erosion models. Earth dam failures should be considered as hyperconcentrated sediment flow events where particle fall velocities are inhibited by fluid matrix velocities and particle collisions. These mud floods or mudflows do not have numerical solutions to the equations of fluid motion to predict scour of embankment sediment. The application of any conventional sediment transport equation based on clear water river dynamics is inappropriate for this purpose and thus precludes the accurate prediction of pipe or channel erosion to the crest breach. Combined with the potential uncertainty of breach stability factors and variation in embankment material and conditions, predicting scour with hyperconcentrated sediment flows make the prospect of developing a reliable breach erosion model in the near future unlikely. In the meantime, it is

recommended that a breach rate (horizontal and vertical) data base from dam failure events be compiled to be used in conjunction with flood routing models.

4. The breach location for long dams or levees can impact the area of inundation requiring the development of locus of failure points to identify the composite flood hazard or worst case scenario.

Comment [JFK200]: Not sure this is needed.
FFTF – we will move to section 4.7.3 on breach formulation 2D models

DRAFT