

United States Nuclear Regulatory Commission Official Hearing Exhibit	
In the Matter of:	Entergy Nuclear Operations, Inc. (Indian Point Nuclear Generating Units 2 and 3)
	ASLBP #: 07-858-03-LR-BD01
	Docket #: 05000247 05000286
	Exhibit #: NYSR00005-00-BD01
	Admitted: 10/15/2012
	Rejected:
Other:	Identified: 10/15/2012
	Withdrawn:
	Stricken:

NYSR00005
Submitted: December 14, 2011

**UNITED STATES
NUCLEAR REGULATORY COMMISSION
ATOMIC SAFETY AND LICENSING BOARD**

-----x
In re: Docket Nos. 50-247-LR; 50-286-LR

License Renewal Application Submitted by ASLBP No. 07-858-03-LR-BD01

Entergy Nuclear Indian Point 2, LLC, DPR-26, DPR-64
Entergy Nuclear Indian Point 3, LLC, and
Entergy Nuclear Operations, Inc. December 12, 2011
-----x

**REPORT OF
DR. ROBERT C. DEGENEFF
IN SUPPORT OF
CONTENTION NYS-8**

TABLE OF CONTENTS

	Page
Summary of Findings.....	1
1. Introduction.....	1
2. NRC Regulations	4
3. Comparison of Transformers to Included Components.....	6
<i>Electric Cables</i>	6
<i>Pipes</i>	7
<i>Heat Exchanger</i>	7
<i>Steam Generator</i>	7
<i>Reactor Vessel & Containment</i>	8
4. Comparison of Transformers to Excluded Components.....	8
<i>Batteries</i>	13
<i>Power inverters</i>	13
<i>Power supply</i>	13
5. Age related degradation in transformers to not readily monitored and management of age related degradation requires a comprehensive inspection program	14
6. Consequences of Inadequate Management of Transformers	17
7. Entergy's Argument.....	22
7.1 Declaration of Dr. Dobbs.....	24
7.2 Declaration of R. Rucker	27
7.3 Declaration of J.W. Craig.....	28

TABLE OF CONTENTS

	Page
7.4 Documents Produced by Entergy	31
8. Conclusion	32
References	33

Summary of Findings

The uncontroversial consensus of the technical community is that transformers are: static components, which do not experience changes in configuration or state during their operation; components in which age related degradation is not readily monitored; and components whose useful life may exceed 60 years and for which periodic replacement is not generally scheduled. After reviewing 10 C.F.R. § 54.21(a), I can also conclude that transformers are components that are more similar to components for which aging management review is required than to components for which aging management review is not required.

In refusing to conduct an aging management review of transformers, Entergy conflates the properties of the transformer with the properties of the electricity flowing through the transformer. Furthermore, Entergy's arguments in this licensing proceeding about the ease of monitoring age related degradation are belied by their own maintenance records, which show that age related degradation in transformers is a common phenomena, detection of which requires invasive inspections of the sort that Entergy requires are not necessary.

1. Introduction

“The almost universal use of the alternating-current system for the transmission and distribution of electrical energy is largely due to the fact that circuits of different voltages can be linked by a simple, convenient, and reliable device – the static transformer. . .” L.F. Blume, Chapter 1, page 1 of *Transformer Engineering*, Copyright 1938, 1951 General Electric Company. The transformer may be assumed to be an essentially perfect device for the transformation of electrical power, *e.g.*, the input volt-amperes will equal the output volt-amperes. The turns ratio (ratio of the turns contained in the input winding divided by the turns in the output winding) may be taken as the voltage transformation ratio between the input and output winding and the inverse of the current transformation ratio.

Transformers typically contain two insulated wires that are wrapped or coiled around a form called a “core” that is frequently made of iron or metal alloys. Transformers contain a primary winding (a winding supplying the energy to the circuit) and one or more secondary windings (the windings through which the power flows out of the transformer). In its most basic form, a transformer need not even contain a physical core: two coils of wire adjacent to one another will act as a transformer. Two wires or cables in proximity will also act as a transformer in that varying current in one wire or conductor will induce voltages and currents in the adjacent wire or conductor.

Transformers do not contain any moving parts for their basic functions.¹ In its most basic form, a transformer is simply two current-carrying conductors or cables adjacent to each other. During their normal operation, there is no change in the configuration of transformers or their constituent parts, nor are there intended changes in the properties of transformers. Transformers possess measurable properties such as turns ratios, conductor dimensions, insulation thickness, and core dimensions. The current that flows into the transformer is essentially established by the voltage that is applied to the primary winding of the transformer and the load that the transformer serves. Both the applied (input) voltage and the load served are completely independent of the transformer of interest. In its basic form the transformer is a static device.

Transformers perform their current and voltage transformation through a phenomenon known as electromagnetism, *e.g.*, when an electric current passes through a wire (or cable or conductor), a magnetic field is generated around that wire. When that generated magnetic field touches (or links) another current carrying conductor, a voltage is generated across the second conductor. If the second conductor is connected so that current can flow, electric power is transformed from the first conductor to the second conductor. This is the simplest form of a transformer, *i.e.*, two current carrying conductors without a core. Conversely, when there is no current flowing into the transformer's primary winding, there is no magnetic field generated; the coils and the core do not produce a magnetic field on their own when there is no incoming electrical current. None of these properties and capabilities is designed to change during normal operation of a transformer.

The Handbook of Transformer Design & Application states that "Transformers are passive devices for transforming voltage and current." Flanagan, The Handbook of Transformer Design & Application (2nd Edition), page 1.1, McGraw-Hill, 1993, ISBN 0-07-021291-0. Another text book states that a transformer is "a static electrical device, involving no continuously moving parts, used in electrical power systems to transfer power between circuits through use of electromagnetic induction." Harlow, Electric Power Transformer Engineering, page 2-1, CRC Press (2004) ISBN 0-8493-1704-5 (referencing ANSI / IEEE); Harlow, Electric Power Transformer Engineering, page 2-1 (2d Edition) CRC Press (2007) ISBN 0-8493-

¹ While there is a subcategory of transformers that could be viewed as containing active components, those devices are not included within Contention 8. Thus, this description would not apply to "Variac" transformers, which are manually or motor operated variable transformers (manufactured by Staco Energy Products and Variac - Trade Mark of Power Designs, Inc.). Additionally, some transformers may have cooling systems or tap-changing mechanisms, but these cooling systems or tap changers are not necessary for the basic functional capability of the transformer.

9186-5. The sixth edition of the IEEE Standard Dictionary of Electrical and Electronic Terms includes the following definition of transformer: "A static electrical device consisting of a winding, or two or more coupled windings, with or without a magnetic core, for introducing mutual coupling between electrical circuits." IEEE Standard Dictionary of Electrical and Electronic Terms, IEEE Std 100-1996 (6th Edition), page 1131, ISBN 1-55937-833-6 (1996). This same definition is repeated in IEEE Standard Terminology for Power and Distribution Transformers, IEEE Std C57.12.80TM-2010. NRC has acknowledged that "transformers perform their primary function without the use of moving parts." NUREG/CR-5753, at 50.

Transformers are built with certain properties, which depend on the intended function of the transformer. These properties, including the turns ratio, conductor size, insulation type and thickness, and cooling capability, among others, remain constant during the lifetime of a given transformer. These properties ensure that even if differing levels of power may be sent through the transformer during its lifetime, each level of power will be transformed in a uniform manner, dependent on the design properties of the transformer. In this way, the power will be transformed in a uniform manner that can be predicted based on the design properties of the transformer.

Transformers play important roles in the operation of a nuclear power plant. Transformers can come in a variety of sizes. By way of example, some large transformers used at power reactors likely would include Station Auxiliary Transformers, Station Service Transformers, Station Black Out (SBO) transformer, 15 KVA GRD Transformer for the gas turbines, instrumentation transformers, and lighting transformers. Some smaller transformers in use at power reactors would include those used in control circuits. A review of various publicly available electrical one-line diagrams for IP2 and IP3 reflects that there are numerous electrical transformers ranging from 345 KV to 120 volts located throughout the Indian Point facilities that perform a function described in §§ 54.4(a)(1)/(2) and (3). The role of some of the transformers in providing for safety functions is described in Chapter 8 (Electrical Systems) of the UFSAR for each Unit on pp. 1167-68, 1333-43 of the UFSAR for IP3 and on pp. 1039-50 of the UFSAR for IP2. The UFSAR for IP2 includes a one-line diagram for the electrical plan for IP2; that diagram identifies some of the transformers at IP2 and the central role that they play in the electrical system of the plant. IP2 UFSAR, figure 8.2-1, 8.2-2, Electrical Distribution & Transmission System, DWG. NO. A250907-21. A diagram for IP3's electrical system identifies transformers and the central role that they play at that plant. Indian Point No.3 Nuclear Power Plant, Electrical Distribution & Transmission System, DWG NO 9321-F-33853, REV 17.

A transformer can be represented by the following electrical engineering symbol:

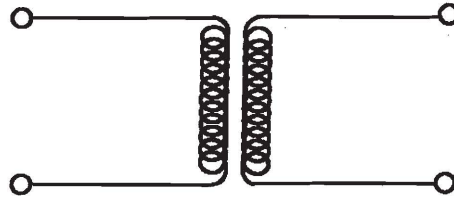

Drawings of electrical systems for the Indian Point facilities use the following symbol to denote a transformer in the electrical systems:

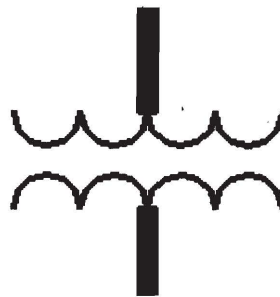

See, e.g.: IP2 Updated Final Safety Analysis Report (UFSAR), Revision 20, Drawing A250907-21, Title: Electrical Distribution and Transmission System - UFSAR Fig. No. 8.2-1 and 8.2-2 (PDF frame 1069 of 1698); *see also* Indian Point No.3 Nuclear Power Plant, Electrical Distribution & Transmission System, DWG NO 9321-F-33853, REV 17 (ML090400895).

2. NRC Regulations

In preparing this declaration, I reviewed 10 C.F.R. § 54.21. Specifically, § 54.21(a)(1) provides:

Structures and components subject to an aging management review shall encompass those structures and components—

- (i) That perform an intended function, as described in § 54.4, without moving parts or without a change in configuration or properties. These structures and components include, but are not limited to, the reactor vessel, the reactor coolant system pressure boundary, steam generators, the pressurizer, piping, pump casings, valve bodies, the core shroud, component supports, pressure retaining boundaries, heat exchangers, ventilation ducts, the containment, the containment liner, electrical and mechanical penetrations, equipment hatches,

seismic Category I structures, electrical cables and connections, cable trays, and electrical cabinets, excluding, but not limited to, pumps (except casing), valves (except body), motors, diesel generators, air compressors, snubbers, the control rod drive, ventilation dampers, pressure transmitters, pressure indicators, water level indicators, switchgears, cooling fans, transistors, batteries, breakers, relays, switches, power inverters, circuit boards, battery chargers, and power supplies; and

(ii) That are not subject to replacement based on a qualified life or specified time period.

10 C.F.R. § 54.21(a)(1)(i), (ii).

Based on my review of 10 C.F.R. § 54.21(a)(1), it is my understanding that NRC regulations provide that structures or components without moving parts or without a change in configuration or properties are included within the scope of the rule. The regulation contains a non-exhaustive list of such structures and components. My understanding of the regulation is that those structures and components are to be included in an aging management review. The regulation also provides another non-exhaustive list of structures and components that are not within the scope of the rule. The NRC has elected to exclude this second category of structures and components from aging management review. 10 C.F.R. § 54.21(a)(1)(i).

The text of § 54.21(a)(1)(i) expressly includes the following components as within the first category and therefore within the scope of the regulation: the reactor vessel, the reactor coolant system pressure boundary, steam generators, the pressurizer, piping, pump casings, valve bodies, the core shroud, component supports, pressure retaining boundaries, heat exchangers, ventilation ducts, the containment, the containment liner, electrical and mechanical penetrations, equipment hatches, seismic Category I structures, electrical cables and connections, cable trays, and electrical cabinets. Because these components are expressly included in the first category, they are subject to aging management review. 10 C.F.R. § 54.21(a)(1)(i).

On the other hand, pumps (except casing), valves (except body), motors, diesel generators, air compressors, snubbers, the control rod drive, ventilation dampers, pressure transmitters, pressure indicators, water level indicators, switchgears, cooling fans, transistors, batteries, breakers, relays, switches, power inverters, circuit boards, battery chargers, and power supplies are included in the second category and therefore are not subject to aging management review. 10 C.F.R. § 54.21(a)(1)(i).

3. Comparison of Transformers to Included Components

In preparing this report, I also reviewed the Atomic Safety and Licensing Board's July 31, 2008 decision concerning the admission of various contentions including the admission of New York State Contention No. 8, which concerns transformers. The Board further stated: "In addressing this contention, the Board will require, *inter alia*, representations from the parties to help us determine whether transformers are more similar to the included, or to the excluded, component examples." July 31, 2008 ASLB Memorandum and Order at 45.

I have reviewed a table previously submitted by the State in this proceeding that compares the included and excluded structures and components expressly listed in 10 C.F.R. § 54.21(a)(1) to transformers. This table entitled, "Comparison of Various Structures and Components," demonstrates that transformers are similar to the category of structures and components that are expressly listed as included in 10 C.F.R. § 54.21(a)(1) in that transformers, like the included structures and components, contain no moving parts, do not change properties or configuration, and do not undergo any change of state. The table summarizes whether a structure or component contains moving parts, experiences a change in configuration or properties, experiences a change in state, is active or passive, and is specifically listed in § 54.21(a)(1).²

To be sure, many of these "included" structures and components do change the "properties" of the fluids, electric power, or fuel that travel through or are contained within those structures and components; however, the "properties" of the included structures and components themselves do not change during their intended use. Likewise, a transformer may increase or decrease the voltage of the electrical power that passes through that transformer; however, the properties of the transformer, itself, do not change during its intended use.

Electric Cables. Electric cables do not have moving parts. The purpose of the electric cable is to transmit electric power from one point to another. When AC current passes through a cable, a varying magnetic field is generated around the cable. The magnitude and phase of the currents through the cable and voltages

² In my review of 10 C.F.R. § 54.21(a)(1)(i), I observed that the provision does not contain the terms "active," "passive," or a "change in state." I am also aware that the Commissioners have stated "Further the Commission has concluded that 'a change in configuration or properties' should be interpreted to include 'a change in state,' which is a term sometimes found in the literature relating to 'passive.'" 60 Fed. Reg. at 22,477.

across the electric cable may change, but the physical properties of the cable (*e.g.*, conductor shape, material composition of the cable, cable insulation and the resultant resistance, capacitance per unit length) are not designed to change. Cables are included as within the scope of § 54.21(a)(1). The physical laws that describe how the magnetic field is developed around a cable are exactly the same physical laws that describe how a magnetic field is developed in a transformer.

In many applications cables are contained in parallel raceways. In the simplest configurations, two cables are laid parallel to each other in a raceway. The equations that describe the electrical performance of these cables are exactly the same equations that describe the performance of a two winding transformer with no iron core. For both cables and transformers, the properties of the device, itself, do not change during its intended use.

Pipes. The properties of fluids contained within a pipe may change. The properties of such fluids include temperature, pressure, velocity, specific volume, specific weight, viscosity, density, etc. The phase of the fluid in a pipe may even change. Yet, a pipe is a component which is included within the scope of § 54.21(a)(1). A pipe's diameter may narrow at a particular location or the pipe may contain a restriction (*e.g.*, "elbow," or "tee") that may change the velocity and/or pressure of the fluid contained in the pipe; however, the properties of the pipe itself have not changed. Stated differently, the properties of the contents of the pipe (a fluid) may change, but not the conduit (pipe). The pipe itself is not designed to change its own properties. In fact, if the pipe's properties changed it would present significant engineering design problems. These comparisons demonstrate that transformers are analogous to the category of structures and components that are expressly listed as included in 10 C.F.R. § 54.21(a)(1). Like pipes, transformers contain no moving parts, do not change properties or configuration, and do not undergo any change of state.

Heat Exchanger. The temperature properties of the fluids contained within a heat exchanger may change, as can a fluid's flow rates. The properties of the fluid in a heat exchanger change in a manner similar to the change in voltage and current that takes place in a transformer when electrical power is passing through it. The heat exchanger (another component which is included within the scope of § 54.21(a)(1)), like the transformer, is not designed to change its own properties.

Steam Generator. The properties and the state of the fluids in a steam generator may both change. The fluid's temperature may increase and the fluid's state may change from liquid to steam. However, the steam generator itself (another component which is included within the scope of § 54.21(a)(1) is not designed to change its own properties during its normal use.

Reactor Vessel & Containment. Further, various nuclear processes do occur within the reactor vessel, the containment liner, or the containment, but those components are included in § 54.21(a)(1). Those processes cause some wear on those components, and that wear is the subject of aging management.

Turning to transformers, transformers do not have moving parts. The magnitude of the currents and voltages in and out of a transformer may change, but the properties and configuration of the transformer and its capabilities (ability to transform electric power from one voltage to another) are not designed to change during normal operation. Furthermore, transformers themselves do not experience a “change of state” as that term is commonly used.

4. Comparison of Transformers to Excluded Components

Because Entergy focuses so heavily on the similarity of transformers to transistors, I will describe at some length the distinctions between the two components, and then more briefly contrast transformers with other electrical components that are “excluded” from aging management review.

Unlike the abovementioned components, the properties of a transistor, itself, do change during its normal intended use. Transistors are commonly three wire solid state devices initially made from germanium (Ge) and silicon (Si) semiconductor material. A semiconductor is a material whose resistivity can be changed by applying an electric current to the material; a semiconductor’s electrical resistance can be made to vary between that of a conductor (full flow or very low resistance) and that of an insulator (very low flow or very high resistance). An external electrical field or voltage changes a semiconductor’s resistivity – which is a property of the semiconductor device itself. A transistor clearly, measurably, undergoes a change in its properties and, in some cases, a change in state (from conductor to insulator).

The change in resistivity that occurs in the semiconductor device can be thought of as a valve whose position may be changed through an external electric stimulus. A small change in the voltage input to a basic transistor gate drive changes the properties (resistance and/or conductance) of the semiconductor’s main conducting path. Nothing of this nature is present in a transformer. As a result of this applied control voltage, the semiconductor changes its properties and, depending upon the gate control input, will act as an insulator, or a conductor, or variable resistor controlling large currents in its main conducting path. These variable device characteristics are the direct result of a change in properties of the semiconductor. Many transistors such as silicon controlled rectifiers undergo a “change of state” from a conductor to an insulator depending on the applied voltage and the polarity of the applied voltage. In contrast, a transformer’s physical characteristics are

completely independent of the applied voltage and the polarity of the applied voltage. The turns ratio, which determines how the power is transformed, is not dependent on what kind of power is fed to the transformer. The turns ratio is designed and built into the transformer when it is assembled and that turns ratio becomes one of its properties. Once a turns ratio has been built into the transformer, the turns ratio does not change.³ If a transformer were like a transistor, the ratio between the voltages of input and output power would depend on the amount of power and the size of the load. This does not occur, however, because unlike a transistor, the transformer does not change its properties in operation.

An examination of how the current flowing through a transformer changes provides another illustration of the distinction between the properties of the transformer and the properties of the electricity flowing through it. When 100 volts are applied to the primary winding of a two winding isolation transformer where the transformer has a one to one turns ratio and the secondary winding of the transformer is connected to a 50 ohm load, the current flowing through the transformer is 2 amperes. If the voltage is increased to 150 volts the current increases to 3 amperes, while if the voltage is reduced to 50 volts the current reduces to 1 ampere. The connecting conductors, transformer and load have not changed. Only the current flowing in the system as a function of the applied voltage has changed, according to a fixed ratio, which ratio is an unchanging property of the transformer.

The example of a cable illustrates the difference between transformers and transistors. If 100 volts are applied to two cables connected to a 50 ohm load, the current in the cables will be 2 amperes. If the voltage is increased to 150 volts, the current increases to 3 amperes, while if the voltage is reduced to 50 volts the current reduces to 1 ampere. In other words, both the transformer and the cable function in the same way. To suggest that the properties or state of the transformer change is incorrect. If one were to observe only the properties of the electricity flowing through either a one to one transformer or through two cables, the performance of the two devices would be indistinguishable.

A transistor relies on external power to operate (like a transformer) but also (unlike a transformer) requires an external source of energy to control or determine its electrical conducting properties.⁴ Because of this intended ability to vary its

³ Some transformers have mechanical devices to change the turns ratio. See note 1, *supra*.

⁴ I understand that when the Commissioners modified the license renewal regulations they said “‘a change in configuration or properties’ should be interpreted to include ‘a change in state,’ which is a term sometimes found in the literature relating to passive. For example a transistor can ‘change its state’ and therefore

resistivity, it is possible to continuously control the operation of a transistor and its valve-like function by changing its state (its resistivity). Accordingly, a transistor and most other solid state devices are considered active devices whose properties continuously change through external control.

An analogy may be helpful to understand the active nature of a transistor. One might imagine a simple garden hose that has properties such as internal and external diameters, length, stiffness, and materials of construction. It may also have design capacities such as maximum flow rate and temperature limitations. I would suggest that a hose is a passive device similar to a pipe or electrical cable. When water flows through a hose, the properties of the hose do not change. Increasing or decreasing the flow does not change the properties of the hose. However, if some external force is applied to the hose such as squeezing or crimping the hose with one's hand or foot in a controlled manner, the properties of the hose are changed as a result of changing the effective internal diameter of the hose. Turning back to electrical components, a resistor is an electrical component that restricts the flow of electrical current, but it does so at a fixed rate much like a section of hose or pipe. In much the same way that a person might squeeze a hose, the invention of the transistor made it possible for a small control voltage from an external source to change the electrical properties of a fixed resistance previously provided by a resistor. Thus, the name "transistor." The semiconductor in the transistor changes state in much the same way that the diameter of the hose is decreased when someone squeezes the hose. The resistivity properties of a transistor can be changed on an ongoing manner through the application of an external electrical stimulus. This is not true of a transformer; whereas a transistor responds to changes in external forces like a hose that is squeezed, the properties of a transformer do not change at all in normal operation, just as the properties of a pipe, *e.g.*, its diameter, will not change unless the pipe is squeezed to its failing point.

I have also prepared two drawings to assist the court and the parties and demonstrate the differences between transformers and transistors.

would not be screened in under this description." Final Rule, Nuclear Power Plant License Renewal; Revisions, 60 Fed. Reg. 22,461, 22,477 (May 8, 1995).

Transformer

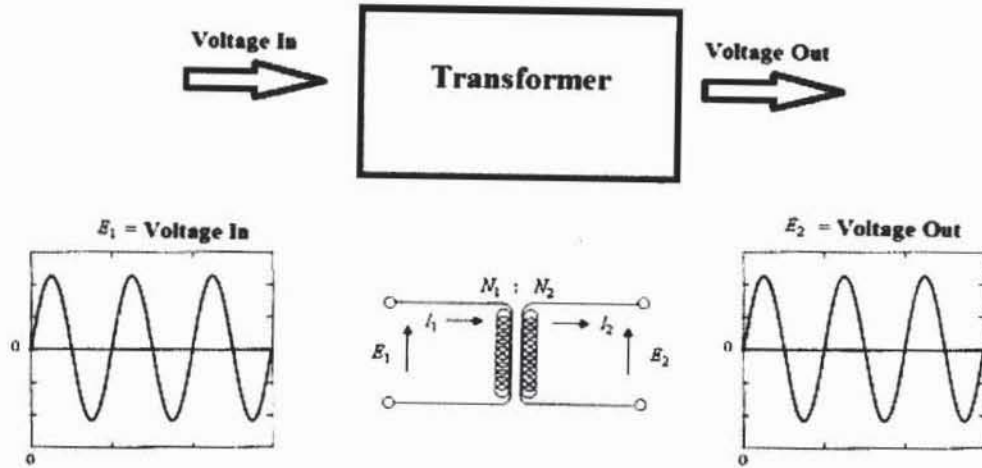

**Relationship between input
voltage and output voltage
always remains the same.**

Transistor

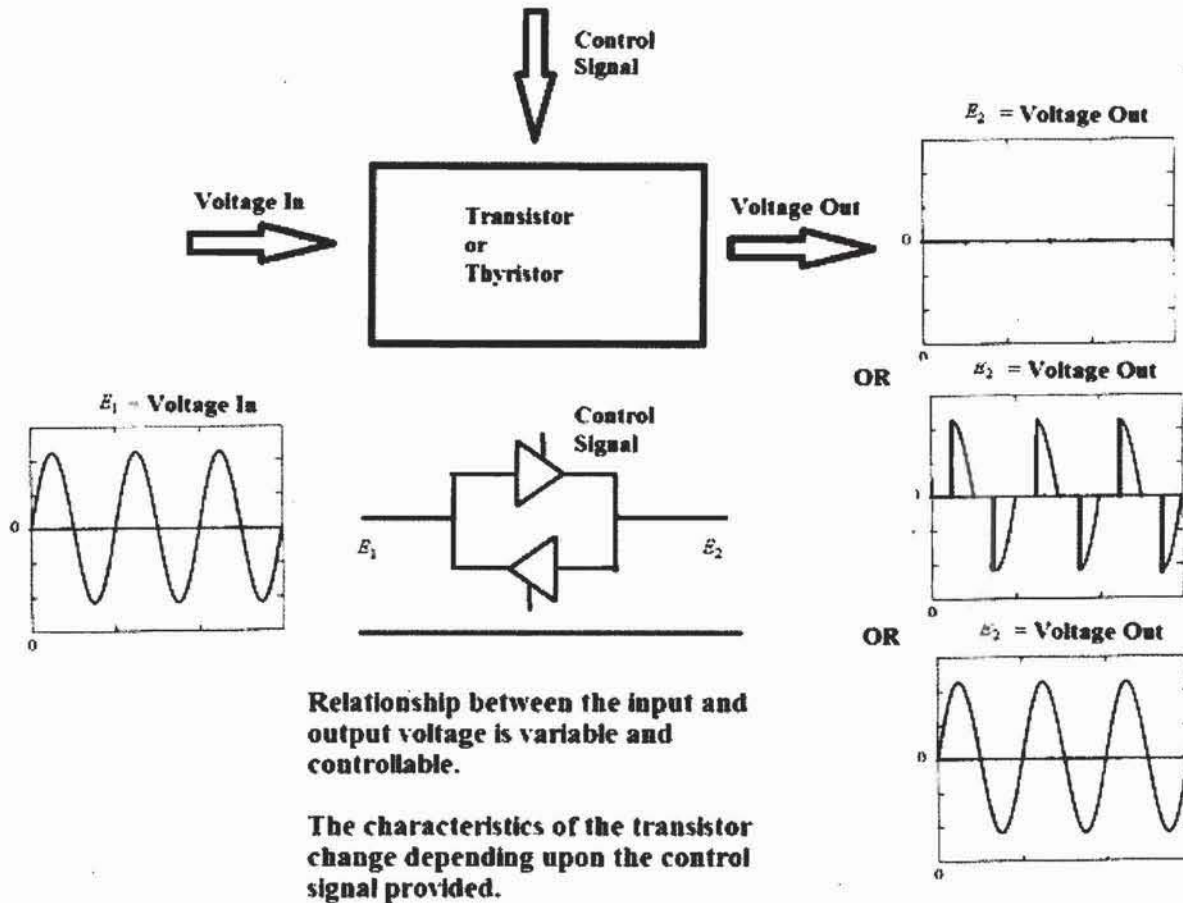

In general, transistors and other active electric devices like electric tubes, magnetic amplifiers, breakers, and other active electric devices have the capability to control and/or switch large amounts of electrical power with the application of a much smaller amount of electric power. Active devices, which include transistors and other solid state devices, typically require two sources of power: the first is a bulk source of power which supplies the large amount of power used by the device to perform its intended function; the second source of power, normally much smaller, is to control the operation of the device. The second source of power controls the operation or state of the device, *e.g.*, determines its configuration or its properties. Passive electrical devices, such as resistors, cables, connectors, capacitors, inductors, and transformers are not designed for or capable of power amplification, changing conductance, or otherwise changing the configuration or properties of the

device based upon an external control signal.⁵ A more detailed description of several of the “excluded” components illustrates their active nature:

Batteries. A battery produces electrical energy through a chemical reaction. The electrolytic properties of the chemicals, which constitute the battery change as the battery discharges. In contrast, only the properties of the power flowing through a transformer change. The key properties of a battery that has been discharged will be different from a full battery, but the key properties of a transformer that has had power flow through it will not be different from the properties of a transformer which has not been used.

Power inverters. Like a transistor, the inverter requires an external control in order to perform its intended function. An inverter takes direct current power and converts it into alternating current power. Inverters accomplish this power conversion by controlling the magnitude, frequency and wave shape of the output power. The external control allows the power inverter to vary the relationship between the input and output power, *e.g.*, to decrease or increase the magnitude, frequency, and wave shape of the power, which is wholly unlike the transformer, in which the relationship between the input and output power is fixed and determined by the characteristics of the power fed into it and the load supplied by it. Moreover, the transformer will not change the magnitude, frequency or wave shape of the power flowing through it.

Power supply. A power supply takes alternating current power and converts it into direct current power. Like the transistor and the inverter, the power supply requires an external control to perform its intended function. Power supplies require voltage regulation, which regulation is controlled by an electric control circuit, apart from the main circuit, which converts the bulk power. The external control will adjust the properties of the power supply to deliver the desired voltage and current to the load that is being supplied. The voltage and current supplied by the transformer, on the other hand, depend on the properties of the load, itself, and not on the properties of the transformer, which only controls the turns ratio. The power supply, decides, so to speak, what kind of power to supply to the load, whereas the transformer can only supply the power that the load requires.

⁵ Unlike transformers, electrical breakers, relays and switches all change configuration in performing their intended function. I do not treat them in detail, because it is undisputed that transformers do not change their configuration in performing their intended function.

5. Age related degradation in transformers is not readily monitored and management of age related degradation requires a comprehensive inspection program

Like many of the components included in the list for AMR, transformers will experience various kinds of age related degradation which are not detectable through remote monitoring. NUREG/CR-5753 at 15. Transformers experiencing age related degradation can continue to function with no observable change in operation until the moment when they fail catastrophically. *Id.*

In 2006, IEEE published a report listing failure modes of transformers and methods for detecting these failures before they occur. IEEE Guide for the Evaluation and Reconditioning of Liquid Immersed Power Transformers (IEEE Std C57.140TM-2006) at 11-15.

In 1994, Sandia National Laboratories published a report identifying aging degradation mechanisms for transformers. Sandia, Aging Management Guideline for Commercial Nuclear Power Plants Power and Distribution Transformers, SAND93-7068 · UC-523 Unlimited Release, May 1994, at 4-1 to 4-23.

These reports make clear that while some modes of transformer failure can be detected by performance monitoring there are significant transformer failure modes that involve aging degradation of transformer components that do not affect transformer operating performance until the transformer fails and for which aging management programs that go beyond performance monitoring are required. For example:

- Polymerization, which results from normal transformer operation, and is the disintegration of longer polymer chains into smaller polymer chains and diminishes the insulation integrity of the transformer windings. Polymerization has a dramatic effect on the electrical strength of the transformer, but until an electrical failure occurs, polymerization does not affect the operating characteristics of the transformer. If a short circuit occurs in a transformer in which a high degree of polymerization has occurred, that short circuit is much more likely to lead to the failure of the transformer, even if the transformer had originally been designed to withstand such a short circuit. Some tests may reveal broad information about the degree of polymerization in a transformer, but insulation degradation is not uniform and a visual inspection is necessary to determine whether the polymerization is occurring to a small degree and without significant risk throughout the insulation or whether it is occurring intensely and with significant risk at a small amount of locations.

- Diminishment in the mechanical and structural integrity of the core and coil assembly may have no effect on the operating characteristics of the transformer, until a loose core and coil assembly result in a devastating short circuit failure of the transformer. Over time, as insulation compacts, the coil assembly will become less tightly packed, and a less tightly packed coil assembly is less able to withstand a short circuit. This form of age related degradation is detectable only through visual inspection, because it does not produce any of the electrical or chemical tracers picked up by other tests.
- Individual windings may also deform and affect adjacent windings, leading to Internal arcing in the insulation structure. Such deformation can occur due to the movement of windings with age or use or abuse. This internal arcing would have no effect on the operating characteristics until it causes failure, and although a dissolved gas analysis could produce some evidence of insulation failure or hotspots, a relatively frequent inspection interval is required to identify whether the problem is worsening, and even then, such testing will not be able to identify the specific places within the winding where the degradation is occurring, since the coil assembly may contain 2,000 or more turns. Eventually, this degradation can cause the transformer to fail.
- Movement of the winding structure due to a short circuit fault in the system could cause a catastrophic insulation failure, but until the failure occurs will have no effect on the operating characteristics of the transformer.
- A corona or radio interference voltage (“RIV”) generated by the transformer will have no effect on the operating characteristics of the transformer but is a sure indication of a problem with the transformer. Although an acoustical test could identify the existence of a corona, a visual inspection is required to identify the actual flaw in the transformer that is causing the corona or RIV.

The aging degradation of some constituent parts of transformers is not detectable by performance monitoring. Moreover, because different kinds of age related degradation require different kinds of tests to detect, a comprehensive and varied approach is required to manage age related degradation in transformers. Nevertheless, aging management programs could be implemented to address transformer component aging and help to ensure that the transformers will be capable of performing their designated function. Not only should transformers in active operating electrical systems be age managed, but so should transformers that are part of electrical systems that are used less frequently such as the IP3 transformers for Appendix R (6.9KV/480V), 15 KVA GRD transformers for the gas turbines, Station Service Transformers and transformers for Station Black Out (SBO). Some of these transformers may not normally be energized and/or operating

under full load conditions.

NRC's Information Notice 2009-10 (ML090540218), EPRI's 2003 report entitled *Large Transformer End-of-Expected-Life Considerations and the Need for Planning* [1013566], IEEE's 2007 report entitled *IEEE Guide for the Evaluation and Reconditioning of Liquid Immersed Power Transformers* [C57.140TM-2006], NUREG/CR-5753, and Nuclear Energy Agency, *Operating Experience Report: Recent Failures of Large Oil-Filled Transformers*, NEA/CRNA/R(2011)6 (Mar. 14, 2011) all indicate that current monitoring procedures for detecting the performance of transformers, such as those in use at Indian Point, are not adequate to detect, in advance of failure, all of the aging defects and degradation phenomena in transformers. Indeed, the NEA report concluded that "weakness in the maintenance and monitoring programmes" is the root cause for many transformer failures. *NEA* at 11

Moreover, simply monitoring the performance of transformers can not ensure that critical transformer components are not degrading to the point of component failure – now or during the period of license extension. As discussed in the 1994 Sandia Report, the 2003 EPRI report, the 2006 EPRI report, and the 2007 IEEE report, monitoring procedures such as component performance monitoring, personnel training, and quality assurance audits are not adequate. Such monitoring procedures do not provide the level of aging management sufficient to demonstrate that the various transformers will perform their intended functions during the period of extended operation including a potential design basis accident or incident. Additional aging management programs could be implemented to detect aging degradation of transformers and their component parts in advance of failure. *See, e.g., EPRI 2003 Report, at 7-2 & sec. 7.1.2.* Aging management programs for age related degradation of transformers may include physical inspections, power factor testing, analysis of insulation resistance, oil leakage, gas-in-oil, comparison with original factory test reports, vibration (humming), and impedance versus frequency analysis. By way of example, the 2003 EPRI Report identifies additional testing, surveillance, and inspection techniques that could support a meaningful aging management program. *See, e.g., EPRI 2003 Report, at 6-1 to 6-16.*

NRC has acknowledged that a comprehensive and *continual* surveillance program is required to manage the effects of aging in transformers:

A continual program of inspection, surveillance, monitoring, and maintenance will help ensure transformer reliability. Such a program will detect and reduce stressors that shorten transformer life, prevent stressors before they cause degradation, and detect degradation in the early stages so that preventive and corrective action can be taken prior to

transformer failure to reduce the rate of aging. An effective program of inspection, surveillance, monitoring, and maintenance consists of periodic cleaning and inspections; testing of dielectric strength; and testing of oil in liquid-filled transformers; testing to verify that electrical characteristics such as winding resistance, insulation resistance, turns ratio, excitation current, and resistance to ground are maintained. Regular measurement of temperature is an important element of a transformer monitoring program.

NUREG/CR-5753 at 50-51.

6. Consequences of Inadequate Management of Transformers

As noted in the State of New York's petition, the failure to properly manage aging of Electrical Transformers at Indian Point may compromise:

- a. The integrity of the reactor coolant pressure boundary;
- b. The capability to shut down the reactor and maintain it in safe shutdown condition; or
- c. The capability to prevent or mitigate the consequences of accidents which could result in potential offsite exposures comparable to those referred to in §§ 50.34(a)(1), 50.67(b)(2), or § 100.11 of this chapter, as applicable. 10 C.F.R. §§ 54.4(a)(1)(2) and (3).

The consequence of failures of Electrical Transformers may result in accidents beyond the Design Basis Accidents resulting in exposures to the public exceeding 10 C.F.R. § 100 limits if a station blackout occurs and the reactor core and spent fuel pools are not able to be properly cooled.

Failure to properly manage aging of electrical transformers could result in loss of emergency power to the 480 volt safety equipment and 6.9kV busses including station blackout loads, in that a failed transformer can prevent power from emergency generators or other backup sources from reaching the safety related busses.

Recently, there have been a number of transformer failures at power reactors. Although NRC staff generally believes that transformers do not need to be subject to aging management programs, these transformer failures underscore the need for the proper maintenance and aging management of transformers.

I have reviewed the transformer failures discussed in NRC Information Notice 2009-10⁶ and in NUREG/CR-5753 which analyzed 88 transformer failures at nuclear power plants, as well as other Licensee Event Reports, Form 366 (“LER”) involving transformers since the date of that report.⁷ I have found that the vast majority of these failures were unanticipated. Further, in my opinion it is unreasonable to expect that these failures could have been predicted with the present measurement technology and or reasonable cost associated with making the measurements necessary to anticipate these failures. Physical inspection of the type done with other in-scope components could have prevented some of these failures, e.g. those due to build up of crud on a bushing. Additionally, although failures in the examples below may have occurred in one type of power transformer, the same failure modes could have occurred in other kinds of power transformer. For example, although many of the failures below occurred in so-called main transformers, they could have occurred in auxiliary and start up transformers as well:

- Indian Point, Unit 3⁸ On April 6, 2007, while operating at 92-percent power, a fault occurred on phase ‘B’ bushing of the No. 31 main transformer resulting in an automatic reactor trip and transformer explosion and fire. Although previous testing indicated that the insulation characteristics of the bushing were adequate for operation, the bushing still failed.
- Limerick Generating Station, Unit 2⁹ On February 1, 2008, a low voltage bushing connection failed on the 2A main transformer resulting in a turbine trip and reactor scram.
- Diablo Canyon, Unit 2¹⁰ On August 16, 2008, an automatic reactor trip

⁶ NRC Information Notice 2009-10, Transformer Failures - Recent Operating Experience, July 7, 2009, (ML090540218).

⁷ Earlier this year, I conducted a keyword search on NRC’s Agencywide Documents Access and Management System (“ADAMS”), which produced all instances of documents containing the word ‘transformer’ in the document type ‘Licensee Event Report.’ I reviewed for instances in which the report was substantially about transformers and excluded those in which the word ‘transformer’ was mentioned, but not the subject of the LER. I found 11 additional instances of reported transformer failures since the since the most recent failure reported in NRC Information Notice 2009-10.

⁸ NRC Information Notice 2009-10.

⁹ *Id.*

¹⁰ LER 50-323/2008-001 (ML082970221).

occurred resulting from the failure of the main electrical transformer C phase. Plant operators subsequently declared a Notification of Unusual Event due to an observed fire at the C phase transformer. The failure was deemed to be a “random component failure.”

- North Anna, Unit 2¹¹ On October 29, 2008, while attempting to place the unit on line, the turbine tripped on a generator lockout relay actuation. The C main transformer was discovered to be spraying oil.
- Oyster Creek¹² On November 28, 2008, an electrical fault internal to the M1A main transformer led to an automatic reactor scram due to load reject. An insufficient testing program may have contributed to the failure to predict failure in the bushing.
- Oyster Creek¹³ On February 1, 2009, a failure occurred at the ‘B’ phase high voltage bushing of the M1A transformer while the reactor was operating at 100% power. This transformer had been installed to replace a previously failed transformer and its failure resulted in a reactor scram and fire.
- LaSalle County Station, Units 1 & 2¹⁴ On May 21, 2009, the surge arrester on the ‘A’ phase of the Unit 1 West Main Power Transformer failed while the reactor was operating at 100% power. The surge arrester had performed without problems until it failed, and a temperature scan conducted before the failure did not indicate any evidence that the arrester was likely to fail.
- Comanche Peak Unit 1¹⁵ On January 9, 2010, the reactor tripped due to a sudden pressure fault of the Unit 1 main generator output transformer, while the reactor was at 100% power. The trip resulted from an internal failure of the transformer that could not be rectified. The exact cause of the fault could not be determined, but later inspection showed that the windings had shifted and that insulation had degraded. The unidentified failure occurred within the transformer, and the identification of that failure might have been made through dissolved gas analysis, acoustic

¹¹ *Id.*

¹² LER 50-219/2008-001 (ML090260082).

¹³ LER 50-219/2009-001 (ML090970735).

¹⁴ LER 50-373/2009-001 (ML092020179).

¹⁵ LER 50-445/2010-001 (ML100740293).

technique, infrared inspection or frequency analysis while the transformer was not energized. The transformer's failure illustrates the need to rigorously pursue a maintenance program consisting of several techniques that can only be implemented effectively when the transformer is not in operation. The fact that the cause of the failure was not identified is itself an indication of the difficulty in detecting age related degradation.

- Fermi, Unit 2¹⁶ On March 25, 2010, the reactor tripped due to a shorted current transformer wire in the Main Generator Z phase line terminal bushing enclosure. The failure led reactor water level to decrease 38 inches below its normal level. Consequently performance monitoring would not have revealed the underlying problem, which was discovered, after the fact, to be shorted CT conductors. It is not clear how quickly the conductors were degrading, but if the degradation was slow, visual or other kinds of detection might have detected it. If the degradation occurred quickly, it is unlikely that such testing would have been effective. The underlying cause of the short was abrasion where the wire entered the bushing, which should have been identified before failure.
- Salem Unit 1¹⁷ On July 7, 2010, the reactor tripped after a fire in the 'B' Phase Main Power Transformer, caused by an arc flash over the bushing when the deluge system automatically activated due to one of its sprinkler heads having fused in conditions of excessive heat.
- Sequoyah Nuclear Plant¹⁸ On September 22, 2010, an intertie transformer in the switch yard caught fire while it was being placed in service after maintenance. Inadequate maintenance procedures led to the intrusion of water into the bus duct.
- Watts Bar¹⁹ On November 14, 2010, the reactor tripped due to a failure of the cooling system to the 'A' phase Main Bank Transformer, which led to rising oil temperatures. The failure of the cooling system was caused by the failure of the transformer that supplies power to the cooling system.

¹⁶ LER 50-341/2010-001 (ML101400553).

¹⁷ LER 50-272/2010-002 (ML102780502).

¹⁸ *Sequoyah Nuclear Plant – Integrated Inspection Report 05000327/201004, 050000328/2010004* October 29, 2010 (ML103020448).

¹⁹ U.S. Nuclear Regulatory Commission, *Event Notification Report for November 15, 2010*; available at: <http://www.nrc.gov/reading-rm/doc-collections/event-status/event/2010/20101115en.html>.

- Turkey Point, Unit 3²⁰ On September 23, 2010, an electrical flashover on the high side of the Unit 3 Generator Step Up transformer occurred, causing the reactor to trip while operating at 100% power. The flashover might have been caused due to contamination of a bushing, but the cause remains undetermined and the failure would not have been preventable based on the tests described by Entergy. A healthy bushing should function normally in the rain, but a bushing covered in contamination can be susceptible to this kind of failure. A simple visual inspection could have revealed that this transformer would likely fail. Similarly, the other bushing failures in this list could have been addressed with more rigorous inspection.
- Indian Point, Unit 2²¹ On November 7, 2010, the 'B' Phase bushing²² of the 21 Main transformer experienced a ground fault, which resulted in an explosion in the transformer, the leak of 14,000 gallons of transformer oil into the Hudson River and the shutdown of Unit 2. The fault in the bushing was unanticipated.
- Oyster Creek²³ On December 10, 2010, a newly installed main transformer failed during start up of the reactor, causing the reactor to remain offline. The failure was clearly unanticipated and indicative of how little used transformers related to safety may fail when called upon in an emergency.

²⁰ LER 50-573/2010-003 (ML103340517)

²¹ LER 50-247/2010-009 (ML110280013)

²² The bushing is an integral part of the high voltage power transformer. A voltage power transformer cannot function reliably without bushings. The bushing is the point of electrical contact between the electrical system and the transformer. The purpose of the electrical characteristics of the bushing are the same as those of the high voltage cable, *i.e.*, to provide a low impedance path over which the power can flow and concomitantly to provide insulation between the conductor and ground (or other phase conductors). Both are static devices. The degradation of the ability of either to perform its intended task cannot be consistently determined by measuring the change in its electrical performance.

²³ Wayne Parry, *NJ's Oyster Creek Must Replace New Transformer*, Associated Press (December 10, 2010), *available at*: <http://abcnews.go.com/Business/wireStory?id=12365227>.

- LaSalle County Station, Unit 1²⁴ On February 11, 2011 an external bushing flashover on the C-phase of the 1W Main Power Transformer caused the reactor to trip while operating at 100% power. Ice build up and contamination with salt and dirt contributed to the flashover. Testing would not have predicted a flashover.
- Perry Nuclear Power Plant²⁵ On October 2, 2011, an internal fault in the Unit 1 startup transformer caused the transformer to fail and cracked the transformer's cooling fluid reservoir.
- Monticello Nuclear Generating Plant²⁶ On October 28, 2011, the auxiliary power transformer failed, which caused the reactor to scram. Coincident with the failure of the transformer, the emergency diesel generators and non-safety related busses experienced difficulties.

In 2003, EPRI published a report that identified a growing problem with failures in large transformers and a wide range of maintenance programs that it recommended be implemented by nuclear utilities to address these problems including the problem of aging degradation of transformers. EPRI Life Cycle Management Planning Sourcebooks, Volume 4, Large Power Transformers, [1007422], March 2003, at 4-1 to 4-6, 4-17 and 6-2 to 6-13.

Moreover, as I describe below in Section 7.4, it appears that Entergy's own staff acknowledges in Entergy documents that detailed and comprehensive inspection routines performed at a regular interval are required to detect the effects of aging.

7. Entergy's Argument

I have reviewed Entergy's submissions in this proceeding, including the August 12, 2009 declarations of Dr. Dobbs, Mr. Craig and Mr. Rucker. Supported by its experts' declarations, Entergy reaches three main conclusions about transformers. In my opinion and as I detail below, Entergy's conclusions and the statements of its experts are technically inaccurate and contrary to Entergy's own internal records regarding transformer maintenance.

Applicant's Motion for Summary Disposition of New York State Contention 8 (Electrical Transformers) ("Entergy Summary Disposition Motion"), page 2 contains the following assertion:

²⁴ LER 11-013/2011-001 (ML110890949)

²⁵ PNO-III-11-012A (ML11292A119)

²⁶ PNO-III-11-015A (ML11301A217)

It is uncontroverted, as a technical matter, that all transformers perform their intended functions through changes in their voltage and current properties, i.e., "a change in state." Therefore, because transformers perform their intended function through a change in state, they are properly excluded from the AMR requirements in Part 54, and no AMP is required.

This assertion is the heart of Entergy's argument and is, quite simply, contrary to the consensus of the technical community. As the technical community recognizes, the transformer performs its intended task without changing its configuration (mechanical or electrical), its material characteristics, or its state, and so is a static device. Power merely passes through a transformer and the unchanging physical properties of the transformer cause that power to change voltage at a ratio determined by the transformer's unchanging design properties. Different amounts of power may be applied to a transformer, but the voltage will always change at the same ratio, because the unchanging properties of the transformer dictate only one ratio. This is exactly the same situation one has when a fluid passes through a pipe with a constriction; when the amount of fluid that passes through the pipe is constant, the pressure of the fluid will change at the constriction, but the pipe remains invariant, its properties and characteristics unchanged.

Page 30 of Entergy's Summary Disposition Motion contains the following assertion:

All transformers are active components because they perform their intended function through a change in configuration or properties, which the Commission has explicitly stated should be interpreted to include "a change in state." They are not passive and long-lived structures or components and, therefore, are not subject to AMR under C.F.R. Part 54.

In my opinion, Entergy's argument is technically inaccurate. The transformer is a static device as defined by the IEEE and its Transformers Committee. See p. 30, supra. A transformer does not change its configuration or its properties when it is performing its intended operation. Neither the physical and electrical configuration nor physical and electrical properties of a transformer change while it is operating. The transformer certainly does not change "state" when it is operating. Each of a transformer's key properties demonstrates that it is a passive device, which is long-lived if properly maintained and monitored. See, e.g., NUREG/CR-5753 at 50.

Page 7 of Entergy's Summary Disposition Motion contains the following assertion:

Thus, potential degradation of the ability of a transformer to perform its intended function is monitorable by changes in the electrical performance of the transformer and/or its associated circuits.

If this statement were true, no transformer would ever fail without warning while in service. Entergy's assertion misapprehends the physical reality of transformer performance in that many failure modes cannot be predicted by way of monitoring changes in the transformers electrical performance. I have already described at length several failure modes in transformers that cannot be predicted from performance monitoring, but, by way of example: the aging of the transformer's insulation structure cannot be determined by monitoring the transformer's electrical performance; the tightness of the core and coils can not be determined by monitoring the transformer's electrical performance; nor can the distortion of windings; arcing within the windings, core and clamps, moisture in the oil or windings, generation of combustible gasses, or turn-to-turn failures be determined by monitoring the transformer's electrical performance. These failure modes and others can not be determined by simply monitoring the electrical performance of the transformer. Entergy and its experts are incorrect to assert otherwise.

7.1 Declaration of Dr. Dobbs

In paragraph 31 of his declaration dated August 12, 2009, Dr. Dobbs makes the following statement:

. . . [V]oltage, current, and heat signature are all properties of a transformer. When the transformer changes from an idle state to an active state, the voltage and current change. Also, the currents and heat signature will change with a variation in load. Because transformers perform their intended function with a change in properties, they are excluded from an AMR according to the defining statement in § 54.21(a)(1)(i).

Voltage and current are not properties of the transformer, but rather are properties of the source of power being supplied to the transformer and of the load being served. The transformer's characteristics or properties (turns ratio, conductor size, insulation type and thickness, cooling capability, etc.) are the same whether the transformer is carrying power or not. If we applied Dr. Dobbs' logic to a pipe, which is conceptually similar to a transformer, he is suggesting that a pipe's properties depend on whether it is carrying fluid. This is incorrect. The properties of the pipe will *not* change depending upon the amount of fluid flowing through the pipe. In

the same manner, the properties of the transformer do not change depending upon the power passing through the transformer. The properties of a transformer, listed above, limit the characteristics of the power to which the transformer can be subjected before it fails, *e.g.*, the voltage that can be applied or current carried by a specific transformer design or the amount of pressure and temperature of the fluid carried in a specific pipe, but its properties remain constant.

In paragraph 20 of his declaration, Dr. Dobbs presents a position that transformers change “properties” in that:

The table above (paragraph 19) demonstrates that the voltage and current properties of a transformer change depending on the load condition of the transformer.

While I agree with the recognition that the “properties” of the current and voltage *inputs to and outputs from* are changed when they pass through a transformer, I disagree with Dr. Dobbs’ implication that the properties of the transformer change. The transformer does not change its configuration or properties during its intended use; the conductors or cables used to construct the windings do not change in size or number or location, nor does the size, weight, and material used to construct the transformer’s core. The electric power passing through a transformer is a function of the voltage applied to that transformer’s primary winding and the load that the transformers services from its output winding. Both the input voltage and the load served are completely independent of the design and characteristics of the transformer. Input and output voltages are not “properties” of the transformer itself. The turns ratio is a property of the transformer and it does not change in normal use. The insulation type and dimensions of the turns in the transformer are properties of the transformer and do not change in normal use. If we assume the transformer has a turns ratio of 10 to 1, *e.g.*, a step down transformer, then an input voltage of 1,000 volts would be transformed to an output voltage of 100 volts; if the input voltage were 500 volts, the output voltage would be 50 volts. The input and output voltages are different in each example, but the ratio between input and output voltages remains constant, because the ratio is a non-changing property of the transformer.

In paragraph 22, Dr. Dobbs states that in a transformer “[a]ll of the voltages and currents must vary in time. The voltages and currents also vary whenever load conditions change.” Dr. Dobbs is correct to acknowledge that a change in the properties of the load will cause the voltage and current to change, but a change in the load does not imply any variability in the transformer’s properties. Neither does the fact that voltage, current and magnetic flux vary over time imply any change in a transformer’s properties. As Dr. Dobbs states in paragraph 17 of his declaration, the changes in the properties of the power flowing through a

transformer are a consequence of the power's being an alternating current. But the determination of whether current is alternating or direct does not come from the properties of the transformer through which it flows, but from the source of the power. It is true that transformers are designed to take advantage of the properties of alternating current, but it is not true that the properties of a transformer change when a certain kind of current is passed through it. A transformer may not operate correctly if it is connected to direct current, but to suggest that a transformer is only a transformer so long as alternating current flows through the transformer is like saying that a hot water pipe's properties have changed because it is hooked up to a cold water source.

In paragraph 15 of his declaration, Dr. Dobbs describes the relationship between the primary and secondary winding's voltage and current as a function of the transformer's turns ratio. In paragraph 16, Dr. Dobbs goes on to state that "Therefore, voltage and current are integral properties of a transformer." It is my opinion that this statement is incorrect in the same way it would be incorrect to say that the fluid passing through a pipe is a property of that pipe or that power flowing through a cable is an integral component or characteristic of that cable. It is my opinion that Dr. Dobbs has conflated the device (in this case the transformer) which is a static device and the element that is flowing through it (in this case electric power which is variable depending upon the driving voltage and the load being served).

In paragraph 25, Dr. Dobbs states that "Voltage, current, and the winding turns ratio are all properties of a transformer. These properties are easily monitored while the transformer is performing its intended function and provide an indication as to the operational health of the transformer." Voltage and current are no more properties of the transformer than water pressure is a property of a pipe that is carrying the liquid. The turns ratio of a transformer is a property of the transformer. But, to measure it accurately while the transformer is operating is not a simple or routine task, as Dr. Dobbs claims. Power transformers have thousands of turns and the ability to measure within the accuracy of one turn would be required to assess the health of the transformer. This is physically impractical with the transformer energized and even difficult when the transformer is off-line.

In paragraphs 32 and 33 of his declaration, Dr. Dobbs argues that it is proper to exclude the transformer from the list of components that require an AMR because the ability of the transformer to perform its intended function can be determined by direct measurement of performance. In these two paragraphs, Dr. Dobbs compares the pipe and the transformer. The statement is made that it is not possible to determine the suitability of the pipe to carry out its function by direct measurement of its function, but it is possible to determine the ability of a transformer to conduct its desired function by direct measurement. This position is not only inaccurate, but

it suggests an operational policy that is dangerous to the facility and the personnel and staff in that facility, as I have already described.

7.2 Declaration of R. Rucker

In paragraph 16 of his declaration, dated August 12, 2009, Mr. Rucker points out that Entergy identified two passive electrical and I&C commodity groups as meeting Section 54.21(a)(1)(i) criteria, *i.e.*, components that perform an intended function without moving parts or without change in configuration. These groups are subject to AMR. In paragraph 17, Mr. Rucker, on behalf of Entergy, then excludes everything that is not included in paragraph 16. As such, transformers are assumed to be active devices not subject to AMR. As I described in my statements regarding Dr. Dobbs' declaration, the classification of a transformer as an active device is incorrect, and so transformers should be subject to AMR.

In paragraph 19, Mr. Rucker makes the following statement:

As explained above, transformers are not subject to AMR and, therefore, no AMP is required under 10 C.F.R. Part 54. Nonetheless, degradation of the ability of a transformer to perform its intended function is monitorable by changes in the electrical performance of the transformer and /or its associated circuits. Moreover, certain IP2 and IP3 transformers, including those necessary for compliance with 10 C.F.R. § 50.48 and 50.63, are subject to direct, ongoing, surveillance, monitoring, maintenance, and inspection. These CLB programs and activities would continue during the period of extended operation, in accordance with 10 C.F.R. § 54.33(d). They are intended to ensure that any degradation or failure of the transformers, as active components, is detected and corrected, and that the transformers continue to perform their intended functions.

I disagree with Mr. Rucker's declaration that the degradation of the ability of a transformer to perform its intended function can be determined simply by measuring the changes in the electrical performance of the transformer and/or its associated circuits. If this were a consistently valid statement, the number of transformer failures would be drastically reduced. This is simply not the case. Additionally, I have already listed at pp. 14-15 five common transformer failure modes that cannot be identified by measuring the performance of the transformer.

In paragraph 20, Mr. Rucker represents that large power transformers are equipped with instrumentation to detect degrading conditions and that personnel

are trained to take appropriate action. I disagree with this statement; the vast majority of degradation to a transformer cannot be observed based on changes in electrical performance. For example, the insulation integrity of a transformer's winding structure can not be determined by monitoring a change in the electrical performance. One must look at the insulation capability of the oil and paper structure. Routine monitoring will not provide this data. Another example would be the ability of the transformer to withstand a short circuit, which can not be determined with routine monitoring, but, rather, requires internal inspection or an impedance versus frequency scan of the winding structure. Any assertion that the health of the transformer is determinable by measuring changes in its electrical performance simply ignores ample evidence of failure modes that are not detectable from performance degradation.

The declaration of Mr. Rucker makes general reference (at paragraphs 19-21) to monitoring programs that seem to be focused on the performance of the transformers, but not on the condition of the transformer components themselves. Mr. Rucker's declaration contains only generalities about performance monitoring. It also contains many qualifiers that make it difficult to understand the depth or the extent of such monitoring. While it makes reference to "transformers" or "certain" transformers, it does not demonstrate that the licensee will monitor the performance of *all* transformers that would be within the scope of Part 54, nor does it explain how the licensee monitors transformers that may not normally be energized and/or operating under full load conditions.

7.3 Declaration of J.W. Craig

In paragraphs 7(a), 7(b) and 7(c) of his declaration, dated August 12, 2009, Mr. Craig repeats Dr. Dobbs' assertions that transformers should be excluded from AMR because they undergo continuous changes in their electrical and magnetic properties during operation, because a transformer's ability to perform its intended function is readily monitorable, and because transformers are similar to components listed in 10 C.F.R. § 54.21(a)(1)(i) that are excluded from the AMR requirements of Part 54. Each of these assertions is incorrect, as I have already described.

In paragraph 7(d), Mr. Craig points out that

"Both the NRC and industry license renewal guidance documents properly conclude that electrical transformers are not subject to AMR under part 54 because effects of aging will be effectively managed during the license renewal term through existing licensee maintenance activities."

I disagree with this statement for two reasons. First, the “health” or ability of a transformer to do its assigned task can not be determined with any degree of certainty by measuring its operating performance. In this document, at pp. 14-15, supra, I have listed 5 conditions that can not be evaluated by measuring operating performance. Second, the failure rate of these transformers has shown that the existing maintenance activity conducted by the licensee needs to be improved. The instances of unanticipated failures described at pp. 18-22, supra demonstrate that the health of a transformer cannot be accurately determined from external measurements.

In paragraph 22, Mr. Craig provides an example of a two winding step down transformer transforming 6.9kV to 480 volts. He makes the statement that

“The voltage in the secondary coil is a result of a continuous change of the magnetic properties or magnetic field in the transformer while in service. Thus, while the transformers do not have moving parts, each of these components of the transformer undergoes changes in electric properties or state when energized much like components in a transistor, inverter, or power supply. When connected to an electrical load or circuit, each of these components must change properties in order to perform its intended function.”

This statement is incorrect for two reasons. First, the voltage in the secondary winding is a result of the rate of change of the magnetic flux created by flowing current in the primary winding, not the magnetic properties of the transformer. The magnetic properties of the transformer are invariant; to represent the properties as variable is technically inaccurate. The magnetic field generated within the transformer is a product of the current flowing through it; the transformer is designed with certain characteristics, *i.e.*, the turns ratio, to ensure that the magnetic field behaves in a certain fashion, but the magnetic field generated by the flow of current will behave in a uniform manner, according to the non-changing properties of the transformer. If the input power changes, the output power will also change, but the change in output power is wholly caused by the change in input power and not by any change in the properties of the transformer. For example, if water is poured through a pipe at a constant rate, the water will come out of that pipe at a constant rate. Only if the rate of water being poured into the pipe changes will the rate at which water comes out of the pipe change. That change will not at all be caused by any change in the property of the pipe. Second, the statement that each of these components of the transformer undergoes changes in electric properties or state when energized much like components in a transistor, inverter, or power supply is incorrect. A transistor changes state (or impedance) as a function of a specific input control signal, making it an active device. An inverter

changes direct current into alternating current and its function (state) is very precisely controlled, making it an active device. A power supply takes alternating current power and converts it into direct current power. The input power's voltage can vary over a very broad range and the output voltage will be constant due to active control in the power supply. The transformer, on the other hand, is a static device, having no moving parts, no control mechanism, and with the relationship between the input and output being fixed by the turns ratio of the windings. Its transformation characteristic is fixed. The transformer, on the other hand, performs precisely the same degree of change to whatever amount of power passed through it. Thus, if the "transformation ratio" is 2 to 1, then the ratio of input to output voltage will always be 2 to 1, and the ratio of input to output current will be 1 to 2 with the input power equaling the output power. See pp. 9-10, *supra*.

In paragraph 26, Mr. Craig, explains his understanding of the technical and regulatory basis for excluding transformers from AMR under 10 C.F.R.:

Transformers perform their intended function through a change in state by stepping down voltage from a higher to a lower value, stepping up voltage to a higher value, or providing isolation to a load. Transformers perform their intended function through a change in state similar to switchgear, power supplies, battery chargers, and power inverters, which have been excluded in § 54.21(a)(1)(i) from an aging management review. Any degradation of the transformer's ability to perform its intended function is readily monitorable by a change in the electrical performance of the transformer and the associated circuits. Trending electrical parameters measured during transformer surveillance and maintenance such as Doble test results, and advanced monitoring methods such as infrared thermography, and electrical circuit characterization and diagnosis provide a direct indication of the performance of the transformer. Therefore, transformers are not subject to an aging management review.

Characterizing stepping up voltage, or stepping down voltage, or providing electrical isolation with a transformer as a change in state is technically inaccurate. The transformer does not change state while it is performing its assigned activity any more than a pipe carrying a fluid changes state as the fluid flows through it. Secondly, to compare the operation of a transformer to that of a power supply, circuit breaker, inverter, or battery charger is incorrect. Each of these devices has a mechanism to dynamically control the relationship between the input and output and as such each of these are truly active devices. A transformer is a passive device, and the relationship between the input and output is fixed. Thirdly, to

represent that the health and operational capability of a transformer can be consistently and reliably determined by “*Trending electrical parameters measured during transformer surveillance and maintenance such as Doble test results, and advanced monitoring methods such as infrared thermography, and electrical circuit characterization and diagnosis*” simply does not agree with the actual failure rate of these transformers. As I have outlined, there are numerous conditions of the transformer that can not be accurately determine by surveillance and on line maintenance or trending. Mr. Craig’s conclusion at the end of the quoted paragraph is based on incorrect information and, in my opinion, is wrong.

In general, Mr. Craig conflates properties of the transformer and properties of the power being transformed (voltage and current) by the transformer. Contrary to Mr. Craig’s assertion, the properties of the transformer are fixed, e.g., the geometrical and physical characteristics of the transformers core and coil. The power passing through the transformer may change, but its characteristics are established by the voltage applied to the primary and the load being supplied with power on the secondary. Both the applied voltage and the load being supplied are completely separate from the transformer.

In paragraph 37, Mr. Craig points out that since 1997 the NRC has taken the position that the transformer are not subject to AMR. This position has been subsequently repeated on numerous occasions since. I would suggest that repeating a mistake does not tend to make that mistake any less erroneous.

7.4 Documents Produced by Entergy

I have reviewed various documents, which Entergy has produced in this proceeding and that are related to its maintenance program for transformers. These reports show that contrary to what it has asserted in its pleadings that Entergy’s maintenance routines cannot evaluate the effects of every type of age related degradation in transformers.

For example, several Entergy owned transformers employ the GE DynaComp clamp; the clamp holds the internal winding in place, and severe degradation of the clamp could lead to fault conditions that end in catastrophic failure. See June 26, 2007 Email String re Status of Regions Single Point Vulnerable Transformers (IPEC00071760). In order to predict failure, Entergy must perform internal inspection, because the other techniques that Entergy includes in its monitoring program will not be able to predict whether the clamp fails. Internal inspections, however, were not part of the regularly scheduled maintenance and were only done when the transformer had already been drained for another reason. *Id.* Even discovering which transformers contained this susceptible clamp requires internal inspection. *Id.* In another instance, Entergy Staff concluded that “dissolved gas

analysis and other PM maintenance tasks are not sufficient to identify all non-random degradation mechanisms internal to the transformer since no indication of this degradation mechanism was observable with existing maintenance.” *Id.* These examples are illustrative of the fact that, as I describe above, age related degradation in transformers is not readily monitorable, but instead requires invasive, expensive and time consuming procedures.

8. Conclusion

Entergy’s argument is technically inaccurate. The transformer is a static device as defined by the IEEE and its Transformers Committee. A transformer does not change its configuration nor its properties when it is performing its intended operation. Neither the physical and electrical configuration nor physical and electrical properties of a transformer change while it is operating. Because the transformer is a static device, age related degradation in the transformer is not readily monitorable. Rather detection of age related degradation in transformers requires a continual surveillance program comprise of various techniques conducted both while the transformer is operating and while it is offline. These facts about the transformer, as well as the similarity of the transformer to components for which the NRC requires an aging management program, indicate that the transformer is precisely the kind of component which would benefit from a rigorous aging management program.

December 9, 2011

Watervliet, New York

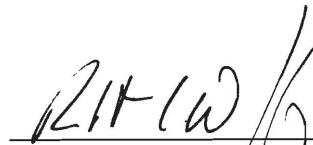

Robert C. Degeneff, D. Eng.
70 Cohoes Road
Watervliet, New York 12189

References

Blume, Transformer Engineering, Chapter 1, page 1, General Electric Co., 1938 (1st Edition), 1951 (2d Edition)

Flanagan, The Handbook of Transformer Design & Application (2d Edition) page 1.1, McGraw-Hill 1993, ISBN 0-07-021291-0

Harlow, Electric Power Transformer Engineering, page 2-1, CRC Press (2004) ISBN 0-8493-1704-5

Harlow, Electric Power Transformer Engineering, page 2-1 (2d Edition) CRC Press (2007) ISBN 0-8493-9186-5

IEEE Standard Dictionary of Electrical and Electronic Terms, IEEE Std 100-1996 (6th Edition), page 1131, ISBN 1-55937-833-6 (1996)

Indian Point UFSAR, Indian Point Unit 2, Chapter 8, Electrical Systems (submitted with license renewal application) (2007)

Indian Point UFSAR, Indian Point Unit 2, figure 8.2-1, 8.2-2 (electrical system drawing) (2007)

Indian Point UFSAR, Indian Point Unit 3, Chapter 8, Electrical Systems (submitted with license renewal application) (2007)

Indian Point No.3 Nuclear Power Plant, Electrical Distribution & Transmission System, DWG NO 9321-F-33853, REV 17 (electrical system drawing) (dated: 2/29/2008) ADAMS ML090400895

NRC Information Notice 2009-10, Transformer Failures - Recent Operating Experience, July 7, 2009, ADAMS ML090540218

EPRI report, EPRI Life Cycle Management Planning Sourcebooks, Volume 4, Large Power Transformers, [1007422], March 2003

EPRI report, Plant Support Engineering: Large Transformer End-of-Expected-Life Considerations and the Need for Planning [1013566], December 2006

IEEE report, IEEE Guide for the Evaluation and Reconditioning of Liquid Immersed Power Transformers [C57.140TM-2006], April, 2007

Sandia National Laboratories report, Aging Management Guideline for Commercial Nuclear Power Plants Power and Distribution Transformers, SAND93-7068 • UC-523, Unlimited Release, May 1994

NUREG/CR-5753, Aging of Safety Class Transformers in Safety Systems of Nuclear Power Plants (Feb. 1996)

Nuclear Power Plant License Renewal; Revisions, 60 Fed. Reg. 22,461 (May 8, 1995)

Preliminary Notification of Event or Unusual Occurrence (PNO-III-11-012A), Perry Nuclear Power Plant, Docket No. 50-440, License No. NPF-58, Perry Unplanned Shutdown Greater than 72 Hours (Update) (Oct. 19, 2011) (ML11292A119)

Preliminary Notification of Event or Unusual Occurrence (PNO-III-11-015A), Monticello Nuclear Generating Plant, Unplanned Shutdown Greater Than 72 Hours Due to a Loss of the Auxiliary Power Transformer (Update) (Oct. 28, 2011) (ML11301A217)

Pacific Gas and Electric Company (PG&E Letter DCL-08-089), Licensee Event Report 2-2008-001-00, Reactor Trip Due to Main Electrical Transformer Failure, Diablo Canyon Unit 2, Docket No. 50-323, OL-DPR-82 (Oct. 15, 2008) (ML082970221)

Exelon Nuclear (RA-09-008), Oyster Creek Nuclear Generating Station, Facility Operating License No. DPR-16, NRC Docket No. 50-219, Licensee Event Report 2008-001-00, Automatic Reactor Shutdown Caused by Main Transformer Failure (Jan. 21, 2009) (ML090260082)

Exelon Nuclear (RA-09-026), Licensee Event Report 2009-001-00, Automatic Reactor Shutdown Caused by Main Transformer Failure, Oyster Creek Nuclear Generating Station, Facility Operating License No. DPR-16, NRC Docket No. 50-219 (Mar. 31, 2009) (ML090970735)

Exelon Nuclear, Licensee Event Report 09-001-00, Automatic Reactor Scram Due to Failure of Main Power Transformer Surge Arrestor, LaSalle County Station Unit 1, Facility Operating License No. 11, NRC Docket No. 50-373 (Jul. 20, 2009) (ML092020179)

Luminant Power (CP-201000074, Log # TXX-10010), Licensee Event Report 445/10-001-00, Trip Due to Pressure Relay Actuation on Main Transformer 01, Comanche Peak Nuclear Power Plant Unit 1, Docket No. 50-445 (Mar. 3, 2010) (ML100740293)

DTE Energy (NRC-10-0043), Licensee Event Report 2010-001, Automatic Reactor Shutdown Due to Generator Current Transformer Wiring Failure, Fermi 2, NRC License No. NPF-43, NRC Docket No. 50-341 (May 19, 2010) (ML101400553)

PSEG Nuclear LLC (LR-N10-0320), Licensee Event Report 272/2010-002, Automatic Reactor Trip Due to Main Power Transformer Bushing Failure, Salem Nuclear Generating Station Unit 1, Facility Operating License No. DPR-70, NRC Docket No. 50-272 (Sept. 2, 2010) (ML102780502)

Event Notification Report, Watts Bar Unit 1, Manual Reactor Trip Due to Loss of Cooling to the "A" Phase Main Bank Transformer, Event Number: 46418, Notification Date: 11/14/2010

FPL (L-2010-272), Licensee Event Report 2010-003-00, Reactor Trip Due to Fault on 230kV Side of Generator Step-Up Transformer, Turkey Point Unit 3, NRC Docket No. 50-250 (Nov. 19, 2010)(ML103340517)

Entergy (NL-11-005), Licensee Event Report 2010-009-00, Automatic Reactor Trip Due to a Turbine Generator Trip Caused by a Fault of the 21 Main Transformer Phase B High Voltage Bushing, Indian Point Unit No. 2, NRC Docket No. 50-247, DPR-26 (Jan. 18, 2011) (ML110280013)

Exelon Nuclear (RA11-013), Licensee Event Report 2011-001-00, Automatic Reactor Scram Due to Main Power Transformer "C" Phase Electrical Fault, LaSalle County Station Unit 1, Facility Operating License No. NPF-11, NRC Docket No. 50-373 (Mar. 25, 2011) (ML110890949)

Email String; June 26, 2007 8:24 AM; Subject: Status of Regions Single Point Vulnerable Transformers; From: R.R. Davis; To: D.P. Wiles, M.A. Krupa, C. Reasoner, and K.D. Nichols; CC: K.A. Jelks, M.A. Wood, G.S. Matharu, R.T. Giguere, S. Saunders; June 26, 2007 3:12 PM; Subject: FW: Status of Regions Single Point Vulnerable Transformers; Attachments: SPF Transformer writeup.doc, EN GSU Evaluation FINAL 6-25-2007.doc; From: R.R. Davis; To: R.A. Penny (IPEC00071760)

EN Large Power Transformer Status (IPEC00071765)

Nuclear Energy Agency, *Operating Experience Report: Recent Failures of Large Oil-Filled Transformers*, NEA/CRNA/R(2011)6 (Mar. 14, 2011)

COMPARISON OF VARIOUS STRUCTURES AND COMPONENTS

Component	Moving Parts	Change In Configuration/ Properties¹	Change In State²	Active or Passive	Included, Excluded In 10 CFR 54.21
Reactor vessel	No	No	No	Passive	Included
Reactor coolant system pressure boundary	No	No	No	Passive	Included
Steam generators	No	No	No	Passive	Included
Pressurizer	No	No	No	Passive	Included
Piping	No	No	No	Passive	Included
Pump Casings	No	No	No	Passive	Included
Valve Bodies	No	No	No	Passive	Included
Core Shroud	No	No	No	Passive	Included
Component Supports	No	No	No	Passive	Included
Pressure Retaining Boundaries	No	No	No	Passive	Included
Heat Exchangers	No	No	No	Passive	Included
Ventilation Ducts	No	No	No	Passive	Included
Containment and Liner Penetrations	No	No	No	Passive	Included
Equipment Hatches	No	No	No	Passive	Included
Seismic Structures	No	No	No	Passive	Included
Cable Trays	No	No	No	Passive	Included
Cables and Connectors	No	No	No	Passive	Included
Electrical Cabinets	No	No	No	Passive	Included
Pumps (except casings)	Yes	Yes	Yes	Active	Excluded
Valves (except bodies)	Yes	Yes	Yes	Active	Excluded
Motors	Yes	Yes	Yes	Active	Excluded
Diesel Generators	Yes	Yes	Yes	Active	Excluded
Air Compressors	Yes	Yes	Yes	Active	Excluded
Snubbers	Yes	No	Yes	Active	Excluded
Control Rod Drive	Yes	Yes	Yes	Active	Excluded
Ventilation Dampers	Yes	Yes	Yes	Active	Excluded
Pressure Transmitters³	Yes	N.A.	Yes	Active ⁴	Excluded
Pressure Indicators	Yes	N.A.	Yes	Active	Excluded
Water Level Indicators	Yes	N.A.	Yes	Active	Excluded
Switchgears	Yes	Yes	Yes	Active	Excluded
Cooling Fans	Yes	Yes	Yes	Active	Excluded
Transistors	No	Yes	Yes	Active	Excluded
Batteries	No	N.A.	Yes	Active	Excluded
Breakers	Yes	Yes	Yes	Active	Excluded

Report of Dr. Robert C. Degeneff
Submitted with Pre-Filed Testimony
Contention NYS-8

Component	Moving Parts	Change In Configuration/ Properties¹	Change In State²	Active or Passive	Included, Excluded In 10 CFR 54.21
Relays	Yes ⁵	Yes	Yes	Active	Excluded
Switches	Yes	Yes	Yes	Active	Excluded
Power Inverters	No	Yes	Yes	Active ⁶	Excluded
Circuit Boards	No	Yes	Yes	Active ⁷	Excluded
Battery Chargers	No	Yes	Yes	Active ⁸	Excluded
Power Supplies	No	No	Yes	Active ⁹	Excluded
Transformers	No	No	No	Passive	Neither Included nor Excluded
Heaters	No	No	No	Passive	Neither Included nor Excluded
Lamps (incandescent)	No	No	No	Passive	Neither Included nor Excluded
Lamps (LED)	No	Yes	Yes	Active ¹⁰	Neither Included nor Excluded
Lamps (CFL)	No	Yes	Yes	Active ¹¹	Neither Included nor Excluded
Fuses	No	No	Yes ¹²	Active	Neither Included nor Excluded
Resistors Capacitors Inductors	No	No	No	Passive	Neither Included nor Excluded

Table Endnotes:

-
- ¹ Change in configuration occurs only with an external energy source applied.
- ² Final Rule, Nuclear Power Plant License Renewal; Revisions, 60 Fed. Reg. 22,461, 22,477 (May 8, 1995): "Further, the Commission has concluded that 'a change in configuration or properties,' should be interpreted to include 'a change in state,' which is a term sometimes found in the literature relating to 'passive.'"
- ³ Pressure and level transmitters may or may not contain moving parts. Solid state indicators (LEDs or plasma) contain no moving parts; however, they do contain solid state devices such as transistors.
- ⁴ Most process transmitters and indicators (level, flow, pressure) contain either moving parts or transistors (solid state devices) and are considered "active."
- ⁵ Solid state relays and switches do not contain moving parts; however, they are considered active based upon the Commission's SOC related to transistors.
- ⁶ Power inverters employ solid state and other active devices to convert DC power to AC power. Power output may be controlled by external inputs.
- ⁷ Circuit boards are assumed for the purpose of this discussion to contain active components such as transistors and other solid state devices.
- ⁸ Battery chargers convert AC voltages and currents to DC using solid state active devices such as transistors and rectifiers. Power output may be controlled by external inputs.
- ⁹ Power supplies convert AC voltages and currents to DC regulated voltages using solid state active devices such as transistors and rectifiers.
- ¹⁰ Light Emitting Diodes (LEDs) change state (conductance) when a voltage is applied. State is determined by the polarity of the applied voltage.
- ¹¹ Compact Fluorescent Lights (CFL) lamps contain active devices such as diodes and transistors and may also contain passive devices including transformers.
- ¹² In order to perform their intended function, fuses undergo a change of state (conductance).