



Nuclear

BFN Fire Risk Reduction and NFPA 805 Transition Update



November 8, 2012



Nuclear

Agenda

- Purpose Joe Shea
- Previously Committed Modifications Joe Williams
- Major Objectives of NFPA 805 Transition Project Joe Williams
- Overall BFN NFPA 805 Project Status Joe Williams
- Fire PRA Overview Ching Guey/Todd Stafford
- NFPA 805 Modifications Brenda Simril
- License Amendment Request (LAR) Development Status Brenda Simril
- Closing Joe Shea



Nuclear

PURPOSE

- Provide update to the NRC on the TVA status of completion of modifications discussed in February 17, 2012 letter
- Describe overall NFPA-805 project status
- Describe Fire PRA status and details
- Discuss modifications identified for NFPA 805 transition (as of November 2, 2012)
- Describe detailed information regarding key elements of LAR



Nuclear

Modifications Described in February 2012 TVA Letter

- Purpose of February 17, 2012 TVA Letter:
 - Identify Modifications to BFN whose completion will:
 - Achieve significant reduction in fire risk in advance of NFPA 805 transition
 - Reduce the number of time-critical Operator Manual Actions required to implement the current safe shutdown strategy
- Modifications from February 17 letter completed to date are shown on the following slides



Nuclear

Modifications Completed Prior To February 2012 TVA Letter

DCN # / Stage #	Description	Basis for Modification	Completion Date
69786/S1	Removed power from the Condensate Storage Tank (CST) supply and return valves to the High Pressure Coolant Injection System (HPCI) and the Reactor Core Isolation Cooling System (RCIC) to prevent spurious closure. 1-FCV-002-0170 & 0171 2-FCV-002-0162 & 0163 3-FCV-002-0166 & 0167	In the event of a fire in Fire Area (FA) 26 (Turbine Building), this modification eliminated the requirement to switch HPCI or RCIC suction to the Suppression pool and increases the availability of the CSTs as makeup source.	9/23/10
69786/S2	Deleted requirements to manually start Unit 3 Diesel Auxiliary Board room fans by crediting automatic start capability 3-FAN-030-0243 and 3-FAN-030-0244	In the event of a fire in numerous FAs, this analysis eliminated OMAs to start the fans locally.	9/23/10
69786/S4	Changed Breaker 710 on Battery Board 3 to be normally OPEN.	In the event of a fire in numerous FAs, this modification eliminated OMAs that were required to open breaker 710 to limit battery loading.	9/23/10
70011	Installed incipient fire detection in 250V Reactor Motor Operated Valve (RMOV) Board 1A Sections 1-6	In the event of a fire in the 250V RMOV Board 1A Sections 1-6 (FA 5), cable trays located directly above this ignition source impact safe shutdown. The incipient detection system reduces the probability of a serious fire from this source.	3/31/11
70019	Installed cable tray bottom covers in selected areas where redundant divisions are in close proximity above Unit 1, 2, and 3 Electrical Board Rooms on Reactor Building Elevation 593'.	The cable tray covers delay cable tray ignition for at least 20 minutes and increase the probability that a cable tray fire will be suppressed prior to its spreading to other trays.	4/4/11



Nuclear

Modifications Completed Prior To February 2012 TVA Letter

DCN # / Stage #	Description	Basis for Modification	Completion Date
69957	Installed a 3 hour fire barrier between the Turbine Building and Intake structure tunnel separating the Intake and the Turbine Building into separate fire areas	Installation of the barrier provided additional divisional separation which allowed for a general revision to the Safe SSIs for the Intake and Turbine Building fire areas (FAs 25 and 26). This revision eliminated operator actions which were no longer required and abandoned the Self Induced Station Blackout (SISBO) strategy used previously, in these FAs.	10/28/11
70434/S1	Install fuses in ammeter circuit for Battery Board 1.	In the event of fire damage to cables between Battery Board 1 and the Control Room, multiple hot shorts could cause the ammeter cables to auto ignite and spread the fire to other areas.	12/23/11
70434/S5	Install fuses in ammeter circuit for Battery Board 5.	In the event of fire damage to cables between Battery Board 5 and the Control Room, multiple hot shorts could cause the ammeter cables to auto ignite and spread the fire to other areas.	12/23/11



Nuclear

Completed Modifications Committed to in February 2012 TVA Letter

DCN # / Stage #	Description	Basis for Modification	Commitment Date/Status
70434/S3	Install fuses in ammeter circuit for Battery Board 3.	In the event of fire damage to cables between Battery Board 3 and the Control Room, multiple hot shorts could cause the ammeter cables to auto ignite and spread the fire to other areas.	9/16/12 Complete
70434/S4	Install fuses in ammeter circuit for Battery Board 4.	In the event of fire damage to cables between Battery Board 4 and the Control Room, multiple hot shorts could cause the ammeter cables to auto ignite and spread the fire to other areas.	6/22/12 Complete
70434/S6	Install fuses in ammeter circuit for Battery Board 6.	In the event of fire damage to cables between Battery Board 6 and the Control Room, multiple hot shorts could cause the ammeter cables to auto ignite and spread the fire to other areas.	4/6/12 Complete
70054	Install controls in the Main Control Room to isolate 4kV Shutdown Board 3EC from fire damage in 4kV Shutdown Board 3EA.	In the event of a fire in FA 22 (4kV Shutdown Board Room 3EA and 3EB), OMAs are currently required at 4kV Shutdown Board 3EC to isolate control circuit faults and operate switchgear locally. Local actions are in the vicinity of the fire and may be hampered by smoke and firefighting activities. The modification will eliminate the need for the OMAs.	Prior to restart from Unit 3 Refueling outage 15 (Spring 2012) Complete
70490/S1	Isolate and abandon local control station for Residual Heat Removal Service Water (RHRSW) Pump A3.	In the event of a fire in FAs 25-1 and 25-2 (Intake Structure), 2 OMAs are currently required at 4kV Shutdown Board 3EA to isolate control circuit faults and operate the switchgear locally. The modification will eliminate the need for the OMAs.	1/11/13 Complete
70490/S2	Isolate and abandon local control station for RHRSW Pump B1.	In the event of a fire in FA 25-1(Intake Structure), an OMA is currently required at 4kV Shutdown Board 3EC to isolate control circuit faults and operate the switchgear locally. The modification will eliminate the need for this OMA.	10/12/12 Complete



Nuclear

Completed Modifications Committed to in February 2012 TVA Letter

DCN # / Stage #	Description	Basis for Modification	Commitment Date/Status
70490/S3	Isolate and abandon local control station for RHRSW Pump B2.	In the event of a fire in FA 25-1 (Intake Structure), an OMA is currently required at 4kV Shutdown Board C to isolate control circuit faults and operate the switchgear locally. The modification will eliminate the need for this OMA.	12/14/12 Complete
70490/S4	Isolate and abandon local control station for RHRSW Pump B3.	In the event of a fire in FA 25-1 (Intake Structure), an OMA is currently required at 4kV Shutdown Board C to isolate control circuit faults and operate the switchgear locally. The modification will eliminate the need for this OMA.	12/14/12 Complete
70490/S5	Isolate and abandon local control station for RHRSW Pump C1.	In the event of a fire in FAs 25-1, 25-3 (Intake Structure) and 26 (Turbine Building), 3 OMAs are currently required at 4kV Shutdown Board B to isolate control circuit faults and operate the switchgear locally. The modification will eliminate the need for the OMAs.	1/4/13 Complete
70490/S6	Isolate and abandon local control station for RHRSW Pump C2.	In the event of a fire in FAs 25-1, 25-3 (Intake Structure), and 26 (Turbine Building), 3 OMAs are currently required at 4kV Shutdown Board B to isolate control circuit faults and operate the switchgear locally. The modification will eliminate the need for the OMAs.	3/1/13 Complete
70490/S7	Isolate and abandon local control station for RHRSW Pump C3.	In the event of a fire in FAs 25-1 and 25-3 (Intake Structure), 2 OMAs are currently required at 4kV Shutdown Board 3EB to isolate control circuit faults and operate the switchgear locally. The modification will eliminate the need for the OMAs.	3/1/13 Complete
70490/S10	Isolate and abandon local control station for RHRSW Pump D3.	In the event of a fire in FA 25-1 (Intake Structure), an OMA is currently required at 4kV Shutdown Board D to isolate control circuit faults and operate the switchgear locally. The modification will eliminate the need for this OMA.	12/14/12 Complete



Nuclear

Modification Breakdown By Type

Protect or Reroute Cables	26 Design Changes/39 Stages
Fusing of Associated Circuits	7 Design Changes/91 Stages
Circuit Protection and Coordination	2 Design Changes/~150 Stages
Interposing Relays for Circuit Isolation	3 Design Changes/18 Stages
Isolation Switches	7 Design Changes/27 Stages
Prevent Spurious Valve Operation	9 Design Changes/28 Stages
Eliminate Unnecessary Circuits/ Functions	8 Design Changes/54 Stages
New Logic Inhibit Switches	4 Design Changes/24 Stages
Fire Protection System Enhancement	5 Design Changes/11 Stages
New High Pressure Injection Pump and backup diesel generator	1 Design Change/3 Stages
Mechanical Isolation	2 Design Changes/12 Stages



Nuclear

Safe Shutdown Pump System Conceptual Flow Diagram

Safe Shutdown Pump System Conceptual Flow Diagram

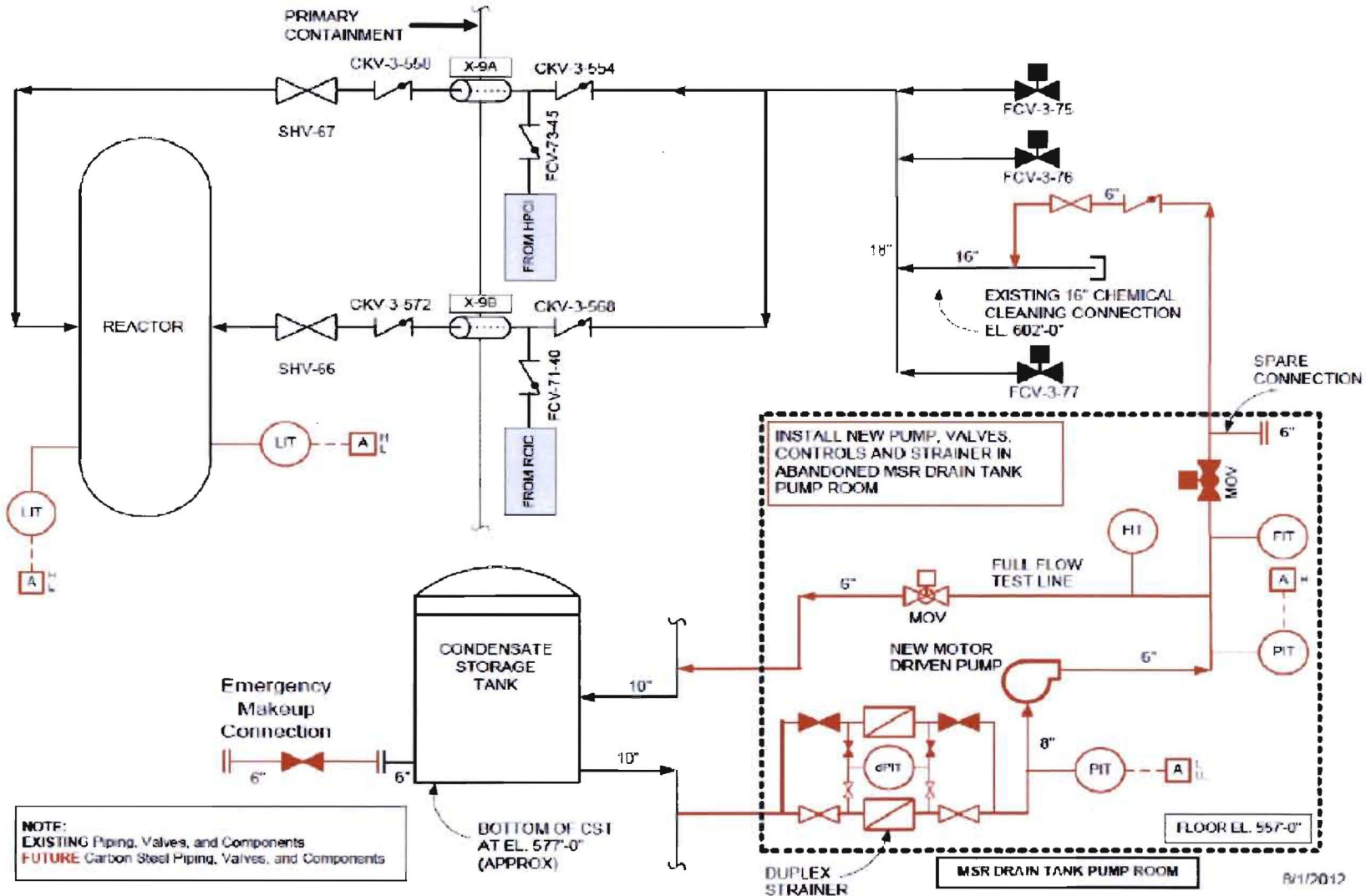



Nuclear

Modification Status

- Design and Installation is in progress
 - 52 Design Changes in Conceptual Design Phase
 - 8 Design Changes in Progress
 - 13 Design Changes Completed Awaiting Installation
 - 1 Design Change/21 Stages installed
- All modifications will be described in summary detail in the LAR



Nuclear

License Amendment Request (LAR) Overview

- LAR submittal package uses NEI LAR Template Rev 10 and additional generic RAIs and lessons learned from plant specific RAIs
- Includes standard components
 - Description of existing fire protection licensing basis
 - Discussion of transition process
 - Compliance with NFPA 805 requirements
 - Fundamental Fire Protection Program and Design Elements
 - Nuclear Safety Capability Assessment (NSCA)
 - Non-Power Operational Modes
 - Radioactive Release Performance Criteria
 - Fire PRA and Performance-Based Approaches
 - Monitoring Program
 - Program Documentation, Configuration Control, and Quality Assurance
 - Regulatory Evaluation
 - References
 - Standard Attachments (e.g., B-1, B-2, B-3 tables)



Nuclear

Closing

- TVA is strongly committed to reducing fire risk at BFN
- TVA is committed to strategy of parallel plant modification and NFPA 805 application development
 - Modifications are progressing consistent with the schedule captured in the TVA commitment letter of February 17, 2012
- BFN NFPA 805 License Amendment is on track for submittal no later than March 29, 2013