

B-403

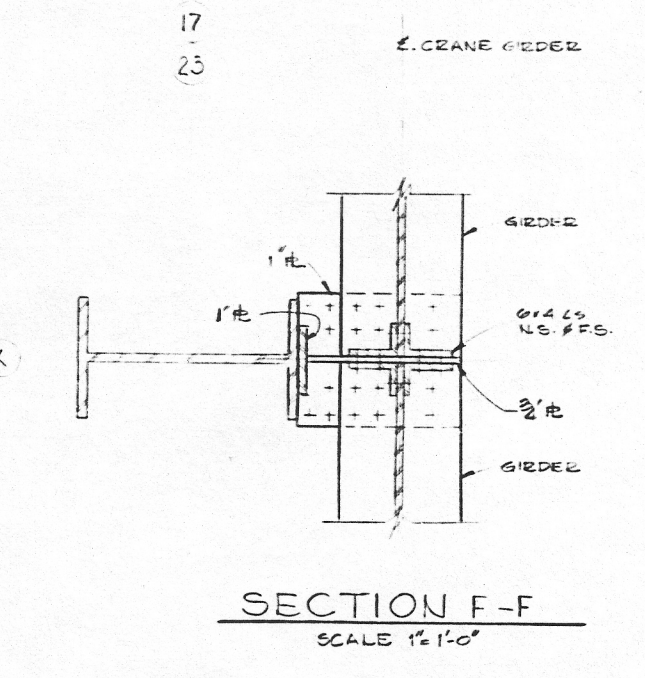

DETAIL 'A' SCALE 1/2" = 1'-0"

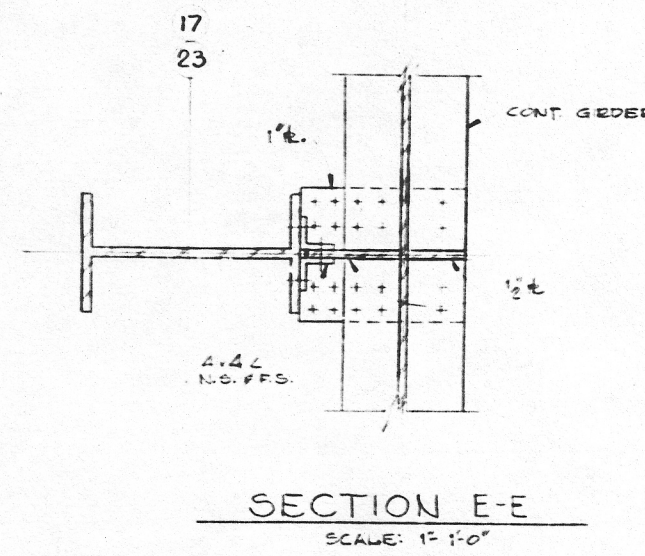
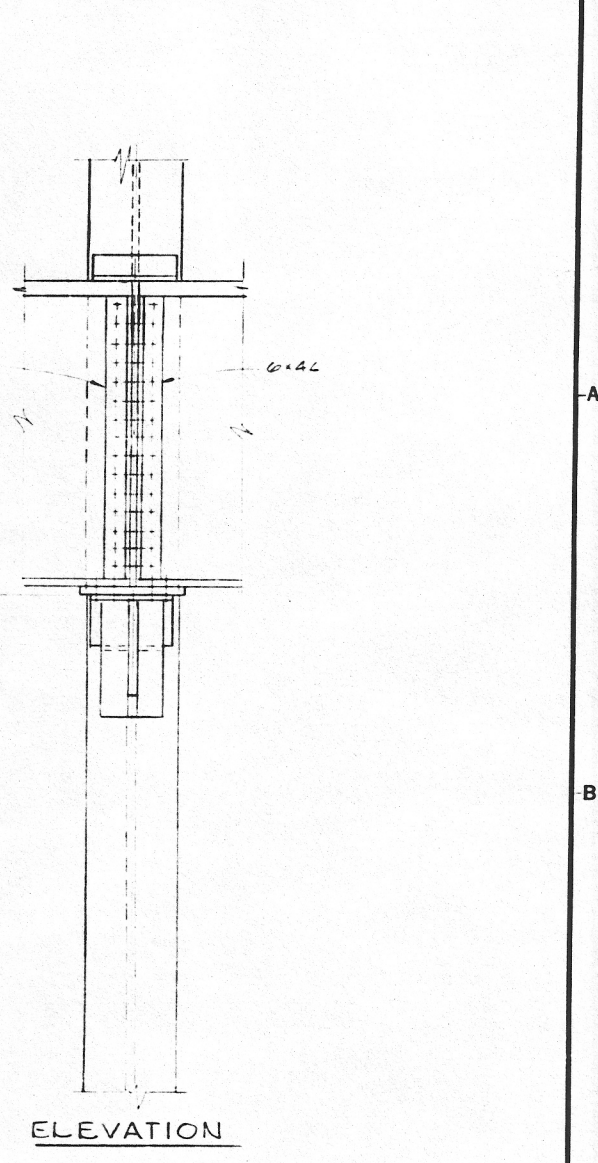
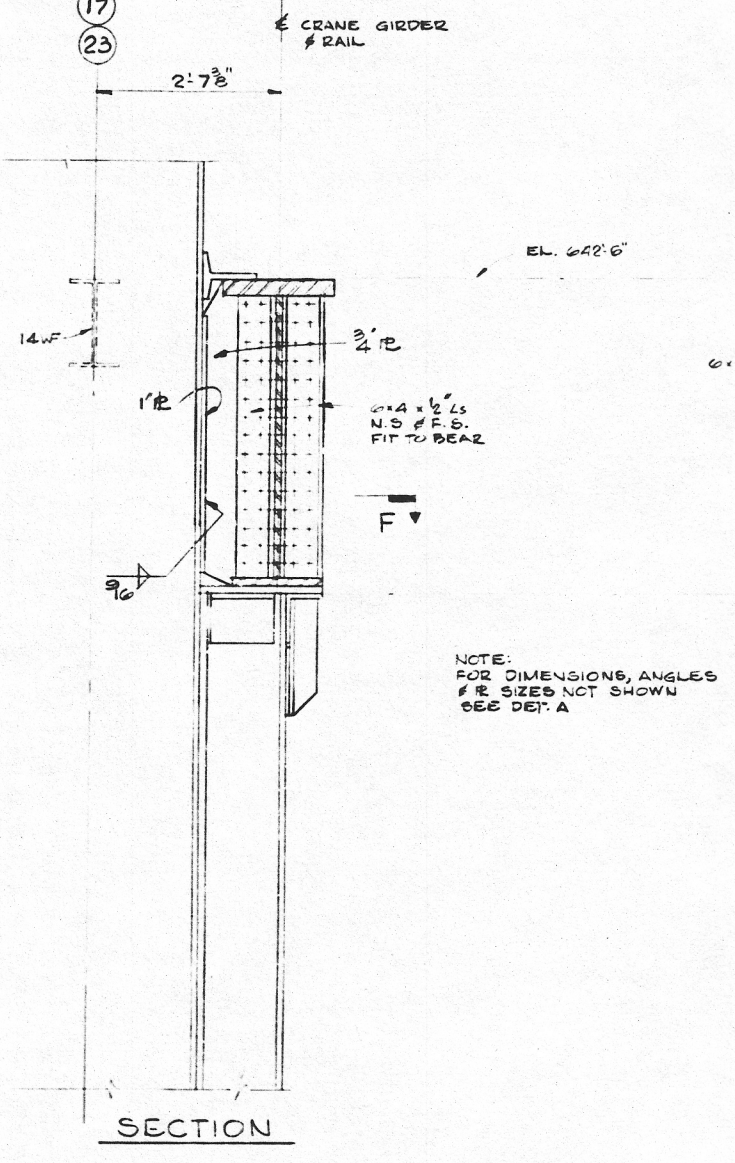
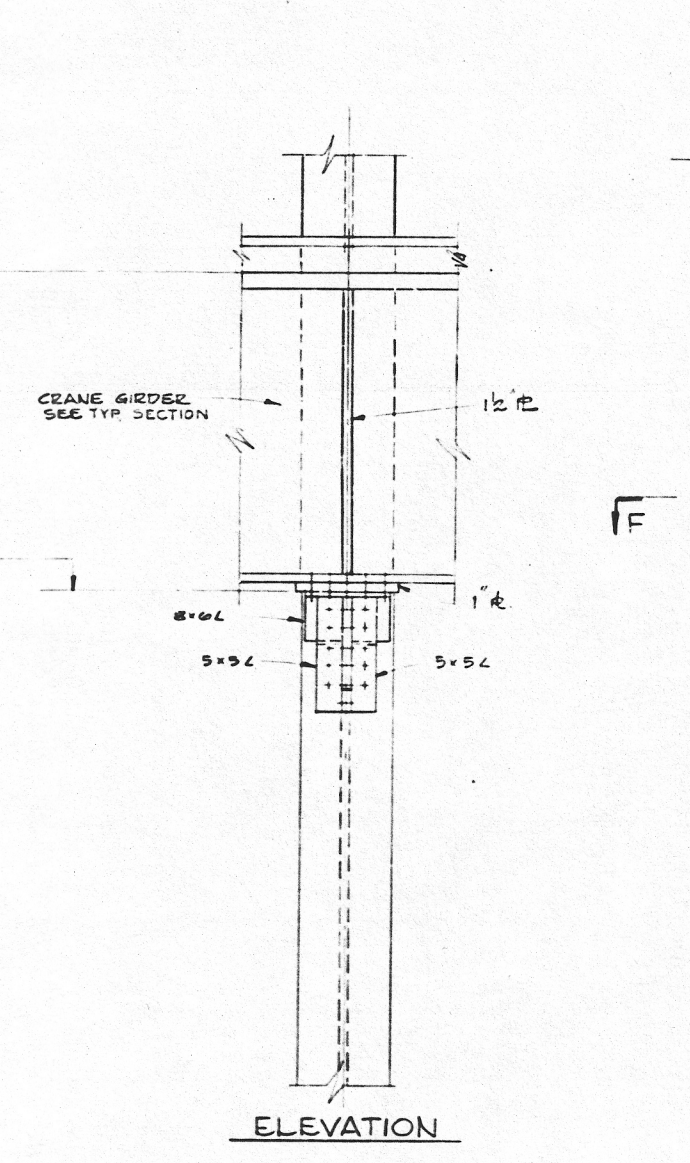
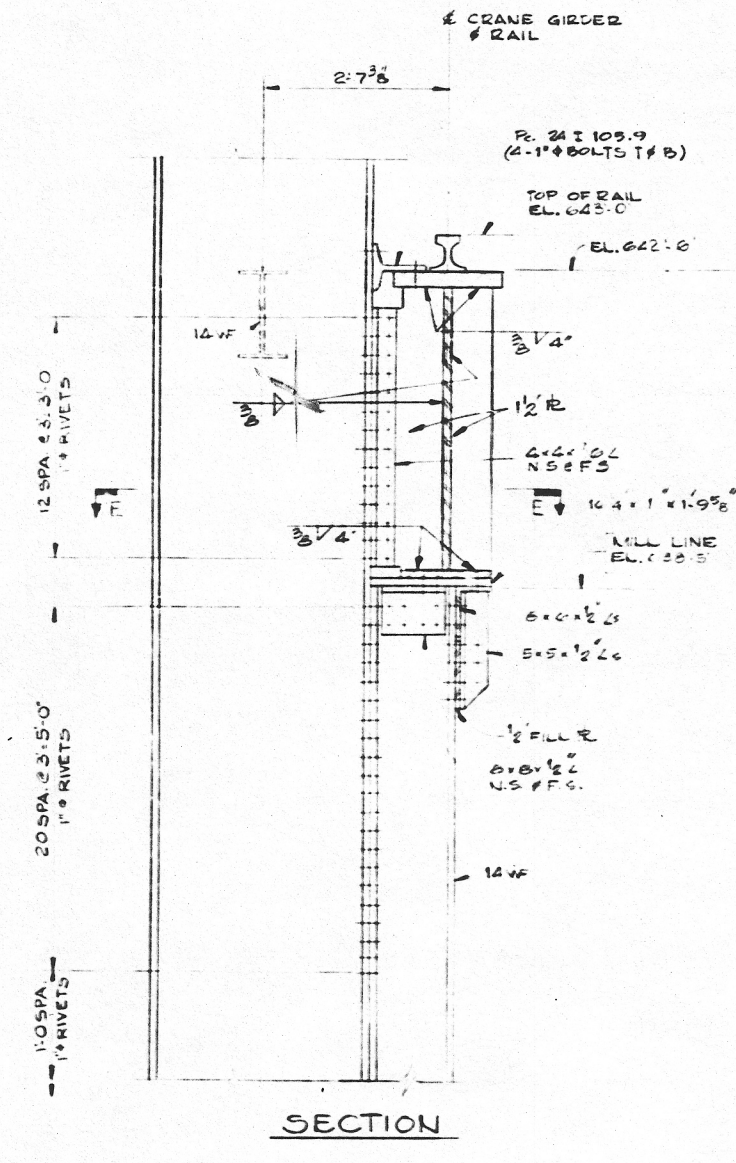
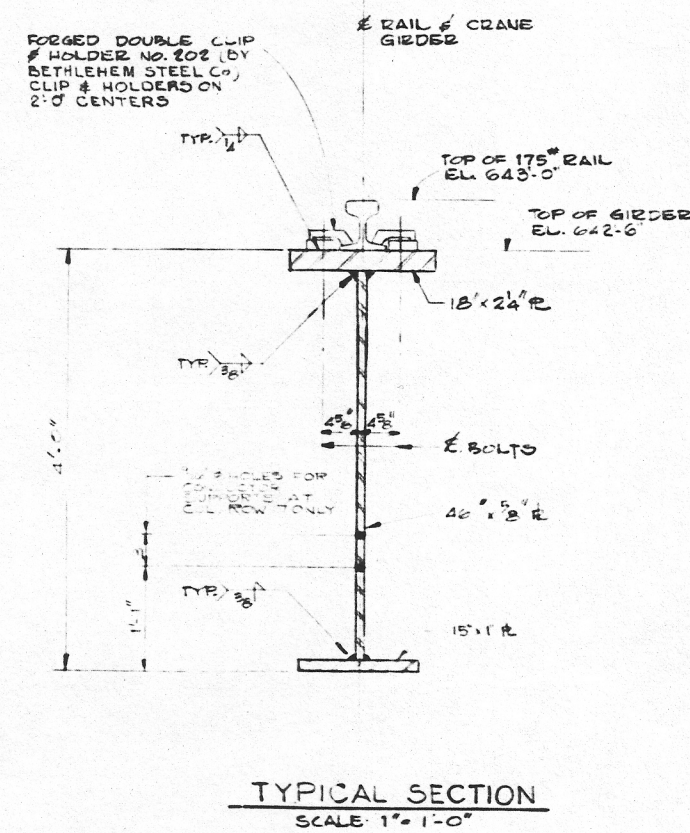
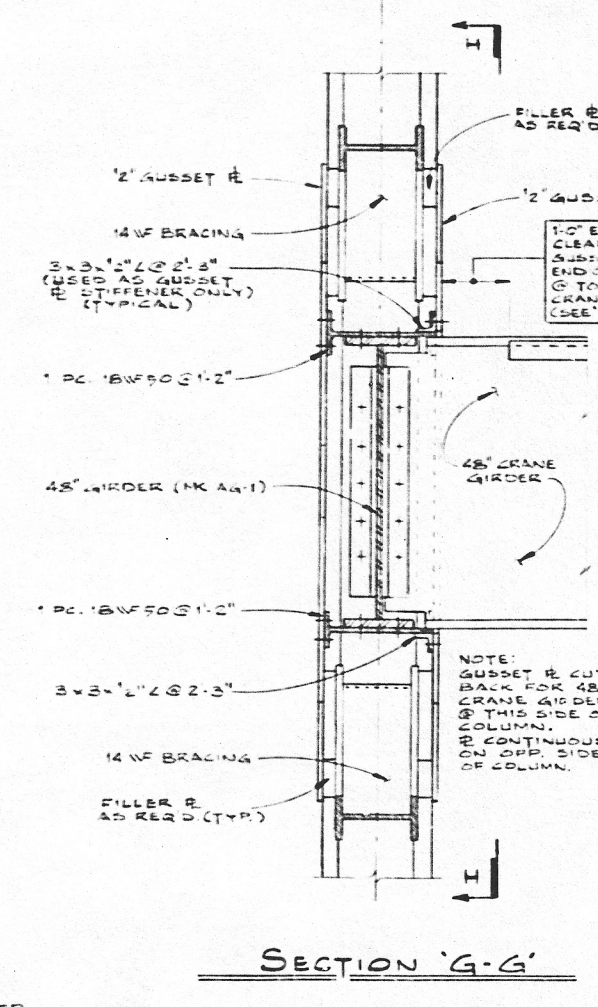

DETAIL 'B' SCALE 1/2" = 1'-0"

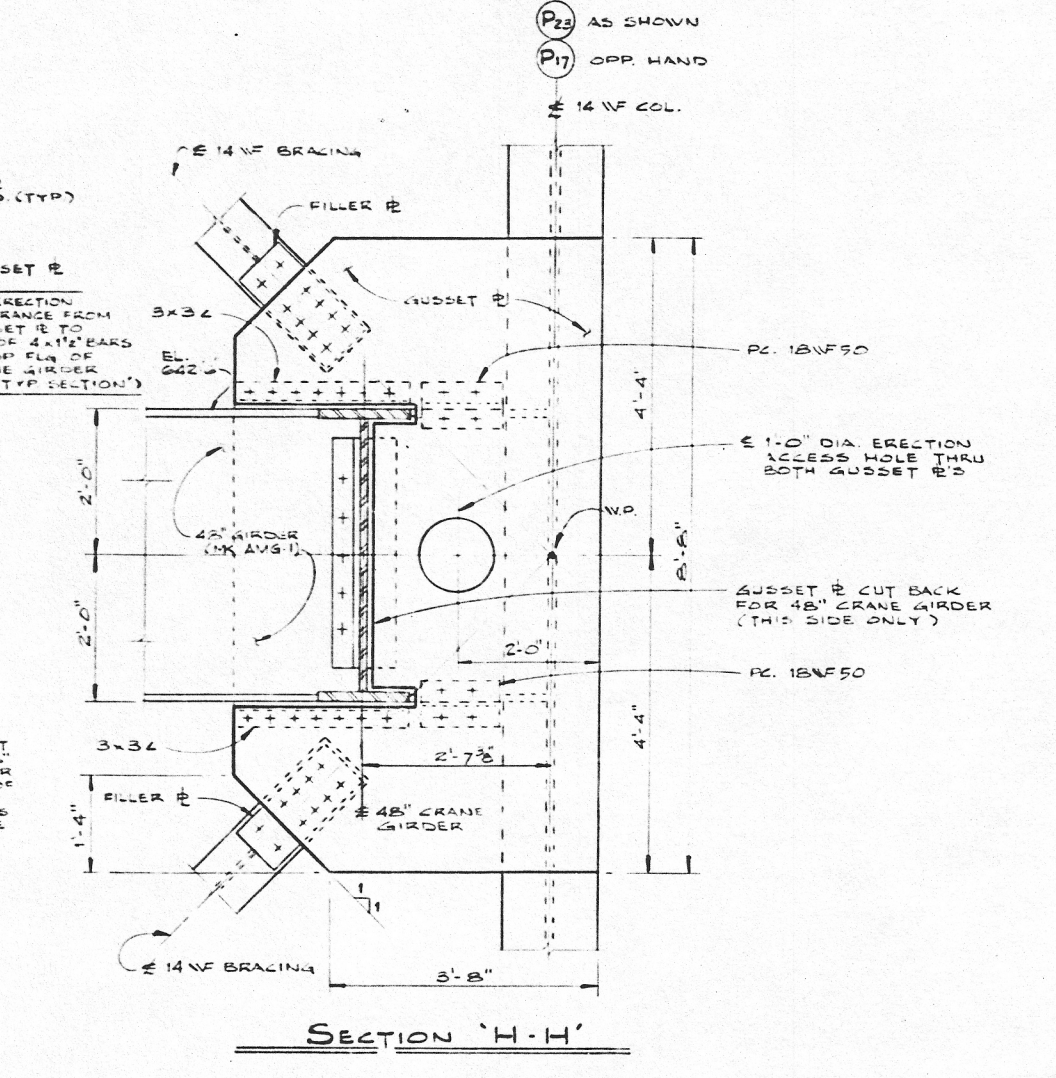

SECTION 'G-G' SCALE 1/2" = 1'-0"

SECTION 'H-H' SCALE 1/2" = 1'-0"

DETAIL 'C' SCALE 1/2" = 1'-0"

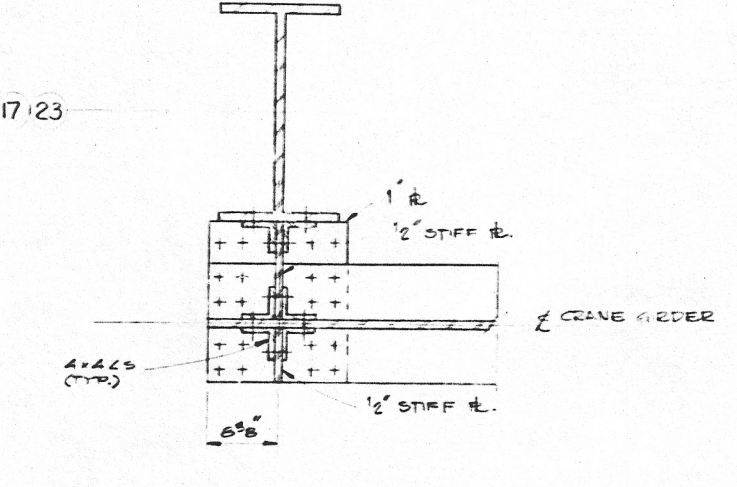

NOTES

1 FOR GENERAL NOTES SEE DWG. B-2B3

REFERENCE DRAWINGS

B-402 FUEL-HOLD-BLOCK CRANE GIRDER CAL. PLAN

Rev.	Date	Description
1	7-3-60	ISSUED
2	7-3-60	REVISION
3	7-3-60	REVISION
4	7-3-60	REVISION
5	7-3-60	REVISION
6	7-3-60	REVISION
7	7-3-60	REVISION
8	7-3-60	REVISION
9	7-3-60	REVISION
10	7-3-60	REVISION
11	7-3-60	REVISION
12	7-3-60	REVISION
13	7-3-60	REVISION
14	7-3-60	REVISION
15	7-3-60	REVISION
16	7-3-60	REVISION
17	7-3-60	REVISION
18	7-3-60	REVISION
19	7-3-60	REVISION
20	7-3-60	REVISION
21	7-3-60	REVISION
22	7-3-60	REVISION
23	7-3-60	REVISION
24	7-3-60	REVISION
25	7-3-60	REVISION
26	7-3-60	REVISION
27	7-3-60	REVISION
28	7-3-60	REVISION
29	7-3-60	REVISION
30	7-3-60	REVISION
31	7-3-60	REVISION
32	7-3-60	REVISION
33	7-3-60	REVISION
34	7-3-60	REVISION
35	7-3-60	REVISION
36	7-3-60	REVISION
37	7-3-60	REVISION
38	7-3-60	REVISION
39	7-3-60	REVISION
40	7-3-60	REVISION
41	7-3-60	REVISION
42	7-3-60	REVISION
43	7-3-60	REVISION
44	7-3-60	REVISION
45	7-3-60	REVISION
46	7-3-60	REVISION
47	7-3-60	REVISION
48	7-3-60	REVISION
49	7-3-60	REVISION
50	7-3-60	REVISION

**FUEL HANDLING BUILDING
CRANE GIRDER SECTIONS & DETAILS
ZION STATION UNIT 1 & 2
COMMONWEALTH EDISON CO.
CHICAGO, ILLINOIS**

SARGENT & LUNDY
ENGINEERS
CHICAGO

SCALE: AS NOTED
DRAWN: J. BRADLEY
CHECKED: J. M. KRAVITZ
ENGINEER: J. M. KRAVITZ
DATE: 12-24-60

DRAWING NO.
B-403

D35