

RS-12-156

10 CFR 50.54(f)

October 25, 2012

U. S. Nuclear Regulatory Commission  
ATTN: Document Control Desk  
Washington, DC 20555-0001

Braidwood Station, Units 1 and 2  
Facility Operating License Nos. NPF-72 and NPF-77  
NRC Docket Nos. STN 50-456 and STN 50-457

Byron Station, Units 1 and 2  
Facility Operating License Nos. NPF-37 and NPF-66  
NRC Docket Nos. STN 50-454 and STN 50-455

Clinton Power Station, Unit 1  
Facility Operating License No. NPF-62  
NRC Docket No. 50-461

Dresden Nuclear Power Station, Units 2 and 3  
Renewed Facility Operating License Nos. DPR-19 and DPR-25  
NRC Docket Nos. 50-237 and 50-249

LaSalle County Station, Units 1 and 2  
Facility Operating License Nos. NPF-11 and NPF-18  
NRC Docket Nos. 50-373 and 50-374

Limerick Generating Station, Units 1 and 2  
Facility Operating License Nos. NPF-39 and NPF-85  
NRC Docket Nos. 50-352 and 50-353

Oyster Creek Nuclear Generating Station  
Renewed Facility Operating License No. DPR-16  
NRC Docket No. 50-219

Peach Bottom Atomic Power Station, Units 2 and 3  
Renewed Facility Operating License Nos. DPR-44 and DPR-56  
NRC Docket Nos. 50-277 and 50-278

Quad Cities Nuclear Power Station, Units 1 and 2  
Renewed Facility Operating License Nos. DPR-29 and DPR-30  
NRC Docket Nos. 50-254 and 50-265

Three Mile Island Nuclear Station, Unit 1  
Renewed Facility Operating License No. DPR-50  
NRC Docket No. 50-289

Subject: Exelon Generation Company, LLC 90-Day Response to NRC Bulletin 2012-01, "Design Vulnerability in Electric Power System"

Reference: NRC Bulletin 2012-01, "Design Vulnerability in Electric Power System," dated July 27, 2012

On July 27, 2012, the referenced NRC Bulletin 2012-01, "Design Vulnerability in Electric Power System," was issued to all holders of operating licenses and combined licenses for nuclear power reactors, except those who have permanently ceased operation and have certified that fuel has been removed from the reactor vessel. The Bulletin requested that all addresses submit a written response within 90 days in accordance with 10 CFR 50.54, "Conditions of licenses," paragraph (f). The Bulletin requested information to determine compliance with 10 CFR 50.55a(h)(2), "Protection systems," 10 CFR 50.55a(h)(3), "Safety systems," and Appendix A to 10 CFR Part 50, GDC 17, "Electric power systems," or equivalent principal design criteria as specified in licensee's Updated Final Safety Analysis Report.

Attachments 1 through 10 to this letter provide Exelon Generation Company, LLC's (EGC's) 90-day response to the requested information for each EGC nuclear operating station with the exception of the evaluation of high impedance grounds. An evaluation of vulnerabilities to high impedance grounds for the EGC nuclear operating fleet is contained in Attachment 11.

There are no regulatory commitments contained in this letter. Should you have any questions concerning this letter, please contact Mr. Mitchel Mathews at (630) 657-2819.

I declare under penalty of perjury that the foregoing is true and correct. Executed on the 25th day of October 2012.

Respectfully,

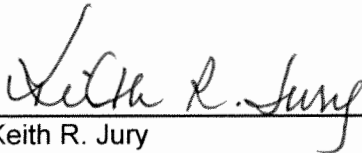

Keith R. Jury  
Vice President - Licensing and Regulatory Affairs  
Exelon Generation Company, LLC

Attachments:

1. Braidwood Station, Units 1 and 2, 90-Day Response to NRC Bulletin 2012-01, "Design Vulnerability in Electric Power System"
2. Byron Station, Units 1 and 2, 90-Day Response to NRC Bulletin 2012-01, "Design Vulnerability in Electric Power System"
3. Clinton Power Station, Unit 1, 90-Day Response to NRC Bulletin 2012-01, "Design Vulnerability in Electric Power System"

4. Dresden Nuclear Power Station, Units 2 and 3, 90-Day Response to NRC Bulletin 2012-01, "Design Vulnerability in Electric Power System"
5. LaSalle County Station, Units 1 and 2, 90-Day Response to NRC Bulletin 2012-01, "Design Vulnerability in Electric Power System"
6. Limerick Generating Station, Units 1 and 2, 90-Day Response to NRC Bulletin 2012-01, "Design Vulnerability in Electric Power System"
7. Oyster Creek Nuclear Generating Station, Unit 1, 90-Day Response to NRC Bulletin 2012-01, "Design Vulnerability in Electric Power System"
8. Peach Bottom Atomic Power Station, Units 2 and 3, 90-Day Response to NRC Bulletin 2012-01, "Design Vulnerability in Electric Power System"
9. Quad Cities Nuclear Power Station, Units 1 and 2, 90-Day Response to NRC Bulletin 2012-01, "Design Vulnerability in Electric Power System"
10. Three Mile Island Nuclear Station, Unit 1, 90-Day Response to NRC Bulletin 2012-01, "Design Vulnerability in Electric Power System"
11. Exelon Generation Company, LLC's Evaluation of the Effects of High Impedance Ground Faults

**ATTACHMENT 1**

**Braidwood Station, Units 1 and 2, 90-Day Response to NRC Bulletin 2012-01,  
"Design Vulnerability in Electric Power System"**

## ATTACHMENT 1

### Braidwood Station, Units 1 and 2 Response to NRC Bulletin 2012-01, "Design Vulnerability in Electric Power System"

#### High Impedance Grounds:

On January 30, 2012, a porcelain insulator broke in the Byron Station switchyard resulting in parting of the C phase conductor of the offsite source. The insulator was on the offsite source side of the Unit 2 System Auxiliary Transformers (SATs), and the connection parted in such a way as to leave an electrically open end on the source side. The parted connection remained electrically connected on the transformer side, and the loose bus bar conductor end fell to the ground. This ground was a direct result of the broken insulator and not an independent event. The connected loose bus bar provided a path to ground for the transformer high voltage terminal, but did not result in a ground fault (i.e., neither solid nor impedance) as seen from the source. Since the switchyard (i.e., source side) relaying was electrically isolated from the fault, it did not detect a fault; therefore, did not operate.

The significant event was the opening of a single phase connection; the ground on the high voltage side of the SAT is of lesser significance. Regardless of phase discontinuity, if the ground impedance is low on the source side, and currents are high, the source side protective relaying will operate and open all circuit phases. If the ground impedance is high, and currents low, the relaying may not operate depending on the magnitude of ground impedance; the circuit will continue to supply power.

A qualitative analysis has been performed to assess the impact of single phase high impedance ground faults. The primary objective of the analysis was to determine if a high impedance ground fault could result in an unbalanced voltage condition sufficient to adversely affect energized ESF equipment. The cases analyzed include a single phase high impedance ground fault with all three phases intact and a single phase high impedance ground fault concurrent with the loss of the same phase. These cases have been analyzed for both the high and low voltage sides of the SATs analyzed.

Attachment 11 provides a summary report of the qualitative analysis; therefore, all information discussed in this response attachment is limited to single-phase open circuit conditions.

#### System Description

NRC Requests 2, 1.d, 2.a, and 2.c request system information and will be addressed in this section.

***NRC Request No. 2: Briefly describe the operating configuration of the ESF buses (Class 1E for current operating plants or non-Class 1E for passive plants) at power (normal operating condition).***

#### Exelon Generation Company, LLC (EGC) Response to NRC Request No. 2

Braidwood Generating Station has two electrically and physically independent Class 1E engineered safety features (ESF) distribution divisions per unit (i.e., Divisions 11 and 12 for Unit 1, and Divisions 21 and 22 for Unit 2). Two physically separate and electrically

# ATTACHMENT 1

## Braidwood Station, Units 1 and 2 Response to NRC Bulletin 2012-01, "Design Vulnerability in Electric Power System"

independent offsite power circuits are provided for each unit, one via the unit's assigned system auxiliary transformers (SATs) and the other from the opposite unit's SATs.

The ESF buses are normally powered directly from offsite power via the two SATs (i.e., 345-6.9/4.16-kV). Each transformer is normally energized providing power to an ESF 4160-volt bus of the unit. Each transformer also serves as a second source of offsite power for the corresponding ESF bus of the other unit. In addition, an emergency diesel generator (EDG) is provided as an emergency power source for each 4160 V ESF bus of the unit.

A simplified one-line diagram of the Braidwood Station, Unit 2 Auxiliary Power System, and similar for Unit 1 is shown in Figure 1 below.

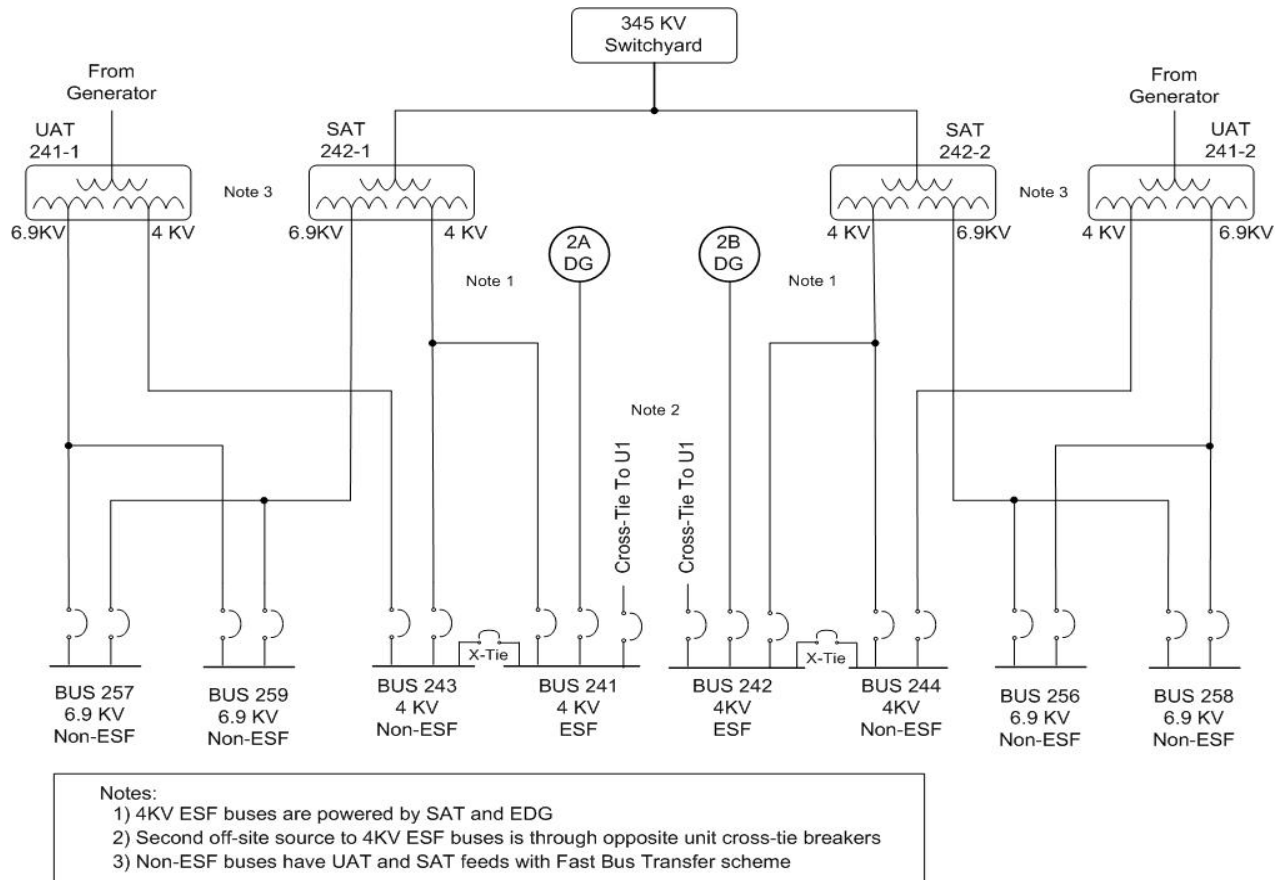

**Figure 1:** Simplified One-Line Diagram of a Braidwood Station Auxiliary Power System

For normal operating conditions at-power, the ESF buses are powered by offsite sources. The ESF buses are normally powered directly from offsite power via two SATs (i.e., 345-6.9/4.16-kV). Each transformer is normally energized providing power to an ESF 4160-volt bus of the unit. Each transformer also serves as a second source of offsite power for the corresponding ESF bus of the other unit.

**ATTACHMENT 1**

**Braidwood Station, Units 1 and 2 Response to  
NRC Bulletin 2012-01, "Design Vulnerability in Electric Power System"**

***NRC Request 1.d: Describe the offsite power transformer (e.g., start-up, reserve, station auxiliary) winding and grounding configurations.***

EGC Response to NRC Request 1.d:

The Braidwood Station offsite power transformer winding and grounding configurations are shown in Table 1 below.

**Table 1:** Braidwood Station Offsite Power Transformer Winding and Grounding Configurations

<b>Transformer</b>	<b>Winding Configuration</b>	<b>MVA Size @ 55 °C Cooling Type (OA/FA/FA)</b>	<b>Voltage Rating (Primary/Secondary)</b>	<b>Grounding Configuration</b>
Station Auxiliary Transformer (SAT) 142-1	Wye-Wye-Wye (3 Leg)	36/48/60	345-6.9/4.16-kV	Neutral Grounded
Station Auxiliary Transformer (SAT) 142-2	Wye-Wye-Wye (3 Leg)	36/48/60	345-6.9/4.16-kV	Neutral Grounded
Station Auxiliary Transformer (SAT) 242-1	Wye-Wye-Wye (3 Leg)	36/48/60	345-6.9/4.16-kV	Neutral Grounded
Station Auxiliary Transformer (SAT) 242-2	Wye-Wye-Wye (3 Leg)	36/48/60	345-6.9/4.16-kV	Neutral Grounded

***NRC Request 2.a: Are the ESF buses powered by offsite power sources? If so, explain what major loads are connected to the buses including their ratings.***

EGC Response to NRC Request 2.a:

Yes, for at power (i.e., normal operating condition) configurations, ESF buses are powered by offsite sources.

## ATTACHMENT 1

### Braidwood Station, Units 1 and 2 Response to NRC Bulletin 2012-01, "Design Vulnerability in Electric Power System"

The Braidwood Station ESF bus power sources are shown in Tables 2 and 3 below.

**Table 2:** ESF Buses Continuously Powered From Offsite Power Source(s)

Description of ESF Bus Power Source	4.16 kV ESF Bus Name (normal operating condition)	Original licensing basis configuration (Y/N)
System Auxiliary Transformer (SAT)142-1	141	Y
System Auxiliary Transformer (SAT) 142-2	142	Y
System Auxiliary Transformer (SAT) 242-1	241	Y
System Auxiliary Transformer (SAT) 242-2	242	Y

**Table 3:** ESF Buses That Are Not Continuously Powered From Offsite Power Source(s)

Description of ESF Bus Power Source	ESF Bus Name (normal operating condition)	Original licensing basis configuration (Y/N)
N/A	N/A	N/A

The ESF buses and their associated major loads that are energized during normal power operations, including ratings, are shown in Table 4 below.

**Table 4:** ESF Bus Major Loads Connected During Normal Power Operations

4kV ESF Bus	Load	Voltage Level (V)	Rating (hp)	Normally Energized
141	Auxiliary Feedwater Pump 1A	4160	1250	N
141	Essential Service Water Pump 1A	4160	1250	Y
141	Containment Spray Pump 1A	4160	600	N
141	Centrifugal Charging Pump 1A	4160	600	Y
141	Auxiliary Building Exhaust Fan 0A	4160	500	Y
141	Control Room Refrig. Unit 0A	4160	461	Y
141	Component Cooling Water Pump 1A	4160	450	Y
141	Safety Injection Pump 1A	4160	400	N
141	RHR Pump 1A	4160	400	N
141	Auxiliary Building Supply Fan 0A	4160	350	Y
141	Transformer 131X Feed	4160	1000kVA	Y
142	Essential Service Water Pump 1B	4160	1250	Y
142	Containment Spray Pump 1B	4160	600	N



**ATTACHMENT 1**

**Braidwood Station, Units 1 and 2 Response to  
NRC Bulletin 2012-01, "Design Vulnerability in Electric Power System"**

<b>4kV ESF Bus</b>	<b>Load</b>	<b>Voltage Level (V)</b>	<b>Rating (hp)</b>	<b>Normally Energized</b>
142	Centrifugal Charging Pump 1B	4160	600	Y
142	Auxiliary Building Exhaust Fan 0B	4160	500	Y
142	Component Cooling Water Pump 1B	4160	450	Y
142	Control Room Refrig. Unit 0B	4160	461	Y
142	Safety Injection Pump 1B	4160	400	N
142	RHR Pump 1B	4160	400	N
142	Auxiliary Building Supply Fan 0B	4160	350	Y
142	Transformer 132X Feed	4160	1333kVA	Y
241	Auxiliary Feedwater Pump 2A	4160	1250	N
241	Essential Service Water Pump 2A	4160	1250	Y
241	Containment Spray Pump 2A	4160	600	N
241	Centrifugal Charging Pump 2A	4160	600	Y
241	Auxiliary Building Exhaust Fan 0C	4160	500	Y
241	Component Cooling Water Pump 2A	4160	450	Y
241	Component Cooling Water Pump 0	4160	450	Y
241	Safety Injection Pump 2A	4160	400	N
241	RHR Pump 2A	4160	400	N
241	Auxiliary Building Supply Fan 0C	4160	350	Y
241	Transformer 231X Feed	4160	1000kVA	Y
242	Essential Service Water Pump 2B	4160	1250	Y
242	Containment Spray Pump 2B	4160	600	N
242	Centrifugal Charging Pump 2B	4160	600	Y
242	Auxiliary Building Exhaust Fan 0D	4160	500	Y
242	Component Cooling Water Pump 2B	4160	450	Y
242	Component Cooling Water Pump 0	4160	450	Y
242	Safety Injection Pump 2B	4160	400	N
242	RHR Pump 2B	4160	400	N
242	Auxiliary Building Supply Fan 0D	4160	350	Y
242	Transformer 232X Feed	4160	1000kVA	Y

## ATTACHMENT 1

### Braidwood Station, Units 1 and 2 Response to NRC Bulletin 2012-01, "Design Vulnerability in Electric Power System"

***NRC Request 2.c: Confirm that the operating configuration of the ESF buses is consistent with the current licensing basis. Describe any changes in offsite power source alignment to the ESF buses from the original plant licensing.***

#### EGC Response to NRC Request 2.c:

The following at power (i.e., normal operating condition) configurations, have been confirmed to be consistent with the current licensing basis (CLB).

Each 4160-volt ESF bus has the following power sources:

- (1) A normal source from the SAT,
- (2) A second (i.e., reserve) source from the other unit's SAT, and
- (3) An emergency source from its respective diesel generator

The unit Class 1E a-c power system is divided into two divisions (i.e., Divisions 11 and 12 for Unit 1, and Divisions 21 and 22 for Unit 2), each of which is supplied from a 4160-volt bus (i.e., Buses 141 and 142, for Unit 1, and Buses 241 and 242 for Unit 2). Each ESF group of each unit is supplied standby power from an individual diesel-generator unit. With this arrangement, alternate or redundant components of all ESF systems are supplied from separate switch groups so that no single failure can jeopardize the proper functioning of redundant ESF loads. The division of the ESF loads among the system buses is such that the total loss of one of the two electrical divisions cannot prevent the safe shutdown of the reactor under any normal or abnormal design condition.

There have been no changes in the offsite power source alignment to the ESF buses from the original plant licensing. Each unit's set of SATs has sufficient capacity to accommodate the auxiliary power requirements of the unit when operating at full load. Furthermore, each unit's set of SATs is capable of supplying the design basis accident (DBA) loads of both divisions of one unit and the safe shutdown loads of both divisions of the other unit simultaneously.

## ATTACHMENT 1

### Braidwood Station, Units 1 and 2 Response to NRC Bulletin 2012-01, "Design Vulnerability in Electric Power System"

#### System Protection

NRC Requests 1, 1.a, 2.b, and 2.d request information regarding electrical system protection, and will be addressed in this section.

***NRC Request 1: Given the requirements above, describe how the protection scheme for ESF buses (Class 1E for current operating plants or non-Class 1E for passive plants) is designed to detect and automatically respond to a single-phase open circuit condition or high impedance ground fault condition on a credited off-site power circuit or another power sources. Also, include the following information:***

#### EGC Response to NRC Request 1:

Consistent with the CLB and 10 CFR 50, Appendix A, "General Design Criteria for Nuclear Power Plants," Criterion (GDC) 17, "Electric power systems," existing protective circuitry will separate the ESF buses from a connected failed offsite source due to a loss of voltage or a sustained, balanced degraded grid voltage concurrent with certain DBAs. The relay systems were not specifically designed to detect an open single phase of a three phase system. Detection of a single-open phase condition is beyond the approved design and licensing basis of the plant.

***NRC Request 1.a: The sensitivity of protective devices to detect abnormal operating conditions and the basis for the protective device setpoint(s).***

#### EGC Response to NRC Request 1.a:

Consistent with the CLB and GDC 17, existing electrical protective devices are sufficiently sensitive to detect design basis conditions like a loss of voltage or a degraded voltage, but were not designed to detect a single phase open circuit condition. The undervoltage protective devices and the basis for the device setpoint(s) are show in Table 5 below.

**Table 5:** Protective Devices

Protection Zone	Protective Device	UV Logic	Setpoint (Nominal)	Basis for Setpoint
4 kV ESF Bus	Loss of Voltage Relay	2 of 2	2870 V	To detect a complete loss of ESF Bus voltage condition
4 kV ESF Bus	Degraded Voltage Relay	2 of 2	3987 V	To detect degraded voltage on an ESF Bus.

**ATTACHMENT 1**

**Braidwood Station, Units 1 and 2 Response to  
NRC Bulletin 2012-01, "Design Vulnerability in Electric Power System"**

<b>Protection Zone</b>	<b>Protective Device</b>	<b>UV Logic</b>	<b>Setpoint (Nominal)</b>	<b>Basis for Setpoint</b>
Normal Feed to ESF Bus	Ground Overcurrent		Tap: 1A CT Turns Ratio 240:1 Set: 240A TD: 3.5	To provide time overcurrent protection for ground faults
Normal Feed to ESF Bus	Phase Overcurrent (A, C)		Tap: 12A CT Turns Ratio 240:1 Set: 2880A TD: 4	To provide time overcurrent protection for phase to ground or phase to phase faults.
Normal Feed to ESF Bus	Phase Overcurrent (B)		Tap: 5A CT Turns Ratio 240:1 Set: 1200A	To provide time delayed overcurrent protection for the ESF bus from overloads while cross-tied to the corresponding ESF bus on the opposite unit. The overcurrent relay is an instantaneous overcurrent relay. This relay is used in conjunction an external time delay relay which alarms after 10 sec and trips a cross-tie breaker after 5 minutes.
Reserve Feed to ESF Bus	Ground Overcurrent		Tap: 0.5A CT Turns Ratio 240:1 Set: 120A TD: 1.5	To provide time overcurrent protection for ground faults.
Reserve Feed to ESF Bus	Phase Overcurrent (A, C)		Tap: 6A CT Turns Ratio 240:1 Set: 1440A TD: 3	To provide time overcurrent protection for phase to ground or phase to phase faults..
Emergency Feed to ESF Bus	Phase Overcurrent		Tap: 7A CT Turns Ratio 240:1 Set: 1680A TD: 5	To provide time overcurrent protection for phase to ground or phase to phase faults.
Emergency Feed to ESF Bus	Differential		0.14A Min Trip	Protects the ESF bus from a faulted Emergency Diesel Generator.

**ATTACHMENT 1**

**Braidwood Station, Units 1 and 2 Response to  
NRC Bulletin 2012-01, "Design Vulnerability in Electric Power System"**

<b>Protection Zone</b>	<b>Protective Device</b>	<b>UV Logic</b>	<b>Setpoint (Nominal)</b>	<b>Basis for Setpoint</b>
SATs and 6.9 kV / 4.16 kV Non-Segregated Bus Ducts	Differential	N/A	CT Turns Ratios: 1) 345 kV Winding = 40:1; 2) 6.9 kV Winding = 1000:1; 3) 4.16 kV Winding = 1600:1; Sensitivity = 30%; Tap Settings: 1) 345 kV Side = 4.2 A; 2) 6.9 kV Side = 8.7 A; 3) 4.16 kV Side = 8.7 A	To protect the ESF and non-ESF buses from a faulted SAT or Non-Segregated Bus Duct
4.16 kV Non-Segregated Bus Ducts	Ground Differential	N/A	CT Turns Ratios: 1) SAT 4.16 kV Neutral = 120:1; Aux CT = 5:1; 2) 4.16 kV ESF Bus = 240:1; Aux CT = 2.5:1 3) 4.16 kV Non-ESF Bus = 600:1; Aux CT = 1:1 Tap: 0.5 A; TD: 3	To protect the ESF and non-ESF buses from a ground fault on the Non-Segregated Bus Ducts
6.9 kV Non-Segregated Bus Ducts	Ground Differential	N/A	CT Turns Ratios: 1) SAT 6.9 kV Neutral = 120:1; Aux CT = 3.33:1; 2) 6.9 kV Bus = 400:1; Aux CT = 1:1 Tap: 0.5 A; TD: 3	To protect the ESF and non-ESF buses from a ground fault on the Non-Segregated Bus Ducts

## ATTACHMENT 1

### Braidwood Station, Units 1 and 2 Response to NRC Bulletin 2012-01, "Design Vulnerability in Electric Power System"

Protection Zone	Protective Device	UV Logic	Setpoint (Nominal)	Basis for Setpoint
SATs and 4.16 kV / 6.9 kV Non-Segregated Bus Ducts	Phase Overcurrent	N/A	Tap: 3.5A CT Turns Ratio 40:1 Set: 140A (Primary Amps) TD: 3	To provide time overcurrent protection for phase to ground or phase to phase faults on the SATs or the Non-Segregated Bus Ducts
SATs and 4.16 kV Non-Segregated Bus Ducts	Ground Overcurrent	N/A	Tap: 2.5A CT Turns Ratio 120:1 Set: 300A (Primary Amps) TD: 5	To provide time overcurrent protection for ground faults on the SAT 4.16 kV winding or Non-Segregated Bus ducts.
SATs and 6.9 kV Non-Segregated Bus Ducts	Ground Overcurrent	N/A	Tap: 2A CT Turns Ratio 120:1 Set: 240A (Primary Amps) TD: 3.5	To provide time overcurrent protection for ground faults on the SAT 6.9 kV windings or Non-Segregated Bus ducts.

Existing electrical protective devices are also sufficiently sensitive to detect a ground fault. Table 5 lists electrical protective devices on the ESF buses and the basis for the device setpoint(s).

## ATTACHMENT 1

### Braidwood Station, Units 1 and 2 Response to NRC Bulletin 2012-01, "Design Vulnerability in Electric Power System"

***NRC Request 2.b. If the ESF buses are not powered by offsite power sources, explain how the surveillance tests are performed to verify that a single-phase open circuit condition or high impedance ground fault condition on an off-site power circuit is detected.***

EGC Response to NRC Request 2.b:

Not Applicable – the ESF buses at Braidwood Station are powered from offsite power sources.

***NRC Request 2.d: Do the plant operating procedures, including off-normal operating procedures, specifically call for verification of the voltages on all three phases of the ESF buses?***

EGC Response to NRC Request 2.d:

Yes, the current plant operating procedures including annunciator response procedures specifically call for verification of the voltages on all three phases of the ESF buses. The off-normal operating procedures were not revised since annunciator response procedures contain sufficient guidance to address a loss of a single phase condition in a timely manner.

## ATTACHMENT 1

### Braidwood Station, Units 1 and 2 Response to NRC Bulletin 2012-01, "Design Vulnerability in Electric Power System"

#### Consequences

NRC Requests 1.b, 1.c, and 2.e request information regarding the electrical consequences of an event, and will be addressed in this section.

***NRC Request 1.b: The differences (if any) of the consequences of a loaded (i.e., ESF bus normally aligned to offsite power transformer) or unloaded (e.g., ESF buses normally aligned to unit auxiliary transformer) power source.***

#### EGC Response to NRC Request 1.b:

Installed relays were not designed to detect single phase open circuit conditions. Existing loss of voltage and degraded voltage relays may respond depending on load and possible grounds.

In general, there will be no plant response for an unloaded (e.g., non- ESF buses normally aligned to unit auxiliary transformers and ESF buses aligned to the reserve feed) power source in the event of a single-phase open circuit on a credited off-site power circuit because there is insufficient current to provide for detection of a single-phase open circuit for this configuration.

The plant response for a loaded power source will vary based upon the amount of loading and the specific loads involved. In most cases the loading will not be sufficient to decrease bus voltage enough during a single-phase open circuit event to trip the degraded voltage relays.

***NRC Request 1.c: If the design does not detect and automatically respond to a single-phase open circuit condition or high impedance ground fault condition on a credited offsite power circuit or another power sources, describe the consequences of such an event and the plant response.***

#### EGC Response to NRC Request 1.c:

Braidwood Station did not credit in the CLB that the Class 1E protection scheme for the ESF buses was designed to detect and automatically respond to a single-phase open circuit condition on the credited off-site power source as described in the Updated Final Safety Analysis Report (UFSAR) and Technical Specifications (TS).

The offsite power circuits at Braidwood Station from the switchyard to the ESF 4.16kV buses consist of two physically separate and electrically independent circuits for each unit. One circuit is via the unit's assigned SATs and the other from the opposite unit's SATs.

Since Braidwood Station did not credit the ESF bus protection scheme as being capable of detecting and automatically responding to a single phase open circuit condition, an open phase fault was not included in the design criteria for either the loss of voltage, the degraded voltage relay scheme or secondary level undervoltage protection system design criteria. Since open



## ATTACHMENT 1

### Braidwood Station, Units 1 and 2 Response to NRC Bulletin 2012-01, "Design Vulnerability in Electric Power System"

phase detection was not credited in the Braidwood Station design or licensing basis, no design basis calculations or design documents exist that previously considered this condition.

The station currently has in place an operability evaluation compensatory action that requires a designated operator to monitor bus voltage and to open the offsite feed breakers to the ESF buses within 30 seconds of identifying a single-open phase condition. After this action is completed, the ESF bus undervoltage relays will automatically start the EDGs and reenergize the ESF buses. This manual action can be completed in a timely manner following the occurrence of a single-phase open circuit to ensure that safe shutdown is achieved and maintained.

Note that a single-phase open circuit condition concurrent with a DBA is considered to be beyond the design basis of the station. However, if a single-phase open circuit condition were to occur concurrent with a DBA, plant systems would be available after the EDGs reenergize the ESF buses.

***NRC Request 2.e: If a common or single offsite circuit is used to supply redundant ESF buses, explain why a failure, such as a single-phase open circuit or high impedance ground fault condition, would not adversely affect redundant ESF buses.***

#### EGC Response to NRC Request 2.e:

Consistent with the CLB and GDC 17, protective circuitry will separate the ESF buses from a failed offsite source due to a loss of voltage or a sustained balanced degraded grid voltage concurrent with certain DBAs. The relay systems were not specifically designed to detect an open single phase of a three phase system. Detection of a single-open phase circuit is beyond the approved design and licensing basis of the plant. Calculations that model various loss of single phase conditions are currently being developed.

Braidwood Station has implemented several interim compensatory measures to minimize the impact should the open phase event occur. These measures include:

- Modification of the SAT 4 kV undervoltage alarm from a two-out-of-two to a one-out-of-two configuration to enhance annunciation for a loss of single phase event
- Alignment of plant voltmeters to ensure all phases are monitored
- Implementation of a designated operator to isolate the safety buses from the grid in a timely fashion
- Completion of required reading packages for operators to enhance operator awareness
- Enhancement of alarm / annunciator response procedures
- Creation of operator aids and placards to enhance operator response

These compensatory actions now provide effective controls to promptly diagnose and mitigate a loss of single-phase event.

**ATTACHMENT 2**

**Byron Station, Units 1 and 2, 90-Day Response to NRC Bulletin 2012-01, "Design Vulnerability in Electric Power System"**

## ATTACHMENT 2

### Byron Station, Units 1 and 2 Response to NRC Bulletin 2012-01, "Design Vulnerability in Electric Power System"

#### High Impedance Grounds:

On January 30, 2012, a porcelain insulator broke in the Byron Station switchyard resulting in parting of the C phase conductor of the offsite source. The insulator was on the offsite source side of the Unit 2 System Auxiliary Transformers (SATs), and the connection parted in such a way as to leave an electrically open end on the source side. The parted connection remained electrically connected on the transformer side, and the loose bus bar conductor end fell to the ground. This ground was a direct result of the broken insulator and not an independent event. The connected loose bus bar provided a path to ground for the transformer high voltage terminal, but did not result in a ground fault (i.e., neither solid nor impedance) as seen from the source. Since the switchyard (i.e., source side) relaying was electrically isolated from the fault, it did not detect a fault; therefore, did not operate.

The significant event was the opening of a single phase connection; the ground on the high voltage side of the SAT is of lesser significance. Regardless of phase discontinuity, if the ground impedance is low on the source side, and currents are high, the source side protective relaying will operate and open all circuit phases. If the ground impedance is high, and currents low, the relaying may not operate depending on the magnitude of ground impedance; the circuit will continue to supply power.

A qualitative analysis has been performed to assess the impact of single phase high impedance ground faults. The primary objective of the analysis was to determine if a high impedance ground fault could result in an unbalanced voltage condition sufficient to adversely affect energized ESF equipment. The cases analyzed include a single phase high impedance ground fault with all three phases intact and a single phase high impedance ground fault concurrent with the loss of the same phase. These cases have been analyzed for both the high and low voltage sides of the SATs analyzed.

Attachment 11 provides a summary report of the qualitative analysis; therefore, all information discussed in this response attachment is limited to single-phase open circuit conditions.

#### **System Description**

NRC Requests 2, 1.d, 2.a, and 2.c request system information, and will be addressed in this section.

***NRC Request No. 2: Briefly describe the operating configuration of the ESF buses (Class 1E for current operating plants or non-Class 1E for passive plants) at power (normal operating condition).***

#### Exelon Generation Company, LLC (EGC) Response to NRC Request No. 2

Byron Station, Units 1 and 2 have two electrically and physically independent Class 1E engineered safety features (ESF) electrical distribution divisions per unit (i.e., Divisions 11 and 12 for Unit 1, and Divisions 21 and 22 for Unit 2). Two physically separate and electrically independent offsite power circuits are provided for each unit, one via the unit's assigned system auxiliary transformers and the other from the opposite unit's system auxiliary transformers.

## ATTACHMENT 2

### Byron Station, Units 1 and 2 Response to NRC Bulletin 2012-01, "Design Vulnerability in Electric Power System"

The ESF buses are normally powered directly from offsite power via the two system auxiliary transformers (345-6.9/4.16-kV). Each transformer is normally energized providing power to an ESF 4160-volt bus of the unit. Each transformer also serves as a second source of offsite power for the corresponding ESF bus of the other unit. In addition, an emergency diesel generator (EDG) is provided as an emergency power source for each 4160 V ESF bus of the unit.

A simplified one-line diagram of the Byron Station, Unit 2 Auxiliary Power System, and similar for Unit 1 is shown in Figure 1 below.

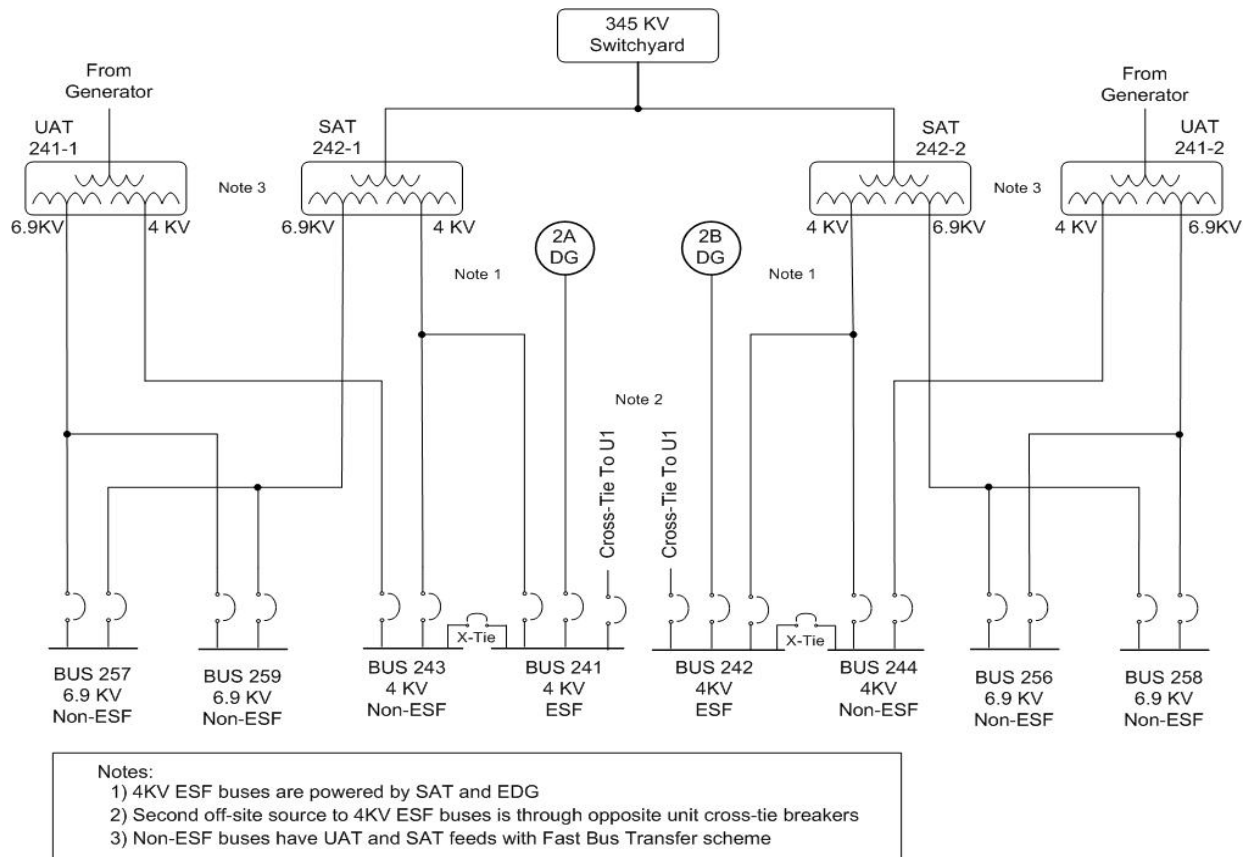

**Figure 1: Byron Station Simplified One-Line Diagram**

For normal operating conditions at-power, the ESF buses are powered by offsite sources. The ESF buses are normally powered directly from offsite power via two SATs (i.e., 345 6.9/4.16 kV). Each transformer is normally energized providing power to an ESF 4160-volt bus of the unit. Each transformer also serves as a second source of offsite power for the corresponding ESF bus of the other unit.

**ATTACHMENT 2**

**Byron Station, Units 1 and 2 Response to  
NRC Bulletin 2012-01, "Design Vulnerability in Electric Power System"**

**NRC Request 1.d: Describe the offsite power transformer (e.g., start-up, reserve, station auxiliary) winding and grounding configurations.**

EGC Response to NRC Request 1.d:

Offsite power transformer winding and grounding configurations are shown in Table 1 below.

**Table 1: Offsite Power Transformer Winding and Grounding Configurations**

Transformer	Winding Configuration	MVA Size @ 55 °C (AO/FA/FA)	Voltage Rating (Primary/Secondary)	Grounding Configuration
System Auxiliary Transformer (SAT) 142-1	Wye-Wye-Wye (3 Leg)	36/48/60 MVA (OA/FA/FA)	345-6.9/4.16-kV	1. Neutral – Solidly Grounded (345kV Winding) 2. Neutral – Resistance Grounded (6.9 & 4.16 kV Windings)
System Auxiliary Transformer (SAT) 142-2	Wye-Wye-Wye (3 Leg)	36/48/60 MVA (OA/FA/FA)	345-6.9/4.16-kV	1. Neutral – Solidly Grounded (345kV Winding) 2. Neutral – Resistance Grounded (6.9 & 4.16 kV Windings)
System Auxiliary Transformer (SAT) 242-1	Wye-Wye-Wye (3 Leg)	36/48/60 MVA (OA/FA/FA)	345-6.9/4.16-kV	1. Neutral – Solidly Grounded (345kV Winding) 2. Neutral – Resistance Grounded (6.9 & 4.16 kV Windings)
System Auxiliary Transformer (SAT) 242-2	Wye-Wye-Wye (3 Leg)	36/48/60 MVA (OA/FA/FA)	345-6.9/4.16-kV	1. Neutral – Solidly Grounded (345kV Winding) 2. Neutral – Resistance Grounded (6.9 & 4.16 kV Windings)

## ATTACHMENT 2

### Byron Station, Units 1 and 2 Response to NRC Bulletin 2012-01, "Design Vulnerability in Electric Power System"

**NRC Request 2.a:** *Are the ESF buses powered by offsite power sources? If so, explain what major loads are connected to the buses including their ratings.*

EGC Response to NRC Request 2.a:

Yes, for at power (normal operating condition) configurations, ESF buses are powered by offsite sources. The Byron Station ESF bus power sources during normal operation are shown Tables 2 and 3 below.

**Table 2 :** Byron Station ESF Buses That Are Normally Powered from Offsite Sources

Description of ESF Bus Power Source	4.16kV ESF Bus Name (normal operating condition)	Original licensing basis configuration (Y/N)
System Auxiliary Transformer (SAT) 142-1	141	Y
System Auxiliary Transformer (SAT) 142-2	142	Y
System Auxiliary Transformer (SAT) 242-1	241	Y
System Auxiliary Transformer (SAT) 242-2	242	Y

**Table 3:** ESF Buses Not Continuously Powered From Offsite Power Source(s)

Description of ESF Bus Power Source	ESF Bus Name (normal operating condition)	Original licensing basis configuration (Y/N)
N/A	N/A	N/A
N/A	N/A	N/A
N/A	N/A	N/A

ESF bus major loads that are energized during normal power operations, including ratings are shown in Table 4 below.

**Table 4:** Major ESF Loads Including Ratings and Status during Normal Power Operations

4kV ESF Bus	Load	Voltage Level (V)	Rating (hp)	Normally Energized
141	Auxiliary Feedwater Pump 1A	4160	1250	N
141	Essential Service Water Pump 1A	4160	1250	Y
141	Containment Spray Pump 1A	4160	600	N
141	Centrifugal Charging Pump 1A	4160	600	Y
141	Auxiliary Building Exhaust Fan 0A	4160	500	Y

## ATTACHMENT 2

### Byron Station, Units 1 and 2 Response to NRC Bulletin 2012-01, "Design Vulnerability in Electric Power System"

4kV ESF Bus	Load	Voltage Level (V)	Rating (hp)	Normally Energized
141	Control Room Refrigeration Unit 0A	4160	461	Y
141	Component Cooling Water Pump 1A	4160	450	Y
141	Component Cooling Water Pump 0	4160	450	Y
141	Safety Injection Pump 1A	4160	400	N
141	Residual Heat Removal (RHR) Pump 1A	4160	400	N
141	Auxiliary Building Supply Fan 0A	4160	350	Y
141	Transformer 131X Feed	4160	1000kVA	Y
141	Transformer 131Z Feed	4160	750kVA	Y
142	Essential Service Water Pump 1B	4160	1250	Y
142	Containment Spray Pump 1B	4160	600	N
142	Centrifugal Charging Pump 1B	4160	600	Y
142	Auxiliary Building Exhaust Fan 0B	4160	500	Y
142	Component Cooling Water Pump 1B	4160	450	Y
142	Component Cooling Water Pump 0	4160	450	Y
142	Control Room Refrigeration Unit 0B	4160	461	Y
142	Safety Injection Pump 1B	4160	400	N
142	RHR Pump 1B	4160	400	N
142	Auxiliary Building Supply Fan 0B	4160	350	Y
142	Transformer 132X Feed	4160	1333kVA	Y
142	Transformer 132Z Feed	4160	750kVA	Y
241	Auxiliary Feedwater Pump 2A	4160	1250	N
241	Essential Service Water Pump 2A	4160	1250	Y
241	Containment Spray Pump 2A	4160	600	N
241	Centrifugal Charging Pump 2A	4160	600	Y
241	Auxiliary Building Exhaust Fan 0C	4160	500	Y
241	Component Cooling Water Pump 2A	4160	450	Y
241	Component Cooling Water Pump 0	4160	450	Y
241	Safety Injection Pump 2A	4160	400	N
241	RHR Pump 2A	4160	400	N

## ATTACHMENT 2

### Byron Station, Units 1 and 2 Response to NRC Bulletin 2012-01, "Design Vulnerability in Electric Power System"

4kV ESF Bus	Load	Voltage Level (V)	Rating (hp)	Normally Energized
241	Auxiliary Building Supply Fan 0C	4160	350	Y
241	Transformer 231X Feed	4160	1000kVA	Y
241	Transformer 231Z Feed	4160	750kVA	Y
242	Essential Service Water Pump 2B	4160	1250	Y
242	Containment Spray Pump 2B	4160	600	N
242	Centrifugal Charging Pump 2B	4160	600	Y
242	Auxiliary Building Exhaust Fan 0D	4160	500	Y
242	Component Cooling Water Pump 2B	4160	450	Y
242	Component Cooling Water Pump 0	4160	450	Y
242	Safety Injection Pump 2B	4160	400	N
242	RHR Pump 2B	4160	400	N
242	Auxiliary Building Supply Fan 0D	4160	350	Y
242	Transformer 232X Feed	4160	1000kVA	Y
242	Transformer 232Z Feed	4160	750kVA	Y

***NRC Request 2.c: Confirm that the operating configuration of the ESF buses is consistent with the current licensing basis. Describe any changes in offsite power source alignment to the ESF buses from the original plant licensing.***

EGC Response to NRC Request 2.c:

The following at power (normal operating condition) configurations, have been confirmed to be consistent with the current licensing basis (CLB).

Each 4160-volt ESF bus has the following:

- (1) A normal feed from the system auxiliary transformer,
- (2) A second (reserve) feed from the other unit's SAT, and
- (3) An emergency feed from its respective diesel generator

The unit Class 1E a-c power system is divided into two divisions (i.e., Divisions 11 and 12 for Unit 1, and Divisions 21 and 22 for Unit 2), each of which is supplied from a 4160-volt bus (i.e., Buses 141 and 142, for Unit 1, and Buses 241 and 242 for Unit 2). Each ESF group of each unit is supplied standby power from an individual diesel-generator unit. With this arrangement, alternate or redundant components of all ESF systems are supplied from separate switch



## **ATTACHMENT 2**

### **Byron Station, Units 1 and 2 Response to NRC Bulletin 2012-01, "Design Vulnerability in Electric Power System"**

groups so that no single failure can jeopardize the proper functioning of redundant ESF loads. The division of the ESF loads among the system buses is such that the total loss of one of the two electrical divisions cannot prevent the safe shutdown of the reactor under any normal or abnormal design condition.

There have been no changes in the offsite power source alignment to the ESF buses from the original plant licensing. Each unit's set of SATs has sufficient capacity to accommodate the auxiliary power requirements of the unit when operating at full load. Furthermore, each unit's set of SATs is capable of supplying the design basis accident (DBA) loads of both divisions of one unit and the safe shutdown loads of both divisions of the other unit simultaneously.

## ATTACHMENT 2

### Byron Station, Units 1 and 2 Response to NRC Bulletin 2012-01, "Design Vulnerability in Electric Power System"

#### System Protection

NRC Requests 1, 1.a, 2.b, and 2.d request information regarding electrical system protection, and will be addressed in this section.

**NRC Request 1:** *Given the requirements above, describe how the protection scheme for ESF buses (Class 1E for current operating plants or non-Class 1E for passive plants) is designed to detect and automatically respond to a single-phase open circuit condition or high impedance ground fault condition on a credited off-site power circuit or another power sources. Also, include the following information:*

#### EGC Response to NRC Request 1:

Consistent with the CLB and 10 CFR 50, Appendix A, "General Design Criteria for Nuclear Power Plants," Criterion (GDC) 17, "Electric power systems," existing protective circuitry will separate the ESF buses from a connected failed offsite source due to a loss of voltage or a sustained, balanced degraded grid voltage concurrent with certain DBAs. The relay systems were not specifically designed to detect an open single phase of a three phase system. Detection of a single-open phase condition is beyond the approved design and licensing basis of the plant.

**NRC Request 1.a:** *The sensitivity of protective devices to detect abnormal operating conditions and the basis for the protective device setpoint(s).*

#### EGC Response to NRC Request 1.a:

Consistent with the CLB and GDC 17, existing electrical protective devices are sufficiently sensitive to detect design basis conditions like a loss of voltage or a degraded voltage, but were not designed to detect a single phase open circuit condition. The Byron Station undervoltage protective devices and the basis for the device setpoint(s) are shown in Table 5 below.

**Table 5:** Protective Devices

Protection Zone	Protective Device	UV Logic	Setpoint (Nominal)	Basis for Setpoint
4 kV ESF Bus	Loss of Voltage	2 of 2	2870 V	To detect a complete loss of ESF Bus voltage condition
4 kV ESF Bus	Degraded Voltage	2 of 2	3847 V	To detect degraded voltage on an ESF Bus.

## ATTACHMENT 2

### Byron Station, Units 1 and 2 Response to NRC Bulletin 2012-01, "Design Vulnerability in Electric Power System"

Protection Zone	Protective Device	UV Logic	Setpoint (Nominal)	Basis for Setpoint
Normal Feed to ESF Bus	Ground Overcurrent	N/A	Tap: 1A CT Ratio 240:1 Set: 240A (Primary Amps) Time Dial (TD): 3.5	To provide time overcurrent protection for ground faults.
Normal Feed to ESF Bus	Phase Overcurrent (A, C)	N/A	Tap: 12A CT Ratio 240:1 Set: 2880A TD: 4	To provide time overcurrent protection for phase to ground or phase to phase faults.
Normal Feed to ESF Bus	Phase Overcurrent (B)	N/A	Tap: 5A CT Ratio 240:1 Set: 1200A	To provide time delayed overcurrent protection for the ESF bus from overloads while cross-tied to the corresponding ESF bus on the opposite unit. The overcurrent relay is an instantaneous overcurrent relay. This relay is used in conjunction an external time delay relay which alarms after 10 sec and trips a cross-tie breaker after 5 minutes.
Reserve Feed to ESF Bus	Ground Overcurrent	N/A	Tap: 0.5A CT Ratio 240:1 Set: 120A TD: 1.5	To provide time overcurrent protection for ground faults.
Reserve Feed to ESF Bus	Phase Overcurrent (A, C)	N/A	Tap: 6A CT Ratio 240:1 Set: 1440A TD: 3	To provide time overcurrent protection for phase to ground or phase to phase faults.
Emergency Feed to ESF Bus	Phase Overcurrent	N/A	Tap: 7A CT Ratio 240:1 Set: 1680A TD: 5	To provide time overcurrent protection for phase to ground or phase to phase faults.

**ATTACHMENT 2**

**Byron Station, Units 1 and 2 Response to  
NRC Bulletin 2012-01, "Design Vulnerability in Electric Power System"**

<b>Protection Zone</b>	<b>Protective Device</b>	<b>UV Logic</b>	<b>Setpoint (Nominal)</b>	<b>Basis for Setpoint</b>
Emergency Feed to ESF Bus	Differential	N/A	CT Ratio 240:1 0.14A Min Trip	Protects the ESF bus from a faulted Emergency Diesel Generator.
SATs and 6.9 kV / 4.16 kV Non-Segregated Bus Ducts	Differential	N/A	CT Turns Ratios: 1) 345 kV Winding = 60:1; 2) 6.9 kV Winding = 1000:1; 3) 4.16 kV Winding = 1600:1; Sensitivity = 30%; Tap Settings: 1) 345 kV Side = 2.9 A; 2) 6.9 kV Side = 8.7 A; 3) 4.16 kV Side = 8.7 A	To protect the ESF and non-ESF buses from a faulted SAT or Non-Segregated Bus Duct
4.16 kV Non-Segregated Bus Ducts	Ground Differential	N/A	CT Turns Ratios: 1) SAT 4.16 kV Neutral = 120:1; Aux CT = 5:1; 2) 4.16 kV ESF Bus = 240:1; Aux CT = 2.5:1 3) 4.16 kV Non-ESF Bus = 600:1; Aux CT = 1:1 Tap: 0.5 A; TD: 3	To protect the ESF and non-ESF buses from a ground fault on the Non-Segregated Bus Ducts

## ATTACHMENT 2

### Byron Station, Units 1 and 2 Response to NRC Bulletin 2012-01, "Design Vulnerability in Electric Power System"

Protection Zone	Protective Device	UV Logic	Setpoint (Nominal)	Basis for Setpoint
6.9 kV Non-Segregated Bus Ducts	Ground Differential	N/A	CT Turns Ratios: 1) SAT 6.9 kV Neutral = 120:1; Aux CT = 3.33:1; 2) 6.9 kV Bus = 400:1; Aux CT = 1:1 Tap: 0.5 A; TD: 3	To protect the ESF and non-ESF buses from a ground fault on the Non-Segregated Bus Ducts
SATs and 4.16 kV / 6.9 kV Non-Segregated Bus Ducts	Phase Overcurrent	N/A	1) CT Turns Ratio = 40:1 2) Tap: 3.5A 3) Set: 140A (Primary Amps) 4) TD: 3	To provide time overcurrent protection for phase to ground or phase to phase faults on the SATs or the Non-Segregated Bus Ducts
SATs and 4.16 kV Non-Segregated Bus Ducts	Ground Overcurrent	N/A	1) CT Turns Ratio 120:1 2) Tap: 2.5A 3) Set: 300A (Primary Amps) 4) TD: 5	To provide time overcurrent protection for ground faults on the SAT 4.16 kV winding or Non-Segregated Bus ducts.
SATs and 6.9 kV Non-Segregated Bus Ducts	Ground Overcurrent	N/A	1) CT Turns Ratio 120:1 2) Tap: 2A 3) Set: 240A (Primary Amps) 4) TD: 3.5	To provide time overcurrent protection for ground faults on the SAT 6.9 kV windings or Non-Segregated Bus ducts.

Existing electrical protective devices are also sufficiently sensitive to detect a ground fault. Table 5 lists electrical protective devices on the ESF buses and the basis for the device setpoint(s).

## ATTACHMENT 2

### Byron Station, Units 1 and 2 Response to NRC Bulletin 2012-01, "Design Vulnerability in Electric Power System"

***NRC Request 2.b: If the ESF buses are not powered by offsite power sources, explain how the surveillance tests are performed to verify that a single-phase open circuit condition or high impedance ground fault condition on an off-site power circuit is detected.***

EGC Response to NRC Request 2.b:

Not Applicable – the ESF buses at Byron Generation Station are powered from offsite power sources.

***NRC Request 2.d: Do the plant operating procedures, including off-normal operating procedures, specifically call for verification of the voltages on all three phases of the ESF buses?***

EGC Response to NRC Request 2.d:

Yes, the current plant operating procedures including annunciator response procedures specifically call for verification of the voltages on all three phases of the ESF buses. The off-normal operating procedures were not revised since annunciator response procedures contain sufficient guidance to address a loss of a single phase condition in a timely manner.

## ATTACHMENT 2

### Byron Station, Units 1 and 2 Response to NRC Bulletin 2012-01, "Design Vulnerability in Electric Power System"

#### Consequences

NRC Requests 1.b, 1.c, and 2.e request information regarding the electrical consequences of an event, and will be addressed in this section.

***NRC Request 1.b: The differences (if any) of the consequences of a loaded (i.e., ESF bus normally aligned to offsite power transformer) or unloaded (e.g., ESF buses normally aligned to unit auxiliary transformer) power source.***

#### EGC Response to NRC Request 1.b:

Installed relays were not designed to detect single-open phase circuit conditions. Existing loss of voltage and degraded voltage relays may respond depending on load and possible grounds.

In general, there will be no plant response for an unloaded (e.g., non- ESF buses normally aligned to unit auxiliary transformers and ESF buses aligned to the reserve feed) power source in the event of a single-phase open circuit on a credited off-site power circuit because there is insufficient current to provide for detection of a single-phase open circuit for this configuration. Note that the normal offsite power source is usually loaded. An unloaded normal offsite power source would only occur during SAT shutdown or start-up.

The plant response for a loaded power source will vary based upon the amount of loading and the specific loads involved. In most cases the loading will not be sufficient to decrease bus voltage enough during a single-phase open circuit event to trip the degraded voltage relays.

***NRC Request 1.c: If the design does not detect and automatically respond to a single-phase open circuit condition or high impedance ground fault condition on a credited offsite power circuit or another power sources, describe the consequences of such an event and the plant response.***

#### EGC Response to NRC Request 1.c:

Byron Station did not credit in the CLB that the Class 1E protection scheme for the ESF buses was designed to detect and automatically respond to a single-phase open circuit condition on the credited off-site power source as described in the Updated Final Safety Analysis Report (UFSAR) and Technical Specifications (TS).

The offsite power circuits at Byron Station consist of two physically separate and electrically independent offsite power circuits, from the switchyard to the ESF 4.16kV buses for each unit. One circuit is via the unit's assigned SATs and the other from the opposite unit's SATs.

Since Byron Station did not credit the ESF bus protection scheme as being capable of detecting and automatically responding to a single phase open circuit condition, an open phase fault was not included in the design criteria for either the loss of voltage, the degraded voltage relay scheme or secondary level undervoltage protection system design criteria. Since open phase

## ATTACHMENT 2

### Byron Station, Units 1 and 2 Response to NRC Bulletin 2012-01, "Design Vulnerability in Electric Power System"

detection was not credited in the Byron Station design or licensing basis, no design basis calculations or design documents exist that previously considered this condition.

The station currently has in place an Operability Evaluation compensatory action that requires a designated operator to monitor bus voltage and to open the offsite feed breakers to the ESF buses within 30 seconds of identifying a single-open phase condition. After this action is completed, the ESF bus undervoltage relays will automatically start the EDGs and reenergize the ESF buses. This manual action can be completed in a timely manner following the occurrence of a single-phase open circuit to ensure that safe shutdown is achieved and maintained.

Note that a single-phase open circuit condition concurrent with a DBA is considered to be beyond the design basis of the station. However, if a single-phase open circuit condition were to occur concurrent with a DBA, plant systems would be available after the EDGs reenergize the ESF buses.

***NRC Request 2.e: If a common or single offsite circuit is used to supply redundant ESF buses, explain why a failure, such as a single-phase open circuit or high impedance ground fault condition, would not adversely affect redundant ESF buses.***

#### EGC Response to NRC Request 2.e:

Consistent with the CLB and GDC 17, protective circuitry will separate the ESF buses from a failed offsite source due to a loss of voltage or a sustained balanced degraded grid voltage concurrent with certain DBAs. The relay systems were not specifically designed to detect an open single phase of a three phase system. Detection of a single-open phase circuit is beyond the approved design and licensing basis of the plant. Calculations that model various loss of single phase conditions are currently being developed.

Byron Station has implemented several interim compensatory measures to minimize the impact should the open phase event occur. These measures include.

- Modification of the SAT 4 kV undervoltage alarm from a two-out-of-two to a one-out-of-two configuration to enhance annunciation for a loss of single phase event
- Alignment of plant voltmeters to ensure all phases are monitored
- Implementation of a designated operator to isolate the safety buses from the grid in a timely fashion
- Completion of required reading packages for operators to enhance operator awareness
- Enhancement of alarm / annunciator response procedures
- Creation of operator aids and placards to enhance operator response

These compensatory actions now provide effective controls to promptly diagnose and mitigate a single-phase event.



**ATTACHMENT 3**

**Clinton Power Station, Unit 1, 90-Day Response to NRC Bulletin 2012-01, "Design Vulnerability in Electric Power System"**

## ATTACHMENT 3

### Clinton Power Station, Unit 1 Response to NRC Bulletin 2012-01, "Design Vulnerability in Electric Power System"

#### High Impedance Grounds:

On January 30, 2012, a porcelain insulator broke in the Byron Station switchyard resulting in parting of the C phase conductor of the offsite source. The insulator was on the offsite source side of the Unit 2 System Auxiliary Transformers (SATs), and the connection parted in such a way as to leave an electrically open end on the source side. The parted connection remained electrically connected on the transformer side, and the loose bus bar conductor end fell to the ground. This ground was a direct result of the broken insulator and not an independent event. The connected loose bus bar provided a path to ground for the transformer high voltage terminal, but did not result in a ground fault (i.e., neither solid nor impedance) as seen from the source. Since the switchyard (i.e., source side) relaying was electrically isolated from the fault, it did not detect a fault; therefore, did not operate.

The significant event was the opening of a single phase connection; the ground on the high voltage side of the SAT is of lesser significance. Regardless of phase discontinuity, if the ground impedance is low on the source side, and currents are high, the source side protective relaying will operate and open all circuit phases. If the ground impedance is high, and currents low, the relaying may not operate depending on the magnitude of ground impedance; the circuit will continue to supply power.

A qualitative analysis has been performed to assess the impact of single phase high impedance ground faults. The primary objective of the analysis was to determine if a high impedance ground fault could result in an unbalanced voltage condition sufficient to adversely affect energized ESF equipment. The cases analyzed include a single phase high impedance ground fault with all three phases intact and a single phase high impedance ground fault concurrent with the loss of the same phase. These cases have been analyzed for both the high and low voltage sides of the SATs analyzed.

Attachment 11 provides a summary report of the qualitative analysis; therefore, all information discussed in this response attachment is limited to single-phase open circuit conditions.

#### System Description

NRC Requests 2, 1.d, 2.a, and 2.c request system information, and will be addressed in this section.

***NRC Request No. 2: Briefly describe the operating configuration of the ESF buses (Class 1E for current operating plants or non-Class 1E for passive plants) at power (normal operating condition).***

#### Exelon Generation Company, LLC (EGC) Response to NRC Request No. 2

Clinton Power Station, Unit 1 (CPS) has three electrically and physically independent Class 1E engineered safety features (ESF) ac buses (i.e., Divisions 1, 2, and 3). The 4kV ESF buses are 1A1, 1B1, and 1C1 in show in Figure 1 below. Two physically independent offsite power

### ATTACHMENT 3

## Clinton Power Station, Unit 1 Response to NRC Bulletin 2012-01, "Design Vulnerability in Electric Power System"

systems provide electrical power to these ESF buses; the 138kV system, and the 345kV system.

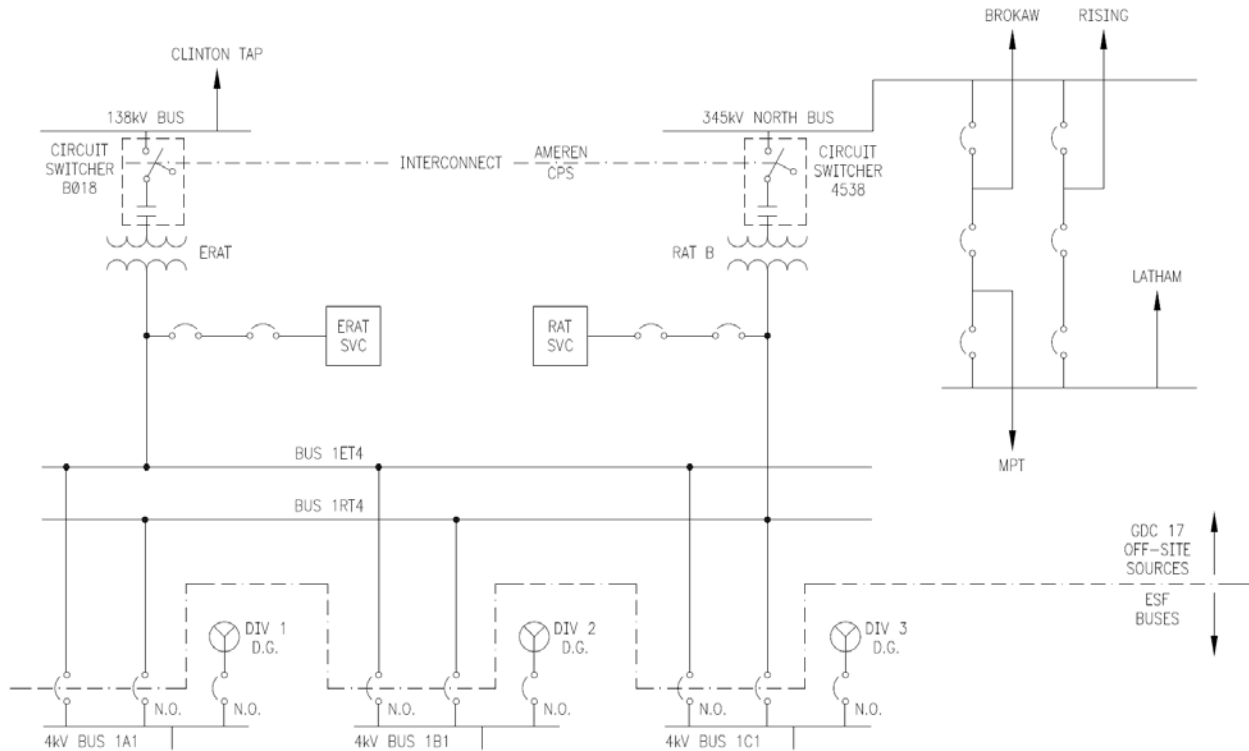

**Figure 1:** One-Line Diagram of CPS Electrical Distribution System

The 138kV system provides power to the station by one, two-terminal transmission line connected to the bulk electric system (BES). The line terminates through a circuit switcher to the Emergency Reserve Auxiliary Transformer (ERAT), which transforms the system voltage to 4.16kV feeding bus 1ET4. Bus 1ET4 provides normal power to Division 1 (i.e., Bus 1A1). The 345kV system provides power to the station through three transmission lines connected to the BES. All three lines terminate at the station switchyard ring bus which feeds Reserve Auxiliary Transformers (RATs) A, B, and C. RAT B transforms the system voltage to 4.16kV feeding bus 1RT4. Bus 1RT4 provides normal power to Division 2 (i.e., Bus 1B1) and Division 3 (i.e., Bus 1C1).

### ATTACHMENT 3

#### Clinton Power Station, Unit 1 Response to NRC Bulletin 2012-01, "Design Vulnerability in Electric Power System"

**NRC Request 1.d:** *Describe the offsite power transformer (e.g., start-up, reserve, station auxiliary) winding and grounding configurations.*

EGC Response to NRC Request 1.d:

The offsite power transformer winding and grounding configurations are shown in Table 1 below.

**Table 1:** CPS Offsite Power Transformer and Grounding Configurations

<b>Transformer</b>	<b>Winding Configuration</b>	<b>MVA Size (Cooling Mode)</b>	<b>Voltage Rating (Primary/Secondary)</b>	<b>Grounding Configuration</b>
Reserve Auxiliary Transformer B	Wye-Wye (3 Leg)	20/26.6/33.34 (ONAN/ONAF/ONAF)	345,000/4160V	High Side Grounded Low Side Resistance Grounded
Emergency Reserve Auxiliary Transformer	Wye-Wye-Buried Tertiary Delta	18/24/30MVA (OA/FA/FA)	137,950/4160V	High Side Grounded Low Side Resistance Grounded Tertiary Delta Grounded (A Phase)

**NRC Request 2.a:** *Are the ESF buses powered by offsite power sources? If so, explain what major loads are connected to the buses including their ratings.*

EGC Response to NRC Request 2.a:

For at-power (i.e., normal operating condition) configurations, the CPS ESF buses are powered by offsite sources. The offsite sources do not carry non-safety loads during normal operations.

The CPS ESF bus power sources are shown in Tables 2 and 3 below.

**Table 2:** CPS ESF Buses Continuously Powered from Offsite Power Source(s)

<b>Description of ESF Bus Power Source</b>	<b>ESF Bus Name (normal operating condition)</b>	<b>Original licensing basis configuration (Y/N)</b>
ERAT	1A1 (i.e., Division 1)	Y
RAT B	1B1 (i.e., Division 2)	Y
RAT B	1C1 (i.e., Division 3)	Y

**ATTACHMENT 3**

**Clinton Power Station, Unit 1 Response to  
NRC Bulletin 2012-01, "Design Vulnerability in Electric Power System"**

**Table 3: ESF Buses Not Continuously Powered From Offsite Power Source(s)**

<b>Description of ESF Bus Power Source</b>	<b>ESF Bus Name (normal operating condition)</b>	<b>Original licensing basis configuration (Y/N)</b>
Not Applicable to CPS	Not Applicable to CPS	Not Applicable to CPS

The major ESF bus loads that are energized during normal power operations, including their ratings, are shown below in Tables 4, 5, and 6 for ESF Buses 1A1, 1B1, and 1C1, respectively.

**Table 4: ESF Bus 1A1 Normally-Energized Major Loads**

<b>Load</b>	<b>Voltage Level (VAC)</b>	<b>Rating (hp/kVA)</b>	<b>Note</b>
480V Unit Sub 1A	4160	750kVA	
480V Unit Sub A1	4160	750kVA	
Drywell Chiller 1A	4000	533kW	1
Fuel Pool Cooling Pump 1A	4000	400hp	1
Shutdown Service Water Pump 1A	4000	1500hp	2
LPCS Pump 1	4000	1250hp	2
RHR Pump 1A	4000	700HP	2

**Table 5: ESF Bus 1B1 Normally-Energized Major Loads**

<b>Load</b>	<b>Voltage Level (VAC)</b>	<b>Rating (hp/kVA)</b>	<b>Note</b>
480V Unit Sub 1B	4160	750kVA	
480V Unit Sub B1	4160	750kVA	
Drywell Chiller 1B	4000	533kW	1
Fuel Pool Cooling Pump 1B	4000	400hp	1
Shutdown Service Water Pump 1B	4000	1500hp	2
RHR Pump 1B	4000	700hp	2
RHR Pump 1C	4000	700hp	2

**Table 6: ESF Bus 1C1 Normally-Energized Major Loads**

<b>Load</b>	<b>Voltage Level (VAC)</b>	<b>Rating (hp/kVA)</b>	<b>Note</b>
480V Unit Sub 1C	4160	225kVA	
HPCS Pump 1	4000	2500hp	2

**Tables 4, 5, and 6 Notes:**

- 1) Normally energized on either bus 1A1 or bus 1B1, but not both.
- 2) Connected, but not energized under normal conditions.

## ATTACHMENT 3

### Clinton Power Station, Unit 1 Response to NRC Bulletin 2012-01, "Design Vulnerability in Electric Power System"

***NRC Request 2.c: Confirm that the operating configuration of the ESF buses is consistent with the current licensing basis. Describe any changes in offsite power source alignment to the ESF buses from the original plant licensing.***

#### EGC Response to NRC Request 2.c:

The Class 1E AC distribution system supplies electrical power to three divisional load groups, with each division powered by an independent Class 1E 4.16 kV ESF bus. Each ESF bus has two separate and independent offsite sources of power. Each ESF bus has a dedicated onsite diesel generator (DG). The ESF systems of any two of the three divisions provide for the minimum safety functions necessary to shut down the unit and maintain it in a safe shutdown condition.

The following at power (i.e., normal operating conditions) configurations have been confirmed to be consistent with the current licensing basis (CLB):

1. Power to ESF bus 1A1 via 138kV system and ERAT.
2. Power to ESF bus 1B1 via 345kV system and RAT B.
3. Power to ESF bus 1C1 via 345kV system and RAT B.

There have been no changes in the offsite power source alignment to the ESF buses from the original plant licensing. RAT B and the ERAT are fully capable of supplying power to all three ESF buses and the plant licensing basis does not specify a particular ESF bus alignment. In response to the Byron Station event, CPS changed the normal bus alignment from all three ESF buses powered by RAT B to a split configuration where Bus 1A1 is powered by one source while Buses 1B1 and 1C1 are maintained on the other source.

## ATTACHMENT 3

### Clinton Power Station, Unit 1 Response to NRC Bulletin 2012-01, "Design Vulnerability in Electric Power System"

#### System Protection

NRC Requests 1, 1.a, 2.b, and 2.d request information regarding electrical system protection, and will be addressed in this section.

***NRC Request 1: Given the requirements above, describe how the protection scheme for ESF buses (Class 1E for current operating plants or non-Class 1E for passive plants) is designed to detect and automatically respond to a single-phase open circuit condition or high impedance ground fault condition on a credited off-site power circuit or another power sources. Also, include the following information:***

#### EGC Response to NRC Request 1:

Consistent with the CLB and 10 CFR 50, Appendix A, "General Design Criteria for Nuclear Power Plants," Criterion (GDC) 17, "Electric power systems," existing protective circuitry will separate the ESF buses from a connected failed offsite source due to a loss of voltage or a sustained, balanced degraded grid voltage concurrent with certain design basis accidents (DBAs). The relay systems were not specifically designed to detect a single open phase of a three phase system. Detection of a single-open phase condition is beyond the approved design and licensing basis of the plant.

CPS utilizes two static VAR compensators (SVCs); one on the secondary side of each offsite source transformer. The SVCs have redundant voltage unbalance relays that have at least some capability of detecting an open single phase. Operating experience at CPS has shown that the relays will actuate with a depressed single phase. The SVC is automatically separated from the secondary side of the respective transformer when a voltage unbalance is detected. The purpose of the relays is to protect the SVC, not the ESF buses; therefore, there is no automatic action taken to separate the offsite source. The extent to which the relays are effective would involve extensive analysis, including the development of detailed plant specific models.

During normal plant operation, ESF bus 1A1 is fed from the ERAT while ESF buses 1B1 and 1C1 are fed from RAT B. An open single-phase on either offsite source would result in the trip of the SVC associated with that source as well as a MCR alarm. Upon receipt of the alarm, Operators verify bus voltages and take appropriate actions to align the affected bus to the other, unaffected, offsite source.

Buses 1A1 and 1B1 have redundant, but non-coincidental loads that are energized during normal operation. Maintenance activities and surveillances determine which bus will be carrying the normally energized loads. If a single open-phase condition were to occur on the offsite source powering the energized loads, it is expected that the protection scheme for the associated load will actuate. The actuation of the protective circuits (e.g., motor overloads, etc.) will provide additional indication to the MCR. With buses 1A1 and 1B1 powered by separate offsite sources, the redundant, non-coincidental loads can be powered by the unaffected offsite source.

**ATTACHMENT 3**

**Clinton Power Station, Unit 1 Response to  
NRC Bulletin 2012-01, "Design Vulnerability in Electric Power System"**

***NRC Request 1.a: The sensitivity of protective devices to detect abnormal operating conditions and the basis for the protective device setpoint(s).***

EGC Response to NRC Request 1.a:

Consistent with the CLB and GDC 17, existing electrical protective devices are sufficiently sensitive to detect design basis conditions like a loss of voltage or a degraded voltage, but were not designed to detect a single phase open circuit condition. Undervoltage protective devices and the basis for the device setpoint(s) are shown in Table 7 below.

**Table 7: Protective Devices**

<b>Protection Zone</b>	<b>Protective Device</b>	<b>UV Logic</b>	<b>Setpoint (Nominal)</b>	<b>Basis for Setpoint</b>
4.16kV ESF Bus 1A1 (1B1)	Loss of Voltage Relay	2 of 2	2870V (69% of 4160V) 2.2s at 0V	To detect complete loss of voltage on bus 1A1 (1B1), bus 1RT4, and bus 1ET4.
4.16kV ESF Bus 1A1 (1B1)	Degraded Voltage Relay	2 of 2	4078V (98% of 4160V) 14.9s Delay	To detect degraded voltage on bus 1A1 (1B1).
4.16kV ESF Bus 1A1 (1B1)	Bus Phase Overcurrent		12A Tap 800:5 TD 10 1.3s	To provide time overcurrent protection for bus 1A1 (1B1).
4.16kV ESF Bus 1A1 (1B1)	Bus Neutral Overcurrent		0.5A Tap 800:5 TD 10 0.75s	To provide ground fault protection for bus 1A1 (1B1).
4.16kV ESF Bus 1C1	Loss of Voltage Relay	1 of 2 Taken Twice	2520V (60.6% of 4160V) 2.5s at 0V	To detect complete loss of voltage on bus 1C1, bus 1RT4, and bus 1ET4.
4.16kV ESF Bus 1C1	Degraded Voltage Relay	2 of 2	4078V (98% of 4160V) 14.9s Delay	To detect degraded voltage on bus 1C1.
4.16kV ESF Bus 1C1	Bus Phase Overcurrent		12A Tap 1200:5 TD 3.5 1.4s	To provide time overcurrent protection for bus 1C1.



**ATTACHMENT 3**

**Clinton Power Station, Unit 1 Response to  
NRC Bulletin 2012-01, "Design Vulnerability in Electric Power System"**

<b>Protection Zone</b>	<b>Protective Device</b>	<b>UV Logic</b>	<b>Setpoint (Nominal)</b>	<b>Basis for Setpoint</b>
4.16kV ESF Bus 1C1	Bus Neutral Overcurrent		0.5A Tap 1200:5 TD 1.5 0.6s	To provide ground fault protection for bus 1C1.
4.16kV Bus 1RT4	Differential Current		195V 3A 5000:5 CT	To provide fault detection for bus 1RT4.
4.16kV Bus 1ET4	Differential Current		75V 3A 4000:5 CT	To provide fault detection for bus 1ET4.
RAT SVC	Voltage Unbalance		1V Tap 10s Dropout=95% of PU = 0.95V (4200-120 PT)	Trips SVC and alarms in MCR. Does not provide protection for the offsite source.
ERAT SVC	Voltage Unbalance		1V Tap 10s Dropout=95% of PU = 0.95V (4200-120 PT)	Trips SVC and alarms in MCR. Does not provide protection for the offsite source.
RAT B	4.16kV Winding Ground Fault		1.5A Tap (360A) TD 2.0 (1200:5)	To provide ground fault detection for the transformer secondary winding and 4kV system that may overload the transformer.
RAT B	345kV Winding Ground Fault		1A Tap (40A) TD 1.0 (200:5)	To provide ground fault detection for the transformer primary winding and 138kV system that may overload the transformer.
RAT B	345kV Instantaneous and Time Overcurrent		2.5A Tap (100A, 175%) TD 2.75 22A (880A)	To provide transformer overload and fault protection.
RAT B	Differential Current		2.9A Tap (200:5 primary 5000:5 secondary)	To provide fault detection between the load side of circuit switcher 4538 and buses 1RT4 and 1ET4.

### ATTACHMENT 3

#### Clinton Power Station, Unit 1 Response to NRC Bulletin 2012-01, "Design Vulnerability in Electric Power System"

Protection Zone	Protective Device	UV Logic	Setpoint (Nominal)	Basis for Setpoint
345kV North Bus	Differential Current		200V 14A	To provide fault detection between RAT B primary winding and breakers 4502 and 4522.
ERAT	4.16kV Winding Ground Fault		0.8A Tap (192A, 16%) TD 3.2 (1200:5)	To provide ground fault detection for the transformer secondary winding and 4kV system that may overload the transformer.
ERAT	138kV Winding Ground Fault		1.5A Tap (180A, 243%) TD 4.0 (600:5)	To provide ground fault detection for the transformer primary winding and 138kV system that may overload the transformer.
ERAT	138kV Instantaneous and Time Overcurrent		5A Tap (200A, 159%) TD 3.8 Inst. = 1640A (200:5)	To provide transformer winding fault detection and backup protection for secondary side faults.
ERAT	Differential Current		4.2A Tap (250:5 primary 4000:5 secondary)	To provide fault detection between the load side of circuit switcher B018 and bus 1ET4.

Existing electrical protective devices are also sufficiently sensitive to detect a ground fault. Ground protection on the ESF buses and the basis for the device setpoint(s) are also shown in Table 7.

***NRC Request 2.b. If the ESF buses are not powered by offsite power sources, explain how the surveillance tests are performed to verify that a single-phase open circuit condition or high impedance ground fault condition on an off-site power circuit is detected.***

EGC Response to NRC Request 2.b:

Not Applicable - the ESF buses at CPS are powered by offsite power sources.

### ATTACHMENT 3

#### Clinton Power Station, Unit 1 Response to NRC Bulletin 2012-01, "Design Vulnerability in Electric Power System"

***NRC Request 2.d: Do the plant operating procedures, including off-normal operating procedures, specifically call for verification of the voltages on all three phases of the ESF buses?***

EGC Response to NRC Request 2.d:

The current plant operating procedures, including operating procedures for off-normal alignments, call for verification of the voltages on all three phases of the ESF buses.

## ATTACHMENT 3

### Clinton Power Station, Unit 1 Response to NRC Bulletin 2012-01, "Design Vulnerability in Electric Power System"

#### Consequences

NRC Requests 1.b, 1.c, and 2.e request information regarding the electrical consequences of an event, and will be addressed in this section.

***NRC Request 1.b: The differences (if any) of the consequences of a loaded (i.e., ESF bus normally aligned to offsite power transformer) or unloaded (e.g., ESF buses normally aligned to unit auxiliary transformer) power source.***

#### EGC Response to NRC Request 1.b:

Installed relays were not designed to detect single phase open circuit conditions. Existing loss of voltage and degraded voltage relays may respond depending on load and possible grounds. The SVCs are designed to provide a reactive load to RAT B and ERAT. This loading enhances the ability of the voltage unbalance relays to detect a single open phase and may provide sufficient current for ground detection.

The plant response for a loaded power source cannot be calculated without specifying the amount of loading and the specific loads involved. Extensive modeling and analysis would have to be performed to determine the impact that SVC loading has on detecting a single open phase.

***NRC Request 1.c: If the design does not detect and automatically respond to a single-phase open circuit condition or high impedance ground fault condition on a credited offsite power circuit or another power sources, describe the consequences of such an event and the plant response.***

#### EGC Response to NRC Request 1.c:

1. CPS did not credit in the CLB that the Class 1E protection scheme ESF buses was designed to detect and automatically respond to a single-phase open circuit condition on the credited offsite power source as described in the Updated Safety Analysis Report (USAR) and Technical Specifications (TS).

The offsite power circuits at CPS consist of two independent circuits. As discussed in the CPS TS Bases B 3.8.1, "AC Sources – Operating," each offsite circuit consists of incoming breakers and disconnects to the respective RAT or ERAT and the respective circuit path including feeder breakers to each of the 4.16kV ESF buses. The first source originates at 345kV Circuit Switcher 4538 and ends at a feeder breaker at each ESF bus. The second source originates at 138kV Circuit Switcher B018 and ends at a feeder breaker at each ESF bus.

## ATTACHMENT 3

### Clinton Power Station, Unit 1 Response to NRC Bulletin 2012-01, "Design Vulnerability in Electric Power System"

The SVC voltage unbalance relays have the capability of detecting a single open phase. The SVCs are automatically separated from the secondary side of their respective transformer when a voltage unbalance is detected, but no automatic action is taken to separate the offsite source. When the SVC trips off-line, an alarm is received in the Main Control Room (MCR). Upon receipt of the alarm, the ESF bus voltages are verified and appropriate actions are taken based on those voltages.

2. Since CPS did not credit the ESF bus protection scheme as being capable of detecting and automatically responding to a single phase open circuit condition, an open phase fault was not included in the design criteria for either the loss of voltage, the degraded voltage relay scheme or secondary level undervoltage protection system design criteria. Since open phase detection was not credited in the CPS design or licensing basis, no design basis calculations or design documents exist that previously considered this condition.
3. Without formalized engineering calculations or engineering evaluations, the electrical consequences of such an open phase event, including the plant response, can only be evaluated to the extent of what has already been published by the Electric Power Research Institute (EPRI) and Basler; which is a generic overview. The difficulty in applying these documents to the CPS specific response is that these are generic assessments and cannot be formally credited as a basis for an accurate response. The primary reason is that detailed plant specific models would need to be developed (e.g., transformer magnetic circuit models, electric distribution models, motor models; including positive, negative, and zero sequence impedances, voltage, and currents), and the models would need to be compiled and analyzed for the CPS specific Class 1E electric distribution system.
4. The SVCs provide reactive load to the associated 4.16kV bus. Neither offsite source is operated unloaded during normal conditions. This loading enhances the ability of the SVC voltage unbalance relay to detect a single open-phase condition.
5. The degraded voltage scheme at CPS utilizes an open delta configuration on the potential transformers with 2 out of 2 coincidence logic. The "B" phase is common to both relays. An open phase on Phase "A" or Phase "C" may not be detected by the existing degraded voltage relay scheme.
6. An open single-phase on RAT B would affect both Division 2 and 3. Division 1 is redundant to Division 2. Division 1 would be unaffected and could accomplish the intended DBA safety function. An open single-phase on the ERAT would only affect Division 1, leaving both Divisions 2 and 3 unaffected and available to respond to a DBA.
7. The following interim compensatory actions were taken to promptly diagnose and respond to degraded offsite power sources due to single-phase open circuit conditions:
  - a. Prepared required reading packages for all Licensed Operators
  - b. Aligned plant voltmeters to ensure all phases are monitored
  - c. Created Operator aids and placards
  - d. Enhanced alarm and annunciator response procedures
  - e. Implemented a designated operator to isolate the safety buses from the grid in a timely fashion

## ATTACHMENT 3

### Clinton Power Station, Unit 1 Response to NRC Bulletin 2012-01, "Design Vulnerability in Electric Power System"

- f. Aligned normal configuration of ESF bus 1A1 on one offsite source with bus 1B1 on the other offsite source
  - g. Aligned non-safety loads on UAT to enhance protection for BOP loads
8. CPS is currently developing a plant modification to provide automatic protection from single open-phase circuit conditions for offsite power sources supplying Class 1E ESF buses.

***NRC Request 2.e: If a common or single offsite circuit is used to supply redundant ESF buses, explain why a failure, such as a single-phase open circuit or high impedance ground fault condition, would not adversely affect redundant ESF buses.***

#### EGC Response to NRC Request 2.e:

Division 1 and 2 are redundant divisions. To minimize the affect of a single open phase on an offsite source, buses 1A1 and 1B1 are maintained on separate sources. However, as discussed in the CPS TS Bases, Division 3 is considered redundant to both Division 1 and 2 with respect to emergency core cooling systems. Therefore, a common offsite source is used to supply redundant ESF buses.

Consistent with the CLB and GDC 17, protective circuitry will separate the ESF buses from a failed offsite source due to a loss of voltage or a sustained balanced degraded grid voltage concurrent with certain DBAs. The relay systems were not specifically designed to detect an single open phase of a three phase system. Detection of a single-open phase circuit is beyond the approved design and licensing basis of CPS. No calculations for this scenario have been done.

Consistent with the current station design, protective circuitry will protect from a ground fault condition with all three phases intact.

CPS Procedure 3501.01, "High Voltage Auxiliary Power System," was revised as a compensatory measure to provide operator additional guidance for quickly identifying and responding to an open single-phase condition. Additional compensatory measures taken include:

- a. Prepared required reading packages for all Licensed Operators
- b. Aligned plant voltmeters to ensure all phases are monitored
- c. Created Operator aids and placards
- d. Enhanced alarm and annunciator response procedures
- e. Implemented a designated operator to isolate the safety buses from the grid in a timely fashion
- f. Aligned normal configuration of ESF bus 1A1 on one offsite source with bus 1B1 on the other offsite source
- g. Aligned non-safety loads on UAT to enhance protection for BOP loads

**ATTACHMENT 4**

**Dresden Nuclear Power Station, Units 2 and 3, 90-Day Response to NRC Bulletin  
2012-01, "Design Vulnerability in Electric Power System"**

## ATTACHMENT 4

### Dresden Nuclear Power Station, Units 2 and 3 Response to NRC Bulletin 2012-01, "Design Vulnerability in Electric Power System"

#### High Impedance Grounds:

On January 30, 2012, a porcelain insulator broke in the Byron Station switchyard resulting in parting of the C phase conductor of the offsite source. The insulator was on the offsite source side of the Unit 2 System Auxiliary Transformers (SATs), and the connection parted in such a way as to leave an electrically open end on the source side. The parted connection remained electrically connected on the transformer side, and the loose bus bar conductor end fell to the ground. This ground was a direct result of the broken insulator and not an independent event. The connected loose bus bar provided a path to ground for the transformer high voltage terminal, but did not result in a ground fault (i.e., neither solid nor impedance) as seen from the source. Since the switchyard (i.e., source side) relaying was electrically isolated from the fault, it did not detect a fault; therefore, did not operate.

The significant event was the opening of a single phase connection; the ground on the high voltage side of the SAT is of lesser significance. Regardless of phase discontinuity, if the ground impedance is low on the source side, and currents are high, the source side protective relaying will operate and open all circuit phases. If the ground impedance is high, and currents low, the relaying may not operate depending on the magnitude of ground impedance; the circuit will continue to supply power.

A qualitative analysis has been performed to assess the impact of single phase high impedance ground faults. The primary objective of the analysis was to determine if a high impedance ground fault could result in an unbalanced voltage condition sufficient to adversely affect energized ESF equipment. The cases analyzed include a single phase high impedance ground fault with all three phases intact and a single phase high impedance ground fault concurrent with the loss of the same phase. These cases have been analyzed for both the high and low voltage sides of the SATs analyzed.

Attachment 11 provides a summary report of the qualitative analysis; therefore, all information discussed in this response attachment is limited to single-phase open circuit conditions.

#### System Description

NRC Requests 2, 1.d, 2.a, and 2.c request system information, and will be addressed in this section.

***NRC Request No. 2: Briefly describe the operating configuration of the ESF buses (Class 1E for current operating plants or non-Class 1E for passive plants) at power (normal operating condition).***

#### Exelon Generation Company, LLC (EGC) Response to NRC Request No. 2

The Dresden Nuclear Power Station (DNPS), Units 2 and 3 engineered safety features (ESF) buses are powered either from the main generator or from offsite power (i.e., capable of being transferred to and/or from the main generator). A simplified one-line diagram is shown in Figure 1 below. Normally the electrical auxiliary distribution system is operated in a split bus



## ATTACHMENT 4

### Dresden Nuclear Power Station, Units 2 and 3 Response to NRC Bulletin 2012-01, "Design Vulnerability in Electric Power System"

configuration where the Division I ESF bus is supplied from the main generator via the unit auxiliary transformer (UAT) and the Division II bus is supplied from the 345kV system via the reserve auxiliary transformer (RAT).

The 345kV system provides continuously connected offsite power to two three winding RATs (i.e., RAT TR22 and RAT TR32) for DNPS, Unit 2 and Unit 3, respectively. A 345/138kV 2 winding auto transformer (i.e., TR86) is installed between the 345kV system and RAT TR22. During normal split bus operation, the RAT TR22 X-winding provides power to ESF 4kV Buses 24/24-1 and the RAT TR32 X-winding provides power to ESF Buses 34/34-1. The transformer Y-windings provide power to the non-ESF 4kV Buses 22 and 32.

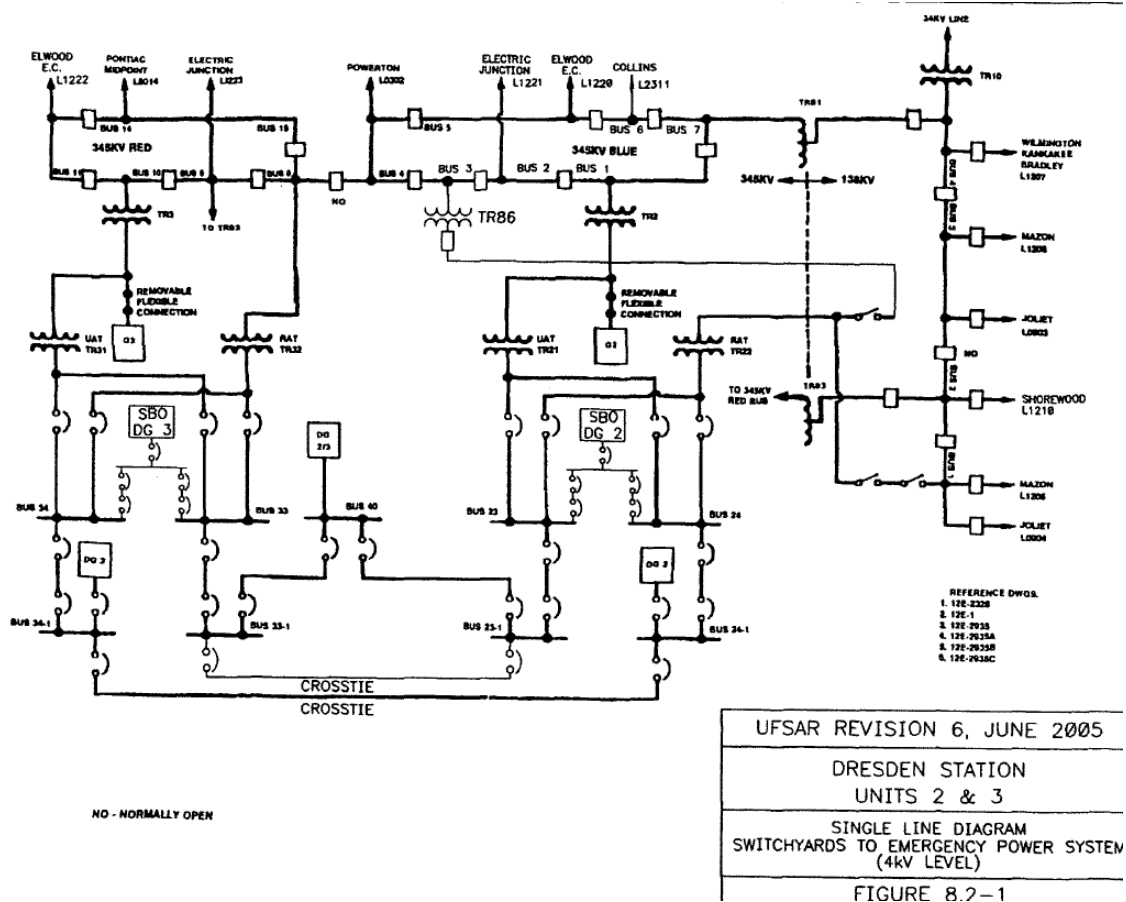

**Figure 1:** Simplified One-Line Diagram

**ATTACHMENT 4**

**Dresden Nuclear Power Station, Units 2 and 3 Response to  
NRC Bulletin 2012-01, "Design Vulnerability in Electric Power System"**

**NRC Request 1.d:** *Describe the offsite power transformer (e.g., start-up, reserve, station auxiliary) winding and grounding configurations.*

EGC Response to NRC Request 1.d:

The DNPS offsite power transformer winding and grounding configurations are shown in Table 1 below.

**Table 1:** Offsite Power Transformer Winding and Grounding Configurations

<b>Unit</b>	<b>Transformer</b>	<b>Winding Configuration</b>	<b>MVA (Cooling Type)</b>	<b>Grounding Configuration</b>
2	138/4.16kV Reserve Auxiliary Transformer TR22	Wye-Wye-Wye (3 Leg)	27.6/36.8/46 (OA/FA/FA) 55°C 30.9/41.2/51.5 (OA/FA/FA) 65°C	Solid Neutral Grounded Primary Resistive Neutral Grounded Secondary
	345/138kV Autotransformer TR86	Wye-Wye (Auto)	100/133/167 (ONAN/ONAF/ONAF) 55°C 112/149/187 (ONAN/ONAF/ONAF) 65°C	Solid Neutral Grounded
3	345/4.28kV Reserve Auxiliary Transformer TR32	Wye-Wye-Wye (3 Leg)	37.5/50/62.5 (ONAN/ONAF/ONAF) 65°C	Solid Neutral Grounded Primary Resistive Neutral Grounded Secondary

**NRC Request 2.a:** *Are the ESF buses powered by offsite power sources? If so, explain what major loads are connected to the buses including their ratings.*

EGC Response to NRC Request 2.a:

For at power (i.e., normal operating conditions) configurations, ESF Division II buses are powered by offsite sources.

The DNPS ESF bus power sources are shown in Tables 2 and 3 below.

**ATTACHMENT 4**

**Dresden Nuclear Power Station, Units 2 and 3 Response to  
NRC Bulletin 2012-01, "Design Vulnerability in Electric Power System"**

**Table 2: DNPS 4kV ESF Buses That Are Continuously Powered from Offsite Power Source(s)**

Description of ESF Bus Power Source	ESF Bus Name (normal operating condition).	Original licensing basis configuration (Y/N)
Unit 2 Circuit #1-Unit 2 345kV Switchyard (Blue System) to 345kV-138kV TR86 to 138-4.16kV RAT TR22	4.16kV Buses 24/24-1 (Division II)	N (See Note)
<b>Note:</b> Unit 2 Original Licensing basis – 138kV Switchyard to 138kV-4.16kV RAT TR22 to 4.16kV ESF Buses 24/24-1 (Division II)		
Unit 3 Circuit #1 -345kV Switchyard (Red System) to 345kV-4.16kV RAT TR32	4.16kV Buses 34/34-1(Division II)	Y

**Table 3: DNPS ESF Buses That Are Not Continuously Powered From Offsite Power Source(s)**

Description of ESF Bus Power Source	ESF Bus Name (normal operating condition).	Original licensing basis configuration (Y/N)
Unit 2 – Main Generator to UAT TR21	4.16kV Buses 23/23-1 (Division I)	Y
Unit 3 – Main Generator to UAT TR31	4.16kV Buses 33/33-1 (Division I)	Y

The DNPS ESF bus major loads that are connected to offsite power during normal power operations, including their ratings are shown in Table 4 below.

**Table 4: Major ESF Loads Including Ratings and Status during Normal Power Operations**

ESF Bus	Load	Voltage Level (kV)	Rating (hp)	Safety Class	Normally Energized (Y/N)
24	Circulating Water Pump 2C	4	1750	NS	Y
24	Service Water Pump 2B	4	1000	NS	Y
24	Service Water Pump 2/3	4	1000	NS	Y*
24	480V Switchgear (SWGR) 20	4	1000 (KVA)	NS	Y
24	480V SWGR 26	4	1500 (KVA)	NS	Y
24	480V SWGR 27	4	1500 (KVA)	NS	Y
24	Condensate & Booster Pump 2C	4	1750	NS	Y
24	Condensate & Booster Pump 2D	4	1750	NS	Y

## ATTACHMENT 4

### Dresden Nuclear Power Station, Units 2 and 3 Response to NRC Bulletin 2012-01, "Design Vulnerability in Electric Power System"

ESF Bus	Load	Voltage Level (kV)	Rating (hp)	Safety Class	Normally Energized (Y/N)
24	Control Rod Drive Feed Pump 2B	4	250	NS	Y
24	Containment Cooling Service Water Pump 2C	4	500	SR	N
24	Containment Cooling Service Water Pump 2D	4	500	SR	N
24-1	Reactor (Rx) Bldg Cooling Water Pump 2B	4	300	NS	Y
24-1	Rx Bldg Cooling Water Pump 2/3	4	300	NS	Y*
24-1	Rx Shut-down Cooling Pump 2B	4	500	NS	N
24-1	Rx Clean-up Recirculation Pump 2B	4	600	NS	Y
24-1	480 SWGR 29	4	1500 (KVA)	SR	Y
24-1	Core Spray Pump 2B	4	800	SR	N
24-1	Low Pressure Coolant Injection Pump 2C	4	700	SR	N
24-1	Low Pressure Coolant Injection Pump 2D	4	700	SR	N
34	Circ Water Pump 3C	4	1750	NS	Y
34	Service Water Pump 3B	4	1000	NS	Y
34	Service Water Pump 2/3	4	1000	NS	Y*
34	480V SWGR 30	4	1000 (KVA)	NS	Y
34	480V SWGR 36	4	1500 (KVA)	NS	Y
34	480V SWGR 37	4	1500 (KVA)	NS	Y
34	Condensate & Booster Pump 3C	4	1750	NS	Y
34	Condensate & Booster Pump 3D	4	1750	NS	Y
34	Control Rod Drive Feed Pump 3B	4	250	NS	Y
34	Containment Cooling Service Water Pump 3C	4	500	SR	N
34	Containment Cooling Service Water Pump 3D	4	500	SR	N
34-1	Rx Bldg Cooling Water Pump 3B	4	300	NS	Y
34-1	Rx Bldg Cooling Water Pump 2/3	4	300	NS	Y*
34-1	RX Shut-down Cooling Pump 3B	4	500	NS	N
34-1	RX Shut-down Cooling Pump 3C	4	500	NS	N

**ATTACHMENT 4**

**Dresden Nuclear Power Station, Units 2 and 3 Response to  
NRC Bulletin 2012-01, "Design Vulnerability in Electric Power System"**

<b>ESF Bus</b>	<b>Load</b>	<b>Voltage Level (kV)</b>	<b>Rating (hp)</b>	<b>Safety Class</b>	<b>Normally Energized (Y/N)</b>
34-1	Rx Clean-up Recirculation Pump 3B	4	600	NS	Y
34-1	480 SWGR 39	4	1500 (KVA)	SR	Y
34-1	Core Spray Pump 3B	4	800	SR	N
34-1	Low Pressure Coolant Injection Pump 3C	4	700	SR	N
34-1	Low Pressure Coolant Injection Pump 3D	4	700	SR	N
<p>*Swing load – may not be energized depending on swing source alignment.                      NS – Non Safety-Related                      SR – Safety Related</p>					

## ATTACHMENT 4

### Dresden Nuclear Power Station, Units 2 and 3 Response to NRC Bulletin 2012-01, "Design Vulnerability in Electric Power System"

***NRC Request 2.c: Confirm that the operating configuration of the ESF buses is consistent with the current licensing basis. Describe any changes in offsite power source alignment to the ESF buses from the original plant licensing.***

#### EGC Response to NRC Request 2.c:

The following at power (i.e., normal operating conditions) configurations have been confirmed to be consistent with the current licensing basis (CLB):

1. Unit 2 Offsite Power Circuit #1- Power to ESF buses via 345kV switchyard (TR86 and RAT TR22)
2. Unit 3 Offsite Power Circuit #1 - Power to ESF buses via 345kV (i.e., RAT TR32)

See Table 2 for any changes in the offsite power source alignment to the ESF buses during normal operation from the original plant licensing.

Additionally, the following offsite power configurations, although not normally operating, are available:

1. Unit 2 Offsite Power Circuit #2 - Power to ESF buses via 345kV switchyard (i.e., RAT TR32) and the unit 4kV bus cross-ties.
2. Unit 3 Offsite Power Circuit #2 - Power to ESF buses via 345kV switchyard (i.e., TR86 and RAT TR22) and the unit 4kV bus cross-ties.
3. An additional source of off-site power for Units 2 and 3 is available when the main generator is off-line by back feeding through the main power/unit auxiliary transformers. The backfeed operation must be manually performed and involves removal of flexible link connections between the main generator and main power transformer (MPT)/UAT.

## ATTACHMENT 4

### Dresden Nuclear Power Station, Units 2 and 3 Response to NRC Bulletin 2012-01, "Design Vulnerability in Electric Power System"

#### System Protection

NRC Requests 1, 1.a, 2.b, and 2.d request information regarding electrical system protection, and will be addressed in this section.

***NRC Request 1: Given the requirements above, describe how the protection scheme for ESF buses (Class 1E for current operating plants or non-Class 1E for passive plants) is designed to detect and automatically respond to a single-phase open circuit condition or high impedance ground fault condition on a credited off-site power circuit or another power sources. Also, include the following information:***

#### EGC Response to NRC Request 1:

Consistent with the CLB and 10 CFR 50, Appendix A, "General Design Criteria for Nuclear Power Plants," Criterion (GDC) 17, "Electric power systems," existing protective circuitry will separate the ESF buses from a connected failed source due to a loss of voltage, or a sustained, balanced degraded grid voltage concurrent with certain design basis accidents. The failure of a single-phase circuit to an open condition is beyond the approved design and licensing basis of the plant and therefore constitutes a beyond design basis event.

#### Normal Plant Operation Considerations:

During normal plant operation (i.e., Modes 1, 2, and 3) the Division I emergency buses (i.e., ESF buses) are powered from the UAT. An open phase on the MPT 345kV side would have no effect on the ESF bus voltage. Since the UAT is tied directly to the generator terminals, it will continue to receive three phase voltage on its primary side for as long as the generator remains online. If the generator trips on negative sequence due to the open MPT phase, the ESF Division I bus on the UAT X-winding and the balance of plant (BOP) bus on the UAT Y-winding will automatically transfer to their alternate source (i.e., the RAT). Therefore, an open phase on the MPT high side while the plant is in normal operation is not of concern.

An open phase on the UAT primary side while the isophase, generator and MPT connections remain intact is not credible due to the isophase bus connection arrangement, which makes it highly unlikely that a phase would open without also shorting to ground and tripping the generator.

During normal plant operation (i.e., Modes 1, 2, or 3) the loss of voltage and degraded voltage relaying scheme is capable of responding to degraded grid conditions as described in applicable NRC and industry guidelines. However, the protection scheme at DNPS is not designed to detect and automatically respond to unbalanced system conditions as a result of single phase open circuit condition or high impedance ground fault condition on a credited off-site power circuit.

The insulator failure at Byron Station resulted in unbalanced system voltage at the ESF buses, and the buses did not automatically separate and realign to the EDGs to restore bus voltage. The Byron Station event was caused by a passive failure of a switchyard component. Detection

## ATTACHMENT 4

### Dresden Nuclear Power Station, Units 2 and 3 Response to NRC Bulletin 2012-01, "Design Vulnerability in Electric Power System"

down to the level of this type of failure is beyond the requirements of NRC documents such as GDC 17 or NRC Branch Technical Position (BTP) PSB-1, "Adequacy of Station Electric Distribution System Voltages," and was not considered as part of original plant design.

GDC 17 did not define degraded voltage as an unbalanced system. As such, the industry failure mode effects analysis (FMEA), implied or otherwise, did not address a single open phase as design criteria for a degraded voltage relay (DVR) scheme. Therefore, open phase detection was not credited in the original plant's design or licensing basis.

DNPS has reviewed the vulnerability for impact on plant operability using the Operability Evaluation process. DNPS has revised several procedures, such as annunciator response and operating procedures as needed in response to the Byron Station event. These procedures now provide effective controls to promptly diagnose and mitigate a single phase event. Operators have been trained to check voltages, currents, and other control room alarms in order to diagnose and respond to a single-phase event.

***NRC Request 1.a: The sensitivity of protective devices to detect abnormal operating conditions and the basis for the protective device setpoint(s).***

EGC Response to NRC Request 1.a:

Consistent with the CLB and GDC 17, existing electrical protective devices are sufficiently sensitive to detect design basis conditions like a loss of voltage or a degraded voltage, but were not designed to detect a single phase open circuit condition. Existing electrical protective devices are also sufficiently sensitive to detect a ground fault.

The undervoltage protective devices and the basis for the device setpoints for DNPS, Units 2 and 3 are shown in Tables 5 and 6 below, respectively. Tables 5 and 6 also list the other protective devices for the offsite circuit and the ESF buses and the basis for the device setpoints.

**Table 5: Unit 2 Protective Devices**

Protection Zone	Protective Device	Trip Logic	Setpoint (Nominal)	Basis for Setpoint
4.16kV ESF Buses 24 and 24-1	Loss of Voltage Relay	2 of 2	2929.5V (70.42% of 4160V)	To actuate upon complete loss of ESF Bus voltage condition
4.16kV ESF Bus 24-1	Degraded Grid	2 of 2	3867.5V (92.97% of 4160V)	To actuate upon degraded ESF Bus voltage condition (Alarm only on 1 of 2 logic)
4.16kV ESF Bus 24 Feed from RAT	Phase Overcurrent	1 of 1	4800A @TL 4.0	To actuate upon ESF Bus overcurrent condition



**ATTACHMENT 4**

**Dresden Nuclear Power Station, Units 2 and 3 Response to  
NRC Bulletin 2012-01, "Design Vulnerability in Electric Power System"**

<b>Protection Zone</b>	<b>Protective Device</b>	<b>Trip Logic</b>	<b>Setpoint (Nominal)</b>	<b>Basis for Setpoint</b>
4.16kV ESF Bus 24-1 Feed from Bus 24	Phase Overcurrent	1 of 1	1920A @TL 4.0	To actuate upon ESF Bus overcurrent condition
4.16kV ESF Bus 24 Feed from RAT	Ground Overcurrent	1 of 1	240A @ TL 4.0	To actuate upon ESF Bus ground fault condition
4.16kV ESF Bus 24-1 Feed from Bus 24	Ground Overcurrent	1 of 1	144A @TL 3.2	To actuate upon ESF Bus ground fault condition
RAT	Differential	1 of 1	252A at 138kV 8700A at 4160V 25% Slope	To actuate upon a RAT H,X,Y-winding protection zone fault
RAT	Phase Overcurrent	1 of 1	277A @TL 5.0	To actuate upon RAT overcurrent condition
RAT	X-Winding Neutral Overcurrent	1 of 1	360A @TL 4.5	To actuate upon RAT X-winding neutral ground fault condition
RAT	X-Winding Ground Differential	1 of 1	480A @TL 3.0	To actuate upon RAT X-winding low level ground fault condition
TR86	Differential Sys 1 (SEL-387)	1 of 1	135.68A at 345kV 339.2A at 138kV 30% Slope	To actuate upon a TR86 protection zone fault
TR86	Differential Sys 2 (SEL-387)	1 of 1	134.4A at 345kV 339.2A at 138kV 30% Slope	To actuate upon a TR86 protection zone fault
TR86	Phase Overcurrent Sys 1 (SEL-321)	1 of 1	256A @TL2.0	To actuate upon transformer or line overcurrent condition

**ATTACHMENT 4**

**Dresden Nuclear Power Station, Units 2 and 3 Response to  
NRC Bulletin 2012-01, "Design Vulnerability in Electric Power System"**

<b>Protection Zone</b>	<b>Protective Device</b>	<b>Trip Logic</b>	<b>Setpoint (Nominal)</b>	<b>Basis for Setpoint</b>
TR86	Phase Overcurrent Sys 2 (SEL-321)	1 of 1	800A @TL 3.0	To actuate upon transformer or line overcurrent condition
TR86	138 kV Line Relay Primary (P544)	1 of 1	600A 30% Slope 4012A 150% Slope	To actuate upon a 138 kV Line fault
TR86	138 kV Line Relay Secondary (SEL-311L)	1 of 1	800A Phase Differential 600A Neg-Seq Differential	To actuate upon a 138 kV Line fault

**Table 6:** Unit 3 Protective Devices

<b>Protection Zone</b>	<b>Protective Device</b>	<b>Trip Logic</b>	<b>Setpoint (Nominal)</b>	<b>Basis for Setpoint</b>
4.16kV ESF Buses 34 and 34-1	Loss of Voltage Relay	2 of 2	2929.5V (70.42% of 4160V)	To actuate upon complete loss of ESF Bus voltage condition
4.16kV ESF Bus 34-1	Degraded Grid	2 of 2	3867.5V (92.97% of 4160V)	To actuate upon degraded ESF Bus voltage condition (Alarm only on 1 of 2 logic)
4.16kV ESF Bus 34 Feed from RAT	Phase Overcurrent	1 of 1	4800A @TL 4.0	To actuate upon ESF Bus overcurrent condition
4.16kV ESF Bus 34-1 Feed from Bus 34	Phase Overcurrent	1 of 1	1920A @TL 4.0	To actuate upon ESF Bus overcurrent condition
4.16kV ESF Bus 34 Feed from RAT	Ground Overcurrent	1 of 1	240A @ TL 4.0	To actuate upon ESF Bus ground fault condition
4.16kV ESF Bus 34-1 Feed from Bus 34	Ground Overcurrent	1 of 1	144A @TL 3.2	To actuate upon ESF Bus ground fault condition

## ATTACHMENT 4

### Dresden Nuclear Power Station, Units 2 and 3 Response to NRC Bulletin 2012-01, "Design Vulnerability in Electric Power System"

Protection Zone	Protective Device	Trip Logic	Setpoint (Nominal)	Basis for Setpoint
RAT	Differential	1 of 1	105A at 345kV 8700A at 4160V 25% Slope	To actuate upon a RAT H,X,Y-winding protection zone fault
RAT	Phase Overcurrent	1 of 1	121.2A @TL 4.0	To actuate upon RAT overcurrent condition
RAT	X-Winding Neutral Overcurrent	1 of 1	360A @TL 4.5	To actuate upon RAT X-winding neutral ground fault condition
RAT	X-Winding Ground Differential	1 of 1	480A @TL 3.0	To actuate upon RAT X-winding low level ground fault condition

***NRC Request 2.b. If the ESF buses are not powered by offsite power sources, explain how the surveillance tests are performed to verify that a single-phase open circuit condition or high impedance ground fault condition on an off-site power circuit is detected.***

EGC Response to NRC Request 2.b:

The DNPS Division II ESF buses are powered by offsite power sources. The DNPS Division I ESF buses are not powered by offsite power sources. The DNPS review of the Byron Station event has also identified potential design vulnerability in the DNPS ESF 4kV bus protection scheme, related to the automatic detection capability of a specific degraded voltage condition (i.e., loss of a single phase) and the subsequent Operator response.

Specific measures implemented at DNPS as interim compensatory measures include the following:

- Modification of plant voltage alarms to annunciate the event
- Alignment of plant voltmeters to ensure all phases are monitored
- Completion of required reading packages for operators
- Enhancement of alarm and annunciator response procedures
- Creation of operator aids and placards for enhanced operator awareness

Performance of switchyard walkdowns and verification that no Ohio Brass insulators are installed.

## ATTACHMENT 4

### Dresden Nuclear Power Station, Units 2 and 3 Response to NRC Bulletin 2012-01, "Design Vulnerability in Electric Power System"

***NRC Request 2.d: Do the plant operating procedures, including off-normal operating procedures, specifically call for verification of the voltages on all three phases of the ESF buses?***

EGC Response to NRC Request 2.d:

The current plant operating procedures call for verification of the voltages on all three phases of the ESF buses.

### Consequences

NRC Requests 1.b, 1.c, and 2.e request information regarding the electrical consequences of an event, and will be addressed in this section.

***NRC Request 1.b: The differences (if any) of the consequences of a loaded (i.e., ESF bus normally aligned to offsite power transformer) or unloaded (e.g., ESF buses normally aligned to unit auxiliary transformer) power source.***

EGC Response to NRC Request 1.b:

Installed relays were not designed to detect single phase open circuit conditions. Existing loss of voltage and degraded voltage relays may respond depending on load and possible grounds. In general, there will be no plant response for an unloaded (e.g., ESF buses normally aligned to UAT) power source in the event of a single-phase open circuit on a credited off-site power circuit because there is insufficient current to provide for detection of a single-phase open circuit for this configuration. The DNPS ESF buses normally operate in a split bus configuration with Division I powered from the UAT and Division II from the RAT (i.e., the offsite source). However, the plant response for a loaded power source cannot be determined without specifying the amount of loading and the specific loads involved.

***NRC Request 1.c: If the design does not detect and automatically respond to a single-phase open circuit condition or high impedance ground fault condition on a credited offsite power circuit or another power sources, describe the consequences of such an event and the plant response.***

EGC Response to NRC Request 1.c:

1. DNPS did not credit in the CLB that the Class 1E protection scheme for the ESF buses was designed to detect and automatically respond to a single-phase open circuit condition on the credited off-site power source as described in the Updated Final Safety Analysis Report (UFSAR) and Technical Specifications (TS).

## ATTACHMENT 4

### Dresden Nuclear Power Station, Units 2 and 3 Response to NRC Bulletin 2012-01, "Design Vulnerability in Electric Power System"

As described in UFSAR Section 8.2.1.3, "Switchyards," and TS Bases B 3.8.1, "AC Sources – Operating," DNPS, Units 2 and 3 each have two independent sources of offsite power available. The normal source of offsite power for DNPS, Unit 3 is supplied by the 345-kV switchyard through RAT 32. The alternate source of offsite power for DNPS, Unit 3 is supplied through the 4-kV crosstie between Safety Buses 34-1 and 24-1 or Safety Buses 23-1 and 33-1. The normal source of offsite power for DNPS, Unit 2 is supplied by the 345-kV switchyard through Transformer 86 and RAT 22. The alternate source of offsite power for DNPS, Unit 2 is supplied through the 4kV crosstie between Safety Buses 24-1 and 34-1 or Safety Buses 23-1 and 33-1.

As stated in TS Bases B3.8, an offsite circuit to each unit consists of the incoming breakers and disconnects to the respective 22 and 32 RATs, RATs 22 and 32, and the respective circuit path including feeder breakers to 4160 V ESF buses. The other qualified offsite circuit for each unit is provided by a bus tie between the corresponding ESF buses of the two units. The breakers connecting the buses must be capable of closure.

2. Since DNPS did not credit the ESF bus protection scheme as being capable of detecting and automatically responding to a single phase open circuit condition, an open phase fault was not included in the design criteria for either the loss of voltage, or the degraded voltage relay design criteria. Since open phase detection was not credited in the DNPS design or licensing basis, no design basis calculations or design documents exist that previously considered this condition.
3. Without formalized engineering calculations or engineering evaluations, the electrical consequences of such an open phase event, including plant response, can only be evaluated to the extent of what has already been published by the Electric Power Research Institute (EPRI) and Basler; which is a generic overview. The difficulty in applying these documents to the DNPS-specific response is that these are generic assessments and cannot be formally credited as a basis for an accurate response. The primary reason is that detailed plant specific models would need to be developed (e.g., transformer magnetic circuit models, electric distribution models, motor models; including positive, negative, and zero sequence impedances, voltage, and currents), and the models would need to be compiled and analyzed for the DNPS-specific Class 1E electric distribution system.

***NRC Request 2.e: If a common or single offsite circuit is used to supply redundant ESF buses, explain why a failure, such as a single-phase open circuit or high impedance ground fault condition, would not adversely affect redundant ESF buses.***

#### EGC Response to NRC Request 2.e:

Consistent with the DNPS CLB and GDC 17, protective circuitry will separate the ESF buses from a failed source due to a loss of voltage or a sustained balanced degraded grid voltage

## ATTACHMENT 4

### **Dresden Nuclear Power Station, Units 2 and 3 Response to NRC Bulletin 2012-01, "Design Vulnerability in Electric Power System"**

concurrent with certain design basis accidents. The failure of a single-phase open circuit is beyond the approved design and licensing basis of the plant.

DNPS has reviewed the vulnerability for impact on plant operability using the Operability Evaluation process. DNPS has implemented several interim compensatory measures including several procedure revisions, such as annunciator response and surveillance procedures as needed in response to the Byron Station event. These procedures now provide effective controls to promptly diagnose and mitigate a single-phase event. Operators have been trained to check voltages, currents, and other control room alarms in order to diagnose and respond to a single-phase event.

Specific measures implemented at DNPS as interim compensatory measures include the following:

- Modification of plant voltage alarms to annunciate the event
- Alignment of plant voltmeters to ensure all phases are monitored
- Completion of required reading packages for operators
- Enhancement of alarm and annunciator response procedures
- Creation of operator aids and placards for enhanced operator awareness
- Performance of switchyard walkdowns and verification that no Ohio Brass insulators are installed.

These actions have been implemented and will be active until permanent solutions can be implemented.

**ATTACHMENT 5**

**LaSalle County Station, Units 1 and 2, 90-Day Response to NRC Bulletin 2012-01,  
"Design Vulnerability in Electric Power System"**

## ATTACHMENT 5

### LaSalle County Station, Units 1 and 2 Response to NRC Bulletin 2012-01, "Design Vulnerability in Electric Power System"

#### **High Impedance Grounds:**

On January 30, 2012, a porcelain insulator broke in the Byron Station switchyard resulting in parting of the C phase conductor of the offsite source. The insulator was on the offsite source side of the Unit 2 System Auxiliary Transformers (SATs), and the connection parted in such a way as to leave an electrically open end on the source side. The parted connection remained electrically connected on the transformer side, and the loose bus bar conductor end fell to the ground. This ground was a direct result of the broken insulator and not an independent event. The connected loose bus bar provided a path to ground for the transformer high voltage terminal, but did not result in a ground fault (i.e., neither solid nor impedance) as seen from the source. Since the switchyard (i.e., source side) relaying was electrically isolated from the fault, it did not detect a fault; therefore, did not operate.

The significant event was the opening of a single phase connection; the ground on the high voltage side of the SAT is of lesser significance. Regardless of phase discontinuity, if the ground impedance is low on the source side, and currents are high, the source side protective relaying will operate and open all circuit phases. If the ground impedance is high, and currents low, the relaying may not operate depending on the magnitude of ground impedance; the circuit will continue to supply power.

A qualitative analysis has been performed to assess the impact of single phase high impedance ground faults. The primary objective of the analysis was to determine if a high impedance ground fault could result in an unbalanced voltage condition sufficient to adversely affect energized ESF equipment. The cases analyzed include a single phase high impedance ground fault with all three phases intact and a single phase high impedance ground fault concurrent with the loss of the same phase. These cases have been analyzed for both the high and low voltage sides of the SATs analyzed.

Attachment 11 provides a summary report of the qualitative analysis; therefore, all information discussed in this response attachment is limited to single-phase open circuit conditions.

#### **System Description**

NRC Requests 2, 1.d, 2.a, and 2.c request system information and will be addressed in this section:

***NRC Request No. 2: Briefly describe the operating configuration of the ESF buses (Class 1E for current operating plants or non-Class 1E for passive plants) at power (normal operating condition).***

#### **Exelon Generation Company, LLC (EGC) Response to NRC Request No. 2**

A simplified one-line diagram of the LaSalle County Station (LSCS), Units 1 and 2 Auxiliary Power Distribution System is shown in Figure 1 below.



ATTACHMENT 5

LaSalle County Station, Units 1 and 2 Response to NRC Bulletin 2012-01, "Design Vulnerability in Electric Power System"

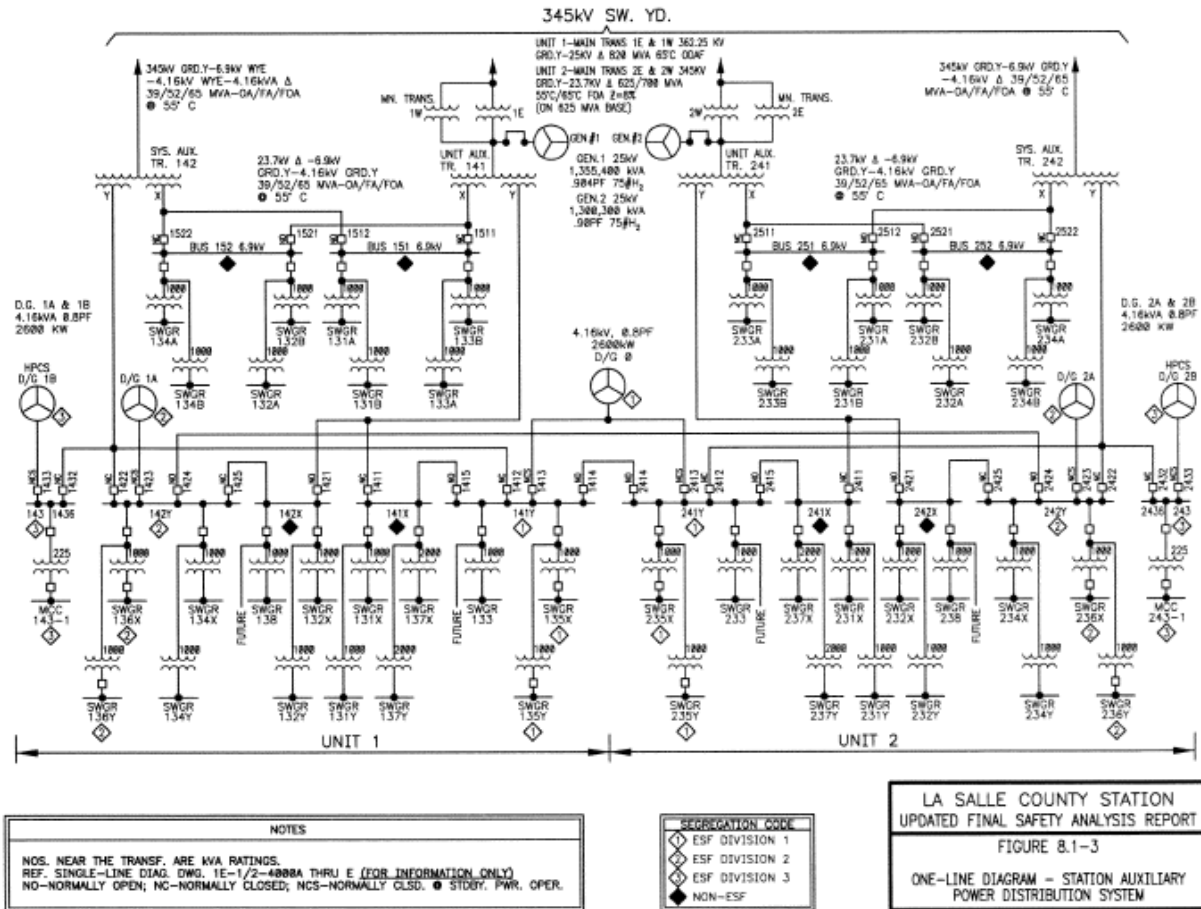

Figure 1: Simplified One-Line Diagram of LSCS, Units 1 and 2 Auxiliary Power System

The 345kV system provides continuously connected offsite power to two (2) three-winding System Auxiliary Transformers (SATs) (i.e., SAT 142 and SAT 242). The 345kV system is comprised of a double ring bus with four incoming lines; two for each unit. The station auxiliaries are connected to secondary side of SATs through two 6.9kV and five 4.16kV buses. The engineered safety features (ESF) loads are fed from three of the 4.16kV buses (i.e., Buses 141Y, 142Y, and 143 for LSCS Unit 1, and Buses 241Y, 242Y, and 243 for Unit 2). The normal source of power for the LSCS ESF buses is the 345kV system offsite through the SAT. When no offsite power is available through the SAT, the preferred configuration is for the ESF buses (i.e., 141Y, 142Y, 241Y, and 242Y) to be fed from the unit (i.e., onsite power) through the unit auxiliary transformer (UAT) and ESF Buses 143 and 243 which are fed from Diesel Generator 1B and 2B for Units 1 and 2, respectively.

**ATTACHMENT 5**

**LaSalle County Station, Units 1 and 2 Response to  
NRC Bulletin 2012-01, "Design Vulnerability in Electric Power System"**

**NRC Request 1.d:** *Describe the offsite power transformer (e.g., start-up, reserve, station auxiliary) winding and grounding configurations.*

EGC Response to NRC Request 1.d:

The LSCS offsite power transformer winding and grounding configurations.

**Table 1:** LSCS, Off-Site Power Transformer Configurations

<b>Transformer</b>	<b>Winding Configuration</b>	<b>Grounding Configuration</b>
System Aux. Transformer SAT142	Wye-Wye-Wye (3 Leg)	HV ---Neutral Grounding LV--- Resistance Grounding
System Aux. Transformer SAT242	Wye-Wye-Wye (3 Leg)	HV ---Neutral Grounding LV--- Resistance Grounding

**NRC Request 2.a:** *Are the ESF buses powered by offsite power sources? If so, explain what major loads are connected to the buses including their ratings.*

EGC Response to NRC Request 2.a:

Yes, ESF buses are normally powered by offsite sources.

The normal power sources for the LSCS ESF buses are shown in Tables 2 and 3 below.

**Table 2:** LSCS ESF Buses That Are Normally Powered From Offsite Sources

<b>Description of ESF Bus Power Source</b>	<b>ESF Bus Name (normal operating condition)</b>	<b>Original licensing basis configuration (Y/N)</b>
SAT-142	141Y	Y
SAT-142	142Y	Y
SAT-142	143	Y
SAT-242	241Y	Y
SAT-242	242Y	Y
SAT-242	243	Y

**ATTACHMENT 5**

**LaSalle County Station, Units 1 and 2 Response to  
NRC Bulletin 2012-01, "Design Vulnerability in Electric Power System"**

**Table 3:** LSCS ESF Buses That Are Not Normally Powered From Offsite Sources

Description of ESF Bus Power Source	ESF Bus Name (normal operating condition)	Original licensing basis configuration (Y/N)
N/A	N/A	N/A
N/A	N/A	N/A
N/A	N/A	N/A

The LSCS major ESF bus loads that are energized during normal power operations, including their ratings, are shown in Table 4 below.

**Table 4:** LSCS Major ESF Bus Loads Including Ratings and Status during Normal Power Operations

ESF Bus	Load	Voltage (kV)	Rating (hp/kVA)
141Y	Unit 1 Low Pressure Core Spray (LPCS) Pump	4.16	1500 hp
141Y	Suppression Pool Cleanup & Transfer Pump 1B	4.16	450 hp
141Y	Residual Heat Removal (RHR) Pump 1A	4.16	800 hp
141Y	Control Rod Drive (CRD) Feed Pump 1A	4.16	300 hp*
141Y	Primary Containment Water Chiller 1A	4.16	804 hp*
141Y	Recirculation Motor Generator (MG) set Drive Motor 1A	4.16	400 hp
141Y	Transformer for 480V Switchgear (SWGR) 135X & 135Y	4.16	2000 kVA*
141Y	Transformer for 480V SWGR. 133	4.16	1000 kVA*
142Y	RHR Pump 1B	4.16	800 hp
142Y	Suppression Pool Cleanup & Transfer Pump 1A	4.16	450 hp
142Y	RHR Pump 1C	4.16	800 hp
142Y	CRD Feed Pump 1B	4.16	300 hp
142Y	Primary Containment water Chiller 1B	4.16	804 hp
142Y	Transformer for 480V SWGR. 136X & 136Y	4.16	2000 kVA*
142Y	Transformer for 480V SWGR. 134X & 134Y	4.16	2000 kVA*
142Y	Recirculation MG set Drive Motor 1B	4.16	400 hp
143	Unit 1 High Pressure Core Spray (HPCS) Pump	4.16	3000 hp
143	Transformer to Feed MCC143-1	4.16	225 kVA*
241Y	Unit 2 LPCS Pump	4.16	1500 hp
241Y	Suppression Pool Cleanup & Transfer Pump 2B	4.16	450 hp
241Y	RHR Pump 2A	4.16	800 hp
241Y	CRD Feed Pump 2A	4.16	300 hp*

## ATTACHMENT 5

### LaSalle County Station, Units 1 and 2 Response to NRC Bulletin 2012-01, "Design Vulnerability in Electric Power System"

ESF Bus	Load	Voltage (kV)	Rating (hp/kVA)
241Y	Primary Containment water Chiller 2A	4.16	804 hp*
241Y	Recirculation MG set Drive Motor 2A	4.16	400 hp
241Y	Transformer for 480V SWGR. 235X & 235Y	4.16	2000 kVA*
241Y	Transformer for 480V SWGR. 233	4.16	1000 kVA*
242Y	RHR Pump 2C	4.16	800 hp
242Y	Suppression Pool Cleanup & Transfer Pump 2A	4.16	450 hp*
242Y	RHR Pump 2B	4.16	800 hp
242Y	CRD Feed Pump 2B	4.16	300 hp
242Y	Transformer for 480V SWGR. 236X & 236Y	4.16	2000 kVA*
242Y	Transformer for 480V SWGR. 234X & 234Y	4.16	2000 kVA*
242Y	Primary Containment water Chiller 2B	4.16	804 hp
242Y	Recirculation MG set Drive Motor 2B	4.16	400 hp
243	Unit 2 HPCS Pump	4.16	3000 hp
243	Transformer to feed MCC243-1	4.16	225 kVA*
*Normally energized load (CRD Feed Pumps and Primary Containment Water Chillers are one per unit)			

***NRC Request 2.c: Confirm that the operating configuration of the ESF buses is consistent with the current licensing basis. Describe any changes in offsite power source alignment to the ESF buses from the original plant licensing.***

**EGC Response to NRC Request 2.c:**

ESF bus configurations have been confirmed to be consistent with the current licensing basis (CLB). There are no changes in offsite power source alignment to the ESF buses from the original plant licensing.

## ATTACHMENT 5

### LaSalle County Station, Units 1 and 2 Response to NRC Bulletin 2012-01, "Design Vulnerability in Electric Power System"

#### System Protection

NRC Requests 1, 1.a, 2.b, and 2.d request information regarding electrical system protection and will be addressed in this section:

***NRC Request 1: Given the requirements above, describe how the protection scheme for ESF buses (Class 1E for current operating plants or non-Class 1E for passive plants) is designed to detect and automatically respond to a single-phase open circuit condition or high impedance ground fault condition on a credited off-site power circuit or another power sources. Also, include the following information:***

#### EGC Response to NRC Request 1:

The loss of voltage and degraded voltage relaying scheme is capable of responding to degraded grid conditions as described in applicable NRC industry guidelines. However, protection scheme at LSCS is not designated to detect and automatically respond to unbalanced system condition as a result of single phase open circuit condition or high impedance ground fault condition on a credited off-site power circuit.

Consistent with the CLB and 10 CFR 50, Appendix A, "General Design Criteria for Nuclear Power Plants," Criterion (GDC) 17, "Electric power systems," existing protective circuitry will separate the ESF buses from a connected field source due to loss of voltage or a sustained, balanced degraded grid voltage concurrent with certain design basis accidents. The failure of a single phase circuit to an open condition is beyond the approved design and licensing basis of the plant; therefore, constitutes a beyond design basis event. The high impedance ground fault in off-site circuits is beyond the approved design and licensing basis.

***NRC Request 1.a: The sensitivity of protective devices to detect abnormal operating conditions and the basis for the protective device setpoint(s).***

#### EGC Response to NRC Request 1.a:

Consistent with the CLB and GDC 17, existing electrical protective devices are sufficiently sensitive to detect design basis conditions like a loss of voltage or a degraded voltage, but were not designed to detect a single phase open circuit condition. The LSCS ground protection and alarms on the ESF buses and the basis for the device setpoint(s) are show in Table 5 below.

**ATTACHMENT 5**

**LaSalle County Station, Units 1 and 2 Response to  
NRC Bulletin 2012-01, "Design Vulnerability in Electric Power System"**

**Table 5: Protective Devices and Alarms**

<b>Protection Zone</b>	<b>Protective Device</b>	<b>UV Logic</b>	<b>Setpoint (Nominal)</b>	<b>Basis for Setpoint</b>
SAT142	1887—AP001A/B/C Percentage Differential	N/A	H Tap = 3.5A X Tap = 8.7A Y Tap = 8.7A	Multiphase and phase to ground protection in HV winding.
SAT142	1851- AP022A/B/C HV winding Time overcurrent (O/C)	N/A	5A Tap (150A primary) T.D. 3.5	Back up protection for transformer internal faults
SAT142	1551- AP003 6.9kV Time O/C	N/A	1.5A Tap (360A primary) T.D. 2.0	Back up protection for phase to ground faults in X-winding (6.9kV) winding.
SAT142	1451- AP004 4.16kV Time O/C	N/A	2.0A Tap (480A primary) T.D. 2.5	Back up protection for phase to ground faults in Y-winding (4.16kV) winding.
SAT142	1587- AP033 X-Winding Gnd. Differential	N/A	0.5A Tap (300A primary) T.D. 1	Phase to ground fault protection within X-winding (6.9kV)
SAT142	1487—AP044 Y-Winding Gnd. Differential	N/A	0.5A Tap (480A primary) T.D. 1	Phase to ground fault protection within Y-winding (4.16kV)
Bus 141Y	1451-AP024A/B 4.16kV Bus O/C	N/A	8A Tap (4800A primary) T.D. 3.5	Back-up protection for multiphase faults on 4.16kV Bus Division 1
Bus 141Y	1451-AP025 4.16kV Bus Ground O/C	N/A	0.6A Tap (360A primary) T.D. 3.0	Back-up protection for ground faults on 4.16kV Bus Division 1
Bus 141Y/241Y	1487-AP020A/B/C 141Y-241Y Tie Differential	N/A	Min. Operating current 0.5A Slope Characteristics 25%	Primary protection for multiphase faults on interconnection between 141Y and 142Y. <b>Note:</b> Protective devices located on bus 141Y.
Bus 141Y	1451-AP026 A/B 4.16KV Bus O/C	N/A	7A Tap (4200A primary) T.D. 1.5	Phase over current protection for bus tie to Switchgear 141X
Bus 141Y	1451-AP027 4.16KV Bus O/C	N/A	0.5A Tap (300A primary) T.D. 1.25	Ground fault protection for bus tie to Switchgear 141X

**ATTACHMENT 5**

**LaSalle County Station, Units 1 and 2 Response to  
NRC Bulletin 2012-01, "Design Vulnerability in Electric Power System"**

<b>Protection Zone</b>	<b>Protective Device</b>	<b>UV Logic</b>	<b>Setpoint (Nominal)</b>	<b>Basis for Setpoint</b>
Bus 141Y	1427-AP037A/B	2 of 2	≤ 3027.15V ( 72.7% of 4160V)	Unit-1 ESF Bus undervoltage. To actuate upon complete loss of ESF Bus voltage condition.
Bus 141Y	1427-AP270A/B	2 of 2	3870V (93% of 4160V)	Unit-1 ESF Bus Degraded voltage
Bus 141Y	1427-AP251	1 of 1	3500V (84% of 4160V)	SAT 142-Y Winding undervoltage alarm
Bus 142Y	1451-AP030A/B 4.16KV Bus O/C	N/A	8A Tap (4800A primary) T.D. 3.5	Secondary protection for multiphase faults on 4.16kV Bus Division 2
Bus 142Y	1451-AP031 4.16kV Bus Ground O/C	N/A	0.6A Tap (360A primary) T.D. 3.0	Secondary protection for ground faults on 4.16kV Bus Division 2
Bus 142Y/242Y	1487-AP021 142Y-242Y Tie Differential	N/A	Min. Operating current 0.5A Slope Characteristics 25%	Primary protection for multiphase faults and ground faults on 142Y-242Y interconnect. <b>Note:</b> protective devices located on bus 142Y
Bus 142Y	1451-AP032A/B	N/A	7A Tap (4200A primary) T.D. 1.5	Phase over current for bus tie to Switchgear 142X
Bus 142Y	1452-AP033	N/A	0.5A Tap (300A primary) T.D. 1.25	Ground fault protection for bus tie to 142X
Bus 142Y	1427-AP039	1 of 1	3500V (84% of 4160V)	SAT 142 Y-winding LUV alarm
Bus 142Y	1427-AP040A/B	2 of 2	≤ 3027.15V (72.7% of 4160V)	Unit-1 ESF Bus undervoltage. To actuate upon complete loss of ESF Bus voltage condition.
Bus 142Y	1427-AP271A/B	2 of 2	≤ 3870V (93% of 4160V)	Unit-1 ESF Bus Degraded voltage

**ATTACHMENT 5**

**LaSalle County Station, Units 1 and 2 Response to  
NRC Bulletin 2012-01, "Design Vulnerability in Electric Power System"**

<b>Protection Zone</b>	<b>Protective Device</b>	<b>UV Logic</b>	<b>Setpoint (Nominal)</b>	<b>Basis for Setpoint</b>
Bus 143	1451-AP034A/B 4.16kV Bus O/C	N/A	16A Tap (3840 A primary) T.D. 5.0	Secondary protection for multiphase faults on 4.16kV Bus Division 3
Bus 143	1451-AP035 4.16kV Bus Ground O/C	N/A	1.0A Tap (240A primary) T.D. 2.0	Secondary protection for ground faults on 4.16kV Bus Division 3
Bus 143	1427-AP041A/B	2 of 2	2870V (68.9% of 4160V)	Unit-1 ESF Bus undervoltage. To actuate upon complete loss of ESF Bus voltage condition
Bus 143	1427-AP272A/B	2 of 2	3870V (93% of 4160V)	Unit-1 ESF Bus degraded voltage
Bus 143	1427-AP245A/B	2 of 2	3255V (78% of 4160V)	SAT 142 Y winding LUV alarm
SAT242	2887-001A/B/C Percentage Differential	N/A	H tap = 3.5A X Tap = 8.7A Y Tap = 8.7A	Multiphase and phase to ground protection in HV winding.
SAT242	2851- AP022A/B/C HV winding Time O/C	N/A	5A Tap (150A primary) T.D. 3.5	Back up protection for transformer internal faults
SAT242	2551-AP003 6.9kV Time O/C	N/A	1.5A Tap (360A primary) T.D. 2.0	Back up protection for phase to ground faults in X-winding (6.9kV) winding.
SAT242	2451-AP004 4.16kV Time O/C	N/A	2.0A Tap (480A primary) T.D. 2.5	Back up protection for phase to ground faults in Y-winding (4.16kV) winding.
SAT242	2587—AP033 X-Winding Ground Differential	N/A	0.5A Tap (300A primary) T.D. 1	Phase to ground fault protection within X-winding (6.9kV)
SAT242	2487—AP044 Y-Winding Ground Differential	N/A	0.5A Tap (480A primary) T.D. 1	Phase to ground fault protection within Y-winding (4.16kV)
Bus 241Y	2451-AP024A/B 4.16kV Bus O/C	N/A	8A Tap (4800A primary) T.D. 3.5	Back-up protection for multiphase faults on 4.16kV Bus Division 1



## ATTACHMENT 5

### LaSalle County Station, Units 1 and 2 Response to NRC Bulletin 2012-01, "Design Vulnerability in Electric Power System"

Protection Zone	Protective Device	UV Logic	Setpoint (Nominal)	Basis for Setpoint
Bus 241Y	2451-AP025 4.16kV Bus Ground O/C	N/A	0.6A Tap (360A primary) T.D. 3.0	Back-up protection for ground faults on 4.16kV bus Division 1
Bus 241Y	2451-AP257A/B	N/A	8A Tap (1920A primary) T.D. 4.0	Phase over current for 141Y-241Y unit-tie interconnection
Bus 241Y	2427-AP037A/B	2 of 2	$\leq 3027.15V$ ( 72.7% of 4160V)	Unit-2 ESF Bus undervoltage. To actuate upon complete loss of ESF bus voltage condition.
Bus 241Y	2451-AP261	N/A	1A Tap (240A primary) T.D. 1.5	Ground fault protection for 141Y-241Y unit tie.
Bus 241Y	2451-AP026A/B	N/A	7A Tap (4200A primary) T.D. 1.5	Phase over current protection for bus tie to Switchgear 241X
Bus 241Y	2451-AP027	N/A	0.5A Tap (300A primary) T.D. 1.25	Ground fault protection for bus tie to Switchgear 241X
Bus 241Y	2427-AP270A/B	2 of 2	3870V (93% of 4160V)	Unit-2 ESF bus degraded voltage
Bus 241Y	2427-AP251	1 of 1	3500V (84% of 4160V)	SAT 242-Y winding undervoltage alarm
Bus 242Y	2451-AP030A/B 4.16KV Bus O/C	N/A	8A Tap (4800A primary) T.D. 3.5	Secondary protection for multiphase faults on 4.16kV Bus Div. 2
Bus 242Y	2451-AP031 4.16KV Bus Ground O/C	N/A	0.6A Tap (360A primary) T.D. 3.0	Secondary protection for ground faults on 4.16kV Bus Div. 2
Bus 242Y	2427-AP040A/B	2 of 2	$\leq 3027.15V$ ( 72.7% of 4160V)	Unit-2 ESF bus undervoltage. To actuate upon complete loss of ESF bus voltage condition.
Bus 242Y	2427-AP271A/B	2 of 2	3870V (93% of 4160V)	Unit-2 ESF Bus degraded voltage
Bus 242Y	2427-AP039	1 of 1	3500V (84% OF 4160v)	SAT242 Y winding undervoltage

## ATTACHMENT 5

### LaSalle County Station, Units 1 and 2 Response to NRC Bulletin 2012-01, "Design Vulnerability in Electric Power System"

Protection Zone	Protective Device	UV Logic	Setpoint (Nominal)	Basis for Setpoint
Bus 242Y	2451-AP258A/B 4.16KV Unit tie O/C	N/A	8A Tap (1920A primary) T.D. 4.0	Phase overcurrent for unit tie buses 241Y-242Y
Bus 242Y	2451-AP262 4.16KV unit tie Ground fault	N/A	1A Tap (240A primary) T.D. 1.5	Ground fault for unit tie buses 142Y-242Y
Bus 242Y	2451-AP032A/B 4.16KV Bus tie O/C	N/A	7A Tap (4200A primary) T.D. 1.5	Phase overcurrent for bus tie to 242X
Bus 242Y	2451-AP033 4.16KV bus tie Ground fault	N/A	0.5A Tap (300A primary) T.D. 1.25	Ground fault for bus tie to 242X
Bus 243	2451-AP034A/B 4.16KV Bus O/C	N/A	16A Tap (3840A primary) T.D. 5.0	Secondary protection for multiphase faults on 4.16kV bus Division 3
Bus 243	2451-AP035 4.16KV Bus Ground O/C	N/A	1.0A Tap (240A primary) T.D. 2.0	Secondary protection for ground faults on 4.16kV bus Division 3
Bus 243	2427-AP041A/B	2 of 2	2870V (68.9% of 4160V)	Unit-2 ESF Bus u/v. To actuate upon complete loss of ESF bus voltage condition
Bus 243	2427-AP272A/B	2 of 2	≤ 3870V (93% of 4160V)	Unit-2 ESF Bus degraded voltage
Bus 243	2427-AP245A/B	2 of 2	3255V (78% of 4160V)	SAT242 Y-winding undervoltage

***NRC Request 2.b. If the ESF buses are not powered by offsite power sources, explain how the surveillance tests are performed to verify that a single-phase open circuit condition or high impedance ground fault condition on an off-site power circuit is detected.***

EGC Response to NRC Request 2.b:

Not Applicable - the ESF buses at LSCS are powered by offsite power sources.

## ATTACHMENT 5

### LaSalle County Station, Units 1 and 2 Response to NRC Bulletin 2012-01, "Design Vulnerability in Electric Power System"

***NRC Request 2.d: Do the plant operating procedures, including off-normal operating procedures, specifically call for verification of the voltages on all three phases of the ESF buses?***

EGC Response to NRC Request 2.d:

The current plant operating procedures, including off-normal operating procedures, specifically call for verification of the voltages on all three phases of the ESF buses.

For the Division I and II ESF buses (i.e., Buses 141Y and 241Y, and 142Y and 242Y for Divisions I and II on Unit 1 and 2, respectively), verification for all three phases is done using voltmeter selector switch in the Main Control Room (MCR). Verification of all three phases of Division III buses (i.e., Buses 143Y and 243Y for Unit 1 and 2, respectively), verification of voltage on all three phases is performed using the voltmeter selector switch on the associated switchgear.

## ATTACHMENT 5

### LaSalle County Station, Units 1 and 2 Response to NRC Bulletin 2012-01, "Design Vulnerability in Electric Power System"

#### Consequences

NRC Requests 1.b, 1.c, and 2.e request information regarding the electrical consequences of an event, and will be addressed in this section.

***NRC Request 1.b: The differences (if any) of the consequences of a loaded (i.e., ESF bus normally aligned to offsite power transformer) or unloaded (e.g., ESF buses normally aligned to unit auxiliary transformer) power source.***

#### EGC Response to NRC Request 1.b:

There is no difference in the response of the present protective relaying scheme. Installed relays were not designed to detect single phase open circuit conditions. Existing loss of voltage and degraded voltage relays may respond depending on load and possible grounds.

***NRC Request 1.c: If the design does not detect and automatically respond to a single-phase open circuit condition or high impedance ground fault condition on a credited offsite power circuit or another power sources, describe the consequences of such an event and the plant response.***

#### EGC Response to NRC Request 1.c:

1. LaSalle did not credit in the CLB that the Class 1E protection scheme (i.e., for the ESF buses) was designed to detect and automatically respond to a single-phase open circuit condition on the credited off-site power source as described in the Updated Final Safety Analysis Report (UFSAR) and Technical Specifications (TS).
2. The offsite power at LSCS is supplied from 345kV system connected to two (2) three winding SATs (i.e., SAT 142 and SAT 242). The 345kV system is comprised of a double ring bus with four incoming lines two for each unit. The station auxiliaries are connected to secondary side of SATs through two 6.9kV and five 4.16kV buses for each unit. The ESF loads are fed from three electrically and physically independent divisions (i.e., Divisions 1, 2, and 3) through the 4.16kV buses (i.e., Bus 141Y, 142Y, and 143 for Unit 1, and Bus 241Y, 242Y, and 243 for Unit 2). The normal source of power for ESF buses is the 345kV system offsite through the SAT. When no offsite power is available through SAT, the preferred configuration is ESF buses 141Y and 241Y and 142Y and 241Y, fed from onsite power through the UATs and ESF Bus 143 and 243 fed from diesel generator 1B and 2B for Unit 1 and 2, respectively.

## ATTACHMENT 5

### LaSalle County Station, Units 1 and 2 Response to NRC Bulletin 2012-01, "Design Vulnerability in Electric Power System"

3. For each unit ESF Division 1 and 2, the 4160V bus (i.e., 141Y(241Y) and 142Y(242Y)), is provided with four independent sources of a-c power as follow:
  - a. A normal (#1 offsite) source which is provided from the 345kV system through the SAT.
  - b. A reserve (#1 onsite) source available during unit operation which is provided from the unit through the UAT.
  - c. A standby (#2 onsite) source which is provided from the onsite diesel generators.
  - d. An emergency (#2 offsite) source from 345kV system through the SAT of the opposite unit.

For each unit ESF Division 3, the 4160V bus is provided with the two independent sources of a-c power are as follows:

- A normal (i.e, offsite) source which is provided from 345kV system through the SAT.
  - A standby (i.e, on-site) source which is provided from the onsite diesel generator.
4. Each ESF 4160V bus (i.e., Divisions 1, 2 & 3), is provided with two levels of under voltage protection: 1) loss of voltage, and 2) degraded bus voltage. The function of these relays is to initiate load shedding and transfer the ESF loads to the onsite diesel generators in case offsite power is lost or degraded. Each 4160V ESF bus has its own independent loss of voltage and degraded voltage instrumentation and associated trip logic.
  5. The EDG start signal on each 4160V ESF bus can be initiated by two loss of voltage relays (i.e., two out of two logic) or two degraded voltage relays (i.e., two out of two logic). These relays sense voltage levels at the bus between Phases A-B and Phases B-C. The logic is part of the original plant design and was evaluated and approved in the original plant safety evaluation report (SER). The relays are combined in this logic in accordance with BTP PSB-1, , "Adequacy of Station Electric Distribution System Voltages," which requires, in part, "The under voltage protection shall include coincidence logic on a per bus basis to preclude spurious trips of the offsite power source."
  6. Since LSCS did not credit the ESF bus protection scheme as being capable of detecting and automatically responding to a single phase open circuit condition, an open phase fault was not included in the design criteria for either the loss of voltage, the degraded voltage relay scheme or secondary level undervoltage protection system design criteria. Since open phase detection was not credited in the LSCS design or licensing basis, no design basis calculations or design documents exist that considered this condition.
  7. Without formalized engineering calculations or engineering evaluations, the electrical consequences of such an open phase event can only be evaluated to the extent of what has already been published by the Electric Power Research Institute (EPRI) and Basler; which is a generic overview. The difficulty in applying these documents to the LSCS-specific response is that these are generic assessments and cannot be formally credited as a basis for an accurate response. The primary reason is that detailed plant specific models would need to be developed (e.g., transformer magnetic circuit models, electric distribution models, motor models; including positive, negative, and zero sequence impedances, voltages, and currents), and the models would need to be compiled and analyzed for the LSCS-specific Class 1E electric distribution system.

## ATTACHMENT 5

### LaSalle County Station, Units 1 and 2 Response to NRC Bulletin 2012-01, "Design Vulnerability in Electric Power System"

LSCS has implemented several interim compensatory measures to minimize the impact should the open phase event occur. These measures include:

- Modification of plant voltage alarms to annunciate the event
- Alignment of plant voltmeters to ensure all phases are monitored
- Implementation of a designated operator to isolate the safety buses from the grid in a timely fashion
- Completion of required reading packages by operators
- Enhancement of alarm and annunciator response procedures
- Creation of operator aids and placards for enhance operator response

***NRC Request 2.e: If a common or single offsite circuit is used to supply redundant ESF buses, explain why a failure, such as a single-phase open circuit or high impedance ground fault condition, would not adversely affect redundant ESF buses.***

EGC Response to NRC Request 2.e:

Not applicable since LaSalle plant does not use a common or single offsite circuit to supply redundant ESF buses.

**ATTACHMENT 6**

**Limerick Generating Station, Units 1 and 2, 90-Day Response to NRC Bulletin  
2012-01, "Design Vulnerability in Electric Power System"**

## ATTACHMENT 6

### Limerick Generating Station, Units 1 and 2 Response to NRC Bulletin 2012-01, "Design Vulnerability in Electric Power System"

#### **High Impedance Grounds:**

On January 30, 2012, a porcelain insulator broke in the Byron Station switchyard resulting in parting of the C phase conductor of the offsite source. The insulator was on the offsite source side of the Unit 2 System Auxiliary Transformers (SATs), and the connection parted in such a way as to leave an electrically open end on the source side. The parted connection remained electrically connected on the transformer side, and the loose bus bar conductor end fell to the ground. This ground was a direct result of the broken insulator and not an independent event. The connected loose bus bar provided a path to ground for the transformer high voltage terminal, but did not result in a ground fault (i.e., neither solid nor impedance) as seen from the source. Since the switchyard (i.e., source side) relaying was electrically isolated from the fault, it did not detect a fault; therefore, did not operate.

The significant event was the opening of a single phase connection; the ground on the high voltage side of the SAT is of lesser significance. Regardless of phase discontinuity, if the ground impedance is low on the source side, and currents are high, the source side protective relaying will operate and open all circuit phases. If the ground impedance is high, and currents low, the relaying may not operate depending on the magnitude of ground impedance; the circuit will continue to supply power.

A qualitative analysis has been performed to assess the impact of single phase high impedance ground faults. The primary objective of the analysis was to determine if a high impedance ground fault could result in an unbalanced voltage condition sufficient to adversely affect energized ESF equipment. The cases analyzed include a single phase high impedance ground fault with all three phases intact and a single phase high impedance ground fault concurrent with the loss of the same phase. These cases have been analyzed for both the high and low voltage sides of the SATs analyzed.

Attachment 11 provides a summary report of the qualitative analysis; therefore, all information discussed in this response attachment is limited to single-phase open circuit conditions.

#### **System Description**

NRC Requests 2, 1.d, 2.a, and 2.c request system information, and will be addressed in this section.

***NRC Request No. 2: Briefly describe the operating configuration of the ESF buses (Class 1E for current operating plants or non-Class 1E for passive plants) at power (normal operating condition).***

#### **Exelon Generation Company, LLC (EGC) Response to NRC Request No. 2**

A simplified one-line diagram of the Limerick Generating Station (LGS), Units 1 and 2 Auxiliary Power System is shown in Figure 1 below.



## ATTACHMENT 6

### Limerick Generating Station, Units 1 and 2 Response to NRC Bulletin 2012-01, "Design Vulnerability in Electric Power System"

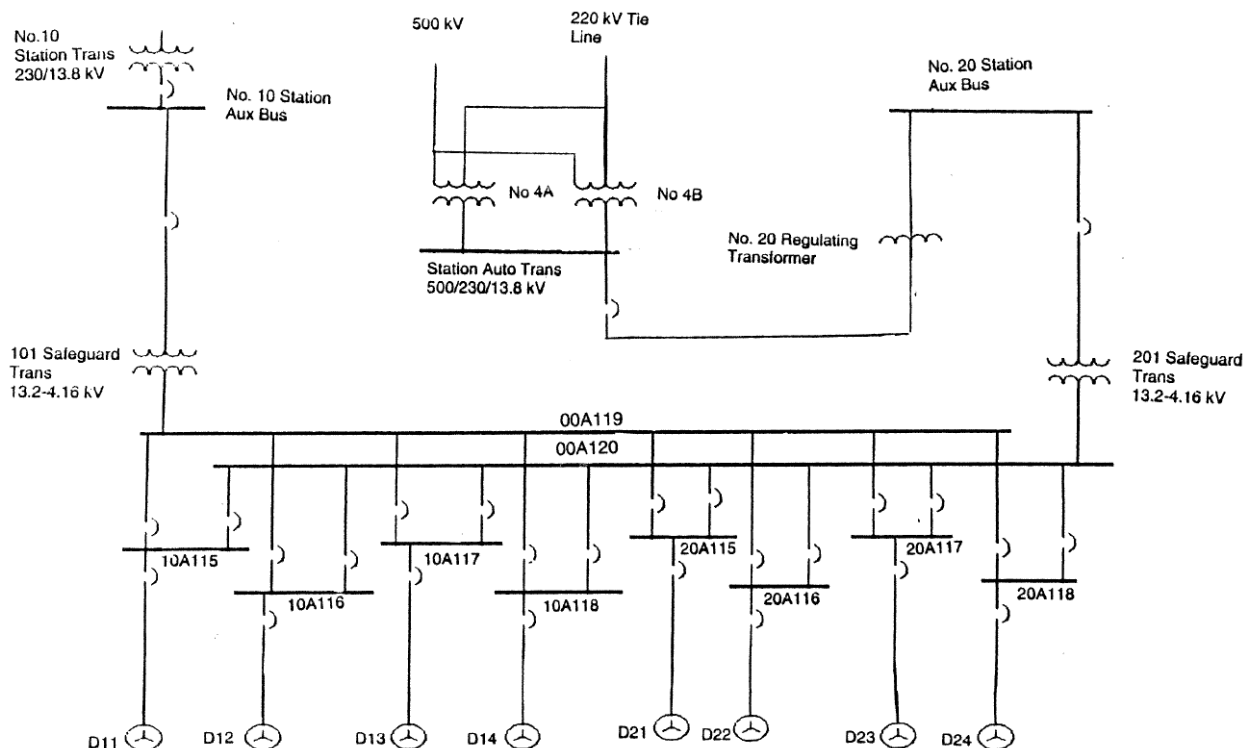

**Figure 1:** Limerick Generating Station Simplified One-Line Diagram

The LGS 220 kV substation supplies offsite power at 13.2 kV via the No. 10 220-13 kV transformer connected to the Station Auxiliary Bus 10A103. The LGS 500 kV substation supplies offsite power at 13.2 kV to Station Auxiliary Bus 20A103 from the tertiary winding of one of the 4A or 4B bus tie autotransformers through the No. 20 13-13 kV regulating transformer. Each offsite source supplies an emergency auxiliary (i.e., safeguard) transformer that steps down the 13.2 kV to 4.16 kV and connects through interlocked circuit breakers to every 4 kV Class 1E bus. Both offsite sources are continuously available to the Class 1E buses.

In addition to the two offsite sources described above, an alternate independent, but not connected, offsite source is available from the 66-13 kV transformer connected to the 6680, 66 kV Cromby – Moser tie line.

The Class 1E ac power system for each unit is divided into Divisions A, B, C, and D. The 4 kV bus of each Class 1E load division is provided with connection to the two offsite power sources, designated as preferred and alternate power supplies. For each load division, one 4 kV feeder circuit breaker is provided for the normal incoming preferred power source, and another 4 kV feeder circuit breaker is provided for the alternate power source. Safeguard Bus 101 Transformer is the preferred power source for Channels A (i.e., Division A) and C (i.e., Division C) for Unit 1 and Channels B (i.e., Division B) and D (i.e., Division D) for Unit 2. Safeguard Bus 101 Transformer is the alternate power source for Channels B (i.e., Division B) and D (i.e., Division D) for Unit 1 and Channels A (i.e., Division A) and C (i.e., Division C) for Unit 2. Safeguard Bus 201 Transformer is the preferred power source for Channels B (i.e., Division B) and D (i.e., Division D) for Unit 1 and Channels A (i.e., Division A) and C (i.e., Division C) for Unit 2.

**ATTACHMENT 6**

**Limerick Generating Station, Units 1 and 2 Response to  
NRC Bulletin 2012-01, "Design Vulnerability in Electric Power System"**

(i.e., Division C) for Unit 2. Safeguard Bus 201 Transformer is the alternate source for Channels A (i.e., Division A) and C (i.e., Division C) for Unit 1 and Channels B (i.e., Division B) and D (i.e., Division D) for Unit 2.

***NRC Request 1.d: Describe the offsite power transformer (e.g., start-up, reserve, station auxiliary) winding and grounding configurations.***

EGC Response to NRC Request 1.d:

The LGS offsite power transformer winding and grounding configurations are shown in Table 1 below.

**Table 1: LGS Offsite Power Transformer Winding and Grounding Configurations**

<b>Transformer</b>	<b>Winding Configuration</b>	<b>MVA Size (Cooling Mode)</b>	<b>Voltage Rating (Primary/Secondary)</b>	<b>Grounding Configuration</b>
No. 10 Station Auxiliary 230-14.18 kV Transformer	Delta Wye	36.96/49.28/61.6 (OA/FOA/FOA)	230/14.18 kV	Wye Resistor (4 ohms, 2000 a) Grounded
No. 4A Station Auxiliary 515-230/132.8-13.8 kV Transformer (Autotransformer) (Preferred Source)	Wye Wye Delta	252/336/420 (OA/FOA/FOA)	515/230/132.8-13.8 kV	Neutral Grounded
No. 4B Station Auxiliary 515-230/132.8-13.8 kV Transformer (Autotransformer) (Alternate Source)	Wye Wye Delta	252/336/420 (OA/FOA/FOA)	515/230/132.8-13.8 kV	Neutral Grounded
No. 20 Regulating 13.8-13.8 kV Transformer	Wye Wye with Delta stabilizing winding	35/46.667/58.3 33 (OA/FA/FA)	13.8/13.8 kV	Wye Resistor (4 ohms 2000 a, 8000 V) Grounded
No.101 Safeguard 13.2-4.16 kV Transformer	Delta Wye	11.2/14 (OA/FA)	13.2/4.16 kV	Wye Resistor (1.2 ohms, 2000 a, 2400 V) Grounded

## ATTACHMENT 6

### Limerick Generating Station, Units 1 and 2 Response to NRC Bulletin 2012-01, "Design Vulnerability in Electric Power System"

Transformer	Winding Configuration	MVA Size (Cooling Mode)	Voltage Rating (Primary/Secondary)	Grounding Configuration
No.201 Safeguard 13.2-4.16 kV Transformer	Delta Wye	11.2/14 (OA/FA)	13.2/4.16 kV	Wye Resistor (1.2 ohms, 2000 a, 2400 V) Grounded

***NRC Request 2.a: Are the ESF buses powered by offsite power sources?  
If so, explain what major loads are connected to the  
buses including their ratings.***

EGC Response to NRC Request 2.a:

For at power (i.e., normal operating condition) configurations, engineered safety features (ESF) buses are powered by offsite sources.

The normal power sources for the LGS ESF Buses are shown in Tables 2 and 3 below.

## ATTACHMENT 6

### Limerick Generating Station, Units 1 and 2 Response to NRC Bulletin 2012-01, "Design Vulnerability in Electric Power System"

**Table 2: LGS ESF Buses That Are Normally Powered From Offsite Sources**

Description of ESF Bus Power Source	ESF Bus Name (Normal Operating Condition)	Original Licensing Basis Configuration (Y/N)
No. 10 Station Auxiliary 230-14.18 kV Transformer through 101 Safeguard 13.2-4.16 kV Transformer	10A115 (Division A)	Y
No. 10 Station Auxiliary 230-14.18 kV Transformer through 101 Safeguard 13.2-4.16 kV Transformer	10A117 (Division C)	Y
No. 10 Station Auxiliary 230-14.18 kV Transformer through 101 Safeguard 13.2-4.16 kV Transformer	20A116 (Division B)	Y
No. 10 Station Auxiliary 230-14.18 kV Transformer through 101 Safeguard 13.2-4.16 kV Transformer	20A118 (Division D)	Y
No. 4A Station Auxiliary 515/230/132.8-13.8 kV Transformer through No. 20 Regulating 13.8-13.8 kV Transformer and 201 Safeguard 13.2-4.16 kV Transformer	10A116 (Division B)	Y
No. 4A Station Auxiliary 515/230/132.8-13.8 kV Transformer Through No. 20 Regulating 13.8-13.8 kV Transformer and 201 Safeguard 13.2-4.16 kV Transformer	10A118 (Division D)	Y
No. 4A Station Auxiliary 515/230/132.8-13.8 kV Transformer Through No. 20 Regulating 13.8-13.8 kV Transformer and 201 Safeguard 13.2-4.16 kV Transformer	20A115 (Division A)	Y
No. 4A Station Auxiliary 515/230/132.8-13.8 kV Transformer Through No. 20 Regulating 13.8-13.8 kV Transformer and 201 Safeguard 13.2-4.16 kV Transformer	20A117 (Division C)	Y

**Table 3: LGS ESF Buses That Are Not Normally Powered From Offsite Sources**

Description of ESF Bus Power Source	ESF Bus Name (normal operating condition)	Original licensing basis configuration (Y/N)
N/A	N/A	N/A

**ATTACHMENT 6**

**Limerick Generating Station, Units 1 and 2 Response to  
NRC Bulletin 2012-01, "Design Vulnerability in Electric Power System"**

The major LGS ESF bus loads that are energized during normal power operations, including their ratings, are shown in Table 4 below.

**Table 4:** Major LGS ESF Loads Including Ratings and Status during Normal Power Operations

<b>ESF Bus</b>	<b>Load</b>	<b>Voltage Level (V)</b>	<b>Rating (hp)</b>
10A115	Load Center Transformer (10X201)	4160-480	1000 kVA
	T-B Equip Compt Exhaust Fan (1AV106)	4000	250
10A117	Control Rod Drive Water Pump (1AP158)	4000	250
	Load Center Transformer (10X203)	4160-480	1000 kVA
	Drywell Chiller (1AK111)	4000	1303 kW
	Control Room Chiller (0AK112)	4000	329 kW
10A116	Load Center Transformer (10X202)	4160-480	1000 kVA
	T-B Equip Compt Exhaust Fan (1BV106)	4000	250
10A118	Control Rod Drive Water Pump (1BP158)	4000	250
	Load Center Transformer (10X204)	4160-480	1000 kVA
	Drywell Chiller (1BK111)	4000	1303 kW
	Control Room Chiller (0BK112)	4000	329 kW

## ATTACHMENT 6

### Limerick Generating Station, Units 1 and 2 Response to NRC Bulletin 2012-01, "Design Vulnerability in Electric Power System"

ESF Bus	Load	Voltage Level (V)	Rating (hp)
20A115	T-B Equip Compt Exhaust Fan (2AV106)	4000	250
	Load Center Transformer (20X201)	4160-480	1000 kVA
	Drywell Chiller (2AK111)	4000	500
20A117	Control Rod Drive Water Pump (2AP158)	4000	250
	Load Center Transformer (20X203)	4160-480	1000 kVA
20A116	Load Center Transformer (20X202)	4160-480	1000 kVA
	T-B Equip Compt Exhaust Fan (2BV106)	4000	250
	Drywell Chiller (2BK111)	4000	500
20A118	Control Rod Drive Water Pump (2BP158)	4000	250
	Load Center Transformer (20X204)	4160-480	1000 kVA

***NRC Request 2.c: Confirm that the operating configuration of the ESF buses is consistent with the current licensing basis. Describe any changes in offsite power source alignment to the ESF buses from the original plant licensing.***

EGC Response to NRC Request 2.c:

The LGS 220 kV substation supplies offsite power at 13.2 kV via the No. 10 220-13 kV transformer connected to the Station Auxiliary Bus 10A103. The LGS 500 kV substation supplies offsite power at 13.2 kV to Station Auxiliary Bus 20A103 from the tertiary winding of

## ATTACHMENT 6

### Limerick Generating Station, Units 1 and 2 Response to NRC Bulletin 2012-01, "Design Vulnerability in Electric Power System"

one of the 4A or 4B bus tie autotransformers through the No. 20 13-13 kV regulating transformer. Each offsite source supplies an emergency auxiliary (i.e., safeguard) transformer with a nominal capacity of 14 MVA that steps down the 13.2 kV to 4.16 kV and connects through interlocked circuit breakers to every 4 kV Class 1E bus. Both offsite sources are available continuously to the Class 1E buses.

The Class 1E ac power system for each unit is divided into Divisions A, B, C, and D. The 4 kV bus of each Class 1E load division is provided with connection to the two offsite power sources, designated as preferred and alternate power supplies. For each load division, one 4 kV feeder circuit breaker is provided for the normal incoming preferred power source, and another 4 kV feeder circuit breaker is provided for the alternate power source. Safeguard Bus 101 Transformer is the preferred power source for Channels A (i.e., Division A) and C (i.e. Division C) for Unit 1 and Channels B (i.e., Division B) and D (i.e., Division D) for Unit 2. Safeguard Bus 201 Transformer is the preferred power source for Channels B (i.e., Division B) and D (i.e., Division D) for Unit 1 and Channels A (i.e., Division A) and C (i.e., Division C) for Unit 2.

The following at power (i.e., normal operating condition) configurations have been confirmed to be consistent with the current licensing basis:

1. Unit 1 Preferred Source – Power to ESF Division A and C Buses via the 220 kV substation through the No.10 Station Transformer and the 101 Safeguard Transformer.
2. Unit 1 Preferred Source – Power to ESF Division B and D Buses via the 500 kV substation through the No.4A Station Transformer, No. 20 Regulating Transformer and the 201 Safeguard Transformer.
3. Unit 1 Alternate Source – Power to ESF Division B and D Buses via the 220 kV substation through the No.10 Station Transformer and the 101 Safeguard Transformer.
4. Unit 1 Alternate Source – Power to ESF Division A and C Buses via the 500 kV substation through the No.4A Station Transformer, No. 20 Regulating Transformer and the 201 Safeguard Transformer.
5. Unit 2 Preferred Source – Power to ESF Division B and D Buses via the 220 kV substation through the No.10 Station Transformer and the 101 Safeguard Transformer.
6. Unit 2 Preferred Source – Power to ESF Division A and C Buses via the 500 kV substation through the No.4A Station Transformer, No. 20 Regulating Transformer and the 201 Safeguard Transformer.
7. Unit 2 Alternate Source – Power to ESF Division A and C Buses via the 220 kV substation through the No.10 Station Transformer and the 101 Safeguard Transformer.
8. Unit 2 Alternate Source – Power to ESF Division B and D Buses via the 500 kV substation through the No.4A Station Transformer, No. 20 Regulating Transformer and the 201 Safeguard Transformer.

## ATTACHMENT 6

### Limerick Generating Station, Units 1 and 2 Response to NRC Bulletin 2012-01, "Design Vulnerability in Electric Power System"

The operating configuration of the offsite source alignment is consistent with the current licensing basis (CLB), and the original Safety Evaluation Report (SER) issued for LGS.

#### **System Protection**

NRC Requests 1, 1.a, 2.b, and 2.d request information regarding electrical system protection, and will be addressed in this section.

***NRC Request 1: Given the requirements above, describe how the protection scheme for ESF buses (Class 1E for current operating plants or non-Class 1E for passive plants) is designed to detect and automatically respond to a single-phase open circuit condition or high impedance ground fault condition on a credited off-site power circuit or another power sources. Also, include the following information:***

#### **EGC Response to NRC Request 1:**

Consistent with the current licensing basis and 10 CFR 50, Appendix A, "General Design Criteria for Nuclear Power Plants," Criterion (GDC) 17, "Electric power systems," existing protective circuitry will separate the ESF buses from a connected failed offsite source due to a loss of voltage or a sustained, balanced degraded grid voltage concurrent with certain design basis accidents. The relay systems were not specifically designed to detect an open single phase of a three phase system. Detection of a single-open phase condition is beyond the approved design and licensing basis of the plant.

The LGS degraded voltage relaying schemes are capable of responding to degraded grid conditions as described in the LGS Updated Final Safety Analysis Report (UFSAR) Section 8.1.6.3.6, "NRC Branch Technical Position (BTP) PSB-1, 'Adequacy of Station Electric Distribution System Voltages.'" The LGS degraded grid and dead bus relaying schemes monitor the A and B phases. This design assumes that grid changes occur symmetrically across all phases. The C phase is unmonitored by the degraded grid relays, the dead bus relays or the Main Control Room (MCR) panel board meters.

The 4 kV distribution system design at LGS is different from that of Byron Station because LGS has two independent offsite sources which provide power to the appropriate 4 kV ESF buses through the 101 and 201 Safeguard Transformers. The 101 Transformer is fed from one offsite source and the 201 Transformer is fed from the second offsite source. The normal LGS configuration for each unit is to have two safeguard buses aligned to the 101 source and two safeguard buses aligned to the 201 source; whereas Byron Station aligns both of their 4 kV ESF buses to one offsite source. Also, the LGS 4 kV safeguard bus configuration consists of four divisions to prevent a total loss of any specific 4 kV safeguard load.

In a normal plant alignment, a loss of phase on one offsite source would affect two of four safeguard buses per unit. The 4 kV degraded voltage (i.e., degraded grid) protective relay



## ATTACHMENT 6

### Limerick Generating Station, Units 1 and 2 Response to NRC Bulletin 2012-01, "Design Vulnerability in Electric Power System"

schemes at LGS are a one-out-of-one logic for each 4 kV safeguard bus which uses potential transformers across the A to B phases to monitor for degraded bus conditions. A loss of the A or B phase at the 4 kV bus feeder or on the 13 kV side of the safeguard transformer would cause the degraded grid relays to trip the 4 kV bus and transfer to the other offsite source. Thus, only a C phase open is undetected. This is different from the Byron Station's design of two-out-of-two logic with two independent relays monitoring the A to B phases and B to C phases. The existing Byron Station scheme requires both relays to actuate to trip on degraded grid.

***NRC Request 1.a: The sensitivity of protective devices to detect abnormal operating conditions and the basis for the protective device setpoint(s).***

EGC Response to NRC Request 1.a:

Consistent with the current licensing basis and GDC 17, existing electrical protective devices are sufficiently sensitive to detect design basis conditions like a loss of voltage or a degraded voltage, but were not designed to detect a single phase open circuit condition. The LGS undervoltage protective devices and the basis for their setpoint(s) are shown in Table 5 below.

**Table 5: LGS Protective Devices, Setpoints, and Basis**

<b>Protection Zone</b>	<b>Protective Device</b>	<b>UV Logic</b>	<b>Setpoint (Nominal)</b>	<b>Basis for Setpoint</b>
4 kV ESF Bus (Note 1)	Loss of Voltage Relay	1 of 1	1664 V (40% of 4160 V)	To actuate upon complete loss of ESF Bus voltage condition
4 kV ESF Bus D11, D12, D21, and D22	Differential Relays	1 of 3	<u>Voltage Unit</u> Pickup-113 V Min Trip Amp 87 primary amps (p.a.). <u>Current Unit</u> Inst 800 p.a.	To actuate for faults on ESF Bus
4 kV ESF Bus D13, D14, D23, and D24	Differential Relays	1 of 3	<u>Voltage Unit</u> Pickup-113 V Min Trip Amp 96 primary amps (p.a.). <u>Current Unit</u> Inst 800 p.a.	To actuate for faults on ESF Bus
4 kV ESF Bus (Note 2)	Loss of Voltage Relay	1 of 1	3910 V (94% of 4160 V)	To actuate upon degraded voltage condition on the feed to the ESF Bus after a 61 second time delay (normal), (10 seconds on loss of coolant accident (LOCA))

## ATTACHMENT 6

### Limerick Generating Station, Units 1 and 2 Response to NRC Bulletin 2012-01, "Design Vulnerability in Electric Power System"

Protection Zone	Protective Device	UV Logic	Setpoint (Nominal)	Basis for Setpoint
4 kV ESF Bus (Note 2)	Loss of Voltage Relay	1 of 1	3640 V (87.5% of 4160 V)	To actuate upon degraded voltage condition on the feed to the ESF Bus after a 52 second time delay
4 kV ESF Bus (Note 2)	Loss of Voltage Relay	1 of 1	2905 V (70% of 4160 V)	To actuate upon loss of voltage condition on the feed to the ESF Bus after a 0.9 second time delay
4 kV ESF Bus (Note 2)	Phase Overcurrent Relays	1 of 3	Current Transformer (CT) 200/1 (4160 V) Time-1600 p.a. 60 cycles @ 400%	To actuate for faults on ESF Bus
4 kV ESF Bus (Note 2)	Ground Overcurrent Relay	1 of 1	CT 200/1 (4160 V) Time-100 p.a 51 cycles @ 400%	To actuate for faults on ESF Bus
No. 10 Unit Auxiliary 230-13.8 kV Transformer	Phase Differential Relays (at 220 kV Substation)	1 of 3	CT 50/1 Pickup DHR-1.14a DOC-30.4a	To actuate upon No. 10 Unit Auxiliary 230-13.8 kV Transformer fault
No. 10 Unit Auxiliary 230-13.8 kV Transformer	Phase Overcurrent Relays (at 220 kV Substation)	1 of 3	CT 50/1 (230 kV) Inst-1450 p.a Time-300 p.a 120 cycles @ 400%	To actuate upon No. 10 Unit Auxiliary 230-13.8 kV Transformer fault
No. 10 Unit Auxiliary 230-13.8 kV Transformer	Ground Overcurrent Relay (at 220 kV Substation)	1 of 1	CT 50/1 (230 kv) Time-75 p.a 15 cycles @ 400%	To actuate upon No. 10 Unit Auxiliary 230-13.8 kV Transformer fault
No. 10 Unit Auxiliary 230-13.8 kV Transformer	Overall Neutral Overcurrent Relay (at 220 kV Substation)	1 of 1	CT 120/1 (13 kv)} Time-480 p.a. 85 cycles @ 400%	To actuate upon No. 10 Unit Auxiliary 230-13.8 kV Transformer fault

## ATTACHMENT 6

### Limerick Generating Station, Units 1 and 2 Response to NRC Bulletin 2012-01, "Design Vulnerability in Electric Power System"

Protection Zone	Protective Device	UV Logic	Setpoint (Nominal)	Basis for Setpoint
No.10 Station Auxiliary Bus and the connection to the 220 kV Substation	Phase Overcurrent Relays (at 220 kV Substation)	1 of 3	CT 400/1 (13 kv) Time-4000 p.a 125 cycles @ 400%	To actuate upon No.10 Station Auxiliary Bus or the connection to the 220 kV substation fault
No.10 Station Auxiliary Bus and the connection to the 220 kV Substation	Ground Overcurrent Relay (at 220 kV Substation)	1 of 1	CT 400/1 (13 kv) Time-400 p.a 70 cycles @ 400%	To actuate upon No.10 Station Auxiliary Bus or the connection to the 220 kV substation fault
No.10 Station Auxiliary Bus and the connection to the 220 kV Substation	Differential Voltage Relays	1 of 3	<u>Voltage Unit</u> Pickup-159 V Min Trip Amp 71 p.a. <u>Current Unit</u> Inst 1200 p.a.	To actuate upon No.10 Station Auxiliary Bus or the connection to the 220 kV substation fault
No.101 Safeguard 13.2-4.16 kV Trans	Phase Differential Relays	1 of 3	CT 200/1(13.2 kV) Pickup DHR-1.14a DOC-30.4a	To actuate upon No. 101 Safeguard 13.2-4.16 kV transformer fault
No.101 Safeguard 13.2-4.16 kV Trans	Phase Overcurrent Relays	1 of 3	CT 200/1 (13.2 kV) Inst-15000 p.a. Time-1000 p.a 132 cycles @ 400%	To actuate upon No. 101 Safeguard 13.2-4.16 kV transformer fault
No.101 Safeguard 13.2-4.16 kV Trans	Ground Overcurrent Relays	1 of 1	CT 10/1 (13.2 kV) Inst-17 p.a.	To actuate upon No. 101 Safeguard 13.2-4.16 kV transformer fault
No.101 Safeguard 13.2-4.16 kV Trans	Overall Neutral Overcurrent Relay	1 of 1	CT 120/1 (4160 V) Time-120 p.a 96 cycles @ 400%	To actuate upon No. 101 Safeguard 13.2-4.16 kV transformer fault
No. 20 Regulating 13.8-13.8 kV Transformer	Differential Relays (At 500 kV Substation)	1 of 3	CT 600/1.73 Pickup DHR-2.61a DOC-69.6a	To actuate upon No. 20 Regulating 13.8-13.8 kV transformer fault

**ATTACHMENT 6**

**Limerick Generating Station, Units 1 and 2 Response to  
NRC Bulletin 2012-01, "Design Vulnerability in Electric Power System"**

<b>Protection Zone</b>	<b>Protective Device</b>	<b>UV Logic</b>	<b>Setpoint (Nominal)</b>	<b>Basis for Setpoint</b>
No. 20 Regulating 13.8-13.8 kV Transformer	Current Balance Relays (At 500 kV Substation)	1 of 3	3.0 amp (relay current)	To actuate upon No. 20 Regulating 13.8-13.8 kV transformer fault
No. 20 Regulating 13.8-13.8 kV Transformer	Phase Overcurrent Relays (At 500 kV Substation)	1 of 3	CT 600/1 Inst-25800 p.a. Time-4200 p.a 120 cycles @ 400%	To actuate upon No. 20 Regulating 13.8-13.8 kV transformer fault
No. 20 Regulating 13.8-13.8 kV Transformer	Ground Overcurrent Relay (at 500 kV Substation)	1 of 1	CT 600/1 Time-360 p.a 70 cycles @ 400%	To actuate upon No. 20 Regulating 13.8-13.8 kV transformer fault
No. 20 Regulating 13.8-13.8 kV Transformer Neutral Resistor	Ground Overcurrent Relay (at 500 kV Substation)	1 of 1	CT 600/1 Time-480 p.a 85 cycles @ 400%	To actuate upon No. 20 Regulating 13.8-13.8 kV transformer fault
No. 20 Regulating 13.8-13.8 kV Transformer and No.20 Station Auxiliary Bus	Pilot Wire Overcurrent Relays (at 500 kV Substation)	1 of 3 elements (single relay)	CT 600/1 <u>Phase</u> Inst 3600 p.a. <u>Ground</u> Inst 1200 p.a.	To actuate upon No. 20 Regulating 13.8-13.8 kV Transformer or No.20 Station Auxiliary Bus fault
No. 20 Regulating 13.8-13.8 kV Transformer and No.20 Station Auxiliary Bus	Pilot Wire Overcurrent Relays	1 of 3 elements (single relay)	CT 600/1 <u>Phase</u> Inst 3600 p.a. <u>Ground</u> Inst 1200 p.a.	To actuate upon No. 20 Regulating 13.8-13.8 kV Transformer or No.20 Station Auxiliary Bus fault
No.201 Safeguard 13.2-4.16 kV Transformer	Phase Differential Relays	1 of 3	CT 200/1(13.2 kV) Pickup DHR-1.14a DOC-30.4a	To actuate upon NO. 201 Safeguard 13.2-4.16 kV transformer fault

**ATTACHMENT 6**

**Limerick Generating Station, Units 1 and 2 Response to  
NRC Bulletin 2012-01, "Design Vulnerability in Electric Power System"**

<b>Protection Zone</b>	<b>Protective Device</b>	<b>UV Logic</b>	<b>Setpoint (Nominal)</b>	<b>Basis for Setpoint</b>
No.201 Safeguard 13.2-4.16 kV Transformer	Phase Overcurrent Relays	1 of 3	CT 200/1 (13.2 kV) Inst-15000 p.a Time-1000 p.a 132 cycles @ 400%	To actuate upon No. 201 Safeguard 13.2-4.16 kV transformer fault
No.201 Safeguard 13.2-4.16 kV Transformer	Ground Overcurrent Relays	1 of 1	CT 10/1 (13.2 kV) Inst-17 p.a.	To actuate upon No. 201 Safeguard 13.2-4.16 kV transformer fault
No.201 Safeguard 13.2-4.16 kV Transformer	Overall Neutral Overcurrent Relay	1 of 1	CT 120/1 (4160 V) Time-120 p.a 96 cycles @ 400%	To actuate upon No. 201 Safeguard 13.2-4.16 kV transformer fault
<b>Note 1:</b> Separate relay for each ESF Bus				
<b>Note 2:</b> Separate relays for each preferred and alternate feeder to each ESF Bus				

Existing electrical protective devices are also sufficiently sensitive to detect a ground fault. Additionally, Table 5 lists ground protection on the ESF buses and the basis for the device setpoint(s).

***NRC Request 2.b. If the ESF buses are not powered by offsite power sources, explain how the surveillance tests are performed to verify that a single-phase open circuit condition or high impedance ground fault condition on an off-site power circuit is detected.***

EGC Response to NRC Request 2.b:

Not Applicable - the ESF buses at LGS, Units 1 and 2 are powered by offsite power sources.

***NRC Request 2.d: Do the plant operating procedures, including off-normal operating procedures, specifically call for verification of the voltages on all three phases of the ESF buses?***

EGC Response to NRC Request 2.d:

LGS Special Event Procedure SE-17, "Loss of Single Phase from Offsite Source," requires checking all three phase to phase voltages at the station auxiliary buses when a single open phase is suspected.

## ATTACHMENT 6

### Limerick Generating Station, Units 1 and 2 Response to NRC Bulletin 2012-01, "Design Vulnerability in Electric Power System"

#### Consequences

NRC Requests 1.b, 1.c, and 2.e request information regarding the electrical consequences of an event, and will be addressed in this section.

***NRC Request 1.b: The differences (if any) of the consequences of a loaded (i.e., ESF bus normally aligned to offsite power transformer) or unloaded (e.g., ESF buses normally aligned to unit auxiliary transformer) power source.***

#### EGC Response to NRC Request 1.b:

Installed relays were not designed to detect single phase open circuit conditions. Existing loss of voltage and degraded voltage relays may respond depending on load and possible grounds. In general, there will be no plant response for an unloaded power source in the event of a single-phase open circuit on a credited off-site power circuit because there is insufficient current to detect a single-phase open circuit for this configuration.

***NRC Request 1.c: If the design does not detect and automatically respond to a single-phase open circuit condition or high impedance ground fault condition on a credited offsite power circuit or another power sources, describe the consequences of such an event and the plant response.***

#### EGC Response to NRC Request 1.c:

1. Limerick Generating Station (LGS) did not credit in the CLB that the Class 1E protection scheme (i.e., for the emergency safeguard feature (ESF) buses) was designed to detect and automatically respond to a single-phase open circuit condition on the credited off-site power source as described in the UFSAR and Technical Specifications (TS).

The offsite power circuits at the LGS consists of two independent circuits one source from the 220-13 kV Startup Transformer in the 220 kV substation, the second source from the 13 kV tertiary winding of the 220-500 kV Bus Tie Autotransformer in the 500 kV substation. Each offsite source is connected as the preferred or alternate source to every 4 kV ESF bus in Unit 1 and Unit 2.

2. Since LGS did not credit the ESF bus protection scheme as being capable of detecting and automatically responding to a single phase open circuit condition, an open phase fault was not included in the design criteria for either the loss of voltage, the degraded voltage relay scheme or secondary level undervoltage protection system design criteria. Since open phase detection was not credited in the design or licensing basis, no design basis calculations or design documents exist that previously considered this condition.

## ATTACHMENT 6

### Limerick Generating Station, Units 1 and 2 Response to NRC Bulletin 2012-01, "Design Vulnerability in Electric Power System"

3. Without formalized engineering calculations or engineering evaluations, the electrical consequences of such an open phase event, including plant response, can only be evaluated to the extent of what has already been published by the Electric Power Research Institute (EPRI) and Basler; which is a generic overview. The difficulty in applying these documents to the LGS specific response is that these are generic assessments and cannot be formally credited as a basis for an accurate response. The primary reason is that detailed plant specific models would need to be developed (e.g., transformer magnetic circuit models, electric distribution models, motor models; including positive, negative, and zero sequence impedances (voltage and currents), and the models would need to be compiled and analyzed for the LGS specific Class 1E Electric Distribution System.

Specific measures implemented at LGS as interim compensatory measures include the following:

- Delivery of required reading packages to operators
- Enhancement of alarm / annunciator response procedures
- Creation of Procedure SE-17, "Loss of Single Phase from Offsite Source"
- Issuance of an Engineering Change Request to modify plant voltage alarms to annunciate for a phase unbalance condition upstream of the No. 10 Station Auxiliary Bus.

***NRC Request 2.e: If a common or single offsite circuit is used to supply redundant ESF buses, explain why a failure, such as a single-phase open circuit or high impedance ground fault condition, would not adversely affect redundant ESF buses.***

EGC Response to NRC Request 2.e:

Not applicable since LGS does not use a common or single offsite circuit to supply redundant ESF busses.

**ATTACHMENT 7**

**Oyster Creek Nuclear Generating Station, Unit 1, 90-Day Response to NRC Bulletin  
2012-01, "Design Vulnerability in Electric Power System"**



## ATTACHMENT 7

### Oyster Creek Nuclear Generating Station Response to NRC Bulletin 2012-01, "Design Vulnerability in Electric Power System"

#### **High Impedance Grounds:**

On January 30, 2012, a porcelain insulator broke in the Byron Station switchyard resulting in parting of the C phase conductor of the offsite source. The insulator was on the offsite source side of the Unit 2 System Auxiliary Transformers (SATs), and the connection parted in such a way as to leave an electrically open end on the source side. The parted connection remained electrically connected on the transformer side, and the loose bus bar conductor end fell to the ground. This ground was a direct result of the broken insulator and not an independent event. The connected loose bus bar provided a path to ground for the transformer high voltage terminal, but did not result in a ground fault (i.e., neither solid nor impedance) as seen from the source. Since the switchyard (i.e., source side) relaying was electrically isolated from the fault, it did not detect a fault; therefore, did not operate.

The significant event was the opening of a single phase connection; the ground on the high voltage side of the SAT is of lesser significance. Regardless of phase discontinuity, if the ground impedance is low on the source side, and currents are high, the source side protective relaying will operate and open all circuit phases. If the ground impedance is high, and currents low, the relaying may not operate depending on the magnitude of ground impedance; the circuit will continue to supply power.

A qualitative analysis has been performed to assess the impact of single phase high impedance ground faults. The primary objective of the analysis was to determine if a high impedance ground fault could result in an unbalanced voltage condition sufficient to adversely affect energized ESF equipment. The cases analyzed include a single phase high impedance ground fault with all three phases intact and a single phase high impedance ground fault concurrent with the loss of the same phase. These cases have been analyzed for both the high and low voltage sides of the SATs analyzed.

Attachment 11 provides a summary report of the qualitative analysis; therefore, all information discussed in this response attachment is limited to single-phase open circuit conditions.

#### **System Description**

NRC Requests 2, 1.d, 2.a, and 2.c request system information, and will be addressed in this section.

***NRC Request No. 2: Briefly describe the operating configuration of the ESF buses (Class 1E for current operating plants or non-Class 1E for passive plants) at power (normal operating condition).***

#### **Exelon Generation Company, LLC (EGC) Response to NRC Request No. 2**

A simplified one-line diagram of the Oyster Creek Nuclear Generating Station (OCNGS) is provided as Figure 1 below.

## ATTACHMENT 7

### Oyster Creek Nuclear Generating Station Response to NRC Bulletin 2012-01, "Design Vulnerability in Electric Power System"

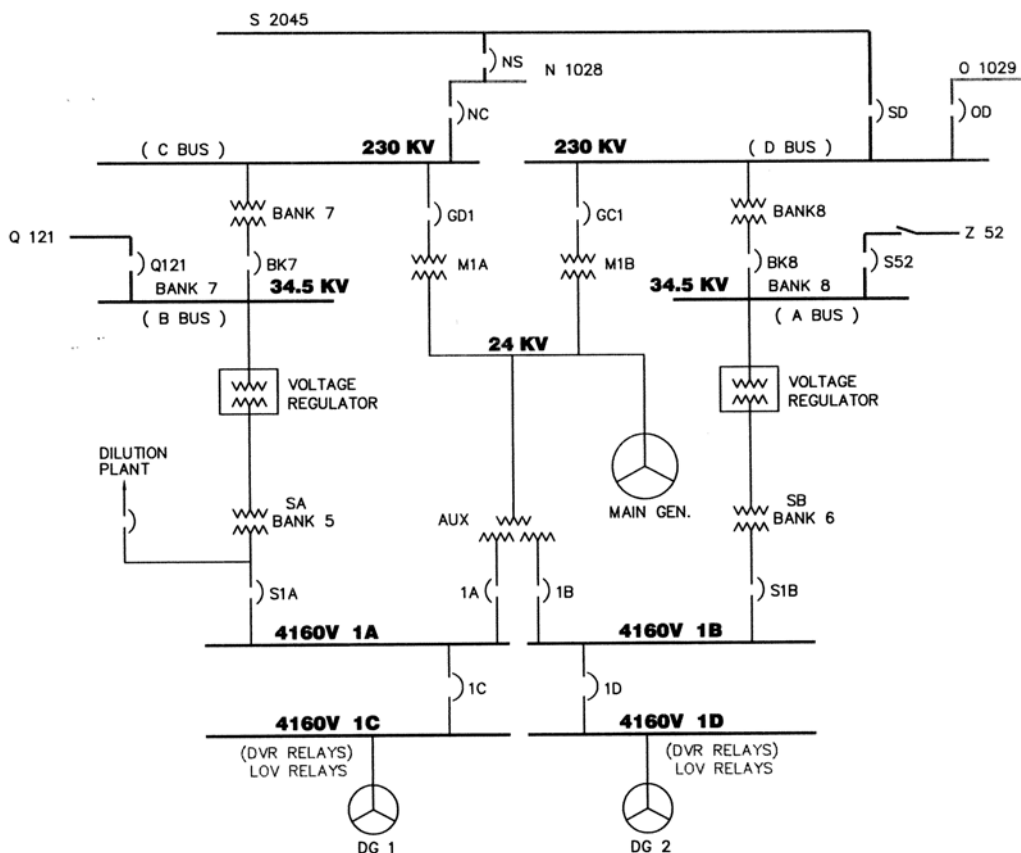

**Figure 1:** Simplified One-Line Diagram

4160V buses 1C and 1D are the engineered safety features (ESF) buses at OCNCS.

During normal power operation, ESF Buses 1C and 1D are powered by the 4160V Buses 1A and 1B, respectively. Buses 1A and 1B are powered by the three winding Unit Auxiliary Transformer (UAT). The UAT is directly connected to the main generator with the iso-phase duct bus.

**NRC Request 1.d:** *Describe the offsite power transformer (e.g., start-up, reserve, station auxiliary) winding and grounding configurations.*

EGC Response to NRC Request 1.d:

The OCNCS startup transformer winding and grounding configurations are shown in Table 1 below.

## ATTACHMENT 7

### Oyster Creek Nuclear Generating Station Response to NRC Bulletin 2012-01, "Design Vulnerability in Electric Power System"

**Table 1:** OCNES Offsite Power Transformer Winding and Grounding Configurations

Transformer	Winding Configuration	MVA Size (AO/FA/FA)	Voltage Rating (Primary/Secondary)	Grounding Configuration
Start-up Transformer SA	Delta-Wye (3 Leg)	12/16/20	34.5kV/4.16kV	Neutral Grounded with 2 Ω Resistor
Start-up Transformer SB	Delta-Wye (3 Leg)	12/16/20	34.5kV/4.16kV	Neutral Grounded with 2 Ω Resistor

**NRC Request 2.a:** *Are the ESF buses powered by offsite power sources? If so, explain what major loads are connected to the buses including their ratings.*

EGC Response to NRC Request 2.a:

For at power (i.e., normal operating condition) configuration, OCNES ESF buses are not powered by offsite sources.

The OCNES ESF bus power sources are shown in Tables 2 and 3 below.

**Table 2:** OCNES ESF Buses that Are Normally Powered from Offsite Sources

Description of ESF Bus Power Source	ESF Bus Name (normal operating condition)	Original licensing basis configuration (Y/N)
N/A	N/A	N/A

**Table 3:** OCNES ESF Buses That Are Not Normally Powered from Offsite Sources

Description of ESF Bus Power Source	ESF Bus Name (normal operating condition)	Original licensing basis configuration (Y/N)
Unit Auxiliary Transformer (UAT)	4kv Bus 1C	Y
Unit Auxiliary Transformer (UAT)	4kv Bus 1D	Y

During normal plant operation, Startup Transformer SA provides power to the Dilution Plant. The purpose of the Dilution Plant is to offset the effects of the main condenser discharge to the canal. Startup Transformer SB does not carry any load during normal power operation.

## ATTACHMENT 7

### Oyster Creek Nuclear Generating Station Response to NRC Bulletin 2012-01, "Design Vulnerability in Electric Power System"

***NRC Request 2.c: Confirm that the operating configuration of the ESF buses is consistent with the current licensing basis. Describe any changes in offsite power source alignment to the ESF buses from the original plant licensing.***

EGC Response to NRC Request 2.c:

The OCNGS offsite power was licensed in accordance with 10 CFR 50, Appendix A, "General Design Criteria for Nuclear Power Plants," Criterion (GDC) 17, "Electric power systems." There have been no changes in the offsite power source alignment to the ESF buses since original plant licensing.

Normal operating condition configurations have been confirmed to be consistent with the current licensing basis (CLB.)

## ATTACHMENT 7

### Oyster Creek Nuclear Generating Station Response to NRC Bulletin 2012-01, "Design Vulnerability in Electric Power System"

#### System Protection

NRC Requests 1, 1.a, 2.b, and 2.d request information regarding electrical system protection, and will be addressed in this section.

***NRC Request 1: Given the requirements above, describe how the protection scheme for ESF buses (Class 1E for current operating plants or non-Class 1E for passive plants) is designed to detect and automatically respond to a single-phase open circuit condition or high impedance ground fault condition on a credited off-site power circuit or another power sources. Also, include the following information:***

#### EGC Response to NRC Request 1:

Consistent with GDC 17, existing protective circuitry will separate the ESF buses from a connected failed offsite source due to a loss of voltage or a sustained, balanced degraded grid voltage concurrent with certain design basis accidents. The relay systems were not specifically designed to detect an open single phase of a three phase system. Detection of a single-open phase condition is beyond the approved design and licensing basis of the plant.

#### Normal Plant Operation Considerations:

During normal plant operation, the ESF 4160V Buses 1C and 1D are powered from the UAT. An open phase on the Main Power Transformer (MPT) 230kV side would have no effect on the ESF bus voltage. Since the UAT is tied directly to the generator terminals, it will continue to receive three phase voltage on its primary side for as long as the generator remains online. If the generator trips on negative sequence due to the open MPT phase on 230 kV side, the 1C and 1D buses and upstream balance of plant (BOP) Buses 1A and 1B will automatically transfer to their alternate source (i.e., Startup Transformers SA and SB). Therefore, an open phase on the MPT 230 kV side while the plant is in normal operation is not of concern.

An open phase on the UAT primary side while the iso-phase bus connections at generator and MPT remain intact is not credible due to the iso-phase bus connection arrangement, which makes it highly unlikely that a phase would open without also shorting to ground and tripping the generator.

During normal plant operation an open single-phase on the Startup Transformer primary side has no effect on ESF bus voltage since these buses are powered from the UAT.

**ATTACHMENT 7**

**Oyster Creek Nuclear Generating Station Response to  
NRC Bulletin 2012-01, "Design Vulnerability in Electric Power System"**

***NRC Request 1.a: The sensitivity of protective devices to detect abnormal operating conditions and the basis for the protective device setpoint(s).***

EGC Response to NRC Request 1.a:

Consistent with GDC 17, existing electrical protective devices are sufficiently sensitive to detect design basis conditions like a loss of voltage or a degraded voltage, but were not designed to detect a single phase open circuit condition. The OCNCS under-voltage protective device setpoints and the basis for the device setpoints are shown in Table 4 below.

**Table 4:** Protective Devices

<b>Protection Zone</b>	<b>Protective Device</b>	<b>UV Logic</b>	<b>Setpoint (Nominal)</b>	<b>Basis for Setpoint</b>
4 kV ESF Buses 1C and 1D	Loss of Voltage Relay	1 of 1	2870 ± 143.5V	To actuate upon complete loss of ESF bus voltage condition
4 kV ESF Buses 1C and 1D	Degraded Grid Voltage Relay	2 of 3	3840 +20, -40V	To actuate upon degraded grid condition sustained for 10 ± 1 seconds
4 kV ESF Buses 1C and 1D	Phase Over current	N/A	2400A @ 3.0TD	Actuates upon fault downstream of device
4 kV ESF Buses 1C and 1D	Neutral Over Current	N/A	240A @ 10.0TD	Actuates upon ground fault downstream of device
SA and SB Differential Relay	Differential	N/A	* See Below	Transformer SA and SB differential protection
S1A and S1B Neutral Over Current	Current Imbalance	N/A	360 A @1.45TD	Phase to ground fault

**\*Relay Type BDD**

<b><u>34.5 kV</u></b>	<b><u>SB (R2)</u></b>	<b><u>SA (R3)</u></b>
CT Ratio	80/1	80/1
Range	2.9-8.7	2.9-8.7
Slope	25%	25%
Tap	4.6	4.6
Amp PU	1.38	1.38

## ATTACHMENT 7

### Oyster Creek Nuclear Generating Station Response to NRC Bulletin 2012-01, "Design Vulnerability in Electric Power System"

<u>4.16 kV</u>	(R1)	(R2)
CT Ratio	600/1	600/1
Tap	8.7	8.7
Amp PU	2.61	2.61

	(R1)
CT Ratio	600/1
Tap	8.7
Amp PU	2.61

Existing electrical protective devices are also sufficiently sensitive to detect a phase over current or ground fault. Table 4 also lists ground protection on the ESF buses and the basis for the device setpoints.

***NRC Request 2.b. If the ESF buses are not powered by offsite power sources, explain how the surveillance tests are performed to verify that a single-phase open circuit condition or high impedance ground fault condition on an off-site power circuit is detected.***

#### EGC Response to NRC Request 2.b:

OCNGS has two off-site power sources. These power sources are from 34.5 kV Buses A and B located in the OCNGS substation. These two buses are tied together with a breaker and each of the buses is powered by several independent sources. The 34.5 kV buses are connected in a ring configuration. Substation Buses B and A power Startup Transformers SA and SB, respectively. Each of these power sources is independent. In turn, the startup transformers SA and SB power plant non safety 4160 V Buses 1A and 1B, respectively. Buses 1A and 1B power the ESF Buses 1C and 1D, respectively.

Per OCNGS Procedure 681.4.005, "Substation Tour Sheet," the tap positions for all three phases of the voltage regulators for the startup transformers is recorded. The tap positions of the voltage regulators for each transformer must be within two steps of each other. If a single phase was open on either of the two startup transformer supply lines, the tap position for the open phase would be different (i.e., by more than two steps) than the other two phases. If the tap positions are out of position by more than two steps, the acceptance criteria of OCNGS Procedure 681.4.005 is not met and an engineering assessment of the condition is performed. The substation tour is normally performed on a daily basis (conditions permitting). However when an ESF system is out of service, the Substation Tour is performed every eight (8) hours in accordance with OCNGS Procedure 681.4.004, "Technical Specification Log Sheet."

## ATTACHMENT 7

### Oyster Creek Nuclear Generating Station Response to NRC Bulletin 2012-01, "Design Vulnerability in Electric Power System"

***NRC Request 2.d: Do the plant operating procedures, including off-normal operating procedures, specifically call for verification of the voltages on all three phases of the ESF buses?***

EGC Response to NRC Request 2.d:

OCNGS design does not provide voltage monitoring on the ESF buses; therefore, the plant operating procedures, including operating procedures for off-normal plant conditions, do not call for verification of the voltages on all three phases of the ESF buses. However, if the voltage on any of the three phases goes below the degraded-grid voltage relay setpoint, associated alarms will be received in the Main Control Room. The alarm response procedures for these alarms require operators to check the currents on the primary side of the startup transformers. If the current is zero (0) in one of the phases, the procedure directs operators to trip Breakers 1C and/or 1D to separate the ESF buses from the offsite power sources. This will start the emergency diesels associated with that ESF bus.

Each bus has three (3) single phase potential transformers (i.e., 4200V / 120V). The loss of voltage relays (i.e., 27-1C / 27-1D) monitor the A and B Potential Transformer secondary phases, while the degraded voltage relays monitor all three line-to-Line voltages (i.e., 27-11C / 27-11D) monitor between A and B phases; (i.e., 27-12C / 27-12D) monitor between B and C phases; and (i.e., 27-13C / 27-13D) monitor between A and C phases.

The loss of voltage circuit uses the single loss of voltage relay in series with a 2-out-of-3 logic scheme from the degraded voltage relays with a time delay of three (3) seconds. In addition to the loss of voltage logic, the degraded voltage relay logic circuit is in parallel with the loss of voltage circuit and utilizes 2-out-of-3 logic from time delay relay contacts set for 10 seconds. Therefore, if the unmonitored phase is lost, then the degraded voltage protective relay scheme will trip the bus in 10 seconds.

See responses to NRC Requests 1.b, 1.c, and 2.e below for further discussion.



## ATTACHMENT 7

### Oyster Creek Nuclear Generating Station Response to NRC Bulletin 2012-01, "Design Vulnerability in Electric Power System"

#### Consequences

NRC Requests 1.b, 1.c, and 2.e request information regarding the electrical consequences of an event and will be addressed in this section:

***NRC Request 1.b: The differences (if any) of the consequences of a loaded (i.e., ESF bus normally aligned to offsite power transformer) or unloaded (e.g., ESF buses normally aligned to unit auxiliary transformer) power source.***

#### EGC Response to NRC Request 1.b:

Installed protective relays were not designed to detect single phase open circuit conditions. Existing loss of voltage and degraded voltage relays may respond depending on load and possible grounds. In general, there will be no plant response for an unloaded (e.g., ESF buses normally aligned to the UAT) power source in the event of a single-phase open circuit on a credited off-site power circuit because there is insufficient current to detect a single-phase open circuit for this configuration.

The plant response for a loaded power source cannot be calculated without specifying the amount of loading and the specific loads involved.

***NRC Request 1.c: If the design does not detect and automatically respond to a single-phase open circuit condition or high impedance ground fault condition on a credited offsite power circuit or another power sources, describe the consequences of such an event and the plant response.***

#### EGC Response to NRC Request 1.c:

A single-phase open condition on an offsite power source will have no effect on OCNGS plant operation.

1. OCNGS did not credit in the CLB that the Class 1E protection scheme for the ESF buses was designed to detect and automatically respond to a single-phase open circuit condition on the credited off-site power source as described in the Updated Final Safety Analysis Report (UFSAR) and Technical Specifications (TS).

The offsite power circuits at the OCNGS consist of two independent circuits from 34.5kV substation buses (i.e., B and A) via startup transformers (i.e., SA and SB) to ESF buses (i.e., 1C and 1D), respectively.

2. Since OCNGS did not credit the ESF bus protection scheme as being capable of detecting and automatically responding to a single phase open circuit condition, an open phase fault was not included in the design criteria for either the loss of voltage, the degraded voltage

## ATTACHMENT 7

### Oyster Creek Nuclear Generating Station Response to NRC Bulletin 2012-01, "Design Vulnerability in Electric Power System"

relay scheme or secondary level under-voltage protection system design criteria. Since open phase detection was not credited in the OCNGS design or licensing basis, no design basis calculations or design documents exist that previously considered this condition.

3. Without formalized engineering calculations or engineering evaluations, the electrical consequences of such an open phase event, including plant response, can only be evaluated to the extent of what has already been published by the Electric Power Research Institute (EPRI) and Basler; which is a generic overview. The difficulty in applying these documents to the OCNGS specific response is that these are generic assessments and cannot be formally credited as a basis for an accurate response. The primary reason is that detailed plant specific models would need to be developed (e.g., transformer magnetic circuit models, electric distribution models, motor models; including positive, negative, and zero sequence impedances, voltages, and currents), and the models would need to be compiled and analyzed for the OCNGS-specific Class 1E electric distribution system.

4160V ESF Buses 1C and 1D, have two (2) levels of voltage protection. The first level of bus protection is with a loss of voltage protective relay <69% (i.e., 2870V) for three (3) seconds and the second level of bus protection is with the three (3) degraded voltage protective relays <92.3% (i.e., 3840 +20V,-40V) for 10 + 1 seconds.

Each bus has three (3) single phase potential transformers (i.e., 4200V / 120V). The loss of voltage relays (27-1C / 27-1D) monitor the A and B potential transformer secondary phases, while the degraded voltage relays monitor all three Line-to-Line voltages; 27-11C (27-11D) monitor between A and B phases; (i.e., 27-12C / 27-12D) monitor between B and C phases; and (i.e., 27-13C / 27-13D) monitor between A and C phases.

The loss of voltage circuit uses the single loss of voltage relay in series with a two-out-of-three logic scheme from the degraded voltage relays with a time delay of three (3) seconds. In addition to the loss of voltage logic, the degraded voltage logic circuit is in parallel with the loss of voltage circuit and utilizes two-out-of-three logic from time delay relay contacts set for 10 seconds. Therefore, if the unmonitored phase is lost, then the degraded voltage protective relay scheme will trip the bus within 10 + 1 seconds.

OCNGS has implemented the following compensatory measures to minimize the impact should single open phase condition occur in the offsite power source.

- All licensed operators were provided training on this issue.
- In accordance with OCNGS Procedure 681.4.005, "Substation Tour Sheet", the tap positions for all three phases of the voltage regulators for the startup transformers is recorded. The tap positions of the voltage regulators for each transformer must be within two steps of each other. If a single phase was open on either of the two startup transformer supply lines, the tap position for the open phase would be different (i.e., by more than two steps) than the other two phases. If the tap positions are out of position by more than two steps, the acceptance criteria of OCNGS Procedure 681.4.005 is not met and an engineering assessment of the condition is performed. The substation tour is normally performed on a daily basis, conditions permitting. However when an ESF system is out of

## ATTACHMENT 7

### Oyster Creek Nuclear Generating Station Response to NRC Bulletin 2012-01, "Design Vulnerability in Electric Power System"

service, the substation tour is performed every eight (8) hours in accordance with OCNGS Procedure 681.4.004, "Technical Specification Log Sheet."

- Alarm response procedures for "BUS 1C VOLTS LO" and "BUS 1D VOLTS LO" have been revised to provide guidance to operators for detection and action to separate the ESF buses from the offsite power source, should a loss of a single phase occur.

***NRC Request 2.e: If a common or single offsite circuit is used to supply redundant ESF buses, explain why a failure, such as a single-phase open circuit or high impedance ground fault condition, would not adversely affect redundant ESF buses.***

EGC Response to NRC Request 2.e:

Not applicable since OCNGS does not use a common or single offsite circuit to supply redundant ESF buses.

**ATTACHMENT 8**

**Peach Bottom Atomic Power Station, Units 2 and 3, 90-Day Response to NRC  
Bulletin 2012-01, "Design Vulnerability in Electric Power System"**

## ATTACHMENT 8

### Peach Bottom Atomic Power Station, Units 2 and 3 Response to NRC Bulletin 2012-01, "Design Vulnerability in Electric Power System"

#### **High Impedance Grounds:**

On January 30, 2012, a porcelain insulator broke in the Byron Station switchyard resulting in parting of the C phase conductor of the offsite source. The insulator was on the offsite source side of the Unit 2 System Auxiliary Transformers (SATs), and the connection parted in such a way as to leave an electrically open end on the source side. The parted connection remained electrically connected on the transformer side, and the loose bus bar conductor end fell to the ground. This ground was a direct result of the broken insulator and not an independent event. The connected loose bus bar provided a path to ground for the transformer high voltage terminal, but did not result in a ground fault (i.e., neither solid nor impedance) as seen from the source. Since the switchyard (i.e., source side) relaying was electrically isolated from the fault, it did not detect a fault; therefore, did not operate.

The significant event was the opening of a single phase connection; the ground on the high voltage side of the SAT is of lesser significance. Regardless of phase discontinuity, if the ground impedance is low on the source side, and currents are high, the source side protective relaying will operate and open all circuit phases. If the ground impedance is high, and currents low, the relaying may not operate depending on the magnitude of ground impedance; the circuit will continue to supply power.

A qualitative analysis has been performed to assess the impact of single phase high impedance ground faults. The primary objective of the analysis was to determine if a high impedance ground fault could result in an unbalanced voltage condition sufficient to adversely affect energized ESF equipment. The cases analyzed include a single phase high impedance ground fault with all three phases intact and a single phase high impedance ground fault concurrent with the loss of the same phase. These cases have been analyzed for both the high and low voltage sides of the SATs analyzed.

Attachment 11 provides a summary report of the qualitative analysis; therefore, all information discussed in this response attachment is limited to single-phase open circuit conditions.

#### **System Description**

NRC Requests 2, 1.d, 2.a, and 2.c request system information, and will be addressed in this section.

***NRC Request No. 2: Briefly describe the operating configuration of the ESF buses (Class 1E for current operating plants or non-Class 1E for passive plants) at power (normal operating condition).***

Exelon Generation Company, LLC (EGC) Response to NRC Request No. 2

A simplified single-line diagram of the Peach Bottom Atomic Power Station (PBAPS), Units 2 and 3 offsite circuits is shown in Figure 1 below.

## ATTACHMENT 8

### Peach Bottom Atomic Power Station, Units 2 and 3 Response to NRC Bulletin 2012-01, "Design Vulnerability in Electric Power System"

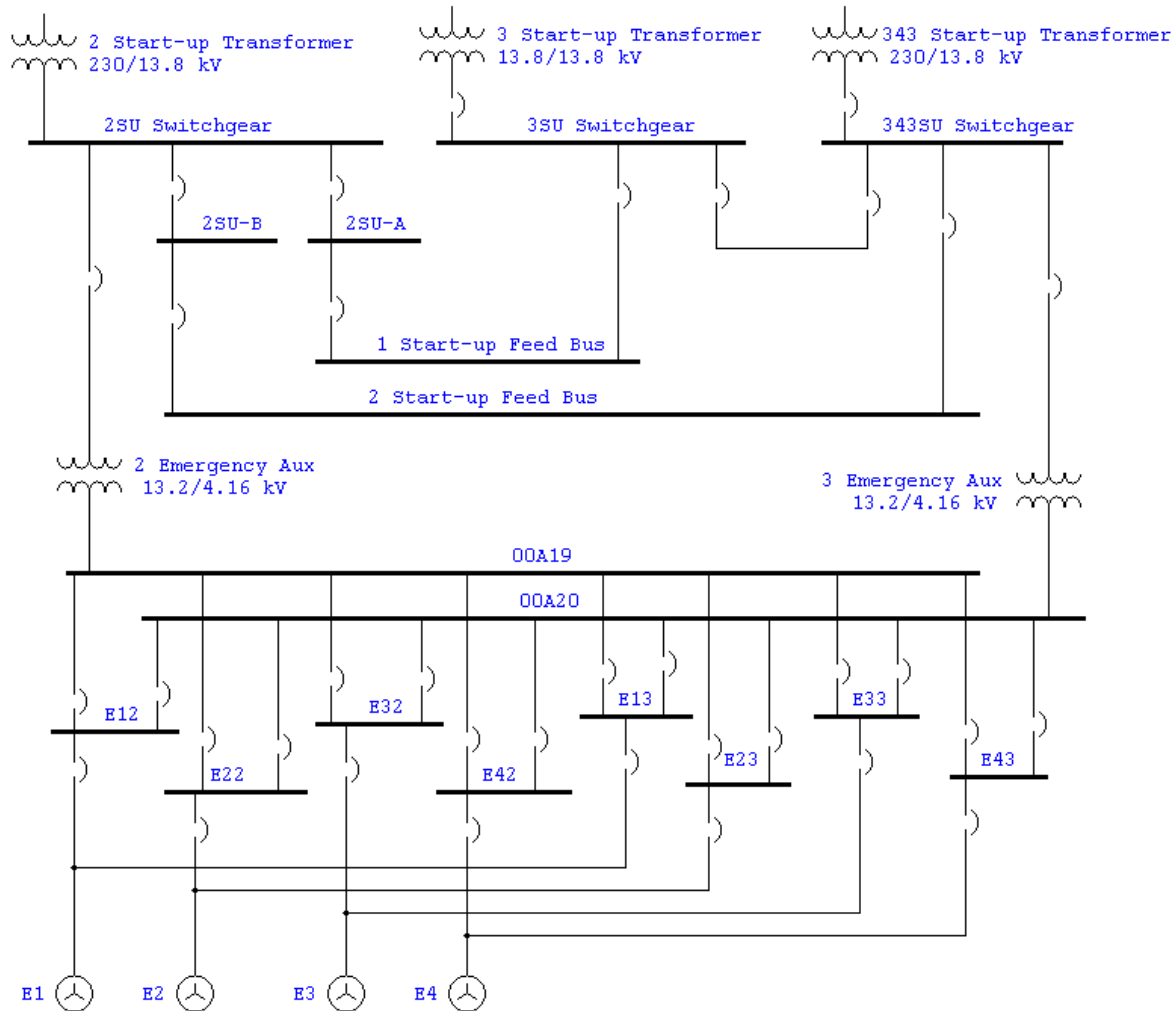

**Figure 1:** PBAPS Simplified One-Line Diagram

The 4kV engineered safety features (ESF) buses are powered only from the dedicated offsite sources, and by procedure cannot be connected to the Main Generator during normal operation.

There are three independent sources of offsite power. One source is an overhead 230kV transmission line which is stepped down to 13kV by the No. 2 startup and emergency auxiliary transformer. The second source is a 230kV overhead transmission line that is stepped down to 13kV by the No. 343 startup transformer. The third source is a 13kV overhead/underground cable from the tertiary winding of the No. 1 autotransformer which connects the 500kV system to the 230kV system transmission lines.

Each offsite source can be used to supply the unit auxiliary buses for plant startup and shutdown and the cooling tower equipment. In addition, each source is stepped down from 13kV to 4kV through an emergency auxiliary transformer, and is connected through interlocked circuit breakers to every 4kV ESF bus. Every 4kV ESF bus is energized from one of these two sources at all times during normal operation. Upon loss of power, automatic transfer is made to

**ATTACHMENT 8**

**Peach Bottom Atomic Power Station, Units 2 and 3 Response to  
NRC Bulletin 2012-01, "Design Vulnerability in Electric Power System"**

the second source. If neither offsite source is available, the 4kV ESF buses are supplied from diesel generator units.

***NRC Request 1.d: Describe the offsite power transformer (e.g., start-up, reserve, station auxiliary) winding and grounding configurations.***

EGC Response to NRC Request 1.d:

The PBAPS offsite power transformer winding and ground configurations including voltage ratings are shown in Table 1 below.

**Table 1:** Offsite Power Transformer Winding and Grounding Configurations

<b>Transformer</b>	<b>Winding Configuration</b>	<b>MVA Size (Cooling Mode)</b>	<b>Voltage Rating (Primary/Secondary) (kV)</b>	<b>Grounding Configuration</b>
2SU Start-Up Transformer	Delta-wye	27/36/45 (OA/FOA/FOA) @ 55°C 50.4 (FOA) @ 65°C	230/13.8	Neutral Resistance Grounded
343SU Start-Up Transformer	Delta-wye	30/40/50 (OA/FA/FA) @ 65°C	230/13.8	Neutral Resistance Grounded
3SU Start-Up transformer	Delta-wye	36/45 (OA/FA) @ 55°C 50.4 (FA) @ 65°C	13.8/13.8	Neutral Resistance Grounded
2 Emergency Auxiliary Transformer	Delta-wye	10.713/13.392 (OA/FA) @ 55°C 11.998/15 (OA/FA) @ 65°C	13.2/4.16	Neutral Resistance Grounded
3 Emergency Auxiliary Transformer	Delta-wye	10.713/13.392 (OA/FA) @ 55°C 11.998/15 (OA/FA) @ 65°C	13.2/4.16	Neutral Resistance Grounded
<b>Note:</b> The 3SU transformer is an autotransformer.				

***NRC Request 2.a: Are the ESF buses powered by offsite power sources? If so, explain what major loads are connected to the buses including their ratings.***

EGC Response to NRC Request 2.a:

During normal operation, the ESF buses are always powered by offsite power sources.

## ATTACHMENT 8

### Peach Bottom Atomic Power Station, Units 2 and 3 Response to NRC Bulletin 2012-01, "Design Vulnerability in Electric Power System"

The PBAPS ESF bus power sources during normal operation are shown in Tables 2 and 3 below.

**Table 2:** PBAPS ESF Buses That Are Normally Powered from Offsite Sources

Description of ESF Bus Power Source	ESF Bus Name (normal operating condition)	Original licensing basis configuration (Y/N)
Preferred Offsite Circuit 1	E12, E42, E23, E33	Y
Preferred Offsite Circuit 2	E22, E32, E13, E43	Y

**Table 3:** PBAPS ESF Buses That Are Not Normally Powered from Offsite Sources

Description of ESF Bus Power Source	ESF Bus Name (normal operating condition)	Original licensing basis configuration (Y/N)
N/A	None	Y

The major loads fed by the ESF buses are shown in Table 4 below.

**Notes:**

1. The tables shown are arranged such that the equivalent buses for each unit are shown together. For example, E12 is the Unit 2 4kV bus backed by the E1 emergency diesel generator (EDG), while E13 is the equivalent Unit 3 4kV bus, also backed by the E1 EDG. All buses are 4kV.
2. The emergency service water (ESW) and ESW Booster pumps are common for both units, but only fed by Unit 2 ESF buses

**Table 4:** Major ESF Loads Including Ratings and Status during Normal Power Operations

Unit	ESF Bus	E12 / E13	
	Major Connected Loads	Voltage Rating (V)	hp/KVA Rating
2	"A" Control Rod Drive (CRD) Water Pump	4000	250hp
2/3	"A" Core Spray Pump	4000	600hp
2/3	Transformer to E124 / E134 Load Center (LC)	4160 / 480	1000kVA
2/3	"A" Residual Heat Removal (RHR) Pump	4000	2000hp
2/3	"A" High Pressure Service Water (HPSW) Pump	4000	1000hp
3	Transformer to E13A4 Cooling Tower LC	4160 / 480	500kVA



**ATTACHMENT 8**

**Peach Bottom Atomic Power Station, Units 2 and 3 Response to  
NRC Bulletin 2012-01, "Design Vulnerability in Electric Power System"**

	<b>ESF Bus</b>	<b>E22 / E23</b>	
<b>Unit</b>	<b>Major Connected Loads</b>	<b>Voltage Rating (V)</b>	<b>hp/kVA Rating</b>
2/3	"B" RHR Pump	4000	2000hp
2	"A" Emergency Service Water (ESW) Pump	4000	250hp
2/3	"B" Core Spray Pump	4000	600hp
2/3	Transformer to E224 / E234 LC	4160 / 480	1000kVA
2/3	"B" HPSW Pump	4000	1000hp
2	"A" ESW Booster Pump	4000	250hp
3	"A" CRD Water Pump	4000	250hp
3	Transformer to E23A4 Cooling Tower LC	4160 / 480	500kVA
	<b>ESF Bus</b>	<b>E32 / E33</b>	
<b>Unit</b>	<b>Major Connected Loads</b>	<b>Voltage Rating (V)</b>	<b>hp/kVA Rating</b>
2/3	"C" RHR Pump	4000	2000hp
2/3	"C" Core Spray Pump	4000	600hp
2/3	Transformer to E324 / E334 LC	4160 / 480	1000kVA
2	"B" ESW Pump	4000	250hp
2/3	"C" HPSW Pump	4000	1000hp
2	"B" ESW Booster Pump	4000	250hp
3	"B" CRD Water Pump	4000	250hp
	<b>ESF Bus</b>	<b>E42 / E43</b>	
<b>Unit</b>	<b>Major Connected Loads</b>	<b>Voltage Rating (V)</b>	<b>hp/kVA Rating</b>
2/3	"D" RHR Pump	4000	2000hp
2/3	"D" Core Spray Pump	4000	600hp
2/3	"D" HPSW Pump	4000	1000hp
2	"B" CRD Water Pump	4000	250hp
2/3	Transformer to E424 / E434 Load Center	4160 / 480	1000kVA
3	Emergency Cooling Water Pump	4000	250hp
3	Transformer to E43A4 Cooling Tower LC	4160 / 480	500kVA

## ATTACHMENT 8

### Peach Bottom Atomic Power Station, Units 2 and 3 Response to NRC Bulletin 2012-01, "Design Vulnerability in Electric Power System"

The PBAPS ESF loads that are normally energized are shown in Table 5 below.

**Table 5:** PBAPS ESF Loads That Are Normally Energized

Load	ESF Bus
1 of the 2 CRD Water Pumps per Unit	Either E12 or E42, AND either E23 or E33
Each 4160/480V Emergency LC Transformer	E12, E22, E32, E42, E13, E23, E33, E43
Each 4160/480V Emergency Cooling Tower LC Transformer	E13, E23, E43

***NRC Request 2.c: Confirm that the operating configuration of the ESF buses is consistent with the current licensing basis. Describe any changes in offsite power source alignment to the ESF buses from the original plant licensing.***

EGC Response to NRC Request 2.c:

The operating configuration of the ESF buses is consistent with the current licensing basis (CLB).

There are three independent sources of offsite power. One source is an overhead 230kV transmission line which is stepped down to 13kV by the No. 2 startup and emergency auxiliary transformer. The second source is a 230kV overhead transmission line that is stepped down to 13kV by the No. 343 startup transformer. The third source is a 13kV overhead/underground cable from the tertiary winding of the No. 1 autotransformer which connects the 500kV system to the 230kV system transmission lines.

Each offsite source can be used to supply the unit auxiliary buses for plant startup and shutdown and the cooling tower equipment. In addition, each source is stepped down from 13kV to 4kV through an emergency auxiliary transformer, and is connected through interlocked circuit breakers to every 4kV ESF bus. Every 4kV ESF bus is energized from one of these two sources at all times during normal operation. Upon loss of power, automatic transfer is made to the second source. If neither offsite source is available, the 4kV ESF buses are supplied from diesel generator units.

Since original plant licensing, the follow change has been made to the offsite power source alignment:

- The installation of an additional transformer (i.e., the No. 343 startup transformer) to supply offsite power to the station, as documented under Amendment Nos. 149 and 152, issued October 2, 1989.

## ATTACHMENT 8

### Peach Bottom Atomic Power Station, Units 2 and 3 Response to NRC Bulletin 2012-01, "Design Vulnerability in Electric Power System"

#### System Protection

NRC Requests 1, 1.a, 2.b, and 2.d request information regarding electrical system protection, and will be addressed in this section.

***NRC Request 1: Given the requirements above, describe how the protection scheme for ESF buses (Class 1E for current operating plants or non-Class 1E for passive plants) is designed to detect and automatically respond to a single-phase open circuit condition or high impedance ground fault condition on a credited off-site power circuit or another power sources. Also, include the following information:***

#### EGC Response to NRC Request 1:

Consistent with the CLB and 10 CFR 50, Appendix A, "General Design Criteria for Nuclear Power Plants," Criterion (GDC) 17, "Electric power systems," existing protective circuitry will separate the ESF buses from a connected failed source due to a loss of voltage or a sustained, balanced degraded grid voltage concurrent with certain design basis accidents. The relay systems were not specifically designed to detect an open single phase of a three phase system, nor a high impedance ground fault. Detection of a single open phase or high impedance ground fault condition is beyond the approved design and licensing basis of the plant.

The PBAPS 4kV undervoltage protection scheme only monitors voltage across the A-B phases. However, the supply to the 4kV ESF buses is substantially different between PBAPS and Byron Station. Byron Station employs a single wye-wye transformer between the offsite power source and the 4kV ESF buses. PBAPS employs two delta-wye transformers. As such, the impact to the 4kV ESF bus voltages, due to a loss of phase condition in the offsite power source, will be different at PBAPS than at Byron Station. A review of plant drawings, protective relays, calculations, and an analysis was done which determined that a loss of "A" or "C" phases in the offsite power source would be detected by the degraded voltage relays and trip the switchgear off of that feed and transfer it. However, for a loss of "B" phase in the offsite power source, the condition would only bring in a Plant Monitoring System (PMS) alarm, and no automatic trip would occur. As such, PBAPS is susceptible to this design vulnerability identified at Byron Station.

Also of importance is the fact that the 4kV switchgear alignment is different at PBAPS. PBAPS typically aligns two of the four 4kV ESF buses, per unit, to each offsite power source, creating a "split" configuration. As such, on a loss of "B" phase in the offsite power source under normal plant alignment, only two of the four buses per Unit would be impacted, rather than all of the associated 4kV buses per Unit, as was experienced at Byron Station.

**ATTACHMENT 8**

**Peach Bottom Atomic Power Station, Units 2 and 3 Response to  
NRC Bulletin 2012-01, "Design Vulnerability in Electric Power System"**

***NRC Request 1.a: The sensitivity of protective devices to detect abnormal operating conditions and the basis for the protective device setpoint(s).***

EGC Response to NRC Request 1.a:

Consistent with the CLB and GDC 17, existing electrical protective devices are sufficiently sensitive to detect design basis conditions like a loss of voltage or a degraded voltage, but were not designed to detect a single phase open circuit condition.

Table 6 below summarizes the undervoltage protection for each 4kV bus. The protection is identical for all eight 4kV buses. The voltage for each 4kV bus is monitored at five levels, which can be considered as two different undervoltage functions: one level of loss of voltage and four levels of degraded voltage. The degraded voltage function is monitored by four (i.e., Function 2 through 5) undervoltage relays per source. The loss of voltage is monitored by one (i.e., Function 1) undervoltage relay for each 4kV bus. All relays operate on a one-out-of-one logic.

**Table 6: PBAPS Degraded Voltage and Loss of Voltage Relaying for the 4kV ESF Buses**

<b>Protection Zone</b>	<b>Protective Device</b>	<b>Setpoint (Nominal)</b>	<b>UV Logic / Time delay</b>	<b>Basis for Setpoint</b>
Function 1	Loss of Voltage Relay	1040V (25% of 4160V)	1 of 1 / Instantaneous	To actuate upon complete loss of ESF Bus voltage condition
Function 2	Degraded Voltage Low Setting	2496V (60%)	1 of 1 / 1.8 seconds nominal (inverse characteristic)	Ensures separation from a source providing voltages that would prevent Class 1E equipment from achieving its safety function, and prevents Class 1E equipment from sustaining damage from prolonged operation at reduced voltage
Function 3	Degraded Voltage High Setting	3619V (87%)	1 of 1 / 30 seconds nominal (inverse characteristic)	
Function 4	Degraded Voltage LOCA	3801V (91.38%)	1 of 1 / 10 seconds nominal	Ensure that the ESF buses have sufficient voltage to support the LOCA load sequencing and maintain adequate voltage to MCC buses.
Function 5	Degraded Voltage Non-LOCA	4151V (99.78%)	1 of 1 / 61 seconds nominal	Ensure that equipment powered from the ESF buses are not damaged by degraded voltage during non-LOCA conditions.

**ATTACHMENT 8**

**Peach Bottom Atomic Power Station, Units 2 and 3 Response to  
NRC Bulletin 2012-01, "Design Vulnerability in Electric Power System"**

The remainder of the relays between the PBAPS 4kV ESF buses and switchyard are shown in Table 7 below. The 4kV ESF protection (i.e, phase / ground overcurrent and differential) as well as the emergency auxiliary transformer protection (i.e., phase / ground overcurrent and differential) is identical for each respective bus / transformer, and therefore the settings are only listed once. The protection for each start-up transformer and associated switchgear, however, varies from source to source, and was therefore listed separately.

**Table 7:** Additional Protective Relaying

<b>Protection Zone</b>	<b>Protective Device</b>	<b>Setpoint (Nominal)</b>	<b>Time Delay (Based On 400% Pickup Unless Otherwise Noted)</b>	<b>Additional Notes or Comments</b>
4kV ESF buses	Differential	124V 191A	Instantaneous	
4kV ESF buses	Phase O/C	1400 A	75 Cycles	
4kV ESF buses	Ground O/C	100 A	50 Cycles	
Emergency Auxiliary Transformers	Differential	Main Unit: 274 A (pri) 905 A (sec)	Instantaneous	
		Inst. Unit: 7296 A (pri) 24140 A (sec)		
		40% slope	-	
Emergency Auxiliary Transformers	Ground O/C (neutral)	120 A	95 Cycles	
Emergency Auxiliary Transformers	Ground O/C (Pri)	17 A	Instantaneous	
Emergency Auxiliary Transformers	Phase O/C (Pri)	960 A	45 Cycles	
		8000 A	Instantaneous	
Line Between 343SU Transformer and Switchgear	Differential	2100 A (phase) 240 A (ground)	Instantaneous	Transformer is approximately one mile from switchgear

**ATTACHMENT 8**

**Peach Bottom Atomic Power Station, Units 2 and 3 Response to  
NRC Bulletin 2012-01, "Design Vulnerability in Electric Power System"**

<b>Protection Zone</b>	<b>Protective Device</b>	<b>Setpoint (Nominal)</b>	<b>Time Delay (Based On 400% Pickup Unless Otherwise Noted)</b>	<b>Additional Notes or Comments</b>
343SU Transformer	Differential	Main Unit: 57.6 A (pri) 905 A (sec)	Instantaneous	
		Inst. Unit: 1536 A (pri) 24140 A (sec)		
		40% slope	-	
343SU Transformer	Phase O/C (pri)	240 A	80 Cycles	
		1020 A	Instantaneous	
343SU Transformer	Ground O/C (pri)	60 A	5 Cycles	
343SU Transformer	Ground O/C (neutral)	480 A	100 Cycles	
343SU Transformer	Underfrequency (sec)	58.5 Hz (V <sub>A-B</sub> )	6 Cycles	Protects the 343SU source in the scenario where Muddy Run is islanded
343SU Transformer	Phase O/C (sec)	3600 A	65 Cycles	
343SU Transformer	Ground O/C (sec)	300 A	90 Cycles	
2SU Transformer and Switchgear	Differential	Main unit: 57.6 A (pri) 905 A (sec)	Instantaneous	
		Inst. Unit: 1536 A (pri) 24140 A (sec)		
		40% slope	-	
2SU Transformer	Ground O/C (neutral)	400A	115 Cycles	

## ATTACHMENT 8

### Peach Bottom Atomic Power Station, Units 2 and 3 Response to NRC Bulletin 2012-01, "Design Vulnerability in Electric Power System"

Protection Zone	Protective Device	Setpoint (Nominal)	Time Delay (Based On 400% Pickup Unless Otherwise Noted)	Additional Notes or Comments
2SU Transformer	Zero Seq. overvoltage (pri)	30.4% V <sub>A-C</sub> (70kV)	9-11 Sec @ 67% (102.7kv)	
2SU Transformer	Undervoltage (pri)	47.8% V <sub>A-B</sub> (110kV)	5 Sec @ 0 V	
<p><b>Note:</b> The 2SU source primary undervoltage relay senses the voltage across the "A" and "B" phases. This relay will detect an open phase condition on either the "A" or "B" phase on the high side of the 2SU source, and trip the source, which would cause a transfer of the 4kV ESF buses being fed from 2SU to the other aligned offsite source.</p>				
2SU Transformer	Phase O/C (pri)	1200A	Instantaneous	
		180 A	150 Cycles	
2SU Transformer	Ground O/C (pri)	90 A	25 Cycles	
3SU Switchgear	Differential 87L	75V Pickup Min fault current to trip = 71.5 A	Instantaneous	Voltage produced by differentially connected CT's
	Differential 87H	1200 A		
Cross-Tie Between 3SU and 343SU	Differential 87L	75V Pickup Min fault current to trip = 38 A	Instantaneous	Voltage produced by differentially connected CT's
	Differential 87H	800 A		
Cross-Tie Between 3SU and 343SU	Phase O/C	2000 A	135 Cycles	
Cross-Tie Between 3SU and 343SU	Ground O/C	240 A	70 Cycles	
Line between 3SU	Pilot wire	Phase: 4 A (both)	Instantaneous	Transformer is approximately one

**ATTACHMENT 8**

**Peach Bottom Atomic Power Station, Units 2 and 3 Response to  
NRC Bulletin 2012-01, "Design Vulnerability in Electric Power System"**

<b>Protection Zone</b>	<b>Protective Device</b>	<b>Setpoint (Nominal)</b>	<b>Time Delay (Based On 400% Pickup Unless Otherwise Noted)</b>	<b>Additional Notes or Comments</b>
Transformer and Switchgear		Ground: 0.5 A (both)		mile from switchgear
	Fault detector	Phase: 6 A (both)	Instantaneous	Arms the pilot wire scheme
Ground: 2 A (swgr) 1 A (trans)				
3SU Transformer	Differential	Main Unit: 905 A (pri and sec)	Instantaneous	
		Inst. Unit: 24140 A (pri and sec)		
		40% slope	-	
3SU Transformer	Ground O/C (neutral)	480 A	100 Cycles	
3SU Transformer	Phase Current Balance	1800 A 120% Slope	12 Cycles At 10 Amps	Protects the exciting winding
3SU Transformer	Phase O/C (pri)	3600 A	65 Cycles	
		15600 A	Instantaneous	
3SU Transformer	Ground O/C (pri)	300 A	90 Cycles	

***NRC Request 2.b. If the ESF buses are not powered by offsite power sources, explain how the surveillance tests are performed to verify that a single-phase open circuit condition or high impedance ground fault condition on an off-site power circuit is detected.***

EGC Response to NRC Request 2.b:

Not applicable – the ESF buses at PBAPS are powered by the offsite power sources.



## ATTACHMENT 8

### Peach Bottom Atomic Power Station, Units 2 and 3 Response to NRC Bulletin 2012-01, "Design Vulnerability in Electric Power System"

***NRC Request 2.d: Do the plant operating procedures, including off-normal operating procedures, specifically call for verification of the voltages on all three phases of the ESF buses?***

EGC Response to NRC Request 2.d:

Yes. The PBAPS plant operating procedure entered by Operations upon a receipt of a plant monitoring system (PMS) alarm that will actuate during a loss of phase event, specifically calls for verification of each phase-to-phase voltage for the offsite source upon receipt of the alarm.

## ATTACHMENT 8

### Peach Bottom Atomic Power Station, Units 2 and 3 Response to NRC Bulletin 2012-01, "Design Vulnerability in Electric Power System"

#### Consequences

NRC Requests 1.b, 1.c, and 2.e request information regarding the electrical consequences of an event, and will be addressed in this section.

***NRC Request 1.b: The differences (if any) of the consequences of a loaded (i.e., ESF bus normally aligned to offsite power transformer) or unloaded (e.g., ESF buses normally aligned to unit auxiliary transformer) power source.***

#### EGC Response to NRC Request 1.b:

Installed relays were not designed to detect single phase open circuit or high impedance ground fault conditions. Existing loss of voltage and degraded voltage relays may respond depending on loading conditions and possible grounds.

Voltage profiles (e.g., magnitude and phase relationship) on the load side of the open phase will vary depending on plant load, such as heavy loading compared to light loading, as well as whether a ground is present or not. A formal calculation is currently under development to determine precise voltages under various different loading scenarios.

***NRC Request 1.c: If the design does not detect and automatically respond to a single-phase open circuit condition or high impedance ground fault condition on a credited offsite power circuit or another power sources, describe the consequences of such an event and the plant response.***

#### EGC Response to NRC Request 1.c:

PBAPS does not credit in the CLB that the Class 1E protection scheme (i.e., for the ESF buses) was designed to detect and automatically respond to a single-phase open circuit condition, nor a high impedance fault condition, on the credited offsite power source as described in the Updated Safety Analysis Report (UFSAR) and Technical Specifications (TS).

Since PBAPS did not credit the ESF bus protection scheme as being capable of detecting and automatically responding to a single phase open circuit condition, an open phase fault was not included in the design criteria for either the loss of voltage, or the degraded voltage relay schemes or design criteria. Open phase detection was not credited in the PBAPS design or licensing basis; therefore, no design basis calculations or design documents exist that previously considered this condition.

Without formalized engineering calculations or engineering evaluations, the electrical consequences of such an open phase event, including plant response, can only be evaluated to the extent of what has already been published by the Electric Power Research Institute (EPRI)

## ATTACHMENT 8

### **Peach Bottom Atomic Power Station, Units 2 and 3 Response to NRC Bulletin 2012-01, "Design Vulnerability in Electric Power System"**

and Basler; which is a generic overview. The difficulty in applying these documents to the PBAPS specific response is that these are generic assessments and cannot be formally credited as a basis for an accurate response. The primary reason is that detailed plant specific models would need to be developed (e.g., transformer magnetic circuit models, electric distribution models, motor models; including positive, negative, and zero sequence impedances, voltage, and currents), and the models would need to be compiled and analyzed for the PBAPS specific Class 1E electric distribution system.

If a similar event occurred, the possibility exists that operating loads would trip or starting loads would not reach rated speed and voltage. Additionally, a PMS alarm will be received in the Main Control Room. Upon receipt of this alarm, Operations enters a procedure which would aid in diagnosing the condition, including voltage checks of all three phases for the offsite sources. At this point, Operations would transfer the 4kV ESF buses being fed by the offsite source experiencing an open phase onto the other aligned offsite source.

PBAPS has implemented interim enhancement actions to minimize the impact should the open phase event occur. These measures include those listed below:

- Distributed a required reading package to all licensed operators
- Enhanced Operations procedure that is entered upon receipt of the PMS alarm, including aligning plant voltmeters to ensure all phases are monitored.

Analyses are being performed for each startup source to evaluate options available to resolve the undesirable plant impacts due to an open phase or high impedance fault condition. The preliminary results of these analyses are that an electro-mechanical relaying solution will not provide both protection from an open phase and prevent nuisance offsite source trips. Based on these results, a vendor has been contracted to develop an algorithm for a digital relay solution that can provide both protection against an open phase condition, and security from undesired trips of the offsite sources.

## ATTACHMENT 8

### Peach Bottom Atomic Power Station, Units 2 and 3 Response to NRC Bulletin 2012-01, "Design Vulnerability in Electric Power System"

***NRC Request 2.e: If a common or single offsite circuit is used to supply redundant ESF buses, explain why a failure, such as a single-phase open circuit or high impedance ground fault condition, would not adversely affect redundant ESF buses.***

#### EGC Response to NRC Request 2.e:

PBAPS requires three of the four 4kV ESF buses in order to ensure safe shutdown of the plant. Due to the lineup of the offsite sources, an open phase or high impedance ground fault condition that does not result in a trip of the offsite source could result in two of the four 4kV ESF buses not being able to perform their design function.

Consistent with the CLB and GDC 17, protective circuitry will separate the ESF buses from a failed source due to a loss of voltage or a sustained balanced degraded grid voltage concurrent with certain design basis accidents. The failure of a single-phase open circuit is beyond the approved design and licensing basis of the plant. Calculations for each offsite source are currently under development.

In the interim, other enhancement actions were incorporated, including:

- Revision of the Operations procedure used when the 13.8kV PMS alarm is received to better diagnose an open phase condition. This included steps to verify voltage on all three phases.
- A required reading on the event was given to all Operators. This reading provided background on the event, the differences between Byron Station and PBAPS, the expected plant response to a similar condition at PBAPS, and the required actions by PBAPS operators.

**ATTACHMENT 9**

**Quad Cities Nuclear Power Station, Units 1 and 2, 90-Day Response to NRC Bulletin  
2012-01, "Design Vulnerability in Electric Power System"**

## ATTACHMENT 9

### Quad Cities Nuclear Power Station, Units 1 and 2 Response to NRC Bulletin 2012-01, "Design Vulnerability in Electric Power System"

#### **High Impedance Grounds:**

On January 30, 2012, a porcelain insulator broke in the Byron Station switchyard resulting in parting of the C phase conductor of the offsite source. The insulator was on the offsite source side of the Unit 2 System Auxiliary Transformers (SATs), and the connection parted in such a way as to leave an electrically open end on the source side. The parted connection remained electrically connected on the transformer side, and the loose bus bar conductor end fell to the ground. This ground was a direct result of the broken insulator and not an independent event. The connected loose bus bar provided a path to ground for the transformer high voltage terminal, but did not result in a ground fault (i.e., neither solid nor impedance) as seen from the source. Since the switchyard (i.e., source side) relaying was electrically isolated from the fault, it did not detect a fault; therefore, did not operate.

The significant event was the opening of a single phase connection; the ground on the high voltage side of the SAT is of lesser significance. Regardless of phase discontinuity, if the ground impedance is low on the source side, and currents are high, the source side protective relaying will operate and open all circuit phases. If the ground impedance is high, and currents low, the relaying may not operate depending on the magnitude of ground impedance; the circuit will continue to supply power.

A qualitative analysis has been performed to assess the impact of single phase high impedance ground faults. The primary objective of the analysis was to determine if a high impedance ground fault could result in an unbalanced voltage condition sufficient to adversely affect energized ESF equipment. The cases analyzed include a single phase high impedance ground fault with all three phases intact and a single phase high impedance ground fault concurrent with the loss of the same phase. These cases have been analyzed for both the high and low voltage sides of the SATs analyzed.

Attachment 11 provides a summary report of the qualitative analysis; therefore, all information discussed in this response attachment is limited to single-phase open circuit conditions.

#### **System Description**

NRC Requests 2, 1.d, 2.a, and 2.c request system information, and will be addressed in this section.

***NRC Request No. 2: Briefly describe the operating configuration of the ESF buses (Class 1E for current operating plants or non-Class 1E for passive plants) at power (normal operating condition).***

#### **Exelon Generation Company, LLC (EGC) Response to NRC Request No. 2**

The electrical distribution system for Quad Cities Nuclear Power Station (QCNPS), Units 1 and 2 is a split-bus configuration, consisting of two divisions of 4.16kV buses. During normal operation, one division (i.e., both safety and non-safety) is fed from the Reserve Auxiliary

# ATTACHMENT 9

## Quad Cities Nuclear Power Station, Units 1 and 2 Response to NRC Bulletin 2012-01, "Design Vulnerability in Electric Power System"

Transformer (RAT) connected to the 345kV switchyard. The other division is normally fed from the Unit Auxiliary Transformer (UAT).

A simplified one-line diagram of the QCNPS electrical distribution system is shown in Figure 1 below.

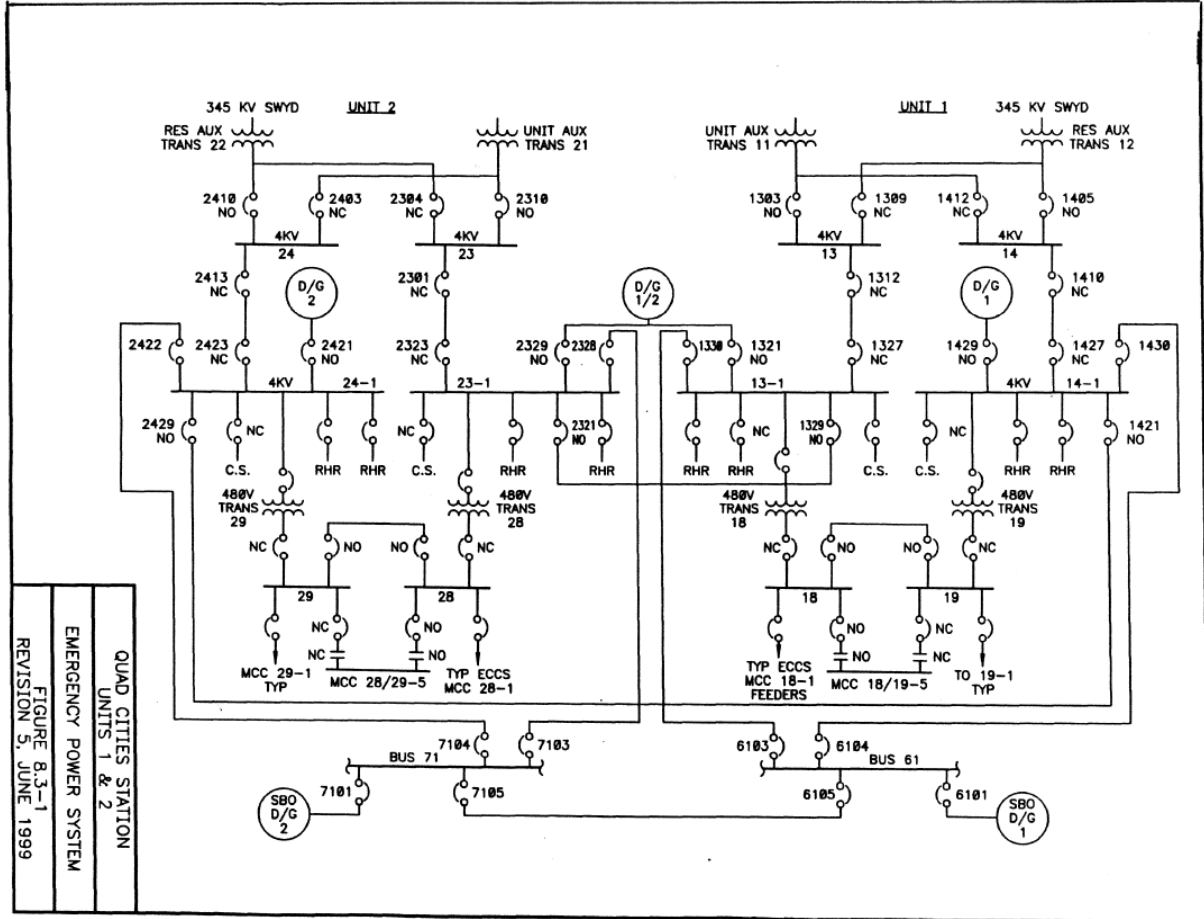

**Figure 1:** QCNPS Simplified One-Line Diagram

**ATTACHMENT 9**

**Quad Cities Nuclear Power Station, Units 1 and 2 Response to  
NRC Bulletin 2012-01, "Design Vulnerability in Electric Power System"**

**NRC Request 1.d: Describe the offsite power transformer (e.g., start-up, reserve, station auxiliary) winding and grounding configurations.**

EGC Response to NRC Request 1.d:

The QCNPS offsite power transformer winding and grounding configurations are shown in Table 1 below.

**Table 1:** Offsite Power Transformer Winding and Grounding Configurations

<b>Transformer</b>	<b>Winding Configuration</b>	<b>MVA Size (Cooling Mode)</b>	<b>Voltage Rating (Primary/Secondary)</b>	<b>Grounding Configuration</b>
RAT 12	Wye-Wye-Wye (3 Leg) with Low-side Delta Tertiary Stabilizing Windings	H – 37.5/50/62.5 MVA (ONAN/ONAF/ONAF) @65°C Y – 18.75/25/31.25 MVA (ONAN/ONAF/ONAF) @65°C X – 18.75/25/31.25 MVA (ONAN/ONAF/ONAF) @65°C	345kV – 4.28kV - 4.28kV	Neutral Grounded Primary, Neutral Resistive Grounded Secondary
RAT 22	Wye-Wye-Wye (3 Leg) with Low-side Delta Tertiary Stabilizing Windings	H – 37.5/50/62.5 MVA (ONAN/ONAF/ONAF) @65°C Y – 18.75/25/31.25 MVA (ONAN/ONAF/ONAF) @65°C X – 18.75/25/31.25 MVA (ONAN/ONAF/ONAF) @65°C	345kV – 4.28kV - 4.28kV	Neutral Grounded Primary, Neutral Resistive Grounded Secondary

**NRC Request 2.a: Are the ESF buses powered by offsite power sources? If so, explain what major loads are connected to the buses including their ratings.**

EGC Response to NRC Request 2.a:

For at power (i.e., normal operating condition) configurations, 1 of 2 divisions of engineered safety features (ESF) buses are powered by offsite sources. Additionally, several non-safety-related loads are fed by the same offsite power sources.



## ATTACHMENT 9

### Quad Cities Nuclear Power Station, Units 1 and 2 Response to NRC Bulletin 2012-01, "Design Vulnerability in Electric Power System"

The power sources for the QCNPS ESF buses during normal power operations are shown in Tables 2 and 3 below.

**Table 2:** QCNPS ESF Buses That Are Normally Powered from Offsite Sources

Description of ESF Bus Power Source	ESF Bus Name (normal operating condition)	Original licensing basis configuration (Y/N)
RAT 12	4kV Bus 13	Y
RAT 12 via 4kV Bus 13	4kV Bus 13-1	Y
RAT 22	4kV Bus 23	Y
RAT 22 via 4kV Bus 23	4kV Bus 23-1	Y

**Table 3:** QCNPS ESF Buses That Are Not Normally Powered from Offsite Sources

Description of ESF Bus Power Source	ESF Bus Name (normal operating condition)	Original licensing basis configuration (Y/N)
UAT 11	4kV Bus 14	Y
UAT 11 via 4kV Bus 14	4kV Bus 14-1	Y
UAT 21	4kV Bus 24	Y
UAT 21 via 4kV Bus 24	4kV Bus 24-1	Y

The major QCNPS ESF bus loads that are energized during normal power operations, including their ratings, are shown in Table 4 below.

**Table 4:** Major ESF Loads That Are Energized during Normal Power Operations

ESF Bus	Normally Energized (Y/N)	Load Quantity/ Description	Voltage Level (V)	Rating (hp/kVA)
4160V Bus 13(23)	Y	2-Circulating Water Pump	4000	1750hp
4160V Bus 13(23)	Y	2-Condensate and Condensate Booster Pump	4000	1750hp
4160V Bus 13(23)	Y	1-Service Water Pump	4000	1000hp
4160V Bus 13(23)	N	2-Residual Heat Remove System (RHRS) Service Water Pump	4000	900hp
4160V Bus 13(23)	Y*	1-Control Rod Drive Feed Pump	4000	250hp
4160V Bus 13(23)	Y	1-480V Transformer 15(25)	4160:480	1500kVA
4160V Bus 13(23)	Y	1-480V Transformer 1A(2A)	4160:480	750kVA

## ATTACHMENT 9

### Quad Cities Nuclear Power Station, Units 1 and 2 Response to NRC Bulletin 2012-01, "Design Vulnerability in Electric Power System"

ESF Bus	Normally Energized (Y/N)	Load Quantity/ Description	Voltage Level (V)	Rating (hp/kVA)
4160V Bus 13-1(23-1)	N	1-Core Spray Pump	4000	800hp
4160V Bus 13-1(23-1)	N	2- RHRS Pump	4000	600hp
4160V Bus 13-1(23-1)	Y	1-480-V Transformer 18(28)	4160:480	1500kVA
4160V Bus 13-1	Y	1-480V Transformer at Pump House (Unit 1 only)	4160:480	500kVA
4160V Bus 13-1(23-1)	Y	1-480-V Transformer 10(20)	4160:480	500kVA
*Only energized non-coincident with another division.				

***NRC Request 2.c: Confirm that the operating configuration of the ESF buses is consistent with the current licensing basis. Describe any changes in offsite power source alignment to the ESF buses from the original plant licensing.***

**EGC Response to NRC Request 2.c:**

The following at power (i.e., normal operating condition) configurations have been confirmed to be consistent with the current licensing basis (CLB):

1. Unit 1 Offsite Power Circuit #1 – Power to ESF buses via 345kV switchyard (RAT 12)
2. Unit 2 Offsite Power Circuit #1 – Power to ESF buses via 345kV switchyard (RAT 22)

The following additional configurations have been confirmed to be consistent with the CLB, although not used during normal operation:

1. Unit 1 Offsite Power Circuit #2 – Power to ESF Buses via 345kV switchyard (RAT 22) and 4kV bus cross-ties.
2. Unit 2 Offsite Power Circuit #2 – Power to ESF Buses via 345kV switchyard (RAT 12) and 4kV bus cross-ties.
3. Additional Unit 1 Offsite Power Circuit– Power to ESF buses from 345kV Switchyard when the main generator is off-line via backfeed ( UAT 11 and Main Power Transformer (MPT) 1)
4. Additional Unit 2 Offsite Power Circuit– Power to ESF buses from 345kV Switchyard when the main generator is off-line via backfeed ( UAT 11 and MPT 2)

The backfeed sources (i.e., items 3 and 4) listed above were not originally part of the plant licensing and is only used during station refueling outages.

**ATTACHMENT 9**

**Quad Cities Nuclear Power Station, Units 1 and 2 Response to  
NRC Bulletin 2012-01, "Design Vulnerability in Electric Power System"**

**System Protection**

NRC Requests 1, 1.a, 2.b, and 2.d request information regarding electrical system protection and will be addressed in this section:

***NRC Request 1: Given the requirements above, describe how the protection scheme for ESF buses (Class 1E for current operating plants or non-Class 1E for passive plants) is designed to detect and automatically respond to a single-phase open circuit condition or high impedance ground fault condition on a credited off-site power circuit or another power sources. Also, include the following information:***

**EGC Response to NRC Request 1:**

Consistent with the CLB and 10 CFR 50, Appendix A, "General Design Criteria for Nuclear Power Plants," Criterion (GDC) 17, "Electric power systems," existing protective circuitry will separate the ESF buses from a connected failed offsite source due to a loss of voltage or a sustained, balanced degraded grid voltage concurrent with certain design basis accidents. The relay systems were not specifically designed to detect an open single phase of a three phase system. Detection of a single-open phase condition is beyond the approved design and licensing basis of the plant.

***NRC Request 1.a: The sensitivity of protective devices to detect abnormal operating conditions and the basis for the protective device setpoint(s).***

**EGC Response to NRC Request 1.a:**

Consistent with the CLB and GDC 17, existing electrical protective devices are sufficiently sensitive to detect design basis conditions like a loss of voltage or a degraded voltage, but were not designed to detect a single phase open circuit condition. The QCNPS undervoltage protective devices, their setpoints, and the basis for the setpoint(s) are shown in Table 5 below.

**Table 5: Protective Devices**

<b>Protection Zone</b>	<b>Protective Device</b>	<b>UV Logic</b>	<b>Setpoint (Nominal)</b>	<b>Basis for Setpoint</b>
RAT 12(22)	Differential Protection	N/A	67A at 345kV 5023A at 4.16kV 25% slope	Actuates upon fault within protection zone. Provides high speed protection of the transformer windings.

**ATTACHMENT 9**

**Quad Cities Nuclear Power Station, Units 1 and 2 Response to  
NRC Bulletin 2012-01, "Design Vulnerability in Electric Power System"**

<b>Protection Zone</b>	<b>Protective Device</b>	<b>UV Logic</b>	<b>Setpoint (Nominal)</b>	<b>Basis for Setpoint</b>
RAT 12(22)	X Winding Neutral Ground Detection	N/A	360A@4TD	Actuates upon ground fault in protection zone. Provides backup protection for transformer windings.
RAT 12(22)	Y Winding Neutral Ground Detection	N/A	480A@2.7TD	Actuates upon ground fault in protection zone. Provides backup protection for transformer windings.
RAT 12(22) and 4.16kV ESF Bus	X Winding Undervoltage	2 of 2	3455V@0.2TD (83% of 4160V)	Actuate upon low voltage at RAT Winding
RAT 12(22) and 4.16kV Bus	Y Winding Undervoltage	2 of 2	3455V@0.2TD (83% of 4160V)	Actuate upon low voltage at RAT Winding
RAT 12(22)	X Winding Ground Differential	N/A	200A@3.0TD	Actuates upon fault within protection zone. Provides high speed protection of the transformer windings.
RAT 12(22)	Y Winding Ground Differential	N/A	400A@2.5TD	Actuates upon fault within protection zone. Provides high speed protection of the transformer windings.
RAT 12(22)	H Winding Phase Overcurrent	N/A	161.7A@2.25TD	Actuates upon fault downstream of device. Provides backup protection in the event a downstream device does not actuate.
4.16kV ESF Buses	Loss of Voltage	2 of 2	2929.5V@1.0TD (70% of 4160V)	Actuates upon complete loss of ESF Bus voltage.

**ATTACHMENT 9**

**Quad Cities Nuclear Power Station, Units 1 and 2 Response to  
NRC Bulletin 2012-01, "Design Vulnerability in Electric Power System"**

<b>Protection Zone</b>	<b>Protective Device</b>	<b>UV Logic</b>	<b>Setpoint (Nominal)</b>	<b>Basis for Setpoint</b>
4.16kV ESF Buses	Second Level Undervoltage	2 of 2	3906V@5TD (94% of 4160V)	Actuates upon degraded voltage provided to the ESF Bus.
4.16kV ESF Buses	Second Level Undervoltage	1 of 2	3906V@5TD (94% of 4160V)	Alarms upon A-B or B-C degraded voltage provided to the ESF Bus
4.16kV ESF Bus 13(23)	Main/Reserve Feed Phase Overcurrent	N/A	4800A@3.5TD	Protection for multiphase faults on station buses.
4.16kV ESF Bus 13(23)	Main/Reserve Feed Ground Fault	N/A	240A@3.5TD	Protection for phase to ground faults on station buses.
4.16kV ESF Bus 13(23) and 13-1(23-1)	Differential Protection	N/A	240A	Provides high-speed protection of bus feeds.
4.16kV ESF Bus 14(24)	Main/Reserve Feed Phase Overcurrent	N/A	4800A@3.5TD	Protection for multiphase faults on station buses.
4.16kV ESF Bus 14(24)	Main/Reserve Feed Ground Fault	N/A	240A@3.5TD	Protection for phase to ground faults on station buses.
4.16kV ESF Bus 14(24) and 14-1(24-1)	Differential Protection	N/A	240A	Provides high-speed protection of bus feeds.
4.16kV ESF Bus 13-1(23-1)	Main/Reserve Feed Phase Overcurrent	N/A	1920A@3.5TD	Protection for multiphase faults on station buses.
4.16kV ESF Bus 13-1(23-1)	Main/Reserve Feed Ground Fault	N/A	120A@3.0TD	Protection for phase to ground faults on station buses.
4.16kV ESF Bus 14-1(24-1)	Main/Reserve Feed Phase Overcurrent	N/A	1920A@3.5TD	Protection for multiphase faults on station buses.

**ATTACHMENT 9**

**Quad Cities Nuclear Power Station, Units 1 and 2 Response to  
NRC Bulletin 2012-01, "Design Vulnerability in Electric Power System"**

<b>Protection Zone</b>	<b>Protective Device</b>	<b>UV Logic</b>	<b>Setpoint (Nominal)</b>	<b>Basis for Setpoint</b>
4.16kV ESF Bus 14-1(24-1)	Main/Reserve Feed Ground Fault	N/A	120A@3TD	Protection for phase to ground faults on station buses.

Existing electrical protective devices are also sufficiently sensitive to detect a ground fault. Table 5 lists ground protection/alarms on the ESF buses and the basis for the device setpoint(s).

***NRC Request 2.b. If the ESF buses are not powered by offsite power sources, explain how the surveillance tests are performed to verify that a single-phase open circuit condition or high impedance ground fault condition on an off-site power circuit is detected.***

EGC Response to NRC Request 2.b:

Not Applicable – one division of ESF buses at Quad Cities Station is powered by offsite power sources. The other division is fed from the UAT and Main Generator through non-segregated bus bar (on-site source). However, operator walkdowns of the offsite power sources are conducted on a regular basis which would detect an open phase or high impedance ground condition.

***NRC Request 2.d: Do the plant operating procedures, including off-normal operating procedures, specifically call for verification of the voltages on all three phases of the ESF buses?***

EGC Response to NRC Request 2.d:

The current plant operating procedures, including operator rounds and operating procedures for off-normal conditions, specifically call for verification of the voltages on all three phases of the ESF buses. The plant operating procedures provide clear operator direction to address a potential single open phase event. This enhances station operator's ability to promptly diagnose and respond to single-phase open circuit conditions on off-site power supplies to Class 1E ESF buses.

## ATTACHMENT 9

### Quad Cities Nuclear Power Station, Units 1 and 2 Response to NRC Bulletin 2012-01, "Design Vulnerability in Electric Power System"

#### Consequences

NRC Requests 1.b, 1.c, and 2.e request information regarding the electrical consequences of an event, and will be addressed in this section.

***NRC Request 1.b: The differences (if any) of the consequences of a loaded (i.e., ESF bus normally aligned to offsite power transformer) or unloaded (e.g., ESF buses normally aligned to unit auxiliary transformer) power source.***

#### EGC Response to NRC Request 1.b:

Installed relays were not designed to detect single phase open circuit conditions. Existing loss of voltage and degraded voltage relays may respond depending on load and possible grounds. In general, there will be no plant response for an unloaded (e.g., ESF buses normally aligned to unit auxiliary transformer) power source in the event of a single-phase open circuit on a credited off-site power circuit because there is insufficient current to detect a single-phase open circuit for this configuration.

The plant response for a loaded power source cannot be calculated without specifying the amount of loading and the specific loads involved.

***NRC Request 1.c: If the design does not detect and automatically respond to a single-phase open circuit condition or high impedance ground fault condition on a credited offsite power circuit or another power sources, describe the consequences of such an event and the plant response.***

#### EGC Response to NRC Request 1.c:

1. Quad Cities Station did not credit in the CLB that the Class 1E protection scheme for the ESF buses was designed to detect and automatically respond to a single-phase open circuit condition on the credited off-site power source as described in the Updated Final Safety Analysis Report (UFSAR) and Technical Specifications.

The offsite power circuits at the QCNPS consist of two independent circuits from the 345kV switchyard to the ESF Buses.

2. Since Quad Cities Station did not credit the ESF bus protection scheme as being capable of detecting and automatically responding to a single phase open circuit condition, an open phase fault was not included in the design criteria for either the loss of voltage, the degraded voltage relay or second level undervoltage protection system design criteria. Since open phase detection was not credited in the QCNPS design or licensing basis, no design basis calculations or design documents exist that considered this condition.

## ATTACHMENT 9

### Quad Cities Nuclear Power Station, Units 1 and 2 Response to NRC Bulletin 2012-01, "Design Vulnerability in Electric Power System"

3. Without formalized engineering calculations or engineering evaluations, the electrical consequences of such an open phase event (including plant response), can only be evaluated to the extent of what has already been published by the Electric Power Research Institute (EPRI) and Basler; which is a generic overview. The difficulty in applying these documents to the QCNPS-specific response is that these are generic assessments and cannot be formally credited as a basis for an accurate response. The primary reason is that detailed plant specific models would need to be developed (e.g., transformer magnetic circuit models, electric distribution models, motor models; including positive, negative, and zero sequence impedances (i.e., voltage and currents), and the models would need to be compiled and analyzed for the QCNPS specific Class 1E electric distribution system..

The loss of voltage and degraded voltage relaying scheme is capable of responding to degraded grid conditions as described in applicable NRC guidelines and remains operable. However, the loss of voltage and degraded voltage relaying scheme are not capable of detecting an unbalanced voltage due to a single phase condition and automatically disconnecting the offsite source in all cases. If a similar event occurred, the possibility exists that operating loads would trip or starting loads would not reach to rated speed and voltage.

Quad Cities Station has implemented several interim compensatory measures to minimize the impact should the open phase event occur. These measures include:

- Modification of plant voltage alarms to annunciate during such an event
- Alignment of plant voltmeters to ensure all phases are monitored
- Preparation of required reading packages for operators for enhanced awareness
- Enhancement of alarm / annunciator response procedures

***NRC Request 2.e: If a common or single offsite circuit is used to supply redundant ESF buses, explain why a failure, such as a single-phase open circuit or high impedance ground fault condition, would not adversely affect redundant ESF buses.***

#### EGC Response to NRC Request 2.e:

Consistent with the CLB and GDC 17, protective circuitry will separate the ESF buses from a failed offsite source due to a loss of voltage or a sustained balanced degraded grid voltage concurrent with certain design basis accidents. The relay systems were not specifically designed to detect an open single phase of a three phase system. Detection of a single-open phase circuit is beyond the approved design and licensing basis of the plant.

QCNPS has reviewed the vulnerability for impact on plant operability using the Operability Evaluation process. QCNPS has implemented several interim compensatory measures including several procedure revisions, such as annunciator response and surveillance procedures, as needed in response to the Byron Station event. These procedures now provide effective controls to promptly diagnose and mitigate a single-phase event. Operators have been trained to check voltages, currents, and other control room alarms in order to diagnose and respond to a single-phase open circuit event.



**ATTACHMENT 10**

**Three Mile Island Nuclear Station, Unit 1, 90-Day Response to NRC Bulletin 2012-01,  
"Design Vulnerability in Electric Power System"**

## ATTACHMENT 10

### Three Mile Island Nuclear Station, Unit 1 Response to NRC Bulletin 2012-01, "Design Vulnerability in Electric Power System"

#### High Impedance Grounds:

On January 30, 2012, a porcelain insulator broke in the Byron Station switchyard resulting in parting of the C phase conductor of the offsite source. The insulator was on the offsite source side of the Unit 2 System Auxiliary Transformers (SATs), and the connection parted in such a way as to leave an electrically open end on the source side. The parted connection remained electrically connected on the transformer side, and the loose bus bar conductor end fell to the ground. This ground was a direct result of the broken insulator and not an independent event. The connected loose bus bar provided a path to ground for the transformer high voltage terminal, but did not result in a ground fault (i.e., neither solid nor impedance) as seen from the source. Since the switchyard (i.e., source side) relaying was electrically isolated from the fault, it did not detect a fault; therefore, did not operate.

The significant event was the opening of a single phase connection; the ground on the high voltage side of the SAT is of lesser significance. Regardless of phase discontinuity, if the ground impedance is low on the source side, and currents are high, the source side protective relaying will operate and open all circuit phases. If the ground impedance is high, and currents low, the relaying may not operate depending on the magnitude of ground impedance; the circuit will continue to supply power.

A qualitative analysis has been performed to assess the impact of single phase high impedance ground faults. The primary objective of the analysis was to determine if a high impedance ground fault could result in an unbalanced voltage condition sufficient to adversely affect energized ESF equipment. The cases analyzed include a single phase high impedance ground fault with all three phases intact and a single phase high impedance ground fault concurrent with the loss of the same phase. These cases have been analyzed for both the high and low voltage sides of the SATs analyzed.

Attachment 11 provides a summary report of the qualitative analysis; therefore, all information discussed in this response attachment is limited to single-phase open circuit conditions.

#### System Description

NRC Requests 2, 1.d, 2.a, and 2.c request system information and will be addressed in this section:

***NRC Request No. 2: Briefly describe the operating configuration of the ESF buses (Class 1E for current operating plants or non-Class 1E for passive plants) at power (normal operating condition).***

#### Exelon Generation Company, LLC (EGC) Response to NRC Request No. 2

Three Mile Island Nuclear Station, Unit 1 (TMI-1) has two Station Auxiliary Transformers (SATs) connected to two 230kV buses. TMI's switchyard buses are designated as the 4 and 8 Bus, and are both fed by the 1091, 1092, and 1051 lines from Met Ed's 230kV grid, and through an autotransformer from the PJM 500kV grid. The 1A Auxiliary Transformer is lined up to Bus 8,

## ATTACHMENT 10

### Three Mile Island Nuclear Station, Unit 1 Response to NRC Bulletin 2012-01, "Design Vulnerability in Electric Power System"

and the 1B Auxiliary Transformer is lined up to Bus 4. There are two 4160V vital switchgear engineered safeguards features (ESF) buses which are each fed by one of the auxiliary transformers. Each transformer also feeds a 6900V switchgear that feeds two Reactor Coolant Pumps. Two 4160V balance of plant (BOP) Switchgear are fed from the 1A Auxiliary Transformer, and one 4160V BOP Switchgear is fed from the 1B Auxiliary Transformer. Each auxiliary transformer is capable of carrying all the loads. If one of the auxiliary transformers loses power, the BOP 4160V and 6900V switchgear are transferred to the energized auxiliary transformer, and the associated emergency diesel will start and supply power to the 4160V ESF switchgear associated with the de-energized transformer.

A simplified one-line diagram is shown in Figure 1 below.



**ATTACHMENT 10**

**Three Mile Island Nuclear Station, Unit 1 Response to  
NRC Bulletin 2012-01, "Design Vulnerability in Electric Power System"**

**NRC Request 1.d: Describe the offsite power transformer (e.g., start-up, reserve, station auxiliary) winding and grounding configurations.**

EGC Response to NRC Request 1.d:

Both auxiliary transformers are identical. They are Y:Y-Delta ( $\Delta$ ) configuration. The primary is 230kV Y with grounded neutral, and a secondary with a 4160V Y with neutral 4ohm ( $\Omega$ ) resistance to ground and a 6900V ungrounded  $\Delta$ . These transformers have a load tap changer (LTC) that maintains the 4160V voltages on the associated 4160V ESF buses between 4162V and 4218V.

The TMI-1 offsite power transformer winding and grounding configurations are shown in Table 1 below.

**Table 1: TMI-1 Offsite Power Transformer Winding and Grounding Configurations**

<b>Transformer</b>	<b>Winding Configuration</b>	<b>MVA Size (AO/FA/FA)</b>	<b>Voltage Rating (Primary/Secondary)</b>	<b>Grounding Configuration</b>
1A Auxiliary Transformer with LTC controlling voltage on the 4160kV ESF bus	Y:Y- $\Delta$	230kV-39/52/65 MVA @ 65°C 6800V-21/28/35 MVA @ 65°C 4160V-18/24/30 @ 65°C	230kV to 4160/6900V	Y – primary neutral grounded, Y – 4160V secondary Neutral 4ohm resistance Grounded; $\Delta$ 6900 ungrounded
1B Auxiliary Transformer with LTC controlling voltage on the 4160kV ESF bus	Y:Y- $\Delta$	230kV-39/52/65 MVA @ 65°C 6900V-21/28/35 MVA @ 65°C 4160V-18/24/30 @ 65°C	230kV to 4160/6900V	Y – primary neutral grounded, Y – 4160V secondary Neutral 4ohm resistance Grounded; $\Delta$ 6900 ungrounded

**ATTACHMENT 10**

**Three Mile Island Nuclear Station, Unit 1 Response to  
NRC Bulletin 2012-01, "Design Vulnerability in Electric Power System"**

***NRC Request 2.a: Are the ESF buses powered by offsite power sources?  
If so, explain what major loads are connected to the  
buses including their ratings.***

EGC Response to NRC Request 2.a:

The two 4160V ESF buses at TMI-1 are continuously powered by offsite power sources during normal power operations. They are not connected to the output of the Main Generator, but each ESF bus has a 3000kW emergency diesel generator as a backup.

The power sources for the TMI-1 ESF buses during normal power operations are shown in Tables 2 and 3 below.

**Table 2:** TMI-1 ESF Buses That Are Normally Powered from Offsite Sources

<b>Description of ESF Bus Power Source</b>	<b>ESF Bus Name (normal operating condition)</b>	<b>Original licensing basis configuration (Y/N)</b>
1A Auxiliary Transformer	1E 4160V Switchgear	Y
1E 4160V Switchgear	1S 480V ESF Bus	Y
1E 4160V Switchgear	1T 480V ESF Bus	Y
1B Auxiliary Transformer	1D 4160V Switchgear	Y
1D 4160V Switchgear	1P 480V ESF Bus	Y
1D 4160V Switchgear	1R 480V ESF bus	Y

**Table 3:** TMI-1 ESF Buses That Are Not Normally Powered from Offsite Sources

<b>Description of ESF Bus Power Source</b>	<b>ESF Bus Name (normal operating condition)</b>	<b>Original licensing basis configuration (Y/N)</b>
N/A		

The TMI-1 ESF bus major loads energized during normal power operations, including their ratings, are shown in Table 4 below.

**ATTACHMENT 10**

**Three Mile Island Nuclear Station, Unit 1 Response to  
NRC Bulletin 2012-01, "Design Vulnerability in Electric Power System"**

**Table 4: Major ESF Loads Including Ratings and Status during Normal Power Operations**

<b>4160V ESF Bus</b>	<b>Load</b>	<b>Voltage Level (V)</b>	<b>Rating (kW)</b>
1D 4160V	*MU-P-1B	4160	588
	1P 480V ESF	4160	1020
	1R 480V ESF	4160	452
	1N 480V (Non-ESF)	4160	476
1E 4160V	1S-480V-ES	4160	1043
	*MU-P-1B	4160	588
	1T-480V-ES	4160	627
<b>Notes:</b>			
*MU-P-1B can be aligned to either the 1D or 1E 4160V Switchgear; however, it is normally aligned to the 1E 4160V Switchgear.			
1C 480V ESF bus can be aligned to either the 1S or 1P-480V-ES; however it is normally aligned to the 1S-480V-ES Switchgear.			
Either AH-C-4A or 4B is normally operating.			

***NRC Request 2.c: Confirm that the operating configuration of the ESF buses is consistent with the current licensing basis. Describe any changes in offsite power source alignment to the ESF buses from the original plant licensing.***

EGC Response to NRC Request 2.c:

The offsite power circuits at the TMI-1 switchyard consist of four independent circuits from the 230kV grid to Bus 4 and Bus 8 and are both fed by the 1091, 1092, and 1051 lines from Met Ed's 230kV grid, and through an autotransformer from the PJM 500kV grid. Each of these buses is aligned to an Auxiliary Transformer that then provides power to one of the two ESF 4160V buses.

The design and operation of the electrical system is consistent with the current licensing basis (CLB) in accordance with the TMI-1 Updated Final Safety Analysis Report (UFSAR), Section 8.1, "Design Bases," UFSAR Section 8.2.2.2, "Auxiliary Transformers," and Technical Specification (TS) 3.07, "Unit Electric Power System."

The TMI-1 at-power (i.e., normal operating condition) configurations have been confirmed to be consistent with the CLB and no changes regarding the alignment of the ESF buses have been made since initial plant licensing.

## ATTACHMENT 10

### Three Mile Island Nuclear Station, Unit 1 Response to NRC Bulletin 2012-01, "Design Vulnerability in Electric Power System"

#### System Protection

NRC Requests 1, 1.a, 2.b, and 2.d request information regarding electrical system protection, and will be addressed in this section.

***NRC Request 1: Given the requirements above, describe how the protection scheme for ESF buses (Class 1E for current operating plants or non-Class 1E for passive plants) is designed to detect and automatically respond to a single-phase open circuit condition or high impedance ground fault condition on a credited off-site power circuit or another power sources. Also, include the following information:***

#### EGC Response to NRC Request 1:

Consistent with the CLB and 10 CFR 50, Appendix A, "General Design Criteria for Nuclear Power Plants," Criterion (GDC) 17, "Electric power systems," existing protective circuitry will separate the ESF buses from a connected failed offsite source due to a loss of voltage or a sustained, balanced degraded grid voltage concurrent with certain design basis accidents. The relay systems were not specifically designed to detect an open single phase of a three phase system. Detection of a single-open phase condition is beyond the approved design and licensing basis of the plant based on an analysis of the above configuration, there may be potential design vulnerability in the TMI-1 protective relaying scheme for protection from an open phase condition.

***NRC Request 1.a: The sensitivity of protective devices to detect abnormal operating conditions and the basis for the protective device setpoint(s).***

#### EGC Response to NRC Request 1.a:

Consistent with the CLB and GDC 17, existing electrical protective devices are sufficiently sensitive to detect design basis conditions like a loss of voltage or a degraded voltage, but were not designed to detect a single phase open circuit condition. The TMI-1 undervoltage protective devices and the basis for the device setpoint(s) are shown in Table 5 below.



**ATTACHMENT 10**

**Three Mile Island Nuclear Station, Unit 1 Response to  
NRC Bulletin 2012-01, "Design Vulnerability in Electric Power System"**

**Table 5: TMI-1 Protective Devices**

<b>Protection Zone</b>	<b>Protective Device</b>	<b>UV Logic</b>	<b>Setpoint (Nominal)</b>	<b>Basis for Setpoint</b>
4kV ESF	Loss of Voltage Relay	2 of 3	2413V (58% of 4160V)	To actuate upon complete loss of ESF Bus voltage condition in 1.5 seconds
4kV ESF	Degraded Grid	2 of 3	3760V (90.4% of 4160V)	To actuate upon degraded grid condition with a 10 second time delay
1A/1B Auxiliary Transformer	230kV Neutral Ground Relays	1 of 1	120 amps	Actuates on a 230kV neutral ground overcurrent
1A/1B Auxiliary Transformer	4160V Neutral Ground Relays	1 of 1	220 amps	Actuates on Aux Transformer 4160V neutral ground overcurrent
1D/1E ESF 4160V SWGR	4160V ESF Neutral Ground Relays	1 of 1	120 amps	Actuates on 4160V ESF Bus neutral ground overcurrent
1A/1B Auxiliary Transformer	Auxiliary Transformer Differential Relays	1 of 1	Slope 30%	Actuates on differential between 230kV input to Aux Transformer and the 6900V bus and the 4160V bus associated with the transformer.
1A/1B Auxiliary Transformer	230 kV Backup Phase Overcurrent Protection	1 of 1	200 amps @ 4.0 seconds TD	The relays operate for a through fault not cleared by a downstream breaker, and are set based on the through fault protection curve for the transformer.

Existing electrical protective devices are also sufficiently sensitive to detect a ground fault. As shown in Table 5, ground protection is listed for the ESF buses along with the basis for the device setpoints.

## ATTACHMENT 10

### Three Mile Island Nuclear Station, Unit 1 Response to NRC Bulletin 2012-01, "Design Vulnerability in Electric Power System"

***NRC Request 2.b. If the ESF buses are not powered by offsite power sources, explain how the surveillance tests are performed to verify that a single-phase open circuit condition or high impedance ground fault condition on an off-site power circuit is detected.***

EGC Response to NRC Request 2.b:

Not Applicable - the ESF buses at TMI-1 are powered by offsite power sources.

***NRC Request 2.d: Do the plant operating procedures, including off-normal operating procedures, specifically call for verification of the voltages on all three phases of the ESF buses?***

EGC Response to NRC Request 2.d:

The current plant operating procedures, including operating procedures for off-normal alignments, specifically call for verification of the voltages on all three phases of the ESF buses.

## ATTACHMENT 10

### Three Mile Island Nuclear Station, Unit 1 Response to NRC Bulletin 2012-01, "Design Vulnerability in Electric Power System"

#### Consequences

NRC Requests 1.b, 1.c, and 2.e request information regarding the electrical consequences of an event, and will be addressed in this section.

***NRC Request 1.b: The differences (if any) of the consequences of a loaded (i.e., ESF bus normally aligned to offsite power transformer) or unloaded (e.g., ESF buses normally aligned to unit auxiliary transformer) power source.***

#### EGC Response to NRC Request 1.b:

Installed relays were not designed to detect single phase open circuit conditions. Existing loss of voltage and degraded voltage relays may respond depending on load and possible grounds. In general, there will be no plant response for an unloaded (e.g., ESF buses normally aligned to unit auxiliary transformer) power source in the event of a single-phase open circuit on a credited off-site power circuit because there is insufficient current to detect a single-phase open circuit for this configuration. The plant response for a loaded power source cannot be calculated without specifying the amount of loading and the specific loads involved.

***NRC Request 1.c: If the design does not detect and automatically respond to a single-phase open circuit condition or high impedance ground fault condition on a credited offsite power circuit or another power sources, describe the consequences of such an event and the plant response.***

#### EGC Response to NRC Request 1.c:

1. TMI-1 did not credit in the CLB that the Class 1E protection scheme for the ESF buses was designed to detect and automatically respond to a single-phase open circuit condition on the credited off-site power source as described in the UFSAR and TS.

The offsite power circuits at the TMI-1 switchyard consists of four independent circuits from the 230kV grid to Bus 4 and Bus 8. Each of these buses is aligned to an Auxiliary Transformer that then provides power to one of the two ESF 4160V buses.

2. Since TMI-1 did not credit the ESF bus protection scheme as being capable of detecting and automatically responding to a single phase open circuit condition, an open phase fault was not included in the design criteria for either the loss of voltage, the degraded voltage relay scheme or secondary level undervoltage protection system design criteria. Since open phase detection was not credited in the TMI-1 design or licensing basis, no design basis calculations or design documents exist that considered this condition.
3. Without formalized engineering calculations or engineering evaluations, the electrical consequences of such an open phase event, including plant response, can only be evaluated to the extent of what has already been published by the Electric Power Research

## ATTACHMENT 10

### Three Mile Island Nuclear Station, Unit 1 Response to NRC Bulletin 2012-01, "Design Vulnerability in Electric Power System"

Institute (EPRI) and Basler; which is a generic overview. The difficulty in applying these documents to the TMI-1 specific response is that these are generic assessments and cannot be formally credited as a basis for an accurate response. The primary reason is that detailed plant specific models would need to be developed (e.g., transformer magnetic circuit models, electric distribution models, motor models; including positive, negative, and zero sequence impedances, voltage, and currents), and the models would need to be compiled and analyzed for the TMI-1 specific Class 1E electric distribution system.

The Byron Station event was reviewed by TMI-1 Engineering for applicability. The TMI-1 degraded voltage relaying schemes are capable of responding to a degraded grid condition as described in TMI-1's UFSAR section 8.2.1.2.f. The TMI-1 degraded grid and dead bus relaying schemes monitor the phase to neutral voltages of all three phases. The 4kV distribution system design at TMI-1 is different from that of Byron Station because TMI-1 has two independent offsite sources which provide power to the appropriate 4kV safeguard buses through the 1A and 1B Auxiliary Transformers, whereas Byron Station aligns both of their 4kV safeguard buses to one offsite source. Also, the TMI-1 4kV safeguard bus configuration is redundant to prevent a total loss of 4kV safeguard loads by means of divisions (i.e., A and B trains). A loss of phase on one offsite source would affect only one train of safeguard busses. The 4kV degraded grid protective relay schemes at TMI-1 is a two-out-of-three logic for each 4kV safeguard bus, which uses a Y-Y potential transformer configuration to monitor degraded voltage condition on all three phases. This is different from the Byron Station design of two-out-of-two logic with two independent relays monitoring the line "A" to "B" phases and the line "B" to "C" phases.

Specific measures implemented at TMI-1 as interim compensatory measures include the following: Operators are instructed to check the incoming currents to the Auxiliary Transformers for an alarm on Main Control Room Annunciator Window B-3-1, which indicates a low voltage on the 4160V ESF bus. This activates when a low voltage or degraded grid voltage relay activates. Follow-on actions if the loss is confirmed are to isolate the 4160V ESF bus from the Auxiliary Transformer and feed it from the associated emergency diesel as required by TSs. Alarm from annunciator AA-3-2 will provide additional indication to the Operators of a low voltage condition. This alarms for a low voltage on the 6900V bus. All operators have been briefed on these procedure revisions for awareness.

***NRC Request 2.e: If a common or single offsite circuit is used to supply redundant ESF buses, explain why a failure, such as a single-phase open circuit or high impedance ground fault condition, would not adversely affect redundant ESF buses.***

#### EGC Response to NRC Request 2.e:

Not applicable since TMI-1 does not use a common or single offsite circuit to supply redundant ESF buses.

**ATTACHMENT 11**

**Exelon Generation Company, LLC's Evaluation of the  
Effects of High Impedance Ground Faults**

## ATTACHMENT 11

### Exelon Generation Company, LLC's Evaluation of the Effects of High Impedance Ground Faults

#### 1. INTRODUCTION

On January 30, 2012, Byron Station, Unit 2 experienced a single open phase in the off-site power circuit that resulted in a reactor trip and loss of off-site power due to the failure of an insulator. The protection schemes associated with detecting the degraded off-site source and faulted lines failed to detect the condition.

NRC Bulletin 2012-01 was issued to document questions the NRC had related to the plant response to this event. The NRC clarified that a single phase high impedance ground be discussed in the bulletin response. Two cases should be discussed: 1) A single phase high impedance ground with all three phases intact, and 2) A single phase high impedance fault concurrent with the loss (i.e. open) of the same phase. The cases should be performed for both high and low voltage side of the transformers.

The following discussion provides a summary report of the qualitative analysis performed for the two cases identified above at the Exelon Generation Company, LLC (EGC) stations. Specifically, the objectives of the study cover the following:

- High impedance ground with all three phases intact on the high voltage (HV) side of the System Auxiliary Transformer (SAT)
- High impedance ground with all three phases intact on the low voltage (LV) side of the SAT
- High impedance ground with a concurrent open on the same phase on the HV side of the SAT, and
- High impedance ground on the LV side of the SAT with a concurrent open on the same phase on the HV side of the SAT.

#### 2. METHODOLOGY

The engineered safety features (ESF) motors connected to the LV side of the SAT are either connected in DELTA or ungrounded WYE. Therefore, these motors have an infinite zero sequence impedance. These ESF motors will not draw any zero sequence current. As a result, zero sequence voltage resulting from system unbalance across the motor terminals will not impact the motor performance. The effect of unbalanced voltages on polyphase induction motors is equivalent to the introduction of a "negative sequence voltage" having a rotation opposite to that occurring with balanced voltages (Reference 4.2).

A system unbalance will also generate negative sequence voltage that will impact the motor performance. It is a well known fact that a small percentage of negative sequence voltage will result in a relatively larger current unbalance due to the low negative sequence impedance of the ESF motors. The relative effect is essentially double frequency current in the rotor. Consequently, the temperature rise of the motor operating at a particular load and voltage unbalance will be greater compared to the motor operating under the same conditions with balanced voltages.

Motor performances are not affected when operated under a voltage unbalance of 1% or

## ATTACHMENT 11

### Exelon Generation Company, LLC's Evaluation of the Effects of High Impedance Ground Faults

less (Reference 4.2). This can be verified using Figure 20-2 (Reference 4.2), where the derating factor for motors with a 1% voltage unbalance is almost 1.00 (i.e., their performance is not affected). Therefore, for voltage unbalance more than 1%, the motors may either stall and/or trip on an over-current protection scheme of the motor. This analysis therefore uses a 1% voltage unbalance to obtain the limiting impedance for the high impedance ground fault.

The following steps will be used to perform a qualitative analysis of the four cases described in Section 1 above.

**Case1:** High impedance ground with all three phases intact on the HV side of the SAT

- a. Determine the magnitude of unbalanced voltage that will not impact the performance of the ESF loads (motors) connected to the LV side of the SAT.
- b. Determine the minimum value of impedance on a line to ground fault that will generate the unbalanced voltage that does not impact the motor performance.
- c. Determine the ground fault current that will flow due to the fault impedance from a line to ground determined in Step b.
- d. Determine if any of the existing relays used in the protection scheme will trip and isolate the high impedance ground fault.
- e. If the existing protection scheme will not trip, then, determine the minimum fault impedance value of a line to ground fault that will be detected by EGC's protection scheme.
- f. Determine the unbalanced voltages that will result at the motor terminals for the minimum fault impedance value (i.e., Step e above) on a line to ground fault.
- g. Evaluate the capability of the ESF motors to withstand the amount of unbalance that will not be detected by the existing protection scheme for a high impedance ground fault.
- h. Determine if any of the protective devices for the loads (e.g., motors) would trip under above conditions.

**Case 2:** High impedance ground with all three phases intact on the LV side of the SAT:

- a. Determine the minimum high impedance ground fault that will be detected by the existing relays used in the protection scheme.
- b. Determine the unbalanced voltage that will result at the ESF motor terminals for the impedance slightly above the impedance determined in Step a above.
- c. Evaluate the capability of the ESF motors to withstand the amount of unbalance determined in Step b.
- d. Determine if any of the protective devices for the loads (e.g., motors) would trip under above conditions.

## ATTACHMENT 11

### Exelon Generation Company, LLC's Evaluation of the Effects of High Impedance Ground Faults

**Case 3:** High impedance ground with a concurrent open on the same phase on the HV side of the SAT:

- a. Determine the unbalanced voltage that will result at the motor terminals as a function of the high impedance ground fault.
- b. Determine the minimum value of impedance on a line to ground fault, which will not be detected by EGC's protection scheme.
- c. Evaluate the capability of the motors to withstand the amount of unbalance that will not be detected by the existing protection scheme for a high impedance ground fault.
- d. Determine if any of the protective devices for the loads (motors) would trip under above conditions.

**Case 4:** High impedance ground on the LV side of the SAT with a concurrent open on the same phase on the HV side of the SAT:

- a. Determine the unbalanced voltage that will result at the motor terminals as a function of the high impedance ground fault.
- b. Determine the minimum value of impedance on a line to ground fault, which will not be detected by the EGC protection scheme.
- c. Evaluate the capability of the motors to withstand the amount of unbalance that will not be detected by the existing protection scheme for a high impedance ground fault.
- d. Determine if any of the protective devices for the loads (e.g., motors) would trip under above conditions.

### 3. SUMMARY AND CONCLUSIONS

This report performed a qualitative analysis for the following conditions:

- 1) A single phase high impedance ground with all three phases intact, and
- 2) A single phase high impedance fault concurrent with the loss (i.e., open) of the same phase.

Specifically, the following cases were studied:

**Case 1:** High impedance ground with all three phases intact on the HV side of the SAT

**Case 2:** High impedance ground with all three phases intact on the LV side of the SAT

**Case 3:** High impedance ground with a concurrent open on the same phase on the HV side of the SAT

**Case 4:** High impedance ground on the LV side of the SAT with a concurrent open on the same phase on the HV side of the SAT

The analysis concludes the following for Braidwood Station, Byron Station, Clinton Power Station, Dresden Nuclear Power Station, LaSalle County Station, Limerick



## ATTACHMENT 11

### Exelon Generation Company, LLC's Evaluation of the Effects of High Impedance Ground Faults

Generating Station, Oyster Creek Nuclear Generating Station, Peach Bottom Atomic Power Station, Quad Cities Nuclear Power Station, and Three Mile Island Nuclear Station:

**Case 1:** High impedance ground on HV side with all the three phases intact on HV side

The existing protection schemes on the auxiliary transformers (i.e., SAT/Reserve Auxiliary Transformer (RAT)/Emergency Reserve Auxiliary Transformer (ERAT)/Startup Transformer (SUT)) will detect and isolate the high impedance ground fault. For a high impedance fault limited to the HV terminals of the auxiliary transformers, the existing protection schemes would prevent the connected ESF motors on the LV side from operating at more than 1% voltage unbalance. Therefore, the performance on the connected ESF motors would not be impacted.

The existing protection scheme on the HV bus (i.e. switchyard side) is also available to provide protection for both bolted and high impedance ground faults on the HV bus. These relays are designed to operate for both phase and ground faults on the HV bus. For high impedance ground faults on one phase of the HV bus, these relays are expected to trip to limit the negative sequence voltage within acceptable levels across the connected ESF motors. In addition, due to the switchyard design configurations and high voltage nature of the system, a high impedance to ground fault is not expected to be credible due to the grounding grid in the switchyard. In the unlikely event this scenario occurs, it is expected to become a "dead bolt fault," which would then be detected and isolated by existing protection schemes.

**Case 2:** High impedance ground on the LV side with all the three phases intact on HV side

The existing protection schemes would detect and isolate the high impedance ground fault. The connected ESF motors on the LV side would not experience more than 1% voltage unbalance. The performance on the connected ESF motors would not be impacted and the over-current protection for these motors would not actuate to trip these motors.

**Case 3:** High impedance ground with a concurrent open on the same phase on the HV side of the auxiliary transformer

The existing protection schemes on the HV side of the transformer may not detect and isolate the high impedance ground fault. However, the degraded voltage relays on the LV side may detect the open phase condition based on the loading of the transformer and the high impedance to ground. A substantial amount of negative sequence voltage would be present based

## ATTACHMENT 11

### Exelon Generation Company, LLC's Evaluation of the Effects of High Impedance Ground Faults

on the high impedance to ground fault and load on the auxiliary transformer at the ESF buses. This may potentially damage the motors. These motors may stall and/or ultimately trip on over-current protection. Efforts are underway to resolve the open phase vulnerability at all EGC Nuclear operating stations. These solutions are at varying states of completion at each site. Interim compensatory actions have been taken to address the vulnerabilities where appropriate as discussed in Attachments 1 through 10.

**Case 4:** High impedance ground on the LV side of the auxiliary transformer with a concurrent open on the same phase on the HV side of the auxiliary transformer

The existing protection schemes on the HV side of the transformer may not detect and isolate the high impedance ground. However, the degraded voltage relays on the LV side may detect the open phase condition based on the loading of the transformer and the high impedance to ground. The 51N relay on the LV side would see fault current but the magnitude of the fault current would depend on the load on the LV side and high impedance ground fault. Therefore, the tripping of this relay would be dependent on several factors. A substantial amount of negative sequence voltage may be present based on the auxiliary transformer load at the ESF buses. This has the potential to degrade and derate the motors. These motors may stall and/or ultimately trip on over-current protection. Efforts are underway to resolve the open phase vulnerability at all EGC Nuclear operating stations. These solutions are at varying states of completion at each site. Interim compensatory actions have been taken to address the vulnerabilities where appropriate as discussed in Attachments 1 through 10.

#### 4. REFERENCES

- 4.1 Power System Analysis by Arthur R. Bergen, Prentice Hall, ISBN 0-13-687864-4, Pages 403 thru 420.
- 4.2 NEMA MG 1-2011, Section 20.24, Figure 20-2.