

CONTENTS

2 STRUCTURAL EVALUATION	2-1
2.1 Description of Structural Design	2-1
2.2 Materials	2-17
2.3 Fabrication and Examination.....	2-23
2.4 General Requirements for All Packages [71.43]	2-25
2.5 Lifting and Tie-Down Standards for All Packages.....	2-26
2.6 Normal Conditions of Transport.....	2-26
2.7 Hypothetical Accident Conditions [71.73]	2-45
2.8 Accident Conditions for Air Transport of Plutonium [71.74]	2-59
2.9 Accident Conditions for Fissile Material Packages for Air Transport [1.55(f)].....	2-59
2.10 Special Form [71.75]	2-59
2.11 Fuel Rods.....	2-59
2.12 Appendix	2-59

2 STRUCTURAL EVALUATION

This section identifies the principal structural members of the Safkeg-HS 3977A package, and the materials and fabrication methods of each are described. The ability of the package to satisfy the regulatory requirements of 10 CFR 71 [2.1], regarding Normal Conditions of Transport (NCT) and Hypothetical Accident Conditions (HAC) tests, is demonstrated in Sections 2.6 and 2.7 by Finite Element Analysis (FEA) of the containment vessel and testing of a prototype keg.

2.1 Description of Structural Design

2.1.1 Discussion

The principal structural members of the Safkeg-HS 3977A package are the 3977 keg, inner cork packing and the 3978 containment vessel. The radioactive contents are carried within product containers and inserts placed inside the containment vessel (see Section 1.2.1).

The keg is designed to absorb impacts, provide protection during handling operations and insulate the containment vessel during the HAC thermal test. The inner cork packing is designed to absorb the impact loads preventing damage to the containment vessel under HAC tests. The containment vessel is designed to provide the containment and shielding of the radioactive material and the insert is designed to provide a confinement boundary and additional shielding for the contents. A description of the structural design of each of these members is provided in the following sections.

3977 Keg

The keg comprises of a body, lid, outer cork and liner assembly as shown in drawing 0C-5942 (Section 1.3.2). The body of the keg is constructed from rolled austenitic stainless steel welded to form a cylinder. A base, top flange, skirts and rims are welded to the rolled

cylinder to form the keg body. The outer cork is placed into the keg with the steel assembly liner fitting inside the cork to protect the outer cork during handling operations. The inner liner is formed from 2mm thick austenitic stainless steel.

The keg closure is facilitated by eight closure studs screwed and glued into position on the top flange and a lock pin which is welded into position. The keg lid is a circular plate with eight holes machined for the closure studs and one hole for the lock pin. The lid is attached to the body with eight M12 austenitic stainless steel nuts and washers. A nitrile O-ring is fitted to a groove in the flange ensuring that a weather tight seal is provided on closure of the keg. Two handles are welded to the lid to allow handling of the lid.

A fuse plug is located in the base plate of the keg body. It is present to prevent the over pressurization of the keg during the HAC thermal test. The fuse plug is austenitic stainless steel with a hole drilled through the centre which is filled with a low melting point alloy. This alloy has a melting point of $95^{\circ}\text{C}\pm 5^{\circ}\text{C}$ which once melted will allow any gases generated within the keg to vent, reducing the pressure in the keg body.

Top and Inner Cork

The inner cork fits inside the keg liner and surrounds the containment vessel. It is designed to reduce impact loads on the keg liner and the containment vessel and provide thermal insulation. The cork surrounds the side walls and the lid of the containment vessel. It varies in width from 56 mm to 36 mm on the side walls due to the variation in diameter of the containment vessel and is 84.5 mm thick above the lid. The cork is agglomerated and coated in a water based varnish. The cork components are shown in detail in drawing 0C-5943 (Section 1.3.2).

3978 Containment Vessel

The containment vessel consists of a body and a removable lid assembly bolted together with 8 closure screws and sealed with an inner and outer O-ring, as shown in drawing 1C-5944 (Section 1.3.2).

The body assembly is formed from a stainless steel shell filled with depleted uranium which is alloyed with 2% molybdenum by weight. The stainless steel shell consists of three austenitic stainless steel pieces, the inner cavity wall/flange, outer wall and base. Each piece is machined from solid austenitic stainless steel. The inner cavity wall/flange and outer wall are welded together with a circumferential full penetration fillet weld which is both visually and liquid penetrant tested. The shielding cavity is filled with the machined to size shielding and the base is welded into position with a circumferential full penetration fillet weld which is both visually and liquid penetrant tested.

The depleted uranium which is alloyed with 2% molybdenum by weight forms the shielding for the walls and base of the containment vessel.

The inner cavity wall/flange and the bolted flange for the containment vessel closure form the cavity into which the radioactive contents are placed. The flange is machined with 8 closure holes into which CV closure screws are fitted.

The containment vessel lid is comprised of two pieces a lid top and a stainless steel clad depleted uranium plug. The CV lid top is a circular plate machined from a stock billet of 304L stainless steel. Eight equally spaced counter bored holes are machined to accommodate the closure screws. Four further holes are machined in the lid, the first accommodates the test port in order to leak test the closure system. The second is a blind hole in the centre of the lid and is fitted with a threaded insert. This allows a lifting eye to be fitted for the handling of the containment vessel. The last two allow jacking screws to be fitted which assist in the removal of the lid. Two grooves are machined onto the underside of the lid top into which the O-rings are fitted.

The depleted uranium is machined to shape and placed within the machined stainless steel casing to form the shielding plug. The plug is welded to the lid top with a circumferential full penetration fillet weld which is liquid penetrant and visually tested.

The containment vessel lid is attached to the body with eight L43 alloy steel screws which are tightened to a torque of 10 ± 0.5 Nm.

The design pressure for the containment vessel is 10 bar (1,000 kPa) gauge which envelopes the MNOP of 7 bar (700 kPa) gauge. The containment boundary is formed by the inner cavity wall/flange, lid and containment O-ring. This containment boundary is leak tested on manufacture, during annual maintenance and on loading.

Insert

Any one of the three inserts specified in Section 1.3.2 shall be used to provide further shielding and confinement for the contents. Two of the inserts, HS-12x95-Tu Design No 3982 and HS-31x114-Tu Design No 3985, are machined from tungsten with one, HS-55x138-SS Design No 3987, machined from stainless steel. All of the inserts consist of a body and a lid which are machined from a solid. The lid screws onto the body with an O-ring seal. The three types of inserts each have different cavity sizes and provide varying levels of shielding. A plastic liner can also be added to the stainless steel insert to allow for liquids to be carried.

2.1.2 Design Criteria

In order to evaluate the containment design, an FEA was performed on the containment vessel under NCT and HAC using the software code Abaqus: as discussed in Arcadis Vectra Report L20008/1/R1 (Section 2.12.2). The initial load combinations used during the evaluation are discussed in Section 2.1.2.1. The resultant calculated stresses are compared against the allowable stresses presented in Section 2.1.2.2. Further evaluation is carried out to determine buckling, fatigue and brittle fracture as discussed in Sections 2.1.2.3, 2.1.2.4 and 2.1.2.5 respectively.

The effectiveness of the packaging components under all the conditions of the regulatory requirements (both NCT and HAC) has been verified by physical tests. As the structural materials of the package are all austenitic stainless steel, the package is not susceptible to failure by brittle fracture. The keg, being a composite structure with the outer skin supported by the cork and the inner shell, it is not susceptible to buckling.

2.1.2.1 Load Combinations

The load combinations used in the structural evaluation of the containment boundary were developed in accordance with Regulatory Guide 7.8 [2.2]. The NCT and HAC load combinations used to determine the stresses within the containment boundary are summarized in Table 2-1 and Table 2-2.

Load Case ID	NCT	Initial Conditions								
		Ambient Temperature		Insolation		Decay Heat		Internal Pressure		Fabrication Stress
		38°C	-29°C	Max	Zero	Max	Zero	Max	Min	
NCT1	Hot environment (38°C ambient temperature)			X		X		X		X
NCT2	Cold environment (-40°C ambient temperature)				X		X		X	X
NCT3	Reduced external pressure (24.5 kPa)	X		X		X		X		X
NCT4	Increased external pressure (140 kPa)		X		X		X		X	X
NCT5	Vibration (10g vertical)	X		X		X		X		X
NCT6			X		X		X		X	X
NCT7	Free drop on lid (1.2m)	X		X		X		X		X
NCT8			X		X		X		X	X
NCT9	Free drop on side (1.2m)	X		X		X		X		X
NCT10			X		X		X		X	X
NCT11	Free drop on corner (1.2 m)	X		X		X		X		X
NCT12			X		X		X		X	X

Table 2-2 Load Combinations for HAC										
Load Case ID	HAC	Initial Conditions								
		Ambient Temperature		Insolation		Decay Heat		Internal Pressure		Fabrication Stress
		38°C	-29°C	Max	Zero	Max	Zero	Max	Min	
HAC1	Free drop on lid (9m)	X		X		X		X		X
HAC2			X		X		X		X	X
HAC3	Free drop on side (9m)	X		X		X		X		X
HAC4			X		X		X		X	X
HAC5	Free drop on corner (9m)	X		X		X		X		X
HAC6			X		X		X		X	X

2.1.2.2 Allowable Stress

The allowable stresses used to calculate the design margins within the containment boundary are given in Table 2-3. The allowable stresses were taken from Regulatory Guide 7.6 [2.3]. These are based on the 1977 edition of the ASME Boiler and Pressure Vessel Code [2.4]. This guide only gives allowable stress values for primary membrane stress, primary membrane plus primary bending stress and primary plus secondary stress for both NCT and HAC loading conditions. The allowable values for bearing stress and for the bolts have been taken from ASME Section III Div 3 [2.5] as these are not given in Reg. Guide 7.6 [2.3]. Guidance for classification of stresses was taken from Table WB-3217-1 in ASME Section III Div 3 [2.5].

To demonstrate conformance with the allowable stress limits, it was necessary to determine the stress intensities at critical cross-sections of the containment vessel. Since the critical cross-section locations are load-condition dependent, several “stress evaluation sections” were defined to ensure that all critical locations were evaluated for every load condition. These stress evaluation sections are illustrated in Figure 2-1. For evaluation of conditions producing a stress distribution in the vessel that is not axisymmetric, stress evaluations were performed at multiple circumferential locations.

The section stresses at each stress evaluation location were obtained using the Abaqus “stress linearization” post-processing feature (Arcadis Vectra Report L20008/1/R1 (Section 2.12.2). The stress linearization provides membrane, bending, membrane plus bending, and peak stress intensities at each section. In Abaqus, the Tresca stress is equal to the stress intensity as defined in Regulatory Guide 7.6 [2.3].

Using the critical sections from each load case, minimum design margins are calculated and reported for all bounding load combinations. The design margin (DM) is defined as follows:

$$DM = \left(\frac{\text{Allowable_Value}}{\text{Calculated_Value}} \right) - 1$$

Therefore a negative design margin indicates that there are areas of high stress.

Table 2-3 Containment System Allowable Design Criteria		
Stress Type	Allowable Stress Limits	
	NCT	HAC
Other Than Bolts		
Primary Membrane Stress Intensity (P_m)	S_m	Lesser of $2.4S_m$ and $0.7S_u$
Primary Local Membrane Stress Intensity (P_L)	$S_m^{(2)}$	N/A ⁽³⁾
Primary + Bending Stress Intensity (P_L or P_m+P_b)	$1.5S_m$	Lesser of $3.6S_m$ and S_u
Primary + Secondary Stress Intensity (P_L or P_m+Q)	$3.0S_m$	N/A
Average Bearing Stress	S_y	N/A
Bolts		
Average Shear Stress	$0.4S_y$	Lesser of $0.42S_u$ and $0.6S_y$
Average Stress ⁽⁴⁾	$2S_m$	Lesser of $3S_m$ and $0.7S_u$
Maximum Stress ⁽⁵⁾	$3S_m$	N/A ⁽⁶⁾

Notes:

1. Stress limits applicable for components and systems evaluated using elastic system analysis.
2. ASME B&PV code [2.5] gives an allowable of $1.5S_m$ for primary local membrane stress, P_L . However, Reg. Guide 7.6 [2.3] does not specify an allowable for this stress, so a lower allowable value of S_m has been adopted for this assessment.
3. Evaluation of secondary stress is not required for HAC.
4. The axial stress component averaged across the bolt cross-section and neglecting stress concentrations.
5. The stress due to internal pressure and gasket seating loads (e.g. bolt torque) shall not exceed one times S_m .
6. Evaluation of maximum bolt stress not required for HAC

2.1.2.3 Buckling

The containment vessel inner shell is evaluated for buckling in accordance with the requirements of ASME Code Case N-284-2 [2.6]. Capacity reduction factors are calculated in accordance with Section -1511 of ASME Code Case N-284-2 [2.6] to account for possible reductions in the capacity of the shells due to imperfections and nonlinearity in geometry and boundary conditions. Plasticity reduction factors, which account for nonlinear material properties when the product of the classical buckling stresses and capacity reduction factors exceed the proportional limit, are calculated in accordance with Section -1610 of ASME Code Case N-284-2 [2.6]. The theoretical buckling stresses of the vessel inner shell under uniform stress fields are calculated in accordance with Section -1712.1.1 of ASME Code Case N-284-2 [2.6]. The geometric parameters used in the buckling assessment are given in Table 2-4. The capacity reduction factors, plasticity reduction factors, and theoretical buckling stresses for the vessel inner shell are summarized in Table 2-4.

The allowable elastic and inelastic buckling stresses for NCT and HAC are calculated in accordance with the formulas given in Section -1713.1.1 and Section -1713.2.1 of ASME Code Case N-284-2 [2.6]. The allowable buckling stresses include factors of safety of 2.0 for NCT and 1.34 for HAC in accordance with Section -1400 of ASME Code Case N-284-2 [2.6]. Table 2-6 provides a summary of the vessel inner shell elastic and inelastic buckling stresses for NCT and HAC. Buckling interaction ratios are calculated for the containment vessel inner shell for all NCT and HAC tests that load the shells in compression. The interaction ratios for elastic buckling and inelastic buckling are calculated using the highest values of compressive stress and shear stress from the finite element analysis solutions in accordance with the formulas given in Section -1713.1.1 and Section -1713.2.1 of ASME Code Case N-284-2 [2.6].

Table 2-4 Containment vessel shell buckling geometric parameters	
Geometric Parameter	Inner Shell
Mean radius, R (mm)	35.25 mm
Shell thickness, t (mm)	4.7 mm
R/t	7.5
Unsupported axial length, l_{ϕ} (mm)	152.4 mm
Unsupported circumferential length, l_{θ} (mm)	236.3 mm

Calculation	Parameter	Hot ambient temperature (NCT) (200°C)	Cold ambient temperature (-29°C)
Capacity reduction factors (-1511)	$\alpha_{\phi L}$	0.2	0.2
	$\alpha_{\theta L}$	0.8	0.8
	$\alpha_{\phi\theta L}$	0.8	0.8
Plasticity reduction factors (-1610)	η_{ϕ}	0	0.0
	η_{θ}	0.1	0.1
	$\eta_{\phi\theta}$	0.0	0.0
Theoretical buckling values (-1712.1.1)	$\sigma_{\phi eL}$	14762 MPa	15972 MPa
	$\sigma_{\theta eL} = \sigma_{reL}$	2162 MPa	2339 MPa
	$\sigma_{\theta eL} = \sigma_{heL}$	2056 MPa	2056 MPa
	$\sigma_{\phi\theta eL}$	5421 MPa	5866 MPa

Buckling Regime	Stress Type	Allowable Buckling Stress (MPa)			
		Hot ambient temp.		Cold ambient temp.	
		NCT	HAC	NCT	HAC
Elastic Buckling	Axial Compression, σ_{xa}	1528	2218	1818	1818
	Hydrostatic Pressure, σ_{ha}	823	1194	890	890
	Hoop Compression, σ_{ra}	865	1256	936	936
	In-plane shear, $\sigma_{\tau a}$	2169	3148	2346	2346
Inelastic Buckling	Axial Compression, σ_{xc}	60.0	84.3	86.0	86.0
	Radial external pressure, σ_{rc}	60.0	84.3	86.0	86.0
	In-plane shear, $\sigma_{\tau c}$	36.0	50.6	51.6	51.6

2.1.2.4 Fatigue

The fatigue analysis was carried out in accordance with section C3 in NRC Regulatory Guide 7.6 [2.3]. The fatigue analysis was performed as follows:

1. The alternating stress, S_{alt} , was calculated as one-half the maximum absolute value of S'_{12} , S'_{23} , S'_{31} for all possible stress states i and j where σ_1 , σ_2 , σ_3 are principal stresses and

$$S'_{12} = (\sigma_{1i} - \sigma_{1j}) - (\sigma_{2i} - \sigma_{2j})$$

$$S'_{23} = (\sigma_{2i} - \sigma_{2j}) - (\sigma_{3i} - \sigma_{3j})$$

$$S'_{31} = (\sigma_{3i} - \sigma_{3j}) - (\sigma_{1i} - \sigma_{1j})$$

State i is after the bolt pre-load has been applied and state j is after all the other loads have been applied. This calculation of S_{alt} is carried out in the post processor.

2. S_{alt} is multiplied by the ratio of the modulus of elasticity given on the design fatigue curve to the modulus of elasticity used in the analysis to obtain a value of stress to be used with the design fatigue curves.
3. The highest value of S_{alt} determined in step 2 is then compared with the design fatigue curves (Figure I-9.2.2) in appendix I of ASME B&PV Section III [2.5].

The number of cycles that the Safkeg HS CV will undergo is approximately 50 cycles/year for 20 years = 1000 cycles. The number of cycles was multiplied by 10 to give 10000 cycles, to give a safety margin.

2.1.2.5 Brittle Fracture

All the structural components of the package are fabricated from austenitic stainless steel which is ductile at low temperatures. According to Regulatory Guide 7.11 [2.7] austenitic stainless steel is not susceptible to brittle fracture at temperatures encountered in transport.

The HAC drop tests have been conducted at -40°C to determine if brittle fracture has any effect on the package, with compliance demonstrated if the containment vessel is undamaged and leak tight on completion of testing.

2.1.3 Weights and Centers of Gravity [71.33]

The nominal weight of the package plus the individual components and the maximum content weights are shown in Table 2-7. The maximum package gross weight is 163 kg. The center of gravity of the assembled package is approximately in the center of the 3977A keg.

The weights of the components in Table 2-7 are calculated maximum weights at extreme tolerance to give maximum material condition with rounding.

Table 2-7 Weights of SAFKEG 3977A		
Components	Maximum Weight Allowing for Manufacturing Tolerances	
	Kg	lbs
Keg Body, Lid, Liner, Outer Cork, Nuts & Washers	40.56	89.42
Cork Packing	2.25	4.96
Keg plus inner and top corks	42.81	94.4
Containment vessel	109.55	241.52
HS SAFKEG 3977A excluding contents	152.4	336
Insert Plus Contents (max)	9.8	21.6
HS SAFKEG 3977A including contents	163 ¹	360

2.1.4 Identification of Codes and Standards for Package Design

The package has been designed to transport normal and special form material in quantities of greater than 3000A₂, therefore it is classified as a Category I package, as defined in Regulatory Guide 7.11 [2.7]. The standards to which the package has been designed, fabricated, tested and maintained have been selected based on the guidance provided in Regulatory Guide 7.6 [2.3] and NUREG/CR-3854 [2.8].

The package containment system was designed in accordance with the applicable requirements of the AMSE Code, Section III subsection NB [2.9]. The non-containment structural components of the package were designed in accordance with the applicable requirements of ASME Code section III, subsection NF for plate and shell type Class 2 supports [2.10].

The design criteria used to assess the containment boundary have been taken from Regulatory Guide 7.6 and the load combinations have been taken from Regulatory Guide 7.8 as discussed in section 2.1.2.1. The buckling evaluation of the containment vessel inner shell is evaluated in accordance with the requirements of ASME code case N-284-2 as discussed in section 2.1.2.3.

Table 2-8 identifies the major components of the HS package and identifies if they provide containment or fulfill the other safety functions such as gamma shielding or support. The drawings in section 1.3 identify whether the items are important to Safety (ITS), the identification was carried out using the guidance of NUREG/CR-6407. Table 2-8 also

¹ Rounded up to next whole number

provides the applicable sections of the ASME code used to purchase materials, fabricate the package, inspect and examine the package. Table 2-9 lists if alternative specifications have been used to the ASME code.

The package containment system is fabricated in accordance with the applicable sections of Section III, Subsection NB of the ASME code as shown in Table 2-8. There are no welds in the containment boundary so there are no requirements listed. The other safety items shown in Table 2-8 have been fabricated in accordance with the applicable requirements of Section III Subsection NF for Class 2 supports in the ASME code

The depleted uranium and the cork impact limiters are specialist materials for which an ASTM standard does not exist. The depleted uranium is fabricated and tested in accordance with standard industry practices. Chemical composition checks and fracture toughness tests are carried out on the DU batch used for the shielding prior to machining, to ensure it satisfies the shielding requirements. A density check of the depleted uranium is carried out after machining to ensure there are no cracks or voids.

The cork is fabricated in accordance with the vendor's standard practices and tested to the requirements of drawing 0C-5943.

Table 2-8 Applicable Codes and Standards for the Manufacture of the 3977A Package						
	Component Safety Group					
	Containment		Other Safety			
Components	CV cavity wall/flange, CV Lid Top, Bolts	CV O-ring	CV DU	CV outer shell	Keg outer shell, keg skirts, keg lid, keg closure nuts	Cork
Function	Containment Boundary	Containment seal	Gamma Shielding	Positioning and support of Lead shielding	Secondary shell and closure	Impact limiters
Design Criteria	AMSE section III, Division 1, subsection NB-3000		AMSE section III, Division 1, subsection NF-3000			Section 2 of this SARP
Materials	NB-2000	Section 2 of this SARP	Section 2 of this SARP	NF-2000	NF-2000	Section 2 of this SARP
Forming, fitting and aligning	Not Applicable	Not Applicable	Not Applicable	NF-4200	NF-4200	Not Applicable
Welding	Not Applicable	Not Applicable	Not Applicable	NF-4400	NF-4400	Not Applicable
Qualification of weld procedure and personnel				NF-4300	NF-4300	

Table 2-8 Applicable Codes and Standards for the Manufacture of the 3977A Package						
	Component Safety Group					
	Containment		Other Safety			
Components	CV cavity wall/flange, CV Lid Top, Bolts	CV O-ring	CV DU	CV outer shell	Keg outer shell, keg skirts, keg lid, keg closure nuts	Cork
Examination of welds				NF-5000	NF-5000	
Acceptance Testing	NB-6000	Section 8 of this SARP and ANSI N14.5	Section 8 of this SARP	Section 8 of this SARP	Section 8 of this SARP	Section 8 of this SARP

Table 2-9 - Alternative Requirements to the ASME Code Requirements			
Component	Code Section	Code Requirement	Alternative Code Used and Justification
CV cavity wall/flange, CV Lid Top, Bolts	NB-2000	Metallic Materials shall be manufactured to an SA, SB of SFA specification.	NUREG/CR-3854 allows ASTM materials to be used. This SARP demonstrates equivalence between the materials.
	NB-2000	Requires materials to be supplied by ASME approved material supplier.	Croft approved suppliers will supply materials with certificates containing at the least information about:

Table 2-9 - Alternative Requirements to the ASME Code Requirements

Component	Code Section	Code Requirement	Alternative Code Used and Justification
			Heat number Material specification and grade Chemical analysis Mechanical properties including tensile strength and yield strength/proof stress
CV outer shell	NF-2000	Metallic Materials shall be manufactured to an SA, SB of SFA specification.	NUREG/CR-3854 allows ASTM materials to be used. This SARP demonstrates equivalence between the materials.
	NF-2000	Requires materials to be supplied by ASME approved material supplier.	Croft approved suppliers will supply materials with certificates containing at the least information about: Heat number Material specification and grade Chemical analysis Mechanical properties including tensile strength and yield strength/proof stress
	NF-5350	Liquid penetrant acceptance standards	NB-5350 has been used to accept the liquid penetrate tests. As allowed by NUREG 3019

Table 2-9 - Alternative Requirements to the ASME Code Requirements			
Component	Code Section	Code Requirement	Alternative Code Used and Justification
			[2.14] welding criteria can be upgraded by Category.
Keg outer shell, keg skirts, keg lid, keg closure nuts	NF-2000	Metallic Materials shall be manufactured to an SA, SB of SFA specification.	NUREG/CR-3854 allows ASTM materials to be used. This SARP demonstrates equivalence between the materials.
	NF-2000	Requires materials to be supplied by ASME approved material supplier.	Croft approved suppliers will supply materials with certificates containing at the least information about: Heat number Material specification and grade Chemical analysis Mechanical properties including tensile strength and yield strength/proof stress
	NF-5350	Liquid penetrant acceptance standards	NB-5350 has been used to accept the liquid penetrate tests. As allowed by NUREG 3019 [2.14] welding criteria can be upgraded by Category.

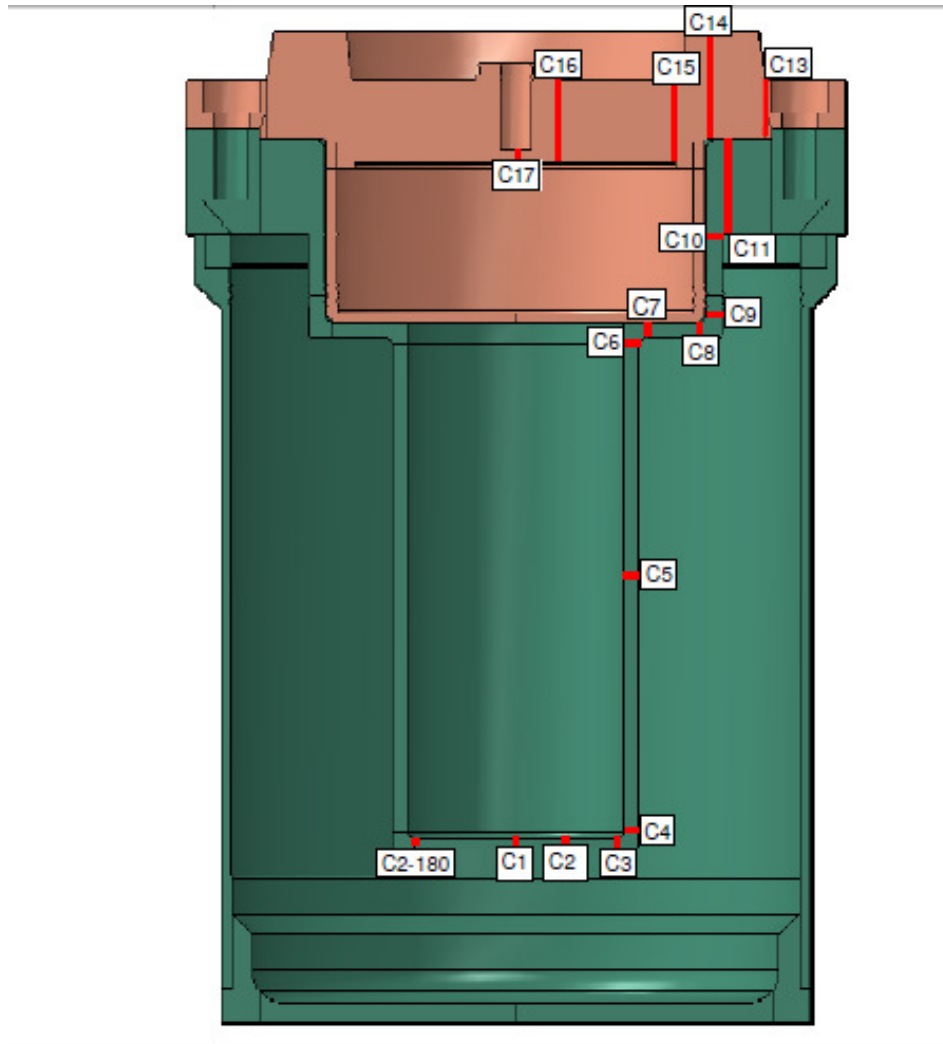

Figure 2-1 Stress Evaluation Locations

2.2 Materials

2.2.1 Material Properties and Specifications

The materials used in the construction of the package are listed in Table 2-10. The mechanical properties of the materials used in the structural evaluation of the containment vessel are presented in Sections 2.2.1.1 to 2.2.1.3.

Table 2-10 Packaging Material Specifications	
Packaging Component	Material
Keg 3977	
Top and bottom rim	Stainless Steel ASTM A554 Type MT304
Top and bottom skirt	Stainless steel ASTM A240/A240M Type 304L
Keg outer shell	Stainless steel ASTM A240/A240M Type 304L
Keg top flange	Stainless Steel ASTM A240/A240M Type 304L
Keg base plate	Stainless Steel ASTM A240/A240M Type 304L
Outer cork	Agglomerated Cork
Keg liner	Stainless Steel ASTM A240/A240M Type 304L
Keg liner disc	Stainless Steel ASTM A240/A240M Type 304L
Keg lid	Stainless Steel ASTM A240/A240M Type 304L
Keg lid handle	Stainless Steel ASTM A240/A240M Type 304L
Keg lid seal	Nitrile 70 ± 10 IRHD
Keg closure stud	Stainless Steel ASTM A479/A479M 304L
Keg closure nut	Stainless Steel A2-70
Keg closure washers	Stainless Steel A2
Lock pin	Stainless Steel ASTM A479/A479M Type 304L
Fuse plug	Stainless steel A2
Fuse plug alloy	Low melting point alloy with melting point of 95±5°C
Inner Cork Packing	
Cork body and lid	Agglomerated Cork
Containment Vessel 3978	
Flange/cavity wall	Stainless Steel ASTM A479/A479M Type 304L
Outer wall	Stainless steel ASTM A511/A511M Type MT304L
Body shielding	Depleted Uranium alloyed with 2% Molybdenum by weight
Base	Stainless Steel ASTM A479/A479M 304L

Table 2-10 Packaging Material Specifications	
Packaging Component	Material
Lid shielding casing	Stainless Steel ASTM A479/A479M 304L
Lid shielding	Depleted Uranium alloyed with 2% Molybdenum by weight
Lid Top	Stainless Steel ASTM A479/A479M 304L
Test point plug	Stainless Steel
Containment seal	Ethylene Propylene Rubber (EP) ASTM D2000 M3 BA 810 A14 B13 F17 Z1 where Z1 stands for hardness of 75±5 IRHD (or Shore A)
Test seal	Ethylene Propylene Rubber (EP) ASTM D2000 M3 BA 810 A14 B13 F17 Z1 where Z1 stands for hardness of 75±5 IRHD (or Shore A)
Test point seal	Ethylene Propylene Rubber (EP)
Closure screws	Alloy steel ASTM A320/A320M Type L43
Jacking screw	Steel
12x95 Tu Insert	ASTM B777 Class 3 Tungsten Alloy
31x114 Tu Insert	ASTM B777 Class 3 Tungsten Alloy
55x138 SS Insert	Stainless Steel
55x138 SS Insert liner	PTFE

2.2.1.1 Structural Materials

The containment vessel is fabricated entirely from stainless steel. The structural members in the main are fabricated from Type 304L stainless steel in either plate or bar form. The only exception is the containment vessel bolts which are fabricated from a high strength grade L43 alloy bolting steel material. All the insulating and shock absorbing material is fabricated from resin bonded cork.

The structural evaluation of the containment vessel was assessed under NCT using a temperature range of – 40°C to 158°C. In order to carry out the stress analysis a Poisson ratio of 0.3 and a density of 8030 kg/m³ were used for the stainless steel 304L components. A Poisson ratio of 0.3 and a density of 7860 kg/m³ were taken for Grade L43 bolting steel.

The mechanical properties used in the structural analysis are taken from the ASME Section II Part D [2.16]. Table 2-11 provides the mechanical properties of stainless steel 304L, which makes up the majority of the structural component materials, over a range of temperatures. Table 2-12 summarizes the mechanical information for SA-320/A320 Grade L43 Bolting Steel which is used for the bolts in the containment vessel.

2.2.1.2 Shielding Material

The shielding is formed from depleted uranium alloyed with $2\pm 2\%$ Molybdenum and 0.2% Carbon maximum by weight. The depleted uranium is alloyed with 2% Molybdenum to provide greater yield strength and improves ductility. The mechanical properties of the depleted uranium used in the structural evaluation are presented in Table 2-13.

2.2.1.3 Cork Packing

The inner and outer cork is machined from resin bonded cork. The cork may be formed from one piece or from several pieces glued with a contact adhesive.

The mechanical properties of the cork have been determined by testing. Loads were applied by a piston at a rate of 4.5 mm/minute to 45 mm thick radially constrained cork samples. The displacement of the cork was then recorded continuously at a rate of 20 readings/second. In order to cover the full range of service temperatures tests were carried out with corks at -29°C , 20°C and 100°C . The test details and results are discussed in the Serco Report SERCO/TAS/002762/01 [Section 2.12.2].

Table 2.14 presents the mechanical properties of the cork determined from testing. The test results show that cork is harder at low temperatures and softer at high temperatures. At an applied stress of 8 MPa, the cork at 100°C showed most deformation: which would indicate the containment vessel will travel a further distance into the cork before it is resisted by the same forces it would be resisted with at room temperature.

2.2.2 Chemical, Galvanic or Other Reactions [71.43(d)]

The package has been evaluated to determine all the material interactions of chemically or galvanic dissimilar materials. These interactions are identified in Table 2-15.

There is no potential for chemical, galvanic or other reactions between the components of the package which are stainless steel and cork in dry conditions, and stainless steel and encapsulated depleted uranium which is sealed and therefore dry. Eutectic formation shall not affect the package performance as the operating temperatures are lower than the eutectic formation temperature. The only contents which could cause reactions or generate gases are liquids carried in product containers within the tungsten or steel inserts which are fitted with an EP O-ring seal. Under NCT and HAC, the liquids are contained within the product containers and inserts and therefore no liquid comes into contact with the containment system. If the liquid contents would react with the stainless steel of the insert a PTFE liner is fitted inside the stainless steel insert, this insert has been shown to completely contain the liquid contents even under HAC conditions.

2.2.3 Effects of Radiation on Materials

The contents of the package emit one or all of alpha, beta, gamma and neutron radiation. Austenitic stainless steel, depleted uranium and cork were chosen for the construction of the package because they are durable materials that are able to withstand the damaging effects from the radiation.

The EP O-ring seals fitted to the containment system are the only material on which the radiation may have an effect; however it has been shown in Section 4.1 that for the radioactive contents limited according to Section 1.2.2, the maximum dose to the containment seal is $\ll 10^4$ Gy (10^6 rad) whereas no change of physical properties of the EP containment seal is expected at radiation levels up to 10^4 Gy (10^6 rad). These seals are required to be replaced annually at maintenance (Section 8.2).

Table 2-11 Material Properties for Grade 304L Stainless Steel									
Stainless Steel ASTM A240/A240m and ASTM A479/A479m Grade 304L Material Properties				Values at Different Temperatures					
				-40°C	20°C	149°C	204°C	232°C	260°C
				-40°F	68°F	300°F	400°F	450°F	500°F
				a	b	c	d	e	d
Design Stress Intensity	S _m	MN/m ²	f	115.1	115.1	115.1	108.9	105.4	102.0
		ksi	g	16.7	16.7	16.7	15.8	15.3	14.8
Yield Strength	S _y	MN/m ²	f	172.3	172.3	132.4	120.7	116.5	113.1
		ksi	h	25.0	25.0	19.2	17.5	16.9	16.4
Tensile Strength	S _u	MN/m ²	f	483	483	422	405	401	396
		ksi	i	70	70	61.2	58.7	58.1	57.5
Coefficient of Thermal Expansion (Mean)	a _m	10 ⁻⁶ m/m °C	f	14.7	15.3	16.6	17.1	17.3	17.5
		10 ⁻⁶ in/in °F	j	8.2	8.5	9.2	9.5	9.6	9.7
Thermal Conductivity	k	W/m K	f	13.9	14.9	17.0	18.0	18.5	18.9
		BTU/h ft °F	k	8.0	8.6	9.8	10.4	10.7	10.9
Modulus of Elasticity	E	GN/m ²	f	198.4	195.0	186.0	182.6	180.2	177.8
		Mpsi	l	28.8	28.3	27	26.5	26.2	25.8
Fatigue Strength @ 10 ⁶ and 10 ⁴ cycles	S _a	MN/m ²	f	195.1 and 441					
		ksi	m	28.3 and 64					

Some values are extrapolated or interpolated

- a -40°F is the lowest temperature to be considered for packaging. Data at 40°F is extrapolated where not given specifically in the ASME code. Note that the packaging is required to remain leak tight at 40°F under no loading; however, the specified structural loadings need not be considered below -20°F.
- b These data are used for calculations at normal ambient temperature
- c The temperature for this data is close to the maximum NCT temperature
- d These data are used to calculate the data at the maximum HAC
- e This data is interpolated from 400°F and 500°F
- f Calculated from the data in imperial units
- g ASME Section II (2001), Part D, Subpart 2 [2.16], Table 2A (pages 312-315)
- h ASME Section II (2001), Part D, Subpart 2 [2.16], Table Y-1 (pages 552-555)
- i ASME Section II (2001), Part D, Subpart 2 [2.16], Table U (pages 450-451)
- k ASME Section II (2001), Part D, Subpart 2 [2.16], Table TE-1 18 Cr-8 Ni (page 651 Group 3)
- l ASME Section II (2001), Part D, Subpart 2 [2.16], Table TM-1 Material Group G - Austenitic steels (page 671)
- m ASME Section III (2001), Appendix I [2.9], Table I-9.1 Line I-9.2.1 (page 4)

Table 2-12 Mechanical Properties of SA-320/A320 Grade L43 Bolting Steel											
Properties				Values at Different Temperatures							
				-40°C	-30°C	25°C	40°C	65°C	100°C	120°C	150°C
				-40°F	-22	77	104	149	212	248	302
a											
Design Stress Intensity	S _m	MN/m ²	1	241	241	241	241	235	226	224	220
		ksi		34.95	34.95	34.95	34.95	34.1	32.8	32.5	31.9
Yield Strength	S _y	MN/m ²	2	723	723	723	723	704	678	671	660
		ksi		104.9	104.9	104.9	104.9	102.1	98.3	97.3	95.7
Tensile Strength	S _u	MN/m ²	3	860	860	860	860	860	860	860	860
		ksi		124.7	124.7	124.7	124.7	124.7	124.7	124.7	124.7
Coefficient of Thermal Expansion (Mean)	a _m	10 ⁻⁶ m/m °C	4	10.9	11.0	11.6	11.7	11.9	12.1	12.2	12.2
		10 ⁻⁶ in/in °F		6.06	6.1	6.4	6.5	6.6	6.7	6.8	6.8
Modulus of Elasticity	E	GN/m ²	5	195	194	191	190	189	187	186	184
		Mpsi		28.3	28.1	27.7	27.6	27.4	27.1	27.0	26.7

- 1 ASME Code, Section II, Part D, Table 4 [2.16]
- 2 In accordance with ASME code, Section II, Part D, Table 4 [2.16] general note (A), the yield strength is equal to 3 times the allowable stress value S_m
- 3 Minimum tensile strength from ASME code, Section II part D, table 4 [2.16]
- 4 ASME Code Section II, Part D, Table TM-1, Material Group G [2.16]
- 5 ASME Code Section II, Part D, Table TE-1, Group 1, Coefficient B (mean from 70°F) [2.16]
- 6 Values in italics are calculated using linear interpolation or linear extrapolation.

Table 2-13 Mechanical Properties of Depleted Uranium				
Temperature	Density (kg/m ³)	Modulus of Elasticity (GPa)	Poisson's Ratio	Mean Coef. of Thermal Expansion (m/m/°C x 10 ⁻⁶)
-40	18952	172	0.3	11.5
-29				11.7
21				12.7
38				13.0
93				14.1

Table 2.14 Average compressive Modulus of Elasticity and Compressive Strength at 10% Relative Deformation for Cork at each Test Temperature

Test Temperature (°C)	Compressive Modulus of Elasticity E (MPa)	Compressive Strength at 10% relative deformation (MPa)
- 29	23.4	1.60
20	15.0	0.57
100	4.6	0.34

Table 2-15 Summary of Material Interactions

	Contents	Stainless Steel Insert	Tungsten shielding insert	Stainless steel	EP O-rings	O-ring lubricant	Depleted Uranium	Cork	Cork sealant	Fuse plug alloy	Nitrile lid seal	Thread lubricant
Contents		NH	NH	H	H	H						
Stainless steel Insert				NH								
Tungsten shielding insert				NH								
Stainless steel					NH	NH	NH	H	NH	NH	NH	NH
EP O-rings						NH						
O-ring lubricant												
Depleted Uranium												
Cork									NH	H		
Cork sealant										NH		NH
Fuse plug alloy												NH
Nitrile lid seal												

N = NCT, H = HAC

2.3 Fabrication and Examination

2.3.1 Fabrication

All work performed in the fabrication of the 3977A is required to be carried out under an NRC approved quality assurance program. The containment system shall be fabricated in accordance with the applicable sections of Division III Subsection NB [2.9] as shown in Table 2-8.

The other safety items are fabricated in accordance with the applicable sections of Section III subsection NF of the ASME code for plate and shell Type class 2 supports [2.10]. These

components are the keg and the outer shell of the containment vessel. All welding procedures and personnel shall be qualified in accordance with AMSE section IX. Welding consumables their supply, certification, control during storage and use, shall comply with the appropriate requirements of ASME III, Division 1 subsection NF 2400. The keg shall be fabricated in accordance with drawing 0C-6042. All welding procedures and personnel shall be qualified in accordance with AMSE section IX.

The Depleted Uranium used shall be alloyed with $2\pm 0.2\%$ Molybdenum and 0.2% carbon maximum by weight as specified in the drawings 1C-5945 and 1C-5946. It shall be fabricated using standard industry practices. The cork shall be tested to demonstrate it meets the required specification in drawing 0C-6043 and marked with a unique identification number which will match it to the corresponding keg.

Any consumables used during manufacture such as thread inserts and O-rings shall be procured from commercial suppliers that are approved to a level commensurate with the safety functions of the consumable purchased.

2.3.2 Examination

All examinations shall be carried out under the scope of an NRC approved quality assurance program. Examinations shall be carried out on materials, components and finished assemblies throughout the manufacturing process. These tests will assure that the manufactured article meets the critical characteristics to allow the safe transport of radioactive material. All tests shall be carried out to approved procedures, with calibrated equipment. The records of the tests will be maintained with the manufacturing records for each package.

The examinations required during manufacture are described below:

Material Tests

Material examinations, from a sample of the stock material, used to fabricate the containment vessel lid top and the flange/cavity are required. These integrity tests will be an Ultrasonic straight beam test to ASME III Division 1 NB 2542 [2.9] and a liquid penetrant test to ASME III Division 1 subsection NB 2546 [2.9].

Sample O-rings shall be tested to ensure they perform satisfactory at the temperatures reached during NCT and HAC conditions. Inner and outer O-rings from each batch will be leak tested after maintaining an operating temperature of 150°C for 1000 hours. Inner and outer O-rings will also be leak tested after maintaining an operating temperature of 200°C for 24 hours.

A specimen of the depleted uranium used as the shield is required to be tested to assure that it meets the required chemical composition, density and Charpy V notch impact energy as defined in drawings 1C-5945 and 1C-5946.

For the cork the supplier is required to provide a Certificate of Conformance to confirm that the properties listed in drawing 0C-5943 are met.

Fabrication Tests and Examinations

Once the containment vessel lid and flange are machined, a helium leak test is required to be carried out in accordance with ANSI N14.5 [2.13]. This leak test is required to demonstrate that the leak rate of the machined items is less than or equal to 1×10^{-7} ref-cm³/s. No additional examinations are required for items which are not primary containment items.

All welds are subjected to non destructive visual and liquid penetrant examination in accordance with ASME section V [2.17]. The applicable acceptance criteria for the visual examinations are given in drawings 1C-6045 and 1C-6046. The acceptance standards for the liquid penetrant examination of the welds is in accordance with AMSE Section III Division 1 sub section NB 5350 of the ASME code.

All components and assemblies are required to be visually inspected and the dimensions measured using calibrated equipment to assure compliance with the dimensions shown on the general arrangement drawings. The weight of the finished containment vessel and fully assembled package are required to be measured to ensure the weight requirements are met.

Acceptance Tests

The completed containment vessels are required to be pressure tested to a maximum pressure of 12.5 barg which meets both the requirement of 10 CFR 71.85 (b) and ASME Section III sub section NB 6000 [2.9].

On completion of manufacture the containment vessel closures are required to be leak tested in accordance with ANSI 14.5 [2.13] to demonstrate the leak rate is less than or equal to 1×10^{-7} ref-cm³/s.

2.4 General Requirements for All Packages [71.43]

2.4.1 Minimum Package Size [71.43 (a)]

10 CFR 71.43(a) states: "The smallest overall dimension of a package may not be less than 10 cm (4 in)." The Keg 3977 has an outer diameter of 424 mm (16.69 in.) and a length of 585 mm (23 in.). Therefore, the smallest overall dimension of the package is not less than 10 cm (4 in), as required in 10 CFR 71.

2.4.2 Tamper Indicating Feature [71.43 (b)]

10 CFR 71.43(b) states: "The outside of a package must incorporate a feature, such as a seal, that is not readily breakable and that, while intact, would be evidence that the package has not been opened by unauthorized persons."

The tamper-proof feature of Keg 3977 is the hole provided in each closure stud which enables a wire security seal to be fitted through the studs. In addition, the keg closure is provided with a lock pin that may be fitted with a padlock. Therefore, the package can be fitted with a tamper indicating seal to provide indication that the package has not been opened.

2.4.3 Positive Closure [71.43 (c)]

10 CFR 71.43(c) states: "Each package must include a containment system securely closed by a positive fastening device that cannot be opened unintentionally or by a pressure that may arise within the package." The lid of the containment vessel is held in place using 8 screws which are screwed into the CV flange. The CV closure screws are tightened or released using appropriate tools to the torque prescribed in the operating requirements (Section 7.1). The keg lid is attached by permanently fitted studs and secured by nuts (see Figure 1-1a). Therefore, the package cannot be inadvertently opened.

The package cannot be opened unintentionally by any pressure that may arise within the package. The information presented in Section 2.6.3 shows that the containment vessels remain closed under the design pressure (which bounds the maximum internal pressure that can be generated). The keg lid will remain in place under any pressure that may arise within the package. This has been demonstrated by the thermal test reported in Section 2.7.4.

2.5 Lifting and Tie-Down Standards for All Packages

2.5.1 Lifting Devices [71.45 (a)]

The package itself has no structural devices designed for lifting the package therefore it is anticipated that the package will be man handled into position and lifted on a truck tail lift or lifted using a fork lift truck with drum clamps fitted. These methods of handling do not stress the structure of the package.

2.5.2 Tie-Down Devices [71.45 (b)]

The SAFKEG has no specifically designed tie-down devices. The normal method of securing the package during transport is expected to be by the use of dunnage, cargo nets or an equivalent system that envelope the package without being attached to it: such a system cannot stress the structure of the package. The package may be secured in either the horizontal or vertical position. Testing of both package positions during the steady state thermal test as described in CTR 2010/02 has demonstrated that either position is safe.

2.6 Normal Conditions of Transport

2.6.1 Heat [71.71 (c)(1)]

According to 10CFR 71.71 (c) (1), the package must be evaluated in an ambient temperature of 38°C, in still air and insolation. Under these conditions the maximum temperature and pressure generated have been calculated and discussed in Section 2.6.1.1. These temperatures

and pressures have then been used to determine the differential thermal expansion in Section 2.6.1.2 and therefore the stresses present in the containment vessel. The calculated stresses are then used to determine if the containment vessel meets the structural design criteria.

2.6.1.1 Summary of Pressures and Temperatures

The calculated maximum temperatures in the containment vessel and keg with maximum heat load of 30W under NCT are shown in Section 3, Table 3-2. The maximum temperature for the containment vessel is 163.2°C. The stress calculations were carried out assuming a temperature of 158°C. The temperatures are divergent by 5°C, which would not cause the results of the test to be any different from those presented here.

The upper pressure experienced by the containment vessel is assumed to be 700 kPa gauge pressure. This value has been used in the structural evaluation.

A calculation of the actual maximum pressure expected under NCT is provided in Calculation Sheet CS 2012/02 (Section 2.12.2) – the calculated maximum pressure is 1.80 bar abs (180 kPa).

The heat load for liquid contents is limited to 5W for which the calculated maximum temperature of the CV under NCT is 78.1°C (Section 3.1.3, Table 3-1). There is therefore no pressure increase due to the vapour pressure of the liquid contents (the liquid contents are aqueous with a boiling point of 100°C).

2.6.1.2 Differential Thermal Expansion

The finite element analysis model investigated the deformations caused within the containment vessel as a result of the differing expansion rates of the depleted uranium shielding and the stainless steel cladding. The results of the analysis included the effect of differential thermal expansion in both the radial and longitudinal directions. The results of analysis indicate that the base of the body was distorted due to the thermal expansion of the lead being greater than that of steel. The expansion of the lead also caused the internal web of the lid to bend upwards.

The 3977 keg is designed to have a 2.5 mm clearance between the cork and containment vessel and another 7 mm clearance between the cork and the keg lid. As the cork is free standing within the keg liner this allows movement of the top cork of up to 7 mm and hence expansion of the containment vessel of 9.5 mm. There was no significant expansion of the vessel therefore it will not impact the structural integrity of the package.

The model has assumed no gap is present between the depleted uranium and the stainless steel and determined the stresses within the containment vessel boundary caused as a result of the differing thermal expansion rates. The results of the stress calculations are discussed in section 2.6.1.3.

2.6.1.3 Stress Calculations

In order to determine the effect of heat on the containment vessel a finite element analysis was carried out as documented in the Arcadis Vectra Report No L20008/1/R1 (Section 2.12.2). The model was applied with a uniform temperature of 158°C across the containment vessel and an internal gauge pressure of 700 kPa.

Stresses within the containment vessel boundary were calculated at the points shown in Figure 2-1. From these calculations the maximum stress intensities were determined and presented in Table 2-16. The stresses in the bolts were calculated and are presented in Table 2-17.

A buckling evaluation was also carried out using the FEA model, as described in the Arcadis Vectra report No L20008/1/R1. The results of the calculation are presented in Table 2-18. The stresses used for the calculations were taken from point C5 in Figure 2-1, which is mid-way along the length of the inner shell of the containment vessel. Where one of the components was tensile in the finite element analysis it should be given a value of 0 Pa however in order to avoid zero errors it was given a very small positive value in the buckling calculation.

In order to determine the effect of repeated cycles of thermal loading on the containment vessel, fatigue calculations have been carried out in accordance with Section 2.1.2.4 and are detailed in the Arcadis Vectra Report L20008/1/R1 (Section 2.12.2). The values calculated are given in Table 2-19.

2.6.1.4 Comparison with Allowable Stress

The maximum stresses calculated were compared against the allowable stresses and the design margin calculated as detailed in Section 2.1.2.2. All the design margins are greater than the design criteria of 0 as shown in Table 2-16, therefore, the containment vessel satisfies the requirements of Regulatory Guide 7.6 [2.3]. The lowest design margin calculated is 0.04 which is due to the bearing stress under the bolts.

The stresses calculated in the bolts have been compared against the allowable stresses and the design margin has been calculated as described in Section 2.1.2.2. All the design margins are greater than 0 as shown in Table 2-17. Therefore the containment vessel bolts satisfy the requirements of Regulatory Guide 7.6 [2.3].

The buckling stresses were compared against the allowable stresses as detailed in Section 2.1.2.3. As all of the stress components were tensile in this case, the design margin is effectively infinite, hence the containment vessel satisfies the requirements of Regulatory Guide 7.6 [2.3] for buckling as shown in Table 2-18.

The fatigue evaluation is given in Table 2-19. As the value of the maximum alternating stress in the containment vessel was below the fatigue threshold, the design margin is

effectively infinite. Hence the containment vessel satisfies the requirements of Regulatory Guide 7.6 [2.3] for fatigue.

Table 2-16 Containment Vessel Stress Summary under Heat Conditions						
NCT Case ID	Description	Stress Type	Maximum Stress Intensity (MPa)	Stress Location	Allowable stress intensity (MPa)	Minimum Design Margin
1	Heat	P _m	14.9	C6b	109	6.30
		P _m +P _b	44.7	C1	163	2.65
		P _m +P _b +Q	38.3	C3	327	7.54
		Bearing	116	Under bolts	121	0.04

Table 2-17 Containment Vessel Bolts Stress Analysis under Heat Conditions					
NCT Case ID	Description	Stress Type	Maximum stress (MPa)	Allowable stress intensity (MPa)	Minimum design margin
1	Heat	Average Shear	2.09	244	115
		Average Stress	163	406	1.49
		Max Stress	175	609	2.47

Table 2-18 Containment Vessel Buckling Calculations Under Heat Conditions					
NCT Case ID	Description	Stress (MPa)			Design Margin
		Axial Compression	Hoop Compression	In-plane shear	
1	Heat	0	0	0.0	n/a

Table 2-19 Containment Vessel Fatigue Evaluation under Heat Conditions			
Maximum alternating stress	Required No of cycles	Cycles to failure	Design Margin
44.72	10000	> 10 ¹¹	n/a

2.6.2 Cold [71.71 (c) (2)]

10CFR 71.71 (c) (2) requires that the package performance is evaluated at an ambient temperature of -40°C in still air and with no insolation. This should be considered along with no internal heat load and the minimum internal pressure.

As discussed in Section 3, at -40°C ambient temperature the package has a minimum internal pressure of 0 kPa absolute and it is assumed the entire package temperature is -40°C . The stresses were calculated in the containment vessel using the FEA analysis described in the Vectra Report L20008/1/R1 (Section 2.12.2). It was assumed that the external pressure was 100 kPa and the internal pressure was 0 kPa absolute, so the internal gauge pressure applied to the model was -100 kPa.

The effect of temperature on the components of the containment vessel was determined with the model, as described in the Vectra Report L20008/1/R1 (Section 2.12.2). Stresses within the containment vessel boundary were calculated at the points shown in Figure 2-1. From these calculations the maximum stress intensities were determined and presented in Table 2-20. The maximum stresses calculated were compared with the allowable stresses and the design margin calculated as detailed in Section 2.1.2.2. All the design margins are greater than 0 as shown in Table 2-20 therefore the containment vessel satisfies the requirements of Regulatory Guide 7.6 [2.3].

The stresses in the bolts were calculated and are presented in Table 2-21. These stresses have been compared against the allowable stresses and the design margin has been calculated as described in Section 2.1.2.2. All the design margins are greater than 0 as shown in Table 2-21. Therefore the containment vessel bolts satisfy the requirements of Regulatory Guide 7.6 [2.3].

A buckling evaluation was also carried out using the FEA model, as described in the Vectra report No 925-3272/R1. The results of the calculation are presented in Table 2-22. The stresses used for the calculations were taken from point C5 in Figure 2-1, which is mid-way along the length of the inner shell of the containment vessel. Where one of the components was tensile in the finite element analysis it should be given a value of 0 Pa however in order to avoid zero errors it was given a very small positive value in the buckling calculation.

The buckling stresses were compared against the allowable stresses as detailed in Section 2.1.2.3. The design margin is 125 which is greater than 0 hence the containment vessel satisfies the requirements of Regulatory Guide 7.6 [2.3] for buckling as shown in Table 2-22.

In order to determine the effect of repeated cycles of thermal loading on the containment vessel, fatigue calculations have been carried out in accordance with Section 2.1.2.4 and are detailed in the Vectra Report L20008/1/R1 (Section 2.12.2). The values calculated are given in Table 2-23. As the value of the maximum alternating stress in the containment vessel was below the fatigue threshold, the design margin is effectively infinite. Hence the containment vessel satisfies the requirements of Regulatory Guide 7.6 [2.3] for fatigue.

Brittle fracture has not been considered because the containment vessel and keg are fabricated from austenitic stainless steel which is ductile even and low temperatures and therefore not susceptible to brittle fracture [2.3].

Table 2-20 Containment Vessel Stress Summary under Cold Conditions						
NCT Case ID	Description	Stress Type	Maximum Stress Intensity (MPa)	Stress Location	Allowable stress intensity (MPa)	Minimum Design Margin
2	Cold	P _m	5.21	C10	115	21.1
		P _m +P _b	6.39	C1	173	26.0
		P _m +P _b +Q	10.2	C11	345	33.0
		Bearing	19.5	Under bolts	173	7.82

Table 2-21 Containment Vessel Bolts Stress Analysis under Cold Conditions					
NCT Case ID	Description	Stress Type	Maximum stress (MPa)	Allowable stress intensity (MPa)	Minimum design margin
2	Cold	Average Shear	0.80	289	358
		Average Stress	27.3	482	16.7
		Max Stress	46.0	723	14.7

Table 2-22 Containment Vessel Buckling Calculations Under Cold Conditions					
NCT Case ID	Description	Stress (MPa)			Design Margin
		Axial Compression	Hoop Compression	In-plane shear	
2	Cold	0.33	0.68	0	125

Table 2-23 Containment Vessel Fatigue Evaluation under Cold Conditions			
Maximum alternating stress	Required No of cycles	Cycles to failure	Design Margin
10.16	10000	> 10 ¹¹	n/a

2.6.3 Reduced External Pressure [71.71 (c) (3)]

Section 71.71 (c) (3) requires that the package is subjected to a reduced external pressure of 25 kPa absolute. According to Regulatory Guide 7.8 [2.2] the reduced external pressure should be combined with the worst case initial conditions shown in Table 2-1.

To determine the effect of the reduced external pressure with the worst case initial conditions a finite element analysis was carried out on the containment vessel as detailed in the Vectra Report L20008/1/R1 (Section 2.12.2). The analysis was carried out with an ambient temperature of 38°C in still air, with insolation and the maximum decay heat. It was assumed that under these conditions the containment vessel was at a uniform temperature of 158°C. The external pressure was 24.5 kPa with the internal pressure at 800 kPa absolute, so the internal gauge pressure applied to the model was 775.5 kPa.

The stresses were calculated at the points shown in Figure 2-1. From these calculations the maximum stress intensities were determined and presented in Table 2-24. As shown all of the design margins are greater than zero therefore satisfying the requirements of Regulatory Guide 7.6 [2.3].

A stress analysis of the containment vessel closure bolts under reduced external pressure was performed. The axial force from the finite element analysis model was extracted and divided by the bearing area of the bolt heads, to give the average bearing stress and divided by the cross sectional area of the bolts to give the average stress.

The calculated values for average shear, average stress and maximum stress of the closure bolts for the vibration load conditions are summarized in Table 2-25. The design margins are all greater than 0 therefore the bolts satisfy the requirements of Regulatory Guide 7.6 [2.3].

Buckling evaluations of the inner containment shell were carried out in accordance with the requirements of ASME Code Case N-284-2 [2.6] as detailed in Section 2.1.2.3. The stresses used for the calculations were taken from point C5 in Figure 2-1, which is mid-way along the length of the inner shell of the containment vessel. Where one of the components was tensile in the finite element analysis it should be given a value of 0 Pa however in order to avoid zero errors it was given a very small positive value in the buckling calculation.

The calculated stress from the FEA is tensile for the reduced external pressure condition. Therefore the stress is 0 MPa for axial and hoop compression, In-plane shear does have a maximum stress of 0 MPa. The design margin for the buckling stress was effectively infinite which is greater than 0, therefore satisfying the requirements of Regulatory Guide 7.6 [2.3].

In accordance with Regulatory Guide 7.8 [2.2] regular pressurization loads should be evaluated to determine how they contribute to mechanical fatigue. The fatigue analysis was carried out in accordance with section C.3 in Regulatory Guide 7.6 [2.3]. It was assumed that the containment vessel would undergo approximately 50 cycles/year, for 20 years, which equates to 1000 cycles in its lifetime. This number was multiplied by 10 to give 10000 cycles, providing a safety margin. The maximum alternating stress was calculated as 49.54 MPa, this

figure is below the fatigue threshold meaning that the design margin is effectively infinite with the number of cycles to failure of $>10^{11}$ far in excess of the actual number of cycles.

The results of the calculations resulting from the reduced external pressure have shown that the containment vessel satisfies the allowable design criteria. Reduced external pressure will not cause the permanent deformation of the containment vessel. It will not cause the failure of the containment vessel boundary or deformation of the bolts therefore it shall not result in any loss or dispersal of the radioactive contents.

NCT Case ID	Description	Stress Type	Maximum Stress Intensity (MPa)	Stress Location	Allowable stress intensity (MPa)	Minimum Design Margin
3	Reduced External Pressure	P_m	16.5	C6b	109	5.6
		P_m+P_b	49.5	C1	163	2.30
		P_m+P_b+Q	42.5	C3	327	6.69
		Bearing	116	Under bolts	121	0.04
4	Increased External Pressure	P_m	3.66	C10	115	30.4
		P_m+P_b	8.94	C1	173	18.3
		P_m+P_b+Q	8.17	C3	345	41.2
		Bearing	60.0	Under bolts	172	1.86

NCT Case ID	Description	Stress Type	Maximum stress (MPa)	Allowable stress intensity (MPa)	Minimum design margin
3	Reduced External Pressure	Average Shear	2.14	244	113
		Average Stress	163	406	1.49
		Max Stress	176	609	2.46
4	Increased External Pressure	Average Shear	1.90	289	151
		Average Stress	84.1	482	4.73
		Max Stress	108.3	723	5.68

2.6.4 Increased External Pressure [71.71 (c) (4)]

10 CFR 71.71 (c) (4) requires that the package is subjected to an increased external pressure of 140 kPa absolute. According to Regulatory Guide 7.8 [2.2] the increase in external pressure should be combined with the worst case initial conditions shown in Table 2-1.

To determine the effect of the increased external pressure with the worst case initial conditions a finite element analysis was carried out on the containment vessel as detailed in the Vectra Report L20008/1/R1 (Section 2.12.2). The analysis was carried out with an ambient temperature of -29°C in still air, with zero insolation and zero decay heat. The external pressure was 140 kPa with the internal pressure at 0 kPa absolute, so the internal gauge pressure applied to the model was -140 kPa. A bolt pre load of 8.12 kN was applied to the bolts at the start of the analysis prior to any other load being applied.

The stresses were calculated at the points shown in Figure 2-1. From these calculations the maximum stress intensities were calculated and are presented in Table 2-24. As shown all of the design margins are greater than zero, therefore satisfying the requirements of Regulatory Guide 7.6 [2.3].

A stress analysis of the containment vessel closure bolts under increased external pressure was performed. The axial force from the finite element analysis model was extracted and divided by the bearing area of the bolt heads, to give the average bearing stress and divided by the cross sectional area of the bolts to give the average stress.

The calculated values for average shear, average stress and maximum stress of the closure bolts for the increased external pressure conditions are summarized in Table 2-25. The design margins are all greater than 0 therefore the bolts satisfy the requirements of Regulatory Guide 7.6 [2.3].

Buckling evaluations of the inner containment shell were carried out in accordance with the requirements of ASME Code Case N-284-2 [2.6] as detailed in Section 2.1.2.3. The stresses used for the calculations were taken from point C5 in Figure 2-1, which is mid-way along the length of the inner shell of the containment vessel. Where one of the components was tensile in the finite element analysis it should be given a value of 0 Pa however in order to avoid zero errors it was given a very small positive value in the buckling calculation.

The calculated stress from the FEA is tensile for the reduced external pressure condition. Therefore the stress is 0.46 MPa for axial and 0.96 MPa for hoop compression, In-plane shear does have a maximum stress of 0. The design margin for the buckling stress was 88.6 which is greater than 0, therefore satisfying the requirements of Regulatory Guide 7.6 [2.3].

In accordance with Regulatory Guide 7.8 [2.2] regular pressurization loads should be evaluated to determine they contribute to mechanical fatigue. The fatigue analysis was carried out in accordance with Section 2.1.2.4. It was assumed that the containment vessel would undergo approximately 50 cycles/year, for 20 years, which equates to 1000 cycles in its lifetime. This number was multiplied by 10 to give 10000 cycles, providing a safely margin.

The maximum alternating stress was calculated as 28.4 MPa, this figure is below the fatigue threshold meaning that the design margin is effectively infinite with the number of cycles to failure of $>10^{11}$ far in excess of the actual number of cycles.

The results of the calculations for increased external pressure have shown that the containment vessel satisfies the allowable design criteria as defined in Regulatory Guide 7.6 [2.3]. Increased external pressure will not cause the permanent deformation of the containment vessel. It will not cause the failure of the containment vessel boundary or deformation of the bolts therefore it shall not result in any loss or dispersal of the radioactive contents.

2.6.5 Vibration [71.71 (c) (5)]

10 CFR 71.71 (c) (5) requires that the package is subjected to vibration normally incident during transport. The package will be transported by all modes of transport and tied down using cargo nets or a similar system that envelope the package.

Vibration analysis has been carried out using a bounding vertical downward acceleration of 10g. Vibration loading has been applied to the containment vessel in combination with temperature and pressure loadings in accordance with Table 2-1. The stresses in the containment vessel were determined using the finite element model discussed in the appended Vectra Report L20008/1/R1. (Section 2.12.2).

Under the hot vibration conditions, a uniform temperature of 158°C and an internal gauge pressure of 700 kPa have been applied to the containment vessel. Under the cold vibration conditions an ambient temperature of -29°C is applied, along with an internal gauge pressure of -100 kPa to the containment vessel. For both tests a body force was applied to the model which was equivalent to a downward vertical acceleration of 10g. A pre load of 8.12 kN was applied to the bolts at the start of the analysis prior to any other loads being imposed. This corresponds to an applied torque of 10 Nm.

Under these vibration loading conditions the primary membrane (Pm), primary plus bending (Pm+Pb), primary plus secondary (Pm+Pb+Q) and bearing stresses have been evaluated at the locations shown on Figure 2-1. The stress distribution is given in the Vectra Report L20008/1/R1 (Section 2.12.2). The stress distribution is similar to the hot conditions stress calculation, which indicates the stresses are dominated by the thermal stress.

The maximum stress intensities calculated, along with the location of the maximum stress is summarized for each vibration load combination in Table 2-26. Each maximum stress is compared to the allowable stress intensity and a design margin given. All the design margins are greater than 0 therefore the containment vessel satisfies the requirements of Regulatory Guide 7.6 [2.3].

A stress analysis of the containment vessel closure bolts under vibration load conditions was performed. The axial force from the finite element analysis model was extracted and divided by the bearing area of the bolt heads, to give the average bearing stress and divided by the cross sectional area of the bolts to give the average stress.

The calculated values for average shear, average stress and maximum stress of the closure bolts for the vibration load conditions are summarized in Table 2-27. The design margins are all greater than 0 therefore the bolts satisfy the requirements of Regulatory Guide 7.6 [2.3].

Buckling evaluations of the inner containment shell were carried out in accordance with the requirements of ASME Code Case N-284-2 [2.6] as detailed in Section 2.1.2.3. The stresses used for the calculations were taken from point C4 in Figure 2-1, which is mid-way along the length of the inner shell of the containment vessel. Where one of the components was tensile in the finite element analysis it should be given a value of 0, however, in order to avoid zero errors it was given a very small positive value in the buckling calculation.

The maximum calculated buckling stresses are shown in Table 2-28 along with the design margin. Table 2-28 shows that all the design margins are greater than 0 therefore the containment vessel will not buckle under an NCT free drop test and satisfies the requirements of Regulatory Guide 7.6 [2.3].

The results of the NCT Vibration structural evaluation show that the containment vessel meets all the applicable stress design criteria. The vibration loads will not result in any permanent deformation of the containment vessel or failure within the containment boundary.

Table 2-26 Containment Vessel Stress Summary for Vibration Loads						
NCT Case ID	Description	Stress Type	Maximum Stress Intensity (MPa)	Stress Location	Allowable stress intensity (MPa)	Minimum Design Margin
5	Vibration (hot)	P_m	16.5	C6b	109	5.60
		P_m+P_b	49.5	C1	163	2.30
		P_m+P_b+Q	8.17	C3	327	38.9
		Bearing	116	Under bolts	121	0.04
6	Vibration (cold)	P_m	99.2	C6b	115	0.16
		P_m+P_b	59.5	C1	173	1.90
		P_m+P_b+Q	10.5	C3	345	31.8
		Bearing	60.1	Under bolts	172	1.86

Table 2-27 Containment Vessel Bolts Stress Analysis under Vibration Load Conditions					
NCT Case ID	Description	Stress Type	Maximum stress (MPa)	Allowable stress intensity (MPa)	Minimum design margin
5	Vibration (hot)	Average Shear	2.14	244	113

Table 2-27 Containment Vessel Bolts Stress Analysis under Vibration Load Conditions					
NCT Case ID	Description	Stress Type	Maximum stress (MPa)	Allowable stress intensity (MPa)	Minimum design margin
		Average Stress	163	406	1.49
		Max Stress	179	609	2.46
6	Vibration (cold)	Average Shear	1.40	289	205
		Average Stress	80.24	482	4.72
		Max Stress	109	723	5.62

Table 2-28 Containment Vessel Buckling Calculations under Vibration Load Conditions					
NCT Case ID	Description	Stress (MPa)			Design Margin
		Axial Compression	Hoop Compression	In-plane shear	
5	Vibration (hot)	0	0	0	n/a
6	Vibration (cold)	0.26	0.40	0	214

2.6.6 Water Spray [71.71 (c) (6)]

10 CFR 71.71 (c) (6) requires that a package must be subjected to a water spray test that simulates exposure to rainfall of approximately 5 cm/hour for at least 1 hour. The package was not subjected to a water spray test. This is because all materials both inside and out are made from materials that are water resistant. The lid of the keg is fitted with an O-ring seal for weather protection which would aid in the prevention of water entry due to water spray (rain). Therefore the water spray test would have no effect on the structural design of the package or its components and has not been performed during the regulatory tests.

2.6.7 Free Drop [71.71 (c) (7)]

10 CFR 71.71 (c) (7) requires that a package of less than 5,000 kg is subjected to a free drop test from a distance of 1.2 m onto an essentially unyielding, horizontal surface, striking in a position for which the maximum damage is expected.

The package was evaluated by dropping a prototype package 1.2m onto its side, top corner and finally onto the top of the package, in all cases the centre of gravity was over the point of impact. These orientations were considered worst case because previous experience has shown that a drop on the side leads to the highest stresses in the package. A drop on the lid or the top rim of the package may distort the lid and open the seals which would be more likely to cause a loss of containment. A finite element analysis of the containment vessel was

carried out on completion of the drop tests to determine the stresses within the containment vessel.

The NCT free drop tests were carried out on a prototype package within the series of NCT and HAC tests, as described in the Croft Report CTR 2010/02, appended in Section 2.12.2. The test package of 153.9 kg mass was dropped 1.2 meters onto a steel target with a mass of 500 kg, which was located on a thick concrete base. The NCT free drop tests were all carried out at an ambient temperature of 5°C.

In order to determine the effect of testing on the package several modifications were made to the containment vessel, cork and keg. To accommodate the wiring for the test equipment small holes of up to 25 mm were drilled through the center of the containment vessel lid, top cork and keg lid. A drain hole on the side of the keg was enlarged to allow the test equipment wiring to pass through it. Finally two cavities and threaded holes were machined into the containment vessel lid to allow the attachment of the accelerometers. The changes are discussed in more detail in the Croft Report CTR 2010/02 (Section 2.12.2). These changes are would not affect the structural integrity of the package or the test results: if anything they would slightly weaken the integrity causing the tests to have a greater effect on the test package than the actual package.

The total mass of the tested package was 153.9 kg which is 5% lighter than the design weight of 163kg given in section 2.1.3. The design weight is greater than the tested package weight to allow for variations due to manufacturing tolerances. In order to account for the lower weight of the test package it was dropped from 10.2 m under the HAC tests, this is a 13% increase in the drop height and energy of the package at impact.

Aside from minor weight differences and the modifications discussed for testing, the prototype package was identical to the manufactured package.

The drop tests caused minimal damage to the top rim of the 3977 keg. No visible damage or deformation was present on the body of the keg after each of the drop tests. This indicates there would be no significant change in the radiation level. Helium leakage testing was carried out prior to and after the entire test series. The leakage testing demonstrated the containment vessel remained leak tight throughout the test series.

A detailed analysis of the stress present in the containment vessel during the free drop test was carried out using a finite element model of the containment vessel as described in Vectra Report L20008/1/R1 appended in Section 2.12.2.

The three drop orientations were modeled under 'hot' and 'cold' conditions as required by Regulatory Guide 7.8 [2.2]. The hot conditions assumed the package experienced the maximum ambient temperature of 38°C, in still air with maximum insolation and decay heat. With these conditions it was assumed that the containment vessel was at a uniform temperature of 158°C. Along with the hot temperature it was assumed that the containment vessel had an internal pressure of 800 kPa. The external pressure was taken as 100 kPa, so the internal gauge pressure was 700 kPa

The cold conditions assumed an ambient temperature of -29°C , in still air with no insolation or decay heat. It has been assumed that the internal pressure is 0 kPa with an external pressure of 100 kPa, so the internal gauge pressure is -100 kPa. The load combinations modeled for the NCT drop tests are outlined in Table 2-1.

For the entire NCT free drop analysis a pre load of 8.12kN was applied to the bolts at the start of the analysis, prior to any other loads being imposed. The bolts were tied to the CV body along the threaded length with the bolt heads free to slide.

Stress calculations were carried out for each free drop load combination. Stress distributions presented in Vectra Report L20008/1/R1 (Section 2.12.2).

The primary membrane (P_m), primary plus bending (P_m+P_b), primary plus secondary (P_m+P_b+Q) and bearing stresses were evaluated at the locations shown on Figure 2-1, for each of the free drop load combination identified in Table 2-1 (NCT load ids 7 – 12). The maximum stress intensities calculated along with the location of the maximum stress is given for each free drop load combination in Table 2-31. Each maximum stress is compared to the allowable stress intensity and the design margin given. From the results of the analysis all the design margins are greater than 0 for the free drop on the lid, however for the drop over the top edge and on the side some of the design margins are less than zero which indicates there are areas of high stress. However most of the high stresses are not found in the sealing area around the flange and the lid. The model itself does not take into account the action of the cork to cushion the CV. The cork was given a modulus 1000 times greater than that measured in order to allow the model to run, because it was rightly demonstrating the failure of the cork. This meant that the model didn't allow any cushioning affect and the CV was subjected to higher loads over a smaller area, however as demonstrated by the drop tests it is the failure of the cork which protects the CV from damage. The drop tests carried out indicated no change in the dimensions of the CV and therefore no stresses that would cause deformation of the CV.

The calculated values for average shear, average stress and maximum stress of the closure bolts for each free drop condition are summarized in Table 2-32. The design margins for drop conditions are all greater than 0 therefore the bolts satisfy the requirements of Regulatory Guide 7.6 [2.3].

Buckling evaluations of the inner containment shell were carried out in accordance with the requirements of ASME Code Case N-284-2 [2.6] as detailed in Section 2.1.2.3, for all the NCT free drop load combinations. The stresses used for the calculations were taken from point C5 in Figure 2-1, which is mid-way along the length of the inner shell of the containment vessel. Where one of the components was tensile in the finite element analysis it should be given a value of 0 Pa however in order to avoid zero errors it was given a very small positive value in the buckling calculation.

The maximum calculated buckling stresses are shown in Table 2-33 along with the design margin. Table 2-33 shows that all the design margins are greater than 0 therefore the

containment vessel will not buckle under an NCT free drop test and satisfies the requirements of Regulatory Guide 7.6 [2.3].

Test			Drop on side	Drop on top rim	Drop on lid	Drop on side	Drop on top rim	Drop on lid
Drop Height (m)			1.2	1.2	1.2	10.2	10.2	10.2
Peak Acceleration	Axial (g)	Accelerometer 1	267	377	424	99	338	NT
		Accelerometer 2	178	374	433	106	NT	NT
	Radial (g)	Accelerometer 1	214	521	520	435	228	NT
		Accelerometer 2	293	590	750	457	NT	NT

Case	Description	Acceleration
NCT7	Free drop on lid from 1.2m (hot)	434g axial
NCT8	Free drop on lid from 1.2m (cold)	434g axial
NCT9	Free drop on corner from 1.2m (hot)	376g axial 590g radial
NCT10	Free drop on corner from 1.2m (cold)	376g axial 590g radial
NCT11	Free drop on side from 1.2 m (hot)	294g radial
NCT12	Free drop on side from 1.2 m (cold)	294g radial
HAC1	Free drop on lid from 10.2 m (hot)	458g axial
HAC2	Free drop on lid from 10.2 m (cold)	458g axial
HAC3	Free drop on corner from 10.2 m (hot)	338g axial 228g radial
HAC4	Free drop on corner from 10.2 m (cold)	338g axial 228g radial
HAC5	Free drop on side from 10.2 m (hot)	458g radial
HAC6	Free drop on side from 10.2 m (cold)	458g radial

Table 2-31 NCT Free Drop Stress Summary						
NCT Case ID ^[1]	Description	Stress Type	Maximum Stress Intensity (MPa)	Stress Location ^[2]	Allowable stress intensity (MPa)	Minimum Design Margin
7	Drop on lid from 1.2m (hot)	P _m	22.3	C10	109	3.89
		P _m +P _b	37.9	C1	163	3.31
		P _m +P _b +Q	43.2	C10	327	6.57
		Bearing	109	Under bolts	121	0.11
8	Drop on lid from 1.2m (cold)	P _m	22.1	C10	115	4.20
		P _m +P _b	26.3	C16	173	5.55
		P _m +P _b +Q	51.1	C8	345	5.74
		Bearing	53.5	Under bolts	172	2.21
9	Drop on corner (hot)	P _m	235	C4-180	109	-0.54
			196	C6b-180		-0.44
			179	C7-180		-0.39
			141	C8-180		-0.23
			152	C9-180		-0.29
		P _m +P _b	52.1	C14-180	163	2.14
		P _m +P _b +Q	396	C6b	327	-0.17
			363	C7		-0.10
			609	C7-180		-0.46
			384	C9-180		-0.15
Bearing	121	Under bolts	121	0.0		
10	Drop on corner (cold)	P _m	116	C6a	115	-0.1
			258	C6b		-0.56
			161	C7		-0.29
			129	C9		-0.11
			401	C6b-180		-0.71
			346	C7-180		-0.67
			242	C8-180		-0.53
			287	C9-180		-0.60
			180	C11-180		-0.36
		P _m +P _b	89	C2-180	173	0.93

Table 2-31 NCT Free Drop Stress Summary						
NCT Case ID ^[1]	Description	Stress Type	Maximum Stress Intensity (MPa)	Stress Location ^[2]	Allowable stress intensity (MPa)	Minimum Design Margin
		P_m+P_b+Q	827	C6b	345	-0.58
			842	C7		-0.59
			459	C8		-0.25
			431	C9		-0.20
			1022	C6b-180		-0.66
			1213	C7-180		-0.72
			919	C8-180		-0.62
			793	C9-180		-0.57
			757	C10-180		-0.54
		393	C11-180	-0.12		
	Bearing	96.7	Under bolts	172	0.78	
11	Drop on side (hot)	P_m	113	C6b	109	-0.03
			184	C4-180		-0.41
			145	C6b-180		-0.25
			115	C7-180		-0.05
		P_m+P_b	64.0	C1	163	1.55
		P_m+P_b+Q	420	C10-180	327	-0.22
			394			-0.17
467		-0.30				
Bearing	133	Under bolts	121	-0.09		
12	Drop on side (cold)	P_m	160	C6b-180	115	-0.28
		P_m+P_b	35.8	C2-180	173	3.81
		P_m+P_b+Q	355	C6b-180	345	-0.03
			380.7	C7-180		-0.09
		Bearing	109	Under bolts	172	0.61

Notes:

1. NCT case IDs are obtained from Table 2-1
2. Stress locations are shown in Figure 2-1. Locations ending -180 are on the opposite side of the vessel to those shown in Figure 2-1, i.e. they are on the side of the vessel closest to the impact with the cork impact limiter.

Table 2-32 Containment Vessel Closure Bolts NCT Free Drop Stress Summary					
NCT Case ID ^[1]	Description	Stress Type	Maximum stress (MPa)	Allowable stress intensity (MPa)	Minimum design margin
7	Drop on lid from 1.2m (hot)	Average Shear	14.3	244	16.0
		Average Stress	153	406	1.65
		Max Stress	174	609	2.50
8	Drop on lid from 1.2m (cold)	Average Shear	7.39	289	38.1
		Average Stress	75.0	482	5.43
		Max Stress	116	723	5.23
9	Drop on corner (hot)	Average Shear	13.3	244	17.3
		Average Stress	170	406	1.39
		Max Stress	184	609	2.31
10	Drop on corner (cold)	Average Shear	11.3	289	24.6
		Average Stress	135	482	2.56
		Max Stress	192	723	2.76
11	Drop on side (hot)	Average Shear	14.2	244	16.3
		Average Stress	186	406	1.18
		Max Stress	222	609	1.74
12	Drop on side (cold)	Average Shear	14.1	289	19.4
		Average Stress	150	482	2.22
		Max Stress	203	723	2.51

Notes:

1. NCT case IDs are obtained from Table 2-1

Table 2-33: NCT Free Drop Buckling Evaluation Summary					
NCT Case ID	Description	Stress (MPa)			Design Margin
		Axial Compression	Hoop Compression	In-plane shear	
7	Drop on lid from 1.2m (hot)	0.68	-4.51	0	87
8	Drop on lid from 1.2m (cold)	3.34	0.68	0	24
9	Drop on side (hot)	0	0	0.71	2570
10	Drop on side (cold)	0	0	0.61	7153
11	Drop on corner (hot)	0	0	0.74	2365
12	Drop on corner (cold)	0	0	0.12	1703

Notes:

1. NCT case IDs are obtained from Table 2-1

2.6.8 Corner Drop [71.71 (c) (8)]

The requirement of 10 CFR 71.71(c) is that a fiberboard, wood or fissile material rectangular package not exceeding 50 kg (110 lbs) and fiberboard, wood, or fissile material cylindrical packages not exceeding 100 kg (220 lbs) must be subjected to a free drop onto each corner of the rectangular package or onto each quarter of each rim of the cylindrical package. The package must be dropped from a height of 0.3 m onto a flat, essentially unyielding surface.

The Safkeg-HS 3977A package is a robust steel shell package which only suffered minor deformation under both 1.2 m and 10.2 m drop tests: these tests demonstrated that a 0.3m drop would have no significant effect on the package.

2.6.9 Compression [71.71 (c) (9)]

According to 71.71(c) (9), the package must be subjected to a compressive load for a period of 24 hours. This load must be applied uniformly to the top and bottom of the package in the position in which the package is normally transported. The load applied must be the greater of 5 times the weight of the package or the equivalent of 13 kPa multiplied by the vertically projected area of the package.

The maximum mass of the package is 163 kg therefore 5 times the mass is 815 kg. The vertically projected area of the package is 0.115 m² multiplied by 13 kPa this results in a force of 1495 N which is equivalent to a stacking weight of 153 kg. Five times the mass of the package (815 kg) is the greater of the two and was used as the appropriate test weight.

The compression test was carried out on a prototype keg. The test procedure and results are documented in the Croft Report CTR 2010/02 appended in Section 2.12.2.

An empty keg body was subjected to a compressive load of 914 kg which is well in excess of the 815 kg required. The keg was weighed and dimensions taken before and after testing. On completion of the test no part of the keg showed any visually observed evidence of plastic deformation and no changes in dimensions or weight was found. These results show that the package satisfies the compression test criteria.

2.6.10 Penetration [71.71 (c) (10)]

In accordance with section 71.71 (c) (10) a 6 kg steel bar with a diameter of 3.2 cm was dropped from a height of 1m onto the side of a prototype package. The side was considered the most vulnerable area to puncture. The penetration test was carried out during the NCT test series and is described in CTR 2009/21 appended in Section 2.12.2. The test caused a dent of 8.06 mm in depth and 290 mm width in the keg skin but the skin was not punctured or torn.

A dent of 8.06 mm was the largest dent encountered during NCT test conditions, therefore this dent shall provide the basis for the allowable dents during the maintenance and package loading checks described in sections 7 and 8.

2.7 Hypothetical Accident Conditions [71.73]

Section 71.51 requires that when subjected to the HAC tests, the damage caused to the package does not lead to the loss of radioactive material exceeding a total amount of A_2 in one week, or an increase in the external radiation dose above 10 mSv/hr at 1m from the external surface of the package. In order to demonstrate compliance a prototype package was subjected to a series of HAC tests and the stresses in the containment vessel were modeled under the HAC test conditions.

The HAC tests were performed on the prototype keg after the NCT penetration and drop tests. The HAC tests were carried out sequentially in the order of 10.2 m drop tests and then puncture tests. Therefore the keg was tested for the cumulative effects of both the NCT and HAC tests. The drop and puncture tests were carried out with the package at -40°C to take into account any brittle failure. The containment vessel was analyzed under the most unfavorable initial conditions for each individual HAC test condition.

2.7.1 Free Drop [71.73 (c)(1)]

10 CFR 71.73 (c) (1) requires that a specimen undergoes a free drop through a distance of 9 m onto a flat and essentially unyielding, horizontal surface striking in a position for which the maximum damage is expected. In order to fulfill this requirement a prototype package was dropped 10.2 meters in several orientations.

The procedure, sequence of testing and results are documented in the Croft Report CTR 2010/02 appended in Section 2.12.2. A series of 10.2 m drop tests were performed at the Croft Associates, Didcot Test Facility, as part of the NCT and HAC test series. This facility has a test target consisting of a 50 mm thick non alloy structural steel plate. This plate sits at

ground level on a one piece, continuously poured, cast in situ concrete block. The mass of the target is 50 tonnes.

The mass of the test package is 5% less than the maximum mass of the package; to compensate for this the test package was dropped from 10.2m which is 13% higher than the 9m specified in the regulations. As a result the energy at impact was 13% greater than required.

Regulatory Guide 7.8 suggests that the following orientations are considered, top end, top corner, side, bottom end and bottom corner. Previous tests on other Safkeg packages have shown that the highest shock is produced by the side impact, based on the assumption that the minimum measured deformation of the package produces the highest deceleration. On the basis of this evidence, and consideration of the damage mechanisms that could lead to loss of containment or failure to meet other regulatory criteria, the first orientation of the 10.2 m drop test was chosen to be a side impact (with axis horizontal). It was considered that a drop on the bottom or bottom rim of the package would cause less damage than a drop on the lid or the rim of the package. A drop on the lid or rim may distort the lid and open the seals however this would not occur with a drop on the bottom or the bottom corner. Therefore the 10.2 m drop tests were carried out in the order of drop with the C of G over the side, C of G over the top rim and finally C of G over the top end.

The drop tests were performed with the test package cooled to -40°C. This temperature was considered the most challenging because brittle fracture is more likely at lower temperatures and the cork is also harder at lower temperatures thus providing less impact protection.

The package for the 10.2 m drop consisted of the fully assembled package with some modifications made to allow for test equipment to be fitted and data to be recorded. Several modifications were made to the containment vessel, cork and keg. To accommodate the wiring of the test equipment small holes of up to 25 mm were drilled through the center of the containment vessel lid, top cork and keg lid. A drain hole on the side of the keg was enlarged to allow the test equipment wiring to pass through it. Finally two cavities and threaded holes were machined into the containment vessel lid to allow the attachment of the accelerometers. The changes are discussed in more detail in the Croft Report CTR 2010/02 (Section 2.12.2). These changes would not affect the structural integrity of the package or the test results.

Aside from minor weight differences, some minor differences in design as discussed in report CTR 2010/02 (Section 2.12.2) and modifications discussed for testing, the prototype package will be identical to the manufactured package. The test package was loaded with the 12 x 95 tungsten insert filled with 68 g (0.09 lb) of lead shot, to simulate the maximum permissible mass of contents.

Prior to the NCT and HAC test series the package and its components were measured and weighed. The containment vessel was also helium leak tested to ensure it was leak tight. On completion of the test series these tests were repeated to determine the damage sustained to the package and if the containment vessel remained leak tight.

Along with the physical tests a stress analysis of the containment vessel under HAC test conditions, was carried out, using a finite element analysis detailed in the Vectra Report L20008/1/R1 (Section 2.12.2). In accordance with Regulatory Guide 7.8 [2.2] each drop orientation was evaluated in combination with the worst case initial conditions. The load conditions used along with each drop test orientation is given in Table 2-2.

Once the load conditions had been applied a body force equivalent to the g value measured during the drop test was applied to the vessel. The g values applied to each test condition are given in Table 2-30.

The maximum stresses in the containment vessel are calculated and shown to satisfy the requirements of ASME Section III Div 3 [2.5] for bearing stress and bolt stress and satisfying Regulatory Guide 7.6 for all other stresses. In addition the containment vessel inner shell was evaluated for buckling in accordance with the requirements of ASME Code Case N-284-2 [2.6].

The results of each drop test and stress analysis are given in the following sections.

2.7.1.1 End Drop

The package was evaluated for a 10.2 m end drop occurring on the top of the package. This orientation is the worst case end drop because a drop on the lid may distort the lid and open the seals however this would not occur with a drop on the bottom. Testing of a prototype established the effect on the package along with a structural analysis determining the effect on the containment vessel.

Package Test

As described in Section 2.7.1. the prototype test package was cooled to -40°C and dropped onto its side, top corner and then the top end with damage from each drop accumulating for the next test. The end drop is described in the appended report CTR 2010/02. The package was slung in the correct orientation and dropped onto the test target. The package impacted the target on the top end bounced and landed on its top rim and then came to rest on the side.

As the package landed the cables relaying the g data to the logging computer were sheared which meant that no acceleration values were recorded for the drop test.

The keg received some minor denting which is discussed in Section 2.7.1.5.

Containment Vessel Evaluation

A detailed analysis of the stress present in the containment vessel during the free drop test was carried out using a finite element model of the containment vessel as described in the Vectra Group report L20008/1/R1 (Section 2.12.2).

The end drop was modeled under 'hot' and 'cold' conditions as required by Regulatory Guide 7.8. The hot conditions assumed the package experienced the maximum ambient temperature of 38°C, in still air with maximum insolation and decay heat. With these conditions it was assumed that the containment vessel was at a uniform temperature of 158°C. Along with the hot temperature it was assumed that the containment vessel had an internal pressure of 800 kPa. The external pressure was taken as 100 kPa, so the internal gauge pressure was 700 kPa

The cold conditions assumed an ambient temperature of -29°C, in still air with no insolation or decay heat. It has been assumed that the internal pressure is 0 kPa with an external pressure of 100 kPa, so the internal gauge pressure is -100 kPa. The load combinations modeled for the NCT drop tests are outlined in Table 2-1.

A body force was applied to the model which was equivalent to an upward vertical acceleration of 458 g. As no g values were taken during testing a g value equivalent to that measured during the side drop has been assumed.

For the entire HAC free drop analysis a pre load of 8.12kN was applied to the bolts at the start of the analysis, prior to any other loads being imposed. The bolts were tied to the CV body along the threaded length with the bolt heads free to slide.

Stress calculations were carried out for both the hot and cold end drop load combinations. Stress distributions presented in VECTRA report L20008/1/R1 (Section 2.12.2).

The primary membrane (Pm), primary plus bending (Pm+Pb) stresses were evaluated at the locations shown on Figure 2-1, for each of the free drop load combination identified in Table 2-2. The maximum stress intensities calculated along with the location of the maximum stress is given for each free drop load combination. Each maximum stress is compared to the allowable stress intensity and the design margin given. All the design margins are greater than 0 therefore the containment vessel satisfies the requirements of Regulatory Guide 7.6.

The calculated values for average shear, average stress and maximum stress of the closure bolts for the end drop condition are summarized in Table 2-35. The design margin for the end drop condition are all greater than 0 therefore the bolts satisfy the requirements of Regulatory Guide 7.6 [2.3].

Buckling evaluations of the inner containment shell were carried out in accordance with the requirements of ASME Code Case N-284-2 [2.6]. The stresses used for the calculations were taken from point C4 in Figure 2-1, which is mid-way along the length of the inner shell of the containment vessel. Where one of the components was tensile in the finite element analysis it should be given a value of 0 Pa however in order to avoid zero errors it was given a very small positive value in the buckling calculation.

The maximum calculated buckling stresses are shown in Table 2-36 along with the design margins. A maximum buckling stress of 55.4 MPa was calculated. Table 2-36 shows that

all the design margins are greater than 0 therefore the containment vessel will not buckle under an end drop and satisfies the requirements of Regulatory Guide 7.6 [2.3].

HAC Case ID	Description	Stress Type	Maximum Stress Intensity (MPa)	Stress Location	Allowable stress intensity (MPa)	Minimum Design Margin
1	Drop on lid from 10.2m (hot)	P _m	26.1	C10	245	9.03
		P _m +P _b	60.6	C10	367	5.47
2	Drop on lid from 10.2m (cold)	P _m	25.5	C10	331	9.82
		P _m +P _b	53.3	C11	497	6.76

HAC Case ID	Description	Stress Type	Maximum stress (MPa)	Allowable stress intensity (MPa)	Minimum design margin
1	Drop on lid from 10.2m (hot)	Average Shear	15.9	361	21.7
		Average Stress	173	602	2.48
2	Drop on lid from 10.2m (cold)	Average Shear	7.32	361	48.3
		Average Stress	74.3	602	7.10

NCT Case ID	Description	Stress (MPa)			Design Margin
		Axial Compression	Hoop Compression	In-plane shear	
7	Drop on lid from 1.2m (hot)	0.88	0	0.01	100
8	Drop on lid from 1.2m (cold)	3.52	0.66	0.0	35

2.7.1.2 Side Drop

The package was evaluated for a 10.2 m side drop. Testing of a prototype established the effect on the package along with a structural analysis determining the effect on the containment vessel.

Package Test

As described in Section 2.7.1, the prototype test package was cooled to -40°C and dropped onto its side, top corner and then the top end with damage from each drop accumulating for the next test. The side drop is described in the appended report CTR 2010/02 (Section 2.12.2). The package was slung in the correct orientation and dropped onto the test target. The package impacted the target on the side and then bounced onto the top rim and came to rest on the side.

The maximum g values recorded during the end drop are given in Table 2-29. The accelerations were measured by accelerometers attached to the lid of the containment vessel. The accelerometers logged at 100,000 samples per second. The raw data was filtered using a low pass digital 4th order Butterworth filter [2.18] with a cut off frequency of 500 Hz. The maximum radial acceleration is 457 g.

The keg received some minor denting on the top and bottom rims which is discussed in Section 2.7.1.5.

Containment Vessel Evaluation

A detailed analysis of the stress present in the containment vessel during the free drop test was carried out using a finite element model of the containment vessel as described in the Vectra Group report L20008/1/R1 (Section 2.12).

The side drop was modelled under ‘hot’ and ‘cold’ conditions as required by Regulatory Guide 7.8. The hot conditions assumed the package experienced the maximum ambient temperature of 38°C , in still air with maximum insolation and decay heat. With these conditions it was assumed that the containment vessel was at a uniform temperature of 192°C . Along with the hot temperature it was assumed that the containment vessel had an internal pressure of 800 kPa. The external pressure was taken as 100 kPa, so the internal gauge pressure was 700 kPa

The cold conditions assumed an ambient temperature of -29°C , in still air with no insolation or decay heat. It has been assumed that the internal pressure is 0 kPa with an external pressure of 100 kPa, so the internal gauge pressure is -100 kPa. The load combinations modelled for the HAC drop tests are outlined in Table 2-1.

A body force was applied to the model which was equivalent to the radial value measured during the test. The measured g values are shown in Table 2-29 with the value of 458 g applied to the model as shown in Table 2-30.

For the entire HAC free drop analysis a pre load of 8.12kN was applied to the bolts at the start of the analysis, prior to any other loads being imposed. The bolts were tied to the CV body along the threaded length with the bolt heads free to slide.

The stress model indicated that under the hot and cold conditions the drop on the side causes the cavity wall to rotate causing the DU shielding to compress.

The primary membrane (P_m), primary plus bending (P_m+P_b) stresses were evaluated at the locations shown on Figure 2-1, for each of the free drop load combination identified in Table 2-2. The maximum stress intensities calculated along with the location of the maximum stress is given for each free drop load combination in. Each maximum stress is compared to the allowable stress intensity and the design margin given. Most of the design margins are greater than 0 however the primary plus bending stress during the hot drop was marginally greater than 0 in position C6b. This position is at the corner of the containment wall so if it did distort in a localised area it should not affect the containment seal. The model itself does not take into account the action of the cork to cushion the CV. The cork was given a modulus 1000 times greater than that measured in order to allow the model to run, because it was rightly demonstrating the failure of the cork. This meant that the model didn't allow any cushioning affect and the CV was subjected to higher loads over a smaller area, however as demonstrated by the drop tests it is the failure of the cork which protects the CV from damage. The drop tests carried out indicated no change in the dimensions of the CV and therefore no stresses that would cause deformation of the CV. Therefore the containment vessel satisfies the requirements of Regulatory Guide 7.6 [2.3].

The calculated values for average shear, average stress and maximum stress of the closure bolts for each free drop condition are summarized in Table 2-38. The design margins for drop condition are all greater than 0 therefore the bolts satisfy the requirements of Regulatory Guide 7.6 [2.3].

Buckling evaluations of the inner containment shell were carried out in accordance with the requirements of ASME Code Case N-284-2 [2.6]. The stresses used for the calculations were taken from point C5 in Figure 2-1, which is mid-way along the length of the inner shell of the containment vessel. Where one of the components was tensile in the finite element analysis it should be given a value of 0 Pa however in order to avoid zero errors it was given a very small positive value in the buckling calculation.

The maximum calculated buckling stresses are shown in along with the design margin. A maximum buckling stress of 51.4 MPa was calculated. Table 2-39 shows that all the design margins are greater than 0 therefore the containment vessel will not buckle under an end drop and satisfies the requirements of Regulatory Guide 7.6 [2.3].

Table 2-37 Side Drop Containment Vessel Stress Summary						
HAC Case ID	Description	Stress Type	Maximum Stress Intensity (MPa)	Stress Location	Allowable stress intensity (MPa)	Minimum Design Margin
3	Drop on side from 9m (hot)	P_m	256	C4-180	245	0.02
		P_m+P_b	457	C6b	367	-0.14
4	Drop on side from 9m (cold)	P_m	189	C6b-180	276	0.46
		P_m+P_b	394	C6b	414	0.05

HAC Case ID	Description	Stress Type	Maximum stress (MPa)	Allowable stress intensity (MPa)	Minimum design margin
3	Drop on side from 9m (hot)	Average Shear	20.8	361	16.3
		Average Stress	236	602	1.55
4	Drop on side from 9m (cold)	Average Shear	21.5	361	15.8
		Average Stress	216	602	1.79

HAC Case ID	Description	Stress (MPa)			Design Margin
		Axial Compression	Hoop Compression	In-plane shear	
3	Drop on side from 9m (hot)	0	0	0.75	5131
4	Drop on side from 9m (cold)	0	0	0.60	1.65x10 ⁴

2.7.1.3 Corner Drop

The package was evaluated for a 10.2 m corner drop occurring on the top of the package. This orientation is considered the worst case corner drop because a drop on the top rim may distort the package lid and open the keg, this however would not occur with a drop on the bottom corner. Testing of a prototype established the effect on the package, with a structural analysis determining the effect on the containment vessel.

Package Test

As described in Section 2.7.1, a prototype test package was cooled to -40°C and dropped onto its side, top corner and then the top end with damage from each drop accumulating for the next test.

The package was slung in the correct orientation, raised to 10.2 m and dropped onto the test target. The package impacted the target on the top rim bounced, spun and landed on its side.

The maximum g values recorded during the corner drop are given in Table 2-29. The accelerations were measured by accelerometers attached to the lid of the containment vessel. The accelerometers logged at 100,000 samples per second. The raw data was filtered using a low pass digital 4th order Butterworth filter [2.18] with a cut off frequency of 500 Hz. The maximum axial acceleration is 338 g and the maximum radial

acceleration is 228 g. During the test one of the cables sending the data to the logging computer was sheared which meant only data from one of the g sensors could be used.

The keg received some minor denting which is discussed in Section 2.7.1.5.

Containment Vessel Evaluation

A detailed analysis of the stress present in the containment vessel during the corner drop test was carried out using a finite element model of the containment vessel as described in the Vectra Group report L20008/1/R1 (Section 2.12).

The corner drop was modeled under 'hot' and 'cold' conditions as required by Regulatory Guide 7.8 [2.2]. The hot conditions assumed the package experienced the maximum ambient temperature of 38°C, in still air with maximum insolation and decay heat. With these conditions it was assumed that the containment vessel was at a uniform temperature of 192°C. Along with the hot temperature it was assumed that the containment vessel had an internal pressure of 800 kPa. The external pressure was taken as 100 kPa, so the internal gauge pressure was 700 kPa

The cold conditions assumed an ambient temperature of -29°C, in still air with no insolation or decay heat. It has been assumed that the internal pressure is 0 kPa with an external pressure of 100 kPa, so the internal gauge pressure is -100 kPa. The load combinations modeled for the HAC drop tests are outlined in Table 2-2.

A body force was applied to the model which was equivalent to a radial acceleration of 228g and axial acceleration of 338g. These g values are the maximum accelerations measured during the 10.2 meter free drop tests. The measured g values are shown in Table 2-29.

For the entire HAC free drop analysis a pre load of 8.12kN was applied to the bolts at the start of the analysis, prior to any other loads being imposed. The bolts were tied to the CV body along the threaded length with the bolt heads free to slide.

The primary membrane (Pm), primary plus bending (Pm+Pb) stresses were evaluated at the locations shown on Figure 2-1, for each of the free drop load combination identified in Table 2-2. The maximum stress intensities calculated along with the location of the maximum stress is given for each corner drop load combination in Table 2-40. Each maximum stress is compared to the allowable stress intensity and the design margin given. Most of the design margins are greater than 0 however at point C17-180 the stresses are less than zero however this is a point stress in the centre of the lid which would not affect containment. The model itself does not take into account the action of the cork to cushion the CV. The cork was given a modulus 1000 times greater than that measured in order to allow the model to run, because it was rightly demonstrating the failure of the cork. This meant that the model didn't allow any cushioning affect and the CV was subjected to higher loads over a smaller area, however as demonstrated by the drop tests it is the failure of the cork which protects the CV from damage. The drop tests carried out indicated no

change in the dimensions of the CV and therefore no stresses that would cause deformation of the CV. Therefore the containment vessel satisfies the requirements of Regulatory Guide 7.6.

The calculated values for average shear, average stress and maximum stress of the closure bolts for each free drop condition are summarized in Table 2-41. The design margins for drop condition are all greater than 0 therefore the bolts satisfy the requirements of Regulatory Guide 7.6 [2.3].

Buckling evaluations of the inner containment shell were carried out in accordance with the requirements of ASME Code Case N-284-2 [2.6]. The stresses used for the calculations were taken from point C4 in Figure 2-1, which is mid-way along the length of the inner shell of the containment vessel. Where one of the components was tensile in the finite element analysis it should be given a value of 0 Pa however in order to avoid zero errors it was given a very small positive value in the buckling calculation.

The maximum calculated buckling stresses are shown in Table 2-42 along with the design margin. Table 2-42 shows that all the design margins are greater than 0 therefore the containment vessel will not buckle under a corner drop, satisfying the requirements of Regulatory Guide 7.6 [2.3].

Table 2-40 Corner Drop Containment Vessel Stress Summary						
HAC Case ID	Description	Stress Type	Maximum Stress Intensity (MPa)	Stress Location	Allowable stress intensity (MPa)	Minimum Design Margin
5	Drop on corner from 9m (hot)	P _m	175	C4-180	245	0.50
		P _m +P _b	444	C17-180	367	-0.12
6	Drop on corner from 9m (cold)	P _m	174	C6b-180	276	0.59
		P _m +P _b	376	C6b	414	0.10

Table 2-41 Corner Drop Containment Vessel Bolt Stress Summary					
HAC Case ID	Description	Stress Type	Maximum stress (MPa)	Allowable stress intensity (MPa)	Minimum design margin
5	Drop on corner from 9m (hot)	Average Shear	10.9	361	32.3
		Average Stress	187	602	2.22
6	Drop on corner from 9m (cold)	Average Shear	7.38	361	47.9
		Average Stress	83.9	602	6.18

Table 2-42 Corner Drop Containment Vessel Buckling Evaluation					
HAC Case ID	Description	Stress (MPa)			Design Margin
		Axial Compression	Hoop Compression	In-plane shear	
5	Drop on corner from 9m (hot)	0	0	0.68	6242
6	Drop on corner from 9m (cold)	0	0	0.6	1.65x10 ⁴

2.7.1.4 Oblique Drops

An oblique drop is considered to produce lower “g”s and less damage to the package as less of the energy of the drop is absorbed in the initial impact. As the package does not have a large length to diameter ratio, increase of impact forces due to slap down cannot occur.

2.7.1.5 Summary of Results

The stress evaluation carried out on the containment vessel indicated that it satisfied all the applicable design criteria, therefore no significant deformation of the containment vessel or the closure bolts will occur. Testing of a prototype package confirmed that on completion of the NCT and HAC test series the containment vessel remained leak tight and undamaged as described in the Croft Associates report CTR 2010/02. The only damage suffered during the HAC drop tests was to the keg body which is discussed below.

HAC End Drop

The end drop was the final drop in the HAC test series so all the damage from the side drop and drop with the C of G over the top rim was present on the keg prior to the test. The end drop caused the top rim and skirt to crumple and flattened the lid lifting handles.

HAC Side Drop

The side drop was the first 10.2m drop carried out on the package. The test caused minimal damage and only flattened the top and bottom rims.

HAC Corner Drop

The corner drop occurred on completion of the side drop, therefore the bottom and top rims were dented. The primary impact of the top rim with the target caused the top skirt to deform. No other damage was caused to the keg.

2.7.2 Crush [71.73 (c)(2)]

The crush test is not required as the package has a density of 2,968 kg/m³. The calculation of the density of the package is described in CS 2012/03 [Section 2.12.2].

2.7.3 Puncture [71.73 (c)(3)]

10 CFR 71.73 (c) (3) requires that a package is dropped from 1m onto the upper end of a solid, vertical, cylindrical mild steel bar mounted on an essentially unyielding, horizontal surface. The package must be dropped onto the bar in the orientation in which the maximum damage is expected.

In order to fulfill this requirement a prototype package was dropped onto a steel punch with a diameter of 150 mm and 150 mm in length in 3 different orientations on its side, on the top rim and finally on the top of the keg. The test procedure and results of the puncture tests are reported in the report CTR 2010/02 (Section 2.12.2) and summarized in this section.

The package was dropped onto the punch in orientations expected to cause the maximum damage to the package. The puncture tests were carried out with the package at -40°C after the 10.2m drop test series. This test allowed the effects of brittle fracture during the punch test to be assessed.

The penetration drops on the bottom end and the top rim resulted in minimal damage to the keg. The side penetration drop resulted in a dent of 11 mm in depth in the side of the keg. No tearing or penetration of the keg skin was observed.

2.7.4 Thermal [71.73 (c)(4)]

10 CFR 71.73 (c) (4) requires that the package can withstand a 30 minute fire with an average flame temperature of 800°C. The requirement was demonstrated by carrying out a thermal analysis on a HS package. This analysis has been bench marked using an actual thermal test on a similar package the 3979A LS package. The thermal results have been reported in Section 3.10.2. The analyses of the structural design during the thermal test are presented within this section.

2.7.4.1 Summary of Pressures and Temperatures

During the thermal test the keg skin reaches a maximum temperature similar to that of the fire (800°C). The containment vessel insulated from the full effect of the fire by the cork reaches a maximum temperature of 208°C with a heat load of 30W from the contents. The temperature each component reaches during the HAC thermal test is within its maximum allowable service temperature.

A calculation of the actual maximum pressure expected under HAC is provided in Calculation Sheet CS 2012/02 (Section 2.12.2) – the calculated maximum pressure is 1.64 bar absolute (164 kPa).

The free volume within the CV is 78 cc – this is based on the air gap between the Tungsten Insert and CV cavity of 33cc + the cavity volume of the Tungsten Insert of 55cc less an allowance of 10 cc for solid contents of the Tungsten Insert (see restriction in Table 1-3-6 under Product containers “The volume limit of the Product containers and packing shall be <10cc). Therefore breaching of the product container containing the gas (of maximum amount 25 bar.cc) would increase the pressure in the CV by a maximum of 0.32 bar (given by the volume ratio 25/78).

The containment vessel maximum internal pressure during the HAC fire is assumed to be 10 bar or 1000 kPa gauge for the design evaluation.

HAC Operating Condition	CV
Assumed Max. Temperature	208°C
Max. Pressure	10 bar (1,000kPa) gauge 11 bar (1,100kPa) abs
Min. Temperature	-40°C
Min. Pressure	-1 bar (-100 kPa) gauge 0 bar (0 kPa) abs

2.7.4.2 Differential Thermal Expansion

The HAC thermal evaluation shows that on initiation and on completion of the fire there is no significant temperature gradient over the depleted uranium shielding and the stainless steel cladding. Therefore it is expected that the differential thermal expansion is bounded by the results for the NCT heat test discussed in section 2.6.1.2.

2.7.4.3 Stress Calculations

In accordance with the ASME code the stresses in the package resulting from temperature loading are classified as secondary and need not be evaluated under HAC. The HAC thermal evaluation shows that the thermal gradient of the containment vessel under HAC will be negligible and therefore bounded by the NCT heat test discussed in section 2.6.1.3.

2.7.4.4 Comparison with Allowable Stress

The HAC thermal test stresses are bounded by the stresses in the NCT thermal test. As detailed in Section 2.6.1.4 all the maximum stresses are less than the allowable stresses. Therefore the package meets the requirements under HAC conditions.

2.7.5 Immersion – Fissile Material [71.73 (c)(5)]

The quantity of fissile material to be carried does not depend on water exclusion for criticality safety and therefore this water immersion test is not required.

2.7.6 Immersion – All Packages [71.73 (c)(6)]

71.73(c)(6) requires that a package be subjected to a maximum external pressure due to immersion under 15 m (50 ft) of water (equivalent pressure is 150 kPa gauge).

The maximum pressure differential that could occur under the water immersion condition arises from external pressure of 150 kPa combined with a reduced internal pressure of 0 kPa absolute giving a maximum pressure differential of 150 kPa.

As described in section 2.6.4, the effect of an increased external pressure of 140 kPa with the worst case initial conditions has been determined: the maximum stresses encountered and the minimum design margins are presented in Table 2-24. In order to determine the effect of an external pressure of 150 kPa, the stresses calculated for an external pressure of 140 kPa have been scaled by $150/140 = 1.07$: the results are given in Table 2-43. Scaling of the stresses indicates that the design margins are all greater than zero. This demonstrates the containment vessel will be acceptable under an immersion test.

.NCT Case ID	Description	Stress Type	Maximum Stress Intensity (MPa)	Stress Location	Allowable stress intensity (MPa)	Minimum Design Margin
4	Increased External Pressure	P_m	3.92	C10	115	28.3
		P_m+P_b	9.57	C1	173	17.1
		P_m+P_b+Q	8.74	C3	345	38.5
		Bearing	64.2	Under bolts	172	1.7

2.7.7 Deep Water Immersion Test (for Type B Packages Containing More than 10^5 A2) [71.61]

Not applicable as the contents are $< 10^5 A_2$.

2.7.8 Summary of Damage

The mechanical damage sustained by the package during the NCT and HAC test series is reported in CTR 2010/02 [Section 2.12.2]. The testing was carried out in series with the NCT drop testing, followed by the HAC drop tests and the HAC puncture tests.

The NCT drop tests caused minimal denting to the rim of the keg at the points of impact. The puncture tests also caused minimal damage to the keg rim however the side puncture test did cause an indent on the side of the keg. The 10.2 meter drop tests caused more severe denting to the top and bottom rims.

On completion of the test series, examination of the containment vessel found no damage and no change in the measured dimensions. Leak tests carried out prior to and on completion of testing detected no signs of leaks, indicating that the containment vessel remained leak tight throughout the NCT and HAC tests. The examination of the containment vessel (as detailed in report CTR 2010/02, Table 11, page 38, under the table section headed Containment Vessel in rows 10 -24), showed the outside diameter of the CV body at the lower and mid diameter are all seen to be close to the nominal diameter of 179.5 mm and there are no significant changes following the drop test program. This demonstrates that there was no distortion of the CV shell.

2.8 Accident Conditions for Air Transport of Plutonium [71.74]

Not applicable – air shipment of $> A_2$ plutonium is not required.

2.9 Accident Conditions for Fissile Material Packages for Air Transport [1.55(f)]

Not applicable – air shipment of fissile materials is not required.

2.10 Special Form [71.75]

Special form is not claimed for the contents or for any part of the package.

2.11 Fuel Rods

Irradiated fuel rods are not to be carried in this package.

2.12 Appendix

2.12.1 References

- [2.1] Title 10, Code of Federal Regulations, Part 71, Office of the Federal Register, Washington D.C.
- [2.2] Regulatory Guide 7.8, *Load Combinations for the Structural Analysis of Shipping Casks for Radioactive Material*, Revision 1, U.S. Nuclear Regulatory Commission, Office of Standards Development, March 1989.
- [2.3] Regulatory Guide 7.6, *Design Criteria for the Structural Analysis of Shipping Cask Containment Vessels*, Revision 1, March 1978.
- [2.4] American Society of Mechanical Engineers (ASME) Boiler and Pressure Vessel Code, Section III, Division 3, *Containment Systems for Storage and Transport Packagings of Spent Nuclear Fuel and High Level Radioactive Material and Waste*, 1977 Edition.

- [2.5] American Society of Mechanical Engineers (ASME) Boiler and Pressure Vessel Code, Section III, Division 3, *Containment Systems for Storage and Transport Packagings of Spent Nuclear Fuel and High Level Radioactive Material and Waste*, 2001 Edition with Addenda through July 1, 2003.
- [2.6] American Society of Mechanical Engineers (ASME) Boiler and Pressure Vessel Code, Section III, Division 1, Code Cases: Nuclear Components, Case N-284-1, *Metal Containment Shell Buckling Design Methods, Class MC*, 2001 Edition with Addenda through July 1, 2003.
- [2.7] Regulatory Guide 7.11, *Fracture Toughness Criteria of Base Material for Ferritic Steel Shipping Cask Containment Vessels with a Maximum Wall Thickness of 4 Inch (0.1 m)*, U.S. Nuclear Regulatory Commission, Office of Standards Development, June 1991.
- [2.8] NUREG/CR-3854, *Fabrication Criteria for Shipping Containers*, U.S. Nuclear Regulatory Commission, Washington D.C., April 1984.
- [2.9] American Society of Mechanical Engineers (ASME) Boiler and Pressure Vessel Code, Section III, Division 1, Subsection NB, *Class 1 Components*, 2001 Edition with Addenda through July 1, 2003.
- [2.10] American Society of Mechanical Engineers (ASME) Boiler and Pressure Vessel Code, Section III, Division 1, Subsection NF, *Supports*, 2001 Edition with Addenda through July 1, 2003.
- [2.11] NUREG/CR-6407, INEL-95/0551, *Classification of Transportation Packaging and Dry Spent Fuel Storage System Components According to Importance to Safety*, February 1996
- [2.12] American Society of Mechanical Engineers (ASME) Boiler and Pressure Vessel Code, Section XI, *Ferrous Material Specification, 2007 Edition with Addenda through July 1, 2009*
- [2.13] American National Standards Institute, for Radioactive Material, *Leakage Tests on Packages for Shipment*, ANSI N14.5-1997
- [2.14] NUREG CR/3019, UCRL-53044 *Recommended Welding Criteria for Use in the Fabrication of Shipping Containers for Radioactive Materials*, March 1984
- [2.15] Parker Hannifin Corporation, *Parker O-ring Handbook*, ORD 5700/USA, 2001.
- [2.16] American Society of Mechanical Engineers (ASME) Boiler and Pressure Vessel Code, Section II, Part D, *Materials*, 2001 Edition with Addenda through July 1, 2003.

- [2.17] American Society of Mechanical Engineers (ASME) Boiler and Pressure Vessel Code, Section V, *Non Destructive Examination*, 2001 Edition, with Addenda through July 1, 2001
- [2.18] *Vibration, Measurement and Analysis*, JD Smith, Butterworth-Heinemann

2.12.2 Supporting Documents

Document Reference	Title
SERCO/TAS/002762/01	Compression Testing of Cork
Arcadis Vectra, L20008/1/R1	Stress Analysis of Safkeg HS Containment Vessel
CTR 2010/02	Prototype SAFKEG HS 3977A/0002 NCT and HAC Regulatory Test Report
CS 2012/02	SAFKEG-HS 3977A – Maximum Pressure in CV
CS 2012/03	Calculation of the Density of the 3977A Package