



Prairie Island Independent Spent Fuel Storage Installation Thermal Conductance License Amendment Request Post-Submittal Meeting



**Rockville, Maryland
September 11, 2012**

Attendees

NSPM

Mike Baumann – Director, Nuclear Fuel Supply

Tim Morrison – Supervisor, Spent Nuclear Fuel Projects

Oley Nelson – Engineer, Spent Nuclear Fuel Projects

Brian Zelenak – Manager, ISFSI Licensing

Transnuclear

Peter Shih – Director, Design Engineering

Don Shaw – Manager, Licensing

Slava Guzeyev – Engineer, Thermal Analysis

Venkata Venigalla – Engineer, Thermal Analysis

Agenda

- **Introductions**
- **Purpose of Meeting**
- **Background**
- **Proposed Changes**
- **Reason for Amendment Request**
- **Thermal Analysis**
- **Summary**
- **Discussion / Q&A**

Purpose Of Meeting

- **Explain the Reasons for and Benefits of the LAR**
- **Explain Proposed TS and SAR Changes**
- **Discuss Supporting Thermal Analysis**
- **Answer Staff Questions**

Background

TN-40HT Cask Basket Design

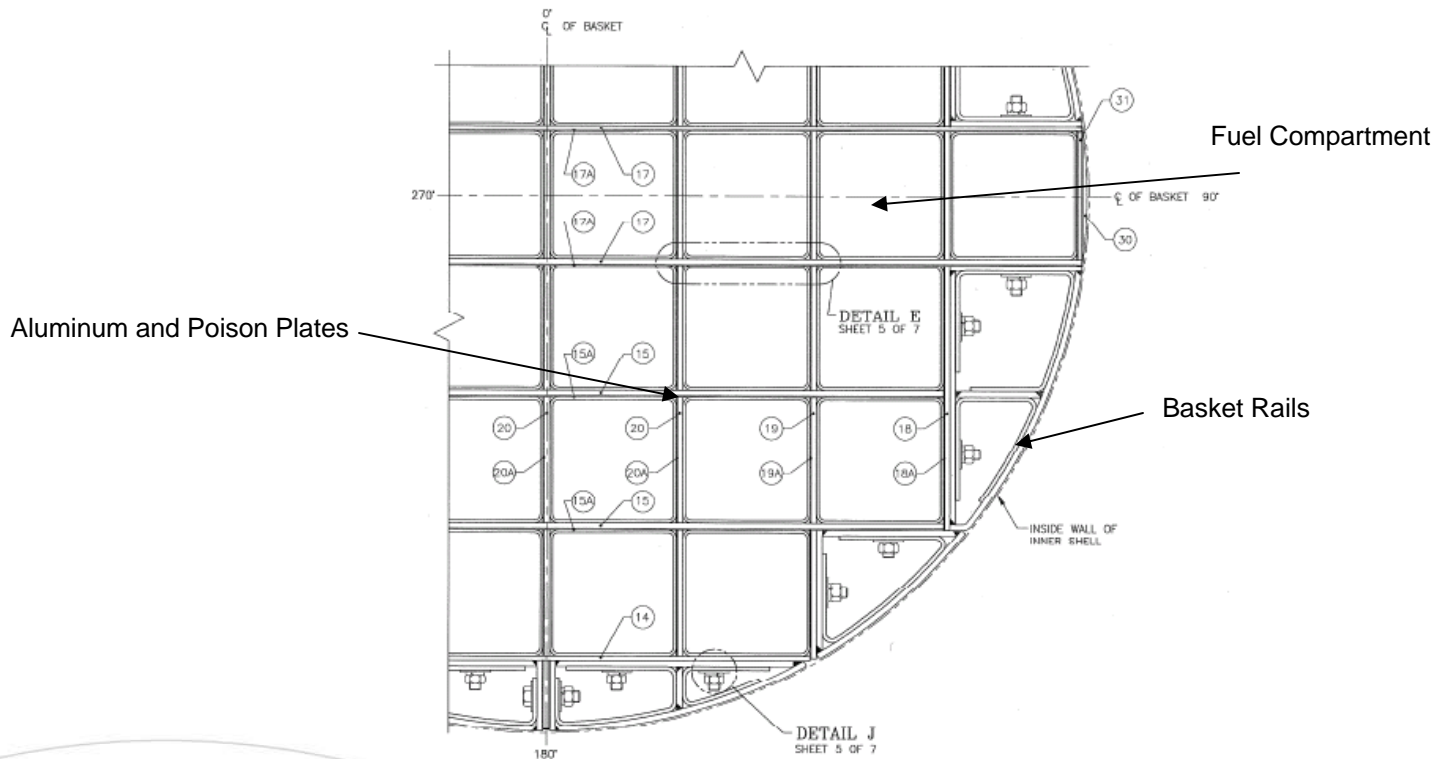

Background

TN-40HT Cask Basket Design

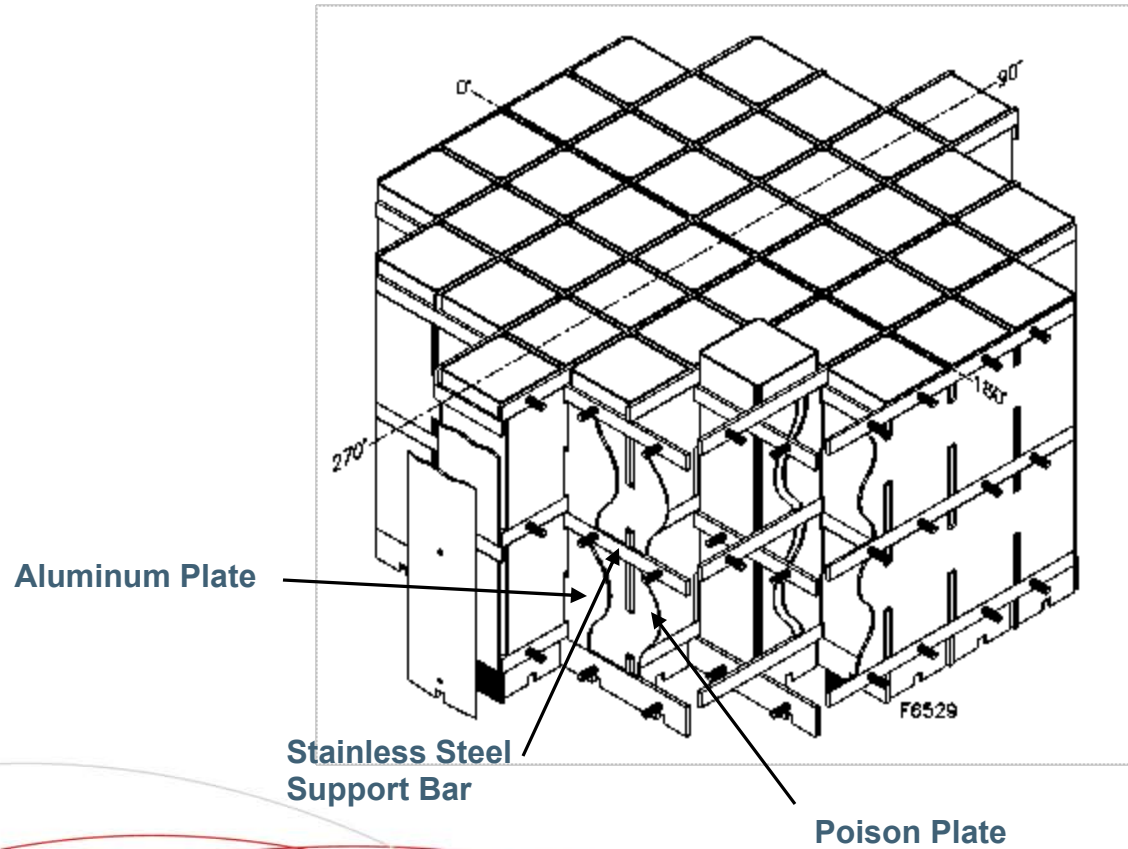

Background

- **TS 4.3.2.b Requires Thermal Conductivity Testing of Neutron Absorbers**
- **Requires Minimum Poison Plate Conductivity such that Total Conductance (Sum Of Conductivity * Thickness) of Poison and Aluminum Plates be ≥ 3.98 Btu/hr-°F**

Background

- **Fabrication of First Three TN-40HT Baskets**
 - ◆ **Utilized Flexibility Provided in Design Drawings**
 - ◆ **As-Fabricated Baskets Would Not Meet TS 4.3.2.b**
- **Baskets Satisfy all Design Bases Functions Except for Compliance with TS 4.3.2.b**
- **Delayed 2012 Cask Loading Until 2013**
- **Fabricating Baskets That Will Meet the Current TS 4.3.2.b Requirements for the 2013 Loading**

Proposed Changes

- **New SAR Section**
 - ◆ **Lower Conductance Thermal Evaluation**
 - ◆ **Demonstrates All Temperature Limits are Met and Bounded by Previous Thermal Analysis**
- **Analysis Performed Using ANSYS Version 10.0**
- **TS 4.3.2.b Minimum Thermal Conductance of Poison and Aluminum Plates from 3.98 to 3.55 Btu/hr-°F**

Proposed Changes

- **TS 4.3.2.b Nominal Thickness of Aluminum Plate at which do not need to Perform Thermal Conductivity Testing on Poison Plate is changed from 0.359 to 0.320 inches**
- **TS Table 4.3-3 Conductivity and Conductance Values, Based on Change to TS Section 4.3.2.b**

Reasons for Amendment Request

- **Flexibility for Future Manufacturing**
 - ◆ **Will Not Require Special Order Aluminum Plates**
 - ◆ **Reduces Potential Fabrication Challenges**
 - ◆ **Fewer Challenges Result in a Higher Quality Baskets**
 - ◆ **Increases the Number of Poison Plate Suppliers**
- **Allows Use of Three Fabricated Baskets**

Reasons for Amendment Request

- **Requested Approval Date of 5/1/13**
 - ◆ **Supports Future Cask Fabrication and Loading Campaigns Scheduled for Spring of 2014**
 - ◆ **Decision Point Based on the Time Required to Build and Deliver Casks with New Baskets**

Thermal Analysis

Objectives

- **Re-analyze All Thermal Conditions**
- **Maintain the Current SAR Analysis as Bounding**
- **Limit the Effect of Reduction of Poison Plate Conductivity to Thermal Design Functions**

Thermal Analysis

Re-Analyzed Conditions

- Normal and Off-Normal
- Accident Conditions
 - ◆ Fire
 - ◆ Buried Cask
- Vacuum Drying

Thermal Analysis

Thermal Model Used

- **Full Length Model Used for Lower Conductance Analysis**
 - ◆ **Full Length Model was Used in SAR to Evaluate Normal/Off-Normal Storage Conditions**
 - ◆ **Cross-Section Model was Used in SAR for Accident / Vacuum Drying Analysis (Saved Computer Memory and Computation Time)**
- **Full Length Model Provides More Accurate Results**
- **Analysis Performed Using ANSYS Version 10.0**

Thermal Analysis

Thermal Inputs

- **Thermal Inputs for Aluminum and Poison Plates Based on Poison Plate Conductivity of 0.68 Btu/hr-in-°F**
 - ◆ **Equates to Thermal Conductance of 3.55 Btu/hr-°F (At 70 °F)**
- **Transverse Effective Fuel Conductivities in Helium were Changed to the Values in SAR Table A3.3-9**
- **All Other Material Properties Remain the Same as Pervious SAR Thermal Analysis**

Thermal Analysis

Normal / Off-Normal Condition

- No Changes Made to Boundary Conditions
- Maximum Fuel Cladding Temperature Decreased from 680 °F to 658 °F (Limit Is 752 °F)
- Basket Rail Temperature Increased from 459 °F to 460 °F
 - ◆ Negligible Change for this Component
- No Change in Other Component Temperatures

Thermal Analysis

Fire Accident Condition

- **No Changes Made to Boundary Conditions**
- **Transient Analysis Followed by Steady State Analysis**
- **Maximum Fuel Cladding Temperature Decreased Slightly from 772 °F to 769 °F (Limit Is 1058 °F)**
- **Other Component Temperatures Also Decreased**

Thermal Analysis

Buried Accident Condition

- **No Changes Made to Boundary Conditions**
- **Maximum Fuel Cladding Temperature at 95.75 Hours Decreased from 1058 °F to 905 °F (Limit Is 1058 °F)**
- **Other Component Temperatures Also Decreased**

Thermal Analysis

Vacuum Drying Condition

- **Conservatively Assumes Cask Remains in Spent Fuel Pool with Boiling Water During Entire Vacuum Drying**
- **Other Boundary Conditions Remain Unchanged**
- **Maximum Fuel Cladding Temperature at 34 hours Decreased from 725 °F to 628 °F (Limit is 752 °F)**

Thermal Analysis

Analysis Summary

- **Maximum Fuel Cladding Temperatures Remain Bounded by the Current SAR Evaluations**
 - ◆ **Using Lowered Conductivity of Poison Plates (0.68 Btu/hr-in-°F)**
 - ◆ **Using More Accurate Transverse Effective Fuel Assembly Conductivity**
 - ◆ **Using Full Length Model Instead of Cross-Section Model for Transient Runs**

Thermal Analysis

Analysis Summary Continued....

- **New SAR Section Describes Lower Conductance Analysis**
- **New SAR Section Concludes that Current SAR Results Remain Conservatively Bounding or Unaffected**
- **Lower Conductance Results Do Not Replace Existing Results in SAR**
- **No Impact on the Other Analyses that Use the Thermal Analysis Results as Input**

Summary

- **Analysis Used Previously Reviewed Thermal Model and Effective Fuel Conductivity**
- **Results of Current SAR Analysis Remain Conservatively Bounding or Unaffected**
- **LAR Provides Flexibility that will Reduce Future Manufacturing Challenges**
- **Request Approval in Time to Support Planning for Future Cask Fabrication and Loading Campaigns**
- **Proposed Changes Do Not Impact the Health and Safety of the Public**



Discussion

Discussion Q&A

