

3.5 Missile Protection

The missile protection design basis for Seismic Category I structures, systems, and components is described in this section. A tabulation of safety-related structures, systems, and components (both inside and outside containment), their location, seismic category, and quality group classification is given in Table 3.2-1. General arrangement drawings showing locations of the structures, systems, and components are presented in Section 1.2.

Missiles considered are those that could result from a plant-related failure or incident including failures within and outside of containment, environmental-generated missiles and site-proximity missiles. The structures, shields, and barriers that have been designed to withstand missile effects, the possible missile loadings, and the procedures to which each barrier has been designed to resist missile impact are described in detail.

3.5.1 Missile Selection and Description

Components and equipment are designed to have a low potential for generation of missiles as a basic safety precaution. In general, the design that results in reduction of missile-generation potential promotes the long life and usability of a component and is well within permissible limits of accepted codes and standards.

Seismic Category I structures have been analyzed and designed to be protected against a wide spectrum of missiles. For example, failure of certain rotating or pressurized components of equipment is considered to be of sufficiently high probability and to presumably lead to generation of missiles. However, the generation of missiles from other equipment is considered to be of low enough probability and is dismissed from further consideration. Tornado-generated missiles and missiles resulting from activities particular to the site are also discussed in this section. The missile protection criteria to which the plant has been analyzed comply with Criterion 4 of 10CFR50 Appendix A, General Design Criteria for Nuclear Power Plants.

Potential missiles that have been identified are listed and discussed in later subsections.

After a potential missile has been identified, its statistical significance is determined. A statistically significant missile is defined as a missile which could cause unacceptable plant consequences or violation of the guidelines of 10CFR100.

The examination of potential missiles and their consequences is done in the following manner to determine statistically significant missiles:

- (1) If the probability of occurrence of the missile (P_1) is determined to be less than 10^{-7} per year, the missile is dismissed from further consideration because it is considered not to be statistically significant.
- (2) If (P_1) is found to be greater than 10^{-7} per year, it is examined for its probability of impacting a design target (P_2).

- (3) If the product of (P_1) and (P_2) is less than 10^{-7} per year, the missile is dismissed from further consideration.
- (4) If the product of (P_1) and (P_2) is greater than 10^{-7} per year, the missile is examined for its damage probability (P_3). If the combined probability (i.e., $P_1 \times P_2 \times P_3 = P_4$) is less than 10^{-7} per year, the missile is dismissed.
- (5) Finally, measures are taken to design acceptable protection against missiles with (P_4) greater than 10^{-7} per year to reduce (P_1), (P_2), and/or (P_3), so that (P_4) is less than 10^{-7} per year.

Protection of safety-related structures, systems, and components is afforded by one or more of the following practices:

- (1) Location of the system or component in an individual missile-proof structure
- (2) Physical separation of redundant systems or components of the system for the missile trajectory path or calculated range
- (3) Provision of localized protection shields or barriers for systems or components
- (4) Design of the particular structure or component to withstand the impact of the most damaging missile
- (5) Provision of design features on the potential missile source to prevent missile generation
- (6) Orientation of the potential missile source to prevent unacceptable consequences due to missile generation

The following criteria have been adopted to provide an acceptable design basis for the plant's capability to withstand the statistically significant missiles postulated inside the reactor building:

- (1) No loss of containment function as a result of missiles generated internal to containment.
- (2) Reasonable assurance that a safe plant shutdown condition can be achieved and maintained.
- (3) Offsite exposure within the 10CFR100 guidelines for those potential missile damage events resulting in radiation activity release.
- (4) The failure of non-safety-related equipment, components, or structures whose failure could result in a missile do not cause the failure of more than one division of safety-related equipment.

- (5) No high energy lines are located near the standby-gas treatment charcoal vaults, the offgas charcoal storage vault, or the spent fuel pool.

The systems requiring protection are:

- (1) Reactor coolant pressure boundary
- (2) Residual Heat Removal System
- (3) High Pressure Core Flooder System
- (4) Reactor Core Isolation Cooling System
- (5) Reactor Building Cooling Water System
- (6) Automatic Depressurization System relief valves
- (7) Standby diesel generator system
- (8) CRD scram system (hydraulic and electrical)
- (9) Fuel Pool Cooling and Cleanup System
- (10) Remote shutdown panel
- (11) Reactor Protection System
- (12) All containment isolation valves
- (13) HVAC emergency cooling water system
- (14) HVAC systems required during operation of items (1) through (12)
- (15) Electrical and control systems and wiring required for operation of items (1) through (14)

The following general criteria are used in the design, manufacture, and inspection of equipment:

- (1) All pressurized equipment and sections of piping that may periodically become isolated under pressure are provided with pressure-relief valves acceptable under ASME Code Section III. The valves ensure that no pressure buildup in equipment or piping sections exceeds the design limits of the materials involved.

- (2) Components and equipment of the various systems are designed and built to the standards established by the ASME Code or other equivalent industrial standard. A stringent quality control program is also enforced during manufacture, testing, and installation.
- (3) Volumetric and ultrasonic testing where required by code coupled with periodic inservice inspections of materials used in components and equipment add further assurance that any material flaws that could permit the generation of missiles are detected.

3.5.1.1 Internally Generated Missiles (Outside Containment)

These missiles are considered to be those missiles resulting internally from plant equipment failures within the ABWR Standard Plant but outside containment.

3.5.1.1.1 Rotating Equipment

3.5.1.1.1.1 Missile Characterization

Equipment within the general categories of pumps, fans, blowers, diesel generators, compressors, and turbines and, in particular, components in systems normally functioning during power reactor operation, has been examined for any possible source of credible and significant missiles.

3.5.1.1.1.2 RCIC Steam Turbine

The RCIC steam turbine driving the pump is not a credible source of missiles. It is provided with mechanical overspeed protection as well as automatic governing; very extensive industrial and nuclear experience with this model of turbine has never resulted in a missile which penetrated the turbine casing.

3.5.1.1.1.3 Main Steam Turbine

Acceptance Criteria 1 of SRP Section 3.5.1.3 considers a plant with a favorable turbine generator placement and orientation and adhering to the guidelines of Regulatory Guide 1.115 adequately protected against turbine missile hazards. Further, this criterion specifies that exclusions of safety-related structures, systems or components from low trajectory turbine missile strike zones constitutes adequate protection against low trajectory turbine missiles. The turbine generator placement and orientation of the ABWR Standard Plant meets the guidelines of Regulatory Guide 1.115 as illustrated in Figure 3.5-2.

In addition, the COL applicant shall:

- (1) Submit for NRC approval, within three years of obtaining an operating license, a turbine system maintenance program including probability calculations of turbine

missile generation based on the NRC approved methodology (such as Reference 3.5-9).

- (2) Volumetrically inspect all low pressure turbine rotors at the second refueling outage and every other (alternate) refueling outage thereafter until a maintenance program is approved by the staff.
- (3) Meet the minimum requirement for the probability of turbine missile generation given in Table 3.5-1.

See Subsection 3.5.4.5 for COL license information.

3.5.1.1.1.4 Other Missile Analysis

No remaining credible missiles meet the significance criteria of having a probability (P_4) greater than 10^{-7} per year for rotating or pressurized equipment, because either:

- (1) The equipment design and manufacturing criteria mentioned previously result in (P_1) being less than 10^{-7} per year.
- (2) Sufficient physical separation (barriers and/or distance) of safety-related and redundant equipment exists so that the combined probability ($P_1 \times P_2$) is less than 10^{-7} per year.

These conclusions are arrived at by noting that pumps, fans, and the like are AC powered. Their speed is governed by the frequency of the AC power supply. Since the AC power supply frequency variation is limited to a narrow range, it is not likely they will attain an overspeed condition. At rated speed, if a piece such as a fan blade breaks off, it will not penetrate the casing. The issue of missile generation in rotating machinery is a general safety problem which is not limited to nuclear applications. The designers and manufacturers of these equipment consider this factor as a requirement in their design. Industrial experience and studies conducted on system components indicate that the probability of a missile escaping the casing is very low. A study was conducted on potential missile generation from electrical machines (motors, exciters, generators), flexible couplings and fluid drives. One example where missile generation is significant is in fluid drives where the rotating part and housing diameters are big and the relative thickness of the housing is small. Based on the results of a study of such a rotating component (Reference 3.5-1), it is concluded that the potential of a missile being generated and leaving the equipment housing is negligibly small.

3.5.1.1.2 Pressurized Components

3.5.1.1.2.1 Missile Characterization

Potential missiles which could result from the failure of pressurized components are analyzed in this subsection. These potential missiles may be categorized as contained fluid-energy

missiles or stored strain-energy (elastic) missiles. These potential missiles have been conservatively evaluated against the design criteria in Subsection 3.5.1.

Examples of potential contained fluid-energy missiles are valve bonnets, valve stems, and retaining bolts. Valve bonnets are considered jet-propelled missiles and have been analyzed as such. Valve stems have been analyzed as piston-type missiles, while retaining bolts are examples of stored strain-energy missiles.

3.5.1.1.2.2 Missile Analyses

Pressurized components outside the containment capable of producing missiles have been reviewed. Although piping failures could result in significant dynamic effects if permitted to whip, they do not form missiles as such because the whipping section remains attached to the remainder of the whip. Since Section 3.6 addresses the dynamic effects associated with pipe breaks, pipes are not included here as potential internal missiles.

All pressurized equipment and sections of piping that may periodically become isolated under pressure are provided with pressure-relief valves acceptable under ASME Code Section III.

The only remaining pressurized components considered to be potentially capable of producing missiles are:

- (1) Valve bonnets (large and small)
- (2) Valve stems
- (3) Pressure vessels
- (4) Thermowells
- (5) Retaining bolts
- (6) Blowout panels

These are analyzed as follows:

- (1) **Valve Bonnets**—Valves of ANSI 6.2 MPa rating and above and constructed in accordance with ASME Code Section III are pressure-seal bonnet-type valves. Valve bonnets are prevented from becoming missiles by limiting stresses in the bolting to those defined by the ASME Code and by designing flanges in accordance with applicable code requirements. Safety factors involved against failure of these type bonnets are sufficiently high that these pressure seal-type valves are not considered a potential missile source (Reference 3.5-8).

Most valves of ANSI 4.1 MPa rating and below are valves with bolted bonnets. These type valves were analyzed for the safety factors against failure, and, coupled with the

low historical incidents of complete severance failure, were determined to not be a potential missile source (Reference 3.5-8).

- (2) **Valve Stems**—All the isolation valves installed in the reactor coolant systems have stems with a back seat which eliminates the possibility of ejecting valve stems even if the stem threads fail. Since a double failure of highly reliable components would be required to produce a valve stem missile, the overall probability of occurrence is less than 10^{-7} per year. Hence, valve stems can be dismissed as a source of missiles.
- (3) **Pressure Vessels**—Moderate energy vessels less than 1.9 MPa are not credible missile sources. The pneumatic system air bottles are designed for 17.2 MPa to ASME Code Section III requirements. These bottles are not considered a credible source of missiles for the following qualitative analysis:
- (a) The bottles are fabricated from heavy-wall rolled steel.
 - (b) The operating orientation is vertical with the ends facing concrete slabs. The bottles are topped with steel covers thick enough to preclude penetration by a missile.
 - (c) The fill connection is protected by a permanent steel collar.
 - (d) The bottles are strapped in a rack to prevent them from toppling over. The rack is seismically designed to ASME Code Section III, Subsection NF, requirements.
- (4) **Thermowells**—Thermowells are welded to socket connections which, in turn, are welded to the wall of the pipe. An analysis of a postulated failure of this weld has been performed. The following expression relates the missile displacement and velocity following the postulated failure:

$$\frac{y}{(W/A)} = v_{\infty} \left[\ln \left(\frac{1}{1 - V/u_{\infty}} \right) - \frac{V}{u_{\infty}} \right] \quad (3.5-1)$$

where:

y = Distance traveled by the missile from the break (m)

W = Missile weight (kg)

A = Frontal area of missile (m^2)

u_{∞} = Asymptotic velocity of jet (m/s)

v_{∞} = Asymptotic specific volume of jet (m^3/kg)

V = Velocity of missile (m/s)

Inherently, the water and steam velocities are equal (i.e., a unity velocity ratio) in a saturated water blowdown. The jet asymptotic velocity (u_{∞}) and the jet asymptotic specific volume are determined by the methods described by Reference 3.5-2. The corresponding velocity-displacement relationships for missiles resulting from saturated water and saturated steam blowdowns are presented in Figure 3.5-1. The ordinate is the missile velocity, V , and the abscissa is the displacement parameter, Y^* , given by:

$$Y^* = \frac{y}{(W/A)} \quad (3.5-2)$$

Included in Figure 3.5-1 is the influence of different values of the friction parameter, f^* , defined by:

$$f^* = \left(\frac{fl}{D}\right)_p \left(\frac{A_E}{A_p}\right)^2 \quad (3.5-3)$$

where:

$\left(\frac{fl}{D}\right)_p$ = Equivalent loss coefficient between the broken pressurized component and fluid reservoir, dimensionless

A_E = Area of break, m^2

A_p = Area of pressurized component between break and fluid reservoir, m^2 (assumes $A_p \geq A_E$)

As illustrated in Figure 3.5-1, the effect of friction on the velocity-displacement relationship is reasonably small. It can be conservatively assumed that the most extreme friction condition persists with $f^* = 100$ for the case of saturated water blowdown and $f^* = 0$ for the case of saturated steam blowdown.

A typical thermowell weighs about 0.91 kg. Based on ejection by steam at 7.2 MPa, the ejection velocity could reach 61 m/s, which is not sufficient to inflict significant damage to critical systems. (P_4) is, therefore, less than 10^{-7} per year.

- (5) **Retaining Bolts**—Nuts, bolts, nut and bolt combinations, and nut and stud combinations have only a small amount of stored energy and, thus, are of no concern as potential missiles.

- (6) **Blowout Panels**—Blowout panels are hinged to prevent them from becoming missiles. Guard rails for personnel protection have been provided where required by the swing pattern. Thus, by design, (P_2) is less than 10^{-7} per year.
- (7) **Compartment Shielding Blocks**—Compartment shielding blocks exist in areas within secondary containment. The shielding blocks will be designed for any HELB load present.

3.5.1.1.3 Missile Barriers and Loadings

For local shields and barriers see the response to Question 410.9.

3.5.1.2 Internally Generated Missiles (Inside Containment)

Internal missiles are those resulting from plant equipment failures within the containment. Potential missile sources from both rotating equipment and pressurized components are considered.

3.5.1.2.1 Rotating Equipment

By an analysis similar to that in Subsection 3.5.1.1.1, it is concluded that no items of rotating equipment inside the containment have the capability of becoming potential missiles. All reactor internal pumps are incapable of achieving an overspeed condition and the motors and impellers are incapable of escaping the casing and the reactor vessel wall, respectively.

All drywell cooler fans are designed such that their blades are incapable of leaving the case.

3.5.1.2.2 Pressurized Components

Identification of potential missiles and their consequences outside containment are specified in Subsection 3.5.1.1.2. The same conclusions are drawn for pressurized components inside of containment. For example, the ADS accumulators are moderate energy vessels and are therefore not considered a credible missile source. One additional item is fine motion control rod drives (FMCRD) under the reactor vessel. The FMCRD mechanisms are not credible missiles. The FMCRD housings are designed (Section 4.6) to prevent any significant nuclear transient in the event of a drive housing break.

3.5.1.2.3 Evaluation of Potential Gravitational Missiles Inside Containment

Gravitational missiles inside the containment have been considered as follows:

Seismic Category I systems, components, and structures are not potential gravitational missile sources.

Non-Seismic Category I items and systems inside containment are considered as Follows:

(1) Cable Tray

All cable trays for both Class 1E and non-Class 1E circuits are seismically supported whether or not a hazard potential is evident.

(2) Conduit and Non-Safety Pipe

Non-Class 1E conduit is seismically supported if it is identified as a potential hazard to safety-related equipment. All ABWR Standard Plant non-safety related piping that is identified as a potential hazard is seismically analyzed per Subsection 3.7.3.13.

(3) Equipment for Maintenance

All other equipment, such as hoists, that is required during maintenance will either be removed prior to operation, moved to a location where it is not a potential hazard to safety-related equipment, or seismically restrained to prevent it from becoming a missile. See Subsection 3.5.4.6 for COL license information.

3.5.1.3 Turbine Missiles

See Subsection 3.5.1.1.1.3.

3.5.1.4 Missiles Generated by Natural Phenomena

Tornado-generated missiles have been determined to be the limiting natural phenomena hazard in the design of all structures required for safe shutdown of the nuclear power plant. Since tornado missiles are used in the design basis, it is not necessary to consider missiles generated from other natural phenomena. The design basis tornado for the ABWR Standard Plant is the maximum tornado windspeed corresponding to a probability of $10E-7$ per year (483 km/h). The other characteristics of this tornado are summarized in Subsection 3.3.2.1. The design basis tornado missiles are per SRP 3.5.1.4, Spectrum I.

Using the design basis tornado and missile spectrum as defined above with the design of the Seismic Category I buildings, compliance with all of the positions of Regulatory Guide 1.117, "Tornado Design Classification," Positions C.1 and C.2 is assured.

The SGTS charcoal absorber beds are housed in the tornado resistant reactor building and, therefore, are protected from the design basis tornado missiles. The offgas system charcoal absorber beds are located deep within the Turbine Building and it is considered very unlikely that these beds could be ruptured as a result of a design basis tornado missile. These features assure compliance with Position C.3 of Regulatory Guide 1.117.

See Subsections 3.5.4.2 and 3.5.4.4 for COL license information requirements.

3.5.1.5 Site Proximity Missiles Except Aircraft

External missiles other than those generated by tornados are not considered as a design basis (i.e. $< 10^{-7}$ per year).

3.5.1.6 Aircraft Hazards

Aircraft hazards are not a design basis event for the ABWR Standard Plant (i.e. $\leq 10^{-7}$ per year). See Subsection 3.5.4.3 for COL license information requirements.

3.5.2 Structures, Systems, and Components to be Protected from Externally Generated Missiles

The sources of external missiles which could affect the safety of the plant are identified in Subsection 3.5.1. Certain items in the plant are required to safely shut down the reactor and maintain it in a safe condition assuming an additional single failure. These items, whether they be structures, systems, or components, must therefore all be protected from externally generated missiles.

These items are the safety-related items listed in Table 3.2-1. Appropriate safety classes and equipment locations are given in this table. All of the safety-related systems except exhaust piping of standby-gas treatment train are located in buildings which are designed as tornado resistant. Since the tornado missiles are the design basis missiles, the systems, structures, and components listed are considered to be adequately protected. Provisions are made to protect the charcoal delay tanks against tornado missiles.

See Subsection 3.5.4.1 and 3.5.4.7 for COL license information requirements.

3.5.3 Barrier Design Procedures

The procedures by which structures and barriers are designed to resist the missiles described in Subsection 3.5.1 are presented in this section. The following procedures are in accordance with Section 3.5.3 of NUREG-0800 (Standard Review Plan).

3.5.3.1 Local Damage Prediction

The prediction of local damage in the impact area depends on the basic material of construction of the structure or barrier (i.e., concrete or steel). The corresponding procedures are presented separately. Composite barriers are not utilized in the ABWR Standard Plant for missile protection.

3.5.3.1.1 Concrete Structures and Barriers

Empirical equations, such as the modified Petry formula (Reference 3.5-3) or the TM 5-855-1 formula (Reference 3.5-4), may be used to estimate missile penetration into concrete. The resulting thickness of concrete required to prevent perforation, spalling, or

scabbing should in no case be less than those for Region II listed in Table 1 of SRP 3.5.3 for protection against tornado missiles.

3.5.3.1.2 Steel Structure and Barriers

The Stanford equation (Reference 3.5-5) is applied for steel structures and barriers.

3.5.3.2 Overall Damage Prediction

The overall response of a structure or barrier to missile impact depends largely upon the location of impact (e.g., near mid-span or near a support), dynamic properties of the structure/barrier and missile, and on the kinetic energy of the missile. In general, it has been assumed that the impact is plastic with all of the initial momentum of the missile transferred to the structure or barrier and only a portion of the kinetic energy absorbed as strain energy within the structure or barrier.

After demonstrating that the missile does not perforate the structure or barrier, an equivalent static load concentrated at the impact area is determined. The structural response to this load, in conjunction with other appropriate design loads, is evaluated using an analysis procedure similar to that in Reference 3.5-6 for rigid missiles, and the procedure in Reference 3.5-7 for deformable missiles.

3.5.4 COL License Information

3.5.4.1 Protection of Ultimate Heat Sink

Compliance with Regulatory Guide 1.27 as related to the ultimate heat sink and connecting conduits being capable of withstanding the effects of externally generated missiles shall be demonstrated (Subsection 3.5.2).

3.5.4.2 Missiles Generated by Other Natural Phenomena

The COL applicant shall identify missiles generated by other site-specific natural phenomena that may be more limiting than those considered in the ABWR design and shall provide protection for the structures, systems, and components against such missiles. The COL applicant will provide this information to the NRC (Subsection 3.5.1.4).

3.5.4.3 Site Proximity Missiles and Aircraft Hazards

Analyses shall be provided that demonstrate that the probability of site proximity missiles (including aircraft) impacting the ABWR Standard Plant and causing consequences greater than 10CFR100 exposure guidelines is $\leq 10^{-7}$ per year (Subsection 3.5.1.6).

3.5.4.4 Impact of Failure of Out of ABWR Standard Plant Scope Non-Safety-Related Structures, Systems, and Components Due to a Design Basis Tornado

An evaluation of all out of ABWR Standard Plant Scope non-safety-related structures, systems, and components (not housed in a tornado structure) whose failure due to a design basis tornado

missile that could adversely impact the safety function of safety-related systems and components will be provided to the NRC by the COL applicant (Subsection 3.5.1.4).

3.5.4.5 Turbine System Maintenance Program

A turbine system maintenance program, including probability calculations of turbine missile generation meeting the minimum requirement for the probability of missile generation, shall be provided to the NRC (Subsection 3.5.1.1.1.3).

3.5.4.6 Maintenance Equipment Missile Prevention Inside Containment

The COL applicant will provide procedures to ensure that all equipment inside containment, such as hoists, that is required during maintenance will either be removed prior to operation, moved to a location where it is not a potential hazard to safety-related equipment, or seismically restrained to prevent it from becoming a missile [Subsection 3.5.1.2.3 (3)].

3.5.4.7 Failure of Structures, Systems, and Components Outside ABWR Standard Plant Scope

Any failure of structures, systems and components outside ABWR Standard Plant scope which may result in external missile generation shall not prevent safety-related structures, systems and components from performing their intended safety function. The COL applicant will provide an evaluation of the adequacy of these designs for external missile protection for NRC review (Subsection 3.5.2).

3.5.5 References

- 3.5-1 "ABWR Reactor Internal Pump Motor-Generator Set Flywheel Integrity Criteria and Methodology", WCAP-17181-P, Revision 1, August 2011.
- 3.5-2 F. J. Moody, "Prediction of Blowdown Thrust and Jet Forces", ASME Publication 69-HT-31, August 1969.
- 3.5-3 A. Amirikan, "Design of Protective Structures", Bureau of Yards and Docks, Publication No. NAVDOCKS P-51, Department of the Navy, Washington, D.C., August 1960.
- 3.5-4 US Department of Army, Fundamentals of Protective Design for Conventional Weapons, TM 5-855-1, November 1986.
- 3.5-5 W. B. Cottrell and A. W. Savolainen, "U. S. Reactor Containment Technology", ORNL- NSIC-5, Vol. 1, Chapter 6, Oak Ridge National Laboratory.
- 3.5-6 R. A. Williamson and R. R. Alvy, "Impact Effect of Fragments Striking Structural Elements", Holmes and Narver, Inc., Revised November 1973.

- 3.5-7 J. D. Riera, "On the Stress Analysis of Structures Subjected to Aircraft Impact Forces", Nuclear Engineering and Design, North Holland Publishing Co., Vol. 8, 1968.
- 3.5-8 "River Bend Station Updated Safety Analysis Report", Docket No. 50-458, Volume 6, pp. 3.5-4 and 3.5-5, August 1987.
- 3.5-9 NUREG-1048, "Safety Evaluation Report Related to the Operation of Hope Creek Generating Station", Supplement No. 6, July 1986.

Table 3.5-1 Requirement for the Probability of Missile Generation for ABWR Standard Plant

Criterion	Probability/Yr	Required Licensee Action
(A)	$P_1 < 10^{-4}$	Criterion (A) is the general, minimum reliability requirement for loading the turbine and bringing the system on line.
(B)	$10^{-4} < P_1 < 10^{-3}$	If Criterion (B) is reached during operation, the turbine may be kept in service until the next scheduled outage, at which time the COL applicant is to take action to reduce P_1 to meet Criterion (A) before returning the turbine to service.
(C)	$10^{-3} < P_1 < 10^{-2}$	If Criterion (C) is reached during operation, the turbine is to be isolated from the steam supply within 60 days, at which time the COL applicant is to take action to reduce P_1 to meet Criterion (A) before returning the turbine to service.
(D)	$10^{-2} < P_1$	If Criterion (D) is reached at any time during the operation, the turbine is to be isolated from the steam supply within 6 days, at which time the COL applicant is to meet Criterion (A) before returning the turbine to service.

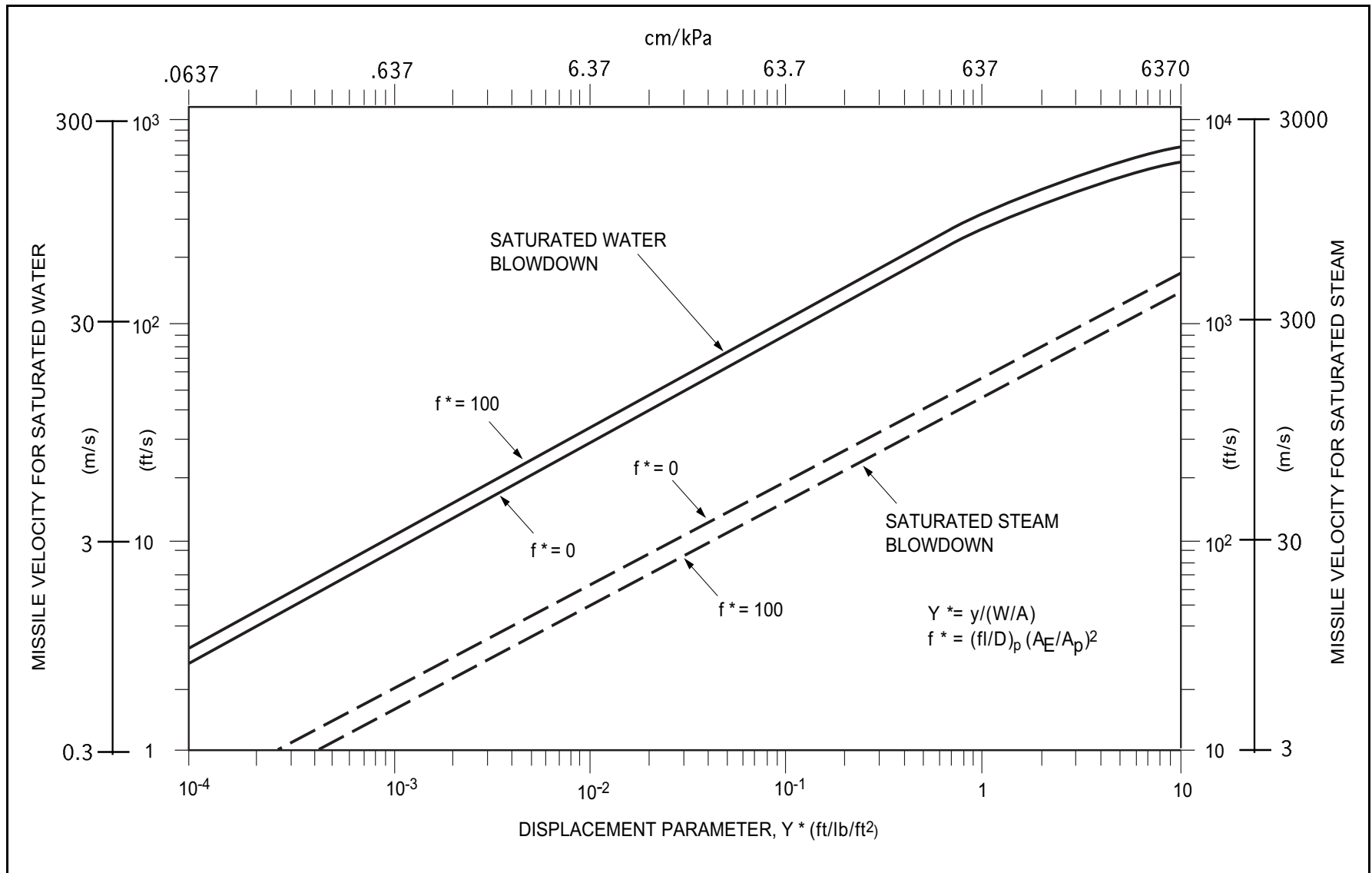
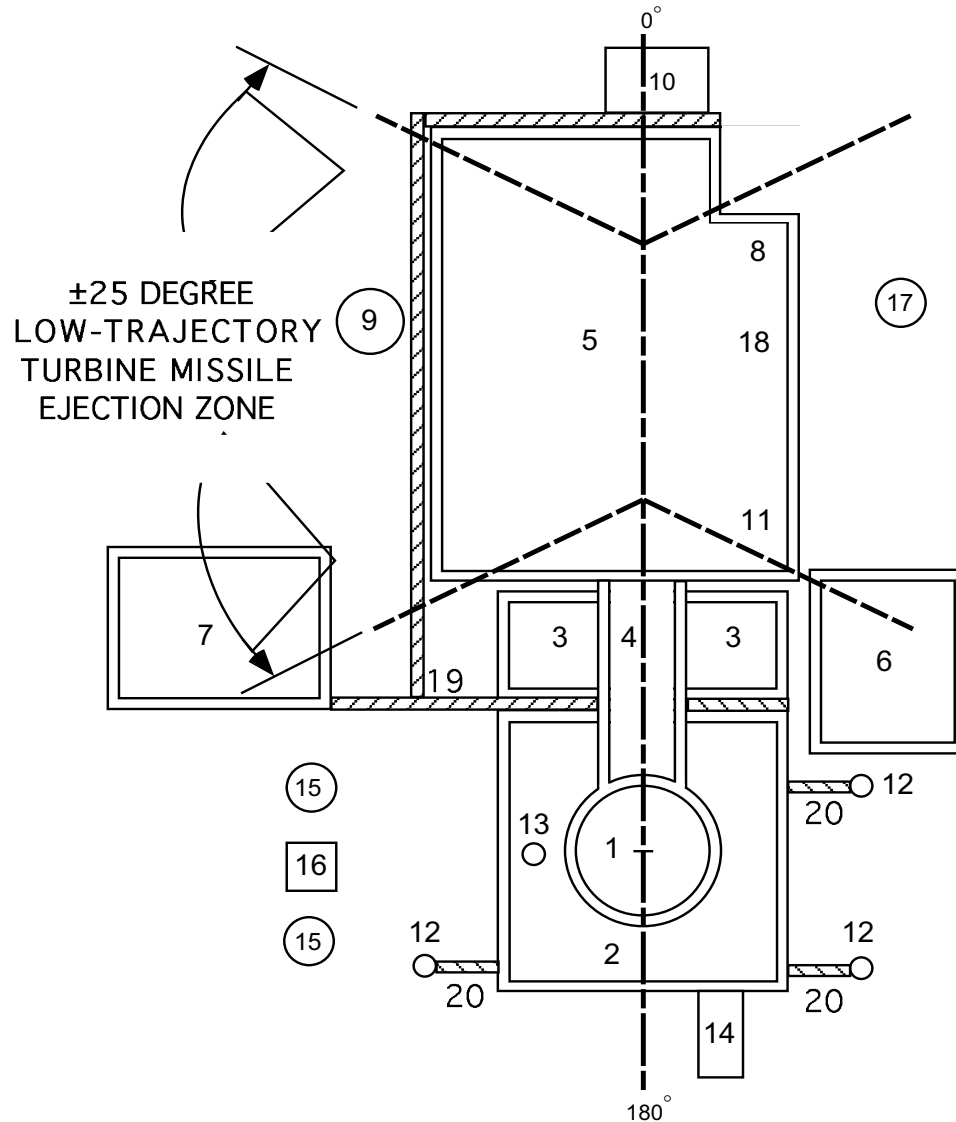

Figure 3.5-1 Missile Velocity and Displacement Characteristics Resulting from Saturated Steam and Water Blowdowns (7.2 MPaA Stagnation Pressure)



No.	FACILITY
1	REACTOR CONTAINMENT
2	REACTOR BUILDING
3	CONTROL BUILDING
4	MAIN STEAM/FEEDWATER TUNNEL
5	TURBINE BUILDING
6	SERVICE BUILDING
7	RADWASTE BUILDING
8	HOUSE BOILER
9	CONDENSATE STORAGE TANK
10	UNIT AUXILIARY TRANSFORMERS
11	NORMAL SWITCHGEAR
12	DIESEL OIL STORAGE TANK (3)
13	STACK
14	EQUIPMENT ENTRY LOCK
15	FIRE PROTECTION WATER STORAGE TANK (2)
16	FIRE PROTECTION PUMPHOUSE
17	BUNKER FUEL TANK
18	COMBUSTION TURBINE GENERATOR
19	RADWASTE TUNNELS RB, CB, TB
20	DG OIL TRANSFER TUNNEL (3)

Figure 3.5-2 ABWR Standard Plant Low-Trajectory Turbine Missile Ejection Zone