



# Buried Pipe NDE Update

**Steve Kenefick**  
Senior Project Manager  
**NRC/Industry Meeting on Buried Pipe**  
April 4<sup>th</sup>, 2012 White Flint, MD

# Buried Pipe NDE Technology

## Objective / Benefits

- Benchmark buried pipe NDE capabilities
- Constructed mock-ups to assess technology
- Resources for vendors to tweak technologies and procedures
- Facilitate vendors understanding of nuclear industry requirements
- Provide utility support in implementing technology



# Technology Identification, Development, and Assessment

- Completed / In-progress Assessments
  - Sonotest– Ultrasonic phased array wheel Probe
  - Olympus NDT– Ultrasonic phased array
  - Applus – Ultrasonic internal crawler
  - Quest Integrity – Ultrasonic flow through device
- License Renewal
  - Applus RTD INCOTEST® – Pulsed eddy current
  - Rock Solid BEM – Pulsed eddy current

# Ultrasonic Phased Array Technology

## Phased array probes

- Rapid Scanning
  - 100% coverage over probe width
- Permanent data storage
- Improved depth and extent sizing
- Sensitive to sharp flaws
- EPRI developed data acquisition and analysis techniques
  - Field trial scheduled
  - Report to be issued



2-in wide array of 64 ultrasonic elements

# Ultrasonic Phased Array Technology



- C-scan (Top View) image of holes

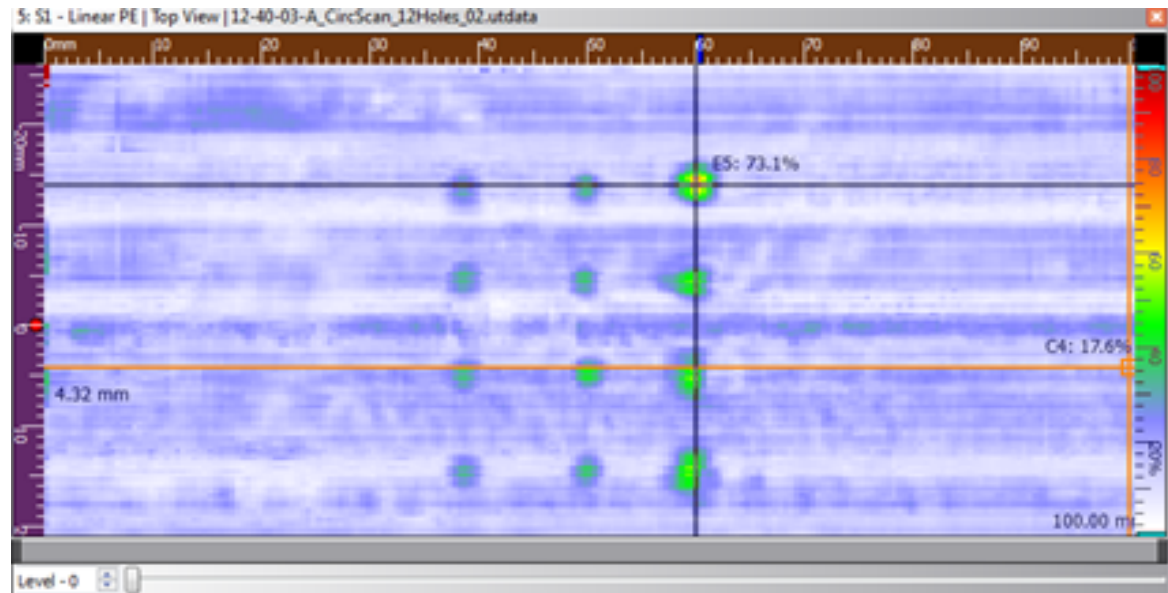

- Twelve 0.188-in diameter holes
- 0.375-in center-to-center
- Patch 0.750-in by 1.125-in

# Ultrasonic Phased Array Technology

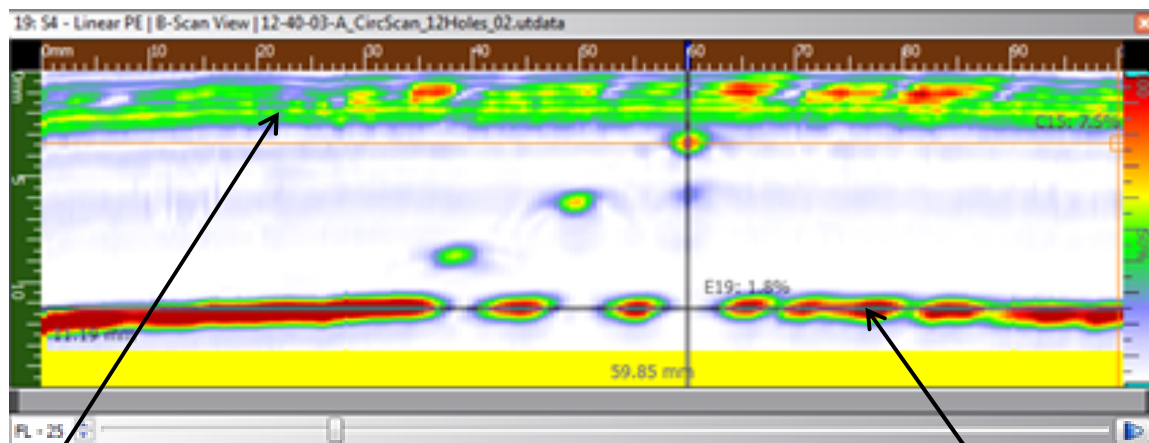
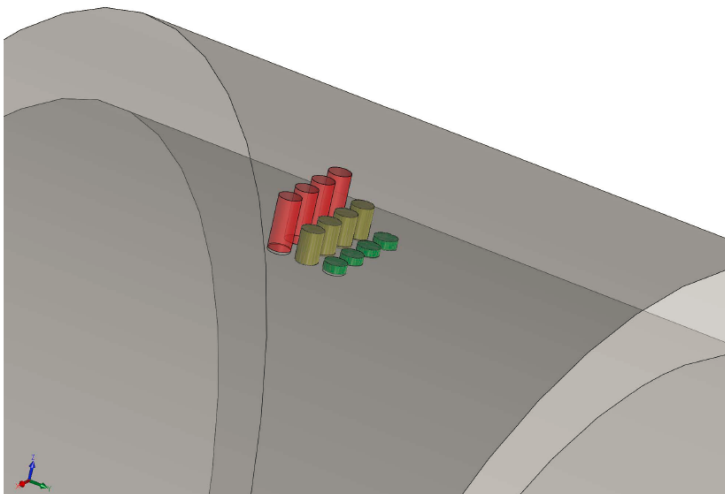

Outer Surface

Inner Surface

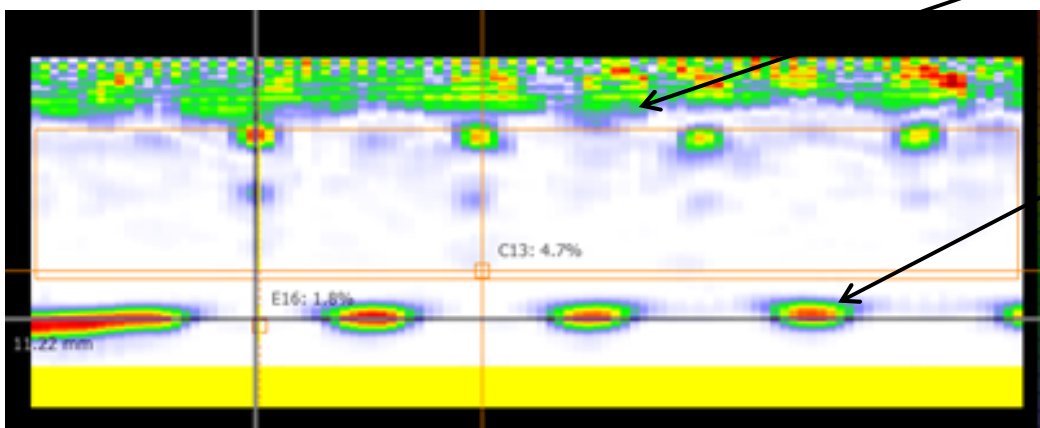

# Ultrasonic Phased Array Technology

Outer Surface

Inner Surface

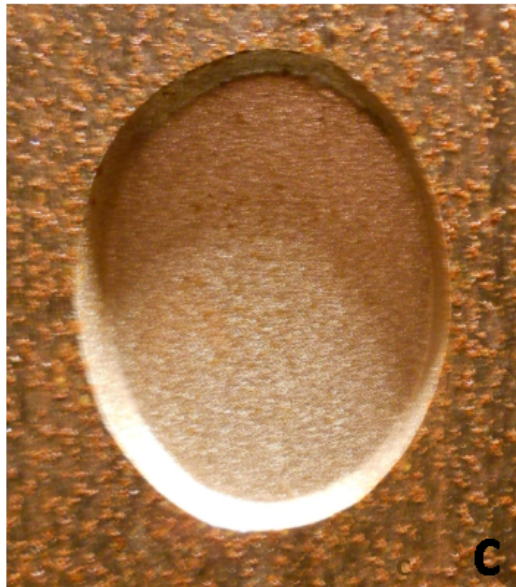

2-in by 1.75-in

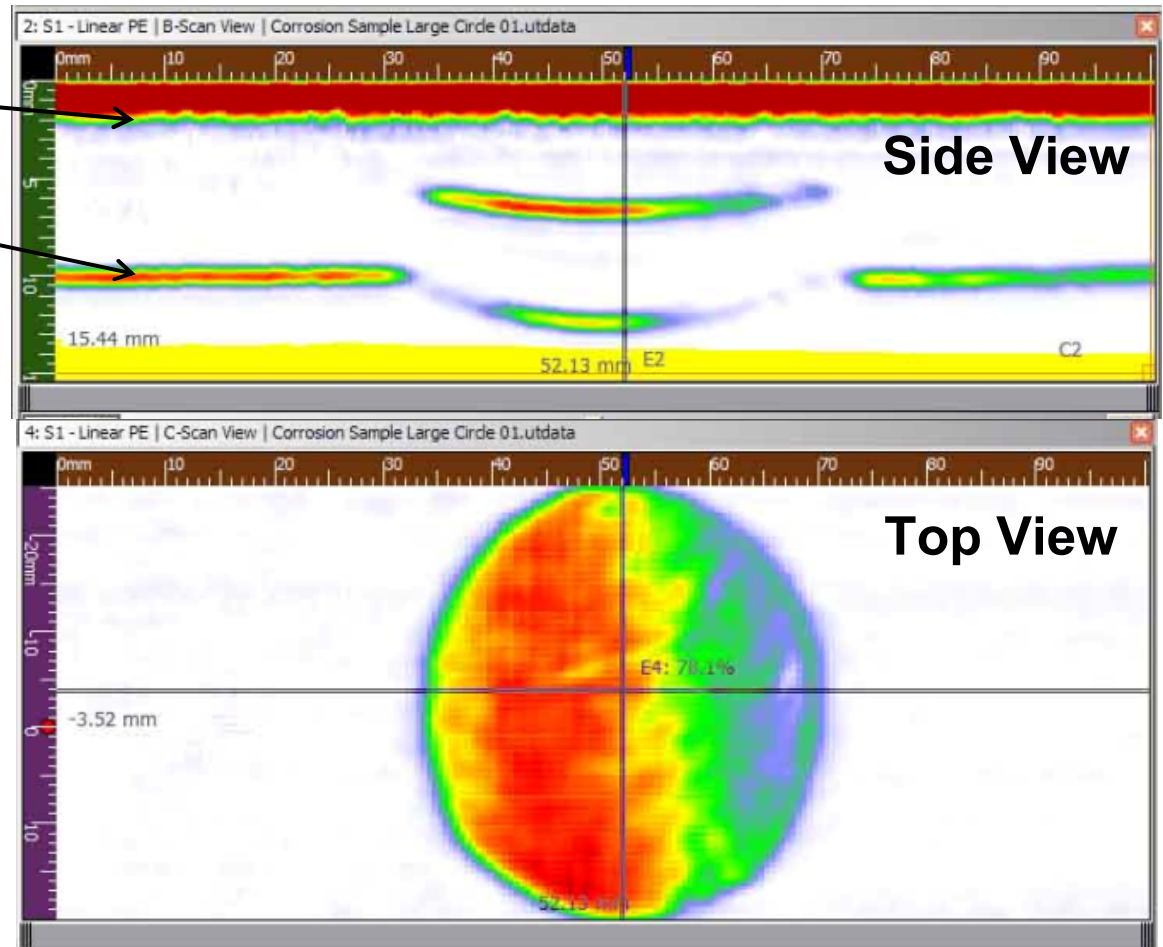

# Ultrasonic Phased Array Technology

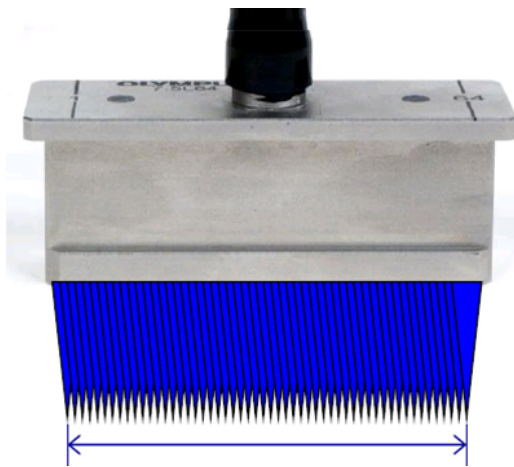
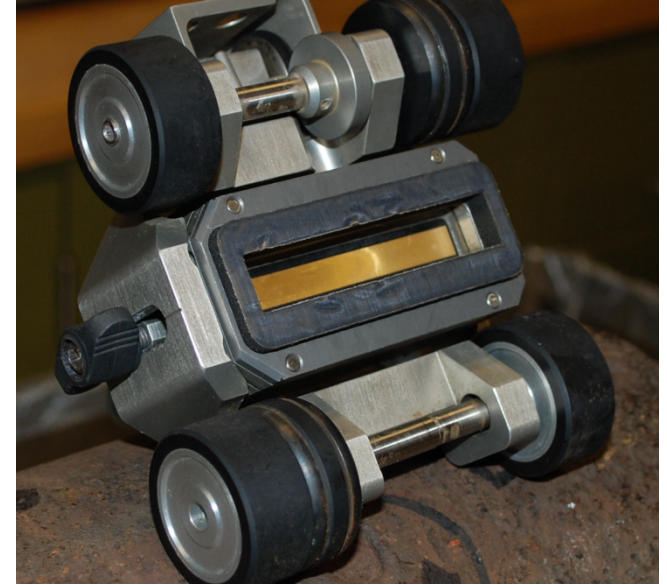
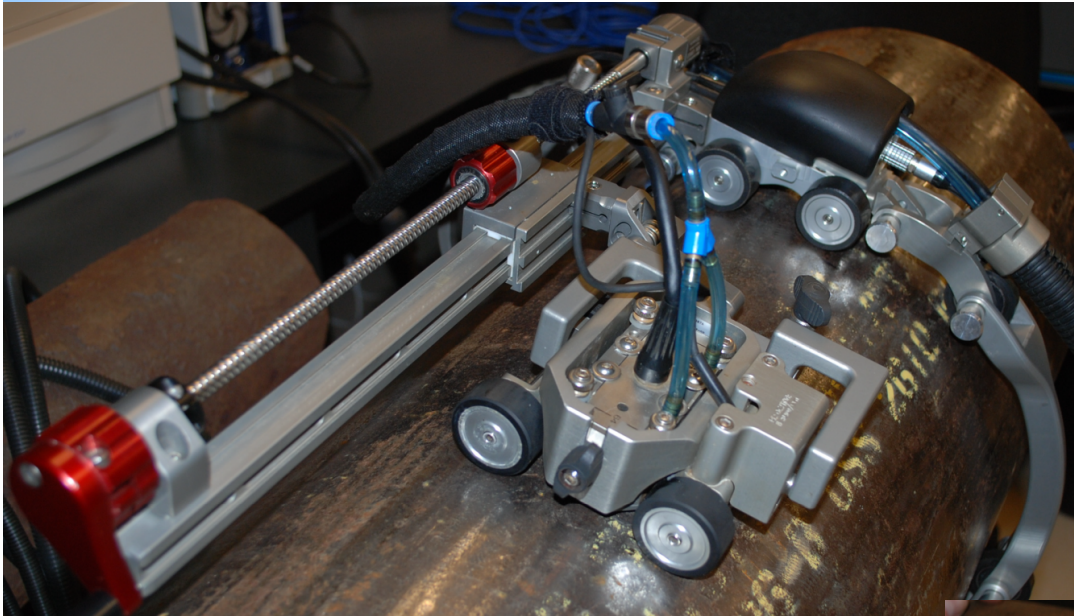



# Ultrasonic Phased Array – results obtained from exterior corroded surface

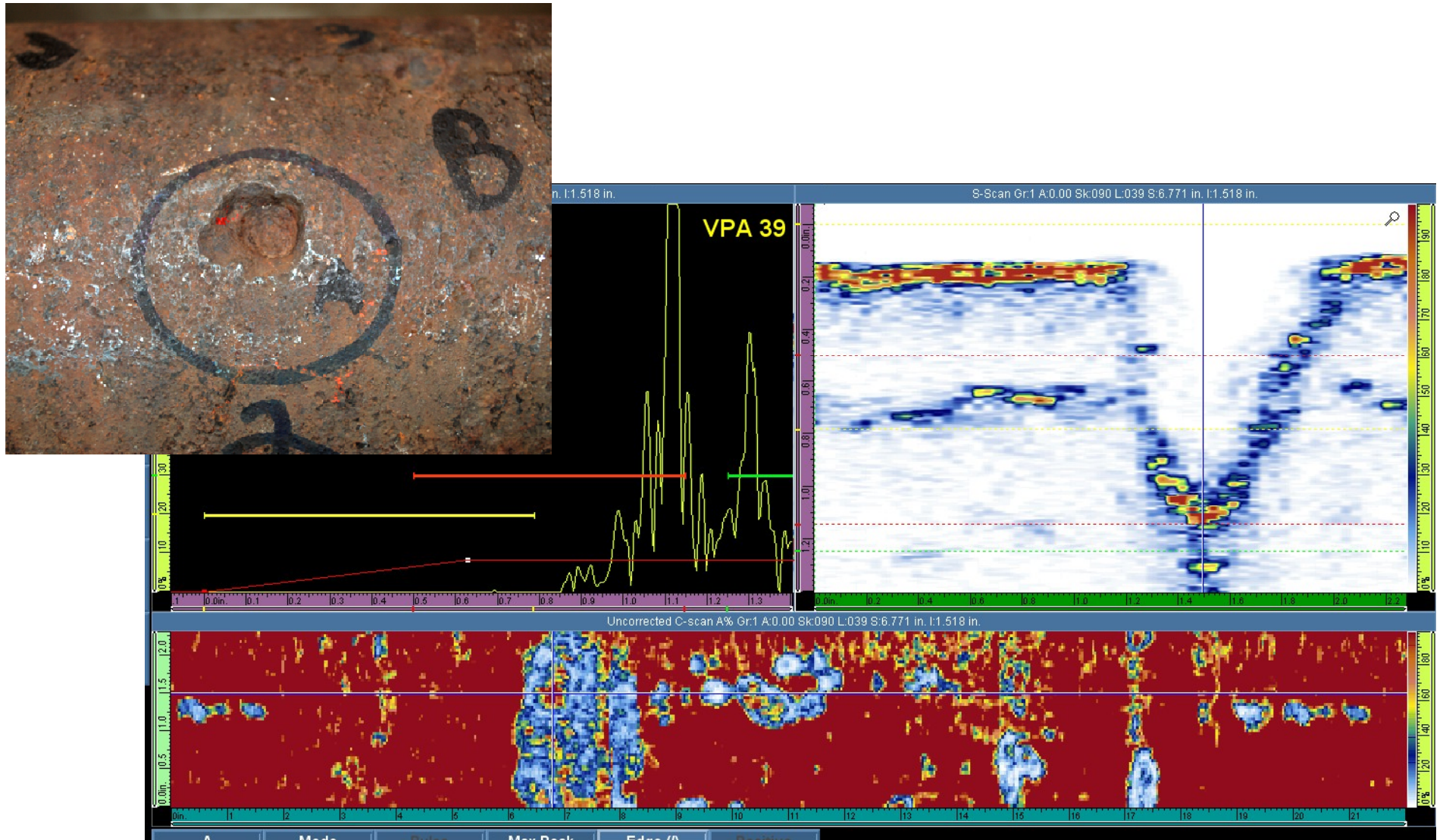

# Ultrasonic Phased Array – results obtained from exterior showing interior surface corrosion

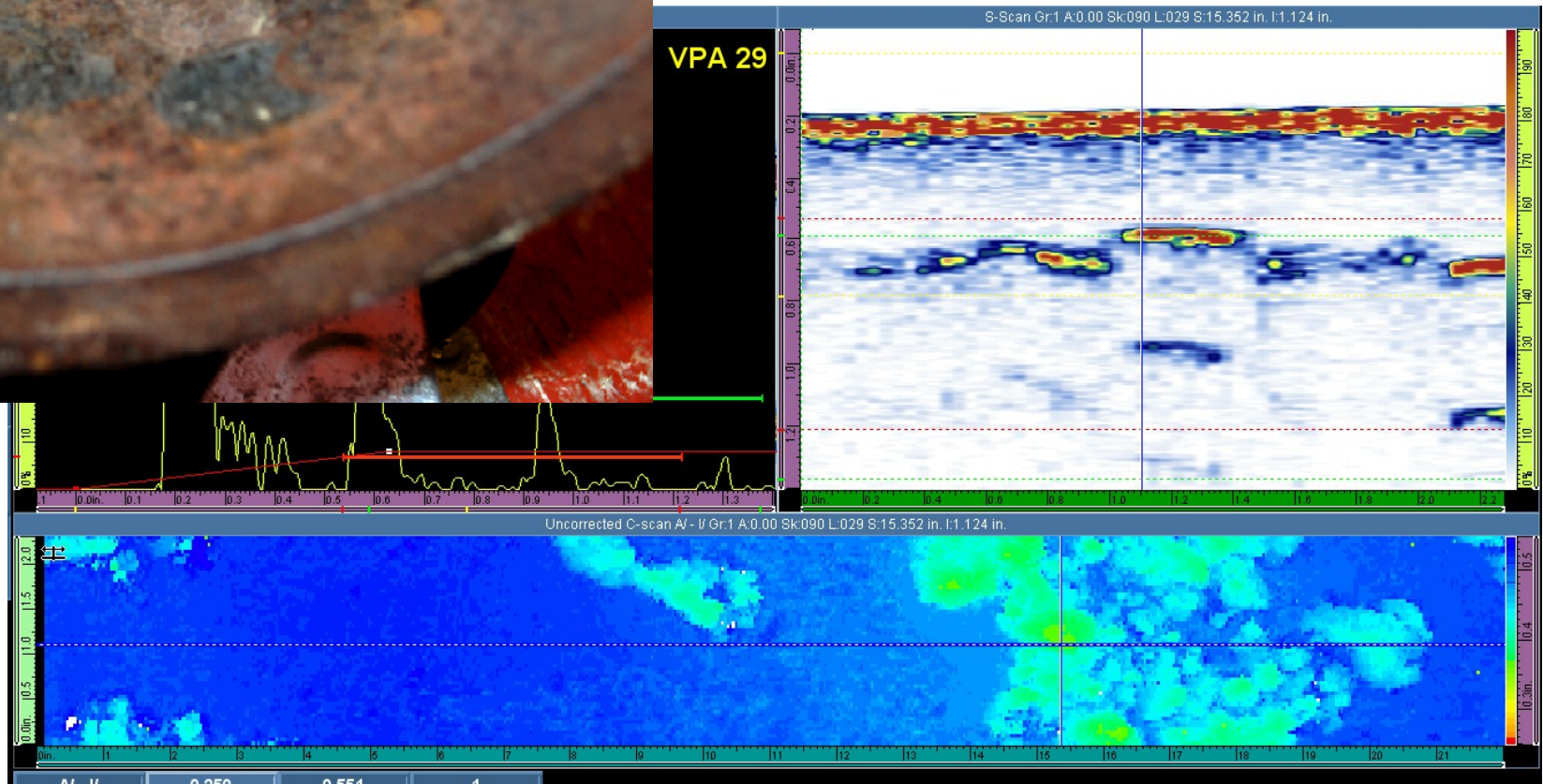

# Internal Ultrasonic In-line Tool

## Free swimming internal ultrasonic

- Used in other industries
- Navigates Short Radius - 1D - 180° bends
- Transducer array provides 100% coverage
- On-board data collection
- Detect internal and external thinning

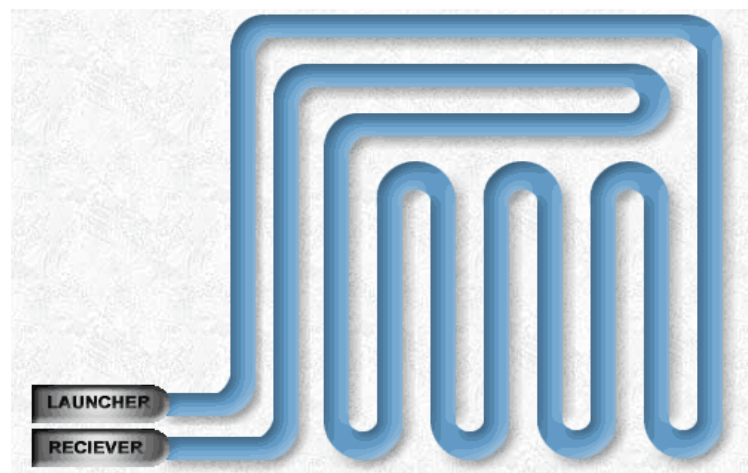
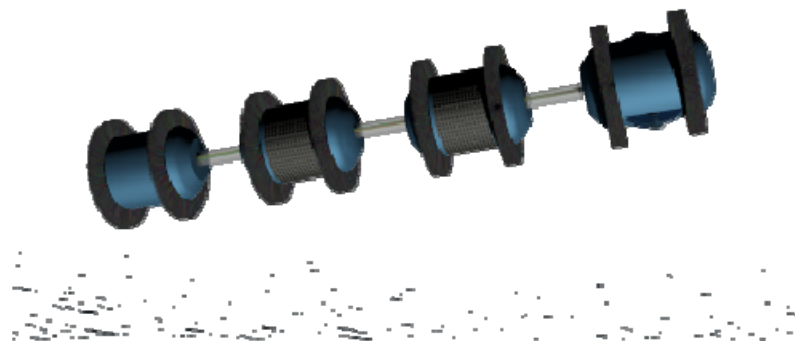

# Internal Ultrasonic Tool



Example of corrosion damage around pipe support. (Courtesy Quest Integrity)

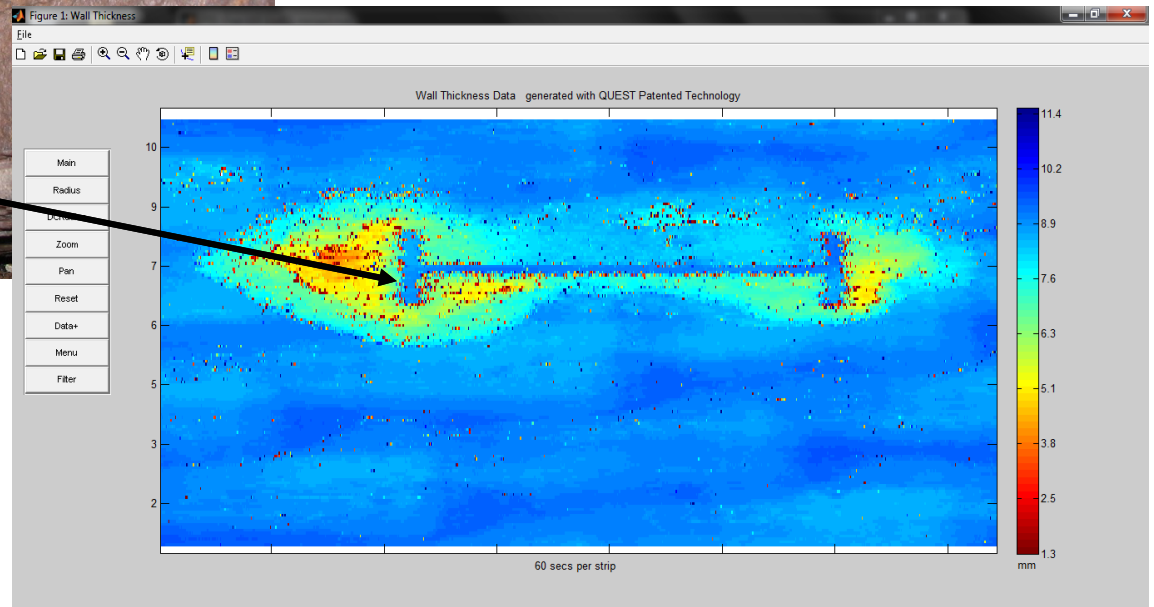

# Recent Internal Ultrasonic Tool Assessment

## Assessment Conducted on 60-ft long 8-in Diameter EPRI Mock-up

- Examined in <1 minute
- Full coverage of straight pipe sections
- Identified inside and outside surface connected discontinuities
- Working to facilitate pilot of technology

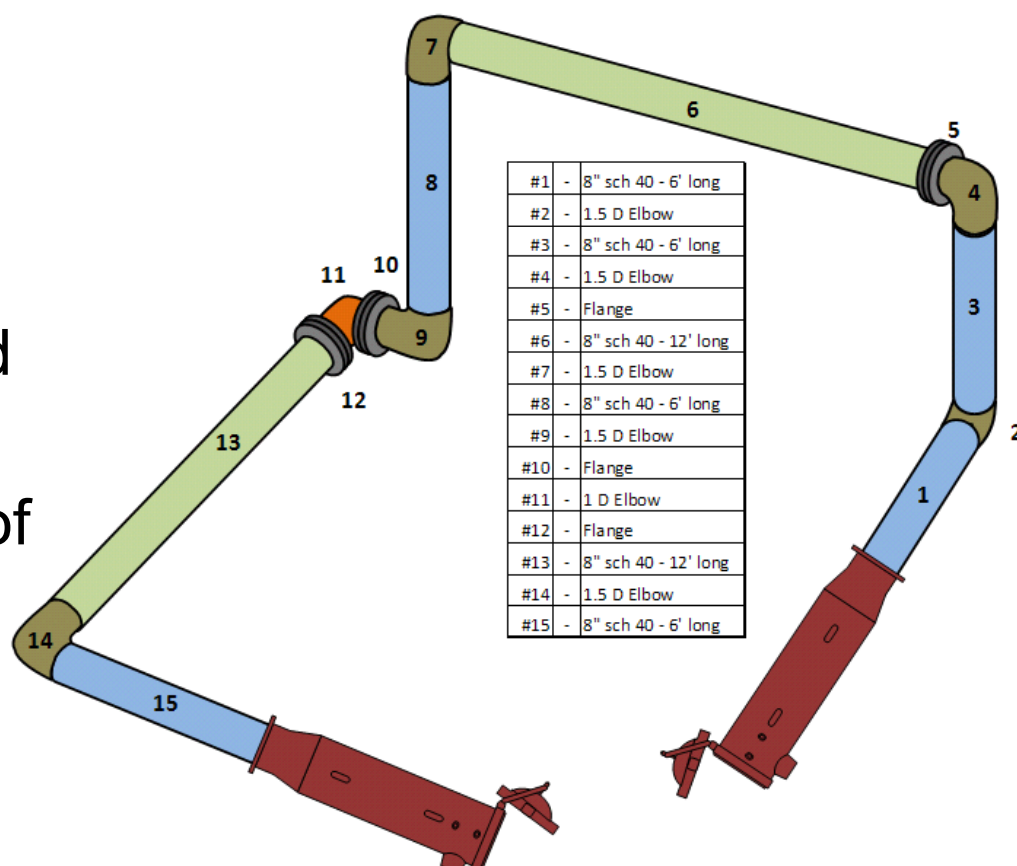

## License Renewal Support

- Support of utility sea water buried conduit examination
  - Material: Ductile iron
  - Diameter: 48”
  - Wall thickness: 1.24”/1.61”
  - Joints: Bell and spigot
  - Lining: cement lined
- Technology demonstration
  - Applus – INCOTEST® (pulsed eddy current)
  - Rock Solid – BEM (pulsed eddy current)
  - Others considering demonstrating

# License Renewal Mockup

- Diameter: 48"
- Thickness: 1.24"/1.61"
- Length: 50 ft
- Material: Ductile iron
- Joints: Bell and spigot
- ID: cement lined



# NDE Technology Assessments

- Scheduled
  - WesDyne – Lamb wave internal crawler
  - General Electric – Saturation Low Frequency Eddy Current (SLOFEC)
  - A.hac – Internal ultrasonic
- Scheduling/considering
  - Diakont – EMATS
  - PICA – RFT
  - Mears – Inline MFL
  - Pure Technology – MFL



# NDE Technology Assessments

## EPRI 24-inch diameter mock-ups



## GE In-line Inspection Tool

- New in-line inspection technology
  - Substantial commitment
  - SLOFEC™ electromagnetic and visual technology
  - Planning to add ultrasonics
- Claimed capabilities
  - Detect and map internal and external corrosion
  - Inspect through 10 mm of coating thickness
  - Inspect wall thickness up 18 mm
  - Flexible, self-propelled tethered robots
  - Can be used in liquid-fill, partially filled and empty pipes
  - Can transverse multiple 1.5D ends

# GE In-line Inspection Tool



# WesDyne In-line Inspection Tool

- New in-line inspection technology
  - Substantial commitment
- Lamb wave ultrasonic
  - 2 transducers generate Lamb waves around circumference of pipe
  - Transducers must be in contact with surface
  - Limited cleaning for small transducer footprint
  - WesDyne uses Lamb waves used in other applications
- Claimed capabilities
  - Detect and map internal and external corrosion
  - Detection capability – 0.25” diameter 20% through wall reflector in 3/8” thick pipe

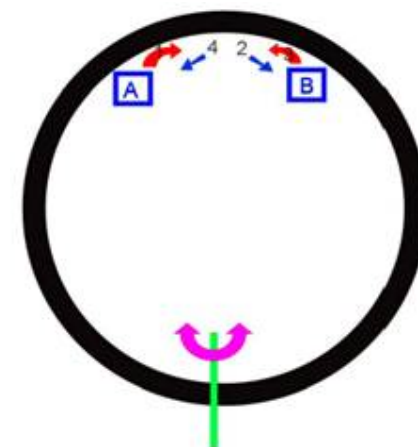

# WesDyne In-line Inspection Tool

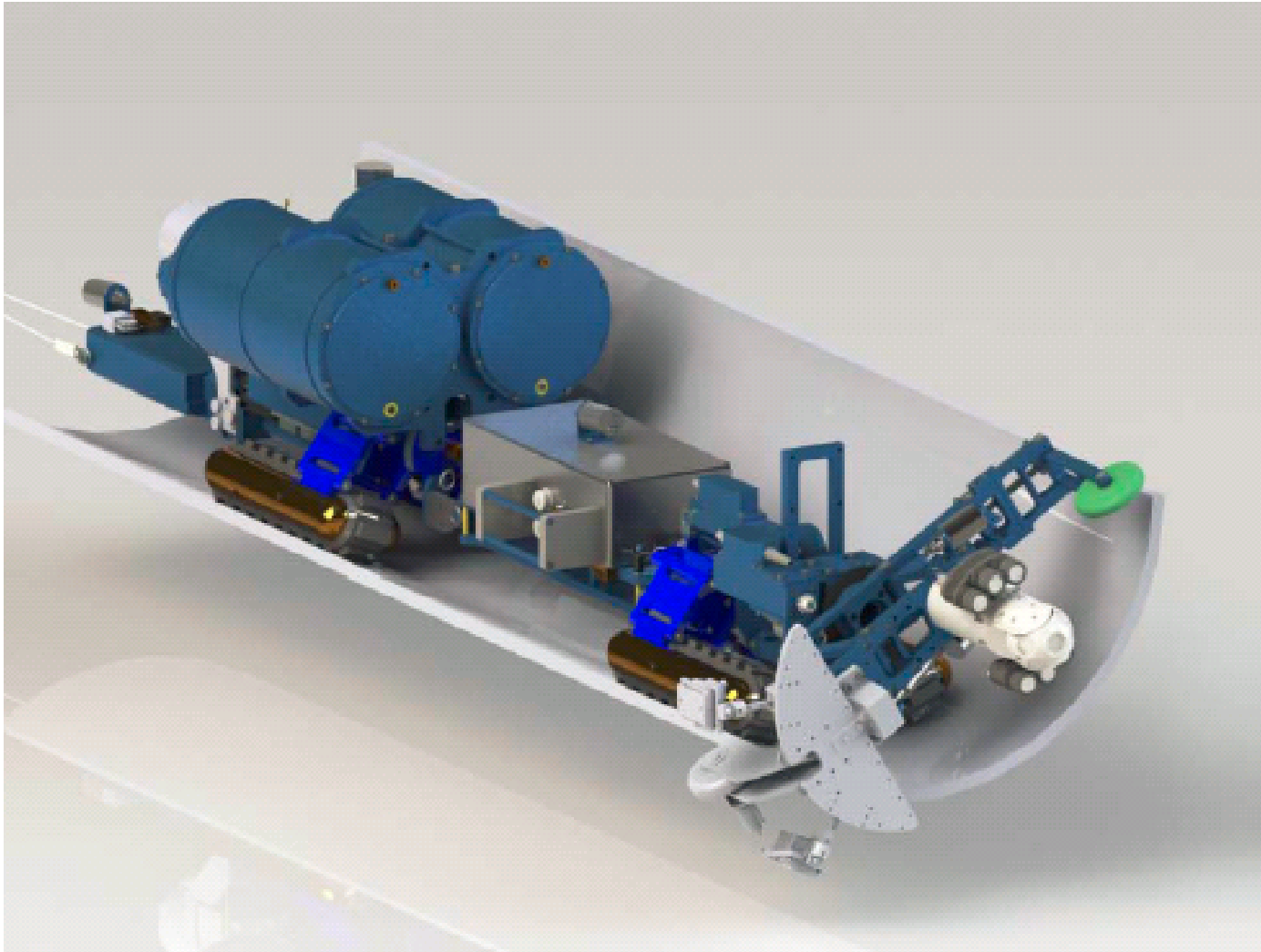

## A.hac Flow-through In-line Inspection Tool

- Rotating 0-degree ultrasonic tool
  - Currently used in other industries
  - Pipe needs to be flooded
  - Clean internal surface required
- Examination performed at ANO
  - 2300-feet of piping in ~2.5 hours
  - Line contained several elbows
  - Ultrasonic Data Acquired
    - Circumferential direction ~2 degree increments
    - Axial direction ~10 mm
    - ~11.5 million measurements

# A.hac Pig Launch and Retrieval Stations



# EPRI In-line RFT Examination Status

- Mechanical development complete
- EPRI license issued to Testex
  - Large diameter buried pipe technology
  - Intermediate diameter buried pipe technology
- RFT data analysis development still in process

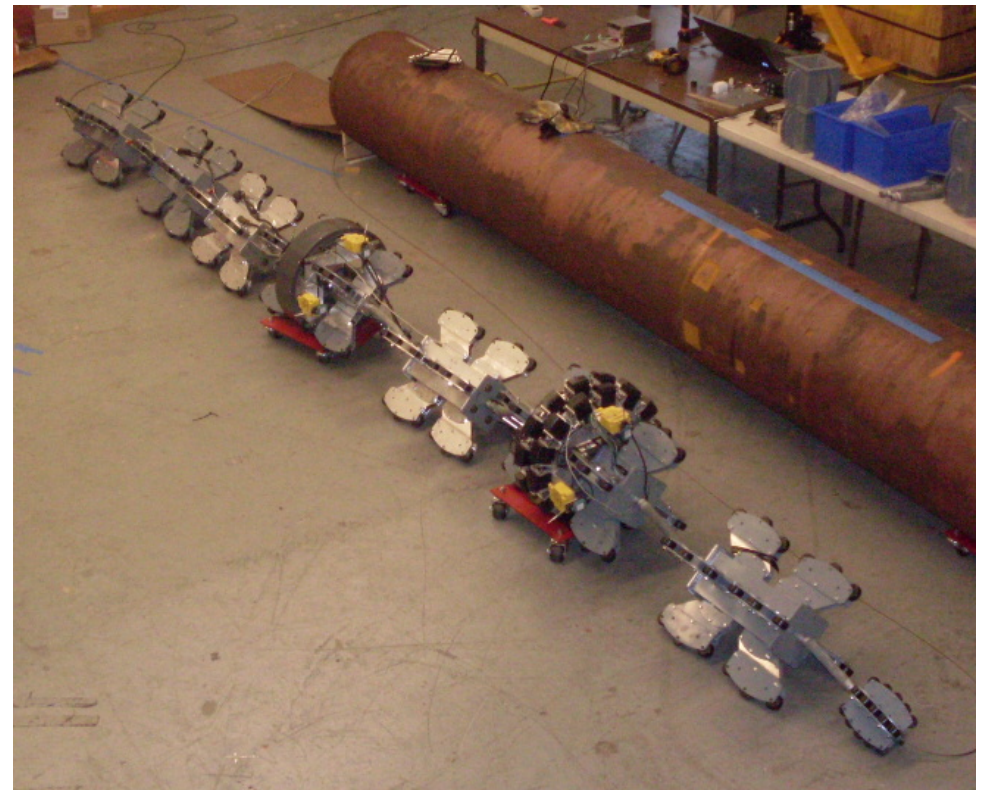



# Electromagnetic Acoustic Transducer (EMATS)

## EMATS

- Electromagnetic method of introducing ultrasonic energy
- Capable of going through some degree of coatings
- Technology evaluation for buried pipe applications in progress

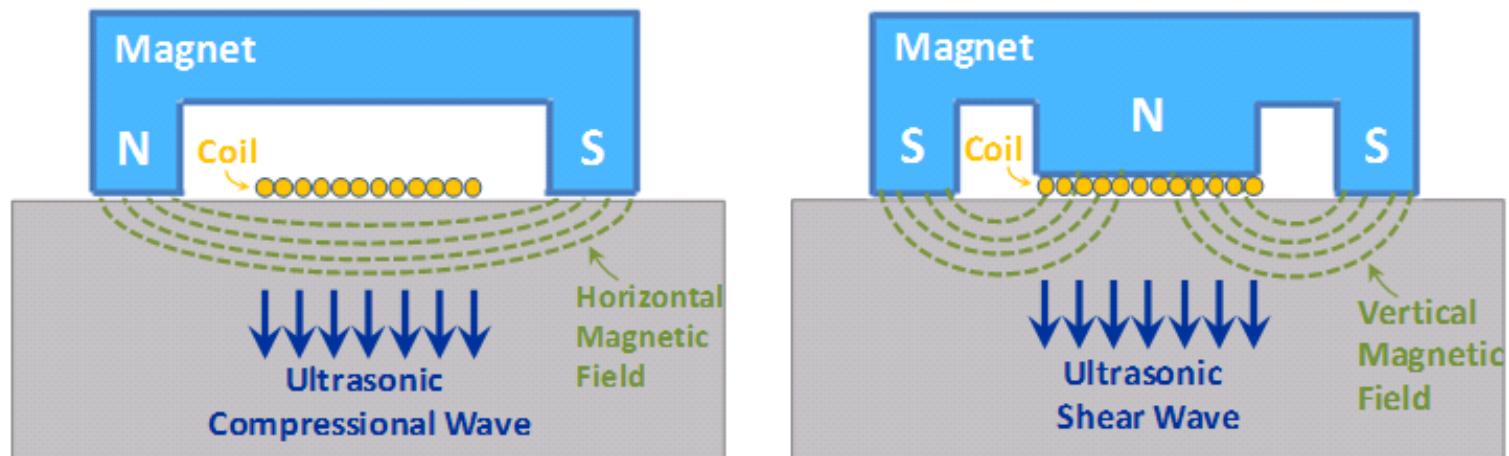

# Guided Wave Personnel Qualifications

## EPRI engaged in development of industry guided wave personnel qualification Codes and Standards

- Guided wave method qualification
  - American Society of Mechanical Engineers (ASME) drafted Section V Article 18
- Personnel Certification
  - American Society of Nondestructive Testing (ASNT)
  - British Institute of Non-Destructive Testing PCN
    - System for certification and qualification of guided wave testing personnel

# Guided Wave Computer Modeling and Empirical Study

## Guided Wave Numerical Modeling:

- Alternative to building mockups
- Optimize data acquisition setups
- Data analysis tool
- Training and testing

## Guided Wave Modeling Work

- Issued a report on results of modeling assessment (1022929)
  - Acquired guided wave data on piping mock-ups
  - Laser profile of discontinuities
  - FEM model of laser profiled discontinuities
  - Modeling data consistent with empirical data

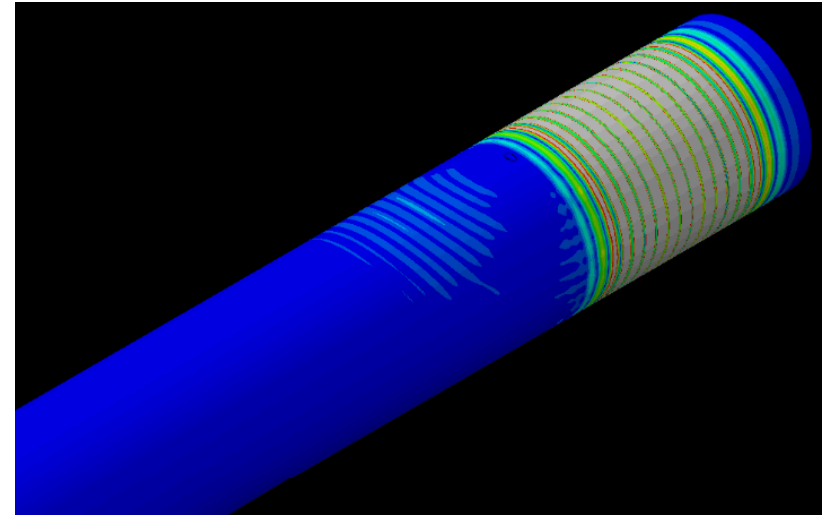

# Guided Wave Training Seminar

- Conducted 4 seminars at EPRI Charlotte in past 3 years
  - ~60 industry attendees
  - NRC attendees
- Seminar slides to be published
- Future seminars to be held on a cost recovery basis

## EPRI Key Buried Pipe NDE Reports

- Nondestructive Evaluation: Buried Pipe Nondestructive Evaluation Reference Guide (1022930)
  - Substantial update replacing report 1021626
  - Overview of available buried pipe NDE technologies
  - Guidance on technology selection
- Buried Pipe Guided Wave Examination Reference Document (1019115)
- Nondestructive Evaluation: Remote Field Technology Assessment for Piping Inspection Including Buried and Limited Access Components (1021153)
- Nondestructive Evaluation: Guided Wave Status Report (1022929)



# Together...Shaping the Future of Electricity