

## ArevaEPRDCPEm Resource

---

**From:** WILLIFORD Dennis (AREVA) [Dennis.Williford@areva.com]  
**Sent:** Thursday, March 29, 2012 4:07 PM  
**To:** Tesfaye, Getachew  
**Cc:** BENNETT Kathy (AREVA); CRIBB Arnie (EXTERNAL AREVA); DELANO Karen (AREVA); HATHCOCK Phillip (AREVA); LEIGHLITER John (AREVA); ROMINE Judy (AREVA); RYAN Tom (AREVA); MEACHAM Robert (AREVA); HUDSON Greg (AREVA)  
**Subject:** DRAFT Response to U.S. EPR Design Certification Application RAI No. 505 (5902,5735,5869,5754,5803,5950,5744), FSAR Ch. 7, Question 07.01-35  
**Attachments:** RAI 505 Question 7.1-35 Response US EPR DC - DRAFT.PDF

Getachew,

Attached is a DRAFT response for Question 07.01-35 of RAI No. 505 (FSAR Ch. 7) provided in the attached file in advance of the May 30, 2012 final date.

Let me know if the staff has any questions or if this response can be sent as final.

Sincerely,

***Dennis Williford, P.E.***  
***U.S. EPR Design Certification Licensing Manager***

**AREVA NP Inc.**

7207 IBM Drive, Mail Code CLT 2B

Charlotte, NC 28262

Phone: 704-805-2223

Email: [Dennis.Williford@areva.com](mailto:Dennis.Williford@areva.com)

---

**From:** WILLIFORD Dennis (RS/NB)  
**Sent:** Friday, March 16, 2012 12:59 PM  
**To:** [Getachew.Tesfaye@nrc.gov](mailto:Getachew.Tesfaye@nrc.gov)  
**Cc:** BENNETT Kathy (RS/NB); DELANO Karen (RS/NB); ROMINE Judy (RS/NB); RYAN Tom (RS/NB)  
**Subject:** Response to U.S. EPR Design Certification Application RAI No. 505 (5902,5735,5869,5754,5803,5950,5744), FSAR Ch. 7, Supplement 12

Getachew,

On September 29, 2011, AREVA NP Inc. provided a schedule for technically correct and complete responses to the 34 questions in RAI 505. In Supplement 1 sent on October 27, 2011, and Supplement 2 sent on November 17, 2011, AREVA NP provided a revised schedule for technically correct and complete responses to 33 questions and a preliminary revised schedule for Question 07.01-33. AREVA NP provided Supplement 3 on November 22, 2011 to provide a final response to 4 questions. On December 9, 2011, AREVA NP provided Supplement 4 to revise the schedule for 7 questions. On December 14, 2011, AREVA NP provided Supplement 5 to revise the schedule for 5 questions. On December 15, 2011, AREVA NP provided Supplement 6 to provide a complete and final response to 6 questions. On January 10, 2012, AREVA NP provided Supplement 7 to provide a complete and final response to 2 questions. On January 19, 2012, AREVA NP provided Supplement 8 to provide a complete and final response to one question and a revised preliminary schedule for the response to Question 07.01-33. On February 9, 2012, AREVA NP provided

Supplement 9 to revise the schedule for 11 questions. On February 17, 2012, AREVA NP provided Supplement 10 to revise the schedule for 20 questions. On February 21, 2012, AREVA NP provided Supplement 11 to revise the schedule for Question 07.01-33.

The attached file, "RAI 505 Supplement 12 Response - US EPR DC.pdf" provides technically correct and complete responses to 2 of the remaining 21 questions (07.01-41 and 07.05-10), and a revised response to 2 questions (07.08-46 and 07.09-72). Appended to this file are affected pages of the U.S. EPR Final Safety Analysis Report in redline-strikeout format which support the responses to Question 07.01-41, 07.05-10, 07.08-46, and 07.09-72. Also appended to this file are affected pages of Technical Reports ANP-10304, ANP-10309P and ANP-10315P. Revisions to these Technical Reports will be submitted by separate letter after completion of all responses to RAI 505.

The following table indicates the respective pages in the response document, "RAI 505 Supplement 12 Response - US EPR DC.pdf," that contain AREVA NP's response to the subject questions.

<b>Question #</b>	<b>Start Page</b>	<b>End Page</b>
RAI 505 — 07.01-41	2	5
RAI 505 — 07.05-10	6	9
RAI 505 — 07.08-46	10	10
RAI 505 — 07.09-72	11	12

The schedule for a technically correct and complete response to the remaining 19 questions remains unchanged as provided below.

<b>Question #</b>	<b>Response Date</b>
RAI 505 — 07.01-33	August 30, 2013
RAI 505 — 07.01-34	May 9, 2012
RAI 505 — 07.01-35	May 30, 2012
RAI 505 — 07.01-36	May 1, 2012
RAI 505 — 07.01-37	April 17, 2012
RAI 505 — 07.01-38	May 1, 2012
RAI 505 — 07.01-39	May 22, 2012
RAI 505 — 07.01-40	May 22, 2012
RAI 505 — 07.01-44	May 9, 2012
RAI 505 — 07.01-45	May 1, 2012
RAI 505 — 07.01-46	May 1, 2012
RAI 505 — 07.01-47	May 22, 2012
RAI 505 — 07.01-48	May 9, 2012
RAI 505 — 07.01-49	May 30, 2012
RAI 505 — 07.01-50	May 30, 2012
RAI 505 — 07.01-51	May 22, 2012
RAI 505 — 07.03-38	April 17, 2012
RAI 505 — 07.08-47	May 30, 2012
RAI 505 — 07.09-71	May 9, 2012

Sincerely,

**Dennis Williford, P.E.**  
**U.S. EPR Design Certification Licensing Manager**  
**AREVA NP Inc.**

7207 IBM Drive, Mail Code CLT 2B

Charlotte, NC 28262

Phone: 704-805-2223

Email: [Dennis.Williford@areva.com](mailto:Dennis.Williford@areva.com)

---

**From:** WILLIFORD Dennis (RS/NB)

**Sent:** Tuesday, February 21, 2012 9:31 PM

**To:** [Getachew.Tesfaye@nrc.gov](mailto:Getachew.Tesfaye@nrc.gov)

**Cc:** BENNETT Kathy (RS/NB); DELANO Karen (RS/NB); ROMINE Judy (RS/NB); RYAN Tom (RS/NB)

**Subject:** Response to U.S. EPR Design Certification Application RAI No. 505 (5902,5735,5869,5754,5803,5950,5744), FSAR Ch. 7, Supplement 11

Getachew,

On September 29, 2011, AREVA NP Inc. provided a schedule for technically correct and complete responses to the 34 questions in RAI 505. In Supplement 1 sent on October 27, 2011, and Supplement 2 sent on November 17, 2011, AREVA NP provided a revised schedule for technically correct and complete responses to 33 questions and a preliminary revised schedule for Question 07.01-33. AREVA NP provided Supplement 3 on November 22, 2011 to provide a final response to 4 questions. On December 9, 2011, AREVA NP provided Supplement 4 to revise the schedule for 7 questions. On December 14, 2011, AREVA NP provided Supplement 5 to revise the schedule for 5 questions. On December 15, 2011, AREVA NP provided Supplement 6 to provide a complete and final response to 6 questions. On January 10, 2012, AREVA NP provided Supplement 7 to provide a complete and final response to 2 questions. On January 19, 2012, AREVA NP provided Supplement 8 to provide a complete and final response to one question and a revised preliminary schedule for the response to Question 07.01-33. On February 9, 2012, AREVA NP provided Supplement 9 to revise the schedule for 11 questions. On February 17, 2012, AREVA NP provided Supplement 10 to revise the schedule for 20 questions.

The schedule for a technically correct and complete response to question 07.01-33 has been changed as provided below. The response schedule for the other questions remains unchanged. This schedule was transmitted to the NRC in AREVA NP letter 12:008 dated February 21, 2012.

<b>Question #</b>	<b>Response Date</b>
RAI 505 — 07.01-33	<b>August 30, 2013</b>
RAI 505 — 07.01-34	May 9, 2012
RAI 505 — 07.01-35	May 30, 2012
RAI 505 — 07.01-36	May 1, 2012
RAI 505 — 07.01-37	April 17, 2012
RAI 505 — 07.01-38	May 1, 2012
RAI 505 — 07.01-39	May 22, 2012
RAI 505 — 07.01-40	May 22, 2012
RAI 505 — 07.01-41	April 17, 2012
RAI 505 — 07.01-44	May 9, 2012
RAI 505 — 07.01-45	May 1, 2012

RAI 505 — 07.01-46	May 1, 2012
RAI 505 — 07.01-47	May 22, 2012
RAI 505 — 07.01-48	May 9, 2012
RAI 505 — 07.01-49	May 30, 2012
RAI 505 — 07.01-50	May 30, 2012
RAI 505 — 07.01-51	May 22, 2012
RAI 505 — 07.03-38	April 17, 2012
RAI 505 — 07.05-10	April 17, 2012
RAI 505 — 07.08-47	May 30, 2012
RAI 505 — 07.09-71	May 9, 2012

Sincerely,

***Dennis Williford, P.E.***  
***U.S. EPR Design Certification Licensing Manager***  
***AREVA NP Inc.***

7207 IBM Drive, Mail Code CLT 2B  
Charlotte, NC 28262  
Phone: 704-805-2223  
Email: [Dennis.Williford@areva.com](mailto:Dennis.Williford@areva.com)

---

**From:** WILLIFORD Dennis (RS/NB)  
**Sent:** Friday, February 17, 2012 4:09 PM  
**To:** [Getachew.Tesfaye@nrc.gov](mailto:Getachew.Tesfaye@nrc.gov)  
**Cc:** BENNETT Kathy (RS/NB); DELANO Karen (RS/NB); ROMINE Judy (RS/NB); RYAN Tom (RS/NB)  
**Subject:** Response to U.S. EPR Design Certification Application RAI No. 505 (5902,5735,5869,5754,5803,5950,5744), FSAR Ch. 7, Supplement 10

Getachew,

On September 29, 2011, AREVA NP Inc. provided a schedule for technically correct and complete responses to the 34 questions in RAI 505. In Supplement 1 sent on October 27, 2011, and Supplement 2 sent on November 17, 2011, AREVA NP provided a revised schedule for technically correct and complete responses to 33 questions and a preliminary revised schedule for Question 07.01-33. AREVA NP provided Supplement 3 on November 22, 2011 to provide a final response to 4 questions. On December 9, 2011, AREVA NP provided Supplement 4 to revise the schedule for 7 questions. On December 14, 2011, AREVA NP provided Supplement 5 to revise the schedule for 5 questions. On December 15, 2011, AREVA NP provided Supplement 6 to provide a complete and final response to 6 questions. On January 10, 2012, AREVA NP provided Supplement 7 to provide a complete and final response to 2 questions. On January 19, 2012, AREVA NP provided Supplement 8 to provide a complete and final response to one question and a revised preliminary schedule for the response to Question 07.01-33. On February 9, 2012, AREVA NP provided Supplement 9 to revise the schedule for 11 questions.

The schedule for a technically correct and complete response to 20 of the remaining 21 questions has been changed as provided below. The response schedule to the other question remains unchanged.

Question #	Response Date
------------	---------------

RAI 505 — 07.01-33	February 21, 2012
RAI 505 — 07.01-34	<b>May 9, 2012</b>
RAI 505 — 07.01-35	<b>May 30, 2012</b>
RAI 505 — 07.01-36	<b>May 1, 2012</b>
RAI 505 — 07.01-37	<b>April 17, 2012</b>
RAI 505 — 07.01-38	<b>May 1, 2012</b>
RAI 505 — 07.01-39	<b>May 22, 2012</b>
RAI 505 — 07.01-40	<b>May 22, 2012</b>
RAI 505 — 07.01-41	<b>April 17, 2012</b>
RAI 505 — 07.01-44	<b>May 9, 2012</b>
RAI 505 — 07.01-45	<b>May 1, 2012</b>
RAI 505 — 07.01-46	<b>May 1, 2012</b>
RAI 505 — 07.01-47	<b>May 22, 2012</b>
RAI 505 — 07.01-48	<b>May 9, 2012</b>
RAI 505 — 07.01-49	<b>May 30, 2012</b>
RAI 505 — 07.01-50	<b>May 30, 2012</b>
RAI 505 — 07.01-51	<b>May 22, 2012</b>
RAI 505 — 07.03-38	<b>April 17, 2012</b>
RAI 505 — 07.05-10	<b>April 17, 2012</b>
RAI 505 — 07.08-47	<b>May 30, 2012</b>
RAI 505 — 07.09-71	<b>May 9, 2012</b>

Sincerely,

***Dennis Williford, P.E.***  
***U.S. EPR Design Certification Licensing Manager***  
***AREVA NP Inc.***

7207 IBM Drive, Mail Code CLT 2B  
Charlotte, NC 28262  
Phone: 704-805-2223  
Email: [Dennis.Williford@areva.com](mailto:Dennis.Williford@areva.com)

---

**From:** WILLIFORD Dennis (RS/NB)  
**Sent:** Thursday, February 09, 2012 8:15 AM  
**To:** [Getachew.Tesfaye@nrc.gov](mailto:Getachew.Tesfaye@nrc.gov)  
**Cc:** BENNETT Kathy (RS/NB); DELANO Karen (RS/NB); ROMINE Judy (RS/NB); RYAN Tom (RS/NB)  
**Subject:** Response to U.S. EPR Design Certification Application RAI No. 505 (5902,5735,5869,5754,5803,5950,5744), FSAR Ch. 7, Supplement 9

Getachew,

On September 29, 2011, AREVA NP Inc. provided a schedule for technically correct and complete responses to the 34 questions in RAI 505. In Supplement 1 sent on October 27, 2011, and Supplement 2 sent on November 17, 2011, AREVA NP provided a revised schedule for technically correct and complete responses to 33 questions and a preliminary revised schedule for Question 07.01-33. AREVA NP provided Supplement 3 on November 22, 2011 to provide a final response to 4 questions. On December 9, 2011, AREVA NP provided Supplement 4 to revise the schedule for 7 questions. On December 14, 2011, AREVA NP provided Supplement 5 to revise the schedule for 5 questions. On December 15, 2011, AREVA NP provided

Supplement 6 to provide a complete and final response to 6 questions. On January 10, 2012, AREVA NP provided Supplement 7 to provide a complete and final response to 2 questions. On January 19, 2012, AREVA NP provided Supplement 8 to provide a complete and final response to one question and a revised preliminary schedule for the response to Question 07.01-33.

The schedule for a technically correct and complete response to 11 of the remaining 21 questions has been changed as provided below. The response schedule to the other 10 questions remains unchanged.

<b>Question #</b>	<b>Response Date</b>
RAI 505 — 07.01-33	February 21, 2012
RAI 505 — 07.01-34	April 5, 2012
RAI 505 — 07.01-35	April 26, 2012
RAI 505 — 07.01-36	<b>April 5, 2012</b>
RAI 505 — 07.01-37	March 8, 2012
RAI 505 — 07.01-38	<b>April 5, 2012</b>
RAI 505 — 07.01-39	<b>April 26, 2012</b>
RAI 505 — 07.01-40	<b>April 26, 2012</b>
RAI 505 — 07.01-41	<b>March 8, 2012</b>
RAI 505 — 07.01-44	<b>April 5, 2012</b>
RAI 505 — 07.01-45	April 26, 2012
RAI 505 — 07.01-46	April 26, 2012
RAI 505 — 07.01-47	<b>April 5, 2012</b>
RAI 505 — 07.01-48	<b>April 5, 2012</b>
RAI 505 — 07.01-49	<b>April 26, 2012</b>
RAI 505 — 07.01-50	April 26, 2012
RAI 505 — 07.01-51	<b>April 26, 2012</b>
RAI 505 — 07.03-38	<b>March 8, 2012</b>
RAI 505 — 07.05-10	March 8, 2012
RAI 505 — 07.08-47	April 26, 2012
RAI 505 — 07.09-71	April 5, 2012

Sincerely,

***Dennis Williford, P.E.***  
***U.S. EPR Design Certification Licensing Manager***  
**AREVA NP Inc.**

7207 IBM Drive, Mail Code CLT 2B  
Charlotte, NC 28262  
Phone: 704-805-2223  
Email: [Dennis.Williford@areva.com](mailto:Dennis.Williford@areva.com)

---

**From:** WILLIFORD Dennis (RS/NB)  
**Sent:** Thursday, January 19, 2012 11:19 AM  
**To:** [Getachew.Tesfaye@nrc.gov](mailto:Getachew.Tesfaye@nrc.gov)  
**Cc:** BENNETT Kathy (RS/NB); DELANO Karen (RS/NB); ROMINE Judy (RS/NB); RYAN Tom (RS/NB)

**Subject:** Response to U.S. EPR Design Certification Application RAI No. 505 (5902,5735,5869,5754,5803,5950,5744), FSAR Ch. 7, Supplement 8

Getachew,

On September 29, 2011, AREVA NP Inc. provided a schedule for technically correct and complete responses to the 34 questions in RAI 505. In Supplement 1 sent on October 27, 2011, and Supplement 2 sent on November 17, 2011, AREVA NP provided a revised schedule for technically correct and complete responses to 33 questions and a preliminary revised schedule for Question 07.01-33. AREVA NP provided Supplement 3 on November 22, 2011 to provide a final response to 4 questions. On December 9, 2011, AREVA NP provided Supplement 4 to revise the schedule for 7 questions. On December 14, 2011, AREVA NP provided Supplement 5 to revise the schedule for 5 questions. On December 15, 2011, AREVA NP provided Supplement 6 to provide a complete and final response to 6 questions. On January 10, 2012, AREVA NP provided Supplement 7 to provide a complete and final response to 2 questions.

The attached file, "RAI 505 Supplement 8 Response US EPR DC.pdf" provides a technically correct and complete final response to 1 of the remaining 22 questions.

The following table indicates the respective pages in the response document, "RAI 505 Supplement 8 Response US EPR DC.pdf," that contain AREVA NP's response to the subject question.

<b>Question #</b>	<b>Start Page</b>	<b>End Page</b>
RAI 505 — 07.01-42	2	2

The schedule for a technically correct and complete response to the remaining 21 questions is provided below. The preliminary schedule for the response to Question 07.01-33 has been revised and is being reevaluated and a new supplement with a revised schedule will be transmitted by February 21, 2012.

<b>Question #</b>	<b>Response Date</b>
RAI 505 — 07.01-33	<b>February 21, 2012</b>
RAI 505 — 07.01-34	April 5, 2012
RAI 505 — 07.01-35	April 26, 2012
RAI 505 — 07.01-36	February 9, 2012
RAI 505 — 07.01-37	March 8, 2012
RAI 505 — 07.01-38	February 9, 2012
RAI 505 — 07.01-39	February 9, 2012
RAI 505 — 07.01-40	February 9, 2012
RAI 505 — 07.01-41	February 9, 2012
RAI 505 — 07.01-44	February 9, 2012
RAI 505 — 07.01-45	April 26, 2012
RAI 505 — 07.01-46	April 26, 2012
RAI 505 — 07.01-47	February 9, 2012
RAI 505 — 07.01-48	February 9, 2012
RAI 505 — 07.01-49	February 9, 2012
RAI 505 — 07.01-50	April 26, 2012

RAI 505 — 07.01-51	February 9, 2012
RAI 505 — 07.03-38	April 26, 2012
RAI 505 — 07.05-10	March 8, 2012
RAI 505 — 07.08-47	April 26, 2012
RAI 505 — 07.09-71	April 5, 2012

Sincerely,

***Dennis Williford, P.E.***  
***U.S. EPR Design Certification Licensing Manager***  
***AREVA NP Inc.***

7207 IBM Drive, Mail Code CLT 2B

Charlotte, NC 28262

Phone: 704-805-2223

Email: [Dennis.Williford@areva.com](mailto:Dennis.Williford@areva.com)

---

**From:** WILLIFORD Dennis (CORP/QP)

**Sent:** Tuesday, January 10, 2012 5:21 PM

**To:** [Getachew.Tesfaye@nrc.gov](mailto:Getachew.Tesfaye@nrc.gov)

**Cc:** BENNETT Kathy (RS/NB); DELANO Karen (RS/NB); ROMINE Judy (RS/NB); RYAN Tom (RS/NB)

**Subject:** Response to U.S. EPR Design Certification Application RAI No. 505 (5902,5735,5869,5754,5803,5950,5744), FSAR Ch. 7, Supplement 7

Getachew,

On September 29, 2011, AREVA NP Inc. provided a schedule for technically correct and complete responses to the 34 questions in RAI 505. In Supplement 1 sent on October 27, 2011, and Supplement 2 sent on November 17, 2011, AREVA NP provided a revised schedule for technically correct and complete responses to 33 questions and a preliminary revised schedule for Question 07.01-33. AREVA NP provided Supplement 3 on November 22, 2011 to provide a final response to 4 questions. On December 9, 2011, AREVA NP provided Supplement 4 to revise the schedule for 7 questions. On December 14, 2011, AREVA NP provided Supplement 5 to revise the schedule for 5 questions. On December 15, 2011, AREVA NP provided Supplement 6 to provide a complete and final response to 6 questions.

The attached file, "RAI 505 Supplement 7 Response US EPR DC.pdf" provides technically correct and complete final responses to 2 of the remaining 24 questions. Appended to this file are affected pages of the U.S. EPR Final Safety Analysis Report in redline-strikeout format which support the response to RAI 505 Question 07.08-48.

The following table indicates the respective pages in the response document, "RAI 505 Supplement 7 Response US EPR DC.pdf," that contain AREVA NP's response to the subject questions.

Question #	Start Page	End Page
RAI 505 — 07.08-44	2	3
RAI 505 — 07.08-48	4	5

The schedule for a technically correct and complete response to the remaining 22 questions has changed as provided below. The preliminary schedule for the response to Question 07.01-33 is being reevaluated and a new supplement with a revised schedule will be transmitted by January 25, 2012.



Question #	Response Date
RAI 505 — 07.01-33	January 25, 2012
RAI 505 — 07.01-34	<b>April 5, 2012</b>
RAI 505 — 07.01-35	<b>April 26, 2012</b>
RAI 505 — 07.01-36	<b>February 9, 2012</b>
RAI 505 — 07.01-37	<b>March 8, 2012</b>
RAI 505 — 07.01-38	<b>February 9, 2012</b>
RAI 505 — 07.01-39	<b>February 9, 2012</b>
RAI 505 — 07.01-40	<b>February 9, 2012</b>
RAI 505 — 07.01-41	<b>February 9, 2012</b>
RAI 505 — 07.01-42	<b>February 9, 2012</b>
RAI 505 — 07.01-44	<b>February 9, 2012</b>
RAI 505 — 07.01-45	<b>April 26, 2012</b>
RAI 505 — 07.01-46	<b>April 26, 2012</b>
RAI 505 — 07.01-47	<b>February 9, 2012</b>
RAI 505 — 07.01-48	<b>February 9, 2012</b>
RAI 505 — 07.01-49	<b>February 9, 2012</b>
RAI 505 — 07.01-50	<b>April 26, 2012</b>
RAI 505 — 07.01-51	<b>February 9, 2012</b>
RAI 505 — 07.03-38	<b>April 26, 2012</b>
RAI 505 — 07.05-10	<b>March 8, 2012</b>
RAI 505 — 07.08-47	<b>April 26, 2012</b>
RAI 505 — 07.09-71	<b>April 5, 2012</b>

Sincerely,

***Dennis Williford, P.E.***  
***U.S. EPR Design Certification Licensing Manager***  
***AREVA NP Inc.***

7207 IBM Drive, Mail Code CLT 2B  
Charlotte, NC 28262  
Phone: 704-805-2223  
Email: [Dennis.Williford@areva.com](mailto:Dennis.Williford@areva.com)

---

**From:** WILLIFORD Dennis (RS/NB)  
**Sent:** Thursday, December 15, 2011 1:49 PM  
**To:** [Getachew.Tesfaye@nrc.gov](mailto:Getachew.Tesfaye@nrc.gov)  
**Cc:** BENNETT Kathy (RS/NB); DELANO Karen (RS/NB); ROMINE Judy (RS/NB); RYAN Tom (RS/NB)  
**Subject:** Response to U.S. EPR Design Certification Application RAI No. 505 (5902,5735,5869,5754,5803,5950,5744), FSAR Ch. 7, Supplement 6

Getachew,

On September 29, 2011, AREVA NP Inc. provided a schedule for technically correct and complete responses to the 34 questions in RAI 505. In Supplement 1 sent on October 27, 2011, and Supplement 2 sent on November 17, 2011, AREVA NP provided a revised schedule for technically correct and complete responses

to 33 questions and a preliminary revised schedule for Question 07.01-33. AREVA NP provided Supplement 3 on November 22, 2011 to provide a final response to 4 questions. On December 9, 2011, AREVA NP provided Supplement 4 to revise the schedule for 7 questions. On December 14, 2011, AREVA NP provided Supplement 5 to revise the schedule for 5 questions.

The attached file, "RAI 505 Supplement 6 Response US EPR DC.pdf" provides technically correct and complete responses to 6 of the remaining 30 questions. Appended to this file are affected pages of the U.S. EPR Final Safety Analysis Report in redline-strikeout format which support the responses. Also appended to this file are affected pages of Technical Reports ANP-10304 and ANP-10309P. Revisions to these Technical Reports will be submitted by separate letter after completion of all responses to RAI 505.

The following table indicates the respective pages in the response document, "RAI 505 Supplement 6 Response US EPR DC.pdf," that contain AREVA NP's response to the subject questions.

<b>Question #</b>	<b>Start Page</b>	<b>End Page</b>
RAI 505 — 07.03-37	2	3
RAI 505 — 07.04-15	4	5
RAI 505 — 07.05-11	6	6
RAI 505 — 07.08-43	7	8
RAI 505 — 07.08-45	9	10
RAI 505 — 07.08-49	11	12

The schedule for a technically correct and complete response to the remaining 24 questions remains unchanged. The preliminary schedule for the response to Question 07.01-33 is being reevaluated and a new supplement with a revised schedule will be transmitted by January 25, 2012.

<b>Question #</b>	<b>Response Date</b>
RAI 505 — 07.01-33	January 25, 2012
RAI 505 — 07.01-34	January 10, 2012
RAI 505 — 07.01-35	February 9, 2012
RAI 505 — 07.01-36	January 10, 2012
RAI 505 — 07.01-37	January 19, 2012
RAI 505 — 07.01-38	January 10, 2012
RAI 505 — 07.01-39	January 10, 2012
RAI 505 — 07.01-40	January 10, 2012
RAI 505 — 07.01-41	January 10, 2012
RAI 505 — 07.01-42	January 10, 2012
RAI 505 — 07.01-44	January 10, 2012
RAI 505 — 07.01-45	February 9, 2012
RAI 505 — 07.01-46	February 9, 2012
RAI 505 — 07.01-47	January 10, 2012
RAI 505 — 07.01-48	January 10, 2012
RAI 505 — 07.01-49	January 10, 2012
RAI 505 — 07.01-50	January 10, 2012
RAI 505 — 07.01-51	January 10, 2012
RAI 505 — 07.03-38	February 9, 2012

RAI 505 — 07.05-10	January 19, 2012
RAI 505 — 07.08-44	January 10, 2012
RAI 505 — 07.08-47	January 10, 2012
RAI 505 — 07.08-48	January 10, 2012
RAI 505 — 07.09-71	January 10, 2012

Sincerely,

***Dennis Williford, P.E.***  
***U.S. EPR Design Certification Licensing Manager***  
***AREVA NP Inc.***

7207 IBM Drive, Mail Code CLT 2B  
Charlotte, NC 28262  
Phone: 704-805-2223  
Email: [Dennis.Williford@areva.com](mailto:Dennis.Williford@areva.com)

---

**From:** WILLIFORD Dennis (RS/NB)  
**Sent:** Wednesday, December 14, 2011 11:30 AM  
**To:** [Getachew.Tesfaye@nrc.gov](mailto:Getachew.Tesfaye@nrc.gov)  
**Cc:** BENNETT Kathy (RS/NB); DELANO Karen (RS/NB); ROMINE Judy (RS/NB); RYAN Tom (RS/NB)  
**Subject:** Response to U.S. EPR Design Certification Application RAI No. 505 (5902,5735,5869,5754,5803,5950,5744), FSAR Ch. 7, Supplement 5

Getachew,

On September 29, 2011, AREVA NP Inc. provided a schedule for technically correct and complete responses to the 34 questions in RAI 505. In Supplement 1 sent on October 27, 2011, and Supplement 2 sent on November 17, 2011, AREVA NP provided a revised schedule for technically correct and complete responses to 33 questions and a preliminary revised schedule for Question 07.01-33. AREVA NP provided Supplement 3 on November 22, 2011 to provide a final response to 4 questions. On December 9, 2011, AREVA NP provided a revised schedule for 7 questions.

The schedule for the response to four questions (Questions 7.1-35, 7.1-45, 7.1-46, and 7.3-38) is being changed, as indicated in bold below. In addition, the preliminary schedule for the response to Question 07.01-33 has been revised as indicated. This schedule is being reevaluated and a new supplement with a revised schedule will be transmitted by January 25, 2012. The schedule for a technically correct and complete response to the remaining 25 questions remains unchanged.

<b>Question #</b>	<b>Response Date</b>
RAI 505 — 07.01-33	<b>January 25, 2012</b>
RAI 505 — 07.01-34	January 10, 2012
RAI 505 — 07.01-35	<b>February 9, 2012</b>
RAI 505 — 07.01-36	January 10, 2012
RAI 505 — 07.01-37	January 19, 2012
RAI 505 — 07.01-38	January 10, 2012
RAI 505 — 07.01-39	January 10, 2012
RAI 505 — 07.01-40	January 10, 2012

RAI 505 — 07.01-41	January 10, 2012
RAI 505 — 07.01-42	January 10, 2012
RAI 505 — 07.01-44	January 10, 2012
RAI 505 — 07.01-45	<b>February 9, 2012</b>
RAI 505 — 07.01-46	<b>February 9, 2012</b>
RAI 505 — 07.01-47	January 10, 2012
RAI 505 — 07.01-48	January 10, 2012
RAI 505 — 07.01-49	January 10, 2012
RAI 505 — 07.01-50	January 10, 2012
RAI 505 — 07.01-51	January 10, 2012
RAI 505 — 07.03-37	January 19, 2012
RAI 505 — 07.03-38	<b>February 9, 2012</b>
RAI 505 — 07.04-15	January 19, 2012
RAI 505 — 07.05-10	January 19, 2012
RAI 505 — 07.05-11	January 19, 2012
RAI 505 — 07.08-43	January 19, 2012
RAI 505 — 07.08-44	January 10, 2012
RAI 505 — 07.08-45	January 10, 2012
RAI 505 — 07.08-47	January 10, 2012
RAI 505 — 07.08-48	January 10, 2012
RAI 505 — 07.08-49	January 19, 2012
RAI 505 — 07.09-71	January 10, 2012

Sincerely,

***Dennis Williford, P.E.***  
***U.S. EPR Design Certification Licensing Manager***  
***AREVA NP Inc.***

7207 IBM Drive, Mail Code CLT 2B  
Charlotte, NC 28262  
Phone: 704-805-2223  
Email: [Dennis.Williford@areva.com](mailto:Dennis.Williford@areva.com)

---

**From:** RYAN Tom (RS/NB)  
**Sent:** Friday, December 09, 2011 8:35 AM  
**To:** [Getachew.Tesfaye@nrc.gov](mailto:Getachew.Tesfaye@nrc.gov)  
**Cc:** BENNETT Kathy (RS/NB); DELANO Karen (RS/NB); ROMINE Judy (RS/NB); RYAN Tom (RS/NB); WILLIFORD Dennis (RS/NB)  
**Subject:** Response to U.S. EPR Design Certification Application RAI No. 505 (5902,5735,5869,5754,5803,5950,5744), FSAR Ch. 7, Supplement 4

Getachew,

On September 29, 2011, AREVA NP Inc. provided a schedule for technically correct and complete responses to the 34 questions in RAI 505. On October 27, 2011, and November 17, 2011, AREVA NP provided a revised schedule for technically correct and complete responses to 33 questions and a preliminary revised schedule for Question 07.01-33. On November 22, 2011, AREVA NP provided a final response to four questions.

The schedule for the response to the questions 7.1-37, 7.3-37, 7.4-15, 7.5-10, 7.5-11, 7.8-43, and 7.8-49 is being changed and indicated in bold below, the remaining 23 questions remains unchanged, as indicated below. In addition, the preliminary schedule for a response to Question 07.01-33 remains unchanged. The schedule for Question 07.01-33 is being reevaluated and a new supplement with a revised schedule will be transmitted by December 14, 2011.

<b>Question #</b>	<b>Response Date</b>
RAI 505 — 07.01-33	December 14, 2011
RAI 505 — 07.01-34	January 10, 2012
RAI 505 — 07.01-35	January 10, 2012
RAI 505 — 07.01-36	January 10, 2012
RAI 505 — 07.01-37	<b>January 19, 2012</b>
RAI 505 — 07.01-38	January 10, 2012
RAI 505 — 07.01-39	January 10, 2012
RAI 505 — 07.01-40	January 10, 2012
RAI 505 — 07.01-41	January 10, 2012
RAI 505 — 07.01-42	January 10, 2012
RAI 505 — 07.01-44	January 10, 2012
RAI 505 — 07.01-45	January 10, 2012
RAI 505 — 07.01-46	January 10, 2012
RAI 505 — 07.01-47	January 10, 2012
RAI 505 — 07.01-48	January 10, 2012
RAI 505 — 07.01-49	January 10, 2012
RAI 505 — 07.01-50	January 10, 2012
RAI 505 — 07.01-51	January 10, 2012
RAI 505 — 07.03-37	<b>January 19, 2012</b>
RAI 505 — 07.03-38	January 10, 2012
RAI 505 — 07.04-15	<b>January 19, 2012</b>
RAI 505 — 07.05-10	<b>January 19, 2012</b>
RAI 505 — 07.05-11	<b>January 19, 2012</b>
RAI 505 — 07.08-43	<b>January 19, 2012</b>
RAI 505 — 07.08-44	January 10, 2012
RAI 505 — 07.08-45	January 10, 2012
RAI 505 — 07.08-47	January 10, 2012
RAI 505 — 07.08-48	January 10, 2012
RAI 505 — 07.08-49	<b>January 19, 2012</b>
RAI 505 — 07.09-71	January 10, 2012

Sincerely,

**Tom Ryan for  
Dennis Williford, P.E.  
U.S. EPR Design Certification Licensing Manager  
AREVA NP Inc.**

7207 IBM Drive, Mail Code CLT 2B  
Charlotte, NC 28262  
Phone: 704-805-2223  
Email: [Dennis.Williford@areva.com](mailto:Dennis.Williford@areva.com)

---

**From:** WILLIFORD Dennis (RS/NB)  
**Sent:** Tuesday, November 22, 2011 2:51 PM  
**To:** [Getachew.Tesfaye@nrc.gov](mailto:Getachew.Tesfaye@nrc.gov)  
**Cc:** BENNETT Kathy (RS/NB); DELANO Karen (RS/NB); ROMINE Judy (RS/NB); RYAN Tom (RS/NB)  
**Subject:** Response to U.S. EPR Design Certification Application RAI No. 505 (5902,5735,5869,5754,5803,5950,5744), FSAR Ch. 7, Supplement 3

Getachew,

On September 29, 2011, AREVA NP Inc. provided a schedule for technically correct and complete responses to the 34 questions in RAI 505. On October 27, 2011, and November 17, 2011, AREVA NP provided a revised schedule for technically correct and complete responses to 33 questions and a preliminary revised schedule for Question 07.01-33.

After discussions with NRC staff, the attached file, "RAI 505 Supplement 3 Response US EPR DC.pdf" provides technically correct and complete responses to 4 of the 34 questions. Appended to this file are affected pages of the U.S. EPR Final Safety Analysis Report in redline-strikeout format which support the responses to RAI 505 Question 07.07-23, Question 07.08 -46 and Question 07.09.02-72.

The following table indicates the respective pages in the response document, "RAI 505 Supplement 3 Response US EPR DC.pdf," that contain AREVA NP's response to the subject questions.

Question #	Start Page	End Page
RAI 505 — 07.01-43	2	3
RAI 505 — 07.07-23	4	4
RAI 505 — 07.08-46	5	5
RAI 505 — 07.09-72	6	7

The schedule for the response to the remaining 30 questions remains unchanged, as indicated below. In addition, the preliminary revised schedule for a response to Question 07.01-33 remains unchanged. The schedule for Question 07.01-33 is being reevaluated and a new supplement with a revised schedule will be transmitted by December 14, 2011.

Question #	Response Date
RAI 505 — 07.01-33	December 14, 2011
RAI 505 — 07.01-34	January 10, 2012
RAI 505 — 07.01-35	January 10, 2012
RAI 505 — 07.01-36	January 10, 2012
RAI 505 — 07.01-37	December 11, 2011
RAI 505 — 07.01-38	January 10, 2012
RAI 505 — 07.01-39	January 10, 2012
RAI 505 — 07.01-40	January 10, 2012

RAI 505 — 07.01-41	January 10, 2012
RAI 505 — 07.01-42	January 10, 2012
RAI 505 — 07.01-44	January 10, 2012
RAI 505 — 07.01-45	January 10, 2012
RAI 505 — 07.01-46	January 10, 2012
RAI 505 — 07.01-47	January 10, 2012
RAI 505 — 07.01-48	January 10, 2012
RAI 505 — 07.01-49	January 10, 2012
RAI 505 — 07.01-50	January 10, 2012
RAI 505 — 07.01-51	January 10, 2012
RAI 505 — 07.03-37	December 11, 2011
RAI 505 — 07.03-38	January 10, 2012
RAI 505 — 07.04-15	December 11, 2011
RAI 505 — 07.05-10	December 11, 2011
RAI 505 — 07.05-11	December 11, 2011
RAI 505 — 07.08-43	December 11, 2011
RAI 505 — 07.08-44	January 10, 2012
RAI 505 — 07.08-45	January 10, 2012
RAI 505 — 07.08-47	January 10, 2012
RAI 505 — 07.08-48	January 10, 2012
RAI 505 — 07.08-49	December 11, 2011
RAI 505 — 07.09-71	January 10, 2012

Sincerely,

***Dennis Williford, P.E.***  
***U.S. EPR Design Certification Licensing Manager***  
***AREVA NP Inc.***

7207 IBM Drive, Mail Code CLT 2B  
Charlotte, NC 28262  
Phone: 704-805-2223  
Email: [Dennis.Williford@areva.com](mailto:Dennis.Williford@areva.com)

---

**From:** WILLIFORD Dennis (RS/NB)  
**Sent:** Thursday, November 17, 2011 5:44 PM  
**To:** [Getachew.Tesfaye@nrc.gov](mailto:Getachew.Tesfaye@nrc.gov)  
**Cc:** BENNETT Kathy (RS/NB); DELANO Karen (RS/NB); ROMINE Judy (RS/NB); RYAN Tom (RS/NB)  
**Subject:** Response to U.S. EPR Design Certification Application RAI No. 505 (5902,5735,5869,5754,5803,5950,5744), FSAR Ch. 7, Supplement 2

Getachew,

On September 29, 2011, AREVA NP Inc. provided a schedule for technically correct and complete responses to the 34 questions in RAI 505. On October 27, 2011, AREVA NP provided a revised schedule for technically correct and complete responses to 13 questions and a preliminary revised schedule for Question 07.01-33.

The schedule for the final responses has been revised, as indicated in bold below. In addition, the preliminary revised schedule for a response to Question 07.01-33 has been revised. The schedule for Question 07.01-33 is being reevaluated and a new supplement with a revised schedule will be transmitted by December 14, 2011.

<b>Question #</b>	<b>Response Date</b>
RAI 505 — 07.01-33	<b>December 14, 2011</b>
RAI 505 — 07.01-34	<b>January 10, 2012</b>
RAI 505 — 07.01-35	<b>January 10, 2012</b>
RAI 505 — 07.01-36	<b>January 10, 2012</b>
RAI 505 — 07.01-37	<b>December 11, 2011</b>
RAI 505 — 07.01-38	January 10, 2012
RAI 505 — 07.01-39	<b>January 10, 2012</b>
RAI 505 — 07.01-40	<b>January 10, 2012</b>
RAI 505 — 07.01-41	<b>January 10, 2012</b>
RAI 505 — 07.01-42	<b>January 10, 2012</b>
RAI 505 — 07.01-43	<b>December 11, 2011</b>
RAI 505 — 07.01-44	January 10, 2012
RAI 505 — 07.01-45	January 10, 2012
RAI 505 — 07.01-46	January 10, 2012
RAI 505 — 07.01-47	January 10, 2012
RAI 505 — 07.01-48	January 10, 2012
RAI 505 — 07.01-49	January 10, 2012
RAI 505 — 07.01-50	January 10, 2012
RAI 505 — 07.01-51	January 10, 2012
RAI 505 — 07.03-37	<b>December 11, 2011</b>
RAI 505 — 07.03-38	January 10, 2012
RAI 505 — 07.04-15	<b>December 11, 2011</b>
RAI 505 — 07.05-10	<b>December 11, 2011</b>
RAI 505 — 07.05-11	<b>December 11, 2011</b>
RAI 505 — 07.07-23	<b>December 11, 2011</b>
RAI 505 — 07.08-43	<b>December 11, 2011</b>
RAI 505 — 07.08-44	<b>January 10, 2012</b>
RAI 505 — 07.08-45	<b>January 10, 2012</b>
RAI 505 — 07.08-46	<b>December 11, 2011</b>
RAI 505 — 07.08-47	January 10, 2012
RAI 505 — 07.08-48	January 10, 2012
RAI 505 — 07.08-49	<b>December 11, 2011</b>
RAI 505 — 07.09-71	<b>January 10, 2012</b>
RAI 505 — 07.09-72	<b>January 10, 2012</b>

Sincerely,

***Dennis Williford, P.E.***  
***U.S. EPR Design Certification Licensing Manager***



**AREVA NP Inc.**

7207 IBM Drive, Mail Code CLT 2B

Charlotte, NC 28262

Phone: 704-805-2223

Email: [Dennis.Williford@areva.com](mailto:Dennis.Williford@areva.com)**From:** WILLIFORD Dennis (RS/NB)**Sent:** Thursday, October 27, 2011 11:22 AM**To:** [Getachew.Tesfaye@nrc.gov](mailto:Getachew.Tesfaye@nrc.gov)**Cc:** BENNETT Kathy (RS/NB); DELANO Karen (RS/NB); ROMINE Judy (RS/NB); RYAN Tom (RS/NB)**Subject:** Response to U.S. EPR Design Certification Application RAI No. 505 (5902,5735,5869,5754,5803,5950,5744), FSAR Ch. 7, Supplement 1

Getachew,

On September 29, 2011, AREVA NP Inc. provided a schedule for a technically correct and complete response to the 34 questions in RAI 505.

The schedule for the final response to Questions 07.01-38, 07.01-44, 07.01-45, 07.01-46, 07.01-47, 07.01-48, 07.01-49, 07.01-50, 07.01-51, 07.03-38, 07.08-43, 07.08-47, 07.08-48 has been revised, as indicated in bold below. In addition, a preliminary revised schedule for a technically correct and complete response to Question 07.01-33 is provided below. The schedule for Question 07.01-33 is being reevaluated and a new supplement with a revised schedule will be transmitted by November 17, 2011.

Question #	Response Date
RAI 505 — 07.01-33	<b>November 17, 2011</b>
RAI 505 — 07.01-34	December 8, 2011
RAI 505 — 07.01-35	November 17, 2011
RAI 505 — 07.01-36	December 8, 2011
RAI 505 — 07.01-37	December 8, 2011
RAI 505 — 07.01-38	<b>January 10, 2012</b>
RAI 505 — 07.01-39	December 8, 2011
RAI 505 — 07.01-40	December 8, 2011
RAI 505 — 07.01-41	November 17, 2011
RAI 505 — 07.01-42	December 20, 2011
RAI 505 — 07.01-43	November 17, 2011
RAI 505 — 07.01-44	<b>January 10, 2012</b>
RAI 505 — 07.01-45	<b>January 10, 2012</b>
RAI 505 — 07.01-46	<b>January 10, 2012</b>
RAI 505 — 07.01-47	<b>January 10, 2012</b>
RAI 505 — 07.01-48	<b>January 10, 2012</b>
RAI 505 — 07.01-49	<b>January 10, 2012</b>
RAI 505 — 07.01-50	<b>January 10, 2012</b>
RAI 505 — 07.01-51	<b>January 10, 2012</b>
RAI 505 — 07.03-37	November 17, 2011
RAI 505 — 07.03-38	<b>January 10, 2012</b>
RAI 505 — 07.04-15	November 17, 2011

RAI 505 — 07.05-10	November 17, 2011
RAI 505 — 07.05-11	November 17, 2011
RAI 505 — 07.07-23	November 17, 2011
RAI 505 — 07.08-43	<b>January 10, 2012</b>
RAI 505 — 07.08-44	December 8, 2011
RAI 505 — 07.08-45	December 8, 2011
RAI 505 — 07.08-46	December 8, 2011
RAI 505 — 07.08-47	<b>January 10, 2012</b>
RAI 505 — 07.08-48	<b>January 10, 2012</b>
RAI 505 — 07.08-49	November 17, 2011
RAI 505 — 07.09-71	December 8, 2011
RAI 505 — 07.09-72	December 8, 2011

Sincerely,

***Dennis Williford, P.E.***  
***U.S. EPR Design Certification Licensing Manager***  
***AREVA NP Inc.***

7207 IBM Drive, Mail Code CLT 2B  
Charlotte, NC 28262  
Phone: 704-805-2223  
Email: [Dennis.Williford@areva.com](mailto:Dennis.Williford@areva.com)

---

**From:** WILLIFORD Dennis (RS/NB)  
**Sent:** Thursday, September 29, 2011 11:04 AM  
**To:** [Getachew.Tesfaye@nrc.gov](mailto:Getachew.Tesfaye@nrc.gov)  
**Cc:** BENNETT Kathy (RS/NB); DELANO Karen (RS/NB); ROMINE Judy (RS/NB); RYAN Tom (RS/NB)  
**Subject:** Response to U.S. EPR Design Certification Application RAI No. 505 (5902,5735,5869,5754,5803,5950,5744), FSAR Ch. 7

Getachew,

Attached please find AREVA NP Inc.'s response to the subject request for additional information (RAI). The attached file, "RAI 505 Response US EPR DC.pdf," provides a schedule since a technically correct and complete response to the 34 questions cannot be provided at this time.

The following table indicates the respective pages in the response document, "RAI 505 Response US EPR DC.pdf," that contain AREVA NP's response to the subject questions.

<b>Question #</b>	<b>Start Page</b>	<b>End Page</b>
RAI 505 — 07.01-33	2	2
RAI 505 — 07.01-34	3	3
RAI 505 — 07.01-35	4	4
RAI 505 — 07.01-36	5	5
RAI 505 — 07.01-37	6	6
RAI 505 — 07.01-38	7	7
RAI 505 — 07.01-39	8	8
RAI 505 — 07.01-40	9	9

RAI 505 — 07.01-41	10	10
RAI 505 — 07.01-42	11	11
RAI 505 — 07.01-43	12	12
RAI 505 — 07.01-44	13	13
RAI 505 — 07.01-45	14	14
RAI 505 — 07.01-46	15	15
RAI 505 — 07.01-47	16	16
RAI 505 — 07.01-48	17	18
RAI 505 — 07.01-49	19	19
RAI 505 — 07.01-50	20	20
RAI 505 — 07.01-51	21	22
RAI 505 — 07.03-37	23	23
RAI 505 — 07.03-38	24	24
RAI 505 — 07.04-15	25	25
RAI 505 — 07.05-10	26	26
RAI 505 — 07.05-11	27	27
RAI 505 — 07.07-23	28	28
RAI 505 — 07.08-43	29	29
RAI 505 — 07.08-44	30	30
RAI 505 — 07.08-45	31	31
RAI 505 — 07.08-46	32	32
RAI 505 — 07.08-47	33	33
RAI 505 — 07.08-48	34	34
RAI 505 — 07.08-49	35	35
RAI 505 — 07.09-71	36	36
RAI 505 — 07.09-72	37	37

A complete answer is not provided for the 34 questions. The schedule for a technically correct and complete response to these questions is provided below.

Please note that the date for the response to Question 07.01-33 is a commitment date to provide a final schedule for the response in a follow-up letter.

<b>Question #</b>	<b>Response Date</b>
RAI 505 — 07.01-33	October 27, 2011
RAI 505 — 07.01-34	December 8, 2011
RAI 505 — 07.01-35	November 17, 2011
RAI 505 — 07.01-36	December 8, 2011
RAI 505 — 07.01-37	December 8, 2011
RAI 505 — 07.01-38	December 20, 2011
RAI 505 — 07.01-39	December 8, 2011
RAI 505 — 07.01-40	December 8, 2011
RAI 505 — 07.01-41	November 17, 2011
RAI 505 — 07.01-42	December 20, 2011
RAI 505 — 07.01-43	November 17, 2011

RAI 505 — 07.01-44	December 20, 2011
RAI 505 — 07.01-45	December 20, 2011
RAI 505 — 07.01-46	December 20, 2011
RAI 505 — 07.01-47	December 8, 2011
RAI 505 — 07.01-48	December 20, 2011
RAI 505 — 07.01-49	December 20, 2011
RAI 505 — 07.01-50	December 20, 2011
RAI 505 — 07.01-51	December 20, 2011
RAI 505 — 07.03-37	November 17, 2011
RAI 505 — 07.03-38	December 20, 2011
RAI 505 — 07.04-15	November 17, 2011
RAI 505 — 07.05-10	November 17, 2011
RAI 505 — 07.05-11	November 17, 2011
RAI 505 — 07.07-23	November 17, 2011
RAI 505 — 07.08-43	December 20, 2011
RAI 505 — 07.08-44	December 8, 2011
RAI 505 — 07.08-45	December 8, 2011
RAI 505 — 07.08-46	December 8, 2011
RAI 505 — 07.08-47	December 20, 2011
RAI 505 — 07.08-48	December 20, 2011
RAI 505 — 07.08-49	November 17, 2011
RAI 505 — 07.09-71	December 8, 2011
RAI 505 — 07.09-72	December 8, 2011

Sincerely,

***Dennis Williford, P.E.***  
***U.S. EPR Design Certification Licensing Manager***  
***AREVA NP Inc.***

7207 IBM Drive, Mail Code CLT 2B  
Charlotte, NC 28262  
Phone: 704-805-2223  
Email: [Dennis.Williford@areva.com](mailto:Dennis.Williford@areva.com)

---

**From:** Tesfaye, Getachew [<mailto:Getachew.Tesfaye@nrc.gov>]

**Sent:** Tuesday, August 30, 2011 1:23 PM

**To:** ZZ-DL-A-USEPR-DL

**Cc:** Zhang, Deanna; Morton, Wendell; Spaulding, Deirdre; Mott, Kenneth; Truong, Tung; Zhao, Jack; Mills, Daniel; Jackson, Terry; Canova, Michael; Colaccino, Joseph; ArevaEPRDCPEm Resource

**Subject:** U.S. EPR Design Certification Application RAI No. 505 (5902,5735,5869,5754,5803,5950,5744), FSAR Ch. 7

Attached please find the subject requests for additional information (RAI). A draft of the RAI was provided to you on August 12, 2011, and discussed with your staff on August 22 and 25, 2011. No change is made to the draft RAI as a result of those discussions. The schedule we have established for review of your application assumes technically correct and complete responses within 30 days of receipt of RAIs. For any RAIs that cannot be answered within 30 days, it is expected that a date for receipt of this information will be provided to the staff within the 30 day period so that the staff can assess how this information will impact the published schedule.

Thanks,  
Getachew Tesfaye  
Sr. Project Manager  
NRO/DNRL/NARP  
(301) 415-3361

**Hearing Identifier:** AREVA\_EPR\_DC\_RAIs  
**Email Number:** 3849

**Mail Envelope Properties** (2FBE1051AEB2E748A0F98DF9EEE5A5D4BAF6DC)

**Subject:** DRAFT Response to U.S. EPR Design Certification Application RAI No. 505 (5902,5735,5869,5754,5803,5950,5744), FSAR Ch. 7, Question 07.01-35  
**Sent Date:** 3/29/2012 4:06:31 PM  
**Received Date:** 3/29/2012 4:05:11 PM  
**From:** WILLIFORD Dennis (AREVA)

**Created By:** Dennis.Williford@areva.com

**Recipients:**

"BENNETT Kathy (AREVA)" <Kathy.Bennett@areva.com>  
Tracking Status: None  
"CRIBB Arnie (EXTERNAL AREVA)" <arnie.cribb.ext@areva.com>  
Tracking Status: None  
"DELANO Karen (AREVA)" <Karen.Delano@areva.com>  
Tracking Status: None  
"HATHCOCK Phillip (AREVA)" <Phillip.Hathcock@areva.com>  
Tracking Status: None  
"LEIGHLITER John (AREVA)" <John.Leighliter@areva.com>  
Tracking Status: None  
"ROMINE Judy (AREVA)" <Judy.Romine@areva.com>  
Tracking Status: None  
"RYAN Tom (AREVA)" <Tom.Ryan@areva.com>  
Tracking Status: None  
"MEACHAM Robert (AREVA)" <Robert.Meacham@areva.com>  
Tracking Status: None  
"HUDSON Greg (AREVA)" <Greg.Hudson@areva.com>  
Tracking Status: None  
"Teschaye, Getachew" <Getachew.Teschaye@nrc.gov>  
Tracking Status: None

**Post Office:** auscharm02.adom.ad.corp

Files	Size	Date & Time	
MESSAGE	44133	3/29/2012 4:05:11 PM	
RAI 505 Question 7.1-35 Response US EPR DC - DRAFT.PDF			3690251

**Options**

**Priority:** Standard  
**Return Notification:** No  
**Reply Requested:** No  
**Sensitivity:** Normal  
**Expiration Date:**  
**Recipients Received:**

**Response to**

**Request for Additional Information No. 505**

**8/30/2011**

**U. S. EPR Standard Design Certification**

**AREVA NP Inc.**

**Docket No. 52-020**

**SRP Section: 07.01 - Instrumentation and Controls - Introduction**

**SRP Section: 07.03 - Engineered Safety Features Systems**

**SRP Section: 07.04 - Safe Shutdown Systems**

**SRP Section: 07.05 - Information Systems Important to Safety**

**SRP Section: 07.07 - Control Systems**

**SRP Section: 07.08 - Diverse Instrumentation and Control Systems**

**SRP Section: 07.09 - Data Communication Systems**

**Application Section: FSAR Chapter 7**

**QUESTIONS for Instrumentation, Controls and Electrical Engineering 1  
(AP1000/EPR Projects) (ICE1)**

**Question 07.01-35:****OPEN ITEM**

Provide failure modes and effects analysis (FMEA) and ITAAC to perform the FMEA for the Safety Automation System (SAS) to verify design commitments made in U.S. EPR FSAR, Tier 2, Section 7.1.

10 CFR 50.55a(h) incorporates by reference IEEE Std. 603-1991. As part of an alternative request, the applicant proposes to use IEEE Std. 603-1998. Clause 5.1 of IEEE Std. 603-1998 require, in part, that safety systems perform all safety functions in the presence of any single detectable failure, all failures caused by a single failure, and all failures or spurious actuations caused by a design basis event. In Tier 2, Section 7.1.2.6.12, the applicant states that an FMEA was performed for the PS and described in ANP-10309P, as a means of meeting the requirements of IEEE Std. 603-1998, Clause 5.1. An FMEA is a typical method of analysis used to demonstrate compliance with single failure criteria of IEEE Std. 603-1998, Clause 5.1. The staff review of the PS FMEA determined that the SAS functionality, as it pertains to ESF functionality, is not addressed in the analysis. The applicant did not state in Section 7.1.2.6.12 that an FMEA was performed for SAS. SAS provides safety-related functions relating to safe shutdown support as well as providing safety-related interlocks for numerous other safety systems. The staff review of Tier 1, Section 2.4.4, determined that there was no ITAAC item verifying the performance of a SAS FMEA, similar to that of the PS ITAAC item provided in Section 2.4.1.

Due to the safety significance of SAS, the staff requests the applicant provide an FMEA, or similar single failure analysis, for SAS that demonstrates SAS failure modes have been accounted for in the U.S. EPR design. The staff also requests the applicant provide an ITAAC item verifying the performance of the SAS FMEA.

**Response to Question 07.01-35:**

A system-level failure modes and effects analysis (FMEA) was performed on the safety automation system (SAS) to identify potential single-point failures and their consequences. The architecture of the SAS is redundant by the means of the use of redundant control units and divisional redundancy. The system is designed so that a single failure during corrective or periodic maintenance, or a single failure and the effects of an internal hazard, do not prevent performance of the safety functions. The FMEA for SAS has been incorporated into the U.S. EPR FSAR Tier 2, Section 7.1, Table 7.1-7 as described in the response to RAI, Question 07.01-36.

The SAS logic diagrams and descriptions have been developed and will be incorporated into the U.S. EPR FSAR Tier 2, Section 7.3 (for SAS Control Functions) and Section 7.6 (for SAS Interlock Functions). An inspections, tests, analyses, and acceptance criteria (ITAAC) item for the SAS FMEA, similar to that of the protection system ITAAC provided in U.S. EPR FSAR Tier 1, Section 2.4.1, was included in U. S. EPR FSAR Tier 1, Section 2.4.4, Item 4.10, as part of the response to RAI 452, Supplement 5 on June 22, 2011. This Tier 1 information has been updated to include conforming changes to match the addition of the SAS logic diagrams.

Conforming changes due to this response to other U.S. EPR FSAR Chapters 3, 6, 8, 9 and 14 are also included in this response to this RAI. These changes include mark-ups of the



corresponding Mechanical System design descriptions in Tier 1 and Chapter 9 to reflect the additional design detail associated with each of the SAS I&C Logic Diagrams. Also included were conforming changes to Chapter 8 and 14 to reflect the corresponding mechanical changes. The inclusion of the additional design details also involved updating the Chapter 3 tables in Sections 3.2, 3.10, and 3.11 for Classification, Seismically Qualified Mechanical Equipment, and Environmentally Qualified Electrical/I&C Equipment.

**FSAR Impact:**

U.S. EPR FSAR, Tier 1, Sections 2.4.4, 2.4.25, 2.6.1, 2.6.3, 2.6.6, 2.6.7, 2.6.8, 2.6.9, and 2.6.13 will be revised as described in the response and indicated on the enclosed markup.

U.S. EPR FSAR, Tier 2, Sections 6.2.3, 7.3, 7.6, 8.3, 9.1.3, 9.2.2, 9.4.1, 9.4.2, 9.4.3, 9.4.5, 9.4.6, 9.4.9, 9.4.11 and 14.2 will be revised as described in the response and indicated on the enclosed markup.

U.S. EPR FSAR, Tier 2, Tables 3.2.2-1, 3.10-1, 3.11-1, 3.11-2 and 7.1-5 will be revised as described in the response and indicated on the enclosed markup.

U.S. EPR FSAR, Tier 2, Table 7.1-7 will be added as described in the response and indicated on the enclosed markup.

DRAFT

# U.S. EPR Final Safety Analysis Report Markups

DRAFT

**Table 2.4.4-2— Safety Automation System Automatic  
Functions and Input Variables  
(7 Sheets)**

<u>Table System</u>	<u>Function Name</u>	<u>Input Variable</u>	
<u>Annulus Ventilation System (AVS)</u>	<u>Accident Filtration Train Heater Control</u>	<u>Isolation Damper Position</u>	
		<u>Heater Fan Running</u>	
	<u>Accident Train Switchover</u>	<u>Pressure</u>	
		<u>Post Heater Temperature</u>	
		<u>Filter Bank Isolation Inlet Damper Position</u>	
		<u>Filter Bank Isolation Outlet Damper Position</u>	
		<u>Exhaust Fan Signal</u>	
	<u>Component Cooling Water System (CCWS)</u>	<u>CCWS Common 1.b Automatic Backup Switchover of Train 1 to Train 2 and Train 2 to Train 1</u>	<u>Train 1 Loss of ESWS Signal</u>
			<u>Train 1 Pump Pressure</u>
			<u>Train 1 Flow Rate</u>
<u>Train 2 Loss of ESWS Signal</u>			
<u>Train 2 Pump Pressure</u>			
<u>Train 2 Flow Rate</u>			
<u>CCWS Common 2.b Automatic Backup Switchover of Train 3 to Train 4 and Train 4 to Train 3</u>		<u>Train 3 Loss of ESWS Signal</u>	
		<u>Train 3 Pump Pressure</u>	
		<u>Train 3 Flow Rate</u>	
		<u>Train 4 Loss of ESWS Signal</u>	
		<u>Train 4 Pump Pressure</u>	
		<u>Train 4 Flow Rate</u>	
<u>CCWS Emergency Temperature Control</u>		<u>Heat Exchanger Temp</u>	
		<u>Heat Exchanger Bypass Valve Position</u>	
<u>CCWS Emergency Leak Detection</u>		<u>Surge Tank Level</u>	
		<u>CCWS Chiller Inlet Flow</u>	
		<u>CCWS Chiller Outlet Flow</u>	
		<u>Common Supply Outlet Flow</u>	
<u>CCWS Emergency Leak Detection – Switchover Valves</u>		<u>Common Supply Inlet Flow</u>	
		<u>Surge Tank 1 Level</u>	
		<u>Surge Tank 2 Level</u>	



**Table 2.4.4-2— Safety Automation System Automatic Functions and Input Variables (7 Sheets)**

<u>Table System</u>	<u>Function Name</u>	<u>Input Variable</u>	
	<u>Leakage or Failure</u>	<u>Surge Tank 3 Level</u>	
		<u>Surge Tank 4 Level</u>	
	<u>CCWS Switchover Valves Interlock</u>	<u>Train 1 Common 1a Supply Valve Position</u>	
		<u>Train 1 Common 1a Return Valve Position</u>	
		<u>Train 1 Common 1b Supply Valve Position</u>	
		<u>Train 1 Common 1b Return Valve Position</u>	
		<u>Train 2 Common 1a Supply Valve Position</u>	
		<u>Train 2 Common 1a Return Valve Position</u>	
		<u>Train 2 Common 1b Supply Valve Position</u>	
		<u>Train 2 Common 1b Return Valve Position</u>	
		<u>Train 3 Common 1a Supply Valve Position</u>	
		<u>Train 3 Common 1a Return Valve Position</u>	
		<u>Train 3 Common 1b Supply Valve Position</u>	
		<u>Train 3 Common 1b Return Valve Position</u>	
		<u>Train 4 Common 1a Supply Valve Position</u>	
		<u>Train 4 Common 1a Return Valve Position</u>	
		<u>Train 4 Common 1b Supply Valve Position</u>	
		<u>Train 4 Common 1b Return Valve Position</u>	
		<u>CCWS RCP Thermal Barrier Containment Isolation Valve</u>	<u>Common 1b Return Outer Valve Position</u>

DRAFT

**Table 2.4.4-2— Safety Automation System Automatic  
Functions and Input Variables  
(7 Sheets)**

<u>Table System</u>	<u>Function Name</u>	<u>Input Variable</u>
		<u>Common 2b Return Outer Valve Position</u>
		<u>Common 2b Supply Outer Valve Position</u>
		<u>Common 1b Return Inner Valve Position</u>
		<u>Common 1b Supply Inner Valve Position</u>
		<u>Common 2b Return Inner Valve Position</u>
		<u>Common 2b Supply Inner Valve Position</u>
	<u>SCWS Condenser Supply Water Flow Control</u>	<u>Condenser Refrigerant Pressure</u>
<u>Emergency Feedwater System (EFWS)</u>	<u>SG Closed Loop Level Control</u>	<u>SG Level</u>
	<u>Pump Flow Protection</u>	<u>Pump Flow Signal</u>
<u>Essential Service Water Pump Building Ventilation System (ESWPBVS)</u>	<u>ESWPBVS ESWS Pump Rooms Temperature Control</u>	<u>Outside Air Temperature</u>
<u>Fuel Building Ventilation System (FBVS)</u>	<u>Safety-Related Room Heater Control</u>	<u>Room Temperature</u>
	<u>FBVS EBS / FPCS Pump Rooms Heat Removal</u>	<u>Recirculation Temperature</u>
	<u>Isolation of FBVS on Containment Isolation</u>	<u>Containment Isolation Signal</u>
	<u>Fuel Pool Area Handling Accident</u>	<u>Fuel Building Ventilation Activity</u>
	<u>Reactor Building Fuel Handling Accident</u>	<u>Containment Building Ventilation Activity</u>
<u>Fuel Pool Cooling and Purification System (FPCPS)</u>	<u>FPCPS Pump Trip on Low Spent Fuel Pool (SFP) Level</u>	<u>SFP Level (WR)</u>
<u>In-Containment Refueling Water Storage Tank System (IRWST)</u>	<u>IRWST Boundary Isolation for Preserving IRWST Water Inventory Interlock</u>	<u>IRWST Level</u>
<u>Main Control Room Air Conditioning System</u>	<u>Iodine Filtration Train Heater Control</u>	<u>Carbon Filter Isolation Damper Position</u>



**Table 2.4.4-2— Safety Automation System Automatic  
Functions and Input Variables  
(7 Sheets)**

<u>Table System</u>	<u>Function Name</u>	<u>Input Variable</u>
<u>(CRACS)</u>		<u>Protective Switch Temperature</u>
		<u>ESF Filtration Status</u>
	<u>Heater Control for Outside Inlet Air</u>	<u>Downstream Temperature</u>
		<u>Inlet Damper Position</u>
		<u>Outlet Damper Position</u>
	<u>Pressure Control</u>	<u>MCR Differential Pressure</u>
	<u>Cooler Temperature Control</u>	<u>Supply Air Temperature</u>
<u>Main Steam System (MSS)</u>	<u>Steam Generator MSRCV Regulation during Pressure Control</u>	<u>MSRIV Position</u>
		<u>MSRIV Actuation Signal (from PS)</u>
		<u>MSRT Setpoint (from PS)</u>
		<u>SG Pressure</u>
	<u>Steam Generator MSRCV Regulation during Standby Position Pressure Control</u>	<u>MSRCV Position</u>
	<u>Nuclear Power Calculation (from PS)</u>	
<u>Safeguard Building Controlled-Area Ventilation System (SBVS)</u>	<u>SIS/RHRS Pump Rooms Heat Removal</u>	<u>LHSI Pump Room Temperature</u>
		<u>MHSI Pump Room Temperature</u>
		<u>SIS/RHR Pump Running Signal</u>
		<u>SIS/RHR Pump Stopped Signal</u>
	<u>CCWS/EFWS Valve Rooms Heat Removal</u>	<u>Room Temperature</u>
<u>Electrical Division of Safeguard Building Ventilation System (SBVSE)</u>	<u>Supply and Recirculation Exhaust Air Flow Control</u>	<u>Supply Air Temperature Downstream of Heaters</u>
		<u>Protective Switch Temperature</u>
		<u>Outside Air Temperature</u>
		<u>Outside Air Damper Open Position Signal</u>
		<u>Outside Air Damper Closed Position Signal</u>

**Table 2.4.4-2— Safety Automation System Automatic  
Functions and Input Variables  
(7 Sheets)**

<u>Table System</u>	<u>Function Name</u>	<u>Input Variable</u>
		<u>Exhaust Damper Open Position Signal</u>
		<u>Exhaust Damper Closed Position Signal</u>
		<u>Recirculation Damper Open Position Signal</u>
		<u>Recirculation Damper Closed Position Signal</u>
	<u>Supply Fan Safe Shut-off</u>	<u>Recirc / Exhaust Fan Stopped Signal</u>
		<u>Outside Air Damper Closed Position Signal</u>
		<u>Recirculation Damper Closed Position Signal</u>
	<u>Recirculation Fan Safe Shut-off</u>	<u>CCW Pump Room Temperature</u>
		<u>EFW Pump Room Temperature</u>
	<u>Exhaust Fan Safe Shut-off</u>	<u>Exhaust Damper Closed Position</u>
	<u>Supply Air Temperature Heater Control</u>	<u>Supply Air Downstream of Heaters Temperature</u>
		<u>Filter Bank Differential Pressure</u>
	<u>Freeze Protection – Supply Air Temperature</u>	<u>Outside Air Temperature</u>
	<u>Supply Air Temperature Control for Supply Air Cooling</u>	<u>Supply Air Downstream of Humidifier Temperature</u>
	<u>Battery Room Heater Control</u>	<u>Battery Room Temperature</u>
	<u>Battery Room Supply Air Temperature Control</u>	<u>Battery Room Supply Air Temperature</u>
	<u>Emergency Feed Water System (EFWS) Pump Room Heat Removal</u>	<u>EFWS Pump Room Temperature</u>
	<u>Component Cooling Water System (CCWS) Pump Room Heat Removal</u>	<u>CCWS Pump Room Temperature</u>



**Table 2.4.4-2— Safety Automation System Automatic Functions and Input Variables (7 Sheets)**

<u>Table System</u>	<u>Function Name</u>	<u>Input Variable</u>
<u>Safety Chilled Water System (SCWS)</u>	<u>SCWS Train 1 to Train 2 Switchover on Train 1 Low Evaporator Flow / Chiller Black Box Internal Fault / SCWS Chiller Evaporator Water Flow Control / LOOP Re-start Failure</u>	<u>Train 1 Chiller Evaporator Outlet Temperature</u>
		<u>Train 1 Chiller Compressor Oil Pressure</u>
		<u>Train 1 Condenser Refrigerant Pressure</u>
		<u>Train 1 Chiller Evaporator Flow Signal</u>
		<u>Train 1 Cross-Tie Valves Position Signal</u>
		<u>Train 2 Cross-Tie Valves Position Signal</u>
		<u>Train 2 Circulating Pump 1 Running Signal</u>
		<u>Train 2 Circulating Pump 2 Running Signal</u>
		<u>Train 2 Evaporator ΔP Signal</u>
		<u>Train 2 Chiller Evaporator Flow Signal</u>
	<u>SCWS Train 2 to Train 1 Switchover on Train 2 Low Evaporator Flow / Chiller Black Box Internal Fault / Loss of UHS-CCWS / SCWS Chiller Evaporator Water Flow Control / LOOP Re-start Failure</u>	<u>Train 1 Circulating Pump 1 Running Signal</u>
		<u>Train 1 Circulating Pump 2 Running Signal</u>
		<u>Train 1 Evaporator ΔP Signal</u>
		<u>Train 1 Chiller Evaporator Flow Signal</u>
		<u>Train 1 Cross-Tie Valves Position Signal</u>
		<u>Train 2 Cross-Tie Valves Position Signal</u>
		<u>Train 2 Chiller Evaporator Flow Signal</u>
		<u>Train 2 Condenser Refrigerant Pressure</u>
		<u>Train 2 Chiller Compressor Oil Pressure</u>





**Table 2.4.4-2— Safety Automation System Automatic Functions and Input Variables (7 Sheets)**

<u>Table System</u>	<u>Function Name</u>	<u>Input Variable</u>
		<u>Train 2 Chiller Evaporator Outlet Temperature</u>
		<u>Train 2 Condenser Flow Rate Signal</u>
	<u>SCWS Train 3 to Train 4 Switchover on Train 3 Low Evaporator Flow / Chiller Black Box Internal Fault / Loss of UHS-CCWS / SCWS Chiller Evaporator Water Flow Control / LOOP Re-start Failure</u>	<u>Train 3 Condenser Flow Rate Signal</u>
		<u>Train 3 Chiller Evaporator Outlet Temperature</u>
		<u>Train 3 Chiller Compressor Oil Pressure</u>
		<u>Train 3 Condenser Refrigerant Pressure</u>
		<u>Train 3 Chiller Evaporator Flow Signal</u>
		<u>Train 3 Cross-Tie Valves Position Signal</u>
		<u>Train 4 Cross-Tie Valves Position Signal</u>
		<u>Train 4 Circulating Pump 1 Running Signal</u>
		<u>Train 4 Circulating Pump 2 Running Signal</u>
		<u>Train 4 Evaporator ΔP Signal</u>
	<u>Train 4 Chiller Evaporator Flow Signal</u>	
	<u>SCWS Train 4 to Train 3 Switchover on Train 4 Low Evaporator Flow / Chiller Black Box Internal Fault / SCWS Chiller Evaporator Water Flow Control / LOOP Re-start Failure</u>	<u>Train 3 Circulating Pump 1 Running Signal</u>
		<u>Train 3 Circulating Pump 2 Running Signal</u>
		<u>Train 3 Evaporator ΔP Signal</u>
		<u>Train 3 Chiller Evaporator Flow Signal</u>
		<u>Train 3 Cross-Tie Valves Position Signal</u>
		<u>Train 4 Cross-Tie Valves Position Signal</u>



**Table 2.4.4-2— Safety Automation System Automatic Functions and Input Variables (7 Sheets)**

<u>Table System</u>	<u>Function Name</u>	<u>Input Variable</u>
		<u>Train 4 Chiller Evaporator Flow Signal</u>
		<u>Train 4 Condenser Refrigerant Pressure</u>
		<u>Train 4 Chiller Compressor Oil Pressure</u>
		<u>Train 4 Chiller Evaporator Outlet Temperature</u>
<u>Safety Injection and Residual Heat Removal System (SIS/RHRS)</u>	<u>Automatic RHRS Flow Rate Control</u>	<u>RHRS Flow Rate Signal</u>
		<u>RHRS Temperature</u>
		<u>LHSI Pump Pressure</u>
	<u>Automatic Trip of LHSI Pump (in RHR Mode) on Low ΔPsat</u>	<u>Hot Leg Temperature (WR)</u>
		<u>Hot Leg Pressure (WR)</u>
	<u>Automatic Trip of LHSI Pump (in RHR Mode) on Low Loop Level</u>	<u>Hot Leg Loop Level</u>
	<u>RHR Isolation Valves Interlock</u>	<u>LHSI Suction Isolation Valve Position</u>
		<u>RHR 1st RCPB Isolation Valve Position</u>
<u>RHR 2nd RCPB Isolation Valve Position</u>		



**Table 2.4.25-2—Signal Conditioning and Distribution System Input Signals (2-7 Sheets)**

Item #	Signal	Source	# Divisions
22	Medium Head Safety Injection Flow (WR)	Safety Injection and Residual Heat Removal System	4
23	Neutron Flux from Intermediate Range Detector (IRD)	Excore Instrumentation System	4
24	Neutron Flux from Power Range Detector (PRD)	Excore Instrumentation System	4
25	Neutron Flux from Self Powered Neutron Detectors (SPND)	Incore Instrumentation System	4
26	Neutron Flux from Source Range (SRD)	Excore Instrumentation System	4
27	Pressurizer Level (NR)	Reactor Coolant System	4
28	Pressurizer Pressure (NR)	Reactor Coolant System	4
29	RCP Bus Breaker Position	Normal Power Supply System	4
30	RCP Breaker Position	Normal Power Supply System	4
31	RCS Loop Flow	Reactor Coolant System	4
33	RCS Loop Level	Reactor Coolant System	4
34	RCP Speed	Reactor Coolant System	4
35	SG Level (NR)	Reactor Coolant System	4
36	SG Level (WR)	Reactor Coolant System	4
37	SG Pressure	Main Steam System	4
38	Temperature compensated rod cluster control assembly (RCCA) positions	Rod Position Measurement System	4
<u>39</u>	<u>Reactor Trip Contactor Position</u>	<u>Control Rod Drive Control System</u>	<u>4</u>
<u>40</u>	<u>Containment Hydrogen Concentration</u>	<u>Hydrogen Monitoring System</u>	<u>2</u>
<u>41</u>	<u>Core Outlet Temperature</u>	<u>Incore Instrumentation System</u>	<u>4</u>
<u>42</u>	<u>AVS Temperature</u>	<u>Annulus Ventilation System</u>	<u>2</u>
<u>43</u>	<u>AVS Isolation Damper Position</u>	<u>Annulus Ventilation System</u>	<u>2</u>
<u>44</u>	<u>AVS Heater Fan Signal</u>	<u>Annulus Ventilation System</u>	<u>2</u>
<u>45</u>	<u>AVS Pressure</u>	<u>Annulus Ventilation System</u>	<u>2</u>
<u>46</u>	<u>AVS Differential Pressure</u>	<u>Annulus Ventilation System</u>	<u>2</u>
<u>47</u>	<u>AVS Post Heater Temperature</u>	<u>Annulus Ventilation System</u>	<u>2</u>
<u>48</u>	<u>AVS Filter Bank Isolation Inlet Damper Position</u>	<u>Annulus Ventilation System</u>	<u>2</u>



**Table 2.4.25-2—Signal Conditioning and Distribution System Input Signals (2-7 Sheets)**

<b>Item #</b>	<b>Signal</b>	<b>Source</b>	<b># Divisions</b>
<u>49</u>	<u>AVS Filter Bank Isolation Outlet Damper Position</u>	<u>Annulus Ventilation System</u>	<u>2</u>
<u>50</u>	<u>AVS Exhaust Fan Signal</u>	<u>Annulus Ventilation System</u>	<u>2</u>
<u>51</u>	<u>CCWS Loss of ESWS Signal</u>	<u>Component Cooling Water System</u>	<u>4</u>
<u>52</u>	<u>CCWS Pump Pressure</u>	<u>Component Cooling Water System</u>	<u>4</u>
<u>53</u>	<u>CCWS Flow Rate</u>	<u>Component Cooling Water System</u>	<u>4</u>
<u>54</u>	<u>CCWS Heat Exchanger Temp</u>	<u>Component Cooling Water System</u>	<u>4</u>
<u>55</u>	<u>CCWS Heat Exchanger Bypass Valve Position</u>	<u>Component Cooling Water System</u>	<u>4</u>
<u>56</u>	<u>CCWS Surge Tank Level</u>	<u>Component Cooling Water System</u>	<u>4</u>
<u>57</u>	<u>CCWS Chiller Inlet Flow</u>	<u>Component Cooling Water System</u>	<u>4</u>
<u>58</u>	<u>CCWS Chiller Outlet Flow</u>	<u>Component Cooling Water System</u>	<u>4</u>
<u>59</u>	<u>CCWS Common Supply Outlet Flow</u>	<u>Component Cooling Water System</u>	<u>4</u>
<u>60</u>	<u>CCWS Common Supply Inlet Flow</u>	<u>Component Cooling Water System</u>	<u>4</u>
<u>61</u>	<u>CCWS Common 1a Supply Valve Position</u>	<u>Component Cooling Water System</u>	<u>4</u>
<u>62</u>	<u>CCWS Common 1a Return Valve Position</u>	<u>Component Cooling Water System</u>	<u>4</u>
<u>63</u>	<u>CCWS Common 1b Supply Valve Position</u>	<u>Component Cooling Water System</u>	<u>4</u>
<u>64</u>	<u>CCWS Common 1b Return Valve Position</u>	<u>Component Cooling Water System</u>	<u>4</u>
<u>65</u>	<u>CCWS Common 1b Return Outer Valve Position</u>	<u>Component Cooling Water System</u>	<u>2</u>
<u>66</u>	<u>CCWS Common 1b Supply Outer Valve Position</u>	<u>Component Cooling Water System</u>	<u>2</u>
<u>67</u>	<u>CCWS Common 2b Return Outer Valve Position</u>	<u>Component Cooling Water System</u>	<u>2</u>



**Table 2.4.25-2—Signal Conditioning and Distribution System Input Signals (2-7 Sheets)**

<b>Item #</b>	<b>Signal</b>	<b>Source</b>	<b># Divisions</b>
<u>68</u>	<u>CCWS Common 2b Supply Outer Valve Position</u>	<u>Component Cooling Water System</u>	<u>2</u>
<u>69</u>	<u>CCWS Common 1b Return Inner Valve Position</u>	<u>Component Cooling Water System</u>	<u>2</u>
<u>70</u>	<u>CCWS Common 1b Supply Inner Valve Position</u>	<u>Component Cooling Water System</u>	<u>2</u>
<u>71</u>	<u>CCWS Common 2b Return Inner Valve Position</u>	<u>Component Cooling Water System</u>	<u>2</u>
<u>72</u>	<u>CCWS Common 2b Supply Inner Valve Position</u>	<u>Component Cooling Water System</u>	<u>2</u>
<u>73</u>	<u>SCWS Condenser Refrigerant Pressure</u>	<u>Component Cooling Water System</u>	<u>2</u>
<u>74</u>	<u>EFW Pump Flow Signal</u>	<u>Emergency Feedwater System</u>	<u>4</u>
<u>75</u>	<u>ESW Outside Air Temperature</u>	<u>Essential Service Water Pump Building Ventilation System</u>	<u>4</u>
<u>76</u>	<u>FBVS Room Temperature</u>	<u>Fuel Building Ventilation Room Temperature System</u>	<u>2</u>
<u>77</u>	<u>EBS / FPCS Recirculation Temperature</u>	<u>Fuel Building Ventilation Room Temperature System</u>	<u>2</u>
<u>78</u>	<u>Spent Fuel Pool Level (WR)</u>	<u>Fuel Pool Cooling and Purification System</u>	<u>2</u>
<u>79</u>	<u>IRWST Level</u>	<u>In-Containment Refueling Water Storage Tank System</u>	<u>4</u>
<u>80</u>	<u>CRACS Carbon Filter Isolation Damper Position</u>	<u>Main Control Room Air Conditioning System</u>	<u>2</u>
<u>81</u>	<u>CRACS Protective Switch Temperature</u>	<u>Main Control Room Air Conditioning System</u>	<u>2</u>
<u>82</u>	<u>CRACS ESF Filtration Fan Status</u>	<u>Main Control Room Air Conditioning System</u>	<u>2</u>
<u>83</u>	<u>CRACS Downstream Temperature</u>	<u>Main Control Room Air Conditioning System</u>	<u>2</u>
<u>84</u>	<u>CRACS Inlet Damper Position</u>	<u>Main Control Room Air Conditioning System</u>	<u>2</u>
<u>85</u>	<u>CRACS Outlet Damper Position</u>	<u>Main Control Room Air Conditioning System</u>	<u>2</u>



Table 2.4.25-2—Signal Conditioning and Distribution System Input Signals (2-7 Sheets)

Item #	Signal	Source	# Divisions
86	<u>MCR Differential Pressure</u>	<u>Main Control Room Air Conditioning System</u>	<u>2</u>
87	<u>CRACS Supply Air Temperature</u>	<u>Main Control Room Air Conditioning System</u>	<u>4</u>
88	<u>MSRIV Position</u>	<u>Main Steam System</u>	<u>4</u>
89	<u>MSRCV Position</u>	<u>Main Steam System</u>	<u>4</u>
90	<u>LHSI Pump Room Temperature</u>	<u>Safeguard Building Pump Room Temperature Controlled-Area Ventilation System</u>	<u>4</u>
91	<u>MHSI Pump Room Temperature</u>	<u>Safeguard Building Pump Room Temperature Controlled-Area Ventilation System</u>	<u>4</u>
92	<u>SIS/RHR Pump Running Signal</u>	<u>Safeguard Building Pump Room Temperature Controlled-Area Ventilation System</u>	<u>4</u>
93	<u>SIS/RHR Pump Stopped Signal</u>	<u>Safeguard Building Pump Room Temperature Controlled-Area Ventilation System</u>	<u>4</u>
94	<u>CCWS/EFWS Valve Room Temperature</u>	<u>Safeguard Building Pump Room Temperature Controlled-Area Ventilation System</u>	<u>4</u>
95	<u>SBVSE Supply Air Temperature Downstream of Heaters</u>	<u>Electrical Division of Safeguard Building Ventilation System</u>	<u>4</u>
96	<u>SBVSE Protective Switch Temperature</u>	<u>Electrical Division of Safeguard Building Ventilation System</u>	<u>4</u>
97	<u>SBVSE Outside Air Temperature</u>	<u>Electrical Division of Safeguard Building Ventilation System</u>	<u>4</u>
98	<u>SBVSE Outside Air Damper Open Position Signal</u>	<u>Electrical Division of Safeguard Building Ventilation System</u>	<u>4</u>



**Table 2.4.25-2—Signal Conditioning and Distribution  
System Input Signals (2-7 Sheets)**

<b>Item #</b>	<b>Signal</b>	<b>Source</b>	<b># Divisions</b>
<u>99</u>	<u>SBVSE Outside Air Damper Closed Position Signal</u>	<u>Electrical Division of Safeguard Building Ventilation System</u>	<u>4</u>
<u>100</u>	<u>SBVSE Exhaust Damper Open Position Signal</u>	<u>Electrical Division of Safeguard Building Ventilation System</u>	<u>4</u>
<u>101</u>	<u>SBVSE Exhaust Damper Closed Position Signal</u>	<u>Electrical Division of Safeguard Building Ventilation System</u>	<u>4</u>
<u>102</u>	<u>SBVSE Recirculation Damper Open Position Signal</u>	<u>Electrical Division of Safeguard Building Ventilation System</u>	<u>4</u>
<u>103</u>	<u>SBVSE Recirculation Damper Closed Position Signal</u>	<u>Electrical Division of Safeguard Building Ventilation System</u>	<u>4</u>
<u>104</u>	<u>SBVSE Recirculation / Exhaust Fan Stopped Signal</u>	<u>Electrical Division of Safeguard Building Ventilation System</u>	<u>4</u>
<u>105</u>	<u>SBVSE Outside Air Damper Closed Position Signal</u>	<u>Electrical Division of Safeguard Building Ventilation System</u>	<u>4</u>
<u>106</u>	<u>SBVSE Recirculation Damper Closed Position Signal</u>	<u>Electrical Division of Safeguard Building Ventilation System</u>	<u>4</u>
<u>107</u>	<u>SBVSE Exhaust Fan Exhaust Damper Closed Position</u>	<u>Electrical Division of Safeguard Building Ventilation System</u>	<u>4</u>
<u>108</u>	<u>Filter Bank Differential Pressure</u>	<u>Electrical Division of Safeguard Building Ventilation System</u>	<u>4</u>
<u>109</u>	<u>Supply Air Downstream of Humidifier Temperature</u>	<u>Electrical Division of Safeguard Building Ventilation System</u>	<u>4</u>
<u>110</u>	<u>Battery Room Supply Air Downstream of Heaters Flow</u>	<u>Electrical Division of Safeguard Building Ventilation System</u>	<u>4</u>
<u>111</u>	<u>Battery Room Temperature</u>	<u>Electrical Division of Safeguard Building Ventilation System</u>	<u>4</u>



**Table 2.4.25-2—Signal Conditioning and Distribution System Input Signals (2-7 Sheets)**

<b>Item #</b>	<b>Signal</b>	<b>Source</b>	<b># Divisions</b>
<u>112</u>	<u>Battery Room Supply Air Temperature</u>	<u>Electrical Division of Safeguard Building Ventilation System</u>	<u>4</u>
<u>113</u>	<u>EFWS Pump Room Temperature</u>	<u>Electrical Division of Safeguard Building Ventilation System</u>	<u>4</u>
<u>114</u>	<u>CCWS Pump Room Temperature</u>	<u>Electrical Division of Safeguard Building Ventilation System</u>	<u>4</u>
<u>115</u>	<u>SCWS Chiller Evaporator Outlet Temperature</u>	<u>Safety Chilled Water System</u>	<u>4</u>
<u>116</u>	<u>SCWS Chiller Compressor Oil Pressure</u>	<u>Safety Chilled Water System</u>	<u>4</u>
<u>117</u>	<u>SCWS Condenser Refrigerant Pressure</u>	<u>Safety Chilled Water System</u>	<u>4</u>
<u>118</u>	<u>SCWS Chiller Evaporator Flow Signal</u>	<u>Safety Chilled Water System</u>	<u>4</u>
<u>119</u>	<u>SCWS Cross-Tie Valves Position Signal</u>	<u>Safety Chilled Water System</u>	<u>4</u>
<u>120</u>	<u>SCWS Circulating Pump 1 Running Signal</u>	<u>Safety Chilled Water System</u>	<u>4</u>
<u>121</u>	<u>SCWS Circulating Pump 2 Running Signal</u>	<u>Safety Chilled Water System</u>	<u>4</u>
<u>122</u>	<u>SCWS Evaporator ΔP Signal</u>	<u>Safety Chilled Water System</u>	<u>4</u>
<u>123</u>	<u>SCWS Chiller Evaporator Flow Signal</u>	<u>Safety Chilled Water System</u>	<u>4</u>
<u>124</u>	<u>RHRS Flow Rate Signal</u>	<u>Safety Injection and Residual Heat Removal System</u>	<u>4</u>
<u>125</u>	<u>RHRS Temperature</u>	<u>Safety Injection and Residual Heat Removal System</u>	<u>4</u>
<u>126</u>	<u>LHSI Pump Pressure</u>	<u>Safety Injection and Residual Heat Removal System</u>	<u>4</u>
<u>127</u>	<u>Hot Leg Loop Level</u>	<u>Safety Injection and Residual Heat Removal System</u>	<u>4</u>
<u>128</u>	<u>Containment Isolation Signal</u>	<u>Fuel Building Ventilation System</u>	<u>4</u>
<u>129</u>	<u>Fuel Building Ventilation Activity</u>	<u>Fuel Building Ventilation System</u>	<u>4</u>
<u>130</u>	<u>Containment Building Ventilation Activity</u>	<u>Fuel Building Ventilation System</u>	<u>4</u>
<u>131</u>	<u>LHSI Suction Isolation Valve Position</u>	<u>Safety Injection and Residual Heat Removal System</u>	<u>4</u>





Table 2.4.25-2—Signal Conditioning and Distribution System Input Signals (2-7 Sheets)

Item #	Signal	Source	# Divisions
<u>132</u>	<u>RHR 1<sup>st</sup> RCPB Isolation Valve Position</u>	<u>Safety Injection and Residual Heat Removal System</u>	<u>4</u>
<u>133</u>	<u>RHR 2<sup>nd</sup> RCPB Isolation Valve Position</u>	<u>Safety Injection and Residual Heat Removal System</u>	<u>4</u>

DRAFT



**Table 2.4.25-3—Signal Conditioning and Distribution System Output Signals (82 Sheets)**

Item #	Signal	Destination Recipient	# Divisions
19	Low Head Safety Injection Flow (WR)	Safety Information and Control System	4
20	Main Control Room (MCR) Air Intake Activity	Protection System	4
21	Main Steam Line Activity	Protection System, Safety Information and Control System	4
22	Medium Head Safety Injection Flow (WR)	Safety Information and Control System	4
23	Neutron Flux from Intermediate Range Detector (IRD)	Protection System, Safety Information and Control System	4
24	Neutron Flux from Power Range Detector (PRD)	Protection System, <del>Safety Automation System,</del> <u>Diverse Actuation System</u>	4
25	Neutron Flux from Self Powered Neutron Detectors (SPND)	Protection System	4
26	Neutron Flux from Source Range (SRD)	Safety Information and Control System	4
27	Pressurizer Level (NR)	Protection System	4
28	Pressurizer Pressure (NR)	Protection System, Safety Information and Control System, <u>Diverse Actuation System</u>	4
29	RCP Bus Breaker Position	Protection System	4
30	RCP Breaker Position	Protection System	4
31	RCS Loop Flow	Protection System, <u>Diverse Actuation System</u>	4
33	RCS Loop Level	Protection System	4
34	RCP Speed	Protection System	4
35	SG Level (NR)	Protection System, <u>Diverse Actuation System</u>	4
36	SG Level (WR)	Protection System, <u>Diverse Actuation System</u> Safety Information and Control System, Safety Automation System	4



**Table 2.4.25-3—Signal Conditioning and Distribution System Output Signals (82 Sheets)**

Item #	Signal	Destination Recipient	# Divisions
37	SG Pressure	Protection System, Safety Information and Control System, Safety Automation System, <u>Diverse Actuation System</u>	4
38	Temperature compensated rod cluster control assembly (RCCA) positions	Protection System	4
39	<u>Reactor Trip Contactor Position</u>	<u>Protection System</u>	<u>4</u>
40	<u>Containment Hydrogen Concentration</u>	<u>Protection System</u>	<u>2</u>
41	<u>Core Outlet Temperature</u>	<u>Protection System</u>	<u>4</u>
42	<u>AVS Temperature</u>	<u>Safety Automation System</u>	<u>2</u>
43	<u>AVS Isolation Damper Position</u>	<u>Safety Automation System</u>	<u>2</u>
44	<u>AVS Heater Fan Signal</u>	<u>Safety Automation System</u>	<u>2</u>
45	<u>AVS Pressure</u>	<u>Safety Automation System</u>	<u>2</u>
46	<u>AVS Differential Pressure</u>	<u>Safety Automation System</u>	<u>2</u>
47	<u>AVS Post Heater Temperature</u>	<u>Safety Automation System</u>	<u>2</u>
48	<u>AVS Filter Bank Isolation Inlet Damper Position</u>	<u>Safety Automation System</u>	<u>2</u>
49	<u>AVS Filter Bank Isolation Outlet Damper Position</u>	<u>Safety Automation System</u>	<u>2</u>
50	<u>AVS Exhaust Fan Signal</u>	<u>Safety Automation System</u>	<u>2</u>
51	<u>CCWS Loss of ESWS Signal</u>	<u>Safety Automation System</u>	<u>4</u>
52	<u>CCWS Pump Pressure</u>	<u>Safety Automation System</u>	<u>4</u>
53	<u>CCWS Flow Rate</u>	<u>Safety Automation System</u>	<u>4</u>
54	<u>CCWS Heat Exchanger Temp</u>	<u>Safety Automation System</u>	<u>4</u>
55	<u>CCWS Heat Exchanger Bypass Valve Position</u>	<u>Safety Automation System</u>	<u>4</u>
56	<u>CCWS Surge Tank Level</u>	<u>Safety Automation System</u>	<u>4</u>
57	<u>CCWS Chiller Inlet Flow</u>	<u>Safety Automation System</u>	<u>4</u>



**Table 2.4.25-3—Signal Conditioning and Distribution System Output Signals (82 Sheets)**

<b>Item #</b>	<b>Signal</b>	<b>Destination Recipient</b>	<b># Divisions</b>
<u>58</u>	<u>CCWS Chiller Outlet Flow</u>	<u>Safety Automation System</u>	<u>4</u>
<u>59</u>	<u>CCWS Common Supply Outlet Flow</u>	<u>Safety Automation System</u>	<u>4</u>
<u>60</u>	<u>CCWS Common Supply Inlet Flow</u>	<u>Safety Automation System</u>	<u>4</u>
<u>61</u>	<u>CCWS Common 1a Supply Valve Position</u>	<u>Safety Automation System</u>	<u>4</u>
<u>62</u>	<u>CCWS Common 1a Return Valve Position</u>	<u>Safety Automation System</u>	<u>4</u>
<u>63</u>	<u>CCWS Common 1b Supply Valve Position</u>	<u>Safety Automation System</u>	<u>4</u>
<u>64</u>	<u>CCWS Common 1b Return Valve Position</u>	<u>Safety Automation System</u>	<u>4</u>
<u>65</u>	<u>CCWS Common 1b Return Outer Valve Position</u>	<u>Safety Automation System</u>	<u>2</u>
<u>66</u>	<u>CCWS Common 1b Supply Outer Valve Position</u>	<u>Safety Automation System</u>	<u>2</u>
<u>67</u>	<u>CCWS Common 2b Return Outer Valve Position</u>	<u>Safety Automation System</u>	<u>2</u>
<u>68</u>	<u>CCWS Common 2b Supply Outer Valve Position</u>	<u>Safety Automation System</u>	<u>2</u>
<u>69</u>	<u>CCWS Common 1b Return Inner Valve Position</u>	<u>Safety Automation System</u>	<u>2</u>
<u>70</u>	<u>CCWS Common 1b Supply Inner Valve Position</u>	<u>Safety Automation System</u>	<u>2</u>
<u>71</u>	<u>CCWS Common 2b Return Inner Valve Position</u>	<u>Safety Automation System</u>	<u>2</u>
<u>72</u>	<u>CCWS Common 2b Supply Inner Valve Position</u>	<u>Safety Automation System</u>	<u>2</u>
<u>73</u>	<u>SCWS Condenser Refrigerant Pressure</u>	<u>Safety Automation System</u>	<u>2</u>
<u>74</u>	<u>EFW Pump Flow Signal</u>	<u>Safety Automation System</u>	<u>4</u>
<u>75</u>	<u>ESW Outside Air Temperature</u>	<u>Safety Automation System</u>	<u>4</u>



**Table 2.4.25-3—Signal Conditioning and Distribution  
System Output Signals (82 Sheets)**

<b>Item #</b>	<b>Signal</b>	<b>Destination Recipient</b>	<b># Divisions</b>
76	<u>FBVS Room Temperature</u>	<u>Safety Automation System</u>	<u>2</u>
77	<u>EBS / FPCS Recirculation Temperature</u>	<u>Safety Automation System</u>	<u>2</u>
78	<u>Spent Fuel Pool Level (WR)</u>	<u>Safety Automation System</u>	<u>2</u>
79	<u>IRWST Level</u>	<u>Safety Automation System</u>	<u>4</u>
80	<u>CRACS Carbon Filter Isolation Damper Position</u>	<u>Safety Automation System</u>	<u>2</u>
81	<u>CRACS Protective Switch Temperature</u>	<u>Safety Automation System</u>	<u>2</u>
82	<u>CRACS ESF Filtration Fan Status</u>	<u>Safety Automation System</u>	<u>2</u>
83	<u>CRACS Downstream Temperature</u>	<u>Safety Automation System</u>	<u>2</u>
84	<u>CRACS Inlet Damper Position</u>	<u>Safety Automation System</u>	<u>2</u>
85	<u>CRACS Outlet Damper Position</u>	<u>Safety Automation System</u>	<u>2</u>
86	<u>MCR Differential Pressure</u>	<u>Safety Automation System</u>	<u>2</u>
87	<u>CRACS Supply Air Temperature</u>	<u>Safety Automation System</u>	<u>4</u>
88	<u>MSRIV Position</u>	<u>Safety Automation System</u>	<u>4</u>
89	<u>MSRCV Position</u>	<u>Safety Automation System</u>	<u>4</u>
90	<u>LHSI Pump Room Temperature</u>	<u>Safety Automation System</u>	<u>4</u>
91	<u>MHSI Pump Room Temperature</u>	<u>Safety Automation System</u>	<u>4</u>
92	<u>SIS/RHR Pump Running Signal</u>	<u>Safety Automation System</u>	<u>4</u>
93	<u>SIS/RHR Pump Stopped Signal</u>	<u>Safety Automation System</u>	<u>4</u>
94	<u>CCWS/EFWS Valve Room Temperature</u>	<u>Safety Automation System</u>	<u>4</u>



**Table 2.4.25-3—Signal Conditioning and Distribution  
System Output Signals (82 Sheets)**

<b>Item #</b>	<b>Signal</b>	<b>Destination Recipient</b>	<b># Divisions</b>
<u>95</u>	<u>SBVSE Supply Air Temperature Downstream of Heaters</u>	<u>Safety Automation System</u>	<u>4</u>
<u>96</u>	<u>SBVSE Protective Switch Temperature</u>	<u>Safety Automation System</u>	<u>4</u>
<u>97</u>	<u>SBVSE Outside Air Temperature</u>	<u>Safety Automation System</u>	<u>4</u>
<u>98</u>	<u>SBVSE Outside Air Damper Open Position Signal</u>	<u>Safety Automation System</u>	<u>4</u>
<u>99</u>	<u>SBVSE Outside Air Damper Closed Position Signal</u>	<u>Safety Automation System</u>	<u>4</u>
<u>100</u>	<u>SBVSE Exhaust Damper Open Position Signal</u>	<u>Safety Automation System</u>	<u>4</u>
<u>101</u>	<u>SBVSE Exhaust Damper Closed Position Signal</u>	<u>Safety Automation System</u>	<u>4</u>
<u>102</u>	<u>SBVSE Recirculation Damper Open Position Signal</u>	<u>Safety Automation System</u>	<u>4</u>
<u>103</u>	<u>SBVSE Recirculation Damper Closed Position Signal</u>	<u>Safety Automation System</u>	<u>4</u>
<u>104</u>	<u>SBVSE Recirculation / Exhaust Fan Stopped Signal</u>	<u>Safety Automation System</u>	<u>4</u>
<u>105</u>	<u>SBVSE Outside Air Damper Closed Position Signal</u>	<u>Safety Automation System</u>	<u>4</u>
<u>106</u>	<u>SBVSE Recirculation Damper Closed Position Signal</u>	<u>Safety Automation System</u>	<u>4</u>
<u>107</u>	<u>SBVSE Exhaust Fan Exhaust Damper Closed Position</u>	<u>Safety Automation System</u>	<u>4</u>
<u>108</u>	<u>Filter Bank Differential Pressure</u>	<u>Safety Automation System</u>	<u>4</u>
<u>109</u>	<u>Supply Air Downstream of Humidifier Temperature</u>	<u>Safety Automation System</u>	<u>4</u>
<u>110</u>	<u>Battery Room Supply Air Downstream of Heaters Flow</u>	<u>Safety Automation System</u>	<u>4</u>



**Table 2.4.25-3—Signal Conditioning and Distribution System Output Signals (82 Sheets)**

<b>Item #</b>	<b>Signal</b>	<b>Destination Recipient</b>	<b># Divisions</b>
<u>111</u>	<u>Battery Room Temperature</u>	<u>Safety Automation System</u>	<u>4</u>
<u>112</u>	<u>Battery Room Supply Air Temperature</u>	<u>Safety Automation System</u>	<u>4</u>
<u>113</u>	<u>EFWS Pump Room Temperature</u>	<u>Safety Automation System</u>	<u>4</u>
<u>114</u>	<u>CCWS Pump Room Temperature</u>	<u>Safety Automation System</u>	<u>4</u>
<u>115</u>	<u>SCWS Chiller Evaporator Outlet Temperature</u>	<u>Safety Automation System</u>	<u>4</u>
<u>116</u>	<u>SCWS Chiller Compressor Oil Pressure</u>	<u>Safety Automation System</u>	<u>4</u>
<u>117</u>	<u>SCWS Condenser Refrigerant Pressure</u>	<u>Safety Automation System</u>	<u>4</u>
<u>118</u>	<u>SCWS Chiller Evaporator Flow Signal</u>	<u>Safety Automation System</u>	<u>4</u>
<u>119</u>	<u>SCWS Cross-Tie Valves Position Signal</u>	<u>Safety Automation System</u>	<u>4</u>
<u>120</u>	<u>SCWS Circulating Pump 1 Running Signal</u>	<u>Safety Automation System</u>	<u>4</u>
<u>121</u>	<u>SCWS Circulating Pump 2 Running Signal</u>	<u>Safety Automation System</u>	<u>4</u>
<u>122</u>	<u>SCWS Evaporator ΔP Signal</u>	<u>Safety Automation System</u>	<u>4</u>
<u>123</u>	<u>SCWS Chiller Evaporator Flow Signal</u>	<u>Safety Automation System</u>	<u>4</u>
<u>124</u>	<u>RHRS Flow Rate Signal</u>	<u>Safety Automation System</u>	<u>4</u>
<u>125</u>	<u>RHRS Temperature</u>	<u>Safety Automation System</u>	<u>4</u>
<u>126</u>	<u>LHSI Pump Pressure</u>	<u>Safety Automation System</u>	<u>4</u>
<u>127</u>	<u>Hot Leg Loop Level</u>	<u>Safety Automation System</u>	<u>4</u>
<u>128</u>	<u>Containment Isolation Signal</u>	<u>Safety Automation System</u>	<u>4</u>
<u>129</u>	<u>Fuel Building Ventilation Activity</u>	<u>Safety Automation System</u>	<u>4</u>
<u>130</u>	<u>Containment Building Ventilation Activity</u>	<u>Safety Automation System</u>	<u>4</u>



Table 2.4.25-3—Signal Conditioning and Distribution  
System Output Signals (82 Sheets)

Item #	Signal	Destination Recipient	# Divisions
<u>131</u>	<u>LHSI Suction Isolation Valve Position</u>	<u>Safety Automation System</u>	<u>4</u>
<u>132</u>	<u>RHR 1<sup>st</sup> RCPB Isolation Valve Position</u>	<u>Safety Automation System</u>	<u>4</u>
<u>133</u>	<u>RHR 2<sup>nd</sup> RCPB Isolation Valve Position</u>	<u>Safety Automation System</u>	<u>4</u>

DRAFT



**Table 2.6.1-2—Main Control Room Air Conditioning System Equipment I&C and Electrical Design (5 Sheets)**

Description	Tag Number <sup>(1)</sup>	Location	IEEE Class 1E <sup>(2)</sup>	PACS	MCR / RSS Displays	MCR / RSS Controls
Protective Switch-off Temperature for Electric Heaters	30SAB01CT002 30SAB04CT002	Safeguard Building 2 Safeguard Building 3	N/A	N/A	Temp / Temp	N/A
Temperature Downstream of Electric Heaters	30SAB01CT003/004 30SAB04CT003/004	Safeguard Building 2 Safeguard Building 3	N/A	N/A	Temp / Temp	N/A
Main Control Room Temperature	30SAB32CT002 30SAB32CT003	Safeguard Building 2	N/A	N/A	Temp / Temp	N/A
Temperature Downstream of Iodine Train Heaters	30SAB11CT002 30SAB14CT002	Safeguard Building 2 Safeguard Building 3	N/A	N/A	Temp / Temp	N/A
Temperature Upstream of Iodine Train Heaters	30SAB11CT001 <del>3</del> 30SAB14CT001 <del>3</del>	Safeguard Building 2 Safeguard Building 3	N/A	N/A	Temp / Temp	N/A
Temperature Upstream of Electric Heaters	<u>30SAB01CT001</u> <u>30SAB04CT001</u>	<u>Safeguard Building 2</u> <u>Safeguard Building 3</u>	<u>N/A</u>	<u>N/A</u>	<u>Temp / Temp</u>	<u>N/A</u>
Temperature Downstream of Carbon Adsorber	<u>30SAB11CT003</u> <u>30SAB14CT003</u>	<u>Safeguard Building 2</u> <u>Safeguard Building 3</u>	<u>N/A</u>	<u>N/A</u>	<u>Temp / Temp</u>	<u>N/A</u>
Conditioning Trains Air Flow	<u>30SAB01/02CF001</u> <u>30SAB03/04CF001</u>	<u>Safeguard Building 2</u> <u>Safeguard Building 3</u>	<u>N/A</u>	<u>N/A</u>	<u>Flow/Flow</u>	<u>N/A</u>

Table 2.6.3-1—Annulus Ventilation System Equipment Mechanical Design

Description	Tag Number <sup>(1)</sup>	Location	ASME AG-1 Code	Function	Seismic Category
<b>Normal Operation Train</b>					
Motor Operated Supply Air Dampers	30KLB34AA002	30UFA21095	Yes	Close	I
	30KLB34AA003	30UFA21095			
Motor Operated Exhaust Air Dampers	30KLB44AA002	30UFA29054	Yes	Close	I
	30KLB44AA003	30UFA29054			
<b>Accident Filtration Train</b>					
Motor Operated Dampers	30KLB21AA003	30UFA17084	Yes	Open	I
	30KLB24AA003	30UFA17082			
Electric Heaters <i>Two stage</i>	30KLB21AH001 <u>A/B</u>	30UFA17084	Yes	On	I
	30KLB24AH001 <u>A/B</u>	30UFA17082			
Prefilters	30KLB21AT001	30UFA17084	Yes	N/A	I
	30KLB24AT001	30UFA17082			
Upstream HEPA Filters	30KLB21AT002	30UFA17084	Yes	N/A	I
	30KLB24AT002	30UFA17082			
Carbon Absorbers	30KLB21AT003	30UFA17084	Yes	N/A	I
	30KLB24AT003	30UFA17082			
Downstream HEPA Filters	30KLB21AT004	30UFA17084	Yes	N/A	I
	30KLB24AT004	30UFA17082			
Motor Operated Dampers	30KLB21AA004	30UFA17084	Yes	Open	I
	30KLB24AA004	30UFA17082			
Exhaust Fans	30KLB21AN001	30UFA17083	Yes	Run	I
	30KLB24AN001	30UFA17081			
Backdraft Dampers	30KLB21AA006	30UFA17083	Yes	N/A	I
	30KLB24AA006	30UFA17081			

1) Equipment tag numbers are provided for information only and are not part of the certified design.



Table 2.6.3-2—Annulus Ventilation System Equipment I&C and Electrical Design (3 Sheets)

Description	Tag Number <sup>(1)</sup>	Location	IEEE Class 1E <sup>(2)</sup>	EQ – Harsh Env.	PACS	MCR / RSS Displays	MCR / RSS Controls
Exhaust Fan	30KLB21AN001	Fuel Building	Division 1 <sup>N</sup> Division 2 <sup>A</sup>	Yes	Yes	On-Off / On-Off	Run-Stop / Run-Stop
Exhaust Fan	30KLB24AN001	Fuel Building	Division 4 <sup>N</sup> Division 3 <sup>A</sup>	Yes	Yes	On-Off / On-Off	Run-Stop / Run-Stop
Electrical Heater <u>Two stage</u>	30KLB21AH001 <u>A/B</u>	Fuel Building	Division 1 <sup>N</sup> Division 2 <sup>A</sup>	Yes	Yes	On-Off / On-Off	Start-Stop / Start-Stop
Electrical Heater <u>Two stage</u>	30KLB24AH001 <u>A/B</u>	Fuel Building	Division 4 <sup>N</sup> Division 3 <sup>A</sup>	Yes	Yes	On-Off / On-Off	Start-Stop / Start-Stop
<b>Instruments</b>							
Annulus Pressure	30KLB21CP001 30KLB24CP001	Fuel Building	N/A	Yes	N/A	Press / Press	N/A
Temperature Upstream of Heaters	30KLB21CT001 30KLB24CT001	Fuel Building	N/A	Yes	N/A	Temp / Temp	N/A
Temperature Limit Switch for Heaters	30KLB21CT002 30KLB24CT002	Fuel Building	N/A	Yes	N/A	Temp / Temp	N/A
Temperature Regulation for Heaters	30KLB21CT003 30KLB24CT003	Fuel Building	N/A	Yes	N/A	Temp / Temp	N/A
Temperature downstream of carbon adsorbers	30KLB21CT004 30KLB24CT004	Fuel Building	N/A	Yes	N/A	Temp / Temp	N/A
Pressure Limit Switch Exhaust Fans	30KLB21CP002 30KLB24CP002	Fuel Building	N/A	Yes	N/A	Press / Press	N/A

**Table 2.6.6-1—Safeguard Building Controlled-Area Ventilation System Equipment Mechanical Design (6 Sheets)**

Description	Tag Number <sup>(1)</sup>	Location	ASME AG-1 Code	Function	Seismic Category
Electric Heaters (Two stage)	30KLC41AH001A/B 30KLC42AH001A/B	30UFA 21082 30UFA 21084	Yes	On / Off (based on ambient conditions)	I
Pre filter/Moisture Separators	30KLC41AT001 30KLC42AT001	30UFA 21082 30UFA 21084	Yes	N/A	I
Upstream HEPA Filters	30KLC41AT002 30KLC42AT002	30UFA 21082 30UFA 21084	Yes	N/A	I
Carbon Absorbers	30KLC41AT003 30KLC42AT003	30UFA 21082 30UFA 21084	Yes	N/A	I
Downstream HEPA Filters	30KLC41AT004 30KLC42AT004	30UFA 21082 30UFA 21084	Yes	N/A	I
Motor Operated dampers	30KLC41AA002 30KLC42AA002	30UFA 21082 30UFA 21084	Yes	N/A	I
Exhaust Fans	30KLC41AN001 30KLC42AN001	30UFA 21083 30UFA 21081	Yes	Run	I
Backdraft dampers	30KLC41AA003 30KLC42AA003	30UFA 21083 30UFA 21081	Yes	N/A	I



**Table 2.6.6-2—Safeguard Building Controlled-Area Ventilation System Equipment I&C and Electrical Design (7 Sheets)**

Description	Tag Number <sup>(1)</sup>	Location	IEEE Class 1E <sup>(2)</sup>	EQ – Harsh Env.	PACS	MCR / RSS Displays	MCR / RSS Controls
Electric Heater <u>(two stage)</u>	30KLC41AH001A/B	Fuel Building	Division 1 <sup>N</sup> Division 2 <sup>A</sup>	Yes	Yes	On-Off/ On-Off	Start-Stop / Start-Stop
Motor Operated Damper	30KLC41AA002	Fuel Building	Division 1 <sup>N</sup> Division 2 <sup>A</sup>	Yes	Yes	Position / Position	Open-Close / Open-Close
Exhaust Fan	30KLC41AN001	Fuel Building	Division 1 <sup>N</sup> Division 2 <sup>A</sup>	Yes	Yes	On-Off / On-Off	Run-Stop / Run-Stop
<b>Iodine Filtration Train 30KLC42</b>							
Motor Operated Damper	30KLC42AA001	Fuel Building	Division 4 <sup>N</sup> Division 3 <sup>A</sup>	Yes	Yes	Position / Position	Open-Close / Open-Close
Electric Heater <u>(two stage)</u>	30KLC42AH001A/B	Fuel Building	Division 4 <sup>N</sup> Division 3 <sup>A</sup>	Yes	Yes	On-Off / On-Off	Start-Stop / Start-Stop
Motor Operated Damper	30KLC42AA002	Fuel Building	Division 4 <sup>N</sup> Division 3 <sup>A</sup>	Yes	Yes	Position / Position	Open-Close / Open-Close
Exhaust Fan	30KLC42AN001	Fuel Building	Division 4 <sup>N</sup> Division 3 <sup>A</sup>	Yes	Yes	On-Off / On-Off	Run-Stop / Run-Stop
<b>Recirculation Cooling Units</b>							
Recirculation Fans	30KLC51AN001 30KLC51AN002 30KLC51AN003	Safeguard Building 1 Safeguard Building 1 Safeguard Building 1	Division 1 <sup>N</sup>	Yes	Yes	On-Off / On-Off	Run-Stop / Run-Stop
Recirculation Fans	30KLC52AN001 30KLC52AN002	Safeguard Building 2 Safeguard Building 2	Division 2 <sup>N</sup>	Yes	Yes	On-Off / On-Off	Run-Stop / Run-Stop
Recirculation Fans	30KLC53AN001 30KLC53AN002	Safeguard Building 3 Safeguard Building 3	Division 3 <sup>N</sup>	Yes	Yes	On-Off / On-Off	Run-Stop / Run-Stop



**Table 2.6.6-2—Safeguard Building Controlled-Area Ventilation System Equipment I&C and Electrical Design (7 Sheets)**

Description	Tag Number <sup>(1)</sup>	Location	IEEE Class 1E <sup>(2)</sup>	EQ – Harsh Env.	PACS	MCR / RSS Displays	MCR / RSS Controls
Electric Heater <i>(two stage)</i>	30KLC41AH001A/B	Fuel Building	Division 1 <sup>N</sup> Division 2 <sup>A</sup>	Yes	Yes	On-Off/ On-Off	Start-Stop / Start-Stop
Motor Operated Damper	30KLC41AA002	Fuel Building	Division 1 <sup>N</sup> Division 2 <sup>A</sup>	Yes	Yes	Position / Position	Open-Close / Open-Close
Exhaust Fan	30KLC41AN001	Fuel Building	Division 1 <sup>N</sup> Division 2 <sup>A</sup>	Yes	Yes	On-Off / On-Off	Run-Stop / Run-Stop
<b>Iodine Filtration Train 30KLC42</b>							
Motor Operated Damper	30KLC42AA001	Fuel Building	Division 4 <sup>N</sup> Division 3 <sup>A</sup>	Yes	Yes	Position / Position	Open-Close / Open-Close
Electric Heater <i>(two stage)</i>	30KLC42AH001A/B	Fuel Building	Division 4 <sup>N</sup> Division 3 <sup>A</sup>	Yes	Yes	On-Off / On-Off	Start-Stop / Start-Stop
Motor Operated Damper	30KLC42AA002	Fuel Building	Division 4 <sup>N</sup> Division 3 <sup>A</sup>	Yes	Yes	Position / Position	Open-Close / Open-Close
Exhaust Fan	30KLC42AN001	Fuel Building	Division 4 <sup>N</sup> Division 3 <sup>A</sup>	Yes	Yes	On-Off / On-Off	Run-Stop / Run-Stop
<b>Recirculation Cooling Units</b>							
Recirculation Fans	30KLC51AN001 30KLC51AN002 30KLC51AN003	Safeguard Building 1 Safeguard Building 1 Safeguard Building 1	Division 1 <sup>N</sup>	Yes	Yes	On-Off / On-Off	Run-Stop / Run-Stop
Recirculation Fans	30KLC52AN001 30KLC52AN002	Safeguard Building 2 Safeguard Building 2	Division 2 <sup>N</sup>	Yes	Yes	On-Off / On-Off	Run-Stop / Run-Stop
Recirculation Fans	30KLC53AN001 30KLC53AN002	Safeguard Building 3 Safeguard Building 3	Division 3 <sup>N</sup>	Yes	Yes	On-Off / On-Off	Run-Stop / Run-Stop

**Table 2.6.6-2—Safeguard Building Controlled-Area Ventilation System Equipment I&C and Electrical Design (7 Sheets)**

Description	Tag Number <sup>(1)</sup>	Location	IEEE Class 1E <sup>(2)</sup>	EQ – Harsh Env.	PACS	MCR / RSS Displays	MCR / RSS Controls
CCW & EFW Valve Room Temperature	30KLC51CT005	Safeguard Building 1	N/A	Yes	N/A	Temp / Temp	N/A
	30KLC51CT006	Safeguard Building 1					
	30KLC52CT005	Safeguard Building 2					
	30KLC52CT006	Safeguard Building 2					
	30KLC53CT005	Safeguard Building 3					
	30KLC53CT006	Safeguard Building 3					
	30KLC54CT005	Safeguard Building 4					
	30KLC54CT006	Safeguard Building 4					
Sampling System Room Temperature	30KLC51CT007	Safeguard Building 1	N/A	Yes	N/A	Temp / Temp	N/A
	30KLC51CT008	Safeguard Building 1					
	30KLC54CT007	Safeguard Building 4					
	30KLC54CT008	Safeguard Building 4					
Temperature Downstream of Iodine Filtration Heater	30KLCB41CT001/002	Fuel Building	N/A	Yes	N/A	Temp / Temp	N/A
	30KLCB42CT001/002						
Temperature Downstream of Carbon Adsorbers	30KLCB41CT003	Fuel Building	N/A	Yes	N/A	Temp / Temp	N/A
	30KLCB42CT003						

**Table 2.6.6-2—Safeguard Building Controlled-Area Ventilation System Equipment I&C and Electrical Design (7 Sheets)**

Description	Tag Number <sup>(1)</sup>	Location	IEEE Class 1E <sup>(2)</sup>	EQ – Harsh Env.	PACS	MCR / RSS Displays	MCR / RSS Controls
Differential Pressure across Iodine Filtration Trains	30KLCB41CP001 30KLCB42CP001	Fuel Building	N/A	Yes	N/A	<u>Press / Press</u> <del>Temp</del> <del>Temp</del>	N/A
<u>Temperature</u> <u>Upstream of</u> <u>Iodine Filtration</u> <u>Trains</u>	<u>30KLC41CT004</u> <u>30KLC42CT004</u>	<u>Fuel Building</u>	<u>N/A</u>	<u>Yes</u>	<u>N/A</u>	<u>Temp /</u> <u>Temp</u>	<u>N/A</u>

1) Equipment tag numbers are provided for information only and are not part of the certified design

2) <sup>N</sup> denotes division the component is normally powered from, while <sup>A</sup> denotes division the component is powered from when alternate feed is implemented.





Table 2.6.7-2—Electrical Division of Safeguard Building Ventilation System Equipment I&C and Electrical Design (9 Sheets)

Description	Tag Number <sup>(1)</sup>	Location	IEEE Class 1E <sup>(2)</sup>	PACS	MCR / RSS Displays	MCR / RSS Controls
Battery Room Exhaust Air Flow	30SAC41CF001	Safeguard Building 1	Division 1	N/A	Flow/ Flow	N/A
Battery Room Exhaust Air Flow	30SAC44CF001	Safeguard Building 4	Division 4	N/A	Flow/ Flow	N/A
Outside Air Temperature Sensors	<u>30SAC01CT001/002</u> <u>30SAC02CT001/002</u> <u>30SAC03CT001/002</u> <u>30SAC04CT001/002</u>	<u>Safeguard Building 1</u> <u>Safeguard Building 2</u> <u>Safeguard Building 3</u> <u>Safeguard Building 4</u>	<u>N/A</u>	<u>N/A</u>	<u>Temp / Temp</u>	<u>N/A</u>
Temperature Sensors Upstream of heaters	<u>30SAC01CT501</u> <u>30SAC02CT501</u> <u>30SAC03CT501</u> <u>30SAC04CT501</u>	<u>Safeguard Building 1</u> <u>Safeguard Building 2</u> <u>Safeguard Building 3</u> <u>Safeguard Building 4</u>	<u>N/A</u>	<u>N/A</u>	<u>Temp / Temp</u>	<u>N/A</u>
Protective Switch-off Temperature for heaters	<u>30SAC01CT003</u> <u>30SAC02CT003</u> <u>30SAC03CT003</u> <u>30SAC04CT003</u>	<u>Safeguard Building 1</u> <u>Safeguard Building 2</u> <u>Safeguard Building 3</u> <u>Safeguard Building 4</u>	<u>N/A</u>	<u>N/A</u>	<u>Temp / Temp</u>	<u>N/A</u>
Temperature Sensors Downstream of heaters	<u>30SAC01CT004/005</u> <u>30SAC02CT004/005</u> <u>30SAC03CT004/005</u> <u>30SAC04CT004/005</u>	<u>Safeguard Building 1</u> <u>Safeguard Building 2</u> <u>Safeguard Building 3</u> <u>Safeguard Building 4</u>	<u>N/A</u>	<u>N/A</u>	<u>Temp / Temp</u>	<u>N/A</u>
Temperature Sensors Downstream of Moisture Separators	<u>30SAC01CT502</u> <u>30SAC02CT502</u> <u>30SAC03CT502</u> <u>30SAC04CT502</u>	<u>Safeguard Building 1</u> <u>Safeguard Building 2</u> <u>Safeguard Building 3</u> <u>Safeguard Building 4</u>	<u>N/A</u>	<u>N/A</u>	<u>Temp / Temp</u>	<u>N/A</u>

Table 2.6.7-2—Electrical Division of Safeguard Building Ventilation System Equipment I&C and Electrical Design (9 Sheets)

Description	Tag Number <sup>(1)</sup>	Location	IEEE Class 1E <sup>(2)</sup>	PACS	MCR / RSS Displays	MCR / RSS Controls
<u>Supply Air Temperature Sensors</u>	<u>30SAC01CT006</u> <u>30SAC02CT006</u> <u>30SAC03CT006</u> <u>30SAC04CT006</u>	<u>Safeguard Building 1</u> <u>Safeguard Building 2</u> <u>Safeguard Building 3</u> <u>Safeguard Building 4</u>	<u>N/A</u>	<u>N/A</u>	<u>Temp / Temp</u>	<u>N/A</u>

1) Equipment tag numbers are provided for information only and are not part of the certified design. N denotes division the component is normally powered from, while A denotes the component is powered from when alternate feed is implemented.



**Table 2.6.8-3—Containment Building Ventilation System Equipment I&C and Electrical Design  
(4 Sheets)**

Description	Tag Number <sup>(1)</sup>	Location	IEEE Class 1E <sup>(2)</sup>	EQ – Harsh Env.	PACS	MCR / RSS Displays	MCR / RSS Controls
Temperature Downstream of Electric Heater	30KLA22CT001	Fuel Building	N/A	Yes	N/A	Temperature/ Temperature	N/A
Temperature Upstream of Electric Heater	30KLA22CT002	Fuel Building	N/A	Yes	N/A	Temperature/ Temperature	N/A
Duct Air Flow	30KLA22CF001	Fuel Building	N/A	Yes	N/A	Flow/Flow	N/A
Iodine Filter Differential Pressure	30KLA22CP505	Fuel Building	N/A	Yes	N/A	N/A	N/A
Temperature Downstream of Carbon Adsorbers	30KLA21CT003	Fuel Building	N/A	Yes	N/A	Temperature/ Temperature	N/A
Temperature Downstream of Carbon Adsorbers	30KLA22CT003	Fuel Building	N/A	Yes	N/A	Temperature/ Temperature	N/A
<u>Temperature Upstream of Electric Heater</u>	<u>30KLA50CT002</u>	<u>Reactor Building</u>	<u>N/A</u>	<u>Yes</u>	<u>N/A</u>	<u>Temperature / Temperature</u>	<u>N/A</u>
<u>Temperature Downstream of Electric Heater</u>	<u>30KLA50CT001</u>	<u>Reactor Building</u>	<u>N/A</u>	<u>Yes</u>	<u>N/A</u>	<u>Temperature / Temperature</u>	<u>N/A</u>
<u>Duct Air Flow</u>	<u>30KLA50CF001</u>	<u>Reactor Building</u>	<u>N/A</u>	<u>Yes</u>	<u>N/A</u>	<u>Flow/Flow</u>	<u>N/A</u>
<u>Temperature Downstream of Carbon Adsorber</u>	<u>30KLA50CT003</u>	<u>Reactor Building</u>	<u>N/A</u>	<u>Yes</u>	<u>N/A</u>	<u>Temperature / Temperature</u>	<u>N/A</u>

## 2.6.9 Emergency Power Generating Building Ventilation System

### 1.0 Description

The emergency power generating building ventilation system (EPGBVS) controls the temperature, ~~humidity~~ and air change rate in the Emergency Power Generating Buildings (EPGB) for personnel comfort, personnel safety, and equipment protection ~~during operation of the emergency diesel generators (EDG)~~. The EPGBVS provides ventilation of the diesel hall, electrical room, and main tank room; and cooling of the electrical room for each of the four divisions of the EPGBs to remove equipment heat, and heat generated from other sources. The EPGBVS also provides heat to maintain a minimum temperature in the buildings.

Each division of the EPGBs has its own independent heating, ventilation and air conditioning system which is not connected to other divisions. Two divisions are located in each of the two EPGBs. EPGBVS Divisions 1 and 2 are located in EPGB 1/2 and Divisions 3 and 4 in EPGB 3/4. During normal plant operation, the emergency diesel generators (EDGs) do not operate, however the EPGBVS maintains an acceptable ambient temperature for the startup of EDGs and for personnel comfort.

The EPGBVS provides the following safety-related functions:

- Removes heat generated by the EDGs during operation of the EDGs to maintain acceptable operating conditions in the diesel hall.
- Maintains acceptable ambient conditions in the electrical room and main tank room.
- Maintains environmental conditions for startup of the EDGs.

The EPGBVS provides the following non-safety-related functions:

- Maintains the room ambient conditions to allow personnel access during normal operation.
- Provides ventilation to maintain required air renewal rates.

### 2.0 Arrangement

2.1 The functional arrangement of the EPGBVS is as shown in the following figures:

- Figure 2.6.9-1—Emergency Power Generating Building Ventilation System Functional Arrangement, Division 1.
- Figure 2.6.9-2—Emergency Power Generating Building Ventilation System Functional Arrangement, Division 2.
- Figure 2.6.9-3—Emergency Power Generating Building Ventilation System Functional Arrangement, Division 3.



- Figure 2.6.9-4—Emergency Power Generating Building Ventilation System Functional Arrangement, Division 4.

2.2 The location of the EPGBVS equipment is as listed in Table 2.6.9-1—Emergency Power Generating Building Ventilation System Equipment Mechanical Design.

2.3 Physical separation exists between ~~the four~~ divisions of the EPGBVS as listed in Table 2.6.9-1.

### 3.0 Mechanical Design Features

3.1 Deleted.

3.2 Class 1E dampers ~~Equipment~~ listed in Table 2.6.9-1 ~~will can perform the function to change position as~~ listed in Table 2.6.9-1 under system operating conditions.

3.3 Components identified as Seismic Category I in Table 2.6.9-1 can withstand seismic design basis loads without a loss of the function listed in Table 2.6.9-1.

3.4 Components listed in Table 2.6.9-1 as ASME AG-1 Code are designed in accordance with ASME AG-1 Code requirements.

3.5 Components listed in Table 2.6.9-1 as ASME AG-1 Code are fabricated in accordance with ASME AG-1 Code requirements, including welding requirements.

3.6 Components listed in Table 2.6.9-1 as ASME AG-1 Code are installed, inspected and tested in accordance with ASME AG-1 Code requirements.

### 4.0 Displays and Controls

4.1 Displays listed in Table 2.6.9-2—Emergency Power Generating Building Ventilation System Equipment I&C and Electrical Design, are ~~retrievable indicated~~ in the main control room (MCR) and the remote shutdown station (RSS) ~~as listed in Table 2.6.9-2.~~

4.2 Controls on the PICS in the MCR and the RSS perform the function ~~The EPGBVS equipment controls are provided in the MCR and RSS as~~ listed in Table 2.6.9-2.

4.3 Equipment listed as being controlled by a priority and actuator control system (PACS) module in Table 2.6.9-2 responds to the state requested ~~by a test signal and provides~~ drive monitoring signals back to the PACS module. The PACS module will protect the equipment by terminating the output command upon the equipment reaching the requested state.

### 5.0 Electrical Power Design Features

5.1 The equipment designated as Class 1E in Table 2.6.9-2 are powered from the Class 1E division as listed in Table 2.6.9-2 in a normal feed condition.

5.2 Deleted. Motor operated dampers listed in Table 2.6.9-2 fail to the position as shown in Table 2.6.9-2 on loss of power.

**Table 2.6.9-1—Emergency Power Generating Building Ventilation System Equipment Mechanical Design (7 Sheets)**

Description	Tag Number <sup>(1)</sup>	Location	ASME AG-1 Code	Function	Seismic Category
<u>Backdraft Dampers</u>	30SAD11AA003	1/2 EPGB, Division 1	<u>Yes</u>	<u>N/A</u>	<u>II</u>
	30SAD21AA003	1/2 EPGB, Division 2			
	30SAD31AA003	3/4 EPGB, Division 3			
	30SAD41AA003	3/4EPGB, Division 4			
<u>Pre-filters</u>	30SAD11AT003	1/2 EPGB, Division 1	<u>Yes</u>	<u>N/A</u>	<u>II</u>
	30SAD21AT003	1/2 EPGB, Division 2			
	30SAD31AT003	3/4 EPGB, Division 3			
	30SAD41AT003	3/4EPGB, Division 4			
<u>Supply Air Fans</u>	30SAD11AN003	1/2 EPGB, Division 1	<u>Yes</u>	<u>N/A</u>	<u>II</u>
	30SAD21AN003	1/2 EPGB, Division 2			
	30SAD31AN003	3/4 EPGB, Division 3			
	30SAD41AN003	3/4EPGB, Division 4			
<u>Motor operated dampers</u>	30SAD11AA004	1/2 EPGB, Division 1	<u>Yes</u>	<u>N/A</u>	<u>I</u>
	30SAD21AA004	1/2 EPGB, Division 2			
	30SAD31AA004	3/4 EPGB, Division 3			
	30SAD41AA004	3/4EPGB, Division 4			
<b>Diesel Hall Air Supply and Exhaust</b>					
Manual Dampers	30SAD12AA001	1/2 EPGB, Division 1	Yes	N/A	I
	30SAD22AA001	1/2 EPGB, Division 2			
	30SAD32AA001	3/4 EPGB, Division 3			
	30SAD42AA001	3/4 EPGB, Division 4			
Manual Dampers	30SAD12AA002	1/2 EPGB, Division 1	Yes	N/A	I
	30SAD22AA002	1/2 EPGB, Division 2			
	30SAD32AA002	3/4 EPGB, Division 3			
	30SAD42AA002	3/4 EPGB, Division 4			

**Table 2.6.9-1—Emergency Power Generating Building Ventilation System Equipment Mechanical Design (7 Sheets)**

Description	Tag Number <sup>(1)</sup>	Location	ASME AG-1 Code	Function	Seismic Category
Back Draft Dampers	30SAD15AA002 30SAD25AA002 30SAD35AA002 30SAD45AA002	1/2 EPGB, Division 1 1/2 EPGB, Division 2 3/4 EPGB, Division 3 3/4 EPGB, Division 4	Yes	N/A	I
<u>Motor operated dampers</u>	30SAD15AA004 30SAD25AA004 30SAD35AA004 30SAD45AA004	1/2 EPGB, Division 1 1/2 EPGB, Division 2 3/4 EPGB, Division 3 3/4EPGB, Division 4	<u>Yes</u>	<u>N/A</u>	<u>I</u>
<u>Exhaust Fans</u>	30SAD15AN003 30SAD25AN003 30SAD35AN003 30SAD45AN003	1/2 EPGB, Division 1 1/2 EPGB, Division 2 3/4 EPGB, Division 3 3/4EPGB, Division 4	<u>Yes</u>	<u>N/A</u>	<u>II</u>
<u>Backdraft Dampers</u>	30SAD15AA003 30SAD25AA003 30SAD35AA003 30SAD45AA003	1/2 EPGB, Division 1 1/2 EPGB, Division 2 3/4 EPGB, Division 3 3/4EPGB, Division 4	<u>Yes</u>	<u>N/A</u>	<u>II</u>
<b>Electrical Room Air Supply and Recirculation</b>					
<del>Motor operated dampers</del>	<del>30SAD13AA001 30SAD23AA001 30SAD33AA001 30SAD43AA001</del>	<del>1/2 EPGB, Division 1 1/2 EPGB, Division 2 3/4 EPGB, Division 3 3/4 EPGB, Division 4</del>	<del>Yes</del>	<del>Open</del>	<del>I</del>
Manual dampers	30SAD13AA002 30SAD23AA002 30SAD33AA002 30SAD43AA002	1/2 EPGB, Division 1 1/2 EPGB, Division 2 3/4 EPGB, Division 3 3/4 EPGB, Division 4	Yes	N/A	I

**Table 2.6.9-1—Emergency Power Generating Building Ventilation System Equipment Mechanical Design (7 Sheets)**

Description	Tag Number <sup>(1)</sup>	Location	ASME AG-1 Code	Function	Seismic Category
Pre-filters	30SAD13AT001 30SAD23AT001 30SAD33AT001 30SAD43AT001	1/2 EPGB, Division 1 1/2 EPGB, Division 2 3/4 EPGB, Division 3 3/4 EPGB, Division 4	Yes	N/A	I
HEPA Filters	30SAD13AT002 30SAD23AT002 30SAD33AT002 30SAD43AT002	1/2 EPGB, Division 1 1/2 EPGB, Division 2 3/4 EPGB, Division 3 3/4 EPGB, Division 4	Yes	N/A	I
Cooling Coils	30SAD13AC001 30SAD23AC001 30SAD33AC001 30SAD43AC001	1/2 EPGB, Division 1 1/2 EPGB, Division 2 3/4 EPGB, Division 3 3/4 EPGB, Division 4	Yes	N/A	I
Moisture Separators	30SAD13AT003 30SAD23AT003 30SAD33AT003 30SAD43AT003	1/2 EPGB, Division 1 1/2 EPGB, Division 2 3/4 EPGB, Division 3 3/4 EPGB, Division 4	Yes	N/A	I
<b>Electric Heaters</b>	<del>30SAD13AH001</del> <del>30SAD23AH001</del> <del>30SAD33AH001</del> <del>30SAD43AH001</del>	<del>1/2 EPGB, Division 1</del> <del>1/2 EPGB, Division 2</del> <del>3/4 EPGB, Division 3</del> <del>3/4 EPGB, Division 4</del>	<b>Yes</b>	<b>On/Off</b>	<b>I</b>
Supply Air Fans	30SAD13AN001 30SAD23AN001 30SAD33AN001 30SAD43AN001	1/2 EPGB, Division 1 1/2 EPGB, Division 2 3/4 EPGB, Division 3 3/4 EPGB, Division 4	Yes	Run	I



**Table 2.6.9-1—Emergency Power Generating Building Ventilation System Equipment Mechanical Design (7 Sheets)**

Description	Tag Number <sup>(1)</sup>	Location	ASME AG-1 Code	Function	Seismic Category
<u>Humidifiers</u>	30SAD13AA002 30SAD23AA002 30SAD33AA002 30SAD43AA002	1/2 EPGB, Division 1 1/2 EPGB, Division 2 3/4 EPGB, Division 3 3/4 EPGB, Division 4	<u>Yes</u>	<u>N/A</u>	<u>II</u>
<u>Back Draft Dampers</u>	30SAD13AA003 30SAD23AA003 30SAD33AA003 30SAD43AA003	1/2 EPGB, Division 1 1/2 EPGB, Division 2 3/4 EPGB, Division 3 3/4 EPGB, Division 4	<u>Yes</u>	<u>N/A</u>	<u>I</u>
<u>Back Draft Dampers</u>	30SAD13AA006 30SAD23AA006 30SAD33AA006 30SAD43AA006	1/2 EPGB, Division 1 1/2 EPGB, Division 2 3/4 EPGB, Division 3 3/4 EPGB, Division 4	<u>Yes</u>	<u>N/A</u>	<u>I</u>
<u>Motor operated dampers</u>	30SAD13AA007 30SAD23AA007 30SAD33AA007 30SAD43AA007	1/2 EPGB, Division 1 1/2 EPGB, Division 2 3/4 EPGB, Division 3 3/4EPGB, Division 4	<u>Yes</u>	<u>N/A</u>	<u>I</u>
<u>Manual Dampers</u>	30SAD13AA008 30SAD23AA008 30SAD33AA008 30SAD43AA008	1/2 EPGB, Division 1 1/2 EPGB, Division 2 3/4 EPGB, Division 3 3/4EPGB, Division 4	<u>Yes</u>	<u>N/A</u>	<u>II</u>
<u>Manual Dampers</u>	30SAD13AA009 30SAD23AA009 30SAD33AA009 30SAD43AA009	1/2 EPGB, Division 1 1/2 EPGB, Division 2 3/4 EPGB, Division 3 3/4EPGB, Division 4	<u>Yes</u>	<u>N/A</u>	<u>II</u>

**Table 2.6.9-1—Emergency Power Generating Building Ventilation System Equipment Mechanical Design (7 Sheets)**

Description	Tag Number <sup>(1)</sup>	Location	ASME AG-1 Code	Function	Seismic Category
<u>Pre-filters</u>	30SAD13AT003 30SAD23AT003 30SAD33AT003 30SAD43AT003	1/2 EPGB, Division 1 1/2 EPGB, Division 2 3/4 EPGB, Division 3 3/4EPGB, Division 4	<u>Yes</u>	<u>N/A</u>	<u>II</u>
<u>Cooling Coils</u>	30SAD13AC002 30SAD23AC002 30SAD33AC002 30SAD43AC002	1/2 EPGB, Division 1 1/2 EPGB, Division 2 3/4 EPGB, Division 3 3/4EPGB, Division 4	<u>Yes</u>	<u>N/A</u>	<u>II</u>
<u>Cooling Coils</u>	30SAD13AC102 30SAD23AC102 30SAD33AC102 30SAD43AC102	1/2 EPGB, Division 1 1/2 EPGB, Division 2 3/4 EPGB, Division 3 3/4EPGB, Division 4	<u>Yes</u>	<u>N/A</u>	<u>II</u>
<u>Supply Air Fans</u>	30SAD13AN002 30SAD23AN002 30SAD33AN002 30SAD43AN002	1/2 EPGB, Division 1 1/2 EPGB, Division 2 3/4 EPGB, Division 3 3/4EPGB, Division 4	<u>Yes</u>	<u>N/A</u>	<u>II</u>
<u>Backdraft dampers</u>	30SAD13AA010 30SAD23AA010 30SAD33AA010 30SAD43AA010	1/2 EPGB, Division 1 1/2 EPGB, Division 2 3/4 EPGB, Division 3 3/4EPGB, Division 4	<u>Yes</u>	<u>N/A</u>	<u>I</u>
<b>Main Tank Room Air Supply and Exhaust</b>					
Back Draft Dampers	30SAD16AA001 30SAD26AA001 30SAD36AA001 30SAD46AA001	1/2 EPGB, Division 1 1/2 EPGB, Division 2 3/4 EPGB, Division 3 3/4 EPGB, Division 4	Yes	N/A	I

**Table 2.6.9-2—Emergency Power Generating Building Ventilation System Equipment I&C and Electrical Design (3 Sheets)**

Description	Tag Number <sup>(1)</sup>	Location	IEEE Class 1E	Failure Position	PACS	MCR / RSS Displays	MCR / RSS Controls
Supply Air Fans	30SAD11AN001	1/2 EPG, Division 1	Division 1	<del>N/A</del>	Yes	On-Off / On-Off	Run-Stop / Run-Stop
	30SAD21AN001	1/2 EPG, Division 2	Division 2	<del>N/A</del>			
	30SAD31AN001	3/4 EPG, Division 3	Division 3	<del>N/A</del>			
	30SAD41AN001	3/4 EPG, Division 4	Division 4	<del>N/A</del>			
Supply Air Fans	30SAD11AN002	1/2 EPG, Division 1	Division 1	<del>N/A</del>	Yes	On-Off / On-Off	Run-Stop / Run-Stop
	30SAD21AN002	1/2 EPG, Division 2	Division 2	<del>N/A</del>			
	30SAD31AN002	3/4 EPG, Division 3	Division 3	<del>N/A</del>			
	30SAD41AN002	3/4 EPG, Division 4	Division 4	<del>N/A</del>			
Exhaust Fans	30SAD15AN001	1/2 EPG, Division 1	Division 1	<del>N/A</del>	Yes	On-Off / On-Off	Run-Stop / Run-Stop
	30SAD25AN001	1/2 EPG, Division 2	Division 2	<del>N/A</del>			
	30SAD35AN001	3/4 EPG, Division 3	Division 3	<del>N/A</del>			
	30SAD45AN001	3/4 EPG, Division 4	Division 4	<del>N/A</del>			
Exhaust Fans	30SAD15AN002	1/2 EPG, Division 1	Division 1	<del>N/A</del>	Yes	On-Off / On-Off	Run-Stop / Run-Stop
	30SAD25AN002	1/2 EPG, Division 2	Division 2	<del>N/A</del>			
	30SAD35AN002	3/4 EPG, Division 3	Division 3	<del>N/A</del>			
	30SAD45AN002	3/4 EPG, Division 4	Division 4	<del>N/A</del>			
<del>Motor Operated Dampers</del>	<del>30SAD13AA001</del>	<del>1/2 EPG, Division 1</del>	<del>Division 1</del>	<del>Close</del>	<del>Yes</del>	<del>Position / Position</del>	<del>Open-Close / Open-Close</del>
	<del>30SAD23AA001</del>	<del>1/2 EPG, Division 2</del>	<del>Division 2</del>				
	<del>30SAD33AA001</del>	<del>3/4 EPG, Division 3</del>	<del>Division 3</del>				
	<del>30SAD43AA001</del>	<del>3/4 EPG, Division 4</del>	<del>Division 4</del>				
Electric Heaters	30SAD13AH001	1/2 EPG, Division 1	Division 1	N/A	Yes	On-Off / On-Off	Start-Stop / Start-Stop
	30SAD23AH001	1/2 EPG, Division 2	Division 2				
	30SAD33AH001	3/4 EPG, Division 3	Division 3				
	30SAD43AH001	3/4 EPG, Division 4	Division 4				

**Table 2.6.9-2—Emergency Power Generating Building Ventilation System Equipment I&C and Electrical Design (3 Sheets)**

Description	Tag Number <sup>(1)</sup>	Location	IEEE Class 1E	Failure Position	PACS	MCR / RSS Displays	MCR / RSS Controls
Supply Air Fans	30SAD13AN001	1/2 EPGB, Division 1	Division 1	<del>N/A</del>	Yes	On-Off / On-Off	Run-Stop / Run-Stop
	30SAD23AN001	1/2 EPGB, Division 2	Division 2				
	30SAD33AN001	3/4 EPGB, Division 3	Division 3				
	30SAD43AN001	3/4 EPGB, Division 4	Division 4				
Motor Operated Dampers	30SAD16AA007	1/2 EPGB, Division 1	Division 1	<del>Close</del>	Yes	Position / Position	Open-Close / Open-Close
	30SAD26AA007	1/2 EPGB, Division 2	Division 2				
	30SAD36AA007	3/4 EPGB, Division 3	Division 3				
	30SAD46AA007	3/4 EPGB, Division 4	Division 4				
Motor Operated Dampers	30SAD16AA008	1/2 EPGB, Division 1	Division 1	<del>Close</del>	Yes	Position / Position	Open-Close / Open-Close
	30SAD26AA008	1/2 EPGB, Division 2	Division 2				
	30SAD36AA008	3/4 EPGB, Division 3	Division 3				
	30SAD46AA008	3/4 EPGB, Division 4	Division 4				
Exhaust Fans	30SAD16AN001	1/2 EPGB, Division 1	Division 1	<del>N/A</del>	Yes	On-Off / On-Off	Run-Stop / Run-Stop
	30SAD26AN001	1/2 EPGB, Division 2	Division 2				
	30SAD36AN001	3/4 EPGB, Division 3	Division 3				
	30SAD46AN001	3/4 EPGB, Division 4	Division 4				
Fan Heaters	30SAD14AH001	1/2 EPGB, Division 1	Division 1	<del>N/A</del>	Yes	On-Off / On-Off	Start-Stop / Start-Stop
	30SAD14AH002						
	30SAD14AH003						
	30SAD14AH004						
Fan Heaters	30SAD24AH001	1/2 EPGB, Division 2	Division 2	<del>N/A</del>	Yes	On-Off / On-Off	Start-Stop / Start-Stop
	30SAD24AH002						
	30SAD24AH003						
	30SAD24AH004						

**Table 2.6.9-2—Emergency Power Generating Building Ventilation System Equipment I&C and Electrical Design (3 Sheets)**

Description	Tag Number <sup>(1)</sup>	Location	IEEE Class 1E	Failure Position	PACS	MCR / RSS Displays	MCR / RSS Controls
Fan Heaters	30SAD34AH001 30SAD34AH002 30SAD34AH003 30SAD34AH004	3/4 EPGB, Division 3	Division 3	<del>N/A</del>	Yes	On-Off / On-Off	Start-Stop / Start-Stop
Fan Heaters	30SAD44AH001 30SAD44AH002 30SAD44AH003 30SAD44AH004	3/4 EPGB, Division 4	Division 4	<del>N/A</del>	Yes	On-Off / On-Off	Start-Stop / Start-Stop
<u>Motor operated dampers</u>	<u>30SAD11AA004</u> <u>30SAD21AA004</u> <u>30SAD31AA004</u> <u>30SAD41AA004</u>	<u>1/2 EPGB, Division 1</u> <u>1/2 EPGB, Division 2</u> <u>3/4 EPGB, Division 3</u> <u>3/4EPGB, Division 4</u>	<u>Division 1</u> <u>Division 2</u> <u>Division 3</u> <u>Division 4</u>		<u>Yes</u>	<u>Position /</u> <u>Position</u>	<u>Open-Close /</u> <u>Open-Close</u>
<u>Motor operated dampers</u>	<u>30SAD15AA004</u> <u>30SAD25AA004</u> <u>30SAD35AA004</u> <u>30SAD45AA004</u>	<u>1/2 EPGB, Division 1</u> <u>1/2 EPGB, Division 2</u> <u>3/4 EPGB, Division 3</u> <u>3/4EPGB, Division 4</u>	<u>Division 1</u> <u>Division 2</u> <u>Division 3</u> <u>Division 4</u>		<u>Yes</u>	<u>Position /</u> <u>Position</u>	<u>Open-Close /</u> <u>Open-Close</u>
<u>Motor operated dampers</u>	<u>30SAD13AA007</u> <u>30SAD23AA007</u> <u>30SAD33AA007</u> <u>30SAD43AA007</u>	<u>1/2 EPGB, Division 1</u> <u>1/2 EPGB, Division 2</u> <u>3/4 EPGB, Division 3</u> <u>3/4EPGB, Division 4</u>	<u>Division 1</u> <u>Division 2</u> <u>Division 3</u> <u>Division 4</u>		<u>Yes</u>	<u>Position /</u> <u>Position</u>	<u>Open-Close /</u> <u>Open-Close</u>

1) Equipment tag numbers are provided for information only and are not part of the certified design.



**Table 2.6.9-3—Emergency Power Generating Building Ventilation System ITAAC (3 Sheets)**

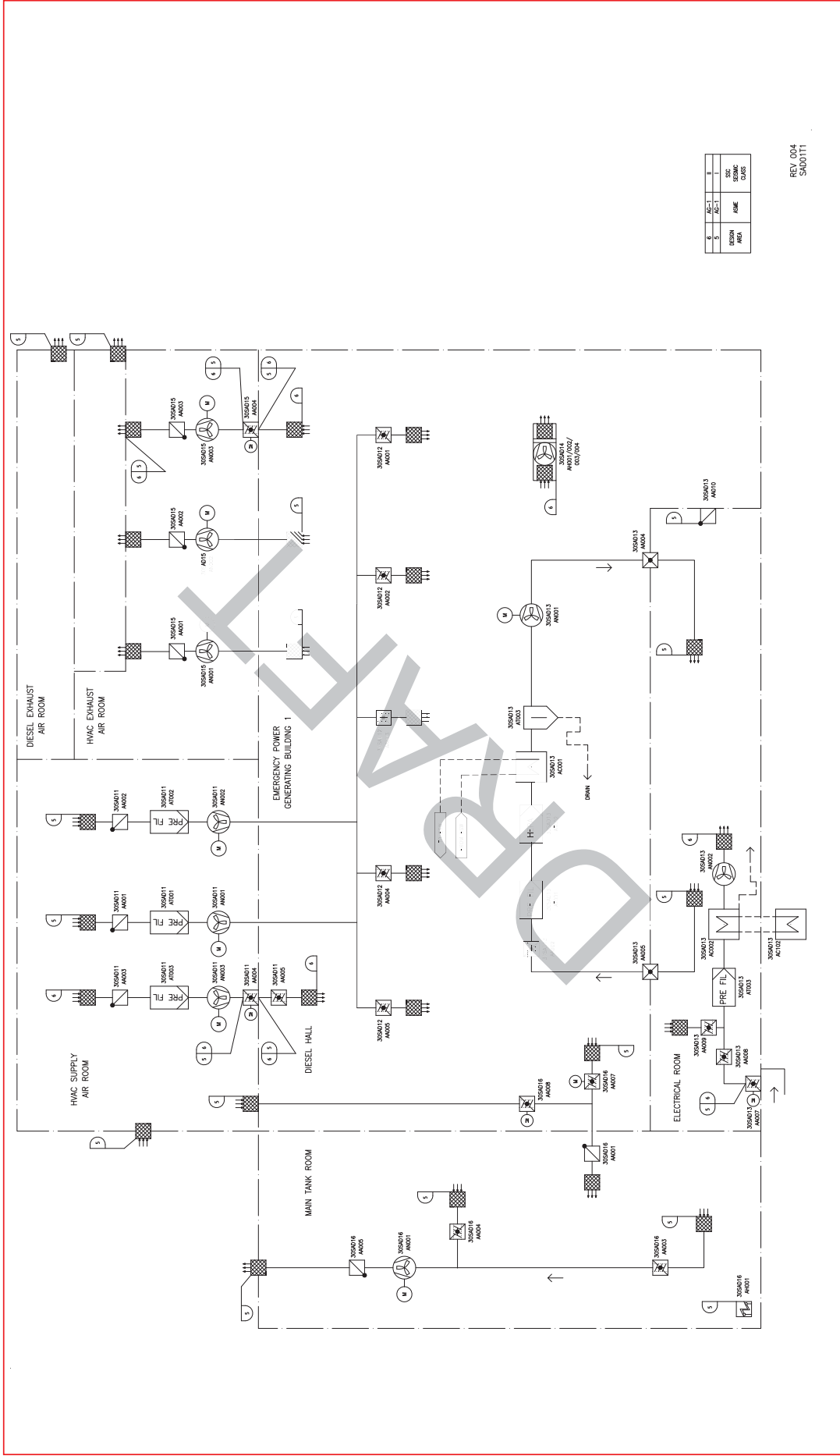
	Commitment Wording	Inspections, Tests, Analyses	Acceptance Criteria
5.2	<del>Motor operated dampers listed in Table 2.6.9-2 fail to the position as shown in Table 2.6.9-2 on loss of power.</del>	<del>Testing will be performed for the motor operated dampers listed in Table 2.6.9-2 to verify the position of dampers on loss of power.</del>	<del>Following loss of power, the motor operated dampers listed in Table 2.6.9-2 fail to the position as shown in Table 2.6.9-2.</del>
6.1	The EPGBVS provides ventilation and cooling to maintain design temperatures in the Emergency Power Generating Buildings, while operating in a design basis accident alignment.	<p>a. An inspection of the <del>manufacturer's documentation of the EPGBVS cooling coils</del> <u>analysis</u> will be performed.</p> <p>b. Tests and analysis of the EPGBVS units will be performed <del>to verify that design temperatures in the Emergency Power Generating Buildings, while operating in a design basis accident alignment.</del></p>	<p>a. <del>A report confirms that each</del> <u>Each</u> EPGBVS cooling coil is capable of providing design cooling requirements.</p> <p>b. <del>A report confirms that the</del> <u>The</u> EPGBVS is capable of providing ventilation and cooling to maintain design temperatures in the Emergency Power Generating Buildings, while operating in a design basis accident alignment.</p> <ul style="list-style-type: none"> <li><del>A report confirms that each</del> <u>Each</u> EPGBVS fan is capable of meeting the design air flow requirements, while operating in a design basis accident alignment.</li> </ul>

Next File

All indicated changes are in response to RAI 505, 07.01-35



Figure 2.6.9-1—Emergency Power Generating Building Ventilation System Functional Arrangement, Division 1



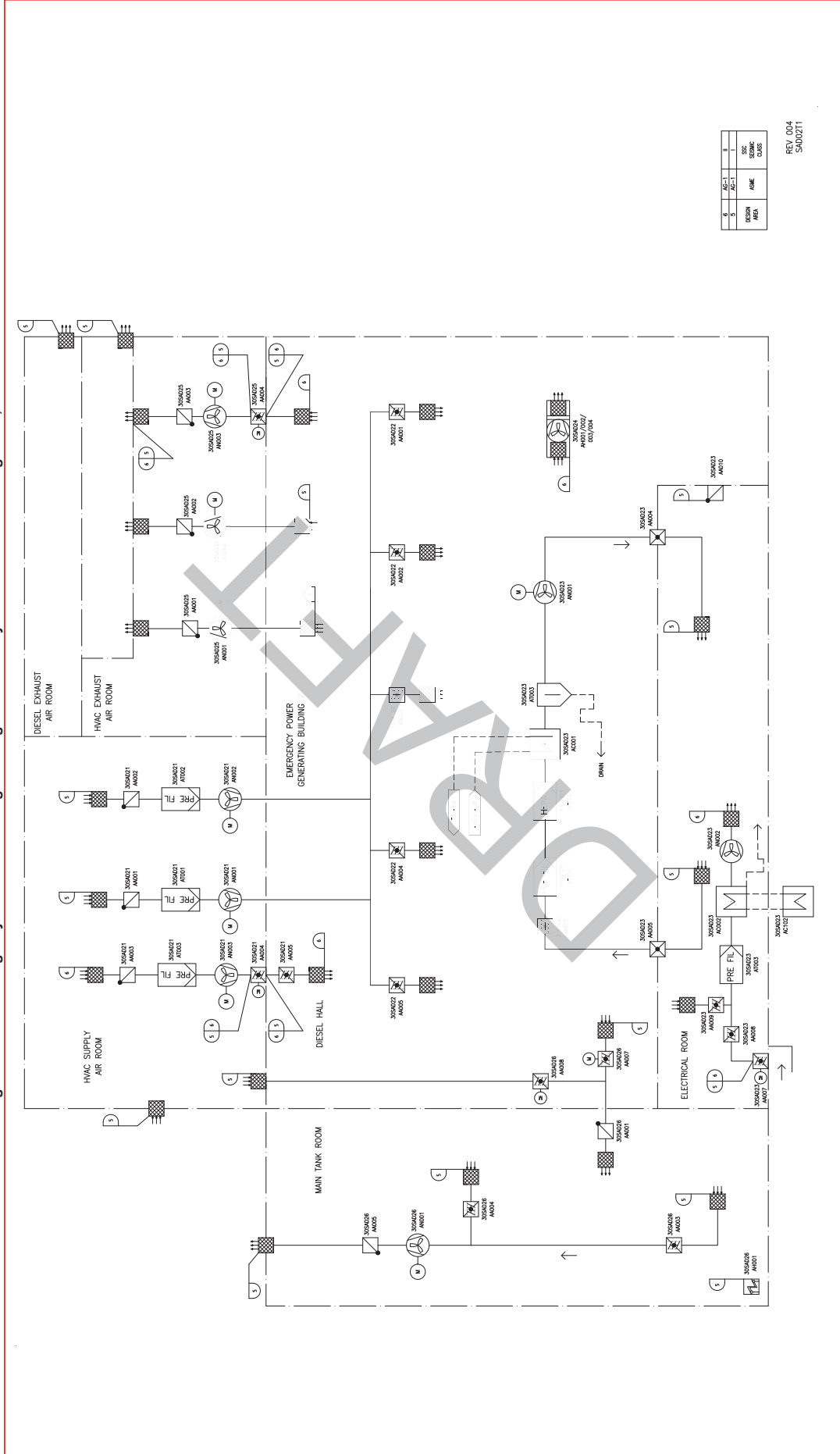
Revision 4—Interim

Tier 1

All indicated changes are in response to RAI 505, 07.01-35



Figure 2.6.9-2—Emergency Power Generating Building Ventilation System Functional Arrangement, Division 2



REV	DATE	BY	CHKD	CLASS
1	05/01/04	AME	AME	DESIGN AREA
2	05/01/04	AME	AME	DESIGN AREA
3	05/01/04	AME	AME	DESIGN AREA
4	05/01/04	AME	AME	DESIGN AREA
5	05/01/04	AME	AME	DESIGN AREA
6	05/01/04	AME	AME	DESIGN AREA

REV: 054  
5400271

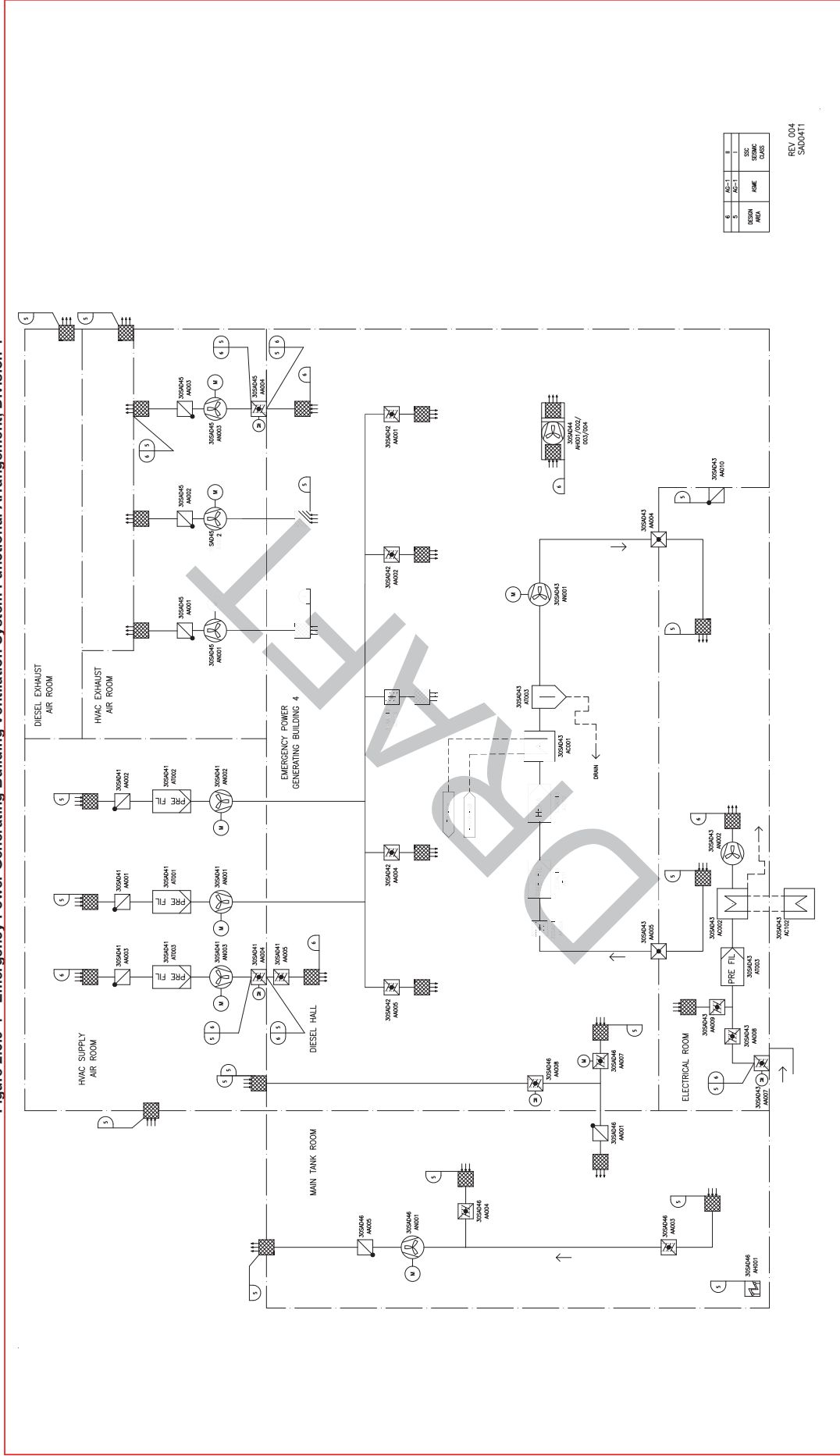




All indicated changes are in response to RAI 505, 07.01-35



Figure 2.6.9-4—Emergency Power Generating Building Ventilation System Functional Arrangement, Division 4



## 2.6.13 Essential Service Water Pump Building Ventilation System

### 1.0 Description

The essential service water pump building ventilation system (ESWPBVS) controls the temperature and air change rate in the essential service water system (ESWS) pump areas for personnel comfort, personnel safety, and equipment protection. ~~during operation of ESWS pumps.~~ The ESWPBVS provides cooling and heating for the ESWS pump area and associated electrical equipment in each of the four ESWS Pump Buildings (ESWPB) to remove equipment heat, and heat generated from other sources. Each building has its own independent ventilation system and is not connected to the other buildings.

The ESWPBVS provides the following safety-related functions:

- Removes heat generated by the ESWS pumps and associated electrical equipment.
- Maintains acceptable temperature limits to support operation of ESWS pumps.

The ESWPBVS provides the following non-safety-related functions:

- Maintains the room ambient conditions to allow personnel access during normal operation.
- Provides ventilation ~~by recirculation of room air only (without outside air)~~ and cooling during plant operation when an ESW pump is not operating.

### 2.0 Arrangement

2.1 The functional arrangement of the ESWPBVS is as shown in Figure 2.6.13-1—Essential Service Water Pump Building Ventilation System Functional Arrangement.

2.2 The location of the ESWPBVS equipment is as listed in Table 2.6.13-1—Essential Service Water Pump Building Ventilation System Equipment Mechanical Design.

2.3 Physical separation exists between ~~the four~~ divisions of the ESWPBVS as shown in Table 2.6.13-1.

### 3.0 Mechanical Design Features

3.1 Deleted.

3.2 Class 1E dampers ~~Equipment~~ listed in Table 2.6.13-1 will ~~can perform the~~ function to change position as listed in Table 2.6.13-1 under system operating conditions.

3.3 Components identified as Seismic Category I in Table 2.6.13-1 can withstand seismic design basis loads without a loss of the function listed in Table 2.6.13-1.

3.4 Components listed in Table 2.6.13-1 as ASME AG-1 Code are designed in accordance with ASME AG-1 Code requirements.



3.5 Components listed in Table 2.6.13-1 as ASME AG-1 Code are fabricated in accordance with ASME AG-1 Code requirements, including welding requirements.

3.6 Components listed in Table 2.6.13-1 as ASME AG-1 Code are installed, inspected and tested in accordance with ASME AG-1 Code requirements.

#### 4.0 Displays and Controls

4.1 Displays listed in Table 2.6.13-2—Essential Service Water Pump Building Ventilation System Equipment I&C and Electrical Design, are ~~retrievable~~ indicated in the main control room (MCR) and the remote shutdown station (RSS) ~~as listed in Table 2.6.13-2~~.

4.2 Controls on the PICS in the MCR and the RSS perform the function ~~The ESWPBVS equipment controls are provided in the MCR and RSS as~~ listed in Table 2.6.13-2.

4.3 Equipment listed as being controlled by a priority and actuator control system (PACS) module in Table 2.6.13-2 responds to the state requested ~~by a test signal~~ and provides drive monitoring signals back to the PACS module. The PACS module will protect the equipment by terminating the output command upon the equipment reaching the requested state.

#### 5.0 Electrical Power Design Features

5.1 The equipment designated as Class 1E in Table 2.6.13-2 are powered from the Class 1E division as listed in Table 2.6.13-2 in a normal feed condition.

#### 6.0 Equipment and System Performance

6.1 The safety-related ESWPBVS provides ~~recirculation~~ cooling to maintain design temperatures in the Essential Service Water Pump Buildings, while operating in a design basis accident alignment.

#### 7.0 Inspections, Tests, Analyses and Acceptance Criteria

Table 2.6.13-3 lists the ESWPBVS ITAAC.

Table 2.6.13-1—Essential Service Water Pump Building Ventilation System Equipment Mechanical Design (2 Sheets)

Description	Tag Number <sup>(1)</sup>	Location	ASME AG-1 Code	Function	Seismic Category
Air Cooling Coils	30SAQ01AC001 30SAQ02AC001 30SAQ03AC001 30SAQ04AC001	ESW Pump Building 1 ESW Pump Building 2 ESW Pump Building 3 ESW Pump Building 4	Yes	N/A	I
Moisture Separators	30SAQ01AT001 30SAQ02AT001 30SAQ03AT001 30SAQ04AT001	ESW Pump Building 1 ESW Pump Building 2 ESW Pump Building 3 ESW Pump Building 4	Yes	N/A	I
Electrical Heaters	30SAQ01AH001/002 30SAQ02AH001/002 30SAQ03AH001/002 30SAQ04AH001/002	ESW Pump Building 1 ESW Pump Building 2 ESW Pump Building 3 ESW Pump Building 4	Yes	On / Off (based on ambient conditions)	I
Recirculation Fans	30SAQ01AN001 30SAQ02AN001 30SAQ03AN001 30SAQ04AN001	ESW Pump Building 1 ESW Pump Building 2 ESW Pump Building 3 ESW Pump Building 4	Yes	Run	I
<del>Manual</del> Motor Operated Outside Air Isolation Dampers	30SAQ01AA007+ 30SAQ02AA007+ 30SAQ03AA007+ 30SAQ04AA007+	ESW Pump Building 1 ESW Pump Building 2 ESW Pump Building 3 ESW Pump Building 4	Yes	N/A	I
Manual <del>Isolation</del> Balancing Dampers	30SAQ01AA002 30SAQ02AA002 30SAQ03AA002 30SAQ04AA002	ESW Pump Building 1 ESW Pump Building 2 ESW Pump Building 3 ESW Pump Building 4	Yes	N/A	I



<u>PreFilter</u>	<u>30SAQ01AT002</u> <u>30SAQ02AT002</u> <u>30SAQ03AT002</u> <u>30SAQ04AT002</u>	<u>ESW Pump Building 1</u> <u>ESW Pump Building 2</u> <u>ESW Pump Building 3</u> <u>ESW Pump Building 4</u>	<u>Yes</u>	<u>N/A</u>	<u>I</u>
------------------	--	--	------------	------------	----------

1) Equipment tag numbers are provided for information only and are not part of the certified design.

FOR REVIEW

Table 2.6.13-2—Essential Service Water Pump Building Ventilation System Equipment I&C and Electrical Design

Description	Tag Number <sup>(1)</sup>	Location	IEEE Class 1E	PACS	MCR / RSS Displays	MCR / RSS Controls
Electrical Heaters	30SAQ01AH001/002	ESW Pump Building 1	Division 1	Yes	On-Off / On-Off	Start-Stop / Start-Stop
	30SAQ02AH001/002	ESW Pump Building 2	Division 2			
	30SAQ03AH001/002	ESW Pump Building 3	Division 3			
	30SAQ04AH001/002	ESW Pump Building 4	Division 4			
Recirculation Fans	30SAQ01AN001	ESW Pump Building 1	Division 1	Yes	On-Off / On-Off	Run-Stop / Run-Stop
	30SAQ02AN001	ESW Pump Building 2	Division 2			
	30SAQ03AN001	ESW Pump Building 3	Division 3			
	30SAQ04AN001	ESW Pump Building 4	Division 4			
Temperature Sensors	<del>30SAQ01CT001</del>	<del>ESW Pump Building 1</del>	<del>Division 1</del>	<del>N/A</del>	Temp / Temp	N/A
	<del>30SAQ02CT001</del>	<del>ESW Pump Building 2</del>	<del>Division 2</del>			
	<del>30SAQ03CT001</del>	<del>ESW Pump Building 3</del>	<del>Division 3</del>			
	<del>30SAQ04CT001</del>	<del>ESW Pump Building 4</del>	<del>Division 4</del>			
Motor Operated Outside Air Isolation Dampers	<u>30SAQ01AA005/007</u>	<u>ESW Pump Building 1</u>	<u>Division 1</u>	<u>Yes</u>	<u>Position/Position</u>	<u>Open-Close/</u> <u>Open-Close</u>
	<u>30SAQ02AA005/007</u>	<u>ESW Pump Building 2</u>	<u>Division 2</u>			
	<u>30SAQ03AA005/007</u>	<u>ESW Pump Building 3</u>	<u>Division 3</u>			
	<u>30SAQ04AA005/007</u>	<u>ESW Pump Building 4</u>	<u>Division 4</u>			
Temperature Sensors—Elec Heaters	<u>30SAQ01CT002/003</u>	<u>ESW Pump Building 1</u>	<u>Division 1</u>	<u>Yes</u>	<u>Temperature/</u> <u>Temperature</u>	<u>N/A</u>
	<u>30SAQ02CT002/003</u>	<u>ESW Pump Building 2</u>	<u>Division 2</u>			
	<u>30SAQ03CT002/003</u>	<u>ESW Pump Building 3</u>	<u>Division 3</u>			
	<u>30SAQ04CT002/003</u>	<u>ESW Pump Building 4</u>	<u>Division 4</u>			
Temperature Sensors—M.O. Outside Air Isol Dampers	<u>30SAQ01CT004</u>	<u>ESW Pump Building 1</u>	<u>Division 1</u>	<u>Yes</u>	<u>N/A</u>	<u>N/A</u>
	<u>30SAQ02CT004</u>	<u>ESW Pump Building 2</u>	<u>Division 2</u>			
	<u>30SAQ03CT004</u>	<u>ESW Pump Building 3</u>	<u>Division 3</u>			
	<u>30SAQ04CT004</u>	<u>ESW Pump Building 4</u>	<u>Division 4</u>			

1) Equipment tag numbers are provided for information only and are not part of the certified design.



**Table 2.6.13-3—Essential Service Water Pump Building Ventilation System ITAAC (3 Sheets)**

Commitment Wording	Inspections, Tests, Analyses	Acceptance Criteria
<p>6.1 The <u>safety-related</u> ESWPBVS provides <u>recirculation</u> cooling to maintain design temperatures in the Essential Service Water Pump Buildings, while operating in a design basis accident alignment.</p>	<p>a. An <del>inspection of the manufacturer's documentation of the ESWPBVS cooling coils</del> <u>analysis</u> will be performed.</p> <p>b. Tests and analysis of the ESWPBVS <u>safety-related</u> cooling units will be performed, <del>to verify that design temperatures in the hot mechanical rooms in the Essential Service Water Pump Buildings, while operating in a design basis accident alignment.</del></p>	<p>a. <del>A report confirms that each</del> <u>Each</u> ESWPBVS <u>safety-related</u> cooling coil is capable of providing design cooling requirements.</p> <p>b. <del>A report confirms that the</del> <u>The</u> <u>safety-related</u> ESWPBVS is capable of providing cooling to maintain design <u>temperatures in the hot mechanical rooms in the</u> Essential Service Water Pump Buildings, while operating in a design basis accident alignment. <del>A report confirms that each</del> <u>Each</u> ESWPBVS <u>safety-related</u> fan is capable of meeting the design air flow requirements, while operating in a design basis accident alignment.</p>

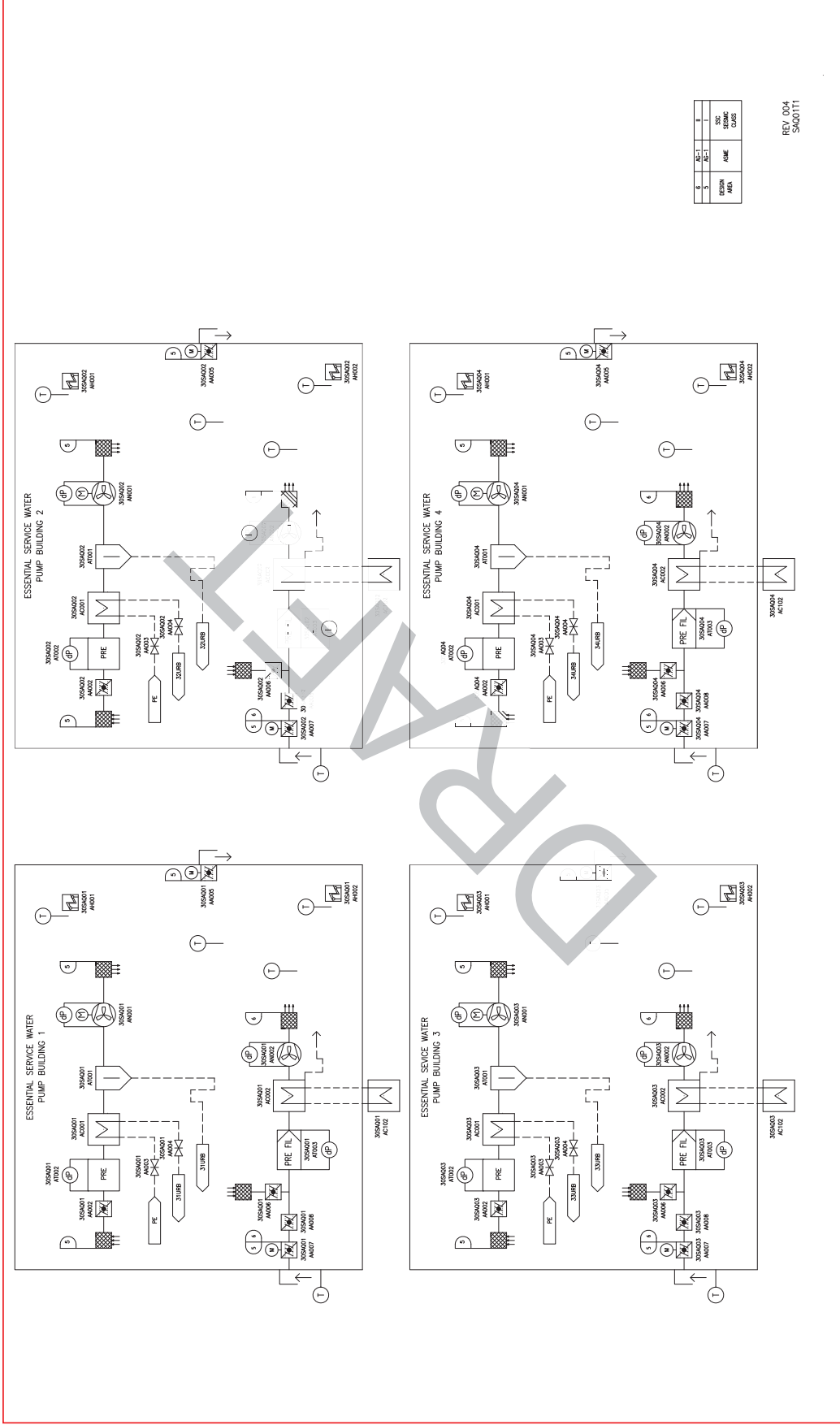
DRAFT

Next File



All indicated changes are in response to RAI 505, 07.01-35

Figure 2.6.13-1—Essential Service Water Pump Building Ventilation System Functional Arrangement



REV	NO.	DATE	BY	CHKD	DESCRIPTION
6	04-1				
5	04-1				

REV. 004  
5/4/07/11



Table 3.2.2-1—Classification Summary  
Sheet 164 of 194

KKS System or Component Code	SSC Description	Safety Classification (Note 15)	Quality Group Classification	Seismic Category (Note 16)	10 CFR 50 Appendix B Program (Note 5)	Location (Note 17)	Comments/ Commercial Code
30SAC05/08 AH002	Electric Heaters - Maintenance Train Supply Air	NS	N/A	NSC	No	1UJK, 4UJK	
30SAC01/02/03/04 AH002	Electric Heaters - Supply Air System	S	N/A	I	Yes	UJK	ASME AG-1 <sup>14</sup>
30SAC51/52/53/54 AN001	Exhaust Air Fans - Battery/SCWS Room Exhaust	S	N/A	I	Yes	UJK	ASME AG-1 <sup>14</sup>
30SAC51/54 AN002	Exhaust Air Fans - Maintenance Train Battery/SCWS Room Exhaust	NS	N/A	NSC	No	1UJK, 4UJK	
30SAC35/38 AN001	Exhaust Fan - Maintenance Train Exhaust Air	NS	N/A	NSC	No	1UJK, 4UJK	
30SAC31/32/33/35 AN001	Exhaust Fans - Exhaust Air System	S	N/A	I	Yes	UJK	ASME AG-1 <sup>14</sup>
<del>30SAC01/02/03/04 AH003/004</del>	<del>Humidifier Heaters—Supply Air System</del>	<del>S</del>	<del>N/A</del>	<del>I</del>	<del>Yes</del>	<del>UJK</del>	<del>ASME-AG-1<sup>14</sup></del>
<del>30SAC05/08 AC003/004</del>	<del>Humidifier Spray- Nozzles— Maintenance Train- Supply Air</del>	<del>NS</del>	<del>N/A</del>	<del>NSC</del>	<del>No</del>	<del>1UJK, 4UJK</del>	



Table 3.2.2-1—Classification Summary  
Sheet 165 of 194

KKS System or Component Code	SSC Description	Safety Classification (Note 15)	Quality Group Classification	Seismic Category (Note 16)	10 CFR 50 Appendix B Program (Note 5)	Location (Note 17)	Comments/ Commercial Code
<del>30SAC01/02/03/04 AT007/008</del>	<del>Humidifier Spray- Nozzles - Supply Air- System</del>	<del>S</del>	<del>N/A</del>	<del>I</del>	<del>Yes</del>	<del>UJK</del>	<del>ASME-AG-1<sup>14</sup></del>
<del>30SAC05/08-AH003/ 004</del>	<del>Humidifiers Heaters- -Maintenance Train- Supply Air</del>	<del>NS</del>	<del>N/A</del>	<del>NSG</del>	<del>No</del>	<del>1UJK, 4UJK</del>	
SAC	Maintenance Supply/ Exhaust Ducts	NS	N/A	NSC	No	UJK	
30SAC35/38 AA001/ 004	Manual Isolation Damper - Maintenance Train Exhaust Air	S	N/A	I	Yes	1UJK, 4UJK	ASME-AG-1 <sup>14</sup>
30SAC51/52/53/54 AA001	Manual Isolation Dampers - Battery/ SCWS Room Exhaust	S	N/A	I	Yes	UJK	ASME-AG-1 <sup>14</sup>
30SAC31/32/33/35 AA001/004	Manual Isolation Dampers - Exhaust Air System	S	N/A	I	Yes	UJK	ASME-AG-1 <sup>14</sup>
30SAC51/54 AA004	Manual Isolation Dampers - Maintenance Train Battery/SCWS Room Exhaust	S	N/A	I	Yes	1UJK, 4UJK	ASME-AG-1 <sup>14</sup>



Table 3.2.2-1—Classification Summary  
Sheet 176 of 194

KKS System or Component Code	SSC Description	Safety Classification (Note 15)	Quality Group Classification	Seismic Category (Note 16)	10 CFR 50 Appendix B Program (Note 5)	Location (Note 17)	Comments/ Commercial Code
30KLC51/52/53/54 AN002	Recirculation Fans	S	N/A	I	Yes	UJH	ASME AG-1 <sup>14</sup>
30KLC51/54 AN003	Recirculation Fans	S	N/A	I	Yes	UJH	ASME AG-1 <sup>14</sup>
30KLC12 AH001	Room Heater	NS	N/A	NSC	No	UJH	
30KLC11/14 AH001/002	Room Heaters	NS	N/A	NSC	No	UJH	
30KLC12/13 AH002-006	Room Heaters	NS	N/A	NSC	No	UJH	
<b>SAD</b>	<del>Emergency Power-Generating-Building-Ventilation-System</del>	<del>S</del>	<del>N/A</del>	<del>I</del>	<del>Yes</del>	<del>UBP</del>	<del>ASME-AG-1<sup>14</sup></del>
<b>SAG</b>	<del>Essential Service-Water-Pump-Building-Ventilation-System</del>	<del>S</del>	<del>N/A</del>	<del>I</del>	<del>Yes</del>	<del>URB</del>	<del>ASME-AG-1<sup>14</sup></del>
<b>SAD</b>	<u>Emergency Power Generating Building Ventilation System</u>						
<u>30SAD11/21/31/41-AA001/AA002</u>	<u>Back Draft Dampers</u>	<u>S</u>	<u>N/A</u>	<u>I</u>	<u>Yes</u>	<u>UBP</u>	<u>ASME AG-1<sup>14</sup></u>
<u>30SAD11/21/31/41-AA003</u>	<u>Back Draft Dampers</u>	<u>NS-AQ</u>	<u>N/A</u>	<u>II</u>	<u>Yes</u>	<u>UBP</u>	<u>ASME AG-1<sup>14</sup></u>



Table 3.2.2-1—Classification Summary  
Sheet 177 of 194

KKS System or Component Code	SSC Description	Safety Classification (Note 15)	Quality Group Classification	Seismic Category (Note 16)	10 CFR 50 Appendix B Program (Note 5)	Location (Note 17)	Comments/Commercial Code
<u>30SAD15/25/35/45-AA001/AA002</u>	<u>Back Draft Dampers</u>	<u>S</u>	<u>N/A</u>	<u>I</u>	<u>Yes</u>	<u>UBP</u>	<u>ASME_AG-1<sup>14</sup></u>
<u>30SAD15/25/35/45-AA003</u>	<u>Back Draft Dampers</u>	<u>NS-AQ</u>	<u>N/A</u>	<u>II</u>	<u>Yes</u>	<u>UBP</u>	<u>ASME_AG-1<sup>14</sup></u>
<u>30SAD13/23/33/43-AA010</u>	<u>Back Draft Dampers</u>	<u>S</u>	<u>N/A</u>	<u>I</u>	<u>Yes</u>	<u>UBP</u>	<u>ASME_AG-1<sup>14</sup></u>
<u>30SAD16/26/36/46-AA001/AA005</u>	<u>Back Draft Dampers</u>	<u>S</u>	<u>N/A</u>	<u>I</u>	<u>Yes</u>	<u>UBP</u>	<u>ASME_AG-1<sup>14</sup></u>
<u>30SAD11/21/31/41-AT001/AT002</u>	<u>Pre-filters</u>	<u>S</u>	<u>N/A</u>	<u>I</u>	<u>Yes</u>	<u>UBP</u>	<u>ASME_AG-1<sup>14</sup></u>
<u>30SAD11/21/31/41-AT003</u>	<u>Pre-filters</u>	<u>NS-AQ</u>	<u>N/A</u>	<u>II</u>	<u>Yes</u>	<u>UBP</u>	<u>ASME_AG-1<sup>14</sup></u>
<u>30SAD13/23/33/43-AT001</u>	<u>Pre-filters</u>	<u>S</u>	<u>N/A</u>	<u>I</u>	<u>Yes</u>	<u>UBP</u>	<u>ASME_AG-1<sup>14</sup></u>
<u>30SAD13/23/33/43-AT003</u>	<u>Pre-filters</u>	<u>NS-AQ</u>	<u>N/A</u>	<u>II</u>	<u>Yes</u>	<u>UBP</u>	<u>ASME_AG-1<sup>14</sup></u>
<u>30SAD11/21/31/41-AN001/AN002</u>	<u>Supply Air Fans</u>	<u>S</u>	<u>N/A</u>	<u>I</u>	<u>Yes</u>	<u>UBP</u>	<u>ASME_AG-1<sup>14</sup></u>
<u>30SAD11/21/31/41-AN003</u>	<u>Supply Air Fans</u>	<u>NS-AQ</u>	<u>N/A</u>	<u>II</u>	<u>Yes</u>	<u>UBP</u>	<u>ASME_AG-1<sup>14</sup></u>
<u>30SAD13/23/33/43-AN001</u>	<u>Supply Air Fans</u>	<u>S</u>	<u>N/A</u>	<u>I</u>	<u>Yes</u>	<u>UBP</u>	<u>ASME_AG-1<sup>14</sup></u>
<u>30SAD13/23/33/43-AN002</u>	<u>Supply Air Fans</u>	<u>NS-AQ</u>	<u>N/A</u>	<u>II</u>	<u>Yes</u>	<u>UBP</u>	<u>ASME_AG-1<sup>14</sup></u>



Table 3.2.2-1—Classification Summary  
Sheet 178 of 194

KKS System or Component Code	SSC Description	Safety Classification (Note 15)	Quality Group Classification	Seismic Category (Note 16)	10 CFR 50 Appendix B Program (Note 5)	Location (Note 17)	Comments/Commercial Code
<u>30SAD11/21/31/41-AA004</u>	<u>Motor Operated Dampers</u>	<u>S</u>	<u>N/A</u>	<u>I</u>	<u>Yes</u>	<u>UBP</u>	<u>ASME_AG-1<sup>14</sup></u>
<u>30SAD15/25/35/45-AA004</u>	<u>Motor Operated Dampers</u>	<u>S</u>	<u>N/A</u>	<u>I</u>	<u>Yes</u>	<u>UBP</u>	<u>ASME_AG-1<sup>14</sup></u>
<u>30SAD13/23/33/43-AA007</u>	<u>Motor Operated Dampers</u>	<u>S</u>	<u>N/A</u>	<u>I</u>	<u>Yes</u>	<u>UBP</u>	<u>ASME_AG-1<sup>14</sup></u>
<u>30SAD16/26/36/46-AA007/AA008</u>	<u>Motor Operated Dampers</u>	<u>S</u>	<u>N/A</u>	<u>I</u>	<u>Yes</u>	<u>UBP</u>	<u>ASME_AG-1<sup>14</sup></u>
<u>30SAD11/21/31/41-AA005</u>	<u>Manual Dampers</u>	<u>NS-AQ</u>	<u>N/A</u>	<u>II</u>	<u>Yes</u>	<u>UBP</u>	<u>ASME_AG-1<sup>14</sup></u>
<u>30SAD12/22/32/42-AA001/AA002/AA003/AA004/AA005</u>	<u>Manual Dampers</u>	<u>S</u>	<u>N/A</u>	<u>I</u>	<u>Yes</u>	<u>UBP</u>	<u>ASME_AG-1<sup>14</sup></u>
<u>30SAD13/23/33/43-AA002</u>	<u>Manual Dampers</u>	<u>S</u>	<u>N/A</u>	<u>I</u>	<u>Yes</u>	<u>UBP</u>	<u>ASME_AG-1<sup>14</sup></u>
<u>30SAD13/23/33/43-AA008/AA009</u>	<u>Manual Dampers</u>	<u>NS-AQ</u>	<u>N/A</u>	<u>II</u>	<u>Yes</u>	<u>UBP</u>	<u>ASME_AG-1<sup>14</sup></u>
<u>30SAD16/26/36/46-AA003/AA004</u>	<u>Manual Dampers</u>	<u>S</u>	<u>N/A</u>	<u>I</u>	<u>Yes</u>	<u>UBP</u>	<u>ASME_AG-1<sup>14</sup></u>
<u>30SAD15/25/35/45-AN001/AN002</u>	<u>Exhaust Fans</u>	<u>S</u>	<u>N/A</u>	<u>I</u>	<u>Yes</u>	<u>UBP</u>	<u>ASME_AG-1<sup>14</sup></u>
<u>30SAD15/25/35/45-AN003</u>	<u>Exhaust Fans</u>	<u>NS-AQ</u>	<u>N/A</u>	<u>II</u>	<u>Yes</u>	<u>UBP</u>	<u>ASME_AG-1<sup>14</sup></u>



Table 3.2.2-1—Classification Summary  
Sheet 179 of 194

KKS System or Component Code	SSC Description	Safety Classification (Note 15)	Quality Group Classification	Seismic Category (Note 16)	10 CFR 50 Appendix B Program (Note 5)	Location (Note 17)	Comments/ Commercial Code
<del>30SAD16/26/36/46-AN001</del>	<u>Exhaust Fans</u>	<u>S</u>	<u>N/A</u>	<u>I</u>	<u>Yes</u>	<u>UBP</u>	<u>ASME_AG-1<sup>14</sup></u>
<del>30SAD13/23/33/43-AT002</del>	<u>HEPA filters</u>	<u>S</u>	<u>N/A</u>	<u>I</u>	<u>Yes</u>	<u>UBP</u>	<u>ASME_AG-1<sup>14</sup></u>
<del>30SAD13/23/33/43-AC001</del>	<u>Cooling Coils</u>	<u>S</u>	<u>C</u>	<u>I</u>	<u>Yes</u>	<u>UBP</u>	<u>ASME_AG-1<sup>14</sup></u> <u>ASME Class 3</u>
<del>30SAD13/23/33/43-AC002/AC102</del>	<u>Cooling Coils</u>	<u>NS-AQ</u>	<u>D</u>	<u>II</u>	<u>Yes</u>	<u>UBP</u>	<u>ASME_AG-1<sup>14</sup></u>
<del>30SAD13/23/33/43-AT003</del>	<u>Moisture Separators</u>	<u>S</u>	<u>N/A</u>	<u>I</u>	<u>Yes</u>	<u>UBP</u>	<u>ASME_AG-1<sup>14</sup></u>
<del>30SAD16/26/36/46-AH001</del>	<u>Electric Heaters</u>	<u>S</u>	<u>N/A</u>	<u>I</u>	<u>Yes</u>	<u>UBP</u>	<u>ASME_AG-1<sup>14</sup></u>
<del>30SAD14/24/34/44-AH001/AH002/AH003/AH004</del>	<u>Fan Heaters</u>	<u>NS-AQ</u>	<u>N/A</u>	<u>II</u>	<u>Yes</u>	<u>UBP</u>	<u>ASME_AG-1<sup>14</sup></u>
<del>30SAD13/23/33/43-AA004/AA005</del>	<u>Fire Dampers</u>	<u>S</u>	<u>N/A</u>	<u>I</u>	<u>Yes</u>	<u>UBP</u>	<u>ASME_AG-1<sup>14</sup></u>
<del>30SAD16/26/36/46-AA002</del>	<u>Fire Dampers</u>	<u>S</u>	<u>N/A</u>	<u>I</u>	<u>Yes</u>	<u>UBP</u>	<u>ASME_AG-1<sup>14</sup></u>
<b>SAQ</b>	<b><u>Essential Service Water Pump Building Ventilation System</u></b>						
<del>30SAQ01/02/03/04-AA003/004</del>	<u>Cooling Coil Isolation Valves</u>	<u>S</u>	<u>C</u>	<u>I</u>	<u>Yes</u>	<u>URB</u>	<u>ASME Class 3<sup>3</sup></u>
<del>SAQ</del>	<u>Balance-of-SAQ System</u>	<u>S</u>	<u>N/A</u>	<u>I</u>	<u>Yes</u>	<u>URB</u>	<u>ASME_AG-1<sup>14</sup></u>



Table 3.2.2-1—Classification Summary  
Sheet 180 of 194

KKS System or Component Code	SSC Description	Safety Classification (Note 15)	Quality Group Classification	Seismic Category (Note 16)	10 CFR 50 Appendix B Program (Note 5)	Location (Note 17)	Comments/ Commercial Code
<u>30SAQ01/02/03/04AC001</u>	<u>Air Cooling Coil</u>	<u>S</u>	<u>C</u>	<u>I</u>	<u>Yes</u>	<u>URB</u>	<u>ASME_AG-1</u> <u>ASME Class 3</u>
<u>30SAQ01/02/03/04AA002</u>	<u>Recirc Chiller Balancing Dampet</u>	<u>S</u>	<u>N/A</u>	<u>I</u>	<u>Yes</u>	<u>URB</u>	<u>ASME_AG-1<sup>14</sup></u>
<u>30SAQ01/02/03/04AT002</u>	<u>Recirc Chiller Prefilter</u>	<u>S</u>	<u>N/A</u>	<u>I</u>	<u>Yes</u>	<u>URB</u>	<u>ASME_AG-1<sup>14</sup></u>
<u>30SAQ01/02/03/04AN001</u>	<u>Recirc Fan</u>	<u>S</u>	<u>N/A</u>	<u>I</u>	<u>Yes</u>	<u>URB</u>	<u>ASME_AG-1<sup>14</sup></u>
<u>30SAQ01/02/03/04AT001</u>	<u>Recirc Chiller Moisture Separator</u>	<u>S</u>	<u>N/A</u>	<u>I</u>	<u>Yes</u>	<u>URB</u>	<u>ASME_AG-1<sup>14</sup></u>
<u>30SAQ01/02/03/04AH001/002</u>	<u>Room Electric Air Heaters</u>	<u>S</u>	<u>N/A</u>	<u>I</u>	<u>Yes</u>	<u>URB</u>	<u>ASME_AG-1<sup>14</sup></u>
<u>30SAQ01/02/03/04AA007/005</u>	<u>Inlet/Exhaust Air Isolation Dampers</u>	<u>S</u>	<u>N/A</u>	<u>I</u>	<u>Yes</u>	<u>URB</u>	<u>ASME_AG-1<sup>14</sup></u>
<u>30SAQ01/02/03/04AA008/006</u>	<u>Split Cooler Balancing Dampers</u>	<u>NS-AQ</u>	<u>N/A</u>	<u>II</u>	<u>Yes</u>	<u>URB</u>	<u>ASME_AG-1<sup>14</sup></u>
<u>30SAQ01/02/03/04AT003</u>	<u>Split Cooler Prefilter</u>	<u>NS-AQ</u>	<u>N/A</u>	<u>II</u>	<u>Yes</u>	<u>URB</u>	<u>ASME_AG-1<sup>14</sup></u>
<u>30SAQ01/02/03/04AC002</u>	<u>Split Cooler Chiller Unit</u>	<u>NS-AQ</u>	<u>D</u>	<u>II</u>	<u>Yes</u>	<u>URB</u>	<u>ASME_AG-1<sup>14</sup></u> <u>ASME Class 3</u>
<u>30SAQ01/02/03/04AC102</u>	<u>Split Cooler Cooling Unit</u>	<u>NS-AQ</u>	<u>D</u>	<u>II</u>	<u>Yes</u>	<u>URB</u>	<u>ASME_AG-1<sup>14</sup></u> <u>ASME Class 3</u>
<u>30SAQ01/02/03/04AN002</u>	<u>Split Cooler Fan</u>	<u>NS-AQ</u>	<u>N/A</u>	<u>II</u>	<u>Yes</u>	<u>URB</u>	<u>ASME_AG-1<sup>14</sup></u>





**Table 3.10-1—List of Seismically and Dynamically Qualified Mechanical and Electrical Equipment  
Sheet 166 of 200**

Name Tag (Equipment Description)	Tag Number	Local Area		EQ Environment (Note 1)	Radiation Environment Zone (Note 2)	EQ Designated Function (Note 3)	Safety Class (Note 4)	EQ Program Designation (Note 5)
		KKS ID (Room Location)	Room Location					
Sep Recirc Unit, JMU Rm, SG1	30KLC51AT003	31UJH10010		M	H	SI	S	Y (3)
Chiller Recirc Unit, KLC SG2	30KLC52AC001	32UJH05002		M	H	SI	S	Y (5)
Chiller Recirc Unit, Viv Rm, KLC SG2	30KLC52AC002	32UJH10002		M	H	SI	S	Y (5)
Fan Recirc Unit, KLC SG2	30KLC52AN001	32UJH05002		M	H	SI	S	Y (5)
Fan Recirc Unit, Viv Rm, KLC SG2	30KLC52AN002	32UJH10002		M	H	SI	S	Y (5)
Sep Recirc Unit, Viv Rm, KLC SG2	30KLC52AT001	32UJH05002		M	H	SI	S	Y (5)
Sep Recirc Unit, Viv Rm, KLC SG2	30KLC52AT002	32UJH10002		M	H	SI	S	Y (5)
Chiller Recirc Unit, KLC SG3	30KLC53AC001	33UJH05002		M	H	SI	S	Y (5)
Chiller Recirc Unit, Viv Rm, KLC SG3	30KLC53AC002	33UJH10002		M	H	SI	S	Y (5)
Fan Recirc Unit, KLC SG3	30KLC53AN001	33UJH05002		M	H	SI	S	Y (5)
Fan Recirc Unit, Viv Rm, KLC SG3	30KLC53AN002	33UJH10002		M	H	SI	S	Y (5)
Sep Recirc Unit, Viv Rm, KLC SG3	30KLC53AT001	33UJH05002		M	H	SI	S	Y (5)
Sep Recirc Unit, Viv Rm, KLC SG3	30KLC53AT002	33UJH10002		M	H	SI	S	Y (5)
Chiller Recirc Unit, KLC SG4	30KLC54AC001	34UJH05004		M	H	SI	S	Y (5)
Chiller Recirc Unit, KAA Viv Rm, SG4	30KLC54AC002	34UJH10004		M	H	SI	S	Y (5)
Chiller Recirc Unit, JMU Rm, SG4	30KLC54AC003	34UJH10010		M	H	SI	S	Y (5)
Fan Recirc Unit, KLC SG4	30KLC54AN001	34UJH05004		M	H	SI	S	Y (5)
Fan Recirc Unit, KAA Viv Rm, SG4	30KLC54AN002	34UJH10004		M	H	SI	S	Y (5)
Fan Recirc Unit, JMU Rm, SG4	30KLC54AN003	34UJH10010		M	H	SI	S	Y (5)
Sep Recirc Unit, KLC SG4	30KLC54AT001	34UJH05004		M	H	SI	S	Y (5)
Sep Recirc Unit, KAA Viv Rm, SG4	30KLC54AT002	34UJH10004		M	H	SI	S	Y (5)
<b>Nuclear Auxiliary Building Ventilation System (NABVS)</b>								
<u>Exhaust Air Backdraft Damper</u>	<u>30KLE50AA001</u>	<u>30UFA34075</u>		<u>M</u>	<u>M</u>	<u>SI</u>	<u>S</u>	<u>Y (5)</u>
<b>Electrical Division of Safeguard Building Ventilation System (SBVSE)</b>								
Outside Air Isolation Damper	30SAC01AA002	31UJK22026		M	M	SI	S	Y (5)
Outside Air Control Damper	30SAC01AA003	31UJK22026		M	M	SI	S	Y (5)
Recirc Air Control Damper	30SAC01AA004	31UJK22028		M	M	SI	S	Y (5)
Supply Air Backdraft Damper	30SAC01AA005	31UJK22026		M	M	SI	S	Y (5)
Supply Air Cooler	30SAC01AC001	31UJK22026		M	M	SI	S	Y (5)
Supply Air Heater	30SAC01AH002	31UJK22026		M	M	SI	S	Y (5)
<del>Exhaust Air Backdraft Damper-KLE</del>	<del>30KLE50AA001</del>	<del>30UFA34075</del>		<del>M</del>	<del>M</del>	<del>SI</del>	<del>S</del>	<del>Y (5)</del>
<del>Humidifier-Heater</del>	<del>30SAC01AH003</del>	<del>31UJK22026</del>		<del>M</del>	<del>M</del>	<del>SH</del>	<del>NS-AQ</del>	<del>Y (5)</del>



**Table 3.10-1—List of Seismically and Dynamically Qualified Mechanical and Electrical Equipment  
Sheet 167 of 200**

Name Tag (Equipment Description)	Tag Number	Local Area			Radiation Environment Zone (Note 2)	EQ Designated Function (Note 3)	Safety Class (Note 4)	EQ Program Designation (Note 5)
		KKS ID (Room Location)	EQ Environment (Note 1)	EQ Environment Zone (Note 2)				
<del>Humidifier Heater</del>	<del>30SAC01AH004</del>	<del>31UJK22026</del>	<del>M</del>	<del>M</del>	<del>SH</del>	<del>NS-AQ</del>	<del>Y (5)</del>	
Fan Motor Heater	30SAC01AH501	31UJK22026	M	M	SI	S	Y (5)	
Supply Air Fan	30SAC01AN001	31UJK22026	M	M	SI	S	Y (5)	
Air Inlet Outside Air	30SAC01AT001	31UJK22026	M	M	SI	S	Y (5)	
Insect Screen Supply Air	30SAC01AT003	31UJK22026	M	M	SI	S	Y (5)	
Supply Air Pre Filter	30SAC01AT004	31UJK22026	M	M	SI	S	Y (5)	
Supply Air Roughing Filter	30SAC01AT005	31UJK22026	M	M	SI	S	Y (5)	
Moisture Separator Supply Air Cooler	30SAC01AT006	31UJK22026	M	M	SI	S	Y (5)	
<del>Supply Air Humidifier</del>	<del>30SAC01AT007</del>	<del>31UJK22026</del>	<del>M</del>	<del>M</del>	<del>SH</del>	<del>NS-AQ</del>	<del>Y (5)</del>	
<del>Supply Air Humidifier</del>	<del>30SAC01AT008</del>	<del>31UJK22026</del>	<del>M</del>	<del>M</del>	<del>SH</del>	<del>NS-AQ</del>	<del>Y (5)</del>	
Supply Air Silencer	30SAC01BS001	31UJK22026	M	M	SI	S	Y (5)	
Supply Air Silencer	30SAC01BS002	31UJK22026	M	M	SI	S	Y (5)	
Recirc Air Silencer	30SAC01BS003	31UJK22039	M	M	SI	S	Y (5)	
Outside Air Isolation Damper	30SAC02AA002	32UJK34005	M	M	SI	S	Y (5)	
Outside Air Control Damper	30SAC02AA003	32UJK34005	M	M	SI	S	Y (5)	
Recirc Air Control Damper	30SAC02AA004	32UJK31032	M	M	SI	S	Y (5)	
Supply Air Backdraft Damper	30SAC02AA005	32UJK31007	M	M	SI	S	Y (5)	
Supply Air Cooler	30SAC02AC001	32UJK34009	M	M	SI	S	Y (5)	
Supply Air Heater	30SAC02AH002	32UJK34008	M	M	SI	S	Y (5)	
Humidifier Heater	30SAC02AH003	32UJK31005	M	M	SII	NS-AQ	Y (5)	
Humidifier Heater	30SAC02AH004	32UJK31005	M	M	SII	NS-AQ	Y (5)	
Fan Motor Heater	30SAC02AH501	32UJK31007	M	M	SI	S	Y (5)	
Supply Air Fan	30SAC02AN001	32UJK31007	M	M	SI	S	Y (5)	
Air Inlet Outside Air	30SAC02AT001	32UJK38006	M	M	SI	S	Y (5)	
Insect Screen Supply Air	30SAC02AT003	32UJK38006	M	M	SI	S	Y (5)	
Supply Air Pre Filter	30SAC02AT004	32UJK34006	M	M	SI	S	Y (5)	
Supply Air Roughing Filter	30SAC02AT005	32UJK34007	M	M	SI	S	Y (5)	
Moisture Separator Supply Air Cooler	30SAC02AT006	32UJK34009	M	M	SI	S	Y (5)	
<del>Supply Air Humidifier</del>	<del>30SAC02AT007</del>	<del>32UJK34005</del>	<del>M</del>	<del>M</del>	<del>SH</del>	<del>NS-AQ</del>	<del>Y (5)</del>	
<del>Supply Air Humidifier</del>	<del>30SAC02AT008</del>	<del>32UJK34005</del>	<del>M</del>	<del>M</del>	<del>SH</del>	<del>NS-AQ</del>	<del>Y (5)</del>	
Air Inlet Outside Air	30SAC02AT010	32UJK38006	M	M	SI	S	Y (5)	
Supply Air Silencer	30SAC02BS001	32UJK31007	M	M	SI	S	Y (5)	
Supply Air Silencer	30SAC02BS002	32UJK31007	M	M	SI	S	Y (5)	



**Table 3.10-1—List of Seismically and Dynamically Qualified Mechanical and Electrical Equipment**  
**Sheet 168 of 200**

Name Tag (Equipment Description)	Tag Number	Local Area			Radiation Environment Zone (Note 2)	EQ Designated Function (Note 3)	Safety Class (Note 4)	EQ Program Designation (Note 5)
		KKS ID (Room Location)	EQ Environment (Note 1)	EQ Environment Zone (Note 2)				
Recirc Air Silencer	30SAC02BS003	32UJK31032	M	M	SI	S	Y (5)	
Outside Air Isolation Damper	30SAC03AA002	33UJK34005	M	M	SI	S	Y (5)	
Outside Air Control Damper	30SAC03AA003	33UJK34005	M	M	SI	S	Y (5)	
Recirc Air Control Damper	30SAC03AA004	33UJK31032	M	M	SI	S	Y (5)	
Supply Air Backdraft Damper	30SAC03AA005	33UJK31007	M	M	SI	S	Y (5)	
Supply Air Cooler	30SAC03AC001	33UJK34009	M	M	SI	S	Y (5)	
Supply Air Heater	30SAC03AH002	33UJK34008	M	M	SI	S	Y (5)	
<del>Humidifier-Heater</del>	<del>30SAC03AH003</del>	<del>33UJK34005</del>	<del>M</del>	<del>M</del>	<del>SH</del>	<del>NS-AQ</del>	<del>Y (5)</del>	
<del>Humidifier-Heater</del>	<del>30SAC03AH004</del>	<del>33UJK34005</del>	<del>M</del>	<del>M</del>	<del>SH</del>	<del>NS-AQ</del>	<del>Y (5)</del>	
Fan Motor Heater	30SAC03AH501	33UJK31007	M	M	SI	S	Y (5)	
Supply Air Fan	30SAC03AN001	33UJK31007	M	M	SI	S	Y (5)	
Air Inlet Outside Air	30SAC03AT001	33UJK38006	M	M	SI	S	Y (5)	
Insect Screen Supply Air	30SAC03AT003	33UJK38006	M	M	SI	S	Y (5)	
Supply Air Pre Filter	30SAC03AT004	33UJK34006	M	M	SI	S	Y (5)	
Supply Air Roughing Filter	30SAC03AT005	33UJK34007	M	M	SI	S	Y (5)	
Moisture Separator Supply Air Cooler	30SAC03AT006	33UJK34009	M	M	SI	S	Y (5)	
<del>Supply Air Humidifier</del>	<del>30SAC03AT008</del>	<del>33UJK34005</del>	<del>M</del>	<del>M</del>	<del>SH</del>	<del>NS-AQ</del>	<del>Y (5)</del>	
Supply Air Silencer	30SAC03BS001	33UJK31007	M	M	SI	S	Y (5)	
Supply Air Silencer	30SAC03BS002	33UJK31007	M	M	SI	S	Y (5)	
Recirc Air Silencer	30SAC03BS003	33UJK31032	M	M	SI	S	Y (5)	
Outside Air Isolation Damper	30SAC04AA002	34UJK22026	M	M	SI	S	Y (5)	
Outside Air Control Damper	30SAC04AA003	34UJK22026	M	M	SI	S	Y (5)	
Recirc Air Control Damper	30SAC04AA004	34UJK22026	M	M	SI	S	Y (5)	
Supply Air Backdraft Damper	30SAC04AC001	34UJK22026	M	M	SI	S	Y (5)	
Supply Air Cooler	30SAC04AC002	34UJK22026	M	M	SI	S	Y (5)	
Supply Air Heater	30SAC04AH002	34UJK22026	M	M	SI	S	Y (5)	
<del>Humidifier-Heater</del>	<del>30SAC04AH003</del>	<del>34UJK22026</del>	<del>M</del>	<del>M</del>	<del>SH</del>	<del>NS-AQ</del>	<del>Y (5)</del>	
<del>Humidifier-Heater</del>	<del>30SAC04AH004</del>	<del>34UJK22026</del>	<del>M</del>	<del>M</del>	<del>SH</del>	<del>NS-AQ</del>	<del>Y (5)</del>	
Fan Motor Heater	30SAC04AH501	34UJK22026	M	M	SI	S	Y (5)	
Supply Air Fan	30SAC04AN001	34UJK22026	M	M	SI	S	Y (5)	
Air Inlet Outside Air	30SAC04AT001	34UJK22026	M	M	SI	S	Y (5)	
Insect Screen Supply Air	30SAC04AT003	34UJK22026	M	M	SI	S	Y (5)	
Supply Air Pre Filter	30SAC04AT004	34UJK22026	M	M	SI	S	Y (5)	



**Table 3.10-1—List of Seismically and Dynamically Qualified Mechanical and Electrical Equipment**  
**Sheet 169 of 200**

Name Tag (Equipment Description)	Tag Number	Local Area			Radiation Environment Zone (Note 2)	EQ Designated Function (Note 3)	Safety Class (Note 4)	EQ Program Designation (Note 5)
		KKS ID (Room Location)	EQ Environment (Note 1)	EQ Environment Zone (Note 2)				
Supply Air Roughing Filter	30SAC04AT005	34UJK22026	M	M	SI	S	Y (5)	
Moisture Separator Supply Air Cooler	30SAC04AT006	34UJK22026	M	M	SI	S	Y (5)	
<del>Supply Air Humidifier</del>	<del>30SAC04AT007</del>	<del>34UJK22026</del>	<del>M</del>	<del>M</del>	<del>SH</del>	<del>MS-AQ</del>	<del>Y (5)</del>	
<del>Supply Air Humidifier</del>	<del>30SAC04AT008</del>	<del>34UJK22026</del>	<del>M</del>	<del>M</del>	<del>SH</del>	<del>MS-AQ</del>	<del>Y (5)</del>	
Supply Air Silencer	30SAC04BS001	34UJK22026	M	M	SI	S	Y (5)	
Supply Air Silencer	30SAC04BS002	34UJK22026	M	M	SI	S	Y (5)	
Recirc Air Silencer	30SAC04BS003	34UJK22039	M	M	SI	S	Y (5)	
Isolation Damper	30SAC05A002	31UJK22026	M	M	SI	S	Y (5)	
Isolation Damper	30SAC08A002	31UKJ22026	M	M	SI	S	Y (5)	
Supply Air Isolation Damper	30SAC11AA001	31UJK22024	M	M	SI	S	Y (5)	
Supply Air Isolation Damper	30SAC11AA003	31UJK22024	M	M	SI	S	Y (5)	
Supply Air Adjustable Damper	30SAC11AA004	31UJK22026	M	M	SI	S	Y (5)	
Supply Air Adjustable Damper	30SAC11AA005	31UJK22026	M	M	SI	S	Y (5)	
Supply Air Adjustable Damper	30SAC11AA006	31UJK22024	M	M	SI	S	Y (5)	
Supply Air Adjustable Damper	30SAC11AA007	31UJK22024	M	M	SI	S	Y (5)	
Fire Damper	30SAC11AA008	31UJK22024	M	M	SI	S	Y (5)	
Fire Damper	30SAC11AA009	31UJK31027	M	M	SI	S	Y (5)	
Fire Damper	30SAC11AA010	31UJK34024	M	M	SI	S	Y (5)	
Fire Damper	30SAC11AA011	31UJK18033	M	M	SI	S	Y (5)	
Fire Damper	30SAC11AA012	31UJK18033	M	M	SI	S	Y (5)	
Supply Air Adjustable Damper	30SAC11AA013	31UJK18026	M	M	SI	S	Y (5)	
Supply Air Adjustable Damper	30SAC11AA014	31UJK18026	M	M	SI	S	Y (5)	
Fire Damper	30SAC11AA015	31UJK18033	M	M	SI	S	Y (5)	
Fire Damper	30SAC11AA016	31UJK18022	M	M	SI	S	Y (5)	
Fire Damper	30SAC11AA017	31UJK18022	M	M	SI	S	Y (5)	
Supply Air Adjustable Damper	30SAC11AA018	31UJK18027	M	M	SI	S	Y (5)	
Fire Damper	30SAC11AA019	31UJK18024	M	M	SI	S	Y (5)	
Supply Air Adjustable Damper	30SAC11AA020	31UJK18027	M	M	SI	S	Y (5)	
Fire Damper	30SAC11AA021	31UJK18027	M	M	SI	S	Y (5)	
Fire Damper	30SAC11AA022	31UJK14033	M	M	SI	S	Y (5)	
Supply Air Adjustable Damper	30SAC11AA023	31UJK14025	M	M	SI	S	Y (5)	
Fire Damper	30SAC11AA024	31UJK14022	M	M	SI	S	Y (5)	
Supply Air Adjustable Damper	30SAC11AA025	31UJK14026	M	M	SI	S	Y (5)	



**Table 3.10-1—List of Seismically and Dynamically Qualified Mechanical and Electrical Equipment**  
Sheet 186 of 200

Name Tag (Equipment Description)	Local Area		EQ Environment (Note 1)	Radiation Environment Zone (Note 2)	EQ Designated Function (Note 3)	Safety Class (Note 4)	EQ Program Designation (Note 5)
	Tag Number	KKS ID (Room Location)					
TechSupport Exhaust Balancing Damp	30SAB42AA012	33UJK26006	M	M	SI	C/NM	Y (5)
TechSupport Exhaust Fire Damper	30SAB42AA013	33UJK26006	M	M	SI	C/NM	Y (5)
I&CServ/SpecialUse Exhaust Balanc Damp	30SAB42AA014	33UJK26044	M	M	SI	C/NM	Y (5)
I&CServ/SpecialUse Exhaust Fire Damp	30SAB42AA015	33UJK26044	M	M	SI	C/NM	Y (5)
Tag/ShiftOffice Exhaust Balancing Damp	30SAB42AA016	32UJK26029	M	M	SI	C/NM	Y (5)
Tag/ShiftOffice Exhaust Fire Damper	30SAB42AA017	32UJK26029	M	M	SI	C/NM	Y (5)
Exhaust Air Fire Damper	30SAB45AA001	32UJK31020	M	M	SI	C/NM	Y (5)
Exhaust Air Isolation Damper - A	30SAB45AA003	32UJK31020	M	M	SI	C/NM	Y (5)
Exhaust Air Isolation Damper - B	30SAB45AA004	32UJK31020	M	M	SI	C/NM	Y (5)
Exhaust Air Balancing Damper	30SAB45AA005	32UJK31020	M	M	SII	NS-AQ	Y (5)
Exhaust Air Back-flow Damper	30SAB45AA006	32UJK31020	M	M	SII	NS-AQ	Y (5)
Restrooms Exhaust Air Fire Damper	30SAB45AA008	32UJK26020	M	M	SI	C/NM	Y (5)
Kitchen Exhaust Fire Damper	30SAB45AA009	33UJK26033	M	M	SI	C/NM	Y (5)
Exhaust Fan	30SAB45AN001	32UJK31020	M	M	SII	C/NM	Y (5)
Exhaust Fan Silencer	30SAB45B5001	32UJK31020	M	M	SII	NS-AQ	Y (5)
<b>Essential Service Water Pump Building Ventilation System (ESWPBVS)</b>							
<del>Elec-Eq-Area-Sup-Damper-Bldg 1</del>	<del>30SAQ01AA004</del>	<del>31UQB02001</del>	<del>M</del>	<del>M</del>	<del>SI</del>	<del>C/NM</del>	<del>Y (5)</del>
<del>ESW-Pump-Area-Sup-Recirc Chiller Balancing Dmpr Bldg 1</del>	30SAQ01AA002	31UQB02001	M	M	SI	C/NM	Y (5)
Plug Valve Chiller Cold Leg Bldg 1	30SAQ01AA003	31UQB02001	M	M	SI	C/NM	Y (5)
Plug Valve Chiller Hot Leg Bldg 1	30SAQ01AA004	31UQB02001	M	M	SI	C/NM	Y (5)
<u>Recirc Chiller Prefilter Bldg 1</u>	<u>30SAQ01AT002</u>	<u>31UQB02001</u>	<u>M</u>	<u>M</u>	<u>SI</u>	<u>C/NM</u>	<u>Y (5)</u>
Recirc Chiller Bldg 1	30SAQ01AC001	31UQB02001	M	M	SI	C/NM	Y (5)
Elec Room Air Heater Bldg 1	30SAQ01AH001	31UQB02001	M	M	SI	C/NM	Y (5)
<u>Elec Room Air Heater Bldg 1</u>	<u>30SAQ01AH002</u>	<u>31UBQ02001</u>	<u>M</u>	<u>M</u>	<u>SI</u>	<u>C/NM</u>	<u>Y (5)</u>
Recirc Fan Bldg 1	30SAQ01AN001	31UQB02001	M	M	SI	C/NM	Y (5)
Impact Sep Bldg 1	30SAQ01AT001	31UQB02001	M	M	SI	C/NM	Y (5)
<u>Inlet Air Isol Dmpr Bldg 1</u>	<u>30SAQ01AH007</u>	<u>31UBQ02001</u>	<u>M</u>	<u>M</u>	<u>SI</u>	<u>C/NM</u>	<u>Y (5)</u>
<u>Exhaust Air Isol Dmpr Bldg 1</u>	<u>30SAQ01AH005</u>	<u>31UBQ02001</u>	<u>M</u>	<u>M</u>	<u>SI</u>	<u>C/NM</u>	<u>Y (5)</u>
Split Cir Inlet Balancing Dmpr Bldg 1	30SAQ01AA008	31UBQ02001	M	M	SII	NS-AQ	Y (5)
Split Cir Recirc Balancing Dmpr Bldg 1	30SAQ01AA006	31UBQ02001	M	M	SII	NS-AQ	Y (5)
Split Cir Prefilter Bldg 1	30SAQ01AT003	31UBQ02001	M	M	SII	NS-AQ	Y (5)
Split Refrig Air Chiller Unit Bldg 1	30SAQ01AC002	31UBQ02001	M	M	SII	NS-AQ	Y (5)



Table 3.10-1—List of Seismically and Dynamically Qualified Mechanical and Electrical Equipment  
Sheet 187 of 200

Name Tag (Equipment Description)	Tag Number	Local Area		EQ Environment (Note 1)	Radiation Environment Zone (Note 2)	EQ Designated Function (Note 3)	Safety Class (Note 4)		EQ Program Designation (Note 5)
		KKS ID (Room Location)	Room Location				NS-AQ	C/NM	
Split Refrig Air Cooler Unit Bldg 1	30SAQ01AC102	31UBQ02001	31UBQ02001	M	M	SII	NS-AQ	C/NM	Y (5)
Split Cooler Fan Bldg 1	30SAQ01AN002	31UBQ02001	31UBQ02001	M	M	SII	NS-AQ	C/NM	Y (5)
<del>Elec Eq Area Sup-Damper-Bldg 2</del>	<del>30SAQ02AA004</del>	<del>32UQB02004</del>	<del>32UQB02004</del>	M	M	S	S	C/NM	<del>Y (5)</del>
<del>ESW Pump Area Sup-Recirc Chiller Balancing</del> Dmpr Bldg 2	<del>30SAQ02AA002</del>	<del>32UQB02001</del>	<del>32UQB02001</del>	M	M	SI	S	C/NM	Y (5)
Plug Valve Chiller Cold Leg Bldg 2	30SAQ02AA003	32UQB02001	32UQB02001	M	M	SI	S	C/NM	Y (5)
Plug Valve Chiller Hot Leg Bldg 2	30SAQ02AA004	32UQB02001	32UQB02001	M	M	SI	S	C/NM	Y (5)
Recirc Chiller Prefilter Bldg 2	30SAQ02AT002	32UBQ02001	32UBQ02001	M	M	SI	S	C/NM	Y (5)
Recirc Chiller Bldg 2	30SAQ02AC001	32UQB02001	32UQB02001	M	M	SI	S	C/NM	Y (5)
Elec Room Air Heater Bldg 2	30SAQ02AH001	32UQB02001	32UQB02001	M	M	SI	S	C/NM	Y (5)
Elec Room Air Heater Bldg 2	30SAQ02AH002	32UBQ02001	32UBQ02001	M	M	SI	S	C/NM	Y (5)
Recirc Fan Bldg 2	30SAQ02AN001	32UQB02001	32UQB02001	M	M	SI	S	C/NM	Y (5)
Impact Sep Bldg 2	30SAQ02AT001	32UQB02001	32UQB02001	M	M	SI	S	C/NM	Y (5)
Inlet Air Isol Dmpr Bldg 2	30SAQ02AH007	32UBQ02001	32UBQ02001	M	M	SI	S	C/NM	Y (5)
Exhaust Air Isol Dmpr Bldg 2	30SAQ02AH005	32UBQ02001	32UBQ02001	M	M	SI	S	C/NM	Y (5)
Split Ch Inlet Balancing Dmpr Bldg 2	30SAQ02AA008	32UBQ02001	32UBQ02001	M	M	SI	NS-AQ	C/NM	Y (5)
Split Ch Recirc Balancing Dmpr Bldg 2	30SAQ02AA006	32UBQ02001	32UBQ02001	M	M	SI	NS-AQ	C/NM	Y (5)
Split Ch Prefilter Bldg 2	30SAQ02AT003	32UBQ02001	32UBQ02001	M	M	SI	NS-AQ	C/NM	Y (5)
Split Refrig Air Chiller Unit Bldg 2	30SAQ02AC002	32UBQ02001	32UBQ02001	M	M	SI	NS-AQ	C/NM	Y (5)
Split Refrig Air Cooler Unit Bldg 2	30SAQ02AC102	32UBQ02001	32UBQ02001	M	M	SI	NS-AQ	C/NM	Y (5)
Split Cooler Fan Bldg 2	30SAQ02AN002	32UBQ02001	32UBQ02001	M	M	SI	NS-AQ	C/NM	Y (5)
<del>Elec Eq Area Sup-Damper-Bldg 3</del>	<del>30SAQ03AA004</del>	<del>33UQB02004</del>	<del>33UQB02004</del>	M	M	S	S	C/NM	<del>Y (5)</del>
<del>ESW Pump Area Sup-Recirc Chiller Balancing</del> Dmpr Bldg 3	30SAQ03AA002	33UQB02001	33UQB02001	M	M	SI	S	C/NM	Y (5)
Plug Valve Chiller Cold Leg Bldg 3	30SAQ03AA003	33UQB02001	33UQB02001	M	M	SI	S	C/NM	Y (5)
Plug Valve Chiller Hot Leg Bldg 3	30SAQ03AA004	33UQB02001	33UQB02001	M	M	SI	S	C/NM	Y (5)
Recirc Chiller Prefilter Bldg 3	30SAQ03AT002	33UBQ02001	33UBQ02001	M	M	SI	S	C/NM	Y (5)
Recirc Chiller Bldg 3	30SAQ03AC001	33UQB02001	33UQB02001	M	M	SI	S	C/NM	Y (5)
Elec Room Air Heater Bldg 3	30SAQ03AH001	33UQB02001	33UQB02001	M	M	SI	S	C/NM	Y (5)
Elec Room Air Heater Bldg 3	30SAQ03AH002	33UBQ02001	33UBQ02001	M	M	SI	S	C/NM	Y (5)
Recirc Fan Bldg 3	30SAQ03AN001	33UQB02001	33UQB02001	M	M	SI	S	C/NM	Y (5)
Impact Sep Bldg 3	30SAQ03AT001	33UQB02001	33UQB02001	M	M	SI	S	C/NM	Y (5)
Inlet Air Isol Dmpr Bldg 3	30SAQ03AH007	33UBQ02001	33UBQ02001	M	M	SI	S	C/NM	Y (5)



Table 3.10-1—List of Seismically and Dynamically Qualified Mechanical and Electrical Equipment  
Sheet 188 of 200

Name Tag (Equipment Description)	Tag Number	Local Area		EQ Environment (Note 1)	Radiation Environment Zone (Note 2)	EQ Designated Function (Note 3)	Safety Class (Note 4)	EQ Program Designation (Note 5)
		KKS ID (Room Location)	Room Location					
Exhaust Air Isol Dmpr Bldg 3	30SAQ03AH005	33UBQ02001	33UBQ02001	M	M	SI	C/NM	Y (5)
Split Cir Inlet Balancing Dmpr Bldg 3	30SAQ03AA008	33UBQ02001	33UBQ02001	M	M	SI	C/NM	Y (5)
Split Cir Recirc Balancing Dmpr Bldg 3	30SAQ03AA006	33UBQ02001	33UBQ02001	M	M	SI	C/NM	Y (5)
Split Cir Prefiler Bldg 3	30SAQ03AT003	33UBQ02001	33UBQ02001	M	M	SI	C/NM	Y (5)
Split Refrig Air Chiller Unit Bldg 3	30SAQ03AC002	33UBQ02001	33UBQ02001	M	M	SI	C/NM	Y (5)
Split Refrig Air Cooler Unit Bldg 3	30SAQ03AC102	33UBQ02001	33UBQ02001	M	M	SI	C/NM	Y (5)
Split Cooler Fan Bldg 3	30SAQ03AN002	33UBQ02001	33UBQ02001	M	M	SI	C/NM	Y (5)
Elec-Eq-Area-Sup-Damper-Bldg 4	30SAQ04AA004	34UQB02004	34UQB02004	M	M	SI	C/NM	Y (5)
ESW-Pump-Area-Sup-Recirc-Chiller-Balancing Dmpr Bldg 4	30SAQ04AA002	34UQB02001	34UQB02001	M	M	SI	C/NM	Y (5)
Plug Valve Chiller Cold Leg Bldg 4	30SAQ04AA003	34UQB02001	34UQB02001	M	M	SI	C/NM	Y (5)
Plug Valve Chiller Hot Leg Bldg 4	30SAQ04AA004	34UQB02001	34UQB02001	M	M	SI	C/NM	Y (5)
Recirc Chiller Prefiler Bldg 4	30SAQ04AT002	34UQB02001	34UQB02001	M	M	SI	C/NM	Y (5)
Recirc Chiller Bldg 4	30SAQ04AC001	34UQB02001	34UQB02001	M	M	SI	C/NM	Y (5)
Elec Room Air Heater Bldg 4	30SAQ04AH001	34UQB02001	34UQB02001	M	M	SI	C/NM	Y (5)
Elec Room Air Heater Bldg 4	30SAQ04AH002	34UQB02001	34UQB02001	M	M	SI	C/NM	Y (5)
Recirc Fan Bldg 4	30SAQ04AN001	34UQB02001	34UQB02001	M	M	SI	C/NM	Y (5)
Impact Sep Bldg 4	30SAQ04AT001	34UQB02001	34UQB02001	M	M	SI	C/NM	Y (5)
Inlet Air Isol Dmpr Bldg 4	30SAQ04AH007	34UQB02001	34UQB02001	M	M	SI	C/NM	Y (5)
Exhaust Air Isol Dmpr Bldg 4	30SAQ04AH005	34UQB02001	34UQB02001	M	M	SI	C/NM	Y (5)
Split Cir Inlet Balancing Dmpr Bldg 4	30SAQ04AA008	34UQB02001	34UQB02001	M	M	SI	C/NM	Y (5)
Split Cir Recirc Balancing Dmpr Bldg 4	30SAQ04AA006	34UQB02001	34UQB02001	M	M	SI	C/NM	Y (5)
Split Cir Prefiler Bldg 4	30SAQ04AT003	34UQB02001	34UQB02001	M	M	SI	C/NM	Y (5)
Split Refrig Air Chiller Unit Bldg 4	30SAQ04AC002	34UQB02001	34UQB02001	M	M	SI	C/NM	Y (5)
Split Refrig Air Cooler Unit Bldg 4	30SAQ04AC102	34UQB02001	34UQB02001	M	M	SI	C/NM	Y (5)
Split Cooler Fan Bldg 4	30SAQ04AN002	34UQB02001	34UQB02001	M	M	SI	C/NM	Y (5)
Emergency Power Generating Building Ventilation System (EPGBVS)								
Building Supply Backdraft Damper - Div 1	30SAD11AA003	31UBP02001	31UBP02001	M	M	SI	C/NM	Y (5)
Building Inlet Prefiler - Div 1	30SAD11AT003	31UBP02001	31UBP02001	M	M	SI	C/NM	Y (5)
Supply Fan - Div 1	30SAD11AN003	31UBP02001	31UBP02001	M	M	SI	C/NM	Y (5)
Supply Air Motor Damper - Div 1	30SAD11AA004	31UBP02001	31UBP02001	M	M	SI	C/NM	Y (5)
Supply Air Manual Damper - Div 1	30SAD11AA005	31UBP01001	31UBP01001	M	M	SI	C/NM	Y (5)
Building Exhaust Motor Damper - Div 1	30SAD15AA004	31UBP02002	31UBP02002	M	M	SI	C/NM	Y (5)



**Table 3.10-1—List of Seismically and Dynamically Qualified Mechanical and Electrical Equipment  
Sheet 189 of 200**

Name Tag (Equipment Description)	Tag Number	Local Area			EQ Environment (Note 1)	Radiation Environment Zone (Note 2)	EQ Designated Function (Note 3)	Safety Class (Note 4)	EQ Program Designation (Note 5)
		KKS ID (Room Location)	EQ Environment (Note 1)	Radiation Environment Zone (Note 2)					
Exhaust Fan - Div.1	30SAD15AN003	31UBP02002	M	M	SI	NS-AQ	C/NM	Y (5)	
Building Exhaust Backdraft Damper - Div.1	30SAD15AA003	31UBP02002	M	M	SI	NS-AQ	C/NM	Y (5)	
Electrical Room Supply Air Motor Damper - Div.1	30SAD13AA007	31UBP01002	M	M	SI	S	C/NM	Y (5)	
Electrical Room Supply Air Manual Damper - Div.1	30SAD13AA008	31UBP01002	M	M	SI	NS-AQ	C/NM	Y (5)	
Electrical Room Supply Air Manual Damper - Div.1	30SAD13AA009	31UBP01002	M	M	SI	NS-AQ	C/NM	Y (5)	
Electrical Room Supply Air Prefilter - Div.1	30SAD13AT003	31UBP01002	M	M	SI	NS-AQ	C/NM	Y (5)	
Electrical Room Supply Air Cooling Coils - Div.1	30SAD13AC002	31UBP01002	M	M	SI	NS-AQ	C/NM	Y (5)	
Electrical Room Supply Air Cooling Coils - Div.1	30SAD13AC102	31UBP01002	M	M	SI	NS-AQ	C/NM	Y (5)	
Electrical Room Supply Air Fan - Div.1	30SAD13AN002	31UBP01002	M	M	SI	NS-AQ	C/NM	Y (5)	
Electrical Room Exhaust Backdraft Damper - Div.1	30SAD13AA010	31UBP01002	M	M	SI	S	C/NM	Y (5)	
Building Supply Backdraft Damper - Div.2	30SAD21AA003	32UBP02001	M	M	SI	NS-AQ	C/NM	Y (5)	
Building Inlet Prefilter - Div.2	30SAD21AT003	32UBP02001	M	M	SI	NS-AQ	C/NM	Y (5)	
Supply Fan - Div.2	30SAD21AN003	32UBP02001	M	M	SI	NS-AQ	C/NM	Y (5)	
Supply Air Motor Damper - Div.2	30SAD21AA004	32UBP02001	M	M	SI	S	C/NM	Y (5)	
Supply Air Manual Damper - Div.2	30SAD21AA005	32UBP01001	M	M	SI	NS-AQ	C/NM	Y (5)	
Building Exhaust Motor Damper - Div.2	30SAD25AA004	32UBP02002	M	M	SI	S	C/NM	Y (5)	
Exhaust Fan - Div.2	30SAD25AN003	32UBP02002	M	M	SI	NS-AQ	C/NM	Y (5)	
Building Exhaust Backdraft Damper - Div.2	30SAD25AA003	32UBP02002	M	M	SI	NS-AQ	C/NM	Y (5)	
Electrical Room Supply Air Motor Damper - Div.2	30SAD23AA007	32UBP01002	M	M	SI	S	C/NM	Y (5)	
Electrical Room Supply Air Manual Damper - Div.2	30SAD23AA008	32UBP01002	M	M	SI	NS-AQ	C/NM	Y (5)	
Electrical Room Supply Air Manual Damper - Div.2	30SAD23AA009	32UBP01002	M	M	SI	NS-AQ	C/NM	Y (5)	
Electrical Room Supply Air Prefilter - Div.2	30SAD23AT003	32UBP01002	M	M	SI	NS-AQ	C/NM	Y (5)	
Electrical Room Supply Air Cooling Coils - Div.2	30SAD23AC002	32UBP01002	M	M	SI	NS-AQ	C/NM	Y (5)	
Electrical Room Supply Air Cooling Coils - Div.2	30SAD23AC102	32UBP01002	M	M	SI	NS-AQ	C/NM	Y (5)	
Electrical Room Supply Air Fan - Div.2	30SAD23AN002	32UBP01002	M	M	SI	NS-AQ	C/NM	Y (5)	
Electrical Room Exhaust Backdraft Damper - Div.2	30SAD23AA010	32UBP01002	M	M	SI	S	C/NM	Y (5)	





**Table 3.10-1—List of Seismically and Dynamically Qualified Mechanical and Electrical Equipment  
Sheet 190 of 200**

Name Tag (Equipment Description)	Tag Number	Local Area		EQ Environment (Note 1)	Radiation Environment Zone (Note 2)	EQ Designated Function (Note 3)	Safety Class (Note 4)	EQ Program Designation (Note 5)	
		KKS ID (Room Location)	Room Location						
Building Supply Backdraft Damper - Div 3	30SAD31AA003	33UBP02001		M	M	SII	NS-AQ	C/NM	Y (5)
Building Inlet Prefilter - Div 3	30SAD31AT003	33UBP02001		M	M	SII	NS-AQ	C/NM	Y (5)
Supply Fan - Div 3	30SAD31AN003	33UBP02001		M	M	SII	NS-AQ	C/NM	Y (5)
Supply Air Motor Damper - Div 3	30SAD31AA004	33UBP02001		M	M	SI	S	C/NM	Y (5)
Supply Air Manual Damper - Div 3	30SAD31AA005	33UBP01001		M	M	SII	NS-AQ	C/NM	Y (5)
Building Exhaust Motor Damper - Div 3	30SAD35AA004	33UBP02002		M	M	SI	S	C/NM	Y (5)
Exhaust Fan - Div 3	30SAD35AN003	33UBP02002		M	M	SII	NS-AQ	C/NM	Y (5)
Building Exhaust Backdraft Damper - Div 3	30SAD35AA003	33UBP02002		M	M	SII	NS-AQ	C/NM	Y (5)
Electrical Room Supply Air Motor Damper - Div 3	30SAD33AA007	33UBP01002		M	M	SI	S	C/NM	Y (5)
Electrical Room Supply Air Manual Damper - Div 3	30SAD33AA008	33UBP01002		M	M	SII	NS-AQ	C/NM	Y (5)
Electrical Room Supply Air Manual Damper - Div 3	30SAD33AA009	33UBP01002		M	M	SII	NS-AQ	C/NM	Y (5)
Electrical Room Supply Air Prefilter - Div 3	30SAD33AT003	33UBP01002		M	M	SII	NS-AQ	C/NM	Y (5)
Electrical Room Supply Air Cooling Coils - Div 3	30SAD33AC002	33UBP01002		M	M	SII	NS-AQ	C/NM	Y (5)
Electrical Room Supply Air Cooling Coils - Div 3	30SAD33AC102	33UBP01002		M	M	SII	NS-AQ	C/NM	Y (5)
Electrical Room Supply Air Fan - Div 3	30SAD33AN002	33UBP01002		M	M	SII	NS-AQ	C/NM	Y (5)
Electrical Room Exhaust Backdraft Damper - Div 3	30SAD33AA010	33UBP01002		M	M	SI	S	C/NM	Y (5)
Building Supply Backdraft Damper - Div 4	30SAD41AA003	34UBP02001		M	M	SII	NS-AQ	C/NM	Y (5)
Building Inlet Prefilter - Div 4	30SAD41AT003	34UBP02001		M	M	SII	NS-AQ	C/NM	Y (5)
Supply Fan - Div 4	30SAD41AN003	34UBP02001		M	M	SII	NS-AQ	C/NM	Y (5)
Supply Air Motor Damper - Div 4	30SAD41AA004	34UBP02001		M	M	SI	S	C/NM	Y (5)
Supply Air Manual Damper - Div 4	30SAD41AA005	34UBP01001		M	M	SII	NS-AQ	C/NM	Y (5)
Building Exhaust Motor Damper - Div 4	30SAD45AA004	34UBP02002		M	M	SI	S	C/NM	Y (5)
Exhaust Fan - Div 4	30SAD45AN003	34UBP02002		M	M	SII	NS-AQ	C/NM	Y (5)
Building Exhaust Backdraft Damper - Div 4	30SAD45AA003	34UBP02002		M	M	SII	NS-AQ	C/NM	Y (5)
Electrical Room Supply Air Motor Damper - Div 4	30SAD43AA007	34UBP01002		M	M	SI	S	C/NM	Y (5)
Electrical Room Supply Air Manual Damper - Div 4	30SAD43AA008	34UBP01002		M	M	SII	NS-AQ	C/NM	Y (5)
Electrical Room Supply Air Manual Damper - Div 4	30SAD43AA009	34UBP01002		M	M	SII	NS-AQ	C/NM	Y (5)



**Table 3.10-1—List of Seismically and Dynamically Qualified Mechanical and Electrical Equipment**  
**Sheet 191 of 200**

Name Tag (Equipment Description)	Tag Number	Local Area		EQ Environment (Note 1)	Radiation Environment Zone (Note 2)	EQ Designated Function (Note 3)	Safety Class (Note 4)		EQ Program Designation (Note 5)
		KKS ID (Room Location)	Room Location				NS-AQ	C/NM	
Electrical Room Supply Air Prefilter - Div 4	<del>30SAD43AT003</del>	34UBP01002	M	M	M	SII	NS-AQ	C/NM	Y (5)
Electrical Room Supply Air Cooling Coils - Div 4	<del>30SAD43AC002</del>	34UBP01002	M	M	M	SII	NS-AQ	C/NM	Y (5)
Electrical Room Supply Air Cooling Coils - Div 4	<del>30SAD43AC102</del>	34UBP01002	M	M	M	SII	NS-AQ	C/NM	Y (5)
Electrical Room Supply Air Fan - Div 4	<del>30SAD43AN002</del>	34UBP01002	M	M	M	SII	NS-AQ	C/NM	Y (5)
Electrical Room Exhaust Backdraft Damper - Div 4	<del>30SAD43AA010</del>	34UBP01002	M	M	M	SI	S	C/NM	Y (5)
Building Supply Backdraft Damper - Div 1	30SAD11AA001	31UBP02001	M	M	M	SI	S	C/NM	Y (5)
Building Supply Backdraft Damper - Div 1	30SAD11AA002	31UBP02001	M	M	M	SI	S	C/NM	Y (5)
Supply Fan - Div 1	30SAD11AN001	31UBP01001	M	M	M	SI	S	C/NM	Y (5)
Supply Fan - Div 1	30SAD11AN002	31UBP01001	M	M	M	SI	S	C/NM	Y (5)
Building Inlet Prefilter - Div 1	30SAD11AT001	31UBP02001	M	M	M	SI	S	C/NM	Y (5)
Building Inlet Prefilter - Div 1	30SAD11AT002	31UBP02001	M	M	M	SI	S	C/NM	Y (5)
Diesel Hall Balancing Damper A - Div 1	30SAD12AA001	31UBP01001	M	M	M	SI	S	C/NM	Y (5)
Diesel Hall Balancing Damper B - Div 1	30SAD12AA002	31UBP01001	M	M	M	SI	S	C/NM	Y (5)
Diesel Hall Balancing Damper C - Div 1	30SAD12AA003	31UBP01001	M	M	M	SI	S	C/NM	Y (5)
Diesel Hall Balancing Damper D - Div 1	30SAD12AA004	31UBP01001	M	M	M	SI	S	C/NM	Y (5)
Diesel Hall Balancing Damper E - Div 1	30SAD12AA005	31UBP01001	M	M	M	SI	S	C/NM	Y (5)
<del>Recirc. Control Damper - Div 4</del>	<del>30SAD13AA004</del>	<del>34UBP04004</del>	M	M	M	SI	S	C/NM	Y (5)
Recirc. Balancing Damper - Div 1	30SAD13AA002	31UBP01001	M	M	M	SI	S	C/NM	Y (5)
<del>Recirc Supply Backdraft Damper - Div 4</del>	<del>30SAD13AA003</del>	<del>34UBP04004</del>	M	M	M	SI	S	C/NM	Y (5)
Fire Damper - Div 1	30SAD13AA004	31UBP01001	M	M	M	SII	NS-AQ	C/NM	Y (5)
Fire Damper - Div 1	30SAD13AA005	31UBP01001	M	M	M	SII	NS-AQ	C/NM	Y (5)
<del>Recirc Exhaust Backdraft Damper - Div 4</del>	<del>30SAD13AA006</del>	<del>34UBP04004</del>	M	M	M	SI	S	C/NM	Y (5)
Recirc Unit Cooling Coil - Div 1	30SAD13AC001	31UBP01001	M	M	M	SI	S	C/NM	Y (5)
<del>Recirc Unit Chiller Compressor - Div 4</del>	<del>30SAD13AC104</del>	<del>34UBP04004</del>	M	M	M	SI	S	C/NM	Y (5)
<del>Recirc Unit Heater - Div 4</del>	<del>30SAD13AH004</del>	<del>34UBP04004</del>	M	M	M	SI	S	C/NM	Y (5)
<del>Recirc Unit Humidifier - Div 4</del>	<del>30SAD13AH002</del>	<del>34UBP04004</del>	M	M	M	SI	S	C/NM	Y (5)
Recirc Unit Supply Fan - Div 1	30SAD13AN001	31UBP01001	M	M	M	SI	S	C/NM	Y (5)
<del>Recirc Unit Chiller Fan - Div 4</del>	<del>30SAD13AN104</del>	<del>34UBP04004</del>	M	M	M	SI	S	C/NM	Y (5)
Recirc Unit Pre-Filter - Div 1	30SAD13AT001	31UBP01001	M	M	M	SI	S	C/NM	Y (5)
Recirc Unit HEPA Filter - Div 1	30SAD13AT002	31UBP01001	M	M	M	SI	S	C/NM	Y (5)
Recirc Unit Moisture Separator - Div 1	30SAD13AT003	31UBP01001	M	M	M	SI	S	C/NM	Y (5)
<del>Recirc Unit Chiller Filter - Div 4</del>	<del>30SAD13AT104</del>	<del>34UBP04004</del>	M	M	M	SI	S	C/NM	Y (5)



**Table 3.10-1—List of Seismically and Dynamically Qualified Mechanical and Electrical Equipment**  
Sheet 192 of 200

Name Tag (Equipment Description)	Tag Number	Local Area		EQ Environment (Note 1)	Radiation Environment Zone (Note 2)	EQ Designated Function (Note 3)	Safety Class (Note 4)		EQ Program Designation (Note 5)
		KKS ID (Room Location)	Room Location				NS-AQ	C/NM	
Diesel Hall Space Heater/Fan 1 - Div 1	30SAD14AH001	31UBP01001	31UBP01001	M	M	SII	NS-AQ	C/NM	Y (5)
Diesel Hall Space Heater/Fan 2 - Div 1	30SAD14AH002	31UBP01001	31UBP01001	M	M	SII	NS-AQ	C/NM	Y (5)
Diesel Hall Space Heater/Fan 3 - Div 1	30SAD14AH003	31UBP01001	31UBP01001	M	M	SII	NS-AQ	C/NM	Y (5)
Diesel Hall Space Heater/Fan 4 - Div 1	30SAD14AH004	31UBP01001	31UBP01001	M	M	SII	NS-AQ	C/NM	Y (5)
Building Exhaust Backdraft Damper-Div 1	30SAD15AA001	31UBP02002	31UBP02002	M	M	SI	S	C/NM	Y (5)
Building Exhaust Backdraft Damper-Div 1	30SAD15AA002	31UBP02002	31UBP02002	M	M	SI	S	C/NM	Y (5)
Exhaust Fan - Div 1	30SAD15AN001	31UBP01001	31UBP01001	M	M	SI	S	C/NM	Y (5)
Exhaust Fan - Div 1	30SAD15AN002	31UBP01001	31UBP01001	M	M	SI	S	C/NM	Y (5)
Main Tank Supply Backdraft Damp - Div 1	30SAD16AA001	31UBP01003	31UBP01003	M	M	SI	S	C/NM	Y (5)
Main Tank Supply Fire Damper - Div 1	30SAD16AA002	31UBP01003	31UBP01003	M	M	SI	S	C/NM	Y (5)
Main Tank Exhaust Balancing Damp A - Div 1	30SAD16AA003	31UBP01003	31UBP01003	M	M	SI	S	C/NM	Y (5)
Main Tank Exhaust Balancing Damp B - Div 1	30SAD16AA004	31UBP01003	31UBP01003	M	M	SI	S	C/NM	Y (5)
Main Tank Exhaust Backflow Damp - Div 1	30SAD16AA005	31UBP01003	31UBP01003	M	M	SI	S	C/NM	Y (5)
Main Tank Supp Damper A - Div 1	30SAD16AA007	31UBP01001	31UBP01001	M	M	SI	S	C/NM	Y (5)
Main Tank Supp Damper B - Div 1	30SAD16AA008	31UBP01001	31UBP01001	M	M	SI	S	C/NM	Y (5)
Fuel Tank Room Space Heater - Div 1	30SAD16AH001	31UBP01003	31UBP01003	M	M	SI	S	C/NM	Y (5)
Fuel Tank Room Ventilation Fan - Div 1	30SAD16AN001	31UBP01003	31UBP01003	M	M	SI	S	C/NM	Y (5)
Building Supply Backdraft Damper - Div 2	30SAD21AA001	32UBP02001	32UBP02001	M	M	SI	S	C/NM	Y (5)
Building Supply Backdraft Damper - Div 2	30SAD21AA002	32UBP02001	32UBP02001	M	M	SI	S	C/NM	Y (5)
Supply Fan - Div 2	30SAD21AN001	32UBP01001	32UBP01001	M	M	SI	S	C/NM	Y (5)
Supply Fan - Div 2	30SAD21AN002	32UBP01001	32UBP01001	M	M	SI	S	C/NM	Y (5)
Building Inlet Prefilter - Div 2	30SAD21AT001	32UBP02001	32UBP02001	M	M	SI	S	C/NM	Y (5)
Building Inlet Prefilter - Div 2	30SAD21AT002	32UBP02001	32UBP02001	M	M	SI	S	C/NM	Y (5)
Diesel Hall Balancing Damper A - Div 24	30SAD22AA001	32UBP02001	32UBP02001	M	M	SI	S	C/NM	Y (5)
Diesel Hall Balancing Damper B - Div 24	30SAD22AA002	32UBP01001	32UBP01001	M	M	SI	S	C/NM	Y (5)
Diesel Hall Balancing Damper C - Div 24	30SAD22AA003	32UBP01001	32UBP01001	M	M	SI	S	C/NM	Y (5)
Diesel Hall Balancing Damper D - Div 24	30SAD22AA004	32UBP01001	32UBP01001	M	M	SI	S	C/NM	Y (5)
Diesel Hall Balancing Damper E - Div 24	30SAD22AA005	32UBP01001	32UBP01001	M	M	SI	S	C/NM	Y (5)
<del>Recirc-Control Damper-Div 2</del>	<del>30SAD23AA004</del>	<del>32UBP01001</del>	<del>32UBP01001</del>	<del>M</del>	<del>M</del>	<del>SI</del>	<del>S</del>	<del>C/NM</del>	<del>Y (5)</del>
Recirc. Balancing Damper - Div 2	30SAD23AA002	32UBP01001	32UBP01001	M	M	SI	S	C/NM	Y (5)
<del>Recirc-Supply-Backdraft-Damper-Div 2</del>	<del>30SAD23AA003</del>	<del>32UBP01001</del>	<del>32UBP01001</del>	<del>M</del>	<del>M</del>	<del>SI</del>	<del>S</del>	<del>C/NM</del>	<del>Y (5)</del>
Fire Damper - Div 2	30SAD23AA004	32UBP01001	32UBP01001	M	M	SII	NS-AQ	C/NM	Y (5)
Fire Damper - Div 2	30SAD23AA005	32UBP01001	32UBP01001	M	M	SII	NS-AQ	C/NM	Y (5)



**Table 3.10-1—List of Seismically and Dynamically Qualified Mechanical and Electrical Equipment  
Sheet 194 of 200**

Name Tag (Equipment Description)	Tag Number	Local Area			Radiation Environment Zone (Note 2)	EQ Designated Function (Note 3)	Safety Class (Note 4)	EQ Program Designation (Note 5)
		KKS ID (Room Location)	EQ Environment (Note 1)	EQ Environment Zone (Note 2)				
Building Inlet Prefilter - Div 3	30SAD31AT002	33UBP02001	M	M	SI	C/NM	Y (5)	
<del>Diesel Hall Balancing Damper A - Div 1</del>	<del>30SAD32AA004</del>	<del>33UBP02004</del>	<del>M</del>	<del>M</del>	<del>SI</del>	<del>C/NM</del>	<del>Y (5)</del>	
<del>Diesel Hall Balancing Damper B - Div 1</del>	<del>30SAD32AA002</del>	<del>33UBP04004</del>	<del>M</del>	<del>M</del>	<del>SI</del>	<del>C/NM</del>	<del>Y (5)</del>	
<del>Diesel Hall Balancing Damper C - Div 1</del>	<del>30SAD32AA003</del>	<del>33UBP04004</del>	<del>M</del>	<del>M</del>	<del>SI</del>	<del>C/NM</del>	<del>Y (5)</del>	
<del>Diesel Hall Balancing Damper D - Div 1</del>	<del>30SAD32AA004</del>	<del>33UBP04004</del>	<del>M</del>	<del>M</del>	<del>SI</del>	<del>C/NM</del>	<del>Y (5)</del>	
<del>Diesel Hall Balancing Damper E - Div 1</del>	<del>30SAD32AA005</del>	<del>33UBP04004</del>	<del>M</del>	<del>M</del>	<del>SI</del>	<del>C/NM</del>	<del>Y (5)</del>	
<del>Recirc. Control Damper - Div 3</del>	<del>30SAD33AA004</del>	<del>33UBP04004</del>	<del>M</del>	<del>M</del>	<del>SI</del>	<del>C/NM</del>	<del>Y (5)</del>	
Recirc. Balancing Damper - Div 3	30SAD33AA002	33UBP01001	M	M	SI	C/NM	Y (5)	
<del>Recirc Supply Backdraft Damper - Div 3</del>	<del>30SAD33AA003</del>	<del>33UBP04004</del>	<del>M</del>	<del>M</del>	<del>SI</del>	<del>C/NM</del>	<del>Y (5)</del>	
Fire Damper - Div 3	30SAD33AA004	33UBP01001	M	M	SI	C/NM	Y (5)	
Fire Damper - Div 3	30SAD33AA005	33UBP01001	M	M	SI	C/NM	Y (5)	
<del>Recirc Exhaust Backdraft Damper - Div 3</del>	<del>30SAD33AA006</del>	<del>33UBP04004</del>	<del>M</del>	<del>M</del>	<del>SI</del>	<del>C/NM</del>	<del>Y (5)</del>	
Recirc Unit Cooling Coil - Div 3	30SAD33AC001	33UBP01001	M	M	SI	C/NM	Y (5)	
<del>Recirc Unit Chiller Compressor - Div 3</del>	<del>30SAD33AC104</del>	<del>33UBP04004</del>	<del>M</del>	<del>M</del>	<del>SI</del>	<del>C/NM</del>	<del>Y (5)</del>	
<del>Recirc Unit Heater - Div 3</del>	<del>30SAD33AH004</del>	<del>33UBP04004</del>	<del>M</del>	<del>M</del>	<del>SI</del>	<del>C/NM</del>	<del>Y (5)</del>	
<del>Recirc Unit Humidifier - Div 3</del>	<del>30SAD33AH002</del>	<del>33UBP04004</del>	<del>M</del>	<del>M</del>	<del>SI</del>	<del>C/NM</del>	<del>Y (5)</del>	
Recirc Unit Supply Fan - Div 3	30SAD33AN001	33UBP01001	M	M	SI	C/NM	Y (5)	
<del>Recirc Unit Chiller Fan - Div 3</del>	<del>30SAD33AN104</del>	<del>33UBP04004</del>	<del>M</del>	<del>M</del>	<del>SI</del>	<del>C/NM</del>	<del>Y (5)</del>	
Recirc Unit Pre-Filter - Div 3	30SAD33AT001	33UBP01001	M	M	SI	C/NM	Y (5)	
Recirc Unit HEPA Filter - Div 3	30SAD33AT002	33UBP01001	M	M	SI	C/NM	Y (5)	
Recirc Unit Moisture Separator - Div 3	30SAD33AT003	33UBP01001	M	M	SI	C/NM	Y (5)	
<del>Recirc Unit Chiller Filter - Div 3</del>	<del>30SAD33AT104</del>	<del>33UBP04004</del>	<del>M</del>	<del>M</del>	<del>SI</del>	<del>C/NM</del>	<del>Y (5)</del>	
Diesel Hall Space Heater/Fan 1 - Div 3	30SAD34AH001	33UBP01001	M	M	SII	NS-AQ	Y (5)	
Diesel Hall Space Heater/Fan 2 - Div 3	30SAD34AH002	33UBP01001	M	M	SII	NS-AQ	Y (5)	
Diesel Hall Space Heater/Fan 3 - Div 3	30SAD34AH003	33UBP01001	M	M	SII	NS-AQ	Y (5)	
Diesel Hall Space Heater/Fan 4 - Div 3	30SAD34AH004	33UBP01001	M	M	SII	NS-AQ	Y (5)	
Building Exhaust Backdraft Damper-Div 3	30SAD35AA001	33UBP02002	M	M	SI	C/NM	Y (5)	
Building Exhaust Backdraft Damper-Div 3	30SAD35AA002	33UBP02002	M	M	SI	C/NM	Y (5)	
Exhaust Fan - Div 3	30SAD35AN001	33UBP01001	M	M	SI	C/NM	Y (5)	
Exhaust Fan - Div 3	30SAD35AN002	33UBP01001	M	M	SI	C/NM	Y (5)	
Main Tank Supply Backdraft Damp - Div 3	30SAD36AA001	33UBP01003	M	M	SI	C/NM	Y (5)	
Main Tank Supply Fire Damper - Div 3	30SAD36AA002	33UBP01003	M	M	SI	C/NM	Y (5)	
Main Tank Exhaust Balancing Damp A - Div 3	30SAD36AA003	33UBP01003	M	M	SI	C/NM	Y (5)	



**Table 3.10-1—List of Seismically and Dynamically Qualified Mechanical and Electrical Equipment  
Sheet 195 of 200**

Name Tag (Equipment Description)	Tag Number	Local Area			EQ Environment (Note 1)	Radiation Environment Zone (Note 2)	EQ Designated Function (Note 3)	Safety Class (Note 4)	EQ Program Designation (Note 5)
		KKS ID (Room Location)	EQ Environment (Note 1)	Radiation Environment Zone (Note 2)					
Main Tank Exhaust Balancing Damp B - Div 3	30SAD36AA004	33UBP01003	M	M	M	SI	C/NM	Y (5)	
Main Tank Exhaust Backflow Damp - Div 3	30SAD36AA005	33UBP01003	M	M	M	SI	C/NM	Y (5)	
Main Tank Supp Damper A - Div 3	30SAD36AA007	33UBP01001	M	M	M	SI	C/NM	Y (5)	
Main Tank Supp Damper B - Div 3	30SAD36AA008	33UBP01001	M	M	M	SI	C/NM	Y (5)	
Fuel Tank Room Space Heater - Div 3	30SAD36AH001	33UBP01003	M	M	M	SI	C/NM	Y (5)	
Fuel Tank Room Ventilation Fan - Div 3	30SAD36AN001	33UBP01003	M	M	M	SI	C/NM	Y (5)	
Building Supply Backdraft Damper - Div 4	30SAD41AA001	34UBP02001	M	M	M	SI	C/NM	Y (5)	
Building Supply Backdraft Damper - Div 4	30SAD41AA002	34UBP02001	M	M	M	SI	C/NM	Y (5)	
Supply Fan - Div 4	30SAD41AN001	34UBP01001	M	M	M	SI	C/NM	Y (5)	
Supply Fan - Div 4	30SAD41AN002	34UBP01001	M	M	M	SI	C/NM	Y (5)	
Building Inlet Prefilter - Div 4	30SAD41AT001	34UBP02001	M	M	M	SI	C/NM	Y (5)	
Building Inlet Prefilter - Div 4	30SAD41AT002	34UBP02001	M	M	M	SI	C/NM	Y (5)	
Diesel Hall Balancing Damper A - Div 1	30SAD42AA001	34UBP02001	M	M	M	SI	C/NM	Y (5)	
Diesel Hall Balancing Damper B - Div 1	30SAD42AA002	34UBP02001	M	M	M	SI	C/NM	Y (5)	
Diesel Hall Balancing Damper C - Div 1	30SAD42AA003	34UBP01001	M	M	M	SI	C/NM	Y (5)	
Diesel Hall Balancing Damper D - Div 1	30SAD42AA004	34UBP01001	M	M	M	SI	C/NM	Y (5)	
Diesel Hall Balancing Damper E - Div 1	30SAD42AA005	34UBP01001	M	M	M	SI	C/NM	Y (5)	
<del>Recirc. Control Damper - Div 4</del>	<del>30SAD43AA001</del>	<del>34UBP04001</del>	<del>M</del>	<del>M</del>	<del>M</del>	<del>SI</del>	<del>C/NM</del>	<del>Y (5)</del>	
Recirc. Balancing Damper - Div 4	30SAD43AA002	34UBP01001	M	M	M	SI	C/NM	Y (5)	
<del>Recirc. Supply Backdraft Damper - Div 4</del>	<del>30SAD43AA003</del>	<del>34UBP04001</del>	<del>M</del>	<del>M</del>	<del>M</del>	<del>SI</del>	<del>C/NM</del>	<del>Y (5)</del>	
Fire Damper - Div 4	30SAD43AA004	34UBP01001	M	M	M	SII	C/NM	Y (5)	
Fire Damper - Div 4	30SAD43AA005	34UBP01001	M	M	M	SII	C/NM	Y (5)	
<del>Recirc. Exhaust Backdraft Damper - Div 4</del>	<del>30SAD43AA006</del>	<del>34UBP04001</del>	<del>M</del>	<del>M</del>	<del>M</del>	<del>SI</del>	<del>C/NM</del>	<del>Y (5)</del>	
Recirc Unit Cooling Coil - Div 4	30SAD43AC001	34UBP01001	M	M	M	SI	C/NM	Y (5)	
<del>Recirc. Unit Chiller Compressor - Div 4</del>	<del>30SAD43AC101</del>	<del>34UBP04001</del>	<del>M</del>	<del>M</del>	<del>M</del>	<del>SI</del>	<del>C/NM</del>	<del>Y (5)</del>	
<del>Recirc. Unit Heater - Div 4</del>	<del>30SAD43AH001</del>	<del>34UBP04001</del>	<del>M</del>	<del>M</del>	<del>M</del>	<del>SI</del>	<del>C/NM</del>	<del>Y (5)</del>	
<del>Recirc. Unit Humidifier - Div 4</del>	<del>30SAD43AH002</del>	<del>34UBP04001</del>	<del>M</del>	<del>M</del>	<del>M</del>	<del>SI</del>	<del>C/NM</del>	<del>Y (5)</del>	
Recirc Unit Supply Fan - Div 4	30SAD43AN001	34UBP01001	M	M	M	SI	C/NM	Y (5)	
<del>Recirc. Unit Chiller Fan - Div 4</del>	<del>30SAD43AN101</del>	<del>34UBP04001</del>	<del>M</del>	<del>M</del>	<del>M</del>	<del>SI</del>	<del>C/NM</del>	<del>Y (5)</del>	
Recirc Unit Pre-Filter - Div 4	30SAD43AT001	34UBP01001	M	M	M	SI	C/NM	Y (5)	
Recirc Unit HEPA Filter - Div 4	30SAD43AT002	34UBP01001	M	M	M	SI	C/NM	Y (5)	
Recirc Unit Moisture Separator - Div 4	30SAD43AT003	34UBP01001	M	M	M	SI	C/NM	Y (5)	
<del>Recirc. Unit Chiller Filter - Div 4</del>	<del>30SAD43AT101</del>	<del>34UBP04001</del>	<del>M</del>	<del>M</del>	<del>M</del>	<del>SI</del>	<del>C/NM</del>	<del>Y (5)</del>	



**Table 3.11-1—List of Environmentally Qualified Electrical/I&C Equipment  
Sheet 78 of 132**

Name Tag (Equipment Description)	Tag Number	Local Area KKS ID (Room Location)	EQ Environment (Note 1)	Radiation Environment Zone (Note 2)	EQ Designated Function (Note 3)	Safety Class (Note 4)	EQ Program Designation (Note 5)
Letdown Line Flow Transmitter	30KBA14CF752	30JFA01084	M	H	SI	S 1E EMC	Y (2) Y (6)
LP Reducing Station Control Valve Positi	30KBA14CG106	30JFA06095	M	H	SI	S 1E EMC	Y (2) Y (6)
VCT Level Transmitter	30KBA20CL750	30JFA10084	M	H	SI	S 1E EMC	Y (2) Y (6)
VCT Level Transmitter	30KBA20CL751	30JFA06084	M	H	SI	S 1E EMC	Y (2) Y (6)
VCT Level Transmitter	30KBA20CL752	30JFA10084	M	H	SI	S 1E EMC	Y (2) Y (6)
Charging Pump Discharge Flow Transmitter	30KBA34CF851A	30JFA01033	M	H	SI	S 1E EMC	Y (2) Y (6)
Charging Pump Discharge Flow Transmitter	30KBA34CF851B	30JFA01033	M	H	SI	S 1E EMC	Y (2) Y (6)
Charging Pump Discharge Flow Transmitter	30KBA34CF852A	30JFA01033	M	H	SI	S 1E EMC	Y (2) Y (6)
Charging Pump Discharge Flow Transmitter	30KBA34CF852B	30JFA01033	M	H	SI	S 1E EMC	Y (2) Y (6)
Boron Concentration Measurement Transmitt	30KBA34CQ857A	30JFA01033	M	H	SI	S 1E EMC	Y (2) Y (6)
Boron Concentration Measurement Transmitt	30KBA34CQ857B	30JFA01033	M	H	SI	S 1E EMC	Y (2) Y (6)
Boron Concentration Measurement Transmitt	30KBA34CQ858A	30JFA01033	M	H	SI	S 1E EMC	Y (2) Y (6)
Boron Concentration Measurement Transmitt	30KBA34CQ858B	30JFA01033	M	H	SI	S 1E EMC	Y (2) Y (6)
Charging Pump Discharge Temperature Tran	30KBA34CT857A	30JFA01033	M	H	SI	S 1E EMC	Y (2) Y (6)
Charging Pump Discharge Temperature Tran	30KBA34CT857B	30JFA01033	M	H	SI	S 1E EMC	Y (2) Y (6)
Charging Pump Discharge Temperature Tran	30KBA34CT858A	30JFA01033	M	H	SI	S 1E EMC	Y (2) Y (6)
Charging Pump Discharge Temperature Tran	30KBA34CT858B	30JFA01033	M	H	SI	S 1E EMC	Y (2) Y (6)
JEW							
RCP Seal Water Injection Outside Cont. I	30JEW01AA005	30JFA06045	M	H	ES PAM SI	S 1E EMC	Y (2) Y (6)
RCP Seal Water Leakoff Inside Containmen	30JEW50AA001	30JJA07016	H	H	ES PAM SI	S 1E EMC	Y (1) Y (5)
RCP Seal Water Leakoff Outside Containme	30JEW50AA002	30JFA06045	M	H	ES PAM SI	S 1E EMC	Y (2) Y (6)
Spent Fuel Pool Wide Range Level Sensor	30FAK31CL003	30JFA29015	M	H	SI	S 1E EMC	Y (2) Y (6)
Spent Fuel Pool Wide Range Level Sensor	30FAK31CL004	30JFA29015	M	H	SI	S 1E EMC	Y (2) Y (6)
Spent Fuel Pool Wide Range Level Sensor	30FAK31CL005	30JFA29015	M	H	SI	S 1E EMC	Y (2) Y (6)
Spent Fuel Pool Wide Range Level Sensor	30FAK31CL006	30JFA29015	M	H	SI	S 1E EMC	Y (2) Y (6)

**AUXILIARY SYSTEMS**

Nuclear Sampling System (NSS)							
RCS HL1 Iso Viv Actuator	30KUA10AA002	30JUA18003	H	H	SI	S 1E EMC	Y (1) Y (5)
RCS HL1 Inner Cont Iso Viv Actuator	30KUA10AA003	30JUA07016	H	H	ES PAM SI	S 1E EMC	Y (1) Y (5)
RCS HL1 Outer Iso Cont Viv Actuator	30KUA10AA004	30JFA06045	M	H	ES PAM SI	S 1E EMC	Y (2) Y (5)
Pressurizer Sample Viv Actuator	30KUA20AA001	30JJB05003	M	M	SI	S 1E EMC	Y (5) Y (6)
Pressurizer Inner Cont Iso Viv Actuator	30KUA20AA002	30JJB05003	M	M	ES PAM SI	S 1E EMC	Y (5) Y (6)



**Table 3.11-1—List of Environmentally Qualified Electrical/I&C Equipment  
Sheet 101 of 135**

Name Tag (Equipment Description)	Tag Number	Local Area KKS ID (Room Location)	EQ Environment (Note 1)	Radiation Environment Zone (Note 2)	EQ Designated Function (Note 3)	Safety Class (Note 4)	EQ Program Designation (Note 5)
Pos Meas 1 KLA10AA003	30KLA10CG003A	30UUA18016	H	H	SI	S 1E EMC	Y (1) Y (5)
Pos Meas 2 KLA10AA003	30KLA10CG003B	30UUA18016	H	H	SI	S 1E EMC	Y (1) Y (5)
Press Meas 1 KLA Supply	30KLA10CP001	30UFA24095	M	H	SII	NS-AQ EMC	Y (2) Y (5) Y (6)
Press Meas 2 KLA Supply	30KLA10CP002	30UFA24095	M	H	SII	NS-AQ EMC	Y (2) Y (5) Y (6)
KLA Purge Vent DP Sens 1	30KLA20CP001	30UUA23013	H	H	SII	NS-AQ EMC	Y (1) Y (5)
KLA Purge Vent DP Sens 2	30KLA20CP002	30UUA23013	H	H	SII	NS-AQ EMC	Y (1) Y (5)
DP Meas KLA21AT001	30KLA21CP501	30UFA24081	M	H	SI	S 1E EMC	Y (2) Y (5) Y (6)
DP Meas KLA21AT002	30KLA21CP502	30UFA24081	M	H	SI	S 1E EMC	Y (2) Y (5) Y (6)
DP Meas KLA21AT003	30KLA21CP503	30UFA24081	M	H	SI	S 1E EMC	Y (2) Y (5) Y (6)
DP Meas KLA21AT004	30KLA21CP504	30UFA24080	M	H	SI	S 1E EMC	Y (2) Y (5) Y (6)
DP Meas 21 Filter Banks	30KLA21CP505	30UFA24081	M	H	SI	S 1E EMC	Y (2) Y (5) Y (6)
Temp Meas KLA21AH005 Downstream	30KLA21CT001	30UFA24081	M	H	SI	S 1E EMC	Y (2) Y (5) Y (6)
Temp Meas KLA21AH005 Upstream	30KLA21CT002	30UFA24081	M	H	SI	S 1E EMC	Y (2) Y (5) Y (6)
Temp Meas KLA21AT003 Downstream	30KLA21CT003	30UFA24081	M	H	SI	S 1E EMC	Y (2) Y (5) Y (6)
KLA Purge Firl Tr-2 Flow Meas	30KLA22CF001	30UFA24081	M	H	SI	S 1E EMC	Y (2) Y (5) Y (6)
DP Meas KLA22AT001	30KLA22CP501	30UFA24081	M	H	SI	S 1E EMC	Y (2) Y (5) Y (6)
DP Meas KLA22AT002	30KLA22CP502	30UFA24081	M	H	SI	S 1E EMC	Y (2) Y (5) Y (6)
DP Meas KLA22AT003	30KLA22CP503	30UFA24081	M	H	SI	S 1E EMC	Y (2) Y (5) Y (6)
DP Meas KLA22AT004	30KLA22CP504	30UFA24081	M	H	SI	S 1E EMC	Y (2) Y (5) Y (6)
DP Meas 22 Filter Banks	30KLA22CP505	30UFA24081	M	H	SI	S 1E EMC	Y (2) Y (5) Y (6)
Temp Meas KLA22AH005 Downstream	30KLA22CT001	30UFA24081	M	H	SI	S 1E EMC	Y (2) Y (5) Y (6)
Temp Meas KLA22AH005 Upstream	30KLA22CT002	30UFA24081	M	H	SI	S 1E EMC	Y (2) Y (5) Y (6)
Temp Meas KLA22AT003 Downstream	30KLA22CT003	30UFA24081	M	H	SI	S 1E EMC	Y (2) Y (5) Y (6)
Pos Meas KLA30AA001	30KLA30CG001	30UFA21085	M	H	SII	NS-AQ EMC	Y (2) Y (5) Y (6)
Pos Meas 1 KLA30AA002	30KLA30CG002A	30UFA17095	M	H	SI	S 1E EMC	Y (2) Y (5) Y (6)
Pos Meas 2 KLA30AA002	30KLA30CG002B	30UFA17095	M	H	SI	S 1E EMC	Y (2) Y (5) Y (6)
Pos Meas 1 KLA30AA003	30KLA30CG003A	30UUA18016	H	H	SI	S 1E EMC	Y (1) Y (5)
Pos Meas 2 KLA30AA003	30KLA30CG003B	30UUA18016	H	H	SI	S 1E EMC	Y (1) Y (5)
Pos Meas 1 KLA40AA002	30KLA40CG002A	30UFA21095	M	H	SI	S 1E EMC	Y (2) Y (5) Y (6)
Pos Meas 2 KLA40AA002	30KLA40CG002B	30UFA21095	M	H	SI	S 1E EMC	Y (2) Y (5) Y (6)
Pos Meas KLA40AA004	30KLA40CG004	30UUA18016	H	H	SII	NS-AQ EMC	Y (1) Y (5)
KLA 5 Flow Measurement	30KLA50CF001	30UUA29022	H	H	SI	S 1E EMC	Y (1) Y (5)
DP Meas KLA50AT001	30KLA50CP501	30UUA29022	H	H	SI	S 1E EMC	Y (1) Y (5)



**Table 3.11-1—List of Environmentally Qualified Electrical/I&C Equipment**  
Sheet 102 of 135

Name Tag (Equipment Description)	Tag Number	Local Area KKS ID (Room Location)	EQ Environment (Note 1)	Radiation Environment Zone (Note 2)	EQ Designated Function (Note 3)	Safety Class (Note 4)	EQ Program Designation (Note 5)
DP Meas KLA50AT002	30KLA50CP502	30UUA29022	H	H	SI	S 1E EMC	Y (1) Y (5)
DP Meas KLA50AT003	30KLA50CP503	30UUA29022	H	H	SI	S 1E EMC	Y (1) Y (5)
DP Meas KLA50AT004	30KLA50CP504	30UUA29022	H	H	SI	S 1E EMC	Y (1) Y (5)
Temp Meas KLA50AH001 Downstream	30KLA50CT001	30UUA29022	H	H	SI	S 1E EMC	Y (1) Y (5)
Temp Meas KLA50AH001 Upstream	30KLA21CT003	30UJA24081	M	H	SI	S 1E EMC	Y (2) Y (5) Y (6)
Temp Meas KLA50AT003 Downstream	30KLA21CT003	30UJA24081	M	H	SI	S 1E EMC	Y (2) Y (5) Y (6)
KLA DP Sens 1 SG1	30KLA60CP851	30UJA13004	M	H	SI	S 1E EMC	Y (2) Y (5) Y (6)
KLA DP Sens 1 SG2	30KLA60CP852	32LUJH10002	M	H	SI	S 1E EMC	Y (2) Y (5) Y (6)
KLA DP Sens 1 SG3	30KLA60CP853	33LUJH10002	M	H	SI	S 1E EMC	Y (2) Y (5) Y (6)
KLA DP Sens 1 SG4	30KLA60CP854	30UJA10052	M	H	SI	S 1E EMC	Y (2) Y (5) Y (6)
KLA 6 Supply Air Temp Meas 1	30KLA61CT001	30UUA23017	H	H	SII	NS-AQ EMC	Y (1) Y (5)
KLA 6 Supply Air Temp Meas 2	30KLA61CT002	30UUA23017	H	H	SII	NS-AQ EMC	Y (1) Y (5)
KLA 6 RCP1 Air Temp Meas	30KLA61CT003	30UUA23002	H	H	SII	NS-AQ EMC	Y (1) Y (5)
KLA 6 RCP2 Air Temp Meas	30KLA61CT004	30UUA34005	H	H	SII	NS-AQ EMC	Y (1) Y (5)
KLA 6 SG1 Air Temp Meas	30KLA61CT005	30UUA34003	H	H	SII	NS-AQ EMC	Y (1) Y (5)
KLA 6 SG2 Air Temp Meas	30KLA61CT006	30UUA34004	H	H	SII	NS-AQ EMC	Y (1) Y (5)
KLA 6 Eq Comp CRDM Air Temp Meas	30KLA61CT007	30UUA15001	H	H	SII	NS-AQ EMC	Y (1) Y (5)
KLA 6 FAL Valves Air Temp Meas	30KLA61CT008	30UUA23020	H	H	SII	NS-AQ EMC	Y (1) Y (5)
KLA 6 KTA Pumps Air Temp Meas	30KLA61CT011	30UUA07022	H	H	SII	NS-AQ EMC	Y (1) Y (5)
KLA 6 Supply Air Temp Meas 3	30KLA63CT001	30UUA23018	H	H	SII	NS-AQ EMC	Y (1) Y (5)
KLA 6 Supply Air Temp Meas 4	30KLA63CT002	30UUA23018	H	H	SII	NS-AQ EMC	Y (1) Y (5)
KLA 6 RCP3 Air Temp Meas	30KLA63CT003	30UUA34006	H	H	SII	NS-AQ EMC	Y (1) Y (5)
KLA 6 RCP4 Air Temp Meas	30KLA63CT004	30UUA23009	H	H	SII	NS-AQ EMC	Y (1) Y (5)
KLA 6 SG3 Air Temp Meas	30KLA63CT005	30UUA34007	H	H	SII	NS-AQ EMC	Y (1) Y (5)
KLA 6 SG4 Air Temp Meas	30KLA63CT006	30UUA34008	H	H	SII	NS-AQ EMC	Y (1) Y (5)
KLA 6 Safety Relief Valve rm Air Temp	30KLA63CT008	30UUA34019	H	H	SII	NS-AQ EMC	Y (1) Y (5)
KLA 6 UJA11024 Air Temp Meas	30KLA63CT009	30UUA11024	H	H	SII	NS-AQ EMC	Y (1) Y (5)
KLA 6 UJA11022 Air Temp Meas	30KLA63CT010	30UUA11022	H	H	SII	NS-AQ EMC	Y (1) Y (5)
KLA 6 Temp Sensor Primary Pipe 1	30KLA65CT001	30UUA11001	H	H	SII	NS-AQ EMC	Y (1) Y (5)
KLA 6 Temp Sensor Primary Pipe 2	30KLA65CT002	30UUA11001	H	H	SII	NS-AQ EMC	Y (1) Y (5)
KLA 6 Temp Sensor Primary Pipe 3	30KLA65CT003	30UUA11001	H	H	SII	NS-AQ EMC	Y (1) Y (5)
KLA 6 Temp Sensor Primary Pipe 4	30KLA65CT004	30UUA11001	H	H	SII	NS-AQ EMC	Y (1) Y (5)
KLA 6 Temp Sensor Primary Pipe 5	30KLA65CT005	30UUA11001	H	H	SII	NS-AQ EMC	Y (1) Y (5)





**Table 3.11-1—List of Environmentally Qualified Electrical/I&C Equipment  
Sheet 104 of 135**

Name Tag (Equipment Description)	Tag Number	Local Area KKS ID (Room Location)	EQ Environment (Note 1)	Radiation Environment Zone (Note 2)	EQ Designated Function (Note 3)	Safety Class (Note 4)	EQ Program Designation (Note 5)
Exhaust Fan (Train 24)	30KLB24AN001	30UFA17081	M	H	ES	S	Y (2) Y (6)
Actuator Supply Air Isolation Damper	30KLB34AA002	30UFA21095	M	H	ES	S	Y (2) Y (6)
Actuator Supply Air Isolation Damper	30KLB34AA003	30UFA21095	M	H	ES	S	Y (2) Y (6)
Actuator Exhaust Air Isolation Damper	30KLB44AA002	30UFA29054	M	H	ES	S	Y (2) Y (6)
Actuator Exhaust Air Isolation Damper	30KLB44AA003	30UFA29054	M	H	ES	S	Y (2) Y (6)
Accident Filtration Train Flow Sensor	30KLB21CF001A	30UFA21095	M	H	ES	S	Y (2) Y (6)
Accident Filtration Train Flow Sensor	30KLB21CF001B	30UFA21095	M	H	ES	S	Y (2) Y (6)
Exhaust Fan Pressure Limit Switch Sensor	30KLB21CP002	30UFA17083	M	H	ES	S	Y (2) Y (6)
Pre- And HEPA Filter DP Gauge (Train 21)	30KLB21CP501	30UFA17084	M	H	ES	S	Y (2) Y (6)
HEPA Filter DP Gauge (Train 21)	30KLB21CP502	30UFA17084	M	H	ES	S	Y (2) Y (6)
Iodine Adsorber DP Gauge (Train 21)	30KLB21CP503	30UFA17084	M	H	ES	S	Y (2) Y (6)
Downstream HEPA Filter DP Gauge	30KLB21CP504	30UFA17084	M	H	ES	S	Y (2) Y (6)
Filter Bank DP Gauge (Train 21)	30KLB21CP505	30UFA17084	M	H	ES	S	Y (2) Y (6)
Temperature Sensor Upstream of Heater	30KLB21CT001	30UFA17084	M	H	ES	S	Y (2) Y (6)
Temp <del>Limit Switch</del> Regulation Sensor for Heater	30KLB21CT002	30UFA17084	M	H	ES	S	Y (2) Y (6)
Temperature Regulation Sensor for Heater	30KLB21CT003	30UFA17084	M	H	ES	S	Y (2) Y (6)
Temperature Sensor Downstream of Carbon Adsorber	30KLB21CT004	30UFA17084	M	H	ES	S	Y (2) Y (6)
Exhaust Fan Pressure Limit Switch Sensor	30KLB24CP002	30UFA17081	M	H	ES	S	Y (2) Y (6)
Pre- and HEPA Filter DP Gauge (Train 24)	30KLB24CP501	30UFA17082	M	H	ES	S	Y (2) Y (6)
HEPA Filter DP Gauge (Train 24)	30KLB24CP502	30UFA17084	M	H	ES	S	Y (2) Y (6)
Iodine Adsorber DP Gauge (Train 24)	30KLB24CP503	30UFA17082	M	H	ES	S	Y (2) Y (6)
Downstream HEPA Filter DP Gauge	30KLB24CP504	30UFA17082	M	H	ES	S	Y (2) Y (6)
Filter Bank DP Gauge (Train 24)	30KLB24CP505	30UFA17084	M	H	ES	S	Y (2) Y (6)
Temperature Sensor Upstream of Heater	30KLB24CT001	30UFA17082	M	H	ES	S	Y (2) Y (6)
Temp <del>Limit Switch</del> Regulation Sensor for Heater	30KLB24CT002	30UFA17082	M	H	ES	S	Y (2) Y (6)
Temperature Regulation Sensor for Heater	30KLB24CT003	30UFA17082	M	H	ES	S	Y (2) Y (6)
Temperature Sensor Downstream of Carbon Adsorber	30KLB24CT004	30UFA17082	M	H	ES	S	Y (2) Y (6)
<b>Safeguard Building Controlled Area Ventilation System (SBVS)</b>							
Vol Cont Dmptr Sup, Div 1	30KLC11AA003	31UJH05025	M	H	SI	S	Y (2) Y (6)



Table 3.11-1—List of Environmentally Qualified Electrical/I&C Equipment  
Sheet 108 of 135

Name Tag (Equipment Description)	Tag Number	Local Area KKS ID (Room Location)	EQ Environment (Note 1)	Radiation Environment Zone (Note 2)	EQ Designated Function (Note 3)	Safety Class (Note 4)	EQ Program Designation (Note 5)
DP 1, SG4	30KLC34CP851	33UJH10001	M	H	SI	S	Y(2) Y(6)
DP 2, SG4	30KLC34CP852	33UJH10001	M	H	SI	S	Y(2) Y(6)
DP 3, SG4	30KLC34CP853	33UJH10001	M	H	SI	S	Y(2) Y(6)
DP 4, SG4	30KLC34CP854	33UJH10001	M	H	SI	S	Y(2) Y(6)
DP, Acc Ex Tr 1	30KLC41CP001	30UFA21082	M	H	SI	S	Y(2) Y(6)
DP KLC41AT001	30KLC41CP501	30UFA21082	M	H	SI	S	Y(2) Y(6)
DP KLC41AT002	30KLC41CP502	30UFA21082	M	H	SI	S	Y(2) Y(6)
DP KLC41AT003	30KLC41CP503	30UFA21082	M	H	SI	S	Y(2) Y(6)
DP KLC41AT004	30KLC41CP504	30UFA21082	M	H	SI	S	Y(2) Y(6)
<del>Upstream Temp, Acc Ex Tr 1</del>	<del>30KLC41CT001</del>	<del>30UFA21082</del>	<del>M</del>	<del>H</del>	<del>SI</del>	<del>S</del>	<del>Y(2) Y(6)</del>
Upstream Temp Sensor Acc Ex Tr 1 Heater	30KLC41CT004	30UFA21082	M	H	SI	S	Y(2) Y(6)
Downstream Temp Sensors Acc Ex Tr 1 Heater	30KLC41CT001/002	30UFA21082	M	H	SI	S	Y(2) Y(6)
Downstream Temp Sensor Acc Ex Tr 1 Carbon Adsorber	30KLC41CT003	30UFA21082	M	H	SI	S	Y(2) Y(6)
DP, Acc Ex Tr 2	30KLC42CP001	30UFA21084	M	H	SI	S	Y(2) Y(6)
DP KLC42AT001	30KLC42CP501	30UFA21084	M	H	SI	S	Y(2) Y(6)
DP KLC42AT002	30KLC42CP502	30UFA21084	M	H	SI	S	Y(2) Y(6)
DP KLC42AT003	30KLC42CP503	30UFA21084	M	H	SI	S	Y(2) Y(6)
DP KLC42AT004	30KLC42CP504	30UFA21084	M	H	SI	S	Y(2) Y(6)
Upstream Temp, Acc Ex Tr 2	30KLC42CT001	30UFA21084	M	H	SI	S	Y(2) Y(6)
<del>Flow Meas 4 Tok Acc Ex</del>	<del>30KLC45CF001</del>	<del>30UFA21085</del>	<del>M</del>	<del>H</del>	<del>SI</del>	<del>S</del>	<del>Y(2) Y(6)</del>
Upstream Temp Sensor Acc Ex Tr 2 Heater	30KLC42CT004	30UFA21084	M	H	SI	S	Y(2) Y(6)
Downstream Temp Sensors Acc Ex Tr 2 Heater	30KLC42CT001/002	30UFA21084	M	H	SI	S	Y(2) Y(6)
Downstream Temp Sensor Acc Ex Tr 2 Carbon Adsorber	30KLC42CT003	30UFA21084	M	H	SI	S	Y(2) Y(6)
Flow Meas 2 Tok Acc Ex	30KLC45CF002	30UFA21085	M	H	SI	S	Y(2) Y(6)
Temp Sens 1 JND Pump Rm, SG1	30KLC51CT001	31UJH01002	M	H	SI	S	Y(2) Y(6)
Temp Sens 2 JND Pump Rm, SG1	30KLC51CT002	31UJH01002	M	H	SI	S	Y(2) Y(6)
Temp Sens 1 JNG Pump Rm, SG1	30KLC51CT003	31UJH01006	M	H	SI	S	Y(2) Y(6)
Temp Sens 2 JNG Pump Rm, SG1	30KLC51CT004	31UJH01006	M	H	SI	S	Y(2) Y(6)
Temp Sens 1 KAA Vlv Rm, SG1	30KLC51CT005	31UJH10004	M	H	SI	S	Y(2) Y(6)
Temp Sens 2 KAA Vlv Rm, SG1	30KLC51CT006	31UJH10004	M	H	SI	S	Y(2) Y(6)



**Table 3.11-1—List of Environmentally Qualified Electrical/I&C Equipment**  
Sheet 111 of 135

Name Tag (Equipment Description)	Tag Number	Local Area KKS ID (Room Location)	EQ Environment (Note 1)	Radiation Environment Zone (Note 2)	EQ Designated Function (Note 3)	Safety Class (Note 4)	EQ Program Designation (Note 5)
Exhaust Fan Motor Heater	30SAC34AH501	34LUK22039	M	M	SI	S	Y (5) Y (6)
Exhaust Fan Motor	30SAC34AN001	34LUK22039	M	M	SI	S	Y (5) Y (6)
Actuator Exhaust Air Control Damper	30SAC42AA001	32LUK22028	M	M	SI	S	Y (5) Y (6)
Actuator Exhaust Air Control Damper	30SAC43AA001	33LUK22028	M	M	SI	S	Y (5) Y (6)
Actuator Battery Room Exhaust	30SAC51AA003	31LUK22030	M	M	SI	S	Y (5) Y (6)
Actuator Battery Room Exhaust-Maint	30SAC51AA006	31LUK22030	M	M	SI	S	Y (5) Y (6)
Battery Room Exhaust Fan Motor	30SAC51AN001	31LUK22030	M	M	SI	S	Y (5) Y (6)
Actuator Battery Room Exhaust	30SAC52AA003	32LUK31032	M	M	SI	S	Y (5) Y (6)
Actuator Battery Room Exhaust-Maint	30SAC52AA006	32LUK31032	M	M	SI	S	Y (5) Y (6)
Battery Room Exhaust Fan	30SAC52AN001	32LUK31032	M	M	SI	S	Y (5) Y (6)
Actuator Battery Room Exhaust	30SAC53AA003	33LUK31032	M	M	SI	S	Y (5) Y (6)
Actuator Battery Room Exhaust-Maint	30SAC53AA006	33LUK31032	M	M	SI	S	Y (5) Y (6)
Battery Room Exhaust Fan	30SAC53AN001	33LUK31032	M	M	SI	S	Y (5) Y (6)
Actuator Battery Room Exhaust	30SAC54AA003	34LUK22028	M	M	SI	S	Y (5) Y (6)
Actuator Battery Room Exhaust-Maint	30SAC54AA006	34LUK22028	M	M	SI	S	Y (5) Y (6)
Battery Room Exhaust Fan Motor	30SAC54AN001	34LUK22028	M	M	SI	S	Y (5) Y (6)
LAS Pump Room Recirc Fan Motor	30SAC61AN001	31LUJH01024	M	H	SI	S	Y (2) Y (6)
AAA Pump Room Recirc Fan Motor	30SAC61AN002	31LUJH01026	M	H	SI	S	Y (2) Y (6)
LAS Pump Room Recirc Fan	30SAC62AN001	32LUJH01024	M	H	SI	S	Y (2) Y (6)
AAA Pump Room Recirc Fan	30SAC62AN002	32LUJH01026	M	H	SI	S	Y (2) Y (6)
LAS Pump Room Recirc Fan	30SAC63AN001	33LUJH01024	M	H	SI	S	Y (2) Y (6)
AAA Pump Room Recirc Fan	30SAC63AN002	33LUJH01026	M	H	SI	S	Y (2) Y (6)
LAS Pump Room Recirc Fan Motor	30SAC64AN001	34LUJH01024	M	H	SI	S	Y (2) Y (6)
AAA Pump Room Recirc Fan Motor	30SAC64AN002	34LUJH01026	M	H	SI	S	Y (2) Y (6)
Supply Air Flow Div 1	30SAC01CF001	31LUK22024	M	M	SI	S	Y (5) Y (6)
Position Indicator Inlet Control Damper	30SAC01CG003	31LUK22026	M	M	SI	S	Y (5) Y (6)
Position Indicator Recirc Control Damper	30SAC01CG004	31LUK22028	M	M	SI	S	Y (5) Y (6)
Filter Bank Diff Pressure Sensor	30SAC01CP001	31LUK22026	M	M	SI	S	Y (5) Y (6)
Pre Filter Diff Pressure Sensor	30SAC01CP501	31LUK22026	M	M	SI	S	Y (5) Y (6)
Filter Differential Pressure Sensor	30SAC01CP502	31LUK22026	M	M	SI	S	Y (5) Y (6)
Outside Air Temperature Sensor	30SAC01CT001	31LUK22026	M	M	SI	S	Y (5) Y (6)
Outside Air Temperature Sensor	30SAC01CT002	31LUK22026	M	M	SI	S	Y (5) Y (6)
Supply Air Temperature Sensor	30SAC01CT003	31LUK22026	M	M	SI	S	Y (5) Y (6)



**Table 3.11-1—List of Environmentally Qualified Electrical/I&C Equipment  
Sheet 112 of 135**

Name Tag (Equipment Description)	Tag Number	Local Area KKS ID (Room Location)	EQ Environment (Note 1)	Radiation Environment Zone (Note 2)	EQ Designated Function (Note 3)	Safety Class (Note 4)	EQ Program Designation (Note 5)
Supply Air Temperature Sensor	30SAC01CT004	31LUK22026	M	M	SI	S 1E EMC	Y (5) Y (6)
Supply Air Temperature Sensor	30SAC01CT005	31LUK22026	M	M	SI	S 1E EMC	Y (5) Y (6)
Supply Air Temperature Sensor	30SAC01CT006	31LUK22026	M	M	SI	S 1E EMC	Y (5) Y (6)
Supply Air Temperature Sensor	30SAC01CT501	31LUK22026	M	M	SI	S 1E EMC	Y (5) Y (6)
Supply Air Temperature Sensor	30SAC01CT502	31LUK22026	M	M	SI	S 1E EMC	Y (5) Y (6)
<u>Supply Air Flow Div 2</u>	<u>30SAC02CF002</u>	<u>32LUK31005</u>	<u>M</u>	<u>M</u>	<u>SI</u>	<u>S 1E EMC</u>	<u>Y (5) Y (6)</u>
<u>Position Indicator Inlet Control Damper</u>	<u>30SAC02CG003</u>	<u>32LUK31005</u>	<u>M</u>	<u>M</u>	<u>SI</u>	<u>S 1E EMC</u>	<u>Y (5) Y (6)</u>
<u>Position Indicator Recirc Control Damper</u>	<u>30SAC02CG003</u>	<u>32LUK31005</u>	<u>M</u>	<u>M</u>	<u>SI</u>	<u>S 1E EMC</u>	<u>Y (5) Y (6)</u>
<u>Filter Bank Diff Pressure Sensor</u>	<u>30SAC02CP001</u>	<u>32LUK31018</u>	<u>M</u>	<u>M</u>	<u>SI</u>	<u>S 1E EMC</u>	<u>Y (5) Y (6)</u>
<u>Pre Filter Bank Diff Pressure Sensor</u>	<u>30SAC02CP501</u>	<u>32LUK31018</u>	<u>M</u>	<u>M</u>	<u>SI</u>	<u>S 1E EMC</u>	<u>Y (5) Y (6)</u>
<u>Filter Differential Pressure Sensor</u>	<u>30SAC02CP502</u>	<u>32LUK31018</u>	<u>M</u>	<u>M</u>	<u>SI</u>	<u>S 1E EMC</u>	<u>Y (5) Y (6)</u>
<u>Outside Air Temperature Sensor</u>	<u>30SAC02CT001</u>	<u>32LUK38006</u>	<u>M</u>	<u>M</u>	<u>SI</u>	<u>S 1E EMC</u>	<u>Y (5) Y (6)</u>
<u>Outside Air Temperature Sensor</u>	<u>30SAC02CT002</u>	<u>32LUK38006</u>	<u>M</u>	<u>M</u>	<u>SI</u>	<u>S 1E EMC</u>	<u>Y (5) Y (6)</u>
<u>Supply Air Temperature Sensor</u>	<u>30SAC02CT003</u>	<u>32LUK34008</u>	<u>M</u>	<u>M</u>	<u>SI</u>	<u>S 1E EMC</u>	<u>Y (5) Y (6)</u>
<u>Supply Air Temperature Sensor</u>	<u>30SAC02CT004</u>	<u>32LUK34008</u>	<u>M</u>	<u>M</u>	<u>SI</u>	<u>S 1E EMC</u>	<u>Y (5) Y (6)</u>
<u>Supply Air Temperature Sensor</u>	<u>30SAC02CT005</u>	<u>32LUK34008</u>	<u>M</u>	<u>M</u>	<u>SI</u>	<u>S 1E EMC</u>	<u>Y (5) Y (6)</u>
<u>Supply Air Temperature Sensor</u>	<u>30SAC02CT006</u>	<u>32LUK31005</u>	<u>M</u>	<u>M</u>	<u>SI</u>	<u>S 1E EMC</u>	<u>Y (5) Y (6)</u>
<u>Supply Air Temperature Sensor</u>	<u>30SAC02CT501</u>	<u>32LUK34008</u>	<u>M</u>	<u>M</u>	<u>SI</u>	<u>S 1E EMC</u>	<u>Y (5) Y (6)</u>
<u>Supply Air Temperature Sensor</u>	<u>30SAC02CT502</u>	<u>32LUK34009</u>	<u>M</u>	<u>M</u>	<u>SI</u>	<u>S 1E EMC</u>	<u>Y (5) Y (6)</u>
<u>Supply Air Flow Div 3</u>	<u>30SAC03CF001</u>	<u>33LUK21005</u>	<u>M</u>	<u>M</u>	<u>SI</u>	<u>S 1E EMC</u>	<u>Y (5) Y (6)</u>
Position Indicator Inlet Control Damper	30SAC03CG003	33LUK34005	M	M	SI	S 1E EMC	Y (5) Y (6)
Position Indicator Recirc Control Damper	30SAC03CG004	33LUK31018	M	M	SI	S 1E EMC	Y (5) Y (6)
<u>Filter Bank Diff Pressure Sensor</u>	<u>30SAC03CP001</u>	<u>32LUK31018</u>	<u>M</u>	<u>M</u>	<u>SI</u>	<u>S 1E EMC</u>	<u>Y (5) Y (6)</u>
Pre Filter Diff Pressure Sensor	30SAC03CP601	33LUK31018	M	M	SI	S 1E EMC	Y (5) Y (6)
Filter Differential Pressure Sensor	30SAC03CP602	33LUK31018	M	M	SI	S 1E EMC	Y (5) Y (6)
Outside Air Temperature Sensor	30SAC03CT001	33LUK38006	M	M	SI	S 1E EMC	Y (5) Y (6)
Outside Air Temperature Sensor	30SAC03CT002	33LUK38006	M	M	SI	S 1E EMC	Y (5) Y (6)
Supply Air Temperature Sensor	30SAC03CT003	33LUK34008	M	M	SI	S 1E EMC	Y (5) Y (6)
Supply Air Temperature Sensor	30SAC03CT004	33LUK34008	M	M	SI	S 1E EMC	Y (5) Y (6)
Supply Air Temperature Sensor	30SAC03CT005	33LUK34008	M	M	SI	S 1E EMC	Y (5) Y (6)
Supply Air Temperature Sensor	30SAC03CT006	33LUK31005	M	M	SI	S 1E EMC	Y (5) Y (6)
Supply Air Temperature Sensor	30SAC03CT501	33LUK34008	M	M	SI	S 1E EMC	Y (5) Y (6)
Supply Air Temperature Sensor	30SAC03CT502	33LUK34009	M	M	SI	S 1E EMC	Y (5) Y (6)



**Table 3.11-1—List of Environmentally Qualified Electrical/I&C Equipment  
Sheet 113 of 135**

Name Tag (Equipment Description)	Tag Number	Local Area KKS ID (Room Location)	EQ Environment (Note 1)	Radiation Environment Zone (Note 2)	EQ Designated Function (Note 3)	Safety Class (Note 4)	EQ Program Designation (Note 5)
Supply Air Flow Div 4	30SAC03CF001	34LUK22026	M	M	SI	SI	Y (5) Y (6)
Position Indicator Inlet Control Damper	30SAC04CG003	34LUK22026	M	M	SI	1E EMC	Y (5) Y (6)
Position Indicator Recirc Control Damper	30SAC04CG004	34LUK22028	M	M	SI	1E EMC	Y (5) Y (6)
Filter Bank Diff Pressure Sensor	30SAC04CP001	34LUK22026	M	M	SI	1E EMC	Y (5) Y (6)
Pre Filter Diff Pressure Sensor	30SAC04CP501	34LUK22026	M	M	SI	1E EMC	Y (5) Y (6)
Filter Differential Pressure Sensor	30SAC04CP502	34LUK22026	M	M	SI	1E EMC	Y (5) Y (6)
Outside Air Temperature Sensor	30SAC04CT001	34LUK22026	M	M	SI	1E EMC	Y (5) Y (6)
Outside Air Temperature Sensor	30SAC04CT002	34LUK22026	M	M	SI	1E EMC	Y (5) Y (6)
Supply Air Temperature Sensor	30SAC04CT003	34LUK22026	M	M	SI	1E EMC	Y (5) Y (6)
Supply Air Temperature Sensor	30SAC04CT004	34LUK22026	M	M	SI	1E EMC	Y (5) Y (6)
Supply Air Temperature Sensor	30SAC04CT005	34LUK22026	M	M	SI	1E EMC	Y (5) Y (6)
Supply Air Temperature Sensor	30SAC04CT006	34LUK22026	M	M	SI	1E EMC	Y (5) Y (6)
Supply Air Temperature Sensor	30SAC04CT501	34LUK22026	M	M	SI	1E EMC	Y (5) Y (6)
Supply Air Temperature Sensor	30SAC04CT502	34LUK22026	M	M	SI	1E EMC	Y (5) Y (6)
Battery Room Supply Air Flow Sensor	30SAC11CF001	31LUK18027	M	M	SI	1E EMC	Y (5) Y (6)
Battery Rm Supply Air Flow Sensor	30SAC11CF002	31LUK14026	M	M	SI	1E EMC	Y (5) Y (6)
Supply Air Flow Sensor	30SAC11CF003	31LUK26026	M	M	SI	1E EMC	Y (5) Y (6)
Position Indicator Maint Supply Air	30SAC11CG003A	31LUK22024	M	M	SI	1E EMC	Y (5) Y (6)
Position Indicator Maint Supply Air	30SAC11CG003B	31LUK22024	M	M	SI	1E EMC	Y (5) Y (6)
Battery Room Supply Air Temp Sensor	30SAC11CT001	31LUK18027	M	M	SI	1E EMC	Y (5) Y (6)
Battery Rm Air Temperature Sensor	30SAC11CT002	31LUK18028	M	M	SI	1E EMC	Y (5) Y (6)
I&C Area Temperature Sensor	30SAC11CT003	31LUK18024	M	M	SI	1E EMC	Y (5) Y (6)
Battery Rm Supply Air Temperature Sensor	30SAC11CT004	31LUH01026	M	H	SI	1E EMC	Y (5) Y (6)
Battery Room Air Temperature Sensor	30SAC11CT005	31LUK14028	M	M	SI	1E EMC	Y (5) Y (6)
Switchgear Rm Air Temp Sensor	30SAC11CT006	31LUK18026	M	M	SI	1E EMC	Y (5) Y (6)
Supply Air Heater Temperature Sen	30SAC11CT008	31LUK26024	M	M	SI	1E EMC	Y (5) Y (6)
Rm Air Temperature Sensor	30SAC11CT009	31LUK26026	M	M	SI	1E EMC	Y (5) Y (6)
Switchgear Rm Air Temp Sensor	30SAC13CT006	33LUK18020	M	M	SI	1E EMC	Y (5) Y (6)
Battery Room Supply Air Flow Sensor	30SAC12CF001	32LUK22028	M	M	SI	1E EMC	Y (5) Y (6)
Position Indicator Maint Supply Air	30SAC12CG005A	32LUK31041	M	M	SI	1E EMC	Y (5) Y (6)
Position Indicator Maint Supply Air	30SAC12CG005B	32LUK31041	M	M	SI	1E EMC	Y (5) Y (6)
Battery Room Supply Air Temp Sensor	30SAC12CT001	32LUK22028	M	M	SI	1E EMC	Y (5) Y (6)
Battery Rm Air Temperature Sensor	30SAC12CT002	32LUK22028	M	M	SI	1E EMC	Y (5) Y (6)



**Table 3.11-1—List of Environmentally Qualified Electrical/I&C Equipment**  
Sheet 119 of 135

Name Tag (Equipment Description)	Tag Number	Local Area KKS ID (Room Location)	EQ Environment (Note 1)	Radiation Environment Zone (Note 2)	EQ Designated Function (Note 3)	Safety Class (Note 4)	EQ Program Designation (Note 5)
<u>Conditioning Train 01 Flow Measurement</u>	<u>30SAB01CF001</u>	<u>32LUK31034</u>	<u>M</u>	<u>M</u>	<u>SI</u>	<u>SI</u>	<u>Y(5) Y(6)</u>
Recirc. HEPA DP - Div 1	30SAB01CP002	32LUK31034	M	M	SI	1E EMC	Y(5) Y(6)
Makeup Air Pre-Filter DP - Div 1	30SAB01CP501	32LUK31034	M	M	SI	1E EMC	Y(5) Y(6)
Recirc. HEPA DP (Local) - Div 1	30SAB01CP504	32LUK31034	M	M	SI	1E EMC	Y(5) Y(6)
Makeup Air Inlet Temp - Div 1	30SAB01CT001	32LUK31034	M	M	SI	1E EMC	Y(5) Y(6)
Makeup Air Heater Outlet Temp - Div 1 A	30SAB01CT002	32LUK31034	M	M	SI	1E EMC	Y(5) Y(6)
Makeup Air Heater Outlet Temp - Div 1 B	30SAB01CT003	32LUK31034	M	M	SI	1E EMC	Y(5) Y(6)
Makeup Air Heater Outlet Temp - Div 1 C	30SAB01CT004	32LUK31034	M	M	SI	1E EMC	Y(5) Y(6)
Recirc. CoolCoil Inlet Temp (Local) -Div 1	30SAB01CT501	32LUK31034	M	M	SI	1E EMC	Y(5) Y(6)
Recirc. CoolCoil Exit Temp (Local) -Div 1	30SAB01CT502	32LUK31034	M	M	SI	1E EMC	Y(5) Y(6)
Smoke Detector	30SAB01SD001	32LUK31034	M	M	SII	NS-AQ	Y(5) Y(6)
<u>Conditioning Train 02 Flow Measurement</u>	<u>30SAB02CF001</u>	<u>32LUK31035</u>	<u>M</u>	<u>M</u>	<u>SI</u>	<u>1E EMC</u>	<u>Y(5) Y(6)</u>
Recirc. HEPA DP - Div 2	30SAB02CP002	32LUK31035	M	M	SI	1E EMC	Y(5) Y(6)
Recirc. HEPA DP (Local) - Div 2	30SAB02CP504	32LUK31035	M	M	SI	1E EMC	Y(5) Y(6)
Recirc. CoolCoil Inlet Temp (Local) -Div 2	30SAB02CT501	32LUK31035	M	M	SI	1E EMC	Y(5) Y(6)
Recirc. CCoil Outlet Temp (Local) - Div 2	30SAB02CT502	32LUK31035	M	M	SI	1E EMC	Y(5) Y(6)
<u>Conditioning Train 03 Flow Measurement</u>	<u>30SAB03CF001</u>	<u>32LUK31035</u>	<u>M</u>	<u>M</u>	<u>SI</u>	<u>1E EMC</u>	<u>Y(5) Y(6)</u>
Recirc. HEPA DP - Div 3	30SAB03CP002	33LUK31034	M	M	SI	1E EMC	Y(5) Y(6)
Recirc. HEPA DP (Local) - Div 3	30SAB03CP504	33LUK31034	M	M	SI	1E EMC	Y(5) Y(6)
Recirc CoolCoil Inlet Temp (Local) -Div 3	30SAB03CT501	33LUK31034	M	M	SI	1E EMC	Y(5) Y(6)
Recirc. Cool Coil Exit Temp (Local) -Div 3	30SAB03CT502	33LUK31034	M	M	SI	1E EMC	Y(5) Y(6)
Recirc Vol Cont Damp Position Indic-Div 4	30SAB04CG012	33LUK31035	M	M	SI	1E EMC	Y(5) Y(6)
<u>Conditioning Train 04 Flow Measurement</u>	<u>30SAB04CF001</u>	<u>32LUK31034</u>	<u>M</u>	<u>M</u>	<u>SI</u>	<u>1E EMC</u>	<u>Y(5) Y(6)</u>
Makeup Air Pre-Filter DP - Div 4	30SAB04CP501	33LUK31035	M	M	SI	1E EMC	Y(5) Y(6)
Recirc. HEPA DP (Local) - Div 4	30SAB04CP504	33LUK31035	M	M	SI	1E EMC	Y(5) Y(6)
Makeup Air Inlet Temp - Div 4	30SAB04CT001	33LUK31035	M	M	SI	1E EMC	Y(5) Y(6)
Makeup Air Heater Outlet Temp - Div 4 A	30SAB04CT002	33LUK31035	M	M	SI	1E EMC	Y(5) Y(6)
Makeup Air Heater Outlet Temp - Div 4 B	30SAB04CT003	33LUK31035	M	M	SI	1E EMC	Y(5) Y(6)
Makeup Air Heater Outlet Temp - Div 4 C	30SAB04CT004	33LUK31035	M	M	SI	1E EMC	Y(5) Y(6)
Recirc CoolCoil Inlet Temp (Local) - Div 4	30SAB04CT501	33LUK31035	M	M	SI	1E EMC	Y(5) Y(6)
Recirc. CoolCoil Exit Temp (Local) - Div 4	30SAB04CT502	33LUK31035	M	M	SI	1E EMC	Y(5) Y(6)
Smoke Detector	30SAB04SD001	32LUK31034	M	M	SII	NS-AQ	Y(5) Y(6)
<u>Iodine Filtration Train 01 Flow Measurement</u>	<u>30SAB11CF001</u>	<u>32LUK31034</u>	<u>M</u>	<u>M</u>	<u>SI</u>	<u>1E EMC</u>	<u>Y(5) Y(6)</u>



**Table 3.11-1—List of Environmentally Qualified Electrical/I&C Equipment  
Sheet 120 of 135**

Name Tag (Equipment Description)	Tag Number	Local Area KKS ID (Room Location)	EQ Environment (Note 1)	Radiation Environment Zone (Note 2)	EQ Designated Function (Note 3)	Safety Class (Note 4)	EQ Program Designation (Note 5)
Iodine Filtr. Filter DP - Div 1	30SAB11CP001	32JUK31034	M	M	SI	S	Y(5) Y(6)
Iodine Filtration Pre-Filter DP - Div 1	30SAB11CP501	32JUK31034	M	M	SI	S	Y(5) Y(6)
Iodine Filtr. Inlet HEPA DP - Div1	30SAB11CP502	32JUK31034	M	M	SI	S	Y(5) Y(6)
Iodine Filtration Charcoal DP - Div 1	30SAB11CP503	32JUK31034	M	M	SI	S	Y(5) Y(6)
Iodine Filtration Outlet HEPA DP - Div 1	30SAB11CP504	32JUK31034	M	M	SI	S	Y(5) Y(6)
SAB11 Filtr Train Temp Sens 1	30SAB11CT001	32JUK31034	M	M	SI	S	Y(5) Y(6)
SAB11 Filtr Train Temp Sens 2	30SAB11CT002	32JUK31034	M	M	SI	S	Y(5) Y(6)
<u>Iodine Filtration Train 01 Carbon Adsorber Outlet Temp Sens.</u>	<u>30SAB11CT003</u>	<u>32JUK31034</u>	<u>M</u>	<u>M</u>	<u>SI</u>	<u>S</u>	<u>Y(5) Y(6)</u>
<u>Iodine Filtration Train 04 Flow Measurement</u>	<u>30SAB14CF001</u>	<u>32JUK31034</u>	<u>M</u>	<u>M</u>	<u>SI</u>	<u>S</u>	<u>Y(5) Y(6)</u>
Iodine Filtration Filter DP - Div 4	30SAB14CP001	33JUK31034	M	M	SI	S	Y(5) Y(6)
Iodine Filtration Pre-Filter DP - Div 4	30SAB14CP501	33JUK31034	M	M	SI	S	Y(5) Y(6)
Iodine Filtration Inlet HEPA DP - Div 4	30SAB14CP502	33JUK31034	M	M	SI	S	Y(5) Y(6)
Iodine Filtration Charcoal DP - Div 4	30SAB14CP503	33JUK31034	M	M	SI	S	Y(5) Y(6)
Iodine Filtration Outlet HEPA DP - Div 4	30SAB14CP504	33JUK31034	M	M	SI	S	Y(5) Y(6)
SAB14 Filtr Train Temp Sens 1	30SAB14CT001	33JUK31034	M	M	SI	S	Y(5) Y(6)
SAB14 Filtr Train Temp Sens 2	30SAB14CT002	33JUK31034	M	M	SI	S	Y(5) Y(6)
<u>Iodine Filtration Train 04 Carbon Adsorber Outlet Temp Sens.</u>	<u>30SAB14CT003</u>	<u>32JUK31034</u>	<u>M</u>	<u>M</u>	<u>SI</u>	<u>S</u>	<u>Y(5) Y(6)</u>
MCR Supply Duct Heater Outlet Air Flow	30SAB32CF001	32JUK26030	M	M	SI	S	Y(5) Y(6)
Tag/Shift Off Supply Duct Heat Exit Flow	30SAB32CF002	33JUK26030	M	M	SI	S	Y(5) Y(6)
WC & Kitchen Supply Duct Heat Exit Flow	30SAB32CF003	32JUK26015	M	M	SI	S	Y(5) Y(6)
Kitchen Supply Duct Heater Exit Flow	30SAB32CF004	33JUK26044	M	M	SI	S	Y(5) Y(6)
I&CService Supply Duct Heat Exit Flow	30SAB32CF005	33JUK26034	M	M	SI	S	Y(5) Y(6)
Special Use Supply Duct Heater Exit Flow	30SAB32CF006	33JUK26032	M	M	SI	S	Y(5) Y(6)
TechSupport Supply Duct Heater Exit Flow	30SAB32CF007	33JUK26030	M	M	SI	S	Y(5) Y(6)
DP between MCR and Anteroom A	30SAB32CP001	32JUK26030	M	M	SI	S	Y(5) Y(6)
DP between MCR and Anteroom B	30SAB32CP002	32JUK26030	M	M	SI	S	Y(5) Y(6)
DP between MCR and Anteroom C	30SAB32CP003	32JUK26030	M	M	SI	S	Y(5) Y(6)
DP between MCR and Anteroom (Local)	30SAB32CP501	32JUK26030	M	M	SI	S	Y(5) Y(6)
MCR Supply Duct Heater Outlet Air Temp	30SAB32CT001	32JUK26030	M	M	SI	S	Y(5) Y(6)
MCR Temp A	30SAB32CT002	32JUK26030	M	M	SI	S	Y(5) Y(6)
MCR Temp B	30SAB32CT003	32JUK26030	M	M	SI	S	Y(5) Y(6)



**Table 3.11-1—List of Environmentally Qualified Electrical/I&C Equipment  
Sheet 121 of 135**

Name Tag (Equipment Description)	Tag Number	Local Area KKS ID (Room Location)	EQ Environment (Note 1)	Radiation Environment Zone (Note 2)	EQ Designated Function (Note 3)	Safety Class (Note 4)	EQ Program Designation (Note 5)
Tagging/ShiftOffice Heater Exit Temp	30SAB32CT004	33LUK26030	M	M	SI	1E EMC	Y (5) Y (6)
Tagging Rm Temp	30SAB32CT005	33LUK26030	M	M	SI	1E EMC	Y (5) Y (6)
I&C Service Center Rm Temp A	30SAB32CT006	33LUK26034	M	M	SI	1E EMC	Y (5) Y (6)
SICS1 / Computer Rm 1 Temp	30SAB32CT007	32LUK26002	M	M	SI	1E EMC	Y (5) Y (6)
SICS2 / Computer Rm 2 Temp	30SAB32CT008	33LUK26002	M	M	SI	1E EMC	Y (5) Y (6)
WC & Kitchen Supply Duct Heat Exit Temp	30SAB32CT009	32LUK26015	M	M	SI	1E EMC	Y (5) Y (6)
Kitchen (MCR Staff) Temp	30SAB32CT010	32LUK26031	M	M	SI	1E EMC	Y (5) Y (6)
Kitchen Supply Duct Heater Outlet Temp	30SAB32CT011	33LUK26044	M	M	SI	1E EMC	Y (5) Y (6)
Kitchen Temp	30SAB32CT012	33LUK26044	M	M	SI	1E EMC	Y (5) Y (6)
I&C Service Supply Duct Heater Exit Temp	30SAB32CT013	33LUK26034	M	M	SI	1E EMC	Y (5) Y (6)
I&C Service Center Rm Temp B	30SAB32CT014	33LUK26034	M	M	SI	1E EMC	Y (5) Y (6)
Special Use Supply Duct Heat Exit Temp	30SAB32CT015	33LUK26032	M	M	SI	1E EMC	Y (5) Y (6)
Special Use Temp	30SAB32CT016	33LUK26032	M	M	SI	1E EMC	Y (5) Y (6)
Tech Supp Supply Duct Heat Exit Temp	30SAB32CT017	33LUK26030	M	M	SI	1E EMC	Y (5) Y (6)
Tech Support Center Temp	30SAB32CT018	33LUK26006	M	M	SI	1E EMC	Y (5) Y (6)
<b>Essential Service Water Pump Building Ventilation System (ESWPBVS)</b>							
Elec Room Air Heater Bldg 1	30SAQ01AH001	31UQB02001	M	M	SI	1E EMC	Y (5) Y (6)
Elec Room Air Heater Bldg 1	30SAQ01AH002	31UQB02001	M	M	SI	1E EMC	Y (5) Y (6)
Recirc Fan Bldg 1	30SAQ01AN001	31UQB02001	M	M	SI	1E EMC	Y (5) Y (6)
Inlet Air Isol Dmpr Bldg 1	30SAQ01AA007	31UQB02001	M	M	SI	1E EMC	Y (5) Y (6)
Exhaust Air Isol Dmpr Bldg 1	30SAQ01AA005	31UQB02001	M	M	SI	1E EMC	Y (5) Y (6)
Split Cooler Fan Bldg 1	30SAQ01AN002	31UQB02001	M	M	SI	1E EMC	Y (5) Y (6)
Split Cooler Condenser Bldg 1	30SAQ01AC102	31UQB02001	M	M	SI	1E EMC	Y (5) Y (6)
Elec Room Air Heater Bldg 2	30SAQ02AH001	32UQB02001	M	M	SI	1E EMC	Y (5) Y (6)
Elec Room Air Heater Bldg 2	30SAQ02AH002	32UQB02001	M	M	SI	1E EMC	Y (5) Y (6)
Recirc Fan Bldg 2	30SAQ02AN001	32UQB02001	M	M	SI	1E EMC	Y (5) Y (6)
Inlet Air Isol Dmpr Bldg 2	30SAQ02AA007	32UQB02001	M	M	SI	1E EMC	Y (5) Y (6)
Exhaust Air Isol Dmpr Bldg 2	30SAQ02AA005	32UQB02001	M	M	SI	1E EMC	Y (5) Y (6)
Split Cooler Fan Bldg 2	30SAQ02AN002	32UQB02001	M	M	SI	1E EMC	Y (5) Y (6)
Split Cooler Condenser Bldg 2	30SAQ02AC102	32UQB02001	M	M	SI	1E EMC	Y (5) Y (6)
Elec Room Air Heater Bldg 3	30SAQ03AH001	33UQB02001	M	M	SI	1E EMC	Y (5) Y (6)
Elec Room Air Heater Bldg 3	30SAQ03AH002	33UQB02001	M	M	SI	1E EMC	Y (5) Y (6)
Recirc Fan Bldg 3	30SAQ03AN001	33UQB02001	M	M	SI	1E EMC	Y (5) Y (6)





**Table 3.11-1—List of Environmentally Qualified Electrical/I&C Equipment**  
Sheet 122 of 135

Name Tag (Equipment Description)	Tag Number	Local Area KKS ID (Room Location)	EQ Environment (Note 1)	Radiation Environment Zone (Note 2)	EQ Designated Function (Note 3)	Safety Class (Note 4)	EQ Program Designation (Note 5)
Inlet Air Isol Dmpr - Bldg 3	30SAQ03AA007	33UQB02001	M	M	SI	1E EMC	Y(5) Y(6)
Exhaust Air Isol Dmpr - Bldg 3	30SAQ03AA005	33UQB02001	M	M	SI	1E EMC	Y(5) Y(6)
Split Cooler Fan Bldg 3	30SAQ03AN002	33UQB02001	M	M	SII	EMC	Y(5) Y(6)
Split Cooler Condenser Bldg 3	30SAQ03AC102	33UQB02001	M	M	SII	EMC	Y(5) Y(6)
Elec Room Air Heater Bldg 4	30SAQ04AH001	34UQB02001	M	M	SI	1E EMC	Y(5) Y(6)
Elec Room Air Heater Bldg 4	30SAQ04AH002	34UQB02001	M	M	SI	1E EMC	Y(5) Y(6)
Recirc Fan Bldg 4	30SAQ04AN001	34UQB02001	M	M	SI	1E EMC	Y(5) Y(6)
Inlet Air Isol Dmpr - Bldg 4	30SAQ04AH002	34UQB02001	M	M	SI	1E EMC	Y(5) Y(6)
Exhaust Air Isol Dmpr - Bldg 4	30SAQ04AA005	34UQB02001	M	M	SI	1E EMC	Y(5) Y(6)
Split Cooler Fan Bldg 4	30SAQ04AN002	34UQB02001	M	M	SII	EMC	Y(5) Y(6)
Split Cooler Condenser Bldg 4	30SAQ04AC102	34UQB02001	M	M	SII	EMC	Y(5) Y(6)
Recessed Outside Air Temp Sensor Bldg 1	30SAQ01CT001	31UQB02001	M	M	SI	1E EMC	Y(5) Y(6)
Recessed Outside Air Temp Sensor Bldg 2	30SAQ02CT001	32UQB02001	M	M	SI	1E EMC	Y(5) Y(6)
Recessed Outside Air Temp Sensor Bldg 3	30SAQ03CT001	33UQB02001	M	M	SI	1E EMC	Y(5) Y(6)
Recessed Outside Air Temp Sensor Bldg 4	30SAQ04CT001	34UQB02001	M	M	SI	1E EMC	Y(5) Y(6)
Electric Heater Temperature Sensor Bldg 1	30SAQ01CT002	31UQB02001	M	M	SI	1E EMC	Y(5) Y(6)
Electric Heater Temperature Sensor Bldg 1	30SAQ01CT003	31UQB02001	M	M	SI	1E EMC	Y(5) Y(6)
Electric Heater Temperature Sensor Bldg 2	30SAQ02CT002	32UQB02001	M	M	SI	1E EMC	Y(5) Y(6)
Electric Heater Temperature Sensor Bldg 2	30SAQ02CT003	32UQB02001	M	M	SI	1E EMC	Y(5) Y(6)
Electric Heater Temperature Sensor Bldg 3	30SAQ03CT002	33UQB02001	M	M	SI	1E EMC	Y(5) Y(6)
Electric Heater Temperature Sensor Bldg 3	30SAQ03CT003	33UQB02001	M	M	SI	1E EMC	Y(5) Y(6)
Electric Heater Temperature Sensor Bldg 4	30SAQ04CT002	34UQB02001	M	M	SI	1E EMC	Y(5) Y(6)
Electric Heater Temperature Sensor Bldg 4	30SAQ04CT003	34UQB02001	M	M	SI	1E EMC	Y(5) Y(6)
<b>Emergency Power Generating Building Ventilation System (EPGBVS)</b>							
Supply Fan - Div 1	30SAD11AN003	31UBP02001	M	M	SII	NS-AQ	Y(5) Y(6)
Supply Air Motor Damper - Div 1	30SAD11AA004	31UBP02001	M	M	SI	S	Y(5) Y(6)
Building Exhaust Motor Damper - Div 1	30SAD15AA004	31UBP02002	M	M	SI	S	Y(5) Y(6)
Exhaust Fan - Div 1	30SAD15AN003	31UBP02002	M	M	SII	NS-AQ	Y(5) Y(6)
Electrical Room Supply Air Motor Damper - Div 1	30SAD13AA007	31UBP01002	M	M	SI	S	Y(5) Y(6)
Electrical Room Supply Air Fan - Div 1	30SAD13AN002	31UBP01002	M	M	SII	NS-AQ	Y(5) Y(6)
Diesel Hall Low/Hi Temperature Alarm Sensor - Div 1	30SAD12CT006	31UBP01001	M	M	SII	NS-AQ	Y(5) Y(6)



**Table 3.11-1—List of Environmentally Qualified Electrical/I&C Equipment  
Sheet 123 of 135**

Name Tag (Equipment Description)	Tag Number	Local Area KKS ID (Room Location)	EQ Environment (Note 1)	Radiation Environment Zone (Note 2)	EQ Designated Function (Note 3)	Safety Class (Note 4)	EQ Program Designation (Note 5)
Diesel Hall Supply/Exhaust Control Temp. Sensor - Div 1	30SAD12CT007	31UBP01001	M	M	SI	S 1E EMC	Y (5) Y (6)
Electrical Room Intake Air Temperature Sensor - Div 1	30SAD13CT005	31UBP01002	M	M	SI	S 1E EMC	Y (5) Y (6)
Electrical Room Supply Air Temperature Sensor - Div 1	30SAD13CT006	31UBP01002	M	M	SI	S 1E EMC	Y (5) Y (6)
Diesel Hall Supply Filter Pressure - Div 1	30SAD11CP513	31UBP02001	M	M	SII	NS-AQ 1E EMC	Y (5) Y (6)
Electrical Room Supply Filter Pressure - Div 1	30SAD13CP503	31UBP01002	M	M	SII	NS-AQ 1E EMC	Y (5) Y (6)
Supply Fan - Div 2	30SAD21AN003	32UBP02001	M	M	SII	NS-AQ 1E EMC	Y (5) Y (6)
Supply Air Motor Damper - Div 2	30SAD21AA004	32UBP02001	M	M	SI	S 1E EMC	Y (5) Y (6)
Building Exhaust Motor Damper - Div 2	30SAD25AA004	32UBP02002	M	M	SI	S 1E EMC	Y (5) Y (6)
Exhaust Fan - Div 2	30SAD25AN003	32UBP02002	M	M	SII	NS-AQ 1E EMC	Y (5) Y (6)
Electrical Room Supply Air Motor Damper - Div 2	30SAD23AA007	32UBP01002	M	M	SI	S 1E EMC	Y (5) Y (6)
Electrical Room Supply Air Fan - Div 2	30SAD23AN002	32UBP01002	M	M	SII	NS-AQ 1E EMC	Y (5) Y (6)
Diesel Hall Low/Hi Temperature Alarm Sensor - Div 2	30SAD22CT006	32UBP01001	M	M	SII	NS-AQ 1E EMC	Y (5) Y (6)
Diesel Hall Supply/Exhaust Control Temp. Sensor - Div 2	30SAD22CT007	32UBP01001	M	M	SI	S 1E EMC	Y (5) Y (6)
Electrical Room Intake Air Temperature Sensor - Div 2	30SAD23CT005	32UBP01002	M	M	SI	S 1E EMC	Y (5) Y (6)
Electrical Room Supply Air Temperature Sensor - Div 2	30SAD23CT006	32UBP01002	M	M	SI	S 1E EMC	Y (5) Y (6)
Diesel Hall Supply Filter Pressure - Div 2	30SAD21CP513	32UBP02001	M	M	SII	NS-AQ 1E EMC	Y (5) Y (6)
Electrical Room Supply Filter Pressure - Div 2	30SAD23CP503	32UBP01002	M	M	SII	NS-AQ 1E EMC	Y (5) Y (6)
Supply Fan - Div 3	30SAD31AN003	33UBP02001	M	M	SII	NS-AQ 1E EMC	Y (5) Y (6)
Supply Air Motor Damper - Div 3	30SAD31AA004	33UBP02001	M	M	SI	S 1E EMC	Y (5) Y (6)
Building Exhaust Motor Damper - Div 3	30SAD35AA004	33UBP02002	M	M	SI	S 1E EMC	Y (5) Y (6)
Exhaust Fan - Div 3	30SAD35AN003	33UBP02002	M	M	SII	NS-AQ 1E EMC	Y (5) Y (6)
Electrical Room Supply Air Motor Damper - Div 3	30SAD33AA007	33UBP01002	M	M	SI	S 1E EMC	Y (5) Y (6)
Electrical Room Supply Air Fan - Div 3	30SAD33AN002	33UBP01002	M	M	SII	NS-AQ 1E EMC	Y (5) Y (6)
Diesel Hall Low/Hi Temperature Alarm Sensor - Div 3	30SAD32CT006	33UBP01001	M	M	SII	NS-AQ 1E EMC	Y (5) Y (6)



**Table 3.11-1—List of Environmentally Qualified Electrical/I&C Equipment  
Sheet 124 of 135**

Name Tag (Equipment Description)	Tag Number	Local Area KKS ID (Room Location)	EQ Environment (Note 1)	Radiation Environment Zone (Note 2)	EQ Designated Function (Note 3)	Safety Class (Note 4)	EQ Program Designation (Note 5)
Diesel Hall Supply/Exhaust Control Temp. Sensor - Div 3	30SAD32CT007	33UBP01001	M	M	SI	S 1E EMC	Y (5) Y (6)
Electrical Room Intake Air Temperature Sensor - Div 3	30SAD33CT005	33UBP01002	M	M	SI	S 1E EMC	Y (5) Y (6)
Electrical Room Supply Air Temperature Sensor - Div 3	30SAD33CT006	33UBP01002	M	M	SI	S 1E EMC	Y (5) Y (6)
Diesel Hall Supply Filter Pressure - Div 3	30SAD31CP513	33UBP02001	M	M	SII	NS-AQ 1E EMC	Y (5) Y (6)
Electrical Room Supply Filter Pressure - Div 3	30SAD33CP503	33UBP01002	M	M	SII	NS-AQ 1E EMC	Y (5) Y (6)
Supply Fan - Div 4	30SAD41AN003	34UBP02001	M	M	SII	NS-AQ 1E EMC	Y (5) Y (6)
Supply Air Motor Damper - Div 4	30SAD41AA004	34UBP02001	M	M	SI	S 1E EMC	Y (5) Y (6)
Building Exhaust Motor Damper - Div 4	30SAD45AA004	34UBP02002	M	M	SI	S 1E EMC	Y (5) Y (6)
Exhaust Fan - Div 4	30SAD45AN003	34UBP02002	M	M	SII	NS-AQ 1E EMC	Y (5) Y (6)
Electrical Room Supply Air Motor Damper - Div 4	30SAD43AA007	34UBP01002	M	M	SI	S 1E EMC	Y (5) Y (6)
Electrical Room Supply Air Fan - Div 4	30SAD43AN002	34UBP01002	M	M	SII	NS-AQ 1E EMC	Y (5) Y (6)
Diesel Hall Low/Hi Temperature Alarm Sensor - Div 4	30SAD42CT006	34UBP01001	M	M	SII	NS-AQ 1E EMC	Y (5) Y (6)
Diesel Hall Supply/Exhaust Control Temp. Sensor - Div 4	30SAD42CT007	34UBP01001	M	M	SI	S 1E EMC	Y (5) Y (6)
Electrical Room Intake Air Temperature Sensor - Div 4	30SAD43CT005	34UBP01002	M	M	SI	S 1E EMC	Y (5) Y (6)
Electrical Room Supply Air Temperature Sensor - Div 4	30SAD43CT006	34UBP01002	M	M	SI	S 1E EMC	Y (5) Y (6)
Diesel Hall Supply Filter Pressure - Div 4	30SAD41CP513	34UBP02001	M	M	SII	NS-AQ 1E EMC	Y (5) Y (6)
Electrical Room Supply Filter Pressure - Div 4	30SAD43CP503	34UBP01002	M	M	SII	NS-AQ 1E EMC	Y (5) Y (6)
Supply Air Fan - Div 1	30SAD11AN001	31UBP02001	M	M	SI	S	Y (5) Y (6)
Supply Air Fan - Div 1	30SAD11AN002	31UBP02001	M	M	SI	S	Y (5) Y (6)
<del>Recirc Control Damper - Div 1</del>	<del>30SAD13AA004</del>	<del>34UBP04004</del>	<del>M</del>	<del>M</del>	<del>S</del>	<del>S 4E EMC</del>	<del>Y (6) Y (6)</del>
<del>Recirc Unit Heater - Div 1</del>	<del>30SAD13AH004</del>	<del>34UBP04004</del>	<del>M</del>	<del>M</del>	<del>S</del>	<del>S 4E EMC</del>	<del>Y (6) Y (6)</del>
Recirc Unit Supply Fan - Div 1	30SAD13AN001	31UBP01001	M	M	SI	S	Y (5) Y (6)
Exhaust Fan - Div 1	30SAD15AN001	31UBP01001	M	M	SI	S	Y (5) Y (6)
Exhaust Fan - Div 1	30SAD15AN002	31UBP01001	M	M	SI	S	Y (5) Y (6)
Main Tank Supp Damper A - Div 1	30SAD16AA007	31UBP01001	M	M	SI	S	Y (5) Y (6)
Main Tank Supp Damper B - Div 1	30SAD16AA008	31UBP01001	M	M	SI	S	Y (5) Y (6)



**Table 3.11-1—List of Environmentally Qualified Electrical/I&C Equipment  
Sheet 125 of 135**

Name Tag (Equipment Description)	Tag Number	Local Area KKS ID (Room Location)	EQ Environment (Note 1)	Radiation Environment Zone (Note 2)	EQ Designated Function (Note 3)	Safety Class (Note 4)	EQ Program Designation (Note 5)
Fuel Tank Room Space Heater - Div 1	30SAD16AH001	31UBP01003	M	M	SI	S	Y (5) Y(6)
Fuel Tank Room Ventilation Fan - Div 1	30SAD16AN001	31UBP01003	M	M	SI	S	Y (5) Y(6)
Supply Air Fan - Div 2	30SAD21AN001	32UBP02001	M	M	SI	S	Y (5) Y(6)
Supply Air Fan - Div 2	30SAD21AN002	32UBP02001	M	M	SI	S	Y (5) Y(6)
<del>Recirc-Control Damper—Div-2</del>	<del>30SAD23AA004</del>	<del>32UBP04004</del>	<del>M</del>	<del>M</del>	<del>SI</del>	<del>S</del>	<del>Y (5) Y(6)</del>
<del>Recirc-Unit Heater—Div-2</del>	<del>30SAD23AH004</del>	<del>32UBP04004</del>	<del>M</del>	<del>M</del>	<del>SI</del>	<del>S</del>	<del>Y (5) Y(6)</del>
Recirc Unit Supply Fan - Div 2	30SAD23AN001	32UBP01001	M	M	SI	S	Y (5) Y(6)
Exhaust Fan - Div 2	30SAD25AN001	32UBP01001	M	M	SI	S	Y (5) Y(6)
Exhaust Fan - Div 2	30SAD25AN002	32UBP01001	M	M	SI	S	Y (5) Y(6)
Main Tank Supp Damper A - Div 2	30SAD26AA007	32UBP01001	M	M	SI	S	Y (5) Y(6)
Main Tank Supp Damper B - Div 2	30SAD26AA008	32UBP01001	M	M	SI	S	Y (5) Y(6)
Fuel Tank Room Space Heater - Div 2	30SAD26AH001	32UBP01003	M	M	SI	S	Y (5) Y(6)
Fuel Tank Room Ventilation Fan - Div 2	30SAD26AN001	32UBP01003	M	M	SI	S	Y (5) Y(6)
Supply Air Fan - Div 3	30SAD31AN001	33UBP02001	M	M	SI	S	Y (5) Y(6)
Supply Air Fan - Div 3	30SAD31AN002	33UBP02001	M	M	SI	S	Y (5) Y(6)
<del>Recirc-Control Damper—Div-3</del>	<del>30SAD33AA004</del>	<del>33UBP04004</del>	<del>M</del>	<del>M</del>	<del>SI</del>	<del>S</del>	<del>Y (5) Y(6)</del>
<del>Recirc-Unit Heater—Div-3</del>	<del>30SAD33AH004</del>	<del>33UBP04004</del>	<del>M</del>	<del>M</del>	<del>SI</del>	<del>S</del>	<del>Y (5) Y(6)</del>
Recirc Unit Supply Fan - Div 3	30SAD33AN001	33UBP01001	M	M	SI	S	Y (5) Y(6)
Exhaust Fan - Div 3	30SAD35AN001	33UBP01001	M	M	SI	S	Y (5) Y(6)
Exhaust Fan - Div 3	30SAD35AN002	33UBP01001	M	M	SI	S	Y (5) Y(6)
Main Tank Supp Damper A - Div 3	30SAD36AA007	33UBP01001	M	M	SI	S	Y (5) Y(6)
Main Tank Supp Damper B - Div 3	30SAD36AA008	33UBP01001	M	M	SI	S	Y (5) Y(6)
Fuel Tank Room Space Heater - Div 3	30SAD36AH001	33UBP01003	M	M	SI	S	Y (5) Y(6)
Fuel Tank Room Ventilation Fan - Div 3	30SAD36AN001	33UBP01003	M	M	SI	S	Y (5) Y(6)
Supply Air Fan - Div 4	30SAD41AN001	34UBP02001	M	M	SI	S	Y (5) Y(6)
Supply Air Fan - Div 4	30SAD41AN002	34UBP02001	M	M	SI	S	Y (5) Y(6)
<del>Recirc-Control Damper—Div-4</del>	<del>30SAD43AA004</del>	<del>34UBP04004</del>	<del>M</del>	<del>M</del>	<del>SI</del>	<del>S</del>	<del>Y (5) Y(6)</del>
<del>Recirc-Unit Heater—Div-4</del>	<del>30SAD43AH004</del>	<del>34UBP04004</del>	<del>M</del>	<del>M</del>	<del>SI</del>	<del>S</del>	<del>Y (5) Y(6)</del>
Recirc Unit Supply Fan - Div 4	30SAD43AN001	34UBP01001	M	M	SI	S	Y (5) Y(6)
Exhaust Fan - Div 4	30SAD45AN001	34UBP01001	M	M	SI	S	Y (5) Y(6)
Exhaust Fan - Div 4	30SAD45AN002	34UBP01001	M	M	SI	S	Y (5) Y(6)
Main Tank Supp Damper A - Div 4	30SAD46AA007	34UBP01001	M	M	SI	S	Y (5) Y(6)
Main Tank Supp Damper B - Div 4	30SAD46AA008	34UBP01001	M	M	SI	S	Y (5) Y(6)



**Table 3.11-1—List of Environmentally Qualified Electrical/I&C Equipment**  
Sheet 126 of 135

Name Tag (Equipment Description)	Tag Number	Local Area KKS ID (Room Location)	EQ Environment (Note 1)	Radiation Environment Zone (Note 2)	EQ Designated Function (Note 3)	Safety Class (Note 4)	EQ Program Designation (Note 5)
Fuel Tank Room Space Heater - Div 4	30SAD46AH001	34UBP01003	M	M	SI	S	Y(5) Y(6)
Fuel Tank Room Ventilation Fan - Div 4	30SAD46AN001	34UBP01003	M	M	SI	S	Y(5) Y(6)
Supply Components Pressure - Div 1	30SAD11CP501	31UBP02001	M	M	SI	S	Y(5) Y(6)
Supply Components Pressure - Div 1	30SAD11CP502	31UBP02001	M	M	SI	S	Y(5) Y(6)
Supply Filter Pressure - Div 1	30SAD11CP511	31UBP02001	M	M	SI	S	Y(5) Y(6)
Supply Filter Pressure - Div 1	30SAD11CP512	31UBP02001	M	M	SI	S	Y(5) Y(6)
Building Supply Air Temperature - Div 1	30SAD11CT001	31UBP02001	M	M	SI	S	Y(5) Y(6)
Diesel Hall Area Temperature A - Div 1	30SAD12CT001	31UBP01001	M	M	SI	S	Y(5) Y(6)
Diesel Hall Area Temperature B - Div 1	30SAD12CT002	31UBP01001	M	M	SI	S	Y(5) Y(6)
Diesel Hall Area Temperature C - Div 1	30SAD12CT003	31UBP01001	M	M	SI	S	Y(5) Y(6)
Diesel Hall Area Temperature D - Div 1	30SAD12CT004	31UBP01001	M	M	SI	S	Y(5) Y(6)
Diesel Hall Area Temperature E - Div 1	30SAD12CT005	31UBP01001	M	M	SI	S	Y(5) Y(6)
<del>Recirc Flow Rate - Div 4</del>	<del>30SAD13CF004</del>	<del>34UBP01004</del>	<del>M</del>	<del>M</del>	<del>SI</del>	<del>S</del>	<del>Y(5) Y(6)</del>
<del>EDG Control Rm Moisture - Div 4</del>	<del>30SAD13CM004</del>	<del>34UBP01002</del>	<del>M</del>	<del>M</del>	<del>SI</del>	<del>NS-AQ</del>	<del>Y(5) Y(6)</del>
Recirc Pre-filter Pressure - Div 1	30SAD13CP501	31UBP01001	M	M	SI	S	Y(5) Y(6)
Recirc HEPA Filter Pressure - Div 1	30SAD13CP502	31UBP01001	M	M	SI	S	Y(5) Y(6)
Recirc Supply Temperature - Div 1	30SAD13CT001	31UBP01001	M	M	SI	S	Y(5) Y(6)
EDG Control Rm Temperature A - Div 1	30SAD13CT002	31UBP01002	M	M	SI	S	Y(5) Y(6)
EDG Control Rm Temperature B - Div 1	30SAD13CT003	31UBP01002	M	M	SI	S	Y(5) Y(6)
<del>Recirc Heater Outlet Temperature - Div 4</del>	<del>30SAD13CT004</del>	<del>34UBP01004</del>	<del>M</del>	<del>M</del>	<del>SI</del>	<del>S</del>	<del>Y(5) Y(6)</del>
Diesel Hall Heater/Fan Temp A - Div 1	30SAD14CT001	31UBP01001	M	M	SII	NS-AQ	Y(5) Y(6)
Diesel Hall Heater/Fan Temp B - Div 1	30SAD14CT002	31UBP01001	M	M	SII	NS-AQ	Y(5) Y(6)
Diesel Hall Heater/Fan Temp C - Div 1	30SAD14CT003	31UBP01001	M	M	SII	NS-AQ	Y(5) Y(6)
Diesel Hall Heater/Fan Temp D - Div 1	30SAD14CT004	31UBP01001	M	M	SII	NS-AQ	Y(5) Y(6)
Main Tank Temperature - Div 1	30SAD16CT001	31UBP01003	M	M	SI	S	Y(5) Y(6)
Supply Components Pressure - Div 2	30SAD21CP501	32UBP02001	M	M	SI	S	Y(5) Y(6)
Supply Components Pressure - Div 2	30SAD21CP502	32UBP02001	M	M	SI	S	Y(5) Y(6)
Supply Filter Pressure - Div 2	30SAD21CP511	32UBP02001	M	M	SI	S	Y(5) Y(6)
Supply Filter Pressure - Div 2	30SAD21CP512	32UBP02001	M	M	SI	S	Y(5) Y(6)
Building Supply Air Temperature - Div 2	30SAD22CT001	32UBP01001	M	M	SI	S	Y(5) Y(6)
Diesel Hall Area Temperature A - Div 2	30SAD22CT001	32UBP01001	M	M	SI	S	Y(5) Y(6)
Diesel Hall Area Temperature B - Div 2	30SAD22CT002	32UBP01001	M	M	SI	S	Y(5) Y(6)
Diesel Hall Area Temperature C - Div 2	30SAD22CT003	32UBP01001	M	M	SI	S	Y(5) Y(6)



**Table 3.11-1—List of Environmentally Qualified Electrical/I&C Equipment**  
Sheet 127 of 135

Name Tag (Equipment Description)	Tag Number	Local Area KKS ID (Room Location)	EQ Environment (Note 1)	Radiation Environment Zone (Note 2)	EQ Designated Function (Note 3)	Safety Class (Note 4)	EQ Program Designation (Note 5)
Diesel Hall Area Temperature D - Div 2	30SAD22CT004	32UBP01001	M	M	SI	S 1E EMC	Y(5) Y(6)
Diesel Hall Area Temperature E - Div 2	30SAD22CT005	32UBP01001	M	M	SI	S 1E EMC	Y(5) Y(6)
<del>Recirc Flow Rate - Div 2</del>	<del>30SAD23CF004</del>	<del>32UBP01004</del>	<del>M</del>	<del>M</del>	<del>SI</del>	<del>S 4E EMC</del>	<del>Y(5) Y(6)</del>
<del>EDG Control Rm Moisture - Div 4</del>	<del>30SAD23GM004</del>	<del>32UBP01002</del>	<del>M</del>	<del>M</del>	<del>SI</del>	<del>S NS-AQ 4E EMC</del>	<del>Y(5) Y(6)</del>
Recirc Pre-filter Pressure - Div 2	30SAD23CP501	32UBP01001	M	M	SI	S 1E EMC	Y(5) Y(6)
Recirc HEPA Filter Pressure - Div 2	30SAD23CP502	32UBP01001	M	M	SI	S 1E EMC	Y(5) Y(6)
Recirc Supply Temperature - Div 2	30SAD23CT001	32UBP01001	M	M	SI	S 1E EMC	Y(5) Y(6)
EDG Control Rm Temperature A - Div 2	30SAD23CT002	32UBP01002	M	M	SI	S 1E EMC	Y(5) Y(6)
EDG Control Rm Temperature B - Div 2	30SAD23CT003	32UBP01002	M	M	SI	S 1E EMC	Y(5) Y(6)
<del>Recirc Heater Outlet Temperature - Div 2</del>	<del>30SAD23CT004</del>	<del>32UBP01004</del>	<del>M</del>	<del>M</del>	<del>SI</del>	<del>S 4E EMC</del>	<del>Y(5) Y(6)</del>
Diesel Hall Heater/Fan Temp A - Div 2	30SAD24CT001	32UBP01001	M	M	SII	NS-AQ 1E EMC	Y(5) Y(6)
Diesel Hall Heater/Fan Temp B - Div 2	30SAD24CT002	32UBP01001	M	M	SII	NS-AQ 1E EMC	Y(5) Y(6)
Diesel Hall Heater/Fan Temp C - Div 2	30SAD24CT003	32UBP01001	M	M	SII	NS-AQ 1E EMC	Y(5) Y(6)
Diesel Hall Heater/Fan Temp D - Div 2	30SAD24CT004	32UBP01001	M	M	SII	NS-AQ 1E EMC	Y(5) Y(6)
Main Tank Temperature - Div 2	30SAD26CT001	32UBP01003	M	M	SI	S 1E EMC	Y(5) Y(6)
Supply Components Pressure - Div 3	30SAD31CP501	33UBP02001	M	M	SI	S 1E EMC	Y(5) Y(6)
Supply Components Pressure - Div 3	30SAD31CP502	33UBP02001	M	M	SI	S 1E EMC	Y(5) Y(6)
Supply Filter Pressure - Div 3	30SAD31CP511	33UBP02001	M	M	SI	S 1E EMC	Y(5) Y(6)
Supply Filter Pressure - Div 3	30SAD31CP512	33UBP02001	M	M	SI	S 1E EMC	Y(5) Y(6)
Building Supply Air Temperature - Div 3	30SAD31CT001	33UBP02001	M	M	SI	S 1E EMC	Y(5) Y(6)
Diesel Hall Area Temperature A - Div 3	30SAD32CT001	33UBP01001	M	M	SI	S 1E EMC	Y(5) Y(6)
Diesel Hall Area Temperature B - Div 3	30SAD32CT002	33UBP01001	M	M	SI	S 1E EMC	Y(5) Y(6)
Diesel Hall Area Temperature C - Div 3	30SAD32CT003	33UBP01001	M	M	SI	S 1E EMC	Y(5) Y(6)
Diesel Hall Area Temperature D - Div 3	30SAD32CT004	33UBP01001	M	M	SI	S 1E EMC	Y(5) Y(6)
Diesel Hall Area Temperature E - Div 3	30SAD32CT005	33UBP01001	M	M	SI	S 1E EMC	Y(5) Y(6)
<del>Recirc Flow Rate - Div 3</del>	<del>30SAD33CF004</del>	<del>33UBP01004</del>	<del>M</del>	<del>M</del>	<del>SI</del>	<del>S 4E EMC</del>	<del>Y(5) Y(6)</del>
<del>EDG Control Rm Moisture - Div 4</del>	<del>30SAD33GM004</del>	<del>33UBP01002</del>	<del>M</del>	<del>M</del>	<del>SI</del>	<del>S NS-AQ 4E EMC</del>	<del>Y(5) Y(6)</del>
Recirc Pre-filter Pressure - Div 3	30SAD33CP501	33UBP01001	M	M	SI	S 1E EMC	Y(5) Y(6)
Recirc HEPA Filter Pressure - Div 3	30SAD33CP502	33UBP01001	M	M	SI	S 1E EMC	Y(5) Y(6)
Recirc Supply Temperature - Div 3	30SAD33CT001	33UBP01001	M	M	SI	S 1E EMC	Y(5) Y(6)
EDG Control Rm Temperature A - Div 3	30SAD33CT002	33UBP01002	M	M	SI	S 1E EMC	Y(5) Y(6)
EDG Control Rm Temperature B - Div 3	30SAD33CT003	33UBP01002	M	M	SI	S 1E EMC	Y(5) Y(6)
<del>Recirc Heater Outlet Temperature - Div 3</del>	<del>30SAD33CT004</del>	<del>33UBP01004</del>	<del>M</del>	<del>M</del>	<del>SI</del>	<del>S 4E EMC</del>	<del>Y(5) Y(6)</del>



**Table 3.11-1—List of Environmentally Qualified Electrical/I&C Equipment**  
Sheet 128 of 135

Name Tag (Equipment Description)	Tag Number	Local Area KKS ID (Room Location)	EQ Environment (Note 1)	Radiation Environment Zone (Note 2)	EQ Designated Function (Note 3)	Safety Class (Note 4)	EQ Program Designation (Note 5)
Diesel Hall Heater/Fan Temp A - Div 3	30SAD34CT001	33UBP01001	M	M	SII	NS-AQ 1E EMC	Y (5) Y(6)
Diesel Hall Heater/Fan Temp B - Div 3	30SAD34CT002	33UBP01001	M	M	SII	NS-AQ 1E EMC	Y (5) Y(6)
Diesel Hall Heater/Fan Temp C - Div 3	30SAD34CT003	33UBP01001	M	M	SII	NS-AQ 1E EMC	Y (5) Y(6)
Diesel Hall Heater/Fan Temp D - Div 3	30SAD34CT004	33UBP01001	M	M	SII	NS-AQ 1E EMC	Y (5) Y(6)
Main Tank Temperature - Div 3	30SAD36CT001	33UBP01003	M	M	SI	S 1E EMC	Y (5) Y(6)
Supply Components Pressure - Div 4	30SAD41CP501	34UBP02001	M	M	SI	S 1E EMC	Y (5) Y(6)
Supply Components Pressure - Div 4	30SAD41CP502	34UBP02001	M	M	SI	S 1E EMC	Y (5) Y(6)
Supply Filter Pressure - Div 4	30SAD41CP511	34UBP02001	M	M	SI	S 1E EMC	Y (5) Y(6)
Supply Filter Pressure - Div 4	30SAD41CP512	34UBP02001	M	M	SI	S 1E EMC	Y (5) Y(6)
Building Supply Air Temperature - Div 4	30SAD41CT001	34UBP02001	M	M	SI	S 1E EMC	Y (5) Y(6)
Diesel Hall Area Temperature A - Div 4	30SAD42CT001	34UBP01001	M	M	SI	S 1E EMC	Y (5) Y(6)
Diesel Hall Area Temperature B - Div 4	30SAD42CT002	34UBP01001	M	M	SI	S 1E EMC	Y (5) Y(6)
Diesel Hall Area Temperature C - Div 4	30SAD42CT003	34UBP01001	M	M	SI	S 1E EMC	Y (5) Y(6)
Diesel Hall Area Temperature D - Div 4	30SAD42CT004	34UBP01001	M	M	SI	S 1E EMC	Y (5) Y(6)
Diesel Hall Area Temperature E - Div 4	30SAD42CT005	34UBP01001	M	M	SI	S 1E EMC	Y (5) Y(6)
<del>Recirc Flow Rate - Div 4</del>	<del>30SAD43CF004</del>	<del>34UBP01004</del>	<del>M</del>	<del>M</del>	<del>SI</del>	<del>S</del> <del>4E</del> <del>EMC</del>	<del>Y (5) Y(6)</del>
<del>EDG Control Rm Moisture - Div 4</del>	<del>30SAD43CM004</del>	<del>34UBP01002</del>	<del>M</del>	<del>M</del>	<del>SI</del>	<del>NS-AQ</del> <del>4E</del> <del>EMC</del>	<del>Y (5) Y(6)</del>
Recirc Pre-filter Pressure - Div 4	30SAD43CP501	34UBP01001	M	M	SI	S 1E EMC	Y (5) Y(6)
Recirc HEPA Filter Pressure - Div 4	30SAD43CP502	34UBP01001	M	M	SI	S 1E EMC	Y (5) Y(6)
Recirc Supply Temperature - Div 4	30SAD43CT001	34UBP01001	M	M	SI	S 1E EMC	Y (5) Y(6)
EDG Control Rm Temperature A - Div 4	30SAD43CT002	34UBP01002	M	M	SI	S 1E EMC	Y (5) Y(6)
EDG Control Rm Temperature B - Div 4	30SAD43CT003	34UBP01002	M	M	SI	S 1E EMC	Y (5) Y(6)
<del>Recirc Heater Outlet Temperature - Div 4</del>	<del>30SAD43CT004</del>	<del>34UBP01004</del>	<del>M</del>	<del>M</del>	<del>SI</del>	<del>S</del> <del>4E</del> <del>EMC</del>	<del>Y (5) Y(6)</del>
Diesel Hall Heater/Fan Temp A - Div 4	30SAD44CT001	34UBP01001	M	M	SII	NS-AQ 1E EMC	Y (5) Y(6)
Diesel Hall Heater/Fan Temp B - Div 4	30SAD44CT002	34UBP01001	M	M	SII	NS-AQ 1E EMC	Y (5) Y(6)
Diesel Hall Heater/Fan Temp C - Div 4	30SAD44CT003	34UBP01001	M	M	SII	NS-AQ 1E EMC	Y (5) Y(6)
Diesel Hall Heater/Fan Temp D - Div 4	30SAD44CT004	34UBP01001	M	M	SII	NS-AQ 1E EMC	Y (5) Y(6)
Main Tank Temperature - Div 4	30SAD46CT001	34UBP01003	M	M	SI	S 1E EMC	Y (5) Y(6)
<b>CONTAINMENT ISOLATION SYSTEMS</b>							
<b>Fuel Pool Cooling and Purification System (FPCPS)</b>							
ILCO Isolation Valve	30FAL10AA003	30JJA11021	H	H	SII	NS-AQ	Y (5)
FPP to RB Pool Inside CI Valve Actuator	30FAL12AA001	30JJA07016	H	H	ES PAM SI	S 1E EMC	Y (1) Y (5)



**Table 3.11-2—List of U.S. EPR Important to Safety Systems Screened for  
the EQ Program  
Sheet 1 of 5**

Category	Systems
Fluid Systems	Reactor Coolant JE (except JEW), JA, JDA <sup>1</sup>
	Safety Injection & Residual Heat Removal JNA, JND, JNG
	Component Cooling Water KA
	Essential Service Water PE
	Safety Chilled Water QK
	Extra Borating JDH
	Feedwater LA
	Emergency Feedwater LAR, LAS
	In-containment Refueling Water Storage Tank (IRWST) JNK
	Main Steam LB
	Steam Generator Blowdown LCQ
	Chemical & Volume Control System KBA, KBD, JEW
	Spent Fuel Pool Cooling FAK
	Auxiliary Systems
Sampling Activity Monitoring KLK	
Emergency Diesel Generator Set XJA, XKA, XJN, XJV, XJG, XJQ, XJR, XJX, XCN	
Combustible Gas Control JMT	



The motor-operated air-tight dampers—located on the normal operation filtration train supply and exhaust ducts—isolate the secondary containment in case of a postulated accident. The redundant dampers in the supply and exhaust trains are powered by different electrical divisions backed by separate emergency diesel generators. The dampers can be operated automatically or manually from the main control room (MCR). In the event of a station blackout (SBO), these dampers are automatically closed by batteries.

The fire dampers on both supply and exhaust trains are located at the wall penetration between the Fuel Building and the annulus. These dampers are equipped with thermal sensors for automatic closing, and can be closed or re-opened remotely if not released by the thermal sensor.

#### 6.2.3.2.2.2 AVS Accident Trains

The AVS accident filtration trains are shown on Figure 6.2.3-2. The filtration trains are engineered safety feature (ESF) filters and are used during postulated accidents to contain leakage from the primary containment by maintaining a subatmospheric pressure in the annulus. The exhaust air from the annulus is filtered before release to the environment via the vent stack.

There are two full capacity ESF trains, each consists of an air-tight motor-controlled damper, ~~an~~ two stage electrical heater, a pre-filter, an upstream HEPA filter, an iodine absorber, a downstream HEPA filter, an air-tight motor controlled damper, a fan, and a back-draft damper. The filter system components are designed in accordance with Regulatory Guide 1.52, and are described in Section 6.5.1.

During a postulated accident, the ESF filtration trains collect the containment leakage from the annulus, remove airborne radioactivity through the filtration train, and release the filtered air to the vent stack. The AVS accident trains reduce the pressure in the annulus to at least -0.25 inches water gauge or less and maintain the lower subatmospheric pressure. The system is capable of maintaining a uniform negative pressure throughout the secondary containment structure following the design basis loss of coolant accident (LOCA).

The exhaust air is monitored and sampled for radiation levels before release to the vent stack, as described in Section 11.5.3.1.10 and Table 11.5-1, Monitors R-27 and R-28.

The two ESF trains are physically separated by being installed in separate rooms of the Fuel Building, which are also in separate fire areas. The two ESF trains are powered by different electrical divisions backed by separate emergency diesel generators.

### 6.2.3.2.2.3 System Operation

The normal operation filtration train is in service during normal plant operation, including cold shutdown and outages. During normal operation, the isolation dampers are in the open position and the annulus is continuously vented. The subatmospheric pressure inside the annulus is maintained by regulating the control damper located on the supply side of the normal operation filtration train. The supply air from the AVS maintains the annulus temperature between 45°F and 113°F.

A failure of the normal operation filtration train leads to the loss of supply and exhaust air to the annulus. In this case, one of the accident filtration trains is started, and the two isolation dampers on the supply and exhaust side of the normal filtration train are closed to isolate the normal operation filtration train and maintain the leak tightness of the annulus.

In case of a postulated accident, a containment isolation signal causes the normal filtration train to automatically stop. The normal filtration train supply air isolation dampers close immediately and the exhaust isolation dampers close with a delay, to maintain the annulus negative pressure during the switchover to the accident filtration trains. Both accident filtration trains start on receipt of a containment isolation signal and an alarm is issued in the MCR.

At the start of an accident, full power of two stage electric heater is switched on when the fans start and filter bank isolation dampers open. As the negative pressure is drawn down in the annulus and when the temperature downstream of the heater increases to 158°F, the first step of heater power is switched off automatically. As the temperature downstream of the heater reaches 176°F, the second step of the heater is also switched off automatically.

### 6.2.3.2.3 Bypass Leakage

Certain containment penetrations introduce the potential for primary containment leakage to bypass the filtered annulus and escape directly to the environment. Potential bypass leakage paths exist through the double seals of the equipment hatch, personnel airlocks, fuel transfer tube, and containment ventilation system isolation valves.

The leak-off system provides a means to capture bypass leakage and route it to the annulus to be processed. The leak-off system is located in the Reactor Containment Building, Reactor Building Annulus, Fuel Building, and Safeguard Buildings 2 and 3, and consists of valves, sensors and piping. It is composed of three main subsystems: containment leakage exhaust subsystem (CLES), containment inflating/deflating subsystem (CIDS), and containment leak-tightness test subsystem (CLTS). The CLES collects leaks from various systems and components in the Reactor Containment



Table 7.1-5—SAS Automatic Safety Function  
Sheet 1 of 45

System <sup>1</sup>	Function Name <sup>2</sup>	Function Safety Basis <sup>3</sup>	Interdivisional Communications <sup>4</sup>	Type of Data <sup>5</sup>	Signal Selection Type <sup>6</sup>	Comments <del>FSAR Section Reference</del>
Annulus Ventilation (AVS)	Accident Filtration Train Heater Control (Figure 7.3-31)	<del>This function is described in Sections 6.2.3, 6.5.1, and 7.3.1.3.1. The AVS has a safety-related function to maintain capability of the iodine absorbers to remove iodine from the annulus exhaust air. The radiological filter air heaters are used to limit the relative humidity to a maximum of 70% when the AVS accident trains are in operation (RG-1.52 and ASME N509-89).</del>	NO	N/A	N/A	<del>The I&amp;G associated with the AVS is described in Sections 6.2.3 and 6.5.1.</del>
Annulus Ventilation (AVS)	Accident Train Switchover (Figure 7.3-32)	<del>This function is described in Sections 6.2.3, 6.5.1, and 7.3.1.3.1. The AVS has a safety-related function to maintain a negative pressure (GDC-16, GDC-43, Containment Leakage Testing per 10 CFR 50 Appendix J, and NRC RG-1.52 Rev 3 to provide filtration of Engineered Safety Feature Atmospheric Cleanup). In case of a failure during accident operation of an operating accident filtration train, and a negative pressure is not being maintained in the annulus, operation shall be switched to the non-operating accident filtration train to maintain a negative pressure.</del>	NO	N/A	N/A	<del>The I&amp;G associated with the AVS is described in Sections 6.2.3 and 6.5.1.</del>

**Table 7.1-5—SAS Automatic Safety Function  
Sheet 2 of 45**

System <sup>1</sup>	Function Name <sup>2</sup>	Function Safety Basis <sup>3</sup>	Interdivisional Communications <sup>4</sup>	Type of Data <sup>5</sup>	Signal Selection Type <sup>6</sup>	Comments
Component Cooling Water System (CCWS)	CCWS-Common 1.b Automatic Backup Switchover of Train 1 to Train 2. (Figure 7.3-33)	<p><del>This function is described in Sections 7.3.1.4.1 and 9.2.2. The CCWS has a safety-related function to remove heat from safety-related components (GDC-44). The safety-related function to perform an automatic switchover from Train 1 to Train 2 verifies that the CCWS is capable of fulfilling its safety-related function to remove heat from safety-related components on the CCWS Common 1.a and 1.b.</del></p>	(1) Div 2 to Div 1 - To switch from Train 1 to Train 2 requires a low Surge Tank Level in Div 2 : (2) Close Train 1 supply and return valves by removing power from the valves associated pilot valves that are powered via Div 1, 2, 3, and 4: (3) Div 1 to Div 2 - Verify Train 1 1.b supply and return valves are closed prior to Train 2 supply and return valves opening (i.e. interlock function): (4) Open Train 2 supply and return valves by applying power to the valves associated pilot valves that are powered via Div 1, 2, 3, and 4	Discrete	Vote	<p>The I&amp;G associated with the CCWS is described in Section 9.2.2</p>



Table 7.1-5—SAS Automatic Safety Function  
Sheet 3 of 45

System <sup>1</sup>	Function Name <sup>2</sup>	Function Safety Basis <sup>3</sup>	Interdivisional Communications <sup>4</sup>	Type of Data <sup>5</sup>	Signal Selection Type <sup>6</sup>	Comments <del>FSAR Section-Reference</del>
Component Cooling Water System (CCWS)	<del>CCWS</del> -Common 1.b Automatic Backup Switchover of Train 2 to Train 1. ( <u>Figure 7.3-33</u> )	<u>This function is described in Sections 7.3.1.4.1 and 9.2.2.</u> <del>The CCWS has a safety-related function to remove heat from safety-related components (GDC-44). The safety-related function to perform an automatic switchover from Train 2 to Train 1 verifies that the CCWS is capable of fulfilling its safety-related function to remove heat from safety-related components on the CCWS Common-1-a and 1-b.</del>	Similar to Train 1 to Train 2 Switchover	Discrete	Vote	<del>The I&amp;G associated with the CCWS is described in Section 9.2.2.</del>
Component Cooling Water System (CCWS)	<del>CCWS</del> -Common 2.b Automatic Backup Switchover of Train 3 to Train 4. ( <u>Figure 7.3-33</u> )	<u>This function is described in Sections 7.3.1.4.1 and 9.2.2.</u> <del>The CCWS has a safety-related function to remove heat from safety-related components (GDC-44). The safety-related function to perform an automatic switchover from Train 3 to Train 4 verifies that the CCWS is capable of fulfilling its safety-related function to remove heat from safety-related components on the CCWS Common-2-a and 2-b.</del>	Similar to Train 1 to Train 2 Switchover, but for Train 3 to Train 4	Discrete	Vote	<del>The I&amp;G associated with the CCWS is described in Section 9.2.2.</del>



Table 7.1-5—SAS Automatic Safety Function  
Sheet 4 of 45

System <sup>1</sup>	Function Name <sup>2</sup>	Function Safety Basis <sup>3</sup>	Interdivisional Communications <sup>4</sup>	Type of Data <sup>5</sup>	Signal Selection Type <sup>6</sup>	Comments <del>FSAR Section-Referenced</del>
Component Cooling Water System (CCWS)	<del>CCWS</del> -Common 2.b Automatic Backup Switchover of Train 4 to Train 3 ( <a href="#">Figure 7.3-33</a> )	<u>This function is described in Sections 7.3.1.4.1 and 9.2.2. The CCWS has a safety-related function to remove heat from safety-related components (GDC-44). The safety-related function to perform an automatic switchover from Train 4 to Train 3 verifies that the CCWS is capable of fulfilling its safety-related function to remove heat from safety-related components on the CCWS Common-2.a and 2.b.</u>	Similar to Train 1 to Train 2 Switchover, but for Train 4 to Train 3	Discrete	Vote	<del>The I&amp;G associated with the CCWS is described in Section 9.2.2.</del>
Component Cooling Water System (CCWS)	<del>CCWS</del> -Emergency Temperature Control ( <a href="#">Figure 7.3-34</a> )	<u>This function is described in Sections 7.3.1.4.1 and 9.2.2. The CCWS has a safety-related function to remove heat from safety-related components (GDC-44). The safety-related function to control the CCWS heat exchanger (HX) outlet temperature is required to maintain the temperature of the cooling water within its limits. This verifies that the CCWS is capable of fulfilling its safety-related function to remove heat from safety-related components.</u>	NO	N/A	N/A	<del>The I&amp;G associated with the CCWS is described in Section 9.2.2.</del>



Table 7.1-5—SAS Automatic Safety Function  
Sheet 5 of 45

System <sup>1</sup>	Function Name <sup>2</sup>	Function Safety Basis <sup>3</sup>	Interdivisional Communications <sup>4</sup>	Type of Data <sup>5</sup>	Signal Selection Type <sup>6</sup>	Comments <del>FSAR Section-Referenced</del>
Component Cooling Water System (CCWS)	<del>CCWS</del> -Emergency Leak Detection (Figure 7.3-35)	<u>This function is described in Sections 7.3.1.4.1 and 9.2.2.</u> <del>The CCWS has a safety-related function to remove heat from safety-related components (GDC-44). The safety-related function for emergency leak detection maintains the required cooling water inventory that supports the safety-related function to remove heat using indications to detect leaks and isolate them (GDC-44).</del>	NO	N/A	N/A	The I&G associated with the CCWS is described in Section 9.2.2.

Table 7.1-5—SAS Automatic Safety Function  
Sheet 6 of 45

System <sup>1</sup>	Function Name <sup>2</sup>	Function Safety Basis <sup>3</sup>	Interdivisional Communications <sup>4</sup>	Type of Data <sup>5</sup>	Signal Selection Type <sup>6</sup>	Comments <del>FSAR Section-Reference</del>
Component Cooling Water System (CCWS)	<del>CCWS</del> Switchover Valve Interlock (Figure 7.6-1)	<u>This function is described in Sections 7.6.1.2.5 and 9.2.2.</u> <del>The CCWS has a safety-related function to remove heat from safety-related components (GDC-44). The interlock function is required to verify that the two trains connected to their common headers remain separated and each are able to provide their corresponding LHSI HX with the required flow for heat removal. Removing heat from the LHSI HX is a safety-related function.</del>	If the either of the supply and return valves for a given Train (1 or 2, 3 or 4) are open with respect to a given header (1.a, 1.b, 2.a, or 2.b) then the other corresponding train supply and return valves are given a close command. Train 1 valves are in Div 1, Train 2 valves in Div 2 and so on. Therefore, the signals are sent across divisions for the close command discussed. Hence, the on coming trains supply and return valves are not allowed to open until the corresponding off going trains supply and return valves are closed.	Discrete	Vote	<del>The I&amp;G associated with the CCWS is described in Sections 7.6 and 9.2.2.</del>



**Table 7.1-5—SAS Automatic Safety Function**  
Sheet 7 of 45

System <sup>1</sup>	Function Name <sup>2</sup>	Function Safety Basis <sup>3</sup>	Interdivisional Communications <sup>4</sup>	Type of Data <sup>5</sup>	Signal Selection Type <sup>6</sup>	Comments
Component Cooling Water System (CCWS)	<del>CCWS</del> RCP Thermal Barrier Containment Isolation Valve Interlock (Figure 7.6-2)	<p><del>This function is described in Sections 7.6.1.2.5 and 9.2.2. The CCWS has a safety-related function to remove heat from safety-related components (GDC-44). The interlock function is required to verify that the Common 1.b and 2.b headers remain separated and each of their trains are able to provide their corresponding LHSI HX with the required flow for heat removal. Removing heat from the LHSI HX is a safety-related function.</del></p>	<p>The Inner and Outer Containment Isolation Valves are powered from different divisions. For the Common 1.b header, the outer valves (supply and return) are supplied by Div 1 and the inner valves by Div 4. The opposite is true for the Common 2.b header. To be able to switch between headers, at least one of the supply valves (outer or inner) and one of the return valves (outer or inner) must be closed. Therefore, the state (open or closed) of these valves must be communicated across divisions.</p>	Discrete	Vote	<p>The I&amp;G associated with the CCWS is described in Sections 7.6 and 9.2.2.</p>



Table 7.1-5—SAS Automatic Safety Function  
Sheet 8 of 45

System <sup>1</sup>	Function Name <sup>2</sup>	Function Safety Basis <sup>3</sup>	Interdivisional Communications <sup>4</sup>	Type of Data <sup>5</sup>	Signal Selection Type <sup>6</sup>	Comments <del>FSAR Section-Referenced</del>
Component Cooling Water System (CCWS)	<del>CCWS Emergency Leak Detection - Switchover Valves Leakage or Failure (Figure 7.3-36)</del>	<del>This function is described in Sections 7.3.1.4.1 and 9.2.2. The CCWS has a safety-related function to remove heat from SAS components (GDC-44). The safety-related function for switchover valve leakage or failure isolates the CCWS trains from their common headers to verify that each train is able to provide their corresponding LHSI HX with the required flow for heat removal. Removing heat from the LHSI HX is a safety-related function.</del>	This function looks at surge tank level in the two corresponding Trains (Trains 1 and 2, Trains 3 and 4) that feed a common header. If the surge tank level in the on-line train is lowering while the surge tank level the off-line train is rising then a seat leakage on one of the off line train switchover valves is likely. Therefore, interdivisional communication is required since information from more than one division is being utilized.	Discrete	Vote	<del>The I&amp;G associated with the CCWS is described in Section 9.2.2.</del>

**Table 7.1-5—SAS Automatic Safety Function**  
Sheet 9 of 45

System <sup>1</sup>	Function Name <sup>2</sup>	Function Safety Basis <sup>3</sup>	Interdivisional Communications <sup>4</sup>	Type of Data <sup>5</sup>	Signal Selection Type <sup>6</sup>	Comments <del>FSAR Section-Reference</del>
Component Cooling Water System (CCWS)	<del>CGWS-SCWS</del> Condenser Supply Water Flow Control (Figure 7.3-37)	<del>This function is described in Sections 7.3.1.4.1 and 9.2.2. The CGWS has a safety-related function that controls CGWS flow to the SCWS condenser and provides a heat sink for heat rejection, therefore providing reasonable assurance that the SCWS is capable of fulfilling these safety-related functions (GDC-44).</del>	NO	NA	NA	<del>The I&amp;G associated with the CGWS is described in Section 9.2.2.</del>
Emergency Feedwater System (EFWS)	SG Closed Loop Level Control (Figure 7.3-4)	<del>This function is described in Sections 7.3.1.3.2 and 10.4.9. The EFWS has a safety-related function to:</del> 1. Provide flow to the steam generators to restore and maintain decay heat removal from the RCS to assist in the cool down and depressurization of the RCS to the RHRS entry conditions following AOCs and PAs.	NO	N/A	N/A	<del>The I&amp;G associated with the EFWS is described in Sections 7.3 and 10.4.9.</del>



Table 7.1-5—SAS Automatic Safety Function  
Sheet 10 of 45

System <sup>1</sup>	Function Name <sup>2</sup>	Function Safety Basis <sup>3</sup>	Interdivisional Communications <sup>4</sup>	Type of Data <sup>5</sup>	Signal Selection Type <sup>6</sup>	Comments <del>FSAR Section-Referenced</del>
Emergency Feedwater System (EFWS)	EFW Pump Flow Control (Figure 7.3-4)	<p>2. <del>Maintain the water inventory in the steam generators following a LOOP, and the resulting loss of MFW, for decay heat removal.</del>                      The safety-related function to provide SG-Closed Loop Level Control verifies that the EFWS is capable of fulfilling its safety-related function of maintaining the SG water inventory for decay heat removal, following a LOOP and the resulting loss of MFW.</p> <p><del>This function is described in Sections 7.3.1.3.2 and 10.4.9. The EFWS has a safety-related function to:</del></p> <p>1. <del>Provide flow to the SGs to restore and maintain decay heat removal from the RCS to assist in the cool down and depressurization of the RCS to the PPRS entry conditions following AOOs and PAs.</del></p>	NO	N/A	N/A	<del>The I&amp;G associated with the EFWS is described in Sections 7.3 and 10.4.9.</del>

**Table 7.1-5—SAS Automatic Safety Function**  
Sheet 11 of 45

System <sup>1</sup>	Function Name <sup>2</sup>	Function Safety Basis <sup>3</sup>	Interdivisional Communications <sup>4</sup>	Type of Data <sup>5</sup>	Signal Selection Type <sup>6</sup>	Comments <del>FSAR Section-Reference</del>
Essential Service Water System (ESWS)	Automatic ESWS Actuation from CGWS Start	<p>2. <del>Maintain the water inventory in the steam generators following a LOOP, and the resulting loss of MFW, for decay heat removal.</del></p> <p><del>The safety related function to provide EFW pump flow control to maintain EFW pump flow at the design flow verifies that the EFWS is capable of fulfilling its safety related function of providing flow to the steam generators, below the maximum allowable flow rate to a depressurized SG, to support its safe shut-down capabilities.</del></p> <p>The ESWS has a safety related function to remove heat from safety related components (GDC 44). The Automatic ESWS Actuation from CGWS Start function removes heat from the CGWS (Trains 2 and 3) and the EDGs ensuring the ESWS is capable of fulfilling its safety related function to remove heat from the corresponding CGWS train.</p>	NO	N/A	N/A	The I&G associated with the ESWS is described in Section 9.2.1.



Table 7.1-5—SAS Automatic Safety Function  
Sheet 12 of 45

System <sup>1</sup>	Function Name <sup>2</sup>	Function Safety Basis <sup>3</sup>	Interdivisional Communications <sup>4</sup>	Type of Data <sup>5</sup>	Signal Selection Type <sup>6</sup>	Comments FSAR- Section- Referenced
Essential Service Water Pump Building Ventilation System (ESWPBVS)	<del>Remove Heat Generated by Essential Service Water Equipment</del> <u>ESWS Pump Rooms Temperature Control (Figure 7.3-38)</u>	<u>This function is described in Sections 7.3.1.4.3 and 9.4.1.1. The ESWPBVS has an safety-related function that maintains ambient conditions for safety-related components during normal operation (GDC 4, GDC 17).</u>	NO	N/A	N/A	The I&G associated with the ESWS systems is described in Section 9.4.1.1.
Fuel Building Ventilation System (FBVS)	<del>Safety-Related Rooms Heater Control</del> <u>(Figure 7.3-39)</u>	<u>This function is described in Sections 7.3.1.4.4 and 9.4.2. The FBVS has an safety-related function that maintains the room ambient conditions for safety-related boron rooms during normal operation, abnormal operation, and postulated accident events (GDC 27, GDC 60, GDC 61).</u>	NO	N/A	N/A	The I&G associated with the FBVS system is described in Section 9.4.2.
Fuel Building Ventilation System (FBVS)	<del>Maintain Ambient Conditions for EBS and FPGEBS / FPCS</del> <u>pump #Rooms Heat Removal (Recirculation Coolers) (Figure 7.3-40)</u>	<u>This function is described in Sections 7.3.1.4.4 and 9.4.2. The FBVS has an safety-related function that maintains the room ambient conditions in the extra borating system pump rooms and fuel pool cooling system pump rooms during normal operation, abnormal operation, and postulated accident events (GDC 27, GDC 60, GDC 61).</u>	NO	N/A	N/A	The I&G associated with the FBVS system is described in Section 9.4.2.



**Table 7.1-5—SAS Automatic Safety Function**  
Sheet 13 of 45

<b>System<sup>1</sup></b>	<b>Function Name<sup>2</sup></b>	<b>Function Safety Basis<sup>3</sup></b>	<b>Interdivisional Communications<sup>4</sup></b>	<b>Type of Data<sup>5</sup></b>	<b>Signal Selection Type<sup>6</sup></b>	<b>Comments</b> <del>FSAR Section-Reference</del>
<u>Fuel Building Ventilation System (FBVS)</u>	<u>Isolation of FBVS on Containment Isolation (Figure 7.3-62)</u>	<u>This function is described in Sections 7.3.1.4.4 and 9.4.2.3.</u>	<u>NO</u>	<u>N/A</u>	<u>N/A</u>	
<u>Fuel Building Ventilation System (FBVS)</u>	<u>Fuel Pool Area Fuel Handling Accident (Figure 7.3-63)</u>	<u>This function is described in Sections 7.3.1.4.4 and 9.4.2.3.</u>	<u>NO</u>	<u>N/A</u>	<u>N/A</u>	
<u>Fuel Building Ventilation System (FBVS)</u>	<u>Reactor Building Fuel Handling Accident (Figure 7.3-64)</u>	<u>This function is described in Sections 7.3.1.4.4 and 9.4.2.3.</u>	<u>NO</u>	<u>N/A</u>	<u>N/A</u>	



Table 7.1-5—SAS Automatic Safety Function  
Sheet 14 of 45

System <sup>1</sup>	Function Name <sup>2</sup>	Function Safety Basis <sup>3</sup>	Interdivisional Communications <sup>4</sup>	Type of Data <sup>5</sup>	Signal Selection Type <sup>6</sup>	Comments <del>FSAR Section-Referenced</del>
Fuel Pool Cooling and Purification System (FPCPS)	<del>FPCPS</del> Pump Trip on Low SFP Level (Figure 7.3-41)	<p><u>This function is described in Sections 7.3.1.4.5 and 9.1.3. The FPCPS has a safety-related function to:</u></p> <ol style="list-style-type: none"> <li>1. Remove decay heat from the spent fuel pool during normal plant operation, outages, AOs, and PAs.</li> <li>2. Provide containment isolation by closure of the reactor pool purification supply and return containment isolation valves.</li> <li>3. Preclude, by design, the drain down of the spent fuel pool (SFP) below its required level to verify that the spent fuel remains covered with water during storage conditions.</li> <li>4. Provide SFP make-up capability (Seismic Category I water sources, pump, and piping) to compensate for normal SFP evaporation for up to seven days.</li> </ol>	NO	N/A	N/A	The I&G associated with the FPCPS is described in Section 9.1.3.



**Table 7.1-5—SAS Automatic Safety Function**  
Sheet 15 of 45

System <sup>1</sup>	Function Name <sup>2</sup>	Function Safety Basis <sup>3</sup>	Interdivisional Communications <sup>4</sup>	Type of Data <sup>5</sup>	Signal Selection Type <sup>6</sup>	Comments <del>FSAR Section-Reference</del>
In-Containment Refueling Water Storage Tank System (IRWST)	IRWST Boundary Isolation for Preserving IRWST Water Inventory. <a href="#">Interlock (Figure 7.6-4)</a>	<p>5. <del>Provide isolation capability of non-safety related FPGPS piping from the reactor building transfer compartment, the fuel building transfer compartment and cask loading pit (per 10 CFR 50.34(e)(1) or 10 CFR 100.11).</del></p> <p><del>The safety related function to trip the FPG pump on low level verifies that the FPGPS is capable of fulfilling its safety related function of precluding the drain down of the SFP to eliminate the potential for fuel damage and its consequences.</del></p> <p><del>This function is described in Sections 6.3 and 7.6.1.2.6. The IRWST has a safety-related function to isolate the IRWST for purposes of preserving the IRWST water inventory to support the safety related function of controlling core reactivity (via safety injection) by closing the IRWST isolation valves. This preserves IRWST inventory for long term availability of safety injection, given a pipe failure in a connected non-safety related system.</del></p>	Interdivisional communications is required because an IRWST low level discrete signal is generated in each division, and 2/4 voting logic is used to close IRWST isolation valves in Division 1 and 4.	Discrete	Vote	<del>The I&amp;G associated with the IRWST is described in Section 6.3</del>



Table 7.1-5—SAS Automatic Safety Function  
Sheet 16 of 45

System <sup>1</sup>	Function Name <sup>2</sup>	Function Safety Basis <sup>3</sup>	Interdivisional Communications <sup>4</sup>	Type of Data <sup>5</sup>	Signal Selection Type <sup>6</sup>	Comments <b>FSAR- Section- Reference<sup>ee</sup></b>
Main Control Room Air Conditioning System (CRACS)	Iodine Filtration Train Heater Control (Figure 7.3-42)	<u>This function is described in Sections 6.5.1, 7.3.1.3.2, and 9.4.1. The CRACS has an safety-related function to preheat the inlet air in order to reduce the airborne moisture prior to entry into the carbon bed within the filter unit. Carbon filter heaters shut down when the respective inlet or outlet dampers are not fully open. The heaters will turn off if the carbon filtration unit fan stops, the carbon filter inlet isolation damper is not open or the carbon filter outlet isolation damper is not open.</u>	NO	N/A	N/A	The I&G associated with the CRACS systems is described in Sections 6.5.1 and 9.4.1.
Main Control Room Air Conditioning System (CRACS)	Heater Control for Outside Inlet Air (Figure 7.3-43)	<u>This function is described in Sections 6.5.1, 7.3.1.3.2, and 9.4.1. The CRACS has an safety-related function to preheat the outside air to verify that the inlet air temperature is not less than 37°F (GDC 19). Inlet air which bypasses the iodine filtration unit is heated by an electric heater for temperature control. Heating of the outside air is performed by multi-stage heaters located in each outside air intake duct.</u>	NO	N/A	N/A	The I&G associated with the CRACS systems is described in Sections 6.5.1 and 9.4.1.



Table 7.1-5—SAS Automatic Safety Function  
Sheet 17 of 45

System <sup>1</sup>	Function Name <sup>2</sup>	Function Safety Basis <sup>3</sup>	Interdivisional Communications <sup>4</sup>	Type of Data <sup>5</sup>	Signal Selection Type <sup>6</sup>	Comments <del>FSAR Section-Referenced</del>
Main Control Room Air Conditioning System (CRACS)	Pressure Control (Figure 7.3-44)	<del>This function is described in Sections 6.5.1, 7.3.1.3.2, and 9.4.1. The CRACS has safety related function to verify the MCR is maintained at a positive pressure with respect to the ambient air pressure in adjacent areas (GDC-19). Differential pressure sensors sense the pressure difference between the MCR and the pressure in a reference space.</del>	NO	N/A	N/A	<del>The I&amp;G associated with the CRACS systems is described in Sections 6.5.1 and 9.4.1.</del>
Main Control Room Air Conditioning System (CRACS)	Cooler Temperature Control (Figure 7.3-45)	<del>This function is described in Sections 6.5.1, 7.3.1.3.2, and 9.4.1. The CRACS has safety related functions that verifies that the air supply temperature is maintained within the preset temperature range (GDC-19). A control signal is developed when the supply air temperature exceeds a preset temperature set point of 58°F. The control signal is used to adjust cooler outlet SGWS control valves to maintain the air supply temperature.</del>	NO	N/A	N/A	<del>The I&amp;G associated with the CRACS systems is described in Sections 6.5.1 and 9.4.1.</del>



Table 7.1-5—SAS Automatic Safety Function  
Sheet 18 of 45

System <sup>1</sup>	Function Name <sup>2</sup>	Function Safety Basis <sup>3</sup>	Interdivisional Communications <sup>4</sup>	Type of Data <sup>5</sup>	Signal Selection Type <sup>6</sup>	Comments <del>FSAR Section-Reference</del>
Main Steam System (MSS)	Steam Generator MSRCV Regulation during Standby Position Control (Figure 7.3-12)	<u>This function is described in Sections 7.3.1.3.3 and 10.3.</u> <del>The MSS has a safety-related function supporting the removal of decay heat and other residual heat from the reactor core (GDC-34). The function modulates the MSRCV to its standby control position, so in the event of an overpressure transient the MSRCVs will already be in its required relieving position.</del>	NO	N/A	N/A	The I&G associated with the MSS is described in Sections 7.3 and 10.3.
Main Steam System (MSS)	Steam Generator MSRCV Regulation during Pressure Control (Figure 7.3-12)	<u>This function is described in Sections 7.3.1.3.3 and 10.3.</u> <del>The MSS has a safety-related function supporting the removal of decay heat and other residual heat from the reactor core (GDC-34). The function modulates the MSRCV to its required position in order to reduce secondary side pressure of the steam generators during overpressure events.</del>	The MSRIV closed position is detected via 2 out of 4 voting (the position switches are associated with Div 1 through 4).	Discrete	Vote	The I&G associated with the MSS is described in Sections 7.3 and 10.3.

Table 7.1-5—SAS Automatic Safety Function  
Sheet 19 of 45

System <sup>1</sup>	Function Name <sup>2</sup>	Function Safety Basis <sup>3</sup>	Interdivisional Communications <sup>4</sup>	Type of Data <sup>5</sup>	Signal Selection Type <sup>6</sup>	Comments <del>FSAR Section-Reference</del>
Residual Heat Removal System (RHR)	Detection of RHR Connected (Figure 7.6-3)	This function is described in Sections 7.6.1.2.8 and 5.4.7.	This function utilizes interdivisional communication because voting is required using discreet signals that are generated in all four divisions. An RHR RCPB valve isolation discreet signal is generated in each division. The RHR outside containment isolation signal is generated in each division. The LHSI suction isolation discreet signal is generated in each division as well as the LHSI hot leg injection isolation signal.	Discrete	Vote	
Residual Heat Removal System (RHR)	RHR Isolation Valves Interlock (Figure 7.6-11)	This function is described in section 7.6.1.2.8 and 5.4.7.	NO	N/A	N/A	

Table 7.1-5—SAS Automatic Safety Function  
Sheet 20 of 45

System <sup>1</sup>	Function Name <sup>2</sup>	Function Safety Basis <sup>3</sup>	Interdivisional Communications <sup>4</sup>	Type of Data <sup>5</sup>	Signal Selection Type <sup>6</sup>	Comments FSAR- Section- Referenced
Safeguard Building Controlled-Area Ventilation System (SBVS)	<del>SIS/RHRS-CCWS/</del> EFWS Pump Rooms Heat Removal (Figure 7.3-46)	<u>This function is described in Sections 7.3.1.3.4 and 9.4.5. The SBVS has a safety-related function that maintains ambient conditions for safety-related components during normal operation (GDC-60, GDC-61).</u>	NO	N/A	N/A	The I&G associated with the SBVS system is described in Section 9.4.5.
Safeguard Building Controlled-Area Ventilation System (SBVS)	<del>SIS/RHRS-CCWS/</del> EFWS Valve Rooms Heat Removal (Figure 7.3-47)	<u>This function is described in Sections 7.3.1.3.4 and 9.4.5. The SBVS has a safety-related function that maintains ambient conditions for safety-related components during normal operation (GDC-60, GDC-61).</u>	NO	N/A	N/A	The I&G associated with the SBVS system is described in Section 9.4.5.



Table 7.1-5—SAS Automatic Safety Function  
Sheet 21 of 45

System <sup>1</sup>	Function Name <sup>2</sup>	Function Safety Basis <sup>3</sup>	Interdivisional Communications <sup>4</sup>	Type of Data <sup>5</sup>	Signal Selection Type <sup>6</sup>	Comments <del>FSAR Section-Referenced</del>
Electrical Division of Safeguard Building Ventilation System (SBVSE)	Supply and Recirculation-Exhaust Air Flow Control (Figure 7.3-48)	<del>This function is described in Sections 7.3.1.4.6 and 9.4.6. The SBVSE has a safety-related function to ventilate and maintain acceptable ambient temperature in the Safeguard Building areas and rooms ventilated by the system (GDC-4, GDC-17). The Supply and Recirculation-Exhaust Air Flow Control function supports this system safety function by controlling supply, exhaust, and recirculation flow as required to maintain ambient temperature and air quality (via filtration) within applicable limits for safety-related equipment located within the Safeguard Building areas and rooms.</del>	NO	N/A	N/A	The I&G associated with the SBVSE is described in Section 9.4.6.



Table 7.1-5—SAS Automatic Safety Function  
Sheet 22 of 45

System <sup>1</sup>	Function Name <sup>2</sup>	Function Safety Basis <sup>3</sup>	Interdivisional Communications <sup>4</sup>	Type of Data <sup>5</sup>	Signal Selection Type <sup>6</sup>	Comments <del>FSAR Section-Reference</del>
Electrical Division of Safeguard Building Ventilation System (SBVSE)	Supply Fan Safe Shut-off (Figure 7.3-49)	<u>This function is described in Sections 7.3.1.4.6 and 9.4.6.</u> <del>The SBVSE has a safety-related function to ventilate and maintain acceptable ambient temperature in the Safeguard Building areas and rooms ventilated by the system (GDC 4, GDC 17). An inadvertent stopping of the supply fan, due to a spurious system action, may cause the SBVSE for a given division to become inoperable. Therefore, to mitigate the risk of system spurious actions, this function is to be designated as safety-related (IEEE 603).</del>	NO	N/A	N/A	<del>The I&amp;G associated with the SBVSE is described in Section 9.4.6.</del>





Table 7.1-5—SAS Automatic Safety Function  
Sheet 23 of 45

System <sup>1</sup>	Function Name <sup>2</sup>	Function Safety Basis <sup>3</sup>	Interdivisional Communications <sup>4</sup>	Type of Data <sup>5</sup>	Signal Selection Type <sup>6</sup>	Comments <del>FSAR Section-Reference</del>
Electrical Division of Safeguard Building Ventilation System (SBVSE)	Recirculation/ <del>Exhaust</del> Fan Safe Shut-off (Figure 7.3-50)	<u>This function is described in Sections 7.3.1.4.6 and 9.4.6.</u> <del>The SBVSE has an safety-related function to ventilate and maintain acceptable ambient temperature in the Safeguard Building areas and rooms ventilated by the system (GDC 4, GDC 17). An inadvertent stopping of the recirculation/exhaust fan, due to a spurious system action, may cause the SBVSE for a given division to become inoperable. Therefore, to mitigate the risk of system spurious actions, this function is to be designated as safety-related (IEEE-603).</del>	NO	N/A	N/A	<del>The I&amp;G associated with the SBVSE is described in Section 9.4.6.</del>



Table 7.1-5—SAS Automatic Safety Function  
Sheet 24 of 45

System <sup>1</sup>	Function Name <sup>2</sup>	Function Safety Basis <sup>3</sup>	Interdivisional Communications <sup>4</sup>	Type of Data <sup>5</sup>	Signal Selection Type <sup>6</sup>	Comments <b>FSAR- Section- Referencee</b>
Electrical Division of Safeguard Building Ventilation System (SBVSE)	Exhaust Fan Safe Shut-off (Figure 7.3-51)	<u>This function is described in Sections 7.3.1.4.6 and 9.4.6. The SBVSE has a safety-related function to ventilate and maintain acceptable ambient temperature in the Safeguard Building areas and rooms ventilated by the system (GDC-4, GDC-17). An inadvertent stopping of the exhaust fan, due to a spurious system action, may cause the SBVSE for a given division to become inoperable. Therefore, to mitigate the risk of system spurious actions, this function is to be designated as safety-related (IEEE-603).</u>	NO	N/A	N/A	The I&G associated with the SBVSE is described in Section 9.4.6.
Electrical Division of Safeguard Building Ventilation System (SBVSE)	Supply Air Temperature Heater Control (Figure 7.3-52)	<u>This function is described in Sections 7.3.1.4.6 and 9.4.6. The SBVSE has a safety-related function to ventilate and maintain acceptable ambient temperature in the Safeguard Building areas and rooms ventilated by the system (GDC-4, GDC-17). The Supply Air Temperature function supports this system safety function by maintaining supply air temperature (downstream of heaters) as required to maintain ambient temperature within applicable limits for safety-related equipment located within the Safeguard Building areas and rooms.</u>	NO	N/A	N/A	The I&G associated with the SBVSE is described in Section 9.4.6.



Table 7.1-5—SAS Automatic Safety Function  
Sheet 25 of 45

System <sup>1</sup>	Function Name <sup>2</sup>	Function Safety Basis <sup>3</sup>	Interdivisional Communications <sup>4</sup>	Type of Data <sup>5</sup>	Signal Selection Type <sup>6</sup>	Comments FSAR Section- Referenced
Electrical Division of Safeguard Building Ventilation System (SBVSE)	Freeze Protection—Supply Air Temperature	The SBVSE has a safety-related function to ventilate and maintain acceptable ambient temperature in the Safeguard Building areas and rooms ventilated by the system (GDC-4, GDC-17). The Freeze Protection Supply Air Temperature function supports this system safety function by maintaining supply air temperature (downstream of heaters) as required to maintain ambient temperature within applicable limits for safety-related equipment located within the Safeguard Building areas and rooms.	NO	N/A	N/A	The I&G associated with the SBVSE is described in Section 9.4.6.
Electrical Division of Safeguard Building Ventilation System (SBVSE)	Freeze Protection—Heat Tracing (Figure 7.3-53)	This function is described in Sections 7.3.1.4.6 and 9.4.6. The SBVSE has a safety-related function to ventilate and maintain acceptable ambient temperature in the Safeguard Building areas and rooms ventilated by the system (GDC-4, GDC-17). The Freeze Protection Heat Tracing function supports this system safety function by preventing ice build-up on the louver bars (i.e. mitigating the risk of not having available makeup air).	NO	N/A	N/A	The I&G associated with the SBVSE is described in Section 9.4.6.



Table 7.1-5—SAS Automatic Safety Function  
Sheet 26 of 45

System <sup>1</sup>	Function Name <sup>2</sup>	Function Safety Basis <sup>3</sup>	Interdivisional Communications <sup>4</sup>	Type of Data <sup>5</sup>	Signal Selection Type <sup>6</sup>	Comments <del>FSAR Section-Reference</del>
Electrical Division of Safeguard Building Ventilation System (SBVSE)	Supply Air Temperature Control for <u>Supply Air Cooling</u> (Figure 7.3-54)	<u>This function is described in Sections 7.3.1.4.6 and 9.4.6. The SBVSE has a safety-related function to ventilate and maintain acceptable ambient temperature in the Safeguard Building areas and rooms ventilated by the system (GDC-4, GDC-17). The Supply Air Temperature Control for Cooling function supports this system safety function by maintaining a constant air temperature as required to maintain ambient temperature within applicable limits for safety-related equipment located within the Safeguard Building areas and rooms.</u>	NO	N/A	N/A	The I&G associated with the SBVSE is described in Section 9.4.6.
Electrical Division of Safeguard Building Ventilation System (SBVSE)	Supply Air Temperature Control for <u>Supply Air Heating</u>	The SBVSE has a safety-related function to ventilate and maintain acceptable ambient temperature in the Safeguard Building areas and rooms ventilated by the system (GDC-4, GDC-17). The Supply Air Temperature Control for Supply Air Heating function supports this system safety function by maintaining a minimal air temperature as required to maintain ambient temperature within applicable limits for safety-related equipment located within the Safeguard Building areas and rooms.	NO	N/A	N/A	The I&G associated with the SBVSE is described in Section 9.4.6.



Table 7.1-5—SAS Automatic Safety Function  
Sheet 27 of 45

System <sup>1</sup>	Function Name <sup>2</sup>	Function Safety Basis <sup>3</sup>	Interdivisional Communications <sup>4</sup>	Type of Data <sup>5</sup>	Signal Selection Type <sup>6</sup>	Comments <del>FSAR Section-Referenced</del>
Electrical Division of Safeguard Building Ventilation System (SBVSE)	Battery Room <del>Temperature Heater Control.</del> (Figure 7.3-56)	<del>This function is described in Sections 7.3.1.4.6 and 9.4.6. The SBVSE has a safety-related function to ventilate and maintain acceptable ambient temperature in the Safeguard Building areas and rooms ventilated by the system (GDC-4, GDC-17). The Battery Room Temperature Control function supports this system safety function by maintaining battery room ambient temperature within applicable limits.</del>	NO	N/A	N/A	<del>The I&amp;G associated with the SBVSE is described in Section 9.4.6.</del>
Electrical Division of Safeguard Building Ventilation System (SBVSE)	Battery Room Supply Air Temperature <del>Control.</del> (Figure 7.3-57)	<del>This function is described in Sections 7.3.1.4.6 and 9.4.6. The SBVSE has a safety-related function to ventilate and maintain acceptable ambient temperature in the Safeguard Building areas and rooms ventilated by the system (GDC-4, GDC-17). The Battery Room Supply Air Temperature function supports this system safety function by maintaining battery room ambient temperature within applicable limits.</del>	NO	N/A	N/A	<del>The I&amp;G associated with the SBVSE is described in Section 9.4.6.</del>



Table 7.1-5—SAS Automatic Safety Function  
Sheet 28 of 45

System <sup>1</sup>	Function Name <sup>2</sup>	Function Safety Basis <sup>3</sup>	Interdivisional Communications <sup>4</sup>	Type of Data <sup>5</sup>	Signal Selection Type <sup>6</sup>	Comments FSAR- Section- Referenced
Electrical Division of Safeguard Building Ventilation System (SBVSE)	<del>Emergency Feedwater</del> EFWS Pump Room Heat Removal (Figure 7.3-58)	<u>This function is described in Sections 7.3.1.4.6 and 9.4.6. The SBVSE has a safety-related function to ventilate and maintain acceptable ambient temperature in the Safeguard Building areas and rooms ventilated by the system (GDC-4, GDC-17). The Emergency Feedwater Pump Room Heat Removal function supports this system safety function by removing heat from the pump room and maintaining room temperature within a temperature band for safety-related equipment.</u>	NO	N/A	N/A	The I&G associated with the SBVSE is described in Section 9.4.6.
Electrical Division of Safeguard Building Ventilation System (SBVSE)	<del>Component Cooling</del> <del>Water System</del> CCWS Pump Rooms Heat Removal (Figure 7.3-59)	<u>This function is described in Sections 7.3.1.4.6 and 9.4.6. The SBVSE has a safety-related function to ventilate and maintain acceptable ambient temperature in the Safeguard Building areas and rooms ventilated by the system (GDC-4, GDC-17). The Component Cooling Water System Rooms Heat Removal function supports this system safety function by removing heat from the applicable rooms and maintaining room temperature within a temperature band for safety-related equipment.</u>	NO	N/A	N/A	The I&G associated with the SBVSE is described in Section 9.4.6.



Table 7.1-5—SAS Automatic Safety Function  
Sheet 29 of 45

System <sup>1</sup>	Function Name <sup>2</sup>	Function Safety Basis <sup>3</sup>	Interdivisional Communications <sup>4</sup>	Type of Data <sup>5</sup>	Signal Selection Type <sup>6</sup>	Comments <del>FSAR Section-Reference</del>
Safety Chilled Water System (SCWS)	<del>SCWS-Train 1 to Train 2</del> Switchover on Train 1 Low Evaporator Flow Interlock (Figure 7.6-5)	<del>This function is described in Sections 7.6.1.2.7 and 9.2.8. The SCWS has a safety-related function 1) to transfer heat loads from safety-related SSC to a heat sink under both normal operating and accident conditions, 2) component redundancy for performance of safety functions assuming a single, active component failure coincident with the loss of offsite power, and 3) the capability to isolate components, systems, or piping, if required, so system safety functions are not compromised. The automatic switchover function verifies that the SCWS is capable of fulfilling these safety-related functions (GDC 44).</del>	Train 1 is associated with Div 1 and Train 2 with Div 2. Div 1 and Div 2 are cross connected. When switching between trains (due to system faults - e.g., low evaporator flow) an auto-start of the standby train occurs. A verification of prerequisites is required to make sure the on-coming train is in <del>ready</del> -standby mode and that the appropriate cross-tie valves are in the open position.	Discrete	Vote	<del>The I&amp;G associated with the SCWS is described in Section 9.2.8.</del>



Table 7.1-5—SAS Automatic Safety Function  
Sheet 30 of 45

System <sup>1</sup>	Function Name <sup>2</sup>	Function Safety Basis <sup>3</sup>	Interdivisional Communications <sup>4</sup>	Type of Data <sup>5</sup>	Signal Selection Type <sup>6</sup>	Comments <del>FSAR Section-Reference</del>
Safety Chilled Water System (SCWS)	<del>SCWS-Train 2 to Train 1</del> Switchover on Train 2 Low Evaporator Flow Interlock (Figure 7.6-6)	<del>This function is described in Sections 7.6.1.2.7 and 9.2.8. The SCWS has a safety-related function 1) to transfer heat loads from safety-related SSC to a heat sink under both normal operating and accident conditions, 2) component redundancy for performance of safety functions assuming a single, active component failure coincident with the loss of offsite power, and 3) the capability to isolate components, systems, or piping, if required, so system safety functions are not compromised. The automatic switchover function verifies that the SCWS is capable of fulfilling these safety-related functions (GDC 44).</del>	Train 1 is associated with Div 1 and Train 2 with Div 2. Div 1 and Div 2 are cross connected. When switching between trains (due to system faults - e.g., low evaporator flow) an auto-start of the standby train occurs. A verification of prerequisites is required to make sure the on-coming train is in <del>ready</del> standby mode and that the appropriate cross-tie valves are in the open position.	Discrete	Vote	<del>The I&amp;G associated with the SCWS is described in Section 9.2.8.</del>



Table 7.1-5—SAS Automatic Safety Function  
Sheet 31 of 45

System <sup>1</sup>	Function Name <sup>2</sup>	Function Safety Basis <sup>3</sup>	Interdivisional Communications <sup>4</sup>	Type of Data <sup>5</sup>	Signal Selection Type <sup>6</sup>	Comments <del>FSAR Section-Reference</del>
Safety Chilled Water System (SCWS)	<del>SCWS-Train 3 to Train 4 Switchover on Train 3 Low Evaporator Flow Interlock (Figure 7.6-7)</del>	<del>This function is described in Sections 7.6.1.2.7 and 9.2.8. The SCWS has an safety-related function 1) to transfer heat loads from safety-related SSC to a heat sink under both normal operating and accident conditions, 2) component redundancy for performance of safety functions assuming a single, active component failure coincident with the loss of offsite power, and 3) the capability to isolate components, systems, or piping, if required, so system safety functions are not compromised. The automatic switchover function verifies that the SCWS is capable of fulfilling these safety-related functions per (GDC-44).</del>	Train 3 is associated with Div 3 and Train 4 with Div 4. Div 3 and Div 4 are cross connected. When switching between trains (due to system faults - e.g., low evaporator flow) an auto-start of the standby train occurs. A verification of prerequisites is required to make sure the on-coming train is in <del>ready</del> standby mode and that the appropriate cross-tie valves are in the open position.	Discrete	Vote	<del>The I&amp;G associated with the SCWS is described in Section 9.2.8.</del>

Table 7.1-5—SAS Automatic Safety Function  
Sheet 32 of 45

System <sup>1</sup>	Function Name <sup>2</sup>	Function Safety Basis <sup>3</sup>	Interdivisional Communications <sup>4</sup>	Type of Data <sup>5</sup>	Signal Selection Type <sup>6</sup>	Comments <del>FSAR Section-Reference</del>
Safety Chilled Water System (SCWS)	<del>SCWS-Train 4 to Train 3 Switchover on Train 4 Low Evaporator Flow Interlock (Figure 7.6-8)</del>	<del>This function is described in Sections 7.6.1.2.7 and 9.2.8. The SCWS has an safety-related function 1) to transfer heat loads from safety-related SSC to a heat sink under both normal operating and accident conditions, 2) component redundancy for performance of safety functions assuming a single, active component failure coincident with the loss of offsite power, and 3) the capability to isolate components, systems, or piping, if required, so system safety functions are not compromised. The automatic switchover function verifies that the SCWS is capable of fulfilling these safety-related functions (GDC 44).</del>	Train 3 is associated with Div 3 and Train 4 with Div 4. Div 3 and Div 4 are cross connected. When switching between trains (due to system faults - e.g., low evaporator flow) an auto-start of the standby train occurs. A verification of prerequisites is required to make sure the on-coming train is in <del>ready</del> standby mode and that the appropriate cross-tie valves are in the open position.	Discrete	Vote	<del>The I&amp;G associated with the SCWS is described in Section 9.2.8.</del>

Table 7.1-5—SAS Automatic Safety Function  
Sheet 33 of 45

System <sup>1</sup>	Function Name <sup>2</sup>	Function Safety Basis <sup>3</sup>	Interdivisional Communications <sup>4</sup>	Type of Data <sup>5</sup>	Signal Selection Type <sup>6</sup>	Comments <del>FSAR Section-Referenced</del>
Safety Chilled Water System (SCWS)	<del>SCWS-Train 1 to Train 2</del> Switchover on Train 1 Chiller Black Box Internal Fault <u>Interlock</u> (Figure 7.6-5)	<u>This function is described in Sections 7.6.1.2.7 and 9.2.8.</u> <del>The SCWS has an safety-related function 1) to transfer heat loads from safety-related SSC to a heat sink under both normal operating and accident conditions, 2) component redundancy for performance of safety functions assuming a single, active component failure coincident with the loss of offsite power, and 3) the capability to isolate components, systems, or piping, if required, so system safety functions are not compromised. The automatic switchover function verifies that the SCWS is capable of fulfilling these safety-related functions (GDC 44).</del>	Train 1 is associated with Div 1 and Train 2 with Div 2. Div 1 and Div 2 are cross connected. When switching between trains (due to system faults - chiller black box internal fault) an auto-start of the standby train occurs. A verification of prerequisites is required to provide reasonable assurance that the on-coming train is in <del>ready</del> standby mode and that the appropriate cross-tie valves are in the open position.	Discrete	Vote	<del>The I&amp;G associated with the SCWS is described in Section 9.2.8.</del>

Table 7.1-5—SAS Automatic Safety Function  
Sheet 34 of 45

System <sup>1</sup>	Function Name <sup>2</sup>	Function Safety Basis <sup>3</sup>	Interdivisional Communications <sup>4</sup>	Type of Data <sup>5</sup>	Signal Selection Type <sup>6</sup>	Comments <del>FSAR Section-Referenced</del>
Safety Chilled Water System (SCWS)	<del>SCWS-Train 2 to Train 1</del> Switchover on Train 2 Chiller Black Box Internal Fault <u>Interlock</u> (Figure 7.6-6)	<u>This function is described in Sections 7.6.1.2.7 and 9.2.8.</u> <del>The SCWS has an safety-related function 1) to transfer heat loads from safety-related SSC to a heat sink under both normal operating and accident conditions, 2) component redundancy for performance of safety functions assuming a single, active component failure coincident with the loss of offsite power, and 3) the capability to isolate components, systems, or piping, if required, so system safety functions are not compromised.</del> The automatic switchover function verifies that the SCWS is capable of fulfilling these safety-related functions (GDC 44).	Train 1 is associated with Div 1 and Train 2 with Div 2. Div 1 and Div 2 are cross connected. When switching between trains (due to system faults - chiller black box internal fault) an auto-start of the standby train occurs. A verification of prerequisites is required to provide reasonable assurance that the on-coming train is in <del>ready</del> standby mode and that the appropriate cross-tie valves are in the open position.	Discrete	Vote	<del>The I&amp;G associated with the SCWS is described in Section 9.2.8.</del>



Table 7.1-5—SAS Automatic Safety Function  
Sheet 35 of 45

System <sup>1</sup>	Function Name <sup>2</sup>	Function Safety Basis <sup>3</sup>	Interdivisional Communications <sup>4</sup>	Type of Data <sup>5</sup>	Signal Selection Type <sup>6</sup>	Comments <del>FSAR Section-Referenced</del>
Safety Chilled Water System (SCWS)	<del>SCWS-Train 3 to Train 4</del> Switchover on Train 3 Chiller Black Box Internal Fault <u>Interlock</u> <u>(Figure 7.6-7)</u>	<u>This function is described in Sections 7.6.1.2.7 and 9.2.8.</u> <del>The SCWS has a safety-related function 1) to transfer heat loads from safety-related SSC to a heat sink under both normal operating and accident conditions, 2) component redundancy for performance of safety functions assuming a single, active component failure coincident with the loss of offsite power, and 3) the capability to isolate components, systems, or piping, if required, so system safety functions are not compromised.</del> The automatic switchover function verifies that the SCWS is capable of fulfilling these safety-related functions (GDC 44).	Train 3 is associated with Div 3 and Train 4 with Div 4. Div 3 and Div 4 are cross connected. When switching between trains (due to system faults - chiller black box internal fault) an auto-start of the standby train occurs. A verification of prerequisites is required to provide reasonable assurance that the on-coming train is in <del>ready</del> standby mode and that the appropriate cross-tie valves are in the open position.	Discrete	Vote	<del>The I&amp;G associated with the SCWS is described in Section 9.2.8.</del>

Table 7.1-5—SAS Automatic Safety Function  
Sheet 36 of 45

System <sup>1</sup>	Function Name <sup>2</sup>	Function Safety Basis <sup>3</sup>	Interdivisional Communications <sup>4</sup>	Type of Data <sup>5</sup>	Signal Selection Type <sup>6</sup>	Comments <del>FSAR Section-Referenced</del>
Safety Chilled Water System (SCWS)	<del>SCWS-Train 4 to Train 3</del> Switchover on Train 4 Chiller Black Box Internal Fault <u>Interlock</u> (Figure 7.6-8)	<u>This function is described in Sections 7.6.1.2.7 and 9.2.8.</u> <del>The SCWS has an safety-related function 1) to transfer heat loads from safety-related SSC to a heat sink under both normal operating and accident conditions, 2) component redundancy for performance of safety functions assuming a single, active component failure coincident with the loss of offsite power, and 3) the capability to isolate components, systems, or piping, if required, so system safety functions are not compromised.</del> The automatic switchover function verifies that the SCWS is capable of fulfilling these safety-related functions (GDC 44).	Train 3 is associated with Div 3 and Train 4 with Div 4. Div 3 and Div 4 are cross connected. When switching between trains (due to system faults - chiller black box internal fault) an auto-start of the standby train occurs. A verification of prerequisites is required to provide reasonable assurance that the on-coming train is in <del>ready</del> standby mode and that the appropriate cross-tie valves are in the open position.	Discrete	Vote	<del>The I&amp;G associated with the SCWS is described in Section 9.2.8.</del>

Table 7.1-5—SAS Automatic Safety Function  
Sheet 37 of 45

System <sup>1</sup>	Function Name <sup>2</sup>	Function Safety Basis <sup>3</sup>	Interdivisional Communications <sup>4</sup>	Type of Data <sup>5</sup>	Signal Selection Type <sup>6</sup>	Comments <del>FSAR Section-Referenced</del>
Safety Chilled Water System (SCWS)	<del>SCWS-Train 2 to Train 1</del> Switchover on Loss of <del>Ultimate Heat Sink (UHS)/UHS-CCWS</del> . <u>Interlock (Figure 7.6-6)</u>	<u>This function is described in Sections 7.6.1.2.7 and 9.2.8.</u> <del>The SCWS has a safety-related function 1) to transfer heat loads from safety-related SSC to a heat sink under both normal operating and accident conditions, 2) component redundancy for performance of safety functions assuming a single, active component failure coincident with the loss of offsite power, and 3) the capability to isolate components, systems, or piping, if required, so system safety functions are not compromised.</del> <u>The automatic switchover function verifies that the SCWS is capable of fulfilling these safety-related functions (GDC 44).</u>	Train 1 is associated with Div 1 and Train 2 with Div 2. Div 1 and Div 2 are cross connected. When switching between Trains (due to an external system fault (loss of <del>UHS-CCWS</del> <del>UHS</del> )) an auto-start of the standby train occurs. A verification of prerequisites is required to make sure the on-coming train is in <del>ready</del> standby mode and that the appropriate cross-tie valves are in the open position.	Discrete	Vote	<del>The I&amp;G associated with the SCWS is described in Section 9.2.8.</del>



Table 7.1-5—SAS Automatic Safety Function  
Sheet 38 of 45

System <sup>1</sup>	Function Name <sup>2</sup>	Function Safety Basis <sup>3</sup>	Interdivisional Communications <sup>4</sup>	Type of Data <sup>5</sup>	Signal Selection Type <sup>6</sup>	Comments <del>FSAR Section-Referenced</del>
Safety Chilled Water System (SCWS)	<del>SCWS-Train 3 to Train 4 Switchover on Loss of Ultimate Heat Sink (LUHS)/UHS-CCWS. Interlock (Figure 7.6-7).</del>	<del>This function is described in Sections 7.6.1.2.7 and 9.2.8. The SCWS has a safety-related function 1) to transfer heat loads from safety-related SSC to a heat sink under both normal operating and accident conditions, 2) component redundancy for performance of safety functions assuming a single, active component failure coincident with the loss of offsite power, and 3) the capability to isolate components, systems, or piping, if required, so system safety functions are not compromised. The automatic switchover function verifies that the SCWS is capable of fulfilling these safety-related functions (GDC 44).</del>	Train 3 is associated with Div 3 and Train 4 with Div 4. Div 3 and Div 4 are cross connected. When switching between Trains (due to an external system fault (loss of UHS-CCW → LUHS)) an auto-start of the standby train occurs. A verification of prerequisites is required to make sure the on-coming train is in <del>ready</del> standby mode and that the appropriate cross-tie valves are in the open position.	Discrete	Vote	<del>The I&amp;G associated with the SCWS is described in Section 9.2.8.</del>





Table 7.1-5—SAS Automatic Safety Function  
Sheet 39 of 45

System <sup>1</sup>	Function Name <sup>2</sup>	Function Safety Basis <sup>3</sup>	Interdivisional Communications <sup>4</sup>	Type of Data <sup>5</sup>	Signal Selection Type <sup>6</sup>	Comments <del>FSAR Section-Reference</del>
Safety Chilled Water System (SCWS)	<del>SCWS-Train 1 to Train 2 Switchover on LOOP Re-start Failure. Interlock (Figure 7.6-5)</del>	<del>This function is described in Sections 7.6.1.2.7 and 9.2.8. The SCWS has a safety-related function 1) to transfer heat loads from safety-related SSC to a heat sink under both normal operating and accident conditions, 2) component redundancy for performance of safety functions assuming a single, active component failure coincident with the loss of offsite power, and 3) the capability to isolate components, systems, or piping, if required, so system safety functions are not compromised. The automatic switchover function verifies that the SCWS is capable of fulfilling these safety-related functions per (GDC-44).</del>	Train 1 is associated with Div 1 and Train 2 with Div 2. Div 1 and Div 2 are cross connected. When switching between trains (LOOP re-start failure of the previous operating train or with its corresponding EDG) an auto-start of the standby train occurs. A verification of prerequisites is required to make sure the on-coming train is in <del>ready</del> standby mode and that the appropriate cross-tie valves are in the open position.	Discrete	Vote	<del>The I&amp;G associated with the SCWS is described in Section 9.2.8.</del>

Table 7.1-5—SAS Automatic Safety Function  
Sheet 40 of 45

System <sup>1</sup>	Function Name <sup>2</sup>	Function Safety Basis <sup>3</sup>	Interdivisional Communications <sup>4</sup>	Type of Data <sup>5</sup>	Signal Selection Type <sup>6</sup>	Comments <del>FSAR Section-Reference</del>
Safety Chilled Water System (SCWS)	<del>SCWS-Train 2 to Train 1 Switchover on LOOP Re-start Failure Interlock (Figure 7.6-6)</del>	<del>This function is described in Sections 7.6.1.2.7 and 9.2.8. The SCWS has a safety-related function 1) to transfer heat loads from safety-related SSC to a heat sink under both normal operating and accident conditions, 2) component redundancy for performance of safety functions assuming a single, active component failure coincident with the loss of offsite power, and 3) the capability to isolate components, systems, or piping, if required, so system safety functions are not compromised. The automatic switchover function verifies that the SCWS is capable of fulfilling these safety-related functions (GDC 44).</del>	Train 1 is associated with Div 1 and Train 2 with Div 2. Div 1 and Div 2 are cross connected. When switching between trains (LOOP re-start failure of the previous operating train or with its corresponding EDG) an auto-start of the standby train occurs. A verification of prerequisites is required to make sure the on-coming train is in <del>ready</del> standby mode and that the appropriate cross-tie valves are in the open position.	Discrete	Vote	<del>The I&amp;G associated with the SCWS is described in Section 9.2.8.</del>

Table 7.1-5—SAS Automatic Safety Function  
Sheet 41 of 45

System <sup>1</sup>	Function Name <sup>2</sup>	Function Safety Basis <sup>3</sup>	Interdivisional Communications <sup>4</sup>	Type of Data <sup>5</sup>	Signal Selection Type <sup>6</sup>	Comments <del>FSAR Section-Reference</del>
Safety Chilled Water System (SCWS)	<del>SCWS-Train 3 to Train 4 Switchover on LOOP Re-start Failure. Interlock (Figure 7.6-7)</del>	<del>This function is described in Sections 7.6.1.2.7 and 9.2.8. The SCWS has a safety-related function 1) to transfer heat loads from safety-related SSC to a heat sink under both normal operating and accident conditions, 2) component redundancy for performance of safety functions assuming a single, active component failure coincident with the loss of offsite power, and 3) the capability to isolate components, systems, or piping, if required, so system safety functions are not compromised. The automatic switchover function verifies that the SCWS is capable of fulfilling these safety-related functions (GDC 44).</del>	Train 3 is associated with Div 3 and Train 4 with Div 4. Div 3 and Div 4 are cross connected. When switching between trains (LOOP re-start failure of the previous operating train or with its corresponding EDG) an auto-start of the standby train occurs. A verification of prerequisites is required to make sure the on-coming train is in <del>ready</del> standby mode and that the appropriate cross-tie valves are in the open position.	Discrete	Vote	<del>The I&amp;G associated with the SCWS is described in Section 9.2.8.</del>

Table 7.1-5—SAS Automatic Safety Function  
Sheet 42 of 45

System <sup>1</sup>	Function Name <sup>2</sup>	Function Safety Basis <sup>3</sup>	Interdivisional Communications <sup>4</sup>	Type of Data <sup>5</sup>	Signal Selection Type <sup>6</sup>	Comments <del>FSAR Section-Reference</del>
Safety Chilled Water System (SCWS)	<del>SCWS-Train 4 to Train 3</del> Switchover on LOOP Re-start Failure. Interlock (Figure 7.6-8).	<del>This function is described in Sections 7.6.1.2.7 and 9.2.8. The SCWS has a safety-related function 1) to transfer heat loads from safety-related SSC to a heat sink under both normal operating and accident conditions, 2) component redundancy for performance of safety functions assuming a single, active component failure coincident with the loss of offsite power, and 3) the capability to isolate components, systems, or piping, if required, so system safety functions are not compromised. The automatic switchover function verifies that the SCWS is capable of fulfilling these safety-related functions (GDC 44).</del>	Train 3 is associated with Div 3 and Train 4 with Div 4. Div 3 and Div 4 are cross connected. When switching between trains (LOOP re-start failure of the previous operating train or with its corresponding EDG) an auto-start of the standby train occurs. A verification of prerequisites is required to make sure the on-coming train is in <del>ready</del> standby mode and that the appropriate cross-tie valves are in the open position.	Discrete	Vote	<del>The I&amp;G associated with the SCWS is described in Section 9.2.8.</del>



Table 7.1-5—SAS Automatic Safety Function  
Sheet 43 of 45

System <sup>1</sup>	Function Name <sup>2</sup>	Function Safety Basis <sup>3</sup>	Interdivisional Communications <sup>4</sup>	Type of Data <sup>5</sup>	Signal Selection Type <sup>6</sup>	Comments <del>FSAR Section-Reference</del>
Safety Chilled Water System (SCWS)	SCWS Chiller Evaporator Water Flow Control (Trains 1 and 4) Interlock (Figure 7.6-5 through Figure 7.6-8)	<del>This function is described in Sections 7.6.1.2.7 and 9.2.8. The SCWS has a safety related function 1) to transfer heat loads from safety related SSC to a heat sink under both normal operating and accident conditions, 2) component redundancy for performance of safety functions assuming a single, active component failure coincident with the loss of offsite power, and 3) the capability to isolate components, systems, or piping, if required, so system safety functions are not compromised. The SCWS Chiller Evaporator Water Flow Control function prevents freezing at the evaporator coil and therefore, verifies that the SCWS is capable of fulfilling these safety related functions (GDC-44).</del>	NO	NA	NA	The I&G associated with the SCWS is described in Section 9.2.8.



Table 7.1-5—SAS Automatic Safety Function  
Sheet 44 of 45

System <sup>1</sup>	Function Name <sup>2</sup>	Function Safety Basis <sup>3</sup>	Interdivisional Communications <sup>4</sup>	Type of Data <sup>5</sup>	Signal Selection Type <sup>6</sup>	Comments FSAR- Section- Reference <sup>ee</sup>
Safety Injection and Residual Heat Removal System (SIS/RHRS)	Automatic RHRS Flow Rate Control (Figure 7.3-60)	<u>This function is described in Sections 5.4.7, 6.3, and 7.3.1.3.5. The SIS/RHRS has a safety-related function to provide the RGS RHR in order to reach cold shutdown, refueling modes and to control primary temperature. The function to automatically control the flow rate of the RHRS supports the safety-related function of providing RHR by modulating the bypass control valve ensuring a constant flow rate through the LHSI pump.</u>	NO	NA	NA	The I&G associated with the SIS/RHRS is described in Section 5.4.7 and 6.3.
Safety Injection and Residual Heat Removal System (SIS/RHRS)	Automatic Trip of LHSI Pump (in RHR Mode) on Low ΔPsat. Interlock (Figure 7.6-9)	<u>This function is described in Sections 5.4.7, 6.3, and 7.6.1.2.2. The SIS/RHRS has a safety-related function to provide the RGS RHR in order to reach cold shutdown, refueling modes and to control primary temperature. The function to automatically trip the LHSI pump upon a low ΔPsat signal supports the safety-related function of providing RHR by maintaining LHSI pump operability by shutting down the pump to prevent pump damage due to inadequate NPSH or unavailability due to steam binding following a failure that results in RGS conditions approaching saturation.</u>	Interdivisional communications is required because a low ΔPsat discrete signal is generated in each division, and 2/4 voting logic is used to trip the LHSI pump.	Discrete	Vote	The I&G associated with the SIS/RHRS is described in Section 5.4.7 and 6.3.



Table 7.1-5—SAS Automatic Safety Function  
Sheet 45 of 45

System <sup>1</sup>	Function Name <sup>2</sup>	Function Safety Basis <sup>3</sup>	Interdivisional Communications <sup>4</sup>	Type of Data <sup>5</sup>	Signal Selection Type <sup>6</sup>	Comments <b>FSAR Section-Referenced</b>
Safety Injection and Residual Heat Removal System (SIS/RHRS)	Automatic Trip of LHSI Pump (in RHR Mode) on Low-Low RCS Loop Level Interlock (Figure 7.6-10)	<u>This function is described in Sections 5.4.7, 6.3, and 7.6.1.2.3. The SIS/RHRS has a safety-related function to provide the RCS RHR in order to reach cold shutdown, refueling modes and to control primary temperature. The function to automatically trip the LHSI pump upon a low RCS loop level signal supports the safety-related function of providing RHR by maintaining LHSI pump operability by shutting down the pump to prevent pump damage or unavailability due to air binding following a failure that results in low RCS loop level.</u>	Interdivisional communications is required because a low-low RCS loop level discrete signal is generated in each division, and 2/4 voting logic is used to trip the LHSI pump.	Discrete	Vote	The I&G associated with the SIS/RHRS is described in Section 5.4.7 and 6.3.
Safety Injection and Residual Heat Removal System (SIS/RHRS)	LHSI Valves Actuation Based on RHRS Alignment	The SIS/RHRS has a safety-related function to provide RCS RHR in order to reach the cold shutdown, refueling modes and to control primary temperature. The function to actuate the LHSI valves supports the safety-related function of RHR by closing the LHSI suction isolation, radial miniflow line check, and tangential miniflow check valves upon RHRS alignment to the RCS thereby preventing diversion of water from the RCS to the IRWST.	NO	NA	NA	The I&G associated with the SIS/RHRS is described in Section 5.4.7 and 6.3.



**Table 7.1-7—SAS FMEA Results**  
Sheet 1 of 33

No	System	SAS Function	Name of Sensor, Functional Unit, or Equipment (2)	Failure Mode (1)	Method of Detection	Inherent Compensating Provision	Effect on the SAS Function	Comments
<b>Systems With Functions in 4 Divisions / Trains</b>								
1	Fuel Building Ventilation System (FBVS)	Isolation of FBVS on Containment Isolation (Figure 7.3-62)	Master CU in 1 Division	a) Detected Failure b) Undetected - Spurious c) Undetected - Blocking	TXS inherent or engineered fault detection mechanism None None	Affected division switches to the hot standby CU Four redundant divisions/trains Four redundant divisions/trains	Master / Hot Standby CU switchover occurs and the function remains operable Spurious trigger of one division / train. Three remaining divisions / trains provide safety function. Loss of one division / train. Three remaining divisions / trains provide safety function.	No effects on the system function
2	Fuel Building Ventilation System (FBVS)	Fuel Pool Area Handling Accident (Figure 7.3-63)	Master CU in 1 Division	a) Detected Failure b) Undetected - Spurious c) Undetected - Blocking	TXS inherent or engineered fault detection mechanism None None	Affected division switches to the hot standby CU Four redundant divisions/trains	Master / Hot Standby CU switchover occurs and the function remains operable Spurious trigger of one division / train. Three remaining divisions / trains provide safety function.	No effects on the system function
3	Fuel Building Ventilation System (FBVS)	Reactor Building Fuel Handling Accident (Figure 7.3-64)	Master CU in 1 Division	a) Detected Failure b) Undetected - Spurious c) Undetected - Blocking	TXS inherent or engineered fault detection mechanism None None	Affected division switches to the hot standby CU Four redundant divisions/trains	Master / Hot Standby CU switchover occurs and the function remains operable Spurious trigger of one division / train. Three remaining divisions / trains provide safety function.	No effects on the system function



All indicated changes are in response to RAI 505, 07.01-35



Table 7.1-7—SAS FMEA Results  
Sheet 2 of 33

No	System	SAS Function	Name of Sensor, Functional Unit, or Equipment (2)	Failure Mode (1)	Method of Detection	Inherent Compensating Provision	Effect on the SAS Function	Comments
4	Safety Injection and Residual Heat Removal System (SIS/ RHRS)	RHR Isolation Valves Interlock (Figure 7.6-11)	Master CU in 1 Division	a) Detected Failure	TXS inherent or engineered fault detection mechanism	Affected division switches to the hot standby CU.	Master / Hot Standby CU. No effects on the system function remains operable	No effects on the system function
				b) Undetected - Spurious	None	Four redundant divisions/trains	Spurious trigger of one division / train. Three remaining divisions / trains provide safety function.	
				c) Undetected - Blocking	None	Four redundant divisions/trains	Loss of one division / train. Three remaining divisions / trains provide safety function.	
5	Electrical Division of Safeguard Building Ventilation System (SBVSE)	SBVSE CCWS Pump Room Heat Removal (Figure 7.3-59)	Master CU in 1 Division	a) Detected Failure	TXS inherent or engineered fault detection mechanism	Affected division switches to the hot standby CU.	Master / Hot Standby CU. No effects on the system function remains operable	No effects on the system function
				b) Undetected - Spurious	None	Four redundant divisions/trains	Spurious trigger of one division / train. Three remaining divisions / trains provide safety function.	
				c) Undetected - Blocking	None	Four redundant divisions/trains	Loss of one division / train. Three remaining divisions / trains provide safety function.	
6	Component Cooling Water System (CCWS)	CCWS Emergency Temperature Control (Figure 7.3-34)	Master CU in 1 Division	a) Detected Failure	TXS inherent or engineered fault detection mechanism	Affected division switches to the hot standby CU.	Master / Hot Standby CU. No effects on the system function remains operable	No effects on the system function
				b) Undetected - Spurious	None	Four redundant divisions/trains	Spurious trigger of one division / train. Three remaining divisions / trains provide safety function.	
				c) Undetected - Blocking	None	Four redundant divisions/trains	Loss of one division / train. Three remaining divisions / trains provide safety function.	

All indicated changes are in response to RAI 505, 07.01-35



Table 7.1-7—SAS FMEA Results  
Sheet 3 of 33

No	System	SAS Function	Name of Sensor, Functional Unit, or Equipment (2)	Failure Mode (1)	Method of Detection	Inherent Compensating Provision	Effect on the SAS Function	Comments
7	Component Cooling Water System (CCWS)	CCWS Emergency Leak Detection. (Figure 7.3-35)	Master CU in I Division.	a) Detected Failure b) Undetected - Spurious c) Undetected - Blocking	TXS inherent or engineered fault detection mechanism None	Affected division switches to the hot standby CU. Four redundant divisions/trains Four redundant divisions/trains	Master / Hot Standby CU. switchover occurs and the function remains operable. Spurious trigger of one division / train. Three remaining divisions / trains provide safety function. Loss of one division / train. Three remaining divisions / trains provide safety function.	No effects on the system function
8	Emergency Feedwater System (EFWS)	SG Closed Loop Level Control. (Figure 7.3-4)	Master CU in I Division.	a) Detected Failure b) Undetected - Spurious c) Undetected - Blocking	TXS inherent or engineered fault detection mechanism None	Affected division switches to the hot standby CU. Four redundant divisions/trains Four redundant divisions/trains	Master / Hot Standby CU. switchover occurs and the function remains operable. Spurious trigger of one division / train. Three remaining divisions / trains provide safety function. Loss of one division / train. Three remaining divisions / trains provide safety function.	No effects on the system function
9	Emergency Feedwater System (EFWS)	EFWS Pump Flow Protection. (Figure 7.3-4)	Master CU in I Division.	a) Detected Failure b) Undetected - Spurious c) Undetected - Blocking	TXS inherent or engineered fault detection mechanism None	Affected division switches to the hot standby CU. Four redundant divisions/trains Four redundant divisions/trains	Master / Hot Standby CU. switchover occurs and the function remains operable. Spurious trigger of one division / train. Three remaining divisions / trains provide safety function. Loss of one division / train. Three remaining divisions / trains provide safety function.	No effects on the system function

All indicated changes are in response to RAI 505, 07.01-35



Table 7.1-7—SAS FMEA Results  
Sheet 4 of 33

No	System	SAS Function	Name of Sensor, Functional Unit, or Equipment (2)	Failure Mode (1)	Method of Detection	Inherent Compensating Provision	Effect on the SAS Function	Comments
10	Essential Service Water Pump Building Ventilation System (ESWPBVS)	ESWPBVS ESWS Pump Rooms Temperature Control (Figure 7.3-38)	Master CU in 1 Division	a) Detected Failure b) Undetected - Spurious c) Undetected - Blocking	TXS inherent or engineered fault detection mechanism None None	Affected division switches to the hot standby CU. Four redundant divisions/trains Four redundant divisions/trains	Master / Hot Standby CU. switchover occurs and the function remains operable. Spurious trigger of one division / train. Three remaining divisions / trains provide safety function. Loss of one division / train. Three remaining divisions / trains provide safety function.	No effects on the system function
11	Main Steam System (MSS)	Steam Generator MSRCV Regulation during Pressure Control (Figure 7.3-12)	Master CU in 1 Division	a) Detected Failure b) Undetected - Spurious c) Undetected - Blocking	TXS inherent or engineered fault detection mechanism None None	Affected division switches to the hot standby CU. Four redundant divisions/trains Four redundant divisions/trains	Master / Hot Standby CU. switchover occurs and the function remains operable. Spurious trigger of one division / train. Three remaining divisions / trains provide safety function. Loss of one division / train. Three remaining divisions / trains provide safety function.	No effects on the system function
12	Main Steam System (MSS)	Steam Generator MSRCV Regulation during Standby Position Control (Figure 7.3-12)	Master CU in 1 Division	a) Detected Failure b) Undetected - Spurious c) Undetected - Blocking	TXS inherent or engineered fault detection mechanism None None	Affected division switches to the hot standby CU. Four redundant divisions/trains Four redundant divisions/trains	Master / Hot Standby CU. switchover occurs and the function remains operable. Spurious trigger of one division / train. Three remaining divisions / trains provide safety function. Loss of one division / train. Three remaining divisions / trains provide safety function.	No effects on the system function

All indicated changes are in response to RAI 505, 07.01-35



Table 7.1-7—SAS FMEA Results  
Sheet 5 of 33

No	System	SAS Function	Name of Sensor, Functional Unit, or Equipment (2)	Failure Mode (1)	Method of Detection	Inherent Compensating Provision	Effect on the SAS Function	Comments
13	Safeguard Building Controlled-Area Ventilation System (SBVS)	SIS/RHRS Pump Rooms Heat Removal (Figure 7.3-46)	Master CU in 1 Division	a) Detected Failure b) Undetected - Spurious c) Undetected - Blocking	TXS inherent or engineered fault detection mechanism None None	Affected division switches to the hot standby CU. Four redundant divisions/trains Four redundant divisions/trains	Master / Hot Standby CU. switchover occurs and the function remains operable. Spurious trigger of one division / train. Three remaining divisions / trains provide safety function. Loss of one division / train. Three remaining divisions / trains provide safety function.	No effects on the system function
14	Safeguard Building Controlled-Area Ventilation System (SBVS)	CCWS/EWS Valve Rooms Heat Removal (Figure 7.3-47)	Master CU in 1 Division	a) Detected Failure b) Undetected - Spurious c) Undetected - Blocking	TXS inherent or engineered fault detection mechanism None None	Affected division switches to the hot standby CU. Four redundant divisions/trains Four redundant divisions/trains	Master / Hot Standby CU. switchover occurs and the function remains operable. Spurious trigger of one division / train. Three remaining divisions / trains provide safety function. Loss of one division / train. Three remaining divisions / trains provide safety function.	No effects on the system function
15	Electrical Division of Safeguard Building Ventilation System (SBVSE)	Supply and Recirculation Exhaust Air Flow Control (Figure 7.3-48)	Master CU in 1 Division	a) Detected Failure b) Undetected - Spurious c) Undetected - Blocking	TXS inherent or engineered fault detection mechanism None None	Affected division switches to the hot standby CU. Four redundant divisions/trains Four redundant divisions/trains	Master / Hot Standby CU. switchover occurs and the function remains operable. Spurious trigger of one division / train. Three remaining divisions / trains provide safety function. Loss of one division / train. Three remaining divisions / trains provide safety function.	No effects on the system function

All indicated changes are in response to RAI 505, 07.01-35



Table 7.1-7—SAS FMEA Results  
Sheet 6 of 33

No	System	SAS Function	Name of Sensor, Functional Unit, or Equipment (2)	Failure Mode (1)	Method of Detection	Inherent Compensating Provision	Effect on the SAS Function	Comments
16	Electrical Division of Safeguard Building Ventilation System (SBVSE)	Supply Fan Safe Shut-off (Figure 7.3-49)	Master CU in 1 Division	a) Detected Failure	TXS inherent or engineered fault detection mechanism	Affected division switches to the hot standby CU.	Master / Hot Standby CU. switchover occurs and the function remains operable	No effects on the system function
				b) Undetected - Spurious	None	Four redundant divisions/trains	Spurious trigger of one division / train. Three remaining divisions / trains provide safety function.	
				c) Undetected - Blocking	None	Four redundant divisions/trains	Loss of one division / train. Three remaining divisions / trains provide safety function.	
17	Electrical Division of Safeguard Building Ventilation System (SBVSE)	Recirculation Fan Safe Shut-off (Figure 7.3-50)	Master CU in 1 Division	a) Detected Failure	TXS inherent or engineered fault detection mechanism	Affected division switches to the hot standby CU.	Master / Hot Standby CU. switchover occurs and the function remains operable	No effects on the system function
				b) Undetected - Spurious	None	Four redundant divisions/trains	Spurious trigger of one division / train. Three remaining divisions / trains provide safety function.	
				c) Undetected - Blocking	None	Four redundant divisions/trains	Loss of one division / train. Three remaining divisions / trains provide safety function.	
18	Electrical Division of Safeguard Building Ventilation System (SBVSE)	Exhaust Fan Safe Shut-off (Figure 7.3-51)	Master CU in 1 Division	a) Detected Failure	TXS inherent or engineered fault detection mechanism	Affected division switches to the hot standby CU.	Master / Hot Standby CU. switchover occurs and the function remains operable	No effects on the system function
				b) Undetected - Spurious	None	Four redundant divisions/trains	Spurious trigger of one division / train. Three remaining divisions / trains provide safety function.	
				c) Undetected - Blocking	None	Four redundant divisions/trains	Loss of one division / train. Three remaining divisions / trains provide safety function.	

All indicated changes are in response to RAI 505, 07.01-35



**Table 7.1-7—SAS FMEA Results**  
Sheet 7 of 33

No	System	SAS Function	Name of Sensor, Functional Unit, or Equipment (2)	Failure Mode (1)	Method of Detection	Inherent Compensating Provision	Effect on the SAS Function	Comments
19	Electrical Division of Safeguard Building Ventilation System (SBVSE)	Supply Air Temperature Heater Control (Figure 7.3-52)	Master CU in 1 Division	a) Detected Failure b) Undetected - Spurious c) Undetected - Blocking	TXS inherent or engineered fault detection mechanism None None	Affected division switches to the hot standby CU. Four redundant divisions/trains Four redundant divisions/trains	Master / Hot Standby CU. switchover occurs and the function remains operable. Spurious trigger of one division / train. Three remaining divisions / trains provide safety function. Loss of one division / train. Three remaining divisions / trains provide safety function.	No effects on the system function
20	Electrical Division of Safeguard Building Ventilation System (SBVSE)	Freeze Protection - Supply Air Temperature (Figure 7.3-53)	Master CU in 1 Division	a) Detected Failure b) Undetected - Spurious c) Undetected - Blocking	TXS inherent or engineered fault detection mechanism None None	Affected division switches to the hot standby CU. Four redundant divisions/trains Four redundant divisions/trains	Master / Hot Standby CU. switchover occurs and the function remains operable. Spurious trigger of one division / train. Three remaining divisions / trains provide safety function. Loss of one division / train. Three remaining divisions / trains provide safety function.	No effects on the system function
21	Electrical Division of Safeguard Building Ventilation System (SBVSE)	Supply Air Temperature Control for Supply Air Cooling (Figure 7.3-54)	Master CU in 1 Division	a) Detected Failure b) Undetected - Spurious c) Undetected - Blocking	TXS inherent or engineered fault detection mechanism None None	Affected division switches to the hot standby CU. Four redundant divisions/trains Four redundant divisions/trains	Master / Hot Standby CU. switchover occurs and the function remains operable. Spurious trigger of one division / train. Three remaining divisions / trains provide safety function. Loss of one division / train. Three remaining divisions / trains provide safety function.	No effects on the system function

All indicated changes are in response to RAI 505, 07.01-35



Table 7.1-7—SAS FMEA Results  
Sheet 8 of 33

No	System	SAS Function	Name of Sensor, Functional Unit, or Equipment (2)	Failure Mode (1)	Method of Detection	Inherent Compensating Provision	Effect on the SAS Function	Comments
22	Electrical Division of Safeguard Building Ventilation System (SBVSE)	Battery Room Heater Control (Figure 7.3-56)	Master CU in 1 Division	a) Detected Failure	TXS inherent or engineered fault detection mechanism	Affected division switches to the hot standby CU.	Master / Hot Standby CU. switchover occurs and the function remains operable	No effects on the system function
				b) Undetected - Spurious	None	Four redundant divisions/trains	Spurious trigger of one division / train. Three remaining divisions / trains provide safety function.	
				c) Undetected - Blocking	None	Four redundant divisions/trains	Loss of one division / train. Three remaining divisions / trains provide safety function.	
23	Electrical Division of Safeguard Building Ventilation System (SBVSE)	Battery Room Supply Air Temperature Control (Figure 7.3-57)	Master CU in 1 Division	a) Detected Failure	TXS inherent or engineered fault detection mechanism	Affected division switches to the hot standby CU.	Master / Hot Standby CU. switchover occurs and the function remains operable	No effects on the system function
				b) Undetected - Spurious	None	Four redundant divisions/trains	Spurious trigger of one division / train. Three remaining divisions / trains provide safety function.	
				c) Undetected - Blocking	None	Four redundant divisions/trains	Loss of one division / train. Three remaining divisions / trains provide safety function.	
24	Electrical Division of Safeguard Building Ventilation System (SBVSE)	Emergency Feed Water System (EFWS) Pump Room Heat Removal (Figure 7.3-58)	Master CU in 1 Division	a) Detected Failure	TXS inherent or engineered fault detection mechanism	Affected division switches to the hot standby CU.	Master / Hot Standby CU. switchover occurs and the function remains operable	No effects on the system function
				b) Undetected - Spurious	None	Four redundant divisions/trains	Spurious trigger of one division / train. Three remaining divisions / trains provide safety function.	
				c) Undetected - Blocking	None	Four redundant divisions/trains	Loss of one division / train. Three remaining divisions / trains provide safety function.	

All indicated changes are in response to RAI 505, 07.01-35



**Table 7.1-7—SAS FMEA Results**  
Sheet 9 of 33

No	System	SAS Function	Name of Sensor, Functional Unit, or Equipment (2)	Failure Mode (1)	Method of Detection	Inherent Compensating Provision	Effect on the SAS Function	Comments
25	Electrical Division of Safeguard Building Ventilation System (SBVSE)	Component Cooling Water System (CCWS) Pump Room Heat Removal (Figure 7.3-60)	Master CU in 1 Division	a) Detected Failure b) Undetected - Spurious c) Undetected - Blocking	TXS inherent or engineered fault detection mechanism None None	Affected division switches to the hot standby CU. Four redundant divisions/trains Four redundant divisions/trains	Master / Hot Standby CU. switchover occurs and the function remains operable. Spurious trigger of one division / train. Three remaining divisions / trains provide safety function. Loss of one division / train. Three remaining divisions / trains provide safety function.	No effects on the system function
26	Safety Chilled Water System (SCWS)	SCWS Train 1 to Train 2 Switchover on Train 1 Low Evaporator Flow / Chiller Black Box Internal Fault / SCWS Chiller Evaporator Water Flow Control / LOOP Re-start Failure (Figure 7.6-5)	Master CU in 1 Division	a) Detected Failure b) Undetected - Spurious c) Undetected - Blocking	TXS inherent or engineered fault detection mechanism None None	Affected division switches to the hot standby CU. Four redundant divisions/trains Four redundant divisions/trains	Master / Hot Standby CU. switchover occurs and the function remains operable. Spurious trigger of one division / train. Three remaining divisions / trains provide safety function. Loss of one division / train. Three remaining divisions / trains provide safety function.	No effects on the system function
27	Safety Chilled Water System (SCWS)	SCWS Train 2 to Train 1 Switchover on Train 2 Low Evaporator Flow / Chiller Black Box Internal Fault / Loss of UHS-CCWS / SCWS Chiller Evaporator Water Flow Control / LOOP Re-start Failure (Figure 7.6-6)	Master CU in 1 Division	a) Detected Failure b) Undetected - Spurious c) Undetected - Blocking	TXS inherent or engineered fault detection mechanism None None	Affected division switches to the hot standby CU. Four redundant divisions/trains Four redundant divisions/trains	Master / Hot Standby CU. switchover occurs and the function remains operable. Spurious trigger of one division / train. Three remaining divisions / trains provide safety function. Loss of one division / train. Three remaining divisions / trains provide safety function.	No effects on the system function



All indicated changes are in response to RAI 505, 07.01-35



Table 7.1-7—SAS FMEA Results  
Sheet 10 of 33

No	System	SAS Function	Name of Sensor, Functional Unit, or Equipment (2)	Failure Mode (1)	Method of Detection	Inherent Compensating Provision	Effect on the SAS Function	Comments
28	Safety Chilled Water System (SCWS)	SCWS Train 3 to Train 4 Switchover on Train 3 Low Evaporator Flow / Chiller Black Box Internal Fault / Loss of UHS-CCWS / SCWS Chiller Evaporator Water Flow Control / LOOP Re-start Failure (Figure 7.6-7)	Master CU in 1 Division	a) Detected Failure b) Undetected - Spurious c) Undetected - Blocking	TXS inherent or engineered fault detection mechanism None None	Affected division switches to the hot standby CU. Four redundant divisions/trains Four redundant divisions/trains	Master / Hot Standby CU. switchover occurs and the function remains operable. Spurious trigger of one division / train. Three remaining divisions / trains provide safety function. Loss of one division / train. Three remaining divisions / trains provide safety function.	No effects on the system function
29	Safety Chilled Water System (SCWS)	SCWS Train 4 to Train 3 Switchover on Train 4 Low Evaporator Flow / Chiller Black Box Internal Fault / SCWS Chiller Evaporator Water Flow Control / LOOP Re-start Failure (Figure 7.6-8)	Master CU in 1 Division	a) Detected Failure b) Undetected - Spurious c) Undetected - Blocking	TXS inherent or engineered fault detection mechanism None None	Affected division switches to the hot standby CU. Four redundant divisions/trains Four redundant divisions/trains	Master / Hot Standby CU. switchover occurs and the function remains operable. Spurious trigger of one division / train. Three remaining divisions / trains provide safety function. Loss of one division / train. Three remaining divisions / trains provide safety function.	No effects on the system function
30	Safety Injection and Residual Heat Removal System (SIS/ RHRS)	Automatic RHRS Flow Rate Control (Figure 7.3-60)	Master CU in 1 Division	a) Detected Failure b) Undetected - Spurious c) Undetected - Blocking	TXS inherent or engineered fault detection mechanism None None	Affected division switches to the hot standby CU. Four redundant divisions/trains Four redundant divisions/trains	Master / Hot Standby CU. switchover occurs and the function remains operable. Spurious trigger of one division / train. Three remaining divisions / trains provide safety function. Loss of one division / train. Three remaining divisions / trains provide safety function.	No effects on the system function

**Table 7.1-7—SAS FMEA Results**  
Sheet 11 of 33

No	System	SAS Function	Name of Sensor, Functional Unit, or Equipment (2)	Failure Mode (1)	Method of Detection	Inherent Compensating Provision	Effect on the SAS Function	Comments
<b>Systems With Functions Within 2 Redundant Train Sets</b>								
31	Main Control Room Air Conditioning System (CRACS)	Cooler Temperature Control (Figure 7.3-45)	Master CU in 1 Division	a) Detected Failure	TXS inherent or engineered fault detection mechanism	Affected division switches to the hot standby CU.	Master / Hot Standby CU. switchover occurs and the function remains operable	No effects on the system function
				b) Undetected - Spurious	None	Two redundant train sets	Spurious trigger of one train pair. One remaining train set provide safety function.	
				c) Undetected - Blocking	None	Two redundant train sets	Loss of one train set. One remaining train set provides safety function.	
32	Annulus Ventilation System (AVS)	Accident Filtration Train Heater Control (Figure 7.3-31)	Master CU in 1 Division	a) Detected Failure	TXS inherent or engineered fault detection mechanism	Affected division switches to the hot standby CU.	Master / Hot Standby CU. switchover occurs and the function remains operable	No effects on the system function
				b) Undetected - Spurious	None	Two redundant train sets	Spurious trigger of one train pair. One remaining train set provide safety function.	
				c) Undetected - Blocking	None	Two redundant train sets	Loss of one train set. One remaining train set provides safety function.	
33	Annulus Ventilation System (AVS)	Accident Train Switchover (Figure 7.3-32)	Master CU in 1 Division	a) Detected Failure	TXS inherent or engineered fault detection mechanism	Affected division switches to the hot standby CU.	Master / Hot Standby CU. switchover occurs and the function remains operable	No effects on the system function
				b) Undetected - Spurious	None	Two redundant train sets	Spurious trigger of one train pair. One remaining train set provide safety function.	
				c) Undetected - Blocking	None	Two redundant train sets	Loss of one train set. One remaining train set provides safety function.	

All indicated changes are in response to RAI 505, 07.01-35



Table 7.1-7—SAS FMEA Results  
Sheet 12 of 33

No	System	SAS Function	Name of Sensor, Functional Unit, or Equipment (2)	Failure Mode (1)	Method of Detection	Inherent Compensating Provision	Effect on the SAS Function	Comments
34	Component Cooling Water System (CCWS)	SCWS Condenser Supply Water Flow Control (Figure 7.3-37)	Master CU in 1 Division	a) Detected Failure	TXS inherent or engineered fault detection mechanism	Affected division switches to the hot standby CU.	Master / Hot Standby CU. switchover occurs and the function remains operable	No effects on the system function
				b) Undetected - Spurious	None	Two redundant train sets	Spurious trigger of one train pair. One remaining train set provide safety function.	
				c) Undetected - Blocking	None	Two redundant train sets	Loss of one train set. One remaining train set provides safety function.	
35	Fuel Building Ventilation System (FBVS)	Safety-Related Room Heater Control (Figure 7.3-39)	Master CU in 1 Division	a) Detected Failure	TXS inherent or engineered fault detection mechanism	Affected division switches to the hot standby CU.	Master / Hot Standby CU. switchover occurs and the function remains operable	No effects on the system function
				b) Undetected - Spurious	None	Two redundant train sets	Spurious trigger of one train pair. One remaining train set provide safety function.	
				c) Undetected - Blocking	None	Two redundant train sets	Loss of one train set. One remaining train set provides safety function.	
36	Fuel Building Ventilation System (FBVS)	FBVS EBS / FPFS Pump Rooms Heat Removal (Figure 7.3-40)	Master CU in 1 Division	a) Detected Failure	TXS inherent or engineered fault detection mechanism	Affected division switches to the hot standby CU.	Master / Hot Standby CU. switchover occurs and the function remains operable	No effects on the system function
				b) Undetected - Spurious	None	Two redundant train sets	Spurious trigger of one train pair. One remaining train set provide safety function.	
				c) Undetected - Blocking	None	Two redundant train sets	Loss of one train set. One remaining train set provides safety function.	

All indicated changes are in response to RAI 505, 07.01-35



Table 7.1-7—SAS FMEA Results  
Sheet 13 of 33

No	System	SAS Function	Name of Sensor, Functional Unit, or Equipment (2)	Failure Mode (1)	Method of Detection	Inherent Compensating Provision	Effect on the SAS Function	Comments
37	Fuel Pool Cooling and Purification System (FPCPS)	FPCPS Pump Trip on Low-Spent Fuel Pool (SFP) Level (Figure 7.3-41)	Master CU in 1 Division	a) Detected Failure	TXS inherent or engineered fault detection mechanism	Affected division switches to the hot standby CU.	Master / Hot Standby CU. switchover occurs and the function remains operable	No effects on the system function
				b) Undetected - Spurious	None	Two redundant train sets	Spurious trigger of one train pair. One remaining train set provide safety function.	
				c) Undetected - Blocking	None	Two redundant train sets	Loss of one train set. One remaining train set provides safety function.	
38	Main Control Room Air Conditioning System (CRACS)	Iodine Filtration Train Heater Control (Figure 7.3-42)	Master CU in 1 Division	a) Detected Failure	TXS inherent or engineered fault detection mechanism	Affected division switches to the hot standby CU.	Master / Hot Standby CU. switchover occurs and the function remains operable	No effects on the system function
				b) Undetected - Spurious	None	Two redundant train sets	Spurious trigger of one train pair. One remaining train set provide safety function.	
				c) Undetected - Blocking	None	Two redundant train sets	Loss of one train set. One remaining train set provides safety function.	
39	Main Control Room Air Conditioning System (CRACS)	Heater Control for Outside Inlet Air (Figure 7.3-43)	Master CU in 1 Division	a) Detected Failure	TXS inherent or engineered fault detection mechanism	Affected division switches to the hot standby CU.	Master / Hot Standby CU. switchover occurs and the function remains operable	No effects on the system function
				b) Undetected - Spurious	None	Two redundant train sets	Spurious trigger of one train pair. One remaining train set provide safety function.	
				c) Undetected - Blocking	None	Two redundant train sets	Loss of one train set. One remaining train set provides safety function.	

**Table 7.1-7—SAS FMEA Results**  
Sheet 14 of 33

No	System	SAS Function	Name of Sensor, Functional Unit, or Equipment (2)	Failure Mode (1)	Method of Detection	Inherent Compensating Provision	Effect on the SAS Function	Comments
<b>CCWS Switchover Functions</b>								
40	Component Cooling Water System (CCWS)	CCWS Common 1.b Automatic Backup Switchover of Train 1 to Train 2 and Train 2 to Train 1 (Figure 7.3-33)	Master CU in 1 Division	a) Detected Failure	TXS inherent or engineered fault detection mechanism	Affected division switches to the hot standby CU.	Master / Hot Standby CU switchover occurs and the function remains operable	No effects on the system function
				b) Undetected - Spurious	None	Two redundant train sets	Spurious trigger of one train pair. One remaining train set provide safety function.	
				c) Undetected - Blocking	None	Two redundant train sets	Loss of one train set. One remaining train set provides safety function.	
41	Component Cooling Water System (CCWS)	CCWS Common 2.b Automatic Backup Switchover of Train 3 to Train 4 and Train 4 to Train 3 (Figure 7.3-33)	Master CU in 1 Division	a) Detected Failure	TXS inherent or engineered fault detection mechanism	Affected division switches to the hot standby CU.	Master / Hot Standby CU switchover occurs and the function remains operable	No effects on the system function
				b) Undetected - Spurious	None	Two redundant train sets	Spurious trigger of one train pair. One remaining train set provide safety function.	
				c) Undetected - Blocking	None	Two redundant train sets	Loss of one train set. One remaining train set provides safety function.	
42	Component Cooling Water System (CCWS)	CCWS Emergency Leak Detection - Switchover Valves Leakage or Failure (Figure 7.3-36)	Master CU in 1 Division	a) Detected Failure	TXS inherent or engineered fault detection mechanism	Affected division switches to the hot standby CU.	Master / Hot Standby CU switchover occurs and the function remains operable	No effects on the system function
				b) Undetected - Spurious	None	Two redundant train sets	Spurious trigger of one train pair. One remaining train set provide safety function.	
				c) Undetected - Blocking	None	Two redundant train sets	Loss of one train set. One remaining train set provides safety function.	

All indicated changes are in response to RAI 505, 07.01-35



Table 7.1-7—SAS FMEA Results  
Sheet 15 of 33

No	System	SAS Function	Name of Sensor, Functional Unit, or Equipment (2)	Failure Mode (1)	Method of Detection	Inherent Compensating Provision	Effect on the SAS Function	Comments
43	Component Cooling Water System (CCWS)	CCWS Switchover Valves Interlock (Figure 7.6-1)	Master CU in 1 Division	a) Detected Failure b) Undetected - Spurious c) Undetected - Blocking	TXS inherent or engineered fault detection mechanism None None	Affected division switches to the hot standby CU Two redundant train sets Two redundant train sets	Master / Hot Standby CU switchover occurs and the function remains operable Spurious trigger of one train pair. One remaining train set provide safety function. Loss of one train set. One remaining train set provides safety function.	No effects on the system function
<b>CCWS RCP Thermal Barrier Interlock Function</b>								
44	Component Cooling Water System (CCWS)	CCWS RCP Thermal Barrier Containment Isolation Valve Interlock (Figure 7.6-2)	Master CU in 1 Division	a) Detected Failure b) Undetected - Spurious c) Undetected - Blocking	TXS inherent or engineered fault detection mechanism None None	Affected division switches to the hot standby CU Two redundant train sets Two redundant train sets	Master / Hot Standby CU switchover occurs and the function remains operable Spurious trigger of one train pair. One remaining train set provide safety function. Loss of one train set. One remaining train set provides safety function.	No effects on the system function
<b>Systems With Functions Utilizing Voting Logic</b>								
45	In-Containment Refueling Water Storage Tank System (IRWST)	IRWST Boundary Isolation for Preserving IRWST Water Inventory Interlock (Figure 7.6-4)	Master CU in 1 Division	a) Detected Failure b) Undetected - Spurious c) Undetected - Blocking	TXS inherent or engineered fault detection mechanism None None	Affected division switches to the hot standby CU Redundant divisions/trains Redundant divisions/trains	Master / Hot Standby CU switchover occurs in faulted division. Voting logic remains 2/4 in faulted division. Voting logic in other divisions is modified to 2/3. Spurious trigger of one division / train. Voting in other divisions becomes 1/3. Loss of one division / train. Voting in other divisions becomes 2/3.	No effects on the system function

All indicated changes are in response to RAI 505, 07.01-35



Table 7.1-7—SAS FMEA Results  
Sheet 16 of 33

No	System	SAS Function	Name of Sensor, Functional Unit, or Equipment (2)	Failure Mode (1)	Method of Detection	Inherent Compensating Provision	Effect on the SAS Function	Comments
46	Safety Injection and Residual Heat Removal System (SIS/ RHRS)	Automatic Trip of LHSI Pump (in RHR Mode) on Low ΔPsat (Figure 7.6-9)	Master CU in 1 Division	a) Detected Failure	TXS inherent or engineered fault detection mechanism	Affected division switches to the hot standby CU	Master / Hot Standby CU. switchover occurs in faulted division. Voting logic remains 2/4 in faulted division. Voting logic in other divisions is modified to 2/3.	No effects on the system function
				b) Undetected - Spurious	None	Redundant divisions/trains	Spurious trigger of one division / train. Voting in other divisions becomes 1/3.	
				c) Undetected - Blocking	None	Redundant divisions/trains	Loss of one division / train. Voting in other divisions becomes 2/3.	
47	Safety Injection and Residual Heat Removal System (SIS/ RHRS)	Automatic Trip of LHSI Pump (in RHR Mode) on Low Loop Level (Figure 7.6-10)	Master CU in 1 Division	a) Detected Failure	TXS inherent or engineered fault detection mechanism	Affected division switches to the hot standby CU	Master / Hot Standby CU. switchover occurs in faulted division. Voting logic remains 2/4 in faulted division. Voting logic in other divisions is modified to 2/3.	No effects on the system function
				b) Undetected - Spurious	None	Redundant divisions/trains	Spurious trigger of one division / train. Voting in other divisions becomes 1/3.	
				c) Undetected - Blocking	None	Redundant divisions/trains	Loss of one division / train. Voting in other divisions becomes 2/3.	

**Table 7.1-7—SAS FMEA Results**  
Sheet 17 of 33

No	System	SAS Function	Name of Sensor, Functional Unit, or Equipment (2)	Failure Mode (1)	Method of Detection	Inherent Compensating Provision	Effect on the SAS Function	Comments
<b>Systems With Functions in 4 Division/Trains</b>								
48	Fuel Building Ventilation System (FBVS)	Isolation of FBVS on Containment Isolation (Figure 7.3-62)	Loss of 1 Division	a) Detected Failure	TXS inherent or engineered fault detection mechanism	Four redundant divisions/trains	Three remaining divisions/trains provide safety function.	No effects on the system function
				b) Undetected - Spurious	None	Four redundant divisions/trains	Spurious trigger of one division / train. Three remaining divisions/trains provide safety function.	
				c) Undetected - Blocking	None	Four redundant divisions/trains	Loss of one division / train. Three remaining divisions / trains provide safety function.	
49	Fuel Building Ventilation System (FBVS)	Fuel Pool Area Handling Accident (Figure 7.3-63)	Loss of 1 Division	a) Detected Failure	TXS inherent or engineered fault detection mechanism	Four redundant divisions/trains	Three remaining divisions/trains provide safety function.	No effects on the system function
				b) Undetected - Spurious	None	Four redundant divisions/trains	Spurious trigger of one division / train. Three remaining divisions/trains provide safety function.	
				c) Undetected - Blocking	None	Four redundant divisions/trains	Loss of one division / train. Three remaining divisions / trains provide safety function.	
50	Fuel Building Ventilation System (FBVS)	Reactor Building Fuel Handling Accident (Figure 7.3-64)	Loss of 1 Division	a) Detected Failure	TXS inherent or engineered fault detection mechanism	Four redundant divisions/trains	Three remaining divisions/trains provide safety function.	No effects on the system function
				b) Undetected - Spurious	None	Four redundant divisions/trains	Spurious trigger of one division / train. Three remaining divisions/trains provide safety function.	
				c) Undetected - Blocking	None	Four redundant divisions/trains	Loss of one division / train. Three remaining divisions / trains provide safety function.	



**Table 7.1-7—SAS FMEA Results**  
Sheet 18 of 33

No	System	SAS Function	Name of Sensor, Functional Unit, or Equipment (2)	Failure Mode (1)	Method of Detection	Inherent Compensating Provision	Effect on the SAS Function	Comments
51	Safety Injection and Residual Heat Removal System (SIS/ RHRS)	RHR Isolation Valves Interlock (Figure 7.6-11)	Loss of 1 Division	a) Detected Failure	TXS inherent or engineered fault detection mechanism	Affected division switches to the hot standby CU	Three remaining divisions /trains provide safety function.	No effects on the system function
				b) Undetected - Spurious	None	Four redundant divisions/trains	Spurious trigger of one division / train. Three remaining divisions /trains provide safety function.	
				c) Undetected - Blocking	None	Four redundant divisions/trains	Loss of one division / train. Three remaining divisions /trains provide safety function.	
52	Component Cooling Water System (CCWS)	CCWS Emergency Temperature Control (Figure 7.3-34)	Loss of 1 Division	a) Detected Failure	TXS inherent or engineered fault detection mechanism	Four redundant divisions/trains	Three remaining divisions /trains provide safety function	No effects on the system function
				b) Undetected - Spurious	None	Four redundant divisions/trains	Spurious trigger of one division / train. Three remaining divisions /trains provide safety function.	
				c) Undetected - Blocking	None	Four redundant divisions/trains	Loss of one division / train. Three remaining divisions /trains provide safety function.	
53	Component Cooling Water System (CCWS)	CCWS Emergency Leak Detection. (Figure 7.3-35)	Loss of 1 Division	a) Detected Failure	TXS inherent or engineered fault detection mechanism	Four redundant divisions/trains	Three remaining divisions /trains provide safety function.	No effects on the system function
				b) Undetected - Spurious	None	Four redundant divisions/trains	Spurious trigger of one division / train. Three remaining divisions /trains provide safety function.	
				c) Undetected - Blocking	None	Four redundant divisions/trains	Loss of one division / train. Three remaining divisions /trains provide safety function.	

All indicated changes are in response to RAI 505, 07.01-35



Table 7.1-7—SAS FMEA Results  
Sheet 19 of 33

No	System	SAS Function	Name of Sensor, Functional Unit, or Equipment (2)	Failure Mode (1)	Method of Detection	Inherent Compensating Provision	Effect on the SAS Function	Comments
54	Emergency Feedwater System (EFWS)	SG Closed Loop Level Control (Figure 7.3-4)	Loss of 1 Division	a) Detected Failure b) Undetected - Spurious c) Undetected - Blocking	TXS inherent or engineered fault detection mechanism None None	Four redundant divisions/trains Four redundant divisions/trains Four redundant divisions/trains	Three remaining divisions /trains provide safety function. Spurious trigger of one division / train. Three remaining divisions /trains provide safety function. Loss of one division / train. Three remaining divisions /trains provide safety function.	No effects on the system function
55	Emergency Feedwater System (EFWS)	EFWS Pump Flow Protection (Figure 7.3-4)	Loss of 1 Division	a) Detected Failure b) Undetected - Spurious c) Undetected - Blocking	TXS inherent or engineered fault detection mechanism None None	Four redundant divisions/trains Four redundant divisions/trains Four redundant divisions/trains	Three remaining divisions /trains provide safety function. Spurious trigger of one division / train. Three remaining divisions /trains provide safety function. Loss of one division / train. Three remaining divisions /trains provide safety function.	No effects on the system function
56	Essential Service Water Pump Building Ventilation System (ESWPBVS)	ESWPBVS ESWS Pump Rooms Temperature Control (Figure 7.3-38)	Loss of 1 Division	a) Detected Failure b) Undetected - Spurious c) Undetected - Blocking	TXS inherent or engineered fault detection mechanism None None	Four redundant divisions/trains Four redundant divisions/trains Four redundant divisions/trains	Three remaining divisions /trains provide safety function. Spurious trigger of one division / train. Three remaining divisions /trains provide safety function. Loss of one division / train. Three remaining divisions /trains provide safety function.	No effects on the system function

All indicated changes are in response to RAI 505, 07.01-35



Table 7.1-7—SAS FMEA Results  
Sheet 20 of 33

No	System	SAS Function	Name of Sensor, Functional Unit, or Equipment (2)	Failure Mode (1)	Method of Detection	Inherent Compensating Provision	Effect on the SAS Function	Comments
57	Main Control Room Air Conditioning System (CRACS)	Cooler Temperature Control (Figure 7.3-45)	Loss of 1 Division	a) Detected Failure b) Undetected - Spurious c) Undetected - Blocking	TXS inherent or engineered fault detection mechanism None None	Four redundant divisions/trains Four redundant divisions/trains Four redundant divisions/trains	Three remaining divisions /trains provide safety function. Spurious trigger of one division / train. Three remaining divisions /trains provide safety function. Loss of one division / train. Three remaining divisions /trains provide safety function.	No effects on the system function
58	Main Steam System (MSS)	Steam Generator MSRCV Regulation during Pressure Control (Figure 7.3-12)	Loss of 1 Division	a) Detected Failure b) Undetected - Spurious c) Undetected - Blocking	TXS inherent or engineered fault detection mechanism None None	Four redundant divisions/trains Four redundant divisions/trains Four redundant divisions/trains	Three remaining divisions /trains provide safety function. Spurious trigger of one division / train. Three remaining divisions /trains provide safety function. Loss of one division / train. Three remaining divisions /trains provide safety function.	No effects on the system function
59	Main Steam System (MSS)	Steam Generator MSRCV Regulation during Standby Position Control (Figure 7.3-12)	Loss of 1 Division	a) Detected Failure b) Undetected - Spurious c) Undetected - Blocking	TXS inherent or engineered fault detection mechanism None None	Four redundant divisions/trains Four redundant divisions/trains Four redundant divisions/trains	Three remaining divisions /trains provide safety function. Spurious trigger of one division / train. Three remaining divisions /trains provide safety function. Loss of one division / train. Three remaining divisions /trains provide safety function.	No effects on the system function

All indicated changes are in response to RAI 505, 07.01-35



Table 7.1-7—SAS FMEA Results  
Sheet 21 of 33

No	System	SAS Function	Name of Sensor, Functional Unit, or Equipment (2)	Failure Mode (1)	Method of Detection	Inherent Compensating Provision	Effect on the SAS Function	Comments
60	Safeguard Building Controlled-Area Ventilation System (SBVS)	SIS/RHRS Pump Rooms Heat Removal (Figure 7.3-46)	Loss of 1 Division	a) Detected Failure b) Undetected - Spurious c) Undetected - Blocking	TXS inherent or engineered fault detection mechanism None None	Four redundant divisions/trains Four redundant divisions/trains Four redundant divisions/trains	Three remaining divisions /trains provide safety function. Spurious trigger of one division / train. Three remaining divisions /trains provide safety function. Loss of one division / train. Three remaining divisions /trains provide safety function.	No effects on the system function
61	Safeguard Building Controlled-Area Ventilation System (SBVS)	CCWS/EFWS Valve Rooms Heat Removal (Figure 7.3-47)	Loss of 1 Division	a) Detected Failure b) Undetected - Spurious c) Undetected - Blocking	TXS inherent or engineered fault detection mechanism None None	Four redundant divisions/trains Four redundant divisions/trains Four redundant divisions/trains	Three remaining divisions /trains provide safety function. Spurious trigger of one division / train. Three remaining divisions /trains provide safety function. Loss of one division / train. Three remaining divisions /trains provide safety function.	No effects on the system function
62	Electrical Division of Safeguard Building Ventilation System (SBVSE)	Supply and Recirculation Exhaust Air Flow Control (Figure 7.3-48)	Loss of 1 Division	a) Detected Failure b) Undetected - Spurious c) Undetected - Blocking	TXS inherent or engineered fault detection mechanism None None	Four redundant divisions/trains Four redundant divisions/trains Four redundant divisions/trains	Three remaining divisions /trains provide safety function. Spurious trigger of one division / train. Three remaining divisions /trains provide safety function. Loss of one division / train. Three remaining divisions /trains provide safety function.	No effects on the system function

All indicated changes are in response to RAI 505, 07.01-35



Table 7.1-7—SAS FMEA Results  
Sheet 22 of 33

No	System	SAS Function	Name of Sensor, Functional Unit, or Equipment (2)	Failure Mode (1)	Method of Detection	Inherent Compensating Provision	Effect on the SAS Function	Comments
63	Electrical Division of Safeguard Building Ventilation System (SBVSE)	Supply Fan Safe Shut-off (Figure 7.3-49)	Loss of 1 Division	a) Detected Failure	TXS inherent or engineered fault detection mechanism	Four redundant divisions/trains	Three remaining divisions /trains provide safety function.	No effects on the system function
				b) Undetected - Spurious	None	Four redundant divisions/trains	Spurious trigger of one division / train. Three remaining divisions /trains provide safety function.	
				c) Undetected - Blocking	None	Four redundant divisions/trains	Loss of one division / train. Three remaining divisions /trains provide safety function.	
64	Electrical Division of Safeguard Building Ventilation System (SBVSE)	Recirculation Fan Safe Shut-off (Figure 7.3-50)	Loss of 1 Division	a) Detected Failure	TXS inherent or engineered fault detection mechanism	Four redundant divisions/trains	Three remaining divisions /trains provide safety function.	No effects on the system function
				b) Undetected - Spurious	None	Four redundant divisions/trains	Spurious trigger of one division / train. Three remaining divisions /trains provide safety function.	
				c) Undetected - Blocking	None	Four redundant divisions/trains	Loss of one division / train. Three remaining divisions /trains provide safety function.	
65	Electrical Division of Safeguard Building Ventilation System (SBVSE)	Exhaust Fan Safe Shut-off (Figure 7.3-51)	Loss of 1 Division	a) Detected Failure	TXS inherent or engineered fault detection mechanism	Four redundant divisions/trains	Three remaining divisions /trains provide safety function.	No effects on the system function
				b) Undetected - Spurious	None	Four redundant divisions/trains	Spurious trigger of one division / train. Three remaining divisions /trains provide safety function.	
				c) Undetected - Blocking	None	Four redundant divisions/trains	Loss of one division / train. Three remaining divisions /trains provide safety function.	

All indicated changes are in response to RAI 505, 07.01-35



**Table 7.1-7—SAS FMEA Results**  
Sheet 23 of 33

No	System	SAS Function	Name of Sensor, Functional Unit, or Equipment (2)	Failure Mode (1)	Method of Detection	Inherent Compensating Provision	Effect on the SAS Function	Comments
66	Electrical Division of Safeguard Building Ventilation System (SBVSE)	Supply Air Temperature Heater Control (Figure 7.3-52)	Loss of 1 Division	a) Detected Failure	TXS inherent or engineered fault detection mechanism	Four redundant divisions/trains	Three remaining divisions /trains provide safety function.	No effects on the system function
				b) Undetected - Spurious	None	Four redundant divisions/trains	Spurious trigger of one division / train. Three remaining divisions /trains provide safety function.	
				c) Undetected - Blocking	None	Four redundant divisions/trains	Loss of one division / train. Three remaining divisions /trains provide safety function.	
67	Electrical Division of Safeguard Building Ventilation System (SBVSE)	Freeze Protection – Supply Air Temperature (Figure 7.3-53)	Loss of 1 Division	a) Detected Failure	TXS inherent or engineered fault detection mechanism	Four redundant divisions/trains	Three remaining divisions /trains provide safety function.	No effects on the system function
				b) Undetected - Spurious	None	Four redundant divisions/trains	Spurious trigger of one division / train. Three remaining divisions /trains provide safety function.	
				c) Undetected - Blocking	None	Four redundant divisions/trains	Loss of one division / train. Three remaining divisions /trains provide safety function.	
68	Electrical Division of Safeguard Building Ventilation System (SBVSE)	Supply Air Temperature Control for Supply Air Cooling (Figure 7.3-54)	Loss of 1 Division	a) Detected Failure	TXS inherent or engineered fault detection mechanism	Four redundant divisions/trains	Three remaining divisions /trains provide safety function.	No effects on the system function
				b) Undetected - Spurious	None	Four redundant divisions/trains	Spurious trigger of one division / train. Three remaining divisions /trains provide safety function.	
				c) Undetected - Blocking	None	Four redundant divisions/trains	Loss of one division / train. Three remaining divisions /trains provide safety function.	

All indicated changes are in response to RAI 505, 07.01-35



Table 7.1-7—SAS FMEA Results  
Sheet 24 of 33

No	System	SAS Function	Name of Sensor, Functional Unit, or Equipment (2)	Failure Mode (1)	Method of Detection	Inherent Compensating Provision	Effect on the SAS Function	Comments
69	Electrical Division of Safeguard Building Ventilation System (SBVSE)	Battery Room Heater Control (Figure 7.3-56)	Loss of 1 Division	a) Detected Failure	TXS inherent or engineered fault detection mechanism	Four redundant divisions/trains	Three remaining divisions /trains provide safety function.	No effects on the system function
				b) Undetected - Spurious	None	Four redundant divisions/trains	Spurious trigger of one division / train. Three remaining divisions /trains provide safety function.	
				c) Undetected - Blocking	None	Four redundant divisions/trains	Loss of one division / train. Three remaining divisions /trains provide safety function.	
70	Electrical Division of Safeguard Building Ventilation System (SBVSE)	Battery Room Supply Air Temperature Control (Figure 7.3-57)	Loss of 1 Division	a) Detected Failure	TXS inherent or engineered fault detection mechanism	Four redundant divisions/trains	Three remaining divisions /trains provide safety function.	No effects on the system function
				b) Undetected - Spurious	None	Four redundant divisions/trains	Spurious trigger of one division / train. Three remaining divisions /trains provide safety function.	
				c) Undetected - Blocking	None	Four redundant divisions/trains	Loss of one division / train. Three remaining divisions /trains provide safety function.	
71	Electrical Division of Safeguard Building Ventilation System (SBVSE)	Emergency Feed Water System (EFWS) Pump Room Heat Removal (Figure 7.3-58)	Loss of 1 Division	a) Detected Failure	TXS inherent or engineered fault detection mechanism	Four redundant divisions/trains	Three remaining divisions /trains provide safety function.	No effects on the system function
				b) Undetected - Spurious	None	Four redundant divisions/trains	Spurious trigger of one division / train. Three remaining divisions /trains provide safety function.	
				c) Undetected - Blocking	None	Four redundant divisions/trains	Loss of one division / train. Three remaining divisions /trains provide safety function.	

**Table 7.1-7—SAS FMEA Results**  
Sheet 25 of 33

No	System	SAS Function	Name of Sensor, Functional Unit, or Equipment (2)	Failure Mode (1)	Method of Detection	Inherent Compensating Provision	Effect on the SAS Function	Comments
72	Electrical Division of Safeguard Building Ventilation System (SBVSE)	SBVSE CCWS Pump Room Heat Removal (Figure 7.3-59)	Loss of 1 Division	a) Detected Failure b) Undetected - Spurious c) Undetected - Blocking	TXS inherent or engineered fault detection mechanism None None	Four redundant divisions/trains Four redundant divisions/trains Four redundant divisions/trains	Three remaining divisions /trains provide safety function. Spurious trigger of one division / train. Three remaining divisions /trains provide safety function. Loss of one division / train. Three remaining divisions /trains provide safety function.	No effects on the system function
73	Electrical Division of Safeguard Building Ventilation System (SBVSE)	Component Cooling Water System (CCWS) Pump Room Heat Removal (Figure 7.3-60)	Loss of 1 Division	a) Detected Failure b) Undetected - Spurious c) Undetected - Blocking	TXS inherent or engineered fault detection mechanism None None	Four redundant divisions/trains Four redundant divisions/trains Four redundant divisions/trains	Three remaining divisions /trains provide safety function. Spurious trigger of one division / train. Three remaining divisions /trains provide safety function. Loss of one division / train. Three remaining divisions /trains provide safety function.	No effects on the system function
74	Safety Chilled Water System (SCWS)	SCWS Train 1 to Train 2 Switchover on Train 1 Low Evaporator Flow / Chiller Black Box Internal Fault / SCWS Chiller Evaporator Water Flow Control / LOOP Re-start Failure (Figure 7.6-5)	Loss of 1 Division	a) Detected Failure b) Undetected - Spurious c) Undetected - Blocking	TXS inherent or engineered fault detection mechanism None None	Four redundant divisions/trains Four redundant divisions/trains Four redundant divisions/trains	Three remaining divisions /trains provide safety function. Spurious trigger of one division / train. Three remaining divisions /trains provide safety function. Loss of one division / train. Three remaining divisions /trains provide safety function.	No effects on the system function



All indicated changes are in response to RAI 505, 07.01-35



Table 7.1-7—SAS FMEA Results  
Sheet 26 of 33

No	System	SAS Function	Name of Sensor, Functional Unit, or Equipment (2)	Failure Mode (1)	Method of Detection	Inherent Compensating Provision	Effect on the SAS Function	Comments
75	Safety Chilled Water System (SCWS)	SCWS Train 2 to Train 1 Switchover on Train 2 Low Evaporator Flow / Chiller Black Box Internal Fault / Loss of UHS-CCWS / SCWS Chiller Evaporator Water Flow Control / LOOP Re-start Failure (Figure 7.6-6)	Loss of 1 Division	a) Detected Failure b) Undetected - Spurious c) Undetected - Blocking	TXS inherent or engineered fault detection mechanism None None	Four redundant divisions/trains Four redundant divisions/trains Four redundant divisions/trains	Three remaining divisions /trains provide safety function Spurious trigger of one division / train. Three remaining divisions /trains provide safety function. Loss of one division / train. Three remaining divisions /trains provide safety function.	No effects on the system function
76	Safety Chilled Water System (SCWS)	SCWS Train 3 to Train 4 Switchover on Train 3 Low Evaporator Flow / Chiller Black Box Internal Fault / Loss of UHS-CCWS / SCWS Chiller Evaporator Water Flow Control / LOOP Re-start Failure (Figure 7.6-7)	Loss of 1 Division	a) Detected Failure b) Undetected - Spurious c) Undetected - Blocking	TXS inherent or engineered fault detection mechanism None None	Four redundant divisions/trains Four redundant divisions/trains Four redundant divisions/trains	Three remaining divisions /trains provide safety function Spurious trigger of one division / train. Three remaining divisions /trains provide safety function. Loss of one division / train. Three remaining divisions /trains provide safety function.	No effects on the system function
77	Safety Chilled Water System (SCWS)	SCWS Train 4 to Train 3 Switchover on Train 4 Low Evaporator Flow / Chiller Black Box Internal Fault / SCWS Chiller Evaporator Water Flow Control / LOOP Re-start Failure (Figure 7.6-8)	Loss of 1 Division	a) Detected Failure b) Undetected - Spurious c) Undetected - Blocking	TXS inherent or engineered fault detection mechanism None None	Four redundant divisions/trains Four redundant divisions/trains Four redundant divisions/trains	Three remaining divisions /trains provide safety function Spurious trigger of one division / train. Three remaining divisions /trains provide safety function. Loss of one division / train. Three remaining divisions /trains provide safety function.	No effects on the system function

All indicated changes are in response to RAI 505, 07.01-35



**Table 7.1-7—SAS FMEA Results**  
Sheet 27 of 33

No	System	SAS Function	Name of Sensor, Functional Unit, or Equipment (2)	Failure Mode (1)	Method of Detection	Inherent Compensating Provision	Effect on the SAS Function	Comments
78	Safety Injection and Residual Heat Removal System (SIS/ RHRS)	Automatic RHRS Flow Rate Control (Figure 7.3-60)	Loss of 1 Division	a) Detected Failure b) Undetected - Spurious c) Undetected - Blocking	TXS inherent or engineered fault detection mechanism None None	Four redundant divisions/ trains Four redundant divisions/ trains Four redundant divisions/ trains	Three remaining divisions /trains provide safety function Spurious trigger of one division / train. Three remaining divisions /trains provide safety function. Loss of one division / train. Three remaining divisions / trains provide safety function.	No effects on the system function
<b>Systems With Functions Within 2 Redundant Train Sets</b>								
79	Annulus Ventilation System (AVS)	Accident Filtration Train Heater Control (Figure 7.3-31)	Loss of 1 Division	a) Detected Failure b) Undetected - Spurious c) Undetected - Blocking	TXS inherent or engineered fault detection mechanism None None	Two redundant train sets Two redundant train sets Two redundant train sets	Loss of one train set. One remaining train set Spurious trigger of one train set. One remaining train set provide safety function. Loss of one train set. One remaining train set provides safety function.	One train set remains functional
80	Annulus Ventilation System (AVS)	Accident Train Switchover (Figure 7.3-32)	Loss of 1 Division	a) Detected Failure b) Undetected - Spurious c) Undetected - Blocking	TXS inherent or engineered fault detection mechanism None None	Two redundant train sets Two redundant train sets Two redundant train sets	Loss of one train set. One remaining train set Spurious trigger of one train set. One remaining train set provide safety function. Loss of one train set. One remaining train set provides safety function.	One train set remains functional

All indicated changes are in response to RAI 505, 07.01-35



Table 7.1-7—SAS FMEA Results  
Sheet 28 of 33

No	System	SAS Function	Name of Sensor, Functional Unit, or Equipment (2)	Failure Mode (1)	Method of Detection	Inherent Compensating Provision	Effect on the SAS Function	Comments
81	Component Cooling Water System (CCWS)	SCWS Condenser Supply Water Flow Control (Figure 7.3-37)	Loss of 1 Division	a) Detected Failure	TXS inherent or engineered fault detection mechanism	Two redundant train sets	Loss of one train set. One remaining train set	One train set remains functional
				b) Undetected - Spurious	None	Two redundant train sets	Spurious trigger of one train set. One remaining train set provide safety function.	
				c) Undetected - Blocking	None	Two redundant train sets	Loss of one train set. One remaining train set provides safety function.	
82	Fuel Building Ventilation System (FBVS)	Safety-Related Room Heater Control (Figure 7.3-39)	Loss of 1 Division	a) Detected Failure	TXS inherent or engineered fault detection mechanism	Two redundant train sets	Loss of one train set. One remaining train set	One train set remains functional
				b) Undetected - Spurious	None	Two redundant train sets	Spurious trigger of one train set. One remaining train set provide safety function.	
				c) Undetected - Blocking	None	Two redundant train sets	Loss of one train set. One remaining train set provides safety function.	
83	Fuel Building Ventilation System (FBVS)	FBVS EBS / FPFS Pump Rooms Heat Removal (Figure 7.3-40)	Loss of 1 Division	a) Detected Failure	TXS inherent or engineered fault detection mechanism	Two redundant train sets	Loss of one train set. One remaining train set	One train set remains functional
				b) Undetected - Spurious	None	Two redundant train sets	Spurious trigger of one train set. One remaining train set provide safety function.	
				c) Undetected - Blocking	None	Two redundant train sets	Loss of one train set. One remaining train set provides safety function.	

All indicated changes are in response to RAI 505, 07.01-35



**Table 7.1-7—SAS FMEA Results**  
Sheet 29 of 33

No	System	SAS Function	Name of Sensor, Functional Unit, or Equipment (2)	Failure Mode (1)	Method of Detection	Inherent Compensating Provision	Effect on the SAS Function	Comments
84	Fuel Pool Cooling and Purification System (FPCPS)	FPCPS Pump Trip on Low-Spent Fuel Pool (SFP) Level (Figure 7.3-41)	Loss of 1 Division	a) Detected Failure	TXS inherent or engineered fault detection mechanism	Two redundant train sets	Loss of one train set. One remaining train set	One train set remains functional
				b) Undetected - Spurious	None	Two redundant train sets	Spurious trigger of one train set. One remaining train set provide safety function.	
				c) Undetected - Blocking	None	Two redundant train sets	Loss of one train set. One remaining train set provides safety function.	
85	Main Control Room Air Conditioning System (CRACS)	Iodine Filtration Train Heater Control (Figure 7.3-42)	Loss of 1 Division	a) Detected Failure	TXS inherent or engineered fault detection mechanism	Two redundant train sets	Loss of one train set. One remaining train set	One train set remains functional
				b) Undetected - Spurious	None	Two redundant train sets	Spurious trigger of one train set. One remaining train set provide safety function.	
				c) Undetected - Blocking	None	Two redundant train sets	Loss of one train set. One remaining train set provides safety function.	
86	Main Control Room Air Conditioning System (CRACS)	Heater Control for Outside Inlet Air (Figure 7.3-43)	Loss of 1 Division	a) Detected Failure	TXS inherent or engineered fault detection mechanism	Two redundant train sets	Loss of one train set. One remaining train set	One train set remains functional
				b) Undetected - Spurious	None	Two redundant train sets	Spurious trigger of one train set. One remaining train set provide safety function.	
				c) Undetected - Blocking	None	Two redundant train sets	Loss of one train set. One remaining train set provides safety function.	

**Systems With Functions Utilizing Voting Logic**

All indicated changes are in response to RAI 505, 07.01-35



Table 7.1-7—SAS FMEA Results  
Sheet 30 of 33

No	System	SAS Function	Name of Sensor, Functional Unit, or Equipment (2)	Failure Mode (1)	Method of Detection	Inherent Compensating Provision	Effect on the SAS Function	Comments
87	In-Containment Refueling Water Storage Tank System (IRWST)	IRWST Boundary Isolation for Preserving IRWST Water Inventory Interlock (Figure 7.6-4)	Loss of 1 Division	a) Detected Failure b) Undetected - Spurious c) Undetected - Blocking	TXS inherent or engineered fault detection mechanism  None  None	Redundant divisions/trains  Redundant divisions/trains  Redundant divisions/trains	Loss of Master CU and Hot Standby CU in faulted division. Voting logic in other divisions is modified to 2/3.  One division sends a spurious actuation. Voting logic in other divisions becomes 1/3.  Loss of Master CU and Hot Standby CU in faulted division. Voting logic in other divisions becomes 2/3.	No effects on the system function
88	Safety Injection and Residual Heat Removal System (SIS/RHRS)	Automatic Trip of LHSL Pump (in RHR Mode) on Low ΔPsat (Figure 7.6-9)	Loss of 1 Division	a) Detected Failure b) Undetected - Spurious c) Undetected - Blocking	TXS inherent or engineered fault detection mechanism  None  None	Redundant divisions/trains  Redundant divisions/trains  Redundant divisions/trains	Loss of Master CU and Hot Standby CU in faulted division. Voting logic in other divisions is modified to 2/3.  One division sends a spurious actuation. Voting logic in other divisions becomes 1/3.  Loss of Master CU and Hot Standby CU in faulted division. Voting logic in other divisions becomes 2/3.	No effects on the system function

All indicated changes are in response to RAI 505, 07.01-35



Table 7.1-7—SAS FMEA Results  
Sheet 31 of 33

No	System	SAS Function	Name of Sensor, Functional Unit, or Equipment (2)	Failure Mode (1)	Method of Detection	Inherent Compensating Provision	Effect on the SAS Function	Comments
89	Safety Injection and Residual Heat Removal System (SIS/ RHRS)	Automatic Trip of LHSI Pump (in RHR Mode) on Low Loop Level (Figure 7.6-10)	Loss of 1 Division	a) Detected Failure b) Undetected - Spurious c) Undetected - Blocking	TXS inherent or engineered fault detection mechanism None None	Redundant divisions/trains Redundant divisions/trains Redundant divisions/trains	Loss of Master CU and Hot Standby CU in faulted division. Voting logic in other divisions is modified to 2/3. One division sends a spurious actuation. Voting logic in other divisions becomes 1/3. Loss of Master CU and Hot Standby CU in faulted division. Voting logic in other divisions becomes 2/3.	No effects on the system function
<b>CCWS Switchover Functions</b>								
90	Component Cooling Water System (CCWS)	CCWS Common 1.b. Automatic Backup Switchover of Train 1 to Train 2 and Train 2 to Train 1 (Figure 7.3-33)	Loss of 1 Division	a) Detected Failure b) Undetected - Spurious c) Undetected - Blocking	TXS inherent or engineered fault detection mechanism None None	Failed sensor marked invalid; two redundant train pairs. Two redundant trains pairs Two redundant trains pairs	Unable to automatically perform switchover function in the faulted division. Loss of 1 train pair Unable to automatically perform switchover function in the faulted division. Loss of 1 train pair Unable to automatically perform switchover function in the faulted division. Loss of 1 train pair	A second pair serves its associated heat loads. Adequate cooling is provided by the second train pair.

All indicated changes are in response to RAI 505, 07.01-35



**Table 7.1-7—SAS FMEA Results**  
Sheet 32 of 33

No	System	SAS Function	Name of Sensor, Functional Unit, or Equipment (2)	Failure Mode (1)	Method of Detection	Inherent Compensating Provision	Effect on the SAS Function	Comments
91	Component Cooling Water System (CCWS)	CCWS Common 2.b. Automatic Backup Switchover of Train 3 to Train 4 and Train 4 to Train 3. (Figure 7.3-33)	Loss of 1 Division	a) Detected Failure	TXS inherent or engineered fault detection mechanism	Failed sensor marked invalid; two redundant train pairs.	Unable to automatically perform switchover function in the faulted division. Loss of 1 train pair	A second pair serves its associated heat loads. Adequate cooling is provided by the second train pair
				b) Undetected - Spurious	None	Two redundant trains pairs	Unable to automatically perform switchover function in the faulted division. Loss of 1 train pair	
				c) Undetected - Blocking	None	Two redundant trains pairs	Unable to automatically perform switchover function in the faulted division. Loss of 1 train pair	
92	Component Cooling Water System (CCWS)	CCWS Emergency Leak Detection - Switchover Valves Leakage or Failure. (Figure 7.3-36)	Loss of 1 Division	a) Detected Failure	TXS inherent or engineered fault detection mechanism	Failed sensor marked invalid; two redundant train pairs.	Unable to automatically perform switchover function in the faulted division. Loss of 1 train pair	A second pair serves its associated heat loads. Adequate cooling is provided by the second train pair
				b) Undetected - Spurious	None	Two redundant trains pairs	Unable to automatically perform switchover function in the faulted division. Loss of 1 train pair	
				c) Undetected - Blocking	None	Two redundant trains pairs	Unable to automatically perform switchover function in the faulted division. Loss of 1 train pair	

**Table 7.1-7—SAS FMEA Results**  
Sheet 33 of 33

No	System	SAS Function	Name of Sensor, Functional Unit, or Equipment (2)	Failure Mode (1)	Method of Detection	Inherent Compensating Provision	Effect on the SAS Function	Comments
93	Component Cooling Water System (CCWS)	CCWS Switchover Valves Interlock (Figure 7.6-1)	Loss of 1 Division	a) Detected Failure b) Undetected - Spurious c) Undetected - Blocking	TXS inherent or engineered fault detection mechanism None None	Failed sensor marked invalid; two redundant train pairs Two redundant trains pairs Two redundant trains pairs	Unable to automatically perform switchover function in the faulted division. Loss of 1 train pair Unable to automatically perform switchover function in the faulted division. Loss of 1 train pair Unable to automatically perform switchover function in the faulted division. Loss of 1 train pair	A second pair serves its associated heat loads. Adequate cooling is provided by the second train pair
<b>CCWS RCP Thermal Barrier Interlock Function</b>								
94	Component Cooling Water System (CCWS)	CCWS RCP Thermal Barrier Containment Isolation Valve Interlock (Figure 7.6-2)	Loss of 1 Division	a) Detected Failure b) Undetected - Spurious c) Undetected - Blocking	TXS inherent or engineered fault detection mechanism None None	Low RCS Flow Rate RT Low RCS Flow Rate RT Low RCS Flow Rate RT	Unable to automatically perform the function Unable to automatically perform the function Unable to automatically perform the function	The loss of this automatic function will result in multiple RCP trips due to insufficient cooling / overheating. This will in turn result in a Low RCS Flow Rate RT.
<b>All SAS Functions</b>								
95	All systems for which SAS performs a function.	All SAS functions	Hot Standby CU in 1 Division	a) Detected Failure b) Undetected - Spurious c) Undetected - Blocking	TXS inherent or engineered fault detection mechanism None None	Master/Hot Standby CU configuration. Master/Hot Standby CU configuration. Master/Hot Standby CU configuration.	None - Master CU in affected division remains functional None - Master CU in affected division remains functional None - Master CU in affected division remains functional	No effects on the system function

**Notes:**

1. Failure Mode – The failure cause is not identified in the system-level analysis. The failure modes are selected to bound the results of any specific failure cause. Specific failure causes can be identified only after specific equipment is selected and application software is developed.
2. This FMEA has been analyzed for loss of a CU and loss of a division failure. These types of failures encompass any single failure within a division. (i.e. loss of a sensor, hardwired logic failure / fault).



actions to manipulate individual components as may be necessary to follow plant operating procedures.

The functional logic for hydrogen mixing dampers opening is shown in Figure 7.3-30—Hydrogen Mixing Dampers Opening.

### 7.3.1.3 Engineered Safety Features Control Functional Descriptions

#### 7.3.1.3.1 Annulus Ventilation System

##### Accident Filtration Train Heater Control

The annulus ventilation system (AVS) has a safety-related function to maintain capability of the iodine absorbers to remove iodine from the annulus exhaust air. The heaters are used to limit the relative humidity to a maximum of 70 percent when the AVS accident trains are in operation (RG 1.52 and ASME N509-89). The functional logic is shown in Figure 7.3-31—AVS Accident Filtration Train Heater Control.

##### Accident Train Switchover

The AVS has a safety-related function to maintain a negative pressure and provide exhaust filtration (GDC 16, GDC 43, Containment Leakage Testing per 10 CFR 50 Appendix J, and NRC RG 1.52 Rev 3). In case of a failure during accident operation of an operating accident filtration train, and a negative pressure is not being maintained in the annulus, operation is switched to the non-operating accident filtration train to maintain a negative pressure and provide exhaust filtration. The functional logic is shown in Figure 7.3-32—AVS Accident Train Switchover.

#### 7.3.1.3.2 Main Control Room Air Conditioning System

##### Iodine Filtration Train Heater Control

The main control room air conditioning system (CRACS) has an safety-related function to preheat the inlet air in order to reduce the airborne moisture prior to entry into the carbon bed within the filter unit. Carbon filter heaters shut down when the respective inlet or outlet dampers are not fully open. The heaters will turn off if the carbon filtration unit fan stops, the carbon filter inlet isolation damper is not open or the carbon filter outlet isolation damper is not open. The functional logic is shown in Figure 7.3-42—CRACS Iodine Filtration Train Heater Control.

##### Heater Control for Outside Air Inlet

The CRACS has an safety-related function to preheat the outside air to verify that the inlet air temperature is not less than 37°F (GDC 19). Inlet air that bypasses the iodine filtration unit is heated by an electric heater for temperature control. Heating of the outside air is performed by multi-stage heaters located in each outside air intake duct.

The functional logic is shown in Figure 7.3-43—CRACS Heater Control for Outside Inlet Air.

### **Pressure Control**

The CRACS has safety-related function to verify the MCR is maintained at a positive pressure with respect to the ambient air pressure in adjacent areas (GDC 19). Differential pressure sensors sense the pressure difference between the MCR and the pressure in a reference areas. The functional logic is shown in Figure 7.3-44—CRACS Pressure Control.

### **Cooler Temperature Control**

The CRACS has safety-related functions that verify that the air supply temperature is maintained within the preset temperature range (GDC 19). A control signal is developed when the supply air temperature exceeds a preset temperature set point of 58°F. The control signal is used to adjust cooler outlet SCWS control valves to maintain the air supply temperature. The functional logic is shown in Figure 7.3-45—CRACS Cooler Temperature Control.

#### **7.3.1.3.3**

### **Main Steam System**

#### **Steam Generator MSRCV Regulation during Standby Position Control**

The main steam system (MSS) has a safety-related function supporting the removal of decay heat and other residual heat from the reactor core (GDC 34). The function modulates the main steam relief control valve (MSRCV) to its standby control position, so in the event of an overpressure transient the MSRCVs will already be in its required relieving position. This function is described further in Section 7.3.1.2.5. The functional logic is shown in Figure 7.3-12—MSRCV Control

#### **Steam Generator MSRCV Regulation during Pressure Control**

The MSS has a safety-related function supporting the removal of decay heat and other residual heat from the reactor core (GDC 34). The function modulates the MSRCV to its required position in order to reduce secondary side pressure of the SGs during overpressure events. This function is described further in Section 7.3.1.2.5. The functional logic is shown in Figure 7.3-12—MSRCV Control.

#### **7.3.1.3.4**

### **Safeguard Building Controlled-Area Ventilation System**

#### **SIS / RHRS Pump Rooms Heat Removal**

The safeguard building controlled-area ventilation system (SBVS) has a safety-related function that maintains ambient conditions for safety-related components (GDC 60.

GDC 61). The functional logic is shown in Figure 7.3-46—SBVS SIS / RHRS Pump Rooms Heat Removal.

### **CCWS / EFWS Valve Rooms Heat Removal**

The SBVS has a safety-related function that maintains ambient conditions for safety-related components (GDC 60, GDC 61). The functional logic is shown in Figure 7.3-47—SBVS CCWS / EFWS Valve Rooms Heat Removal.

#### **7.3.1.3.5 Safety Injection System/Residual Heat Removal System**

##### **Automatic RHRS Flow Rate Control**

The SIS/RHRS has a safety-related function to provide RCS decay heat removal to reach cold shutdown, refueling modes and to control primary temperature. The function to automatically control the flow rate of the RHRS supports the safety-related function of providing decay heat removal by modulating the bypass control valve ensuring a constant flow rate through the LHSI heat exchanger. The functional logic is shown in Figure 7.3-60—SIS / RHRS Automatic RHRS Flow Rate Control.

#### **7.3.1.4 Essential Auxiliary Support Controls Functional Descriptions**

##### **7.3.1.4.1 Component Cooling Water System**

##### **Common 1.b Automatic Backup Switchover of Train 1 to Train 2**

The component cooling water system (CCWS) has a safety-related function to remove heat from safety-related components (GDC 44). The safety-related function to perform an automatic switchover from Train 1 to Train 2 verifies that the CCWS is capable of fulfilling its safety-related function to remove heat from safety-related components on the CCWS Common 1.a and 1.b headers. The functional logic is shown in Figure 7.3-33—CCWS Common 1.b Automatic Backup Switchover of Train 1 to Train 2 and Train 2 to 1.

##### **Common 1.b Automatic Backup Switchover of Train 2 to 1**

The CCWS has a safety-related function to remove heat from safety-related components (GDC 44). The safety-related function to perform an automatic switchover from Train 2 to Train 1 verifies that the CCWS is capable of fulfilling its safety-related function to remove heat from safety-related components on the CCWS Common 1.a and 1.b headers. The functional logic is shown in Figure 7.3-33—CCWS Common 1.b Automatic Backup Switchover of Train 1 to Train 2 and Train 2 to 1.

##### **Common 2.b Automatic Backup Switchover of Train 3 to 4**

The CCWS has a safety-related function to remove heat from safety-related components (GDC 44). The safety-related function to perform an automatic

switchover from Train 3 to Train 4 verifies that the CCWS is capable of fulfilling its safety-related function to remove heat from safety-related components on the CCWS Common 2.a and 2.b headers. The functional logic is shown in Figure 7.3-33—CCWS Common 1.b Automatic Backup Switchover of Train 1 to Train 2 and Train 2 to 1.

### **Common 2.b Automatic Backup Switchover of Train 4 to 3**

The CCWS has a safety-related function to remove heat from safety-related components (GDC 44). The safety-related function to perform an automatic switchover from Train 4 to Train 3 verifies that the CCWS is capable of fulfilling its safety-related function to remove heat from safety-related components on the CCWS Common 2.a and 2.b headers. The functional logic is shown in Figure 7.3-33—CCWS Common 1.b Automatic Backup Switchover of Train 1 to Train 2 and Train 2 to 1.

### **Emergency Temperature Control**

The CCWS has a safety-related function to remove heat from safety-related components (GDC 44). The safety-related function to control the CCWS heat exchanger (HX) outlet temperature is required to maintain the temperature of the cooling water within its limits. This verifies that the CCWS is capable of fulfilling its safety-related function to remove heat from safety-related components. The functional logic is shown in Figure 7.3-34—CCWS Emergency Temperature Control.

### **Emergency Leak Detection**

The CCWS has a safety-related function to remove heat from safety-related components (GDC 44). The safety-related function for emergency leak detection maintains the required cooling water inventory that supports the safety-related function to remove heat using indications to detect leaks and isolate them (GDC 44). The functional logic is shown in Figure 7.3-35—CCWS Emergency Leak Detection.

### **Emergency Leak Detection - Switchover Valves Leakage or Failure**

The CCWS has a safety-related function to remove heat from safety-related components (GDC 44). The safety-related function for switchover valve leakage or failure isolates the CCWS trains from their common headers so that each train is able to provide their corresponding LHSI HX with the required flow for heat removal. Removing heat from the LHSI HX is a safety-related function. The functional logic is shown in Figure 7.3-36—CCWS Emergency Leak Detection - Switchover Valves Leakage or Failure.

### **SCWS Condenser Supply Water Flow Control**

The CCWS has a safety-related function that controls CCWS flow to the SCWS condenser and provides a heat sink for heat rejection, therefore providing reasonable assurance that the SCWS is capable of fulfilling its safety-related functions (GDC 44).

The functional logic is shown in Figure 7.3-37—SCWS Condenser Supply Water Flow Control.

#### 7.3.1.4.2 **Essential Service Water System**

##### **Automatic ESWS Actuation from CCWS Start**

The essential service water system (ESWS) has a safety-related function to remove heat from safety-related components (GDC 44). The Automatic ESWS Actuation from CCWS Start function starts the corresponding train ESWS pump so that the SCWS is capable of fulfilling its safety-related function to remove heat from the corresponding CCWS train. The functional logic is shown in Figure 7.3-33—CCWS Common 1.b Automatic Backup Switchover of Train 1 to Train 2 and Train 2 to 1.

#### 7.3.1.4.3 **Essential Service Water Pump Building Ventilation System**

##### **ESWS Pump Rooms Temperature Control**

The essential service water pump building ventilation system (ESWPBVS) has a safety-related function that maintains the ESWS pump room temperature when the ESWS pumps are operating at rated load and the outside air is at maximum site design ambient temperature (GDC 4, GDC 17). The functional logic is shown in Figure 7.3-38—ESWPBVS ESWS Pump Rooms Temperature Control.

#### 7.3.1.4.4 **Fuel Building Ventilation System**

##### **Safety-Related Rooms Heater Control**

The fuel building ventilation system (FBVS) has an safety-related function that maintains the temperature in the boron rooms and surrounding extra borating system tanks to prevent crystallization in extra borating system piping (GDC 27, GDC 60, GDC 61). The functional logic is shown in Figure 7.3-39—FBVS Safety-Related Rooms Heater Control.

##### **EBS / FPCS Pump Rooms Heater Removal**

The FBVS has an safety-related function that maintains the room ambient conditions in the extra borating system pump rooms and fuel pool cooling system pump rooms (GDC 27, GDC 60, GDC 61). The functional logic is shown in Figure 7.3-40—FBVS EBS / FPCS Pump Rooms Heat Removal.

##### **Isolation of FBVS on Containment Isolation**

The FBVS has a safety-related function to automatically isolate the NABVS supply and exhaust ducts in the event of a containment isolation signal. The functional logic is shown in Figure 7.3-62—Isolation of FBVS on Containment Isolation.

### Isolation of FBVS on Fuel Pool Area Fuel Handling Accident

The FBVS has a safety-related function to automatically isolate the supply and exhaust air to the fuel handling hall to mitigate the consequences of a fuel handling accident in the hall. The functional logic is shown in Figure 7.3-63—Fuel Pool Area Fuel Handling Accident.

### Isolation of Reactor Building on Fuel Handling Accident

The FBVS has a safety-related function to automatically isolate the supply airflow to the room in front of the emergency airlock in order to mitigate the consequences of a fuel handling accident in the Reactor Building. The functional logic is shown in Figure 7.3-64—Reactor Building Fuel Handling Accident.

#### 7.3.1.4.5

### Fuel Pool Cooling and Purification System

#### FPCPS Pump Trip on Low SFP Level

The safety-related function to trip the FPC pump on low level so that the FPCPS is capable of fulfilling its safety-related function of precluding the drain down of the SFP to eliminate the potential for fuel damage and its consequences. The functional logic is shown in Figure 7.3-41—FPCPS Pump Trip on Low SFP Level.

#### 7.3.1.4.6

### Electrical Division of Safeguard Building Ventilation System

#### Supply and Recirculation-Exhaust Air Flow Control

The safeguard building ventilation system (electrical) (SBVSE) has a safety-related function to ventilate and maintain acceptable ambient temperature in the Safeguard Building areas and rooms ventilated by the system (GDC 4, GDC 17). The Supply and Recirculation-Exhaust Air Flow Control function supports this system safety function by controlling supply, exhaust, and recirculation air flow as required to maintain ambient temperature and air quality (via filtration) within applicable limits for safety-related equipment located within the Safeguard Building areas and rooms. The functional logic is shown in Figure 7.3-48—SBVSE Supply and Recirculation-Exhaust Air Flow Control.

#### Supply Fan Safe Shut-Off

The SBVSE has a safety-related function to ventilate and maintain acceptable ambient temperature in the Safeguard Building areas and rooms ventilated by the system (GDC 4, GDC 17). An inadvertent stopping of the supply fan, due to a spurious system action, may cause the SBVSE for a given division to become inoperable. Therefore, to mitigate the risk of system spurious actions, this function is to be designated as safety-related (IEEE 603). The functional logic is shown in Figure 7.3-49—SBVSE Supply Fan Safe Shut-Off.

### **Recirculation Fan Safe Shut-Off**

The SBVSE has a safety-related function to ventilate and maintain acceptable ambient temperature in the Safeguard Building areas and rooms ventilated by the system (GDC 4, GDC 17). An inadvertent stopping of the recirculation/exhaust fan, due to a spurious system action, may cause the SBVSE for a given division to become inoperable. Therefore, to mitigate the risk of system spurious actions, this function is to be designated as safety-related (IEEE 603). The functional logic is shown in Figure 7.3-50—SBVSE Recirculation Fan Safe Shut-Off.

### **Exhaust Fan Safe Shut-Off**

The SBVSE has a safety-related function to ventilate and maintain acceptable ambient temperature in the Safeguard Building areas and rooms ventilated by the system (GDC 4, GDC 17). An inadvertent stopping of the exhaust fan, due to a spurious system action, may cause the SBVSE for a given division to become inoperable. Therefore, to mitigate the risk of system spurious actions, this function is to be designated as safety-related (IEEE 603). The functional logic is shown in Figure 7.3-51—SBVSE Exhaust Fan Safe Shut-Off.

### **Supply Air Temperature Heater Control**

The SBVSE has a safety-related function to ventilate and maintain acceptable ambient temperature in the Safeguard Building areas and rooms ventilated by the system (GDC 4, GDC 17). The Supply Air Temperature Heater Control function supports this system safety function by maintaining supply air temperature (downstream of heaters) as required to maintain ambient temperature within applicable limits for safety-related equipment located within the Safeguard Building areas and rooms. The functional logic is shown in Figure 7.3-52—SBVSE Supply Air Temperature Heater Control.

### **Freeze Protection**

The SBVSE has a safety-related function to ventilate and maintain acceptable ambient temperature in the Safeguard Building areas and rooms ventilated by the system (GDC 4, GDC 17). The Freeze Protection function supports this system safety function by preventing ice buildup on the louver bars (specifically, mitigating the risk of not having available makeup air). The functional logic is shown in Figure 7.3-53—SBVSE Freeze Protection.

### **Supply Air Temperature Control for Supply Air Cooling**

The SBVSE has a safety-related function to ventilate and maintain acceptable ambient temperature in the Safeguard Building areas and rooms ventilated by the system (GDC 4, GDC 17). The Supply Air Temperature Control for Supply Air Cooling function supports this system safety function by maintaining a constant air temperature, as



required, to maintain ambient temperature within applicable limits for safety-related equipment located within the Safeguard Building areas and rooms. The functional logic is shown in Figure 7.3-54—SBVSE Supply Air Temperature Control for Supply Air Cooling.

#### **Battery Room Heater Control**

The SBVSE has a safety-related function to ventilate and maintain acceptable ambient temperature in the Safeguard Building areas and rooms ventilated by the system (GDC 4, GDC 17). The Battery Room Temperature Control function supports this system safety function by maintaining battery room ambient temperature within applicable limits. The functional logic is shown in Figure 7.3-56—SBVSE Battery Room Heater Control.

#### **Battery Room Supply Air Temperature Control**

The SBVSE has a safety-related function to ventilate and maintain acceptable ambient temperature in the Safeguard Building areas and rooms ventilated by the system (GDC 4, GDC 17). The Battery Room Supply Air Temperature Control function supports this system safety function by maintaining battery room ambient temperature within applicable limits. The functional logic is shown in Figure 7.3-57—SBVSE Battery Room Supply Air Temperature Control.

#### **EFWS Pump Room Heat Removal**

The SBVSE has a safety-related function to ventilate and maintain acceptable ambient temperature in the Safeguard Building areas and rooms ventilated by the system (GDC 4, GDC 17). The EFWS Heat Removal function supports this system safety function by removing heat from the pump room and maintaining room temperature within a temperature band for safety-related equipment. The functional logic is shown in Figure 7.3-58—SBVSE EFWS Pump Room Heat Removal.

#### **CCWS Pump Room Heat Removal**

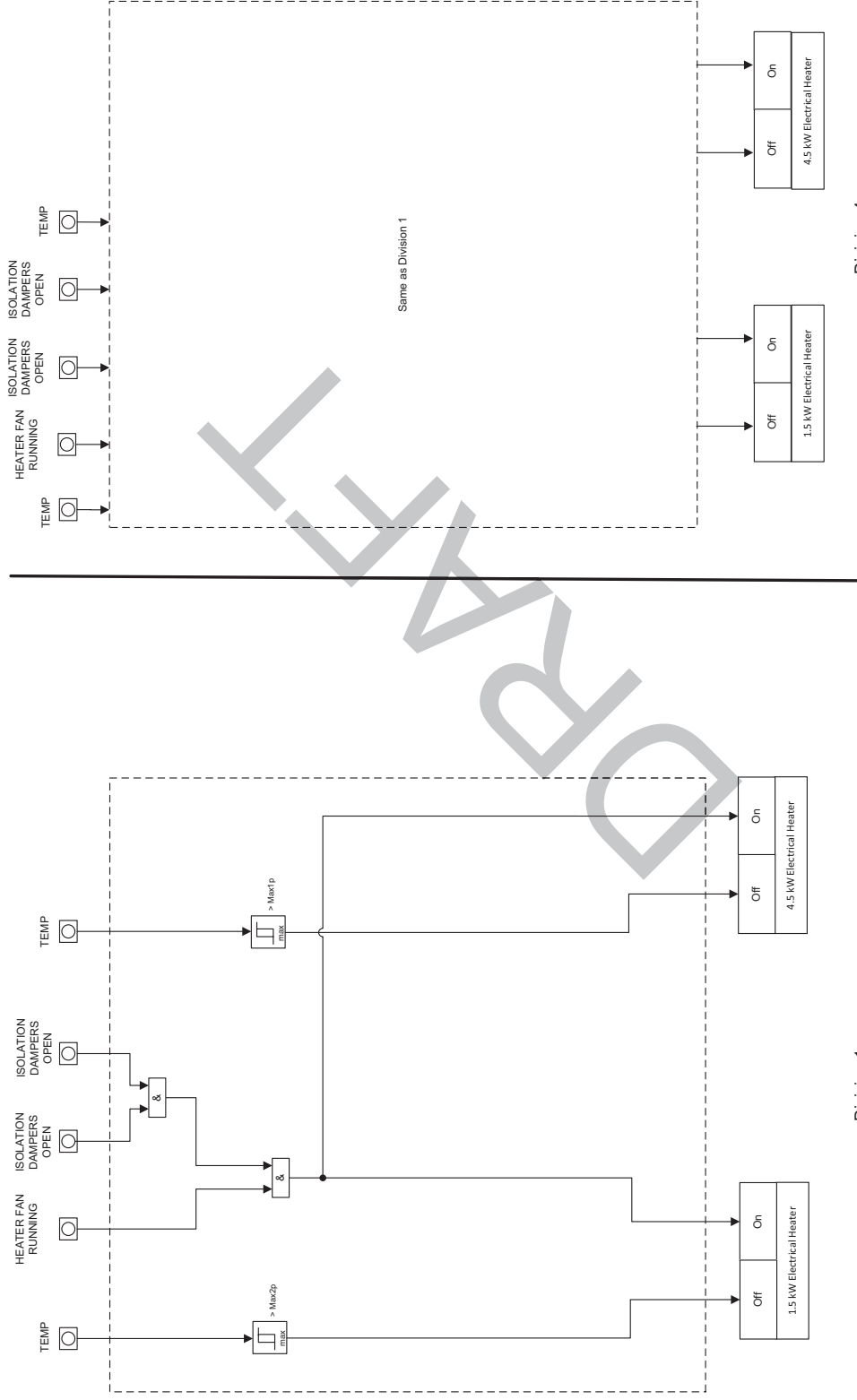
The SBVSE has a safety-related function to ventilate and maintain acceptable ambient temperature in the Safeguard Building areas and rooms ventilated by the system (GDC 4, GDC 17). The CCWS Pump Room Heat Removal function supports this system safety function by removing heat from the applicable rooms and maintaining room temperature within a temperature band for safety-related equipment. The functional logic is shown in Figure 7.3-59—SBVSE CCWS Pump Room Heat Removal.



All indicated changes are in response to RAI 505, 07.01-35

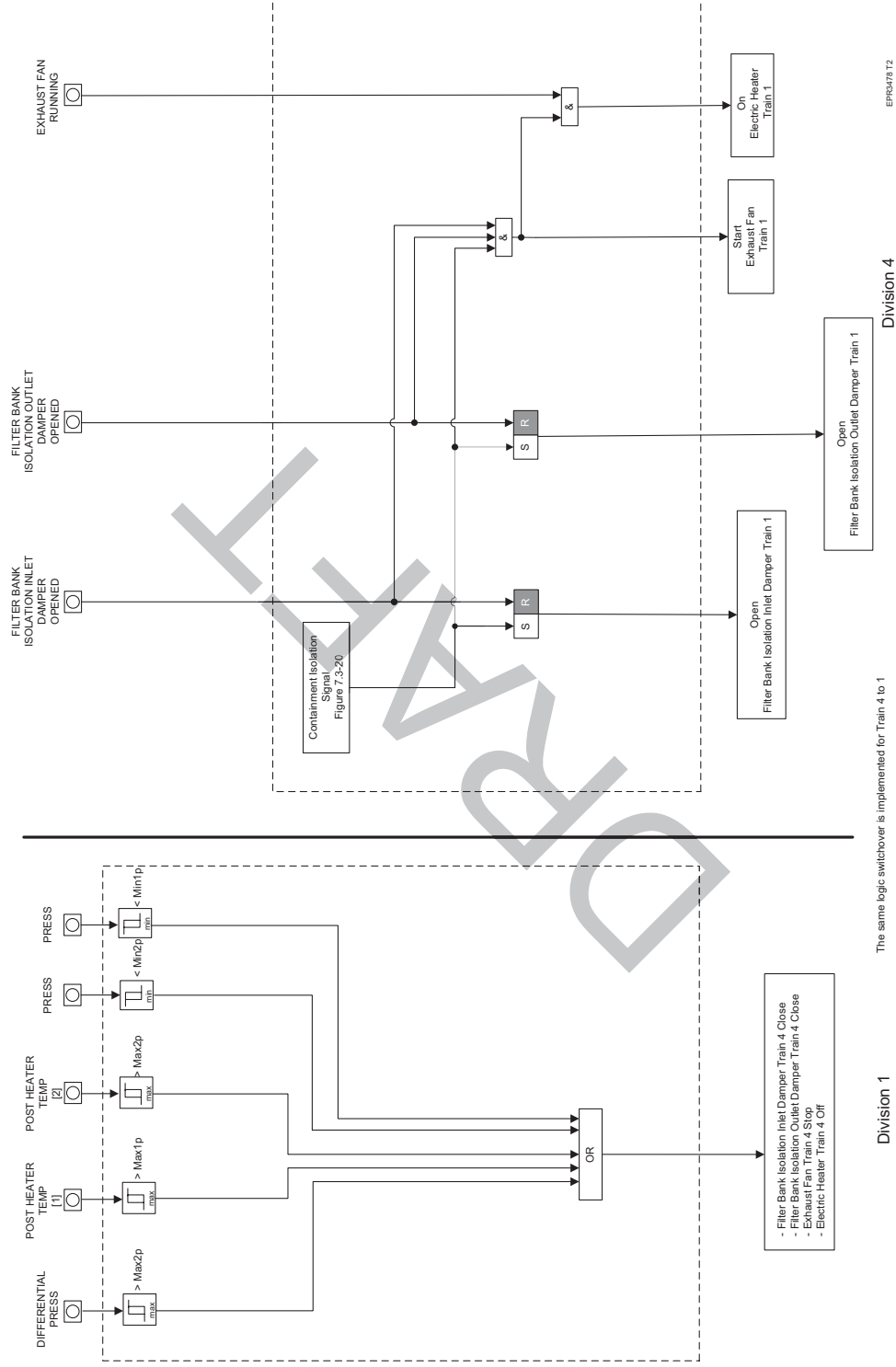


Figure 7.3-31—AVS Accident Filtration Train Heater Control



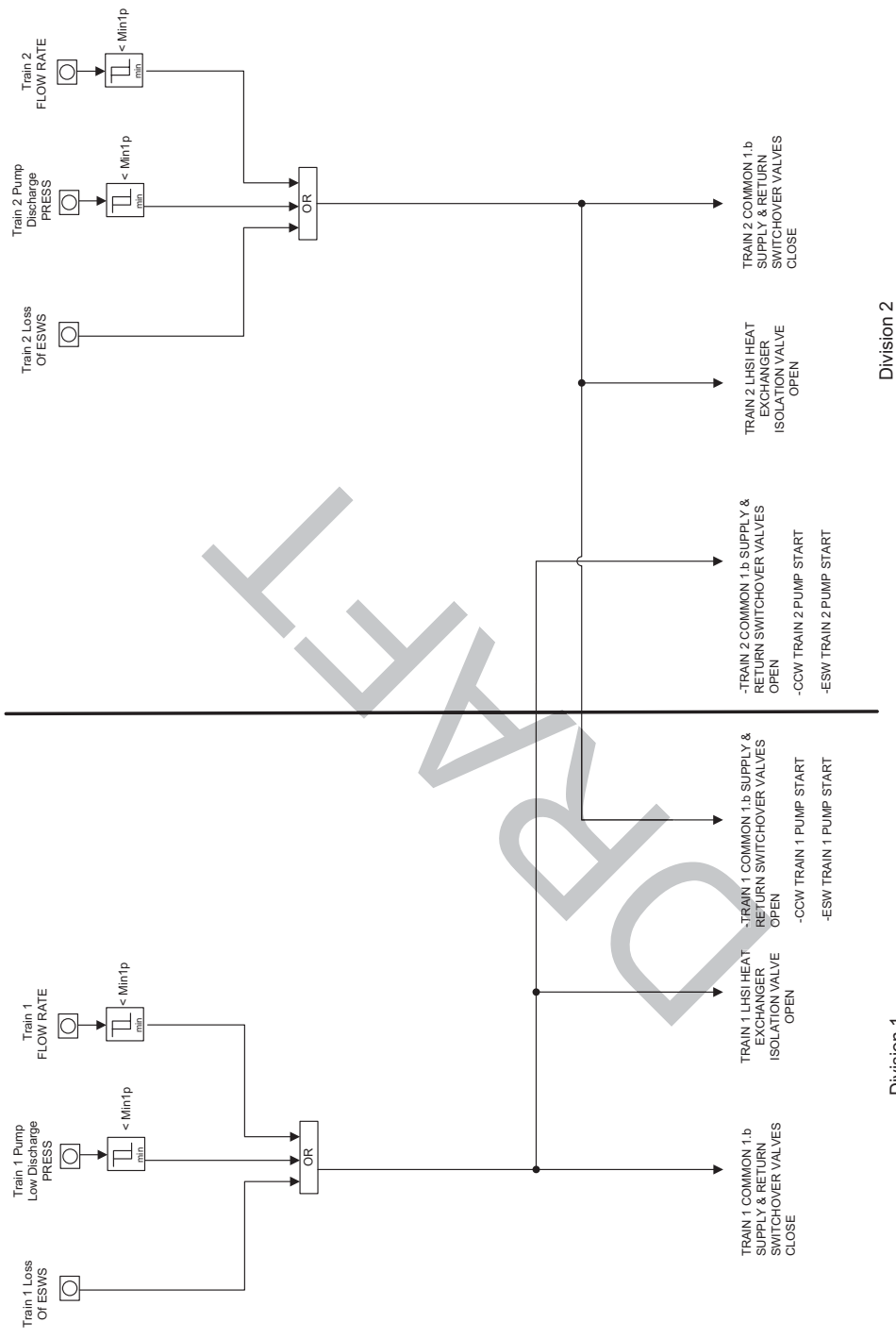
EPR3476 T2

Figure 7.3-32—AVS Accident Train Switchover



EPR0478 T2

**Figure 7.3-33—CCWS Common 1.b Automatic Backup Switchover of Train 1 to Train 2 and Train 2 to 1**



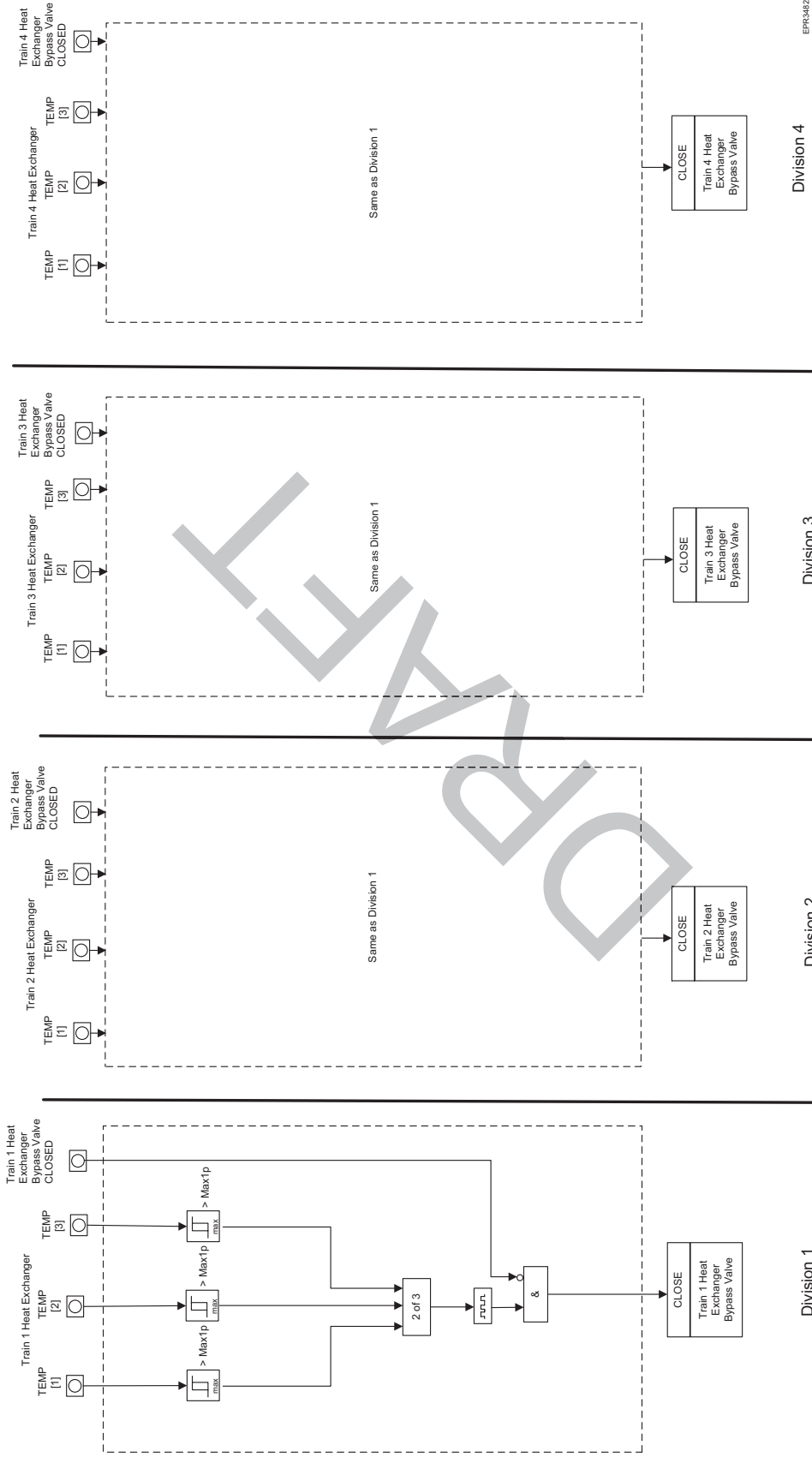
Logic shown for SAS Divisions 1 and 2. The same logic is implemented between Divisions 3 and 4 with respect to Common 2b.

EPR34872

All indicated changes are in response to RAI 505, 07.01-35



Figure 7.3-34—CCWS Emergency Temperature Control

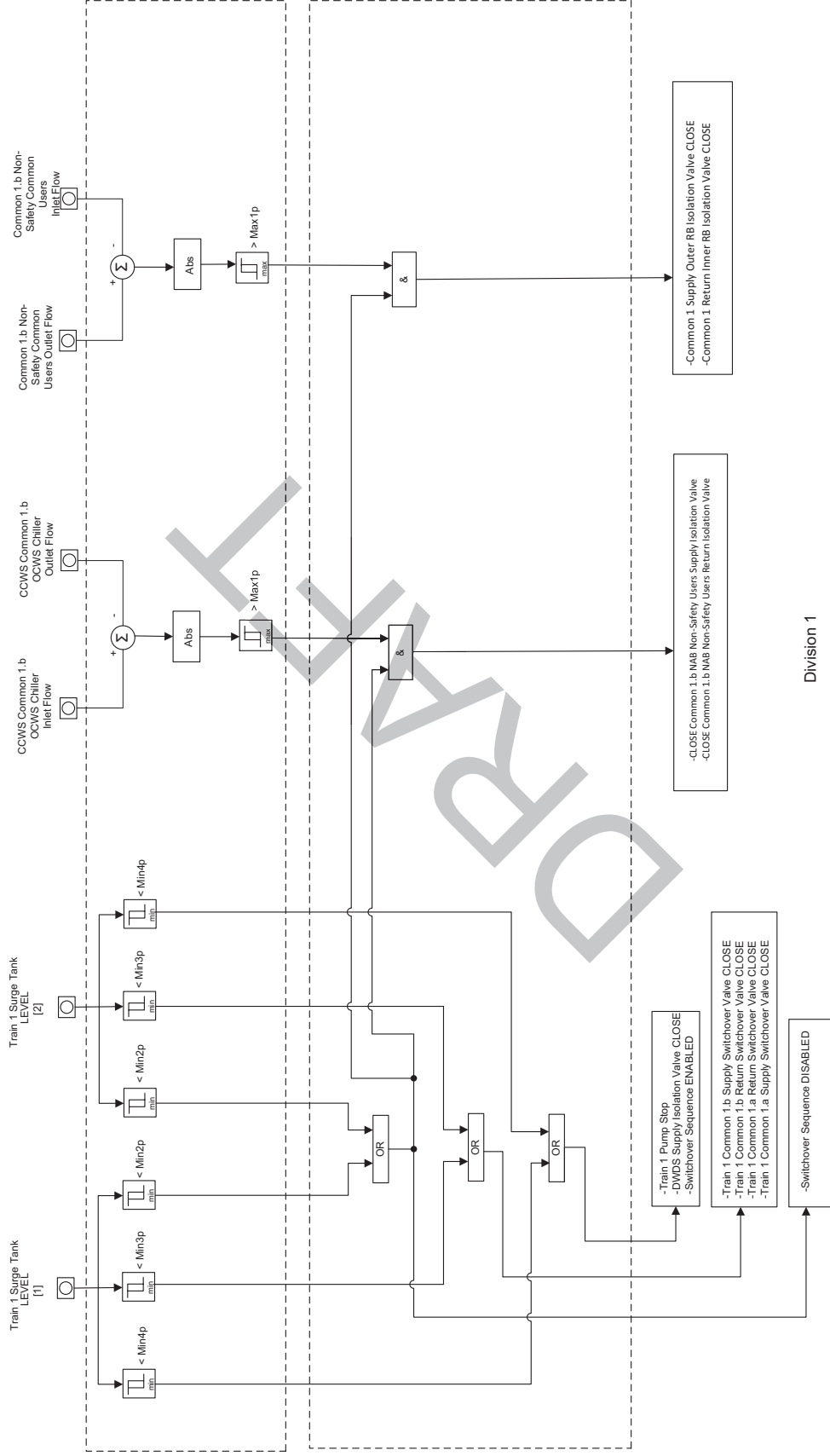


EPR48272

All indicated changes are in response to RAI 505, 07.01-35



Figure 7.3-35—CCWS Emergency Leak Detection

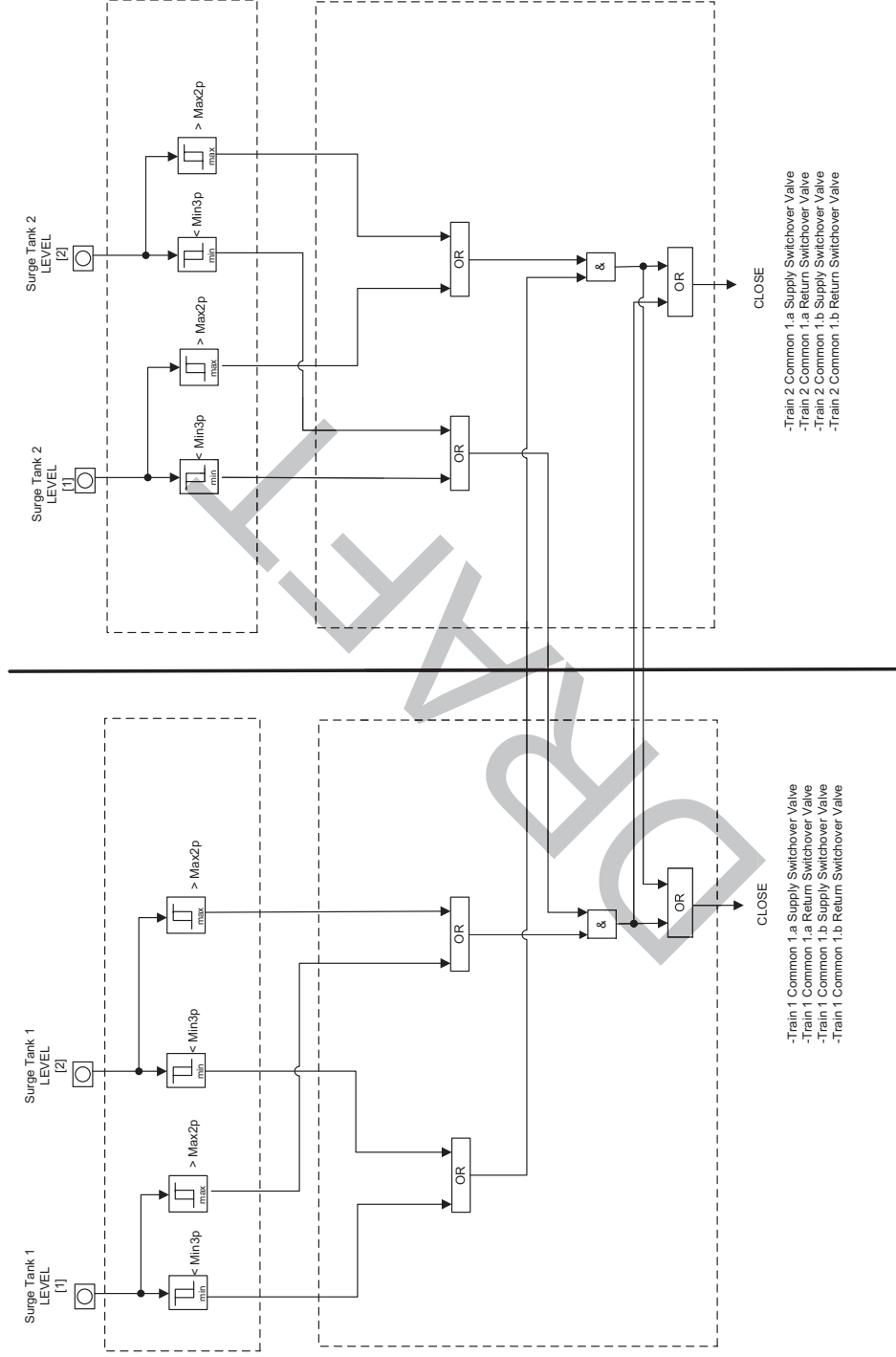


The same logic is implemented for Divisions 2,3,& 4

All indicated changes are in response to RAI 505, 07.01-35



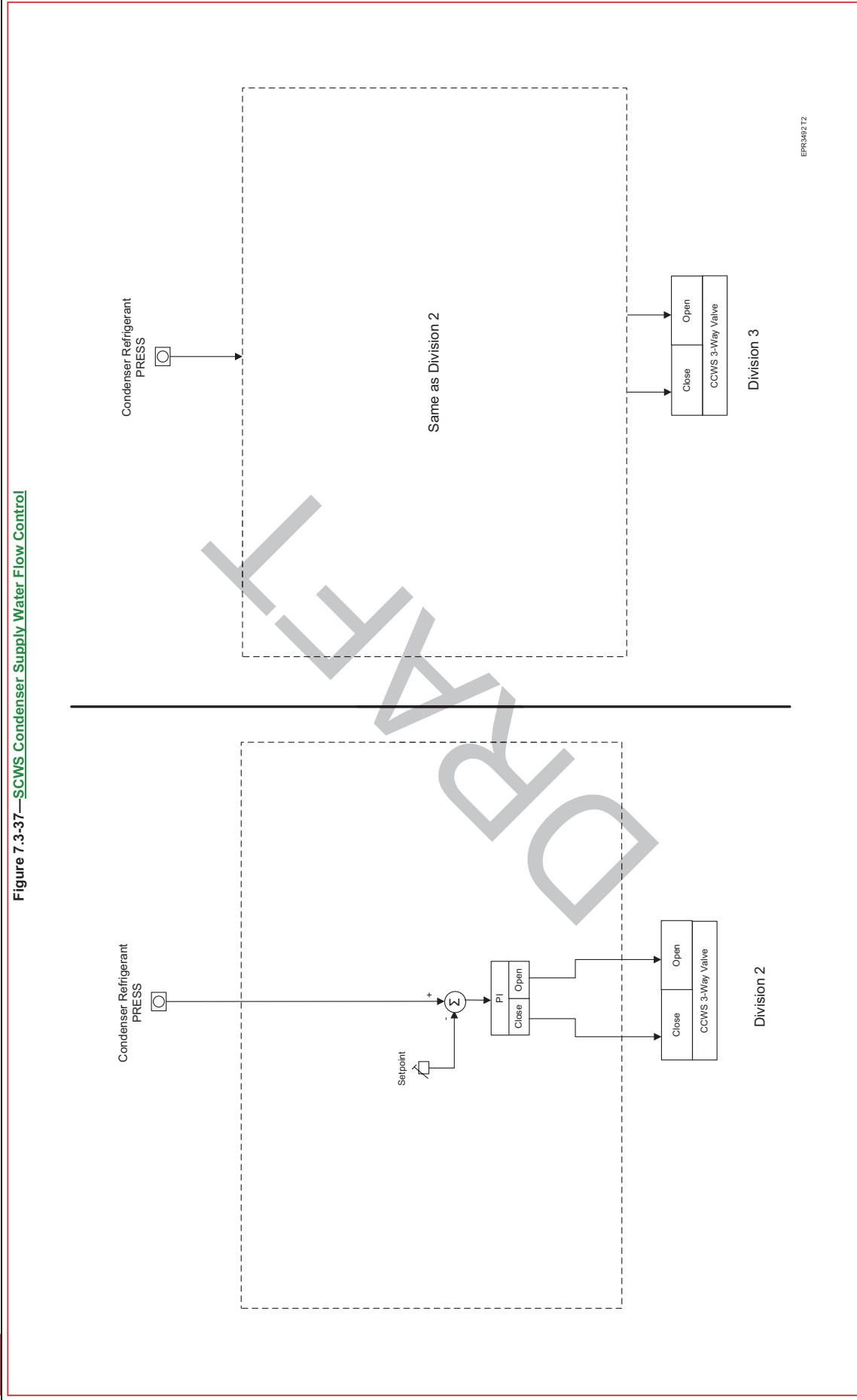
Figure 7.3-36—CCWS Emergency Leak Detection - Switchover Valves Leakage or Failure



Division 1      The same logic is implemented for SAS Division 3 & 4      Division 2

EPR0490 T2

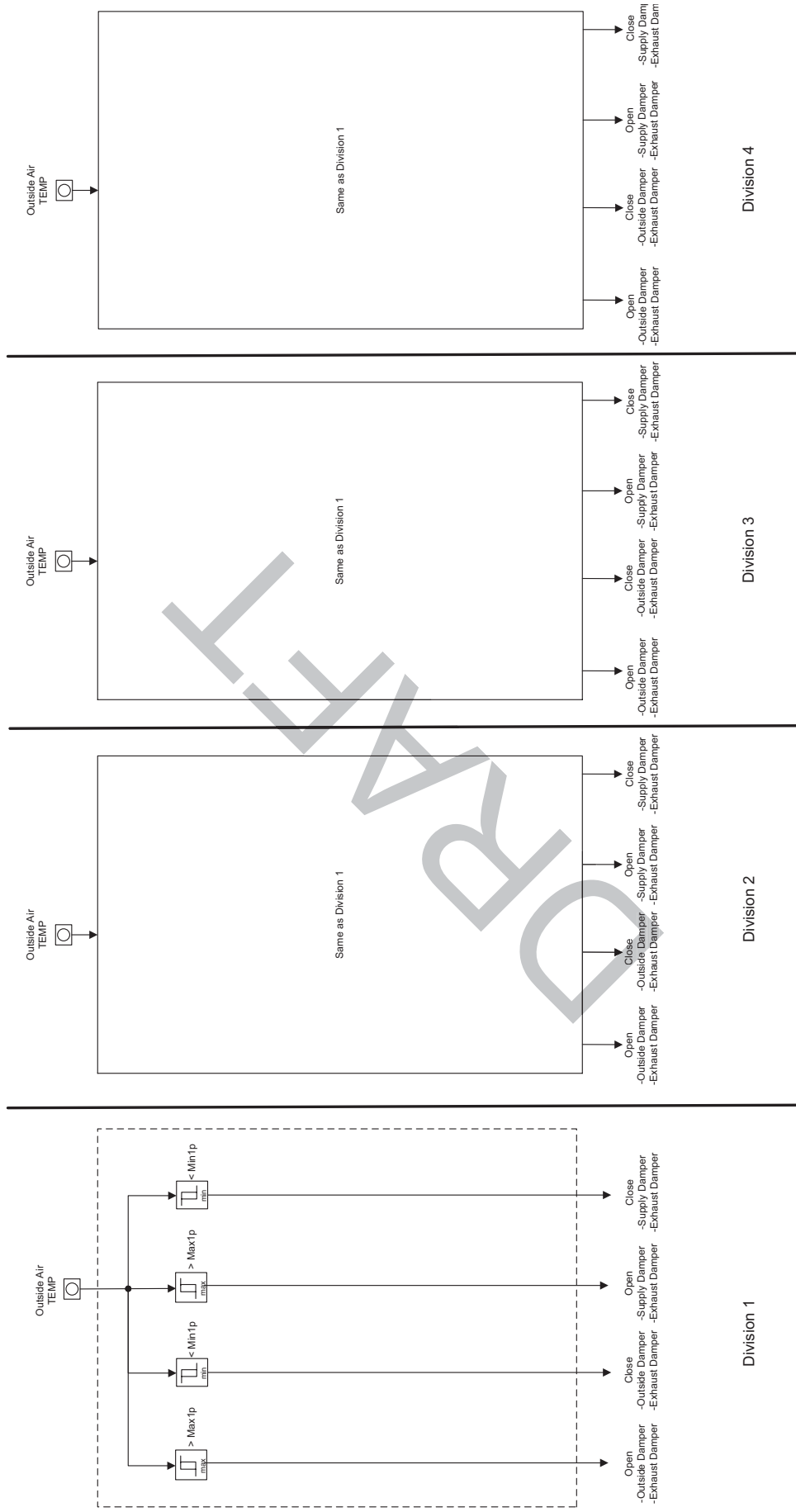
Figure 7.3-37—SCWS Condenser Supply Water Flow Control



All indicated changes are in response to RAI 505, 07.01-35



Figure 7.3-38—ESWPBVS ESWS Pump Rooms Temperature Control



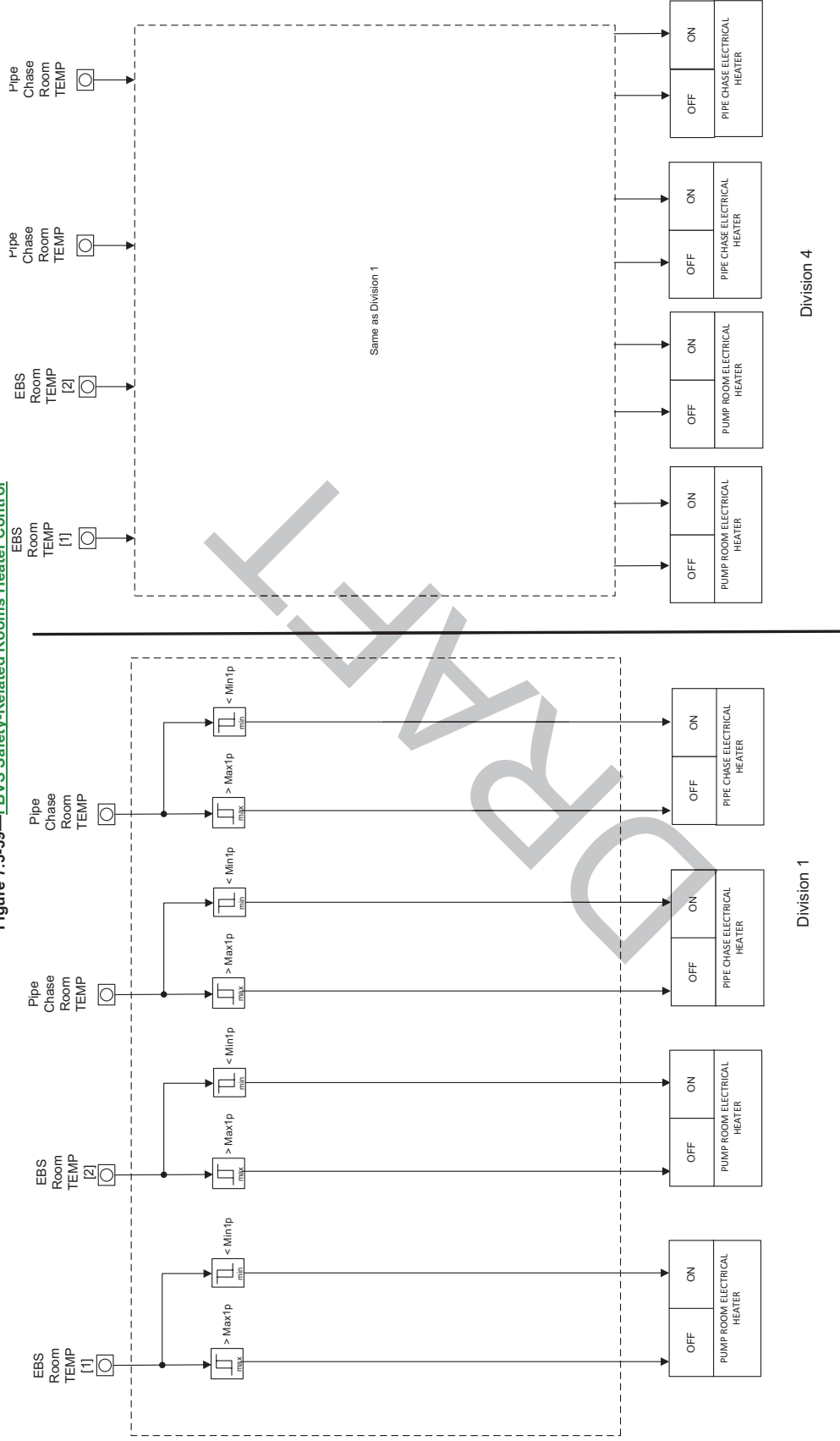
EPR04812



All indicated changes are in response to RAI 505, 07.01-35

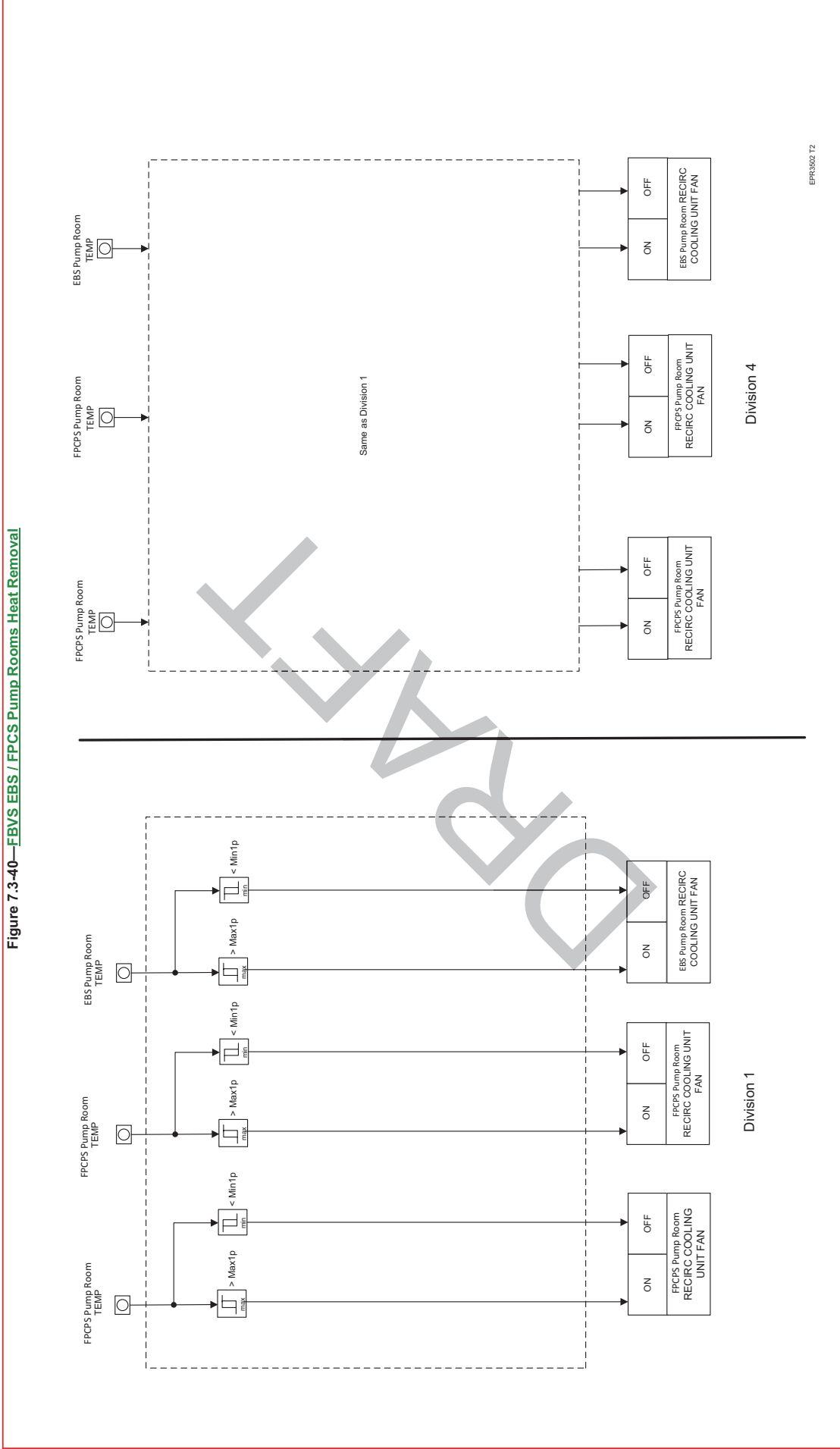


Figure 7.3-39—FBVS Safety-Related Rooms Heater Control



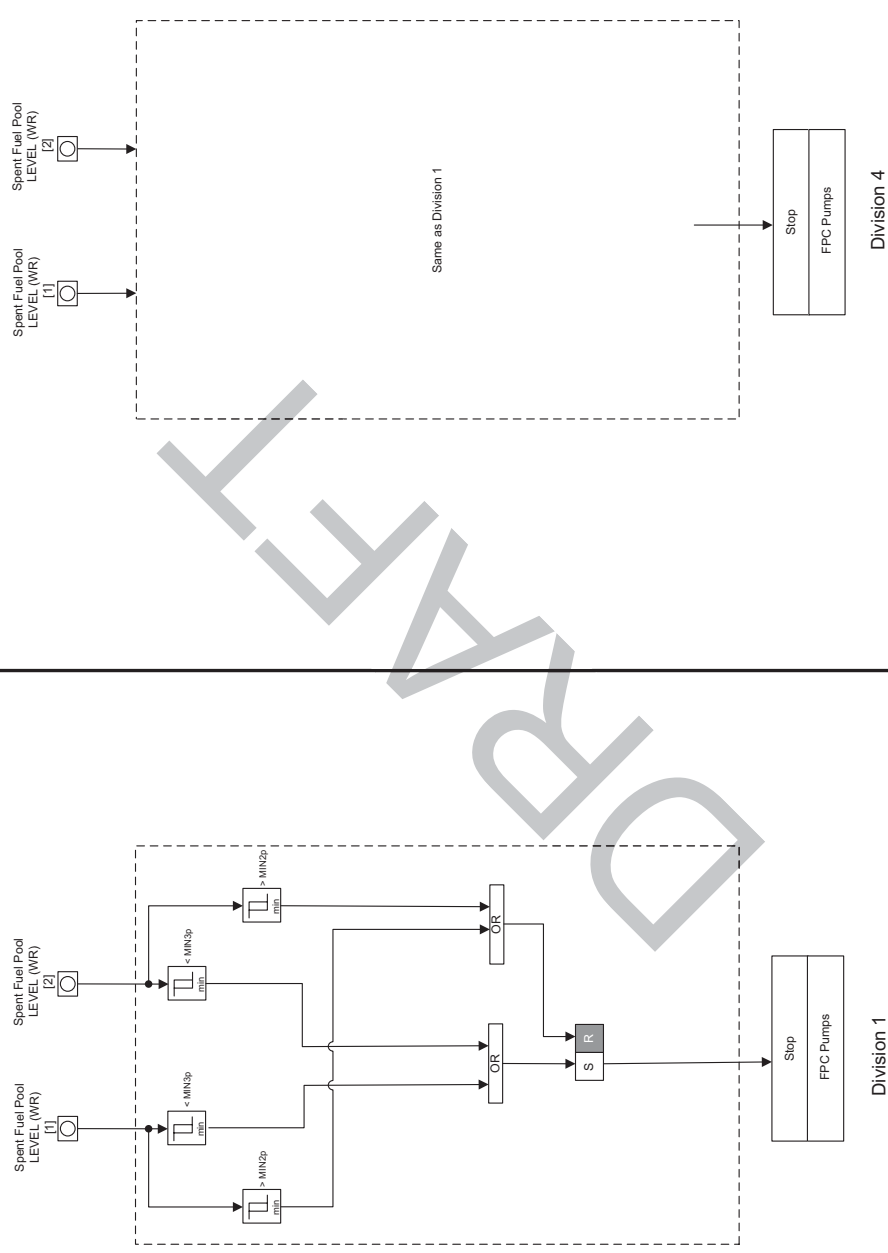
EPR3500 I2

Figure 7.3-40—FBVS EBS / FPCS Pump Rooms Heat Removal



All indicated changes are in response to RAI 505, 07.01-35

Figure 7.3-41—FPCPS Pump Trip on Low SFP Level

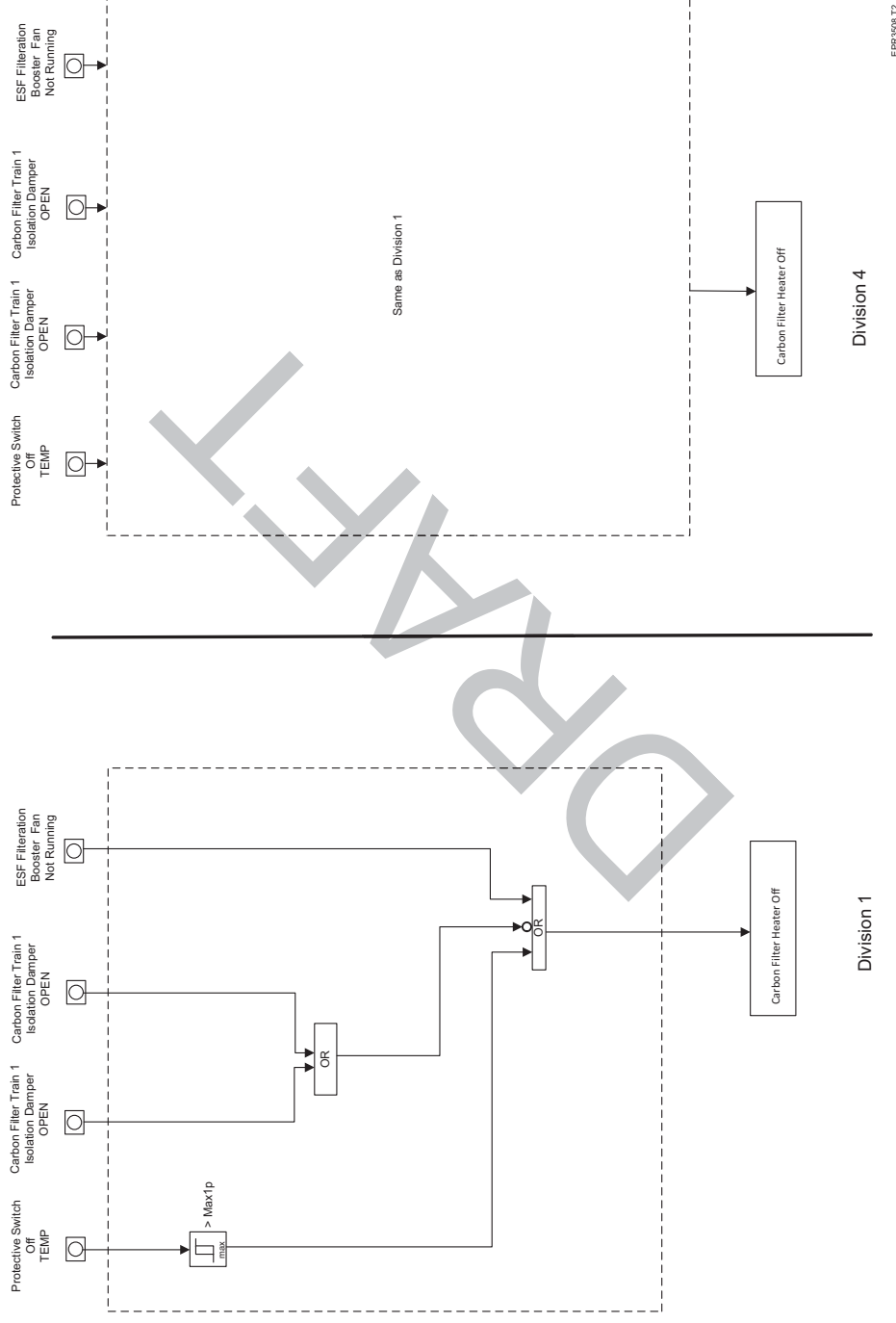


EPR3504 T2

All indicated changes are in response to RAI 505, 07.01-35

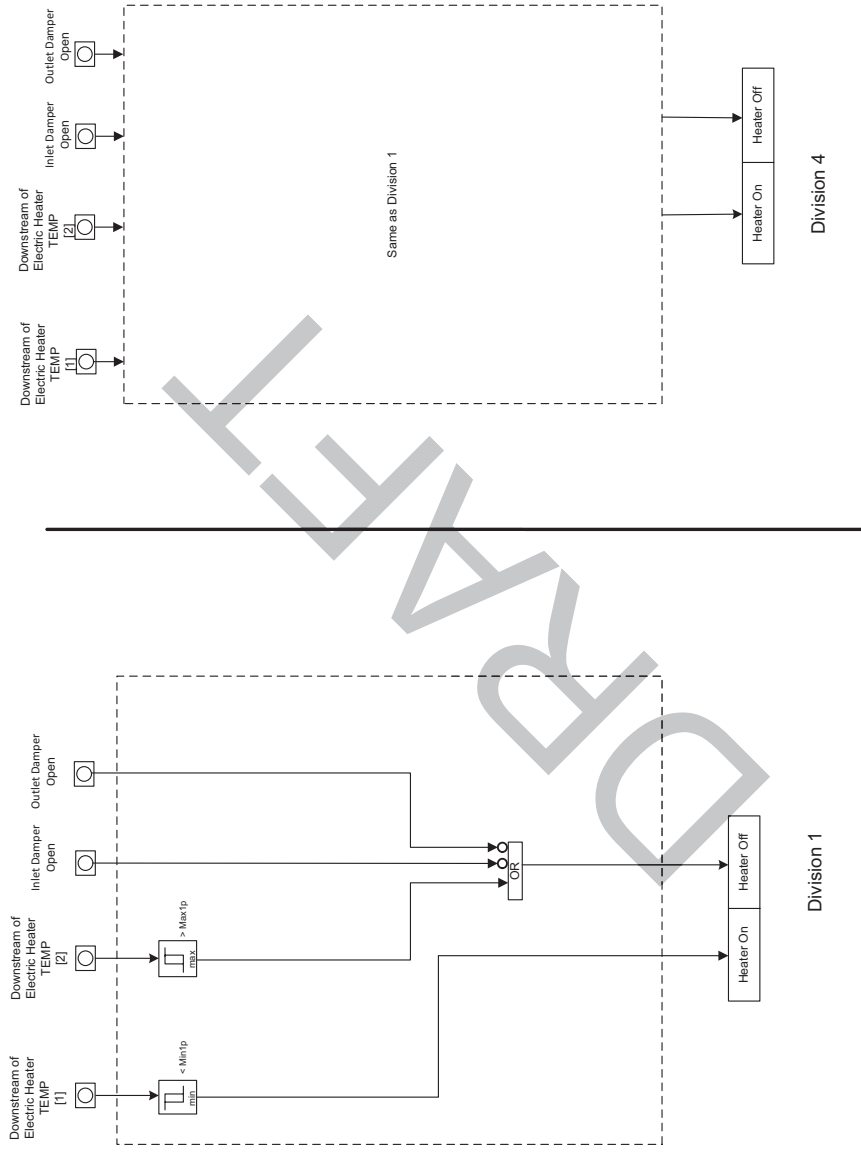


Figure 7.3-42—CRACS Iodine Filtration Train Heater Control



All indicated changes are in response to RAI 505, 07.01-35

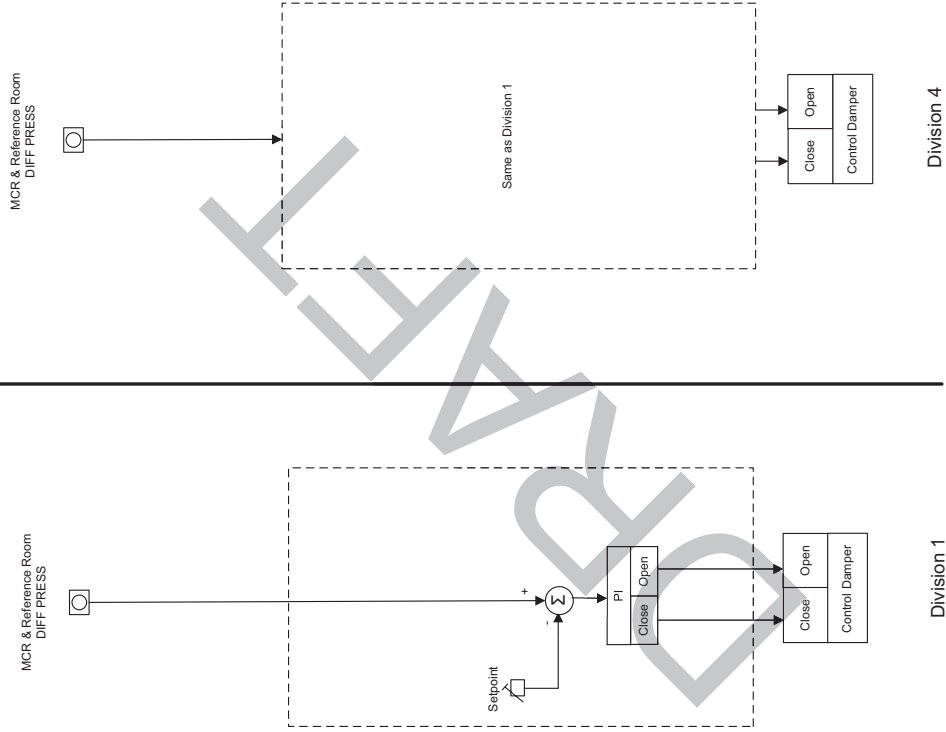
Figure 7.3-43—CRACS Heater Control for Outside Inlet Air



EPRS310 T2

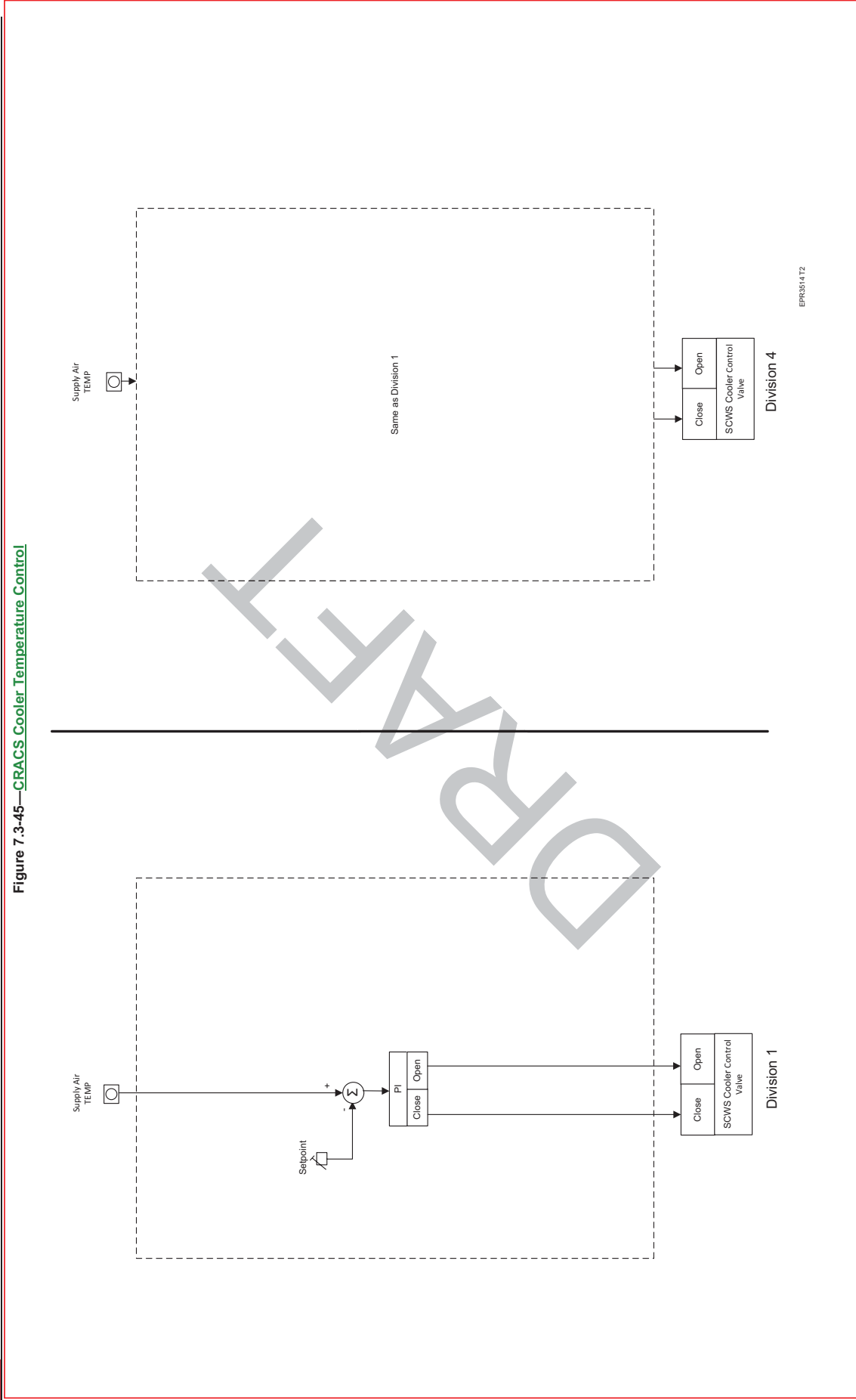
All indicated changes are in response to RAI 505, 07.01-35

Figure 7.3-44—CRACS Pressure Control



EPR3512 T2

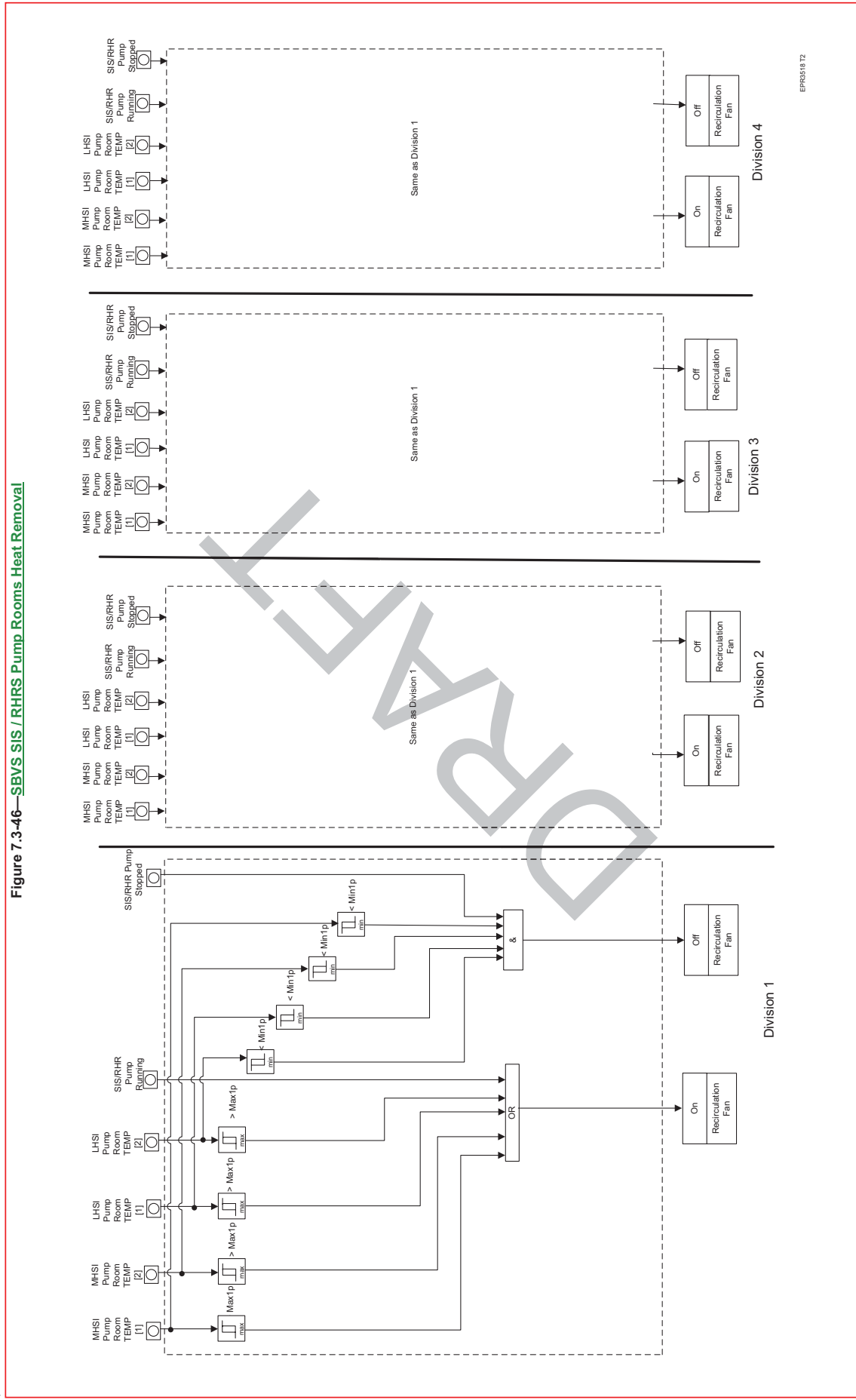
Figure 7.3-45—CRACS Cooler Temperature Control



All indicated changes are in response to RAI 505, 07.01-35



Figure 7.3-46—SBVS SIS / RHRs Pump Rooms Heat Removal

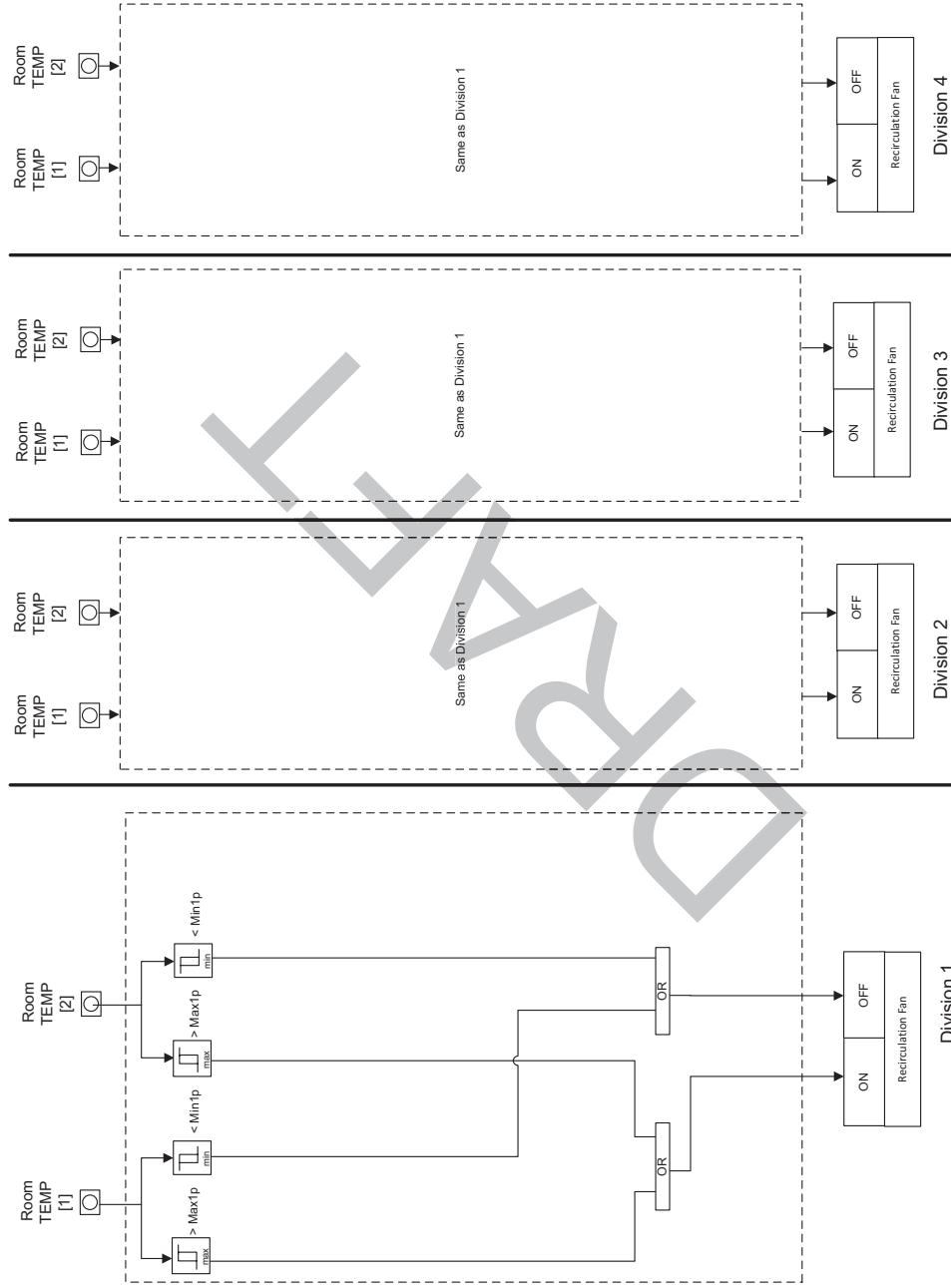




All indicated changes are in response to RAI 505, 07.01-35



Figure 7.3-47—SBVS CCWS / EFWS Valve Rooms Heat Removal

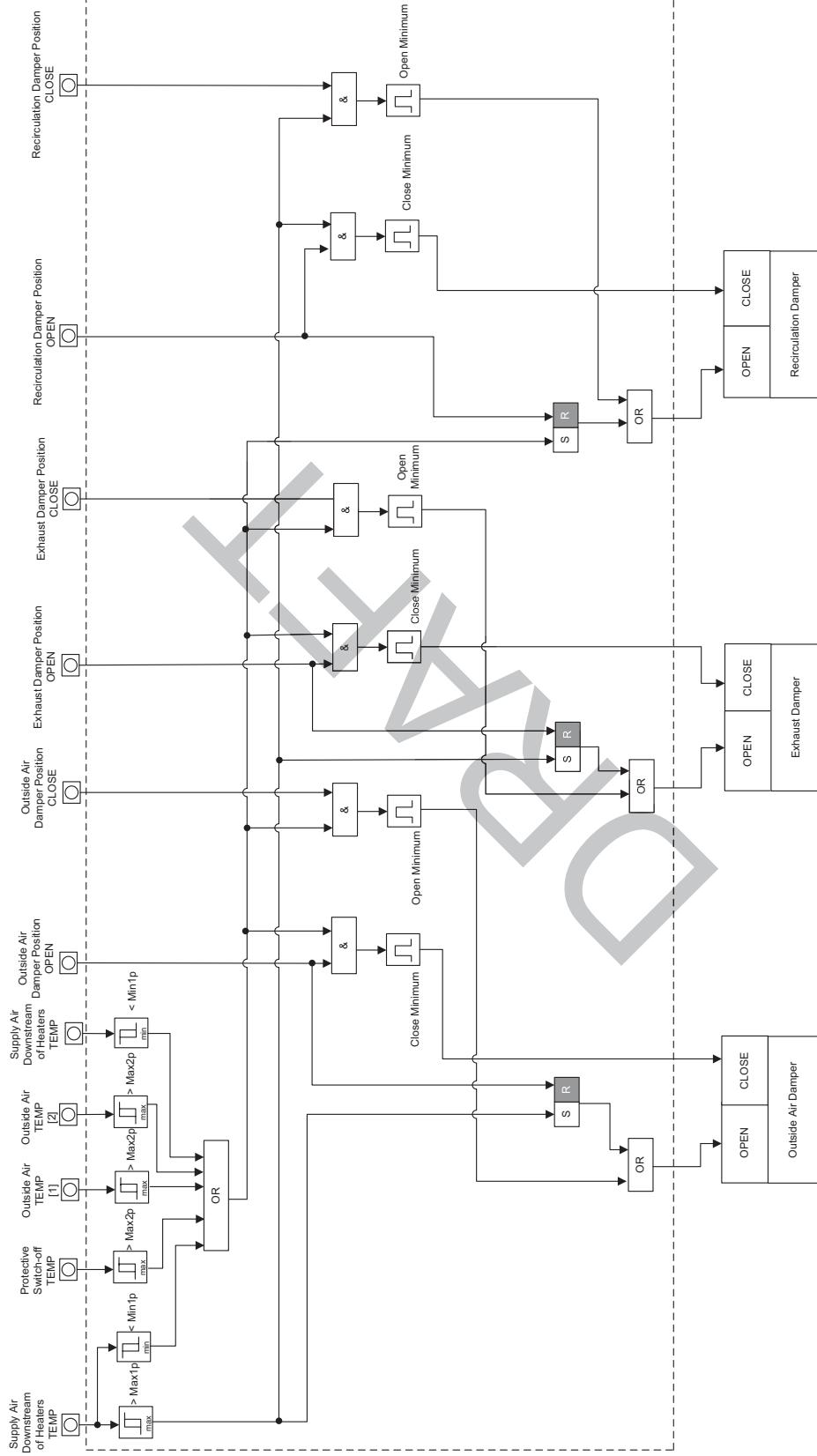


EPR350 T2

All indicated changes are in response to RAI 505, 07.01-35



Figure 7.3-48—SBYSE Supply and Recirculation-Exhaust Air Flow Control



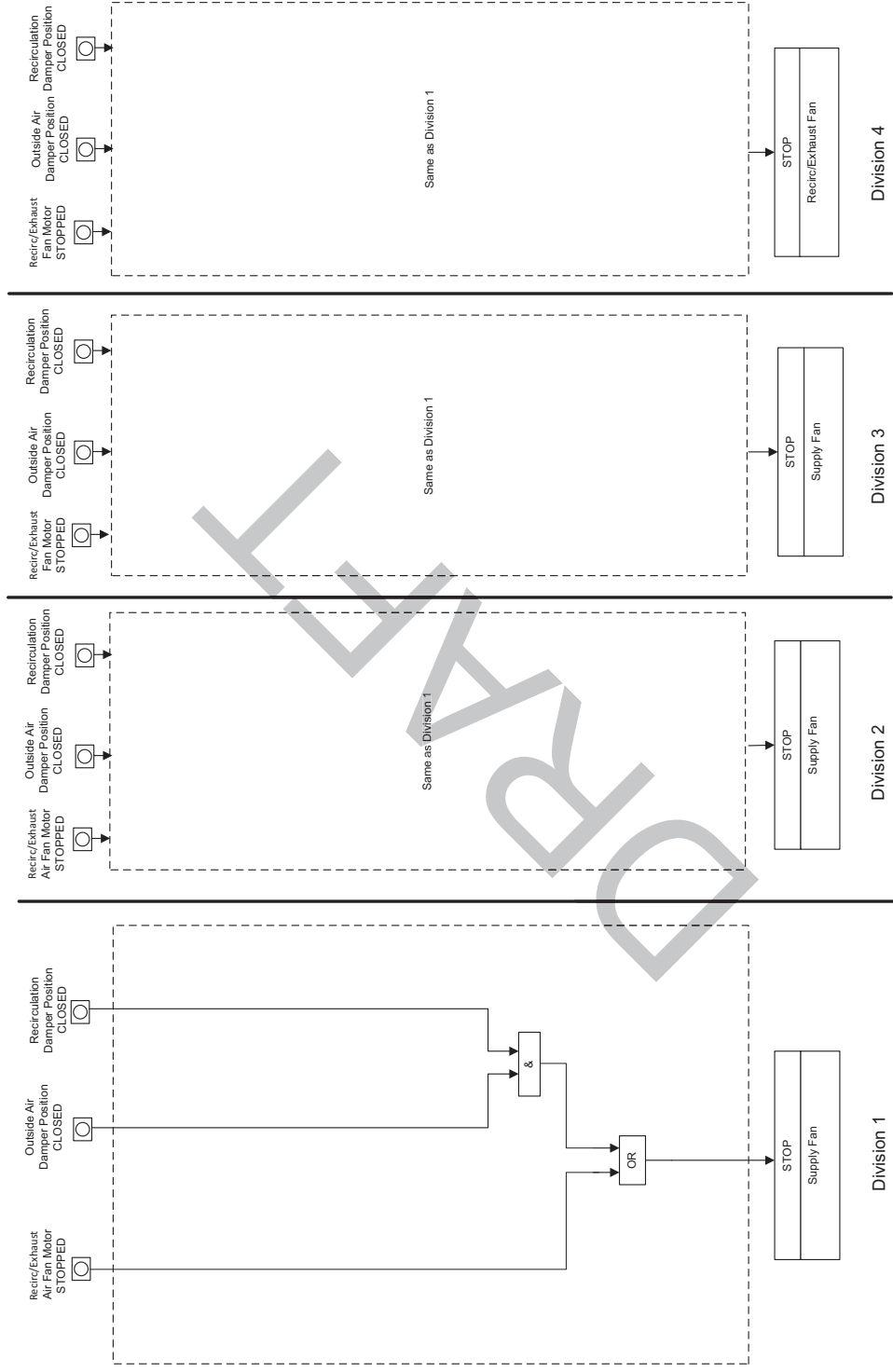
EPR352 T2

SAS Division 1  
The same logic is implemented for Divisions 2,3,& 4

All indicated changes are in response to RAI 505, 07.01-35



Figure 7.3-49—SBVSE Supply Fan Safe Shut-Off

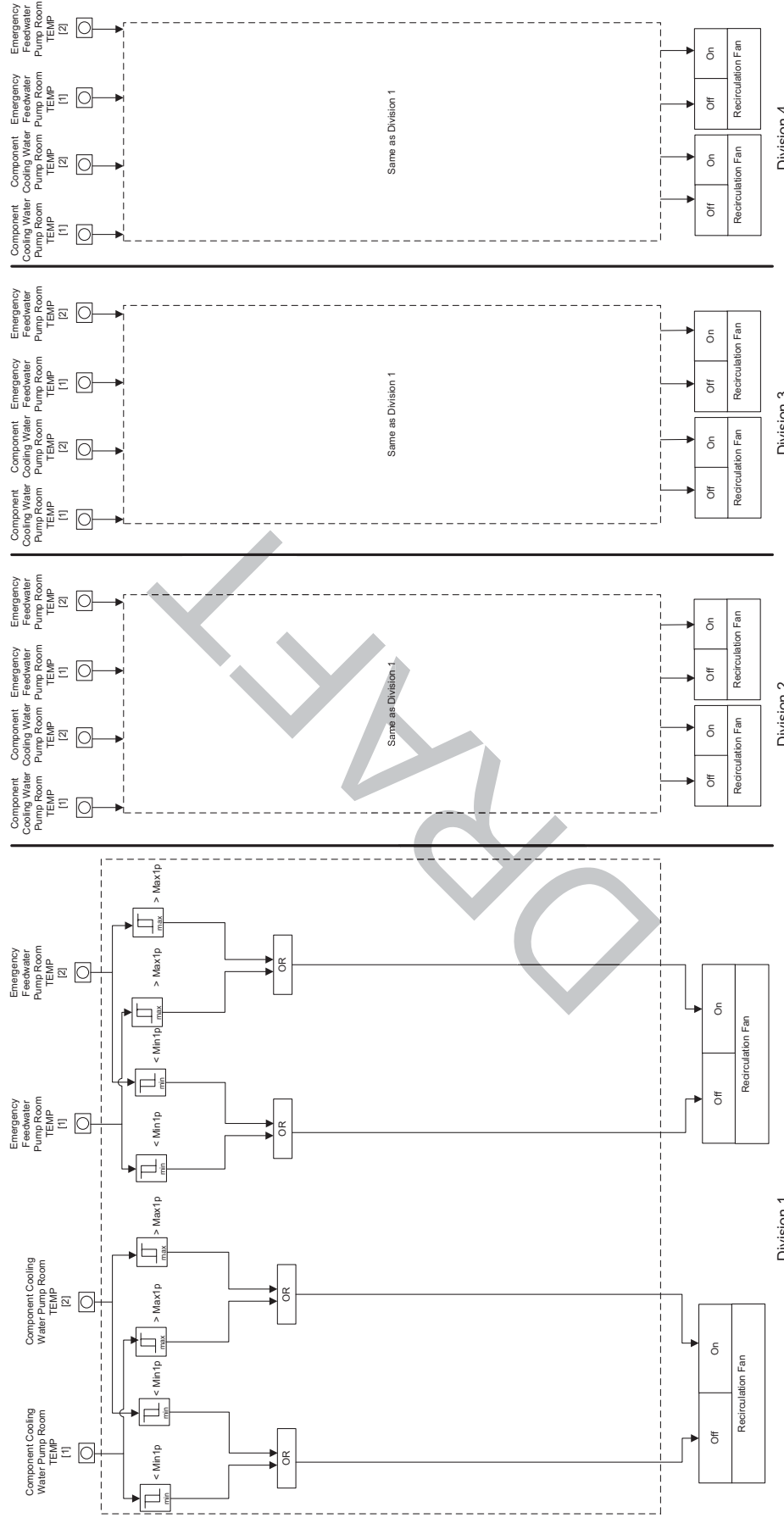


EPR1501 T2

All indicated changes are in response to RAI 505, 07.01-35



Figure 7.3-50—SBVSE Recirculation Fan Safe Shut-Off

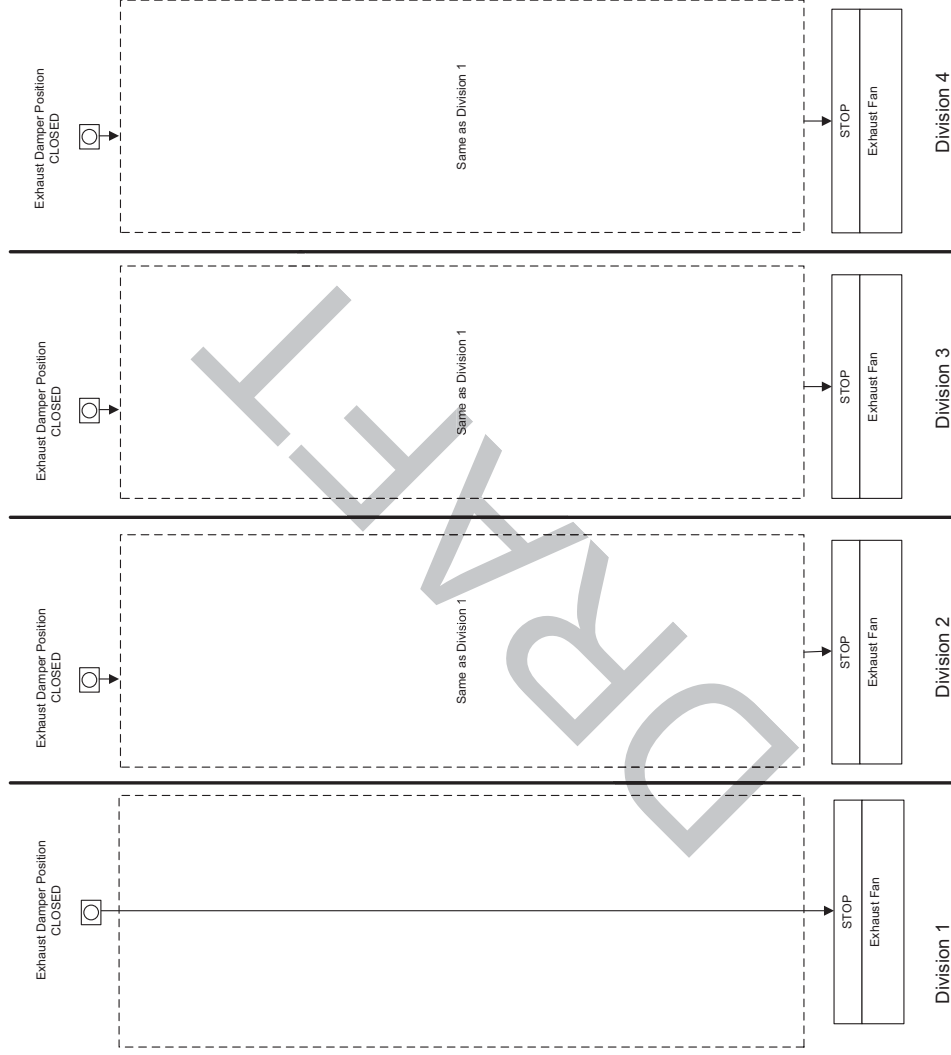


EPR3506 T2

All indicated changes are in response to RAI 505, 07.01-35



Figure 7.3-51—SBVSE Exhaust Fan Safe Shut-Off

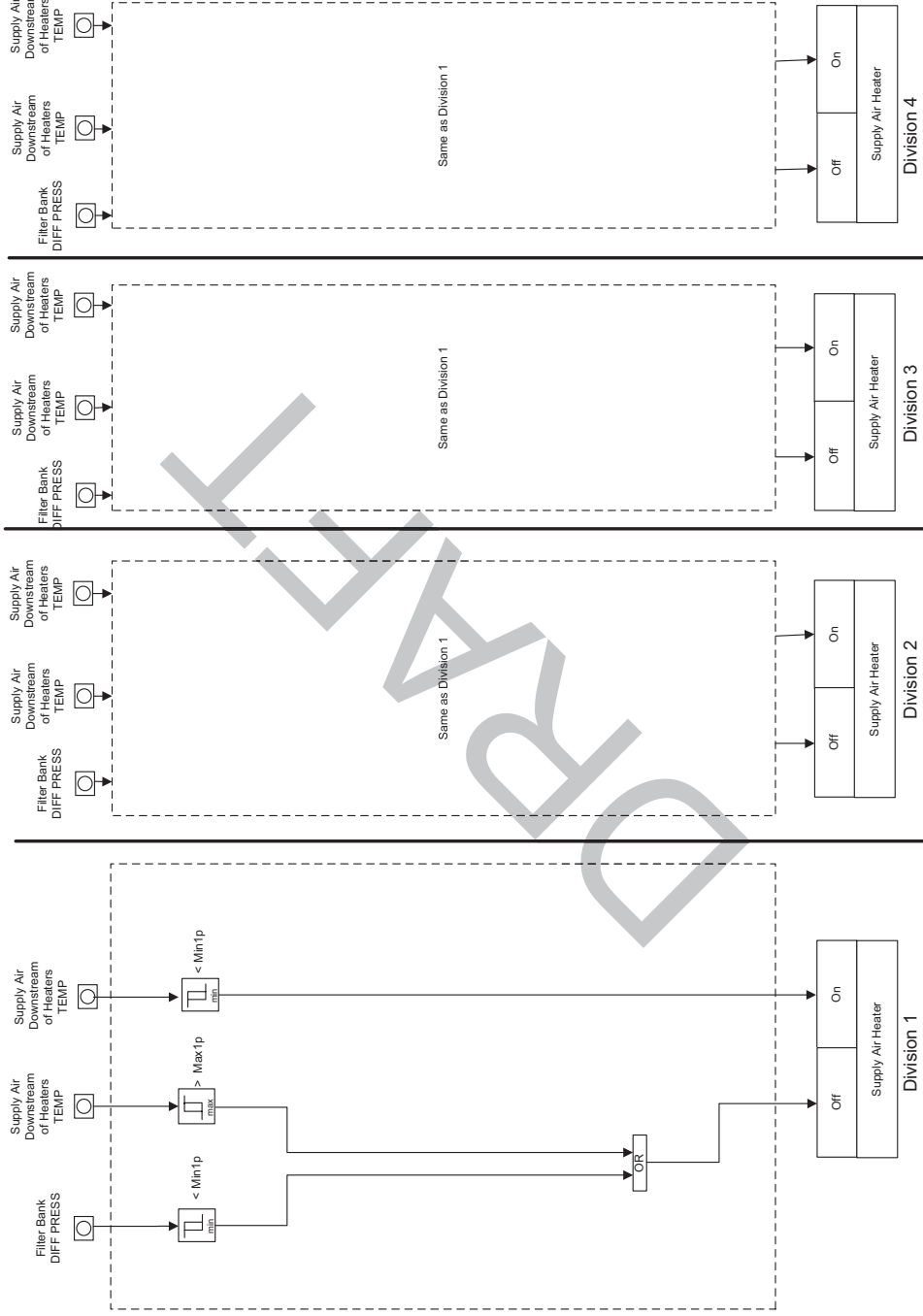


EPR052812

All indicated changes are in response to RAI 505, 07.01-35



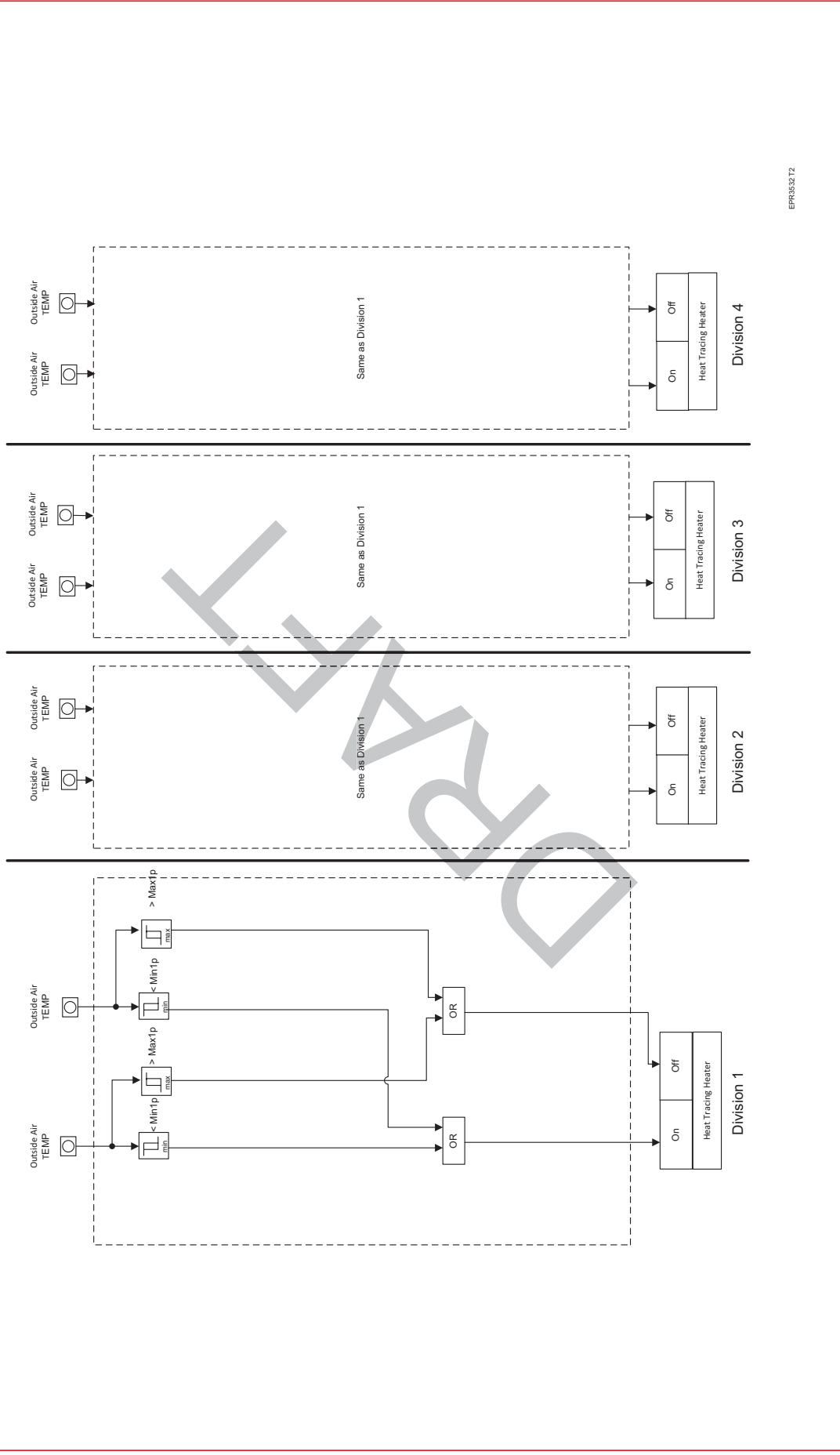
Figure 7.3-52—SBVSE Supply Air Temperature Heater Control



All indicated changes are in response to RAI 505, 07.01-35



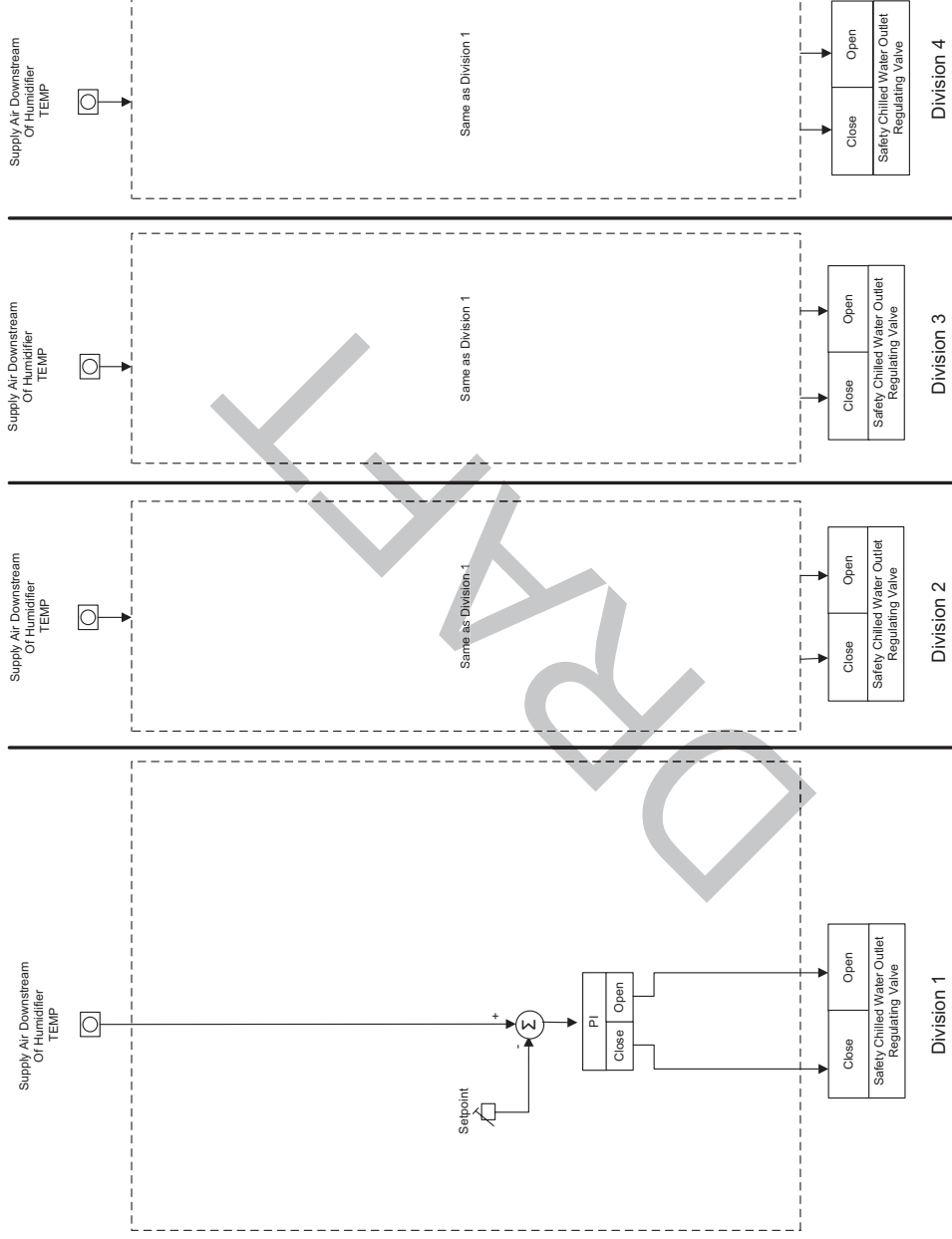
Figure 7.3-53—SBVSE Freeze Protection



All indicated changes are in response to RAI 505, 07.01-35



Figure 7.3-54—SBVSE Supply Air Temperature Control for Supply Air Cooling



EPR3534 T2

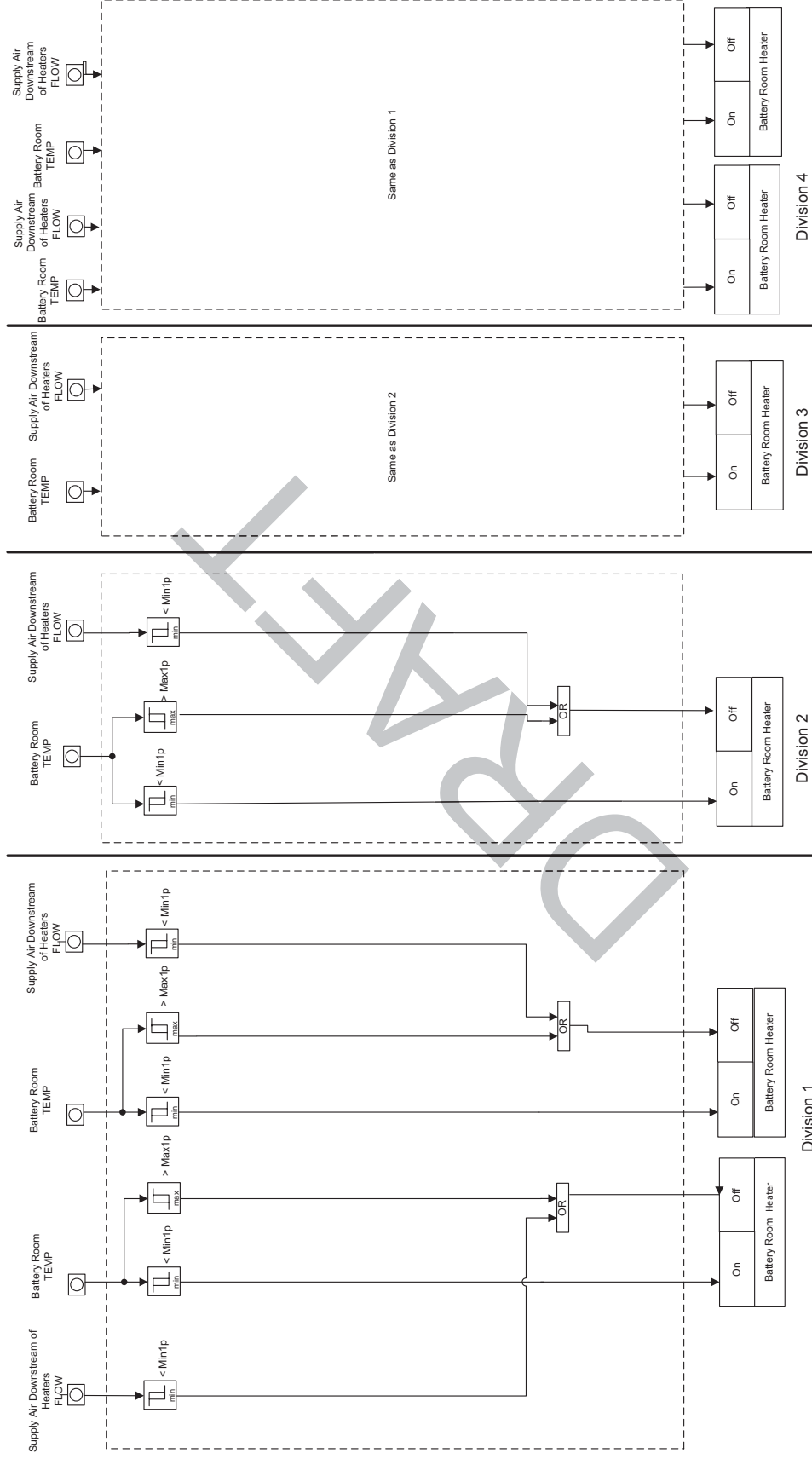
Figure 7.3-55—Deleted



All indicated changes are in response to RAI 505, 07.01-35



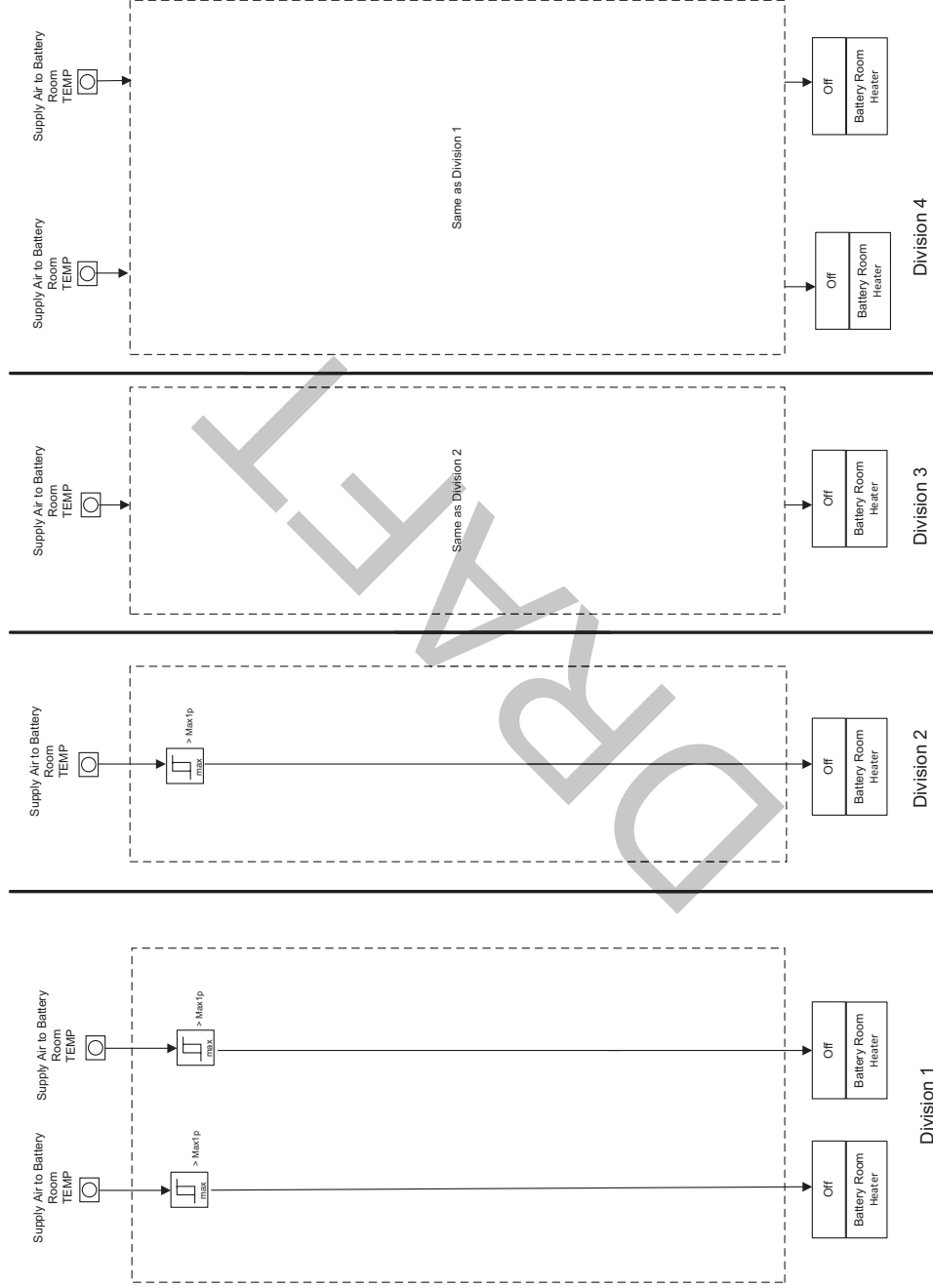
Figure 7.3-56—SBVSE Battery Room Heater Control



EPR3538 T2

All indicated changes are in response to RAI 505, 07.01-35

Figure 7.3-57—SBVSE Battery Room Supply Air Temperature Control

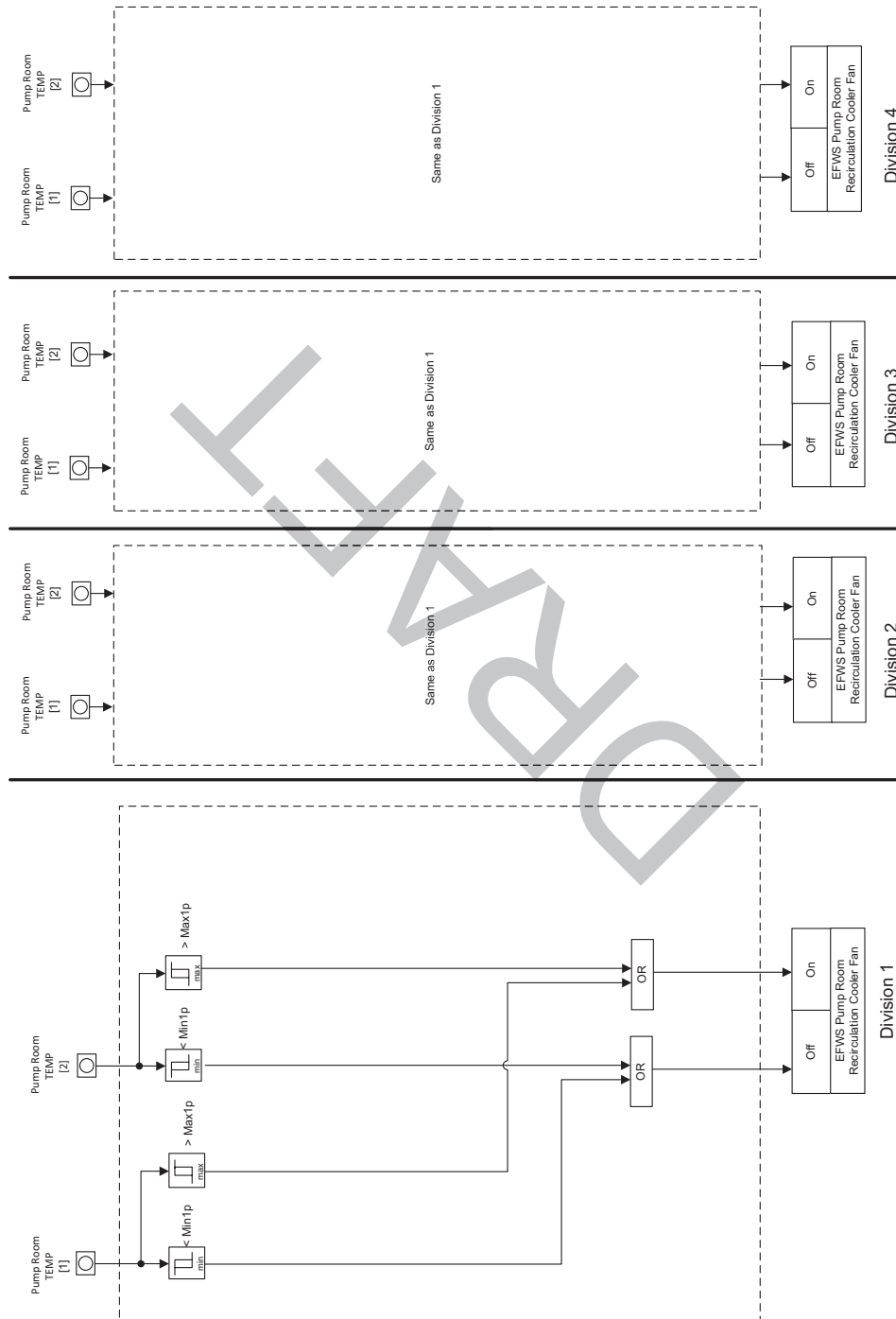


EPR3540 T2

All indicated changes are in response to RAI 505, 07.01-35



Figure 7.3-58—SBVSE EFWS Pump Room Heat Removal

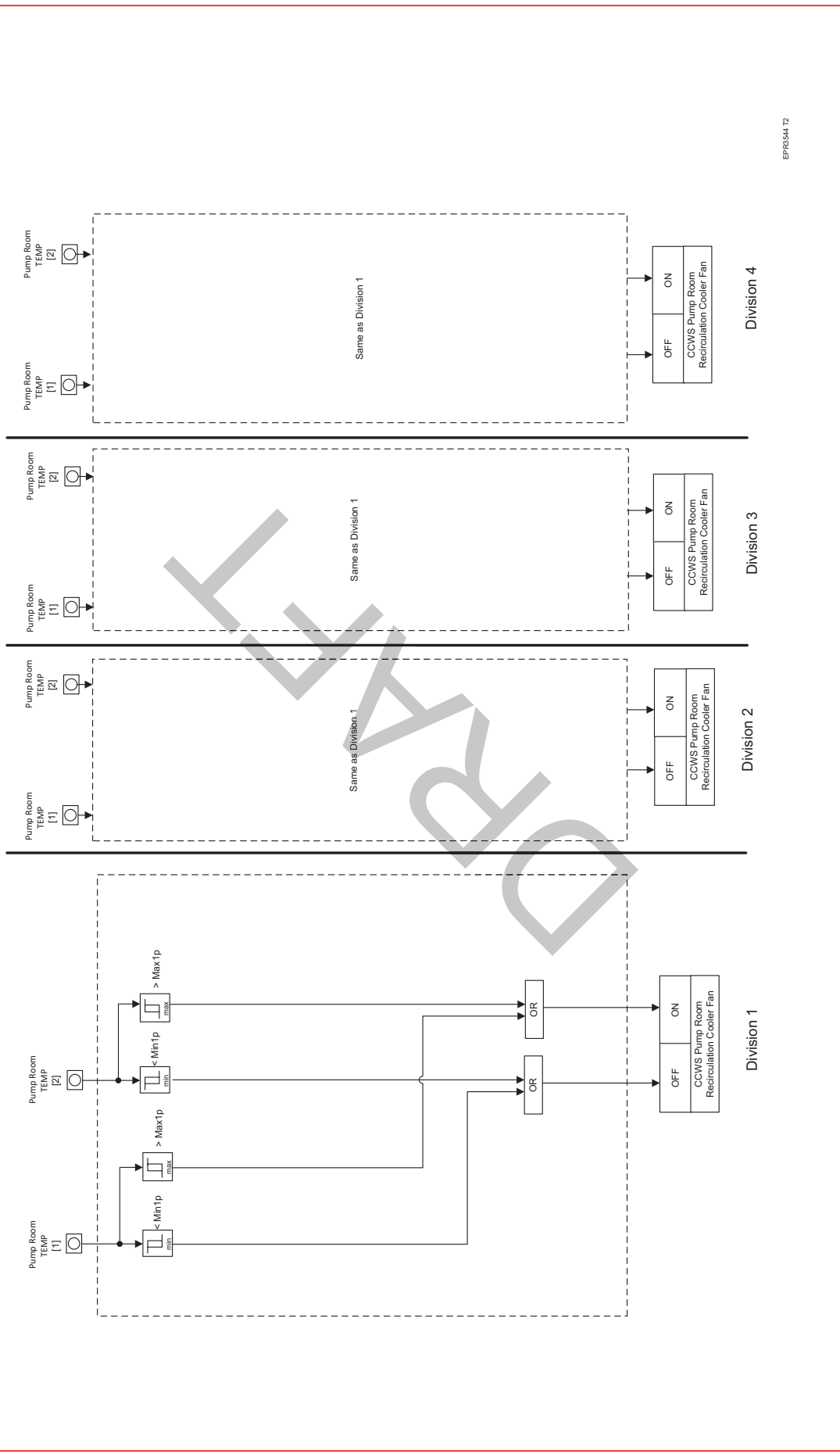


EPR34212

All indicated changes are in response to RAI 505, 07.01-35



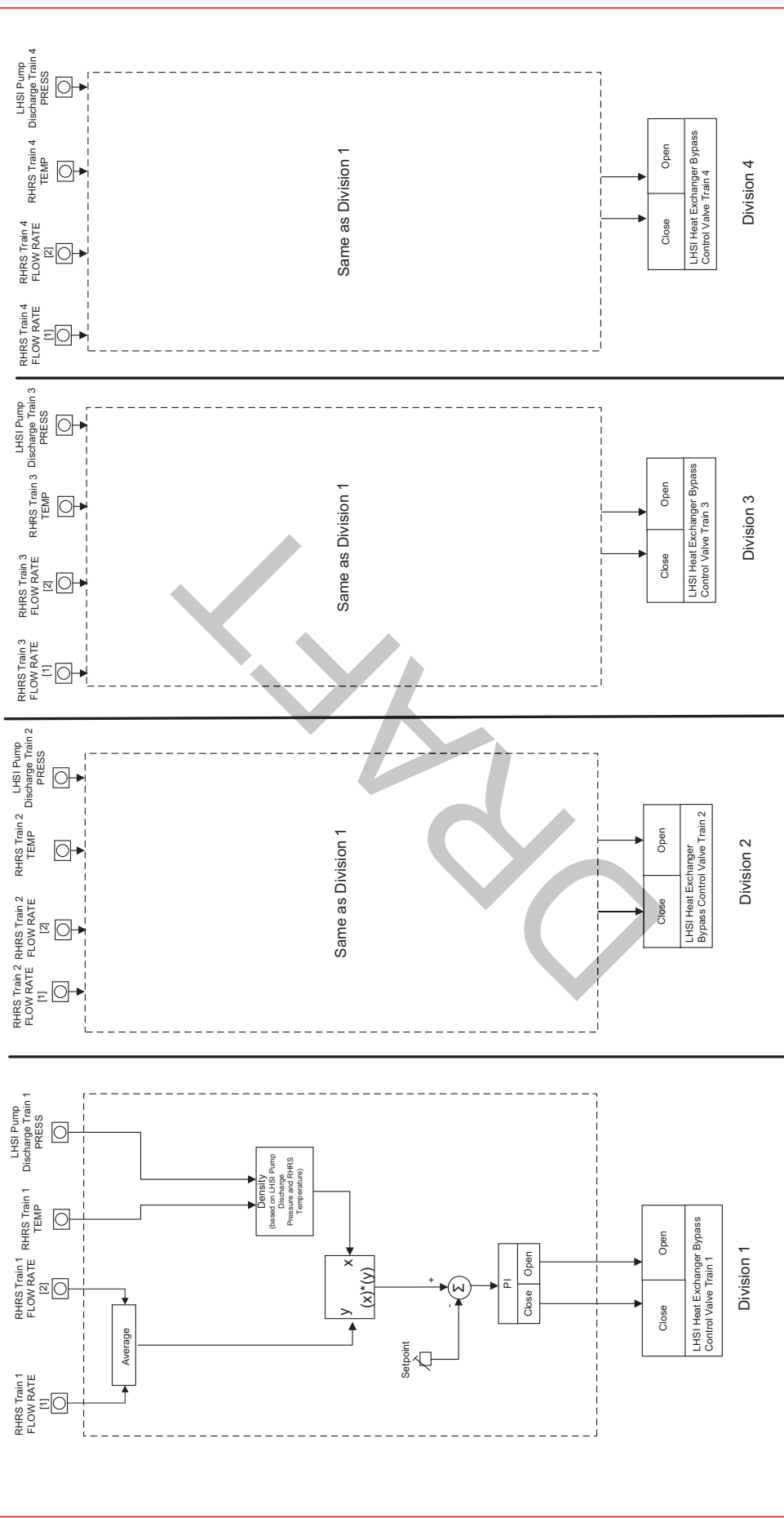
Figure 7.3-59—SBVSE CCWS Pump Room Heat Removal



All indicated changes are in response to RAI 505, 07.01-35



Figure 7.3-60—SIS / RHRS Automatic RHRS Flow Rate Control

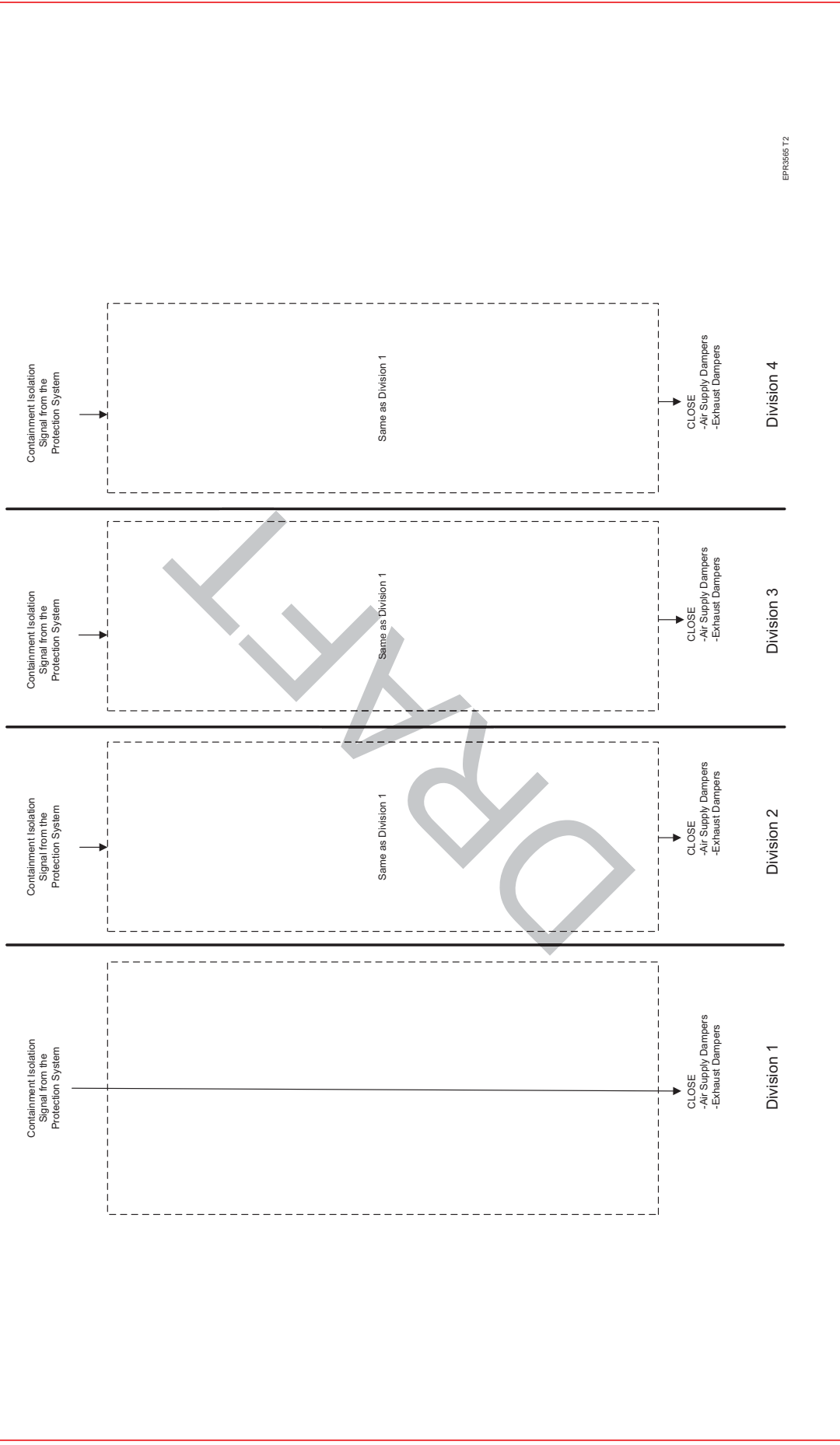


EPR3554 T2

Figure 7.3-61—Deleted

All indicated changes are in response to RAI 505, 07.01-35

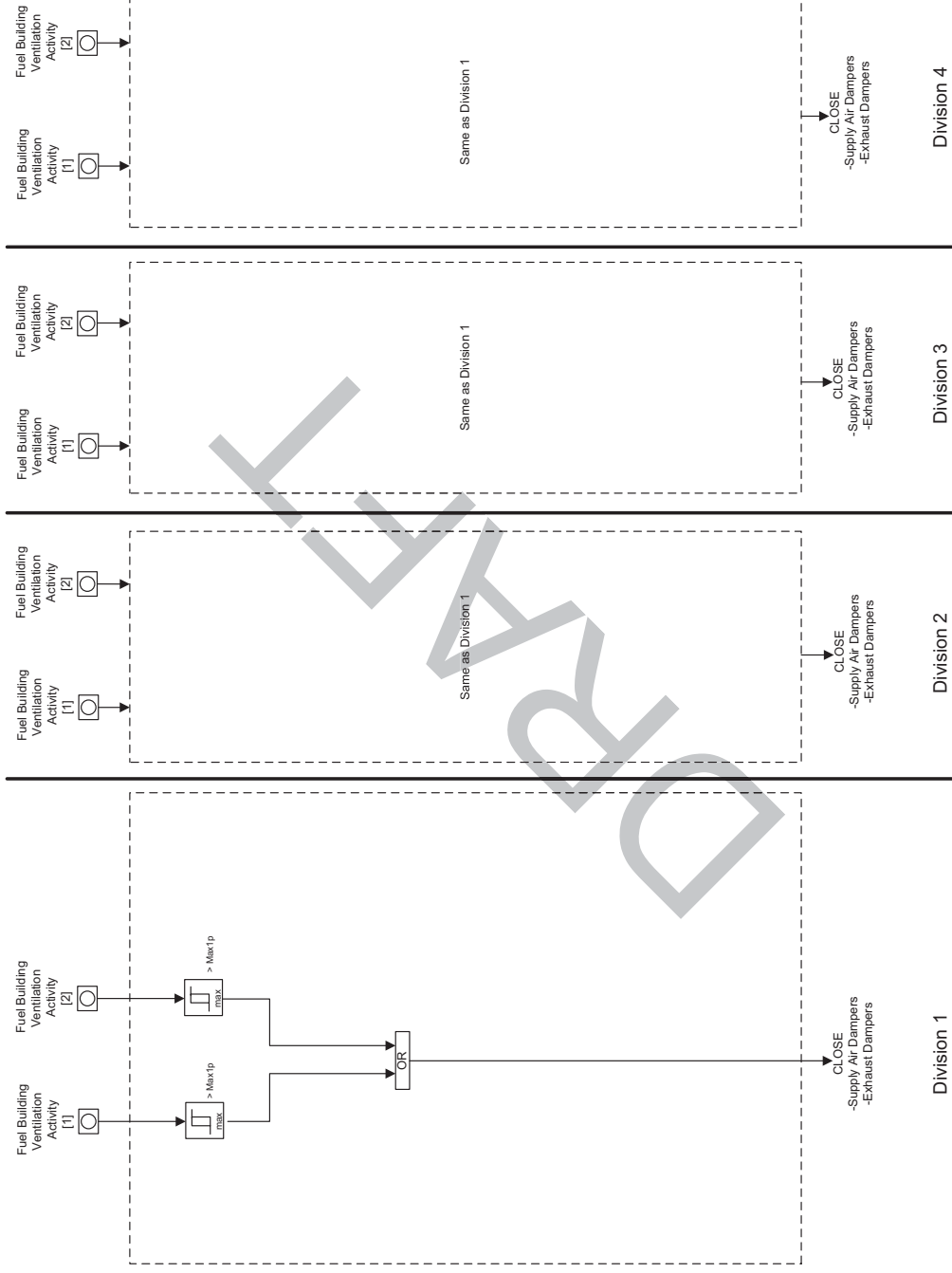
Figure 7.3-62—Isolation of FBYS on Containment Isolation



All indicated changes are in response to RAI 505, 07.01-35



Figure 7.3-63—Fuel Pool Area Fuel Handling Accident

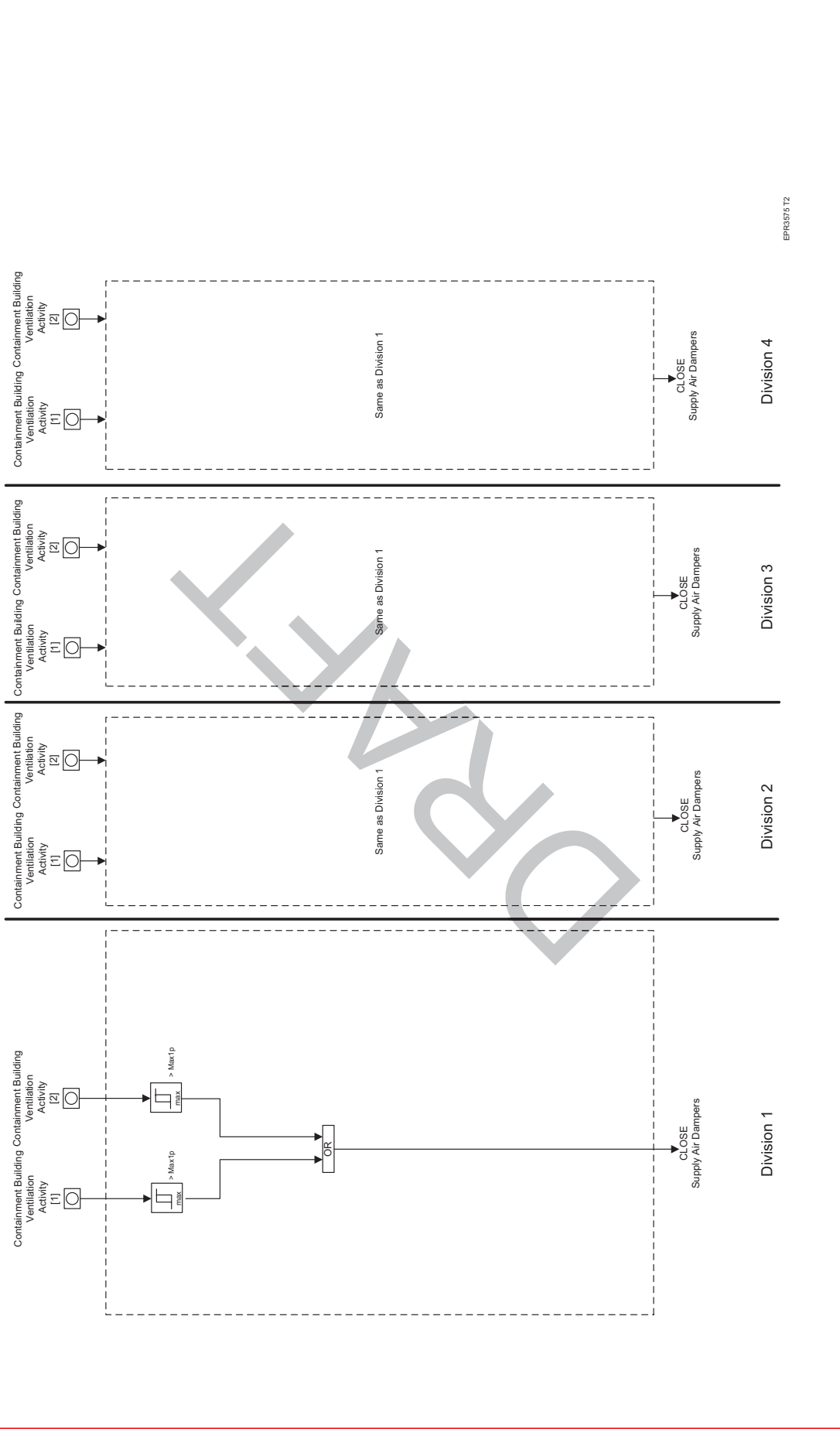


EPR3570 T2

All indicated changes are in response to RAI 505, 07.01-35



Figure 7.3-64—Reactor Building Fuel Handling Accident







the P14 permissive, providing a third diverse condition that must be satisfied to allow valve opening.

When RHR is connected, an inadvertent increase in RCS pressure does not result in an automatic signal to close the RHR RCPB isolation valves. However, the following design features prevent an increasing pressure from exceeding the RHR system design pressure:

- Interlock holding the MHSI large miniflow lines open (see Section 7.6.1.2.8).
- Pressurizer safety relief valves operating in their LTOP mode (see Section 7.3.1.2.13).
- Spring loaded safety valves on the RHR suction lines.

During an intentional increase in pressure, when RCS temperature and pressure exceed the P14 permissive setpoint, the operator is prompted to manually inhibit the P14 permissive, and is then allowed to close the RHR RCPB isolation valves.

The operational status of the PS on a divisional basis is provided to the operator. Indications and alarms are provided to the operator regarding the state of the P14 permissive signal. Additionally, the following indications are provided to the operator to verify correct operation of the interlock:

- Open or closed position of first RHR RCPB isolation valve (each train).
- Open or closed position of second RHR RCPB isolation valve (each train).

#### 7.6.1.2.2

#### SIS /RHRS Automatic Trip of LHSI Pump (in RHR Mode) on Low $\Delta$ Psat Interlock

The SIS/RHRS has a safety-related function to provide the RCS residual heat removal to reach cold shutdown, refueling modes and to control primary temperature. The function to automatically trip the LHSI pump upon a low  $\Delta$ Psat signal supports the safety-related function of providing residual heat removal by maintaining LHSI pump operability by shutting down the pump to prevent pump damage due to inadequate net positive suction head (NPSH) or unavailability due to steam binding following a failure that results in RCS conditions approaching saturation. The functional logic is shown in Figure 7.6-9—SIS / RHRS Automatic Trip of LHSI Pump (in RHR Mode) on Low  $\Delta$ Psat Interlock.

#### 7.6.1.2.3

#### SIS / RHRS Automatic Trip of LHSI Pump (in RHR Mode) on Low-Low RCS Loop Level Interlock

The SIS/RHRS has a safety-related function to provide the RCS residual heat removal to reach cold shutdown, refueling modes and to control primary temperature. The function to automatically trip the LHSI pump upon a low RCS loop level signal



supports the safety-related function of providing residual heat removal by maintaining LHSI pump operability by shutting down the pump to prevent pump damage or unavailability due to air binding following a failure that results in low RCS loop level. The functional logic is shown in Figure 7.6-10—SIS / RHRS Automatic Trip of LHSI Pump (in RHR Mode) on Low-Low RCS Loop Level Interlock.

#### 7.6.1.2.4 Safety Injection Accumulator Interlocks

There are four accumulators, one associated with each of the four independent SIS trains. Borated water is injected into the RCS from the accumulators when RCS pressure falls below the internal pressure of the accumulators.

The operation of the SI accumulators is described in Section 6.3.

Each accumulator is connected to the cold leg injection line of its respective RCS loop through two check valves and a motor operated isolation valve in series. Each isolation valve is interlocked to remain open above a specified RCS pressure value. This pressure value is the P12 permissive threshold.

Generation of the P12 permissive signal is described in Section 7.2.1.3.7.

Normally, the operator opens the isolation valves when RCS pressure exceeds accumulator pressure. Regardless, when RCS pressure increases above the P12 permissive threshold, the PS provides automatic signals to open the accumulator isolation valves. Once the valves are verified to be in the open position, control power is removed from the valves to prevent inadvertent closure. During a normal decrease in pressure, power is restored to the valves at a point in time determined by the operating procedures. Then, after RCS pressure decreases below the P12 permissive threshold, the operator is prompted to manually validate the P12 permissive, which allows the isolation valves to be closed before RCS pressure is reduced below the accumulator pressure.

A pressure region exists below the P12 permissive pressure threshold where the accumulators are required to be available but Plant Technical Specifications allow an accumulator isolation valve to be closed for a short period of time. To accommodate operation in this pressure region, an automatic 'open' signal is sent to the accumulator isolation valves when an SIS actuation occurs. The SIS actuation function is described in Section 7.3.1.2.1.

Two redundant ALUs within a division send the automatic opening signal through a "functional OR" logic to the isolation valve of the corresponding accumulator (i.e., PS Division 1 opens the isolation valve related to the Train 1 accumulator). This arrangement precludes a single actuator logic unit (ALU) failure from preventing the opening of a valve. Any other single failure which could prevent opening of a valve, such as failure of a PACS module or of the valve itself, is detected immediately by

failure of the valve to open. Corrective actions can then be taken before continued increase in pressure.

The operational status of the PS on a divisional basis is provided to the operator. Indications and alarms are provided to the operator regarding the state of the P12 permissive signal. Additionally, the following indications are provided to the operator to verify correct operation of the interlock:

- Pressure and level of each accumulator.
- Open or closed position of each accumulator isolation valve.

#### 7.6.1.2.5 ~~Interlocks Isolating Redundant CCWS Trains~~ CCWS Valves Interlocks

The CCWS is comprised of four closed-loop, safety-related supply trains that function to cool and transfer heat load from safety-related users to the emergency service water system (ultimate heat sink). The common loads cooled by the CCWS consist of two separate sets, referred to as Common-1 and Common-2. The Common-1 header is supplied by either CCWS Train 1 or Train 2 while the Common-2 header is supplied by either CCWS Train 3 or Train 4. Each common header is further divided into two sub-headers designated as Common 1a and 1b or Common 2a and 2b.

The operation of the CCWS is described in Section 9.2.2.

#### Switchover Valves Interlock

Interlocks are provided so that no two redundant CCWS trains are connected to the same common header at the same time. Each CCWS train is provided with four switchover valves to perform the required train separation.

CCWS Train 1 has a single valve on the supply side and a single valve on the return side of Common 1a. Train 2 also has a single valve on both the supply and return sides of Common 1a. These valves are interlocked so that both valves (supply and return) on Train 1 must be closed before either valve on Train 2 can be opened. Likewise, both valves on Train 2 must be closed before either valve on Train 1 can be opened. The same valve arrangement and interlocks are provided relative to Common 1b to provide separation between Trains 1 and 2, and on Common 2a and 2b to provide separation between Trains 3 and 4. The functional logic for the switchover valve interlock is shown in Figure 7.6-1—CCWS Switchover Valves Interlock.

~~Another interlocking function is required concerning the cooling paths of the Common 1b and Common 2b headers for the reactor coolant pump (RCP) thermal barriers. Either the Common 1b or 2b header can provide cooling to the RCP thermal barriers. To maintain strict CCWS train separation, one of the supply containment isolation valves (CIV) and one of the return CIVs on the RCP thermal barriers cooling path must be closed on the header being removed from service (1b or 2b) prior to~~

~~opening the CIVs on the header being placed in service (2b or 1b, respectively). The functional logic for the CIV interlock is shown in Figure 7.6-2.~~

The interlock functions maintaining separation between redundant CCWS trains are performed by the SAS. Each switchover valve is assigned to a SAS division based on the CCWS train it belongs to (i.e., switchover valves on Train 1 are assigned to SAS Division 1). Each division of SAS acquires position information from the valves to which it is assigned, and controls those same valves. In any SAS division, the information about the position of valves in other trains that is needed to control a switchover valve is provided via network connection by the SAS division which acquires the information. For example, the positions of the Train 2 valves on the supply and return of Common 1a are acquired by SAS Division 2. This information is provided via a network connection to SAS Division 1 to perform the interlock function for the Train 1 valves on the supply and return of Common 1a.

### RCP Thermal Barrier Containment Isolation Valves Interlock

Another interlocking function is required concerning the cooling paths of the Common 1b and Common 2b headers for the reactor coolant pump (RCP) thermal barriers. Either the Common 1b or 2b header can provide cooling to the RCP thermal barriers. To maintain strict CCWS train separation, one of the supply containment isolation valves (CIV) and one of the return CIVs on the RCP thermal barriers cooling path must be closed on the header being removed from service (1b or 2b) prior to opening the CIVs on the header being placed in service (2b or 1b, respectively). The functional logic for the CIV interlock is shown in Figure 7.6-2—CCWS RCP Thermal Barrier Containment Isolation Valves Interlock.

The interlock function concerning the CIVs is also performed by the SAS, but is only performed in Divisions 1 and 4. The CIVs are assigned to SAS divisions for control based on which electrical division provides power to the valves (i.e., valves powered by electrical Division 1 are controlled by SAS Division 1). The closed position indications of the CIVs on Common 1b are used to allow opening of the CIVs on Common 2b, and the closed position indication of the CIVs in Common 2b are used to allow the opening of the CIVs on Common 1b.

Redundant SAS controllers are provided in each division, and redundant networks are used between the divisions so that no single failure within the SAS can result in inadvertent connection of redundant CCWS trains. Each valve is equipped with redundant open/closed position sensors so that a single sensor failure does not result in inadvertent connection of redundant CCWS trains. While each switchover valve is controlled by one SAS division, PACS modules in multiple divisions, acting on multiple solenoid devices, are required in order to change the position of a switchover valve. Therefore, a single PACS module failure does not result in inadvertent connection of redundant CCWS trains. For the CIV interlock, redundancy is obtained

through the use of inner and outer CIVs, each controlled by a different division of SAS.

The single failure tolerance of the CCWS with respect to availability of the required cooling function is encompassed within the redundancy of the mechanical system design, as described in Section 9.2.2.

The following indications are provided to the operator relative to these interlocks:

- Indication of open or closed position of each interlocked valve.
- Alarm indicating position conflict between supply and return switchover valve of the same CCWS train relative to the same common header.
- Alarm indicating position conflict between CIVs of the same common header.
- Alarm indicating connection of two CCWS trains to the same common header.

#### 7.6.1.2.6 IRWSTS Boundary Isolation for Preserving IRWST Water Inventory Interlock

The CCWS has a safety-related function to remove heat from safety-related components (GDC 44). The interlock function is required to verify that the two trains connected to their common headers remain separated and each are able to provide their corresponding LHSI HX with the required flow for heat removal. Removing heat from the LHSI HX is a safety-related function. The functional logic is shown in Figure 7.6-4—IRWSTS Boundary Isolation for Preserving IRWST Water Inventory Interlock.

#### 7.6.1.2.7 Safety Chilled Water System Interlocks

The SCWS has the following safety-related functions:

1. Transfer of heat loads from safety-related SSC to a heat sink under both normal operating and accident conditions.
2. Component redundancy for performance of safety functions assuming a single, active component failure coincident with the loss of offsite power.
3. The capability to isolate components, systems, or piping, if required, so system safety functions are not compromised.

The following automatic switchover functions verify that the SCWS is capable of fulfilling the safety-related functions in compliance with GDC 44:

- SCWS Train 1 to Train 2 Switchover on Train 1 Low Evaporator Flow:

The functional logic is shown in Figure 7.6-5—SCWS Train 1 to Train 2 Switchover on Train 1 Low Evaporator Flow / Chiller Blackbox Internal Fault /

SCWS Chiller Evaporator Water Flow Control / LOOP Re-Start Failure Interlock.

- SCWS Train 2 to Train 1 Switchover on Train 2 Low Evaporator Flow:

The functional logic is shown in Figure 7.6-6—SCWS Train 2 to Train 1 Switchover on Train 2 Low Evaporator Flow / Chiller Blackbox Internal Fault / Loss of UHS-CCWS / SCWS Chiller Evaporator Water Flow Control / LOOP Re-Start Failure Interlock.

- SCWS Train 3 to Train 4 Switchover on Train 3 Low Evaporator Flow:

The functional logic is shown in Figure 7.6-7—SCWS Train 3 to Train 4 Switchover on Train 3 Low Evaporator Flow / Chiller Blackbox Internal Fault / Loss of UHS-CCWS / SCWS Chiller Evaporator Water Flow Control / LOOP Re-Start Failure Interlock.

- SCWS Train 4 to Train 3 Switchover on Train 4 Low Evaporator Flow:

The functional logic is shown in Figure 7.6-8—SCWS Train 4 to Train 3 Switchover on Train 4 Low Evaporator Flow / Chiller Blackbox Internal Fault / SCWS Chiller Evaporator Water Flow Control / LOOP Re-Start Failure Interlock.

- SCWS Train 1 to Train 2 Switchover on Train 1 Chiller Blackbox Internal Fault:

The functional logic is shown in Figure 7.6-5—SCWS Train 1 to Train 2 Switchover on Train 1 Low Evaporator Flow / Chiller Blackbox Internal Fault / SCWS Chiller Evaporator Water Flow Control / LOOP Re-Start Failure Interlock.

- SCWS Train 2 to Train 1 Switchover on Train 2 Chiller Blackbox Internal Fault:

The functional logic is shown in Figure 7.6-6—SCWS Train 2 to Train 1 Switchover on Train 2 Low Evaporator Flow / Chiller Blackbox Internal Fault / Loss of UHS-CCWS / SCWS Chiller Evaporator Water Flow Control / LOOP Re-Start Failure Interlock.

- SCWS Train 3 to Train 4 Switchover on Train 3 Chiller Blackbox Internal:

The functional logic is shown in Figure 7.6-7—SCWS Train 3 to Train 4 Switchover on Train 3 Low Evaporator Flow / Chiller Blackbox Internal Fault / Loss of UHS-CCWS / SCWS Chiller Evaporator Water Flow Control / LOOP Re-Start Failure Interlock.

- SCWS Train 4 to Train 3 Switchover on Train 4 Chiller Blackbox Internal Fault:

The functional logic is shown in Figure 7.6-8—SCWS Train 4 to Train 3 Switchover on Train 4 Low Evaporator Flow / Chiller Blackbox Internal Fault / SCWS Chiller Evaporator Water Flow Control / LOOP Re-Start Failure Interlock.

- SCWS Train 2 to Train 1 Switchover on Train 2 Loss of UHS-CCWS:





The functional logic is shown in Figure 7.6-6—SCWS Train 2 to Train 1 Switchover on Train 2 Low Evaporator Flow / Chiller Blackbox Internal Fault / Loss of UHS-CCWS / SCWS Chiller Evaporator Water Flow Control / LOOP Re-Start Failure Interlock.

- SCWS Train 3 to Train 4 Switchover on Train 3 Loss of UHS-CCWS:

The functional logic is shown in Figure 7.6-7—SCWS Train 3 to Train 4 Switchover on Train 3 Low Evaporator Flow / Chiller Blackbox Internal Fault / Loss of UHS-CCWS / SCWS Chiller Evaporator Water Flow Control / LOOP Re-Start Failure Interlock.

- SCWS Train 1 to Train 2 Switchover on Train 1 LOOP Re-Start Failure:

The functional logic is shown in Figure 7.6-5—SCWS Train 1 to Train 2 Switchover on Train 1 Low Evaporator Flow / Chiller Blackbox Internal Fault / SCWS Chiller Evaporator Water Flow Control / LOOP Re-Start Failure Interlock.

- SCWS Train 2 to Train 1 Switchover on Train 2 LOOP Re-Start Failure:

The functional logic is shown in Figure 7.6-6—SCWS Train 2 to Train 1 Switchover on Train 2 Low Evaporator Flow / Chiller Blackbox Internal Fault / Loss of UHS-CCWS / SCWS Chiller Evaporator Water Flow Control / LOOP Re-Start Failure Interlock.

- SCWS Train 3 to Train 4 Switchover on Train 3 LOOP Re-Start Failure:

The functional logic is shown in Figure 7.6-7—SCWS Train 3 to Train 4 Switchover on Train 3 Low Evaporator Flow / Chiller Blackbox Internal Fault / Loss of UHS-CCWS / SCWS Chiller Evaporator Water Flow Control / LOOP Re-Start Failure Interlock.

- SCWS Train 4 to Train 3 Switchover on Train 4 LOOP Re-Start Failure:

The functional logic is shown in Figure 7.6-8—SCWS Train 4 to Train 3 Switchover on Train 4 Low Evaporator Flow / Chiller Blackbox Internal Fault / SCWS Chiller Evaporator Water Flow Control / LOOP Re-Start Failure Interlock.

The following automatic control function verifies that the SCWS is capable of fulfilling its safety-related functions in compliance with GDC 44:

- SCWS Chiller Evaporator Water Flow Control for Trains 1 and 4 to prevent freezing at the evaporator coil:

The functional logic is shown in Figures 7.6-5 through 7.6-8.

### 7.6.1.2.8 Interlocks to Provide Low Temperature Over-Pressure Protection

Section 5.2.2 describes LTOP for the U.S. EPR design. Low temperature RCPB overpressure events include mass input events and heat input events. A start of four

valves are no longer able to inject due to a higher RCS pressure caused by the single MHSI pump with its large miniflow valve closed. Therefore the other three MHSI pumps re-circulate through their miniflow lines to the IRWST. This leaves the one MHSI pump with its (failed) closed large miniflow valve injecting into the RCS. The RHR spring loaded safety valves are sized based on the pressure and flow rate of one MHSI pump, with large miniflow line isolated, injecting into the RCS while RHR is connected.

#### *P17 temperature > RCS temperature*

When the P17 permissive is validated, the MHSI large miniflow valves are interlocked in the open position. The PSRVs operating in their LTOP mode along with the interlock holding the large miniflow valves open provide over-pressure protection of the RHR system in this temperature regime.

The LTOP setpoints for opening of PSRVs are lower than the RHR spring-loaded safety valve setpoints. Therefore, during the postulated pressure addition event, the PSRVs relieve pressure before the design pressure of the connected RHR system is reached. The PSRV setpoints and sizing are based on the pressure and flow rate of four MHSI pumps, with one miniflow line isolated, injecting into the RCS. Actuation of the PSRVs by the PS in an LTOP capacity is described in Section 7.3.

Generation of the P14 and P17 permissive signals is described in Sections 7.2.1.2.9 and 7.2.1.3.12.

Detection of the RHR connected condition is shown in Figure 7.6-3. RHR isolation valves interlock is shown in Figure 7.6-11.

Two redundant ALUs within a PS division each send the interlock signal to the large miniflow line isolation valve of one MHSI train. This arrangement precludes a single ALU failure from preventing the opening of a valve. The failure of a single PACS module or of a single valve results in one MHSI large miniflow line being isolated, which is accounted for in the design of the RHR safety valves and PSRVs as previously described.

Additionally, no single failure can prevent the isolation valve from being closed on at least one MHSI injection path during power operation when maximum MHSI discharge pressure is required.

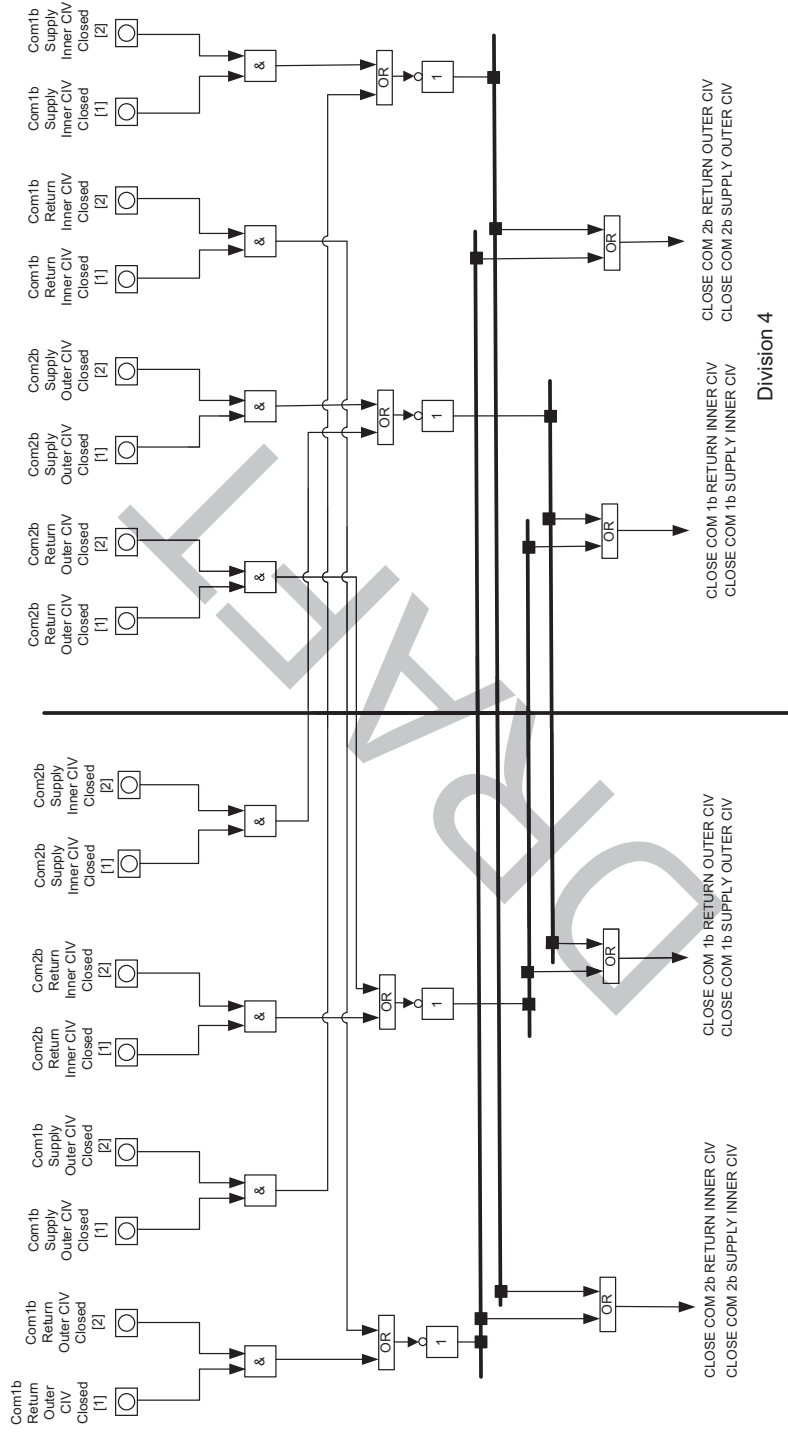
The operational status of the PS on a divisional basis is provided to the operator. Indications and alarms are provided to the operator regarding the state of the P14 and P17 permissives. Additionally, the following indications are provided to the operator to verify correct operation of the interlock:



All indicated changes are in response to RAI 505, 07.01-35



Figure 7.6-2—CCWS RCP Thermal Barrier Containment Isolation Valves Interlock

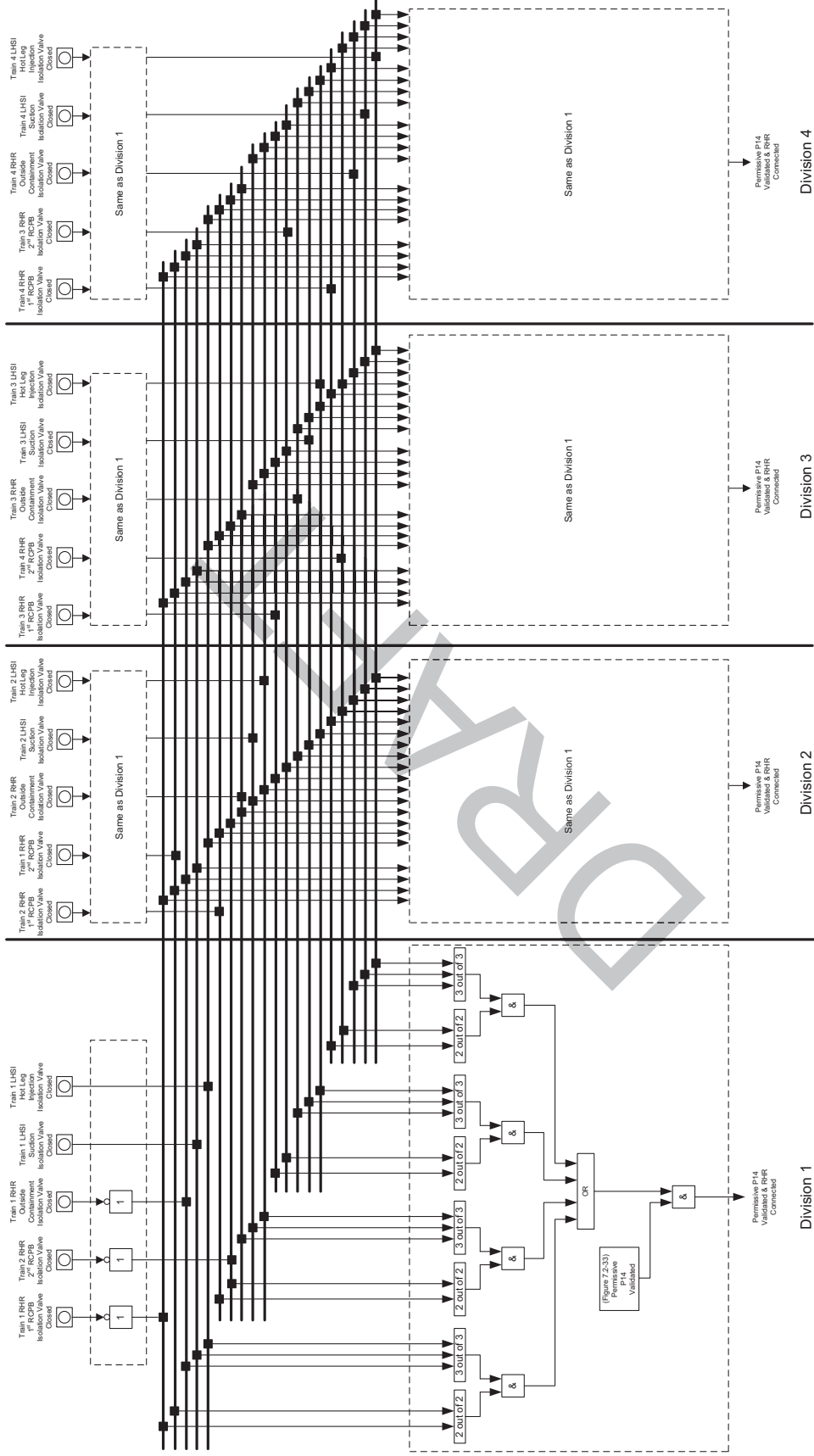


REV/004  
EPR3430 T2

All indicated changes are in response to RAI 505, 07.01-35



Figure 7.6-3—Detection of RHR Connected Interlock

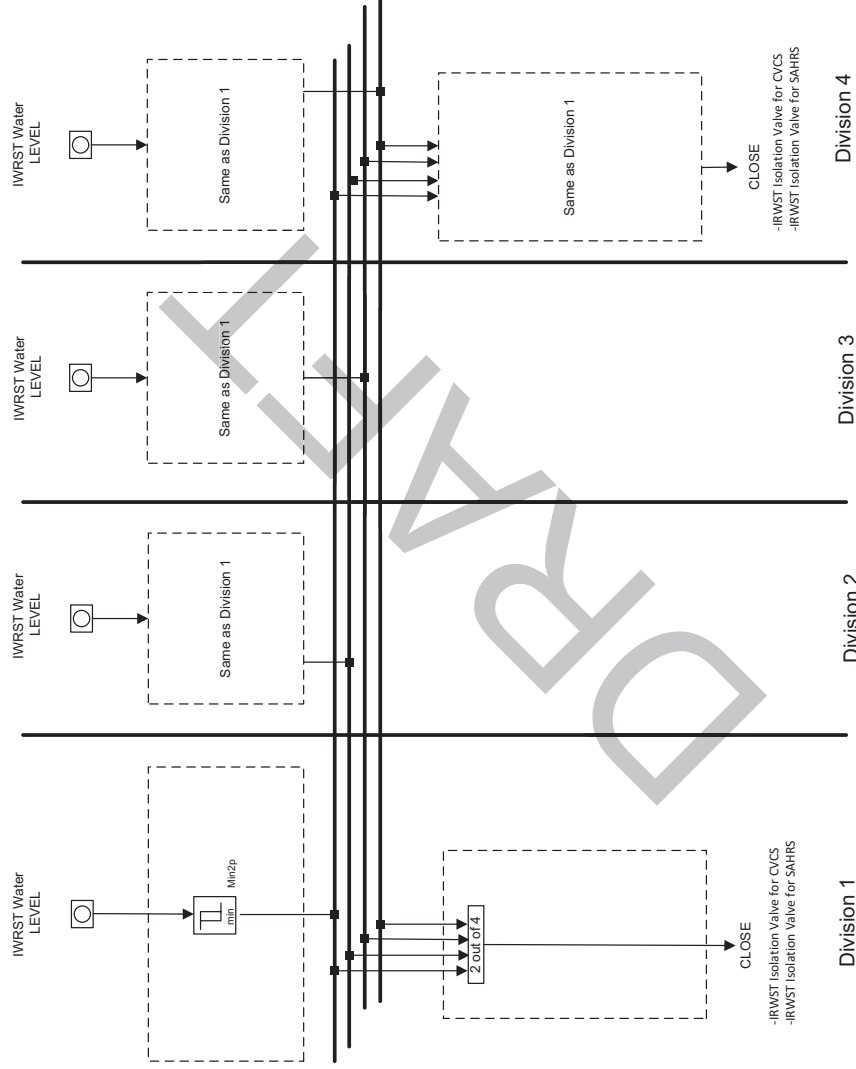


REV 004  
EPR040112

All indicated changes are in response to RAI 505, 07.01-35



Figure 7.6.4—IRWSTS Boundary Isolation for Preserving IRWST Water Inventory Interlock

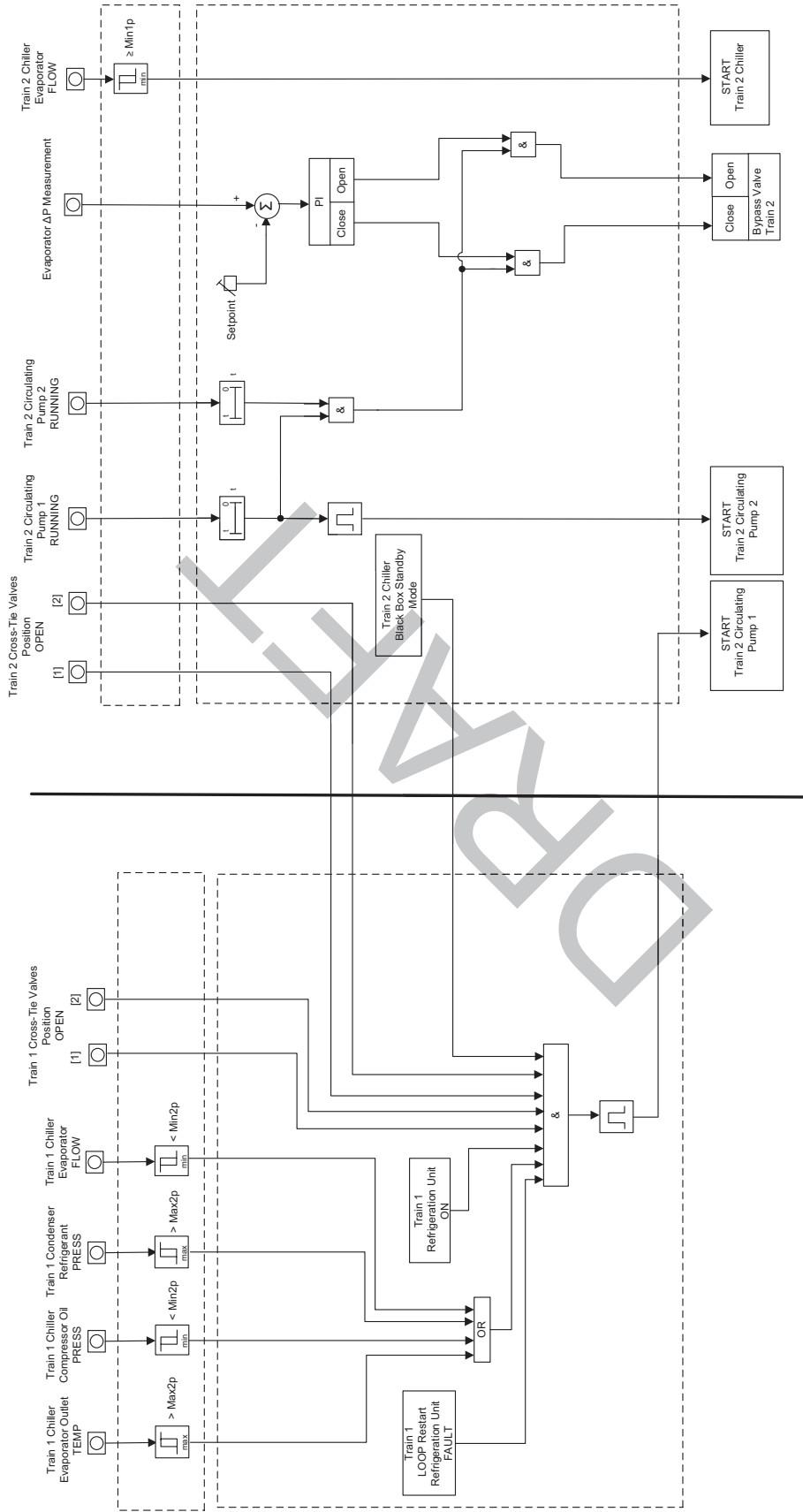


EPR5606 T2

All indicated changes are in response to RAI 505, 07.01-35



Figure 7.6-5—SCWS Train 1 to Train 2 Switchover on Train 1 Low Evaporator Flow / Chiller Blackbox Internal Fault / SCWS Chiller Evaporator Water Flow Control / LOOP Re-Start Failure Interlock



Division 1

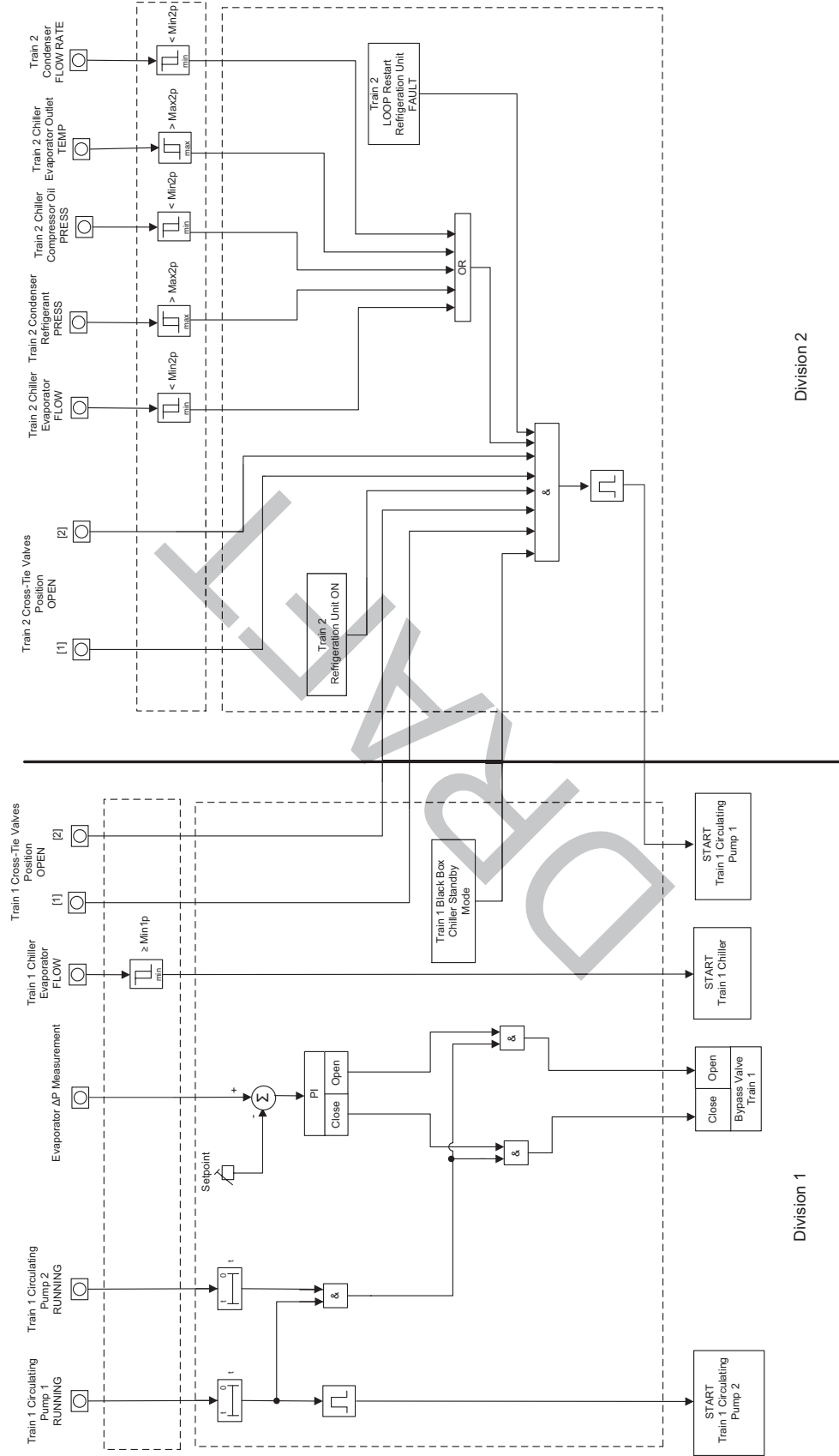
Division 2

EPRI546 T2

All indicated changes are in response to RAI 505, 07.01-35



**Figure 7.6-6—SCWS Train 2 to Train 1 Switchover on Train 2 Low Evaporator Flow / Chiller Blackbox Internal Fault / Loss of UHS-CCWS / SCWS Chiller Evaporator Water Flow Control / LOOP Re-Start Failure Interlock**



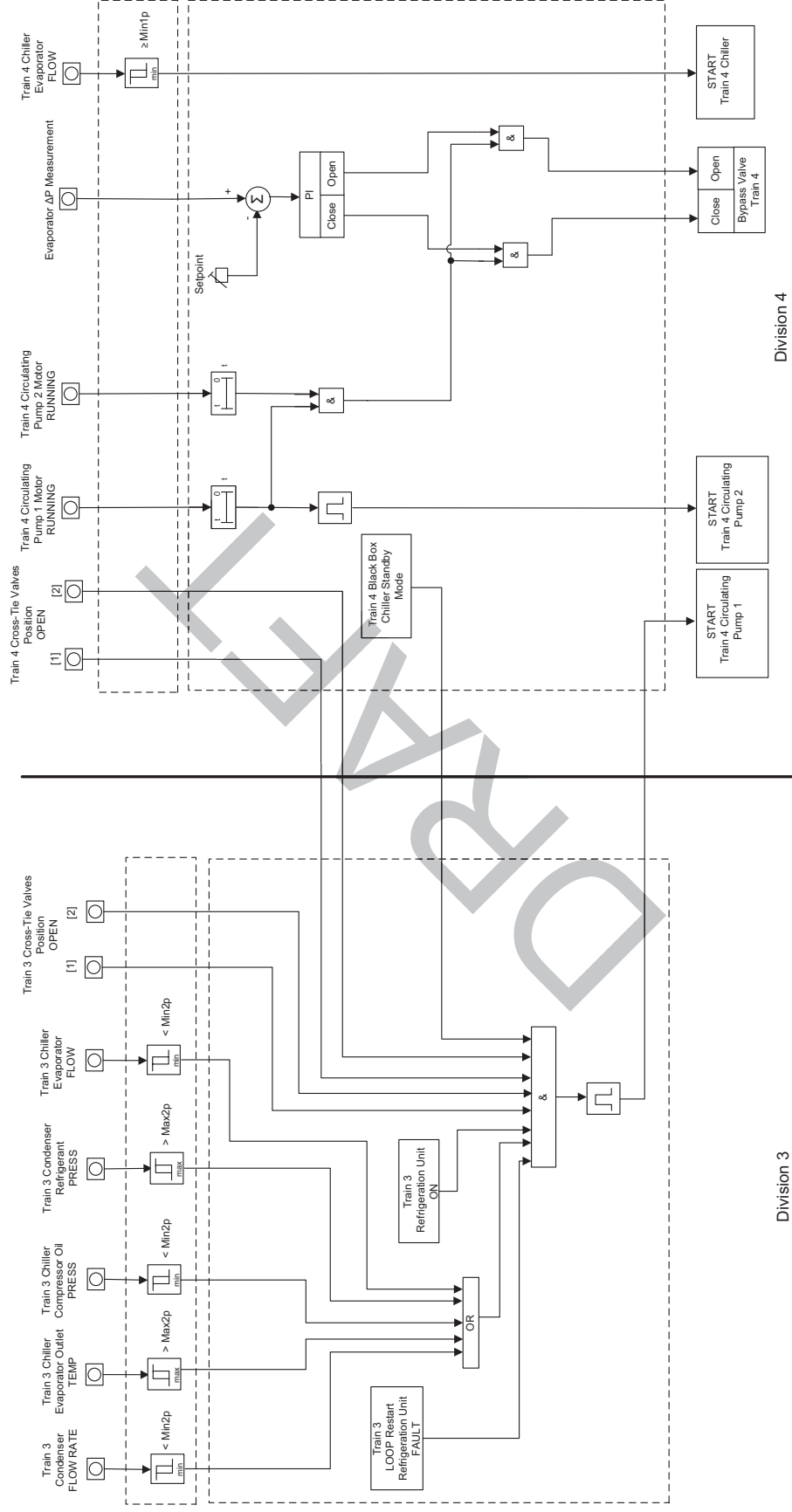
Division 1

Division 2

EPR3548 T2

All indicated changes are in response to RAI 505, 07.01-35

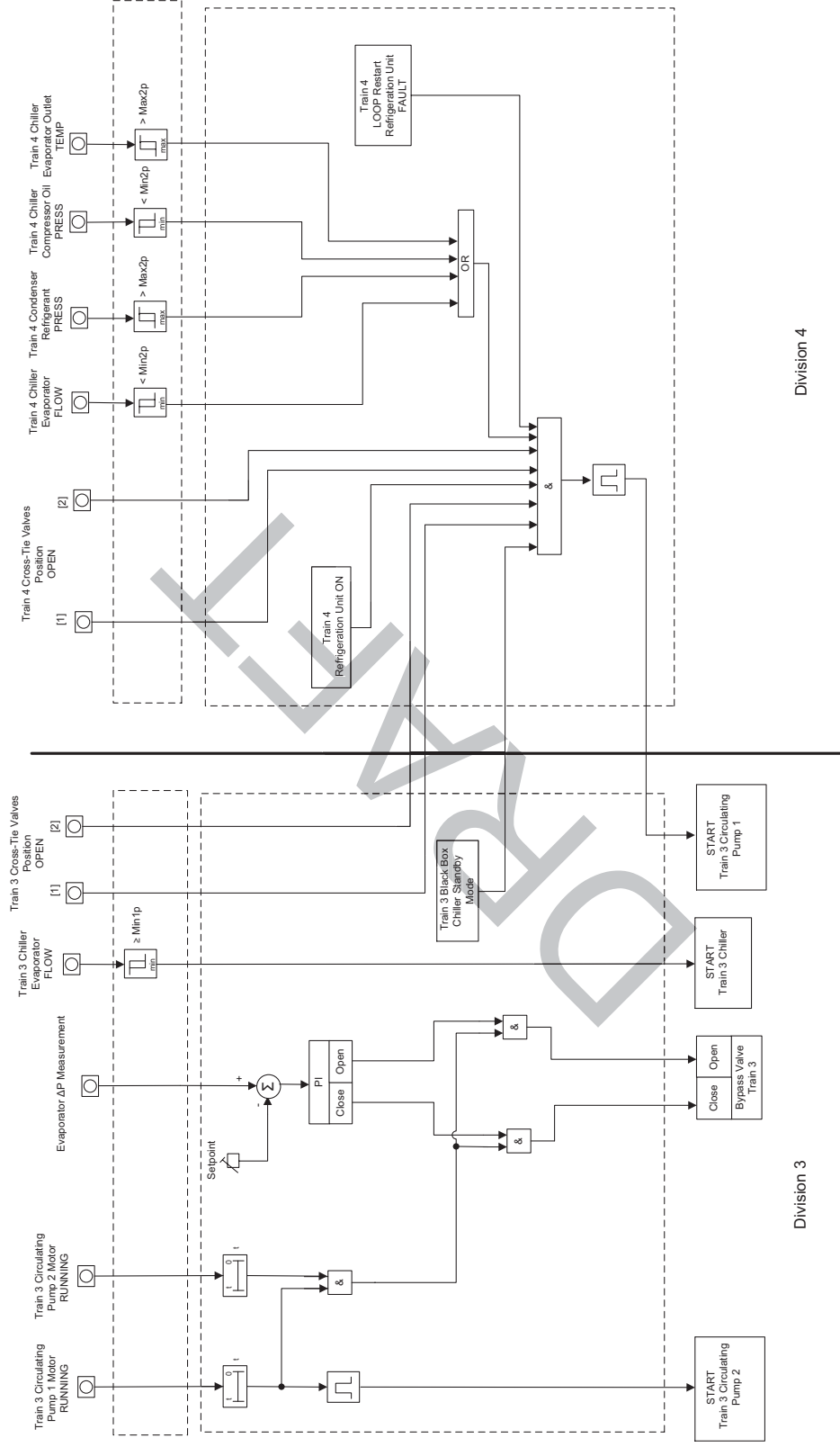
Figure 7.6-7—SCWS Train 3 to Train 4 Switchover on Train 3 Low Evaporator Flow / Chiller Blackbox Internal Fault / Loss of UHS-CCWS / SCWS Chiller Evaporator Water Flow Control / LOOP Re-Start Failure Interlock



EPR3550 T2

All indicated changes are in response to RAI 505, 07.01-35

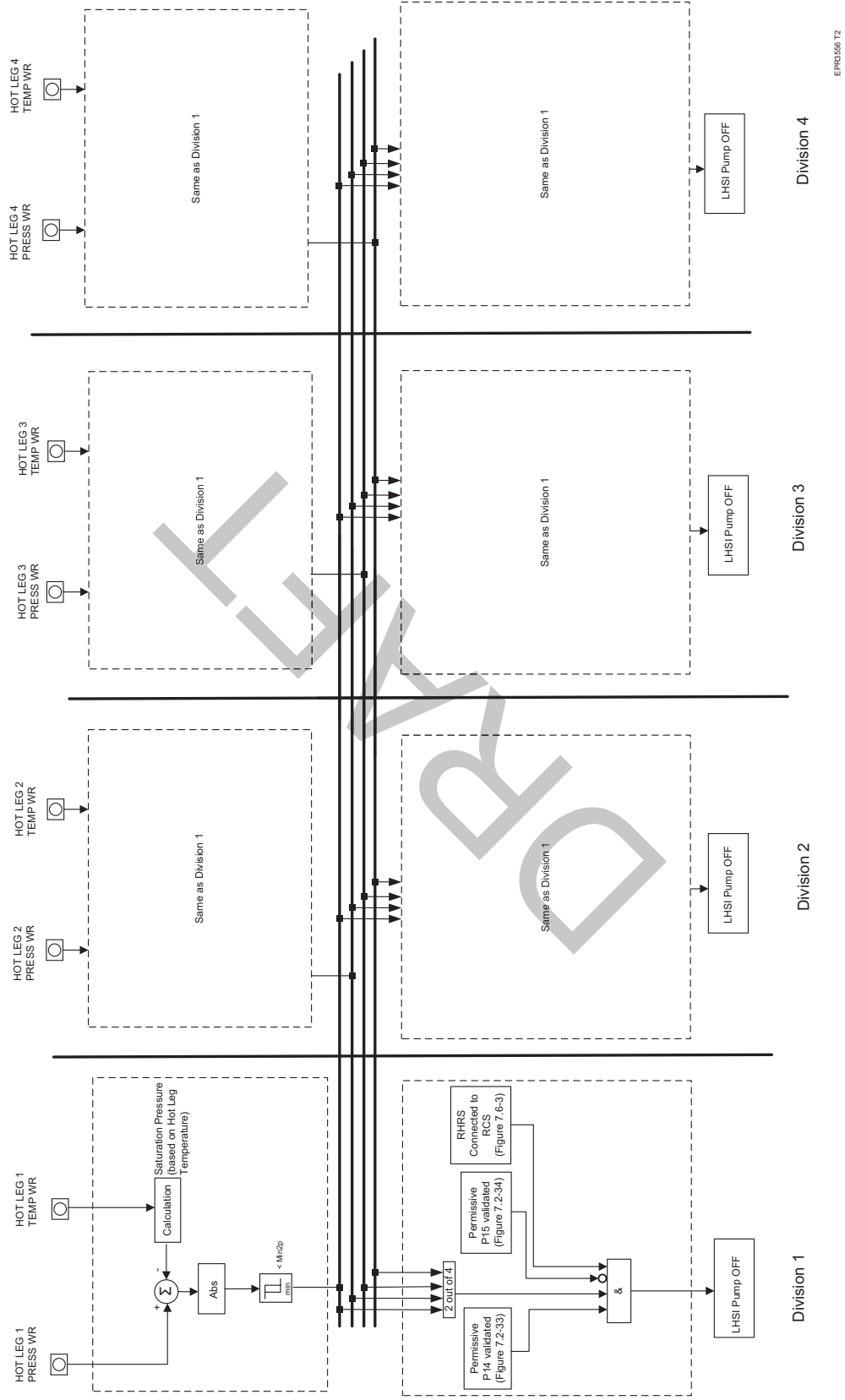
Figure 7.6-8—SCWS Train 4 to Train 3 Switchover on Train 4 Low Evaporator Flow / Chiller Blackbox Internal Fault / SCWS Chiller Evaporator Water Flow Control / LOOP Re-Start Failure Interlock



EPR050272

All indicated changes are in response to RAI 505, 07.01-35

Figure 7.6-9—SIS / RHRS Automatic Trip of LHSI Pump (in RHR Mode) on Low ΔP<sub>sat</sub> Interlock

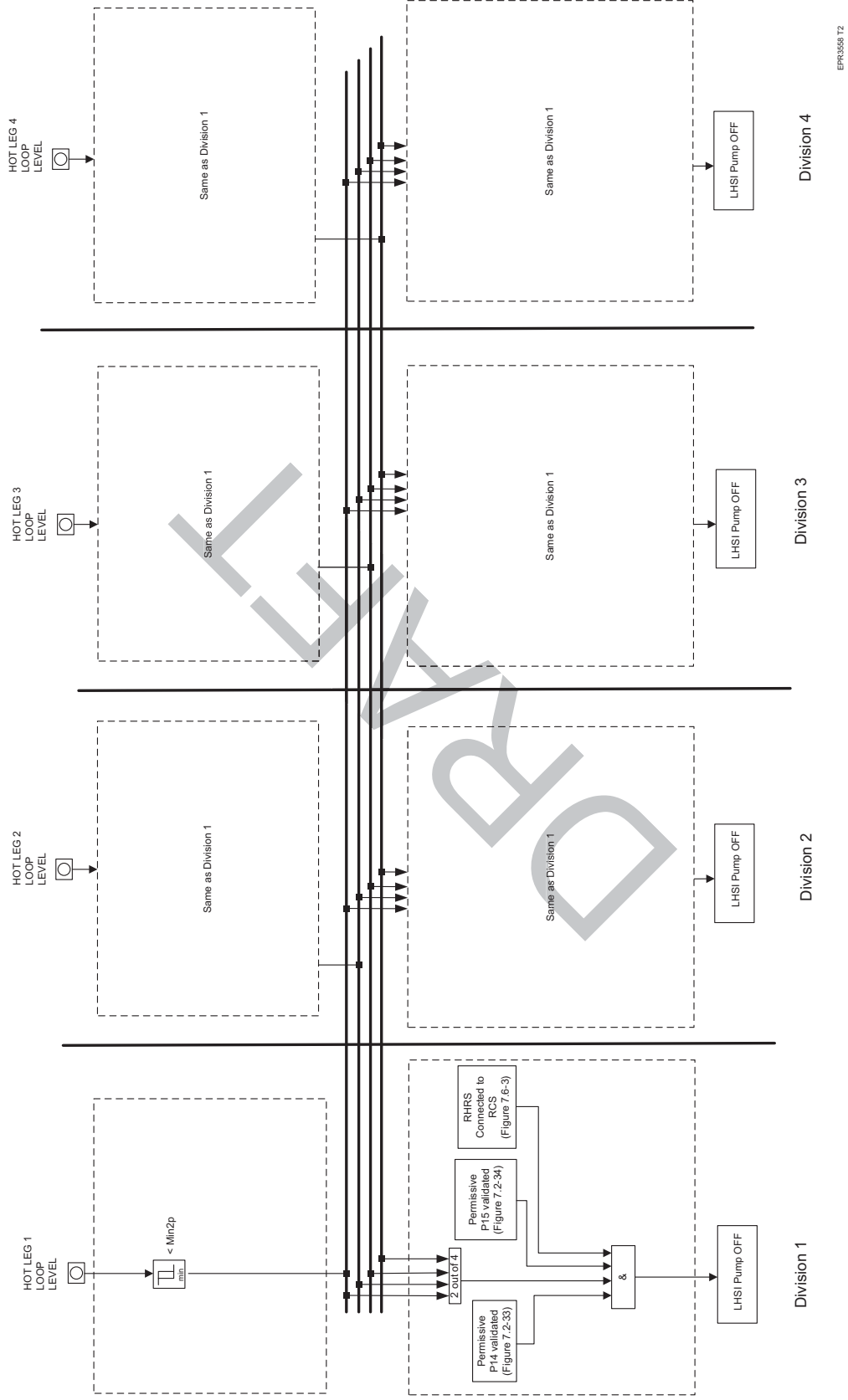


EPR556 T2



All indicated changes are in response to RAI 505, 07.01-35

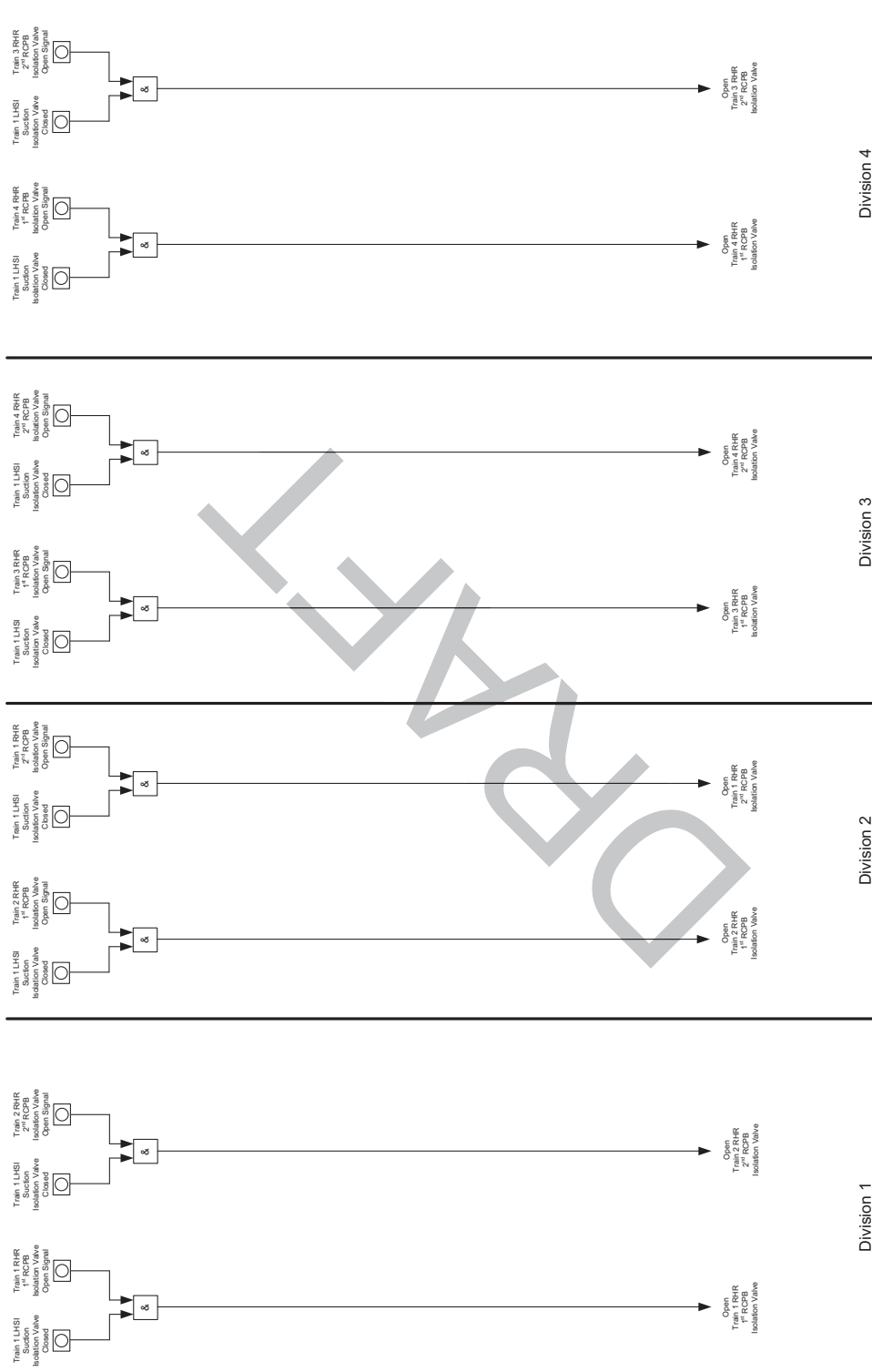
Figure 7.6-10—SIS / RHRS Automatic Trip of LHSI Pump (in RHR Mode) on Low-Low RCS Loop Level Interlock



All indicated changes are in response to RAI 505, 07.01-35



Figure 7.6-11—RHR Isolation Valves Interlock



EPR3590 T2

**Table 8.3-4—Division 1 Emergency Diesel Generator Nominal Loads**  
Sheet 1 of 6

Time Seq. (s) <sup>(13)</sup>	Load Description <sup>(8)</sup> <sup>(15)</sup> <sup>(19)</sup>	Volts	Rating (hp/kW) <sup>(3)</sup>	Alternate Feed Load (kW) <sup>(1)</sup> <sup>(12)</sup>	Operating Load LOOP (kW) <sup>(1)</sup> <sup>(12)</sup>	Operating Load DBA/ LOOP (kW) <sup>(1)</sup> <sup>(12)</sup>
Load Step Group 1						
0	Start Signal					
15	EDG reaches rated speed and voltage/output breaker closes					
15	<del>Emergency power generating building electric room chiller unit</del>	480	18.5 kW		18.5	18.5
15	Emergency power generating building electric room supply fan	480	10 Bhp		8.3	8.3
15	Emergency power generating building fuel oil storage tank room fan	480	13.4 Bhp		11.1	11.1
15	EDG starting air compressor	480	61 Bhp		50.6	50.6
15	EDG auxiliary loads	480	9.7 kW		9.7	9.7
15	Vent stack monitoring	480	13 kW		13	13
15	Division 1 EUPS battery charger <sup>(4)</sup>	480	106 kW		106	106
15	Annulus ventilation heating unit	480	6 kW		4.2 <sup>(2)</sup>	4.2 <sup>(2)</sup>
15	Annulus ventilation fan	480	4.3 Bhp		3.6	3.6
15	AAA/LAR valve room cooling fan	480	5 Bhp		4.1	4.1
15	Extra boration room cooling fan	480	14 Bhp		11.6	11.6
15	Fuel pool cooling pump room cooling fan	480	7.75 Bhp		6.4	6.4
15	Fuel pool cooling pump room cooling fan	480	7.75 Bhp		6.4	6.4
15	Fuel building ventilation heating unit <sup>(7)</sup>	480	15 kW		0	0



Table 8.3-4—Division 1 Emergency Diesel Generator Nominal Loads  
Sheet 2 of 6

Time Seq. (s) <sup>(13)</sup>	Load Description <sup>(8)</sup> <sup>(15)</sup> <sup>(19)</sup>	Volts	Rating (hp/kW) <sup>(3)</sup>	Alternate Feed Load (kW) <sup>(1)</sup> <sup>(12)</sup>	Operating Load LOOP (kW) <sup>(1)</sup> <sup>(12)</sup>	Operating Load DBA/ LOOP (kW) <sup>(1)</sup> <sup>(12)</sup>
15	Safety chilled water pump <sup>(6)</sup>	480	100 Bhp		82.9	82.9
15	Safety chilled water pump <sup>(6)</sup>	480	100 Bhp		82.9	82.9
15	Safety chiller condenser fans	480	240 kW		240	240
15	Main control room air conditioning fan	480	27 Bhp		22.4	22.4
15	Main control room air conditioning filtration unit heater <sup>(11)</sup>	480	10 kW			7 <sup>(2)</sup>
15	Main control room air conditioning iodine filtration fan <sup>(11)</sup>	480	10 Bhp			8.3
15	Safeguard building ventilation heaters <sup>(7)</sup>	480	210 kW		0	0
15	Safeguard building ventilation supply fan	480	78 Bhp		64.7	64.7
15	Safeguard building ventilation return fan	480	43 Bhp		35.6	35.6
<u>15</u>	<u>Main control room air conditioning fan</u>	<u>480</u>	<u>27 Bhp</u>	<u>22.4</u>		
15	Safeguard building battery exhaust fan	480	7 Bhp		5.8	5.8
15	Emergency feed water room ventilation recirculation fan	480	2 Bhp		1.7	1.7
15	Emergency lighting panels <sup>(18)</sup>	480	165.7 kW		165.7	165.7
15	Component cooling water valve hydraulic pump	480	5 Bhp		4.1	4.1
15	Component cooling valve hydraulic pump	480	5 Bhp		4.1	4.1
15	Component cooling water valve hydraulic pump	480	5 Bhp		4.1	4.1



**Table 8.3-4—Division 1 Emergency Diesel Generator Nominal Loads**  
Sheet 5 of 6

Time Seq. (s) <sup>(13)</sup>	Load Description <sup>(8)</sup> <sup>(15)</sup> <sup>(19)</sup>	Volts	Rating (hp/kW) <sup>(3)</sup>	Alternate Feed Load (kW) <sup>(1)</sup> <sup>(12)</sup>	Operating Load LOOP (kW) <sup>(1)</sup> <sup>(12)</sup>	Operating Load DBA/ LOOP (kW) <sup>(1)</sup> <sup>(12)</sup>
15	Emergency power generating building supply fan 2	480	100 hp		82.9	82.9
15	Emergency power generating building exhaust fan 1	480	75 hp		62.2	62.2
15	Emergency power generating building exhaust fan 2	480	75 hp		62.2	62.2
15	Additional connected loads	480	90.9 kW		90.9	90.9
15	Load contribution from transformer and cable losses		160 kW	40	120	120
Subtotal Load Step Group 1						
Load Step Group 2 <sup>(17)</sup>						
20	MHSI pump	6.9 kV	700 hp			580
Subtotal Load Step Group 2						
Load Step Group 3 <sup>(17)</sup>						
25	LHSI pump	6.9 kV	500 hp			414
Subtotal Load Step Group 3						
Load Step Group 4 <sup>(14)</sup>						
30	CCW pump	6.9 kV	1250 hp		1036	1036
Subtotal Load Step Group 4						
Load Step Group 5 <sup>(14)</sup>						
35	ESW pump	6.9 kV	1250 hp		1036	1036
Subtotal Load Step Group 5						
				447.3	1640.5	1678.0
				469.7 <sup>(10)</sup>	1622.0	1659.5



**Table 8.3-4—Division 1 Emergency Diesel Generator Nominal Loads**  
Sheet 6 of 6

Time Seq. (s) <sup>(13)</sup>	Load Description <sup>(8)</sup> (15) (19)	Volts	Rating (hp/kW) <sup>(3)</sup>	Alternate Feed Load (kW) <sup>(1)</sup> (12)	Operating Load LOOP (kW) <sup>(1)</sup> (12)	Operating Load DBA/ LOOP (kW) <sup>(1)</sup> (12)
Load Step Group 6 <sup>(14)</sup>						
40	EFW pump	6.9 kV	700 hp		(5)	580
Subtotal Load Step Group 6						
Load Step Group 7 <sup>(14)</sup>						
45	Division 1 safety chilled water compressor	6.9 kV	900 kW		1000	1000
Subtotal Load Step Group 7						
Load Step Group 8 <sup>(14)</sup>						
50	Essential service water UHS fan 1	480	250 hp		207.2	207.2
50	Essential service water UHS fan 2	480	250 hp		207.2	207.2
Subtotal Load Step Group 8						
Subtotal Alternate Feed Loads						
				447.3469.7		
Total Automatically Sequenced Loads without alternate feed installed						
				5108.75127.2	6721.06739.5	
Total Automatically Sequenced Loads with alternate feed installed						
				5578.45574.5	7190.77186.5	
Additional Manually Connected Loads						
		480	144 kW		144	
		480	163 Bhp		0 <sup>(20)</sup>	0 <sup>(20)</sup>
		480	137 Bhp		113.6	113.6
Total Manually Connected Loads						
				257.6		113.6
Total Division 1 EDG Loading						
				5835.95832.1	7304.37300.4	

**Table 8.3-5—Division 2 Emergency Diesel Generator Nominal Loads**  
Sheet 1 of 6

Time Seq. (s) <sup>(13)</sup>	Load Description <sup>(8)</sup> <sup>(15)</sup> <sup>(19)</sup>	Volts	Rating (hp/kW) <sup>(3)</sup>	Alternate Feed Load (kW) <sup>(1)</sup> <sup>(12)</sup>	Operating Load LOOP (kW) <sup>(1)</sup> <sup>(12)</sup>	Operating Load DBA/ LOOP (kW) <sup>(1)</sup> <sup>(12)</sup>
Load Step Group 1						
0	Start Signal					
15	EDG reaches rated speed and voltage/output breaker closes					
15	<del>Emergency power generating building electric room chiller unit</del>	480	18.5 kW		18.5	18.5
15	Emergency power generating building electric room supply fan	480	10 Bhp		8.3	8.3
15	Emergency power generating building fuel oil storage tank room fan	480	13.4 Bhp		11.1	11.1
15	EDG starting air compressor	480	61 Bhp		50.6	50.6
15	EDG auxiliary loads	480	9.7 kW		9.7	9.7
15	Main control room air conditioning fan	480	27 Bhp		22.4	22.4
15	MHSI/LHSI room recirculation fan	480	5 Bhp		4.1	4.1
15	Main control room air conditioning heaters <sup>(7)</sup>	480	21 kW		0	0
15	Division 2 EUPS battery charger <sup>(4)</sup>	480	106 kW		106	106
15	Reactor building ventilation filtration fan	480	10 Bhp		8.3	8.3
15	KAA/LAR valve room cooling fan	480	5 Bhp		4.1	4.1
15	Safety chilled water pump <sup>(6)</sup>	480	100 Bhp		82.9	82.9
15	Safety chilled water pump <sup>(6)</sup>	480	100 Bhp		82.9	82.9
15	Safeguard building ventilation heaters <sup>(7)</sup>	480	180 kW		0	0



Table 8.3-5—Division 2 Emergency Diesel Generator Nominal Loads  
Sheet 5 of 6

Time Seq. (s) <sup>(13)</sup>	Load Description <sup>(8)</sup> (15) (19)	Volts	Rating (hp/kW) <sup>(3)</sup>	Alternate Feed Load (kW) <sup>(1)</sup> (12)	Operating Load LOOP (kW) <sup>(1)</sup> (12)	Operating Load DBA/ LOOP (kW) <sup>(1)</sup> (12)
15	Additional connected loads	480	84.4 kW		84.4	84.4
15	Lighting <sup>(18)</sup>	480	300 kW		300	300
15	Reserved for special use <sup>(18)</sup>	480	125 kW		125	125
15	Load contribution from transformer and cable losses		160 kW	40	120	120
Subtotal Load Step Group 1				647.2 <sup>(10)</sup>	1619.016375	1619.016375
Load Step Group 2 <sup>(17)</sup>						
20	MHSI pump	6.9 kV	700 hp			580
Subtotal Load Step Group 2						580
Load Step Group 3 <sup>(17)</sup>						
25	LHSI pump	6.9 kV	500 hp			414
Subtotal Load Step Group 3						414
Load Step Group 4 <sup>(14)</sup>						
30	CCW pump	6.9 kV	1250 hp		1036	1036
Subtotal Load Step Group 4					1036	1036
Load Step Group 5 <sup>(14)</sup>						
35	ESW pump	6.9 kV	1250 hp		1036	1036
Subtotal Load Step Group 5					1036	1036
Load Step Group 6 <sup>(14)</sup>						
40	EFW pump	6.9 kV	700 hp		(5)	580
Subtotal Load Step Group 6					(5)	580



**Table 8.3-5—Division 2 Emergency Diesel Generator Nominal Loads**  
Sheet 6 of 6

Time Seq. (s) <sup>(13)</sup>	Load Description <sup>(8)</sup> (15) (19)	Volts	Rating (hp/kW) <sup>(3)</sup>	Alternate Feed Load (kW) <sup>(1)</sup> (12)	Operating Load LOOP (kW) <sup>(1)</sup> (12)	Operating Load DBA/ LOOP (kW) <sup>(1)</sup> (12)
Load Step Group 7 <sup>(14)</sup>						
45	Division 2 safety chilled water compressor	6.9 kV	900 kW		1000	1000
Subtotal Load Step Group 7						
Load Step Group 8 <sup>(14)</sup>						
50	Essential service water UHS fan 1	480	250 hp		207.2	207.2
50	Essential service water UHS fan 2	480	250 hp		207.2	207.2
Subtotal Load Step Group 8						
Subtotal Alternate Feed Loads				647.2		
Total Automatically Sequenced Loads without alternate feed installed						
					5105.651241	6680.56699.0
Total Automatically Sequenced Loads with alternate feed installed						
					5752.95771.4	7327.87346.3
Additional Manually Connected Loads						
Extra boration pump			480	163 Bhp	0 <sup>(20)</sup>	
Fuel pool cooling pump <sup>(21)</sup>			480	137 Bhp	113.6	
Emergency pressurizer heaters <sup>(16)</sup>			480	144 kW	144	
Total Manually Connected Loads				113.6	144	
Total Division 2 EDG Loading					6010.46028.9	7441.37459.8

**Notes:**

1. The kW rating derived from hp rating multiplied by 0.746 conversion factor. Indicated hp is considered rated. Where brake horsepower (Bhp) is indicated, this is from the system mechanical requirements.
2. A diversity factor of 0.7 is assumed in load contribution due to cyclical nature of load.

**Table 8.3-6—Division 3 Emergency Diesel Generator Nominal Loads**  
Sheet 1 of 6

Time Seq. (s) <sup>(13)</sup>	Load Description <sup>(8)</sup> <sup>(15)</sup> <sup>(19)</sup>	Volts	Rating (hp/kW) <sup>(3)</sup>	Alternate Feed Load (kW) <sup>(1)</sup> <sup>(12)</sup>	Operating Load LOOP (kW) <sup>(1)</sup> <sup>(12)</sup>	Operating Load DBA/ LOOP (kW) <sup>(1)</sup> <sup>(12)</sup>
Load Step Group 1						
0	Start Signal					
15	EDG reaches rated speed and voltage/output breaker closes					
15	<del>Emergency power generating building electric room chiller unit</del>	480	18.5 kW		18.5	18.5
15	Emergency power generating building electric room supply fan	480	10 Bhp		8.3	8.3
15	Emergency power generating building fuel oil storage tank room fan	480	13.4 Bhp		11.1	11.1
15	EDG starting air compressor	480	61 Bhp		50.6	50.6
15	EDG auxiliary loads	480	8.7 kW		8.7	8.7
15	Main control room air conditioning fan	480	27 Bhp		22.4	22.4
15	MHSI/LHSI room recirculation fan	480	5 Bhp		4.1	4.1
15	Main control room air conditioning heaters <sup>(7)</sup>	480	21 kW		14.7 <sup>(2)</sup>	14.7 <sup>(2)</sup>
15	Division 3 EUPS battery charger <sup>(4)</sup>	480	106 kW		106	106
15	AAA/LAR valve room cooling fan	480	5 Bhp		4.1	4.1
15	Safety chilled water pump <sup>(6)</sup>	480	100 Bhp		82.9	82.9
15	Safety chilled water pump <sup>(6)</sup>	480	100 Bhp		82.9	82.9
15	Safeguard building ventilation heaters	480	180 kW		0	0
15	Safeguard building ventilation supply fan	480	72 Bhp		59.7	59.7



Table 8.3-6—Division 3 Emergency Diesel Generator Nominal Loads  
Sheet 5 of 6

Time Seq. (s) <sup>(13)</sup>	Load Description <sup>(8)</sup> <sup>(15)</sup> <sup>(19)</sup>	Volts	Rating (hp/kW) <sup>(3)</sup>	Alternate Feed Load (kW) <sup>(1)</sup> <sup>(12)</sup>	Operating Load LOOP (kW) <sup>(1)</sup> <sup>(12)</sup>	Operating Load DBA/ LOOP (kW) <sup>(1)</sup> <sup>(12)</sup>
15	Reserved for special use <sup>(18)</sup>	480	125 kW		125	125
15	Lighting <sup>(18)</sup>	480	300 kW		300	300
15	Load contribution from transformer and cable losses		160 kW	40	120	120
Subtotal Load Step Group 1						
Load Step Group 2 <sup>(17)</sup>						
20	MHSI pump	6.9 kV	700 hp			580
Subtotal Load Step Group 2						
Load Step Group 3 <sup>(17)</sup>						
25	LHSI pump	6.9 kV	500 hp			414
Subtotal Load Step Group 3						
Load Step Group 4 <sup>(14)</sup>						
30	CCW pump	6.9 kV	1250 hp		1036	1036
Subtotal Load Step Group 4						
Load Step Group 5 <sup>(14)</sup>						
35	ESW pump	6.9 kV	1250 hp		1036	1036
Subtotal Load Step Group 5						
Load Step Group 6 <sup>(14)</sup>						
40	EFW pump	6.9 kV	700 hp		(5)	580
Subtotal Load Step Group 6						
				689.8 <sup>(10)</sup>	1644.5 <del>1663.0</del>	1644.5 <del>1663.0</del>



**Table 8.3-6—Division 3 Emergency Diesel Generator Nominal Loads**  
Sheet 6 of 6

Time Seq. (s) <sup>(13)</sup>	Load Description <sup>(8)</sup> (15) (19)	Volts	Rating (hp/kW) <sup>(3)</sup>	Alternate Feed Load (kW) <sup>(1)</sup> (12)	Operating Load LOOP (kW) <sup>(1)</sup> (12)	Operating Load DBA/ LOOP (kW) <sup>(1)</sup> (12)
Load Step Group 7 <sup>(14)</sup>						
45	Division 3 safety chilled water compressor	6.9 kV	900 kW		1000	1000
Subtotal Load Step Group 7						
Load Step Group 8 <sup>(14)</sup>						
50	Essential service water UHS fan 1	480	250 hp		207.2	207.2
50	Essential service water UHS fan 2	480	250 hp		207.2	207.2
Subtotal Load Step Group 8						
Subtotal Alternate Feed Loads				689.8		
Total Automatically Sequenced Loads without alternate feed installed						
					5131.15149.6	6706.06724.5
Total Automatically Sequenced Loads with alternate feed installed						
					5821.05839.5	7395.97414.4
Additional Manually Connected Loads						
	Extra boration pump	480	163 Bhp	0 <sup>(20)</sup>		
	Fuel pool cooling pump <sup>(21)</sup>	480	137 Bhp	113.6		
	Emergency pressurizer heaters <sup>(16)</sup>	480	144 kW		144	
Total Manually Connected Loads				113.6	144	
Total Division 3 EDG Loading					6078.56097.0	7509.47527.9

**Notes:**

1. The kW rating derived from hp rating multiplied by 0.746 conversion factor. Indicated hp is considered rated. Where brake horsepower (Bhp) is indicated, this is from the system mechanical requirements.
2. A diversity factor of 0.7 is assumed in load contribution due to cyclical nature of load.



Table 8.3-7—Division 4 Emergency Diesel Generator Nominal Loads  
Sheet 1 of 7

Time Seq. (s) <sup>(13)</sup>	Load Description <sup>(8)</sup> <sup>(15)</sup> <sup>(19)</sup>	Volts	Rating (hp/kW) <sup>(3)</sup>	Alternate Feed Load (kW) <sup>(1)</sup> <sup>(12)</sup>	Operating Load LOOP (kW) <sup>(1)</sup> <sup>(12)</sup>	Operating Load DBA/ LOOP (kW) <sup>(1)</sup> <sup>(12)</sup>
Load Step Group 1						
0	Start Signal					
15	EDG reaches rated speed and voltage/output breaker closes					
15	<del>Emergency power generating building-ventilation-chiller unit</del>	480	18.5 kW		18.5	18.5
15	Emergency power generating building electric room supply fan	480	10 Bhp		8.3	8.3
15	Emergency power generating building fuel oil storage tank room fan	480	13.4 Bhp		11.1	11.1
15	EDG starting air compressor	480	61 Bhp		50.6	50.6
15	EDG auxiliary loads	480	8.7 kW		8.7	8.7
15	Vent stack monitoring	480	13 kW		13	13
15	Division 4 EUPS battery charger <sup>(13)</sup>	480	106 kW		106	106
15	Annulus ventilation heating unit	480	6 kW		4.2 <sup>(2)</sup>	4.2 <sup>(2)</sup>
15	Annulus ventilation fan	480	4.3 Bhp		3.6	3.6
15	AAA/LAR valve room cooling fan	480	5 Bhp		4.1	4.1
15	Extra boration room cooling fan	480	14 Bhp		11.6	11.6
15	Fuel pool cooling pump room cooling fan	480	7.75 Bhp		6.4	6.4
15	Fuel pool cooling pump room cooling fan	480	7.75 Bhp		6.4	6.4
15	Fuel building ventilation heating unit <sup>(7)</sup>	480	15 kW		0	0



**Table 8.3-7—Division 4 Emergency Diesel Generator Nominal Loads**  
Sheet 3 of 7

Time Seq. (s) <sup>(13)</sup>	Load Description <sup>(8)</sup> <sup>(15)</sup> <sup>(19)</sup>	Volts	Rating (hp/kW) <sup>(3)</sup>	Alternate Feed Load (kW) <sup>(1)</sup> <sup>(12)</sup>	Operating Load LOOP (kW) <sup>(1)</sup> <sup>(12)</sup>	Operating Load DBA/ LOOP (kW) <sup>(1)</sup> <sup>(12)</sup>
15	Component cooling water valve hydraulic pump	480	5 Bhp		4.1	4.1
15	Component cooling water valve hydraulic pump	480	5 Bhp		4.1	4.1
15	Division 3 EUPS battery charger	480	106 kW	106		
15	KAA/LAR valve room cooling fan	480	5 Bhp	4.1		
15	Safeguard building ventilation heaters <sup>(7)</sup>	480	180 kW	0		
15	Safeguard building ventilation supply fan	480	72 Bhp	59.7		
15	Safeguard building ventilation return fan	480	43 Bhp	35.6		
<u>15</u>	<u>Main control room air conditioning fan</u>	<u>480</u>	<u>27 Bhp</u>	<u>22.4</u>		
15	Safeguard building battery exhaust fan	480	6 Bhp	5		
15	Emergency feed water ventilation recirculation fan KAA pump room recirculation fan	480	2 Bhp	1.7		
15	KAA pump room recirculation fan	480	2 Bhp	1.7		
15	Emergency lighting panels <sup>(18)</sup>	480	155.7 kW	155.7		
15	Component cooling water valve hydraulic pump	480	5 Bhp	4.1		
15	Component cooling water valve hydraulic pump	480	5 Bhp	4.1		
15	Component cooling water valve hydraulic pump	480	5 Bhp	4.1		



Table 8.3-7—Division 4 Emergency Diesel Generator Nominal Loads  
Sheet 5 of 7

Time Seq. (s) <sup>(13)</sup>	Load Description <sup>(8)</sup> (15) (19)	Volts	Rating (hp/kW) <sup>(3)</sup>	Alternate Feed Load (kW) <sup>(1)</sup> (12)	Operating Load LOOP (kW) <sup>(1)</sup> (12)	Operating Load DBA/ LOOP (kW) <sup>(1)</sup> (12)
15	Safeguard building controlled-area fan	480	9 Bhp			7.5
15	Emergency power generating building supply fan 1	480	100 hp		82.9	82.9
15	Emergency power generating building supply fan 2	480	100 hp		82.9	82.9
15	Emergency power generating building exhaust fan 1	480	75 hp		62.2	62.2
15	Emergency power generating building exhaust fan 2	480	75 hp		62.2	62.2
15	Additional connected loads	480	179.8 kW		179.8	179.8
15	Load contribution from transformer and cable losses		160 kW	40	120	120
Subtotal Load Step Group 1				495.7 <sup>(10)</sup> 473.3	1725.4 1743.9	1790.0 1808.5
Load Step Group 2 <sup>(17)</sup>						
20	MHSI pump	6.9 kV	700 hp			580
Subtotal Load Step Group 2						580
Load Step Group 3 <sup>(17)</sup>						
25	LHSI pump	6.9 kV	500 hp			414
Subtotal Load Step Group 3						414
Load Step Group 4 <sup>(14)</sup>						
30	CCW pump	6.9 kV	1250 hp		1036	1036
Subtotal Load Step Group 4					1036	1036



**Table 8.3-7—Division 4 Emergency Diesel Generator Nominal Loads**  
Sheet 6 of 7

Time Seq. (s) <sup>(13)</sup>	Load Description <sup>(8)</sup> (15) (19)	Volts	Rating (hp/kW) <sup>(3)</sup>	Alternate Feed Load (kW) <sup>(1)</sup> (12)	Operating Load LOOP (kW) <sup>(1)</sup> (12)	Operating Load DBA/ LOOP (kW) <sup>(1)</sup> (12)
Load Step Group 5 <sup>(14)</sup>						
35	ESW pump	6.9 kV	1250 hp		1036	1036
Subtotal Load Step Group 5						
Load Step Group 6 <sup>(14)</sup>						
40	EFW pump	6.9 kV	700 hp	(5)	(5)	580
Subtotal Load Step Group 6						
Load Step Group 7 <sup>(14)</sup>						
45	Division 4 safety chilled water compressor	6.9 kV	900 kW		1000	1000
Subtotal Load Step Group 7						
Load Step Group 8 <sup>(14)</sup>						
50	Essential service water UHS fan 1	480	250 hp		207.2	207.2
50	Essential service water UHS fan 2	480	250 hp		207.2	207.2
Subtotal Load Step Group 8						
Subtotal Alternate Feed Loads				495.74473		
Total Automatically Sequenced Loads without alternate feed installed				5212.152306	6851.668701	
Total Automatically Sequenced Loads with alternate feed installed				5707.857039	7347.373434	
Additional Manually Connected Loads						
	Emergency pressurizer heaters <sup>(16)</sup>	480	144 kW		144	
	Extra boration pump	480	163 Bhp		0 <sup>(20)</sup>	0 <sup>(20)</sup>
	Fuel pool cooling pump <sup>(21)</sup>	480	137 Bhp		113.6	113.6





**Table 8.3-7—Division 4 Emergency Diesel Generator Nominal Loads**  
Sheet 7 of 7

Time Seq. (s) <sup>(13)</sup>	Load Description <sup>(8)</sup> <sup>(15)</sup> <sup>(19)</sup>	Volts	Rating (hp/kW) <sup>(3)</sup>	Alternate Feed Load (kW) <sup>(1)</sup> <sup>(12)</sup>	Operating Load LOOP (kW) <sup>(1)</sup> <sup>(12)</sup>	Operating Load DBA/ LOOP (kW) <sup>(1)</sup> <sup>(12)</sup>
	Severe accident heat removal pump <sup>(16)</sup>	6.9 kV	400 hp		0 <sup>(20)</sup>	0 <sup>(20)</sup>
Total Manually Connected Loads						
Total Division 4 EDG Loading						
					5965.35961-4	7460.87457-0

**Notes:**

1. The kW rating derived from hp rating multiplied by 0.746 conversion factor. Indicated hp is considered rated. Where brake horsepower (Bhp) is indicated, this is from the system mechanical requirements.
2. A diversity factor of 0.7 is assumed in load contribution due to cyclical nature of load.
3. Motor efficiencies estimated at 90 percent.
4. One EUPS battery charger is in service with the other battery charger in standby. Contribution to EDG loading is calculated considering only one battery charger.
5. During a LOOP-only EDG loading sequence, the EFW start is prevented until load step group six, which occurs at 30 seconds. At load step six, the start inhibit is removed and the EFW pump start sequence is based on steam generator low level initiation. If a steam generator low level initiation exists, EFW pump start is given priority over subsequent load steps.  
During a LOOP/LOCA condition, the EFW pump is started at the sequence step indicated.
6. The divisional safety chilled water pumps and chiller are assumed operating for EDG loading purposes.
7. Worst case EDG loading occurs during summer operation when safety chilled water loading is highest. Area heater loads are shown, but do not contribute to overall EDG loading since operating conditions where heater operation is expected does not reflect bounding EDG loading scenario.

section C.2 with regard to provisions for decontamination is provided in Section 12.3.1.

12. The safety-related components and systems of the FPCPS are not shared among nuclear power units (GDC 5).

13. Designed to provide acceptable performance for the environments anticipated under normal, testing, and design basis conditions in compliance with the requirements of 10 CFR 50.49.

### 9.1.3.2 System Description

#### 9.1.3.2.1 General Description

The FPCPS system is described in following four sections:

- Fuel Building and Reactor Building pools.
- Fuel pool cooling system.
- SFP makeup capability.
- Fuel pool purification system.

#### 9.1.3.2.2 Fuel Building and Reactor Building Pools

The Fuel Building pool (see also the description of the Fuel Building in Section 3.8.4 and the Spent Fuel Storage Facility in Section 9.1.2.2.2) includes the following three compartments:

- The Fuel Building Transfer Compartment is used for transfer of used or new fuel between the Fuel Building and the Reactor Building. This compartment is filled from the in-containment refueling water storage tank (IRWST) before refueling.
- The Cask Loading Pit is filled with water when spent fuel transfer from the pool is required. The water needed to fill this compartment is stored in the Fuel Building Transfer Compartment.
- The SFP is dedicated to the storage and cooling of the spent fuel.

The Reactor Building pool (see also the description of the Reactor Building in Section 1.2 and Section 3.8) includes the following four compartments:

- The Reactor Building transfer compartment is connected to the Fuel Building Transfer Compartment by a transfer tube (see Section 9.1.4), and is used for transfer of used or new fuel between the Fuel Building and the Reactor Building.
- The instrumentation lance compartment is used to store instrumentation (e.g., core outlet thermocouples, in-core detectors, and probes). This compartment remains flooded during all modes of plant operation.



isolation valve (KAA10/20/30/40 AA027) is also closed in order to avoid DW water supply to a train with a leak.

The surge tank level is detected by two redundant analog level measurements.

#### Switchover Valves Leakage or Failure

In the event of a switchover valve seat leakage or failure and depending upon the difference in pressure between the two CCWS trains, a water transfer could occur. If the water transfer leads to a MAX2 in one of the two associated trains and a MIN3 on the other, the common users are automatically isolated from the safety trains. This action allows both trains to perform their main safety-related function. The function logic is shown on Figure 7.3-36.

#### Safety Chilled Water Condenser Supply Water Flow Control

The SCWS chillers of Trains 2 and 3 are permanently cooled by one of two associated CCWS common headers. They are isolable from all other associated Common header users by means of manual valves ((KAA22/32AA003/004). They are fitted with a three-way flow control valve (KAA22/32AA101) that is controlled by the chiller condenser pressure. The function logic is shown in Figure 7.3-37.

#### *CCWS Actuation from Safety Injection Signal*

Upon receipt of a safety injection signal, the four CCWS trains are started, supplying all SIS pump coolers and the four LHSI heat exchangers. The non-safety-related users outside of the RB are also isolated.

The system response optimizes the CCWS to cool the SIS pumps and LHSI heat exchangers. The following CCWS actuations are automatically initiated:

- Start CCWS pumps (KAA10/20/30/40 AP001), if not previously running.
- Open LHSI HX isolation valves (KAA12/22/32/42 AA005).
- Open LHSI pump seal cooler isolation valves (KAA22/32 AA013).
- Close isolation valves for non-safety related users outside of RB (KAB50 AA001/004/006 & KAB80 AA015/016/019).

Simultaneous operation of LHSI heat exchanger isolation valves (opening) and non-safety-related user isolation valves (closing) maintains pump operation in a safe range.

A safety injection signal initiates a concurrent containment isolation Stage 1 signal.

## CREF (Iodine Filtration) Train Subsystem

The CREF (iodine filtration) train subsystem is illustrated in Figure 9.4.1-1.

The train 1 outside air inlet duct and train 1 CREF (iodine filtration) train is located in Safeguard Building 2. The train 4 outside air inlet duct and train 4 CREF (iodine filtration) train is located in Safeguard Building 3. Each CREF (iodine filtration) train pulls air from its respective outside air inlet. The outside inlet air for each CREF is ducted to allow the CREF (iodine filtration) train to operate in the filtered or the unfiltered (bypass) alignment.

In the CREF filtered alignment, a maximum of 1000 cfm of outside air mixes with 3000 cfm of CRE recirculated air and is pulled through the CREF (iodine filtration) train by the CREF booster fan and delivers this air to the common recirculation plenum. In the filtered alignment, the filter bypass duct has two motor-operated bypass dampers in series. In the filtered alignment both of these dampers close to provide redundancy and single-failure protection to prevent the outside air from bypassing the CREF (iodine filtration) trains.

In the CREF unfiltered (bypass) alignment, the CREF filtration unit inlet, outlet and CRE recirculation dampers are all closed and both bypass dampers are open. The outside unfiltered air bypasses the CREF iodine filtration unit. In the unfiltered (bypass) alignment, the outside air flows through a prefilter and a preheater that is temperature controlled. The outside air then flows through ducting and is pulled into the common recirculation plenum. In this unfiltered (bypass) alignment, the CREF booster fan does not operate and outside air is pulled into the common recirculation plenum by the CRACS air handling units.

## Air Conditioning and Recirculation Air Handling Subsystem

The air conditioning and recirculation air handling subsystem is illustrated in Figure 9.4.1-2—Control Room Air Conditioning and Recirculation Air Handling Subsystem.

There are four recirculation air handling units located in Safeguard Buildings 2 and 3 (two trains in each building). Recirculated and fresh air is processed through these air handling units and supplied to a common supply air plenum. Each train includes an isolation damper, a volume control manual damper, a cooling coil, a moisture separator, fan suction and discharge silencers, a supply air fan, a HEPA filter, and a non-return damper. The cooling coil is supplied with chilled water from the safety chilled water system (SCWS).

During normal and emergency operation, each CRACS cooling unit provides 50

percent of the cooling for the rooms within the CRE. ~~However, each CRACS air handling unit is capable of cooling up to 75 percent.~~ Each CRACS air handling unit is

designed for 50 percent cooling of the normal and emergency cooling load to allow a single CRACS air handling unit to cool the CRE rooms during a station blackout (SBO) event. During an SBO, the single CRACS air handling unit prevents the CRE room temperature from exceeding 104°F.

The air conditioning system for the CRE area operates in the recirculation mode with fresh air makeup. The fresh air flow rate corresponds to the exhaust of kitchens and restrooms and the leakage rate in the CRE area due to controlled overpressure. The exhaust from the kitchen and restrooms is directed to the electrical division of the SB ventilation system (SBVSE) air outlet duct (refer to Section 9.4.6).

### CRE Air Supply and Recirculation Subsystem

The CRE air supply and recirculation subsystem is illustrated in Figure 9.4.1-3—Control Room Envelope Air Supply and Recirculation Subsystem.

The common supply air plenum receives air from the operating CRACS air handling units and provides conditioned air to the CRE areas through the duct distribution network. Electric air heaters are installed in the supply air ducts to maintain individual room temperatures. The exhaust air from the CRE area, except from the kitchen and restrooms, flows through the recirculation air handling units. The exhaust from kitchen and restrooms is separated from the recirculated return air and is processed separately through the SBVSE.

#### 9.4.1.2.2 Component Description

The major components of the CRACS are listed below, along with the applicable codes and standards. Table 3.2.2-1 provides the seismic design and other design classifications for components in the CRACS.

#### Ductwork and Accessories

The main supply and exhaust air plenums are constructed of concrete with painted surfaces. The air supply and exhaust duct branches for each area are fed from the main supply and exhaust air plenum. These ducts are constructed of galvanized sheet steel and are structurally designed for fan shutoff pressures. The ductwork meets the design, testing and construction requirements per ASME AG-1 (Reference 1).

#### Electric Heaters (Duct Heaters)

The electric heaters (duct heaters) are installed in the supply duct to maintain room ambient conditions. These are controlled by local room temperature sensors and control circuits. The heaters meet the requirements of Reference 1.

## Cooling Coils and Moisture Separator

The cooling coils are of the finned tube, coil type and are connected to the safety chilled water system (SCWS). The cooling coils have a total cooling capacity of 470,000 Btu/hr and are designed in accordance with Reference 1. The moisture separator collects condensate which is directed to the drain system.

### 9.4.1.2.3 System Operation

#### Normal Plant Operation

~~During normal plant operation, fresh air is admitted via air intake trains 1 and 4. The fresh air passes through the unfiltered bypass duct and bypass dampers. The fresh air passes through a prefilter, electrical heaters, and then mixes with the recirculated air from the CRE area.~~

During normal plant operation, fresh air is admitted via air intake trains 1 and 4. The fresh air passes through the unfiltered bypass duct and bypass dampers. The fresh air is then mixed with the recirculated air from the CRE area, and the mixed air passes through a prefilter and electrical heater. Two sets of temperature sensors are located downstream of the electrical heater. One temperature sensor turns on the heater when the air inlet temperature drops below 37°F; the other temperature sensor turns off the heater when the air inlet temperature reaches 50°F.

The fresh and recirculated air is admitted through two of four air handling units which provide heating and cooling of the supply air. The conditioned air is then distributed through a ductwork distribution network to the CRE area. The room air conditioning is provided by the supply and exhaust air flows based on minimum air renewal rate, equipment and personnel heat loads and heat balance between the rooms.

Heating of air streams is provided by electric heaters located in the supply air ducts. The operation of heaters is automatically controlled by the temperature sensors located in the corresponding rooms.

The CRE area is maintained at a pressure above atmospheric pressure to provide habitability in the event of radioactive contamination of the environment.

Both CREF (iodine filtration) trains are isolated with outside air bypassing the CREF (iodine filtration) trains. The CREF iodine filtration train inlet and outlet motor operated isolation dampers are closed. In addition, the CRE recirculation motor operated isolation damper is closed to prevent the recirculation of air from the CRE rooms.

The air conditioning system for the CRE area operates in the recirculation mode with fresh air makeup. During the recirculation mode, the fresh air supply rate is equal to

the rate of exhaust air from the kitchens and restrooms plus accounting for the leakage rate in the area due to controlled overpressure.

Exhaust air from the kitchen and restrooms is not recirculated. During normal operation, air is exhausted from the restrooms and the kitchen area to the SBVSE CREF (iodine filtration) air outlet. The CRACS has design features which will allow it to continue to maintain a minimum positive pressure of 0.01 inch water gauge in the CRE. Approximately twice as much outside air is supplied to the CRE during normal operation compared to operation during accident conditions. Each train of the CRACS is equipped with a pressure control damper. This damper will open and close as required to increase or decrease the amount of outside air that enters the control room. During normal operation, air is exhausted from the restrooms and the kitchen area through a small throttle damper that minimizes the open CRE boundary area.

### **Abnormal Operating Conditions**

Redundancy of air supply and air conditioning trains is provided. A loss of function or power to any single train or component does not affect overall system operation. The train separation and independent power source limit common mode failure of active multiple trains and abnormal operating conditions.

Loss of a single CRACS air conditioning train will not result in a loss of system functional capability because only two of the four cooling trains are required to operate for both normal and accident operation. The CREF (iodine filtration) trains do not operate during normal plant operation, but loss of a single CREF (iodine filtration) train during any design basis accident will not result in a loss of iodine filtration capability because two CREF (iodine filtration) trains are provided.

#### Loss of Coolant Accident

Upon receipt of a containment isolation signal, the following functions are initiated automatically:

- Opens Control Room Emergency Filtration (CREF) iodine filtration trains isolation dampers.
- Closes CREF iodine filtration trains bypass dampers.
- Opens Control Room Envelope (CRE) recirculation dampers to provide clean air and positive pressurization for the rooms within the CRE.

#### *Loss of Offsite Power*

During loss of offsite power (LOOP), the air intake and air conditioning and recirculation air handling electrical components located inside SB division two receive power for one train from the emergency diesel generators (EDG) of division two, and





Prior to opening the equipment hatch during an outage, the air supply and exhaust for the equipment area in front of the hatch are isolated by closing the dampers dedicated to this area.

#### *Loss of Coolant Accident (LOCA)*

Upon receipt of a containment isolation signal, the following functions are initiated automatically:

- Closes FBVS exhaust air isolation dampers to NABVS.
- Closes FBVS supply air isolation dampers from NABVS.
- Opens FBVS exhaust air isolation dampers to exhaust air from the entire Fuel Building to the SBVS.
- Opens isolation dampers for the SBVS Accident Exhaust Iodine Filtration Trains.
- Starts SBVS iodine filtration train fans to pull air through SBVS Accident Exhaust Iodine Filtration Trains and to direct exhaust air to the vent stack. The SBVS maintains negative pressure in the Fuel Building.

~~In the event of LOCA, the containment isolation signal or high radiation signal in the RB initiates isolation of the FB from NABVS supply and exhaust duct to limit leakage into the FB. The SBVS maintains negative pressure in the FB and exhaust air from the FB is directed to the SBVS iodine filtration trains.~~

#### *Loss of Offsite Power (LOOP)*

Upon loss of offsite power, all motorized dampers will fail as is, limiting pathways for potentially contaminated air to leak out to the environment.

The following equipment will remain operational during LOOP:

- Electric heaters in the extra borating pump rooms and pipe chase.
- Recirculation cooling units in the fuel pool cooling system pump rooms, and extra borating system pump rooms.
- Dampers for isolating the fuel pool room and FB.

The power for the equipment listed above is supplied from the corresponding emergency diesel generators.

#### *Station Blackout (SBO)*

In the event of SBO, the following equipment will remain operational:

- Electric heaters in the extra borating system pump rooms and pipe chase.



are designed to provide adequate outside air to meet the distribution requirements of supply air under design conditions of the plant.

The air intake plenum supplies air through three filtration trains. Each train consists of a preheater, prefilter, cooling coil, heater, silencer, humidifier, and air dampers. Four supply air fans take suction from the supply fan inlet plenum and supply air to the outlet air shaft for further distribution to the supply shafts of different buildings.

The design supply air flow to serve the NAB, FB, annulus ventilation system, and Containment Building would require all three trains to be in operation. However, during normal operation, a reduced air flow rate can be used that requires only one supply train to be in operation.

### **Nuclear Auxiliary Building Air Supply Subsystem**

This subsystem supplies air to the NAB to maintain ambient conditions within the prescribed limits for equipment operation and personnel access. See Figure 9.4.3-2—Nuclear Auxiliary Building Air Supply and Exhaust Subsystem.

The conditioned air is supplied to all levels of the building through air shaft cells and a duct distribution network. The flow rate to each room is calculated based on the room volume and equipment heat loads to maintain ambient conditions. The normal operation of the system is to maintain a negative pressure in the building with respect to the outside atmosphere to prevent leakage of potentially contaminated air to the environment. The air flow paths within the NAB are designed so that if radiation is detected, migration of contaminated air from areas of potentially high radioactivity to areas of potentially low radioactivity is limited.

The recirculation cooling units are provided for the rooms with high heat loads. Cooling coil units with fans provide recycled cooled air to the rooms where vapor compressors, electrical switchgear, and transformers are located.

### **Exhaust Air Subsystem**

This subsystem processes exhaust air through filtration trains and charcoal filtration trains to limit airborne radioactivity released through the vent stack. See Figure 9.4.3-3—Nuclear Auxiliary Building Exhaust Filtration Trains Subsystem.

The system processes air exhaust from the following areas:

- FB Cell 5 exhaust (refer to Section 9.4.2).
- FB Cell 4 exhaust (refer to Section 9.4.2).
- NAB Cell 3 exhaust, including annulus exhaust.

are designed to provide adequate outside air to meet the distribution requirements of supply air under design conditions of the plant.

The air intake plenum supplies air through three filtration trains. Each train consists of a preheater, prefilter, cooling coil, heater, silencer, humidifier, and air dampers. Four supply air fans take suction from the supply fan inlet plenum and supply air to the outlet air shaft for further distribution to the supply shafts of different buildings.

The design supply air flow to serve the NAB, FB, annulus ventilation system, and Containment Building would require all three trains to be in operation. However, during normal operation, a reduced air flow rate can be used that requires only one supply train to be in operation.

### **Nuclear Auxiliary Building Air Supply Subsystem**

This subsystem supplies air to the NAB to maintain ambient conditions within the prescribed limits for equipment operation and personnel access. See Figure 9.4.3-2—Nuclear Auxiliary Building Air Supply and Exhaust Subsystem.

The conditioned air is supplied to all levels of the building through air shaft cells and a duct distribution network. The flow rate to each room is calculated based on the room volume and equipment heat loads to maintain ambient conditions. The normal operation of the system is to maintain a negative pressure in the building with respect to the outside atmosphere to prevent leakage of potentially contaminated air to the environment. The air flow paths within the NAB are designed so that if radiation is detected, migration of contaminated air from areas of potentially high radioactivity to areas of potentially low radioactivity is limited.

The recirculation cooling units are provided for the rooms with high heat loads. Cooling coil units with fans provide recycled cooled air to the rooms where vapor compressors, electrical switchgear, and transformers are located.

### **Exhaust Air Subsystem**

This subsystem processes exhaust air through filtration trains and charcoal filtration trains to limit airborne radioactivity released through the vent stack. See Figure 9.4.3-3—Nuclear Auxiliary Building Exhaust Filtration Trains Subsystem.

The system processes air exhaust from the following areas:

- FB Cell 5 exhaust (refer to Section 9.4.2).
- FB Cell 4 exhaust (refer to Section 9.4.2).
- NAB Cell 3 exhaust, including annulus exhaust.

## Heaters

Supply air trains have hot water heaters. The heater design is based on the minimum outside air design temperature and supply air temperature requirements. The coils are constructed and tested in accordance with Reference 1. Electric heaters are located upstream of iodine filters to prevent excessive moisture accumulation in the charcoal beds.

## ~~Humidifiers~~

~~Humidifiers add moisture to the supply air as needed to maintain acceptable ambient conditions. The design of humidifiers is based on the outside air design conditions and supply air humidity requirements.~~

## Prefilters

The prefilters are located upstream of HEPA filters and collect large particles to increase the useful life of the high efficiency filters. The prefilters will meet the requirements of ANSI/ASHRAE Standard 52.2-1999 (Reference 2).

## HEPA Filters

HEPA filters are constructed, qualified and tested in accordance with Reference 1. The periodic in-place testing of HEPA filters to determine the leak-tightness is performed per ASME N510-1989 (Reference 3).

## Adsorbers

Carbon filters are used to remove radioactive iodine from the exhaust air. The efficiency for removal of methyl iodine is based on the decontamination efficiency assigned during the laboratory tests. The periodic in-place testing of the adsorbers to determine the leak-tightness is performed per Reference 3. The activated carbon total bed depth requirement will be 2 inches with a maximum assigned activated carbon decontamination efficiency of 95 percent.

## Fans

The supply and exhaust fans are centrifugal or vane-axial design with electrical motor drivers. Fan performance is rated in accordance with ANSI/AMCA-210-99 (Reference 4), ANSI/AMCA-211-1987 (Reference 5) and ANSI/AMCA-300-1985 (Reference 6).

## Isolation Dampers

The isolation dampers are located upstream and downstream of each filtration train. The motor-operated dampers will fail to “close” or “open” position in case of loss of power, depending on the safety function of the dampers. The performance and testing

Section 9.4.3).

- Accident Air Exhaust Mode—If airborne contamination is detected in any of the four hot mechanical areas of the SBs or there is a containment isolation signal, the SBVS will automatically direct the exhaust air (accident exhaust) via four separate exhaust air ducts and isolation dampers to one common concrete duct in the annulus. This exhaust duct connects to two accident iodine exhaust filtration trains located in the FB. The exhaust air is processed through one of two redundant and independent iodine filtration trains prior to release through the plant stack. Each iodine filtration train includes inlet and outlet dampers, moisture separator, two stage electric heater, inlet and outlet high efficiency particulate air (HEPA) filters, carbon adsorber, exhaust fan, and backdraft damper. The fans direct the exhaust air to the plant stack.

In case of a fuel handling accident in the FB, the accident exhaust air from these buildings is directed and filtered through the SBVS iodine exhaust filtration trains located in the FB, and released through the plant stack.

In case of containment isolation signal, the SBVS maintains a negative pressure and filters all areas of the FB and the hot mechanical area of the SB in addition to performing the SBVS accident air exhaust filtration function.

The supply and exhaust duct network of the hot mechanical area in the SBs is equipped with isolation dampers to isolate the following areas from the other rooms:

- Rooms where safety injection and residual heat removal system components in divisions one and four are installed.
- Rooms where severe accident heat removal system components in division four are installed.
- Personnel air lock area in division two.

Recirculation cooling units are provided for the following rooms where high heat load equipment is located:

- Rooms in the SB, divisions one through four, where safety injection and residual heat removal system components are installed.
- Valve rooms in the SB, divisions one through four, where component cooling water system and emergency feedwater system components are installed.
- Rooms where hydrogen and containment atmosphere monitoring system (divisions one and four), and severe accident sampling system (division four) components are installed.

Electric air heating convectors are provided in the service corridors, interconnecting passageway, and stairways to maintain the minimum allowable temperatures in these areas.

The SBVS is designed to circulate sufficient air to prevent accumulation of flammable or explosive gas or fuel-vapor mixture from components such as storage batteries and stored fuel.

Refer to Section 12.3.6.5.6 for ventilation system design features which demonstrate compliance with the requirements of 10 CFR 20.1406.

#### 9.4.5.2.2 Component Description

The major components of the SBVS are listed below, along with the applicable code and standards. Table 3.2.2-1 provides the seismic design and other design classifications for components in the SBVS.

##### Ductwork and Accessories

The main supply and exhaust air shafts are constructed of concrete with painted surfaces. The air supply and exhaust duct branches for each area are fed from the main supply and exhaust air shafts. These ducts are constructed of steel and structurally designed for fan shutoff pressures. The ductwork meets the design, testing and construction requirements per ASME AG-1 (Reference 2).

##### Electric Air Heating Convectors (Area Heaters)

The electrical air heating convectors are installed to maintain room ambient conditions. The convectors are controlled by local room temperature sensors and control circuits.

##### Moisture Separator

The moisture separator is a combination of moisture separator and prefilter. The moisture separator must meet the requirements of RG 1.52 (Reference 10), ASME N509 (Reference 9), and ASME AG-1 (Reference 2). The moisture separator is located upstream of the filter air heater and the HEPA prefilter. The moisture separator shall be a design that has been qualified by testing in accordance with the procedures described in Reference 9.

##### Filter Air Heaters

~~Filter air~~ Two stage electric heaters are located upstream of HEPA and iodine filtration units to prevent excessive moisture accumulation in the charcoal filter beds. At the start of an accident, full power of two stage electric heater is switched on when the fans start and filter bank isolation dampers open. As the negative pressure is drawn in the FB and SB, and when the temperature downstream of heater increases to 158°F, one step of heater power is switched off automatically. As the temperature downstream of heater reaches 176°F, second step of the heater is also switched off automatically. The heaters meet the requirements of Reference 2.

- Recirculation cooling units in the SB divisions one and four, where the EFW valves are located.

#### *Loss of Ultimate Heat Sink*

During loss of ultimate heat sink (LUHS), the air flow of the recirculation cooling units is cooled by the chilled water provided by the SCWS. Two water-cooled chillers are located in divisions two and three, and two air-cooled chillers are located in divisions one and four. In case of LUHS, the water-cooled chillers are not available. With the safety chilled water divisions 1/2 and 3/4 interconnect, the safety chilled water is then supplied by air-cooled chillers which provide the cooling function for the recirculation cooling units located in divisions one, two, three and four.

#### *Loss of Coolant Accident*

~~In the event of a loss of coolant accident (LOCA), a containment isolation signal initiates isolation of the SB controlled areas from the supply to the SBVSE and the exhaust from the NABVS. Air is supplied from the SB controlled areas and exhausted through the SBVS iodine exhaust filtration trains (located in the FB) and discharged to the plant vent stack. To support the operation of plant equipment, recirculation cooling units maintain rooms in the SB controlled areas at ambient conditions.~~

Upon receipt of a containment isolation signal, the following functions are initiated automatically:

- Closes SBVS supply air isolation dampers from SBVSE.
- Closes SBVS exhaust air isolation dampers to NABVS.
- Opens SBVS exhaust air isolation dampers to exhaust air from the hot mechanical areas of SB to the SBVS Accident Exhaust Iodine Filtration Trains (located in the FB).
- Opens isolation dampers for the SBVS Accident Exhaust Iodine Filtration Trains.
- Starts SBVS iodine filtration train fans to pull air through SBVS Accident Exhaust Iodine Filtration Trains and to direct exhaust air to the vent stack.

In the event of a LOCA, the containment isolation signal initiates isolation of the FB from NABVS supply and exhaust duct to limit leakage into the FB. The SBVS maintains a negative pressure in the FB and exhaust air from the FB is directed to the SBVS iodine filtration trains (refer to Section 9.4.2).

#### *Iodine Presence in the SB Rooms*

In the event of a failed fuel element and residual heat removal pump seal leakage, high iodine is expected to be present in only one of the four divisions at a time, and it is



- The cooling supply units are designed to provide cooling as required to prevent the SBVSE room temperatures from exceeding their maximum design temperature.
- Winter heating loads will be calculated with the plant operating in an outage alignment configuration. Winter heat loads will be calculated with a minimum outside air design temperature 0 percent exceedance value, using U.S. EPR Site Design Envelope Temperature (See Table 2.1-1).
- The SBVSE supply air duct heaters are designed to operate as required when the supply air temperature is less than the minimum set point value.

With outside air ambient design temperature conditions of -40°F to 115°F, the SBVSE maintains the following temperature and humidity ranges for the areas serviced.

Room	Temperature	Humidity
Rest Rooms, changing rooms	65°F - 78°F	310 - 60%
RSS	65°F - 78°F	310 - 60%
Switchgear Rooms	59°F - 104°F	310 - 60%
Cable Floor	41°F - 95°F	310 - 60%
I&C Equipment Room	68°F - 82°F	310 - 60%
Battery Rooms	65°F - 77°F	310 - 60%
HVAC Rooms	50°F - 95°F	210 - 80%
Cold Mechanical Areas, Emergency Feedwater Pump Rooms, and Component Cooling Water Pump Rooms	41°F - 104°F	310 - 60%
Corridors	50°F - 104°F	310 - 60%

The SBVSE performs the following safety-related system functions:

- Maintains acceptable ambient conditions for the safety-related components in the electrical and instrumentation and controls (I&C) rooms in the SB during accident conditions, taking into account internal and external heat loads.
- Maintains acceptable ambient conditions inside the emergency feed water system (EFWS) pumps and component cooling water system (CCWS) component rooms of the SB during accident conditions, taking into account internal and external heat loads.



Additional electric heaters installed in supply air ducts are used to maintain the minimum temperatures in battery rooms and toilet rooms.

For each division, the SBVSE consists of:

- A single air intake equipped with a damper and grilles. The SBVSE air intakes in divisions 2 and 3 are common for the main control room (MCR) air conditioning system (CRACS) (refer to Section 9.4.1) and SCS of the same division (refer to Section 9.4.13).
- A safety-related air conditioning train. Mixing is done with control dampers, filtration with filters, heating with electric air heater, and cooling with air cooling coil, ~~ventilation with supply air fan, and humidification with non-safety-related air humidifiers~~. The train also has the associated exhaust air train, with exhaust fan and control damper.
- A connection with a non-safety-related air conditioning train. Mixing is done with control dampers, filtration with filters, heating with electric air heater, cooling with air cooling coil, and ventilation with supply air fan, ~~and humidification with air humidifiers~~. The train also has the associated exhaust air train, with exhaust fan and control damper.
- Cross-connected ducts between divisions 1 and 2 and divisions 4 and 3 for the HVAC supply and exhaust with the non-safety-related maintenance trains for use when one SBVSE safety-related train of division 2 or 3 is unavailable. Manual isolation dampers equipped with “opened” and “closed” limit switches are installed in the cross-connected ducts (i.e., supply and exhaust ducts of division 1 and 2 and division 3 and 4).
- Connections providing air to the mechanical controlled area (interface with SBVS).
- A single ductwork providing air to the electrical rooms and mechanical non-controlled rooms.
- Two independent exhaust ductworks:
  - The first exhaust ductwork is used for the rooms in the non-controlled area of the SB, except for rooms served by the second exhaust ductwork. It is connected to one of the two recirculation-exhaust fans. One of the fans is a safety-related fan and is located in the same division. The other is a non-safety-related fan for maintenance operation, which is common for the two combined divisions 1 and 2 (located in division 1) and the two combined divisions 3 and 4 (located in division 4). The exhaust air of transformers and inverters is directly exhausted through exhaust hoods above the equipment.
  - The second exhaust ductwork is used for the rooms which could accumulate specific gas (hydrogen in the battery rooms and refrigerant gas in the rooms of the SCWS) and for the non-controlled mechanical area. The air is directly exhausted outside using one of two exhaust fans (one safety-related fan, or one





- Air cooling coil of finned tube coil type has a total cooling capacity of 1,134,900 Btu/hr, supplied with chilled water by the SCWS of the same division.
- Droplet separator, connected to the nuclear island drain and vent system (NIDVS).
- Silencer on fan suction side, splitter type.
- Supply air fan, free wheel radial type, direct driven, with a design air flow of 29,500 scfm.
- Non-return damper.
- Silencer on fan discharge side, splitter type.
- ~~Two air humidifiers, electrically heated and connected to the potable and sanitary water system (PSWS), and NIDVS.~~

### Recirculation-Exhaust Air – Safety-Related Train

The recirculation and exhaust air trains are located in divisions 1 and 4 at elevation +39 ft and in divisions 2 and 3 at elevation +69 ft.

Each train includes:

- Isolation dampers, manually operated.
- Recirculation and exhaust air fan, radial type, direct driven, with a design air flow of 29,500 scfm.
- Control damper with electrical actuator.
- Non-return damper.
- Isolation damper, manually operated.
- Dampers.
- Weather protection grilles.

### Exhaust Air for Battery-Safety Chilled Water Room and Non-controlled Mechanical Area – Safety-Related Train

The exhaust air trains are located in divisions 1 and 4 at elevation +39 ft and in divisions 2 and 3 at elevation +69 ft.

Each train includes:

- Isolation damper, manually operated.
- Exhaust air fan, radial type, direct driven.

- Non-return damper.
- Isolation damper with electrical actuator.

### Supply Air System – Maintenance Train

The maintenance train is non-safety-related. The supply air units are located in divisions 1 and 4 at elevation +39 ft. The components are installed in a sheet metal structure.

Each air conditioning train includes:

- Insect protection screen.
- Isolation damper, manually operated.
- Set of control dampers with electrical actuator.
- Prefilter.
- Roughing filter.
- Electric heater, with tubular elements, comprised of four heating stages.
- Air cooling coil of finned tube coil type, has a total cooling capacity of 1,134,900 Btu/hr supplied with chilled water by the operational chilled water system (OCWS).
- Droplet separator, connected to the NIDVS.
- Silencer on fan suction side, splitter type.
- Supply air fan, free wheel radial type, direct driven, with a design air flow of 29,500 scfm.
- Non-return damper.
- Silencer on fan discharge side, splitter type.
- ~~Two air humidifiers, electrically heated and connected to the PSWS and the NIDVS.~~

### Recirculation-Exhaust Air – Maintenance Train

The maintenance train is non-safety related. The recirculation-exhaust air trains are located in divisions 1 and 4 at elevation +39 ft.

Each train includes:

- Isolation dampers, manually operated.

### Exhaust Air – Non-Safety Related

One exhaust fan is assigned to the toilet rooms located in divisions 1 and 4 at elevation + 55 ft. The fans are located at elevation +81 ft with the following components:

- Exhaust fan, axial type, direct driven.
- Non-return damper.
- Isolation damper, manually operated.

#### 9.4.6.2.3 System Operation

##### Normal Plant Operation

The SBVSE operates during normal plant operation and during outage conditions. The HVAC for each division (1 to 4) is provided by an air supply train and associated exhaust train (with the same safety classification). The normal operation for each division follows:

- The safety-related train is in service to provide filtration, heating, ~~and cooling and humidification~~. Outside makeup air is supplied to each train of the SBVSE through a separate air intake. This outside air mixes with the recirculated air upstream of the supply air filters. The amount of outside air admitted depends on the outside air temperature and is automatically adjusted by control dampers. If required, air heating is performed by the electric air heater. Air cooling is performed by the air cooling coil. The supply air fan supplies the air to the rooms of the SB division. ~~If required, humidification is performed by the air humidifiers.~~
- The maintenance train (non-safety-related) for supply air and exhaust air is shut down.
- Air is supplied to the non-contaminable rooms of the SB plus the hot (controlled) mechanical area, which is exhausted by the SBVS.
- Air is exhausted from all rooms, except the controlled area exhausted by the SBVS.
- Air is released from the rooms representing the risk of accumulation of specific gas (i.e., hydrogen in battery rooms and refrigerant gas in SCWS room) and the rooms of the cold (i.e., non-controlled) mechanical area to the outside by a dedicated exhaust fan.
- Exhaust air is released from the toilet rooms of division 1 and 4 to the outside, also by a dedicated exhaust fan.
- The exhaust air of the remaining rooms is collected and directed to the recirculation-exhaust fan where a portion of the air can be recirculated or directly discharged to the outside. The amount of air to be recirculated depends on the outside air temperature and is automatically adjusted by the control damper.



Each SBVSE train is located in a separate enclosure and is independently powered to limit common mode active failures of multiple trains. Common mode failures of the SBVSE are minimized due to the diversity of fans of the safety-related trains (i.e., divisions 1 and 4 as opposed to divisions 2 and 3) and because of the diversity of the cooling and the heat sinks for the associated SCWS.

Failure of a SBVSE component will not adversely affect the operation of the interfacing systems SCWS, ~~or OCWS, or PSWS.~~

If the SBVSE in one division fails, switchover from the safety-related train to the maintenance train of either division 1 or 2 or division 3 or 4 is possible. Therefore, ventilation of electrical and I&C equipment in all divisions is provided even in case of failure of one of the four divisions.

Additionally, the SCWS has the same configuration as the SBVSE. If the SCWS in one division fails, switchover from the safety-related train to the maintenance train in either division 1 and 2 or division 3 and 4 is possible.

If a failure of a safety-related train of the SB is postulated during maintenance of an SB HVAC train, two SB trains remain available.

#### *Loss of Offsite Power (LOOP)*

In case of LOOP, fans and actuators of each safety-related train of the SBVSE (division 1 to division 4) are backed up by the corresponding emergency diesel generator, ~~with the exception of the humidifiers. Humidifiers are not required for safety function.~~

#### *Loss of Ultimate Heat Sink (LUHS)*

For the SBVSE, the chilled water to the safety trains is provided by the SCWS, with the following key features:

- Two water-cooled chillers, cooled by the CCWS, in divisions 2 and 3.
- Two air-cooled chillers at elevation +39 ft in divisions 1 and 4.

In case of loss of ultimate heat sink (LUHS), the SCWS air-cooled chillers will continue to provide the cooling function of the SBVSE of the two divisions 1, 2, 3, and 4.

### 9.4.6.3 Safety Evaluation

The safety-related portion of the SBVSE is located in the associated SB. The SB is a Seismic Category I structure that is designed to withstand the effects of earthquakes, tornadoes, hurricanes, floods, external missiles, and other appropriate natural phenomena. Sections 3.3, 3.4, 3.5, 3.7, and 3.8 provide the bases for the adequacy of the structural design of this building.

## 9.4.9 Emergency Power Generating Building Ventilation System

The emergency power generating building ventilation system (EPGBVS) maintains acceptable ambient conditions and air renewals of the diesel hall, electrical room, and main tank room of each of the four divisions of the Emergency Power Generating Buildings (EPGB). Each division has its own independent heating, ventilation and air conditioning (HVAC) system which is not connected to other divisions. Two divisions are located in each of the two EPGBs.

### 9.4.9.1 Design Bases

~~The EPGBVS is safety related and designed to meet Seismic Category I requirements.~~  
The EPGBVS consists of safety-related and non-safety-related air supply and exhaust systems. The safety-related portion is designed to Seismic Category I requirements, and the non-safety-related portion is designed to Seismic Category II requirements.

The EPGBVS performs the following safety-related system function and complies with the general design criteria (GDC) indicated below:

- The EPGBVS maintains acceptable temperatures and air renewals in each of the four divisions to support the operation of the emergency diesel generators (EDG) and electrical control panels. The EDGs are required to provide onsite emergency power for the safety-related equipment to achieve and maintain the plant in a safe shutdown condition following a design basis accident, including loss of offsite power (LOOP).
- In accordance with GDC 2, the EPGBVS components are located inside the EPGBs, which are designed to withstand the effects of natural phenomena, such as earthquakes, tornados, hurricanes, floods and external missiles.
- In accordance with GDC 4, the EPGBVS components remain functional and continue to perform their intended safety function after anticipated operational occurrences and design basis accidents, such as fire, internal missiles, or pipe breaks.
- In accordance with GDC 5, the safety-related components and systems of the EPGBVS are not shared with other nuclear power units.
- In accordance with GDC 17, the U.S. EPR contains an onsite and offsite electric power system that supports the functioning of structures, systems, and components important to safety in the event of postulated accidents and anticipated operational occurrences. The EPGBVS maintains a minimum clearance of 20 feet from the bottom of fresh air intakes to grade elevation, and electrical cabinets are provided with suitable seals or gaskets. These features maintain proper functioning of the essential electric power system by meeting the guidelines of NUREG-CR/0660 (Reference 1), as related to the accumulation of dust and particulate material.

The essential onsite electrical power systems meet the guidance of NUREG-CR/0660 for protection of essential electrical components (such as contactors, relays, circuit breakers) from failure due to the accumulation of dust and particulate materials. This is accomplished by the use of filters and supply air units in the EPGBVS.

Air conditioning and heating loads for the EDG rooms are calculated using methodology identified in ASHRAE Handbook (Reference 8).

- Summer cooling loads will be calculated with a maximum outside air design temperature 0 percent exceedance value, using U.S. EPR Site Design Envelope Temperature (See Table 2.1-1). The analysis will be completed for both a normal and accident plant alignment configuration with EDG in operation.
- The cooling supply units are designed to provide outside air for cooling as required to prevent the EDG room temperatures from exceeding their maximum design temperature.
- Winter heating loads will be calculated with the plant operating in an outage alignment configuration, without diesel operation. Winter heat loads will be calculated with a minimum outside air design temperature 0 percent exceedance value, using U.S. EPR Site Design Envelope Temperature (See Table 2.1-1).

Though the EDGs are in standby mode during normal plant operation, the EPGBVS is available in any plant operating condition. With outside air ambient design temperature conditions of -40°F to 115°F, the EPGBVS is designed to meet the following safety-related functional criteria:

- Maintains the diesel hall temperature between 59°F and 140°F.
- Maintains the electrical room temperature between 5940°F and 95113°F with 35 to 70 percent relative humidity.
- Maintains the main tank room temperature between 59°F and 120°F.

The EPGBVS performs the following non-safety system functions:

- Provide outside air and cooling to the diesel hall when the EDGs are not in operation, or safety-related supply and exhaust fans are not required to operate.
- Provide outside air and cooling to the electrical room.

#### 9.4.9.2 System Description

##### 9.4.9.2.1 General Description

The EPGBVS ventilates the diesel generators using outside air as the cooling medium. Air is supplied into the building to slightly pressurize the building, and is then vented from the building through exhaust air louver openings.



The EPGBVS includes ventilation of diesel divisions 1 through 4. Divisions 1 and 2 are located inside the EPGB located on one side of the Reactor Building (RB), and divisions 3 and 4 are located inside the EPGB located on the opposite side of the RB. Each division has a separate and independent HVAC system. The HVAC systems for each of the four divisions are identical.

The air intake and exhaust stack of the EPGBVS are located such that exhaust gases being drawn into the air inlet stream are limited to an insignificant level. The exhaust stack is located approximately 70 feet from the air intake, and the exhaust air flow is directed away from the air intake flow.

One of the divisions of the EPGBVS is illustrated in Figure 9.4.9-1—Emergency Power Generating Building Ventilation System. The other three divisions are identical.

The EPGBVS consists of following subsystems for each division:

- Ventilation of diesel hall.
- Ventilation of electric room.
- Ventilation of main tank room.

#### Ventilation of Diesel Hall

The outside air is drawn into the HVAC supply room through an air intake screen or grill which prevents large objects from entering the air intake. The fresh air intake is located approximately fifty feet above grade elevation and is protected against tornado missiles. The screen or grill is heated during the winter to prevent ice buildup.

The air from the HVAC supply room is supplied through two separate air trains which include back draft damper, prefilter, and supply fan. ~~Each Diesel Hall supply fan air flow is designed for 85,000 scfm. The supply air is then delivered through ductwork to the diesel hall. The main tank room supply air is supplied from the diesel hall or HVAC supply air room.~~ Each diesel hall supply and exhaust fans maintain the diesel hall temperature between 59°F and 140°F. The supply air is delivered through ductwork to the diesel hall.

An additional non-safety-related air supply and exhaust ventilation system to the diesel hall is also installed that operates when the large safety-related supply and exhaust system is not required to operate during maintenance or when the moderate outside temperature does not allow the large supply and exhaust fans to operate. The non-safety-related air supply is drawn from the HVAC supply room, the system includes an air intake screen or grill, backdraft damper, prefilter, supply fan, motor operated damper, and manual damper. The non-safety-related air exhausts to the HVAC air exhaust room, the system includes a motor operated damper, exhaust fan and backdraft damper.



The non-safety-related ventilation system prevents frequent starting and stopping of the large safety-related supply and exhaust fans. A safety-related temperature sensor in the diesel hall controls operation of one or both safety-related supply/exhaust fans as required to maintain design temperature in the diesel hall. Initially, the non-safety fans operate, and as the diesel hall temperature increases both safety-related supply/exhaust fans start operating. Operation of safety-related fans shuts down the non-safety fans and closes the motor operated dampers. A separate safety-related temperature sensor in the diesel hall provides low/high room temperature alarm in the MCR. This sensor also closes the safety-related motor operated dampers located on the non-safety-related air supply/exhaust system when the diesel hall temperature reaches at or below 59°F.

During winter conditions, when the EDGs are not in operation, the air in the diesel hall is recirculated through four electrical air fan heaters. These fans are controlled by local thermostats to maintain the required minimum temperature.

The exhaust air from the diesel hall is directed to the HVAC exhaust room through two separate ducts which include an exhaust fan and a back draft damper. The exhaust plenum is split into two sections: one is for the diesel engine exhaust, and the other is for HVAC exhaust. This separation of exhaust prevents diesel exhaust back pressure from affecting the HVAC exhaust ventilation fans. This boundary prevents inadvertent entry of diesel engine exhaust into the diesel room if one of the HVAC exhaust damper fails to close. This partition also protects the HVAC equipment and improves working environment inside the area. ~~Each Diesel Hall supply fan air flow is designed for 85,000 scfm. The exhaust air is then directed to the building exhaust through an outlet screen or grill.~~

### **Ventilation of Electric Room**

A non-safety-related inlet air supply for the electrical room is drawn from outside air through a motor operated damper, manual damper, prefilter, refrigerant evaporator cooler, and fan. The operation of this unit is automatically controlled by a room thermostat that maintains the electrical room temperature between 40°F and 113°F. A safety-related temperature sensor located outside under a tornado protective hood, sends a signal to open or close the safety-related motor operated damper that is located on the non-safety-related inlet air supply. This damper automatically closes when outside air temperature is below 50°F or above 100°F. This prevents entry of hot or cold outside air. The non-safety-related cooling system operates only when the EDGs are not operating. A backdraft damper is installed at the boundary of electrical room and diesel hall to allow the electrical room air to exhaust to the diesel hall.

A safety-related cooling system for the electrical room operates when the EDGs are also operating. This system recirculates the electrical room air through an air conditioning unit that consists of fire dampers, manual damper, prefilter, HEPA filter,



cooling coil, moisture separator, and supply fan. The fan air flow maintains electrical room temperature within the design temperature limits of 40°F and 113°F. The water for the cooling coil is supplied from the ESW system. The recirculated air from the electrical room is controlled to maintain ambient conditions inside the electrical room.

~~The inlet air supply for the electric room is drawn from HVAC supply air room through an electric louver damper. The supply air is then directed through an air conditioning unit which consists of a manual louver damper, prefilter, high efficiency particulate air (HEPA) filter, cooling coil, moisture separator, electric heater, supply fan, and a humidifier. The control/electrical room supply fan air flow is designed for 6,000 scfm. The cooling coil has a total cooling capacity of 140,000 Btu/hr and is cooled by a packaged chiller unit. The conditioned air is supplied to the electric room through a back draft damper and a fire damper. The electric heater increases the supply air temperature during winter conditions.~~

~~The exhaust air from the electric room is recirculated back to the air conditioning unit through a fire damper and a back draft damper. The outside air supply and recirculated air from the electric room are controlled to maintain ambient conditions inside the electric room.~~

### Ventilation of Main Tank Room

The air supply to the main tank room is drawn from the diesel hall or HVAC supply air room through an electric louver damper, a back draft damper, and a fire damper. The exhaust air from the main tank room is directed through louver damper, exhaust fan, and a back draft damper. The exhaust air is then directed to the building exhaust through an outlet screen or grill. The exhaust fan is designed to maintain the required ventilation rate of the main tank room. The main tank room exhaust design air flow is 3,200 scfm. During winter, local heaters maintain the required minimum temperature inside the main tank room. These heaters are controlled by local thermostats.

#### 9.4.9.2.2 Component Description

The major components of the EPGBVS are listed in the following paragraphs, along with the applicable codes and standards. Table 3.2.2-1 provides the seismic design and other design classifications for components in the EPGBVS.

#### Ductwork and Accessories

The supply and exhaust air ducts are constructed of galvanized or stainless steel plates or sheets, and structurally designed for fan shutoff pressures. The ductwork meets the design, testing and construction requirements of ASME AG-1 (Reference 1).

## Electric Air Heating Convectors (Area Heaters)

The electric area heaters are installed in the main tank room to maintain room ambient conditions and controlled by local room temperature sensors. Electrical heating coils are fin tubular type and meet the requirements of Reference 1.

### ~~In-line Electric Air Heaters~~

~~In-line electric air heaters are installed in the air conditioning ductwork for the electric room and used to heat the supply air to the acceptable temperature. The heaters will meet the requirements of Reference 1.~~

## Fan Heaters

Fan heaters are used in the diesel hall to maintain acceptable temperature in the area. The fan heaters include a fan and electric heater. These fan heaters are controlled by a thermostat.

## Prefilters

~~The~~ Prefilters are located upstream of HEPA filters and on all supply air inlets. ~~collect large particles to increase the useful life of high efficiency filters.~~ The prefilters meet the requirements of ANSI/ASHRAE Standard 52.2 (Reference 2).

## HEPA Filters

HEPA filters are constructed, qualified and tested in accordance with Reference 1. The periodic in-place testing of HEPA filters to determine the leak-tightness is performed in accordance with ASME N510 (Reference 3).

## Fans

The supply and exhaust fans are centrifugal or axial type with electrical motor drivers. Fan performance is rated in accordance with ANSI/AMCA 210-99 (Reference 4), ANSI/AMCA-211-1987 (Reference 5), and ANSI/AMCA 300-1985 (Reference 6).

## Isolation Dampers

Manual dampers are adjusted during initial plant testing to establish accurate flow balance between the rooms. The motor-operated dampers will fail in the “as-is” position in the case of power loss. The performance and testing requirements of the dampers are in accordance with Reference 1.

## Fire Dampers

Fire dampers are installed where ductwork penetrates a fire barrier. Fire damper design meets the requirements of UL 555 (Reference 7) and the damper fire rating is

commensurate with the fire rating of the barrier penetrated. The fire dampers are included in the discussion of the EPGB fire protection system (refer to Appendix 9A.3.6).

### Cooling Coils

Cooling coils are installed in the supply and recirculation train for cooling of the electrical room. The cooling coils are of finned tube coil type and designed in accordance with Reference 1. The coil in the non-safety air cooling system is cooled using a refrigerant evaporator cooler. The safety recirculation cooling coil is cooled by the ESW system. ~~The coil is cooled using a refrigerant from a packaged chiller unit.~~

### Humidifiers

~~A humidifier is installed in the air conditioning train to maintain humidity conditions as required in the electric room. Humidity levels are controlled by the humidity sensors in the room.~~

### Moisture Separator

The moisture separator is installed in the air conditioning train to collect condensate, which is directed to the drain system.

#### 9.4.9.2.3

### System Operation

#### Normal Plant Operation

The EPGBVS maintains acceptable ambient conditions in the diesel hall, electric room, and main tank room of each of the four EPGB divisions. During normal plant operation, the EDGs do not operate. However, outside air is supplied to the diesel hall to maintain an acceptable ambient temperature for the startup of the EDGs and personnel comfort. In winter conditions, four fan heaters are available to maintain the required minimum temperature in the diesel hall. When the EDGs are in operation, the exhaust air removes the heat generated in the diesel hall. The operation of air supply fans and the opening of dampers depend on the diesel hall temperature detected by the sensors. The diesel hall temperature is kept in the appropriate band by controlling the position of dampers and operating the air supply fans.

Air renewals for the ~~electrical room~~, diesel hall, and main tank room are maintained as needed to obtain the required ambient temperatures. The non-safety-related split system air conditioner supplies the electrical room with outside air that is mixed with the recycled air from the electrical room. The mixed air is then processed through the air conditioning train and supplied to the electrical room. The safety-related ESW cooling unit will operate only when the EDGs are operating or during the tests of EDGs. ~~The electrical room is supplied with outside air and mixed with recycled air from the electrical room. The mixed air is then processed through the air conditioning~~

~~train and supplied to the electrical room. The mixed air supply temperature and humidity is adjusted by an electrical heater, cooling coils, and humidifier located in the air conditioning train for the electric room.~~

The main tank room is ventilated by air supplied from the HVAC supply air room or diesel hall. The main tank room air is discharged through the exhaust duct to an exhaust fan and then out of the building. The main tank room is heated by a local electric heater, which is activated by a thermostat to maintain a minimum required room temperature.

Fire dampers are located on the ventilation system to avoid fire propagation in the building. The rooms are completely isolated in case of a fire in the room. Fire is detected by a fire alarm system which automatically closes the corresponding fire damper.

### **Abnormal System Operating Conditions**

#### *Failure of Diesel Hall Air Supply*

If one or more components of the diesel hall supply air fail, the EPGBVS is not able to maintain the required ambient conditions. At lower outside temperature, the system uses only one supply fan to provide sufficient ventilation for the proper operation of the EDGs. Since there are four redundant EPGB divisions, the failure of the diesel hall air supply in one division does not affect the other three divisions.

#### *Failure of Diesel Hall Fan Heater*

The diesel hall has four fan heaters. In the case of failure of one heater fan, the other three fans are able to maintain the required temperature in the diesel hall.

#### *Failure of Electric Room Safety-Related Air Cooling Unit ~~Air Supply~~*

In the case of failure of a component on the safety-related air conditioning train for the electric room, the required ambient conditions are not maintained in the electric room when EDG is operating. However, other unaffected divisions are available to provide necessary power during this event.

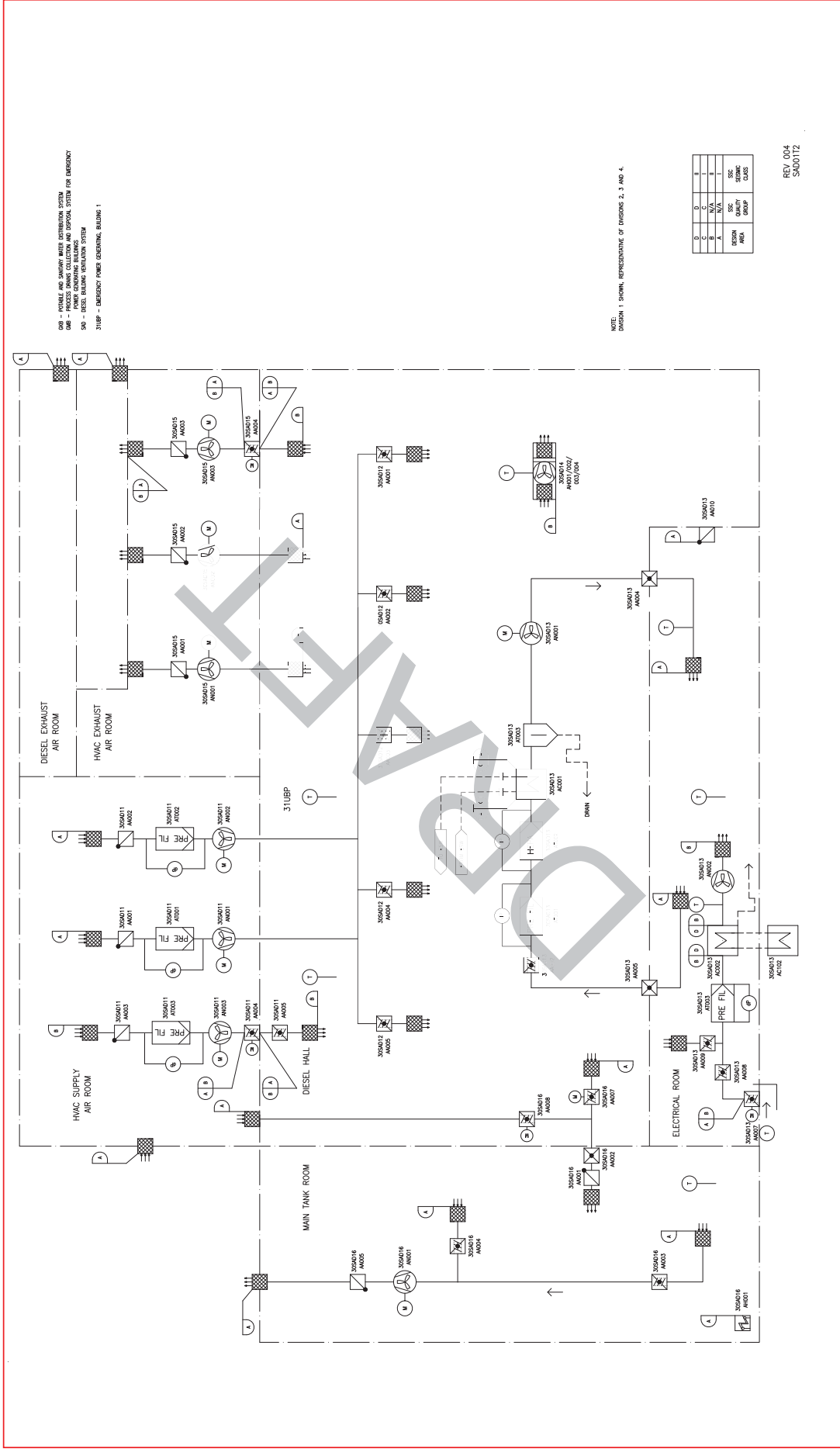
#### *Failure of Exhaust Components*

In the case of failure of any of the EPGBVS exhaust components, proper ambient conditions are not maintained. However, other unaffected divisions are available to provide necessary power during this event.

All indicated changes are in response to RAI 505, 07.01-35



Figure 9.4.9-1—Emergency Power Generating Building Ventilation System



## 9.4.11 Essential Service Water Pump Building Ventilation System

The essential service water pump building ventilation system (ESWPBVS) provides conditioned air to the essential service water system (ESWS) pump areas and associated electrical equipment areas. The ESWPBVS provides an environment suitable for the operation of the ESWS pumps (refer to Section 9.2.1) and associated electrical equipment by maintaining acceptable temperature conditions in each of the four ESWS Pump Buildings. Each building has its own independent ventilation system and is not connected to the other buildings.

### 9.4.11.1 Design Bases

The ESWPBVS consists of a safety-related cooling system and room air heaters and a non-safety related cooling unit. The safety-related portion is designed to Seismic Category I criteria. The non-safety-related portion is designed to Seismic Category II. ~~All components of the ESWPBVS are safety related and designed to Seismic Category I requirements.~~ The ESWPBVS performs the following safety-related system functions and complies with the general design criteria (GDC) indicated below:

- The ESWPBVS maintains acceptable temperature limits to support operation of the ESWS pumps that are required to operate during design basis accident conditions. The ESWPBVS maintains a minimum temperature of 41°F and a maximum temperature of 104-113°F in the ESWS Pump Buildings for personnel accessibility and to support operation of the ESWS pumps. This temperature range maintains a mild environment in these buildings, as defined in Section 3.11.
- The ESWPBVS components are located inside the ESWS Pump Buildings, which are designed to withstand the effects of natural phenomena, such as earthquakes, tornadoes, hurricanes, floods, and external missiles (GDC 2).
- The ESWPBVS components are appropriately protected against dynamic effects and designed to accommodate the effects of, and to be compatible with, the environmental conditions associated with normal operation, maintenance, testing and postulated accidents. The components of the ESWPBVS remain functional and perform their intended safety function after anticipated operational occurrences and design basis accidents, such as a fire, internal missiles, or pipe break (GDC 4).
- The safety-related components and systems of the ESWPBVS are not shared among nuclear power units (GDC 5).
- The essential onsite electrical power systems meet the guidance of NUREG-CR/0660 (Reference 1) (subsection A–item 2, and subsection C–item 1) for protection of essential electrical components (such as contactors, relays, circuit breakers) from failure due to the accumulation of dust and particulate materials (GDC 17).
- Power and control functions are designed in accordance with RG 1.32.

Air conditioning and heating loads for the ESWS pump rooms are calculated using methodology identified in ASHRAE Handbook (Reference 8).

- Summer air conditioning loads will be calculated with a maximum outside air design temperature 0 percent exceedance value, using U.S. EPR Site Design Envelope Temperature (See Table 2.1-1). The analysis will be completed for both a normal and accident plant alignment configuration.
- The safety-related cooling supply units are designed to provide cooling as required to prevent the ESWS pump room temperatures from exceeding their maximum design temperature.
- Winter heating loads will be calculated with the plant operating in an outage alignment configuration. Winter heat loads will be calculated with a minimum outside air design temperature 0 percent exceedance value, using U.S. EPR Site Design Envelope Temperature (See Table 2.1-1).

The ESWPBVS performs the following non safety-related system functions:

- Provides outside air and cooling to the ESWPB when the ESW pumps are not operating.

#### 9.4.11.2 System Description

##### 9.4.11.2.1 General Description

A drawing of the ESWPBVS applicable to each of the four ESWS Pump Buildings is shown in Figure 9.4.11-1—Essential Service Water Pump Building Ventilation System.

The ESWPBVS supplies the recirculation air for cooling or heating of the ESWS pump area and electrical equipment area located inside each of the four ESWS Pump Buildings. Each building has its own independent ventilation system.

This ventilation system is not expected to contain or interface with any radioactive materials, and so is not considered an Engineered-Safety-Feature Atmospheric Clean-Up System.

#### Safety-Related Cooling and Heating

The safety-related cooling units operate when the ESW pump is operating in that building. Room air is drawn through an air inlet grill and processed through an air conditioning train. The conditioned air is supplied to the ESWS pump area and electrical equipment area. The room air is then returned to the air conditioning train. The air conditioning train for each building is comprised of the following components:

- Recirculation supply air ductwork.

- Manual balancing damper.
- Prefilter.

Each ESWPB has two safety-related room air heater units to prevent freezing within the ESW pump rooms during winter.

- Cooling coils, which cool the recirculation air to the required supply air temperature, have a total cooling capacity of 619,400 Btu/hr. The cooling coils are supplied with water from the ESWS pump and the water is discharged into the respective cooling tower basin. Manual isolation valves are provided to isolate the cooling coils for maintenance.
- Moisture separator, which drains the condensate to the cooling tower basin.
- Heaters, which heat the recirculation air during winter conditions to maintain the minimum required temperature.
- Supply air recirculation fans, are designed to provide an air flow rate of 30,000 scfm.

- ~~Supply air louver dampers, which control the air flow to the ESWS pumps area and electrical equipment area.~~
- Motor operated outside air inlet and outlet isolation dampers.

#### Non-Safety Related Cooling Unit

The non-safety-related cooling units in each pump house pull in outside air through a grille protected by a tornado barrier. The outside air is mixed with recirculated room air through balancing dampers and processed through an air conditioning train. The non-safety-related air conditioning train for each building is comprised of the following components:

- Supply ducting with bird screen.
- Manual balancing dampers.
- Prefilters.
- Split system refrigerant air conditioning cooling coil.
- Supply air fan.

#### 9.4.11.2.2 Component Description

The major safety-related components of the ESWPBVS are listed in the following paragraphs, along with the applicable codes and standards. Table 3.2.2-1 provides the seismic design and other design classifications for components in the ESWPBVS.



### Ductwork and Accessories

The supply air duct is constructed of galvanized sheet steel and is structurally designed for the fan shutoff pressure. The ductwork meets the design, construction and testing requirements of ASME AG-1 (Reference 2).

### Cooling Coils

The cooling coils are designed in accordance with Reference 2.

### Cooling Coil Isolation Valves

The cooling coil isolation valves are designed to meet ASME Boiler and Pressure Vessel Code, Section III, Class 3 (Reference 7).

### Moisture Separators

Each moisture separator is installed to collect the condensate which is directed to the cooling tower basin.

### ~~Electric Heaters~~

~~The electric heaters meet the requirements of Reference 2.~~

### Air Supply Fan

The fan is centrifugal or axial type with an electrical motor driver. Fan performance is rated in accordance with ANSI/AMCA-210 (Reference 4), ANSI/AMCA-211 (Reference 5), and ANSI/AMCA-300 (Reference 6).

### ~~Isolation~~ Balancing Dampers

Manual dampers are adjusted during initial plant testing to establish an accurate flow balance. The performance and testing requirements of the dampers are per Reference 2.

### Motor Operated Isolation Dampers

The motor operated isolation dampers will fail in position in case of power loss. The outside air inlet/outlet motor operated isolation dampers are designed to ASME AG-1 (Reference 2) damper isolation leakage class II requirements.

### Electric Heaters

The electric heaters meet the requirements of Reference 2.



### 9.4.11.2.3 System Operation

#### Normal Plant Operation

During normal plant operation, the non-safety-related cooler maintains the ESW Pump Room between 50°F and 100°F, during summer months when the ESW pumps are not in operation. The safety-related cooler for a particular ESWPB will operate when the ESW pump in that building is in operation. The non-safety-related cooler can operate concurrent with the safety-related cooler with or without the ESW pumps in operation. A safety-related temperature sensor (located outside under the tornado protective hood for inlet outside air) sends a signal to open or close the safety-related inlet and outlet motor operated isolation dampers when the outside air temperature is above 100°F or below 50°F. This will prevent the entry of the hot or cold outside air, which could allow the temperature in the ESW building to fall above or below the maximum/minimum design temperature of 113°F/40°F.

During winter, the room air is heated by two safety-related wall mounted electric heaters. Local thermostats start and stop the safety-related heater units to maintain the ESW pump room temperature between 50°F and 100°F.

~~During normal plant operation, two ESWS pumps are in operation. The room air is recirculated through the air conditioning train, which supplies the required air flow at the required temperature. During winter, the recirculated air is heated by the electric heaters to maintain the required temperatures in the building. The heaters automatically start when the room temperature drops to 41°F, and shut off when it rises above 60°F.~~

~~The ESWPBVS also functions when the ESWS pumps are not in operation to maintain acceptable room temperatures for start of the ESWS pumps and personnel comfort. The room temperature is monitored by the temperature sensors for each building.~~

#### Abnormal Operating Conditions

If one or more components of the ESWPBVS fail, the ESWPBVS is not able to maintain the required ambient conditions in the affected building. Because there are four independent ESWS pump buildings, the failure in one building does not affect the other three buildings.

##### *Loss of Off-Site Power*

In the event of loss of offsite power (LOOP), the safety-related ESWPBVS cooling system and room air heaters continues to operate. The power is supplied from the Class 1E emergency power supply system (EPSS).

### *Station Blackout*

In the event of station blackout (SBO), the ESWPBVS is not operable.

### *Plant Accident Conditions*

The ~~safety-related~~ ESWPBVS ~~cooling system and room air heaters~~ ~~is~~ ~~are~~ required to operate during design basis accident conditions. Even if the ESWS pumps are not required to operate, the ~~safety-related~~ ESWPBVS maintains conditions in the ESWS pump buildings in case the ESWS pumps are required to operate.

#### **9.4.11.3 Safety Evaluation**

The ESWPBVS has sufficient cooling capacity to maintain the pump room temperature below ~~120~~113°F when the ESWS pump motors are operating at rated load and the outside air is at the maximum site design ambient temperature of 115°F. The heater is controlled by a local temperature control system having a predetermined temperature setpoint.

The ESWPBVS is located in the ESWS Pump Building, which is designed to withstand the effects of earthquakes, tornadoes, hurricanes, floods, external missiles, and other similar natural phenomena. Section 3.3, Section 3.4, Section 3.5, Section 3.7, and Section 3.8 provide the bases for the adequacy of the structural design of these buildings.

The components of the ESWPBVS remain functional and perform their intended safety function after anticipated operational occurrences and design basis accidents, such as a fire, internal missiles, or pipe break (GDC 4). Section 3.5.1.1 provides the bases for this determination for internally generated missiles outside containment. For missiles generated by tornadoes and extreme winds, see Section 3.5.1.4 and Section 3.5.2. Piping failures due to high energy line breaks are addressed in Section 3.6.1.

Since redundancy of the ESWPBVS is provided, no single failure compromises the safety functions of the system. Vital power is supplied from either onsite or offsite power systems, as described in Chapter 8.

The power supplies and control functions necessary for safe function of the ESWPBVS are from a Class 1E system, as described in Chapter 7 and Chapter 8.

#### **9.4.11.4 Inspection and Testing Requirements**

The ESWPBVS major components, such as dampers, motors, fans, filters, coils, heaters, and ducts are located to provide access for initial and periodic testing to verify their integrity.



- 5.1.7 SBVS alarms, indicating lights and status lights meet design requirements.
- 5.1.8 SBVS meets duct/housing total leakage requirements.
- 5.2 Verify that safety-related components meet electrical independence and redundancy requirements.
- 5.3 The SBVS meets design requirements to monitor radiation (refer to Table 11.5-1, Monitors R-25 and R-26).

#### 14.2.12.8.12 Emergency Power Generating Building Ventilation System (Test #084)

##### 1.0 OBJECTIVE

- 1.1 To demonstrate proper operation of the emergency power generating building ventilation system (EPGBVS).
- 1.2 To demonstrate proper operation of the EPGBVS.
- 1.3 To demonstrate electrical independence and redundancy of power supplies.

##### 2.0 PREREQUISITES

- 2.1 Construction activities on the EPGBVS have been completed.
- 2.2 EPGBVS instrumentation has been calibrated and is operating satisfactorily prior to performing the following test.
- 2.3 Support systems required for operation of the EPGBVS are complete and functional.
- 2.4 Test instrumentation is available and calibrated.

##### 3.0 TEST METHOD

- 3.1 Verify control logic.
- 3.2 Verify design air flow with each EPGBVS in operation.
- 3.3 Verify design temperature can be maintained in each Emergency Power Generating Building.
- 3.4 Verify alarms, indicating instruments, and status lights are functional.
- 3.5 Check electrical independence and redundancy of power supplies for safety-related functions by selectively removing power and determining loss of function.

- 3.6 Verify that operation of dampers meet the requirements of ASME AG-1.
- 3.7 Verify that duct/housing leakage re

##### 4.0 DATA REQUIRED

- 4.1 Fan and damper operating data.

- 4.2 Air flow verification
- 4.3 Setpoint at which alarms, interlocks, and controls occur.
- 4.4 Temperature data of each Emergency Power Generating Building.

#### 5.0 ACCEPTANCE CRITERIA

- 5.1 The EPGBVS operates as designed (refer to Section 9.4.9):
  - 5.1.1 EPGBVS alarms, interlocks, protective devices, and controls (manual and automatic) function as designed.
  - 5.1.2 EPGBVS fan performance meets design requirements.
  - 5.1.3 EPGBVS dampers/valve performance (i.e., thrust, opening times, closing times, and ability to control flow) meets design requirements.
  - 5.1.4 EPGBVS air balance meets design requirements.
  - 5.1.5 EPGBVS meets duct/housing total leakage requirements.
- 5.2 Verify that safety-related components meet electrical independence and redundancy requirements.

#### 14.2.12.8.13 Smoke Confinement System (Test #085)

##### 1.0 OBJECTIVE

- 1.1 To demonstrate the operation of the smoke confinement system (SCS) for Nuclear Island.

##### 2.0 PREREQUISITES

- 2.1 Construction activities in the SCS are complete with penetrations sealed.
- 2.2 SCS instrumentation has been calibrated and is operating satisfactorily prior to performing the following test.
- 2.3 Support systems required for operation of the SCS.
- 2.4 Test instrumentation is available and calibrated.

##### 3.0 TEST METHOD

- 3.1 Verify control logic.
- 3.2 Verify the operation of the supply air fans.
- 3.3 Verify operation of the smoke purge fans.
- 3.4 Verify alarms, indicating lights and status lights are functional.
- 3.5 Perform air flow balancing of the SCS.
- 3.6 Verify that operation of dampers meets design requirements.



#### 14.2.12.8.16 Essential Service Water Pump Building Ventilation System (Test #088)

##### 1.0 OBJECTIVE

- 1.1 To verify the essential service water pump building ventilation system (ESWPBVS) can maintain the space temperature as required.
- 1.2 To demonstrate electrical independence and redundancy of power supplies.

##### 2.0 PREREQUISITES

- 2.1 Construction activities on the ESWPBVS have been completed.
- 2.2 ESWPBVS instrumentation has been calibrated and is operating satisfactorily prior to performing the following test.
- 2.3 Support systems required for operation of the ESWPBVS are complete and functional.
- 2.4 Test Instrumentation is available and calibrated.

##### 3.0 TEST METHOD

- 3.1 Verify control logic and interlock.
- 3.2 Verify design air flow of each fan.
- 3.3 Verify alarms, indicating instruments and status lights are functional.
- 3.4 Verify design temperatures can be maintained in the structure.
- 3.5 Check electrical independence and redundancy of power supplies for safety-related functions by selectively removing power and determining loss of function.

3.6 Verify that operation of isolation dampers meet the requirements of ASME AG-1.

3.7 Verify operation of the electric air convectors (area heaters).

##### 4.0 DATA REQUIRED

- 4.1 Temperature data for the structure from each fan unit.
- 4.2 Air balancing report, including fan operating data.
- 4.3 Setpoints at which alarms and interlocks occur.

##### 5.0 ACCEPTANCE CRITERIA

- 5.1 The ESWPBVS operates as designed (refer to Section 9.4.11):
  - 5.1.1 ESWPBVS alarms, interlocks, protective devices, and controls (manual and automatic) function as designed.
  - 5.1.2 ESWPBVS fan performance meets design requirements.



- 5.1.3 ESWPBVS dampers/valve performance (i.e., thrust, opening times, closing times, and ability to control flow) meets design requirements.
- 5.1.4 ESWPBVS air balance meets design requirements.
- 5.1.5 ESWPBVS electric air heaters meet design requirements.
- 5.2 Verify that safety-related components meet electrical independence and redundancy requirements.

#### 14.2.12.8.17 Main Steam and Feedwater Valve Room System (Test #089)

- 1.0 OBJECTIVE
  - 1.1 To demonstrate that the main steam and feedwater valve room ventilation system (VRVS) provides a suitable operating environment for equipment and personnel during normal operations.
- 2.0 PREREQUISITES
  - 2.1 Construction activities on the VRVS have been completed.
  - 2.2 VRVS instrumentation has been calibrated and is operating satisfactorily prior to performing the following test.
  - 2.3 Support systems required for operation of the VRVS are complete and functional.
  - 2.4 Test instrumentation is available and calibrated.
- 3.0 TEST METHOD
  - 3.1 Verify control logic.
  - 3.2 Verify design air flow with each VRVS in operation.
  - 3.3 Verify design temperature can be maintained in each main steam and feedwater valve room.
  - 3.4 Verify alarms, indicating instruments, and status lights are functional.
- 4.0 DATA REQUIRED
  - 4.1 Fan and damper operating data.
  - 4.2 Air flow verification.
  - 4.3 Setpoint at which alarms, interlocks, and controls, occur.
  - 4.4 Temperature data for each main steam and feedwater valve room train.
- 5.0 ACCEPTANCE CRITERIA
  - 5.1 The VRVS operates as described in Section 9.4.12.