

9A Fire Hazards Analysis

The information in this appendix of the reference ABWR DCD, including all subsections, tables, and figures, as modified by the STP Nuclear Operating Company Application to Amend the Design Certification rule for the U.S. Advanced Boiling Water Reactor (ABWR), "ABWR STP Aircraft Impact Assessment (AIA) Amendment Revision 3," dated September 23, 2010 is incorporated by reference with the following departures and supplement to 9A.1 Introduction. Additionally, the Fire Hazards Analysis for the Turbine Building in Section 9A.4.3 is replaced in its entirety.

STD DEP T1 2.4-1 (Table 9A.6-2)

STD DEP T1 2.4-3 (Table 9A.6-2)

STD DEP T1 2.14-1 (Figure 9A.4-4, Figure 9A.4-9, Table 9A.6-2)

STD DEP T1 3.4-1 (Figure 9A.5-2)

STD DEP 1.2-1 (Table 9A.6-3)

STP DEP 1.2-2 (Figures 9A.4-17 through 9A.4-21, 9A.4-33, 9A.4-34, Table 9A.6-4)

STD DEP 11.5-1

STD DEP 3.8-1 (Figures 9A.4-28 through 9A.4-32)

STP DEP 9.5-7

STD DEP Admin

9A.1 Introduction

As stated in Fire Protection System ITAAC (Tier 1, Section 2.15.6), a fire hazards report will exist for the as-built plant which concludes that, for each postulated fire, the plant can be shut down and maintained in a safe shut down condition.

Such fire hazards report will reflect the final plant layout, purchased equipment type, quantity, and final location, cable routing, and distribution of other combustibles, after as-built drawings are prepared and verified.

The preparation of the fire hazards report will take into consideration the following recognized departures from the certified ABWR design:

- Approved departures made in conjunction with changes to the Turbine Building general arrangement
- Approved departures made in conjunction with changes to the Radwaste Building general arrangement
- Other approved departures as documented in COLA Part 7 (includes complete list and description of departures from certified ABWR DCD) which can have impact

on fire zoning, fire loading, location of safety-related structures, equipment and components and which affect the fire hazards analysis

The above departures will be reviewed using the same criteria used in the certified ABWR design. These criteria consider potential fire hazards and assess the effect of postulated fires on the ability to shutdown and cooldown the reactor to a cold shutdown condition; each postulated fire will be documented in the fire hazard report. (COM 9A-1)

9A.4 Analysis

STD DEP T1 2.4-3

STD DEP T1 2.14-1 (Figure 9A.4-4, Figure 9A.4-9)

STD DEP T1 3.4-1

STP DEP 1.2-2 (Figures 9A-4-17 through 9A-4-21, 9A.4-33, 9A.4-34, Table 9A.6-4)

STD DEP 3.8-1 (Figures 9A.4-28 through 9A-4-32)

9A.4.1.1.4 RCIC Room A (Rm No. 112)

(5) *Combustibles Present:*

<i>Fire Loading</i>	<i>Total Heat of Combustion (MJ)</i>
<i>17 m of divisional cable trays containing 14 kg/m of XLPE-FR cable insulation</i>	<i>727 MJ/m², NCLL (727 MJ/m² maximum average) applies.</i>
<i>106 liters of Class III-B lube oil.</i>	<i>4.6 x 10³</i>

(13) *Remarks:*

(a) *The room contains electrical cables in trays. Cable insulation in trays is discussed in Subsection 9A.3.4.*

(b) *Not Used*

9A.4.1.3.3 Emergency Electric Room A (Rm No. 310)

(1) *Fire Area—F3100*

(2) *Equipment: See Table 9A.6-2*

<i>Safety-Related</i>	<i>Provides Core Cooling</i>
<i>Yes, D1</i>	<i>Yes, D1</i>

(3) *Radioactive Material Present—None.*

- (4) *Qualifications of Fire Barriers—Floor, the exterior wall common with corridor (clean area for personnel access) leading to the control building, the wall common with RIP panel room (Rm 315), the wall common with the elevator and the stairwell, the wall common with corridor A (Rm 311), the wall common with corridor D (Rm 344), the wall common with room 342, the wall common with ~~division 4 multiplexing~~ Remote Digital Logic Controller room (Rm 381), and the ceiling which is in common with fire area F4900, F4100, F4101, F4102 on the 12300 mm level, and Fire area F1200 on the 8500 mm level are of 3 h fire-resistive concrete construction. The remainder of the walls are concrete and are not rated as they are internal to fire area F3100. There is one 3 h fire-resistive double door which provides access from the control building, and one 3 h fire resistive door which provides access to ~~division 4 multiplexing~~ Remote Digital Logic Controller room.*

9A.4.1.3.21 Emergency Electrical Room B (Rm No. 326)

- (4) *Qualifications of Fire Barriers—The wall common with the emergency electrical room C (Rm 337), the wall common with corridor C (Rm. 335), the wall common with ~~the~~ corridor B (Rm 321), the portion of the wall common with elevator and stair tower 3, the wall common with ~~the~~ RIP Panel Room (320), the exterior wall, the floor and the ceiling are of 3 h fire-resistive concrete construction. Two 3 h fire-resistive double doors provide access and egress from ~~the~~ emergency electrical room C (Rm 337) and ~~the~~ RIP Panel room (Rm 320). Two piping spaces ~~are entered to enter~~ enter this room at elevation 10300 mm ~~to facilitate the FCS piping to the next elevation~~. The walls of these piping spaces are fire barrier of 3 h fire resistive concrete construction.*

9A.4.1.3.27 Corridor D (Rm No. 344)

- (4) *Qualifications of Fire Barriers—The wall common with RPV instrument rack IV room (Rm345), The wall common with RIP Panel room (Rm 340), The wall common with Remote Shutdown Panel Rooms (RM 341 and Rm 383), The wall common with ~~division 4 Remote Multiplexing~~ Remote Digital Logic Controller unit room (Rm 381) and portion of the wall common with Emergency Electrical Room A (Rm 310), the wall common with room 342, and portion of the ceiling which is in common with fire area F3400 on the 8500 mm level are fire barriers and are of 3 h fire-resistive concrete construction. Primary containment acts as one wall of the room. The remainder of the walls, the remainder of the ceiling, and the floor are concrete and are not rated as they are internal to fire area F1200. Access to the corridor is provided from corridor B (Rm. No. 321) via an open direct connection, and from room 342 via a 3 hour fire-resistive door.*

9A.4.1.3.28 RIP Panel A Room (Rm No. 340)

- (4) *Qualifications of Fire Barriers—Floor, the building exterior wall, the wall common with Remote Shutdown Panel Room A (Rm 341), the wall common with division 4 ~~Remote multiplexing~~ Remote Digital Logic Controller Unit (Rm 381), the wall common with corridor D (Rm 344), The wall common with elevator No.4, and portion of the ceiling which is common to fire area F4201 are of 3 h fire-resistive concrete construction. The remaining walls, and the remainder of ceiling are concrete and are not rated as they are internal to fire area F3200. Access to the room is provided via a 3 h fire-resistive double door from the corridor (R/B clean area) leading to control building, and via a direct opening from room 320.*

9A.4.1.3.38 Division 4 ~~Remote Multiplexing~~ Remote Digital Logic Controller Room (Rm No. 381)**9A.4.1.4.8 Corridor C (Equipment Entry) (Rm No. 430A and 430B)**

- (4) *Qualifications of Fire Barriers—Room 430 is divided into rooms 430A and 430B. Room 430B provides a separate fire area F4303 between room 430A (fire area F4301) and room 410 (fire area F4101). There is a 3-hour fire rated door at each end of room 430B providing a vestibule between room 430A and room 410. The floors and walls of room 430B serve as fire barriers and are of 3-hour fire-resistive concrete construction. The ceiling of room 430B is not rated as it is common to room 530B above within fire area F4303. Room 430B provides access to ECCS Valve Room C (Rm 431) via a 3-hour fire-rated door. The walls common with the C diesel generator room (Rm 432), valve room (C) (Rm 431), corridor B (Rm 420), ~~the Flammability Control System room (Rm 436)~~ and the exterior wall serve as fire barriers and are of 3 h fire-resistive concrete construction. The floor of room 430A is also a fire barrier to limit the size of the fire areas below and to protect the lower regions of the building, which contains the majority of the ESF equipment. The walls of room 430A are concrete and are not rated as they are internal to fire area F4301. A section of the ceiling common to fire areas F4300, F1300 and F3300 above is of 3 h fire-resistive concrete construction. The remainder of the ceiling is not fire rated as it is internal to fire area F4301. Access to corridor A room 430A is provided from room 430B and corridor B (Rm 420) via 3 h fire-resistive doors. Room 430A provides direct access to the electrical and instrumentation penetration room (Rm 433) through a non-rated door and valve room (C) (Rm 431) ~~and the Flammability Control System room (Rm 436)~~ through a 3 h fire-rated door. There is an open hatch in Room 430A to the floors above. A large steel non-fire-rated door provides access to the reactor building for moving in fuel and other large loads.*

9A.4.1.4.11 ~~Flammability Control System Room (Div. 3) (Rm No. 436)~~ Not Used

- (1) ~~Fire Area F4320~~

(2) ~~Equipment: See Table 9A.6-2~~

Safety-Related	Provides Core-Cooling
Yes, D1, and D2	No

(3) ~~Radioactive Material Present—None that can be released as a result of fire.~~

(4) ~~Qualifications of Fire Barriers—The floor and interior and exterior walls are fire barriers and are of 3-h fire resistive concrete construction. The ceiling is formed by the bottom of the spent fuel storage pool (F4301) and is a 3-h fire barrier. Personnel access is provided via a 3-h fire resistive door from corridor C (Rm 430).~~

(5) ~~Combustibles Present:~~

(6) ~~Detection Provided—Class A supervised POC in the room and manual alarm~~

Fire Loading	Total Heat of Combustion (MJ)
Cable Tray	727 MJ/M ² NCLL (727 MJ/M ² maximum average) applies

~~pull station at Col. 5.9 F.2 and 2.1 F.1.~~

(7) ~~Suppression Available~~

(8) ~~Fire Protection Design Criteria Employed:~~

Type	Location/Actuation
Standpipe and hose reel	Col. 2.2 F.1/Manual
ABC hand extinguishers	Col. 2.1 F.1/Manual

(a) ~~The function is located in a separate fire resistive enclosure.~~

(b) ~~Fire detection and suppression capability is provided and accessible.~~

(9) ~~Consequences of Fire—The postulated fire assumes the loss of the function.~~

~~Smoke from a fire will be removed by the EHVA(B) system operating in its smoke removal mode.~~

(10) ~~Consequences of Fire Suppression—Suppression extinguishes the fire. Refer to Section 3.4, "Water Level (Flood) Design", for the drain system.~~

- ~~(11) Design Criteria Used for Protection Against Inadvertent Operation, Careless Operation or Rupture of the Suppression System:~~
- ~~(a) Location of the manual suppression system external to the room~~
 - ~~(b) Provision of raised supports for the equipment~~
 - ~~(c) Refer to Section 3.4, "Water Level (Flood) Design", for the drain system.~~
 - ~~(d) ANSI B31.1 standpipe (rupture unlikely)~~
- ~~(12) Fire Containment or Inhibiting Methods Employed:~~
- ~~(a) The functions are located in a separate fire resistive enclosure.~~
 - ~~(b) The means of fire detection, suppression and alarming are provided and accessible.~~
- ~~(13) Remarks—None.~~

9A.4.1.4.12 Corridor B (Rm No. 420)

- (4) *Qualifications of Fire Barriers—The walls common with the ~~Flammability Control System Room (Rm 425)~~, the elevator and stair well walls, the Diesel Generator B Room (Rm 423) and the ECCS Valve B Room (Rm 421) serve as fire barriers and are of 3 h fire-resistive concrete construction. The floor is also a fire barrier to limit the size of the fire areas below and to protect the lower regions of the building, which contains the majority of the ESF equipment. The walls common with the E and I Penetration Room (Rm 422) and the ceiling are fire-resistive concrete but are nonrated as they are internal to fire area F4201. Access to the corridor is provided from corridor D (Rm 445), corridor C (Rm 430) and stairs and elevator No.3. A 3 h fire damper is installed in the HVAC duct (located next to the elevator) where it passes through the fire barrier floor to the division 2 areas on the level below. This fire barrier divides the division 2 area of the building to limit the magnitude of possible damage due to a single fire.*

9A.4.1.4.15 Diesel Generator B Room (Rm No. 423)

- (4) *Qualifications of Fire Barriers—The building exterior walls, the walls common with Corridor B (Rm 420), the wall common with ~~FCS room (Rm 425)~~, the wall common with stair wells (Rms 193 and 329), and the floor are of 3 h fire resistive concrete construction. The interior partition walls, and ceiling are not fire rated as they are internal to fire F4200. The ceiling of the room is not a fire barrier as the fan room is located directly above this diesel generator room. The exterior wall of the room has a removable section for removal of equipment from the diesel generator room. Access to this room is provided from the Clean Area Access C/D (Rm 426) through a 3 h fire-rated door and through the removable section of the external wall.*

9A.4.1.4.27 Not Used

- (1) ~~Fire Area—F4230~~
- (2) ~~Equipment: See Table 9A.6-2~~

Safety-Related	Provides Core Cooling
Yes, D2	No

- (3) ~~Radioactive Material Present—None that can be released as a result of fire.~~
- (4) ~~Qualifications of Fire Barriers—The floor and interior and exterior walls are fire barriers and are of 3-h fire resistive concrete construction. The ceiling is formed by the bottom of the spent fuel storage pool (F4301) and is a 3-h fire barrier. Access to the room is provided from Corridor B (Rm 420) through with a three-hour fire-rated door.~~
- (5) ~~Combustibles Present:~~
- (6) ~~Detection Provided—Class A supervised POC in the room and manual alarm~~

Fire Loading	Total Heat of Combustion (MJ)
Cable Tray	272 MJ/m²-NGLL (727 MJ/m²-maximum average) applies

~~pull station at Col. 2.1 F.1.~~

- (7) ~~Suppression Available:~~

Type	Location/Actuation
Standpipe and hose reel	Col. 2.1 F.1/Manual
ABC hand extinguishers	Col. 2.1 F.1/Manual

- (8) ~~Fire Protection Design Criteria Employed:~~
- (a) ~~The function is located in a separate fire resistive enclosure.~~
- (b) ~~Fire detection and suppression capability is provided and accessible.~~
- (9) ~~Consequences of Fire—The postulated fire assumes the loss of the function. Smoke from a fire will be removed by the EHVAC(B) system operating in its smoke removal mode.~~
- (10) ~~Consequences of Fire Suppression—Suppression extinguishes the fire. Refer to Section 3.4, "Water Level (Flood) Design", for the drain system.~~

- ~~(11) Design Criteria Used for Protection Against Inadvertent Operation, Careless Operation or Rupture of the Suppression System:~~
- ~~(a) Location of the manual suppression system external to the room~~
 - ~~(b) Provision of raised supports for the equipment~~
 - ~~(c) Refer to Section 3.4, "Water Level (Flood) Design", for the drain system.~~
 - ~~(d) ANSI B31.1 standpipe (rupture unlikely)~~
- ~~(12) Fire Containment or Inhibiting Methods Employed:~~
- ~~(a) The functions are located in a separate fire resistive enclosure.~~
 - ~~(b) The means of fire detection, suppression and alarming are provided and accessible.~~
- ~~(13) Remarks—None.~~

9A.4.2.5.6 ~~Recirc Internal Pump MG Sets and Control Panels~~ Rm Nos. 501,502,503 and 504

- ~~(4) Qualification of Fire Barriers—The MG set and control room spaces (consisting of Rm Nos. 501, 502, 503 and 504) are in a common fire area. The walls enclosing these spaces are common to adjacent fire areas FC4220 and FC4310 and are designated as fire barriers. Therefore they are of three hour fire-resistive concrete construction. The ceiling is common to fire areas FC4910, FC6210 and FC1210 above and is of three hour fire-resistive concrete construction. The floor is common ~~to~~ the fire area FC4910 below and is also of three hour fire-resistive concrete construction. Access to Rm Nos. 501 and 503 is provided from Rm No. 521 via three hour fire rated doors. Rm Nos. 502 and 504 are accessible from Rm Nos. 501 and 503, respectively.~~
- ~~(5) Combustibles Present—(NCLL Applies)~~
- | Fire Loading | Total Heat of Combustion (MJ) |
|--|--|
| Lubricating oil internal to the MG Sets-
Gable in trays Electrical
Panels | 727 MJ/m² NCLL (727 MJ/m² maximum-
average) applies |
| Negligible | Negligible |
- ~~(9) Consequences of Fire—Postulated fire assumes loss of the function. Loss of the RIP MG Sets will either necessitate a manual scram or initiate an automatic scram. Room cooling is provided by coolers which receive chilled water from the turbine building chilled water system. Room purge (supply and exhaust) is provided by the division 2 HVAC which would be switched to the smoke removal mode upon detection of smoke. The combustion products would then be exhausted directly to the atmosphere without being returned to the division 2 areas. Smoke detection is provided in the branch exhaust duct for the non-safety-related rooms in this fire area (Rm Nos. 501, 502, 503,~~

and 504). This is an aid to determining that a fire is in the non-safety-related rooms and not in the division 2 rooms served by the common purge system. Refer to Subsection 9.5.1.1.6 for additional information.

(13) Remarks:

- (a) Room exhaust and makeup air capability is provided by the division 2 control building HVAC System.
- (b) The Recirc. Internal Pump MG Sets and Control Panels have been relocated to the Control Building Annex.

9A.4.2.5.8 Passageway (Rm No. 521)

- (4) *Qualification of Fire Barriers—Rm No. 521 is a passageway which provides equipment and personnel access to ~~the RIP MG Set rooms~~ Rm. Nos. 501 and 503 (FC5010) via three hour fire-resistive doors. The interior walls and building exterior walls of Rm No. 521 are designated as fire barriers and are of three hour fire-resistive concrete construction. Portion of the ceiling of Rm No. 521 is common to fire areas FC4220 and FC4310 above and is of three hour fire-resistive concrete construction. The remaining portion of the ceiling is not fire rated barrier. The floor is common to fire area FC4910 below and is also of three hour fire-resistive concrete construction. Access to Rm No. 521 from above and below is provided by a stairwell (Rm No.325) and from room 592 via a 3 h fire rated door.*

9A.4.3 Turbine Building

STD DEP 1.2-2

9A.4.3.1 Floor B1F (El. 2.3m (2'-2")) - See Figure 9A.4-17 and Table 9A.4.3.1 Summary of Fire Protection Criteria Floor B1F

9A.4.3.1.1 Fire Area – FT1500 (General Area)

(1) Fire Area Boundary Description

Floor B1F shares fire area FT1500 with all other floors in the Turbine Building. Large overhead openings exist between floor B1F and mezzanine MB1F in the high pressure condensate pump area (room 132) and condenser vacuum pump area (room 121).

Open metal grating and non-fire rated equipment access hatches are installed in different locations/elevations between floor B1F and the upper floors in fire area FT1500.

The low pressure condensate pump area (room 140) extends vertically up to and through a non-fire rated equipment hatch in the turbine operating deck floor (floor 3F, elevation 27.8m (85'-10 1/2")).

Non-fire rated equipment access hatches between floor B1F and floor MB1F exist in the northwest corridor, high pressure heater drain pump area (room 113), and turbine cooling water equipment area (room 224).

The resin storage tank area and condensate filter backwash receiving tank area extend from floor B1F up through floor MB1F to their respective ceilings at the underside of floor 1F (elevation 12.3m (35'-0")). In the resin storage tank area (room 1X1) open grating is located at elevation 6.3m (15'-3 1/2") (floor MB1F).

The offgas charcoal adsorber area (room 112) extends vertically upward through floors MB1F and 1F to the underside of floor 2F (elevation 19.7m (59'-3 1/2")). In room 112, metal grating is installed at elevation 12.3m (floor 1F (35'-0")) with an non-fire rated equipment access hatch at room ceiling level, elevation 19.7m (59'-3 1/2") (floor 2F).

Open grating is also installed above the B1F floor level in and around the main condenser area (room 120) at elevation 4.5m (9'-6 1/2").

Fire area FT1500 is bounded by:

- The Turbine Building exterior walls
- The interior walls enclosing stairwell no. 2 (room 122, fire area FT1503)
- The interior walls enclosing stairwell no. 4 (room 249, fire area FT2504)
- The interior walls enclosing stairwell no. 6 (room 1X3, fire area FT15X1)
- The interior walls enclosing stairwell no. 7 (room 1X4, fire area FT15X2)
- The interior wall between this floor and the stairwell (room 141, fire area FT15X3) leading down to the access to the Radwaste Tunnel and condensate filter backwash transfer pump area (room 144).
- The floor above the Radwaste Tunnel.
- The ceiling beneath the oil purification unit (room 230, fire area FT2500) on floor MB1F
- The ceiling beneath the oil storage tank (room 1Y1, fire area FT15Y3)) on floor MB1F
- The ceiling beneath the EHC hydraulic power unit (room 232, fire area FT15Y4) on floor MB1F

(2) Equipment: See Table 9A.6-4

Safety-Related	Provides Core Cooling
Yes	No

- (3) Radioactive Material Present—None that can be released as a result of fire.
- (4) Qualification of Fire Barriers –

The Turbine Building is classified as Type IA construction in accordance with the International Building Code (IBC), 2006. Type IA construction is non-combustible. The building structural frame, and all exterior and interior bearing walls, are required to be of 3 hour fire-resistive construction. The building floor is required to be of not less than 2 hour fire resistive construction, including supporting beams and joists. Also, the building roof is required to be of not less than 1 ½ hour fire resistive construction.

The enclosed stairwells that serve floor B1F, stairwell nos. 2, 4, 6 and 7 are of 2 hour fire-resistive concrete construction. Enclosed stairwell nos. 2 and 4 serve to access and exit controlled areas within the Turbine Building and extend vertically upwards to floor 3F at elevation 27.8m (85'-10 ½"). Enclosed stairwell nos. 6 and 7 provide for access and exit from uncontrolled Turbine Building areas associated with the Turbine Cooling Water (TCW) System and extend upwards to floor 1F at grade (elevation 12.3m (35'-0")).

Enclosed stairwell nos. 2, 4, 6 and 7 are separate fire areas and are discussed in subsections 9A.4.3.1.2 through 9A.4.3.1.5 (fire areas FT1503, FT2504, FT15X1, and FT15X2, respectively).

The Radwaste Tunnel is separated from the Turbine Building by 3 hour fire-resistive concrete construction. This separation includes interior walls between the condensate filter backwash receiving tank area (room 143), condensate filter backwash transfer pump area (room 144), and the B1F floor at elevation 2.3m (2'-2"), adjacent to and above the Radwaste Tunnel.

An unenclosed stairway leading down to the Radwaste Tunnel and condensate filter backwash transfer pump area (room 144) is located in room 141. This stairway is separated from the Turbine Building by a 3 hour fire-resistive concrete wall and 3 hour fire-rated door.

The Radwaste Tunnel is separated from the Turbine Building exterior by 3 hour fire-resistive concrete construction along the west side of the building. Also, the pipe space exterior to the Turbine Building along the south wall at this elevation is of 3 hour fire-resistive concrete construction.

The remaining exterior walls are constructed of concrete backed by exterior fill.

Remaining floor areas are made up of the concrete base mat.

The remaining portion of the ceiling of floor B1F is concrete but is not designated as a fire-resistive barrier except where this ceiling falls beneath floor areas associated with the lube oil purification unit (room 230, fire area FT2500), EHC hydraulic power unit (room 232, fire area FT15Y4), and

turbine lube oil storage tank areas (room 1Y1, fire area FT15Y3) located on floor MB1F.

(5) Combustibles Present:

Fire Loading	Total Heat of Combustion (MJ)
(a) Cable in conduit, and less than the equivalent of 0.6m cable trays	Acceptable
(b) Limited quantities of lubricants in pumps	Negligible
(c) Charcoal in offgas charcoal bed	Does not contribute to fire loading
(d) Resin in resin storage tanks	Does not contribute to fire loading

(6) Detection Provided – Class A supervised POC, and manual alarm pull stations at Columns – Rows (C-R) TA.4-T7.5, TJ.7-T7.5, TJ.6-T2.2, TG.3-T2.

(7) Suppression Available:

Type	Location/Actuation
Modified Class III standpipes	Stairwells No.2 <122>, No.4 <249>, No.6, and No.7
ABC hand extinguishers and hose stations	TA.1-T6.4, TB.9-T6.4, TC.5-T6.3, TD.2-T6.1, TE.3-T7, TG-T7.2, TB.7-T5.8, TB.1-T5.2, TA.9-T7.8, TC.8-T7.8, TE.7-T7.8, TG.5-T7.8, TH.3-T7.8, TC.2-T3.2, TB.1-T2.9, TB.2-T1.1, TC.6-T2.2, TE.1-T2, TF.9-T2, TC.4-T4, TD.1-T5.6, TG-T5.7, TH.1-T3.9, TG.4-T2.1, TJ-T2.1, TH.3-T4.1, TJ.9-T4.1, TH.8-T6
Wet pipe sprinkler system Design density 12.2 L/min-m ² (0.3 gpm/ft ²) over 464.5 m ² (5000 ft ²) Wet Pipe Sprinkler	Throughout floor B1F
Design density 8.2 L/min-m ² (0.20 gpm/ft ²) over 139 m ² (1,500 ft ²) Wet Pipe Sprinkler	Stairwell Access to Radwaste Tunnel (Room 141)

(8) Fire Protection Design Criteria Employed:

- (a) Fire detection and suppression capability is provided and accessible;
- (b) Fire stops are provided for penetrations through rated fire barriers.

- (9) Consequences of Fire – Postulated fire assumes loss of function. Smoke from a fire would be removed by the normal HVAC system except for the following rooms:
- (a) Rooms 110 and 142 by normal HVAC and process exhaust.
 - (b) Rooms 112 and 144 by process exhaust.
- (10) Consequences of Fire Suppression – Suppression extinguishes the fire. Refer to Section 3.4, “Water Level (Flood) Design,” for drain system.
- (11) Design Criteria Used for Protection Against Inadvertent Operation, Careless Operation or Rupture of the Suppression System:
- (a) Provision of raised supports for the equipment
 - (b) Refer to Section 3.4, “Water Level (Flood) Design,” for drain system.
- (12) Fire Containment or Inhibiting Methods Employed:
- (a) Fire stops are provided for penetrations through fire rated barriers.
 - (b) The means of fire detection, suppression and alarming are provided and accessible.
- (13) Remarks:
- (a) Smoke detectors and temperature controllers are mounted in the exhaust duct of the offgas system to detect any fire in the charcoal beds. The fire is contained by isolating the charcoal adsorber vessel and purging the vessel with nitrogen gas.
 - (b) The following safety-related equipment representing all four safety divisions is mounted on this floor:

B21-PT301 A-D
 - (c) Section 9A.5, Special Cases, provides justification for locating equipment from multiple safety divisions on this floor of the turbine building.
 - (d) Electrical cable insulation in conduit does not represent a combustible fire load.
 - (e) The total flow of the wet pipe sprinkler system on floor B1F with a 1893 L/min (500 gpm) hose stream allowance is estimated to be 10,410 L/min (2750 gpm).

- (f) The total flow of the wet pipe sprinkler system in the stairwell access to the Radwaste Tunnel (Room 141) with a 1893 L/min (500 gpm) hose stream allowance is estimated to be 3,596 L/min (950 gpm).

9A.4.3.1.2 Fire Area – FT1503 (Stairwell No. 2 – Room 122)

- (1) Fire Area Boundary Description

Stairwell No. 2 serves controlled areas inside the Turbine Building at floor level B1F.

Fire area FT1503 extends vertically upward from floor B1F through floor MB1F, and adjacent to floors 1F, 2F, and 3F (elevation 27.8m (85'-10 1/2")).

Access is provided to stairwell no. 2 from B1F and each of the upper floors.

Stairwell no. 2 is a separate fire area bounded by interior fire walls at floor levels B1F and MB1F. At floors 1F, 2F, and 3F, stairwell no. 2 is bounded by interior and exterior fire-resistive walls.

- (2) Equipment – See Table 9A.6-4

Safety Related	Provides Core Cooling
No	No

- (3) Radioactive Material Present – None.

- (4) Qualification of Fire Barriers – At floor levels B1F and MB1F, walls enclosing stairwell no. 2 are a minimum of 2 hour fire-resistive concrete construction. Stairwell doors are a minimum of 1-1/2 hour fire rated (doors are 3-hour fire rated for consistency throughout the Turbine Building). The floor is the concrete basemat of floor B1F.

At floor levels 1F, 2F, and 3F, interior and exterior walls are of 3 hour fire-resistive concrete construction. Doors leading into stairwell no. 2 from inside the Turbine Building are a minimum of 1-1/2 hour fire rated (doors are 3-hour fire rated for consistency throughout the Turbine Building) at all levels. The door at the exit discharge at grade level (floor 1F, elevation 12.3m) is a 3 hour fire rated door.

- (5) Combustibles Present – No significant quantities of exposed combustibles.
- (6) Detection Provided – Class A supervised POC at each building floor elevation and manual pull station external to the enclosed stairway at each floor elevation.
- (7) Suppression Available:

Type	Location/Actuation
Modified Class III standpipe	Stairwell No.2 <122>
ABC portable (hand) extinguishers and hose station	TG.4-T2.1
Wet pipe sprinkler system Design density 6.1 L/min-m ² (0.15 gpm/ft ²)	Stairwell No. 2

- (8) Fire Protection Design Criteria Employed:
- (a) The stairwell is located in a separate fire-resistive enclosure.
 - (b) Fire detection and suppression capability is provided and accessible.
- (9) Consequences of Fire – The postulated fire assumes loss of function of the enclosed stairway. Smoke from a fire would be removed by the normal HVAC system.
- (10) Consequences of Fire Suppression – Suppression extinguishes the fire. Refer to Section 3.4, “Water Level (Flood) Design,” for drain system.
- (11) Design Criteria Used for Protection Against Inadvertent Operation, Careless Operation or Rupture of the Suppression System:
- (a) Refer to Section 3.4, “Water Level (Flood) Design,” for drain system.
- (12) Fire Containment or Inhibiting Methods Employed:
- (a) The function is provided in a fire-resistive enclosure.
 - (b) Fire stops are provided for penetrations through fire rated barriers.
 - (c) The means of fire detection, suppression and alarming are provided and accessible.
- (13) Remarks – The total flow of the wet pipe sprinkler system with a 1893 L/min (500 gpm) hose stream allowance is estimated to be 3,218 L/min (850 gpm).

9A.4.3.1.3 Fire Area – FT2504 (Stairwell No. 4 – Room 249)

- (1) Fire Area Boundary Description

Stairwell No. 4 serves controlled areas inside the Turbine Building at floor level B1F.

Fire area FT2504 extends vertically upward from floor B1F through floor MB1F, and adjacent to floors 1F, 2F, and 3F (elevation 27.8m (85'-10 1/2"))).

Access is provided to stairwell no. 4 from B1F and each of the upper floors.

Stairwell no. 4 is a separate fire area bounded by interior and exterior fire-resistive walls at floor levels B1F, MB1F, 1F, 2F, and 3F.

- (2) Equipment:

Safety Related	Provides Core Cooling
No	No

- (3) Radioactive Material Present – None.

- (4) Qualification of Fire Barriers – At floor levels B1F, MB1F, 1F, 2F, and 3F, interior walls enclosing stairwell no. 4 are a minimum of 2 hour fire-resistive concrete construction. Stairwell doors are a minimum of 1-1/2 hour fire rated (doors are 3-hour fire rated for consistency throughout the Turbine Building). The floor is the concrete basemat of floor B1F.

At floor levels 1F, 2F, and 3F, exterior walls are of 3 hour fire-resistive concrete construction. Doors leading into stairwell no. 4 from inside the Turbine Building are a minimum of 1-1/2 hour fire rated (doors are 3-hour fire rated for consistency throughout the Turbine Building) at all levels. The door at the exit discharge at grade level (floor 1F, elevation 12.3m (35'-0")) is a 3 hour fire rated door.

- (5) Combustibles Present – No significant quantities of exposed combustibles.

- (6) Class A supervised POC at each building floor elevation and manual pull station external to the enclosed stairway at each floor elevation.

- (7) Suppression Available:

Type	Location/Actuation
Modified Class III standpipe	Stairwell No.4 <249>
ABC portable (hand) extinguishers and hose stations	TA.1-T6.4, TA.9-T7.8,
Wet pipe sprinkler system Design density 6.1 L/min-m ² (0.15 gpm/ft ²)	Stairwell No. 4

- (8) Fire Protection Design Criteria Employed:

- (a) The stairwell is located in a separate fire-resistive enclosure.
(b) Fire detection and suppression capability is provided and accessible.

- (9) Consequences of Fire – The postulated fire assumes loss of function of the enclosed stairway. Smoke from a fire would be removed by the normal HVAC system.

- (10) Consequences of Fire Suppression – Suppression extinguishes the fire. Refer to to Section 3.4, "Water Level (Flood) Design," for drain system.

- (11) Design Criteria Used for Protection Against Inadvertent Operation, Careless Operation or Rupture of the Suppression System:
- (a) Refer to Section 3.4, "Water Level (Flood) Design," for drain system.
- (12) Fire Containment or Inhibiting Methods Employed:
- (a) The function is provided in a fire-resistive enclosure.
- (b) Fire stops are provided for penetrations through fire rated barriers.
- (c) The means of fire detection, suppression and alarming are provided and accessible.
- (13) Remarks – The total flow of the wet pipe sprinkler system with a 1893 L/min (500 gpm) hose stream allowance is estimated to be 3,218 L/min (850 gpm).

9A.4.3.1.4 Fire Area – FT15X1 (Stairwell No. 6 - Room 1X3)

- (1) Fire Area Boundary Description

Stairwell No. 6 serves uncontrolled areas associated with the turbine cooling water system inside the Turbine Building at floor level B1F, and adjustable speed drive equipment at floor levels MB1F and 1F.

Fire area FT15X1 extends vertically upward from floor B1F, through floor MB1F, and terminates on floor 1F (elevation 12.3m (35'-0")).

Access is provided to stairwell no. 6 from B1F and each of the upper floors.

Stairwell no. 6 is a separate fire area bounded by interior and exterior fire-resistive walls at floor levels B1F, MB1F, and 1F.

- (2) Equipment:

Safety Related	Provides Core Cooling
No	No

- (3) Radioactive Material Present – None.

- (4) Qualification of Fire Barriers – At floor levels B1F, MB1F, and 1F interior walls enclosing stairwell no. 6 are a minimum of 2 hour fire-resistive concrete construction. Stairwell doors are a minimum of 1-1/2 hour fire rated (doors are 3-hour fire rated for consistency throughout the Turbine Building). The floor is the concrete basemat of floor B1F.

At floor level 1F, the exterior wall is of 3 hour fire-resistive concrete construction. Doors leading into stairwell no. 6 from inside the Turbine Building are a minimum of 1-1/2 hour fire rated (doors are 3-hour fire rated for consistency throughout the Turbine Building) at all levels. The door at the exit

discharge at grade level (floor 1F, elevation 12.3m (35'-0")) is a 3 hour fire rated door.

- (5) Combustibles Present – No significant quantities of exposed combustibles.
- (6) Class A supervised POC at each building floor elevation and manual pull station external to the enclosed stairway at each floor elevation.
- (7) Suppression Available:

Type	Location/Actuation
Modified Class III standpipe	Stairwell No.6
ABC portable (hand) extinguishers and hose station	TJ-T2.1
Wet pipe sprinkler system Design density 6.1 L/min-m ² (0.15 gpm/ft ²)	Stairwell No. 6

- (8) Fire Protection Design Criteria Employed:
 - (a) The stairwell is located in a separate fire-resistive enclosure.
 - (b) Alternate access and egress routes are provided by a separate enclosed stairwell at this floor level (stairwell no. 7).
 - (c) Fire detection and suppression capability is provided and accessible.
- (9) Consequences of Fire – The postulated fire assumes loss of function of the enclosed stairway. Access to other enclosed stairways at this floor level is maintained. Smoke from a fire would be removed by the normal HVAC system.
- (10) Consequences of Fire Suppression – Suppression extinguishes the fire. Refer to to Section 3.4, "Water Level (Flood) Design," for drain system.
- (11) Design Criteria Used for Protection Against Inadvertent Operation, Careless Operation or Rupture of the Suppression System:
 - (a) Refer to Section 3.4, "Water Level (Flood) Design," for drain system.
- (12) Fire Containment or Inhibiting Methods Employed:
 - (a) The function is provided in a fire-resistive enclosure.
 - (b) Fire stops are provided for penetrations through fire rated barriers.
 - (c) The means of fire detection, suppression and alarming are provided and accessible.

- (13) Remarks – The total flow of the wet pipe sprinkler system with a 1893 L/min (500 gpm) hose stream allowance is estimated to be 3,218 L/min (850 gpm).

9A.4.3.1.5 Fire Area – FT15X2 (Stairwell No. 7 – Room)

- (1) Fire Area Boundary Description

Stairwell No. 7 serves uncontrolled areas associated with the turbine cooling water system inside the Turbine Building at floor level B1F, and adjustable speed drive equipment at floor levels MB1F and 1F.

Fire area FT15X2 extends vertically upward from floor B1F, through floor MB1F, and terminates on floor 1F.(elevation 12.3m (35'-0"))).

Access is provided to stairwell no. 6 from B1F and each of the upper floors.

Stairwell no. 7 is a separate fire area bounded by interior and exterior fire-resistive walls at floor levels B1F, MB1F, and 1F.

- (2) Equipment:

Safety Related	Provides Core Cooling
No	No

- (3) Radioactive Material Present – None.

- (4) Qualification of Fire Barriers – At floor levels B1F, MB1F, and 1F interior walls enclosing stairwell no. 7 are a minimum of 2 hour fire-resistive concrete construction. Stairwell doors are a minimum of 1-1/2 hour fire rated (doors are 3-hour fire rated for consistency throughout the Turbine Building). The floor is the concrete basemat of floor B1F.

At floor level 1F, the exterior wall is of 3 hour fire-resistive concrete construction. Doors leading into stairwell no. 7 from inside the Turbine Building are a minimum of 1-1/2 hour fire rated (doors are 3-hour fire rated for consistency throughout the Turbine Building) at all levels. The door at the exit discharge at grade level (floor 1F, elevation 12.3m (35'-0")) is a 3 hour fire rated door.

- (5) Combustibles Present – No significant quantities of exposed combustibles.
- (6) Class A supervised POC at each building floor elevation and manual pull station external to the enclosed stairway at each floor elevation.

(7) Suppression Available:

Type	Location/Actuation
Modified Class III standpipe	Stairwell No.7
ABC portable (hand) extinguishers and hose station	TH.8-T6
Wet pipe sprinkler system Design density 6.1 L/min-m ² (0.15 gpm/ft ²)	Stairwell No. 7

(8) Fire Protection Design Criteria Employed:

- (a) The stairwell is located in a separate fire-resistive enclosure.
- (b) Alternate access and egress routes are provided by a separate enclosed stairwell at this floor level (stairwell no. 6).
- (c) Fire detection and suppression capability is provided and accessible.

(9) Consequences of Fire – The postulated fire assumes loss of function of the enclosed stairway. Access to other enclosed stairways at this floor level is maintained. Smoke from a fire would be removed by the normal HVAC system.

(10) Consequences of Fire Suppression – Suppression extinguishes the fire. Refer to to Section 3.4, “Water Level (Flood) Design,” for drain system.

(11) Design Criteria Used for Protection Against Inadvertent Operation, Careless Operation or Rupture of the Suppression System:

- (a) Refer to Section 3.4, “Water Level (Flood) Design,” for drain system.

(12) Fire Containment or Inhibiting Methods Employed:

- (a) The function is provided in a fire-resistive enclosure.
- (b) Fire stops are provided for penetrations through fire rated barriers.
- (c) The means of fire detection, suppression and alarming are provided and accessible.

(13) Remarks – The total flow of the wet pipe sprinkler system with a 1893 L/min (500 gpm) hose stream allowance is estimated to be 3,218 L/min (850 gpm).

**Table 9A.4.3.1 - Summary of Fire Protection Criteria
Floor B1F**

Fire Area	Description	Adjacent Fire Area	Adjacent Fire Area Description	Fire Rated Separation	Fire Separation Criteria	Automatic Suppression Type	Density	Suppression Criteria
FT1500	General Area	FT1503	Stairwell No. 2 (Room 122)	Walls: 2-hour fire resistive Doors: 3-hour fire rated	Walls: NFPA 101, paragraph 8.5.6.(1) Doors: NFPA 101, Table 8.3.4.2	Wet pipe sprinkler	0.30 gpm/ft ² (12.2 L/min-m ²) over minimum application of 5000 ft ² (464.5 m ²) Total flow (Est.): 2750 gpm (10,410 L/min)	(a) NFPA 804, 2006, paragraph 10.8.2.1(2) (b) NEIL LCM, March 2008, A3.2.20.5.2.1.1..
		FT2504	Stairwell No. 4 (Room 249)	Walls: 2-hour fire resistive Doors: 3-hour fire rated	Walls: NFPA 101, paragraph 8.5.6.(1) Doors: NFPA 101, Table 8.3.4.2			
		FT15X1	Stairwell No. 6 (Room 1X3)	Walls: 2-hour fire resistive Doors: 3-hour fire rated	Walls: NFPA 101, paragraph 8.5.6.(1) Doors: NFPA 101, Table 8.3.4.2			
		FT15X2	Stairwell No. 7 (Room 1X4)	Walls: 2-hour fire resistive Doors: 3-hour fire rated	Walls: NFPA 101, paragraph 8.5.6.(1) Doors: NFPA 101, Table 8.3.4.2			

**Table 9A.4.3.1 - Summary of Fire Protection Criteria
Floor B1F (Continued)**

Fire Area	Description	Adjacent Fire Area	Adjacent Fire Area Description	Fire Rated Separation	Fire Separation Criteria	Automatic Suppression Type	Density	Suppression Criteria
FT1500	General Area	External to Turbine Building	Radwaste Tunnel	Exterior Turbine Building Wall: 3-hour fire resistive Floor: 3-hour fire resistive	NEIL LCM, March 2008, 3.2.9.1 NFPA 804, paragraph 8.1.2.3 Also, based on (IBC) H-4 Occupancy and Type 1A construction Exterior Turbine Bldg. Wall: IBC, 2006, Table 601 Turbine Bldg. Floor over Radwaste Building (treated as separation between buildings): IBC, 2006, Table 601	Wet pipe sprinkler	0.30 gpm/ft ² (12.2 L/min-m ²) over minimum application of 5000 ft ² (464.5 m ²) Total flow (Est.): 2750 gpm (10,410 L/min)	(a) NFPA 804, 2006, paragraph 10.8.2.1(2) (b) NEIL LCM, March 2008, A3.2.20.5.2.1.1..
		FT15X3	Stairwell Access to Radwaste Tunnel (Room 141)	Wall: 3-hour fire resistive Door: 3-hour fire rated	NEIL LCM, March 2008, 3.2.9.1 NFPA 804, paragraph 8.1.2.3 Also, based on (IBC) H-4 Occupancy and Type 1A construction Exterior Turbine Bldg. Wall: IBC, 2006, Table 601 Turbine Bldg. Floor over Radwaste Building (treated as separation between buildings): IBC, 2006, Table 601			

**Table 9A.4.3.1 - Summary of Fire Protection Criteria
Floor B1F (Continued)**

Fire Area	Description	Adjacent Fire Area	Adjacent Fire Area Description	Fire Rated Separation	Fire Separation Criteria	Automatic Suppression Type	Density	Suppression Criteria
FT1500	General Area	FT2500	Lube Oil Purification Unit on Floor MB1F (Room 230)	Ceiling: 3-hour fire resistive	NEIL LCM, March 2008, 3.2.9.1 NFPA 804, paragraph 8.1.2.3	Wet pipe sprinkler	0.30 gpm/ft ² (12.2 L/min-m ²) over minimum application of 5000 ft ² (464.5 m ²) Total flow (Est.): 2750 gpm (10,410 L/min)	(a) NFPA 804, 2006, paragraph 10.8.2.1(2) (b) NEIL LCM, March 2008, A3.2.20.5.2.1.1..
		FT15Y3	Lube Oil Storage Tanks on Floor MB1F (Room 1Y1)	Ceiling: 3-hour fire resistive	NEIL LCM, March 2008, 3.2.9.1 NFPA 804, paragraph 8.1.2.3			
		FT15Y4	EHC Hydraulic Power Unit Floor MB1F (Room 232)	Ceiling: 3-hour fire resistive	NEIL LCM, March 2008, 3.2.9.1			
FT1503	Stairwell No. 2 (Room 122)	FT1500	General Area	Walls: 2-hour fire resistive Doors: 3-hour fire rated	Walls: NFPA 101, paragraph 8.5.6.(1) Doors: NFPA 101, Table 8.3.4.2	Wet pipe sprinkler	0.15 gpm/ft ² (6.1 L/min-m ²) over 1500 ft ² (139 m ²) Total flow (Est.): 850 gpm (3218 L/min)	Ordinary Hazard Group 1 per NFPA 13, paragraph 5.3.1
FT2504	Stairwell No. 4 (Room 249)	FT1500	General Area	Walls: 2-hour fire resistive Doors: 3-hour fire rated	Walls: NFPA 101, paragraph 8.5.6.(1) Doors: NFPA 101, Table 8.3.4.2	Wet pipe sprinkler	0.15 gpm/ft ² (6.1 L/min-m ²) over 1500 ft ² (139 m ²) Total flow (Est.): 850 gpm (3218 L/min)	Ordinary Hazard Group 1 per NFPA 13, paragraph 5.3.1

**Table 9A.4.3.1 - Summary of Fire Protection Criteria
Floor B1F (Continued)**

Fire Area	Description	Adjacent Fire Area	Adjacent Fire Area Description	Fire Rated Separation	Fire Separation Criteria	Automatic Suppression Type	Density	Suppression Criteria
FT15X1	Stairwell No. 6 (Room 1X3)	FT1500	General Area	Walls: 2-hour fire resistive Doors: 3-hour fire rated	Walls: NFPA 101, paragraph 8.5.6.(1) Doors: NFPA 101, Table 8.3.4.2	Wet pipe sprinkler	0.15 gpm/ft ² (6.1 L/min-m ²) over 1500 ft ² (139 m ²) Total flow (Est.): 850 gpm (3218 L/min)	Ordinary Hazard Group 1 per NFPA 13, paragraph 5.3.1
FT15X2	Stairwell No. 7 (Room 1X4)	FT1500	General Area	Walls: 2-hour fire resistive Doors: 3-hour fire rated	Walls: NFPA 101, paragraph 8.5.6.(1) Doors: NFPA 101, Table 8.3.4.2	Wet pipe sprinkler	0.15 gpm/ft ² (6.1 L/min-m ²) over 1500 ft ² (139 m ²) Total flow (Est.): 850 gpm (3218 L/min)	Ordinary Hazard Group 1 per NFPA 13, paragraph 5.3.1
FT15X3	Stairwell Access to Radwaste Tunnel (Room 141)	FT1500	General Area	Wall: 3-hour fire resistive Door: 3-hour fire rated Ceiling: 3-hour fire resistive	NEIL LCM, March 2008, 3.2.9.1 NFPA 804, paragraph 8.1.2.3 Also, based on (IBC) H-4 Occupancy and Type 1A construction Exterior Turbine Bldg. Wall: IBC, 2006, Table 601 Turbine Bldg. Floor over Radwaste Building (treated as separation between buildings): IBC, 2006, Table 601	Wet pipe sprinkler	0.20 gpm/ft ² (8.2 L/min-m ²) over 1500 ft ² (139 m ²) Total flow (Est.): 950 gpm (3596 L/min)	Ordinary Hazard Group 2 per NFPA 13, paragraph 5.3.2

9A.4.3.2 Floor MB1F (El. 6.3m (15'-3 ½")) - See Figure 9A.4-18 and Table 9A.4.3.2 Summary of Fire Protection Criteria Floor MB1F

9A.4.3.2.1 Fire Area - FT1500 (General Area)

(1) Fire Area Boundary Description

Floor MB1F shares fire area FT1500 with all other floors in the Turbine Building. Large overhead openings exist between floor MB1F and B1F over the high pressure condensate pump area (room 132) and condenser vacuum pump area (room 121).

Open metal grating and non-fire rated equipment access hatches are installed in different locations/elevations between floor MB1F and the upper and lower floors in fire area FT1500.

The low pressure condensate pump area (room 140) extends vertically up from floor B1F, through floors MB1F, 1F and 2F, to and through an non-fire rated equipment hatch in the turbine operating deck floor (floor 3F, elevation 27.8m (85'-10 ½")).

Non-fire rated equipment access hatches are installed in the floor between MB1F and floor B1F in the northwest corridor area (room 242), in the pipe space over the high pressure heater drain pump area, and in the adjustable speed drive area (room 214-2) over the turbine cooling water equipment area below.

The resin storage tank area (room 1X1) and condensate filter backwash receiving tank area (room 143) extend from floor B1F up through floor MB1F to their respective ceilings at the underside of floor 1F (elevation 12.3m (35'-0")).

The offgas charcoal adsorber area (room 112) extends vertically upward from floor B1F through floors MB1F and 1F to the underside of floor 2F (elevation 19.7m (59'-3 ½")). Room 112 is part of fire area FT1500. In the off-gas charcoal bed area (room 112), metal grating is installed at elevation 12.3m (floor 1F) with an non-fire rated equipment access hatch at room ceiling level, elevation 19.7m (59'-3 ½") (floor 2F).

Access to the resin storage tank area (room 1X1) and condensate filter backwash receiving tank area (room 143) is from floor MB1F – these areas are part of fire area FT1500. In room 1X1 open grating is installed at this floor level.

Fire area FT1500 is bounded by:

- The Turbine Building exterior walls

- The interior walls enclosing stairwell no. 2 (room 122, fire area FT1503)
- The interior walls enclosing stairwell no. 3 (room 212, fire area FT2502)
- The interior walls enclosing stairwell no. 4 (room 249, fire area FT2504)
- The interior walls enclosing stairwell no. 6 (room 1X3, fire area FT15X1)
- The interior walls enclosing stairwell no. 7 (room 1X4, fire area FT15X2)
- The interior walls enclosing the elevator shaft (room 250, fire area FT15Y2)
- The floor above the access to the Radwaste Tunnel, Room 141, on floor B1F below
- The interior walls enclosing the area housing the lube oil purification unit (room 230, fire area FT2500)
- The interior walls enclosing the area housing the lube oil storage tanks (room 1Y1, fire area FT15Y3)
- The interior walls enclosing the area housing the EHC hydraulic power unit (room 232, fire area FT15Y4)
- The interior wall between the house boiler area (room 247, fire area FT2503) and this fire area, along building column line T8.
- The interior wall between the chiller area (room 248, fire area FT1501) and this fire area, along column line T8.

(2) Equipment – See Table 9A.6-4

Safety Related

No

Provides Core Cooling

No

(3) Radioactive Material Present – None that can be released as a result of fire.

(4) Qualification of Fire Barriers –

The Turbine Building is classified as Type IA construction in accordance with the International Building Code (IBC), 2006. Type IA construction is non-combustible. The building structural frame, and all exterior and interior bearing walls, are required to be of 3 hour fire-resistive construction. The building floor is required to be of not less than 2 hour fire resistive construction, including supporting beams and joists. Also, the building roof is required to be of not less than 1 ½ hour fire resistive construction.

The enclosed stairwells that serve floor MB1F, stairwell nos. 1, 2, 3, 4, 6, 7 and 8 are of 2 hour fire-resistive concrete construction.

Enclosed stairwell nos. 2, 4, 6, and 7 are separate fire areas and are discussed in subsections 9A.4.3.1.2 through 9A.4.3.1.5 (fire areas FT1503, FT2504, FT15X1, and FT15X2).

Enclosed stairwells 1, 3 and 8 are described in subsections 9A.4.3.2.2 through 9A.4.3.2.4 (fire areas FT1502, FT2502 and FT15Y1), respectively.

The elevator shaft (room 250) is of 2 hour fire-resistive concrete construction, is a separate fire area (FT15Y2), and is described in subsection 9A.4.3.2.5.

The walls enclosing the lube oil purification unit (room 230, fire area FT2500), lube oil storage tank area (room 1Y1, fire area FT15Y3), and the EHC hydraulic power unit (room 232, fire area FT15Y4) are separated from fire area FT1500 by 3 hour fire-resistive concrete construction with 3 hour fire rated doors. These rooms are described as separate fire areas in subsections 9A.4.3.2.6 through 9A.4.3.2.8, respectively.

The house boiler area (room 247, fire area FT2503) is separated from fire area FT1500 by 3 hour fire-resistive concrete construction along building column line T8. The fire area (FT2503) associated with room 247 is addressed in subsection 9A.4.3.2.9.

The HNCW chiller area (room 248) and instrument, service, and breathing air system area (room 111) are located in one fire area (FT1501) and separated from fire area FT1500 by 2 hour fire-resistive concrete construction along building column line T8. Fire area FT1501 is discussed in subsection 9A.4.3.2.10.

The Turbine Building is separated from the horizontal passageway that runs exterior and parallel to the southernmost building wall by 3 hour fire-resistive concrete construction. This horizontal passageway provides a protected exit and access from the Turbine Building to the Control Building and Service Building.

On the west side and exterior to the Turbine Building, between elevation 6.3m (MB1F) and elevation 12.3m (35'-0") (grade) is a large exposed dry pit. The exterior Turbine Building wall at this location is of 3 hour fire-resistive construction.

The remaining exterior walls are of 3 hour fire-resistive concrete construction, consistent with the requirements of the IBC, and are backed by exterior fill.

Remaining floor areas are concrete basemat or 2 hour fire-resistive concrete construction consistent with the requirements of the IBC for a Type IA structure.

(5) Combustibles Present:

Fire Loading	Total Heat of Combustion (MJ)
(a) Cable in conduit, and less than the equivalent of 0.6m cable trays	Acceptable
(b) Limited quantities of lubricants in pumps	Negligible
(c) Charcoal in offgas charcoal bed	Does not contribute to fire loading
(d) Resin in resin storage tanks	Does not contribute to fire loading

(6) Detection Provided – Class A supervised POC, and manual alarm pull stations at Columns – Rows (C-R)

Manual Pull Locations: TA.4-T7.5, TH.5-T7.9, TJ.7-T7.5, TJ.6-T2.2, TG.6-T2, TJ.9-T6.8, TJ.9-T6.1, TJ.9-T3.1.

(7) Suppression Available:

Type	Location/Actuation
Modified Class III standpipes	Stairwells No.2 <122>, No.3 <212>, No.4 <249>, No.6, and No.7
ABC portable (hand) extinguishers and hose stations	TA.9-T1.1, TA.1-T6.4, TB-T2.9, TB-T5.2, TC.2-T4.2, TB.6-T7.8, TD.4-T7.8, TF.3-T7.8, TH.2-T7.8, TH.5-T6.3, TH.8-T4.5, TG.8-T2.9, TB.9-T7, TC.9-T6.2, TG-T6.2, TJ.9-T7.2, TJ.1-T5.8, TJ.9-T5.1, TJ.1-T3.7, TJ.9-T2.6, TJ.1-T1.1, TG.9-T1.8 <1Y1> TH.5-T2.8 <232> TH.7-T3, TH.8-T4.5 <230> TH.5-T6.3 <FT2503> <247> TA.6-T8.1, TA.9-T9.1 <FT1501> TC.8-T8.1, TH.5-T8.3, TC.2-T9.3, TE.1-T9, TF.9-T9, TH.5-T8.3, TJ.9-T9.4, TH.9-T9.4, TF.9-T9.4, TE-T9.9, TC.1-T9.9
Wet pipe sprinkler system Design density 12.2 L/min-m ² (0.3 gpm/ft ²) over 464.5 m ² (5000 ft ²)	Throughout floor MB1F

(8) Fire Protection Design Criteria Employed:

- (a) Fire detection and suppression capability is provided and accessible;
- (b) Fire stops are provided for penetrations through rated fire barriers.

(9) Consequences of Fire – Postulated fire assumes loss of function. Smoke from a fire would be removed by the normal HVAC system except for the following rooms:

- (a) Room 142 by normal HVAC and process exhaust.
- (b) Room 112 by process exhaust.

(10) Consequences of Fire Suppression – Suppression extinguishes the fire. Refer to Section 3.4, “Water Level (Flood) Design,” for drain system.

- (11) Design Criteria Used for Protection Against Inadvertent Operation, Careless Operation or Rupture of the Suppression System:
- (a) Provision of raised supports for the equipment
 - (b) Refer to Section 3.4, "Water Level (Flood) Design," for drain system.
- (12) Fire Containment or Inhibiting Methods Employed:
- (a) Fire stops are provided for penetrations through fire rated barriers.
 - (b) The means of fire detection, suppression and alarming are provided and accessible.
- (13) Remarks:
- (a) Smoke detectors, and temperature controllers are mounted in the exhaust duct of the offgas system to detect any fire in the charcoal beds. The fire is contained by isolating the charcoal adsorber vessel and purging the vessel with nitrogen gas.
 - (b) Electrical cable insulation in conduit does not represent a combustible fire load.
 - (c) The total flow of the wet pipe sprinkler system on floor MB1F with a 1893 L/min (500 gpm) hose stream allowance is estimated to be 10,410 L/min (2750 gpm).

9A.4.3.2.2 Fire Area – FT1502 (Stairwell No. 1 – Room 114)

- (1) Fire Area Boundary Description

Stairwell No. 1 serves uncontrolled areas inside the Turbine Building at floor levels MB1F, 1F, and 2F.

Fire area FT1502 extends vertically upward from floor MB1F through floor 2F (elevation 24.4m (74'-8 1/2")). Stairwell no. 1 is bounded by interior and exterior fire-resistive concrete construction.

Access is provided to stairwell no. 1 from floor MB1F and each of the upper floors.

- (2) Equipment – See Table 9A.6-4

Safety Related	Provides Core Cooling
No	No

- (3) Radioactive Material Present – None.

- (4) Qualification of Fire Barriers – At floor levels MB1F, 1F and 2F; interior walls enclosing stairwell no. 1 are a minimum of 2 hour fire-resistive concrete construction. Exterior walls are of 3 hour fire-resistive concrete construction.

Interior stairwell doors are a minimum of 1-1/2 hour fire rated (doors are 3-hour fire rated for consistency throughout the Turbine Building). The door at the exit discharge at grade level (floor 1F, elevation 12.3m) is a 3 hour fire rated door.

The floor is the concrete basemat of floor MB1F.

- (5) Combustibles Present – No significant quantities of exposed combustibles.
- (6) Detection Provided – Class A supervised POC at each building floor elevation and manual pull station external to the enclosed stairway at each floor elevation.
- (7) Suppression Available:

Type	Location/Actuation
Modified Class III standpipe	Stairwell No. 1 <114>
ABC portable (hand) extinguishers and hose station	TJ.9-T9.4
Wet Pipe Sprinkler Design density 6.1 L/min-m ² (0.15 gpm/ft ²)	Stairwell No. 1

- (8) Fire Protection Design Criteria Employed:
- (a) The stairwell is located in a separate fire-resistive enclosure.
- (b) Fire detection and suppression capability is provided and accessible.
- (9) Consequences of Fire – The postulated fire assumes loss of function of the enclosed stairway. Smoke from a fire would be removed by the normal HVAC system.
- (10) Consequences of Fire Suppression – Suppression extinguishes the fire. Refer to Section 3.4, “Water Level (Flood) Design,” for drain system.
- (11) Design Criteria Used for Protection Against Inadvertent Operation, Careless Operation or Rupture of the Suppression System:
- (a) Refer to Section 3.4, “Water Level (Flood) Design,” for drain system.

- (12) Fire Containment or Inhibiting Methods Employed:
- (a) The function is provided in a fire-resistive enclosure.
 - (b) Fire stops are provided for penetrations through fire rated barriers.
 - (c) The means of fire detection, suppression and alarming are provided and accessible.
- (13) Remarks – The total flow of the wet pipe sprinkler system with a 1893 L/min (500 gpm) hose stream allowance is estimated to be 3,218 L/min (850 gpm).

9A.4.3.2.3 Fire Area – FT2502 (Stairwell No. 3 – Room 212)

- (1) Fire Area Boundary Description

Stairwell No. 3 serves controlled areas inside the Turbine Building at floor levels MB1F, 1F, 2F and 3F.

Fire area FT2502 extends vertically upward from floor MB1F through floor 3F (elevation 27.8m (85'-10 1/2")). Stairwell no. 3 is bounded by interior fire-resistive concrete construction.

Access is provided to stairwell no. 3 from floor MB1F and each of the upper floors.

- (2) Equipment – See Table 9A.6-4

Safety Related	Provides Core Cooling
No	No

- (3) Radioactive Material Present – None.
- (4) Qualification of Fire Barriers – At floor levels MB1F, 1F, 2F and 3F, walls enclosing stairwell no. 3 are a minimum of 2 hour fire-resistive concrete construction. Stairwell doors are a minimum of 1-1/2 hour fire rated (doors are 3-hour fire rated for consistency throughout the Turbine Building). The floor is the concrete basemat of floor MB1F.
- (5) Combustibles Present – No significant quantities of exposed combustibles.
- (6) Detection Provided – Class A supervised POC at each building floor elevation and manual pull station external to the enclosed stairway at each floor elevation.

(7) Suppression Available:

Type	Location/Actuation
Modified Class III standpipe	Stairwell No.3 <212>
ABC portable (hand) extinguishers and hose station	TH.2-T7.8
Wet Pipe Sprinkler Design density 6.1 L/min-m ² (0.15 gpm/ft ²)	Stairwell No. 3

(8) Fire Protection Design Criteria Employed:

- (a) The stairwell is located in a separate fire-resistive enclosure.
- (b) Alternate access and egress routes are provided by separate enclosed stairways at this floor level.
- (c) Fire detection and suppression capability is provided and accessible.

(9) Consequences of Fire – The postulated fire assumes loss of function of the enclosed stairway. Smoke from a fire would be removed by the normal HVAC system.

(10) Consequences of Fire Suppression – Suppression extinguishes the fire. Refer to Section 3.4, “Water Level (Flood) Design,” for drain system.

(11) Design Criteria Used for Protection Against Inadvertent Operation, Careless Operation or Rupture of the Suppression System:

- (a) Refer to Section 3.4, “Water Level (Flood) Design,” for drain system.

(12) Fire Containment or Inhibiting Methods Employed:

- (a) The function is provided in a fire-resistive enclosure.
- (b) Fire stops are provided for penetrations through fire rated barriers.
- (c) The means of fire detection, suppression and alarming are provided and accessible.

(13) Remarks – The total flow of the wet pipe sprinkler system with a 1893 L/min (500 gpm) hose stream allowance is estimated to be 3,218 L/min (850 gpm).

9A.4.3.2.4 Fire Area – FT15Y1 (Stairwell No. 8 – Room 1Y5)

(1) Fire Area Boundary Description

Stairwell No. 8 serves uncontrolled areas inside the Turbine Building at floor levels MB1F, 1F, 2F, 3F and 4F.

Fire area FT15Y1 extends vertically upward from floor MB1F through floor 4F (elevation 38.3m). Stairwell no. 8 is bounded by interior and exterior fire-resistive concrete construction.

Access is provided to stairwell no. 8 from floor MB1F and each of the upper floors.

- (2) Equipment – See Table 9A.6-4

Safety Related	Provides Core Cooling
No	No

- (3) Radioactive Material Present – None.

- (4) Qualification of Fire Barriers – At floor levels MB1F, 1F, 2F, 3F and 4F, interior walls enclosing stairwell no. 8 are a minimum of 2 hour fire-resistive concrete construction. Exterior walls are of 3 hour fire-resistive concrete construction.

Interior stairwell doors are a minimum of 1-1/2 hour fire rated (doors are 3-hour fire rated for consistency throughout the Turbine Building). The door at the exit discharge at grade level (floor 1F, elevation 12.3m) is a 3 hour fire rated door.

The floor is the concrete basemat of floor MB1F.

- (5) Combustibles Present – No significant quantities of exposed combustibles.
- (6) Detection Provided – Class A supervised POC at each building floor elevation and manual pull station external to the enclosed stairway at each floor elevation.
- (7) Suppression Available:

Type	Location/Actuation
Modified Class III standpipe	Stairwell No.8
ABC portable (hand) extinguishers and hose station	TA.6-T8.1
Wet Pipe Sprinkler Design density 6.1 L/min-m ² (0.15 gpm/ft ²)	Stairwell No. 8

- (8) Fire Protection Design Criteria Employed:
- (a) The stairwell is located in a separate fire-resistive enclosure.
- (b) Fire detection and suppression capability is provided and accessible.

- (9) Consequences of Fire – The postulated fire assumes loss of function of the enclosed stairway. Smoke from a fire would be removed by the normal HVAC system.
- (10) Consequences of Fire Suppression – Suppression extinguishes the fire. Refer to Section 3.4, “Water Level (Flood) Design,” for drain system.
- (11) Design Criteria Used for Protection Against Inadvertent Operation, Careless Operation or Rupture of the Suppression System:
 - (a) Refer to Section 3.4, “Water Level (Flood) Design,” for drain system.
- (12) Fire Containment or Inhibiting Methods Employed:
 - (a) The function is provided in a fire-resistive enclosure.
 - (b) Fire stops are provided for penetrations through fire rated barriers.
 - (c) The means of fire detection, suppression and alarming are provided and accessible.
- (13) Remarks – The total flow of the wet pipe sprinkler system with a 1893 L/min (500 gpm) hose stream allowance is estimated to be 3,218 L/min (850 gpm).

9A.4.3.2.5 Fire Area – FT15Y2 (Elevator Shaft – Room 250)

- (1) Fire Area Boundary Description

The elevator shaft serves controlled areas inside the Turbine Building. Fire area FT15Y2 extends vertically upward from floor MB1F through floors 1F, 2F, and 3F (elevation 27.8m (85'-10 1/2")). This fire area is bounded by interior fire-resistive walls.

- (2) Equipment – See Table 9A.6-4

Safety Related	Provides Core Cooling
No	No

- (3) Radioactive Material Present – None.
- (4) Qualification of Fire Barriers – The walls enclosing the elevator shaft are of a minimum of 2 hour fire-resistive concrete construction. Elevator doors are 1-1/2 hour fire rated doors.

- (5) Combustibles Present – (NCLL Applies)

Fire Loading	Total Heat of Combustion (MJ)
Electrical Cables	727 MJ/m ² NCLL (727 MJ/m ² maximum average) applies
Small amount of elevator motor lubricants	Negligible

- (6) Detection Provided – Class A supervised POC in the elevator shaft and manual pull station near the elevator door at each elevation.

- (7) Suppression Available:

Type	Location/Actuation
Modified Class III standpipe	Stairwell No.3 <212>
ABC portable (hand) extinguishers and hose station	TH.2-T7.8
Wet Pipe Sprinkler Design density 8.2 L/min-m ² (0.20 gpm/ft ²)	Elevator Shaft

- (8) Fire Protection Design Criteria Employed:

- (a) The stairwell is located in a separate fire-resistive enclosure.
- (b) Alternate access and egress routes are provided by separate enclosed stairways at this floor level.
- (c) Fire detection and suppression capability is provided and accessible.

- (9) Consequences of Fire – The postulated fire assumes loss of function of the enclosed elevator shaft. Smoke from a fire would be removed by the normal HVAC system.

- (10) Consequences of Fire Suppression – Suppression extinguishes the fire. Refer to Section 3.4, “Water Level (Flood) Design,” for drain system.

- (11) Design Criteria Used for Protection Against Inadvertent Operation, Careless Operation or Rupture of the Suppression System:

- (a) Refer to Section 3.4, “Water Level (Flood) Design,” for drain system.

- (12) Fire Containment or Inhibiting Methods Employed:

- (a) The function is provided in a fire-resistive enclosure.
- (b) Fire stops are provided for penetrations through fire rated barriers.
- (c) The means of fire detection, suppression and alarming are provided and accessible.

- (13) Remarks – The total flow of the wet pipe sprinkler system with a 1893 L/min (500 gpm) hose stream allowance is estimated to be 3,596 L/min (950 gpm).

9A.4.3.2.6 Fire Area – FT2500 (Lube Oil Purification Unit - Room 230)

- (1) Fire Area Boundary Description

The interior walls, ceiling and floor of fire area FT2500, containing the lube oil purification unit, consists of fire-resistive concrete construction.

- (2) Equipment – See Table 9A.6-4

Safety Related	Provides Core Cooling
No	No

- (3) Radioactive Material Present – None.

- (4) Qualification of Fire Barriers – The walls, ceiling and floor enclosing the lube oil purification unit (room 230) are of 3 hour fire-resistive-concrete construction with 3 hour fire rated doors.

- (5) Combustibles Present:

Fire Loading	Total Heat of Combustion (MJ)
Turbine Lube Oil, Class IIIB Combustible Liquid Volume: 7,571 L (2000 gal.) (Est.)	316,500 MJ (299,984,105 Btu)

- (6) Detection Provided – Class A supervised rate compensated thermal detectors. The detection system is a cross zoned system requiring two detectors, one in each zone to sense fire before initiating the suppression system. A manual alarm pull station is located at each door.

- (7) Suppression Available:

Type	Location/Actuation
Modified Class III standpipe	Stairwell No.3 <212>
ABC portable (hand) extinguishers and hose station	TH.5-T6.3
Deluge foam water spray system Foam water density: 20.4 L/min-m ² (0.5 gpm/ft ²) (Est.)	Room 230

- (8) Fire Protection Design Criteria Employed:
 - (a) Room 230 is configured as a separate fire-resistive enclosure.
 - (b) Alternate access and egress routes are provided by separate enclosed stairways at this floor level.
 - (c) Fire detection and suppression capability is provided and accessible.
- (9) Consequences of Fire – The postulated fire assumes loss of function of the enclosed area and affected equipment. Smoke from a fire would be removed by the normal HVAC system.
- (10) Consequences of Fire Suppression – Suppression extinguishes the fire. Refer to Section 3.4, “Water Level (Flood) Design,” for drain system.
- (11) Design Criteria Used for Protection Against Inadvertent Operation, Careless Operation or Rupture of the Suppression System:
 - (a) Location of the manual suppression system external to the room
 - (b) Provision of raised supports for equipment
 - (c) Refer to Section 3.4, “Water Level (Flood) Design,” for drain system.
 - (d) Cross zoned detectors for initiation of deluge system
- (12) Fire Containment or Inhibiting Methods Employed:
 - (a) The function is provided in a fire-resistive enclosure.
 - (b) Fire stops are provided for penetrations through fire rated barriers.
 - (c) The means of fire detection, suppression and alarming are provided and accessible.
- (13) Remarks –The lube oil purification unit contains approximately 7,571 L (2,000 gallons), therefore the deluge foam water sprinkler system must be capable of suppressing any fire in this room. The total flow of the deluge foam sprinkler system with a 1893 L/min (500 gpm) hose stream allowance is estimated to be 3,710 L/min (980 gpm).

9A.4.3.2.7 Fire Area –FT15Y3 (Lube Oil Storage Tank Area - Room 1Y1)

- (1) Fire Area Boundary Description

The interior walls, ceiling and floor of fire area FT15Y3, containing two (2) lube oil storage tanks, consists of fire-resistive concrete construction.

- (2) Equipment – See Table 9A.6-4

Safety Related	Provides Core Cooling
No	No

- (3) Radioactive Material Present – None.

- (4) Qualification of Fire Barriers – The walls, ceiling and floor enclosing the lube oil storage tanks (room 1Y1, fire area FT15Y3) are of 3 hour fire-resistive-concrete construction with 3 hour fire rated doors.

- (5) Combustibles Present:

Fire Loading	Total Heat of Combustion (MJ)
Turbine Lube Oil, Class IIIB Combustible Liquid Volume: 81,386 L (21,500 gal.) (Est.)	3,402,375 MJ (3,224,829,130 Btu)

- (6) Detection Provided – Class A supervised rate compensated thermal detectors. The detection system is a cross zoned system requiring two detectors, one in each zone to sense fire before initiating the suppression system. A manual alarm pull station is located at each door.

- (7) Suppression Available:

Type	Location/Actuation
Modified Class III standpipe	Stairwell No.2 <122>
ABC portable (hand) extinguishers and hose stations	TH.5-T2.8, TG.8-T2.9
Deluge foam water spray system Foam water density: 20.4 L/min-m ² (0.5 gpm/ft ²) (Est.)	Room 1Y1

- (8) Fire Protection Design Criteria Employed:

- (a) Room 1Y1 is configured as a separate fire-resistive enclosure.
- (b) Alternate access and egress routes are provided by separate enclosed stairways at this floor level.
- (c) Fire detection and suppression capability is provided and accessible.

- (9) Consequences of Fire – The postulated fire assumes loss of function of the enclosed area and affected equipment. Smoke from a fire would be removed by the normal HVAC system.

- (10) Consequences of Fire Suppression – Suppression extinguishes the fire. Refer to Section 3.4, “Water Level (Flood) Design,” for drain system.

- (11) Design Criteria Used for Protection Against Inadvertent Operation, Careless Operation or Rupture of the Suppression System:
- (a) Location of the manual suppression system external to the room
 - (b) Provision of raised supports for equipment
 - (c) Refer to Section 3.4, "Water Level (Flood) Design," for drain system.
 - (d) Cross zoned detectors for initiation of deluge system
- (12) Fire Containment or Inhibiting Methods Employed:
- (a) The function is provided in a fire-resistive enclosure.
 - (b) Fire stops are provided for penetrations through fire rated barriers.
 - (c) The means of fire detection, suppression and alarming are provided and accessible.
- (13) Remarks –The lube oil storage tank area contains approximately 81,386 L (21,500 gallons), therefore the deluge foam water sprinkler system must be capable of suppressing any fire in this room. The total flow of the deluge foam sprinkler system with a 1893 L/min (500 gpm) hose stream allowance is estimated to be 5,867 L/min (1,550 gpm).

9A.4.3.2.8 Fire Area –FT15Y4 (EHC hydraulic power unit - Room 232)

- (1) Fire Area Boundary Description

The interior walls, ceiling and floor of fire area FT15Y4, containing the EHC hydraulic power unit, consists of fire-resistive concrete construction.

- (2) Equipment – See Table 9A.6-4

Safety Related	Provides Core Cooling
Yes	No

- (3) Radioactive Material Present – None.

- (4) Qualification of Fire Barriers – The walls, ceiling and floor enclosing EHC hydraulic power unit (room 1Y1, fire area FT15Y4) are of 3 hour fire-resistive-concrete construction with 3 hour fire rated doors.

- (5) Combustibles Present:

Fire Loading	Total Heat of Combustion (MJ)
Hydraulic Fluid, Class IIIB Combustible Liquid Volume: 6,435 L (1700 gal.) (Est.)	269,025 MJ (254,986,489 Btu)

- (6) Detection Provided – Class A supervised rate compensated thermal detectors. The detection system is a cross zoned system requiring two detectors, one in each zone to sense fire before initiating the suppression system. A manual alarm pull station is located at each door.

- (7) Suppression Available:

Type	Location/Actuation
Modified Class III standpipe	Stairwell No.2 <122>
ABC portable (hand) extinguishers and hose stations	TH.7-T3, TH.8-T4.5, TG.8-T2.9
Deluge foam water spray system Foam water density: 20.4 L/min-m ² (0.5 gpm/ft ²) (Est.)	Room 232

- (8) Fire Protection Design Criteria Employed:

- (a) Room 232 is configured as a separate fire-resistive enclosure.
- (b) Alternate access and egress routes are provided by separate enclosed stairways at this floor level.
- (c) Fire detection and suppression capability is provided and accessible.

- (9) Consequences of Fire – The postulated fire assumes loss of function of the enclosed area and affected equipment. Smoke from a fire would be removed by the normal HVAC system.

- (10) Consequences of Fire Suppression – Suppression extinguishes the fire. Refer to Section 3.4, “Water Level (Flood) Design,” for drain system.

- (11) Design Criteria Used for Protection Against Inadvertent Operation, Careless Operation or Rupture of the Suppression System:

- (a) Location of the manual suppression system external to the room
- (b) Provision of raised supports for equipment
- (c) Refer to Section 3.4, “Water Level (Flood) Design,” for drain system.
- (d) Cross zoned detectors for initiation of deluge system

(12) Fire Containment or Inhibiting Methods Employed:

- (a) The function is provided in a fire-resistive enclosure.
- (b) Fire stops are provided for penetrations through fire rated barriers.
- (c) The means of fire detection, suppression and alarming are provided and accessible.

(13) Remarks:

- (a) The EHC hydraulic power unit contains approximately 6,435 L (1,700 gallons), therefore the deluge foam water sprinkler system must be capable of suppressing any fire in this room. The total flow of the deluge foam sprinkler system with a 1893 L/min (500 gpm) hose stream allowance is estimated to be 5,072 L/min (1,340 gpm).
- (b) The following safety-related equipment representing all four safety divisions is mounted on this floor:

C71-PS002 A-D
- (c) Section 9A.5, Special Cases, provides justification for locating equipment from multiple safety divisions on this floor of the turbine building.

9A.4.3.2.9 Fire Area –FT2503 (House Boiler Area - Room 247)

(1) Fire Area Boundary Description

The house boiler area (room 247) is enclosed by fire-resistive construction. The interior and exterior walls and ceiling that enclose house boiler equipment are of fire-resistive concrete construction.

Adjacent fire areas separated from room 247 include the HCNW chiller area (room 248) instrument, service and breathing air system equipment areas (rooms 111 and 1Y2) in fire area FT1501 and stairwell no. 8 (room 1Y5, fire area FT15Y1). Also, the combustion gas turbine area (room 317 – FT3500) is located on floor 1F above.

The house boiler area floor is the concrete basemat.

The house boiler area is an uncontrolled access area. Fire-resistive concrete construction separates room 247 from controlled access areas in the Turbine Building along column line T8.

The main portion of Room 247 extends vertically upward to the underside of floor 2F (elevation 19.7m). Separation between room 247 at this level for this area and the adjacent combustion turbine generator area (room 248 –

FT3500) is provided by fire-resistive concrete construction, including the ceiling, above which is switchgear room 'B' (room 310 – FT1501).

- (2) Equipment – See Table 9A.6-4

Safety Related	Provides Core Cooling
No	No

- (3) Radioactive Material Present – None.

- (4) Qualification of Fire Barriers – The interior and exterior walls and ceiling that enclose the house boiler area (room 247 – FT2503) are of 3 hour fire-rated concrete construction with 3 hour fire rated doors.

The enclosed stairwell that serves the house boiler area on floor MB1F, stairwell no. 8, is of 2 hour fire-resistive concrete construction.

STP DEP 9.5-7

- (5) Combustibles Present:

Fire Loading	Total Heat of Combustion (MJ)
(a) Cable in conduit, and dispersed in cable trays	Limited quantities
(b) Lubricants in pumps	Negligible

Note: The house boiler is electric which eliminates the possibility of fire involving significant quantities of combustible liquid in this area.

- (6) Detection Provided – Class A supervised POC at each building floor elevation and manual pull station external to the enclosed stairway at each floor elevation.

Manual Pull Location: TA.3-T8.2

- (7) Suppression Available:

Type	Location/Actuation
Modified Class III standpipe	Stairwell No.8
ABC portable (hand) extinguishers and hose stations	TA.6-T8.1, TA.9-T9.1
Wet pipe sprinkler system Design density 10.2 L/min-m ² (0.25 gpm/ft ²)	Room 247

- (8) Fire Protection Design Criteria Employed:
 - (a) Room 247 is configured as a separate fire-resistive enclosure.
 - (b) Fire detection and suppression capability is provided and accessible.
- (9) Consequences of Fire – The postulated fire assumes loss of function of the enclosed area and affected equipment. Smoke from a fire would be removed by the normal HVAC system.
- (10) Consequences of Fire Suppression – Suppression extinguishes the fire. Refer to Section 3.4, “Water Level (Flood) Design,” for drain system.
- (11) Design Criteria Used for Protection Against Inadvertent Operation, Careless Operation or Rupture of the Suppression System:
 - (a) Provision of raised supports and equipment
 - (b) Refer to Section 3.4, “Water Level (Flood) Design,” for drain system.
- (12) Fire Containment or Inhibiting Methods Employed:
 - (a) The function is provided in a fire-resistive enclosure.
 - (b) Fire stops are provided for penetrations through fire rated barriers.
 - (c) The means of fire detection, suppression and alarming are provided and accessible.
- (13) Remarks:
 - (a) The total flow of the wet pipe sprinkler system with a 1893 L/min (500 gpm) hose stream allowance is estimated to be 9,615 L/min (2,540 gpm).
 - (b) Electrical cable insulation in conduit does not represent a combustible fire load.

9A.4.3.2.10 Fire Area –FT1501 (HNCW Chiller Area – Room 248, Instrument and Service Air Equipment Area (Room 111) and Breathing Air Equipment Area - Room 1Y2)

- (1) Fire Area Boundary Description

Non fire-resistive walls separate the HNCW chiller area (room 248), instrument and service air system equipment area (room 111) and breathing air system equipment area (room 1Y2). These rooms are part of the same fire area (FT1501).

Fire area FT 1501 is separated by fire-resistive construction from enclosed stairwell no. 3, the elevator shaft, enclosed stairwell no. 1, and the adjacent house boiler area (room 247).

The ceiling in this fire area separates rooms 248 and 111 from the combustion turbine generator area (rooms 317 and 2X8 - FT3500) on floor 1F above and is of fire-resistive construction.

The ceiling in fire area FT1501 provides a fire-resistive separation between rooms 248 and 111 and the combustion turbine generator switchgear room (room 2X5 - FT25X1) on floor 1F above.

The ceiling in fire area FT1501 also provides a fire-resistant separation between rooms 248, 111 and 1Y2 and switchgear room 'B' (room 210 - FT25X3) on floor 1F above.

The HNCW chiller area (room 248), instrument and service air equipment area (room 111) and breathing air equipment area (room 1Y2) are uncontrolled access areas. Fire-resistive concrete construction separates fire area FT1501 from controlled access areas in the Turbine Building associated with fire area FT1500 along cloumn line T8.

The floor beneath FT1501 is concrete basemat.

- (2) Equipment - See Table 9A.6-4.

Safety Related

No

Provides Core Cooling

No

- (3) Radioactive Material Present - None.
- (4) Qualification of Fire Barriers – The interior and exterior walls that enclose fire area FT1501, which includes the HNCW chiller area (room 248), instrument and service air equipment area (room 111) and breathing air equipment area (room 1Y2), are of 3 hour fire-resistive concrete construction with the exception of bounding walls separating this area from enclosed stairwells, elevator shaft, and ceiling.

The ceiling is of a minimum of 1 hour fire-resistive construction.

Enclosed stairwells no. 1 and 3, and the elevator shaft, are of 2 hour fire-resistive concrete construction. These components are described separately in subsections 9A.4.3.2.2, 9A.4.3.2.3, and 9A.4.3.2.5, respectively.

- (5) Combustibles Present:

Fire Loading	Total Heat of Combustion (MJ)
(a) Cable in conduit, and dispersed in cable trays	Acceptable
(b) Limited quantity of lubricants in pumps	Negligible

- (6) Detection Provided – Class A supervised POC at each building floor elevation and manual pull stations.

Manual Pull Locations: TJ.6-T9.8, TJ.9-T9.1

- (7) Suppression Available:

Type	Location/Actuation
Modified Class III standpipes	Stairwells No. 1 <114>
ABC portable (hand) extinguishers and hose stations	TC.8-T8.1, TH.5-T8.3, TC.2-T9.3, TE.1-T9, TF.9-T9, TH.5-T8.3, TJ.9-T9.4, TH.9-T9.4, TF.9-T9.4, TE-T9.9, TC.1-T9.9
Wet pipe sprinkler system Design density: 8.2 L/min-m ² (0.20 gpm/ft ²) over 1500 ft ²	Rooms 248, 111 and 1Y2

- (8) Fire Protection Design Criteria Employed:

- (a) Fire detection and suppression capability is provided and accessible.
- (b) Fire stops are provided for penetrations through fire rated barriers.

- (9) Consequences of Fire - The postulated fire assumes loss of function of the enclosed area and affected equipment. Smoke from a fire would be removed by the normal HVAC system.

- (10) Consequences of Fire Suppression - Suppression extinguished the fire. Refer to Section 3.4, "Water Level (Flood) Design," for drain system.

- (11) Design Criteria Used for Protection Against Inadvertent Operation, Careless Operation or Rupture of the Suppression System:

- (a) Provision of raised supports for equipment
- (b) Refer to Section 3.4, "Water Level (Flood Design)," for drain system.

- (12) Fire Containment or Inhibiting Methods Employed:
 - (a) Fire stops are provided for penetrations through fire rated barriers.
 - (b) The means of fire detection, suppression and alarming are provided and accessible.

- (13) Remarks:
 - (a) The total flow of the wet pipe sprinkler system with a 1893 L/min (500 gpm) hose stream allowance is estimated to be 3,596 L/min (950 gpm).
 - (b) Electrical cable insulation in conduit does not represent a combustible fire load.

**Table 9A.4.3.2 - Summary of Fire Protection Criteria
Floor MB1F**

Fire Area	Description	Adjacent Fire Area	Adjacent Fire Area Description	Fire Rated Separation	Fire Separation Criteria	Automatic Suppression Type	Density	Suppression Criteria
FT1500	General Area	FT1503	Stairwell No. 2 (Room 122)	Walls: 2-hour fire resistive Doors: 3-hour fire rated	Walls: NFPA 101, paragraph 8.5.6.(1) Doors: NFPA 101, Table 8.3.4.2	Wet pipe sprinkler	0.30 gpm/ft ² (12.2 L/min-m ²) over minimum application of 5000 ft ² (464.5 m ²) Total flow (Est.): 2750 gpm (10,410 L/min)	a) NFPA 804, 2006, paragraph 10.8.2.1(2) (b) NEIL LCM, March 2008, A3.2.20.5.2.1.1.
		FT2502	Stairwell No. 3 (Room 212)	Walls: 2-hour fire resistive Doors: 3-hour fire rated	Walls: NFPA 101, paragraph 8.5.6.(1) Doors: NFPA 101, Table 8.3.4.2			
		FT2504	Stairwell No. 4 (Room 249)	Walls: 2-hour fire resistive Doors: 3-hour fire rated	Walls: NFPA 101, paragraph 8.5.6.(1) Doors: NFPA 101, Table 8.3.4.2			
		FT15X1	Stairwell No. 6 (Room 1X3)	Walls: 2-hour fire resistive Doors: 3-hour fire rated	Walls: NFPA 101, paragraph 8.5.6.(1) Doors: NFPA 101, Table 8.3.4.2			
		FT15X2	Stairwell No. 7 (Room 1X4)	Walls: 2-hour fire resistive Doors: 3-hour fire rated	Walls: NFPA 101, paragraph 8.5.6.(1) Doors: NFPA 101, Table 8.3.4.2			
		FT15Y2	Elevator Shaft (Room 250)	Walls: 2-hour fire resistive Doors: 1 1/2-hour fire rated	NFPA 804, paragraphs 8.1.2.4 and 8.1.2.5			

**Table 9A.4.3.2 - Summary of Fire Protection Criteria
Floor MB1F (Continued)**

Fire Area	Description	Adjacent Fire Area	Adjacent Fire Area Description	Fire Rated Separation	Fire Separation Criteria	Automatic Suppression Type	Density	Suppression Criteria
FT1500	General Area	FT2500	Lube Oil Purification Unit (Room 230)	Walls: 3-hour fire resistive Doors: 3-hour fire rated	NEIL LCM, March 2008, 3.2.9.1 NFPA 804, paragraph 8.1.2.3	Wet pipe sprinkler	0.30 gpm/ft ² (12.2 L/min-m ²) over minimum application of 5000 ft ² (464.5 m ²) Total flow (Est.): 2750 gpm (10,410 L/min)	a) NFPA 804, 2006, paragraph 10.8.2.1(2) (b) NEIL LCM, March 2008, A3.2.20.5.2.1.1.
		FT15Y3	Lube Oil Storage Tanks (Room 1Y1)	Walls: 3-hour fire resistive Doors: 3-hour fire rated	NEIL LCM, March 2008, 3.2.9.1 NFPA 804, paragraph 8.1.2.3			
		FT15Y4	EHC Hydraulic Power Unit (Room 232)	Walls: 3-hour fire resistive Doors: 3-hour fire rated	NEIL LCM, March 2008, 3.2.9.1 NFPA 804, paragraph 8.1.2.3			
		FT15X3	Stairwell Access to Radwaste Tunnel (Room 141)	Floor: 3-hour fire rated	NEIL LCM, March 2008, 3.2.9.1 NFPA 804, paragraph 8.1.2.3 Also, based on (IBC) H-4 Occupancy and Type 1A construction Exterior Turbine Bldg. Wall: IBC, 2006, Table 601 Turbine Bldg. Floor over Radwaste Building (treated as separation between buildings): IBC, 2006, Table 601			

**Table 9A.4.3.2 - Summary of Fire Protection Criteria
Floor MB1F (Continued)**

Fire Area	Description	Adjacent Fire Area	Adjacent Fire Area Description	Fire Rated Separation	Fire Separation Criteria	Automatic Suppression Type	Density	Suppression Criteria
FT1500	General Area	FT2503	House Boiler Area (Room 247)	Wall: 3-hour fire resistive	NEIL LCM, March 2008, 3.2.9.6 NOTE: 3-hour wall is specified based on fuel fired boiler. Specified rating may be reduced in the future due to planned electric boiler.	Wet pipe sprinkler	0.30 gpm/ft ² (12.2 L/min-m ²) over minimum application of 5000 ft ² (464.5 m ²) Total flow (Est.): 2750 gpm (10,410 L/min)	a) NFPA 804, 2006, paragraph 10.8.2.1(2) (b) NEIL LCM, March 2008, A3.2.20.5.2.1.1.
		FT1501	HNCW Chiller Area (Room 248), Instrument, Service, and Breathing Air System Equipment Areas (Rooms 111 and 1Y2)	Wall: 2-hour fire resistive	Specified by FPE at this location.			
		External to Turbine Building	Horizontal passageway between Turbine Building and Control Building	Exterior Turbine Bldg. Wall: 3-hour fire resistive Doors: 3-hour fire rated	NEIL LCM, March 2008, 3.2.9.1 NFPA 804, paragraph 8.1.2.3 Also, based on (IBC) H-4 Occupancy and Type 1A construction Exterior Turbine Bldg. Wall: IBC, 2006, Table 601			
FT1503	Stairwell No. 1 (Room 114)	FT1501	HNCW Chiller Area (Room 248), Instrument, Service, and Breathing Air System Equipment Areas (Rooms 111 and 1Y2)	Walls: 2-hour fire resistive Doors: 3-hour fire rated	Walls: NFPA 101, paragraph 8.5.6.(1) Doors: NFPA 101, Table 8.3.4.2	Wet pipe sprinkler	0.15 gpm/ft ² (6.1 L/min-m ²) over 1500 ft ² (139 m ²) Total flow (Est.): 850 gpm (3218 L/min)	Ordinary Hazard Group 1 per NFPA 13, paragraph 5.3.1

**Table 9A.4.3.2 - Summary of Fire Protection Criteria
Floor MB1F (Continued)**

Fire Area	Description	Adjacent Fire Area	Adjacent Fire Area Description	Fire Rated Separation	Fire Separation Criteria	Automatic Suppression Type	Density	Suppression Criteria
FT1503	Stairwell No. 1 (Room 114)	External to Turbine Building	Horizontal passageway between Turbine Building and Control Building	Exterior Turbine Bldg. Wall: 3-hour fire resistive	NEIL LCM, March 2008, 3.2.9.1 NFPA 804, paragraph 8.1.2.3 Also, based on (IBC) H-4 Occupancy and Type 1A construction Exterior Turbine Bldg. Wall: IBC, 2006, Table 601	Wet pipe sprinkler	0.15 gpm/ft ² (6.1 L/min-m ²) over 1500 ft ² (139 m ²) Total flow (Est.): 850 gpm (3218 L/min)	Ordinary Hazard Group 1 per NFPA 13, paragraph 5.3.1
FT1503	Stairwell No. 2 (Room 122)	FT1500	General Area	Walls: 2-hour fire resistive Doors: 3-hour fire rated	Walls: NFPA 101, paragraph 8.5.6.(1) Doors: NFPA 101, Table 8.3.4.2	Wet pipe sprinkler	0.15 gpm/ft ² (6.1 L/min-m ²) over 1500 ft ² (139 m ²) Total flow (Est.): 850 gpm (3218 L/min)	Ordinary Hazard Group 1 per NFPA 13, paragraph 5.3.1
FT2504	Stairwell No. 3 (Room 212)	FT1500	General Area	Walls: 2-hour fire resistive Doors: 3-hour fire rated	Walls: NFPA 101, paragraph 8.5.6.(1) Doors: NFPA 101, Table 8.3.4.2	Wet pipe sprinkler	0.15 gpm/ft ² (6.1 L/min-m ²) over 1500 ft ² (139 m ²) Total flow (Est.): 850 gpm (3218 L/min)	Ordinary Hazard Group 1 per NFPA 13, paragraph 5.3.1
		FT15Y2	Elevator Shaft (Room 250)	Walls: 2-hour fire resistive	NFPA 804, paragraphs 8.1.2.4 and 8.1.2.5			
		FT1501	HNCW Chiller Area (Room 248), Instrument, Service, and Breathing Air System Equipment Areas (Rooms 111 and 1Y2)	Walls: 2-hour fire resistive	Walls: NFPA 101, paragraph 8.5.6.(1)			

**Table 9A.4.3.2 - Summary of Fire Protection Criteria
Floor MB1F (Continued)**

Fire Area	Description	Adjacent Fire Area	Adjacent Fire Area Description	Fire Rated Separation	Fire Separation Criteria	Automatic Suppression Type	Density	Suppression Criteria
FT2504	Stairwell No. 4 (Room 249)	FT1500	General Area	Walls :2-hour fire resistive Doors: 3-hour fire rated	Walls: NFPA 101, paragraph 8.5.6.(1) Doors: NFPA 101, Table 8.3.4.2	Wet pipe sprinkler	0.15 gpm/ft ² (6.1 L/min-m ²) over 1500 ft ² (139 m ²) Total flow (Est.): 850 gpm (3218 L/min)	Ordinary Hazard Group 1 per NFPA 13, paragraph 5.3.1
		FT15Y1	Stairwell No. 8	Walls: 3-hour fire resistive	Walls: NFPA 101, paragraph 8.5.6.(1)			
FT15X1	Stairwell No. 6 (Room 1X3)	FT1500	General Area	Walls: 2-hour fire resistive Doors: 3-hour fire rated	Walls: NFPA 101, paragraph 8.5.6.(1) Doors: NFPA 101, Table 8.3.4.2	Wet pipe sprinkler	0.15 gpm/ft ² (6.1 L/min-m ²) over 1500 ft ² (139 m ²) Total flow (Est.): 850 gpm (3218 L/min)	Ordinary Hazard Group 1 per NFPA 13, paragraph 5.3.1
FT15X2	Stairwell No. 7 (Room 1X4)	FT1500	General Area	Walls: 2-hour fire resistive Doors: 3-hour fire rated	Walls: NFPA 101, paragraph 8.5.6.(1) Doors: NFPA 101, Table 8.3.4.2	Wet pipe sprinkler	0.15 gpm/ft ² (6.1 L/min-m ²) over 1500 ft ² (139 m ²) Total flow (Est.): 850 gpm (3218 L/min)	Ordinary Hazard Group 1 per NFPA 13, paragraph 5.3.1
		FT1501	HNCW Chiller Area (Room 248), Instrument, Service, and Breathing Air System Equipment Areas (Rooms 111 and 1Y2)	Walls: 2-hour fire resistive	Walls: NFPA 101, paragraph 8.5.6.(1)			

**Table 9A.4.3.2 - Summary of Fire Protection Criteria
Floor MB1F (Continued)**

Fire Area	Description	Adjacent Fire Area	Adjacent Fire Area Description	Fire Rated Separation	Fire Separation Criteria	Automatic Suppression Type	Density	Suppression Criteria
FT15X2	Stairwell No. 7 (Room 1X4)	External to Turbine Building	Horizontal passageway between Turbine Building and Control Building	Exterior Turbine Bldg. Wall: 3-hour fire resistive	NEIL LCM, March 2008, 3.2.9.1 NFPA 804, paragraph 8.1.2.3 Also, based on (IBC) H-4 Occupancy and Type 1A construction Exterior Turbine Bldg. Wall: IBC, 2006, Table 601	Wet pipe sprinkler	0.15 gpm/ft ² (6.1 L/min-m ²) over 1500 ft ² (139 m ²) Total flow (Est.): 850 gpm (3218 L/min)	Ordinary Hazard Group 1 per NFPA 13, paragraph 5.3.1
FT15Y1	Stairwell No. 8 (Room 1X4)	FT2504	Stairwell No. 4 (Room 249)	Walls: 3-hour fire resistive	Walls: NFPA 101, paragraph 8.5.6.(1)	Wet pipe sprinkler	0.15 gpm/ft ² (6.1 L/min-m ²) over 1500 ft ² (139 m ²) Total flow (Est.): 850 gpm (3218 L/min)	Ordinary Hazard Group 1 per NFPA 13, paragraph 5.3.1
		FT2503	House Boiler Area (Room 247)	Walls: 3-hour fire resistive	Walls: NFPA 101, paragraph 8.5.6.(1)			

**Table 9A.4.3.2 - Summary of Fire Protection Criteria
Floor MB1F (Continued)**

Fire Area	Description	Adjacent Fire Area	Adjacent Fire Area Description	Fire Rated Separation	Fire Separation Criteria	Automatic Suppression Type	Density	Suppression Criteria
FT15Y2	Elevator Shaft (Room 250)	FT1500	General Area	Walls: 2-hour fire resistive Doors: 3-hour fire rated	NFPA 804, paragraphs 8.1.2.4 and 8.1.2.5	Wet pipe sprinkler	0.20 gpm/ft ² (8.2 L/min-m ²) over 1500 ft ² (139 m ²) Total flow (Est.): 950 gpm (3596 L/min)	Ordinary Hazard Group 2 per NFPA 13, paragraph 5.3.2
		FT1501	HNCW Chiller Area (Room 248), Instrument, Service, and Breathing Air System Equipment Areas (Rooms 111 and 1Y2)	Walls: 2-hour fire resistive	Walls: NFPA 101, paragraph 8.5.6.(1)			
		FT2502	Stairwell No. 3 (Room 212)	Walls: 2-hour fire resistive Doors: 3-hour fire rated	Walls: NFPA 101, paragraph 8.5.6.(1) Doors: NFPA 101, Table 8.3.4.2			
FT2500	Lube Oil Purification Unit (Room 230)	FT1500	General Area	Walls: 3-hour fire resistive Doors: 3-hour fire rated Floor: 3-hour fire resistive Ceiling: 3-hour fire resistive	NEIL LCM, paragraph 3.2.9.1 NFPA 804, paragraph 8.1.2.3	Deluge Foam Water Spray	0.50 gpm/ ft ² (20.4 L/min-m ²) over the entire area (Est. 640 ft ² (59.5 m ²)) Total flow (Est.): 980 gpm (3710 L/min)	NEIL LCM, paragraph 3.2.20.5 and Appendix A.3.2.20.5 NFPA 15, paragraphs 7.2.1.3 and 7.3.3 NFPA 16, paragraph 7.3.2 and Appendix A.7.3.2

**Table 9A.4.3.2 - Summary of Fire Protection Criteria
Floor MB1F (Continued)**

Fire Area	Description	Adjacent Fire Area	Adjacent Fire Area Description	Fire Rated Separation	Fire Separation Criteria	Automatic Suppression Type	Density	Suppression Criteria
FT15Y3	Lube Oil Storage Tanks (Room 1Y1)	FT1500	General Area	Walls: 3-hour fire resistive Doors: 3-hour fire rated Floor: 3-hour fire resistive Ceiling: 3-hour fire resistive	NEIL LCM, paragraph 3.2.9.1 NFPA 804, paragraph 8.1.2.3	Deluge Foam Water Spray	0.50 gpm/ ft ² (20.4 L/min-m ²) over the entire area (Est. 1400 ft ² (130 m ²)) Total flow (Est.): 1550 gpm (5867 L/min)	NEIL LCM, paragraph 3.2.20.5 and Appendix A.3.2.20.5 NFPA 15, paragraphs 7.2.1.3 and 7.3.3 NFPA 16, paragraph 7.3.2 and Appendix A.7.3.2
FT15Y4	EHC Hydraulic Power Unit (Room 232)	FT1500	General Area	Walls: 3-hour fire resistive Doors: 3-hour fire rated Floor: 3-hour fire resistive Ceiling: 3-hour fire resistive	NEIL LCM, paragraph 3.2.9.1 NFPA 804, paragraph 8.1.2.3	Deluge Foam Water Spray	0.50 gpm/ ft ² (20.4 L/min-m ²) over the entire area (Est. 1120 ft ² (104 m ²)) Total flow (Est.): 1340 gpm (5072 L/min)	NEIL LCM, paragraph 3.2.20.5 and Appendix A.3.2.20.5 NFPA 15, paragraphs 7.2.1.3 and 7.3.3 NFPA 16, paragraph 7.3.2 and Appendix A.7.3.2

**Table 9A.4.3.2 - Summary of Fire Protection Criteria
Floor MB1F (Continued)**

Fire Area	Description	Adjacent Fire Area	Adjacent Fire Area Description	Fire Rated Separation	Fire Separation Criteria	Automatic Suppression Type	Density	Suppression Criteria
FT2503	House Boiler Area (Room 247)	FT1500	General Area	Wall: 3-hour fire resistive	NEIL LCM, March 2008, 3.2.9.6 NOTE: 3-hour wall is specified based on fuel fired boiler. Specified rating may be reduced in the future due to planned electric boiler.	Wet pipe sprinkler	0.25 gpm/ft ² (10.2 L/min-m ²) over 5440 ft ² (505 m ²) – entire area Total flow (Est.): 2540 gpm (9615 L/min)	NEIL LCM, paragraph 3.2.20.5 NFPA 804, paragraph 10.24.3
		FT1501	HNCW Chiller Area (Room 248), Instrument, Service, and Breathing Air System Equipment Areas (Rooms 111 and 1Y2)	Walls: 3-hour fire resistive Doors: 3-hour fire rated	NEIL LCM, March 2008, 3.2.9.6 NOTE: 3-hour wall is specified based on fuel fired boiler. Specified rating may be reduced in the future due to planned electric boiler.			
FT2503	House Boiler Area (Room 247)	FT15Y1	Stairwell No. 8	Walls: 3-hour fire resistive	Walls: NFPA 101, paragraph 8.5.6.(1)	Wet pipe sprinkler	0.25 gpm/ft ² (10.2 L/min-m ²) over 5440 ft ² (505 m ²) – entire area Total flow (Est.): 2540 gpm (9615 L/min)	NEIL LCM, paragraph 3.2.20.5 NFPA 804, paragraph 10.24.3

**Table 9A.4.3.2 - Summary of Fire Protection Criteria
Floor MB1F (Continued)**

Fire Area	Description	Adjacent Fire Area	Adjacent Fire Area Description	Fire Rated Separation	Fire Separation Criteria	Automatic Suppression Type	Density	Suppression Criteria
FT1501	HNCW Chiller Area (Room 248), Instrument, Service, and Breathing Air System Equipment Areas (Rooms 111 and 1Y2)	FT1500	General Area	Wall: 2-hour fire resistive	Specified by FPE at this location.	Wet pipe sprinkler	0.20 gpm/ft ² (8.2 L/min-m ²) over 1500 ft ² (139 m ²) Total flow (Est.): 950 gpm (3596 L/min)	Ordinary Hazard Group 2 per NFPA 13, paragraph 5.3.2
		FT2502	Stairwell No. 3 (Room 212)	Walls: 2-hour fire resistive Doors: 3-hour fire rated	Walls:NFPA 101, paragraph 8.5.6.(1) Doors:NFPA 101, Table 8.3.4.2			
		FT15Y2	Elevator Shaft (Room 250)	Walls: 2-hour fire resistive	NFPA 804, paragraphs 8.1.2.4 and 8.1.2.5			
		FT1503	Stairwell No. 1 (Room 114)	Walls: 2-hour fire resistive Doors: 3-hour fire rated	Walls:NFPA 101, paragraph 8.5.6.(1) Doors:NFPA 101, Table 8.3.4.2			
		FT3500	Combustion Turbine Generator Area (Rooms 2X8 and 317)	Ceiling: 3-hour fire resistive	NFPA 804, paragraph 8.1.2.3			
		FT25X1	Combustion Turbine Generator Switchgear Area (Room 2X5)	Ceiling: Minimum 1-hour fire resistive	NEIL LCM, March 2008, 3.2.9.5 NFPA 13, paragraph 8.15.10			
		FT25X3	Switchgear Room 'A' (Room 210)	Ceiling: Minimum 1-hour fire resistive	NEIL LCM, March 2008, 3.2.9.5 NFPA 13, paragraph 8.15.10			

**Table 9A.4.3.2 - Summary of Fire Protection Criteria
Floor MB1F (Continued)**

Fire Area	Description	Adjacent Fire Area	Adjacent Fire Area Description	Fire Rated Separation	Fire Separation Criteria	Automatic Suppression Type	Density	Suppression Criteria
FT1501	HNCW Chiller Area (Room 248), Instrument, Service, and Breathing Air System Equipment Areas (Rooms 111 and 1Y2)	FT2503	House Boiler Area (Room 247)	Walls: 3-hour fire resistive Doors: 3-hour fire rated	NEIL LCM, March 2008, 3.2.9.6 NOTE: 3-hour wall is specified based on fuel fired boiler. Specified rating may be reduced in the future due to planned electric boiler.	Wet pipe sprinkler	0.20 gpm/ft ² (8.2 L/min-m ²) over 1500 ft ² (139 m ²) Total flow (Est.): 950 gpm (3596 L/min)	Ordinary Hazard Group 2 per NFPA 13, paragraph 5.3.2
		External to Turbine Building	Horizontal passageway between Turbine Building and Control Building	Exterior Turbine Bldg. Wall: 3-hour fire resistive Doors: 3-hour fire rated	NEIL LCM, March 2008, 3.2.9.1 NFPA 804, paragraph 8.1.2.3 Also, based on (IBC) H-4 Occupancy and Type 1A construction Exterior Turbine Bldg. Wall: IBC, 2006, Table 601			

9A.4.3.3 Floor 1F (El. 12.3m (35'-0")) – See Figure 9A.4-19 and Table 9A.4.3.3 Summary of Fire Protection Criteria Floor 1F

9A.4.3.3.1 Fire Area – FT1500 (General Area)

(1) Fire Area Boundary Description

Floor 1F shares fire area FT1500 with all other floors in the Turbine Building.

Non fire-rated equipment access hatches are installed in the floor between floor 1F and floor MB1F in the northwest corridor area (room 242).

Non-fire rated equipment access hatches exist in the ceiling of the condensate filter vessel area (room 241) beneath the condensate filter maintenance area (room 342) on floor 2F above.

Additionally, a large non fire-rated equipment hatch is installed in the ceiling above the unloading bay leading to floor 2F above.

The offgas charcoal adsorber area (room 112) extends vertically upward from floor B1F through floors MB1F and 1F to the underside of floor 2F (elevation 19.7m (59'-3 ½")). In room 112, a non fire-rated equipment access hatch is installed at room ceiling level, elevation 19.7m (59'-3 ½") (floor 2F).

The low pressure condensate pump area (room 140) extends vertically up from floor B1F, through floors MB1F, 1F and 2F, to and through an non-fire rated equipment hatch in the turbine operating deck floor (floor 3F, elevation 27.8m (85'-10 ½"))

The steam jet air ejector area (room 311) and gland seal steam condenser area (room 314) extend vertically up from floor 1F, through floor 2F, to and through an non-fire rated equipment hatch in the operating deck floor (floor 3F, elevation 27.8m (85'-10 ½")).

Access to the offgas charcoal adsorber area (room 112) is from floor 1F with open grating is installed at this floor level.

Fire area FT1500 is bounded by:

- The Turbine Building exterior walls
- The exterior walls separating stairwell no. 2 (room 122, fire area FT1503)
- The interior walls enclosing stairwell no. 3 (room 212, fire area FT2502)
- The interior walls enclosing stairwell no. 4 (room 249, fire area FT2504)
- The interior walls enclosing stairwell no. 6 (room 1X3, fire area FT15X1)

- The interior walls enclosing stairwell no. 7 (room 1X4, fire area FT15X2)
 - The interior walls enclosing the elevator shaft (room 250, fire area FT15Y2)
 - The floor above the area housing the lube oil purification unit (room 230, fire area FT2500) on floor MB1F
 - The floor above the area housing the lube oil storage tanks (room 1Y1, fire area FT15Y3) on floor MB1F
 - The floor above the area housing the EHC hydraulic power unit (room 232, fire area FT15Y4) on floor MB1F
 - The interior wall between the house boiler area (room 247, fire area FT2503) and this fire area, along building column line T8.
 - The interior wall between the combustion turbine generator auxiliary equipment area (room 2X8, fire area FT3500) and this fire area, along column line T8
 - The interior wall between the combustion gas turbine switchgear area (room 2X5, fire area FT25X1) and this fire area, along column line T8
 - The interior wall between switchgear room 'A' (room 210, fire area FT25X3) and this fire area, along column line T8
 - The ceiling between this fire area and the Main Turbine Lube Oil Tank area (room 330, fire area FT3501)
 - The ceiling between this fire area and the Generator Seal Oil Unit area (room 3X2, fire area FT35X9)
 - The ceiling between this fire area and the Low Pressure Condensate Pump Switchgear area (room 31X-2, fire area FT35X1)
- (2) Equipment – See Table 9A.6-4
- | Safety Related | Provides Core Cooling |
|-----------------------|------------------------------|
| No | No |
- (3) Radioactive Material Present – None that can be released as a result of fire.
- (4) Qualification of Fire Barriers –

The Turbine Building is classified as Type IA construction in accordance with the International Building Code (IBC), 2006. Type IA construction is non-combustible. The building structural frame, and all exterior and interior bearing walls, are required to be of 3 hour fire-resistive construction. The building floor is required to be of not less than 2 hour fire resistive

construction, including supporting beams and joists. Also, the building roof is required to be of not less than 1 ½ hour fire resistive construction.

The enclosed stairwells that serve floor 1F, stairwell nos. 1, 2, 3, 4, 6, 7 and 8 are of 2 hour fire-resistive concrete construction.

Enclosed stairwell nos. 2, 4, 6, and 7 are separate fire areas and are discussed in subsections 9A.4.3.1.2 through 9A.4.3.1.5 (fire areas FT1503, FT2504, FT15X1, and FT15X2).

Enclosed stairwells 1, 3 and 8 are described in subsections 9A.4.3.2.2 through 9A.4.3.2.4 (fire areas FT1502, FT2502 and FT15Y1), respectively.

The elevator shaft (room 250) is of 2 hour fire-resistive concrete construction, is a separate fire area (FT15Y2), and is described in subsection 9A.4.3.2.5.

Floor areas on this level located above the lube oil purification unit (room 230, fire area FT2500), lube oil storage tank area (room 1Y1, fire area FT15Y3), and the EHC hydraulic power unit (room 232, fire area FT15Y4) are of 3 hour fire-resistive construction. These rooms are described as separate fire areas in subsections 9A.4.3.2.6 through 9A.4.3.2.8, respectively.

The house boiler area (room 247, fire area FT2503) is separated from fire area FT1500 by 3 hour fire-resistive concrete construction along building column line T8. The fire area (FT2503) associated with room 247 is addressed in subsection 9A.4.3.2.9.

The combustion turbine generator area (rooms 317 and 2X8, fire area FT3500) is separated from FT1500 on floor 1F by 3 hour fire-resistive concrete construction along building column line T8. Fire area FT3500 is discussed in subsection 9A.4.3.3.2.

Combustion turbine generator switchgear (room 2X5, fire area FT25X1) is separated from fire area FT1500 by 3 hour fire-resistive concrete construction along column line T8. This fire area is described in subsection 9A.4.3.3.3.

Fire area FT1500 is separated from the area housing switchgear room 'A' (room 210, fire area FT25X3) by 2 hour fire-resistive concrete construction along column line T8. Fire area FT25X3 is described in subsection 9A.4.3.3.4.

The Turbine Building is separated from the horizontal passageway that runs exterior and parallel to the southernmost building wall by 3 hour fire-resistive concrete construction. This horizontal passageway provides a protected exit and access from the Turbine Building to the Control Building and Service Building.

The exterior Turbine Building walls are of 3 hour fire-resistive concrete construction, consistent with the requirements of the IBC.

The ceiling between this fire area and areas on floor 2F above is 3 hour fire-resistive concrete construction. These areas include the Main Turbine Lube Oil Tank area (room 330, fire area FT3501, Safety Related Low Pressure Condensate Pump Switchgear (room 31X-2, fire area FT35X1), and the Generator Seal Oil Unit (room 3X2, FT35X9).

(5) Combustibles Present:

Fire Loading	Total Heat of Combustion (MJ)
(a) Cable in conduit, and less than the equivalent of 0.6m cable trays	Acceptable
(b) Limited quantities of lubricants in pumps	Negligible
(c) Charcoal in offgas charcoal bed	Does not contribute to fire loading

(6) Detection Provided – Class A supervised POC, and manual alarm pull stations.

Manual Pull Locations: TA.4-T7.5, TH.5-T7.9, TJ.7-T7.5, TJ.6-T2.2, TG.2-T2, TJ.9-T8.1.

(7) Suppression Available:

Type	Location/Actuation
Modified Class III standpipes	Stairwells No. 1 <114>, No.2 <122>, No.3 <212>, No.4 <249>, No.6 <1X3>, No.7 <1X4>, and No.8 <1Y5>
ABC portable (hand) extinguishers and hose stations	TA.1-T2.7, TA.9-T4.8, TA.1-T6.4, TB.6-T7.8, TD.4-T7.8, TF.3-T7.8, TH.2-T7.8, TH.1-T6, TH.7-T4.9, TH.9-T2.8, TG.2-T2.1, TB.4-T1.2, TC.5-T2.9, TB.1-T.29, TB.7-T3.4, TC.5-T5, TB.9-T6, TC.6-T6.9, TE.3-T6.9, TJ.9-T6.6, TJ.1-T5.9, TJ.9-T5.2, TJ.1-T4.3, TJ.9-T3.3,
Wet pipe sprinkler system Design density 12.2 L/min-m ² (0.3 gpm/ft ²) over 464.5 m ² (5000 ft ²)	Throughout floor 1F

- (8) Fire Protection Design Criteria Employed:
- (a) Fire detection and suppression capability is provided and accessible;
 - (b) Fire stops are provided for penetrations through rated fire barriers.
- (9) Consequences of Fire – Postulated fire assumes loss of function. Smoke from a fire would be removed by the normal HVAC system except for the following rooms:
- (a) Rooms 314 and 344 by normal HVAC and process exhaust
- (10) Consequences of Fire Suppression – Suppression extinguishes the fire. Refer to Section 3.4, “Water Level (Flood) Design,” for drain system.
- (11) Design Criteria Used for Protection Against Inadvertent Operation, Careless Operation or Rupture of the Suppression System:
- (a) Provision of raised supports for the equipment
 - (b) Refer to Section 3.4, “Water Level (Flood) Design,” for drain system.
- (12) Fire Containment or Inhibiting Methods Employed:
- (a) Fire stops are provided for penetrations through fire rated barriers.
 - (b) The means of fire detection, suppression and alarming are provided and accessible.
- (13) Remarks:
- (a) Smoke detectors, and temperature controllers are mounted in the exhaust duct of the offgas system to detect any fire in the charcoal beds. The fire is contained by isolating the charcoal adsorber vessel and purging the vessel with nitrogen gas.
 - (b) Electrical cable insulation in conduit does not represent a combustible fire load.
 - (c) The total flow of the wet pipe sprinkler system on floor 1F with a 1893 L/min (500 gpm) hose stream allowance is estimated to be 10,410 L/min (2750 gpm).

9A.4.3.3.2 Fire Area – FT3500 (Combustion Turbine Generator Area – Rooms 317 and 2X8)

(1) Fire Area Boundary Description

The combustion turbine generator area (room 317) and associated equipment area (room 2X8) are bounded by concrete fire-resistive wall, floor and ceiling construction.

Adjacent fire areas include the house boiler area (room 247, fire area FT2503), switchgear room 'A' (room 210, fire area FT25X3), the combustion turbine generator switchgear room (room 2X5, fire area FT25X1), and enclosed stairwell no. 8 (room 1Y5, fire area FT15Y1).

The combustion turbine generator area is located above the HNCW chiller area (room 248) and instrument and service air equipment area (room 111) on floor MB1F below (fire area FT1501). The floor separating fire area FT3500 and FT1501 is of fire-resistive concrete construction.

Combustion turbine generator room 317 extends vertically upward from floor 1F, through floor 2F, to the underside of the roof deck at elevation 27.8m.

(2) Equipment – See Table 9A.6-4

Safety Related	Provides Core Cooling
No	No

(3) Radioactive Material Present – None.

(4) Qualification of Fire Barriers – The interior and exterior walls enclosing the combustion turbine generator area (rooms 317 and 2X8, FT3500), except for walls enclosing stairwell no. 8, are of 3 hour fire-resistive concrete construction.

Stairwell no. 8 is of 2 hour fire-resistive concrete construction and is described in subsection 9A.4.3.2.4.

The floor in rooms 317 and 2X8 is of 3 hour fire resistive concrete construction.

Combustion turbine generator room 317 extends vertically upward to the roof deck at elevation 27.8m. The ceiling (and roof deck) is of 1 ½ hour fire-resistive concrete construction consistent with the requirements for a Type IA structure described in the IBC.

The ceiling above the combustion turbine generator equipment area (room 2X8) is of 3 hour fire-resistive concrete construction.

(5) Combustibles Present:

Fire Loading	Total Heat of Combustion (MJ)
Turbine lube oil tank, Capacity 189 L (50 gal.) (Est.)	7,915 MJ (7,501,972 Btu)
Generator lube oil tank, Capacity 1 325 L (350 gal.) (Est.)	55,405 MJ (52,513,805 Btu)
Fuel oil day tank, No. 2 Diesel Capacity 2000 gal. (Est.)	289,600 MJ (274,487,826 Btu)
Fuel filtering and metering, No. 2 Diesel, Capacity 114 L (30 gal.) (Est.)	4,344 MJ (4,117,317 Btu)
Hydraulic start package, Hydraulic fluid Capacity 378 L (100 gal.) (Est.)	14,000 MJ (13,269,439 Btu)
Diesel starter day tank, No. 2 Diesel Capacity 4 542 L (1,200 gal.) (Est.)	173,760 MJ (164,692,695 Btu)
Diesel starter lube oil tank, Capacity 189 L (50 gal.) (Est.)	7,915 MJ (7,501,972 Btu)

(6) Detection Provided – Class A supervised rate compensated thermal detectors. The detection system is a cross zoned system requiring two detectors, one in each zone, to sense fire before initiating the suppression system. Manual alarm pull stations at exits.

(7) Suppression Available:

Type	Location/Actuation
Modified Class III standpipe	Stairwell No. 1 <114>
ABC portable (hand) extinguishers and hose stations'	TC.1-T8.2, TD-T8.9, TD.9-T8.2, TA.1-T9.3, TB.9-T9.1, TD.8-T9.1, TF.4-T9.5, TB.9-T9.9, TD.8-T9.9
Deluge foam water sprinkler system Design density 12.2 L/min-m ² (0.3 gpm/ft ²) over 464.5 m ² (5000 ft ²)	Rooms 317 and 2X8

(8) Fire Protection Design Criteria Employed:

- (a) Rooms 317 and 2X8 are configured as a separate fire-resistive enclosure.
- (b) Fire detection and suppression capability is provided and accessible.
- (c) Fire stops are provided for penetrations through rated fire barriers.

(9) Consequences of Fire – The postulated fire assumes loss of function of the enclosed area and affected equipment. Smoke from a fire would be removed by the normal HVAC system.

- (10) Consequences of Fire Suppression – Suppression extinguishes the fire. Refer to Section 3.4, “Water Level (Flood) Design,” for drain system.
- (11) Design Criteria Used for Protection Against Inadvertent Operation, Careless Operation or Rupture of the Suppression System:
 - (a) Location of the manual suppression system external to the room
 - (b) Provision of raised supports for equipment
 - (c) Refer to Section 3.4, “Water Level (Flood) Design,” for drain system.
 - (d) Cross zoned detectors for initiation of deluge system
- (12) Fire Containment or Inhibiting Methods Employed:
 - (a) Fire stops are provided for penetrations through fire rated barriers.
 - (b) The means of fire detection, suppression and alarming are provided and accessible.
- (13) Remarks: The total flow of the wet pipe sprinkler system on floor 1F with a 1893 L/min (500 gpm) hose stream allowance is estimated to be 10,410 L/min (2750 gpm).

9A.4.3.3.3 Fire Area –FT25X1 (Combustion Turbine Generator Switchgear - Room 2X5)

- (1) Fire Area Boundary Description

The combustion turbine generator switchgear area (room 2X5) is bounded by a concrete fire-resistive wall, floor and ceiling construction.

Adjacent fire areas include the combustion turbine generator area (rooms 317 and 2XS, fire area FT3500), switchgear room ‘A’ (room 210, fire area FT25X3), and the controlled access areas on floor 1F in the Turbine Building (fire area FT1500).

Fire-resistive concrete construction separates the switchgear room ‘A’ from fire area FT1500 along column line T8.

- (2) Equipment – See Table 9A.6-4

Safety Related	Provides Core Cooling
No	No

- (3) Radioactive Material Present – None.

- (4) Qualification of Fire Barriers – The combustion turbine generator switchgear room (room 2X5) is separated from the combustion turbine generator area (rooms 317 and 2X8) by 3 hour fire-resistive concrete construction.

The interior separation between room 2X5 and fire area FT1500 at column line T8 is of 2 hour fire-resistive concrete construction. Additionally, the separation between the combustion turbine switchgear room (room 2X5) and switchgear room 'A' is a minimum of 1 hour fire-resistive construction

The ceiling and floor in room 2X5 are of a minimum 1 hour fire-resistive concrete construction.

- (5) Combustibles Present:

Fire Loading	Total Heat of Combustion (MJ)
Cable in conduit	Acceptable
Cable Trays	1454 MJ/m ² (0.1425 Btu/ft ²) ECLL (maximum average) applies

- (6) Detection Provided – Class A supervised POC at each building floor elevation and manual pull station external to the enclosed stairway at each floor elevation.
- (7) Suppression Available:

Type	Location/Actuation
Modified Class III standpipe	Stairwell No. 1 <114>
ABC portable (hand) extinguisher and hose station	TF.4-TB.3
Wet Pipe Sprinkler Design density: 8.2 L/min-m ² (0.20 gpm/ft ²) over 1500 ft ²	Room 2X5

- (8) Fire Protection Design Criteria Employed:

Fire detection and suppression capability is provided and accessible.

Fire stops are provided for penetrations through fire rated barriers.

- (9) Consequences of Fire – The postulated fire assumes loss of function. Smoke from a fire would be removed by the normal HVAC system.
- (10) Consequences of Fire Suppression – Suppression extinguishes the fire. Refer to Section 3.4, "Water Level (Flood) Design," for drain system.

- (11) Design Criteria Used for Protection Against Inadvertent Operation, Careless Operation or Rupture of the Suppression System:
 - (a) Provision of raised supports for equipment.
 - (b) Refer to Section 3.4, "Water Level (Flood) Design," for drain system.
- (12) Fire Containment or Inhibiting Methods Employed:
 - (a) Fire stops are provided for penetrations through fire rated barriers.
 - (b) The means of fire detection, suppression and alarming are provided and accessible.
- (13) Remarks:
 - (a) The total flow of the wet pipe sprinkler system with a 1893 L/min (500 gpm) hose stream allowance is estimated to be 3,596 L/min (950 gpm).
 - (b) Electrical cable insulation in conduit does not represent a combustible fire load.

9A.4.3.3.4 Fire Area –FT25X3 (Switchgear Room ‘A’ - Room 210)

- (1) Fire Area Boundary Description

Switchgear room ‘A’ is bounded by a concrete fire-resistive wall, floor and ceiling construction.

Adjacent fire areas include the combustion turbine generator area (room 317, fire area FT3500), the combustion turbine generator switchgear area (room 2X5, fire area FT25X1), the controlled access areas on floor 1F in the Turbine Building (fire area FT1500), enclosed stairwell no. 1 (room 114, fire area FT1502), enclosed stairwell no. 3 (room no. 212, fire area FT2502), and the elevator shaft (room no. 250, fire area FT15Y2).

The ceiling of Room 210 is of fire-resistive concrete construction, separating switchgear room ‘A’ from switchgear room ‘B’ (room 310, fire area FTFT35X8), 250Vdc battery rooms (rooms 3X4, fire area FT35X3, and 3X5, fire area FT35X2), and electrical equipment area (room 3X9, fire area FT35X7), on floor 2F above.

The floor of Room 110 is of fire-resistive concrete construction to separate this electrical switchgear area from the HNCW chiller area and breathing air system equipment area (rooms 248 and 1Y2, fire area FT1501) on floor MB1F below.

A fire-rated equipment hatch is installed in the floor of room 210 providing equipment access to the HNCW chiller area (room 248) below.

- (2) Equipment – See Table 9A.6-4

Safety Related	Provides Core Cooling
No	No

- (3) Radioactive Material Present – None.

- (4) Qualification of Fire Barriers – Switchgear room 'A' (room 210) is separated from the combustion turbine generator area (room 317) by 3 hour fire-resistive concrete construction.

Room 210 is separated from stairwell no. 1 (room 114, fire area FT1502), stairwell no. 3 (room 212, fire area FT2502), and the elevator shaft (room 250, fire area FT15Y2), by 2 hour fire-resistive concrete construction. These fire-resistive separations are described in subsections 9A.4.3.2.2, 9A.4.3.2.3, and 9A.4.3.2.5, respectively.

Separation from the combustion turbine generator switchgear room is a minimum of a 1 hour fire-resistive construction with a minimum of a $\frac{3}{4}$ hour fire rated (doors are 3-hour fire rated for consistency throughout the Turbine Building).

The interior separation between switchgear room 'A' (room 210) and fire area FT1500 at column line T8 is of 2 hour fire-resistive concrete construction.

The ceiling and floor in room 210 are of a minimum 1 hour fire-resistive concrete construction.

- (5) Combustibles Present:

Fire Loading	Total Heat of Combustion (MJ)
Cable in conduit	Acceptable
Cable trays	1454 MJ/m ² (0.1425 Btu/ft ²) ECLL (maximum average) applies

- (6) Detection Provided – Class A supervised POC at each building floor elevation and manual pull station external to the enclosed stairway at each floor elevation.

Manual Pull Locations: TJ.5-T10

(7) Suppression Available:

Type	Location/Actuation
Modified Class III standpipe	Stairwell No. 1 <114>
ABC portable (hand) extinguishers and hose stations	TG.1-T9, TH.9-T9
Wet Pipe Sprinkler Design density: 8.2 L/min-m ² (0.20 gpm/ft ²) over 1500 ft ²	Room 210

(8) Fire Protection Design Criteria Employed:

- (a) Fire detection and suppression capability is provided and accessible.
- (b) Fire stops are provided for penetrations through fire rated barriers.

(9) Consequences of Fire – The postulated fire assumes loss of function. Smoke from a fire would be removed by the normal HVAC system.

(10) Consequences of Fire Suppression – Suppression extinguishes the fire. Refer to Section 3.4, “Water Level (Flood) Design,” for drain system.

(11) Design Criteria Used for Protection Against Inadvertent Operation, Careless Operation or Rupture of the Suppression System:

- (a) Provision of raised supports for equipment.
- (b) Refer to Section 3.4, “Water Level (Flood) Design,” for drain system.

(12) Fire Containment or Inhibiting Methods Employed:

- (a) Fire stops are provided for penetrations through fire rated barriers.
- (b) The means of fire detection, suppression and alarming are provided and accessible.

(13) Remarks:

- (a) The total flow of the wet pipe sprinkler system with a 1893 L/min (500 gpm) hose stream allowance is estimated to be 3,596 L/min (950 gpm).
- (b) Electrical cable insulation in conduit does not represent a combustible fire load.

**Table 9A.4.3.3 - Summary of Fire Protection Criteria
Floor 1F**

Fire Area	Description	Adjacent Fire Area	Adjacent Fire Area Description	Fire Rated Separation	Fire Separation Criteria	Automatic Suppression Type	Density	Suppression Criteria
FT1500	General Area	FT1503	Stairwell No. 2 (Room 122)	Walls: 3-hour fire resistive Doors: 3 - hour fire rated	NEIL LCM, March 2008, 3.2.9.1 NFPA 804, paragraph 8.1.2.3 Also, based on (IBC) H-4 Occupancy and Type 1A construction Exterior Turbine Bldg. Wall: IBC, 2006, Table 601 Turbine Bldg. Floor over Radwaste Building (treated as separation between buildings): IBC, 2006, Table 601 Walls: NFPA 101, paragraph 8.5.6.(1) Doors: NFPA 101, Table 8.3.4.2	Wet pipe sprinkler	0.30 gpm/ft ² (12.2 L/min-m ²) over minimum application of 5000 ft ² (464.5 m ²) Total flow (Est.): 2750 gpm (10,410 L/min)	a) NFPA 804, 2006, paragraph 10.8.2.1(2) b) NEIL LCM, March 2008, A3.2.20.5.2.1.1.
		FT2502	Stairwell No. 3 (Room 212)	Walls: 2-hour fire resistive Doors: 3-hour fire rated	Walls: NFPA 101, paragraph 8.5.6.(1) Doors: NFPA 101, Table 8.3.4.2			
		FT2504	Stairwell No. 4 (Room 249)	Walls: 2-hour fire resistive Doors: 3-hour fire rated	Walls: NFPA 101, paragraph 8.5.6.(1) Doors: NFPA 101, Table 8.3.4.2			
		FT15X1	Stairwell No. 6 (Room 1X3)	Walls: 2-hour fire resistive Doors: 3-hour fire rated	Walls: NFPA 101, paragraph 8.5.6.(1) Doors: NFPA 101, Table 8.3.4.2			

**Table 9A.4.3.3 - Summary of Fire Protection Criteria
Floor 1F (Continued)**

Fire Area	Description	Adjacent Fire Area	Adjacent Fire Area Description	Fire Rated Separation	Fire Separation Criteria	Automatic Suppression Type	Density	Suppression Criteria
FT1500	General Area	FT15X2	Stairwell No. 7 (Room 1X4)	Walls: 2-hour fire resistive Doors: 3-hour fire rated	Walls: NFPA 101, paragraph 8.5.6.(1) Doors: NFPA 101, Table 8.3.4.2	Wet pipe sprinkler	0.30 gpm/ft ² (12.2 L/min-m ²) over minimum application of 5000 ft ² (464.5 m ²) Total flow (Est.): 2750 gpm (10,410 L/min)	a) NFPA 804, 2006, paragraph 10.8.2.1(2) (b) NEIL LCM, March 2008, A3.2.20.5.2.1.1.
		FT15Y2	Elevator Shaft (Room 250)	Walls: 2-hour fire resistive Doors: 3-hour fire rated	NFPA 804, paragraphs 8.1.2.4 and 8.1.2.5			
		FT2500	Lube Oil Purification Unit (Room 230)	Floor: 3-hour fire resistive	NEIL LCM, March 2008, 3.2.9.1 NFPA 804, paragraph 8.1.2.3			
		FT15Y3	Lube Oil Storage Tanks (Room 1Y1)	Floor: 3-hour fire resistive	NEIL LCM, March 2008, 3.2.9.1 NFPA 804, paragraph 8.1.2.3			
		FT15Y4	EHC Hydraulic Power Unit (Room 232)	Floor: 3-hour fire resistive	NEIL LCM, March 2008, 3.2.9.1 NFPA 804, paragraph 8.1.2.3			
		FT2503	House Boiler Area (Room 247)	Wall: 3-hour fire resistive	NEIL LCM, March 2008, 3.2.9.6 NOTE: 3-hour wall is specified based on fuel fired boiler. Specified rating may be reduced in the future due to planned electric boiler.			
		FT3500	Combustion Turbine Generator Area (Rooms 317 and 2X8)	Wall: 3-hour fire resistive	NFPA 804, paragraph 8.1.2.3			

**Table 9A.4.3.3 - Summary of Fire Protection Criteria
Floor 1F (Continued)**

Fire Area	Description	Adjacent Fire Area	Adjacent Fire Area Description	Fire Rated Separation	Fire Separation Criteria	Automatic Suppression Type	Density	Suppression Criteria
FT1500	General Area	FT25X1	Combustion Turbine Generator Switchgear (Room 2X5)	Wall: 2-hour fire resistive	Specified by FPE at this location. NEIL LCM, March 2008, 3.2.9.5 NFPA 13, paragraph 8.15.10	Wet pipe sprinkler	0.30 gpm/ft ² (12.2 L/min-m ²) over minimum application of 5000 ft ² (464.5 m ²) Total flow (Est.): 2750 gpm (10,410 L/min)	a) NFPA 804, 2006, paragraph 10.8.2.1(2) (b) NEIL LCM, March 2008, A3.2.20.5.2.1.1.
		FT25X3	Switchgear Room 'A' (Room 210)	Wall: 2-hour fire resistive	Specified by FPE at this location. NEIL LCM, March 2008, 3.2.9.5 NFPA 13, paragraph 8.15.10			
		FT2505	Main Steam Tunnel (Room 219)	Exterior Turbine Bldg. Wall: 3-hour fire resistive	NEIL LCM, March 2008, 3.2.9.1 NFPA 804, paragraph 8.1.2.3 Also, based on (IBC) H-4 Occupancy and Type 1A construction Exterior Turbine Bldg. Wall: IBC, 2006, Table 601			
		FT3501	Main Turbine Lube Oil Tank (Room 330)	Ceiling: 3-hour fire resistive	NEIL LCM, March 2008, 3.2.9.1 NFPA 804, paragraph 8.1.2.3			
		FT35X1	Safety Related Low Pressure Condensate Switchgear (Room 31X-2)	Ceiling: 3-hour fire resistive	NEIL LCM, March 2008, 3.2.9.1			

**Table 9A.4.3.3 - Summary of Fire Protection Criteria
Floor 1F (Continued)**

Fire Area	Description	Adjacent Fire Area	Adjacent Fire Area Description	Fire Rated Separation	Fire Separation Criteria	Automatic Suppression Type	Density	Suppression Criteria
FT1500	General Area	FT35X9	Generator Seal Oil Unit (Room 3X2)	Ceiling: 3-hour fire resistive	NEIL LCM, March 2008, 3.2.9.1	Wet pipe sprinkler	0.30 gpm/ft ² (12.2 L/min-m ²) over minimum application of 5000 ft ² (464.5 m ²) Total flow (Est.): 2750 gpm (10,410 L/min)	a) NFPA 804, 2006, paragraph 10.8.2.1(2) (b) NEIL LCM, March 2008, A3.2.20.5.2.1.1.
		External to Turbine Building	Horizontal passageway between Turbine Building and Control Building	Exterior Turbine Bldg. Wall: 3-hour fire resistive Doors: 3-hour fire rated	NEIL LCM, March 2008, 3.2.9.1 NFPA 804, paragraph 8.1.2.3 Also, based on (IBC) H-4 Occupancy and Type 1A construction Exterior Turbine Bldg. Wall: IBC, 2006, Table 601			
FT1502	Stairwell No. 1 (Room 114)	FT25X3	Switchgear Room 'A' (Room 210)	Walls: 2-hour fire resistive Door: 3-hour fire rated	Walls: NFPA 101, paragraph 8.5.6.(1) Doors: NFPA 101, Table 8.3.4.2	Wet pipe sprinkler	0.15 gpm/ft ² (6.1 L/min-m ²) over 1500 ft ² (139 m ²) Total flow (Est.): 850 gpm (3218 L/min)	Ordinary Hazard Group 1 per NFPA 13, paragraph 5.3.1
		External to Turbine Building	Horizontal passageway between Turbine Building and Control Building	Exterior Turbine Bldg. Wall: 3-hour fire resistive	NEIL LCM, March 2008, 3.2.9.1 NFPA 804, paragraph 8.1.2.3 Also, based on (IBC) H-4 Occupancy and Type 1A construction Exterior Turbine Bldg. Wall: IBC, 2006, Table 601			

**Table 9A.4.3.3 - Summary of Fire Protection Criteria
Floor 1F (Continued)**

Fire Area	Description	Adjacent Fire Area	Adjacent Fire Area Description	Fire Rated Separation	Fire Separation Criteria	Automatic Suppression Type	Density	Suppression Criteria
FT1503	Stairwell No. 2 (Room 122)	FT1500	General Area	Walls: 3-hour fire resistive Doors: 3 - hour fire rated	NEIL LCM, March 2008, 3.2.9.1 NFPA 804, paragraph 8.1.2.3 Also, based on (IBC) H-4 Occupancy and Type 1A construction Exterior Turbine Bldg. Wall: IBC, 2006, Table 601 Turbine Bldg. Floor over Radwaste Building (treated as separation between buildings): IBC, 2006, Table 601 Walls: NFPA 101, paragraph 8.5.6.(1) Doors :NFPA 101, Table 8.3.4.2	Wet pipe sprinkler	0.15 gpm/ft ² (6.1 L/min-m ²) over 1500 ft ² (139 m ²) Total flow (Est.): 850 gpm (3218 L/min)	Ordinary Hazard Group 1 per NFPA 13, paragraph 5.3.1

**Table 9A.4.3.3 - Summary of Fire Protection Criteria
Floor 1F (Continued)**

Fire Area	Description	Adjacent Fire Area	Adjacent Fire Area Description	Fire Rated Separation	Fire Separation Criteria	Automatic Suppression Type	Density	Suppression Criteria
FT2502	Stairwell No. 3 (Room 212)	FT1500	General Area	Walls: 2-hour fire resistive Doors: 3-hour fire rated	Walls: NFPA 101, paragraph 8.5.6.(1) Doors: NFPA 101, Table 8.3.4.2	Wet pipe sprinkler	0.15 gpm/ft ² (6.1 L/min-m ²) over 1500 ft ² (139 m ²) Total flow (Est.): 850 gpm (3218 L/min)	Ordinary Hazard Group 1 per NFPA 13, paragraph 5.3.1
		FT15Y2	Elevator Shaft (Room 250)	Walls: 2-hour fire resistive	NFPA 804, paragraphs 8.1.2.4 and 8.1.2.5			
		FT25X3	Switchgear Room 'A' (Room 210)	Wall: 2-hour fire resistive	Specified by FPE at this location. NEIL LCM, March 2008, 3.2.9.5 NFPA 13, paragraph 8.15.10			
FT2504	Stairwell No. 4 (Room 249)	FT1500	General Area	Walls: 2-hour fire resistive Doors: 3-hour fire rated	Walls: NFPA 101, paragraph 8.5.6.(1) Doors: NFPA 101, Table 8.3.4.2	Wet pipe sprinkler	0.15 gpm/ft ² (6.1 L/min-m ²) over 1500 ft ² (139 m ²) Total flow (Est.): 850 gpm (3218 L/min)	Ordinary Hazard Group 1 per NFPA 13, paragraph 5.3.1
		FT15Y1	Stairwell No. 8	Walls: 3-hour fire resistive	Walls: NFPA 101, paragraph 8.5.6.(1)			
FT15X1	Stairwell No. 6 (Room 1X3)	FT1500	General Area	Walls: 2-hour fire resistive Doors: 3-hour fire rated	Walls: NFPA 101, paragraph 8.5.6.(1) Doors: NFPA 101, Table 8.3.4.2	Wet pipe sprinkler	0.15 gpm/ft ² (6.1 L/min-m ²) over 1500 ft ² (139 m ²) Total flow (Est.): 850 gpm (3218 L/min)	Ordinary Hazard Group 1 per NFPA 13, paragraph 5.3.1

**Table 9A.4.3.3 - Summary of Fire Protection Criteria
Floor 1F (Continued)**

Fire Area	Description	Adjacent Fire Area	Adjacent Fire Area Description	Fire Rated Separation	Fire Separation Criteria	Automatic Suppression Type	Density	Suppression Criteria
FT15X2	Stairwell No. 7 (Room 1X4)	FT1500	General Area	Walls: 2-hour fire resistive Doors: 3-hour fire rated	Walls: NFPA 101, paragraph 8.5.6.(1) Doors: NFPA 101, Table 8.3.4.2	Wet pipe sprinkler	0.15 gpm/ft ² (6.1 L/min-m ²) over 1500 ft ² (139 m ²) Total flow (Est.): 850 gpm (3218 L/min)	Ordinary Hazard Group 1 per NFPA 13, paragraph 5.3.1
		External to Turbine Building	Horizontal passageway between Turbine Building and Control Building	Exterior Turbine Bldg. Wall: 3-hour fire resistive	NEIL LCM, March 2008, 3.2.9.1 NFPA 804, paragraph 8.1.2.3 Also, based on (IBC) H-4 Occupancy and Type 1A construction Exterior Turbine Bldg. Wall: IBC, 2006, Table 601			
FT15Y1	Stairwell No. 8 (Room 1X4)	FT2504	Stairwell No. 4 (Room 249)	Walls: 3-hour fire resistive	Walls: NFPA 101, paragraph 8.5.6.(1)	Wet pipe sprinkler	0.15 gpm/ft ² (6.1 L/min-m ²) over 1500 ft ² (139 m ²) Total flow (Est.): 850 gpm (3218 L/min)	Ordinary Hazard Group 1 per NFPA 13, paragraph 5.3.1
		FT2503	House Boiler Area (Room 247)	Walls: 3-hour fire resistive	Walls: NFPA 101, paragraph 8.5.6.(1)			

**Table 9A.4.3.3 - Summary of Fire Protection Criteria
Floor 1F (Continued)**

Fire Area	Description	Adjacent Fire Area	Adjacent Fire Area Description	Fire Rated Separation	Fire Separation Criteria	Automatic Suppression Type	Density	Suppression Criteria
FT15Y2	Elevator Shaft (Room 250)	FT1500	General Area	Walls: 2-hour fire resistive Doors: 1 ½ -hour fire rated	NFPA 804, paragraphs 8.1.2.4 and 8.1.2.5	Wet pipe sprinkler	0.20 gpm/ft ² (8.2 L/min-m ²) over 1500 ft ² (139 m ²) Total flow (Est.): 950 gpm (3596 L/min)	Ordinary Hazard Group 2 per NFPA 13, paragraph 5.3.2
		FT25X3	Switchgear Room 'A' (Room 210)	Walls: 2-hour fire resistive	Specified by FPE at this location. NEIL LCM, March 2008, 3.2.9.5 NFPA 13, paragraph 8.15.10			
		FT2502	Stairwell No. 3 (Room 212)	Wall: 2-hour fire resistive	Walls: NFPA 101, paragraph 8.5.6.(1) Doors: NFPA 101, Table 8.3.4.2			
FT2503	House Boiler Area (Room 247)	FT1500	General Area	Walls: 3-hour fire resistive	NEIL LCM, March 2008, 3.2.9.6 NOTE: 3-hour wall is specified based on fuel fired boiler. Specified rating may be reduced in the future due to planned electric boiler.	Wet pipe sprinkler	0.25 gpm/ft ² (10.2 L/min-m ²) over 5440 ft ² (505 m ²) – entire area Total flow (Est.): 2540 gpm (9615 L/min)	NEIL LCM, paragraph 3.2.20.5 NFPA 804, paragraph 10.24.3

**Table 9A.4.3.3 - Summary of Fire Protection Criteria
Floor 1F (Continued)**

Fire Area	Description	Adjacent Fire Area	Adjacent Fire Area Description	Fire Rated Separation	Fire Separation Criteria	Automatic Suppression Type	Density	Suppression Criteria
FT2503	House Boiler Area (Room 247)	FT15Y1	Stairwell No. 8 (Room 1X4)	Walls: 3-hour fire resistive	NEIL LCM, March 2008, 3.2.9.6 NOTE: 3-hour wall is specified based on fuel fired boiler. Specified rating may be reduced in the future due to planned electric boiler. Walls:NFPA 101, paragraph 8.5.6.(1)	Wet pipe sprinkler	0.25 gpm/ft ² (10.2 L/min-m ²) over 5440 ft ² (505 m ²) – entire area Total flow (Est.): 2540 gpm (9615 L/min)	NEIL LCM, paragraph 3.2.20.5 NFPA 804, paragraph 10.24.3
		FT3500	Combustion Turbine Generator Area (Rooms 317 and 2X8)	Walls: 3-hour fire resistive	NEIL LCM, March 2008, 3.2.9.6 NOTE: 3-hour wall is specified based on fuel fired boiler. Specified rating may be reduced in the future due to planned electric boiler.			
		FT35X8	Switchgear Room 'B' (Room 310)	Ceiling: 3-hour fire resistive	NEIL LCM, March 2008, 3.2.9.6 NOTE: 3-hour wall is specified based on fuel fired boiler. Specified rating may be reduced in the future due to planned electric boiler.			

**Table 9A.4.3.3 - Summary of Fire Protection Criteria
Floor 1F (Continued)**

Fire Area	Description	Adjacent Fire Area	Adjacent Fire Area Description	Fire Rated Separation	Fire Separation Criteria	Automatic Suppression Type	Density	Suppression Criteria
FT3500	Combustion Turbine Generator Area (Rooms 317 and 2X8)	FT1501	HNCW Chiller Area (Room 248), Instrument, Service, and Breathing Air System Equipment Areas (Rooms 111 and 1Y2)	Floor: 3-hour fire resistive	NFPA 804, paragraph 8.1.2.3	Wet Pipe Sprinkler	0.25 gpm/ft ² (10.2 L/min-m ²) over 2500 ft ² (230 m ²) Total flow (Est.): 1440 gpm (5451 L/min)	NFPA 37, paragraph 11.4.5.1 NOTE: Realistic criteria taken from NFPA 37. Flow and density taken from NFPA 804, paragraph 10.9.3, is very demanding (over entire area) and is not realistic for the size of STP 3 & 4 CTG Area.
		FT35X8	Switchgear Room 'B' (Room 310)	Ceiling: 3-hour fire resistive	NFPA 804, paragraph 8.1.2.3			
		FT1500	General Area	Wall: 3-hour fire resistive	NFPA 804, paragraph 8.1.2.3			
		FT2503	House Boiler Area (Room 247)	Wall: 3-hour fire resistive	NFPA 804, paragraph 8.1.2.3			
		FT25X1	Combustion Turbine Generator Switchgear (Room 2X5)	Wall: 3-hour fire resistive	NFPA 804, paragraph 8.1.2.3			
		FT25X3	Switchgear Room 'A' (Room 210)	Wall: 3-hour fire resistive Door: 3-hour fire rated	NFPA 804, paragraph 8.1.2.3			
FT25X1	Combustion Turbine Generator Switchgear (Room 2X5)	FT1500	General Area	Wall: 2-hour fire resistive	Specified by FPE at this location. NEIL LCM, March 2008, 3.2.9.5 NFPA 13, paragraph 8.15.10	Wet pipe sprinkler	0.20 gpm/ft ² (8.2 L/min-m ²) over 1500 ft ² (139 m ²) Total flow (Est.): 950 gpm (3596 L/min)	Ordinary Hazard Group 2 per NFPA 13, paragraph 5.3.2
		FT1501	HNCW Chiller Area (Room 248), Instrument, Service, and Breathing Air System Equipment Areas (Rooms 111 and 1Y2)	Floor: Minimum 1-hour fire resistive	NEIL LCM, March 2008, 3.2.9.5 NFPA 13, paragraph 8.15.10			

**Table 9A.4.3.3 - Summary of Fire Protection Criteria
Floor 1F (Continued)**

Fire Area	Description	Adjacent Fire Area	Adjacent Fire Area Description	Fire Rated Separation	Fire Separation Criteria	Automatic Suppression Type	Density	Suppression Criteria
FT25X1	Combustion Turbine Generator Switchgear (Room 2X5)	FT35X8	Switchgear Room 'B' (Room 310)	Ceiling: Minimum 1-hour fire resistive	NEIL LCM, March 2008, 3.2.9.5 NFPA 13, paragraph 8.15.10	Wet pipe sprinkler	0.20 gpm/ft ² (8.2 L/min-m ²) over 1500 ft ² (139 m ²) Total flow (Est.): 950 gpm (3596 L/min)	Ordinary Hazard Group 2 per NFPA 13, paragraph 5.3.2
		FT3500	Combustion Turbine Generator Area (Rooms 317 and 2X8)	Wall: 3-hour fire resistive	NFPA 804, paragraph 8.1.2.3			
		FT25X3	Switchgear Room 'A' (Room 210)	Wall: Minimum 1-hour fire resistive Door: Minimum 1-hour fire rated	NEIL LCM, March 2008, 3.2.9.5 NFPA 13, paragraph 8.15.10			

**Table 9A.4.3.3 - Summary of Fire Protection Criteria
Floor 1F (Continued)**

Fire Area	Description	Adjacent Fire Area	Adjacent Fire Area Description	Fire Rated Separation	Fire Separation Criteria	Automatic Suppression Type	Density	Suppression Criteria
FT25X3	Switchgear Room 'A' (Room 210)	FT1500	General Area	Wall: 2-hour fire resistive	Specified by FPE at this location. NEIL LCM, March 2008, 3.2.9.5 NFPA 13, paragraph 8.15.10	Wet pipe sprinkler	0.20 gpm/ft ² (8.2 L/min-m ²) over 1500 ft ² (139 m ²) Total flow (Est.): 950 gpm (3596 L/min)	Ordinary Hazard Group 2 per NFPA 13, paragraph 5.3.2
		FT1501	HNCW Chiller Area (Room 248), Instrument, Service, and Breathing Air System Equipment Areas (Rooms 111 and 1Y2)	Floor: Minimum 1-hour fire resistive	NEIL LCM, March 2008, 3.2.9.5 NFPA 13, paragraph 8.15.10			
		FT35X8	Switchgear Room 'B' (Room 310)	Ceiling: Minimum 1-hour fire resistive	NEIL LCM, March 2008, 3.2.9.5 NFPA 13, paragraph 8.15.10			
		FT3500	Combustion Turbine Generator Area (Rooms 317 and 2X8)	Wall: 3-hour fire resistive	NFPA 804, paragraph 8.1.2.3			
		FT25X1	Combustion Turbine Generator Switchgear (Room 2X5)	Wall: Minimum 1-hour fire resistive Door: Minimum 1-hour fire rated	NEIL LCM, March 2008, 3.2.9.5 NFPA 13, paragraph 8.15.10			

**Table 9A.4.3.3 - Summary of Fire Protection Criteria
Floor 1F (Continued)**

Fire Area	Description	Adjacent Fire Area	Adjacent Fire Area Description	Fire Rated Separation	Fire Separation Criteria	Automatic Suppression Type	Density	Suppression Criteria
FT25X3	Switchgear Room 'A' (Room 210)	FT2502	Stairwell No. 3 (Room 212)	Walls: 2-hour fire resistive	Walls: NFPA 101, paragraph 8.5.6.(1) Doors: NFPA 101, Table 8.3.4.2	Wet pipe sprinkler	0.20 gpm/ft ² (8.2 L/min-m ²) over 1500 ft ² (139 m ²) Total flow (Est.): 950 gpm (3596 L/min)	Ordinary Hazard Group 2 per NFPA 13, paragraph 5.3.2
		FT1502	Stairwell No. 1 (Room 114)	Walls: 2-hour fire resistive Door: 3-hour fire rated	Walls: NFPA 101, paragraph 8.5.6.(1) Doors :NFPA 101, Table 8.3.4.2			
		FT15Y2	Elevator Shaft (Room 250)	Walls: 2-hour fire resistive	NFPA 804, paragraphs 8.1.2.4 and 8.1.2.5			
		External to Turbine Building	Horizontal passageway between Turbine Building and Control Building	Exterior Turbine Bldg. Wall: 3-hour fire resistive	NEIL LCM, March 2008, 3.2.9.1 NFPA 804, paragraph 8.1.2.3 Also, based on (IBC) H-4 Occupancy and Type 1A construction Exterior Turbine Bldg. Wall: IBC, 2006, Table 601			

9A.4.3.4 Floor 2F (El. 19.7m (59'-3 ½")) – See Figure 9A.4-20 and Table 9A.4.3.4 Summary of Fire Protection Criteria Floor 2F

9A.4.3.4.1 Fire Area – FT1500 (General Area)

(1) Fire Area Boundary Description

Floor 2F shares fire area FT1500 with all other floors in the Turbine Building.

A non fire-rated equipment access hatch is installed in the floor above the offgas charcoal adsorber room (room 112). Room 112 is part of fire area FT1500.

Additionally, a large non fire-rated equipment hatch exists in the floor on the northwest side of the building leading vertically down to the unloading bay on floor 1F below. Above, in the ceiling, a large grated opening and non-fire rated equipment hatch directly connect floors 2F and 3F.

Non-fire rated equipment access hatches exist in the floor of the condensate filter maintenance area (room 342) over the condensate filter vessel area (room 241) on floor 1F below.

The low pressure condensate pump area (room 140) extends vertically up from floor B1F, through floors MB1F, 1F and 2F, to and through an unprotected equipment hatch in the turbine operating deck floor (floor 3F, elevation 27.8m (85'-10 ½")). The low pressure condensate pump area is part of fire area FT1500.

The steam jet air ejector area (room 311) and gland seal steam condenser area (room 314) extend vertically up from floor 1F, through floor 2F, to and through a non fire-rated equipment hatch in the operating deck floor (floor 3F, elevation 27.8m (85'-10 ½")). Rooms 311 and 314 are part of fire area FT1500.

Fire area FT1500 is bounded by:

- The Turbine Building exterior walls
- The exterior walls separating stairwell no. 2 (room 122, fire area FT1503)
- The interior walls enclosing stairwell no. 3 (room 212, fire area FT2502)
- The interior walls enclosing stairwell no. 4 (room 249, fire area FT2504)
- The interior walls enclosing the elevator shaft (room 250, fire area FT15Y2)

- The interior walls enclosing the area housing the main turbine lube oil tank (room 330, fire area FT3501)
- The interior walls enclosing the area housing the safety related low pressure condensate pump switchgear (room 31X-2, fire area FT35X1)
- The interior walls enclosing the area housing the generator oil seal unit (room 3X2, fire area FT35X9)
- The interior wall between switchgear area 'B' (room 310, fire area FT35X8) and this fire area, along building column line T8.
- The interior wall between 125Vdc and 250Vdc battery rooms (rooms 3X4, 3X5, 3X6, 3X7 and 3X8, fire areas FT35X3, FT35X2, FT35X4, FT35X5, and FT35X6, respectively) and this fire area, along column line T8
- The interior and exterior walls enclosing the steam tunnel area (room 219, fire area FT2505)

(2) Equipment – See Table 9A.6-4

Safety Related	Provides Core Cooling
No	No

(3) Radioactive Material Present – None that can be released as a result of fire.

(4) Qualification of Fire Barriers –

The Turbine Building is classified as Type IA construction in accordance with the International Building Code (IBC), 2006. Type IA construction is non-combustible. The building structural frame, and all exterior and interior bearing walls, are required to be of 3 hour fire-resistive construction. The building floor is required to be of not less than 2 hour fire resistive construction, including supporting beams and joists. Also, the building roof is required to be of not less than 1 ½ hour fire resistive construction.

The enclosed stairwells that serve fire area FT1500 on floor 2F, stairwell nos. 2, 3, and 4 are of 2 hour fire-resistive concrete construction. These stairwells are separate fire areas and are discussed in subsections 9A.4.3.1.2, 9A.4.3.2.3 and 9A.4.3.1.3 (fire areas FT1503, FT2502 and FT2504).

The elevator shaft (room 250) is of 2 hour fire-resistive concrete construction, is a separate fire area (FT15Y2) and is described in subsection 9A.4.3.2.5.

The walls of the area housing the main turbine lube oil tank (room 330, fire area FT3501), generator hydrogen seal oil unit (room 3X2, fire area FT35X9) and safety related low pressure condensate pump switchgear (room 31X-2, fire area FT35X1) are separated from fire area FT1500 by 3 hour fire-resistive concrete construction with 3 hour fire rated doors. These rooms are

described as separate fire areas in subsections 9A.4.3.4.2 through 9A.4.3.4.4, respectively.

Fire area FT1500 is separated from the area housing switchgear room 'B' (room 210, fire area FT35X8) by 2 hour fire-resistive concrete construction along column line T8. Fire area FT35X8 is described in subsection 9A.4.3.4.5.

The 125Vdc and 250Vdc battery rooms (rooms 3X4, 3X5, 3X6, 3X7 and 3X8, fire areas FT35X3, FT35X2, FT35X4, FT35X5, and FT35X6, respectively) are separated from fire area FT1500 by 2 hour fire-resistive concrete construction along column line T8. The fire-resistive construction of these battery rooms is described in subsection 9A.4.3.4.7.

The steam tunnel area (room 219, fire area FT2505) is separated from the turbine building by 3 hour fire-resistive concrete construction. The steam tunnel is described in subsection 9A.4.3.4.8.

(5) Combustibles Present:

Fire Loading	Total Heat of Combustion (MJ)
(a) Cable in conduit and dispersed in cable trays	Acceptable
(b) Limited quantities of lubricants in pumps	Negligible

(6) Detection Provided – Class A supervised POC, and manual alarm pull stations.

Manual Pull Locations: TA.4-T7.5, TH.5-T7.9, TG.6-T2

(7) Suppression Available:

Type	Location/Actuation
Modified Class III standpipes	Stairwells No.2 <122>, No.3 <212>, and No.4 <249>
ABC portable (hand) extinguishers and hose stations	TB.1-T2, TB.3-T3.1, TB-T4.6, TC.9-T5.4, TA.9-T5.9, TA.6-T7.8, TC.4-T7.8, TE.2-T7.8, TG-T7.8, TH.5-T7.8, TD.3-T6.1, TE.7-T5.9, TD.4-T1.1, TF.1-T2, TG.4-T2.3, TJ.1-T2.1, TJ.1-T4, TH.9-T6, TG.1-T6
Wet pipe sprinkler system Design density 12.2 L/min-m ² (0.3 gpm/ft ²) over 464.5 m ² (5000 ft ²)	Throughout floor 2F

- (8) Fire Protection Design Criteria Employed:
 - (a) Fire detection and suppression capability is provided and accessible;
 - (b) Fire stops are provided for penetrations through rated fire barriers.
- (9) Consequences of Fire – Postulated fire assumes loss of function. Smoke from a fire would be removed by the normal HVAC.
- (10) Consequences of Fire Suppression – Suppression extinguishes the fire. Refer to Section 3.4, “Water Level (Flood) Design,” for drain system.
- (11) Design Criteria Used for Protection Against Inadvertent Operation, Careless Operation or Rupture of the Suppression System:
 - (a) Provision of raised supports for the equipment
 - (b) Refer to Section 3.4, “Water Level (Flood) Design,” for drain system.
- (12) Fire Containment or Inhibiting Methods Employed:
 - (a) Fire stops are provided for penetrations through fire rated barriers.
 - (b) The means of fire detection, suppression and alarming are provided and accessible.
- (13) Remarks:
 - (a) The following safety-related equipment representing all four safety divisions is mounted on this floor:
 - C71-PoS001 A-D
 - C71-PoS004 A-D
 - B21-PS028 A-D
 - (b) Section 9A.5, Special Cases, provides justification for locating equipment from multiple safety divisions on this floor of the turbine building.
 - (c) The safety related low pressure condensate pump switchgear is located on this floor.
 - (d) Electrical cable insulation in conduit does not represent a combustible fire load.

9A.4.3.4.2 Fire Area – FT3501 (Main Turbine Lube Oil Tank – Room 330)

- (1) Fire Area Boundary Description

The interior walls, ceiling and floor of fire area FT3501, containing the main turbine lube oil tank consists of fire-resistive concrete construction.

- (2) Equipment – See Table 9A.6-4

Safety Related	Provides Core Cooling
No	No

- (3) Radioactive Material Present – None.

- (4) Qualification of Fire Barriers – The walls, ceiling and floor enclosing the lube oil purification unit (room 230) are of 3 hour fire-resistive-concrete construction with 3 hour fire rated doors.

- (5) Combustibles Present:

Fire Loading	Total Heat of Combustion (MJ)
Turbine lube oil tank, Capacity 69,966 L (18,483 gal.) (Est.)	2,925,858 MJ (2,773,178,180 Btu)

- (6) Detection Provided – Class A supervised rate compensated thermal detectors. The detection system is a cross zoned system requiring two detectors, one in each zone to sense fire before initiating the suppression system. A manual alarm pull station is located at the door.

- (7) Suppression Available:

Type	Location/Actuation
Modified Class III standpipe	Stairwells No.3 <212>
ABC portable (hand) extinguishers and hose stations	TG.8-T6.7, TJ.1-T7
Deluge foam water spray system Foam water density: 20.4 L/min-m ² (0.5 gpm/ft ²) (Est.)	Room 330

- (8) Fire Protection Design Criteria Employed:

- (a) Room 330 is configured as a separate fire-resistive enclosure.
- (b) Alternate access and egress routes are provided by separate enclosed stairways at this floor level.
- (c) Fire detection and suppression capability is provided and accessible.

- (9) Consequences of Fire – The postulated fire assumes loss of function of the enclosed area and affected equipment. Smoke from a fire would be removed by the normal HVAC system.
- (10) Consequences of Fire Suppression – Suppression extinguishes the fire. Refer to Section 3.4, “Water Level (Flood) Design,” for drain system.
- (11) Design Criteria Used for Protection Against Inadvertent Operation, Careless Operation or Rupture of the Suppression System:
- (a) Location of the manual suppression system external to the room
 - (b) Provision of raised supports for equipment
 - (c) Refer to Section 3.4, “Water Level (Flood) Design,” for drain system.
 - (d) Cross zoned detectors for initiation of deluge system
- (12) Fire Containment or Inhibiting Methods Employed:
- (a) The function is provided in a fire-resistive enclosure.
 - (b) Fire stops are provided for penetrations through fire rated barriers.
 - (c) The means of fire detection, suppression and alarming are provided and accessible.
- (13) Remarks –The main turbine lube oil tank contains approximately 69,966 L (18,483 gallons), therefore the deluge foam water sprinkler system must be capable of suppressing any fire in this room. The total flow of the deluge foam spray system with a 1893 L/min (500 gpm) hose stream allowance is estimated to be 4,618 L/min (1,220 gpm).

9A.4.3.4.3 Fire Area –FT35X9 (Generator Hydrogen Seal Oil Unit – Room 3X2)

- (1) Fire Area Boundary Description

The interior walls, ceiling and floor of fire area FT35X9, containing the generator hydrogen seal oil unit consists of fire-resistive concrete construction.

- (2) Equipment – See Table 9A.6-4

Safety Related	Provides Core Cooling
No	No

- (3) Radioactive Material Present – None.

- (4) Qualification of Fire Barriers – The walls, ceiling and floor enclosing the generator hydrogen seal oil unit (room 3X2) are of 3 hour fire-resistive-concrete construction with 3 hour fire rated doors.

- (5) Combustibles Present:

Fire Loading	Total Heat of Combustion (MJ)
Generator hydrogen seal oil tank, Capacity 5,148 L (1,360 gal.) (Est.)	215,288 MJ (204,053,643 Btu)

- (6) Detection Provided – Class A supervised rate compensated thermal detectors. The detection system is a cross zoned system requiring two detectors, one in each zone to sense fire before initiating the suppression system. A manual alarm pull station is located at the door.

- (7) Suppression Available:

Type	Location/Actuation
Modified Class III standpipe	Stairwells No.4 <249>
ABC portable (hand) extinguishers and hose stations	TB.3-T3.1, TB.1-T2
Deluge foam water spray system Foam water density: 20.4 L/min-m ² (0.5 gpm/ft ²) (Est.)	Room 3X2

- (8) Fire Protection Design Criteria Employed:

- (a) Room 3X2 is configured as a separate fire-resistive enclosure.
- (b) Alternate access and egress routes are provided by separate enclosed stairways at this floor level.
- (c) Fire detection and suppression capability is provided and accessible.

- (9) Consequences of Fire – The postulated fire assumes loss of function of the enclosed area and affected equipment. Smoke from a fire would be removed by the normal HVAC system.

- (10) Consequences of Fire Suppression – Suppression extinguishes the fire. Refer to Section 3.4, “Water Level (Flood) Design,” for drain system.

- (11) Design Criteria Used for Protection Against Inadvertent Operation, Careless Operation or Rupture of the Suppression System:
- (a) Location of the manual suppression system external to the room
 - (b) Provision of raised supports for equipment
 - (c) Refer to Section 3.4, "Water Level (Flood) Design," for drain system.
 - (d) Cross zoned detectors for initiation of deluge system
- (12) Fire Containment or Inhibiting Methods Employed:
- (a) The function is provided in a fire-resistive enclosure.
 - (b) Fire stops are provided for penetrations through fire rated barriers.
 - (c) The means of fire detection, suppression and alarming are provided and accessible.
- (13) Remarks – The generator hydrogen seal oil unit contains approximately 5,148 L (1,360 gallons), therefore the deluge foam water spray system must be capable of suppressing any fire in this room. The total flow of the deluge foam spray system with a 1893 L/min (500 gpm) hose stream allowance is estimated to be 3,426 L/min (905 gpm).

9A.4.3.4.4 Fire Area –FT35X1 (Safety Related Low Pressure Condensate Pump Switchgear (Room 31X-2))

Fire area FT1500 is separated from the area housing switchgear room 'B' (room 210, fire area FT35X8) by 2 hour fire-resistive concrete construction along column line T8. Fire area FT35X8 is described in subsection 9A.4.3.4.5.

(1) Fire Area Boundary Description

The safety-related low pressure condensate pump switchgear room (room 31X-2, fire area FT35X1) is separated from fire area FT1500 by a concrete fire-resistive wall, floor and ceiling construction.

(2) Equipment – See Remarks

Safety Related	Provides Core Cooling
Yes	No

(3) Radioactive Material Present – None.

(4) Qualification of Fire Barriers – The safety-related low pressure condensate switchgear room is enclosed in 3 hour fire-resistant concrete construction including 3 hour fire rated doors.

- (5) Combustibles Present:

Fire Loading	Total Heat of Combustion (MJ)
Cable in conduit	Acceptable
Cable trays	1454 MJ/m ² (0.1425 Btu/ft ²) ECLL (maximum average) applies

- (6) Detection Provided – Class A supervised POC at each building floor elevation and manual pull station external to the enclosed stairway at each floor elevation.

- (7) Suppression Available:

Type	Location/Actuation
Modified Class III standpipes	Stairwells No. 1 <114>, No.3 <212>
ABC portable (hand) extinguishers and hose station	TE.9-T6.6
Wet Pipe Sprinkler Design density: 8.2 L/min-m ² (0.20 gpm/ft ²) over 1500 ft ²	Room 3X-2

- (8) Fire Protection Design Criteria Employed:

- (a) Fire detection and suppression capability is provided and accessible.
- (b) Fire stops are provided for penetrations through fire rated barriers.

- (9) Consequences of Fire – The postulated fire assumes loss of function. Smoke from a fire would be removed by the normal HVAC system.

- (10) Consequences of Fire Suppression – Suppression extinguishes the fire. Refer to Section 3.4, “Water Level (Flood) Design,” for drain system.

- (11) Design Criteria Used for Protection Against Inadvertent Operation, Careless Operation or Rupture of the Suppression System:

- (a) Provision of raised supports for equipment.
- (b) Refer to Section 3.4, “Water Level (Flood) Design,” for drain system.

- (12) Fire Containment or Inhibiting Methods Employed:

- (a) Fire stops are provided for penetrations through fire rated barriers.
- (b) The means of fire detection, suppression and alarming are provided and accessible.

(13) Remarks:

- (a) Electrical cable insulation in conduit does not represent a combustible fire load.
- (b) The low pressure condensate pumps are required to automatically trip when a feedwater line break inside the drywell is detected. This is a safety related trip function but is not included in any post-fire safe shutdown success path (i.e., it is not required to safely shutdown to reactor to a hot or cold shutdown condition, or to maintain the reactor in a safe shutdown condition).

This trip function is accomplished by the Safety System Logic and Control (SSLC) which controls the application of divisional 125Vdc control power routed through the Turbine Building to two independent trip coils, respectively, within each safety related breaker.

All four safety related low pressure condensate pump breakers are located in the same fire area (room 3X2, fire area FT35X1). These safety related breakers are protected from a fire inside of the Turbine Building. The 125Vdc divisional control power enters this area from the common fire area (FT1500) to provide for the required trip function.

The SSLC circuits and 125Vdc control power are separated by electrical isolation devices. Therefore, a fire in the Turbine Building, including a fire inside the low pressure condensate pump switchgear room will not affect the SSLC system.

- (c) The total flow of the wet pipe sprinkler system with a 1893 L/min (500 gpm) hose stream allowance is estimated to be 2,983 L/min (788 gpm).

9A.4.3.4.5 Fire Area –FT35X8 (Switchgear Room ‘B’ - Room 310)

(1) Fire Area Boundary Description

Switchgear room ‘B’ is bounded by a concrete fire-resistive wall, floor and ceiling construction.

Adjacent fire areas include:

- The combustion turbine generator area (room 317, fire area FT3500)
- An electrical equipment area (room 3X9, fire area FT35X7)
- The controlled access areas on floor 2F in the Turbine Building (fire area FT1500)
- Enclosed stairwell no. 1 (room 114, fire area FT1502)
- Enclosed stairwell no. 3 (room no. 212, fire area FT2502)

- Enclosed stairwell no. 8 (room no. 1Y5, fire area FT15Y1)
- The elevator shaft (room no. 250, fire area FT15Y2)
- 125Vdc and 250Vdc battery rooms (room nos. 3X4, 3X5, 3X6, 3X7, and 3X8, and respective fire areas FT35X3, FT35X2, FT35X4, FT35X5, and FT35X6)

The switchgear room 'B' floor is fire-resistive and separate this area from switchgear room 'A' (room 210, fire area FT25X3), house boiler area (room 247, fire area FT2503) and the combustion turbine generator switchgear area (room 2X5, fire area FT2X1) on floor 1F below.

The ceiling is of fire-resistive construction, separating switchgear room 'B' from roof areas, the reactor building exhaust fan area (room 412, fire area FT1500), the turbine building equipment exhaust fan area (room 4X3), and lube oil exhaust fan area on floor 3F above.

A non fire-rated equipment hatch is installed in the floor of room 310 providing equipment access to switchgear area 'A' below.

- (2) Equipment – See Table 9A.6-4

Safety Related	Provides Core Cooling
No	No

- (3) Radioactive Material Present – None.

- (4) Qualification of Fire Barriers – Switchgear room 'B' (room 210) is separated from the combustion turbine generator area (room 317) by 3 hour fire-resistive concrete construction. This fire resistive separation is described in subsection 9A.4.3.3.2.

Room 310 is separated from stairwell no. 1 (room 114, fire area FT1502), stairwell no. 3 (room 212, fire area FT2502), stairwell no. 8 (room 1Y5, fire area FT15Y1), and the elevator shaft (room 250, fire area FT15Y2), by 2 hour fire-resistive concrete construction. These fire-resistive separations are described in subsections 9A.4.3.2.2, 9A.4.3.2.3, 9A.4.3.2.4, and 9A.4.3.2.5, respectively.

Separation from the electrical equipment room (room 3X9, fire area FT35X7), 125Vdc, and 250Vdc battery rooms is a minimum of 1 hour fire-resistive construction with a minimum of a $\frac{3}{4}$ hour fire rated door (doors are 3-hour fire rated for consistency throughout the Turbine Building). Room 3X9 (fire area FT35X7) is described in subsection 9A.4.3.4.8. The 125Vdc and 250Vdc battery rooms (room nos. 3X4, 3X5, 3X6, 3X7, and 3X8, and respective fire areas FT35X3, FT35X2, FT35X4, FT35X5, and FT35X6) are described in subsection 9A.4.3.4.7.

The interior separation between switchgear room 'B' (room 310) and fire area FT1500 at column line T8 is of 2 hour fire-resistive concrete construction.

The ceiling above switchgear room 'B' is a minimum of 1-1/2 hour fire resistive construction when this ceiling is the underside of the roof deck, or a minimum 1 hour fire-resistive construction beneath the reactor building exhaust fan area (room 412), turbine building equipment exhaust fan area (room 4X3), and lube oil exhaust fan area (room 413) on floor 3F (elevation 27.8m) above. Rooms 412, 4X3 and 413 are part of fire area FT1500 on floor 3F.

The switchgear room 'B' floor is of 3 hour fire-resistive construction where located above the house boiler area (room 247, fire area FT2503) and combustion turbine generator area (room 2X8, fire area FT3500). The floor is a minimum 1 hour fire-resistive concrete construction where located over switchgear room 'A' (room 210, fire area FT25X3) and the combustion turbine generator switchgear area (room 2X5, fire area FT25X1).

(5) Combustibles Present:

Fire Loading	Total Heat of Combustion (MJ)
Cable in conduit	Acceptable
Cable trays	1454 MJ/m ² (0.1425 Btu/ft ²) ECLL (maximum average) applies

(6) Detection Provided – Class A supervised POC at each building floor elevation and manual pull station external to the enclosed stairway at each floor elevation.

Manual Pull Locations: TJ.5-T10, TA.2-T8.2

(7) Suppression Available:

Type	Location/Actuation
Modified Class III standpipes	Stairwells No. 1 <114>, and No.8 <1Y5>
ABC portable (hand) extinguishers and hose stations	TA.3-T8.2, TC.1-T8.9, TD.2-T8.1, TE.4-T8.9, TG.1-T8.8, TH.9-T9
Wet Pipe Sprinkler Design density: 8.2 L/min-m ² (0.20 gpm/ft ²) over 1500 ft ²	Room 310

(8) Fire Protection Design Criteria Employed:

- (a) Fire detection and suppression capability is provided and accessible.
- (b) Fire stops are provided for penetrations through fire rated barriers.

- (9) Consequences of Fire – The postulated fire assumes loss of function. Smoke from a fire would be removed by the normal HVAC system.
- (10) Consequences of Fire Suppression – Suppression extinguishes the fire. Refer to Section 3.4, “Water Level (Flood) Design,” for drain system.
- (11) Design Criteria Used for Protection Against Inadvertent Operation, Careless Operation or Rupture of the Suppression System:
 - (a) Provision of raised supports for equipment.
 - (b) Refer to Section 3.4, “Water Level (Flood) Design,” for drain system.
- (12) Fire Containment or Inhibiting Methods Employed:
 - (a) Fire stops are provided for penetrations through fire rated barriers.
 - (b) The means of fire detection, suppression and alarming are provided and accessible.
- (13) Remarks:
 - (a) Electrical cable insulation in conduit does not represent a combustible fire load.
 - (b) The total flow of the wet pipe sprinkler system with a 1893 L/min (500 gpm) hose stream allowance is estimated to be 3,596 L/min (950 gpm).

9A.4.3.4.6 Fire Area –FT35X7 (Electrical Equipment Area - Room 3X9)

- (1) Fire Area Boundary Description

The electrical equipment area (room 3X9, fire area FT35X7) is enclosed on one side by turbine building exterior walls and on 3 sides by fire-resistant separation walls separating this area from switchgear room ‘B’ (room 310, fire area FT35X8).

The electrical equipment area floor separates this room from the combustion turbine generator room (room 317, fire are FT3500) and switchgear room ‘A’ (room 210, fire area FT25X3) on floor 1F below.

The fire resistive properties of the electrical equipment area ceiling are consistent with the requirements of the IBC for Type IA fire-resistive structures where the ceiling is made up of the roof deck above.

- (2) Equipment – See Table 9A.6-4

Safety Related	Provides Core Cooling
No	No

- (3) Radioactive Material Present – None.
- (4) Qualification of Fire Barriers – The Turbine Building is classified as Type IA construction in accordance with the International Building Code (IBC), 2006. Type IA construction is non-combustible. The building structural frame, and all exterior and interior bearing walls, are required to be of 3 hour fire-resistive construction. The building floor is required to be of not less than 2 hour fire resistive construction, including supporting beams and joists. Also, the building roof is required to be of not less than 1 ½ hour fire resistive construction.

The interior walls and floor that separate the electrical equipment room from adjacent switchgear room 'B' (room 310, fire area FT35X8) and switchgear room 'A' (room 210, fire area FT25X3) on floor 1F below are a minimum 1 hour fire-resistive construction.

- (5) Combustibles Present:

Fire Loading	Total Heat of Combustion (MJ)
Cable in conduit.	Acceptable
Cable trays	1454 MJ/m ² (0.1425 Btu/ft ²) ECLL (maximum average) applies

- (6) Detection Provided – Class A supervised POC at each building floor elevation and manual pull station external to the enclosed stairway at each floor elevation.

Manual Pull Locations: TJ.5-T10, TA.2-T8.2

- (7) Suppression Available:

Type	Location/Actuation
Modified Class III standpipes	Stairwells No. 1 <114>, and No.8 <1Y5>
ABC portable (hand) extinguishers and hose stations	TE.4-T8.9, TG.1-T8.8, TH.9-T9
Wet Pipe Sprinkler Design density: 8.2 L/min-m ² (0.20 gpm/ft ²) over 1500 ft ²	Room 3X9

- (8) Fire Protection Design Criteria Employed:
- (a) Fire detection and suppression capability is provided and accessible.
 - (b) Fire stops are provided for penetrations through fire rated barriers.
- (9) Consequences of Fire – The postulated fire assumes loss of function. Smoke from a fire would be removed by the normal HVAC system.

- (10) Consequences of Fire Suppression – Suppression extinguishes the fire. Refer to Section 3.4, “Water Level (Flood) Design,” for drain system.
- (11) Design Criteria Used for Protection Against Inadvertent Operation, Careless Operation or Rupture of the Suppression System:
- (a) Provision of raised supports for equipment.
 - (b) Refer to Section 3.4, “Water Level (Flood) Design,” for drain system.
- (12) Fire Containment or Inhibiting Methods Employed:
- (a) Fire stops are provided for penetrations through fire rated barriers.
 - (b) The means of fire detection, suppression and alarming are provided and accessible.
- (13) Remarks:
- (a) Electrical cable insulation in conduit does not represent a combustible fire load.
 - (b) The total flow of the wet pipe sprinkler system with a 1893 L/min (500 gpm) hose stream allowance is estimated to be 3,596 L/min (950 gpm).

9A.4.3.4.7 Fire Areas – FT35X3, FT35X2, FT35X4, FT35X5, and FT35X6 (125Vdc and 250Vdc Battery Rooms – Room Nos. 3X4, 3X5, 3X6, 3X7, and 3X8)

- (1) Fire Area Boundary Description

The walls, floor and ceiling of battery rooms (room nos. 3X4, 3X5, 3X6, 3X7, and 3X8, fire areas FT35X3, FT35X2, FT35X4, FT35X5, and FT35X6) provide a fire-resistive separation between these rooms and adjacent switchgear room ‘B’ (room 310, fire area FT35X8) and switchgear room ‘A’ (room 210, fire area FT25X3) on floor 1F below.

A fire-resistive separation is also required between the 125Vdc and 250Vdc battery rooms and the controlled turbine building areas. This fire separation is located along column line T8.

- (2) Equipment – See Table 9A.6-4

Safety Related	Provides Core Cooling
No	No

- (3) Radioactive Material Present – None.

(4) Qualification of Fire Barriers –

The interior walls, floor and ceiling of the 125Vdc and 250Vdc battery rooms (room nos. 3X4, 3X5, 3X6, 3X7, and 3X8, fire areas FT35X3, FT35X2, FT35X4, FT35X5, and FT35X6) are of minimum 1 hour fire-resistive construction.

The wall along column line T8 that separates these battery rooms from controlled turbine building areas is of 2 hour fire-resistive construction.

(5) Combustibles Present:

Fire Loading	Total Heat of Combustion (MJ)
Cable in conduit	Acceptable
Cable trays.	1454 MJ/m ² (0.1425 Btu/ft ²) ECLL (maximum average) applies
HVAC will maintain hydrogen gas concentration less than 1% by volume	Acceptable

(6) Detection Provided – Class A supervised POC at each building floor elevation and manual pull station external to the enclosed stairway at each floor elevation.

Manual Pull Locations: TJ.5-T10, TA.2-T8.2

(7) Suppression Available:

Type	Location/Actuation
Modified Class III standpipes	Stairwells No. 1 <114>, and No.8 <1Y5>
ABC portable (hand) extinguishers and hose stations	TE.4-T8.9, TG.1-T8.8, TH.9-T9
Wet Pipe Sprinkler Design density: 8.2 L/min-m ² (0.20 gpm/ft ²) over 1500 ft ²	Rooms 3X4, 3X5, 3X6, 3X7, and 3X8

(8) Fire Protection Design Criteria Employed:

- (a) Fire detection and suppression capability is provided and accessible.
- (b) Fire stops are provided for penetrations through fire rated barriers.

(9) Consequences of Fire – The postulated fire assumes loss of function. Smoke from a fire would be removed by the normal HVAC system.

(10) Consequences of Fire Suppression – Suppression extinguishes the fire. Refer to Section 3.4, "Water Level (Flood) Design," for drain system.

- (11) Design Criteria Used for Protection Against Inadvertent Operation, Careless Operation or Rupture of the Suppression System:
- (a) Provision of raised supports for batteries..
 - (b) Refer to Section 3.4, "Water Level (Flood) Design," for drain system.
- (12) Fire Containment or Inhibiting Methods Employed:
- (a) Functions provided by batteries are located in separate fire-resistive enclosures
 - (b) Fire stops are provided for penetrations through fire rated barriers.
 - (c) The means of fire detection, suppression and alarming are provided and accessible.
- (13) Remarks:
- (a) Electrical cable insulation in conduit does not represent a combustible fire load.
 - (b) The total flow of the wet pipe sprinkler system with a 1893 L/min (500 gpm) hose stream allowance is estimated to be 3,596 L/min (950 gpm).

9A.4.3.4.8 Fire Area –FT2505 (Steam Tunnel - Room 219)

- (1) Fire Area Boundary Description

The steam tunnel (room 219, fire area FT2505) is separated from all other areas by fire-resistive construction. The steam tunnel extends vertically upward along the exterior turbine building wall to an elevation directly beneath the turbine building roof structure.

- (2) Equipment – See Table 9A.6-4

Safety Related	Provides Core Cooling
Yes	No

- (3) Radioactive Material Present – None that can be release as a result of a fire.
- (4) Qualification of Fire Barriers – The steam tunnel walls, floor and ceiling are all of 3 hour fire-resistive concrete construction.

- (5) Combustibles Present:

Fire Loading	Total Heat of Combustion (MJ)
Cable in conduit and dispersed in cable trays	Acceptable

(6) Detection Provided – Class A supervised rate compensated thermal detectors.

(7) Suppression Available:

Type	Location/Actuation
Modified Class III standpipe	Stairwells No.3 <212> (outside of FT2505)
ABC portable (hand) extinguishers and hose stations	TH.5-T7.8, TJ.1-T4, TH.9-T6 (floor 2F, outside of FT2505)
	TG.9-T6.8, TH.3-T8, TJ.1-T6, TG.6-T5.1, TJ.9-T4, TG.6-T2.9, TJ.1-T2 (floor 3F, outside of FT2505)

(8) Fire Protection Design Criteria Employed:

- (a) Fire detection and suppression capability is provided and accessible.
- (b) Fire stops are provided for penetrations through fire rated barriers.

(9) Consequences of Fire – The postulated fire assumes loss of function. Smoke from a fire would be removed by the normal HVAC system.

(10) Consequences of Fire Suppression – Suppression extinguishes the fire. Refer to Section 3.4, “Water Level (Flood) Design,” for drain system.

(11) Design Criteria Used for Protection Against Inadvertent Operation, Careless Operation or Rupture of the Suppression System:

- (a) Location of manual suppression system external to room.
- (b) No floor mounted equipment.
- (c) Refer to Section 3.4, “Water Level (Flood) Design,” for drain system.

(12) Fire Containment or Inhibiting Methods Employed:

- (a) Fire stops are provided for penetrations through fire rated barriers.
- (b) The means of fire detection, suppression and alarming are provided and accessible.

(13) Remarks:

- (a) The following safety-related equipment representing all four safety divisions are mounted in the steam tunnel:
 - (i) E31-TE021-029 A-D

- (b) Section 9A.5. Special Cases, provides justification for locating equipment from multiple safety divisions on this floor of the turbine building.
- (c) Electrical cable insulation in conduit does not represent a combustible fire load.

**Table 9A.4.3.4 - Summary of Fire Protection Criteria
Floor 2F**

Fire Area	Description	Adjacent Fire Area	Adjacent Fire Area Description	Fire Rated Separation	Fire Separation Criteria	Automatic Suppression Type	Density	Suppression Criteria
FT1500	General Area	FT1503	Stairwell No. 2 (Room 122)	Walls :3-hour fire resistive Doors: 3 - hour fire rated	NEIL LCM, March 2008, 3.2.9.1 NFPA 804, paragraph 8.1.2.3 Also, based on (IBC) H-4 Occupancy and Type 1A construction Exterior Turbine Bldg. Wall: IBC, 2006, Table 601 Turbine Bldg. Floor over Radwaste Building (treated as separation between buildings): IBC, 2006, Table 601 Walls: NFPA 101, paragraph 8.5.6.(1) Doors: NFPA 101, Table 8.3.4.2	Wet pipe sprinkler	0.30 gpm/ft ² (12.2 L/min-m ²) over minimum application of 5000 ft ² (464.5 m ²) Total flow (Est.): 2750 gpm (10,410 L/min)	a) NFPA 804, 2006, paragraph 10.8.2.1(2) b) NEIL LCM, March 2008, A3.2.20.5.2.1.1.
		FT2502	Stairwell No. 3 (Room 212)	Walls: 2-hour fire resistive Doors: 3-hour fire rated	Walls: NFPA 101, paragraph 8.5.6.(1) Doors: NFPA 101, Table 8.3.4.2			
		FT2504	Stairwell No. 4 (Room 249)	Walls: 2-hour fire resistive Doors: 3-hour fire rated	Walls: NFPA 101, paragraph 8.5.6.(1) Doors: NFPA 101, Table 8.3.4.2			
		FT15Y2	Elevator Shaft (Room 250)	Walls: 2-hour fire resistive Doors: 1 ½ - hour fire rated	NFPA 804, paragraphs 8.1.2.4 and 8.1.2.5			

**Table 9A.4.3.4 - Summary of Fire Protection Criteria
Floor 2F (Continued)**

Fire Area	Description	Adjacent Fire Area	Adjacent Fire Area Description	Fire Rated Separation	Fire Separation Criteria	Automatic Suppression Type	Density	Suppression Criteria
FT1500	General Area	FT3501	Main Turbine Lube Oil Tank (Room 330)	Walls: 3-hour fire resistive Doors: 3-hour fire rated	NEIL LCM, March 2008, 3.2.9.1 NFPA 804, paragraph 8.1.2.3	Wet pipe sprinkler	0.30 gpm/ft ² (12.2 L/min-m ²) over minimum application of 5000 ft ² (464.5 m ²) Total flow (Est.): 2750 gpm (10,410 L/min)	a) NFPA 804, 2006, paragraph 10.8.2.1(2) (b) NEIL LCM, March 2008, A3.2.20.5.2.1.1.
		FT35X1	Safety Related Low Pressure Condensate Switchgear (Room 31X-2)	Walls: 3-hour fire resistive Doors: 3-hour fire rated	NEIL LCM, March 2008, 3.2.9.1			
		FT35X9	Generator Seal Oil Unit (Room 3X2)	Walls: 3-hour fire resistive Doors: 3-hour fire rated	NEIL LCM, March 2008, 3.2.9.1			
		FT35X8	Switchgear Room 'B' (Room 310)	Wall: 2-hour fire resistive	Specified by FPE at this location. NEIL LCM, March 2008, 3.2.9.5 NFPA 13, paragraph 8.15.10			
		FT35X3 FT35X2 FT35X4 FT35X5 FT35X6	125Vdc and 250Vdc Battery Rooms (Rooms 3X4, 3X5, 3X6, 3X7 and 3X8)	Wall: 2-hour fire resistive	Specified by FPE at this location. NFPA 804, paragraph 10.7.2 (Guidance followed for Safety Related equipment)			
		FT45X1	Stairwell No. 9 (Room 4X5)	Ceiling: 2-hour fire resistive	NFPA 101, paragraph 8.5.6.(1)			

**Table 9A.4.3.4 - Summary of Fire Protection Criteria
Floor 2F (Continued)**

Fire Area	Description	Adjacent Fire Area	Adjacent Fire Area Description	Fire Rated Separation	Fire Separation Criteria	Automatic Suppression Type	Density	Suppression Criteria
FT1500	General Area	FT2505	Main Steam Tunnel (Room 219)	Exterior Turbine Bldg. Wall: 3-hour fire resistive	NEIL LCM, March 2008, 3.2.9.1 NFPA 804, paragraph 8.1.2.3 Also, based on (IBC) H-4 Occupancy and Type 1A construction Exterior Turbine Bldg. Wall: IBC, 2006, Table 601	Wet pipe sprinkler	0.30 gpm/ft ² (12.2 L/min-m ²) over minimum application of 5000 ft ² (464.5 m ²) Total flow (Est.): 2750 gpm (10,410 L/min)	a) NFPA 804, 2006, paragraph 10.8.2.1(2) (b) NEIL LCM, March 2008, A3.2.20.5.2.1.1.
FT1502	Stairwell No. 1 (Room 114)	FT35X8	Switchgear Room 'B' (Room 310)	Walls: 2-hour fire resistive Door: 3-hour fire rated	Walls: NFPA 101, paragraph 8.5.6.(1) Doors: NFPA 101, Table 8.3.4.2	Wet pipe sprinkler	0.15 gpm/ft ² (6.1 L/min-m ²) over 1500 ft ² (139 m ²) Total flow (Est.): 850 gpm (3218 L/min)	Ordinary Hazard Group 1 per NFPA 13, paragraph 5.3.1

**Table 9A.4.3.4 - Summary of Fire Protection Criteria
Floor 2F (Continued)**

Fire Area	Description	Adjacent Fire Area	Adjacent Fire Area Description	Fire Rated Separation	Fire Separation Criteria	Automatic Suppression Type	Density	Suppression Criteria
FT1503	Stairwell No. 2 (Room 122)	FT1500	1 - General Area 2 - General Area 3 - Elevator Shaft (Room 250) 4 - Switchgear Room 'B' (Room 310)	Walls: 3-hour fire resistive Doors: 3 - hour fire rated	NEIL LCM, March 2008, 3.2.9.1 NFPA 804, paragraph 8.1.2.3 Also, based on (IBC) H-4 Occupancy and Type 1A construction Exterior Turbine Bldg. Wall: IBC, 2006, Table 601 Turbine Bldg. Floor over Radwaste Building (treated as separation between buildings): IBC, 2006, Table 601 Walls:NFPA 101, paragraph 8.5.6.(1) Doors:NFPA 101, Table 8.3.4.2	Wet pipe sprinkler	0.15 gpm/ft ² (6.1 L/min-m ²) over 1500 ft ² (139 m ²) Total flow (Est.): 850 gpm (3218 L/min)	Ordinary Hazard Group 1 per NFPA 13, paragraph 5.3.1
FT2502	Stairwell No. 3 (Room 212)	FT1500		Walls: 2-hour fire resistive Doors: 3-hour fire rated	Walls: NFPA 101, paragraph 8.5.6.(1) Doors: NFPA 101, Table 8.3.4.2	Wet pipe sprinkler	0.15 gpm/ft ² (6.1 L/min-m ²) over 1500 ft ² (139 m ²) Total flow (Est.): 850 gpm (3218 L/min)	Ordinary Hazard Group 1 per NFPA 13, paragraph 5.3.1
		FT15Y2		Walls: 2-hour fire resistive	NFPA 804, paragraphs 8.1.2.4 and 8.1.2.5			
		FT35X8		Wall: 2-hour fire resistive	Specified by FPE at this location. NEIL LCM, March 2008, 3.2.9.5 NFPA 13, paragraph 8.15.10			

**Table 9A.4.3.4 - Summary of Fire Protection Criteria
Floor 2F (Continued)**

Fire Area	Description	Adjacent Fire Area	Adjacent Fire Area Description	Fire Rated Separation	Fire Separation Criteria	Automatic Suppression Type	Density	Suppression Criteria
FT2504	Stairwell No. 4 (Room 249)	FT1500	General Area	Walls: 2-hour fire resistive Doors: 3-hour fire rated	Walls: NFPA 101, paragraph 8.5.6.(1) Doors: NFPA 101, Table 8.3.4.2	Wet pipe sprinkler	0.15 gpm/ft ² (6.1 L/min-m ²) over 1500 ft ² (139 m ²) Total flow (Est.): 850 gpm (3218 L/min)	Ordinary Hazard Group 1 per NFPA 13, paragraph 5.3.1
		FT15Y1	Stairwell No. 8	Walls: 3-hour fire resistive	Walls: NFPA 101, paragraph 8.5.6.(1)			
FT15Y2	Elevator Shaft (Room 250)	FT1500	General Area	Walls: 2-hour fire resistive Doors: 3-hour fire rated	NFPA 804, paragraphs 8.1.2.4 and 8.1.2.5	Wet pipe sprinkler	0.20 gpm/ft ² (8.2 L/min-m ²) over 1500 ft ² (139 m ²) Total flow (Est.): 950 gpm (3596 L/min)	Ordinary Hazard Group 2 per NFPA 13, paragraph 5.3.2
		FT25X3	Switchgear Room 'A' (Room 210)	Wall: 2-hour fire resistive	Specified by FPE at this location. NEIL LCM, March 2008, 3.2.9.5 NFPA 13, paragraph 8.15.10			
		FT2502	Stairwell No. 3 (Room 212)	Walls: 2-hour fire resistive Doors: 3-hour fire rated	Walls: NFPA 101, paragraph 8.5.6.(1) Doors: NFPA 101, Table 8.3.4.2			
FT3501	Main Turbine Lube Oil Tank (Room 330)	FT1500	General Area	Walls: 3-hour fire resistive Doors: 3-hour fire rated Floor: 3-hour fire resistive Ceiling: 3-hour fire resistive	NEIL LCM, March 2008, 3.2.9.1 NFPA 804, paragraph 8.1.2.3	Deluge Foam Water Spray	0.50 gpm/ ft ² (20.4 L/min-m ²) over the entire area (Est.) 960 ft ² (89 m ²) Total flow (Est.): 1220 gpm (4618 L/min)	NEIL LCM, paragraph 3.2.20.5 and Appendix A.3.2.20.5 NFPA 15, paragraphs 7.2.1.3 and 7.3.3 NFPA 16, paragraph 7.3.2 and Appendix A.7.3.2

**Table 9A.4.3.4 - Summary of Fire Protection Criteria
Floor 2F (Continued)**

Fire Area	Description	Adjacent Fire Area	Adjacent Fire Area Description	Fire Rated Separation	Fire Separation Criteria	Automatic Suppression Type	Density	Suppression Criteria
FT35X1	Safety Related Low Pressure Condensate Switchgear (Room 31X-2)	FT1500	General Area	Walls: 3-hour fire resistive Doors: 3-hour fire rated Floor: 3-hour fire resistive Ceiling: 3-hour fire resistive	NEIL LCM, March 2008, 3.2.9.1	Wet pipe sprinkler	0.20 gpm/ft ² (8.2 L/min-m ²) over entire area (Est.)960 ft ² (89 m ²) Total flow (Est.): 788 gpm (2983 L/min)	Ordinary Hazard Group 2 per NFPA 13, paragraph 5.3.2
FT35X9	Generator Seal Oil Unit (Room 3X2)	FT1500	General Area	Walls: 3-hour fire resistive Doors: 3-hour fire rated Floor: 3-hour fire resistive Ceiling: 3-hour fire resistive	NEIL LCM, March 2008, 3.2.9.1	Deluge Foam Water Spray	0.50 gpm/ ft ² (20.4 L/min-m ²) over the entire area (Est. 540 ft ² (50 m ²)) Total flow (Est.): 905 gpm (3426 L/min)	NEIL LCM, paragraph 3.2.20.5 and Appendix A.3.2.20.5 NFPA 15, paragraphs 7.2.1.3 and 7.3.3 NFPA 16, paragraph 7.3.2 and Appendix A.7.3.2

**Table 9A.4.3.4 - Summary of Fire Protection Criteria
Floor 2F (Continued)**

Fire Area	Description	Adjacent Fire Area	Adjacent Fire Area Description	Fire Rated Separation	Fire Separation Criteria	Automatic Suppression Type	Density	Suppression Criteria
FT35X8	Switchgear Room 'B' (Room 310)	FT1500	General Area	Wall: 2-hour fire resistive Ceiling: Minimum 1-hour fire resistive	Specified by FPE at this location. NEIL LCM, March 2008, 3.2.9.5 NFPA 13, paragraph 8.15.10	Wet pipe sprinkler	0.20 gpm/ft ² (8.2 L/min-m ²) over 1500 ft ² (139 m ²) Total flow (Est.): 950 gpm (3596 L/min)	Ordinary Hazard Group 2 per NFPA 13, paragraph 5.3.2
		FT25X3	Switchgear Room 'A' (Room 210)	Floor: Minimum 1-hour fire resistive	NEIL LCM, March 2008, 3.2.9.5 NFPA 13, paragraph 8.15.10			
		FT1502	Stairwell No. 1 (Room 114)	Walls: 2-hour fire resistive Door: 3-hour fire rated	Walls: NFPA 101, paragraph 8.5.6.(1) Doors: NFPA 101, Table 8.3.4.2			

**Table 9A.4.3.4 - Summary of Fire Protection Criteria
Floor 2F (Continued)**

Fire Area	Description	Adjacent Fire Area	Adjacent Fire Area Description	Fire Rated Separation	Fire Separation Criteria	Automatic Suppression Type	Density	Suppression Criteria
FT35X8	Switchgear Room 'B' (Room 310)	FT2502	Stairwell No. 3 (Room 212)	Walls: 2-hour fire resistive	Walls:NFPA 101, paragraph 8.5.6.(1)	Wet pipe sprinkler	0.20 gpm/ft ² (8.2 L/min-m ²) over 1500 ft ² (139 m ²) Total flow (Est.): 950 gpm (3596 L/min)	Ordinary Hazard Group 2 per NFPA 13, paragraph 5.3.2
		FT15Y1	Stairwell No. 8 (Room 1Y5)	Walls: 2-hour fire resistive Door: 3-hour fire rated	Walls:NFPA 101, paragraph 8.5.6.(1) Doors:NFPA 101, Table 8.3.4.2			
		FT15Y2	Elevator Shaft (Room 250)	Walls: 2-hour fire resistive	NFPA 804, paragraphs 8.1.2.4 and 8.1.2.5			
		FT35X3 FT35X2 FT35X4 FT35X5 FT35X6	125Vdc and 250Vdc Battery Rooms (Rooms 3X4, 3X5, 3X6, 3X7 and 3X8)	Walls :Minimum 1-hour fire resistive Doors: 3-hour fire rated Floors: Minimum 1-hour fire resistive Ceilings: Minimum 1-hour fire resistive	NFPA 804, paragraph 10.7.2 (Guidance followed for Safety Related equipment) NFPA 13, paragraph 8.15.10			
		FT3500	Combustion Turbine Generator Area (Rooms 317 and 2X8)	Walls: 3-hour fire resistive	NFPA 804, paragraph 8.1.2.3			
		FT35X7	Electrical Equipment (Room 3X9)	Walls: Minimum 1-hour fire resistive	NEIL LCM, March 2008, 3.2.9.5 NFPA 13, paragraph 8.15.10			

**Table 9A.4.3.4 - Summary of Fire Protection Criteria
Floor 2F (Continued)**

Fire Area	Description	Adjacent Fire Area	Adjacent Fire Area Description	Fire Rated Separation	Fire Separation Criteria	Automatic Suppression Type	Density	Suppression Criteria
FT35X3 FT35X2 FT35X4 FT35X5 FT35X6	125Vdc and 250Vdc Battery Rooms (Rooms 3X4, 3X5, 3X6, 3X7 and 3X8)	FT1500	General Area	Wall: 2-hour fire resistive	Specified by FPE at this location. NFPA 804, paragraph 10.7.2 (Guidance followed for Safety Related equipment) NFPA 13, paragraph 8.15.10	Wet pipe sprinkler	0.20 gpm/ft ² (8.2 L/min-m ²) over 1500 ft ² (139 m ²) Total flow (Est.): 950 gpm (3596 L/min)	Ordinary Hazard Group 2 per NFPA 13, paragraph 5.3.2
FT35X3 FT35X2 FT35X4 FT35X5 FT35X6	125Vdc and 250Vdc Battery Rooms (Rooms 3X4, 3X5, 3X6, 3X7 and 3X8)	FT35X3 FT35X2 FT35X4 FT35X5 FT35X6	125Vdc and 250Vdc Battery Rooms (Rooms 3X4, 3X5, 3X6, 3X7 and 3X8)	Walls: Minimum 1-hour fire resistive Doors: 3-hour fire rated Floors: Minimum 1-hour fire resistive Ceilings: Minimum 1-hour fire resistive	NFPA 804, paragraph 10.7.2 (Guidance followed for Safety Related equipment) NFPA 13, paragraph 8.15.10	Wet pipe sprinkler	0.20 gpm/ft ² (8.2 L/min-m ²) over 1500 ft ² (139 m ²) Total flow (Est.): 950 gpm (3596 L/min)	Ordinary Hazard Group 2 per NFPA 13, paragraph 5.3.2
		FT35X8	Switchgear Room 'B' (Room 310)	Walls: Minimum 1-hour fire resistive Doors: 3-hour fire rated Ceilings: Minimum 1-hour fire resistive	NFPA 804, paragraph 10.7.2 (Guidance followed for Safety Related equipment) NFPA 13, paragraph 8.15.10			
		FT2502	Stairwell No. 3 (Room 212)	Wall: 2-hour fire resistive	Specified by FPE at this location. NEIL LCM, March 2008, 3.2.9.5 NFPA 13, paragraph 8.15.10			

**Table 9A.4.3.4 - Summary of Fire Protection Criteria
Floor 2F (Continued)**

Fire Area	Description	Adjacent Fire Area	Adjacent Fire Area Description	Fire Rated Separation	Fire Separation Criteria	Automatic Suppression Type	Density	Suppression Criteria
FT15Y1	Stairwell No. 8 (Room 1X4)	FT35X8	Switchgear Room 'B' (Room 310)	Walls: 2-hour fire resistive Door: 3-hour fire rated	Walls: NFPA 101, paragraph 8.5.6.(1) Doors: NFPA 101, Table 8.3.4.2	Wet pipe sprinkler	0.15 gpm/ft ² (6.1 L/min-m ²) over 1500 ft ² (139 m ²)	Ordinary Hazard Group 1 per NFPA 13, paragraph 5.3.1
		FT2504	Stairwell No. 4 (Room 249)	Walls: 3-hour fire resistive	Walls: NFPA 101, paragraph 8.5.6.(1)		Total flow (Est.): 850 gpm (3218 L/min)	
FT3500	Combustion Turbine Generator Area (Rooms 317 and 2X8)	FT35X8	Switchgear Room 'B' (Room 310)	Walls: 3-hour fire resistive	NFPA 804, paragraph 8.1.2.3	Wet Pipe Sprinkler	0.25 gpm/ft ² (10.2 L/min-m ²) over 2500 ft ² (230 m ²) Total flow (Est.): 1440 gpm (5451 L/min)	NFPA 37, paragraph 11.4.5.1 NOTE: Realistic criteria taken from NFPA 37. Flow and density taken from NFPA 804, paragraph 10.9.3, is very demanding (over entire area) and is not realistic for the size of STP 3 & 4 CTG Area.
FT35X7	Electrical Equipment (Room 3X9)	FT35X8	Switchgear Room 'B' (Room 310)	Walls: Minimum 1-hour fire resistive	NEIL LCM, March 2008, 3.2.9.5 NFPA 13, paragraph 8.15.10	Wet pipe sprinkler	0.20 gpm/ft ² (8.2 L/min-m ²) over 1500 ft ² (139 m ²) Total flow (Est.): 950 gpm (3596 L/min)	Ordinary Hazard Group 2 per NFPA 13, paragraph 5.3.2 Ordinary Hazard Group 2 per NFPA 13, paragraph 5.3.2

9A.4.3.5 Floor 3F (El. 27.8m (85'-10 1/2")) – See Figure 9A.4-21 and Table 9A.4.3.5 Summary of Fire Protection Criteria Floor 3F

9A.4.3.5.1 Fire Area – FT1500 (General Area)

(1) Fire Area Boundary Description

Floor 3F shares fire area FT1500 with all other floors in the Turbine Building.

The following openings or non-fire rated openings are present in floor 3F extending downward to floor areas below:

- A large non fire-rated equipment hatch and grated opening exists in the floor on the northwest side of the building leading vertically down to floors 1F and 2F below
- A non-fire rated equipment access hatch is installed above the condensate filter maintenance area (room 342) on floor 2F below
- A non fire-rated equipment access hatch is installed above the low pressure condensate pump area (room 140) on floor B1F below
- A non fire-rated hatch is located above the turbine bypass valve on floor 2F below
- Two (2) large non fire-rated hatches are installed in floor 3F above the 5th and 6th stage feedwater heaters on floor 2F below
- A large non fire-rated hatch is installed above the turbine stop valves and turbine control valves on floor 2F below
- Large gaps and openings in floor 3F beneath the main turbine skirt that extend downward to the main condenser pit area (room 120)

Fire area FT1500 is bounded by:

- The Turbine Building exterior walls
- The exterior walls separating stairwell no. 2 (room 122, fire area FT1503)
- The interior walls enclosing stairwell no. 3 (room 212, fire area FT2502)
- The interior walls enclosing stairwell no. 4 (room 249, fire area FT2504)
- The interior walls enclosing the elevator shaft (room 250, fire area FT15Y2)
- The interior walls enclosing stairwell no. 9 (room 4X5, fire area FT45X1)

- A fire-rated hatch or concrete cover block, if necessary to obtain the proper fire-resistance, is installed over the safety-related low pressure condensate pump switchgear room (room 31X-2, fire area FT35X1) on floor 2F below
- A large fire-rated hatch or concrete cover block, if necessary to obtain the proper fire-resistance, is installed over the main turbine lube oil tank (room 330, fire area FT3501) on floor 2F below
- The exterior turbine building wall providing separation from the steam tunnel area (room 219, fire area FT2505)
- The floor 3F areas above switchgear room 'B' (room 310, fire area FT35X8), electrical equipment area (room 3X9, fire area FT35X7) and 125Vdc and 250Vdc battery rooms (room nos. 3X4, 3X5, 3X6, 3X7 and 3X8, fire areas FT35X3, FT35X2, FT35X4, FT35X5, and FT35X6, respectively)

(2) Equipment – See Table 9A.6-4

Safety Related	Provides Core Cooling
Yes	No

(3) Radioactive Material Present – None that can be released as a result of fire.

(4) Qualification of Fire Barriers –

The Turbine Building is classified as Type IA construction in accordance with the International Building Code (IBC), 2006. Type IA construction is non-combustible. The building structural frame, and all exterior and interior bearing walls, are required to be of 3 hour fire-resistive construction. The building floor is required to be of not less than 2 hour fire resistive construction, including supporting beams and joists. Also, the building roof is required to be of not less than 1 ½ hour fire resistive construction.

The enclosed stairwells that serve fire area FT1500 on floor 3F, stairwell nos. 2, 3, and 4 are of 2 hour fire-resistive concrete construction. These stairwells are separate fire areas and are discussed in subsections 9A.4.3.1.2, 9A.4.3.2.3 and 9A.4.3.1.3 (fire areas FT1503, FT2502 and FT2504).

Enclosed stairwell no. 9 provides access to floor 4F (elevation 38.3m (120'-4")). This stairwell is of 2 hour fire-resistive concrete construction. Stairwell no. 9 is described in subsection 9A.4.3.5.2.

The elevator shaft (room 250) is of 2 hour fire-resistive concrete construction, is a separate fire area (FT15Y2) and is described in subsection 9A.4.3.2.5.

The equipment access hatches, concrete cover blocks, or other method of providing the required fire-resistance rating, between the safety-related low

pressure condensate pump switchgear room (room 31X-2, fire area FT35X1) and main turbine lube oil tank area (room 330, fire area FT3501) and FT1500, are required to have a 3 hour fire-resistance rating.

Floor 3F areas above switchgear room 'B' (room 310, fire area FT35X8), electrical equipment area (room 3X9, fire area FT35X7) and 125Vdc and 250Vdc battery rooms (room nos. 3X4, 3X5, 3X6, 3X7 and 3X8, fire areas FT35X3, FT35X2, FT35X4, FT35X5, and FT35X6, respectively) are of a minimum 1 hour fire-resistive concrete construction. These floor areas include the reactor building exhaust fan area (room 412), turbine building equipment compartment exhaust fan area (room 4X3) and the lube oil area exhaust fan area.

(5) Combustibles Present:

Fire Loading	Total Heat of Combustion (MJ)
(a) Cable in conduit and dispersed in cable trays	Acceptable
(b) Limited quantities of lubricants in pumps	Negligible

(6) Detection Provided – Class A supervised POC, and manual alarm pull stations.

Manual Pull Locations: TA.4-T7.5, TH.5-T7.9, TJ.6-T7.6, TG.6-T1.9, TA.2-T8.2, TJ.5-T9.6

(7) Suppression Available:

Type	Location/Actuation
Modified Class III standpipes	Stairwells No. 1 <114>, No.2 <122>, No.3 <212>, No.4 <249>, No.8 <1Y5>, No.8 <1Y5>, and No. 9 <4X5>
ABC portable (hand) extinguishers and hose stations	TB.1-T2, TC.6-T2.8, TB-T4, TC.6-T5.1, TA.1-T5.8, TB.8-T6.9, TD.4-T6.4, TF.2-T6.8, TG.9-T6.8, TH.3-T8, TJ.1-T6, TG.6-T5.1, TJ.9-T4, TG.6-T2.9, TJ.1-T2, TE.1-T6.9, TG-T6.9, TE.1-T2.1, TF.9-T2.1, TF.5-T7, TE.2-T8.2, TH-T8.5, TF.3-T8.4,
Wet pipe sprinkler system Design density 12.2 L/min-m ² (0.3 gpm/ft ²) over 464.5 m ² (5000 ft ²)	Throughout floor 3F
Closed head pre-action spray system Design density 12.2 L/min-m ² (0.3 gpm/ft ²), Assume 20 spray heads over 10 bearings at coverage of 4.65 m ² (50 ft ²) per head	Turbine generator bearings
Wet pipe sprinkler system Design density 12.2 L/min-m ² (0.3 gpm/ft ²) (5000 ft ²)	Beneath turbine skirt

(8) Fire Protection Design Criteria Employed:

- (a) Fire detection and suppression capability is provided and accessible;
 - (b) Fire stops are provided for penetrations through rated fire barriers.
- (9) Consequences of Fire – Postulated fire assumes loss of function. Smoke from a fire would be removed by the normal HVAC.
- (10) Consequences of Fire Suppression – Suppression extinguishes the fire. Refer to Section 3.4, “Water Level (Flood) Design,” for drain system.
- (11) Design Criteria Used for Protection Against Inadvertent Operation, Careless Operation or Rupture of the Suppression System:
- (a) Provision of raised supports for the equipment
 - (b) Refer to Section 3.4, “Water Level (Flood) Design,” for drain system.

(12) Fire Containment or Inhibiting Methods Employed:

- (a) Fire stops are provided for penetrations through fire rated barriers.
- (b) The means of fire detection, suppression and alarming are provided and accessible.

(13) Remarks:

- (a) The following safety-related equipment representing all four safety divisions is mounted on this floor:

C71-PT003 A-D
- (b) Section 9A.5, Special Cases, provides justification for locating equipment from multiple safety divisions on this floor of the turbine building.
- (c) Electrical cable insulation in conduit does not represent a combustible fire load.
- (d) The total flow of the wet pipe sprinkler system on floor 3F with 1893 L/min (500 gpm) hose stream allowance is estimated to be 7,571 L/min (2750 gpm).
- (e) The total flow of the closed head preaction spray system on main turbine bearings with a 1893 L/min (500 gpm) hose stream allowance is estimated to be 3,596 L/min (950 gpm).
- (f) The total flow of the wet pipe sprinkler system beneath the main turbine skirt with a 1893 L/min (500 gpm) hose stream allowance is estimated to be 10,410 L/min (2750 gpm).

9A.4.3.5.2 Fire Area – FT45X1 (Stairwell No. 9 – Room 4X5)

(1) Fire Area Boundary Description

Stairwell No. 9 serves controlled areas inside the Turbine Building at floor level 3F.

Fire area FT45X1 extends vertically upward from floor 3F through floor 4F and provides access to and from floor 4F (elevation 38.3m (120'-4")).

Stairwell no. 9 is a separate fire area bounded by interior fire walls at floor levels 3F and 4F.

- (2) Equipment – See Table 9A.6-4

Safety Related	Provides Core Cooling
No	No

- (3) Radioactive Material Present – None.
- (4) Qualification of Fire Barriers – At floor levels 3F and 4F, walls enclosing stairwell no. 9 are a minimum of 2 hour fire-resistive concrete construction. Stairwell doors are a minimum of 1-1/2 hour fire rated (doors are 3-hour fire rated for consistency throughout the Turbine Building).
- (5) Combustibles Present – No significant quantities of exposed combustibles.
- (6) Detection Provided – Class A supervised POC at each building floor elevation and manual pull station external to the enclosed stairway at each floor elevation.

- (7) Suppression Available:

Type	Location/Actuation
Modified Class III standpipe	Stairwell No. 9 <4X5>
ABC portable (hand) extinguishers and hose stations	TH.3-T8, TJ.1-T6, TH-T8.5
Wet pipe sprinkler system Design density 6.1 L/min-m ² (0.15 gpm/ft ²)	Stairwell No. 9

- (8) Fire Protection Design Criteria Employed:
- (a) The stairwell is located in a separate fire-resistive enclosure.
- (b) Fire detection and suppression capability is provided and accessible.
- (9) Consequences of Fire – The postulated fire assumes loss of function of the enclosed stairway. Smoke from a fire would be removed by the normal HVAC system.
- (10) Consequences of Fire Suppression – Suppression extinguishes the fire. Refer to to Section 3.4, “Water Level (Flood) Design,” for drain system.
- (11) Design Criteria Used for Protection Against Inadvertent Operation, Careless Operation or Rupture of the Suppression System:
- (a) Refer to Section 3.4, “Water Level (Flood) Design,” for drain system.

- (12) Fire Containment or Inhibiting Methods Employed:
 - (a) The function is provided in a fire-resistive enclosure.
 - (b) Fire stops are provided for penetrations through fire rated barriers.
 - (c) The means of fire detection, suppression and alarming are provided and accessible.

- (13) Remarks – The total flow of the wet pipe sprinkler system with a 1893 L/min (500 gpm) hose stream allowance is estimated to be 3,218 L/min (850 gpm).

**Table 9A.4.3.5 - Summary of Fire Protection Criteria
Floor 3F**

Fire Area	Description	Adjacent Fire Area	Adjacent Fire Area Description	Fire Rated Separation	Fire Separation Criteria	Automatic Suppression Type	Density	Suppression Criteria
FT1500	General Area	FT1503	Stairwell No. 2 (Room 122)	Walls: 3-hour fire resistive Doors: 3 - hour fire rated	NEIL LCM, March 2008, 3.2.9.1 NFPA 804, paragraph 8.1.2.3 Also, based on (IBC) H-4 Occupancy and Type 1A construction Exterior Turbine Bldg. Wall: IBC, 2006, Table 601 Turbine Bldg. Floor over Radwaste Building (treated as separation between buildings): IBC, 2006, Table 601 Walls: NFPA 101, paragraph 8.5.6.(1) Doors: NFPA 101, Table 8.3.4.2	Wet pipe sprinkler	0.30 gpm/ft ² (12.2 L/min-m ²) over minimum application of 5000 ft ² (464.5 m ²) Total flow (Est.): 2750 gpm (10,410 L/min)	a) NFPA 804, 2006, paragraph 10.8.2.1(2) (b) NEIL LCM, March 2008, A3.2.20.5.2.1.1.
		FT2502	Stairwell No. 3 (Room 212)	Walls: 2-hour fire resistive Doors: 3-hour fire rated	Walls: NFPA 101, paragraph 8.5.6.(1) Doors: NFPA 101, Table 8.3.4.2			
		FT2504	Stairwell No. 4 (Room 249)	Walls: 2-hour fire resistive Doors: 3-hour fire rated	Walls: NFPA 101, paragraph 8.5.6.(1) Doors: NFPA 101, Table 8.3.4.2			
		FT15Y2	Elevator Shaft (Room 250)	Walls: 2-hour fire resistive Doors: 1 ½ - hour fire rated	NFPA 804, paragraphs 8.1.2.4 and 8.1.2.5			

**Table 9A.4.3.5 - Summary of Fire Protection Criteria
Floor 3F (Continued)**

Fire Area	Description	Adjacent Fire Area	Adjacent Fire Area Description	Fire Rated Separation	Fire Separation Criteria	Automatic Suppression Type	Density	Suppression Criteria
FT1500 General Area		FT45X1	Stairwell No. 9 (Room 4X5)	Walls: 2-hour fire resistive Doors: 3-hour fire rated	Walls: NFPA 101, paragraph 8.5.6.(1) Doors: NFPA 101, Table 8.3.4.2	Wet pipe sprinkler	0.30 gpm/ft ² (12.2 L/min-m ²) over minimum application of 5000 ft ² (464.5 m ²) Total flow (Est.): 2750 gpm (10,410 L/min)	a) NFPA 804, 2006, paragraph 10.8.2.1(2) b) NEIL LCM, March 2008, A3.2.20.5.2.1.1.
		FT55X1	Stairwell No. 10 (Room 5X1)	Ceiling: 2-hour fire resistive	NFPA 101, paragraph 8.5.6.(1)			
		FT2505	Main Steam Tunnel (Room 219)	Exterior Turbine Bldg. Wall: 3-hour fire resistive	NEIL LCM, March 2008, 3.2.9.1 NFPA 804, paragraph 8.1.2.3 Also, based on (IBC) H-4 Occupancy and Type 1A construction Exterior Turbine Bldg. Wall: IBC, 2006, Table 601			
		FT35X1	Safety Related Low Pressure Condensate Switchgear (Room 31X-2)	Floor Hatch or Cover Block: 3-hour fire resistive	NEIL LCM, March 2008, 3.2.9.1			
		FT3501	Main Turbine Lube Oil Tank (Room 330)	Floor Hatch or Cover Block: 3-hour fire resistive	NEIL LCM, March 2008, 3.2.9.1 NFPA 804, paragraph 8.1.2.3			
		FT35X8	Switchgear Room 'B' (Room 310)	Floor: Minimum 1-hour fire resistive	NEIL LCM, March 2008, 3.2.9.5 NFPA 13, paragraph 8.5.10			

**Table 9A.4.3.5 - Summary of Fire Protection Criteria
Floor 3F (Continued)**

Fire Area	Description	Adjacent Fire Area	Adjacent Fire Area Description	Fire Rated Separation	Fire Separation Criteria	Automatic Suppression Type	Density	Suppression Criteria
FT1500	General Area	FT3500	Combustion Turbine Generator Area (Rooms 317 and 2X8)	Floor: 3-hour fire resistive	NFPA 804, paragraph 8.1.2.3	Wet pipe sprinkler	0.30 gpm/ft ² (12.2 L/min-m ²) over minimum application of 5000 ft ² (464.5 m ²) Total flow (Est.): 2750 gpm (10,410 L/min)	a) NFPA 804, 2006, paragraph 10.8.2.1(2)
		FT35X7	Electrical Equipment (Room 3X9)	Floor: Minimum 1-hour fire resistive	NEIL LCM, March 2008, 3.2.9.5 NFPA 13, paragraph 8.15.10			(b) NEIL LCM, March 2008, A3.2.20.5.2.1.1.
FT1500	General Area	--	Main Turbine Bearings	--		Closed head pre-action spray	0.30 gpm/ft ² (12.2 L/min-m ²) over 500 ft ² (46.5 m ²) Total flow (Est.): 3,596 L/min (950 gpm)	NEIL LCM, March 2008, 3.2.20.5 NFPA 804, paragraph 10.8.3
		--	Beneath Main Turbine Skirt	--		Wet pipe sprinkler	0.30 gpm/ft ² (12.2 L/min-m ²) over minimum application of 5000 ft ² (464.5 m ²) Total flow (Est.): 2750 gpm (10,410 L/min)	NEIL LCM, March 2008, 3.2.20.5 NFPA 804, paragraph 10.8.2

**Table 9A.4.3.5 - Summary of Fire Protection Criteria
Floor 3F (Continued)**

Fire Area	Description	Adjacent Fire Area	Adjacent Fire Area Description	Fire Rated Separation	Fire Separation Criteria	Automatic Suppression Type	Density	Suppression Criteria
FT1503	Stairwell No. 2 (Room 122)	FT1500	General Area	Walls: 3-hour fire resistive Doors: 3 - hour fire rated	NEIL LCM, March 2008, 3.2.9.1 NFPA 804, paragraph 8.1.2.3 Also, based on (IBC) H-4 Occupancy and Type 1A construction Exterior Turbine Bldg. Wall: IBC, 2006, Table 601 Turbine Bldg. Floor over Radwaste Building (treated as separation between buildings): IBC, 2006, Table 601 Walls: NFPA 101, paragraph 8.5.6.(1) Doors: NFPA 101, Table 8.3.4.2	Wet pipe sprinkler	0.15 gpm/ft ² (6.1 L/min-m ²) over 1500 ft ² (139 m ²) Total flow (Est.): 850 gpm (3218 L/min)	Ordinary Hazard Group 1 per NFPA 13, paragraph 5.3.1
FT2502	Stairwell No. 3 (Room 212)	FT1500	FT1500	General Area	Walls: 2-hour fire resistive Doors: 1 ½ - hour fire rated	Wet pipe sprinkler	0.15 gpm/ft ² (6.1 L/min-m ²) over 1500 ft ² (139 m ²) Total flow (Est.): 850 gpm (3218 L/min)	Ordinary Hazard Group 1 per NFPA 13, paragraph 5.3.1
			FT15Y2	Elevator Shaft (Room 250)	Walls: 2-hour fire resistive			

**Table 9A.4.3.5 - Summary of Fire Protection Criteria
Floor 3F (Continued)**

Fire Area	Description	Adjacent Fire Area	Adjacent Fire Area Description	Fire Rated Separation	Fire Separation Criteria	Automatic Suppression Type	Density	Suppression Criteria
FT2504	Stairwell No. 4 (Room 249)	FT1500	General Area	Walls: 2-hour fire resistive Doors: 3- hour fire rated	Walls: NFPA 101, paragraph 8.5.6.(1) Doors: NFPA 101, Table 8.3.4.2	Wet pipe sprinkler	0.15 gpm/ft ² (6.1 L/min-m ²) over 1500 ft ² (139 m ²) Total flow (Est.): 850 gpm (3218 L/min)	Ordinary Hazard Group 1 per NFPA 13, paragraph 5.3.1
		FT15Y1	Stairwell No. 8	Walls: 3-hour fire resistive	Walls: NFPA 101, paragraph 8.5.6.(1)			
FT15Y2	Elevator Shaft (Room 250)	FT1500	General Area	Walls: 2-hour fire resistive Doors: 1 ½ - hour fire rated	NFPA 804, paragraphs 8.1.2.4 and 8.1.2.5	Wet pipe sprinkler	0.20 gpm/ft ² (8.2 L/min-m ²) over 1500 ft ² (139 m ²) Total flow (Est.): 950 gpm (3596 L/min)	Ordinary Hazard Group 2 per NFPA 13, paragraph 5.3.2
		FT2502	Stairwell No. 3 (Room 212)	Walls: 2-hour fire resistive	Walls: NFPA 101, paragraph 8.5.6.(1) Doors: NFPA 101, Table 8.3.4.2			
FT15Y1	Stairwell No. 8 (Room 1X4)	FT2504	Stairwell No. 4 (Room 249)	Walls: 3-hour fire resistive	Walls: NFPA 101, paragraph 8.5.6.(1)	Wet pipe sprinkler	0.15 gpm/ft ² (6.1 L/min-m ²) over 1500 ft ² (139 m ²) Total flow (Est.): 850 gpm (3218 L/min)	Ordinary Hazard Group 1 per NFPA 13, paragraph 5.3.1
FT45X1	Stairwell No. 9 (Room 4X5)	FT1500	General Area	Walls: 2-hour fire resistive Doors: 3- hour fire rated Floor: 2-hour fire resistive	Walls and Ceiling: NFPA 101, paragraph 8.5.6.(1) Doors: NFPA 101, Table 8.3.4.2	Wet pipe sprinkler	0.15 gpm/ft ² (6.1 L/min-m ²) over 1500 ft ² (139 m ²) Total flow (Est.): 850 gpm (3218 L/min)	Ordinary Hazard Group 1 per NFPA 13, paragraph 5.3.1

9A.4.3.6 Floor 4F (El. 38.3m (120'-4")) – See Figure 9A.4-33 and Table 9A.4.3.6 Summary of Fire Protection Criteria Floor 4F

9A.4.3.6.1 Fire Area – FT1500 (General Area)

(1) Fire Area Boundary Description

Floor 4F shares fire area FT1500 with all other floors in the Turbine Building.

Fire area FT1500 is bounded by:

- The Turbine Building exterior walls
- The interior walls enclosing stairwell no. 9 (room 4X5, fire area FT45X1)
- The interior walls enclosing stairwell no. 10 (room 5X1, fire area FT55X1)

(2) Equipment – See Table 9A.6-4

Safety Related	Provides Core Cooling
No	No

(3) Radioactive Material Present – None that can be released as a result of fire.

(4) Qualification of Fire Barriers –

The Turbine Building is classified as Type IA construction in accordance with the International Building Code (IBC), 2006. Type IA construction is non-combustible. The building structural frame, and all exterior and interior bearing walls, are required to be of 3 hour fire-resistive construction. The building floor is required to be of not less than 2 hour fire resistive construction, including supporting beams and joists. Also, the building roof is required to be of not less than 1 ½ hour fire resistive construction.

Enclosed stairwell no. 9 extends upward from floor 3F and provides access to equipment on floor 4F. This stairwell is of 2 hour fire-resistive concrete construction. Stairwell no. 9 is described in subsection 9A.4.3.5.2.

Enclosed stairwell no. 10 extends upward from floor 4F and provides access to equipment on floor 5F. This stairwell is of 2 hour fire-resistive concrete construction. Stairwell no. 10 is described in subsection 9A.4.3.6.2.

- (5) Combustibles Present:

Fire Loading	Total Heat of Combustion (MJ)
(a) Cable in conduit and dispersed in cable trays	Acceptable
(b) Limited quantities of lubricants in pumps	Negligible

- (6) Detection Provided – Class A supervised POC, and manual alarm pull stations.

Manual Pull Locations: TA.4-T8, TJ.6-T7.6, TF-T6.6

- (7) Suppression Available:

Type	Location/Actuation
Modified Class III standpipes	Stairwells No.8 <1Y5>, No. 9 <4X5>, and No. 10 <5X1>
ABC portable (hand) extinguishers and hose stations	TD.9-T2, TF.1-T2, TD.9-T6, TF.1-T6, TB.1-T8, TC.9-T8, TE.4-T8, TF.5-T8, TH.9-T8, TG.8-T6.8
Wet pipe sprinkler system Design density 12.2 L/min-m ² (0.3 gpm/ft ²) over 464.5 m ² (5000 ft ²)	Throughout floor 4F

- (8) Fire Protection Design Criteria Employed:

- (a) Fire detection and suppression capability is provided and accessible;
- (b) Fire stops are provided for penetrations through rated fire barriers.

- (9) Consequences of Fire – Postulated fire assumes loss of function. Smoke from a fire would be removed by the normal HVAC.

- (10) Consequences of Fire Suppression – Suppression extinguishes the fire. Refer to Section 3.4, “Water Level (Flood) Design,” for drain system.

- (11) Design Criteria Used for Protection Against Inadvertent Operation, Careless Operation or Rupture of the Suppression System:

- (a) Provision of raised supports for the equipment
- (b) Refer to Section 3.4, “Water Level (Flood) Design,” for drain system.

- (12) Fire Containment or Inhibiting Methods Employed:
- (a) Fire stops are provided for penetrations through fire rated barriers.
 - (b) The means of fire detection, suppression and alarming are provided and accessible.
- (13) Remarks – The total flow of the wet pipe sprinkler system on floor 4F with a 1893 L/min (500 gpm) hose stream allowance is estimated to be 10,410 L/min (2750 gpm).

9A.4.3.6.2 Fire Area – FT55X1 (Stairwell No. 10 – Room 5X1)

- (1) Fire Area Boundary Description

Stairwell No. 10 serves controlled areas inside the Turbine Building at floor level 4F.

Fire area FT55X1 extends vertically upward from floor 4F through floor 5F and provides access to and from floor 5F (elevation 47.2m).

Stairwell no. 10 is a separate fire area bounded by interior fire walls at floor levels 4F and 5F.

- (2) Equipment – See Table 9A.6-4

Safety Related	Provides Core Cooling
No	No

- (3) Radioactive Material Present – None.
- (4) Qualification of Fire Barriers – At floor levels 4F and 5F, walls enclosing stairwell no. 10 are a minimum of 2 hour fire-resistive concrete construction. Stairwell doors are a minimum of 1-1/2 hour fire rated (doors are 3-hour fire rated for consistency throughout the Turbine Building).
- (5) Combustibles Present – No significant quantities of exposed combustibles.
- (6) Detection Provided – Class A supervised POC at each building floor elevation and manual pull station external to the enclosed stairway at each floor elevation.
- (7) Suppression Available:
- | Type | Location/Actuation |
|------------------------------|------------------------|
| Modified Class III standpipe | Stairwell No. 10 <5X1> |

ABC portable (hand) extinguishers and hose stations TE.4-T8, TF.5-T8

Wet pipe sprinkler system Stairwell No. 10
Design density 6.1 L/min-m² (0.15 gpm/ft²)

- (8) Fire Protection Design Criteria Employed:
- (a) The stairwell is located in a separate fire-resistive enclosure.
 - (b) Fire detection and suppression capability is provided and accessible.
- (9) Consequences of Fire – The postulated fire assumes loss of function of the enclosed stairway. Smoke from a fire would be removed by the normal HVAC system.
- (10) Consequences of Fire Suppression – Suppression extinguishes the fire. Refer to Section 3.4, “Water Level (Flood) Design,” for drain system.
- (11) Design Criteria Used for Protection Against Inadvertent Operation, Careless Operation or Rupture of the Suppression System:
- (a) Refer to Section 3.4, “Water Level (Flood) Design,” for drain system.
- (12) Fire Containment or Inhibiting Methods Employed:
- (a) The function is provided in a fire-resistive enclosure.
 - (b) Fire stops are provided for penetrations through fire rated barriers.
 - (c) The means of fire detection, suppression and alarming are provided and accessible.
- (13) Remarks – The total flow of the wet pipe sprinkler system with a 1893 L/min (500 gpm) hose stream allowance is estimated to be 3,218 L/min (850 gpm)

**Table 9A.4.3.6 - Summary of Fire Protection Criteria
Floor 4F**

Fire Area	Description	Adjacent Fire Area	Adjacent Fire Area Description	Fire Rated Separation	Fire Separation Criteria	Automatic Suppression Type	Density	Suppression Criteria
FT1500	General Area	FT15Y1	Stairwell No. 8 (Room 1X4)	Walls: 3-hour fire resistive Doors: 3 - hour fire rated	NEIL LCM, March 2008, 3.2.9.1 NFPA 804, paragraph 8.1.2.3 Also, based on (IBC) H-4 Occupancy and Type 1A construction Exterior Turbine Bldg. Wall: IBC, 2006, Table 601 Turbine Bldg. Floor over Radwaste Building (treated as separation between buildings): IBC, 2006, Table 601 Walls: NFPA 101, paragraph 8.5.6.(1) Doors: NFPA 101, Table 8.3.4.2	Wet pipe sprinkler	0.30 gpm/ft ² (12.2 L/min-m ²) over minimum application of 5000 ft ² (464.5 m ²) Total flow (Est.): 2750 gpm (10,410 L/min)	a) NFPA 804, 2006, paragraph 10.8.2.1(2) b) NEIL LCM, March 2008, A3.2.20.5.2.1.1.
		FT45X1	Stairwell No. 9 (Room 4X5)	Walls: 2-hour fire resistive Doors: 3 - hour fire rated	Walls: NFPA 101, paragraph 8.5.6.(1) Doors: NFPA 101, Table 8.3.4.2			
		FT55X1	Stairwell No. 10 (Room 5X1)	Walls: 2-hour fire resistive Doors: 3 - hour fire rated	Walls: NFPA 101, paragraph 8.5.6.(1) Doors: NFPA 101, Table 8.3.4.2			

**Table 9A.4.3.6 - Summary of Fire Protection Criteria
Floor 4F (Continued)**

Fire Area	Description	Adjacent Fire Area	Adjacent Fire Area Description	Fire Rated Separation	Fire Separation Criteria	Automatic Suppression Type	Density	Suppression Criteria
FT1500	General Area	FT2505	Main Steam Tunnel (Room 219)	Exterior Turbine Bldg. Wall: 3-hour fire resistive	NEIL LCM, March 2008, 3.2.9.1 NFPA 804, paragraph 8.1.2.3 Also, based on (IBC) H-4 Occupancy and Type 1A construction Exterior Turbine Bldg. Wall: IBC, 2006, Table 601	Wet pipe sprinkler	0.30 gpm/ft ² (12.2 L/min- m ²) over minimum application of 5000 ft ² (464.5 m ²) Total flow (Est.): 2750 gpm (10,410 L/min)	a) NFPA 804, 2006, paragraph 10.8.2.1(2) (b) NEIL LCM, March 2008, A3.2.20.5.2.1.1.
FT15Y1	Stairwell No. 8 (Room 1X4)	FT1500	General Area	Walls: 3-hour fire resistive Doors: 3 - hour fire rated	NEIL LCM, March 2008, 3.2.9.1 NFPA 804, paragraph 8.1.2.3 Also, based on (IBC) H-4 Occupancy and Type 1A construction Exterior Turbine Bldg. Wall: IBC, 2006, Table 601 Walls: NFPA 101, paragraph 8.5.6.(1) Doors: NFPA 101, Table 8.3.4.2	Wet pipe sprinkler	0.15 gpm/ft ² (6.1 L/min-m ²) over 1500 ft ² (139 m ²) Total flow (Est.): 850 gpm (3218 L/min)	Ordinary Hazard Group 1 per NFPA 13, paragraph 5.3.1

**Table 9A.4.3.6 - Summary of Fire Protection Criteria
Floor 4F (Continued)**

Fire Area	Description	Adjacent Fire Area	Adjacent Fire Area Description	Fire Rated Separation	Fire Separation Criteria	Automatic Suppression Type	Density	Suppression Criteria
FT45X1	Stairwell No. 9 (Room 4X5)	FT1500	General Area	Walls: 2-hour fire resistive Doors: 3 - hour fire rated	Walls: NFPA 101, paragraph 8.5.6.(1) Doors: NFPA 101, Table 8.3.4.2	Wet pipe sprinkler	0.15 gpm/ft ² (6.1 L/min-m ²) over 1500 ft ² (139 m ²) Total flow (Est.): 850 gpm (3218 L/min)	Ordinary Hazard Group 1 per NFPA 13, paragraph 5.3.1
FT55X1	Stairwell No. 10 (Room 5X1)	FT1500	General Area	Walls: 2-hour fire resistive Doors: 3 - hour fire rated Floor: 2-hour fire resistive	Walls: NFPA 101, paragraph 8.5.6.(1) Doors: NFPA 101, Table 8.3.4.2	Wet pipe sprinkler	0.15 gpm/ft ² (6.1 L/min-m ²) over 1500 ft ² (139 m ²) Total flow (Est.): 850 gpm (3218 L/min)	Ordinary Hazard Group 1 per NFPA 13, paragraph 5.3.1

9A.4.3.7 Floor 5F (El. 47.2m) – See Figure 9A.4-34 and Table 9A.4.3.7 Summary of Fire Protection Criteria Floor 5F

9A.4.3.7.1 Fire Area – FT1500 (General Area)

(1) Fire Area Boundary Description

Floor 5F shares fire area FT1500 with all other floors in the Turbine Building.

Fire area FT1500 is bounded by:

- The Turbine Building exterior walls
- The interior walls enclosing stairwell no. 10 (room 5X1, fire area FT55X1)

(2) Equipment – See Table 9A.6-4

Safety Related	Provides Core Cooling
No	No

(3) Radioactive Material Present – None that can be released as a result of fire.

(4) Qualification of Fire Barriers –

The Turbine Building is classified as Type IA construction in accordance with the International Building Code (IBC), 2006. Type IA construction is non-combustible. The building structural frame, and all exterior and interior bearing walls, are required to be of 3 hour fire-resistive construction. The building floor is required to be of not less than 2 hour fire resistive construction, including supporting beams and joists. Also, the building roof is required to be of not less than 1 ½ hour fire resistive construction.

Enclosed stairwell no. 10 extends upward from floor 4F and provides access to equipment on floor 5F. This stairwell is of 2 hour fire-resistive concrete construction. Stairwell no. 10 is described in subsection 9A.4.3.6.2.

(5) Combustibles Present:

Fire Loading	Total Heat of Combustion (MJ)
(a) Cable in conduit and dispersed in cable trays	Acceptable
(b) Limited quantities of lubricants in pumps	Negligible

(6) Detection Provided – Class A supervised POC, and manual alarm pull stations.

Manual Pull Locations: TF-T6.6

(7) Suppression Available:

Type	Location/Actuation
Modified Class III standpipe	Stairwells No. 10 <5X1>
ABC portable (hand) extinguishers and hose stations	TB.8-T7, TB.8-T6.2, TD.1-T6.2, TF-T6.2
Wet pipe sprinkler system Design density 12.2 L/min-m ² (0.3 gpm/ft ²) over 464.5 m ² (5000 ft ²)	Throughout floor 5F

(8) Fire Protection Design Criteria Employed:

- (a) Fire detection and suppression capability is provided and accessible.
- (b) Fire stops are provided for penetrations through rated fire barriers.

(9) Consequences of Fire – Postulated fire assumes loss of function. Smoke from a fire would be removed by the normal HVAC.

(10) Consequences of Fire Suppression – Suppression extinguishes the fire. Refer to Section 3.4, “Water Level (Flood) Design,” for drain system.

(11) Design Criteria Used for Protection Against Inadvertent Operation, Careless Operation or Rupture of the Suppression System:

- (a) Provision of raised supports for the equipment
- (b) Refer to Section 3.4, “Water Level (Flood) Design,” for drain system.

(12) Fire Containment or Inhibiting Methods Employed:

- (a) Fire stops are provided for penetrations through fire rated barriers.
- (b) The means of fire detection, suppression and alarming are provided and accessible.

(13) Remarks – The total flow of the wet pipe sprinkler system on floor 5F with a 1893 L/min (500 gpm) hose stream allowance is estimated to be 10,410 L/min (2750 gpm).

**Table 9A.4.3.7 - Summary of Fire Protection Criteria
Floor 5F**

Fire Area	Description	Adjacent Fire Area	Adjacent Fire Area Description	Fire Rated Separation	Fire Separation Criteria	Automatic Suppression Type	Density	Suppression Criteria
FT1500	General Area	FT55X1	Stairwell No. 10 (Room 5X1)	Walls: 2-hour fire resistive Doors: 3 - hour fire rated	NEIL LCM, March 2008, 3.2.9.1 NFPA 804, paragraph 8.1.2.3 Also, based on (IBC) H-4 Occupancy and Type 1A construction Exterior Turbine Bldg. Wall: IBC, 2006, Table 601 Walls: NFPA 101, paragraph 8.5.6.(1) Doors: NFPA 101, Table 8.3.4.2	Wet pipe sprinkler	0.30 gpm/ft ² (12.2 L/min-m ²) over minimum application of 5000 ft ² (464.5 m ²) Total flow (Est.): 2750 gpm (10,410 L/min)	a) NFPA 804, 2006, paragraph 10.8.2.1(2) b) NEIL LCM, March 2008, A3.2.20.5.2.1.1.

**Table 9A.4.3.7 - Summary of Fire Protection Criteria
Floor 5F (Continued)**

Fire Area	Description	Adjacent Fire Area	Adjacent Fire Area Description	Fire Rated Separation	Fire Separation Criteria	Automatic Suppression Type	Density	Suppression Criteria
FT1500	General Area	FT2505	Main Steam Tunnel (Room 219)	Exterior Turbine Bldg. Wall: 3-hour fire resistive	NEIL LCM, March 2008, 3.2.9.1 NFPA 804, paragraph 8.1.2.3 Also, based on (IBC) H-4 Occupancy and Type 1A construction Exterior Turbine Bldg. Wall: IBC, 2006, Table 601			
FT55X1	Stairwell No. 10 (Room 5X1)	FT1500	General Area	Walls: 2-hour fire resistive Doors: 3 - hour fire rated	NEIL LCM, March 2008, 3.2.9.1 NFPA 804, paragraph 8.1.2.3 Also, based on (IBC) H-4 Occupancy and Type 1A construction Exterior Turbine Bldg. Wall: IBC, 2006, Table 601 Walls: NFPA 101, paragraph 8.5.6.(1) Doors NFPA 101, Table 8.3.4.2	Wet pipe sprinkler	0.15 gpm/ft ² (6.1 L/min-m ²) over 1500 ft ² (139 m ²) Total flow (Est.): 850 gpm (3218 L/min)	Ordinary Hazard Group 1 per NFPA 13, paragraph 5.3.1

The following figures are located in Chapter 21:

- Figure 9A.4-4 Reactor Building Fire Protection at Elevation 12300 mm
- Figure 9A.4-9 Reactor Building Fire Protection, Section A-A
- Figure 9A.4-17 Turbine Building Fire Protection at El. 2300 mm
- Figure 9A.4-18 Turbine Building Fire Protection at El. 6300 mm
- Figure 9A.4-19 Turbine Building Fire Protection at El. 12300 mm
- Figure 9A.4-20 Turbine Building Fire Protection at El. 19700 mm
- Figure 9A.4-21 Turbine Building Fire Protection at El. 27800 mm
- Figure 9A.4-28 Radwaste Building Fire Protection, ~~Section A-A~~ RWB Sections
- Figure 9A.4-29 Radwaste Building Fire Protection at El - ~~1500~~ 1700 mm
- Figure 9A.4-30 Radwaste Building Fire Protection at El ~~4800~~ 5300 mm
- Figure 9A.4-31 Radwaste Building Fire Protection at El 12300 mm
- Figure 9A.4-32 Radwaste Building Fire Protection at El ~~21000~~ 18300 mm
- Figure 9A.4-33 Turbine Building Fire Protection at El. 38300 mm
- Figure 9A.4-34 Turbine Building Fire Protection at El. 47200 mm

9A.5 Special Cases

STD DEP T1 2.14-1

STD DEP T1 3.4-1

9A.5.5.3 Main Steamline ADS Relief Valves

The Division 1 and 2 signal cables are run in separate conduit from their location on the valve to the appropriate divisional penetration and, from there, via divisional raceways to their ~~multiplex~~ data communication interfaces.

9A.5.5.5 Under the Reactor Vessel

(2) FMCRD Separation Switch Cables

The FMCRD cables for the Class 1E separation switches of each FMCRD are classified as safety related and separated into two groups (A and B) for routing out of the undervessel area to two separate divisions of the essential ~~multiplexing system~~ communications function (ECF). The cables are routed under the vessel through pull boxes inside the pedestal; then through cable boxes and raceways to electrical containment (RCCV) penetrations. The separation switch cables are then routed from the containment penetrations to ~~essential multiplexing system~~ ECF panels in the reactor building. The installation of these Class 1E cables is arranged so that "A" and "B" cables travel in opposite directions from under the vessel and pass through penetrations on the opposite side of the reactor building.

The cables receive low-voltage (approx. 48 volts) power from the ~~essential multiplex system~~ ECF power supplies. This provides natural circuit protection in event of shorts or grounds on the system. Such events would not jeopardize the integrity or independence of the higher voltage divisional power busses which are upstream of the power supplies.

9A.5.5.9 ~~Flammability Control System~~ Not Used

The flammability control system equipment is located in a large enclosed area at grade level at approximately 180 degrees azimuth. The rooms have a fire barrier floor and is completely surrounded by fire barrier walls and doors. There are large access doors to the outside at the centerline of the room.

The FCS is made up of two independent redundant divisions (Divisions 2 and 3), and each division is located in the fire area division 2 and 3 respectively. Each division has two suction isolation valves (inboard and outboard) and two return isolation valves (inboard and outboard). The inboard isolation valves are motor operated (MO) valves, and the outboard isolation valves are fail close (FC) air operated (AO) solenoid valves (two solenoids per valve). They are powered from division 1 and 4. Fire in either division may cause the inboard valves (Div. 2 or 3) to fail to operate, but the outboard isolation valves are still capable to isolate because they are powered from different

~~divisions (Div. 1 and 4). Loss of a complete division is acceptable because FCS is made up of two independent redundant divisions mounted in two separated fire areas.~~

9A.5.5.13 Reactor Building Operating Deck Radiation Monitors

STD DEP 11.5-1

Radiation monitoring within this area is facilitated by two independent systems. The area radiation monitoring system and the process radiation monitoring system.

The area radiation monitoring (ARM) system is non-safety related and uses two radiation channels in the fuel storage and handling areas. It has no system actuation function, but is used for monitoring of background radiation and radiation resulting from accidental fuel drops. The sensors are mounted on the walls within the fire zone area. These detectors are designed to annunciate local and control room alarms for both high and low radiation conditions. The low condition is an indication of an inoperative radiation monitor. Loss of these detectors, due to fire, does not impact plant safety.

The process radiation monitoring (PRM) channels that are utilized in this area are safety related, and are used to perform isolation functions. The ~~Gieger-Mueller~~ detectors are mounted in the reactor building ventilation system exhaust duct (Rm 643). They are safety related, and receive their power from a dual auctioneered class 1E divisional ~~high voltage~~ power supplies of the Digital ARM radiation monitor (D11-Z602A-D Div, 1-4). Each divisional Digital ARM radiation monitor output voltage is hard wired to its associated detector and ~~it is its voltage and current are limited to 700 VDC, and 3 ma current.~~ Each divisional power cable is routed separately in separate metal conduit. A fire in the room can develop a short on any detector power cable/or all the detectors power cables. A series resistor has been placed in each channel of the auctioneer power supplies, therefore, current drain on the high voltage power supply will be limited and the fault will not propagate any further. A short on a power cable shall generate a down scale inop trip alarm to the ARM radiation monitor control logic in the control room. The ARM radiation monitor control logic requires 2 out of 4 trip to initiate isolation of the reactor building ventilation exhaust duct automatically. Although a fire could cause the system to issue an isolation signal due to its effect on the radiation detectors, the containment isolation valves can be manually reopened from the control room by the operator.

The detectors are mounted in the fuel handling exhaust radiation monitor area (Rms 716, 721, 733 and 742 respectively). They are safety related, and receive their power from a dual auctioneered class 1E divisional power supplies of the radiation monitor (D11-Z602A-D Div. 1-4). Each divisional radiation monitor output voltage is hard wired to its associated detector and its voltage and current are limited. Each divisional power cable is routed separately in separate metal conduit. A fire in any of the rooms can develop a short on a detector power cable. A series resistor has been placed in each channel of the auctioneered power supplies, the current drain on the power supply will be limited and the fault will not propagate further. A short on power cable will generate a down scale inop trip alarm to the radiation monitor control logic in the control room. The radiation monitor control logic requires 2 out of 4 trip to initiate isolation of the fuel

handling exhaust duct automatically. Therefore loss of one or all four divisional detectors in the area due to the fire is acceptable.

The PRM channels are designed such that any two-out-of-four signals, based on very high or very low radiation conditions within the HVAC duct, will initiate the standby gas treatment system (SGTS), isolate the HVAC for the reactor building secondary containment, and initiate closure of the containment vent and purge ducts. The very low radiation trip assures the safety action will be initiated in spite of sensor failure.

The four divisions of PRM sensors are located within close proximity to each other in order to provide true two-out-of-four actuation logic. The arrangement is justified by the automatic actuation of the system's safety function should two or more sensors fail and by the fact that the secondary containment isolation valves can be reopened from the control room by the operator.

9A.5.7 Typical Circuits Analysis of Special Cases

STD DEP T1 3.4-1

STD DEP Admin

Type 2A, Thermocouple

Cables are routed in low level signal cable trays with covers or in conduit so that there are no voltage sources within the raceways which could short to the thermocouples leads to create overvoltage situations in the thermocouple circuits. Loss of signal is all that could occur as a result of failures in the thermocouple circuits. Transfer of voltage disturbances upstream is blocked by the millivolt readout circuits of the I/O signal unit multiplexer. Tables referencing this typical circuit analysis should have a column which gives the justification for the acceptability of the loss of function of the device.

Type 2B, Process Instrument Transmitters

Cables for transmitters for process instruments are routed in low level signal cable trays with covers or in conduit so that there are no voltage sources within the raceways which could short and create overvoltage situations in the instrument circuits. Loss of signal could occur as a result of failures in the transmitter circuits. Upscale and/or downscale trips and/or alarms are provided. The current power supply in the I/O signal unit multiplexer blocks upstream transfer of voltage and current disturbances which may occur in the cable or transmitter. Tables referencing this typical circuit analysis should have a column which gives the justification for the acceptability of the loss of function of the device.

Type 3B, AC Solenoid Valves

The power for operating AC solenoid valves is supplied from the 120 VAC distribution system to the ~~demultiplexer~~ I/O unit for the valve. A current limiting fuse is installed on the power feed line to the ~~multiplexer~~ I/O unit, so that any fault on solenoid valve is isolated and does not propagate back up into the portions of the AC distribution system common with other systems.

Type 3C, DC Solenoid Valves

The power for operating DC solenoid valves is supplied from the DC distribution system to the ~~demultiplexer~~ I/O unit for the valve. Both the supply and return for the DC are fused ~~at the multiplexer~~ so that faults are isolated and do not propagate back up into the portions of the DC system common with other systems.

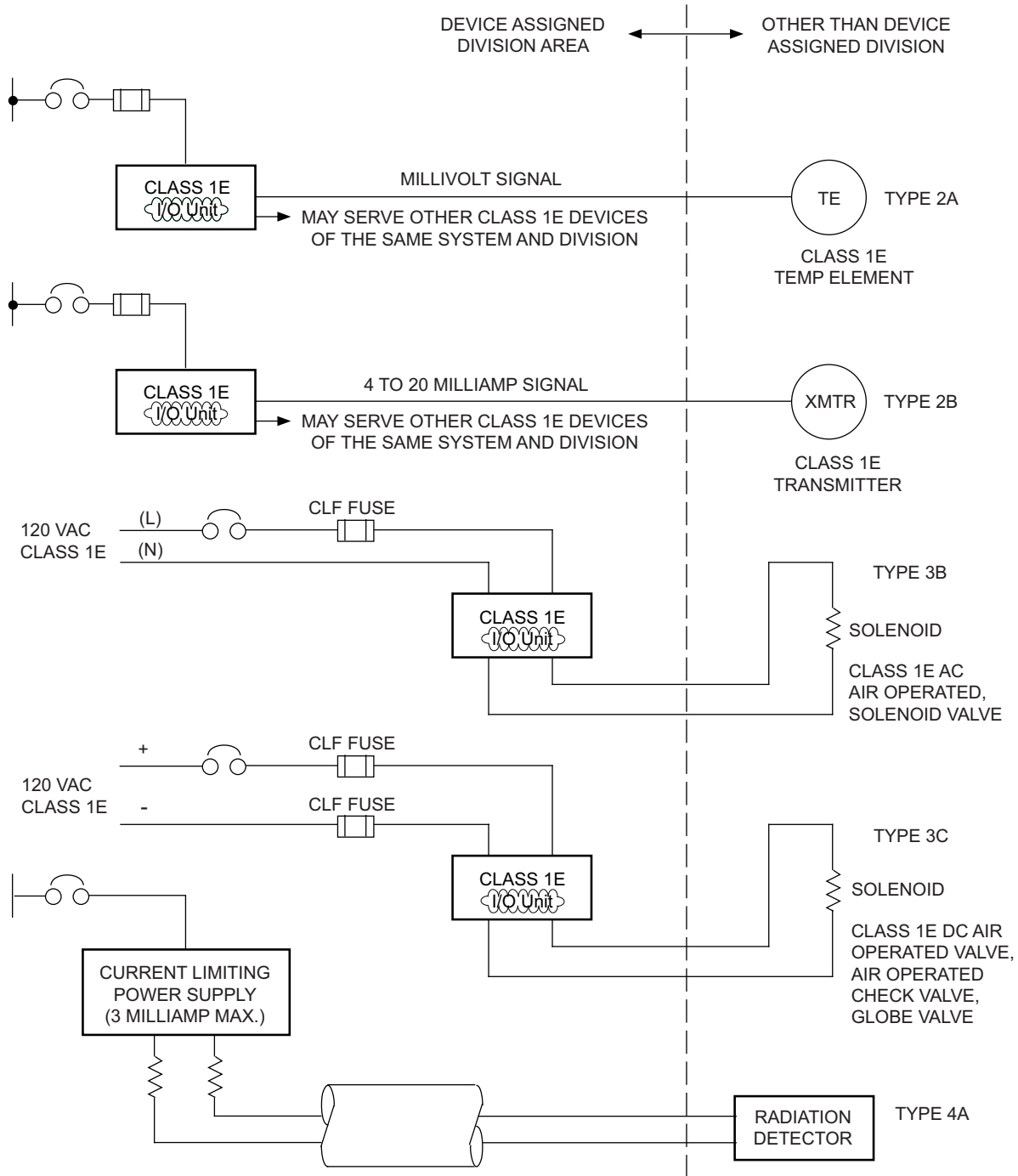
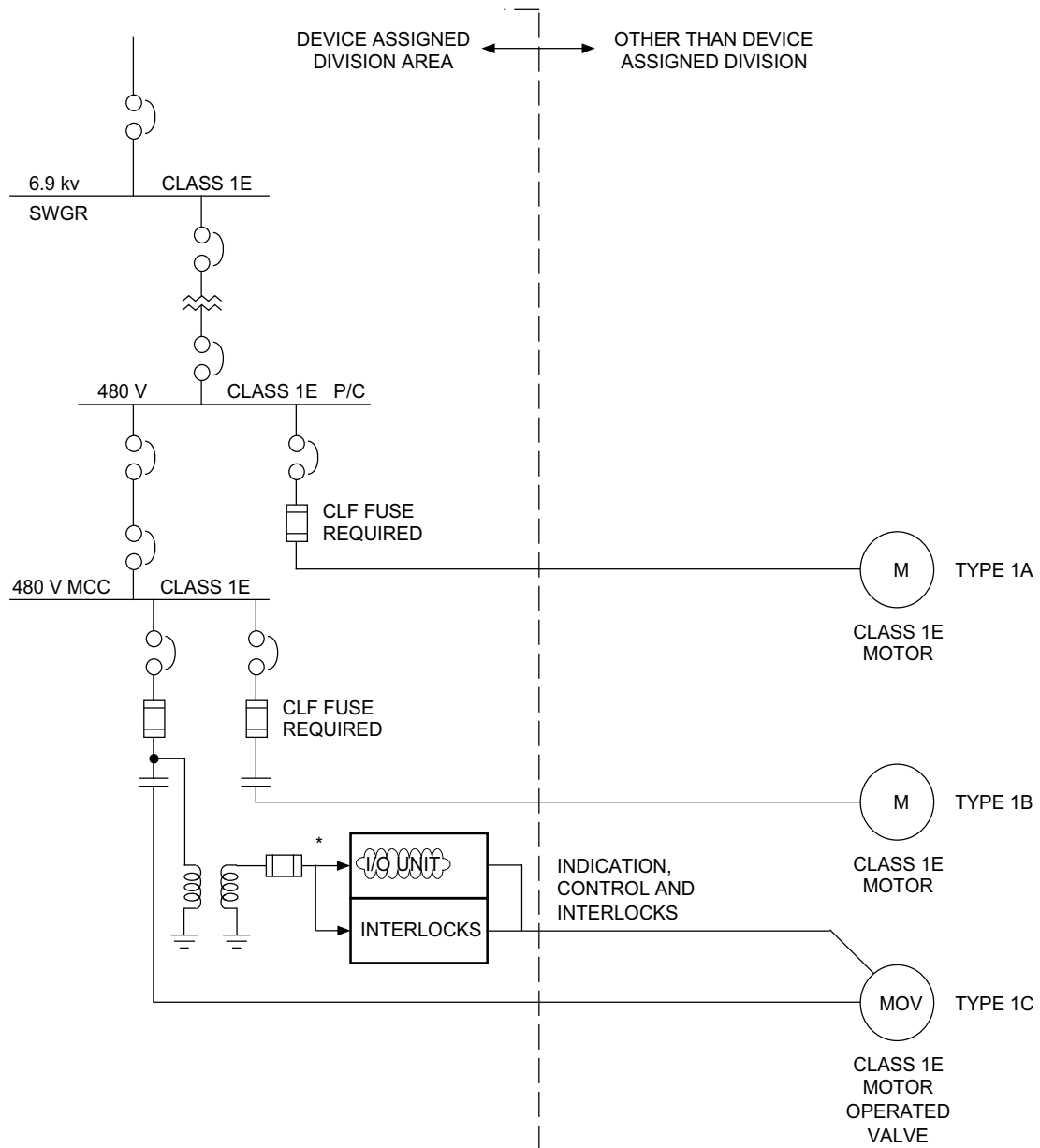

Figure 9A.5-2 Typical Electrical Equipment Connection Block Diagrams of Special Cases



* IT IS A REQUIREMENT THAT THE INDICATION, CONTROL AND INTERLOCK POWER FOR THIS DIVISIONAL CROSS-OVER TYPE BE FROM A CONTROL POWER TRANSFORMER IN THE CUBICLE SUPPLYING POWER TO THE MOV.

Figure 9A.5-2 (Continued) Typical Electrical Equipment Connection Block Diagrams of Special Cases

9A.6 Fire Hazard Analysis Database

STD DEP T1 2.4-1 (Table (9A.6-2)

STD DEP T1 2.14-1 (Table 9A.6-2)

STD DEP T1 3.4-1

STP DEP 1.2-2 (Figures 9A.4-17 through 9A.34-21, 9A.4-33, 9A.4-34, Table 9A.6-4)

STD DEP 8.3-1

**Table 9A.6-2 Fire Hazard Analysis
Equipment Database Sorted by Room — Reactor Building**

Item No.	MPL No	Elect Div.	Elev. Location	Location Number Coord.	Location Alpha Coord.	Description	System Drawing	Room No.
TBD	E11-F014A	1	TBD	TBD	TBD	MO GATE VALVE (FPC)	TBD	TBD
TBD	E11-F015A	1	TBD	TBD	TBD	MO GATE VALVE (FPC)	TBD	TBD
59	E51-C901*	4	-8200	6.3	C.9	RCIC VACUUM PUMP	103E1795/1	112
60	E51-C902*	4	-8200	6.4	C.9	RCIC CONDENSATE PUMP	103E1795/1	112
63	E51-F031	4	-8200	6.3	C.6	AO GLOBE VALVE	103E1795/1	112
64	E51-F032	4	-8200	6.3	C.6	AO GLOBE VALVE	103E1795/1	112
71	E51-LS901*	4	-8200	6.4	C.9	LEVEL SW (BARO TK)	103E1795/1	112
72	E51-LS902*	4	-8200	6.4	C.9	LEVEL SW (BARO TK)	103E1795/1	112
73	E51-PS901*	4	-8200	6.4	C.9	LEVEL SW (BARO TK)	103E1795/1	112
90	E51-F012	4	-8200	6.0	C.5	MO GLOBE VALVE (LO)	103E1795/1	112
92	E51-F045	4	-8200	6.0	C.5	MO GLOBE VALVE (STBYP)	103E1795/1	112
103	H23-P001*	N	-8200	5.5	A.3	MULTIPLEXER I/O DEVICE	----?----	116
221	H23-P002*	N	-8200	4.2	F.8	MULTIPLEXER I/O DEVICE	----?----	123
222	H23-P003*	N	-8200	4.0	F.8	MULTIPLEXER I/O DEVICE	----?----	123
223	H23-P004*	N	-8200	3.8	F.8	MULTIPLEXER I/O DEVICE	----?----	123
514	H23-P005*	N	-1700	5.8	B.0	MULTIPLEXER I/O DEVICE	----?----	210
565	E51-F047	4	1200	5.9	C.6	MO GATE VALVE (VPDISC)	103E1795/1	212
593	H23-P006*	N	-1700	2.6	F.0	MULTIPLEXER I/O DEVICE	----?----	221
594	H23-P007*	N	-1700	2.8	F.0	MULTIPLEXER I/O DEVICE	----?----	221
595	T49-F006B	2	800	2.8	E.5	MO GATE VALVE	107E6047/0	221
596	T49-F007B	2	800	2.8	E.5	AO GATE VALVE	107E6047/0	221
597	T49-F007B-1	4	800	2.8	E.5	SOLENOID VALVE	107E6047/0	221
598	T49-F007B-2	4	800	2.8	E.5	SOLENOID VALVE	107E6047/0	221
599	X-242	2	800	2.7	E.5	FCS RETURN	NT-1006643	221
639	T49-F006C	3	800	5.8	D.5	MO GATE VALVE	107E6047/0	230
640	T49-F007A-1	4	800	5.8	D.5	SOLENOID VALVE	107E6047/0	230
641	T49-F007A-2	4	800	5.8	D.5	SOLENOID VALVE	107E6047/0	230
642	T49-F007C	3	800	5.8	D.5	AO GATE VALVE	107E6047/0	230
1277	H23-P008*	1	4800	2.4	A.3	MULTIPLEXER I/O DEVICE	----?----	310

**Table 9A.6-2 Fire Hazard Analysis
Equipment Database Sorted by Room — Reactor Building (Continued)**

Item No.	MPL No	Elect Div.	Elev. Location	Location Number Coord.	Location Alpha Coord.	Description	System Drawing	Room No.
1278	H23-P009*	1	4800	2.2	A.3	MULTIPLEXER I/O DEVICE	---?---	310
1279	H23-P010*	1	4800	2.1	A.3	MULTIPLEXER I/O DEVICE	---?---	310
1280	H23-P012*	1	4800	2.1	A.1	MULTIPLEXER I/O DEVICE	---?---	310
1281	H23-P013*	1	4800	2.3	A.1	MULTIPLEXER I/O DEVICE	---?---	310

**Table 9A.6-2 Fire Hazard Analysis
Equipment Database Sorted by Room — Reactor Building (Continued)**

Item- No.	MPL No	Elect Div.	Elev- Location	Location- Number- Coord.	Location- Alpha- Coord.	Description	System- Drawing	Room- No.
1288	X-215	1	5800	5.7	C.0	RCIC VAC PUMP EXHAUST	795E883/4	313
1353	H23-P021*	N	4800	1.9	F.9	MULTIPLEXER I/O DEVICE	----?----	320
1369	H23-P022*	N	4800	2.8	F.0	MULTIPLEXER I/O DEVICE	----?----	321
1372	H23-P023*	N	4800	3.8	F.0	MULTIPLEXER I/O DEVICE	----?----	321
1420	H23-P014*	2	4800	2.4	F.6	MULTIPLEXER I/O DEVICE	----?----	326
1423	H23-P015*	2	4800	2.6	F.5	MULTIPLEXER I/O DEVICE	----?----	326
1424	H23-P016*	2	4800	2.6	F.3	MULTIPLEXER I/O DEVICE	----?----	326
1425	H23-P017*	2	4800	2.6	F.2	MULTIPLEXER I/O DEVICE	----?----	326
1433	H23-P018*	2	4800	4.3	F.9	MULTIPLEXER I/O DEVICE	----?----	326
1483	H23-P025*	N	4800	5.6	E.3	MULTIPLEXER I/O DEVICE	----?----	335
1486	H23-P024*	N	4800	4.8	F.0	MULTIPLEXER I/O DEVICE	----?----	335
1490	H23-P019*	3	4800	5.0	F.1	MULTIPLEXER I/O DEVICE	----?----	337
1491	H23-P020*	3	4800	5.2	F.1	MULTIPLEXER I/O DEVICE	----?----	337
1617	H23-P011*	4	4800	1.7	A.1	MULTIPLEXER I/O DEVICE	----?----	381
1655	H23-P026*	N	12300	5.7	B.2	MULTIPLEXER I/O DEVICE	----?----	410
1761	T49-A001B	2	12300	3.1	F.7	RECOMBINER	107E6047/0	425
1762	T49-B001B	2	12300	3.1	F.7	SPRAY COOLER	107E6047/0	425
1763	T49-C001B	2	12300	3.1	F.7	BLOWER	107E6047/0	425
1764	T49-D001B	2	12300	3.1	F.7	WATER SEPARATOR	107E6047/0	425
1765	T49-D002B*	2	12300	3.1	F.7	RECOMB HEATER	107E6047/0	425
1766	T49-F003B	2	12300	3.1	F.7	MO GLOBE VALVE	107E6047/0	425
1767	T49-F004B	2	12300	3.1	F.7	MO GLOBE VALVE	107E6047/0	425
1768	T49-F008B	2	12300	3.1	F.7	MO GLOBE VALVE	107E6047/0	425
1769	T49-F009B	2	12300	3.1	F.7	MAN OPER GLOBE VALVE	107E6047/0	425
1770	T49-F010B	2	12300	3.1	F.7	MO GLOBE VALVE	107E6047/0	425
1771	T49-F013B	2	12300	3.1	F.7	MAN OPER GATE VALVE	107E6047/0	425
1772	T49-F014B	2	12300	3.1	F.7	MAN OPER GATE VALVE	107E6047/0	425
1773	T49-F016B	2	12300	3.1	F.7	MAN OPER GATE VALVE	107E6047/0	425
1774	T49-FT002B	2	12300	3.1	F.7	FLOW TRANSMITTER	107E6047/0	425
1775	T49-FT004B	2	12300	3.1	F.7	FLOW TRANSMITTER	107E6047/0	425
1776	T49-LS011B	2	12300	3.1	F.7	LEVEL SWITCH	107E6047/0	425
1777	T49-LS012B	2	12300	3.1	F.7	LEVEL SWITCH	107E6047/0	425
1778	T49-LS013B	2	12300	3.1	F.7	LEVEL SWITCH	107E6047/0	425
1779	T49-PT003B	2	12300	3.1	F.7	PRESS TRANSMITTER	107E6047/0	425

**Table 9A.6-2 Fire Hazard Analysis
Equipment Database Sorted by Room — Reactor Building (Continued)**

Item- No.	MPL No	Elect Div.	Elev.- Location	Location- Number- Coord.	Location- Alpha- Coord.	Description	System- Drawing	Room- No.
1780	T49-TE001B	2	12300	3.1	F.7	TEMP ELEMENT	107E6047/0	425
1781	T49-TE005B	2	12300	3.1	F.7	TEMP ELEMENT	107E6047/0	425
1782	T49-TE006B-1	2	12300	3.1	F.7	TEMP ELEMENT	107E6047/0	425
1783	T49-TE006B-2	2	12300	3.1	F.7	TEMP ELEMENT	107E6047/0	425
1784	T49-TE007B-1	2	12300	3.1	F.7	TEMP ELEMENT	107E6047/0	425
1785	T49-TE007B-2	2	12300	3.1	F.7	TEMP ELEMENT	107E6047/0	425
1786	T49-TE008B-1	2	12300	3.1	F.7	TEMP ELEMENT	107E6047/0	425
1787	T49-TE008B-2	2	12300	3.1	F.7	TEMP ELEMENT	107E6047/0	425
1788	T49-TE009B-1	2	12300	3.1	F.7	TEMP ELEMENT	107E6047/0	425
1789	T49-TE009B-2	2	12300	3.1	F.7	TEMP ELEMENT	107E6047/0	425
1790	T49-TE010B-1	2	12300	3.1	F.7	TEMP ELEMENT	107E6047/0	425
1791	T49-TE010B-2	2	12300	3.1	F.7	TEMP ELEMENT	107E6047/0	425
1792	T49-TE011B	2	12300	3.1	F.7	TEMP ELEMENT	107E6047/0	425
1793	T49-TT609B	2	12300	3.1	F.7	TEMP TRANSMITTER	107E6047/0	425
1794	U41-D108	2	12300	2.7	F.5	FCS ROOM (B)-HVH	107E5189/0	425
1831	T49-A001A	3	12300	4.0	F.7	RECOMBINER	107E6047/0	436
1832	T49-B001A	3	12300	4.0	F.7	SPRAY COOLER	107E6047/0	436
1833	T49-C001A	3	12300	4.0	F.7	BLOWER	107E6047/0	436
1834	T49-D001A	3	12300	4.0	F.7	WATER SEPARATOR	107E6047/0	436
1835	T49-D002A*	3	12300	4.0	F.7	RECOMB HEATER	107E6047/0	436
1836	T49-F003A	3	12300	4.0	F.7	MO GLOBE VALVE	107E6047/0	436
1837	T49-F004A	3	12300	4.0	F.7	MO GLOBE VALVE	107E6047/0	436
1838	T49-F008A	3	12300	4.0	F.7	MO GLOBE VALVE	107E6047/0	436
1839	T49-F009A	3	12300	4.0	F.7	MAN OPER GLOBE VALVE	107E6047/0	436
1840	T49-F010A	3	12300	4.0	F.7	MO GLOBE VALVE	107E6047/0	436
1841	T49-F013A	3	12300	4.0	F.7	MAN OPER GATE VALVE	107E6047/0	436
1842	T49-F014A	3	12300	4.0	F.7	MAN OPER GATE VALVE	107E6047/0	436
1843	T49-F016A	3	12300	4.0	F.7	MAN OPER GATE VALVE	107E6047/0	436
1844	T49-FT002A	3	12300	4.0	F.7	FLOW TRANSMITTER	107E6047/0	436
1845	T49-FT004A	3	12300	4.0	F.7	FLOW TRANSMITTER	107E6047/0	436
1846	T49-LS011A	3	12300	4.0	F.7	LEVEL SWITCH	107E6047/0	436
1847	T49-LS012A	3	12300	4.0	F.7	LEVEL SWITCH	107E6047/0	436
1848	T49-LS013A	3	12300	4.0	F.7	LEVEL SWITCH	107E6047/0	436

**Table 9A.6-2 Fire Hazard Analysis
Equipment Database Sorted by Room — Reactor Building (Continued)**

Item- No.	MPL No	Elect Div.	Elev.- Location	Location- Number- Coord.	Location- Alpha- Coord.	Description	System- Drawing	Room- No.
1849	T49-PT003A	3	12300	4.0	F.7	PRESS TRANSMITTER	107E6047/0	436
1850	T49-TE001A	3	12300	4.0	F.7	TEMP ELEMENT	107E6047/0	436
1851	T49-TE005A	3	12300	4.0	F.7	TEMP ELEMENT	107E6047/0	436
1852	T49-TE006A-1	3	12300	4.0	F.7	TEMP ELEMENT	107E6047/0	436
1853	T49-TE006A-2	3	12300	4.0	F.7	TEMP ELEMENT	107E6047/0	436
1854	T49-TE007A-1	3	12300	4.0	F.7	TEMP ELEMENT	107E6047/0	436
1855	T49-TE007A-2	3	12300	4.0	F.7	TEMP ELEMENT	107E6047/0	436
1856	T49-TE008A-1	3	12300	4.0	F.7	TEMP ELEMENT	107E6047/0	436
1857	T49-TE008A-2	3	12300	4.0	F.7	TEMP ELEMENT	107E6047/0	436
1858	T49-TE009A-1	3	12300	4.0	F.7	TEMP ELEMENT	107E6047/0	436
1859	T49-TE009A-2	3	12300	4.0	F.7	TEMP ELEMENT	107E6047/0	436
1860	T49-TE010A-1	3	12300	4.0	F.7	TEMP ELEMENT	107E6047/0	436
1861	T49-TE010A-2	3	12300	4.0	F.7	TEMP ELEMENT	107E6047/0	436
1862	T49-TE011A	3	12300	4.0	F.7	TEMP ELEMENT	107E6047/0	436
1863	T49-TT609A	3	12300	4.0	F.7	TEMP TRANSMITTER	107E6047/0	436
1864	U41-D107	3	12300	4.6	F.9	FGS ROOM (C) HVH	107E5189/0	436
2222	T49-F001C		20100	2.7	E.4	MO GATE VALVE	107E6047/0	521
2223	T49-F002B		20100	2.7	E.4	AO GATE VALVE	107E6047/0	521
2224	T49-F002B-1		20100	2.7	E.4	SOLENOID VALVE	107E6047/0	521
2225	T49-F002B-2		20100	2.7	E.4	SOLENOID VALVE	107E6047/0	521
2227	X-082	2	20100	2.7	E.4	FGS INTAKE	NT-1006643	521
2247	T49-F001B		20100	5.7	D.8	MO GATE VALVE	107E6047/0	530
2248	T49-F002C		20100	5.7	D.8	AO GATE VALVE	107E6047/0	530
2249	T49-F002C-1		20100	5.7	D.8	SOLENOID VALVE	107E6047/0	530
2250	T49-F002C-2		20100	5.7	D.8	SOLENOID VALVE	107E6047/0	530
2301	H23-P027*	N	18100	1.9	B.2	MULTIPLEXER I/O DEVICE	----?----	547
2302	H23-P028*	N	18100	1.9	B.3	MULTIPLEXER I/O DEVICE	----?----	547
2474	R23-P/C EN110A	N1	23500	1.5	A.5	P/C EN110A LO VOLT SWTGR	107E5072/0	640
2472	R23-P/C EN110B	N2	23500	1.2	A.5	P/C EN110A LO VOLT SWTGR	107E5072/0	640
2473	R23-P/C EN110C	N3	23500	1.2	A.2	P/C EN110C LO VOLT SWTGR	107E5072/0	640

**Table 9A.6-2 Fire Hazard Analysis
Equipment Database Sorted by Room — Reactor Building (Continued)**

Item- No.	MPL No	Elect Div.	Elev. Location	Location- Number- Coord.	Location- Alpha- Coord.	Description	System- Drawing	Room- No.
2475	R24-MCC- EN110A	N1	23500	1.3	B-5	MCC EN110A R/B	107E5072/0	640
2475a	R24-MCC- EN110B	N2	23500	1.3	B-6	MCC EN110B R/B	107E5072/0	640
2476	R24-MCC- EN110C	N3	23500	1.3	B-7	MCC EN110C R/B	107E5072/0	640
2477	H23-P029*	N	23500	1.9	C.3	MULTIPLEXER I/O DEVICE	----?----	640
2478	H23-P030*	N	23500	1.9	C.5	MULTIPLEXER I/O DEVICE	----?----	640
2479	H23-P031*	N	23500	1.9	C.7	MULTIPLEXER I/O DEVICE	----?----	640
2774	H23-P032*	N	31700	6.2	E.4	MULTIPLEXER I/O DEVICE	----?----	715
2775	H23-P033*	N	31700	6.2	E.5	MULTIPLEXER I/O DEVICE	----?----	715
2776	H23-P034*	N	31700	6.2	E.7	MULTIPLEXER I/O DEVICE	----?----	715

Table 9A.6-3 Fire Hazard Analysis Equipment Data Base — Sorted by Room — Control Building

<u>ITEM NO.</u>	<u>MPL NO.</u>	<u>ELECT DIV.</u>	<u>ELEV. LOCATION</u>	<u>LOCATION NUMBER COORD.</u>	<u>LOCATION ALPHA COORD.</u>	<u>DESCRIPTION</u>	<u>SYSTEM DRAWING</u>	<u>ROOM NO.</u>
169	C81-D001A*	N	12300	2.50	J-3	RIP-MG-SET-A	107E5072	501
170	U41-D132A	N	12300	1.80	J-4	MG-SET-ROOM-FCU-A	107E5189/0	501
171	C81-P001A	N	12300	2.50	J-7	RIP-MG-A-CONTROL-PNL	—?—	502
172	C81-D001B*	N	12300	2.50	K-1	RIP-MG-SET-B	107E5072	503
173	U41-D132B	N	12300	1.80	K-4	MG-SET-ROOM-FCU-B	107E5189/0	503
174	C81-P001B	N	12300	2.50	K-4	RIP-MG-B-CONTROL-PNL	—?—	504

**Table 9A.6-4 Fire Hazard Analysis
Equipment Database Sorted by Room - Turbine Building**

WBS	Elec Div.	Elev Loc.	Loc No. Coord	Loc Alpha Coord	Description	Room No.
K11	N	2300	7.8	B.2	LCW SUMP (A)	110
K11	N	2300	7.8	B.8	HCW SUMP (A)	110
K11	N	2300	7.2	B.2	SD SUMP (A)	110
P52	N	6300	10.4	C.7	INSTRUMENT AIR COMPRESSOR (A)	111
P52	N	6300	10.4	D.3	INSTRUMENT AIR COMPRESSOR (B)	111
P52	N	6300	10.4	C.4	INSTRUMENT AIR RECEIVER TANK	111
P52	N	6300	10.5	B.3	INSTRUMENT AIR DRYER PACKAGE UNIT (A)	111
P52	N	6300	10.5	B.7	INSTRUMENT AIR DRYER PACKAGE UNIT (B)	111
P51	N	6300	10.4	E.0	STATION AIR COMPRESSOR (A)	111
P51	N	6300	10.4	E.5	STATION AIR COMPRESSOR (B)	111
P51	N	6300	10.5	D.7	STATION AIR RECEIVER TANK	111
U41	N	6300	10.5	E.9	IA&SA ROOM L/C	111
N62	N	2300	2.3	C.2	OG CHARCOAL ABSORBER	112
N62	N	2300	2.3	C.5	OG CHARCOAL ABSORBER	112
N62	N	2300	2.7	C.2	OG CHARCOAL ABSORBER	112
N62	N	2300	2.7	C.5	OG CHARCOAL ABSORBER	112
N22	N	2300	7.5	G.7	HIGH PRESSURE HEATER DRAIN PUMP (A)	113
N22	N	2300	7.5	G.4	HIGH PRESSURE HEATER DRAIN PUMP (B)	113
N22	N	2300	7.5	F.7	HIGH PRESSURE HEATER DRAIN PUMP (C)	113
N22	N	2300	7.5	F.4	HIGH PRESSURE HEATER DRAIN PUMP (D)	113
N61	N	2300	4.0	F.5	CONDENSER (A)	120
N61	N	2300	4.0	E.5	CONDENSER (B)	120
N61	N	2300	4.0	D.5	CONDENSER (C)	120
N22	N	2300	2.3	F.0	1ST FEED WATER HEATER DRAIN COOLER (A)	120
N22	N	2300	3.8	E.6	1ST FEED WATER HEATER DRAIN COOLER (B)	120
N22	N	2300	2.3	D.7	1ST FEED WATER HEATER DRAIN COOLER (C)	120
N71	N	2300	3.2	B.9	CW SUMP	121
N21	N	2300	8.5	H.6	CONDENSATE WATER RECOVERY TANK	131
N21	N	2300	6.4	A.4	HIGH PRESSURE CONDENSATE PUMP (A)	132
N21	N	2300	5.5	A.4	HIGH PRESSURE CONDENSATE PUMP (B)	132
N21	N	2300	4.9	A.4	HIGH PRESSURE CONDENSATE PUMP (C)	132
N21	N	2300	3.9	A.4	HIGH PRESSURE CONDENSATE PUMP (D)	132
N21	N	2300	7.7	E.8	LOW PRESSURE CONDENSATE PUMP (A)	140

**Table 9A.6-4 Fire Hazard Analysis
Equipment Database Sorted by Room - Turbine Building (Continued)**

WBS	Elec Div.	Elev Loc.	Loc No. Coord	Loc Alpha Coord	Description	Room No.
N21	N	2300	7.7	E.5	LOW PRESSURE CONDENSATE PUMP (B)	140
N21	N	2300	7.7	E.2	LOW PRESSURE CONDENSATE PUMP (C)	140
N21	N	2300	7.7	D.8	LOW PRESSURE CONDENSATE PUMP (D)	140
N21	N	2300	7.8	D.5	CAND WATER COLLECTING PUMP	140
K11	N	2300	3.6	G.8	LCW SUMP (B)	142
K11	N	2300	3.2	G.8	HCW SUMP (B)	142
K11	N	2300	3.2	G.3	SD SUMP (B)	142
K21	N	2300	7.4	C.2	CF BACKWASH TRANSFER TANK	143
K21	N	2300	7.2	C.8	CF BACKWASH TRANSFER PUMP (A)	144
K21	N	2300	7.6	C.8	CF BACKWASH TRANSFER PUMP (B)	144
N27	N	2300	6.4	B.2	DRAIN STRAINER	1X1
N27	N	2300	6.5	B.5	RESIN STORAGE TANK	1X1
N27	N	2300	6.5	B.8	RESIN STORAGE TANK	1X1
H22	N	2300	5.8	B.4	LOCAL RACK	1X2
H22	N	2300	5.8	B.6	LOCAL RACK	1X2
H22	N	2300	4.2	B.2	LOCAL RACK	1X2
H22	N	2300	4.5	B.1	LOCAL RACK	1X2
H22	N	2300	4.8	B.4	LOCAL RACK	1X2
H22	N	2300	4.8	B.6	LOCAL RACK	1X2
H22	N	2300	4.5	B.8	LOCAL RACK	1X2
H22	N	2300	4.2	C.1	LOCAL RACK	1X2
C81	N	2300	6.8	B.4	CD RECIRCULATION PUMP	1X3
H21	N	2300	5.3	B.1	LOCAL PANEL	1X3
H21	N	2300	5.4	B.1	LOCAL PANEL	1X3
H21	N	2300	5.6	B.1	LOCAL PANEL	1X3
H21	N	2300	5.8	B.1	LOCAL PANEL	1X3
N34	N	6300	3.6	H.3	OIL STORAGE TANK (A)	1Y1
N34	N	6300	3.6	H.7	OIL STORAGE TANK (B)	1Y1
N34	N	6300	3.8	H.5	OIL TRANSFER PUMP	1Y1
H22	N	6300	3.8	H.6	LOCAL RACK	1Y1
P81	N	6300	10.4	G.9	BREATHING AIR COMPRESSOR AREA	1Y2
R24	N	6300	8.7	B.4	Non-1E MCC SA130	1Y3
R24	N	6300	8.7	C.1	Non-1E MCC SA131	1Y3
R24	N	6300	8.7	D.6	Non-1E MCC SA132	1Y3

**Table 9A.6-4 Fire Hazard Analysis
Equipment Database Sorted by Room - Turbine Building (Continued)**

WBS	Elec Div.	Elev Loc.	Loc No. Coord	Loc Alpha Coord	Description	Room No.
R24	N	6300	8.7	E.1	Non-1E MCC SA133	1Y3
R24	N	6300	8.7	E.5	Non-1E MCC SB130	1Y3
R24	N	6300	7.1	C.6	Non-1E MCC SB131	1Y3
R24	N	6300	7.6	C.6	Non-1E MCC SB132	1Y3
R24	N	6300	7.4	D.4	Non-1E MCC SB133	1Y3
R24	N	6300	8.7	G.2	Non-1E MCC SC130	1Y3
R24	N	6300	8.7	G.6	Non-1E MCC SC132	1Y3
H22	N	6300	4.2	B.8	LOCAL RACK	1Y4
H22	N	6300	4.5	B.8	LOCAL RACK	1Y4
R22	N	12300	10.2	H.5	Non-1E M/C A1	210
R22	N	12300	10.5	H.5	Non-1E M/C C1	210
R22	N	12300	10.2	G.3	Non-1E M/C B1	210
R22	N	12300	10.6	G.3	Non-1E M/C D1	210
R22	N	12300	10.9	H.4	Non-1E M/C A2-4-5	210
R22	N	12300	9.4	H.4	Non-1E M/C B2-4-5	210
R22	N	12300	9.6	H.4	Non-1E M/C C2-4-5	210
N62	N	12300	2.7	B.9	OG FILTER	211
N62	N	12300	2.3	B.8	GUARD BED	211
N21	N	12300	6.6	H.5	MD-RFP (A)	213
N21	N	12300	6.6	G.5	MD-RFP (B)	213
R22	N	12300	6.6	H.5	M/D RFP Motor A	213
R22	N	12300	6.6	G.5	M/D RFP Motor B	213
U41	N	12300	7.2	G.2	CONDENSER ROOM L/C (A)	213
U41	N	12300	7.7	G.2	CONDENSER ROOM L/C (B)	213
R22	N	12300	7.7	J.5	M/D RFP ASD (A)	214
R22	N	12300	4.2	J.5	M/D RFP ASD (B)	214
R22	N	6300	7.7	J.5	MD RFP ASD (C)	214-2
R22	N	6300	4.2	J.5	MD RFP ASD (D)	214-2
N21	N	12300	3.6	H.5	MD-RFP (C)	215
N21	N	12300	3.6	G.5	MD-RFP (D)	215
R22	N	12300	3.6	H.5	M/D RFP Motor C	215
R22	N	12300	3.6	G.5	M/D RFP Motor D	215
N26	N	6300	5.5	C.0	BACKWASH AIR TANK	221
N26	N	6300	5.5	B.6	PRE-AIR FILTER VESSEL	221

**Table 9A.6-4 Fire Hazard Analysis
Equipment Database Sorted by Room - Turbine Building (Continued)**

WBS	Elec Div.	Elev Loc.	Loc No. Coord	Loc Alpha Coord	Description	Room No.
N26	N	6300	5.9	B.7	AIR FILTER VESSEL	221
H22	N	6300	5.9	B.4	LOCAL RACK	221
H22	N	6300	5.9	B.6	LOCAL RACK	221
H22	N	6300	4.0	B.6	LOCAL RACK	221
H22	N	6300	4.4	B.1	LOCAL RACK	221
H22	N	6300	4.6	B.1	LOCAL RACK	221
H22	N	6300	4.9	B.2	LOCAL RACK	221
H22	N	6300	4.9	B.4	LOCAL RACK	221
H22	N	6300	3.0	B.5	LOCAL RACK	221
P22	N	2300	7.4	J.0	TCW PUMP (A)	224
P22	N	2300	7.7	J.0	TCW PUMP (B)	224
P22	N	2300	6.3	J.0	TCW PUMP (C)	224
P22	N	2300	5.9	H.5	TCW HEAT EXCHANGER (A)	224
P22	N	2300	5.9	H.8	TCW HEAT EXCHANGER (B)	224
P22	N	2300	5.9	J.4	TCW HEAT EXCHANGER (C)	224
K11	N	2300	7.1	H.4	NRD SUMP	224
N34	N	6300	7.5	H.3	OIL PURIFICATION UNIT	230
N34	N	6300	7.8	H.3	OIL FLUSHING FILTER UNIT	230
N32	N	6300	4.2	H.5	EHC HYDRAULIC POWER UNIT	232
H22	N	6300	4.7	H.5	LOCAL RACK	232
R24	N	12300	8.7	B.5	Non-1E MCC A330	240
R24	N	12300	8.7	C.2	Non-1E MCC A331	240
R24	N	12300	8.7	D.9	Non-1E MCC B330	240
R24	N	12300	8.7	E.4	Non-1E MCC B331	240
R24	N	12300	8.7	E.6	Non-1E MCC C330	240
R24	N	12300	8.7	F.5	Non-1E MCC C331	240
R24	N	12300	8.7	F.9	Non-1E MCC C332	240
N26	N	12300	7.3	B.7	CF FILTER VESSEL (A)	241
N26	N	12300	7.6	B.7	CF FILTER VESSEL (B)	241
N26	N	12300	7.6	B.3	CF FILTER VESSEL (C)	241
P62	N	6300	10.5	A.5	BOILER (HB)	247
P62	N	6300	9.5	B.0	BOILER (HB)	247
P24	N	6300	9.3	C.5	HNCW CHILLER (A)	248
P24	N	6300	9.3	D.5	HNCW CHILLER (B)	248

**Table 9A.6-4 Fire Hazard Analysis
Equipment Database Sorted by Room - Turbine Building (Continued)**

WBS	Elec Div.	Elev Loc.	Loc No. Coord	Loc Alpha Coord	Description	Room No.
P24	N	6300	9.3	E.5	HNCW CHILLER (C)	248
P24	N	6300	9.3	F.5	HNCW CHILLER (D)	248
P24	N	6300	9.3	G.5	HNCW CHILLER (E)	248
P24	N	6300	9.4	C.9	HNCW PUMP (A)	248
P24	N	6300	9.4	D.9	HNCW PUMP (B)	248
P24	N	6300	9.4	E.9	HNCW PUMP (C)	248
P24	N	6300	9.4	F.9	HNCW PUMP (D)	248
P24	N	6300	9.4	G.9	HNCW PUMP (E)	248
N22	N	12300	7.6	F.5	HIGH PRESSURE DRAIN TANK	2X3
H22	N	12300	7.4	F.3	LOCAL RACK	2X3
N62	N	12300	3.4	B.6	OG PRE HEATER (A)	2X4
N62	N	12300	3.4	C.6	OG PRE HEATER (B)	2X4
N62	N	12300	3.7	B.6	OG RECOMBINER (A)	2X4
N62	N	12300	3.7	C.6	OG RECOMBINER (B)	2X4
N62	N	12300	3.6	B.3	OG CONDENSER (A)	2X4
N62	N	12300	3.6	C.4	OG CONDENSER (B)	2X4
N62	N	12300	3.7	B.8	OG COOLER CONDENSER (A)	2X4
N62	N	12300	3.7	C.1	OG COOLER CONDENSER (B)	2X4
R22	N	12300	9.2	E.3	Non-1E M/C CTG1	2X5
R22	N	12300	9.5	E.2	Non-1E M/C CTG2	2X5
R22	N	12300	9.5	E.7	Non-1E M/C CTG3	2X5
R23	N	12300	9.2	E.9	Non-1E P/C CTG-1	2X5
R24	N	12300	9.4	F.3	Non-1E CTG MCC	2X5
C95	N	12300	5.5	B.9	CF/CD CONTROL PANEL	2X6
C95	N	12300	5.5	C.1	CF/CD CONTROL PANEL	2X6
H22	N	12300	6.2	A.3	LOCAL RACK	2X7
H22	N	12300	6.6	A.2	LOCAL RACK	2X7
H22	N	12300	6.8	A.2	LOCAL RACK	2X7
H22	N	12300	6.8	A.4	LOCAL RACK	2X7
R22	N	12300	9.5	D.0	CTG AUXILIARY EQUIPMENT AREA	2X8
R23	N	19700	9.2	A.4	Non-1E P/C SA10	310
R23	N	19700	9.5	A.4	Non-1E P/C SB10	310
R23	N	19700	9.2	B.0	Non-1E P/C SC10	310
R23	N	19700	9.5	B.0	Non-1E P/C SD10	310

**Table 9A.6-4 Fire Hazard Analysis
Equipment Database Sorted by Room - Turbine Building (Continued)**

WBS	Elec Div.	Elev Loc.	Loc No. Coord	Loc Alpha Coord	Description	Room No.
R23	N	19700	9.2	D.6	Non-1E P/C SA12	310
R23	N	19700	9.2	B.7	Non-1E P/C SB12	310
R23	N	19700	9.5	B.7	Non-1E P/C SC13	310
R23	N	19700	9.8	B.7	Non-1E P/C SD13	310
R42	N	19700	9.2	H.4	Non-1E 125VDC CHG/PC/DB A	310
R42	N	19700	9.4	H.4	Non-1E 125VDC CHG/PC/DB B	310
R42	N	19700	9.7	H.4	Non-1E 125VDC CHG/PC/DB C	310
R42	N	19700	9.6	F.2	Non-1E 250VDC CHG/PC/DB A1	310
R42	N	19700	9.6	E.4	Non-1E 250VDC CHG/PC/DB B1	310
R42	N	19700	9.8	F.2	Non-1E 250VDC CHG/PC/DB A2	310
R42	N	19700	9.8	E.4	Non-1E 250VDC CHG/PC/DB B2	310
R23	N	19700	9.2	C.3	PIP P/C A30	310
R23	N	19700	9.2	D.0	PIP P/C A31	310
R23	N	19700	9.5	C.3	PIP P/C A34	310
R23	N	19700	9.5	D.0	PIP P/C B31	310
R23	N	19700	9.8	D.0	PIP P/C B35	310
R23	N	19700	9.8	C.3	PIP P/C C31	310
R23	N	19700	9.5	D.6	PIP P/C B30	310
R23	N	19700	9.8	D.6	PIP P/C C32	310
R23	N	19700	9.8	B.0	PIP P/C C30	310
N21	N	12300	6.7	C.6	STEAM EJECTOR UNIT (A)	311
N21	N	12300	6.7	C.3	STEAM EJECTOR UNIT (B)	311
U41	N	19700	8.6	H.9	MS TUNNEL L/C	313
U41	N	19700	8.6	J.6	MS TUNNEL L/C	313
N33	N	12300	7.3	D.6	GRAND STEAM CONDENSER	314
N33	N	12300	7.2	E.6	GRAND STEAM EXHAUSTER (A)	314
N33	N	12300	7.4	E.6	GRAND STEAM EXHAUSTER (B)	314
N21	N	2300	3.6	B.4	CONDENSATE VACUUM PUMP (A)	315
N21	N	2300	2.5	B.4	CONDENSATE VACUUM PUMP (B)	315
N21	N	19700	7.3	H.3	6TH FEED WATER HEATER (A)	316
N21	N	19700	7.7	H.3	5TH FEED WATER HEATER (A)	316
N37	N	19700	7.8	F.5	TURBINE BYPASS VALVE	316
H22	N	19700	7.4	H.3	LOCAL RACK	316
H22	N	19700	7.6	H.5	LOCAL RACK	316

**Table 9A.6-4 Fire Hazard Analysis
Equipment Database Sorted by Room - Turbine Building (Continued)**

WBS	Elec Div.	Elev Loc.	Loc No. Coord	Loc Alpha Coord	Description	Room No.
R40	N	12300	10.5	B.9	COMBUSTION TURBINE GENERATOR	317
R40	N	12300	10.6	E.2	DIESEL GENERATOR	317
N62	N	19700	2.4	B.8	OG EXTRACTOR (A)	31X-1
N62	N	19700	2.4	C.3	OG EXTRACTOR (B)	31X-1
R22	Class 1E	19700	7.2	D.8	SAFETY RELATED LPCP SWITCHGEAR (A)	31X-2
R22	Class 1E	19700	7.4	D.8	SAFETY RELATED LPCP SWITCHGEAR (B)	31X-2
R22	Class 1E	19700	7.2	E.4	SAFETY RELATED LPCP SWITCHGEAR (C)	31X-2
R22	Class 1E	19700	7.4	E.4	SAFETY RELATED LPCP SWITCHGEAR (D)	31X-2
U41	N	19700	2.4	A.7	OFF-GAS CHARCOAL BED L/C	320
U41	N	19700	7.9	A.1	IPB COOLING UNIT ROOM L/C	320
U41	N	19700	5.2	B.5	SCR PANEL ROOM L/C	320
U41	N	19700	5.5	C.5	IPB/Z L/C	320
U41	N	19700	6.4	A.5	IPB COOLING UNIT	320
N43	N	19700	3.5	C.5	STATOR COIL COOLING UNIT	320
H21	N	19700	3.1	C.8	STATOR COIL COOLING CTRL PANEL	320
H21	N	19700	3.7	B.2	GENERATOR OIL&GAS CTRL PANEL	320
H21	N	19700	3.7	B.3	GENERATOR OIL&GAS CTRL PANEL	320
H21	N	19700	6.4	A.9	PT&SA PANEL	320
H21	N	19700	4.0	B.9	VT Panel	320
H21	N	19700	4.0	B.5	NGR PANEL	320
R22	N	19700	6.4	B.8	GENERATOR CIRCUIT BREAKER	320
N21	N	19700	4.1	F.6	4TH FEED WATER HEATER (A)	321
N21	N	19700	4.1	E.6	4TH FEED WATER HEATER (B)	321
N21	N	19700	4.1	D.6	4TH FEED WATER HEATER (C)	321
N21	N	19700	4.3	F.4	3RD FEED WATER HEATER (A)	321
N21	N	19700	4.3	E.4	3RD FEED WATER HEATER (B)	321
N21	N	19700	4.3	D.4	3RD FEED WATER HEATER (C)	321
N21	N	19700	2.3	F.2	1ST FEED WATER HEATER DRAIN TANK (A)	321
N21	N	19700	2.3	D.9	1ST FEED WATER HEATER DRAIN TANK (B)	321
N21	N	19700	2.4	C.9	1ST FEED WATER HEATER DRAIN TANK (C)	321
N21	N	24400	4.2	F.4	1ST FEED WATER HEATER (A)	321
N21	N	24400	4.2	E.4	1ST FEED WATER HEATER (B)	321
N21	N	24400	4.2	D.4	1ST FEED WATER HEATER (C)	321
N21	N	24400	4.1	F.6	2ND FEED WATER HEATER (A)	321

**Table 9A.6-4 Fire Hazard Analysis
Equipment Database Sorted by Room - Turbine Building (Continued)**

WBS	Elec Div.	Elev Loc.	Loc No. Coord	Loc Alpha Coord	Description	Room No.
N21	N	24400	4.1	E.6	2ND FEED WATER HEATER (B)	321
N21	N	24400	4.1	D.6	2ND FEED WATER HEATER (C)	321
N22	N	24400	3.7	E.3	MOISTURE SEPARATOR DRAIN TANK	321
N22	N	24400	3.7	E.7	MOISTURE SEPARATOR DRAIN TANK	321
N22	N	24400	6.3	E.3	MOISTURE SEPARATOR DRAIN TANK	321
N22	N	24400	6.3	E.7	MOISTURE SEPARATOR DRAIN TANK	321
N22	N	24400	3.5	D.3	MSH 1ST STAGE HEATER DRAIN TANK	321
N22	N	24400	3.7	F.6	MSH 1ST STAGE HEATER DRAIN TANK	321
N22	N	24400	6.5	D.3	MSH 1ST STAGE HEATER DRAIN TANK	321
N22	N	24400	6.3	F.6	MSH 1ST STAGE HEATER DRAIN TANK	321
N22	N	24400	3.7	D.3	MSH 2ND STAGE HEATER DRAIN TANK	321
N22	N	24400	3.6	F.2	MSH 2ND STAGE HEATER DRAIN TANK	321
N22	N	24400	6.3	D.3	MSH 2ND STAGE HEATER DRAIN TANK	321
N22	N	24400	6.4	F.2	MSH 2ND STAGE HEATER DRAIN TANK	321
N34	N	19700	7.3	H.5	MAIN TURBINE LUBE OIL TANK	330
N34	N	19700	7.3	J.4	MAIN FLUSHING PUMP	330
N21	N	19700	3.3	H.3	6TH FEED WATER HEATER (B)	331
N21	N	19700	3.7	H.3	5TH FEED WATER HEATER (B)	331
H22	N	19700	3.4	H.5	LOCAL RACK	331
H22	N	19700	3.6	H.6	LOCAL RACK	331
N31	N	19700	4.0	H.5	MAIN STEAM STOP VALVE	334
N31	N	19700	4.0	H.5	MAIN STEAM CONTROL VALVE	334
N42	N	19700	3.7	B.8	GENERATOR HYDROGEN GAS DRYER	340
R24	N	19700	8.7	B.7	Non-1E MCC SC132	340
R24	N	19700	8.7	C.2	Non-1E MCC SC133	340
R24	N	19700	8.7	C.5	Non-1E MCC SD130	340
R24	N	19700	8.7	D.4	Non-1E MCC SD131	340
R24	N	19700	8.7	D.9	Non-1E MCC SD132	340
R24	N	19700	8.7	E.4	Non-1E MCC SD133	340
N26	N	19700	7.3	B.2	CF MODULE TANK	342
C95	N	12300	6.3	B.8	CONDENSATE DEMINERALIZER (A)	344
C95	N	12300	6.6	B.8	CONDENSATE DEMINERALIZER (B)	344
C95	N	12300	6.9	B.8	CONDENSATE DEMINERALIZER (C)	344
C95	N	12300	6.3	B.2	CONDENSATE DEMINERALIZER (D)	344

**Table 9A.6-4 Fire Hazard Analysis
Equipment Database Sorted by Room - Turbine Building (Continued)**

WBS	Elec Div.	Elev Loc.	Loc No. Coord	Loc Alpha Coord	Description	Room No.
C95	N	12300	6.6	B.2	CONDENSATE DEMINERALIZER (E)	344
C95	N	12300	6.9	B.2	CONDENSATE DEMINERALIZER (F)	344
N44	N	19700	3.3	B.6	GENERATOR OIL SEAL UNIT	3X2
H22	N	19700	3.1	B.5	LOCAL RACK	3X2
H22	N	19700	3.1	B.6	LOCAL RACK	3X2
H22	N	19700	3.4	B.4	LOCAL RACK	3X2
H22	N	19700	3.4	B.5	LOCAL RACK	3X2
H21	N	19700	5.2	A.5	EXCITER RECTIFIER PANEL	3X3
H21	N	19700	5.6	A.5	EXCITER CTRL PANEL	3X3
R42	N	19700	9.8	F.7	Non-1E 250VDC Battery A1	3X4
R42	N	19700	9.8	G.0	Non-1E 250VDC Battery B1	3X4
R42	N	19700	9.4	F.7	SINK	3X4
R42	N	19700	9.8	G.4	Non-1E 250VDC Battery A2	3X5
R42	N	19700	9.8	G.8	Non-1E 250VDC Battery B2	3X5
R42	N	19700	9.4	G.4	SINK	3X5
R42	N	19700	9.7	F.6	Non-1E 125VDC Battery A	3X6
R42	N	19700	9.4	F.9	SINK	3X6
R42	N	19700	9.7	G.3	Non-1E 125VDC Battery B	3X7
R42	N	19700	9.4	G.3	SINK	3X7
R42	N	19700	9.7	G.7	Non-1E 125VDC Battery C	3X8
R42	N	19700	9.4	G.6	SINK	3X8
U41	N	19700	10.5	F.7	ELECTRICAL EQUIPMENT AREA	3X9
U41	N	38300	8.8	D.3	R/B SUPPLY FAN (A)	411
U41	N	38300	8.8	D.7	R/B SUPPLY FAN (B)	411
U41	N	38300	8.8	E.4	R/B SUPPLY FAN (C)	411
P22	N	47200	7.7	E.8	HNCW,TCW SURGE TANK	411
U41	N	27800	9.5	E.5	R/B EXHAUST FAN (A)	412
U41	N	27800	9.5	F.5	R/B EXHAUST FAN (B)	412
U41	N	27800	9.5	G.5	R/B EXHAUST FAN (C)	412
U41	N	27800	9.1	E.5	R/B EXHAUST FAN FILTER (A)	412
U41	N	27800	9.1	F.5	R/B EXHAUST FAN FILTER (B)	412
U41	N	27800	9.1	G.5	R/B EXHAUST FAN FILTER (C)	412
H22	N	27800	3.8	G.2	LOCAL RACK	413
H22	N	27800	2.1	G.9	LOCAL RACK	413

**Table 9A.6-4 Fire Hazard Analysis
Equipment Database Sorted by Room - Turbine Building (Continued)**

WBS	Elec Div.	Elev Loc.	Loc No. Coord	Loc Alpha Coord	Description	Room No.
H22	N	27800	2.1	H.9	LOCAL RACK	413
U41	N	27800	3.9	C.6	MSH ROOM L/C	420
N41	N	27800	4.0	C.4	GENERATOR	421
N35	N	27800	6.5	E.5	MOISTURE SEPARATOR AND REHEATER (A)	423
N35	N	27800	3.6	E.5	MOISTURE SEPARATOR AND REHEATER (B)	423
N31	N	27800	4.0	F.5	LOW PRESSURE TURBINE (A)	423
N31	N	27800	4.0	E.5	LOW PRESSURE TURBINE (B)	423
N31	N	27800	4.0	D.5	LOW PRESSURE TURBINE (C)	423
N31	N	27800	6.9	G.3	COMBINED INTERMEDIATE VALVE	431
N31	N	27800	3.1	G.3	COMBINED INTERMEDIATE VALVE	431
N34	N	27800	3.9	H.6	MIST SEPARATOR	431
N31	N	27800	4.0	G.5	HIGH PRESSURE TURBINE	432
U41	N	27800	6.1	C.6	MSH ROOM L/C	441
H22	N	27800	6.9	C.6	LOCAL RACK	441
U41	N	38300	8.2	A.3	R/B T/B SUPPLY ROOM L/C	443
U41	N	38300	8.8	A.6	T/B EXHAUST FAN (A)	443
U41	N	38300	8.8	B.5	T/B EXHAUST FAN (B)	443
U41	N	38300	8.8	C.5	T/B EXHAUST FAN (C)	443
U41	N	38300	8.5	F.3	R/B T/B EXHAUST ROOM L/C	445
U41	N	38300	8.7	G.3	T/B SUPPLY FAN (A)	445
U41	N	38300	8.7	H.3	T/B SUPPLY FAN (B)	445
U41	N	38300	8.7	J.3	T/B SUPPLY FAN (C)	445
N33	N	27800	8.5	D.5	GRAND STEAM GENERATOR	4X1
H22	N	27800	8.8	D.3	LOCAL RACK	4X1
H22	N	27800	8.8	D.6	LOCAL RACK	4X1
N33	N	27800	8.9	C.3	GRAND STEAM GENERATOR FEEDWATER PUMP (A)	4X2
N33	N	27800	8.9	C.5	GRAND STEAM GENERATOR FEEDWATER PUMP (B)	4X2
U41	N	27800	8.0	F.5	T/B EQUIPMENT COMPARTMENT EXHAUST FAN	4X3
H22	N	27800	8.4	E.1	LOCAL RACK	4X3
H22	N	27800	8.7	E.1	LOCAL RACK	4X3
U41	N	27800	9.2	B.5	ELECTRIC BOILER ROOM ROOF EXHAUSTER	4X4
U41	N	27800	9.2	A.5	ELECTRIC BOILER ROOM ROOF EXHAUSTER	4X4
U41	N	27800	10.3	B.3	COMBUSTION TURBINE GENERATOR ROOM ROOF EXHAUSTER	4X4

**Table 9A.6-4 Fire Hazard Analysis
Equipment Database Sorted by Room - Turbine Building (Continued)**

WBS	Elec Div.	Elev Loc.	Loc No. Coord	Loc Alpha Coord	Description	Room No.
U41	N	27800	10.3	B.7	COMBUSTION TURBINE GENERATOR ROOM ROOF EXHAUSTER	4X4
U41	N	27800	10.3	C.3	COMBUSTION TURBINE GENERATOR ROOM ROOF EXHAUSTER	4X4
U41	N	27800	10.3	C.7	COMBUSTION TURBINE GENERATOR ROOM ROOF EXHAUSTER	4X4
U41	N	27800	10.3	D.3	COMBUSTION TURBINE GENERATOR ROOM ROOF EXHAUSTER	4X4
U41	N	27800	10.3	D.7	COMBUSTION TURBINE GENERATOR ROOM ROOF EXHAUSTER	4X4
U41	N	27800	10.7	B.3	COMBUSTION TURBINE GENERATOR ROOM ROOF EXHAUSTER	4X4
U41	N	27800	10.7	B.7	COMBUSTION TURBINE GENERATOR ROOM ROOF EXHAUSTER	4X4
U41	N	27800	10.7	C.3	COMBUSTION TURBINE GENERATOR ROOM ROOF EXHAUSTER	4X4
U41	N	27800	10.7	C.7	COMBUSTION TURBINE GENERATOR ROOM ROOF EXHAUSTER	4X4
U41	N	27800	10.7	D.3	COMBUSTION TURBINE GENERATOR ROOM ROOF EXHAUSTER	4X4
U41	N	27800	10.7	D.7	COMBUSTION TURBINE GENERATOR ROOM ROOF EXHAUSTER	4X4

**Table 9A.6-4 Fire Hazard Analysis
Equipment Database Sorted by Room - Turbine Building (Continued)**

MPL No.	Elec Div.	Elev. Loc.	Loc No. Coord	Loc Alpha Coord	Description	Room No.
B21-PT301A	1	1500	TBD	TBD	PRESSURE TRANSMITTER	120
B21-PT301B	2	1500	TBD	TBD	PRESSURE TRANSMITTER	120
B21-PT301C	3	1500	TBD	TBD	PRESSURE TRANSMITTER	120
B21-PT301D	4	1500	TBD	TBD	PRESSURE TRANSMITTER	120
E31-TE021A	1	14750	5.5	K.8	MSL TEMPERATURE SENSOR	219
E31-TE021B	2	14750	5.8	K.8	MSL TEMPERATURE SENSOR	219
E31-TE021C	3	14750	6.2	K.8	MSL TEMPERATURE SENSOR	219
E31-TE021D	4	14750	6.4	K.8	MSL TEMPERATURE SENSOR	219
E31-TE022A	1	15100	5.5	K.8	TEMPERATURE ELEMENT	219
E31-TE022B	2	15100	5.8	K.8	TEMPERATURE ELEMENT	219
E31-TE022C	3	15100	6.2	K.8	TEMPERATURE ELEMENT	219
E31-TE022D	4	15100	6.4	K.8	TEMPERATURE ELEMENT	219
E31-TE023A	1	15450	5.5	K.8	TEMPERATURE ELEMENT	219
E31-TE023B	2	15450	5.8	K.8	TEMPERATURE ELEMENT	219
E31-TE023C	3	15450	6.2	K.8	TEMPERATURE ELEMENT	219
E31-TE023D	4	15450	6.4	K.8	TEMPERATURE ELEMENT	219
E31-TE024A	1	15800	5.5	K.8	TEMPERATURE ELEMENT	219
E31-TE024B	2	15800	5.8	K.8	TEMPERATURE ELEMENT	219
E31-TE024C	3	15800	6.2	K.8	TEMPERATURE ELEMENT	219
E31-TE024D	4	15800	6.4	K.8	TEMPERATURE ELEMENT	219
E31-TE025A	1	16150	5.5	K.8	TEMPERATURE ELEMENT	219
E31-TE025B	2	16150	5.8	K.8	TEMPERATURE ELEMENT	219
E31-TE025C	3	16150	6.2	K.8	TEMPERATURE ELEMENT	219
E31-TE025D	4	16150	6.4	K.8	TEMPERATURE ELEMENT	219
E31-TE026A	1	16500	5.5	K.8	TEMPERATURE ELEMENT	219
E31-TE026B	2	16500	5.8	K.8	TEMPERATURE ELEMENT	219
E31-TE026C	3	16500	6.2	K.8	TEMPERATURE ELEMENT	219
E31-TE026D	4	16500	6.4	K.8	TEMPERATURE ELEMENT	219
E31-TE027A	1	16850	5.5	K.8	TEMPERATURE ELEMENT	219
E31-TE027B	2	16850	5.8	K.8	TEMPERATURE ELEMENT	219
E31-TE027C	3	16850	6.2	K.8	TEMPERATURE ELEMENT	219
E31-TE027D	4	16850	6.4	K.8	TEMPERATURE ELEMENT	219
E31-TE028A	1	17100	5.5	K.8	TEMPERATURE ELEMENT	219

**Table 9A.6-4 Fire Hazard Analysis
Equipment Database Sorted by Room - Turbine Building (Continued)**

MPL No.	Elec Div.	Elev. Loc.	Loc No. Coord	Loc Alpha Coord	Description	Room No.
E31-TE028B	2	17100	5.8	K.8	TEMPERATURE ELEMENT	219
E31-TE028C	3	17100	6.2	K.8	TEMPERATURE ELEMENT	219
E31-TE028D	4	17100	6.4	K.8	TEMPERATURE ELEMENT	219
E31-TE029A	1	17450	5.5	K.8	TEMPERATURE ELEMENT	219
E31-TE029B	2	17450	5.8	K.8	TEMPERATURE ELEMENT	219
E31-TE029C	3	17450	6.2	K.8	TEMPERATURE ELEMENT	219
E31-TE029D	4	17450	6.4	K.8	TEMPERATURE ELEMENT	219
C71-PS002A	1	8000	TBD	TBD	PRESSURE SWITCH	232
C71-PS002B	2	8000	TBD	TBD	PRESSURE SWITCH	232
C71-PS002C	3	8000	TBD	TBD	PRESSURE SWITCH	232
C71-PS002D	4	8000	TBD	TBD	PRESSURE SWITCH	232
B21-PT028A	1	17000	3.6	K.0	PRESSURE TRANSMITTER	333
B21-PT028B	2	17000	3.8	K.0	PRESSURE TRANSMITTER	333
B21-PT028C	3	17000	4.2	K.0	PRESSURE TRANSMITTER	333
B21-PT028D	4	17000	4.4	K.0	PRESSURE TRANSMITTER	333
C71-PoS001	1	22000	3.6	H.6	POSITION SWITCH	334
C71-PoS001	2	22000	3.8	H.6	POSITION SWITCH	334
C71-PoS001	3	22000	4.2	H.6	POSITION SWITCH	334
C71-PoS001	4	22000	4.4	H.6	POSITION SWITCH	334
C71-PoS004	1	22000	3.6	H.7	POSITION SWITCH	334
C71-PoS004	2	22000	3.8	H.7	POSITION SWITCH	334
C71-PoS004	3	22000	4.2	H.7	POSITION SWITCH	334
C71-PoS004	4	22000	4.4	H.7	POSITION SWITCH	334
C71-PT003A	1	27800	TBD	TBD	PRESSURE TRANSMITTER	431
C71-PT003B	2	27800	TBD	TBD	PRESSURE TRANSMITTER	431
C71-PT003C	3	27800	TBD	TBD	PRESSURE TRANSMITTER	431
C71-PT003D	4	27800	TBD	TBD	PRESSURE TRANSMITTER	431

