

# MACTEC ENGINEERING AND CONSULTING, INC.

## RALEIGH, NORTH CAROLINA

IN SITU DETERMINATION OF ROCK MASS PERMEABILITY USING WATER PRESSURE TEST  
IN ACCORDANCE WITH CORPS OF ENGINEERS,  
(WATERWAYS EXPERIMENT STATION, RTH 381-80)

**PROJECT NAME: NORTH ANNA COL**  
**PROJECT NUMBER: 6468-06-1472**  
**REPORT DATE: 12/7/2006** Revised 1-13-07  
**BORING NO: B-949**

**Given Parameters**

Test Section Length, <i>l</i> , ft:	5	Prepared by: <u>ZO</u>	Date: <u>12-7-06</u>
Radius of Borehole <i>r</i> <sub>0</sub> , in:	2.00	Checked by: <u>[Signature]</u>	Date: <u>1-17-07</u>
GW Depth, ft:	23.00	(from top of casing) 21.40	(from ground surface)

Test Number	Q (GPM)	P <sub>Test</sub> (psi)	P <sub>T</sub> (psi)	P <sub>M</sub> (psi)	P <sub>B</sub> (psi)	Q (cfs)	H <sub>M</sub> (ft)	K <sub>e</sub> (fpy)
<b>Interval 1, ft: 84 - 89 (from ground surface)</b>								
1	TNP							
2	0.6072	39.66	3.06	28.43	31.18	25.91538	91.52	178.24
3	1.7712	60.1	3.06	28.43	31.18	73.08462	138.69	184.36
4	0	30	3.06	28.43	31.18	3.62308	69.23	0.00
5	1.6763	60.1	3.06	28.43	31.18	73.08462	138.69	174.49
<b>K<sub>e</sub>, ft/year:</b>								<b>173.05</b>

<b>Interval 2, ft: 89 - 94 (from ground surface)</b>								
1	TNP							
2	25.10769231	41.5	3.22	30.62	33.42	25.1076923	95.77	0.00
3	74.4923	62.9	3.22	30.62	33.42	74.4923077	145.15	38.11
4	1.8	31.4	3.22	30.62	33.42	1.8	72.46	0.00
5	74.4923	62.9	3.22	30.62	33.42	74.4923077	145.15	58.97
Report Ke as average of intervals 3 and 5 = 48.5								<b>NA</b>

<b>Interval 3, ft: 95 - 99.5 (from ground surface)</b>								
1	TNP	21.79	3.15	33.01	35.72			
2	8.05	43.57	3.1	32.75	35.54	0.01793	100.55	2451.8
3	17.52	66.03	3.1	32.75	35.54	0.03903	152.38	3390.4
4	0.00	33.01	3.15	33.01	35.72	0.00000	76.18	NA
5	18.15	66.03	3.15	33.01	35.72	0.04044	152.38	1939.5
<b>K<sub>e</sub>, ft/year:</b>								<b>2293.2</b>

Notations:

Q = flow rate	H <sub>M</sub> = P <sub>Test</sub> converted to feet of head (P <sub>Test</sub> *144in <sup>2</sup> /ft <sup>2</sup> /γ <sub>w</sub> )
P <sub>Test</sub> = total test pressure	K <sub>e</sub> = ((Q/(H <sub>M</sub> -P <sub>m</sub> ))*(1/l))*1/2π*ln(R/r <sub>0</sub> )*(525.600 min/year)*(0.1337ft <sup>3</sup> /gal)
P <sub>T</sub> = pressure above top packer, near water surface	R = total length between packers, <i>l</i>
P <sub>M</sub> = initial pressure in the test section	TNP = Test not performed
P <sub>B</sub> = pressure below bottom packer	NM = not measured

Note: Pressures P<sub>t</sub>, P<sub>m</sub> and P<sub>b</sub> taken from initial data for transducers.  
Outside diameter of boring is 4 in.

**IN SITU DETERMINATION OF ROCK MASS PERMEABILITY USING WATER PRESSURE TEST  
IN ACCORDANCE WITH CORPS OF ENGINEERS,  
WATERWAYS EXPERIMENT STATION, RTH 381-80**

Project Name: NORTH ANNA COL  
Project Number: 6468-06-1472  
Date: 8/16/2006

Prepared by: ZO Date: 12-7-06  
Checked by: *[Signature]* Date: 1-17-07

Boring No: B-949  
Test Interval: 85.6 ft to 90.6 ft (below top of casing)  
Stick up length: 1.6 ft  
Test Interval: 84.0 ft to 89 ft (from surface)  
Test Type: Double Packer Technique

Depth of Water  
Table= 23.00 ft (from top of casing)  
h1= 23.00 (from top of casing)  
h2 = 65.1 ft (from top of casing)  
 $\rho_w = 62.4 \text{ lb/ft}^3$

**Abbreviations:**  
N.O. Not Observed  
N.A. Not Applicable

$P_0 \text{ Max} = 60.11 \text{ psi}$  Value on field data sheet= 60.1  
Target excess pressures were 1/3Pmax, 2/3Pmax, Pmax, 1/2 Pmax and Pmax. Actual excess pressures given below.

TEST #1				TEST #2				TEST #3			
Actual Excess Pressure= -8.63 psi				Actual Excess Pressure= 11.23 psi				Actual Excess Pressure= 31.67 psi			
Initial Middle Transducer Reading= 28.43 psi				Initial Middle Transducer Reading= 28.43 psi				Initial Middle Transducer Reading= 28.43 psi			
Test Pressure= 19.80 psi				Test Pressure= 39.66 psi				Test Pressure= 60.10 psi			
Time (min)	Flow Meter Reading (Gal)	Q (GPM)	Surface Gauge (psi)	Time (min)	Flow Meter Reading (Gal)	Q (GPM)	Surface Gauge (psi)	Time (min)	Flow Meter Reading (Gal)	Q (GPM)	Surface Gauge (psi)
Test not performed				0	2752.2		0.2	0	2756		0.4
				0.5	2752.6	0.8	7.3	0.5	2757.5	3.0	26
				1	2753.2	1.2	10.1	1	2758.7	2.4	27.4
				1.5	2753.5	0.6	5.8	1.5	2759.6	1.8	27.7
				2	2753.7	0.4	8.5	2	2760.6	2.0	25.5
				2.5	2754.1	0.8	8.8	2.5	2761.5	1.8	25.3
				3	2754.5	0.8	10.4	3	2762.1	1.2	24.8
			3.5	2754.8	0.6	9.1	3.5	2762.9	1.6	24.2	
			4	2754.9	0.2	8.2	4	2763.7	1.6	24	
			4.5	2755.2	0.6	8.3	4.5	2764.5	1.6	23.7	
			5	2755.4	0.4	8.2	5	2765.3	1.6	23.6	
			6	2755.9	0.5	8.3	6	2767.2	1.9	23.6	

Average Q: gpm      Average Q: 0.54 gpm      Average Q: 1.7 gpm  
Excess Pore pressure: -8.63 psi      Excess Pore pressure: 11.23 psi      Excess Pore pressure: 31.67 psi

Joe 1-17-07

TEST #4				TEST #5			
Actual Excess Pressure=		1.57 psi		Actual Excess Pressure=		31.67 psi	
Initial Middle Transducer		28.43 psi		Initial Middle Transducer		28.43 psi	
Test Pressure=		30.00 psi		Test Pressure=		60.1 psi	
Time (min)	Flow Meter Reading (Gal)	Q (GPM)	Surface Gauge (psi)	Time (min)	Flow Meter Reading (Gal)	Q (GPM)	Surface Gauge (psi)
0	2767.2			0	2767.3		-2
0.5	2767.2	0.0	-2	0.5	2768.6	2.6	25.6
1	2767.2	0.0	-1	1	2769.6	2.0	23.4
1.5	2767.2	0.0	-0.8	1.5	2770.4	1.6	23.9
2	2767.2	0.0	-0.8	2	2771.2	1.6	24
2.5	2767.2	0.0	-0.5	2.5	2772	1.6	23.7
3	2767.2	0.0	-0.4	3	2772.7	1.4	23.4
3.5	2767.2	0.0	-0.6	3.5	2773.4	1.4	23.4
4	2767.2	0.0	-0.6	4	2774.2	1.6	23.3
4.5	2767.2	0.0	-0.6	4.5	2775.6	2.8	23.2
5	2767.2	0.0	-0.6	5	2776.7	2.2	23.2
6	2767.2	0.0	-0.6	6	2777.2	0.5	22.9

Boring No: B-949  
 Test Interval: 84 ft to 89 ft (below surface)

Density of water,  $\rho_w = 62.4$  lb/ft<sup>3</sup>  
 = 0.0361 lb/in<sup>3</sup>  
 Length = 5 ft  
 Borehole radius = 2.00 in  
 R ranges from 5-10 ft:  
 choose R = 5 ft

	Excess Pressure (psi)	Q* (gpm)	Test Pres. (ft)	k <sub>e</sub> (fpy)
1	-8.63	TNP	-19.92	
2	11.23	0.607	25.92	178.24
3	31.67	1.771	73.08	184.36
4	1.57	0.000	3.62	0.00
5	31.67	1.676	73.1	174.49

\* Q obtained from graph Flow Rate-1

Average Q: 0 gpm      Average Q: 1.8 gpm  
 Excess Pore pressure: 1.57 psi      Excess Pore pressure: 31.67 psi

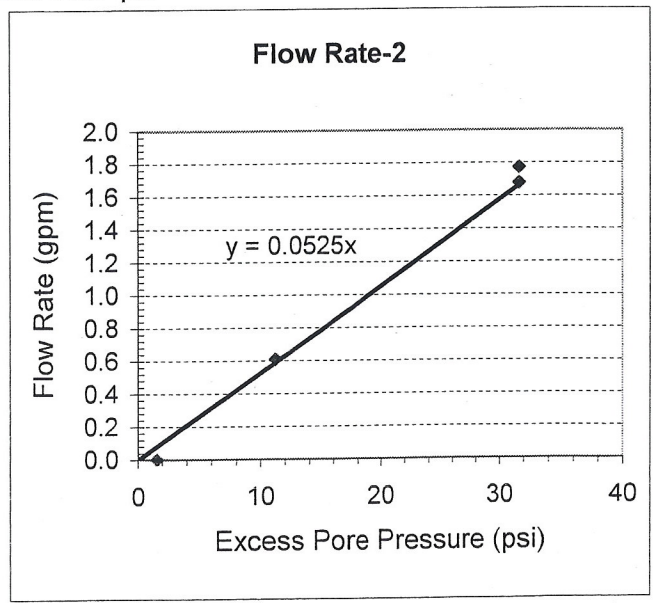
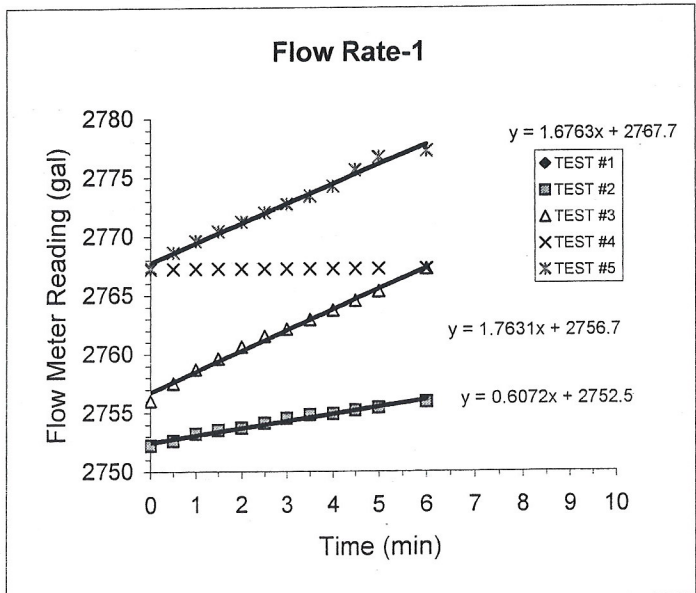

obtain Q from graph 2 in gpm/psi --> 0.0525 gal/psi

$$k_e = Q^* \ln(R/r_0) / (2\pi L H_0)$$

$$k_e = 1.67E-04 \text{ cm/sec} = 173.05 \text{ ft/year}$$

# Pressure Decay Test

Project Name: NORTH ANNA COL  
 Project Number: 6468-06-1472  
 Date: 8/16/2006  
 Boring No: B-949  
 Test Interval: 84 ft to 89 ft

(below surface)  
 N.O. Not Observed  
 N.A. Not Applicable

Prepared by: Z Date: 12-7-06  
 Checked by: J Date: 1-17-07

Test #1			Test #2			Test #3		
Time (min)	Surface Gauge (psi)	Center Tranducer (psi)	Time (min)	Surface Gauge (psi)	Center Tranducer (psi)	Time (min)	Surface Gauge (psi)	Center Tranducer (psi)
Test not conducted			0.0	8.3	39.53	0.0	23.6	60.15
			0.5	3.5	33.58	0.5	3	37.42
			1.0	2.5	31.56	1.0	1.6	34.87
			1.5	1.7	33.39	1.5	0.5	32.94
			2.0	1.2	29.58	2.0	0.0	31.56
			2.5	0.9	29.09	2.5	-0.6	30.56
			3.0	0.8	28.84	3.0	-1.1	29.77
			3.5	0.6	28.57	3.5	-1.4	29.30
			4.0	0.6	28.57	4.0	-1.7	28.99
			4.5	0.5	28.48	4.5	-1.6	28.76
			5.0	0.5	28.45	5.0	-1.8	28.66
			5.5	0.5	28.44	5.5	-1.9	28.57
			6.0	0.5	28.43	6.0	-1.9	28.52
6.5	0.5	28.42	6.5	-1.9	28.48			

Test #4			Test #5		
Time (min)	Surface Gauge (psi)	Center Tranducer (psi)	Time (min)	Surface Gauge (psi)	Center Tranducer (psi)
0.0	-0.6	30.14	0.0	22.9	60.19
0.5	-1.1	29.64	0.5	4.3	40.08
1.0	-1.4	29.15	1.0	1	35.98
1.5	-1.6	28.84	1.5	-1	33.40
2.0	-1.7	28.67	2.0	-1.8	31.61
2.5	-1.8	28.56	2.5	-2.6	30.48
3.0	-1.9	28.50	3.0	-3.0	29.75
3.5	-1.9	28.47	3.5	-3.3	29.28
4.0	-1.9	28.45	4.0	-3.5	29.01
4.5	-1.9	28.44	4.5	-3.6	28.78
5.0	-1.9	28.43	5.0	-3.7	28.68
5.5	-1.9	28.43	5.5	-3.7	28.61
6.0	-1.9	28.43	6.0	-3.7	28.57
			6.5	-3.7	28.52
			7.0	-3.8	28.50
			7.5	-3.8	28.48
			8	-3.7	28.48

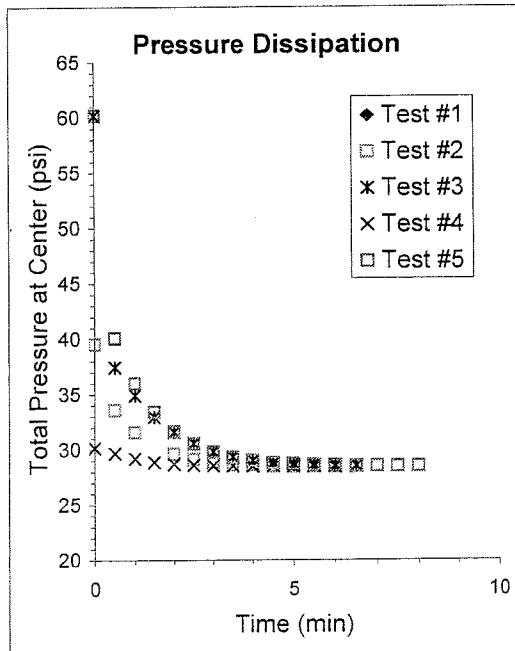

**IN SITU DETERMINATION OF ROCK MASS PERMEABILITY USING WATER PRESSURE TEST  
IN ACCORDANCE WITH CORPS OF ENGINEERS,  
WATERWAYS EXPERIMENT STATION, RTH 381-80**

Project Name: NORTH ANNA COL  
Project Number: 6468-06-1472  
Date: 8/30/2006

Prepared by: ZO Date: 12-7-06  
Checked by: [Signature] Date: 1-17-07

**Boring No:** B-949  
**Test Interval:** 90.6 ft to 95.6 ft (below top of casing)  
**Stick up length:** 1.6 ft  
**Test Interval:** 89.0 ft to 94 ft (from surface)  
**Test Type:** Double Packer Technique

Depth of Water  
Table = 23.00 ft (from top of casing)  
h1 = 23.00 (from top of casing)  
h2 = 70.1 ft (from top of casing)  
 $\rho_w = 62.4 \text{ lb/ft}^3$

**Abbreviations:**  
N.O. Not Observed  
N.A. Not Applicable

**P<sub>0</sub> Max = 62.96 psi** Value on field data sheet = 62.9  
Target excess pressures were 1/3Pmax, 2/3Pmax, Pmax, 1/2 Pmax and Pmax. **Actual** excess pressures given below.

TEST #1				TEST #2				TEST #3			
Actual Excess Pressure = -9.92 psi		Initial Middle Transducer Reading = 30.62 psi		Actual Excess Pressure = 10.88 psi		Initial Middle Transducer Reading = 30.62 psi		Actual Excess Pressure = 32.28 psi		Initial Middle Transducer Reading = 30.6 psi	
Test Pressure = 20.70 psi				Test Pressure = 41.50 psi				Test Pressure = 62.9 psi			
Time (min)	Flow Meter Reading (Gal)	Q (GPM)	Surface Gauge (psi)	Time (min)	Flow Meter Reading (Gal)	Q (GPM)	Surface Gauge (psi)	Time (min)	Flow Meter Reading (Gal)	Q (GPM)	Surface Gauge (psi)
Test not performed				0	2741		-0.2	0	2741.6		0
				0.5	2741.4	0.8	8.2	0.5	2743	2.8	26
				1	2741.6	0.4	7.6	1	2743.5	1.0	27.1
				1.5	2741.6	0.0	7.6	1.5	2743.9	0.8	26.8
				2	2741.6	0.0	7.9	2	2744.1	0.4	25
				2.5	2741.6	0.0	7.9	2.5	2744.4	0.6	25.7
				3	2741.6	0.0	7.9	3	2744.7	0.6	26
				3.5	2741.6	0.0	8.1	3.5	2745	0.6	26
				4	2741.6	0.0	7.9	4	2745.3	0.6	25.7
				4.5	2741.6	0.0	8	4.5	2745.5	0.4	25.5
				5	2741.6	0.0	7.9	5	2745.8	0.6	25.5
							6	2746.3	0.5	24.7	
							7	2746.8	0.5	26.1	
							8	2747.3	0.5	26.4	
							9	2747.7	0.4	26.4	
							10	2748.3	0.6	26.1	

**Average Q: 0.0 gpm**      **Average Q: 0.5 gpm**      **Average Q: 0.5 gpm**  
**Excess Pore pressure: -9.92 psi**      **Excess Pore pressure: 10.88 psi**      **Excess Pore pressure: 32.28 psi**

JA2-17-07

TEST #4

TEST #5

TEST #4				TEST #5			
Actual Excess Pressure=		0.78 psi		Actual Excess Pressure=		32.28 psi	
Initial Middle Transducer		30.62 psi		Initial Middle Transducer		30.62 psi	
Test Pressure=		31.40 psi		Test Pressure=		62.9 psi	
Time (min)	Flow Meter Reading (Gal)	Q (GPM)	Surface Gauge (psi)	Time (min)	Flow Meter Reading (Gal)	Q (GPM)	Surface Gauge (psi)
0	2748.5		-1.6	0	2748.6		-1.6
0.5	2748.5	0.0	-1.6	0.5	2749.5	1.8	26.6
1	2748.5	0.0	-1.5	1	2749.7	0.4	25.6
1.5	2748.6	0.2	-0.5	1.5	2749.9	0.4	24.4
2	2748.6	0.0	-0.7	2	2750.1	0.4	24.1
2.5	2748.6	0.0	-0.9	2.5	2750.3	0.4	25.5
3	2748.6	0.0	-1	3	2750.5	0.4	26.1
3.5	2748.6	0.0	-1.2	3.5	2750.8	0.6	24.3
4	2748.6	0.0	-1.1	4	2750.9	0.2	22.2
4.5	2748.6	0.0	-0.7	4.5	2751.1	0.4	23.7
5	2748.6	0.0	-0.7	5	2751.2	0.2	23.6
				5.5	2751.3	0.2	23.2
				6	2751.5	0.4	24.6
				7	2751.6	0.1	24.5
				7.5	2752	0.8	24.7
				8	2752.1	0.2	24.7

Boring No: 84  
 Test Interval: 89 ft to 94 ft (below surface)

Density of water,  $\rho_w = 62.4$  lb/ft<sup>3</sup>  
 = 0.0361 lb/in<sup>3</sup>  
 Length = 5 ft  
 Borehole radius = 2.00 in  
 R ranges from 5-10 ft:  
 choose R = 5 ft

	Excess Pressure (psi)	Q* (gpm)	Test Pres. (ft)	k <sub>e</sub> (fpy)
1	-9.92	0.000	-22.89	0
2	10.88	0.000	25.11	0
3	32.28	0.373	74.49	38.11
4	0.78	0.000	1.80	0
5	32.28	0.577	74.5	58.97

\* Q obtained from graph Flow Rate-1

Average Q: 0.0 gpm  
 Excess Pore pressure: 0.78 psi

Average Q: 0.4 gpm  
 Excess Pore pressure: 32.28 psi

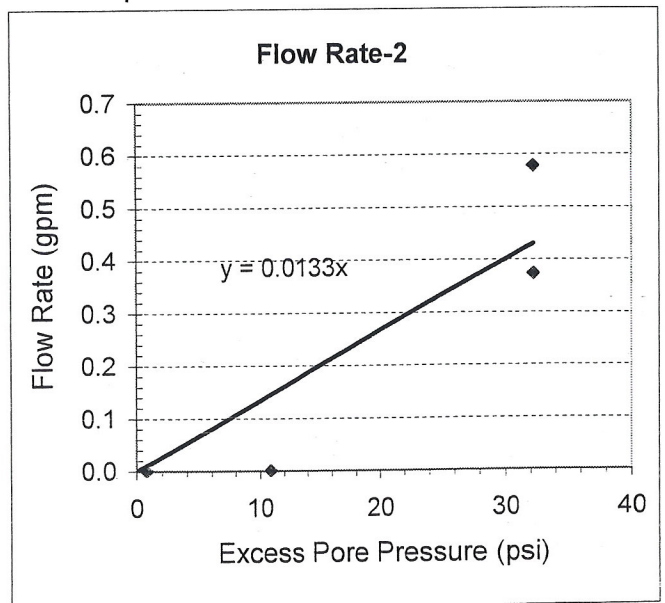
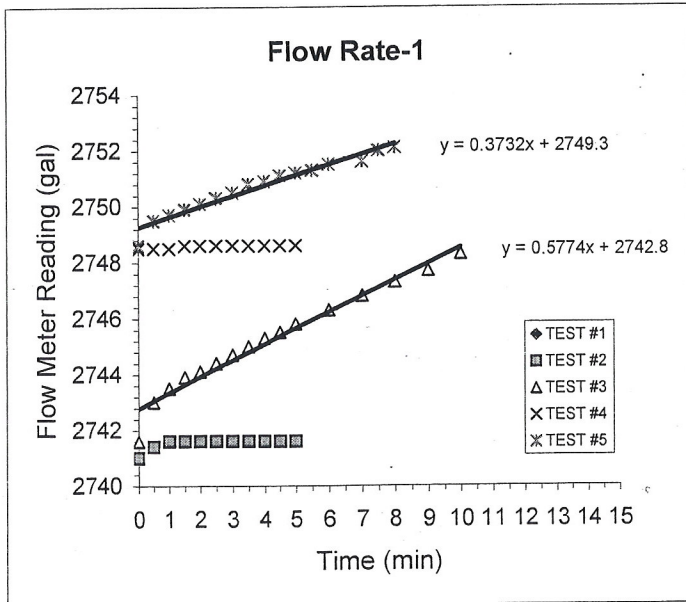

Note: Graph 2 not applicable as flow only at one pressure. Use average of Ke for Tests 3 and 5  
 obtain Q from graph 2 in gpm/psi --> NA gal/psi

$k_e = Q^* \ln(R/r_0) / (2\pi L H_0)$   
 k<sub>e</sub> = #VALUE! cm/sec  
 = NA ft/year

**Pressure Decay Test**

Project Name: NORTH ANNA COL  
 Project Number: 6468-06-1472  
 Date: 8/18/2006  
 Boring No: B-949  
 Test Interval: 89 ft to 94 ft

(below surface)  
 N.O. Not Observed  
 N.A. Not Applicable

Prepared by: ZO Date: 12-7-06  
 Checked by: *[Signature]* Date: 1-17-07

Test #1			Test #2			Test #3		
Time (min)	Surface Gauge (psi)	Center Tranducer (psi)	Time (min)	Surface Gauge (psi)	Center Tranducer (psi)	Time (min)	Surface Gauge (psi)	Center Tranducer (psi)
			0.0	7.9	41.44	0.0	26.1	64.32
			0.5	5.3	38.11	0.5	13.1	49.20
			1.0	3.9	36.29	1.0	8.9	45.02
			1.5	2.9	34.95	1.5	5.3	40.65
			2.0	2.4	33.94	2.0	3.5	38.29
			2.5	1.8	33.18	2.5	2	36.29
			3.0	1.5	32.65	3.0	1.4	35.32
			3.5	1.2	32.14	3.5	0.6	34.24
			4.0	1	31.8	4.0	0.2	33.54
			4.5	0.8	31.52	4.5	-0.1	32.98
			5.0	0.7	31.29	5.0	-0.5	32.46
			6.0	0.6	31.12	5.5	-0.7	32.05
			7.0	0.5	30.97	6.0	-1	31.52
			8.0	0.4	30.89	6.5	-1.2	31.33
			9.0	0.4	30.81	7.0	-1.2	31.19
			10.0	0.3	30.76	7.5	-1.3	31.10
			11.0	0.3	30.72	8.0	-1.4	31.02
			12.0	0.3	30.7	8.5	-1.4	30.91
						9.0	-1.5	30.85
						9.5	-1.5	30.82
						10.0	-1.5	30.79

Test #4			Test #5		
Time (min)	Surface Gauge (psi)	Center Tranducer (psi)	Time (min)	Surface Gauge (psi)	Center Tranducer (psi)
0.0	-0.7	31.87	0.0	24.7	63.27
0.5	-0.9	31.65	0.5	9.6	46.44
1.0	-1.1	31.45	1.0	5.8	42.11
1.5	-1.2	31.28	1.5	3.0	39.00
2.0	-1.3	31.16	2.0	2.1	37.36
2.5	-1.3	31.06	2.5	0.9	35.71
3.0	-1.4	30.97	3.0	0.1	34.49
3.5	-1.4	30.91	3.5	-0.3	33.69
4.0	-1.5	30.85	4.0	-0.7	33.08
4.5	-1.5	30.80	4.5	-1.1	32.54
5.0	-1.5	30.77	5.0	-1.3	32.21
5.5	-1.6	30.75	5.5	-1.6	31.87
6.0	-1.6	30.74	6.0	-1.7	31.54
6.5	-1.6	30.73	66.5	-1.9	31.34
7	-1.6	30.71	7	-2.0	31.21
			7.5	-2.0	31.08
			8	-2.1	30.98
			8.5	-2.1	30.90
			9	-2.2	30.85
			9.5	-2.3	30.79
			10	-2.3	30.74
			10.5	-2.3	30.73
			11	-2.3	30.71

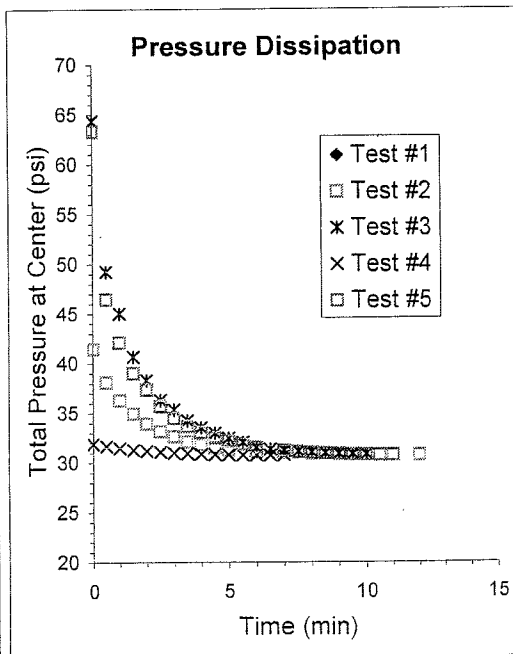

**IN SITU DETERMINATION OF ROCK MASS PERMEABILITY USING WATER PRESSURE TEST  
IN ACCORDANCE WITH CORPS OF ENGINEERS,  
WATERWAYS EXPERIMENT STATION, RTH 381-80**

Project Name: NORTH ANNA COL  
Project Number: 6468-06-1472  
Date: 8/16/2006

Prepared by: ZO Date: 12-7-06  
Checked by: [Signature] Date: 1-17-07

**Boring No:** B-949  
**Test Interval:** 96.1 ft to 101.1 ft (below top of casing)  
**Stick up length:** 1.6 ft  
**Test Interval:** 94.5 ft to 99.5 ft (from surface)  
**Test Type:** Double Packer Technique

Depth of Water  
Table= 23.10 ft (from top of casing)  
h1= 23.00 (from top of casing)  
h2 = 75.50 ft (from top of casing)  
 $\rho_w = 62.4 \text{ lb/ft}^3$

**Abbreviations:**  
N.O. Not Observed  
N.A. Not Aplicable

**P<sub>0</sub> Max= 66.04 psi** Value on field data sheet= 66.03

Target excess pressures were 1/3Pmax, 2/3Pmax, Pmax, 1/2 Pmax and Pmax. **Actual** excess pressures given below.

TEST #1				TEST #2				TEST #3			
Actual Excess Pressure= -11.22 psi Initial Middle Transducer Reading= 33.01 psi Test Pressure= 21.79 psi				Actual Excess Pressure= 10.82 psi Initial Middle Transducer Reading= 32.75 psi Test Pressure= 43.57 psi				Actual Excess Pressure= 17.03 psi Initial Middle Transducer Reading= 32.75 psi Test Pressure (max achievable)= 49.78 psi			
Time (min)	Flow Meter Reading (Gal)	Q (GPM)	Surface Gauge (psi)	Time (min)	Flow Meter Reading (Gal)	Q (GPM)	Surface Gauge (psi)	Time (min)	Flow Meter Reading (Gal)	Q (GPM)	Surface Gauge (psi)
Test not conducted				0	2509.7		0	0	2548		-10.3
				0.5	2509.7	0.0	0.1	0.5	2549.1	2.2	10.8
				1	2510.1	0.8	10.9	1	2556	13.8	14.7
				1.5	2515.4	10.6	13.4	1.5	2566.7	21.4	27.8
				2	2520.4	10.0	3.6	2	2575.7	18.0	28.7
				2.5	2525.3	9.8	3.7	2.5	2584.9	18.4	29.6
				3	2529.7	8.8	3.9	3	2593.9	18.0	31.3
				3.5	2532.9	6.4	3.9	3.5	2602.9	18.0	31.6
				4	2538.2	10.6	3.2	4	2611.6	17.4	31.4
				4.5	2542.2	8.0	3.2	4.5	2621.7	20.2	32.2
			5	2546.5	8.6	3.4	5	2631.1	18.8	32.2	

Average Q: ##### gpm  
Excess Pore pressure: -11.2 psi

Average Q: 9.1 gpm  
Excess Pore pressure: 10.82 psi

Average Q: 18.8 gpm  
Excess Pore pressure: 17.03 psi



902-1-17-07

**TEST #4**

**TEST #5**

Actual Excess Pressure= 0.00 psi				Actual Excess Pressure= 30.85 psi			
Initial Middle Transducer 33.01 psi				Initial Middle Transducer 33.01 psi			
Test Pressure= 33.01 psi				Test Pressure (max achievable)= 63.86 psi			
Time (min)	Flow Meter Reading (Gal)	Q (GPM)	Surface Gauge (psi)	Time (min)	Flow Meter Reading (Gal)	Q (GPM)	Surface Gauge (psi)
0	2632.1		-10.2	0	2633		-0.7
0.5	2632.1	0.0	-10.2	0.5	2636.8	7.6	25.2
1	2632.1	0.0	-10.1	1	2645.8	18.0	28.1
1.5	2632.2	0.2	-9.9	1.5	2655.9	20.2	30.3
2	2632.3	0.2	-9.6	2	2665.9	20.0	31.3
2.5	2632.6	0.6	-9.5	2.5	2674.3	16.8	31.5
3	2632.7	0.2	-9.5	3	2684.2	19.8	31.7
3.5	2632.8	0.2	-9.5	3.5	2692.8	17.2	32.5
4	2632.9	0.2	-9.4	4	2701.9	18.2	32.4
4.5	2633	0.2	-9.4	4.5	2711.3	18.8	33.1
5	2633	0.0	-9.4	5	2722.9	23.2	33.1
6	2633	0.0	-9.4	6	2737	14.1	33.1

**Boring No:** B-949  
**Test Interval:** 94.5 ft to 99.5 ft  
 (below surface)

Density of water,  $\rho_w = 62.4$  lb/ft<sup>3</sup>  
 = 0.0361 lb/in<sup>3</sup>  
 Length = 5 ft  
 Borehole radius = 2.00 in  
 R ranges from 5-10 ft:  
 choose R = 5 ft

	Excess Pressure (psi)	Q* (gpm)	Test Pres. (ft)	k <sub>e</sub> (fpy)
1	-11.22	0.000	-25.89	0
2	10.82	8.047	24.97	2452
3	17.03	17.52	39.30	3390
4	0.00	0.000	0.00	#DIV/0!
5	30.85	18.15	71.19	1939

\* Q obtained from graph Flow Rate-1

Average Q: 0.2 gpm  
 Excess Pore pressure: 0.00 psi

Average Q: 18.7 gpm  
 Excess Pore pressure: 30.85 psi

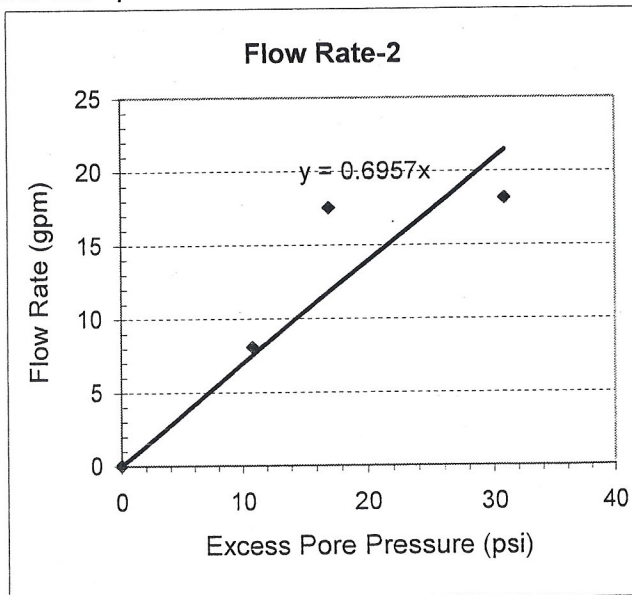
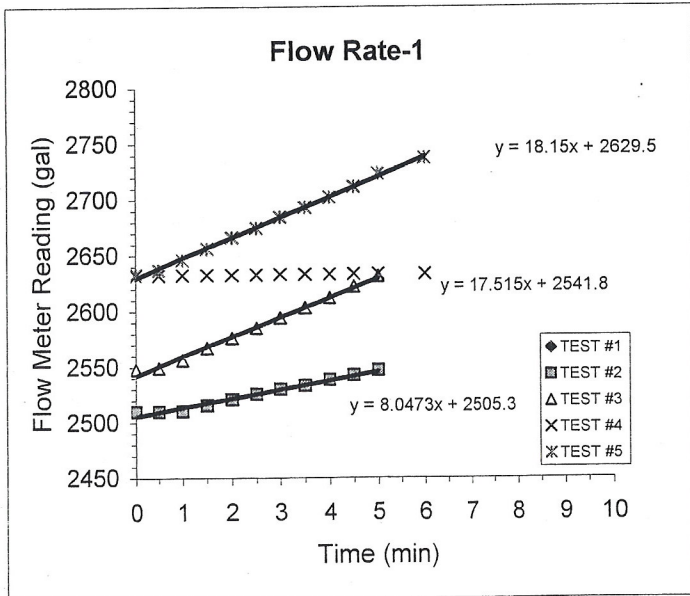

obtain Q from graph 2 in gpm/psi --> 0.6957 gal/psi

$$k_e = Q^* \ln(R/r_0) / (2\pi L H_0)$$

$$k_e = 2.22E-03 \text{ cm/sec} = 2293.17 \text{ ft/year}$$

**Pressure Decay Test**

Project Name: NORTH ANNA COL  
 Project Number: 6468-06-1472  
 Date: 8/16/2006  
 Boring No: B-949  
 Test Interval: 94.5 ft to 99.5 ft (from surface)

Prepared by: ZI Date: 12-7-06  
 Checked by: *[Signature]* Date: 1-17-07

Test #1			Test #2			Test #3		
Time (min)	Surface Gauge (psi)	Center Tranducer (psi)	Time (min)	Surface Gauge (psi)	Center Tranducer (psi)	Time (min)	Surface Gauge (psi)	Center Tranducer (psi)
Test not conducted			0.0	3.4	43.62	0.0	32.2	49.78
			0.5	-8.4	35.31	0.5	-3.8	38.94
			1.0	-8.3	34.66	1.0	-5.6	37.32
			1.5	-8.7	34.18	1.5	-6.6	36.22
			2.0	-9	33.88	2.0	-7.2	35.66
			2.5	-9.2	33.68	2.5	-7.8	35.12
			3.0	-9.4	33.52	3.0	-8.1	34.79
			3.5	-9.5	33.39	3.5	-8.5	34.50
			4.0	-9.6	33.31	4.0	-8.7	34.28
			4.5	-9.7	33.21	4.5	-8.8	
			5.0	-9.8	33.15	5.0	-9	33.95
			5.5	-9.9	33.1	5.5	-9.1	33.82
			6.0	-9.9	33.05	6.0	-9.2	33.69
			6.5	-9.9	33.02	6.5	-9.3	33.60
			7.0	-10.0	32.98	7.0	-9.4	33.53
			7.5	-10.0	32.95	7.5	-9.5	33.47
		8.0	-10.0	32.93	8.0	-9.5	33.40	
					8.5	-9.6	33.34	
					9.0	-9.7	33.3	
					9.5	-9.7	33.26	

Test #4			Test #5		
Time (min)	Surface Gauge (psi)	Center Tranducer (psi)	Time (min)	Surface Gauge (psi)	Center Tranducer (psi)
0.0	-9.4	33.34	0.0	33.1	63.86
0.5	-9.8	33	0.5	-1.9	40.86
1.0	-9.9	32.95	1.0	-3.8	38.92
1.5	-9.9	32.92	1.5	-5.7	37.40
2.0	-9.9	32.9	2.0	-6.3	36.56
2.5	-9.9	32.89	2.5	-7.0	35.92
3.0	-9.9	32.88	3.0	-7.5	35.37
3.5	-9.9	32.88	3.5	-7.8	35.08
4.0	-9.9	32.87	4.0	-8.1	34.78
4.5	-10	32.86	4.5	-8.3	34.55
5.0	-9.9	32.85	5.0	-8.5	34.35
			5.5	-8.7	34.18
			6.0	-8.8	34.05
			6.5	-9.0	33.92
			7	-9.1	33.83
			7.5	-9.2	33.74
			8	-9.3	33.67
			8.5	-9.3	33.59
			9	-9.4	33.52

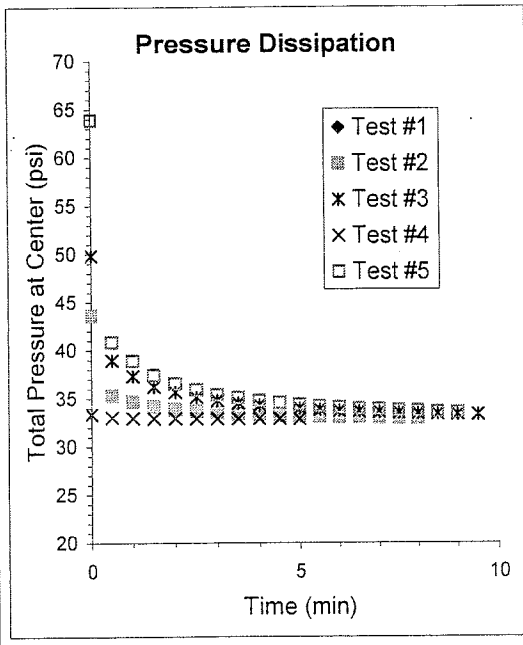

84.0      89.0  
 1.6      1.6  
 85.6      90.6

JGJ  
 12-5-06

PACKER TESTING CALCULATIONS FOR P(MAX)

Date: 8-16-06

Boring No. B949

Test Interval: 85.6 to 90.6 feet from Datum

Casing Stickup 1.6 feet

PoMAX = (h<sub>1</sub> x 1) + (h<sub>2</sub> x 0.57). h<sub>1</sub> and h<sub>2</sub> are in feet, see sketch. PoMAX is in psi

h<sub>1</sub> = Distance from the datum to the water level

h<sub>2</sub> = Distance from the water level to the center of the test interval

h<sub>1</sub> = 23.0

h<sub>2</sub> = 88.1 - 23.0 = 65.1

P MAX = 23.0 + 37.1 = 60.1

SKETCH

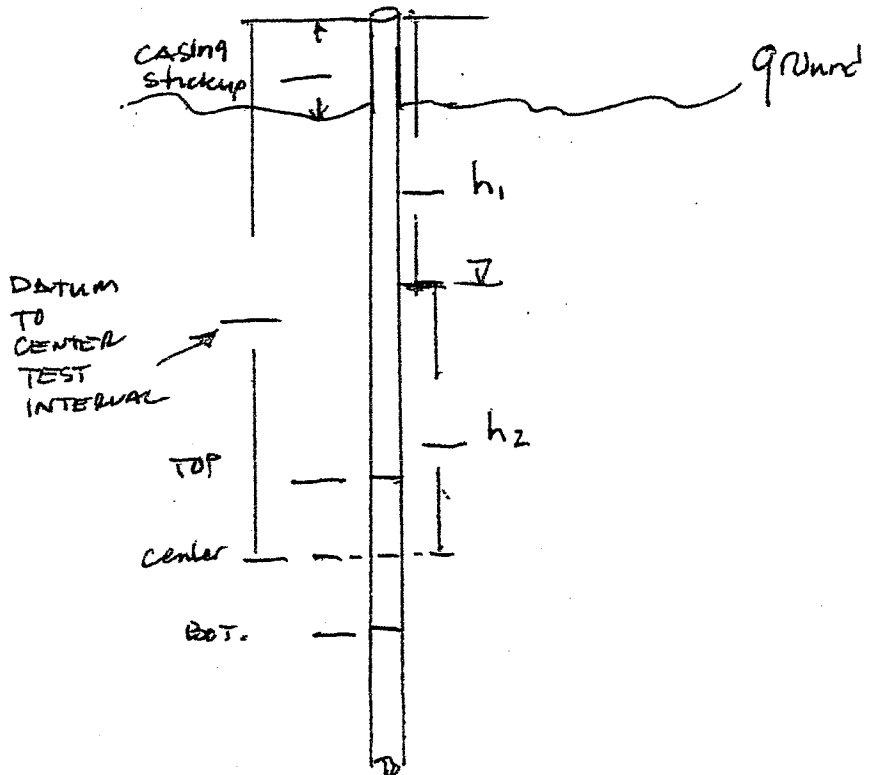

## DOUBLE PACKER BOREHOLE PERMEABILITY TEST DATA SHEET

MACTEC ENGINEERING AND CONSULTING, INC.

PROJECT: NORTH ANNA COL PROJECT NO.: 6468-06-1472

*JH 2*  
*12-5-06*

DATA COLLECTED BY: Stonard DATE COLLECTED: 8-16-06

BORING NO. B949 BOREHOLE DIAMETER: 4 IN.

SURFACE CASING HEIGHT ABOVE GROUND: 1.6 FT.

CHECK DATUM USED: TOP OF CASING X GROUND SURFACE     

DATUM ELEVATION NA

DISTANCE BOTTOM OF TOP PACKER TO TOP OF BOTTOM PACKER 5.0 FT.

TEST INTERVAL DEPTH (FROM DATUM): FROM 85.6 FT. TO 90.6 FT.

TOTAL BORING DEPTH FROM DATUM: 108.0 FT.

(A) DEPTH TO WATER TABLE FROM DATUM: 23.0 FT.

(B) SURFACE GAUGE HEIGHT ABOVE DATUM: 1.0 FT.

(C) DISTANCE WATER TABLE TO CENTER OF TEST INTERVAL: 65.1 FT.

1/3

MAXIMUM TEST PRESSURE,  $P_0$  60.1 ( $P_0 = [(A+B) * 1] + C * .57$  psi)

TEST NUMBER: 1 TEST PRESSURE 19.8 psi PACKER PRESSURE: 100 psi

Initial Transducer Readings: Top 3.06, Middle 28.43, Bottom 31.18

Transducer Readings after initial pressurization:

Top         , Middle         , Bottom         

Transducer Readings after final flow measurement:

Top         , Middle         , Bottom         

TIME (MIN)	FLOW METER READING, (GAL)	Q (GPM)	SURFACE GAUGE, PSI	REMARKS

Test was not performed due to the natural test pressure being higher than test pressure  
JH  
8-17

84.0      89.0  
1.6      1.6  
85.6      90.6

*JGJ*  
12-5-06

PACKER TESTING CALCULATIONS FOR P(MAX)

Date: 8-16-06

Boring No. B949

Test Interval: 85.6 to 90.6 feet from Datum

Casing Stickup 1.6 feet

PoMAX = (h<sub>1</sub> x 1) + (h<sub>2</sub> x 0.57). h<sub>1</sub> and h<sub>2</sub> are in feet, see sketch. PoMAX is in psi

h<sub>1</sub> = Distance from the datum to the water level

h<sub>2</sub> = Distance from the water level to the center of the test interval

h<sub>1</sub> = 23.0

h<sub>2</sub> = 88.1 - 23.0 = 65.1

P MAX = 23.0 + 37.1 = 60.1

SKETCH

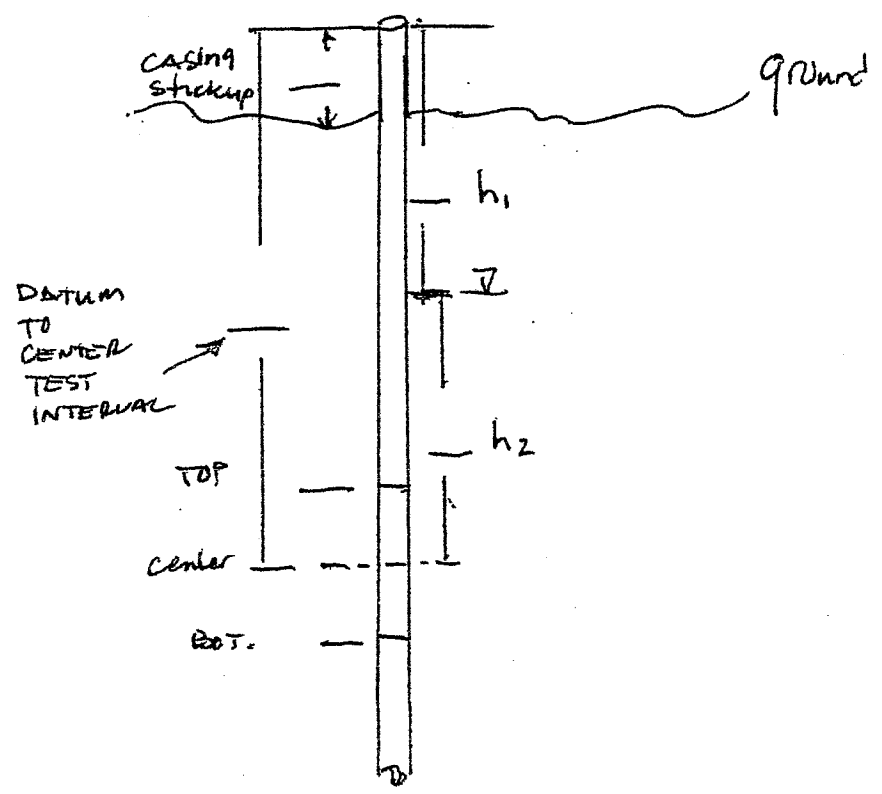

DOUBLE PACKER BOREHOLE PERMEABILITY TEST DATA SHEET

*JH*  
12-5-06

MACTEC ENGINEERING AND CONSULTING, INC.

PROJECT: NORTH ANNA COL PROJECT NO.: 6468-06-1472

DATA COLLECTED BY: J Howard DATE COLLECTED: 8-16-06

BORING NO. B949 BOREHOLE DIAMETER: 4 IN.

SURFACE CASING HEIGHT ABOVE GROUND: 1.6 FT.

CHECK DATUM USED: TOP OF CASING  GROUND SURFACE

DATUM ELEVATION NA

DISTANCE BOTTOM OF TOP PACKER TO TOP OF BOTTOM PACKER 5.0 FT.

TEST INTERVAL DEPTH (FROM DATUM): FROM 85.6 FT. TO 90.6 FT.

TOTAL BORING DEPTH FROM DATUM: 108.0 FT.

(A) DEPTH TO WATER TABLE FROM DATUM: 23.0 FT.

(B) SURFACE GAUGE HEIGHT ABOVE DATUM: 1.0 FT.

(C) DISTANCE WATER TABLE TO CENTER OF TEST INTERVAL: 65.1 FT.

*2/3*

MAXIMUM TEST PRESSURE,  $P_o$  60.1 ( $P_o = [(A+B) * 1] + C * .57$  psi)

TEST NUMBER: 2 TEST PRESSURE 39.66 psi PACKER PRESSURE: 100 psi

Initial Transducer Readings: Top 3.06, Middle 28.43, Bottom 31.18

Transducer Readings after initial pressurization:  
Top 3.16, Middle 28.58, Bottom 31.23

Transducer Readings after final flow measurement:  
Top 2.99, Middle 28.41, Bottom 31.21

TIME (MIN)	FLOW METER READING, (GAL)	Q (GPM)	SURFACE GAUGE, PSI	REMARKS
0.0	2752.2	/	0.2	
0.5	2752.6	.8	7.3	
1.0	2753.2	1.2	10.1	
1.5	2753.5	.6	5.8	
2.0	2753.7	.4	8.5	
2.5	2754.1	.8	8.8	
3.0	2754.5	.8	10.4	
3.5	2754.8	.6	9.1	
4.0	2754.9	.2	8.2	
4.5	2755.2	.6	8.3	
5.0	2755.4	.4	8.2	
6.0	2755.9	1.0	8.3	

**DOUBLE PACKER BOREHOLE PERMEABILITY TEST DATA SHEET**

MACTEC ENGINEERING AND CONSULTING, INC.

PROJECT: NORTH ANNA COL PROJECT NO.: 6468-06-1472

*JA 2*  
*8-16-06*

DATA COLLECTED BY: Howard DATE COLLECTED: 8-16-06

BORING NO. B949 BOREHOLE DIAMETER: 4 IN.

SURFACE CASING HEIGHT ABOVE GROUND: 1.6 FT.

CHECK DATUM USED: TOP OF CASING  GROUND SURFACE

DATUM ELEVATION NA

DISTANCE BOTTOM OF TOP PACKER TO TOP OF BOTTOM PACKER 5.0 FT.

TEST INTERVAL DEPTH (FROM DATUM): FROM 85.6 FT. TO 90.6 FT.

TOTAL BORING DEPTH FROM DATUM: 108.0 FT.

(A) DEPTH TO WATER TABLE FROM DATUM: 23.0 FT.

(B) SURFACE GAUGE HEIGHT ABOVE DATUM: 1.0 FT.

(C) DISTANCE WATER TABLE TO CENTER OF TEST INTERVAL: 65.1 FT.

MAXIMUM TEST PRESSURE,  $P_o$  60.1 ( $P_o = [(A+B) * 1] + C * .57$  psi)

*1/3*

TEST NUMBER: 1 TEST PRESSURE 19.8 psi PACKER PRESSURE: 100 psi

Initial Transducer Readings: Top 3.06, Middle 28.43, Bottom 31.18

Transducer Readings after initial pressurization:  
Top \_\_\_\_\_, Middle \_\_\_\_\_, Bottom \_\_\_\_\_

Transducer Readings after final flow measurement:  
Top \_\_\_\_\_, Middle \_\_\_\_\_, Bottom \_\_\_\_\_

TIME (MIN)	FLOW METER READING, (GAL)	Q (GPM)	SURFACE GAUGE, PSI	REMARKS

Test was not performed due to the natural Test pressure being higher than Test pressure

DOUBLE PACKER TEST DATA SHEET, MACTEC PROJECT NO. 6468-06-1472

BORING NO.: B949

DATE: 8-16-06

TEST NUMBER: 2

TEST INTERVAL (FROM DATUM): FROM 85.6 FT. TO 90.6 FT.

DATA COLLECTED BY: S. Howell

*2*  
*12-T-06*

SHUT-IN TEST

PRESSURE: \_\_\_\_\_ psi

TIME, MIN	SURFACE GAUGE PRESSURE, PSI	MIDDLE TRANSDUCER PRESSURE, PSI
0.0	8.3	39.53
0.5	3.5	33.58
1.0	2.5	31.56
1.5	1.7	33.39
2.0	1.2	29.58
2.5	0.9	29.09
3.0	0.8	28.84
3.5	0.6	28.57
4.0	0.6	28.57
4.5	0.5	28.48
5.0	0.5	28.45
5.5	0.5	28.44
6.0	0.5	28.43
6.5	0.5	28.42

EQUIPMENT USED

Transducers: Mini Troll Serial Numbers: 10417 (Top), 10191 (Middle), 10036 (Bottom)  
 Surface Pressure Gauge: Omega DPG serial number 2634708001  
 Flow Meter Omega FTB-4110 serial number 32019518  
 Stop Watch: serial number SW1

Above calibrated 5-5-06 or 5-18-06

Tests: B949-M285-90  
 " B285 "  
 " T285 "



**DOUBLE PACKER BOREHOLE PERMEABILITY TEST DATA SHEET**

*JHJ*  
*12-5-06*

MACTEC ENGINEERING AND CONSULTING, INC.

PROJECT: NORTH ANNA COL PROJECT NO.: 6468-06-1472

DATA COLLECTED BY: S Howard DATE COLLECTED: 8-16-06

BORING NO. B948 BOREHOLE DIAMETER: 4 IN.

SURFACE CASING HEIGHT ABOVE GROUND: 1.6 FT.

CHECK DATUM USED: TOP OF CASING X GROUND SURFACE     

DATUM ELEVATION NA

DISTANCE BOTTOM OF TOP PACKER TO TOP OF BOTTOM PACKER 5.0 FT.

TEST INTERVAL DEPTH (FROM DATUM): FROM 85.6 FT. TO 90.6 FT.

TOTAL BORING DEPTH FROM DATUM: 108.0 FT.

(A) DEPTH TO WATER TABLE FROM DATUM: 27.0 FT.

(B) SURFACE GAUGE HEIGHT ABOVE DATUM: 1.0 FT.

(C) DISTANCE WATER TABLE TO CENTER OF TEST INTERVAL: 63.1 FT.

MAXIMUM TEST PRESSURE,  $P_o$  60.1 ( $P_o = [(A+B) * 1] + C * .57$  psi)

TEST NUMBER: 3 TEST PRESSURE 60.1 psi PACKER PRESSURE: 100 psi

Initial Transducer Readings: Top 3.06, Middle 28.43, Bottom 31.18

Transducer Readings after initial pressurization:  
Top 2.99, Middle 28.41, Bottom 31.21

Transducer Readings after final flow measurement:  
Top 2.95, Middle 28.42, Bottom 31.22

TIME (MIN)	FLOW METER READING, (GAL)	Q (GPM)	SURFACE GAUGE, PSI	REMARKS
0.0	27 56.0	/	.4	
0.5	27 57.5	3.0	26.0	
1.0	27 58.7	2.4	27.4	
1.5	27 59.6	1.8	27.7	
2.0	27 60.6	2.0	25.5	
2.5	27 61.5	1.8	25.3	
3.0	27 62.1	1.2	24.8	
3.5	27 62.9	1.6	24.2	
4.0	27 63.7	1.6	24.0	
4.5	27 64.5	1.6	23.7	
5.0	27 65.3	1.6	23.6	
6.0	27 67.2	1.8	23.6	

BORING NO.: B949

DATE: 8-16-06

TEST NUMBER: 3

TEST INTERVAL (FROM DATUM): FROM 85.6 FT. TO 90.6 FT.

DATA COLLECTED BY: J Howard

*Jed*  
*12-5-06*

SHUT-IN TEST

PRESSURE: \_\_\_\_\_ psi

TIME, MIN	SURFACE GAUGE PRESSURE, PSI	MIDDLE TRANSDUCER PRESSURE, PSI
0.0	23.6	60.15
0.5	3.0	37.42
1.0	1.6	34.87
1.5	.5	32.94
2.0	0	31.56
2.5	-.6	30.56
3.0	-1.1	29.77
3.5	-1.4	29.30
4.0	-1.7	28.99
4.5	-1.6	28.76
5.0	-1.8	28.66
5.5	-1.9	28.57
6.0	-1.9	28.52
6.5	-1.9	28.48

EQUIPMENT USED

- Transducers: Mini Troll Serial Numbers: 10417 (Top), 10191 (Middle), 10036 (Bottom)
- Surface Pressure Gauge: Omega DPG serial number 2634708001
- Flow Meter Omega FTB-4110 serial number 32019518
- Stop Watch: serial number SW1

Above calibrated 5-5-06 or 5-18-06

Tests: B949 - M385 - 90  
          "      B385   "  
          "      T385   "

DOUBLE PACKER BOREHOLE PERMEABILITY TEST DATA SHEET

*Jan 12-5-06*

MACTEC ENGINEERING AND CONSULTING, INC.

PROJECT: NORTH ANNA COL PROJECT NO.: 6468-06-1472

DATA COLLECTED BY: S Howard DATE COLLECTED: 8-16-06

BORING NO. B 949 BOREHOLE DIAMETER: 4 IN.

SURFACE CASING HEIGHT ABOVE GROUND: 1.6 FT.

CHECK DATUM USED: TOP OF CASING  GROUND SURFACE

DATUM ELEVATION na

DISTANCE BOTTOM OF TOP PACKER TO TOP OF BOTTOM PACKER 5.0 FT.

TEST INTERVAL DEPTH (FROM DATUM): FROM 85.6 FT. TO 90.6 FT.

TOTAL BORING DEPTH FROM DATUM: 108.0 FT.

(A) DEPTH TO WATER TABLE FROM DATUM: 23.0 FT.

(B) SURFACE GAUGE HEIGHT ABOVE DATUM: 1.0 FT.

(C) DISTANCE WATER TABLE TO CENTER OF TEST INTERVAL: 65.1 FT.

MAXIMUM TEST PRESSURE,  $P_o$  <sup>65.1</sup> 32.5 <sup>27 8-16</sup> (Po = [(A+B) \* 1] + C \* .57 psi)

TEST NUMBER: 4 TEST PRESSURE <sup>27 8-16</sup> 30.0 psi PACKER PRESSURE: 100 psi

Initial Transducer Readings: Top 3.06, Middle 28.43, Bottom 31.18

Transducer Readings after initial pressurization:

Top 2.95, Middle 28.42, Bottom 31.22

Transducer Readings after final flow measurement:

Top 2.95, Middle 28.45, Bottom 31.22

TIME (MIN)	FLOW METER READING, (GAL)	Q (GPM)	SURFACE GAUGE, PSI	REMARKS
0.0	2767.2	/	-2.0	
0.5	2767.2	∅	-1.0	
1.0	2767.2	∅	-0.8	
1.5	2767.2	∅	-0.8	
2.0	2767.2	∅	-0.5	
2.5	2767.2	∅	-0.4	
3.0	2767.2	∅	-0.6	
3.5	2767.2	∅	-0.6	
4.0	2767.2	∅	-0.6	
4.5	2767.2	∅	-0.6	
5.0	2767.2	∅	-0.6	

Flow during this test was lower than the Flowmeter could read

DOUBLE PACKER TEST DATA SHEET, MACTEC PROJECT NO. 6468-06-1472

BORING NO.: B949

DATE: 8-16-06

TEST NUMBER: 4

TEST INTERVAL (FROM DATUM): FROM 85.6 FT. TO 90.6 FT.

DATA COLLECTED BY: J Howard

*Jan 12-2006*

SHUT-IN TEST

PRESSURE: \_\_\_\_\_ psi

TIME, MIN	SURFACE GAUGE PRESSURE, PSI	MIDDLE TRANSDUCER PRESSURE, PSI
0.0	-1.6	29.14
0.5	-1.4	29.64
1.0	-1.4	29.15
1.5	-1.6	28.84
2.0	-1.7	28.67
2.5	-1.8	28.56
3.0	-1.9	28.50
3.5	-1.9	28.47
4.0	-1.9	28.45
4.5	-1.9	28.44
5.0	-1.9	28.43
5.5	-1.9	28.43
6.0	-1.9	28.43

EQUIPMENT USED

Transducers: Mini Troll Serial Numbers: 10417 (Top), 10191 (Middle), 10036 (Bottom)  
 Surface Pressure Gauge: Omega DPG serial number 2634708001  
 Flow Meter Omega FTB-4110 serial number 32019518  
 Stop Watch: serial number SW1

Above calibrated 5-5-06 or 5-18-06

*Tests: B949-M485-90  
 " B485 "  
 " T485 "*

DOUBLE PACKER BOREHOLE PERMEABILITY TEST DATA SHEET

*Jed*  
12-5-06

MACTEC ENGINEERING AND CONSULTING, INC.

PROJECT: NORTH ANNA COL PROJECT NO.: 6468-06-1472

DATA COLLECTED BY: S Howard DATE COLLECTED: 8-16-06

BORING NO. B 949 BOREHOLE DIAMETER: 4 IN.

SURFACE CASING HEIGHT ABOVE GROUND: 1.6 FT.

CHECK DATUM USED: TOP OF CASING X GROUND SURFACE     

DATUM ELEVATION NA

DISTANCE BOTTOM OF TOP PACKER TO TOP OF BOTTOM PACKER 5.0 FT.

TEST INTERVAL DEPTH (FROM DATUM): FROM 85.0 FT. TO 90.6 FT.

TOTAL BORING DEPTH FROM DATUM: 108.0 FT.

(A) DEPTH TO WATER TABLE FROM DATUM: 23.0 FT.

(B) SURFACE GAUGE HEIGHT ABOVE DATUM: 1.0 FT.

(C) DISTANCE WATER TABLE TO CENTER OF TEST INTERVAL: 65.1 FT.

MAXIMUM TEST PRESSURE,  $P_o$  60.1 ( $P_o = [(A+B) * 1] + C * .57$  psi)

TEST NUMBER: 5 TEST PRESSURE 60.1 psi PACKER PRESSURE: 100 psi

Initial Transducer Readings: Top 3.06, Middle 28.13, Bottom 31.18

Transducer Readings after initial pressurization:  
Top 2.95, Middle 28.41, Bottom 31.22

Transducer Readings after final flow measurement:  
Top 2.95, Middle 28.45, Bottom 31.25

TIME (MIN)	FLOW METER READING, (GAL)	Q (GPM)	SURFACE GAUGE, PSI	REMARKS
0.0	2767.3	/	2.0	
0.5	2768.6	2.6	25.6	
1.0	2769.6	2.0	23.4	
1.5	2770.4	1.6	23.9	
2.0	2771.2	1.6	24.0	
2.5	2772.0	1.6	23.7	
3.0	2772.7	1.4	23.4	
3.5	2773.4	1.4	23.4	
4.0	2774.2	1.6	23.3	
4.5	2775.0	4.8208	23.2	
5.0	2775.7	2.2	23.2	
6.0	2777.2	1.0	22.9	

DOUBLE PACKER TEST DATA SHEET, MACTEC PROJECT NO. 6468-06-1472

PAGE 3

BORING NO.: B949

DATE: 8-16-06

TEST NUMBER: TSB816 5

TEST INTERVAL (FROM DATUM): FROM 85.5 FT. TO 90.5 FT.

DATA COLLECTED BY: J. Howell

*J. Howell*  
12-5-06

SHUT-IN TEST

PRESSURE: \_\_\_\_\_ psi

TIME, MIN	SURFACE GAUGE PRESSURE, PSI	MIDDLE TRANSDUCER PRESSURE, PSI
0.0	22.9	60.19
0.5	4.3	40.08
1.0	1.0	35.98
1.5	-1.0	33.40
2.0	-1.8	31.61
2.5	-2.6	30.48
3.0	-3.0	29.75
3.5	-3.3	29.28
4.0	-3.5	29.01
4.5	-3.6	28.78
5.0	-3.7	28.68
5.5	-3.7	28.61
6.0	-3.7	28.57
6.5	-3.7	28.52
7.0	-3.8	28.50
7.5	-3.8	28.48
8.0	-3.7	28.518

EQUIPMENT USED

- Transducers: Mini Troll Serial Numbers: 10417 (Top), 10191 (Middle), 10036 (Bottom)
- Surface Pressure Gauge: Omega DPG serial number 2634708001
- Flow Meter Omega FTB-4110 serial number 32019518
- Stop Watch: serial number SW1

Above calibrated 5-5-06 or 5-18-06  
 Tests: B949-M585-90  
           " - T585 - 11  
           " - B585 - 11

J.S.  
12-5-06

# PACKER TESTING CALCULATIONS FOR P(MAX)

Date: 8-16-06

Boring No. B949

Test Interval: 95.6 to 90.6 feet from Datum

Casing Stickup 1.6 feet

PoMAX =  $(h_1 \times 1) + (h_2 \times 0.57)$ .  $h_1$  and  $h_2$  are in feet, see sketch. PoMAX is in psi

$h_1$  = Distance from the datum to the water level

$h_2$  = Distance from the water level to the center of the test interval

---

$$h_1 = \underline{23.0}$$

$$h_2 = \underline{93.1} - \underline{23.0} = \underline{70.1}$$

$$P_{MAX} = \underline{23.0} + \underline{39.96} = \underline{62.9}$$

24.0  
 $93.1 - 23.0 = 70.1$   
24.

63.9

## SKETCH

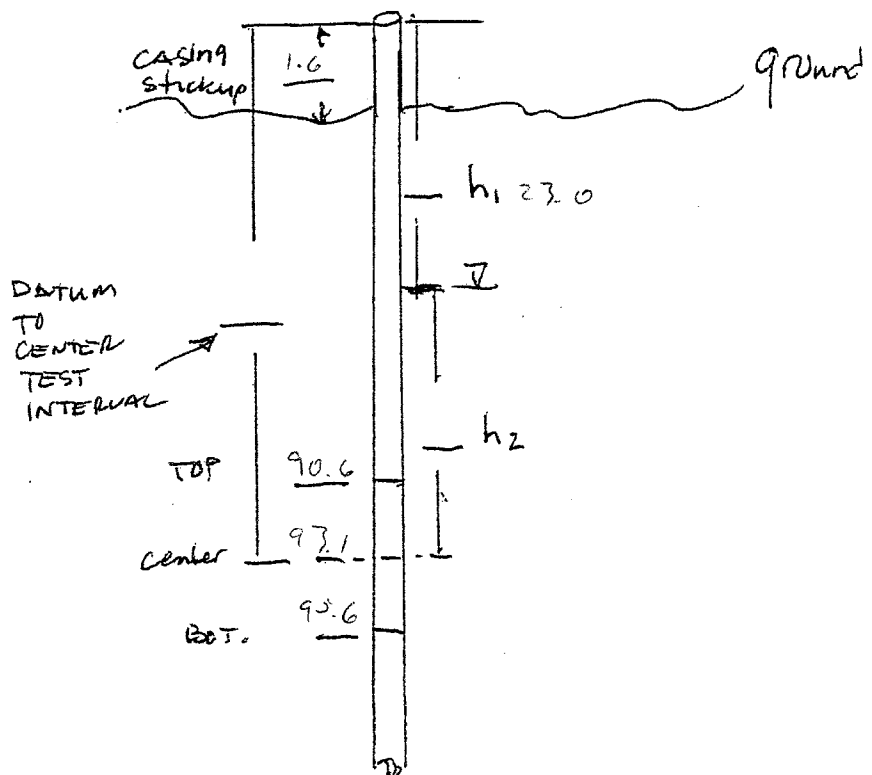

**DOUBLE PACKER BOREHOLE PERMEABILITY TEST DATA SHEET**

*JH*  
12-5-06

MACTEC ENGINEERING AND CONSULTING, INC.

PROJECT: NORTH ANNA COL PROJECT NO.: 6468-06-1472

DATA COLLECTED BY: S Howard DATE COLLECTED: 8-18-06

BORING NO. B 949 BOREHOLE DIAMETER: 4 IN.

SURFACE CASING HEIGHT ABOVE GROUND: 1.6 FT.

CHECK DATUM USED: TOP OF CASING X GROUND SURFACE     

DATUM ELEVATION NA

DISTANCE BOTTOM OF TOP PACKER TO TOP OF BOTTOM PACKER 5.0 FT.

TEST INTERVAL DEPTH (FROM DATUM): FROM 95.6 FT. TO 90.6 FT.

TOTAL BORING DEPTH FROM DATUM: 108.0 FT.

(A) DEPTH TO WATER TABLE FROM DATUM: 23.0 FT.

(B) SURFACE GAUGE HEIGHT ABOVE DATUM: -1.8 FT. <sup>8-16</sup>

(C) DISTANCE WATER TABLE TO CENTER OF TEST INTERVAL: 70.1 FT.

MAXIMUM TEST PRESSURE,  $P_0$  62.9 ( $P_0 = [(A+B) * 1] + C * .57$  psi)

TEST NUMBER: 1 TEST PRESSURE 20.7 psi PACKER PRESSURE: 100 psi

Initial Transducer Readings: Top 3.22, Middle 30.62, Bottom 33.42

Transducer Readings after initial pressurization:  
Top \_\_\_\_\_, Middle \_\_\_\_\_, Bottom \_\_\_\_\_

Transducer Readings after final flow measurement:  
Top \_\_\_\_\_, Middle \_\_\_\_\_, Bottom \_\_\_\_\_

1/3

TIME (MIN)	FLOW METER READING, (GAL)	Q (GPM)	SURFACE GAUGE, PSI	REMARKS

Test Couldn't be done due to the natural pressure being greater than the test pressure



BORING NO.: B949

DATE: 8-17-06

TEST NUMBER: 2

TEST INTERVAL (FROM DATUM): FROM 95.6 FT. TO 90.6 FT.

DATA COLLECTED BY: Howard

2  
JY  
12-5-06

SHUT-IN TEST

PRESSURE: \_\_\_\_\_ psi

TIME, MIN	SURFACE GAUGE PRESSURE, PSI	MIDDLE TRANSDUCER PRESSURE, PSI
0.0	7.9	41.44
0.5	5.3	38.11
1.0	3.9	36.29
1.5	2.9	34.95
2.0	2.4	33.94
2.5	1.8	33.18
3.0	1.5	32.65
3.5	1.2	32.14
4.0	1.0	31.80
4.5	0.8	31.52
5.0	.7	31.29
5.5	.6	31.12
6.0	.5	30.97
6.5	.4	30.89
	.4	30.81
	.3	30.76
	.3	30.72
	.3	30.70

EQUIPMENT USED

Transducers: Mini Troll Serial Numbers: 10417 (Top), 10191 (Middle), 10036 (Bottom)  
 Surface Pressure Gauge: Omega DPG serial number 2634708001  
 Flow Meter Omega FTB-4110 serial number 32019518  
 Stop Watch: serial number SW1

Above calibrated 5-5-06 or 5-18-06

Tests: B949-MZ 90.6-95.6  
 " BZ "  
 " TZ "

DOUBLE PACKER BOREHOLE PERMEABILITY TEST DATA SHEET

*AD*  
12-5-06

MACTEC ENGINEERING AND CONSULTING, INC.

PROJECT: NORTH ANNA COL PROJECT NO.: 6468-06-1472

DATA COLLECTED BY: S Howard DATE COLLECTED: 8-17-06

BORING NO. B949 BOREHOLE DIAMETER: 4 IN.

SURFACE CASING HEIGHT ABOVE GROUND: 1.6 FT.

CHECK DATUM USED: TOP OF CASING  GROUND SURFACE

DATUM ELEVATION NA

DISTANCE BOTTOM OF TOP PACKER TO TOP OF BOTTOM PACKER 5.0 FT.

TEST INTERVAL DEPTH (FROM DATUM): FROM 95.6 FT. TO 90.6 FT.

TOTAL BORING DEPTH FROM DATUM: 95.6 FT. <sup>248-16</sup> 108.0

(A) DEPTH TO WATER TABLE FROM DATUM: 23.0 FT.

(B) SURFACE GAUGE HEIGHT ABOVE DATUM: 1.6 FT. <sup>g/r</sup> 1.0 FT.

(C) DISTANCE WATER TABLE TO CENTER OF TEST INTERVAL: 70.1 FT.

2/  
13

MAXIMUM TEST PRESSURE,  $P_o$  62.9 ( $P_o = [(A+B) * 1] + C * .57$  psi)

TEST NUMBER: 2 TEST PRESSURE 41.5 psi PACKER PRESSURE: 100 psi

Initial Transducer Readings: Top 3.22, Middle 30.62, Bottom 33.42

Transducer Readings after initial pressurization:  
Top 3.19, Middle 30.69, Bottom 33.43

Transducer Readings after final flow measurement:  
Top 3.12, Middle 30.36, Bottom 33.47

TIME (MIN)	FLOW METER READING, (GAL)	Q (GPM)	SURFACE GAUGE, PSI	REMARKS
0.0	27 41.0	/	-0.2	
0.5	27 41.4	.8	8.2	
1.0	27 41.6	.4	7.6	
1.5	27 41.6	Ø	7.6	
2.0	27 41.6	Ø	7.9	
2.5	27 41.6	Ø	7.9	
3.0	27 41.6	Ø	7.9	
3.5	27 41.6	Ø	8.1	
4.0	27 41.6	Ø	7.9	
4.5	27 41.6	Ø	8.0	
5.0	27 41.6	Ø	7.9	
6.0				

**DOUBLE PACKER BOREHOLE PERMEABILITY TEST DATA SHEET**

MACTEC ENGINEERING AND CONSULTING, INC.

*JOZ*  
12-5-06

PROJECT: NORTH ANNA COL PROJECT NO.: 6468-06-1472

DATA COLLECTED BY: S Howard DATE COLLECTED: 8-12-06

BORING NO. B949 BOREHOLE DIAMETER: 4 IN.

SURFACE CASING HEIGHT ABOVE GROUND: 1.6 FT.

CHECK DATUM USED: TOP OF CASING  GROUND SURFACE

DATUM ELEVATION NA

DISTANCE BOTTOM OF TOP PACKER TO TOP OF BOTTOM PACKER 5.0 FT.

TEST INTERVAL DEPTH (FROM DATUM): FROM 95.6 FT. TO 90.6 FT.

TOTAL BORING DEPTH FROM DATUM: 108.0 FT.

(A) DEPTH TO WATER TABLE FROM DATUM: 23.0 FT.

(B) SURFACE GAUGE HEIGHT ABOVE DATUM: 1.0 FT.

(C) DISTANCE WATER TABLE TO CENTER OF TEST INTERVAL: 70.1 FT.

MAXIMUM TEST PRESSURE,  $P_0$  62.9 ( $P_0 = [(A+B) * 1] + C * .57$  psi)

TEST NUMBER: 3 TEST PRESSURE 62.9 psi PACKER PRESSURE: 100 psi

Initial Transducer Readings: Top 3.22, Middle 30.62, Bottom 33.42

Transducer Readings after initial pressurization:

Top 3.12, Middle 30.63, Bottom 33.47

Transducer Readings after final flow measurement:

Top 3.03, Middle 30.70, Bottom 33.40

TIME (MIN)	FLOW METER READING, (GAL)	Q (GPM)	SURFACE GAUGE, PSI	REMARKS
0.0	27 41.6	/	0.0	
0.5	27 43.0	2.8	26.0	
1.0	27 43.5	1.0	27.1	
1.5	27 43.9	.8	26.8	
2.0	27 44.1	.4	25.0	
2.5	27 44.4	.6	25.7	
3.0	27 44.7	.6	26.0	
3.5	27 45.0	.6	26.0	
4.0	27 45.3	.6	25.7	
4.5	27 45.5	.4	25.5	
5.0	27 45.8	.6	25.5	
6.0	27 46.3	1.0	24.7	
7.0	27 46.8	1.0	26.1	

DOUBLE PACKER TEST DATA SHEET, MACTEC PROJECT NO. 6468-06-1472

BORING NO: B944

DATE: 8-15-06 17 ~~27~~

TEST NUMBER: 3

TEST INTERVAL (FROM DATUM): FROM 95.6 FT. TO 90.6 FT.

DATA COLLECTED BY: J Howard

*JCH*  
*12-5-06*

TIME (MIN)	FLOW METER READING, (GAL)	Q (GPM)	SURFACE GAUGE, PSI	REMARKS
8.0	2747.3	1.0	26.4	
9.0	2747.7	.8	26.4	
10.0	2748.3	1.2	26.1	

BORING NO.: B949

DATE: 8-18-06

TEST NUMBER: 3

TEST INTERVAL (FROM DATUM): FROM 90.6 FT. TO 90.6 FT.

DATA COLLECTED BY: S. Homan

*JH*  
12-5-06

SHUT-IN TEST

PRESSURE: \_\_\_\_\_ psi

TIME, MIN	SURFACE GAUGE PRESSURE, PSI	MIDDLE TRANSDUCER PRESSURE, PSI
0.0	26.1	64.72
.5	13.1	49.20
1.0	8.9	45.02
1.5	5.3	40.65
2.0	3.5	38.29
2.5	2.0	36.29
3.0	1.4	35.32
3.5	.6	34.24
4.0	.2	33.54
4.5	-.1	32.98
5.0	-.5	32.46
5.5	-.7	32.05
6.0	-1.0	31.52
6.5	-1.2	31.33
7.0	-1.2	31.19
7.5	-1.3	31.10
8.0	-1.4	31.02
8.5	-1.4	30.91
9.0	-1.5	30.85
9.5	-1.5	30.82
10.0	-1.5	30.79

EQUIPMENT USED

Transducers: Mini Troll Serial Numbers: 10417 (Top), 10191 (Middle), 10036 (Bottom)

Surface Pressure Gauge: Omega DPG serial number 2634708001

Flow Meter Omega FTB-4110 serial number 32019518

Stop Watch: serial number SW1

Above calibrated 5-5-06 or 5-18-06

Tests: B949-M390-95  
 " B390 "  
 " T390 "

**DOUBLE PACKER BOREHOLE PERMEABILITY TEST DATA SHEET**

*JHJ*  
125-06

MACTEC ENGINEERING AND CONSULTING, INC.

PROJECT: NORTH ANNA COL PROJECT NO.: 6468-06-1472

DATA COLLECTED BY: T Howard DATE COLLECTED: 8-18-06

BORING NO. B94a BOREHOLE DIAMETER: 4 IN.

SURFACE CASING HEIGHT ABOVE GROUND: 1.6 FT.

CHECK DATUM USED: TOP OF CASING  GROUND SURFACE

DATUM ELEVATION NA

DISTANCE BOTTOM OF TOP PACKER TO TOP OF BOTTOM PACKER 5.0 FT.

TEST INTERVAL DEPTH (FROM DATUM): FROM 95.4 FT. TO 90.6 FT.

TOTAL BORING DEPTH FROM DATUM: 108.0 FT.

(A) DEPTH TO WATER TABLE FROM DATUM: 23.0 FT.

(B) SURFACE GAUGE HEIGHT ABOVE DATUM: 1.0 FT.

(C) DISTANCE WATER TABLE TO CENTER OF TEST INTERVAL: 70.1 FT.

*1/2*

MAXIMUM TEST PRESSURE,  $P_o$  62.9 ( $P_o = [(A+B) * 1] + C * .57$  psi)

TEST NUMBER: 4 TEST PRESSURE 31.4 psi PACKER PRESSURE: 100 psi

Initial Transducer Readings: Top 3.22, Middle 30.62, Bottom 33.42

Transducer Readings after initial pressurization:

Top 3.03, Middle 30.70, Bottom 33.40

Transducer Readings after final flow measurement:

Top \_\_\_\_\_, Middle \_\_\_\_\_, Bottom \_\_\_\_\_

TIME (MIN)	FLOW METER READING, (GAL)	Q (GPM)	SURFACE GAUGE, PSI	REMARKS
0.0	2748.5	/	-1.6	
0.5	2748.5	Ø	-1.6	
1.0	2748.5	Ø	-1.5	
1.5	2748.6	.2	-0.5	
2.0	2748.5	Ø	-0.7	
2.5	2748.6	Ø	-0.9	
3.0	2748.6	Ø	-1.0	
3.5	2748.6	Ø	-1.2	
4.0	2748.6	Ø	-1.1	
4.5	2748.6	Ø	-0.7	
5.0	2748.6		-0.7	

DOUBLE PACKER TEST DATA SHEET, MACTEC PROJECT NO. 6468-06-1472

PAGE 3

BORING NO.: B949

DATE: 8-17-06

TEST NUMBER: 4

TEST INTERVAL (FROM DATUM): FROM 95.6 FT. TO 90.6 FT.

DATA COLLECTED BY: S. Howard

2  
8-12-5-06

SHUT-IN TEST

PRESSURE: \_\_\_\_\_ psi

TIME, MIN	SURFACE GAUGE PRESSURE, PSI	MIDDLE TRANSDUCER PRESSURE, PSI
0.0	-0.7	31.87
0.5	-0.9	31.65
1.0	-1.1	31.45
1.5	-1.2	31.28
2.0	-1.3	31.16
2.5	-1.3	31.06
3.0	-1.4	30.97
3.5	-1.4	30.91
4.0	-1.5	30.85
4.5	-1.5	30.80
5.0	-1.5	30.77
5.5	-1.6	30.75
6.0	-1.6	30.74
6.5	-1.6	30.73
7.0	-1.6	30.71

EQUIPMENT USED

Transducers: Mini Troll Serial Numbers: 10417 (Top), 10191 (Middle), 10036 (Bottom)

Surface Pressure Gauge: Omega DPG serial number 2634708001

Flow Meter Omega FTB-4110 serial number 32019518

Stop Watch: serial number SW1

Above calibrated 5-5-06 or 5-18-06

Tests: B949-M490-95  
" B9490 " "  
" T490 " "

**DOUBLE PACKER BOREHOLE PERMEABILITY TEST DATA SHEET**

*JAG*  
12-5-06

MACTEC ENGINEERING AND CONSULTING, INC.

PROJECT: NORTH ANNA COL PROJECT NO.: 6468-06-1472

DATA COLLECTED BY: S Howard DATE COLLECTED: 8-17-06

BORING NO. B949 BOREHOLE DIAMETER: 4 IN.

SURFACE CASING HEIGHT ABOVE GROUND: 1.6 FT.

CHECK DATUM USED: TOP OF CASING  GROUND SURFACE

DATUM ELEVATION na

DISTANCE BOTTOM OF TOP PACKER TO TOP OF BOTTOM PACKER 5.0 FT.

TEST INTERVAL DEPTH (FROM DATUM): FROM 95.6 FT. TO 90.6 FT.

TOTAL BORING DEPTH FROM DATUM: 108.0 FT.

(A) DEPTH TO WATER TABLE FROM DATUM: 23.0 FT.

(B) SURFACE GAUGE HEIGHT ABOVE DATUM: 1.0 FT.

(C) DISTANCE WATER TABLE TO CENTER OF TEST INTERVAL: 70.1 FT.

MAXIMUM TEST PRESSURE, Po 62.9 (Po = [(A+B) \* 1] + C\*.57 psi)

TEST NUMBER: 5 TEST PRESSURE 62.9 psi PACKER PRESSURE: 100 psi

Initial Transducer Readings: Top 3.22, Middle 30.62, Bottom 33.42

Transducer Readings after initial pressurization:  
Top 2.06, Middle 30.670, Bottom 33.42

Transducer Readings after final flow measurement:  
Top 2.98, Middle 30.66, Bottom 33.44

TIME (MIN)	FLOW METER READING, (GAL)	Q (GPM)	SURFACE GAUGE, PSI	REMARKS
0.0	2748.6	/	-1.6	
0.5	2749.5	1.8	26.6	
1.0	2749.7	.4	25.6	
1.5	2749.9	.4	24.4	
2.0	2750.1	.4	24.1	
2.5	2750.3	.4	25.5	
3.0	2750.5	.4	26.1	
3.5	2750.8	.6	24.3	
4.0	2750.9	.2	27.2	
4.5	2751.1	.4	23.7	
5.0	2751.2	.2	23.6	
<del>6.0</del> 5.5	2751.3	.2	23.2	
6.0	2751.5	.4	24.6	



BORING NO: S Howard

DATE: 8-17-06

TEST NUMBER: 5

TEST INTERVAL (FROM DATUM): FROM 95.6 FT. TO 90.6 FT.

DATA COLLECTED BY: S Howard

JAF  
12-5-06

TIME (MIN)	FLOW METER READING, (GAL)	Q (GPM)	SURFACE GAUGE, PSI	REMARKS
7.0	2751.6	.2	24.5	
7.5	2752.0	.8	24.7	
8.0	2752.1	.2	24.7	

BORING NO.: ~~B-6-06~~ <sup>B-28-16</sup> B949

DATE: 8-17-06

TEST NUMBER: 5

TEST INTERVAL (FROM DATUM): FROM 95.6 FT. TO 40.6 FT.

DATA COLLECTED BY: Stewart

*AS*  
12-5-06

SHUT-IN TEST

PRESSURE: \_\_\_\_\_ psi

TIME, MIN	SURFACE GAUGE PRESSURE, PSI	MIDDLE TRANSDUCER PRESSURE, PSI
0.0	24.7	67.27
0.5	9.6	46.44
1.0	5.8	42.11
1.5	3.0	39.00
2.0	2.1	37.36
2.5	0.9	35.71
3.0	0.1	34.49
3.5	-0.3	33.69
4.0	-0.7	33.08
4.5	-1.1	32.54
5.0	-1.3	32.21
5.5	-1.6	31.87
6.0	-1.7	31.59
6.5	-1.9	31.34
7.0	-2.0	31.21
7.5	-2.0	31.08
8.0	-2.1	30.98
8.5	-2.1	30.90
9.0	-2.2	30.85
9.5	-2.3	30.79
10.0	-2.3	30.74
10.5	-2.3	30.73
11.0	-2.3	30.71

EQUIPMENT USED

Transducers: Mini Troll Serial Numbers: 10417 (Top), 10191 (Middle), 10036 (Bottom)

Surface Pressure Gauge: Omega DPG serial number 2634708001

Flow Meter Omega FTB-4110 serial number 32019518

Stop Watch: serial number SW1

Above calibrated 5-5-06 or 5-18-06

Tests: B949 - M590-95  
 " B590 "  
 " T590 "

PACKER TESTING CALCULATIONS FOR P(MAX)

JAZ  
12-5-06

Date: 8-16-06

Boring No. B-949

Test Interval: ~~24.5~~<sup>24</sup> to ~~99.5~~<sup>8.5</sup> feet from Datum 96.1 - 101.1

Casing Stickup 1.6 feet

PoMAX = (h<sub>1</sub> x 1) + (h<sub>2</sub> x 0.57). h<sub>1</sub> and h<sub>2</sub> are in feet, see sketch. PoMAX is in psi

h<sub>1</sub> = Distance from the datum to the water level

h<sub>2</sub> = Distance from the water level to the center of the test interval

h<sub>1</sub> = 23.0

h<sub>2</sub> = 23.1 - 98.6 = 75.5

P MAX = 23.0 + 43.03 = 66.03

SKETCH

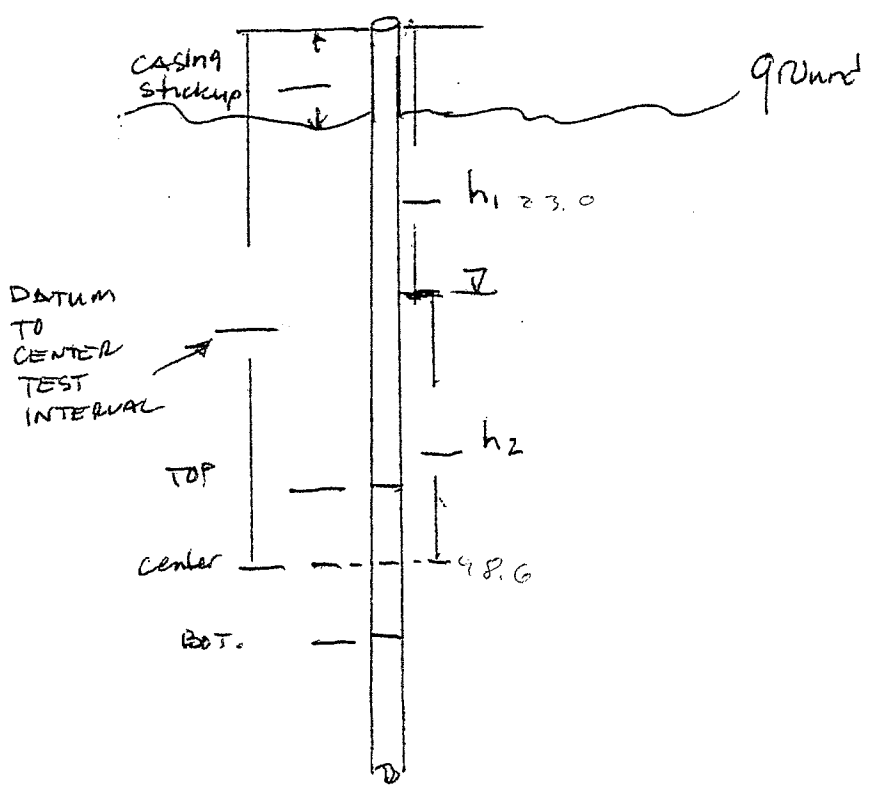

DOUBLE PACKER BOREHOLE PERMEABILITY TEST DATA SHEET

*JH 12-5-06*

MACTEC ENGINEERING AND CONSULTING, INC.

PROJECT: NORTH ANNA COL PROJECT NO.: 6468-06-1472

DATA COLLECTED BY: *Sharan* DATE COLLECTED: 8-16-06

BORING NO. B949 BOREHOLE DIAMETER: 4 IN.

SURFACE CASING HEIGHT ABOVE GROUND: 1.6 FT.

CHECK DATUM USED: TOP OF CASING  GROUND SURFACE

DATUM ELEVATION NA

DISTANCE BOTTOM OF TOP PACKER TO TOP OF BOTTOM PACKER 5.0 FT.

TEST INTERVAL DEPTH (FROM DATUM): FROM 96.1 FT. TO 101.1 FT.

TOTAL BORING DEPTH FROM DATUM: 108.0 FT.

(A) DEPTH TO WATER TABLE FROM DATUM: 23.0 FT.

(B) SURFACE GAUGE HEIGHT ABOVE DATUM: ~~75.5~~ 8.16 + 1.0 FT.

(C) DISTANCE WATER TABLE TO CENTER OF TEST INTERVAL: 75.5 FT.

MAXIMUM TEST PRESSURE,  $P_0$  66.03 ( $P_0 = [(A+B) * 1] + C * .57$  psi)

TEST NUMBER: 1 TEST PRESSURE 21.79 psi PACKER PRESSURE: 100 psi

Initial Transducer Readings: Top ~~31.5~~ 31.5, Middle 27.90, Bottom 35.72

Transducer Readings after initial pressurization: Top 32.90, Middle 32.90, Bottom 35.72

Transducer Readings after final flow measurement: Top —, Middle —, Bottom —

TIME (MIN)	FLOW METER READING, (GAL)	Q (GPM)	SURFACE GAUGE, PSI	REMARKS
0.0	25197		0.0	
0.5				
1.0				
1.5				
2.0				
2.5				
3.0				
3.5				
4.0				
4.5				
5.0				

*Test pressure is exceeded by natural pressure  
Skip & so for test 2*

DOUBLE PACKER BOREHOLE PERMEABILITY TEST DATA SHEET

*Handwritten initials and date:* 12-5-06

MACTEC ENGINEERING AND CONSULTING, INC.

PROJECT: NORTH ANNA COL PROJECT NO.: 6468-06-1472

DATA COLLECTED BY: S Howard DATE COLLECTED: 8-16-06

BORING NO. B949 BOREHOLE DIAMETER: 4" IN.

SURFACE CASING HEIGHT ABOVE GROUND: 1.6 FT.

CHECK DATUM USED: TOP OF CASING  GROUND SURFACE

DATUM ELEVATION NA

DISTANCE BOTTOM OF TOP PACKER TO TOP OF BOTTOM PACKER 5.0 FT.

TEST INTERVAL DEPTH (FROM DATUM): FROM 94.1 FT. TO 101.1 FT.

TOTAL BORING DEPTH FROM DATUM: 108.0 FT.

(A) DEPTH TO WATER TABLE FROM DATUM: 23.0 FT.

(B) SURFACE GAUGE HEIGHT ABOVE DATUM: ~~1.6~~ <sup>1.2</sup> 1.0 FT.

(C) DISTANCE WATER TABLE TO CENTER OF TEST INTERVAL: 75.5 FT.

*Handwritten:* 2/3

MAXIMUM TEST PRESSURE,  $P_o$  66.03 ( $P_o = [(A+B) * 1] + C * .57$  psi)

TEST NUMBER: 2 TEST PRESSURE 43.57 psi PACKER PRESSURE: 100 psi

Initial Transducer Readings: Top 3.151, Middle 33.01, Bottom 35.78

Transducer Readings after initial pressurization: Top 3.08, Middle 32.75, Bottom 35.56

Transducer Readings after final flow measurement: Top 3.00, Middle 32.76, Bottom 35.63

TIME (MIN)	FLOW METER READING, (GAL)	Q (GPM)	SURFACE GAUGE, PSI	REMARKS
0.0	2509.7	/	0.0	
0.5	2509.7	0	.1	
1.0	2510.1	0.8	10.9	
1.5	2515.4	10.6	13.4	
2.0	2520.4	10.0	3.6	
2.5	2525.3	9.8	3.7	
3.0	2529.7	8.8	3.9	
3.5	2532.9	6.4	3.9	
4.0	2538.2	10.6	3.2	
4.5	2542.2	8.0	3.2	
5.0	2546.5	8.6	3.4	

BORING NO.: B949

DATE: 8-16-06

TEST NUMBER: 2

TEST INTERVAL (FROM DATUM): FROM 96.1 FT. TO 101.1 FT.

DATA COLLECTED BY: S. Howard

2  
J2 5-06  
12

SHUT-IN TEST

PRESSURE: 43.62 psi

TIME, MIN	SURFACE GAUGE PRESSURE, PSI	MIDDLE TRANSDUCER PRESSURE, PSI
0.0	43.4	43.62
0.5	-8.4	35.21
1.0	-8.3	34.66
1.5	-8.7	34.18
2.0	-9.0	33.88
2.5	-9.2	33.68
3.0	-9.4	33.52
3.5	-9.5	33.39
4.0	-9.6	33.31
4.5	-9.7	33.21
5.0	-9.8	33.15
5.5	-9.9	33.10
6.0	-9.9	33.05
6.5	-9.9	33.02
7.0	-10.0	32.98
7.5	-10.0	32.95
8.0	-10.0	32.97

EQUIPMENT USED

Transducers: Mini Troll Serial Numbers: 10417 (Top), 10191 (Middle), 10036 (Bottom)  
 Surface Pressure Gauge: Omega DPG serial number 2634708001  
 Flow Meter Omega FTB-4110 serial number 32019518  
 Stop Watch: serial number SW1

Above calibrated 5-5-06 or 5-18-06

Tests: B949-M296-101  
 B949-T296-101  
 B949-B296-101

**DOUBLE PACKER BOREHOLE PERMEABILITY TEST DATA SHEET**

*JG*  
12-5-06

MACTEC ENGINEERING AND CONSULTING, INC.

PROJECT: NORTH ANNA COL PROJECT NO.: 6468-06-1472

DATA COLLECTED BY: J Howard DATE COLLECTED: 8-16-06

BORING NO. B949 BOREHOLE DIAMETER: 4 IN.

SURFACE CASING HEIGHT ABOVE GROUND: 15.6 FT.

CHECK DATUM USED: TOP OF CASING X GROUND SURFACE     

DATUM ELEVATION NA

DISTANCE BOTTOM OF TOP PACKER TO TOP OF BOTTOM PACKER 5.0 FT.

TEST INTERVAL DEPTH (FROM DATUM): FROM 96.1 FT. TO 101.1 FT.

TOTAL BORING DEPTH FROM DATUM: 102.0 FT.

(A) DEPTH TO WATER TABLE FROM DATUM: 23.0 FT.

(B) SURFACE GAUGE HEIGHT ABOVE DATUM: 1.6 FT.

(C) DISTANCE WATER TABLE TO CENTER OF TEST INTERVAL: 72.5 FT.

MAXIMUM TEST PRESSURE,  $P_o$  66.03 ( $P_o = [(A+B) * 1] + C * .57$  psi)

TEST NUMBER: 3 TEST PRESSURE 66.03 psi PACKER PRESSURE: 100 psi

Initial Transducer Readings: Top 3.15, Middle 35.01, Bottom 35.25

Transducer Readings after initial pressurization:  
Top 3.00, Middle 32.76, Bottom 35.63

Transducer Readings after final flow measurement:  
Top 2.47, Middle 32.88, Bottom 35.84

TIME (MIN)	FLOW METER READING, (GAL)	Q (GPM)	SURFACE GAUGE, PSI	REMARKS
0.0	2548.0	/	-10.3	
0.5	2549.1	2.2	+10.8	
1.0	2556.0	13.8	14.7	
1.5	2566.7	21.4	27.2	
2.0	2575.7	18.0	28.7	
2.5	2584.9	18.4	29.6	
3.0	2593.9	18.0	31.3	
3.5	2602.9	18.0	31.6	
4.0	2611.6	$\frac{17.4}{2.4} = 7.25$	31.4	
4.5	2621.7	20.2	32.2	
5.0	2631.1	18.8	32.2	
6.0				

*JG* Flow was mixed & could not match stabilization  
Stopped @ 5 min

BORING NO.: B944

DATE: 8-16-06

TEST NUMBER: 3

TEST INTERVAL (FROM DATUM): FROM 96.1 FT. TO 101.1 FT.

DATA COLLECTED BY: J Howard

*JJ*  
12-5-06

SHUT-IN TEST

PRESSURE: 49.78 psi

*Use this for calculations for*

TIME, MIN	SURFACE GAUGE PRESSURE, PSI	MIDDLE TRANSDUCER PRESSURE, PSI
0.0	32.2	49.78
0.5	- 2.8	38.94
1.0	- 5.6	37.32
1.5	- 6.6	36.22
2.0	- 7.2	35.66
2.5	- 7.8	35.12
3.0	- 8.1	34.79
3.5	- 8.5	34.50
4.0	- 8.7	34.28
4.5	- 8.8	<del>33.95</del> 8.17 missed
5.0	- 9.0	33.95
5.5	- 9.1	33.82
6.0	- 9.2	33.69
6.5	- 9.3	33.60
7.0	- 9.4	33.53
7.5	- 9.5	33.47
8.0	- 9.5	33.40
8.5	- 9.6	33.34
9.0	- 9.7	33.30
9.5	- 9.7	33.26

EQUIPMENT USED

Transducers: Mini Troll Serial Numbers: 10417 (Top), 10191 (Middle), 10036 (Bottom)

Surface Pressure Gauge: Omega DPG serial number 2634708001

Flow Meter Omega FTB-4110 serial number 32019518

Stop Watch: serial number SW1

Above calibrated 5-5-06 or 5-18-06

*Test: B944-M3 96-101  
B944-B3 96-101  
B944-T3 96-101*



DOUBLE PACKER BOREHOLE PERMEABILITY TEST DATA SHEET

*JHJ*  
12.5.06

MACTEC ENGINEERING AND CONSULTING, INC.

PROJECT: NORTH ANNA COL PROJECT NO.: 6468-06-1472

DATA COLLECTED BY: S Howard DATE COLLECTED: 8-16-06

BORING NO. B949 BOREHOLE DIAMETER: 4 IN.

SURFACE CASING HEIGHT ABOVE GROUND: 1.6 FT.

CHECK DATUM USED: TOP OF CASING  GROUND SURFACE

DATUM ELEVATION NA

DISTANCE BOTTOM OF TOP PACKER TO TOP OF BOTTOM PACKER 5.0 FT.

TEST INTERVAL DEPTH (FROM DATUM): FROM 96.1 FT. TO 101.1 FT.

TOTAL BORING DEPTH FROM DATUM: 108.0 FT.

(A) DEPTH TO WATER TABLE FROM DATUM: 23.0 FT.

(B) SURFACE GAUGE HEIGHT ABOVE DATUM:  $\frac{27+5-16}{1.6}$  1.0 FT.

(C) DISTANCE WATER TABLE TO CENTER OF TEST INTERVAL: 75.5 FT.

$\frac{1}{2}$  MAXIMUM TEST PRESSURE,  $P_o$  66.03 ( $P_o = [(A+B) * 1] + C * .57$  psi)

TEST NUMBER: 4 TEST PRESSURE 37.01 \* psi PACKER PRESSURE: 100 psi

Initial Transducer Readings: Top 3.15, Middle 33.01, Bottom 35.72

Transducer Readings after initial pressurization:  
Top 2.97, Middle 32.88, Bottom 35.84

Transducer Readings after final flow measurement:  
Top 2.94, Middle 32.84, Bottom 35.64

TIME (MIN)	FLOW METER READING, (GAL)	Q (GPM)	SURFACE GAUGE, PSI	REMARKS
0.0	<del>26</del> 26 32.1	/	-10.2	
0.5	26 32.1	Ø	-10.2	
1.0	26 32.1	Ø	-10.1	
1.5	26 32.2	.2	-9.9	
2.0	26 32.3	.2	-9.6	
2.5	26 32.6	.6	-9.5	
3.0	26 32.7	.2	-9.5	
3.5	26 32.8	.2	-9.5	
4.0	26 32.9	.2	-9.4	
4.5	26 33.0	.2	-9.4	
5.0	26 33.0	Ø	9.4	
6.0	26 33.0	Ø	-9.4	

Tried to keep mid Transducer @ 33.4 or 33.5 since the test was so close to the nature pressure

BORING NO.: B949

DATE: 8-16-06

TEST NUMBER: 4

TEST INTERVAL (FROM DATUM): FROM 96.1 FT. TO 101.1 FT.

DATA COLLECTED BY: J Howard

*2*  
*JJ*  
*8-5-06*

**SHUT-IN TEST**

PRESSURE: \_\_\_\_\_ psi

TIME, MIN	SURFACE GAUGE PRESSURE, PSI	MIDDLE TRANSDUCER PRESSURE, PSI
0.0	-9.6	37.34 ✓
0.5	-9.8	37.00
1.0	-9.9	37.95
1.5	-9.9	37.92
2.0	-9.9	37.90
2.5	-9.9	37.89
3.0	-9.9	37.88
3.5	-9.9	37.88
4.0	-9.9	37.87
4.5	-10.0	37.86
5.0	-9.9	37.85

**EQUIPMENT USED**

- Transducers: Mini Troll Serial Numbers: 10417 (Top), 10191 (Middle), 10036 (Bottom)
- Surface Pressure Gauge: Omega DPG serial number 2634708001
- Flow Meter Omega FTB-4110 serial number 32019518
- Stop Watch: serial number SW1

Above calibrated 5-5-06 or 5-18-06

*Test: B949-M496-101*  
*B949-B496-101*  
*B949-T496-101*

**DOUBLE PACKER BOREHOLE PERMEABILITY TEST DATA SHEET**

*JAJ*  
12-5-06

MACTEC ENGINEERING AND CONSULTING, INC.

PROJECT: NORTH ANNA COL PROJECT NO.: 6468-06-1472

DATA COLLECTED BY: S Howard DATE COLLECTED: 8-16-00

BORING NO. B949 BOREHOLE DIAMETER: 4 IN.

SURFACE CASING HEIGHT ABOVE GROUND: 1.6 FT.

CHECK DATUM USED: TOP OF CASING  GROUND SURFACE

DATUM ELEVATION NA

DISTANCE BOTTOM OF TOP PACKER TO TOP OF BOTTOM PACKER 5.0 FT.

TEST INTERVAL DEPTH (FROM DATUM): FROM 96.1 FT. TO 101.1 FT.

TOTAL BORING DEPTH FROM DATUM: 108.0 FT.

(A) DEPTH TO WATER TABLE FROM DATUM: 23.0 FT.

(B) SURFACE GAUGE HEIGHT ABOVE DATUM: 1.6 FT.

(C) DISTANCE WATER TABLE TO CENTER OF TEST INTERVAL: 75.5 FT.

MAXIMUM TEST PRESSURE,  $P_o$  66.03 ( $P_o = [(A+B) * 1] + C * .57$  psi)

TEST NUMBER: 5 TEST PRESSURE 66.03 psi PACKER PRESSURE: 100 psi

Initial Transducer Readings: Top 3.15, Middle 33.01, Bottom 35.72

Transducer Readings after initial pressurization:  
Top 2.44, Middle 32.84, Bottom 35.64

Transducer Readings after final flow measurement:  
Top 3.02, Middle 33.33, Bottom 36.22

TIME (MIN)	FLOW METER READING, (GAL)	Q (GPM)	SURFACE GAUGE, PSI	REMARKS
0.0	2633.0	/	-0.7	
0.5	2646.8	7.6	25.2	
1.0	2645.8	18.0	28.1	
1.5	2655.9	20.2	30.3	
2.0	2665.9	20.0	31.3	
2.5	2674.3	16.8	31.5	
3.0	2684.2	19.8	31.7	
3.5	2692.8	17.2	32.5	
4.0	2701.9	18.2	32.4	
4.5	2711.3	18.8	33.1	
5.0	2721.9	21.2	33.1	
6.0	2737.0	30.2	33.1	

*JAJ* \* Same as test 3, could not reach max pressure

BORING NO.: B949

DATE: 8-16-06

TEST NUMBER: 5

TEST INTERVAL (FROM DATUM): FROM 96.1 FT. TO 101.1 FT.

DATA COLLECTED BY: J Howard

*Jan 12-5-06*

SHUT-IN TEST

PRESSURE: \_\_\_\_\_ psi

*Use this for calculator*

TIME, MIN	SURFACE GAUGE PRESSURE, PSI	MIDDLE TRANSDUCER PRESSURE, PSI
0.0	33.1	63.86
0.5	- 1.9	40.86
1.0	- 3.8	38.92
1.5	- 5.7	37.40
2.0	- 6.7	36.56
2.5	- 7.0	35.92
3.0	- 7.5	35.37
3.5	- 7.8	35.08
4.0	- 8.1	34.78
4.5	- 8.3	34.55
5.0	- 8.5	34.35
5.5	- 8.7	34.18
6.0	- 8.8	34.05
6.5	- 9.0	33.92
7.0	- 9.1	33.87
7.5	- 9.2	33.74
8.0	- 9.3	33.67
8.5	- 9.3	33.54
9.0	- 9.4	33.52

EQUIPMENT USED

Transducers: Mini Troll Serial Numbers: 10417 (Top), 10191 (Middle), 10036 (Bottom)

Surface Pressure Gauge: Omega DPG serial number 2634708001

Flow Meter Omega FTB-4110 serial number 32019518

Stop Watch: serial number SW1

Above calibrated 5-5-06 or 5-18-06

*Test: B949 - M596-101  
 B949 - B596-101  
 B949 - T596-101*

②

511

8-15-06

James Howard

DATA REPORT Rev. 0

MACTEC ENGINEERING & CONSULTING, INC.

1/23/07

7:00 Arrive  
7:30 safety meet  
8am - 12:45 Ready Pucker tests

~~Work Inst~~  
~~8:15 - 12:45~~ Safety meet

1 - 4:30 Pucker stand by & setup 3949

1.5 hrs stand by

③

5H

8-16-06

James Howard

Miller, Mark Hughes, Tim Garland

7am Arrive

7:30-7:45 Safety meeting

7:45-10 Setup For Packer-B949

10-11:30 Water Run

11:30-12:15 Standby

12:45-1:15 Water run

1:15-4:30 More setup

4:30-4:45 Breakdown for night

Had issues w/ Packer & Pressure  
test & talked w/ Garrett <sup>8-16</sup> ~~8-16~~ Jan

Also had issue w/ Nitrogen leak

Garrett will look at pressure issue

tonight &amp; will run test tomorrow

at 2/3 rds max

4:45-5 Paperwork

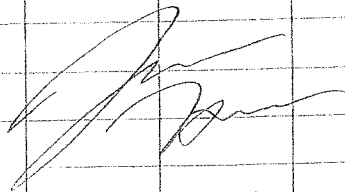

4)

8-17-06  
 James Howan  
 Miller, Mark Hughes, Tim Garland  
 B949

7am arrive

730 safety meeting

745-805 Setup

815-10 Test B949 101-96

10-1030 Move up to next interval

1030-1 Stand by Driller looking for space for Nitrogen line

1-130 Fix line

130-345 Packer 90-95

345-5 Packer 85-90

5-5306 Paperwork

2-10  
8-7

511

standing level @ 23.0 from  
 datum

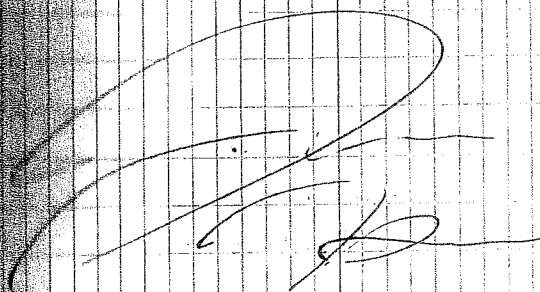







**MACTEC ENGINEERING AND CONSULTING, INC.**

**RALEIGH, NORTH CAROLINA**

**IN SITU DETERMINATION OF ROCK MASS PERMEABILITY USING WATER PRESSURE TEST  
IN ACCORDANCE WITH CORPS OF ENGINEERS,  
(WATERWAYS EXPERIMENT STATION, RTH 381-80)**

**PROJECT NAME: NORTH ANNA COL  
PROJECT NUMBER: 6468-06-1472  
REPORT DATE: 12/7/2006 Revised 1-13-07  
BORING NO: B-950**

**Given Parameters**

Test Section Length, *l*, ft: 5  
 Radius of Borehole *r*<sub>0</sub>, in: 2.00  
 GW Depth, ft: 23.00 (from top of casing) 21.00 (from ground surface)

Prepared by: ZO  
 Checked by: [Signature]

Date: 12-7-06  
 Date: 1-17-07

Test Number	Q (GPM)	P <sub>Test</sub> (psi)	P <sub>T</sub> (psi)	P <sub>M</sub> (psi)	P <sub>B</sub> (psi)	Q (cfs)	H <sub>M</sub> (ft)	K <sub>e</sub> (fpy)
<b>Interval 1, ft: 55 - 60</b>		(from ground surface)						
1	0.00	17.41	0.03	7.41	10.11	0.00	40.18	0.00
2	0.00	34.82	0.03	7.41	10.11	0.00	80.35	0.00
3	0.00	52.77	0.03	7.41	10.11	0.00	121.78	0.00
4	TNP	26.3					60.69	
5	TNP	52.77					121.78	
								<b>K<sub>e</sub>, ft/year: 0.00</b>

<b>Interval 2, ft: 60 - 65</b>		(from ground surface)						
1	0.00	18.35	0.24	9.64	12.42	0.00	42.35	0.00
2	0.00	36.17	0.24	9.64	12.42	0.00	83.47	0.00
3	0.00	55.62	0.24	9.64	12.42	0.00	128.35	0.00
4	0.00	27.81	0.24	9.64	12.42	0.00	64.18	0.00
5	0.00	55.62	0.24	9.64	12.42	0.00	128.35	0.00
								<b>K<sub>e</sub>, ft/year: 0.00</b>

<b>Interval 3, ft: 82 - 87</b>		(from ground surface)						
1	0.00	30.96	8.52	26.36	29.14			0.00
2	0.00	44.98	8.52	26.49	29.14	0.00000	103.80	0.00
3	0.00	68.16	8.52	26.36	29.14	0.00000	157.29	0.00
4	0.00	34.08	8.52	26.36	29.14	0.00000	78.65	0.00
5	0.00	68.16	8.52	26.36	29.14	0.00000	157.29	0.00
								<b>K<sub>e</sub>, ft/year: 0.0</b>

**Notations:**

- Q = flow rate
- P<sub>Test</sub> = total test pressure
- P<sub>T</sub> = pressure above top packer, near water surface
- P<sub>M</sub> = pressure in the test section
- P<sub>B</sub> = pressure below bottom packer
- H<sub>M</sub> = P<sub>Test</sub> converted to feet of head (P<sub>Test</sub> \* 144 in<sup>2</sup>/ft<sup>2</sup>/γ<sub>w</sub>)
- K<sub>e</sub> = ((Q/(H<sub>M</sub>-P<sub>m</sub>))\*(1/l))\*1/2π\*ln(R/r<sub>0</sub>)\*(525,600 min/year)\*(0.1337 ft<sup>3</sup>/gal)
- R = total length between packers, *l*
- TNP = Test not performed
- NM = not measured

Note: Pressures P<sub>t</sub>, P<sub>m</sub> and P<sub>b</sub> taken from initial data for transducers.  
 Outside diameter of boring is 4 in.

**IN SITU DETERMINATION OF ROCK MASS PERMEABILITY USING WATER PRESSURE TEST  
IN ACCORDANCE WITH CORPS OF ENGINEERS,  
WATERWAYS EXPERIMENT STATION, RTH 381-80**

Project Name: NORTH ANNA COL

Project Number: 6468-06-1472

Date: 8/21/2006

Boring No: B-950

Test Interval: 57.0 ft to 62 ft (from Datum)

Stick up length: 2 ft

Test Interval: 55.0 ft to 60 ft (from surface)

Test Type: Double Packer Technique

Prepared by: ZO

Date: 12-7-06

Checked by: *Jr*

Date: 1-17-07

Depth of Water

Table= 42.70 ft (from top of casing)

h1= 43.20 (from top of casing)

h2 = 16.80 ft (from top of casing)

$\rho_w = 62.4 \text{ lb/ft}^3$

**Abbreviations:**

N.O. Not Observed

N.A. Not Aplicable

$P_0 \text{ Max} = 52.78 \text{ psi}$

Value on field data sheet=

Target excess pressures were 1/3Pmax, 2/3Pmax, Pmax, 1/2 Pmax and Pmax. **Actual** excess pressures given below.

**TEST #1**

**TEST #2**

**TEST #3**

TEST #1				TEST #2				TEST #3			
Actual Excess Pressure=		10.00 psi		Actual Excess Pressure=		27.41 psi		Actual Excess Pressure=		45.36 psi	
Initial Middle Transducer Reading=		7.41 psi		Initial Middle Transducer Reading=		7.41 psi		Initial Middle Transducer Reading=		7.41 psi	
Test Pressure=		17.41 psi		Test Pressure=		34.82 psi		Test Pressure=		52.77 psi	
Time (min)	Flow Meter Reading (Gal)	Q (GPM)	Surface Gauge (psi)	Time (min)	Flow Meter Reading (Gal)	Q (GPM)	Surface Gauge (psi)	Time (min)	Flow Meter Reading (Gal)	Q (GPM)	Surface Gauge (psi)
0	2792.6		1.5	0	2793.1		6	0	2793.5		15.8
0.5	2792.6	0.0	1.5	0.5	2793.2	0.2	6	0.5	2793.9	0.8	29.8
1	2793.1	1.0	7.1	1	2793.5	0.6	15.6	1	2793.9	0.0	29.9
1.5	2793.1	0.0	7.1	1.5	2793.5	0.0	16.9	1.5	2793.9	0.0	29.9
2	2793.1	0.0	7.1	2	2793.5	0.0	16.9	2	2793.9	0.0	31.5
2.5	2793.1	0.0	7.0	2.5	2793.5	0.0	16.9	2.5	2793.9	0.0	31.5
3	2793.1	0.0	7.0	3	2793.5	0.0	16.9	3	2793.9	0.0	31.2
3.5	2793.1	0.0	6.9	3.5	2793.5	0.0	16.9	3.5	2793.9	0.0	32.1
4	2793.1	0.0	6.9	4	2793.5	0.0	16.9	4	2793.9	0.0	32.2
4.5	2793.1	0.0	6.9	4.5	2793.5	0.0	16.9	4.5	2793.9	0.0	32.1
5	2793.1	0.0	6.8	5	2793.5	0.0	16.9	5	2793.9	0.0	32.1

Average Q: 0.0 gpm  
Excess Pore pressure: 10.00 psi

Average Q: 0.0 gpm  
Excess Pore pressure: 27.41 psi

Average Q: 0.0 gpm  
Excess Pore pressure: 45.36 psi

02-17-07

TEST #4

TEST #5

TEST #4				TEST #5			
Actual Excess Pressure= NA psi				Actual Excess Pressure= NA psi			
Initial Middle Transducer 7.41 psi				Initial Middle Transducer 7.41 psi			
Test Pressure= psi				Test Pressure= psi			
Time (min)	Flow Meter Reading (Gal)	Q (GPM)	Surface Gauge (psi)	Time (min)	Flow Meter Reading (Gal)	Q (GPM)	Surface Gauge (psi)
Hole is not taking any water --> Test not performed				Hole is not taking any water --> Test not performed			

Boring No: B-950  
 Test Interval: 55 ft to 60 ft (from surface)

Density of water,  $\rho_w = 62.4$  lb/ft<sup>3</sup>  
 = 0.0361 lb/in  
 Length = 5 ft  
 Borehole radius = 2.00 in  
 R ranges from 5-10 ft:  
 choose R = 5 ft

	Excess Pressure (psi)	Q* (gpm)	Test Pres. (ft)	k <sub>e</sub> (fpy)
1	10.00	0.00	23.08	0.00
2	27.41	0.00	63.25	0.00
3	45.36	0.00	104.68	0.00
4				
5				

\* Q obtained from graph Flow Rate-1

Average Q: gpm      Average Q: gpm  
 Excess Pore pressure: psi      Excess Pore pressure: psi

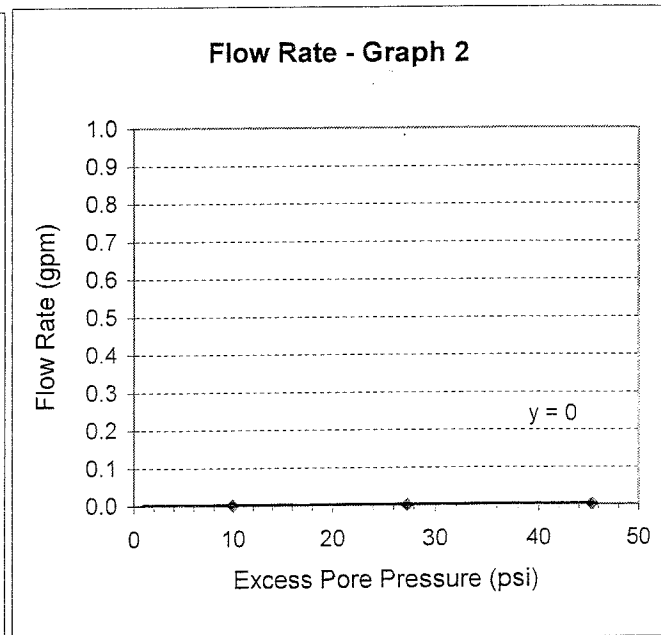
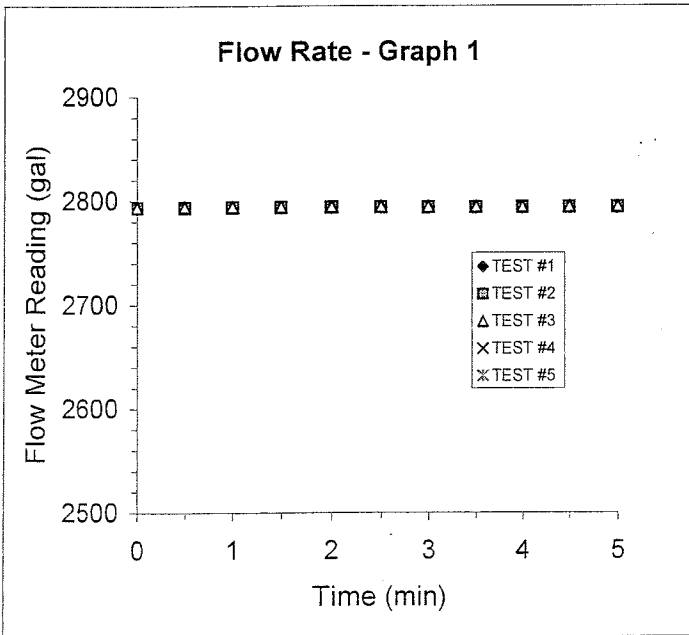

obtain Q from graph 2 in gpm/psi --> 0.0000 gal/psi

$$k_e = Q^* \ln(R/r_0) / (2\pi L H_0)$$

$$k_e = 0.00E+00 \text{ cm/sec} = 0.00 \text{ ft/year}$$

# Pressure Decay Test

Project Name: NORTH ANNA COL  
 Project Number: 6468-06-1472  
 Date: 8/21/2006  
 Boring No: B-950  
 Test Interval: 55 ft to 60 ft

Prepared by: ZO Date: 12-7-06  
 Checked by: OOI Date: 1-17-07  
 N.O. Not Observed  
 N.A. Not Applicable

(from surface)

Test #1			Test #2			Test #3		
Time (min)	Surface Gauge (psi)	Center Tranducer (psi)	Time (min)	Surface Gauge (psi)	Center Tranducer (psi)	Time (min)	Surface Gauge (psi)	Center Tranducer (psi)
0.0	6.8	20	0.0	16.9	34.26	0.0	32.1	52.67
0.5	6.8	19.97	0.5	16.9	34.23	0.5	31.9	52.50
1.0	6.8	19.96	1.0	16.7	34.2	1.0	31.8	52.40
1.5	6.7	19.94	1.5	16.7	34.16	1.5	31.7	52.27
2.0	6.7	19.92	2.0	16.7	34.12	2.0	31.6	52.14
2.5	6.7	19.9	2.5	16.6	34.08	2.5	31.5	52.02
3.0	6.7	19.87	3.0	16.6	34.04	3.0	31.4	51.88
3.5	6.7	19.85	3.5	16.6	34.00	3.5	31.2	51.76
4.0	6.6	19.83	4.0	16.5	33.98	4.0	31.1	51.64
4.5	6.6	19.8	4.5	16.5	33.94	4.5	31.0	51.51
5.0	6.6	19.79	5.0	16.5	33.91	5.0	30.9	51.37
6.0	6.6	19.75	6.0	16.4	33.85	6.0	30.6	51.00
7.0	6.5	19.72	7.0	16.4	33.79	7.0	30.5	50.96
8.0	6.5	19.68	8.0	16.3	33.74	8.0	30.4	50.87
9.0	6.5	19.65	9.0	16.3	33.69	9.0	30.2	50.63
10.0	6.4	19.62	10.0	16.2	33.64	10.0	29.9	50.25
11.0	6.4	19.58	11.0	16.2	33.61	11.0	29.5	49.90
12.0	6.4	19.56	12.0	16.1	33.52	12.0	29.3	49.65
13.0	6.3	19.53	13.0	16.1	33.53	13.0	29.2	49.54
14.0	6.3	19.5	14.0	16.1	33.51	14.0	29.1	49.44
15.0	6.3	19.47	15.0	16.0	33.48	15.0	29.1	49.34
20.0	6.2	19.38						
25.0	6.1	19.31						
30.0	6.1	19.24						
35.0	6.0	19.19						

Test #4			Test #5		
Time (min)	Surface Gauge (psi)	Center Tranducer (psi)	Time (min)	Surface Gauge (psi)	Center Tranducer (psi)
No data Test not conducted			No data Test not conducted		

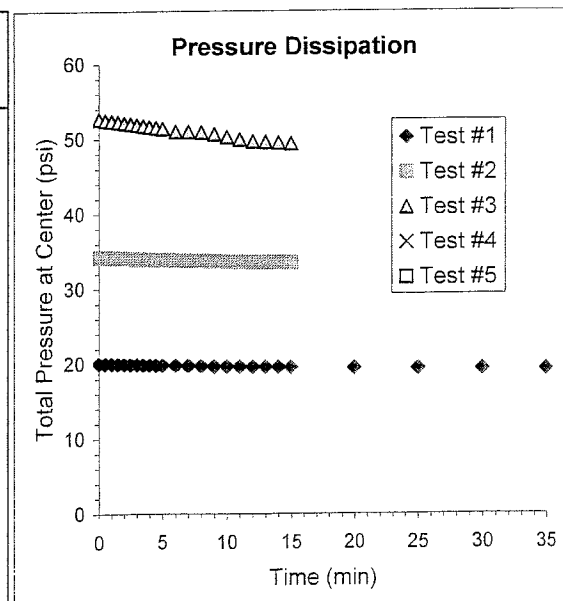

**IN SITU DETERMINATION OF ROCK MASS PERMEABILITY USING WATER PRESSURE TEST  
IN ACCORDANCE WITH CORPS OF ENGINEERS,  
WATERWAYS EXPERIMENT STATION, RTH 381-80**

Project Name: NORTH ANNA COL  
Project Number: 6468-06-1472  
Date: 8/18/2006

Prepared by: ZO Date: 12-7-06  
Checked by: *[Signature]* Date: 1-17-07

Boring No: B-950  
Test Interval: 62 ft to 67 ft  
Stick up length: 2 ft  
Test Interval: 60.0 ft to 65 ft (from surface)  
Test Type: Double Packer Technique

Depth of Water  
Table = 42.70 ft (from top of casing)  
h1 = 43.20 (from top of casing)  
h2 = 21.80 ft (from top of casing)  
 $\rho_w = 62.4 \text{ lb/ft}^3$

**Abbreviations:**  
N.O. Not Observed  
N.A. Not Applicable

$P_0 \text{ Max} = 55.63 \text{ psi}$  Value on field data sheet=  
Target excess pressures were 1/3Pmax, 2/3Pmax, Pmax, 1/2 Pmax and Pmax. **Actual** excess pressures given below.

TEST #1				TEST #2				TEST #3			
Actual Excess Pressure=		8.71 psi		Actual Excess Pressure=		32.25 psi		Actual Excess Pressure=		45.98 psi	
Initial Middle Transducer Reading=		9.64 psi		Initial Middle Transducer Reading=		9.64 psi		Initial Middle Transducer Reading=		9.64 psi	
Test Pressure=		18.35 psi		Test Pressure=		41.89 psi		Test Pressure=		55.62 psi	
Time (min)	Flow Meter Reading (Gal)	Q (GPM)	Surface Gauge (psi)	Time (min)	Flow Meter Reading (Gal)	Q (GPM)	Surface Gauge (psi)	Time (min)	Flow Meter Reading (Gal)	Q (GPM)	Surface Gauge (psi)
0	2787		1.0	0	2788.1		4.1	0	2789.2		8.3
0.5	2787	0.0	1.0	0.5	2788.8	1.4	8.9	0.5	2790.4	2.4	39.3
1	2787.4	0.8	1.4	1	2789.1	0.6	18.9	1	2790.4	0.0	38.2
1.5	2788.1	1.4	10.6	1.5	2789.2	0.2	17.9	1.5	2790.5	0.2	31.1
2	2788.1	0.0	10.5	2	2789.2	0.0	17.6	2	2790.5	0.0	32.9
2.5	2788.1	0.0	6.1	2.5	2789.2	0.0	17.3	2.5	2790.5	0.0	33.2
3	2788.1	0.0	5.9	3	2789.2	0.0	17.1	3	2790.5	0.0	33.3
3.5	2788.1	0.0	5.8	3.5	2789.2	0.0	16.9	3.5	2790.5	0.0	32.6
4	2788.1	0.0	5.8	4	2789.2	0.0	16.7	4	2790.5	0.0	32.5
4.5	2788.1	0.0	5.8	4.5	2789.2	0.0	17.4	4.5	2790.5	0.0	33.1
5	2788.1	0.0	5.7	5	2789.2	0.0	17.3	5	2790.5	0.0	33.2

Average Q: 0.2 gpm  
Excess Pore pressure: 8.71 psi

Average Q: 0.0 gpm  
Excess Pore pressure: 32.25 psi

Average Q: 0.0 gpm  
Excess Pore pressure: 45.98 psi

Joe 1-17-07

**TEST #4**

**TEST #5**

Actual Excess Pressure= 18.17 psi				Actual Excess Pressure= 45.98 psi			
Initial Middle Transducer 9.64 psi				Initial Middle Transducer 9.64 psi			
Test Pressure= 27.81 psi				Test Pressure= 55.62 psi			
Time (min)	Flow Meter Reading (Gal)	Q (GPM)	Surface Gauge (psi)	Time (min)	Flow Meter Reading (Gal)	Q (GPM)	Surface Gauge (psi)
0	2790.5		2.2	0	2791.2		2.9
0.5	2791.2	1.4	10.6	0.5	2792.6	2.8	32.8
1	2791.2	0.0	10.8	1	2792.6	0.0	37.2
1.5	2791.2	0.0	10.6	1.5	2792.6	0.0	35.7
2	2791.2	0.0	10.5	2	2792.6	0.0	34.2
2.5	2791.2	0.0	10.7	2.5	2792.6	0.0	32.6
3	2791.2	0.0	10.9	3	2792.6	0.0	33.5
3.5	2791.2	0.0	11.0	3.5	2792.6	0.0	34
4	2791.2	0.0	11.1	4	2792.6	0.0	33.8
4.5	2791.2	0.0	11.3	4.5	2792.6	0.0	33.9
5	2791.2	0.0	11.4	5	2792.6	0.0	33.4

Boring No: B-950  
 Test Interval: 60 ft to 65 ft  
 (from surface)

Density of water,  $\rho_w = 62.4$  lb/ft<sup>3</sup>  
 = 0.0361 lb/in<sup>3</sup>  
 Length = 5 ft  
 Borehole radius = 2.00 in  
 R ranges from 5-10 ft:  
 choose R = 5 ft

	Excess Pressure (psi)	Q* (gpm)	Test Pres. (ft)	k <sub>e</sub> (fpy)
1	8.71	0.000	20.10	0.00
2	32.25	0.000	74.42	0.00
3	45.98	0.000	106.11	0.00
4	18.17	0.000	41.93	0.00
5	45.98	0.000	106.1	0.00

\* Q obtained from graph Flow Rate-1

Average Q: 0.0 gpm  
 Excess Pore pressure: 18.17 psi

Average Q: 0.0 gpm  
 Excess Pore pressure: 45.98 psi

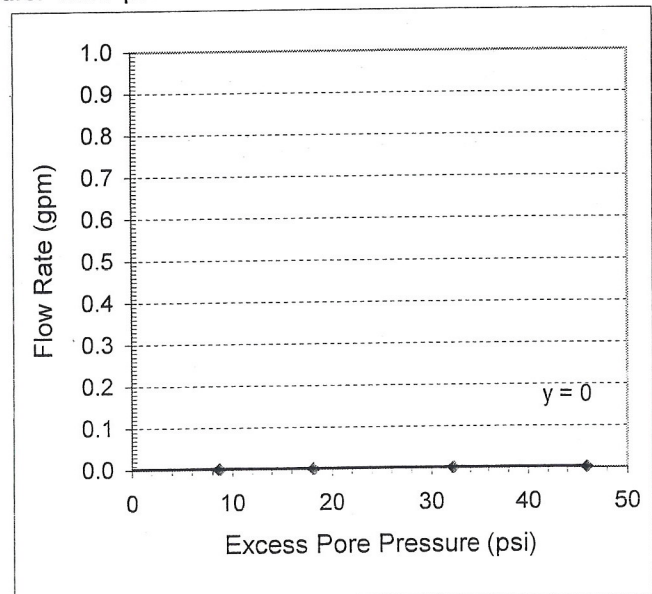
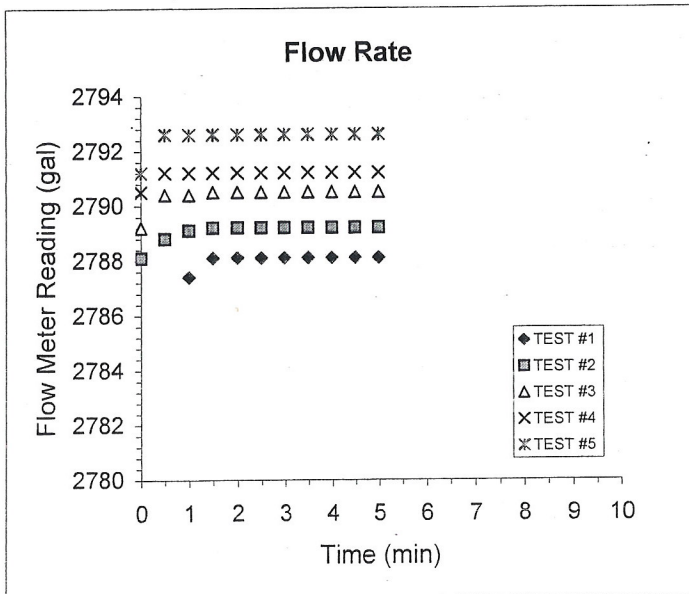

obtain Q from graph 2 in gpm/psi -> 0.0000 gal/psi

$$k_e = Q^* \ln(R/r_0) / (2\pi LH_0)$$

$$k_e = 0.00E+00 \text{ cm/sec}$$

$$= 0.00 \text{ ft/year}$$

# Pressure Decay Test

Project Name: NORTH ANNA COL  
 Project Number: 6468-06-1472  
 Date: 8/18/2006  
 Boring No: B-950  
 Test Interval: 60 ft to 65 ft

Prepared by: ZO Date: 12-7-06  
 Checked by: JA Date: 1-17-07  
 N.O. Not Observed  
 N.A. Not Applicable

Test #1			Test #2			Test #3		
Time (min)	Surface Gauge (psi)	Center Tranducer (psi)	Time (min)	Surface Gauge (psi)	Center Tranducer (psi)	Time (min)	Surface Gauge (psi)	Center Tranducer (psi)
0.0	5.7	19.07	0.0	17.3	36.29	0.0	33.2	55.42
0.5	5.7	19.00	0.5	17.0	36.04	0.5	31.8	54.44
1.0	5.7	18.93	1.0	16.8	35.68	1.0	30.4	52.83
1.5	5.6	18.85	1.5	16.6	35.47	1.5	29.3	51.55
2.0	5.6	18.79	2.0	16.3	35.19	2.0	28.1	50.28
2.5	5.6	18.71	2.5	16.1	35.00	2.5	27.2	49.08
3.0	5.5	18.65	3.0	16.0	34.68	3.0	26.2	47.96
3.5	5.4	18.57	3.5	15.7	34.31	3.5	25.3	46.98
4.0	5.4	18.5	4.0	15.5	34.16	4.0	24.5	45.99
4.5	5.4	18.46	4.5	15.4	33.9	4.5	23.6	45.07
5.0	5.4	18.4	5.0	15.4	33.48	5.0	22.8	44.15
6.0	5.3	18.28	6.0	14.8	33.15	6.0	21.7	42.60
7.0	5.2	18.17	7.0	14.4	32.65	7.0	20.5	41.13
8	5.2	18.07	8.0	14.1	32.22	8.0	19.3	39.74
9	5.1	17.98	9.0	13.8	31.82	9.0	18.3	38.43
10	5.1	17.88	10.0	13.5	31.34	10.0	17.3	37.32
11	5.0	17.78	11.0	13.2	30.94	11.0	16.5	36.25
12	5.0	17.69	12.0	12.9	30.52	12.0	15.8	35.29
13	4.9	17.59	13.0	12.6	30.11	13.0	15.0	34.23
14	4.9	17.5	14.0	12.4	29.75	14.0	14.4	33.4
15	4.8	17.4	15.0	12.1	29.39	15.0	13.7	32.52
16	4.8	17.31	20.0	10.9	27.68	20.0	11.1	28.93
20	4.6	16.95	25.0	9.9	26.18	25.0	9.0	26.02
25	4.3	16.54						

Test #4			Test #5		
Time (min)	Surface Gauge (psi)	Center Tranducer (psi)	Time (min)	Surface Gauge (psi)	Center Tranducer (psi)
0.0	11.4	28.1	0.0	33.4	55.64
0.5	11.2	27.92	0.5	32.0	54.03
1.0	11	27.62	1.0	30.9	52.81
1.5	10.8	27.29	1.5	29.5	51.22
2.0	10.5	26.98	2.0	28.5	49.99
2.5	10.3	26.62	2.5	27.7	48.70
3.0	10.1	26.35	3.0	26.6	47.91
3.5	9.9	26.07	3.5	25.7	46.85
4.0	9.7	25.76	4.0	24.6	45.79
4.5	9.4	25.49	4.5	24.0	45.04
5.0	9.3	25.18	5.0	23.4	44.10
6.0	9	24.69	6.0	22.1	42.58
7.0	8.6	24.16	7.0	20.9	41.00
8	8.3	23.69	8	19.9	39.20
9	8.1	23.23	9	18.8	38.46
10	7.7	22.78	10	17.9	37.29
11	7.4	22.34	11	17.2	36.28
12	7.1	21.92	12	16.4	35.30
13	6.1	21.51	13	15.8	34.35
14	6.6	21.00	14	15.1	33.40
15	6.4	20.74	15	14.4	32.58
20	5.4	19.00	20	11.9	29.06
			25	9.8	26.14
			30	8.4	23.98
			35	2.1	22.02

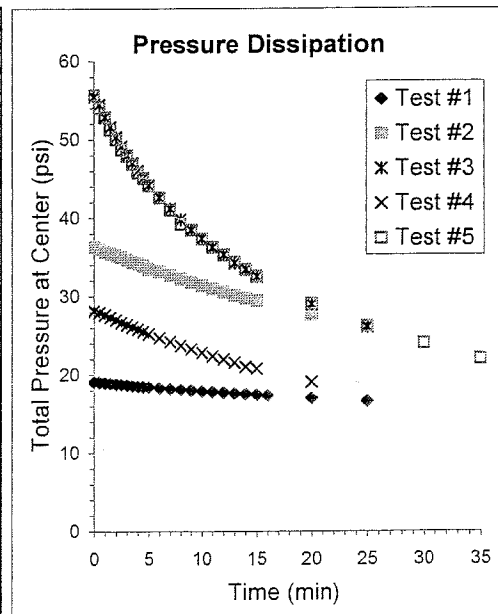

**IN SITU DETERMINATION OF ROCK MASS PERMEABILITY USING WATER PRESSURE TEST  
IN ACCORDANCE WITH CORPS OF ENGINEERS,  
WATERWAYS EXPERIMENT STATION, RTH 381-80**

Project Name: NORTH ANNA COL

Project Number: 6468-06-1472

Date: 8/18/2006

Boring No: B-950

Test Interval: 84 ft to 89 ft

Stick up length: 2 ft

Test Interval: 82.0 ft to 87 ft (from surface)

Test Type: Double Packer Technique

Prepared by: ZO Date: 12-7-06

Checked by: [Signature] Date: 1-17-07

Depth of Water

Table = 42.70 ft (from top of casing)

h1 = 43.20 (from top of casing)

h2 = 43.80 ft (from top of casing)

$\rho_w = 62.4 \text{ lb/ft}^3$

**Abbreviations:**

N.O. Not Observed

N.A. Not Applicable

$P_0 \text{ Max} = 68.17 \text{ psi}$

Value on field data sheet =

Target excess pressures were 1/3Pmax, 2/3Pmax, Pmax, 1/2 Pmax and Pmax. Actual excess pressures given below.

TEST #1				TEST #2				TEST #3			
Actual Excess Pressure =		4.60 psi		Actual Excess Pressure =		18.49 psi		Actual Excess Pressure =		29.26 psi	
Initial Middle Transducer Reading =		26.36 psi		Initial Middle Transducer Reading =		26.49 psi		Initial Middle Transducer Reading =		26.36 psi	
Test Pressure =		30.96 psi		Test Pressure =		44.98 psi		Test Pressure =		55.62 psi	
Time (min)	Flow Meter Reading (Gal)	Q (GPM)	Surface Gauge (psi)	Time (min)	Flow Meter Reading (Gal)	Q (GPM)	Surface Gauge (psi)	Time (min)	Flow Meter Reading (Gal)	Q (GPM)	Surface Gauge (psi)
0	2777.6		-1.4	0	2780.3		2.1	0	2781.3		3.8
0.5	2777.6	0.0	-1.0	0.5	2781.0	1.4	4.5	0.5	2783	3.4	33.9
1	2779.1	3.0	8.2	1	2781.0	0.0	23.3	1	2783.1	0.2	38.2
1.5	2779.3	0.4	9.1	1.5	2781.0	0.0	21.1	1.5	2783.2	0.2	35.5
2	2779.3	0.0	8.9	2	2781.0	0.0	19.4	2	2783.3	0.2	39
2.5	2779.3	0.0	8.6	2.5	2781.0	0.0	17.8	2.5	2783.3	0.0	36.3
3	2779.3	0.0	8.4	3	2781.0	0.0	16.3	3	2783.3	0.0	37.1
3.5	2779.3	0.0	8.1	3.5	2781.0	0.0	15.5	3.5	2783.3	0.0	38.1
4	2779.3	0.0	7.8	4	2781.0	0.0	14.7	4	2783.3	0.0	35.9
4.5	2779.3	0.0	7.6	4.5	2781.0	0.0	19.7	4.5	2783.3	0.0	37.8
5	2779.3	0.0	7.4	5	2781.0	0.0	18.8	5	2783.4	0.2	37.1
				6	2781.0	0.0	18.7	6	2783.5	0.1	34.4
								7	2783.5	0.0	38.1

Average Q: 0.3 gpm  
Excess Pore pressure: 4.60 psi

Average Q: 0.0 gpm  
Excess Pore pressure: 18.49 psi

Average Q: NA gpm  
Excess Pore pressure: 29.26 psi



JA21-17-07

TEST #4

TEST #5

TEST #4				TEST #5			
Actual Excess Pressure= 7.72 psi				Actual Excess Pressure= 41.80 psi			
Initial Middle Transducer 26.36 psi				Initial Middle Transducer 26.36 psi			
Test Pressure= 34.08 psi				Test Pressure= 68.16 psi			
Time (min)	Flow Meter Reading (Gal)	Q (GPM)	Surface Gauge (psi)	Time (min)	Flow Meter Reading (Gal)	Q (GPM)	Surface Gauge (psi)
0	2783.5		2.8	0	2784.7		2.3
0.5	2783.9	0.8	6.5	0.5	2785.6	1.8	14
1	2784.7	1.6	16.7	1	2786.6	2.0	34.3
1.5	2784.7	0.0	15.7	1.5	2786.6	0.0	35.6
2	2784.7	0.0	14.5	2	2786.7	0.2	38.1
2.5	2784.7	0.0	13.4	2.5	2786.8	0.2	40
3	2784.7	0.0	12.5	3	2786.8	0.0	36.6
3.5	2784.7	0.0	11.7	3.5	2786.8	0.0	36.9
4	2784.7	0.0	11.1	4	2786.9	0.2	38
4.5	2784.7	0.0	10.5	4.5	2786.9	0.0	38.1
5	2784.7	0.0	10.0	5	2786.9	0.0	37.7
				6	2787.0	0.1	37.3

Boring No: B-950  
 Test Interval 82 ft to 87 ft  
 (from surface)

Density of water,  $\rho_w = 62.4$  lb/ft<sup>3</sup>  
 = 0.0361 lb/in<sup>3</sup>  
 Length = 5 ft  
 Borehole radius = 2.00 in  
 R ranges from 5-10 ft:  
 choose R = 5 ft

	Excess Pressure (psi)	Q* (gpm)	Test Pres. (ft)	$k_e$ (fpy)
1	4.60	0.000	10.62	0.00
2	18.49	0.000	42.67	0.00
3	29.26	0.000	67.52	0.00
4	7.72	0.000	17.82	0.00
5	41.80	0.000	96.5	0.00

\* Q obtained from graph Flow Rate-1

Average Q: 0.0 gpm  
 Excess Pore pressure: 7.72 psi

Average Q: NA gpm  
 Excess Pore pressure: 41.80 psi

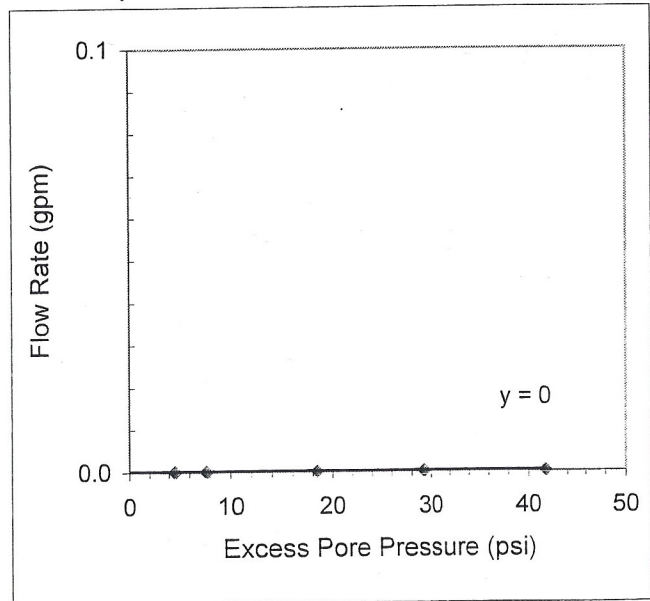
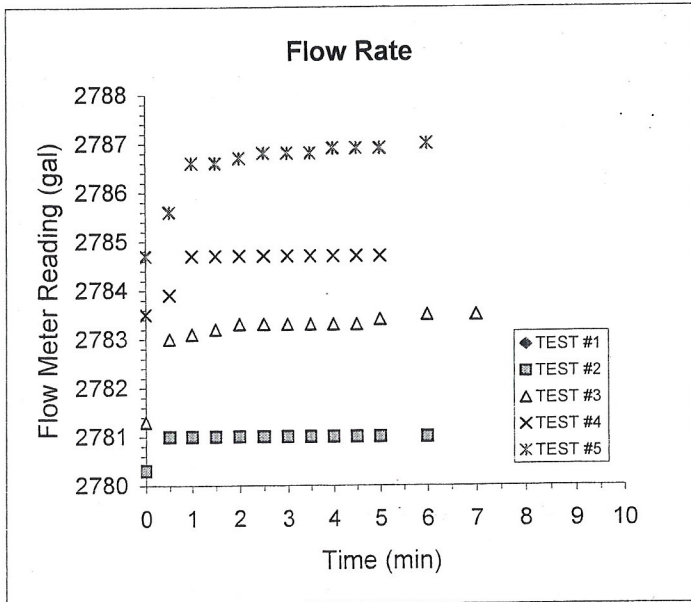

obtain Q from graph 2 in gpm/psi --> 0.0000 gal/psi

$$k_e = \frac{Q^* \ln(R/r_0)}{2\pi L H_0}$$

$$k_e = 0.00E+00 \text{ cm/sec}$$

$$= 0.00 \text{ ft/year}$$

# Pressure Decay Test

Project Name: NORTH ANNA COL  
 Project Number: 6468-06-1472  
 Date: 8/18/2006  
 Boring No: B-950  
 Test Interval: 82 ft to 87 ft (from surface)

Prepared by: ZO Date: 12-7-06  
 Checked by: A Date: 1-17-07  
 N.O. Not Observed  
 N.A. Not Aplicable

Test #1			Test #2			Test #3		
Time (min)	Surface Gauge (psi)	Center Tranducer (psi)	Time (min)	Surface Gauge (psi)	Center Tranducer (psi)	Time (min)	Surface Gauge (psi)	Center Tranducer (psi)
0.0	7.4	31.39	0.0	18.7	45.29	0.0	38.1	69.10
0.5	7.1	30.87	0.5	17.8	44.03	0.5	30	60.80
1.0	7	30.53	1.0	16.6	42.47	1.0	26.7	55.91
1.5	6.8	30.15	1.5	15.6	41.08	1.5	23.7	52.15
2.0	6.6	29.75	2.0	14.7	39.92	2.0	21.2	48.64
2.5	6.4	29.34	2.5	13.9	38.69	2.5	18.8	46.13
3.0	6.2	28.96	3.0	13.1	37.58	3.0	17.4	44.17
3.5	6	28.62	3.5	12.5	36.65	3.5	15.7	42.01
4.0	6	28.38	4.0	11.9	35.77	4.0	14.6	40.36
4.5	5.8	28.05	4.5	11.4	34.89	4.5	13.7	38.80
5.0	5.7	27.77	5.0	10.9	34.24	5.0	12.8	37.74
6.0	5.4	27.26	6.0	10	32.84	6.0	11.4	35.70
7.0	5.2	26.77	7.0	9.3	31.67	7.0	10.2	33.84
8	4.9	26.36	8.0	8.7	30.65	8.0	9.3	32.40
9	4.7	25.94	9.0	8.1	29.71	9.0	8.5	31.05
10	4.6	25.56	10.0	7.6	28.9	10.0	7.8	29.93
11	4.4	25.2	11.0	7.2	28.15	11.0	7.2	28.95
12	4.3	24.85	12.0	6.9	27.47	12.0	6.7	28.05
13	4.1	24.54	13.0	6.5	26.87	13.0	6.2	27.29
14	3.9	24.21	14.0	6.2	26.3	14.0	5.8	26.6
15	3.8	23.91	15.0	5.9	25.78	15.0	5.5	25.97
16	3.6	23.64	16.0	5.6	25.31	16.0	5.2	25.41
20	3.1	22.66	20.0	4.8	23.76	20.0	4.2	23.62

Test #4			Test #5		
Time (min)	Surface Gauge (psi)	Center Tranducer (psi)	Time (min)	Surface Gauge (psi)	Center Tranducer (psi)
0.0	10	33.07	0.0	37.3	67.95
0.5	9.3	31.94	0.5	31.1	61.05
1.0	8.9	31.28	1.0	26.4	55.67
1.5	8.4	30.56	1.5	22.7	50.91
2.0	8	29.97	2.0	20.1	47.61
2.5	7.4	28.82	2.5	18.1	45.60
3.0	7	28.23	3.0	16.2	43.04
3.5	6.8	27.81	3.5	15.0	40.78
4.0	6.5	27.37	4.0	13.6	38.89
4.5	6.3	26.97	4.5	12.1	36.76
5.0	5.8	26.21	5.0	11.4	35.16
6.0	5.4	25.53	6.0	10.7	34.52
7.0	5.1	24.97	7.0	9.3	32.63
8	4.8	24.39	8	8.6	31.22
9	4.6	23.93	9	7.9	30.00
10	4.7	23.47	10	7.3	28.88
11	4.1	23.07	11	6.6	27.85
12	3.9	22.71	12	6.2	27.05
13	3.7	22.41	13	5.7	26.31
14	3.6	22.10	14	5.4	25.61
15	3.4	21.83	15	5.0	25.05
16	3.3	21.58	16	4.8	24.52
20	2.9	20.95	20	3.9	22.97

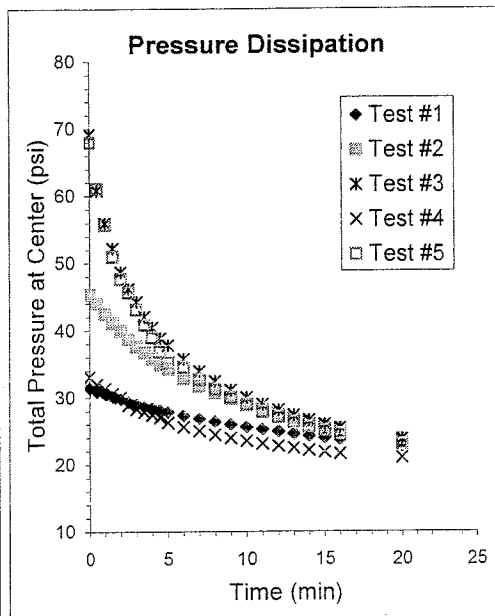

DOUBLE PACKER BOREHOLE PERMEABILITY TEST DATA SHEET

MACTEC ENGINEERING AND CONSULTING, INC.

*JGJ*  
12-3-06

PROJECT: NORTH ANNA COL PROJECT NO.: 6468-06-1472

DATA COLLECTED BY: S Howard DATE COLLECTED: 8-21-06

BORING NO. B950 BOREHOLE DIAMETER: 4 IN.

SURFACE CASING HEIGHT ABOVE GROUND: 2.0 FT.

CHECK DATUM USED: TOP OF CASING  GROUND SURFACE

DATUM ELEVATION NA

DISTANCE BOTTOM OF TOP PACKER TO TOP OF BOTTOM PACKER 5.0 FT.

TEST INTERVAL DEPTH (FROM DATUM): FROM 57.0 FT. TO 62.0 FT.

TOTAL BORING DEPTH FROM DATUM: 102.0 FT.

(A) DEPTH TO WATER TABLE FROM DATUM: 42.7 FT.

(B) SURFACE GAUGE HEIGHT ABOVE DATUM: .5 FT.

(C) DISTANCE WATER TABLE TO CENTER OF TEST INTERVAL: 16.8 FT.

1/3

MAXIMUM TEST PRESSURE,  $P_0$  52.77 ( $P_0 = [(A+B) * 1] + C * .57$  psi)

TEST NUMBER: 1 TEST PRESSURE 17.41 psi PACKER PRESSURE: 100 psi

Initial Transducer Readings: Top .03, Middle 7.41, Bottom 10.11

Transducer Readings after initial pressurization:

Top .24, Middle 11.09, Bottom 9.40

Transducer Readings after final flow measurement:

Top .23, Middle 19.15, Bottom 9.19

TIME (MIN)	FLOW METER READING, (GAL)	Q (GPM)	SURFACE GAUGE, PSI	REMARKS
0.0	2792.6	/	1.5	
0.5	2792.6	Ø	1.5	
1.0	2793.1	1.0	7.1	
1.5	2793.1	Ø	7.1	
2.0	2793.1	Ø	7.1	
2.5	2793.1	Ø	7.0	
3.0	2793.1	Ø	7.0	
3.5	2793.1	Ø	6.9	
4.0	2793.1	Ø	6.9	
4.5	2793.1	Ø	6.9	
5.0	2793.1	Ø	6.8	
6.0				

DOUBLE PACKER TEST DATA SHEET, MACTEC PROJECT NO. 6468-06-1472

PAGE 3

BORING NO.: B950

DATE: 2-21-06

TEST NUMBER: 1

TEST INTERVAL (FROM DATUM): FROM 57.0 FT. TO 62.0 FT.

DATA COLLECTED BY: Shovan

*Handwritten:* 12-306

SHUT-IN TEST

PRESSURE: \_\_\_\_\_ psi

TIME, MIN	SURFACE GAUGE PRESSURE, PSI	MIDDLE TRANSDUCER PRESSURE, PSI
0.0	6.8	20.00
0.5	6.8	19.97
1.0	6.8	19.96
1.5	6.7	19.94
2.0	6.7	19.92
2.5	6.7	19.90
3.0	6.7	19.87
3.5	6.7	19.85
4.0	6.6	19.83
4.5	6.6	19.80
5.0	6.6	19.79
6.0	6.6	19.75
7.0	6.5	19.72
8.0	6.5	19.68
9.0	6.5	19.65
10.0	6.4	19.62
11.0	6.4	19.58
12.0	6.4	19.56
13.0	6.3	19.53
14.0	6.3	19.50
15.0	6.3	19.47
20.0	6.2	19.38
25.0	6.1	19.31
30.0	6.1	19.24
35.0	6.0	19.19

EQUIPMENT USED

Transducers: Mini Troll Serial Numbers: 10417 (Top), 10191 (Middle), 10036 (Bottom)

Surface Pressure Gauge: Omega DPG serial number 2634708001

Flow Meter Omega FTB-4110 serial number 32019518

Stop Watch: serial number SW1

Above calibrated 5-5-06 or 5-18-06

*Handwritten:* Tests: B950-M157-62  
 " - B157-11  
 " - T157-11

DOUBLE PACKER BOREHOLE PERMEABILITY TEST DATA SHEET

*JD*  
12-3-06

MACTEC ENGINEERING AND CONSULTING, INC.

PROJECT: NORTH ANNA COL PROJECT NO.: 6468-06-1472

DATA COLLECTED BY: S. Howard DATE COLLECTED: 8-21-06

BORING NO. B-30 BOREHOLE DIAMETER: 4 IN.

SURFACE CASING HEIGHT ABOVE GROUND: 2.0 FT.

CHECK DATUM USED: TOP OF CASING Y GROUND SURFACE     

DATUM ELEVATION NA

DISTANCE BOTTOM OF TOP PACKER TO TOP OF BOTTOM PACKER 0.0 FT.

TEST INTERVAL DEPTH (FROM DATUM): FROM 57.0 FT. TO 62.0 FT.

TOTAL BORING DEPTH FROM DATUM: 102.0 FT.

(A) DEPTH TO WATER TABLE FROM DATUM: 42.7 FT.

(B) SURFACE GAUGE HEIGHT ABOVE DATUM: .5 FT.

(C) DISTANCE WATER TABLE TO CENTER OF TEST INTERVAL: 16.8 FT.

*2/3*

MAXIMUM TEST PRESSURE,  $P_o$  52.77 ( $P_o = [(A+B) * 1] + C * .57$  psi)

TEST NUMBER: 2 TEST PRESSURE 34.82 psi PACKER PRESSURE: 100 psi

Initial Transducer Readings: Top .03, Middle 7.41, Bottom 10.11

Transducer Readings after initial pressurization:

Top .23, Middle 19.15, Bottom 9.19

Transducer Readings after final flow measurement:

Top .23, Middle 33.34, Bottom 9.19

TIME (MIN)	FLOW METER READING, (GAL)	Q (GPM)	SURFACE GAUGE, PSI	REMARKS
0.0	2793.1	/	6.0	
0.5	2797.2	.2	6.0	
1.0	2797.5	.6	15.6	
1.5	2797.5	Ø	16.9	
2.0	2797.5	Ø	16.9	
2.5	2797.5	Ø	16.9	
3.0	2797.5	Ø	16.9	
3.5	2797.5	Ø	16.9	
4.0	2797.5	Ø	16.9	
4.5	2797.5	Ø	16.9	
5.0	2797.5	Ø	16.9	
6.0				

DOUBLE PACKER TEST DATA SHEET, MACTEC PROJECT NO. 6468-06-1472

BORING NO.: B950

DATE: 8-21-06

TEST NUMBER: Z

TEST INTERVAL (FROM DATUM): FROM 57.0 FT. TO 62.0 FT.

DATA COLLECTED BY: J Howard

*JH*  
12-3-06

SHUT-IN TEST

PRESSURE: \_\_\_\_\_ psi

TIME, MIN	SURFACE GAUGE PRESSURE, PSI	MIDDLE TRANSDUCER PRESSURE, PSI
0.0	16.9	34.26
0.5	16.9	34.23
1.0	16.7	34.20
1.5	16.7	34.16
2.0	16.7	34.12
2.5	16.6	34.08
3.0	16.6	34.04
3.5	16.6	34.00
4.0	16.5	33.98
4.5	16.5	33.94
5.0	16.5	33.91
6.0	16.4	33.85
7.0	16.4	33.79
8.0	16.3	33.74
9.0	16.3	33.69
10.0	16.2	33.64
11.0	16.2	33.61
12.0	16.1	33.57
13.0	16.1	33.53
14.0	16.1	33.51
15.0	16.0	33.48

EQUIPMENT USED

Transducers: Mini Troll Serial Numbers: 10417 (Top), 10191 (Middle), 10036 (Bottom)

Surface Pressure Gauge: Omega DPG serial number 2634708001

Flow Meter Omega FTB-4110 serial number 32019518

Stop Watch: serial number SW1

Above calibrated 5-5-06 or 5-18-06

Tests: B950-M257-62  
 " - B257 - "  
 " - T257 - "

**DOUBLE PACKER BOREHOLE PERMEABILITY TEST DATA SHEET**

*JAJ*  
12-3-06

MACTEC ENGINEERING AND CONSULTING, INC.

PROJECT: NORTH ANNA COL PROJECT NO.: 6468-06-1472

DATA COLLECTED BY: J Howard DATE COLLECTED: 8-21-06

BORING NO. B 950 BOREHOLE DIAMETER: 4 IN.

SURFACE CASING HEIGHT ABOVE GROUND: 2.0 FT.

CHECK DATUM USED: TOP OF CASING  GROUND SURFACE

DATUM ELEVATION na

DISTANCE BOTTOM OF TOP PACKER TO TOP OF BOTTOM PACKER 5.0 FT.

TEST INTERVAL DEPTH (FROM DATUM): FROM 57.0 FT. TO 62.0 FT.

TOTAL BORING DEPTH FROM DATUM: 102.0 FT.

(A) DEPTH TO WATER TABLE FROM DATUM: 42.7 FT.

(B) SURFACE GAUGE HEIGHT ABOVE DATUM: .5 FT.

(C) DISTANCE WATER TABLE TO CENTER OF TEST INTERVAL: 16.8 FT.

MAXIMUM TEST PRESSURE,  $P_0$  52.77 ( $P_0 = [(A+B) * 1] + C * .57$  psi)

TEST NUMBER: 3 TEST PRESSURE 52.77 psi PACKER PRESSURE: 100 psi

Initial Transducer Readings: Top .03, Middle 7.41, Bottom 10.11

Transducer Readings after initial pressurization:  
Top .23, Middle 33.34, Bottom 9.19

Transducer Readings after final flow measurement:  
Top 6.23, Middle 49.34, Bottom 9.19

TIME (MIN)	FLOW METER READING, (GAL)	Q (GPM)	SURFACE GAUGE, PSI	REMARKS
00	2793.5	/	15.8	
0.5	2793.9	.8	29.8	
1.0	2793.9	Ø	29.9	
1.5	2793.9	Ø	29.9	
2.0	2793.9	Ø	29.9	
2.5	2793.9	Ø	31.5	
3.0	2793.9	Ø	31.2	
3.5	2793.9	Ø	32.1	
4.0	2793.9	Ø	32.2	
4.5	2793.9	Ø	32.1	
5.0	2793.9	Ø	32.1	

BORING NO.: B 950

DATE: 8-21-06

TEST NUMBER: 3

TEST INTERVAL (FROM DATUM): FROM 57.0 FT. TO 62.0 FT.

DATA COLLECTED BY: J Howard

2  
12-3-06

SHUT-IN TEST

PRESSURE: \_\_\_\_\_ psi

TIME, MIN	SURFACE GAUGE PRESSURE, PSI	MIDDLE TRANSDUCER PRESSURE, PSI
0.0	32.1	52.67
0.5	31.9	52.50
1.0	31.8	52.40
1.5	31.7	52.27
2.0	31.6	52.14
2.5	31.5	52.02
3.0	31.4	51.88
3.5	31.2	51.76
4.0	31.1	51.64
4.5	31.0	51.51
5.0	30.9	51.37
6.6	30.6	51.10
7.0	30.5	50.96
8.0	30.4	50.87
9.0	30.2	50.63
10.0	29.9	50.25
11.0	29.5	49.90
12.0	29.3	49.65
13.0	29.2	49.54
14.0	29.1	49.44
15.0	29.1	49.34

EQUIPMENT USED

Transducers: Mini Troll Serial Numbers: 10417 (Top), 10191 (Middle), 10036 (Bottom)

Surface Pressure Gauge: Omega DPG serial number 2634708001

Flow Meter Omega FTB-4110 serial number 32019518

Stop Watch: serial number SW1

Above calibrated 5-5-06 or 5-18-06

Tests: B 950 - M3 57-62  
 " - B3 57- "  
 " - T3 57- "



DOUBLE PACKER BOREHOLE PERMEABILITY TEST DATA SHEET

JAD  
12-3-06

MACTEC ENGINEERING AND CONSULTING, INC.

PROJECT: NORTH ANNA COL PROJECT NO.: 6468-06-1472

DATA COLLECTED BY: J Howard DATE COLLECTED: 8-21-06

BORING NO. B 950 BOREHOLE DIAMETER: 4 IN.

SURFACE CASING HEIGHT ABOVE GROUND: 2.0 FT.

CHECK DATUM USED: TOP OF CASING X GROUND SURFACE

DATUM ELEVATION N/A

DISTANCE BOTTOM OF TOP PACKER TO TOP OF BOTTOM PACKER 5.0 FT.

TEST INTERVAL DEPTH (FROM DATUM): FROM 57.0 FT. TO 62.0 FT.

TOTAL BORING DEPTH FROM DATUM: 102.0 FT.

(A) DEPTH TO WATER TABLE FROM DATUM: 42.7 FT.

(B) SURFACE GAUGE HEIGHT ABOVE DATUM: .5 FT.

(C) DISTANCE WATER TABLE TO CENTER OF TEST INTERVAL: 16.8 FT.

1/2 MAXIMUM TEST PRESSURE,  $P_0$  52.77 ( $P_0 = [(A+B) * 1] + C * .57$  psi)

TEST NUMBER: 4 TEST PRESSURE 52.77 psi Packer Pressure: 100 psi

Initial Transducer Readings: Top \_\_\_\_\_, Middle \_\_\_\_\_, Bottom \_\_\_\_\_

Transducer Readings after initial pressurization:

Top \_\_\_\_\_, Middle \_\_\_\_\_, Bottom \_\_\_\_\_

Transducer Readings after final flow measurement:

Top \_\_\_\_\_, Middle \_\_\_\_\_, Bottom \_\_\_\_\_

TIME (MIN)	FLOW METER READING, (GAL)	Q (GPM)	SURFACE GAUGE, PSI	REMARKS
0.0				
0.5				
1.0				
1.5				
2.0				
2.5				
3.0				
3.5				
4.0				
4.5				
5.0				

Test Skipped, Hole won't take water

DOUBLE PACKER BOREHOLE PERMEABILITY TEST DATA SHEET

*Jed*  
12-3-06

MACTEC ENGINEERING AND CONSULTING, INC.

PROJECT: NORTH ANNA COL PROJECT NO.: 6468-06-1472

DATA COLLECTED BY: J Howard DATE COLLECTED: 8-21-06

BORING NO. 0950 BOREHOLE DIAMETER: 4 IN.

SURFACE CASING HEIGHT ABOVE GROUND: 2.0 FT.

CHECK DATUM USED: TOP OF CASING  GROUND SURFACE

DATUM ELEVATION NA

DISTANCE BOTTOM OF TOP PACKER TO TOP OF BOTTOM PACKER 5.0 FT.

TEST INTERVAL DEPTH (FROM DATUM): FROM 57.0 FT. TO 62.0 FT.

TOTAL BORING DEPTH FROM DATUM: 102.0 FT.

(A) DEPTH TO WATER TABLE FROM DATUM: 42.7 FT.

(B) SURFACE GAUGE HEIGHT ABOVE DATUM: .5 FT.

(C) DISTANCE WATER TABLE TO CENTER OF TEST INTERVAL: 16.8 FT.

MAXIMUM TEST PRESSURE,  $P_0$  52.77 ( $P_0 = [(A+B) * 1] + C * .57$  psi)

TEST NUMBER: 5 TEST PRESSURE 52.77 psi PACKER PRESSURE: 100 psi

Initial Transducer Readings: Top \_\_\_\_\_, Middle \_\_\_\_\_, Bottom \_\_\_\_\_

Transducer Readings after initial pressurization:  
Top \_\_\_\_\_, Middle \_\_\_\_\_, Bottom \_\_\_\_\_

Transducer Readings after final flow measurement:  
Top \_\_\_\_\_, Middle \_\_\_\_\_, Bottom \_\_\_\_\_

TIME (MIN)	FLOW METER READING, (GAL)	Q (GPM)	SURFACE GAUGE, PSI	REMARKS
0.0				
0.5				
1.0				
1.5				
2.0				
2.5				
3.0				
3.5				
4.0				
4.5				
5.0				

*Test skipped, hole won't take water*

JAG  
12-3-06

# PACKER TESTING CALCULATIONS FOR P(MAX)

Date: 8-18-06

Boring No. B 950

Test Interval: 57.0 to 62.0 feet from Datum

Casing Stickup 2.0 feet

PoMAX =  $(h_1 \times 1) + (h_2 \times 0.57)$ .  $h_1$  and  $h_2$  are in feet, see sketch. PoMAX is in psi

$h_1$  = Distance from the <sup>same</sup> datum to the water level

$h_2$  = Distance from the water level to the center of the test interval

---

$h_1 = \underline{43.2}$

$h_2 = \underline{59.2} - \underline{42.7} = \underline{16.8}$

P MAX =  $\underline{43.2} + \underline{9.57} = \underline{52.77}$

## SKETCH

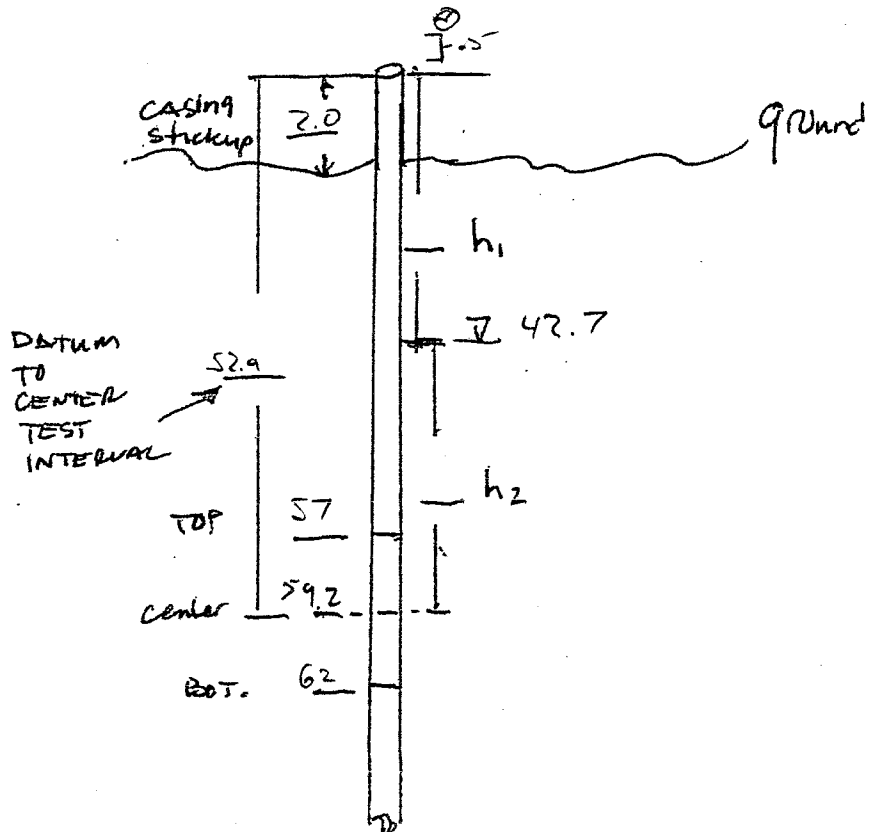

PACKER TESTING CALCULATIONS FOR P(MAX)

*JLJ*  
12-3-06

Date: 8-18-06

Boring No. B 950

Test Interval: 62.0 to 67.0 feet from Datum

Casing Stickup 2.0 feet

PoMAX = (h<sub>1</sub> x 1) + (h<sub>2</sub> x 0.57). h<sub>1</sub> and h<sub>2</sub> are in feet, see sketch. PoMAX is in psi

h<sub>1</sub> = Distance from the <sup>5.9'</sup> datum to the water level

h<sub>2</sub> = Distance from the water level to the center of the test interval

h<sub>1</sub> = 43.2

h<sub>2</sub> = 64.5 - <sup>21.7</sup>~~42.7~~ 42.7 = 21.8

P MAX = 43.2 + 12.62 = 55.62

SKETCH

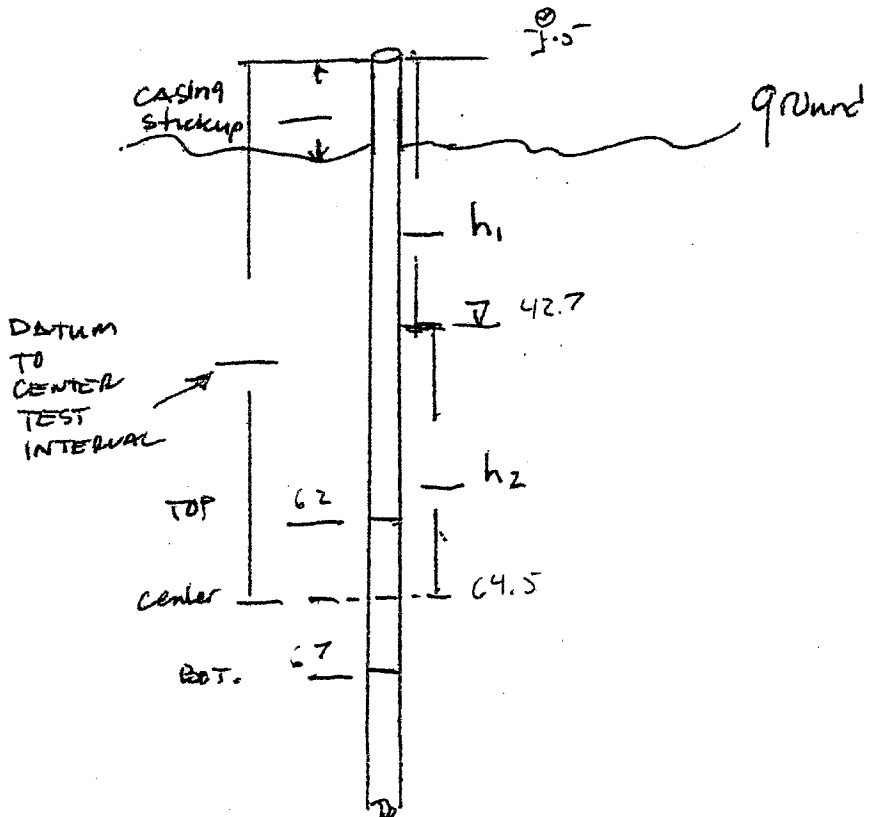

**DOUBLE PACKER BOREHOLE PERMEABILITY TEST DATA SHEET**

*JJ*  
23-06

MACTEC ENGINEERING AND CONSULTING, INC.

PROJECT: NORTH ANNA COL PROJECT NO.: 6468-06-1472

DATA COLLECTED BY: J Howard DATE COLLECTED: 8-18-06

BORING NO. B950 BOREHOLE DIAMETER: 4 IN.

SURFACE CASING HEIGHT ABOVE GROUND: 2.0 FT.

CHECK DATUM USED: TOP OF CASING  GROUND SURFACE

DATUM ELEVATION NA

DISTANCE BOTTOM OF TOP PACKER TO TOP OF BOTTOM PACKER 5.0 FT.

TEST INTERVAL DEPTH (FROM DATUM): FROM 62.0 FT. TO 67.0 FT.

TOTAL BORING DEPTH FROM DATUM: 102.0 FT.

(A) DEPTH TO WATER TABLE FROM DATUM: 42.7 FT.

(B) SURFACE GAUGE HEIGHT ABOVE DATUM: .5 FT.

(C) DISTANCE WATER TABLE TO CENTER OF TEST INTERVAL: 21.8 FT.

MAXIMUM TEST PRESSURE,  $P_o$  55.62 ( $P_o = [(A+B) * 1] + C * .57$  psi)

TEST NUMBER: 1 TEST PRESSURE 18.35 psi PACKER PRESSURE: 100 psi

Initial Transducer Readings: Top .24, Middle 9.64, Bottom 12.42

Transducer Readings after initial pressurization:  
Top .22, Middle 12.63, Bottom 11.62

Transducer Readings after final flow measurement:  
Top .24, Middle 16.46, Bottom 11.38

TIME (MIN)	FLOW METER READING, (GAL)	Q (GPM)	SURFACE GAUGE, PSI	REMARKS
0.0	2787.0	/	1.0	
0.5	2787.0	Ø	1.0	
1.0	2787.4	.8	1.4	
1.5	2788.1	1.4	10.6	
2.0	2788.1	Ø	10.5	
2.5	2788.1	Ø	6.1	
3.0	2788.1	Ø	5.9	
3.5	2788.1	Ø	5.8	
4.0	2788.1	Ø	5.8	
4.5	2788.1	Ø	5.8	
5.0	2788.1	Ø	5.7	
6.0				

BORING NO.: B950

DATE: 8-18-06

TEST NUMBER: 1

TEST INTERVAL (FROM DATUM): FROM 62.0 FT. TO 67.0 FT.

DATA COLLECTED BY: S Howard

2  
12-3-06

SHUT-IN TEST

PRESSURE: \_\_\_\_\_ psi

TIME, MIN	SURFACE GAUGE PRESSURE, PSI	MIDDLE TRANSDUCER PRESSURE, PSI
0.0	5.7	19.07
0.5	5.7	18.00
1.0	5.7	18.97
1.5	5.6	18.85
2.0	5.6	18.79
2.5	5.6	18.71
3.0	5.5	18.65
3.5	5.4	18.57
4.0	5.4	18.50
4.5	5.4	18.46
5.0	5.4	18.40
6.0	5.3	18.28
7.0	5.2	18.17
8.0	5.2	18.07
9.0	5.1	17.98
10.0	5.1	17.88
11.0	5.0	17.78
12.0	5.0	17.69
13.0	4.9	17.59
14.0	4.9	17.50
15.0	4.8	17.40
16.0	4.8	17.31
20.0	4.6	16.95
25.0	4.3	16.54

EQUIPMENT USED

Transducers: Mini Troll Serial Numbers: 10417 (Top), 10191 (Middle), 10036 (Bottom)

Surface Pressure Gauge: Omega DPG serial number 2634708001

Flow Meter Omega FTB-4110 serial number 32019518

Stop Watch: serial number SW1

Above calibrated 5-5-06 or 5-18-06

Tests: B950 - M162 - 67  
 " - B162 - "  
 " - T162 - "

DOUBLE PACKER BOREHOLE PERMEABILITY TEST DATA SHEET

*Handwritten:* 12-306

MACTEC ENGINEERING AND CONSULTING, INC.

PROJECT: NORTH ANNA COL PROJECT NO.: 6468-06-1472

DATA COLLECTED BY: J Howard DATE COLLECTED: 8-18-06

BORING NO. B950 BOREHOLE DIAMETER: 4 IN.

SURFACE CASING HEIGHT ABOVE GROUND: 2.0 FT.

CHECK DATUM USED: TOP OF CASING  GROUND SURFACE

DATUM ELEVATION NA

DISTANCE BOTTOM OF TOP PACKER TO TOP OF BOTTOM PACKER 5.0 FT.

TEST INTERVAL DEPTH (FROM DATUM): FROM 62.0 FT. TO 67.0 FT.

TOTAL BORING DEPTH FROM DATUM: 102.0 FT.

(A) DEPTH TO WATER TABLE FROM DATUM: 42.7 FT.

(B) SURFACE GAUGE HEIGHT ABOVE DATUM: .5 FT.

(C) DISTANCE WATER TABLE TO CENTER OF TEST INTERVAL: 21.8 FT.

*Handwritten:* 2/3

MAXIMUM TEST PRESSURE,  $P_0$  55.62 ( $P_0 = [(A+B) * 1] + C * .57$  psi)

TEST NUMBER: 2 TEST PRESSURE 36.17 psi PACKER PRESSURE: 100 psi

Initial Transducer Readings: Top 2.1, Middle 9.64, Bottom 12.42

Transducer Readings after initial pressurization:  
Top 6.24, Middle 16.46, Bottom 11.38

Transducer Readings after final flow measurement:  
Top 2.1, Middle 25.18, Bottom 11.36

TIME (MIN)	FLOW METER READING, (GAL)	Q (GPM)	SURFACE GAUGE, PSI	REMARKS
0.0	2788.1	/	4.1	
0.5	2788.8	1.4	8.9	
1.0	2789.1	.6	18.9	
1.5	2789.2	.4	17.9	
2.0	2789.2	Ø	17.6	
2.5	2789.2	Ø	17.3	
3.0	2789.2	Ø	17.1	
3.5	2789.2	Ø	16.9	
4.0	2789.2	Ø	16.7	
4.5	2789.2	Ø	17.4	
5.0	2789.2	Ø	17.3	
6.0				

BORING NO.: B950

DATE: 8-18-06

TEST NUMBER: 2

TEST INTERVAL (FROM DATUM): FROM 62.0 FT. TO 67.0 FT.

DATA COLLECTED BY: S Howard

*Handwritten:* 2  
12-3-06

SHUT-IN TEST

PRESSURE: \_\_\_\_\_ psi

TIME, MIN	SURFACE GAUGE PRESSURE, PSI	MIDDLE TRANSDUCER PRESSURE, PSI
0.0	17.3	36.29
0.5	17.0	36.04
1.0	16.8	35.68
1.5	16.6	35.47
2.0	16.3	35.19
2.5	16.1	35.00
3.0	16.0	34.68
3.5	15.7	34.31
4.0	15.5	34.16
4.5	15.4	33.90
5.0	15.4	33.48
6.0	14.8	33.15
7.0	14.4	32.65
8.0	14.1	32.22
9.0	13.8	31.80
10.0	13.5	31.34
11.0	13.2	30.94
12.0	12.9	30.52
13.0	12.6	30.11
14.0	12.4	29.75
15.0	12.1	29.35
20.0	10.9	27.68
25.0	9.9	26.18

EQUIPMENT USED

Transducers: Mini Troll Serial Numbers: 10417 (Top), 10191 (Middle), 10036 (Bottom)

Surface Pressure Gauge: Omega DPG serial number 2634708001

Flow Meter Omega FTB-4110 serial number 32019518

Stop Watch: serial number SW1

Above calibrated 5-5-06 or 5-18-06

Tests: B950 - 8262-67  
 " - T262-11  
 " - M262-11



**DOUBLE PACKER BOREHOLE PERMEABILITY TEST DATA SHEET**

*JJ 12-3-06*

MACTEC ENGINEERING AND CONSULTING, INC.

PROJECT: NORTH ANNA COL PROJECT NO.: 6468-06-1472

DATA COLLECTED BY: J Howard DATE COLLECTED: 8-18-06

BORING NO. B 950 BOREHOLE DIAMETER: 4 IN.

SURFACE CASING HEIGHT ABOVE GROUND: 2.0 FT.

CHECK DATUM USED: TOP OF CASING  GROUND SURFACE

DATUM ELEVATION NA

DISTANCE BOTTOM OF TOP PACKER TO TOP OF BOTTOM PACKER 5.0 FT.

TEST INTERVAL DEPTH (FROM DATUM): FROM 62.0 FT. TO 67.0 FT.

TOTAL BORING DEPTH FROM DATUM: 102.0 FT.

(A) DEPTH TO WATER TABLE FROM DATUM: 42.7 FT.

(B) SURFACE GAUGE HEIGHT ABOVE DATUM: .5 FT.

(C) DISTANCE WATER TABLE TO CENTER OF TEST INTERVAL: 21.8 FT.

MAXIMUM TEST PRESSURE,  $P_o$  55.62 ( $P_o = [(A+B) * 1] + C * .57$  psi)

TEST NUMBER: 3 TEST PRESSURE 55.62 psi PACKER PRESSURE: 100 psi

Initial Transducer Readings: Top .24, Middle 9.64, Bottom 12.42

Transducer Readings after initial pressurization:  
Top .21, Middle 25.18, Bottom 11.36

Transducer Readings after final flow measurement:  
Top .18, Middle 25.50, Bottom 11.37

TIME (MIN)	FLOW METER READING, (GAL)	Q (GPM)	SURFACE GAUGE, PSI	REMARKS
0.0	2789.2	/	8.3	
0.5	2790.4	2.4	39.3	
1.0	2790.4	Ø	38.2	
1.5	2790.5	.2	31.1	Bleed at some pressure
2.0	2790.5	Ø	32.9	
2.5	2790.5	Ø	33.2	
3.0	2790.5	Ø	33.3	
3.5	2790.5	Ø	32.6	
4.0	2790.5	Ø	32.5	
4.5	2790.5	Ø	33.1	
5.0	2790.5	Ø	33.2	
6.0				

BORING NO.: B 950

DATE: 8-18-06

TEST NUMBER: 3

TEST INTERVAL (FROM DATUM): FROM 62.0 FT. TO 67.0 FT.

DATA COLLECTED BY: S Howard

2  
JCY  
12-3-06

SHUT-IN TEST

PRESSURE: \_\_\_\_\_ psi

TIME, MIN	SURFACE GAUGE PRESSURE, PSI	MIDDLE TRANSDUCER PRESSURE, PSI
0.0	37.2	55.42
0.5	31.8	54.44
1.0	30.4	52.83
1.5	29.3	51.55
2.0	28.1	50.28
2.5	27.2	49.08
3.0	26.2	47.96
3.5	25.3	46.98
4.0	24.5	45.99
4.5	<del>24.5</del> 23.6	45.07
5.0	22.8	44.15
6.0	21.7	42.60
7.0	20.5	41.13
8.0	19.3	39.74
9.0	18.3	38.43
10.0	17.3	37.32
11.0	16.5	36.25
12.0	15.8	35.29
13.0	15.0	34.23
14.0	14.4	33.40
15.0	13.7	32.52
20.0	11.1	28.93
25.0	9.0	26.02

EQUIPMENT USED

Transducers: Mini Troll Serial Numbers: 10417 (Top), 10191 (Middle), 10036 (Bottom)

Surface Pressure Gauge: Omega DPG serial number 2634708001

Flow Meter Omega FTB-4110 serial number 32019518

Stop Watch: serial number SW1

Above calibrated 5-5-06 or 5-18-06

Tests: B950 - M362-67  
 " - T3 62 - 11  
 " - B3 62 - 11

DOUBLE PACKER BOREHOLE PERMEABILITY TEST DATA SHEET

*JHJ*  
12-3-06

MACTEC ENGINEERING AND CONSULTING, INC.

PROJECT: NORTH ANNA COL PROJECT NO.: 6468-06-1472

DATA COLLECTED BY: J Howard DATE COLLECTED: 8-18-06

BORING NO. B 950 BOREHOLE DIAMETER: 4 IN.

SURFACE CASING HEIGHT ABOVE GROUND: 2.0 FT.

CHECK DATUM USED: TOP OF CASING X GROUND SURFACE     

DATUM ELEVATION NA

DISTANCE BOTTOM OF TOP PACKER TO TOP OF BOTTOM PACKER 5.0 FT.

TEST INTERVAL DEPTH (FROM DATUM): FROM 62.0 FT. TO 67.0 FT.

TOTAL BORING DEPTH FROM DATUM: 102.0 FT.

(A) DEPTH TO WATER TABLE FROM DATUM: 42.7 FT.

(B) SURFACE GAUGE HEIGHT ABOVE DATUM: .5 FT.

(C) DISTANCE WATER TABLE TO CENTER OF TEST INTERVAL: 21.8 FT.

$\frac{1}{2}$  MAXIMUM TEST PRESSURE,  $P_o$  55.62 ( $P_o = [(A+B) * 1] + C * .57$  psi)

TEST NUMBER: 4 TEST PRESSURE 27.81 psi PACKER PRESSURE: 100 psi

Initial Transducer Readings: Top .24, Middle 9.64, Bottom 12.42

Transducer Readings after initial pressurization:

Top .18, Middle 25.50, Bottom 11.36

Transducer Readings after final flow measurement:

Top .20, Middle 14.86, Bottom 11.36

TIME (MIN)	FLOW METER READING, (GAL)	Q (GPM)	SURFACE GAUGE, PSI	REMARKS
0.0	2790.5	/	2.2	
0.5	2791.2	1.4	10.6	
1.0	2791.2	Ø	10.8	
1.5	2791.2	Ø	10.6	
2.0	2791.2	Ø	10.5	
2.5	2791.2	Ø	10.7	
3.0	2791.2	Ø	10.9	
3.5	2791.2	Ø	11.0	
4.0	2791.2	Ø	11.1	
4.5	2791.2	Ø	11.3	
5.0	2791.2	Ø	11.4	
6.0				

DOUBLE PACKER BOREHOLE PERMEABILITY TEST DATA SHEET

JA 8  
12-3-06

MACTEC ENGINEERING AND CONSULTING, INC.

PROJECT: NORTH ANNA COL PROJECT NO.: 6468-06-1472

DATA COLLECTED BY: J Howard DATE COLLECTED: 9-18-06

BORING NO. B 950 BOREHOLE DIAMETER: 4 IN.

SURFACE CASING HEIGHT ABOVE GROUND: 2.0 FT.

CHECK DATUM USED: TOP OF CASING  GROUND SURFACE

DATUM ELEVATION NA

DISTANCE BOTTOM OF TOP PACKER TO TOP OF BOTTOM PACKER 5.0 FT.

TEST INTERVAL DEPTH (FROM DATUM): FROM 62.0 FT. TO 67.0 FT.

TOTAL BORING DEPTH FROM DATUM: 162.0 FT.

(A) DEPTH TO WATER TABLE FROM DATUM: 47.7 FT.

(B) SURFACE GAUGE HEIGHT ABOVE DATUM: .5 FT.

(C) DISTANCE WATER TABLE TO CENTER OF TEST INTERVAL: 21.8 FT.

MAXIMUM TEST PRESSURE,  $P_0$  55.62 ( $P_0 = [(A+B) * 1] + C * .57$  psi)

TEST NUMBER: 5 TEST PRESSURE 55.62 psi ~~18.55~~ PACKER PRESSURE: 100 psi

Initial Transducer Readings: Top .024, Middle 9.64, Bottom 17.42

Transducer Readings after initial pressurization:

Top .20, Middle 14.86, Bottom 11.36

Transducer Readings after final flow measurement:

Top .14, Middle 25.84, Bottom 11.36

TIME (MIN)	FLOW METER READING, (GAL)	Q (GPM)	SURFACE GAUGE, PSI	REMARKS
0.0	2791.2	/	2.9	
0.5	2792.6	2.8	32.8	
1.0	2792.6	Ø	37.2	
1.5	2792.6	Ø	35.7	
2.0	2792.6	Ø	34.2	
2.5	2792.6	Ø	32.6	
3.0	2792.6	Ø	33.5	
3.5	2792.6	Ø	34.0	
4.0	2792.6	Ø	37.8	
4.5	2792.6	Ø	33.9	
5.0	2792.6	Ø	33.4	
6.0				

DOUBLE PACKER TEST DATA SHEET, MACTEC PROJECT NO. 6468-06-1472

PAGE 3

BORING NO.: B950

DATE: 8-18-06

TEST NUMBER: 5

TEST INTERVAL (FROM DATUM): FROM 62.0 FT. TO 67.0 FT.

DATA COLLECTED BY: Showard

2  
12-306

SHUT-IN TEST

PRESSURE: \_\_\_\_\_ psi

TIME, MIN	SURFACE GAUGE PRESSURE, PSI	MIDDLE TRANSDUCER PRESSURE, PSI
0.0	33.4	55.64
0.5	32.0	54.03
1.0	30.9	52.81
1.5	29.5	51.22
2.0	28.5	49.99
2.5	27.7	48.70
3.0	26.6	47.91
3.5	25.7	46.85
4.0	24.6	45.79
4.5	24.0	45.04
5.0	23.4	44.10
6.0	22.1	42.58
7.0	20.9	41.00
8.0	19.9	39.00 <sup>70</sup>
9.0	18.8	38.46
10.0	17.9	37.29
11.0	17.2	36.28
12.0	16.4	35.30
13.0	15.8	34.35
14.0	15.1	33.40
15.0	14.4	32.58
20.0	11.9	29.06
25.0	9.8	26.14
30.0	8.4	23.98
35.0	7.1	22.02

EQUIPMENT USED

Transducers: Mini Troll Serial Numbers: 10417 (Top), 10191 (Middle), 10036 (Bottom)

Surface Pressure Gauge: Omega DPG serial number 2634708001

Flow Meter Omega FTB-4110 serial number 32019518

Stop Watch: serial number SW1

Above calibrated 5-5-06 or 5-18-06

Tests: B950 - M562-67  
 " - T562 - "  
 " - B562 - "

DOUBLE PACKER TEST DATA SHEET, MACTEC PROJECT NO. 6468-06-1472

PAGE 3

BORING NO.: B950

DATE: 8-17-06

TEST NUMBER: 4

TEST INTERVAL (FROM DATUM): FROM 62.0 FT. TO 670 FT.

DATA COLLECTED BY: Steward

*2*  
*12-3-06*

SHUT-IN TEST

PRESSURE: \_\_\_\_\_ psi

TIME, MIN	SURFACE GAUGE PRESSURE, PSI	MIDDLE TRANSDUCER PRESSURE, PSI
0.0	11.4	28.10
0.5	11.2	27.92
1.0	11.0	27.62
1.5	10.8	27.20
2.0	10.5	26.98
2.5	10.3	26.62
3.0	10.1	26.35
3.5	9.9	26.07
4.0	9.7	25.76
4.5	9.4	25.42
5.0	9.3	25.18
6.0	9.0	24.69
7.0	8.6	24.16
8.0	8.3	23.69
9.0	8.1	23.23
10.0	7.7	22.78
11.0	7.4	22.34
12.0	7.1	21.92
13.0	6.9	21.51
14.0	6.6	21.00
15.0	6.4	20.74
20.0	6.4	19.00
<del>25.0</del>		

EQUIPMENT USED

Transducers: Mini Troll Serial Numbers: 10417 (Top), 10191 (Middle), 10036 (Bottom)

Surface Pressure Gauge: Omega DPG serial number 2634708001

Flow Meter Omega FTB-4110 serial number 32019518

Stop Watch: serial number SW1

Above calibrated 5-5-06 or 5-18-06

Tests: B950 - M462 - 67  
 " - T462 - 11  
 " - B462 - 11

PACKER TESTING CALCULATIONS FOR P(MAX)

82  
11-3-06

Date: 8-18-06

Boring No. B950

Test Interval: 84.0 to 89.0 feet from Datum

Casing Stickup 2.0 feet

PoMAX = (h<sub>1</sub> x 1) + (h<sub>2</sub> x 0.57). h<sub>1</sub> and h<sub>2</sub> are in feet, see sketch. PoMAX is in psi

h<sub>1</sub> = Distance from the datum to the water level + Height of Gauge above Datum.

h<sub>2</sub> = Distance from the water level to the center of the test interval

h<sub>1</sub> = 42.7 + .5 = 43.2

h<sub>2</sub> = 86.5 - 42.7 = 43.8

P MAX = 43.2 + 24.9 = 68.16

SKETCH

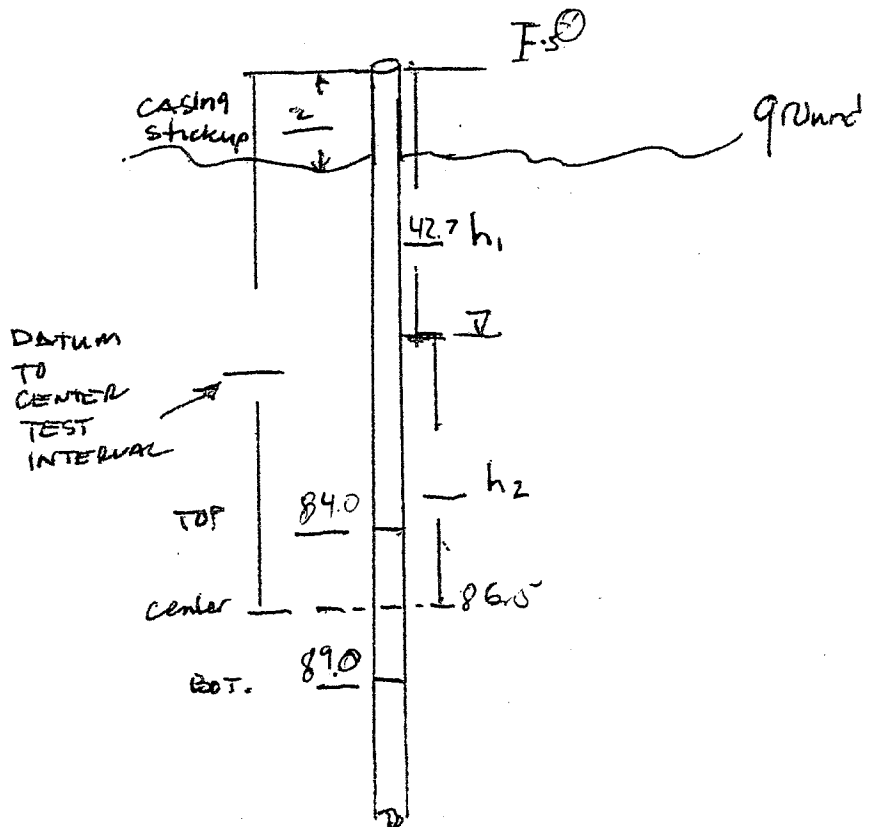

DOUBLE PACKER BOREHOLE PERMEABILITY TEST DATA SHEET

*JJ*  
12-3-06

MACTEC ENGINEERING AND CONSULTING, INC.

PROJECT: NORTH ANNA COL PROJECT NO.: 6468-06-1472

DATA COLLECTED BY: S Howard DATE COLLECTED: 8-18-06

BORING NO. B950 BOREHOLE DIAMETER: 4 IN.

SURFACE CASING HEIGHT ABOVE GROUND: 2.0 FT.

CHECK DATUM USED: TOP OF CASING  GROUND SURFACE

DATUM ELEVATION NA

DISTANCE BOTTOM OF TOP PACKER TO TOP OF BOTTOM PACKER 5.0 FT.

TEST INTERVAL DEPTH (FROM DATUM): FROM 84.0 FT. TO 89.0 FT.

TOTAL BORING DEPTH FROM DATUM: 102.0 FT.

(A) DEPTH TO WATER TABLE FROM DATUM: 42.7 FT.

(B) SURFACE GAUGE HEIGHT ABOVE DATUM: 5 FT.

(C) DISTANCE WATER TABLE TO CENTER OF TEST INTERVAL: 43.8 FT.

MAXIMUM TEST PRESSURE,  $P_o$  68.16 ( $P_o = [(A+B) * 1] + C * .57$  psi)

TEST NUMBER: 1 TEST PRESSURE 22.49 psi PACKER PRESSURE: 100 psi

Initial Transducer Readings: Top 8.52, Middle 26.36, Bottom 29.14

Transducer Readings after initial pressurization:  
Top 9.07, Middle 28.15, Bottom 37.29

Transducer Readings after final flow measurement:  
Top 7.85, Middle 22.66, Bottom 26.86

TIME (MIN)	FLOW METER READING, (GAL)	Q (GPM)	SURFACE GAUGE, PSI	REMARKS
0.0	2777.6	/	-0.4	
0.5	2777.6	0	-1.0	
1.0	2779.1	3.0	+8.2	
1.5	2779.3	.4	9.1	
2.0	2779.3	0	8.9	
2.5	2779.3	0	8.6	
3.0	2779.3	0	8.4	
3.5	2779.3	0	8.1	
4.0	2779.3	0	7.8	
4.5	2779.3	0	7.6	
5.0	2779.3	0	7.4	
6.0				

\* Per ALTice's instructions we will be using 1.1x the natural pressure instead of the  $\frac{1}{3}$  Max  $P_o$ , which is below Nat. Pressure 30.96



BORING NO.: B950

DATE: 8-18-06

TEST NUMBER: 1

TEST INTERVAL (FROM DATUM): FROM 89.0 FT. TO 84.0 FT.

DATA COLLECTED BY: J Howard

2  
12-3-06

SHUT-IN TEST

PRESSURE: \_\_\_\_\_ psi

TIME, MIN	SURFACE GAUGE PRESSURE, PSI	MIDDLE TRANSDUCER PRESSURE, PSI
6.0	7.4	31.39
0.5	7.1	30.87
1.0	7.0	30.53
1.5	6.8	30.15
2.0	6.6	29.75
2.5	6.4	29.34
3.0	6.2	28.96
3.5	6.0	28.62
4.0	6.0	28.38
4.5	5.8	28.05
5.0	5.7	27.77
5.5	5.5	27.50
6.0	5.4	27.26
6.5	5.3	27.00
7.0	5.2	26.77
7.5	5.0	26.56
8.0	4.9	26.36
8.5	4.8	26.14
9.0	4.7	25.94
9.5	4.7	25.75
10.0	4.6	25.56
10.5	4.5	25.36
11.0	4.4	25.20
11.5	4.3	25.03
12.0	4.2	24.85
12.5	4.1	24.67
13.0	4.1	24.54
13.5	4.0	24.36
14.0	3.9	24.21
14.5	3.8	24.05

12. EQUIPMENT USED

Transducers: Mini Troll Serial Numbers: 10417 (Top), 10191 (Middle), 10036 (Bottom)

Surface Pressure Gauge: Omega DPG serial number 2634708001

Flow Meter Omega FTB-4110 serial number 32019518

Stop Watch: serial number SW1

Above calibrated 5-5-06 or 5-18-06

Tests: B950-M184-89  
11 - B184-11  
11 - T184-11

15.0	3.8	23.91
15.5	3.7	23.77
16.0	3.6	23.64
16.5	3.6	23.50
17.0	3.5	23.37
20.0	3.1	22.66

DOUBLE PACKER BOREHOLE PERMEABILITY TEST DATA SHEET

*John J*  
12-3-06

MACTEC ENGINEERING AND CONSULTING, INC.

PROJECT: NORTH ANNA COL PROJECT NO.: 6468-06-1472

DATA COLLECTED BY: S Howard DATE COLLECTED: 8-18-06

BORING NO. B 950 BOREHOLE DIAMETER: 4 IN.

SURFACE CASING HEIGHT ABOVE GROUND: 2.0 FT.

CHECK DATUM USED: TOP OF CASING X GROUND SURFACE     

DATUM ELEVATION NA

DISTANCE BOTTOM OF TOP PACKER TO TOP OF BOTTOM PACKER 5.0 FT.

TEST INTERVAL DEPTH (FROM DATUM): FROM 84.0 FT. TO 89.0 FT.

TOTAL BORING DEPTH FROM DATUM: 102.0 FT.

(A) DEPTH TO WATER TABLE FROM DATUM: 42.7 FT.

(B) SURFACE GAUGE HEIGHT ABOVE DATUM: .5 FT.

(C) DISTANCE WATER TABLE TO CENTER OF TEST INTERVAL: 43.8 FT.

2/3

MAXIMUM TEST PRESSURE,  $P_o$  68.16 ( $P_o = [(A+B) * 1] + C * .57$  psi)

TEST NUMBER: 2 TEST PRESSURE 44.98 psi PACKER PRESSURE: 100 psi

Initial Transducer Readings: Top 8.52, Middle 26.49, Bottom 29.14

Transducer Readings after initial pressurization:  
Top 7.85, Middle 22.66, Bottom 27.29

Transducer Readings after final flow measurement:  
Top 6.50, Middle 22.54, Bottom 28.17

TIME (MIN)	FLOW METER READING, (GAL)	Q (GPM)	SURFACE GAUGE, PSI	REMARKS
0.0	2779.3	/	2.1	
0.5	2781.0	1.4	4.5	
1.0	2781.0	∅	23.3	
1.5	2781.0	∅	21.1	
2.0	2781.0	∅	19.4	
2.5	2781.0	∅	17.8	
3.0	2781.0	∅	16.3	
3.5	2781.0	∅	15.5	
4.0	2781.0	∅	14.7	
4.5	2781.0	∅	19.7	
5.0	2781.0	∅	18.8	
6.0	2781.0	∅	18.7	

BORING NO.: B 950

DATE: 8-18-06

TEST NUMBER: 2

TEST INTERVAL (FROM DATUM): FROM 84.0 FT. TO 89.0 FT.

DATA COLLECTED BY: J Howard

*JJ* 10-3-06

SHUT-IN TEST

PRESSURE: \_\_\_\_\_ psi

TIME, MIN	SURFACE GAUGE PRESSURE, PSI	MIDDLE TRANSDUCER PRESSURE, PSI
0.0	18.7	45.29
0.5	17.8	44.03
1.0	16.6	42.47
1.5	16.6	41.08
2.0	14.7	39.92
2.5	13.4	38.69
3.0	13.1	37.58
3.5	12.5	36.65
4.0	11.9	35.77
4.5	11.4	34.89
5.0	10.9	34.24
6.0	10.0	32.84
7.0	9.3	31.67
8.0	8.7	30.65
9.0	8.1	29.71
10.0	7.6	28.90
11.0	7.2	28.15
12.0	6.9	27.47
13.0	6.5	26.87
14.0	6.2	26.30
15.0	5.9	25.78
16.0	5.6	25.31
20.0	4.8	23.76

EQUIPMENT USED

Transducers: Mini Troll Serial Numbers: 10417 (Top), 10191 (Middle), 10036 (Bottom)

Surface Pressure Gauge: Omega DPG serial number 2634708001

Flow Meter Omega FTB-4110 serial number 32019518

Stop Watch: serial number SW1

Above calibrated 5-5-06 or 5-18-06

Tests: B 950 - M284-89  
 " - T284 - "  
 " - B284 - "

**DOUBLE PACKER BOREHOLE PERMEABILITY TEST DATA SHEET**

*AD 12-3-06*

MACTEC ENGINEERING AND CONSULTING, INC.

PROJECT: NORTH ANNA COL PROJECT NO.: 6468-06-1472

DATA COLLECTED BY: J Howard DATE COLLECTED: 5-18-06

BORING NO. B950 BOREHOLE DIAMETER: 4 IN.

SURFACE CASING HEIGHT ABOVE GROUND: 2.0 FT.

CHECK DATUM USED: TOP OF CASING  GROUND SURFACE

DATUM ELEVATION NA

DISTANCE BOTTOM OF TOP PACKER TO TOP OF BOTTOM PACKER 5.0 FT.

TEST INTERVAL DEPTH (FROM DATUM): FROM 84.0 FT. TO 89.0 FT.

TOTAL BORING DEPTH FROM DATUM: 102.0 FT.

(A) DEPTH TO WATER TABLE FROM DATUM: 42.7 FT.

(B) SURFACE GAUGE HEIGHT ABOVE DATUM: .5 FT.

(C) DISTANCE WATER TABLE TO CENTER OF TEST INTERVAL: 43.8 FT.

MAXIMUM TEST PRESSURE,  $P_o$  68.16 ( $P_o = [(A+B) * 1] + C * .57$  psi)

TEST NUMBER: 3 TEST PRESSURE 68.16 psi PACKER PRESSURE: 100 psi

Initial Transducer Readings: Top 852, Middle 270.36, Bottom 29.14

Transducer Readings after initial pressurization:

Top 6.50, Middle 22.54, Bottom 28.12

Transducer Readings after final flow measurement:

Top 5.45, Middle 29.91, Bottom 35.70

TIME (MIN)	FLOW METER READING, (GAL)	Q (GPM)	SURFACE GAUGE, PSI	REMARKS
0.0	2781.3	—	3.8	
0.5	2783.0	3.4	33.9	
1.0	2783.1	.2	38.2	
1.5	2783.2	.2	35.5	
2.0	2783.3	.2	39.0	
2.5	2783.3	∅	36.3	
3.0	2783.3	∅	37.1	
3.5	2783.3	∅	38.1	
4.0	2783.3	∅	35.9	
4.5	2783.3	∅	37.8	
5.0	2783.4	.2	37.1	
6.0	2783.5	.2	34.4	
7.0	2783.5	∅	38.1	

BORING NO.: B950

DATE: 8-18-06

TEST NUMBER: 3

TEST INTERVAL (FROM DATUM): FROM 84.0 FT. TO 89.0 FT.

DATA COLLECTED BY: Sho...

2  
12-3-06

SHUT-IN TEST

PRESSURE: \_\_\_\_\_ psi

TIME, MIN	SURFACE GAUGE PRESSURE, PSI	MIDDLE TRANSDUCER PRESSURE, PSI
0.0	38.1	69.10
0.5	30.0	60.80
1.0	26.7	55.91
1.5	23.7	52.15
2.0	21.2	48.64
2.5	18.8	46.13
3.0	17.4	44.17
3.5	15.7	42.01
4.0	14.6	40.36
4.5	13.7	38.80
5.0	12.8	37.74
6.0	11.4	35.70
7.0	10.2	33.84
8.0	9.3	32.40
9.0	8.5	31.05
10.0	7.8	29.93
11.0	7.2	28.95
12.0	6.7	28.05
13.0	6.2	27.29
14.0	5.8	26.60
15.0	5.8	25.97
16.0	5.2	25.41
20.0	4.2	23.62

EQUIPMENT USED

Transducers: Mini Troll Serial Numbers: 10417 (Top), 10191 (Middle), 10036 (Bottom)

Surface Pressure Gauge: Omega DPG serial number 2634708001

Flow Meter Omega FTB-4110 serial number 32019518

Stop Watch: serial number SW1

Above calibrated 5-5-06 or 5-18-06

Tests: B950 - M384-89  
 " - B384-11  
 " - T384-11

**DOUBLE PACKER BOREHOLE PERMEABILITY TEST DATA SHEET**

*JGJ*  
12-3-06

MACTEC ENGINEERING AND CONSULTING, INC.

PROJECT: NORTH ANNA COL PROJECT NO.: 6468-06-1472

DATA COLLECTED BY: J Howard DATE COLLECTED: 8-18-06

BORING NO. B 950 BOREHOLE DIAMETER: 4 IN.

SURFACE CASING HEIGHT ABOVE GROUND: 2.0 FT.

CHECK DATUM USED: TOP OF CASING  GROUND SURFACE

DATUM ELEVATION NA

DISTANCE BOTTOM OF TOP PACKER TO TOP OF BOTTOM PACKER 5.0 FT.

TEST INTERVAL DEPTH (FROM DATUM): FROM 84.0 FT. TO 89.0 FT.

TOTAL BORING DEPTH FROM DATUM: 102.0 FT.

(A) DEPTH TO WATER TABLE FROM DATUM: 42.7 FT.

(B) SURFACE GAUGE HEIGHT ABOVE DATUM: 0.5 FT.

(C) DISTANCE WATER TABLE TO CENTER OF TEST INTERVAL: 43.8 FT.

<sup>1/2</sup> MAXIMUM TEST PRESSURE,  $P_o$  68.16 ( $P_o = [(A+B) * 1] + C * .57$  psi) *24*  
*214* *125\**  
TEST NUMBER: 4 TEST PRESSURE 34.08 psi PACKER PRESSURE: 100 psi

Initial Transducer Readings: Top 8.52, Middle 26.36, Bottom 29.14

Transducer Readings after initial pressurization:  
Top 5.45, Middle 29.91, Bottom 35.70

Transducer Readings after final flow measurement:  
Top 4.64, Middle 19.63, Bottom 35.70

TIME (MIN)	FLOW METER READING, (GAL)	Q (GPM)	SURFACE GAUGE, PSI	REMARKS
0.0	2783.5	/	2.8	
0.5	2783.9	.8	6.5	
1.0	2784.7	1.2	16.7	
1.5	2784.7	∅	15.7	
2.0	2784.7	∅	14.5	
2.5	2784.7	∅	13.4	
3.0	2784.7	∅	12.5	
3.5	2784.7	∅	11.7	
4.0	2784.7	∅	11.1	
4.5	2784.7	∅	10.5	
5.0	2784.7	∅	10.0	

DOUBLE PACKER TEST DATA SHEET, MACTEC PROJECT NO. 6468-06-1472

PAGE 1

BORING NO.: B 950

DATE: 8-18-06

TEST NUMBER: 4

TEST INTERVAL (FROM DATUM): FROM 84.0 FT. TO 89.0 FT.

DATA COLLECTED BY: S Howard

2  
12-3-06

SHUT-IN TEST

PRESSURE: \_\_\_\_\_ psi

TIME, MIN	SURFACE GAUGE PRESSURE, PSI	MIDDLE TRANSDUCER PRESSURE, PSI
0.0	10.0	33.07
0.5	9.3	31.94
1.0	9.2	31.28
1.5	8.4	30.56
2.0	8.0	29.97
2.5	7.4	28.82
3.0	7.0	28.23
3.5	6.8	27.81
4.0	6.5	27.37
4.5	6.3	26.97
5.0	5.8	26.21
6.0	5.4	25.53
7.0	5.1	24.94
8.0	4.8	24.39
9.0	4.6	23.93
10.0	4.3	23.47
11.0	4.1	23.07
12.0	3.9	22.71
13.0	3.7	22.41
14.0	3.6	22.10
15.0	3.4	21.83
<del>20.0</del> 16.0	3.3	21.58
20.0	2.9	20.95

EQUIPMENT USED

Transducers: Mini Troll Serial Numbers: 10417 (Top), 10191 (Middle), 10036 (Bottom)

Surface Pressure Gauge: Omega DPG serial number 2634708001

Flow Meter Omega FTB-4110 serial number 32019518

Stop Watch: serial number SW1

Above calibrated 5-5-06 or 5-18-06

Tests: B 950 - M 484 - 89  
 // B4 84 //  
 // T4 89 //

**DOUBLE PACKER BOREHOLE PERMEABILITY TEST DATA SHEET**

*JH*  
12-3-06

MACTEC ENGINEERING AND CONSULTING, INC.

PROJECT: NORTH ANNA COL PROJECT NO.: 6468-06-1472

DATA COLLECTED BY: S Howard DATE COLLECTED: 8-18-06

BORING NO. B950 BOREHOLE DIAMETER: 4 IN.

SURFACE CASING HEIGHT ABOVE GROUND: 2.0 FT.

CHECK DATUM USED: TOP OF CASING X GROUND SURFACE     

DATUM ELEVATION Na

DISTANCE BOTTOM OF TOP PACKER TO TOP OF BOTTOM PACKER 5.0 FT.

TEST INTERVAL DEPTH (FROM DATUM): FROM 89.0 FT. TO 89.0 FT.

TOTAL BORING DEPTH FROM DATUM: 102.0 FT.

(A) DEPTH TO WATER TABLE FROM DATUM: 42.7 FT.

(B) SURFACE GAUGE HEIGHT ABOVE DATUM: .5 FT.

(C) DISTANCE WATER TABLE TO CENTER OF TEST INTERVAL: 43.8 FT.

MAXIMUM TEST PRESSURE,  $P_0$  68.16 ( $P_0 = [(A+B) * 1] + C * .57$  psi)

TEST NUMBER: 5 TEST PRESSURE 68.16 psi PACKER PRESSURE: 125 psi

Initial Transducer Readings: Top 8.56, Middle 26.36, Bottom 29.14

Transducer Readings after initial pressurization:

Top 4.64, Middle 19.63, Bottom 35.70

Transducer Readings after final flow measurement:

Top 4.09, Middle 22.78, Bottom 36.50

TIME (MIN)	FLOW METER READING, (GAL)	Q (GPM)	SURFACE GAUGE, PSI	REMARKS
0.0	2784.7	/	2.3	
0.5	2785.6	1.8	14.0	
1.0	2786.6	2.0	34.3	
1.5	2786.6	Ø	35.6	
2.0	2786.7	.2	38.1	
2.5	2786.8	.2	40.0	
3.0	2786.8	Ø	36.6	
3.5	2786.8	Ø	36.9	
4.0	2786.9	.2	38.0	
4.5	2786.9	Ø	38.1	
5.0	2786.9	Ø	37.7	
6.0	2787.0	.2	37.3	



DOUBLE PACKER TEST DATA SHEET, MACTEC PROJECT NO. 6468-06-1472

PAGE 3

BORING NO.: B950

DATE: 8-18-06

TEST NUMBER: 5

TEST INTERVAL (FROM DATUM): FROM 84.0 FT. TO 89.0 FT.

DATA COLLECTED BY: J Howard

2  
12-3-06

SHUT-IN TEST

PRESSURE: \_\_\_\_\_ psi

TIME, MIN	SURFACE GAUGE PRESSURE, PSI	MIDDLE TRANSDUCER PRESSURE, PSI
0.0	37.3	67.95
0.5	31.1	61.05
1.0	26.4	55.67
1.5	27.7	50.91
2.0	20.1	47.61
2.5	18.1	45.6
3.0	16.2	43.04
3.5	15.0	40.78
4.0	13.6	38.89
4.5	12.1	36.76
5.0	11.4	35.16
6.0	10.7	34.52
7.0	9.3	32.63
8.0	8.6	31.22
9.0	7.9	30.00
10.0	7.3	28.88
11.0	6.6	27.85
12.0	6.2	27.05
13.0	5.7	26.31
14.0	5.4	25.61
15.0	5.0	25.05
16.0	4.8	24.52
20.0	3.9	22.97

EQUIPMENT USED

Transducers: Mini Troll Serial Numbers: 10417 (Top), 10191 (Middle), 10036 (Bottom)

Surface Pressure Gauge: Omega DPG serial number 2634708001

Flow Meter Omega FTB-4110 serial number 32019518

Stop Watch: serial number SW1

Above calibrated 5-5-06 or 5-18-06

Tests: B950 - M584-89  
 " - T584-11  
 " - B584-11

(5)

51

8-18-06

James Howard

M. Miller: Mark Hughes, Tom Garin  
B949 & 950

Arrive 7

Safety meeting 730

Breakdown: Robertson B949 8-830

Move & Setup on B950 830-930

Get water 930-10

More setup 10-1115

Lunch 1115-1145

Packer tests 1145-345 (84-89)

BD 345-4

Paperwork 4-4130

DATA REPORT Rev. 0

MACTEC ENGINEERING & CONSULTING, INC.

1/23/07

⑥ 8.20.06

James Howard  
Miller, Mark Hughes, Tim Garland  
B 950

8 arrive

830 meeting

9-Packages setup

10-130 Packages @ ~~170~~ 8-21 62-67

130-430 packages @ 57-62

430-5 Paperwork

0 11

⑥ 47.2

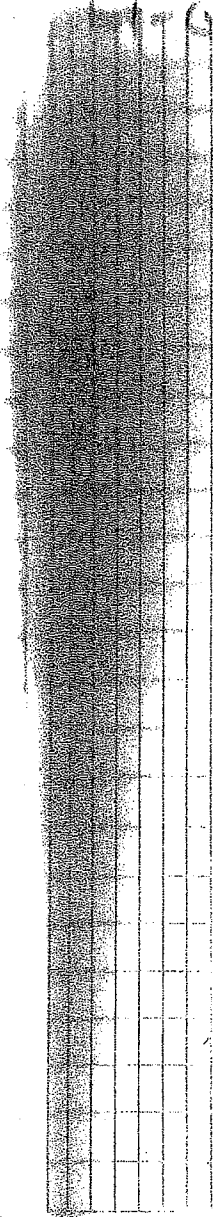

*[Handwritten signature]*





**MACTEC ENGINEERING AND CONSULTING, INC.**

**RALEIGH, NORTH CAROLINA**

**IN SITU DETERMINATION OF ROCK MASS PERMEABILITY USING WATER PRESSURE TEST  
IN ACCORDANCE WITH CORPS OF ENGINEERS,  
(WATERWAYS EXPERIMENT STATION, RTH 381-80)**

**PROJECT NAME: NORTH ANNA COL  
PROJECT NUMBER: 6468-06-1472  
REPORT DATE: 12/7/2006 Revised 1-13-07  
BORING NO: B-951**

**Given Parameters**

Test Section Length,  $l$ , ft: 5  
 Radius of Borehole  $r_0$ , in: 2.00  
 GW Depth, ft: 23.00 (from top of casing) 21.50 (from top of casing)

Prepared by: ZO  
 Checked by: JM

Date: 12-7-06  
 Date: 1-17-07

Test Number	Q (GPM)	$P_{Test}$ (psi)	$P_T$ (psi)	$P_M$ (psi)	$P_B$ (psi)	Q (cfs)	$H_M$ (ft)	$K_e$ (fpy)
<b>Interval 1, ft: 71 - 76</b>		(from ground surface)						
1	0.00	37.63	5.63	31.54	34.26	0.0	86.8	0.00
2	0.00	39.63	5.63	31.54	34.26	0.0	91.5	0.00
3	0.00	45.06	5.63	31.54	34.26	0.0	104.0	0.00
4	TNP	22.53	-	-	-	-	52.0	
5	TNP	45.06	-	-	-	-	104.0	
<b><math>K_e</math>, ft/year:</b>								<b>0.00</b>

<b>Interval 2, ft: 78 - 83</b>		(from ground surface)						
1	0.00	39.67	5.94	34.74	37.33	0.0	91.5	0.00
2	0.00	32.37	5.94	34.74	37.33	0.0	74.7	0.00
3	0.00	49.05	5.94	34.74	37.33	0.0	113.2	0.00
4	TNP	24.52	-	-	-	-	56.6	#VALUE!
5	TNP	49.05	-	-	-	-	113.2	#VALUE!
<b><math>K_e</math>, ft/year:</b>								<b>0.00</b>

**Notations:**

Q = flow rate  
 $H_M = P_{Test}$  converted to feet of head ( $P_{Test} * 144 \text{ in}^2 / \text{ft}^2 / \gamma_w$ )  
 $P_{Test}$  = total test pressure  
 $K_e = ((Q / (H_M - P_m)) * (1/l)) * 1/2\pi * \ln(R/r_0) * (525,600 \text{ min/year}) * (0.1337 \text{ ft}^3/\text{gal})$   
 $P_T$  = pressure above top packer, near water surface  
 R = total length between packers,  $l$   
 $P_M$  = pressure in the test section  
 TNP = Test not performed  
 $P_B$  = pressure below bottom packer  
 NM = not measured

Note: Pressures  $P_t$ ,  $P_m$  and  $P_b$  taken from initial data for transducers.  
 Outside diameter of boring is 4 in.

**IN SITU DETERMINATION OF ROCK MASS PERMEABILITY USING WATER PRESSURE TEST  
IN ACCORDANCE WITH CORPS OF ENGINEERS,  
WATERWAYS EXPERIMENT STATION, RTH 381-80**

Project Name: NORTH ANNA COL  
Project Number: 6468-06-1472  
Date: 8/23/2006

Prepared by: ZO Date: 12-7-06  
Checked by: [Signature] Date: 1-17-07

**Boring No:** B-951  
**Test Interval:** 72.5 ft to 77.5 ft (from Datum)  
**Stick up length:** 1.5 ft  
**Test Interval:** 71.0 ft to 76 ft (from surface)  
**Test Type:** Double Packer Technique

**Depth of Water**

Table= 2.60 ft (from top of casing)  
h1= 3.80 (from top of casing)  
h2 = 72.40 ft (from top of casing)  
 $\rho_w = 62.4 \text{ lb/ft}^3$

<b>Abbreviations:</b>	
N.O.	Not Observed
N.A.	Not Aplicable

**P<sub>0</sub> Max= 45.07 psi** Value on field data sheet= 45.06

Target excess pressures were 1/3Pmax, 2/3Pmax, Pmax, 1/2 Pmax and Pmax. **Actual** excess pressures given below.

TEST #1				TEST #2				TEST #3			
Actual Excess Pressure=		6.09 psi		Actual Excess Pressure=		8.09 psi		Actual Excess Pressure=		13.52 psi	
Initial Middle Transducer Reading=		31.54 psi		Initial Middle Transducer Reading=		31.54 psi		Initial Middle Transducer Reading=		31.54 psi	
Test Pressure=		37.63 psi		Test Pressure=		39.63 psi		Test Pressure=		45.06 psi	
Time (min)	Flow Meter Reading (Gal)	Q (GPM)	Surface Gauge (psi)	Time (min)	Flow Meter Reading (Gal)	Q (GPM)	Surface Gauge (psi)	Time (min)	Flow Meter Reading (Gal)	Q (GPM)	Surface Gauge (psi)
0	2795.1		0.2	0	2795.2		2.1	0	2795.4		1.8
0.5	2795.1	0.0	0.2	0.5	2795.4	0.4	8.2	0.5	2795.7	0.6	9
1	2795.2	0.2	5.5	1	2795.4	0.0	9.4	1	2795.7	0.0	13.4
1.5	2795.2	0.0	6.2	1.5	2795.4	0.0	8.7	1.5	2795.7	0.0	14.8
2	2795.2	0.0	6	2	2795.4	0.0	8.5	2	2795.7	0.0	13.8
2.5	2795.2	0.0	6.5	2.5	2795.4	0.0	8	2.5	2795.7	0.0	13.4
3	2795.2	0.0	6.8	3	2795.4	0.0	10.5	3	2795.7	0.0	13.4
3.5	2795.2	0.0	6.6	3.5	2795.4	0.0	9.8	3.5	2795.7	0.0	13.6
4	2795.2	0.0	6.7	4	2795.4	0.0	9.3	4	2795.7	0.0	13.2
4.5	2795.2	0.0	6.5	4.5	2795.4	0.0	8.9	4.5	2795.7	0.0	13.7
5	2795.2	0.0	6.6	5	2795.4	0.0	8.4	5	2795.7	0.0	13.2

Average Q: 0.0 gpm  
Excess Pore pressure: 6.09 psi

Average Q: 0.0 gpm  
Excess Pore pressure: 8.09 psi

Average Q: 0.0 gpm  
Excess Pore pressure: 13.52 psi

JA 1-17-07

**TEST #4**

**TEST #5**

TEST #4				TEST #5			
Actual Excess Pressure=		22.53 psi		Actual Excess Pressure=		45.07 psi	
Initial Middle Transducer		31.54 psi		Initial Middle Transducer		31.54 psi	
Test Pressure=		psi		Test Pressure=		psi	
Time (min)	Flow Meter Reading (Gal)	Q (GPM)	Surface Gauge (psi)	Time (min)	Flow Meter Reading (Gal)	Q (GPM)	Surface Gauge (psi)
Hole is not taking any water --> Test not performed				Hole is not taking any water --> Test not performed			

Boring No: B-951  
 Test Interval 71 ft to 76 ft  
 (from surface)

Density of water,  $\rho_w = 62.4$  lb/ft<sup>3</sup>  
 = 0.0361 lb/in  
 Length = 5 ft  
 Borehole radius = 2.00 in  
 R ranges from 5-10 ft:  
 choose R = 5 ft

	Excess Pressure (psi)	Q (gpm)	Test Pres. (ft)	$k_e$ (fpy)
1	6.09	0.00	14.05	0.00
2	8.09	0.00	18.67	0.00
3	13.52	0.00	31.2	0.00
4	0.00	0.00	0.0	
5	0.00	0.00	0.0	

\* Q obtained from graph Flow Rate-1

Average Q: gpm  
 Excess Pore pressure: psi

Average Q: gpm  
 Excess Pore pressure: psi

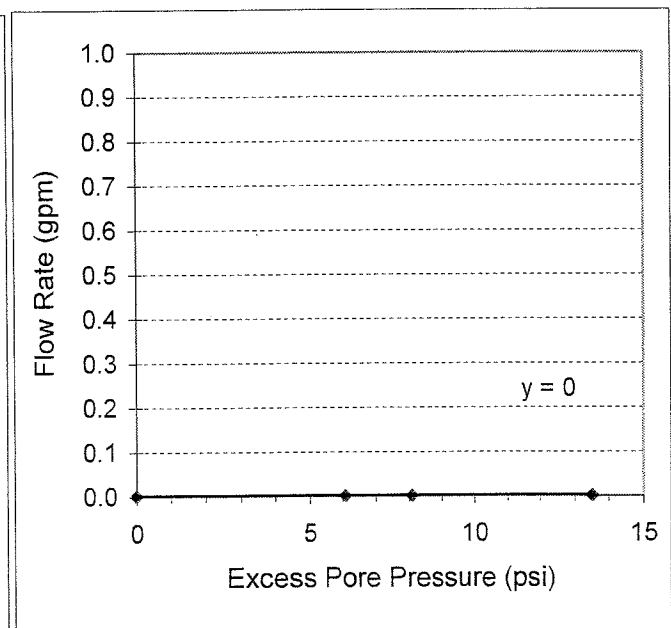
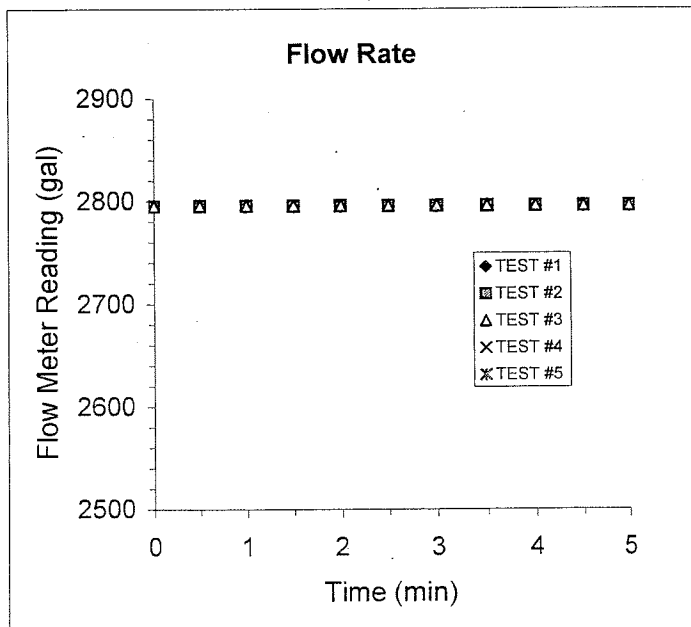

obtain Q from graph 2 in gpm/psi --> 0.0000 gal/psi

$$k_e = Q \cdot \ln(R/r_0) / (2\pi L H_0)$$

$$k_e = 0.00E+00 \text{ cm/sec}$$

$$= 0.00 \text{ ft/year}$$

# Pressure Decay Test

Project Name: NORTH ANNA COL  
 Project Number: 6468-06-1472  
 Date: 8/23/2006  
 Boring No: B-951  
 Test Interval: 71 ft to 76 ft (from surface)

Prepared by: ZQ Date: 12-7-06  
 Checked by: [Signature] Date: 1-17-07  
 N.O. Not Observed  
 N.A. Not Applicable

Test #1			Test #2			Test #3		
Time (min)	Surface Gauge (psi)	Center Tranducer (psi)	Time (min)	Surface Gauge (psi)	Center Tranducer (psi)	Time (min)	Surface Gauge (psi)	Center Tranducer (psi)
0.0	6.6	37.63	0.0	8.4	39.74	0.0	15.2	45.87
0.5	6.1	37.29	0.5	8	39.3	0.5		
1.0	5.9	37.04	1.0	7.6	38.92	1.0	12.8	44.64
1.5	5.6	36.76	1.5	7.3	38.57	1.5	12.1	43.22
2.0	5.4	36.53	2.0	7	38.24	2.0	11.4	42.97
2.5	5.3	36.32	2.5	6.7	37.92	2.5	10.8	42.26
3.0	5.1	36.13	3.0	6.5	37.63	3.0	10.2	41.71
3.5	4.9	35.92	3.5	6.2	37.4	3.5	9.7	41.18
4.0	4.7	35.75	4.0	6	37.15	4.0	9.2	40.66
4.5	4.6	35.59	4.5	5.8	36.91	4.5	8.8	40.19
5.0	4.4	35.44	5.0	5.6	36.7	5.0	8.5	39.80
6.0	4.2	35.14	6.0	5.3	36.31	6.0	7.8	39.08
7.0	4	34.89	7.0	5	35.96	7.0	7.2	38.42
8.0	3.8	34.69	8.0	4.7	35.64	8.0	6.7	37.88
9.0	3.6	34.47	9.0	4.4	35.36	9.0	6.2	37.40
10.0	3.4	34.28	10.0	4.3	35.33	10.0	5.4	36.98
11.0	3.3	34.11	11.0	4	34.88	11.0	5.5	36.58
12.0	3.2	33.96	12.0	3.8	34.67	12.0	5.2	36.2
13.0	3	33.81	13.0	3.7	34.49	13.0	4.9	35.93
14.0	2.9	33.68	14.0	3.5	34.3	14.0	4.7	35.64
15.0	2.8	33.57	15.0	3.4	34.16	15.0	4.5	35.39
20.0	2.4	33.11	20.0	2.8	33.5	20.0	3.6	34.4

Test #4			Test #5		
Time (min)	Surface Gauge (psi)	Center Tranducer (psi)	Time (min)	Surface Gauge (psi)	Center Tranducer (psi)
No data Test not conducted?			No data Test not conducted?		

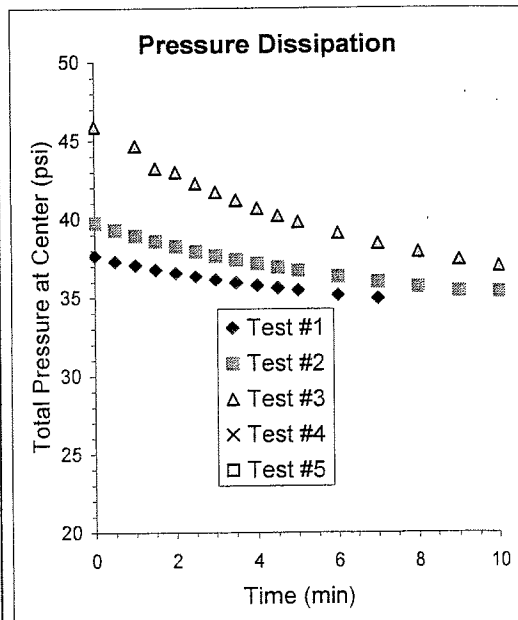



**IN SITU DETERMINATION OF ROCK MASS PERMEABILITY USING WATER PRESSURE TEST  
IN ACCORDANCE WITH CORPS OF ENGINEERS,  
WATERWAYS EXPERIMENT STATION, RTH 381-80**

Project Name: NORTH ANNA COL

Project Number: 6468-06-1472

Date: 8/23/2006

Boring No: B-951

Test Interval: 79.5 ft to 84.5 ft

Stick up length: 1.5 ft

Test Interval: 78.0 ft to 83 ft (from surface)

Test Type: Double Packer Technique

Prepared by: ZO

Date: 12-7-06

Checked by: *[Signature]*

Date: 1-17-07

Depth of Water

Table= 2.60 ft (from top of casing)

h1= 3.80 (from top of casing)

h2 = 79.40 ft (from top of casing)

$\rho_w = 62.4 \text{ lb/ft}^3$

**Abbreviations:**

N.O. Not Observed

N.A. Not Applicable

$P_0 \text{ Max} = 49.06 \text{ psi}$

Value on field data sheet=

Target excess pressures were 1/3Pmax, 2/3Pmax, Pmax, 1/2 Pmax and Pmax. **Actual** excess pressures given below.

TEST #1				TEST #2				TEST #3			
Actual Excess Pressure= 16.35 psi				Actual Excess Pressure= 32.71 psi				Actual Excess Pressure= 14.31 psi			
Initial Middle Transducer Reading= 34.74 psi				Initial Middle Transducer Reading= 34.74 psi				Initial Middle Transducer Reading= 34.7 psi			
Test Pressure= 39.67 psi				Test Pressure= 41.89 psi				Test Pressure= 49.05 psi			
Time (min)	Flow Meter Reading (Gal)	Q (GPM)	Surface Gauge (psi)	Time (min)	Flow Meter Reading (Gal)	Q (GPM)	Surface Gauge (psi)	Time (min)	Flow Meter Reading (Gal)	Q (GPM)	Surface Gauge (psi)
0	2793.9		0.2	0	2794.3		0	0	2794.5		-0.1
0.5	2793.9	0.0	0.5	0.5	2794.3	0.0	0.2	0.5	2794.8	0.6	9.1
1	2794.3	0.8	3.8	1	2794.5	0.4	4.7	1	2795.1	0.6	13.2
1.5	2794.3	0.0	3.7	1.5	2794.5	0.0	5.5	1.5	2795.1	0.0	13.1
2	2794.3	0.0	3.7	2	2794.5	0.0	5.6	2	2795.1	0.0	13.1
2.5	2794.3	0.0	3.7	2.5	2794.5	0.0	5.5	2.5	2795.1	0.0	13.1
3	2794.3	0.0	3.7	3	2794.5	0.0	5.5	3	2795.1	0.0	13.1
3.5	2794.3	0.0	3.7	3.5	2794.5	0.0	5.5	3.5	2795.1	0.0	13.1
4	2794.3	0.0	3.7	4	2794.5	0.0	5.5	4	2795.1	0.0	13.2
4.5	2794.3	0.0	3.7	4.5	2794.5	0.0	5.6	4.5	2795.1	0.0	13.1
5	2794.3	0.0	3.7	5	2794.5	0.0	5.5	5	2795.1	0.0	13.1

Average Q: 0.0 gpm  
Excess Pore pressure: 4.93 psi

Average Q: 0.0 gpm  
Excess Pore pressure: 7.15 psi

Average Q: 0.0 gpm  
Excess Pore pressure: 14.31 psi

1-17-07

TEST #4

TEST #5

TEST #4			TEST #5				
Actual Excess Pressure= NA psi			Actual Excess Pressure= NA psi				
Initial Middle Transducer 34.74 psi			Initial Middle Transducer 34.74 psi				
Test Pressure= NA psi			Test Pressure= NA psi				
Time (min)	Flow Meter Reading (Gal)	Q (GPM)	Surface Gauge (psi)	Time (min)	Flow Meter Reading (Gal)	Q (GPM)	Surface Gauge (psi)
Hole is not taking any water --> Test not performed			Hole is not taking any water --> Test not performed				

Boring No: B-951  
 Test Interval 78 ft to 83 ft  
 (from surface)

Density of water,  $\rho_w = 62.4$  lb/ft<sup>3</sup>  
 = 0.0361 lb/in<sup>3</sup>  
 Length = 5 ft  
 Borehole radius = 2.00 in  
 R ranges from 5-10 ft:  
 choose R = 5 ft

	Excess Pressure (psi)	Q (gpm)	Test Pres. (ft)	$k_e$ (fpy)
1	4.93	0.000	37.74	0.00
2	7.15	0.000	75.47	0.00
3	14.31	0.000	33.02	0.00
4	0.00	0.000	#####	#VALUE!
5	0.00	0.002	#####	#VALUE!

\* Q obtained from graph Flow Rate-1

Average Q: gpm      Average Q: gpm  
 Excess Pore pressure: psi      Excess Pore pressure: psi

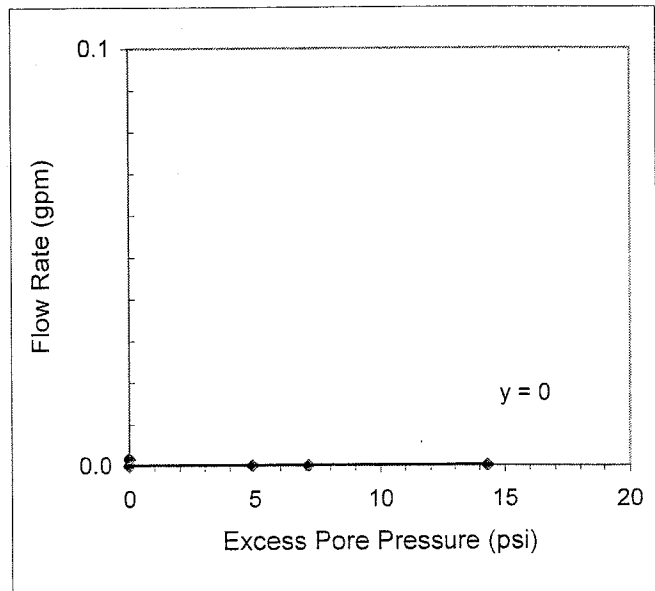
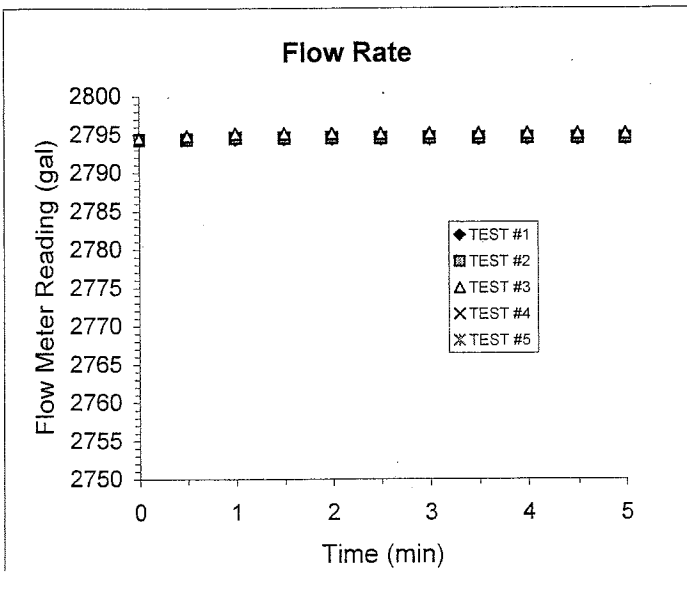

obtain Q from graph 2 in gpm/psi --> 0.0000 gal/psi

$$k_e = Q * \ln(R/r_0) / (2\pi L H_0)$$

$$k_e = 0.00E+00 \text{ cm/sec} = 0.00 \text{ ft/year}$$

# Pressure Decay Test

Project Name: NORTH ANNA COL  
 Project Number: 6468-06-1472  
 Date: 8/23/2006  
 Boring No: B-951  
 Test Interval: 78 ft to 83 ft (from surface)

Prepared by: ZO Date: 12-7-06  
 Checked by: [Signature] Date: 1-17-07  
 N.O. Not Observed  
 N.A. Not Applicable

Test #1			Test #2			Test #3		
Time (min)	Surface Gauge (psi)	Center Tranducer (psi)	Time (min)	Surface Gauge (psi)	Center Tranducer (psi)	Time (min)	Surface Gauge (psi)	Center Tranducer (psi)
0.0	3.7	40.04	0.0	5.5	41.89	0.0	13.1	49.06
0.5	3.7	40.04	0.5	5.5	41.87	0.5	13.1	49.02
1.0	3.7	40.05	1.0	5.5	41.87	1.0	13.1	49.00
1.5	3.7	40.04	1.5	5.5	41.86	1.5	13.1	48.96
2.0	3.7	40.04	2.0	5.5	41.86	2.0	13.1	48.96
2.5	3.7	40.04	2.5	5.5	41.86	2.5	13.0	48.92
3.0	3.7	40.04	3.0	5.5	41.85	3.0	13.0	48.89
3.5	3.7	40.04	3.5	5.5	41.84	3.5	13.0	48.87
4.0	3.7	40.03	4.0	5.5	41.83	4.0	13.0	48.85
4.5	3.7	40.03	4.5	5.5	41.81	4.5	13.0	48.84
5.0	3.7	40.03	5.0	5.5	41.81	5.0	13	48.82
						6.0	12.9	48.77
						7.0	12.9	48.73
						8.0	12.9	48.69
						9.0	12.9	48.67
						10.0	12.8	48.63

Test #4			Test #5		
Time (min)	Surface Gauge (psi)	Center Tranducer (psi)	Time (min)	Surface Gauge (psi)	Center Tranducer (psi)

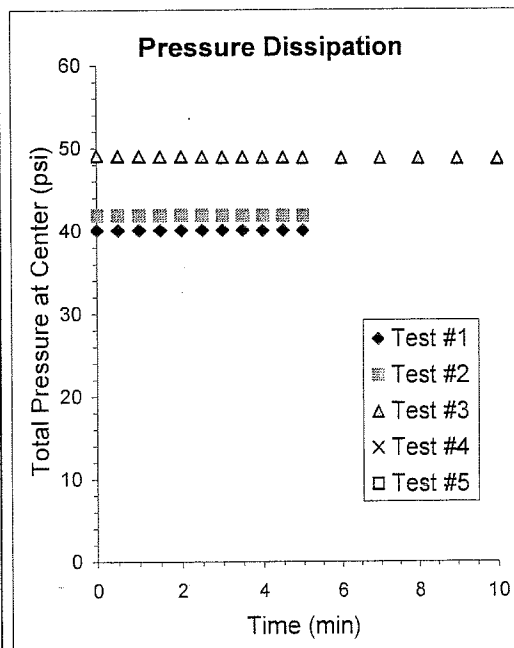

Joe  
12-3-06

PACKER TESTING CALCULATIONS FOR P(MAX)

Date: 8-22-06

Boring No. B951

Test Interval: 72.5 to 77.5 feet from Datum

L=5'

Casing Stickup 1.5 feet

PoMAX = (h<sub>1</sub> x 1) + (h<sub>2</sub> x 0.57). h<sub>1</sub> and h<sub>2</sub> are in feet, see sketch. PoMAX is in psi

h<sub>1</sub> = Distance from the <sup>stage</sup> datum to the water level

h<sub>2</sub> = Distance from the water level to the center of the test interval

h<sub>1</sub> = 3.8

h<sub>2</sub> = 2.6 - 75.0 = 72.4

P MAX = 3.8 + 41.26 = 45.06

SKETCH

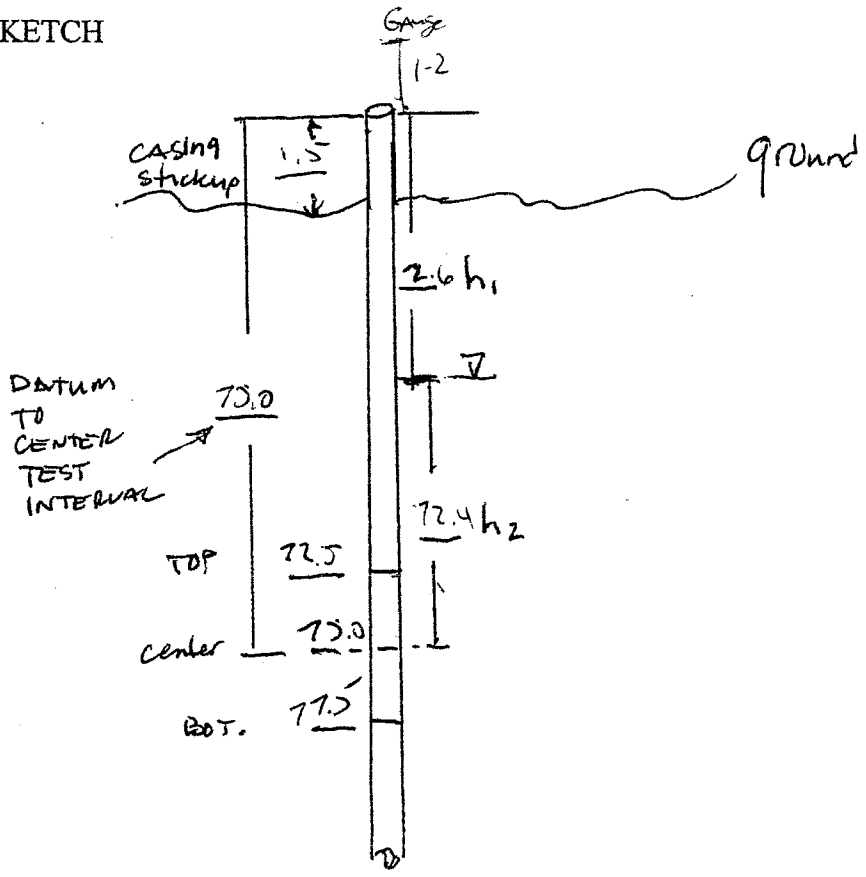

DOUBLE PACKER BOREHOLE PERMEABILITY TEST DATA SHEET

102 12-3-06

MACTEC ENGINEERING AND CONSULTING, INC.

PROJECT: NORTH ANNA COL PROJECT NO.: 6468-06-1472

DATA COLLECTED BY: J Howard DATE COLLECTED: 8-23-06

BORING NO. B 951 BOREHOLE DIAMETER: 4 IN.

SURFACE CASING HEIGHT ABOVE GROUND: 1.5 FT.

CHECK DATUM USED: TOP OF CASING X GROUND SURFACE

DATUM ELEVATION NO

DISTANCE BOTTOM OF TOP PACKER TO TOP OF BOTTOM PACKER 5.0 FT.

TEST INTERVAL DEPTH (FROM DATUM): FROM 72.5 FT. TO 77.5 FT.

TOTAL BORING DEPTH FROM DATUM: 102.5 FT.

(A) DEPTH TO WATER TABLE FROM DATUM: 2.6 FT.

(B) SURFACE GAUGE HEIGHT ABOVE DATUM: 1.2 FT.

(C) DISTANCE WATER TABLE TO CENTER OF TEST INTERVAL: 72.4 FT.

1/3 MAXIMUM TEST PRESSURE,  $P_o$  45.06 ( $P_o = [(A+B) * 1] + C * .57$  psi)

TEST NUMBER: 1 TEST PRESSURE 14.87 \* psi PACKER PRESSURE: 100 psi

Initial Transducer Readings: Top 5.62, Middle 31.54, Bottom 34.26

Transducer Readings after initial pressurization:  
Top 6.09, Middle 34.21, Bottom 34.99

Transducer Readings after final flow measurement:  
Top 5.63, Middle 33.04, Bottom 34.50

TIME (MIN)	FLOW METER READING, (GAL)	Q (GPM)	SURFACE GAUGE, PSI	REMARKS
0.0	27 95.1	/	<del>1.4</del> .2	
0.5	27 95.1	Ø	.2	
1.0	27 95.2	.2	5.5	
1.5	27 95.2	Ø	6.2	
2.0	27 95.2	Ø	6.0	
2.5	27 95.2	Ø	6.5	
3.0	27 95.2	Ø	6.8	
3.5	27 95.2	Ø	6.6	
4.0	27 95.2	Ø	6.7	
4.5	27 95.2	Ø	6.5	
5.0	27 95.2	Ø	6.6	

20  
8-23  
Test pressure increased due to the natural pressure being higher than the test pressure, per Altice's instructions \* 37.63

DOUBLE PACKER TEST DATA SHEET, MACTEC PROJECT NO. 6468-06-1472

PAGE 3

BORING NO.: B951

DATE: 8-27-06

TEST NUMBER: 1

TEST INTERVAL (FROM DATUM): FROM 2.5 FT. TO 77.5 FT.

DATA COLLECTED BY: J Howard

2  
*[Signature]*  
 12-3-06

SHUT-IN TEST

PRESSURE: \_\_\_\_\_ psi

TIME, MIN	SURFACE GAUGE PRESSURE, PSI	MIDDLE TRANSDUCER PRESSURE, PSI
0.0	6.6	37.67
0.5	6.1	37.29
1.0	5.9	37.04
1.5	5.6	36.76
2.0	5.4	36.53
2.5	5.3 <sup>3</sup>	36.32
3.0	5.1	36.13
3.5	4.9	35.92
4.0	4.7	35.75
4.5	4.6	35.59
5.0	4.4	35.44
6.0	4.2	35.14
7.0	4.0	34.89
8.0	3.8	34.67
9.0	3.6	34.47
10.0	3.4	34.28
11.0	3.3	34.11
12.0	3.2	33.96
13.0	3.0	33.81
14.0	2.9	33.68
15.0	2.8	33.57
20.0	2.4	33.11

EQUIPMENT USED

Transducers: Mini Troll Serial Numbers: 10417 (Top), 10191 (Middle), 10036 (Bottom)

Surface Pressure Gauge: Omega DPG serial number 2634708001

Flow Meter Omega FTB-4110 serial number 32019518

Stop Watch: serial number SW1

Above calibrated 5-5-06 or 5-18-06

Tests: B951-M172-77  
 11 - B172 - 11  
 11 - T172 - 11

DOUBLE PACKER BOREHOLE PERMEABILITY TEST DATA SHEET

JAV  
12-3-06

MACTEC ENGINEERING AND CONSULTING, INC.

PROJECT: NORTH ANNA COL PROJECT NO.: 6468-06-1472

DATA COLLECTED BY: J Howard DATE COLLECTED: 8-23-06

BORING NO. B951 BOREHOLE DIAMETER: 4 IN.

SURFACE CASING HEIGHT ABOVE GROUND: 1.5 FT.

CHECK DATUM USED: TOP OF CASING X GROUND SURFACE     

DATUM ELEVATION NA

DISTANCE BOTTOM OF TOP PACKER TO TOP OF BOTTOM PACKER 5.0 FT.

TEST INTERVAL DEPTH (FROM DATUM): FROM 72.5 FT. TO 77.5 FT.

TOTAL BORING DEPTH FROM DATUM: 102.5 FT.

(A) DEPTH TO WATER TABLE FROM DATUM: 2.6 FT.

(B) SURFACE GAUGE HEIGHT ABOVE DATUM: 1.2 FT.

(C) DISTANCE WATER TABLE TO CENTER OF TEST INTERVAL: 72.4 FT.

2/3

MAXIMUM TEST PRESSURE,  $P_o$  45.06 ( $P_o = [(A+B) * 1] + C * .57$  psi)

TEST NUMBER: 2 TEST PRESSURE 29.74\* psi PACKER PRESSURE: 100 psi

Initial Transducer Readings: Top 5.62, Middle 31.54, Bottom 34.26

Transducer Readings after initial pressurization:  
Top 5.63, Middle 33.04, Bottom 34.50

Transducer Readings after final flow measurement:  
Top 5.62, Middle 32.80, Bottom 34.49

TIME (MIN)	FLOW METER READING, (GAL)	Q (GPM)	SURFACE GAUGE, PSI	REMARKS
0.0	2795.2	/	2.1	
0.5	2795.4	.4	8.2	
1.0	2795.4	Ø	9.4	
1.5	2795.4	Ø	8.7	
2.0	2795.4	Ø	8.5	
2.5	2795.4	Ø	8.0	
3.0	2795.4	Ø	10.5	
3.5	2795.4	Ø	9.8	
4.0	2795.4	Ø	9.3	
4.5	2795.4	Ø	8.9	
5.0	2795.4	Ø	8.4	

See test #1

\* 39.63

DOUBLE PACKER TEST DATA SHEET, MACTEC PROJECT NO. 6468-06-1472  
 BORING NO.: B951  
 DATE: 8-23-06  
 TEST NUMBER: 2  
 TEST INTERVAL (FROM DATUM): FROM 72.5 FT. TO 77.5 FT.  
 DATA COLLECTED BY: Stoward

PAGE 3

2  
 J.S.  
 12-3-06

SHUT-IN TEST

PRESSURE: \_\_\_\_\_ psi

TIME, MIN	SURFACE GAUGE PRESSURE, PSI	MIDDLE TRANSDUCER PRESSURE, PSI
0.0	8.11	39.74
0.5	8.0	39.70
1.0	7.6	38.92
1.5	7.3	38.57
2.0	7.0	38.24
2.5	6.7	37.92
3.0	6.5	37.63
3.5	6.2	37.40
4.0	6.0	37.15
4.5	5.8	36.91
5.0	5.6	36.70
6.0	5.3	36.31
7.0	5.0	35.96
8.0	4.7	35.64
9.0	4.4	35.36
10.0	4.3	35.33
11.0	4.0	34.85
12.0	3.8	34.67
13.0	3.7	34.49
14.0	3.5	34.30
15.0	3.4	34.16
20.0	2.8	33.50

EQUIPMENT USED

Transducers: Mini Troll Serial Numbers: 10417 (Top), 10191 (Middle), 10036 (Bottom)  
 Surface Pressure Gauge: Omega DPG serial number 2634708001  
 Flow Meter Omega FTB-4110 serial number 32019518  
 Stop Watch: serial number SW1

Above calibrated 5-5-06 or 5-18-06

Tests: B951-M272-77  
 " - B272-11  
 " - T272-11



DOUBLE PACKER BOREHOLE PERMEABILITY TEST DATA SHEET

*JH* 12-3-06

MACTEC ENGINEERING AND CONSULTING, INC.

PROJECT: NORTH ANNA COL PROJECT NO.: 6468-06-1472

DATA COLLECTED BY: J Howard DATE COLLECTED: 8-23-06

BORING NO. 13951 BOREHOLE DIAMETER: 4 IN.

SURFACE CASING HEIGHT ABOVE GROUND: 1.5 FT.

CHECK DATUM USED: TOP OF CASING  GROUND SURFACE

DATUM ELEVATION NA

DISTANCE BOTTOM OF TOP PACKER TO TOP OF BOTTOM PACKER 5.0 FT.

TEST INTERVAL DEPTH (FROM DATUM): FROM 72.5 FT. TO 77.5 FT.

TOTAL BORING DEPTH FROM DATUM: 102.5 FT.

(A) DEPTH TO WATER TABLE FROM DATUM: 2.6 FT.

(B) SURFACE GAUGE HEIGHT ABOVE DATUM: 1.2 FT.

(C) DISTANCE WATER TABLE TO CENTER OF TEST INTERVAL: 72.4 FT.

MAXIMUM TEST PRESSURE,  $P_0$  45.06 ( $P_0 = [(A+B) * 1] + C * .57$  psi)

TEST NUMBER: 3 TEST PRESSURE 45.06 psi PACKER PRESSURE: 100 psi

Initial Transducer Readings: Top 5.62, Middle 31.54, Bottom 34.26

Transducer Readings after initial pressurization:  
Top 5.62, Middle 32.80, Bottom 34.49

Transducer Readings after final flow measurement:  
Top 5.62, Middle 34.30, Bottom 34.51

TIME (MIN)	FLOW METER READING, (GAL)	Q (GPM)	SURFACE GAUGE, PSI	REMARKS
0.0	2795.4	✓	1.8	
0.5	2795.7	.6	4.0	
1.0	2795.7	∅	13.4	
1.5	2795.7	∅	14.8	
2.0	2795.7	∅	13.8	
2.5	2795.7	∅	13.4	
3.0	2795.7	∅	13.4	
3.5	2795.7	∅	13.6	
4.0	2795.7	∅	13.2	
4.5	2795.7	∅	13.7	
5.0	2795.7	∅	15.2	

DOUBLE PACKER TEST DATA SHEET, MACTEC PROJECT NO. 6468-06-1472

PAGE 2

BORING NO.: B951

DATE: 8-23-06

TEST NUMBER: 7

TEST INTERVAL (FROM DATUM): FROM 72.5 FT. TO 77.5 FT.

DATA COLLECTED BY: Howard

*Handwritten signature*  
12-3-06

SHUT-IN TEST

PRESSURE: \_\_\_\_\_ psi

TIME, MIN	SURFACE GAUGE PRESSURE, PSI	MIDDLE TRANSDUCER PRESSURE, PSI
0.0	15.2	45.87
0.5		
1.0	12.8	44.64
1.5	12.8	43.72
2.0	11.4	42.97
2.5	10.8	42.26
3.0	10.2	41.72
3.5	9.7	41.18
4.0	9.2	40.66
4.5	8.8	40.19
5.0	8.5	39.80
6.0	7.8	39.08
7.0	7.2	38.42
8.0	6.7	37.88
9.0	6.2	37.40
10.0	5.4	36.98
11.0	5.5	36.58
12.0	5.2	36.20
13.0	4.9	35.93
14.0	4.7	35.64
15.0	4.5	35.39
20.0	3.4	34.40

EQUIPMENT USED

Transducers: Mini Troll Serial Numbers: 10417 (Top), 10191 (Middle), 10036 (Bottom)

Surface Pressure Gauge: Omega DPG serial number 2634708001

Flow Meter Omega FTB-4110 serial number 32019518

Stop Watch: serial number SW1

Above calibrated 5-5-06 or 5-18-06

Test: B951 - M972 - 77  
 " - B972 - 11  
 " - T972 - 11

DOUBLE PACKER BOREHOLE PERMEABILITY TEST DATA SHEET

*Handwritten initials*  
12-3-06

MACTEC ENGINEERING AND CONSULTING, INC.

PROJECT: NORTH ANNA COL PROJECT NO.: 6468-06-1472

DATA COLLECTED BY: J Howard DATE COLLECTED: 8-1-06

BORING NO. B951 BOREHOLE DIAMETER: 4 IN.

SURFACE CASING HEIGHT ABOVE GROUND: 1.5 FT.

CHECK DATUM USED: TOP OF CASING  GROUND SURFACE

DATUM ELEVATION NA

DISTANCE BOTTOM OF TOP PACKER TO TOP OF BOTTOM PACKER 5.0 FT.

TEST INTERVAL DEPTH (FROM DATUM): FROM 72.5 FT. TO 77.5 FT.

TOTAL BORING DEPTH FROM DATUM: 102.5 FT.

(A) DEPTH TO WATER TABLE FROM DATUM: 2.6 FT.

(B) SURFACE GAUGE HEIGHT ABOVE DATUM: 1.2 FT.

(C) DISTANCE WATER TABLE TO CENTER OF TEST INTERVAL: 72.4 FT.

<sup>1/2</sup> MAXIMUM TEST PRESSURE, P<sub>0</sub> 45.06 (P<sub>0</sub> = [(A+B) \* 1] + C\*.57 psi)

TEST NUMBER: 4 TEST PRESSURE 22.53 psi PACKER PRESSURE: 100 psi

Initial Transducer Readings: Top \_\_\_\_\_, Middle \_\_\_\_\_, Bottom \_\_\_\_\_

Transducer Readings after initial pressurization:  
Top \_\_\_\_\_, Middle \_\_\_\_\_, Bottom \_\_\_\_\_

Transducer Readings after final flow measurement:  
Top \_\_\_\_\_, Middle \_\_\_\_\_, Bottom \_\_\_\_\_

TIME (MIN)	FLOW METER READING, (GAL)	Q (GPM)	SURFACE GAUGE, PSI	REMARKS
0.0				
0.5				
1.0				
1.5				
2.0				
2.5				
3.0				
3.5				
4.0				
4.5				
5.0				

*Hole not taking water, so test not performed*

DOUBLE PACKER BOREHOLE PERMEABILITY TEST DATA SHEET

*JAD*  
12-3-06

MACTEC ENGINEERING AND CONSULTING, INC.

PROJECT: NORTH ANNA COL PROJECT NO.: 6468-06-1472

DATA COLLECTED BY: J Howard DATE COLLECTED: 8-23-06

BORING NO. B 951 BOREHOLE DIAMETER: 4 IN.

SURFACE CASING HEIGHT ABOVE GROUND: 1.5 FT.

CHECK DATUM USED: TOP OF CASING X GROUND SURFACE     

DATUM ELEVATION NA

DISTANCE BOTTOM OF TOP PACKER TO TOP OF BOTTOM PACKER 5.0 FT.

TEST INTERVAL DEPTH (FROM DATUM): FROM 77.5 FT. TO 77.5 FT.

TOTAL BORING DEPTH FROM DATUM: 102.5 FT.

(A) DEPTH TO WATER TABLE FROM DATUM: 2.6 FT.

(B) SURFACE GAUGE HEIGHT ABOVE DATUM: 1.2 FT.

(C) DISTANCE WATER TABLE TO CENTER OF TEST INTERVAL: 72.41 FT.

MAXIMUM TEST PRESSURE,  $P_0$  45.06 ( $P_0 = [(A+B) * 1] + C * .57$  psi)

TEST NUMBER: 5 TEST PRESSURE 45.06 psi PACKER PRESSURE: 100 psi

Initial Transducer Readings: Top     , Middle     , Bottom     

Transducer Readings after initial pressurization:  
Top     , Middle     , Bottom     

Transducer Readings after final flow measurement:  
Top     , Middle     , Bottom     

TIME (MIN)	FLOW METER READING, (GAL)	Q (GPM)	SURFACE GAUGE, PSI	REMARKS
0.0				
0.5				
1.0				
1.5				
2.0				
2.5				
3.0				
3.0'				
4.0				
4.5				
5.0				

*Hole not taking water, so test not performed*

78 P3  
 1.5 + 1.5  
 79.5 84.5

PACKER TESTING CALCULATIONS FOR P(MAX)

Date: 8-22

Boring No. B951

JW 12-3-06

Test Interval: 79.5 to 84.5 feet from Datum

Casing Stickup 1.5 feet

PoMAX = (h<sub>1</sub> x 1) + (h<sub>2</sub> x 0.57). h<sub>1</sub> and h<sub>2</sub> are in feet, see sketch. PoMAX is in psi

h<sub>1</sub> = Distance from the <sup>Gauge</sup>~~datum~~ to the water level

h<sub>2</sub> = Distance from the water level to the center of the test interval

h<sub>1</sub> = 3.8

h<sub>2</sub> = 82.0 - 2.6 = 79.4

P MAX = 3.8 + 45.25 = 49.05

SKETCH

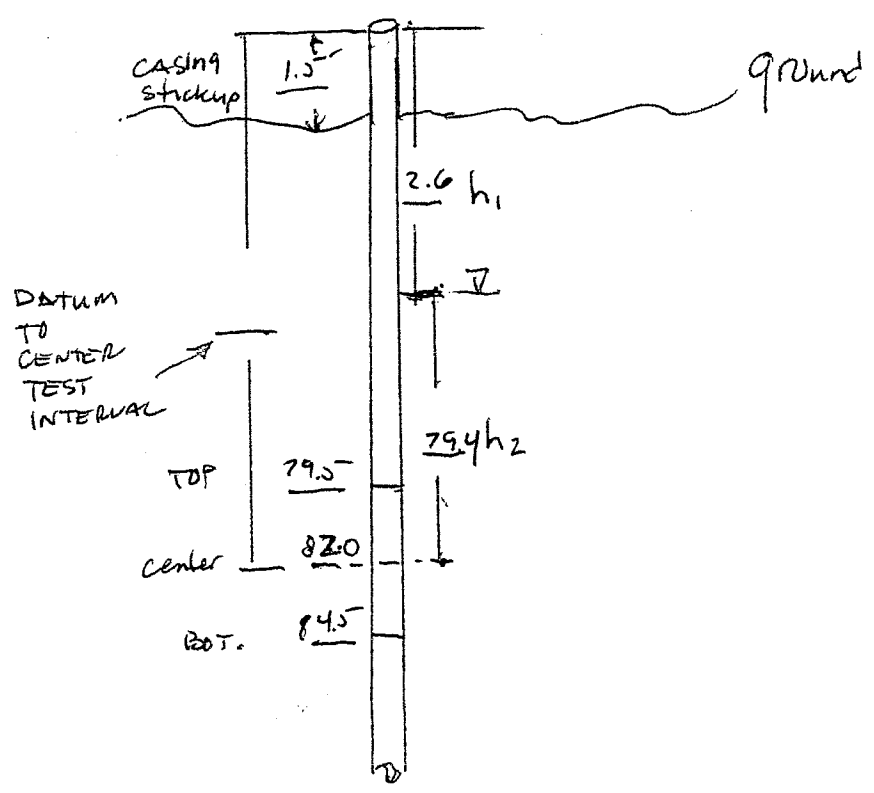

DOUBLE PACKER BOREHOLE PERMEABILITY TEST DATA SHEET

JJ 23-06

MACTEC ENGINEERING AND CONSULTING, INC.

PROJECT: NORTH ANNA COL PROJECT NO.: 6468-06-1472

DATA COLLECTED BY: J Howard DATE COLLECTED: 8-22-06

BORING NO. 5951 BOREHOLE DIAMETER: 4 IN.

SURFACE CASING HEIGHT ABOVE GROUND: 1.5 FT.

CHECK DATUM USED: TOP OF CASING  GROUND SURFACE

DATUM ELEVATION NA

DISTANCE BOTTOM OF TOP PACKER TO TOP OF BOTTOM PACKER 5.0 FT.

TEST INTERVAL DEPTH (FROM DATUM): FROM 79.5 FT. TO 84.5 FT.

TOTAL BORING DEPTH FROM DATUM: 102.5 FT.

(A) DEPTH TO WATER TABLE FROM DATUM: 2.6 FT.

(B) SURFACE GAUGE HEIGHT ABOVE DATUM: 1.2 FT.

(C) DISTANCE WATER TABLE TO CENTER OF TEST INTERVAL: 79.4 FT.

1/3 MAXIMUM TEST PRESSURE,  $P_o$  49.05 ( $P_o = [(A+B) * 1] + C * .57$  psi)

TEST NUMBER: 1 TEST PRESSURE 16.18\* psi PACKER PRESSURE: 100 psi

Initial Transducer Readings: Top 5.94, Middle 34.74, Bottom 37.33

Transducer Readings after initial pressurization:  
Top 6.13, Middle 36.07, Bottom 37.74

Transducer Readings after final flow measurement:  
Top 5.80, Middle 40.05, Bottom 37.48

TIME (MIN)	FLOW METER READING, (GAL)	Q (GPM)	SURFACE GAUGE, PSI	REMARKS
0.0	2793.9	/	.2	
0.5	2797.2	0	.5	
1.0	2794.3	.8	3.8	
1.5	2794.3	0	3.7	
2.0	2794.3	0	3.7	
2.5	2794.3	0	3.7	
3.0	2794.3	0	3.7	
3.5	2794.3	0	3.7	
4.0	2794.3	0	3.7	
4.5	2794.3	0	3.7	
5.0	2794.3	0	3.7	

Pressure raised per Altice's instructions; Test pressure below natural pressure

39.67\*

BORING NO.: B951

DATE: 8-22-06

TEST NUMBER: 1

TEST INTERVAL (FROM DATUM): FROM 79.5 FT. TO 84.5 FT.

DATA COLLECTED BY: J. Howan

*Handwritten notes:*  
2  
12-3-06

SHUT-IN TEST

PRESSURE: \_\_\_\_\_ psi

TIME, MIN	SURFACE GAUGE PRESSURE, PSI	MIDDLE TRANSDUCER PRESSURE, PSI
0.0	3.7	40.04
0.5	3.7	40.04
1.0	3.7	40.05
1.5	3.7	40.04
2.0	3.7	40.04
2.5	3.7	40.04
3.0	3.7	40.04
3.5	3.7	40.04
4.0	3.7	40.03
4.5	3.7	40.03
5.0	3.8	40.03

**EQUIPMENT USED**  
 Transducers: Mini Troll Serial Numbers: 10417 (Top), 10191 (Middle), 10036 (Bottom)  
 Surface Pressure Gauge: Omega DPG serial number 2634708001  
 Flow Meter Omega FTB-4110 serial number 32019518  
 Stop Watch: serial number SW1

Above calibrated 5-5-06 or 5-18-06

*Handwritten notes:*  
Tests: B951 - M179 - 84  
          "      - B179 - "  
          "      - T179 - "

DOUBLE PACKER BOREHOLE PERMEABILITY TEST DATA SHEET

*Handwritten initials and date:* 12-3-06

MACTEC ENGINEERING AND CONSULTING, INC.

PROJECT: NORTH ANNA COL PROJECT NO.: 6468-06-1472

DATA COLLECTED BY: Sho Ward DATE COLLECTED: 8-22-06

BORING NO. B951 BOREHOLE DIAMETER: 4 IN.

SURFACE CASING HEIGHT ABOVE GROUND: 1.5 FT.

CHECK DATUM USED: TOP OF CASING X GROUND SURFACE     

DATUM ELEVATION NA

DISTANCE BOTTOM OF TOP PACKER TO TOP OF BOTTOM PACKER 5.0 FT.

TEST INTERVAL DEPTH (FROM DATUM): FROM 79.5 FT. TO 84.5 FT.

TOTAL BORING DEPTH FROM DATUM: 102.5 FT.

(A) DEPTH TO WATER TABLE FROM DATUM: 2.6 FT.

(B) SURFACE GAUGE HEIGHT ABOVE DATUM: 1.2 FT.

(C) DISTANCE WATER TABLE TO CENTER OF TEST INTERVAL: 79.4 FT.

2/3 MAXIMUM TEST PRESSURE,  $P_0$  49.05 (  $P_0 = [(A+B) * 1] + C * .57$  psi)

TEST NUMBER: 2 TEST PRESSURE 32.37 \* psi PACKER PRESSURE: 100 psi

Initial Transducer Readings: Top 5.24, Middle 34.74, Bottom 37.33

Transducer Readings after initial pressurization:

Top 5.80, Middle 35.83, Bottom 37.46

Transducer Readings after final flow measurement:

Top 5.80, Middle 41.81, Bottom 37.46

TIME (MIN)	FLOW METER READING, (GAL)	Q (GPM)	SURFACE GAUGE, PSI	REMARKS
0.0	2794.3	/	00.0	
0.5	2794.3	Ø	0.2	
1.0	2794.5	.4	4.7	
1.5	2794.5	Ø	5.5	
2.0	2794.5	Ø	5.6	
2.5	2794.5	Ø	5.5	
3.0	2794.5	Ø	5.5	
3.5	2794.5	Ø	5.5	
4.0	2794.5	Ø	5.5	
4.5	2794.5	Ø	5.6	
5.0	2794.5	Ø	5.5	

\* 41.89 Sec. test 1



DOUBLE PACKER TEST DATA SHEET, MACTEC PROJECT NO. 6468-06-1472  
BORING NO.: B951  
DATE: 8-22  
TEST NUMBER: 2  
TEST INTERVAL (FROM DATUM): FROM <sup>off</sup> ~~84.79~~ 84.0 FT. TO 84.0 FT.  
DATA COLLECTED BY: Blaw and

PAGE 3  
2

102 12-3-06

SHUT-IN TEST

PRESSURE: \_\_\_\_\_ psi

TIME, MIN	SURFACE GAUGE PRESSURE, PSI	MIDDLE TRANSDUCER PRESSURE, PSI
0.0	5.5	41.89
0.5	5.5	41.87
1.0	5.5	41.87
1.5	5.5	41.86
2.0	5.5	41.86
2.5	5.5	41.86
3.0	5.5	41.85
3.5	5.5	41.84
4.0	5.5	41.83
4.5	5.5	41.81
5.0	5.5	41.81

EQUIPMENT USED

Transducers: Mini Troll Serial Numbers: 10417 (Top), 10191 (Middle), 10036 (Bottom)  
Surface Pressure Gauge: Omega DPG serial number 2634708001  
Flow Meter Omega FTB-4110 serial number 32019518  
Stop Watch: serial number SW1

Above calibrated 5-5-06 or 5-18-06

Tests:  
B951 - M279 - 84  
" - B279 - 11  
" - T279 - 11

DOUBLE PACKER BOREHOLE PERMEABILITY TEST DATA SHEET

*Handwritten initials and date: 12-3-06*

MACTEC ENGINEERING AND CONSULTING, INC.

PROJECT: NORTH ANNA COL PROJECT NO.: 6468-06-1472

DATA COLLECTED BY: J Howard DATE COLLECTED: 8-22-06

BORING NO. B951 BOREHOLE DIAMETER: 4 IN.

SURFACE CASING HEIGHT ABOVE GROUND: 1.5 FT.

CHECK DATUM USED: TOP OF CASING  GROUND SURFACE

DATUM ELEVATION NA

DISTANCE BOTTOM OF TOP PACKER TO TOP OF BOTTOM PACKER 5.0 FT.

TEST INTERVAL DEPTH (FROM DATUM): FROM 79.5 FT. TO 84.5 FT.

TOTAL BORING DEPTH FROM DATUM: 102.5 FT.

(A) DEPTH TO WATER TABLE FROM DATUM: 2.6 FT.

(B) SURFACE GAUGE HEIGHT ABOVE DATUM: 1.2 FT.

(C) DISTANCE WATER TABLE TO CENTER OF TEST INTERVAL: 79.4 FT.

MAXIMUM TEST PRESSURE,  $P_o$  49.05 ( $P_o = [(A+B) * 1] + C * .57$  psi)

TEST NUMBER: 3 TEST PRESSURE 49.05 psi PACKER PRESSURE: 100 psi

Initial Transducer Readings: Top 5.94, Middle 34.74, Bottom 37.33

Transducer Readings after initial pressurization:  
Top 9.80, Middle 35.61, Bottom 37.45

Transducer Readings after final flow measurement:  
Top 5.79, Middle 48.58, Bottom 37.47

TIME (MIN)	FLOW METER READING, (GAL)	Q (GPM)	SURFACE GAUGE, PSI	REMARKS
0.0	2794.5	/	-0.1	
0.5	2794.8	0.6	9.1	
1.0	2795.1	0.6	13.2	
1.5	2795.1	∅	13.1	
2.0	2795.1	∅	13.1	
2.5	2795.1	∅	13.1	
3.0	2795.1	∅	13.1	
3.5	2795.1	∅	13.1	
4.0	2795.1	∅	13.2	
4.5	2795.1	∅	13.1	
5.0	2795.1	∅	13.1	

BORING NO.: B951

DATE: 8-22-06

TEST NUMBER: 3

TEST INTERVAL (FROM DATUM): FROM 84.5 FT. TO 79.5 FT.

DATA COLLECTED BY: Howard

*[Signature]*  
12-3-06

SHUT-IN TEST

PRESSURE: \_\_\_\_\_ psi

TIME, MIN	SURFACE GAUGE PRESSURE, PSI	MIDDLE TRANSDUCER PRESSURE, PSI
0.0	13.1	49.06
0.5	13.1	49.02
1.0	13.1	48.80
1.5	13.1	48.96
2.0	13.1	48.96
2.5	13.0	48.92
3.0	13.0	48.89
3.5	13.0	48.87
4.0	13.0	48.85
4.5	13.0	48.84
5.0	13.0	48.82
6.0	12.9	48.77
7.0	12.9	48.73
8.0	12.9	48.69
9.0	12.9	48.67
10.0	12.8	48.63

EQUIPMENT USED

Transducers: Mini Troll Serial Numbers: 10417 (Top), 10191 (Middle), 10036 (Bottom)

Surface Pressure Gauge: Omega DPG serial number 2634708001

Flow Meter Omega FTB-4110 serial number 32019518

Stop Watch: serial number SW1

Above calibrated 5-5-06 or 5-18-06

Tests: B951 - M379 - 84  
           "      - B379 - 11  
           "      - T379 - 11

DOUBLE PACKER BOREHOLE PERMEABILITY TEST DATA SHEET

*JS*  
12-306

MACTEC ENGINEERING AND CONSULTING, INC.

PROJECT: NORTH ANNA COL PROJECT NO.: 6468-06-1472

DATA COLLECTED BY: S Howard DATE COLLECTED: 8-22-06

BORING NO. B951 BOREHOLE DIAMETER: 4 IN.

SURFACE CASING HEIGHT ABOVE GROUND: 1.5 FT.

CHECK DATUM USED: TOP OF CASING~~x~~ GROUND SURFACE

DATUM ELEVATION NA

DISTANCE BOTTOM OF TOP PACKER TO TOP OF BOTTOM PACKER 5.0 FT.

TEST INTERVAL DEPTH (FROM DATUM): FROM 79.5 FT. TO 84.5 FT.

TOTAL BORING DEPTH FROM DATUM: 107.5 FT.

(A) DEPTH TO WATER TABLE FROM DATUM: 2.6 FT.

(B) SURFACE GAUGE HEIGHT ABOVE DATUM: 1.2 FT.

(C) DISTANCE WATER TABLE TO CENTER OF TEST INTERVAL: 79.4 FT.

<sup>1/2</sup> MAXIMUM TEST PRESSURE,  $P_o$  49.05 ( $P_o = [(A+B) * 1] + C * .57$  psi)

TEST NUMBER: 4 TEST PRESSURE 24.52 psi PACKER PRESSURE: 100 psi

Initial Transducer Readings: Top \_\_\_\_\_, Middle \_\_\_\_\_, Bottom \_\_\_\_\_

Transducer Readings after initial pressurization:  
Top \_\_\_\_\_, Middle \_\_\_\_\_, Bottom \_\_\_\_\_

Transducer Readings after final flow measurement:  
Top \_\_\_\_\_, Middle \_\_\_\_\_, Bottom \_\_\_\_\_

TIME (MIN)	FLOW METER READING, (GAL)	Q (GPM)	SURFACE GAUGE, PSI	REMARKS
0.0				
0.5				
1.0				
1.5				
2.0				
2.5				
3.0				
3.5				
4.0				
4.5				
5.0				

*No Test, Hole not taking water*

DOUBLE PACKER TEST DATA SHEET, MACTEC PROJECT NO. 6468-06-1472  
BORING NO.: B951  
DATE: 8-22-06  
TEST NUMBER: 4  
TEST INTERVAL (FROM DATUM): FROM 29.5 FT. TO 84.5 FT.  
DATA COLLECTED BY: Stoward

PAGE 3

*2*  
*PJ*  
*12-3-06*

SHUT-IN TEST

PRESSURE: \_\_\_\_\_ psi

TIME, MIN	SURFACE GAUGE PRESSURE, PSI	MIDDLE TRANSDUCER PRESSURE, PSI
0.0		
0.5		
1.0		
1.5		
2.0		
2.5		
3.0		
3.5		
4.0		
4.5		
5.0		

EQUIPMENT USED

Transducers: Mini Troll Serial Numbers: 10417 (Top), 10191 (Middle), 10036 (Bottom)  
Surface Pressure Gauge: Omega DPG serial number 2634708001  
Flow Meter Omega FTB-4110 serial number 32019518  
Stop Watch: serial number SW1

Above calibrated 5-5-06 or 5-18-06

Tests: B951- M479-84  
11- T475-11  
11- B479-11

DOUBLE PACKER BOREHOLE PERMEABILITY TEST DATA SHEET

*Handwritten:* 12-3-06

MACTEC ENGINEERING AND CONSULTING, INC.

PROJECT: NORTH ANNA COL PROJECT NO.: 6468-06-1472

DATA COLLECTED BY: S Howard DATE COLLECTED: 8-22-06

BORING NO. B 957 BOREHOLE DIAMETER: 4 IN.

SURFACE CASING HEIGHT ABOVE GROUND: 1.5 FT.

CHECK DATUM USED: TOP OF CASING  GROUND SURFACE

DATUM ELEVATION no

DISTANCE BOTTOM OF TOP PACKER TO TOP OF BOTTOM PACKER 5.0 FT.

TEST INTERVAL DEPTH (FROM DATUM): FROM 79.5 FT. TO 84.5 FT.

TOTAL BORING DEPTH FROM DATUM: 102.5 FT.

(A) DEPTH TO WATER TABLE FROM DATUM: 2.6 FT.

(B) SURFACE GAUGE HEIGHT ABOVE DATUM: 1.2 FT.

(C) DISTANCE WATER TABLE TO CENTER OF TEST INTERVAL: 79.4 FT.

MAXIMUM TEST PRESSURE,  $P_0$  49.05 ( $P_0 = [(A+B) * 1] + C * .57$  psi)

TEST NUMBER: 5 TEST PRESSURE 49.05 psi PACKER PRESSURE: 100 psi

Initial Transducer Readings: Top \_\_\_\_\_, Middle \_\_\_\_\_, Bottom \_\_\_\_\_

Transducer Readings after initial pressurization:  
Top \_\_\_\_\_, Middle \_\_\_\_\_, Bottom \_\_\_\_\_

Transducer Readings after final flow measurement:  
Top \_\_\_\_\_, Middle \_\_\_\_\_, Bottom \_\_\_\_\_

TIME (MIN)	FLOW METER READING, (GAL)	Q (GPM)	SURFACE GAUGE, PSI	REMARKS
0.0				
0.5				
1.0				
1.5				
2.0				
2.5				
3.0				
3.5				
4.0				
4.5				
5.0				

*Handwritten:* no test Hole not taking water

DOUBLE PACKER TEST DATA SHEET, MACTEC PROJECT NO. 6468-06-1472

PAGE 3

BORING NO.: B951

DATE: 8-22-06

TEST NUMBER: 3

TEST INTERVAL (FROM DATUM): FROM 845 FT. TO 795 FT.

DATA COLLECTED BY: S Howard

71.5/07 12-306  
 845/08

12-306

SHUT-IN TEST

PRESSURE: \_\_\_\_\_ psi

TIME, MIN	SURFACE GAUGE PRESSURE, PSI	MIDDLE TRANSDUCER PRESSURE, PSI
0.0	13.1	49.06
0.5	13.1	49.02
1.0	13.1	48.99
1.5	13.1	48.96
2.0	13.1	48.96
2.5	13.0	48.92
3.0	13.0	48.89
3.5	13.0	48.87
4.0	13.0	48.85
4.5	13.0	48.84
5.0	13.0	48.82
6.0	12.9	48.77
7.0	12.9	48.73
8.0	12.9	48.69
9.0	12.9	48.67
10.0	12.8	48.63

EQUIPMENT USED

Transducers: Mini Troll Serial Numbers: 10417 (Top), 10191 (Middle), 10036 (Bottom)  
 Surface Pressure Gauge: Omega DPG serial number 2634708001  
 Flow Meter Omega FTB-4110 serial number 32019518  
 Stop Watch: serial number SW1

Above calibrated 5-5-06 or 5-18-06

Tests: B951 - M379 - 84  
 " - B379 - 11  
 " - T379 - 11

8/22/06

James Howard

Miller, Mark Hughes, Tim Garland

B950 & 951

8/22  
A2

Arrived 7am

Meeting 730-8

Break Pouch B950 8-9

Stand b. For Planks to cross ditch at B951

9-1030-11

Lunch 11-1130

1130-1230 looked guys making cut stand bridge

1230-1 Sattymeting

1-2 setup packages

2-345 Packer test B951 <sup>27</sup> ~~26~~ 79.5-84

345-4 Break down + Move packer up

4-430 Paperwork



(1)  
8/17/66

James Howard

William; Mark Hughes, Tim Garland

1931

Arrive 7am

Safety Meeting 7:30am

8-8:30 set up packer tests

8:30-10:30 Test Interval 12.5-77.5

10:30-11:30 Breakdown

11:30-12:30 lunch

12:30-1:45 Breakdown

1:45-4:30 Dr. H. B. 14 w/George Alkin

u 6006 to 80.8 (Rockco.)

4:30-5 Breakdown/clean up

5-5:30 Paper work

