

MONTICELLO NUCLEAR GENERATING PLANT
OFFSITE DOSE CALCULATION MANUAL
(ODCM)

REV. 7

DOCKET NO. 50-263

NORTHERN STATES POWER COMPANY
MINNEAPOLIS, MINNESOTA

ALARA REVIEWED BY: Car Mathison DATE: 2/1/90

PREPARED BY: [Signature]

REVIEWED BY: [Signature] DATE: 2/1/90

OPERATIONS COMMITTEE FINAL REVIEW DATE: 2-22-90

APPROVED BY: [Signature] DATE: 2/23/90

9009070086 900829
PDR ADOCK 050*****
R PNU

MONTICELLO NUCLEAR
GENERATING PLANT
Monticello, Minnesota
UNIT 1

OFFSITE DOSE CALCULATION MANUAL
N O R T H E R N S T A T E S P O W E R C O M P A N Y
Minneapolis, Minnesota

TABLE OF CONTENTS

<u>Section</u>	<u>Title</u>	<u>Page</u>
	Table of Contents	ii
	List of Figures	v
	List of Tables	vi
	Record of Revisions	viii
	List of Effective Pages	ix
1.0	INTRODUCTION	1-1
2.0	LIQUID EFFLUENTS	2-1
2.1	<u>Monitor Alarm Setpoint Determination</u>	2-1
2.1.1	Radwaste Discharge Line Monitor	2-1
2.1.2	Discharge Canal Monitor	2-3
2.1.3	Service Water Discharge Pipe Monitor	2-5
2.1.4	Turbine Building Normal Drain Sump Monitor	2-6
2.1.5	Multiple Release Points	2-8
2.2	<u>Liquid Effluent Concentration - Compliance With 10 CFR 20</u>	2.10
2.2.1	Batch Releases	2.10
2.3	<u>Liquid Effluent Doses - Compliance with 10 CFR 50</u>	2.11
2.3.1	Determination of Liquid Effluent Dilution	2.11
2.3.2	Dose Calculations	2.11
2.3.3	Cumulation of Doses	2.12
2.3.4	Projection of Doses	2.13
3.0	GASEOUS EFFLUENTS	3-1
3.1	<u>Monitor Alarm Setpoint Determination</u>	3-2
3.1.1	Effluent Monitors	3-2
3.1.1.1	Reactor Building Vent Isolation Setpoint	3-3
3.1.1.2	Stack Isolation Setpoint	3-6

3.1.2	Accident Monitors	3-8
3.1.2.1	Maximum Release Rate	3-8
3.1.2.2	Maximum Concentration	3-8
3.1.2.3	Monitor Reading	3-9
3.1.2.4	Monitor High High Set-point	3-9
3.1.3	Offgas Storage Tank Maximum Activity	3-9
3.2	<u>Gaseous Effluent Dose Rate - Compliance with 10 CFR 20</u>	3-17
3.2.1	Noble Gases	3-17
3.2.2	Radioiodine and Radioactive Particulates and Other Radionuclides	3-17
3.2.3	Critical Receptor Identification	3-19
3.3	<u>Gaseous Effluents - Compliance with 10 CFR 50</u>	3-21
3.3.1	Noble Gases	3-21
3.3.1.1	Air Dose Bases on Historical Meteorology	3-21
3.3.1.2	Air Dose Based on Contemporaneous Meteorology Using MIDAS	3-24
3.3.2	Radioiodine, Particulates, and Other Radionuclides	3-25
3.3.2.1	Dose from Radioiodines and Particulates Based on Historical Meteorology	3-26
3.3.2.2	Dose Based on Contemporaneous Meteorology Using MIDAS	3-27
3.3.3	Cumulation of Doses	3-29
3.3.4	Projection of Doses	3-29
3.3.5	Critical Receptor Identification	3-30
4.0	INFORMATION RELATED TO 40 CFR 190 AND 40 CFR 141	4-1
5.0	RADIATION ENVIRONMENTAL MONITORING PROGRAMS	5-1

APPENDIX A	Metorological Dispersion Parameters	A-1
APPENDIX B	10 Meter Joint Frequency Distribution Tables	B-1
APPENDIX C	100 Meter Joint Frequency Distribution Tables	C-1
APPENDIX D	Summary of EBARR Computer Program	D-1
APPENDIX E	Dose Parameters for Radioiodines, Particulates, and Tritium	E-1
APPENDIX F	MIDAS Program Descriptions	F-1

LIST OF FIGURES

<u>Figure</u>		<u>Page</u>
2-1	Liquid and Solid Radwaste Treatment and Effluent Flowpath	2-18
3-1	Gaseous Radwaste Treatment Flowpath	3-53
3-2	Ventilation Release Flowpath	3-54
5.1-1	Monticello Nuclear Generating Plant radiation environmental monitoring program	5-6
5.1-2	Site boundary TLD locations	5-7
5.1-3	4-5 mile ring, control, and special interest TLD locations	5-8

RECORD OF REVISIONS

<u>Revision No.</u>	<u>Date</u>	<u>Reason for Revision</u>
Original	May 2, 1979	
1	Feb. 29, 1980	Incorporation of NRC Staff comments and correction of miscellaneous errors.
2	July 23, 1982	Incorporation of NRC Staff comments, addition of short term vent dispersion parameters, and addition of Appendices D and E.
3	March 24, 1983	Change in milk sampling location
4	December 12, 1983	Change in milk sampling locations and remove formula for converting uci/sec to mrad/hr for stack and vent wide range gas monitors.
5	March 27, 1984	Change Table 3.2-1
6	January - 1988	Incorporation of MIDAS and complete retyping.
7	January - 1990	Incorporation of NRC staff comments correction of miscellaneous errors, clarification of term abnormal release and addition of references to MNGP ODCM computer program.

LIST OF EFFECTIVE PAGES

<u>Page No.</u>	<u>Revision</u>	<u>Page No.</u>	<u>Revision</u>
i to ix	7	1-1	7
2-1 to 2-18	7	3-1 to 3-54	7
4-1 to 4-3	7	5-1 to 5-8	7
A-1 to A-75	7	B-1 to B-11	7
C-1 to C-11	7	D-1 to D-7	7
E-1 to E-13	7	F-1 to F-155	7

1.0 INTRODUCTION

This Offsite Dose Calculational Manual (ODCM) provides the information and methodologies to be used by Monticello Nuclear Generating Plant (MNGP) to assure compliance with MNGP's operating technical specifications related to liquid and gaseous radiological effluents. They are intended to show compliance with 10 CFR 20, 10 CFR 50.361, 10 CFR 50, Appendix A (GDC 60 & 64) and Appendix I, and 40 CFR 190.

This ODCM is based on "Radiological Effluent Technical Specifications for BWR's (NUREG-0473, Draft)," "Preparation of Radiological Effluent Technical Specifications for Nuclear Power Plants (NUREG-0133)," and other inputs from the Nuclear Regulatory Commission (USNRC). Specific plant procedures for implementation of this manual are provided elsewhere. These procedures will be utilized by the operating staff of MNGP to assure compliance with the technical specifications.

Also included in this manual is information related to the Radiological Environmental Monitoring Program (REMP) in the form of Figures 5.1-1, 5.1-2, 5.1-3, and Table 5.1-1. These figures and table designate specific sample types and locations currently used to satisfy the technical specification requirements for the REMP. They are subject to change based on the results of the periodic land use census.

Calculations described in this manual may be performed using computer programs designed to implement these algorithms. In addition, the current meteorological data and χ/Q data may be generated by the MIDAS programs. MIDAS programs implement the regulatory guidance found in Regulatory Guide 1.109, 1.23 and 1.111.

MIDAS is a set of programs designed to collect and process meteorological data, radiological release data and other data to permit prompt reporting of off-site radiological consequences during emergency release conditions. MIDAS algorithms may be used when appropriate to perform dose calculations from routine airborne releases, for computation of doses from liquid releases, and to identify critical receptors.

Regulatory Guide 1.21 defines abnormal releases as "unplanned or uncontrolled release of radioactive material from the site boundary."

MNGP further defines abnormal gaseous releases as any gaseous release where the effluent release rate significantly exceeds an established normal release rate.

Abnormal releases as stated above will typically be due to personnel error, procedure inadequacy, training deficiency, or equipment malfunction.

This ODCM has been prepared as generically as possible in order to minimize the need for future revisions. Some changes to the ODCM will be needed in the future. Any such changes will be properly reviewed and approved as indicated in the Administrative Control Section of the MNGP Technical Specifications.

2.0 LIQUID EFFLUENTS

It is MNGP's policy to make no routine liquid releases, however, in the event of a release this section is used to:

- o Determine alarm set points for liquid monitors;
- o Determine that liquid concentrations in effluents are below the allowable concentrations given in 10 CFR 20;
- o Calculate dose commitments to individuals; and
- o Project doses for the next month due to liquid radioactive effluents.

2.1 Monitor Alarm Setpoint Determination

Monitor alarm setpoints are determined to assure compliance with 10 CFR 20. The setpoints indicate if the concentration of radionuclides in the liquid effluent at the site boundary exceeds the concentrations specified in 10 CFR 20, Appendix B, Table II, Column 2 for radionuclides other than dissolved or entrained noble gases. The setpoints will also assure that a concentration of 2×10^{-4} $\mu\text{Ci/ml}$ for dissolved or entrained noble gases is not exceeded.

Monitor alarm setpoints are calculated monthly. The calculation is performed by the LIQDOS computer program in conjunction with Surveillance Test 0378 IAW MNGP Technical Specification 3.8.A.1.d. The calculation is based on radionuclides detected in effluent from the release point during the previous month in the following manner:

- a. If there were no detectable radionuclides during the previous month, the BWR GALE Code source terms (Table 2.1-1) will be used as the basis for the monthly release rate.
- b. If the calculated setpoint is less than the existing monitor setpoint, the setpoint will be reduced to the new lower value.
- c. If the calculated setpoint is greater than the existing monitor setpoint, the setpoint may remain at the lower value or be increased to the new value.

2.1.1 Radwaste Discharge Line Monitor

The following method applies to liquid releases from the plant via the discharge canal when determining the high-high alarm setpoint for the Liquid Radwaste Effluent Monitor during all operational conditions. The radwaste discharge flowrate is assumed to be maintained relatively constant at or near the maximum design flowrate.

2.1.1.1 Determine the "mix" (radionuclides and composition) of the liquid effluent.

- a. Determine the liquid source terms that are representative of the "mix" of the liquid effluent. Liquid source terms are the total

curies of each isotope released during the previous month. Table 2.1-1 source terms may be used if there have been no liquid releases.

- b. Determine S_i (the fraction of the total radioactivity in the liquid effluent comprised by radionuclide i) for each individual radionuclide in the liquid effluent.

$$S_i = \frac{A_i}{\sum_i A_i} \quad 2.1-1$$

where

A_i = The radioactivity of radionuclide i in the liquid effluent from Table 2.1-1.

- 2.1.1.2 Determine C_t , the maximum acceptable total radioactivity concentration of all radionuclides in the liquid effluent prior to dilution ($\mu\text{Ci/ml}$).

$$C_t = \frac{F}{f \sum_i \frac{S_i}{\text{MPC}_i}} \quad 2.1-2$$

where

F = Dilution water flowrate (gpm);

= 240,000 gpm from two circulating water pumps;

f = The maximum acceptable discharge flowrate prior to dilution (gpm);

= 50 gpm from the Liquid Radwaste pump⁽¹⁾; and

MPC_i = The liquid effluent radioactivity concentration limit for radionuclide i ($\mu\text{Ci/ml}$) from Table 2.1-1.

- 2.1.1.3 Determine C_m , the maximum acceptable total radioactivity concentration of the radionuclides (minus tritium) in the liquid discharge prior to dilution ($\mu\text{Ci/ml}$).

$$C_m = C_t - (C_t S_H) \quad 2.1-3$$

where

S_H = The fraction of the total radioactivity in the liquid effluent comprised of tritium and other radionuclides that do not emit gamma or x ray radiation.

2.1.1.4 Determine C.R., the calculated monitor count rate above background attributed to the radionuclides (ncps).

$$C.R. = \frac{C_m}{E} \quad 2.1-4$$

where

E = The detection efficiency of the monitor ($\mu\text{Ci/cc/cps}$) from Plant Chemistry Surveillance procedures.

2.1.1.5 The monitor high-high alarm setpoint above background (ncps) should be set at the C.R. value. Since only one tank can be released at a time, adjustment of this value is not necessary to compensate for releases from more than one source.

2.1.2 Discharge Canal Monitor

The following method determines the high-high alarm set-point for the Discharge Canal Monitor during all operational conditions.

2.1.2.1 Determine the "mix" (radionuclides and composition) of all liquids released into the discharge canal.

- a. Determine the liquid source terms that are representative of the "mix" of all liquid released into discharge canal. Liquid source terms are the total curies of each isotope released during the previous month. Table 2.1-1 source terms may be used if there have been no liquid releases.
- b. Determine S_i (the fraction of the total radioactivity of all liquids released into the discharge canal comprised by radionuclide i) for each individual radionuclide released into the discharge canal.

$$S_i = \frac{A_i}{\sum A_i} \quad 2.1-5$$

where A_i = The radioactivity of radionuclide i released into the discharge canal.

2.1.2.2 Determine C_d , the maximum acceptable diluted radioactivity concentration of all radionuclides released into the discharge canal ($\mu\text{Ci/ml}$).

$$C_d = \frac{1}{\sum_i \frac{S_i}{\text{MPC}_i}} \quad 2.1-6$$

where MPC_i = The liquid effluent radioactivity concentration limit for radionuclide i ($\mu\text{Ci/ml}$) from Table 2.1.1.

2.1.2.3 Determine C_m , the maximum acceptable total radioactivity concentration of the radionuclides (minus tritium) released into the discharge canal ($\mu\text{Ci/ml}$).

$$C_m = C_d - (C_d S_H) \quad 2.1-7$$

where

S_H = The fraction of the total radioactivity released into the discharge canal comprised of tritium and other radionuclides that do not emit gamma or x-ray radiation.

2.1.2.4 Determine C.R., the calculated monitor count rate above background attributed to the radionuclides (ncps).

$$\text{C.R.} = \frac{C_m}{E} \quad 2.1-8$$

where

E = The detection efficiency of the monitor ($\mu\text{Ci/cc/cps}$) from Plant Chemistry Surveillance procedures.

2.1.2.5 The monitor high high alarm set-point above background (ncps) should be set at the C.R. value.

2.1.3 Service Water Discharge Pipe Monitor

The following method determines the high-high alarm set-point for the Service Water Discharge Pipe Monitor during all operational conditions.

2.1.3.1 Determine the "mix" (radionuclides and composition) of the service water effluent.

- a. Determine the liquid source terms that are representative of the "mix" of the service water effluent. Liquid source terms are the total curies of each isotope released during the previous month. Table 2.1-I source terms may be used if there have been no liquid releases.
- b. Determine S_i , the fraction of the total radioactivity in the service water effluent comprised by radionuclide i , for each individual radionuclide in the liquid effluent.

$$S_i = \frac{A_i}{\sum_i A_i} \quad 2.1-9$$

where

A_i = The radioactivity of radionuclide i in the service water effluent.

2.1.3.2 Determine C_t (the maximum acceptable total radioactivity concentration of all radionuclides in the service water effluent prior to dilution ($\mu\text{Ci}/\text{ml}$)).

$$C_t = \frac{F}{f \sum_i \frac{S_i}{\text{MPC}_i}} \quad 2.1-10$$

where

F = Dilution water flowrate (gpm).

= 240,000 gpm from two circulating water pumps;

f = The maximum acceptable service water discharge flowrate prior to dilution (gpm).

= 10,000 gpm;

MPC_i = The liquid effluent radioactivity concentration limit for radionuclide i ($\mu\text{Ci/ml}$) from Table 2.1-1.

2.1.3.3 Determine C_m (the maximum acceptable total radioactivity concentration of the radionuclides (minus tritium) in the service water prior to dilution ($\mu\text{Ci/ml}$)).

$$C_m = C_t - (C_t S_H) \quad 2.1-11$$

where

S_H = The fraction of the total radioactivity in the service water effluent comprised of tritium and other radionuclides that do not emit gamma or x-ray radiation.

2.1.3.4 Determine C.R. (the calculated monitor count rate above background attributed to the radionuclides (ncps)).

$$C.R. = \frac{C_m}{E} \quad 2.1-12$$

where

E = The detection efficiency of the monitor ($\mu\text{Ci/cc/cps}$) from Plant Chemistry Surveillance procedures.

2.1.3.5 The monitor high-high alarm setpoint above background (ncps) should be set at the C.R. value.

2.1.4 Turbine Building Normal Drain Sump Monitor

The following method determines the high-high alarm set-point for the Turbine Building Normal Drain Sump Monitor during all operational conditions.

2.1.4.1 Determine the "mix" (radionuclides and composition) of the TBNS effluent.

- a. Determine the liquid source terms that are representative of the "mix" of the TBNS effluent. Liquid source terms are the total curies of each isotope released during the previous month. Table 2.1-I source terms may be used if there have been no liquid releases.

- b. Determine S_i , the fraction of the total radioactivity in the TBNDS effluent comprised by radionuclide i , for each individual radionuclide in the liquid effluent.

$$S_i = \frac{A_i}{\sum_i A_i} \quad 2.1-13$$

where

A_i = The radioactivity of radionuclide i in the TBNDS effluent.

- 2.1.4.2 Determine C_t (the maximum acceptable total radioactivity concentration of all radionuclides in the TBNDS effluent prior to dilution ($\mu\text{Ci/ml}$)).

$$C_t = \frac{F}{f \sum_i \frac{S_i}{\text{MPC}_i}} \quad 2.1-14$$

where

F = Dilution water flowrate (gpm).

= 240,000 gpm from two circulating water pumps;

f = The maximum acceptable TBNDS discharge flowrate prior to dilution (gpm).

MPC_i = The liquid effluent radioactivity concentration limit for radionuclide i ($\mu\text{Ci/ml}$) from Table 2.1-1.

- 2.1.4.3 Determine C_m (the maximum acceptable total radioactivity concentration of the radionuclides (minus tritium) in the TBNDS prior to dilution ($\mu\text{Ci/ml}$)).

$$C_m = C_t - (C_t S_H) \quad 2.1-15$$

where

S_H = The fraction of the total radioactivity in the TBNDS effluent comprised of tritium and other radionuclides that do not emit gamma or x-ray radiation.

- 2.1.4.4 Determine C.R. (the calculated monitor count rate above background attributed to the radionuclides (ncps)).

$$C.R. = \frac{C_m}{E} \quad 2.1-16$$

where

E = The detection efficiency of the monitor ($\mu\text{Ci/cc/cps}$) from Plant Chemistry Surveillance procedures.

- 2.1.4.5 The monitor high-high alarm setpoint above background (ncps) should be set at the C.R. value.

2.1.5 Multiple Release Points

The discharge canal monitor, service water discharge and TBND line monitor are provided to detect unplanned or accidental releases. All normal releases are monitored by the radwaste discharge line monitor. There are, therefore, no multiple release points and monitor settings do not have to be reduced to account for multiple releases.

TABLE 2.1-1
Liquid Source Terms*

Radionuclide	Radioactivity A, Ci/yr	MPC, μ Ci/ml
H-3	2.1E-1	3E-3
Na-24	1.7E-1	3E-5
Mn-54	2.6E-3	1E-4
Mn-56	2.7E-1	1E-4
Fe-59	8.1E-4	5E-5
Co-58	9.3E-3	9E-5
Co-60	2.0E-2	3E-5
Cu-64	5.4E-1	2E-4
Zn-65	5.3E-3	2E-4
Zn-69m	3.7E-2	6E-5
Br-83	1.4E-2	3E-6
Sr-89	2.8E-3	3E-6
Sr-90	1.7E-4	3E-7
Sr-91	6.4E-2	5E-5
Sr-92	5.8E-2	6E-5
Y-92	1.0E-1	6E-5
Y-93	6.6E-2	3E-5
Mo-99	5.0E-2	4E-5
I-131	1.3E-1	3E-7
I-132	1.3E-1	8E-6
I-133	4.0E-1	1E-6
I-134	6.4E-2	2E-5
I-135	2.5E-1	4E-6
Cs-134	8.3E-2	9E-6
Cs-136	2.6E-2	6E-5
Cs-137	1.2E-1	2E-5
Cs-138	1.5E-1	2E-4
Ba-140	1.1E-2	2E-5
La-141	5.7E-3	3E-6
Ce-141	8.5E-4	9E-5
Ce-144	5.3E-3	1E-5
Np-239	1.7E-1	1E-4
Noble Gases	-	2E-4
Total	2.40E1	

* These source terms were calculated in accordance with NUREG-0016 by using the USNRC "GALE" Code.

2.2 Liquid Effluent Concentration - Compliance With 10 CFR 20

In order to show compliance with 10 CFR 20 (2) the concentrations of radionuclides in liquid effluents are determined and compared with the maximum permissible concentrations (MPC) as defined in Appendix B, Table II of 10 CFR 20. The concentration of radioactivity in effluents prior to dilution is determined. The concentration in diluted effluent is calculated by the LIQDOS computer program in conjunction with Surveillance Test Numbers 0377, 0238, 0239, 0240 and 0242 IAW MNGP Technical Specification 4.8.A.1.b, using these results before each batch release, and following each batch release.

2.2.1 Batch Releases

2.2.1.1 Prerelease

The radioactivity content of each batch release is determined prior to release. MNGP will show compliance with 10 CFR 20 in the following manner:

The concentration of the various radionuclides in the batch release prior to dilution, is divided by the minimum dilution flow to obtain the concentration at the unrestricted area. This calculation is shown in the following equation:

$$\text{Conc}_i = \frac{C_i R}{\text{MDF}} \quad 2.2-1$$

where

Conc_i = concentration of radionuclide i at the unrestricted area, $\mu\text{Ci/ml}$;

C_i = concentration of radionuclide i in the potential batch release, $\mu\text{Ci/ml}$;

R = release rate of the batch, gpm ;

MDF = minimum dilution flow, gpm .

The projected concentration in the unrestricted area is compared to the concentrations in Appendix B, Table II of 10 CFR 20. These concentrations are given in Table 2.1-1. Before a release may occur, equation 2.2-2 must be met for all nuclides. For the MNGP the MDF is 240,000 gpm . The maximum release rate is 50 gpm .

$$\sum_i \left[\frac{\text{Conc}_i}{\text{MPC}_i} \right] \leq 1 \quad 2.2-2$$

where

MPC_i = maximum concentration of radionuclide i from Reference 2, $\mu\text{Ci/ml}$.

2.3 Liquid Effluent Doses - Compliance with 10 CFR 50

Doses resulting from liquid effluents are calculated monthly to show compliance with 10 CFR 50. These calculations are performed by the LIQDOS computer program in conjunction with Surveillance Test 0374 IAW MNGP Technical Specification 3.8.A.2.a. A cumulative summation of total body and organ doses for each calendar quarter and calendar year is maintained as well as projected doses for the next month.

2.3.1 Determination of Liquid Effluent Dilution

To determine doses from liquid effluents the near field average dilution factor for the period of release must be calculated. This dilution factor must be calculated for each batch release. The dilution factor is determined by:

$$F_k = \frac{R_k}{X \text{ ADF}_k} \quad 2.3-1$$

where

R_k = release rate of the batch during time period k , gpm;
and

ADF_k = actual dilution flow during the time period of release k , gpm.

The value of X is the site specific value for the mixing effect of the MNGP discharge structure. This value is 1.0 for MNGP while operating in the once-through cooling mode. Although not expected to occur, if radioactive material is discharged while operating in the recycle mode, this value may be 1.86. (4)

2.3.2 Dose Calculations

The dose contribution from the release of liquid effluents is calculated monthly. The dose contribution is calculated using the following equation:

$$D_j = \sum_k \sum_i A_{ij} t_k C_{ik} F_k \quad 2.3-2$$

where

D_j = the dose commitment to the total body or any organ, from the liquid effluents for the 31 day period, mrem;

C_{ik} = the average concentration of radionuclide, i , in undiluted liquid effluent for release k , ($\mu\text{Ci/ml}$);

- A_{ij} = the site related ingestion dose commitment factor to the total body or any organ j for each identified principal gamma and beta emitter, mrem/hr per ($\mu\text{Ci/ml}$);
- F_k = the near field average dilution factor for C_{ik} during liquid effluent release k , as defined in Section 2.3.1; and
- t_k = the length of time for release k , hours.

The dose factor A_{ij} was calculated for an adult for each isotope using the following equation:

$$A_{ij} = 1.14 \times 10^5 (730/D_w + 21BF_i) DF_{ij} \quad 2.3-3$$

where

$$1.14 \times 10^5 = \frac{10^6 \text{ pCi}}{\mu\text{Ci}} \quad \frac{10^3 \text{ ml}}{\text{liter}} \quad \frac{1 \text{ yr.}}{8760 \text{ hr}}$$

730 = adult water consumption rate, liters/yr;

D_w = dilution factor from the near field area to the potable water intake for adult water consumption;

21 = adult fish consumption, kg/yr;

BF_i = bioaccumulation factor for radionuclide i in fish from Table A-1 of Regulatory Guide 1.109 Rev. 1, ⁽⁵⁾ pCi/Kg per pCi/liter;

DF_{ij} = dose conversion factor for radionuclide i for adults for particular organ j from Table E-11 of Regulatory Guide 1.109 Rev.1, mrem/pCi.

The A_{ij} values for an adult at the MNGP are given in Table 2.3-1. The far field dilution factor, D_w for the MNGP is 7:1 for the nearest downstream water supply in St. Paul. This value was determined by assuming that effluents are completely mixed in 50 percent of the Mississippi River flow (7431 cfs at Anoka, Minnesota). ⁽⁷⁾

2.3.3 Cumulation of Doses

Doses calculated monthly are summed for comparison with quarterly and annual limits. The monthly results should be added to the doses cumulated from the other months in the quarter of interest and in the year of interest. This summation is performed by the LIQDOS computer program.

For the quarter,

D < 1.5 mrem total body 2.3-4

D < 5 mrem any organ 2.3-5

For the Calendar year,

D < 3 mrem total body 2.3-6

D < 10 mrem any organ 2.3-7

The quarterly limits given above represent one half of the annual design objective⁽⁸⁾. If these quarterly or annual limits are exceeded, a special report should be submitted stating the reason and corrective action to be taken. This report will include results of analyses of Mississippi River water and an analysis of possible impacts through the drinking water pathway. If twice these limits are exceeded, a special report will be submitted showing compliance with 40 CFR 190⁽⁹⁾.

2.3.4 Projection of Doses

Anticipated doses resulting from the release of liquid effluents are projected monthly. If the projected doses for the month exceeds two percent of Equation 2.3-6 or 2.3-7, additional components of the liquid radwaste treatment system will be used to process waste. The projected doses are calculated using Equation 2.3-2. This calculation is performed by the LIQDOS computer program in conjunction with Surveillance Test 0375 IAW MNGP Technical Specification 3.8.A.3.a. The dilution factor, F_k , is calculated by replacing the term ADF_k in Equation 2.3-1 with the term MDF from Equation 2.2-1.

The total source term utilized for the most recent dose calculation should be used for the projections unless information exists indicating that actual releases could differ significantly in the next month. In this case, the source term would be adjusted to reflect this information and the justification for the adjustment noted. This adjustment should account for any radwaste equipment which was operated during the previous month that could be out of service in the coming month.

REFERENCES - SECTION 2

- (1) NSP - Monticello Nuclear Generating Plant, Appendix I Analysis - Supplement No. 1 - Docket No. 50-263, Table 2.1-1.
- (2) USNRC, Title 10, Code of Federal Regulation, Part 20, "Standards for Protection Against Radiation", Appendix B, Table II, Column 2.
- (3) NSP - Monticello Nuclear Generating Plant, Appendix I Analysis - Supplement No. 1 - Docket No. 50-263, Figure 2.1-2.
- (4) Boegli, J.S., et. al. Eds, Section 4.3 in "Preparation of Radiological Effluent Technical Specifications for Nuclear Power Plants, NUREG-0133, 1978, NTIS, Springfield Va.
- (5) USNRC, Regulatory Guide 1.109. "Calculation of Annual Doses to Man from Routine Releases of Reactor Effluents for the Purpose of Evaluating Compliance with 10 CFR 50, Appendix I", Rev. 1, Oct. 1977, USNRC, Washington D.C.
- (6) USNRC, Title 10, Code of Federal Regulation, Part 50, "Domestic Licensing of Production and Utilization Facilities", Appendix I, "Numerical Guides for Design Objectives and Limiting Conditions for Operation to Meet the Criterion As Low as is Reasonably Achievable' for Radioactive Material in Light-Water-Cooled Nuclear Power Reactor Effluents"
- (7) NSP - Monticello Nuclear Generating Plant, Final Draft Safety Analysis Report - Amendment 4, Question 3.3, and Amendment 8 in entirety.
- (8) Pickard, Lowe and Garrick, Inc., (Proprietary), "MIDAS Users Manual", Section 2.2.6, "Environmental Pathway and Dose Calculations for Liquid and Gaseous Effluents"
- (9) EPA, Title 40, Code of Federal Regulations, Part 190 "Environmental Radiation Protection Standards for Nuclear Power Operations"

Table 2.3-1

A_{ij} Values for the Monticello Nuclear Generating Plant
(mrem/hr per $\mu\text{Ci/ml}$)

Nuclide	Bone	Liver	T. Body	Thyroid	Kidney	Lung	GI-LLI
1 H-3	0.00E 00	1.47E 00	1.47E 00	1.47E 00	1.47E 00	1.47E 00	1.47E 00
6 C 14	3.13E 04	6.26E 03	6.26E 03	6.26E 03	6.26E 03	6.26E 03	6.26E 03
11 Na-24	4.27E 02	4.27E 02	4.27E 02	4.27E 02	4.27E 02	4.27E 02	4.27E 02
24 Cr-51	0.00E 00	0.00E 00	1.31E 00	7.80E 01	2.38E 01	1.73E 00	3.28E 02
25 Mn-54	0.00E 00	4.43E 03	8.45E 02	0.00E 00	1.32E 03	0.00E 00	1.36E 04
25 Mn-56	0.00E 00	1.11E 02	1.98E 01	0.00E 00	1.42E 02	0.00E 00	3.56E 03
26 Fe-55	6.91E 02	4.77E 02	1.11E 02	0.00E 00	0.00E 00	2.66E 02	2.74E 02
26 Fe-59	1.09E 03	2.56E 03	9.83E 02	0.00E 00	0.00E 00	7.16E 02	8.54E 03
27 Co-58	0.00E 00	9.80E 01	2.20E 02	0.00E 00	0.00E 00	0.00E 00	1.99E 03
27 Co-60	0.00E 00	2.82E 02	6.21E 02	0.00E 00	0.00E 00	0.00E 00	5.29E 03
28 Ni-63	3.27E 04	2.26E 03	1.10E 03	0.00E 00	0.00E 00	0.00E 00	4.72E 02
28 Ni-65	1.33E 02	1.72E 01	7.87E 00	0.00E 00	0.00E 00	0.00E 00	4.37E 02
29 Cu-64	0.00E 00	1.10E 01	5.15E 00	0.00E 00	2.76E 01	0.00E 00	9.34E 02
30 Zn-65	2.32E 04	7.39E 04	3.34E 04	0.00E 00	4.94E 04	0.00E 00	4.66E 04
30 Zn-69	4.94E 01	9.46E 01	6.58E 00	0.00E 00	6.14E 01	0.00E 00	1.42E 01
35 Br-83	0.00E 00	0.00E 00	4.09E 01	0.00E 00	0.00E 00	0.00E 00	5.89E 01
35 Br-84	0.00E 00	0.00E 00	5.30E 01	0.00E 00	0.00E 00	0.00E 00	4.16E-04
35 Br-85	0.00E 00	0.00E 00	2.18E 00	0.00E 00	0.00E 00	0.00E 00	1.02E-15
37 Rb-86	0.00E 00	1.01E 05	4.72E 04	0.00E 00	0.00E 00	0.00E 00	2.00E 04
37 Rb-88	0.00E 00	2.90E 02	1.54E 02	0.00E 00	0.00E 00	0.00E 00	4.01E-09
37 Rb-89	0.00E 00	1.92E 02	1.35E 02	0.00E 00	0.00E 00	0.00E 00	1.12E-11
38 Sr-89	2.58E 04	0.00E 00	7.40E 02	0.00E 00	0.00E 00	0.00E 00	4.14E 03
38 Sr-90	6.35E 05	0.00E 00	1.56E 05	0.00E 00	0.00E 00	0.00E 00	1.83E 04
38 Sr-91	4.75E 02	0.00E 00	1.92E 01	0.00E 00	0.00E 00	0.00E 00	2.26E 03
38 Sr-92	1.80E 02	0.00E 00	7.78E 00	0.00E 00	0.00E 00	0.00E 00	3.57E 03

continued

Table 2.3-1 (continued)

A_{ij} Values for the Monticello Nuclear Generating Plant
(mrem/hr per $\mu\text{Ci/ml}$)

Nuclide	Bone	Liver	T. Body	Thyroid	Kidney	Lung	GI-LLI
39 Y-90	6.90E-01	0.00E 00	1.35E-02	0.00E 00	0.00E 00	0.00E 00	7.32E 03
39 Y-91m	6.52E-03	0.00E 00	2.53E-04	0.00E 00	0.00E 00	0.00E 00	1.92E-02
39 Y-91	1.01E 01	0.00E 00	2.70E-01	0.00E 00	0.00E 00	0.00E 00	5.57E 03
39 Y-92	6.06E-02	0.00E 00	1.77E-03	0.00E 00	0.00E 00	0.00E 00	1.06E 03
39 Y-93	1.92E-01	0.00E 00	5.31E-03	0.00E 00	0.00E 00	0.00E 00	6.10E 03
40 Zr-95	6.02E-01	1.93E-01	1.31E-01	0.00E 00	3.03E-01	0.00E 00	6.11E 02
40 Zr-97	3.32E-02	6.71E-03	3.07E-03	0.00E 00	1.01E-02	0.00E 00	2.08E 03
41 Nb-95	4.47E 02	2.49E 02	1.34E 02	0.00E 00	2.46E 02	0.00E 00	1.51E 06
42 Mo-99	0.00E 00	1.54E 02	2.94E 01	0.00E 00	3.50E 02	0.00E 00	3.58E 02
43 Tc-99m	1.13E-02	3.34E-02	4.25E-01	0.00E 00	5.07E-01	1.63E-02	1.97E 01
43 Tc-101	1.21E-02	1.75E-02	1.72E-01	0.00E 00	3.15E-01	8.94E-03	5.26E-14
44 Ru-103	6.63E 00	0.00E 00	2.86E 00	0.00E 00	2.53E 01	0.00E 00	7.74E 02
44 Ru-105	5.52E 01	0.00E 00	2.18E-01	0.00E 00	7.13E 00	0.00E 00	3.38E 02
44 Ru-106	9.85E 01	0.00E 00	1.25E 01	0.00E 00	1.90E 02	0.00E 00	6.38E 03
47 Ag-110m	2.78E 00	2.57E 00	1.53E 00	0.00E 00	5.06E 00	0.00E 00	1.05E 03
52 Te-125m	2.60E 03	9.41E 02	3.48E 02	7.81E 02	1.06E 04	0.00E 00	1.04E 04
52 Te-127m	6.56E 03	2.35E 03	8.00E 02	1.68E 03	2.67E 04	0.00E 00	2.20E 04
52 Te-127	1.07E 02	3.83E 01	2.31E 01	7.90E 01	4.34E 02	0.00E 00	3.42E 03
52 Te-129m	1.11E 04	4.16E 03	1.76E 03	3.83E 03	4.65E 04	0.00E 00	5.61E 04
52 Te-129	3.04E 01	1.14E 01	7.42E 00	2.34E 01	1.23E 02	0.00E 00	2.30E 01
52 Te-131m	1.68E 03	8.20E 02	6.83E 02	1.30E 03	9.31E 03	0.00E 00	8.14E 04
52 Te-131	1.81E 01	7.98E 00	6.03E 00	1.57E 01	8.37E 01	0.00E 00	2.70E 00
52 Te-132	2.44E 03	1.58E 03	1.48E 03	1.75E 03	1.52E 04	0.00E 00	7.47E 04
53 I-130	3.61E 01	1.07E 02	4.21E 01	9.03E 03	1.66E 02	0.00E 00	9.18E 01
53 I-131	1.99E 02	2.84E 02	1.63E 02	9.32E 04	4.88E 02	0.00E 00	7.50E 01
53 I-132	9.70E 00	2.60E 01	9.08E 00	9.08E 02	4.13E 01	0.00E 00	4.88E 00
53 I-133	6.79E 01	1.18E 02	3.60E 01	1.74E 04	2.06E 02	0.00E 00	1.06E 02
53 I-134	5.07E 00	1.38E 01	4.92E 00	2.39E 02	2.19E 01	0.00E 00	1.20E-02
53 I-135	2.12E 01	5.54E 01	2.05E 01	3.66E 03	8.89E 01	0.00E 00	6.26E 01

continued

Table 2.3-1 (continued)

A_{ij} Values for the Monticello Nuclear Generating Plant
(mrem/hr Per $\mu\text{Ci/ml}$)

Nuclide	Bone	Liver	T. Body	Thyroid	Kidney	Lung	GI-LLI
55 Cs-134	2.99E 05	7.10E 05	5.81E 05	0.00E 00	2.30E 05	7.63E 04	1.24E 04
55 Cs-136	3.12E 04	2.23E 05	8.88E 04	0.00E 00	6.86E 04	9.41E 03	1.40E 04
55 Cs-137	3.83E 05	5.23E 05	3.43E 05	0.00E 00	1.78E 05	5.90E 04	1.01E 04
55 Cs-138	2.65E 02	5.23E 02	2.59E 02	0.00E 00	3.84E 02	3.80E 01	2.23E-03
56 Ba-139	2.08E 00	1.48E-03	6.10E-02	0.00E 00	1.39E-03	8.41E 04	3.69E 00
56 Ba-140	4.36E 02	5.47E-01	2.85E 01	0.00E 00	1.86E-01	3.13E 01	8.97E 02
56 Ba-141	1.01E 00	7.64E-04	3.41E-02	0.00E 00	7.10E-04	4.34E 04	4.77E-10
56 Ba-142	4.57E-01	4.70E-04	2.88E-02	0.00E 00	3.97E-04	2.66E 04	6.44E-19
57 La-140	1.79E-01	9.04E-02	2.39E-02	0.00E 00	0.00E 00	0.00E 00	6.64E 03
57 La-142	9.18E-03	4.18E-03	1.04E-03	0.00E 00	0.00E 00	0.00E 00	3.05E 01
58 Ce-141	1.34E-01	9.04E-02	1.03E-02	0.00E 00	4.20E-02	0.00E 00	3.46E 02
58 Ce-143	2.36E-02	1.74E 01	1.93E-03	0.00E 00	7.67E-03	0.00E 00	6.51E 02
58 Ce-144	6.97E 00	2.91E 00	3.74E-01	0.00E 00	1.73E 00	0.00E 00	2.36E 03
59 Pr-143	6.60E-01	2.65E-01	3.27E-02	0.00E 00	1.53E-01	0.00E 02	2.89E 03
59 Pr-144	2.16E-03	8.97E-04	1.10E-04	0.00E 00	5.06E-04	0.00E 00	3.11E-14
60 Nd-147	4.51E-01	5.22E-01	3.12E-02	0.00E 00	3.05E-01	0.00E 00	2.50E 04
74 W-187	2.97E 02	2.48E 02	8.68E 01	0.00E 00	0.00E 00	0.00E 00	8.13E 04
93 Np-239	4.26E-02	4.19E-03	2.31E-03	0.00E 00	1.31E-02	0.00E 00	8.60E 02

RADWASTE

CLEAN
DIRTY
SOLID WASTE

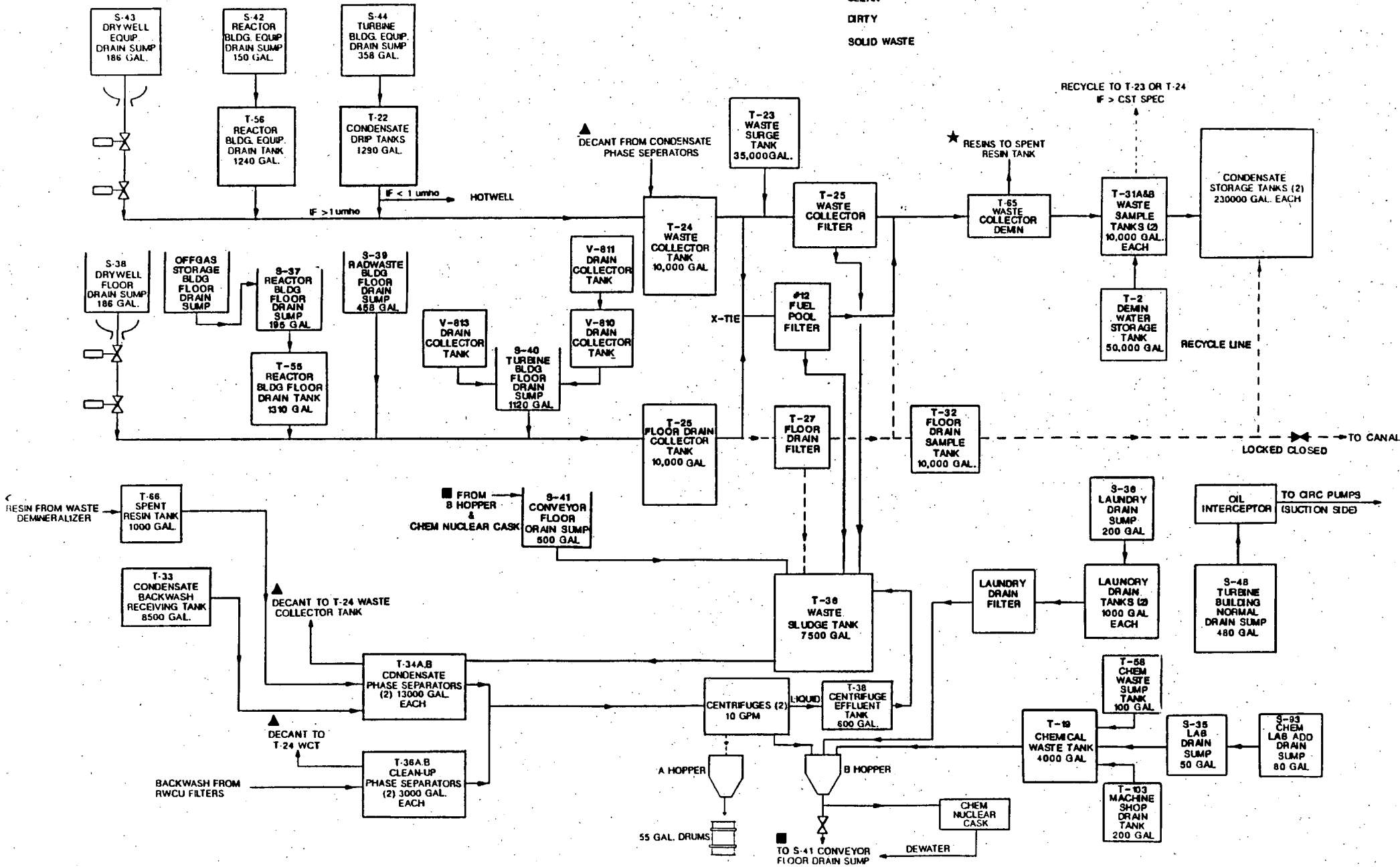

FIGURE 2-1
2 - 18

Revision 7

3.0 GASEOUS EFFLUENTS

This section describes the procedures used by MNGP to:

- o Determine alarm point settings for gaseous effluent monitors;
- o Determine that dose rates at the site boundary from noble gases, particulates and iodines remain below the limits of 10 CFR 20⁽¹⁾; and
- o Determine that the total dose from airborne effluents for the year is within the limits of Appendix I of 10 CFR 50⁽²⁾.

The computations of this section may be done manually, by use of computer programs which implement these algorithms, and or by use of applicable MIDAS algorithms. MIDAS is a set of programs used at Monticello for the accident dose assessment. The applicable MIDAS dose evaluation routines for gaseous effluents may be utilized to perform the dose and dose rate assessments specified in this section.

3.1 Monitor Alarm Setpoint Determination

This procedure determines the effluent monitor alarm setpoint that indicates if the dose rate at or beyond the site boundary due to noble gas radionuclides in the gaseous effluent released from the site exceeds 500 mrem/year to the whole body or exceeds 3000 mrem/year to the skin. Accident monitors are set to limit effluent releases to a small fraction of the limits specified in 10 CFR 100. In addition this section calculates the maximum activity permitted in each offgas storage tank.

Monitor high alarm or isolation setpoints are established in one of the following ways:

- a. Monthly calculation of setpoints using the methodology of Section 3.1.1 for noble gas nuclides in releases during the previous month.
- b. Prior to each containment purge, recalculation of the setpoint using the methodology of Section 3.1.1 based on the sample taken prior to purging.

3.1.1 Effluent Monitors

Monitor alarm setpoints are determined to assure compliance with 10CFR20. The setpoints indicate that the dose rate at or beyond the site boundary due to noble gas radionuclides in the gaseous effluent released from the site exceeds 500 mrem/year to the whole body or exceeds 3000 mrem/year to the skin.

Monitor alarm setpoints are calculated for the Reactor Building Ventilation Plenum Noble Gas monitors and the Stack Noble Gas Monitors once per month. These calculations are based on the noble gas isotopes in releases made during the previous month. The calculations are performed by the DOSGAS computer program in conjunction with Surveillance Test 0342 IAW MNGP Technical Specification 3.8.B.1.a.1.

In addition, prior to containment purge and venting, the monitor setpoint for the monitor release point is recalculated. This calculation is performed by the DWCAL computer program in conjunction with Surveillance Test 0362 IAW MNGP Technical Specification 4.8.4. The monitor setpoint is determined as follows:

- a. If no detectable noble gas activity is found in the purge sample, the values used as the basis for the alarm point setting are from the column, "Drywell venting" in Table 3.1-1, Gaseous Source Terms.
- b. If any calculated setpoint is less than the existing monitor setpoint, the setpoint is reduced to the new value.

- c. If the calculated setpoint is greater than the existing monitor setpoint, the setpoint may remain at the lower value or be increased to the new value.
- d. The setpoint during purging may not be increased above the setpoint determined for continuous releases, however.

Except for containment inerting and deinerting, all containment purging and venting is done via the standby gas treatment system and plant stack. Containment inerting and deinerting releases are made via the reactor building vent. The small amount of containment atmosphere released by the containment sampling system on a continuous basis is not considered a venting operation.

3.1.1.1 Reactor Building Vent Isolation Setpoint

The following method applies to gaseous releases via the Reactor Building Vent when determining the high-high alarm setpoint for the Reactor Building Vent Plenum Monitor which initiates isolation of Reactor Building releases. This method is applied to both continuous releases and batch releases (containment inerting and deinerting).

- a. Determine the "mix" (noble gas radionuclides and composition) of the gaseous effluent.
 - (1) Determine the gaseous source terms that are representative of the "mix" of the gaseous effluent. Gaseous source terms are the total curies of each noble gas released during the previous month or a representative analysis of the gaseous effluent. Table 3.1-1 source terms may be used if the Reactor Building releases for the previous month were below the lower limits of detection (LLD), or, in the case of inerting and deinerting releases, no detectable activity was found in the grab sample taken prior to purging.
 - (2) Determine S_i , the fraction of the total radioactivity in the gaseous effluent comprised by noble gas radionuclide "i", for each individual noble gas radionuclide in the gaseous effluent.

$$S_i = \frac{A_i}{\sum_i A_i} \quad 3.1-1$$

where

A_i = The radioactivity of noble gas radionuclide "i" in the gaseous effluent

- b. Determine Q_t , the maximum acceptable total release rate of all noble gas radionuclides in the gaseous effluent ($\mu\text{Ci}/\text{sec}$), based upon the whole body exposure limit (500 mrem/yr).

$$Q_t = \frac{500}{(\chi/Q)_v \sum_i K_i S_i} \quad 3.1-2$$

where

$(\chi/Q)_v$ = The highest calculated annual average relative concentration of effluents released via the Reactor Building Vent for any area at or beyond the site boundary for all sectors (sec/m^3) from Appendix A, Table A-3. For purge releases, substitute $(\chi/q)_v$, the highest short term dispersion factor from Table A-12.

K_i The total whole body dose factor due to gamma emissions from noble gas radionuclide "i" ($\text{mrem}/\text{year}/\mu\text{Ci}/\text{m}^3$) from Table 3.1-2.

- c. Determine Q_t based upon the skin exposure limit (3000 mrem/yr).

$$Q_t = \frac{3000}{(\chi/Q)_v \sum_i (L_i + 1.1 M_i) S_i} \quad 3.1-3$$

where

$L_i + 1.1 M_i$ = the total skin dose factor due to emissions from noble gas radionuclide "i" ($\text{mrem}/\text{year}/\mu\text{Ci}/\text{m}^3$) from Table 3.1-2.

- d. Determine HHSP (the monitor high-high alarm setpoint above background (net $\mu\text{Ci}/\text{sec}$)).

NOTE: Use the lower of the Q_t values obtained in Sections 3.1.1.1b and 3.1.1.1c.

$$\text{HHSP} = 0.50 Q_t \quad 3.1-4$$

0.50 = Fraction of the total radioactivity from the site via the monitored release point to ensure that the site boundary limit is not exceeded due to simultaneous releases from several release points.

3.1.1.2 Stack Isolation Setpoint

The following method applies to gaseous releases via the Stack when determining the high-high alarm setpoint for the Stack Gas Monitor which initiates isolation of Stack releases. The method is applied to both continuous releases and batch releases (containment purges). Mechanical vacuum pump releases (relatively insignificant) will be controlled using the continuous setpoint.

- a. Determine the "mix" (noble gases and composition) of the gaseous effluent.
 - (1) Determine the gaseous source terms that are representative of the "mix" of the gaseous effluent. Gaseous source terms are the total curies of each noble gas released during the previous month or a representative analysis of the gaseous effluent. Table 3.1-1 source terms may be used if the Stack releases for the previous month were below the lower limits of detection (LLD).
 - (2) Determine S_i , the fraction of the total radioactivity in the gaseous effluent comprised by noble gas radionuclide "i", for each individual noble gas radionuclide in the gaseous effluent.

$$S_i = \frac{A_i}{\sum_i A_i} \quad 3.1-5$$

where

A_i = The radioactivity of noble gas radionuclide "i" in the gaseous effluent.

- b. Determine Q_t , the maximum acceptable total release rate of all noble gas radionuclides in the gaseous effluent ($\mu\text{Ci}/\text{sec}$), based upon the whole body exposure limit (500 mrem/yr).

$$Q_t = \frac{500}{\sum_i V_i S_i} \quad 3.1-6$$

NOTE: For short-term batch releases (equal to or less than 500 hrs/years) via drywell purging, substitute v_i for V_i in Equation 3.1-6.

where

V_i = The constant for long-term releases (greater than 500 hrs/yr) for noble gas radionuclide "i" accounting for the gamma radiation from the elevated finite plume (mrem/year/ μ Ci/sec) from Table 3.1-2.

v_i = The constant for short-term releases (equal to or less than 500 hrs/year) for noble gas radionuclide "i" accounting for the gamma radiation from the elevated finite plume (mrem/ μ Ci/sec) Table 3.1-2.

- c. Determine Q_t based upon the skin exposure limit (3000 mrem/yr).

$$Q_t = \frac{3000}{\sum_i (L_i(\chi/Q)_s + 1.1B_i) S_i} \quad 3.1-7$$

NOTE: For short-term batch releases (equal to or less than 500 hours per year) via drywell purging, use the short-term (χ/q) value and substitute b_i for B_i in Equation 3.1-7.

where

$L_i(\chi/Q)_s + 1.1B_i$ The total skin dose constant for long-term releases (greater than 500 hours per year) due to emissions from noble gas radionuclide "i", Table 3.1-2, mrem/year/ μ Ci/sec;

$L_i(\chi/q)_s + 1.1b_i$ The total skin dose constant for short-term releases (less than or equal to 500 hours per year) due to emissions from noble gas radionuclide "i", Table 3.1.2, mrem/year/ μ Ci/sec.

- d. Determine HHSP (the monitor high-high alarm setpoint above background (μ Ci/sec)).

NOTE: Use the lower of the Q_t values obtained in Sections 3.1.1.2b^t and 3.1.1.2c.

$$HHSP = 0.50 Q_t \quad 3.1-8$$

0.50 = Fraction of the total radioactivity from the site via the monitored release point to ensure that the site boundary limit is not exceeded due to simultaneous releases from several release points.

3.1.2 Accident Monitors

The gross radioactivity in noble gases removed from the main condenser by means of steam jet air ejectors as measured prior to entering the treatment, adsorption, and delay systems shall be limited by an alarm setpoint for the Off-Gas Monitor.

This procedure determines the monitor alarm setpoint that indicates if the potential body accident dose to an individual at or beyond the site boundary due to noble gas radionuclides in the gaseous effluent released from the site exceeds a small fraction of the limits specified in 10CFR100 in the event this effluent, including the radioactivity accumulated in the treatment system, is inadvertently discharged directly to the environment without treatment. This calculation is performed by the OFFGAS computer program on a routine or an as needed basis. Off-Gas flow is automatically terminated when this setpoint is reached.

3.1.2.1 Maximum Release Rate

Determine Q_t , the maximum acceptable total release rate in $\mu\text{Ci}/\text{sec}$ of all noble gas radionuclides in the gaseous effluent at the Off Gas Monitor after a 5-minute decay, based on the maximum acceptable total release rate of $2.60\text{E}5$ $\mu\text{Ci}/\text{sec}$ after a 30-minute decay.

- a. Determine the off-gas mixture of the gaseous effluent. The off-gas mixture is the fraction of the off-gas noble gas radioactivity caused by each recoil diffusion, and equilibrium component. The off-gas mixture is determined, monthly, in conjunction with Monticello Technical Specification 4.8.B.5.c.
- b. Determine Q_t based on the off-gas mixture using Table 3.1-3. This table was prepared using a variation of the NSP EBARR computer code (Appendix D).

3.1.2.2 Maximum Concentration

Determine C_t , the maximum acceptable total radioactivity concentration of all noble gas radionuclides in the gaseous effluent ($\mu\text{Ci}/\text{cc}$).

$$C_t = 2.12 \text{ E-}03 \frac{Q_t}{F} \quad 3.1-9$$

where

f = The maximum acceptable effluent flowrate at the point of release (cfm);
= 85.5 cfm.

3.1.2.3 Monitor Reading

Determine C.R., the calculated monitor reading above background attributed to the noble gas radionuclides (mR/hr).

$$C.R. = \frac{C_t}{E} \quad 3.1-10$$

where

E = The detection efficiency of the monitor for noble gas radionuclides represented in main condenser off-gas ($\mu\text{Ci/cc/mR/hr}$) from Plant Chemistry Surveillance procedures.

3.1.2.4 Monitor High High Set-point

The monitor high-high alarm setpoint above background (mR/hr) should be set at or below the C.R. value.

3.1.3 Offgas Storage Tank Maximum Activity

The Technical Specifications limit the maximum activity in each storage tank to less than 22,000 curies of noble gas (considered as dose equivalent Xe-133) after 12 hours of holdup. To verify that this limit is not exceeded, Table 3.1-3 is used.

The gross radioactivity of noble gases from the main condenser air ejector is determined by isotopic analysis monthly and whenever a significant increase in offgas activity is noted. Analysis of this data is used to determine the primary mode of fission product release from the fuel (recoil, equilibrium, or diffusion) and the gross release rate. This information combined with the condenser air leakage rate (cfm) and the air ejector monitor release rate is used to confirm that the maximum tank contents limit is not exceeded. This calculation is performed by the OFFGAS computer program on a routine or as needed basis IAW MNGP Technical Specification 4.8.B.4.a.

Table 3.1-3 is entered with the offgas mixture (fraction recoil, diffusion, and equilibrium rounded to one decimal place) and the air leakage rate (in cfm determined from the last tank fill time). The resulting tank activity is

multiplied by the current total release rate after a 30 minute decay ($\mu\text{Ci}/\text{sec}$) and divided by the maximum permitted air ejector release rate rate of 260,000 $\mu\text{Ci}/\text{sec}$. Linear interpolation of air inleakage is used.

As noted earlier, Table 3.1-3 is derived from the EBARR computer program described in Appendix D. It is extremely unlikely that the maximum tank activity limit will be exceeded.

Table 3.1-1
Gaseous Source Terms⁽³⁾

A_i, Ci/yr

Radio-nuclide	Reactor Building Vent	Gland Seal	Mechanical Vacuum Pump	Gaseous Radwaste	Drywell Venting
Kr-83m	--	2.3E 01	--	--	--
Kr-85m	7.1E 01	4.1E 01	--	--	3.0E 00
Kr-85	--	--	--	1.3E 02	--
Kr-87	1.33E 02	1.4E 02	--	--	3.0E 00
Kr-88	2.33E 02	1.4E 02	--	--	3.0E 00
Kr-89	--	6.0E 02	--	--	--
Kr-90	--	--	--	--	--
Xe-131m	--	--	--	4.5E 01	--
Xe-133m	--	2.0E 00	--	2.7E 01	--
Xe-133	3.26E 02	5.6E 01	2.3E 03	8.9E 03	6.6E 01
Xe-135m	6.96E 02	1.7E 01	--	--	4.6E 01
Xe-135	7.09E 02	1.5E 02	3.5E 02	--	3.4E 01
Xe-137	--	7.3E 02	--	--	--
Xe-138	1.41E 03	5.6E 02	--	--	7.0E 00
Xe-139	--	--	--	--	--
Ar-41	--	--	--	--	--
Total	3.58E 03	2.46E 03	2.65E 03	9.10E 03	1.62E 02

Table 3.1-2

Dose Factors and Constants
for the
Total Body and for Skin
for Gaseous Radionuclides

Radio- nuclide	Total Whole Body Dose Factor K_i (mrem/yr per $\mu\text{Ci}/\text{m}^3$)	Total Skin Dose Factor $L_i + 1.1M_i$ (mrem/yr per $\mu\text{Ci}/\text{m}^3$)	Total Body Dose Constant for Long Term Releases V_i (mrem/yr per $\mu\text{Ci}/\text{sec}$)
Kr-83m	7.56E-02	2.12E 01	2.61E-09
Kr-85m	1.17E 03	2.81E 03	1.39E-04
Kr-85	1.61E 01	1.36E 03	2.10E-06
Kr-87	5.92E 03	1.65E 04	6.33E-04
Kr-88	1.47E 04	1.91E 04	1.66E-03
Kr-89	1.66E 04	2.91E 04	1.12E-03
Kr-90	1.56E 04	2.52E 04	1.61E-04
Xe-131m	9.15E 01	6.48E 02	3.31E-05
Xe-133m	2.51E 02	1.35E 03	2.51E-05
Xe-133	2.94E 02	6.94E 02	2.61E-05
Xe-135m	3.12E 03	4.41E 03	3.34E-04
Xe-135	1.81E 03	3.97E 03	2.24E-04
Xe-137	1.42E 03	1.39E 04	9.99E-05
Xe-138	8.83E 03	1.43E 04	9.90E-04
Xe-139	5.02E 03	7.10E 04	5.79E-05
Ar-41	8.84E 03	1.29E 04	1.20E-03

continued

Table 3.1-2 (continued)
Dose Factors and Constants
for the
Total Body and for Skin
for Gaseous Radionuclides

Radio- nuclide	Total Body Dose Constant for Short Term Releases v_i (mrem/Yr per $\mu\text{Ci}/\text{sec}$)	Total Skin Dose Constant for Long Term Releases $L_i(\chi/Q)_s \cdot 1.1B_i^*$ (mrem)/Yr per $\mu\text{Ci}/\text{sec}$)	Total Skin Dose Constant for Short Term Releases $L_i(\chi/q)_s + 1.1b_i^*$ (mrem/Yr per $\mu\text{Ci}/\text{sec}$)
Kr-83m	2.99E-09	4.15E-07	4.75E-07
Kr-85m	1.59E-04	3.90E-04	7.07E-04
Kr-85	2.40E-06	1.52E-04	4.14E-04
Kr-87	7.25E-04	2.13E-03	4.18E-03
Kr-88	1.90E-03	3.00E-03	4.86E-03
Kr-89	1.28E-03	2.97E-03	5.20E-03
Kr-90	1.85E-04	1.08E-03	2.54E-03
Xe-131m	3.79E-05	1.10E-04	2.11E-04
Xe-133m	2.87E-05	1.55E-04	3.56E-04
Xe-133	2.99E-05	7.88E-05	1.45E-04
Xe-135m	3.82E-04	6.36E-04	8.54E-04
Xe-135	2.57E-04	5.77E-04	9.94E-04
Xe-137	1.14E-04	1.52E-03	3.92E-03
Xe-138	1.13E-03	2.10E-03	3.13E-03
Xe-139	6.63E-05	7.33E-03	2.01E-02
Ar-41	1.57E-03	2.28E-03	3.10E-03

* $(\chi/Q)_s$, $(\chi/q)_s$, B_i , and b_i values obtained from other tables in the ODCM.

TABLE 3.1-3

Air Ejector Monitor Trip Setting and Storage Tank Contents
Storage Tank Activity in Dose Equivalent Curies Xe-133 12 Hours After Completion of Tank Fill
Release Rate Set to 1.00 of Maximum Trip Setting

Recoil/Diff/Eq			Qtot(5 min)	Qtot(30 Min)	Inleakage, cfm									
3	6	9	12	15	18	21	24	27	30					
1.0	0.0	0.0	2.149E 06	2.600E 05	956.	1492.	1806.	1970.	2045.	2068.	2062.	2039.	2005.	1965.
0.9	0.1	0.0	1.876E 06	2.600E 05	2008.	2459.	2743.	2880.	2923.	2912.	2872.	2815.	2750.	2680.
0.9	0.0	0.1	2.042E 06	2.600E 05	2480.	2585.	2702.	2747.	2738.	2697.	2639.	2572.	2502.	2431.
0.8	0.2	0.0	1.664E 06	2.600E 05	2823.	3206.	3469.	3584.	3602.	3565.	3499.	3416.	3326.	3234.
0.8	0.1	0.1	1.772E 06	2.600E 05	3371.	3444.	3556.	3589.	3558.	3490.	3403.	3308.	3209.	3111.
0.8	0.0	0.2	1.925E 06	2.600E 05	4145.	3779.	3680.	3595.	3495.	3384.	3269.	3155.	3045.	2939.
0.7	0.3	0.0	1.495E 06	2.600E 05	3471.	3802.	4046.	4144.	4143.	4086.	3998.	3895.	3785.	3674.
0.7	0.2	0.1	1.565E 06	2.600E 05	4053.	4102.	4211.	4233.	4186.	4098.	3989.	3871.	3751.	3633.
0.7	0.1	0.2	1.661E 06	2.600E 05	4842.	4507.	4434.	4554.	4243.	4114.	3977.	3840.	3705.	3576.
0.7	0.0	0.3	1.797E 06	2.600E 05	5971.	5088.	4752.	4526.	4325.	4137.	3960.	3794.	3640.	3496.
0.6	0.4	0.0	1.358E 06	2.600E 05	4000.	4288.	4517.	4602.	4585.	4510.	4405.	4285.	4160.	4034.
0.6	0.3	0.1	1.402E 06	2.600E 05	4593.	4621.	4728.	4743.	4682.	4578.	4452.	4317.	4180.	4045.
0.6	0.2	0.2	1.460E 06	2.600E 05	5370.	5059.	5005.	4928.	4810.	4667.	4514.	4358.	4206.	4060.
0.6	0.1	0.3	1.540E 06	2.600E 05	6435.	5659.	5383.	5182.	4985.	4789.	4598.	4415.	4242.	4080.
0.6	0.0	0.4	1.655E 06	2.600E 05	7982.	6530.	5934.	5551.	5240.	4967.	4721.	4498.	4295.	4109.
0.5	0.5	0.0	1.243E 06	2.600E 05	4440.	4691.	4909.	4982.	4951.	4862.	4743.	4609.	4471.	4332.
0.5	0.4	0.1	1.270E 06	2.600E 05	5030.	5043.	5148.	5156.	5084.	4967.	4827.	4678.	4527.	4379.
0.5	0.3	0.2	1.303E 06	2.600E 05	5784.	5492.	5453.	5379.	5254.	5101.	4934.	4765.	4599.	4439.
0.5	0.2	0.3	1.347E 06	2.600E 05	6782.	6086.	5856.	5673.	5479.	5278.	5076.	4881.	4694.	4518.
0.5	0.1	0.4	1.408E 06	2.600E 05	8165.	6909.	6415.	6082.	5791.	5523.	5273.	5041.	4826.	4627.
0.5	0.0	0.5	1.498E 06	2.600E 05	10208.	8126.	7241.	6685.	6552.	5885.	5663.	5277.	5021.	4788.

TABLE 3.1-3 (continued)

Air Ejector Monitor Trip Setting and Storage Tank Contents
Storage Tank Activity in Dose Equivalent Curies Xe-133 12 Hours After Completion of Tank Fill
Release Rate Set to 1.00 of Maximum Trip Setting

Recoil/Diff/Eq			Qtot(5 min)	Qtot(30 Min)	Inleakage, cfm									
					3	6	9	12	15	18	21	24	27	30
0.4	0.6	0.0	1.147E 06	2.600E 05	4811.	5032.	5240.	5302.	5261.	5160.	5028.	4883.	4733.	4584.
0.4	0.5	0.1	1.160E 06	2.600E 05	5391.	5391.	5494.	5497.	5417.	5289.	5137.	4976.	4814.	4655.
0.4	0.4	0.2	1.176E 06	2.600E 05	6118.	5840.	5813.	5741.	5612.	5450.	5273.	5092.	4915.	4744.
0.4	0.3	0.3	1.197E 06	2.600E 05	7052.	6418.	6223.	6055.	5864.	5657.	5448.	5242.	5045.	4858.
0.4	0.2	0.4	1.225E 06	2.600E 05	8300.	7190.	6771.	6475.	6199.	5934.	5681.	5442.	5218.	5010.
0.4	0.1	0.5	1.265E 06	2.600E 05	10051.	8273.	7540.	7063.	6670.	6322.	6008.	5723.	5462.	5223.
0.4	0.0	0.6	1.324E 06	2.600E 05	12686.	9902.	8697.	7948.	7378.	6907.	6501.	6145.	5828.	5544.
0.3	0.7	0.0	1.064E 06	2.600E 05	5148.	5324.	5522.	5577.	5526.	5415.	5273.	5117.	4958.	4800.
0.3	0.6	0.1	1.068E 06	2.600E 05	5695.	5684.	5786.	5784.	5697.	5559.	5398.	5227.	5055.	4887.
0.3	0.5	0.2	1.072E 06	2.600E 05	6392.	6127.	6110.	6040.	5907.	5737.	5551.	5362.	5175.	4995.
0.3	0.4	0.3	1.078E 06	2.600E 05	7268.	6684.	6517.	6361.	6171.	5961.	5744.	5531.	5325.	5129.
0.3	0.3	0.4	1.085E 06	2.600E 05	8404.	7406.	7046.	6777.	6513.	6251.	5995.	5751.	5521.	5304.
0.3	0.2	0.5	1.092E 06	2.600E 05	9937.	8380.	7758.	7338.	6975.	6642.	6333.	6047.	5784.	5540.
0.3	0.1	0.6	1.108E 06	2.600E 05	12115.	9765.	8771.	8136.	7632.	7197.	6813.	6469.	6158.	5876.
0.3	0.0	0.7	1.129E 06	2.600E 05	15459.	11891.	10326.	9361.	8639.	8051.	7550.	7115.	6732.	6391.
0.2	0.8	0.0	9.929E 05	2.600E 05	5403.	5576.	5767.	5814.	5755.	5635.	5484.	5320.	5153.	4987.
0.2	0.7	0.1	9.894E 05	2.600E 05	5954.	5934.	6034.	6029.	5935.	5790.	5620.	5441.	5261.	5085.
0.2	0.6	0.2	9.052E 05	2.600E 05	6621.	6366.	6358.	6289.	6153.	5977.	5784.	5587.	5393.	5204.
0.2	0.5	0.3	9.799E 05	2.600E 05	7444.	6901.	6757.	6610.	6422.	6209.	5987.	5768.	5555.	5352.
0.2	0.4	0.4	9.733E 05	2.600E 05	8487.	7577.	7263.	7017.	6762.	6502.	6244.	5996.	5760.	5538.
0.2	0.3	0.5	9.646E 05	2.600E 05	9849.	8462.	7924.	7548.	7207.	6885.	6508.	6295.	6029.	5782.
0.2	0.2	0.6	9.528E 05	2.600E 05	11706.	9667.	8825.	8272.	7814.	7406.	7038.	6702.	6395.	6114.
0.2	0.1	0.7	9.357E 05	2.600E 05	14384.	11405.	10124.	9316.	8689.	8159.	7698.	7289.	6923.	6593.
0.2	0.0	0.8	9.090E 05	2.600E 05	18586.	14132.	12163.	10954.	10061.	9340.	8734.	8210.	7751.	7345.

TABLE 3.1-3 (continued)

Air Ejector Monitor Trip Setting and Storage Tank Contents
 Storage Tank Activity in Dose Equivalent Curies Xe-133 12 Hours After Completion of Tank Fill
 Release Rate Set to 1.00 of Maximum Trip Setting

Recoil/Diff/Eq			Qtot(5 min)	Qtot(30 Min)	Inleakage, cfm									
3	6	9	12	15	18	21	24	27	30					
0.1	0.9	0.0	9.305E 05	2.600E 05	5643.	5796.	5981.	6022.	5955.	5827.	5669.	5497.	5322.	5150.
0.1	0.8	0.1	9.217E 05	2.600E 05	6178.	6149.	6249.	6240.	6141.	5989.	5812.	5625.	5439.	5256.
0.1	0.7	0.2	9.112E 05	2.600E 05	6816.	6570.	6568.	6501.	6362.	6181.	5982.	5778.	5577.	5383.
0.1	0.6	0.3	8.985E 05	2.600E 05	7591.	7082.	6957.	6818.	6631.	6415.	6190.	5964.	5746.	5537.
0.1	0.5	0.4	8.826E 05	2.600E 05	8554.	7717.	7440.	7212.	6965.	6706.	6447.	6195.	5955.	5728.
0.1	0.4	0.5	8.624E 05	2.600E 05	9781.	8526.	8055.	7713.	7309.	7076.	6775.	6490.	6222.	5972.
0.1	0.3	0.6	8.358E 05	2.600E 05	11397.	9593.	8865.	8374.	7951.	7564.	7207.	6877.	6573.	6293.
0.1	0.2	0.7	7.992E 05	2.600E 05	13625.	11062.	9982.	9284.	8723.	8236.	7802.	7411.	7058.	6736.
0.1	0.1	0.8	7.454E 05	2.600E 05	16890.	13216.	11619.	10619.	9856.	9222.	8675.	8194.	7768.	7385.
0.1	0.0	0.9	6.591E 05	2.600E 05	22138.	16679.	14250.	12764.	11676.	10805.	10077.	9453.	8909.	8428.
0.0	1.0	0.0	8.755E 05	2.600E 05	5855.	5990.	6169.	6205.	6132.	5997.	5832.	5653.	5472.	5293.
0.0	0.9	0.1	8.628E 05	2.600E 05	6372.	6336.	6435.	6424.	6320.	6162.	5979.	5786.	5593.	5405.
0.0	0.8	0.2	8.477E 05	2.600E 05	6983.	6745.	6750.	6683.	6542.	6357.	6152.	5943.	5732.	5536.
0.0	0.7	0.3	8.296E 05	2.600E 05	7716.	7235.	7126.	6994.	6808.	6590.	6361.	6131.	5908.	5694.
0.0	0.6	0.4	8.075E 05	2.600E 05	8610.	7832.	7586.	7373.	7133.	6875.	6615.	6360.	6117.	5886.
0.0	0.5	0.5	7.799E 05	2.600E 05	9725.	8578.	8160.	7846.	7538.	7231.	6932.	6647.	6378.	6126.
0.0	0.4	0.6	7.446E 05	2.600E 05	11156.	9535.	8897.	8454.	8058.	7687.	7339.	7014.	6713.	6433.
0.0	0.3	0.7	6.976E 05	2.600E 05	13059.	10807.	9876.	9261.	8749.	8293.	7880.	7508.	7158.	6843.
0.0	0.2	0.8	6.320E 05	2.600E 05	15713.	12581.	11241.	10386.	9713.	9139.	8634.	8184.	7779.	7413.
0.0	0.1	0.9	5.342E 05	2.600E 05	19670.	15227.	13277.	12065.	11151.	10401.	9759.	9200.	8705.	8264.
0.0	0.0	1.0	3.727E 05	2.600E 05	26207.	19597.	16640.	14838.	13527.	12484.	11617.	10878.	10235.	9670.

3.2 Gaseous Effluent Dose Rate - Compliance with 10 CFR 20

Dose rates resulting from the release of noble gases, and from radioiodines and particulates must be calculated to show compliance with 10 CFR 20. The dose rate limits of 10 CFR 20 are conservatively applied on an instantaneous basis at the hypothetical worst case location.

3.2.1 Noble Gases

The dose rate in unrestricted areas resulting from noble gas effluents is limited by 10 CFR 20 to 500 mrem/yr to the total body and 3000 mrem/yr to the skin. The setpoint determinations discussed in the previous section are based on the dose rate calculation method presented in NUREG-0133. (4) This represents a backward solution to the limiting dose rate equations in NUREG-0133. Setting alarm trip setpoints in this manner will insure that the limits of 10 CFR 20 are met for noble gas releases. Therefore, no routine dose rate calculations for noble gases will be needed to show compliance with this part. Routine calculations are made for dose rates from noble gas releases to show compliance with 10 CFR 50, Appendix I by performing the DOSGAS computer program.

3.2.2 Radioiodine and Radioactive Particulates and Other Radionuclides

The dose rate in unrestricted areas resulting from the release of radioiodines and particulates with half lives greater than 8 days is limited by 10 CFR 20 to 1500 mrem/yr to any organ. The calculation of dose rate from radioiodines and particulates is performed for drywell purges prior to the release and weekly for all releases. This calculation is performed by the DWCAL computer program for drywell purges and 1/week by the IPART computer program for all releases, which is run in conjunction with Surveillance Test 0356 IAW MNGP Technical Specification 3.8.B.1.a.2. The calculations are based on the results of analyses obtained pursuant to the MNGP Technical Specifications. To show compliance with 10 CFR 20, Equation 3.2-1 or the MIDAS equations shown in Appendix F will be evaluated for I-131, I-133, tritium, and radioactive particulates with half lives greater than eight days.

$$\sum P_{iI} [(x/Q_V) Q_{iV} + (x/Q_S) Q_{iS}] < 1500 \text{ mrem/yr} \quad 3.2-1$$

where

P_{iI} = child critical organ dose parameter for radionuclide i for the inhalation pathway, mrem/yr per $\mu\text{Ci}/\text{m}^3$;

$(\chi/Q)_v$ = annual average relative concentration for long-term release from the reactor building vent at the critical location, sec/m^3 (Appendix A, Table A-3);

$(\chi/Q)_s$ = annual average relative concentration for long-term releases from the off-gas stack at the critical location, sec/m^3 (Appendix A, Table A-6);

Q_{iv} = the release rate of radionuclide i from the reactor building vent for the week of interest, $\mu\text{Ci}/\text{sec}$;

Q_{is} = the release rate of radionuclide i from the off-gas stack for the week of interest, $\mu\text{Ci}/\text{sec}$.

The χ/Q values presented in Tables A-3 and A-6 have been calculated using the USNRC computer code "XOQDOQ." (10) Dose rate calculations using Equation 3.2-1 are made once per week. The source terms Q_{iv} and Q_{is} are determined from the results of analysis of weekly stack and reactor building particulate filters and charcoal cartridges. These source terms include all gaseous releases from MNGP. They are recorded and reported as the total dose for compliance with 10 CFR 20.

Radioiodines and particulates may be released from both the off gas stack and the reactor building vent. As specified in NUREG-0133, the critical receptor location is identified based on the reactor building vent χ/Q .

A component of the total stack or vent source term may be due to short term releases occurring as a result of containment drywell purging. Dose rate calculations are made on this component separately to further assure compliance with 10 CFR 20 prior to release. The calculated dose rate is used only to determine whether or not the drywell can be purged. All dose rates from drywell purges will be accounted for and reported through the weekly calculations discussed above. Release rates are determined from the results of analyses of samples from the drywell.

The term Q_{is} for the calculation of drywell purge dose rate is determined by multiplying the concentration of each nuclide in the drywell by the rate of release. Credit will be taken for the expected reduction in radionuclide concentration due to use of the standby gas treatment system. Equation 3.2-2 is used to calculate purge dose rates. Only one source term is used depending on the release point (stack or reactor building vent). Short term values of χ/q from the Table A-9 or Table A-12 is used in the purge dose rate calculation. The limiting dose rate limit for each purge is determined using:

$$BL = 1500 - (D_{sv} + D_{cs} - D_{dw})$$

3.2-2
Revision 7

where

- BL = limiting dose rate for the batch, mrem/yr;
- D_{cv} = previous week's dose rate from reactor building continuous and batch releases, mrem/yr;
- D_{cs} = previous week's dose rate from off-gas stack continuous and batch releases, mrem/yr;
- D_{dw} = previous week's total dose rate from drywell purge releases, mrem/yr, for the purge release point.

Although mechanical vacuum pump releases are batch mode, they cannot be sampled prior to release. For this reason, no prerelease dose rate calculations can be made from this source. Experience has shown mechanical vacuum pump release to be well within 10 CFR 20 limits.

3.2.3 Critical Receptor Identification

As stated in 5.2.1 of NUREG-0133, when the critical receptor is different for stack and vent releases, the controlling location for vent releases should be used. For this reason, the reactor building vent dispersion parameters are used to identify the critical receptor. The real time atmospheric dispersion factor (χ/Q) is calculated by performing the MIDAS XP computer program IAW MNGP Chemistry Procedure I.6.07. As discussed previously, weekly and batch dose rate calculations are performed for the critical boundary location. The critical boundary location is based on reactor vent long term χ/Q (Table A-3) is 0.43 miles in the SSE sector.

Table 3.2-1

Child Critical Organ Dose Parameters
for Radionuclide i
for the Inhalation Pathway

Nuclide	P_{iI}
	mrem/yr
	$\mu\text{Ci}/\text{m}^3$
H-3	1.12E 03
Cr-51	1.70E 04
Mn-54	1.58E 06
Fe-59	1.27E 06
Co-58	1.11E 06
Co-60	7.07E 06
Zn-65	9.95E 05
Rb-86	1.98E 05
Sr-89	2.16E 06
Sr-90	1.01E 08
Y-91	2.63E 06
Zr-95	2.23E 06
Nb-95	6.14E 05
Ru-103	6.62E 05
Ru-106	1.43E 07
Ag-110m	5.48E 06
Te-127m	1.48E 06
Te-129m	1.76E 06
Cs-134	1.01E 06
Cs-136	1.71E 05
Cs-137	9.07E 05
Ba-140	1.74E 06
Ce-141	5.44E 05
Ce-144	1.20E 07
I-131	1.62E 07
I-133	3.85E 06
I-135	7.92E 05

3.3 Gaseous Effluents - Compliance with 10 CFR 50

Doses resulting from the release of noble gases, and radioiodines and particulates must be calculated to show compliance with Appendix I of 10 CFR 50. The calculations are performed monthly for all gaseous effluents. Calculation of the doses received due to the release of noble gases is performed by the DOSGAS computer program. Similarly the dose received due to the release of radioiodines and particulates is calculated by the DOSPIT computer program. These two programs are performed monthly or as required in conjunction with Surveillance Test #0342 IAW MNGP Technical Specification 3.8.B.2.a and 3.8.B.3.a respectively.

This section describes the methods and equations used at MNGP to perform the dose evaluation using manual methods based on historical meteorological dispersion parameters and using the MIDAS computer methods with contemporaneous meteorological dispersion parameters.

3.3.1 Noble Gases

The air dose in unrestricted areas at MNGP is limited to:

- a. for any calendar quarter:
 $D_{\gamma} < 5$ mrad due to gamma radiation; and
 $D_{\beta} < 10$ mrad due to beta radiation; and
- b. for any calendar year:
 $D_{\gamma} < 10$ mrad due to gamma radiation; and
 $D_{\beta} < 20$ mrad due to beta radiation.

Air doses may be calculated using historical meteorological data using the highest normalized concentration statistics as the best estimator of the atmospheric dispersion, or the doses may be computed using the contemporary meteorological data during the period of the release. Either method may be used and both are described below.*

3.3.1.1 Air Dose Based on Historical Meteorology

The limiting air dose, D, based on historical meteorology is based on the critical receptor in the unrestricted area. For air doses the critical receptor is described by the offsite location with the highest long term annual average relative concentration (χ/Q) at or beyond the restricted area boundary. For short-term vent releases (less than 500 hours per year), the location with the highest short-term average relative concentration (χ/q) is chosen. The critical receptor is described in Section 3.3.5.

For gamma radiation, the air dose is given by:

$$D_{\gamma} = 3.17 \times 10^{-8} \sum_i (M_i [(x/Q) v_{iv} + (x/q) v_{iv}] + B_i Q_{is} + b_i q_{is}) \quad 3.3-1$$

The historical meteorological data base is the basis for the method described in the original MNGP ODCM. With the addition of the MIDAS system to the MNGP, it is now possible to estimate doses based on contemporaneous data.

For beta radiation, the air dose is:

$$D_{\beta} = 3.17 \times 10^{-8} \sum_i N_i [(\chi/Q)_V q_{iV} + (\chi/q)_V q_{iV} + (\chi/Q)_S q_{iS} + (\chi/q)_S q_{iS}] \quad 3.3-2$$

where:

M_i = The air dose factor due to gamma emission for each identified noble gas radionuclide i , mrad/yr per $\mu\text{Ci}/\text{m}^3$; (Table 3.3-1)

N_i = the air dose factor due to beta emissions for each identified noble gas radionuclide i , mrad/yr per $\mu\text{Ci}/\text{m}^3$; (Table 3.3-1)

$(\chi/Q)_V$ = the annual average relative concentration for areas at or beyond the site boundary for long-term reactor building vent releases (greater than 500 hr/yr), sec/m^3 , (Appendix A, Table A-3);

$(\chi/q)_V$ = the relative concentration for areas at or beyond the site boundary for short-term reactor building vent releases (equal to or less than 500 hr/yr), sec/m^3 , (Appendix A, Table A-12);

$(\chi/Q)_S$ = the annual average relative concentration for areas at or beyond the site boundary for long-term off-gas stack releases (greater than 500 hr/yr), sec/m^3 , (Appendix A, Table A-6);

$(\chi/q)_S$ = the relative concentration for areas at or beyond the site boundary for short-term off-gas stack releases (equal to or less than 500 hr/yr), sec/m^3 (Appendix A, Table A-9);

q_{iS} = the average release of the noble gas radionuclide i in gaseous effluents for short-term off-gas stack releases (equal to or less than 500 hr/yr), μCi ;

q_{iV} = the average total release of the noble gas radionuclide i in gaseous effluents for short-term reactor building vent releases (equal to or less than 500 hr/yr), μCi ;

- Q_{is} = the total release of noble gas radionuclide i in gaseous releases for long-term off-gas stack releases (greater than 500 hr/yr), μCi ;
- Q_{iv} = the total release of noble gas radionuclide i in gaseous effluents for long-term reactor building vent releases (greater than 500 hr/yr), μCi ;
- B_i = the constant for long-term releases (greater than 500 hr/yr) for each identified noble gas radionuclide i accounting for the gamma radiation from the elevated finite plume, $\text{mrad/yr per } \mu\text{Ci/sec}$;
- b_i = the constant for short-term releases (less than or equal to 500 hr/yr) for each identified noble gas radionuclide i accounting for the gamma radiation from the elevated finite plume, $\text{mrad/yr per } \mu\text{Ci/sec}$;

3.17×10^{-8} = the inverse of the number of seconds in a year.

Noble gases are continuously released from the reactor building vent and the plant stack. These long-term releases rates are determined from the continuous noble gas monitor readings and periodic radionuclide analyses. There are infrequent containment purges from either release point. To separate the short-term release from the long term release (the continuous monitor records both), the drywell source term should be subtracted from the total source term whenever a purge release occurs. Periodic radionuclide analysis of main condenser off-gas and radionuclide analysis of each purge prior to release are used in conjunction with the total activity measured by the monitor to quantify individual noble gas nuclides released.

Long-term and short-term χ/Q 's are given in Appendix A for both the reactor building vent and the plant stack. Short-term χ/q 's were calculated using the USNRC computer code "XOQDOQ"⁽¹⁰⁾ assuming 144 hours per year drywell purge. Values of M and N were calculated using the methodology presented in NUREG-0133⁽⁹⁾ and are given in Table 3.3-1. Table 3.3-2 presents values of B_i and b_i calculated using the USNRC computer code "RABFIN." This code was also used to calculate values of V_i presented in Section 3.1. Values of v_i were calculated by multiplying V_i by the ratio of b_i to B_i . The v_i , B_i , and b_i values of Table 3.3-2 are the maximum values for the site boundaries location. This location, 0.51 mi SSE, is different than the critical site boundary location based upon the reactor building vent χ/Q .

3.3.1.2 Air Dose Based on Contemporaneous Meteorology Using MIDAS

The air dose based on contemporaneous meteorology is performed in MIDAS⁽⁸⁾ using the XDAIR routine. XDAIR uses the methods described under XDCALC with some parameters defined to provide the air dose computations. The XDCALC function is used to calculate atmospheric dispersion and doses according to the models prescribed in Regulatory Guides 1.109⁽⁷⁾ and 1.111.⁽⁸⁾ The MIDAS equations are given in Appendix F.

Hourly values of χ/Q are calculated and are used to compute beta and gamma air doses. These doses are cumulated for the duration of the release. Calculations use hourly site meteorological data averages. Average, centerline, depletion, and deposition calculations are performed.

For gamma or beta radiations the air doses are given by:

$$D_{\gamma,air} = 3.6 \times 10^{-6} \chi/Q \sum_{i=3}^{17} DF_i^{\gamma} Q_i, \text{ or}$$

$$D_{\beta,air} = 3.6 \times 10^{-6} \chi/Q \sum_{i=3}^{17} DF_i^{\beta} Q_i \quad 3.3-3$$

where:

$D_{\gamma,air}$ = gamma air dose, rad/hour;

$D_{\beta,air}$ = beta air dose, rad/hour;

χ/Q = appropriate χ/Q for ground, mixed, or elevated release, sec/m^3 (see Appendix F);

$i(3 \text{ to } 17)$ = nuclide indices in MIDAS for noble gases;

DF_i^{γ} = the air dose factor due to gamma radiation for each identified noble gas radionuclide. in $(\text{mrad m}^3)/(\text{Ci sec})$ (see Table 3.3-2.);

DF_i^{β} = the air dose factor due to beta radiation for each identified noble gas radionuclide. in $(\text{mrad m}^3)/(\text{Ci sec})$ (see Table 3.3-2.);

Q_i = release rate in uCi/sec for each nuclide; and

$$3.6 \times 10^{-6} = \frac{\text{rad}}{\text{mrad}} \frac{\text{Ci}}{\mu\text{Ci}} \frac{3600 \text{ sec}}{\text{hour}}$$

The MNGP uses both an elevated stack and building vents for releases. MIDAS uses the appropriate χ/Q for the computation depending on the source of the release. The computation of χ/Q in MIDAS for all cases is given in Appendix F under the section describing the Program XDCALC.

3.3.2 Radioiodine, Particulates, and Other Radionuclides

The dose, D_{aj} , to an individual from radioiodines, radioactive materials in particulate form and radionuclides other than noble gases with half lives greater than eight days in gaseous effluents released to unrestricted areas shall be limited to:

$$\begin{aligned} D_{aj} &\leq 7.5 \text{ mrem for any calendar quarter} \\ D_{aj} &\leq 15 \text{ mrem for any calendar year} \end{aligned}$$

These limits apply to the receptor location where the combination of existing pathways and age groups indicates the maximum exposure. For this reason the MIDAS dose assessment algorithms should be used if available. Alternatively the infant dose at the historical highest χ/Q may be used. Both methods are described below.

3.3.2.1 Dose from Radioiodines and Particulates Based on Historical Meteorology

The worst case dose to an individual from I-131, tritium and radioactive particulates with half-lives greater than eight days in gaseous effluents released to unrestricted areas is determined by the following expressions:

$$D_{aj} = 3.17 \times 10^{-8} \sum_{pi} \sum R_{iapj} [w_v Q_{iv} + w_v q_{iv} + w_s Q_{is} + w_s q_{is}] \quad 3.3-4$$

where:

- Q_{is} = release of radionuclide i for long-term off-gas stack releases (greater than 500 hr/yr), μCi ;
- Q_{iv} = release of radionuclide i for long-term reactor building vent releases (greater than 500 hr/yr), μCi ;
- q_{is} = release of radionuclide i for short-term off-gas stack purge releases (equal to or less than 500 hr/yr); μCi ;
- q_{iv} = release of radionuclide i for short-term reactor building vent purge releases (equal to or less than 500 hr/yr); μCi ;
- w_s = the dispersion parameter for estimating the dose to an individual at the controlling location for long-term off-gas stack releases (greater than 500 hr/yr), sec/m^3 or m^2 ;
- w_v = the dispersion parameter for estimating the dose to an individual at the controlling location for long-term reactor building vent releases (greater than 500 hr/yr), sec/m^3 or m^2 ;
- w_s = the dispersion parameter for estimating the dose to an individual at the controlling location for short-term off-gas stack releases (equal to or less than 500 hr/yr), sec/m^3 or m^2 ;
- w_v = the dispersion parameter for estimating the dose to an individual at the controlling location for short-term reactor building vent releases (equal to or less than 500 hr/yr), sec/m^3 or m^2 ;

3.17×10^{-8} = the inverse of the number of seconds in a year;

R_{iapj} = the dose factor for each identified radionuclide i , pathway p , age group a , and organ j , m^2 mrem/yr per $\mu\text{Ci}/\text{sec}$ or mrem/yr per $\mu\text{Ci}/\text{m}^3$.

The above equation is applied to each combination of age group and organ. Values of R_{iapj} have been calculated using the methodology given in NUREG-0133 and are given in Tables 3.3-3 through 3.3-21. The equation is applied to a controlling location which will be one of the following:

- a. residence,
- b. vegetable garden,
- c. milk animal.

The selection of the actual receptor is discussed in Section 3.3.3. The source terms and dispersion parameters in Equation 3.3-3 are obtained in the same manner as in Section 3.2. The W values are in terms of χ/Q (sec/m^3) for the inhalation pathways and for tritium and in terms of D/Q (m^2) for all other pathways.

Appendix E contains the methodology for calculating R_{iapj} values. This method will be used to compute dose factors for nuclides not tabulated in Tables 3.3-3 through 3.3-21 if they are encountered.

3.3.2.2 Dose Based on Contemporaneous Meteorology Using MIDAS

The dose to individuals from I-131, tritium and radioactive particulates may be calculated using the MIDAS system algorithms. In MIDAS the Program GASPRO computes the accumulation of dose to individual receptors or to the surrounding population based on hourly meteorological data collected by MIDAS and release data from other computer programs utilizing the algorithms in this manual or other manual inputs.

Dose calculations are performed for each important nuclide for each pathway, organ, age group, distance and direction.

Radionuclide and pathway are used in GASPRO to determine the appropriate dispersion type to be used. Three types of atmospheric dispersion factors are used, χ/Q , $\chi/Q(\text{depleted})$, and D/Q , depending on pathway and nuclide.

Hourly meteorological data is used so atmospheric conditions are contemporaneous with release.

The GASPRO calculations are based on the environmental pathways-to-man models prescribed by the NRC in Regulatory Guide 1.109. Dose factors for the individual doses (and for population doses) are based on results run-off line using the Pickard, Lowe, and Garrick (PLG) version of GASPAR. These data are tabled and used by the MIDAS routine in a look-up mode. These tables are given in MIDAS Tables 2.2.6.3-1 and 2.2.6.3-2 for Individual Dose Factors and Population Dose Factors, respectively. These tables are included in this manual in Appendix F.

GASPRO calculates doses for the following pathways, organs and age groups.

<u>Index</u>	MIDAS <u>Pathway</u>
1	Plume
2	Ground Shine
3	Vegetable
4	Meat
5	Cow Milk
6	Goat Milk
7	Inhalation

<u>Index</u>	MIDAS <u>Organ</u>
1	Total Body
2	GI Tract
3	Bone
4	Lives
5	Kidney
6	Thyroid
7	Lung
8	Skin

<u>INDEX</u>	MIDAS <u>Age Group</u>
1	Adult
2	Teen
3	Child
4	Infant

Five types of receptors as indicated below can be located at up to 10 distances in each of the direction sectors.

<u>Index</u>	<u>MIDAS Receptors</u>
1	Residents
2	Vegetable
	Gardens
3	Meat Animals
4	Cows
5	Goats

The resident location is used to calculate plume shine dose, ground shine from deposited material, and inhalation dose. Normal dispersion, depleted dispersion and ingestion pathways are used as appropriate. Average χ/Q , depleted χ/Q and deposition are computed using the current hour meteorological data.

Doses are computed and accumulated hourly by direction, distance organ or receptor, age group, and pathway. A finite plume gamma dose model is used to calculate the dose from noble gases. Submersion skin dose is calculated separately from whole body dose and the total skin dose from noble gases is computed by adding the finite gamma plume dose to the submersion skin dose using the appropriate Reg. Guide 1.109 dose factors. The equations used in MIDAS for the dose computations are given in Appendix F.

3.3.3 Cumulation of Doses

Doses calculated monthly are summed for comparison with quarterly and annual limits. The monthly results are added to the doses cumulated from the other months in the quarter of interest and in the year of interest and compared to the limits given in Sections 3.3.1 and 3.3.2. This summation is performed by the DOSGAS and the DOSPIT computer program for doses from exposures due to noble gas, and radioiodine and particulates respectively. If these limits are exceeded, a Special Report will be submitted to the USNRC in accordance with the MNGP Technical Specifications. If twice the limits are exceeded, a Special Report showing compliance with 40 CFR 190⁽¹³⁾ will be submitted.

3.3.4 Projection of Doses

Projection of doses is not necessary. The Technical Specifications require the offgas holdup system to be operated at all times.

3.3.5 Critical Receptor Identification

The critical receptors for compliance with 10 CFR 50, Appendix I will be identified. For the noble gas specification the critical location is based on the external dose pathway only. This location is the off-site location with the highest long-term reactor building vent χ/Q and is selected using the χ/Q values given in Appendix A, Table A-4. The critical receptor location is used for showing compliance with 10 CFR 20 and remains the same unless meteorological data is re-evaluated or the site boundary changes.

The critical location for the radioiodine and particulate pathway is selected once per year. This selection follows the annual land use census performed within 5 miles of the MNGP. Each of the following locations is evaluated as a potential critical receptor before implementing the effluent technical specifications:

1. Residences in each sector.
2. Vegetable garden producing leafy green vegetables.
3. All identified milk animal locations.

The critical receptor is selected based on this evaluation.

Following the annual survey, doses are calculated using Equation 3.3-3 for all newly identified receptors and those receptors whose characteristics have changed significantly. The calculation includes appropriate information shown to exist at each location. The dispersion parameters given in this manual should be employed. The total releases reported for the previous calendar year should be used as the source term.

REFERENCES - SECTION 3

- (1) NSP - Monticello Nuclear Generating Plant, Appendix I Analysis - Supplement No. 1 - Docket No. 50-263, Table 2.1-4.
- (2) NSP - Monticello Nuclear Generating Plant, Appendix I Analysis - Supplement No. 1 - Docket No. 50-263, Figure 2.1-5.
- (3) NSP - Monticello Nuclear Generating Plant, Appendix I Analysis - Supplement No. 1 - Docket No. 50-263, Table 2.1-3.
- (4) Monticello Nuclear Generating Plant Technical Specifications, TS-B.2.4-Radioactive Effluents, Specification 2.4.3F Rev 25.
- (5) "NSP - Monticello Nuclear Generating Plant", FSAR, Vol 3, Table 9-3-1.
- (6) USNRC, Title 10, Code of Federal Regulation, Part 20, "Standards for Protection Against Radiation"
- (7) USNRC, Title 10, Code of Federal Regulation, Part 50, "Domestic Licensing of Production and Utilization Facilities", Appendix I, "Numerical Guides for Design Objectives and Limiting Conditions for Operation to Meet the Criterion 'As Low as is Reasonably Achievable' for Radioactive Material in Light-Water-Cooled Nuclear Power Reactor Effluents"
- (8) Pickard, Lowe and Garrick, Inc., (Proprietary), "MIDAS Users Manual", Section 2.2.6, "Environmental Pathway and Dose Calculations for Liquid and Gaseous Effluents"
- (9) Boegli, J.S., et. al. Eds, "Preparation of Radiological Effluent Technical Specifications for Nuclear Power Plants, NUREG-0133, 1978, NTIS, Springfield Va.
- (10) Sangendorf, J.F. and J. T. Goll, "XOQDOQ - Program for the Meteorological Evaluation of Routine Effluent Releases at Nuclear Power Stations", NUREG-0324, 1977, USNRC, Washington, D.C.
- (11) USNRC, Regulatory Guide 1.109, "Calculation of Annual Doses to Man from Routine Releases of Reactor Effluents for the Purpose of Evaluating Compliance with 10 CFR 50, Appendix I", Rev. 1, Oct. 1977, USNRC, Washington D.C.
- (12) USNRC, Regulatory Guide 1.111, "Methods for Estimating Atmospheric Transport and Dispersion of Gaseous Effluents in Routine Releases from Light-Water-Cooled Reactors", July 1977. USNRC, Washington, D.C.
- (13) EPA, Title 40, Code of Federal Regulations, Part 190 "Environmental Radiation Protection Standards for Nuclear Power Operations"

Table 3.3-1

Dose Factors for Noble Gases and Daughters
that may be Detected in Gaseous Effluents

Radio- nuclide	Total Body Dose Factor	Skin Dose Factor	Gamma Air Dose Factor	Beta Air Dose Factor
	K_i	L_i	M_i	N_i
	$\frac{\text{mrem/yr}}{3}$	$\frac{\text{mrem/yr}}{3}$	$\frac{\text{mrad/yr}}{3}$	$\frac{\text{mrad/yr}}{3}$
	$\mu\text{Ci/m}$	$\mu\text{Ci/m}$	$\mu\text{Ci/m}$	$\mu\text{Ci/m}$
Kr-83m	7.56E-02	--	1.93E+01	2.88E+02
Kr-85m	1.17E+03	1.46E+03	1.23E+03	1.97E+03
Kr-85	1.61E+01	1.34E+03	1.72E+01	1.95E+03
Kr-87	5.92E+03	9.73E+03	6.17E+03	1.03E+04
Kr-88	1.47E+04	2.37E+03	1.52E+04	2.93E+03
Kr-89	1.66E+04	1.01E+04	1.73E+04	1.06E+04
Kr-90	1.56E+04	7.29E+03	1.63E+04	7.83E+03
Xe-131m	9.15E+01	4.76E+02	1.56E+02	1.11E+03
Xe-133m	2.51E+02	9.94E+02	3.27E+02	1.48E+03
Xe-133	2.94E+02	3.06E+02	3.53E+02	1.05E+03
Xe-135m	3.12E+03	7.11E+02	3.36E+03	7.39E+02
Xe-135	1.81E+03	1.86E+03	1.92E+03	2.46E+03
Xe-137	1.42E+03	1.22E+04	1.51E+03	1.27E+04
Xe-138	8.83E+03	4.13E+03	9.21E+03	4.75E+03
Xe-139	5.02E+03	6.52E+04	5.28E+03	6.52E+04
Ar-41	8.84E+03	2.69E+03	9.30E+03	3.28E+03

Table 3.3-2

Dose Parameters for Finite Evaluated Plumes
for the Critical Boundary Location
0.51 mi from the Stack in the SSE Sector

Noble Gas Radio- nuclide	Long Term Release*		Short Term Release**	
	Total Body	Gamma Air	Total Body	Gamma Air
	V_i mrem/yr Ci/sec	B_i mrad/yr Ci/sec	v_i mrem/yr Ci/sec	b_i mrad/yr Ci/sec
Kr-83m	2.61E-09	3.77E-07	2.99E-09	4.32E-07
Kr-85m	1.39E-04	2.07E-04	1.59E-04	2.37E-04
Kr-85	2.10E-06	3.18E-06	2.40E-06	3.64E-06
Kr-87	6.33E-04	9.52E-04	7.25E-02	1.09E-03
Kr-88	1.66E-03	2.49E-03	1.90E-03	2.85E-03
Kr-89	1.12E-03	1.68E-03	1.28E-03	1.92E-03
Kr-90	1.61E-04	2.42E-04	1.85E-04	2.78E-04
Xe-131m	3.31E-05	5.21E-05	3.79E-05	5.97E-05
Xe-133m	2.51E-05	4.09E-05	2.87E-05	4.68E-05
Xe-133	2.61E-05	4.08E-05	2.99E-05	4.67E-05
Xe-135m	3.34E-04	5.06E-04	3.82E-04	5.79E-04
Xe-135	2.24E-04	3.37E-04	2.57E-04	3.89E-04
Xe-137	9.99E-05	1.51E-04	1.14E-04	1.73E-04
Xe-138	9.90E-04	1.49E-03	1.13E-03	1.70E-03
Xe-139	5.79E-05	8.69E-05	6.63E-05	9.95E-05
Ar-41	1.20E-03	1.80E-03	1.38E-03	2.07E-03

* Values are annual average.

** Values are for 144 hours per year purge.

Table 3.3-3

R_i Values for the Monticello Nuclear Generating Plant*
Ground Pathway

Nuclide	T. Body	GI Tract	Bone	Liver	Kidney	Thyroid	Lung	Skin
Cr-51	4.66E 06	4.66E 06	4.66E 06	4.66E 06	4.66E 06	4.66E 06	4.66E 06	5.51E 06
Mn-54	1.34E 09	1.34E 09	1.34E 09	1.34E 09	1.34E 09	1.34E 09	1.34E 09	1.57E 09
Fe-59	2.75E 08	2.75E 08	2.75E 08	2.75E 08	2.75E 08	2.75E 08	2.75E 08	3.23E 08
Co-58	3.79E 08	3.79E 08	3.79E 08	3.79E 08	3.79E 08	3.79E 08	3.79E 08	4.44E 08
Co-60	2.15E 10	2.15E 10	2.15E 10	2.15E 10	2.15E 10	2.15E 10	2.15E 10	2.52E 10
Zn-65	7.49E 08	7.49E 08	7.49E 08	7.49E 08	7.49E 08	7.49E 08	7.49E 08	8.69E 08
Sr-89	2.23E 04	2.23E 04	2.23E 04	2.23E 04	2.23E 04	2.23E 04	2.23E 04	2.58E 04
Zr-95	2.49E 08	2.49E 08	2.49E 08	2.49E 08	2.49E 08	2.49E 08	2.49E 08	2.89E 08
I-131	1.72E 07	1.72E 07	1.72E 07	1.72E 07	1.72E 07	1.72E 07	1.72E 07	2.09E 07
I-133	2.47E 06	2.47E 06	2.47E 06	2.47E 06	2.47E 06	2.47E 06	2.47E 06	3.00E 06
I-135	2.52E 06	2.52E 06	2.52E 06	2.52E 06	2.52E 06	2.52E 06	2.52E 06	2.94E 06
Cs-134	6.82E 09	6.82E 09	6.82E 09	6.82E 09	6.82E 09	6.82E 09	6.82E 09	7.96E 09
Cs-136	1.49E 08	1.49E 08	1.49E 08	1.49E 08	1.49E 08	1.49E 08	1.49E 08	1.69E 08
Cs-137	1.03E 10	1.03E 10	1.03E 10	1.03E 10	1.03E 10	1.03E 10	1.03E 10	1.20E 10
Ba-140	2.05E 07	2.05E 07	2.05E 07	2.05E 07	2.05E 07	2.05E 07	2.05E 07	2.34E 07
Ce-141	1.36E 07	1.36E 07	1.36E 07	1.36E 07	1.36E 07	1.36E 07	1.36E 07	1.53E 07
Ce-144	6.96E 07	6.96E 07	6.96E 07	6.96E 07	6.96E 07	6.96E 07	6.96E 07	8.04E 07
Nb-95	1.36E 08	1.36E 08	1.36E 08	1.36E 08	1.36E 08	1.36E 08	1.36E 08	1.60E 08
Ru-103	1.08E 08	1.08E 08	1.08E 08	1.08E 08	1.08E 08	1.08E 08	1.08E 08	1.26E 08

* R_i values are in units of mrem/yr per $\mu\text{Ci}/\text{m}^3$ for inhalation and tritium, and in units of m^2 mrem/yr per $\mu\text{Ci}/\text{sec}$ for all others.

Table 3.3-4

R_i Values for the Monticello Nuclear Generating Plant*

Vegetable Pathway

Adult Age Group

Nuclide	T. Body	GI Tract	Bone	Liver	Kidney	Thyroid	Lung	Skin
H-3	2.28E 03	2.28E 03	0.00E 00	2.28E 03	2.28E 03	2.28E 03	2.28E 03	2.28E 03
Cr-51	4.60E 04	1.16E 07	0.00E 00	0.00E 00	1.01E 04	2.75E 04	6.10E 04	0.00E 00
Mn-54	5.83E 07	9.36E 08	0.00E 00	3.05E 08	9.09E 07	0.00E 00	0.00E 00	0.00E 00
Fe-59	1.12E 08	9.75E 08	1.24E 08	2.93E 08	0.00E 00	0.00E 00	8.17E 07	0.00E 00
Co-58	6.71E 07	6.07E 08	0.00E 00	2.99E 07	0.00E 00	0.00E 00	0.00E 00	0.00E 00
Co-60	3.67E 08	3.12E 09	0.00E 00	1.66E 08	0.00E 00	0.00E 00	0.00E 00	0.00E 00
Zn-65	5.77E 08	8.04E 08	4.01E 08	1.28E 09	8.54E 08	0.00E 00	0.00E 00	0.00E 00
Sr-89	2.87E 08	1.60E 09	1.00E 10	0.00E 00	0.00E 00	0.00E 00	0.00E 00	0.00E 00
Sr-90	1.64E 11	1.93E 10	6.70E 11	0.00E 00	0.00E 00	0.00E 00	0.00E 00	0.00E 00
Zr-95	2.51E 05	1.17E 09	1.16E 06	3.71E 05	5.82E 05	0.00E 00	0.00E 00	0.00E 00
I-131	6.61E 07	3.04E 07	8.07E 07	1.15E 08	1.98E 08	3.78E 10	0.00E 00	0.00E 00
I-133	1.12E 06	3.30E 06	2.11E 06	3.67E 06	6.40E 06	5.39E 08	0.00E 00	0.00E 00
I-135	3.73E 04	1.14E 05	3.86E 04	1.01E 05	1.62E 05	6.67E 06	0.00E 00	0.00E 00
Cs-134	8.83E 09	1.89E 08	4.54E 09	1.08E 10	3.49E 09	0.00E 00	1.16E 09	0.00E 00
Cs-136	1.19E 08	1.88E 07	4.19E 07	1.66E 08	9.21E 07	0.00E 00	1.26E 07	0.00E 00
Cs-137	5.94E 08	1.76E 08	6.63E 09	9.07E 09	3.08E 09	0.00E 00	1.02E 09	0.00E 00
Ba-140	8.40E 06	2.64E 08	1.28E 08	1.61E 05	5.47E 04	0.00E 00	9.22E 04	0.00E 00
Ce-141	1.48E 04	4.99E 08	1.93E 05	1.31E 05	6.07E 04	0.00E 00	0.00E 00	0.00E 00
Ce-144	1.69E 06	1.07E 10	3.15E 07	1.32E 07	7.82E 06	0.00E 00	0.00E 00	0.00E 00
Nb-95	4.19E 04	4.73E 08	1.40E 05	7.80E 04	7.71E 04	0.00E 00	0.00E 00	0.00E 00
Ru-103	2.03E 06	5.51E 08	4.72E 06	0.00E 00	1.80E 07	0.00E 00	0.00E 00	0.00E 00

* R_i values are in units of mrem/yr per $\mu\text{Ci}/\text{m}^3$ for inhalation and tritium, and in units of m^2 mrem/yr per $\mu\text{Ci}/\text{sec}$ for all others.

Table 3.3-5
 R_i Values for the Monticello Nuclear Generating Plant*
 Vegetable Pathway
 Teen Age Group

Nuclide	T. Body	GI Tract	Bone	Liver	Kidney	Thyroid	Lung	Skin
H-3	2.61E 03	2.61E 03	0.00E 00	2.61E 03	2.61E 03	2.61E 03	2.61E 03	2.61E 03
Cr-51	6.11E 04	1.03E 07	0.00E 00	0.00E 00	1.34E 04	3.39E 04	8.72E 04	0.00E 00
Mn-54	8.79E 07	9.09E 08	0.00E 00	4.43E 08	1.32E 08	0.00E 00	0.00E 00	0.00E 00
Fe-59	1.60E 08	9.78E 08	1.77E 08	4.14E 08	0.00E 00	0.00E 00	1.30E 08	0.00E 00
Co-58	9.79E 07	5.85E 08	0.00E 00	4.25E 07	0.00E 00	0.00E 00	0.00E 00	0.00E 00
Co-60	5.57E 08	3.22E 09	0.00E 00	2.47E 08	0.00E 00	0.00E 00	0.00E 00	0.00E 00
Zn-65	8.68E 08	7.88E 08	5.36E 08	1.86E 09	1.19E 09	0.00E 00	0.00E 00	0.00E 00
Sr-89	4.36E 08	1.81E 09	1.52E 10	0.00E 00	0.00E 00	0.00E 00	0.00E 00	0.00E 00
Sr-90	2.05E 11	2.33E 10	8.32E 11	0.00E 00	0.00E 00	0.00E 00	0.00E 00	0.00E 00
Zr-95	3.68E 05	1.23E 09	1.69E 06	5.35E 05	7.86E 05	0.00E 00	0.00E 00	0.00E 00
I-131	5.77E 07	2.13E 07	7.68E 07	1.07E 08	1.85E 08	3.14E 10	0.00E 00	0.00E 00
I-133	1.01E 06	2.51E 06	1.96E 06	3.32E 06	5.83E 06	4.64E 08	0.00E 00	0.00E 00
I-135	3.33E 04	9.96E 04	3.49E 04	8.98E 04	1.42E 05	5.78E 06	0.00E 00	0.00E 00
Cs-134	7.54E 09	2.02E 08	6.90E 09	1.62E 10	5.16E 10	0.00E 00	1.97E 09	0.00E 00
Cs-136	1.13E 08	1.35E 07	4.28E 07	1.68E 08	9.16E 07	0.00E 00	1.44E 07	0.00E 00
Cs-137	4.90E 09	2.00E 08	1.06E 10	1.41E 10	4.78E 09	0.00E 00	1.86E 09	0.00E 00
Ba-140	8.88E 06	2.12E 08	1.38E 08	1.69E 05	5.72E 04	0.00E 00	1.14E 05	0.00E 00
Ce-141	2.12E 04	5.29E 08	2.77E 05	1.85E 05	8.70E 04	0.00E 00	0.00E 00	0.00E 00
Ce-144	2.72E 06	1.27E 10	5.05E 07	2.09E 07	1.25E 07	0.00E 00	0.00E 00	0.00E 00
Nb-95	5.78E 04	4.49E 08	1.89E 05	1.05E 05	1.02E 05	0.00E 00	0.00E 00	0.00E 00
Ru-103	2.88E 06	5.64E 08	6.75E 06	0.00E 00	2.38E 07	0.00E 00	0.00E 00	0.00E 00

* R_i values are in units of mrem/yr per $\mu\text{Ci}/\text{m}^3$ for inhalation and tritium, and in units of m^2 mrem/yr per $\mu\text{Ci}/\text{sec}$ for all others.

Table 3.3-6

R_i Values for the Monticello Nuclear Generating Plant*
Vegetable Pathway
Child Age Group

Nuclide	T. Body	GI Tract	Bone	Liver	Kidney	Thyroid	Lung	Skin
H-3	4.04E 03	4.04E 03	0.00E 00	4.04E 03	4.04E 03	4.04E 03	4.04E 03	4.04E 03
Cr-51	1.16E 05	6.15E 06	0.00E 00	0.00E 00	1.76E 04	6.44E 04	1.18E 05	0.00E 00
Mn-54	1.73E 08	5.44E 08	0.00E 00	6.49E 08	1.82E 08	0.00E 00	0.00E 00	0.00E 00
Fe-59	3.17E 08	6.62E 08	3.93E 08	6.36E 08	0.00E 00	0.00E 00	1.84E 08	0.00E 00
Co-58	1.92E 08	3.66E 08	0.00E 00	6.27E 07	0.00E 00	0.00E 00	0.00E 00	0.00E 00
Co-60	1.11E 09	2.08E 09	0.00E 00	3.76E 08	0.00E 00	0.00E 00	0.00E 00	0.00E 00
Zn-65	1.70E 09	4.81E 08	1.03E 09	2.74E 09	1.73E 09	0.00E 00	0.00E 00	0.00E 00
Sr-89	1.03E 09	1.40E 09	3.62E 10	0.00E 00	0.00E 00	0.00E 00	0.00E 00	0.00E 00
Sr-90	3.49E 11	1.86E 10	1.38E 12	0.00E 00	0.00E 00	0.00E 00	0.00E 00	0.00E 00
Zr-95	7.44E 05	8.71E 08	3.80E 06	8.35E 05	1.20E 06	0.00E 00	0.00E 00	0.00E 00
I-131	8.16E 07	1.28E 07	1.43E 08	1.44E 08	2.36E 08	4.75E 10	0.00E 00	0.00E 00
I-133	1.67E 06	1.78E 06	3.57E 06	4.42E 06	7.36E 06	8.21E 08	0.00E 00	0.00E 00
I-135	5.28E 04	8.50E 04	6.20E 04	1.12E 05	1.71E 05	9.88E 06	0.00E 00	0.00E 00
Cs-134	5.40E 09	1.38E 08	1.56E 10	2.56E 10	7.93E 09	0.00E 00	2.84E 09	0.00E 00
Cs-136	1.43E 08	7.77E 06	8.04E 07	2.21E 08	1.18E 08	0.00E 00	1.76E 07	0.00E 00
Cs-137	3.52E 09	1.50E 08	2.40E 10	2.39E 10	7.78E 09	0.00E 00	2.80E 09	0.00E 00
Ba-140	1.61E 07	1.40E 08	2.76E 08	2.42E 05	7.87E 04	0.00E 00	1.44E 05	0.00E 00
Ce-141	4.75E 04	3.99E 08	6.42E 05	3.20E 05	1.40E 05	0.00E 00	0.00E 00	0.00E 00
Ce-144	6.50E 06	9.95E 09	1.22E 08	3.82E 07	2.11E 07	0.00E 00	0.00E 00	0.00E 00
Nb-95	1.12E 05	2.91E 08	4.04E 05	1.57E 05	1.48E 05	0.00E 00	0.00E 00	0.00E 00
Ru-103	5.83E 06	3.92E 08	1.52E 07	0.00E 00	3.82E 07	0.00E 00	0.00E 00	0.00E 00

* R_i values are in units of mrem/yr per $\mu\text{Ci}/\text{m}^3$ for inhalation and tritium, and in units of m^2 mrem/yr per $\mu\text{Ci}/\text{sec}$ for all others.

Table 3.3-7

 R_i Values for the Monticello Nuclear Generating Plant*Meat Pathway
Adult Age Group

Nuclide	T. Body	GI Tract	Bone	Liver	Kidney	Thyroid	Lung	Skin
H-3	3.27E 02	3.27E 02	0.00E 00	3.27E 02	3.27E 02	3.27E 02	3.27E 02	3.27E 02
Cr-51	3.26E 03	8.21E 05	0.00E 00	0.00E 00	7.19E 02	1.95E 03	4.33E 03	0.00E 00
Mn-54	8.98E 05	1.44E 07	0.00E 00	4.71E 06	1.40E 06	0.00E 00	0.00E 00	0.00E 00
Fe-59	1.12E 08	9.73E 08	1.24E 08	2.92E 08	0.00E 00	0.00E 00	8.16E 07	0.00E 00
Co-58	1.95E 07	1.76E 08	0.00E 00	8.68E 06	0.00E 00	0.00E 00	0.00E 00	0.00E 00
Co-60	8.87E 07	7.55E 08	0.00E 00	4.02E 07	0.00E 00	0.00E 00	0.00E 00	0.00E 00
Zn-65	3.06E 08	4.27E 08	2.13E 08	6.78E 08	4.53E 08	0.00E 00	0.00E 00	0.00E 00
Sr-89	4.12E 06	2.30E 07	1.43E 08	0.00E 00	0.00E 00	0.00E 00	0.00E 00	0.00E 00
Sr-90	1.76E 09	2.07E 08	7.17E 09	0.00E 00	0.00E 00	0.00E 00	0.00E 00	0.00E 00
Zr-95	1.94E 05	9.07E 08	8.92E 05	2.86E 05	4.49E 05	0.00E 00	0.00E 00	0.00E 00
I-131	4.33E 06	1.99E 06	5.28E 06	7.55E 06	1.29E 07	2.48E 09	0.00E 00	0.00E 00
I-133	1.13E-01	3.34E-01	2.14E-01	3.72E-01	6.49E-01	5.46E 01	0.00E 00	0.00E 00
I-135	1.78E-17	5.38E-17	1.82E-17	4.77E-17	7.64E-17	3.14E-15	0.00E 00	0.00E 00
Cs-134	6.68E 08	1.43E 07	3.43E 08	8.17E 08	2.64E 08	0.00E 00	8.78E 07	0.00E 00
Cs-136	1.61E 07	2.53E 06	5.65E 06	2.23E 07	1.24E 07	0.00E 00	1.70E 06	0.00E 00
Cs-137	4.33E 08	1.28E 07	4.83E 08	6.61E 08	2.24E 08	0.00E 00	7.46E 07	0.00E 00
Ba-140	9.01E 05	2.83E 07	1.38E 07	1.73E 04	5.87E 03	0.00E 00	9.89E 03	0.00E 00
Ce-141	4.96E 02	1.67E 07	6.47E 03	4.38E 03	2.03E 03	0.00E 00	0.00E 00	0.00E 00
Ce-144	3.94E 04	2.48E 08	7.34E 05	3.07E 05	1.82E 05	0.00E 00	0.00E 00	0.00E 00
Nb-95	3.00E 05	3.39E 09	1.01E 06	5.59E 05	5.52E 05	0.00E 00	0.00E 00	0.00E 00
Ru-103	2.00E 07	5.42E 09	4.64E 07	0.00E 00	1.77E 08	0.00E 00	0.00E 00	0.00E 00

* R_i values are in units of mrem/yr per $\mu\text{Ci}/\text{m}^3$ for inhalation and tritium, and in units of m^2 mrem/yr per $\mu\text{Ci}/\text{sec}$ for all others.

Table 3.3-8

R_i Values for the Monticello Nuclear Generating Plant*Meat Pathway
Teen Age Group

Nuclide	T. Body	GI Tract	Bone	Liver	Kidney	Thyroid	Lung	Skin
H-3	1.95E 02	1.95E 02	0.00E 00	1.95E 02	1.95E 02	1.95E 02	1.95E 02	1.95E 02
Cr-51	2.61E 03	4.39E 05	0.00E 00	0.00E 00	5.72E 02	1.45E 03	3.75E 03	0.00E 00
Mn-54	7.12E 05	7.37E 06	0.00E 00	3.59E 06	1.07E 06	0.00E 00	0.00E 00	0.00E 00
Fe-59	8.95E 07	5.48E 08	9.93E 07	2.32E 08	0.00E 00	0.00E 00	7.31E 07	0.00E 00
Co-58	1.54E 07	9.22E 07	0.00E 00	6.69E 06	0.00E 00	0.00E 00	0.00E 00	0.00E 00
Co-60	7.03E 07	4.06E 08	0.00E 00	3.12E 07	0.00E 00	0.00E 00	0.00E 00	0.00E 00
Zn-65	2.43E 08	2.20E 08	1.50E 08	5.20E 08	3.33E 08	0.00E 00	0.00E 00	0.00E 00
Sr-89	3.47E 06	1.44E 07	1.21E 08	0.00E 00	0.00E 00	0.00E 00	0.00E 00	0.00E 00
Sr-90	1.15E 09	1.30E 08	4.64E 09	0.00E 00	0.00E 00	0.00E 00	0.00E 00	0.00E 00
Zr-95	1.55E 05	5.02E 08	7.15E 05	2.25E 05	3.31E 05	0.00E 00	0.00E 00	0.00E 00
I-131	3.30E 06	1.22E 06	4.39E 06	6.14E 06	1.06E 07	1.79E 09	0.00E 00	0.00E 00
I-133	9.25E-02	2.30E-01	1.79E-01	3.03E-01	5.32E-01	4.23E 01	0.00E 00	0.00E 00
I-135	1.41E-17	4.22E-17	1.48E-17	3.81E-17	6.02E-17	2.45E-17	0.00E 00	0.00E 00
Cs-134	2.98E 08	7.99E 06	2.73E 08	6.42E 08	2.04E 08	0.00E 00	7.79E 07	0.00E 00
Cs-136	1.16E 07	1.40E 06	4.41E 06	1.73E 07	9.44E 06	0.00E 00	1.49E 06	0.00E 00
Cs-137	1.86E 08	7.59E 06	4.01E 08	5.34E 08	1.82E 08	0.00E 00	7.06E 07	0.00E 00
Ba-140	7.33E 05	1.75E 07	1.14E 07	1.39E 04	4.72E 03	0.00E 00	9.37E 03	0.00E 00
Ce-141	4.17E 02	1.04E 07	5.43E 03	3.63E 03	1.71E 03	0.00E 00	0.00E 00	0.00E 00
Ce-144	3.32E 04	1.56E 08	6.18E 05	2.56E 05	1.53E 05	0.00E 00	0.00E 00	0.00E 00
Nb-95	2.39E 05	1.86E 09	7.84E 05	4.35E 05	4.22E 05	0.00E 00	0.00E 00	0.00E 00
Ru-103	1.62E 07	3.16E 09	3.79E 07	0.00E 00	1.33E 08	0.00E 00	0.00E 00	0.00E 00

* R_i values are in units of mrem/yr per $\mu\text{Ci}/\text{m}^3$ for inhalation and tritium, and in units of m^2 mrem/yr per $\mu\text{Ci}/\text{sec}$ for all others.

Table 3.3-9

R_i Values for the Monticello Nuclear Generating Plant*

Meat Pathway

Child Age Group

Nuclide	T. Body	GI Tract	Bone	Liver	Kidney	Thyroid	Lung	Skin
H-3	2.36E 02	2.36E 02	0.00E 00	2.36E 02	2.36E 02	2.36E 02	2.36E 02	2.36E 02
Cr-51	4.07E 03	2.16E 05	0.00E 00	0.00E 00	6.17E 02	2.26E 03	4.12E 03	0.00E 00
Mn-54	1.09E 05	3.45E 06	0.00E 00	4.11E 06	1.15E 06	0.00E 00	0.00E 00	0.00E 00
Fe-59	1.42E 08	2.79E 08	1.76E 08	2.85E 08	0.00E 00	0.00E 00	8.26E 07	0.00E 00
Co-58	2.39E 07	4.56E 07	0.00E 00	7.82E 06	0.00E 00	0.00E 00	0.00E 00	0.00E 00
Co-60	1.09E 08	2.05E 08	0.00E 00	3.70E 07	0.00E 00	0.00E 00	0.00E 00	0.00E 00
Zn-65	3.72E 08	1.05E 08	2.25E 08	5.99E 08	3.77E 08	0.00E 00	0.00E 00	0.00E 00
Sr-89	6.55E 06	8.87E 06	2.29E 08	0.00E 00	0.00E 00	0.00E 00	0.00E 00	0.00E 00
Sr-90	1.52E 09	8.08E 07	6.00E 09	0.00E 00	0.00E 00	0.00E 00	0.00E 00	0.00E 00
Zr-95	2.48E 05	2.91E 08	1.27E 06	2.79E 05	3.99E 05	0.00E 00	0.00E 00	0.00E 00
I-131	4.65E 06	7.29E 05	8.14E 06	8.19E 06	1.34E 07	2.71E 09	0.00E 00	0.00E 00
I-133	1.55E-01	1.66E-01	3.32E-01	4.11E-01	6.85E-01	7.63E 01	0.00E 00	0.00E 00
I-135	2.28E-17	3.67E-17	2.68E-17	4.82E-17	7.39E-17	4.27E-15	0.00E 00	0.00E 00
Cs-134	1.67E 08	4.26E 06	4.81E 08	7.90E 08	2.45E 08	0.00E 00	8.78E 07	0.00E 00
Cs-136	1.35E 07	7.34E 05	7.60E 06	2.09E 07	1.11E 07	0.00E 00	1.66E 06	0.00E 00
Cs-137	1.04E 08	4.43E 06	7.39E 08	7.07E 08	2.30E 08	0.00E 00	8.29E 07	0.00E 00
Ba-140	1.22E 06	1.06E 07	2.10E 07	1.84E 04	5.98E 03	0.00E 00	1.10E 04	0.00E 00
Ce-141	7.57E 02	6.36E 06	1.02E 04	5.10E 03	2.24E 03	0.00E 00	0.00E 00	0.00E 00
Ce-144	6.22E 04	9.53E 09	1.17E 06	3.66E 05	2.02E 05	0.00E 00	0.00E 00	0.00E 00
Nb-95	3.77E 05	9.75E 08	1.35E 06	5.27E 05	4.95E 05	0.00E 00	0.00E 00	0.00E 00
Ru-103	2.63E 07	1.77E 09	6.83E 07	0.00E 00	1.72E 08	0.00E 00	0.00E 00	0.00E 00

*

R_i values are in units of mrem/yr per $\mu\text{Ci}/\text{m}^3$ for inhalation and tritium, and in units of m^2 mrem/yr per $\mu\text{Ci}/\text{sec}$ for all others.

Table 3.3-10

R_i Values for the Monticello Nuclear Generating Plant*

Cow Milk Pathway

Adult Age Group

Nuclide	T. Body	GI Tract	Bone	Liver	Kidney	Thyroid	Lung	Skin
H-3								
Cr-51	1.32E 04	3.32E 06	0.00E 00	0.00E 00	2.91E 03	7.90E 03	1.75E 04	0.00E 00
Mn-54	8.25E 05	1.32E 07	0.00E 00	4.32E 06	1.29E 06	0.00E 00	0.00E 00	0.00E 00
Fe-59	1.25E 07	1.09E 08	1.39E 07	3.26E 07	0.00E 00	0.00E 00	9.10E 06	0.00E 00
Co-58	5.03E 06	4.55E 07	0.00E 00	2.24E 06	0.00E 00	0.00E 00	0.00E 00	0.00E 00
Co-60	1.93E 07	1.65E 08	0.00E 00	8.77E 06	0.00E 00	0.00E 00	0.00E 00	0.00E 00
Zn-65	1.18E 09	1.65E 09	8.21E 08	2.61E 09	1.75E 09	0.00E 00	0.00E 00	0.00E 00
Sr-89	1.97E 07	1.10E 08	6.85E 08	0.00E 00	0.00E 00	0.00E 00	0.00E 00	0.00E 00
Sr-90	6.62E 09	7.80E 08	2.70E 10	0.00E 00	0.00E 00	0.00E 00	0.00E 00	0.00E 00
Zr-95	9.72E 01	4.55E 05	4.48E 02	1.44E 02	2.25E 02	0.00E 00	0.00E 00	0.00E 00
I-131	1.19E 08	5.49E 07	1.45E 08	2.08E 08	3.57E 08	6.82E 10	0.00E 00	0.00E 00
I-133	1.05E 06	3.09E 06	1.98E 06	3.44E 06	6.01E 06	5.06E 08	0.00E 00	0.00E 00
I-135	5.70E 03	1.74E 04	5.90E 03	1.54E 04	2.48E 04	1.02E 06	0.00E 00	0.00E 00
Cs-134	5.74E 09	1.23E 08	2.95E 09	7.02E 09	2.27E 09	0.00E 00	7.54E 08	0.00E 00
Cs-136	3.55E 08	5.60E 07	1.25E 08	4.93E 08	2.74E 08	0.00E 00	3.76E 07	0.00E 00
Cs-137	3.66E 09	1.08E 08	4.09E 09	5.59E 09	1.90E 09	0.00E 00	6.31E 08	0.00E 00
Ba-140	8.43E 05	2.65E 07	1.29E 07	1.62E 04	5.49E 03	0.00E 00	9.25E 03	0.00E 00
Ce-141	1.71E 02	5.78E 06	2.24E 03	1.51E 03	7.02E 02	0.00E 00	0.00E 00	0.00E 00
Ce-144	4.67E 03	6.09E 07	1.80E 05	7.53E 04	4.46E 04	0.00E 00	0.00E 00	0.00E 00
Nb-95	1.08E 04	1.22E 08	3.60E 04	2.01E 04	1.98E 04	0.00E 00	0.00E 00	0.00E 00
Ru-103	1.93E 02	5.24E 04	4.49E 02	0.00E 00	1.71E 03	0.00E 00	0.00E 00	0.00E 00

* R_i values are in units of mrem/yr per $\mu\text{Ci}/\text{m}^3$ for inhalation and tritium, and in units of m^2 mrem/yr per $\mu\text{Ci}/\text{sec}$ for all others.

Table 3.3-11
 R_i Values for the Monticello Nuclear Generating Plant*
 Cow Milk Pathway
 Teen Age Group

Nuclide	T. Body	GI Tract	Bone	Liver	Kidney	Thyroid	Lung	Skin
H-3	1.00E 03	1.00E 03	0.00E 00	1.00E 03	1.00E 03	1.00E 03	1.00E 03	1.00E 03
Cr-51	2.31E 04	3.88E 06	0.00E 00	0.00E 00	5.06E 03	1.28E 04	3.30E 04	0.00E 00
Mn-54	1.43E 06	1.48E 07	0.00E 00	7.20E 06	2.15E 06	0.00E 00	0.00E 00	0.00E 00
Fe-59	2.18E 07	1.34E 08	2.42E 07	5.65E 07	0.00E 00	0.00E 00	1.78E 07	0.00E 00
Co-58	8.70E 06	5.21E 07	0.00E 00	3.78E 06	0.00E 00	0.00E 00	0.00E 00	0.00E 00
Co-60	3.35E 07	1.94E 08	0.00E 00	1.49E 07	0.00E 00	0.00E 00	0.00E 00	0.00E 00
Zn-65	2.04E 09	1.85E 09	1.26E 09	4.38E 09	2.80E 09	0.00E 00	0.00E 00	0.00E 00
Sr-89	3.62E 07	1.50E 08	1.26E 09	0.00E 00	0.00E 00	0.00E 00	0.00E 00	0.00E 00
Sr-90	9.42E 09	1.07E 09	3.81E 10	0.00E 00	0.00E 00	0.00E 00	0.00E 00	0.00E 00
Zr-95	1.70E 02	5.70E 05	7.83E 02	2.47E 02	3.63E 02	0.00E 00	0.00E 00	0.00E 00
I-131	1.98E 08	7.31E 07	2.64E 08	3.69E 08	6.36E 08	1.08E 11	0.00E 00	0.00E 00
I-133	1.87E 06	4.64E 06	3.61E 06	6.13E 06	1.08E 07	8.56E 08	0.00E 00	0.00E 00
I-135	9.99E 03	2.99E 04	1.05E 04	2.70E 04	4.26E 04	1.74E 06	0.00E 00	0.00E 00
Cs-134	5.60E 09	1.50E 08	5.12E 09	1.21E 10	3.83E 09	0.00E 00	1.46E 09	0.00E 00
Cs-136	5.62E 08	6.73E 07	2.13E 08	8.37E 08	4.55E 08	0.00E 00	7.18E 07	0.00E 00
Cs-137	3.44E 09	1.40E 08	7.42E 09	9.87E 09	3.36E 09	0.00E 00	1.30E 09	0.00E 00
Ba-140	1.50E 06	3.58E 07	2.32E 07	2.84E 04	9.65E 03	0.00E 00	1.91E 04	0.00E 00
Ce-141	3.14E 02	7.83E 06	4.10E 03	2.74E 03	1.29E 03	0.00E 00	0.00E 00	0.00E 00
Ce-144	1.78E 04	8.33E 07	3.31E 05	1.37E 05	8.19E 04	0.00E 00	0.00E 00	0.00E 00
Nb-95	1.88E 04	1.46E 07	6.16E 04	3.42E 04	3.31E 04	0.00E 00	0.00E 00	0.00E 00
Ru-103	3.41E 02	6.67E 04	7.99E 02	0.00E 00	2.82E 03	0.00E 00	0.00E 00	0.00E 00

* R_i values are in units of mrem/yr per $\mu\text{Ci}/\text{m}^3$ for inhalation and tritium, and in units of m^2 mrem/yr per $\mu\text{Ci}/\text{sec}$ for all others.

Table 3.3-12

R_i Values for the Monticello Nuclear Generating Plant*

Cow Milk Pathway

Child Age Group

Nuclide	T. Body	GI Tract	Bone	Liver	Kidney	Thyroid	Lung	Skin
H-3	1.58E 03	1.58E 03	0.00E 00	1.58E 03	1.58E 03	1.58E 03	1.58E 03	1.58E 03
Cr-51	4.71E 04	2.50E 06	0.00E 00	0.00E 00	7.14E 03	2.61E 04	4.77E 04	0.00E 00
Mn-54	2.87E 06	9.04E 06	0.00E 00	1.08E 07	3.02E 06	0.00E 00	0.00E 00	0.00E 00
Fe-59	4.52E 07	9.45E 07	5.61E 07	9.08E 07	0.00E 00	0.00E 00	2.63E 07	0.00E 00
Co-58	1.77E 07	3.37E 07	0.00E 00	5.77E 06	0.00E 00	0.00E 00	0.00E 00	0.00E 00
CO-60	6.81E 07	1.28E 08	0.00E 00	2.31E 07	0.00E 00	0.00E 00	0.00E 00	0.00E 00
Zn-65	4.10E 09	1.16E 09	2.47E 09	6.59E 09	4.15E 09	0.00E 00	0.00E 00	0.00E 00
Sr-89	8.93E 07	1.21E 08	3.13E 09	0.00E 00	0.00E 00	0.00E 00	0.00E 00	0.00E 00
Sr-90	1.63E 10	8.68E 08	6.44E 10	0.00E 00	0.00E 00	0.00E 00	0.00E 00	0.00E 00
Zr-95	3.56E 02	4.17E 05	1.82E 03	4.00E 02	5.72E 02	0.00E 00	0.00E 00	0.00E 00
I-131	3.66E 08	5.73E 07	6.40E 08	6.44E 08	1.06E 09	2.13E 11	0.00E 00	0.00E 00
I-133	4.11E 06	4.38E 06	8.78E 06	1.09E 07	1.81E 07	2.02E 09	0.00E 00	0.00E 00
I-135	2.11E 04	3.40E 04	2.48E 04	4.46E 04	6.85E 04	3.95E 06	0.00E 00	0.00E 00
Cs-134	4.09E 09	1.05E 08	1.18E 10	1.94E 10	6.01E 09	0.00E 00	2.16E 09	0.00E 00
Cs-136	8.53E 08	4.63E 07	4.80E 08	1.32E 09	7.02E 08	0.00E 00	1.05E 08	0.00E 00
Cs-137	2.52E 09	1.07E 08	1.79E 10	1.71E 10	5.57E 09	0.00E 00	2.00E 09	0.00E 00
Ba-140	3.27E 06	2.84E 07	5.60E 07	4.91E 04	1.60E 04	0.00E 00	2.93E 04	0.00E 00
Ce-141	7.47E 02	6.28E 06	1.01E 04	5.03E 03	2.21E 03	0.00E 00	0.00E 00	0.00E 00
Ce-144	4.36E 04	6.68E 07	8.17E 05	2.56E 05	1.42E 05	0.00E 00	0.00E 00	0.00E 00
Nb-95	3.87E 04	1.00E 08	1.39E 05	5.41E 04	5.09E 04	0.00E 00	0.00E 00	0.00E 00
Ru-103	7.26E 02	4.88E 04	1.89E 03	0.00E 00	4.75E 03	0.00E 00	0.00E 00	0.00E 00

* R_i values are in units of mrem/yr per $\mu\text{Ci}/\text{m}^3$ for inhalation and tritium, and in units of m^2 mrem/yr per $\mu\text{Ci}/\text{sec}$ for all others.

Table 3.3-13

R_i Values for the Monticello Nuclear Generating Plant*
 Cow Milk Pathway
 Infant Age Group

Nuclide	T. Body	GI Tract	Bone	Liver	Kidney	Thyroid	Lung	Skin
H-3	2.40E 03	2.40E 03	0.00E 00	2.40E 03	2.40E 03	2.40E 03	2.40E 03	2.40E 03
Cr-51	7.46E 04	2.17E 06	0.00E 00	0.00E 00	1.06E 04	4.87E 04	9.47E 04	0.00E 00
Mn-54	4.54E 06	7.36E 06	0.00E 00	2.00E 07	4.44E 06	0.00E 00	0.00E 00	0.00E 00
Fe-59	7.21E 07	8.74E 07	1.05E 08	1.83E 08	0.00E 00	0.00E 00	5.41E 07	0.00E 00
Co-58	2.88E 07	2.88E 07	0.00E 00	1.15E 07	0.00E 00	0.00E 00	0.00E 00	0.00E 00
Co-60	1.11E 08	1.12E 08	0.00E 00	4.71E 07	0.00E 00	0.00E 00	0.00E 00	0.00E 00
Zn-65	5.26E 09	9.63E 09	3.32E 09	1.14E 10	5.53E 09	0.00E 00	0.00E 00	0.00E 00
Sr-89	1.70E 08	1.22E 08	5.94E 09	0.00E 00	0.00E 00	0.00E 00	0.00E 00	0.00E 00
Sr-90	1.79E 10	8.75E 08	7.01E 10	0.00E 00	0.00E 00	0.00E 00	0.00E 00	0.00E 00
Zr-95	5.58E 02	3.92E 05	3.23E 03	7.87E 02	8.48E 02	0.00E 00	0.00E 00	0.00E 00
I-131	6.92E 08	5.62E 07	1.34E 09	1.57E 09	1.84E 09	5.17E 11	0.00E 00	0.00E 00
I-133	7.91E 06	4.57E 06	1.85E 07	2.70E 07	3.17E 07	4.91E 09	0.00E 00	0.00E 00
I-135	3.74E 04	3.71E 04	5.16E 04	1.03E 05	1.14E 05	9.20E 06	0.00E 00	0.00E 00
Cs-134	3.59E 09	9.65E 07	1.90E 10	3.55E 10	9.14E 09	0.00E 00	3.75E 09	0.00E 00
Cs-136	1.03E 09	4.19E 07	9.37E 08	2.76E 09	1.10E 09	0.00E 00	2.25E 08	0.00E 00
Cs-137	2.37E 09	1.04E 08	2.85E 10	3.34E 10	8.96E 09	0.00E 00	3.63E 09	0.00E 00
Ba-140	5.94E 06	2.83E 07	1.15E 08	1.15E 05	2.74E 04	0.00E 00	7.08E 04	0.00E 00
Ce-141	1.44E 03	6.30E 06	2.00E 04	1.22E 04	3.76E 03	0.00E 00	0.00E 00	0.00E 00
Ce-144	6.56E 04	6.72E 07	1.17E 06	4.79E 05	1.94E 05	0.00E 00	0.00E 00	0.00E 00
Nb-95	6.18E 09	9.02E 07	2.59E 05	1.07E 05	7.66E 04	0.00E 00	0.00E 00	0.00E 00
Ru-103	1.28E 03	4.65E 04	3.82E 03	0.00E 00	7.96E 03	0.00E 00	0.00E 00	0.00E 00

* R_i values are in units of mrem/yr per $\mu\text{Ci}/\text{m}^3$ for inhalation and tritium, and in units of m^2 mrem/yr per $\mu\text{Ci}/\text{sec}$ for all others.

Table 3.3-14

R_i Values for the Monticello Nuclear Generating Plant*

Goat Milk Pathway

Adult Age Group

Nuclide	T. Body	GI Tract	Bone	Liver	Kidney	Thyroid	Lung	Skin
H-3	1.57E 03	1.57E 03	0.00E 00	1.57E 03	1.57E 03	1.57E 03	1.57E 03	1.57E 03
Cr-51	1.59E 03	3.99E 05	0.00E 00	0.00E 00	3.49E 02	9.48E 02	2.11E 03	0.00E 00
Mn-54	9.89E 04	1.59E 06	0.00E 00	0.00E 00	1.59E 05	9.48E 02	0.00E 00	0.00E 00
Fe-59	1.62E 05	1.41E 06	1.80E 05	4.23E 05	0.00E 00	0.00E 00	1.18E 05	0.00E 00
Co-58	6.03E 05	5.46E 06	0.00E 00	2.69E 05	0.00E 00	0.00E 00	0.00E 00	0.00E 00
Co-60	2.32E 06	1.98E 07	0.00E 00	1.05E 06	0.00E 00	0.00E 00	0.00E 00	0.00E 00
Zn-65	1.42E 08	1.97E 08	9.85E 07	3.14E 08	2.10E 08	0.00E 00	0.00E 00	0.00E 00
Sr-89	4.13E 07	2.31E 08	1.44E 09	0.00E 00	0.00E 00	0.00E 00	0.00E 00	0.00E 00
Sr-90	1.39E 10	1.64E 09	5.67E 10	0.00E 00	0.00E 00	0.00E 00	0.00E 00	0.00E 00
Zr-95	1.17E 01	5.46E 04	5.37E 01	1.72E 01	2.70E 01	0.00E 00	0.00E 00	0.00E 00
I-131	1.43E 08	6.59E 07	1.74E 08	2.50E 08	4.28E 08	8.18E 10	0.00E 00	0.00E 00
I-133	1.26E 06	3.71E 06	2.37E 06	4.13E 06	7.21E 06	6.07E 08	0.00E 00	0.00E 00
I-135	6.83E 03	2.09E 04	7.08E 03	1.85E 04	2.97E 04	1.22E 06	0.00E 00	0.00E 00
Cs-134	1.72E 10	3.69E 08	8.85E 09	2.11E 10	6.82E 09	0.00E 00	2.26E 09	0.00E 00
Cs-136	1.06E 09	1.68E 08	3.75E 08	1.48E 09	8.25E 08	0.00E 00	1.13E 08	0.00E 00
Cs-137	1.10E 10	3.25E 08	1.23E 10	1.68E 10	5.70E 09	0.00E 00	1.89E 09	0.00E 00
Ba-140	1.01E 05	3.18E 06	1.54E 06	1.94E 03	6.59E 02	0.00E 00	1.11E 03	0.00E 00
Ce-141	2.06E 01	6.94E 05	2.68E 02	1.81E 02	8.43E 01	0.00E 00	0.00E 00	0.00E 00
Ce-144	0.00E 00	0.00E 00	0.00E 00	0.00E 00	0.00E 00	0.00E 00	0.00E 00	0.00E 00
Nb-95	0.00E 00	0.00E 00	0.00E 00	0.00E 00	0.00E 00	0.00E 00	0.00E 00	0.00E 00
Ru-103	0.00E 00	0.00E 00	0.00E 00	0.00E 00	0.00E 00	0.00E 00	0.00E 00	0.00E 00

* R_i values are in units of mrem/yr per $\mu\text{Ci}/\text{m}^3$ for inhalation and tritium, and in units of m^2 mrem/yr per $\mu\text{Ci}/\text{sec}$ for all others.

Table 3.3-15

R_i Values for the Monticello Nuclear Generating Plant*

Goat Milk Pathway

Teen Age Group

Nuclide	T. Body	GI Tract	Bone	Liver	Kidney	Thyroid	Lung	Skin
H-3	2.04E 03	2.04E 03	0.00E 00	2.04E 03	2.04E 03	2.04E 03	2.04E 03	2.04E 03
Cr-51	2.77E 03	4.66E 05	0.00E 00	0.00E 00	6.07E 02	1.54E 03	3.95E 03	0.00E 00
Mn-54	1.71E 05	1.77E 06	0.00E 00	8.64E 05	2.58E 05	0.00E 00	0.00E 00	0.00E 00
Fe-59	2.83E 05	1.74E 06	3.14E 05	7.34E 05	0.00E 00	0.00E 00	2.31E 05	0.00E 00
Co-58	1.04E 06	6.25E 06	0.00E 00	4.53E 05	0.00E 00	0.00E 00	0.00E 00	0.00E 00
Co-60	4.02E 06	2.32E 07	0.00E 00	1.78E 06	0.00E 00	0.00E 00	0.00E 00	0.00E 00
Zn-65	2.45E 08	2.22E 08	1.51E 08	5.25E 08	3.36E 08	0.00E 00	0.00E 00	0.00E 00
Sr-89	7.59E 07	3.16E 08	2.65E 09	0.00E 00	0.00E 00	0.00E 00	0.00E 00	0.00E 00
Sr-90	1.98E 10	2.25E 09	8.01E 10	0.00E 00	0.00E 00	0.00E 00	0.00E 00	0.00E 00
Zr-95	2.04E 01	6.84E 04	9.40E 01	2.97E 01	4.36E 01	0.00E 00	0.00E 00	0.00E 00
I-131	2.38E 08	8.77E 07	3.17E 08	4.43E 08	7.63E 08	1.29E 11	0.00E 00	0.00E 00
I-133	2.24E 06	5.57E 06	4.34E 06	7.36E 06	1.29E 07	1.03E 09	0.00E 00	0.00E 00
I-135	1.20E 04	3.59E 04	1.26E 04	3.24E 04	5.11E 04	2.08E 06	0.00E 00	0.00E 00
Cs-134	1.68E 10	4.50E 08	1.54E 10	3.62E 10	1.15E 10	0.00E 00	4.39E 09	0.00E 00
Cs-136	1.69E 09	2.02E 08	6.38E 08	2.51E 09	1.37E 09	0.00E 00	2.15E 08	0.00E 00
Cs-137	1.03E 10	4.21E 08	2.22E 10	2.96E 10	1.01E 10	0.00E 00	3.91E 09	0.00E 00
Ba-140	1.80E 05	4.30E 06	2.79E 06	3.41E 03	1.16E 03	0.00E 00	2.30E 03	0.00E 00
Ce-141	3.77E 01	9.39E 05	4.92E 02	3.28E 02	1.55E 02	0.00E 00	0.00E 00	0.00E 00
Ce-144	0.00E 00	0.00E 00	0.00E 00	0.00E 00	0.00E 00	0.00E 00	0.00E 00	0.00E 00
Nb-95	0.00E 00	0.00E 00	0.00E 00	0.00E 00	0.00E 00	0.00E 00	0.00E 00	0.00E 00
Ru-103	0.00E 00	0.00E 00	0.00E 00	0.00E 00	0.00E 00	0.00E 00	0.00E 00	0.00E 00

* R_i values are in units of mrem/yr per $\mu\text{Ci}/\text{m}^3$ for inhalation and tritium, and in units of m^2 mrem/yr per $\mu\text{Ci}/\text{sec}$ for all others.

Table 3.3-16

R_i Values for the Monticello Nuclear Generating Plant*
Goat Milk Pathway
Child Age Group

Nuclide	T. Body	GI Tract	Bone	Liver	Kidney	Thyroid	Lung	Skin
H-3	3.23E 03	3.23E 03	0.00E 00	3.23E 03	3.23E 03	3.23E 03	3.23E 03	3.23E 03
Cr-51	5.65E 03	3.00E 05	0.00E 00	0.00E 00	8.57E 02	3.14E 03	5.73E 03	0.00E 00
Mn-54	3.44E 05	1.08E 06	0.00E 00	1.29E 06	3.62E 05	0.00E 00	0.00E 00	0.00E 00
Fe-59	5.88E 05	1.23E 06	7.29E 05	1.18E 06	0.00E 00	0.00E 00	3.42E 05	0.00E 00
Co-58	2.12E 06	4.04E 06	0.00E 00	6.92E 05	0.00E 00	0.00E 00	0.00E 00	0.00E 00
Co-60	8.17E 06	1.53E 07	0.00E 00	2.77E 06	0.00E 00	0.00E 00	0.00E 00	0.00E 00
Zn-65	4.92E 08	1.39E 08	2.97E 08	7.19E 08	4.98E 08	0.00E 00	0.00E 00	0.00E 00
Sr-89	1.87E 08	2.54E 08	6.56E 09	0.00E 00	0.00E 00	0.00E 00	0.00E 00	0.00E 00
Sr-90	3.43E 10	1.82E 09	1.35E 11	0.00E 00	0.00E 00	0.00E 00	0.00E 00	0.00E 00
Zr-95	4.27E 01	5.01E 04	2.18E 02	4.80E 01	6.87E 01	0.00E 00	0.00E 00	0.00E 00
I-131	4.39E 08	6.88E 07	7.68E 08	7.72E 08	1.27E 09	2.55E 11	0.00E 00	0.00E 00
I-133	4.93E 06	5.25E 06	1.05E 07	1.30E 07	2.17E 07	2.42E 09	0.00E 00	0.00E 00
I-135	2.53E 04	4.08E 04	2.98E 04	5.36E 04	8.22E 04	4.74E 06	0.00E 00	0.00E 00
Cs-134	1.23E 10	3.14E 08	3.55E 10	5.82E 10	1.80E 10	0.00E 00	6.47E 09	0.00E 00
Cs-136	2.56E 09	1.39E 08	1.44E 09	3.96E 09	2.11E 09	0.00E 00	3.14E 08	0.00E 00
Cs-137	7.57E 09	3.21E 08	5.36E 10	5.13E 10	1.67E 10	0.00E 00	6.01E 09	0.00E 00
Ba-140	3.92E 05	3.41E 06	6.72E 06	5.89E 03	1.92E 03	0.00E 00	3.51E 03	0.00E 00
Ce-141	8.97E 01	7.54E 05	1.21E 03	6.04E 02	2.65E 02	0.00E 00	0.00E 00	0.00E 00
Ce-144	0.00E 00	0.00E 00	0.00E 00	0.00E 00	0.00E 00	0.00E 00	0.00E 00	0.00E 00
Nb-95	0.00E 00	0.00E 00	0.00E 00	0.00E 00	0.00E 00	0.00E 00	0.00E 00	0.00E 00
Ru-103	0.00E 00	0.00E 00	0.00E 00	0.00E 00	0.00E 00	0.00E 00	0.00E 00	0.00E 00

* R_i values are in units of mrem/yr per $\mu\text{Ci}/\text{m}^3$ for inhalation and tritium, and in units of m^2 mrem/yr per $\mu\text{Ci}/\text{sec}$ for all others.

Table 3.3-17

R_i Values for the Monticello Nuclear Generating Plant*
Goat Milk Pathway
Infant Age Group

Nuclide	T. Body	GI Tract	Bone	Liver	Kidney	Thyroid	Lung	Skin
H-3	4.90E 03	4.90E 03	0.00E 00	4.90E 03	4.90E 03	4.90E 03	4.90E 03	4.90E 03
Cr-51	8.95E 03	2.61E 05	0.00E 00	0.00E 00	1.28E 03	5.84E 03	1.14E 04	0.00E 00
Mn-54	5.45E 05	8.83E 05	0.00E 00	2.40E 06	5.33E 05	0.00E 00	0.00E 00	0.00E 00
Fe-59	9.37E 05	1.14E 06	1.36E 06	2.38E 06	0.00E 00	0.00E 00	7.03E 05	0.00E 00
Co-58	3.45E 06	3.45E 06	0.00E 00	1.38E 06	0.00E 00	0.00E 00	0.00E 00	0.00E 00
Co-60	1.34E 07	1.35E 07	0.00E 00	5.65E 06	0.00E 00	0.00E 00	0.00E 00	0.00E 00
Zn-65	6.31E 08	1.16E 09	3.99E 08	1.37E 09	6.63E 08	0.00E 00	0.00E 00	0.00E 00
Sr-89	3.58E 08	2.57E 08	1.25E 10	0.00E 00	0.00E 00	0.00E 00	0.00E 00	0.00E 00
Sr-90	3.75E 10	1.84E 09	1.47E 11	0.00E 00	0.00E 00	0.00E 00	0.00E 00	0.00E 00
Zr-95	6.70E 01	4.70E 04	3.88E 02	9.45E 01	1.02E 02	0.00E 00	0.00E 00	0.00E 00
I-131	8.31E 08	6.74E 07	1.60E 09	1.89E 09	2.21E 09	6.21E 11	0.00E 00	0.00E 00
I-133	9.49E 06	5.48E 06	2.23E 07	3.24E 07	3.81E 07	5.89E 09	0.00E 00	0.00E 00
I-135	4.49E 04	4.46E 04	6.19E 04	1.23E 05	1.37E 05	1.10E 07	0.00E 00	0.00E 00
Cs-134	1.08E 10	2.89E 08	5.71E 10	1.07E 11	2.74E 10	0.00E 00	1.12E 10	0.00E 00
Cs-136	3.09E 09	1.26E 08	2.81E 09	8.27E 09	3.30E 09	0.00E 00	6.74E 08	0.00E 00
Cs-137	7.10E 09	3.13E 08	8.55E 10	1.00E 11	2.69E 10	0.00E 00	1.09E 10	0.00E 00
Ba-140	7.13E 05	3.40E 06	1.38E 04	1.38E 07	3.29E 03	0.00E 00	8.50E 03	0.00E 00
Ce-141	1.72E 02	7.57E 05	2.40E 03	1.46E 03	4.52E 02	0.00E 00	0.00E 00	0.00E 00
Ce-144	0.00E 00	0.00E 00	0.00E 00	0.00E 00	0.00E 00	0.00E 00	0.00E 00	0.00E 00
Nb-95	0.00E 00	0.00E 00	0.00E 00	0.00E 00	0.00E 00	0.00E 00	0.00E 00	0.00E 00
Ru-103	0.00E 00	0.00E 00	0.00E 00	0.00E 00	0.00E 00	0.00E 00	0.00E 00	0.00E 00

* R_i values are in units of mrem/yr per $\mu\text{Ci}/\text{m}^3$ for inhalation and tritium, and in units of m^2 mrem/yr per $\mu\text{Ci}/\text{sec}$ for all others.

Table 3.3-18

R_i Values for the Monticello Nuclear Generating Plant*

Inhalation Pathway

Adult Age Group

Nuclide	T. Body	GI Tract	Bone	Liver	Kidney	Thyroid	Lung	Skin
H-3	1.26E 03	1.26E 03	0.00E 00	1.26E 03	1.26E 03	1.26E 03	1.26E 03	1.26E 03
Cr-51	9.99E 01	3.32E 03	0.00E 00	0.00E 00	2.28E 01	5.94E 01	1.44E 04	0.00E 00
Mn-54	6.29E 03	7.72E 04	0.00E 00	3.95E 04	9.83E 03	0.00E 00	1.40E 06	0.00E 00
Fe-59	1.05E 04	1.88E 05	1.17E 04	2.77E 04	0.00E 00	0.00E 00	1.01E 06	0.00E 00
Co-58	2.07E 03	1.06E 05	0.00E 00	1.58E 03	0.00E 00	0.00E 00	9.27E 05	0.00E 00
Co-60	1.48E 04	2.84E 05	0.00E 00	1.15E 04	0.00E 00	0.00E 00	5.96E 06	0.00E 00
Zn-65	4.65E 04	5.34E 04	3.24E 04	1.03E 05	6.89E 04	0.00E 00	8.63E 05	0.00E 00
Sr-89	8.71E 03	3.49E 05	3.04E 05	0.00E 00	0.00E 00	0.00E 00	1.40E 06	0.00E 00
Sr-90	6.09E 06	7.21E 05	9.91E 07	0.00E 00	0.00E 00	0.00E 00	9.59E 06	0.00E 00
Zr-95	2.32E 04	1.50E 05	1.07E 05	3.44E 04	5.41E 04	0.00E 00	1.77E 06	0.00E 00
I-131	2.05E 04	6.27E 03	2.52E 04	3.57E 04	6.12E 04	1.19E 07	0.00E 00	0.00E 00
I-133	4.51E 03	8.87E 03	8.63E 03	1.48E 04	2.58E 04	2.15E 06	0.00E 00	0.00E 00
I-135	2.57E 03	5.25E 03	2.68E 03	6.98E 03	1.11E 04	4.48E 05	0.00E 00	0.00E 00
Cs-134	7.27E 05	1.04E 04	3.72E 05	8.47E 05	2.87E 05	0.00E 00	9.75E 04	0.00E 00
Cs-136	1.10E 05	1.17E 04	3.90E 04	1.46E 05	8.55E 04	0.00E 00	1.20E 04	0.00E 00
Cs-137	4.27E 05	8.39E 03	4.78E 05	6.20E 05	2.22E 05	0.00E 00	7.51E 04	0.00E 00
Ba-140	2.56E 03	2.18E 05	3.90E 04	4.90E 01	1.67E 01	0.00E 00	1.27E 06	0.00E 00
Ce-141	1.53E 03	1.20E 05	1.99E 04	1.35E 04	6.25E 03	0.00E 00	3.61E 05	0.00E 00
Ce-144	1.84E 05	8.16E 05	3.43E 06	1.43E 06	8.48E 05	0.00E 00	7.78E 06	0.00E 00
Nb-95	4.21E 03	1.04E 05	1.41E 03	7.82E 03	7.72E 03	0.00E 00	5.05E 05	0.00E 00
Ru-103	6.58E 02	1.10E 05	1.53E 03	0.00E 00	5.83E 03	0.00E 00	5.05E 05	0.00E 00

* R_i values are in units of mrem/yr per $\mu\text{Ci}/\text{m}^3$ for inhalation and tritium, and in units of m^2 mrem/yr per $\mu\text{Ci}/\text{sec}$ for all others.

Table 3.3-19
 R_i Values for the Monticello Nuclear Generating Plant*
 Inhalation Pathway
 Teen Age Group

Nuclide	T. Body	GI Tract	Bone	Liver	Kidney	Thyroid	Lung	Skin
H-3	1.72E 03	1.27E 03	0.00E 00	1.27E 03	1.27E 03	1.27E 03	1.27E 03	1.27E 03
Cr-51	1.35E 02	3.00E 03	0.00E 00	0.00E 00	3.07E 01	7.49E 01	2.09E 04	0.00E 00
Mn-54	8.39E 03	6.67E 04	0.00E 00	5.10E 04	1.27E 04	0.00E 00	1.98E 06	0.00E 00
Fe-59	1.43E 04	1.78E 05	1.59E 04	3.69E 04	0.00E 00	0.00E 00	1.53E 06	0.00E 00
Co-58	2.77E 03	9.51E 04	0.00E 00	2.07E 03	0.00E 00	0.00E 00	1.34E 06	0.00E 00
Co-60	1.98E 04	2.59E 05	0.00E 00	1.51E 04	0.00E 00	0.00E 00	8.71E 06	0.00E 00
Zn-65	6.23E 04	4.66E 04	3.85E 04	1.33E 05	8.63E 04	0.00E 00	1.24E 06	0.00E 00
Sr-89	1.25E 04	3.71E 05	4.34E 05	0.00E 00	0.00E 00	0.00E 00	2.41E 06	0.00E 00
Sr-90	6.67E 06	7.64E 05	1.08E 08	0.00E 00	0.00E 00	0.00E 00	1.65E 07	0.00E 00
Zr-95	3.15E 04	1.49E 05	1.45E 05	4.58E 04	6.73E 04	0.00E 00	2.68E 06	0.00E 00
I-131	2.64E 04	6.48E 03	3.54E 04	4.90E 04	8.39E 04	1.46E 07	0.00E 00	0.00E 00
I-133	6.21E 03	1.03E 04	1.21E 04	2.05E 04	3.59E 04	2.92E 06	0.00E 00	0.00E 00
I-135	3.49E 03	6.95E 03	3.70E 03	9.44E 03	1.49E 04	6.21E 05	0.00E 00	0.00E 00
Cs-134	5.48E 05	9.75E 03	5.02E 05	1.13E 06	3.75E 05	0.00E 00	1.46E 05	0.00E 00
Cs-136	1.37E 05	1.09E 04	5.14E 04	1.93E 05	1.10E 05	0.00E 00	1.77E 04	0.00E 00
Cs-137	3.11E 05	8.47E 03	6.69E 05	8.47E 05	3.04E 05	0.00E 00	1.21E 05	0.00E 00
Ba-140	3.51E 03	2.28E 05	5.46E 04	6.69E 01	2.28E 01	0.00E 00	2.03E 06	0.00E 00
Ce-141	2.16E 03	1.26E 05	2.84E 04	1.89E 04	8.87E 03	0.00E 00	6.13E 05	0.00E 00
Ce-144	2.62E 05	8.64E 05	4.89E 06	2.02E 06	1.21E 06	0.00E 00	1.34E 07	0.00E 00
Nb-95	5.66E 03	9.68E 04	1.86E 04	1.03E 04	1.00E 04	0.00E 00	7.51E 05	0.00E 00
Ru-103	8.96E 02	1.09E 05	2.10E 03	0.00E 00	7.43E 03	0.00E 00	7.83E 05	0.00E 00

* R_i values are in units of mrem/yr per $\mu\text{Ci}/\text{m}^3$ for inhalation and tritium, and in units of m^2 mrem/yr per $\mu\text{Ci}/\text{sec}$ for all others.

Table 3.3-20

R_i Values for the Monticello Nuclear Generating Plant*
 Inhalation Pathway
 Child Age Group

Nuclide	T. Body	GI Tract	Bone	Liver	Kidney	Thyroid	Lung	Skin
H-3	1.21E 03	1.12E 03	0.00E 00	1.12E 03	1.12E 03	1.12E 03	1.12E 03	1.12E 03
Cr-51	1.54E 02	1.08E 03	0.00E 00	0.00E 00	2.43E 01	8.53E 01	1.70E 04	0.00E 00
Mn-54	9.50E 03	2.29E 04	0.00E 00	4.29E 04	1.00E 04	0.00E 00	1.57E 06	0.00E 00
Fe-59	1.67E 04	7.06E 04	2.07E 04	3.34E 04	0.00E 00	0.00E 00	1.27E 06	0.00E 00
Co-58	3.16E 03	3.43E 04	0.00E 00	1.77E 03	0.00E 00	0.00E 00	1.10E 06	0.00E 00
Co-60	2.26E 04	9.61E 04	0.00E 00	1.31E 04	0.00E 00	0.00E 00	7.06E 06	0.00E 00
Zn-65	7.02E 04	1.63E 04	4.25E 04	1.13E 05	7.13E 04	0.00E 00	9.94E 05	0.00E 00
Sr-89	1.72E 04	1.67E 05	5.99E 05	0.00E 00	0.00E 00	0.00E 00	2.15E 06	0.00E 00
Sr-90	6.43E 06	3.43E 05	1.01E 08	0.00E 00	0.00E 00	0.00E 00	1.47E 07	0.00E 00
Zr-95	3.69E 04	6.10E 04	1.90E 05	4.17E 04	5.95E 04	0.00E 00	2.23E 06	0.00E 00
I-131	2.72E 04	2.84E 03	4.80E 04	4.80E 04	7.87E 04	1.62E 07	0.00E 00	0.00E 00
I-133	7.68E 03	5.47E 03	1.66E 04	2.03E 04	3.37E 04	3.84E 06	0.00E 00	0.00E 00
I-135	4.14E 03	4.44E 03	4.92E 03	8.73E 03	1.34E 04	7.92E 05	0.00E 00	0.00E 00
Cs-134	2.24E 05	3.84E 03	6.50E 05	1.01E 06	3.30E 05	0.00E 00	1.21E 05	0.00E 00
Cs-136	1.16E 05	4.17E 03	6.50E 04	1.71E 05	9.53E 04	0.00E 00	1.45E 04	0.00E 00
Cs-137	1.28E 05	3.61E 03	9.05E 05	8.24E 05	2.82E 05	0.00E 00	1.04E 05	0.00E 00
Ba-140	4.32E 03	1.02E 05	7.39E 04	6.47E 01	2.11E 01	0.00E 00	1.74E 06	0.00E 00
Ce-141	2.89E 03	5.65E 04	3.92E 04	1.95E 04	8.53E 03	0.00E 00	5.43E 05	0.00E 00
Ce-144	3.61E 05	3.88E 05	6.77E 06	2.12E 06	1.17E 06	0.00E 00	1.19E 07	0.00E 00
Nb-95	6.55E 03	3.70E 04	2.35E 04	9.18E 03	8.62E 03	0.00E 00	6.14E 05	0.00E 00
Ru-103	1.07E 03	4.48E 04	2.79E 03	0.00E 00	7.03E 03	0.00E 00	6.62E 05	0.00E 00

* R_i values are in units of mrem/yr per $\mu\text{Ci}/\text{m}^3$ for inhalation and tritium, and in units of m^2 mrem/yr per $\mu\text{Ci}/\text{sec}$ for all others.

Table 3.3-21

R_i Values for the Monticello Nuclear Generating Plant*

Inhalation Pathway

Infant Age Group

Nuclide	T. Body	GI Tract	Bone	Liver	Kidney	Thyroid	Lung	Skin
H-3	6.46E 02	6.46E 02	0.00E 00	6.46E 02	6.46E 02	6.46E 02	6.46E 02	6.46E 02
Cr-51	8.93E 01	3.56E 02	0.00E 00	0.00E 00	1.32E 01	5.75E 01	1.28E 04	0.00E 00
Mn-54	4.98E 03	7.05E 03	0.00E 00	2.53E 04	4.98E 03	0.00E 00	9.98E 05	0.00E 00
Fe-59	9.46E 03	2.47E 04	1.35E 04	2.35E 04	0.00E 00	0.00E 00	1.01E 06	0.00E 00
Co-58	1.82E 03	1.11E 04	0.00E 00	1.22E 03	0.00E 00	0.00E 00	7.76E 05	0.00E 00
Co-60	1.18E 04	3.19E 04	0.00E 00	8.01E 03	0.00E 00	0.00E 00	4.50E 06	0.00E 00
Zn-65	3.10E 04	5.13E 04	1.93E 04	6.25E 04	3.24E 04	0.00E 00	6.46E 05	0.00E 00
Sr-89	1.14E 04	6.39E 04	3.97E 05	0.00E 00	0.00E 00	0.00E 00	2.03E 06	0.00E 00
Sr-90	2.59E 06	1.31E 05	4.08E 07	0.00E 00	0.00E 00	0.00E 00	1.12E 07	0.00E 00
Zr-95	2.03E 04	2.17E 04	1.15E 05	2.78E 04	3.10E 04	0.00E 00	1.75E 06	0.00E 00
I-131	1.96E 04	1.06E 03	3.79E 04	4.43E 04	5.17E 04	1.48E 07	0.00E 00	0.00E 00
I-133	5.59E 03	2.15E 03	1.32E 04	1.92E 04	2.24E 04	3.55E 06	0.00E 00	0.00E 00
I-135	2.77E 03	1.83E 03	3.86E 03	7.60E 03	8.47E 03	6.96E 05	0.00E 00	0.00E 00
Cs-134	7.44E 04	1.33E 03	3.96E 05	7.02E 05	1.90E 05	0.00E 00	7.95E 04	0.00E 00
Cs-136	5.28E 04	1.43E 03	4.82E 04	1.34E 05	5.63E 04	0.00E 00	1.17E 04	0.00E 00
Cs-137	4.54E 04	1.33E 03	5.48E 05	6.11E 05	1.72E 05	0.00E 00	7.12E 04	0.00E 00
Ba-140	2.89E 03	3.83E 04	5.59E 04	5.59E 01	1.34E 01	0.00E 00	1.59E 06	0.00E 00
Ce-141	1.99E 03	2.15E 04	2.77E 04	1.66E 04	5.24E 03	0.00E 00	5.16E 05	0.00E 00
Ce-144	1.76E 05	1.48E 05	3.19E 06	1.21E 06	5.38E 05	0.00E 00	9.84E 06	0.00E 00
Nb-95	3.78E 03	1.27E 04	1.57E 04	4.79E 05	4.72E 03	0.00E 00	4.79E 05	0.00E 00
Ru-103	6.79E 02	1.61E 04	2.02E 03	0.00E 00	4.24E 03	0.00E 00	5.52E 05	0.00E 00

* R_i values are in units of mrem/yr per $\mu\text{Ci}/\text{m}^3$ for inhalation and tritium, and in units of m^2 mrem/yr per $\mu\text{Ci}/\text{sec}$ for all others.

GASEOUS RADWASTE

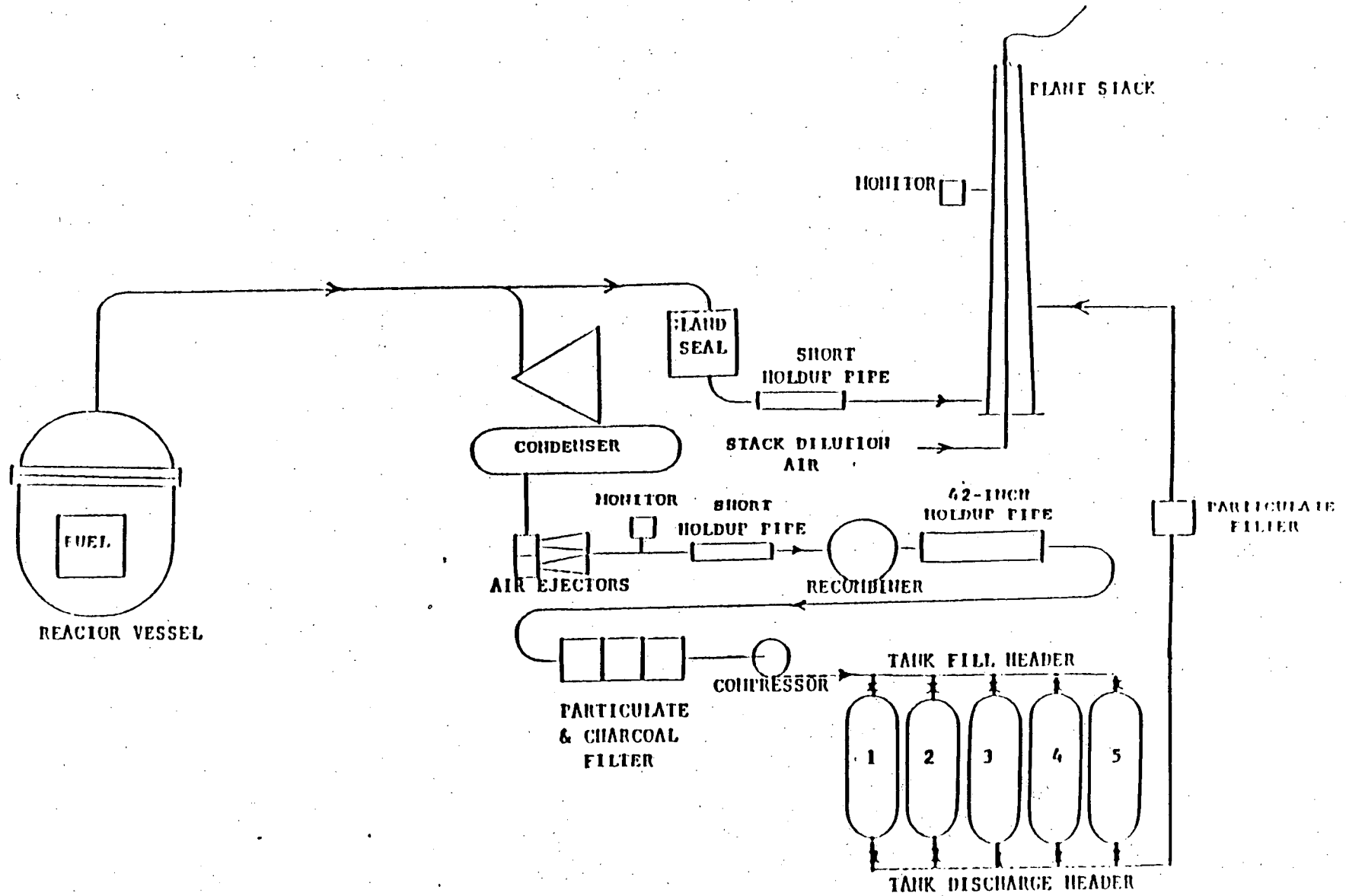
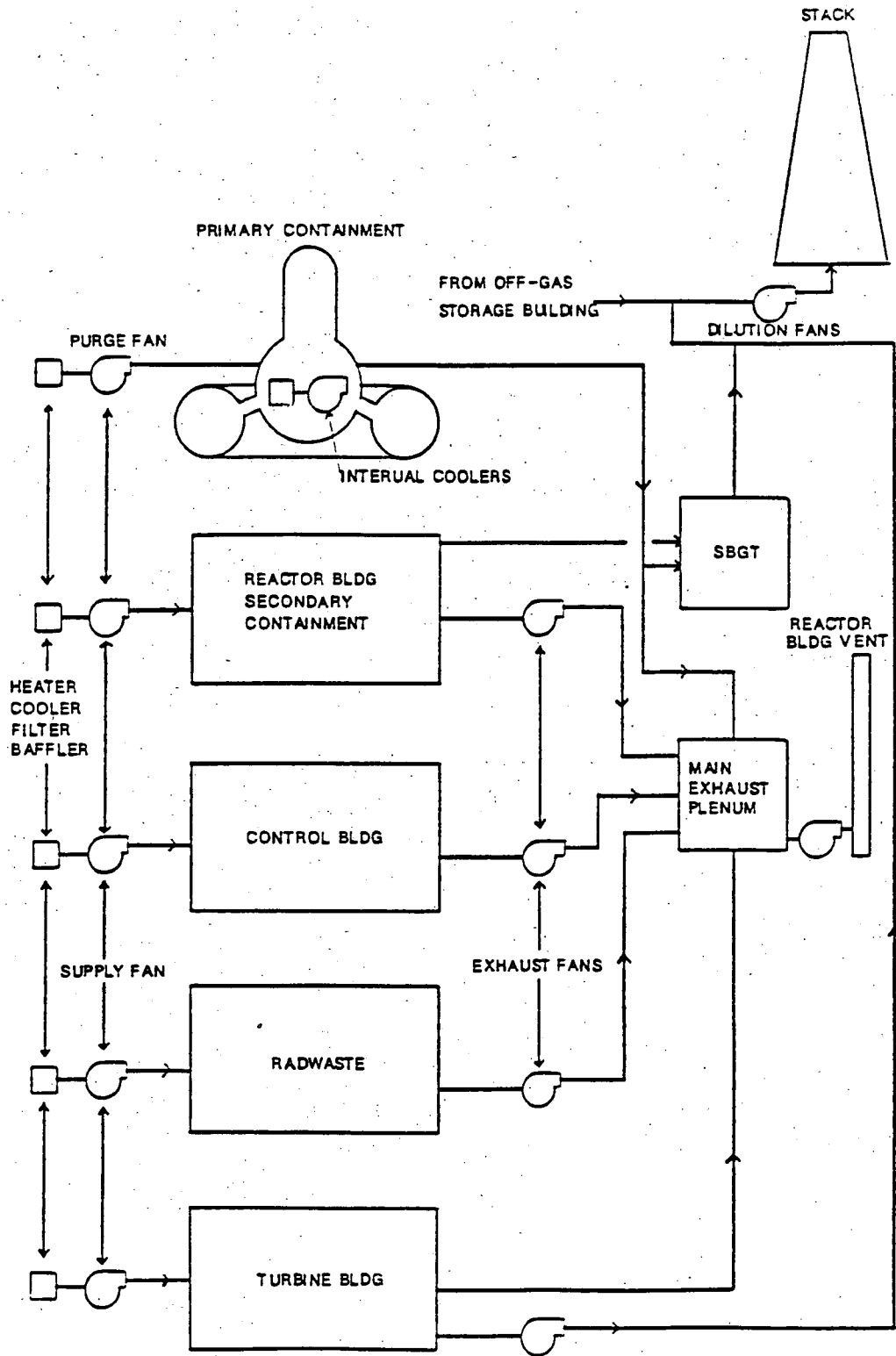

FIGURE 3-1
3 - 53

Revision 7



VENTILATION SYSTEM

4.0 INFORMATION RELATED TO 40 CFR 190 AND 40 CFR 141

The Technical Specifications require that when the calculated doses associated with the effluent releases exceed twice the limits of any section, the licensee shall prepare and submit a Special Report to the Commission and limit subsequent releases such that the dose or dose commitment to a real individual from all uranium fuel cycle sources is limited to 25 mrem to the total body or any organ (except the thyroid, which is limited to 75 mrem) over 12 consecutive months. This special report is to include an analysis which demonstrates that radiation exposures to all real individuals from all uranium fuel cycle sources (including all liquid and gaseous effluent pathways and direct radiation) are less than the standards in 40 CFR Part 190, Environmental Radiation Protection Standards for Nuclear Power Operations.

If analysis indicates that releases resulting in doses that exceed the 40 CFR 190 Standard may have occurred, then a variance from the Commission to Permit such releases will be requested or if possible, action will be taken to reduce subsequent releases.

The "Uranium fuel cycle" is defined in 40 CFR Part 190.02(b) as:

"Uranium fuel cycle means the operations of milling of uranium ore, chemical conversion of uranium, isotopic enrichment of uranium, fabrication of uranium fuel, generation of electricity by a light-water-cooled nuclear power plant using uranium fuel, and reprocessing of spent uranium fuel, to the extent that these directly support the production of electrical power for public use utilizing nuclear energy, but excludes mining operations, operations at waste disposal sites, transportation of any radioactive material in support of these operations, and the reuse of recovered non-uranium special nuclear and by-product materials from the cycle."

The Special Report will contain:

- 1) A determination of which uranium fuel cycle facilities or operations, in addition to the nuclear power reactor units at the site, contribute to the annual dose to the maximum exposed member of the public. Nuclear fuel facilities over five miles from MNGP need not be considered in this determination.
- 2) A determination of the maximum exposed member of the public.
- 3) A determination of the total annual dose to this person from all existing pathways and sources of radioactive effluents and direct radiation using the methodologies described in this ODCM. Where additional information on pathways and nuclides is needed, the best available information will be used and documented.

- 4) A determination of the dose resulting from direct radiation from the plant and storage facilities.

The total body and organ doses resulting from liquid effluents from the MNGP will be summed with the doses resulting from releases of noble gases, radioiodines and particulates. These doses will be based upon releases from the MNGP during the past 3 quarters and from the quarter in which twice the specification was exceeded. The doses from the MNGP will be summed with the doses to the maximum exposed individual contributed from other operation of the uranium fuel cycle.

The direct dose components will be determined by either calculation or actual measurement. The N-16 component of direct radiation may be calculated using SKYSHINE, A Computer Procedure for Evaluation Effects of Structure Design on N-16 Gamma-Ray Dose Rates, Radiation Research Associates, Inc. Report RRA-17209, per R.R. November 1972. (AVAILABLE IN THE NSP- NSS LIBRARY).

MNGP shine dose computations have been made and are contained in a report introduced into the FTOL hearing record as exhibit number 2 (see response to interrogatories 5 and 6, Docket 50-263). The calculation or actual measurement will be documented in this Special Report.

If the quarterly or annual doses due to liquid releases exceed the values listed in Section 2.3.3, a special report shall be submitted to the USNRC and shall include information related to 40 CFR 141 such as analysis of Mississippi River waste and an analysis of possible impacts through the drinking water pathways.

REFERENCES SECTION 4

- (1) EPA, Title 40, Code of Federal Regulations, Part 190, "Environmental Radiation Protection Standards for Nuclear Power Operations".
- (2) Radiation Research Associates, Inc., SKYSHINE, A Computer Procedure for Evaluating Effects of Structure Design on N-16 Gamma-Ray Dose Rates, Report RRA-17209, November 1972.

5.0 RADIATION ENVIRONMENTAL MONITORING PROGRAM

5.1 Sampling

Table 5.1-1 and Figure 5.1-1 specify the current sampling locations for the radiation environmental monitoring program. These sampling locations are based on the latest land use census.

If it is learned from an annual census that milk animals or gardens are present at the location which yields a calculated thyroid dose greater than those locations previously sampled, the new milk animal or garden locations resulting in the higher calculated doses shall be added to the surveillance program as soon as practicable. Sample locations (except the control) having lower calculated doses may be dropped from the program at the end of the grazing or growing season (October 31) to keep the total number of sample locations constant.

If the plant begins routine discharges of liquid radioactive waste into the Mississippi River, a land use survey will be conducted to determine whether any crops are irrigated with water taken from the Mississippi River between the plant discharge canal and a point 5 miles downstream. If edible crops are being irrigated from Mississippi River water, appropriate samples will be collected and analyzed per Technical Specifications Table 4.16.1.

5.2 Interlaboratory Comparison Program

Analyses shall be performed on radioactive samples supplied by the EPA crosscheck program. This program involves the analyses of samples provided by a control laboratory and comparison of results with those of the control laboratory as well as with other laboratories which receive portions of the same samples. Media used in this program (air, milk, water, etc) shall be limited to those found in the radiation environmental monitoring program. The results of analyses performed as a part of the crosscheck program shall be included in the Annual Radiation Environmental Monitoring Report.

Table 5.1-1

Monticello Nuclear Generating Plant
Radiation Environmental Monitoring Program
Sampling Locations

Type of Sample	Code	Collection Site	Location		
			Distance miles	Compass Heading	Sector
River water	M-8 ^C	Upstream of plant	0.2	285	WNW
River water	M-9	Downstream of plant	0.2	62	ENE
Drinking water	M-14	City of Minneapolis	36.	128	SE
Well water	M-10 ^C	Kirchenbauer Farm	11.5	323	NW
Well water	M-11	City of Monticello	3.2	128	SE
Well water	M-12	Plant Well #1	0.2	267	W
Well water	M-13	Biegert Residence	0.5	191	SSW
Sediment-River	M-8 ^C	Upstream of plant	0.2	285	WNW
Sediment-River	M-9	Downstream of plant	0.2	62	ENE
Sediment-Shoreline	M-15	Montissippi Park	1.6	117	ESE
Periphyton or Macroinvertebrates	M-8 ^C	Upstream of plant	0.2	285	WNW
	M-9	Downstream of plant	0.2	62	ENE
Fish	M-8 ^C	Upstream of plant	0.2	285	WNW
Fish	M-9	Downstream of plant	0.2	62	ENE
Milk	M-10 ^C	Kirchenbauer Farm	11.5	323	NW
Milk	M-18	Witschen Farm	3.0	260	W
Milk	M-24	Holthaus Farm	4.1	173	S
Milk	M-26	Peterson Farm	2.5	111	ESE
Milk	M-28	Hoglund Farm	3.7	300	WNW

continued

Table 5.1-1 (continued)

Monticello Nuclear Generating Plant
Radiation Environmental Monitoring Program
Sampling Locations

Type of Sample	Code	Collection Site	Location		
			Distance miles	Compass Heading	Sector
Cultivated crops					
(leafy green vegetables)					
	M-10 ^c	Kirchenbauer Farm	11.5	323	NW
	M-27	Highest D/Q Garden	0.6	208	SSW
(corn)*					
(potatoes)*					
Particulates and Radioiodine					
(air)	M-1 ^c	Air Station M-1	11.1	306	NW
(air)	M-2	Air station M-2	0.8	140	SE
(air)	M-3	Air Station M-3	0.6	104	ESE
(air)	M-4	Air Station M-4	0.9	150	SSE
(air)	M-5	Air Station M-5	2.7	136	SE
Direct Radiation - (general area of the site boundary)					
(TLD)	M01A	North Boundary Rd.	0.7	353	N
(TLD)	M02A	North Boundary Rd.	0.8	23	NNE
(TLD)	M03A	North Boundary Rd.	1.0	43	NE
(TLD)	M04A	Biology Station Rd.	0.7	92	E
(TLD)	M05A	Biology Station Rd.	0.6	112	ESE
(TLD)	M06A	Biology Station Rd.	0.6	133	SE
(TLD)	M07A	County Road 75	0.5	158	SSE
(TLD)	M08A	County Road 75	0.5	183	S
(TLD)	M09A	County Road 75	0.4	203	SSW
(TLD)	M10A	County Road 75	0.3	225	SW
(TLD)	M11A	County Road 75	0.4	250	WSW
(TLD)	M12A	County Road 75	0.7	273	W
(TLD)	M13A	North Boundary Rd.	1.1	317	NW
(TLD)	M14A	North Boundary Rd.	0.8	338	NNW

continued

* Collected only if plant discharges radioactive effluent into the river, then only from river irrigated fields. (See Sec. 5.1)

Table 5.1 1 (continued)

Monticello Nuclear Generating Plant
Radiation Environmental Monitoring Program
Sampling Locations

Type of Sample	Code	Collection Site	Location		
			Distance miles	Compass Heading	Sector
Direct Radiation - (about 4 to 5 miles distant from the plant)					
(TLD)	M01B	Sherco #1 Air Sta.	4.6	2	N
(TLD)	M02B	County Road 11	4.4	17	NNE
(TLD)	M03B	County Rd. 73 & 81	4.5	49	NE
(TLD)	M04B	Sherco #6 Air Sta.	4.2	67	ENE
(TLD)	M05B	City of Big Lake	4.4	87	E
(TLD)	M06B	County Rd 14 & 196 St	4.3	116	ESE
(TLD)	M07B	Monte Industrial Dr.	4.4	135	SE
(TLD)	M08B	Dale Larson Res.	4.6	162	SSE
(TLD)	M09B	Norbert Weinand Farm	4.7	180	S
(TLD)	M10B	John Reisewitz Farm	4.4	206	SSW
(TLD)	M11B	Clifford Vanlith Farm	4.2	225	SW
(TLD)	M12B	Lake Maria St. Park	4.4	253	WSW
(TLD)	M13B	Bridgewater Sta.	4.1	271	W
(TLD)	M14B	Richard Anderson Res.	4.5	288	WNW
(TLD)	M15B	Gary Williamson Res.	4.5	308	NW
(TLD)	M16B	Sand Plain Research Farm	4.3	338	NNW
Direct Radiation - (special interest locations)					
(TLD)	M01S	Dickson Res.	0.5	166	SSE
(TLD)	M02S	Edgar Klucas Res.	0.7	142	SE
(TLD)	M03S	Big Oaks Park	1.3	89	E
(TLD)	M04S	Pinewood School	2.3	132	SE
(TLD)	M05S	Roman Greener Res.	2.5	112	ESE
(TLD)	M06S	Monte Service Center	2.7	136	SE
(TLD)	M01C	Kirchenbauer Farm	11.5	323	NW

Notes on Table 5.1-1:

"c" denotes control locations. All other locations are indicator locations.

The letters after TLD code numbers have the following meanings:

- A Locations in the general area of the site boundary;
- B Locations about 4 to 5 miles distant from the plant;
- S Special interest locations.

JMS3004

5 - 6

Revision 7

FIGURE 5.1-1
 SAMPLING LOCATIONS
 MONTICELLO NUCLEAR GENERATING PLANT
 RADIATION ENVIRONMENTAL MONITORING PROGRAM

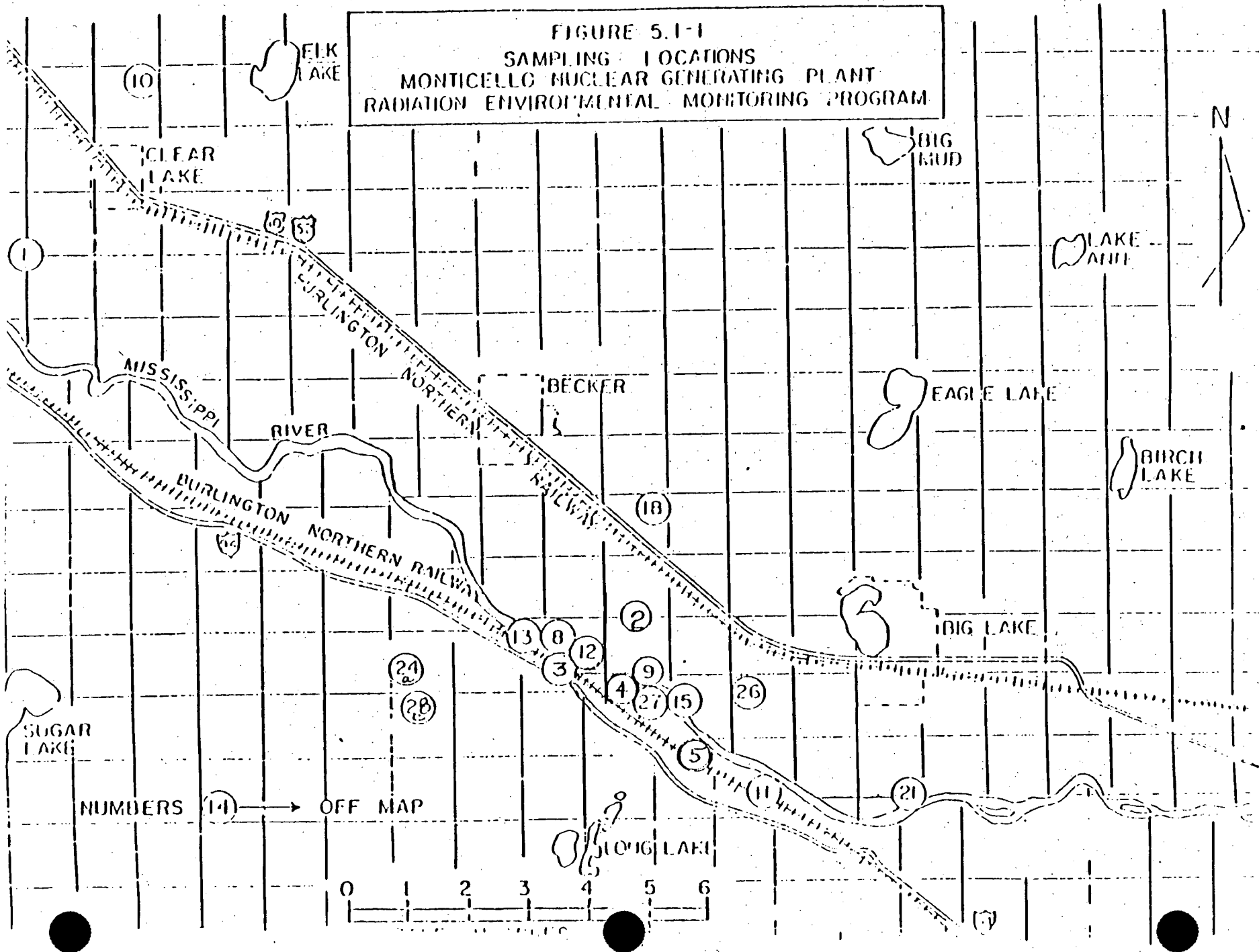

NUMBERS 14 → OFF MAP

0 1 2 3 4 5 6

JMS3004

5 - 7

Revision 7

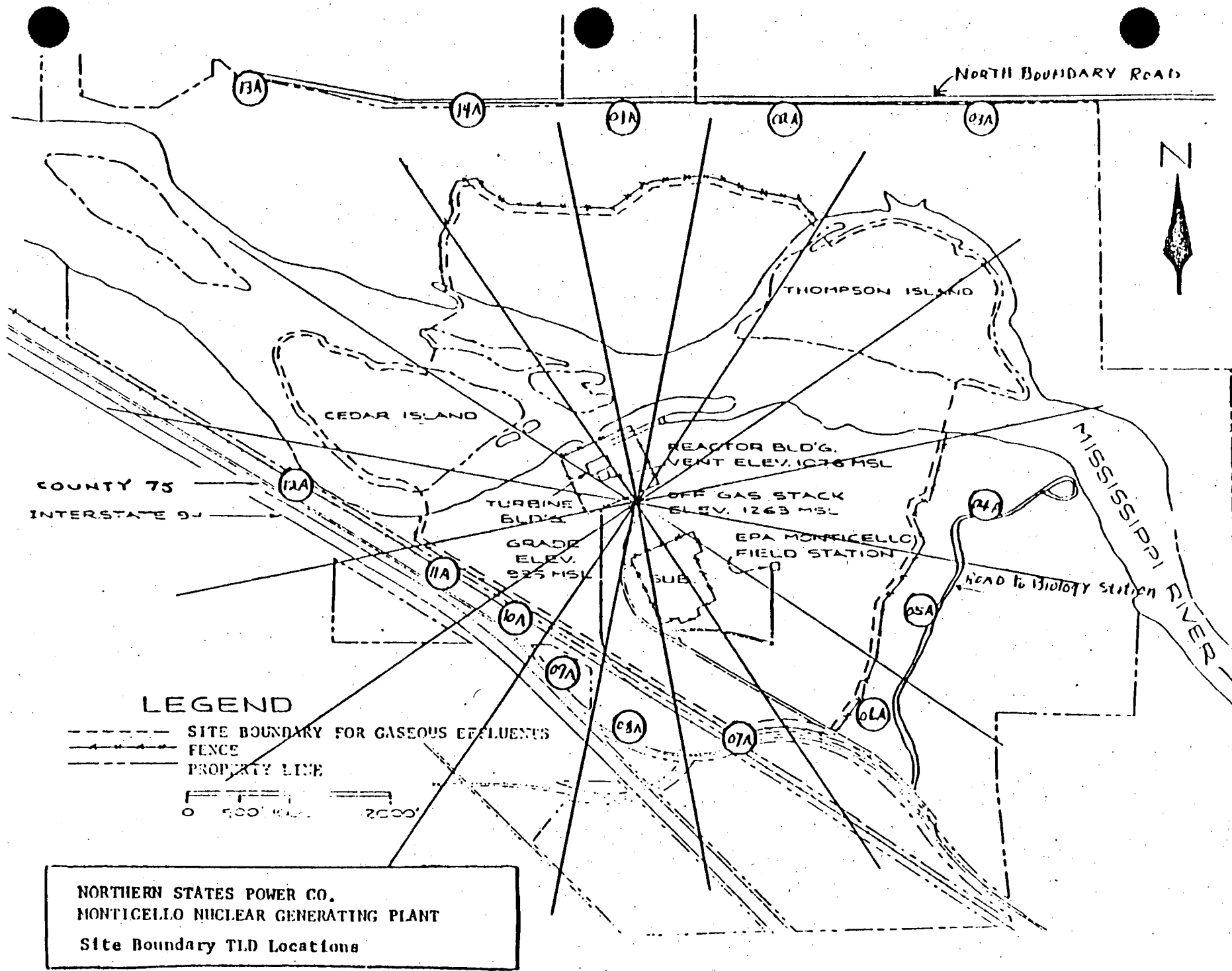

**NORTHERN STATES POWER CO.
MONTICELLO NUCLEAR GENERATING PLANT
Site Boundary TLD Locations**

JMS3004

5-8

Revision 7

NORTHERN STATES POWER CO.
MONTICELLO NUCLEAR GENERATING PLANT
4 - 5 Mile Ring, Control, and Special Interest TLD Locations
0 1 2 3 4 miles

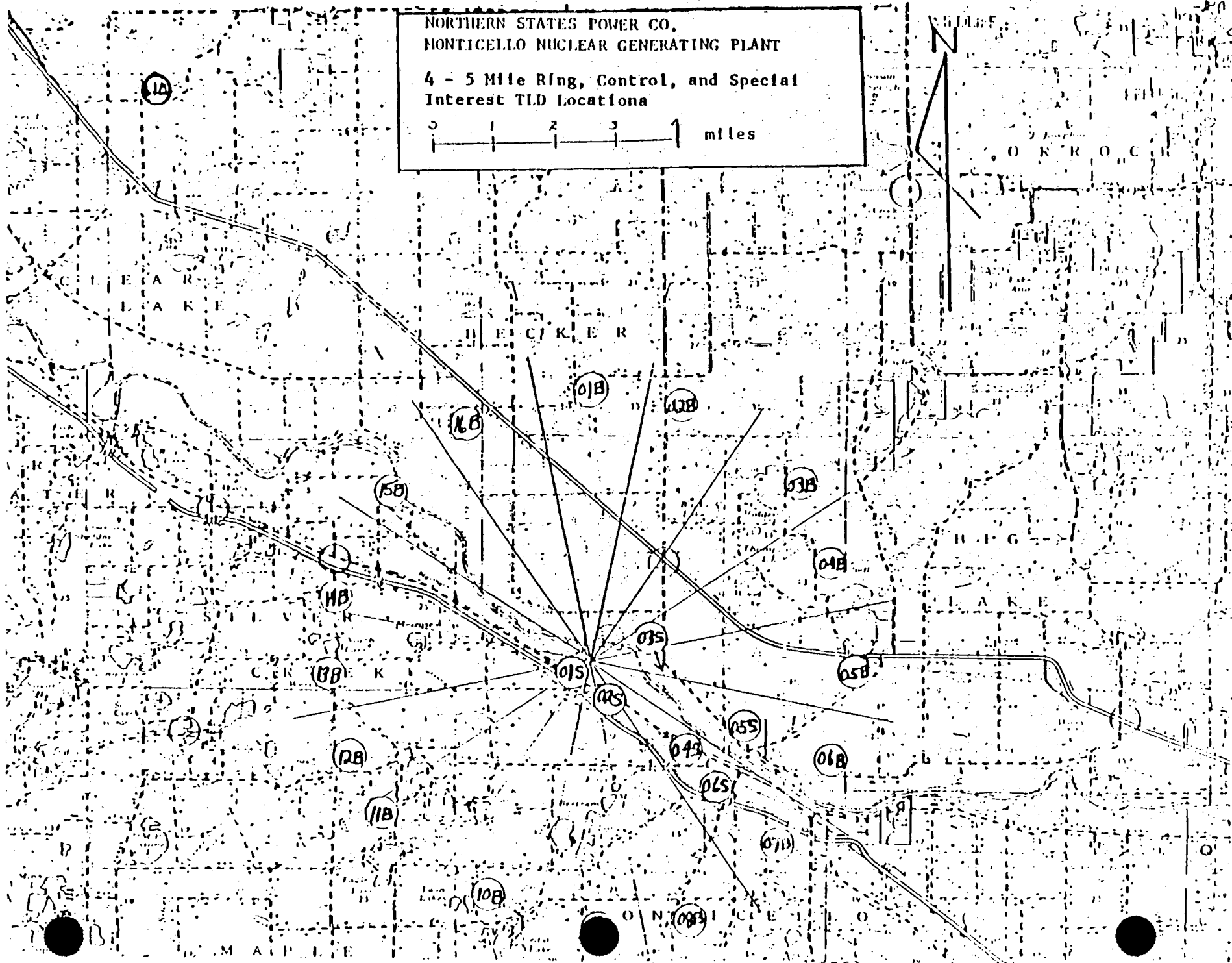

APPENDIX A
Meteorological Analysis

APPENDIX A
METEOROLOGICAL ANALYSIS

Summary of Dispersion Computational Procedures
Tables: Monticello Release Conditions

Distances to Controlling Unrestricted Area Boundary Locations

Monticello Reactor Vent Dispersion Parameters Monticello Off-Gas
Stack Dispersion Parameters Monticello Reactor Building Vent
Dispersion Parameters

APPENDIX - A

Summary of Dispersion Computational Procedures

Updepleted, undecayed dispersion parameters were computed using the computer program XOQDOQ (Sagendorf and Goll, 1977). Specifically, sector average χ/Q and D/Q values were obtained for a sector width of 22.5 degrees. Credit was taken for momentum plume rise and effective plume height was adjusted for local terrain height for elevated releases. Building wake corrections were used to adjust calculations for ground-level releases. Standard open terrain recirculation correction factors were also applied as available as default values in XOQDOQ.

Dispersion calculations were based on mixed mode releases for the reactor vent and on elevated releases for the off-gas stack. A summary of release conditions used as input to XOQDOQ is presented in Table A-1 and controlling site boundary distances are defined in Table A-2. Computed χ/Q and D/Q values for unrestricted area boundary locations (relative to release points) and for standard distances (to five miles from the source in 0.1 mile increments) are presented in Tables A-3 through A-11.

For certain meteorological and release conditions, the enveloping interpolation routines in XOQDOQ used to compute short-term χ/Q and D/Q values do not provide reasonable results. Because of this, results were reviewed for consistency and where possible, the distributions of calculated χ/Q values were enveloped and interpolated by hand.

In some cases, use of the NRC methodology is implemented in XOQDOQ for estimating short term dispersion values results in values which are lower than the annual values. For these cases, the annual average χ/Q and D/Q values are used to conservatively represent short-term values. χ/Q and D/Q values for onsite EPA locations were adjusted (multiplied by a factor of 0.238) to account for limited daily exposure of workers in accordance with NUREG-0473 (2).

Onsite meteorological data for the period September 1, 1976 through August 31, 1978 (as presented in Appendices B and C) were used as input to XOQDOQ. Data were collected and ΔT stability classes were defined in conformance with NRC Regulatory Guide 1.23⁽³⁾. Dispersion calculations for the reactor vent were based on $\Delta T_{42, 7-10m}$ and 10 meter wind data (joint data recovery of 94 percent). Dispersion calculations for the off gas stack were based on $\Delta T_{100-10m}$ and 100 meter wind data (joint data recovery of 95 percent).

References - Appendix A

1. Sagendorf, J. F. and Goll, J. T., XOQDQ Program for the Evaluation of Routine Effluent Releases at Nuclear Power Stations. NUREG 0324, U.S. Nuclear Regulatory Commission, September 1977.
2. NUREG-0473
3. USNRC Regulatory Guide 1.23

Table A-1
Monticello Release Conditions

	Reactor Vent	Off-Gas Stack
Release Type	Mixed mode (Long and short-term)	Elevated Long and short-term)
Release point height, m	42	100
Adjacent building height, m	42	42
Relative location to adjacent structures	Adjacent to turbine building	400' SE of reactor building
Exit velocity, m/sec	6.1	19.0
Internal stack diameter, m	2.41	0.36
Building cross-sectional area*, m ²	1480	N.A
Purge frequency**, times per year	6	6
Purge duration**, hours/release	24	24

* Applied to ground level releases.

** Applied to short term calculations only.

Table A-2
 Distances to Controlling
 Unrestricted Area Boundary Locations
 Miles

Column 1 As measured from Reactor Vent		Column 2* As Measured from Off-Gas Stack	
Sector	Distance	Sector	Distance
N	0.51	N	0.59
NNE	0.58	N	0.63
NE	0.65	NNE	0.65
ENE	0.83	ENE	0.78
E	0.59	E	0.50
ESE	0.59	E	0.50
SE	0.61	SSE	0.51
SSE	0.43	S	0.36
S	0.34	SSW	0.31
SSW	0.32	SW	0.33
SW	0.32	SW	0.33
WSW	0.35	WSW	0.38
W	0.48	W	0.56
WNW	0.68	NW	0.78
NW	0.43	NW	0.53
NNW	0.53	NNW	0.61

continued

* Locations specified in Column 2 are the same geographic points as specified in Column 1 although the reference points are different.

Table A-2 (continued)

Distances to Controlling
Unrestricted Area Boundary Locations**
EPA Onsite Monitoring Area

Miles

Column 1 As measured from Reactor Vent		Column 2* As Measured from Off-Gas Stack	
Sector	Distance	Sector	Distance
Minimum Distance			
E	0.38	E	0.29
ESE	0.31	ESE	0.20
SE	0.36	ESE	0.26
Maximum Distance			
E	0.57	E	0.48
ESE	0.62	E	0.52
SE	0.50	ESE	0.39

* Locations specified in Column 2 are the same geographic Points as specified in Column 1 although the reference points are different.

** The unrestricted area is defined in the MNGP Technical Specifications.

Table A-3
 Monticello Reactor Vent Dispersion Parameters
 for
 Long Term Mixed Mode Releases
 >500 Hrs/Yr or >150 Hrs/Qtr
 For Unrestricted Area Boundary Locations
 (Identified in Table A-2)

Site Boundary Sector*	χ/Q (sec/m ³)	D/Q (m ⁻²)
N	2.09E-06	2.89E-08
NNE	1.29E-06	1.82E-08
NE	7.76E-07	9.42E-09
ENE	6.11E-07	5.62E-09
E	1.38E-06	1.45E-08
ESE	2.42E-06	3.15E-08
SE	2.53E-06	3.30E-08
SSE	4.08E-06	5.95E-08
S	2.30E-06	3.08E-08
SSW	1.80E-06	2.13E-08
SW	1.96E-06	2.54E-08
WSW	1.54E-06	1.72E-08
W	1.10E-06	1.23E-08
WNW	1.22E-06	1.19E-08
NW	2.11E-06	2.61E-08
NNW	1.87E-06	2.55E-08
E**	5.52E-07	6.57E-09
ESE**	1.31E-06	1.96E-08
SE**	1.16E-06	1.69E-08
E**	3.38E-07	3.62E-09
ESE**	5.55E-07	7.12E-09
SE**	7.64E-07	1.06E-08

Period of record: 9-1-76 to 8-31-78.

* Measured relevant to the Reactor Vent.

** On-site EPA locations.

TABLE A-4

Monticello Reactor Vent Dispersion Parameters
for
Long Term Mixed Mode Releases
>500 Hrs/Yr or >150 Hrs/Qtr

For Standard Distances (As Measured from the Reactor Vent)

(χ/Q) , sec/m^3

Sector*	Miles						
	0.1	0.2	0.3	0.4	0.5	0.6	0.7
N	2.94E-05	8.91E-06	4.59E-06	2.98E-06	2.17E-06	1.74E-06	1.46E-06
NNE	1.98E-05	6.24E-06	3.25E-06	2.11E-06	1.55E-06	1.25E-06	1.06E-06
NE	1.22E-05	3.84E-06	2.02E-06	1.33E-06	9.98E-07	8.21E-07	7.09E-07
ENE	1.25E-05	3.91E-06	2.05E-06	1.35E-06	1.01E-06	8.46E-07	7.44E-07
E	1.97E-05	6.02E-06	3.20E-06	2.16E-06	1.64E-06	1.36E-06	1.19E-06
ESE	3.48E-05	1.05E-05	5.71E-06	3.89E-06	2.94E-06	2.40E-06	2.04E-06
SE	3.91E-05	1.17E-05	6.34E-06	4.28E-06	3.20E-06	2.57E-06	2.15E-06
SSE	4.15E-05	1.26E-05	6.78E-06	4.52E-06	3.35E-06	2.70E-06	2.28E-06
S	1.60E-05	4.95E-06	2.69E-06	1.82E-06	1.39E-06	1.16E-06	1.02E-06
SSW	1.14E-05	3.54E-06	1.97E-06	1.39E-06	1.11E-06	9.79E-07	8.94E-07
SW	1.28E-05	3.85E-06	2.15E-06	1.51E-06	1.21E-06	1.06E-06	9.58E-07
WSW	1.08E-05	3.29E-06	1.85E-06	1.32E-06	1.06E-06	9.52E-07	8.89E-07
W	1.21E-05	3.73E-06	2.01E-06	1.37E-06	1.07E-06	9.24E-07	8.42E-07
WNW	1.96E-05	6.01E-06	3.24E-06	2.17E-06	1.64E-06	1.37E-06	1.19E-06
NW	2.15E-05	6.49E-06	3.45E-06	2.32E-06	1.76E-06	1.45E-06	1.25E-06
NNW	2.71E-05	8.24E-06	4.24E-06	2.74E-06	2.00E-06	1.61E-06	1.36E-06

continued

* Period of Record: 9-1-76 to 8-31-78
Measured relevant to the Reactor Vent.

TABLE A-4 (continued)

Monticello Reactor Vent Dispersion Parameters
for
Long Term Mixed Mode Releases
>500 Hrs/Yr or >150 Hrs/Qtr

For Standard Distances (As Measured from the Reactor Vent)
(χ/Q), sec/m^3

Sector*	Miles						
	0.8	0.9	1.0	1.1	1.2	1.3	1.4
N	1.21E-06	9.77E-07	8.18E-07	7.00E-07	6.10E-07	5.39E-07	4.82E-07
NNE	8.85E-07	7.19E-07	6.07E-07	5.24E-07	4.59E-07	4.08E-07	3.66E-07
NE	6.02E-07	4.94E-07	4.19E-07	3.61E-07	3.16E-07	2.80E-07	2.50E-07
ENE	6.46E-07	5.41E-07	4.69E-07	4.13E-07	3.69E-07	3.32E-07	3.02E-07
E	1.02E-06	8.42E-07	7.16E-07	6.20E-07	5.45E-07	4.85E-07	4.35E-07
ESE	1.69E-06	1.35E-06	1.11E-06	9.35E-07	7.99E-07	6.92E-07	6.06E-07
SE	1.76E-06	1.39E-06	1.13E-06	9.46E-07	8.03E-07	6.93E-07	6.04E-07
SSE	1.89E-06	1.51E-06	1.25E-06	1.06E-06	9.14E-07	7.98E-07	7.06E-07
S	8.69E-07	7.17E-07	6.09E-07	5.27E-07	4.63E-07	4.12E-07	3.71E-07
SSW	7.94E-07	6.74E-07	5.85E-07	5.14E-07	4.57E-07	4.10E-07	3.70E-07
SW	8.43E-07	7.09E-07	6.09E-07	5.31E-07	4.68E-07	4.16E-07	3.73E-07
WSW	8.07E-07	6.97E-07	6.12E-07	5.44E-07	4.87E-07	4.39E-07	3.99E-07
W	7.50E-07	6.40E-07	5.59E-07	4.95E-07	4.42E-07	3.99E-07	3.63E-07
WNW	1.02E-06	8.42E-07	7.17E-07	6.22E-07	5.47E-07	4.87E-07	4.38E-07
NW	1.05E-06	8.55E-07	7.15E-07	6.10E-07	5.29E-07	4.64E-07	4.11E-07
NNW	1.13E-06	9.14E-07	7.68E-07	6.60E-07	5.76E-07	5.10E-07	4.57E-07

continued

* Period of Record: 9-1-76 to 8-31-78
Measured relevant to the Reactor Vent.

TABLE A-4 (continued)

Monticello Reactor Vent Dispersion Parameters
for
Long Term Mixed Mode Releases
>500 Hrs/Yr or >150 Hrs/Qtr

For Standard Distances (As Measured from the Reactor Vent)
(χ/Q), sec/m^3

Sector*	Miles						
	1.5	1.6	1.7	1.8	1.9	2.0	2.1
N	4.35E-07	3.91E-07	3.54E-07	3.23E-07	2.96E-07	2.72E-07	2.52E-07
NNE	3.32E-07	3.00E-07	2.72E-07	2.49E-07	2.28E-07	2.11E-07	1.95E-07
NE	2.25E-07	2.07E-07	1.92E-07	1.78E-07	1.67E-07	1.57E-07	1.48E-07
ENE	2.77E-07	2.56E-07	2.37E-07	2.21E-07	2.07E-07	1.94E-07	1.83E-07
E	3.94E-07	3.57E-07	3.25E-07	2.97E-07	2.73E-07	2.53E-07	2.34E-07
ESE	5.36E-07	4.78E-07	4.29E-07	3.88E-07	3.53E-07	3.23E-07	2.97E-07
SE	5.33E-07	4.80E-07	4.35E-07	3.97E-07	3.65E-07	3.37E-07	3.12E-07
SSE	6.31E-07	5.63E-07	5.05E-07	4.57E-07	4.16E-07	3.80E-07	3.49E-07
S	3.36E-07	3.03E-07	2.74E-07	2.49E-07	2.28E-07	2.10E-07	1.94E-07
SSW	3.37E-07	3.20E-07	3.05E-07	2.92E-07	2.81E-07	2.71E-07	2.62E-07
SW	3.37E-07	3.17E-07	2.99E-07	2.83E-07	2.70E-07	2.58E-07	2.47E-07
WSW	3.64E-07	3.44E-07	3.26E-07	3.10E-07	2.95E-07	2.82E-07	2.71E-07
W	3.32E-07	3.16E-07	3.01E-07	2.89E-07	2.78E-07	2.69E-07	2.61E-07
WNW	3.97E-07	3.74E-07	3.54E-07	3.37E-07	3.23E-07	3.12E-07	3.02E-07
NW	3.68E-07	3.33E-07	3.03E-07	2.78E-07	2.57E-07	2.38E-07	2.21E-07
NNW	4.13E-07	3.73E-07	3.39E-07	3.10E-07	2.85E-07	2.63E-07	2.44E-07

continued

Period of Record: 9-1-76 to 8-31-78
Measured relevant to the Reactor Vent.

*

TABLE A-4 (continued)

Monticello Reactor Vent Dispersion Parameters
for
Long Term Mixed Mode Releases
>500 Hrs/Yr or >150 Hrs/Qtr

For Standard Distances (As Measured from the Reactor Vent)
(χ/Q), sec/m^3

Sector*	Miles						
	2.2	2.3	2.4	2.5	2.6	2.7	2.8
N	2.34E-07	2.18E-07	2.04E-07	1.92E-07	1.83E-07	1.75E-07	1.68E-07
NNE	1.82E-07	1.70E-07	1.59E-07	1.50E-07	1.41E-07	1.33E-07	1.26E-07
NE	1.40E-07	1.32E-07	1.26E-07	1.20E-07	1.13E-07	1.07E-07	1.02E-07
ENE	1.73E-07	1.64E-07	1.56E-07	1.49E-07	1.41E-07	1.34E-07	1.27E-07
E	2.18E-07	2.04E-07	1.91E-07	1.80E-07	1.69E-07	1.60E-07	1.51E-07
ESE	2.74E-07	2.53E-07	2.36E-07	2.20E-07	2.05E-07	1.93E-07	1.81E-07
SE	2.91E-07	2.73E-07	2.56E-07	2.41E-07	2.26E-07	2.12E-07	1.99E-07
SSE	2.22E-07	2.99E-07	2.78E-07	2.59E-07	2.43E-07	2.29E-07	2.15E-07
S	1.80E-07	1.68E-07	1.57E-07	1.47E-07	1.42E-07	1.37E-07	1.33E-07
SSW	2.55E-07	2.48E-07	2.41E-07	2.35E-07	2.20E-07	2.06E-07	1.94E-07
SW	2.38E-07	2.30E-07	2.22E-07	2.15E-07	2.04E-07	1.93E-07	1.83E-07
WSW	2.60E-07	2.51E-07	2.42E-07	2.34E-07	2.18E-07	2.04E-07	1.92E-07
W	2.54E-07	2.48E-07	2.42E-07	2.37E-07	2.25E-07	2.14E-07	2.04E-07
WNW	2.93E-07	2.85E-07	2.79E-07	2.73E-07	2.64E-07	2.55E-07	2.47E-07
NW	2.07E-07	1.94E-07	1.82E-07	1.72E-07	1.66E-07	1.60E-07	1.55E-07
NNW	2.28E-07	2.13E-07	2.00E-07	1.88E-07	1.78E-07	1.68E-07	1.60E-07

continued

Period of Record: 9-1-76 to 8-31-78
* Measured relevant to the Reactor Vent.

TABLE A-4 (continued)

Monticello Reactor Vent Dispersion Parameters
for
Long Term Mixed Mode Releases
>500 Hrs/Yr or >150 Hrs/Qtr

For Standard Distances (As Measured from the Reactor Vent)
(χ/Q), sec/m^3

Sector*	Miles						
	2.9	3.0	3.1	3.2	3.3	3.4	3.5
N	1.62E-07	1.56E-07	1.51E-07	1.46E-07	1.41E-07	1.37E-07	1.33E-07
NNE	1.20E-07	1.14E-07	1.09E-07	1.04E-07	9.91E-08	9.49E-08	9.10E-08
NE	9.64E-08	9.16E-08	8.73E-08	8.33E-08	7.96E-08	7.62E-08	7.30E-08
ENE	1.21E-07	1.16E-07	1.11E-07	1.06E-07	1.02E-07	9.75E-08	9.37E-08
E	1.44E-07	1.36E-07	1.30E-07	1.24E-07	1.18E-07	1.13E-07	1.09E-07
ESE	1.71E-07	1.61E-07	1.53E-07	1.45E-07	1.38E-07	1.31E-07	1.25E-07
SE	1.88E-07	1.77E-07	1.68E-07	1.59E-07	1.51E-07	1.44E-07	1.37E-07
SSE	2.04E-07	1.93E-07	1.83E-07	1.74E-07	1.66E-07	1.58E-07	1.51E-07
S	1.29E-07	1.26E-07	1.22E-07	1.19E-07	1.17E-07	1.14E-07	1.12E-07
SSW	1.83E-07	1.73E-07	1.63E-07	1.55E-07	1.47E-07	1.40E-07	1.33E-07
SW	1.75E-07	1.67E-07	1.59E-07	1.52E-07	1.46E-07	1.40E-07	1.34E-07
WSW	1.80E-07	1.70E-07	1.60E-07	1.52E-07	1.44E-07	1.37E-07	1.30E-07
W	1.95E-07	1.87E-07	1.79E-07	1.72E-07	1.65E-07	1.59E-07	1.53E-07
WNW	2.40E-07	2.33E-07	2.26E-07	2.19E-07	2.13E-07	2.07E-07	2.01E-07
NW	1.50E-07	1.46E-07	1.42E-07	1.39E-07	1.36E-07	1.33E-07	1.31E-07
NNW	1.52E-07	1.45E-07	1.38E-07	1.32E-07	1.26E-07	1.21E-07	1.17E-07

continued

Period of Record: 9-1-76 to 8-31-78
Measured relevant to the Reactor Vent.

*

TABLE A-4 (continued)

Monticello Reactor Vent Dispersion Parameters
for
Long Term Mixed Mode Releases
>500 Hrs/Yr or >150 Hrs/Qtr

For Standard Distances (As Measured from the Reactor Vent)
(χ/Q), sec/m^3

Sector*	Miles						
	3.6	3.7	3.8	3.9	4.0	4.1	4.2
N	1.28E-07	1.23E-07	1.18E-07	1.14E-07	1.10E-07	1.06E-07	1.02E-07
NNE	8.74E-08	8.40E-08	8.09E-08	7.80E-08	7.52E-08	7.26E-08	7.02E-08
NE	7.01E-08	6.74E-08	6.48E-08	6.24E-08	6.02E-08	5.81E-08	5.61E-08
ENE	9.02E-08	8.69E-08	8.38E-08	8.10E-08	7.82E-08	7.57E-08	7.33E-08
E	1.04E-07	1.00E-07	9.62E-08	9.26E-08	8.92E-08	8.61E-08	8.31E-08
ESE	1.19E-07	1.14E-07	1.09E-07	1.05E-07	1.01E-07	9.66E-07	9.29E-08
SE	1.31E-07	1.25E-07	1.20E-07	1.15E-07	1.10E-07	1.06E-07	1.02E-07
SSE	1.45E-07	1.40E-07	1.36E-07	1.31E-07	1.27E-07	1.23E-07	1.19E-07
S	1.08E-07	1.05E-07	1.02E-07	9.95E-08	9.69E-08	9.44E-08	9.20E-08
SSW	1.29E-07	1.25E-07	1.21E-07	1.17E-07	1.13E-07	1.10E-07	1.07E-07
SW	1.31E-07	1.27E-07	1.24E-07	1.20E-07	1.17E-07	1.14E-07	1.11E-07
WSW	1.27E-07	1.23E-07	1.20E-07	1.17E-07	1.14E-07	1.11E-07	1.09E-07
W	1.46E-07	1.39E-07	1.33E-07	1.28E-07	1.22E-07	1.17E-07	1.13E-07
WNW	1.91E-07	1.82E-07	1.74E-07	1.66E-07	1.59E-07	1.52E-07	1.46E-07
NW	1.26E-07	1.23E-07	1.19E-07	1.16E-07	1.13E-07	1.10E-07	1.07E-07
NNW	1.12E-07	1.08E-07	1.04E-07	1.01E-07	9.73E-08	9.41E-08	9.11E-08

continued

* Period of Record: 9-1-76 to 8-31-78
Measured relevant to the Reactor Vent

TABLE A.4 (continued)

Monticello Reactor Vent Dispersion Parameters
for
Long Term Mixed Mode Releases
>500 Hrs/Yr or >150 Hrs/Qtr

For Standard Distances (As Measured from the Reactor Vent)
(χ/Q), sec/m^3

Sector*	Miles						
	4.3	4.4	4.5	4.6	4.7	4.8	4.9
N	9.86E-08	9.54E-08	9.23E-08	8.95E-08	8.68E-08	8.42E-08	8.18E-08
NNE	6.79E-08	6.57E-08	6.37E-08	6.18E-08	6.00E-08	5.83E-08	5.66E-08
NE	5.43E-08	5.25E-08	5.09E-08	4.93E-08	4.78E-08	4.65E-08	4.51E-08
ENE	7.10E-08	6.89E-08	6.68E-08	6.49E-08	6.31E-08	6.14E-08	5.97E-08
E	8.09E-08	7.77E-08	7.53E-08	7.29E-08	7.07E-08	6.87E-08	6.67E-08
ESE	8.05E-08	8.63E-08	8.33E-08	8.04E-08	7.78E-08	7.52E-08	7.28E-08
SE	9.84E-08	9.48E-08	9.15E-08	8.84E-08	8.55E-08	8.27E-08	8.01E-08
SSE	1.16E-07	1.13E-07	1.10E-07	1.06E-07	1.03E-07	9.92E-08	9.61E-08
S	8.98E-08	8.77E-08	8.57E-08	8.28E-08	8.00E-08	7.74E-08	7.50E-08
SSW	1.04E-07	1.01E-07	9.84E-08	9.49E-08	9.16E-08	8.85E-08	8.55E-08
SW	1.08E-07	1.05E-07	1.02E-07	9.82E-08	9.46E-08	9.12E-08	8.79E-08
WSW	1.06E-07	1.03E-07	1.01E-07	9.72E-08	9.36E-08	9.03E-08	8.72E-08
W	1.08E-07	1.04E-07	1.00E-07	9.69E-08	9.36E-08	9.04E-08	8.74E-08
WNW	1.40E-07	1.35E-07	1.30E-07	1.25E-07	1.20E-07	1.16E-07	1.12E-07
NW	1.04E-07	1.02E-07	9.92E-08	9.58E-08	9.26E-08	8.95E-08	8.67E-08
NNW	8.83E-08	8.57E-08	8.32E-08	8.07E-08	7.82E-08	7.60E-08	7.38E-08

continued

Period of Record: 9-1-76 to 8-31-78
Measured relevant to the Reactor Vent.

*

TABLE A-4 (Continued)

Monticello Reactor Vent Dispersion Parameters
 for
 Long Term Mixed Mode Releases
 >500 Hrs/Yr or >150 Hrs/Qtr

For Standard Distances (As Measured from the Reactor Vent)
 (χ/Q), sec/m^3

Sector*	Miles
	5.0
N	7.94E-08
NNE	5.51E-08
NE	4.39E-08
ENE	5.82E-08
E	6.48E-08
ESE	7.06E-08
SE	7.76E-08
SSE	9.31E-08
S	7.26E-08
SSW	8.28E-08
SW	8.49E-08
WSW	8.42E-08
W	8.46E-08
WNW	1.08E-07
NW	8.40E-08
NNW	7.18E-08

* Period of Record: 9-1-76 to 8-31-78
 Measured relevant to the Reactor Vent

TABLE A-5

Monticello Reactor Vent Dispersion Parameters
for
Long Term Mixed Mode Releases
>500 Hrs/Yr or >150 Hrs/Qtr

For Standard Distances (As Measured from the Reactor Vent)
(D/Q), m²

Sector*	Miles						
	0.1	0.2	0.3	0.4	0.5	0.6	0.7
N	2.75E-07	1.10E-07	6.31E-08	4.18E-08	3.01E-08	2.28E-08	1.80E-08
NNE	1.89E-07	7.89E-08	4.70E-08	3.17E-08	2.30E-08	1.74E-08	1.37E-08
NE	1.11E-07	4.68E-08	2.81E-08	1.91E-08	1.39E-08	1.06E-08	8.41E-09
ENE	1.03E-07	4.32E-08	2.61E-08	1.78E-08	1.31E-08	1.00E-08	7.94E-09
E	1.58E-07	6.46E-08	3.08E-08	2.56E-08	1.87E-08	1.42E-08	1.13E-08
ESE	3.79E-07	1.49E-07	8.53E-08	5.66E-08	4.09E-08	3.11E-08	2.46E-08
SE	4.31E-07	1.67E-07	9.41E-08	6.19E-08	4.43E-08	3.36E-08	2.65E-08
SSE	4.49E-07	1.77E-07	1.01E-07	6.65E-08	4.78E-08	3.62E-08	2.86E-08
S	1.47E-07	6.03E-08	3.58E-08	2.43E-08	1.79E-08	1.38E-08	1.10E-08
SSW	9.22E-08	3.85E-08	2.33E-08	1.62E-08	1.21E-08	9.50E-09	7.72E-09
SW	1.21E-07	4.80E-08	2.79E-08	1.90E-08	1.41E-08	1.10E-08	8.89E-09
WSW	8.33E-08	3.44E-08	2.07E-08	1.44E-08	1.09E-08	8.57E-09	7.01E-09
W	9.09E-08	3.80E-08	2.29E-08	1.58E-08	1.18E-08	9.18E-09	7.41E-09
WNW	1.51E-07	6.14E-08	3.65E-08	2.49E-08	1.83E-08	1.41E-08	1.13E-08
NW	1.86E-07	7.43E-08	4.30E-08	2.89E-08	2.11E-08	1.62E-08	1.29E-08
NNW	2.45E-07	9.85E-08	5.73E-08	3.82E-08	2.76E-08	2.10E-08	1.66E-08

continued

* Period of Record: 9-1-76 to 8-31-78
Measured relevant to the Reactor Vent.

TABLE A 5 (continued)

Monticello Reactor Vent Dispersion Parameters
for
Long Term Mixed Mode Releases
>500 Hrs/Yr or >150 Hrs/Otr

For Standard Distances (As Measured from the Reactor Vent)
(D/Q), m²

Sector*	Miles						
	0.8	0.9	1.0	1.1	1.2	1.3	1.4
N	1.38E-08	1.02E-08	7.88E-09	6.23E-09	5.03E-09	4.14E-09	3.55E-09
NNE	1.05E-08	7.83E-09	6.02E-09	4.76E-09	3.85E-09	3.17E-09	2.72E-09
NE	6.48E-09	4.84E-09	3.74E-09	2.96E-09	2.40E-09	1.98E-09	1.66E-09
ENE	6.14E-09	4.60E-09	3.56E-09	2.83E-09	2.30E-09	1.90E-09	1.60E-09
E	8.71E-09	6.51E-09	5.04E-09	4.00E-09	3.24E-09	2.68E-09	2.24E-09
ESE	1.89E-08	1.41E-08	1.09E-08	8.64E-09	7.00E-09	5.77E-09	4.83E-09
SE	2.03E-08	1.51E-08	1.17E-08	9.22E-09	7.45E-09	6.14E-09	5.13E-09
SSE	2.19E-08	1.63E-08	1.26E-08	9.93E-09	8.03E-09	6.61E-09	5.75E-09
S	8.57E-09	6.44E-09	5.01E-09	3.99E-09	3.46E-09	2.85E-09	2.38E-09
SSW	6.08E-09	4.63E-09	3.63E-09	2.92E-09	2.39E-09	2.09E-09	1.76E-09
SW	6.99E-09	5.31E-09	4.16E-09	3.34E-09	2.73E-09	2.41E-09	2.02E-09
WSW	5.56E-09	4.86E-09	3.36E-09	2.71E-09	2.23E-09	1.86E-09	1.63E-09
W	5.81E-09	4.41E-09	3.45E-09	2.77E-09	2.27E-09	1.89E-09	1.65E-09
WNW	8.82E-09	7.50E-09	5.17E-09	4.13E-09	3.76E-09	2.79E-09	2.48E-09
NW	9.99E-09	7.50E-09	5.82E-09	4.63E-09	3.76E-09	3.11E-09	2.61E-09
NNW	1.27E-08	9.47E-09	7.30E-09	5.78E-09	4.67E-09	3.85E-09	3.32E-09

continued

* Period of Record: 9-1-76 to 8-31-78
Measured relevant to the Reactor Vent.

TABLE A-5 (continued)

Monticello Reactor Vent Dispersion Parameters
for
Long Term Mixed Mode Releases
>500 Hrs/Yr or >150 Hrs/Qtr

For Standard Distances (As Measured from the Reactor Vent)
(D/Q), m²

Sector*	Miles						
	1.5	1.6	1.7	1.8	1.9	2.0	2.1
N	3.00E-09	2.57E-09	2.22E-09	1.93E-09	1.70E-09	1.51E-09	1.34E-09
NNE	2.30E-09	1.97E-09	1.71E-09	1.49E-09	1.31E-09	1.16E-09	1.04E-09
NE	1.41E-09	1.21E-09	1.05E-09	9.18E-10	8.12E-10	7.20E-10	6.44E-10
ENE	1.36E-09	1.17E-09	1.01E-09	8.84E-10	7.81E-10	6.94E-10	6.20E-10
E	1.91E-09	1.64E-09	1.42E-09	1.24E-09	1.09E-09	9.71E-10	8.67E-10
ESE	4.09E-09	3.51E-09	3.04E-09	2.65E-09	2.34E-09	2.07E-09	1.85E-09
SE	4.34E-09	3.72E-09	3.22E-09	2.81E-09	2.48E-09	2.19E-09	1.96E-09
SSE	4.86E-09	4.16E-09	3.59E-09	3.13E-09	2.75E-09	2.43E-09	2.17E-09
S	2.03E-09	1.74E-09	1.50E-09	1.31E-09	1.16E-09	1.02E-09	9.13E-10
SSW	1.50E-09	1.33E-09	1.15E-09	1.01E-09	9.52E-10	8.43E-10	7.52E-10
SW	1.72E-09	1.52E-09	1.32E-09	1.15E-09	1.08E-09	9.53E-10	8.49E-10
WSW	1.39E-09	1.25E-09	1.09E-09	9.54E-10	9.16E-10	8.11E-10	7.23E-10
W	1.40E-09	1.24E-09	1.08E-09	9.44E-10	8.93E-10	7.91E-10	7.05E-10
WNW	2.10E-09	1.84E-09	1.59E-09	1.39E-09	1.28E-09	1.13E-09	1.01E-09
NW	2.22E-09	1.91E-09	1.65E-09	1.45E-09	1.28E-09	1.13E-09	1.01E-09
NWN	2.81E-09	2.40E-09	2.08E-09	1.81E-09	1.59E-09	1.42E-09	1.27E-09

continued

* Period of Record: 9-1-76 to 8-31-78
Measured relevant to the Reactor Vent.

TABLE A.5 (continued)

Monticello Reactor Vent Dispersion Parameters
for
Long Term Mixed Mode Releases
>500 Hrs/Yr or >150 Hrs/Qtr

For Standard Distances (As Measured from the Reactor Vent)
(D/Q), m²

Sector*	Miles						
	2.2	2.3	2.4	2.5	2.6	2.7	2.8
N	1.21E-09	1.09E-09	9.85E-10	8.97E-10	8.29E-10	7.64E-10	7.05E-10
NNE	9.29E-10	8.38E-10	7.60E-10	6.92E-10	6.33E-10	5.81E-10	5.35E-10
NE	5.78E-10	5.23E-10	4.83E-10	4.40E-10	4.03E-10	3.70E-10	3.41E-10
ENE	5.70E-10	5.14E-10	4.67E-10	4.25E-10	3.89E-10	3.57E-10	3.29E-10
E	7.79E-10	7.03E-10	6.38E-10	5.82E-10	5.32E-10	4.89E-10	4.51E-10
ESE	1.66E-09	1.50E-09	1.36E-09	1.24E-09	1.13E-09	1.04E-09	9.56E-10
SE	1.81E-09	1.63E-09	1.47E-09	1.35E-09	1.23E-09	1.13E-09	1.04E-09
SSE	1.94E-09	1.75E-09	1.59E-09	1.44E-09	1.32E-09	1.21E-09	1.11E-09
S	8.91E-10	7.38E-10	6.69E-10	6.09E-10	5.59E-10	5.16E-10	4.76E-10
SSW	6.74E-10	6.08E-10	5.51E-10	5.02E-10	4.60E-10	4.22E-10	3.90E-10
SW	7.61E-10	6.86E-10	6.22E-10	5.66E-10	5.18E-10	4.75E-10	4.38E-10
WSW	6.49E-10	5.85E-10	5.30E-10	4.83E-10	4.42E-10	4.07E-10	3.75E-10
W	6.33E-10	5.71E-10	5.18E-10	4.72E-10	4.32E-10	3.98E-10	3.67E-10
WNW	9.02E-10	8.14E-10	7.38E-10	6.72E-10	6.15E-10	5.66E-10	5.22E-10
NW	9.09E-10	8.48E-10	7.69E-10	7.00E-10	6.48E-10	5.95E-10	5.52E-10
NNW	1.14E-09	1.03E-09	9.29E-10	8.46E-10	7.77E-10	7.14E-10	6.59E-10

continued

Period of Record: 9-1-76 to 8-31-78
* Measured relevant to the Reactor Vent

TABLE A-5 (continued)

Monticello Reactor Vent Dispersion Parameters
for
Long Term Mixed Mode Releases
>500 Hrs/Yr or >150 Hrs/Qtr

For Standard Distances (As Measured from the Reactor Vent)

$$(D/Q), m^{-2}$$

Sector*	Miles						
	2.9	3.0	3.1	3.2	3.3	3.4	3.5
N	6.52E-10	6.09E-10	5.67E-10	5.30E-10	5.00E-10	4.71E-10	4.46E-10
NNE	4.95E-10	4.59E-10	4.26E-10	3.97E-10	3.71E-10	3.48E-10	3.27E-10
NE	3.15E-10	2.92E-10	2.72E-10	2.53E-10	2.37E-10	2.22E-10	2.08E-10
ENE	3.04E-10	2.82E-10	2.62E-10	2.44E-10	2.28E-10	2.14E-10	2.01E-10
E	4.16E-10	3.86E-10	3.59E-10	3.34E-10	3.12E-10	2.93E-10	2.75E-10
ESE	8.83E-10	8.18E-10	7.60E-10	7.08E-10	6.61E-10	6.19E-10	5.80E-10
SE	9.59E-10	8.88E-10	8.25E-10	7.68E-10	7.17E-10	6.71E-10	6.30E-10
SSE	1.03E-09	9.56E-10	8.89E-10	8.28E-10	7.73E-10	7.24E-10	6.79E-10
S	4.42E-10	4.12E-10	3.93E-10	3.68E-10	3.44E-10	3.24E-10	3.05E-10
SSW	3.61E-10	3.35E-10	3.13E-10	2.92E-10	2.74E-10	2.58E-10	2.43E-10
SW	4.05E-10	3.76E-10	3.50E-10	3.27E-10	3.06E-10	2.87E-10	2.71E-10
WSW	3.47E-10	3.23E-10	3.01E-10	2.81E-10	2.64E-10	2.48E-10	2.34E-10
W	3.40E-10	3.16E-10	2.95E-10	2.76E-10	2.60E-10	2.44E-10	2.31E-10
WNW	4.83E-10	4.49E-10	4.19E-10	3.91E-10	3.68E-10	3.90E-10	3.98E-10
NW	5.13E-10	4.78E-10	4.54E-10	4.25E-10	3.99E-10	3.75E-10	3.53E-10
NNW	6.10E-10	5.66E-10	5.27E-10	4.92E-10	4.61E-10	4.33E-10	4.08E-10

continued

Period of Record: 9-1-76 to 8-31-78
* Measured relevant to the Reactor Vent.

TABLE A-5 (continued)

Monticello Reactor Vent Dispersion Parameters
for
Long Term Mixed Mode Releases
>500 Hrs/Yr or >150 Hrs/Qtr

For Standard Distances (As Measured from the Reactor Vent)
(D/Q), m^2

Sector*	Miles						
	3.6	3.7	3.8	3.9	4.0	4.1	4.2
N	4.22E-10	4.00E-10	3.80E-10	3.62E-10	3.45E-10	3.30E-10	3.16E-10
NNE	3.08E-10	2.90E-10	2.74E-10	2.59E-10	2.46E-10	2.34E-10	2.22E-10
NE	1.96E-10	1.87E-10	1.75E-10	1.65E-10	1.57E-10	1.49E-10	1.41E-10
ENE	1.89E-10	1.78E-10	1.68E-10	1.59E-10	1.51E-10	1.43E-10	1.36E-10
E	2.58E-10	2.43E-10	2.29E-10	2.17E-10	2.05E-10	1.95E-10	1.85E-10
ESE	5.45E-10	5.13E-10	4.84E-10	4.57E-10	4.33E-10	4.10E-10	3.89E-10
SE	5.93E-10	5.58E-10	5.27E-10	4.98E-10	4.72E-10	4.48E-10	4.26E-10
SSE	6.46E-10	6.09E-10	5.76E-10	5.55E-10	5.27E-10	5.02E-10	4.79E-10
S	2.88E-10	2.73E-10	2.59E-10	2.46E-10	2.35E-10	2.24E-10	2.14E-10
SSW	2.30E-10	2.18E-10	2.07E-10	1.97E-10	1.88E-10	1.80E-10	1.72E-10
SW	2.55E-10	2.42E-10	2.29E-10	2.18E-10	2.28E-10	2.33E-10	2.22E-10
WSW	2.21E-10	2.10E-10	1.99E-10	1.90E-10	1.81E-10	1.73E-10	1.66E-10
W	2.19E-10	2.08E-10	1.98E-10	1.88E-10	1.80E-10	1.72E-10	1.65E-10
WNW	3.75E-10	3.55E-10	3.36E-10	3.19E-10	3.04E-10	2.89E-10	2.76E-10
NW	3.34E-10	3.17E-10	3.01E-10	2.86E-10	2.73E-10	2.61E-10	2.50E-10
NNW	3.85E-10	3.64E-10	3.45E-10	3.28E-10	3.12E-10	3.04E-10	2.90E-10

continued

* Period of Record: 9-1-76 to 8-31-78
Measured relevant to the Reactor Vent.

TABLE A-5 (continued)

Monticello Reactor Vent Dispersion Parameters
for
Long Term Mixed Mode Releases
>500 Hrs/Yr or >150 Hrs/Qtr.

For Standard Distances (As Measured from the Reactor Vent)
(D/Q), m²

Sector*	Miles						
	4.3	4.4	4.5	4.6	4.7	4.8	4.9
N	3.03E-10	2.91E-10	2.80E-10	2.70E-10	2.61E-10	2.52E-10	2.44E-10
NNE	2.12E-10	2.02E-10	1.93E-10	1.84E-10	1.76E-10	1.69E-10	1.62E-10
NE	1.35E-10	1.28E-10	1.23E-10	1.17E-10	1.12E-10	1.07E-10	1.03E-10
ENE	1.29E-10	1.23E-10	1.18E-10	1.12E-10	1.08E-10	1.03E-10	9.88E-11
E	1.76E-10	1.67E-10	1.59E-10	1.52E-10	1.45E-10	1.39E-10	1.33E-10
ESE	3.70E-10	3.52E-10	3.35E-10	3.20E-10	3.05E-10	2.92E-10	2.79E-10
SE	4.05E-10	3.87E-10	3.69E-10	3.53E-10	3.38E-10	3.24E-10	3.11E-10
SSE	4.61E-10	4.41E-10	4.26E-10	4.09E-10	3.94E-10	3.80E-10	3.66E-10
S	2.05E-10	1.97E-10	1.90E-10	1.83E-10	1.76E-10	1.70E-10	1.65E-10
SSW	1.65E-10	1.59E-10	1.53E-10	1.48E-10	1.43E-10	1.38E-10	1.34E-10
SW	2.42E-10	2.42E-10	2.41E-10	2.30E-10	2.20E-10	2.10E-10	2.01E-10
WSW	1.59E-10	1.53E-10	1.58E-10	1.52E-10	1.47E-10	1.42E-10	1.37E-10
W	1.59E-10	1.53E-10	1.48E-10	1.43E-10	1.38E-10	1.34E-10	1.30E-10
WNW	2.64E-10	2.53E-10	2.42E-10	2.33E-10	2.24E-10	2.16E-10	2.08E-10
NW	2.39E-10	2.30E-10	2.22E-10	2.14E-10	2.07E-10	2.00E-10	1.93E-10
NNW	2.78E-10	2.67E-10	2.57E-10	2.47E-10	2.38E-10	2.30E-10	2.22E-10

continued

* Period of Record: 9-1-76 to 8-31-78
Measured relevant to the Reactor Vent.

TABLE A-5 (continued)

Monticello Reactor Vent Dispersion Parameters
for
Long Term Mixed Mode Releases
>500 Hrs/Yr or >150 Hrs/0tr

For Standard Distances (As Measured from the Reactor Vent)
(D/Q), m²

Sector*	Miles
	5.0
<hr/>	
N	2.36E-10
NNE	1.56E-10
NE	9.90E-11
ENE	9.49E-11
E	1.27E-10
ESE	2.68E-10
SE	2.99E-10
SSE	3.54E-10
S	1.60E-10
SSW	1.30E-10
SW	1.93E-10
WSW	1.33E-10
W	1.27E-10
WNW	2.01E-10
NW	1.87E-10
NNW	2.15E-10

* Period of Record: 9-1-76 to 8-31-78
Measured relevant to the Reactor Vent.

TABLE A-6

Monticello Off-Gas Stack Dispersion Parameters
for
Long Term Elevated Releases
>500 Hrs/Yr or >150 Hrs/0tr

For Site Boundary Locations
(Identified in Table A-2)

Site Boundary Sector*	χ/Q (sec/m ³)	D/Q (m ⁻²)
N	7.04E-08	4.51E-09
NNE	7.06E-08	4.30E-09
NE	1.00E-07	6.18E-09
ENE	6.20E-08	2.34E-09
E	4.46E-08	2.77E-09
ESE	5.28E-08	3.93E-09
SE	5.50E-08	4.98E-09
SSE	3.99E-08	4.20E-09
S	1.83E-08	2.63E-09
SSW	1.17E-08	1.46E-09
SW	1.17E-08	1.46E-09
WSW	1.34E-08	1.34E-09
W	3.42E-08	1.67E-09
WNW	7.22E-08	2.43E-09
NW	5.67E-08	2.82E-09
NNW	1.08E-07	5.80E-09
E**	5.02E-09	8.28E-10
ESE**	1.74E-09	8.50E-10
SE**	4.47E-09	1.14E-09
E**	1.03E-08	6.74E-10
ESE**	1.09E-08	6.45E-10
SE**	9.95E-09	1.04E-09

Period of Record: 9-1 76 to 8-31-78
Measured relevant to the reactor vent
On-site EPA locations

*

**

TABLE A-7

Monticello Off-Gas Stack Dispersion Parameters
for
Long Term Elevated Releases
>500 Hrs/Yr or >150 Hrs/Qtr

For Standard Distances (As Measured from the Off Gas Stack)
(χ/Q), sec/m^3

Sector*	Miles						
	0.1	0.2	0.3	0.4	0.5	0.6	0.7
N	2.39E-11	4.33E-08	6.96E-08	7.18E-08	7.08E-08	7.05E-08	7.15E-08
NNE	3.93E-11	6.93E-08	1.04E-07	1.03E-07	1.02E-07	1.01E-07	9.96E-08
NE	1.15E-11	2.27E-08	4.42E-08	5.50E-08	6.09E-08	6.34E-08	6.46E-08
ENE	1.00E-11	1.96E-08	3.74E-08	4.75E-08	5.48E-08	5.94E-08	6.22E-08
E	3.09E-12	7.35E-09	2.33E-08	3.64E-08	4.44E-08	4.93E-08	5.30E-08
ESE	2.80E-12	7.63E-09	2.67E-08	4.30E-08	5.31E-08	5.99E-08	6.61E-08
SE	5.57E-12	1.31E-08	3.90E-08	5.97E-08	7.41E-08	8.66E-08	9.91E-08
SSE	6.56E-12	1.40E-08	3.27E-08	4.50E-08	5.37E-08	6.41E-08	7.81E-08
S	4.93E-12	1.23E-08	3.06E-08	4.42E-08	5.35E-08	6.15E-08	6.95E-08
SSW	1.62E-12	4.83E-09	1.73E-08	2.93E-08	3.77E-08	4.45E-08	5.11E-08
SW	5.96E-13	2.06E-09	9.62E-09	1.69E-08	2.21E-08	2.73E-08	3.37E-08
WSW	3.07E-13	1.30E-09	7.80E-09	1.43E-08	1.87E-08	2.33E-08	2.94E-08
W	1.87E-12	6.43E-09	1.74E-08	2.59E-08	3.15E-08	3.63E-08	4.14E-08
WNW	1.56E-12	5.49E-09	2.06E-08	3.41E-08	4.21E-08	4.76E-08	5.27E-08
NW	5.29E-12	1.20E-08	3.15E-08	4.53E-08	5.46E-08	6.24E-08	6.92E-08
NNW	3.03E-11	5.55E-08	9.01E-08	9.73E-08	1.02E-07	1.07E-07	1.11E-07

continued

Period of Record: 9-1-76 to 8-31-78
* Measured relevant to the Off-Gas Stack.

TABLE A-7 (continued)

Monticello Off-Gas Stack Dispersion Parameters
for
Long Term Elevated Releases
>500 Hrs/Yr or >150 Hrs/Qtr

For Standard Distances (As Measured from the Off Gas Stack)
(χ/Q), sec/m^3

Sector*	Miles						
	0.8	0.9	1.0	1.1	1.2	1.3	1.4
N	7.07E-08	6.72E-08	6.55E-08	6.42E-08	6.30E-08	6.18E-08	6.05E-08
NNE	9.48E-08	8.63E-08	8.08E-08	7.65E-08	7.29E-08	6.97E-08	6.67E-08
NE	6.26E-08	5.76E-08	5.41E-08	5.13E-08	4.89E-08	4.69E-08	4.50E-08
ENE	6.13E-08	5.70E-08	5.38E-08	5.12E-08	4.89E-08	4.67E-08	4.47E-08
E	5.36E-08	5.10E-08	4.91E-08	4.74E-08	4.58E-08	4.43E-08	4.27E-08
ESE	6.89E-08	6.75E-08	6.63E-08	6.51E-08	6.36E-08	6.19E-08	6.00E-08
SE	1.06E-07	1.05E-07	1.04E-07	1.02E-07	9.96E-08	9.66E-08	9.32E-08
SSE	9.01E-08	9.61E-08	1.01E-07	1.04E-07	1.06E-07	1.06E-07	1.05E-07
S	7.41E-08	7.41E-08	7.42E-08	7.39E-08	7.31E-08	7.19E-08	7.04E-08
SSW	5.49E-08	5.49E-08	5.49E-08	5.44E-08	5.37E-08	5.26E-08	5.13E-08
SW	3.88E-08	4.13E-08	4.31E-08	4.43E-08	4.49E-08	4.49E-08	4.45E-08
WSW	3.49E-08	3.82E-08	4.10E-08	4.32E-08	4.46E-08	4.55E-08	4.58E-08
W	4.50E-08	4.59E-08	4.69E-08	4.77E-08	4.80E-08	4.80E-08	4.77E-08
WNW	5.52E-08	5.45E-08	5.42E-08	5.39E-08	5.33E-08	5.26E-08	5.16E-08
NW	7.18E-08	6.96E-08	6.77E-08	6.59E-08	6.40E-08	6.21E-08	6.01E-08
NNW	1.08E-07	9.96E-08	9.36E-08	8.85E-08	8.40E-08	8.00E-08	7.63E-08

continued

Period of Record: 9-1-76 to 8-31-78
* Measured relevant to the Off-Gas Stack.

TABLE A-7 (continued)

Monticello Off-Gas Stack Dispersion Parameters
for
Long Term Elevated Releases
>500 Hrs/Yr or >150 Hrs/Qtr

For Standard Distances (As Measured from the Off-Gas Stack)
(χ/Q), sec/m^3

Sector*	Miles						
	1.5	1.6	1.7	1.8	1.9	2.0	2.1
N	5.91E-08	5.66E-08	5.43E-08	5.20E-08	4.99E-08	4.78E-08	4.59E-08
NNE	6.40E-08	6.06E-08	5.74E-08	5.45E-08	5.17E-08	4.92E-08	4.69E-08
NE	4.33E-08	4.23E-08	4.14E-08	4.06E-08	3.96E-08	3.88E-08	3.79E-08
ENE	4.28E-08	4.10E-08	3.93E-08	3.77E-08	3.62E-08	3.47E-08	3.34E-08
E	4.12E-08	3.94E-08	3.76E-08	3.60E-08	3.44E-08	3.29E-08	3.15E-08
ESE	5.80E-08	5.59E-08	5.39E-08	5.18E-08	4.98E-08	4.78E-08	4.60E-08
SE	8.97E-08	8.77E-08	8.55E-08	8.32E-08	8.07E-08	7.83E-08	7.59E-08
SSE	1.04E-08	9.98E-08	9.58E-08	9.19E-08	8.80E-08	8.42E-08	8.06E-08
S	6.85E-08	6.54E-08	6.23E-08	5.93E-08	5.65E-08	5.39E-08	5.14E-08
SSW	4.99E-08	5.03E-08	5.04E-08	5.04E-08	5.02E-08	4.99E-08	4.95E-08
SW	4.37E-08	4.46E-08	4.51E-08	4.54E-08	4.55E-08	4.54E-08	4.52E-08
WSW	4.57E-08	4.71E-08	4.81E-08	4.88E-08	4.92E-08	4.94E-08	4.95E-08
W	4.71E-08	4.79E-08	4.85E-08	4.89E-08	4.90E-08	4.90E-08	4.89E-08
WNW	5.05E-08	5.10E-08	5.12E-08	5.13E-08	5.12E-08	5.11E-08	5.08E-08
NW	5.81E-08	5.64E-08	5.47E-08	5.30E-08	5.13E-08	4.97E-08	4.82E-08
NNW	7.29E-08	6.89E-08	6.52E-08	6.18E-08	5.87E-08	5.58E-08	5.31E-08

continued

* Period of Record: 9-1-76 to 8-31-78
Measured relevant to the Off Gas Stack.

TABLE A-7 (continued)

Monticello Off-Gas Stack Dispersion Parameters
for
Long Term Elevated Releases
>500 Hrs/Yr or >150 Hrs/Qtr

For Standard Distances (As Measured from the Off-Gas Stack)
(χ/Q), sec/m^3

Sector*	Miles						
	2.2	2.3	2.4	2.5	2.6	2.7	2.8
N	4.41E-08	4.23E-08	4.07E-08	3.92E-08	3.82E-08	3.73E-08	3.64E-08
NNE	4.48E-08	4.28E-08	4.09E-08	3.92E-08	3.76E-08	3.61E-08	3.47E-08
NE	3.71E-08	3.63E-08	3.53E-08	3.47E-08	3.35E-08	3.24E-08	3.13E-08
ENE	3.21E-08	3.09E-08	2.98E-08	2.87E-08	2.76E-08	2.65E-08	2.55E-08
E	3.02E-08	2.90E-08	2.78E-08	2.67E-08	2.57E-08	2.47E-08	2.38E-08
ESE	4.42E-08	4.25E-08	4.09E-08	3.94E-08	3.79E-08	3.66E-08	3.53E-08
SE	7.35E-08	7.12E-08	6.89E-08	6.68E-08	6.38E-08	6.11E-08	5.85E-08
SSE	7.72E-08	7.39E-08	7.08E-08	6.79E-08	6.53E-08	6.28E-08	6.05E-08
S	4.91E-08	4.69E-08	4.48E-08	4.29E-08	4.20E-08	4.11E-08	4.03E-08
SSW	4.90E-08	4.85E-08	4.79E-08	4.73E-08	4.51E-08	4.30E-08	4.11E-08
SW	4.49E-08	4.46E-08	4.42E-08	4.38E-08	4.23E-08	4.09E-08	3.96E-08
WSW	4.93E-08	4.91E-08	4.88E-08	4.84E-08	4.63E-08	4.42E-08	4.24E-08
W	4.86E-08	4.83E-08	4.79E-08	4.75E-08	4.59E-08	4.44E-08	4.30E-08
WNW	5.05E-08	5.01E-08	4.97E-08	4.93E-08	4.84E-08	4.75E-08	4.66E-08
NW	4.67E-08	4.52E-08	4.38E-08	4.25E-08	4.19E-08	4.14E-08	4.08E-08
NNW	5.06E-08	4.83E-08	4.62E-08	4.42E-08	4.24E-08	4.07E-08	3.91E-08

continued

Period of Record: 9-1-76 to 8-31-78
* Measured relevant to the Off-Gas Stack.

TABLE A-7

Monticello Off-Gas Stack Dispersion Parameters
for
Long Term Elevated Releases
>500 Hrs/Yr or >150 Hrs/Qtr

For Standard Distances (As Measured from the Off-Gas Stack)
(χ/Q), sec/m^3

Sector*	Miles						
	2.9	3.0	3.1	3.2	3.3	3.4	3.5
N	3.55E-08	3.47E-08	3.39E-08	3.31E-08	3.24E-08	3.17E-08	3.10E-08
NNE	3.34E-08	3.22E-08	3.11E-08	3.00E-08	2.90E-08	2.80E-08	2.71E-08
NE	3.03E-08	2.93E-08	2.84E-08	2.76E-08	2.67E-08	2.60E-08	2.52E-08
ENE	2.46E-08	2.37E-08	2.29E-08	2.21E-08	2.14E-08	2.07E-08	2.00E-08
E	2.30E-08	2.22E-08	2.14E-08	2.07E-08	2.00E-08	1.94E-08	1.88E-08
ESE	3.41E-08	3.29E-08	3.18E-08	3.08E-08	2.98E-08	2.89E-08	2.80E-08
SE	5.62E-08	5.39E-08	5.18E-08	4.98E-08	4.80E-08	4.62E-08	4.46E-08
SSE	5.83E-08	5.62E-08	5.42E-08	5.23E-08	5.05E-08	4.89E-08	4.73E-08
S	3.94E-08	3.86E-08	3.78E-08	3.70E-08	3.63E-08	3.55E-08	3.49E-08
SSW	3.93E-08	3.77E-08	3.61E-08	3.47E-08	3.34E-08	3.21E-08	3.09E-08
SW	3.84E-08	3.72E-08	3.61E-08	3.51E-08	3.41E-08	3.32E-08	3.23E-08
WSW	4.06E-08	3.90E-08	3.74E-08	3.60E-08	3.47E-08	3.34E-08	3.22E-08
W	4.17E-08	4.04E-08	3.93E-08	3.81E-08	3.70E-08	3.60E-08	3.50E-08
WNW	4.58E-08	4.50E-08	4.42E-08	4.34E-08	4.27E-08	4.20E-08	4.14E-08
NW	4.02E-08	3.96E-08	3.90E-08	3.85E-08	3.79E-08	3.74E-08	3.68E-08
NNW	3.76E-08	3.62E-08	3.49E-08	3.36E-08	3.25E-08	3.14E-08	3.03E-08

continued

* Period of Record: 9-1-76 to 8-31-78
Measured relevant to the Off-Gas Stack.

TABLE A-7.(continued)

Monticello Off Gas Stack Dispersion Parameters
for
Long Term Elevated Releases
>500 Hrs/Yr or >150 Hrs/Qtr

For Standard Distances (As Measured from the Off Gas Stack)
(χ/Q), sec/m^3

Sector*	Miles						
	3.6	3.7	3.8	3.9	4.0	4.1	4.2
N	3.00E-08	2.91E-08	2.82E-08	2.74E-08	2.66E-08	2.59E-08	2.51E-08
NNE	2.63E-08	2.54E-08	2.47E-08	2.40E-08	2.33E-08	2.26E-08	2.20E-08
NE	2.45E-08	2.39E-08	2.32E-08	2.26E-08	2.20E-08	2.15E-08	2.09E-08
ENE	1.94E-08	1.88E-08	1.83E-08	1.77E-08	1.73E-08	1.68E-08	1.63E-08
E	1.82E-08	1.77E-08	1.71E-08	1.66E-08	1.62E-08	1.57E-08	1.53E-08
ESE	2.72E-08	2.64E-08	2.56E-08	2.49E-08	2.42E-08	2.35E-08	2.29E-08
SE	4.30E-08	4.16E-08	4.02E-08	3.89E-08	3.77E-08	3.65E-08	3.54E-08
SSE	4.60E-08	4.49E-08	4.37E-08	4.27E-08	4.16E-08	4.06E-08	3.97E-08
S	3.39E-08	3.30E-08	3.22E-08	3.14E-08	3.06E-08	2.99E-08	2.92E-08
SsW	3.01E-08	2.93E-08	2.86E-08	2.79E-08	2.72E-08	2.65E-08	2.59E-08
SW	3.17E-08	3.12E-08	3.07E-08	3.02E-08	2.98E-08	2.93E-08	2.89E-08
WSW	3.17E-08	3.12E-08	3.07E-08	3.03E-08	2.98E-08	2.94E-08	2.89E-08
W	3.38E-08	3.26E-08	3.15E-08	3.05E-08	2.95E-08	2.86E-08	2.77E-08
WNW	3.99E-08	3.84E-08	3.71E-08	3.58E-08	3.46E-08	3.35E-08	3.24E-08
NW	3.60E-08	3.51E-08	3.43E-08	3.35E-08	3.28E-08	3.20E-08	3.13E-08
NNW	2.94E-08	2.84E-08	2.76E-08	2.67E-08	2.60E-08	2.52E-08	2.45E-08

continued

Period of Record: 9-1-76 to 8-31-78
* Measured relevant to the Off-Gas Stack.

TABLE A-7 (continued)

Monticello Off-Gas Stack Dispersion Parameters
for
Long Term Elevated Releases
>500 Hrs/Yr or >150 Hrs/Qtr

For Standard Distances (As Measured from the Off-Gas Stack)
(χ/Q), sec/m^3

Sector*	Miles						
	4.3	4.4	4.5	4.6	4.7	4.8	4.9
N	2.45E-08	2.38E-08	2.32E-08	2.26E-08	2.20E-08	2.15E-08	2.10E-08
NNE	2.14E-08	2.08E-08	2.03E-08	1.98E-08	1.93E-08	1.88E-08	1.84E-08
NE	2.04E-08	1.99E-08	1.95E-08	1.90E-08	1.86E-08	1.82E-08	1.78E-08
ENE	1.59E-08	1.55E-08	1.51E-08	1.47E-08	1.44E-08	1.40E-08	1.37E-08
E	1.49E-08	1.45E-08	1.42E-08	1.38E-08	1.35E-08	1.31E-08	1.28E-08
ESE	2.23E-08	2.18E-08	2.12E-08	2.07E-08	2.02E-08	1.97E-08	1.93E-08
SE	3.43E-08	3.33E-08	3.24E-08	3.15E-08	3.06E-08	2.98E-08	2.90E-08
SSE	3.88E-08	3.79E-08	3.71E-08	3.60E-08	3.50E-08	3.41E-08	3.32E-08
S	2.85E-08	2.79E-08	2.73E-08	2.65E-08	2.57E-08	2.50E-08	2.43E-08
SSW	2.53E-08	2.48E-08	2.42E-08	2.35E-08	2.28E-08	2.22E-08	2.16E-08
SW	2.85E-08	2.81E-08	2.77E-08	2.69E-08	2.61E-08	2.53E-08	2.46E-08
WSW	2.85E-08	2.81E-08	2.77E-08	2.69E-08	2.61E-08	2.53E-08	2.46E-08
W	2.68E-08	2.60E-08	2.53E-08	2.46E-08	2.39E-08	2.33E-08	2.26E-08
WNW	3.14E-08	3.05E-08	2.95E-08	2.87E-08	2.79E-08	2.71E-08	2.64E-08
NW	3.07E-08	3.00E-08	2.94E-08	2.86E-08	2.78E-08	2.70E-08	2.63E-08
NNW	2.38E-08	2.32E-08	2.26E-08	2.20E-08	2.14E-08	2.08E-08	2.03E-08

continued

Period of Record: 9-1-76 to 8-31-78
* Measured relevant to the Off Gas Stack.

TABLE A-7 (continued)

Monticello Off Gas Stack Dispersion Parameters
 for
 Long Term Elevated Releases
 >500 Hrs/Yr or >150 Hrs/Qtr

For Standard Distances (As Measured from the Off-Gas Stack)
 (x/Q), sec/m³

Sector*	Miles
	5.0
N	2.05E-08
NNE	1.79E-08
NE	1.74E-08
ENE	1.34E-08
E	1.25E-08
ESE	1.88E-08
SE	2.82E-08
SSE	3.23E-08
S	2.36E-08
SSW	2.10E-08
SW	2.39E-08
WSW	2.39E-08
W	2.21E-08
WNW	2.57E-08
NW	2.57E-08
NNW	1.98E-08

Period of Record: 9-1-76 to 8-31 78
 Measured relevant to the Off-Gas Stack.

*

Table A-8

Monticello Off-Gas Stack Dispersion Parameters
for
Long Term Elevated Releases
>500 Hrs/Yr or >150 Hrs/Qtr

For Standard Distances (As Measured from the Off-Gas Stack)
(D/Q), m²

Sector*	Miles						
	0.1	0.2	0.3	0.4	0.5	0.6	0.7
N	1.44E-09	4.89E-09	6.31E-09	5.66E-09	5.00E-09	4.44E-09	4.00E-09
NNE	2.25E-09	7.63E-09	9.79E-09	8.72E-09	7.59E-09	6.61E-09	5.82E-09
NE	1.06E-09	3.60E-09	4.65E-09	4.17E-09	3.68E-09	3.27E-09	2.94E-09
ENE	9.73E-10	3.30E-09	4.25E-09	3.81E-09	3.34E-09	2.95E-09	2.64E-09
E	7.84E-10	2.67E-09	3.45E-09	3.11E-09	2.77E-09	2.49E-09	2.27E-09
ESE	1.06E-09	3.61E-09	4.70E-09	4.31E-09	3.92E-09	3.63E-09	3.42E-09
SE	1.42E-09	4.87E-09	6.41E-09	6.00E-09	5.64E-09	5.40E-09	5.30E-09
SSE	1.19E-09	4.11E-09	5.46E-09	5.20E-09	5.00E-09	4.92E-09	4.96E-09
S	9.90E-10	3.38E-09	4.42E-09	4.08E-09	3.75E-09	3.50E-09	3.34E-09
SSW	5.92E-10	2.02E-09	2.65E-09	2.45E-09	2.25E-09	2.11E-09	2.03E-09
SW	3.23E-10	1.11E-09	1.48E-09	1.41E-09	1.35E-09	1.33E-09	1.34E-09
WSW	2.97E-10	1.03E-09	1.38E-09	1.33E-09	1.31E-09	1.32E-09	1.36E-09
W	4.41E-10	1.51E-09	1.98E-09	1.85E-09	1.72E-09	1.64E-09	1.59E-09
WNW	6.23E-10	2.13E-09	1.78E-09	2.56E-09	2.35E-09	2.20E-09	2.10E-09
NW	7.59E-10	2.59E-09	3.39E-09	3.13E-09	2.87E-09	2.69E-09	2.57E-09
NNW	1.94E-09	6.59E-09	8.48E-09	7.59E-09	6.66E-09	5.88E-09	5.25E-09

continued

Period of Record: 9-1-76 to 8-31-78
Measured relevant to the Off-Gas stack.

*

Table A-8 (continued)

Monticello Off-Gas Stack Dispersion Parameters
for
Long Term Elevated Releases
>500 Hrs/Yr or >150 Hrs/Qtr

For Standard Distances (As Measured from the Off Gas Stack)
(D/Q), m²

Sector*	Miles						
	0.8	0.9	1.0	1.1	1.2	1.3	1.4
N	3.47E-09	2.90E-09	2.39E-09	1.98E-09	1.67E-09	1.42E-09	1.23E-09
NNE	4.93E-09	4.00E-09	3.24E-09	2.65E-09	2.20E-09	1.85E-09	1.58E-09
NE	2.56E-09	2.13E-09	1.76E-09	1.46E-09	1.23E-09	1.05E-09	9.02E-10
ENE	2.27E-09	1.88E-09	1.54E-09	1.27E-09	1.06E-09	9.03E-10	7.75E-10
E	2.01E-09	1.70E-09	1.41E-09	1.18E-09	1.00E-09	8.59E-10	7.45E-10
ESE	3.12E-09	2.74E-09	2.32E-09	1.97E-09	1.69E-09	1.47E-09	1.29E-09
SE	5.02E-09	4.56E-09	3.94E-09	3.38E-09	2.94E-09	2.58E-09	2.29E-09
SSE	4.81E-09	4.46E-09	3.89E-09	3.37E-09	2.95E-09	2.61E-09	2.32E-09
S	3.09E-09	2.74E-09	2.34E-09	1.99E-09	1.72E-09	1.50E-09	1.32E-09
SSW	1.88E-09	1.67E-09	1.43E-09	1.22E-09	1.05E-09	9.18E-10	8.09E-10
SW	1.30E-09	1.21E-09	1.05E-09	9.14E-10	8.00E-10	7.06E-10	6.29E-10
WSW	1.35E-09	1.27E-09	1.12E-09	9.76E-10	8.59E-10	7.62E-10	6.81E-10
W	1.49E-09	1.35E-09	1.16E-09	9.93E-10	8.61E-10	7.54E-10	6.66E-10
WNW	1.93E-09	1.71E-09	1.46E-09	1.24E-09	1.07E-09	9.35E-10	8.22E-10
NW	2.37E-09	2.10E-09	1.80E-09	1.53E-09	1.32E-09	1.15E-09	1.01E-09
NNW	4.52E-09	3.73E-09	3.06E-09	2.53E-09	2.12E-09	1.80E-09	1.54E-09

continued

* Period of Record: 9-1-76 to 8-31-78
Measured relevant to the Off-Gas Stack.

Table A-8 (continued)

Monticello Off-Gas Stack Dispersion Parameters
for
Long Term Elevated Releases
>500 Hrs/Yr or >150 Hrs/Qtr

For Standard Distances (As Measured from the Off-Gas Stack)
(D/Q), m²

Sector*	Miles						
	1.5	1.6	1.7	1.8	1.9	2.0	2.1
N	1.07E-09	9.36E-10	8.27E-10	7.36E-10	6.92E-10	6.30E-10	5.75E-10
NNE	1.36E-09	1.18E-09	1.03E-09	9.08E-10	8.58E-10	7.77E-10	7.07E-10
NE	7.84E-10	6.88E-10	6.08E-10	5.41E-10	5.09E-10	4.63E-10	4.23E-10
ENE	6.72E-10	5.88E-10	5.18E-10	4.59E-10	4.32E-10	3.93E-10	3.58E-10
E	6.51E-10	5.75E-10	5.10E-10	4.56E-10	4.28E-10	3.90E-10	3.57E-10
ESE	1.14E-09	1.01E-09	9.06E-10	8.16E-10	7.64E-10	6.99E-10	6.43E-10
SE	2.04E-09	1.83E-09	1.65E-09	1.50E-09	1.40E-09	1.28E-09	1.18E-09
SSE	2.08E-09	1.87E-09	1.70E-09	1.54E-09	1.44E-09	1.32E-09	1.22E-09
S	1.17E-09	1.04E-09	9.35E-10	8.44E-10	7.89E-10	7.23E-10	6.66E-10
SSW	7.17E-10	6.41E-10	5.76E-10	5.20E-10	4.86E-10	4.46E-10	4.10E-10
SW	5.63E-10	5.08E-10	4.60E-10	4.18E-10	3.90E-10	3.59E-10	3.31E-10
WSW	6.12E-10	5.53E-10	5.02E-10	4.58E-10	4.26E-10	3.93E-10	3.63E-10
W	5.93E-10	5.32E-10	4.79E-10	4.34E-10	4.05E-10	3.72E-10	3.42E-10
WNW	7.28E-10	6.50E-10	5.84E-10	5.27E-10	4.92E-10	4.51E-10	4.15E-10
NW	8.97E-10	8.01E-10	7.20E-10	6.50E-10	6.07E-10	5.57E-10	5.12E-10
NNW	1.34E-09	1.17E-09	1.03E-09	9.12E-10	8.59E-10	7.81E-10	7.12E-10

continued

* Period of Record: 9-1-76 to 8-31-78
Measured relevant to the Off-Gas Stack.

Table A-8 (continued)

Monticello Off-Gas Stack Dispersion Parameters
for
Long Term Elevated Releases
>500 Hrs/Yr or >150 Hrs/Qtr

For Standard Distances (As Measured from the Off-Gas Stack)
(D/Q), m²

Sector*	Miles						
	2.2	2.3	2.4	2.5	2.6	2.7	2.8
N	5.28E-10	4.86E-10	4.49E-10	4.17E-10	3.87E-10	3.61E-10	3.37E-10
NNE	6.46E-10	5.93E-10	5.46E-10	5.05E-10	4.68E-10	4.35E-10	4.06E-10
NE	3.88E-10	3.58E-10	3.30E-10	3.06E-10	2.85E-10	2.65E-10	2.48E-10
ENE	3.28E-10	3.02E-10	2.79E-10	2.58E-10	2.40E-10	2.24E-10	2.09E-10
E	3.28E-10	3.03E-10	2.80E-10	2.60E-10	2.42E-10	2.26E-10	2.11E-10
ESE	5.93E-10	5.48E-10	5.09E-10	4.73E-10	4.41E-10	4.12E-10	3.86E-10
SE	1.09E-09	1.01E-09	9.43E-10	8.78E-10	8.21E-10	7.68E-10	7.20E-10
SSE	1.13E-09	1.05E-09	9.78E-10	9.12E-10	8.52E-10	7.98E-10	7.48E-10
S	6.14E-10	5.69E-10	5.28E-10	4.92E-10	4.59E-10	4.29E-10	4.02E-10
SSW	3.79E-10	3.76E-10	3.90E-10	3.92E-10	3.62E-10	3.34E-10	3.10E-10
SW	3.07E-10	2.98E-10	3.09E-10	3.18E-10	2.93E-10	2.71E-10	2.51E-10
WSW	3.36E-10	3.41E-10	3.44E-10	3.58E-10	3.30E-10	3.05E-10	2.83E-10
W	3.17E-10	3.11E-10	3.09E-10	3.19E-10	2.94E-10	2.72E-10	2.53E-10
WNW	3.83E-10	3.86E-10	3.86E-10	3.89E-10	3.59E-10	3.45E-10	3.20E-10
NW	4.73E-10	4.38E-10	4.07E-10	3.78E-10	3.53E-10	3.30E-10	3.09E-10
NNW	6.53E-10	6.01E-10	5.55E-10	5.14E-10	4.77E-10	4.44E-10	4.15E-10

continued

Period of Record: 9-1-76 to 8-31-78
* Measured relevant to the Off-Gas Stack.

Table A-8 (continued)

Monticello Off-Gas Stack Dispersion Parameters
for
Long Term Elevated Releases
>500 Hrs/Yr or >150 Hrs/Qtr

For Standard Distances (As Measured from the Off-Gas Stack)
(D/Q), m²

Sector*	Miles						
	2.9	3.0	3.1	3.2	3.3	3.4	3.5
N	3.16E-10	2.96E-10	2.78E-10	2.62E-10	2.47E-10	2.33E-10	2.20E-10
NNE	3.79E-10	3.55E-10	3.33E-10	3.13E-10	2.95E-10	2.78E-10	2.63E-10
NE	2.32E-10	2.18E-10	2.04E-10	1.92E-10	1.81E-10	1.71E-10	1.62E-10
ENE	1.95E-10	1.83E-10	1.72E-10	1.62E-10	1.52E-10	1.44E-10	1.36E-10
E	1.98E-10	1.86E-10	1.75E-10	1.64E-10	1.55E-10	1.46E-10	1.39E-10
ESE	3.62E-10	3.40E-10	3.20E-10	3.02E-10	2.85E-10	2.69E-10	2.55E-10
SE	6.76E-10	6.35E-10	5.98E-10	5.64E-10	5.33E-10	5.04E-10	4.77E-10
SSE	7.03E-10	6.62E-10	6.23E-10	5.88E-10	5.56E-10	5.26E-10	4.98E-10
S	3.77E-10	3.54E-10	3.33E-10	3.14E-10	2.97E-10	2.81E-10	2.66E-10
SSW	2.88E-10	2.68E-10	2.50E-10	2.34E-10	2.20E-10	2.06E-10	1.94E-10
SW	2.44E-10	2.27E-10	2.12E-10	1.98E-10	1.86E-10	1.75E-10	1.64E-10
WSW	2.63E-10	2.45E-10	2.29E-10	2.14E-10	2.01E-10	1.89E-10	1.78E-10
W	2.47E-10	2.30E-10	2.15E-10	2.01E-10	1.88E-10	1.77E-10	1.66E-10
WNW	2.97E-10	2.76E-10	2.58E-10	2.41E-10	2.26E-10	2.12E-10	2.00E-10
NW	2.90E-10	2.73E-10	2.57E-10	2.42E-10	2.26E-10	2.16E-10	2.04E-10
NNW	3.88E-10	3.64E-10	3.41E-10	3.21E-10	3.03E-10	2.86E-10	2.70E-10

continued

* Period of Record: 9-1-76 to 8-31-78
Measured relevant to the Off-Gas Stack.

Table A-8 (continued)

Monticello Off-Gas Stack Dispersion Parameters
for
Long Term Elevated Releases
>500 Hrs/Yr or >150 Hrs/Qtr

For Standard Distances (As Measured from the Off-Gas Stack)
(D/Q), m²

Sector*	Miles						
	3.6	3.7	3.8	3.9	4.0	4.1	4.2
N	2.09E-10	1.98E-10	1.88E-10	1.78E-10	1.70E-10	1.62E-10	1.54E-10
NNE	2.49E-10	2.36E-10	2.24E-10	2.13E-10	2.02E-10	1.93E-10	1.84E-10
NE	1.53E-10	1.45E-10	1.38E-10	1.31E-10	1.25E-10	1.19E-10	1.13E-10
ENE	1.29E-10	1.22E-10	1.16E-10	1.10E-10	1.05E-10	9.98E-11	9.51E-11
E	1.31E-10	1.24E-10	1.18E-10	1.12E-10	1.07E-10	1.02E-10	9.71E-11
ESE	2.42E-10	2.29E-10	2.18E-10	2.07E-10	1.97E-10	1.88E-10	1.79E-10
SE	4.53E-10	4.30E-10	4.08E-10	3.88E-10	3.69E-10	3.52E-10	3.36E-10
SSE	4.72E-10	4.48E-10	4.26E-10	4.05E-10	3.85E-10	3.67E-10	3.50E-10
S	2.52E-10	2.46E-10	2.34E-10	2.32E-10	2.34E-10	2.23E-10	2.12E-10
SSW	1.83E-10	1.73E-10	1.64E-10	1.59E-10	1.51E-10	1.43E-10	1.36E-10
SW	1.55E-10	1.46E-10	1.38E-10	1.31E-10	1.24E-10	1.18E-10	1.12E-10
WSW	1.68E-10	1.62E-10	1.54E-10	1.46E-10	1.38E-10	1.31E-10	1.25E-10
W	1.57E-10	1.48E-10	1.40E-10	1.33E-10	1.26E-10	1.20E-10	1.14E-10
WNW	1.88E-10	1.78E-10	1.68E-10	1.59E-10	1.51E-10	1.44E-10	1.37E-10
NW	1.94E-10	1.86E-10	1.77E-10	1.73E-10	1.76E-10	1.67E-10	1.59E-10
NNW	2.56E-10	2.43E-10	2.30E-10	2.19E-10	2.08E-10	1.98E-10	1.89E-10

continued

* Period of Record: 9-1-76 to 8-31-78
Measured relevant to the Off-Gas Stack

Table A-8 (continued)

Monticello Off-Gas Stack Dispersion Parameters
for
Long Term Elevated Releases
>500 Hrs/Yr or >150 Hrs/Qtr

For Standard Distances (As Measured from the Off-Gas Stack)
(D/Q), m²

Sector*	Miles						
	4.3	4.4	4.5	4.6	4.7	4.8	4.9
N	1.47E-10	1.41E-10	1.34E-10	1.29E-10	1.23E-10	1.18E-10	1.13E-10
NNE	1.75E-10	1.67E-10	1.60E-10	1.53E-10	1.47E-10	1.41E-10	1.35E-10
NE	1.08E-10	1.03E-10	9.88E-11	9.45E-11	9.05E-11	8.68E-11	8.32E-11
ENE	9.08E-11	8.67E-11	8.29E-11	7.94E-11	7.60E-11	7.28E-11	6.99E-11
E	9.26E-11	8.85E-11	8.46E-11	8.10E-11	7.75E-11	7.43E-11	7.13E-11
ESE	1.71E-10	1.63E-10	1.56E-10	1.49E-10	1.43E-10	1.37E-10	1.31E-10
SE	3.20E-10	3.06E-10	2.92E-10	2.80E-10	2.68E-10	2.57E-10	2.46E-10
SSE	3.34E-10	3.19E-10	3.05E-10	2.92E-10	2.80E-10	2.68E-10	2.57E-10
S	2.08E-10	1.98E-10	1.89E-10	1.81E-10	1.73E-10	1.66E-10	1.59E-10
SSW	1.30E-10	1.24E-10	1.18E-10	1.13E-10	1.08E-10	1.03E-10	9.90E-11
SW	1.08E-10	1.03E-10	9.82E-11	9.39E-11	8.98E-11	8.59E-11	8.24E-11
WSW	1.19E-10	1.13E-10	1.08E-10	1.03E-10	9.88E-11	9.46E-11	9.06E-11
W	1.08E-10	1.03E-10	9.87E-11	9.43E-11	9.02E-11	8.64E-11	8.28E-11
WNW	1.30E-10	1.24E-10	1.18E-10	1.13E-10	1.08E-10	1.04E-10	9.94E-11
NW	1.58E-10	1.51E-10	1.44E-10	1.38E-10	1.32E-10	1.26E-10	1.21E-10
NNW	1.80E-10	1.72E-10	1.65E-10	1.58E-10	1.51E-10	1.45E-10	1.39E-10

continued

Period of Record: 9-1-76 to 8-31-78
* Measured relevant to the Off-Gas Stack.

Table A-8 (continued)

Monticello Off-Gas Stack Dispersion Parameters
 for
 Long Term Elevated Releases
 >500 Hrs/Yr or >150 Hrs/Qtr

For Standard Distances (As Measured from the Off-Gas Stack)
 (D/Q), m²

Sector*	Miles
5.0	

N	1.09E-10
NNE	1.30E-10
NE	7.99E-11
ENE	6.71E-11
E	6.84E-11
ESE	1.26E-10
sE	2.36E-10
SSE	2.46E-10
S	1.52E-10
SSW	9.49E-11
SW	7.90E-11
WSW	8.69E-11
W	7.94E-11
WNW	9.53E-11
NW	1.16E-10
NNW	1.33E-10

* Period of Record: 9-1-76 to 8-31-78
 Measured relevant to the Off-Gas Stack.

Table A-9
 Monticello Off-Gas Stack Dispersion Parameters
 for
 Short Term Elevated Releases
 ≤ 500 Hrs/Yr or ≤ 150 Hrs/Qtr
 For Site Boundary Locations
 (Identified in Table A-2)

Site Boundary Sector*	χ/q (sec/m^3)	D/q (m^2)
N	1.55E-07	9.93E-09
NNE	1.41E-07	8.59E-09
NE	1.88E-07	1.16E-08
ENE	1.60E-07	6.04E-09
E	1.47E-07	9.15E-09
ESE	***	***
SE	***	***
SSE	***	***
S	***	***
SSW	***	***
SW	***	***
WSW	***	***
W	5.95E-08	2.91E-09
WNW	1.39E-07	4.68E-09
NW	***	***
NNW	2.33E-07	1.25E-08
E**	***	***
ESE**	***	***
SE**	***	***
E**	3.40E-08	2.23E-09
ESE**	3.50E-08	2.08E-09
SE**	***	***

Period of Record: 9-1-76 to 8-31-78

- * Measured relevant to the reactor vent.
- ** On-site EPA locations.
- *** See appropriate off-gas stack long term elevated release values.

Table A-10

Monticello Off-Gas Stack Dispersion Parameters
for
Short Term Elevated Releases
≤ 500 Hrs/Yr or ≤ 150 Hrs/Qtr

For Standard Distances (As Measured from the Off-Gas Stack)
(χ/q), sec/m^3

Sector*	Miles						
	0.1	0.2	0.3	0.4	0.5	0.6	0.7
N	**	**	**	1.67E-07	1.85E-07	1.50E-07	1.18E-07
NNE	**	**	**	2.82E-07	2.50E-07	2.12E-07	1.69E-07
NE	**	**	**	7.93E-08	1.29E-07	1.21E-07	1.08E-07
ENE	**	**	**	1.63E-07	1.87E-07	1.77E-07	1.46E-07
E	**	**	**	8.63E-08	1.47E-07	1.29E-07	1.07E-07
ESE	**	**	**	***	***	6.17E-08	1.02E-07
SE	**	**	**	***	***	***	1.17E-07
SSE	**	**	**	***	***	***	1.04E-07
S	**	**	**	***	***	7.75E-08	1.13E-07
SSW	**	**	**	***	***	7.15E-08	1.03E-07
SW	**	**	**	***	***	4.73E-08	8.22E-08
WSW	**	**	**	***	***	3.82E-08	6.85E-08
W	**	**	**	***	4.06E-08	7.49E-08	8.73E-08
WNW	**	**	**	***	4.56E-08	8.41E-08	9.88E-08
NW	**	**	**	***	***	7.36E-08	1.08E-07
NNW	**	**	**	2.73E-07	2.57E-07	2.37E-07	1.94E-07

continued

Period of Record: 9-1-76 to 8-31-78

Measured relevant to the Off-Gas stack.

Values less than the value for 0.4 miles

See appropriate off-gas stack long term elevated release values.

*

**

Table A-10 (continued)

Monticello Off-Gas Stack Dispersion Parameters
for
Short Term Elevated Releases
≤ 500 Hrs/Yr or ≤ 150 Hrs/Qtr

For Standard Distances (As Measured from the Off-Gas Stack)
(χ/q), sec/m^3

Sector*	Miles						
	0.8	0.9	1.0	1.1	1.2	1.3	1.4
N	1.52E-07	1.77E-07	1.94E-07	1.82E-07	1.96E-07	1.87E-07	2.07E-07
NNE	1.83E-07	2.05E-07	2.18E-07	2.30E-07	2.15E-07	1.99E-07	2.13E-07
NE	1.30E-07	1.60E-07	1.67E-07	1.75E-07	1.76E-07	1.61E-07	1.55E-07
ENE	1.62E-07	1.80E-07	1.75E-07	1.84E-07	1.96E-07	1.94E-07	1.91E-07
E	1.38E-07	1.62E-07	1.65E-07	1.75E-07	1.72E-07	1.59E-07	1.77E-07
ESE	1.36E-07	1.62E-07	1.71E-07	1.57E-07	1.62E-07	1.64E-07	1.70E-07
SE	1.56E-07	1.84E-07	1.98E-07	1.93E-07	2.02E-07	2.06E-07	2.46E-07
SSE	1.42E-07	1.78E-07	1.97E-07	2.50E-07	2.26E-07	2.35E-07	2.77E-07
S	1.55E-07	1.86E-07	2.07E-07	1.92E-07	2.08E-07	2.01E-07	2.71E-07
SSW	1.43E-07	1.64E-07	1.81E-07	1.86E-07	1.83E-07	1.79E-07	2.01E-07
SW	1.17E-07	1.45E-07	1.63E-07	1.77E-07	1.70E-07	1.74E-07	2.58E-07
WSW	9.91E-07	1.25E-07	1.31E-07	1.43E-07	1.62E-07	1.59E-07	2.45E-07
W	1.25E-07	1.56E-07	1.76E-07	1.86E-07	2.00E-07	2.04E-07	2.77E-07
WNW	1.39E-07	1.71E-07	1.89E-07	1.96E-07	2.04E-07	2.12E-07	2.79E-07
NNW	2.00E-07	2.24E-07	2.43E-07	2.48E-07	2.36E-07	2.14E-07	3.06E-07

continued

Period of Record: 9-1-76 to 8-31-78

* Measured relevant to the Off-Gas Stack

** Values less than the value for 0.4 miles.

*** See appropriate off-gas stack long term elevated release values.

Table A-10 (continued)

Monticello Off-Gas Stack Dispersion Parameters
for
Short Term Elevated Releases
≤ 500 Hrs/Yr. or ≤ 150 Hrs/Qtr

For Standard Distances (As Measured from the Off-Gas Stack)
(χ/q), sec/m^3

Sector*	Miles						
	1.5	1.6	1.7	1.8	1.9	2.0	2.1
N	2.56E-07	1.89E-07	2.10E-07	2.05E-07	1.94E-07	1.88E-07	1.79E-07
NNE	2.59E-07	1.94E-07	2.23E-07	2.13E-07	1.97E-07	1.87E-07	1.77E-07
NE	1.71E-07	1.63E-07	1.55E-07	1.86E-07	1.77E-07	1.74E-07	1.66E-07
ENE	1.82E-07	1.67E-07	2.13E-07	1.89E-07	1.74E-07	1.69E-07	1.64E-07
E	1.73E-07	1.61E-07	1.51E-07	1.88E-07	1.75E-07	1.66E-07	1.59E-07
ESE	1.84E-07	1.77E-07	1.70E-07	***	1.55E-07	1.52E-07	1.50E-07
SE	2.06E-07	2.05E-07	1.90E-07	2.00E-07	2.01E-07	1.89E-07	1.77E-07
SSE	2.25E-07	2.10E-07	2.01E-07	2.21E-07	1.77E-07	1.78E-07	1.78E-07
S	2.10E-07	***	2.38E-07	2.35E-07	2.18E-07	2.04E-07	2.97E-07
SSW	1.90E-07	1.84E-07	2.46E-07	2.34E-07	2.24E-07	2.20E-07	2.17E-07
SW	1.80E-07	1.74E-07	1.69E-07	1.87E-07	2.01E-07	1.99E-07	1.91E-07
WSW	1.78E-07	1.76E-07	1.72E-07	1.89E-07	2.00E-07	1.99E-07	1.94E-07
W	2.14E-07	2.22E-07	2.50E-07	2.50E-07	2.32E-07	2.31E-07	2.23E-07
WNW	1.96E-07	1.87E-07	1.81E-07	1.97E-07	2.11E-07	2.09E-07	2.01E-07
NW	2.00E-07	1.90E-07	2.59E-07	2.40E-07	2.28E-07	2.10E-07	2.01E-07
NNW	2.28E-07	2.01E-07	1.96E-07	1.92E-07	1.87E-07	1.81E-07	1.74E-07

continued

- Period of Record: 9-1-76 to 8-31-78
 * Measured relevant to the Off-Gas Stack
 ** Values less than the value for 0.4 miles.
 *** See appropriate off-gas stack long term elevated release values.

Table A-10 (continued)

Monticello Off-Gas Stack Dispersion Parameters
for
Short Term Elevated Releases
≤500 Hrs/Yr or ≤150 Hrs/Qtr

For Standard Distances (As Measured from the Off-Gas Stack)
(χ/q), sec/m^3

Sector*	Miles						
	2.2	2.3	2.4	2.5	2.6	2.7	2.8
N	1.70E-07	1.66E-07	1.58E-07	1.54E-07	1.51E-07	1.47E-07	1.37E-07
NNE	1.70E-07	1.62E-07	1.57E-07	1.51E-07	1.46E-07	1.44E-07	1.38E-07
NE	1.60E-07	1.53E-07	1.53E-07	1.47E-07	1.40E-07	1.36E-07	1.30E-07
ENE	1.57E-07	1.50E-07	1.47E-07	1.44E-07	1.36E-07	1.33E-07	1.28E-07
E	1.49E-07	1.44E-07	1.36E-07	1.33E-07	1.27E-07	1.23E-07	1.17E-07
ESE	1.48E-07	1.46E-07	1.43E-07	1.38E-07	1.33E-07	1.28E-07	1.23E-07
SE	1.95E-07	1.68E-07	1.64E-07	1.61E-07	1.55E-07	1.66E-07	1.60E-07
SSE	1.69E-07	1.58E-07	1.58E-07	1.50E-07	1.42E-07	1.35E-07	1.60E-07
S	1.65E-07	1.58E-07	1.51E-07	1.46E-07	1.41E-07	1.40E-07	1.65E-07
SSW	2.10E-07	2.11E-07	2.12E-07	1.89E-07	1.82E-07	1.76E-07	1.71E-07
SW	1.81E-07	1.90E-07	1.93E-07	1.93E-07	2.32E-07	2.23E-07	2.11E-07
WSW	1.82E-07	1.86E-07	1.79E-07	1.72E-07	1.90E-07	1.84E-07	2.12E-07
W	2.15E-07	2.18E-07	2.20E-07	2.19E-07	2.10E-07	2.08E-07	2.05E-07
WNW	1.89E-07	1.89E-07	1.90E-07	1.93E-07	2.26E-07	2.18E-07	2.11E-07
NW	1.91E-07	1.86E-07	1.80E-07	1.76E-07	1.72E-07	1.69E-07	1.64E-07
NNW	1.72E-07	1.68E-07	1.68E-07	1.59E-07	1.54E-07	1.45E-07	1.36E-07

continued

Period of Record: 9-1-76 to 8-31-78

* Measured relevant to the Off-Gas Stack.

** Values less than the value for 0.4 miles.

*** See appropriate off-gas stack long term elevated release values.

Table A-10 (continued)

Monticello Off-Gas Stack Dispersion Parameters
for
Short Term Elevated Releases
≤500 Hrs/Yr or ≤150 Hrs/Qtr

For Standard Distances (As Measured from the Off-Gas Stack)
(x/q), sec/m³

Sector*	Miles						
	2.9	3.0	3.1	3.2	3.3	3.4	3.5
N	1.35E-07	1.34E-07	1.32E-07	1.30E-07	1.28E-07	1.25E-07	1.23E-07
NNE	1.30E-07	1.26E-07	1.22E-07	1.19E-07	1.15E-07	1.12E-07	1.09E-07
NE	1.22E-07	1.20E-07	1.16E-07	1.14E-07	1.11E-07	1.09E-07	1.06E-07
ENE	1.21E-07	1.81E-07	1.15E-07	1.13E-07	1.10E-07	1.07E-07	1.04E-07
E	1.13E-07	1.10E-07	1.05E-07	1.03E-07	1.01E-07	1.01E-07	9.17E-08
ESE	1.19E-07	1.14E-07	1.08E-07	1.06E-07	1.03E-07	9.93E-08	9.89E-08
SE	1.31E-07	1.33E-07	1.35E-07	1.32E-07	1.26E-07	1.20E-07	1.15E-07
SSE	1.30E-07	1.32E-07	1.34E-07	1.35E-07	1.31E-07	1.26E-07	1.22E-07
S	1.63E-07	1.54E-07	1.46E-07	1.42E-07	1.34E-07	1.33E-07	1.32E-07
SSW	1.66E-07	1.57E-07	1.51E-07	1.46E-07	1.39E-07	1.34E-07	1.31E-07
SW	1.97E-07	1.82E-07	1.79E-07	1.71E-07	1.64E-07	1.59E-07	1.54E-07
WSW	2.02E-07	1.95E-07	1.85E-07	1.77E-07	1.69E-07	1.62E-07	1.54E-07
W	2.01E-07	1.92E-07	1.90E-07	1.84E-07	1.82E-07	1.78E-07	1.71E-07
WNW	2.02E-07	1.96E-07	1.92E-07	1.90E-07	1.85E-07	1.78E-07	1.75E-07
NW	1.70E-07	1.50E-07	1.48E-07	1.47E-07	1.39E-07	1.37E-07	1.38E-07
NNW	1.31E-07	1.30E-07	1.27E-07	1.22E-07	1.19E-07	1.16E-07	1.13E-07

continued

Period of Record: 9-1-76 to 8-31-78

Measured relevant to the Off-Gas Stack.

Values less than the value for 0.4 miles.

See appropriate off-gas stack long term elevated release values.

*

**

Table A-10 (continued)

Monticello Off-Gas Stack Dispersion Parameters
for
Short Term Elevated Releases
≤500 Hrs/yr or ≤150 Hrs/Qtr.

For Standard Distances (As Measured from the Off-Gas Stack)
(χ/q), sec/m³

Sector*	Miles						
	3.6	3.7	3.8	3.9	4.0	4.1	4.2
N	1.18E-07	1.15E-07	1.14E-07	1.11E-07	1.08E-07	1.06E-07	1.05E-07
NNE	1.07E-07	1.05E-07	1.01E-07	9.83E-08	9.61E-08	9.38E-08	9.04E-08
NE	1.03E-07	1.01E-07	9.84E-08	9.65E-08	9.20E-08	9.00E-08	8.81E-08
ENE	1.03E-07	1.01E-07	9.56E-08	9.34E-08	9.07E-08	8.79E-08	8.58E-08
E	9.00E-08	8.74E-08	8.37E-08	8.17E-08	7.94E-08	7.80E-08	7.64E-08
ESE	9.67E-08	9.46E-08	8.97E-08	8.91E-08	8.79E-08	8.64E-08	8.45E-08
SE	1.10E-07	1.06E-07	1.06E-07	1.02E-07	9.89E-08	1.03E-07	9.99E-08
SSE	1.18E-07	1.15E-07	1.11E-07	1.08E-07	1.12E-07	1.10E-07	1.08E-07
S	1.27E-07	1.23E-07	1.21E-07	1.17E-07	1.13E-07	1.10E-07	1.10E-07
SSW	1.27E-07	1.24E-07	1.21E-07	1.17E-07	1.15E-07	1.13E-07	1.08E-07
SW	1.52E-07	1.46E-07	1.43E-07	1.43E-07	1.41E-07	1.40E-07	1.38E-07
WSW	1.49E-07	1.43E-07	1.44E-07	1.43E-07	1.34E-07	1.33E-07	1.34E-07
W	1.66E-07	1.61E-07	1.56E-07	1.49E-07	1.42E-07	1.39E-07	1.35E-07
WNW	1.73E-07	1.67E-07	1.63E-07	1.58E-07	1.54E-07	1.49E-07	1.45E-07
NW	1.34E-07	1.27E-07	1.25E-07	1.24E-07	1.21E-07	1.19E-07	1.17E-07
NNW	1.10E-07	1.07E-07	1.02E-07	1.00E-07	9.75E-08	9.52E-08	9.37E-08

continued

Period of Record: 9-1-76 to 8-31-78

Measured relevant to the Off-Gas Stack

Values less than the value for 0.4 miles.

See appropriate off-gas stack long term elevated release values.

*

**

Table A.10 (continued)

Monticello Off-Gas Stack Dispersion Parameters
for
Short Term Elevated Releases
≤500 Hrs/Yr or ≤150 Hrs/Qtr

For Standard Distances (As Measured from the Off-Gas Stack)
(χ/q), sec/m³

Sector*	Miles						
	4.3	4.4	4.5	4.6	4.7	4.8	4.9
N	1.01E-07	9.83E-08	9.37E-08	9.14E-08	8.97E-08	8.80E-08	8.61E-08
NNE	8.88E-08	8.71E-08	8.63E-08	8.42E-08	8.14E-08	8.00E-08	7.84E-08
NE	8.69E-08	8.53E-08	8.40E-08	8.25E-08	8.19E-08	8.02E-08	7.81E-08
ENE	8.42E-08	8.26E-08	8.09E-08	7.87E-08	7.69E-08	7.55E-08	7.38E-08
E	7.33E-08	7.27E-08	7.02E-08	6.85E-08	6.71E-08	6.56E-08	6.40E-08
ESE	8.27E-08	8.10E-08	7.40E-08	7.77E-08	7.61E-08	7.46E-08	7.32E-08
SE	9.71E-08	9.47E-08	9.24E-08	9.01E-08	8.78E-08	8.56E-08	8.18E-08
SSE	1.07E-07	1.02E-07	1.02E-07	9.90E-08	9.66E-08	9.41E-08	1.19E-07
S	1.06E-07	1.04E-07	1.02E-07	9.72E-08	9.63E-08	9.35E-08	9.03E-08
SSW	1.05E-07	1.03E-07	1.01E-07	9.78E-08	9.46E-08	9.20E-08	9.00E-08
SW	1.38E-07	1.37E-07	1.34E-07	1.30E-07	1.26E-07	1.24E-07	1.22E-07
WSW	1.31E-07	1.28E-07	1.28E-07	1.22E-07	1.20E-07	1.19E-07	1.18E-07
W	1.33E-07	1.28E-07	1.25E-07	1.24E-07	1.20E-07	1.17E-07	1.15E-07
WNW	1.43E-07	1.38E-07	1.35E-07	1.33E-07	1.33E-07	1.27E-07	1.25E-07
NW	1.14E-07	1.12E-07	1.11E-07	1.07E-07	1.04E-07	1.01E-07	9.74E-08
NNW	9.12E-08	8.89E-08	8.64E-08	8.31E-08	8.26E-08	8.08E-08	7.72E-08

continued

Period of Record: 9-1-76 to 8-31-78

* Measured relevant to the Off-Gas Stack.

** Values less than the value for 0.4 miles

*** See appropriate off-gas stack long term elevated release values.

Table A-10. (continued)

Monticello Off-Gas Stack Dispersion Parameters
for

Score Term Elevated Releases
≤500 Hrs/Yr or ≤150 Hrs/Qtr.

For Standard Distances (As Measured from the Off-Gas Stack)
(χ/q), sec/m^3

Sector*	Miles
5.0	
N	8.28E-08
NNE	7.56E-08
NE	7.58E-08
ENE	7.11E-08
E	6.33E-08
ESE	7.16E-08
SE	8.10E-08
SSE	1.11E-07
S	8.84E-08
SSW	8.80E-08
SW	1.19E-07
WSW	1.13E-07
W	1.13E-07
WNW	1.21E-07
NW	9.51E-08
NNW	7.53E-08

* Period of Record: 9-1-76 to 8-31-78
 ** Measured relevant to the Off-Gas Stack.
 ** Values less than the value for 0.4 miles
 *** See appropriate off-gas stack long term elevated release values.

Table A-11

Monticello Off-Gas Stack Dispersion Parameters
for
Short Term Elevated Releases
≤500 Hrs/Yr or ≤150 Hrs/Qtr

For Standard Distances (As Measured from the Off-Gas Stack)
(D/q), m²

Sector*	Miles						
	0.1	0.2	0.3	0.4	0.5	0.6	0.7
N	**	**	**	1.32E-08	1.31E-08	9.45E-09	6.60E-09
NNE	**	**	**	2.39E-08	1.86E-08	1.39E-09	9.88E-09
NE	**	**	**	6.01E-09	7.80E-09	6.24E-09	4.92E-09
ENE	**	**	**	1.31E-08	1.14E-08	8.79E-09	6.20E-09
E	**	**	**	7.37E-09	9.17E-09	6.52E-09	4.58E-09
ESE	**	**	**	***	***	3.74E-09	5.28E-09
SE	**	**	**	***	***	***	6.26E-09
SSE	**	**	**	***	***	***	6.60E-09
S	**	**	**	***	***	4.41E-09	5.43E-09
SSW	**	**	**	***	***	3.39E-09	4.09E-09
SW	**	**	**	***	***	2.30E-09	3.34E-09
WSW	**	**	**	***	***	2.16E-09	3.17E-09
W	**	**	**	***	2.22E-09	3.38E-09	3.35E-09
WNW	**	**	**	***	2.55E-09	3.89E-09	3.94E-09
NW	**	**	**	***	***	3.17E-09	4.01E-09
NNW	**	**	**	2.13E-08	1.68E-08	1.30E-08	9.18E-09

continued

Period of Record: 9-1-76 to 8-31-78
Measured relevant to the Off-Gas Stack

*

Table A-11 (continued)

Monticello Off-Gas Stack Dispersion Parameters
for
Short Term Elevated Releases
≤500 Hrs/Yr or ≤150 Hrs/Qtr

For Standard Distances, (As Measured from the Off-Gas Stack)
(D/q), m²

Sector*	Miles						
	0.8	0.9	1.0	1.1	1.2	1.3	1.4
N	7.46E-09	7.64E-09	7.08E-09	5.61E-09	5.20E-09	4.30E-09	4.21E-09
NNE	9.52E-09	9.50E-09	8.74E-09	7.97E-09	6.49E-09	5.28E-09	5.05E-09
NE	5.32E-09	5.92E-09	5.43E-09	4.98E-09	4.43E-09	3.60E-09	3.11E-09
ENE	6.00E-09	5.94E-09	5.01E-09	4.56E-09	4.25E-09	3.75E-09	3.31E-09
E	5.18E-09	5.40E-09	4.74E-09	4.36E-09	3.76E-09	3.08E-09	3.09E-09
ESE	6.16E-09	6.58E-09	5.98E-09	4.72E-09	4.30E-09	3.89E-09	3.66E-09
SE	7.39E-09	7.99E-09	7.50E-09	6.40E-09	5.96E-09	5.50E-09	6.04E-09
SSE	7.58E-09	8.26E-09	7.59E-09	6.02E-09	6.29E-09	5.79E-09	6.12E-09
S	6.46E-09	6.88E-09	6.53E-09	5.17E-09	4.89E-09	4.19E-09	5.08E-09
SSW	4.90E-09	4.99E-09	4.71E-09	4.17E-09	3.58E-09	3.12E-09	3.17E-09
SW	5.67E-09	4.25E-09	3.97E-09	3.65E-09	3.03E-09	2.74E-09	3.65E-09
WSW	3.83E-09	4.16E-09	3.58E-09	3.23E-09	3.12E-09	2.66E-09	3.64E-09
W	4.14E-09	4.59E-09	4.35E-09	3.87E-09	3.59E-09	3.20E-09	3.87E-09
WNW	4.86E-09	5.37E-09	5.09E-09	4.51E-09	4.10E-09	3.77E-09	4.44E-09
NW	4.75E-09	5.16E-09	5.03E-09	4.25E-09	3.55E-09	3.43E-09	3.86E-09
NNW	8.37E-09	8.39E-09	7.94E-09	7.09E-09	5.96E-09	4.82E-09	6.18E-09

continued

* Period of Record: 9-1-76 to 8-31-78
Measured relevant to the Off-Gas Stack

Table A-11 (continued)

Monticello Off-Gas Stack Dispersion Parameters
for
Short Term Elevated Releases
≤500 Hrs/Yr or ≤150 Hrs/Qtr

For Standard Distances (As Measured from the Off-Gas Stack)
(D/q), m²

Sector*	Miles						
	1.5	1.6	1.7	1.8	1.9	2.0	2.1
N	4.63E-09	3.13E-09	3.20E-09	2.90E-09	2.69E-09	2.48E-09	2.24E-09
NNE	5.50E-09	3.78E-09	4.02E-09	3.56E-09	3.27E-09	2.95E-09	2.66E-09
NE	3.10E-09	2.65E-09	2.28E-09	2.48E-09	2.27E-09	2.08E-09	1.85E-09
ENE	2.86E-09	2.40E-09	2.81E-09	2.31E-09	2.08E-09	1.91E-09	1.76E-09
E	2.73E-09	2.35E-09	2.05E-09	2.39E-09	2.18E-09	1.96E-09	1.81E-09
ESE	3.62E-09	3.20E-09	2.86E-09	***	2.38E-09	2.22E-09	2.10E-09
SE	4.68E-09	4.28E-09	3.67E-09	3.61E-09	3.49E-09	3.09E-09	2.75E-09
SSE	4.50E-09	3.93E-09	3.57E-09	3.70E-09	2.90E-09	2.79E-09	2.69E-09
S	3.59E-09	***	3.58E-09	3.34E-09	3.04E-09	2.74E-09	2.55E-09
SSW	2.73E-09	2.34E-09	2.81E-09	2.42E-09	2.17E-09	1.97E-09	1.80E-09
SW	2.32E-09	1.98E-09	1.72E-09	1.72E-09	1.72E-09	1.57E-09	1.40E-09
WSW	2.38E-09	2.07E-09	1.80E-09	1.77E-09	1.73E-09	1.58E-09	1.42E-09
W	2.70E-09	2.47E-09	2.47E-09	2.22E-09	1.92E-09	1.75E-09	1.57E-09
WNW	2.83E-09	2.38E-09	2.06E-09	2.02E-09	2.03E-09	1.84E-09	1.64E-09
NW	3.09E-09	2.70E-09	3.41E-09	2.94E-09	2.70E-09	2.35E-09	2.13E-09
NNW	4.19E-09	3.41E-09	3.09E-09	2.84E-09	2.74E-09	2.54E-09	2.33E-09

continued

Period of Record: 9-1-76 to 8-31-78
* Measured relevant to the Off-Gas Stack
*** See appropriate long term values.

Table A-11 (continued)

Monticello Off-Gas Stack Dispersion Parameters
for
Short Term Elevated Releases
<500 Hrs/Yr or <150 Hrs/Qtr

For Standard Distances (As Measured from the Off-Gas Stack)
(D/q), m²

Sector*	Miles						
	2.2	2.3	2.4	2.5	2.6	2.7	2.8
N	2.04E-09	1.90E-09	1.75E-09	1.64E-09	1.53E-09	1.42E-09	1.27E-09
NNE	2.45E-09	2.25E-09	2.10E-09	1.95E-09	1.82E-09	1.73E-09	1.61E-09
NE	1.67E-09	1.51E-09	1.42E-09	1.30E-09	1.19E-09	1.11E-09	1.03E-09
ENE	1.61E-09	1.47E-09	1.38E-09	1.29E-09	1.18E-09	1.12E-09	1.04E-09
E	1.62E-09	1.51E-09	1.37E-09	1.30E-09	1.20E-09	1.12E-09	1.04E-09
ESE	1.99E-09	1.88E-09	1.78E-09	1.66E-09	1.55E-09	1.44E-09	1.34E-09
SE	2.89E-09	2.38E-09	2.24E-09	2.12E-09	1.97E-09	2.09E-09	1.97E-09
SSE	2.47E-09	2.24E-09	2.18E-09	2.01E-09	1.85E-09	1.72E-09	1.98E-09
S	2.06E-09	1.92E-09	1.80E-09	1.67E-09	1.54E-09	1.46E-09	1.64E-09
SSW	1.62E-09	1.64E-09	1.73E-09	1.57E-09	1.46E-09	1.37E-09	1.29E-09
SW	1.24E-09	1.27E-09	1.35E-09	1.40E-09	1.60E-09	1.48E-09	1.34E-09
WSW	1.24E-09	1.29E-09	1.26E-09	1.27E-09	1.35E-09	1.27E-09	1.42E-09
W	1.40E-09	1.40E-09	1.42E-09	1.47E-09	1.35E-09	1.27E-09	1.20E-09
WNW	1.43E-09	1.46E-09	1.48E-09	1.52E-09	1.68E-09	1.58E-09	1.44E-09
NW	1.93E-09	1.80E-09	1.67E-09	1.57E-09	1.45E-09	1.35E-09	1.25E-09
NNW	2.22E-09	2.09E-09	2.02E-09	1.85E-09	1.74E-09	1.58E-09	1.44E-09

continued

* Period of Record: 9-1-76 to 8-31-78
Measured relevant to the Off-Gas Stack

Table A-11 (continued)

Monticello Off-Gas Stack Dispersion Parameters
for
Short Term Elevated Releases
≤500 Hrs/Yr or ≤150 Hrs/Qtr

For Standard Distances (As Measured from the Off-Gas Stack)
(D/q), m²

Sector*	Miles						
	2.9	3.0	3.1	3.2	3.3	3.4	3.5
N	1.20E-09	1.15E-09	1.08E-09	1.03E-09	9.77E-10	9.22E-10	8.74E-10
NNE	1.47E-09	1.39E-09	1.31E-09	1.25E-09	1.17E-09	1.11E-09	1.06E-09
NE	9.37E-10	8.90E-10	8.37E-10	7.98E-10	7.54E-10	7.19E-10	6.82E-10
ENE	9.64E-10	9.11E-10	8.65E-10	8.28E-10	7.85E-10	7.41E-10	7.09E-10
E	9.72E-10	9.18E-10	8.55E-10	8.15E-10	7.80E-10	7.63E-10	6.77E-10
ESE	1.26E-09	1.18E-09	1.09E-09	1.04E-09	9.85E-10	9.24E-10	9.01E-10
SE	1.58E-09	1.57E-09	1.56E-09	1.49E-09	1.40E-09	1.31E-09	1.23E-09
SSE	1.57E-09	1.55E-09	1.54E-09	1.52E-09	1.44E-09	1.36E-09	1.28E-09
S	1.56E-09	1.41E-09	1.29E-09	1.21E-09	1.10E-09	1.05E-09	1.01E-09
SSW	1.22E-09	1.12E-09	1.04E-09	9.83E-10	9.12E-10	8.63E-10	8.24E-10
SW	1.25E-09	1.11E-09	1.05E-09	9.69E-10	8.96E-10	8.36E-10	7.83E-10
WSW	1.31E-09	1.22E-09	1.13E-09	1.05E-09	9.80E-10	9.14E-10	8.49E-10
W	1.19E-09	1.09E-09	1.04E-09	9.69E-10	9.26E-10	8.75E-10	8.11E-10
WNW	1.31E-09	1.21E-09	1.12E-09	1.06E-09	9.78E-10	9.00E-10	8.43E-10
NW	1.23E-09	1.03E-09	9.72E-10	9.26E-10	8.37E-10	7.94E-10	7.63E-10
NNW	1.35E-09	1.30E-09	1.25E-09	1.17E-09	1.11E-09	1.06E-09	1.44E-09

continued

Period of Record: 9-1-76 to 8-31-78
Measured relevant to the Off-Gas Stack

*

Table A-11 (continued)

Monticello Off-Gas Stack Dispersion Parameters
for
Short Term Elevated Releases
≤500 Hrs/Yr or ≤150 Hrs/Qtr

For Standard Distances (As Measured from the Off-Gas Stack)
(D/q), m²

Sector*	Miles						
	3.6	3.7	3.8	3.9	4.0	4.1	4.2
N	8.20E-10	7.85E-10	7.57E-10	7.26E-10	6.90E-10	6.64E-10	6.42E-10
NNE	1.01E-09	9.76E-10	9.14E-10	8.72E-10	8.35E-10	7.98E-10	7.55E-10
NE	6.45E-10	6.15E-10	5.85E-10	5.60E-10	5.22E-10	4.99E-10	4.77E-10
ENE	6.83E-10	6.52E-10	6.06E-10	5.79E-10	5.51E-10	5.22E-10	5.00E-10
E	6.49E-10	6.16E-10	5.77E-10	5.51E-10	5.25E-10	5.05E-10	4.85E-10
ESE	8.60E-10	8.21E-10	7.64E-10	7.41E-10	7.16E-10	6.91E-10	6.61E-10
SE	1.16E-09	1.10E-09	1.08E-09	1.02E-09	9.68E-10	9.93E-10	9.48E-10
SSE	1.21E-09	1.15E-09	1.08E-09	1.02E-09	1.04E-09	9.94E-10	9.52E-10
S	9.44E-10	9.15E-10	8.76E-10	8.65E-10	8.63E-10	8.23E-10	7.95E-10
SSW	7.76E-10	7.35E-10	6.96E-10	6.69E-10	6.35E-10	6.08E-10	5.70E-10
SW	7.42E-10	6.82E-10	6.45E-10	6.21E-10	5.90E-10	5.64E-10	5.37E-10
WSW	7.90E-10	7.45E-10	7.21E-10	6.88E-10	6.21E-10	5.94E-10	5.78E-10
W	7.69E-10	7.29E-10	6.93E-10	6.50E-10	6.08E-10	5.83E-10	5.56E-10
WNW	8.16E-10	7.73E-10	7.41E-10	7.05E-10	6.72E-10	6.38E-10	6.11E-10
NW	7.24E-10	6.75E-10	6.45E-10	6.43E-10	6.48E-10	6.19E-10	5.95E-10
NNW	9.60E-10	9.10E-10	8.53E-10	8.18E-10	7.82E-10	7.49E-10	7.22E-10

continued

* Period of Record: 9-1-76 to 8-31-78
Measured relevant to the Off-Gas Stack

Table A-11 (continued)

Monticello Off-Gas Stack Dispersion Parameters
for
Short Term Elevated Releases
≤500 Hrs/Yr or ≤150 Hrs/Qtr

For Standard Distances (As Measured from the Off-Gas Stack)
(D/q), m²

Sector*	Miles						
	4.3	4.4	4.5	4.6	4.7	4.8	4.9
N	6.07E-10	5.80E-10	5.43E-10	5.20E-10	5.01E-10	4.83E-10	4.65E-10
NNE	7.27E-10	7.00E-10	6.81E-10	6.52E-10	6.20E-10	5.98E-10	5.76E-10
NE	4.61E-10	4.42E-10	4.27E-10	4.10E-10	3.99E-10	3.83E-10	3.66E-10
ENE	4.81E-10	4.63E-10	4.45E-10	4.24E-10	4.07E-10	3.92E-10	3.76E-10
E	4.55E-10	4.43E-10	4.19E-10	4.02E-10	3.86E-10	3.71E-10	3.55E-10
ESE	6.34E-10	6.06E-10	5.45E-10	5.59E-10	5.39E-10	5.19E-10	4.97E-10
SE	9.05E-10	8.70E-10	8.33E-10	8.01E-10	7.69E-10	7.38E-10	6.94E-10
SSE	9.43E-10	8.59E-10	8.39E-10	8.03E-10	7.73E-10	7.40E-10	9.18E-10
S	7.75E-10	7.42E-10	7.10E-10	6.65E-10	6.49E-10	6.21E-10	5.91E-10
SSW	5.39E-10	5.15E-10	4.91E-10	4.69E-10	4.47E-10	4.28E-10	4.13E-10
SW	5.23E-10	5.02E-10	4.74E-10	4.53E-10	4.35E-10	4.22E-10	4.08E-10
WSW	5.46E-10	5.16E-10	4.98E-10	4.69E-10	4.55E-10	4.45E-10	4.34E-10
W	5.35E-10	5.09E-10	4.89E-10	4.77E-10	4.53E-10	4.36E-10	4.20E-10
WNW	5.91E-10	5.61E-10	5.41E-10	5.24E-10	5.16E-10	4.87E-10	4.69E-10
NW	5.88E-10	5.66E-10	5.44E-10	5.17E-10	4.96E-10	4.72E-10	4.48E-10
NNW	6.90E-10	6.60E-10	6.30E-10	5.96E-10	5.83E-10	5.61E-10	5.28E-10

continued

* Period of Record: 9-1-76 to 8-31-78
Measured relevant to the Off-Gas Stack

Table A-11 (continued)

Monticello Off-Gas Stack Dispersion Parameters
for
Short Term Elevated Releases
≤500 Hrs/Yr or ≤150 Hrs/Qtr

For Standard Distances (As Measured from the Off-Gas Stack)
(D/g), m²

Sector*	Miles
	5.0
N	4.39E-10
NNE	5.46E-10
NE	3.48E-10
ENE	3.56E-10
E	3.45E-10
ESE	4.80E-10
SE	6.78E-10
SSE	8.45E-10
S	5.70E-10
SSW	3.98E-10
SW	3.92E-10
WSW	4.12E-10
W	4.05E-10
WNW	4.48E-10
NW	4.31E-10
NNW	5.06E-10

* Period of Record: 9-1-76 to 8-31-78
Measured relevant to the Off-Gas Stack

Table A-12

Monticello Reactor Building Vent Dispersion Parameters
for

Short Term Elevated Releases
≤500 Hrs/Yr or ≤150 Hrs/Qtr

For Site Boundary Locations (Identified in Table A-2)

Sector*	Distance		$\frac{x}{g}$ (sec/m ³) No Decay Undepleted	$\frac{D}{g}$ (m ²)
	Miles	Meters		
N	0.51	821.	5.18E-06	7.19E-08
NNE	0.58	933.	3.51E-06	5.02E-08
NE	0.65	1046.	2.33E-06	2.93E-08
ENE	0.83	1336.	1.82E-06	1.69E-08
E	0.59	950.	3.67E-06	3.90E-08
ESE	0.59	950.	4.95E-06	6.51E-08
SE	0.61	982.	4.96E-06	6.49E-08
SSE	0.43	692.	8.06E-06	1.18E-07
S	0.34	547.	6.92E-06	9.30E-08
SSW	0.32	515.	5.92E-06	7.04E-08
SW	0.32	515.	6.31E-06	8.24E-08
WSW	0.35	563.	4.91E-06	5.50E-08
W	0.48	772.	3.38E-06	3.82E-08
WNW	0.68	1094.	2.94E-06	2.88E-08
NW	0.43	692.	5.70E-06	7.09E-08
NNW	0.53	853.	4.44E-06	6.09E-08
E**	0.38	612.	1.61E-06	1.93E-08
ESE**	0.31	499.	2.83E-06	4.24E-08
SE**	0.36	579.	2.43E-06	3.59E-08
E**	0.57	917.	9.16E-07	9.92E-09
ESE**	0.62	998.	1.10E-06	1.42E-08
SE**	0.50	805.	1.54E-06	2.14E-08

Period of Record: 9-1-76 to 8-31-78

* Measured relevant to the reactor vent.

** On-site EPA locations.

Table A-13

Reactor Building Vent Dispersion Parameters
for
Short Term Elevated Releases
≤500 Hrs/Yr or ≤150 Hrs/Qtr

For Standard Distances (As Measured from the Off-Gas Stack)
(χ/q), sec/m^3

Sector*	Miles						
	0.1	0.2	0.3	0.4	0.5	0.6	0.7
N	7.30E-05	2.19E-05	1.10E-05	7.14E-06	5.28E-06	4.19E-06	3.46E-06
NNE	5.81E-05	1.77E-05	8.96E-06	5.84E-06	4.23E-06	3.34E-06	2.79E-06
NE	4.26E-05	1.29E-05	6.69E-06	4.33E-06	3.19E-06	2.54E-06	2.16E-06
ENE	4.27E-05	1.29E-05	6.65E-06	4.32E-06	3.15E-06	2.53E-06	2.16E-06
E	5.76E-05	1.73E-05	9.22E-06	6.20E-06	4.51E-06	3.63E-06	3.04E-06
ESE	7.80E-05	2.30E-05	1.24E-05	8.28E-06	6.16E-06	4.84E-06	4.01E-06
SE	8.52E-05	2.48E-05	1.31E-05	8.85E-06	6.46E-06	5.08E-06	4.18E-06
SSE	8.87E-05	2.60E-05	1.36E-05	8.91E-06	6.53E-06	5.15E-06	4.22E-06
S	4.89E-05	1.47E-05	7.95E-06	5.35E-06	3.95E-06	3.17E-06	2.63E-06
SSW	4.04E-05	1.19E-05	6.58E-06	4.38E-06	3.34E-06	2.80E-06	2.46E-06
SW	4.37E-05	1.34E-05	7.26E-06	4.76E-06	3.62E-06	2.97E-06	2.62E-06
WSW	3.65E-05	1.09E-05	6.13E-06	4.11E-06	3.17E-06	2.70E-06	2.43E-06
W	4.07E-05	1.23E-05	6.47E-06	4.32E-06	3.19E-06	2.67E-06	2.35E-06
WNW	5.53E-05	1.65E-05	8.74E-06	5.74E-06	4.22E-06	3.37E-06	2.85E-06
NW	6.25E-05	1.85E-05	9.62E-06	6.32E-06	4.65E-06	3.76E-06	3.15E-06
NNW	7.11E-05	2.11E-05	1.04E-05	6.70E-06	4.78E-06	3.76E-06	3.15E-06

continued

Period of Record: 9-1-76 to 8-31-78
Measured relevant to the reactor vent.

*

Table A-13 (continued)

Reactor Building Vent Dispersion Parameters
for
Short Term Elevated Releases
≤500 Hrs/Yr or ≤150 Hrs/Qtr

For Standard Distances (As Measured from the Off-Gas Stack)
(χ/q), sec/m^3

Sector*	Miles						
	0.8	0.9	1.0	1.1	1.2	1.3	1.4
N	2.84E-06	2.43E-06	2.05E-06	1.79E-06	1.61E-06	1.46E-06	1.31E-06
NNE	2.33E-06	2.02E-06	1.71E-06	1.51E-06	1.37E-06	1.24E-06	1.12E-06
NE	1.83E-06	1.58E-06	1.37E-06	1.21E-06	1.11E-06	9.99E-06	9.23E-06
ENE	1.87E-06	1.64E-06	1.46E-06	1.31E-06	1.20E-06	1.11E-06	1.04E-06
E	2.51E-06	2.18E-06	1.87E-06	1.64E-06	1.50E-06	1.38E-06	1.26E-06
EsE	3.34E-06	2.77E-06	2.38E-06	2.07E-06	1.80E-06	1.59E-06	1.44E-06
SE	3.42E-06	2.82E-06	2.39E-06	2.07E-06	1.78E-06	1.57E-06	1.40E-06
SSE	3.47E-06	2.89E-06	2.43E-06	2.12E-06	1.86E-06	1.64E-06	1.47E-06
S	2.27E-06	1.96E-06	1.70E-06	1.51E-06	1.38E-06	1.27E-06	1.15E-06
SSW	2.18E-06	1.93E-06	1.74E-06	1.52E-06	1.48E-06	1.33E-06	1.21E-06
SW	2.26E-06	1.99E-06	1.81E-06	1.58E-06	1.44E-06	1.32E-06	1.21E-06
WSW	2.18E-06	1.94E-06	1.82E-06	1.63E-06	1.48E-06	1.39E-06	1.29E-06
W	2.07E-06	1.87E-06	1.67E-06	1.52E-06	1.41E-06	1.29E-06	1.19E-06
WNW	2.47E-06	2.15E-06	1.86E-06	1.68E-06	1.52E-06	1.37E-06	1.26E-06
NW	2.60E-06	2.22E-06	1.89E-06	1.64E-06	1.49E-06	1.34E-06	1.22E-06
NNW	2.64E-06	2.25E-06	1.90E-06	1.68E-06	1.50E-06	1.37E-06	1.25E-06

continued

Period of Record: 9-1-76 to 8-31-78
* Measured relevant to the reactor vent.

Table A-13 (continued)

Reactor Building Vent Dispersion Parameters
forShort Term Elevated Releases
≤500 Hrs/Yr or ≤150 Hrs/QtrFor Standard Distances (As Measured from the Off-Gas Stack)
(χ/q), sec/m³

Sector*	Miles						
	1.5	1.6	1.7	1.8	1.9	2.0	2.1
N	1.28E-06	1.15E-06	1.05E-06	9.60E-07	9.00E-07	8.28E-07	7.67E-07
NNE	1.11E-06	9.94E-07	9.14E-07	8.44E-07	7.91E-07	7.31E-07	6.94E-07
NE	8.63E-07	7.69E-07	7.26E-07	7.09E-07	6.71E-07	6.31E-07	6.08E-07
ENE	9.50E-07	9.08E-07	8.65E-07	8.22E-07	7.80E-07	7.31E-07	7.00E-07
E	1.15E-06	1.06E-06	1.02E-06	9.40E-07	8.72E-07	8.20E-07	7.72E-07
ESE	1.31E-06	1.16E-06	1.07E-06	1.03E-06	9.41E-07	8.73E-07	8.08E-07
SE	1.26E-06	1.15E-06	1.06E-06	1.01E-06	9.48E-07	8.74E-07	8.19E-07
SSE	1.33E-06	1.17E-06	1.09E-06	1.05E-06	9.69E-07	9.01E-07	8.34E-07
S	1.13E-06	1.00E-06	9.21E-07	8.55E-07	7.94E-07	7.33E-07	6.96E-07
SSW	1.19E-06	1.12E-06	1.08E-06	1.04E-06	1.02E-06	1.02E-06	9.95E-07
SW	1.18E-06	1.09E-06	1.06E-06	1.01E-06	9.62E-07	9.53E-07	9.34E-07
WSW	1.27E-06	1.21E-06	1.16E-06	1.09E-06	1.05E-06	1.04E-06	1.02E-06
W	1.19E-06	1.12E-06	1.06E-06	1.02E-06	1.01E-06	9.95E-07	9.91E-07
WNW	1.25E-06	1.16E-06	1.11E-06	1.06E-06	1.02E-06	1.01E-06	9.90E-07
NW	1.09E-06	9.91E-07	9.57E-07	8.87E-07	8.18E-07	7.65E-07	7.25E-07
NNW	1.24E-06	1.12E-06	1.03E-06	9.46E-07	8.85E-07	8.17E-07	7.74E-07

continued

* Period of Record: 9-1-76 to 8-31-78
Measured relevant to the reactor vent.

Table A-13 (continued)

Reactor Building Vent Dispersion Parameters
for
Short Term Elevated Releases
≤500 Hrs/Yr or ≤150 Hrs/Qtr

For Standard Distances (As Measured from the Off-Gas Stack)
(χ/q), sec/m^3

Sector*	Miles						
	2.2	2.3	2.4	2.5	2.6	2.7	2.8
N	7.21E-07	6.79E-07	6.38E-07	6.10E-07	5.92E-07	5.77E-07	5.62E-07
NNE	6.47E-07	6.14E-07	5.79E-07	5.45E-07	5.26E-07	4.99E-07	4.80E-07
NE	5.81E-07	5.55E-07	5.23E-07	5.11E-07	4.86E-07	4.63E-07	4.47E-07
ENE	6.68E-07	6.41E-07	6.10E-07	5.90E-07	5.62E-07	5.41E-07	5.22E-07
E	7.25E-07	6.92E-07	6.51E-07	6.19E-07	5.74E-07	5.53E-07	5.35E-07
ESE	7.53E-07	7.07E-07	6.62E-07	6.25E-07	5.91E-07	5.56E-07	5.28E-07
SE	7.76E-07	7.36E-07	7.02E-07	6.75E-07	6.37E-07	6.04E-07	5.74E-07
SSE	7.74E-07	7.28E-07	6.87E-07	6.46E-07	6.10E-07	5.77E-07	5.51E-07
S	6.44E-07	6.08E-07	5.80E-07	5.54E-07	5.40E-07	5.25E-07	5.14E-07
SSW	9.71E-07	9.89E-07	9.88E-07	9.58E-07	9.03E-07	8.47E-07	8.10E-07
SW	9.09E-07	9.03E-07	8.97E-07	8.65E-07	8.24E-07	7.90E-07	7.65E-07
WSW	9.86E-07	9.81E-07	9.76E-07	9.48E-07	8.87E-07	8.35E-07	7.92E-07
W	9.66E-07	9.80E-07	9.78E-07	9.56E-07	9.12E-07	8.87E-07	8.66E-07
WNW	9.90E-07	9.88E-07	9.97E-07	9.75E-07	9.54E-07	9.43E-07	9.29E-07
NW	6.91E-07	6.47E-07	6.07E-07	5.89E-07	5.72E-07	5.60E-07	5.51E-07
NNW	7.27E-07	6.76E-07	6.47E-07	6.28E-07	5.95E-07	5.74E-07	5.52E-07

continued

Period of Record: 9-1-76 to 8-31-78
Measured relevant to the reactor vent.

*

Table A-13 (continued)

Reactor Building Vent Dispersion Parameters
for
Short Term Elevated Releases
≤500 Hrs/Yr or ≤150 Hrs/Qtr

For Standard Distances (As Measured from the Off-Gas Stack)
(χ/q), sec/m^3

Sector*	Miles						
	2.9	3.0	3.1	3.2	3.3	3.4	3.5
N	5.48E-07	5.29E-07	5.16E-07	5.02E-07	4.91E-07	4.99E-07	4.82E-07
NNE	4.65E-07	4.49E-07	4.30E-07	4.15E-07	3.98E-07	3.83E-07	3.71E-07
NE	4.31E-07	4.13E-07	3.96E-07	3.82E-07	3.66E-07	3.51E-07	3.39E-07
ENE	5.06E-07	4.87E-07	4.64E-07	4.52E-07	4.36E-07	4.25E-07	4.14E-07
E	5.13E-07	5.00E-07	4.80E-07	4.62E-07	4.45E-07	4.27E-07	4.09E-07
ESE	5.01E-07	4.74E-07	4.57E-07	4.36E-07	4.15E-07	3.99E-07	3.83E-07
SE	5.51E-07	5.28E-07	5.05E-07	4.78E-07	4.55E-07	4.35E-07	4.16E-07
SSE	5.27E-07	5.06E-07	4.85E-07	4.59E-07	4.44E-07	4.26E-07	4.10E-07
S	5.03E-07	4.91E-07	5.05E-07	4.93E-07	4.96E-07	4.76E-07	4.67E-07
SSW	7.70E-07	7.34E-07	7.03E-07	6.76E-07	6.48E-07	6.25E-07	5.97E-07
SW	7.38E-07	7.09E-07	6.87E-07	6.61E-07	6.43E-07	6.16E-07	5.94E-07
Wsw	7.52E-07	7.13E-07	6.84E-07	6.52E-07	6.24E-07	6.02E-07	5.73E-07
W	8.43E-07	8.16E-07	7.91E-07	7.64E-07	7.44E-07	7.09E-07	6.90E-07
WNW	9.07E-07	8.94E-07	8.62E-07	8.44E-07	8.18E-07	8.00E-07	7.84E-07
NW	5.34E-07	5.22E-07	5.28E-07	5.15E-07	5.16E-07	5.04E-07	4.97E-07
NNW	5.28E-07	5.08E-07	4.93E-07	4.74E-07	4.55E-07	4.35E-07	4.20E-07

continued

Period of Record: 9-1-76 to 8-31-78
Measured relevant to the reactor vent.

*

Table A-13 (continued)

Reactor Building Vent Dispersion Parameters
forShort Term Elevated Releases
≤500 Hrs/Yr or ≤150 Hrs/QtrFor Standard Distances (As Measured from the Off-Gas Stack)
(x/q), sec/m³

Sector*	Miles						
	3.6	3.7	3.8	3.9	4.0	4.1	4.2
N	4.65E-07	4.49E-07	4.32E-07	4.19E-07	4.06E-07	3.95E-07	3.83E-07
NNE	3.58E-07	3.47E-07	3.37E-07	3.25E-07	3.16E-07	3.18E-07	3.08E-07
NE	3.29E-07	3.18E-07	3.10E-07	3.01E-07	2.93E-07	2.90E-07	2.77E-07
ENE	4.02E-07	3.90E-07	3.80E-07	3.72E-07	3.60E-07	3.55E-07	3.46E-07
E	3.97E-07	3.83E-07	3.72E-07	3.74E-07	3.66E-07	3.55E-07	3.44E-07
ESE	3.71E-07	3.57E-07	3.42E-07	3.37E-07	3.28E-07	3.17E-07	3.06E-07
SE	4.01E-07	3.86E-07	3.70E-07	3.61E-07	3.48E-07	3.44E-07	3.42E-07
SSE	3.92E-07	3.78E-07	3.68E-07	3.66E-07	3.52E-07	3.41E-07	3.29E-07
S	4.49E-07	4.43E-07	4.36E-07	4.29E-07	4.22E-07	4.16E-07	4.12E-07
SSW	5.79E-07	5.58E-07	5.49E-07	5.38E-07	5.25E-07	5.14E-07	5.02E-07
SW	5.80E-07	5.64E-07	5.48E-07	5.28E-07	5.15E-07	5.04E-07	4.94E-07
WSW	5.61E-07	5.59E-07	5.50E-07	5.35E-07	5.23E-07	5.13E-07	4.90E-07
W	6.66E-07	6.40E-07	6.16E-07	5.94E-07	5.73E-07	5.54E-07	5.36E-07
WNW	7.52E-07	7.22E-07	6.90E-07	6.65E-07	6.37E-07	6.19E-07	5.97E-07
NW	4.79E-07	4.71E-07	4.66E-07	4.57E-07	4.49E-07	4.41E-07	4.38E-07
NNW	4.07E-07	3.95E-07	3.86E-07	3.72E-07	3.68E-07	3.57E-07	3.51E-07

continued

Period of Record: 9-1-76 to 8-31-78

* Measured relevant to the reactor vent.

Table A-13 (continued)

Reactor Building Vent Dispersion Parameters
for
Short Term Elevated Releases
≤500 Hrs/Yr or ≤150 Hrs/Qtr

For Standard Distances (As Measured from the Off-Gas Stack)
(χ/q), sec/m³

Sector*	Miles						
	4.3	4.4	4.5	4.6	4.7	4.8	4.9
N	3.65E-07	3.55E-07	3.41E-07	3.33E-07	3.25E-07	3.20E-07	3.12E-07
NNE	3.08E-07	3.00E-07	2.85E-07	2.79E-07	2.72E-07	2.66E-07	2.59E-07
NE	2.79E-07	2.69E-07	2.53E-07	2.53E-07	2.48E-07	2.41E-07	2.36E-07
ENE	3.36E-07	3.29E-07	3.12E-07	3.07E-07	3.00E-07	2.98E-07	2.91E-07
E	3.37E-07	3.28E-07	3.19E-07	3.11E-07	3.02E-07	2.95E-07	2.85E-07
ESE	2.98E-07	2.89E-07	2.80E-07	2.71E-07	2.63E-07	2.56E-07	2.48E-07
SE	3.32E-07	3.20E-07	3.10E-07	3.01E-07	2.92E-07	2.83E-07	2.75E-07
SSE	3.21E-07	3.11E-07	3.02E-07	2.92E-07	2.84E-07	2.75E-07	2.68E-07
S	4.03E-07	3.94E-07	3.87E-07	3.76E-07	3.65E-07	3.53E-07	3.43E-07
SSW	4.92E-07	4.81E-07	4.71E-07	4.57E-07	4.39E-07	4.26E-07	4.11E-07
SW	4.84E-07	4.79E-07	4.69E-07	4.54E-07	4.39E-07	4.25E-07	4.12E-07
WSW	4.89E-07	4.77E-07	4.66E-07	4.50E-07	4.35E-07	4.24E-07	4.11E-07
W	5.19E-07	5.03E-07	4.87E-07	4.73E-07	4.56E-07	4.43E-07	4.25E-07
WNW	5.78E-07	5.59E-07	5.41E-07	5.25E-07	5.09E-07	4.92E-07	4.78E-07
NW	4.29E-07	4.20E-07	4.11E-07	4.00E-07	3.88E-07	3.77E-07	3.66E-07
NNW	3.45E-07	3.32E-07	3.22E-07	3.15E-07	3.07E-07	2.98E-07	2.91E-07

continued

* Period of Record: 9-1-76 to 8-31-78
Measured relevant to the reactor vent

Table A-13 (continued)

Reactor Building Vent Dispersion Parameters
for
Short Term Elevated Releases
≤500 Hrs/Yr or ≤150 Hrs/Qtr

For Standard Distances (As Measured from the Off-Gas Stack)
(χ/q), sec/m^3

Sector*	Miles
	5.0
N	3.03E-07
NNE	2.52E-07
NE	2.30E-07
ENE	2.84E-07
E	2.82E-07
ESE	2.41E-07
SE	2.67E-07
SSE	2.62E-07
S	4.67E-07
SSW	4.00E-07
SW	3.99E-07
WSW	3.99E-07
W	4.12E-07
WNW	4.66E-07
NW	3.52E-07
NNW	2.78E-07

Period of Record: 9-1-76 to 8-31-78

* Measured relevant to the reactor vent

Table A-14

Reactor Building Vent Dispersion Parameters
for
Short Term Elevated Releases
≤500 Hrs/Yr or ≤150 Hrs/Qtr

For Standard Distances (As Measured from the Off-Gas Stack)
(D/q), m²

Sector*	Miles						
	0.1	0.2	0.3	0.4	0.5	0.6	0.7
N	6.91E-07	2.69E-07	1.52E-07	1.01E-07	7.36E-08	5.53E-08	4.28E-08
NNE	5.55E-07	2.24E-07	1.30E-07	8.81E-08	6.33E-08	4.71E-08	3.65E-08
NE	3.90E-07	1.58E-07	9.37E-08	6.24E-08	4.48E-08	3.32E-08	2.59E-08
ENE	3.50E-07	1.43E-07	8.49E-08	5.71E-08	4.08E-08	3.02E-08	2.33E-08
E	4.63E-07	1.86E-07	1.10E-07	7.39E-08	5.16E-08	3.82E-08	2.91E-08
ESE	8.49E-07	3.27E-07	1.86E-07	1.21E-07	8.62E-08	6.33E-08	4.88E-08
SE	9.41E-07	3.56E-07	1.96E-07	1.29E-07	9.01E-08	6.69E-08	5.19E-08
SSE	9.60E-07	3.67E-07	2.02E-07	1.32E-07	9.36E-08	6.99E-08	5.40E-08
S	4.50E-07	1.79E-07	1.06E-07	7.18E-08	5.11E-08	3.80E-08	2.88E-08
SSW	3.27E-07	1.30E-07	7.81E-08	5.13E-08	3.67E-08	2.75E-08	2.15E-08
SW	4.13E-07	1.67E-07	9.51E-08	6.02E-08	4.24E-08	3.12E-08	2.46E-08
WSW	2.82E-07	1.14E-07	6.90E-08	4.53E-08	3.27E-08	2.46E-08	1.94E-08
W	3.06E-07	1.25E-07	7.41E-08	5.02E-08	3.55E-08	2.68E-08	2.10E-08
WNW	4.25E-07	1.69E-07	9.89E-08	6.61E-08	4.73E-08	3.52E-08	2.73E-08
NW	5.40E-07	2.12E-07	1.21E-07	7.91E-08	5.61E-08	4.23E-08	3.28E-08
NNW	6.42E-07	2.53E-07	1.42E-07	9.39E-08	6.65E-08	4.95E-08	3.87E-08

continued

Period of Record: 9-1-76 to 8-31-78
Measured relevant to the Off-Gas Stack

*

Table A-14 (continued)

Reactor Building Vent Dispersion Parameters
for
Short Term Elevated Releases
≤500 Hrs/Yr or ≤150 Hrs/Qtr

For Standard Distances (As Measured from the Off-Gas Stack)
(D/q), m⁻²

Sector*	Miles						
	0.8	0.9	1.0	1.1	1.2	1.3	1.4
N	3.25E-08	2.57E-08	1.99E-08	1.61E-08	1.34E-08	1.13E-08	9.77E-09
NNE	2.79E-08	2.22E-08	1.71E-08	1.39E-08	1.16E-08	9.77E-09	8.45E-09
NE	1.99E-08	1.56E-08	1.23E-08	1.00E-08	8.52E-09	7.15E-09	6.20E-09
ENE	1.80E-08	1.41E-08	1.12E-08	9.11E-09	7.57E-09	6.45E-09	5.55E-09
E	2.17E-08	1.70E-08	1.33E-08	1.07E-08	9.01E-09	7.69E-09	6.56E-09
ESE	3.78E-08	2.92E-08	2.35E-08	1.93E-08	1.59E-08	1.34E-08	1.16E-08
SE	3.99E-08	3.10E-08	2.48E-08	2.04E-08	1.67E-08	1.40E-08	1.20E-08
SSE	4.16E-08	3.26E-08	2.57E-08	2.12E-08	1.76E-08	1.48E-08	1.27E-08
S	2.26E-08	1.78E-08	1.41E-08	1.16E-08	9.75E-09	8.85E-09	7.48E-09
SSW	1.69E-08	1.34E-08	1.10E-08	9.02E-09	7.60E-09	6.52E-09	5.84E-09
SW	1.89E-08	1.51E-08	1.25E-08	1.01E-08	8.52E-09	7.27E-09	6.61E-09
WSW	1.52E-08	1.20E-08	1.01E-08	8.20E-09	6.85E-09	5.94E-09	5.35E-09
W	1.62E-08	1.31E-08	1.04E-08	8.64E-09	7.29E-09	6.19E-09	5.49E-09
WNW	2.16E-08	1.72E-08	1.36E-08	1.12E-08	9.47E-09	7.95E-09	7.18E-09
NW	2.49E-08	1.97E-08	1.55E-08	1.26E-08	1.07E-08	9.05E-09	7.82E-09
NNW	3.00E-08	2.36E-08	1.82E-08	1.49E-08	1.22E-08	1.05E-08	9.21E-09

continued

Period of Record: 9-1-76 to 8-31-78
Measured relevant to the Off-Gas Stack

*

Table A-14 (continued)

Reactor Building Vent Dispersion Parameters
for
Short Term Elevated Releases
≤500 Hrs/Yr or ≤150 Hrs/Qtr

For Standard Distances (As Measured from the Off-Gas Stack)
(D/q), m²

Sector*	Miles						
	1.5	1.6	1.7	1.8	1.9	2.0	2.1
N	8.90E-09	7.61E-09	6.62E-09	5.81E-09	5.23E-09	4.63E-09	4.13E-09
NNE	7.75E-09	6.61E-09	5.79E-09	5.10E-09	4.56E-09	4.07E-09	3.71E-09
NE	5.46E-09	4.54E-09	4.02E-09	3.69E-09	3.30E-09	2.93E-09	2.48E-09
ENE	4.71E-09	4.19E-09	3.73E-09	3.33E-09	2.98E-09	2.64E-09	2.40E-09
E	5.63E-09	4.93E-09	4.49E-09	3.96E-09	3.53E-09	3.18E-09	2.88E-09
ESE	1.01E-08	8.60E-09	7.60E-09	7.07E-09	6.28E-09	5.64E-09	5.07E-09
SE	1.03E-08	9.00E-09	7.94E-09	7.17E-09	6.48E-09	5.74E-09	5.17E-09
SSE	1.10E-08	9.30E-09	8.32E-09	7.72E-09	6.89E-09	6.20E-09	5.56E-09
S	6.89E-09	5.81E-09	5.11E-09	4.54E-09	4.06E-09	3.61E-09	3.30E-09
SSW	5.34E-09	4.70E-09	4.14E-09	3.63E-09	3.26E-09	3.21E-09	2.88E-09
SW	6.60E-09	5.31E-09	4.72E-09	4.14E-09	3.66E-09	3.56E-09	3.24E-09
WSW	4.91E-09	4.44E-09	3.92E-09	3.40E-09	3.03E-09	3.03E-09	2.76E-09
W	5.07E-09	4.44E-09	3.82E-09	3.36E-09	3.07E-09	2.96E-09	2.71E-09
WNW	6.67E-09	5.78E-09	5.06E-09	4.43E-09	3.92E-09	3.71E-09	3.34E-09
NW	6.67E-09	5.73E-09	5.26E-09	4.65E-09	4.11E-09	3.68E-09	3.35E-09
NNW	8.53E-09	7.30E-09	6.36E-09	5.58E-09	5.00E-09	4.42E-09	4.03E-09

continued

* Period of Record: 9-1-76 to 8-31-78
Measured relevant to the Off-Gas stack

Table A-14 (continued)

Reactor Building Vent Dispersion Parameters
for

Short Term Elevated Releases
≤500 Hrs/Yr or ≤150 Hrs/Qtr

For Standard Distances (As Measured from the Off-Gas Stack)
(D/q), m²

Sector*	Miles						
	2.2	2.3	2.4	2.5	2.6	2.7	2.8
N	3.75E-09	3.42E-09	3.11E-09	2.88E-09	2.68E-09	2.53E-09	2.38E-09
NNE	3.34E-09	3.06E-09	2.79E-09	2.55E-09	2.38E-09	2.20E-09	2.06E-09
NE	2.43E-09	2.21E-09	2.02E-09	1.89E-09	1.74E-09	1.61E-09	1.51E-09
ENE	2.18E-09	2.03E-09	1.85E-09	1.70E-09	1.57E-09	1.46E-09	1.36E-09
E	2.61E-09	2.41E-09	2.20E-09	2.02E-09	1.82E-09	1.71E-09	1.61E-09
ESE	4.60E-09	4.21E-09	3.84E-09	3.54E-09	3.28E-09	3.01E-09	2.80E-09
SE	4.71E-09	4.43E-09	4.07E-09	3.79E-09	3.49E-09	3.24E-09	3.02E-09
SSE	5.01E-09	4.58E-09	4.21E-09	3.86E-09	3.55E-09	3.28E-09	3.06E-09
S	2.95E-09	2.70E-09	2.50E-09	2.32E-09	2.15E-09	2.00E-09	1.86E-09
SSW	2.60E-09	2.45E-09	2.28E-09	2.06E-09	1.90E-09	1.75E-09	1.64E-09
SW	2.93E-09	2.72E-09	2.53E-09	2.29E-09	2.11E-09	1.96E-09	1.84E-09
WSW	2.48E-09	2.31E-09	2.16E-09	1.98E-09	1.81E-09	1.68E-09	1.56E-09
W	2.44E-09	2.29E-09	2.12E-09	1.93E-09	1.77E-09	1.66E-09	1.57E-09
WNW	3.09E-09	2.85E-09	2.67E-09	2.43E-09	2.25E-09	2.11E-09	1.98E-09
NW	3.06E-09	2.76E-09	2.58E-09	2.41E-09	2.25E-09	2.10E-09	1.98E-09
NNW	3.64E-09	3.26E-09	3.04E-09	2.85E-09	2.62E-09	2.45E-09	2.29E-09

continued

* Period of Record: 9-1-76 to 8-31-78
Measured relevant to the Off-Gas Stack

Table A-14 (continued)

Reactor Building Vent Dispersion Parameters
for
Short Term Elevated Releases
≤500 Hrs/Yr or ≤150 Hrs/Qtr

For Standard Distances (As Measured from the Off-Gas Stack)
(D/q), m²

Sector*	Miles						
	2.9	3.0	3.1	3.2	3.3	3.4	3.5
N	2.23E-09	2.09E-09	1.96E-09	1.84E-09	1.74E-09	1.73E-09	1.63E-09
NNE	1.94E-09	1.82E-09	1.71E-09	1.61E-09	1.51E-09	1.42E-09	1.35E-09
NE	1.42E-09	1.33E-09	1.25E-09	1.17E-09	1.10E-09	1.03E-09	9.77E-10
ENE	1.28E-09	1.20E-09	1.11E-09	1.05E-09	9.92E-10	9.42E-10	8.97E-10
E	1.50E-09	1.43E-09	1.34E-09	1.26E-09	1.19E-09	1.11E-09	1.04E-09
ESE	2.60E-09	2.42E-09	2.29E-09	2.15E-09	2.00E-09	1.90E-09	1.79E-09
SE	2.84E-09	2.67E-09	2.50E-09	2.32E-09	2.18E-09	2.05E-09	1.93E-09
SSE	2.86E-09	2.69E-09	2.53E-09	2.34E-09	2.23E-09	2.10E-09	1.98E-09
S	1.74E-09	1.63E-09	1.64E-09	1.54E-09	1.48E-09	1.36E-09	1.29E-09
SSW	1.53E-09	1.44E-09	1.36E-09	1.29E-09	1.22E-09	1.16E-09	1.10E-09
SW	1.73E-09	1.61E-09	1.52E-09	1.43E-09	1.36E-09	1.27E-09	1.21E-09
WSW	1.46E-09	1.37E-09	1.29E-09	1.22E-09	1.15E-09	1.10E-09	1.04E-09
W	1.48E-09	1.40E-09	1.32E-09	1.24E-09	1.18E-09	1.10E-09	1.05E-09
WNW	1.84E-09	1.74E-09	1.61E-09	1.52E-09	1.42E-09	1.52E-09	1.56E-09
NW	1.83E-09	1.72E-09	1.67E-09	1.59E-09	1.53E-09	1.42E-09	1.36E-09
NNW	2.13E-09	2.01E-09	1.90E-09	1.79E-09	1.67E-09	1.57E-09	1.49E-09

continued

Period of Record: 9-1-76 to 8-31-78

* Measured relevant to the Off-Gas Stack

Table A-14 (continued)

Reactor Building Vent Dispersion Parameters
for
Short Term Elevated Releases
≤500 Hrs/Yr or ≤150 Hrs/Qtr

For Standard Distances (As Measured from the Off-Gas Stack)
(D/q), m²

Sector*	Miles						
	3.6	3.7	3.8	3.9	4.0	4.1	4.2
N	1.55E-09	1.47E-09	1.40E-09	1.34E-09	1.29E-09	1.24E-09	1.20E-09
NNE	1.27E-09	1.21E-09	1.16E-09	1.09E-09	1.04E-09	1.03E-09	9.85E-10
NE	9.27E-10	8.82E-10	8.44E-10	8.04E-10	7.68E-10	7.48E-10	7.05E-10
ENE	8.50E-10	8.08E-10	7.71E-10	7.38E-10	7.01E-10	6.78E-10	6.48E-10
E	9.92E-10	9.39E-10	8.94E-10	8.83E-10	8.48E-10	8.09E-10	7.71E-10
ESE	1.71E-09	1.61E-09	1.53E-09	1.48E-09	1.42E-09	1.35E-09	1.29E-09
SE	1.83E-09	1.73E-09	1.64E-09	1.57E-09	1.50E-09	1.46E-09	1.44E-09
SSE	1.86E-09	1.76E-09	1.69E-09	1.65E-09	1.56E-09	1.49E-09	1.42E-09
S	1.20E-09	1.16E-09	1.11E-09	1.07E-09	1.03E-09	9.96E-10	9.67E-10
SSW	1.04E-09	9.85E-10	9.51E-10	9.16E-10	8.78E-10	8.46E-10	8.15E-10
SW	1.14E-09	1.08E-09	1.02E-09	9.62E-10	1.01E-09	9.88E-10	9.93E-10
WSW	9.89E-10	9.58E-10	9.19E-10	8.74E-10	8.35E-10	8.03E-10	7.53E-10
W	1.01E-09	9.61E-10	9.21E-10	8.85E-10	8.52E-10	8.21E-10	7.93E-10
WNW	1.49E-09	1.42E-09	1.34E-09	1.29E-09	1.23E-09	1.18E-09	1.14E-09
NW	1.28E-09	1.23E-09	1.19E-09	1.14E-09	1.10E-09	1.06E-09	1.03E-09
NNW	1.41E-09	1.34E-09	1.29E-09	1.22E-09	1.19E-09	1.14E-09	1.10E-09

continued

Period of Record: 9-1-76 to 8-31-78

* Measured relevant to the Off-Gas Stack

Table A-14 (continued)

Reactor Building Vent Dispersion Parameters
for
Short Term Elevated Releases
≤500 Hrs/Yr or ≤150 Hrs/Qtr

For Standard Distances (As Measured from the Off-Gas Stack)
(D/q), m²

Sector*	Miles						
	4.3	4.4	4.5	4.6	4.7	4.8	4.9
N	1.13E-09	1.09E-09	1.05E-09	1.02E-09	9.85E-10	9.67E-10	9.40E-10
NNE	9.68E-10	9.29E-10	8.71E-10	8.40E-10	8.07E-10	7.79E-10	7.49E-10
NE	6.98E-10	6.63E-10	6.16E-10	6.06E-10	5.87E-10	5.62E-10	5.45E-10
ENE	6.19E-10	5.96E-10	5.55E-10	5.37E-10	5.17E-10	5.06E-10	4.86E-10
E	7.43E-10	7.10E-10	6.81E-10	6.53E-10	6.25E-10	6.01E-10	5.72E-10
ESE	1.24E-09	1.18E-09	1.13E-09	1.08E-09	1.04E-09	9.99E-10	9.57E-10
SE	1.38E-09	1.31E-09	1.26E-09	1.21E-09	1.16E-09	1.12E-09	1.07E-09
SSE	1.36E-09	1.30E-09	1.25E-09	1.18E-09	1.14E-09	1.09E-09	1.05E-09
S	9.28E-10	8.94E-10	8.64E-10	8.38E-10	8.12E-10	7.83E-10	7.60E-10
SSW	7.88E-10	7.61E-10	7.38E-10	7.17E-10	6.89E-10	6.70E-10	6.49E-10
SW	1.09E-09	1.06E-09	1.11E-09	1.07E-09	1.02E-09	9.83E-10	9.46E-10
WSW	7.39E-10	7.09E-10	7.33E-10	7.08E-10	6.86E-10	6.70E-10	6.50E-10
W	7.67E-10	7.44E-10	7.22E-10	7.02E-10	6.79E-10	6.61E-10	6.36E-10
WNW	1.10E-09	1.06E-09	1.02E-09	9.86E-10	9.55E-10	9.22E-10	8.94E-10
NW	9.96E-10	9.60E-10	9.27E-10	9.00E-10	8.73E-10	8.48E-10	8.24E-10
NNW	1.07E-09	1.02E-09	1.01E-09	9.77E-10	9.43E-10	9.13E-10	8.84E-10

continued

* Period of Record: 9-1-76 to 8-31-78
Measured relevant to the Off-Gas Stack

Table A-14 (continued)

Reactor Building Vent Dispersion Parameters
for
Short Term Elevated Releases
≤500 Hrs/Yr. or ≤150 Hrs/Qtr

For Standard Distances (As Measured from the Off-Gas Stack)
(D/q), m²

Sector*	Miles
5.0	
N	9.09E-10
NNE	7.21E-10
NE	5.24E-10
ENE	4.68E-10
E	5.58E-10
ESE	9.19E-10
SE	1.04E-09
SSE	1.01E-09
S	1.29E-09
SSW	6.32E-10
SW	9.10E-10
WSW	6.32E-10
W	6.21E-10
WNW	8.70E-10
NW	7.93E-10
NNW	8.42E-10

* Period of Record: 9-1-76 to 8-31-78
Measured relevant to the Off-Gas Stack

APPENDIX B

Monticello 10 Meter Wind
and
 $\Delta T_{42.7 - 10}$ Meter Stability
Joint Frequency Distributions

September 1, 1976 to August 31, 1978

CONTENTS, APPENDIX B

<u>Site Meteorology - Frequency Distribution Tables</u>			<u>Page</u>
Table B-1	Stability Class A	10 meter Elevation	B-3
Table B-2	Stability Class B	10 meter Elevation	B-4
Table B-3	Stability Class C	10 meter Elevation	B-5
Table B-4	Stability Class D	10 meter Elevation	B-6
Table B-5	Stability Class E	10 meter Elevation	B-7
Table B-6	Stability Class F	10 meter Elevation	B-8
Table B-7	Stability Class G	10 meter Elevation	B-9
Table B-8	All Classes Combined	10 meter Elevation	B-10

Table B-1

Monticello Nuclear Generating Plant
 Site Meteorology - Frequency Distribution Tables

Hours at each Wind Speed and Direction

Period of record: 9-1-76 through 8-31-78

Stability Class A
 Elevation 10 meters

Wind Speed (mph) at 10 meter Level

<u>Direction</u>	<u>1 to 3</u>	<u>4 to 7</u>	<u>8 to 12</u>	<u>13 to 18</u>	<u>19 to 24</u>	<u>Above 24</u>	<u>Total</u>
N	4	18	63	30	7	0	122
NNE	2	20	30	14	2	0	68
NE	1	13	21	26	2	2	65
NNE	1	14	16	4	0	0	35
E	0	28	40	12	0	0	80
ESE	3	33	50	5	6	0	97
SE	2	26	50	35	12	3	128
SSE	8	46	96	122	11	0	283
S	9	36	68	117	42	3	275
SSW	5	63	94	58	20	4	244
SW	4	35	64	32	5	3	143
WSW	3	25	74	26	0	0	128
W	0	29	47	18	1	0	95
WNW	4	34	73	79	14	0	204
NW	3	29	58	61	3	0	154
NNW	6	29	109	67	13	0	224
VAR	0	0	0	0	0	0	0

Total Hours This Class:	2350
Hours of Calm This Class:	5
Percent of All Data This Class:	14.27

Table B-2

Monticello Nuclear Generating Plant
 Site Meteorology - Frequency Distribution Tables
 Hours at each Wind Speed and Direction

Period of record: 9-1-76 through 8-31-78

Stability Class B
 Elevation 10 meters

Wind Speed (mph) at 10 meter Level

<u>Direction</u>	<u>1 to 3</u>	<u>4 to 7</u>	<u>8 to 12</u>	<u>13 to 18</u>	<u>19 to 24</u>	<u>Above 24</u>	<u>Total</u>
N	2	14	19	4	0	1	40
NNE	4	10	8	5	0	0	27
NE	0	6	3	2	0	0	11
ENE	1	11	7	2	0	0	21
E	0	13	4	0	0	0	17
ESE	1	15	10	3	3	0	32
SE	0	9	9	9	0	0	27
SSE	2	12	9	9	0	0	32
S	2	13	21	7	1	0	44
SSW	1	22	19	4	0	0	46
SW	0	11	10	3	0	0	24
WSW	1	12	11	3	0	0	27
W	0	12	19	8	2	1	42
WNW	0	11	20	21	5	1	58
NW	1	8	22	13	3	0	47
NNW	1	8	40	26	4	1	80
Var	0	0	0	0	0	0	0

Total Hours This Class: 575
 Hours of Calm This Class: 0
 Percent of All Data This Class: 3.49

Table B-3

Monticello Nuclear Generating Plant
 Site Meteorology - Frequency Distribution Tables
 Hours at each Wind Speed and Direction

Period of record: 9-1-76 through 8-31-78

Stability Class C
 Elevation 10 meters

Wind Speed (mph) at 10 meter Level

<u>Direction</u>	<u>1 to 3</u>	<u>4 to 7</u>	<u>8 to 12</u>	<u>13 to 18</u>	<u>19 to 24</u>	<u>Above 24</u>	<u>Total</u>
N	0	12	16	8	0	0	36
NNE	3	13	13	4	1	0	34
NE	2	10	11	5	2	0	30
ENE	1	19	4	2	0	0	26
E	0	8	10	2	0	0	20
ESE	2	14	12	5	2	0	35
SE	0	12	16	9	0	0	37
SSE	0	10	21	8	0	0	39
S	6	12	28	18	3	0	67
SSW	3	16	12	3	2	1	37
SW	3	11	14	3	1	0	32
WSW	2	5	11	2	0	0	20
W	4	22	19	5	1	0	51
WNW	4	23	38	19	3	0	87
NW	3	17	18	30	4	0	72
NNW	2	22	40	27	5	1	97
VAR	0	0	0	0	0	0	0

Total Hours This Class:	720
Hours of Calm This Class:	0
Percent of All Data This Class:	4.37

Table B-4

Monticello Nuclear Generating Plant
 Site Meteorology - Frequency Distribution Tables
 Hours at each Wind Speed and Direction

Period of record: 9-1-76 through 8-31-78

Stability Class D
 Elevation 10 meters

Wind Speed (mph) at 10 meter Level

<u>Direction</u>	<u>1 to 3</u>	<u>4 to 7</u>	<u>8 to 12</u>	<u>13 to 18</u>	<u>19 to 24</u>	<u>Above 24</u>	<u>Total</u>
N	9	107	135	39	1	0	291
NNE	32	132	87	18	1	0	270
NE	37	129	116	50	3	0	335
ENE	43	153	66	30	1	0	293
E	29	125	64	27	0	0	245
ESE	28	107	148	60	4	0	347
SE	16	103	153	36	2	0	310
SSE	13	97	103	35	2	0	250
S	19	84	96	33	1	0	233
SSW	16	73	70	19	6	1	185
SW	19	58	52	10	4	0	143
WSW	14	69	63	14	2	1	163
W	16	79	98	33	3	5	234
WNW	13	112	262	159	25	2	573
NW	17	82	255	232	61	3	650
NNW	19	104	247	246	49	1	666
VAR	0	0	0	0	0	0	0

Total Hours This Class: 5198
 Hours of Calm This Class: 10
 Percent of All Data This Class: 31.56

Table B-5

Monticello Nuclear Generating Plant
 Site Meteorology - Frequency Distribution Tables
 Hours at each Wind Speed and Direction

Period of record: 9-1-76 through 8-31-78

Stability Class E
 Elevation 10 meters

Wind Speed (mph) at 10 meter Level

Direction	1 to 3	4 to 7	8 to 12	13 to 18	19 to 24	Above 24	Total
N	20	98	57	6	0	0	181
NNE	43	81	35	2	0	0	161
NE	35	94	41	6	2	0	178
ENE	50	122	29	10	0	0	211
E	36	109	40	2	0	0	187
ESE	26	117	46	6	0	0	195
SE	19	111	136	18	2	0	286
SSE	20	95	116	33	1	0	265
S	22	84	144	43	1	0	294
SSW	22	72	99	25	9	0	227
SW	23	84	57	10	2	0	176
WSW	37	86	44	4	0	0	171
W	30	156	123	12	4	0	325
WNW	24	195	233	41	2	0	495
NW	20	133	247	84	0	0	484
NNW	25	145	217	38	1	0	426
VAR	0	0	0	0	0	0	0

Total Hours This Class:	4269
Hours of Calm This Class:	7
Percent of All Data This Class:	25.92

Table B-6

Monticello Nuclear Generating Plant
 Site Meteorology - Frequency Distribution Tables

Hours at each Wind Speed and Direction

Period of record: 9-1-76 through 8-31-78

Stability Class F
 Elevation 10 meters

Wind Speed (mph) at 10 meter Level

Direction	1 to 3	4 to 7	8 to 12	13 to 18	19 to 24	Above 24	Total
N	30	62	3	0	0	0	95
NNE	37	54	0	0	0	0	91
NE	29	29	0	0	0	0	58
ENE	32	28	0	0	0	0	60
E	32	59	5	0	0	0	96
ESE	25	97	11	0	0	0	133
SE	22	83	19	0	0	0	124
SSE	16	122	12	0	0	0	150
S	24	93	31	3	0	0	151
SSW	27	67	14	0	0	0	108
SW	27	52	7	0	0	0	86
WSW	52	68	8	0	0	0	128
W	51	91	14	0	0	0	156
WNW	28	68	9	0	0	0	105
NW	36	67	12	0	0	0	115
NNW	30	119	29	0	0	0	178
VAR	0	0	0	0	0	0	0

Total Hours This Class: 1847
 Hours of Calm This Class: 13
 Percent of All Data This Class: 11.21

Table B-7

Monticello Nuclear Generating Plant
 Site Meteorology - Frequency Distribution Tables
 Hours at each Wind Speed and Direction

Period of record: 9-1-76 through 8-31-78

Stability Class G
 Elevation 10 meters

Wind Speed (mph) at 10 meter Level

Direction	1 to 3	4 to 7	8 to 12	13 to 18	19 to 24	Above 24	Total
N	45	31	0	0	0	0	76
NNE	40	16	0	0	0	0	56
NE	33	12	0	0	0	0	45
ENE	31	5	0	0	0	0	36
E	46	18	0	0	0	0	64
ESE	47	54	2	0	0	0	103
SE	52	34	1	1	0	0	88
SSE	67	111	3	6	0	0	187
S	64	109	23	2	0	0	198
SSW	61	65	10	2	0	0	138
SW	43	32	1	0	0	0	76
WSW	77	37	0	0	0	0	114
W	53	31	0	0	0	0	84
WNW	37	13	2	0	0	0	52
NW	49	15	3	4	0	0	71
NNW	47	48	2	0	0	0	97
VAR	0	0	0	0	0	0	0

Total Hours This Class: 1512
 Hours of Calm This Class: 27
 Percent of All Data This Class: 9.18

Table B-8

Monticello Nuclear Generating Plant
 Site Meteorology - Frequency Distribution Tables
 Hours at each Wind Speed and Direction

Period of record: 9-1-76 through 8-31-78

All Classes Combined
 Elevation 10 meters

Wind Speed (mph) at 10 meter Level

<u>Direction</u>	<u>1 to 3</u>	<u>4 to 7</u>	<u>8 to 12</u>	<u>13 to 18</u>	<u>19 to 24</u>	<u>Above 24</u>	<u>Total</u>
N	110	342	293	87	8	1	841
NNE	161	326	173	43	4	0	707
NE	137	293	192	89	9	2	722
ENE	159	352	122	48	1	0	682
E	143	360	163	43	0	0	709
ESE	132	437	279	79	15	0	942
SE	111	378	384	108	16	3	1000
SSE	126	493	360	213	14	0	1206
S	146	431	411	223	48	3	1262
SSW	135	378	318	111	37	6	985
SW	119	283	205	58	12	3	680
WSW	186	302	211	49	2	1	751
W	154	420	320	76	11	6	987
WNW	110	456	637	319	49	3	1574
NW	129	351	615	424	71	3	1593
NNW	130	475	684	404	72	3	1768
VAR	0	0	0	0	0	0	0

continued

Table B-8 (continued)

Monticello Nuclear Generating Plant
Site Meteorology - Frequency Distribution Tables
Hours at each Wind Speed and Direction

Period of record: 9-1-76 through 8-31-78

All Classes Combined
Elevation 10 meters

Data Recovery for the Period

Total Hours:	17520
Hours of Calm:	62
Hours of Bad Data:	1049
Percent Data Recovery:	94.01

Percent Acceptable Observations in each Stability Class

Class A	14.27
Class B	3.49
Class C	4.37
Class D	31.56
Class E	25.92
Class F	11.21
Class G	9.18

Average Wind Speed for each Wind Category

1 to 3 mph	2.5
4 to 7 mph	5.5
8 to 12 mph	9.7
13 to 18 mph	14.7
19 to 24 mph	20.6
Above 24 mph	27.2

APPENDIX C

Monticello 100 Meter Wind
and
 $\Delta T_{100 - 10}$ Meter Stability
Joint Frequency Distributions

September 1, 1976 to August 31, 1978

CONTENTS, APPENDIX C

Site Meteorology - Frequency Distribution Tables

Table C-1	Stability Class A	100 meter Elevation	C-3
Table C-2	Stability Class B	100 meter Elevation	C-4
Table C-3	Stability Class C	100 meter Elevation	C-5
Table C-4	Stability Class D	100 meter Elevation	C-6
Table C-5	Stability Class E	100 meter Elevation	C-7
Table C-6	Stability Class F	100 meter Elevation	C-8
Table C-7	Stability Class G	100 meter Elevation	C-9
Table C-8	All Classes Combined	110 meter Elevation	C-10

Table C-1

Monticello Nuclear Generating Plant
 Site Meteorology - Frequency Distribution Tables
 Hours at each Wind Speed and Direction

Period of record: 9-1-76 through 8-31-78

Stability Class A
 Elevation 100 meters

Wind Speed (mph) at 100 meter Level

Direction	1 to 3	4 to 7	8 to 12	13 to 18	19 to 24	Above 24	Total
N	0	1	2	10	1	0	14
NNE	0	1	1	1	0	0	3
NE	0	0	1	0	0	0	1
ENE	0	0	0	0	1	0	1
E	0	1	4	0	0	0	5
ESE	0	0	4	0	0	0	4
SE	0	0	4	8	0	6	18
SSE	0	1	5	42	36	15	99
S	0	1	3	28	35	12	79
SSW	0	1	10	37	53	39	140
SW	0	0	4	19	6	5	36
WSW	0	0	3	16	10	1	30
W	0	0	0	7	2	0	9
WNW	0	0	2	4	1	2	9
NW	0	0	3	6	6	3	18
NNW	0	0	1	14	4	0	19
VAR	0	0	0	0	0	0	0

Total Hours This Class: 489
 Hours of Calm This Class: 4
 Percent of All Data This Class: 2.95

Table C-2

Monticello Nuclear Generating Plant
 Site Meteorology - Frequency Distribution Tables
 Hours at each Wind Speed and Direction

Period of record: 9-1-76 through 8-31-78

Stability Class B
 Elevation 100 meters

Wind Speed (mph) at 100 meter Level

Direction	1 to 3	4 to 7	8 to 12	13 to 18	19 to 24	Above 24	Total
N	0	3	13	18	3	0	37
NNE	0	6	3	9	2	2	22
NE	0	1	7	6	0	0	14
ENE	0	2	3	7	2	0	14
E	0	2	15	1	0	0	18
ESE	0	5	17	3	0	2	27
SE	1	7	15	9	2	2	36
SSE	1	9	28	12	8	2	60
S	0	5	23	18	3	0	49
SSW	0	8	23	17	5	2	60
SW	0	7	18	8	5	1	39
WSW	0	7	8	14	2	1	32
W	0	4	8	18	5	0	35
WNW	0	4	12	17	7	6	46
NW	1	5	14	23	12	5	60
NNW	0	1	8	25	11	2	47
VAR	0	0	0	0	0	0	0

Total Hours This Class: 602
 Hours of Calm This Class: 6
 Percent of All Data This Class: 3.64

Table C-3

Monticello Nuclear Generating Plant
 Site Meteorology - Frequency Distribution Tables
 Hours at each Wind Speed and Direction

Period of record: 9-1-76 through 8-31-78

Stability Class C
 Elevation 100 meters

Wind Speed (mph) at 100 meter Level

<u>Direction</u>	<u>1 to 3</u>	<u>4 to 7</u>	<u>8 to 12</u>	<u>13 to 18</u>	<u>19 to 24</u>	<u>Above 24</u>	<u>Total</u>
N	3	9	26	25	13	2	78
NNE	2	12	14	14	8	2	52
NE	1	7	9	8	2	0	27
ENE	0	5	12	6	1	0	24
E	0	13	19	1	2	0	35
ESE	0	13	25	11	1	1	51
SE	2	17	12	8	4	0	43
SSE	0	26	38	19	10	2	95
S	0	15	23	13	7	4	62
SSW	0	28	33	23	11	2	97
SW	0	20	24	17	4	0	65
WSW	3	17	27	14	3	1	65
W	3	10	20	14	8	3	58
WNW	3	10	16	27	18	9	83
NW	2	8	22	38	26	10	106
NNW	2	3	16	42	19	8	90
VAR	0	0	0	0	0	0	0

Total Hours This Class: 1041
 Hours of Calm This Class: 10
 Percent of All Data This Class: 4.29

Table C-4

Monticello Nuclear Generating Plant
 Site Meteorology - Frequency Distribution Tables
 Hours at each Wind Speed and Direction

Period of record: 9-1-76 through 8-31-78

Stability Class D
 Elevation 100 meters

Wind Speed (mph) at 100-meter Level

<u>Direction</u>	<u>1 to 3</u>	<u>4 to 7</u>	<u>8 to 12</u>	<u>13 to 18</u>	<u>19 to 24</u>	<u>Above 24</u>	<u>Total</u>
N	11	51		95	181	130	82
NNE	11	41	106	120	50	12	340
NE	15	53	105	93	25	8	299
ENE	14	41	131	83	59	12	340
E	18	61	103	62	38	6	288
ESE	17	55	101	85	47	31	336
SE	13	57	108	152	68	23	421
SSE	9	63	119	148	71	17	427
S	16	61	95	122	61	8	363
SSW	14	61	85	120	46	34	360
SW	14	54	80	74	32	11	265
WSW	13	52	69	44	21	11	210
W	8	45	89	59	29	17	247
WNW	14	51	141	165	77	62	510
NW	7	50	170	366	312	143	1048
NNW	12	52	176	312	350	229	1131
VAR	0	0	0	0	0	0	0

Total Hours This Class: 7264
 Hours of Calm This Class: 129
 Percent of All Data This Class: 43.87

Table C-5

Monticello Nuclear Generating Plant
 Site Meteorology - Frequency Distribution Tables
 Hours at each Wind Speed and Direction

Period of record: 9-1-76 through 8-31-78

Stability Class E
 Elevation 100 meters

Wind Speed (mph) at 100 meter Level

Direction	1 to 3	4 to 7	8 to 12	13 to 18	19 to 24	Above 24	Total
N	4	17	59	99	82	11	272
NNE	7	18	37	68	32	3	165
NE	4	16	47	58	20	2	147
ENE	4	33	68	93	27	9	234
E	4	27	64	75	15	2	187
ESE	5	20	46	74	37	11	193
SE	10	23	63	97	58	3	254
SSE	5	22	58	94	105	16	300
S	5	13	57	140	97	20	332
SSW	2	25	49	115	125	22	338
SW	7	24	67	102	84	18	302
WSW	3	19	42	73	37	8	182
W	5	20	47	55	35	2	164
WNW	4	18	63	136	93	13	327
NW	6	15	71	172	141	12	417
NNW	3	27	86	244	198	17	575
VAR	0	0	0	0	0	0	0

Total Hours This Class: 4433
 Hours of Calm This Class: 44
 Percent of All Data This Class: 26.77

Table C-6

Monticello Nuclear Generating Plant
 Site Meteorology - Frequency Distribution Tables
 Hours at each Wind Speed and Direction

Period of record: 9-1-76 through 8-31-78

Stability Class F
 Elevation 100 meters

Wind Speed (mph) at 100 meter Level

<u>Direction</u>	<u>1 to 3</u>	<u>4 to 7</u>	<u>8 to 12</u>	<u>13 to 18</u>	<u>19 to 24</u>	<u>Above 24</u>	<u>Total</u>
N	3	12	28	45	28	0	116
NNE	2	4	15	39	16	1	77
NE	4	7	23	49	17	1	101
ENE	1	7	19	40	6	3	76
E	4	10	26	15	3	0	58
ESE	8	16	28	31	14	2	99
SE	2	7	28	46	19	5	107
SSE	2	8	25	62	40	1	138
S	1	12	30	60	36	1	140
SSW	1	11	28	58	57	4	159
SW	3	14	19	75	33	2	146
WSW	5	6	22	28	29	0	90
W	1	14	22	27	16	0	80
WNW	4	10	44	49	27	1	135
NW	4	12	37	87	29	0	169
NNW	4	14	38	51	21	1	129
VAR	0	0	0	0	0	0	0

Total Hours This Class: 1826
 Hours of Calm This Class: 6
 Percent of All Data This Class: 11.03

Table C-7

Monticello Nuclear Generating Plant
 Site Meteorology - Frequency Distribution Tables
 Hours at each Wind Speed and Direction

Period of record: 9-1-76 through 8-31-78

Stability Class G
 Elevation 100 meters

Wind Speed (mph) at 100 meter Level

Direction	1 to 3	4 to 7	8 to 12	13 to 18	19 to 24	Above 24	Total
N	6	8	16	9	0	0	39
NNE	3	12	15	8	1	0	39
NE	4	6	11	16	4	0	41
ENE	6	11	15	11	3	1	47
E	8	7	11	11	1	0	38
ESE	1	12	9	16	2	0	40
SE	5	9	10	5	9	1	39
SSE	6	6	12	8	11	1	44
S	2	6	13	30	12	1	64
SSW	1	14	26	55	21	0	117
SW	1	9	21	26	25	3	85
WSW	5	16	29	16	14	0	80
W	3	14	8	16	18	2	61
WNW	5	15	23	21	9	0	73
NW	2	7	14	17	1	0	41
NNW	8	13	21	7	5	0	54
VAR	0	0	0	0	0	0	0

Total Hours This Class:	904
Hours of Calm This Class:	2
Percent of All Data This Class:	5.46

Table C-8

Monticello Nuclear Generating Plant
 Site Meteorology - Frequency Distribution Tables
 Hours at each Wind Speed and Direction

Period of record: 9-1-76 through 8-31-78

All Classes Combined
 Elevation 100 meters

Wind Speed (mph) at 100 meter Level							
<u>Direction</u>	<u>1 to 3</u>	<u>4 to 7</u>	<u>8 to 12</u>	<u>13 to 18</u>	<u>19 to 24</u>	<u>Above 24</u>	<u>Total</u>
N	27	101	239	387	257	95	1106
NNE	25	94	191	259	109	20	698
NE	28	90	203	230	68	11	630
ENE	25	99	248	240	99	25	736
E	34	121	242	165	59	8	629
ESE	31	121	230	220	101	47	750
SE	33	120	240	325	160	40	918
SSE	23	135	285	385	281	54	1163
S	24	113	244	411	251	46	1089
SSW	18	148	259	425	318	103	1271
SW	25	128	233	321	191	40	938
WSW	29	117	200	205	116	22	689
W	20	107	194	196	113	24	654
WNW	30	108	301	419	232	93	1183
NW	22	97	331	709	527	173	1859
NNW	29	110	346	695	608	257	2045
VAR	0	0	0	0	0	0	0

continued

Table C-8. (continued)

Monticello Nuclear Generating Plant
Site Meteorology - Frequency Distribution Tables
Hours at each Wind Speed and Direction

Period of record: 9-1-76 through 8-31-78

All Classes Combined
Elevation 100 meters

Data Recovery for the Period

Total Hours:	17520
Hours of Calm:	201
Hours of Bad Data:	961
Percent Data Recovery:	94.51

Percent Acceptable Observations in each Stability Class

Class A	2.95
Class B	3.64
Class C	6.29
Class D	43.87
Class E	26.77
Class F	11.03
Class G	5.46

Average Wind Speed for each Wind Category

1 to 3 mph	2.5
4 to 7 mph	5.8
8 to 12 mph	10.1
13 to 18 mph	15.4
19 to 24 mph	20.9
Above 24 mph	28.1

APPENDIX D

Summary of EBARR Computer Program

Description of the Problem Solved

The basic task performed by EBARR is to predict the offgas composition and activity at various stages of waste gas treatment and at the time of release (Figure D-1). The basic data supplied to EBARR consists of the release rate, in $\mu\text{Ci}/\text{sec}$ measured at the steam jet air ejector (SJAE), * Kr-88, Kr-87, and Xe-138. There are nine other noble gases of interest from a radioactive effluent point of view. They are: Kr-90, Xe-139, Kr-89, Xe-137, Xe-135m, Kr-83m, Xe-133m, Xe-131m, and Kr-85. Many of these nine gases are not directly measurable in the presence of the others. By establishing the offgas release mode from the six measured release rates, EBARR computes the release rates of the other nine gases known to be present.

The first step performed by EBARR is to correct the release rates of the six measured noble gases for decay during their transit from the reactor vessel to the SJAE:

$$A_i(0) = A_i(t_{\text{dly}}) e^{\lambda_i t_{\text{dly}}} \quad \text{D.1}$$

where

$A_i(t)$ = release rate of noble gas i at the time t after leaving reactor, $\mu\text{Ci}/\text{sec}$;

t_{dly} = transit time from reactor to SJAE, sec;

λ_i = decay constant of noble gas i , sec^{-1} .

* of six readily measureable fission product noble gases:
Xe-133, Xe-135, Kr-85m

EBARR then uses a least square fitting routine to determine the values of B_1 , B_2 , and B_3 giving the best fit to $A_1(0)$ through $A_6(0)$ in the equation:

$$\log \left| \frac{A_i}{y_i \lambda_i} \right| = \log \left| B_1 + \frac{B_2}{\sqrt{\lambda_i}} + \frac{B_3}{\lambda_i} \right| \quad D.2$$

where

y_i = fraction of all fissions yielding noble gas i .

This equation consists of three terms; a recoil release mode term, a diffusion release mode term, and an equilibrium release mode term. This is the standard General Electric offgas distribution model. See references (1) and (2) for a detailed discussion of this model.

The values of B_1 , B_2 , and B_3 , are used by EBARR to characterize the offgas release mechanism in terms of percent recoil, percent diffusion, and percent equilibrium type release. This characterization is useful in fuel performance evaluation. The equations for these three fractions are:

$$\% \text{ Recoil} = 100 \times \frac{\sum_{i=1,6} B_1 y_i \lambda_i}{\sum_{i=1,6} (B_1 y_i \lambda_i + B_2 y_i \sqrt{\lambda_i} + B_3 y_i)} \quad D.3$$

$$\% \text{ Diffusion} = 100 \times \frac{\sum_{i=1,6} B_2 y_i \sqrt{\lambda_i}}{\sum_{i=1,6} (B_1 y_i \lambda_i + B_2 y_i \sqrt{\lambda_i} + B_3 y_i)} \quad D.4$$

$$\% \text{ Equilibrium} = 100 \times \frac{\sum_{i=1,6} B_3 y_i}{\sum_{i=1,6} (B_1 y_i \lambda_i + B_2 y_i \sqrt{\lambda_i} + B_3 y_i)} \quad D.5$$

Then release rate from the reactor vessel for the nine noble gases not measured is then:

$$A_i(0) = B_1 y_i \lambda_i + B_2 y_i \sqrt{\lambda_i} + B_3 y_i \quad D.6$$

At any time, t, after leaving the reactor vessel the release rate is:

$$A_i(t) = A_i(0) e^{-\lambda_i t}, \text{ for } i=3 \text{ through } 14 \quad \text{D.7}$$

and

$$A_i(t) = A_i(0) e^{-\lambda_i t} + \frac{\alpha_j \lambda_j A_j(0)}{\lambda_i - \lambda_j} (e^{-\lambda_j t} - e^{-\lambda_i t}),$$

for $i = 1, 2, \text{ and } 15$ D.8

where α_j = fraction of disintegrations of isotope j producing isotope i.

Equation (D.8) contains an additional factor to account for the decay of Xe-131m to Xe-133, Xe-135m to Xe-135, and Kr-85m to Kr-85. This factor is normally small.

As shown in Figure D-1, the plant stack noble gas release consists of three components:

- (a) main condenser non-condensibles;
- (b) gland exhaust; and
- (c) stack dilution air drawn from reactor and turbine buildings.

Source (c) is considered to be negligible compared to sources (a) and (b). The composition of the gland exhaust release is assumed to be identical to the offgas mixture at the SJAE. Therefore, the stack release rate of isotope i is:

$$R_i(t) = A_i(t) + F_{loc} A_i(t_{dly}) \quad \text{D.9}$$

where

F_{loc} = fraction of main steam flow diverted to gland seal steam supply.

and the total noble gas release rate at any time is:

$$R_{tot}(t) = \sum_{i=1, 15} [A_i(t) + F_{loc} A_i(t_{dly})] \quad \text{D.10}$$

EBARR also performs a secondary task of computing the compressed offgas storage tank contents in terms of dose equivalent Xe-133. Technical Specifications limit this quantity to 22,000 Curies 12 hours after placing a tank in storage (when the discharge valve interlock permits the tank to be released).

Prior to reaching the storage tanks (Figure D-1), the offgas stream is delayed several hours flowing from the recombiners to the compressors via the 42-inch holdup pipe. Offgas reaching the tanks is therefore delayed by:

$$t_{ddly} = t_{dly} + \frac{P_{42} V_{42}}{P_a L} \quad D.11$$

where

- V_{42} = 42-inch pipe volume;
- P_{42} = 42-inch pipe pressure;
- L = total air inleakage, scfm, (Bleed air and condenser inleakage);
- P_a = atmospheric pressure.

While a tank is being filled, offgas enters the tank at rate L . The activity of each isotope in the tank, C_i , is a function of time from the start of filling, t_f , is computed by EBARR using:

$$C_i(t_f) = \frac{A_i(t_{ddly})}{\lambda_i} (1 - e^{-\lambda_i t_f}) \text{ for } i=3 \text{ to } 14 \quad D.12$$

and

$$C_i(t_f) = \alpha_i \frac{A_i(t_{ddly})}{\lambda_i} (1 - e^{-\lambda_i t_f}) + \frac{\alpha_i \lambda_i A_j(t_{ddly})}{\lambda_j} \left[\frac{e^{-\lambda_i t_f} - e^{-\lambda_j t_f}}{\lambda_i - \lambda_j} + \frac{1 - e^{-\lambda_i t_f}}{\lambda_i} \right] \text{ for } i=1, 2, \text{ and } 15. \quad D.13$$

Equation (13) contains an additional factor to account for the decay of Xe-133m to Xe-133, Xe-135m to Xe-135, and Kr-85m to Kr-85. This factor is normally small.

Pressure builds up in the tank at the rate:

$$p(t_f) = \frac{t_f L P_a}{V_{tk}} \quad D.14$$

where

- V_{tk} = volume of storage tank.

When the pressure in the tank reaches the design value, P_{\max} , at t_{fill} , EBARR assumes the tank is full. Total tank activity, C , and total tank Xe-133 dose equivalent activity, D , is computed at t_{rel} when the interlock on the tank discharge valve permits the tank to be released after an additional delay of t_{intk} :

$$t_{\text{fill}} = \frac{P_{\max} V_{\text{tk}}}{P_a L} \quad \text{D.15}$$

$$t_{\text{rel}} = t_{\text{fill}} + t_{\text{intk}} \quad \text{D.16}$$

$$C_i(t_{\text{rel}}) = C_i(t_{\text{fill}}) e^{-\lambda_i t_{\text{intk}}} \quad \text{for } i=3 \text{ to } 14 \quad \text{D.17}$$

and

$$C_i(t_{\text{rel}}) = (C_i(t_{\text{fill}}) e^{-\lambda_i t_{\text{intk}}} + \frac{\alpha_i \lambda_i C_j(t_{\text{fill}})}{\lambda_i - \lambda_j} (e^{-\lambda_j t_{\text{intk}}} - e^{-\lambda_i t_{\text{intk}}})) \quad \text{for } i=1, 2, \text{ and } 15 \quad \text{D.18}$$

$$C(t_{\text{rel}}) = \sum_{i=1, 15} C_i(t_{\text{rel}}) \quad \text{D.19}$$

$$D(t_{\text{rel}}) = \frac{\sum_{i=1, 15} C_i(t_{\text{rel}}) K_i}{K_1} \quad \text{D.20}$$

where

$$K_1 = \text{value of } K_i \text{ for Xe-133. (i=1).}$$

The minimum offgas holdup time is:

$$t_{\text{holdup}} = t_{\text{ddly}} + t_{\text{rel}} \quad \text{D.21}$$

When the system is operating normally, however, with all five holdup tanks in service, the holdup time is given by:

$$t_{\text{holdup}} = t_{\text{ddly}} + 4 t_{\text{fill}} \quad \text{D.22}$$

Table D-1

Table of Radioisotope Constants Used by EBARR

i	Isotope	Fission Yield	Decay Constant
1	Xe-133	0.0669	0.00000152
2	Xe-135	0.0630	0.0000210
3	Kr-85m	0.0130	0.0000438
3	Kr-88	0.0356	0.00000690
4	Kr-87	0.0253	0.000152
5	Xe-138	0.0590	0.000814
6	Kr-90	0.0500	0.0210
7	Xe-139	0.0540	0.0169
8	Kr-89	0.0459	0.00361
10	Xe-137	0.0600	0.00296
11	Xe-135m	0.00720	0.000722
12	Kr-83m	0.00520	0.000103
13	Xe-133m	0.00160	0.00000348
14	Xe-131m	0.000170	0.000000668
15	Kr-85	0.00271	0.0000000204

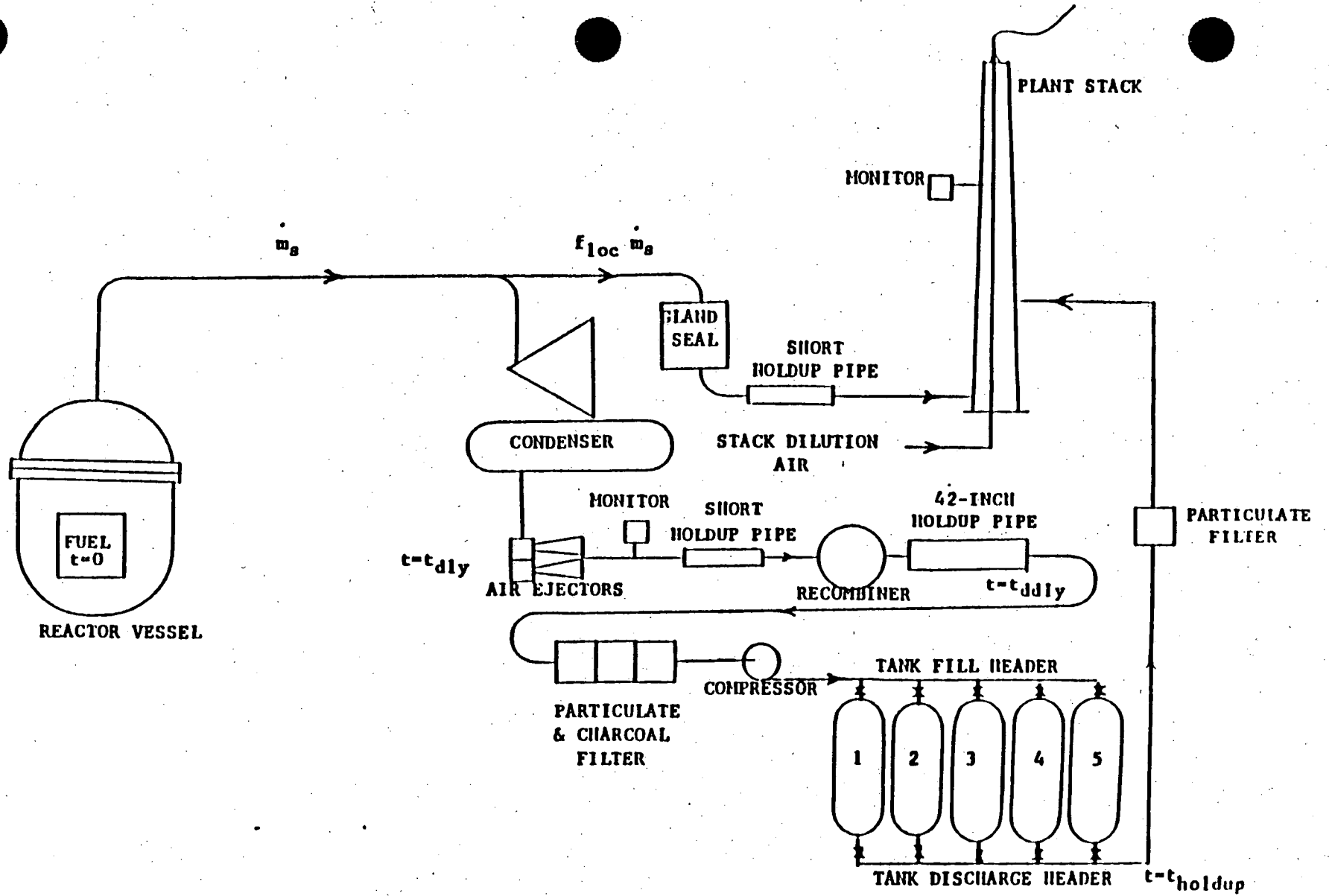

Figure D-1 Offgas system model

APPENDIX E
METHODOLOGY FOR COMPUTATION
OF
DOSE PARAMETERS
FOR
RADIOIODINES, PARTICULATES AND TRITIUM

CONTENTS - APPENDIX E

<u>Section</u>	<u>Title</u>	<u>Page</u>
E.1	<u>Calculation of P_i</u>	E-3
E.1.1	Inhalation Pathway	E-3
E.2	<u>Calculation of R_i</u>	E-4
E.2.1	Inhalation Pathway	E-5
E.2.2	Ground Plane Pathway	E-6
E.2.3	Grass-Cow or Goat-Milk Pathway	E-7
E.2.4	Grass-Cow-Meat Pathway	E-10
E.2.5	Vegetation Pathway	E-11

Tables - Appendix E

<u>Table</u>	<u>Title</u>	<u>Page</u>
E-1	Parameters for Cow and Goat Milk Pathways	E-14
E-2	Parameters for the Meat Pathway	E-15
E-3	Parameters for the Vegetable Pathway	E-16

APPENDIX E

DOSE PARAMETERS FOR RADIOIODINES, PARTICULATES AND TRITIUM

This appendix contains the methodology which was used to calculate the dose parameters for radioiodines, particulates, and tritium to show compliance with 10 CFR 20 and Appendix I of 10 CFR 50 for gaseous effluents. These dose parameters, P_i and R_i were calculated using the methodology outlined in NUREG-0133 along with Regulatory Guide 1.109 Revision 1. The following sections provide the specific methodology which was utilized in calculating the P_i and R_i values for the various exposure pathways.

E.1 Calculation of P_i

The parameter, P_i , contained in the radioiodine and particulates portion of Section 3.2, includes pathway transport parameters of the i th radionuclide, the receptor's usage of the pathway media and the dosimetry of the exposure. Pathway usage rates and the internal dosimetry are functions of the receptor's age; however, the child age group will always receive the maximum dose under the exposure conditions for Technical Specification.

E.1.1 Inhalation Pathway

$$P_{iI} = K'(BR) DFA_i \quad E.1-1$$

where:

P_{iI} = dose parameter for radionuclide i for the inhalation pathway, mrem/yr per $\mu\text{Ci}/\text{m}^3$;

K' = a constant of unit conversion,

= 10^6 pCi/ μCi ;

BR = the breathing rate of the child age group, m^3/yr ;

DFA_i = the maximum organ inhalation dose factor for the child age group for radionuclide i , mrem/pCi.

The age group considered is the child group. The child's breathing rate is taken as $3700 \text{ m}^3/\text{yr}$ from Table E-5 of Regulatory Guide 1.109 Revision 1. The inhalation dose factors for the child, DFA_i , are presented in Table E-9 of Regulatory Guide 1.109 in units of mrem/pCi. The total body is considered as an organ in the selection of DFA_i .

The incorporation of breathing rate of the child and the unit conversion factor results in the following:

$$P_{iI} = 3.7E9 \times DFA_i \quad E.1-2$$

E.2 Calculation of R_i

The radioiodine and particulate Technical Specification 3.8.B.3 is applicable to the location in the unrestricted area where the combination of existing pathways and receptor age groups indicates the maximum potential exposure occurs. The inhalation and ground plane exposure pathways shall be considered to exist at all locations. The grass-goat-milk, the grass-cow-milk, grass-cow-meat, and vegetation pathways are considered based on their existence at the various locations. R_i values have been calculated for the adult, teen, child, and infant age groups for the ground plane, cow milk, goat milk, vegetable and beef ingestion pathways. The methodology which was utilized to calculate these values is presented below.

E.2.1 Inhalation Pathway

$$R_{iI} = K'(BR)_a (DFA_i)_a \quad E.2-1$$

where:

- R_{iI} = dose factor for each identified radionuclide i of the organ of interest, mrem/yr per μCi/m³
- K' = a constant of unit conversion,
= 10⁶ pCi/μCi;
- (BR)_a = breathing rate of the receptor of age group a, m³/yr;
- (DFA_i)_a = organ inhalation dose factor for radionuclide i for the receptor of age group a, mrem/pCi.

The breathing rates (BR)_a for the various age groups are tabulated below, as given in Table E-5 of the Regulatory Guide 1.109 Revision 1.

<u>Age Group (a)</u>	<u>Breathing Rate (m³/yr)</u>
Infant	1400
Child	3700
Teen	8000
Adult	8000

Inhalation dose factors (DFA_i)_a for the various age groups are given in Tables E-7 through E-10 of Regulatory Guide 1.109 Revision 1.

E.2.2 Ground Plane Pathway

$$R_{iG} = I_i K' K'' (SF) DFG_i (1 - e^{-\lambda_i t}) / \lambda_i \quad E.2-2$$

where:

R_{iG} = dose factor for the ground plane pathway for each identified radionuclide i for the organ of interest, mrem/yr per $\mu\text{Ci}/\text{sec}$ per m^2 ;

K' = a constant of unit conversion,
= 10^6 pCi/ μCi ;

K'' = a constant of unit conversion,
= 8760 hr/year;

λ_i = the radiological decay constant for radionuclide i , sec^{-1} ;

t = the exposure time, sec,
= 4.73×10^8 sec (15 years);

DFG_i = the ground plane dose conversion factor for radionuclide i , mrem/hr per pCi/ m^2 ;

SF = the shielding factor (dimensionless);

I_i = factor to account for fractional deposition of radionuclide i .

For radionuclides other than iodine, the factor I_i is equal to one. For radiiodines, the value of I_i may vary. However, a value of 1.0 was used in calculating the R values in Table 3.3-3.

A shielding factor of 0.7 is suggested in Table E-15 of Regulatory Guide 1.109 Revision 1. A tabulation of DFG_i values is presented in Table E-6 of Regulatory Guide 1.109 Revision 1.

E.2.3 Grass-Cow or Goat-Milk Pathway

$$R_{iM} = I_i K' Q_F U_{ap} F_m (DFL_i)_a e^{-\lambda_i t_f} \left[f_p f_s \left[\frac{r(1 - e^{-\lambda_E t_{ep}})}{Y_p \lambda_{E_i}} \right] + \frac{B_{iv} (1 - e^{-\lambda_i t_b})}{P \lambda_i} \right] + (1 - f_p f_s) \left[\frac{r(1 - e^{-\lambda_E t_{es}})}{Y_s \lambda_{E_i}} + \frac{B_{iv} (1 - e^{-\lambda_i t_b})}{P \lambda_i} \right] e^{-\lambda_i t_h} \quad E.2-3$$

where:

- R_{iM} = dose factor for the cow milk or goat milk pathway, for each identified radionuclide i for the organ of interest, mrem/yr per $\mu\text{Ci}/\text{sec}$ per m^2 ;
- K' = a constant of unit conversion,
= 10^6 pCi/ μCi ;
- Q_F = the cow or goat feed consumption rate, kg/day (wet weight);
- U_{ap} = the receptor's milk consumption rate for age group a , liters/yr;
- Y_p = the agricultural productivity by unit area of pasture feed grass, kg/m^2 ;
- Y_s = the agricultural productivity by unit area of stored feed, kg/m^2 ;
- F_m = the stable element transfer coefficients, pCi/liter per pCi/day;
- r = fraction of deposited activity retained on cow feed grass;
- $(\text{DFL}_i)_a$ = the organ ingestion dose factor for radionuclide i for the receptor in age group a , mrem/pCi;
- λ_{E_i} = $\lambda_i + \lambda_w$;
- λ_i = the radiological decay constant for radionuclide i , sec^{-1} ;
- λ_w = the decay constant for removal of activity on leaf and plant surfaces by weathering, sec^{-1} ,
= $5.73 \times 10^{-7} \text{ sec}^{-1}$ (corresponding to a 14 day half-life);
- t_f = the transport time from feed to cow or goat, to milk, to receptor, sec;
- t_h = the transport time from harvest, to cow or goat, to consumption, sec;
- t_b = period of time that activity builds up in soil, sec;

- B_{iv} = concentration factor for uptake of radionuclide i from the soil by the edible parts of crops, pCi/kg (wet weight) per pCi/kg (dry soil);
- P = effective surface density for soil, kg (dry soil)/m²;
- f_p = fraction of the year that the cow or goat is on pasture;
- f_s = fraction of the cow feed that is pasture grass while the cow is on pasture;
- t_{ep} = period of pasture grass and crop exposure during the growing season, sec;
- t_{es} = period of crop exposure during the growing season (stored feed); sec;
- I_i = factor to account for fractional deposition of radionuclide i .

For radionuclides other than iodine, the factor I_i is equal to one. For radioiodines, the value of I_i may vary. However, a value of 1.0 was used in calculating the R values Tables 3.3-10 through 3.3-17.

Milk cattle and goats are considered to be fed from two potential sources, pasture grass and stored feeds. Following the development in Regulatory Guide 1.109 Revision 1, the value of f_s is considered unity in lieu of site-specific information. The value of f_p is 0.500 based upon an 6 month grazing period.

Table E-1 contains the appropriate parameter values and their source in Regulatory Guide 1.109 Revision 1.

The concentration of tritium in milk is based on the airborne concentration rather than the deposition. Therefore, the R_i is based on χ/Q :

$$R_{TM} = K'K''F_m Q U_{ap} (DFL_i)_a 0.75(0.5/H) \quad E.2-4$$

where:

- R_{TM} = dose factor for the cow or goat milk pathway for tritium for the organ of interest, mrem/yr per mCi/m³;
- K'' = a constant of unit conversion,
- = 10³ gm/kg;
- H = absolute humidity of the atmosphere, gm/m³;
- 0.75 = the fraction of total feed that is water;
- 0.5 = the ratio of the specific activity of the feed grass water to the atmospheric water;

and the other parameters and values are as given above. A value for H of 8 grams/meter³, was used in lieu of site-specific information.

E.2.4 Grass-Cow-Meat Pathway

The integrated concentration in meat follows in a similar manner to the development for the milk pathway, therefore:

$$R_{iB} = I_i K' Q_F U_{ap} F_m (DFL_i)_a e^{-\lambda_i t_f} \left[f_p f_s \left[\frac{r(1-e^{-\lambda_{E_i} t_{ep}})}{Y_p \lambda_{E_i}} + \frac{B_{iv} (1-e^{-\lambda_i t_b})}{P \lambda_i} \right] + (1-f_p f_s) \left[\frac{r(1-e^{-\lambda_{E_i} t_{es}})}{Y_s \lambda_{E_i}} + \frac{B_{iv} (1-e^{-\lambda_i t_b})}{P \lambda_i} \right] \right] e^{-\lambda_i t_h} \quad \text{E.2-5}$$

where:

- R_{iB} = dose factor for the meat ingestion pathway for radionuclide i for any organ of interest, mrem/yr per $\mu\text{Ci}/\text{sec}$ per m^2 ;
- F_f = the stable element transfer coefficient, pCi/kg per pCi/day;
- U_{ap} = the receptor's meat consumption rate for age group a, kg/yr;
- t_s = the transport time from slaughter to meat consumption, sec;
- t_h = the transport time from harvest to animal consumption, sec;
- t_{ep} = period of pasture grass exposure during the growing season, sec;
- t_{es} = period of crop exposure during the growing season (stored feed); sec;
- I_i = factor to account for fractional deposition of radionuclide i.

For radionuclides other than iodine, the factor I_i is equal to one. For radioiodines, the value of I_i may vary. However, a value of 1.0 was used in calculating the R values in Tables 3.3-7 through 3.3-9.

All other terms remain the same as defined in Equation E.2-3. Table E-2 contains the values which were used in calculating R_i for the meat pathway.

The concentration of tritium in meat is based on its airborne concentration rather than the deposition. Therefore, the R_i is based on χ/Q .

$$R_{TB} = K' K'' F_f Q_F U_{ap} (DFL_i)_a 0.75(0.5/H) \quad \text{E.2-6}$$

where:

R_{TB} = dose factor for the meat ingestion pathway for tritium for any organ of interest, mrem/yr per $\mu\text{Ci}/\text{m}^3$.

All other terms are defined in Equation E.2-4 and E.2-5, above.

E.2.5 Vegetation Pathway

The integrated concentration in vegetation consumed by man follows the expression developed in the derivation of the milk factor. Man is considered to consume two types of vegetation (fresh and stored) that differ only in the time period between harvest and consumption, therefore:

$$R_{iV} = I_i K' (DFL_i)_a \left[U_{aL}^L e^{-\lambda_i t_L} \left[\frac{r(1-e^{-\lambda_{E_i} t_e})}{Y_V \lambda_{E_i}} + \frac{B_{iV} (1-e^{-\lambda_i t_b})}{P \lambda_i} \right] + U_{aG}^S e^{-\lambda t_h} \left[\frac{r(1-e^{-\lambda_{E_i} t_e})}{Y_V \lambda_{E_i}} + \frac{B_{iV} (1-e^{-\lambda_i t_b})}{P \lambda_i} \right] \right] \quad \text{E.2-7}$$

where:

R_{iV} = dose factor for vegetable pathway for radionuclide i for the organ of interest, mrem/yr per $\mu\text{Ci}/\text{sec per m}^2$;

K' = a constant of unit conversion.

= 10^6 pCi/ μCi ;

U_a^L = the consumption rate of fresh leafy vegetation by the receptor in age group a , kg/yr;

U_a^S = the consumption rate of stored vegetation by the receptor in age group a , kg/yr;

f_L = the fraction of the annual intake of fresh leafy vegetation grown locally;

f_g = the fraction of the annual intake of stored vegetation grown locally;

t_L = the average time between harvest of leafy vegetation and its consumption, sec;

- t_h = the average time between harvest of stored vegetation and its consumption, sec;
- Y_v = the vegetation areal density, kg/m²;
- t_e = period of leafy vegetable exposure during growing season, sec;
- I_i = factor to account for fractional deposition of radionuclide i.

For radionuclides other than iodine, the factor I_i is equal to one. For radioiodines, the value of I_i may vary. However, a value of 1.0 was used in calculating the R values in Tables 3.3-4 through 3.3-6. All other factors were defined above.

Table E-3 presents the appropriate parameter values and their source in Regulatory Guide 1.109 Revision 1.

In lieu of site-specific data, default values for f_l and f_g , 1.0 and 0.76, respectively, were used in the calculation of R_i . These values were obtained from Table E-15 of Regulatory Guide 1.109 Revision 1.

The concentration of tritium in vegetation is based on the airborne concentration rather than the deposition. Therefore, the R_i is based on ∂/Q :

$$R_{TV} = K'K'' [U_a^L f_L = U_a^S f_g] (DFL_i)_a 0.75(0.5/H) \quad E.28$$

where:

$$R_{TV} = \text{dose factor for the vegetable pathway for tritium for any organ of interest, mrem/yr per } \mu\text{Ci/m}^3.$$

All other terms remain the same as those in Equations E.2-4 and E.2-7.

TABLE E-1

Parameters For Cow and Goat Milk Pathways

Parameter	Value	Reference in Reg. Guide 1.109 Rev. 1
Q_F (kg/day)	50 (cow) 6 (goat)	Table E-3 Table E-3
t_f (seconds)	1.73×10^5 (2 days)	Table E-15
r	1.0 (radioiodines) 0.2 (particulates)	Table E-15 Table E-15
$(DFL_i)_a$ (mrem/pCi)	Each radionuclide	Table E-11 to E-14
F_m (pCi/day per pCi/liter)	Each stable element	Table E-1 (cow) Table E-2 (goat)
t_b (seconds)	4.73×10^8 (15 yr)	Table E-15
Y_s (kg/m ²)	2.0	Table E-15
Y_p (kg/m ²)	.75	Table E-15
t_h (seconds)	7.78×10^6 (90 days)	Table E-15
U_{ap} (liters/yr)	330 infant 330 child 400 teen 310 adult	Table E-5 Table E-5 Table E-5 Table E-5
t_{ep} (seconds)	2.59×10^6 (pasture)	Table E-15
t_{es} (seconds)	5.18×10^6 (stored feed)	Table E-15
B_{iv} (pCi/kg (wet weight) per pCi/kg (dry soil))	Each stable element	Table E-1
P (kg dry soil/m ²)	240	Table E-15

TABLE E-2

Parameters for the Cow Meat Pathway

Parameter	Value	Reference in Reg. Guide 1.109 Rev. 1
r	1.0 (radioiodines) 0.2 (particulates)	Table E-15 Table E-15
F_f (pCi/kg per pCi/day)	Each stable element	Table E-1
U_{ap} (kg/yr)	0 infant 41 child 65 teen 110 adult	Table E-5 Table E-5 Table E-5 Table E-5
$(DFL_i)_a$ (mrem/pCi)	Each radionuclide	Tables E-11 to E-14
Y_p (kg/m ²)	0.7	Table E-15
Y_s (kg/m ²)	2.0	Table E-15
t_b (seconds)	4.73×10^8 (15 yr)	Table E-15
t_s (seconds)	1.73×10^6 (20 days)	Table E-15
t_h (seconds)	7.78×10^6 (90 days)	Table E-15
t_{ep} (seconds)	2.59×10^6 (pasture)	Table E-15
t_{es} (seconds)	5.18×10^6 (stored feed)	Table E-15
Q_F (kg/day)	50	Table E-3
B_{iv} (pCi/kg (wet weight) per pCi/kg (dry soil))	Each stable element	Table E-1
P (kg (dry soil)/m ²)	240	Table E-15

TABLE E-3

Parameters for the Vegetable Pathway

Parameter	Value	Reference in Reg. Guide 1.109 Rev. 1
r (dimensionless)	1.0 (radioiodines) 0.2 (particulates)	Table E-1 Table E-1
$(DFL_i)_a$ (mrem/Ci)	Each radionuclide	Tables E-11 to E-14
U_a^L (kg/yr)	0 Infant 26 Child 42 Teen 64 Adult	Table E-5 Table E-5 Table E-5 Table E-5
U_a^S (kg/yr)	0 Infant 520 Child 630 Teen 520 Adult	Table E-5 Table E-5 Table E-5 Table E-5
t_L (seconds)	8.6×10^4 (1 day)	Table E-15
t_h (seconds)	5.18×10^6 (60 days)	Table E-15
Y_v (kg/m ²)	2.0	Table E-15
t_e (seconds)	5.18×10^6 (60 days)	Table E-15
t_b (seconds)	4.73×10^8 (15 yr)	Table E-15
P (kg/(dry soil)/m ²)	240	Table E-15
B_{iv} (pCi/kg(wet weight) per pCi/kg (dry soil))	Each stable element	Table E-1

APPENDIX F

MIDAS Program Descriptions

<u>MIDAS Section</u>	<u>Program Name</u>
2.2.5.2.2	XDCALC
2.2.6.1	XDAIR
2.2.6.3	GASPRO
2.2.6.5	HYP0
2.2.6.6	DOSLI
2.2.6.8	DOSUM

2.2.5.2.2 XDCALC (Generic All-Purpose Routine for Calculation of Cumulative X/Q and Dose Using Straight-Line Gaussian Model) Preliminary Information

PROGRAM NAME: XDCALC (see also XDACCU, XDPRT, XDAIR, XDMAN)

FUNCTION: Calculates atmospheric dispersion and doses according to the Class A straight-line Gaussian type models prescribed in Regulatory Guides 1.3, 1.4, 1.111 and 1.109. Prints hourly values of X/Q or dose and accumulates values over any specified time period. The basic computational routine in XDCALC is also used in GASPRO (for routine releases). Accumulated results are printed using the XDXQP task.

All calculations use hourly or 15-minute site meteorological data averages. To account for different kinds of releases (ground, elevated, or mixed mode), a table of job control selectors has been established which can be edited using the MIDER task. XDCALC uses these when determining dispersion types or calculating doses for each release point.

Average, centerline, depletion, and deposition calculations for all release points are performed. Whole body gamma dose, beta skin dose, adult inhalation thyroid dose, finite plume dose and air-gamma dose are calculated simultaneously. Beta skin and air doses are calculated using Regulatory Guide 1.109 dose factors. Doses may be computed hourly from information in the release (Q) files edited by MIDEQ (or created using MIDEY OR MIDGB processing). In addition, they may be computed in near real-time from effluent vent and flow inputs either hourly or every 15-minutes.

Section 2.2.5.2.2 (continued)

PURPOSE:

This routine is extremely versatile and can be used to do a variety of dispersion and dose calculations. Many are used directly in emergencies or Regulatory Guide 1.21 reports but not all. Also, X/Q or dose values for each hour can be printed. A separate version (XDAIR) is used to compute accumulated air doses.

FILE(S) USED:

				DRWK or DRMT	DRRQ, DRDF, or DRQD
	<u>DRST</u>	<u>DR1D</u>	<u>DDCURV</u>	<u>DRMT</u>	<u>DRQD</u>
Input	Yes	Yes	Yes	Yes	Yes
Change	Yes	No	No	No	No
	<u>DRXL</u>	<u>DRDL</u>	<u>AIRD</u>		
Input	No	No	No		
Change	Yes	Yes	Yes		

TASKS USING FILES
EDITED BY THIS TASK:

No files are edited by this task.

TASKS USING FILES
CONTAINING CALCULATED RESULTS FROM
THIS TASK:

XDXQP, MIDPL, DOSUM, XDMAN

PREREQUISITES:

There must be valid data in the raw or workspace meteorological data base. The MIDER, MIDEX, MIDET, MIDEF and MIDEF tasks in MIDAS (MIDEQ, MIDEF, MIDEI or MIDEK tasks of MIDAS if dose calculations are selected) must contain proper input constants for the desired reactor unit.

Section 2.2.5.2.2 XDCALC - User Instructions

USER INSTRUCTIONS:

The user schedules XDCALC from the menu and is prompted for 10 options plus the date. After responding to the prompts, the results are printed or accumulated. Versions of XDCALC are available with responses to the options hardwired (see XDPRT and XDACCU).

*** Refer to attached sample printout ***

Section 2.2.5.2.2 (continued)

ENTER: [XX] SITE ID
[RETURN] EXIT

QA

SITE: DGI QUALITY FILE

11/07/82 16:09

DATES OF HOURLY MET FILES

1 DATA COLLECTION QA 0 0 0 0 TO 0 0 0 0
WORK SPACE TX 79 3 1 1 TO 79 61024

DATES OF QUARTER HOUR MET FILES

DATA COLLECTION QA 0 0 0 0 0 TO 0 0 0 0 0
WORK SPACE ** 70 53 1 1 0 TO 70 6 62445

2 ENTER: [RA] RAW
[WK] WORKSPACE
[EX] EXIT

WK

ENTER: [HR] HOURLY
[QU] QUARTER HOURLY
[RETURN] PREVIOUS PROMPT

3 HR
ENTER: [DE] DEFAULT MET DESIRED
[ND] NO DEFAULT MET DESIRED
[EX] EXIT

DE

ENTER: [XQ] X/Q
[DO] DOSE
[EX] EXIT

DO

TERRAIN TABLE DESIRED?
4 ENTER: [YE] YES
[NO] NO
[RETURN] GO BACK TO PREVIOUS OPTION

YE

Section 2.2.5.2.2 (continued)

NRC TERRAIN CORRECTION FACTORS DESIRED?
5 ENTER: [YE] YES
 [NO] NO
 [RETURN] GO BACK TO PREVIOUS OPTION

YE

GAMMA SELECTOR FOR RELEASE POINT 2

6 ENTER: [EB] EBAR GAMMA DOSE
 [FI] FINITE PLUME GAMMA DOSE
 [AI] AIR GAMMA DOSE
 [RETURN] GO BACK TO PREVIOUS OPTION

FI

7 ENTER: [EB] EBAR BETA DOSE
 [RG] REG. GUIDE 1.109 BETA DOSE
 [AI] AIR BETA DOSE
 [RETURN] GO BACK TO PREVIOUS OPTION

RG

8 ENTER: [MP] MAXIMUM PERMISSABLE CONCENTRATIONS DESIRED
 [NP] NO. MAX. PERMISSABLE CONCENTRATIONS DESIRED
 [RETURN] GO BACK TO PREVIOUS OPTION

NP

9 ENTER: [PR] PRINT
 [AC] ACCUMULATE
 [RETURN] GO BACK TO PREVIOUS OPTION

AC

ENTER: [YRMODAHRYRMODAHR] START AND END DATE (HOURS)
 [99] LAST 8 HOURS
 [88] FUTURE (NEXT 8 HOUR FORECAST)
 [77] LAST 4 HOURS PLUS FUTURE 4 HOURS
 [RETURN] GO BACK TO PREVIOUS OPTION

7906010179060106

Section 2.2.5.2.2 XDCALC - User Instructions (Notes)

USER INSTRUCTIONS:

The following notes correspond to the numbers on the example printout on the previous page(s).

- *1* Available data on the raw (data collection) meteorology and workspace is printed first for both hourly and quarter-hourly files.
- *2* The user is then prompted for the type of meteorological data to be used.
- *3* For longer runs, the user is given the opportunity to select default meteorological parameters. They are stored in the MIDEX task for day and night conditions and are used whenever there is bad meteorological data. Direction is determined using a random number method which weights direction according to the wind rose frequencies entered in MIDEX.
- *4* This option will select either flat or normal terrain height. The terrain is entered using the MIDEF task.
- *5* Terrain correction factors are unrelated to the terrain heights. They are factors entered via the MIDEF task and account for long-term recirculation patterns at the site. They should not be used for short runs.
- *6* See the Program Design section for each type of gamma dose. FI is the best to use for routine or accident dose. Air is used only for Appendix I reports.

Section 2.2.5.2.2 (continued)

- *7* Again refer to the program design section for beta dose. The RG option is normally correct unless Appendix I air doses are being computed.
- *8* This should never be used unless MIDEK is set up with the proper constants.
- *9* If print is selected, the results will be printed line-by-line. If accumulate is selected the accumulated results can be printed using the XDXQP task or plotted using the MIDPL task.

Section 2.2.5.2.2 XDCALC - Program Design

PROGRAM DESIGN:

Refer to Figure 2.2.5.2.2-1 for a functional flow diagram for the XDCALC routine. Figure 2.2.5.2.2-1 shows the input files that must be properly edited before any run. It also shows how the same dispersion and dose calculation routines are used for both the hourly and accumulate options. The "last" accumulation files are used by the XDXQP task to print and manipulate accumulate results.

Values of vertical and horizontal dispersion coefficients (σ_z, σ_y) for each of the 10 distances entered by the MIDEX task are obtained by linear interpolation between 10 values which are stored in data statements (see Table 2.2.5.2.2-1.). Values of depletion and deposition as functions of release height are obtained by an interpolation of the curves presented in Regulatory Guide 1.111 and summarized in Tables 2.2.5.2.2-2 and 2.2.5.2.2-3. Table look-ups and interpolations speed up the processing time without significant loss of accuracy.

When running XDCALC, the following characteristics should be kept in mind. If meteorological data defaults are selected, they are used only when a meteorological parameter required for the current release point is bad. The defaults are defined in the MIDEX task. Values for wind speed, delta temperature, or ambient temperature are substituted using the day or night value as appropriate. The wind direction substitution uses a random number generator and the historical wind rose (in MIDEX table.) If sufficient default data are used, the wind direction frequencies will be the same as for the historical records.

Section 2.2.5.2.2 (continued)

Terrain correction factors (if selected) are applied to all dispersion calculations. If the terrain correction factor table (MIDDEF option) is all zeros, all factors are set to one (i.e., no changes in dispersion calculations).

All calculations are done for all selected release points. Subroutine XQINIT returns all job control selectors that are contained in the MIDER table. Subroutine XQSUB4 (internal to XDCALC) performs all X/Q and dose calculations.

COMPUTATIONAL MODEL:

The XDCALC routine includes flexibility to compute atmospheric dispersion factors and plume doses using many different relationships. In the discussion which follows, all of the associated equations and input data are presented.

The following symbols and their definitions apply to the dispersion equations that follow.

\bar{u}_{m_g} = wind speed for ground release (subscript e for elevated) (m/sec). This wind speed is determined at the reference height entered in MIDER using an exponential correction described in the ACRISO documentation (Section 2.2.5.2.1).

Section 2.2.5.2.2 (continued)

- σ_{y_g} = horizontal dispersion coefficient for ground release, subscript e for elevated (m)*
- σ_{z_g} = vertical dispersion coefficient for ground release, subscript e for elevated (m)*
- cA_g = coefficient times building area, A, from MIDER table (c usually equals 0.5) (m²)
- T_f = terrain correction factor for each direction group and distance. These factors are entered using the MIDEF task.
- H_c = building height (m), ground release (e.g., containment) MIDER table entry is converted from feet to meters)
- x = distance (m) of calculation or site boundary distance (for site boundary hourly calculation only)
- H_p = height of plume (m), if jet is selected in MIDEX table it is height of plume using Briggs jet calculations (see "Plume Rise", Briggs 1969, page 59); otherwise, plume height is set to stack height for elevated release or zero for ground release. Elevated release is corrected for terrain heights in both nonrise and Briggs jet plume rise models.
- *Note: Stability may be determined from a different sensor (set in MIDER) for ground and elevated releases.
- D_e = exit diameter (m) of stack for elevated release
- F_{13} = $1.44 * D_e$, used in Briggs jet equations
- AP = ratio of elevated exit velocity from stack to wind speed at stack height

Section 2.2.5.2.2 (continued)

$$R = (V_e / U_{m_e})^{2/3}$$

$$R_p = (x/D_e)^{1/3}$$

H_f = final plume rise in Briggs jet calculation, m (height where plume levels off)

V_e = exit velocity from elevated stack, m/sec

$$F = (D_e^2 * v_e^2) / 4$$

$$F_{25} = (F / \bar{u}_m)^{1/3}$$

T_z = potential temperature gradient for Briggs jet calculation, °C/m

$$T_z = 0.025 \text{ for E stability}$$

$$T_z = 0.05 \text{ for F stability}$$

$$T_z = 0.075 \text{ for G stability}$$

H_T = terrain height (m)

H_s = stack height (m)

H = plume height above terrain (m)

$$S_{16} = S^{-0.1667}$$

$$S = 9.8 T_z / (273 + T_{AMB})$$

T_{AMB} = ambient air temperature (°C)

Q_{iso} = release rate, $\mu\text{Ci/sec}$ of each isotope

Section 2.2.5.2.2 (continued)

OTHER INPUT INFORMATION

Dose factors are given in Table 2.2.5.2.2-4. Values of σ_y and σ_z versus distance for each stability are given in Table 2.2.5.2.2-1. Values of depletion and deposition from Regulatory Guide 1.111 are given in Tables 2.2.5.2.2-2 and 2.2.5.2.2-3.

XDCALC DISPERSION CALCULATIONS (X/Q AND DEPLETED X/Q in sec/m³, D/Q IN m⁻²)

The equations for each computational model are presented in the following. The nomenclature (headings) printed above each column in the output appear in parentheses after the name for each calculation:

(1) Ground Centerline X/Q (XQGCL)

$$\frac{X/Q}{q_c} = X/Q * T_f$$

where

$$X/Q = \text{maximum of } \frac{1}{\bar{u}_{m_g} (\sigma_{y_g} \sigma_{z_g} \pi + cA)}$$

or

$$\frac{1}{3\bar{u}_{m_g} \sigma_{y_g} \sigma_{z_g} \pi}$$

and

$$T_f = 1 \text{ if terrain correction option is not selected.}$$

Refer to Regulatory Guide 1.145 (no meander)

Section 2.2.5.2.2 (continued)

(2) Ground Average X/Q (XQGAV)

$$X/Q_{ga} = 2.03 / (\bar{u}_{mg} * x * \sigma_g) * T_f$$

where

$$\sigma_g = \text{minimum of } \sigma^2 \frac{H^2}{z_g + \frac{c}{2\pi}}$$

or

$$\sigma_{zg} \sqrt{3}$$

$T_f = 1$ if terrain correction option is not selected.

Refer to Regulatory Guide 1.111

(3) Elevated Centerline X/Q (XQECL)

$$X/Q_{ec} = \frac{1}{u_{me} \sigma_{ye} \sigma_{ze} \pi} * \exp(E) * t_f$$

for $E \geq -40$

$X/Q_{ec} = 0$, for $E < -40$

where

$T_f = 1$ if terrain correction not selected.

and

$$E = \frac{-H_z^2}{2\sigma_{ze}^2}$$

$H_z = 0$, for $H \leq 0$

$H_z = H$, for $H > 0$

where

$$H = H_p - H_T$$

$H_p = \text{minimum of } (F_{13} * R * R_p + H_s)$, or H_f

Section 2.2.5.2.2 (continued)

where

$H_f =$ minimum of H_{f1} or H_{f2} , for stable conditions (i.e., Pasquill Classes E, F or G)

$H_f =$ H_{f1} , for neutral or unstable conditions

$H_{f1} =$ $3.0 * V_s * D_e / u_{me} + H_s$

$H_{f2} =$ $1.5 * F_{25} * S_{16} + H_s$

Refer to Regulatory Guide 1.3 and Briggs Plume Rise (TID-25075)

(4) Elevated Average X/Q (XQEAV)

$$X/Q_{ea} = \frac{2.03}{\bar{u}_m * x * \sigma_{ze}} * \exp(E) * T_f$$

for $E \geq -40$

$X/Q_{ea} = 0$, for $E < -40$

where

$T_f =$ 1 if terrain correction is not selected.

and

H_p , H_z , E are the same as above.

Refer to Regulatory Guide 1.111

Section 2.2.5.2.2 (continued)

(5) Ground Depletion (DPLETN)
$$X/Q_{gd} = X/Q_{ga} * DPL_J$$

where

DPL_J = ground depletion factor for J^{th} distance interpolated from Table 2.2.5.2.2-2 from Regulatory Guide 1.111

(6) Ground Deposition (DEPOSN)

$$D/Q = \frac{DEP_J}{x * 0.3927} * T_f$$

where

T_f = 1 if terrain correction not selected.

0.3927 = radians per 22-1/2 degree direction sector

x = The J^{th} distance (m)

DEP_J = ground deposition factor for the J^{th} distance interpolated from Table 2.2.5.2.2-3 from Regulatory Guide 1.111

(7) Elevated Depletion (DPLETN). Note uses same name since only one value is calculated for either elevated or ground level releases.

Section 2.2.5.2.2 (continued)

$$X/Q_{Depl_e} = X/Q_{ea} * DPL_J$$

where

DPL_J = elevated depletion factor interpolated from Table 2.2.5.2.2-2 for J^{th} distance as a function of plume height and stability from Regulatory Guide 1.111

(8) Elevated Deposition (DEPOSN). Uses same name as for ground since only one is calculated

$$D/Q_e = \frac{DEP_J * T_f}{X * 0.3927}$$

where

T_f = 1 if terrain correction
not selected.

DEP_J = elevated deposition factor
interpolated from Table 2.2.5.2.2-3 for
the J th distance as a function of plume
height and stability from Regulatory
Guide 1.111

x = as above

0.3927 = as above

Section 2.2.5.2.2 (continued)

(9) CALCULATION OF DISPERSION IF RELEASE IS PARTIALLY ELEVATED AND PARTIALLY IN THE WAKE OF BUILDINGS

During periods when wind speed is within limits specified below, both the ground and elevated equations are used and a mixed mode (wake split) model is used for computing dispersion:

If mixed mode (wake split) is selected, the following general equation is used for computing dispersion:

$$X/Q_{\text{wake}} = ET * X/Q_{\text{ga}} + (1 - ET) * X/Q_{\text{ea}}$$

Similarly, for depletion and deposition, the parameter ET is used to weight the X/Q depletion and D/Q parameters. ET is defined as follows:

AP = velocity out stack exit/wind speed
as before

ET = 1.0, if AP < 1.0

ET = 2.58 - 1.58 * AP,
if 1.0 < AP < 1.5

ET = 0.3 - 0.06 * AP;
if 1.5 < AP < 5.0

ET = 0, if AP > 5.0

Refer to Regulatory Guide 1.111

Section 2.2.5.2.2 (continued)

XDCALC DOSE CALCULATIONS

- (10) SEMI-INFINITE PLUME (SUBMERSION) WHOLE BODY GAMMA (q) DOSE (rem/hr) Uses X/Q from (1) through (4) or (9)

and $\bar{E}_{\gamma, iso}$ or values from Table

2.2.5.2.2-4. Note that this is referred to as "EBAR GAMMA" in the prompt. The dose computed is actually the gamma component of the surface tissue dose.

$$D_{\gamma} = (9.0 \times 10^{-4}) * X/Q * \sum_{iso=1}^{35} Q_{iso} * \bar{E}_{\gamma, iso}$$
$$9.0 \times 10^{-4} = (0.25)(3600)(1.0 \times 10^{-6})$$

(see ACRISO writeup)

where iso is the isotope index number from Table 2.2.5.2.2-4 and the constant 0.25 is from Regulatory Guide 1.3 and 1.4.

- (11) FINITE PLUME GAMMA DOSE (rem/hr) The semi-infinite plume whole body gamma dose calculation in (10) results in a conservative (high) dose for all cases except when the plume is

Section 2.2.5.2.2 (continued)

overhead resulting in a "shine" dose. The finite plume model calculates a more realistic dose to surface tissue due to gamma exposure. The finite plume dose model follows the method of Gamertsfelder (see Equation 7.62 in Meteorology and Atomic Energy, 1968). The integration uses a numerical solution developed by Hamawi [see Appendix F to Regulatory Guide 1.109 (Revision 1)]. Abundances are given in Table 2.2.5.2.2-4 for six energy groups for each of the noble gases. Noble gases are the only isotopes used. For the finite plume wake split release, finite plume γ doses are computed for both ground and elevated releases and weighted by ET as for the X/Q in (9). Refer to the GASPRO discussion (Section 2.2.6.3) for further elaboration on the finite plume model.

Centerline finite plume gamma doses are not calculated in XDCALC. If the finite selector is chosen, the sector average calculation commonly used for longer averaging times in XDCALC will

Section 2.2.5.2.2 (continued)

use finite equations; however, for a centerline calculation, the semi-infinite (EBAR GAMMA) dose is computed.

(12) SEMI-INFINITE PLUME (SUBMERSION)

BETA DOSE This calculation uses
X/Q from (1)

through (4) or (9) and $\bar{E}_{\beta, iso}$ values from Table 2.2.5.2.2-4. Note this option is referred to as "EBAR BETA DOSE" in the prompt. The following equation gives the beta component of the skin dose in units of rad/hr using the dosimetry model in Regulatory Guide 1.3 or 1.4. Accumulated MIDAS results are labelled rem in the XDCALC output.

$$D_{\beta} = (8.28 \times 10^{-4}) * X/Q * \sum_{iso=1}^{35} Q_{iso}$$

$$\bar{E}_{\beta, iso} \\ 8.28 \times 10^{-4} = (0.23)(3600)(1.0 \times 10^{-6})$$

(13) GAMMA AIR DOSE (rad/hr)

The air dose is computed in accordance with Regulatory Guide 1.109 as follows. For ground level releases, the dose factors $D_{f, air, r}$ from

Table 2.2.5.2.2-4 are used.

Section 2.2.5.2.2 (continued)

$$D_{\gamma,air} = X/Q_{ga} \cdot \overset{17}{iso=3} * D_{f,air,\gamma} * Q_{iso} * \frac{10^{-3} * 31.536}{8760}$$

(Only noble gas isotopes are used.)

$$\frac{10^{-3} * 31.536}{8760} = \frac{\text{rad}}{\text{mrad}} \frac{\text{Ci-sec}}{\text{yr-}\mu\text{Ci}} \frac{\text{yr}}{\text{hr}}$$

For elevated releases, the finite plume gamma surface tissue dose following the Hamawi method is used as in (11) and divided by a factor of 1.1 to obtain air dose.

For the elevated plume calculation of a mixed mode (wake split) case, Regulatory Guide 1.109 does not allow use of the finite plume model; thus, for mixed mode calculations the above equation for $D_{\gamma,air}$ is used with the wake split X/Q from (9) above in place of X/Q_{ga} .

(14) BETA SKIN DOSE FROM REGULATORY GUIDE 1.109 (rem/hr)

A more refined beta dose to the skin than that described in (12) above is defined in Regulatory Guide 1.109 which uses dose factors, $D_{f,\beta,1.109}$

Section 2.2.5.2.2 (continued)

for each isotope rather than energy. These dose factors are given in Table 2.2.5.2.2-4. X/Q values from (1) through (4) and (9) above can be used.

$$D_{\beta, \text{skin}} = 0.114 * X/Q * \sum_{\text{iso}=1}^{35} * Q_{\text{iso}} * D_{f, \beta, 1.109}$$

$$0.114 = \frac{10^6 \text{ pCi}/\mu\text{Ci}}{1.14 \times 10^4 \text{ yrs/hr}} * 10^{-3} \text{ rem/mrem}$$

(15) BETA AIR DOSE (rad/hr)

The air dose due to beta is computed using dose factors from Regulatory Guide 1.109 which are repeated here in Table 2.2.5.2.2-4. Values of X/Q from (1) through (4) or (9) mentioned previously can be used in the following equation:

$$D_{\beta, \text{air}} = X/Q * \sum_{\text{iso}=3}^{17} * D_{f, \text{air}, \beta} * Q_{\text{iso}}$$

$\frac{10^{-3} * 31.536}{8760}$ see conversion in (13) above

Again, only noble gases are used.

Section 2.2.5.2. (continued)

(16) THYROID INHALATION DOSE (rem/hr) Adult thyroid
inhalation dose is computed using X/Q from (1) through
(4) or

(9) and $\bar{E}_{t,iso}$ which are the thyroid inhalation dose
factors from Table 2.2.5.2.2-4.

$$D_{Thy} = (8.35 \times 10^{-7}) * X/Q * \sum_{iso=34}^{35} Q_{iso}$$

$$* \bar{E}_{t,iso}$$

$$8.35 \times 10^{-7} = \frac{(2.32 \times 10^{-4} \text{ m}^3/\text{sec})}{(3600 \text{ sec/hr})} \\ (1.0 \times 10^{-6} \text{ Ci}/\mu\text{Ci})$$

$$2.32 \times 10^{-4} = \text{average daily breathing} \\ \text{rate from Regulatory} \\ \text{Guide 1.3}$$

Table 2.2.5.2.2-1

VALUES OF σ_y AND σ_z FROM PASQUILL-GIFFORD CURVES IN REGULATORY GUIDE 1.145

DISTANCE (meters)	σ_y (m) Stability Class							σ_z (m) Stability Class						
	A	B	C	D	E	F	G	A	B	C	D	E	F	G
200	44	33	25	16	12	8	6	31	21	15	10	6	4	3
500	109	80	58	39	28	20	15	120	55	34	19	13	8	5
1000	205	151	109	74	54	38	28	530	124	64	32	21	13	8
2000	390	287	205	140	101	70	53	1000	340	120	52	34	20	13
3000	550	415	300	200	145	101	71	1000	800	170	68	44	25	16
6000	1000	760	550	365	270	184	140	1000	1000	300	110	71	35	23
10000	1500	1180	850	560	410	285	195	1000	1000	450	147	85	45	28
30000	3800	2950	2200	1400	1015	705	480	1000	1000	1000	275	130	65	40
50000	5800	4500	3400	2150	1650	1080	730	1000	1000	1000	350	155	75	50
80000	7400	6500	5000	3200	2400	1600	1100	1000	1000	1000	460	180	85	55

TABLE 2.2.5.2.2-2

DEPLETION FACTORS FROM FIGURES 2 THROUGH 5 OF REGULATORY GUIDE 1.111

Height of Release (m)	Pasquill Stability Class	200	500	1,000	2,000	3,000	6,000	10,000	30,000	50,000	80,000
Ground	All	0.970	0.936	0.900	0.860	0.832	0.770	0.714	0.590	0.517	0.440
30	A,B,C	0.990	0.964	0.935	0.900	0.875	0.828	0.793	0.680	0.590	0.478
30	D	1.000	0.985	0.960	0.920	0.900	0.850	0.810	0.707	0.650	0.593
30	E,F,G	1.000	1.000	1.000	1.000	1.000	1.000	0.970	0.792	0.664	0.546
60	A,B,C	1.000	0.985	0.967	0.942	0.928	0.878	0.839	0.700	0.617	0.500
60	D	1.000	1.000	1.000	0.970	0.950	0.910	0.870	0.767	0.707	0.646
60	E,F,G	1.000	1.000	1.000	1.000	1.000	1.000	1.000	1.000	1.000	0.977
100	A,B,C	1.000	1.000	0.978	0.950	0.932	0.885	0.850	0.725	0.628	0.500
100	D	1.000	1.000	1.000	0.989	0.982	0.946	0.910	0.807	0.746	0.685
100	E,F,G	1.000	1.000	1.000	1.000	1.000	1.000	1.000	1.000	1.000	1.000

Table 2.2.5.2.2-1

Relative Deposition

Height of Release (m)	Pasquill Stability Class	<u>Distance (meters)</u>									
		200	500	1000	2000	3000	6000	10,000	30,000	50,000	80,000
30	ABC	1.1E-4	8.0E-5	4.2E-5	2.3E-5	1.8E-5	1.1E-5	8.0E-6	4.83E-6	4.0E-6	3.2E-6
30	D	5.8E-6	4.2E-5	4.8E-5	3.0E-5	2.1E-5	1.1E-5	8.0E-6	3.2E-6	2.2E-6	1.6E-6
30	EFG	1.0	1.0	1.0	1.0	1.0E-7	1.9E-6	6.3E-6	8.4E-6	5.2E-6	3.0E-6
60	PBC	2.7E-5	4.3E-5	3.8E-5	2.2E-5	1.6E-5	1.1E-5	8.2E-7	5.0E-6	4.1E-6	3.5E-6
60	D	2.3E-7	5.3E-6	1.5E-5	2.0E-5	1.7E-5	1.2E-5	8.4E-7	3.5E-6	2.4E-6	1.8E-6
60	EFG	1.0	1.0	1.0	1.0	1.0	1.0	1.0	1.5E-8	2.0E-7	7.0E-7
100	ABC	3.7E-6	2.5E-5	3.1E-5	2.3E-5	1.8E-5	1.1E-5	8.0E-6	5.0E-6	4.4E-6	3.7E-6
100	D	1.0	2.5E-7	2.6E-6	9.0E-6	1.1E-5	1.0E-5	7.5E-6	3.8E-6	2.7E-6	1.9E-6
100	EFG	1.0	1.0	1.0	1.0	1.0	1.0	1.0	1.0	1.0	1.0

TABLE 2.2.5.2.2-4
DOSE FACTORS IN XDCALC
Assumed Finite Plume Gamma Abundance⁽⁵⁾
(fraction) for each Energy (MeV)

Index	Isotope	Decay Factor (sec ⁻¹)	Assumed Finite Plume Gamma Abundance ⁽⁵⁾ (fraction) for each Energy (MeV)						Semi-infinite Plume Gamma		Semi-infinite Plume Beta			Thyroid ⁽⁴⁾ Dose Factors, F _t
			\bar{E}_1 0.032	\bar{E}_2 0.081	\bar{E}_3 0.15	\bar{E}_4 0.25	\bar{E}_5 0.53	\bar{E}_6 1.0	\bar{E} (1) γ	D _f (2) air γ	\bar{E} (1) β	D _f (3) $\beta, 1.109$	D _f (2) air, β	
1	not used	--	--	--	--	--	--	--	--	--	--	--	--	--(6)
2	not used	--	--	--	--	--	--	--	--	--	--	--	--	--(6)
3	AR-41	1.05-4	0	0	0	0	0	1.3	1.18	2.95+2	0.45	2.69-3	1.04+2	--
4	Kr-83M	1.05-4	0.0005	0	0	0	0	0	2.44-3	6.12-1	0.039	0	9.13	--
5	Kr-85M	4.29-5	0	0	0.749	0.183	0	0.0001	1.56-1	3.90+1	0.27	1.46-3	6.24+1	--
6	Kr-85	2.0-9	0	0	0	0	0.0041	0	2.20-3	5.45-1	0.27	1.34-3	6.18+1	--
7	Kr-87	1.5-4	0	0	0	0	0.4	0.56	7.84-1	1.96+2	1.42	9.73-3	3.27+2	--
8	Kr-88	6.7-5	0.025	0	0.037	0.202	0.003	1.75	1.93	4.82+2	0.4	2.37-3	9.29+1	--
9	Kr-89	3.6-3	0	0.0097	0	0.113	0.304	1.83	2.19	5.48+2	1.46	1.01-2	3.36+2	--
10	Kr-90	2.1-2	0	0	0.36	0.14	0.24	0.89	2.07	5.14+2	1.08	7.29-3	2.48+2	--
11	Xe-131M	6.7-7	0.54	0	0.22	0	0	0	1.98-2	4.95	0.15	4.76-4	3.52+1	--
12	Xe-133M	3.6-6	0.567	0	0	0.1	0	0	4.16-2	1.04+1	0.2	9.94-4	4.69+1	--
13	Xe-133	1.5-6	0.468	0.373	0.0007	0	0	0	4.48-2	1.12+1	0.14	3.06-4	3.33+1	--
14	Xe-135M	7.3-4	0.134	0	0	0	0.812	0	4.28-1	1.07+2	0.1	7.11-4	2.34+1	--
15	Xe-135	2.1-5	0.049	0	0.0024	0.91	0.03	0.0007	2.44-1	6.09+1	0.34	1.86-3	7.80+1	--
16	Xe-137	3.0-3	0	0	0	0	0.322	0.048	1.92-1	4.79+1	1.75	1.22-2	4.03+2	--
17	Xe-138	8.1-4	0.033	0	0.06	0.327	0.128	0.96	1.17	2.92+2	0.65	4.13-3	1.51+2	--
18-33	not used	--	--	--	--	--	--	--	--	--	--	--	--	--(7)
34	I-131	9.9-7	0.045	0.026	0	0.072	0.676	0	0.380	0	0.191	1.27-3	0	1.48+6
35	I-133	9.2-6	0	0	0	0	0.909	0.122	0.607	0	0.409	2.86-3	0	4.0+5

- (1) Factors are in units of mev/dis₃ (inferred from Regulatory Guide 1.109)
(2) Factors are in units of (mrad-m³)/(Ci-sec) (reference Regulatory Guide 1.109, Revision 1)
(3) Factors for β skin dose are in units of (mrem-m³)/(pCi-yr) (reference Regulatory Guide 1.109, Revision 1)
(4) Thyroid dose factors are in units of rem/Ci (Reference TID-14844)
(5) Abundances are verified using Kocher et al, (ORNL/NUREG/TM-102) and are based on energy and air attenuation
(6) H-3 and C-14 are not used in XDCALC or ACRISCO calculations
(7) Particulate isotopes are not used in ACRISO finite gamma calculations. Dose factors for semi-infinite plume calculations are normally set to 0 in ACRISO and XDCALC.

FIGURE 2.2.5.2.2-1

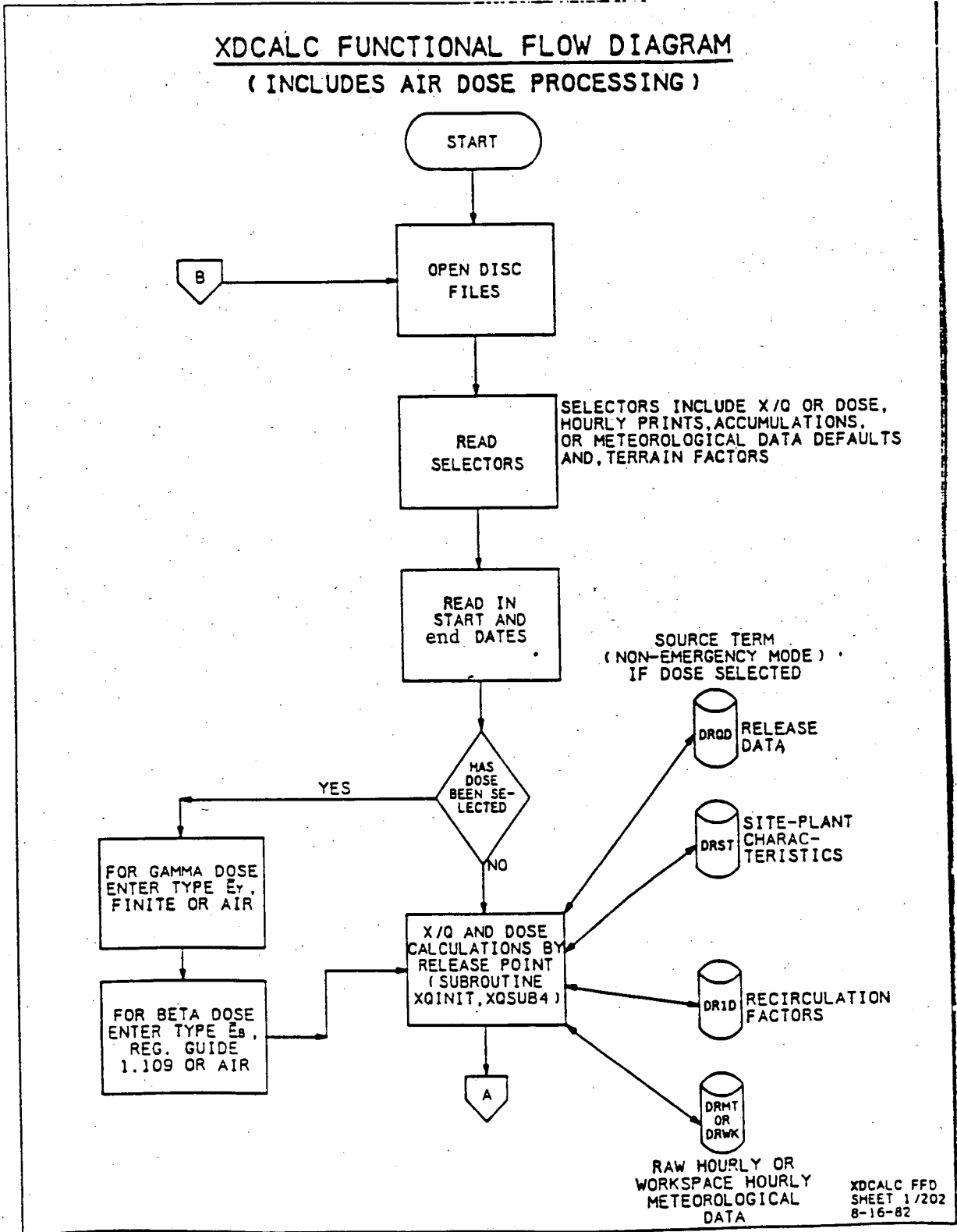

FIGURE 2.2.5.2.2-1

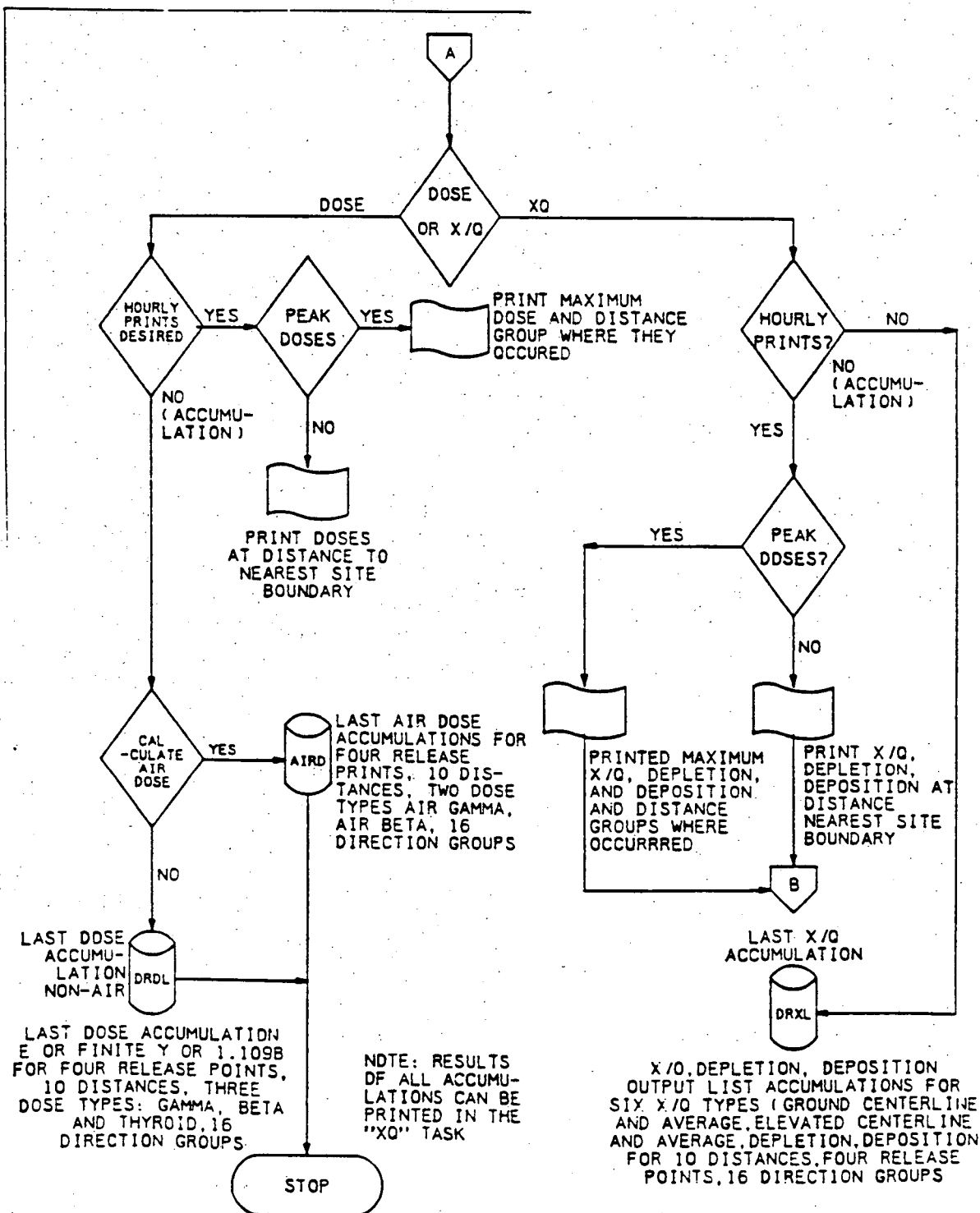
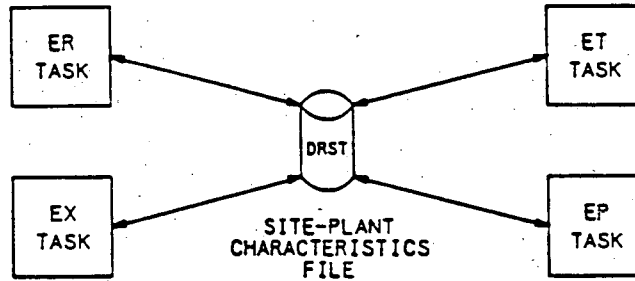
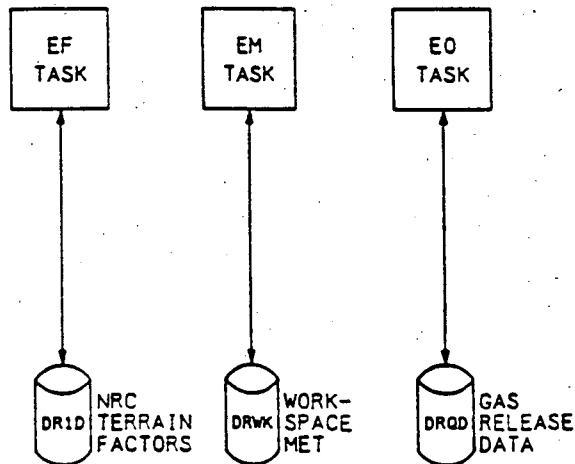

FIGURE 2.2.5.2.2-2

XDCALC PRELIMINARY EDITS



EDITS THAT CHANGE FILE DRST-SITE PLANT CHARACTERISTICS FILE FOR THE REACTOR UNIT.



EDITS THAT CHANGE FILES DRID (NRC RECIRCULATION TERRIAN FACTORS) AND DRWK (METEOROLOGICAL WORKSPACE) FOR THE SITE; AND DRQD (GASEOUS RELEASE DATA) FOR THE REACTOR UNIT.

XDCALC PREL EDITS
SHEET 1/202
A-16-A2

2.2.6 Environmental Pathway and Dose Calculations for Liquid and Gaseous Effluents

2.2.6.1 XDAIR (Accumulate Air Doses) - Preliminary Information

PROGRAM NAME: XDAIR

FUNCTION: Computes air dose results for use in Regulatory Guide 1.21 reports and Appendix I calculations based on routine releases. Dispersion calculations and dose calculations are the same as the air dose calculations described in the XDCALC task documentation.

PURPOSE: To provide air dose results for reporting in the DOSUM task. Results can be printed using the XDAIRP task.

FILE(S) USED:

<u>DRQP</u>	<u>DRMT</u>	<u>DRST</u>	<u>AIRD</u>	<u>DRTN</u>	<u>DRWK</u>			
Yes	Yes	Yes	No	Yes	Yes	No	No	Yes
Yes	No	No						

TASKS USING FILES EDITED BY THIS TASK: No files are edited by this task.

TASKS USING FILES CONTAINING CALCULATED RESULTS FROM THIS TASK: XDAIRP

PREREQUISITES:

The effluent data in the compressed Q file must be available along with hourly or quarter-hourly meteorological data in raw or workspace data files.

Section 2.2.6.1

XDAIR - User Instructions

USER INSTRUCTIONS:

The user schedules this task from the menu and is prompted for unit and dates. Either workspace or raw data meteorological files for hourly or quarter-hourly data can be used. After entering a start and end date the accumulation begins. Results are printed using the XDAIRP task and the peaks are found in DOSUM. The hourly or quarter-hourly calculations share the same file. Refer to XDCALC for further information.

*** Refer to attached sample printout ***

(There are no notes for this task)

XDAIR
ENTER: [XX] SITE ID
[RETURN] EXIT

DV
ENTER: [DV] UNIT 1
[U2] UNIT 2
[EX] EXIT

DV
SITE: DEVELOPMENT 11/07/82 16:00

DATES OF HOURLY MET FILES
DATA COLLECTION DV 82 9 1 1 TO 8210 824
WORK SPACE ** 8210 1 1 TO 8211 724

DATES OF QUARTER HOUR MET FILES
DATA COLLECTION DV 82 9 1 1 0 TO 82 9142445
WORK SPACE ** 8210 1 1 0 TO 821014 1 0

ENTER: [RA] RAW
[WK] WORKSPACE
[EX] EXIT

WK
ENTER: [HR] HOURLY
[QU] QUARTER HOURLY
[RETURN] PREVIOUS PROMPT

HR
ENTER: [YRMODAHRYRMODAHR] START AND END DATE (HOURS)
[99] LAST 8 HOURS
[88] FUTURE (NEXT 8 HOUR FORECAST)
[77] LAST 4 HOURS PLUS FUTURE 4 HOURS
[RETURN] EXIT

8210010182100601
XDAIR DONE

Section 2.2.6.1

XDAIR - Program Design

PROGRAM DESIGN:

The program is identical to the XDCALC program with answers to prompts hardwired to provide cumulative air doses. Refer to the air dose equations provided in the XDCALC task description.

The same code is used for air dose as for the other dose tables, but different files are used. Subroutine QCKCNG compiled with the DDXQ routine which drives the XQ option moves the XQ dose file information into a temporary location and loads the air dose file information. Before exiting option, subroutine CNGBCK returns the dose file control information back to the "XQ" dose status.

2.2.6.3

GASPRO

(Individual Gaseous Release Processing
for Environmental Pathway Doses) Preliminary
Information

PROGRAM NAME:

GASPRO (Also has versions referred to
in the MENU as GASPRI and GASPRP for
individual and population doses,
respectively)

FUNCTION:

Computes accumulation of dose to
individual receptors or the surrounding population
based on hourly meteorology and release data.
Calculations consider the effect of each important
isotope for each pathway, organ, age group, distance,
and direction. Isotope and pathway are used to
determine the type of dispersion. Three types of
atmospheric dispersion factors are used (i.e., normal
X/Q, depleted X/Q or deposition D/Q) depending on
pathway and isotope. Use of hourly data increases
accuracy compared with the use of joint frequency data
since atmospheric conditions are contemporaneous with
release.

Section 2.2.6.3

PURPOSE:

To assess the radiological environmental impact of plant operations and provide reports in conformance with NRC requirements under 10CFR50, Appendix I and the ODCMs for each plant.

FILE(S) USED:

	<u>GSDS</u>	<u>GMDS</u>	<u>DR1D</u>	<u>GMRD</u>	<u>DDCURV</u>
Input	Yes	Yes	Yes	Yes	Yes
Change	Yes	No	No	No	No

	<u>DRST</u>	<u>DRWK</u>	<u>DRMT</u>	<u>GSDF</u>	<u>MRDF</u>
Input	Yes	Yes	Yes	Yes	Yes
Change	No	No	No	No	No

TASKS USING FILES
EDITED BY THIS TASK:

No files are edited by this routine.

TASKS USING FILES
CONTAINING CALCULATED RESULTS FROM
THIS TASK:

HYP0, GDSPT

PREREQUISITES:

Meteorological and gaseous release data must be available for the time period of the run.

USER INSTRUCTIONS:

The user schedules either the GASPRI (individual) or GASPRP, (population) version from the menu and is prompted for raw or workspace data. Pertinent data for the run are printed and the opportunity to exit before starting the run is provided. These runs can use more than one hour of computer time and for population runs several hours may be required. The progress can be monitored on the screen or another program can be started. The results are not printed at the end of the run. They are obtained using the GDSPT task (and its menu versions).

*** Refer to attached sample printout ***

GI
 SCHEDULING: CALCULATE INDIVIDUAL DOSES (GASPRI)
 GASPRO DOSE DATA INQUIRY SERVICE 11/13/82 10:52
 ENTER: [XX] SITE ID
 [RETURN] EXIT

QA
 ENTER: [RA] RAW
 [WK] WORKSPACE
 [EX] EXIT

WK

1 THIS IS THE INDIVIDUAL ACCU. OPTION OF GASPRO

DISTANCES FOR X/Q AND DOSE

804.00	2413.00	4022.00	5631.00	7240.00
12067.00	24135.00	40225.00	56315.00	72405.00

START OF GRAZING PERIOD 3 1 1 0
 END OF GRAZING PERIOD 10312445
 RELEASE POINT SELECTORS 0 1 0 0
 RELEASE TYPE (0=GRND, 1=ELEV, 2=WAKE SPLIT) 2 2 2 0
 PLUME RISE SELECTOR (0=NO PLUME RISE, 1=BRIGGS JET) 1

<u>SITE</u>	<u>WORKSPACE</u>	<u>START DATE</u>	<u>END DATE</u>
TX	HOURLY MET	79030101	79061024

WARNING THIS PROGRAM CLEARS LAST ACCUMULATION DOSE FILES

ENTER: [EX] EXIT
 [RETURN] TO CONTINUE

2 ENTER: [MD] USE MET DATA DFAULTS FOR MISSING DATA
 [DN] DFAULTS NOT USED
 [RETURN] EXIT

MD

3 ENTER: [SE] USE BOTH START AND END DATE
[ED] USE END DATE ONLY
[RETURN] EXIT

SE
ENTER: [YRMODYHRYRMODYHR] START AND END DATE
[RETURN] EXIT

7906010179060106

GASPRO DOSE ACCUMULATOR RUNNING
START DATE 79 6 1 1 END DATE 79 6 1 6

4 START, END, FILE 79 3 1 1 0 79 61024 DRWKQA
PROCESSING MONTH 6 PASS 1
GASPRI DONE *****

GP
 SCHEDULING: CALCULATE POPULATION DOSES (GASPRP)
 GASPRO DOSE DATA INQUIRY SERVICE 11/13/82 11:21
 ENTER: [XX] SITE ID
 [RETURN] EXIT

QA
 ENTER: [RA] RAW
 [WK] WORKSPACE
 [EX] EXIT

WK
 THIS IS THE POPULATION ACCU. OPTION OF GASPRO

DISTANCES FOR X/Q AND DOSE

804.00	2413.00	4022.00	5631.00	7240.00
12067.00	24135.00	40225.00	56315.00	72405.00

START OF GRAZING PERIOD 3 1 1 0
 END OF GRAZING PERIOD 10312445
 RELEASE POINT SELECTORS 0 1 0 0
 RELEASE TYPE (0=GRND, 1=ELEV, 2=WAKE SPLIT) 2 2 2 0
 PLUME RISE SELECTOR (0=NO PLUME RISE, 1=BRIGGS JET) 1

<u>SITE</u>	<u>WORKSPACE</u>	<u>START DATE</u>	<u>END DATE</u>
TX	HOURLY MET	79030101	79061024

WARNING THIS PROGRAM CLEARS LAST ACCUMULATION DOSE FILES

ENTER: [EX] EXIT
 [RETURN] TO CONTINUE

ENTER: [MD] USE MET DATA DEFAULTS FOR MISSING DATA
 [DN] DEFAULTS NOT USED
 [RETURN] EXIT

MD
 ENTER: [SE] USE BOTH START AND END DATE
 [ED] USE END DATA ONLY
 [RETURN] EXIT

SE
 ENTER: [YRMODEYHRYRMODEYHR] START AND END DATE
 [RETURN] EXIT

7906010179060106
 GASPRO DOSE ACCUMULATOR RUNNING
 START DATE 79 6 1 1 END DATE 79 6 1 6

START, END, FILE 79 3 1 1 0 79 61024 DRWKQA
 7 ***PROCESSING MONTH 6 PASS 1***
 START, END, FILE 79 3 1 1 0 79 61024 DRWKQA
 PROCESSING MONTH 6 PASS 2
 GASPRP DONE*****

USER INSTRUCTIONS:

The following notes correspond to the numbers on the example printout on the previous page(s).

- *1* This is an example of an individual run.
- *2* Pertinent parameters from the MIDEX and MIDER edit tables are printed first.
- *3* If defaults are used to "fill-in" for missing meteorological data, they are the values entered in the MIDES task. They should normally be used for longer runs.
- *4* GASPRO runs can be made end to end with the end date retained for the last run (which would be the first date for the next run). Each run can be run with separate alternating start and end dates (this is the normal mode). This prompt controls the start date printed in the GDSVRT task.

Section 2.2.6.3 (continued)

5 progress can be monitored for each month. Only one pass is used for individual runs.

6 An example of a population run starts here.

7 The calculation is similar to the individual run except that there are 2 passes per month which can be monitored during the run.

PROGRAM DESIGN:

Due to the large output files which contain hourly dose calculations (i.e., dose for each distance group, age group, organ type, pathway type, and direction group) and the number of input dose factors (i.e., for each pathway, age group, organ type, and isotope), the program must use masscore for transferring dose factors from another memory segment. Meteorological data input and X/Q, depletion and deposition calculations are processed in a subroutine similar to those in XDCALC (see Section 2.2.5.2.2). The dose calculations of all groups are calculated and summed in another subroutine. For each hour of meteorological data, the "last" accumulation files for the individual pathways doses and the "last" population accumulation dose workspace file are read, updated, and written back to the disc. The actual

Section 2.2.6.3 (continued)

population dose accumulation results are computed at the end of processing from the population work file. A functional flow diagram is given in Figure 2.2.6.3-1.

COMPUTATIONAL MODEL:

The GASPRO routine is the heart of the pathways dose calculations for gaseous effluent releases. Calculations are based on the environmental pathways-to-man models prescribed by the NRC in Regulatory Guide 1.109. Dose factors for both the individual or population doses are based on results run off-line (on a separate computer system) using the PLG version of a computer program called GASPAR. Results from this program provide input to the GASPRO routine in the form of a "look-up" table of the dose factors for each isotope (documented in Tables 2.2.6.3-1 and 2.2.6.3-2). The 35 gaseous isotopes are indexed as shown in Table 2.2.5.2.2-4. All 35 gaseous and particulate isotopes are listed in MIDAG (Section 2.2.2.4.1) reading from left to right in the example printout. This table can be updated if regulatory requirements and/or models change using the GDSFIL or MRDFIL utility routines.

Section 2.2.6.3 (continued)

GASPRO calculates doses for the following pathways, age groups and organs:

<u>Pathways</u>	<u>Organ</u>	<u>Age Groups</u>
1-Plume	1-Total Body	1-Adult
2-Ground Shine	2-GI Tract	2-Teen
3-Vegetables	3-Bone	3-Child
4-Meat	4-Liver	4-Infant
5-Cows	5-Kidney	
6-Goats	6-Thyroid	
7-Inhalation	7-Lung	
	8-Skin	

Five types of receptors including residents, vegetable gardens (produce including leafy and nonleafy vegetables, grains), meat animals, cows, and goats can be located at up to 5 distances in each of the 16 direction sectors. The resident location will receive the plume shine dose, ground shine from deposited material, and the inhalation dose. The appropriate dispersion is set to one of the three dispersion types, normal X/Q (for noble gases), depleted X/Q (for airborne halogens and particulates), deposition (for halogens and particulates). Values

Section 2.2.6.3 (continued)

for σ_y and σ_z (the atmospheric dispersion coefficients in the Gaussian plume model) for each receptor are determined by linear interpolation between values for specific distances set in data statements. Average X/Q , depleted X/Q , and deposition are computed using the current hour's meteorological data at six distances (individual dose) determined by the MIDEX task (see MIDEX task, Section 2.2.3.2, parameter 5, first six distances) for all release points (vents) that are selected in the MIDER task. Dispersion equations are the same as those used in the XDCALC task. After computing dispersion factors (X/Q) for the distances selected in the MIDER task, a log-log interpolation is made to determine the appropriate dispersion factors for the receptor distances. If there are no receptors in the current direction group, the hour is counted good but no calculations are made.

During the loop on release point, the appropriate release data are read in if the date has changed. In the next

Section 2.2.6.3 (continued)

loop on isotope, the isotope is skipped if the current isotopic release is zero. Similarly, if there are no receptors during the loop on pathway, that location is also skipped. This process avoids unnecessary computations and results in a considerable saving of time.

Doses are computed for each hour and accumulated on disc by direction group. One direction group (with up to five receptor distances, eight organs, four age groups and seven pathways) is in core at any one time. The previous hour's dose accumulations are written out to disc and the current hour is read in whenever the direction group (1-16) changes (refer to GASPRO flow chart). A finite plume gamma dose model is used when appropriate to calculate the plume dose to the total body and skin in accordance with Regulatory Guide 1.109. A log-log interpolation for each receptor distance in the current direction group is used to determine the appropriate dose for each receptor.

Section 2.2.6.3 (continued)

In the discussion that follows, the equations to be used for each pathway and organ as well as for ground level or elevated releases will be presented. Precomputed dose factors are used for all pathways except shine from elevated plumes. A further complication exists due to the fact that the skin dose factors are based on submersion in the plume which is not always the case for elevated releases. Therefore, the following discussion will treat ground and elevated releases separately.

GLOSSARY OF GASPRO SYMBOLS X/Q or D/Q = Normal
X/Q, (sec/m³)
depleted X/Q (sec/m³) or deposition (m⁻²) at receptor distance using the sector average dispersion models described in the XDCALC task description

RECPT_{i,n} = Receptor distance (m)

ie = Energy group 1-6

Section 2.2.6.3 (continued)

iso	=	Isotope number 1-35 (3-17 are noble gases)
i	=	Distance group (1-5)
n	=	Pathway number (1-7)
k	=	Organ type (1-8, total body, GI tract, bone, liver, kidney, thyroid, lung, skin)
l	=	Age groups 1-4 (adult, teen, child, infant)
E_{ie}	=	Energy of six energy groups (MEV) (0.032, 0.81, 0.150, 0.250, 0.530, 1.0)
X_k	=	Buildup factor for air
X_{mua}	=	Absorption coefficient for air (m^{-1})
\bar{u}	=	Wind speed at reference height, (m/sec). See speed correction

Section 2.2.6.3 (continued)

equations in Section 2.2.5.2.1, ACRISO Program Design.

- $ABUN_{ie,iso}$ = Abundance of isotopes in this energy group; i.e., See Table 2.2.5.2.2-4.
- λ_{iso} = Decay coefficient of isotope (hr^{-1})
- Q_{iso} = Release rate of isotope in ($\mu Ci/sec$)
- $DF_{k,l,n,iso}$ = Precomputed dose factor (using Regulatory Guide 1.109 equations) for organ type k, age group l, pathway n, for each isotope (See Table 2.2.6.3-1.) Age group weighted dose factors for population doses are given in Table 2.2.6.3-2. Units are provided in the tables, equations used are provided at the end of this section.

Section 2.2.6.3 (continued)

GAM_i	=	Finite gamma dose at distance group i (rem/hr)
\bar{I}_1, \bar{I}_2	=	Dimensionless numerical integration constants (see Meteorology and Atomic Energy, Equation 7.62)
$Dose_{k,l,n,iso}$	=	Organ dose as a function of isotope, pathway and age group (rem/hr)
IDADD	=	Distance offset, 0 for the first set of five distances and equals 5 for the second set of five distances

GROUND (OR WAKE SPLIT) RELEASES, ALL ORGANS AND PATHWAYS

The following equation applies to all hourly dose calculations for ground level or wake split (partial ground and elevated) releases. This same relationship is used for all 8 organs and 7 pathways.

Section 2.2.6.3 (continued)

$$\text{Dose}_{k,l,n,iso} = (X/Q \text{ or } D/Q) * DF_{k,l,n,iso} * Q_{iso} * 10^{-3} * 31.52/8760^{(1)}$$

- (1) Note these constants convert mrem-microcuries/Ci-sec to rem/hr

The short-lived noble gas isotopes are decayed during travel time to the receptor for the "plume" pathway only.

ELEVATED RELEASES, ALL ORGANS AND PATHWAYS EXCEPT SKIN AND TOTAL BODY FROM PLUME PATHWAY

Dose calculations for these cases are done the same way as for the ground release cases with the appropriate elevated dispersion factors. Decay in transit is not accounted for in nonplume pathways calculations.

ELEVATED RELEASES, ALL ORGANS EXCEPT SKIN PLUME PATHWAY

The whole body gamma dose for the plume (shine) pathway must be calculated using a finite plume model since a receptor could receive a shine dose from the plume without being submerged in it. The gamma dose GAM is computed as follows:

$$GAM_i = \frac{17}{iso} Q_{iso} * GSUM_{iso,i,n}$$

iso=3
(noble gas)

Section 2.2.6.3 (continued)

Where

$$\begin{aligned}
 \text{GSUM}_{\text{iso},i,n} = & \sum_{ie=3}^{17} \left(\bar{I}_1 + X_k \bar{I}_2 E_{ie} * X_{\text{mau},ie} * \right. \\
 & 0.00103 / (\text{RECPT}_{i,n} * 0.3927 * \bar{u} * \\
 & \text{ABUN}(ie, \text{iso}_{\text{noble}}) * 0.7 * \\
 & \left. \exp - (\lambda_{\text{iso}_{\text{noble}}} * \text{RECPT}_{i,n} / \bar{u}) \right)
 \end{aligned}$$

$$\begin{aligned}
 0.00103 = & (3600 \text{ sec/hr}) (10^{-6} \text{ Ci}/\mu\text{Ci})(0.2865), \\
 & (0.2865 \text{ is from equation 7.62 of} \\
 & \text{Meteorology and Atomic Energy})
 \end{aligned}$$

$$\begin{aligned}
 0.2865 = & \frac{3 \text{ rem-m -radian-dis}}{\text{sec-mev-Ci}}
 \end{aligned}$$

The factor, 0.2865, is the equivalent of the factor, 260, that in Regulatory Guide 1.109, Equation (6) except for tissue-to-air conversion (tissue dose = 1.11 times the air dose) and units are rem instead of mrem.

$$\begin{aligned}
 0.3927 & = \pi/8 \text{ (radians in a sector)} \\
 0.7 & = \text{shielding factor} \\
 \exp & = \text{factor to account for decay in transit}
 \end{aligned}$$

The plume dose for each organ except skin is simply that due to the shine calculated above (pathway n=1). Thus the dose to internal organs is assumed to

Section 2.2.6.3 (continued)

be equivalent to the "tissue dose" reported in Meteorology and Atomic Energy (equation 7.62) which is identical to the gamma skin dose.

$$DOSE_{(i,k,l,n=1)} = GAM_i$$

ELEVATED RELEASE, SKIN FROM PLUME PATHWAY

For the skin (organ type 8), the total body semi-infinite plume dose is subtracted from the skin semi-infinite plume dose and the finite plume shine skin dose added as follows:

$$DOSE_{(i,8,1,n=1)} = (X/Q \text{ or } D/Q) * Q_{iso} * \\ (DF_{8,1,n=1} - DF_{total\ body,1,n=1}) * \\ \exp - (\lambda_{iso_{noble}} * RECPT_i / \bar{u}) * \\ 10^{-3} * 31.52/8760 + GAM_i$$

Subtraction of the total body dose factor above is conservative because it is slightly lower than the semi-infinite (i.e., skin gamma dose). (The total body dose factor accounts for attenuation in 5 cm of tissue.)

Section 2.2.6.3 (continued)

FOR POPULATION DOSE

If population dose is selected, two passes through the distance loop and all internal loops are made five at a time to include the second set of receptor distances 6-10, which should extend to 50 miles (see MIDEG task). In this case the 10 distances to the center of each population sector are used rather than at specific receptor locations. The two passes are necessary because the program is limited to five of the distance groups at a time. The population dose from gaseous effluents is computed by organ type, k, and pathway, n, as follows:

$$\text{DOSE}_{\text{pop}}(k,n) = \sum_{\text{IDG}=1}^{16} \sum_{i=1}^5 \text{DOSE}(i + \text{IDADD}, \text{IDG}, k, n) * \text{POP}(\text{IDG}, [i + \text{IDADD}], n)$$

The variable DOSE in the above equation is computed using the equation for dose given on Page 10 above. However, the dose factors, DF_{k,n,iso} (see Table 2.2.6.3-2) differ. These precomputed population dose factors are calculated in a manner similar to that used for individuals except that Regulatory Guide 1.109, Revision 1 assumptions for average individuals are used rather than for maximum exposed individuals and they are averaged over all age groups after weighting by the fraction of population in each age group. POP is the number of people affected by pathway n (see MIDEP task), at direction group (from) IDG at distance i.

Section 2.2.6.3 (continued)

METHODS USED TO COMPUTE MIDAS ENVIRONMENTAL DOSE FACTORS

The methodology used in MIDAS for computing Appendix I environmental pathways dose factors is based on NRC Regulatory Guide 1.109. This summary provides the basic relationships used to compute dose factors that are resident in the MIDAS system. Additional details are found in NRC Regulatory Guide 1.109.

Appendix I to 10CFR Part 50 provides guidance on the doses to members of the general public resulting from effluent releases. This summary describes models and assumptions used for calculating the estimated doses to man from radionuclides discharged to the hydrosphere and from noble gases, radioiodines and other radionuclides discharged to the atmosphere. The models and assumptions for calculating population doses (man-rem) from radionuclide releases to the atmosphere and hydrosphere are also described.

The population is considered to be made up of infants (0 to 1 year), children (1 to 11 years), teenagers (11 to 17 years) and adults (17 years and older). For the purpose of evaluating dose commitment, the maximum infant is assumed to be newborn, the maximum child is taken to be four years old, the maximum teenager is taken to be 14 years old and the maximum adult is taken to be 17 years old.

Section 2.2.6.3 (continued)

Since the radiation dose commitment per unit intake of a given radionuclide usually varies as a function of age, four sets of internal dose conversion factors are given by Regulatory Guide 1.109. These dose factors are appropriate for the four different age groups defined above. Specifically, these dose factors are based on continuous intake over a one-year environmental exposure period and an associated dose commitment extending over a 50-year period from initiation of intake.

The equations provided below are used to estimate radiation exposure for maximum individuals and the population within 50 miles. These equations are appropriate for the exposure pathways normally considered by the NRC. To compute the appropriate "dose factors" for input to the MIDAS, the equations are used with the dilution factors set to 1.0 and the release (or Q) value set to 1.0. Separate age-weighted dose factors are computed for population doses.

The following relationships are used to compute the dose factors for iodines, particulates and noble gases. Values for all parameters are those in Regulatory Guide 1.109, Revision 1 unless stated otherwise.

- (1) Dose Factor from External Irradiation from Radionuclides Deposited onto the Ground Surface

$$D_{ij}^G = 8760 S_F C_i^G DFG_{ij} \quad \text{(referred to as } DF_{k,1,2,iso} \text{ in the equation on page 10 of this section)}$$

Section 2.2.6.3 (continued)

where

C_i^G = is the ground plane concentration (pCi/m²) of radionuclide i for a unit release rate (Ci/yr) and a unit D/Q, ground concentration dispersion parameter (m²), in pCi/m² * yr/Ci * 1/m²

DFG_{ij} = is the open field ground plane dose conversion factor for organ j from radionuclide i, in mrem-m²/pCi-hr from Regulatory Guide 1.109, Appendix E of Revision 1. Internal organs are considered to have the same dose as the whole body.

D_{ij}^G = is the annual dose from isotope i to the organ j, in mrem-m²/Ci equivalent to mrem/yr * yr/Ci * 1/m⁻²

S_F = is a shielding factor that accounts for the dose reduction due to shielding provided by residential structures during occupancy (dimensionless). Maximum exposed individual = 0.7, population dose = 0.5.

8760 = is the number of hours in a year

(2) Dose Factor from Inhalation of Radionuclides in Air

$D_{ija}^A = R_a \chi_i \cdot DFA_{ija}$ (referred to as $DF_{k,1,7,iso}$ in the equation on page 10 of this section)

where

D_{ija}^A = is the annual dose from isotope i to organ j of an individual in the age group a due to inhalation, in mrem-m³/Ci-sec (equivalent to mrem/yr * yr/Ci * m³/sec)

Section 2.2.6.3 (continued)

- DFA_{ija} = is the inhalation dose factor for radionuclide i , organ j , and age group a , in mrem/pCi from Appendix E, Regulatory Guide 1.109, Revision 1. The value for skin, not included in Regulatory Guide 1.109, is assumed to be 0.
- R_a = is the annual air intake for individuals in age group a , in m^3/yr
- X_i = is the annual average concentration of radionuclide i in air (pCi/m^3), for a unit release rate (Ci/yr) and a unit X/Q , atmospheric dispersion parameter (sec/m^3), in $pCi/m^3 * yr/Ci * m^3/sec$

(3) Dose Factor from Ingestion of Atmospherically Released Radionuclides in Food

$$DF_{k,1,3,iso} = DFI_{ija} U_{ag}^V C_i^V + U_{al}^L C_i^L$$

$$DF_{k,1,4,iso} = DFI_{ija} U_{ai}^F C_i^F$$

$$DF_{k,1,5 \text{ or } 6,iso} = DFI_{ija} U_{ai}^m C_i^m$$

(Referred to as D_{ija}^D in Regulatory Guide 1.109.

Ingestion doses for each of four pathways (n) are computed separately in MIDAS.)

where

C_i^V, C_i^m , are the concentrations of radionuclide i , in produce (non-leafy-vegetables, fruits, and grains), milk, leafy vegetables and meat, respectively (pCi/kg or pCi/l) for a unit release rate (Ci/yr) and a unit D/Q , ground concentration

C_i^L, C_i^F

Section 2.2.6.3 (continued)

dispersion parameter (m^{-2}), or,
 for H-3 and C-14, a unit X/Q, atmospheric
 dispersion parameter (sec/m^3), in $pCi/kg * yr/Ci * l/m^{-2}$ or $pCi/kg * yr/Ci * m^3/sec$ or
 $pCi/l * yr/Ci * l/m^{-2}$ or $pCi/l * yr/Ci * m^3/sec$

D_{ija}^D = is the annual dose from isotope i
 (iso in MIDAS terminology) to the
 organ j (k in MIDAS terminology) of an
 individual in age group, a (l in MIDAS
 terminology) from ingestion of
 produce, milk, leaf₂ vegetables
 and meat, in $mrem-m^2/Ci$ or, H-3 and
 C-14, $mrem-m^3/Ci-sec$ (see
 definitions for DA, DG). This
 calculation in MIDAS is separated into
 four pathways (n).

DFI_{ija} = is the ingestion dose factor for
 radionuclide i, organ j, and age group a, in $mrem/pCi$
 from Appendix E of Regulatory Guide 1.109, Revision 1.

f_g, f_l = are the respective fractions of the ingestion rates of
 produce and leafy vegetables that are produced in the
 garden of interest

$U_a^V, U_a^M, U_a^F, U_a^L$ = are the annual intake (usage) of
 produce, milk, meat, and leafy
 vegetables, respectively, for individuals in the age
 group a, in kg/yr or l/yr

(4) Total Body Dose Factors from Exposure to
 Semi-Infinite Plume (Ground Release)

$$D^T = S_F \sum x_i DFB_i$$

Section 2.2.6.3 (continued)

where

DF_{Bi} = whole body gamma dose factor from Table B-1 of Regulatory Guide 1.109 in $(mrem\text{-}m^3)/(pCi\text{-}yr)$

D_i^T = total body gamma dose factor (referred to as $DF_{k=1-7,1 n=1}$ in the equation on page 10 of this section) in $(mrem\text{-}m^3)/(Ci\text{-}sec)$

(5) Skin Dose Factors from Exposure to Semi-Infinite Plumes (Ground Release)

$$D_i^S = (1.11 S_F DF_i^Y + DFS_i) * \chi_i$$

where

DF_i^Y = is gamma air dose from semi-infinite plume from Table B-1 of Regulatory Guide 1.109 in $(mrad\text{-}m^3)/(pCi\text{-}yr)$

DFS_i = is the skin dose factor from Table B-1 of Regulatory Guide 1.109 in $(mrem\text{-}m^3)/(pCi\text{-}yr)$

D_i^S = skin dose factor referred to as $DF_{k=8,1,n=1}$ in the equation on page 10 of this section in $(mrem\text{-}m^3)/(Ci\text{-}sec)$

1.11 = tissue to air conversion factor (mrem/mrad)

(6) Total Body and Skin Dose Factors (Elevated Release)
Derivation of these factors is discussed in the text.

FIGURE 2.2.6.3-1

GASPRO FUNCTIONAL FLOW DIAGRAM

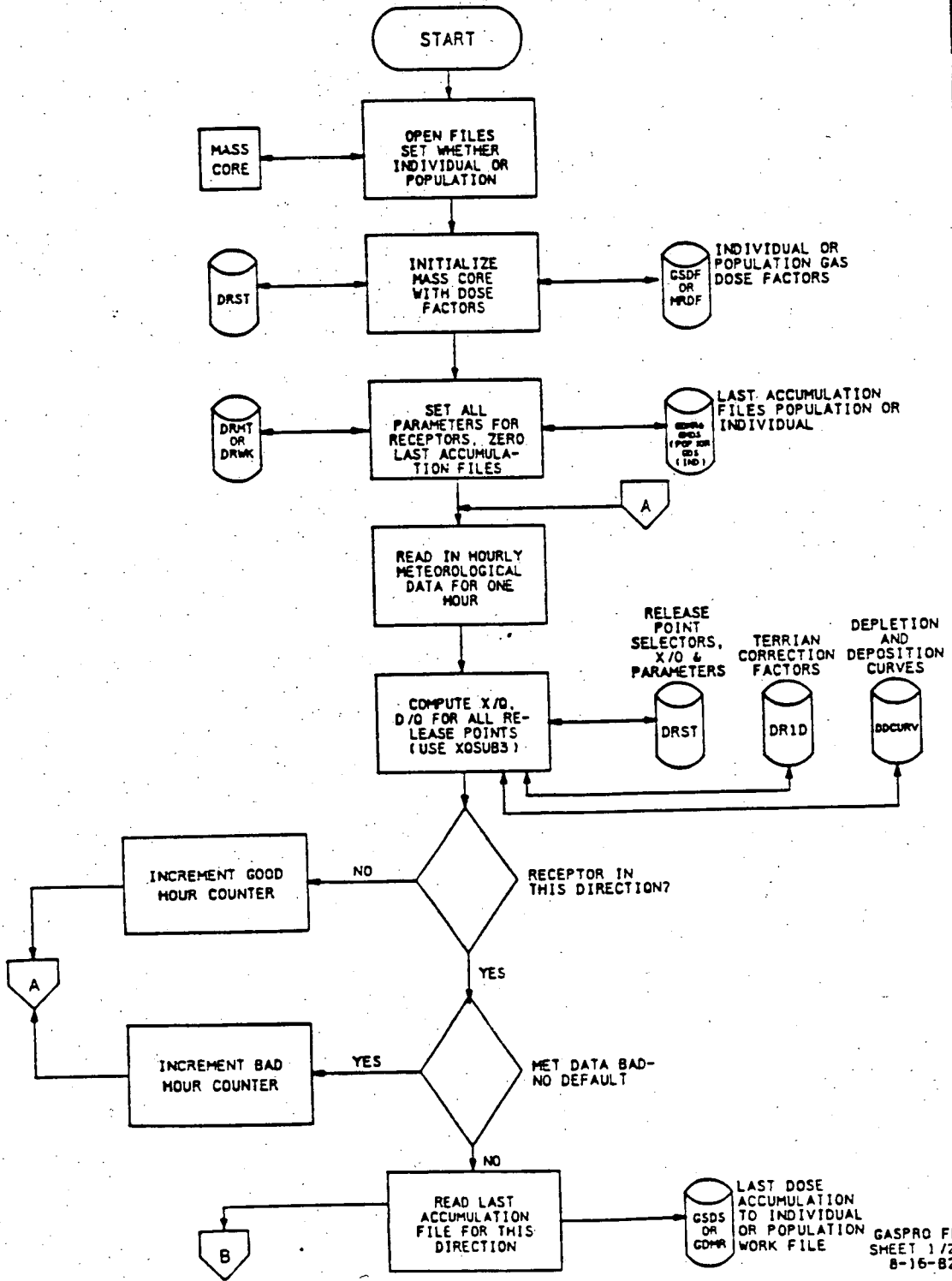

GASPRO FFD
SHEET 1/202
8-16-82

FIGURE 2.2.6.3-1 (continued)

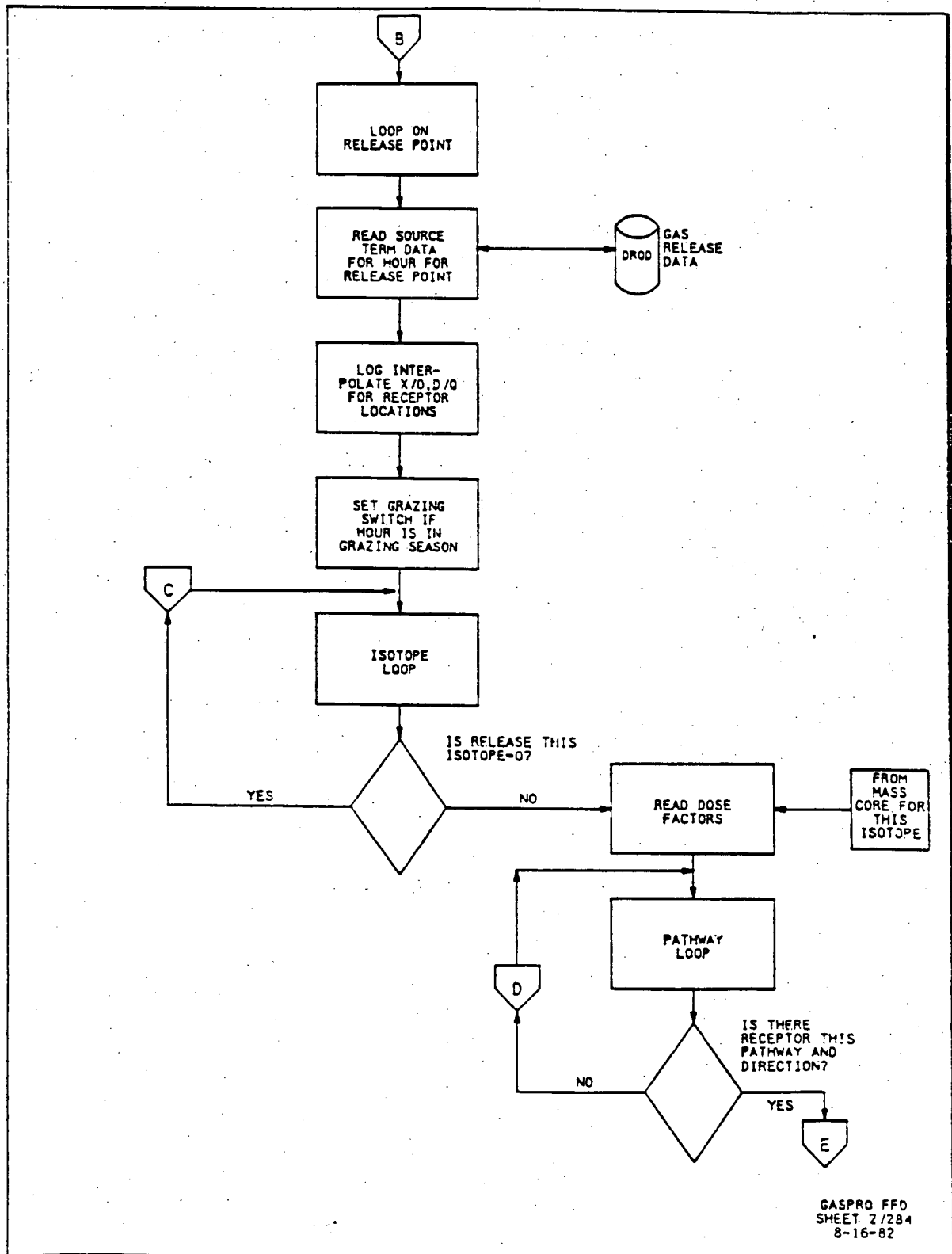

GASPRO FFD
SHEET 2/284
8-16-82

FIGURE 2.2.6.3-1 (continued)

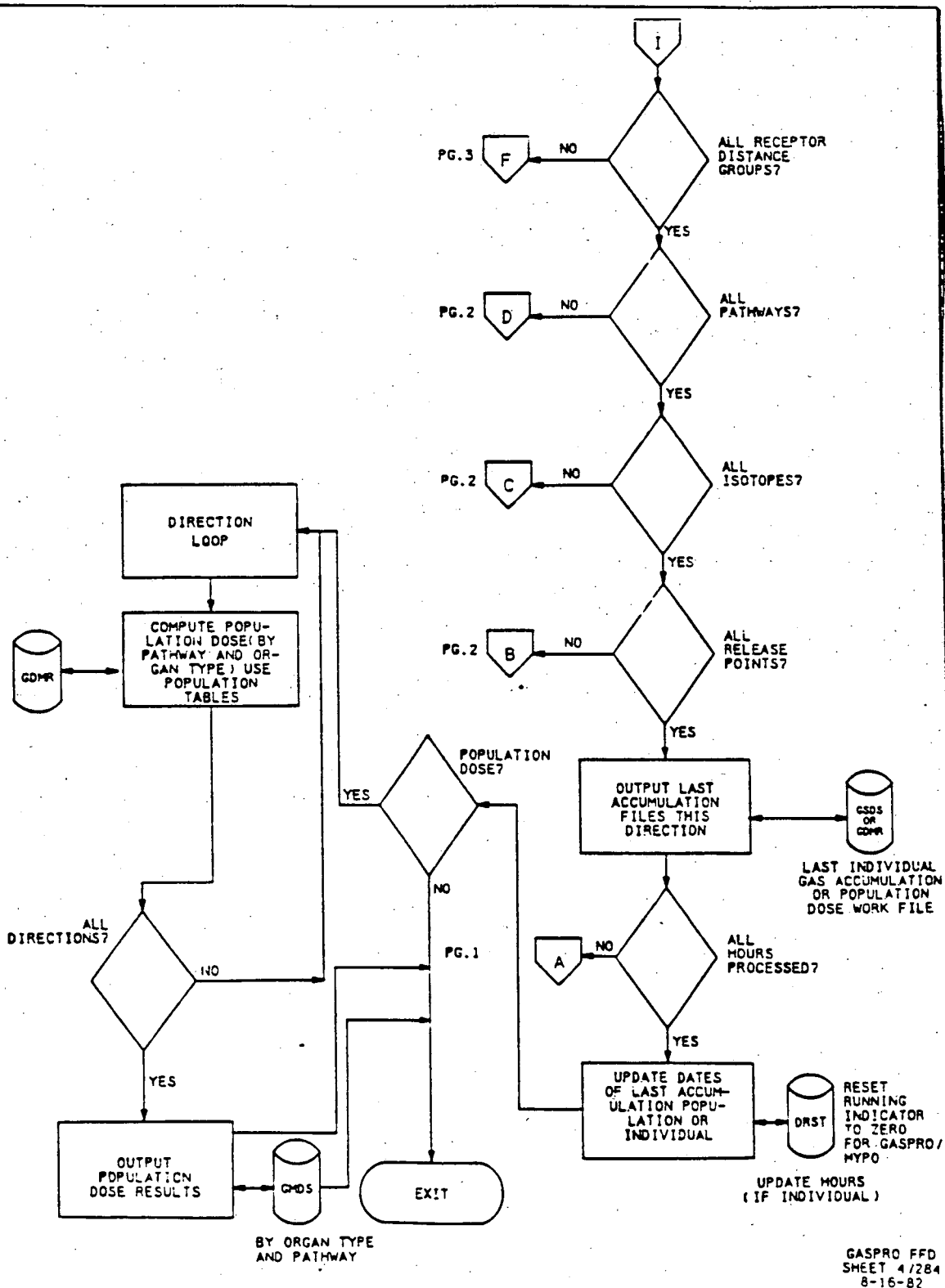

TABLE 2.2.6.3-1
INDIVIDUAL DOSE FACTORS FOR GASPRO TASK

Units for airborne pathways are $\text{mrem}\cdot\text{m}^3/\text{Ci}\cdot\text{sec}$

Units for deposition pathway are $\text{mrem}\cdot\text{m}^2/\text{Ci}$

INDIVIDUAL DOSE FACTORS FOR GASEOUS EFFLUENTS. FOR ISOTOPE NUMBER 1

FOR PATHWAY 1

AGE GP 1 FOR 8 ORGANS:	0.00E-01	0.00E-01	0.00E-01	0.00E-01	0.00E-01	0.00E-01	0.00E-01	0.00E-01	0.00E-01
AGE GP 2 FOR 8 ORGANS:	0.00E-01	0.00E-01	0.00E-01	0.00E-01	0.00E-01	0.00E-01	0.00E-01	0.00E-01	0.00E-01
AGE GP 3 FOR 8 ORGANS:	0.00E-01	0.00E-01	0.00E-01	0.00E-01	0.00E-01	0.00E-01	0.00E-01	0.00E-01	0.00E-01
AGE GP 4 FOR 8 ORGANS:	0.00E-01	0.00E-01	0.00E-01	0.00E-01	0.00E-01	0.00E-01	0.00E-01	0.00E-01	0.00E-01

FOR PATHWAY 2

AGE GP 1 FOR 8 ORGANS:	0.00E-01	0.00E-01	0.00E-01	0.00E-01	0.00E-01	0.00E-01	0.00E-01	0.00E-01	0.00E-01
AGE GP 2 FOR 8 ORGANS:	0.00E-01	0.00E-01	0.00E-01	0.00E-01	0.00E-01	0.00E-01	0.00E-01	0.00E-01	0.00E-01
AGE GP 3 FOR 8 ORGANS:	0.00E-01	0.00E-01	0.00E-01	0.00E-01	0.00E-01	0.00E-01	0.00E-01	0.00E-01	0.00E-01
AGE GP 4 FOR 8 ORGANS:	0.00E-01	0.00E-01	0.00E-01	0.00E-01	0.00E-01	0.00E-01	0.00E-01	0.00E-01	0.00E-01

FOR PATHWAY 3

AGE GP 1 FOR 8 ORGANS:	7.23E+01	7.23E+01	0.00E-01	7.23E+01	7.23E+01	7.23E+01	7.23E+01	7.23E+01	7.23E+01
AGE GP 2 FOR 8 ORGANS:	8.28E+01	8.28E+01	0.00E-01	8.28E+01	8.28E+01	8.28E+01	8.28E+01	8.28E+01	8.28E+01
AGE GP 3 FOR 8 ORGANS:	1.28E+01	1.28E+02	0.00E-01	1.28E+02	1.28E+02	1.28E+02	1.28E+02	1.28E+02	1.28E+02
AGE GP 4 FOR 8 ORGANS:	0.00E-01	0.00E-01	0.00E-01	0.00E-01	0.00E-01	0.00E-01	0.00E+01	0.00E+01	0.00E-01

FOR PATHWAY 4

AGE GP 1 FOR 8 ORGANS:	1.04E+01	1.04E+01	0.00E-01	1.04E+01	1.04E+01	1.04E+01	1.04E+01	1.04E+01	1.04E+01
AGE GP 2 FOR 8 ORGANS:	6.20E+00	6.20E+00	0.00E-01	6.20E+00	6.20E+00	6.20E+00	6.20E+00	6.20E+00	6.20E+00
AGE GP 3 FOR 8 ORGANS:	7.49E+00	7.49E+00	0.00E-01	7.49E+00	7.49E+00	7.49E+00	7.49E+00	7.49E+00	7.49E+00
AGE GP 4 FOR 8 ORGANS:	0.00E-01	0.00E-01	0.00E-01	0.00E-01	0.00E-01	0.00E-01	0.00E-01	0.00E-01	0.00E-00

FOR PATHWAY 5

AGE GP 1 FOR 8 ORGANS:	2.44E+01	2.44E+01	0.00E-01	2.44E+01	2.44E+01	2.44E+01	2.44E+01	2.44E+01	2.44E+01
AGE GP 2 FOR 8 ORGANS:	3.18E+01	3.18E+01	0.00E-01	3.18E+01	3.18E+01	3.18E+01	3.18E+01	3.18E+01	3.18E+01
AGE GP 3 FOR 8 ORGANS:	5.02E+01	5.02E+01	0.00E-01	5.02E+01	5.02E+01	5.02E+01	5.02E+01	5.02E+01	5.02E+01
AGE GP 4 FOR 8 ORGANS:	7.62E+01	7.62E+01	0.00E-01	7.62E+01	7.62E+01	7.62E+01	7.62E+01	7.62E+01	7.62E+01

FOR PATHWAY 6

AGE GP 1 FOR 8 ORGANS:	4.98E+01	4.98E+01	0.00E-01	4.98E+01	4.98E+01	4.98E+01	4.98E+01	4.98E+01	4.98E+01
AGE GP 2 FOR 8 ORGANS:	6.49E+01	6.49E+01	0.00E-01	6.49E+01	6.49E+01	6.49E+01	6.49E+01	6.49E+01	6.49E+01
AGE GP 3 FOR 8 ORGANS:	1.02E+02	1.02E+02	0.00E-01	1.02E+02	1.02E+02	1.02E+02	1.02E+02	1.02E+02	1.02E+02
AGE GP 4 FOR 8 ORGANS:	1.56E+02	1.56E+02	0.00E-01	1.56E+02	1.56E+02	1.56E+02	1.56E+02	1.56E+02	1.56E+02

FOR PATHWAY 7

AGE GP 1 FOR 8 ORGANS:	4.01E+01	4.01E+01	0.00E-01	4.01E+01	4.01E+01	4.01E+01	4.01E+01	4.01E+01	4.01E+01
AGE GP 2 FOR 8 ORGANS:	4.03E+01	4.03E+01	0.00E-01	4.03E+01	4.03E+01	4.03E+01	4.03E+01	4.03E+01	4.03E+01
AGE GP 3 FOR 8 ORGANS:	3.57E+01	3.57E+01	0.00E-01	3.57E+01	3.57E+01	3.57E+01	3.57E+01	3.57E+01	3.57E+01
AGE GP 4 FOR 8 ORGANS:	2.05E+01	2.05E+01	0.00E-01	2.05E+01	2.05E+01	2.05E+01	2.05E+01	2.05E+01	2.05E+01

TABLE 2.2.6.3-1 (continued)

INDIVIDUAL DOSE FACTORS FOR GASEOUS EFFLUENTS.

FOR ISOTOPE NUMBER 2

FOR PATHWAY 1

AGE GP 1 FOR 8 ORGANS:	0.00E-01	0.00E-01	0.00E-01	0.00E-01	0.00E-01	0.00E-01	0.00E-01	0.00E-01	0.00E-01
AGE GP 2 FOR 8 ORGANS:	0.00E-01	0.00E-01	0.00E-01	0.00E-01	0.00E-01	0.00E-01	0.00E-01	0.00E-01	0.00E-01
AGE GP 3 FOR 8 ORGANS:	0.00E-01	0.00E-01	0.00E-01	0.00E-01	0.00E-01	0.00E-01	0.00E-01	0.00E-01	0.00E-01
AGE GP 4 FOR 8 ORGANS:	0.00E-01	0.00E-01	0.00E-01	0.00E-01	0.00E-01	0.00E-01	0.00E-01	0.00E-01	0.00E-01

FOR PATHWAY 2

AGE GP 1 FOR 8 ORGANS:	0.00E-01	0.00E-01	0.00E-01	0.00E-01	0.00E-01	0.00E-01	0.00E-01	0.00E-01	0.00E-01
AGE GP 2 FOR 8 ORGANS:	0.00E-01	0.00E-01	0.00E-01	0.00E-01	0.00E-01	0.00E-01	0.00E-01	0.00E-01	0.00E-01
AGE GP 3 FOR 8 ORGANS:	0.00E-01	0.00E-01	0.00E-01	0.00E-01	0.00E-01	0.00E-01	0.00E-01	0.00E-01	0.00E-01
AGE GP 4 FOR 8 ORGANS:	0.00E-01	0.00E-01	0.00E-01	0.00E-01	0.00E-01	0.00E-01	0.00E-01	0.00E-01	0.00E-01

FOR PATHWAY 3

AGE GP 1 FOR 8 ORGANS:	5.74E+03	5.74E+03	2.87E+04	5.74E+03	5.74E+03	5.74E+03	5.74E+03	5.74E+03	5.74E+03
AGE GP 2 FOR 8 ORGANS:	9.30E+03	9.30E+03	4.65E+04	9.30E+03	9.30E+03	9.30E+03	9.30E+03	9.30E+03	9.30E+03
AGE GP 3 FOR 8 ORGANS:	2.24E+04	2.24E+04	1.12E+05	2.24E+04	2.24E+04	2.24E+04	2.24E+04	2.24E+04	2.24E+04
AGE GP 4 FOR 8 ORGANS:	0.00E-01	0.00E-01	0.00E-01	0.00E-01	0.00E-01	0.00E-01	0.00E-01	0.00E-01	0.00E-01

FOR PATHWAY 4

AGE GP 1 FOR 8 ORGANS:	2.13E+03	2.13E+03	1.07E+04	2.13E+03	2.13E+03	2.13E+03	2.13E+03	2.13E+03	2.13E+03
AGE GP 2 FOR 8 ORGANS:	1.80E+03	1.80E+03	9.00E+03	1.80E+03	1.80E+03	1.80E+03	1.80E+03	1.80E+03	1.80E+03
AGE GP 3 FOR 8 ORGANS:	3.38E+03	3.38E+03	1.69E+04	3.38E+03	3.38E+03	3.38E+03	3.38E+03	3.38E+03	3.38E+03
AGE GP 4 FOR 8 ORGANS:	0.00E-01	0.00E-01	0.00E-01	0.00E-01	0.00E-01	0.00E-01	0.00E-01	0.00E-01	0.00E-01

FOR PATHWAY 5

AGE GP 1 FOR 8 ORGANS:	2.32E+03	2.32E+03	1.16E+04	2.32E+03	2.32E+03	2.32E+03	2.32E+03	2.32E+03	2.32E+03
AGE GP 2 FOR 8 ORGANS:	4.29E+03	4.29E+03	2.14E+04	4.29E+03	4.29E+03	4.29E+03	4.29E+03	4.29E+03	4.29E+03
AGE GP 3 FOR 8 ORGANS:	1.05E+04	1.05E+04	5.27E+04	1.05E+04	1.05E+04	1.05E+04	1.05E+04	1.05E+04	1.05E+04
AGE GP 4 FOR 8 ORGANS:	2.20E+04	2.20E+04	1.03E+05	2.20E+04	2.20E+04	2.20E+04	2.20E+04	2.20E+04	2.20E+04

FOR PATHWAY 6

AGE GP 1 FOR 8 ORGANS:	2.32E+03	2.32E+03	1.16E+04	2.32E+03	2.32E+03	2.32E+03	2.32E+03	2.32E+03	2.32E+03
AGE GP 2 FOR 8 ORGANS:	4.29E+03	4.29E+03	2.14E+04	4.29E+03	4.29E+03	4.29E+03	4.29E+03	4.29E+03	4.29E+03
AGE GP 3 FOR 8 ORGANS:	1.05E+04	1.05E+04	5.27E+04	1.05E+04	1.05E+04	1.05E+04	1.05E+04	1.05E+04	1.05E+04
AGE GP 4 FOR 8 ORGANS:	2.20E+04	2.20E+04	1.03E+05	2.20E+04	2.20E+04	2.20E+04	2.20E+04	2.20E+04	2.20E+04

FOR PATHWAY 7

AGE GP 1 FOR 8 ORGANS:	5.76E+02	1.08E+02	1.08E+02	1.08E+02	1.08E+02	1.08E+02	1.08E+02	1.08E+02	0.00E-01
AGE GP 2 FOR 8 ORGANS:	8.24E+02	1.54E+02	1.54E+02	1.54E+02	1.54E+02	1.54E+02	1.54E+02	1.54E+02	0.00E-01
AGE GP 3 FOR 8 ORGANS:	1.14E+03	2.13E+02	2.13E+02	2.13E+02	2.13E+02	2.13E+02	2.13E+02	2.13E+02	0.00E-01
AGE GP 4 FOR 8 ORGANS:	8.39E+02	1.68E+02	1.68E+02	1.68E+02	1.68E+02	1.68E+02	1.68E+02	1.68E+02	0.00E-01

TABLE 2.2.6.3-1 (Continued)

INDIVIDUAL DOSE FACTORS FOR GASEOUS EFFLUENTS, FOR ISOTOPE NUMBER 18

FOR PATHWAY 1									
AGE GP 1 FOR 8 ORGANS:	0.00E-01	0.00E-01	0.00E-01	0.00E-01	0.00E-01	0.00E-01	0.00E-01	0.00E-01	0.00E-01
AGE GP 2 FOR 8 ORGANS:	0.00E-01	0.00E-01	0.00E-01	0.00E-01	0.00E-01	0.00E-01	0.00E-01	0.00E-01	0.00E-01
AGE GP 3 FOR 8 ORGANS:	0.00E-01	0.00E-01	0.00E-01	0.00E-01	0.00E-01	0.00E-01	0.00E-01	0.00E-01	0.00E-01
AGE GP 4 FOR 8 ORGANS:	0.00E-01	0.00E-01	0.00E-01	0.00E-01	0.00E-01	0.00E-01	0.00E-01	0.00E-01	0.00E-01
FOR PATHWAY 2									
AGE GP 1 FOR 8 ORGANS:	1.47E+05	1.47E+05	1.47E+05	1.47E+05	1.47E+05	1.47E+05	1.47E+05	1.47E+05	1.74E+05
AGE GP 2 FOR 8 ORGANS:	1.47E+05	1.47E+05	1.47E+05	1.47E+05	1.47E+05	1.47E+05	1.47E+05	1.47E+05	1.74E+05
AGE GP 3 FOR 8 ORGANS:	1.47E+05	1.47E+05	1.47E+05	1.47E+05	1.47E+05	1.47E+05	1.47E+05	1.47E+05	1.74E+05
AGE GP 4 FOR 8 ORGANS:	1.47E+05	1.47E+05	1.47E+05	1.47E+05	1.47E+05	1.47E+05	1.47E+05	1.47E+05	1.74E+05
FOR PATHWAY 3									
AGE GP 1 FOR 8 ORGANS:	1.45E+03	3.65E+05	0.00E-01	0.00E-01	3.20E-02	8.68E+02	1.98E+03	0.00E-01	0.00E-01
AGE GP 2 FOR 8 ORGANS:	1.93E+03	3.24E+05	0.00E-01	0.00E-01	4.23E+02	1.07E+03	2.75E+03	0.00E-01	0.00E-01
AGE GP 3 FOR 8 ORGANS:	3.66E+03	1.94E+05	0.00E-01	0.00E-01	5.56E-02	2.03E+03	3.71E+03	0.00E-01	0.00E-01
AGE GP 4 FOR 8 ORGANS:	0.00E-01	0.00E-01	0.00E-01	0.00E-01	0.00E-01	0.00E-01	0.00E-01	0.00E-01	0.00E-01
FOR PATHWAY 4									
AGE GP 1 FOR 8 ORGANS:	1.86E+02	4.68E+04	0.00E-01	0.00E-01	4.10E+01	1.11E+02	2.47E+02	0.00E-01	0.00E-01
AGE GP 2 FOR 8 ORGANS:	1.49E+02	2.50E+04	0.00E-01	0.00E-01	3.26E+01	8.26E+01	2.12E+02	0.00E-01	0.00E-01
AGE GP 3 FOR 8 ORGANS:	2.32E+02	1.23E+04	0.00E-01	0.00E-01	3.52E+01	1.29E+02	2.35E+02	0.00E-01	0.00E-01
AGE GP 4 FOR 8 ORGANS:	0.00E-01	0.00E-01	0.00E-01	0.00E-01	0.00E-01	0.00E-01	0.00E-01	0.00E-01	0.00E-01
FOR PATHWAY 5									
AGE GP 1 FOR 8 ORGANS:	7.55E+02	1.90E+05	0.00E-01	0.00E-01	1.66E+02	4.51E+02	1.00E+03	0.00E-01	0.00E-01
AGE GP 2 FOR 8 ORGANS:	1.32E+03	2.21E+05	0.00E-01	0.00E-01	2.89E+02	7.32E+02	1.88E+03	0.00E-01	0.00E-01
AGE GP 3 FOR 8 ORGANS:	2.69E+03	1.43E+05	0.00E-01	0.00E-01	4.08E+02	1.49E+03	2.72E+03	0.00E-01	0.00E-01
AGE GP 4 FOR 8 ORGANS:	4.26E+03	1.24E+05	0.00E-01	0.00E-01	6.07E+02	2.78E+03	5.41E+03	0.00E-01	0.00E-01
FOR PATHWAY 6									
AGE GP 1 FOR 8 ORGANS:	9.06E+01	2.28E+04	0.00E-01	0.00E-01	1.99E+01	5.41E+01	1.20E+01	0.00E-01	0.00E-01
AGE GP 2 FOR 8 ORGANS:	1.58E+02	2.66E+04	0.00E-01	0.00E-01	3.47E+01	8.79E+01	2.26E+02	0.00E-01	0.00E-01
AGE GP 3 FOR 8 ORGANS:	3.23E+02	1.71E+04	0.00E-01	0.00E-01	4.89E+01	1.79E+02	3.27E+02	0.00E-01	0.00E-01
AGE GP 4 FOR 8 ORGANS:	5.11E+02	1.49E+04	0.00E-01	0.00E-01	7.28E+02	3.33E+02	6.49E+02	0.00E-01	0.00E-01
FOR PATHWAY 7									
AGE GP 1 FOR 8 ORGANS:	3.17E+00	1.05E+02	0.00E-01	0.00E-01	7.23E-01	1.89E+00	4.56E+02	0.00E-01	0.00E-01
AGE GP 2 FOR 8 ORGANS:	4.29E+00	9.51E+01	0.00E-01	0.00E-01	9.74E-01	2.38E+00	6.64E+02	0.00E-01	0.00E-01
AGE GP 3 FOR 8 ORGANS:	4.89E+00	3.44E+01	0.00E-01	0.00E-01	7.71E-00	2.71E+00	5.38E+02	0.00E-01	0.00E-01
AGE GP 4 FOR 8 ORGANS:	2.84E+00	1.13E+01	0.00E-01	0.00E-01	4.19E-01	1.82E+00	4.07E+02	0.00E-01	0.00E-01

TABLE 2.2.6. (continued)
FOR ISOTOPE NUMBER 19

INDIVIDUAL DOSE FACTORS FOR GASEOUS EFFLUENTS

FOR PATHWAY 1									
AGE GP 1 FOR 8 ORGANS:	0.00E-01	0.00E-01	0.00E-01	0.00E-01	0.00E-01	0.00E-01	0.00E-01	0.00E-01	0.00E-01
AGE GP 2 FOR 8 ORGANS:	0.00E-01	0.00E-01	0.00E-01	0.00E-01	0.00E-01	0.00E-01	0.00E-01	0.00E-01	0.00E-01
AGE GP 3 FOR 8 ORGANS:	0.00E-01	0.00E-01	0.00E-01	0.00E-01	0.00E-01	0.00E-01	0.00E-01	0.00E-01	0.00E-01
AGE GP 4 FOR 8 ORGANS:	0.00E-01	0.00E-01	0.00E-01	0.00E-01	0.00E-01	0.00E-01	0.00E-01	0.00E-01	0.00E-01
FOR PATHWAY 2									
AGE GP 1 FOR 8 ORGANS:	4.39E+07	4.39E+07	4.39E+07	4.39E+07	4.39E+07	4.39E+07	4.39E+07	4.39E+07	5.14E+07
AGE GP 2 FOR 8 ORGANS:	4.39E+07	4.39E+07	4.39E+07	4.39E+07	4.39E+07	4.39E+07	4.39E+07	4.39E+07	5.14E+07
AGE GP 1 FOR 8 ORGANS:	4.39E+07	4.39E+07	4.39E+07	4.39E+07	4.39E+07	4.39E+07	4.39E+07	4.39E+07	5.14E+07
AGE GP 2 FOR 8 ORGANS:	4.39E+07	4.39E+07	4.39E+07	4.39E+07	4.39E+07	4.39E+07	4.39E+07	4.39E+07	5.14E+07
FOR PATHWAY 3									
AGE GP 1 FOR 8 ORGANS:	1.86E+06	2.99E+07	0.00E-01	9.75E+06	2.90E+06	0.00E-01	0.00E-01	0.00E-01	0.00E-01
AGE GP 2 FOR 8 ORGANS:	2.81E+06	2.90E+07	0.00E-01	1.42E+07	4.22E+06	0.00E-01	0.00E-01	0.00E-01	0.00E-01
AGE GP 3 FOR 8 ORGANS:	5.52E+06	1.74E+07	0.00E-01	2.07E+07	5.81E+06	0.00E-01	0.00E-01	0.00E-01	0.00E-01
AGE GP 4 FOR 8 ORGANS:	0.00E-01	0.00E-01	0.00E-01	0.00E-01	0.00E-01	0.00E-01	0.00E-01	0.00E-01	0.00E-01
FOR PATHWAY 4									
AGE GP 1 FOR 8 ORGANS:	4.14E+04	6.64E+05	0.00E-01	2.71E+05	6.45E+04	0.00E-01	0.00E-01	0.00E-01	0.00E-01
AGE GP 2 FOR 8 ORGANS:	3.28E+04	3.39E+05	0.00E-01	1.65E+05	4.93E+04	0.00E-01	0.00E-01	0.00E-01	0.00E-01
AGE GP 3 FOR 8 ORGANS:	5.04E+04	1.59E+05	0.00E-01	1.89E+05	5.31E+04	0.00E-01	0.00E-01	0.00E-01	0.00E-01
AGE GP 4 FOR 8 ORGANS:	0.00E-01	0.00E-01	0.00E-01	0.00E-01	0.00E-01	0.00E-01	0.00E-01	0.00E-01	0.00E-01
FOR PATHWAY 5									
AGE GP 1 FOR ORGANS:	3.79E+04	6.09E+05	0.00E-01	1.99E+05	5.91E+04	0.00E-01	0.00E-01	0.00E-01	0.00E-01
AGE GP 2 FOR ORGANS:	6.57E+04	6.79E+05	0.00E-01	3.31E+05	9.88E+04	0.00E-01	0.00E-01	0.00E-01	0.00E-01
AGE GP 3 FOR ORGANS:	1.32E+05	4.16E+05	0.00E-01	4.95E+05	1.39E+05	0.00E-01	0.00E-01	0.00E-01	0.00E-01
AGE GP 4 FOR ORGANS:	2.09E+05	3.38E+05	0.00E-01	9.21E+05	2.04E+05	0.00E-01	0.00E-01	0.00E-01	0.00E-01
FOR PATHWAY 6									
AGE GP 1 FOR ORGANS:	4.55E+03	7.31E+04	0.00E-01	2.39E+04	7.10E+03	0.00E-01	0.00E-01	0.00E-01	0.00E-01
AGE GP 2 FOR ORGANS:	7.88E+03	8.15E+04	0.00E-01	3.97E+04	1.19E+04	0.00E-01	0.00E-01	0.00E-01	0.00E-01
AGE GP 3 FOR ORGANS:	1.58E+04	4.99E+04	0.00E-01	5.94E+04	1.67E+04	0.00E-01	0.00E-01	0.00E-01	0.00E-01
AGE GP 4 FOR ORGANS:	2.51E+04	4.06E+04	0.00E-01	1.11E+05	2.45E+04	0.00E-01	0.00E-01	0.00E-01	0.00E-01
FOR PATHWAY 7									
AGE GP 1 FOR ORGANS:	2.00E+02	2.45E+03	0.00E-01	1.26E+03	3.12E+02	0.00E-01	4.44E+04	0.00E-01	0.00E-01
AGE GP 2 FOR ORGANS:	2.66E+02	2.12E+03	0.00E-01	1.62E+03	4.03E+02	0.00E-01	6.29E+04	0.00E-01	0.00E-01
AGE GP 3 FOR ORGANS:	3.01E+02	7.26E+02	0.00E-01	1.36E+03	3.18E+02	0.00E-01	5.00E+04	0.00E-01	0.00E-01
AGE GP 4 FOR ORGANS:	1.58E+02	2.24E+02	0.00E-01	8.03E+02	1.58E+02	0.00E-01	3.17E+04	0.00E-01	0.00E-01

TABLE 2.2.6.3-1 (continued)
FOR ISOTOPE NUMBER 20

INDIVIDUAL DOSE FACTORS FOR GASEOUS EFFLUENTS.

FOR PATHWAY 1									
AGE GP 1 FOR 8 ORGANS:	0.00E-01	0.00E-01	0.00E-01	0.00E-01	0.00E-01	0.00E-01	0.00E-01	0.00E-01	0.00E-01
AGE GP 2 FOR 8 ORGANS:	0.00E-01	0.00E-01	0.00E-01	0.00E-01	0.00E-01	0.00E-01	0.00E-01	0.00E-01	0.00E-01
AGE GP 3 FOR 8 ORGANS:	0.00E-01	0.00E-01	0.00E-01	0.00E-01	0.00E-01	0.00E-01	0.00E-01	0.00E-01	0.00E-01
AGE GP 4 FOR 8 ORGANS:	0.00E-01	0.00E-01	0.00E-01	0.00E-01	0.00E-01	0.00E-01	0.00E-01	0.00E-01	0.00E-01
FOR PATHWAY 2									
AGE GP 1 FOR 8 ORGANS:	8.64E+06	8.64E+06	8.64E+06	8.64E+06	8.64E+06	8.64E+06	8.64E+06	8.64E-06	1.02E+07
AGE GP 2 FOR 8 ORGANS:	8.64E+06	8.64E+06	8.64E+06	8.64E+06	8.64E+06	8.64E+06	8.64E+06	8.64E-06	1.02E+07
AGE GP 3 FOR 8 ORGANS:	8.64E+06	8.64E+06	8.64E+06	8.64E+06	8.64E+06	8.64E+06	8.64E+06	8.64E-06	1.02E+07
AGE GP 4 FOR 8 ORGANS:	8.64E+06	8.64E+06	8.64E+06	8.64E+06	8.64E+06	8.64E+06	8.64E+06	8.64E-06	1.02E+07
FOR PATHWAY 3									
AGE GP 1 FOR 8 ORGANS:	3.53E+06	3.07E+07	3.91E+06	9.20E+06	0.00E-01	0.00E-01	2.57E+06	0.00E-01	
AGE GP 2 FOR 8 ORGANS:	5.02E+06	3.07E+07	5.57E+06	1.30E+07	0.00E-01	0.00E-01	4.10E+06	0.00E-01	
AGE GP 3 FOR 8 ORGANS:	9.94E+06	2.08E+07	1.23E+07	2.00E+07	0.00E-01	0.00E-01	5.78E+06	0.00E-01	
AGE GP 4 FOR 8 ORGANS:	0.00E-01	0.00E-01	0.00E-01	0.00E-01	0.00E-01	0.00E-01	0.00E+01	0.00E-01	
FOR PATHWAY 4									
AGE GP 1 FOR 8 ORGANS:	6.07E+06	5.28E+07	6.73E+06	1.58E+07	0.00E-01	0.00E-01	4.42E+06	0.00E-01	
AGE GP 2 FOR 8 ORGANS:	4.85E+06	2.97E+07	5.38E+06	1.26E+07	0.00E-01	0.00E-01	3.96E+06	0.00E-01	
AGE GP 3 FOR 8 ORGANS:	7.69E+06	1.61E+07	9.54E+06	1.54E+07	0.00E-01	0.00E-01	4.48E+06	0.00E-01	
AGE GP 4 FOR 8 ORGANS:	0.00E-01	0.00E-01	0.00E-01	0.00E-01	0.00E-01	0.00E-01	0.00E-01	0.00E-01	
FOR PATHWAY 5									
AGE GP 1 FOR 8 ORGANS:	6.79E+05	5.90E+06	7.54E+05	1.77E+06	0.00E-01	0.00E-01	4.95E+05	0.00E-01	
AGE GP 2 FOR 8 ORGANS:	1.19E+06	7.26E+06	1.32E+06	3.07E+06	0.00E-01	0.00E-01	9.68E+05	0.00E-01	
AGE GP 3 FOR 8 ORGANS:	2.46E+06	5.14E+06	3.05E+06	4.93E+06	0.00E-01	0.00E-01	1.43E+06	0.00E-01	
AGE GP 4 FOR 8 ORGANS:	3.92E+06	4.75E+06	5.69E+06	9.94E+06	0.00E-01	0.00E-01	2.94E+06	0.00E-01	
FOR PATHWAY 6									
AGE GP 1 FOR 8 ORGANS:	8.83E+04	7.67E+05	9.80E+04	2.30E+05	0.00E-01	0.00E-01	6.43E+04	0.00E-01	
AGE GP 2 FOR 8 ORGANS:	1.54E+05	9.44E+05	1.71E+05	3.99E+05	0.00E-01	0.00E-01	1.26E+05	0.00E-01	
AGE GP 3 FOR 8 ORGANS:	3.20E+05	6.68E+05	3.96E+05	6.42E+05	0.00E-01	0.00E-01	1.86E+05	0.00E-01	
AGE GP 4 FOR 8 ORGANS:	5.09E+05	6.18E+05	7.40E+05	1.20E+05	0.00E-01	0.00E-01	3.82E+05	0.00E-01	
FOR PATHWAY 7									
AGE GP 1 FOR 8 ORGANS:	3.35E+02	5.96E+03	3.73E+02	8.80E+02	0.00E-01	0.00E-01	3.22E+04	0.00E-01	
AGE GP 2 FOR 8 ORGANS:	4.54E+02	5.66E+03	5.05E+02	1.17E+03	0.00E-01	0.00E-01	4.84E+04	0.00E-01	
AGE GP 3 FOR 8 ORGANS:	5.29E+02	2.24E+03	6.56E+02	1.06E+03	0.00E-01	0.00E-01	4.02E+04	0.00E-01	
AGE GP 4 FOR 8 ORGANS:	3.00E+02	7.86E+02	4.30E+02	7.46E+02	0.00E-01	0.00E-01	3.22E+04	0.00E-01	

TABLE 2.2.6.3-1 (continued)
FOR ISOTOPE NUMBER 21

INDIVIDUAL DOSE FACTORS FOR GASEOUS EFFLUENTS.

FOR PATHWAY 1									
AGE GP 1 FOR 8 ORGANS:	0.00E-01	0.00E-01	0.00E-01	0.00E-01	0.00E-01	0.00E-01	0.00E-01	0.00E-01	0.00E-01
AGE GP 2 FOR 8 ORGANS:	0.00E-01	0.00E-01	0.00E-01	0.00E-01	0.00E-01	0.00E-01	0.00E-01	0.00E-01	0.00E-01
AGE GP 3 FOR 8 ORGANS:	0.00E-01	0.00E-01	0.00E-01	0.00E-01	0.00E-01	0.00E-01	0.00E-01	0.00E-01	0.00E-01
AGE GP 4 FOR 8 ORGANS:	0.00E-01	0.00E-01	0.00E-01	0.00E-01	0.00E-01	0.00E-01	0.00E-01	0.00E-01	0.00E-01
FOR PATHWAY 2									
AGE GP 1 FOR 8 ORGANS:	1.20E+07	1.20E+07	1.20E+07	1.20E+07	1.20E+07	1.20E+07	1.20E+07	1.20E+07	1.41E+07
AGE GP 2 FOR 8 ORGANS:	1.20E+07	1.20E+07	1.20E+07	1.20E+07	1.20E+07	1.20E+07	1.20E+07	1.20E+07	1.41E+07
AGE GP 3 FOR 8 ORGANS:	1.20E+07	1.20E+07	1.20E+07	1.20E+07	1.20E+07	1.20E+07	1.20E+07	1.20E+07	1.41E+07
AGE GP 4 FOR 8 ORGANS:	1.20E+07	1.20E+07	1.20E+07	1.20E+07	1.20E+07	1.20E+07	1.20E+07	1.20E+07	1.41E+07
FOR PATHWAY 3									
AGE GP 1 FOR 8 ORGANS:	2.13E+06	1.93E+07	0.00E-01	9.50E+05	0.00E-01	0.00E-01	0.00E-01	0.00E-01	0.00E-01
AGE GP 2 FOR 8 ORGANS:	3.11E+06	1.86E+07	0.00E-01	1.35E+06	0.00E-01	0.00E-01	0.00E-01	0.00E-01	0.00E-01
AGE GP 3 FOR 8 ORGANS:	6.10E+06	1.16E+07	0.00E-01	1.99E+06	0.00E-01	0.00E-01	0.00E-01	0.00E-01	0.00E-01
AGE GP 4 FOR 8 ORGANS:	0.00E-01	0.00E-01	0.00E-01	0.00E-01	0.00E-01	0.00E-01	0.00E-01	0.00E+01	0.00E-01
FOR PATHWAY 4									
AGE GP 1 FOR 8 ORGANS:	1.01E+06	9.10E+06	0.00E-01	4.49E+05	0.00E-01	0.00E-01	0.00E-01	0.00E-01	0.00E-01
AGE GP 2 FOR 8 ORGANS:	7.98E+05	4.77E+06	0.00E-01	3.46E+05	0.00E-01	0.00E-01	0.00E-01	0.00E-01	0.00E-01
AGE GP 3 FOR 8 ORGANS:	1.24E+06	2.36E+06	0.00E-01	4.04E+05	0.00E-01	0.00E-01	0.00E-01	0.00E-01	0.00E-01
AGE GP 4 FOR 8 ORGANS:	0.00E-01	0.00E-01	0.00E-01	0.00E-01	0.00E-01	0.00E-01	0.00E-01	0.00E-01	0.00E-00
FOR PATHWAY 5									
AGE GP 1 FOR 8 ORGANS:	2.60E+05	2.35E+06	0.00E-01	1.16E+05	0.00E-01	0.00E-01	0.00E-01	0.00E-01	0.00E-01
AGE GP 2 FOR 8 ORGANS:	4.50E+05	2.69E+06	0.00E-01	1.95E+05	0.00E-01	0.00E-01	0.00E-01	0.00E-01	0.00E-01
AGE GP 3 FOR 8 ORGANS:	9.14E+05	1.74E+06	0.00E-01	2.98E+05	0.00E-01	0.00E-01	0.00E-01	0.00E-01	0.00E-01
AGE GP 4 FOR 8 ORGANS:	1.49E+06	1.49E+06	0.00E-01	5.97E+05	0.00E-01	0.00E-01	0.00E-01	0.00E-01	0.00E-01
FOR PATHWAY 6									
AGE GP 1 FOR 8 ORGANS:	3.12E+04	2.82E+05	0.00E-01	1.39E+04	0.00E-01	0.00E-01	0.00E-01	0.00E-01	0.00E-01
AGE GP 2 FOR 8 ORGANS:	5.40E+04	3.23E+05	0.00E-01	2.34E+04	0.00E-01	0.00E-01	0.00E-01	0.00E-01	0.00E-01
AGE GP 3 FOR 8 ORGANS:	1.10E+05	2.09E+05	0.00E-01	3.58E+04	0.00E-01	0.00E-01	0.00E-01	0.00E-01	0.00E-01
AGE GP 4 FOR 8 ORGANS:	1.79E+05	1.79E+05	0.00E-01	7.16E+04	0.00E-01	0.00E-01	0.00E-01	0.00E-01	0.00E-01
FOR PATHWAY 7									
AGE GP 1 FOR 8 ORGANS:	6.57E+01	3.37E+03	0.00E-01	5.02E+01	0.00E-01	0.00E-01	2.94E+04	0.00E-01	0.00E-01
AGE GP 2 FOR 8 ORGANS:	8.80E+01	3.02E+03	0.00E-01	6.57E+01	0.00E-01	0.00E-01	4.26E+04	0.00E-01	0.00E-01
AGE GP 3 FOR 8 ORGANS:	1.00E+02	1.09E+03	0.00E-01	5.62E+01	0.00E-01	0.00E-01	3.51E+04	0.00E-01	0.00E-01
AGE GP 4 FOR 8 ORGANS:	5.77E+01	3.53E+02	0.00E-01	3.87E+01	0.00E-01	0.00E-01	2.46E+04	0.00E-01	0.00E-01

TABLE 2.2.6.3-1 (continued)
FOR ISOTOPE NUMBER 22

INDIVIDUAL DOSE FACTORS FOR GASEOUS EFFLUENTS.									
FOR PATHWAY 1									
AGE GP 1 FOR 8 ORGANS:	0.00E-01	0.00E-01	0.00E-01	0.00E-01	0.00E-01	0.00E-01	0.00E-01	0.00E-01	0.00E-01
AGE GP 2 FOR 8 ORGANS:	0.00E-01	0.00E-01	0.00E-01	0.00E-01	0.00E-01	0.00E-01	0.00E-01	0.00E-01	0.00E-01
AGE GP 3 FOR 8 ORGANS:	0.00E-01	0.00E-01	0.00E-01	0.00E-01	0.00E-01	0.00E-01	0.00E-01	0.00E-01	0.00E-01
AGE GP 4 FOR 8 ORGANS:	0.00E-01	0.00E-01	0.00E-01	0.00E-01	0.00E-01	0.00E-01	0.00E-01	0.00E-01	0.00E-01
FOR PATHWAY 2									
AGE GP 1 FOR 8 ORGANS:	6.82E+08	6.82E+08	6.82E+08	6.82E+08	6.82E+08	6.82E+08	6.82E+08	6.82E+08	8.03E+08
AGE GP 2 FOR 8 ORGANS:	6.82E+08	6.82E+08	6.82E+08	6.82E+08	6.82E+08	6.82E+08	6.82E+08	6.82E+08	8.03E+08
AGE GP 3 FOR 8 ORGANS:	6.82E+08	6.82E+08	6.82E+08	6.82E+08	6.82E+08	6.82E+08	6.82E+08	6.82E+08	8.03E+08
AGE GP 4 FOR 8 ORGANS:	6.82E+08	6.82E+08	6.82E+08	6.82E+08	6.82E+08	6.82E+08	6.82E+08	6.82E+08	8.03E+08
FOR PATHWAY 3									
AGE GP 1 FOR 8 ORGANS:	1.16E+07	9.92E+07	0.00E-01	5.28E+06	0.00E-01	0.00E-01	0.00E-01	0.00E-01	0.00E-01
AGE GP 2 FOR 8 ORGANS:	1.77E+07	1.02E+08	0.00E-01	7.85E+06	0.00E-01	0.00E-01	0.00E-01	0.00E-01	0.00E-01
AGE GP 3 FOR 8 ORGANS:	3.52E+07	6.62E+07	0.00E-01	1.19E+07	0.00E-01	0.00E-01	0.00E-01	0.00E-01	0.00E-01
AGE GP 4 FOR 8 ORGANS:	0.00E-01	0.00E-01	0.00E-01	0.00E-01	0.00E-01	0.00E-01	0.00E-01	0.00E+01	0.00E-01
FOR PATHWAY 4									
AGE GP 1 FOR 8 ORGANS:	3.89E+06	3.32E+07	0.00E-01	1.76E+06	0.00E-01	0.00E-01	0.00E-01	0.00E-01	0.00E-01
AGE GP 2 FOR 8 ORGANS:	3.08E+06	1.78E+07	0.00E-01	1.37E+06	0.00E-01	0.00E-01	0.00E-01	0.00E-01	0.00E-01
AGE GP 3 FOR 8 ORGANS:	4.80E+06	9.01E+06	0.00E-01	1.63E+06	0.00E-01	0.00E-01	0.00E-01	0.00E-01	0.00E-01
AGE GP 4 FOR 8 ORGANS:	0.00E-01	0.00E-01	0.00E-01	0.00E-01	0.00E-01	0.00E-01	0.00E-01	0.00E-01	0.00E-00
FOR PATHWAY 5									
AGE GP 1 FOR 8 ORGANS:	8.49E+05	7.23E+06	0.00E-01	3.85E+05	0.00E-01	0.00E-01	0.00E-01	0.00E-01	0.00E-01
AGE GP 2 FOR 8 ORGANS:	1.47E+06	8.50E+06	0.00E-01	6.52E+05	0.00E-01	0.00E-01	0.00E-01	0.00E-01	0.00E-01
AGE GP 3 FOR 8 ORGANS:	2.99E+06	5.61E+06	0.00E-01	1.01E+06	0.00E-01	0.00E-01	0.00E-01	0.00E-01	0.00E-01
AGE GP 4 FOR 8 ORGANS:	4.88E+06	4.92E+06	0.00E-01	2.07E+06	0.00E-01	0.00E-01	0.00E-01	0.00E-01	0.00E-01
FOR PATHWAY 6									
AGE GP 1 FOR 8 ORGANS:	1.02E+05	8.68E+05	0.00E-01	4.62E+04	0.00E-01	0.00E-01	0.00E-01	0.00E-01	0.00E-01
AGE GP 2 FOR 8 ORGANS:	1.76E+05	1.02E+06	0.00E-01	7.83E+04	0.00E-01	0.00E-01	0.00E-01	0.00E-01	0.00E-01
AGE GP 3 FOR 8 ORGANS:	3.59E+05	6.74E+05	0.00E-01	1.22E+05	0.00E-01	0.00E-01	0.00E-01	0.00E-01	0.00E-01
AGE GP 4 FOR 8 ORGANS:	5.86E+05	5.91E+05	0.00E-01	2.48E+05	0.00E-01	0.00E-01	0.00E-01	0.00E-01	0.00E-01
FOR PATHWAY 7									
AGE GP 1 FOR 8 ORGANS:	4.69E+02	9.03E+03	0.00E-01	3.65E+02	0.00E-01	0.00E-01	1.89E+05	0.00E-01	0.00E-01
AGE GP 2 FOR 8 ORGANS:	6.29E+02	8.22E+03	0.00E-01	4.79E+02	0.00E-01	0.00E-01	2.76E+05	0.00E-01	0.00E-01
AGE GP 3 FOR 8 ORGANS:	7.18E+02	3.05E+03	0.00E-01	4.16E+02	0.00E-01	0.00E-01	2.24E+05	0.00E-01	0.00E-01
AGE GP 4 FOR 8 ORGANS:	3.73E+02	1.01E+03	0.00E-01	2.54E+02	0.00E-01	0.00E-01	1.43E+05	0.00E-01	0.00E-01

TABLE 2.2.6.3-1 (continued)
FOR ISOTOPE NUMBER 23

INDIVIDUAL DOSE FACTORS FOR GASEOUS EFFLUENTS.

FOR PATHWAY 1									
AGE GP 1 FOR 8 ORGANS:	0.00E-01	0.00E-01	0.00E-01	0.00E-01	0.00E-01	0.00E-01	0.00E-01	0.00E-01	0.00E-01
AGE GP 2 FOR 8 ORGANS:	0.00E-01	0.00E-01	0.00E-01	0.00E-01	0.00E-01	0.00E-01	0.00E-01	0.00E-01	0.00E-01
AGE GP 3 FOR 8 ORGANS:	0.00E-01	0.00E-01	0.00E-01	0.00E-01	0.00E-01	0.00E-01	0.00E-01	0.00E-01	0.00E-01
AGE GP 4 FOR 8 ORGANS:	0.00E-01	0.00E-01	0.00E-01	0.00E-01	0.00E-01	0.00E-01	0.00E-01	0.00E-01	0.00E-01
FOR PATHWAY 2									
AGE GP 1 FOR 8 ORGANS:	2.36E+07	2.36E+07	2.36E+07	2.36E+07	2.36E+07	2.36E+07	2.36E+07	2.36E+07	2.72E+07
AGE GP 2 FOR 8 ORGANS:	2.36E+07	2.36E+07	2.36E+07	2.36E+07	2.36E+07	2.36E+07	2.36E+07	2.36E+07	2.72E+07
AGE GP 3 FOR 8 ORGANS:	2.36E+07	2.36E+07	2.36E+07	2.36E+07	2.36E+07	2.36E+07	2.36E+07	2.36E+07	2.72E+07
AGE GP 4 FOR 8 ORGANS:	2.36E+07	2.36E+07	2.36E+07	2.36E+07	2.36E+07	2.36E+07	2.36E+07	2.36E+07	2.72E+07
FOR PATHWAY 3									
AGE GP 1 FOR 8 ORGANS:	1.83E+07	2.55E+07	1.27E+07	4.04E+07	2.70E+07	0.00E-01	0.00E-01	0.00E-01	0.00E-01
AGE GP 2 FOR 8 ORGANS:	2.75E+07	2.50E+07	1.70E+07	5.89E+07	3.77E+07	0.00E-01	0.00E-01	0.00E-01	0.00E-01
AGE GP 3 FOR 8 ORGANS:	5.39E+07	1.52E+07	3.25E+07	8.67E+07	5.46E+07	0.00E-01	0.00E-01	0.00E-01	0.00E-01
AGE GP 4 FOR 8 ORGANS:	0.00E-01	0.00E-01	0.00E-01	0.00E-01	0.00E-01	0.00E-01	0.00E-01	0.00E-01	0.00E-01
FOR PATHWAY 4									
AGE GP 1 FOR 8 ORGANS:	1.37E+07	1.91E+07	9.55E+06	3.04E+07	2.03E+07	0.00E-01	0.00E-01	0.00E-01	0.00E-01
AGE GP 2 FOR 8 ORGANS:	1.09E+07	9.87E+06	6.71E+06	2.33E+07	1.49E+07	0.00E-01	0.00E-01	0.00E-01	0.00E-01
AGE GP 3 FOR 8 ORGANS:	1.67E+07	4.71E+06	1.01E+07	2.68E+07	1.69E+07	0.00E-01	0.00E-01	0.00E-01	0.00E-01
AGE GP 4 FOR 8 ORGANS:	0.00E-01	0.00E-01	0.00E-01	0.00E-01	0.00E-01	0.00E-01	0.00E-01	0.00E-01	0.00E-01
FOR PATHWAY 5									
AGE GP 1 FOR 8 ORGANS:	5.29E+07	7.38E+07	3.68E+07	1.17E+08	7.83E+07	0.00E-01	0.00E-01	0.00E-01	0.00E-01
AGE GP 2 FOR 8 ORGANS:	9.16E+07	8.31E+07	5.65E+07	1.96E+08	1.26E+08	0.00E-01	0.00E-01	0.00E-01	0.00E-01
AGE GP 3 FOR 8 ORGANS:	1.84E+08	5.19E+07	1.11E+08	2.96E+08	1.86E+08	0.00E-01	0.00E-01	0.00E-01	0.00E-01
AGE GP 4 FOR 8 ORGANS:	2.36E+08	4.32E+08	1.49E+08	5.11E+08	2.48E+08	0.00E-01	0.00E-01	0.00E-01	0.00E-01
FOR PATHWAY 6									
AGE GP 1 FOR 8 ORGANS:	6.35E+06	8.85E+06	4.42E+06	1.41E+07	9.40E+06	0.00E-01	0.00E-01	0.00E-01	0.00E-01
AGE GP 2 FOR 8 ORGANS:	1.10E+07	9.97E+06	6.78E+06	2.36E+07	1.51E+07	0.00E-01	0.00E-01	0.00E-01	0.00E-01
AGE GP 3 FOR 8 ORGANS:	2.21E+07	6.23E+06	1.33E+07	3.55E+07	2.23E+07	0.00E-01	0.00E-01	0.00E-01	0.00E-01
AGE GP 4 FOR 8 ORGANS:	2.83E+07	5.18E+07	1.79E+07	6.13E+07	2.97E+07	0.00E-01	0.00E-01	0.00E-01	0.00E-01
FOR PATHWAY 7									
AGE GP 1 FOR 8 ORGANS:	1.48E+03	1.69E+03	1.03E+03	3.27E+03	2.19E+03	0.00E-01	2.74E+04	0.00E-01	0.00E-01
AGE GP 2 FOR 8 ORGANS:	1.98E+03	1.48E+03	1.22E+03	4.24E+03	2.74E+03	0.00E-01	3.93E+04	0.00E-01	0.00E-01
AGE GP 3 FOR 8 ORGANS:	2.23E+03	5.17E+02	1.35E+03	3.59E+03	2.26E+03	0.00E-01	3.16E+04	0.00E-01	0.00E-01
AGE GP 4 FOR 8 ORGANS:	9.85E+02	1.63E+03	6.12E+02	1.98E+03	1.03E+03	0.00E-01	2.05E+04	0.00E-01	0.00E-01

TABLE 2.2.6.3-1 (continued)
FOR ISOTOPE NUMBER 24

INDIVIDUAL DOSE FACTORS FOR GASEOUS EFFLUENTS.
FOR PATHWAY 1

AGE GP 1 FOR 8 ORGANS:	0.00E-01	0.00E-01	0.00E-01	0.00E-01	0.00E-01	0.00E-01	0.00E-01	0.00E-01	0.00E-01
AGE GP 2 FOR 8 ORGANS:	0.00E-01	0.00E-01	0.00E-01	0.00E-01	0.00E-01	0.00E-01	0.00E-01	0.00E-01	0.00E-01
AGE GP 3 FOR 8 ORGANS:	0.00E-01	0.00E-01	0.00E-01	0.00E-01	0.00E-01	0.00E-01	0.00E-01	0.00E-01	0.00E-01
AGE GP 4 FOR 8 ORGANS:	0.00E-01	0.00E-01	0.00E-01	0.00E-01	0.00E-01	0.00E-01	0.00E-01	0.00E-01	0.00E-01

FOR PATHWAY 2

AGE GP 1 FOR 8 ORGANS:	6.85E+02	6.85E+02	6.85E+02	6.85E+02	6.85E+02	6.85E+02	6.85E+02	6.85E+02	7.95E+02
AGE GP 2 FOR 8 ORGANS:	6.85E+02	6.85E+02	6.85E+02	6.85E+02	6.85E+02	6.85E+02	6.85E+02	6.85E+02	7.95E+02
AGE GP 3 FOR 8 ORGANS:	6.85E+02	6.85E+02	6.85E+02	6.85E+02	6.85E+02	6.85E+02	6.85E+02	6.85E+02	7.95E+02
AGE GP 4 FOR 8 ORGANS:	6.85E+02	6.85E+02	6.85E+02	6.85E+02	6.85E+02	6.85E+02	6.85E+02	6.85E+02	7.95E+02

FOR PATHWAY 3

AGE GP 1 FOR 8 ORGANS:	8.88E+06	4.96E+07	3.09E+08	0.00E-01	0.00E-01	0.00E-01	0.00E-01	0.00E-01	0.00E-01
AGE GP 2 FOR 8 ORGANS:	1.35E+07	5.60E+07	4.70E+08	0.00E-01	0.00E-01	0.00E-01	0.00E-01	0.00E-01	0.00E-01
AGE GP 3 FOR 8 ORGANS:	3.19E+07	4.32E+07	1.12E+09	0.00E-01	0.00E-01	0.00E-01	0.00E-01	0.00E-01	0.00E-01
AGE GP 4 FOR 8 ORGANS:	0.00E-01	0.00E-01	0.00E-01	0.00E-01	0.00E-01	0.00E-01	0.00E-01	0.00E+01	0.00E-01

FOR PATHWAY 4

AGE GP 1 FOR 8 ORGANS:	2.18E+05	1.22E+06	7.59E+06	0.00E-01	0.00E-01	0.00E-01	0.00E-01	0.00E-01	0.00E-01
AGE GP 2 FOR 8 ORGANS:	1.83E+05	7.63E+05	6.40E+06	0.00E-01	0.00E-01	0.00E-01	0.00E-01	0.00E-01	0.00E-01
AGE GP 3 FOR 8 ORGANS:	3.46E+05	4.69E+05	1.21E+07	0.00E-01	0.00E-01	0.00E-01	0.00E-01	0.00E-01	0.00E-01
AGE GP 4 FOR 8 ORGANS:	0.00E-01	0.00E-01	0.00E-01	0.00E-01	0.00E-01	0.00E-01	0.00E-01	0.00E-01	0.00E-00

FOR PATHWAY 5

AGE GP 1 FOR 8 ORGANS:	1.05E+06	5.86E+06	3.65E+07	0.00E-01	0.00E-01	0.00E-01	0.00E-01	0.00E-01	0.00E-01
AGE GP 2 FOR 8 ORGANS:	1.93E+06	8.02E+06	6.73E+07	0.00E-01	0.00E-01	0.00E-01	0.00E-01	0.00E-01	0.00E-01
AGE GP 3 FOR 8 ORGANS:	4.76E+06	6.45E+06	1.67E+08	0.00E-01	0.00E-01	0.00E-01	0.00E-01	0.00E-01	0.00E-01
AGE GP 4 FOR 8 ORGANS:	9.09E+06	6.51E+06	3.17E+08	0.00E-01	0.00E-01	0.00E-01	0.00E-01	0.00E-01	0.00E-01

FOR PATHWAY 6

AGE GP 1 FOR 8 ORGANS:	2.20E+06	1.23E+07	7.67E+07	0.00E-01	0.00E-01	0.00E-01	0.00E-01	0.00E-01	0.00E-01
AGE GP 2 FOR 8 ORGANS:	4.05E+06	1.68E+07	1.41E+08	0.00E-01	0.00E-01	0.00E-01	0.00E-01	0.00E-01	0.00E-01
AGE GP 3 FOR 8 ORGANS:	9.99E+06	1.35E+07	3.50E+08	0.00E-01	0.00E-01	0.00E-01	0.00E-01	0.00E-01	0.00E-01
AGE GP 4 FOR 8 ORGANS:	1.91E+07	1.37E+07	6.65E+08	0.00E-01	0.00E-01	0.00E-01	0.00E-01	0.00E-01	0.00E-01

FOR PATHWAY 7

AGE GP 1 FOR 8 ORGANS:	2.76E+02	1.11E+04	9.64E+03	0.00E-01	0.00E-01	0.00E-01	4.44E+04	0.00E-01	0.00E-01
AGE GP 2 FOR 8 ORGANS:	3.96E+02	1.18E+04	1.38E+04	0.00E-01	0.00E-01	0.00E-01	7.66E+04	0.00E-01	0.00E-01
AGE GP 3 FOR 8 ORGANS:	5.47E+02	5.30E+03	1.90E+04	0.00E-01	0.00E-01	0.00E-01	6.84E+04	0.00E-01	0.00E-01
AGE GP 4 FOR 8 ORGANS:	3.62E+02	2.03E+03	1.26E+04	0.00E-01	0.00E-01	0.00E-01	6.44E+04	0.00E-01	0.00E-01

TABLE 2.2.6.5-1 (continued)
FOR ISOTOPE NUMBER 25

INDIVIDUAL DOSE FACTORS FOR GASEOUS EFFLUENTS.

FOR PATHWAY 1									
AGE GP 1 FOR 8 ORGANS:	0.00E-01	0.00E-01	0.00E-01	0.00E-01	0.00E-01	0.00E-01	0.00E-01	0.00E-01	0.00E-01
AGE GP 2 FOR 8 ORGANS:	0.00E-01	0.00E-01	0.00E-01	0.00E-01	0.00E-01	0.00E-01	0.00E-01	0.00E-01	0.00E-01
AGE GP 3 FOR 8 ORGANS:	0.00E-01	0.00E-01	0.00E-01	0.00E-01	0.00E-01	0.00E-01	0.00E-01	0.00E-01	0.00E-01
AGE GP 4 FOR 8 ORGANS:	0.00E-01	0.00E-01	0.00E-01	0.00E-01	0.00E-01	0.00E-01	0.00E-01	0.00E-01	0.00E-01
FOR PATHWAY 2									
AGE GP 1 FOR 8 ORGANS:	0.00E-01	0.00E-01	0.00E-01	0.00E-01	0.00E-01	0.00E-01	0.00E-01	0.00E-01	0.00E-01
AGE GP 2 FOR 8 ORGANS:	0.00E-01	0.00E-01	0.00E-01	0.00E-01	0.00E-01	0.00E-01	0.00E-01	0.00E-01	0.00E-01
AGE GP 3 FOR 8 ORGANS:	0.00E-01	0.00E-01	0.00E-01	0.00E-01	0.00E-01	0.00E-01	0.00E-01	0.00E-01	0.00E-01
AGE GP 4 FOR 8 ORGANS:	0.00E-01	0.00E-01	0.00E-01	0.00E-01	0.00E-01	0.00E-01	0.00E-01	0.00E-01	0.00E-01
FOR PATHWAY 3									
AGE GP 1 FOR 8 ORGANS:	5.22E+09	6.15E+08	2.13E+10	0.00E-01	0.00E-01	0.00E-01	0.00E-01	0.00E-01	0.00E-01
AGE GP 2 FOR 8 ORGANS:	6.52E+09	7.41E+08	2.64E+10	0.00E-01	0.00E-01	0.00E-01	0.00E-01	0.00E-01	0.00E-01
AGE GP 3 FOR 8 ORGANS:	1.11E+10	5.82E+08	4.37E+10	0.00E-01	0.00E-01	0.00E-01	0.00E-01	0.00E-01	0.00E-01
AGE GP 4 FOR 8 ORGANS:	0.00E-01	0.00E-01	0.00E-01	0.00E-01	0.00E-01	0.00E-01	0.00E-01	0.00E-01	0.00E-01
FOR PATHWAY 4									
AGE GP 1 FOR 8 ORGANS:	7.53E+07	8.87E+06	3.07E+08	0.00E-01	0.00E-01	0.00E-01	0.00E-01	0.00E-01	0.00E-01
AGE GP 2 FOR 8 ORGANS:	4.91E+07	5.58E+06	1.92E+08	0.00E-01	0.00E-01	0.00E-01	0.00E-01	0.00E-01	0.00E-01
AGE GP 3 FOR 8 ORGANS:	6.51E+07	3.46E+06	2.57E+08	0.00E-01	0.00E-01	0.00E-01	0.00E-01	0.00E-01	0.00E-01
AGE GP 4 FOR 8 ORGANS:	0.00E-01	0.00E-01	0.00E-01	0.00E-01	0.00E-01	0.00E-01	0.00E-01	0.00E-01	0.00E-01
FOR PATHWAY 5									
AGE GP 1 FOR 8 ORGANS:	2.83E+08	3.34E+07	1.15E+09	0.00E-01	0.00E-01	0.00E-01	0.00E-01	0.00E-01	0.00E-01
AGE GP 2 FOR 8 ORGANS:	4.03E+08	4.58E+07	1.63E+09	0.00E-01	0.00E-01	0.00E-01	0.00E-01	0.00E-01	0.00E-01
AGE GP 3 FOR 8 ORGANS:	6.99E+08	3.71E+07	2.76E+09	0.00E-01	0.00E-01	0.00E-01	0.00E-01	0.00E-01	0.00E-01
AGE GP 4 FOR 8 ORGANS:	7.64E+08	3.75E+07	3.00E+09	0.00E-01	0.00E-01	0.00E-01	0.00E-01	0.00E-01	0.00E-01
FOR PATHWAY 6									
AGE GP 1 FOR 8 ORGANS:	5.95E+08	7.01E+07	2.43E+09	0.00E-01	0.00E-01	0.00E-01	0.00E-01	0.00E-01	0.00E-01
AGE GP 2 FOR 8 ORGANS:	8.46E+08	9.62E+07	3.43E+09	0.00E-01	0.00E-01	0.00E-01	0.00E-01	0.00E-01	0.00E-01
AGE GP 3 FOR 8 ORGANS:	1.47E+09	7.80E+07	5.79E+09	0.00E-01	0.00E-01	0.00E-01	0.00E-01	0.00E-01	0.00E-01
AGE GP 4 FOR 8 ORGANS:	1.60E+09	7.87E+07	6.30E+09	0.00E-01	0.00E-01	0.00E-01	0.00E-01	0.00E-01	0.00E-01
FOR PATHWAY 7									
AGE GP 1 FOR 8 ORGANS:	1.93E+05	2.29E+04	3.14E+06	0.00E-01	0.00E-01	0.00E-01	3.04E+05	0.00E-01	
AGE GP 2 FOR 8 ORGANS:	2.12E+05	2.42E+04	3.42E+06	0.00E-01	0.00E-01	0.00E-01	5.22E+05	0.00E-01	
AGE GP 3 FOR 8 ORGANS:	2.04E+05	1.09E+04	3.20E+06	0.00E-01	0.00E-01	0.00E-01	4.68E+05	0.00E-01	
AGE GP 4 FOR 8 ORGANS:	8.21E+04	4.15E+03	1.30E+06	0.00E-01	0.00E-01	0.00E-01	3.56E+05	0.00E-01	

TABLE 2.2.6.3-1 (continued)
FOR ISOTOPE NUMBER 26

INDIVIDUAL DOSE FACTORS FOR GASEOUS EFFLUENTS.

FOR PATHWAY 1									
AGE GP 1 FOR 8 ORGANS:	0.00E-01	0.00E-01	0.00E-01	0.00E-01	0.00E-01	0.00E-01	0.00E-01	0.00E-01	0.00E-01
AGE GP 2 FOR 8 ORGANS:	0.00E-01	0.00E-01	0.00E-01	0.00E-01	0.00E-01	0.00E-01	0.00E-01	0.00E-01	0.00E-01
AGE GP 3 FOR 8 ORGANS:	0.00E-01	0.00E-01	0.00E-01	0.00E-01	0.00E-01	0.00E-01	0.00E-01	0.00E-01	0.00E-01
AGE GP 4 FOR 8 ORGANS:	0.00E-01	0.00E-01	0.00E-01	0.00E-01	0.00E-01	0.00E-01	0.00E-01	0.00E-01	0.00E-01
FOR PATHWAY 2									
AGE GP 1 FOR 8 ORGANS:	7.97E+06	7.97E+06	7.97E+06	7.97E+06	7.97E+06	7.97E+06	7.97E+06	7.97E+06	9.24E+06
AGE GP 2 FOR 8 ORGANS:	7.97E+06	7.97E+06	7.97E+06	7.97E+06	7.97E+06	7.97E+06	7.97E+06	7.97E+06	9.24E+06
AGE GP 3 FOR 8 ORGANS:	7.97E+06	7.97E+06	7.97E+06	7.97E+06	7.97E+06	7.97E+06	7.97E+06	7.97E+06	9.24E+06
AGE GP 4 FOR 8 ORGANS:	7.97E+06	7.97E+06	7.97E+06	7.97E+06	7.97E+06	7.97E+06	7.97E+06	7.97E+06	9.24E+06
FOR PATHWAY 3									
AGE GP 1 FOR 8 ORGANS:	8.01E+03	3.75E+07	3.69E+04	1.18E+04	1.86E+04	0.00E-01	0.00E-01	0.00E-01	0.00E-01
AGE GP 2 FOR 8 ORGANS:	1.17E+04	3.94E+07	5.41E+04	1.71E+04	2.51E+04	0.00E-01	0.00E-01	0.00E-01	0.00E-01
AGE GP 3 FOR 8 ORGANS:	2.37E+04	2.78E+07	1.21E+05	2.67E+04	3.82E+04	0.00E-01	0.00E-01	0.00E-01	0.00E-01
AGE GP 4 FOR 8 ORGANS:	0.00E-01	0.00E-01	0.00E-01	0.00E-01	0.00E-01	0.00E-01	0.00E-01	0.00E-01	0.00E-01
FOR PATHWAY 4									
AGE GP 1 FOR 8 ORGANS:	1.01E+04	4.75E+07	4.67E+04	1.50E+04	2.35E+04	0.00E-01	0.00E-01	0.00E-01	0.00E-01
AGE GP 2 FOR 8 ORGANS:	8.12E+03	2.73E+07	3.74E+04	1.18E+04	1.74E+04	0.00E-01	0.00E-01	0.00E-01	0.00E-01
AGE GP 3 FOR 8 ORGANS:	1.30E+04	1.52E+07	6.65E+04	1.46E+04	2.09E+04	0.00E-01	0.00E-01	0.00E-01	0.00E-01
AGE GP 4 FOR 8 ORGANS:	0.00E-01	0.00E-01	0.00E-01	0.00E-01	0.00E-01	0.00E-01	0.00E-01	0.00E-01	0.00E-00
FOR PATHWAY 5									
AGE GP 1 FOR 8 ORGANS:	5.08E+00	2.83E+04	2.34E+01	7.51E+00	1.18E+01	0.00E-01	0.00E-01	0.00E-01	0.00E-01
AGE GP 2 FOR 8 ORGANS:	8.89E+00	2.98E+04	4.10E+01	1.29E+01	1.90E+01	0.00E-01	0.00E-01	0.00E-01	0.00E-01
AGE GP 3 FOR 8 ORGANS:	1.86E+01	2.18E+04	9.51E+01	2.09E+01	2.99E+01	0.00E-01	0.00E-01	0.00E-01	0.00E-01
AGE GP 4 FOR 8 ORGANS:	2.92E+01	2.05E+04	1.69E+02	4.12E+01	4.44E+01	0.00E-01	0.00E-01	0.00E-01	0.00E-01
FOR PATHWAY 6									
AGE GP 1 FOR 8 ORGANS:	6.10E-01	2.86E+03	2.81E+00	9.01E-01	1.41E+00	0.00E-01	0.00E-01	0.00E-01	0.00E-01
AGE GP 2 FOR 8 ORGANS:	1.07E+00	3.58E+03	4.91E+00	1.55E+00	2.28E+00	0.00E-01	0.00E-01	0.00E-01	0.00E-01
AGE GP 3 FOR 8 ORGANS:	2.23E+00	2.62E+03	1.14E+01	2.51E+00	3.59E+00	0.00E-01	0.00E-01	0.00E-01	0.00E-01
AGE GP 4 FOR 8 ORGANS:	3.50E+00	2.46E+03	2.03E+01	4.94E+00	5.32E+00	0.00E-01	0.00E-01	0.00E-01	0.00E-01
FOR PATHWAY 7									
AGE GP 1 FOR 8 ORGANS:	7.38E+02	4.77E+03	3.40E+03	1.09E+03	1.72E+03	0.00E-01	5.60E+04	0.00E-01	0.00E-01
AGE GP 2 FOR 8 ORGANS:	9.99E+02	4.72E+03	4.62E+03	1.45E+03	2.14E+03	0.00E-01	8.52E+04	0.00E-01	0.00E-01
AGE GP 3 FOR 8 ORGANS:	1.17E+03	1.94E+03	6.02E+03	1.33E+03	1.89E+03	0.00E-01	7.07E+04	0.00E-01	0.00E-01
AGE GP 4 FOR 8 ORGANS:	6.44E+02	6.88E+02	3.66E+03	8.83E+02	9.85E+02	0.00E-01	5.55E+04	0.00E-01	0.00E-01

TABLE 2.2.6.1 (continued)
FOR ISOTOPE NUMBER 27

INDIVIDUAL DOSE FACTORS FOR GASEOUS EFFLUENTS:

FOR PATHWAY 1									
AGE GP 1 FOR 8 ORGANS:	0.00E-01	0.00E-01	0.00E-01	0.00E-01	0.00E-01	0.00E-01	0.00E-01	0.00E-01	0.00E-01
AGE GP 2 FOR 8 ORGANS:	0.00E-01	0.00E-01	0.00E-01	0.00E-01	0.00E-01	0.00E-01	0.00E-01	0.00E-01	0.00E-01
AGE GP 3 FOR 8 ORGANS:	0.00E-01	0.00E-01	0.00E-01	0.00E-01	0.00E-01	0.00E-01	0.00E-01	0.00E-01	0.00E-01
AGE GP 4 FOR 8 ORGANS:	0.00E-01	0.00E-01	0.00E-01	0.00E-01	0.00E-01	0.00E-01	0.00E-01	0.00E-01	0.00E-01
FOR PATHWAY 2									
AGE GP 1 FOR 8 ORGANS:	1.90E+07	1.90E+07	1.90E+07	1.90E+07	1.90E+07	1.90E+07	1.90E+07	1.90E+07	2.19E+07
AGE GP 2 FOR 8 ORGANS:	1.90E+07	1.90E+07	1.90E+07	1.90E+07	1.90E+07	1.90E+07	1.90E+07	1.90E+07	2.19E+07
AGE GP 3 FOR 8 ORGANS:	1.90E+07	1.90E+07	1.90E+07	1.90E+07	1.90E+07	1.90E+07	1.90E+07	1.90E+07	2.19E+07
AGE GP 4 FOR 8 ORGANS:	1.90E+07	1.90E+07	1.90E+07	1.90E+07	1.90E+07	1.90E+07	1.90E+07	1.90E+07	2.19E+07
FOR PATHWAY 3									
AGE GP 1 FOR 8 ORGANS:	1.27E+06	9.12E+07	3.21E+06	6.07E+04	0.00E-01	7.79E+03	2.50E+06	0.00E-01	
AGE GP 2 FOR 8 ORGANS:	1.87E+06	9.64E+07	4.78E+06	8.82E+04	0.00E-01	1.09E+04	4.18E+06	0.00E-01	
AGE GP 3 FOR 8 ORGANS:	3.82E+06	6.82E+07	1.09E+07	1.42E+05	0.00E-01	2.41E+04	6.05E+06	0.00E-01	
AGE GP 4 FOR 8 ORGANS:	0.00E-01	0.00E-01	0.00E-01	0.00E-01	0.00E-01	0.00E-01	0.00E+01	0.00E-01	
FOR PATHWAY 4									
AGE GP 1 FOR 8 ORGANS:	1.95E+05	1.40E+07	4.92E+05	9.30E+03	0.00E-01	1.19E+03	3.83E+05	0.00E-01	
AGE GP 2 FOR 8 ORGANS:	1.57E+05	8.10E+06	4.02E+05	7.41E+03	0.00E-01	9.12E+02	3.51E+05	0.00E-01	
AGE GP 3 FOR 8 ORGANS:	2.55E+05	4.55E+06	7.28E+05	9.44E+03	0.00E-01	1.61E+03	4.04E+05	0.00E-01	
AGE GP 4 FOR 8 ORGANS:	0.00E-01	0.00E-01	0.00E-01	0.00E-01	0.00E-01	0.00E-01	0.00E-01	0.00E-00	
FOR PATHWAY 5									
AGE GP 1 FOR 8 ORGANS:	2.54E+05	1.82E+07	6.40E+05	1.21E+04	0.00E-01	1.55E+03	4.98E+05	0.00E-01	
AGE GP 2 FOR 8 ORGANS:	4.45E+05	2.30E+07	1.14E+06	2.10E+04	0.00E-01	2.59E+03	9.97E+05	0.00E-01	
AGE GP 3 FOR 8 ORGANS:	9.47E+05	1.69E+07	2.70E+06	3.50E+04	0.00E-01	5.96E+03	1.50E+06	0.00E-01	
AGE GP 4 FOR 8 ORGANS:	1.61E+06	1.61E+07	5.21E+06	7.67E+04	0.00E-01	1.38E+04	3.26E+06	0.00E-01	
FOR PATHWAY 6									
AGE GP 1 FOR 8 ORGANS:	3.04E+04	2.18E+06	7.68E+04	1.45E+03	0.00E-01	1.86E+02	5.98E+04	0.00E-01	
AGE GP 2 FOR 8 ORGANS:	5.34E+04	2.76E+06	1.37E+05	2.52E+03	0.00E-01	3.11E+02	1.20E+05	0.00E-01	
AGE GP 3 FOR 8 ORGANS:	1.14E+05	2.03E+06	3.24E+05	4.20E+03	0.00E-01	7.15E+02	1.80E+05	0.00E-01	
AGE GP 4 FOR 8 ORGANS:	1.94E+05	1.93E+06	6.25E+05	9.20E+03	0.00E-01	1.66E+03	3.91E+05	0.00E-01	
FOR PATHWAY 7									
AGE GP 1 FOR 8 ORGANS:	3.93E+02	1.29E+04	9.89E+02	1.87E+01	0.00E-01	2.39E+00	7.86E+04	0.00E-01	
AGE GP 2 FOR 8 ORGANS:	5.33E+02	1.26E+04	1.36E+03	2.52E+01	0.00E-01	3.09E+00	1.22E+05	0.00E-01	
AGE GP 3 FOR 8 ORGANS:	6.35E+02	5.20E+03	1.82E+03	2.35E+01	0.00E-01	4.00E+00	1.03E+05	0.00E-01	
AGE GP 4 FOR 8 ORGANS:	3.80E+02	1.87E+03	1.20E+03	1.76E+01	0.00E-01	3.19E+00	8.39E+04	0.00E-01	

TABLE 2.2.6.3-1 (continued)
FOR ISOTOPE NUMBER 28

INDIVIDUAL DOSE FACTORS FOR GASEOUS EFFLUENTS.

FOR PATHWAY 1									
AGE GP 1 FOR 8 ORGANS:	0.00E-01	0.00E-01	0.00E-01	0.00E-01	0.00E-01	0.00E-01	0.00E-01	0.00E-01	0.00E-01
AGE GP 2 FOR 8 ORGANS:	0.00E-01	0.00E-01	0.00E-01	0.00E-01	0.00E-01	0.00E-01	0.00E-01	0.00E-01	0.00E-01
AGE GP 3 FOR 8 ORGANS:	0.00E-01	0.00E-01	0.00E-01	0.00E-01	0.00E-01	0.00E-01	0.00E-01	0.00E-01	0.00E-01
AGE GP 4 FOR 8 ORGANS:	0.00E-01	0.00E-01	0.00E-01	0.00E-01	0.00E-01	0.00E-01	0.00E-01	0.00E-01	0.00E-01
FOR PATHWAY 2									
AGE GP 1 FOR 8 ORGANS:	2.17E+08	2.17E+08	2.17E+08	2.17E+08	2.17E+08	2.17E+08	2.17E+08	2.17E+08	2.53E+08
AGE GP 2 FOR 8 ORGANS:	2.17E+08	2.17E+08	2.17E+08	2.17E+08	2.17E+08	2.17E+08	2.17E+08	2.17E+08	2.53E+08
AGE GP 3 FOR 8 ORGANS:	2.17E+08	2.17E+08	2.17E+08	2.17E+08	2.17E+08	2.17E+08	2.17E+08	2.17E+08	2.53E+08
AGE GP 4 FOR 8 ORGANS:	2.17E+08	2.17E+08	2.17E+08	2.17E+08	2.17E+08	2.17E+08	2.17E+08	2.17E+08	2.53E+08
FOR PATHWAY 3									
AGE GP 1 FOR 8 ORGANS:	2.80E+08	6.00E+06	1.44E+08	3.43E+08	1.11E+08	0.00E-01	3.68E+07	0.00E-01	
AGE GP 2 FOR 8 ORGANS:	2.39E+08	6.41E+06	2.19E+08	5.16E+08	1.64E+08	0.00E-01	6.26E+07	0.00E-01	
AGE GP 3 FOR 8 ORGANS:	1.71E+08	4.38E+06	4.95E+08	8.12E+08	2.52E+08	0.00E-01	9.03E+07	0.00E-01	
AGE GP 4 FOR 8 ORGANS:	0.00E-01	0.00E-01	0.00E-01	0.00E-01	0.00E-01	0.00E-01	0.00E+01	0.00E-01	
FOR PATHWAY 4									
AGE GP 1 FOR 8 ORGANS:	2.98E+07	6.38E+05	1.53E+07	3.65E+07	1.18E+07	0.00E-01	3.92E+06	0.00E-01	
AGE GP 2 FOR 8 ORGANS:	1.33E+07	3.57E+05	1.22E+07	2.87E+07	9.12E+06	0.00E-01	3.48E+06	0.00E-01	
AGE GP 3 FOR 8 ORGANS:	7.44E+06	1.90E+05	2.15E+07	3.53E+07	1.09E+07	0.00E-01	3.92E+06	0.00E-01	
AGE GP 4 FOR 8 ORGANS:	0.00E-01	0.00E-01	0.00E-01	0.00E-01	0.00E-01	0.00E-01	0.00E-01	0.00E-00	
FOR PATHWAY 5									
AGE GP 1 FOR 8 ORGANS:	2.56E+08	5.49E+06	1.32E+08	3.14E+08	1.01E+08	0.00E-01	3.37E+07	0.00E-01	
AGE GP 2 FOR 8 ORGANS:	2.50E+08	6.70E+06	2.29E+08	5.39E+08	1.71E+08	0.00E-01	6.53E+07	0.00E-01	
AGE GP 3 FOR 8 ORGANS:	1.83E+08	4.67E+06	5.28E+08	8.66E+08	2.68E+08	0.00E-01	9.63E+07	0.00E-01	
AGE GP 4 FOR 8 ORGANS:	1.60E+08	4.31E+06	8.50E+08	1.59E+09	4.08E+08	0.00E-01	1.67E+08	0.00E-01	
FOR PATHWAY 6									
AGE GP 1 FOR 8 ORGANS:	7.69E+08	1.65E+07	3.95E+08	9.41E+08	3.04E+08	0.00E-01	1.01E+08	0.00E-01	
AGE GP 2 FOR 8 ORGANS:	7.50E+08	2.01E+07	6.86E+08	1.62E+09	5.13E+08	0.00E-01	1.96E+08	0.00E-01	
AGE GP 3 FOR 8 ORGANS:	5.48E+08	1.40E+07	1.58E+09	2.60E+09	8.50E+08	0.00E-01	2.89E+08	0.00E-01	
AGE GP 4 FOR 8 ORGANS:	4.80E+08	1.29E+07	2.55E+09	4.76E+09	1.22E+09	0.00E-01	5.02E+08	0.00E-01	
FOR PATHWAY 7									
AGE GP 1 FOR 8 ORGANS:	2.31E+04	3.30E+02	1.18E+04	2.69E+04	9.10E+03	0.00E-01	3.09E+03	0.00E-01	
AGE GP 2 FOR 8 ORGANS:	1.74E+04	3.09E+02	1.59E+04	3.58E+04	1.19E+04	0.00E-01	4.64E+03	0.00E-01	
AGE GP 3 FOR 8 ORGANS:	7.12E+03	1.22E+02	2.06E+04	3.21E+04	1.05E+04	0.00E-01	3.84E+03	0.00E-01	
AGE GP 4 FOR 8 ORGANS:	2.36E+03	4.23E+01	1.26E+04	2.23E+04	6.04E+03	0.00E-01	2.53E+03	0.00E-01	

TABLE 2.2.6. (continued)
FOR ISOTOPE NUMBER 29

INDIVIDUAL DOSE FACTORS FOR GASEOUS EFFLUENTS.

FOR PATHWAY 1									
AGE GP 1 FOR 8 ORGANS:	0.00E-01	0.00E-01	0.00E-01	0.00E-01	0.00E-01	0.00E-01	0.00E-01	0.00E-01	0.00E-01
AGE GP 2 FOR 8 ORGANS:	0.00E-01	0.00E-01	0.00E-01	0.00E-01	0.00E-01	0.00E-01	0.00E-01	0.00E-01	0.00E-01
AGE GP 3 FOR 8 ORGANS:	0.00E-01	0.00E-01	0.00E-01	0.00E-01	0.00E-01	0.00E-01	0.00E-01	0.00E-01	0.00E-01
AGE GP 4 FOR 8 ORGANS:	0.00E-01	0.00E-01	0.00E-01	0.00E-01	0.00E-01	0.00E-01	0.00E-01	0.00E-01	0.00E-01
FOR PATHWAY 2									
AGE GP 1 FOR 8 ORGANS:	4.76E+06	4.76E+06	4.76E+06	4.76E+06	4.76E+06	4.76E+06	4.76E+06	4.76E+06	5.40E+06
AGE GP 2 FOR 8 ORGANS:	4.76E+06	4.76E+06	4.76E+06	4.76E+06	4.76E+06	4.76E+06	4.76E+06	4.76E+06	5.40E+06
AGE GP 3 FOR 8 ORGANS:	4.76E+06	4.76E+06	4.76E+06	4.76E+06	4.76E+06	4.76E+06	4.76E+06	4.76E+06	5.40E+06
AGE GP 4 FOR 8 ORGANS:	4.76E+06	4.76E+06	4.76E+06	4.76E+06	4.76E+06	4.76E+06	4.76E+06	4.76E+06	5.40E+06
FOR PATHWAY 3									
AGE GP 1 FOR 8 ORGANS:	3.82E+06	6.03E+05	1.34E+06	5.31E+06	2.95E+06	0.00E-01	4.05E+05	0.00E-01	0.00E-01
AGE GP 2 FOR 8 ORGANS:	3.64E+06	4.36E+05	1.38E+06	5.41E+06	2.95E+06	0.00E-01	4.64E+05	0.00E-01	0.00E-01
AGE GP 3 FOR 8 ORGANS:	4.61E+06	2.50E+05	2.59E+06	7.12E+06	3.79E+06	0.00E-01	5.65E+05	0.00E-01	0.00E-01
AGE GP 4 FOR 8 ORGANS:	0.00E-01	0.00E-01	0.00E-01	0.00E-01	0.00E-01	0.00E-01	0.00E+01	0.00E-01	0.00E-01
FOR PATHWAY 4									
AGE GP 1 FOR 8 ORGANS:	9.61E+05	1.52E+05	3.38E+05	1.33E+06	7.43E+05	0.00E-01	1.02E+05	0.00E-01	0.00E-01
AGE GP 2 FOR 8 ORGANS:	6.97E+05	8.35E+04	2.64E+05	1.04E+06	5.65E+05	0.00E-01	8.90E+04	0.00E-01	0.00E-01
AGE GP 3 FOR 8 ORGANS:	8.09E+05	4.39E+04	4.55E+05	1.25E+06	6.66E+05	0.00E-01	9.93E+04	0.00E-01	0.00E-01
AGE GP 4 FOR 8 ORGANS:	0.00E-01	0.00E-01	0.00E-01	0.00E-01	0.00E-01	0.00E-01	0.00E-01	0.00E-01	0.00E-00
FOR PATHWAY 5									
AGE GP 1 FOR 8 ORGANS:	2.11E+07	3.32E+06	7.41E+06	2.93E+07	1.63E+07	0.00E-01	2.23E+06	0.00E-01	0.00E-01
AGE GP 2 FOR 8 ORGANS:	3.33E+07	4.00E+06	1.26E+07	4.97E+07	2.70E+07	0.00E-01	4.26E+06	0.00E-01	0.00E-01
AGE GP 3 FOR 8 ORGANS:	5.07E+07	2.75E+06	2.85E+07	7.83E+07	4.17E+07	0.00E-01	6.22E+06	0.00E-01	0.00E-01
AGE GP 4 FOR 8 ORGANS:	6.11E+07	2.48E+06	5.56E+07	1.64E+08	6.52E+07	0.00E-01	1.33E+07	0.00E-01	0.00E-01
FOR PATHWAY 6									
AGE GP 1 FOR 8 ORGANS:	6.32E+07	9.97E+06	2.22E+07	8.78E+07	4.88E+07	0.00E-01	6.69E+06	0.00E-01	0.00E-01
AGE GP 2 FOR 8 ORGANS:	1.00E+08	1.20E+07	3.79E+07	1.49E+08	8.11E+07	0.00E-01	1.28E+07	0.00E-01	0.00E-01
AGE GP 3 FOR 8 ORGANS:	1.52E+08	8.25E+06	8.54E+07	2.35E+08	1.25E+08	0.00E-01	1.87E+07	0.00E-01	0.00E-01
AGE GP 4 FOR 8 ORGANS:	1.83E+08	7.45E+06	1.67E+08	4.91E+08	1.96E+08	0.00E-01	4.00E+07	0.00E-01	0.00E-01
FOR PATHWAY 7									
AGE GP 1 FOR 8 ORGANS:	3.50E+03	3.70E+02	1.24E+03	4.64E+03	2.71E+03	0.00E-01	3.80E+02	0.00E-01	0.00E-01
AGE GP 2 FOR 8 ORGANS:	4.34E+03	3.45E+02	1.63E+03	6.14E+03	3.50E+03	0.00E-01	5.63E+02	0.00E-01	0.00E-01
AGE GP 3 FOR 8 ORGANS:	3.68E+03	1.33E+02	2.06E+03	5.42E+03	3.03E+03	0.00E-01	4.61E+02	0.00E-01	0.00E-01
AGE GP 4 FOR 8 ORGANS:	1.68E+03	4.53E+01	1.53E+03	4.26E+03	1.79E+03	0.00E-01	3.73E+02	0.00E-01	0.00E-01

TABLE 2.2.6.3-1 (continued)
FOR ISOTOPE NUMBER 30

INDIVIDUAL DOSE FACTORS FOR GASEOUS EFFLUENTS.

FOR PATHWAY 1									
AGE GP 1 FOR 8 ORGANS:	0.00E-01	0.00E-01	0.00E-01	0.00E-01	0.00E-01	0.00E-01	0.00E-01	0.00E-01	0.00E-01
AGE GP 2 FOR 8 ORGANS:	0.00E-01	0.00E-01	0.00E-01	0.00E-01	0.00E-01	0.00E-01	0.00E-01	0.00E-01	0.00E-01
AGE GP 3 FOR 8 ORGANS:	0.00E-01	0.00E-01	0.00E-01	0.00E-01	0.00E-01	0.00E-01	0.00E-01	0.00E-01	0.00E-01
AGE GP 4 FOR 8 ORGANS:	0.00E-01	0.00E-01	0.00E-01	0.00E-01	0.00E-01	0.00E-01	0.00E-01	0.00E-01	0.00E-01
FOR PATHWAY 2									
AGE GP 1 FOR 8 ORGANS:	3.26E+08	3.26E+08	3.26E+08	3.26E+08	3.26E+08	3.26E+08	3.26E+08	3.26E+08	3.81E+08
AGE GP 2 FOR 8 ORGANS:	3.26E+08	3.26E+08	3.26E+08	3.26E+08	3.26E+08	3.26E+08	3.26E+08	3.26E+08	3.81E+08
AGE GP 3 FOR 8 ORGANS:	3.26E+08	3.26E+08	3.26E+08	3.26E+08	3.26E+08	3.26E+08	3.26E+08	3.26E+08	3.81E+08
AGE GP 4 FOR 8 ORGANS:	3.26E+08	3.26E+08	3.26E+08	3.26E+08	3.26E+08	3.26E+08	3.26E+08	3.26E+08	3.81E+08
FOR PATHWAY 3									
AGE GP 1 FOR 8 ORGANS:	1.89E+08	5.57E+06	2.11E+08	2.88E+08	9.77E+07	0.00E-01	3.25E+07	0.00E-01	
AGE GP 2 FOR 8 ORGANS:	1.55E+08	6.35E+06	3.35E+08	4.46E+08	1.52E+08	0.00E-01	5.90E+07	0.00E-01	
AGE GP 3 FOR 8 ORGANS:	1.12E+08	4.75E+06	7.92E+08	7.58E+08	2.47E+08	0.00E-01	8.89E+07	0.00E-01	
AGE GP 4 FOR 8 ORGANS:	0.00E-01	0.00E-01	0.00E-01	0.00E-01	0.00E-01	0.00E-01	0.00E+01	0.00E-01	
FOR PATHWAY 4									
AGE GP 1 FOR 8 ORGANS:	1.87E+07	5.53E+05	2.09E+07	2.86E+07	9.70E+06	0.00E-01	3.22E+06	0.00E-01	
AGE GP 2 FOR 8 ORGANS:	8.04E+06	3.28E+05	1.73E+07	2.31E+07	7.85E+06	0.00E-01	3.05E+06	0.00E-01	
AGE GP 3 FOR 8 ORGANS:	4.51E+06	1.91E+05	3.19E+07	3.06E+07	9.96E+06	0.00E-01	3.59E+06	0.00E-01	
AGE GP 4 FOR 8 ORGANS:	0.00E-01	0.00E-01	0.00E-01	0.00E-01	0.00E-01	0.00E-01	0.00E-01	0.00E-00	
FOR PATHWAY 5									
AGE GP 1 FOR 8 ORGANS:	1.58E+08	4.68E+06	1.77E+08	2.42E+08	8.21E+07	0.00E-01	2.73E+07	0.00E-01	
AGE GP 2 FOR 8 ORGANS:	1.49E+08	6.07E+06	3.21E+08	4.26E+08	1.45E+08	0.00E-01	5.64E+07	0.00E-01	
AGE GP 3 FOR 8 ORGANS:	1.09E+08	4.68E+06	7.72E+08	7.39E+08	2.41E+08	0.00E-01	8.67E+07	0.00E-01	
AGE GP 4 FOR 8 ORGANS:	1.02E+08	4.51E+06	1.23E+09	1.44E+09	3.87E+08	0.00E-01	1.57E+08	0.00E-01	
FOR PATHWAY 6									
AGE GP 1 FOR 8 ORGANS:	4.75E+08	1.40E+07	5.30E+08	7.25E+08	2.46E+08	0.00E-01	8.19E+07	0.00E-01	
AGE GP 2 FOR 8 ORGANS:	4.46E+08	1.82E+07	9.62E+08	1.28E+09	4.35E+08	0.00E-01	1.69E+08	0.00E-01	
AGE GP 3 FOR 8 ORGANS:	3.27E+08	1.39E+07	2.32E+09	2.22E+09	7.23E+08	0.00E-01	2.60E+08	0.00E-01	
AGE GP 4 FOR 8 ORGANS:	3.07E+08	1.35E+07	3.70E+09	4.33E+09	1.16E+09	0.00E-01	4.70E+08	0.00E-01	
FOR PATHWAY 7									
AGE GP 1 FOR 8 ORGANS:	1.36E+04	2.66E+02	1.52E+04	1.97E+04	7.05E+03	0.00E-01	2.38E+03	0.00E-01	
AGE GP 2 FOR 8 ORGANS:	9.87E+03	2.69E+02	2.13E+04	2.69E+04	9.64E+03	0.00E-01	3.83E+03	0.00E-01	
AGE GP 3 FOR 8 ORGANS:	4.07E+03	1.15E+02	2.87E+04	2.62E+04	8.95E+03	0.00E-01	3.30E+03	0.00E-01	
AGE GP 4 FOR 8 ORGANS:	1.44E+03	4.23E+01	1.74E+04	1.94E+04	5.46E+03	0.00E-01	2.26E+03	0.00E-01	

TABLE 2.2.6.1 (continued)
FOR ISOTOPE NUMBER 31

INDIVIDUAL DOSE FACTORS FOR GASEOUS EFFLUENTS.

FOR PATHWAY 1									
AGE GP 1 FOR 8 ORGANS:	0.00E-01	0.00E-01	0.00E-01	0.00E-01	0.00E-01	0.00E-01	0.00E-01	0.00E-01	0.00E-01
AGE GP 2 FOR 8 ORGANS:	0.00E-01	0.00E-01	0.00E-01	0.00E-01	0.00E-01	0.00E-01	0.00E-01	0.00E-01	0.00E-01
AGE GP 3 FOR 8 ORGANS:	0.00E-01	0.00E-01	0.00E-01	0.00E-01	0.00E-01	0.00E-01	0.00E-01	0.00E-01	0.00E-01
AGE GP 4 FOR 8 ORGANS:	0.00E-01	0.00E-01	0.00E-01	0.00E-01	0.00E-01	0.00E-01	0.00E-01	0.00E-01	0.00E-01
FOR PATHWAY 2									
AGE GP 1 FOR 8 ORGANS:	6.51E+05	6.51E+05	6.51E+05	6.51E+05	6.51E+05	6.51E+05	6.51E+05	6.51E+05	7.44E+05
AGE GP 2 FOR 8 ORGANS:	6.51E+05	6.51E+05	6.51E+05	6.51E+05	6.51E+05	6.51E+05	6.51E+05	6.51E+05	7.44E+05
AGE GP 3 FOR 8 ORGANS:	6.51E+05	6.51E+05	6.51E+05	6.51E+05	6.51E+05	6.51E+05	6.51E+05	6.51E+05	7.44E+05
AGE GP 4 FOR 8 ORGANS:	6.51E+05	6.51E+05	6.51E+05	6.51E+05	6.51E+05	6.51E+05	6.51E+05	6.51E+05	7.44E+05
FOR PATHWAY 3									
AGE GP 1 FOR 8 ORGANS:	2.67E+05	8.38E+06	4.07E+06	5.11E+03	1.74E+03	0.00E-01	2.93E+03	0.00E-01	
AGE GP 2 FOR 8 ORGANS:	2.82E+05	6.75E+06	4.37E+06	5.36E+03	1.82E+03	0.00E-01	3.60E+03	0.00E-01	
AGE GP 3 FOR 8 ORGANS:	5.11E+05	4.44E+06	8.76E+06	7.68E+03	2.50E+03	0.00E-01	4.58E+03	0.00E-01	
AGE GP 4 FOR 8 ORGANS:	0.00E-01	0.00E-01	0.00E-01	0.00E-01	0.00E-01	0.00E-01	0.00E+01	0.00E-01	
FOR PATHWAY 4									
AGE GP 1 FOR 8 ORGANS:	5.33E+04	1.67E+06	8.13E+05	1.02E+03	3.47E+02	0.00E-01	5.85E+02	0.00E-01	
AGE GP 2 FOR 8 ORGANS:	4.33E+04	1.04E+06	6.72E+05	8.23E+02	2.79E+02	0.00E-01	5.54E+02	0.00E-01	
AGE GP 3 FOR 8 ORGANS:	7.24E+04	6.28E+05	1.24E+06	1.09E+03	3.54E+02	0.00E-01	6.48E+02	0.00E-01	
AGE GP 4 FOR 8 ORGANS:	0.00E-01	0.00E-01	0.00E-01	0.00E-01	0.00E-01	0.00E-01	0.00E-01	0.00E-00	
FOR PATHWAY 5									
AGE GP 1 FOR 8 ORGANS:	4.98E+04	1.57E+06	7.60E+05	9.55E+02	3.25E+02	0.00E-01	5.47E+02	0.00E-01	
AGE GP 2 FOR 8 ORGANS:	8.84E+04	2.12E+06	1.37E+06	1.68E+03	5.70E+02	0.00E-01	1.13E+03	0.00E-01	
AGE GP 3 FOR 8 ORGANS:	1.93E+05	1.68E+06	3.31E+06	2.90E+03	9.45E+02	0.00E-01	1.73E+03	0.00E-01	
AGE GP 4 FOR 8 ORGANS:	3.51E+05	1.67E+06	6.82E+06	6.82E+03	1.62E+03	0.00E-01	4.18E+03	0.00E-01	
FOR PATHWAY 6									
AGE GP 1 FOR 8 ORGANS:	5.98E+03	1.88E+05	9.12E+04	1.15E+02	3.90E+01	0.00E-01	6.56E+01	0.00E-01	
AGE GP 2 FOR 8 ORGANS:	1.06E+04	2.54E+05	1.65E+05	2.02E+02	6.84E+01	0.00E-01	1.36E+02	0.00E-01	
AGE GP 3 FOR 8 ORGANS:	2.32E+04	2.01E+05	3.97E+05	3.48E+02	1.13E+02	0.00E-01	2.08E+02	0.00E-01	
AGE GP 4 FOR 8 ORGANS:	4.21E+04	2.01E+05	8.18E+05	8.18E+02	1.94E+02	0.00E-01	5.02E+02	0.00E-01	
FOR PATHWAY 7									
AGE GP 1 FOR 8 ORGANS:	8.14E+01	6.92E+03	1.24E+03	1.55E+00	5.30E-01	0.00E-01	4.03E+04	0.00E-01	
AGE GP 2 FOR 8 ORGANS:	1.12E+02	7.25E+03	1.73E+03	2.13E+00	7.23E-01	0.00E-01	6.44E+04	0.00E-01	
AGE GP 3 FOR 8 ORGANS:	1.37E+02	3.23E+03	2.35E+03	2.95E+00	6.70E-01	0.00E-01	5.52E+04	0.00E-01	
AGE GP 4 FOR 8 ORGANS:	9.19E+01	1.22E+03	1.78E+03	1.78E+00	4.26E-01	0.00E-01	5.06E+04	0.00E-01	

TABLE 2.2.6.3-1 (continued)

INDIVIDUAL DOSE FACTORS FOR GASEOUS EFFLUENTS.

FOR ISOTOPE NUMBER 32

FOR PATHWAY 1

AGE GP 1 FOR 8 ORGANS:	0.00E-01	0.00E-01	0.00E-01	0.00E-01	0.00E-01	0.00E-01	0.00E-01	0.00E-01	0.00E-01
AGE GP 2 FOR 8 ORGANS:	0.00E-01	0.00E-01	0.00E-01	0.00E-01	0.00E-01	0.00E-01	0.00E-01	0.00E-01	0.00E-01
AGE GP 3 FOR 8 ORGANS:	0.00E-01	0.00E-01	0.00E-01	0.00E-01	0.00E-01	0.00E-01	0.00E-01	0.00E-01	0.00E-01
AGE GP 4 FOR 8 ORGANS:	0.00E-01	0.00E-01	0.00E-01	0.00E-01	0.00E-01	0.00E-01	0.00E-01	0.00E-01	0.00E-01

FOR PATHWAY 2

AGE GP 1 FOR 8 ORGANS:	4.33E+05	4.33E+05	4.33E+05	4.33E+05	4.33E+05	4.33E+05	4.33E+05	4.33E+05	4.88E+05
AGE GP 2 FOR 8 ORGANS:	4.33E+05	4.33E+05	4.33E+05	4.33E+05	4.33E+05	4.33E+05	4.33E+05	4.33E+05	4.88E+05
AGE GP 3 FOR 8 ORGANS:	4.33E+05	4.33E+05	4.33E+05	4.33E+05	4.33E+05	4.33E+05	4.33E+05	4.33E+05	4.88E+05
AGE GP 4 FOR 8 ORGANS:	4.33E+05	4.33E+05	4.33E+05	4.33E+05	4.33E+05	4.33E+05	4.33E+05	4.33E+05	4.88E+05

FOR PATHWAY 3

AGE GP 1 FOR 8 ORGANS:	4.72E+02	1.59E+07	6.16E+03	4.16E+03	1.93E+03	0.00E-01	0.00E-01	0.00E-01	0.00E-01
AGE GP 2 FOR 8 ORGANS:	6.78E+02	1.69E+07	8.84E+03	5.90E+03	2.78E+03	0.00E-01	0.00E-01	0.00E-01	0.00E-01
AGE GP 3 FOR 8 ORGANS:	1.52E+03	1.27E+07	2.05E+04	1.02E+04	4.48E+03	0.00E-01	0.00E-01	0.00E-01	0.00E-01
AGE GP 4 FOR 8 ORGANS:	0.00E-01	0.00E-01	0.00E-01	0.00E-01	0.00E-01	0.00E-01	0.00E+01	0.00E-01	0.00E-01

FOR PATHWAY 4

AGE GP 1 FOR 8 ORGANS:	2.81E+01	9.46E+05	3.66E+02	2.47E+02	1.15E+02	0.00E-01	0.00E-01	0.00E-01	0.00E-01
AGE GP 2 FOR 8 ORGANS:	2.36E+01	5.87E+05	3.07E+02	2.05E+02	9.65E+01	0.00E-01	0.00E-01	0.00E-01	0.00E-01
AGE GP 3 FOR 8 ORGANS:	4.28E+01	3.60E+05	5.78E+02	2.88E+02	1.26E+02	0.00E-01	0.00E-01	0.00E-01	0.00E-01
AGE GP 4 FOR 8 ORGANS:	0.00E-01	0.00E-01	0.00E-01	0.00E-01	0.00E-01	0.00E-01	0.00E-01	0.00E-01	0.00E-01

FOR PATHWAY 5

AGE GP 1 FOR 8 ORGANS:	5.81E+01	1.96E+06	7.57E+02	5.12E+02	2.38E+02	0.00E-01	0.00E-01	0.00E-01	0.00E-01
AGE GP 2 FOR 8 ORGANS:	1.06E+02	2.65E+06	1.39E+03	9.27E+02	4.36E+02	0.00E-01	0.00E-01	0.00E-01	0.00E-01
AGE GP 3 FOR 8 ORGANS:	2.53E+02	2.13E+06	3.42E+03	1.70E+03	7.47E+02	0.00E-01	0.00E-01	0.00E-01	0.00E-01
AGE GP 4 FOR 8 ORGANS:	4.87E+02	2.14E+06	6.78E+03	4.13E+03	1.27E+03	0.00E-01	0.00E-01	0.00E-01	0.00E-01

FOR PATHWAY 6

AGE GP 1 FOR 8 ORGANS:	6.97E+00	2.35E+05	9.09E+01	6.14E+01	2.85E+01	0.00E-01	0.00E-01	0.00E-01	0.00E-01
AGE GP 2 FOR 8 ORGANS:	1.28E+01	3.18E+05	1.67E+02	1.11E+02	5.24E+01	0.00E-01	0.00E-01	0.00E-01	0.00E-01
AGE GP 3 FOR 8 ORGANS:	3.04E+01	2.55E+05	4.10E+02	2.05E+02	8.97E+01	0.00E-01	0.00E-01	0.00E-01	0.00E-01
AGE GP 4 FOR 8 ORGANS:	5.84E+01	2.56E+05	8.13E+02	4.96E+02	1.53E+02	0.00E-01	0.00E-01	0.00E-01	0.00E-01

FOR PATHWAY 7

AGE GP 1 FOR 8 ORGANS:	4.84E+01	3.80E+03	6.31E+02	4.29E+02	1.99E+02	0.00E-01	1.15E+04	0.00E-01	0.00E-01
AGE GP 2 FOR 8 ORGANS:	6.87E+01	4.01E+03	9.00E+02	6.01E+02	2.81E+02	0.00E-01	1.95E+04	0.00E-01	0.00E-01
AGE GP 3 FOR 8 ORGANS:	9.18E+01	1.79E+03	1.24E+03	6.19E+02	2.71E+02	0.00E-01	1.72E+04	0.00E-01	0.00E-01
AGE GP 4 FOR 8 ORGANS:	6.30E+01	6.83E+02	8.79E+02	5.28E+02	1.66E+02	0.00E-01	1.64E+04	0.00E-01	0.00E-01

TABLE 2.2.6.3 (continued)

INDIVIDUAL DOSE FACTORS FOR GASEOUS EFFLUENTS.

FOR ISOTOPE NUMBER 33

FOR PATHWAY 1

AGE GP 1 FOR 8 ORGANS:	0.00E-01	0.00E-01	0.00E-01	0.00E-01	0.00E-01	0.00E-01	0.00E-01	0.00E-01	0.00E-01
AGE GP 2 FOR 8 ORGANS:	0.00E-01	0.00E-01	0.00E-01	0.00E-01	0.00E-01	0.00E-01	0.00E-01	0.00E-01	0.00E-01
AGE GP 3 FOR 8 ORGANS:	0.00E-01	0.00E-01	0.00E-01	0.00E-01	0.00E-01	0.00E-01	0.00E-01	0.00E-01	0.00E-01
AGE GP 4 FOR 8 ORGANS:	0.00E-01	0.00E-01	0.00E-01	0.00E-01	0.00E-01	0.00E-01	0.00E-01	0.00E-01	0.00E-01

FOR PATHWAY 2

AGE GP 1 FOR 8 ORGANS:	2.20E+06	2.20E+06	2.20E+06	2.20E+06	2.20E+06	2.20E+06	2.20E+06	2.20E+06	2.54E+06
AGE GP 2 FOR 8 ORGANS:	2.20E+06	2.20E+06	2.20E+06	2.20E+06	2.20E+06	2.20E+06	2.20E+06	2.20E+06	2.54E+06
AGE GP 3 FOR 8 ORGANS:	2.20E+06	2.20E+06	2.20E+06	2.20E+06	2.20E+06	2.20E+06	2.20E+06	2.20E+06	2.54E+06
AGE GP 4 FOR 8 ORGANS:	2.20E+06	2.20E+06	2.20E+06	2.20E+06	2.20E+06	2.20E+06	2.20E+06	2.20E+06	2.54E+06

FOR PATHWAY 3

AGE GP 1 FOR 8 ORGANS:	5.36E+04	3.38E+08	9.98E+05	4.17E+05	2.48E+05	0.00E-01	0.00E-01	0.00E-01	0.00E-01
AGE GP 2 FOR 8 ORGANS:	8.60E+04	4.02E+08	1.60E+06	6.62E+05	3.96E+05	0.00E-01	0.00E-01	0.00E-01	0.00E-01
AGE GP 3 FOR 8 ORGANS:	2.06E+05	3.15E+08	3.86E+06	1.21E+06	6.70E+05	0.00E-01	0.00E-01	0.00E-01	0.00E-01
AGE GP 4 FOR 8 ORGANS:	0.00E-01	0.00E-01	0.00E-01	0.00E-01	0.00E-01	0.00E-01	0.00E+01	0.00E-01	0.00E-01

FOR PATHWAY 4

AGE GP 1 FOR 8 ORGANS:	1.83E+03	1.15E+07	3.41E+04	1.42E+04	8.45E+03	0.00E-01	0.00E-01	0.00E-01	0.00E-01
AGE GP 2 FOR 8 ORGANS:	1.54E+03	7.22E+06	2.87E+04	1.19E+04	7.10E+03	0.00E-01	0.00E-01	0.00E-01	0.00E-01
AGE GP 3 FOR 8 ORGANS:	2.89E+03	4.42E+06	5.41E+04	1.70E+04	9.39E+03	0.00E-01	0.00E-01	0.00E-01	0.00E-01
AGE GP 4 FOR 8 ORGANS:	0.00E-01	0.00E-01	0.00E-01	0.00E-01	0.00E-01	0.00E-01	0.00E-01	0.00E-01	0.00E-01

FOR PATHWAY 5

AGE GP 1 FOR 8 ORGANS:	2.69E+03	1.70E+07	5.02E+04	2.10E+04	1.24E+04	0.00E-01	0.00E-01	0.00E-01	0.00E-01
AGE GP 2 FOR 8 ORGANS:	4.96E+03	2.32E+07	9.23E+04	3.82E+04	2.28E+04	0.00E-01	0.00E-01	0.00E-01	0.00E-01
AGE GP 3 FOR 8 ORGANS:	1.21E+04	1.86E+07	2.28E+05	7.14E+04	3.95E+04	0.00E-01	0.00E-01	0.00E-01	0.00E-01
AGE GP 4 FOR 8 ORGANS:	1.83E+04	1.87E+07	3.26E+05	1.34E+05	5.40E+04	0.00E-01	0.00E-01	0.00E-01	0.00E-01

FOR PATHWAY 6

AGE GP 1 FOR 8 ORGANS:	3.23E+02	2.04E+06	6.02E+03	2.52E+03	1.49E+03	0.00E-01	0.00E-01	0.00E-01	0.00E-01
AGE GP 2 FOR 8 ORGANS:	5.95E+02	2.79E+06	1.11E+04	4.58E+03	2.74E+03	0.00E-01	0.00E-01	0.00E-01	0.00E-01
AGE GP 3 FOR 8 ORGANS:	1.46E+03	2.23E+06	2.73E+04	8.56E+03	4.74E+03	0.00E-01	0.00E-01	0.00E-01	0.00E-01
AGE GP 4 FOR 8 ORGANS:	2.19E+03	2.25E+06	3.91E+04	1.60E+04	6.47E+03	0.00E-01	0.00E-01	0.00E-01	0.00E-01

FOR PATHWAY 7

AGE GP 1 FOR 8 ORGANS:	5.83E+03	2.59E+04	1.09E+05	4.54E+04	2.69E+04	0.00E-01	2.46E+05	0.00E-01	0.00E-01
AGE GP 2 FOR 8 ORGANS:	8.32E+03	2.74E+04	1.55E+05	6.42E+04	3.83E+04	0.00E-01	4.24E+05	0.00E-01	0.00E-01
AGE GP 3 FOR 8 ORGANS:	1.15E+04	1.23E+04	2.15E+05	6.71E+04	3.72E+04	0.00E-01	3.79E+05	0.00E-01	0.00E-01
AGE GP 4 FOR 8 ORGANS:	5.59E+03	4.70E+03	1.01E+05	3.84E+04	1.70E+04	0.00E-01	3.12E+05	0.00E-01	0.00E-01

TABLE 2.2.6.3-1 (continued)

INDIVIDUAL DOSE FACTORS FOR GASEOUS EFFLUENTS. FOR ISOTOPE NUMBER 34

FOR PATHWAY 1									
AGE GP 1 FOR 8 ORGANS:	0.00E-01	0.00E-01	0.00E-01	0.00E-01	0.00E-01	0.00E-01	0.00E-01	0.00E-01	0.00E-01
AGE GP 2 FOR 8 ORGANS:	0.00E-01	0.00E-01	0.00E-01	0.00E-01	0.00E-01	0.00E-01	0.00E-01	0.00E-01	0.00E-01
AGE GP 3 FOR 8 ORGANS:	0.00E-01	0.00E-01	0.00E-01	0.00E-01	0.00E-01	0.00E-01	0.00E-01	0.00E-01	0.00E-01
AGE GP 4 FOR 8 ORGANS:	0.00E-01	0.00E-01	0.00E-01	0.00E-01	0.00E-01	0.00E-01	0.00E-01	0.00E-01	0.00E-01
FOR PATHWAY 2									
AGE GP 1 FOR 8 ORGANS:	2.73E+05	2.73E+05	2.73E+05	2.73E+05	2.73E+05	2.73E+05	2.73E+05	2.73E+05	3.31E+05
AGE GP 2 FOR 8 ORGANS:	2.73E+05	2.73E+05	2.73E+05	2.73E+05	2.73E+05	2.73E+05	2.73E+05	2.73E+05	3.31E+05
AGE GP 3 FOR 8 ORGANS:	2.73E+05	2.73E+05	2.73E+05	2.73E+05	2.73E+05	2.73E+05	2.73E+05	2.73E+05	3.31E+05
AGE GP 4 FOR 8 ORGANS:	2.73E+05	2.73E+05	2.73E+05	2.73E+05	2.73E+05	2.73E+05	2.73E+05	2.73E+05	3.31E+05
FOR PATHWAY 3									
AGE GP 1 FOR 8 ORGANS:	1.05E+06	4.83E+05	1.28E+06	1.83E+06	3.14E+06	6.00E+08	0.00E-01	0.00E-01	0.00E-01
AGE GP 2 FOR 8 ORGANS:	9.16E+05	3.37E+05	1.22E+06	1.70E+06	2.93E+06	4.97E+08	0.00E-01	0.00E-01	0.00E-01
AGE GP 3 FOR 8 ORGANS:	1.29E+06	2.03E+05	2.26E+06	2.28E+06	3.74E+06	7.53E+08	0.00E-01	0.00E-01	0.00E-01
AGE GP 4 FOR 8 ORGANS:	0.00E-01	0.00E-01	0.00E-01	0.00E-01	0.00E-01	0.00E-01	0.00E+01	0.00E-01	0.00E-01
FOR PATHWAY 4									
AGE GP 1 FOR 8 ORGANS:	1.28E+05	5.89E+04	1.56E+05	2.23E+05	3.83E+05	7.32E+07	0.00E-01	0.00E-01	0.00E-01
AGE GP 2 FOR 8 ORGANS:	9.76E+04	3.59E+04	1.30E+05	1.82E+05	3.13E+05	5.30E+07	0.00E-01	0.00E-01	0.00E-01
AGE GP 3 FOR 8 ORGANS:	1.37E+05	2.15E+04	2.41E+05	2.42E+05	3.97E+05	8.00E+07	0.00E-01	0.00E-01	0.00E-01
AGE GP 4 FOR 8 ORGANS:	0.00E-01	0.00E-01	0.00E-01	0.00E-01	0.00E-01	0.00E-01	0.00E-01	0.00E-01	0.00E-01
FOR PATHWAY 5									
AGE GP 1 FOR 8 ORGANS:	3.53E+06	1.62E+06	4.30E+06	6.16E+06	1.06E+07	2.02E+09	0.00E-01	0.00E-01	0.00E-01
AGE GP 2 FOR 8 ORGANS:	5.87E+06	2.16E+06	7.81E+06	1.09E+07	1.88E+07	3.19E+09	0.00E-01	0.00E-01	0.00E-01
AGE GP 3 FOR 8 ORGANS:	1.08E+07	1.70E+06	1.89E+07	1.91E+07	3.13E+07	6.30E+09	0.00E-01	0.00E-01	0.00E-01
AGE GP 4 FOR 8 ORGANS:	2.06E+07	1.66E+06	3.95E+07	4.66E+07	5.44E+07	1.53E+10	0.00E-01	0.00E-01	0.00E-01
FOR PATHWAY 6									
AGE GP 1 FOR 8 ORGANS:	4.23E+06	1.95E+06	5.17E+06	7.39E+06	1.27E+07	2.42E+09	0.00E-01	0.00E-01	0.00E-01
AGE GP 2 FOR 8 ORGANS:	7.05E+06	2.60E+06	9.37E+06	1.31E+07	2.26E+07	3.83E+09	0.00E-01	0.00E-01	0.00E-01
AGE GP 3 FOR 8 ORGANS:	1.30E+07	2.04E+06	2.27E+07	2.29E+07	3.75E+07	7.56E+09	0.00E-01	0.00E-01	0.00E-01
AGE GP 4 FOR 8 ORGANS:	2.46E+07	2.00E+06	4.75E+07	5.59E+07	6.53E+07	1.84E+10	0.00E-01	0.00E-01	0.00E-01
FOR PATHWAY 7									
AGE GP 1 FOR 8 ORGANS:	6.49E+02	1.99E+02	7.99E+02	1.13E+03	1.94E+03	3.78E+05	0.00E-01	0.00E-01	0.00E-01
AGE GP 2 FOR 8 ORGANS:	8.37E+02	2.06E+02	1.12E+03	1.56E+03	2.66E+03	4.64E+05	0.00E-01	0.00E-01	0.00E-01
AGE GP 3 FOR 8 ORGANS:	8.64E+02	9.01E+01	1.52E+03	1.52E+03	2.50E+03	5.15E+05	0.00E-01	0.00E-01	0.00E-01
AGE GP 4 FOR 8 ORGANS:	6.21E+02	3.36E+01	1.20E+03	1.41E+03	1.64E+03	4.70E+05	0.00E-01	0.00E-01	0.00E-01

TABLE 2.2.6.3 (continued)

INDIVIDUAL DOSE FACTORS FOR GASEOUS EFFLUENTS. FOR ISOTOPE NUMBER 35

FOR PATHWAY 1									
AGE GP 1 FOR 8 ORGANS:	0.00E-01	0.00E-01	0.00E-01	0.00E-01	0.00E-01	0.00E-01	0.00E-01	0.00E-01	0.00E-01
AGE GP 2 FOR 8 ORGANS:	0.00E-01	0.00E-01	0.00E-01	0.00E-01	0.00E-01	0.00E-01	0.00E-01	0.00E-01	0.00E-01
AGE GP 3 FOR 8 ORGANS:	0.00E-01	0.00E-01	0.00E-01	0.00E-01	0.00E-01	0.00E-01	0.00E-01	0.00E-01	0.00E-01
AGE GP 4 FOR 8 ORGANS:	0.00E-01	0.00E-01	0.00E-01	0.00E-01	0.00E-01	0.00E-01	0.00E-01	0.00E-01	0.00E-01
FOR PATHWAY 2									
AGE GP 1 FOR 8 ORGANS:	3.88E+04	3.88E+04	3.88E+04	3.88E+04	3.88E+04	3.88E+04	3.88E+04	3.88E+04	4.72E+04
AGE GP 2 FOR 8 ORGANS:	3.88E+04	3.88E+04	3.88E+04	3.88E+04	3.88E+04	3.88E+04	3.88E+04	3.88E+04	4.72E+04
AGE GP 3 FOR 8 ORGANS:	3.88E+04	3.88E+04	3.88E+04	3.88E+04	3.88E+04	3.88E+04	3.88E+04	3.88E+04	4.72E+04
AGE GP 4 FOR 8 ORGANS:	3.88E+04	3.88E+04	3.88E+04	3.88E+04	3.88E+04	3.88E+04	3.88E+04	3.88E+04	4.72E+04
FOR PATHWAY 3									
AGE GP 1 FOR 8 ORGANS:	1.75E+04	5.15E+04	3.29E+04	5.73E+04	9.99E+04	8.41E+06	0.00E-01	0.00E-01	0.00E-01
AGE GP 2 FOR 8 ORGANS:	1.58E+04	3.92E+04	3.06E+04	5.19E+04	9.10E+04	7.24E+06	0.00E-01	0.00E-01	0.00E-01
AGE GP 3 FOR 8 ORGANS:	2.61E+04	2.78E+04	5.57E+04	6.89E+04	1.15E+05	1.28E+07	0.00E-01	0.00E-01	0.00E-01
AGE GP 4 FOR 8 ORGANS:	0.00E-01	0.00E-01	0.00E-01	0.00E-01	0.00E-01	0.00E-01	0.00E+01	0.00E-01	0.00E-01
FOR PATHWAY 4									
AGE GP 1 FOR 8 ORGANS:	2.85E-03	8.40E-03	5.37E-03	9.34E-03	1.63E-02	1.37E+00	0.00E-01	0.00E-01	0.00E-01
AGE GP 2 FOR 8 ORGANS:	2.32E-03	5.77E-03	4.49E-03	7.62E-03	1.34E-02	1.06E+00	0.00E-01	0.00E-01	0.00E-01
AGE GP 3 FOR 8 ORGANS:	3.91E-03	4.16E-03	8.35E-03	1.03E-02	1.72E-02	1.92E+00	0.00E-01	0.00E-01	0.00E-01
AGE GP 4 FOR 8 ORGANS:	0.00E-01	0.00E-01	0.00E-01	0.00E-01	0.00E-01	0.00E-01	0.00E-01	0.00E-01	0.00E-01
FOR PATHWAY 5									
AGE GP 1 FOR 8 ORGANS:	3.03E+04	8.94E+04	5.72E+04	9.95E+04	1.74E+05	1.46E+07	0.00E-01	0.00E-01	0.00E-01
AGE GP 2 FOR 8 ORGANS:	5.40E+04	1.34E+05	1.04E+05	1.77E+05	3.11E+05	2.47E+07	0.00E-01	0.00E-01	0.00E-01
AGE GP 3 FOR 8 ORGANS:	1.19E+05	1.26E+05	2.54E+05	3.14E+05	5.23E+05	5.83E+07	0.00E-01	0.00E-01	0.00E-01
AGE GP 4 FOR 8 ORGANS:	2.29E+05	1.32E+05	5.36E+05	7.80E+05	9.18E+05	1.42E+08	0.00E-01	0.00E-01	0.00E-01
FOR PATHWAY 6									
AGE GP 1 FOR 8 ORGANS:	3.64E+04	1.07E+05	6.86E+04	1.19E+05	2.08E+05	1.75E+07	0.00E-01	0.00E-01	0.00E-01
AGE GP 2 FOR 8 ORGANS:	6.49E+04	1.61E+05	1.25E+05	2.13E+05	3.73E+05	2.97E+07	0.00E-01	0.00E-01	0.00E-01
AGE GP 3 FOR 8 ORGANS:	1.43E+05	1.52E+05	3.05E+05	3.77E+05	6.28E+05	7.00E+07	0.00E-01	0.00E-01	0.00E-01
AGE GP 4 FOR 8 ORGANS:	2.74E+05	1.58E+05	6.43E+05	9.36E+05	1.10E+05	1.70E+08	0.00E-01	0.00E-01	0.00E-01
FOR PATHWAY 7									
AGE GP 1 FOR 8 ORGANS:	1.43E+02	2.81E+02	2.74E+02	4.69E+02	8.19E+02	6.82E+04	0.00E-01	0.00E-01	0.00E-01
AGE GP 2 FOR 8 ORGANS:	1.97E+02	3.27E+02	3.85E+02	6.49E+02	1.14E+03	9.26E+04	0.00E-01	0.00E-01	0.00E-01
AGE GP 3 FOR 8 ORGANS:	2.44E+02	1.74E+02	5.25E+02	6.44E+02	1.07E+03	1.22E+05	0.00E-01	0.00E-01	0.00E-01
AGE GP 4 FOR 8 ORGANS:									

TABLE 2.2.6.3-2

POPULATION DOSE FACTORS FOR GASPRO TASK

Units for airborne pathways are $\text{mrem}\cdot\text{m}^3/\text{Ci}\cdot\text{sec}$

Units for deposition pathway are $\text{mrem}\cdot\text{m}^2/\text{Ci}$

TABLE 2.2.6 (continued)

POPULATION DOSE FACTORS FOR GASEOUS EFFLUENTS, FOR ISOTOPE NUMBER 1

0.000E-01	0.000E-01	0.000E-01	0.000E-01	0.000E-01	0.000E-01	0.000E-01	0.000E-01
0.000E-01	0.000E-01	0.000E-01	0.000E-01	0.000E-01	0.000E-01	0.000E-01	0.000E-01
3.600E+01	3.600E+01	0.000E-01	3.600E+01	3.600E+01	3.600E+01	3.600E+01	0.000E-01
8.110E+00	8.110E+00	0.000E-01	8.110E+00	8.110E+00	8.110E+00	8.110E+00	0.000E-01
1.240E+01	1.240E+01	0.000E-01	1.240E+01	1.240E+01	1.240E+01	1.240E+01	0.000E-01
0.000E-01	0.000E-01	0.000E-01	0.000E-01	0.000E-01	0.000E-01	0.000E-01	0.000E-01
3.930E+01	3.930E+01	0.000E-01	3.930E+01	3.930E+01	3.930E+01	3.930E+01	0.000E-01

POPULATION DOSE FACTORS FOR GASEOUS EFFLUENTS, FOR ISOTOPE NUMBER 2

0.000E-01	0.000E-01	0.000E-01	0.000E-01	0.000E-01	0.000E-01	0.000E-01	0.000E-01
0.000E-01	0.000E-01	0.000E-01	0.000E-01	0.000E-01	0.000E-01	0.000E-01	0.000E-01
4.040E+03	4.040E+03	2.020E+04	4.040E+03	4.040E+03	4.040E+03	4.040E+03	0.000E-01
2.020E+03	2.020E+03	1.010E+04	2.020E+03	2.020E+03	2.020E+03	2.020E+03	0.000E-01
1.780E+03	1.780E+03	8.910E+03	1.780E+03	1.780E+03	1.780E+03	1.780E+03	0.000E-01
0.000E-01	0.000E-01	0.000E-01	0.000E-01	0.000E-01	0.000E-01	0.000E-01	0.000E-01

POPULATION DOSE FACTORS FOR GASEOUS EFFLUENTS, FOR ISOTOPE NUMBER 3

1.400E+02	1.400E+02	1.400E+02	1.400E+02	1.400E+02	1.400E+02	1.400E+02	2.480E+02
0.000E-01	0.000E-01	0.000E-01	0.000E-01	0.000E-01	0.000E-01	0.000E-01	0.000E-01
0.000E-01	0.000E-01	0.000E-01	0.000E-01	0.000E-01	0.000E-01	0.000E-01	0.000E-01
0.000E-01	0.000E-01	0.000E-01	0.000E-01	0.000E-01	0.000E-01	0.000E-01	0.000E-01
0.000E-01	0.000E-01	0.000E-01	0.000E-01	0.000E-01	0.000E-01	0.000E-01	0.000E-01
0.000E-01	0.000E-01	0.000E-01	0.000E-01	0.000E-01	0.000E-01	0.000E-01	0.000E-01
0.000E-01	0.000E-01	0.000E-01	0.000E-01	0.000E-01	0.000E-01	0.000E-01	0.000E-01

POPULATION DOSE FACTORS FOR GASEOUS EFFLUENTS, FOR ISOTOPE NUMBER 4

1.200E-03	1.200E-03	1.200E-03	1.200E-03	1.200E-03	1.200E-03	9.340E-02	3.390E-01
0.000E-01	0.000E-01	0.000E-01	0.000E-01	0.000E-01	0.000E-01	0.000E-01	0.000E-01
0.000E-01	0.000E-01	0.000E-01	0.000E-01	0.000E-01	0.000E-01	0.000E-01	0.000E-01
0.000E-01	0.000E-01	0.000E-01	0.000E-01	0.000E-01	0.000E-01	0.000E-01	0.000E-01
0.000E-01	0.000E-01	0.000E-01	0.000E-01	0.000E-01	0.000E-01	0.000E-01	0.000E-01
0.000E-01	0.000E-01	0.000E-01	0.000E-01	0.000E-01	0.000E-01	0.000E-01	0.000E-01
0.000E-01	0.000E-01	0.000E-01	0.000E-01	0.000E-01	0.000E-01	0.000E-01	0.000E-01

TABLE 2.2.6 (continued)

POPULATION DOSE FACTORS FOR GASEOUS EFFLUENTS, FOR ISOTOPE NUMBER 17

1.400E+02	1.400E+02	1.400E+02	1.400E+02	1.400E+02	1.400E+02	1.420E+02	2.930E+02
0.000E-01	0.000E-01	0.000E-01	0.000E-01	0.000E-01	0.000E-01	0.000E-01	0.000E-01
0.000E-01	0.000E-01	0.000E-01	0.000E-01	0.000E-01	0.000E-01	0.000E-01	0.000E-01
0.000E-01	0.000E-01	0.000E-01	0.000E-01	0.000E-01	0.000E-01	0.000E-01	0.000E-01
0.000E-01	0.000E-01	0.000E-01	0.000E-01	0.000E-01	0.000E-01	0.000E-01	0.000E-01
0.000E-01	0.000E-01	0.000E-01	0.000E-01	0.000E-01	0.000E-01	0.000E-01	0.000E-01
0.000E-01	0.000E-01	0.000E-01	0.000E-01	0.000E-01	0.000E-01	0.000E-01	0.000E-01

POPULATION DOSE FACTORS FOR GASEOUS EFFLUENTS, FOR ISOTOPE NUMBER 18

0.000E-01	0.000E-01	0.000E-01	0.000E-01	0.000E-01	0.000E-01	0.000E-01	0.000E-01
1.020E+05	1.020E+05	1.020E+05	1.020E+05	1.020E+05	1.020E+05	1.020E+05	1.200E+05
2.360E+03	3.760E+05	0.000E-01	0.000E-01	4.530E+02	1.360E+03	2.860E+03	0.000E-01
2.140E+02	4.260E+04	0.000E-01	0.000E-01	4.380E+01	1.250E+02	2.710E+02	0.000E-01
6.240E+02	8.930E+04	0.000E-01	0.000E-01	1.170E+02	3.560E+02	7.420E+02	0.000E-01
0.000E-01	0.000E-01	0.000E-01	0.000E-01	0.000E-01	0.000E-01	0.000E-01	0.000E-01
3.600E+00	9.140E+01	0.000E-01	0.000E-01	7.590E-01	2.090E+00	4.940E+02	0.000E-01

POPULATION DOSE FACTORS FOR GASEOUS EFFLUENTS, FOR ISOTOPE NUMBER 19

0.000E-01	0.000E-01	0.000E-01	0.000E-01	0.000E-01	0.000E-01	0.000E-01	0.000E-01
3.020E+07	3.030E+07	3.020E+07	3.020E+07	3.020E+07	3.020E+07	3.020E+07	3.550E+07
1.500E+05	1.510E+07	0.000E-01	6.900E+06	2.010E+06	0.000E-01	0.000E-01	0.000E-01
4.690E+01	5.960E+05	0.000E-01	2.300E+05	6.770E+04	0.000E-01	0.000E-01	0.000E-01
3.220E+04	2.910E+05	0.000E-01	1.450E+05	4.210E+04	0.000E-01	0.000E-01	0.000E-01
0.000E-01	0.000E-01	0.000E-01	0.000E-01	0.000E-01	0.000E-01	0.000E-01	0.000E-01
2.250E+02	2.100E+03	0.000E-01	1.310E+03	3.230E+02	0.000E-01	4.740E+04	0.000E-01

POPULATION DOSE FACTORS FOR GASEOUS EFFLUENTS, FOR ISOTOPE NUMBER 20

0.000E-01	0.000E-01	0.000E-01	0.000E-01	0.000E-01	0.000E-01	0.000E-01	0.000E-01
5.960E+06	5.960E+06	5.960E+06	5.960E+06	5.960E+06	5.960E+06	5.960E+06	7.000E+06
2.550E+07	5.270E+06	1.070E+07	0.000E-01	0.000E-01	3.070E+06	0.000E-01	0.000E-01
4.860E+07	7.960E+06	1.720E+07	0.000E-01	0.000E-01	4.910E+06	0.000E-01	0.000E-01
2.930E+06	6.760E+05	1.330E+06	0.000E-01	0.000E-01	3.850E+05	0.000E-01	0.000E-01
0.000E-01	0.000E-01	0.000E-01	0.000E-01	0.000E-01	0.000E-01	0.000E-01	0.000E-01
5.260E+03	4.380E+02	9.450E+02	0.000E-01	0.000E-01	3.540E+04	0.000E-01	0.000E-01

TABLE 2.2.6.3-2 (continued)

POPULATION DOSE FACTORS FOR GASEOUS EFFLUENTS,				FOR ISOTOPE NUMBER 21			
0.000E-01	0.000E-01	0.000E-01	0.000E-01	0.000E-01	0.000E-01	0.000E-01	0.000E-01
8.270E+06	8.270E+06	8.270E+06	8.270E+06	8.270E+06	8.270E+06	8.270E+06	9.680E+06
2.250E+06	1.290E+07	0.000E-01	8.900E+05	0.000E-01	0.000E-01	0.000E-01	0.000E-01
1.150E+06	8.230E+06	0.000E-01	4.800E+05	0.000E-01	0.000E-01	0.000E-01	0.000E-01
2.190E+06	1.130E+06	0.000E-01	8.480E+04	0.000E-01	0.000E-01	0.000E-01	0.000E-01
0.000E-01	0.000E-01	0.000E-01	0.000E-01	0.000E-01	0.000E-01	0.000E-01	0.000E-01
7.440E+01	2.920E+03	0.000E-01	5.300E+01	0.000E-01	0.000E-01	3.190E+04	0.000E-01

POPULATION DOSE FACTORS FOR GASEOUS EFFLUENTS,				FOR ISOTOPE NUMBER 22			
0.000E-01	0.000E-01	0.000E-01	0.000E-01	0.000E-01	0.000E-01	0.000E-01	0.000E-01
4.700E+08	4.700E+08	4.700E+08	4.700E+02	4.700E+02	4.700E+02	4.700E+02	5.520E+08
8.750E-06	4.770E+07	0.000E-01	3.540E+06	0.000E-01	0.000E-01	0.000E-01	0.000E-01
4.420E+06	3.000E+07	0.000E-01	1.890E+06	0.000E-01	0.000E-01	0.000E-01	0.000E-01
7.270E+06	3.570E+06	0.000E-01	2.880E+05	0.000E-01	0.000E-01	0.000E-01	0.000E-01
0.000E-01	0.000E-01	0.000E-01	0.000E-01	0.000E-01	0.000E-01	0.000E-01	0.000E-01
5.310E+02	7.860E+03	0.000E-01	3.870E-02	0.000E-01	0.000E-01	2.050E+05	0.000E-01

POPULATION DOSE FACTORS FOR GASEOUS EFFLUENTS,				FOR ISOTOPE NUMBER 23			
0.000E-01	0.000E-01	0.000E-01	0.000E-01	0.000E-01	0.000E-01	0.000E-01	0.000E-01
1.630E+07	1.630E+07	1.630E+07	1.630E+07	1.630E+07	1.630E+07	1.630E+07	1.880E+07
1.410E+07	1.270E+07	9.360E+06	2.820E+07	1.840E+07	0.000E-01	0.000E-01	0.000E-01
1.319E+07	1.670E+07	1.010E+07	3.140E+07	2.070E+07	0.000E-01	0.000E-01	0.000E-01
4.369E+07	3.460E+07	2.790E+07	8.340E+07	5.410E+07	0.000E-01	0.000E-01	0.000E-01
0.000E-01	0.000E-01	0.000E-01	0.000E-01	0.000E-01	0.000E-01	0.000E-01	0.000E-01
1.65E+03	1.450E+03	1.110E+03	3.430E+03	2.260E+03	0.000E-01	2.940E+04	0.000E-01

POPULATION DOSE FACTORS FOR GASEOUS EFFLUENTS,				FOR ISOTOPE NUMBER 24			
0.000E-01	0.000E-01	0.000E-01	0.000E-01	0.000E-01	0.000E-01	0.000E-01	0.000E-01
4.730E+02	4.730E+02	4.730E+02	4.730E+02	4.730E+02	4.730E+02	4.730E+02	5.480E+02
1.200E+07	4.120E+07	4.200E+08	0.000E-01	0.000E-01	0.000E-01	0.000E-01	0.000E-01
2.660E+05	1.150E+06	9.300E+06	0.000E-01	0.000E-01	0.000E-01	0.000E-01	0.000E-01
1.010E+06	3.130E+06	3.530E+07	0.000E-01	0.000E-01	0.000E-01	0.000E-01	0.000E-01
0.000E-01	0.000E-01	0.000E-01	0.000E-01	0.000E-01	0.000E-01	0.000E-01	0.000E-01
3.310E+02	1.010E+04	1.180E+04	0.000E-01	0.000E-01	0.000E-01	5.220E+04	0.000E-01

TABLE 2.2.6 (continued)

POPULATION DOSE FACTORS FOR GASEOUS EFFLUENTS, FOR ISOTOPE NUMBER 25

0.000E-01	0.000E-01	0.000E-01	0.000E-01	0.000E-01	0.000E-01	0.000E-01	0.000E-01
0.000E-01	0.000E-01	0.000E-01	0.000E-01	0.000E-01	0.000E-01	0.000E-01	0.000E-01
3.259E+09	3.110E+08	1.310E+10	0.000E-01	0.000E-01	0.000E-01	0.000E-01	0.000E-01
7.740E+07	3.230E+06	3.140E+08	0.000E-01	0.000E-01	0.000E-01	0.000E-01	0.000E-01
1.999E+08	1.800E+07	7.990E+08	0.000E-01	0.000E-01	0.000E-01	0.000E-01	0.000E-01
0.000E-01	0.000E-01	0.000E-01	0.000E-01	0.000E-01	0.000E-01	0.000E-01	0.000E-01
1.970E+05	2.090E+04	3.190E+06	0.000E-01	0.000E-01	0.000E-01	3.580E+05	0.000E-01

POPULATION DOSE FACTORS FOR GASEOUS EFFLUENTS, FOR ISOTOPE NUMBER 26

0.000E-01	0.000E-01	0.000E-01	0.000E-01	0.000E-01	0.000E-01	0.000E-01	0.000E-01
5.340E+06	5.340E+06	5.340E+06	5.340E+06	5.340E+06	5.340E+06	5.340E+06	6.200E+06
3.770E+06	2.670E+07	4.230E+01	1.160E+04	1.750E+04	0.000E-01	0.000E-01	0.000E-01
1.169E+01	4.350E+07	5.480E+04	1.620E+04	2.480E+04	0.000E-01	0.000E-01	0.000E-01
4.350E+00	1.200E+04	2.120E+01	5.670E+00	8.470E+00	0.000E-01	0.000E-01	0.000E-01
0.000E-01	0.000E-01	0.000E-01	0.000E-01	0.000E-01	0.000E-01	0.000E-01	0.000E-01
3.450E+02	4.250E+03	4.000E+03	1.170E+03	1.790E+03	0.000E-01	6.190E+04	0.000E-01

POPULATION DOSE FACTORS FOR GASEOUS EFFLUENTS, FOR ISOTOPE NUMBER 27

0.000E-01	0.000E-01	0.000E-01	0.000E-01	0.000E-01	0.000E-01	0.000E-01	0.000E-01
0.000E-01	0.000E-01	0.000E-01	0.000E-01	0.000E-01	0.000E-01	0.000E-01	0.000E-01
0.000E-01	0.000E-01	0.000E-01	0.000E-01	0.000E-01	0.000E-01	0.000E-01	0.000E-01
0.000E-01	0.000E-01	0.000E-01	0.000E-01	0.000E-01	0.000E-01	0.000E-01	0.000E-01
0.000E-01	0.000E-01	0.000E-01	0.000E-01	0.000E-01	0.000E-01	0.000E-01	0.000E-01
0.000E-01	0.000E-01	0.000E-01	0.000E-01	0.000E-01	0.000E-01	0.000E-01	0.000E-01
0.000E-01	0.000E-01	0.000E-01	0.000E-01	0.000E-01	0.000E-01	0.000E-01	0.000E-01

POPULATION DOSE FACTORS FOR GASEOUS EFFLUENTS, FOR ISOTOPE NUMBER 28

0.000E-01	0.000E-01	0.000E-01	0.000E-01	0.000E-01	0.000E-01	0.000E-01	0.000E-01
1.500E+08	1.500E+08	1.500E+08	1.500E+08	1.500E+08	1.500E+08	1.500E+08	1.750E+08
1.340E+08	3.020E+06	1.170E+08	2.410E+08	7.650E+07	0.000E-01	2.660E+07	0.000E-01
2.660E+07	5.840E+05	1.800E+07	3.950E+07	1.270E+07	0.000E-01	4.320E+06	0.000E-01
1.219E+08	2.780E+06	1.210E+08	2.400E+08	7.620E+07	0.000E-01	2.670E+07	0.000E-01
0.000E-01	0.000E-01	0.000E-01	0.000E-01	0.000E-01	0.000E-01	0.000E-01	0.000E-01
1.960E+04	2.900E+02	1.390E+04	2.880E+04	9.660E+03	0.000E-01	3.400E+03	0.000E-01

TABLE 2.2.6.3 (continued)

POPULATION DOSE FACTORS FOR GASEOUS EFFLUENTS, FOR ISOTOPE NUMBER 29

0.000E-01	0.000E-01	0.000E-01	0.000E-01	0.000E-01	0.000E-01	0.000E-01	0.000E-01
3.290E+06	3.290E+06	3.290E+06	3.290E+06	3.290E+06	3.290E+06	3.290E+06	3.720E+06
7.010E+06	8.360E+05	2.970E+06	1.020E+07	5.570E+06	0.000E-01	8.010E+05	0.000E-01
1.020E+06	1.390E+05	3.950E+05	1.450E+06	7.970E+05	0.000E-01	1.120E+05	0.000E-01
1.370E+07	1.510E+06	6.000E+06	2.000E+07	1.090E+07	0.000E-01	1.580E+06	0.000E-01
0.000E-01	0.000E-01	0.000E-01	0.000E-01	0.000E-01	0.000E-01	0.000E-01	0.000E-01
3.620E+03	3.250E+02	1.430E+03	4.950E+03	2.860E+03	0.000E-01	4.150E+02	0.000E-01

POPULATION DOSE FACTORS FOR GASEOUS EFFLUENTS, FOR ISOTOPE NUMBER 30

0.000E-01	0.000E-01	0.000E-01	0.000E-01	0.000E-01	0.000E-01	0.000E-01	0.000E-01
2.240E+03	2.240E+08	2.240E+08	2.240E+08	2.240E+08	2.240E+08	2.240E+08	2.620E+08
3.520E+07	2.770E+06	1.710E+08	2.010E+08	6.730E+07	0.000E-01	2.350E+07	0.000E-01
1.640E+07	5.090E+06	2.490E+07	3.130E+07	1.060E+07	0.000E-01	3.620E+06	0.000E-01
7.360E+07	2.460E+06	1.690E+08	1.930E+08	6.450E+07	0.000E-01	2.280E+07	0.000E-01
0.000E-01	0.000E-01	0.000E-01	0.000E-01	0.000E-01	0.000E-01	0.000E-01	0.000E-01
1.150E+04	2.390E+02	1.830E+04	2.160E+04	7.680E+03	0.000E-01	2.710E+03	0.000E-01

POPULATION DOSE FACTORS FOR GASEOUS EFFLUENTS, FOR ISOTOPE NUMBER 31

0.000E-01	0.000E-01	0.000E-01	0.000E-01	0.000E-01	0.000E-01	0.000E-01	0.000E-01
4.480E+05	4.480E+05	4.480E+05	4.480E+05	4.480E+05	4.480E+05	4.480E+05	5.120E+05
5.930E+05	1.220E+07	9.550E+06	1.030E+04	3.440E+03	0.000E-01	6.110E+03	0.000E-01
6.240E+01	1.580E+06	9.820E+05	1.130E+03	3.820E+02	0.000E-01	6.650E+02	0.000E-01
1.060E+04	7.660E+05	6.600E+05	6.920E+02	2.310E+02	0.000E-01	4.140E+02	0.000E-01
0.000E-01	0.000E-01	0.000E-01	0.000E-01	0.000E-01	0.000E-01	0.000E-01	0.000E-01
9.480E+01	6.290E+03	1.490E+03	1.710E+00	5.760E-01	0.000E-01	4.570E+04	0.000E-01

POPULATION DOSE FACTORS FOR GASEOUS EFFLUENTS, FOR ISOTOPE NUMBER 32

0.000E-01	0.000E-01	0.000E-01	0.000E-01	0.000E-01	0.000E-01	0.000E-01	0.000E-01
2.980E+05	2.980E+05	2.980E+05	2.980E+05	2.980E+05	2.980E+05	2.980E+05	3.360E+05
7.730E+02	1.620E+07	1.020E+04	6.060E+03	2.760E+03	0.000E-01	0.000E-01	0.000E-01
3.390E+01	8.920E+05	4.470E+02	2.800E+02	1.290E+02	0.000E-01	0.000E-01	0.000E-01
3.550E+00	1.710E+05	1.190E+02	6.910E+01	3.130E+01	0.000E-01	0.000E-01	0.000E-01
0.000E-01	0.000E-01	0.000E-01	0.000E-01	0.000E-01	0.000E-01	0.000E-01	0.000E-01
5.350E+01	3.460E+03	7.710E+02	4.820E+02	2.210E+02	0.000E-01	1.340E+04	0.000E-01

TABLE 2.2.6 (continued)

POPULATION DOSE FACTORS FOR GASEOUS EFFLUENTS, FOR ISOTOPE NUMBER 33

0.000E-01	0.000E-01	0.000E-01	0.000E-01	0.000E-01	0.000E-01	0.000E-01	0.000E-01
1.510E+06	1.510E+06	1.510E+06	1.510E+06	1.510E+06	1.510E+06	1.510E+06	1.750E+06
4.930E+01	1.910E+08	9.210E+05	3.390E+05	1.960E+05	0.000E-01	0.000E-01	0.000E-01
2.230E+03	1.090E+07	4.160E+04	1.620E+04	9.480E+03	0.000E-01	0.000E-01	0.000E-01
4.400E+02	1.540E+06	8.230E+03	2.970E+03	1.710E+03	0.000E-01	0.000E-01	0.000E-01
0.000E-01	0.000E-01	0.000E-01	0.000E-01	0.000E-01	0.000E-01	0.000E-01	0.000E-01
7.120E+03	2.360E+04	1.330E+05	5.140E+04	3.000E+04	0.000E-01	2.900E+05	0.000E-01

POPULATION DOSE FACTORS FOR GASEOUS EFFLUENTS, FOR ISOTOPE NUMBER 34

0.000E-01	0.000E-01	0.000E-01	0.000E-01	0.000E-01	0.000E-01	0.000E-01	0.000E-01
1.880E+05	1.880E+05	1.880E+05	1.880E+05	1.880E+05	1.880E+05	1.880E+05	2.280E+05
1.350E+05	4.480E+05	1.980E+06	2.370E+06	4.010E+06	7.700E+08	0.000E-01	0.000E-01
1.140E+05	4.450E+04	1.520E+05	2.000E+05	3.400E+05	6.510E+07	0.000E-01	0.000E-01
1.920E+06	5.930E+05	2.830E+06	3.390E+06	5.700E+06	1.100E+09	0.000E-01	0.000E-01
0.000E-01	0.000E-01	0.000E-01	0.000E-01	0.000E-01	0.000E-01	0.000E-01	0.000E-01
7.090E+02	1.800E+02	9.650E+02	1.250E+03	2.120E+05	4.120E+05	0.000E-01	0.000E-01

POPULATION DOSE FACTORS FOR GASEOUS EFFLUENTS, FOR ISOTOPE NUMBER 35

0.000E-01	0.000E-01	0.000E-01	0.000E-01	0.000E-01	0.000E-01	0.000E-01	0.000E-01
2.680E+04	2.680E+04	2.680E+04	2.680E+04	2.680E+04	2.680E+04	2.680E+04	3.260E+04
2.460E+00	5.090E+00	4.920E+00	7.380E+00	1.270E+01	1.190E+03	0.000E-01	0.000E-01
2.800E-03	6.850E-03	5.460E-03	8.740E-03	1.510E-02	1.350E+00	0.000E-01	0.000E-01
4.530E+03	8.730E+03	9.160E+03	1.340E+04	2.290E+04	2.190E+06	0.000E-01	0.000E-01
0.000E-01	0.000E-01	0.000E-01	0.000E-01	0.000E-01	0.000E-01	0.000E-01	0.000E-01
1.670E+00	2.670E+02	3.310E+02	5.200E+02	9.000E+02	8.060E+04	0.000E-01	0.000E-01

Section 2.2.6.5

HYP0 - User Instructions

USER INSTRUCTIONS:

The user schedules this task from the menu and is asked for the form of the output (for Regulatory Guide 1.21 or not). The difference is that the Appendix I (Regulatory Guide 1.21) organ dose limits do not include plume shine dose. Therefore, if the Regulatory Guide 1.21 option is chosen the printout and the results available to the HYP0 task do not include the contribution from the plume shine dose. The plume shine dose is treated separately in the DOSUM task output.

If the Regulatory Guide 1.21 option is not chosen then receptor doses are totaled with the plume shine dose included.

After the file has been searched to find the receptor combination that produces the highest possible dose, the results are printed.

*** Refer to attached sample printout ***

HYP0

HYPOTHETICAL DOSE INQUIRY SERVICE 11/13/82 11:16

ENTER: [XX] SITE ID
[RETURN] EXIT

QA

1

ENTER: [RE] RUN FOR REG. GUIDE 1.21
[RETURN] RUN NOT REG. GUIDE 1.21
[EX] EXIT

RE

2

ENTER: [LA] LAST INDIVIDUAL GAS ACCUMULATION
[TO] TOTAL INDIVIDUAL GAS ACCUMULATION
[RETURN] EXIT

LA

DOSE FILE NOW BEING REORDERED
DOSE REORDERING COMPLETE

3

NUMBER OF GOOD HOURS FO GASEOUS DOSE ACCUMULATION 6
NUMBER OF BAD HOURS NO GAS DOSE ACCUMULATION 0
DOSE RATIO (NGOOD(BAD)NGOOD) IS 1.0000
DOSES ARE NOT RATED
ORGAN: T. BODY MAXIMUM NUMBER 1

	PATHWAY	AGE	DR-TO	DIST(M)	DOSE(REM)	STD	%STD
4	GROUND	ADULT	E	690.0	.648E-06	.150E 02	.0
	VEGET	ADULT	E	1290.0	.266E-05	.150E 02	.0
	MEAT	ADULT	E	1290.0	.713E-06	.150E 02	.0
5	COW	ADULT	E	5000.0	.107E-05	.150E 02	.0
	GOAT	ADULT	N	1610.0	.109E-05	.150E 02	.0
	INALL	ADULT	E	690.0	.223E-05	.150E 02	.0
		TEEN	E	690.0	.648E-06	.150E 02	.0
		TEEN	E	1290.0	.372E-05	.150E 02	.0
		TEEN	E	1290.0	.560E-06	.150E 02	.0
		TEEN	E	5000.0	.175E-05	.150E 02	.0
		TEEN	N	1610.0	.156E-05	.150E 02	.0
		TEEN	E	690.0	.243E-05	.150E 02	.0
		CHILD	E	690.0	.648E-06	.150E 02	.0
		CHILD	E	1290.0	.775E-05	.150E 02	.1
		CHILD	E	1290.0	.985E-06	.150E 02	.0
		CHILD	E	5000.0	.381E-05	.150E 02	.0
		CHILD	N	1610.0	.292E-05	.150E 02	.0
		CHILD	E	690.0	.247E-05	.150E 02	.0
		INFANT	E	690.0	.648E-06	.150E 02	.0
		INFANT					
		INFANT					
		INFANT	E	5000.0	.750E-05	.150E 02	.1
		INFANT	N	1610.0	.539E-05	.150E 02	.0
		INFANT	E	690.0	.156E-05	.150E 02	.0
4	SUBTOTAL	ADULT			.734E-05	.150E 02	.0
	(NO PLUME)	TEEN			.911E-05	.150E 02	.1
		CHILD			.157E-04	.150E 02	.1
		INFANT			.971E-05	.150E 02	.1
	TOTAL	ADULT			.734E-05	.250E 02	.0
		TEEN			.911E-05	.250E 02	.0
		CHILD			.157E-04	.250E 02	.1
		INFANT			.971E-05	.250E 02	.0

ENTER: [RETURN] NEXT ORGAN TYPE - THIS MAX
[NE] NEXT 2 ORGANS - SKIP NEXT MAXIMA
[ST] STOP ALL PRINTS
[EX] EXIT

SITE: DGI QUALITY FILE
 ORGAN: GI-TRACT

11/13/82 11:17

MAXIMUM NUMBER 1

PATHWAY	AGE	DR-TO	DIST(M)	DOSE(REM)	STD	%STD
GROUND	ADULT	E	690.0	.648E-06	.150E 02	.0
VEGAT	ADULT	E	1290.0	.259E-05	.150E 02	.0
MEAT	ADULT	E	1290.0	.717E-06	.150E 02	.0
COW	ADULT	E	5000.0	.106E-05	.150E 02	.0
GOAT	ADULT	N	1610.0	.867E-06	.150E 02	.0
INALL	ADULT	E	690.0	.186E-05	.150E 02	.0
	TEEN	E	690.0	.648E-06	.150E 02	.0
	TEEN	E	1290.0	.366E-05	.150E 02	.0
	TEEN	E	1290.0	.563E-06	.150E 02	.0
	TEEN	E	5000.0	.173E-05	.150E 02	.0
	TEEN	N	1610.0	.134E-05	.150E 02	.0
	TEEN	E	690.0	.191E-05	.150E 02	.0
	CHILD	E	690.0	.648E-06	.150E 02	.0
	CHILD	E	1290.0	.767E-05	.150E 02	.1
	CHILD	E	1290.0	.983E-06	.150E 02	.0
	CHILD	E	5000.0	.379E-05	.150E 02	.0
	CHILD	N	1610.0	.269E-05	.150E 02	.0
	CHILD	E	690.0	.175E-05	.150E 02	.0
	INFANT	E	690.0	.648E-06	.150E 02	.0
	INFANT					
	INFANT					
	INFANT	E	5000.0	.746E-05	.150E 02	.0
	INFANT	N	1610.0	.507E-05	.150E 02	.0
	INFANT	E	690.0	.104E-05	.150E 02	.0
SUBTOTAL	ADULT			.687E-05	.150E 02	.0
(NO PLUME)	TEEN			.851E-05	.150E 02	.1
	CHILD			.148E-04	.150E 02	.1
	INFANT			.915E-05	.150E 02	.1
TOTAL	ADULT			.687E-05	.250E 02	.0
	TEEN			.851E-05	.250E 02	.0
	CHILD			.148E-04	.250E 02	.1
	INFANT			.915E-05	.250E 02	.0

ENTER: [RETURN] NEXT ORGAN TYPE - THIS MAX
 [NE] NEXT 2 ORGANS - SKIP NEXT MAXIMA
 [ST] STOP ALL PRINTS
 [EX] EXIT

NE

SITE: DGI QUALITY FILE
 ORGAN: GI-TRACT

MAXIMUM NUMBER 1

11/13/82 11:17

PATHWAY	AGE	DR-TO	DIST(M)	DOSE(REM)	STD	%STD
GROUND	ADULT	E	690.0	.648E-06	.150E 02	.0
VEGET	ADULT	E	1290.0	.752E-05	.150E 02	.1
MEAT	ADULT	E	1290.0	.276E-05	.150E 02	.0
COW	ADULT	E	5000.0	.330E-05	.150E 02	.0
GOAT	ADULT	N	1610.0	.211E-05	.150E 02	.0
INALL	ADULT	E	690.0	.896E-07	.150E 02	.0
	TEEN	E	690.0	.648E-06	.150E 02	.0
	TEEN	E	1290.0	.148E-06	.150E 02	.1
	TEEN	E	1290.0	.232E-05	.150E 02	.0
	TEEN	E	5000.0	.609E-05	.150E 02	.0
	TEEN	N	1610.0	.388E-05	.150E 02	.0
	TEEN	E	690.0	.127E-06	.150E 02	.0
	CHILD	E	690.0	.648E-06	.150E 02	.0
	CHILD	E	1290.0	.292E-04	.150E 02	.2
	CHILD	E	1290.0	.436E-05	.150E 02	.0
	CHILD	E	5000.0	.150E-04	.150E 02	.1
	CHILD	N	1610.0	.953E-05	.150E 02	.1
	CHILD	E	690.0	.648E-06	.150E 02	.0
	INFANT	E	690.0	.648E-06	.150E 02	.0
	INFANT					
	INFANT					
	INFANT	E	5000.0	.293E-04	.150E 02	.2
	INFANT	N	1610.0	.184E-04	.150E 02	.1
	INFANT	E	690.0	.136E-06	.150E 02	.0
SUBTOTAL	ADULT			.143E-04	.150E 02	.1
(NO PLUME)	TEEN			.213E-04	.150E 02	.1
	CHILD			.494E-04	.150E 02	.3
	INFANT			.301E-04	.150E 02	.2
TOTAL	ADULT			.143E-04	.250E 02	.1
	TEEN			.213E-04	.250E 02	.1
	CHILD			.494E-04	.250E 02	.2
	INFANT			.301E-04	.250E 02	.1

ENTER: [RETURN] NEXT ORGAN TYPE - THIS MAX
 [NE] NEXT 2 ORGANS - SKIP NEXT MAXIMA
 [ST] STOP ALL PRINTS
 [EX] EXIT

ST

*** CALCULATIONS CONTINUING...***

HYP0 DONE

6 HYPOTHETICAL DOSE INQUIRY SERVICE 11/13/82 14:23

ENTER: [XX] SITE ID
[RETURN] EXIT

QA

ENTER: [RE] RUN FOR REG. GUIDE 1.21
[RETURN] RUN NOT REG. GUIDE 1.21
6 [EX] EXIT

ENTER: [LA] LAST INDIVIDUAL GAS ACCUMULATION
[TO] TOTAL INDIVIDUAL GAS ACCUMULATION
[RETURN] EXIT

LA

DOSE FILE NOW BEING REORDERED
DOSE REORDERING COMPLETE

NUMBER OF GOOD HOURS OF GASEOUS DOSE ACCUMULATION 6
NUMBER OF BAD HOURS - NO GAS DOSE ACCUMULATION 0
DOSE RATIO (NGOOD+NBAD)/NGOOD IS 1.0000
DOSES ARE NOT RATIOED
ORGAN: T. BODY MAXIMUM NUMBER 1

	PATHWAY	AGE	DR-TO	DIST(M)	DOSE(REM)	STD	%STD
6	PLUME	ADULT	E	690.0	.132E-04	.500E 01	.3
	GROUND	ADULT	E	690.0	.648E-06	.150E 02	.0
	VEGET	ADULT	E	1290.0	.266E-05	.150E 02	.0
	MEAT	ADULT	E	1290.0	.713E-06	.150E 02	.0
	COW	ADULT	E	5000.0	.107E-05	.150E 02	.0
	GOAT	ADULT	N	1610.0	.109E-05	.150E 02	.0
	INALL	ADULT	E	690.0	.223E-05	.150E 02	.0
		TEEN	E	690.0	.132E-04	.500E 01	.3
		TEEN	E	690.0	.648E-06	.150E 02	.0
		TEEN	E	1290.0	.372E-05	.150E 02	.0
		TEEN	E	1290.0	.560E-06	.150E 02	.0
		TEEN	E	5000.0	.175E-05	.150E 02	.0
		TEEN	N	1610.0	.156E-05	.150E 02	.0
		TEEN	E	690.0	.243E-05	.150E 02	.0
		CHILD	E	690.0	.132E-04	.500E 01	.3
		CHILD	E	690.0	.648E-06	.150E 02	.0
		CHILD	E	1290.0	.775E-05	.150E 02	.1
		CHILD	E	1290.0	.985E-06	.150E 02	.0
		CHILD	E	5000.0	.381E-05	.150E 02	.0
		CHILD	N	1610.0	.292E-05	.150E 02	.0
		CHILD	E	690.0	.247E-05	.150E 02	.0
		INFANT	E	690.0	.132E-04	.500E 01	.3
		INFANT	E	690.0	.648E-06	.150E 02	.0
		INFANT					
		INFANT	E	5000.0	.750E-05	.150E 02	.1
		INFANT	N	1610.0	.539E-05	.150E 02	.0
		INFANT	E	690.0	.156E-05	.150E 02	.0
7	SUBTOTAL	ADULT			.734E-05	.150E 02	.0
	(NO PLUME)	TEEN			.911E-05	.150E 02	.1
		CHILD			.157E-04	.150E 02	.1
		INFANT			.971E-05	.150E 02	.1
	TOTAL	ADULT			.205E-04	.250E 02	.1
		TEEN			.223E-04	.250E 02	.1
		CHILD			.288E-04	.250E 02	.1
		INFANT			.229E-04	.250E 02	.1

ENTER: [RETURN] NEXT ORGAN TYPE - THIS MAX
 [NE] NEXT 2 ORGANS - SKIP NEXT MAXIMA
 [ST] STOP ALL PRINTS
 [EX] EXIT

ST
 CALCULATIONS CONTINUING...
 HYPO DONE

Section 2.2.6.5

HYP0 - User Instructions (Notes)

USER INSTRUCTIONS:

The following notes correspond to the numbers on the example printout on the previous page(s).

- *1* If the Regulatory Guide 1.21 option is chosen, the plume shine pathway doses are not included in the hypothetically highest exposed search since the plume dose is treated separately in Appendix I, 10CFR50, limits.
- *2* The same concept of last and total found in XDCALC is used in GASPRO and HYP0. LAST and TOTAL tables cannot be mixed between GASPRO and DOSLI or other runs for DOSUM input. All precalculations for DOSUM must be for one or the other.
- *3* This information is reprinted from GASPRO results. If there is considerable bad data and this ratio is large, the GASPRO run should be done over after editing the meteorological data, or with default meteorological data. An alternative could be to ratio all doses up by this factor. There is presently no means for doing this in MIOAS.

- *4* Note that the plume shine dose is left out of the print and that the subtotal (no plume) is the same as the totals.
- *5* Results for the maximum dose are printed for each organ. The user will be prompted at the bottom of each page for more pages or to stop the run.
- *6* Example of a run including plume shine - not used in Regulatory Guide 1.21 reports is shown here.
- *7* Note also that the subtotals and totals are different.

Section 2.2.6.5

HYP0 - Program Design

PROGRAM DESIGN:

HYP0 uses the GASPRO output accumulation file for dose to the individual as input (HYP0 is not used for population doses). This file is ordered by direction with 19 records per direction. To speed up finding, the file is reordered (which may require about 5 minutes) such that there are then records for each of 32 age group and organ combinations. The program finds the maximum for each organ in all age groups. Searches are made for two organs at a time for all age groups. This search requires little time once the file is reordered.

If the 1.21 option is selected (used for the dose summary report, DOSUM), the plume dose (pathway 1) is separate from the selection. The worst case plume doses are found during the file reordering and are saved on the ALLD file. Pathways 2 through 7 then are sorted and the worst cases are also written to the ALLD file.

The ground and inhalation doses in the 1.21 option are taken together since they must occur at the same distances and directions for each residence, and only the plume dose is separated since it is reported separately in DOSUM (i.e., the search includes all combinations of pathway except plume dose for each age group-organ group combination). If the 1.21 option is not selected, the plume, ground, and inhalation doses are taken together for each residence (receptor).

A functional flow diagram is provided in Figure 2.2.6.5-1.

NOTE: HYPO can be run more than once on the same set of GASPRO results using either the last or total accumulation files, since the reordered dose accumulation file is a separate file.

COMPUTATIONAL MODEL:

HYPO is essentially a sort routine that includes adding and selecting of combinations closest to limits.

FIGURE 2.2.6.5-1

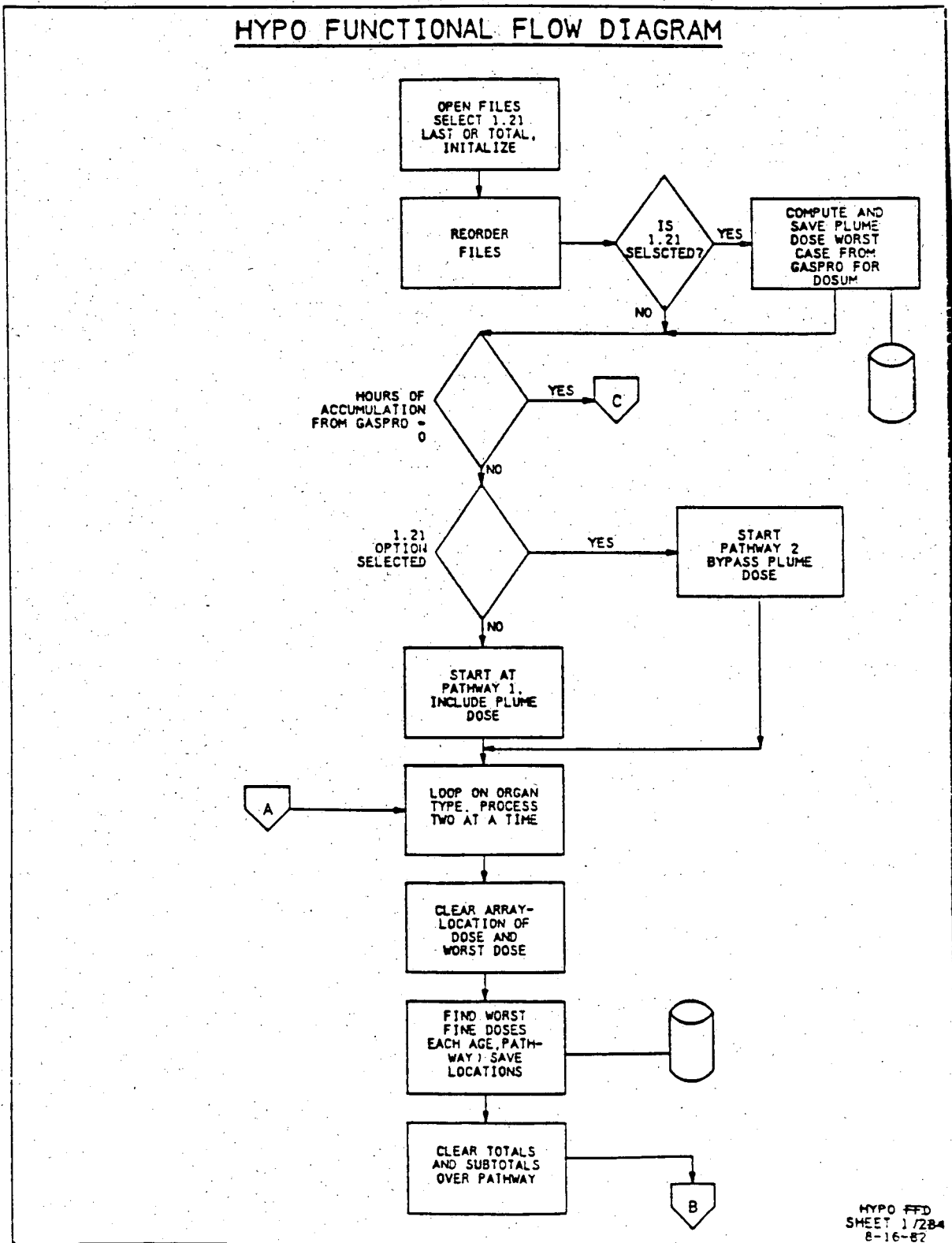

HYPO FFD
SHEET 1/284
8-16-87

FIGURE 2.2.6.5-1

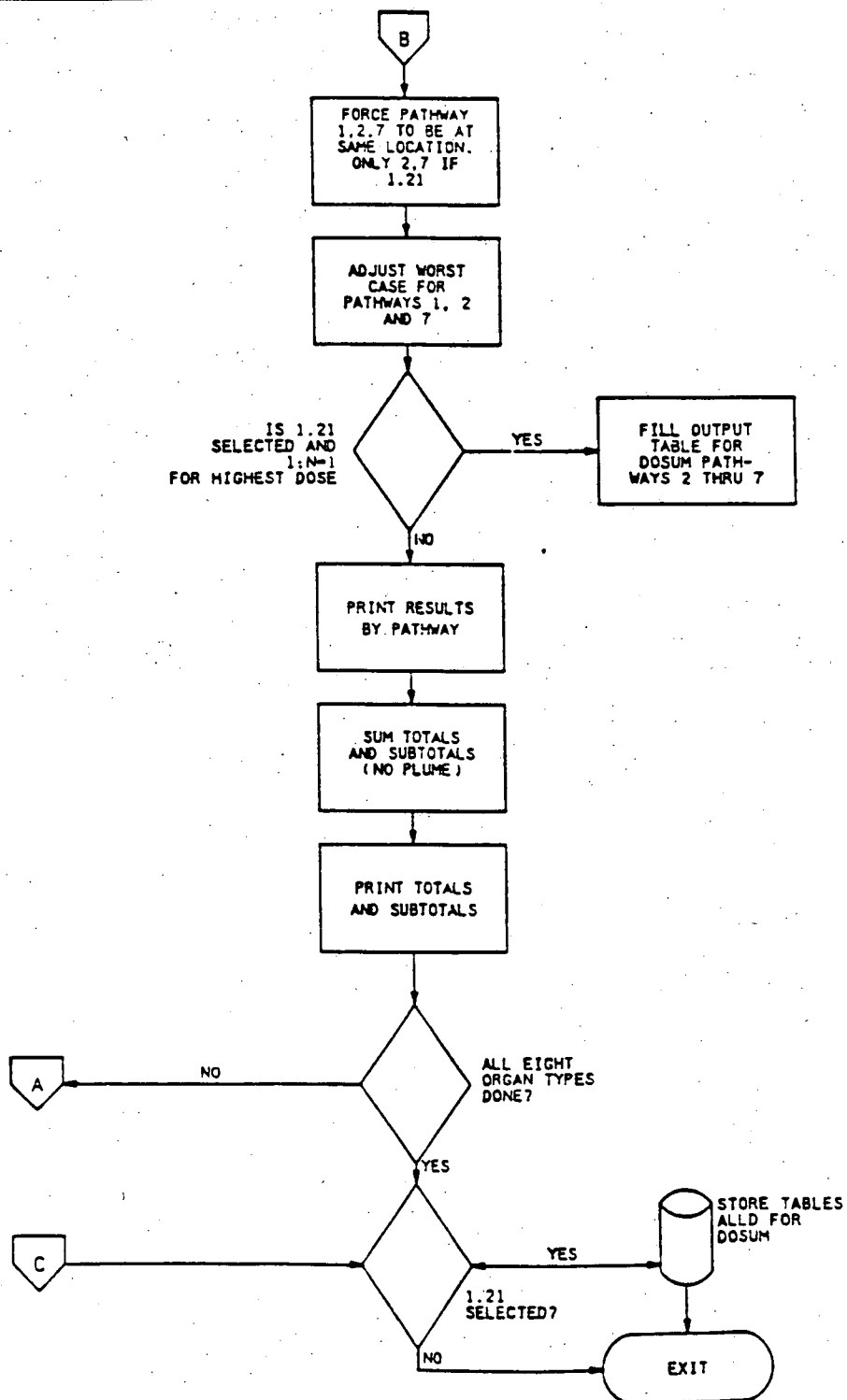

HYPO FFD
SHEET 2/284
8-16-47

2.2.6.6 DOSLI (Individual Liquid Pathways Dose Calculation) - Preliminary Information

PROGRAM NAME: DOSLI (DOSLQ and DOSLP versions are used in menu for preselected individual and population doses, respectively)

FUNCTION: Computes the individual dose (rem) or population dose (man-rem) for up to 5 receptors (and/or the surrounding population) for 14 liquid pathways due to release of radioactive liquid effluents. The task sums over all batches released in the requested time period.

PURPOSE: To satisfy NRC requirements as set forth in 10CFR50, Appendix I, and in the ODCMs for each plant.

FILE(S) USED:

	<u>LQDS</u>	<u>LIQP</u>	<u>LQPP</u>	<u>LQDF</u>
Input	No	Yes	Yes	Yes
Change	Yes	Yes	Yes	No

	<u>LPCA</u>	<u>DRLD</u>
Input	No	Yes
Change	Yes	No

TASKS USING FILES EDITED BY THIS TASK: No files are edited by this task.

TASKS USING FILES CONTAINING CALCULATED RESULTS FROM THIS TASKS:
DOSUM

LDSPRT,

PREREQUISITES:

The date entered via MIDEL, MIDEB, and
MIDLB tasks must have been checked and verified to be
correct.

Section 2.2.6.6

DOSLI - User Instructions

USER INSTRUCTIONS:

The user schedules either DOSLQ (for individual doses) or DOSLP (for population dose) and is prompted for start and end date. After answering several site and time dependent input questions the calculations is made and the run exits. Results are printed using LDSPRT.

Generally one individual and one population (man-rem) dose run are required for Regulatory Guide 1.21 reports.

Seven site specific prompts for information beyond this point will be requested. They are the same for population dose as for the individual. The user must input certain information for each run that fluctuates with season and other conditions as follows:

- (1) Irrigation rate - fraction of time on pasture and fraction of feed on pasture - are explained in Regulatory Guide 1.109.

- (2) The shore width factor - defines the type of water body. See Table A-2, page 15 of Regulatory Guide 1.109.
- (3) The fraction of water contaminated for pathways 12 (irrigated cow milk), 13 (irrigated goat milk), and 14 (irrigated beef) - refers to the amount of water consumed in food that was contaminated.

The value for delay time and waste dilution flow specific to each batch and are printed as each batch is processed.)

*** Refer to attached sample printout. ***

LD

SCHEDULING: CALCULATE LIQUID PATHWAY INDIVIDUAL DOSES (DOSLQ)
LIQUID DOSE ACCUMULATION PROGRAM 11/13/82 11:52
ENTER: [XX] SITE ID
[RETURN] EXIT

QA

1 THIS IS THE INDIVIDUAL DOSE ACCU. OPTION OF DOSLI

LIQUID DOSE ACCUMULATOR RUNNING

ENTER: [YRMODYHRYRMODYHR] START AND END DATE
[RETURN] EXIT
7906010179060106

ENTER PARAMETERS FOR RECEPTOR 1

2 ENTER: [N.N] IRRIGATION RATE (L/M2-HR)

10
ENTER: [N.N] FRACTION OF TIME ON PASTURE
[RETURN] GO BACK TO PREVIOUS OPTION

.4
ENTER: [N.N] FRACTION OF FEED ON PASTURE
[RETURN] GO BACK TO PREVIOUS OPTION

.4
ENTER: [N.N] SHORE-WIDTH FACTOR (0.1 TO 1.0)
[RETURN] GO BACK TO PREVIOUS OPTION

.3
FOR PATHWAY 12 IRRIGATED COW MILK
ENTER: [N.N,N.N,N.N] FRACTIONS OF WATER CONCENTRATION
STORED FEED, AND PASTURE IRRIGATED
[RETURN] EXIT

.1,.1,.1,
FOR PATHWAY 13 IRRIGATED GOAT MILK
ENTER: [N.N,N.N,N.N] FRACTIONS OF WATER CONCENTRATION
STORED FEED, AND PASTURE IRRIGATED
[RETURN] EXIT

.1,.1,.1
FOR PATHWAY 14 IRRIGATED BEEF
ENTER: [N.N,N.N,N.N] FRACTIONS OF WATER CONCENTRATION
STORED FEED, AND PASTURE IRRIGATED
[RETURN] EXIT

.1,.1,.1

TD, GENERAL DELAY TIME (HRS) 5.000E 01
FLO, WASTE DILUTION FLOW RATE (CFS) 1.300E 02
ZERO RELEASE DATA ENCOUNTERED, END OF RELEASE DATA FILE
GOING TO NEXT RECEPTOR

3 ENTER PARAMETERS FOR RECEPTOR 2

ENTER: [N.N] IRRIGATION RATE(L/M2-HR)

100

ENTER: [N.N] FRACTION OF TIME ON PASTURE
[RETURN] GO BACK TO PREVIOUS OPTION

.5

ENTER: [N.N] FRACTION OF FEED ON PASTURE
[RETURN] GO BACK TO PREVIOUS OPTION

.5

ENTER: [N.N] SHORE-WIDTH FACTOR (0.1 TO 1.0)
[RETURN] GO BACK TO PREVIOUS OPTION

.2

FOR PATHWAY 12 IRRIGATED COW MILK

ENTER: [N.N,N.N,N.N] FRACTIONS OF WATER CONCENTRATION
STORED FEED, AND PASTURE IRRIGATED

.1,.1,.1,

FOR PATHWAY 13 IRRIGATED GOAT MILK

ENTER: [N.N,N.N,N.N] FRACTIONS OF WATER CONCENTRATION
STORED FEED, AND PASTURE IRRIGATED
[RETURN] EXIT

.1,.1,.1,

FOR PATHWAY 14 IRRIGATED BEEF

ENTER: [N.N,N.N,N.N] FRACTIONS OF WATER CONCENTRATION
STORED FEED, AND PASTURE IRRIGATED
[RETURN] EXIT

.1,.1,.1

4 TD, GENERAL DELAY TIME (HRS) 5.000E 01
FLO, WASTE DILUTION FLOW RATE (CFS) 1.300E 02
ZERO RELEASE DATA ENCOUNTERED, END OF RELEASE DATA FILE
GOING TO NEXT RECEPTOR
DOSLQ DONE, ALL CALCULATIONS PERFORMED

PD
5 SCHEDULING: CALCULATE LIQUID PATHWAY POPULATION DOSES (DOSLP)
LIQUID DOSE ACCUMULATION PROGRAM 11/13/82 12:1
ENTER: [XX] SITE ID
[RETURN] EXIT

QA
THIS IS THE POPULATION DOSE ACCU. OPTION OF DOSLI
LIQUID DOSE ACCUMULATOR RUNNING

ENTER: [YRMOYHRYRMOYHR] START AND END DATE
[RETURN] EXIT
7906010179060106

ENTER PARAMETERS FOR RECEPTOR 1

ENTER: [N.N] IRRIGATION RATE(L/M2-HR)

120
ENTER: [N.N] FRACTION OF TIME ON PASTURE
[RETURN] GO BACK TO PREVIOUS OPTION

.4
ENTER: [N.N] FRACTION OF FEED ON PASTURE
[RETURN] GO BACK TO PREVIOUS OPTION

.4
ENTER: [N.N] SHORE-WIDTH FACTOR (0.1 TO 1.0)
[RETURN] GO BACK TO PREVIOUS OPTION

.2
FOR PATHWAY 12 IRRIGATED COW MILK
ENTER: [N.N,N.N,N.N] FRACTIONS OF WATER CONCENTRATION
STORED FEED, AND PASTURE IRRIGATED
[RETURN] EXIT

.1,.1,.1
FOR PATHWAY 13 IRRIGATED GOAT MILK
ENTER: [N.N,N.N,N.N] FRACTIONS OF WATER CONCENTRATION
STORED FEED, AND PASTURE IRRIGATED
[RETURN] EXIT

.1,.1,.1
FOR PATHWAY 14 IRRIGATED BEEF
ENTER: [N.N,N.N,N.N] FRACTIONS OF WATER CONCENTRATION
STORED FEED, AND PASTURE IRRIGATED
[RETURN] EXIT

.1,.1,.1
TD, GENERAL DELAY TIME (HRS) 5.00E 01
FLO, WASTE DILUTION FLOW RATE (CFS) 1.300E 02
ZERO RELEASE DATA ENCOUNTERED, END OF RELEASE DATA FILE
GOING TO NEXT RECEPTOR

ENTER PARAMETERS FOR RECEPTOR 2

ENTER: [N.N] IRRIGATION RATE(L/M2-HR)

100

ENTER: [N.N] FRACTION OF TIME ON PASTURE
[RETURN] GO BACK TO PREVIOUS OPTION

.5

ENTER: [N.N] FRACTION OF FEED ON PASTURE
[RETURN] GO BACK TO PREVIOUS OPTION

.5

ENTER: [N.N] SHORE-WIDTH FACTOR (0.1 TO 1.0)
[RETURN] GO BACK TO PREVIOUS OPTION

.2

FOR PATHWAY 12 IRRIGATED COW MILK

ENTER: [N.N,N.N,N.N] FRACTIONS OF WATER CONCENTRATION
STORED FEED, ADN PASTURE IRRIGATED
[RETURN] EXIT

.1,.1,.1

FOR PATHWAY 13 IRRIGATED GOAT MILK

ENTER: [N.N,N.N,N.N] FRACTIONS OF WATER CONCENTRATION
STORED FEED, AND PASTURE IRRIGATED
[RETURN] EXIT

.1,.1,.1

FOR PATHWAY 14 IRRIGATED BEEF

ENTER: [N.N,N.N,N.N] FRACTIONS OF WATER CONCENTRATION
STORED FEED, AND PASTURE IRRIGATED
[RETURN] EXIT

.1,.1,.1

TD, GENERAL DELAY TIME (HRS) 5.000E 01
FLO, WASTE DILUTION FLOW RATE (CFS) 1.300E 02
ZERO RELEASE DATA ENCOUNTERED, END OF RELEASE DATA FILE
GOING TO NEXT RECEPTOR
DOSLP DONE, ALL CALCULATIONS PERFORMED

Section 2.2.6.6

DOSLI - User Instructions (Notes)

USER INSTRUCTIONS:

The following notes correspond to the numbers on the example printout on the previous page(s).

- *1* This example is for an individual dose run.
- *2* These run factors are found in Regulatory Guide 1.21.
- *3* Run factors must be repeated for each receptor. This is the beginning of the second receptor.
- *4* Information for each batch is printed here.
- *5* A sample liquid population dose run starts here. All prompts for the remainder of the run are identical to those for the individual case.

Section 2.2.6.6

DOSLI - Program Design

PROGRAM DESIGN:

The DOSLI program was written in accordance with Regulatory Guide 1.109 for liquid effluents. The program calculates doses for up to five receptors. Each receptor is exposed to the same release from up to four release points. Batch release information is stored in the file edited by the MIDEB task. LAST dose accumulations to individuals and/or the local population are zeroed at the start of the program. The receptor selectors are entered. Reference should be made to Section 2.3 for site-plant information available to the task.

Some input for each receptor are required by the DOSLI program in addition to other parameters set up by the MIDEB task and the LDFLPM utility. The program then loops on batch release, accumulating all that are between the start and end dates. Note that the start and end dates entered must span complete batches and no overlap is allowed. These dates

and the dates on the release point data are checked. All parameters must remain the same for one run (i.e., dilution flow, etc.). Only delay time, release point, and flow rate are allowed to change with each batch.

The following steps are used in the program to obtain the dose accumulations. The time delay and waste dilution flow rate is printed from each batch as it is processed. The release values (isotopes 1-73 only) are compressed so that only nonzero isotopic releases are processed. All concentrations are calculated for each selected liquid pathway. These are then consolidated into one array by isotope and pathway type. Ingestion doses followed by ground shine doses are then computed. Individual doses are summed over all pathways and saved as totals separately for each combination of pathway, age group, and organ type. If population dose is selected, the dose results are multiplied by the number of receptors in the liquid population table (entered in the MIDEF task for liquids as a function of pathway and receptor). Results are then multiplied by the fraction of the population assumed to be in each age group (adult, teen, child and infant; 0.71, 0.11, 0.18 and 0.0, respectively). Population doses are saved by pathway and organ.

A functional flow diagram is provided in Figure 2.2.6.6-1.

COMPUTATIONAL MODEL:

The dose calculations for each receptor type use Equations (1) through (5) given on page 1.109-2 and 3 of Regulatory Guide 1.109. The program starts with the ingestion dose factors for each isotope (not pathway as in GASPRO) in data statements and proceeds to calculate the uptake into foodstuffs through 30 different media. These condense into 14 different pathways to which each of 5 receptors could be exposed. The need to use final dose factors was

obviated by the relatively few passes through the program (once per batch) compared with GASPRO which makes one per hour of data. The ingestion dose factors and other assumptions are taken from Regulatory Guide 1.109, Appendices A and E.

Population doses are computed by assigning an exposed population to each receptor and summing results over all receptors.

FIGURE 2.2.6.6-1

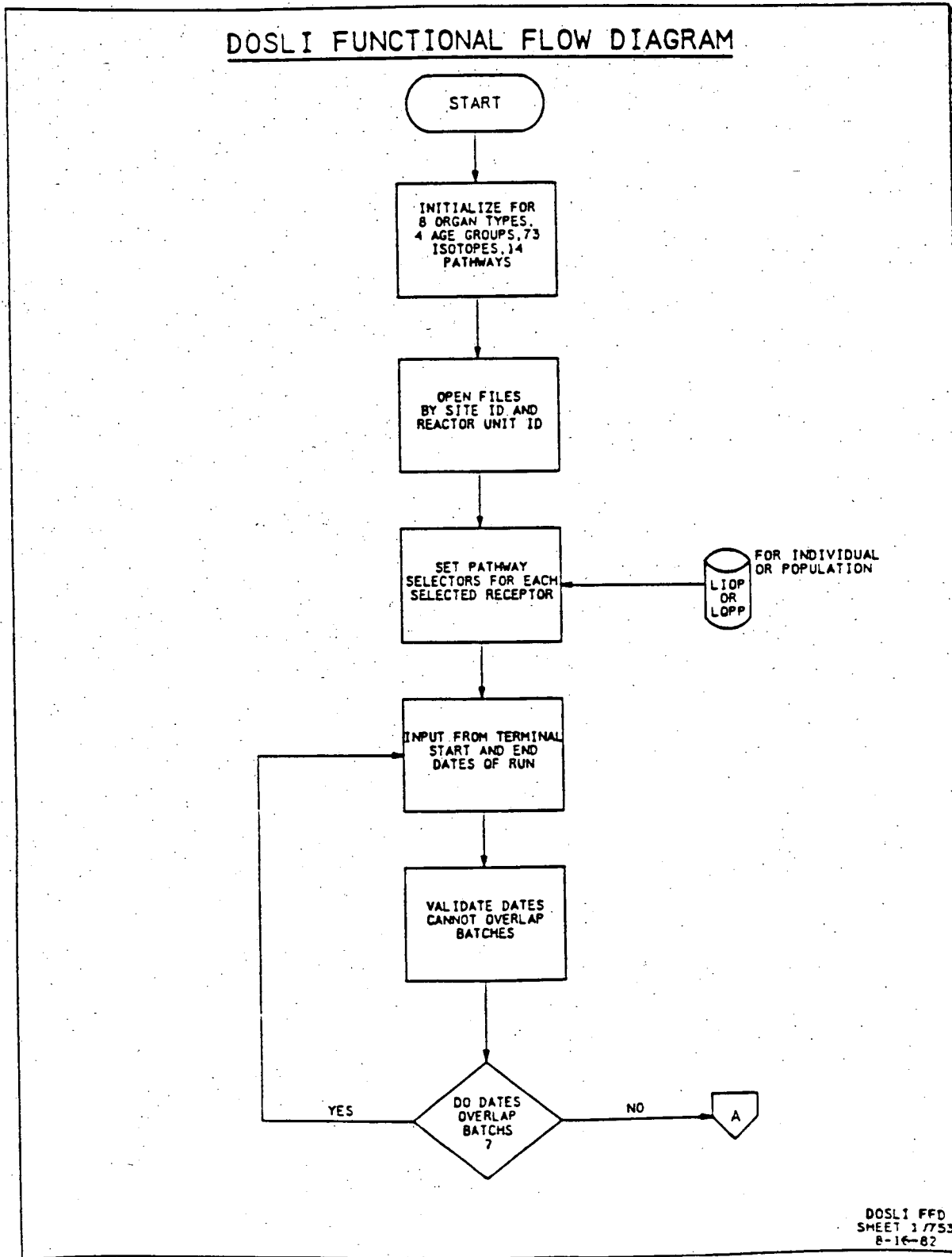
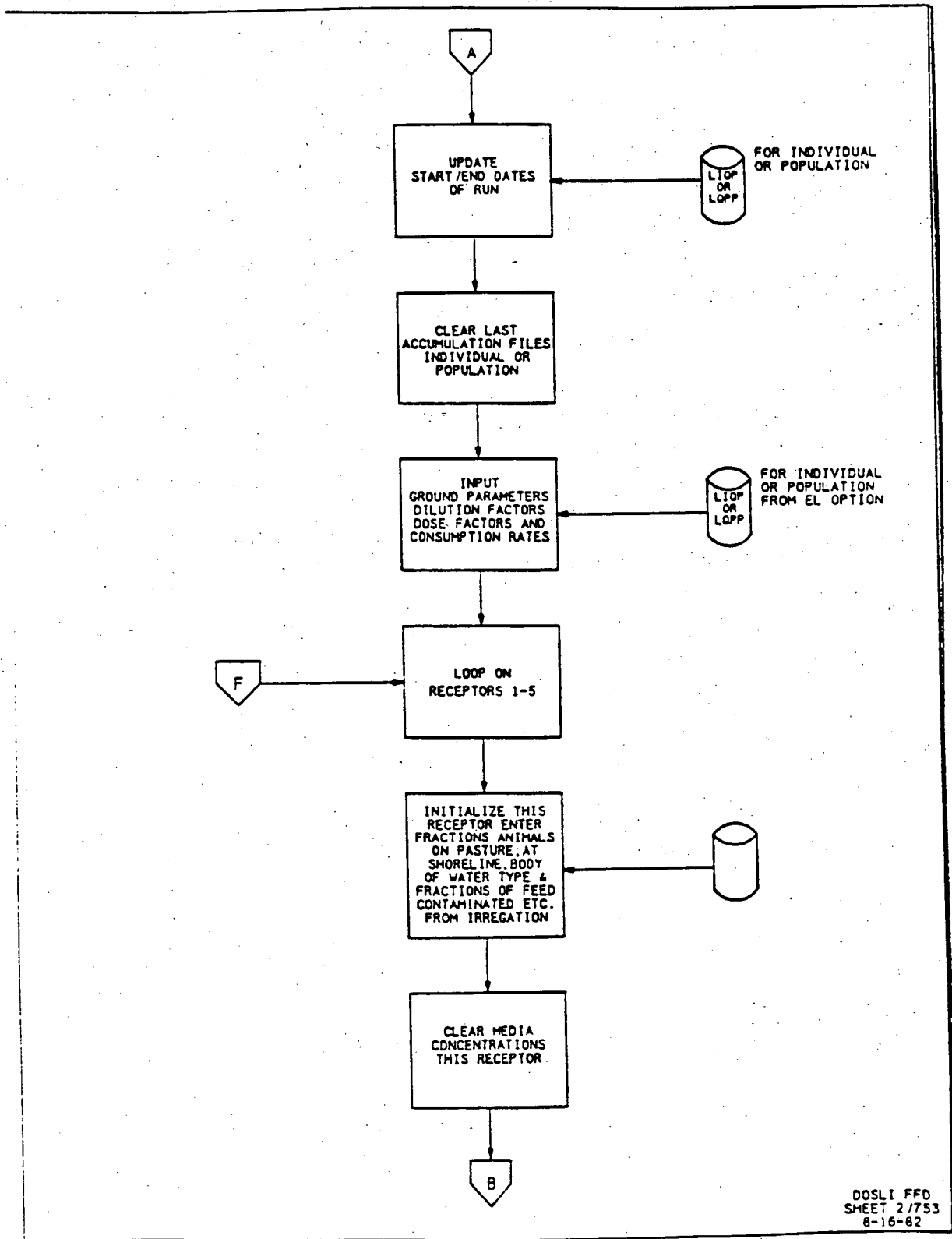
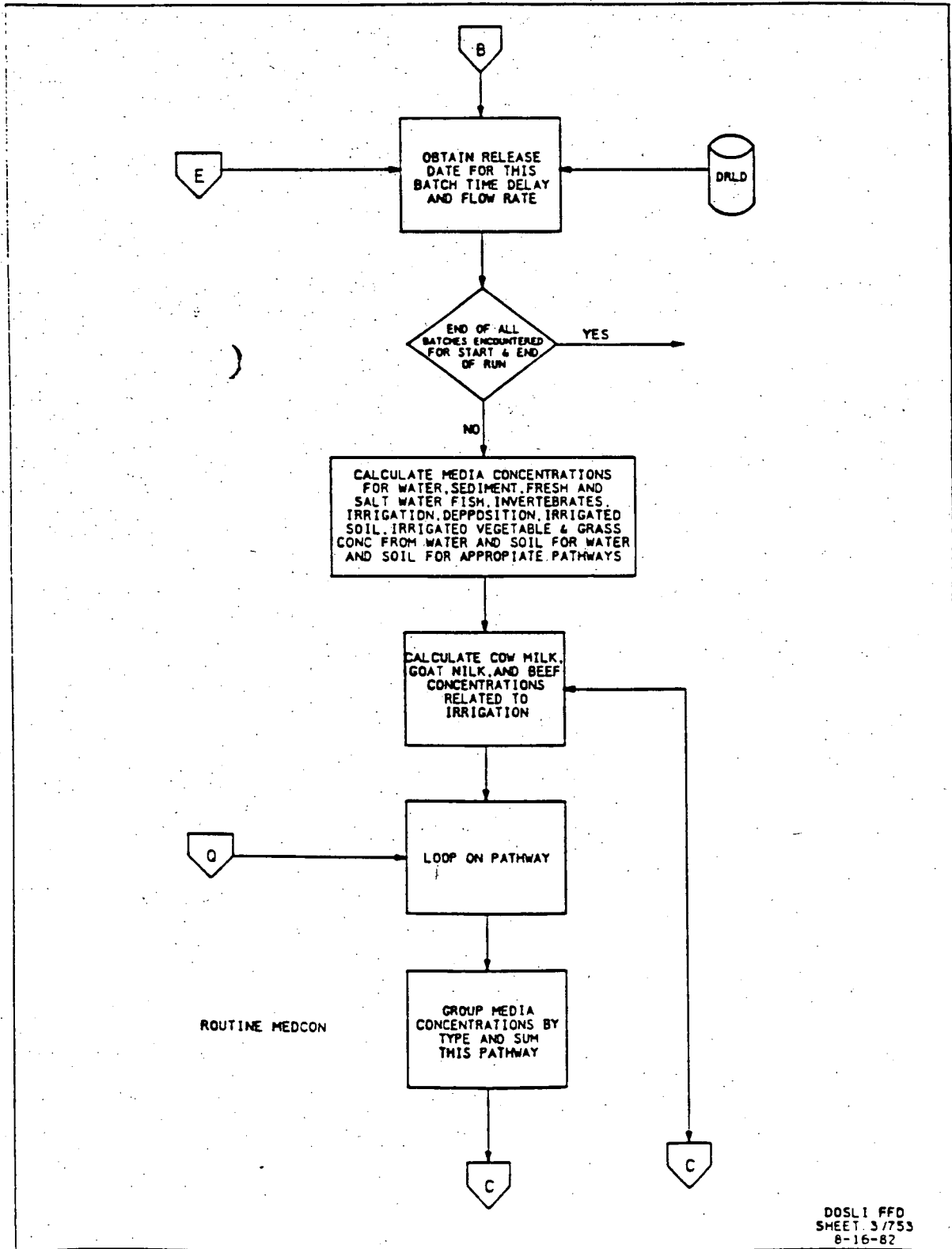

FIGURE 2.2.6.6-1 (continued)



OOSLI FFD
SHEET 2/753
8-16-82

FIGURE 2.2.6.6-1 (continued)



DOSLI FFD
SHEET 3/753
8-16-82

FIGURE 2.2.6.6-1 (continued)

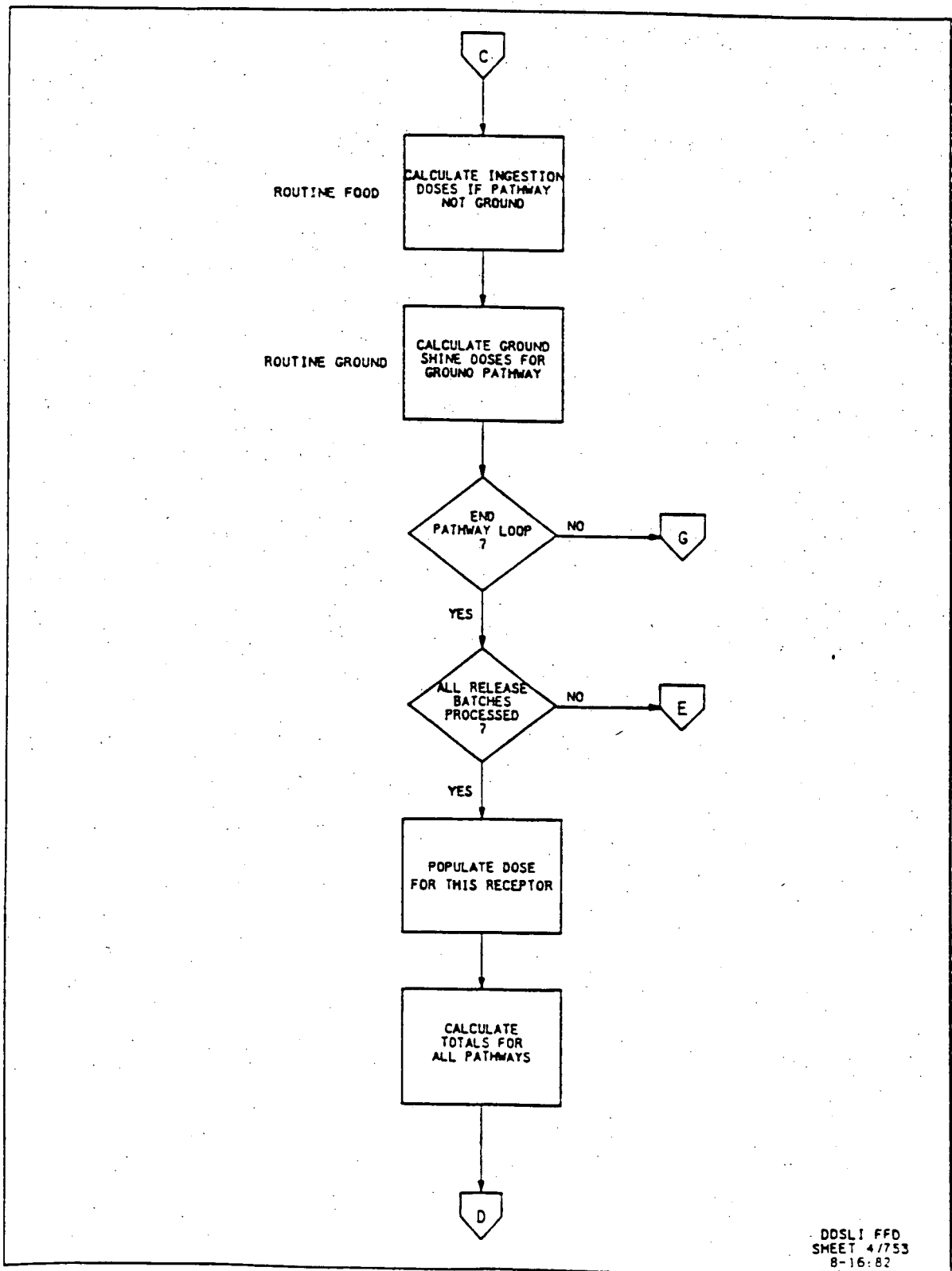

DDSLI FFD
SHEET 4/753
8-16-82

FIGURE 2.2.6.6-1 (continued)

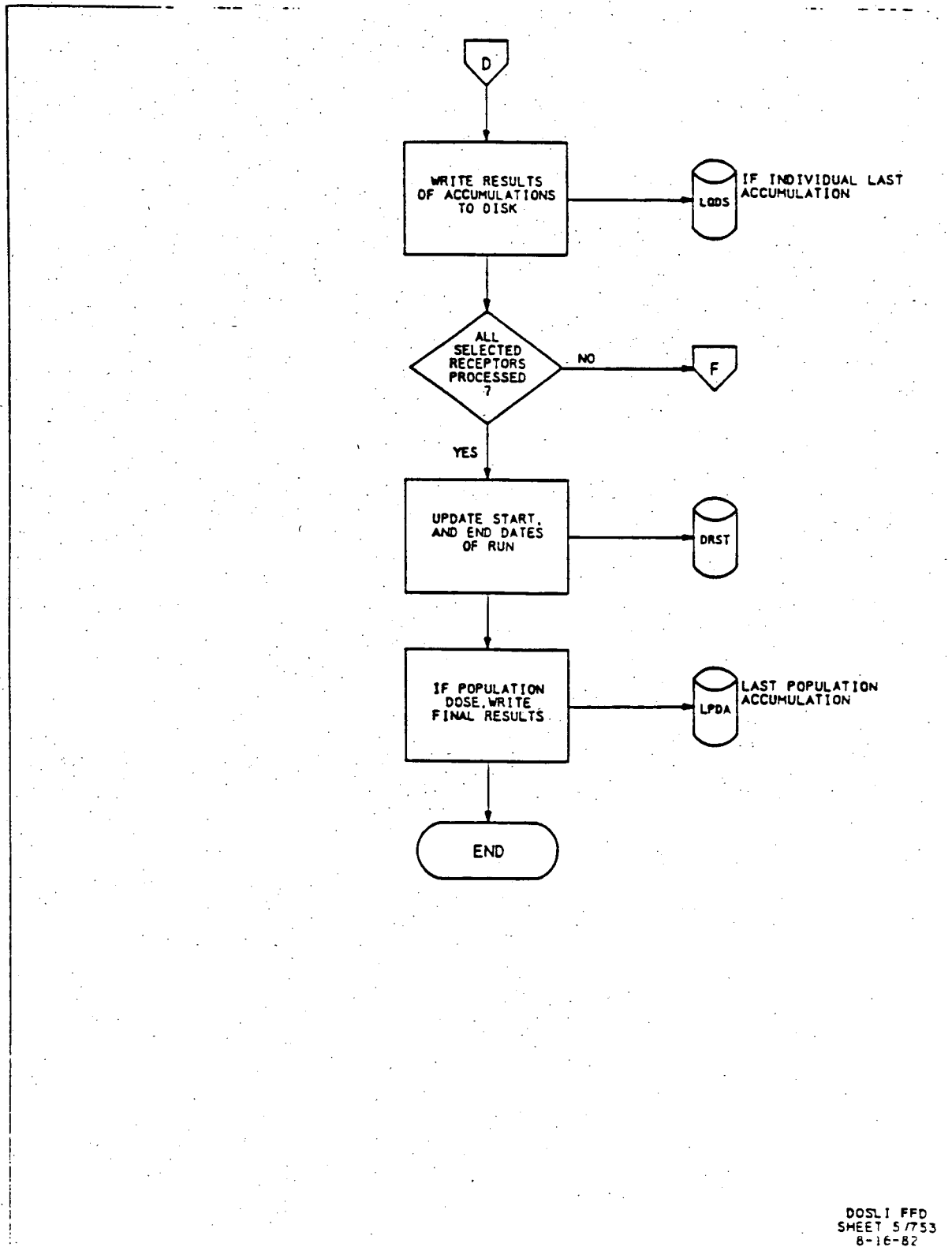

DOSI FFD
SHEET 5/753
8-16-82

2.2.6.8 DOSUM (Print Pathways Dose Summary for
Appendix I Reports) - Preliminary Information

PROGRAM NAME: DOSUM

FUNCTION: After a series of prerequisite runs
have been made, the DOSUM task searches the results
files to find all maximum liquid and gaseous pathway
individual doses. These highest exposures are then
printed in a one-page summary table. Each line item
is compared with the appropriate dose limit.
Population doses are also printed.

PURPOSE: To provide a concise summary of
offsite environmental dose calculations for inclusion
in Regulatory Guide 1.21 reports.

FILE(S) USED:

	<u>AIRD</u>	<u>AIRT</u>	<u>GPTD</u>	<u>GMDS</u>	<u>DRST</u>	<u>LQDS</u>
Input	Yes	Yes	Yes	Yes	Yes	Yes
Change	No	No	No	No	No	No
	<u>LIQP</u>	<u>LQPP</u>	<u>LQTD</u>	<u>LPDA</u>	<u>LPTD</u>	<u>ALLD</u>
Input	Yes	Yes	Yes	Yes	Yes	Yes
Change	No	No	No	No	No	No

TASKS USING FILES

EDITED BY THIS TASK: No files are edited by this task.

TASKS USING FILES CONTAINING CALCULATED RESULTS FROM THIS TASK:

None

PREREQUISITES:

XDAIR (air beta and gamma), GASPRO (individual and population), HYPO (individual), DOSLI (individual and population) must all have been run on the same file (LAST or TOTAL).

Section 2.2.6.8

DOSUM - User Instructions

USER INSTRUCTIONS:

The user schedules this task from the menu and is prompted for last or total. The search of the files is made and results printed. The user should scan the dates indicated for each type of data to assure that the correct files were used.

*** Refer to attached sample printout ***

DM
SCHEDULING: PRINT ACCUMULATED DOSE RESULTS (DOSUM)

***** DOSE SUMMARY TABLE *****

ENTER: [XX] SITE ID
[RETURN] EXIT

QA
ENTER: [XXXX] USER INITIAL
[RETURN] GO BACK TO PREVIOUS OPTION

1 KW
ENTER: [LA] LAST ACCUMULATION
[TO] TOTAL ACCUMULATION
[RETURN] GO BACK TO PREVIOUS OPTION

LA
SITE: DGI QUALITY FILE 11/13/82 12:08

2 USER: KW SUMMARY OF MAXIMUM INDIVIDUAL DOSES
LAST ACCUMULATIONS FOR PERIODS:
LIQUID 79 6 1 1-79 6 1 6
GASEOUS 79 6 1 1-79 6 1 6
AIR 79 6 1 1-79 6 1 6

EFFLUENT	APPLICABLE ORGAN	ESTIMATED DOSE (MREM)	AGE GROUP	LOCATION DIST DIR (M) (TOWARD)	% OF APPLICABLE LIMIT	LIMIT (MR)	
3	LIQUID	TOTAL BODY	1.86E 07	ADULT	RECEPTOR 1	6.2E 08	3.0
	LIQUID	LIVER	6.69E 07	CHILD	RECEPTOR 1	6.7E 08	10.0

4	NOBLE GAS	AIR DOSE (GAMMA-MRAD)	1.85E-02		550. E	1.8E-01	10.0
	NOBLE GAS	AIR DOSE (BETA-MRAD)	4.17E-02		550. E	2.1E-01	20.0
5	NOBLE GAS	T. BODY	1.32E-02	ALL	690. E	2.6E-01	5.0
	NOBLE GAS	SKIN	3.39E-02	ALL	690. E	2.3E-01	15.0

5	IODINE&	THYROID	1.64E-01	INFANT	690. E	1.1E 00	15.0

EFFLUENT

APPLICABLE
ORGAN

ESTIMATED
POPULATION DOSE
(PERSON-REM)

SUMMARY OF POPULATION DOSES
LAST ACCUMULATINGS FOR PERIODS:

2

LIQUID 79 6 1 1-79 6 1 6
GASEOUS 79 6 1 1-79 6 1 6

EFFLUENT

APPLICABLE
ORGAN

ESTIMATED
POPULATION DOSE
(PERSON-REM)

LIQUID
LIQUID
GASEOUS
GASEOUS

TOTAL BODY
THYROID
TOTAL BODY
THYROID

2.0E 06
1.1E 06
3.4E 38
3.4E 38

END OF REPORT

DOSUM DONE

Section 2.2.6.8 DOSUM - User Instructions (Notes)

USER INSTRUCTIONS:

The following notes correspond to the numbers on the example printout on the previous page(s).

- *1* If accumulations have been made, the TOTAL tables for all prerequisite runs must be used. However, if all prerequisite runs were made for a single run period (i.e., no ADDS were made) use of the LAST table is sufficient. Note that the run dates for ALL prerequisite tasks must be constant when using either LAST or TOTAL files.
- *2* Dates should be inspected for consistency. This is a good check to make sure correct files and runs were used.
- *3* From DOSLI (included)
- *4* From XDAIR
- *5* From HYPO (individual)
- *6* From DOSLI (population)
- *7* From GASPRO (population)

PROGRAM DESIGN:

All files are opened in routine DSINIT by site and by unit and type of accumulations (last or total) desired. Dates of last or total accumulations are set for printing. All dose summaries are computed in a separate routine for each organ. A search for the maximum individual liquid dose for total body and the other seven organ types is made and the highest receptor dose is saved along with the corresponding age group. The liquid receptors and the individual liquid pathways (selected by MIDEL task) determine which dose accumulations are used in the search. A search for the maximum gamma and beta air dose is made and the location (distance and direction) where each occurred is saved. The dose accumulations are summed over the selected gaseous effluent release points (determined by MIDER task). The maximum iodine and particulate doses summing pathways 2 through 7, excluding plume dose) and the age group and organ type of each dose are returned along with the receptor location (distance and direction). Note that the 1.21 option in HYPO prints results separately for the noble gas plume dose which is printed in DOSUM.

The liquid and gaseous population dose to total body and to the thyroid are determined by searching the DOSLI and GASPRO output files. In both cases, all respective pathways are summed (14 for liquid, 7 for gas). All selected receptors during the DOSLI population accumulation are already summed. Doses to all gaseous pathway receptors are already summed in GASPRO population dose calculations at all 16 directions and 10 distances. Note that receptors are assumed to be in all locations when population is selected in GASPRO.

Functional flow diagrams are provided in Figures 2.2.6.8-1 and 2.2.6.8-2.

COMPUTATIONAL MODEL: The only computations in this task are searched for peaks in several tables.

FIGURE 2.2.6.8-1

DOSUM PRECALCULATIONS (QUARTER HOUR)

EDITS: ER, EX, ET, EP, EF, EG, EL, EG

WORK: RAW ISOTOPIC
 NET RELEASE
 FILES: DRNDCP, DRNDCP, DRNDCP, 1,2, DRNDCP, 1,2

ALL SAME DATES AND USED LAST ACCUMULATION FILES

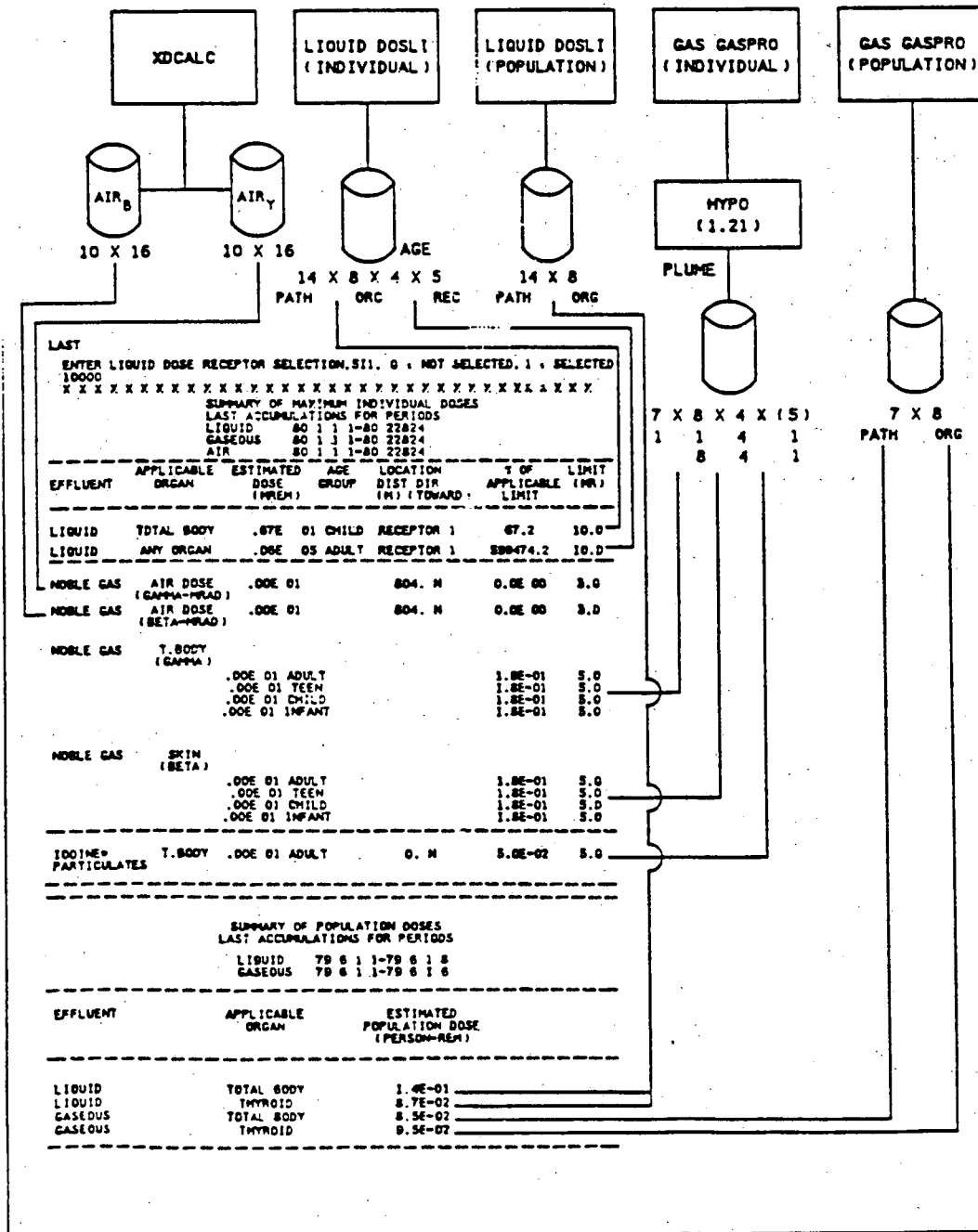

DOSUM PRECAL
 SHEET 1/202
 8-16-82

FIGURE 2.2.6.8-2

DOSUM FUNCTIONAL FLOW DIAGRAM

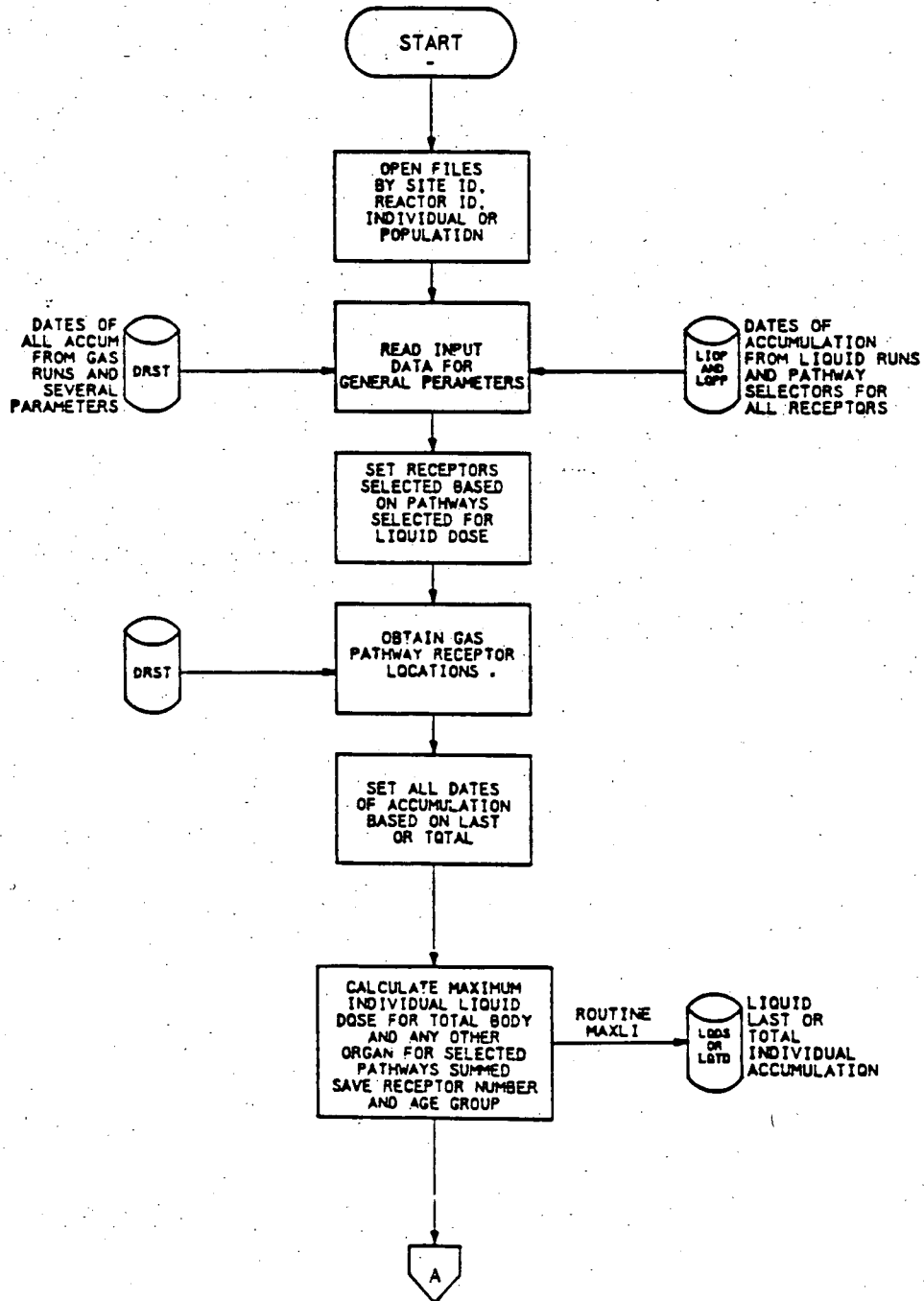

DOSUM FFD
SHEET 1/202
8-16-82

FIGURE 2.2.6.8-2 (continued)

DOSUM FUNCTIONAL FLOW DIAGRAM

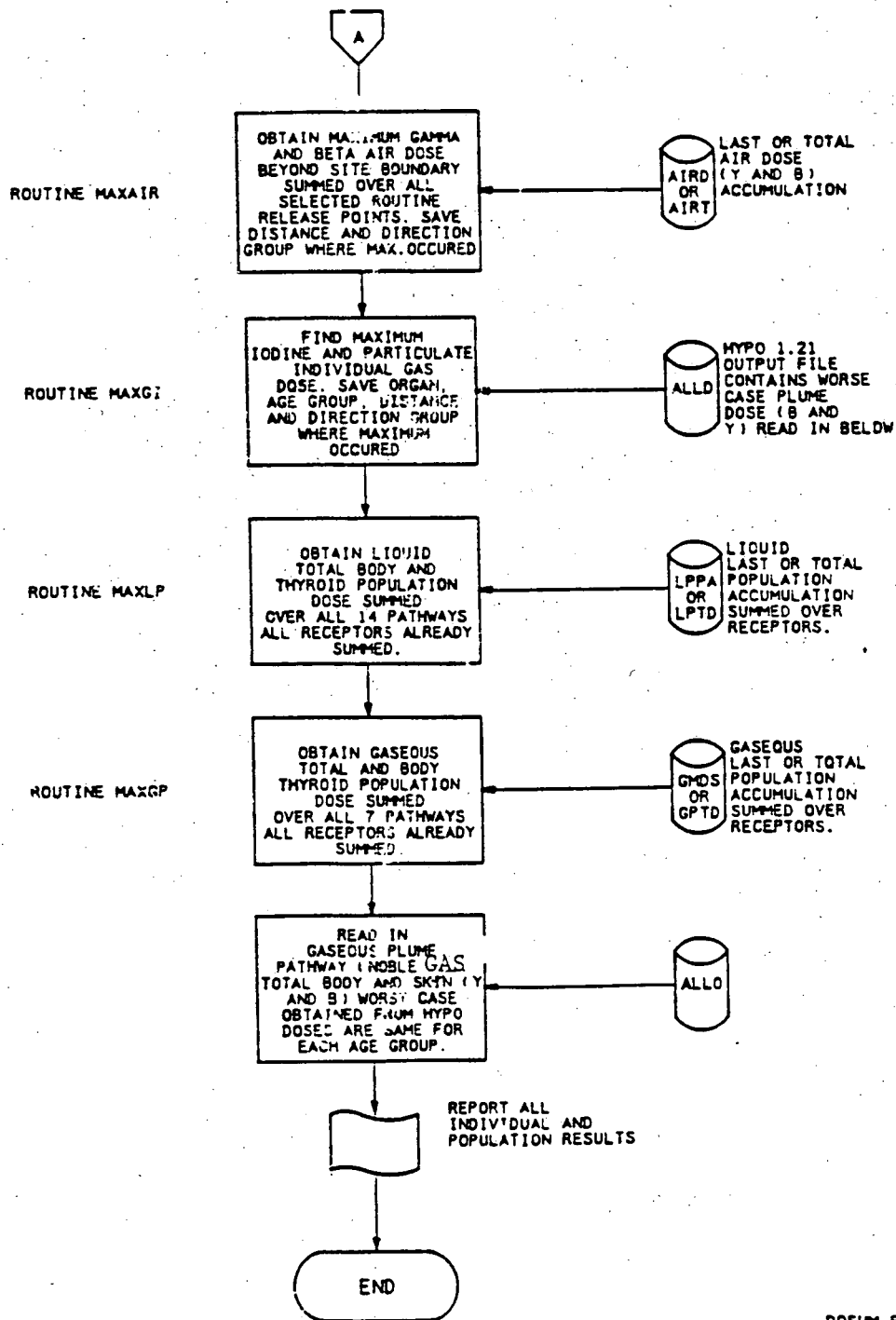

DOSUM FFD
SHEET 1/753
8-16-82