

**APPENDIX E**  
**Sediment Basin Calculations**

Sediment Basin Design Calculations:



Client/Subject: PPL Bell Bend, LLC  
 Description: Sediment Basin Calculation  
 Prepared by: J. Volonakis  
 Date: 17 Aug 11

Print Date: 12 Sep 11 10:29 AM  
 Project #: PPLS0902

Checked by: D. Molinaro
----------------------------

**Objective:**

This spreadsheet will assist with the design of sediment basins as erosion and sediment control measures. The calculations below are based on the criteria mandated by the PA E&S Manual (March '00 version) on pages 40 to 63.

**Basic Input:**

**Sediment Basin Name: SEDIMENT BASIN 1**

Drainage Area to Basin: 17.8 acres (if < 5.0 acres, consider sediment trap also)  
 Disturbed Area Tributary to Basin: 17.8 acres

**Requirements:**

Required Sediment Storage volume: 17,820 ft<sup>3</sup> (1000 ft<sup>3</sup>/disturbed acre)  
 Is the basin in a HQ or EV watershed? Yes. **Reductions not allowed in a HQ or EV watershed.**

Dewatering Zone Volume Determination (Standard Dewatering Zone = 5000 ft<sup>3</sup>/acre)

Does the basin dewater via a skimmer? Yes.  
 Does the basin have >18" permanent pool? No.  
 Is flow length to width greater than 4:1? Yes.  
 Does basin dewater between 4 and 7 days? Yes. (4.5 days)

Actual Dewatering Zone criteria: 5,000 ft<sup>3</sup>/acre after reductions (minimum of 3600 ft<sup>3</sup>/acre)

Required Dewatering Zone volume: 89,100 ft<sup>3</sup> (5000 ft<sup>3</sup>/total acre)

**Minimum total storage volume: 106,920 ft<sup>3</sup> (Dewatering Zone PLUS Sediment Storage volume)**

**Elevation-Storage Data:**

	Elevation	Plan Area	Δ Vol	Σ Vol
Bottom of Basin Elevation:	665.00	43699.0		
	666.00	47,404.0	45,551.5	45,551.5
	668.00	54,921.0	102,325.0	147,876.5
	670.00	62,562.0	117,483.0	265,359.5
Embankment Top Elevation:	672.00	70,354.0	132,916.0	398,275.5

**Actual Storage Volumes and Riser Height**

Elevation of Top of Sed. Storage (cleanout): 665.40 feet (provides Required Sediment storage volume)  
 Crest of Principal Spillway (Riser): 669.00 feet (minimum elev to provide Dewatering Zone: 667.24 ft)  
 Actual Storage volume provided at riser crest: 204,708 ft<sup>3</sup>

**Other Basin Characteristics**

Flow length through basin: 700 feet 2 to 1 (minimum flow length: 341.74 ft; see page 56)  
 Average width of basin: 50 feet 4 to 1 (minimum flow length: 484.73 ft; see page 56)  
 Length to width ratio: 14.0 to 1 (minimum 2 to 1)

Sediment Basin Name: **SEDIMENT BASIN 1**

LCULATIONS\EROSION & SEDIMENTATION CALC\SEDIMENT BASINS AND TRAPS\SEDIMENT BASINS\|PPLS0902\_Sed Basin Design 1.xls\Sed Basin Design

**Embankment Criteria**

Embankment top width must be at least 8 feet wide.

Embankment side slopes may not be steeper than 2H:1V

**Embankment Spillway Weir Dimensions**

Emergency Spillway outlet width, L:	15.0	feet	(minimum bottom width is 8', see page 40)
Emergency Spillway outlet side slopes:	3 to 1		
Emergency Spillway crest elevation:	670.00	feet	(minimum crest elev: 669.50 ft; 6 in over riser crest) (maximum crest elev: 671.50 ft; 6 in below top of berm)

**Required Discharge from Basin**

Minimum discharge capacity (2 cfs/ac) Q = 35.6 cfs (at maximum water surface elevation)

**Water Surface Elevation at Required Discharge**

Discharge through riser/barrel = 35.6 cfs

**Riser Flow:**

Length/Width of Principal Spillway (Riser): 4.0 feet by 2.0 feet

Crest of Principal Spillway (Riser): 669.00 feet

Orifice flow from Riser:  $Q = 0.9 A_{\text{riser}} (2gh)^{0.5}$ 

Solve for h = 0.38

Weir flow from Riser:  $Q = 3.1 P_{\text{riser}} h^{1.5}$ 

Solve for h = 0.97 feet. Elev: 669.97 feet

Weir controls over Orifice.

**Barrel Flow:**

Discharge pipe invert elevation at basin: 665.00 feet

Diameter of Barrel: 2.5 feet

(maximum diameter is riser diameter / 1.25, see pg 40)

Barrel length, L = 54 feet

Slope of the barrel : 1.9%

Discharge pipe invert elev at outlet end of pipe: 664.00 feet

Barrel Manning's n = 0.011

(use 0.025 for CMP, 0.015 for RCP, see page 45)

Pipe flow from Barrel: (where h = head over centerline of outlet end of pipe)

 $Q = A_{\text{barrel}} \{ (2gh) / [1 + 1 + (5087 * n^2 / d_i^{1.33}) * L] \}^{0.5}$ 

Solve for h = 1.93 feet. Elev: 667.18 feet

**Determine which part of structure controls (higher W.S. Elev):****Riser capacity controls over Barrel.**

Does Emergency Spillway contribute to outflow? No.

Required Q through the riser/barrel is 35.6 cfs

**Maximum Water Surface Elevation and Required Freeboard**

Maximum water surface elevation: 669.97 feet (at maximum discharge capacity)

Top of Embankment: 672.00 feet. Freeboard provided: 24 inches



**Sediment Basin Name: SEDIMENT BASIN 1**

LCULATIONS\EROSION & SEDIMENTATION CALCS\SEDIMENT BASINS AND TRAPS\SEDIMENT BASINS\{PPLS0902\_Sed Basin Design 1.xls}Sed Basin Design

**Skimmer Design** (as an alternate to the dewatering orifices on the riser.)

**Basic Input:**

Volume to top of Dewatering Zone , V:	186,888 cu ft	
Dewatering Time, t:	4.5 days	Dewatering time entered by user.
Floor of basin elevation:	665.00 feet	
Top of dewatering zone elevation:	669.00 feet	

**Calculations:**

Calculated skimmer orifice diameter: 4.42 in (from figure 7, page 44 of PA E&S manual)

Use 1/2" diameter orifices on the skimmer to provide 4.42 inches of orifice area.

Orifice area of a 1/2" diameter orifice: 0.20 sq in Area= 15.34 sq in

**Number of 1/2" dia. orifices required: 77**

*The arm of the skimmer must form an angle with the basin floor of 45 degrees or less when the water surface elevation is at the top of dewatering zone.*

Water depth:	4.00 feet
Minimum length of skimmer arm:	5.66 feet
<b>Use skimmer arm length of:</b>	<b>6 feet</b>

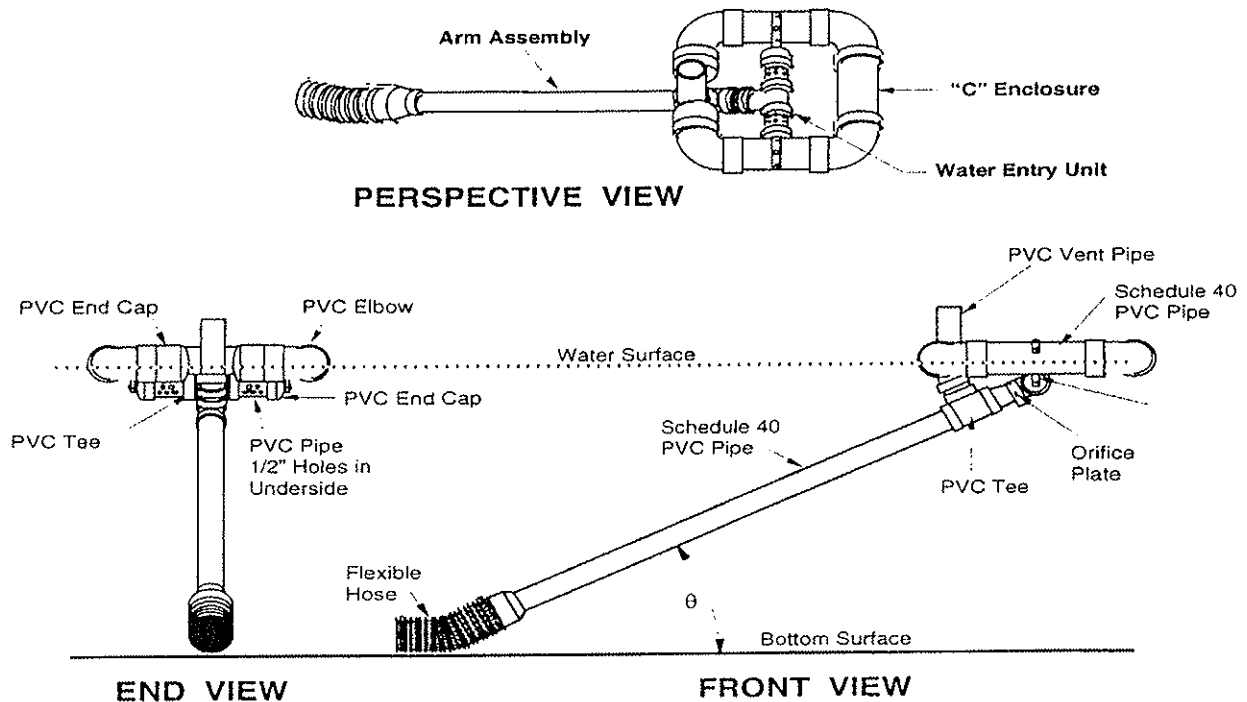

**STANDARD WORKSHEET #12**  
**Sediment Basin Capacity Requirements**

PROJECT NAME: Bell Bend Nuclear Power Plant  
 LOCATION: Salem Township, Luzerne County  
 PREPARED BY: J. Volonakis DATE: 8/17/2011  
 CHECKED BY: D. Molinaro DATE: 8/17/2011

BASIN NUMBER	SEDIMENT BASIN 1
(A) MAXIMUM TOTAL DRAINAGE AREA (AC)	17.82
(I) INITIAL REQ'D SETTLING VOLUME (5,000 X A) (CF)	89,100
(T) REDUCTION FOR TOP DEWATERING (-700 X A) (CF)	X
(P) REDUCTION FOR PERMANENT POOL (-700 X A) (CF)	X
(L) RED. FOR 4:1 FLOW LENGTH:WIDTH (-350 X A) (CF)	X
(D) RED. FOR 4 TO 7 DAY DEWATERING (- 350 X A) (CF)	X
*** (Sv) REQUIRED SETTLING VOLUME [I - (T+P+L+D)] (CF)	89,100
(Sd) REQUIRED SEDIMENT STORAGE VOLUME (1000 X a) <sup>1</sup> (CF)	17,820
(St) TOTAL REQUIRED STORAGE VOLUME (Sv + Sd) (CF)	106,920
**** TOTAL STORAGE VOLUME PROVIDED (CF)	204,708
REQUIRED DISCHARGE CAPACITY (2 X A) (CFS)	35.6
PRINCIPAL SPILLWAY CAPACITY (@ ELEV # ) (CFS)	35.6
* EMERGENCY SPILLWAY CAPACITY (@ ELEV ↴ ) (CFS)	0.0
** EMERGENCY SPILLWAY PROTECTIVE LINING	Pyramat

**X Reductions not allowed in a High Quality/Exceptional Value watershed.**

\* Provide supporting computations.

\*\* If grass lining is proposed, spillway must be constructed in original ground.

\*\*\* 5000 cubic feet per acre settling volume is required for basins located in Special Protection (HQ & EV) watersheds. In other watersheds, the basin settling volume may be reduced per the Department's "Erosion and Sediment Pollution Control Program Manual," No. 363-2134-008 (January 1996), as amended and updated. The minimum settling volume for such basins is (3600 X A).

\*\*\*\* Total Storage Volume provided at riser crest.

<sup>1</sup> a = Disturbed Acres in Drainage Area      a = 17.82 acres

**STANDARD WORKSHEET #13**  
**Sediment Basin Dimensions and Elevations**

PROJECT NAME: Bell Bend Nuclear Power Plant  
 LOCATION: Salem Township, Luzerne County  
 PREPARED BY: J. Volonakis DATE: 8/17/2011  
 CHECKED BY: D. Molinaro DATE: 8/17/2011

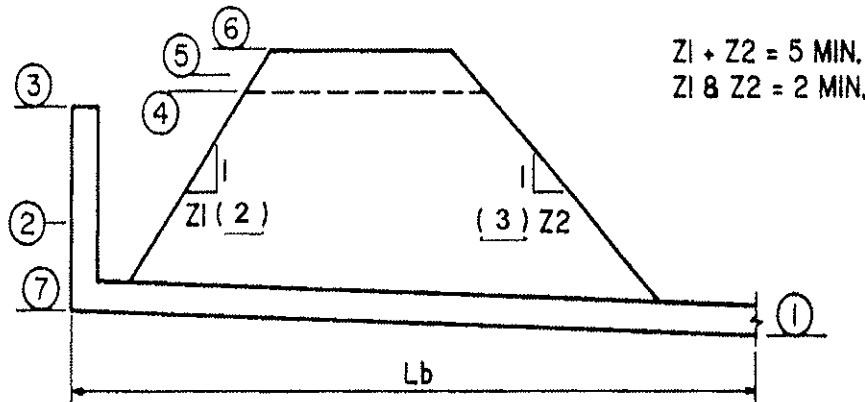

BASIN NUMBER	SEDIMENT BASIN 1
1. DISCHARGE PIPE ELEVATION	664.00
2. TOP OF SEDIMENT STORAGE ZONE (@ Sd)	665.40
3. ELEVATION AT TOP OF DEWATERING ZONE (St) (CREST OF PRINCIPAL SPILLWAY)	669.00
4. EMERGENCY SPILLWAY CREST ELEVATION (MIN. 0.5' ABOVE ELEVATION ①)	670.00
5. 2 CFS/ACRE FLOW ELEVATION	669.97
6. TOP OF EMBANKMENT ELEVATION (MIN. 24" ABOVE ELEVATION ④)	672.00
7. BOTTOM ELEVATION	665.00
AVERAGE BOTTOM WIDTH (FT)	50
AVERAGE BOTTOM LENGTH (FT)	700
EMBANKMENT TOP WIDTH (FT, 8' MIN.)	8
RISER DIAMETER/TYPE (15" MIN.)	Type M Inlet Box
BARREL DIAMETER/TYPE (12" MIN.)	30 in. RCP
Lb (BARREL LENGTH (FT)	54.0
EMERGENCY SPILLWAY WIDTH (FT)	15.0
EMERGENCY SPILLWAY SIDE SLOPES (H:V)	3.0

**SHOW ALL DETAILS AND CONSTRUCTION DIMENSIONS ON PLAN DRAWINGS  
 USING STANDARD CONSTRUCTION DETAIL SHEETS.**



Sediment Basin Design Calculations:



Client/Subject: PPL Bell Bend, LLC  
 Description: Sediment Basin Calculation  
 Prepared by: J. Volonakis  
 Date: 23 Aug 11

Print Date: 12 Sep 11 10:31 AM  
 Project #: PPLS0902

Checked by: D. Molinaro
----------------------------

**Objective:**

This spreadsheet will assist with the design of sediment basins as erosion and sediment control measures. The calculations below are based on the criteria mandated by the PA E&S Manual (March '00 version) on pages 40 to 63.

**Basic Input:**

**Sediment Basin Name: SEDIMENT BASIN 1A**

Drainage Area to Basin: 13.0 acres (if < 5.0 acres, consider sediment trap also)  
 Disturbed Area Tributary to Basin: 13.0 acres

**Requirements:**

Required Sediment Storage volume: 12,990 ft<sup>3</sup> (1000 ft<sup>3</sup>/disturbed acre)  
 Is the basin in a HQ or EV watershed? Yes. **Reductions not allowed in a HQ or EV watershed.**

Dewatering Zone Volume Determination (Standard Dewatering Zone = 5000 ft<sup>3</sup>/acre)

Does the basin dewater via a skimmer? Yes.  
 Does the basin have >18" permanent pool? No.  
 Is flow length to width greater than 4:1? Yes.  
 Does basin dewater between 4 and 7 days? Yes. (4.5 days)

Actual Dewatering Zone criteria: 5,000 ft<sup>3</sup>/acre after reductions (minimum of 3600 ft<sup>3</sup>/acre)

Required Dewatering Zone volume: 64,950 ft<sup>3</sup> (5000 ft<sup>3</sup>/total acre)

**Minimum total storage volume: 77,940 ft<sup>3</sup> (Dewatering Zone PLUS Sediment Storage volume)**

**Elevation-Storage Data:**

	Elevation	Plan Area	Δ Vol	Σ Vol
Bottom of Basin Elevation:	659.00	23499.0		
	660.00	26,183.0	24,841.0	24,841.0
	662.00	31,307.0	57,490.0	82,331.0
	664.00	38,175.0	69,482.0	151,813.0
Embankment Top Elevation:	666.00	44,953.0	83,128.0	234,941.0

**Actual Storage Volumes and Riser Height**

Elevation of Top of Sed. Storage (cleanout): 659.54 feet (provides Required Sediment storage volume)  
 Crest of Principal Spillway (Riser): 661.86 feet (minimum elev to provide Dewatering Zone: 661.86 ft)  
 Actual Storage volume provided at riser crest: 77,973 ft<sup>3</sup>

**Other Basin Characteristics**

Flow length through basin: 400 feet 2 to 1 (minimum flow length: 248.05 ft; see page 56)  
 Average width of basin: 50 feet 4 to 1 (minimum flow length: 351.84 ft; see page 56)  
 Length to width ratio: 8.0 to 1 (minimum 2 to 1)

Sediment Basin Name: **SEDIMENT BASIN 1A**

JULATIONS\EROSION & SEDIMENTATION CALCS\SEDIMENT BASINS AND TRAPS\SEDIMENT BASINS\{PPLS0902\_Sed Basin Design 1A.xls}Sed Basin Design

**Embankment Criteria**

Embankment top width must be at least 8 feet wide.

Embankment side slopes may not be steeper than 2H:1V

**Embankment Spillway Weir Dimensions**

Emergency Spillway outlet width, L: 10.0 feet (minimum bottom width is 8', see page 40)  
 Emergency Spillway outlet side slopes: 3 to 1  
 Emergency Spillway crest elevation: 663.00 feet (minimum crest elev: 662.36 ft; 6 in over riser crest)  
 (maximum crest elev: 665.50 ft; 6 in below top of berm)

**Required Discharge from Basin**

Minimum discharge capacity (2 cfs/ac) Q = 26.0 cfs (at maximum water surface elevation)

**Water Surface Elevation at Required Discharge**

Discharge through riser/barrel = 26.0 cfs

**Riser Flow:**

Length/Width of Principal Spillway (Riser): 4.0 feet by 2.0 feet

Crest of Principal Spillway (Riser): 661.86 feet

Orifice flow from Riser:  $Q = 0.9 A_{\text{riser}} (2gh)^{0.5}$ 

Solve for h = 0.20

Weir flow from Riser:  $Q = 3.1 P_{\text{riser}} h^{1.5}$ 

Solve for h = 0.79 feet. Elev: 662.65 feet

Weir controls over Orifice.

**Barrel Flow:**

Discharge pipe invert elevation at basin: 659.00 feet

Diameter of Barrel: 2.0 feet

(maximum diameter is riser diameter / 1.25, see pg 40)

Barrel length, L = 55 feet

Slope of the barrel : 1.8%

Discharge pipe invert elev at outlet end of pipe: 658.01 feet

Barrel Manning's n = 0.011

(use 0.025 for CMP, 0.015 for RCP, see page 45)

Pipe flow from Barrel: (where h = head over centerline of outlet end of pipe)

 $Q = A_{\text{barrel}} \{ (2gh) / [1 + 1 + (5087 * n^2 / d_i^{1.33}) * L] \}^{0.5}$ 

Solve for h = 2.65 feet. Elev: 661.66 feet

**Determine which part of structure controls (higher W.S. Elev):****Riser capacity controls over Barrel.**

Does Emergency Spillway contribute to outflow? No.

Required Q through the riser/barrel is 26.0 cfs

**Maximum Water Surface Elevation and Required Freeboard**

Maximum water surface elevation: 662.65 feet (at maximum discharge capacity)

Top of Embankment: 666.00 feet. Freeboard provided: 40 inches



Sediment Basin Name: **SEDIMENT BASIN 1A**

...ULATIONS\EROSION & SEDIMENTATION CALC\SSEDIMENT BASINS AND TRAPS\SSEDIMENT BASINS\...S0902\_Sed Basin Design 1A.xls\Sed Basin Design

**Skimmer Design** (as an alternate to the dewatering orifices on the riser.)

**Basic Input:**

Volume to top of Dewatering Zone , V:	64,983 cu ft	
Dewatering Time, t:	4.5 days	Dewatering time entered by user.
Floor of basin elevation:	659.00 feet	
Top of dewatering zone elevation:	661.86 feet	

**Calculations:**

Calculated skimmer orifice diameter: 2.75 in (from figure 7, page 44 of PA E&S manual)

Use 1/2" diameter orifices on the skimmer to provide 2.75 inches of orifice area.

Orifice area of a 1/2" diameter orifice: 0.20 sq in Area= 5.96 sq in

**Number of 1/2" dia. orifices required: 30**

*The arm of the skimmer must form an angle with the basin floor of 45 degrees or less when the water surface elevation is at the top of dewatering zone.*

Water depth:	2.86 feet
Minimum length of skimmer arm:	4.04 feet
<b>Use skimmer arm length of:</b>	<b>5 feet</b>

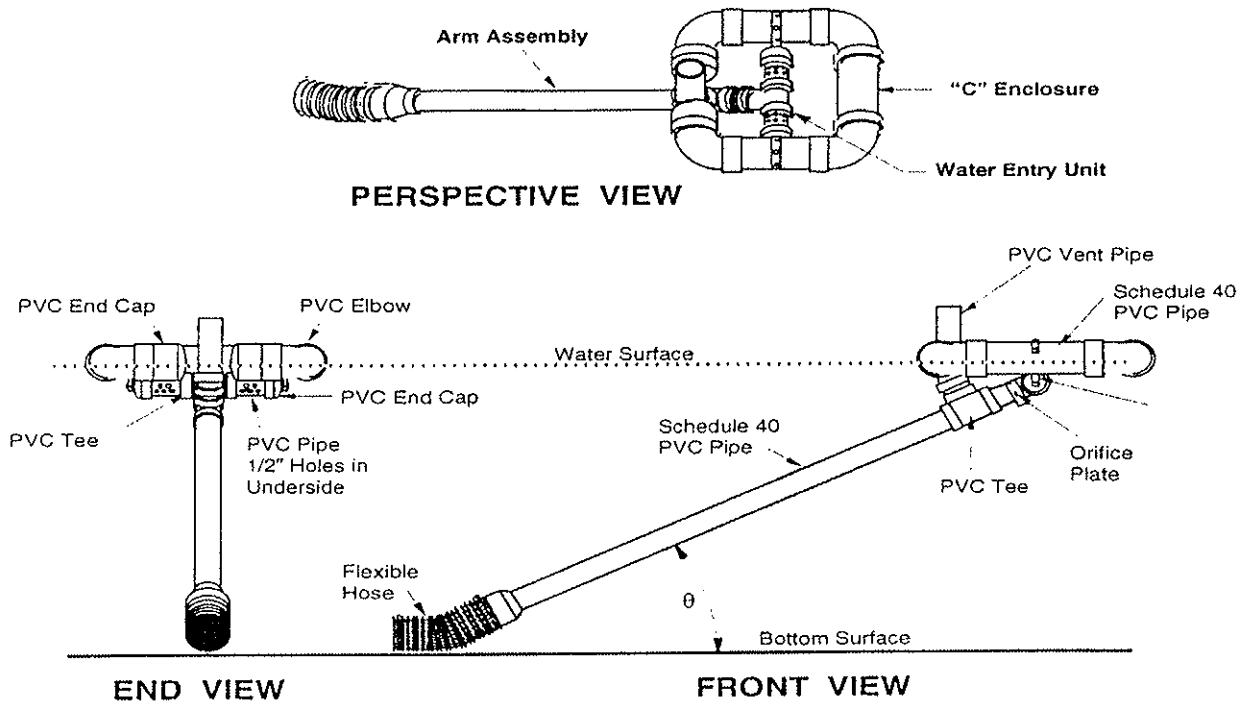

**STANDARD WORKSHEET #12**  
**Sediment Basin Capacity Requirements**

PROJECT NAME: Bell Bend Nuclear Power Plant

LOCATION: Salem Township, Luzerne County

PREPARED BY: J. Volonakis DATE: 8/23/2011

CHECKED BY: D. Molinaro DATE: 8/23/2011

BASIN NUMBER	SEDIMENT BASIN 1A
(A) MAXIMUM TOTAL DRAINAGE AREA (AC)	12.99
(I) INITIAL REQ'D SETTLING VOLUME (5,000 X A) (CF)	64,950
(T) REDUCTION FOR TOP DEWATERING (-700 X A) (CF)	X
(P) REDUCTION FOR PERMANENT POOL (-700 X A) (CF)	X
(L) RED. FOR 4:1 FLOW LENGTH:WIDTH (-350 X A) (CF)	X
(D) RED. FOR 4 TO 7 DAY DEWATERING (- 350 X A) (CF)	X
*** (Sv) REQUIRED SETTLING VOLUME [I - (T+P+L+D)] (CF)	64,950
(Sd) REQUIRED SEDIMENT STORAGE VOLUME (1000 X a) <sup>1</sup> (CF)	12,990
(St) TOTAL REQUIRED STORAGE VOLUME (Sv + Sd) (CF)	77,940
**** TOTAL STORAGE VOLUME PROVIDED (CF)	77,973
REQUIRED DISCHARGE CAPACITY (2 X A) (CFS)	26.0
PRINCIPAL SPILLWAY CAPACITY (@ ELEV # ) (CFS)	26.0
* EMERGENCY SPILLWAY CAPACITY (@ ELEV ↴ ) (CFS)	0.0
** EMERGENCY SPILLWAY PROTECTIVE LINING	Pyramat

**X Reductions not allowed in a High Quality/Exceptional Value watershed.**

\* Provide supporting computations.

\*\* If grass lining is proposed, spillway must be constructed in original ground.

\*\*\* 5000 cubic feet per acre settling volume is required for basins located in Special Protection (HQ & EV) watersheds. In other watersheds, the basin settling volume may be reduced per the Department's "Erosion and Sediment Pollution Control Program Manual," No. 363-2134-008 (January 1996), as amended and updated. The minimum settling volume for such basins is (3600 X A).

\*\*\*\* Total Storage Volume provided at riser crest.

<sup>1</sup> a = Disturbed Acres in Drainage Area      a = 12.99 acres

**STANDARD WORKSHEET #13**  
**Sediment Basin Dimensions and Elevations**

PROJECT NAME: Bell Bend Nuclear Power Plant  
 LOCATION: Salem Township, Luzerne County  
 PREPARED BY: J. Volonakis DATE: 8/23/2011  
 CHECKED BY: D. Molinaro DATE: 8/23/2011

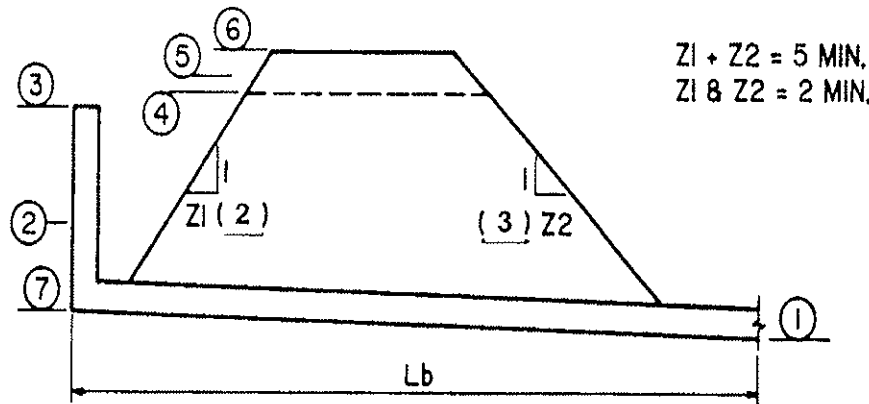

BASIN NUMBER	SEDIMENT BASIN 1A
1. DISCHARGE PIPE ELEVATION	658.01
2. TOP OF SEDIMENT STORAGE ZONE (@ Sd)	659.54
3. ELEVATION AT TOP OF DEWATERING ZONE (St) (CREST OF PRINCIPAL SPILLWAY)	661.86
4. EMERGENCY SPILLWAY CREST ELEVATION (MIN. 0.5' ABOVE ELEVATION ① )	663.00
5. 2 CFS/ACRE FLOW ELEVATION	662.65
6. TOP OF EMBANKMENT ELEVATION (MIN. 24" ABOVE ELEVATION ④ )	666.00
7. BOTTOM ELEVATION	659.00
AVERAGE BOTTOM WIDTH (FT)	50
AVERAGE BOTTOM LENGTH (FT)	400
EMBANKMENT TOP WIDTH (FT, 8' MIN.)	8
RISER DIAMETER/TYPE (15" MIN.)	Type M Inlet Box
BARREL DIAMETER/TYPE (12" MIN.)	24 in. RCP
Lb (BARREL LENGTH (FT)	55.0
EMERGENCY SPILLWAY WIDTH (FT)	10.0
EMERGENCY SPILLWAY SIDE SLOPES (H:V)	3.0

**SHOW ALL DETAILS AND CONSTRUCTION DIMENSIONS ON PLAN DRAWINGS  
 USING STANDARD CONSTRUCTION DETAIL SHEETS.**



Sediment Basin Design Calculations:



Client/Subject: PPL Bell Bend, LLC  
 Description: Sediment Basin Calculation  
 Prepared by: J. Volonakis  
 Date: 18 Aug 11

Print Date: 12 Sep 11 2:52 PM  
 Project #: PPLS0902

Checked by: D. Molinaro
----------------------------

**Objective:**

This spreadsheet will assist with the design of sediment basins as erosion and sediment control measures. The calculations below are based on the criteria mandated by the PA E&S Manual (March '00 version) on pages 40 to 63.

**Basic Input:**

**Sediment Basin Name: Sediment Basin POI 3**

Drainage Area to Basin: 16.7 acres (if < 5.0 acres, consider sediment trap also)  
 Disturbed Area Tributary to Basin: 16.7 acres

**Requirements:**

Required Sediment Storage volume: 16,700 ft<sup>3</sup> (1000 ft<sup>3</sup>/ disturbed acre)  
 Is the basin in a HQ or EV watershed? Yes. **Reductions not allowed in a HQ or EV watershed.**

Dewatering Zone Volume Determination (Standard Dewatering Zone = 5000 ft<sup>3</sup>/acre)

Does the basin dewater via a skimmer? Yes.  
 Does the basin have >18" permanent pool? No.  
 Is flow length to width greater than 4:1? Yes.  
 Does basin dewater between 4 and 7 days? Yes. (4.5 days)

Actual Dewatering Zone criteria: 5,000 ft<sup>3</sup>/acre after reductions (minimum of 3600 ft<sup>3</sup>/acre)

Required Dewatering Zone volume: 83,500 ft<sup>3</sup> (5000 ft<sup>3</sup>/ total acre)

**Minimum total storage volume: 100,200 ft<sup>3</sup> (Dewatering Zone PLUS Sediment Storage volume)**

**Elevation-Storage Data:**

	Elevation	Plan Area	Δ Vol	Σ Vol
Bottom of Basin Elevation:	651.00	54220.0		
	652.00	57,292.0	55,756.0	55,756.0
	654.00	63,510.0	120,802.0	176,558.0
	656.00	69,829.0	133,339.0	309,897.0
	658.00	76,249.0	146,078.0	455,975.0
Embankment Top Elevation:	660.00	82,769.0	159,018.0	614,993.0

**Actual Storage Volumes and Riser Height**

Elevation of Top of Sed. Storage (cleanout): 651.31 feet (provides Required Sediment storage volume)  
 Crest of Principal Spillway (Riser): 657.00 feet (minimum elev to provide Dewatering Zone: 652.77 ft)  
 Actual Storage volume provided at riser crest: 381,331 ft<sup>3</sup>

**Other Basin Characteristics**

Flow length through basin: 680 feet 2 to 1 (minimum flow length: 381.06 ft; see page 56)  
 Average width of basin: 79 feet 4 to 1 (minimum flow length: 540.51 ft; see page 56)  
 Length to width ratio: 8.6 to 1 (minimum 2 to 1)



## Sediment Basin Name: Sediment Basin POI 3

LCULATIONS\EROSION & SEDIMENTATION CALC\SEDIMENT BASINS AND TRAPS\SEDIMENT BASINS\{PPLS0902\_Sed Basin Design 3.xls}Sed Basin Design

### Embankment Criteria

Embankment top width must be at least 8 feet wide.

Embankment side slopes may not be steeper than 2H:1V

### Embankment Spillway Weir Dimensions

Emergency Spillway outlet width, L: 10.0 feet (minimum bottom width is 8', see page 40)  
 Emergency Spillway outlet side slopes: 3 to 1  
 Emergency Spillway crest elevation: 659.00 feet (minimum crest elev: 657.50 ft; 6 in over riser crest)  
 (maximum crest elev: 659.50 ft; 6 in below top of berm)

### Required Discharge from Basin

Minimum discharge capacity (2 cfs/ac) Q = 33.4 cfs (at maximum water surface elevation)

### Water Surface Elevation at Required Discharge

Discharge through riser/barrel = 33.4 cfs

#### Riser Flow:

Length/Width of Principal Spillway (Riser): 4.0 feet by 2.0 feet  
 Crest of Principal Spillway (Riser): 657.00 feet

Orifice flow from Riser:  $Q = 0.9 A_{\text{riser}} (2gh)^{0.5}$  Solve for h = 0.33  
 Weir flow from Riser:  $Q = 3.1 P_{\text{riser}} h^{1.5}$  Solve for h = 0.93 feet. Elev: 657.93 feet  
 Weir controls over Orifice.

#### Barrel Flow:

Discharge pipe invert elevation at basin: 650.00 feet  
 Diameter of Barrel: 3.0 feet (maximum diameter is riser diameter / 1.25, see pg 40)  
 Barrel length, L = 90 feet  
 Slope of the barrel : 1.7%  
 Discharge pipe invert elev at outlet end of pipe: 648.50 feet  
 Barrel Manning's n = 0.011 (use 0.025 for CMP, 0.015 for RCP, see page 45)

Pipe flow from Barrel: (where h = head over centerline of outlet end of pipe)  
 $Q = A_{\text{barrel}} \left\{ \frac{(2gh)}{[1 + 1 + (5087 * n^2 / d_i^{1.33}) * L]} \right\}^{0.5}$  Solve for h = 0.86 feet. Elev: 650.85 feet

Determine which part of structure controls (higher W.S. Elev): Riser capacity controls over Barrel.

Does Emergency Spillway contribute to outflow? No.

Required Q through the riser/barrel is 33.4 cfs

### Maximum Water Surface Elevation and Required Freeboard

Maximum water surface elevation: 657.93 feet (at maximum discharge capacity)  
 Top of Embankment: 660.00 feet. Freeboard provided: 25 inches



Sediment Basin Name: **Sediment Basin POI 3**

LCULATIONS\EROSION & SEDIMENTATION CALC\SISEDIMENT BASINS AND TRAPS\SISEDIMENT BASINS\PPLS0902\_Sed Basin Design 3.xls\Sed Basin Design

**Skimmer Design** (as an alternate to the dewatering orifices on the riser.)

**Basic Input:**

Volume to top of Dewatering Zone , V:	364,631 cu ft	
Dewatering Time, t:	4.5 days	Dewatering time entered by user.
Floor of basin elevation:	651.00 feet	
Top of dewatering zone elevation:	657.00 feet	

**Calculations:**

Calculated skimmer orifice diameter: 5.96 in (from figure 7, page 44 of PA E&S manual)

Use 1/2" diameter orifices on the skimmer to provide 5.96 inches of orifice area.

Orifice area of a 1/2" diameter orifice: 0.20 sq in Area= 27.89 sq in

**Number of 1/2" dia. orifices required: 140**

The arm of the skimmer must form an angle with the basin floor of 45 degrees or less when the water surface elevation is at the top of dewatering zone.

Water depth:	6.00 feet
Minimum length of skimmer arm:	8.49 feet
<b>Use skimmer arm length of:</b>	<b>9 feet</b>

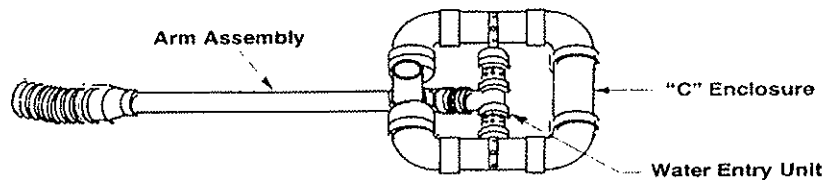

**PERSPECTIVE VIEW**

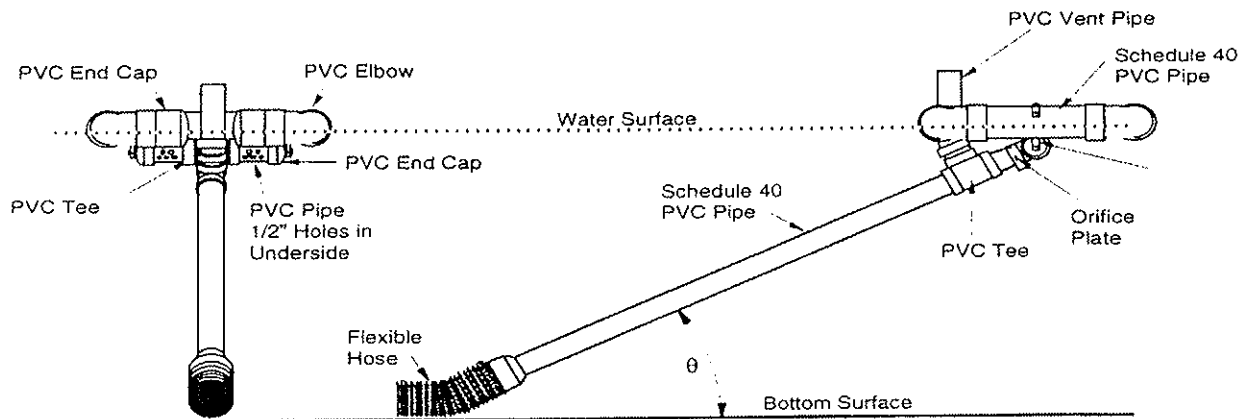

**END VIEW**

**FRONT VIEW**

**STANDARD WORKSHEET #12**  
**Sediment Basin Capacity Requirements**

PROJECT NAME: Bell Bend Nuclear Power Plant

LOCATION: Salem Township, Luzerne County

PREPARED BY: J. Volonakis DATE: 8/18/2011

CHECKED BY: D. Molinaro DATE: 8/18/2011

BASIN NUMBER	Sediment Basin POI 3
(A) MAXIMUM TOTAL DRAINAGE AREA (AC)	16.7
(I) INITIAL REQ'D SETTLING VOLUME (5,000 X A) (CF)	83,500
(T) REDUCTION FOR TOP DEWATERING (-700 X A) (CF)	X
(P) REDUCTION FOR PERMANENT POOL (-700 X A) (CF)	X
(L) RED. FOR 4:1 FLOW LENGTH:WIDTH (-350 X A) (CF)	X
(D) RED. FOR 4 TO 7 DAY DEWATERING (- 350 X A) (CF)	X
*** (Sv) REQUIRED SETTLING VOLUME [I - (T+P+L+D)] (CF)	83,500
(Sd) REQUIRED SEDIMENT STORAGE VOLUME (1000 X a) <sup>1</sup> (CF)	16,700
(St) TOTAL REQUIRED STORAGE VOLUME (Sv + Sd) (CF)	100,200
**** TOTAL STORAGE VOLUME PROVIDED (CF)	381,331
REQUIRED DISCHARGE CAPACITY (2 X A) (CFS)	33.4
PRINCIPAL SPILLWAY CAPACITY (@ ELEV # ) (CFS)	33.4
* EMERGENCY SPILLWAY CAPACITY (@ ELEV ↴ ) (CFS)	0.0
** EMERGENCY SPILLWAY PROTECTIVE LINING	Pyramat

**X Reductions not allowed in a High Quality/Exceptional Value watershed.**

\* Provide supporting computations.

\*\* If grass lining is proposed, spillway must be constructed in original ground.

\*\*\* 5000 cubic feet per acre settling volume is required for basins located in Special Protection (HQ & EV) watersheds. In other watersheds, the basin settling volume may be reduced per the Department's "Erosion and Sediment Pollution Control Program Manual," No. 363-2134-008 (January 1996), as amended and updated. The minimum settling volume for such basins is (3600 X A).

\*\*\*\* Total Storage Volume provided at riser crest.

<sup>1</sup> a = Disturbed Acres in Drainage Area      a = 16.7 acres

**STANDARD WORKSHEET #13**  
**Sediment Basin Dimensions and Elevations**

PROJECT NAME: Bell Bend Nuclear Power Plant

LOCATION: Salem Township, Luzerne County

PREPARED BY: J. Volonakis DATE: 8/18/2011

CHECKED BY: D. Molinaro DATE: 8/18/2011

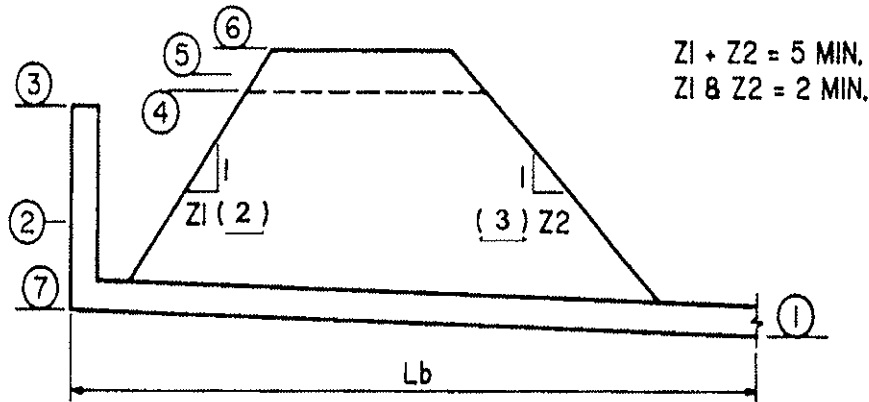

BASIN NUMBER	Sediment Basin POI 3
1. DISCHARGE PIPE ELEVATION	648.50
2. TOP OF SEDIMENT STORAGE ZONE (@ Sd)	651.31
3. ELEVATION AT TOP OF DEWATERING ZONE (St) (CREST OF PRINCIPAL SPILLWAY)	657.00
4. EMERGENCY SPILLWAY CREST ELEVATION (MIN. 0.5' ABOVE ELEVATION ① )	659.00
5. 2 CFS/ACRE FLOW ELEVATION	657.93
6. TOP OF EMBANKMENT ELEVATION (MIN. 24" ABOVE ELEVATION ④ )	660.00
7. BOTTOM ELEVATION	651.00
AVERAGE BOTTOM WIDTH (FT)	79
AVERAGE BOTTOM LENGTH (FT)	680
EMBANKMENT TOP WIDTH (FT, 8' MIN.)	8
RISER DIAMETER/TYPE (15" MIN.)	Type M Inlet Box
BARREL DIAMETER/TYPE (12" MIN.)	36 in. RCP
Lb (BARREL LENGTH (FT)	90.0
EMERGENCY SPILLWAY WIDTH (FT)	10.0
EMERGENCY SPILLWAY SIDE SLOPES (H:V)	3.0

**SHOW ALL DETAILS AND CONSTRUCTION DIMENSIONS ON PLAN DRAWINGS  
 USING STANDARD CONSTRUCTION DETAIL SHEETS.**



Sediment Basin Design Calculations:



Client/Subject: PPL Bell Bend, LLC  
 Description: Sediment Basin Calculation  
 Prepared by: J. Volonakis  
 Date: 18 Aug 11

Print Date: 12 Sep 11 10:33 AM  
 Project #: PPLS0902

Checked by: D. Molinaro
----------------------------

**Objective:**

This spreadsheet will assist with the design of sediment basins as erosion and sediment control measures. The calculations below are based on the criteria mandated by the PA E&S Manual (March '00 version) on pages 40 to 63.

**Basic Input:**

**Sediment Basin Name: SEDIMENT BASIN POI 6**

Drainage Area to Basin: 39.9 acres (if < 5.0 acres, consider sediment trap also)  
 Disturbed Area Tributary to Basin: 39.9 acres

**Requirements:**

Required Sediment Storage volume: 39,920 ft<sup>3</sup> (1000 ft<sup>3</sup>/disturbed acre)  
 Is the basin in a HQ or EV watershed? Yes. **Reductions not allowed in a HQ or EV watershed.**

Dewatering Zone Volume Determination (Standard Dewatering Zone = 5000 ft<sup>3</sup>/acre)

Does the basin dewater via a skimmer? Yes.  
 Does the basin have >18" permanent pool? No.  
 Is flow length to width greater than 4:1? No.  
 Does basin dewater between 4 and 7 days? Yes. (4.5 days)

Actual Dewatering Zone criteria: 5,000 ft<sup>3</sup>/acre after reductions (minimum of 3600 ft<sup>3</sup>/acre)

Required Dewatering Zone volume: 199,600 ft<sup>3</sup> (5000 ft<sup>3</sup>/total acre)

**Minimum total storage volume: 239,520 ft<sup>3</sup> (Dewatering Zone PLUS Sediment Storage volume)**

**Elevation-Storage Data:**

	Elevation	Plan Area	Δ Vol	Σ Vol
Bottom of Basin Elevation:	632.00	128144.0		
	634.00	136,016.0	264,160.0	264,160.0
	636.00	144,016.0	280,032.0	544,192.0
	638.00	152,144.0	296,160.0	840,352.0
	640.00	160,400.0	312,544.0	1,152,896.0
Embankment Top Elevation:	641.00	164,576.0	162,488.0	1,315,384.0

**Actual Storage Volumes and Riser Height**

Elevation of Top of Sed. Storage (cleanout): 632.31 feet (provides Required Sediment storage volume)  
 Crest of Principal Spillway (Riser): 637.00 feet (minimum elev to provide Dewatering Zone: 633.82 ft)  
 Actual Storage volume provided at riser crest: 690,240 ft<sup>3</sup>

**Other Basin Characteristics**

Flow length through basin is increased using baffles.

Flow length through basin: 588 feet 2 to 1 (minimum flow length: 542.58 ft; see page 56)  
 Average width of basin: 163 feet 4 to 1 (minimum flow length: 769.62 ft; see page 56)  
 Length to width ratio: 3.6 to 1 (minimum 2 to 1)

Sediment Basin Name: **SEDIMENT BASIN POI 6**

LCULATIONS\EROSION & SEDIMENTATION CALC\SEDIMENT BASINS AND TRAPS\SEDIMENT BASINS\{PPLS0902\_Sed Basin Design 6.xls\}Sed Basin Design

**Embankment Criteria**

Embankment top width must be at least 8 feet wide.  
Embankment side slopes may not be steeper than 2H:1V

**Embankment Spillway Weir Dimensions**

Emergency Spillway outlet width, L: 10.0 feet (minimum bottom width is 8', see page 40)  
Emergency Spillway outlet side slopes: 3 to 1  
Emergency Spillway crest elevation: 640.00 feet (minimum crest elev: 637.50 ft; 6 in over riser crest)  
(maximum crest elev: 640.50 ft; 6 in below top of berm)

**Required Discharge from Basin**

Minimum discharge capacity (2 cfs/ac) Q = 79.8 cfs (at maximum water surface elevation)

**Water Surface Elevation at Required Discharge**

Discharge through riser/barrel = 79.8 cfs

**Riser Flow:**

Length/Width of Principal Spillway (Riser): 4.0 feet by 2.0 feet  
Crest of Principal Spillway (Riser): 637.00 feet

Orifice flow from Riser:  $Q = 0.9 A_{\text{riser}} (2gh)^{0.5}$  Solve for h = 1.91 feet. Elev: 638.91 feet

Weir flow from Riser:  $Q = 3.1 P_{\text{riser}} h^{1.5}$  Solve for h = 1.66

Orifice controls over Weir.

**Barrel Flow:**

Discharge pipe invert elevation at basin: 632.00 feet  
Diameter of Barrel: 3.0 feet (maximum diameter is riser diameter / 1.25, see pg 40)  
Barrel length, L = 144 feet  
Slope of the barrel: 2.1%

Discharge pipe invert elev at outlet end of pipe: 629.00 feet  
Barrel Manning's n = 0.011 (use 0.025 for CMP, 0.015 for RCP, see page 45)

Pipe flow from Barrel: (where h = head over centerline of outlet end of pipe)

$Q = A_{\text{barrel}} \left\{ \frac{(2gh)}{[1 + 1 + (5087 * n^2 / d_i^{1.33}) * L]} \right\}^{0.5}$  Solve for h = 5.46 feet. Elev: 635.96 feet

Determine which part of structure controls (higher W.S. Elev):

**Riser capacity controls over Barrel.**

Does Emergency Spillway contribute to outflow? No.

Required Q through the riser/barrel is 79.8 cfs

**Maximum Water Surface Elevation and Required Freeboard**

Maximum water surface elevation: 638.91 feet (at maximum discharge capacity)  
Top of Embankment: 641.00 feet. Freeboard provided: 25 inches



Sediment Basin Name: **SEDIMENT BASIN POI 6**

LCULATIONS\VEROSION & SEDIMENTATION CALCS\SEDIMENT BASINS AND TRAPS\SEDIMENT BASINS\{PPLS0902\_Sed Basin Design 6.xls}Sed Basin Design

**Skimmer Design** (as an alternate to the dewatering orifices on the riser.)

**Basic Input:**

Volume to top of Dewatering Zone , V:	650,320 cu ft	
Dewatering Time, t:	4.5 days	Dewatering time entered by user.
Floor of basin elevation:	632.00 feet	
Top of dewatering zone elevation:	637.00 feet	

**Calculations:**

Calculated skimmer orifice diameter: 7.72 in (from figure 7, page 44 of PA E&S manual)

Use 1/2" diameter orifices on the skimmer to provide 7.72 inches of orifice area.

Orifice area of a 1/2" diameter orifice: 0.20 sq in Area= 46.81 sq in

**Number of 1/2" dia. orifices required: 234**

The arm of the skimmer must form an angle with the basin floor of 45 degrees or less when the water surface elevation is at the top of dewatering zone.

Water depth:	5.00 feet
Minimum length of skimmer arm:	7.07 feet
<b>Use skimmer arm length of:</b>	<b>8 feet</b>

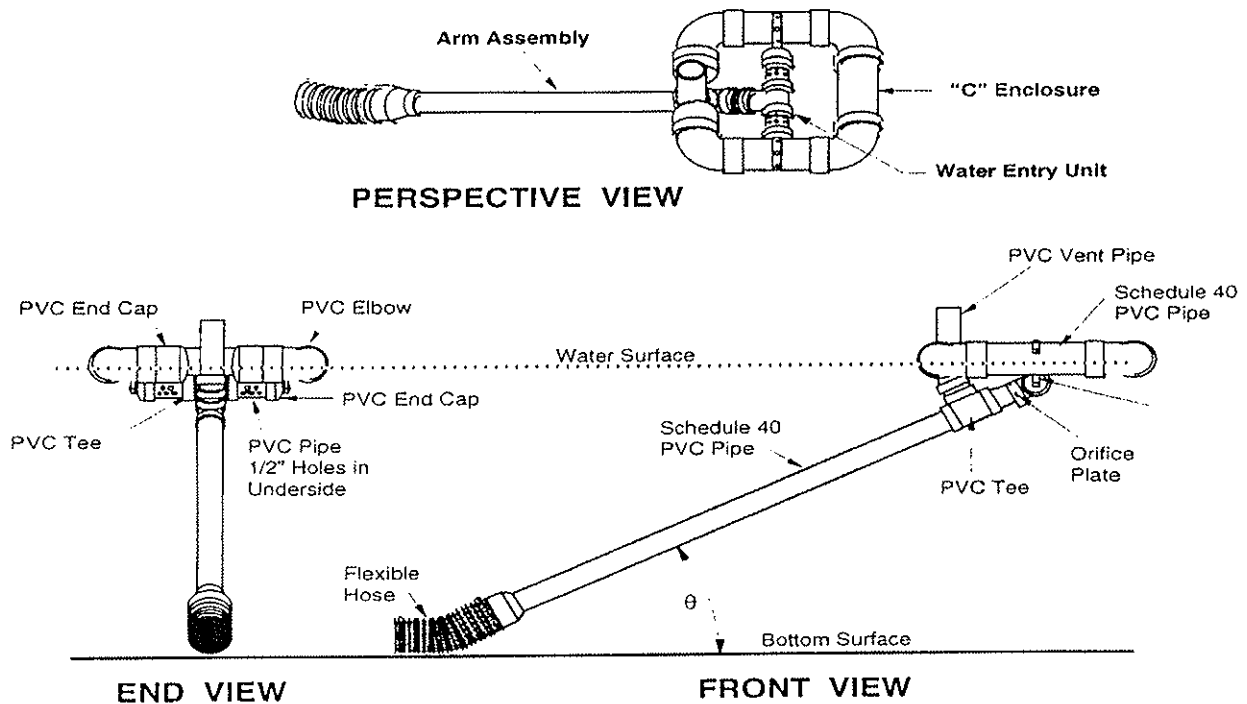

**STANDARD WORKSHEET #12**  
**Sediment Basin Capacity Requirements**

PROJECT NAME: Bell Bend Nuclear Power Plant

LOCATION: Salem Township, Luzerne County

PREPARED BY: J. Volonakis DATE: 8/18/2011

CHECKED BY: D. Molinaro DATE: 8/18/2011

BASIN NUMBER	SEDIMENT BASIN POI 6
(A) MAXIMUM TOTAL DRAINAGE AREA (AC)	39.92
(I) INITIAL REQ'D SETTLING VOLUME (5,000 X A) (CF)	199,600
(T) REDUCTION FOR TOP DEWATERING (-700 X A) (CF)	X
(P) REDUCTION FOR PERMANENT POOL (-700 X A) (CF)	X
(L) RED. FOR 4:1 FLOW LENGTH:WIDTH (-350 X A) (CF)	X
(D) RED. FOR 4 TO 7 DAY DEWATERING (- 350 X A) (CF)	X
*** (Sv) REQUIRED SETTLING VOLUME [I - (T+P+L+D)] (CF)	199,600
(Sd) REQUIRED SEDIMENT STORAGE VOLUME (1000 X a) <sup>1</sup> (CF)	39,920
(St) TOTAL REQUIRED STORAGE VOLUME (Sv + Sd) (CF)	239,520
**** TOTAL STORAGE VOLUME PROVIDED (CF)	690,240
REQUIRED DISCHARGE CAPACITY (2 X A) (CFS)	79.8
PRINCIPAL SPILLWAY CAPACITY (@ ELEV # ) (CFS)	79.8
* EMERGENCY SPILLWAY CAPACITY (@ ELEV ↴ ) (CFS)	0.0
** EMERGENCY SPILLWAY PROTECTIVE LINING	Pyramat

**X Reductions not allowed in a High Quality/Exceptional Value watershed.**

\* Provide supporting computations.

\*\* If grass lining is proposed, spillway must be constructed in original ground.

\*\*\* 5000 cubic feet per acre settling volume is required for basins located in Special Protection (HQ & EV) watersheds. In other watersheds, the basin settling volume may be reduced per the Department's "Erosion and Sediment Pollution Control Program Manual," No. 363-2134-008 (January 1996), as amended and updated. The minimum settling volume for such basins is (3600 X A).

\*\*\*\* Total Storage Volume provided at riser crest.

<sup>1</sup> a = Disturbed Acres in Drainage Area      a = 39.92 acres

**STANDARD WORKSHEET #13**  
**Sediment Basin Dimensions and Elevations**

PROJECT NAME: Bell Bend Nuclear Power Plant

LOCATION: Salem Township, Luzerne County

PREPARED BY: J. Volonakis DATE: 8/18/2011

CHECKED BY: D. Molinaro DATE: 8/18/2011

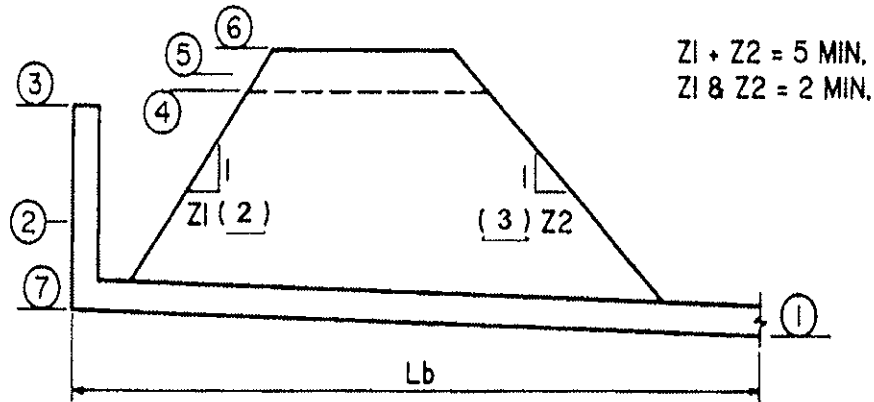

BASIN NUMBER	SEDIMENT BASIN POI 6
1. DISCHARGE PIPE ELEVATION	629.00
2. TOP OF SEDIMENT STORAGE ZONE (@ Sd)	632.31
3. ELEVATION AT TOP OF DEWATERING ZONE (St) (CREST OF PRINCIPAL SPILLWAY)	637.00
4. EMERGENCY SPILLWAY CREST ELEVATION (MIN. 0.5' ABOVE ELEVATION ① )	640.00
5. 2 CFS/ACRE FLOW ELEVATION	638.91
6. TOP OF EMBANKMENT ELEVATION (MIN. 24" ABOVE ELEVATION ⑤ )	641.00
7. BOTTOM ELEVATION	632.00
AVERAGE BOTTOM WIDTH (FT)	163
AVERAGE BOTTOM LENGTH (FT)	588
EMBANKMENT TOP WIDTH (FT, 8' MIN.)	8
RISER DIAMETER/TYPE (15" MIN.)	Type M Inlet Box
BARREL DIAMETER/TYPE (12" MIN.)	36 in. RCP
Lb (BARREL LENGTH (FT)	144.0
EMERGENCY SPILLWAY WIDTH (FT)	10.0
EMERGENCY SPILLWAY SIDE SLOPES (H:V)	3.0

**SHOW ALL DETAILS AND CONSTRUCTION DIMENSIONS ON PLAN DRAWINGS  
 USING STANDARD CONSTRUCTION DETAIL SHEETS.**



Sediment Basin Design Calculations:



Client/Subject: PPL Bell Bend, LLC  
 Description: Sediment Basin Calculation  
 Prepared by: J. Volonakis  
 Date: 12 Aug 11

Print Date: 12 Sep 11 10:34 AM  
 Project #: PPLS0902

Checked by: D. Molinaro
----------------------------

**Objective:**

This spreadsheet will assist with the design of sediment basins as erosion and sediment control measures. The calculations below are based on the criteria mandated by the PA E&S Manual (March '00 version) on pages 40 to 63.

**Basic Input:**

**Sediment Basin Name: SEDIMENT BASIN 8**

Drainage Area to Basin: 16.2 acres (if < 5.0 acres, consider sediment trap also)  
 Disturbed Area Tributary to Basin: 16.2 acres

**Requirements:**

Required Sediment Storage volume: 16,240 ft<sup>3</sup> (1000 ft<sup>3</sup>/ disturbed acre)  
 Is the basin in a HQ or EV watershed? Yes. **Reductions not allowed in a HQ or EV watershed.**

Dewatering Zone Volume Determination (Standard Dewatering Zone = 5000 ft<sup>3</sup>/acre)

Does the basin dewater via a skimmer? Yes.  
 Does the basin have >18" permanent pool? No.  
 Is flow length to width greater than 4:1? Yes.  
 Does basin dewater between 4 and 7 days? Yes. (4.5 days)

Actual Dewatering Zone criteria: 5,000 ft<sup>3</sup>/acre after reductions (minimum of 3600 ft<sup>3</sup>/acre)

Required Dewatering Zone volume: 81,200 ft<sup>3</sup> (5000 ft<sup>3</sup>/ total acre)

**Minimum total storage volume: 97,440 ft<sup>3</sup> (Dewatering Zone PLUS Sediment Storage volume)**

**Elevation-Storage Data:**

	Elevation	Plan Area	Δ Vol	Σ Vol
Bottom of Basin Elevation:	664.00	40875.0		
	666.00	45,899.0	86,774.0	86,774.0
	668.00	51,051.0	96,950.0	183,724.0
Embankment Top Elevation:	670.00	56,331.0	107,382.0	291,106.0

**Actual Storage Volumes and Riser Height**

Elevation of Top of Sed. Storage (cleanout): 664.39 feet (provides Required Sediment storage volume)  
 Crest of Principal Spillway (Riser): 667.00 feet (minimum elev to provide Dewatering Zone: 666.24 ft)  
 Actual Storage volume provided at riser crest: 133,961 ft<sup>3</sup>

**Other Basin Characteristics**

Flow length through basin: 545 feet 2 to 1 (minimum flow length: 310.44 ft; see page 56)  
 Average width of basin: 75 feet 4 to 1 (minimum flow length: 440.34 ft; see page 56)  
 Length to width ratio: 7.3 to 1 (minimum 2 to 1)

Sediment Basin Name: **SEDIMENT BASIN 8**

LCULATIONS\EROSION & SEDIMENTATION CALC\SEDIMENT BASINS AND TRAPS\SEDIMENT BASINS\{PPLS0902\_Sed Basin Design 8.xls\}Sed Basin Design

**Embankment Criteria**

Embankment top width must be at least 8 feet wide.

Embankment side slopes may not be steeper than 2H:1V

**Embankment Spillway Weir Dimensions**

Emergency Spillway outlet width, L: 10.0 feet (minimum bottom width is 8', see page 40)  
 Emergency Spillway outlet side slopes: 3 to 1  
 Emergency Spillway crest elevation: 668.00 feet (minimum crest elev: 667.50 ft; 6 in over riser crest)  
 (maximum crest elev: 669.50 ft; 6 in below top of berm)

**Required Discharge from Basin**

Minimum discharge capacity (2 cfs/ac) Q = 32.5 cfs (at maximum water surface elevation)

**Water Surface Elevation at Required Discharge**

Discharge through riser/barrel = 32.5 cfs

**Riser Flow:**

Length/Width of Principal Spillway (Riser): 4.0 feet by 2.0 feet

Crest of Principal Spillway (Riser): 667.00 feet

Orifice flow from Riser:  $Q = 0.9 A_{\text{riser}} (2gh)^{0.5}$ 

Solve for h = 0.32

Weir flow from Riser:  $Q = 3.1 P_{\text{riser}} h^{1.5}$ 

Solve for h = 0.91 feet. Elev: 667.91 feet

Weir controls over Orifice.

**Barrel Flow:**

Discharge pipe invert elevation at basin: 664.00 feet

Diameter of Barrel: 2.5 feet

(maximum diameter is riser diameter / 1.25, see pg 40)

Barrel length, L = 98.5 feet

Slope of the barrel : 1.0%

Discharge pipe invert elev at outlet end of pipe: 663.02 feet

Barrel Manning's n = 0.011

(use 0.025 for CMP, 0.015 for RCP, see page 45)

Pipe flow from Barrel: (where h = head over centerline of outlet end of pipe)

 $Q = A_{\text{barrel}} \{ (2gh) / [1 + 1 + (5087 * n^2 / d_i^{1.33}) * L] \}^{0.5}$ 

Solve for h = 1.81 feet. Elev: 666.07 feet

**Determine which part of structure controls (higher W.S. Elev):****Riser capacity controls over Barrel.**

Does Emergency Spillway contribute to outflow? No.

Required Q through the riser/barrel is 32.5 cfs

**Maximum Water Surface Elevation and Required Freeboard**

Maximum water surface elevation: 667.91 feet (at maximum discharge capacity)

Top of Embankment: 670.00 feet. Freeboard provided: 25 inches



Sediment Basin Name: **SEDIMENT BASIN 8**

LCULATIONS\EROSION & SEDIMENTATION CALCS\SEDIMENT BASINS AND TRAPS\SEDIMENT BASINS\{PPLS0902\_Sed Basin Design 8.xls}Sed Basin Design

**Skimmer Design** (as an alternate to the dewatering orifices on the riser.)

**Basic Input:**

Volume to top of Dewatering Zone , V:	117,721 cu ft	
Dewatering Time, t:	4.5 days	Dewatering time entered by user.
Floor of basin elevation:	664.00 feet	
Top of dewatering zone elevation:	667.00 feet	

**Calculations:**

Calculated skimmer orifice diameter: 3.59 in (from figure 7, page 44 of PA E&S manual)

Use 1/2" diameter orifices on the skimmer to provide 3.59 inches of orifice area.

Orifice area of a 1/2" diameter orifice: 0.20 sq in Area= 10.14 sq in

**Number of 1/2" dia. orifices required: 51**

*The arm of the skimmer must form an angle with the basin floor of 45 degrees or less when the water surface elevation is at the top of dewatering zone.*

Water depth:	3.00 feet
Minimum length of skimmer arm:	4.24 feet
<b>Use skimmer arm length of:</b>	<b>5 feet</b>

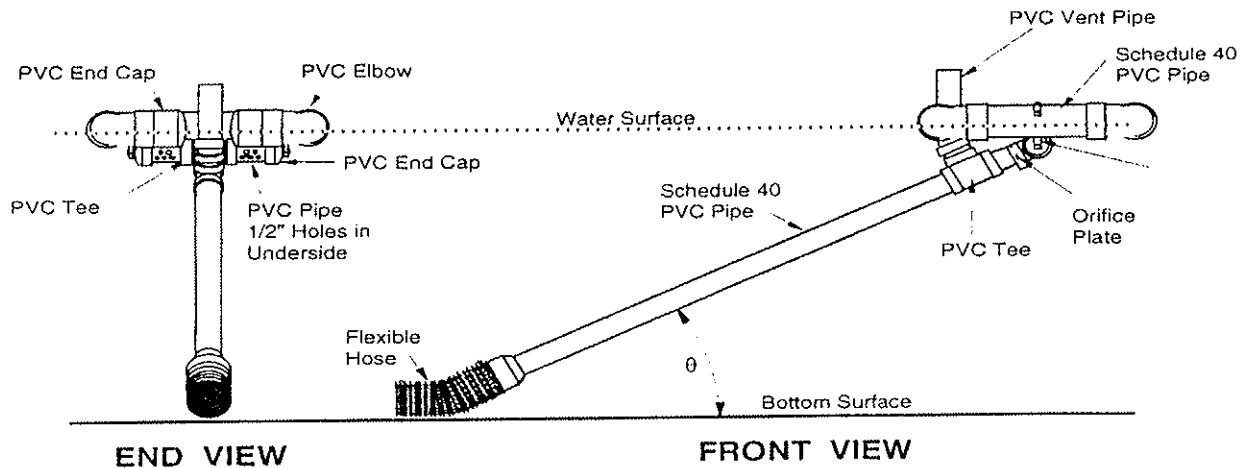
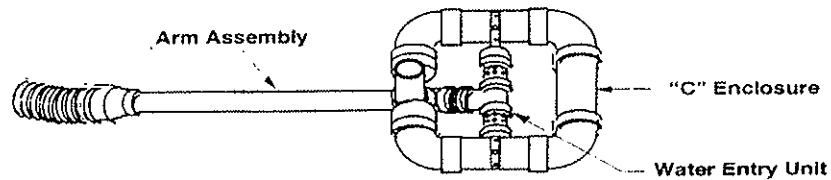

**STANDARD WORKSHEET #12**  
**Sediment Basin Capacity Requirements**

PROJECT NAME: Bell Bend Nuclear Power Plant

LOCATION: Salem Township, Luzerne County

PREPARED BY: J. Volonakis DATE: 8/15/2011

CHECKED BY: D. Molinaro DATE: 8/15/2011

BASIN NUMBER	SEDIMENT BASIN 8
(A) MAXIMUM TOTAL DRAINAGE AREA (AC)	16.24
(I) INITIAL REQ'D SETTLING VOLUME (5,000 X A) (CF)	81,200
(T) REDUCTION FOR TOP DEWATERING (-700 X A) (CF)	X
(P) REDUCTION FOR PERMANENT POOL (-700 X A) (CF)	X
(L) RED. FOR 4:1 FLOW LENGTH:WIDTH (-350 X A) (CF)	X
(D) RED. FOR 4 TO 7 DAY DEWATERING (- 350 X A) (CF)	X
*** (Sv) REQUIRED SETTLING VOLUME [I - (T+P+L+D)] (CF)	81,200
(Sd) REQUIRED SEDIMENT STORAGE VOLUME (1000 X a) <sup>1</sup> (CF)	16,240
(St) TOTAL REQUIRED STORAGE VOLUME (Sv + Sd) (CF)	97,440
**** TOTAL STORAGE VOLUME PROVIDED (CF)	133,961
REQUIRED DISCHARGE CAPACITY (2 X A) (CFS)	32.5
PRINCIPAL SPILLWAY CAPACITY (@ ELEV # ) (CFS)	32.5
* EMERGENCY SPILLWAY CAPACITY (@ ELEV ↴ ) (CFS)	0.0
** EMERGENCY SPILLWAY PROTECTIVE LINING	Pyramat

**X Reductions not allowed in a High Quality/Exceptional Value watershed.**

\* Provide supporting computations.

\*\* If grass lining is proposed, spillway must be constructed in original ground.

\*\*\* 5000 cubic feet per acre settling volume is required for basins located in Special Protection (HQ & EV) watersheds. In other watersheds, the basin settling volume may be reduced per the Department's "Erosion and Sediment Pollution Control Program Manual," No. 363-2134-008 (January 1996), as amended and updated. The minimum settling volume for such basins is (3600 X A).

\*\*\*\* Total Storage Volume provided at riser crest.

<sup>1</sup> a = Disturbed Acres in Drainage Area      a = 16.24 acres

**STANDARD WORKSHEET #13**  
**Sediment Basin Dimensions and Elevations**

PROJECT NAME: Bell Bend Nuclear Power Plant

LOCATION: Salem Township, Luzerne County

PREPARED BY: J. Volonakis DATE: 8/15/2011

CHECKED BY: D. Molinaro DATE: 8/15/2011

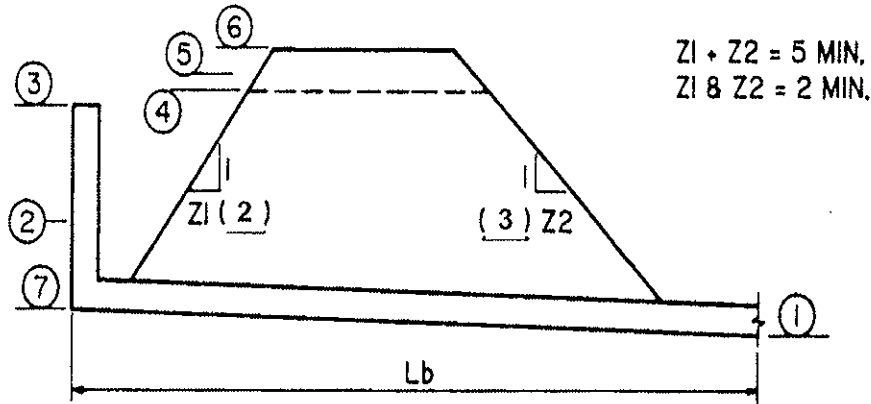

BASIN NUMBER	SEDIMENT BASIN 8
1. DISCHARGE PIPE ELEVATION	663.02
2. TOP OF SEDIMENT STORAGE ZONE (@ Sd)	664.39
3. ELEVATION AT TOP OF DEWATERING ZONE (St) (CREST OF PRINCIPAL SPILLWAY)	667.00
4. EMERGENCY SPILLWAY CREST ELEVATION (MIN. 0.5' ABOVE ELEVATION ①)	668.00
5. 2 CFS/ACRE FLOW ELEVATION	667.91
6. TOP OF EMBANKMENT ELEVATION (MIN. 24" ABOVE ELEVATION ④)	670.00
7. BOTTOM ELEVATION	664.00
AVERAGE BOTTOM WIDTH (FT)	75
AVERAGE BOTTOM LENGTH (FT)	545
EMBANKMENT TOP WIDTH (FT, 8' MIN.)	8
RISER DIAMETER/TYPE (15" MIN.)	Type M Inlet Box
BARREL DIAMETER/TYPE (12" MIN.)	30 in. RCP
Lb (BARREL LENGTH (FT)	98.5
EMERGENCY SPILLWAY WIDTH (FT)	10.0
EMERGENCY SPILLWAY SIDE SLOPES (H:V)	3.0

**SHOW ALL DETAILS AND CONSTRUCTION DIMENSIONS ON PLAN DRAWINGS  
 USING STANDARD CONSTRUCTION DETAIL SHEETS.**



Sediment Basin Design Calculations:



Client/Subject: PPL Bell Bend, LLC  
 Description: Sediment Basin Calculation  
 Prepared by: J. Volonakis  
 Date: 15 Aug 11

Print Date: 12 Sep 11 10:34 AM  
 Project #: PPLS0902

Checked by: D. Molinaro
----------------------------

**Objective:**

This spreadsheet will assist with the design of sediment basins as erosion and sediment control measures. The calculations below are based on the criteria mandated by the PA E&S Manual (March '00 version) on pages 40 to 63.

**Basic Input:**

Sediment Basin Name: **SEDIMENT BASIN POI 9**

Drainage Area to Basin: 5.5 acres (if < 5.0 acres, consider sediment trap also)  
 Disturbed Area Tributary to Basin: 5.5 acres

**Requirements:**

Required Sediment Storage volume: 5,523 ft<sup>3</sup> (1000 ft<sup>3</sup>/ disturbed acre)  
 Is the basin in a HQ or EV watershed? Yes. **Reductions not allowed in a HQ or EV watershed.**

Dewatering Zone Volume Determination (Standard Dewatering Zone = 5000 ft<sup>3</sup>/acre)

Does the basin dewater via a skimmer? Yes.  
 Does the basin have >18" permanent pool? No.  
 Is flow length to width greater than 4:1? Yes.  
 Does basin dewater between 4 and 7 days? Yes. (4.5 days)

Actual Dewatering Zone criteria: 5,000 ft<sup>3</sup>/acre after reductions (minimum of 3600 ft<sup>3</sup>/acre)

Required Dewatering Zone volume: 27,617 ft<sup>3</sup> (5000 ft<sup>3</sup>/ total acre)

**Minimum total storage volume: 33,141 ft<sup>3</sup> (Dewatering Zone PLUS Sediment Storage volume)**

**Elevation-Storage Data:**

	Elevation	Plan Area	Δ Vol	Σ Vol
Bottom of Basin Elevation:	678.00	13,750.0		
	680.00	18,414.0	32,164.0	32,164.0
	682.00	23,206.0	41,620.0	73,784.0
Embankment Top Elevation:	684.00	28,126.0	51,332.0	125,116.0

**Actual Storage Volumes and Riser Height**

Elevation of Top of Sed. Storage (cleanout): 678.39 feet (provides Required Sediment storage volume)  
 Crest of Principal Spillway (Riser): 680.50 feet (minimum elev to provide Dewatering Zone: 680.06 ft)  
 Actual Storage volume provided at riser crest: 41,671 ft<sup>3</sup>

**Other Basin Characteristics**

Flow length through basin: 280 feet 2 to 1 (minimum flow length: 197.46 ft; see page 56)  
 Average width of basin: 25 feet 4 to 1 (minimum flow length: 280.09 ft; see page 56)  
 Length to width ratio: 11.2 to 1 (minimum 2 to 1)

Sediment Basin Name: **SEDIMENT BASIN POI 9**

LCULATIONS\EROSION & SEDIMENTATION CALC\SSEDIMENT BASINS AND TRAPS\SEDIMENT BASINS\PP\PLS0902\_Sed Basin Design 9.xls\Sed Basin Design

**Embankment Criteria**

Embankment top width must be at least 8 feet wide.

Embankment side slopes may not be steeper than 2H:1V

**Embankment Spillway Weir Dimensions**

Emergency Spillway outlet width, L:	10.0	feet	(minimum bottom width is 8', see page 40)
Emergency Spillway outlet side slopes:	3 to 1		
Emergency Spillway crest elevation:	682.00	feet	(minimum crest elev: 681.00 ft; 6 in over riser crest) (maximum crest elev: 683.50 ft; 6 in below top of berm)

**Required Discharge from Basin**

Minimum discharge capacity (2 cfs/ac) Q = 11.0 cfs (at maximum water surface elevation)

**Water Surface Elevation at Required Discharge**

Discharge through riser/barrel = 11.0 cfs

**Riser Flow:**

Length/Width of Principal Spillway (Riser): 4.0 feet by 2.0 feet

Crest of Principal Spillway (Riser): 680.50 feet

Orifice flow from Riser:  $Q = 0.9 A_{\text{riser}} (2gh)^{0.5}$  Solve for h = 0.04Weir flow from Riser:  $Q = 3.1 P_{\text{riser}} h^{1.5}$  Solve for h = 0.45 feet. Elev: 680.95 feet  
Weir controls over Orifice.**Barrel Flow:**

Discharge pipe invert elevation at basin: 676.00 feet

Diameter of Barrel: 1.5 feet (maximum diameter is riser diameter / 1.25, see pg 40)

Barrel length, L = 75 feet

Slope of the barrel : 3.0%

Discharge pipe invert elev at outlet end of pipe: 673.75 feet

Barrel Manning's n = 0.011 (use 0.025 for CMP, 0.015 for RCP, see page 45)

Pipe flow from Barrel: (where h = head over centerline of outlet end of pipe)

 $Q = A_{\text{barrel}} \left\{ \frac{(2gh)}{[1 + 1 + (5087 * n^2 / d_p^{1.33}) * L]} \right\}^{0.5}$  Solve for h = 1.81 feet. Elev: 676.31 feet**Determine which part of structure controls (higher W.S. Elev):****Riser capacity controls over Barrel.**

Does Emergency Spillway contribute to outflow? No.

Required Q through the riser/barrel is 11.0 cfs

**Maximum Water Surface Elevation and Required Freeboard**

Maximum water surface elevation: 680.95 feet (at maximum discharge capacity)

Top of Embankment: 684.00 feet. Freeboard provided: 37 inches



Sediment Basin Name: **SEDIMENT BASIN POI 9**

LCULATIONS\EROSION & SEDIMENTATION CALC\SEDIMENT BASINS AND TRAPS\SEDIMENT BASINS\{PPLS0902\_Sed Basin Design 9.xls\}Sed Basin Design

**Skimmer Design** (as an alternate to the dewatering orifices on the riser.)

**Basic Input:**

Volume to top of Dewatering Zone , V:	36,147 cu ft	
Dewatering Time, t:	4.5 days	Dewatering time entered by user.
Floor of basin elevation:	678.00 feet	
Top of dewatering zone elevation:	680.50 feet	

**Calculations:**

Calculated skimmer orifice diameter: 2.12 in (from figure 7, page 44 of PA E&S manual)

Use 1/2" diameter orifices on the skimmer to provide 2.12 inches of orifice area.

Orifice area of a 1/2" diameter orifice: 0.20 sq in Area= 3.53 sq in

**Number of 1/2" dia. orifices required: 18**

*The arm of the skimmer must form an angle with the basin floor of 45 degrees or less when the water surface elevation is at the top of dewatering zone.*

Water depth:	2.50 feet
Minimum length of skimmer arm:	3.54 feet
<b>Use skimmer arm length of:</b>	<b>4 feet</b>

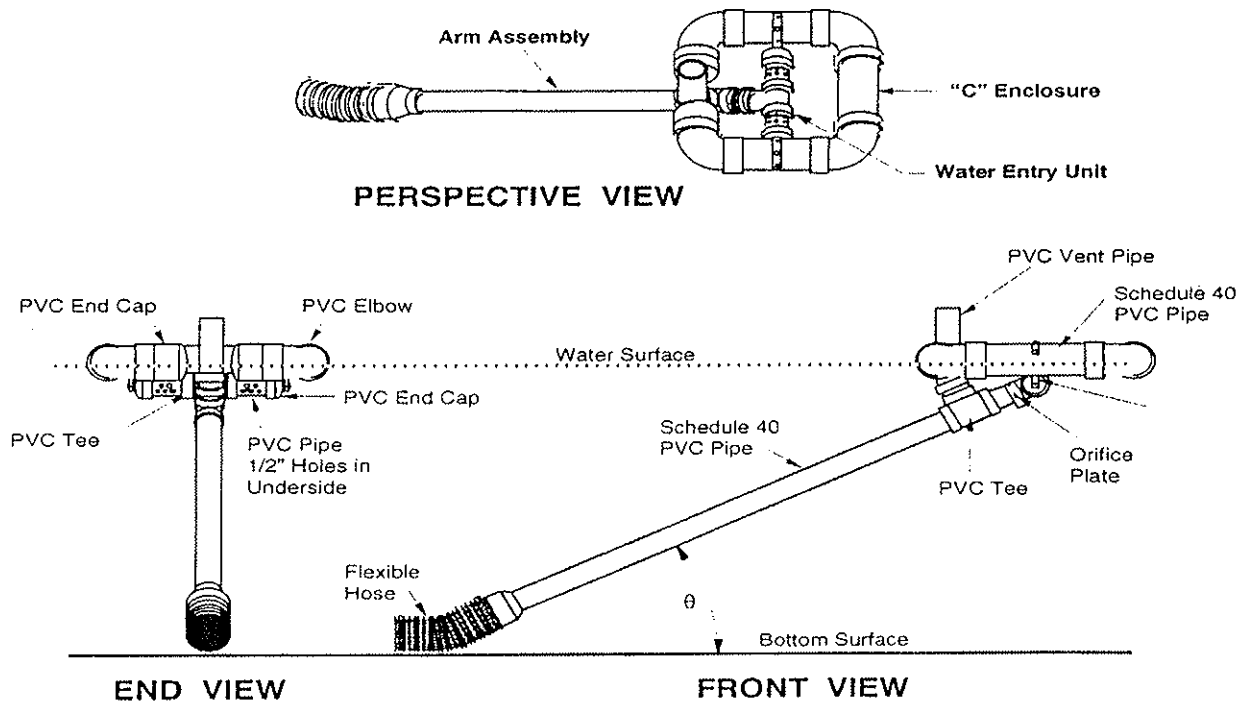

**STANDARD WORKSHEET #12**  
**Sediment Basin Capacity Requirements**

PROJECT NAME: Bell Bend Nuclear Power Plant

LOCATION: Salem Township, Luzerne County

PREPARED BY: M. Fenick DATE: 11/5/2010

CHECKED BY: D. Molinaro DATE: 11/5/2010

BASIN NUMBER	SEDIMENT BASIN POI 9
(A) MAXIMUM TOTAL DRAINAGE AREA (AC)	5.52343
(I) INITIAL REQ'D SETTLING VOLUME (5,000 X A) (CF)	27,617
(T) REDUCTION FOR TOP DEWATERING (-700 X A) (CF)	X
(P) REDUCTION FOR PERMANENT POOL (-700 X A) (CF)	X
(L) RED. FOR 4:1 FLOW LENGTH:WIDTH (-350 X A) (CF)	X
(D) RED. FOR 4 TO 7 DAY DEWATERING (- 350 X A) (CF)	X
*** (Sv) REQUIRED SETTLING VOLUME [I - (T+P+L+D)] (CF)	27,617
(Sd) REQUIRED SEDIMENT STORAGE VOLUME (1000 X a) <sup>1</sup> (CF)	5,523
(St) TOTAL REQUIRED STORAGE VOLUME (Sv + Sd) (CF)	33,141
**** TOTAL STORAGE VOLUME PROVIDED (CF)	41,671
REQUIRED DISCHARGE CAPACITY (2 X A) (CFS)	11.0
PRINCIPAL SPILLWAY CAPACITY (@ ELEV # ) (CFS)	11.0
* EMERGENCY SPILLWAY CAPACITY (@ ELEV ↴ ) (CFS)	0.0
** EMERGENCY SPILLWAY PROTECTIVE LINING	Pyramat

**X Reductions not allowed in a High Quality/Exceptional Value watershed.**

\* Provide supporting computations.

\*\* If grass lining is proposed, spillway must be constructed in original ground.

\*\*\* 5000 cubic feet per acre settling volume is required for basins located in Special Protection (HQ & EV) watersheds. In other watersheds, the basin settling volume may be reduced per the Department's "Erosion and Sediment Pollution Control Program Manual," No. 363-2134-008 (January 1996), as amended and updated. The minimum settling volume for such basins is (3600 X A).

\*\*\*\* Total Storage Volume provided at riser crest.

<sup>1</sup> a = Disturbed Acres in Drainage Area      a = 5.52 acres

**STANDARD WORKSHEET #13**  
**Sediment Basin Dimensions and Elevations**

PROJECT NAME: Bell Bend Nuclear Power Plant

LOCATION: Salem Township, Luzerne County

PREPARED BY: M. Fenick DATE: 11/5/2010

CHECKED BY: D. Molinaro DATE: 11/5/2010

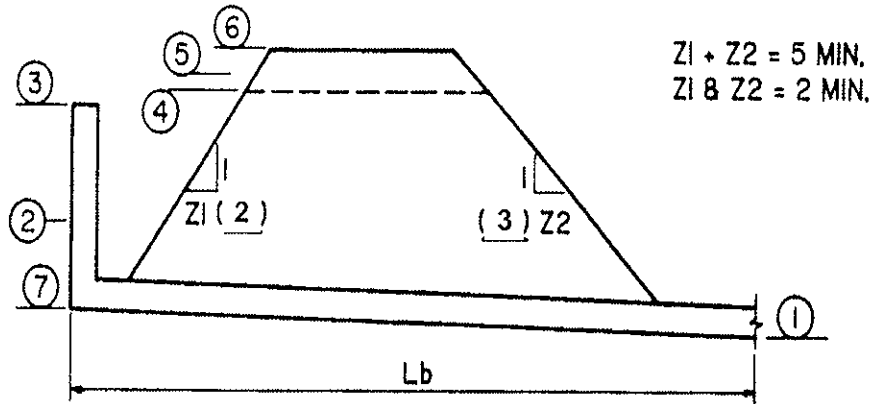

BASIN NUMBER	SEDIMENT BASIN POI 9
1. DISCHARGE PIPE ELEVATION	673.75
2. TOP OF SEDIMENT STORAGE ZONE (@ Sd)	678.39
3. ELEVATION AT TOP OF DEWATERING ZONE (St) (CREST OF PRINCIPAL SPILLWAY)	680.50
4. EMERGENCY SPILLWAY CREST ELEVATION (MIN. 0.5' ABOVE ELEVATION ① )	682.00
5. 2 CFS/ACRE FLOW ELEVATION	680.95
6. TOP OF EMBANKMENT ELEVATION (MIN. 24" ABOVE ELEVATION ④ )	684.00
7. BOTTOM ELEVATION	678.00
AVERAGE BOTTOM WIDTH (FT)	25
AVERAGE BOTTOM LENGTH (FT)	280
EMBANKMENT TOP WIDTH (FT, 8' MIN.)	8
RISER DIAMETER/TYPE (15" MIN.)	Type M Inlet Box
BARREL DIAMETER/TYPE (12" MIN.)	18 in. RCP
Lb (BARREL LENGTH (FT)	75.0
EMERGENCY SPILLWAY WIDTH (FT)	10.0
EMERGENCY SPILLWAY SIDE SLOPES (H:V)	3.0

**SHOW ALL DETAILS AND CONSTRUCTION DIMENSIONS ON PLAN DRAWINGS  
 USING STANDARD CONSTRUCTION DETAIL SHEETS.**



Sediment Basin Design Calculations:



Client/Subject: PPL Bell Bend, LLC  
 Description: Sediment Basin Calculation  
 Prepared by: J. Volonakis  
 Date: 10 Aug 11

Print Date: 12 Sep 11 10:34 AM  
 Project #: PPLS0902

Checked by: D. Molinaro
----------------------------

**Objective:**

This spreadsheet will assist with the design of sediment basins as erosion and sediment control measures. The calculations below are based on the criteria mandated by the PA E&S Manual (March '00 version) on pages 40 to 63.

**Basic Input:**

**Sediment Basin Name: SEDIMENT BASIN 10**

Drainage Area to Basin: 34.6 acres (if < 5.0 acres, consider sediment trap also)  
 Disturbed Area Tributary to Basin: 34.6 acres

**Requirements:**

Required Sediment Storage volume: 34,600 ft<sup>3</sup> (1000 ft<sup>3</sup>/disturbed acre)  
 Is the basin in a HQ or EV watershed? Yes. **Reductions not allowed in a HQ or EV watershed.**

Dewatering Zone Volume Determination (Standard Dewatering Zone = 5000 ft<sup>3</sup>/acre)

Does the basin dewater via a skimmer? Yes.  
 Does the basin have >18" permanent pool? No.  
 Is flow length to width greater than 4:1? Yes.  
 Does basin dewater between 4 and 7 days? No. (4.5 days)

Actual Dewatering Zone criteria: 5,000 ft<sup>3</sup>/acre after reductions (minimum of 3600 ft<sup>3</sup>/acre)

Required Dewatering Zone volume: 173,000 ft<sup>3</sup> (5000 ft<sup>3</sup>/total acre)

**Minimum total storage volume: 207,600 ft<sup>3</sup> (Dewatering Zone PLUS Sediment Storage volume)**

**Elevation-Storage Data:**

	Elevation	Plan Area	Δ Vol	Σ Vol
Bottom of Basin Elevation:	663.00	62161.0		
	664.00	65,719.0	63,940.0	63,940.0
	666.00	73,477.0	139,196.0	203,136.0
	668.00	82,092.0	155,569.0	358,705.0
Embankment Top Elevation:	670.00	91,723.0	173,815.0	532,520.0

**Actual Storage Volumes and Riser Height**

Elevation of Top of Sed. Storage (cleanout): 663.55 feet (provides Required Sediment storage volume)  
 Crest of Principal Spillway (Riser): 666.07 feet (minimum elev to provide Dewatering Zone: 666.07 ft)  
 Actual Storage volume provided at riser crest: 208,290 ft<sup>3</sup>

**Other Basin Characteristics**

Flow length through basin: 755 feet 2 to 1 (minimum flow length: 382.99 ft; see page 56)  
 Average width of basin: 80 feet 4 to 1 (minimum flow length: 543.24 ft; see page 56)  
 Length to width ratio: 9.4 to 1 (minimum 2 to 1)

Sediment Basin Name: **SEDIMENT BASIN 10**

C:\P\Projects\EROSION & SEDIMENTATION CALC\SEDIMENT BASINS AND TRAPS\SEDIMENT BASINS\{PPLS0902\_Sed Basin Design 10.xls}Sed Basin Design

**Embankment Criteria**

Embankment top width must be at least 8 feet wide.

Embankment side slopes may not be steeper than 2H:1V

**Embankment Spillway Weir Dimensions**

Emergency Spillway outlet width, L:	15.0	feet	(minimum bottom width is 8', see page 40)
Emergency Spillway outlet side slopes:	3 to 1		
Emergency Spillway crest elevation:	668.00	feet	(minimum crest elev: 666.57 ft; 6 in over riser crest) (maximum crest elev: 669.50 ft; 6 in below top of berm)

**Required Discharge from Basin**

Minimum discharge capacity (2 cfs/ac) Q = 69.2 cfs (at maximum water surface elevation)

**Water Surface Elevation at Required Discharge**

Discharge through riser/barrel = 69.2 cfs

**Riser Flow:**

Length/Width of Principal Spillway (Riser): 4.0 feet by 2.0 feet

Crest of Principal Spillway (Riser): 666.07 feet

Orifice flow from Riser:  $Q = 0.9 A_{riser} (2gh)^{0.5}$  Solve for h = 1.43Weir flow from Riser:  $Q = 3.1 P_{riser} h^{1.5}$  Solve for h = 1.51 feet. Elev: 667.58 feet  
Weir controls over Orifice.**Barrel Flow:**

Discharge pipe invert elevation at basin: 661.70 feet

Diameter of Barrel: 3.0 feet

Barrel length, L = 70 feet

Slope of the barrel : 1.0%

Discharge pipe invert elev at outlet end of pipe: 661.00 feet

Barrel Manning's n = 0.011

(maximum diameter is riser diameter / 1.25, see pg 40)

(use 0.025 for CMP, 0.015 for RCP, see page 45)

Pipe flow from Barrel: (where h = head over centerline of outlet end of pipe)

 $Q = A_{barrel} \{ (2gh) / [1 + 1 + (5087 * n^2 / d_i^{1.33}) * L] \}^{0.5}$  Solve for h = 3.52 feet. Elev: 666.02 feet**Determine which part of structure controls (higher W.S. Elev):****Riser capacity controls over Barrel.**

Does Emergency Spillway contribute to outflow? No.

Required Q through the riser/barrel is 69.2 cfs

**Maximum Water Surface Elevation and Required Freeboard**

Maximum water surface elevation: 667.58 feet (at maximum discharge capacity)

Top of Embankment: 670.00 feet. Freeboard provided: 29 inches



Sediment Basin Name: **SEDIMENT BASIN 10**

C:\P\PLS0902\_Sed Basin Design 10.xls\Sed Basin Design

**Skimmer Design** (as an alternate to the dewatering orifices on the riser.)

**Basic Input:**

Volume to top of Dewatering Zone , V:	173,690 cu ft	
Dewatering Time, t:	4.5 days	Dewatering time entered by user.
Floor of basin elevation:	663.00 feet	
Top of dewatering zone elevation:	666.07 feet	

**Calculations:**

Calculated skimmer orifice diameter: 4.28 in (from figure 7, page 44 of PA E&S manual)

Use 1/2" diameter orifices on the skimmer to provide 4.28 inches of orifice area.

Orifice area of a 1/2" diameter orifice: 0.20 sq in Area= 14.36 sq in

**Number of 1/2" dia. orifices required: 72**

The arm of the skimmer must form an angle with the basin floor of 45 degrees or less when the water surface elevation is at the top of dewatering zone.

Water depth:	3.07 feet
Minimum length of skimmer arm:	4.34 feet
<b>Use skimmer arm length of:</b>	<b>5 feet</b>

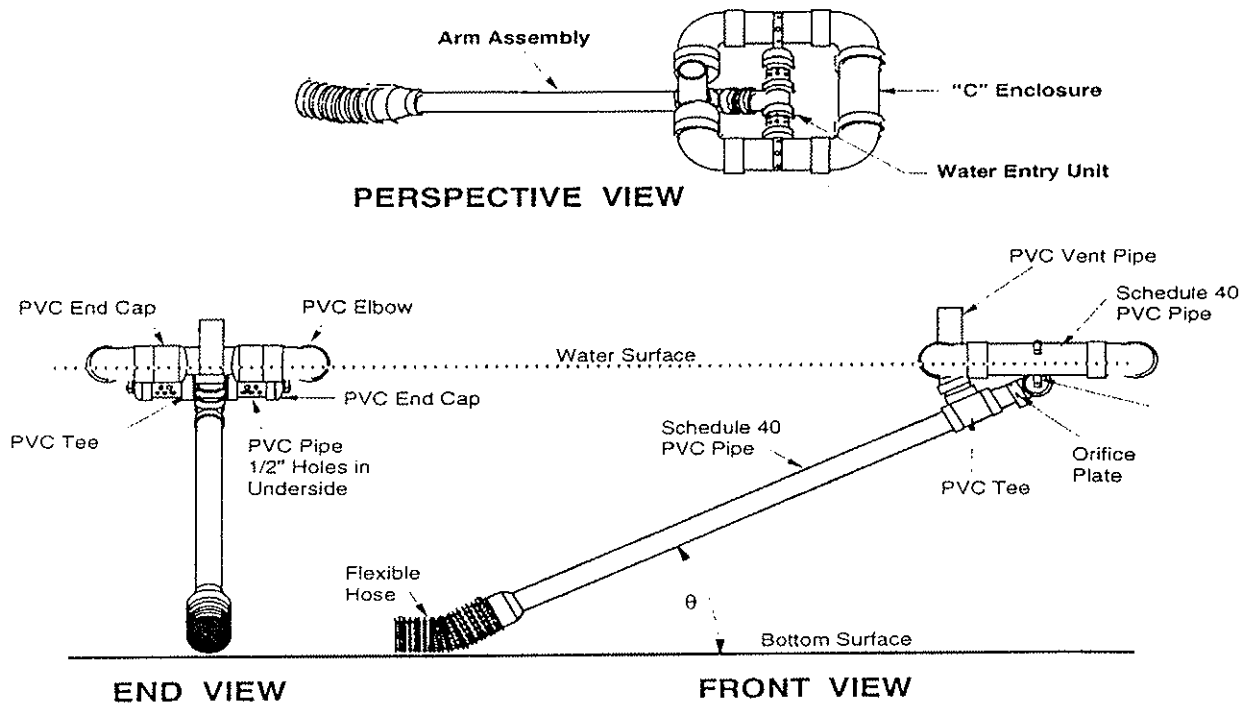

**STANDARD WORKSHEET #12**  
**Sediment Basin Capacity Requirements**

PROJECT NAME: Bell Bend Nuclear Power Plant

LOCATION: Salem Township, Luzerne County

PREPARED BY: J. Volonakis DATE: 8/10/2011

CHECKED BY: D. Molinaro DATE: 8/10/2011

BASIN NUMBER	SEDIMENT BASIN 10
(A) MAXIMUM TOTAL DRAINAGE AREA (AC)	34.6
(I) INITIAL REQ'D SETTLING VOLUME (5,000 X A) (CF)	173,000
(T) REDUCTION FOR TOP DEWATERING (-700 X A) (CF)	X
(P) REDUCTION FOR PERMANENT POOL (-700 X A) (CF)	X
(L) RED. FOR 4:1 FLOW LENGTH:WIDTH (-350 X A) (CF)	X
(D) RED. FOR 4 TO 7 DAY DEWATERING (- 350 X A) (CF)	X
*** (Sv) REQUIRED SETTLING VOLUME [I - (T+P+L+D)] (CF)	173,000
(Sd) REQUIRED SEDIMENT STORAGE VOLUME (1000 X a) <sup>1</sup> (CF)	34,600
(St) TOTAL REQUIRED STORAGE VOLUME (Sv + Sd) (CF)	207,600
**** TOTAL STORAGE VOLUME PROVIDED (CF)	208,290
REQUIRED DISCHARGE CAPACITY (2 X A) (CFS)	69.2
PRINCIPAL SPILLWAY CAPACITY (@ ELEV $\Phi$ ) (CFS)	69.2
* EMERGENCY SPILLWAY CAPACITY (@ ELEV $\Psi$ ) (CFS)	0.0
** EMERGENCY SPILLWAY PROTECTIVE LINING	Pyramat

**X Reductions not allowed in a High Quality/Exceptional Value watershed.**

\* Provide supporting computations.

\*\* If grass lining is proposed, spillway must be constructed in original ground.

\*\*\* 5000 cubic feet per acre settling volume is required for basins located in Special Protection (HQ & EV) watersheds. In other watersheds, the basin settling volume may be reduced per the Department's "Erosion and Sediment Pollution Control Program Manual," No. 363-2134-008 (January 1996), as amended and updated. The minimum settling volume for such basins is (3600 X A).

\*\*\*\* Total Storage Volume provided at riser crest.

<sup>1</sup> a = Disturbed Acres in Drainage Area      a = 34.6 acres

**STANDARD WORKSHEET #13**  
**Sediment Basin Dimensions and Elevations**

PROJECT NAME: Bell Bend Nuclear Power Plant

LOCATION: Salem Township, Luzerne County

PREPARED BY: J. Volonakis DATE: 8/10/2011

CHECKED BY: D. Molinaro DATE: 8/10/2011

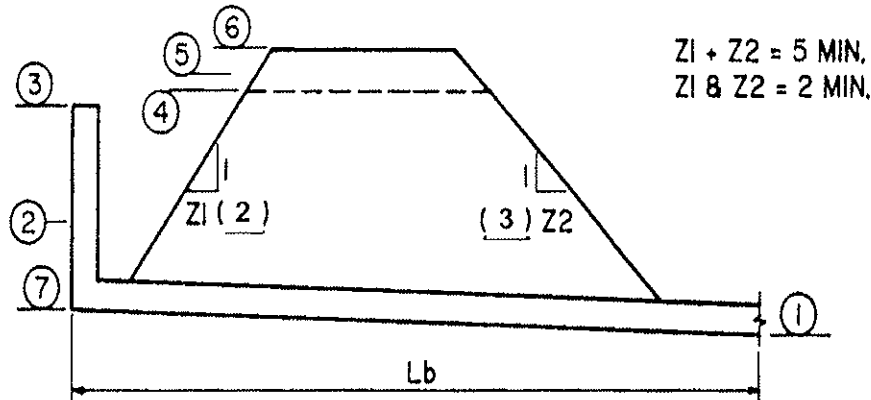

BASIN NUMBER	SEDIMENT BASIN 10
1. DISCHARGE PIPE ELEVATION	661.00
2. TOP OF SEDIMENT STORAGE ZONE (@ Sd)	663.55
3. ELEVATION AT TOP OF DEWATERING ZONE (St) (CREST OF PRINCIPAL SPILLWAY)	666.07
4. EMERGENCY SPILLWAY CREST ELEVATION (MIN. 0.5' ABOVE ELEVATION ① )	668.00
5. 2 CFS/ACRE FLOW ELEVATION	667.58
6. TOP OF EMBANKMENT ELEVATION (MIN. 24" ABOVE ELEVATION ④ )	670.00
7. BOTTOM ELEVATION	663.00
AVERAGE BOTTOM WIDTH (FT)	80
AVERAGE BOTTOM LENGTH (FT)	755
EMBANKMENT TOP WIDTH (FT, 8' MIN.)	8
RISER DIAMETER/TYPE (15" MIN.)	Type M Inlet Box
BARREL DIAMETER/TYPE (12" MIN.)	36 in. RCP
Lb (BARREL LENGTH (FT)	70.0
EMERGENCY SPILLWAY WIDTH (FT)	15.0
EMERGENCY SPILLWAY SIDE SLOPES (H:V)	3.0

**SHOW ALL DETAILS AND CONSTRUCTION DIMENSIONS ON PLAN DRAWINGS  
 USING STANDARD CONSTRUCTION DETAIL SHEETS.**



Sediment Basin Design Calculations:



Client/Subject: PPL Bell Bend, LLC  
 Description: Sediment Basin Calculation  
 Prepared by: J. Volonakis  
 Date: 11 Aug 11

Print Date: 12 Sep 11 10:34 AM  
 Project #: PPLS0902

Checked by: D. Molinaro
----------------------------

**Objective:**

This spreadsheet will assist with the design of sediment basins as erosion and sediment control measures. The calculations below are based on the criteria mandated by the PA E&S Manual (March '00 version) on pages 40 to 63.

**Basic Input:**

Sediment Basin Name: **SEDIMENT BASIN 10A**

Drainage Area to Basin: 45.4 acres (if < 5.0 acres, consider sediment trap also)  
 Disturbed Area Tributary to Basin: 45.4 acres

**Requirements:**

Required Sediment Storage volume: 45,350 ft<sup>3</sup> (1000 ft<sup>3</sup>/disturbed acre)  
 Is the basin in a HQ or EV watershed? Yes. **Reductions not allowed in a HQ or EV watershed.**

Dewatering Zone Volume Determination (Standard Dewatering Zone = 5000 ft<sup>3</sup>/acre)

Does the basin dewater via a skimmer? Yes.  
 Does the basin have >18" permanent pool? No.  
 Is flow length to width greater than 4:1? No.  
 Does basin dewater between 4 and 7 days? Yes. (4.5 days)

Actual Dewatering Zone criteria: 5,000 ft<sup>3</sup>/acre after reductions (minimum of 3600 ft<sup>3</sup>/acre)

Required Dewatering Zone volume: 226,750 ft<sup>3</sup> (5000 ft<sup>3</sup>/total acre)

**Minimum total storage volume: 272,100 ft<sup>3</sup> (Dewatering Zone PLUS Sediment Storage volume)**

**Elevation-Storage Data:**

	Elevation	Plan Area	Δ Vol	Σ Vol
Bottom of Basin Elevation:	688.00	131373.0		
	691.00	139,792.3	406,748.0	406,748.0
	692.00	143,654.9	141,723.6	548,471.6
	694.00	151,466.8	295,121.7	843,593.3
Embankment Top Elevation:	695.00	151,291.0	151,378.9	994,972.3

**Actual Storage Volumes and Riser Height**

Elevation of Top of Sed. Storage (cleanout): 688.34 feet (provides Required Sediment storage volume)  
 Crest of Principal Spillway (Riser): 691.70 feet (minimum elev to provide Dewatering Zone: 690.03 ft)  
 Actual Storage volume provided at riser crest: 505,549 ft<sup>3</sup>

**Other Basin Characteristics**

Flow length through basin is increased using baffles.  
 Flow length through basin: 900 feet 2 to 1 (minimum flow length: 532.26 ft; see page 56)  
 Average width of basin: 435 feet 4 to 1 (minimum flow length: 754.97 ft; see page 56)  
 Length to width ratio: 2.1 to 1 (minimum 2 to 1)

Sediment Basin Name: **SEDIMENT BASIN 10A**

.ACALCULATIONS\EROSION &amp; SEDIMENTATION CALCS\SEDIMENT BASINS AND TRAPS\SEDIMENT BASINS\{PPLS0902\_Sed Basin Design 10A.xls\}Sed Basin Design

**Embankment Criteria**

Embankment top width must be at least 8 feet wide.

Embankment side slopes may not be steeper than 2H:1V

**Embankment Spillway Weir Dimensions**

Emergency Spillway outlet width, L: 36.0 feet (minimum bottom width is 8', see page 40)  
 Emergency Spillway outlet side slopes: 3 to 1  
 Emergency Spillway crest elevation: 692.50 feet (minimum crest elev: 692.20 ft; 6 in over riser crest)  
 (maximum crest elev: 694.50 ft; 6 in below top of berm)

**Required Discharge from Basin**

Minimum discharge capacity (2 cfs/ac) Q = 90.7 cfs (at maximum water surface elevation)

**Water Surface Elevation at Required Discharge**

Discharge through riser/barrel = 55.1 cfs

**Riser Flow:**

Length/Width of Principal Spillway (Riser): 4.0 feet by 2.0 feet  
 Crest of Principal Spillway (Riser): 691.70 feet

Orifice flow from Riser:  $Q = 0.9 A_{\text{riser}} (2gh)^{0.5}$  Solve for h = 0.91  
 Weir flow from Riser:  $Q = 3.1 P_{\text{riser}} h^{1.5}$  Solve for h = 1.30 feet. Elev: 693.00 feet  
 Weir controls over Orifice.

**Barrel Flow:**

Discharge pipe invert elevation at basin: 686.00 feet  
 Diameter of Barrel: 3.0 feet (maximum diameter is riser diameter / 1.25, see pg 40)  
 Barrel length, L = 75 feet  
 Slope of the barrel : 3.0%  
 Discharge pipe invert elev at outlet end of pipe: 683.75 feet  
 Barrel Manning's n = 0.011 (use 0.025 for CMP, 0.015 for RCP, see page 45)

Pipe flow from Barrel: (where h = head over centerline of outlet end of pipe)

$$Q = A_{\text{barrel}} \left\{ \frac{(2gh)}{[1 + 1 + (5087 * n^2 / d_i^{1.33}) * L]} \right\}^{0.5}$$
 Solve for h = 2.26 feet. Elev: 687.51 feet
**Determine which part of structure controls (higher W.S. Elev):****Riser capacity controls over Barrel.**

Does Emergency Spillway contribute to outflow? Yes.

Emergency Spillway Discharge:  $Q = 2.8 L h^{1.5}$  (C = 2.8 from page 55 of PA E&S manual)

Emergency Spillway crest elevation: 692.50 feet

At W.S. elev 693.00, the head over the emergency spillway is 0.50 feet.

Q through the emergency spillway is 35.6 cfs  
 Required Q through the riser/barrel is 55.1 cfs

**Maximum Water Surface Elevation and Required Freeboard**

Maximum water surface elevation: 693.00 feet (at maximum discharge capacity)  
 Top of Embankment: 695.00 feet. Freeboard provided: 24 inches



Sediment Basin Name: **SEDIMENT BASIN 10A**

.\CALCULATIONS\EROSION & SEDIMENTATION CALCS\SEDIMENT BASINS AND TRAPS\SEDIMENT BASINS\[PPLS0902\_Sed Basin Design 10A.xls]Sed Basin Design

**Skimmer Design** (as an alternate to the dewatering orifices on the riser.)

**Basic Input:**

Volume to top of Dewatering Zone , V: 460,199 cu ft  
 Dewatering Time, t: 4.5 days Dewatering time entered by user.  
 Floor of basin elevation: 688.00 feet  
 Top of dewatering zone elevation: 691.70 feet

**Calculations:**

Calculated skimmer orifice diameter: 6.61 in (from figure 7, page 44 of PA E&S manual)

Use 1/2" diameter orifices on the skimmer to provide 6.61 inches of orifice area.

Orifice area of a 1/2" diameter orifice: 0.20 sq in Area= 34.35 sq in

**Number of 1/2" dia. orifices required: 172**

The arm of the skimmer must form an angle with the basin floor of 45 degrees or less when the water surface elevation is at the top of dewatering zone.

Water depth: 3.70 feet  
 Minimum length of skimmer arm: 5.23 feet  
**Use skimmer arm length of: 6 feet**

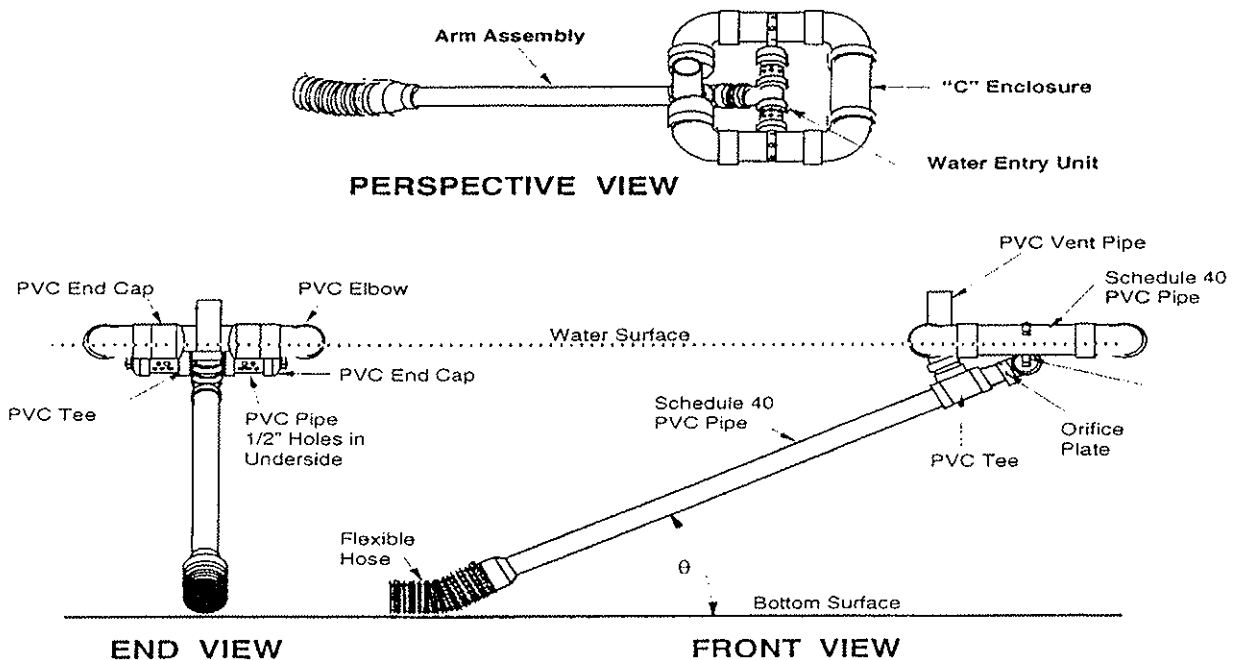

**STANDARD WORKSHEET #12**  
**Sediment Basin Capacity Requirements**

PROJECT NAME: Bell Bend Nuclear Power Plant

LOCATION: Salem Township, Luzerne County

PREPARED BY: J. Volonakis DATE: 8/11/2011

CHECKED BY: D. Molinaro DATE: 8/11/2011

BASIN NUMBER	SEDIMENT BASIN 10A
(A) MAXIMUM TOTAL DRAINAGE AREA (AC)	45.35
(I) INITIAL REQ'D SETTLING VOLUME (5,000 X A) (CF)	226,750
(T) REDUCTION FOR TOP DEWATERING (-700 X A) (CF)	X
(P) REDUCTION FOR PERMANENT POOL (-700 X A) (CF)	X
(L) RED. FOR 4:1 FLOW LENGTH:WIDTH (-350 X A) (CF)	X
(D) RED. FOR 4 TO 7 DAY DEWATERING (- 350 X A) (CF)	X
*** (Sv) REQUIRED SETTLING VOLUME [I - (T+P+L+D)] (CF)	226,750
(Sd) REQUIRED SEDIMENT STORAGE VOLUME (1000 X a) <sup>1</sup> (CF)	45,350
(St) TOTAL REQUIRED STORAGE VOLUME (Sv + Sd) (CF)	272,100
**** TOTAL STORAGE VOLUME PROVIDED (CF)	505,549
REQUIRED DISCHARGE CAPACITY (2 X A) (CFS)	90.7
PRINCIPAL SPILLWAY CAPACITY (@ ELEV # ) (CFS)	55.1
* EMERGENCY SPILLWAY CAPACITY (@ ELEV ♣ ) (CFS)	35.6
** EMERGENCY SPILLWAY PROTECTIVE LINING	Pyramat

**X Reductions not allowed in a High Quality/Exceptional Value watershed.**

\* Provide supporting computations.

\*\* If grass lining is proposed, spillway must be constructed in original ground.

\*\*\* 5000 cubic feet per acre settling volume is required for basins located in Special Protection (HQ & EV) watersheds. In other watersheds, the basin settling volume may be reduced per the Department's "Erosion and Sediment Pollution Control Program Manual," No. 363-2134-008 (January 1996), as amended and updated. The minimum settling volume for such basins is (3600 X A).

\*\*\*\* Total Storage Volume provided at riser crest.

<sup>1</sup>a = Disturbed Acres in Drainage Area      a = 45.35 acres

**STANDARD WORKSHEET #13**  
**Sediment Basin Dimensions and Elevations**

PROJECT NAME: Bell Bend Nuclear Power Plant  
 LOCATION: Salem Township, Luzerne County  
 PREPARED BY: J. Volonakis DATE: 8/11/2011  
 CHECKED BY: D. Molinaro DATE: 8/11/2011

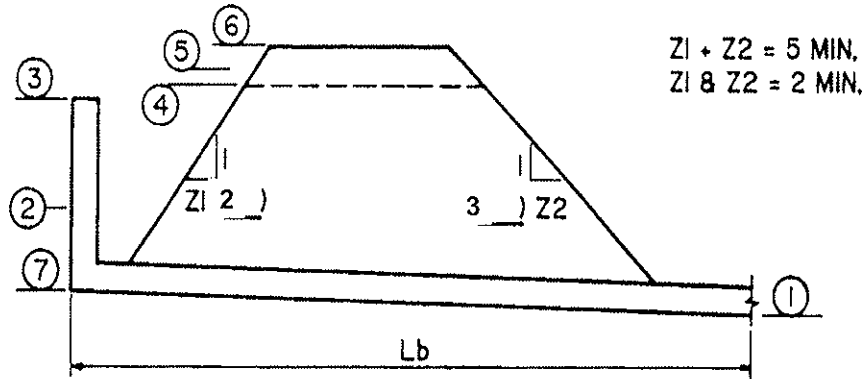

BASIN NUMBER	SEDIMENT BASIN 10A
1. DISCHARGE PIPE ELEVATION	683.75
2. TOP OF SEDIMENT STORAGE ZONE (@ Sd)	688.34
3. ELEVATION AT TOP OF DEWATERING ZONE (St) (CREST OF PRINCIPAL SPILLWAY)	691.70
4. EMERGENCY SPILLWAY CREST ELEVATION (MIN. 0.5' ABOVE ELEVATION ① )	692.50
5. 2 CFS/ACRE FLOW ELEVATION	693.00
6. TOP OF EMBANKMENT ELEVATION (MIN. 24" ABOVE ELEVATION ⑤ )	695.00
7. BOTTOM ELEVATION	688.00
AVERAGE BOTTOM WIDTH (FT)	435
AVERAGE BOTTOM LENGTH (FT)	900
EMBANKMENT TOP WIDTH (FT, 8' MIN.)	8
RISER DIAMETER/TYPE (15" MIN.)	Type M Inlet Box
BARREL DIAMETER/TYPE (12" MIN.)	36 in. RCP
Lb (BARREL LENGTH (FT)	75.0
EMERGENCY SPILLWAY WIDTH (FT)	36.0
EMERGENCY SPILLWAY SIDE SLOPES (H:V)	3.0

**SHOW ALL DETAILS AND CONSTRUCTION DIMENSIONS ON PLAN DRAWINGS  
 USING STANDARD CONSTRUCTION DETAIL SHEETS.**



Sediment Basin Design Calculations:

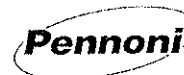

Client/Subject: PPL Bell Bend, LLC  
 Description: Sediment Basin Calculation  
 Prepared by: J. Volonakis  
 Date: 11 Aug 11

Print Date: 12 Sep 11 10:35 AM  
 Project #: PPLS0902

Checked by: D. Molinaro
----------------------------

**Objective:**

This spreadsheet will assist with the design of sediment basins as erosion and sediment control measures. The calculations below are based on the criteria mandated by the PA E&S Manual (March '00 version) on pages 40 to 63.

**Basic Input:**

Sediment Basin Name: **SEDIMENT BASIN POI 12**

Drainage Area to Basin: 41.8 acres (if < 5.0 acres, consider sediment trap also)  
 Disturbed Area Tributary to Basin: 41.8 acres

**Requirements:**

Required Sediment Storage volume: 41,820 ft<sup>3</sup> (1000 ft<sup>3</sup>/disturbed acre)  
 Is the basin in a HQ or EV watershed? Yes. **Reductions not allowed in a HQ or EV watershed.**

Dewatering Zone Volume Determination (Standard Dewatering Zone = 5000 ft<sup>3</sup>/acre)

Does the basin dewater via a skimmer? Yes.  
 Does the basin have >18" permanent pool? No.  
 Is flow length to width greater than 4:1? No.  
 Does basin dewater between 4 and 7 days? Yes. (4.5 days)

Actual Dewatering Zone criteria: 5,000 ft<sup>3</sup>/acre after reductions (minimum of 3600 ft<sup>3</sup>/acre)

Required Dewatering Zone volume: 209,100 ft<sup>3</sup> (5000 ft<sup>3</sup>/total acre)

**Minimum total storage volume: 250,920 ft<sup>3</sup> (Dewatering Zone PLUS Sediment Storage volume)**

**Elevation-Storage Data:**

	Elevation	Plan Area	Δ Vol	Σ Vol
Bottom of Basin Elevation:	677.50	123388.0		
	678.00	124,884.0	62,068.0	62,068.0
	680.00	130,946.0	255,830.0	317,898.0
	682.00	165,127.0	296,073.0	613,971.0
Embankment Top Elevation:	683.00	170,778.0	167,952.5	781,923.5

**Actual Storage Volumes and Riser Height**

Elevation of Top of Sed. Storage (cleanout): 677.84 feet (provides Required Sediment storage volume)  
 Crest of Principal Spillway (Riser): 679.50 feet (minimum elev to provide Dewatering Zone: 679.49 ft)  
 Actual Storage volume provided at riser crest: 252,804 ft<sup>3</sup>

**Other Basin Characteristics**

Flow length through basin is increased using baffles.

Flow length through basin: 550 feet 2 to 1 (minimum flow length: 507.27 ft; see page 56)  
 Average width of basin: 250 feet 4 to 1 (minimum flow length: 719.53 ft; see page 56)  
 Length to width ratio: 2.2 to 1 (minimum 2 to 1)

Sediment Basin Name: **SEDIMENT BASIN POI 12**

C:\P\Projects\SIEROSION & SEDIMENTATION CALC\SEDIMENT BASINS AND TRAPS\SEDIMENT BASINS\{PPLS0902\_Sed Basin Design 12.xls}Sed Basin Design

**Embankment Criteria**

Embankment top width must be at least 8 feet wide.  
Embankment side slopes may not be steeper than 2H:1V

**Embankment Spillway Weir Dimensions**

Emergency Spillway outlet width, L: 30.0 feet (minimum bottom width is 8', see page 40)  
Emergency Spillway outlet side slopes: 3 to 1  
Emergency Spillway crest elevation: 680.60 feet (minimum crest elev: 680.00 ft; 6 in over riser crest)  
(maximum crest elev: 682.50 ft; 6 in below top of berm)

**Required Discharge from Basin**

Minimum discharge capacity (2 cfs/ac) Q = 83.6 cfs (at maximum water surface elevation)

**Water Surface Elevation at Required Discharge**

Discharge through riser/barrel = 65.6 cfs

**Riser Flow:**

Length/Width of Principal Spillway (Riser): 4.0 feet by 2.0 feet  
Crest of Principal Spillway (Riser): 679.50 feet

Orifice flow from Riser:  $Q = 0.9 A_{\text{riser}} (2gh)^{0.5}$  Solve for h = 1.29  
Weir flow from Riser:  $Q = 3.1 P_{\text{riser}} h^{1.5}$  Solve for h = 1.46 feet. Elev: 680.96 feet  
Weir controls over Orifice.

**Barrel Flow:**

Discharge pipe invert elevation at basin: 675.00 feet  
Diameter of Barrel: 3.0 feet (maximum diameter is riser diameter / 1.25, see pg 40)  
Barrel length, L = 185 feet  
Slope of the barrel: 3.8%  
Discharge pipe invert elev at outlet end of pipe: 667.97 feet  
Barrel Manning's n = 0.011 (use 0.025 for CMP, 0.015 for RCP, see page 45)

Pipe flow from Barrel: (where h = head over centerline of outlet end of pipe)  
 $Q = A_{\text{barrel}} \left\{ (2gh) / [1 + 1 + (5087 * n^2 / d_i^{1.33}) * L] \right\}^{0.5}$  Solve for h = 3.97 feet. Elev: 673.44 feet

**Determine which part of structure controls (higher W.S. Elev):** **Riser capacity controls over Barrel.**

Does Emergency Spillway contribute to outflow? Yes.

Emergency Spillway Discharge:  $Q = 2.8 L h^{1.5}$  (C = 2.8 from page 55 of PA E&S manual)

Emergency Spillway crest elevation: 680.60 feet  
At W.S. elev 680.96, the head over the emergency spillway is 0.36 feet.

Q through the emergency spillway is 18.1 cfs  
Required Q through the riser/barrel is 65.6 cfs

**Maximum Water Surface Elevation and Required Freeboard**

Maximum water surface elevation: 680.96 feet (at maximum discharge capacity)  
Top of Embankment: 683.00 feet. Freeboard provided: 24 inches



Sediment Basin Name: **SEDIMENT BASIN POI 12**

CULATIONS/VEROSION & SEDIMENTATION CALCS/SEDIMENT BASINS AND TRAPS/SEDIMENT BASINS\{PPLS0902\_Sed Basin Design 12.xls}Sed Basin Design

**Skimmer Design** (as an alternate to the dewatering orifices on the riser.)

**Basic Input:**

Volume to top of Dewatering Zone , V: 210,984 cu ft  
 Dewatering Time, t: 4.5 days      Dewatering time entered by user.  
 Floor of basin elevation: 677.50 feet  
 Top of dewatering zone elevation: 679.50 feet

**Calculations:**

Calculated skimmer orifice diameter: 4.67 in      (from figure 7, page 44 of PA E&S manual)

Use 1/2" diameter orifices on the skimmer to provide 4.67 inches of orifice area.

Orifice area of a 1/2" diameter orifice: 0.20 sq in      Area= 17.10 sq in

**Number of 1/2" dia. orifices required: 86**

*The arm of the skimmer must form an angle with the basin floor of 45 degrees or less when the water surface elevation is at the top of dewatering zone.*

Water depth: 2.00 feet  
 Minimum length of skimmer arm: 2.83 feet  
**Use skimmer arm length of: 3 feet**

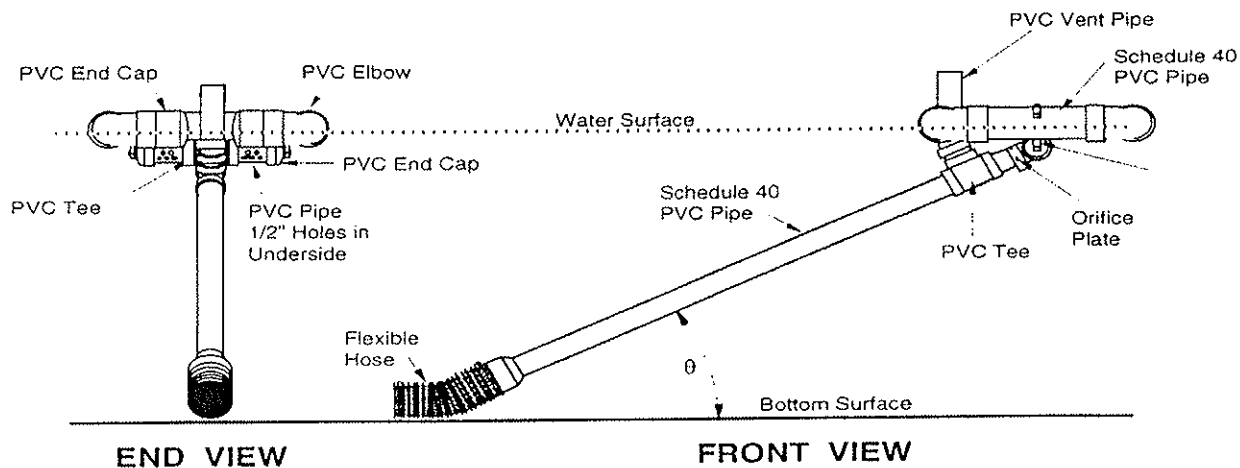
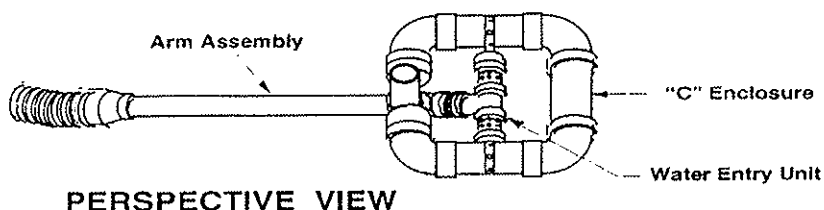

**STANDARD WORKSHEET #12**  
**Sediment Basin Capacity Requirements**

PROJECT NAME: PPL Bell Bend Nuclear Power Plant

LOCATION: Salem Township, Luzerne County

PREPARED BY: J. Volonakis DATE: 8/11/2011

CHECKED BY: D. Molinaro DATE: 8/11/2011

BASIN NUMBER	SEDIMENT BASIN POI 12
(A) MAXIMUM TOTAL DRAINAGE AREA (AC)	41.82
(I) INITIAL REQ'D SETTLING VOLUME (5,000 X A) (CF)	209,100
(T) REDUCTION FOR TOP DEWATERING (-700 X A) (CF)	X
(P) REDUCTION FOR PERMANENT POOL (-700 X A) (CF)	X
(L) RED. FOR 4:1 FLOW LENGTH:WIDTH (-350 X A) (CF)	X
(D) RED. FOR 4 TO 7 DAY DEWATERING (- 350 X A) (CF)	X
*** (Sv) REQUIRED SETTLING VOLUME [I - (T+P+L+D)] (CF)	209,100
(Sd) REQUIRED SEDIMENT STORAGE VOLUME (1000 X a) <sup>1</sup> (CF)	41,820
(St) TOTAL REQUIRED STORAGE VOLUME (Sv + Sd) (CF)	250,920
**** TOTAL STORAGE VOLUME PROVIDED (CF)	252,804
REQUIRED DISCHARGE CAPACITY (2 X A) (CFS)	83.6
PRINCIPAL SPILLWAY CAPACITY (@ ELEV # ) (CFS)	65.6
* EMERGENCY SPILLWAY CAPACITY (@ ELEV ↴ ) (CFS)	18.1
** EMERGENCY SPILLWAY PROTECTIVE LINING	Pyramat

**X Reductions not allowed in a High Quality/Exceptional Value watershed.**

\* Provide supporting computations.

\*\* If grass lining is proposed, spillway must be constructed in original ground.

\*\*\* 5000 cubic feet per acre settling volume is required for basins located in Special Protection (HQ & EV) watersheds. In other watersheds, the basin settling volume may be reduced per the Department's "Erosion and Sediment Pollution Control Program Manual," No. 363-2134-008 (January 1996), as amended and updated. The minimum settling volume for such basins is (3600 X A).

\*\*\*\* Total Storage Volume provided at riser crest.

<sup>1</sup> a = Disturbed Acres in Drainage Area      a = 41.82 acres

**STANDARD WORKSHEET #13  
Sediment Basin Dimensions and Elevations**

PROJECT NAME: PPL Bell Bend Nuclear Power Plant  
 LOCATION: Salem Township, Luzerne County  
 PREPARED BY: J. Volonakis DATE: 8/11/2011  
 CHECKED BY: D. Molinaro DATE: 8/11/2011

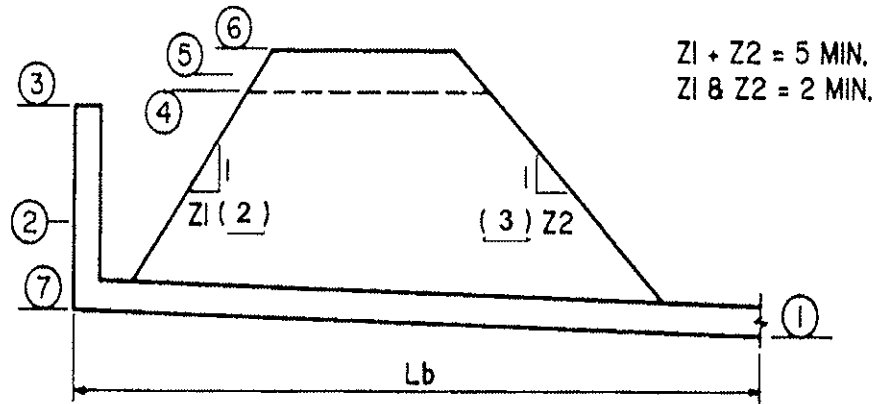

BASIN NUMBER	SEDIMENT BASIN POI 12
1. DISCHARGE PIPE ELEVATION	667.97
2. TOP OF SEDIMENT STORAGE ZONE (@ Sd)	677.84
3. ELEVATION AT TOP OF DEWATERING ZONE (St) (CREST OF PRINCIPAL SPILLWAY)	679.50
4. EMERGENCY SPILLWAY CREST ELEVATION (MIN. 0.5' ABOVE ELEVATION ①)	680.60
5. 2 CFS/ACRE FLOW ELEVATION	680.96
6. TOP OF EMBANKMENT ELEVATION (MIN. 24" ABOVE ELEVATION ④)	683.00
7. BOTTOM ELEVATION	677.50
AVERAGE BOTTOM WIDTH (FT)	250
AVERAGE BOTTOM LENGTH (FT)	550
EMBANKMENT TOP WIDTH (FT, 8' MIN.)	8
RISER DIAMETER/TYPE (15" MIN.)	Type M Inlet Box
BARREL DIAMETER/TYPE (12" MIN.)	36 in. RCP
Lb (BARREL LENGTH (FT)	185.0
EMERGENCY SPILLWAY WIDTH (FT)	30.0
EMERGENCY SPILLWAY SIDE SLOPES (H:V)	3.0

**SHOW ALL DETAILS AND CONSTRUCTION DIMENSIONS ON PLAN DRAWINGS  
USING STANDARD CONSTRUCTION DETAIL SHEETS.**



Sediment Basin Design Calculations:



Client/Subject: PPL Bell Bend, LLC  
 Description: Sediment Basin Calculation  
 Prepared by: J. Volonakis  
 Date: 22 Aug 11

Print Date: 12 Sep 11 10:35 AM  
 Project #: PPLS0902

Checked by: D. Molinaro
----------------------------

**Objective:**

This spreadsheet will assist with the design of sediment basins as erosion and sediment control measures. The calculations below are based on the criteria mandated by the PA E&S Manual (March '00 version) on pages 40 to 63.

**Basic Input:**

**Sediment Basin Name: SEDIMENT BASIN 15**

Drainage Area to Basin: 6.8 acres (if < 5.0 acres, consider sediment trap also)  
 Disturbed Area Tributary to Basin: 6.8 acres

**Requirements:**

Required Sediment Storage volume: 6,820 ft<sup>3</sup> (1000 ft<sup>3</sup>/ disturbed acre)  
 Is the basin in a HQ or EV watershed? Yes. **Reductions not allowed in a HQ or EV watershed.**

Dewatering Zone Volume Determination (Standard Dewatering Zone = 5000 ft<sup>3</sup>/acre)

Does the basin dewater via a skimmer? Yes.  
 Does the basin have >18" permanent pool? No.  
 Is flow length to width greater than 4:1? Yes.  
 Does basin dewater between 4 and 7 days? Yes. (4.5 days)

Actual Dewatering Zone criteria: 5,000 ft<sup>3</sup>/acre after reductions (minimum of 3600 ft<sup>3</sup>/acre)

Required Dewatering Zone volume: 34,100 ft<sup>3</sup> (5000 ft<sup>3</sup>/ total acre)

**Minimum total storage volume: 40,920 ft<sup>3</sup> (Dewatering Zone PLUS Sediment Storage volume)**

**Elevation-Storage Data:**

	Elevation	Plan Area	Δ Vol	Σ Vol
Bottom of Basin Elevation:	990.00	12,083.0		
	992.00	15,514.0	27,597.0	27,597.0
	994.00	19,072.0	34,586.0	62,183.0
Embankment Top Elevation:	996.00	22,758.0	41,830.0	104,013.0

**Actual Storage Volumes and Riser Height**

Elevation of Top of Sed. Storage (cleanout): 990.54 feet (provides Required Sediment storage volume)  
 Crest of Principal Spillway (Riser): 993.00 feet (minimum elev to provide Dewatering Zone: 992.83 ft)  
 Actual Storage volume provided at riser crest: 44,001 ft<sup>3</sup>

**Other Basin Characteristics**

Flow length through basin: 195 feet 2 to 1 (minimum flow length: 185.42 ft; see page 56)  
 Average width of basin: 31 feet 4 to 1 (minimum flow length: 263.01 ft; see page 56)  
 Length to width ratio: 6.3 to 1 (minimum 2 to 1)

Sediment Basin Name: **SEDIMENT BASIN 15**

C:\P\Projects\2015\SEDIMENT BASINS AND TRAPS\SEDIMENT BASINS\PLS0902\_Sed Basin Design 15.xls\Sed Basin Design

**Embankment Criteria**

Embankment top width must be at least 8 feet wide.

Embankment side slopes may not be steeper than 2H:1V

**Embankment Spillway Weir Dimensions**

Emergency Spillway outlet width, L: 10.0 feet (minimum bottom width is 8', see page 40)  
 Emergency Spillway outlet side slopes: 3 to 1  
 Emergency Spillway crest elevation: 994.00 feet (minimum crest elev: 993.50 ft; 6 in over riser crest)  
 (maximum crest elev: 995.50 ft; 6 in below top of berm)

**Required Discharge from Basin**

Minimum discharge capacity (2 cfs/ac) Q = 13.6 cfs (at maximum water surface elevation)

**Water Surface Elevation at Required Discharge**

Discharge through riser/barrel = 13.6 cfs

**Riser Flow:**

Length/Width of Principal Spillway (Riser): 4.0 feet by 2.0 feet

Crest of Principal Spillway (Riser): 993.00 feet

Orifice flow from Riser:  $Q = 0.9 A_{\text{riser}} (2gh)^{0.5}$  Solve for h = 0.06

Weir flow from Riser:  $Q = 3.1 P_{\text{riser}} h^{1.5}$  Solve for h = 0.51 feet. Elev: 993.51 feet  
 Weir controls over Orifice.

**Barrel Flow:**

Discharge pipe invert elevation at basin: 990.00 feet

Diameter of Barrel: 2.0 feet (maximum diameter is riser diameter / 1.25, see pg 40)

Barrel length, L = 26 feet

Slope of the barrel : 2.0%

Discharge pipe invert elev at outlet end of pipe: 989.48 feet

Barrel Manning's n = 0.011 (use 0.025 for CMP, 0.015 for RCP, see page 45)

Pipe flow from Barrel: (where h = head over centerline of outlet end of pipe)

$Q = A_{\text{barrel}} \{ (2gh) / [1 + 1 + (5087 * n^2 / d_i^{1.33}) * L] \}^{0.5}$  Solve for h = 0.65 feet. Elev: 991.13 feet

Determine which part of structure controls (higher W.S. Elev):

**Riser capacity controls over Barrel.**

Does Emergency Spillway contribute to outflow? No.

Required Q through the riser/barrel is 13.6 cfs

**Maximum Water Surface Elevation and Required Freeboard**

Maximum water surface elevation: 993.51 feet (at maximum discharge capacity)

Top of Embankment: 996.00 feet. Freeboard provided: 30 inches



Sediment Basin Name: **SEDIMENT BASIN 15**

C:\PPLS0902\_Sed Basin Design 15.xls\Sed Basin Design

**Skimmer Design** (as an alternate to the dewatering orifices on the riser.)

**Basic Input:**

Volume to top of Dewatering Zone , V:	37,181 cu ft	
Dewatering Time, t:	4.5 days	Dewatering time entered by user.
Floor of basin elevation:	990.00 feet	
Top of dewatering zone elevation:	993.00 feet	

**Calculations:**

Calculated skimmer orifice diameter: 2.15 in (from figure 7, page 44 of PA E&S manual)

Use 1/2" diameter orifices on the skimmer to provide 2.15 inches of orifice area.

Orifice area of a 1/2" diameter orifice: 0.20 sq in Area= 3.62 sq in

**Number of 1/2" dia. orifices required: 18**

The arm of the skimmer must form an angle with the basin floor of 45 degrees or less when the water surface elevation is at the top of dewatering zone.

Water depth:	3.00 feet
Minimum length of skimmer arm:	4.24 feet
<b>Use skimmer arm length of:</b>	<b>5 feet</b>

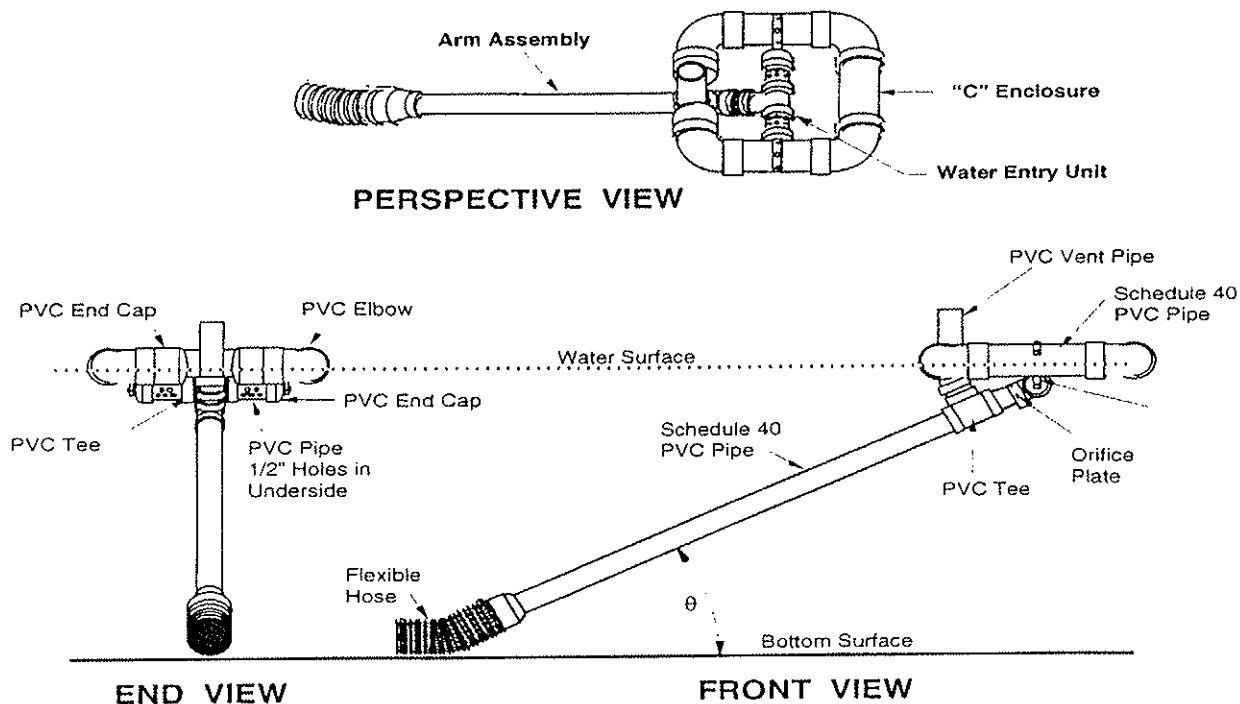

**STANDARD WORKSHEET #12**  
**Sediment Basin Capacity Requirements**

PROJECT NAME: PPL Bell Bend Nuclear Power Plant

LOCATION: Salem Township, Luzerne County

PREPARED BY: J. Volonakis DATE: 8/22/2011

CHECKED BY: D. Molinaro DATE: 8/22/2011

BASIN NUMBER	SEDIMENT BASIN 15
(A) MAXIMUM TOTAL DRAINAGE AREA (AC)	6.82
(I) INITIAL REQ'D SETTLING VOLUME (5,000 X A) (CF)	34,100
(T) REDUCTION FOR TOP DEWATERING (-700 X A) (CF)	X
(P) REDUCTION FOR PERMANENT POOL (-700 X A) (CF)	X
(L) RED. FOR 4:1 FLOW LENGTH:WIDTH (-350 X A) (CF)	X
(D) RED. FOR 4 TO 7 DAY DEWATERING (- 350 X A) (CF)	X
*** (Sv) REQUIRED SETTLING VOLUME [I - (T+P+L+D)] (CF)	34,100
(Sd) REQUIRED SEDIMENT STORAGE VOLUME (1000 X a) <sup>1</sup> (CF)	6,820
(St) TOTAL REQUIRED STORAGE VOLUME (Sv + Sd) (CF)	40,920
**** TOTAL STORAGE VOLUME PROVIDED (CF)	44,001
REQUIRED DISCHARGE CAPACITY (2 X A) (CFS)	13.6
PRINCIPAL SPILLWAY CAPACITY (@ ELEV # ) (CFS)	13.6
* EMERGENCY SPILLWAY CAPACITY (@ ELEV ↴ ) (CFS)	0.0
** EMERGENCY SPILLWAY PROTECTIVE LINING	Pyramat

**X Reductions not allowed in a High Quality/Exceptional Value watershed.**

\* Provide supporting computations.

\*\* If grass lining is proposed, spillway must be constructed in original ground.

\*\*\* 5000 cubic feet per acre settling volume is required for basins located in Special Protection (HQ & EV) watersheds. In other watersheds, the basin settling volume may be reduced per the Department's "Erosion and Sediment Pollution Control Program Manual," No. 363-2134-008 (January 1996), as amended and updated. The minimum settling volume for such basins is (3600 X A).

\*\*\*\* Total Storage Volume provided at riser crest.

<sup>1</sup> a = Disturbed Acres in Drainage Area      a = 6.82 acres

**STANDARD WORKSHEET #13**  
**Sediment Basin Dimensions and Elevations**

PROJECT NAME: PPL Bell Bend Nuclear Power Plant  
 LOCATION: Salem Township, Luzerne County  
 PREPARED BY: J. Volonakis DATE: 8/22/2011  
 CHECKED BY: D. Molinaro DATE: 8/22/2011

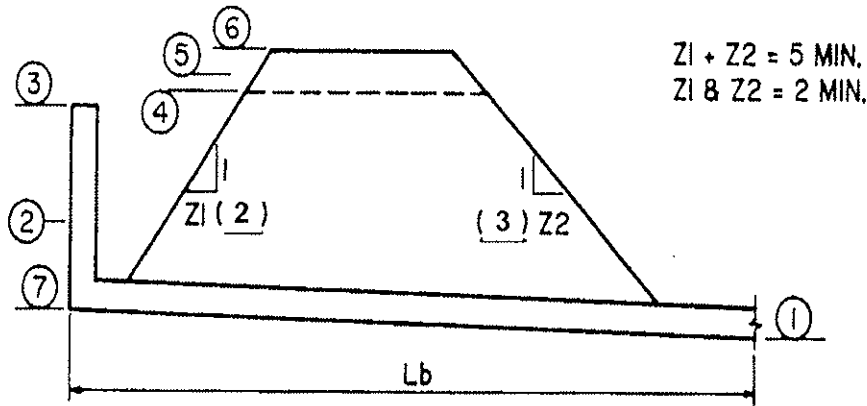

BASIN NUMBER	SEDIMENT BASIN 15
1. DISCHARGE PIPE ELEVATION	989.48
2. TOP OF SEDIMENT STORAGE ZONE (@ Sd)	990.54
3. ELEVATION AT TOP OF DEWATERING ZONE (St) (CREST OF PRINCIPAL SPILLWAY)	993.00
4. EMERGENCY SPILLWAY CREST ELEVATION (MIN. 0.5' ABOVE ELEVATION ①)	994.00
5. 2 CFS/ACRE FLOW ELEVATION	993.51
6. TOP OF EMBANKMENT ELEVATION (MIN. 24" ABOVE ELEVATION ④)	996.00
7. BOTTOM ELEVATION	990.00
AVERAGE BOTTOM WIDTH (FT)	31
AVERAGE BOTTOM LENGTH (FT)	195
EMBANKMENT TOP WIDTH (FT, 8' MIN.)	8
RISER DIAMETER/TYPE (15" MIN.)	Type M Inlet Box
BARREL DIAMETER/TYPE (12" MIN.)	24 in. RCP
Lb (BARREL LENGTH (FT)	26.0
EMERGENCY SPILLWAY WIDTH (FT)	10.0
EMERGENCY SPILLWAY SIDE SLOPES (H:V)	3.0

**SHOW ALL DETAILS AND CONSTRUCTION DIMENSIONS ON PLAN DRAWINGS  
 USING STANDARD CONSTRUCTION DETAIL SHEETS.**



Sediment Basin Design Calculations:



Client/Subject: PPL Bell Bend, LLC  
 Description: Sediment Basin Calculation  
 Prepared by: J. Volonakis  
 Date: 22 Aug 11

Print Date: 12 Sep 11 10:35 AM  
 Project #: PPLS0902

Checked by: D. Molinaro
----------------------------

**Objective:**

This spreadsheet will assist with the design of sediment basins as erosion and sediment control measures. The calculations below are based on the criteria mandated by the PA E&S Manual (March '00 version) on pages 40 to 63.

**Basic Input:**

**Sediment Basin Name: SEDIMENT BASIN 15A**

Drainage Area to Basin: 8.9 acres (if < 5.0 acres, consider sediment trap also)  
 Disturbed Area Tributary to Basin: 8.9 acres

**Requirements:**

Required Sediment Storage volume: 8,850 ft<sup>3</sup> (1000 ft<sup>3</sup>/ disturbed acre)  
 Is the basin in a HQ or EV watershed? Yes. **Reductions not allowed in a HQ or EV watershed.**

Dewatering Zone Volume Determination (Standard Dewatering Zone = 5000 ft<sup>3</sup>/acre)

Does the basin dewater via a skimmer? Yes.  
 Does the basin have >18" permanent pool? No.  
 Is flow length to width greater than 4:1? Yes.  
 Does basin dewater between 4 and 7 days? Yes. (4.5 days)

Actual Dewatering Zone criteria: 5,000 ft<sup>3</sup>/acre after reductions (minimum of 3600 ft<sup>3</sup>/acre)

Required Dewatering Zone volume: 44,250 ft<sup>3</sup> (5000 ft<sup>3</sup>/ total acre)

**Minimum total storage volume: 53,100 ft<sup>3</sup> (Dewatering Zone PLUS Sediment Storage volume)**

**Elevation-Storage Data:**

	Elevation	Plan Area	Δ Vol	Σ Vol
Bottom of Basin Elevation:	985.00	5974.0		
	986.00	7,672.0	6,823.0	6,823.0
	988.00	11,159.0	18,831.0	25,654.0
	990.00	14,768.0	25,927.0	51,581.0
	992.00	18,498.0	33,266.0	84,847.0
Embankment Top Elevation:	994.00	22,498.0	40,996.0	125,843.0

**Actual Storage Volumes and Riser Height**

Elevation of Top of Sed. Storage (cleanout): 986.26 feet (provides Required Sediment storage volume)  
 Crest of Principal Spillway (Riser): 990.50 feet (minimum elev to provide Dewatering Zone: 990.11 ft)  
 Actual Storage volume provided at riser crest: 59,198 ft<sup>3</sup>

**Other Basin Characteristics**

Flow length through basin: 200 feet 2 to 1 (minimum flow length: 176.68 ft; see page 56)  
 Average width of basin: 10 feet 4 to 1 (minimum flow length: 250.60 ft; see page 56)  
 Length to width ratio: 20.0 to 1 (minimum 2 to 1)

Sediment Basin Name: **SEDIMENT BASIN 15A**

ULATIONS\EROSION & SEDIMENTATION CALCS\SEDIMENT BASINS AND TRAPS\SEDIMENT BASINS\{PPLS0902\_Sed Basin Design 15A.xls\}Sed Basin Design

**Embankment Criteria**

Embankment top width must be at least 8 feet wide.  
Embankment side slopes may not be steeper than 2H:1V

**Embankment Spillway Weir Dimensions**

Emergency Spillway outlet width, L: 10.0 feet (minimum bottom width is 8', see page 40)  
Emergency Spillway outlet side slopes: 3 to 1  
Emergency Spillway crest elevation: 992.00 feet (minimum crest elev: 991.00 ft; 6 in over riser crest)  
(maximum crest elev: 993.50 ft; 6 in below top of berm)

**Required Discharge from Basin**

Minimum discharge capacity (2 cfs/ac) Q = 17.7 cfs (at maximum water surface elevation)

**Water Surface Elevation at Required Discharge**

Discharge through riser/barrel = 17.7 cfs

**Riser Flow:**

Length/Width of Principal Spillway (Riser): 4.0 feet by 2.0 feet  
Crest of Principal Spillway (Riser): 990.50 feet

Orifice flow from Riser:  $Q = 0.9 A_{\text{riser}} (2gh)^{0.5}$  Solve for h = 0.09  
Weir flow from Riser:  $Q = 3.1 P_{\text{riser}} h^{1.5}$  Solve for h = 0.61 feet. Elev: 991.11 feet  
Weir controls over Orifice.

**Barrel Flow:**

Discharge pipe invert elevation at basin: 982.00 feet  
Diameter of Barrel: 1.5 feet (maximum diameter is riser diameter / 1.25, see pg 40)  
Barrel length, L = 62 feet  
Slope of the barrel: 6.0%  
Discharge pipe invert elev at outlet end of pipe: 978.28 feet  
Barrel Manning's n = 0.011 (use 0.025 for CMP, 0.015 for RCP, see page 45)

Pipe flow from Barrel: (where h = head over centerline of outlet end of pipe)  
 $Q = A_{\text{barrel}} \left\{ \frac{(2gh)}{[1 + 1 + (5087 * n^2 / d_i^{1.33}) * L]} \right\}^{0.5}$  Solve for h = 4.39 feet. Elev: 983.42 feet

**Determine which part of structure controls (higher W.S. Elev):** Riser capacity controls over Barrel.

Does Emergency Spillway contribute to outflow? No.

Required Q through the riser/barrel is 17.7 cfs

**Maximum Water Surface Elevation and Required Freeboard**

Maximum water surface elevation: 991.11 feet (at maximum discharge capacity)  
Top of Embankment: 994.00 feet. Freeboard provided: 35 inches



Sediment Basin Name: **SEDIMENT BASIN 15A**

ULATIONS\EROSION & SEDIMENTATION CALCS\SEDIMENT BASINS AND TRAPS\SEDIMENT BASINS\{PPLS0902\_Sed Basin Design 15A.xls}Sed Basin Design

**Skimmer Design** (as an alternate to the dewatering orifices on the riser.)

**Basic Input:**

Volume to top of Dewatering Zone , V:	50,348 cu ft	
Dewatering Time, t:	4.5 days	Dewatering time entered by user.
Floor of basin elevation:	985.00 feet	
Top of dewatering zone elevation:	990.50 feet	

**Calculations:**

Calculated skimmer orifice diameter: 2.46 in (from figure 7, page 44 of PA E&S manual)

Use 1/2" diameter orifices on the skimmer to provide 2.46 inches of orifice area.

Orifice area of a 1/2" diameter orifice: 0.20 sq in Area= 4.74 sq in

**Number of 1/2" dia. orifices required: 24**

*The arm of the skimmer must form an angle with the basin floor of 45 degrees or less when the water surface elevation is at the top of dewatering zone.*

Water depth:	5.50 feet
Minimum length of skimmer arm:	7.78 feet
<b>Use skimmer arm length of:</b>	<b>8 feet</b>

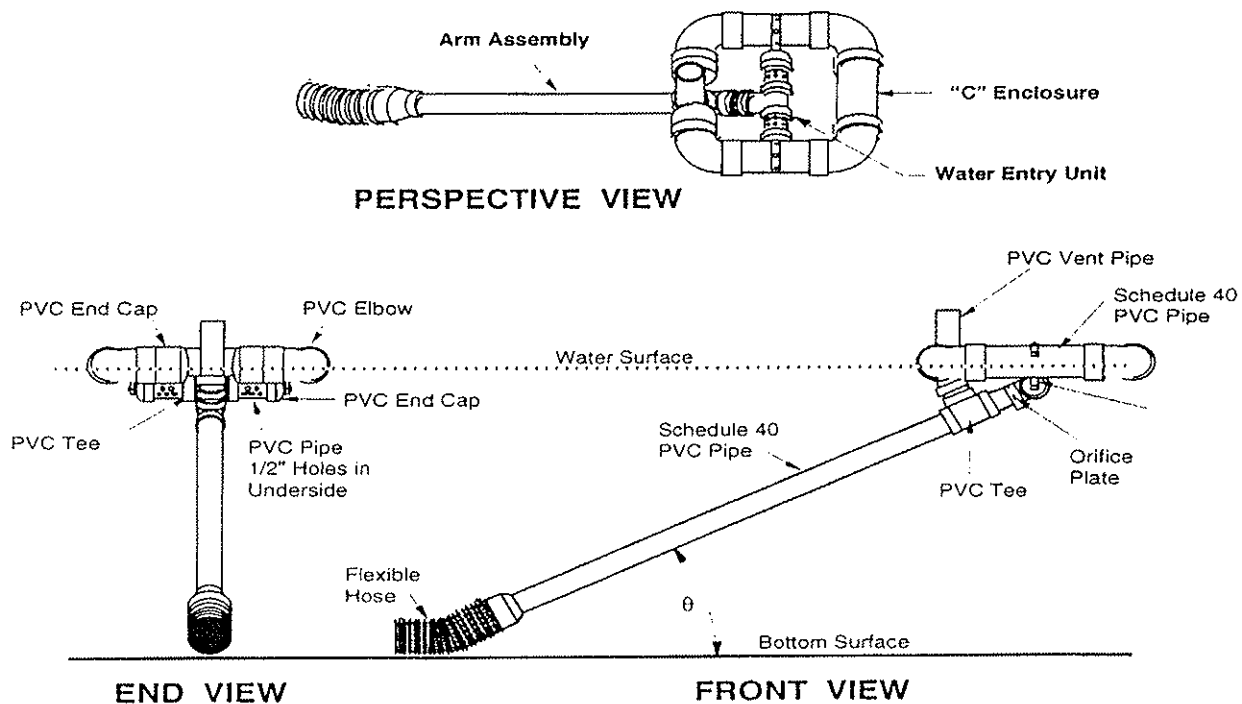

**STANDARD WORKSHEET #12**  
**Sediment Basin Capacity Requirements**

PROJECT NAME: PPL Bell Bend Nuclear Power Plant  
 LOCATION: Salem Township, Luzerne County  
 PREPARED BY: J. Volonakis DATE: 8/22/2011  
 CHECKED BY: D. Molinaro DATE: 8/22/2011

BASIN NUMBER	SEDIMENT BASIN 15A
(A) MAXIMUM TOTAL DRAINAGE AREA (AC)	8.85
(I) INITIAL REQ'D SETTLING VOLUME (5,000 X A) (CF)	44,250
(T) REDUCTION FOR TOP DEWATERING (-700 X A) (CF)	X
(P) REDUCTION FOR PERMANENT POOL (-700 X A) (CF)	X
(L) RED. FOR 4:1 FLOW LENGTH:WIDTH (-350 X A) (CF)	X
(D) RED. FOR 4 TO 7 DAY DEWATERING (- 350 X A) (CF)	X
*** (Sv) REQUIRED SETTLING VOLUME [(I - (T+P+L+D))] (CF)	44,250
(Sd) REQUIRED SEDIMENT STORAGE VOLUME (1000 X a) <sup>1</sup> (CF)	8,850
(St) TOTAL REQUIRED STORAGE VOLUME (Sv + Sd) (CF)	53,100
**** TOTAL STORAGE VOLUME PROVIDED (CF) -	59,198
REQUIRED DISCHARGE CAPACITY (2 X A) (CFS)	17.7
PRINCIPAL SPILLWAY CAPACITY (@ ELEV # ) (CFS)	17.7
* EMERGENCY SPILLWAY CAPACITY (@ ELEV ↘ ) (CFS)	0.0
** EMERGENCY SPILLWAY PROTECTIVE LINING	Pyramat

**X Reductions not allowed in a High Quality/Exceptional Value watershed.**

\* Provide supporting computations.

\*\* If grass lining is proposed, spillway must be constructed in original ground.

\*\*\* 5000 cubic feet per acre settling volume is required for basins located in Special Protection (HQ & EV) watersheds. In other watersheds, the basin settling volume may be reduced per the Department's "Erosion and Sediment Pollution Control Program Manual," No. 363-2134-008 (January 1996), as amended and updated. The minimum settling volume for such basins is (3600 X A).

\*\*\*\* Total Storage Volume provided at riser crest.

<sup>1</sup> a = Disturbed Acres in Drainage Area      a = 8.85 acres

**STANDARD WORKSHEET #13**  
**Sediment Basin Dimensions and Elevations**

PROJECT NAME: PPL Bell Bend Nuclear Power Plant  
 LOCATION: Salem Township, Luzerne County  
 PREPARED BY: J. Volonakis DATE: 8/22/2011  
 CHECKED BY: D. Molinaro DATE: 8/22/2011

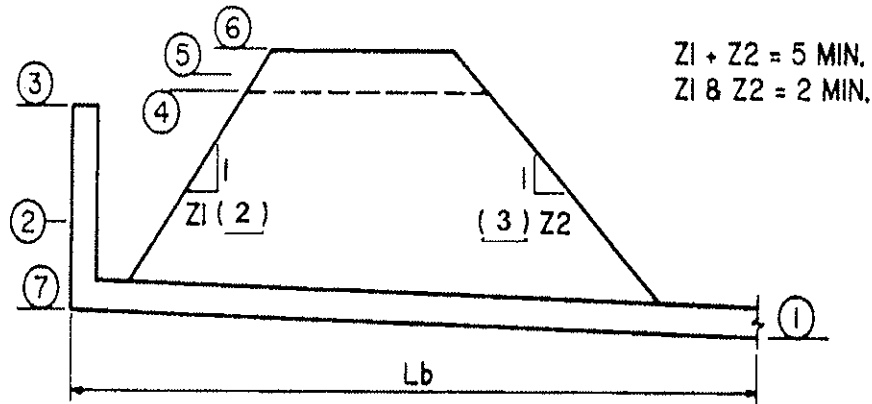

BASIN NUMBER	SEDIMENT BASIN 15A
1. DISCHARGE PIPE ELEVATION	978.28
2. TOP OF SEDIMENT STORAGE ZONE (@ Sd)	986.26
3. ELEVATION AT TOP OF DEWATERING ZONE (St) (CREST OF PRINCIPAL SPILLWAY)	990.50
4. EMERGENCY SPILLWAY CREST ELEVATION (MIN. 0.5' ABOVE ELEVATION ① )	992.00
5. 2 CFS/ACRE FLOW ELEVATION	991.11
6. TOP OF EMBANKMENT ELEVATION (MIN. 24" ABOVE ELEVATION ④ )	994.00
7. BOTTOM ELEVATION	985.00
AVERAGE BOTTOM WIDTH (FT)	10
AVERAGE BOTTOM LENGTH (FT)	200
EMBANKMENT TOP WIDTH (FT, 8' MIN.)	8
RISER DIAMETER/TYPE (15" MIN.)	Type M Inlet Box
BARREL DIAMETER/TYPE (12" MIN.)	18 in. RCP
Lb (BARREL LENGTH (FT)	62.0
EMERGENCY SPILLWAY WIDTH (FT)	10.0
EMERGENCY SPILLWAY SIDE SLOPES (H:V)	3.0

**SHOW ALL DETAILS AND CONSTRUCTION DIMENSIONS ON PLAN DRAWINGS  
 USING STANDARD CONSTRUCTION DETAIL SHEETS.**



Sediment Basin Design Calculations:



Client/Subject: PPL Bell Bend, LLC  
 Description: Sediment Basin Calculation  
 Prepared by: J. Volonakis  
 Date: 16 Aug 11

Print Date: 12 Sep 11 10:35 AM  
 Project #: PPLS0902

Checked by: D. Molinaro
----------------------------

**Objective:**

This spreadsheet will assist with the design of sediment basins as erosion and sediment control measures. The calculations below are based on the criteria mandated by the PA E&S Manual (March '00 version) on pages 40 to 63.

**Basic Input:**

Sediment Basin Name: **SEDIMENT BASIN 18**

Drainage Area to Basin: 13.1 acres (if < 5.0 acres, consider sediment trap also)  
 Disturbed Area Tributary to Basin: 13.1 acres

**Requirements:**

Required Sediment Storage volume: 13,130 ft<sup>3</sup> (1000 ft<sup>3</sup>/ disturbed acre)  
 Is the basin in a HQ or EV watershed? Yes. **Reductions not allowed in a HQ or EV watershed.**

Dewatering Zone Volume Determination (Standard Dewatering Zone = 5000 ft<sup>3</sup>/acre)

Does the basin dewater via a skimmer? Yes.  
 Does the basin have >18" permanent pool? No.  
 Is flow length to width greater than 4:1? Yes.  
 Does basin dewater between 4 and 7 days? Yes. (4.5 days)

Actual Dewatering Zone criteria: 5,000 ft<sup>3</sup>/acre after reductions (minimum of 3600 ft<sup>3</sup>/acre)

Required Dewatering Zone volume: 65,650 ft<sup>3</sup> (5000 ft<sup>3</sup>/ total acre)

**Minimum total storage volume: 78,780 ft<sup>3</sup> (Dewatering Zone PLUS Sediment Storage volume)**

**Elevation-Storage Data:**

	Elevation	Plan Area	Δ Vol	Σ Vol
Bottom of Basin Elevation:	621.00	40615.0		
	622.00	42,594.0	41,604.5	41,604.5
	624.00	46,628.0	89,222.0	130,826.5
	626.00	50,766.0	97,394.0	228,220.5
	628.00	55,006.0	105,772.0	333,992.5
Embankment Top Elevation:	630.00	59,348.0	114,354.0	448,346.5

**Actual Storage Volumes and Riser Height**

Elevation of Top of Sed. Storage (cleanout): 621.32 feet (provides Required Sediment storage volume)  
 Crest of Principal Spillway (Riser): 626.00 feet (minimum elev to provide Dewatering Zone: 622.86 ft)  
 Actual Storage volume provided at riser crest: 228,221 ft<sup>3</sup>

**Other Basin Characteristics**

Flow length through basin is increased using baffles.  
 Flow length through basin: 400 feet 2 to 1 (minimum flow length: 317.69 ft; see page 56)  
 Average width of basin: 100 feet 4 to 1 (minimum flow length: 450.63 ft; see page 56)  
 Length to width ratio: 4.0 to 1 (minimum 2 to 1)

Sediment Basin Name: **SEDIMENT BASIN 18**

C:\P\PLS0902\_Sed Basin Design 18.xls\Sed Basin Design

**Embankment Criteria**

Embankment top width must be at least 8 feet wide.  
Embankment side slopes may not be steeper than 2H:1V

**Embankment Spillway Weir Dimensions**

Emergency Spillway outlet width, L: 10.0 feet (minimum bottom width is 8', see page 40)  
Emergency Spillway outlet side slopes: 3 to 1  
Emergency Spillway crest elevation: 628.00 feet (minimum crest elev: 626.50 ft; 6 in over riser crest)  
(maximum crest elev: 629.50 ft; 6 in below top of berm)

**Required Discharge from Basin**

Minimum discharge capacity (2 cfs/ac) Q = 26.3 cfs (at maximum water surface elevation)

**Water Surface Elevation at Required Discharge**

Discharge through riser/barrel = 26.3 cfs

**Riser Flow:**

Length/Width of Principal Spillway (Riser): 4.0 feet by 2.0 feet  
Crest of Principal Spillway (Riser): 626.00 feet

Orifice flow from Riser:  $Q = 0.9 A_{\text{riser}} (2gh)^{0.5}$

Solve for h = 0.21

Weir flow from Riser:  $Q = 3.1 P_{\text{riser}} h^{1.5}$

Solve for h = 0.79 feet. Elev: 626.79 feet

Weir controls over Orifice.

**Barrel Flow:**

Discharge pipe invert elevation at basin: 621.00 feet  
Diameter of Barrel: 2.0 feet (maximum diameter is riser diameter / 1.25, see pg 40)  
Barrel length, L = 74 feet  
Slope of the barrel : 2.7%

Discharge pipe invert elev at outlet end of pipe: 619.00 feet  
Barrel Manning's n = 0.011 (use 0.025 for CMP, 0.015 for RCP, see page 45)

Pipe flow from Barrel: (where h = head over centerline of outlet end of pipe)

$Q = A_{\text{barrel}} \left\{ \frac{(2gh)}{[1 + 1 + (5087 * n^2 / d_i^{1.33}) * L]} \right\}^{0.5}$  Solve for h = 2.89 feet. Elev: 622.89 feet

**Determine which part of structure controls (higher W.S. Elev): Riser capacity controls over Barrel.**

Does Emergency Spillway contribute to outflow? No.

Required Q through the riser/barrel is 26.3 cfs

**Maximum Water Surface Elevation and Required Freeboard**

Maximum water surface elevation: 626.79 feet (at maximum discharge capacity)  
Top of Embankment: 630.00 feet. Freeboard provided: 38 inches



Sediment Basin Name: **SEDIMENT BASIN 18**

C:\P\PLS0902\_Sed Basin Design 18.xls\Sed Basin Design

**Skimmer Design** (as an alternate to the dewatering orifices on the riser.)

**Basic Input:**

Volume to top of Dewatering Zone , V:	215,091 cu ft	
Dewatering Time, t:	4.5 days	Dewatering time entered by user.
Floor of basin elevation:	621.00 feet	
Top of dewatering zone elevation:	626.00 feet	

**Calculations:**

Calculated skimmer orifice diameter: 4.71 in (from figure 7, page 44 of PA E&S manual)

Use 1/2" diameter orifices on the skimmer to provide 4.71 inches of orifice area.

Orifice area of a 1/2" diameter orifice: 0.20 sq in Area= 17.39 sq in

**Number of 1/2" dia. orifices required: 87**

The arm of the skimmer must form an angle with the basin floor of 45 degrees or less when the water surface elevation is at the top of dewatering zone.

Water depth:	5.00 feet
Minimum length of skimmer arm:	7.07 feet
<b>Use skimmer arm length of:</b>	<b>8 feet</b>

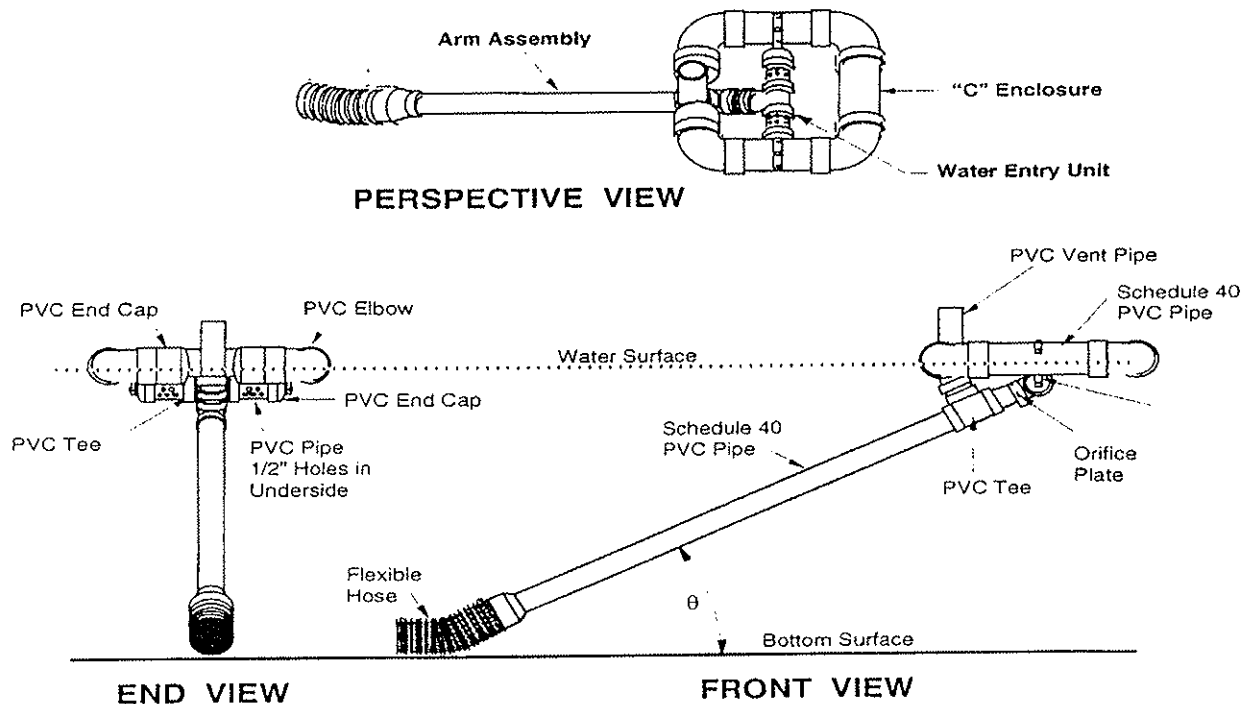

**STANDARD WORKSHEET #12**  
**Sediment Basin Capacity Requirements**

PROJECT NAME: PPL Bell Benc Nuclear Power Plant

LOCATION: Salem Township, Luzerne County

PREPARED BY: J. Volonakis DATE: 8/16/2011

CHECKED BY: D. Molinaro DATE: 8/16/2011

BASIN NUMBER	SEDIMENT BASIN 18
(A) MAXIMUM TOTAL DRAINAGE AREA (AC)	13.13
(I) INITIAL REQ'D SETTLING VOLUME (5,000 X A) (CF)	65,650
(T) REDUCTION FOR TOP DEWATERING (-700 X A) (CF)	X
(P) REDUCTION FOR PERMANENT POOL (-700 X A) (CF)	X
(L) RED. FOR 4:1 FLOW LENGTH:WIDTH (-350 X A) (CF)	X
(D) RED. FOR 4 TO 7 DAY DEWATERING (- 350 X A) (CF)	X
*** (Sv) REQUIRED SETTLING VOLUME [I - (T+P+L+D)] (CF)	65,650
(Sd) REQUIRED SEDIMENT STORAGE VOLUME (1000 X a) <sup>1</sup> (CF)	13,130
(St) TOTAL REQUIRED STORAGE VOLUME (Sv + Sd) (CF)	78,780
**** TOTAL STORAGE VOLUME PROVIDED (CF)	228,221
REQUIRED DISCHARGE CAPACITY (2 X A) (CFS)	26.3
PRINCIPAL SPILLWAY CAPACITY (@ ELEV # ) (CFS)	26.3
* EMERGENCY SPILLWAY CAPACITY (@ ELEV ↴ ) (CFS)	0.0
** EMERGENCY SPILLWAY PROTECTIVE LINING	Pyramat

**X Reductions not allowed in a High Quality/Exceptional Value watershed.**

\* Provide supporting computations.

\*\* If grass lining is proposed, spillway must be constructed in original ground.

\*\*\* 5000 cubic feet per acre settling volume is required for basins located in Special Protection (HQ & EV) watersheds. In other watersheds, the basin settling volume may be reduced per the Department's "Erosion and Sediment Pollution Control Program Manual," No. 363-2134-008 (January 1996), as amended and updated. The minimum settling volume for such basins is (3600 X A).

\*\*\*\* Total Storage Volume provided at riser crest.

<sup>1</sup> a = Disturbed Acres in Drainage Area      a = 13.13 acres

**STANDARD WORKSHEET #13**  
**Sediment Basin Dimensions and Elevations**

PROJECT NAME: PPL Bell Benc Nuclear Power Plant  
 LOCATION: Salem Township, Luzerne County  
 PREPARED BY: J. Volonakis DATE: 8/16/2011  
 CHECKED BY: D. Molinaro DATE: 8/16/2011

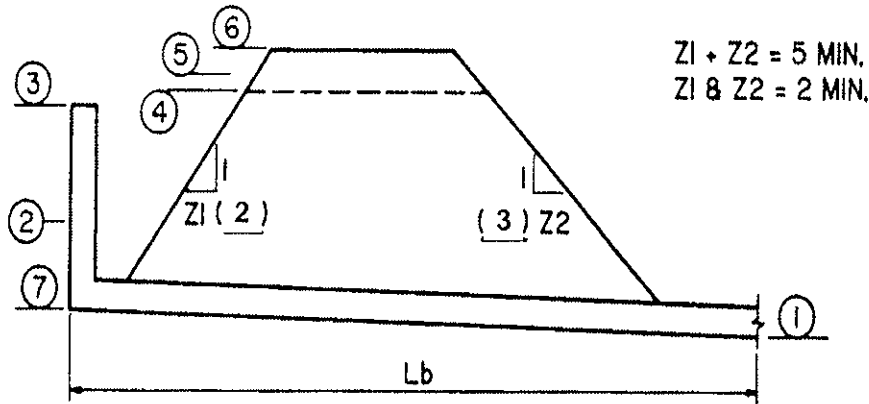

BASIN NUMBER	SEDIMENT BASIN 18
1. DISCHARGE PIPE ELEVATION	619.00
2. TOP OF SEDIMENT STORAGE ZONE (@ Sd)	621.32
3. ELEVATION AT TOP OF DEWATERING ZONE (St) (CREST OF PRINCIPAL SPILLWAY)	626.00
4. EMERGENCY SPILLWAY CREST ELEVATION (MIN. 0.5' ABOVE ELEVATION ①)	628.00
5. 2 CFS/ACRE FLOW ELEVATION	626.79
6. TOP OF EMBANKMENT ELEVATION (MIN. 24" ABOVE ELEVATION ④)	630.00
7. BOTTOM ELEVATION	621.00
AVERAGE BOTTOM WIDTH (FT)	100
AVERAGE BOTTOM LENGTH (FT)	400
EMBANKMENT TOP WIDTH (FT, 8' MIN.)	8
RISER DIAMETER/TYPE (15" MIN.)	Type M Inlet Box
BARREL DIAMETER/TYPE (12" MIN.)	24 in. RCP
Lb (BARREL LENGTH (FT)	74.0
EMERGENCY SPILLWAY WIDTH (FT)	10.0
EMERGENCY SPILLWAY SIDE SLOPES (H:V)	3.0

**SHOW ALL DETAILS AND CONSTRUCTION DIMENSIONS ON PLAN DRAWINGS  
 USING STANDARD CONSTRUCTION DETAIL SHEETS.**



Sediment Basin Design Calculations:



Client/Subject: PPL Bell Bend, LLC  
 Description: Sediment Basin Calculation  
 Prepared by: J. Volonakis  
 Date: 24 Aug 11

Print Date: 12 Sep 11 10:35 AM  
 Project #: PPLS0902

Checked by: D. Molinaro
----------------------------

**Objective:**

This spreadsheet will assist with the design of sediment basins as erosion and sediment control measures. The calculations below are based on the criteria mandated by the PA E&S Manual (March '00 version) on pages 40 to 63.

**Basic Input:**

**Sediment Basin Name: SEDIMENT BASIN 21**

Drainage Area to Basin: 98.1 acres (if < 5.0 acres, consider sediment trap also)  
 Disturbed Area Tributary to Basin: 98.1 acres

**Requirements:**

Required Sediment Storage volume: 98,080 ft<sup>3</sup> (1000 ft<sup>3</sup>/ disturbed acre)  
 Is the basin in a HQ or EV watershed? Yes. **Reductions not allowed in a HQ or EV watershed.**

Dewatering Zone Volume Determination (Standard Dewatering Zone = 5000 ft<sup>3</sup>/acre)

Does the basin dewater via a skimmer? Yes.  
 Does the basin have >18" permanent pool? No.  
 Is flow length to width greater than 4:1? Yes.  
 Does basin dewater between 4 and 7 days? Yes. (4.5 days)

Actual Dewatering Zone criteria: 5,000 ft<sup>3</sup>/acre after reductions (minimum of 3600 ft<sup>3</sup>/acre)

Required Dewatering Zone volume: 490,400 ft<sup>3</sup> (5000 ft<sup>3</sup>/ total acre)

**Minimum total storage volume: 588,480 ft<sup>3</sup> (Dewatering Zone PLUS Sediment Storage volume)**

**Elevation-Storage Data:**

	Elevation	Plan Area	Δ Vol	Σ Vol
Bottom of Basin Elevation:	531.00	106548.9		
	532.00	111,875.3	109,212.1	109,212.1
	534.00	122,611.3	234,486.6	343,698.7
	536.00	133,554.3	256,165.6	599,864.3
	538.00	144,635.0	278,189.3	878,053.5
Embankment Top Elevation:	540.00	155,855.1	300,490.1	1,178,543.6

**Actual Storage Volumes and Riser Height**

Elevation of Top of Sed. Storage (cleanout): 531.90 feet (provides Required Sediment storage volume)  
 Crest of Principal Spillway (Riser): 535.92 feet (minimum elev to provide Dewatering Zone: 535.92 ft)  
 Actual Storage volume provided at riser crest: 589,197 ft<sup>3</sup>

**Other Basin Characteristics**

Flow length through basin: 1200 feet 2 to 1 (minimum flow length: 514.44 ft; see page 56)  
 Average width of basin: 100 feet 4 to 1 (minimum flow length: 729.70 ft; see page 56)  
 Length to width ratio: 12.0 to 1 (minimum 2 to 1)

Sediment Basin Name: **SEDIMENT BASIN 21**

C:\P\Projects\SIEROSION & SEDIMENTATION CALCS\SEDIMENT BASINS AND TRAPS\SEDIMENT BASINS\{PPLS0902\_Sed Basin Design 21.xls\}Sed Basin Design

**Embankment Criteria**

Embankment top width must be at least 8 feet wide.

Embankment side slopes may not be steeper than 2H:1V

**Embankment Spillway Weir Dimensions**

Emergency Spillway outlet width, L:	40.0	feet	(minimum bottom width is 8', see page 40)
Emergency Spillway outlet side slopes:	3 to 1		
Emergency Spillway crest elevation:	537.00	feet	(minimum crest elev: 536.42 ft; 6 in over riser crest) (maximum crest elev: 539.50 ft; 6 in below top of berm)

**Required Discharge from Basin**

Minimum discharge capacity (2 cfs/ac) Q = 196.2 cfs (at maximum water surface elevation)

**Water Surface Elevation at Required Discharge**

Discharge through riser/barrel = 152.5 cfs

**Riser Flow:**

Length/Width of Principal Spillway (Riser): 6.0 feet by 6.0 feet  
Crest of Principal Spillway (Riser): 535.92 feet

Orifice flow from Riser:  $Q = 0.9 A_{\text{riser}} (2gh)^{0.5}$  Solve for h = 0.34

Weir flow from Riser:  $Q = 3.1 P_{\text{riser}} h^{1.5}$  Solve for h = 1.61 feet. Elev: 537.53 feet  
Weir controls over Orifice.

**Barrel Flow:**

Discharge pipe invert elevation at basin: 531.00 feet  
Diameter of Barrel: 4.0 feet (maximum diameter is riser diameter / 1.25, see pg 40)  
Barrel length, L = 232 feet  
Slope of the barrel: 1.0%

Discharge pipe invert elev at outlet end of pipe: 528.68 feet  
Barrel Manning's n = 0.011 (use 0.025 for CMP, 0.015 for RCP, see page 45)

Pipe flow from Barrel: (where h = head over centerline of outlet end of pipe)

$Q = A_{\text{barrel}} \{ (2gh) / [1 + 1 + (5087 * n^2 / d_i^{1.33}) * L] \}^{0.5}$  Solve for h = 6.47 feet. Elev: 537.15 feet

Determine which part of structure controls (higher W.S. Elev):

**Riser capacity controls over Barrel.**

Does Emergency Spillway contribute to outflow? Yes.

Emergency Spillway Discharge:  $Q = 2.8 L h^{1.5}$  (C = 2.8 from page 55 of PA E&S manual)

Emergency Spillway crest elevation: 537.00 feet

At W.S. elev 537.53, the head over the emergency spillway is 0.53 feet.

Q through the emergency spillway is 43.6 cfs

Required Q through the riser/barrel is 152.5 cfs

**Maximum Water Surface Elevation and Required Freeboard**

Maximum water surface elevation: 537.53 feet (at maximum discharge capacity)

Top of Embankment: 540.00 feet. Freeboard provided: 30 inches



Sediment Basin Name: **SEDIMENT BASIN 21**

C:\CULATIONS\EROSION & SEDIMENTATION CALCS\SEDIMENT BASINS AND TRAPS\SEDIMENT BASINS\{PPLS0902\_Sed Basin Design 21.xls}Sed Basin Design

**Skimmer Design** (as an alternate to the dewatering orifices on the riser.)

**Basic Input:**

Volume to top of Dewatering Zone , V:	491,117 cu ft	
Dewatering Time, t:	4.5 days	Dewatering time entered by user.
Floor of basin elevation:	531.00 feet	
Top of dewatering zone elevation:	535.92 feet	

**Calculations:**

Calculated skimmer orifice diameter: 6.81 in (from figure 7, page 44 of PA E&S manual)

Use 1/2" diameter orifices on the skimmer to provide 6.81 inches of orifice area.

Orifice area of a 1/2" diameter orifice: 0.20 sq in Area= 36.41 sq in

**Number of 1/2" dia. orifices required: 182**

The arm of the skimmer must form an angle with the basin floor of 45 degrees or less when the water surface elevation is at the top of dewatering zone.

Water depth:	4.92 feet
Minimum length of skimmer arm:	6.96 feet
<b>Use skimmer arm length of:</b>	<b>7 feet</b>

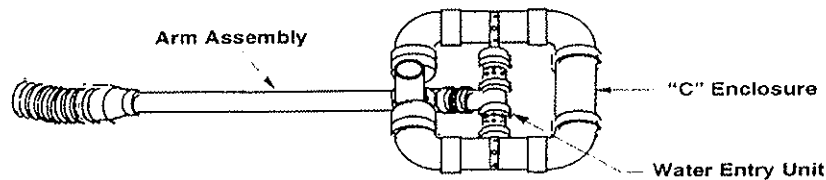

**PERSPECTIVE VIEW**

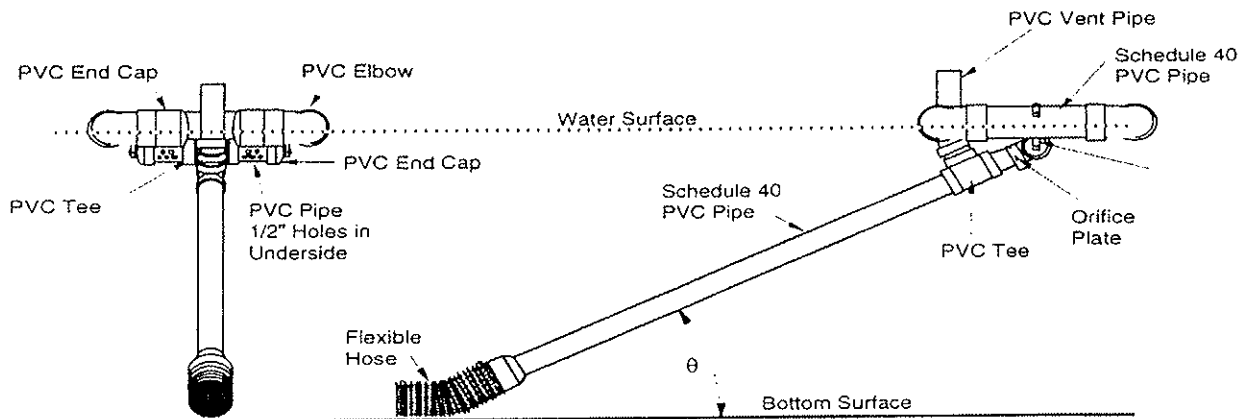

**END VIEW**

**FRONT VIEW**

**STANDARD WORKSHEET #12**  
**Sediment Basin Capacity Requirements**

PROJECT NAME: Bell Bend Nuclear Power Plant  
 LOCATION: Salem Township, Luzerne County  
 PREPARED BY: J. Volonakis DATE: 8/15/2011  
 CHECKED BY: D. Molinaro DATE: 8/15/2011

BASIN NUMBER	SEDIMENT BASIN 21
(A) MAXIMUM TOTAL DRAINAGE AREA (AC)	98.08
(I) INITIAL REQ'D SETTLING VOLUME (5,000 X A) (CF)	490,400
(T) REDUCTION FOR TOP DEWATERING (-700 X A) (CF)	X
(P) REDUCTION FOR PERMANENT POOL (-700 X A) (CF)	X
(L) RED. FOR 4:1 FLOW LENGTH:WIDTH (-350 X A) (CF)	X
(D) RED. FOR 4 TO 7 DAY DEWATERING (- 350 X A) (CF)	X
*** (Sv) REQUIRED SETTLING VOLUME [I - (T+P+L+D)] (CF)	490,400
(Sd) REQUIRED SEDIMENT STORAGE VOLUME (1000 X a) <sup>1</sup> (CF)	98,080
(St) TOTAL REQUIRED STORAGE VOLUME (Sv + Sd) (CF)	588,480
**** TOTAL STORAGE VOLUME PROVIDED (CF)	589,197
REQUIRED DISCHARGE CAPACITY (2 X A) (CFS)	196.2
PRINCIPAL SPILLWAY CAPACITY (@ ELEV # ) (CFS)	152.5
* EMERGENCY SPILLWAY CAPACITY (@ ELEV ↘ ) (CFS)	43.6
** EMERGENCY SPILLWAY PROTECTIVE LINING	Pyramat

**X Reductions not allowed in a High Quality/Exceptional Value watershed.**

\* Provide supporting computations.

\*\* If grass lining is proposed, spillway must be constructed in original ground.

\*\*\* 5000 cubic feet per acre settling volume is required for basins located in Special Protection (HQ & EV) watersheds. In other watersheds, the basin settling volume may be reduced per the Department's "Erosion and Sediment Pollution Control Program Manual," No. 363-2134-008 (January 1996), as amended and updated. The minimum settling volume for such basins is (3600 X A).

\*\*\*\* Total Storage Volume provided at riser crest.

<sup>1</sup>a = Disturbed Acres in Drainage Area      a = 98.08 acres

**STANDARD WORKSHEET #13**  
**Sediment Basin Dimensions and Elevations**

PROJECT NAME: Bell Bend Nuclear Power Plant  
 LOCATION: Salem Township, Luzerne County  
 PREPARED BY: J. Volonakis DATE: 8/15/2011  
 CHECKED BY: D. Molinaro DATE: 8/15/2011

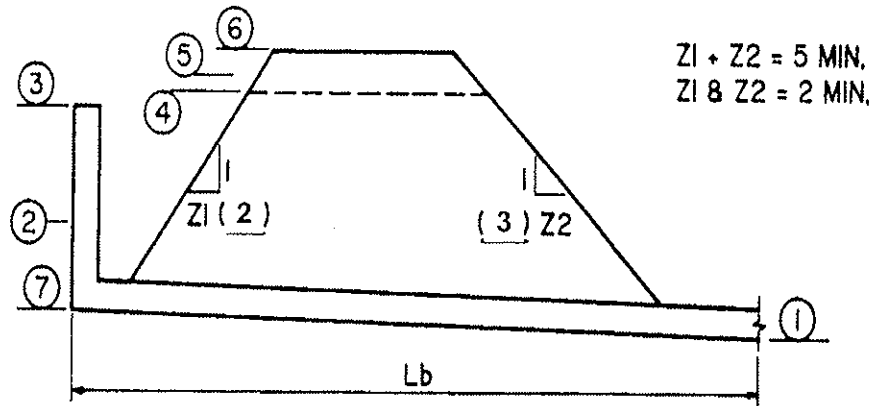

BASIN NUMBER	SEDIMENT BASIN 21
1. DISCHARGE PIPE ELEVATION	528.68
2. TOP OF SEDIMENT STORAGE ZONE (@ Sd)	531.90
3. ELEVATION AT TOP OF DEWATERING ZONE (St) (CREST OF PRINCIPAL SPILLWAY)	535.92
4. EMERGENCY SPILLWAY CREST ELEVATION (MIN. 0.5' ABOVE ELEVATION ① )	537.00
5. 2 CFS/ACRE FLOW ELEVATION	537.53
6. TOP OF EMBANKMENT ELEVATION (MIN. 24" ABOVE ELEVATION ④ )	540.00
7. BOTTOM ELEVATION	531.00
AVERAGE BOTTOM WIDTH (FT)	100
AVERAGE BOTTOM LENGTH (FT)	1,200
EMBANKMENT TOP WIDTH (FT, 8' MIN.)	8
RISER DIAMETER/TYPE (15" MIN.)	Type M Inlet Box
BARREL DIAMETER/TYPE (12" MIN.)	48 in. RCP
Lb (BARREL LENGTH (FT)	232.0
EMERGENCY SPILLWAY WIDTH (FT)	40.0
EMERGENCY SPILLWAY SIDE SLOPES (H:V)	3.0

**SHOW ALL DETAILS AND CONSTRUCTION DIMENSIONS ON PLAN DRAWINGS  
 USING STANDARD CONSTRUCTION DETAIL SHEETS.**





Project: PPLS0902

By: JCV Date: 9/1/2011

BASIN: 1

Chk'd: JMO Date: 9/2/2011

FIGURE 7.6  
Anti-Seep Collar Design

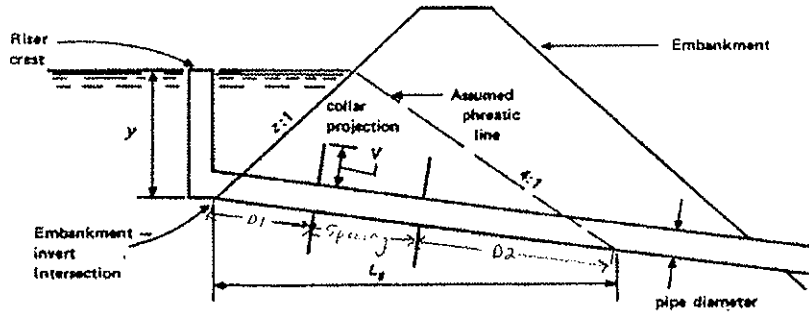

EPA - 625/3-76-006

Extension Box Elev. (Ft) =	669
Outlet Barrel Invert Elevation (Ft) =	665
Pipe slope (ft/ft) =	0.019
Basin Type (Temp or Perm) =	Temp
Pipe diameter (Ft) =	2.5

Length of Pipe in Saturated Zone

$$L_s = y(z + 4) \left[ 1 + \frac{\text{pipe slope } \left(\frac{ft}{ft}\right)}{0.25 - \text{pipe slope}} \right]$$

- y = 4 Distance from upstream invert of principal spillway riser to top of dewatering volume.
- z = 2 Horizontal component of upstream embankment slope (ft)
- L<sub>s</sub> = 25.97 Length of pipe in saturated zone (ft)

Required Increase in Flow Path

For flow path for a temporary basin provide a minimum of 10% increase to L<sub>s</sub>.  
For flow path for a permanent basin provide a minimum of 15% increase to L<sub>s</sub>.

L<sub>f</sub> = 28.57

Minimum Collar Projection (ft) (Rounded to nearest 3" increment)

V<sub>min</sub> = 1.25 (1/2 the increase in Flow Path for one collar)  
Therefore: Use one collar

Number of Collars if >1 =

V<sub>min</sub> = N/A

Project: PPLS0902

By: JCV Date: 9/1/2011

**BASIN: 1**

Chk'd: JMO Date: 9/2/2011

Maximum Spacing between Collars (ft)

Max Spacing = 14

Min Spacing = 5

Anti-seep Collars should be located below the phreatic line in the embankment and should be evenly spaced.

ft  
D1 = 7.50

D2= 15.00

Spacing of collars  
starting at D1 or  
Distance to first collar

if only one collar  
used= 7.50 Spacing Ok

Project: PPLS0902

By: JCV Date: 9/1/2011

BASIN: 1A

Chk'd: JMO Date: 9/2/2011

FIGURE 7.6  
Anti-Seep Collar Design

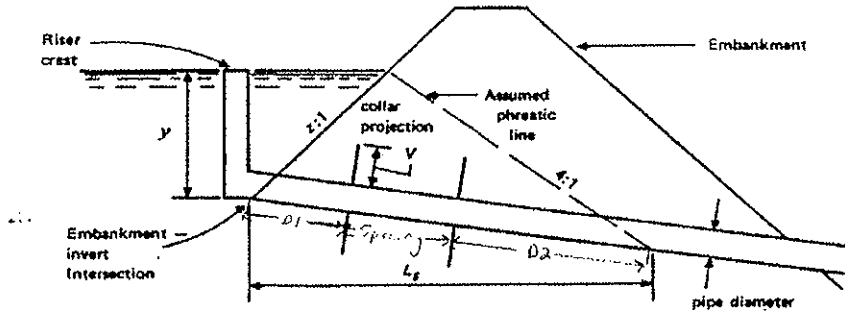

EPA - 625/3-76-006

Extension Box Elev. (Ft) =	661.86
Outlet Barrel Invert Elevation (Ft) =	659
Pipe slope (ft/ft) =	0.018
Basin Type (Temp or Perm) =	Temp
Pipe diameter (Ft) =	2

Length of Pipe in Saturated Zone

$$L_S = y(z + 4) \left[ 1 + \frac{\text{pipe slope } \left(\frac{ft}{ft}\right)}{0.25 - \text{pipe slope}} \right]$$

Distance from upstream invert of principal spillway riser to top of dewatering volume.

y = 2.86

z = 2 Horizontal component of upstream embankment slope (ft)

L<sub>S</sub> = 18.49 Length of pipe in saturated zone (ft)

Required Increase in Flow Path

For flow path for a temporary basin provide a minimum of 10% increase to L<sub>S</sub>.

For flow path for a permanent basin provide a minimum of 15% increase to L<sub>S</sub>.

L<sub>F</sub> = 20.34

Minimum Collar Projection (ft) (Rounded to nearest 3" increment)

V<sub>min</sub> = 1.00 (1/2 the increase in Flow Path for one collar)

Therefore: Use one collar

Number of Collars if >1 =

V<sub>min</sub> = N/A

Project: PPLS0902

By: JCV Date: 9/1/2011

BASIN: 1A

Chk'd: JMO Date: 9/2/2011

Maximum Spacing between Collars (ft)

Max Spacing = 14

Min Spacing = 5

Anti-seep Collars should be located below the phreatic line in the embankment and should be evenly spaced.

ft  
D1 = 6.00  
D2 = 12.00

Spacing of collars  
starting at D1 or  
Distance to first collar  
if only one collar  
used= 6.00 Spacing Ok

Project: PPLS0902

By: JCV Date: 9/1/2011

BASIN: 3

Chk'd: JMO Date: 9/2/2011

FIGURE 7.6  
Anti-Seep Collar Design

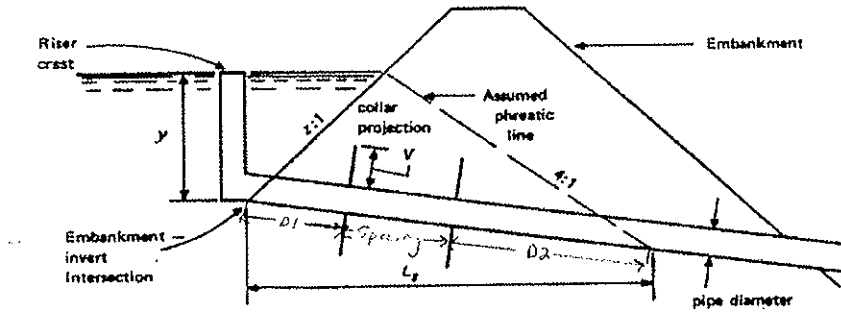

EPA - 625/3-76-006

Extension Box Elev. (Ft) =	657
Outlet Barrel Invert Elevation (Ft) =	650
Pipe slope (ft/ft) =	0.017
Basin Type (Temp or Perm) =	Perm
Pipe diameter (Ft) =	3

Length of Pipe in Saturated Zone

$$L_s = y(z + 4) \left[ 1 + \frac{\text{pipe slope } \left(\frac{ft}{ft}\right)}{0.25 - \text{pipe slope}} \right]$$

$y =$  7 Distance from upstream invert of principal spillway riser to top of dewatering volume.

$z =$  2 Horizontal component of upstream embankment slope (ft)

$L_s =$  45.06 Length of pipe in saturated zone (ft)

Required Increase in Flow Path

For flow path for a temporary basin provide a minimum of 10% increase to  $L_s$ .

For flow path for a permanent basin provide a minimum of 15% increase to  $L_s$ .

$L_f =$  51.82

Minimum Collar Projection (ft) (Rounded to nearest 3" increment)

$V_{min} =$  3.50 (1/2 the increase in Flow Path for one collar)

Therefore: Use additional Collars with  $V_{min} > 1$

Number of Collars if  $>1 =$  2

$V_{min} =$  1.75

Project: PPLS0902

By: JCV Date: 9/1/2011

**BASIN: 3**

Chk'd: JMO Date: 9/2/2011

Maximum Spacing between Collars (ft)

Max Spacing = 45

Min Spacing = 10

Anti-seep Collars should be located below the phreatic line in the embankment and should be evenly spaced.

ft  
D1 = 9.50  
D2 = 18.99

Spacing of collars  
starting at D1 or  
Distance to first collar  
if only one collar  
used= 16.57 Spacing Ok

Project: PPLS0902

By: JCV Date: 9/1/2011

BASIN: 6

Chk'd: JMO Date: 9/2/2011

FIGURE 7.6 Anti-Seep Collar Design

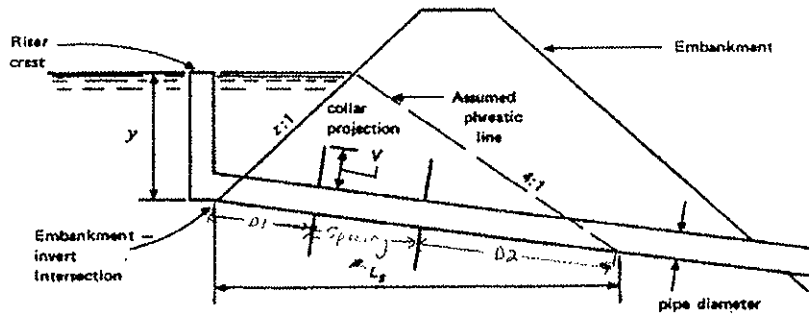

EPA - 625/3-76-006

Extension Box Elev. (Ft) =	637
Outlet Barrel Invert Elevation (Ft) =	632
Pipe slope (ft/ft) =	0.021
Basin Type (Temp or Perm) =	Temp
Pipe diameter (Ft) =	3

Length of Pipe in Saturated Zone

$$L_s = y(z + 4) \left[ 1 + \frac{\text{pipe slope } \left(\frac{ft}{ft}\right)}{0.25 - \text{pipe slope}} \right]$$

Distance from upstream invert of principal spillway riser to top of dewatering volume.

- y = 5
- z = 2 Horizontal component of upstream embankment slope (ft)
- L<sub>s</sub> = 32.75 Length of pipe in saturated zone (ft)

Required Increase in Flow Path

For flow path for a temporary basin provide a minimum of 10% increase to L<sub>s</sub>.  
For flow path for a permanent basin provide a minimum of 15% increase to L<sub>s</sub>.

L<sub>f</sub> = 36.03

Minimum Collar Projection (ft) (Rounded to nearest 3" increment)

V<sub>min</sub> = 1.75 (1/2 the increase in Flow Path for one collar)  
Therefore: Use one collar

Number of Collars if >1 =

V<sub>min</sub> = N/A

Project: PPLS0902

By: JCV Date: 9/1/2011

**BASIN: 6**

Chk'd: JMO Date: 9/2/2011

Maximum Spacing between Collars (ft)

Max Spacing = 14

Min Spacing = 5

Anti-seep Collars should be located below the phreatic line in the embankment and should be evenly spaced.

ft  
D1 = 9.50

D2= 18.99

Spacing of collars  
starting at D1 or  
Distance to first collar  
if only one collar  
used=

9.50 Spacing Ok

Project: PPLS0902

By: JCV Date: 9/1/2011

BASIN: 8

Chk'd: JMO Date: 9/2/2011

FIGURE 7.6  
Anti-Seep Collar Design

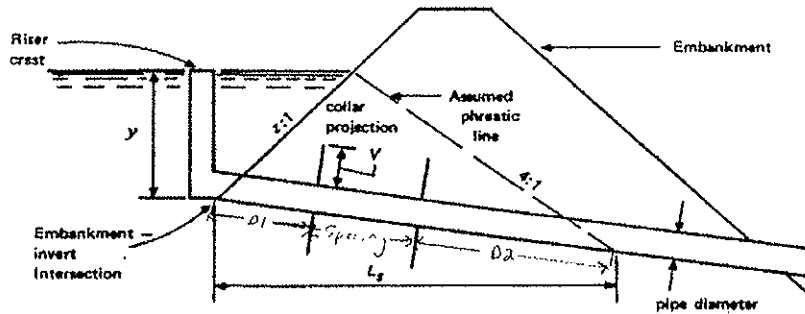

EPA - 625/3-76-006

Extension Box Elev. (Ft) =	667
Outlet Barrel Invert Elevation (Ft) =	664
Pipe slope (ft/ft) =	0.01
Basin Type (Temp or Perm) =	Temp
Pipe diameter (Ft) =	2.5

Length of Pipe in Saturated Zone

$$L_s = y(z + 4) \left[ 1 + \frac{\text{pipe slope } \left(\frac{ft}{ft}\right)}{0.25 - \text{pipe slope}} \right]$$

Distance from upstream invert of principal spillway riser to top of dewatering volume.

- y = 3
- z = 2 Horizontal component of upstream embankment slope (ft)
- L<sub>s</sub> = 18.75 Length of pipe in saturated zone (ft)

Required Increase in Flow Path

For flow path for a temporary basin provide a minimum of 10% increase to L<sub>s</sub>.  
For flow path for a permanent basin provide a minimum of 15% increase to L<sub>s</sub>.

L<sub>f</sub> = 20.63

Minimum Collar Projection (Rounded to nearest 3" increment)

V<sub>min</sub> = 1.00 (1/2 the increase in Flow Path for one collar)

Therefore: Use one collar

Number of Collars if >1 =

V<sub>min</sub> = N/A

Project: PPLS0902

By: JCV Date: 9/1/2011

**BASIN: 8**

Chk'd: JMO Date: 9/2/2011

Maximum Spacing between Collars

Max Spacing = 14

Min Spacing = 5

Anti-seep Collars should be located below the phreatic line in the embankment and should be evenly spaced.

D1 = 7.00

D2 = 14.00

Spacing of collars  
starting at D1 or  
Distance to first collar  
if only one collar  
used=

6.00 Spacing Ok

Project: PPLS0902

By: JCV Date: 9/1/2011

BASIN: 9

Chk'd: JMO Date: 9/2/2011

FIGURE 7.6  
Anti-Seep Collar Design

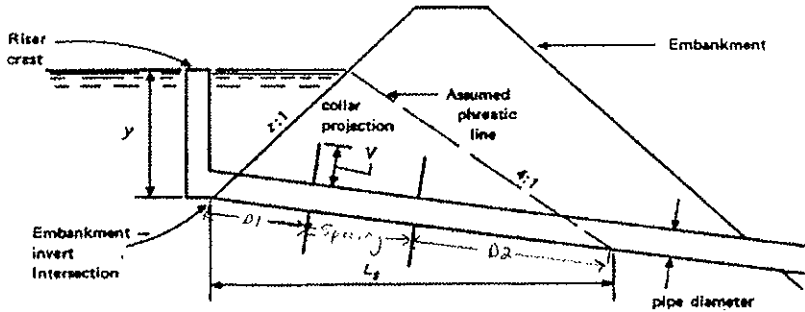

EPA -- 625/3-76-006

Extension Box Elev. (Ft) =	680.5
Outlet Barrel Invert Elevation (Ft) =	676
Pipe slope (ft/ft) =	0.03
Basin Type (Temp or Perm) =	Temp
Pipe diameter (Ft) =	1.5

Length of Pipe in Saturated Zone

$$L_s = y(z + 4) \left[ 1 + \frac{\text{pipe slope } \left(\frac{ft}{ft}\right)}{0.25 - \text{pipe slope}} \right]$$

y = 4.5 Distance from upstream invert of principal spillway riser to top of dewatering volume.

z = 2 Horizontal component of upstream embankment slope (ft)

L<sub>s</sub> = 30.68 Length of pipe in saturated zone (ft)

Required Increase in Flow Path

For flow path for a temporary basin provide a minimum of 10% increase to L<sub>s</sub>.

For flow path for a permanent basin provide a minimum of 15% increase to L<sub>s</sub>.

L<sub>f</sub> = 33.75

Minimum Collar Projection (ft) (Rounded to nearest 3" increment)

V<sub>min</sub> = 1.50 (1/2 the increase in Flow Path for one collar)

Therefore: Use one collar

Number of Collars if >1 =

V<sub>min</sub> = N/A

Project: PPLS0902

By: JCV Date: 9/1/2011

**BASIN: 9**

Chk'd: JMO Date: 9/2/2011

Maximum Spacing between Collars (ft)

Max Spacing = 14

Min Spacing = 5

Anti-seep Collars should be located below the phreatic line in the embankment and should be evenly spaced.

D1 = 6.00 ft

D2= 12.00

Spacing of collars  
starting at D1 or  
Distance to first collar  
if only one collar  
used=

6.00 Spacing Ok

Project: PPLS0902

By: JCV Date: 9/1/2011

BASIN: 10

Chk'd: JMO Date: 9/2/2011

**FIGURE 7.6  
Anti-Seep Collar Design**

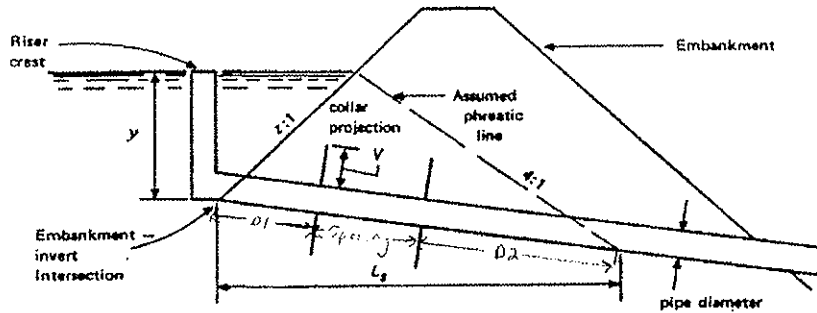

EPA - 625/3-76-006

Extension Box Elev. (Ft) =	666.07
Outlet Barrel Invert Elevation (Ft) =	661.7
Pipe slope (ft/ft) =	0.01
Basin Type (Temp or Perm) =	Temp
Pipe diameter (Ft) =	3

Length of Pipe in Saturated Zone

$$L_s = y(z + 4) \left[ 1 + \frac{\text{pipe slope } \left(\frac{ft}{ft}\right)}{0.25 - \text{pipe slope}} \right]$$

- y = 4.37 Distance from upstream invert of principal spillway riser to top of dewatering volume.
- z = 2 Horizontal component of upstream embankment slope (ft)
- L<sub>s</sub> = 27.31 Length of pipe in saturated zone (ft)

Required Increase in Flow Path

For flow path for a temporary basin provide a minimum of 10% increase to L<sub>s</sub>.  
 For flow path for a permanent basin provide a minimum of 15% increase to L<sub>s</sub>.

L<sub>f</sub> = 30.04

Minimum Collar Projection (ft) (Rounded to nearest 3" increment)

V<sub>min</sub> = 1.25 (1/2 the increase in Flow Path for one collar)  
 Therefore: Use one collar

Number of Collars if >1 =

V<sub>min</sub> = N/A

Project: PPLS0902

By: JCV Date: 9/1/2011

**BASIN: 10**

Chk'd: JMO Date: 9/2/2011

Maximum Spacing between Collars (ft)

Max Spacing = 14

Min Spacing = 5

Anti-seep Collars should be located below the phreatic line in the embankment and should be evenly spaced.

D1 = 8.50 ft

D2 = 17.00

Spacing of collars  
starting at D1 or  
Distance to first collar  
if only one collar  
used =

8.50 Spacing Ok

Project: PPLS0902

By: JCV Date: 9/1/2011

BASIN: 10A

Chk'd: JMO Date: 9/2/2011

FIGURE 7.6  
Anti-Seep Collar Design

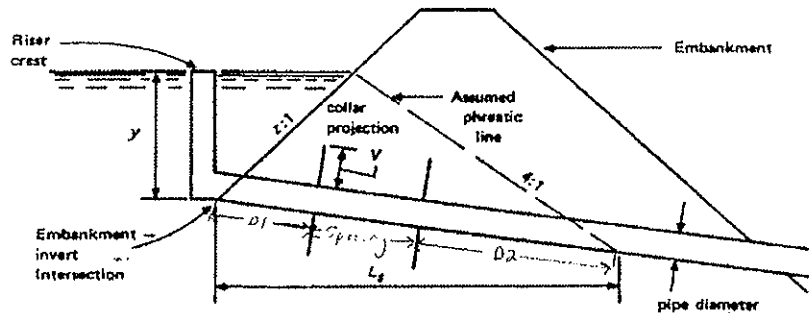

EPA - 625/3-76-006

Extension Box Elev. (Ft) =	691.7
Outlet Barrel Invert Elevation (Ft) =	686
Pipe slope (ft/ft) =	0.03
Basin Type (Temp or Perm) =	Temp
Pipe diameter (Ft) =	3

Length of Pipe in Saturated Zone

$$L_s = y(z + 4) \left[ 1 + \frac{\text{pipe slope } \left(\frac{ft}{ft}\right)}{0.25 - \text{pipe slope}} \right]$$

y = 5.7 Distance from upstream invert of principal spillway riser to top of dewatering volume.

z = 2 Horizontal component of upstream embankment slope (ft)

L<sub>s</sub> = 38.86 Length of pipe in saturated zone (ft)

Required Increase in Flow Path

For flow path for a temporary basin provide a minimum of 10% increase to L<sub>s</sub>.

For flow path for a permanent basin provide a minimum of 15% increase to L<sub>s</sub>.

L<sub>f</sub> = 42.75

Minimum Collar Projection (ft) (Rounded to nearest 3" increment)

V<sub>min</sub> = 2.00 (1/2 the increase in Flow Path for one collar)

Therefore: Use one collar

Number of Collars if >1 =

V<sub>min</sub> = N/A

Project: PPLS0902

By: JCV Date: 9/1/2011

**BASIN: 10A**

Chk'd: JMO Date: 9/2/2011

Maximum Spacing between Collars (ft)

Max Spacing = 14

Min Spacing = 5

Anti-seep Collars should be located below the phreatic line in the embankment and should be evenly spaced.

ft  
D1 = 10.00

D2= 19.99

Spacing of collars  
starting at D1 or  
Distance to first collar  
if only one collar  
used= 10.00 Spacing Ok

Project: PPLS0902

By: JCV Date: 9/1/2011

BASIN: 12

Chk'd: JMO Date: 9/2/2011

FIGURE 7.6  
Anti-Seep Collar Design

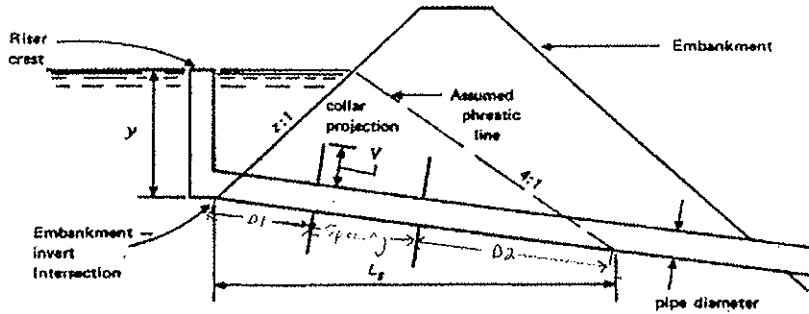

EPA - 625/3-76-006

Extension Box Elev. (Ft) =	679.5
Outlet Barrel Invert Elevation (Ft) =	675
Pipe slope (ft/ft) =	0.038
Basin Type (Temp or Perm) =	Temp
Pipe diameter (Ft) =	3

Length of Pipe in Saturated Zone

$$L_s = y(z + 4) \left[ 1 + \frac{\text{pipe slope } \left(\frac{ft}{ft}\right)}{0.25 - \text{pipe slope}} \right]$$

- y = 4.5 Distance from upstream invert of principal spillway riser to top of dewatering volume.
- z = 2 Horizontal component of upstream embankment slope (ft)
- L<sub>s</sub> = 31.84 Length of pipe in saturated zone (ft)

Required Increase in Flow Path

For flow path for a temporary basin provide a minimum of 10% increase to L<sub>s</sub>.  
 For flow path for a permanent basin provide a minimum of 15% increase to L<sub>s</sub>.

L<sub>f</sub> = 35.02

Minimum Collar Projection (ft) (Rounded to nearest 3" increment)

V<sub>min</sub> = 1.50 (1/2 the increase in Flow Path for one collar)  
 Therefore: Use one collar

Number of Collars if >1 =

V<sub>min</sub> = N/A

Project: PPLS0902

By: JCV Date: 9/1/2011

BASIN: 12

Chk'd: JMO Date: 9/2/2011

Maximum Spacing between Collars (ft)

Max Spacing = 14

Min Spacing = 5

Anti-seep Collars should be located below the phreatic line in the embankment and should be evenly spaced.

ft  
D1 = 9.00

D2= 17.99

Spacing of collars  
starting at D1 or  
Distance to first collar  
if only one collar  
used=

9.00 Spacing Ok

Project: PPLS0902

By: JCV Date: 9/1/2011

BASIN: 15

Chk'd: JMO Date: 9/2/2011

FIGURE 7.6  
Anti-Seep Collar Design

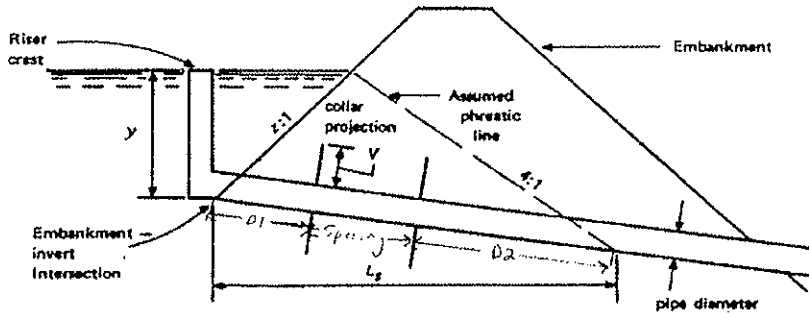

EPA - 625/3-76-006

Extension Box Elev. (Ft) =	993
Outlet Barrel Invert Elevation (Ft) =	990
Pipe slope (ft/ft) =	0.02
Basin Type (Temp or Perm) =	Temp
Pipe diameter (Ft) =	2

Length of Pipe in Saturated Zone

$$L_s = y(z + 4) \left[ 1 + \frac{\text{pipe slope } \left(\frac{ft}{ft}\right)}{0.25 - \text{pipe slope}} \right]$$

Distance from upstream invert of principal spillway riser to top of dewatering volume.

y = 3

z = 2 Horizontal component of upstream embankment slope (ft)

L<sub>s</sub> = 19.57 Length of pipe in saturated zone (ft)

Required Increase in Flow Path

For flow path for a temporary basin provide a minimum of 10% increase to L<sub>s</sub>.

For flow path for a permanent basin provide a minimum of 15% increase to L<sub>s</sub>.

L<sub>f</sub> = 21.52

Minimum Collar Projection (ft) (Rounded to nearest 3" increment)

V<sub>min</sub> = 1.00 (1/2 the increase in Flow Path for one collar)

Therefore: Use one collar

Number of Collars if >1 =

V<sub>min</sub> = N/A

Project: PPLS0902

By: JCV Date: 9/1/2011

**BASIN: 15**

Chk'd: JMO Date: 9/2/2011

Maximum Spacing between Collars (ft)

Max Spacing = 14

Min Spacing = 5

Anti-seep Collars should be located below the phreatic line in the embankment and should be evenly spaced.

ft  
D1 = 6.00  
D2 = 12.00

Spacing of collars  
starting at D1 or  
Distance to first collar  
if only one collar  
used =

6.00 Spacing Ok

Project: PPLS0902

By: JCV Date: 9/1/2011

BASIN: 15A

Chk'd: JMO Date: 9/2/2011

**FIGURE 7.6  
Anti-Seep Collar Design**

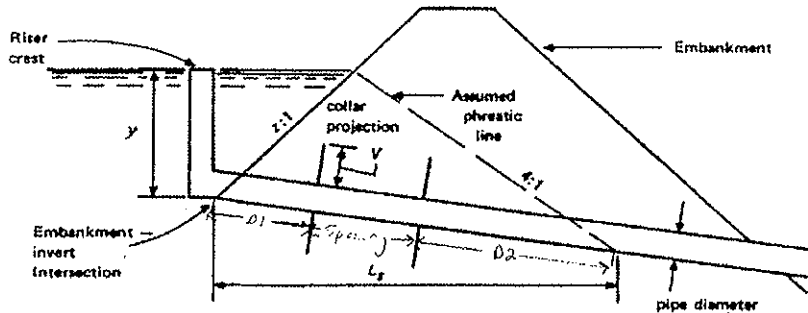

EPA - 625/3-76-006

Extension Box Elev. (Ft) =	990.5
Outlet Barrel Invert Elevation (Ft) =	982
Pipe slope (ft/ft) =	0.06
Basin Type (Temp or Perm) =	Temp
Pipe diameter (Ft) =	1.5

Length of Pipe in Saturated Zone

$$L_s = y(z + 4) \left[ 1 + \frac{\text{pipe slope } \left(\frac{ft}{ft}\right)}{0.25 - \text{pipe slope}} \right]$$

- y = 8.5 Distance from upstream invert of principal spillway riser to top of dewatering volume.
- z = 2 Horizontal component of upstream embankment slope (ft)
- L<sub>s</sub> = 67.11 Length of pipe in saturated zone (ft)

Required Increase in Flow Path

For flow path for a temporary basin provide a minimum of 10% increase to L<sub>s</sub>.  
 For flow path for a permanent basin provide a minimum of 15% increase to L<sub>s</sub>.

L<sub>F</sub> = 73.82

Minimum Collar Projection (ft) (Rounded to nearest 3" increment)

V<sub>min</sub> = 3.25 (1/2 the increase in Flow Path for one collar)  
 Therefore: Use additional Collars with V<sub>min</sub> > 1

Number of Collars if >1 = 3

V<sub>min</sub> = 1.00

Project: PPLS0902

By: JCV Date: 9/1/2011

**BASIN: 15A**

Chk'd: JMO Date: 9/2/2011

Maximum Spacing between Collars (ft)

Max Spacing = 42

Min Spacing = 15

Anti-seep Collars should be located below the phreatic line in the embankment and should be evenly spaced.

ft  
D1 = 5.00  
D2 = 10.00

Spacing of collars  
starting at D1 or  
Distance to first collar  
if only one collar  
used= 26.05 Spacing Ok

Project: PPLS0902

By: JCV Date: 9/1/2011

BASIN: 18

Chk'd: JMO Date: 9/2/2011

FIGURE 7.6  
Anti-Seep Collar Design

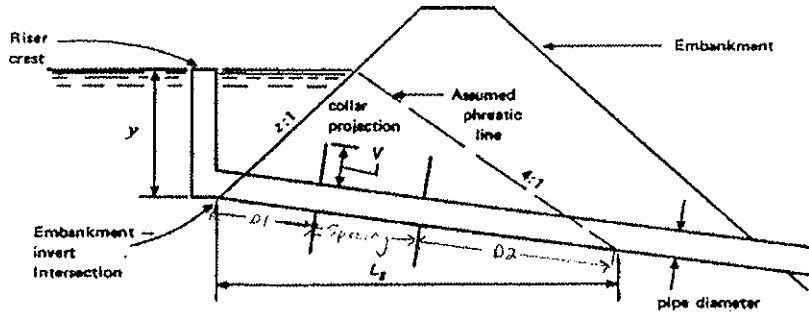

EPA - 625/3-76-006

Extension Box Elev. (Ft) =	626
Outlet Barrel Invert Elevation (Ft) =	621
Pipe slope (ft/ft) =	0.027
Basin Type (Temp or Perm) =	Perm
Pipe diameter (Ft) =	2

Length of Pipe in Saturated Zone

$$L_s = y(z + 4) \left[ 1 + \frac{\text{pipe slope } \left(\frac{ft}{ft}\right)}{0.25 - \text{pipe slope}} \right]$$

- y = 5 Distance from upstream invert of principal spillway riser to top of dewatering volume.
- z = 2 Horizontal component of upstream embankment slope (ft)
- L<sub>s</sub> = 33.63 Length of pipe in saturated zone (ft)

Required Increase in Flow Path

For flow path for a temporary basin provide a minimum of 10% increase to L<sub>s</sub>.  
For flow path for a permanent basin provide a minimum of 15% increase to L<sub>s</sub>.

L<sub>f</sub> = 38.68

Minimum Collar Projection (ft) (Rounded to nearest 3" increment)

V<sub>min</sub> = 2.50 (1/2 the increase in Flow Path for one collar)  
Therefore: Use additional Collars with V<sub>min</sub> > 1

Number of Collars if >1 = 2

V<sub>min</sub> = 1.25

Project: PPLS0902

By: JCV Date: 9/1/2011

**BASIN: 18**

Chk'd: JMO Date: 9/2/2011

Maximum Spacing between Collars (ft)

Max Spacing = 34

Min Spacing = 10

Anti-seep Collars should be located below the phreatic line in the embankment and should be evenly spaced.

D1 = 6.50 ft

D2= 13.00

Spacing of collars  
starting at D1 or  
Distance to first collar  
if only one collar  
used=

14.14 Spacing Ok

Project: PPLS0902

By: JCV Date: 9/1/2011

BASIN: 21

Chk'd: JMO Date: 9/2/2011

**FIGURE 7.6**  
**Anti-Seep Collar Design**

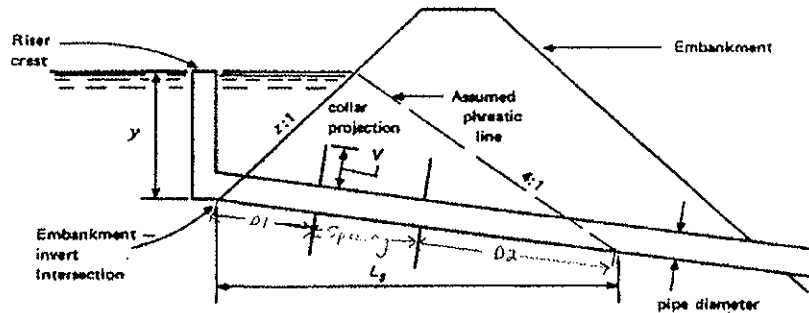

EPA - 625/3-76-006

Extension Box Elev. (Ft) =	535.92
Outlet Barrel Invert Elevation (Ft) =	531
Pipe slope (ft/ft) =	0.01
Basin Type (Temp or Perm) =	Perm
Pipe diameter (Ft) =	4

Length of Pipe in Saturated Zone

$$L_s = y(z + 4) \left[ 1 + \frac{\text{pipe slope } \left(\frac{ft}{ft}\right)}{0.25 - \text{pipe slope}} \right]$$

- y = 4.92 Distance from upstream invert of principal spillway riser to top of dewatering volume.
- z = 2 Horizontal component of upstream embankment slope (ft)
- L<sub>s</sub> = 30.75 Length of pipe in saturated zone (ft)

Required Increase in Flow Path

For flow path for a temporary basin provide a minimum of 10% increase to L<sub>s</sub>.  
 For flow path for a permanent basin provide a minimum of 15% increase to L<sub>s</sub>.

L<sub>f</sub> = 35.36

Minimum Collar Projection (ft) (Rounded to nearest 3" increment)

V<sub>min</sub> = 2.25 (1/2 the increase in Flow Path for one collar)  
 Therefore: Use additional Collars with V<sub>min</sub> > 1

Number of Collars if >1 =

V<sub>min</sub> = N/A

Project: PPLS0902

By: JCV Date: 9/1/2011

BASIN: 21

Chk'd: JMO Date: 9/2/2011

Maximum Spacing between Collars (ft)

Max Spacing = 14

Min Spacing = 5

Anti-seep Collars should be located below the phreatic line in the embankment and should be evenly spaced.

D1 = 12.50 ft

D2 = 24.99

Spacing of collars  
starting at D1 or  
Distance to first collar  
if only one collar  
used =

9.84 Spacing Ok