

Pressurizer Level Control

Chapter 6.2



Objectives

1. State the purpose of the pressurizer level control system (PLCS).
2. List the purpose of each PLCS input.
3. Explain the reason pressurizer level is programmed.

Objectives (continued)

4. List the devices that are controlled by pressurizer level.
5. Explain the purpose of the pressurizer low level interlock.

Purpose of PLCS

1. Accommodates the change to RCS volume
2. Supply signals for indications, alarms, and control

Figure 6.2-1 Pressurizer Level Program

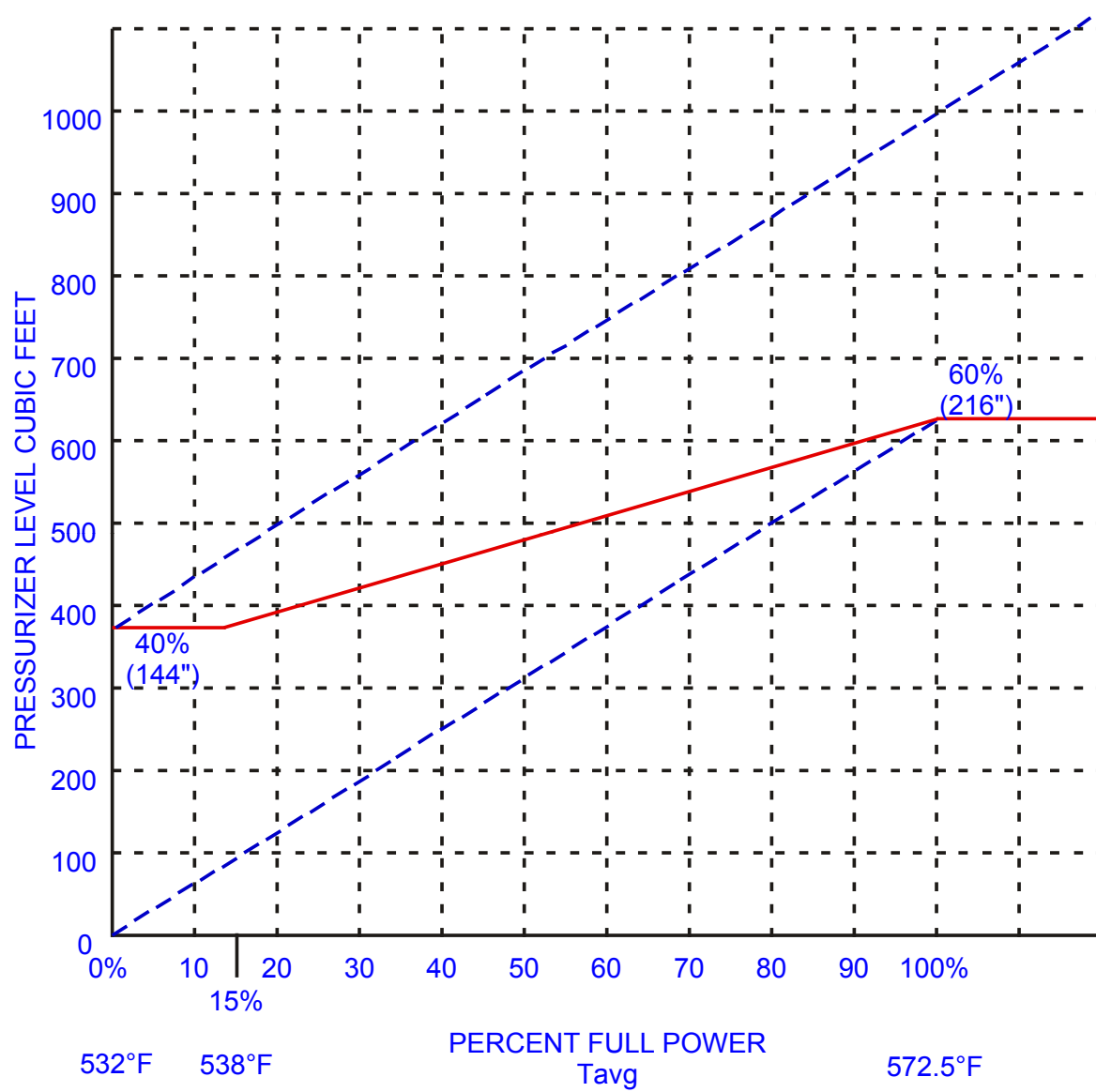

Pressurizer Level Control System
Figure 6.2-2

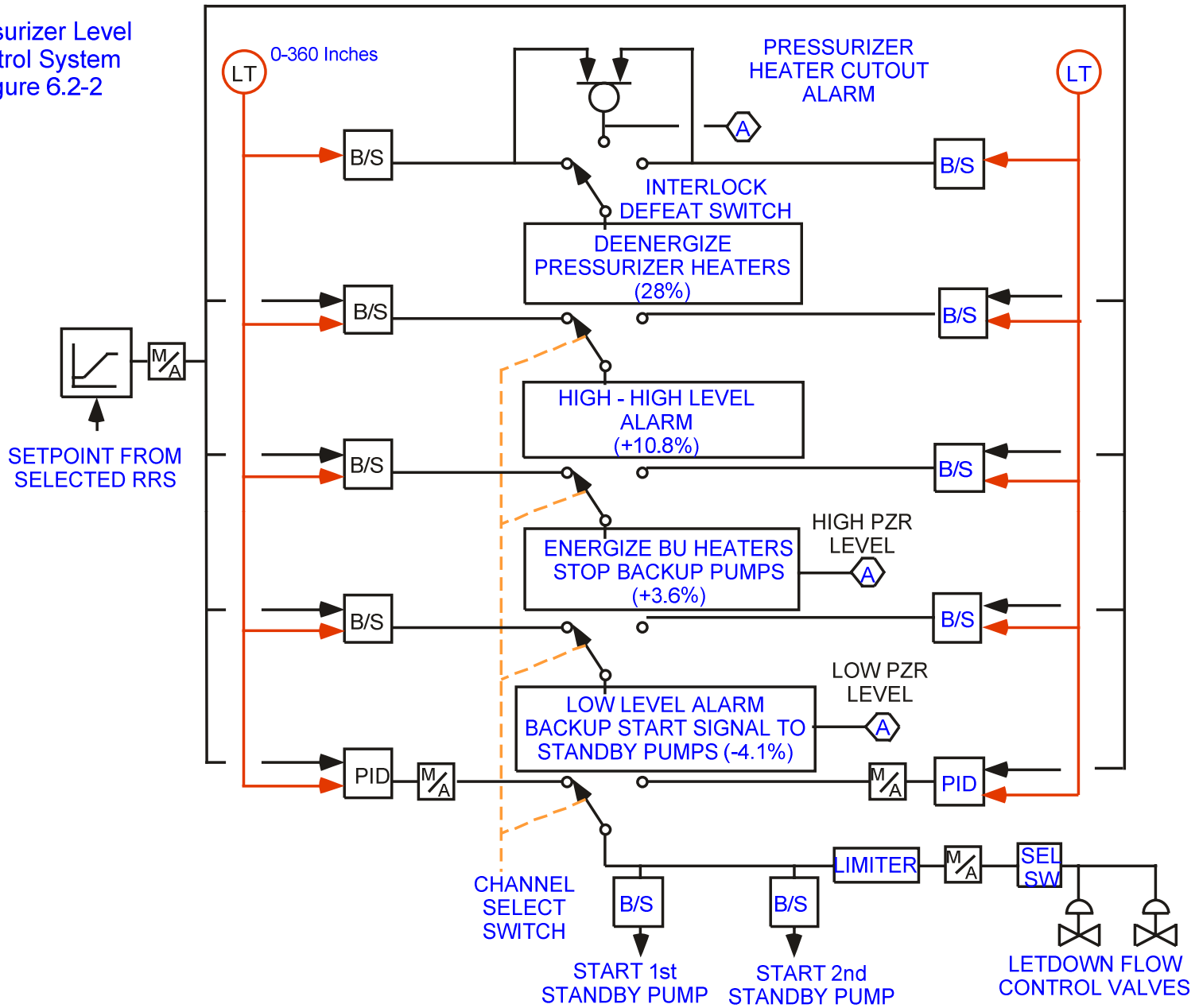
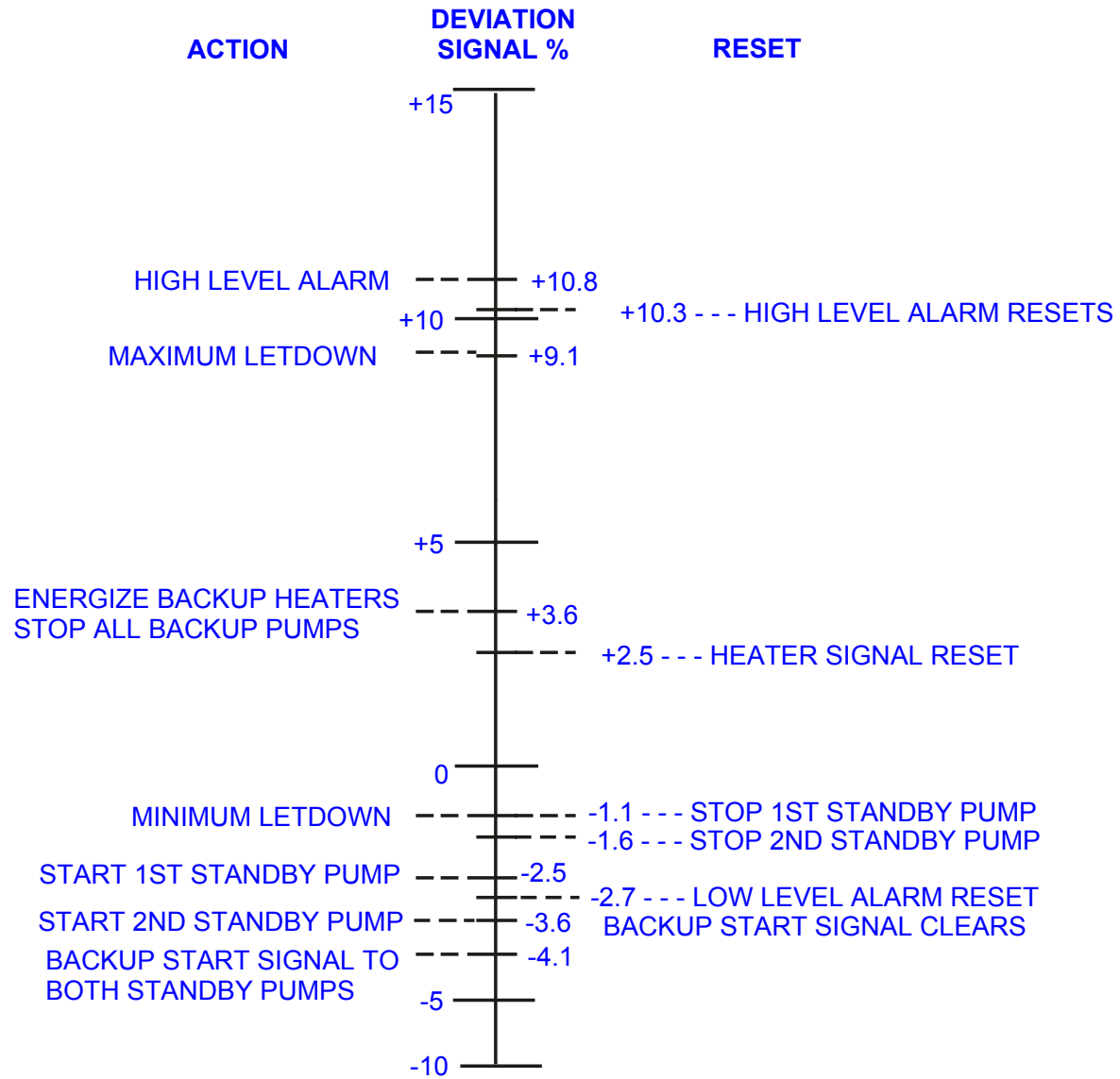

Figure 6.2-3 Control System Actions



The End