

Chemical Volume and Control System

Chapter 5.0



Learning Objectives

1. List the purposes of the chemical and volume control system (CVCS).
2. List in flow path order and state the purpose of the following major components of the CVCS:
 - a. Regenerative heat exchanger
 - b. Letdown flow control valves
 - c. Letdown heat exchanger
 - d. Letdown back pressure regulator
 - e. Letdown filter
 - f. Ion exchangers
 - g. Volume control tank (VCT)
 - h. Charging pump

Learning Objectives

3. Identify the components in the CVCS that are used to purify the reactor coolant and the types of contaminants each is designed to remove.
4. Describe how the makeup system is used to borate, dilute, and makeup a blended flow of boric acid to the reactor coolant system (RCS).
5. Explain why and for what plant conditions the following chemicals are added to the RCS:
 - a. Lithium hydroxide
 - b. Hydrogen
 - c. Hydrazine

Learning Objectives

6. Describe the emergency boration flowpath, and identify the plant conditions which would require its use.
7. List the plant operations that result in large amounts of in fluent into the boron management system.
8. Identify the changes in the CVCS that occur upon the receipt of an engineered safety features signal (ESF).

Learning Objectives

9. Explain how the CVCS is designed to prevent the following:
 - a. Flashing and pressure transients in the regenerative and letdown heat exchangers.
 - b. High temperature in the letdown ion exchangers
10. List the automatic actions initiated by VCT level instrumentation.

System Purposes

1. Purification of the RCS,
2. Control of RCS boron concentration,
3. Control of RCS volume (pressurizer level),
4. The addition of corrosion inhibiting chemicals to the RCS,
5. Collection of RCP controlled bleed off,

System Purposes

6. Adds boron to the RCS in the event of an accident,
7. Supplies pressurizer auxiliary spray,
8. Provides continuous on-line measurement of RCS boron concentration and RCS activity and
9. Provides a means of testing the high pressure safety injection (HPSI) check valves.

Figure 5-1 Simplified Chemical and Volume Control System

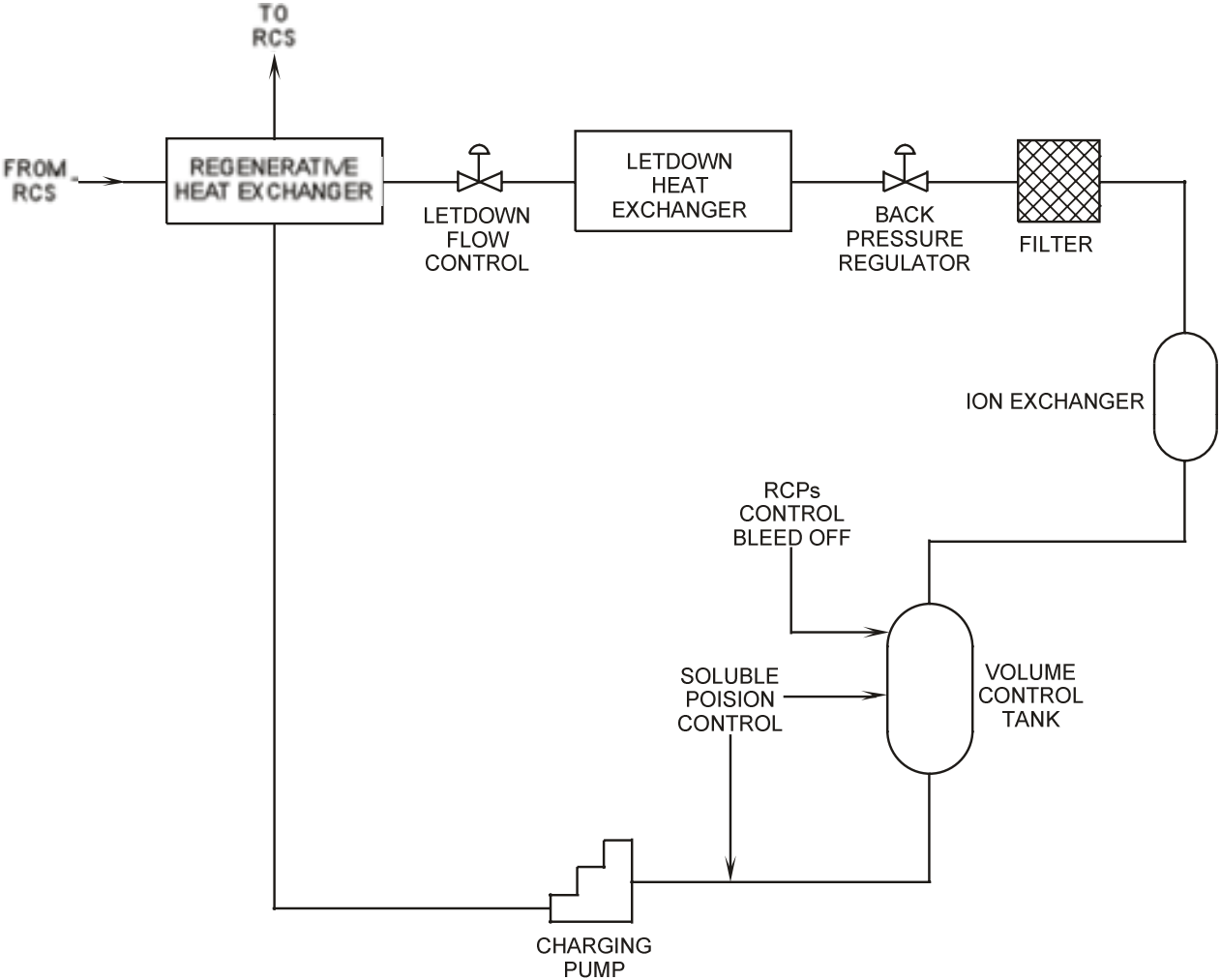

Figure 5-2 CVCS Diagram

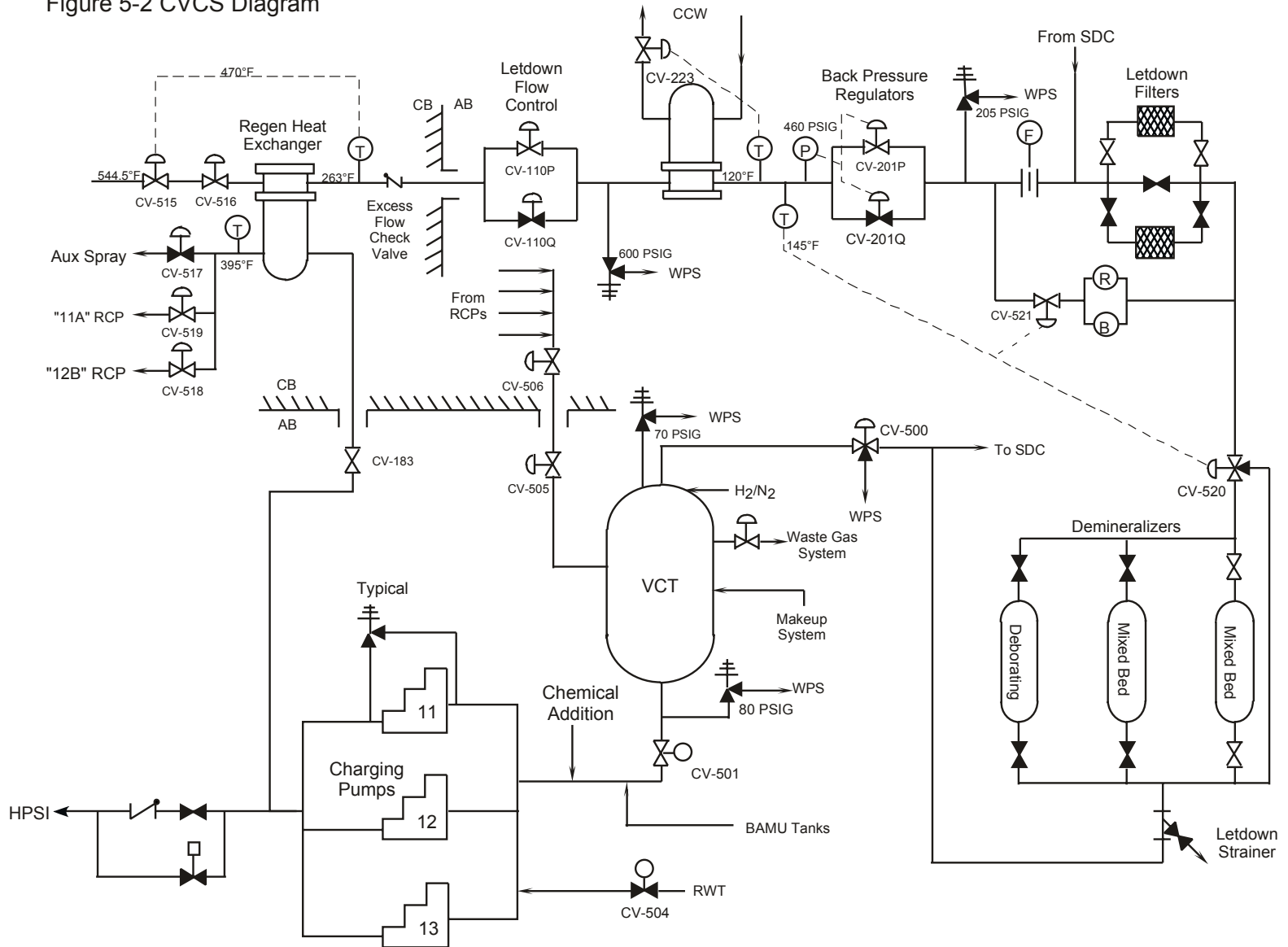

Figure 5-3 Boronometer Assembly

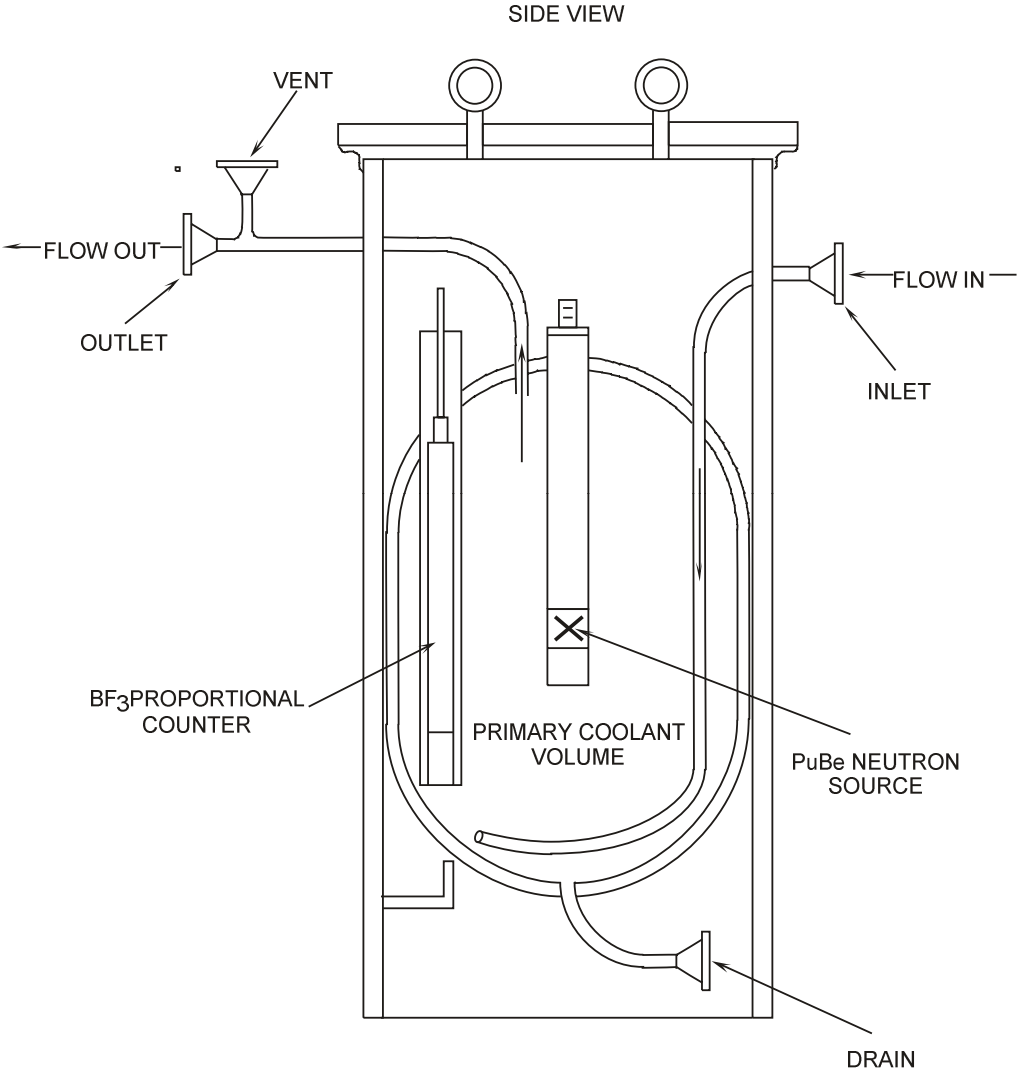
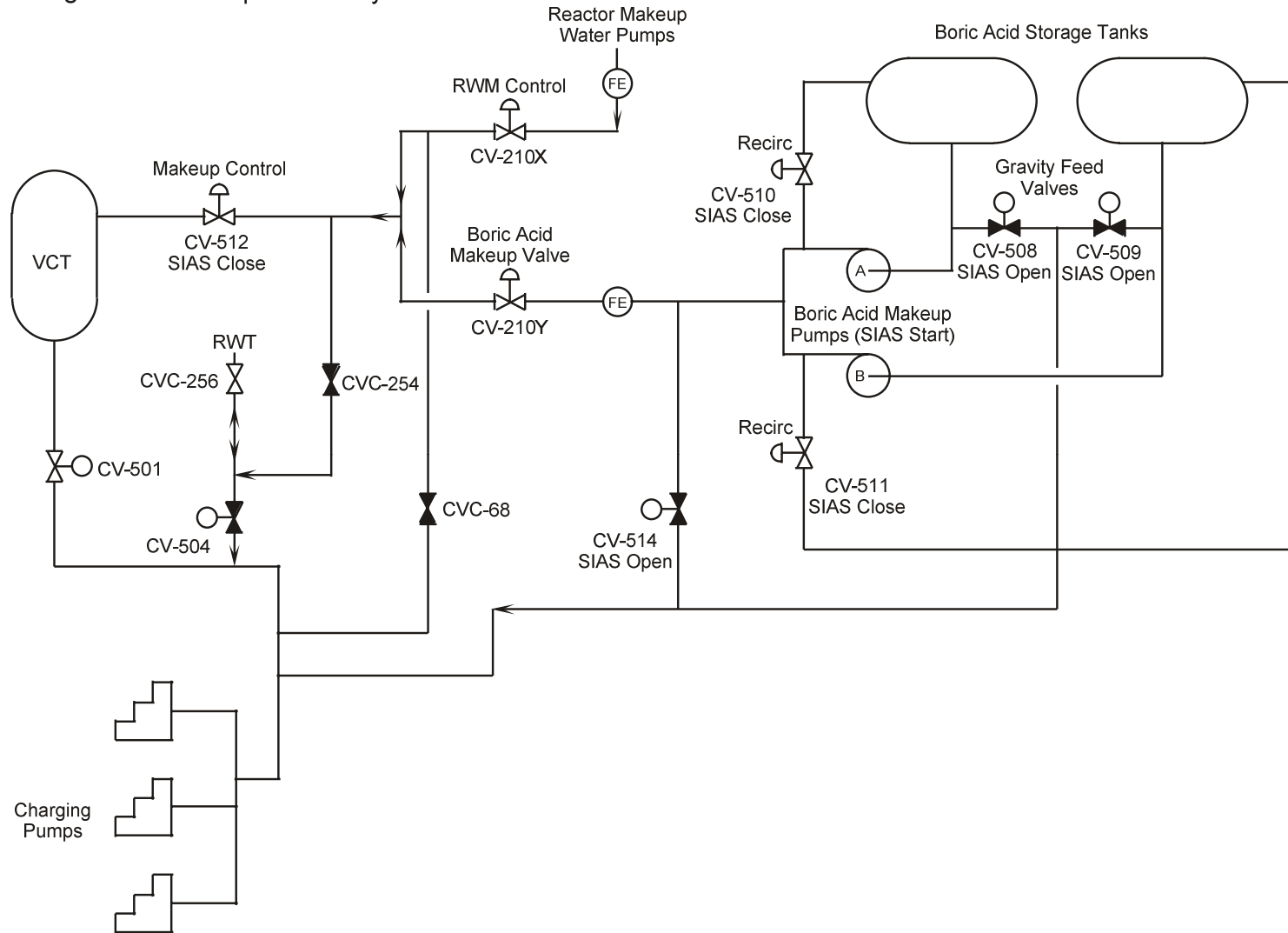

Figure 5-4 Makeup Control System



The End