

Reactor Coolant System

Chapter 2.1



Objectives

1. State the purpose of the reactor coolant system (RCS).
2. List and state the purpose of the following RCS penetrations:
 - a. Hot leg (Th, reactor outlet piping)
 1. Pressurizer surge line
 2. Shutdown cooling system suction
 - b. Cold leg (Tc, reactor inlet piping).
 1. Chemical and volume control system (CVCS) letdown connection
 2. Pressurizer spray line
 3. Common penetration for high pressure safety injection (HPSI), safety injection tank (SIT), low pressure safety injection (LPSI) and shutdown cooling (SDC)
 4. CVCS charging connections

Objectives (Continued)

3. State the purpose of the following:
 - a. Pressurizer
 - b. Pressurizer safety valves
 - c. Power operated relief valves (PORVs)
 - d. Pressurizer spray valves
 - e. Pressurizer heaters
 - f. Quench tank
 - g. Pressurizer auxiliary spray

4. Describe the methods for determining pressurizer relief valve leakage.

Objectives (Continued)

5. State the safety-related functions of the following RCS Instrumentation:
 - a. Th resistance temperature detectors (RTDs)
 - b. Tc RTDs
 - c. Pressurizer pressure
 - d. RCS flow

6. Explain the following:
 - a. Pressurizer spray driving force
 - b. Purpose of pressurizer spray bypass
 - c. Low temperature/overpressure protection (LTOP)

Purposes

1. Transfer the heat produced in the reactor to the steam generators.
2. Provide the second barrier to prevent the escape of fission products to the public.

Figure 2.1-1 RCS - Elevation View

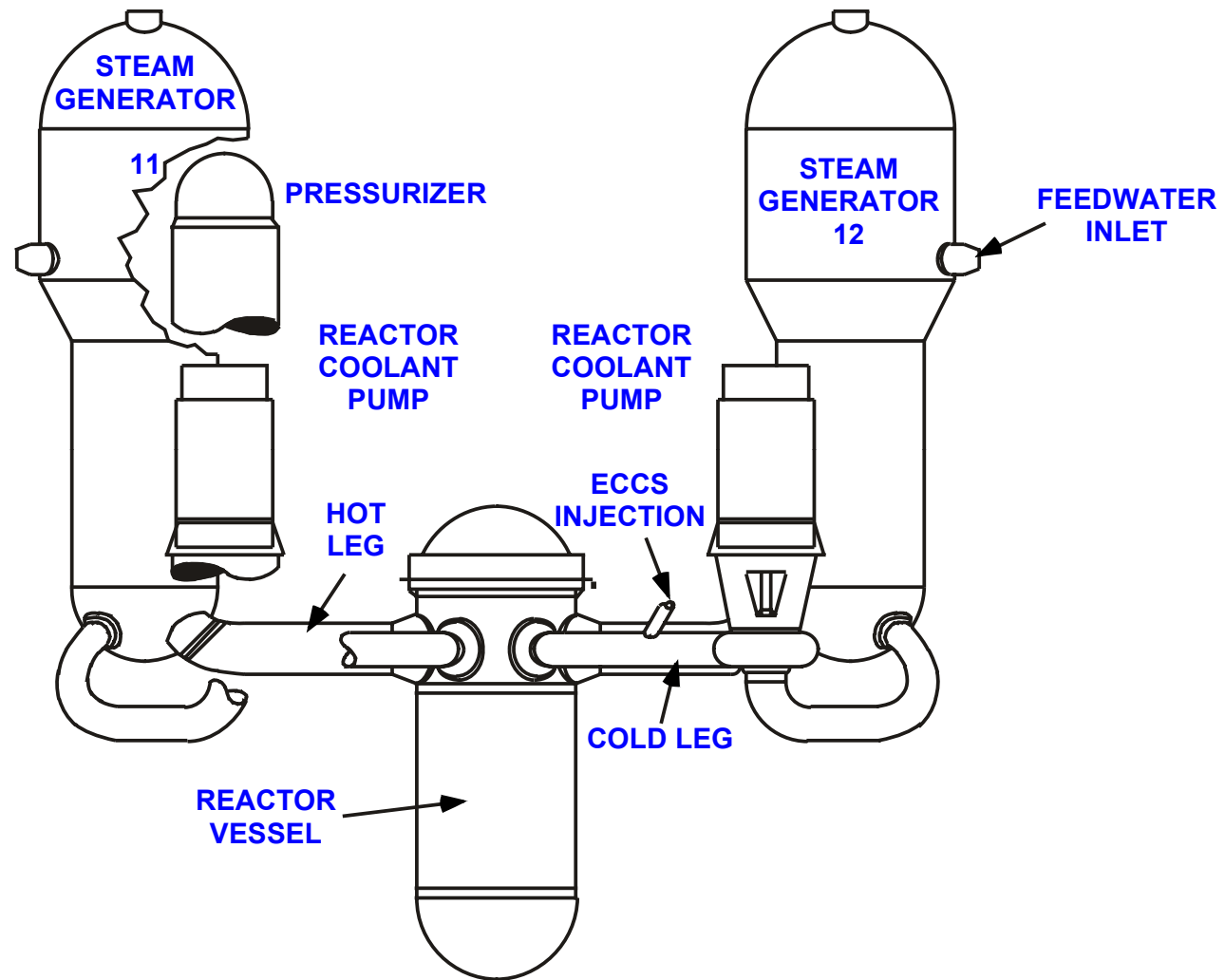
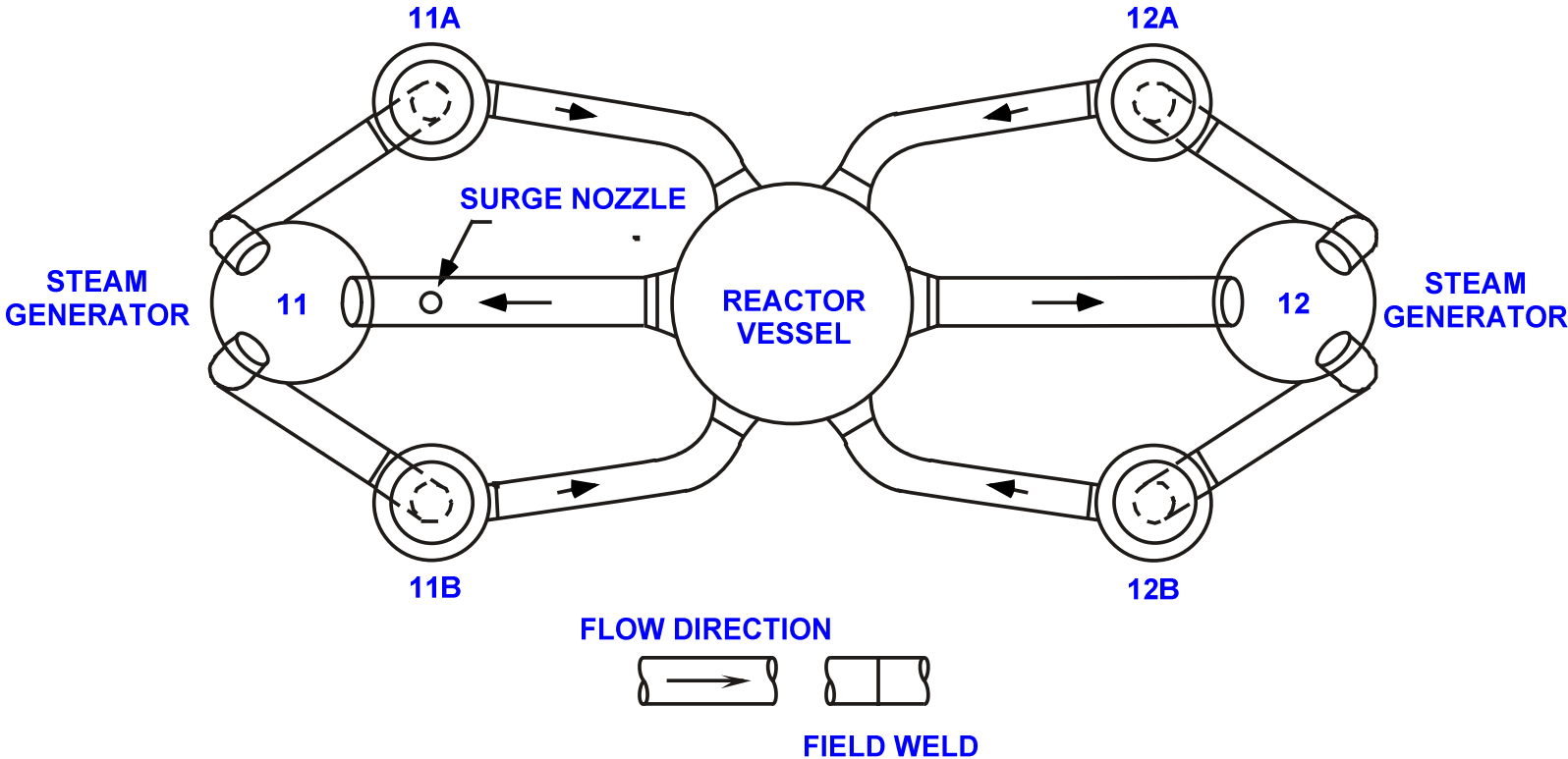

Figure 2.1-2 RCS - Plan View



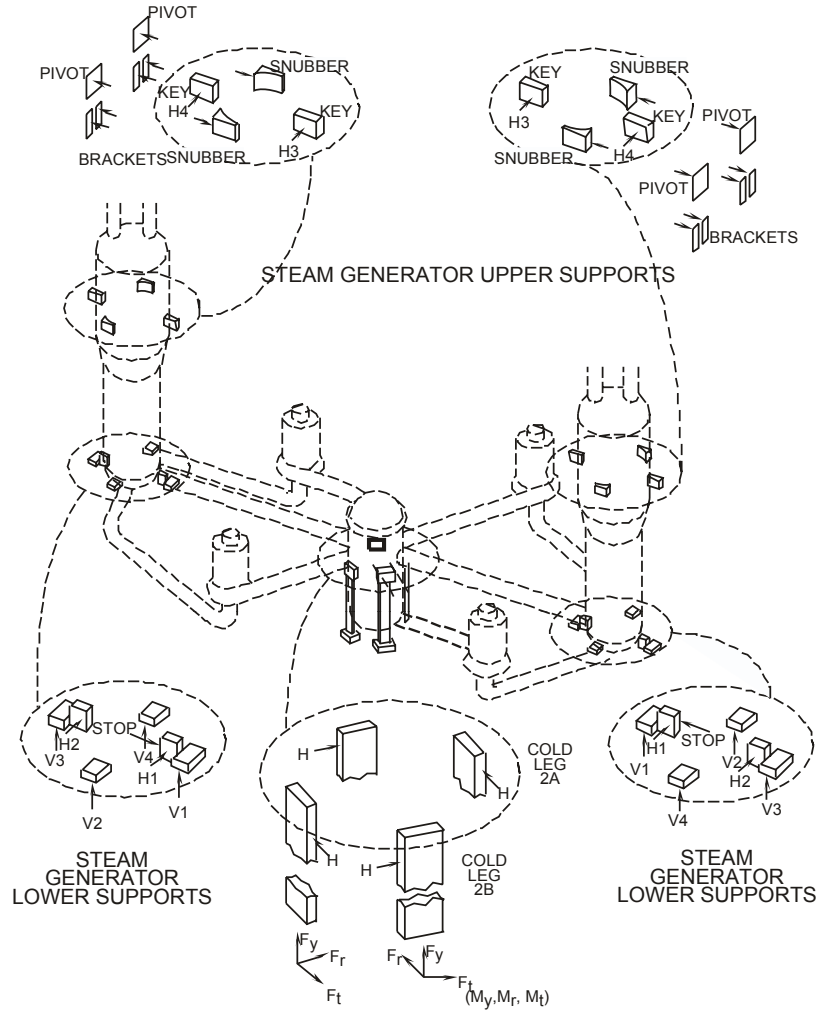

Figure 2.1-3 RCS Supports (Typical)

Figure 2.1-4 RCS Flow Diagram

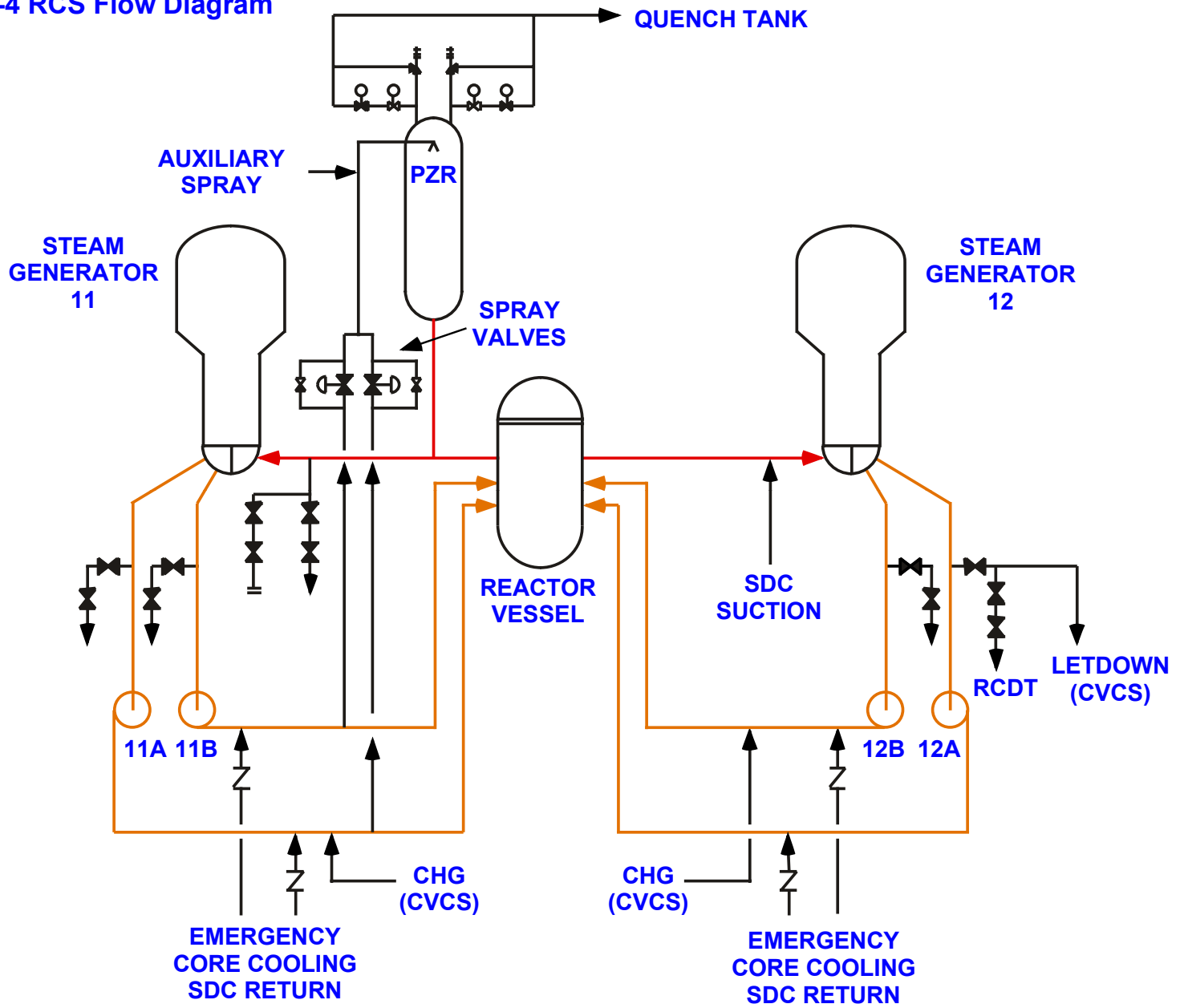
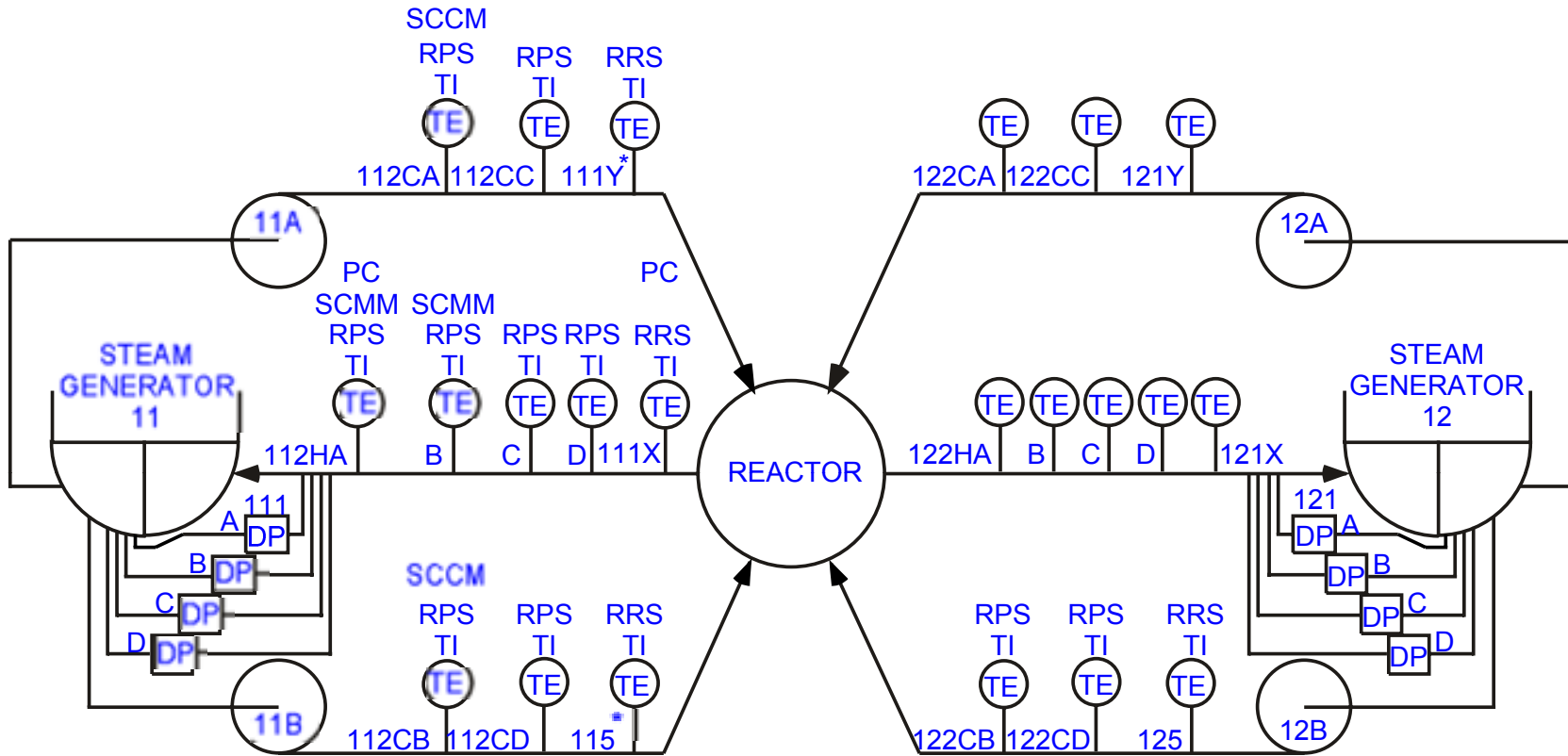

Figure 2.1-5 RCS Instrumentation



*S SUPPLY THROUGH A SELECTOR SWITCH

- RPS - Reactor Protection System
- SCMM - Subcooled Margin Monitor
- TI - Temperature Indication
- PC - Plant Computer
- CEDS - Control Element Drive System
- AWP - Automatic Withdrawal Prohibit
- RRS - Reactor Regulating System

Figure 2.1-6 Pressurizer

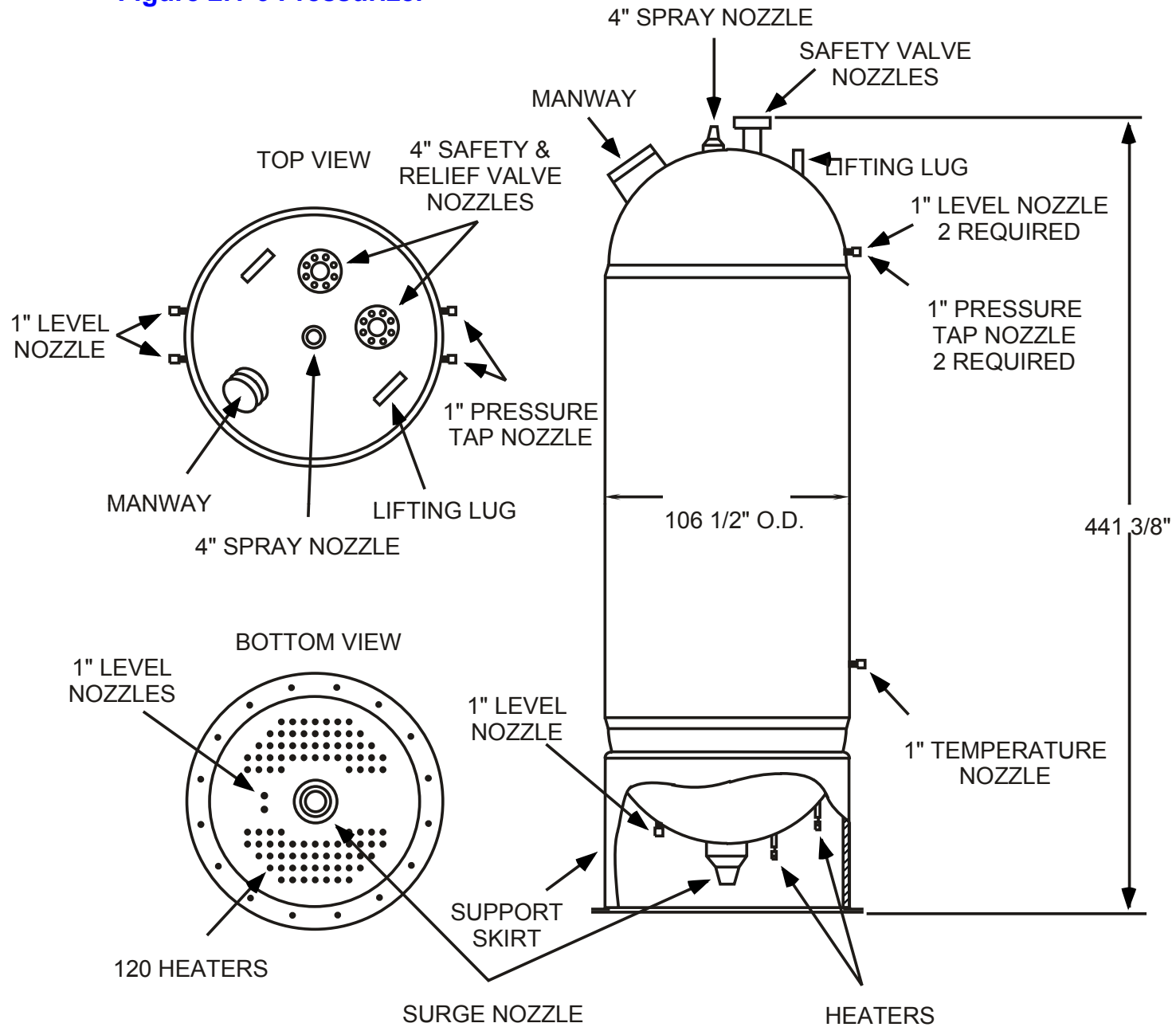

Figure 2.1-7 Pressurizer Piping Diagram

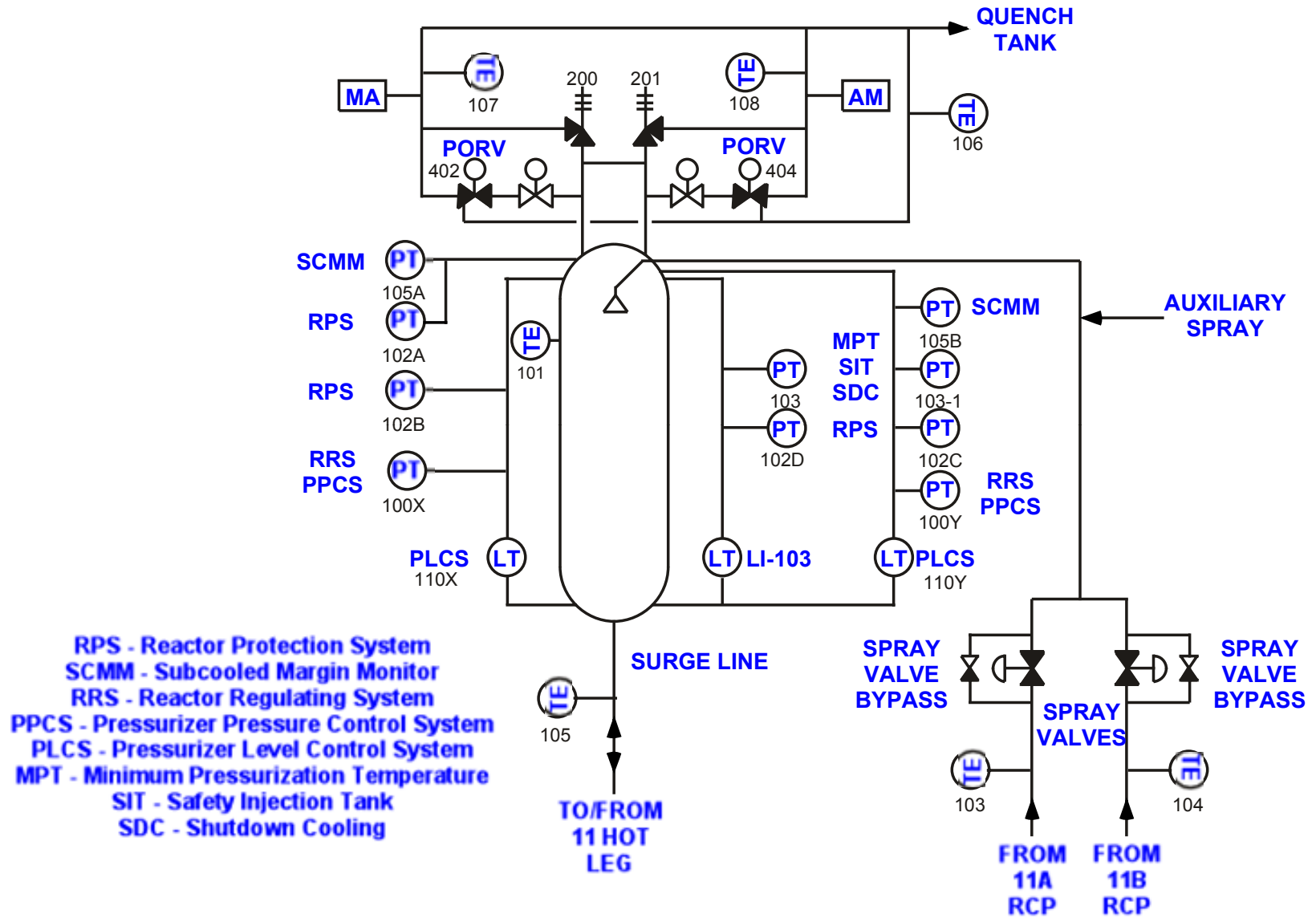
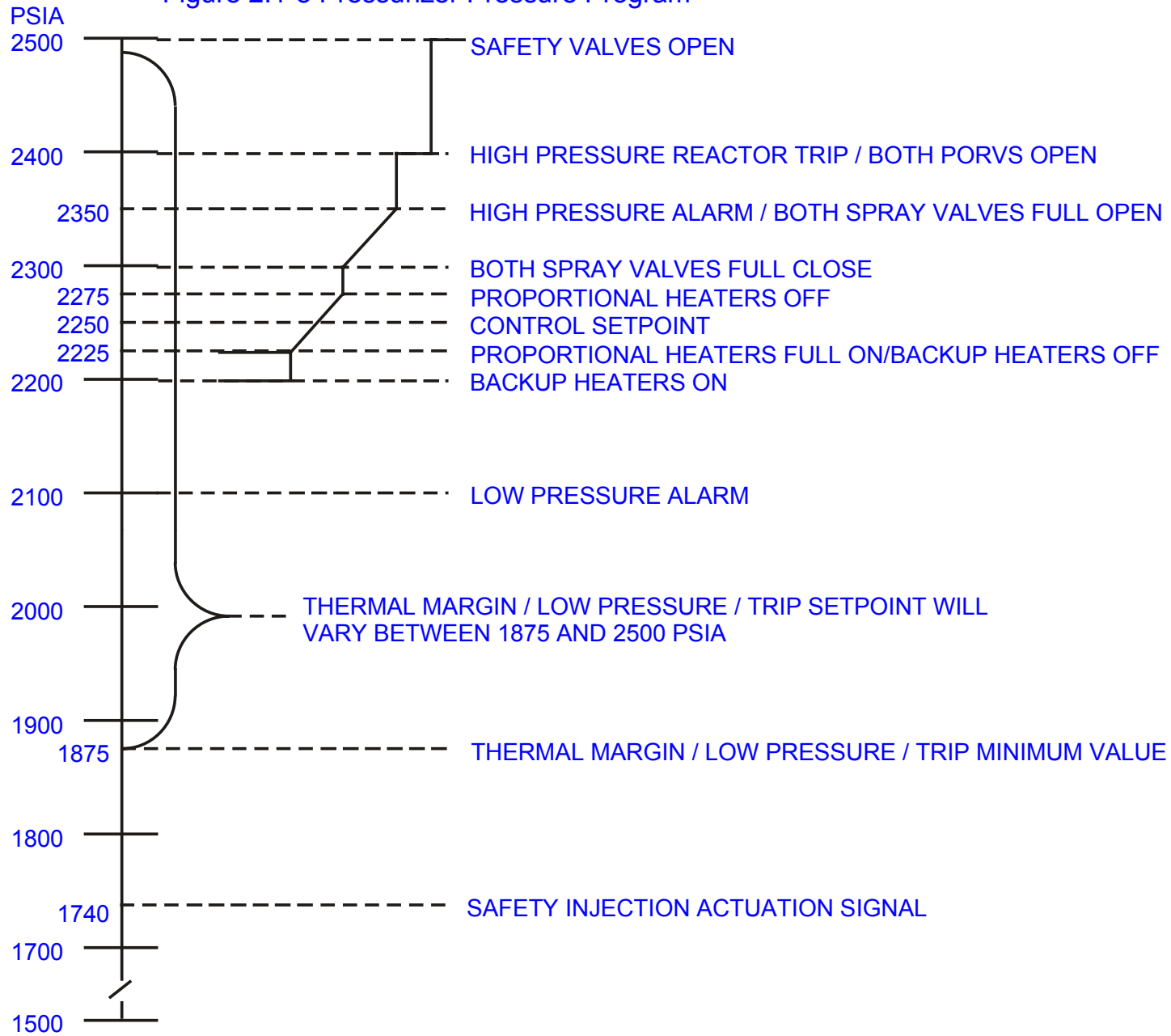

Figure 2.1-8 Pressurizer Pressure Program



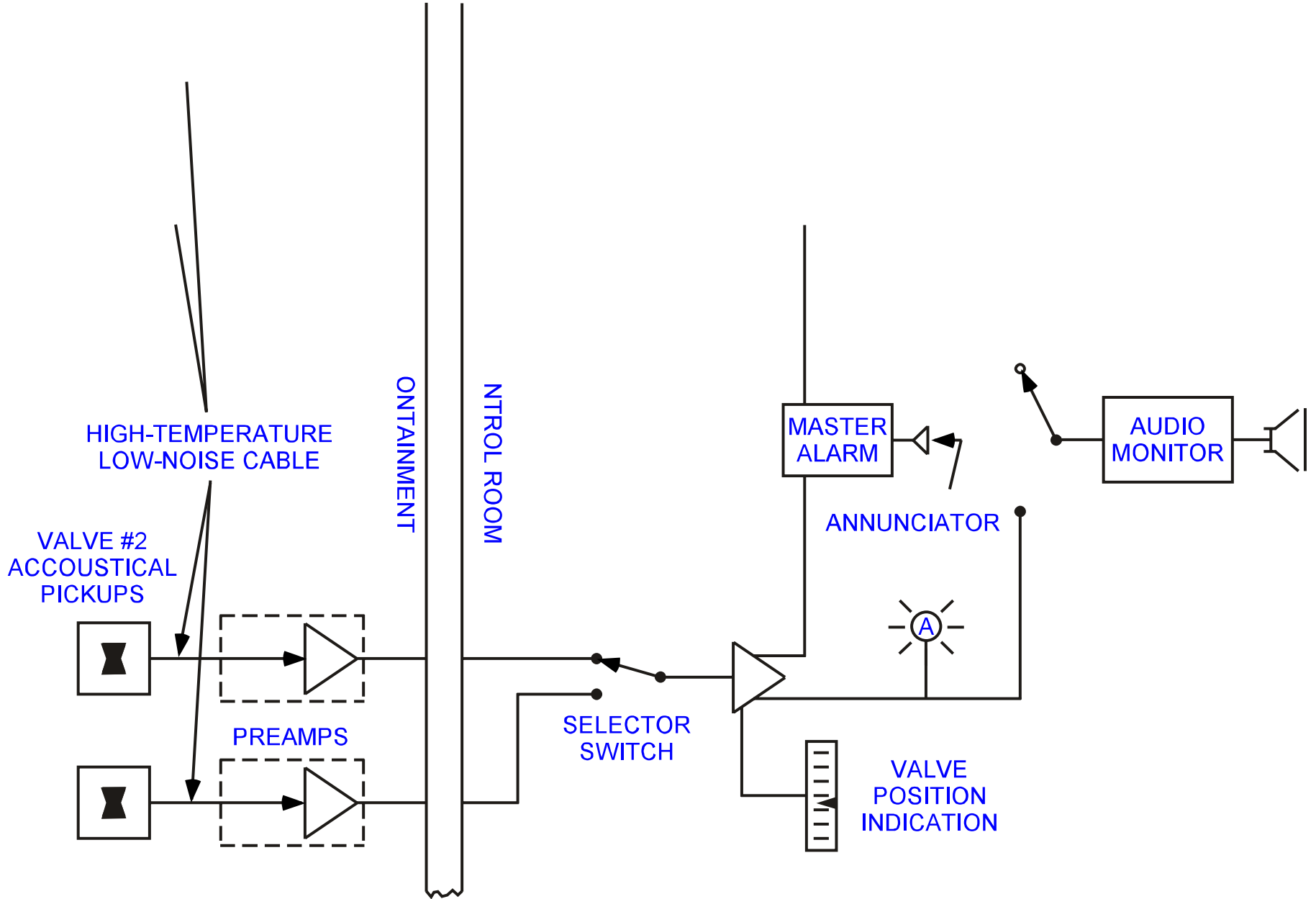

Figure 2.1-10 Quench Tank

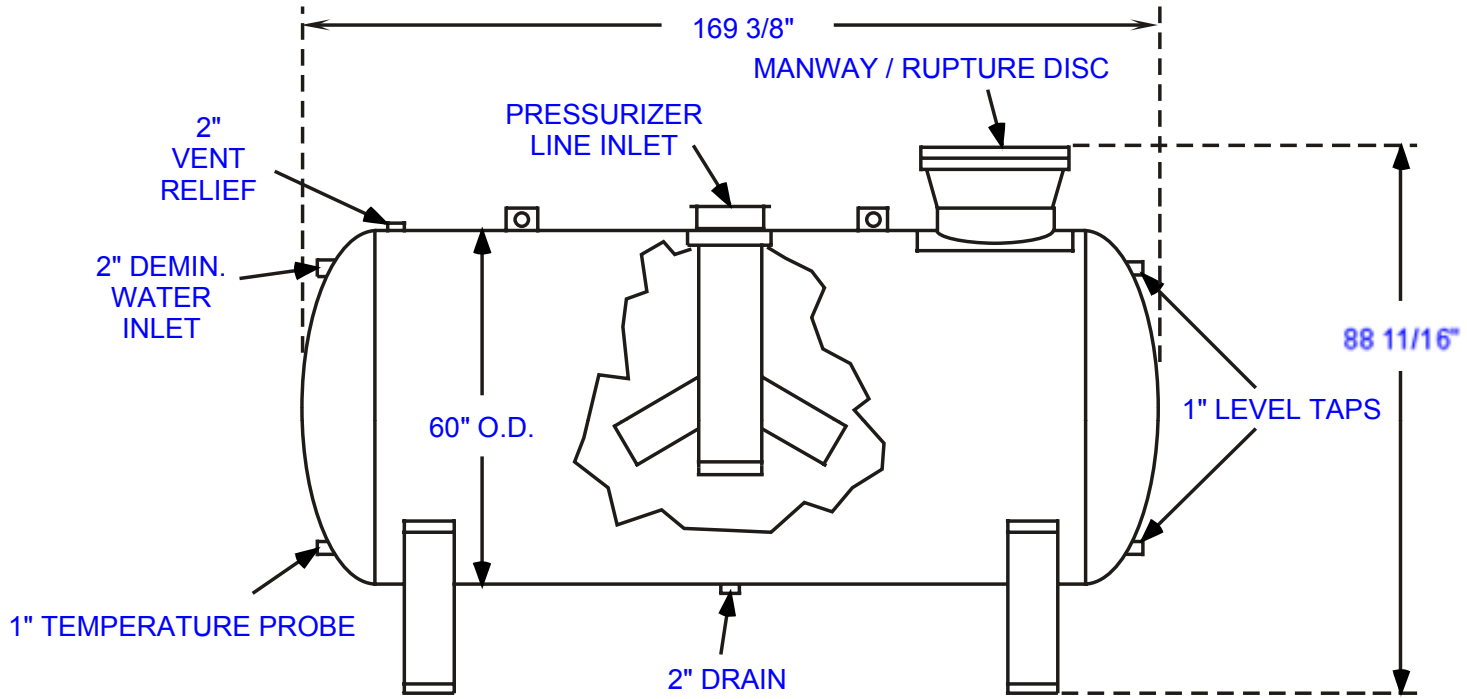
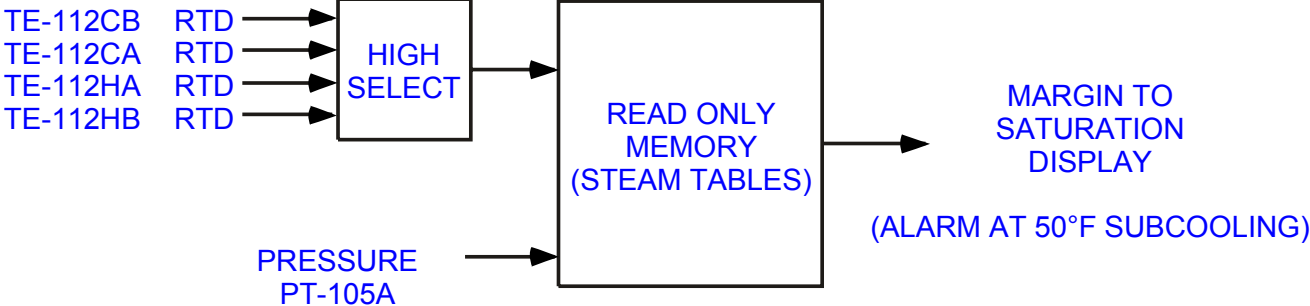
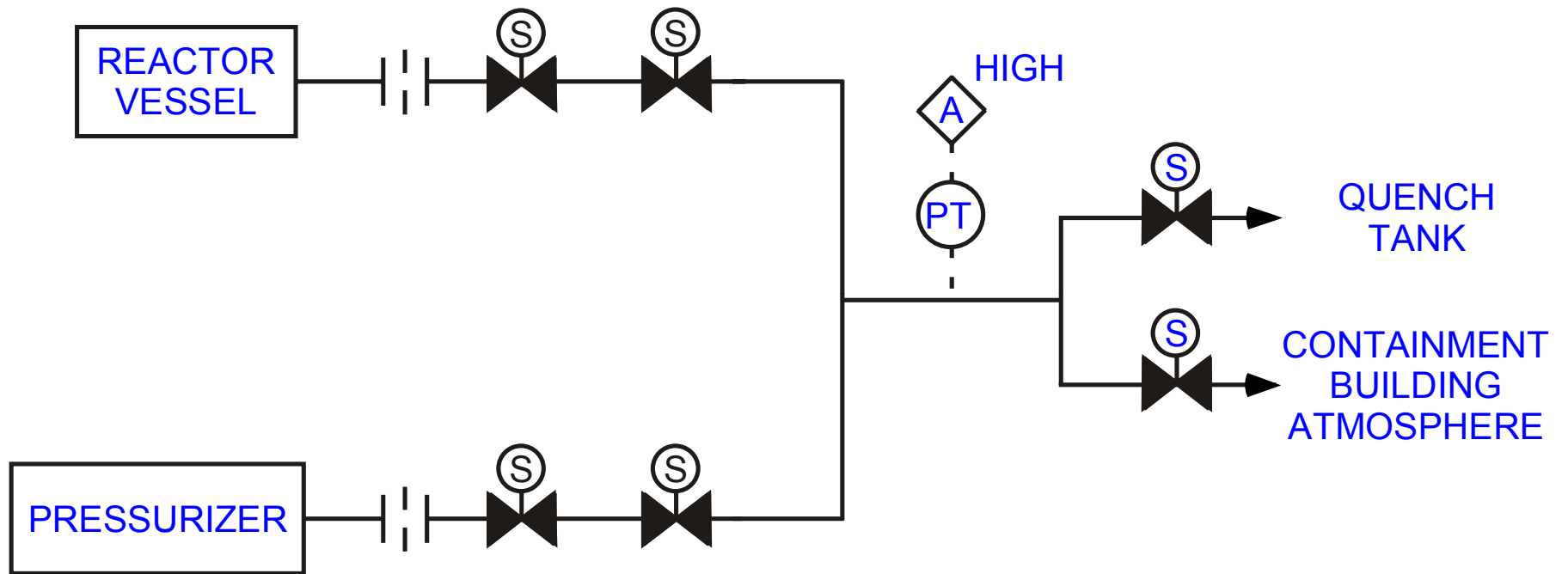

Figure 2.1-11 Subcooled Margin Monitor (SCMM)



TYPICAL OF TWO CHANNELS, "A" SHOWN

Figure 2.1-12 High Point Vents



ALL VALVES ARE NORMALLY LOCKED CLOSED

Figure 2.1-13 Reactor Vessel Level Indication

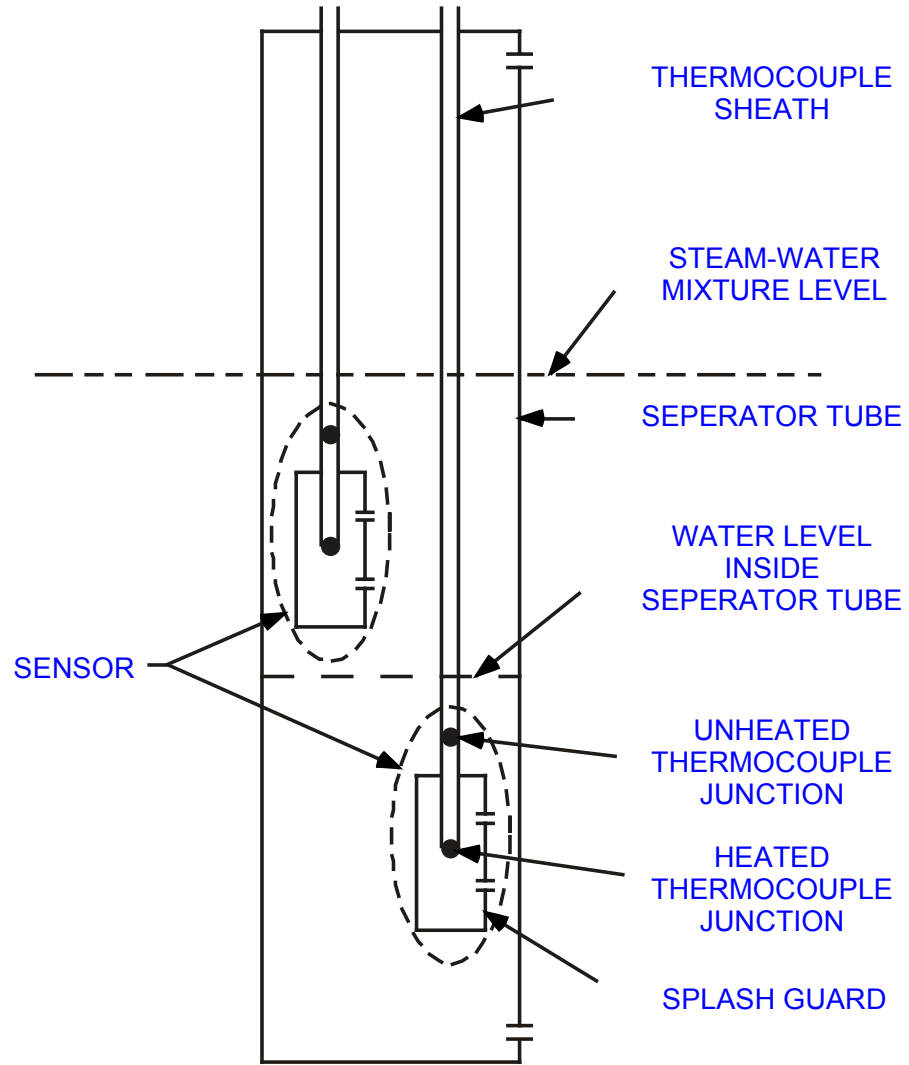

The End