

TABLE OF CONTENTS

6.1	PRESSURIZER PRESSURE CONTROL SYSTEM	1
6.1.1	Introduction	1
6.1.2	System Description	2
6.1.2.1	Heater Operation	3
6.1.2.2	Spray Valve Operation.....	4
6.1.3	Normal Operation.....	5
6.1.4	Summary.....	5

LIST OF FIGURES

Figure 6.1-1 Pressurizer Pressure Control System

Figure 6.1-2 Pressurizer Pressure Control Output vs. Pressure Deviation

Figure 6.1-3 Pressurizer Pressure Control System Actions

6.1 PRESSURIZER PRESSURE CONTROL SYSTEM

Learning Objectives:

1. State the purposes of the pressurizer pressure control system (PPCS).
2. List the sequence of actions performed by the PPCS for an increasing or decreasing pressure control signal.

6.1.1 Introduction

The purpose of the PPCS is to:

1. Maintain RCS pressure at 2250 psia,
2. Minimize pressure excursions during transient operations,
3. Provide pressure signals for indication, alarms and control.

The system consists of a combination of heater banks and spray valves actuated at the proper times by a pressure controller. The heaters and spray valves are set to operate at various fixed pressure deviation points from the controller set point.

During steady state conditions, approximately one half the pressurizer volume is saturated water and the remainder is saturated steam. The pressure control system is capable of affecting this steam volume sufficiently during design transient conditions such that a reactor trip will not result.

The pressurizer heaters are divided into two groups consisting of two banks of proportional heaters and four banks of backup (on-off) heaters. These heaters maintain the equilibrium heat balance in the pressurizer during steady state conditions. If system pressure decreases significantly from the set point, the proportional heaters would provide maximum heat output and, in addition, the backup heaters would be energized on. For a system pressure increase above the normal set point, all heaters would be deenergized and the spray valves would be opened (proportionally over a fixed pressure range) to admit cooler RCS water into the pressurizer steam volume.

6.1.2 System Description

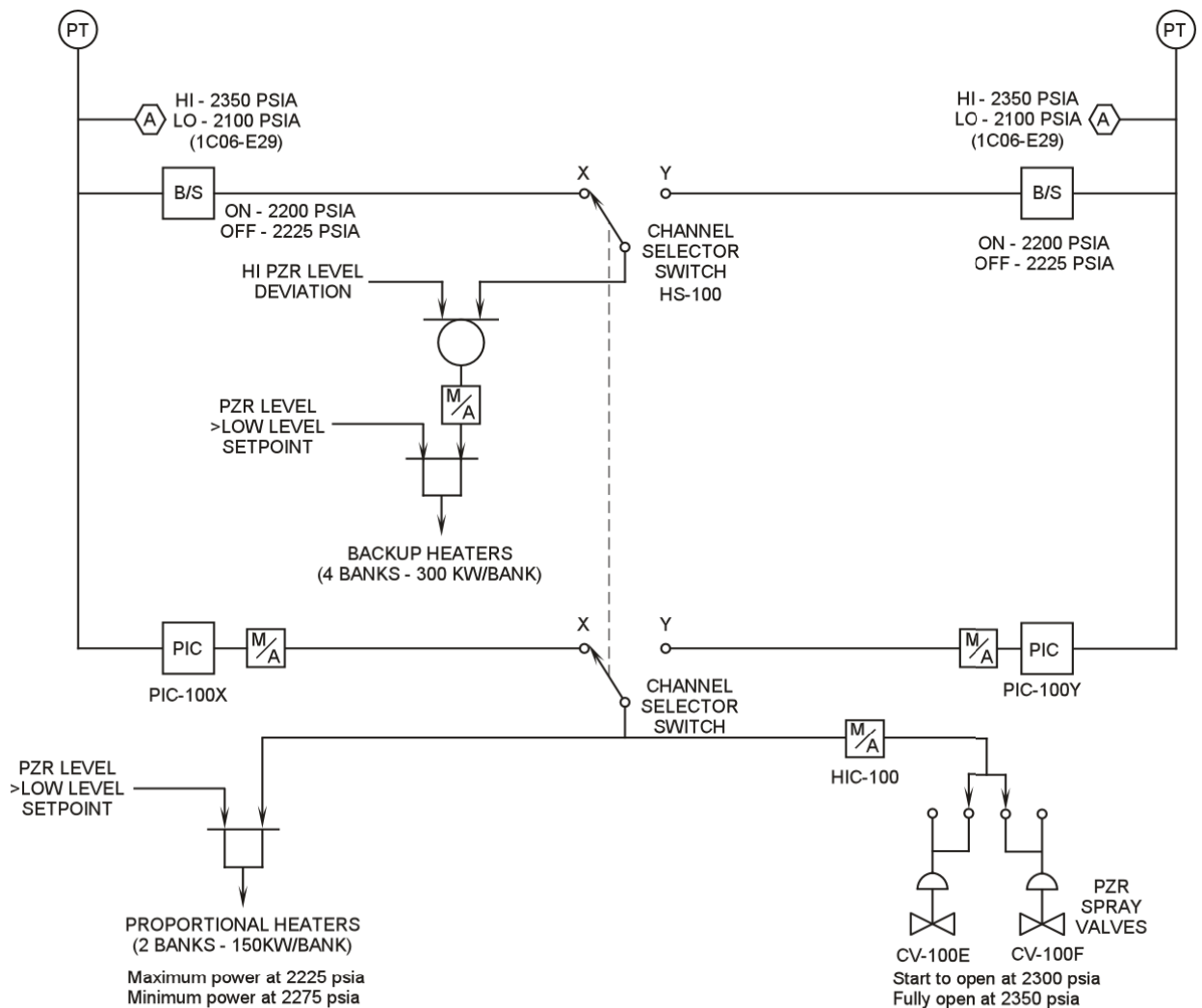

Figure 6.1-1 Pressurizer Pressure Control System

Figure 6.1-1 is a functional block diagram of the pressurizer pressure control system. Two separate pressure channels are provided for control of pressurizer pressure. A pressure detector transmits a signal proportional with pressurizer pressure to two bistables and a pressure indicator controller. A channel selector switch determines which channel bistable and pressure transmitter outputs are used for the various control functions.

The pressurizer pressure control station provides manual to automatic and automatic to manual transfer capability as well as the manual control capability for the modulating control of the proportional heaters. It provides the set point adjustment for the modulating automatic control and displays both the set point and the selected pressurizer pressure signal.

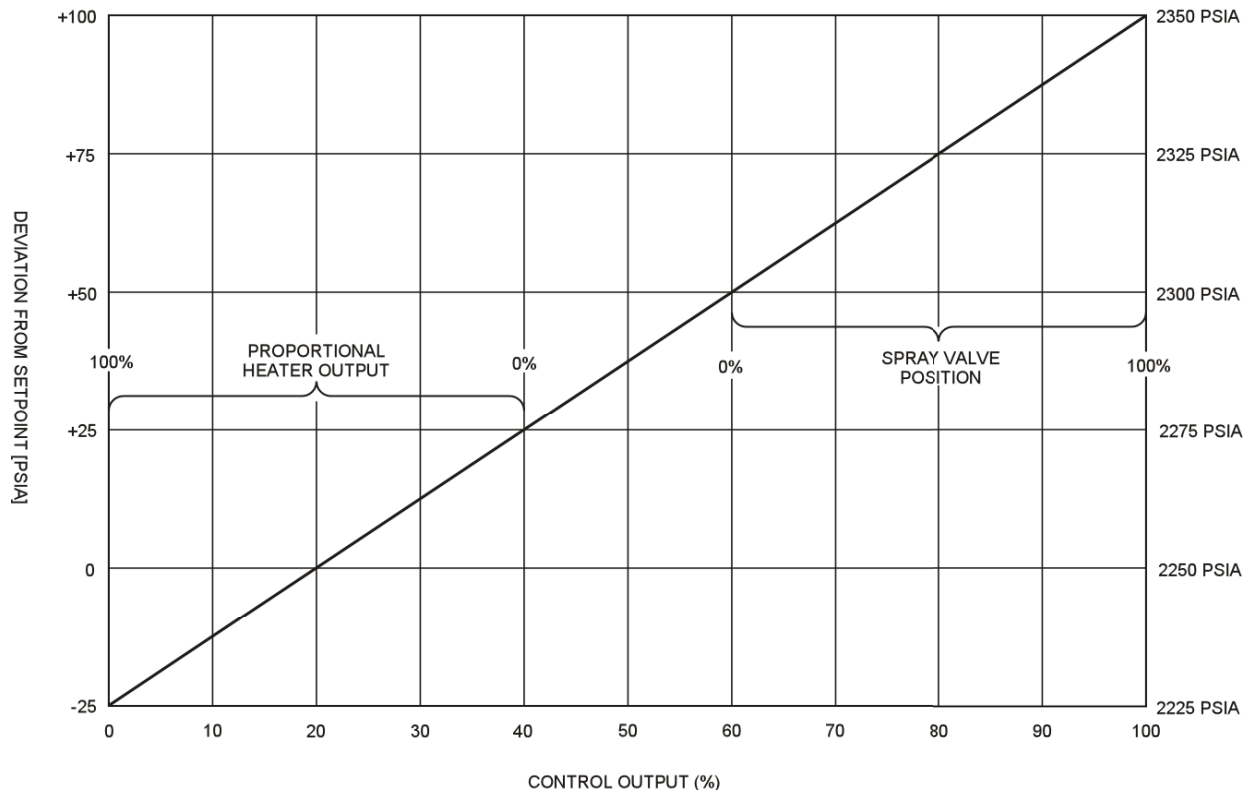

Figure 6.1-2 Pressurizer Pressure Control Output vs. Pressure Deviation

The output from the proportional-only pressure indicator controller will be the difference between the set point and the measured pressure of the pressurizer when in automatic, or the value set by the operator when in manual. Figure 6.1-2 shows the pressure controller output compared to the pressure deviation. This signal will be sent to the selected spray valve electro-pneumatic controller and to the proportional power control unit. As the pressure controller output increases from 0% to 40%, the power supplied to the proportional heaters will go from full power to zero power. As the output of the pressure controller increases from 60% to 100% the output of the spray valve controller, if in auto, will increase from 0% to 100%. This will stroke the selected spray valve from full closed to full open.

Pressure indication for each channel is provided on the pressure indicator controllers and on a two pen recorder. Range of pressure indication is 1500 psia to 2500 psia. A dual-action bistable provides a pressurizer pressure channel pressure alarm for each channel. A common alarm window annunciates if either bistable actuates.

6.1.2.1 Heater Operation

Six banks of independently powered immersion heaters are available to add energy to the pressurizer to increase the RCS pressure. Heater banks 1 and 2 are assigned to be controlled proportionally. They are designed to be at least 200% greater than the system heat losses with the spray bypass valves open.

The pressurizer pressure indicating controller sends a control signal to the proportional heater and spray valve controllers. This analog control signal is proportional to the actual pressure deviation from the controller set point. The proportional heaters operate in a 50 psia range around the controller set point. Normally, these heaters are at half power in the middle of the control band.

There are two banks of proportional heaters each having a capacity of 150 kW. A three position hand switch (off, on, and auto) operates a breaker to supply power to selenium control rectifiers. These rectifiers vary the power to the proportional heaters in response to the control signal from the selected pressure indicating controller. Maximum power is supplied when pressurizer pressure is 2225 psia, and minimum power is supplied when pressurizer pressure is 2275 psia. A low level in the pressurizer will open the supply breakers to the proportional heater selenium control rectifiers and the backup heaters.

The remaining heater banks are designated as backup heaters, and are either on or off, unlike the variable output capability of the proportional heaters. A bistable in the selected pressurizer pressure control channel is set to energize the four backup heater banks at a decreasing pressure (2200 psia) and to deenergize them at an increasing pressure (2225 psia), provided that the backup heater control switches are in the automatic position. Each bank of backup heaters has a capacity of 300 kW.

Backup heater banks may also be operated from the remote shutdown panel. A high pressurizer level deviation of three and six-tenths percent (+3.6%) from programmed level will energize the backup heaters if the heater control switches are in automatic (section 6.2). A low pressurizer level of 28% will de-energize the backup heaters. An indication light for each bank of heaters is mounted on the main control board to provide indication to the operator whenever the circuit breaker of the bank is closed.

6.1.2.2 Spray Valve Operation

The output of the selected pressure indicating controller is also sent to the spray valve controller. The spray valve controller is set to start opening the spray valves when the input reaches 2300 psia. The spray valves will be fully open when the input reaches 2350 psia. The operator can take manual control of the spray valve controller and position the valves at any desired position.

A single spray nozzle, supplied by two parallel valves, is available to reduce pressure. The spray coolant is taken from the discharge lines of two of the four reactor coolant pumps (RCPs), both from the same steam generator. A total minimum spray flow capacity of 375 gpm is available from the two spray valves under design conditions. Under design conditions, each 1 gpm spray flow corresponds to approximately 18 kW of heat loss.

Each spray control valve has an associated small capacity bypass valve. They are adjusted locally to supply a minimum flow through the spray lines and spray nozzle in order to maintain the temperature of the spray piping and to provide continuous trim for the pressurizer heat balance. In steady state, heat must be added to the pressurizer to compensate for the heat loss through the vessel walls (approximately 42.5 kW), and for the heat defect introduced by the continuous spray flow (approximately 1.5 gpm corresponding to 27 kW).

6.1.3 Normal Operation

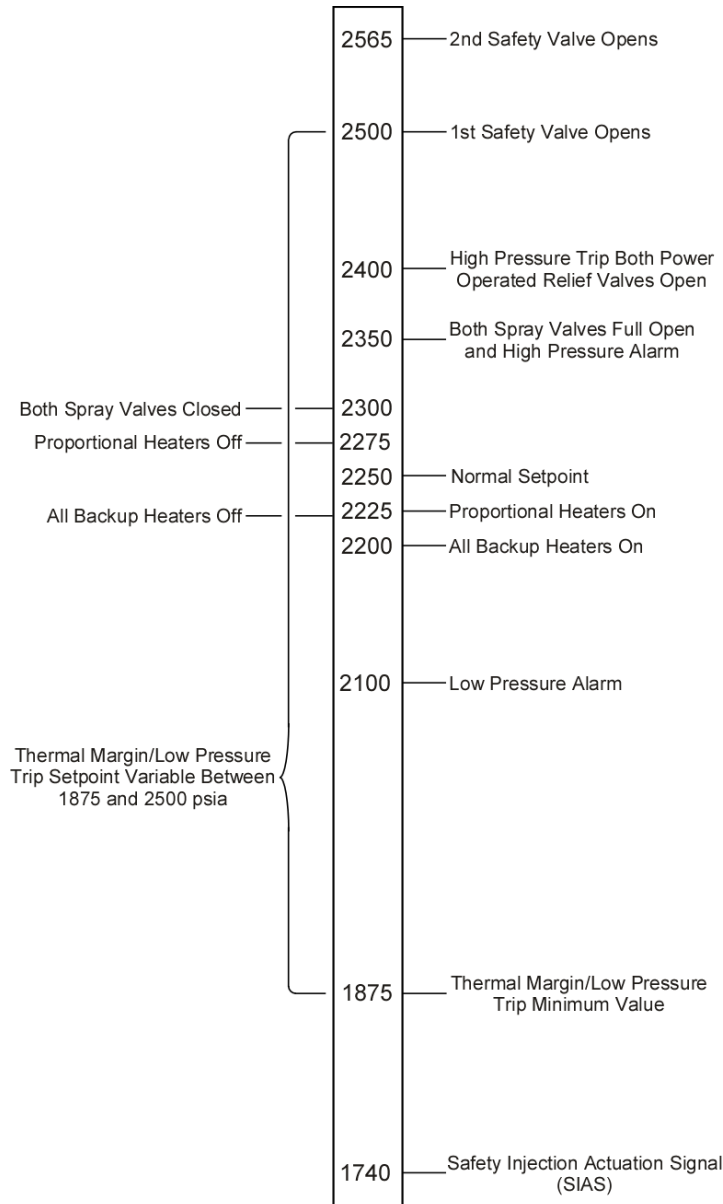

Figure 6.1-3 Pressurizer Pressure Control System Actions

Assuming an initial controller set point of 2250 psia, and an initial pressure of 2225 psia, the proportional heaters will be at full power at 2225 psia and zero power at 2275 psia. The selected spray valves will start to open at 2300 psia and will be fully open at 2350 psia.

Figure 6.1-3 illustrates system and plant response to changing pressurizer pressure.

When making significant changes in RCS boron concentration it is necessary to increase spray flow to equalize pressurizer and RCS boron concentration. This is done by manually energizing backup heaters. The subsequent rise in pressure causes spray valves to open. Since the controller is proportional-only, pressure must remain above setpoint to keep the spray valves open. The operator must adjust the controller setpoint to maintain desired pressure during boron equalization.

6.1.4 Summary

The pressurizer pressure control system maintains the RCS pressure at or near 2250 psia. The system uses heaters and spray valves which are actuated when actual pressure deviates from the desired set point.

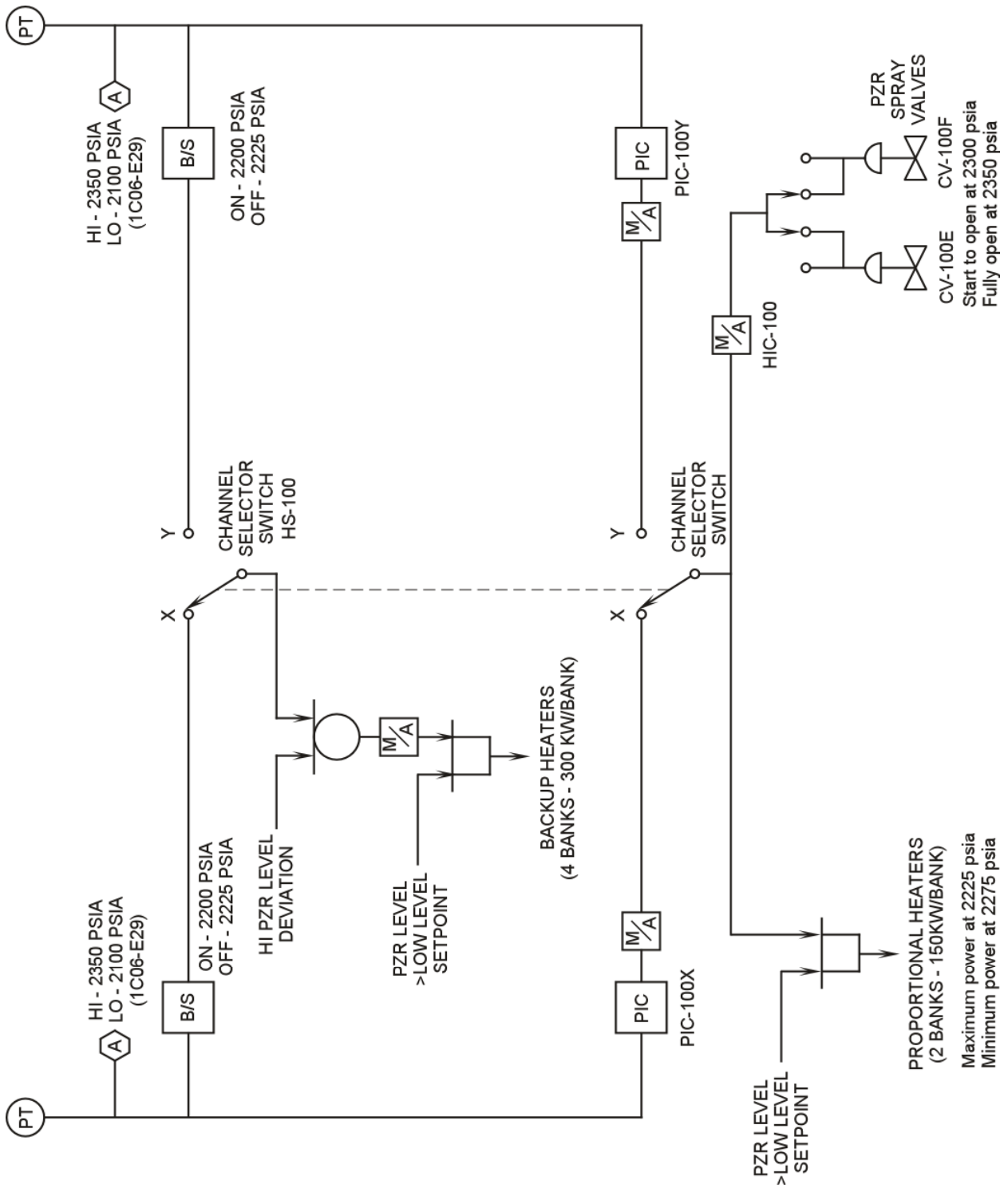

Figure 6.1-1 Pressurizer Pressure Control System

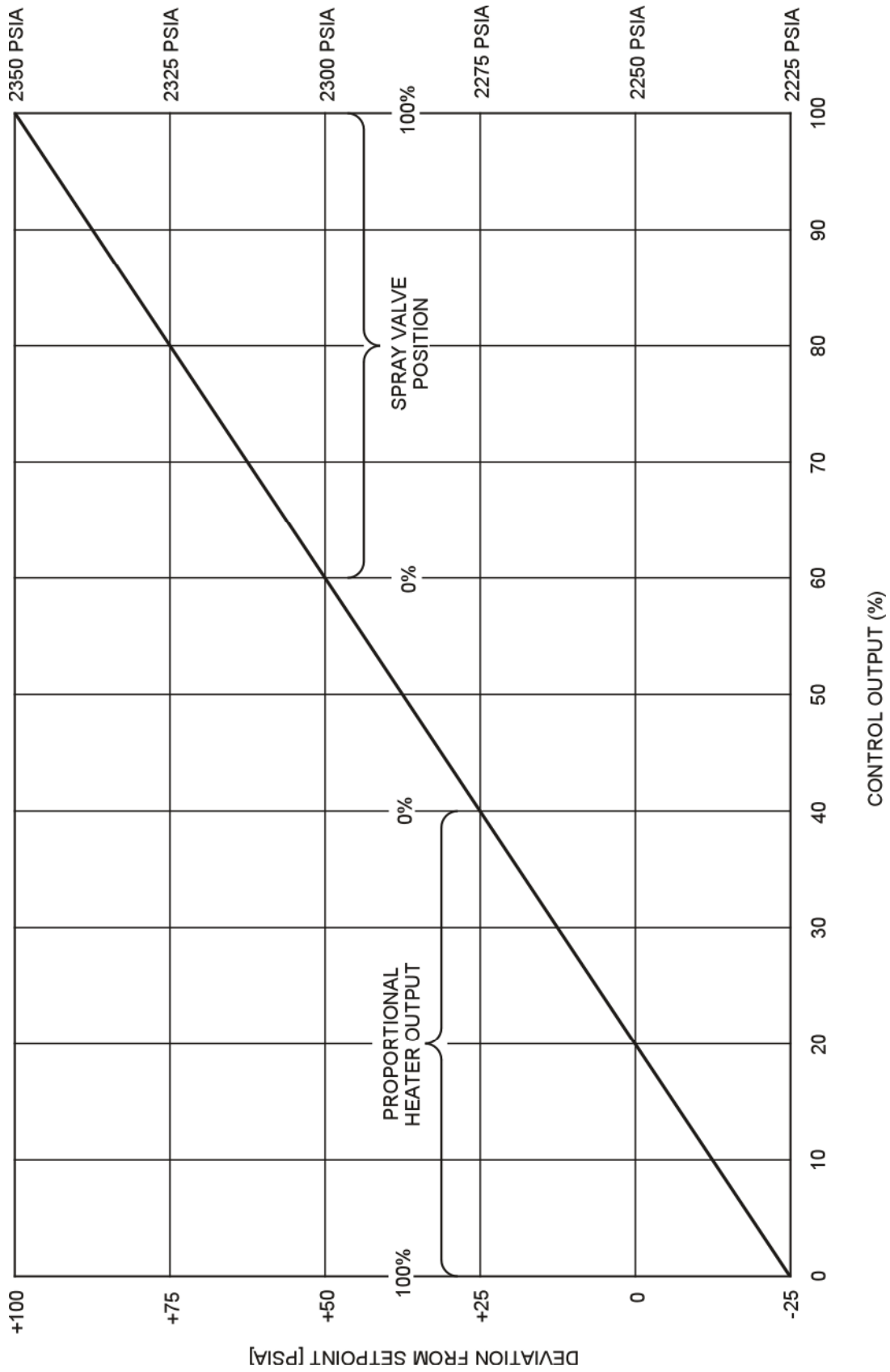

Figure 6.1-2 Pressurizer Pressure Control Output vs. Pressure Deviation

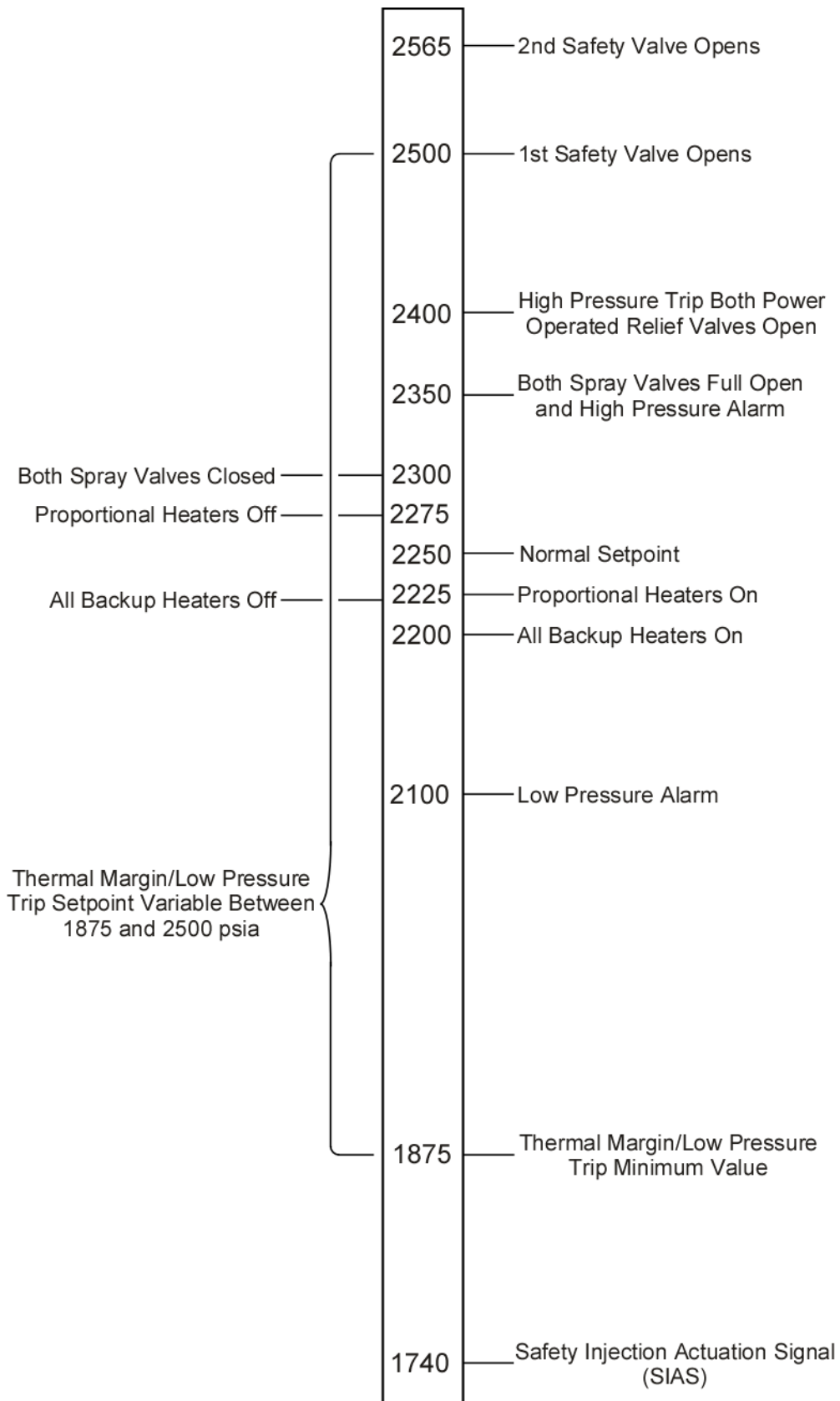

Figure 6.1-3 Pressurizer Pressure Control System Actions