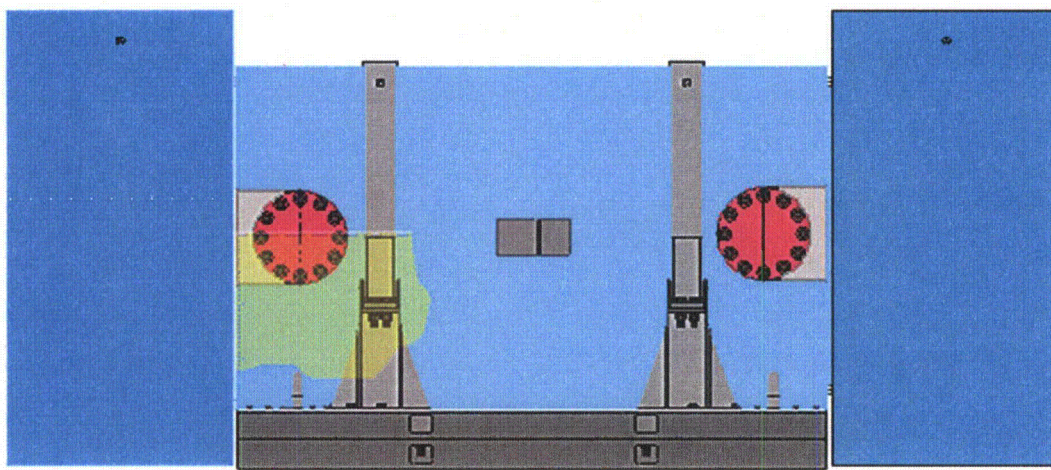




**TRANSNUCLEAR**  
AN AREVA COMPANY

**Non-Proprietary**

**NUHOMS<sup>®</sup>-MP197  
MULTI-PURPOSE  
CASK**



**TRANSPORT  
PACKAGING**

**SAFETY ANALYSIS REPORT**

**NUH09.0101**

**Volume 1 of 4**

**NON-PROPRIETARY**



**TRANSNUCLEAR INC.**

**NUHOMS<sup>®</sup>-MP197 TRANSPORT PACKAGING  
SAFETY ANALYSIS REPORT**

**Revision 10**

**TRANSNUCLEAR INC.**

---

7135 Minstrel Way • Suite 300 • Columbia, MD 21045

**NUHOMS®-MP197 PACKAGING  
SAFETY ANALYSIS REPORT**

**TABLE OF CONTENTS**

	<u>Page</u>
<b>1. GENERAL INFORMATION .....</b>	<b>1-1</b>
<b>1.1 Introduction .....</b>	<b>1-1</b>
<b>1.2 Package Description .....</b>	<b>1-2</b>
<b>1.2.1 Packaging .....</b>	<b>1-3</b>
<b>1.2.2 Operational Features .....</b>	<b>1-7</b>
<b>1.2.3 Contents of Packaging.....</b>	<b>1-8</b>
<b>1.3 References .....</b>	<b>1-12</b>
<b>1.4 Appendix .....</b>	<b>1-13</b>
<b>2. STRUCTURAL EVALUATION.....</b>	<b>2-1</b>
<b>2.1 Structural Design.....</b>	<b>2-1</b>
<b>2.1.1 Discussion .....</b>	<b>2-1</b>
<b>2.1.2 Design Criteria .....</b>	<b>2-4</b>
<b>2.2 Weights and Center-of-Gravity.....</b>	<b>2-9</b>
<b>2.3 Mechanical Properties of Materials.....</b>	<b>2-10</b>
<b>2.3.1 Cask Material Properties .....</b>	<b>2-10</b>
<b>2.3.2 Basket Material Properties .....</b>	<b>2-10</b>
<b>2.3.3 Impact Limiter Material .....</b>	<b>2-10</b>
<b>2.3.4 Fracture Toughness .....</b>	<b>2-10</b>
<b>2.4 General Standards for All Packages.....</b>	<b>2-11</b>
<b>2.4.1 Minimum Package Size.....</b>	<b>2-11</b>
<b>2.4.2 Tamper-proof Feature .....</b>	<b>2-11</b>
<b>2.4.3 Positive Closure .....</b>	<b>2-11</b>
<b>2.4.4 Chemical and Galvanic Reactions.....</b>	<b>2-11</b>
<b>2.5 Lifting and Tie-Down Standards.....</b>	<b>2-21</b>
<b>2.5.1 Lifting Devices.....</b>	<b>2-21</b>
<b>2.5.2 Tie-Down Devices.....</b>	<b>2-28</b>

## TABLE OF CONTENTS (CONT)

2.6	Normal Conditions of Transport .....	2-32
2.6.1	Heat .....	2-33
2.6.2	Cold Environment .....	2-35
2.6.3	Reduced External Pressure .....	2-35
2.6.4	Increased External Pressure .....	2-35
2.6.5	Transport Shock Loading .....	2-36
2.6.6	Transport Vibration Loading .....	2-37
2.6.7	Water Spray .....	2-38
2.6.8	Free Drop .....	2-38
2.6.9	Corner Drop .....	2-38
2.6.10	Compression .....	2-38
2.6.11	Penetration .....	2-39
2.6.12	Fabrication Stresses .....	2-39
2.6.13	Lid Bolt Analysis .....	2-39
2.6.14	Fatigue Analysis of Containment Boundary .....	2-40
2.6.15	Summary of Normal Condition Cask Body Structural Analysis .....	2-44
2.6.16	Structural Evaluation of the Basket/Canister Under Normal Condition Loads .....	2-44
2.7	Hypothetical Accident Conditions .....	2-47
2.7.1	30 Foot Free Drop .....	2-48
2.7.2	Puncture .....	2-52
2.7.3	Thermal .....	2-55
2.7.4	Water Immersion .....	2-55
2.7.5	Buckling Evaluation of the Containment Vessel due to Accident End Drop Loads .....	2-57
2.7.6	Summary of Accident Condition Cask Body Structural Analysis .....	2-58
2.7.7	Structural Evaluation of the Basket/Canister under Accident Loads .....	2-59
2.8	Special Form / Fuel Rods .....	2-61
2.8.1	Special Form .....	2-61
2.8.2	Fuel Rods .....	2-61
2.9	References .....	2-62
2.10	Appendices .....	2-64
2.10.1	NUHOMS <sup>®</sup> -MP197 Cask Body Structural Evaluation .....	2.10.1-1
2.10.2	NUHOMS <sup>®</sup> -MP197 Cask Lid Bolt Analysis .....	2.10.2-1
2.10.3	NUHOMS <sup>®</sup> -61BT DSC (Canister and Basket) Structural Evaluation .....	2.10.3-1
2.10.4	NUHOMS <sup>®</sup> -MP197 Cask Lead Slump Analysis .....	2.10.4-1
2.10.5	NUHOMS <sup>®</sup> -MP197 Cask Inner Containment Buckling Analysis .....	2.10.5-1

## TABLE OF CONTENTS (CONT)

2.10.6	Dynamic Amplification Factor Determination .....	2.10.6-1
2.10.7	Evaluation of Fuel Assembly under Accident Impacts .....	2.10.7-1
2.10.8	Structural Evaluation of the NUHOMS <sup>®</sup> -MP197 Package Impact Limiters .....	2.10.8-1
2.10.9	NUHOMS <sup>®</sup> -MP197 Package Impact Limiter Testing .....	2.10.9-1
2.11	ASME Code Exceptions .....	2-65
3.	THERMAL EVALUATION.....	3-1
3.1.	Discussion .....	3-1
3.2.	Summary of Thermal Properties of Components.....	3-3
3.3.	Technical Specifications for Components.....	3-9
3.4.	Thermal Evaluation for Normal Conditions of Transport.....	3-10
3.4.1.	Thermal Model .....	3-10
3.4.2.	Maximum Temperatures .....	3-14
3.4.3.	Maximum Accessible Surface Temperature in the Shade .....	3-14
3.4.4.	Minimum Temperatures .....	3-14
3.4.5.	Maximum Internal Pressure .....	3-14
3.4.6.	Maximum Thermal Stresses.....	3-14
3.4.7.	Evaluation of Package Performance for Normal Conditions .....	3-15
3.5.	Thermal Evaluation for Accident Conditions .....	3-16
3.5.1.	Fire Accident Evaluation.....	3-16
3.5.2.	Cask Cross Section Model .....	3-16
3.5.3.	Cask Body Model.....	3-17
3.5.4.	Trunnion Region Model.....	3-17
3.5.5.	Bearing Block Region Model.....	3-18
3.5.6.	Maximum Internal Pressure .....	3-18
3.5.7.	Summary of the Results .....	3-18
3.5.8.	Evaluation of Package Performance during Fire Accident Conditions..	3-19
3.6.	References.....	3-20
3.7.	Appendices	
3.7.1.	Effective Thermal Conductivity for the Fuel Assembly .....	3.7.1-1
3.7.2.	Average Heat Transfer Coefficient for Fire Accident Conditions .....	3.7.2-1
3.7.3.	Maximum Internal Operating Pressures.....	3.7.3-1
3.7.4.	Thermal Evaluation for Vacuum Drying Conditions.....	3.7.4-1

## TABLE OF CONTENTS (CONT)

<b>4.</b>	<b>CONTAINMENT</b>	
4.1	Containment Boundary .....	4-1
4.1.1	Containment Vessel.....	4-1
4.1.2	Containment Penetrations .....	4-2
4.1.3	Seals and Welds .....	4-2
4.1.4	Closure .....	4-3
4.2	Requirements for Normal Conditions of Transport .....	4-4
4.2.1	Containment of Radioactive Material .....	4-4
4.2.2	Pressurization of Containment Vessel.....	4-4
4.2.3	Containment Criterion.....	4-4
4.3	Containment Requirements for Hypothetical Accident Conditions.....	4-5
4.3.1	Fission Gas Products .....	4-5
4.3.2	Containment of Radioactive Material .....	4-5
4.3.3	Containment Criterion.....	4-5
4.4	Special Requirements.....	4-6
4.5	References .....	4-7
<b>5.</b>	<b>SHIELDING EVALUATION</b>	
5.1	Discussion and Results.....	5-1
5.2	Source Specification.....	5-2
5.2.1	Axial Source Distribution .....	5-4
5.2.2	Gamma Source .....	5-4
5.2.3	Neutron Source.....	5-5
5.3	Model Specification .....	5-6
5.3.1	Description of Radial and Axial Shielding Configuration.....	5-6
5.3.2	Shield Regional Densities .....	5-7
5.4	Shielding Evaluation .....	5-9
5.5	References .....	5-10
5.6	Appendix .....	5-11
5.6.1	SAS2H/ORIGENS Input File.....	5-11
5.6.2	MCNP Neutron Model Input File .....	5-13
5.6.3	MCNP Primary Gamma Input File (Preferential Loading).....	5-21

## TABLE OF CONTENTS (CONT)

<b>6</b>	<b>CRITICALITY EVALUATION</b>	
6.1	Discussion and Results .....	6-1
6.2	Package Fuel Loading .....	6-1
6.3	Model Specification .....	6-2
6.3.1	Description of Calculational Model .....	6-2
6.3.2	Package Regional Densities .....	6-3
6.4	Criticality Calculation .....	6-3
6.4.1	Calculational Method .....	6-3
6.4.2	Fuel Loading Optimization .....	6-5
6.4.3	Criticality Results .....	6-8
6.5	Criticality Benchmark Experiments .....	6-8
6.5.1	Benchmark Experiments and Applicability .....	6-9
6.5.2	Results of the Benchmark Calculations .....	6-10
6.6	Appendix: Most Reactive Fuel Analysis.....	6-6-1
<b>7.</b>	<b>OPERATING PROCEDURES .....</b>	<b>7-1</b>
7.1	Procedures for Loading the Package.....	7-1
7.1.1	Preparation of the NUHOMS <sup>®</sup> -MP197 Cask for Use.....	7-1
7.1.2	Wet Loading the NUHOMS <sup>®</sup> -MP197 Cask and 61BT DSC.....	7-3
7.1.3	Loading the DSC into the Cask from an HSM.....	7-10
7.1.4	Preparing the Cask for Transportation .....	7-11
7.1.5	Placing the Cask onto the Railcar .....	7-11
7.1.6	Glossary.....	7-12
7.2	Procedures for Unloading the Cask.....	7-14
7.2.1	Receipt of the Loaded NUHOMS <sup>®</sup> -MP197 Cask .....	7-14
7.2.2	Unloading the NUHOMS <sup>®</sup> -MP197 Cask to a Staging Module .....	7-15
7.2.3	Unloading the NUHOMS <sup>®</sup> -MP197 Cask to a Fuel Pool .....	7-16
7.2.4	Unloading the NUHOMS <sup>®</sup> -MP197 Cask to a Dry Cell.....	7-18
7.3	Preparation of an Empty Cask for Transport .....	7-19
7.4	Leakage rate Testing of the containment Boundary.....	7-20
7.5	References .....	7-24

**TABLE OF CONTENTS (CONT)****8. ACCEPTANCE TESTS AND MAINTENANCE PROGRAM**

8.1	Acceptance Tests .....	8-1
8.1.1	Visual Inspection .....	8-1
8.1.2	Structural and Pressure Tests .....	8-1
8.1.3	Leak Tests .....	8-2
8.1.4	Component Tests .....	8-3
8.1.5	Shielding Tests .....	8-4
8.1.6	Neutron Absorber Tests .....	8-6
8.2	Maintenance Program .....	8-12
8.2.1	Structural and Pressure Tests .....	8-12
8.2.2	Leak Tests .....	8-12
8.2.3	Subsystem Maintenance .....	8-13
8.2.4	Valves, Rupture Discs, and Gaskets on Containment Vessel .....	8-13
8.2.5	Shielding .....	8-13
8.2.6	Thermal .....	8-13
8.3	References .....	8-14

*See Appendix A for a Table of Contents for Appendix A.*



# NUHOMS®-MP197 TRANSPORT PACKAGING

## CHAPTER 1

### TABLE OF CONTENTS

	<u>Page</u>
1. GENERAL INFORMATION .....	1-1
1.1 Introduction.....	1-1
1.2 Package Description .....	1-2
1.2.1 Packaging .....	1-2
1.2.2 Operational Features .....	1-7
1.2.3 Contents of Packaging .....	1-8
1.3 References.....	1-12
1.4 Appendix.....	1-13

### LIST OF TABLES

- 1-1 Nominal Dimensions and Weights of the NUHOMS®-MP197 Packaging

### LIST OF FIGURES

- 1-1 General Arrangement NUHOMS®-MP197 Packaging

## CHAPTER 1

### GENERAL INFORMATION

#### 1.1 INTRODUCTION

This Safety Analysis Report (SAR) presents the evaluation of a Type B(U) spent fuel transport packaging developed by Transnuclear, Inc. and designated the NUHOMS<sup>®</sup>-MP197 packaging. This SAR describes the design features and presents the safety analyses, which demonstrate that the NUHOMS<sup>®</sup>-MP197 complies with applicable requirements of 10 CFR 71 [1]. The format and content of this SAR follow the guidelines of Regulatory Guide 7.9 [2].

The NUHOMS<sup>®</sup>-MP197 packaging consists of the NUHOMS<sup>®</sup>-MP197 Transport Cask, which is utilized for the off-site transportation of NUHOMS<sup>®</sup>-61BT Dry Shielded Canisters (DSCs) in accordance with 10CFR71 [1]. The packaging is intended to be shipped as exclusive use. The *Criticality Safety Index (CSI)* for nuclear criticality control for the packaging is determined to be zero (0) in accordance with 10 CFR 71.59. See Chapter 6.

Transnuclear, Inc. has a NRC approved quality assurance program (Docket Number 71-0250) which satisfies the requirements of 10 CFR 71 Subpart H.

*Chapters 1 through 8 of this SAR address the NUHOMS<sup>®</sup>-MP197 packaging with the NUHOMS<sup>®</sup>-61BT DSC payload containing BWR spent fuel assemblies. Appendix A to this SAR addresses the NUHOMS<sup>®</sup>-MP197HB packaging with the payloads described in Section A.1.2.3.*

## 1.2 PACKAGE DESCRIPTION

### 1.2.1 Packaging

The NUHOMS<sup>®</sup>-MP197 packaging will be used to transport 61 intact standard Boiling Water Reactor (BWR) fuel assemblies with or without fuel channels, contained in a single NUHOMS<sup>®</sup>-61BT DSC. The NUHOMS<sup>®</sup>-MP197 packaging is designed for a maximum heat load of 15.9 kW or 260 W/assembly. The fuel that may be transported in the NUHOMS<sup>®</sup>-MP197 packaging is presented in Section 1.2.3.

The NUHOMS<sup>®</sup>-MP197 packaging consists of the following components:

- A NUHOMS<sup>®</sup>-61BT Dry Shielded Canister (DSC) consisting of a cylindrical shell, top and bottom shield plugs, inner and outer bottom closure plates, and inner and outer top cover plates. After loading, the DSC is vacuum dried and back-filled with an inert gas.
- A fuel basket assembly, located inside the DSC, which locates and supports the fuel assemblies, transfers heat to the DSC wall, and provides neutron absorption to satisfy nuclear criticality requirements. A basket hold down ring is installed on top of the basket, after fuel loading, to prevent axial motion of the basket within the canister.
- A NUHOMS<sup>®</sup>-MP197 transport cask consisting of a containment boundary, structural shell, gamma shielding material, and solid neutron shield. The containment boundary consists of a cylindrical shell, bottom end (closure) plate with a ram access penetration, top end forging ring, bottom and top cover plates (lids) with associated seals and bolts, and vent and drain port closure bolts and seals. The transport cask cavity also contains an inert gas atmosphere.
- Sets of removable upper and lower trunnions, bolted to the outer shell of the cask that provide support, lifting, and rotation capability for the NUHOMS<sup>®</sup>-MP197 cask.
- Impact limiters consisting of balsa and redwood, encased in stainless steel shells, are attached to each end of the NUHOMS<sup>®</sup>-MP197 cask during shipment. A thermal shield is provided between the bottom impact limiter and the cask to minimize heat transfer to the bottom limiter. Each impact limiter is held in place by twelve (12) attachment bolts.

A personnel barrier is mounted to the transport frame to prevent unauthorized access to the cask body. The overall dimensions of the NUHOMS<sup>®</sup>-MP197 packaging are 281.25 inches long and 122.00 inches in diameter with both impact limiters installed. The transport cask body is 208.00 inches long and 82.00 inches in diameter. The cask diameter including the radial neutron shield is 91.50 inches. The cask cavity is 197 inches long and 68.00 inches in diameter. Detailed design drawings for the NUHOMS<sup>®</sup>-MP197 packaging are provided in Appendix 1.4. The materials used to fabricate the packaging are shown in the Parts List on Drawing 1093-71-3. Where more than one material has been specified for a component, the most limiting properties are used in the analyses in the subsequent chapters of this SAR.

The maximum gross weight of the loaded package is 132.5 tons including a maximum payload of 21.5 tons. Table 1-1 summarizes the dimensions and weights of the NUHOMS<sup>®</sup>-MP197 packaging components. Trunnions, attached to the cask body, are provided for lifting and handling operations, including rotation of the packaging between the horizontal and vertical orientations. The NUHOMS<sup>®</sup>-MP197 packaging is transported in the horizontal orientation, on a specially designed shipping frame, with the lid end facing the direction of travel.

During normal operating conditions the maximum pressure within the DSC is 1.67 atm (9.8 psig). Within the cask body the maximum normal operating pressure is 1.37 atm (5.4 psig). A cask cavity and canister cavity pressure of 50 psig is conservatively used for the purposes of structural analyses. The spent fuel payload is shipped dry in a helium atmosphere. Both the transport cask cavity and the DSC cavity are filled with helium. The heat generated by the spent fuel assemblies is rejected to the surrounding air by convection and radiation. No forced cooling or cooling fins are required.

The following sections provide a physical and functional description of each major component. Detail drawings showing dimensions of significance to the safety analyses, welding and NDE information, as well as a complete materials list are provided in Appendix 1.4. Reference to these drawings is made in the following physical description sections, and in general, throughout this SAR. Fabrication of the NUHOMS<sup>®</sup>-MP197 packaging is performed in accordance with these drawings.

#### 1.2.1.1 NUHOMS<sup>®</sup>-61BT DSC

A Dry Shielded Canister (DSC) consists of a cylindrical shell, top and bottom shield plugs, inner and outer bottom closure plates, and inner and outer top cover plates. The overall length and the outer diameter of the DSC is 199.67 inches and 67.25 inches respectively. The DSC assembly and details are shown in drawings 1093-71-13 through 1093-71-18. The shell assembly is a high integrity stainless steel (SA-240 Type 304) welded pressure vessel that provides containment of radioactive materials, encapsulates the fuel in an inert atmosphere (the canister is back-filled with Helium before being seal welded closed), and provides biological shielding (in axial direction). The DSC has double redundant seal welds that join the shell and the top and bottom cover plate assemblies to seal the canister. The bottom end assembly welds are made during fabrication of the DSC. The top end closure welds are made after fuel loading. Both top plug penetrations (siphon and vent ports) are redundantly sealed after the DSC drying operations are complete.

The canister is designed to contain the fuel basket and fuel assemblies, and is completely supported by the transport cask. Under normal transport conditions, the canister rests on four transfer support rails, attached to the inside surface of the transport cask.

### 1.2.1.2 Fuel Basket

The basket structure is designed, fabricated and inspected in accordance with ASME B&PV Code Subsection NG [3]. Exceptions to the code are provided in Section 2.11. The overall length and outer diameter of the basket, including the hold down ring, is 178.5 inches and 66.00 inches respectively. The details of the NUHOMS<sup>®</sup>-61BT Fuel Basket are shown in drawings 1093-71-10 through -12. The NUHOMS<sup>®</sup>-61BT basket is designed to accommodate 61 intact standard BWR fuel assemblies with or without fuel channels. The basket structure consists of a welded assembly of stainless steel tubes (fuel compartments) separated by poison plates and surrounded by larger stainless steel boxes and support rails.

The basket structure is open at each end. Therefore, longitudinal fuel assembly loads are applied directly on the canister/cask body and not on the fuel basket structure. The fuel assemblies are laterally supported by the stainless steel structural boxes. The basket is laterally supported by the basket rails and the canister shell. The stainless steel basket rails are oriented parallel to the axis of the canister, and are attached to the periphery of the basket to provide support, and to establish and maintain basket orientation.

A shear key, welded to the inner wall of the DSC, mates with a notch in one of the basket support rails to prevent the basket from rotating during normal operations. Also, a hold down ring is installed above the basket, after fuel loading is complete, to prevent the basket from moving axially during transport.

The poison plates are constructed from borated aluminum, an aluminum/B<sub>4</sub>C metal matrix composite, or Boral<sup>®</sup>, and provide a heat conduction path from the fuel assemblies to the canister wall, as well as the necessary criticality control.

### 1.2.1.3

### NUHOMS<sup>®</sup>-MP197 Transport Cask

The cask is fabricated primarily of stainless steel. Non-stainless steel members include the cast lead shielding between the containment boundary inner shell and the structural shell, the o-ring seals, the borated polyester resin neutron shield material and the carbon steel closure bolts. Socket headed cap screws (bolts) are used to secure the top closure lid to the cask body and the RAM access closure plate to the bottom of the cask. The body of the cask consists of a 1.25 inch, 68 inch inside diameter stainless steel inner (containment) shell and a 2.5-inch thick, 82.00 inch outside diameter stainless steel structural shell which sandwich the 3.25 inch thick cast lead shielding material.

The overall external dimensions of the cask are 208.00 inches long and 91.5 inches outer diameter. The weight of the cask body (excluding the lid and lid bolts, which weighs approximately 5,610 pounds) is approximately 143,000 pounds, including 9,960 pounds of neutron shield material and roughly 60,000 pounds of cast lead. The following components comprise the NUHOMS<sup>®</sup>-MP197 Transport Cask.

#### A. Containment Vessel

The cask containment boundary consists of the inner shell, a 6.50 inch thick bottom plate with a 23.88 inch diameter, 2.5 inch thick RAM access closure, a top closure flange, a 4.50 inch thick top closure lid with closure bolts, vent and drain port closures and bolts, and double O-ring seals for each of the penetrations. A 68 inch diameter, 197 inch long cavity is provided.

The containment vessel prevents leakage of radioactive material from the cask cavity. It also maintains an inert atmosphere (helium) in the cask cavity. Helium assists in heat removal and provides a non-reactive environment to protect fuel assemblies against fuel cladding degradation. To preclude air in-leakage, the cask cavity is pressurized with helium to above atmospheric pressure.

The inner containment shell is SA-240, Type XM-19, and the bottom, and top flange materials are SA-182, Type FXM19. The top closure lid is constructed from SA-705, Type 630, H1100. The NUHOMS<sup>®</sup>-MP197 packaging containment vessel is designed, fabricated, examined and tested in accordance with the requirements of Subsection NB [4] of the ASME Code to the maximum practical extent. In addition, the design meets the requirements of Subsection WB of the ASME Section III, Division 3 [5] and Regulatory Guides 7.6 [6] and 7.8 [7]. Exceptions to the ASME Code are discussed in Section 2.11 of Chapter 2. The construction of the containment boundary is shown in drawings 1093-71-2, 3 and 4 provided in Appendix 1.4. The design of the containment boundary is discussed in Chapter 2 and the fabrication requirements (including examination and testing) of the containment boundary are discussed in Chapter 4.

## B. Gamma and Radial Neutron Shielding

The lead and steel shells of the transport cask provide shielding between the fuel and the exterior surface of the package for the attenuation of gamma radiation (Drawings 1093-71-2, -3 and -4).

Neutron shielding is provided by a borated polyester resin compound surrounding the outer shell. The resin compound is cast into long, slender aluminum containers. The containers are constructed from 6063-T5 aluminum. The total thickness of the resin and aluminum is 4.56 inches. The array of resin-filled containers is enclosed within a smooth 3/16 inch thick outer steel shell (SA-240, Type 304). In addition to serving as resin containers, the aluminum provides a conduction path, from the cask body to the neutron shield shell, for heat transfer.

The resin material is an unsaturated polyester cross-linked with styrene, with about 50% weight mineral and fiberglass reinforcement. The components are polyester resin, styrene monomer, alpha methyl styrene, aluminum oxide, zinc borate, and chopped fiberglass which produce the elemental resin composition shown below.

Element	% Weight
H	5.05
B	1.05
C	35.13
Al	14.93
O + Zn (balance)	43.84

Noncontainment welds are inspected in accordance with the NDE acceptance criteria of ASME B&PV Code Subsection NF.

The structural analysis of the NUHOMS<sup>®</sup>-MP197 cask body is presented in Chapter 2.

### 1.2.1.4 Tiedown and Lifting Devices

There are four trunnion sockets on the cask; two front trunnion sockets, and two rear trunnion sockets. They accommodate removable trunnions for handling, lifting, and rotating of the cask. These trunnion sockets are attached to the structural shell. Two types of trunnions are provided for the NUHOMS<sup>®</sup>-MP197 transport package lifting. One type of trunnion has a double shoulder (non-single failure proof). The other type of trunnion has a single shoulder (single failure proof). The top (lifting) set of trunnions could be either type depending on site and transfer operation requirements. The bottom set of trunnions are the double shoulder type. The trunnions are fabricated and tested in accordance with ANSI N14.6 [9]. During transport, four trunnion plugs, containing neutron shielding material, will be bolted to the four trunnion sockets.

When the cask is in the horizontal position, a shear key receptacle on the bottom of the cask reacts the longitudinal tiedown loads. The shear key receptacle is welded to the structural shell and protrudes through the neutron shield. During transport the receptacle interfaces with the shear block attached to the transport skid.

### 1.2.1.5 Impact Limiters

The front and rear impact limiters, shown in TN Drawings 1093-71-1, -8, and -9, absorb energy during impact events by crushing balsa and redwood. The top and bottom impact limiters are identical. Each has an outside diameter of 122 inches and a height of 60.75 inches. The inner and outer shells are Type 304 stainless steel joined by radial gussets of the same material. The gussets limit the stresses in the 0.25 in. thick stainless steel outer cylinder and end plates due to pressure differentials caused by elevation and temperature changes during normal transport, and provide wood confinement during impact. The metal structure locates, supports, confines, and protects the wood energy absorption material. The external surfaces of the impact limiter shells are painted.

The impact limiters are attached to the NUHOMS<sup>®</sup>-MP197 cask by twelve (12) attachment bolts. The attachment bolts are designed to keep the impact limiters attached to the cask body during all normal and hypothetical accident conditions.

Each impact limiter is provided with seven fusible plugs that are designed to melt during a fire accident, thereby relieving excessive internal pressure. Each impact limiter has two hoist rings for handling, and two support angles for supporting the impact limiter in a vertical position during storage. The hoist rings are threaded into the impact limiter shell, while the support angles are welded to the shell. During transportation, the impact limiter hoist rings are removed.

An aluminum thermal shield is added to the bottom impact limiter to reduce the impact limiter wood temperature. The details of the thermal shield are included in TN drawing 1093-71-9.

The functional description as well as the performance analysis of the impact limiters is provided in Appendix 2.10.8. The description and results of the impact limiter dynamic testing program are provided in Appendix 2.10.9.

### 1.2.2 Operational Features

The NUHOMS<sup>®</sup>-MP197 package is not considered to be operationally complex and is designed to be compatible with spent fuel pool loading/unloading methods. All operational features are readily apparent from inspection of the General Arrangement Drawings provided in Section 1.4. The sequential steps to be followed for cask loading, testing, and unloading operations are provided in Chapter 7.



### 1.2.3 Contents of Packaging

The contents of the NUHOMS<sup>®</sup>-MP197 packaging are limited to the following.

- Fuel parameters

The NUHOMS<sup>®</sup>-61BT DSC is designed to store 61 intact standard Boiling Water Reactor (BWR) fuel assemblies with or without fuel channels. Nominal channel thicknesses up to 0.120 inches thick are acceptable for transport.

Partial fuel assemblies (spent fuel assemblies from which fuel rods are missing) shall not be classified as intact fuel assemblies unless dummy fuel rods are used to displace an amount of water equal to that displaced by the original rod(s).

Permissible fuel assembly types are listed below.

GE Type	Designation	# of Fueled Rods	Uranium Content (MTU/assembly)
7x7	2A	49	0.1977
7x7	2, 2B	49	0.1977
7x7	3, 3A, 3B	49	0.1896
8x8	4, 4A, 4B	63	0.1880
8x8	5, 6, 6B, 7, 7B	62	0.1876
8x8	8, 8B	62	0.1885
8x8	8, 8B, 9, 9B, 10	60	0.1824
9x9	11,13	74	0.1757
10x10	12	92	0.1857

Fuel characteristics are provided in the following table.

BWR Fuel Assembly Design Characteristics <sup>(1)(3)</sup>							
Transnuclear, ID	7 × 7- 49/0	8 × 8- 63/1	8 × 8- 62/2	8 × 8 - 60/4	8 × 8- 60/1	9 × 9- 74/2	10×10- 92/2
GE Designations	GE2 GE3	GE4	GE-5 GE-Pre GE-Barrier GE8 Type I	GE8 Type II	GE9 GE10	GE11 GE13	GE12
Max Length (in)	176.2	176.2	176.2	176.2	176.2	176.2	176.2
Max Width (in) (excluding channels)	5.44	5.44	5.44	5.44	5.44	5.44	5.44
Channel Internal Width (in)	5.278	5.278	5.278	5.278	5.278	5.278	5.278
Maximum MTU/assembly <sup>(2)</sup>	0.1977	0.1880	0.1856	0.1825	0.1834	0.1766	0.1867

- (1) Any fuel channel thickness from 0.065 to 0.120 inch is acceptable on any of the fuel designs.  
 (2) The maximum MTU/assembly is calculated based on the theoretical density. The calculated value is higher than the actual.  
 (3) Maximum fuel assembly weight with channel is 705 lb.

Provided all the requirements listed in this section are met, the bounding fuel characteristics for the intact fuel assemblies are:

<b>Intact BWR Fuel Assembly Characteristics</b>	
<b>Physical Parameters:</b>	
Fuel Design:	7x7, 8x8, 9x9, or 10x10 BWR fuel assemblies manufactured by General Electric or equivalent reload fuel
Cladding Material:	Zircaloy
Fuel Damage:	Cladding damage in excess of pinhole leaks or hairline cracks is not authorized to be stored as "Intact BWR Fuel".
Channels:	Fuel may be stored with or without fuel channels
<b>Radiological Parameters:</b>	
<b>Group 1:</b>	
Maximum Burnup:	27,000 MWd/MTU
Minimum Cooling Time:	6-years
Maximum Initial Enrichment:	See Poison Material Design Requirements Table
Minimum Initial Bundle Average Enrichment:	2.0 wt. % U-235
Maximum Initial Uranium Content:	198 kg/assembly
Maximum Decay Heat:	260 W/assembly
<b>Group 2:</b>	
Maximum Burnup:	35,000 MWd/MTU
Minimum Cooling Time:	12-years
Maximum Initial Enrichment:	See Poison Material Design Requirements Table
Minimum Initial Bundle Average Enrichment:	2.65 wt. % U-235
Maximum Initial Uranium Content:	198 kg/assembly
Maximum Decay Heat:	260 W/assembly
<b>Group 3:</b>	
Maximum Burnup:	37,200 MWd/MTU
Minimum Cooling Time:	12-years
Maximum Initial Enrichment:	See Poison Material Design Requirements Table
Minimum Initial Bundle Average Enrichment:	3.38 wt. % U-235
Maximum Initial Uranium Content:	198 kg/assembly
Maximum Decay Heat:	260 W/assembly
<b>Group 4:</b>	
Maximum Burnup:	40,000 MWd/MTU
Minimum Cooling Time:	15-years
Maximum Initial Enrichment:	See Poison Material Design Requirements Table
Minimum Initial Bundle Average Enrichment:	3.4 wt. % U-235
Maximum Initial Uranium Content:	198 kg/assembly
Maximum Decay Heat:	260 W/assembly

- The maximum weight of the BWR fuel assemblies shall not exceed 43,000 lb., or 705 lb. per fuel assembly
- The total decay heat of the cavity contents shall not exceed 15.9 kW or 260 W/assembly.
- Measured external radiation levels shall not exceed the requirements of 10 CFR 71.47. Measured surface contamination levels shall not exceed the requirements of 10 CFR 71.87(i).

Chapter 5 provides the shielding analysis. Chapter 6 covers the criticality safety of the NUHOMS<sup>®</sup>-MP197 and its contents, listing material densities, moderator ratios, and geometric configurations.

### BWR Fuel Assembly Poison Material Design Requirements

*Borated aluminum, Boralyn<sup>®</sup>, Metamic<sup>®</sup>, or equivalent metal matrix composites*

NUHOMS <sup>®</sup> - 61BT DSC Type	Maximum Lattice Average Enrichment <sup>(1)</sup> (wt% U-235)	Minimum B-10 Areal Density in Poison Plates (g/cm <sup>2</sup> )	% Credit of B10 used in Criticality Calculation	Poison Material Coupon Testing
A	3.7	0.021	90	Neutron Transmission plus Radiography
B	4.1	0.032	90	Neutron Transmission plus Radiography
C	4.4	0.040	90	Neutron Transmission plus Radiography

*Boral<sup>®</sup>*

NUHOMS <sup>®</sup> - 61BT DSC Type	Maximum Lattice Average Enrichment <sup>(1)</sup> (wt% U-235)	Minimum B-10 Areal Density in Poison Plates (g/cm <sup>2</sup> )	% Credit of B10 used in Criticality Calculation
A	3.7	0.025	75
B	4.1	0.038	75
C	4.4	0.048	75

<sup>(1)</sup> Maximum pin enrichment is 5% U235 in all cases.

### 1.3 REFERENCES

1. 10 CFR 71, Packaging and Transportation of Radioactive Material.
2. USNRC Regulatory Guide 7.9, "Standard Format and Content of Part 71 Applications for Approval of Packaging for Radioactive Material", Rev. 2, May 1986.
3. American Society of Mechanical Engineers, ASME Boiler and Pressure Vessel Code, Section III, Subsection NG, 1998 with 1999 Addenda.
4. American Society of Mechanical Engineers, ASME Boiler and Pressure Vessel Code, Section III, Subsection NB, 1998 with 1999 Addenda.
5. American Society of Mechanical Engineers, ASME Boiler and Pressure Vessel Code, Section III, Division 3, Subsection WB, 1998 with 1999 Addenda.
6. USNRC Regulatory Guide 7.6, "Design Criteria for the Structural Analysis of Shipping Cask Containment Vessel", Rev. 1, March 1978.
7. USNRC Regulatory Guide 7.8, "Load Combinations for the Structural Analysis of Shipping Cask", Rev. 1, March 1989.
8. American Society of Mechanical Engineers, ASME Boiler and Pressure Vessel Code, Section III, Subsection NF, 1998 with 1999 Addenda.
9. American National Standards Institute, ANSI N14.6, American National Standard for Special Lifting Devices for Shipping Containers Weighing 10,000 Pounds or More for Nuclear Materials, 1993.

## 1.4 APPENDIX – NUHOMS®-MP197 PACKAGING DRAWINGS

The following Transnuclear drawings are enclosed:

Drawing No	Title
1093-71-1	NUHOMS®-MP197 Packaging, Transport Configuration
1093-71-2	NUHOMS®-MP197 Packaging, General Arrangement, Parts List
1093-71-3	NUHOMS®-MP197 Packaging, General Arrangement
1093-71-4	NUHOMS®-MP197 Packaging, Cask Body Assembly
1093-71-5	NUHOMS®-MP197 Packaging, Cask Body Details
1093-71-6	NUHOMS®-MP197 Packaging, Cask Body Details
1093-71-7	NUHOMS®-MP197 Packaging, Lid Assembly & Details
1093-71-8	NUHOMS®-MP197 Packaging, Impact Limiter Assembly
1093-71-9	NUHOMS®-MP197 Packaging, Impact Limiter Details
1093-71-10	NUHOMS®-61B Transportable Canister, for BWR Fuel Basket Assembly
1093-71-11	NUHOMS®-61B Transportable Canister, for BWR Fuel Basket Details
1093-71-12	NUHOMS®-61B Transportable Canister, for BWR Fuel Basket Details
1093-71-13	NUHOMS®-61B Transportable Canister, for BWR Fuel General Assembly
1093-71-14	NUHOMS®-61B Transportable Canister, for BWR Fuel General Assembly
1093-71-15	NUHOMS®-61B Transportable Canister, for BWR Fuel Shell Assembly
1093-71-16	NUHOMS®-61B Transportable Canister, for BWR Fuel Shell Assembly
1093-71-17	NUHOMS®-61B Transportable Canister, for BWR Fuel Canister Details
1093-71-18	NUHOMS®-61B Transportable Canister, for BWR Fuel Canister Details
1093-71-20	NUHOMS®-MP197 Packaging, Regulatory Plate
1093-71-21	NUHOMS®-MP197 Packaging, on Transport Skid
1093-71-22	NUHOMS®-MP197 Packaging, ASME Code Compliance and Exceptions

The cask containment boundary and the canister shell, the inner top cover plate, the inner bottom cover plate, the siphon vent block, and the siphon/vent port cover plates of the DSC are designed, fabricated and inspected in accordance with the ASME Code Subsections NB to the maximum practical extent. The basket is designed, fabricated and inspected in accordance with ASME Code Subsection NG to the maximum practical extent. Other cask components (such as the shield shell and neutron shielding) and canister components (such as outer bottom cover, top and bottom shield plugs) are not governed by the ASME Code.

**ASME Code Exceptions for the NUHOMS-MP197 Transport Cask Containment Boundary**

ASME Code Section/Article	Code Requirement	Exception, Justification & Compensatory Measures
NCA	All	Not compliant with NCA
NB-1100	Requirements for Code Stamping of Components	The NUHOMS-MP197 Transport Cask containment boundary is designed & fabricated in accordance with the ASME Code, Section III, Subsection NB to the maximum extent practical. However, Code Stamping is not required. As Code Stamping is not required, the fabricator is not required to hold an ASME "N" or "NPT" stamp, or to be ASME Certified.
NB-1131	The design specification shall define the boundary of a component to which other components are attached.	A code design specification is not prepared for the NUHOMS-MP197 Transport Cask. A TN design criteria document is prepared in accordance with TN's QA program.
NB-2130	Material must be supplied by ASME approved material suppliers	Material is certified to meet all ASME Code criteria but is not eligible for certification or Code Stamping if a non-ASME fabricator is used. As the fabricator is not required to be ASME certified, material certification to NB-2130 is not possible. Material tractability & certification are maintained in accordance with TN's NRC approved QA program.
NB-4121	Material Certification by Certificate Holder	
NB-7000	Overpressure Protection	No overpressure protection is provided for the NUHOMS-MP197 Transport Cask. The function of the NUHOMS-MP197 Transport Cask is to contain radioactive materials under normal, off-normal, and hypothetical accident conditions postulated to occur during transportation. The NUHOMS-MP197 Transport Cask is designed to withstand the maximum internal pressure considering 100% fuel rod failure at maximum accident temperature. The NUHOMS-MP197 Transport Cask is pressure tested in accordance with the requirements of 10CFR71 and TN's approved QA program.
NB-8000	Requirements for nameplates, stamping & reports per NCA-8000	The NUHOMS-MP197 Transport Cask nameplates provide the information required by 10CFR71 and 49CFR173 as appropriate. Code stamping is not required for the NUHOMS-MP197 Transport Cask. QA Data packages are prepared in accordance with the requirements of 10CFR71 and TN's approved QA program.

**ASME Code Exceptions for the NUHOMS-61BT Canister**

ASME Code Section/Article	Code Requirement	Exception, Justification & Compensatory Measures
NCA	All	Not compliant with NCA
NB-1100	Requirements for Code Stamping of Components	The canister shell, the inner top cover plate, the inner bottom cover plate, the siphon vent block, and the siphon/vent port cover plates of the DSC are designed & fabricated in accordance with the ASME Code, Section III, Subsection NB to the maximum extent practical. However, Code Stamping is not required. As Code Stamping is not required, the fabricator is not required to hold an ASME "N" or "NPT" stamp, or to be ASME Certified.
NB-2130	Material must be supplied by ASME approved material suppliers	Material is certified to meet all ASME Code criteria, but is not eligible for certification or Code Stamping if a non-ASME fabricator is used. As the fabricator is not required to be ASME certified, material certification to NB-2130 is not possible. Material traceability & certification are maintained in accordance with TN's NRC approved QA program.
NB-4121	Material Certification by Certificate Holder	
NB-4243 and NB-5230	Category C weld joints in vessels and similar weld joints in other components shall be full penetration joints. These welds shall be examined by UT or RT and either PT or MT	The joint between the top outer and inner cover plates and the shell are design and fabricated per ASME Code Case N-595-1. The welds are partial penetration welds and the root and final layer are PT examined.
NB-6100 and 6200	All completed pressure retaining systems shall be pressure tested	The vent and siphon block is also not pressure tested due to the manufacturing sequence. The siphon block weld is helium leak tested when fuel is loaded and then covered with the outer top closure plate. Meets ASME code per code case N-591-1.
NB-7000	Overpressure Protection	No overpressure protection is provided for the NUHOMS-61BT DSC. The function of the NUHOMS-61BT DSC is to contain radioactive materials under normal, off-normal, and hypothetical accident conditions postulated to occur during transportation. The NUHOMS-61BT DSC is designed to withstand the maximum internal pressure considering 100% fuel rod failure at maximum accident temperature. The NUHOMS-61BT DSC is pressure tested in accordance with the requirements of 10CFR71 and TN's approved QA program.
NB-8000	Requirements for nameplates, stamping & reports per NCA-8000	The NUHOMS-61BT DSC nameplates provide the information required by 10CFR71, 49CFR173, and 10CFR72 as appropriate. Code stamping is not required for the NUHOMS-61BT DSC. QA Data packages are prepared in accordance with the requirements of 10CFR71, 10CFR72, and TN's approved QA program.
NB-2531	Vent & Siphon Port Covers: Straight beam UT per SA-578 for all plates for vessels	SA-578 applies to 3/8" and thicker plate only; allow alternate UT techniques to achieve meaningful UT results. <span style="float: right;">▲</span>

**ASME Code Exceptions for the NUHOMS-61BT DSC Fuel Basket**

ASME Code Section/Article	Code Requirement	Exception, Justification & Compensatory Measures
NG-1100	Requirement for Code Stamping of Components	The NUHOMS-61BT DSC baskets are designed & fabricated in accordance with the ASME Code, Section III, Subsection NG to the maximum extent practical as described in the SAR, but Code Stamping is not required. As Code Stamping is not required, the fabricator is not required to hold an ASME N or NPT stamp or be ASME Certified.
NG-2000	Use of ASME Material	Material is certified to meet all ASME Code criteria but is not eligible for certification or Code Stamping if a non-ASME fabricator is used. As the fabricator is not required to be ASME certified, material certification to NG-2130 is not possible. Material tractability & certification are maintained in accordance with TN's NRC approved QA program. The poison material and aluminum plates are not used for structural analysis, but to provide criticality control and heat transfer. They are not ASME Code Class I materials.
NCA	All	Not compliant with NCA as no code stamp is used.

REV	DATE	BY	CHKD	DATE	BY	CHKD
1	10/26/93	DCN	1093-88	10/26/93	DCN	1093-88
APPROVAL DATE			APPROVAL DATE			
P.E.	DATE	BY	TRANSNUCLEAR, INC.			
V.R.S.	MAY 91	BY	NUHOMS-MP197 PACKAGING			
J.C.	MAY 91	BY	ASME CODE COMPLIANCE			
P.S.	MAY 91	BY	AND EXCEPTIONS SAR			
J.T.G.	DATE	BY	NONE	B	1093-71-22	1
SCALE	REVISION	DATE	SCALE	REVISION	DATE	SCALE

**Table 1-1  
Nominal Dimensions and Weights of the NUHOMS<sup>®</sup>-61B Packaging**

<b>Nominal Dimensions (In.)</b>	
NUHOMS <sup>®</sup> -MP197 packaging overall length with impact limiters and thermal shield	281.25
NUHOMS <sup>®</sup> -MP197 packaging overall length without impact limiters and thermal shield	208.00
NUHOMS <sup>®</sup> -MP197 cask impact limiter outside diameter	122.00
NUHOMS <sup>®</sup> -MP197 cask outside diameter (w/o impact limiters and thermal shield)	91.50
NUHOMS <sup>®</sup> -MP197 cask cavity inner diameter	68.00
NUHOMS <sup>®</sup> -MP197 cask cavity length	197.00
NUHOMS <sup>®</sup> -MP197 cask inner containment shell radial thickness	1.25
NUHOMS <sup>®</sup> -MP197 cask lead gamma shield radial thickness	3.25
NUHOMS <sup>®</sup> -MP197 cask body outer shell	2.50
NUHOMS <sup>®</sup> -MP197 cask closure lid thickness	4.50
NUHOMS <sup>®</sup> -MP197 cask bottom thickness	6.50
NUHOMS <sup>®</sup> -MP197 cask resin and aluminum box thickness	4.50
NUHOMS <sup>®</sup> -61BT DSC overall length (does not include grapple ring at bottom)	195.9
NUHOMS <sup>®</sup> -61BT DSC outer diameter	67.25
NUHOMS <sup>®</sup> -61BT DSC cavity length	179.50
NUHOMS <sup>®</sup> -61BT DSC cavity inner diameter	66.25
Overall NUHOMS <sup>®</sup> -61BT DSC fuel basket length (with hold down ring)	178.5
NUHOMS <sup>®</sup> -61BT DSC fuel basket outer diameter	66.00
<b>Nominal Weights (lb.×1000)</b>	
Weight of fuel assemblies	43.0
Loaded weight of NUHOMS <sup>®</sup> -MP197 Packaging without impact limiters	237.23
Weight of impact limiters, thermal shield, and attachments.	27.87
Total loaded weight of NUHOMS-MP197 <sup>®</sup> Packaging (without transport skid)	265.1

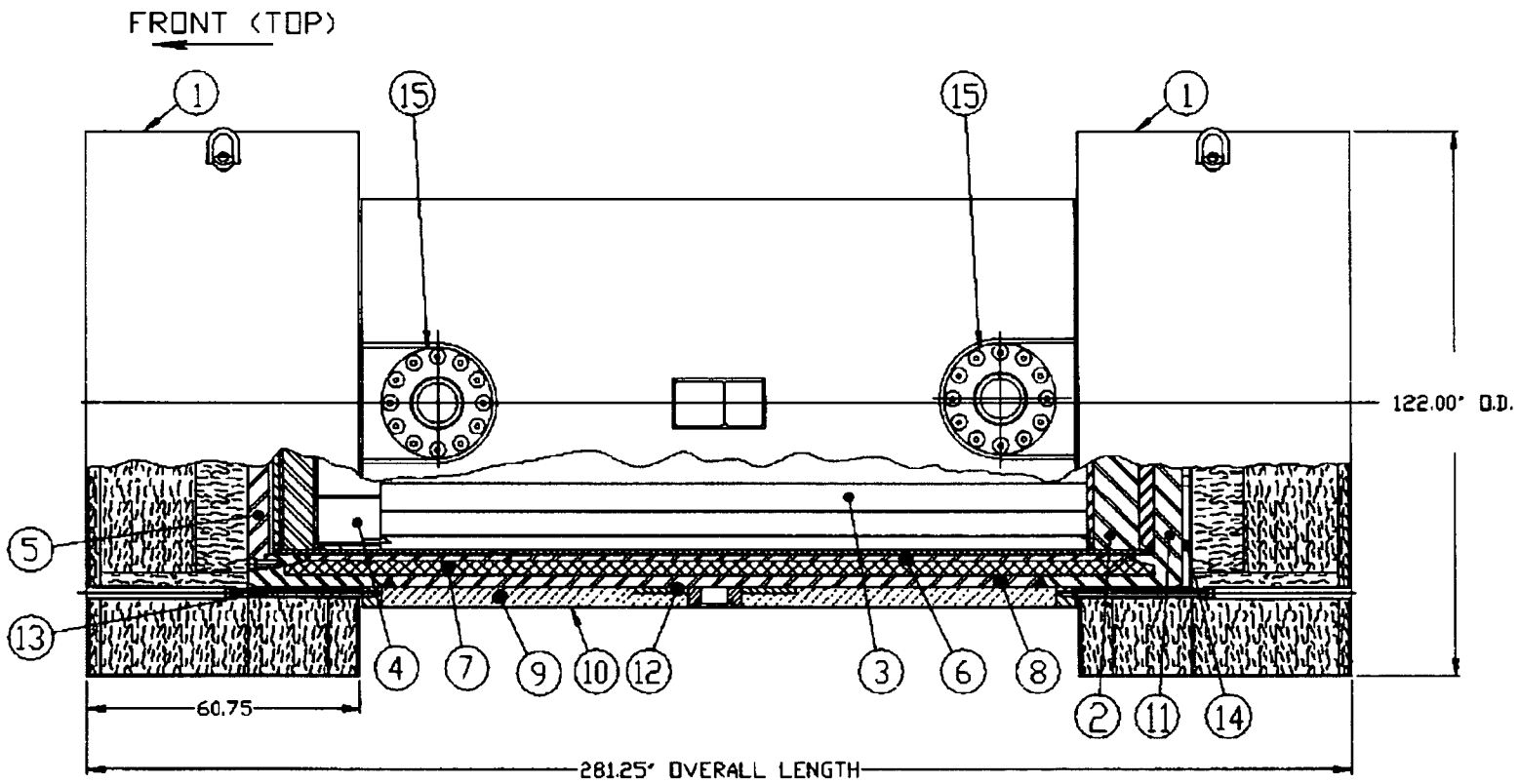


**Notes to Figure 1-1**

**A. Some details exaggerated for clarity.**

**B. Components are listed below:**

- 1 Impact Limiter**
- 2 Canister**
- 3 Fuel Basket**
- 4 Hold Down Ring**
- 5 Transport Cask Lid**
- 6 Transport Cask Inner Shell**
- 7 Transport Cask Gamma (Lead) Shield**
- 8 Transport Cask Outer Shell**
- 9 Transport Cask Neutron (Resin) Shield**
- 10 Transport Cask Shield Shell**
- 11 Transport Cask Bottom Closure**
- 12 Transport Cask Bearing Block**
- 13 Impact Limiter Attachment Bolt**
- 14 Thermal Shield**
- 15 Trunnion**



General Arrangement  
 NUHOMS-MP197 Packaging

Figure 1-1

# NUHOMS®-MP197 TRANSPORT PACKAGING

## CHAPTER 2

### TABLE OF CONTENTS

	<u>Page</u>
2. STRUCTURAL EVALUATION	
2.1 Structural Design.....	2-1
2.1.1 Discussion .....	2-1
2.1.2 Design Criteria.....	2-4
2.2 Weights and Center-of-Gravity.....	2-9
2.3 Mechanical Properties of Materials.....	2-10
2.3.1 Cask Material Properties .....	2-10
2.3.2 Basket Material Properties .....	2-10
2.3.3 Impact Limiter Material .....	2-10
2.3.4 Fracture Toughness.....	2-10
2.4 General Standards for All Packages.....	2-11
2.4.1 Minimum Package Size .....	2-11
2.4.2 Tamper-proof Feature .....	2-11
2.4.3 Positive Closure.....	2-11
2.4.4 Chemical and Galvanic Reactions.....	2-11
2.5 Lifting and Tie-Down Standards.....	2-21
2.5.1 Lifting Devices .....	2-21
2.5.2 Tie-Down Devices .....	2-29
2.6 Normal Conditions of Transport.....	2-32
2.6.1 Heat.....	2-33
2.6.2 Cold Environment.....	2-35
2.6.3 Reduced External Pressure.....	2-35
2.6.4 Increased External Pressure.....	2-35
2.6.5 Transport Shock Loading.....	2-36
2.6.6 Transport Vibration Loading.....	2-37
2.6.7 Water Spray.....	2-38
2.6.8 Free Drop .....	2-38
2.6.9 Corner Drop.....	2-38
2.6.10 Compression.....	2-38
2.6.11 Penetration.....	2-39
2.6.12 Fabrication Stresses .....	2-39
2.6.13 Lid Bolt Analysis.....	2-39

**TABLE OF CONTENTS**  
(continued)

2.6.14	Fatigue Analysis of Containment Boundary .....	2-40
2.6.15	Summary of Normal Condition Cask Body Structural Analysis.....	2-44
2.6.16	Structural Evaluation of the Basket/Canister Under Normal Condition Loads.....	2-44
2.7	Hypothetical Accident Conditions .....	2-47
2.7.1	30 Foot Free Drop.....	2-48
2.7.2	Puncture .....	2-52
2.7.3	Thermal .....	2-55
2.7.4	Water Immersion .....	2-55
2.7.5	Buckling Evaluation of the Containment Vessel due to Accident End Drop Loads.....	2-57
2.7.6	Summary of Accident Condition Cask Body Structural Analysis .....	2-58
2.7.7	Structural Evaluation of the Basket/Canister under Accident Loads .....	2-59
2.8	Special Form / Fuel Rods.....	2-61
2.8.1	Special Form.....	2-61
2.8.2	Fuel Rods .....	2-61
2.9	References.....	2-62
2.10	Appendices.....	2-64
2.10.1	NUHOMS <sup>®</sup> -MP197 Cask Body Structural Evaluation .....	2.10.1-1
2.10.2	NUHOMS <sup>®</sup> -MP197 Cask Lid Bolt Analysis.....	2.10.2-1
2.10.3	NUHOMS <sup>®</sup> -61BT DSC (Canister and Basket) Structural Evaluation .....	2.10.3-1
2.10.4	NUHOMS <sup>®</sup> -MP197 Cask Lead Slump Analysis .....	2.10.4-1
2.10.5	NUHOMS <sup>®</sup> -MP197 Cask Inner Containment Buckling Analysis..	2.10.5-1
2.10.6	Dynamic Amplification Factor Determination.....	2.10.6-1
2.10.7	Evaluation of Fuel Assembly under Accident Impacts.....	2.10.7-1
2.10.8	Structural Evaluation of the NUHOMS <sup>®</sup> -MP197 Package Impact Limiters.....	2.10.8-1
2.10.9	NUHOMS <sup>®</sup> -MP197 Package Impact Limiter Testing.....	2.10.9-1
2.11	ASME Code Exceptions .....	2-65

## LIST OF TABLES

2-1	Evaluation Method Employed to Demonstrate Compliance with Specific Regulatory Requirements
2-2	Containment Vessel Stress Limits
2-3	Containment Bolt Stress Limits
2-4	Basket Stress Limits
2-5	Mechanical Material Properties
2-6	Reference Temperatures for Stress Analysis Acceptance Criteria
2-7	Bijlaard Computation Sheet
2-8	NUHOMS <sup>®</sup> -MP197 Performance Evaluation Overview (Normal Conditions of Transport)
2-9	Individual Load Conditions
2-10	Summary of Load Combinations for Normal Condition of Transport
2-11	Summary of Load Combinations for Accident Condition of Transport
2-12	40 in. Puncture on Lid End
2-13	40 in. Puncture on Bottom Ram Port Cover
2-14	NUHOMS <sup>®</sup> -MP197 Cask Body Allowable Stress

## LIST OF FIGURES

2-1	Effect of pH on Corrosion of Iron in Aerated Soft Water, Room Temperature
2-2	Potential versus pH Diagram for Aluminum-Water System
2-3	Trunnion Geometry
2-4	Standard Reporting Locations
2-5	Puncture Drop of Lid End Loading
2-6	Puncture Drop on Bottom Ram Cover Loading

## CHAPTER 2 STRUCTURAL EVALUATION

### 2.1 STRUCTURAL DESIGN

This chapter, including its appendices, presents the structural evaluation of the NUHOMS<sup>®</sup>-MP197 packaging. This evaluation consists of numerical analyses and impact limiter testing which demonstrate that the NUHOMS<sup>®</sup>-MP197 packaging satisfies applicable requirements for a Type B(U) packaging.

#### 2.1.1 Discussion

The structural integrity of the packaging under normal conditions of transport and hypothetical accident conditions specified in 10CFR71 [1] is shown to meet the design criteria described in Section 2.1.2. The NUHOMS<sup>®</sup>-MP197 transport package consists of three major structural components: the cask body, the 61B transportable canister (shell assembly and basket assembly), and the impact limiters (front and rear). These components are described in Chapter 1 and are shown on drawings provided in Appendix 1.4.

- Cask Body

Drawing 1093-71-1 shows the overall transport configuration of the NUHOMS<sup>®</sup>-MP197 packaging. Drawing 1093-71-2 shows the general arrangement of the NUHOMS<sup>®</sup>-MP197 packaging. Drawing 1093-71-3 shows the part list. Drawing 1093-71-4 shows the cask body assembly. Drawings 1093-71-5 and 6 show the cask body details. Drawing 1093-71-7 presents the lid assembly. Drawings 1093-71-8 and 9 provide details of the impact limiter design. The regulatory plate is provided on drawing 1093-71-20. Drawing 1093-71-21 shows the NUHOMS<sup>®</sup>-MP197 packaging on the transport skid. ASME Code compliance and exemptions are provided in drawing 1093-71-22.

The shell or cask body cylinder assembly is an open ended (at the top) cylindrical unit with an integral closed bottom end. This assembly consists of concentric inner shell (SA-240 Gr. XM 19) and outer shell (SA-240 Gr. 316), welded to a massive closure flange (SA-240 Gr. XM 19) at the lid end and a flat stainless steel plate (SA-182 Gr. FXM 19) at the bottom end. The closure lid material is SA-705 Type 690 H1100. The annulus between the shells is filled with lead shielding. The lead is poured into the annulus in a molten state using a carefully controlled procedure.

The two rear trunnions are cylindrical, SA-182 F304 stainless steel forgings. The rear pair of trunnions is designed for horizontal lifting of the cask and also provides the capability to rotate the cask. Two sets of front trunnions are designed. One set of trunnions has double shoulders and is used for lifting. The double shoulder front trunnions have a minimum factor of safety of three against yield stress or five against ultimate stress; whichever is most restrictive. The other set of front trunnions has a single shoulder and is also used for lifting. The single shoulder front

trunnions have a minimum factor of safety of six against yield stress or ten against ultimate stress; whichever is most restrictive. Only one set of trunnions will be used depending on-site and transfer operation requirements. The two sets of front trunnions are made from SA-182 F304 stainless steel forgings and are designed to lift the loaded NUHOMS<sup>®</sup>-MP197 cask vertically and horizontally. Both the front and rear trunnions are bolted to the cask body with a flange connection, using 12-1 ¼" diameter bolts made of SA-540 Gr. B24 Cl. 1. The front trunnions are designed to meet the requirements of ANSI N14.6 [2]. The trunnions are shown in Drawing 1093-71-5.

The shield shell around the neutron shield consists of a cylindrical shell section, with closure plates at each end. The closure plates are welded to the outer surface of the outer shell of the cask body. The shield shell provides an enclosure for the resin-filled aluminum containers, and maintains the resin in the proper location with respect to the active length of the fuel assemblies in the cask cavity. The shield shell has no structural function. The shell is made of SA-240 Type 304 stainless steel.

- 61B Transportable Canister (Shell and Basket Assemblies)

The canister shell assembly and details are shown on drawings 1093-71-13 through 18. The shell assembly is a high integrity stainless steel (SA-240 Type 304) welded pressure vessel that provides containment of radioactive materials, encapsulates the fuel in an inert atmosphere (the canister is backfilled with Helium before being seal welded closed), and provides biological shielding (in axial direction).

The details of the NUHOMS<sup>®</sup>-61BT Basket are shown in drawings 1093-71-10 to 12. The NUHOMS<sup>®</sup>-61BT basket is a welded assembly of stainless steel boxes and is designed to accommodate 61 intact standard BWR fuel assemblies with or without fuel channels. The basket structure consists of an assembly of stainless steel tubes (fuel compartments) separated by poison plates and surrounded by larger stainless steel boxes and support rails.

The basket structure is open at each end. Therefore, longitudinal fuel assembly loads are applied directly on the canister/cask body and not on the fuel basket structure. The fuel assemblies are laterally supported in the stainless steel structural boxes, and the basket is laterally supported by the rails and the canister inner shell.

The basket is keyed to the canister at 180° in order to fix the basket's orientation with respect to the canister. Under normal conditions of transport, the canister rests on four transfer support rails, attached to the inside surface of the NUHOMS<sup>®</sup>-MP197 Cask.

As described above, the basket structure consists of an assembly of stainless steel tubes (fuel compartments) separated by poison plates (borated aluminum, an aluminum/B<sub>4</sub>C metal matrix composite, or Boral<sup>®</sup>) and surrounded by larger stainless steel boxes (outer wraps) and support rails. The assembly includes:

1. Four (4) 2 by 2 large boxes (four compartment assembly), each box consists of 4 stainless steel fuel compartments (0.12 in. thick) separated by poison plates (0.31 in. thick) and wrapped in a 0.105 in. thick stainless sheet.
2. Five (5) 3 by 3 large boxes (nine compartment assembly), each box consists of 9 stainless steel fuel compartments (0.135 in. thick) separated by poison plates (0.31 in. thick) and wrapped in a 0.105 in. thick stainless sheet.
3. Eight (8) type 1 stainless steel rails; the rails are fabricated from 0.19/0.25 in. thick, SA-240, type 304 stainless steel.
4. Four (4) type 2 stainless steel rails; the rails are also fabricated from 0.19/0.25 in. thick, SA-240, type 304 stainless steel.

The poison plates provide the heat conduction path from the fuel assemblies to the canister cavity wall, and also provide the necessary criticality control.

The nominal open dimension of each fuel compartment cell is 6.0 in. × 6.0 in., which provides clearance around the fuel assemblies. The overall basket length including the hold down ring (178.5 in.) is less than the canister cavity length of the canister (179.30 in.) to allow for thermal expansion, tolerances, and access to the top of the fuel assemblies.

Stainless steel rails are oriented parallel to the axis of the canister and attached to the periphery of the basket to establish and maintain basket orientation and to support the basket.

Stainless steel plate inserts (0.31 in. thick × 3 in. wide × 3.5 in. long) are placed between the stainless steel fuel compartments and between the outer wrappers at the top and bottom of the basket assembly. These plate inserts are fillet welded to the stainless steel tubes and wrappers to prevent the poison plates from sliding in the axial direction.

The basket hold down ring is set between the top of the basket assembly and inside surface of the canister top shield plug assembly. The hold down ring is used to prevent the basket assembly from sliding freely in the axial direction during the normal transport conditions.



- **NUHOMS<sup>®</sup>-MP197 Transport Package**

The cask body and the transportable canister together with the two impact limiters, form the packaging designed to meet all of the applicable 10CFR71 requirements for a Type B(U) packaging.

The cask body wall thickness (excluding the shield shell, shield shell closure plates and neutron shield) enables the packaging to withstand the hypothetical puncture accident. The shell is designed to be both strong and ductile. The top and bottom impact limiters absorb the kinetic energy from the 1 ft. normal and 30 ft. hypothetical accident condition free drops.

Table 2-1 summarizes the specific evaluation methods that are used to demonstrate compliance with the regulations. Numerical analyses have been performed for the normal and accident conditions, as well as for the lifting and tie-down loads. In general, numerical analyses have been performed for the regulatory events. These analyses are summarized in the main body of this section, and described in detail in Appendices 2.10.1 through 2.10.8. Testing of the impact limiters is conducted to confirm the analytical assumptions and results. The test results are included in Appendix 2.10.9.

The detailed structural analysis of the NUHOMS<sup>®</sup>-MP197 packaging is included in the following appendices:

Appendix 2.10.1	NUHOMS <sup>®</sup> -MP197 Cask Body Structural Evaluation
Appendix 2.10.2	NUHOMS <sup>®</sup> -MP197 Cask Lid Bolt Analysis
Appendix 2.10.3	NUHOMS <sup>®</sup> -61BT DSC (Canister and Basket) Structural Evaluation
Appendix 2.10.4	NUHOMS <sup>®</sup> -MP197 Cask Lead Slump Analysis
Appendix 2.10.5	NUHOMS <sup>®</sup> -MP197 Cask Inner Containment Buckling Analysis
Appendix 2.10.6	Dynamic Amplification Factor Determination
Appendix 2.10.7	Evaluation of Fuel Assembly under Accident Impacts
Appendix 2.10.8	Structural Evaluation of the NUHOMS <sup>®</sup> -MP197 Package Impact Limiters
Appendix 2.10.9	NUHOMS <sup>®</sup> -MP197 Package Impact Limiter Testing

### 2.1.2 Design Criteria

The packaging consists of three major components:

- Cask Body
- Canister/Basket
- Impact Limiters

The structural design criteria for these components are described below.

## 2.1.2.1 Cask Body

### 2.1.2.1.1 Containment Vessel

The containment vessel consists of the inner shell with a flange out to the seal seating surface, the bottom closure, and the lid. The lid bolts and seals are also part of the containment vessel as are the drain and vent port plugs, bolts and seals. The containment vessel is designed to the maximum practical extent as an ASME Class I component in accordance with the rules of the ASME Boiler and Pressure Vessel Code, Section III, Subsection NB [3]. The Subsection NB rules for materials, design, fabrication and examination are applied to all of the above components to the maximum practical extent. In addition, the design meets the requirements of Subsection WB of the ASME Section III, Division 3 [4] and Regulatory Guides 7.6 [5] and 7.8 [6]. Exceptions to the ASME Code are discussed in Section 2.11 of this Chapter.

The acceptability of the containment vessel under the applied loads, is based on the following criteria:

- Title 10, Chapter 1, Code of Federal Regulations, Part 71.
- Regulatory Guide 7.6 Design Criteria
- ASME Code Design Stress Intensities
- Preclusion of Fatigue Failure
- Preclusion of Brittle Fracture

The stresses due to each load are categorized as to the type of stress induced, e.g. membrane, bending, etc., and the classification of stress, e.g. primary, secondary, etc. Stress limits for containment vessel components, other than bolts, for Normal (Level A) and Hypothetical Accident (Level D) Loading Conditions are given in Table 2-2. The stress limits used for Level D conditions, determined on an elastic basis, are based on the entire structure (containment shell and gamma shielding material) resisting the accident load. Local yielding is permitted at the point of contact where the load is applied.

The primary membrane stress and primary membrane plus bending stress are limited to  $S_m$  ( $S_m$  is the code allowable stress intensity) and  $1.5 S_m$ , respectively, at any location in the cask for normal load conditions.

The hypothetical impact accidents are evaluated as short duration, Level D conditions. The stress criteria are taken from Section III, Appendix F of ASME Code [7]. For elastic quasi-static analysis, the primary membrane stress intensity ( $P_m$ ) is limited to the smaller of the  $2.4 S_m$  or  $0.7 S_u$ , and membrane plus bending stress intensities ( $P_m + P_b$ ) are limited to the smaller of the  $3.6 S_m$  or  $S_u$ .

The allowable stress limits for the containment bolts are listed in Table 2-3. The allowable stress limits for the lid bolts are listed separately in Tables 2.10.2-3 and 2.10.2-4.

The allowable stress intensity value,  $S_m$ , as defined by the Code, is taken at the maximum temperature calculated for each service load condition.

### 2.1.2.1.2 Non-Containment Structure

Certain components such as the outer shell, the neutron shield shell and the trunnions are not part of the cask containment vessel but do have structural functions. These components referred to as non-containment structures are required to react to the containment environmental loads, and in some cases share the loads with the containment vessel. The stress limits for the outer shell structures are the same as given in Table 2-2 for the containment structure. The neutron shield shell is designed, fabricated and inspected in accordance with the ASME Code Subsection NF [3], to the maximum practical extent. Other structural and structural attachment welds are examined by the liquid penetrant method, in accordance with Section V, Article 6 of the ASME Code [8]. The liquid penetrant examination acceptance standards are in accordance with Section III, Subsection NF, Paragraphs NF-5350 [3].

Seal welds are examined visually, or by liquid penetrant method, in accordance with Section V of the ASME Code [8]. Electrodes, wire, and fluxes used for fabrication comply with the applicable requirements of the ASME Code, Section II, Part C [9].

The welding procedures, welders and weld operators are qualified in accordance with Section IX of the ASME Code [10].

The radial neutron shield, including the stainless steel enclosure, have not been designed to withstand all of the hypothetical accident loads. The shielding may degrade during the fire or due to the 40 inch drop onto the puncture bar. Therefore a bounding shielding analysis, assuming that the exterior neutron shielding is completely removed, has been performed. This analysis shows that the accident dose rates are not exceeded. These accident shielding analyses are described in Chapter 5.

### 2.1.2.2 Canister and Basket

#### 2.1.2.2.1 Canister

The canister shell, the inner top cover plate, the inner bottom cover plate, the siphon vent block, and the siphon/vent port cover plate are designed, fabricated and inspected in accordance with the ASME Code Subsection NB to the maximum practical extent with the exception listed in Section 2-11 of this SAR. The basis for the allowable stresses is ASME Code Section III, Division I, Subsection NB Article NB-3200 for normal condition loads (Level A), and Appendix F for accident condition loads (Level D). Stress limits for Normal (Level A) and Hypothetical Accident (Level D) Loading Conditions are given in Table 2-2. When evaluating the results from the non-linear elastic-plastic analysis for the accident conditions, the general primary membrane stress intensity,  $P_m$ , shall not exceed  $0.7 S_u$  and the maximum stress intensity at any location ( $P_m + P_b$ ) shall not exceed  $0.9 S_u$ .

#### 2.1.2.2.2 Basket

The basket is designed, fabricated and inspected in accordance with the ASME Code Subsection NG [3], to the maximum practical extent. The following exceptions are taken:

The poison and aluminum plates are not used for structural analysis. Therefore, the materials are not required to be code materials. The quality assurance requirements of NQA-1 is imposed in lieu of NCA-3800. The basket will not be code stamped. Therefore the requirements of NCA are not imposed. Fabrication and inspection surveillance is performed by the design organization in lieu of an authorized nuclear inspector

The basket is designed to meet the heat transfer, nuclear criticality, and the structural requirements. The basket structure must provide sufficient rigidity to maintain a subcritical configuration under the applied loads. The 304 stainless steel members in the NUHOMS®-61BT basket are the primary structural components. The neutron poison plates are the primary heat conductors, and provide the necessary criticality control.

The stress analyses of the basket for normal and accident conditions do not take credit for the poison plates except for through-thickness-compression. However, the weight of the poison plates is included in the stress evaluations.

The stress limits for the basket are summarized in Table 2-4. The basis for the allowable stresses for the 304 stainless steel fuel compartment wraps and rails is Section III, Division I, Subsection NG of the ASME Code. The primary membrane stress and primary membrane plus bending stress are limited to  $S_m$  ( $S_m$  is the code allowable stress intensity) and  $1.5 S_m$ , respectively, at any location in the basket for normal (Design and Level A) load conditions.

The hypothetical impact accidents are evaluated as short duration, Level D conditions. The stress criteria are taken from Section III, Appendix F of the ASME Code [7]. For elastic quasi-static analysis, the primary membrane stress intensity ( $P_m$ ) is limited to the smaller of  $2.4 S_m$  or  $0.7 S_u$ , and membrane plus bending stress intensities ( $P_m + P_b$ ) are limited to smaller of  $3.6 S_m$  or  $S_u$ . When evaluating the results from the non-linear elastic-plastic analysis for the accident conditions, the general primary membrane stress intensity,  $P_m$  shall not exceed  $0.7 S_u$  and the maximum stress intensity at any location ( $P_m + P_b$ ) shall not exceed  $0.9 S_u$ .

The fuel compartment walls under compressive loads are also evaluated against the ASME Code rules for component supports, to ensure that buckling will not occur. The acceptance criteria (allowable buckling loads) are taken from the ASME Code, Section III, Appendix F, paragraph F-1341.3, Collapse Load. The allowable buckling load is determined by plastic analysis collapse load according to the criteria given in Section III, Subsection NB, Paragraph NB-3213.25.

The basket hold down ring is set between the top of the basket assembly and inside surface of the lid assembly. The hold down ring is used to prevent the basket assembly from sliding freely in the axial direction during the normal/accident transport conditions. The basket hold down ring is designed, fabricated, and inspected in accordance with the ASME Code Subsection NF [3] to the maximum practical extent.

### 2.1.2.3 Impact Limiters (Front and Rear)

The NUHOMS<sup>®</sup>-MP197 packaging is provided with an impact limiter at each end of the cask body. The limiters are identical. The inside diameter of the limiter is determined by the diameter of the cask body. The length and outside diameter of the limiters are sized to limit the cask inertial loads during the 1 foot normal and 30 foot accident drop events, so that the containment vessel (and the non-containment structures) meets the design criteria.

The impact limiter stainless steel cylinders, gussets, and end plates, are designed to position and confine the balsa and redwood blocks so that the impact energy is properly absorbed. The stainless steel shell is also designed to support and protect the wood blocks under normal environmental conditions (moisture, pressure, temperature, etc.).

The impact limiter and attachments are designed to withstand the applied loads and to prevent separation of the limiters from the cask during an impact. The design criteria for the impact limiters and attachments are both unique and specific. They are specified in Appendix 2.10.9.

### 2.1.2.4 Trunnions

NUHOMS<sup>®</sup>-MP197 cask includes removable front and rear trunnions, as shown in drawing 1093-71-5, which are used for on-site lifting and transfer operations. The trunnions are removed prior to transportation and replaced with non-protruding plugs to provide the required crush clearance distance for the impact limiter. The trunnion plugs allow the largest possible stopping distance and minimize the package impact loads resulting from the postulated accident condition drop. The trunnion plugs also provide shielding in the trunnion regions during transportation.

The evaluation and design criteria for the lifting/tiedown trunnions are based on the requirements of 10CFR71.45. The details of the evaluation are presented in Section 2.5. Two sets of front trunnions are designed. One set of trunnion has double shoulders and is used for lifting. The double shoulder front trunnions have a minimum factor of safety of three against yield stress or five against ultimate stress; whichever is most restrictive. The other set of trunnions has a single shoulder and is also used for lifting. The single shoulder front trunnions have a minimum factor of safety of six against yield or ten against ultimate; whichever is most restrictive. Only one set of trunnions will be used depending on-site and transfer operation requirements. The design and fabrication of the lifting trunnions are in accordance with the requirements of ANSI N14.6.

### 2.1.2.5 Tie-Down Device

NUHOMS<sup>®</sup>-MP197 cask includes a bearing block, located at the mid-length, on the bottom of the cask, designed to react all longitudinal loads encountered during transportation. As shown in drawing 1093-71-21, the package is supported by saddles and tie-down straps. The saddles and tie-down straps are designed to support the vertical, lateral, and rotational loads encountered during transport, while the bearing block resists the cask longitudinal and transportation loads. The details of the tie-down evaluation are presented in Section 2.5.

## 2.2 WEIGHTS AND CENTER-OF-GRAVITY

The weight of the NUHOMS<sup>®</sup>-MP197 packaging is 132.55 tons. The weights of the major individual subassemblies are listed in following table. The center of gravity of the cask is located on the axial centerline approximately 102.85 inches from the base of the cask.

### Cask Weight and Center Gravity

Component	Nominal Weight (lbs. x 1000)
Cask Body	63.19
Lid and Lid Bolts	5.61
Neutron Shield Aluminum Boxes	2.02
Resin	9.96
Gamma Shield (Lead)	59.74
Outer Shield Shell	2.47
Impact Limiter Attachment Blocks	0.85
Trunnion replacement Plug	1.96
Trunnion Block	2.33
Shear Key Bearing Block	0.71
<b>Cask Weight w/o Impact Limiters and Attachments</b>	<b>148.84</b>
Canister	22.47
Basket	22.92
Impact Limiters w/Attachment bolts and Thermal Shield	27.87
<b>Total Package Weight (Empty)</b>	<b>222.10</b>
Fuel Assemblies	43.0
<b>Total Package Weight (Loaded)</b>	<b>265.1</b>

Summary of weights used for structural analysis:

- |  |                         |
|--|-------------------------|
| 1. Front (Top) Trunnion Lifting (W/o Limiters) | 260.3 kips w/1.1 factor |
| 2. Cask Body Stress Analysis                   | 266.3 kips.             |
| 3. Puncture Analysis                           | 265.1 kips              |

## 2.3 MECHANICAL PROPERTIES OF MATERIALS

### 2.3.1 Cask Material Properties

This section provides the mechanical properties of materials used in the structural evaluation of the NUHOMS<sup>®</sup>-MP197 cask. Table 2-5 lists the materials selected, the applicable components, and the minimum yield, ultimate, and design stress values specified by the ASME Code, Section II, Part D [9].

Table 2-6 summarizes the thermal analysis results from Chapter 3. These results support the selection of cask body, canister, and basket component design temperatures for structural analysis purposes.

### 2.3.2 Canister/Basket Material Properties

The material properties of the 304 stainless steel plates are taken from the ASME Code, Section II, Part D [9]. These properties are listed with specific references in Table 2-5.

### 2.3.3 Impact Limiter Material Properties

Mechanical properties of the energy absorbing wood and wood adhesive used in the impact limiters are both unique and specific. They are specified in Appendix 2.10.8 (Tables 2.10.8-1 and 2).

### 2.3.4 Fracture Toughness Requirements

#### A. NUHOMS<sup>®</sup>-MP197 cask

With the exception of the NUHOMS<sup>®</sup>-MP197 cask closure fasteners, all of the structural components are fabricated from ASME SA-240 Type/Grade 304, 316, or XM19 and SA-705 type 630 H1100 stainless steel. Stainless steel materials do not undergo a ductile to brittle transition in the temperature of interest ( $> -40^{\circ}\text{F}$ ) and therefore are not subject to brittle fracture.

The fracture toughness requirements of the lid bolts meet the criteria of ASME Code, Section III, Division 3, Subsection WB (Para. WB-2333) [4]. Charpy V-Notch testing is performed at  $-20^{\circ}\text{F}$ . The acceptance criteria is that the material exhibit at least 25 mils lateral expansion (Table WB-2333-1).

#### B. Canister

The containment components of the canister are fabricated from Type 304 stainless steel. Stainless steel materials do not undergo a ductile to brittle transition in the temperature of interest (down to  $-40^{\circ}\text{F}$ ), and therefore are not subject to brittle fracture.

## 2.4 GENERAL STANDARDS FOR ALL PACKAGES

The NUHOMS<sup>®</sup>-MP197 transport package is designed to comply with the general standards for all packages specified by 10CFR71.43.

### 2.4.1 Minimum Package Size

The overall package dimensions of 281.25 inches long and 122 inches in diameter exceed the minimum dimension requirement of 10 cm (4 inches).

### 2.4.2 Tamper-proof Feature

The primary access path into the package is through the closure lid. The vent port, test port, drain port and bottom ram closure are smaller access paths. During transport the top (front) impact limiter entirely covers and prevents access to the cask closure lid and the test port & vent port penetrations. A security wire seal is installed in the upper impact limiter attachment bolt prior to each shipment. The presence of this seal demonstrates that unauthorized entry into the package has not occurred. The bottom impact limiter covers and prevents access to the drain port, test port and bottom ram cover closure.

### 2.4.3 Positive Closure

Positive fastening of all access openings through the containment vessel is accomplished by bolted closures which preclude unintentional opening. In addition, the presence of the impact limiters and security seal described in Section 2.4.2 provide further protection against unintentional opening.

### 2.4.4 Chemical and Galvanic Reactions

The materials of the NUHOMS<sup>®</sup>-MP197 cask have been reviewed to determine whether chemical, galvanic or other reactions among the materials, contents and environment might occur during any phase of loading, unloading, handling or transport.

- The materials from which NUHOMS<sup>®</sup>-MP197 transportation package is fabricated will not experience significant chemical, galvanic, or other reaction in air, helium, or water environment.
- During wet loading, the canister and the cask are submerged in BWR pool water or clean deionized water. The discussion that follows will demonstrate that no significant corrosion or hydrogen generation will occur in this environment for the wetted materials.
- During transportation, the exterior of the cask and impact limiters is exposed to ambient environmental conditions of temperature, rain, snow, etc. All of the exterior surfaces with the exception of bolts and fusible plugs are fabricated from stainless steel. Therefore, the cask exterior is protected from chemical, galvanic or other reactions during transportation.



- During transportation, the interior of the canister and the space between the canister and the cask is exposed to an inert helium environment. The canister is vacuum-dried; the space between the cask and the canister is vacuum-dried if loaded wet. Both the canister and cask are backfilled with helium. The inert environment precludes general or galvanic corrosion on the interior surfaces.
- Various materials are sealed under air at the fabricator, and remain sealed during all normal operations:
  - a) radial neutron shielding materials and the aluminum resin boxes are sealed between stainless steel shells
  - b) lead shielding is sealed between stainless steel shells
  - c) wood is sealed inside the stainless steel impact limiter shell
  - d) a carbon steel shield plug is sealed between the stainless steel inner and outer bottom covers of the canister

The free volume in these spaces is small. Consequently the amount of oxygen or moisture is too insufficient to cause significant corrosion or galvanic reactions between these materials. The neutron shielding material is inert after it has cured and does not affect the aluminum boxes.

Dissimilar materials in contact in the NUHOMS<sup>®</sup>-MP197, and the material environments are summarized in the following table.

Component	Dissimilar Materials in Contact	Wet Loading Environment	Transport Environment
Basket	304 stainless steel / aluminum 304 stainless steel / neutron poison (aluminum-based)	BWR pool water	vacuum dried, helium backfill
Canister	stainless steel / nickel-plated carbon steel top shield plug	BWR pool water	vacuum dried, helium backfill
Canister	304 stainless steel / bare carbon steel bottom shield plug	air, sealed at fabricator	air, sealed at fabricator
cask (interior)	304 stainless steel / lubricant (slide rails)	BWR pool water	vacuum dried, helium backfill
Cask	lead / stainless steel <sup>1</sup> aluminum / borated polyester aluminum / stainless steel <sup>1</sup>	air, sealed at fabricator	air, sealed at fabricator
Cask	alloy steel bolts / stainless steel <sup>1</sup>	air, lubricant	air, lubricant
Cask	fluorocarbon seals / stainless steel <sup>1</sup>	air, helium	air, helium, ambient weather
Cask	304 stainless steel / brass (trunnion bolt plug)	BWR water	not applicable
Cask	304 stainless steel / lead (security wire and seal)	not applicable	ambient weather
Cask	304 stainless steel / polypropylene (trunnion plug)	not applicable	air
Cask	stainless steel <sup>1</sup> / transport saddle <sup>2</sup>	not applicable	ambient weather
impact limiter (IL)	304 stainless steel / nylon (fusible plug) 304 stainless steel / fluorocarbon (fusible plug seal) 304 stainless steel / alloy steel (lift ring bolt)	not applicable	ambient weather
cask & IL	stainless steel <sup>1</sup> / aluminum (thermal shield)	not applicable	air
IL	wood / wood glue / 304 stainless steel	not applicable	air, sealed at fabricator

**Notes:**

1. Stainless steel may be 304, XM19, or 17-4 PH; contact between these three materials is not listed as dissimilar material contact in this table.
2. Transport saddle is not part of this SAR: points of contact between cask and saddle may be stainless steel, painted carbon steel, or elastomer sheet

#### 2.4.4.1 Cask/Canister Interior

The NUHOMS®-MP197 cask and NUHOMS®-61BT DSC materials are shown in the Parts List on Drawing 1093-71-3. Both of the cask and canister vessels are made from stainless steel.

Within the canister cavity, there is a basket with support rails made from SA-240 Type 304 stainless steel. The basket structure consists of an assembly of stainless steel tubes (fuel compartments) separated by poison plates and surrounded by larger stainless steel boxes and support rails.

The neutron poison is not welded or bolted to the stainless steel, but is captured by the geometry of the boxes and stainless steel plates.

Potential sources of chemical or galvanic reactions are the interaction between the aluminum, aluminum-based neutron poison and stainless steel within the basket itself, and the interaction of the stainless steel rails with the stainless steel canister cavity wall and the pool water.

Typical water chemistry in a BWR Spent Fuel pool is as follows:

pH	5.6 - 7.1
Chloride	1 - 10 ppb
Conductivity	0.7 - 1.8 $\mu$ mho
Silica	2.5 - 2.7 ppm
Pool Temperature	70 - 115°F

#### Behavior of Aluminum in Deionized Water

Aluminum is used for many applications in spent fuel pools. In order to understand the corrosion resistance of aluminum within the normal operating conditions of spent fuel storage pools, a discussion of each of the types of corrosion is addressed separately. None of these corrosion mechanisms are expected to occur in the short time period that the cask is submerged in the spent fuel pool.

#### *General Corrosion*

General corrosion is a uniform attack of the metal over the entire surfaces exposed to the corrosive media. The severity of general corrosion of aluminum depends upon the chemical nature and temperature of the electrolyte and can range from superficial etching and staining to dissolution of the metal. Figure 2-1 shows a potential -pH diagram for aluminum in high purity water at 77°F. The potential for aluminum coupled with stainless steel and the limits of pH for BWR pools are shown in the diagram to be well within the passivation domain. The passivated surface of aluminum (hydrated oxide of aluminum) affords protection against corrosion in the domain shown because the coating is insoluble, non-porous and adherent to the surface of the aluminum. The protective surface formed on the aluminum is known to be stable up to 275°F and in a pH range of 4.5 to 8.5 [13].

### *Galvanic Corrosion*

Galvanic corrosion is a type of corrosion which could cause degradation of dissimilar metals exposed to a corrosive environment for a long period of time.

Galvanic corrosion is associated with the current of a galvanic cell consisting of two dissimilar conductors in an electrolyte. The two dissimilar conductors of interest in this discussion are aluminum and stainless steel in deionized water. There is little galvanic corrosion in deionized water since the water conductivity is very low. There is also less galvanic current flow between the aluminum-stainless steel couple than the potential difference on stainless steel which is known as polarization. It is because of this polarization characteristic that stainless steel is compatible with aluminum in all but severe marine, or high chloride, environmental conditions [14].

### *Pitting Corrosion*

Pitting corrosion is the forming of small sharp cavities in a metal surface. The first step in the development of corrosion pits is a local destruction of the protective oxide film. Pitting will not occur on commercially pure aluminum when the water is kept sufficiently pure, even when the aluminum is in electrical contact with stainless steel. Pitting and other forms of localized corrosion occur under conditions like those that cause stress corrosion, and are subject to an induction time which is similarly affected by temperature and the concentration of oxygen and chlorides. As with stress corrosion, at the low temperatures and low chloride concentrations of a spent fuel pool, the induction time for initiation of localized corrosion will be greater than the time that the cask internal components are exposed to the aqueous environment.

### *Crevice Corrosion*

Crevice corrosion is the corrosion of a metal that is caused by the concentration of dissolved salts, metal ions, oxygen or other gases in crevices or pockets remote from the principal fluid stream, with a resultant build-up of differential galvanic cells that ultimately cause pitting. Crevice corrosion could occur in the basket plates, around the stainless steel welds. However, due to the short time in the spent fuel pool, this type of corrosion is not expected to be significant.

### *Intergranular Corrosion*

Intergranular corrosion is corrosion occurring preferentially at grain boundaries or closely adjacent regions without appreciable attack of the grains or crystals of the metal itself. Intergranular corrosion does not occur with commercially pure aluminum and other common work hardened aluminum alloys.

### Behavior of Austenitic Stainless Steel in Deionized Water

The fuel compartments and the structural plates which support the fuel compartments are made from type 304 stainless steel. Stainless steel does not exhibit general corrosion when immersed in deionized water. Galvanic reactions with aluminum are discussed above.

Stress corrosion cracking in the 304 stainless steel welds is also not expected to occur, since the baskets are not highly stressed during normal operations. Of the corrosive agents that could initiate stress corrosion cracking in the 304 stainless steel basket welds, only the combination of chloride ions with dissolved oxygen could occur in spent fuel pool water. Although stress corrosion cracking can take place at very low chloride concentrations and temperatures such as those in spent fuel pools (less than 10 ppb and 160°F, respectively), the effect of low chloride concentration and low temperature is to greatly increase the induction time, that is, the period during which the corrodent is breaking down the passive oxide film on the stainless steel surface. Below 60°C (140°F), stress corrosion cracking of austenitic stainless steel does not occur at all. At 100 °C (212 °F), chloride concentration on the order of 15% is required to initiate stress corrosion cracking [16]. At 288 °C (550 °F), with tensile stress at 100% of yield in BWR water containing 100 ppm O<sub>2</sub>, time to crack is about 40 days in sensitized 304 stainless steel [17]. Thus, the combination of low chlorides, low temperature and short time of exposure to the corrosive environment eliminates the possibility of stress corrosion cracking in the basket welds.

### Behavior of Aluminum Based Neutron Poison in Deionized Water

The aluminum component of the borated aluminum is a ductile metal having a high resistance to corrosion. Its corrosion resistance is provided by the buildup of a protective oxide film on the metal surface when exposed to a corrosive environment. As stated above for aluminum, once a stable film develops, the corrosion process is arrested at the surface of the metal. The film remains stable over a pH range of 4.5 to 8.5.

Tests were performed by Eagle Picher [18] which concluded that borated aluminum exhibits a strong corrosion resistance at room temperature in deionized water. Satisfactory long-term usage in these environments is expected. At high temperature, the borated aluminum still exhibits high corrosion resistance in the pure water environment.

From tests on pure aluminum, it was found that borated aluminum was more resistant to uniform corrosion attack than pure aluminum.

An alternate neutron poison material is a boron carbide / aluminum composite, which is a matrix of full-density aluminum with a fine dispersion of boron carbide particles throughout. The corrosion behavior is similar to that of the base aluminum alloy.

The third neutron poison material is Boral<sup>®</sup>. The faces of the Boral sheet are 1100 aluminum, while the aluminum/boron carbide core is exposed at the edges of the sheet.

There are no chemical, galvanic or other reactions that could reduce the areal density of boron in any of the poison plate materials for the NUHOMS<sup>®</sup>-61BT.

## Electroless Nickel Plated Carbon Steel

The carbon steel top shield plug of the DSC is plated with electroless nickel. This coating is identical to the coating used on the 52B DSC. It has been evaluated for potential galvanic reactions in Transnuclear West's response to NRC Bulletin 96-04 [28]. In BWR pools, the reported corrosion rates are insignificant and are expected to result in a negligible rate of reaction for the NUHOMS® BWR systems.

### 2.4.4.2 Cask Exterior

The exterior of the cask is made from stainless steel and will not cause significant chemical, galvanic or other reactions in air or water environments.

Potential galvanic couples are:

- The brass bolt covers and the stainless 304 trunnions during wet loading. The bolt covers are not important to safety components.
- The thermal shield and the stainless steel cask bottom and impact limiter. The aluminum is not directly exposed to the weather, road salt, etc., because it is covered by the impact limiter. The thermal shield is not an important to safety component.
- The low alloy steel bolts and stainless steel. The lid, test, drain cover, and ram cover bolts are not directly exposed to the weather, road salt, etc, because they are covered by the impact limiters. The impact limiter hoist ring replacement bolts and the trunnion plug bolts will be exposed,

In all these cases, minor sacrificial galvanic corrosion of these anodic (non-stainless) components will have no adverse affect on an important to safety function.

### 2.4.4.3 Lubricants and Cleaning Agents

A lubricant may be used to coat the threads and shoulders of the bolts and the slide rails and the contact areas of the trunnions during lifting operations. Lubricants are generally selected from the list of materials approved for contact with the pool water at the facility where wet loading occurs.

Cask and DSC components are cleaned to remove all temporary markings, expendable materials, etc., during fabrication, using approved procedures.

After loading, exterior surfaces of the cask will be decontaminated using procedures and decontamination agents approved at the loading facility.

The cleaning agents and lubricants have no significant effect on the cask materials.

#### 2.4.4.4 Hydrogen Generation

The NUHOMS 61BT canister is wet loaded, either in the MP-197 transport cask, or in a transfer cask. In the latter case, the seal canister may, at a later date, be dry loaded into the MP-197 directly from the horizontal storage module. In either event, there is no mechanism for galvanic corrosion in the space between the canister and the MP-197, because both the inner shell of the MP-197 and the outer shell of the canister are stainless steel, and because the canister is sealed before the lid is placed on the MP-197. Therefore, the following discussion applies entirely to the potential for the generation of hydrogen inside the canister during wet loading.

During the initial passivation of the stainless steel and aluminum components, small amounts of hydrogen gas may be generated in the DSC. The passivation stage may occur prior to submersion of the transport cask into the spent fuel pool. Any amounts of hydrogen generated in the DSC will be insignificant and will not result in a flammable gas mixture within the DSC. In order for concentrations of hydrogen in the cask to reach flammability levels, most of the DSC would have to be filled with water for the hydrogen generation to occur, and the lid would have to be in place with both the vent and drain ports closed. This does not occur during DSC loading or unloading operations.

After loading fuel into the NUHOMS®-61BT DSC, the shield plug is placed in the DSC and the transport cask and DSC are raised to the pool surface. At this time the DSC is completely filled with water.

An estimate of the maximum hydrogen concentration can be made, ignoring the effects of radiolysis, recombination, and solution of hydrogen in water. Testing was conducted by Transnuclear [19] to determine the rate of hydrogen generation for aluminum metal matrix composite in intermittent contact with 304 stainless steel. The samples represent the neutron poison plates paired with the basket compartment tubes. The test specimens were submerged in deionized water for 12 hours at 70 °F to represent the period of initial submersion and fuel loading, followed by 12 hours at 150 °F to represent the period after the fuel is loaded, until the water is drained. The hydrogen generated during each period was removed from the water and the test vessel and measured.

The test results were:

	12 hour @ 70 °F		12 hour @ 150 °F	
	cm <sup>3</sup> hr <sup>-1</sup> dm <sup>-2</sup>	ft <sup>3</sup> hr <sup>-1</sup> ft <sup>-2</sup>	cm <sup>3</sup> hr <sup>-1</sup> dm <sup>-2</sup>	ft <sup>3</sup> hr <sup>-1</sup> ft <sup>-2</sup>
aluminum MMC/SS304	0.517	1.696E-4	0.489	1.604E-4

The total surface area of the aluminum/stainless steel interface at the neutron absorber/compartment wall interface is 1462 ft<sup>2</sup>. This surface area, combined with the test data at 150 °F above result in a hydrogen generation rate of

$$(1.6 \times 10^{-4} \text{ ft}^3/\text{ft}^2\text{hr})(1462 \text{ ft}^2) = 0.23 \text{ ft}^3/\text{hr}$$

in the 61BT DSC. During welding of the top inner plate, the DSC is partially filled with water. The minimum free volume of the DSC is 120 ft<sup>3</sup>. (Operations require draining 1100 gallons, equal to 147 ft<sup>3</sup>). The following assumptions are made to arrive at a conservative estimate of hydrogen concentration:

- All generated hydrogen is released instantly to the plenum between the water and the shield plug, that is, no dissolved hydrogen is pumped out with the water, and no released hydrogen escapes through the open vent port, and
- The welding and backfilling process takes 8 hours to complete.

Under these assumptions, the hydrogen concentration in the space between the water and the shield plug is a function of the time water is in the DSC prior to backfilling with helium. The hydrogen concentration is  $(0.23 \text{ ft}^3 \text{ H}_2/\text{hr}) \cdot (8 \text{ hr}) / (120 \text{ ft}^3) = 1.5 \%$ . Monitoring of the hydrogen concentration before and during welding operations will be performed to ensure that the hydrogen concentration does not exceed 2.4%. If the concentration exceeds 2.4%, welding operations will be suspended and the DSC will be purged with an inert gas. In an inert atmosphere, a flammable gas mixture will not be generated.

#### 2.4.4.5 Seals

All closure seals are low temperature fluorocarbon conforming to AMS-R-83485[29]. This material is suitable for use from -40 to 400 °F. All o-ring temperatures reported in Chapter 3 are within this range for both normal and accident conditions.

All sealing surfaces are stainless steel 304 or XM-19.

To evaluate irradiation damage to the seals, note that the energy absorption of polymers and tissue is similar. Therefore, the gamma radiation energy absorbed by the seals may be approximated as the rad equivalent of the surface dose in rem. The absorbed neutron energy may be estimated as half the neutron dose rate to account for the tissue quality factor. From Chapter 5, the maximum dose rate at the surface of the MP-197 is 13 mrem/hour gamma, and 125 neutron. This is approximately equivalent to 0.076 rad/hr absorbed dose rate in polymers. If we increase that by a factor of 100 to account for the fact that the seals are somewhat below the surface, at the end of one year of continuous exposure, this would result in absorbed energy in the seals of about  $7 \times 10^4$  rad, well below the threshold of polymer damage, generally about  $10^6$  rad.

#### 2.4.4.6 Neutron Shielding

The radial neutron shield is a proprietary reinforced polymer. Information on the composition and the radiation and temperature resistance of the material was provided to the NRC in the TN-68 SAR [30]. The fire retardant mineral fill makes it self-extinguishing. Furthermore, the material is contained in aluminum tubes inside a steel shell, so that it is retained in place and isolated from sources of ignition.



The trunnion plugs include polypropylene neutron shielding in a stainless 304 case. Polypropylene is slow burning to non-burning according to Table 24, Section 1 of the Handbook of Plastics and Elastomers[31].

#### 2.4.4.7 Coatings

Corrosion-resistant coatings are optional on alloy steel bolts. The top shield plug is electroless nickel coated, as described above. There are no other coatings on the MP-197.

#### 2.4.4.8 Effect of Chemical and Galvanic Reactions on the Performance of the Cask

There are no significant reactions that could reduce the overall integrity of the cask or its contents during transportation. The cask and fuel cladding thermal properties are provided in Chapter 3. The emissivity of the fuel compartment is 0.3, which is typical for non-polished stainless steel surfaces. If the stainless steel is oxidized, this value would increase, improving heat transfer. The fuel rod emissivity value used is 0.8, which is a typical value for oxidized Zircaloy. Therefore, the passivation reactions would not reduce the thermal properties of the component cask materials or the fuel cladding.

There are no reactions that would cause binding of the mechanical surfaces or the fuel to basket compartment boxes due to galvanic or chemical reactions.

There is no significant degradation of any important-to-safety components caused directly by the effects of the reactions or by the effects of the reactions combined with the effects of exposure of the materials to neutron or gamma radiation, high temperatures, or other possible conditions.

## 2.5 LIFTING AND TIE-DOWN STANDARDS

### 2.5.1 Lifting Devices

10CFR 71-45(a) requires that a minimum factor of safety of three against yield is required for all lifting attachments which are structural parts of the package. In addition, the package must be designed such that failure of any lifting device under excessive load would not impair the ability of the package to meet the requirements of 10CFR71. Section 2.5.1.1 provides the analysis of the trunnions which are the only components used to lift the cask. Two sets of trunnions will be provided for the NUHOMS<sup>®</sup>-MP197 transport package lifting. One set of trunnions has double shoulders (non single failure proof). The other set of trunnions has a single shoulder (single failure proof). Only one set of trunnions will be used depending on site and transfer operation requirements. Appendix 2.10.1 provides an analysis of the global stresses in the cask wall due to the effects of lifting loads on the trunnions. The global stress intensities from the ANSYS run at the stress reporting locations of the containment vessel and outer shell are presented in Table 2.10.1-9. The local stress intensities in the cask wall due to the 3G (double shoulder trunnion) and 6G (single shoulder trunnion) lifting load are calculated below and presented in Tables 2-11 and 2-14. The maximum combined stress intensity for 3G lifting is 18.36 ksi. The maximum combined stress intensity for 6G lifting is 22.99 ksi. These stresses are less than the yield stress of the outer shell material (24.65 ksi, SA-240 Gr. 316 at 250°F). Therefore the requirements of 10CFR 71-45(a) are met. The stress analyses of the front trunnion and trunnion flange bolts are provided in the following sections.

#### 2.5.1.1 Trunnion Analysis

NUHOMS<sup>®</sup>-MP197 cask includes removable front and rear trunnions, as shown on drawing 1093-71-5, which are used for on-site lifting and transfer operations. The trunnions are removed prior to transportation and replaced with non-protruding plugs to provide the required crush distance for the impact limiter. This section provides the structural analysis of the NUHOMS<sup>®</sup>-MP197 cask trunnions.

##### A. Double Shoulder Front Trunnions (Non-Single Failure Proof)

#### Trunnion Stress Calculations

These two front trunnions are used for lifting the cask and are designed to the requirements of ANSI N14.6 [2]. They can support a loading equal to 3 times the weight of the cask without generating stresses in excess of the minimum yield strength of the material. They can also lift 5 times the weight of the cask without exceeding the ultimate tensile strength of the material. A dynamic load factor of 1.1 is used in evaluating the trunnion stresses.

Figure 2-3 shows the basic dimensions of the front trunnions. A cask weight of 260,000 lbs. is used in this calculation. Following table shows the cross sectional area and moment of inertia at shoulder cross Section A-A, Section B-B, and Section C-C of the front trunnions. The loads applied to this section (for 3 W and 5 W loading) to evaluate the yield and ultimate limits are also listed.

**Front (Top) Trunnion Section Properties and Loads  
(Double Shoulder Trunnion)**

Item	Section A-A	Section B-B	Section C-C
Cross Section Area, In <sup>2</sup>	56.41	89.91	109.54
Area Moment of Inertia, In <sup>4</sup>	429.52	924.2	954.93
Yield Condition* Shear Force, Lbs	429,000	429,000	429,000
Yield Condition* Bending Moment, In- Lbs	1,450,020	3,058,770	3,406,260
Ultimate Condition** Shear Force, Lbs.	715,000	715,000	715,000
Ultimate Condition** Bending Moment, In-Lbs	2,416,700	5,097,950	5,677,100

- \* Trunnion Loads to Support (3 × 1.1) times Cask Weight (260,000 lbs)
- \*\* Trunnion Loads to Support (5 × 1.1) times Cask Weight (260,000 lbs)

Following table presents a summary of the stresses at the same location to compare against the trunnion yield and ultimate strengths.

**Front (Top) Trunnion Stresses When Loaded  
By 3 and 5 Times Cask Weight  
(Double Shoulder Trunnion)**

Stress	Yield Limit (Ksi)	Yield Limit (Ksi)	Yield Limit (Ksi)
	SECTION A-A	SECTION B-B	SECTION C-C
Shear Stress	7.61	4.77	3.92
Bending Stress	16.61	19.54	21.06
Stress Intensity	22.52	21.67	22.47
Allowable Stress, S <sub>y</sub> (SA-182 F304 at 250°F)	23.6	23.6	23.6
	Ultimate Limit (ksi)	Ultimate Limit (ksi)	Ultimate Limit (ksi)
Shear Stress	12.68	7.95	6.53
Bending Stress	27.68	32.57	35.10
Stress Intensity	37.53	36.12	37.45
Allowable Stress, S <sub>u</sub> (SA-182 F304 at 250°F)	68.6	68.6	68.6

## Stress at Trunnion/Cask Outer Shell Intersection

The local stresses induced in the outer shell cylinder by the trunnions are calculated using "Bijlaard's" method. The neutron shield and thin outer shell are not considered to strengthen either the trunnions or outer shell. The trunnion is approximated by an equivalent attachment so that the curves of the Reference WRC-107 [22] can be used to obtain the necessary coefficients. These resulting coefficients are inserted into blanks in the column entitled "Read Curves For," in a standard computation form, a sample of which is attached as Table 2-7. The stresses are calculated by performing the indicated multiplication in the column entitled "Compute Absolute Values of Stress and Enter Result". The resulting stress is inserted into the stress table at the eight stress locations, i.e., AU, AL, BU, BL, etc. Note that the sign convention for this table is defined in the figure by the load directions shown. The membrane plus bending stresses are calculated by completing Table 2-7. The maximum stress intensities in the outer shell calculated by this methodology are 18.36 ksi (3G load) and 30.61 ksi (5G load). These stresses are summarized in the following table to compare against the outer shell yield and ultimate strengths.

### Trunnion Bolt Stresses

The front trunnion flange is attached to the outer shell by twelve 1.25-7UNC-2A bolts constructed from SA-540 Gr. B24 Cl. 1 material. The bolted flange is tightly fitted into the trunnion attachment block, which is welded to the cask outer shell. This trunnion block recess provides a bearing area between the outside perimeter of the trunnion flange and the block. The radial clearance between the bolt shank and trunnion flange bolt holes is large enough so that shear loads are carried by the trunnion flange-to-block recess interface and not the bolts. The bolts develop only the tensile load due to trunnion moment and thermal loads.

Bolt Stresses due to Trunnion Moment:

The bending moment at the flange interface due to 3G is equal to  $3(260,000)(1.1)(0.5)(11.19) = 4,800,510$  in-lbs. From Reference 20, Case 3, (for bolt patterns symmetrical about the vertical axis and flange rotating about the bottom bolt) the maximum bolt force due to bending moment,  $M$ , is:

$$F_{max} = (4/(3RN)) M$$

Where,

$R$  = Bolt circle radius = 10.5 in.

$N$  = No. of bolts = 12

$$F_{max} = 4(4,800,510)/(3 \times 10.5 \times 12) = 50,800 \text{ lbs.}$$

## Thermal Stresses:

The bolts are made of SA-540, Gr. B24, Cl. 1 and trunnion block are manufactured from SA-182, Type F304. These two materials have different coefficients of thermal expansion, which results in a thermal load at 250° F. From Reference 25, Table 4.4, the bolt force due to different thermal expansion is calculated as follows.

$$\text{Bolt Force} = 0.25\pi D_b^2 E_b (\alpha T_1 - \alpha_b T_b)$$

Where:

$D_b$  = Nominal Bolt diameter = 1.25 in.

$E_b$  = Bolt Young Modulus =  $26.9 \times 10^6$  psi

$\alpha$  = Coefficient of thermal expansion, block (SA-182, Type F304) =  $9.1 \times 10^{-6}$  in/in/°F

$\alpha_b$  = Coefficient of thermal expansion, bolt (SA-540, Gr. B24) =  $6.8 \times 10^{-6}$  in/in/°F

$T_1$  = Temperature Change, block =  $250 - 70 = 180^\circ\text{F}$

$T_b$  = Temperature Change, bolt =  $250 - 70 = 180^\circ\text{F}$

Therefore,

$$\text{Bolt Force} = 0.25\pi(1.25^2)(26.9 \times 10^6)(180)(9.1 \times 10^{-6} - 6.8 \times 10^{-6}) = 13,667 \text{ lb.}$$

For yield load (3G), the total bolt force = 13,667 lb. + 50,800 lb. = 64,467 lb.

The bolt stress area = 0.969 in<sup>2</sup>

For yield load (3G), the maximum tensile stress =  $64,467/0.969 = 66.53$  ksi.

Bolt allowable tensile stress for yield load =  $S_y$  (at 250°F) = 141.0 ksi > 66.53 ksi

For tensile load (5G), the total bolt force =  $(5/3)(50,800 \text{ lb.}) + 13,667 \text{ lb.} = 98,334 \text{ lb.}$

For tensile load (5G), the maximum tensile stress =  $98,334/0.969 = 101.48$  ksi

The bolt allowable tensile stress =  $S_u$  (at 250°F) = 165.0 ksi.

Therefore the bolt stresses are acceptable for both 5G (ultimate) and 3G (yield) trunnion loads.

## Summary of the Double Shoulder Trunnion Stress Analysis

The maximum calculated stresses and their margin of safety are summarized in the following table. All the calculated stresses are less than the allowable stresses. Based on these calculations, the minimum margin of safety occurs at the trunnion shoulder. Therefore, an excessive load would damage the trunnion, but the cask would not lose its structural integrity, satisfying the requirements of the 10CFR71.45(a).

Stress Summary (Double Shoulder Trunnion)

3G Loading				
Component	Stress Type	Maximum Calculated Stress (ksi)	Allowable Stress (ksi)	Margin of Safety
Trunnion Shoulder	Stress Intensity	22.52	23.6	0.05
Trunnion Attachment Bolt	Tensile	66.53	141.0	1.12
Trunnion Flange	Stress Intensity	7.17	23.6	2.29
Cask – Block Intersection	Stress Intensity	18.36	24.65	0.34
5G Loading				
Component	Stress Type	Maximum Calculated Stress (ksi)	Allowable Stress (ksi)	Margin of Safety
Trunnion Shoulder	Stress Intensity	37.5	68.6	0.83
Trunnion Attachment Bolt	Tensile	101.48	165.0	0.63
Trunnion Flange	Stress Intensity	11.95	68.6	4.74
Cask – Block Intersection	Stress Intensity	30.61	73.95	1.42

**B. Single Shoulder Front Trunnions (Single Failure Proof)**

Trunnion Stress Calculations

These two optional front trunnions are used for lifting the cask and are designed to the requirements of ANSI N14.6 [2]. They can support a loading equal to 6 times the weight of the cask without generating stresses in excess of the minimum yield strength of the material. They can also lift 10 times the weight of the cask without exceeding the ultimate tensile strength of the material. A dynamic load factor of 1.1 is used in evaluating the trunnion stresses.

Figure 2-3 shows the basic dimensions of these front trunnions. A cask weight of 260,000 lbs. is used in this calculation. The following table shows the cross sectional area and moment of inertia at shoulder cross section A-A of the single shoulder front trunnions. The loads applied to this section (for 6 W and 10 W loading) to evaluate the yield and ultimate limits are also listed.

**Front (Top) Trunnion Section Properties and Loads  
(Single Shoulder Trunnion)**

Item	Section A-A
Cross Section Area, In <sup>2</sup>	93.64
Area Moment of Inertia, In <sup>4</sup>	934.8
Yield Condition* Shear Force, Lbs	858,000
Yield Condition* Bending Moment, In- Lbs	2,145,000
Ultimate Condition** Shear Force, Lbs.	1,430,000
Ultimate Condition** Bending Moment, In-Lbs	3,575,000

\* Trunnion Loads to Support (6 × 1.1) times Cask Weight (260,000 lbs)

\*\* Trunnion Loads to Support (10 × 1.1) times Cask Weight (260,000 lbs)

Following table presents a summary of the stresses at the same location to compare against the trunnion yield and ultimate strengths.

**Front (Top) Trunnion Stresses When Loaded  
By 3 And 5 Times Cask Weight  
(Double Shoulder Trunnion)**

Stress Category	Yield Limit (Ksi)
	SECTION A-A
Shear Stress	9.16
Bending Stress	13.55
Stress Intensity	22.79
Allowable Stress, $S_y$	23.6 (SA-182 F304 at 250°F)
	Ultimate Limit (ksi)
	SECTION A-A
Shear Stress	15.27
Bending Stress	22.58
Stress Intensity	37.98
Allowable Stress, $S_u$	68.6 (SA-182 F304 at 250°F)

### Stress at Trunnion/Cask Outer Shell Intersection

The local stresses induced in the outer shell cylinder by the trunnions are calculated using "Bijlaard's" method. The neutron shield and thin outer shell are not considered to strengthen either the trunnions or outer shell. The trunnion is approximated by an equivalent attachment so that the curves of the Reference WRC-107 [22] can be used to obtain the necessary coefficients. These resulting coefficients are inserted into blanks in the column entitled "Read Curves For," in a standard computation form, a sample of which is attached as Table 2-7. The stresses are calculated by performing the indicated multiplication in the column entitled "Compute Absolute Values of Stress and Enter Result". The resulting stress is inserted into the stress table at the eight stress locations, i.e., AU, AL, BU, BL, etc. Note that the sign convention for this table is defined in the figure by the load directions shown. The membrane plus bending stresses are calculated by completing Table 2-7. The maximum stress intensities in outer shell calculated by this methodology are 22.99 ksi (6G load) and 38.32 ksi (10G load). These stresses are summarized in the following table to compare against the outer shell yield and ultimate strengths.

### Trunnion Bolt Stresses

The front trunnion flange is attached to the outer shell by twelve 1.25-7UNC-2A bolts constructed from SA-540 Gr. B24 Cl. 1 material. The bolted flange is tightly fitted into the trunnion attachment block, which is welded to the cask outer shell. This trunnion block recess provides a bearing area between the outside perimeter of the trunnion flange and the block. The radial clearance between the bolt shank and trunnion flange bolt holes is large enough so that shear loads are carried by the trunnion flange-to-block recess interface and not the bolts. The bolts develop only the tensile load due to a trunnion moment.

The bending moment at the flange interface due to 6G is equal to  $6(260,000)(1.1)(0.5)(5.75) = 4,933,500$  in-lbs. From Reference 20, Case 3, (for bolt patterns symmetrical about the vertical axis and flange rotating about the bottom bolt) the maximum bolt force due to bending moment  $M$  is:

$$F_{max} = (4/(3RN)) M$$

Where:

$R$  = Bolt circle radius = 10.5 in.

$N$  = No. of bolts = 12

$$F_{max} = 4(4,933,500)/(3 \times 10.5 \times 12) = 52,206 \text{ lbs.}$$

Bolt force due to thermal loads = 13,667 lb.

For yield load (6G), the total bolt force = 13,667 lb. + 52,206 lb. = 65,783 lb.

The bolt stress area =  $0.969 \text{ in}^2$

For yield load (6G), the maximum tensile stress =  $65,783/0.969 = 67.98 \text{ ksi}$ .

Bolt allowable tensile stress for yield load =  $S_y$  (at 250°F) = 141.0 ksi > 67.98 ksi

For tensile load (10G), the total bolt force =  $(10/6)(52,206 \text{ lb.}) + 13,667 \text{ lb.} = 100,677 \text{ lb.}$

For tensile load (10G), the maximum tensile stress =  $100,677/0.969 = 103.90 \text{ ksi}$



The bolt allowable tensile stress =  $S_u$  (at 250°F) = 165.0 ksi.

Therefore the bolt stresses are acceptable for both 5G (ultimate) and 3G (yield) trunnion loads.

Summary of the Single Shoulder Trunnion Stress Analysis

The maximum calculated stresses and their margins of safety are summarized in the following table. All the calculated stresses are less than the allowable stresses. Based on these calculations, the minimum margin of safety occurs at the trunnion shoulder. Therefore, an excessive load would damage the trunnion, but the cask would not lose its structural integrity, satisfying the requirements of 10CFR71.45(a).

Stress Summary (Single Shoulder Trunnion)

6G Loading				
Component	Stress Type	Maximum Calculated Stress (ksi)	Allowable Stress (ksi)	Margin of Safety
Trunnion Shoulder	Stress Intensity	22.79	23.6	0.04
Trunnion Attachment Bolt	Tensile	67.98	141.0	1.07
Trunnion Flange	Stress Intensity	7.36	23.6	2.2
Cask – Block Intersection	Stress Intensity	22.99	24.65	0.07
10G Loading				
Component	Stress Type	Maximum Calculated Stress (ksi)	Allowable Stress (ksi)	Margin of Safety
Trunnion Shoulder	Stress Intensity	37.98	68.6	0.81
Trunnion Attachment Bolt	Tensile	103.9	165.0	0.59
Trunnion Flange	Stress Intensity	12.27	68.6	4.59
Cask – Block Intersection	Stress Intensity	38.32	73.95	0.93

C. Double Shoulder Rear Trunnion Stress Analysis

These two rear trunnions are used to lift the cask in the horizontal position and to rotate the cask from the horizontal orientation to the vertical orientation. The dimensions of the two rear trunnions are identical to the front double shoulder trunnions. During the horizontal lifting, the load is shared by four (4) trunnions instead of two trunnions. Therefore, the stresses in the front trunnions bound the stresses in the rear trunnions.

## 2.5.2 Tie-Down Devices

The structural components of the NUHOMS<sup>®</sup>-MP197 cask are designed to withstand transportation loads of 2G in the vertical direction, 5G in the transverse direction, and 10G in the longitudinal direction without generating stress in excess of the material's yield strength, per requirements of 10CFR71.45(b)(1).

The NUHOMS<sup>®</sup>-MP197 transportation package is secured during transport by the transportation skid. The cask shear key is designed to transfer the longitudinal cask transport loads to the skid. The vertical and transverse cask transport loads are supported by saddles and tie-down straps.

Section 2.10.1.4 provides an analysis of the global stresses in the cask wall due to the effect of a 2/5/10G tie-down load. The global stress intensities from the ANSYS run at the stress reporting locations of the containment vessel and outer shell are presented in Table 2.10.1-46. All the stresses are less than the yield stress of the cask outer shell material. The bearing stress, local weld stresses and stresses in the cask wall/shear key bearing block pad due to the 2/5/10G tie-down load are calculated below.

### Discussion

The shear key bearing block is a part of the cask structure, and is designed to resist the 10g longitudinal transportation load. The bearing block is a welded structure that mates with the shear key, which is part of the transport skid. A 36" × 37.20" × 1.5" pad plate is used to spread the load over a large area of the cask outer shell. The bearing block and pad plate are manufactured from SA-240, Type XM-19 stainless steel. The shear key is made of ASTM A514.

### Bearing Stress between Shear Key and Bearing Block

The bearing stress due to the 10g longitudinal transportation load is calculated assuming the load is applied uniformly to one face of bearing block.

$$L_1 = 22.25 - 2[5 \tan(12.5)] = 20.033 \text{ in.}$$

$$L_2 = 20.033 + 2[4.25 \tan(12.5)] = 21.917 \text{ in.}$$

$$Y = [45.25^2 - (21.917/2)^2]^{0.5} - 41.0 = 2.903 \text{ in}$$

$$\text{Area } A_1 = \frac{1}{2}(20.033 + 21.917) \times 2.903 = 60.89 \text{ in}^2$$

$$\text{Segment Area, } A_2 = \frac{1}{2} R^2 [2\alpha - \sin(2\alpha)]$$

$$\sin \alpha = L_2 / 2(45.25) = 21.917 / 2(45.25) = 0.242 \quad \alpha = 14^\circ = 0.245 \text{ rad.}$$

$$A_2 = \frac{1}{2} 45.25^2 [2 \times 0.245 - \sin(28)] = 21.017 \text{ in}^2$$

$$\text{Bearing Area} = 60.89 + 21.017 = 81.907 \text{ in}^2$$

$$\text{Load} = 10 \times 280,000 = 2,800,000 \text{ lb.}$$

$$\text{Bearing Stress} = 2,800,000 / 81.907 = 34,185 \text{ psi} \approx 34.19 \text{ ksi}$$

The allowable average bearing stress is limited to  $S_y$ . The yield strength of SA-240, Type XM-19 stainless steel, at 300° F, is 43.3 ksi. The yield strength of shear key material (A514) is much higher than that of XM-19. Therefore, the margin of safety is:

$$M.S. = \frac{43.3}{34.19} - 1.0 = 0.27$$

#### Weld between Pad and Outer Shell

The shear key pad is welded to the cask structure all around with 1" partial penetration groove weld and a 5/8" fillet weld. The shear stress in the base metal of cask outer shell (SA-240, Gr. 316) is calculated in the following way:

$$\begin{aligned} \text{Shear area} &= (36 \times 37.2) - (34 \times 35.2) + 2(36 + 37.2) \times 5/8 \\ &= 142.40 + 91.5 = 233.9 \text{ in}^2 \end{aligned}$$

$$\text{Shear Stress} = 2,800,000/233.9 = 11,970 \text{ psi} = 11.97 \text{ ksi}$$

The average primary shear stress across a section loaded in pure shear is limited to 0.6  $S_y$ . For SA-316, the yield strength at 300° F is 23.4 ksi. Therefore, the allowable weld shear stress is 14.04 ksi.

The margin of safety in the base metal is:

$$M.S. = \frac{14.04}{11.97} - 1.0 = 0.17$$

The allowable for XM-19 is higher than the allowable for SA-316.

#### Weld Between Bearing Block and Pad Plate

The bearing block is welded to the 1.5" thick plate with a full penetration weld and a 1/2" outside cover fillet weld. The welds are loaded in bending, resulting from the offset 'e' of the 10g longitudinal load point, to the center of pad plate, which is calculated as follows:

$$M = P \times e = 2,800,000 [4.25/2 - 1.5/2] = 3,850,000 \text{ in.lb.}$$

Section modulus of the weld is computed by treating the weld as line per unit thickness,  $t_{eff}$

$$S_w = (bd + d^2/3) t_{eff}$$

$$t_{eff} = 1.5 + 0.707(0.5) = 1.8535 \text{ in.}$$

$$S_w = (26.3 \times 12.06 + 12.06^2/3) 1.8535 = 677.75 \text{ in}^3$$

$$\text{Bending Stress} = 3,850,000 / 677.75 = 5,680 \text{ psi} = 5.68 \text{ ksi}$$

The allowable maximum bending stress is limited to  $S_y$ . The yield strength of SA-240, Type XM-19 stainless steel, at 300° F, is 43.3 ksi. Therefore, the margin of safety is:

$$\text{M.S.} = \frac{43.3}{5.68} - 1.0 = 6.62$$

#### Stress at the Shear Key Bearing Block/Cask Outer Shell Intersection

The local stresses induced in the outer shell cylinder by the shear key bearing block are calculated using "Bijlaard's" method. The neutron shield and thin outer shell are not considered to strengthen either the bearing block or outer shell. The bearing block/welding pad is approximated by an equivalent attachment so that the curves of the Reference WRC-107 can be used to obtain the necessary coefficients. These resulting coefficients are inserted into blanks in the column entitled "Read Curves For," in a standard computation form, a sample of which is attached as Table 2-7. The stresses are calculated by performing the indicated multiplication in the column entitled "Compute Absolute Values of Stress and Enter Result". The resulting stress is inserted into the stress table at the eight stress locations, i.e., AU, AL, BU, BL, etc. Note that the sign convention for this table is defined on the figure by the load directions shown. The membrane plus bending stresses are calculated by completing Table 2-10. The maximum stress intensities in outer shell calculated by this methodology are 10.88 ksi (10G load) which is less than the outer shell (SA-240 Type 316) yield strength (23.4 ksi at 300°F). Therefore, the margin of safety is:

$$\text{M.S.} = \frac{23.4}{10.88} - 1.0 = 1.15$$

#### Conclusions

All the stresses calculated above are less than the allowable stresses. In the event of excessive loading during normal transport, the weld between the shear key pad plate and the cask outer shell would fail in shear (has lowest margin of safety), leaving the cask body intact without impairing the ability of package to meet the requirements of 10CFR71.45(b)(3).

## 2.6 NORMAL CONDITIONS OF TRANSPORT

### Overview

This section describes the response of the NUHOMS<sup>®</sup>-MP197 package to the loading conditions specified by 10CFR71.71. The design criteria established for the NUHOMS<sup>®</sup>-MP197 for the normal conditions of transport are described in Section 2.1.2. These criteria are selected to ensure that the package performance standards specified by 10CFR71.43 and 71.51 are satisfied. Under normal conditions of transport there will be no loss or dispersal of radioactive contents, no significant increase in external radiation levels, and no substantial reduction in the effectiveness of the packaging. Under hypothetical accident conditions, the cask is protected so that there is no escape of radioactive material exceeding a total amount  $A_2$  in one week, and no external dose rate exceeding one rem per hour at one meter from the external surface of the package.

Detailed structural analyses of various NUHOMS<sup>®</sup>-MP197 package components subjected to individual loads are provided in the Appendices to this chapter. The limiting results from these analyses are used in this section to quantify package performance in response to the normal condition of transport load combinations, specified in 10CFR71.71 and Regulatory Guide 7.8. Table 2-8 provides an overview of the performance evaluations reported in each load combination subsection. Each subsection provides the limiting structural analysis result for the affected cask component(s) in comparison to the established design criteria. This comparison permits the minimum margin of safety for a given component subjected to a given loading condition to be readily identified. In all cases, the acceptability of the NUHOMS<sup>®</sup>-MP197 packaging design with respect to established criteria, and consequently with respect to 10CFR71 performance standards is demonstrated.

The structural analysis of the cask body is presented in Appendix 2.10.1 and covers a wide range of individual loading conditions. The stress results from the various individual loads must be combined in order to represent the stress condition in the cask body under the specified condition evaluated in this section. An explanation of the reporting format used for the results, and the stress combination technique used in applying the results from Appendix 2.10.1 is provided here.

### Reporting Method for Cask Body Stresses

Appendix 2.10.1 provides the detailed description of the structural analyses of the NUHOMS<sup>®</sup>-MP197 cask body. That appendix describes the detailed ANSYS model used to analyze various applied loads. Table 2-9 identifies the individual loads analyzed which are applicable to normal conditions of transport. Some of these individual loads are axisymmetric (e.g. pressure) and others are asymmetric (e.g. gravity). Due to the nonlinearities associated with contact elements, it is not possible to run the separate individual load cases and then combine the results by superposition. Rather, it's necessary to run each of the individual load cases or combined load cases independently and post process the results separately. Table 2-10 identifies the combined load cases for the normal condition of transport. A total of 26 separate loading conditions (individual and combined load cases) are executed.

- A. Individual load conditions: Runs 1-12, see Table 2-9. The stress results are presented in Table 2.10.1-4 to 2.10.1-15. Some of the stress results from these runs will be used for fatigue analysis.
- B. Load combinations for normal conditions of transport: Runs 13-26, see Table 2-10. The stress results are presented in Table 2.10.1-16 to 2.10.1-29.

Figure 2-4 shows the selected locations on the cask body numbered 1 through 35 where stress results for these analyses are reported. Detailed stresses are available at as many locations as there are nodes in the finite element model. However, for practical considerations, the reporting of stress results is limited to those locations shown on Figures 2-4. These locations were selected to be representative of the stress distribution in the cask body with special attention given to areas subject to high stresses. The maximum stress may occur at a different location for each individual load.

Several other items should be noted. In the NUHOMS<sup>®</sup>-MP197 cask body, thermal stresses occur due to the effects of differential thermal expansion between the inner shell, lead, and outer shell. These thermal stresses are conservatively treated as primary stresses. The combined stresses due to primary loads (like pressure) and differential expansion (such as heating from 70°F to hot thermal conditions) are also evaluated as primary stresses.

For the axisymmetric cases, the stress is constant around the circumference of the cask at each stress reporting location. The load cases, where there are significant differences in stress magnitudes at different orientations of the cask (usually contact side and side away from contact for an asymmetric impact load), are reported in separate columns.

For the increased external pressure load combination, it is assumed that the NUHOMS<sup>®</sup>-MP197 cask cavity is at 0 psia. Since the specified load combination condition is 20 psia, the net differential pressure acting on the cask body is 20 psi. However, for conservatism, a 25 psi external pressure is used for the load combinations.

## 2.6.1 Heat

Chapter Three describes the thermal analyses performed for the NUHOMS<sup>®</sup>-MP197 package subjected to hot environment conditions. These thermal analysis results are used to support various aspects of the structural evaluations as described in the following subsections.

### 2.6.1.1 Maximum Temperatures

Allowable Stresses for packaging components are a function of the component temperatures. They are based on actual maximum calculated temperatures or conservatively selected higher temperatures. Table 3-1 of Chapter Three summarizes significant temperatures calculated for the NUHOMS<sup>®</sup>-MP197 subjected to hot environment conditions. These temperatures are used to establish the allowable stress values for every normal and accident (except the thermal accident, which has higher temperatures) load combination evaluated in this Safety Analysis Report.

### 2.6.1.2 Maximum Pressure

The thermal analysis presented in Chapter Three also provides the average cavity gas temperature (276°F) under hot environment conditions. This value is used in Chapter Four (Containment) to determine the Maximum Normal Operating Pressure (MNOP). Calculation of MNOP includes cavity gas heating effects and the assumption that 1% of the fuel rods fail while in the loaded cask. The resulting calculated MNOP is 7.9 psig. For the purpose of the structural analysis of containment a value of 50 psig is conservatively assumed. Because of the thick walled construction of the NUHOMS<sup>®</sup>-MP197 containment vessel, this pressure loading provides a minimal contribution to calculated stress intensities. This pressure loading is analyzed using ANSYS as described in Appendix 2.10.1. The results using the 3D ANSYS model are reported in Tables 2.10.1-5 of Appendix 2.10.1.

### 2.6.1.3 Thermal Stresses

The thermal analysis of the NUHOMS<sup>®</sup>-MP197 Packaging, described in Chapter Three, is performed using a 3D ANSYS model. The temperature distribution from this analysis is used to perform an ANSYS structural thermal stress analysis of containment vessel with stress results reported at the standard locations shown in Figure 2-4. The stress results for this load case are reported in Table 2.10.1-7 of Appendix 2.10.1.

### 2.6.1.4 Containment Vessel Stresses - Hot Environment

Containment vessel stresses for the hot environment normal condition of transport are obtained from a combined load case (run # 13) as indicated in Table 2-10. For this condition it is assumed that the cask is in its normal transport configuration, mounted horizontally on the transport skid, and supported by the saddles and tie down straps. The combined loads included in the run are as follows:

- Bolt Preload
- Gravity (1G Down)
- 50 psig Internal pressure
- Thermal hot

The stress results for this load case are reported on Table 2.10.1-16 of Appendix 2.10.1.

## 2.6.2 Cold Environment

The Regulatory Guide 7.8 [6] cold environment load combination results in all cask components in thermal equilibrium at  $-40^{\circ}\text{F}$ . As with hot environment, for this condition it is assumed that the cask is in its normal transport configuration, mounted horizontally on the transport skid, and supported by the saddles and tie down straps. The combined loads included in the run are as follows:

- Bolt Preload
- Gravity (1G Down)
- 25 psig External Pressure
- $-40^{\circ}\text{F}$  Thermal Uniform

The stress results for this load case are reported on Table 2.10.1-17 of Appendix 2.10.1.

## 2.6.3 Reduced External Pressure

Containment vessel stresses for the 3.5 psia ambient normal condition of transport are obtained from a combined load case (run # 16) as indicated in Table 2-10. The conservatively assumed MNOP of 7.9 psig results in a net pressure loading of 19.1 psig ( $7.9 + 14.7 - 3.5$ ) (cask stresses are conservatively calculated based on 50 psi pressure). For this condition it is assumed that the cask is in its normal transport configuration, mounted horizontally on the transport skid, and supported by the saddles and tie down straps. The combined loads included in the run are as follows:

- Bolt Preload
- Gravity (1G Down)
- 50 psig Internal pressure
- $100^{\circ}\text{F}$  Thermal hot

The stress results for this load case are reported on Table 2.10.1-19 of Appendix 2.10.1.

## 2.6.4 Increased External Pressure

Containment vessel stresses for the 20 psia ambient normal condition of transport are obtained from a combined load case (run # 15) as indicated in Table 2-10. This load combination is similar to the cold environment load combination with the exception of the pressure loading. The conservatively assumed minimum cask cavity pressure of 0 psia results in a net external pressure loading of 20 psi (25 psi is conservatively used). For this condition, the cask is in the horizontal orientation mounted on the transport skid, and supported by the saddles and tie down straps. The combined loads included in the run are as follows:

- Bolt Preload
- Gravity (1G Down)
- 25 psig External Pressure
- $-20^{\circ}\text{F}$  Thermal Cold



The stress results for this load case are reported on Table 2.10.1-18 of Appendix 2.10.1.

### 2.6.5 Transport Shock Loading

#### Transport By Rail

The transport rail shock loading used to evaluate the NUHOMS<sup>®</sup>-MP197 cask are based on NUREG 766510 [24] which specifies a maximum inertia loading of 4.7G in each of the three x-y-z coordinate directions:

Vertical	4.7G
Longitudinal	4.7G
Lateral	4.7G

The resultant transverse load is  $(4.7^2 + 4.7^2)^{1/2} = 6.65 \text{ G}$

The stresses due to the transport rail shock load case are obtained from a combined load case (run #s 19 and 20) as indicated in Table 2-10. Table 2.10.1-22 lists the combined stresses under hot thermal conditions where the load combination is performed for the maximum temperature thermal stresses. Lid bolt pre-load, internal pressure, and the thermal effects are included.

In addition, Table 2.10.1-23 lists the combined stresses under  $-20^{\circ}\text{F}$  thermal conditions where the load combination is performed for the  $-20^{\circ}\text{F}$  thermal stresses. Lid bolt pre-load, external pressure, and the thermal effects are also included.

#### Transport By Truck

The transport truck shock loading used to evaluate the NUHOMS<sup>®</sup>-MP197 cask are based on truck bed accelerations in ANSI N14.23 [23] which are :

Vertical	3.5G
Longitudinal	2.3G
Lateral	1.6G

The resultant transverse load is  $(3.5^2 + 1.6^2)^{1/2} = 3.85 \text{ G}$

The truck shock loadings are less than the rail car shock loadings, therefore, the rail car shock loadings are used for structural analysis of the cask body.

## 2.6.6 Transport Vibration Loading

### Transport By Rail

The input loading conditions used to evaluate the NUHOMS<sup>®</sup>-MP197 cask for transport rail vibration are obtained from NUREG 766510. The peak inertia values used are:

Vertical	0.37G
Longitudinal	0.19G
Lateral	0.19G

The resultant transverse load is  $(0.37^2 + 0.19^2)^{1/2} = 0.416 \text{ G}$

The stresses due to the transport rail vibration load case are obtained from a combined load case (run # 17 And 18) as indicated in Table 2-10. Table 2.10.1-20 lists the combined stresses under hot thermal conditions where the load combination is performed for the maximum temperature thermal stresses. Lid bolt pre-load, internal pressure, and the thermal effects are included.

In addition, Table 2.10.1-21 lists the combined stresses under  $-20^{\circ}\text{F}$  thermal conditions where the load combination is performed for the  $-20^{\circ}\text{F}$  thermal stresses. Lid bolt pre-load, external pressure, and the thermal effects are included.

### Transport By Truck

The input loading conditions used to evaluate the NUHOMS<sup>®</sup>-MP197 cask for truck transport vibration are also obtained from truck bed accelerations in ANSI N14.23 [23]. The peak inertia values used are:

Vertical	0.60G
Longitudinal	0.30G
Lateral	0.30G

The resultant transverse load is  $(0.6^2 + 0.3^2)^{1/2} = 0.67 \text{ G}$

Since vibration accelerations are higher on a truck than on a rail car, the truck vibration loads are considered bounding. The maximum stress intensity generated by truck vibration is computed by extrapolating from the maximum stress intensity obtained in the railcar vibration load case. The truck vibration load is roughly 160% of the railcar vibration load. The maximum stress intensity in the NUHOMS<sup>®</sup>-MP197 cask due to railcar vibration is 7.06 ksi (Table 2.10.1-11, location 5). Therefore the maximum stress intensity in the NUHOMS<sup>®</sup>-MP197 cask due to truck vibration would be roughly 11.3 ksi, this stress is used for containment fatigue analysis.

### 2.6.7 Water Spray

All exterior surfaces of the NUHOMS<sup>®</sup>-MP197 cask body are metal and therefore not subject to soaking or structural degradation from water absorption. The water spray condition is therefore of no consequence to the NUHOMS<sup>®</sup>-MP197 cask body.

### 2.6.8 Free Drop

Two drop orientations are considered credible for the one-foot free drop normal condition of transport. The structural response of the NUHOMS<sup>®</sup>-MP197 cask body is evaluated for a one-foot end drop of the package on the bottom end, one foot end drop of the package on the lid end, and a one-foot side drop. The assessment of cask body stresses follows the same logic as that established in the previous sections. For the three drop cases, the evaluations are performed for both the high temperature environment and at the -20°F minimum transport temperature.

The load combinations performed to evaluate these drop events are indicated in Table 2-10. In all cases, bolt pre-load effects and fabrication stress are included. For the hot environment condition, thermal stress load, 50 psi internal pressure, and impact load cases are combined. For the cold environment evaluation, -20°F thermal stress, 25 psi external pressure, and impact load cases are combined.

Table 2.10.1-24 lists the combined stress intensities for the lid end drop under hot environment conditions. Table 2.10.1-25 lists the combined stress for the lid end drop under cold environment conditions

Table 2.10.1-26 lists the combined stress intensities for the bottom end drop under hot environment conditions. Table 2.10.1-27 lists the combined stress for the bottom end drop under cold environment conditions.

Table 2.10.1-28 lists the combined stress intensities for the side drop under hot environment conditions. Table 2.10.1-29 lists the combined stress for the side drop under cold environment conditions.

### 2.6.9 Corner Drop

This test does not apply to the NUHOMS<sup>®</sup>-MP197 Package since the package weight is in excess of 100 kg (220 lbs.).

### 2.6.10 Compression

This test does not apply to the NUHOMS<sup>®</sup>-MP197 Package since the package weight is in excess of 5,000 kg (11,000 lbs.).

### 2.6.11 Penetration

Due to lack of sensitive external protuberances, the one meter (40 in.) drop of a 13 pound steel cylinder of 1-1/4 inch diameter, with a hemispherical head, is of negligible consequence to the NUHOMS®-MP197 Package.

### 2.6.12 Fabrication Stresses

The NUHOMS®-MP197 cask is subjected to stresses during the lead pouring process and subsequent cool down. These stresses relax over time and do not add significantly to the cask stresses due to normal operating conditions.

The primary concern during lead pouring and cool down is buckling of the containment vessel. A detail evaluation of this event is shown in Section 2.10.1.5.

From the results of that analyses, it is concluded that the cask fabrication stresses due to the molten lead pouring process and subsequent freezing to room temperature are small. The differential contraction induced stresses, during the -40° F normal condition, are negligible. Further, the fabrication stresses remaining in the cask components at the time the cask will be used for transportation will be insignificant.

### 2.6.13 Lid Bolt Analysis

The lid bolts are analyzed for both normal and accident condition loadings in Appendix 2.10.2. The analysis is based on NUREG/CR-6007 [25]. The bolts are analyzed for the following normal and accident loading conditions: operating pre-load, gasket seating load, internal pressure, temperature changes, impact loads, and puncture loads.

The bolt preload is calculated to withstand the worst case load combination and to maintain a clamping (compressive) force on the closure joint, under both normal and accident conditions. Based upon the load combination results (see Appendix 2.10.2, Section 2.10.2.3), it is shown that a positive (compressive) load is maintained on the clamped joint for all load combinations. Therefore, in both normal and accident load cases, the maximum non-prying tensile force of 110,000 lb. from preload + temperature load is used for bolt stress calculations.

A summary of the calculated stresses is listed in the Appendix 2.10.2, Section 2.10.2.5. The calculations result in a maximum average tensile stress of 86.0 ksi, which is below the allowable tensile stress of 95.6 ksi. The maximum average shear stress in the bolts is due to torsion during pre-loading. This stress is 19.3 ksi, which is well below the allowable shear stress of 57.4 ksi. The maximum combined stress intensity due to tension plus shear plus bending is 121.5 ksi., which is also less than the maximum allowable stress intensity of 129.1 ksi.

The lid bolt fatigue analysis is also presented in Appendix 2.10.2. This analysis shows that the bolts should be replaced after approximately 85 shipments. This is primarily due to the pre-load stresses.

#### 2.6.14 Fatigue Analysis of the Containment Boundary

The purpose of the fatigue analysis is to show that the containment vessel stresses are within acceptable limits under normal transport conditions. This is done by determining the fatigue damage factor for each normal transport event at locations on the containment vessel with the highest stresses. The cumulative fatigue damage or usage factor for all of the events is conservatively determined by adding the fatigue usage factors for the individual events, assuming these maximum stress intensities occur at the same location.

The fatigue analysis is based on the procedure described in Regulatory Guide 7.6 and ASME Code Section III [7]. When determining the stress cycles, consideration is given to the superposition of individual loads which can occur together and produce a total stress intensity range greater than the stress intensity range of individual loads. Also, the maximum stress intensities for all individual loads are conservatively combined simultaneously. The following sequence of events was assumed for the fatigue evaluation. The fatigue evaluation is based on 1000 shipments.

1. Operating bolt preload
2. Test pressure
3. Road shock/vibration
4. Pressure and temperature fluctuations
5. 1 foot normal condition drop

##### Bolt Preload

Assuming that the bolt torque is applied twice every round trip, the number of preload cycle is two times the number trips  $2 \times 1,000$ , or 2,000 cycles.

The maximum stress intensity in the NUHOMS<sup>®</sup>-MP197 cask due to bolt preload is 4,310 psi (Table 2.10.1-4, location 5).

##### Test Pressure

The proof test is  $1.25 \times (\text{maximum design pressure, 50 psi.}) = 62.5 \text{ psi}$ , and will only be performed once. The test pressure loads are calculated using the pressure loads computed in Appendix 2.10.1, Table 2.10.1-5. Table 2.10.1-5 lists the stresses based on 50 psi internal pressure. The maximum stress occurs in the containment vessel is 4,940 psi, and occurs at location 5. Therefore, the maximum stress due to 62.5 psi test pressure is  $4,940 \times 1.25 = 6,175 \text{ psi}$ .

## Shock

The NUHOMS<sup>®</sup>-MP197 cask may be shipped either by truck or by railcar. ANSI N14.23 specifies a peak shock loading of 2.3 g longitudinal, 1.6g lateral, 3.5g vertical up, and 1.5g vertical down, for truck transport, while NUREG 766510 [24] specifies a peak shock loading of 4.7 gs in all directions for rail car transport. Consequently, only the inertial loading caused by a railcar shock is considered, since it is bounding.

Assume 1000 round trip shipments, averaging 3,000 miles each way. NUREG 766510 reports that there are roughly 9 shock cycles per 100 miles of rail car transport. Therefore the total number of cycles is 3,000 (miles) × 2 (round trip) × 1,000 (shipments) × 0.09 (Shocks per mile) = 540,000 cycles.

The maximum stress intensity in the NUHOMS<sup>®</sup>-MP197 cask due to railcar shock is 12,710 psi. (Table 2.10.1-10, location 1).

## Vibration

Since vibration accelerations are higher on a truck than on a rail car, the truck vibration loads are considered bounding. According to ANSI N14.23, the peak vibration load at the bed of a truck is 0.3g longitudinal, 0.3g transverse, and 0.6g vertical. The maximum stress intensity generated by truck vibration is computed by extrapolating from the maximum stress intensity obtained in the railcar vibration load case. The NUREG 766510 specifies a peak vibration loading of railcar is 0.19g longitudinal, 0.19g transverse, and 0.37g vertical. Therefore the truck vibration load is roughly 160% of the railcar vibration load. The maximum stress intensity in the NUHOMS<sup>®</sup>-MP197 cask due to railcar vibration is 7,060 psi. (Table 2.10.1-11). Therefore the maximum stress intensity in the NUHOMS<sup>®</sup>-MP197 cask due to truck vibration would be roughly 11,296 psi.

The transport vibration inertia loading assumed for the containment vessel stress analysis was obtained from NUREG 766510. Data from that reference indicates that the vibration loading occurs over a frequency range of 30-45 cps. Using the upper bound frequency of 45 cps and based on an average speed of 40 mph for the 2000 one-way trips, the total number of vibration cycles is:

$$n = 2,000 \text{ trips} \times (3,000 \text{ miles}/40 \text{ mph}) \times 3,600 \text{ sec/hr.} \times 45 \text{ cps} = 24.4 \times 10^9$$

## Pressure Fluctuations

Assuming the temperature cycle occurs once each one way shipment, the total number of temperature fluctuation cycles is 2,000.

The maximum stress intensity in the NUHOMS<sup>®</sup>-MP197 cask due to normal condition pressure loads is 4,940 psi. (Table 2.10.1-5, location 5)

## Temperature Fluctuations

Assuming the temperature cycle occurs once each one way shipment, the total number of temperature fluctuation cycles is 2,000.

The maximum stress intensity in the NUHOMS<sup>®</sup>-MP197 cask due to normal condition thermal loads occurs in the 100° F ambient load case, and is 17,190 psi. (2.10.1-7, location 20).

### 1 Foot Normal Condition Drop

Conservatively assume that the cask is dropped once per shipment, resulting in 1,000 normal condition drops.

The maximum stress intensity in the NUHOMS<sup>®</sup>-MP197 cask due to normal condition impact loads occurs in the 1 foot side drop load case, and is 24,160 psi. (Table 2.10.1-14, location 14).

### NUHOMS<sup>®</sup>-MP197 cask Fatigue Evaluation – Usage Factor Calculation

The following damage factors are computed based on the stresses and cyclic histories described above, and the fatigue curves shown in Figures I-9.2.1 and I-9.2.2 of ASME Section III Appendices. Since the model used for stress analysis of the NUHOMS<sup>®</sup>-MP197 cask includes detailed meshing of corners and bolt holes, the fatigue strength reduction factor,  $K_F$ , which accounts for stress concentrations, is already accounted for in the stresses reported above. However, for conservatism, a strength reduction factor of 2 is used. The value of the alternating stress,  $S_a$ , is determined as follows:

If one cycle goes from 0 to S.I:

$$S_a = S.I. \times K_F \times K_E / 2$$

If one cycle goes from -S.I. to S.I:

$$S_a = S.I. \times K_F \times K_E$$

Where,

$K_F$  = fatigue strength reduction factor, 2

$K_E$  = correction factor for modulus of elasticity.

The NUHOMS®-MP197 cask containment boundary is constructed from SA-240, Type XM-19, and SA-693, Type 630. The modulus of elasticity of SA-240, Type XM-19 is  $27.0 \times 10^6$  psi. @ 300° F, and the modulus of elasticity of SA-693, Type 630 is  $27.2 \times 10^6$  psi. @ 300° F. Therefore, the modulus of elasticity of SA-240, Type XM-19 is conservatively used, since it yields the higher value of  $K_E$ . Consequently,  $K_E = 28.3 \times 10^6 / 27.0 \times 10^6 = 1.0481$ .

Event	Stress Intensity (psi.)	S.I. $\times K_F \times K_E$ (psi.)	$S_e$ (psi.)	Cycles		Damage Factor $n/N$
				$n$	$N$	
Bolt Preload	4,310	9,035	4,518	2,000	$\infty^*$	0.00
Pressure Test	6,175	12,944	6,472	1,000	$\infty^*$	0.00
Pressure Fluctuations	4,940	10,356	10,356	2,000	$\infty^*$	0.00
Temperature Fluctuations	17,190	36,034	36,034	2,000	$2 \times 10^5$	0.01
Shock Load	12,710	26,644	26,644	540,000	$2 \times 10^6$	0.27
Vibration Load	11,296	23,680	23,680	$24.4 \times 10^9$	$\infty^*$	0.00
1 Foot Drop Impact Load	24,160	50,646	25,323	1,000	$7 \times 10^6$	0.00
$\Sigma$						0.28

\* The maximum stresses for these load cases occur in locations away from welds, and stresses in the weld locations are small. Therefore, Curve A in Figure I-9.2.2 is used.

The above table shows that the total damage factor is less than one. Therefore the fatigue effects on the NUHOMS®-MP197 containment vessel are acceptable.

A separate fatigue analysis of the lid bolts is presented in Appendix 2.10.2.



### 2.6.15 Summary of Normal Condition Cask Body Structural Analysis

The following table lists the highest stress intensities in the cask body and also identifies the load combination tables and locations where these maximum stresses occur. The stress limits based on the Section 2.1.2 structural design criteria are also listed in the table.

Comparison of the Maximum Stress Intensities with the Allowables  
(Cask Body)

Component	Maximum Stress Intensity (ksi)	Stress Category (ksi)	Stress Result Table	Allowable Stress Intensity <sup>(1)</sup> (ksi)
Lid	18.31	$P_m + P_b$	2.10.1-22 Location 2	$P_m = 46.7$
				$P_m + P_b = 70.05$
Upper Flange	27.99	$P_m + P_b$	2.10.1-29 Location 14	$P_m = 31.4$
				$P_m + P_b = 47.1$
Inner Shell	17.94	$P_m + P_b$	2.10.1-22 Location 10	$P_m = 31.4$
				$P_m + P_b = 47.1$
Outer Shell	18.43	$P_m + P_b$	2.10.1-29 Location 23	$P_m = 20.0$
				$P_m + P_b = 30.0$
Bottom	26.07	$P_m + P_b$	2.10.1-28 Location 30	$P_m = 31.4$
				$P_m + P_b = 47.1$

Note: 1. See Table 2-14 for cask body allowable stresses at different components.

From the analysis results presented in the above table, it can be shown that the normal loads will not result in any structural damage to the cask and that the containment function of the basket and fuel assembly will be maintained.

### 2.6.16 Structural Evaluation of the Basket/Canister under Normal Condition Loads

#### 2.6.16.1 Basket Stress Analysis

The loading conditions considered in the evaluation of the fuel basket consist of inertial loads resulting from normal inertial loading (1 foot drop), accident inertial loading (30 foot drop) and thermal loads. The inertial loads of significance for the basket analysis are those transverse to the cask and basket longitudinal axes, so that the loading from the fuel assemblies is applied normal to the basket plates and transferred to the cask wall by the basket.

To determine the structural adequacy of the basket plate in the NUHOMS®-61B BWR fuel assembly basket under a normal condition free drop, the basket is evaluated for a 30G end drop and a 30G side drop. The G loads and drop orientations used for the structural analysis of the basket are described in Appendix 2.10.8. The stress analysis of the basket due to inertial and thermal loads is described in detail in Appendix 2.10.3. The results of the analyses are summarized in the following table. Based on the results of these analyses, all the calculated stresses in the basket, rails, and hold down ring are within the allowable stress limits.

Therefore, the basket is structurally adequate and it will properly support and position the fuel assemblies under normal loading conditions.

**Summary of Basket Normal Condition Stress Analysis**

Drop Orientation	Component	Stress Category	Max. Stress Due to 1 foot drop (ksi)	Max. Thermal Stress (ksi)	Combined Stress (ksi)	Allowable Stress (ksi)
End Drop	Fuel Compartment & Outer Wrapper	$P_m$	2.7	-	2.7	16.40
		$P_m+P_b+Q$	2.7	12.95	15.65	49.20
	Plate Insert Weld	Shear	4.50	-	4.50	9.84
	Rail Stud	Shear	5.70	-	5.70	9.84
	Hold Down Ring	$P_m$	3.0	-	3.00	16.40
45° Side Drop	Basket	$P_m$	6.42	-	6.42	16.40
		$P_m+P_b$	22.72	-	22.72	24.60
		$P_m+P_b+Q$	29.85	12.95	42.80	49.20
	Rails	$P_m$	5.81	-	5.81	17.50
		$P_m+P_b$	19.19	-	19.19	26.25
		$P_m+P_b+Q$	22.22	1.76	23.98	52.50
60° Side Drop	Basket	$P_m$	8.14	-	8.14	16.40
		$P_m+P_b$	21.30	-	21.30	24.60
		$P_m+P_b+Q$	29.25	12.95	42.20	49.20
	Rails	$P_m$	9.49	-	9.49	17.50
		$P_m+P_b$	25.03	-	25.03	26.25
		$P_m+P_b+Q$	30.88	1.76	32.64	52.50
90° Side Drop	Basket	$P_m$	7.92	-	7.92	16.40
		$P_m+P_b$	13.75	-	13.75	24.60
		$P_m+P_b+Q$	13.75	8.80	22.55	49.20
	Rails	$P_m$	15.17	-	15.17	17.50
		$P_m+P_b$	26.11	-	26.11	26.25
		$P_m+P_b+Q$	26.11	1.76	27.87	52.50
180° Side Drop, Impact on support Rails	Basket	$P_m$	6.32	-	6.32	16.40
		$P_m+P_b$	11.98	-	11.98	24.60
		$P_m+P_b+Q$	11.98	8.80	20.78	49.20
	Rails	$P_m$	13.62	-	13.62	17.50
		$P_m+P_b$	18.24	-	18.24	26.25
		$P_m+P_b+Q$	18.24	1.76	20.00	52.50

## 2.6.16.2 Canister Stress Analysis

The loading conditions considered in the evaluation of the canister consist of inertial loads resulting from normal condition inertial loading (1 foot drop), accident condition inertial loading (30 foot drop), 50 psig internal /external pressures and thermal loads. The inertial loads of significance for the canister analysis are those transverse to the cask and canister longitudinal axes, so that the loadings from the fuel assemblies and basket are transferred to the cask wall by the canister.

To determine the structural adequacy of the canister in the NUHOMS®-MP197 cask during a normal condition free drop, the canister is evaluated for 30G end drop and 30G side drop. The G loads and drop orientations used for structural analysis of the basket are described in Appendix 2.10.8. The stress analysis of the canister is described in detail in Appendix 2.10.3. The results of the analyses are summarized in the following table. Based on the results of these analyses, all the calculated stresses in the canister are within the allowable stresses.

**Summary of Canister Normal Condition Stress Analysis**

Load Combination		Stress Category	Maximum Stress (ksi.)	Allowable Membrane Stress Intensity (ksi.)
30g Front End Drop	External Pressure, Cold Environment	$P_m + P_b$	9.2	18.7*
	Internal Pressure, Hot Environment	$P_m + P_b$	9.0	18.7*
30g Rear End Drop	External Pressure, Cold Environment	$P_m + P_b$	11.6	18.7*
	Internal Pressure, Hot Environment	$P_m + P_b$	10.3	18.7*
45° Azimuth 30g Side Drop	External Pressure, Cold Environment	$P_m$	6.2	18.7
	External Pressure, Cold Environment	$P_m + P_b$	15.1	28.1
	Internal Pressure, Hot Environment	$P_m$	11.4	18.7
	Internal Pressure, Hot Environment	$P_m + P_b$	20.4	28.1
60° Azimuth 30g Side Drop	External Pressure, Cold Environment	$P_m$	6.4	18.7
	External Pressure, Cold Environment	$P_m + P_b$	19.3	28.1
	Internal Pressure, Hot Environment	$P_m$	11.6	18.7
	Internal Pressure, Hot Environment	$P_m + P_b$	24.6	28.1
90° Azimuth 30g Side Drop	External Pressure, Cold Environment	$P_m$	6.6	18.7
	External Pressure, Cold Environment	$P_m + P_b$	12.4	28.1
	Internal Pressure, Hot Environment	$P_m$	11.8	18.7
	Internal Pressure, Hot Environment	$P_m + P_b$	17.7	28.1
180° Azimuth 30g Side Drop	External Pressure, Cold Environment	$P_m$	7.2	18.7
	External Pressure, Cold Environment	$P_m + P_b$	15.0	28.1
	Internal Pressure, Hot Environment	$P_m$	12.5	18.7
	Internal Pressure, Hot Environment	$P_m + P_b$	20.2	28.1

\*The stress intensities (membrane + bending) generated in the canister during the end drop events are conservatively compared with the membrane allowable stress,  $P_m$  for SA-240, Type 304.

## 2.7 HYPOTHETICAL ACCIDENT CONDITIONS

### Overview

This section describes the response of the NUHOMS<sup>®</sup>-MP197 package to the accident loading conditions specified by 10CFR71.73. The design criteria established for the NUHOMS<sup>®</sup>-MP197 Packaging for the hypothetical accident conditions are described in Section 2.1.2. These criteria are selected to ensure that the packaging performance standards specified by 10CFR71.51 are satisfied.

The presentation of the hypothetical accident condition analyses and results is accomplished in the same manner as that used for the normal condition analysis. Table 2-11 provides an overview of the performance evaluations presented in this section. The detailed analyses of the various packaging components under different loading conditions are presented in the Appendices to this Chapter. The limiting results for the specified hypothetical accident loading conditions are taken from the Appendices and summarized here along with a comparison made to the established design criteria. In all cases, the acceptability of the NUHOMS<sup>®</sup>-MP197 packaging design with respect to hypothetical accident loads is demonstrated.

Drop Testing of the 1/3 scale impact limiters and test body was performed. The results of the testing is presented in Appendix 2.10.9. In addition, an analytical evaluation of the impact limiters is also presented in Appendix 2.10.8. The test and analytical results presented in Appendix 2.10.9 and 2.10.8 are used to determine the g loads used in the cask and basket structural evaluations.

### Reporting Method for Containment Vessel Stresses

Appendix 2.10.1 provides the detailed description of the structural analyses of the NUHOMS<sup>®</sup>-MP197 cask body. That appendix describes the detailed ANSYS model used to analyze various applied loads. Due to the nonlinearities associated with contact elements, it is not possible to run the separate individual load cases and then combine the results by superposition. Rather, it's necessary to run each of the combined load cases independently and post process the results separately. Table 2-11 provides a matrix of the individual loads and how they are combined to determine the cask body stresses for the hypothetical accident conditions. The thermal stresses due to the hot and cold conditions are actually secondary stresses that could be evaluated using higher allowables than for primary stresses. They are conservatively added to the primary stresses, and the combined stresses are evaluated using the primary stress allowables. A total of 16 separate loading conditions (combined load cases) are executed.

The load combinations for accident conditions of transport were performed in Runs 27 - 42, as shown in Table 2-11. The stress results are presented in Table 2.10.1- 30 to 2.10.1- 45.

Figure 2-4 shows the selected locations on the cask body numbered 1 through 35 where stress results for these analyses are reported. Detailed stresses are available at as many locations as there are nodes in the finite element model. However, for practical considerations, the reporting of stress results is limited to those locations shown on Figures 2-4. These locations were

selected to be representative of the stress distribution in the cask body with special attention given to areas subject to high stresses. The maximum stress may occur at a different location for each individual load.

For the axisymmetric cases, the stress is constant around the circumference of the cask at each stress reporting location. The load cases, where there are significant differences in stress magnitudes at different orientations of the cask (usually contact side and side away from contact for a asymmetric impact loads), are reported in separate columns of the table.

### 2.7.1 30 Foot Free Drop

The response of the NUHOMS<sup>®</sup>-MP197 Packaging is evaluated for a free drop from a height of 30 feet onto an unyielding surface at various orientations. The inertial loading applied to the NUHOMS<sup>®</sup>-MP197 components is determined in the dynamic analysis presented in Appendix 2.10.8. The 30 foot drop is measured from the impact surface to the bottom of the impact limiter; the C.G. of the cask is much higher than 30 feet.

The stresses in the cask body are reported for the following drop orientations:

- End drop onto bottom end
- End drop onto lid end
- Side drop
- C. G. over corner drop on bottom end
- C. G. over corner drop on lid end
- 20° slap down impact on lid end
- 20° slap down impact on bottom end

#### 2.7.1.1 End Drop

The dynamic impact analysis of the NUHOMS<sup>®</sup>-MP197 packaging shows that the maximum expected inertia loading from the 30-foot end drop is 50 g's. Because of the symmetry of the cask and impact limiters, these values are applicable for both the bottom end drop and lid end drop.

The structural analysis of the cask body for these loading conditions was conservatively performed using an inertial loading of 75g. The load combinations performed to evaluate these drop events are indicated in Table 2-11. In all cases, bolt pre-load stresses are included. For the hot environment condition, 100° F thermal stress, 50 psi internal pressure, and impact load cases are combined. For the cold environment evaluation, -20°F thermal stress, 25 psi external pressure, and impact load cases are combined.

Table 2.10.1-30 lists the combined stress intensities for the bottom end drop under hot environment conditions. Table 2.10.1-31 lists the combined stress for the bottom end drop under -20°F cold environment conditions.

Table 2.10.1-32 lists the combined stress intensities for the lid end drop under hot environment conditions. Table 2.10.1-33 lists the combined stress for the lid end drop under -20°F cold environment conditions.

#### 2.7.1.2 Side Drop

The dynamic analysis of the 30-foot side drop provided a maximum expected inertial loading of 60 g (Appendix 2.10.8). The structural analysis of the cask body for this loading condition was conservatively performed using an inertial loading of 75g. The load combinations performed to evaluate these drop events are indicated in Table 2-11. In all cases, bolt pre-load stresses are included. For the hot environment condition, 100° F thermal stress, 50 psi internal pressure, and impact load cases are combined. For the cold environment evaluation, -20°F thermal stress, 25 psi external pressure, and impact load cases are combined.

Table 2.10.1-34 lists the combined stress intensities for the side drop (contact side and 90° away from contact side) under hot environment conditions.

Table 2.10.1-35 lists the combined stress intensities for the side drop (contact side and 90° away from contact side) under -20°F cold environment conditions.

#### 2.7.1.3 C.G. Over Corner Drop

The response of the NUHOMS®-MP197 package to the 30-foot corner drops was analyzed for impact on the bottom and lid ends. The analyses were performed using the ANSYS model described in Appendix 2.10.1. The C.G. over corner drop occurs at a drop angle of approximately 60°. That is, the longitudinal axis of the containment vessel is at an angle of 60° from the impact surface. The dynamic analysis (Appendix 2.10.8) of the 60° drop orientation calculated maximum inertia loadings of 34g (axial) along the cask longitudinal axis and 12g transverse to the longitudinal axis. The ANSYS analysis of the C.G. over corner drop was conservatively performed using a higher axial inertia loading of 45g and higher transverse inertia loading of 16g.

The load combinations performed to evaluate these two drop events are indicated in Table 2-11. In all cases, bolt pre-load stresses are included. For the hot environment condition, 100° F thermal stress, 50 psi internal pressure, and impact load cases are combined. For the cold environment evaluation, -20°F thermal stress, 25 psi external pressure, and impact load cases are combined.

Table 2.10.1-36 lists the combined stress intensities for the C.G. over corner bottom end drop (contact side and 90° away from contact side) under hot environment conditions. Table 2.10.1-37 also list the combined stress intensities for the C.G. over corner bottom end drop (contact side and 90° away from contact side) under hot environment conditions.

Table 2.10.1-38 lists the combined stress intensities for the C.G. over corner lid end drop (contact side and 90° away from contact side) under -20°F cold environment conditions. Table

2.10.1-39 lists the combined stress intensities for the C.G. over corner lid end drop (contact side and 90° away from contact side) under -20°F cold environment conditions.

#### 2.7.1.4 20° Slap Down Impact

The limiting oblique drop for the containment vessel occurs at a drop angle of 20°. Based on the dynamic impact analysis, this drop orientation is limiting because it results in the highest impact force and total inertial loads over the full length of the containment vessel. The 20° slap down impact has a maximum combined transverse inertia load of 133g ( $G_{\text{normal}} = 53$ ,  $G_{\text{rotational}} = 80$ ) at the package end which first contacts the target (Appendix 2.10.8). The simultaneous inertia load at the opposite end is 28g, and the average value which corresponds to that at the center of gravity is 53 g. The stress analysis of the cask body was performed using the ANSYS model as described in Appendix 2.10.1. The maximum normal and rotational accelerations are conservatively increased to 66G and 198G, respectively for the ANSYS analysis.

The load combinations performed to evaluate this drop event are indicated in Table 2-11. In all cases, bolt pre-load stresses are included. For the hot environment condition, 100° F thermal stress, 50 psi internal pressure, and impact load cases are combined. For the cold environment evaluation, -20°F thermal stress, the 25 psi external pressure, and impact load cases are combined.

Table 2.10.1-40 lists the combined stress intensities for the 20° oblique impact on lid end (contact side and 90° away from impact side) under hot environment conditions. Table 2.10.1-41 lists the combined stress intensities for the 20° oblique impact on lid end (contact side and 90° away from impact side) under -20°F cold environment conditions.

Table 2.10.1-42 lists the combined stress intensities for the 20° oblique impact on bottom end (contact side and 90° away from impact side) under hot environment conditions. Table 2.10.1-43 lists the combined stress intensities for the 20° oblique impact on bottom end (contact side and 90° away from impact side) under -20°F cold environment conditions.

#### 2.7.1.5 Lid Bolts

The lid bolts are analyzed for normal and accident condition loadings in Appendix 2.10.2. The analysis is based on NUREG/CR-6007 [25]. The bolts are analyzed for the following normal and accident conditions: operating pre-load, gasket seating load, internal pressure, temperature changes, impact loads, and puncture loads.

The bolt preload is calculated to withstand the worst case load combination and to maintain a clamping (compressive ) force on the closure joint, both under normal and accident conditions. Based upon the load combination results (see Appendix 2.10.2, Section 2.10.2.3), it is shown that a positive (compressive) load is maintained on the clamped joint for all load combinations. Therefore, in both normal and accident load cases, the maximum non-prying tensile force of 110,000 lbs from preload + temperature load is used for bolt stress calculations.

A summary of the calculated stresses is listed in Appendix 2.10.2, Section 2.10.2.5. The maximum average tensile stress is 86.0 ksi, which is below the allowable tensile stress of 115.5 ksi. The average shear stress in the bolts is due to torsion during pre-loading. This stress is 19.3 ksi, which is well below the allowable shear stress of 69.3 ksi.

**2.7.1.6 Impact Limiter Attachments**

The impact limiters must remain attached to the cask body before, during, and after each hypothetical accident drop condition.

The limiting loading condition for the impact limiter attachments is the secondary impact (slap-down) associated with the 20° slap down 30-foot drop. This loading condition applies the greatest overturning moment on to the impact limiter and cask body interface. Although this loading condition is not limiting with respect to any other cask component, an evaluation of the attachments is performed to demonstrate that the effected impact limiter remains in place to insulate the cask during the subsequent hypothetical thermal accident.

The analysis and results, summarized here, are provided in detail in Section 2.10.8.6 of Appendix 2.10.8.

The analysis concludes that the impact limiter attachment design is sufficiently strong to ensure that the impact limiters remain attached to the cask body during and following all hypothetical accident conditions.

**2.7.1.7 Cask Lead Slump analysis**

In the event of a cask drop, permanent deformation of the lead gamma shield may result for certain impact orientations. The lead gamma shield is supported by friction between the lead and cask shells, in addition to bearing at end of the lead column. In order to determine the amount of permanent lead slump for the postulated end drop, an elastic-plastic analysis is required. The detailed lead slump analysis using a finite element model is described in detail in Appendix 2.10.4.

The following table summarizes the lead slump cavity length for all four load combinations analyzed. Nodal displacement distributions for the four load combinations are shown Figures 2.10.4-3 through 2.10.4-6.

<b>Load Combination</b>	<b>Lead Slump Cavity Length</b>
75g Lid End Drop, Hot Environment	0 in.
75g Lid End Drop, Cold Environment	0.235 in.
75g Bottom End Drop, Hot Environment	0 in.
75g Bottom End Drop, Cold Environment	0.107 in.



The table above shows that the maximum longitudinal cavity length, caused by lead slump, is 0.235 inches, and occurs during the accident condition lid end drop, in the cold environment. The table above, as well as the displacement plots (Figures 2.10.4-3 through 2.10.4-6) also show that in the hot environment, differential thermal expansion between the lead shield and the structural shells precludes cavity formation during both lid and end drops. An upper bound lead slump of 3.5 inches is conservatively assumed for the post drop shielding evaluation in Chapter 5.

## 2.7.2 Puncture

An evaluation of the puncture drop event includes the local effects in the containment vessel at the impact point as well as the overall inertia loading on the packaging components.

### 2.7.2.1 Puncture Drop Impact on the Outer Cylindrical Shell

The impact limiters will protect the ends of the cask body from a 40-inch drop, onto a 6-inch diameter bar. Consequently, the most severe damage to the cask body, resulting from the puncture drop will occur on the outer cylindrical shell, between the impact limiters. Since this portion of the package is not the containment vessel, release of the contents cannot occur.

For this load condition it is conservatively assumed that the cask outer shell surface impacts the puncture bar directly (eliminated the neutron shield and stainless steel shield shell). The puncture bar as specified in 10CFR71, is a solid, vertical, cylindrical, mild steel bar, 6 inches in diameter.

#### Required Thickness

The required thickness,  $t_{req}$ , to preclude puncture is calculated using the Nelms[4] equation for lead backed shells, which is given by

$$t_{req} = \left[ \frac{W}{S_u} \right]^{0.71}$$

Where,  $W$  is the weight of the package (265,100 lb.),  $S_u$  is the ultimate strength of the outer shell material (73,680 psi @ 263° F)

$$t_{req} = \left[ \frac{265,100}{73,680} \right]^{0.71} = 2.48 \text{ in.}$$

The thickness of the outer shell is 2.5 in., which is greater than the required thickness computed above. Therefore, the outer shell will preclude penetration of the bar during the postulated puncture event. This analysis is conservative since the cask outer shell is protected by a neutron shield (4.5625" thick.) and a 3/16" thick stainless steel shield shell, so that the puncture bar will not directly impact the outer shell.

## Stress Analysis

The maximum force,  $F_p$ , acting on the outer shell due to impact on the puncture bar is:

$$F_p = \sigma_y A_b$$

Where  $\sigma_y$  is the yield strength of the bar, 45 ksi (typical yield strength of the mild steel, such as SA-36, is 36 ksi), and  $A_b$  is the cross sectional area of the 6 inch diameter bar, 28.27 in.<sup>2</sup>.

Therefore,

$$F_p = 1.272 \times 10^6 \text{ lb.}$$

This force produces a cask deceleration and induces a bending moment at the midsection of the cask. If the cask is considered a beam uniformly loaded (downward) by its inertial load and supported by the puncture bar at the center, the deceleration,  $g$ , caused by the puncture drop is then the following.

$$g = \frac{F_p}{W_{\text{package}}} = \frac{1.272 \times 10^6}{265,100} = 4.8$$

Here,  $W_{\text{package}}$  is the weight of the NUHOMS<sup>®</sup>-MP197 transport package. If the cask body is considered to be uniformly loaded and supported as described above, then the maximum moment,  $M$ , in the cask shell is:

$$M = \frac{F_p L}{8} = \frac{(1.272 \times 10^6)(208.0)}{8} = 3.307 \times 10^7 \text{ in. lb.}$$

Conservatively neglecting the inner shell, lead, neutron shield, and shield shell, the moment of inertia of the cask outer shell is:

$$I = \frac{\pi}{4} (r_o^4 - r_i^4) = \frac{\pi}{4} (41.00^4 - 38.50^4) = 4.938 \times 10^5 \text{ in.}^4$$

The shell bending stress is then:

$$\sigma_b = \frac{Mr_o}{I} = \frac{(3.307 \times 10^7)(41.00)}{4.938 \times 10^5} = 2,746 \text{ psi.}$$

Since the stress is nearly constant through the wall thickness, it should be treated as a membrane stress,  $P_m$ . The allowable stress for this accident condition is  $2.4S_m$  (smaller of  $0.7S_u$  or  $2.4S_m$ , Appendix F-1331.1) or  $2.4(20,000) = 48,000 \text{ psi}$  ( $S_m$  for SA-240 Type 316 = 20.0 ksi.

@ 263° F), which is well above  $\sigma_b$ .

The deceleration of 4.8 gs is small compared to the g-loads that will occur during the 30-foot free drop. Therefore, the global stresses that result from the inertial forces are bounded by those of

the 30-foot free drop event, and can be neglected in the load combinations. The bending stress of 2,746 psi at the center of the cask is also negligible compared to stresses due to other loads considered.

### 2.7.2.2 Puncture Drop Impacting the Lid End and Bottom Ram Port Cover

The impact limiters will protect the ends of the cask body from a 40-inch drop, onto a 6-inch diameter bar. However, for these load conditions it is conservatively assumed that the cask lid and bottom ram port cover outer surfaces impact the puncture bar directly. No credit is taken for the energy absorption provided by the impact limiter.

The stresses in the cask lid and bottom ram cover closure are evaluated using an 2D ANSYS finite element analysis of the containment vessel as described in Appendix 2.10.1 (Section 2.10.1.2). The elastic analysis was performed by applying static forces corresponding to a 6g inertial loading (actual g load is 4.8 as calculated in Section 2.7.2.1). The reaction force due to the puncture bar is applied to the center of the lid or bottom ram port cover in order to maximize the resulting bending stresses. Figures 2-5 and 2-6 illustrate the loading conditions. The results of the two puncture analysis cases are reported in the same manner as that used for the previously described containment vessel ANSYS analyses. Tables 2-12 and 2-13 list the stress intensities for the 40 inch puncture on the lid and ram port cover respectively. All the calculated stresses are less than the code allowables.

To investigate the seal status during the impact event, the contact elements at the seal location are examined. All contact elements located near the lid and bottom ram port cover seals remained closed for both puncture drop load cases. It is concluded that during the 40 inch puncture events, positive (compressive) loads are maintained at the lid closure and ram port cover seals.

### 2.7.2.3 Puncture Drop Impacting Other Penetration Covers

An evaluation of the local effects of a puncture impact on the remaining penetration ports was also performed. Following table summarizes the key parameters in this evaluation.

Penetration	Containment Boundary	Max. Diameter of Penetration
Vent Port (Lid)	Yes	3 in.
Test Port (Lid)	No	3 in.
Test Port (Bottom Ram Cover Closure)	No	3 in.
Drain Port (Bottom Plate)	Yes	3 in.

All the penetrations are protected by the impact limiters. The maximum diameter of the penetrations is 3 inches which is less than the 6 inch diameter puncture bar. Therefore the shear area available to resist the puncture bar loading includes the wall thickness of the outer shell at these locations. Since the penetrations are covered by the impact limiters, and the penetration diameters are smaller than the puncture bar diameter, the penetrations are sufficiently protected against a potential puncture impact.

### 2.7.3 Thermal

#### 2.7.3.1 Summary of Pressures and Temperatures

The analysis of the thermal accident is presented in Chapter Three. The maximum internal pressure during the thermal accident is calculated in Section 4.3. The calculated pressure is 1.64 atm, or 9.4 psig. However, the structural analysis is performed conservatively assuming a 50 psi internal pressure for the pressure stress calculations.

An ANSYS transient thermal analysis of the cask for the 30 minute thermal accident is reported in Chapter 3. The initial condition is steady state, at an ambient temperature of 100°F and maximum decay heat. The initial steady state condition is followed by a 0.5 hour severe thermal transient which is then followed by a cool-down period. The temperatures from the thermal analysis are reported in Chapter 3.

The temperature through the cross section of the cask, at the time of the maximum thermal gradient, is used for input to the cask model for thermal stress analysis.

#### 2.7.3.2 Thermal Stresses due to Fire Accident

The load combination performed to evaluate the fire accident event is indicated in Table 2-11. In this case, bolt preload effect and 50 psig internal pressure are also included. Table 2.10.1-45 of Appendix 2.10.1 lists the combined stress intensities for the fire accident condition.

### 2.7.4 Water Immersion

#### 2.7.4.1 Immersion - Fissile Material (Water Head of 3 feet, 1.3 psi External Pressure)

The criticality evaluation presented in Chapter 6.0 considers the effect of water in-leakage. Thus, the requirements of 10CFR71.73(c)(5) are met. The cask body stresses for this immersion condition (1.3 psi external pressure) is bounded by the immersion condition for all packages (water pressure of 290 psi) described in Section 2.7.4.3 below.

#### 2.7.4.2 Immersion - All Packages (Water Head of 50 feet, 21.7 psi External Pressure)

The immersion loading condition results in an external pressure applied to the cask body corresponding to a 50 foot head of water. Assuming a 0 psia cask cavity pressure, this results in a maximum external pressure loading of 36.4 psi (21.7 + 14.7). The cask body stresses for this immersion condition (36.4 psi external pressure) is enveloped by the immersion condition for all packages (water pressure of 290 psi) described in Section 2.7.4.3 below.

### 2.7.4.3 Immersion - All Packages (Water Pressure of 290 psi)

#### Stress Analysis

10CFR 71.61 requires that the package be subjected to an external water pressure of 290 psi for a period of not less than one hour without collapse, buckling, or inleakage of water. The load combination performed to evaluate this event is indicated in Table 2-11. In this case, bolt preload and  $-20^{\circ}\text{F}$  thermal stress effects are also included.

Table 2.10.1-44 of Appendix 2.10.1 lists the combined stress intensities for this accident event.

#### Buckling Analysis of the Inner Containment Vessel

Additional analysis is also performed to evaluate the inner cylindrical shell stability when subject to the 290 psi external pressure. Code Case N-284 [27] is used for calculating the buckling stress due to this load case.

The following table summarizes the code case N-284 buckling stress calculations.

Summary of Code Case N-284 Buckling Stress Calculations

Code Case N-284 Reference Paragraphs	Stress Calculations
Maximum Stress Intensity Based on 290 psi External Pressure + Thermal Cold	17.81 ksi
Factor of Safety (Para. 1400)	1.34
	23.87 ksi
Capacity Reduction Factor (Para. 1500)	0.8
Elastic Amplified Stress	29.83 ksi
Plastic Reduction Factor (Para. 1600)	1
Plastic Amplified Stress	29.83 ksi
Theoretical Buckling Stress (Para. 1712)	31.5 ksi
Analysis Result	29.83 ksi < 31.5 ksi

It is concluded that the containment vessel is adequate to withstand a 290 psi external pressure caused by immersion. The buckling pressure of the containment vessel is higher than 290 psi external pressure and thus there is no potential of buckling of the containment vessel structure.

Therefore, the NUHOMS<sup>®</sup>-MP197 cask satisfies all of the immersion requirements for a package that is used for shipment of radioactive materials.

### **2.7.5 Buckling Evaluation of the Containment Vessel due to Accident End Drop Loads**

Additional analysis is also performed to evaluate the inner cylindrical shell stability when subject to the 75g end drop impact loads. The impact loads are combined with thermal loads corresponding to a 100° F ambient environment and a -20° F ambient environment. The analysis is based on the methodology provided in ASME Code Case N-284-1 and the Collapse Load Analysis described in ASME B&PV Code Appendix F.

During a hypothetical accident condition end drop, permanent deformation of the lead gamma shield may occur. The lead gamma shield is supported by friction between the lead and cask shells, in addition to bearing at the end of the lead column. During fabrication, a small gap may develop between the lead gamma shield and the cask structural shells due to differential thermal expansion of the dissimilar materials during cooling after the lead pour. The gap between the lead and cask shells reduces the stresses in the cask shells during the postulated end drop, while maximizing the amount of permanent deformation in the lead column (i.e. lead slump). Therefore, for the purpose of analysis, the lead is conservatively assumed to be initially in contact with both the cask inner and structural shells.

A nonlinear finite element analysis is performed in order to evaluate the buckling capacity of the inner shell of the NUHOMS®-MP197 cask. A 2-dimensional axisymmetric ANSYS [21] finite element model is constructed for this purpose. The results of the finite element analysis provide both stresses and displacements generated during the end drop event. The resulting stress distribution is compared with the allowable buckling stresses in both the hoop and the axial directions as dictated by ASME Code CASE N-284-1. The resulting deformation is used to perform a collapse load analysis described in ASME B&PV Code Appendix F. The detail analysis is provided in Appendix 2.10.5.

The following table summarizes the maximum allowable collapse load and the maximum calculated and allowable hoop and axial stresses generated in the inner shell for all four load combinations analyzed.

Load Combination	Collapse Load	Stress Category	Maximum Stress (psi.)	Allowable Buckling Stress (psi.)
75g Lid End Drop, Hot Environment	>100 gs	Axial Stress	24,756	32,148
		Hoop Stress	10,677	18,796
75g Lid End Drop, Cold Environment	> 100 gs	Axial Stress	17,808	32,148
		Hoop Stress	5,386	18,796
75g Bottom End Drop, Hot Environment	>100 gs	Axial Stress	26,603	32,148
		Hoop Stress	12,594	18,796
75g Bottom End Drop, Cold Environment	>100 gs	Axial Stress	22,645	32,148
		Hoop Stress	15,934	18,796

### 2.7.6 Summary of Accident Condition cask body Structural Analysis

The following table lists the highest stress intensities in the cask body and also identifies the load combination tables and locations where these maximum stresses occur. Also listed in the tables are the stress limits based on the Section 2.1.2 structural design criteria.

#### Comparison of the Maximum Stress Intensities with the Allowables (Cask Body)

Component	Maximum Stress Intensity (ksi)	Stress Category (ksi)	Stress Result Table	Allowable Stress Intensity <sup>(1)</sup> (ksi)
Lid	107.8	$P_m = 9.36$ $P_m + P_b = 107.0$	2.10.1-38	$P_m = 98.0$
			Location 2	$P_m + P_b = 140.0$
Upper Flange	71.84	$P_m = 54.95$ $P_m + P_b = 71.84$	2.10.1-40	$P_m = 65.94$
			Location 6	$P_m + P_b = 94.2$
Inner Shell	30.23	$P_m + P_b = 30.23$	2.10.1-34	$P_m = 65.94$
			Location 20	$P_m + P_b = 94.2$
Outer Shell	37.9	$P_m + P_b = 37.9$	2.10.1-43	$P_m = 48.0$
			Location 23	$P_m + P_b = 72.0$
Bottom	63.19	$P_m + P_b = 63.19$	2.10.1-34	$P_m = 65.94$
			Location 30	$P_m + P_b = 94.2$

Note: 1. See Table 2-14 for cask body allowable stresses at different components.

From the analysis results presented in the above table, it can be shown that the accident loads will not result in any structural damage to the cask and that the containment function of the basket and fuel assembly will be maintained.

## 2.7.7 Structural Evaluation of the Basket/Canister Under Accident Loads.

### 2.7.7.1 Basket Stress analysis

To determine the structural adequacy of the basket plates in the NUHOMS®-61BT DSC fuel basket under the accident condition free drop, 75g end and side drop load cases are conservatively performed. The g loads and drop orientations used for the structural analysis of the basket are described in Appendix 2.10.8. The stress and buckling analysis of the basket due to inertial loading is described in detail in Appendix 2.10.3. The results of the stress analyses are summarized in the following table. Based on the results of these analyses, all the calculated stresses in the basket, rails, and hold down ring are within the allowable stress limits.

The basket is structurally adequate and will properly support and position the fuel assemblies under accident loading conditions.

#### Summary of Basket Accident Condition Stress Analysis

Drop Orientation	Component	Stress Category	Max. Stress Due to 1 foot drop (ksi)	Max. Thermal Stress (ksi)	Combined Stress (ksi)	Allowable Stress (ksi)
End Drop	Fuel Compartment & Outer Wrapper	$P_m$	6.75	-	6.75	44.38
		$P_m + P_b + Q$	6.75	12.95	19.70	57.06
	Plate Insert Weld	Shear	11.25	-	11.25	26.63
	Rail Stud	Shear	14.25	-	14.25	26.63
	Hold Down Ring	$P_m$	7.5	-	7.5	44.38
45° Side Drop	Basket	$P_m$	14.54	-	14.54	44.38
		$P_m + P_b$	27.12	-	27.12	57.06
		$P_m + P_b + Q$	27.12	12.95	40.07	57.06
	Rails	$P_m$	16.52	-	16.52	44.38
		$P_m + P_b$	25.27	-	25.27	57.06
		$P_m + P_b + Q$	25.27	1.76	27.03	57.06
60° Side Drop	Basket	$P_m$	14.43	-	14.43	44.38
		$P_m + P_b$	27.30	-	27.3	57.06
		$P_m + P_b + Q$	27.30	12.95	40.25	57.06
	Rails	$P_m$	20.85	-	20.85	44.38
		$P_m + P_b$	28.72	-	28.72	57.06
		$P_m + P_b + Q$	28.72	1.76	30.48	57.06
90° Side Drop	Basket	$P_m$	18.02	-	18.02	44.38
		$P_m + P_b$	22.78	-	22.78	57.06
		$P_m + P_b + Q$	22.78	12.95	35.73	57.06
	Rails	$P_m$	29.03	-	29.03	44.38
		$P_m + P_b$	32.79	-	32.79	57.06
		$P_m + P_b + Q$	32.79	1.76	34.55	57.06
180° Side Drop, Impact on support rails	Basket	$P_m$	17.18	-	17.18	44.38
		$P_m + P_b$	22.54	-	22.54	57.06
		$P_m + P_b + Q$	22.54	12.95	35.49	57.06
	Rails	$P_m$	19.01	-	19.01	44.38
		$P_m + P_b$	28.16	-	28.16	57.06
		$P_m + P_b + Q$	28.16	1.76	29.92	57.06



### 2.7.7.2 Canister Stress Analysis

The loading conditions considered in the evaluation of the canister consist of inertial loads resulting from a 30 foot accident conditions drop, 50 psig internal /external pressures and thermal loads. The inertial loads of significance for the canister analysis are those transverse to the cask and canister longitudinal axes, so that the loads from the fuel assemblies and basket are transferred to the cask wall by the canister.

To determine the structural adequacy of the NUHOMS<sup>®</sup>-61BT DSC in the NUHOMS<sup>®</sup>-MP197 cask under an accident condition free drop, the canister is evaluated for 75g end drop and 75g side drop. The g loads and drop orientations used for the structural analysis of the basket are described in Appendix 2.10.8. The stress and buckling analysis of the canister is described in detail in Appendix 2.10.3. The results of the analysis are summarized in the following table. Based on the results of the analysis, all of the calculated stresses in the canister are within the allowable stresses.

**Summary of Canister Accident Condition Stress Analysis**

Load Combination		Stress Category	Maximum Stress (ksi.)	Allowable Membrane Stress Intensity (ksi.)
75g Front End Drop	Hot Environment, Internal Pressure	$P_m + P_b$	13.6	44.8*
	Cold Environment, External Pressure	$P_m + P_b$	16.8	44.8*
75g Rear End Drop	Hot Environment, Internal Pressure	$P_m + P_b$	17.8	44.8*
	Cold Environment, External Pressure	$P_m + P_b$	17.0	44.8*
45° Azimuth 75g Side Drop	External Pressure, Cold Environment	$P_m$	7.2	44.8
		$P_m + P_b$	24.8	57.6
	Internal Pressure, Hot Environment	$P_m$	12.4	44.8
		$P_m + P_b$	30.0	57.6
60° Azimuth 75g Side Drop	External Pressure, Cold Environment	$P_m$	7.6	44.8
		$P_m + P_b$	24.7	57.6
	Internal Pressure, Hot Environment	$P_m$	12.9	44.8
		$P_m + P_b$	30.0	57.6
90° Azimuth 75g Side Drop	External Pressure, Cold Environment	$P_m$	8.3	44.8
		$P_m + P_b$	22.0	57.6
	Internal Pressure, Hot Environment	$P_m$	13.6	44.8
		$P_m + P_b$	27.2	57.6
180° Azimuth 75g Side Drop	External Pressure, Cold Environment	$P_m$	8.7	44.8
		$P_m + P_b$	24.9	57.6
	Internal Pressure, Hot Environment	$P_m$	13.9	44.8
		$P_m + P_b$	30.1	57.6

\*The stress intensities (membrane + bending) generated in the canister during the end drop events are conservatively compared with the membrane allowable stress,  $P_m$  for SA-240, Type 304.

## 2.8 SPECIAL FORM/FUEL RODS

### 2.8.1 Special Form

This section does not apply to the NUHOMS®-MP197 Packaging.

### 2.8.2 Fuel Rods

As discussed in Chapter 4, containment of the radioactive material is provided by the cask containment boundary. Analyses of the cask boundary for all normal conditions of transport and hypothetical conditions defined by the Part 71 Regulations demonstrate that the cask remains leak tight.

In addition, Appendix 2.10.7 of the SAR assesses the response of a typical BWR fuel assembly during 30 foot hypothetical end drop and 30 foot hypothetical side drop. Results from these analyses indicate that the lowest buckling load for GE fuel assemblies is about 95g, which is well above the 80g end drop and the maximum stress due to the side drop load is much less than the yield stress of the irradiated zicaloy tube. Therefore, the integrity of the fuel rods will not be breached during the normal and hypothetical accident loads.

## 2.9 REFERENCES

1. 10 CFR PART 71, Packaging and Transportation of Radioactive Material.
2. American National Standards Institute, ANSI N14.6, American National Standard for Special Lifting Devices for Shipping Containers Weighing 10,000 Pounds or More for Nuclear Materials, 1993.
3. American Society of Mechanical Engineers, ASME Boiler and Pressure Vessel Code, Section III, 1998 including 1999 addenda.
4. American Society of Mechanical Engineers, ASME Boiler and Pressure Vessel Code, Section III, Division 3, Subsection WB, 1998 including 1999 addenda.
5. USNRC Regulatory Guide 7.6, "Design Criteria for the Structural Analysis of Shipping Cask Containment Vessel", Rev. 1, March 1978.
6. USNRC Regulatory Guide 7.8, "Load Combinations for the Structural Analysis of Shipping Cask", Rev. 1, March 1989.
7. American Society of Mechanical Engineers, ASME Boiler and Pressure Vessel Code, Section III, Appendices, 1998 including 1999 addenda.
8. American Society of Mechanical Engineers, ASME Boiler and Pressure Vessel Code, Section V, 1998 including 1999 addenda.
9. American Society of Mechanical Engineers, ASME Boiler and Pressure Vessel Code, Section II, Part C and Part D, 1998 including 1999 addenda.
10. American Society of Mechanical Engineers, ASME Boiler and Pressure Vessel Code, Section IX, 1998 including 1999 addenda.
11. NUREG/CR-3854, "Fabrication Criteria for Shipping Container".
12. NUREG-1617, "Standard Review Plan for Transportation Packages for Spent Nuclear Fuel", March 1998, Draft.
13. Brooks and Perkins, Boral Product Performance Report 624.
14. Pacific Northwest Laboratory Annual Report - FY 1979, Spent Fuel and Fuel Pool Component Integrity, May, 1980.
15. H. H. Uhlig, Corrosion and Corrosion Control, 2nd ed., Wiley 1971.

16. G. Wranglen, An Introduction to Corrosion and Protection of Metals, Chapman and Hall, 1985, pp. 109-112.
17. A.J. McEvily, Jr., ed., Atlas of Stress Corrosion and Corrosion Fatigue Curves, ASM Int'l, 1995, p. 185.
18. Baratta, et al. Evaluation of Dimensional Stability and Corrosion Resistance of Borated Aluminum, Final Report submitted to Eagle-Picher Industries, Inc. by the Nuclear Engineering Department, Pennsylvania State University.
19. Hydrogen Generation Analysis Report for TN-68 Cask Materials, Test Report No. 61123-99N, Rev 0, Oct 23, 1998, National Technical Systems.
20. Machine Design, August 17, 1967, "Eccentrically Loaded Joints", Richard T. Berger.
21. ANSYS Engineering Analysis System, Users Manual for ANSYS Rev. 5.6, Swanson Analysis Systems, Inc., Houston, PA, 1995.
22. WRC Bulletin 107, March 1979 Revision "Local Stresses in Spherical and Cylindrical Shells Due to External Loadings."
23. ANSI N14.23, "Draft American National Standard Design Basis for Resistance to Shock and Vibration of Radioactive Material Packages Greater Than One Ton in Truck Transport", May, 1980.
24. NUREG 766510, "Shock and Vibration Environments for Large Shipping Containers on Rail Cars and Trucks", June, 1977.
25. NUREG/CR-6007 "Stress Analysis of Closure Bolts for Shipping Casks", By Mok, Fischer, and Hsu, Lawrence Livermore National Laboratory, 1992.
26. NUREG/CR-4554, "SCANS A Microcomputer Based Analysis System for shipping Cask Design review", April, 1989.
27. ASME Section III, Code Case No. N-284, "Metal Containment Shell Buckling Design Methods", 1998.
28. Transnuclear West letter 31-B9604-97-003 dated Dec 19, 1997 from Dave Dawson to Tim McGinty, NRC
29. AMS-R-83485, "Rubber, Fluorocarbon, Improved Performance at Low Temperatures"
30. Final Safety Analysis Report, rev 0, TN-68 Dry Storage Cask, Appendix 9A
31. Harper, Charles A., ed., "Handbook of Plastics and Elastomers," McGraw-Hill, 1975

## 2.10 APPENDICES

The detailed structural analyses of the NUHOMS<sup>®</sup>-MP197 packaging are included in the following appendices:

Appendix 2.10.1	NUHOMS <sup>®</sup> -MP197 Cask Body Structural Evaluation
Appendix 2.10.2	NUHOMS <sup>®</sup> -MP197 Cask Lid Bolt Analysis
Appendix 2.10.3	NUHOMS <sup>®</sup> -61BT DSC (Canister and Basket) Structural Evaluation
Appendix 2.10.4	NUHOMS <sup>®</sup> -MP197 Cask Lead Slump Analysis
Appendix 2.10.5	NUHOMS <sup>®</sup> -MP197 Cask Inner Containment Buckling Analysis
Appendix 2.10.6	Dynamic Amplification Factor Determination
Appendix 2.10.7	Evaluation of Fuel Assembly under Accident Impacts
Appendix 2.10.8	Structural Evaluation of the NUHOMS <sup>®</sup> -MP197 Package Impact Limiters
Appendix 2.10.9	NUHOMS <sup>®</sup> -MP197 Package Impact Limiter Testing
Appendix 2.10.10	NUHOMS <sup>®</sup> -MP197 Package Finite Element Analysis Details

## 2.11 ASME Code Exceptions

The cask containment boundary and the canister shell, the inner top plate, the inner bottom cover plate, the siphon vent block, and the siphon/vent port cover plate of the DSC are designed, fabricated and inspected in accordance with the ASME Code Subsections NB to the maximum practical extent. The basket is designed, fabricated and inspected in accordance with ASME Code Subsection NG to the maximum practical extent. Other cask components (such as the shield shell and neutron shielding) and canister components (such as outer bottom cover, top and bottom shield plugs) are not governed by the ASME Code.

### ASME Code Exceptions for the NUHOMS<sup>®</sup>-MP197 Cask Containment Boundary

Reference ASME Code Section/Article	Code Requirement	Exception, Justification & Compensatory Measures
NCA	All	Not compliant with NCA
NB-1100	Requirements for Code Stamping of Components	The NUHOMS <sup>®</sup> -MP197 cask containment boundary is designed & fabricated in accordance with the ASME Code, Section III, Subsection NB to the maximum extent practical. However, Code Stamping is not required. As Code Stamping is not required, the fabricator is not required to hold an ASME "N" or "NPT" stamp, or to be ASME Certified.
NB-1131	The design specification shall define the boundary of a component to which other components are attached.	A code design specification is not prepared for the NUHOMS <sup>®</sup> -MP197 cask. A TN design criteria is prepared in accordance with TN's QA program.
NB-2130	Material must be supplied by ASME approved material suppliers	Material is certified to meet all ASME Code criteria but is not eligible for certification or Code Stamping if a non-ASME fabricator is used. As the fabricator is not required to be ASME certified, material certification to NB-2130 is not possible. Material tractability & certification are maintained in accordance with TN's NRC approved QA program.
NB-4121	Material Certification by Certificate Holder	
NB-7000	Overpressure Protection	No overpressure protection is provided for the NUHOMS <sup>®</sup> -MP197 cask. The function of the NUHOMS <sup>®</sup> -MP197 cask is to contain radioactive materials under normal, off-normal, and hypothetical accident conditions postulated to occur during transportation. The NUHOMS <sup>®</sup> -MP197 cask is designed to withstand the maximum internal pressure considering 100% fuel rod failure at maximum accident temperature. The NUHOMS <sup>®</sup> -MP197 cask is pressure tested in accordance with the requirements of 10CFR71 and TN's approved QA program.
NB-8000	Requirements for nameplates, stamping & reports per NCA-8000	The NUHOMS <sup>®</sup> -MP197 cask nameplates provide the information required by 10CFR71 and 49CFR173 as appropriate. Code stamping is not required for the NUHOMS <sup>®</sup> -MP197 cask. QA Data packages are prepared in accordance with the requirements of 10CFR71 and TN's approved QA program.

**ASME Code Exceptions for the NUHOMS®-61BT Canister**

Reference ASME Code Section/Article	Code Requirement	Exception, Justification & Compensatory Measures
NCA	All	Not compliant with NCA
NB-1100	Requirements for Code Stamping of Components	The canister shell, the inner top cover plate, the inner bottom cover plate, the siphon vent block, and the siphon/vent port cover plate of the DSC are designed & fabricated in accordance with the ASME Code, Section III, Subsection NB to the maximum extent practical. However, Code Stamping is not required. As Code Stamping is not required, the fabricator is not required to hold an ASME "N" or "NPT" stamp, or to be ASME Certified.
NB-2130	Material must be supplied by ASME approved material suppliers	Material is certified to meet all ASME Code criteria but is not eligible for certification or Code Stamping if a non-ASME fabricator is used. As the fabricator is not required to be ASME certified, material certification to NB-2130 is not possible. Material traceability & certification are maintained in accordance with TN's NRC approved QA program.
NB-4121	Material Certification by Certificate Holder	
NB-4243 and NB-5230	Category C weld joints in vessels and similar weld joints in other components shall be full penetration joints. This welds shall be examined by UT or RT and either PT or MT	The joint between the top outer and inner cover plates and shell are design and fabricated per ASME Code Case N-595-1. The welds are partial penetration welds and the root and final layer are PT examined.
NB-5231	Full penetration corner weld joints require the fusion zone and the parent metal beneath the attachment surface to be UT after welding.	The inner bottom cover plate weld joint is full penetration per Fig. NB-4243-1. The required UT inspection is performed on a best effort basis. The joint is examined by RT and either PT or MT methods.
NB-6100 and 6200	All completed pressure retaining systems shall be pressure tested	The vent and siphon block is also not pressure tested due to the manufacturing sequence. The siphon block weld is helium leak tested when fuel is loaded and then covered with the outer top closure plate.
NB-7000	Overpressure Protection	No overpressure protection is provided for the NUHOMS®-61BT DSC. The function of the NUHOMS®-61BT DSC is to contain radioactive materials under normal, off-normal, and hypothetical accident conditions postulated to occur during transportation. The NUHOMS®-61BT DSC is designed to withstand the maximum internal pressure considering 100% fuel rod failure at maximum accident temperature. The NUHOMS®-61BT DSC is pressure tested in accordance with the requirements of 10CFR71 and TN's approved QA program.
NB-2531	Vent and siphon port covers; Straight Beam UT per SA-578 for all plates for vessels	SA-578 applies only to plates 3/8 inches and thicker. Allow alternate UT technique to achieve meaningful UT results.
NB-8000	Requirements for nameplates, stamping & reports per NCA-8000	The NUHOMS®-61BT DSC nameplates provide the information required by 10CFR71, 49CFR173, and 10CFR72 as appropriate. Code stamping is not required for the NUHOMS®-61BT DSC. QA Data packages are prepared in accordance with the requirements of 10CFR71, 10CFR72, and TN's approved QA program.

**ASME Code Exceptions for the NUHOMS®-61BT DSC Fuel Basket**

<b>Reference ASME Code Section/Article</b>	<b>Code Requirement</b>	<b>Exception, Justification &amp; Compensatory Measures</b>
NG-1100	Requirement for Code Stamping of Components	The NUHOMS®-61BT DSC baskets are designed & fabricated in accordance with the ASME Code, Section III, Subsection NG to the maximum extent practical as described in the SAR, but Code Stamping is not required. As Code Stamping is not required, the fabricator is not required to hold an ASME N or NPT stamp or be ASME Certified.
NG-2000	Use of ASME Material	Material is certified to meet all ASME Code criteria but is not eligible for certification or Code Stamping if a non-ASME fabricator is used. As the fabricator is not required to be ASME certified, material certification to NG-2130 is not possible. Material traceability & certification are maintained in accordance with TN's NRC approved QA program. The poison material and aluminum plates are not used for structural analysis, but to provide criticality control and heat transfer. They are not ASME Code Class I materials.
NCA	All	Not compliant with NCA as no code stamp is used.



**Table 2-1**  
**Evaluation Method Employed to Demonstrate Compliance With**  
**Specific Regulatory Requirements**

<b>10CFR71</b>		<b>Numerical Analysis</b>	<b>Material Test</b>	<b>Model Tests</b>
<b>Normal Condition</b>	Heat	X		
	Cold	X		
	Reduced External Pressure	X		
	Increased External Pressure	X		
	Shock and Vibration	X		
	One Foot Free drop	X		
<b>Accident Condition</b>	30 foot Free Drop-Cask and Basket	X		
	30 foot Free Drop- Impact Limiters	X	X	X
	Puncture	X		
	Thermal Event	X		
	Water Immersion	X		
<b>others</b>	Lifting	X		
	Tie-Down	X		

**Table 2-2**  
**Containment Vessel Stress Limits**

<b>CLASSIFICATION</b>	<b>STRESS INTENSITY LIMIT</b>
<b>Normal (Level A) Conditions<sup>(1)</sup></b>	
$P_m$	$S_m$
$P_l$	$1.5 S_m$
$(P_m \text{ or } P_l) + P_b$	$1.5 S_m$
Shear Stress	$0.6 S_m$
Bearing Stress	$S_y$
$(P_m \text{ or } P_l) + P_b + Q$	$3 S_m$
$(P_m \text{ or } P_l) + P_b + Q + F$	$S_a$
<b>Hypothetical Accident (Level D)<sup>(2)</sup></b>	
$P_m$	Smaller of $2.4 S_m$ or $0.7 S_u$
$P_l$	Smaller of $3.6 S_m$ or $S_u$
$(P_m \text{ or } P_l) + P_b$	Smaller of $3.6 S_m$ or $S_u$
Shear Stress	$0.42 S_u$

**Notes:**

1. Classifications and Stress Intensity Limits are as defined in ASME B&PV Code, Section III, Subsection NB.
2. Stress intensity limits are in accordance with ASME B&PV Code, Section III, Appendix F.

**Table 2-3**  
Containment Bolt Stress Limits <sup>(1)(5)</sup>

CLASSIFICATION	STRESS INTENSITY LIMIT
<b>Normal (Level A) Conditions <sup>(2)</sup></b>	
Average Tensile Stress	$2 S_m$
Maximum Combined Stress	$3 S_m$
Bearing Stress	$S_y$
<b>Hypothetical Accident (Level D) <sup>(3)</sup></b>	
Average Tensile Stress	Smaller of $S_y$ or $0.7 S_u$
Average Shear Stress	Smaller of $0.4 S_u$ or $0.6 S_y$
Maximum Combined Stress	$S_u$
Combined Shear & Tension	$R_t^2 + R_s^2 < 1^{(4)}$

**Notes:**

1. The stress analysis of the lid bolt is performed in accordance with NUREG/CR-6007 [25] described in Appendix 2.10.2. The stress limits for the lid bolt are listed separately in Tables 2.10.2-3 and 4.
2. Classification and stress limits are as defined in ASME B&PV Code, Section III, Subsection NB.
3. Stress limits are in accordance with ASME B&PV Code, Section III, Appendix F.
4.  $R_t$  : Ratio of average tensile stress to allowable average tensile stress  
 $R_s$  : Ratio of average shear stress to allowable average shear stress
5. All stresses include the effect of tensile and torsional loads due to bolt preloading.

**Table 2-4**  
**Basket Stress Limits**

CLASSIFICATION	STRESS INTENSITY LIMIT
<b>Normal (Level A) Conditions <sup>(1)</sup></b>	
$P_m$	$S_m$
$P_l$	$1.5 S_m$
$(P_m + P_l) + P_b$	$1.5 S_m$
$(P_m + P_l) + P_b + Q$	$3 S_m$
$(P_m + P_l) + P_b + Q + F$	$S_a$
Shear Stress	$0.6 S_m$
<b>Hypothetical Accident (Level D) <sup>(2)</sup></b>	
$P_m$	Smaller of $2.4 S_m$ or $0.7 S_u$
$P_l$	Smaller of $3.6 S_m$ or $S_u$
$(P_m + P_l) + P_b$	Smaller of $3.6 S_m$ or $S_u$
Shear Stress	$0.42 S_u$

**Notes:**

1. Classifications and stress intensity limits are as defined in ASME B&PV Code, Section III, Subsection NG.
2. Limits are in accordance with ASME B&PV Code, Section III, Appendix F.

**Table 2-5**  
**MECHANICAL MATERIAL PROPERTIES**  
(Data From ASME Code, section II, Part D, 1998 w/1999 Addenda)

Material	Class	Temp (F°)	S <sub>y</sub> (ksi)	S <sub>u</sub> (ksi)	S <sub>m</sub> (ksi)	E (10 <sup>6</sup> psi)	α <sub>m</sub> 10 <sup>-6</sup>
SA-540, Gr. B24, Cl. 1 (2 Ni-3/4Cr-1/3Mo)	Sec III, Class 1 (Bolt)	70	150.0	165.0	50.0	27.8	6.4
		200	143.4	165.0	47.8	27.1	6.7
		300	138.6	165.0	46.2	26.7	6.9
		400	134.4	165.0	44.8	26.1	7.1
		500	130.2	165.0	43.4	25.7	7.3
		600	124.2	165.0	41.4	25.2	7.4
		Ref. pg	510 <sup>(1)</sup>	See Note 2	422	606.1	580
SA-240 Gr. 316	Sec III, Class 1	70	30.9	75.0	20.0	28.3	8.5
		200	25.9	75.0	20.0	27.6	8.9
		300	23.4	72.9	20.0	27.0	9.2
		400	21.4	71.9	19.3	26.5	9.5
		500	20.0	71.8	18.0	25.8	9.7
		600	18.9	71.8	17.0	25.3	9.8
		Ref. pg	508	450	316	606.1	583
SA-240, Gr. 304 (18Cr-8 Ni)	Sec III, Class I	70	30	75.0	20.0	28.3	8.5
		200	25.0	71.0	20.0	27.6	8.9
		300	22.4	66.2	20.0	27.0	9.2
		400	20.7	64.0	18.7	26.5	9.5
		500	19.4	63.4	17.5	25.8	9.7
		600	18.4	63.4	16.4	25.3	9.8
		650	18.0	63.4	16.2	25.1	9.9
Ref. pg	520	453.4	330	606.1	583		
SA-240, Gr. XM-19 (22Cr-13 Ni-5Mn)	Sec III, Class I	70	55.0	100.0	33.3	28.3	8.2
		200	47.1	99.4	33.2	27.6	8.5
		300	43.3	94.2	31.4	27.0	8.8
		400	40.7	91.1	30.2	26.5	8.9
		500	38.8	89.1	29.7	25.8	9.1
		600	37.4	87.7	29.2	25.3	9.2
		Ref. pg	540	453.14	350	606.1	583
SA-693 Type 630 H1100 (17Cr-4 Ni-4Cu) or SA-705 Type 630 H1100	Sec III Class 1	70	115	140	46.7	28.5	5.89
		200	106.3	140	46.7	27.8	5.90
		300	101.8	140	46.7	27.2	5.90
		400	98.3	136.1	45.5	26.6	5.91
		500	95.2	133.4	44.4	26.1	5.91
		600	92.7	131.4	43.8	25.5	5.93
		650	91.5	130.1	43.5	25.2	5.93
		Ref. pg	492	442	300	606.1	590 <sup>(1)</sup>

**Table 2-5 (continued)**  
**Mechanical Properties of ASTM B-29 Chemical Lead**

ASTM B-29 Chemical Lead	Temp (°F)	Poisson's Ratio	Density (lbs/in <sup>3</sup> )	E (10 <sup>6</sup> psi)	$\alpha_m$ (10 <sup>-6</sup> )
	70	0.45	0.41	2.49	16.07
	100			2.35	16.21
	200			2.28	16.70
	250			2.13	16.95
	300			2.06	17.34
	See Note 3 Pg. 84	See Note 3 Pg. 84	See Note 4 Pg. 66	See Note 4 Pg. 56	

**Dynamic Stress-Strain Lead Properties<sup>(5)</sup>**

Strain (in/in)	Stress at Temperature (ksi)		
	100°F	230°F	300°F <sup>(6)</sup>
0.000485	1.14	1.06	1.00
0.03	2.2	2.0	1.70
0.10	3.3	2.8	2.38
0.30	4.9	3.2	2.72
0.50	5.6	3.6	3.06

**Notes:**

1. Data at elevated temperatures is not available in 1998 ASME Code with 1999 Addenda. Data is taken from 1995 ASME Code with 1997 Addenda.
2. Data at elevated temperatures is not available in 1998 ASME Code with 1999 Addenda. Data is taken from a material with a similar chemical composition (SA-479-316, 16Cr 12Ni 2Mo).
3. Cask Design Guide, ORNL-NSIC-68, February, 1970.
4. NUREG/CR-0481, An Assessment of Stress-Strain Data Suitable for Finite-Element Elastic-Plastic Analysis of Shipping Containers.
5. U.S. Energy Research and Development Administration, "A Survey of Strain Rate Effects for some Common structural Materials Used in Radioactive Material Packaging and transportation System," Battelle Columbus Laboratories, August, 1976.
6. By ratio: 0.85 × stress at 230°F.

**Table 2-6**  
**Reference Temperatures For**  
**Stress Analysis Acceptance Criteria<sup>(1)</sup>**

<b>Component</b>	<b>Max. Calculated Temperature, °F</b>	<b>Selected Design<sup>(2)</sup> Temperature, °F</b>
Outer Shell	275	300
Gamma Shield (Lead)	299	300
Inner Shell	302	300
Lid Bolts	199	300
Basket Rail	482	500
Basket	578	600
Canister	388	400
Front Trunnion	225	250
Front Trunnion Bolts	225	250
Rear Trunnion	230	250

Notes:

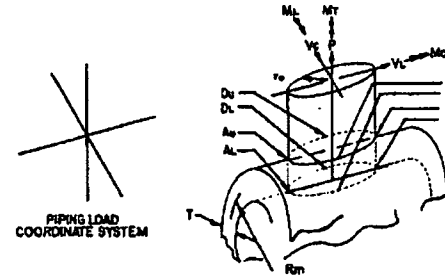
1. For normal loading conditions
2. Temperatures specified are used to determine allowable stresses. They are not a maximum use temperature for the material.

**Table 2-7**  
**Bijlaard Computation Sheet**

**1. APPLIED LOADS**  
 RADIAL LOAD  $P$  \_\_\_\_\_ LB.  
 CIRC. MOMENT  $M_c$  \_\_\_\_\_ IN-LB.  
 LONG. MOMENT  $M_L$  \_\_\_\_\_ IN-LB.  
 TORSION MOMENT  $M_T$  \_\_\_\_\_ IN-LB.  
 SHEAR LOAD  $V_c$  \_\_\_\_\_ LB.  
 SHEAR LOAD  $V_L$  \_\_\_\_\_ LB.

**2. GEOMETRY**  
 VESSEL THICKNESS  $T$  \_\_\_\_\_ IN.  
 ATTACHMENT RADIUS  $r_a$  \_\_\_\_\_ IN.  
 VESSEL RADIUS  $R_m$  \_\_\_\_\_ IN.

**3. GEOMETRIC PARAMETERS**  
 $\gamma = \frac{R_m}{T}$  \_\_\_\_\_  
 $\beta = (0.675) \frac{r_a}{R_m}$  \_\_\_\_\_



NOTE: ENTER ALL FORCE VALUES IN ACCORDANCE WITH SIGN CONVENTION

FROM FIG.	READ CURVES FOR	COMPUTE ABSOLUTE VALUES OF STRESS AND ENTER RESULT	STRESSES - IF LOAD IS OPPOSITE THAT SHOWN, REVERSE SIGNS SHOWN							
			$\sigma_{Au}$	$\sigma_{Al}$	$\sigma_{Bu}$	$\sigma_{Bl}$	$\sigma_{Cu}$	$\sigma_{Cl}$	$\sigma_{Du}$	$\sigma_{Dl}$
3C AND 4C	$\frac{N_s}{P/R_m}$	$\left(\frac{N_s}{P/R_m}\right) \cdot \frac{P}{R_m T}$	+	+	+	+	+	+	+	+
1C AND 2C-1	$\frac{M_c}{P}$	$\left(\frac{M_c}{P}\right) \cdot \frac{6P}{T}$	+	-	+	-	+	-	+	-
3A	$\frac{N_s}{M_c/R_m \beta}$	$\left(\frac{N_s}{M_c/R_m \beta}\right) \cdot \frac{M_c}{R_m \beta T}$					-	-	+	+
1A	$\frac{M_c}{M_c/R_m \beta}$	$\left(\frac{M_c}{M_c/R_m \beta}\right) \cdot \frac{6M_c}{R_m \beta T}$					-	+	+	-
3B	$\frac{M_L}{M_L/R_m \beta}$	$\left(\frac{M_L}{M_L/R_m \beta}\right) \cdot \frac{M_L}{R_m \beta T}$	-	-	+	+				
1B OR 1B-1	$\frac{M_T}{M_L/R_m \beta}$	$\left(\frac{M_T}{M_L/R_m \beta}\right) \cdot \frac{6M_L}{R_m \beta T}$	-	+	+	-				
ADD ALGEBRAICALLY FOR SUMMATION OF $\sigma$ STRESSES $\sigma_s$										
3C AND 4C	$\frac{N_s}{P/R_m}$	$\left(\frac{N_s}{P/R_m}\right) \cdot \frac{P}{R_m T}$	+	+	+	+	+	+	+	+
1C-1 AND 2C	$\frac{M_c}{P}$	$\left(\frac{M_c}{P}\right) \cdot \frac{6P}{T}$	+	-	+	-	+	-	+	-
4A	$\frac{N_s}{M_c/R_m \beta}$	$\left(\frac{N_s}{M_c/R_m \beta}\right) \cdot \frac{M_c}{R_m \beta T}$					-	-	+	+
2A	$\frac{M_c}{M_c/R_m \beta}$	$\left(\frac{M_c}{M_c/R_m \beta}\right) \cdot \frac{6M_c}{R_m \beta T}$					-	+	+	-
4B	$\frac{M_L}{M_L/R_m \beta}$	$\left(\frac{M_L}{M_L/R_m \beta}\right) \cdot \frac{M_L}{R_m \beta T}$	-	-	+	+				
2B OR 2B-1	$\frac{M_T}{M_L/R_m \beta}$	$\left(\frac{M_T}{M_L/R_m \beta}\right) \cdot \frac{6M_L}{R_m \beta T}$	-	+	+	-				
ADD ALGEBRAICALLY FOR SUMMATION OF $\sigma_x$ STRESSES $\sigma_x$										
SHEAR STRESS DUE TO TORSION $M_T$		$T \tau_x = T \tau_y = \frac{M_T}{2R_m T}$	+	+	+	+	+	+	+	+
SHEAR STRESS DUE TO LOAD $V_c$		$T \tau_y = \frac{V_c}{R_m T}$	+	+	-	-				
SHEAR STRESS DUE TO LOAD $V_L$		$T \tau_x = \frac{V_L}{R_m T}$					+	+	-	-
ADD ALGEBRAICALLY FOR SUMMATION OF SHEAR STRESSES $\tau$										

PRESSURE STRESS LONGITUDINAL BENDING STRESS TOTAL MEMBRANE STRESS TOTAL SURFACE STRESS	PR-0.6PT 2ET	LONGITUDINAL $\sigma_x$ _____ _____ _____ _____	PR-0.6PT ET	CIRCUMFERENTIAL $\sigma_\theta$ _____ _____ _____ _____	NOZZLE NO. _____ PIPING LOAD CODE _____ ANALYSIS POINT _____	COMPUTATION SHEET FOR LOCAL STRESSES IN CYLINDRICAL SHELLS _____ _____ _____ _____
---	-----------------	---	----------------	---	--	---



**Table 2-8**  
**NUHOMS<sup>®</sup>-MP197 Package Performance Evaluation Overview**  
**(Normal Conditions of Transport)**

<b>Loading Condition</b>	<b>SAR Section</b>	<b>Scope of Evaluation</b>
Heat 71.71(c)(1)	2.6.1.1	Maximum component temperatures for material allowables
	2.6.1.2	Cask cavity maximum pressure, 50 psi
	2.6.1.3	Cask body thermal gradients
	2.6.1.4	Cask body stresses due to hot environment load combinations
Cold 71.71(c)(2)	2.6.2	Cask body stresses due to cold environment load combinations
Reduced External pressure 71.71(c)(3)	2.6.3	Cask body stresses due to 50 psi internal pressure load combinations
Increase External Pressure 71.71(c)(4)	2.6.4	Cask body stresses due to 25 psi external pressure load combinations
Shock Loads 71.71(c)(5)	2.6.5	Cask body stresses due to truck shock loads
		Cask body stresses due to rail shock loads
Vibration Loads 71.71(c)(5)	2.6.6	Cask body stresses due to truck vibration loads
		Cask body stresses due to rail vibration loads
Water Spray 71.71(c)(6)	2.6.7	Negligible for NUHOMS <sup>®</sup> -MP197 cask
Free Drop 71.71(c)(7)	2.6.8	Cask body stresses due to 1 foot bottom end drop
		Cask body stresses due to 1 foot lid end drop
		Cask body stresses due to 1 foot side drop
Corner Drop 71.71(c)(8)	2.6.9	Not applicable
Compression 71.71(c)(9)	2.6.10	Not applicable
Penetration 71.71(c)(10)	2.6.11	Not applicable
Fabrication Stress	2.6.12	Discuss the cask stresses during the lead pouring process and subsequent cool down
Lid Bolt Analysis	2.6.13	Bolt stresses due to preload, pressure loads, temperature, impact and puncture loads
Fatigue Analysis of Containment Vessel	2.6.14	Fatigue evaluation of containment vessel due to lifting, pressure, temperature, shock/vibration, and 1 foot drop loads
Summary of Normal Condition Cask Analysis	2.6.15	Lists the highest stress intensities in the containment vessel and gamma shield and compares results with the allowables
Basket/canister Evaluation	2.6.16	Structural analysis of the basket/canister due to 1 foot end drop and 1 foot side drop loads

**Table 2-9**  
**Individual Load Conditions<sup>(1)</sup>**

<b>Run No.</b>	<b>Applicable Individual Loads</b>	<b>Load Used in Run</b>	<b>Stress Result Tables</b>
1	Bolt preload	-	2.10.1-4
2	Internal pressure	50 psig	2.10.1-5
3	External pressure	25 psig	2.10.1-6
4	Thermal stresses at hot environment	-	2.10.1-7
5	Thermal stresses at -20° F cold environment	-	2.10.1-8
6	3G lifting	3G	2.10.1-9
7	Rail Car Shock loads	4.7G - all directions	2.10.1-10
8	Rail car vibration loads	0.37G - vertical 0.19G -lateral 0.19G - longitudinal	2.10.1-11
9	1 foot end drop on lid end	30 G	2.10.1-12
10	1 foot end drop on bottom end	30 G	2.10.1-13
11	1 foot side drop	30 G	2.10.1-14
12	1G gravity loading	1 G	2.10.1-15

Note:

1. Bolt Preload is included in all individual load cases.

**Table 2-10**  
**Summary of Load Combinations for Normal Condition of Transport**

Run No.	Load Combination	Applicable Individual Loads Applied in the ANSYS Model									
		Bolt Pre-load	Gravity 1g	Int. Pres.	Ext. Pres.	Thermal Hot	Thermal Cold	Thermal -40°F Uniform	Rail Car Vib.	Rail Car shock	Stress Result Table
13	Hot Environment (100° F amb.)	x	x	x		x					2.10.1-16
14	Cold Environment (-40° F amb.)	x	x		x			x			2.10.1-17
15	Increased External Pressure	x	x		x		x				2.10.1-18
16	Min. External Pressure	x	x	x		x					2.10.1-19
17	Rail Car Vibration	x		x		x			x		2.10.1-20
18		x			x		x		x		2.10.1-21
19	Rail Car Shock	x		x		x				x	2.10.1-22
20		x			x		x			x	2.10.1-23

Run No.	Load Combination	Applicable Individual Loads Applied in the ANSYS Model								
		Bolt Pre-load	Internal Pres. (50 psi)	External Pres. (25 psi)	Thermal Hot	Thermal Cold	Lid End Drop	Bottom End Drop	Side drop	Stress Result Table
21	1 Ft End Drop on Lid End	x	x		x		x			2.10.1-24
22		x		x		x	x			2.10.1-25
23	1 Ft End Drop on Bottom End	x	x		x			x		2.10.1-26
24		x		x		x		x		2.10.1-27
25	1 Ft Side Drop	x	x		x				x	2.10.1-28
26		x		x		x			x	2.10.1-29

**Table 2-11**  
**Summary of Load Combinations for Accident Condition of Transport**

Run No.	Load Combination	Applicable Individual Loads Applied in the ANSYS Model								
		Bolt Pre-Load	Int. Pres. (50 psi)	Ext. Pres. (25 psi)	Thermal Hot	Thermal Cold	Lid End Drop	Bot. End Drop	Side Drop	Stress Result Table
27	30 Ft. End Drop on Bottom End	x	x		x			x		2.10.1-30
28		x		x		x		x		2.10.1-31
29	30 Ft. End Drop on Lid End	x	x		x		x			2.10.1-32
30		x		x		x	x			2.10.1-33
31	30 Ft. Side Drop	x	x		x				x	2.10.1-34
32		x		x		x			x	2.10.1-35

Run No.	Load Combination	Applicable Individual Loads Applied in the ANSYS Model								
		Bolt Pre-Load	Int. Pres. (50 psi)	Ext. Pres. (25 psi)	Thermal Hot	Thermal Cold	Corner Drop Lid End	Corner Drop Bot End	Oblique Drop Lid End	Stress Result Table
33	30 Ft. CG Over Corner Drop on Bottom End	x	x		x			x		2.10.1-36
34		x		x		x		x		2.10.1-37
35	30 Ft. CG Over Corner Drop on Lid End	x	x		x		x			2.10.1-38
36		x		x		x	x			2.10.1-39
37	30 Ft. 20° Oblique Impact on Lid End	x	x		x				x	2.10.1-40
38		x		x		x			x	2.10.1-41

**Table 2-11(continued)**  
**Summary of Load Combinations for Accident Condition of Transport (continued)**

Run No.	Load Combination	Applicable Individual Loads Applied in the ANSYS Model							
		Bolt Pre-load	Int. Pres. (50 psi)	Ext. Pres. (25 psi)	Thermal Hot	Thermal Cold	Oblique Drop Lid End	Oblique Drop Bottom End	Stress Result Table
39	30 Ft. 20° Oblique Impact on Bottom End	x	x		x			x	2.10.1-42
40		x		x		x		x	2.10.1-43

Run No.	Load Combination	Applicable Individual Loads Applied in the ANSYS Model								
		Bolt Pre-load	Int. Pres. (50 psi)	Ext. Pres. (25 psi)	Thermal Hot	Thermal Cold	Immersion Ext. Pres. (290 psi)	Fire	Oblique Drop Bottom End	Stress Result Table
41	Immersion (290 psi)	x				x	x			2.10.1-44
42	Fire Accident	x	x					x		2.10.1-45

**Table 2-12**  
**40 in. Puncture on Lid End**

<b>Component</b>	<b>location</b>	<b>Max Stress Intensity <math>P_m + P_b</math> (ksi)</b>	<b>Allowable Membrane Stress Intensity (ksi)</b>
<b>Lid</b>	1	94.37	98.00
	2	82.08	98.00
	3	15.32	98.00
	4	19.54	98.00
<b>Upper Cask Wall</b>	5	2.71	65.94
	6	0.72	65.94
	7	17.84	65.94
	8	16.89	65.94
	9	9.58	65.94
	10	4.85	65.94
	11	2.42	65.94
	12	3.01	65.94
	13	5.12	65.94
	14	6.12	65.94
<b>Upper Trunnion</b>	15	8.62	65.94
	16	8.71	65.94
	17	8.01	65.94
	18	6.93	48.00
<b>Mid Cask Wall</b>	19	8.41	48.00
	20	16.70	65.94
	21	14.38	65.94
	22	9.81	48.00
	23	13.82	48.00
<b>Lower Trunnion</b>	24	10.81	65.94
	25	9.43	65.94
	26	7.58	48.00
<b>Lower Cask wall</b>	27	10.05	48.00
	28	6.61	65.94
	29	7.44	65.94
	30	7.03	65.94
<b>Base</b>	31	3.00	65.94
	32	2.68	65.94
	33	2.94	65.94
	34	3.12	65.94
	35	3.53	65.94

**Table 2-13**  
**40 in. Puncture on Bottom Ram Port Cover**

Component	location	Max Stress Intensity $P_m + P_b$ (ksi)	Allowable Membrane Stress Intensity (ksi)
Lid	1	3.37	98.00
	2	3.76	98.00
	3	2.59	98.00
	4	3.40	98.00
Upper Cask Wall	5	5.64	65.94
	6	3.57	65.94
	7	5.61	65.94
	8	6.40	65.94
	9	16.00	65.94
	10	5.83	65.94
	11	4.72	65.94
	12	8.43	65.94
	13	7.82	65.94
	14	3.74	65.94
	15	3.27	65.94
Upper Trunnion	16	8.17	65.94
	17	7.40	65.94
	18	6.75	48.00
Mid Cask Wall	19	8.29	48.00
	20	16.67	65.94
	21	14.35	65.94
	22	9.77	48.00
Lower Trunnion	23	13.78	48.00
	24	11.45	65.94
	25	9.98	65.94
	26	7.72	48.00
Lower Cask wall	27	10.18	48.00
	28	10.38	65.94
	29	4.68	65.94
	30	6.83	65.94
Base	31	10.19	65.94
	32	15.07	65.94
	33	10.58	65.94
	34	38.67	65.94
	35	55.59**	65.94

\*\* High stress is observed radially inward of location 35 ( $\approx 2.75$  in., see Figure 2-4). The stress across that section is linearized, the max.  $P_m$  is 50.12 ksi ( $< 65.94$  ksi, membrane allowable) and  $P_m + P_b$  is 90.39 ksi ( $< 94.2$  ksi, membrane + bending allowable).

Table 2-14  
 NUHOMS<sup>®</sup>-MP197 Cask Body Allowable Stress  
 (See Figure 2-4 for Stress Report Locations )

Normal Conditions  
 (Based on Temperature at 300°F)

Component	Material	Allowable Stress (ksi)	
		$P_m$ ( $S_m$ )	$P_m + P_b$ ( $1.5 S_m$ )
Lid	SA-693, Type 630	46.7	70.05
Flange, Bottom Cover & Ram Plate, Inner Shell, Bearing Block & Tie Bar & Pad Plate	SA-240 Gr. XM-19	31.4	47.1
Outer Shell	SA-240 Type 316	20.0	30.0

Accident Conditions  
 (Based on Temperature at 300°F)

Component	Material	Allowable Stress (ksi)	
		$P_m$ (Smaller of $2.4 S_m$ or $0.7 S_u$ )	$P_m + P_b$ Smaller of $3.6 S_m$ or $S_u$ )
Lid	SA-693, Type 630	98	140
Flange, Bottom Cover & Ram Plate, Inner Shell, Bearing Block & Tie Bar & Pad Plate	SA-240 Gr. XM-19	65.94	94.2
Outer Shell	SA-240 Gr. 316	48.0	72.0



Figure 2-1  
Effect of pH on Corrosion of Iron in Aerated Soft Water, Room Temperature

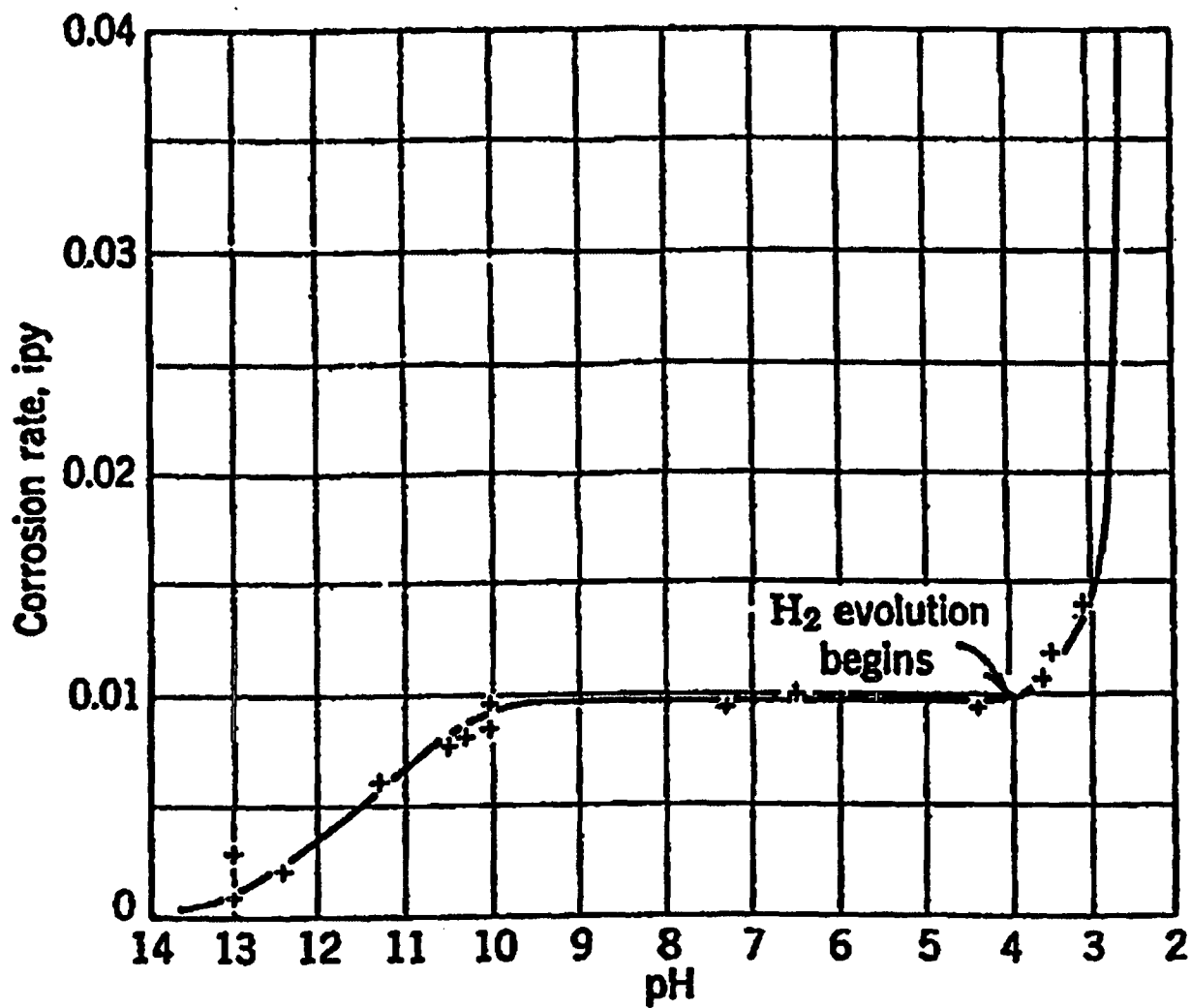
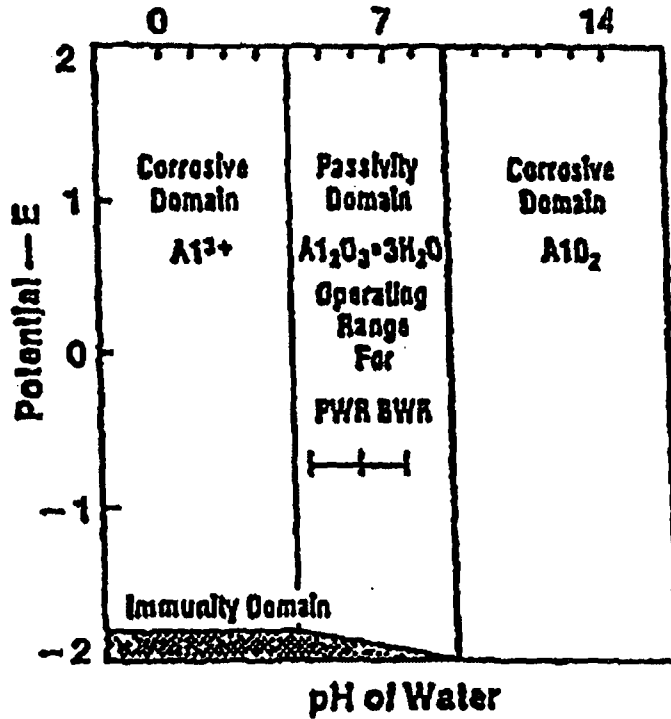


Figure 2-2  
 Potential versus pH Diagram for Aluminum-Water System

At 25°C (77°F):



At 60°C (140°F):

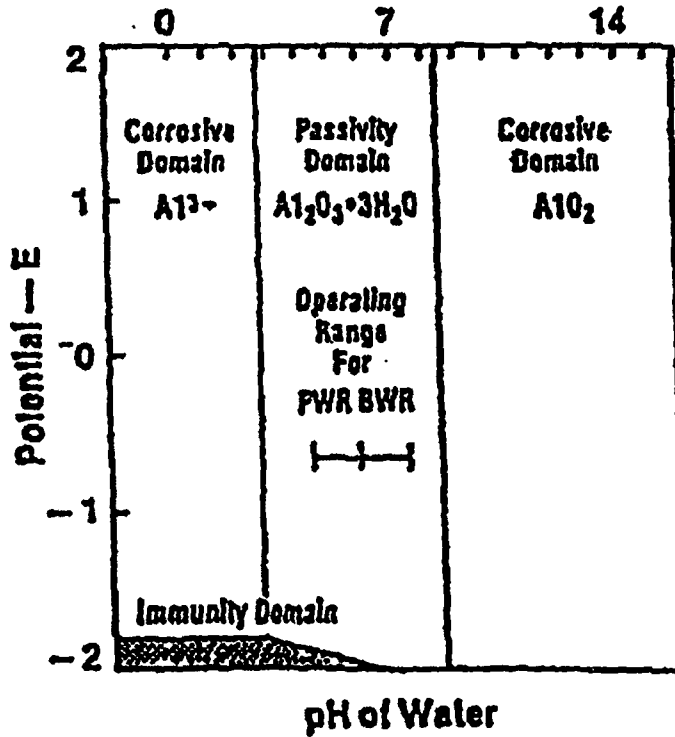
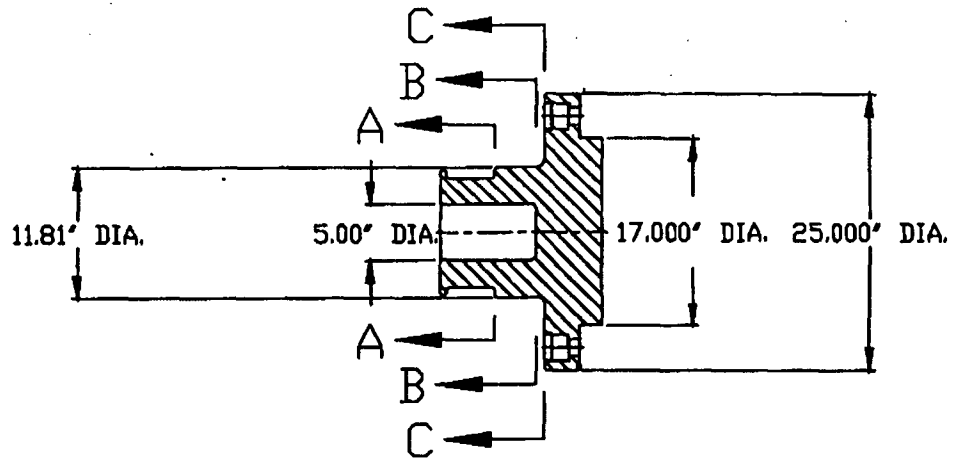
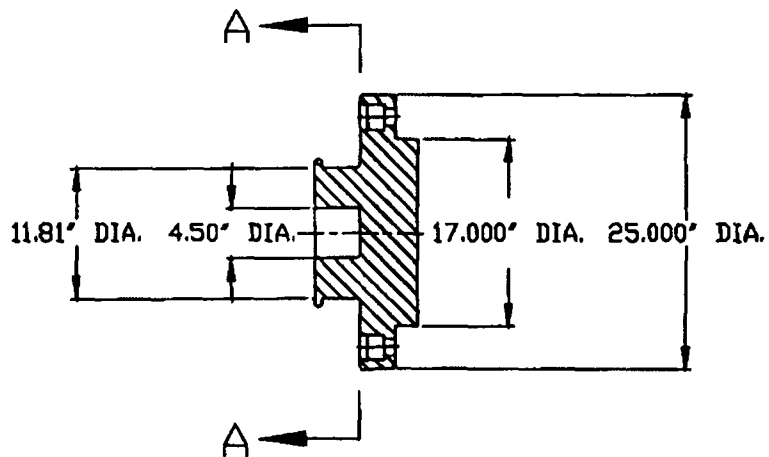


Figure 2-3  
Trunnion Geometry



DOUBLE SHOULDER FRONT TRUNNION



SINGLE SHOULDER FRONT TRUNNION

Figure 2-4  
Standard Stress Report Locations

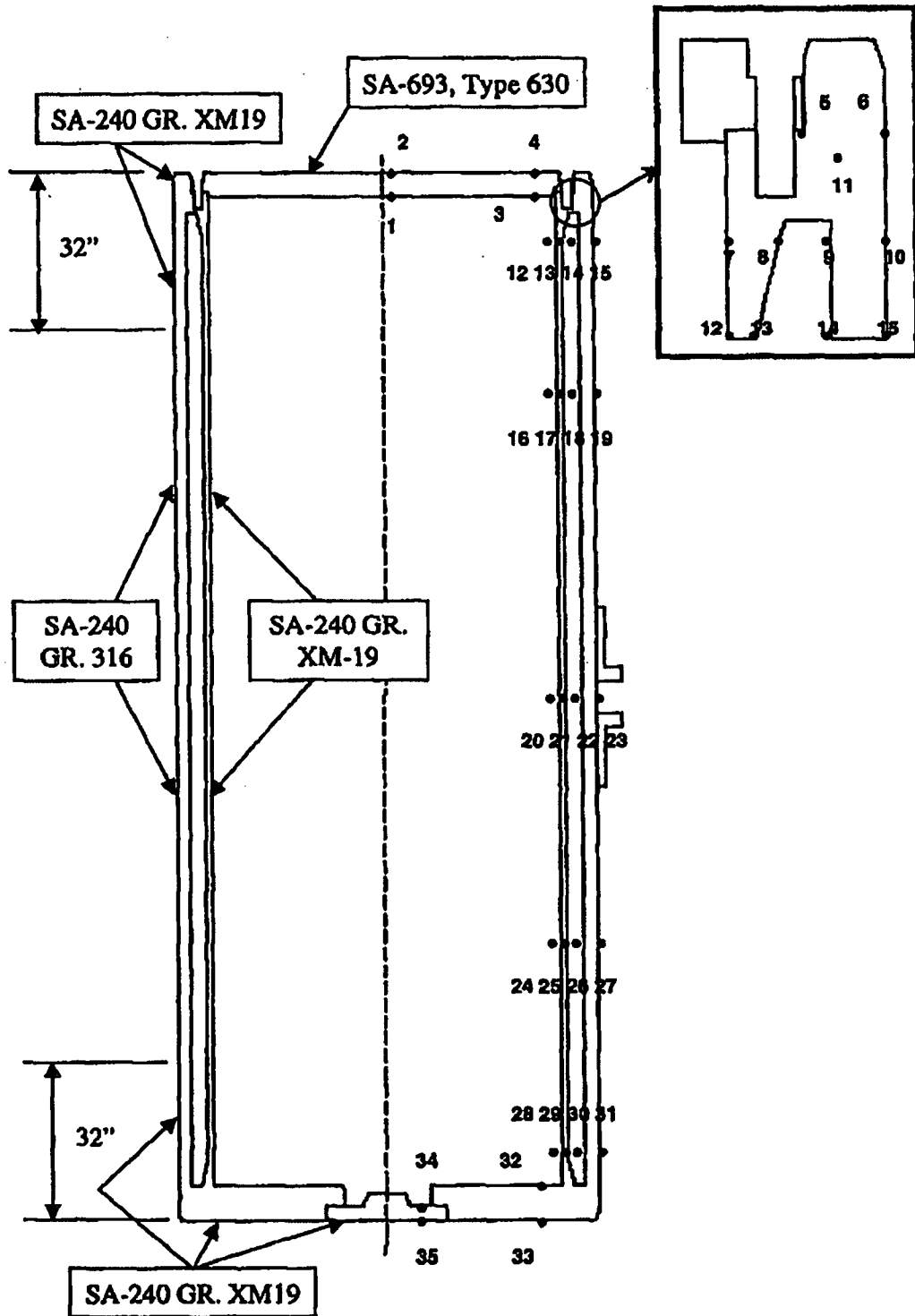


Figure 2-5  
40 Inch Puncture on Lid End Loading

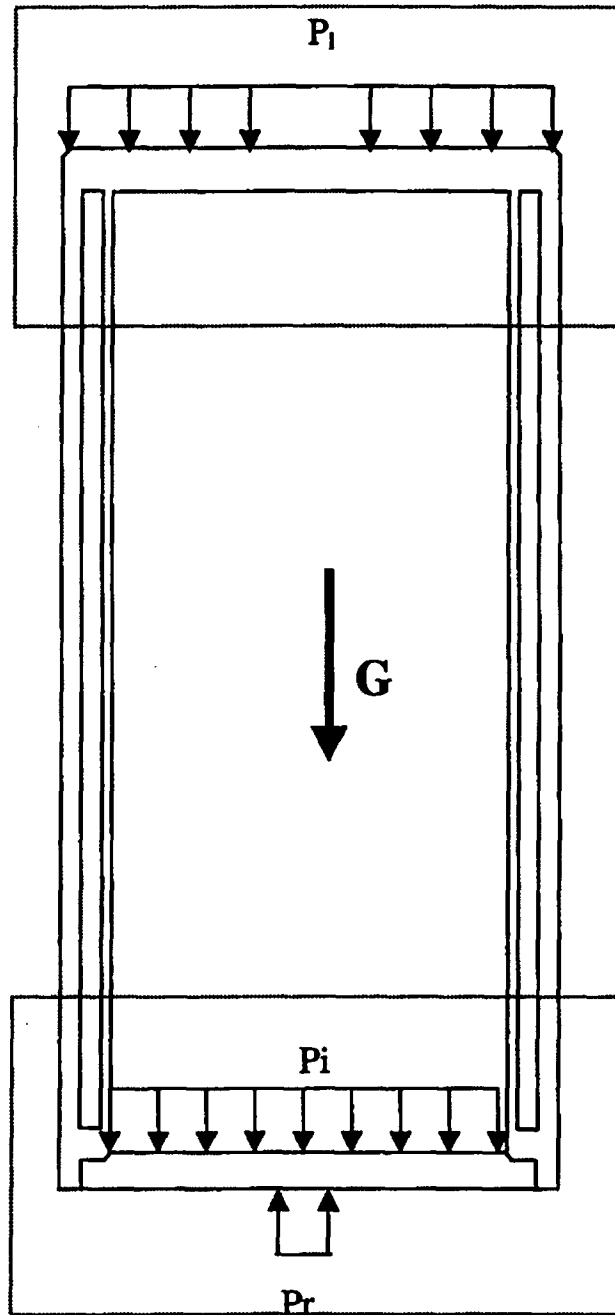
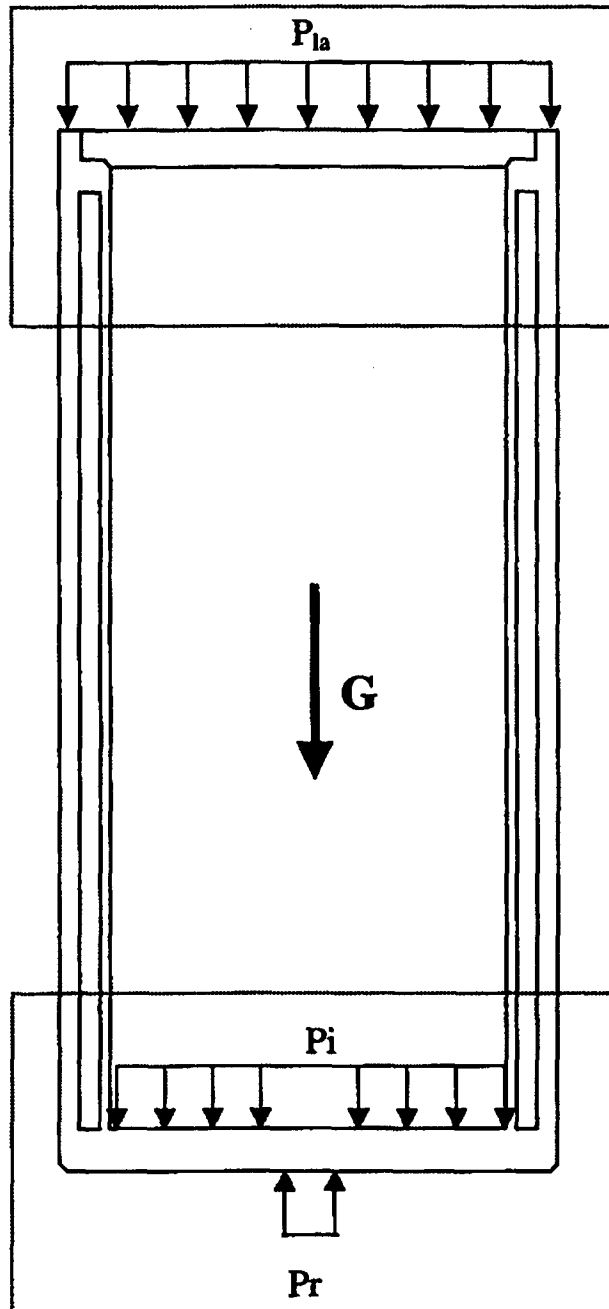


Figure 2-6  
40 Inch Puncture on Bottom Ram Cover Loading



## APPENDIX 2.10.1

### TABLE OF CONTENTS

	<u>Page</u>
<b>2.10.1 NUHOMS<sup>®</sup>-MP197 CASK BODY STRUCTURAL ANALYSIS .....</b>	<b>2.10.1-1</b>
2.10.1.1 Introduction .....	2.10.1-1
2.10.1.2 ANSYS Analysis .....	2.10.1-1
2.10.1.3 ANSYS Analysis Results and Reporting Methodology .....	2.10.1-26
2.10.1.4 Tie-Down Load .....	2.10.1-27
2.10.1.5 Fabrication Stress Calculation .....	2.10.1-28
2.10.1.6 Bolt Preload Discussion .....	2.10.1-33
2.10.1.7 Verification of Computer Stress Results due to 1-Foot End Drop on Lid End .....	2.10.1-36
2.10.1.8 References .....	2.10.1-40

### LIST OF TABLES

2.10.1-1	Individual Load Conditions
2.10.1-2	Summary of Load Combinations for Normal Condition of Transport
2.10.1-3	Summary of Load Combinations for Accident Condition of Transport
2.10.1-4	Bolt Preload
2.10.1-5	Internal Pressure (50 psi.) only
2.10.1-6	External Pressure (25 psi.) only
2.10.1-7	Thermal Stresses at Hot Environment (100° F)
2.10.1-8	Thermal Stresses at Cold Environment (-20° F)
2.10.1-9	3g Lifting
2.10.1-10	Rail Car Shock Loads
2.10.1-11	Rail Car Vibration Loads
2.10.1-12	1 Foot End Drop on Lid End
2.10.1-13	1 Foot End Drop on Bottom End
2.10.1-14	1 Foot Side Drop
2.10.1-15	1g Gravity Loading
2.10.1-16	1g Side Loading, Hot Environment (100° F)
2.10.1-17	1g Side Loading, Cold Environment (-40° F Ambient)
2.10.1-18	1g Side Loading, Increased External Pressure (25 psig.)
2.10.1-19	1g Side Loading, Reduced External Pressure (50 psig.)
2.10.1-20	Rail Car Vibration Loads, Internal Pressure, Hot Environment
2.10.1-21	Rail Car Vibration Loads, External Pressure, Cold Environment

LIST OF TABLES (continued)

- 2.10.1-22 Rail Car Shock Loads, Internal Pressure, Hot Environment
- 2.10.1-23 Rail Car Shock Loads, External Pressure, Cold Environment
- 2.10.1-24 1 Foot End Drop on Lid End, Internal Pressure, Hot Environment
- 2.10.1-25 1 Foot End Drop on Lid End, External Pressure, Cold Environment
- 2.10.1-26 1 Foot End Drop on Bottom End, Internal Pressure, Hot Environment
- 2.10.1-27 1 Foot End Drop on Bottom End, External Pressure, Cold Environment
- 2.10.1-28 1 Foot Side Drop, Hot Environment, Internal Pressure
- 2.10.1-29 1 Foot Side Drop, Cold Environment, External Pressure
- 2.10.1-30 30 Foot End Drop on Bottom End, Internal Pressure, Hot Environment
- 2.10.1-31 30 Foot End Drop on Bottom End, External Pressure, Cold Environment
- 2.10.1-32 30 Foot End Drop on Lid End, Internal Pressure, Hot Environment
- 2.10.1-33 30 Foot End Drop on Lid End, External Pressure, Cold Environment
- 2.10.1-34 30 Foot Side Drop, Hot Environment, Internal Pressure
- 2.10.1-35 30 Foot Side Drop, Cold Environment, External Pressure
- 2.10.1-36 30 Foot CG Over Corner Drop on Bottom End, Hot Environment, Internal Pressure
- 2.10.1-37 30 Foot CG Over Corner Drop on Bottom End, Cold Environment, External Pressure
- 2.10.1-38 30 Foot CG Over Corner Drop on Lid End, Hot Environment, Internal Pressure
- 2.10.1-39 30 Foot CG Over Corner Drop on Lid End, Cold Environment, External Pressure
- 2.10.1-40 30 Foot 20° Oblique Drop on Lid End, Hot Environment, Internal Pressure
- 2.10.1-41 30 Foot 20° Oblique Drop on Lid End, Cold Environment, External Pressure
- 2.10.1-42 30 Foot 20° Oblique Drop on Bottom End, Hot Environment, Internal Pressure
- 2.10.1-43 30 Foot 20° Oblique Drop on Bottom End, Cold Environment, External Pressure
- 2.10.1-44 Immersion, Cold Environment, 290 psi. External Pressure
- 2.10.1-45 Fire Accident
- 2.10.1-46 Tie Down Loading



## LIST OF FIGURES

- 2.10.1-1 NUHOMS<sup>®</sup>-MP197 Key Dimensions
- 2.10.1-2 NUHOMS<sup>®</sup>-MP197 2D Finite Element Model
- 2.10.1-3 NUHOMS<sup>®</sup>-MP197 3D Finite Element Model
- 2.10.1-4 NUHOMS<sup>®</sup>-MP197 Bolt Representation
- 2.10.1-5a 2D Lid End Drop – Boundary Condition
- 2.10.1-5b 2D Bottom End Drop – Boundary Condition
- 2.10.1-5c 3D Transport Boundary Condition
- 2.10.1-5d 3D Side Drop Boundary Condition
- 2.10.1-5e 3D Lid End and Lid Corner Drop Boundary Condition
- 2.10.1-5f 3D Bottom End – Bottom Corner Drop Boundary Condition
- 2.10.1-5g 3D 3g Lift Boundary Condition
- 2.10.1-6 Internal Pressure Loading
- 2.10.1-7 External Pressure Loading
- 2.10.1-8 3g Lift Loading
- 2.10.1-9 Rail Car Transportation Loading
- 2.10.1-10 1g Loading
- 2.10.1-11 End Drop on Lid Loading
- 2.10.1-12 End Drop on Base Loading
- 2.10.1-13 Side Drop Loading
- 2.10.1-14 30 Foot CG Over Corner Drop on Lid End Loading
- 2.10.1-15 30 Foot CG Over Corner Drop on Bottom End Loading
- 2.10.1-16 30 Foot Oblique Impact on Lid End Loading
- 2.10.1-17 30 Foot Oblique Impact on Bottom End Loading
- 2.10.1-18 Tie-Down Loading
- 2.10.1-19 Standard Stress Report Location
- 2.10.1-20 Typical Stress-Strain Curve for Pure Lead
- 2.10.1-21 Stress Relaxation versus Time at Constant Strain Values of 0.2%, 0.5%, 1.0%, and 2.0% for Pure Lead
- 2.10.1-22 Total Strain versus Creep Time for Pure Lead

## APPENDIX 2.10.1

### NUHOMS<sup>®</sup>-MP197 CASK BODY STRUCTURAL ANALYSIS

#### 2.10.1.1 Introduction

This appendix presents the structural analyses of the NUHOMS<sup>®</sup>-MP197 cask body including the cylindrical shell assembly and bottom assembly, the lid, the local stresses at the trunnion / cask body interface, and the shear key block/cask body interface. The specific methods, models and assumptions used to analyze the cask body for the various individual loading conditions specified in 10CFR71.71 [1] and 10CFR71.73 [2] are described. Stress results are reported at selected locations for each load case. Maximum stresses from this appendix are evaluated in Sections 2.6 and 2.7 of Chapter Two where the load combinations outlined in Regulatory Guide 7.8 [3] are performed and the results evaluated against the ASME Code [4] and Regulatory Guide 7.6 [5] design criteria described in Section 2.1.2.

The NUHOMS<sup>®</sup>-MP197 cask body structural analyses generally use static or quasistatic linear elastic methods. The stresses and deformations due to the applied loads are generally determined using the ANSYS [6] computer program.

The detailed calculations for the lid bolts are presented in Appendix 2.10.2. Stress evaluations for the lifting and tie-down devices are described in Section 2.5 of Chapter 2.

The analysis methods described in this appendix and used to evaluate the cask body for the loading conditions are:

- ° ANSYS Analysis - Axisymmetric and Asymmetric Loads

#### 2.10.1.2 ANSYS Analysis

##### Geometry Description

The containment vessel is the primary containment boundary of the packaging. Key dimensions of the containment vessel are shown in Figure 2.10.1-1. The shell, or cask body cylinder assembly, is an open ended (at the top) cylindrical unit with an integral closed bottom end. This assembly consists of concentric inner shell (SA-240 Gr. XM 19) and an outer shell (SA-240 Gr. 316) welded to a massive closure flange (SA-240 Gr. XM 19) at the lid end and a flat stainless steel plate (SA-240 Gr. XM 19) at the bottom end. The annulus between the shells is filled with lead shielding. The lead is poured into the annulus in a molten state using a carefully controlled procedure. The lid is bolted to the cylindrical shell by 48-1 1/2 in. diameter high strength bolts and sealed with two O-rings. A detailed physical description of the containment vessel is provided in Chapter One. Appendix 1.3 of Chapter One contains reference drawings of the NUHOMS<sup>®</sup>-MP197 cask which are the source of dimensions and other information used to develop analysis models.

## ANSYS Cask Finite Element Models

### NUHOMS<sup>®</sup>-MP197 Cask, Lid & Ram Cover Closure FEM Construction:

Two separate FEMs were constructed. The first, is a 2-dimensional, axisymmetric representation of the cask, which is constructed with plane elements. The second model is a 180°, 3-dimensional "brick" element representation. Due to the cyclic symmetry of the NUHOMS<sup>®</sup>-MP197, all nodes in the FEM are rotated into a cylindrical coordinate system, with an origin at the cask axis of rotation (i.e. global Cartesian  $X = Y = Z = 0.0$ ). To effectively model the cask wall & lid interaction, node-to-node contact elements are utilized. The lead/cask wall interaction is modeled with surface-to-surface contact elements. A total of 2050 elements and 2250 nodes comprise the NUHOMS<sup>®</sup>-MP197 2D FEM, while a total of 38075 elements and 9575 nodes comprise the NUHOMS<sup>®</sup>-MP197 3D FEM. The finite element models are shown in Figures 2.10.1-2 and 2.10.1-3.

### NUHOMS<sup>®</sup>-MP197 Bolt & FEM Representation:

The NUHOMS-MP197 180° FEM includes 24 lid bolts & 12 ram cover plate bolts utilizing a series of link elements as shown in the following figures. The bolt modeling methodology is intended to transfer the compressive force generated between the lid and cask flange. A similar methodology is adapted for the 2D model, where the total lid & ram closure bolt loads are simulated with single link elements (with the full 360° preload). It's noted that the methodology does not account for any bending stiffness, or shear strength of the bolts. The Stress on the lid bolts are calculated in Appendix 2.10.2, based on NUREG-6007.

The 2D FEM includes the modeling the lid and ram cover closure bolts, which are simulated using a series of LINK1 elements. To effectively model the lead, cask walls and lid interactions, point-to-point CONTACT 12 elements are used in the radial and axial orientations.

**Bolt Head:** 8 - Link1 elements connect the bolt head to the lid and are used to simulate the axial stiffness of the actual bolt head. Bolt head stiffness is calculated based on the area, elastic modulus & length [ $K_b = \text{No. Bolts} \times (AE / (L \times n))$ ], where  $n$  = the total number of link elements representing the bolt head.

**Bolt Shank:** A single Link1 element connects to the bolt head elements, and is used to simulate the axial prestrain of the actual 1.450" Dia. Bolt shank. Bolt shank prestrain is calculated based on [ $\epsilon = \text{No. of Bolts} \times (\sigma / E)$ ].

The 3D FEM includes the modeling of 24 lid bolts, which are simulated using a series of LINK8 elements as shown on Figure 2.10.1-4. To effectively model the cask wall & lid interaction, point-to-point CONTACT 52 elements are used in the radial and axial orientations as shown in Figure 2.10.1-4. The contact interaction between the lead and cask walls is modeled using surface-to-surface CONTACT 171/173 elements.

**Bolt Head:** Several Link8 elements (arranged in a “spider” configuration) are used to connect the bolt head to the lid counterbore, and are used to simulate the axial stiffness of the actual bolt head. Bolt head stiffness is calculated based on the area, elastic modulus, length & number of elements ( $K_b = AE/L \times n$ ). Note, no thread element prestrain is considered, since the bolt shank accounts for the entire bolt prestrain.

**Bolt Shank:** A single Link8 element is used to connect the bolt head and thread elements, and is used to simulate the axial prestrain of the actual 1.450” diameter bolt shank. Bolt shank prestrain is calculated based on ( $\epsilon = \sigma/E$ ), where  $\sigma$  is the bolt prestress (87ksi and 25ksi for lid and ram cover plate respectively).

**Bolt Threads:** A series of Link8 elements (arranged in a “spider” configuration) are used to connect the shank to the cask wall. No thread element prestrain is considered, since the bolt shank accounts for the entire bolt prestrain. Stiffness of the threads is assumed to be 100 times that of the shank.

**Weak Spring Element Methodology:**

To help aid in convergence, “key option” in ANSYS is used, which models a “weak” spring element across each pair of nodes comprising a contact52 element. The option is used for the tension capabilities developed in order to “hold” the cask wall and lid together, and thus prevent rigid body motion. ANSYS ensures the elements do not transfer a substantial amount of tensile load between the cask wall and lid by assigning an axial stiffness equal to  $1 \times 10^{-6}$  times the assigned normal contact stiffness (KN).

**Boundary Conditions:**

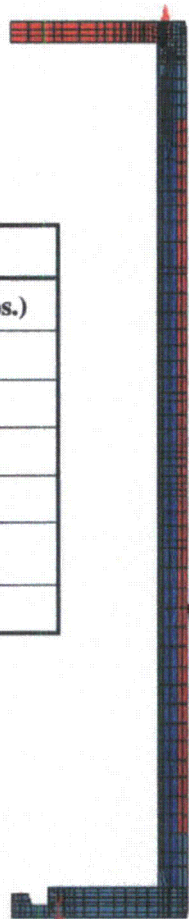
For the various loading cases analyzed (42), 7 separate sets of boundary conditions are required, see Table below. The BC sets are used to prevent rigid body motion and are assigned based on the specific loading configuration. In each of the BC sets, displacement constraints are fixed such that no displacement is permitted in the prescribed direction. All 3D boundary condition sets have the symmetry plane fixed in the hoop direction.

<b>Listing of Various Boundary Conditions Applied</b>	
<u>BC Description</u>	<u>Figure</u>
2D-End Drop on Lid	Figure 2.10.1-5a
2D-End Drop on Bottom	Figure 2.10.1-5b
3D-Transport & 1G Gravity Loading	Figure 2.10.1-5c
3D-Side Drop	Figure 2.10.1-5d
3D-End Drop on Lid & Lid End Corner Drop	Figure 2.10.1-5e
3D-End Drop on Bottom & Bottom End Corner Drop	Figure 2.10.1-5f
3D-3G Lift	Figure 2.10.1-5g

2D-Finite Element Model Assumed Weights:

To accurately model the correct NUHOMS<sup>®</sup>-MP197 component weights, the material densities were scaled and adjusted based on assumed and actual FEM weights. This was accomplished by multiplying the ratio of actual component weight (tabulated below) over the model "component" weight.

NUHOMS <sup>®</sup> -MP197 Cask	
Component	Weight (kips.)
Cask	144.42
Lid	5.61
Internals	88.39
Front Impact Limiter	13.78
Rear Impact Limiter w/Thermal Shield	14.09
Total	266.29



The mass of the internals, and impact limiters are *not* included in the FEM. This mass is accounted for in the applied loading

The mass of the neutron shield is accounted for at the outer wall elements and is "smeared" into the density as appropriate.

Note: 266.29 kips is conservatively used for structural analysis (including weight of trunnions), actual weight during transportation is 265.1 kips (trunnions will be removed and replaced with trunnion replacement plugs)

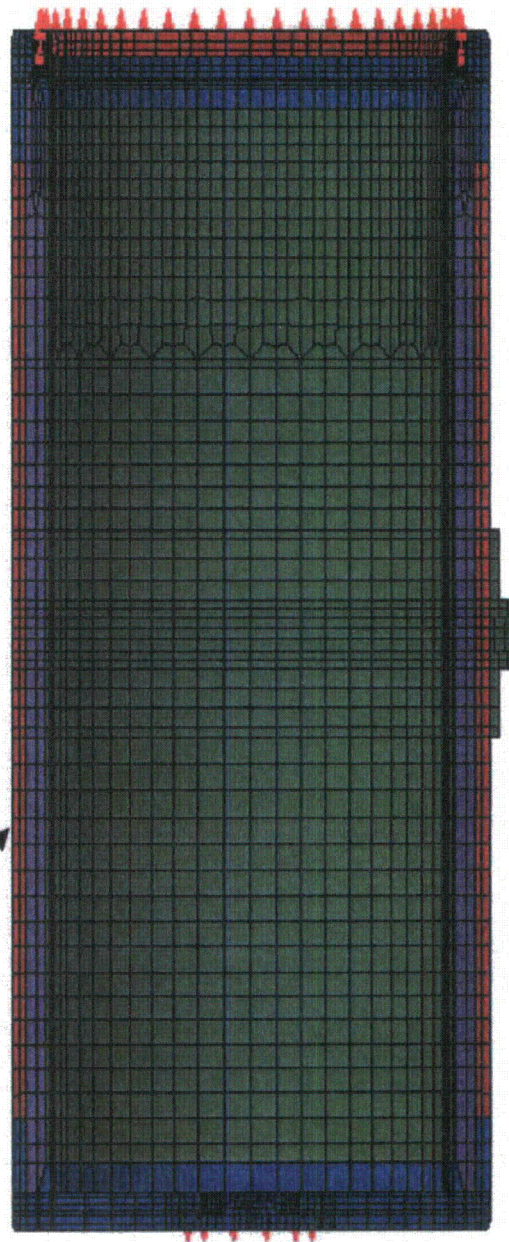
### 3D-Finite Element Model Assumed Weights

To accurately model the correct NUHOMS<sup>®</sup>-MP197 component weights, the material densities were scaled and adjusted based on assumed and actual FEM weights. This was accomplished by multiplying the ratio of actual component weight (tabulated below) over the model "component" weight.

NUHOMS <sup>®</sup> -MP197 Cask	
Component	Weight (kips.)
Cask Body	144.42
Lid	5.61
Internals	88.39
Front Impact Limiter	13.78
Rear Impact Limiter w/Thermal Shield	14.09
Total	266.29

The mass of the internals, and impact limiters are *not* included in the 3D FEM. This mass is accounted for in the applied loading

The mass of the neutron shield is accounted for at the outer wall elements and is "smeared" into the density as appropriate.



Note: 266.29 kips is conservatively used for Structural analysis (including weight of trunnions), actual weight during transportation is 265.1 kips (trunnions will be removed and replaced with trunnion replacement plugs)

## Loading

The loading conditions analyzed simulate the normal conditions of transport and hypothetical accident conditions specified in 10CFR71. The 22 individual load cases for the NUHOMS<sup>®</sup>-MP197 containment vessel are described in this section.

NUHOMS <sup>®</sup> -MP197 22 Individual Load Cases		
Load Case	Loading Condition	FEM Model
1	Bolt preload (Cask in horizontal orientation and held at bearing block in the longitudinal direction, supported by two saddles and held by tie down straps)	2D & 3D
2	Internal pressure loading (50 psig) (Cask in horizontal orientation and held at bearing block in the longitudinal direction, supported by two saddles and held by tie down straps)	3D
3	External pressure loading (25 psig) (Cask in horizontal orientation and held at bearing block in the longitudinal direction, supported by two saddles and held by tie down straps)	3D
4	External pressure loading (immersion) (290 psig) (Cask in horizontal orientation and held at bearing block in the longitudinal direction, supported by two saddles and held by tie down straps)	3D
5	Hot environment condition thermal stresses (100°F ambient) (Cask in horizontal orientation and held at bearing block in the longitudinal direction, supported by two saddles and held by tie down straps)	3D
6	Cold environment condition thermal stresses (-20°F ambient) (Cask in horizontal orientation and held at bearing block in the longitudinal direction, supported by two saddles and held by tie down straps)	3D
7	Cold environment condition thermal stresses (-40°F uniform) (Cask in horizontal orientation and held at bearing block in the longitudinal direction, supported by two saddles and held by tie down straps)	3D
8	Fire accident thermal stresses (Cask in horizontal orientation and held at bearing block in the longitudinal direction, supported by two saddles and held by tie down straps)	3D
9	3G lifting (3G up, cask at vertical orientation and held at two top trunnion locations)	3D
10	Rail car shock loads (4.7G all directions) (Cask in horizontal orientation and held at bearing block in the longitudinal direction, supported by two saddles and held by tie down straps)	3D
11	Rail car vibration loads (0.37G vertical, 0.19G lateral, and 0.19G longitudinal. (Cask in horizontal orientation and held at bearing block in the longitudinal direction, supported by two saddles and held by tie down straps)	3D
12	1G loading (Cask in horizontal orientation and held at bearing block in the longitudinal direction, supported by two saddles and held by tie down straps)	3D
13	1-foot end drop on lid end (30G)	2D
14	1-foot end drop on bottom end (30G)	2D
15	1-foot side drop (30G)	3D
16	30-foot end drop on lid end (75G)	2D
17	30-foot end drop on bottom end (75G)	2D
18	30-foot side drop (75G)	3D
19	30-foot CG over corner drop on lid end (45G Axial, 16G Transverse)	3D
20	30-foot CG over corner drop on bottom end (45G Axial, 16G Transverse)	3D
21	30-foot oblique impact on lid end (35G Axial, 60G Normal, 198G Rotational)	3D
22	30-foot oblique impact on bottom end (35G Axial, 60G Normal, 196G Rotational)	3D

## Method of Load Applies to the Cask Body

Pressures applied in the axial direction are calculated based on load divided by area pressure calculation. For example, to calculate the pressure applied due to internal loading on the inner bottom cask surface due to 1-foot End Drop on Lid End, divide the total load applied by the cross-sectional area. See Section 2.10.1.2.1 for example numerical calculation.

Pressures applied in the radial direction were based on cosine distributed pressure functions. These pressure distributions simulate the internal cask contents applying pressure to the inner cask wall, or the contact between the impact limiter and the outer surface of the cask. The pressure distribution is assumed to be in the longitudinal direction over a specified length and vary with a cosine distribution around the circumference of the cask. For the impact conditions, the angle of contact is dependent upon the amount of crush occurring in the impact limiter. Two separate cosine distributed pressure functions have been utilized. Cosine distributed cosine pressure loading and Cosine  $\times$  Hyperbolic Cosine distributed cosine pressure loading, see Section 2.10.1.2.2 for detailed information.

### 1. Bolt Preload and Lid Seating Pressure

The axial prestress of 87 & 25 ksi at the lid bolt & ram cover plate bolt shanks are simulated by specifying an initial strain to the link elements representing the bolts. The required initial strain value was determined by first calculating the initial strain required to produce an axial stress of 87.0 ksi (i.e.  $\epsilon = \sigma/E = 87.0 \times 10^3 / 26.7 \times 10^6 = 0.003258$ ). Then, an initial "dummy" analysis with the hand calculated strain was conducted, and the resulting bolt prestress determined. Since, a portion of the assigned strain becomes strain in the clamped parts, the backed out prestress from the initial analysis does not produce the desired 87.0 ksi. The initial value was then updated by multiplying the link element real constant by the ratio of (desired prestress / initial analysis prestress). A second dummy analysis was conducted to verify the desired 87.0 ksi bolt prestress.

The bolt preload case is calculated by both 2D and 3D models and the results are listed in Table 2.10.1-4. Since the modeling methodologies of the 2D and 3D differ with respect to the lid modeling. A discussion of these differences and how they effect the load combinations are presented in Section 2.10.1.6.

### 2. Internal Pressure Loading

An internal pressure of 50 psig is applied to the cavity surface as shown in Figure 2.10.1-6. The pressure is applied up to the lid seal inner radius.

### 3-4. External Pressure Loading

An external pressure of 25 psig (case 3) & 290 psig (case4) is applied to the outer surface of the cask body as shown in Figure 2.10.1-7. The pressure is applied up to the lid seal outer radius.



#### 5. Thermal Stress for Hot Environment Condition at 100°F Ambient Temperature

The normal condition of transport thermal analysis of the cask body is described in Chapter 3. The thermal model is used to obtain the steady state metal temperatures in the cask body for the normal condition which includes a 100° F daily averaged ambient air temperature, maximum decay heat, and maximum solar heat loading. These temperatures are then used as ANSYS input for the thermal stress analysis.

#### 6. Thermal Stresses for Cold Environment Condition at -20°F Ambient Temperature

The minimum ambient temperature thermal analysis of the cask body is described in Chapter 3. The thermal model is used to obtain the steady state metal temperatures in the cask body for the minimum condition which includes a -20° F daily averaged ambient air temperature, minimum decay heat, and minimum solar heat loading. These temperatures are then used as ANSYS input for the thermal stress analysis.

#### 7. Thermal Stresses for Cold Test at -40°F Ambient Temperature

A uniform temperature of -40°F is input on the structural model, which simulates a constant cask temperature of -40°F.

#### 8. Thermal Accident Condition

An ANSYS transient thermal analysis of the cask for the 0.5-hour thermal accident is reported in Chapter 3. The initial condition is steady state at 100°F ambient conditions with maximum decay heating. The initial steady state condition is followed by a 0.5-hour severe thermal transient, which is then followed by a cool-down period. The maximum thermal gradient load step is used as input to the cask model for thermal stress analysis.

#### 9. 3G Lifting

The cask is oriented vertically and held by the 2 top trunnions. Applying a 3G vertical acceleration to the finite element model simulates the inertial loading. Figure 2.10.1-8 illustrates the loading condition. Since the internals are not included in the model, their loading effects are simulated by a distributed pressure ( $P_1 = 71.2$  psi) acting on the inside bottom surface of the cask cavity.

## 10. Rail Car Shock Loading

For rail car shock loading, the cask is oriented horizontally and secured to the transport skid at the bearing block in the longitudinal direction, supported at two saddles and held by tie down straps. The peak inertia (acceleration) values used are based on NUREG 766510 [8]:

### Rail Car Shock

Vertical	4.7 G
Longitudinal	4.7 G
Lateral	4.7 G

The forces acting in this case are listed below and illustrated in Figure 2.10.1-9.

#### A. Cask / Lid Inertial loads:

- A longitudinal 4.7G acceleration (applied in the axial direction)
- The resultant of the vertical & lateral accelerations (applied in the vertical direction) and calculated at  $(4.7^2 + 4.7^2)^{1/2} = 6.65G$

#### B. Axial Pressure Due to Rear Impact Limiter:

A pressure due to the weight of the rear impact limiter ( $P_{ra} = 12.5$  psi) is applied axially at the outer bottom surface:

#### C. Pressure Due to Internals:

An axial pressure from the internals is applied on the inside surface of the lid ( $P_{ia} = 114.4$  psi). A radial pressure ( $P_{iv} = 61.9$  psi) acting on the lower half of the inner cask surface due to the weight of internals is represented as a cosine varying pressure around the lower radial portion ( $0^\circ$  to  $75^\circ$  range) of the cavity.

#### D. Radial Pressures Due to Impact Limiters:

In addition, radial pressure due to the front impact limiter weight ( $P_{fr} = 67.2$  psi) is applied along the contacting surfaces of the limiter and the lid/cask wall. The pressure follows a cosine variation and is applied from ( $105^\circ$  to  $180^\circ$ ).

A radial pressure due to the rear impact limiter weight ( $P_{rr} = 74.2$  psi) is also applied along the contacting surfaces of the limiter and the cask wall. Similar to the front impact limiter, the cosine varying pressure is applied from ( $105^\circ$  to  $180^\circ$ ).

## E. Reaction Pressure

To simulate the reaction pressure at the skid bands, pressures applied by the rear and front transport skid saddle and tiedown strap reactions ( $P_{spr} = 592.9$  psi and  $P_{spr} = 2829.8$  psi) on the lower longitudinal half of the outer cask body during impact. These pressures are assumed to vary in a cosine distribution around the bottom half of the outer surfaces ( $0^\circ$  to  $75^\circ$ ) and are calculated just as the internal pressures are. However, the total force applied in the equation is based on the total reaction loads required to support equilibrium. That is, a dummy analysis was first executed by applying all necessary loading except the reaction pressures. The model was then constrained radially at the transport skid support saddle (at  $0^\circ$ ) and solved. The "vertical" reactions calculated by ANSYS were then used as input to the cosine distributed pressure loading. All additional loading was reapplied and the model solved.

### 11. Rail Car Vibration Loading

For rail car vibration loading, the cask is oriented horizontally and secured to the transport skid at the bearing block in the longitudinal direction, supported at two saddles and held by tie down straps. The peak inertia (acceleration) values used are based on NUREG 766510 [8]:

#### Rail Car Vibration

Vertical	0.37 G
Longitudinal	0.19 G
Lateral	0.19 G

The forces acting in this case are listed below and illustrated in Figure 2.10.1-9.

#### A. Cask / Lid Inertial loads:

- A longitudinal 0.19G acceleration (applied in the axial direction)
- The resultant of the vertical & lateral accelerations (applied in the vertical direction) and calculated at  $(0.19^2 + 0.37^2)^{1/2} = 0.416G$

#### B. Axial Pressure Due to Rear Impact Limiter:

A pressure due to the weight of the rear impact limiter ( $P_{ra} = 0.52$  psi) is applied axially at the outer bottom surface:

#### C. Pressure Due to Internals:

An axial pressure from the internals is applied on the inside surface of the lid ( $P_{ia} = 4.62$  psi). A radial pressure ( $P_{iv} = 3.88$  psi) acting on the lower half of the inner cask surface due to the weight of internals is represented as a cosine varying pressure around the lower radial portion ( $0^\circ$  to  $75^\circ$  range) of the cavity.

**D. Radial Pressures Due to Impact Limiters:**

In addition, radial pressure due to the front impact limiter weight ( $P_{fr} = 4.21$  psi) is applied along the contacting surfaces of the limiter and the lid/cask wall. The pressure follows a cosine variation and is applied from ( $105^\circ$  to  $180^\circ$ ).

A radial pressure due to the rear impact limiter weight ( $P_{rr} = 4.65$  psi) is also applied along the contacting surfaces of the limiter and the cask wall. Similar to the front impact limiter, the cosine varying pressure is applied from ( $105^\circ$  to  $180^\circ$ ).

**E. Reaction Pressure:**

To simulate the reaction pressure at the skid bands, pressures are applied by the rear and front transport skid saddle and tiedown strap reactions ( $P_{spr} = 62.7$  psi and  $P_{spf} = 151.5$  psi) on the lower longitudinal half of the outer cask body during impact. These pressures are assumed to vary in a cosine distribution around the bottom half of the outer surfaces ( $0^\circ$  to  $75^\circ$ ) and are calculated just as the internal pressures are. However, the total force applied in the equation is based on the total reaction loads required to support equilibrium. That is, a dummy analysis was first executed by applying all necessary loading except the reaction pressures. The model was then constrained radially at the transport skid support saddle (at  $0^\circ$ ) and solved. The "vertical" reactions calculated by ANSYS were then used as input to the cosine distributed pressure loading. All additional loading was reapplied.

**12. 1G Loading (Cask in Horizontal Position)**

For the 1G loading, the cask is oriented horizontally and secured radially to the transport skid support saddle. For the inertial loading, a vertical acceleration of 1G is applied in the global X direction. Figure 2.10.1-10 illustrates the loading condition. A brief explanation of the applied loading is presented below:

**A. Pressure due to Internals:**

Radial pressure ( $P_{iv} = 9.32$  psi) acting on the lower half of the inner cask surface due to the weight of internals is represented as a cosine varying pressure applied around the lower radial portion ( $0^\circ$  to  $75^\circ$  range) of the cavity.

**B. Pressure due to Front Impact Limiter:**

In addition, radial pressure due to the front impact limiter weight ( $P_{fr} = 10.1$  psi) is applied along the contacting surfaces of the limiter and the lid/cask wall. The pressure follows a cosine distribution and is applied from the vertical ( $Y=180^\circ$ ) to ( $Y=105^\circ$ ).

**C. Pressure due to Rear Impact Limiter:**

A radial pressure due to the rear impact limiter weight ( $P_r = 11.2$  psi) is also applied along the contacting surfaces of the limiter and the cask wall. Similar to the front impact limiter, the pressure follows a cosine distribution and is applied from the vertical ( $Y=180^\circ$ ) to ( $Y=105^\circ$ ).

**D. Reaction Pressure**

To simulate the reaction pressure at the skid bands, pressures are applied by the rear and front saddle reactions ( $P_r = 400.07$  psi and  $P_f = 373.3$  psi) on the lower longitudinal half of the outer cask body during impact. These pressures are assumed to vary in a cosine distribution around the bottom half of the outer surfaces ( $0^\circ$  to  $75^\circ$ ) and are calculated just as the internal pressures are. However, the total force applied in the equation is based on the total reaction loads required to support equilibrium. That is, a dummy analysis was first executed by applying all necessary loading except the reaction pressures. The model was then constrained radially at the transport skid support saddle (at  $0^\circ$ ) and solved. The "vertical" reactions calculated by ANSYS were then used as input to the cosine distributed pressure loading. All additional loading was reapplied.

**13. 1-Foot End Drop on Lid (Front Impact Limiter)**

The dynamic analysis described in Appendix 2.10.8 determined the inertial load on the NUHOMS<sup>®</sup>-MP197 packaging for a 1-foot end drop onto an unyielding surface, and calculated a maximum axial deceleration of 10G. However, 30G is conservatively used for stress analysis of the cask. Since the payload and the impact limiters are not included in the FEM, their loading effects are simulated as distributed pressures applied to the cask at the appropriate locations. The contacting impact limiter force on the cask is applied as the reaction pressure on the lid required to balance the inertial forces of the system. Thus, the cask body is in equilibrium under the applied forces. The system of forces on the cask body is presented in Figure 2.10.1-11. The following loads are applied to the FEM:

**A. Cask / Lid Inertial loads:**

30G vertical acceleration to the finite element model simulates the cask/lid inertial loading.

**B. Pressure Due to Internals:**

An axial pressure due to internals ( $P_i = 730.2$  psi) is applied at the inner lid surface.

**C. Pressure Due to Rear Impact Limiter:**

An axial pressure due to the rear impact limiter ( $P_r = 82.9$  psi) is applied at the cask bottom including the chamfer.

#### D. Reaction Pressures

The axial reaction pressure due to cask body and rear impact limiter ( $P_{rlo} = 6,784$  psi) is applied at the outer area of the lid (i.e. it is assumed the entire inertial load flows down the cask wall only, and is reacted out at the outer lid surface only). An axial reaction pressure due to internals and middle lid portion ( $P_{rlm} = 771.2$  psi) is applied at the mid-area of the lid.

#### 14. 1-Foot End Drop on Bottom (Rear Impact Limiter)

An analysis similar to that of the 1-foot drop on the lid is performed for the 1-foot drop on the bottom. The same inertial forces (30G) are used for the bottom (rear) impact case as for the front impact case. A similar methodology used for the lid drop is applied for this case. A brief explanation of the applied loading is presented below.

##### A. Cask / Lid Inertial loads:

A 30G vertical acceleration to the finite element model simulates the inertial loading.

##### B. Pressure Due to Internals:

An axial pressure due to internals ( $P_i = 781.9$  psi) is applied at the inner base surface.

##### C. Pressure Due to Front Impact Limiter:

An axial pressure due to the front impact limiter ( $P_{fa} = 83.5$  psi) is applied at the outer lid surfaces based on the projected area.

##### D. Reaction Pressures:

The axial reaction pressure due to cask body and front impact limiter ( $P_{rbo} = 3,148$  psi) is applied at the outer area of the base. The entire inertial load flows down the cask wall, and is reacted out at the projected chamfer area only. An axial reaction pressure due to internals and middle base portion ( $P_{rbm} = 761.7$  psi) is applied at the mid area of the lid.

The system of forces on the cask body is presented in Figure 2.10.1-12.

## 15. 1-Foot Side Drop

The dynamic analysis described in Appendix 2.10.8 determined the inertial load on the NUHOMS<sup>®</sup>-MP197 packaging for a 1-foot side drop onto an unyielding surface and resulted in a maximum transverse deceleration of 24G. However, 30G is conservatively used for stress analysis of the cask. Since the payload & impact limiters are not included in the FEM, their loading effects are simulated as distributed pressures applied on the cask at the appropriate locations. The contacting impact limiter forces on the cask & lid are applied as reaction pressures required to balance the inertial forces of the system. Thus, the cask is in equilibrium under the applied forces. During the side drop, the pressure at the inner surface due to internals and the reaction pressure on the outer side from the impact limiters are assumed to vary as cosine functions over 180°. The system of forces acting on the cask is presented in Figure 2.10.1-13. The loads acting in this case are:

### A. Cask Body Inertia

Applying 30G vertical acceleration to the finite element model in the transverse direction simulates inertial loading.

### B. Pressure Due to Internals

Radial pressure ( $P_{iv} = 279.6$  psi) acting on the lower half of the inner cask surface due to the weight of internals is represented as a cosine varying pressure applied from 0 to 75 degrees on the lower radial portion of the cavity wall.

### C. Impact Reaction Pressures:

$P_r$  (2,888 psi) and  $P_{fr}$  (2,568 psi) are the pressures applied by the rear and front impact limiter reactions on the lower longitudinal half of the outer cask body during impact. These pressures are assumed to vary in a cosine distribution around the bottom half of the outer surfaces (0° to 180°) and are calculated just as the internal pressures are. However, the total force applied in the equation is based on the total reaction loads required to support equilibrium. That is, a dummy analysis was first executed by applying all necessary loading except the reaction pressures. The model was then constrained radially at the impact limiters (at 0°) and solved. The “vertical” reactions calculated by ANSYS were then used as input to the cosine distributed pressure loading. All additional loading was reapplied.

## 16. 30-Foot End Drop on Lid (Front Impact Limiter)

The dynamic analysis described in Appendix 2.10.8 determined the inertial load on the NUHOMS<sup>®</sup>-MP197 packaging for a 30-foot end drop onto an unyielding surface, and resulted in a maximum axial deceleration of 50G. However, 75G is conservatively used for stress analysis of the cask. The loading applied for this case is identical to that applied for the 1-foot lid drop case except that the pressures applied are scaled based on the increased acceleration.

17. 30-Foot End Drop on Bottom (Rear Impact Limiter)

The loading applied for this case is identical to that applied for the 1-foot bottom drop case except that the pressures applied are scaled based on the increased acceleration.

18. 30-Foot Side Drop

The dynamic analysis described in Appendix 2.10.8 determined the inertial load on the NUHOMS<sup>®</sup>-MP197 packaging for a 30-foot side drop onto an unyielding surface, and resulted in a maximum radial deceleration of 60G. However, 75G is conservatively used for stress analysis of the cask. The loading applied for this case is identical to that applied for the 1-foot side drop case except that the pressures applied are scaled based on the increased acceleration.

19. 30-foot CG Over the Corner Drop on Lid End

For CG over corner, the cask is inclined at approximately 60° from the horizontal. All the applied loads and reaction forces are transformed into axial and normal components. The axial pressure components due to the internals, bottom impact limiter and impact reaction are assumed uniformly distributed. All radial pressure components (i.e. pressure due to internals, rear impact limiter and impact reactions) are assumed to have cosine variation over a determined arc length. The system of forces acting on the cask is presented in Figure 2.10.1-14.

The forces acting in this case are:

A. Cask Body Inertia

The component accelerations (45G axial & 16G Radial) are applied as translational inertial loads in the axial and radial directions respectively. In addition, a rotational acceleration of 32G is applied at the vessel CG to counteract the out-of-balance caused by the component's acceleration resultant, which is not normal to the horizontal. That is, the component translational accelerations applied have been conservatively rounded, which results in a slight resultant moment (out-of-balance) when the solution is executed. This moment is counteracted by the applied angular acceleration (torque) and the model returned to static equilibrium.

B. Pressure Due to Internals:

Radial pressure ( $P_{ir} = 199.1$  psi) acting on the inner cask wall due to the weight of internals is represented as a cosine varying pressure applied along the contact surface between the internals (197" total contact length assumed) and the inner cask wall (105° to 180°). In addition, an axial pressure ( $P_{ia} = 1095.2$  psi) due to the weight of the internals is applied to the cask inner lid surface.



**C. Pressure Due to Rear Impact Limiter:**

The inertia load of the nonstriking impact limiter is also applied to the cask in two mutually perpendicular directions. The axial component ( $P_{ra} = 123.1$  psi) is applied as a uniform pressure over the outside surface at the interface with the impact limiter on the bottom end. The radial component ( $P_{rr} = 178.5$  psi) is applied as a cosine varying pressure along the contact surface (23.25" total contact length assumed) between the rear limiter and the outer cask wall from ( $0^\circ$  to  $75^\circ$ ).

**D. Reaction Pressures Due to Front Impact Limiter**

The reaction pressure of the striking impact limiter is also applied to the cask in two mutually perpendicular directions. The axial component ( $P_{fa} = 4,692$  psi) is applied as a uniform pressure over  $\frac{1}{2}$  the lid surface area. The radial component pressure ( $P_{fr} = 4,264$  psi) follows the cosine distribution around the radial crush footprint from  $90^\circ$  to  $180^\circ$  on the cask, and is applied along the contact surface (25" total contact length assumed) between the front limiter and the outer cask wall.

The loading applied is summarized in the table below.

Load Description	Loading Formulae	Symbol on Figure
Pressure applied in radial direction due to weight of internals	Cosine Dist. over 75deg	Pir
Pressure applied in axial direction due to weight of internals	P/A	Pia
Pressure applied in axial direction due to weight of rear impact limiters	P/A	Pra
Pressure applied in radial direction due to weight of rear impact limiters	Cosine Dist. over 75deg	Prr
Radial reaction pressures due to front impact limiter	Cosine Dist. over 90deg	Pfr
Axial reaction pressures due to front impact limiter	P/A	Pfa

**20. 30-foot CG Over the Corner Drop on Bottom End**

For this corner drop, the cask is again inclined at approximately  $60^\circ$  from the horizontal. The applied loads are transformed into axial and normal components, and are applied using the same methodology adopted for the CG over corner lid drop. All radial pressure components (i.e. pressure due to internals, front impact limiter and impact reactions) are assumed to have cosine variation over a determined arc length. The system of forces acting on the cask is presented in Figure 2.10.1-15.

A brief explanation of the applied loading is presented below:

#### **A. Cask Body Inertia**

The component accelerations (i.e. 45G axial & 16G Radial) are applied as translational inertial loads in the axial and radial directions respectively. In addition, a rotational acceleration of 32G is applied at the vessel CG to counter act the out-of-balance and return the model to static equilibrium.

#### **B. Pressure Due to Internals:**

Radial pressure ( $P_{ir} = 199.1$  psi) acting on the inner cask wall due to the weight of internals is represented as a cosine varying pressure applied along the contact surface between the internals (197" total contact length assumed) and the inner cask wall ( $0^\circ$  to  $75^\circ$ ). In addition, an axial pressure ( $P_{ia} = 1,180$  psi) due to the weight of the internals is applied to the cask inner bottom surface.

#### **C. Pressure Due to Front Impact Limiter:**

The inertia load of the nonstriking impact limiter is also applied to the cask in two mutually perpendicular directions. The axial component ( $P_{fa} = 128.0$  psi) is applied as a uniform pressure over the outside surface at the interface with the impact limiter on the front end. The radial component ( $P_{fr} = 162.1$  psi) is applied as a cosine varying pressure along the contact surface (25" total contact length assumed) between the front limiter and the outer cask wall from ( $105^\circ$  to  $180^\circ$ ).

#### **D. Reaction Pressures Due to Rear Impact Limiter**

The reaction pressure of the striking impact limiter is also applied to the cask in two mutually perpendicular directions. The axial component ( $P_{ra} = 4,450$  psi) is applied as a uniform pressure over  $\frac{1}{2}$  the bottom surface area. The radial component pressure ( $P_{rr} = 2,878$  psi) follows the cosine distribution around the radial crush footprint from  $0^\circ$  to  $90^\circ$  on the cask, and is applied along the contact surface (23.25" total contact length assumed) between the rear limiter and the outer cask wall.

The loading applied is summarized in the table below.

30 Foot CG Over the Corner Drop on Bottom End		
Load Description	Loading Formulae/Appendix	Symbol on Figure
Pressure applied in radial direction due to weight of internals	Cosine Dist. over 75deg	Pir
Pressure applied in axial direction due to weight of internals	P/A	Pia
Axial pressures due to front impact limiter	P/A	Pfa
Radial pressures due to front impact limiter	Cosine Dist. over 75deg	Pfr
Radial reaction pressures due to rear impact limiter	Cosine Dist. over 90deg	Prr
Axial reaction pressures due to rear impact limiter	P/A	Pra

21. 30-Foot Oblique Impact on Lid End

For oblique lid impact, the cask is inclined at 20° from the horizontal. All applied loads and reaction forces are transformed into axial and normal components respectively. The axial pressure components due to the internals, bottom impact limiter and impact reaction are assumed uniformly distributed. All radial pressure components (i.e. pressure due to internals & rear impact limiter) are assumed to have cosine variation over a 90° determined arc length. In addition, the radial pressures due to the internals are input as a linear distribution based on the axial location of the element with maximum values applied toward the crush end. The reaction pressures are applied using a cosxcosh distribution over the 90° arc length (based on the 180° model), see Appendix D. The system of forces acting on the cask is presented in Figure 2.10.1-16.

A brief explanation of the applied loading is presented below:

A. Cask Body Inertia

The component accelerations (i.e. 35G axial & 60G radial) are applied as translational inertial loads in the axial and radial directions respectively. In addition, a rotational acceleration of 198G is applied at the vessel CG to counter act the out-of-balance forces due to the induced torque (i.e. the perpendicularly offset CG from the impact location) and return the model to static equilibrium.

B. Pressure Due to Internals:

Radial pressure (Pir = 1,165 psi) acting on the impact side of the inner cask wall due to the weight of internals is represented as a cosine varying pressure around the upper radial portion (105° to 180° range) of the cavity. The pressure also varies linearly as a function of axial position with respect to the overall applied length (197" total length assumed). In addition, an axial pressure (Pia = 851.9 psi) due to the weight of the internals is applied to the cask inner lid surface.

**C. Pressure Due to Rear Impact Limiter:**

The inertia load of the nonstriking impact limiter is also applied to the cask in two mutually perpendicular directions. The axial component ( $P_{ra} = 95.7$  psi) is applied as a uniform pressure over the outside bottom cask surface at the interface with the rear impact limiter. The radial component ( $P_{rr} = 669.5$  psi) is applied as a cosine varying pressure along the contact surface (25" total contact length assumed) between the rear limiter and the outer cask wall from ( $0^\circ$  to  $75^\circ$ ).

**D. Reaction Pressures Due to Front Impact Limiter**

The axial component ( $P_{fa} = 1,778$  psi) is applied as a uniform pressure over the entire outer lid surface area. The radial component pressure follows a cos $\times$ cosh distribution around the radial crush footprint from  $90^\circ$  to  $180^\circ$  on the cask.

The loading applied is summarized in the table below.

Load Description	Loading Formulae	Symbol on Figure
Pressure applied in radial direction due to weight of internals	Cosine Dist. over 75deg	Pir
Pressure applied in axial direction due to weight of internals	P/A	Pia
Pressure applied in axial direction due to weight of rear impact limiters	P/A	Pra
Pressure applied in radial direction due to weight of rear impact limiters	Cosine Dist. over 75deg	Prr
Radial reaction pressures due to front impact limiter	Cos*cosh dist. Over 90deg	Pfr
Axial reaction pressures due to front impact limiter	P/A	Pfa

**22. 30-foot Oblique Impact on Bottom End**

For oblique bottom impact, the cask is inclined at  $20^\circ$  from the horizontal. The loading applied is similar to the oblique lid drop with applied loads and reaction forces transformed into axial and normal components respectively. The axial pressure components due to the internals, front impact limiter and impact reaction are assumed uniformly distributed. All radial pressure components (i.e. pressure due to internals & front impact limiter) are assumed to have cosine variation over a  $90^\circ$  determined arc length. In addition, the radial pressures due to the internals are input as a linear distribution based on the axial location of the element, with maximum values applied toward the crush end. The reaction pressures are applied using a cos $\times$ cosh distribution over the  $90^\circ$  arc length (based on the  $180^\circ$  model) (see Section 2.10.1.2.2). The system of forces acting on the cask is presented in Figure 2.10.1-17.

A brief explanation of the applied loading is presented below:

**A. Cask Body Inertia**

The component accelerations (i.e. 35G axial and 60G radial) are applied as translational inertial loads in the axial and radial directions respectively. In addition, a rotational acceleration of 196G is applied at the vessel CG to counter act the out-of-balance forces due to the induced torque (i.e. the perpendicularly offset CG from the impact location) and return the model to static equilibrium.

**B. Pressure Due to Internals:**

Radial pressure ( $P_{ir} = 1,153$  psi) acting on the impact side of the inner cask wall due to the weight of internals is represented as a cosine varying pressure around the upper radial portion ( $105^\circ$  to  $180^\circ$  range) of the cavity. The pressure also varies linearly as a function of axial position with respect to the overall applied length (197" total length assumed). The axial component of pressure ( $P_{ia} = 917.6$  psi) due to the weight of the internals is applied to the cask inner lid surface.

**C. Pressure Due to Front Impact Limiter:**

The inertia load of the nonstriking impact limiter is also applied to the cask in two mutually perpendicular directions. The axial component ( $P_{fa} = 97.0$  psi) is applied as a uniform pressure over the outside lid/cask surface at the interface with the impact limiter. The radial component ( $P_{fr} = 605.9$  psi) is applied as a cosine varying pressure along the contact surface (25" total contact length assumed) between the front limiter and the outer cask wall from ( $0^\circ$  to  $75^\circ$ ).

**D. Reaction Pressures Due to Rear Impact Limiter**

The axial component ( $P_{ra} = 1,689$  psi) is applied as a uniform pressure over the entire outer bottom surface area. The radial component pressure follows a  $\cos \times \cosh$  distribution around the radial crush footprint from  $90^\circ$  to  $180^\circ$  on the cask, and is applied along the contact surface (25" total contact length assumed) between the rear limiter and the outer cask wall.

The loading applied is summarized in the table below.

30 Foot Oblique Impact on Bottom End		
Load Description	Loading Formulae	Symbol on Figure
Pressure applied in radial direction due to weight of internals	Cosine Dist. over 75deg	$P_{ir}$
Pressure applied in axial direction due to weight of internals	P/A	$P_{ia}$
Axial pressures due to front impact limiter	P/A	$P_{fa}$
Radial pressures due to front impact limiter	Cosine Dist. over 75deg	$P_{fr}$
Radial reaction pressures due to rear impact limiter	$\text{Cos} \times \cosh$ dist. Over 90deg	$P_{rr}$
Axial reaction pressures due to rear impact limiter	P/A	$P_{ra}$

**2.10.1.2.1 Evenly distributed pressure over contact area of cask for impact load in axial direction**

Pressures applied in the axial direction are calculated based on load divided by area pressure calculation. For example, to calculate the pressure applied due to internal loading on the inner bottom cask surface due to 1-foot End Drop on Lid End, divide the total load applied by the cross-sectional area.

$$P_i = P_{total} / A$$

$$P_i = W_i \times G_{axial} / (\pi \times r^2)$$

$$P_i = 88,390 \times 30 / (\pi \times 34^2)$$

$$P_i = 730.2 \text{ psi}$$

### 2.10.1.2.2 Cosine Distributed Pressure Functions:

#### A. Cosine Distributed Pressure Loading:

The circumferential cosine pressure distribution over a half angle,  $\theta$ , is calculated as follows:

$$P_i = P_{\max} \cos(\pi\theta_i / 2\theta)$$

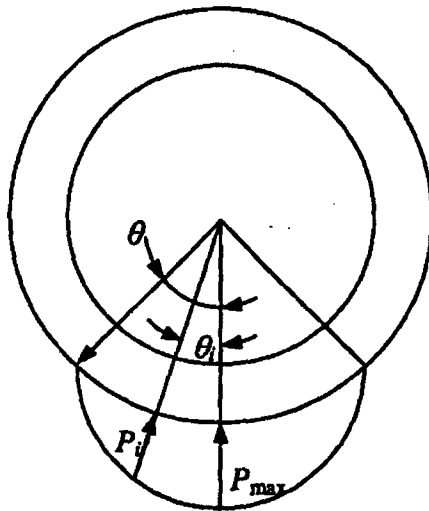
Where:

$P_i$  = Pressure load at angle  $\theta_i$ .

$P_{\max}$  = Peak pressure load, at point of impact.

$\theta_i$  = Angle corresponding to point of interest.

The circumferential pressure distribution is illustrated in following Sketch.



The peak pressure load,  $P_{\max}$ , is determined by setting the integral of the vertical pressure components,  $Q_i$ , equal to the total transverse impact load,  $F_i$ , as follows:

$$\begin{aligned} F_i &= \int_{-\theta}^{\theta} Q_i LR d\theta_i = \int_{-\theta}^{\theta} P_i \cos(\theta_i) LR d\theta_i = \int_{-\theta}^{\theta} P_{\max} \cos\left(\frac{\pi\theta_i}{2\theta}\right) \cos(\theta_i) LR d\theta_i \\ &= \frac{P_{\max} LR}{2} \int_{-\theta}^{\theta} \left[ \cos\left(\frac{\pi\theta_i}{2\theta} + \theta_i\right) + \cos\left(\frac{\pi\theta_i}{2\theta} - \theta_i\right) \right] d\theta_i \\ &= P_{\max} LR \left[ \frac{\sin\left(\frac{\pi}{2} + \theta\right)}{\left(\frac{\pi}{2\theta}\right) + 1} + \frac{\sin\left(\frac{\pi}{2} - \theta\right)}{\left(\frac{\pi}{2\theta}\right) - 1} \right] \end{aligned}$$

Rearranging terms gives the peak pressure,  $P_{\max}$ , as follows:

$$P_{\max} = \frac{F_i}{LR} \left[ \frac{\sin\left(\frac{\pi}{2} + \theta\right)}{\left(\frac{\pi}{2\theta}\right) + 1} + \frac{\sin\left(\frac{\pi}{2} - \theta\right)}{\left(\frac{\pi}{2\theta}\right) - 1} \right]^{-1}$$

Therefore, the pressure at any circumferential location is given by:

$$P_i = \frac{F_i}{LR} \left[ \frac{\sin\left(\frac{\pi}{2} + \theta\right)}{\left(\frac{\pi}{2\theta}\right) + 1} + \frac{\sin\left(\frac{\pi}{2} - \theta\right)}{\left(\frac{\pi}{2\theta}\right) - 1} \right]^{-1} \cos\left(\frac{\pi\theta_i}{2\theta}\right)$$

$$F_i = G \times W$$

Where,  $W$  is the weight of internals or impact limiter,  $G$  is the acceleration in the transverse direction. Therefore,

$$P_i = G \frac{W}{LR} \left[ \frac{\sin\left(\frac{\pi}{2} + \theta\right)}{\left(\frac{\pi}{2\theta}\right) + 1} + \frac{\sin\left(\frac{\pi}{2} - \theta\right)}{\left(\frac{\pi}{2\theta}\right) - 1} \right]^{-1} \cos\left(\frac{\pi\theta_i}{2\theta}\right)$$



For example, to calculate the maximum internal pressure applied for the 1ft Side Drop condition;

$$P_i = G \frac{F}{LR} \frac{1}{\frac{\sin\left(\frac{\pi}{2} + \theta\right)}{\frac{\pi}{2\theta} + 1} + \frac{\sin\left(\frac{\pi}{2} - \theta\right)}{\frac{\pi}{2\theta} - 1}} \times \cos\left(\frac{\pi\theta i}{2\theta}\right)$$

Where:

$G$  = Acceleration

$\theta$  = Angle of application

$\theta(i)$  = Circumferential angle pressure

is applied

$F$  = Weight of internals

$L$  = Length pressure is applied

$$P_i = 30 \frac{88,390}{197.0 \times 34.0} \frac{1}{\frac{\sin(90+75)}{\left(\frac{180}{2 \times 75}\right) + 1} + \frac{\sin(90-75)}{\left(\frac{180}{2 \times 75}\right) - 1}} \times \cos\left(\frac{180 \times 0}{2 \times 75}\right)$$

$$P_i = 280.2 \text{ psi}$$

#### B. Cosine $\times$ Hyperbolic Cosine Distributed Pressure Loading:

The circumferential  $\cos \times \cosh$  pressure distribution over an angle of  $90^\circ$  is calculated as follows:

$$P_i = P_{\max} \cos(x) \times \cosh(x)$$

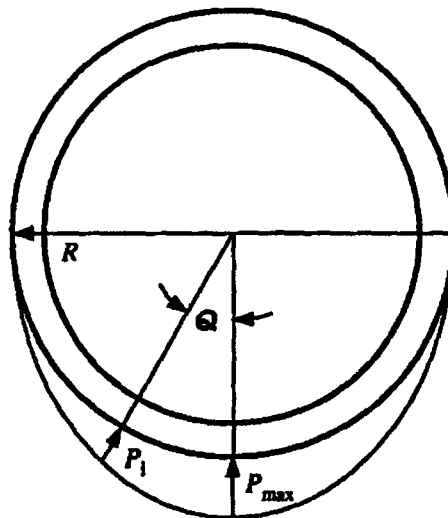
Where:

$P_i$  = Pressure load at angle  $\theta_i$ .

$P_{\max}$  = Peak pressure load, at point of impact.

$x$  = Angle corresponding to point of interest.

The circumferential pressure distribution is illustrated in following Illustration.



The peak pressure load,  $P_{\max}$ , is determined by setting the integral of the vertical pressure components,  $Q_i$ , equal to the total transverse impact load,  $F_i$ , as follows:

$$F_i = \int_{-\theta}^{\theta} Q_i LR d\theta_i = \int_{-\theta}^{\theta} P_i \cos(\theta_i) LR d\theta_i = \int_{-\theta}^{\theta} P_{\max} \cos(\theta) \cosh(\theta) \times \cos(\theta) LR d\theta$$

Evaluating the integral from  $\pi/2$  to  $-\pi/2$ , then rearranging terms gives the peak pressure,  $P_{\max}$ , as follows:

$$= P_{\max} LR \int_{-\frac{\pi}{2}}^{\frac{\pi}{2}} \cos^2(\theta) \cosh(\theta) d\theta$$

$$= P_{\max} LR \left[ \frac{1}{2} \sinh(\theta) + \frac{1}{10} (\sinh(\theta) \cos(2\theta) + 2 \cosh(\theta) \sin(2\theta)) \right]_{-\frac{\pi}{2}}^{\frac{\pi}{2}}$$

$$P_{\max} = \frac{F_i}{LR} (0.543)$$

Therefore, the pressure at any circumferential location is given by:

$$P_i = \frac{F_i \times 0.543}{LR} \cos(\theta)$$

$$\text{Where } F_i = G \times W$$

Where,  $W$  is the weight of internals or impact limiter,  $G$  is the acceleration in the transverse direction.

### 2.10.1.3 ANSYS Analysis Results and Reporting Methodology

Due to the nonlinearities associated with contact elements, it is not possible to run the 22 separate load cases and then combine the results by superposition. Rather, it's necessary to run each of the individual load case or combined load case independently and post process the results separately. A total of 43 separate loading conditions (individual and combined load cases) are executed based on combinations of the previous discusses 22 individual load cases and are grouped into three categories:

- A. Individual load conditions: These analyses (runs 1-12) are based on 12 of the 22 individual load cases (see Table 2.10.1-1). Some of the stress results from these runs are used for the fatigue analysis.
- B. Load combinations for normal condition of transport: These analyses (runs 13-26) are based on combinations of the 22 individual load cases. See Table 2.10.1-2.
- C. Load combinations for accident condition of transport: These analyses (runs 27-42) are also based on combinations of the 22 individual load cases, but simulate accident conditions of transport. See Table 2.10.1-3.

Detailed stresses and displacements in the ANSYS model of the NUHOMS®-MP197 are obtained for each of the 42 load cases listed in the Tables 2.10.1-1, -2, and -3. Boundary conditions used for these runs are shown in Figures 2.10.1-5a to 5g. To simplify results interpretation, the analysis results are post processed with tabulated stresses ( $S_{stress\ intensity}$ ) created at 35 assigned locations on the transport cask structure shown in Figure 2.10.1-19. These locations give an overall global state of stress within the structure during various loading conditions. It should be noted that, for the axisymmetric load analyses, the stress is constant around the cask at every location. For asymmetric load analyses with significant differences in stress magnitudes on the extreme opposite sides of the cask, the stresses at locations on different sides of the cask (impact side and side away from impact) are reported.

The locations selected as shown in Figure 2.10.1-19 are key points that, when carefully studied, indicate the global stress state of the entire structure. However, the maximum stress may occur at a different location for each load case.

Stress intensities at nodal locations on the inner and outer surfaces of the cask body components for the load cases analyzed in Table 2.10.1-1 are reported in Tables 2.10.1-4 through 2.10.1-15. For load cases such as 3G lifting, railcar shock, and railcar vibration, the stresses at the trunnion and transport skid bearing block locations are not considered accurate due to the limitations of the finite element mesh. As a result, the local stresses at the trunnion/transport skid bearing block locations are calculated from the "Bijlaard" analysis as described in the Section 2.5 of this SAR. There are no specific limits for individual stress components. Some of the stress results from these runs are used for the fatigue analysis as described in Sections 2.6.

Stress intensities at nodal locations on the inner and outer surfaces of the cask body component for the normal condition load combinations are listed in tables 2.10.1-13 to 2.10.1-26. These stress intensities are determined for each location, classified, and compared with the design criteria of Section 2.1.2 in Section 2.6.

Stress intensities at nodal locations on the inner and outer surfaces of the cask body component for the accident condition load combinations are listed in tables 2.10.1-27 to 2.10.1-42. These stress intensities are determined for each location, classified and compared with the design criteria of Section 2.1.2 in Section 2.7.

#### 2.10.1.4 Tie-Down Load

For the tie-down loading, the cask is oriented horizontally and secured to the transport skid at the bearing block in the longitudinal direction, supported at two saddles and held by tie down straps. The peak inertia (acceleration) values used are:

##### Rail Car Vibration

Vertical	2 G
Longitudinal	10 G
Lateral	5 G

The forces acting in this case are listed below and illustrated in Figure 2.10.1-18.

#### A. Cask / Lid Inertial loads:

- A longitudinal 10G acceleration (applied in the axial direction)
- The resultant of the vertical & lateral accelerations (applied in the lateral direction) and calculated at  $(2^2 + 5^2)^{1/2} = 5.3G$

#### B. Axial Pressure Due to Rear Impact Limiter:

A pressure due to the weight of the rear impact limiter ( $P_{ra} = 0.51$  psi) is applied axially at the outer bottom surface:

#### C. Pressure Due to Internals:

An axial pressure from the internals is applied on the inside surface of the lid ( $P_{ia} = 243.4$  psi). A radial pressure ( $P_{iv} = 63.2$  psi) acting on the lower half of the inner cask surface due to the weight of internals is represented as a cosine varying pressure around the lower radial portion ( $0^\circ$  to  $75^\circ$  range) of the cavity.

#### D. Radial Pressures Due to Impact Limiters:

In addition, radial pressure due to the front impact limiter weight ( $P_f = 67.5$  psi) is applied along the contacting surfaces of the limiter and the lid/cask wall. The pressure follows a cosine variation and is applied from ( $105^\circ$  to  $180^\circ$ ).

A radial pressure due to the rear impact limiter weight ( $P_r = 69.0$  psi) is also applied along the contacting surfaces of the limiter and the cask wall. Similar to the front impact limiter, the cosine varying pressure is applied from ( $105^\circ$  to  $180^\circ$ ).

#### E. Reaction Pressure

To simulate the reaction pressure at the skid bands, pressures applied by the rear and front transport skid saddle and tiedown strap reactions ( $P_{spr} = 1047.7$  psi and  $P_{spf} = 3820.7$  psi) on the lower longitudinal half of the outer cask body during impact. These pressures are assumed to vary in a cosine distribution around the bottom half of the outer surfaces ( $0^\circ$  to  $75^\circ$ ) and are calculated just as the internal pressures are. However, the total force applied in the equation is based on the total reaction loads required to support equilibrium. That is, a dummy analysis was first executed by applying all necessary loading except the reaction pressures. The model was then constrained radially at the transport skid support saddle (at  $0^\circ$ ) and solved. The "vertical" reactions calculated by ANSYS were then used as input to the cosine distributed pressure loading. All additional loading was reapplied.

#### Results

The tie-down analysis stress results are presented in Table 2.10.1-46. All the calculated stresses are less than the yield stresses of the component materials.

#### 2.10.1.5 Fabrication Stress Calculation

##### Introduction

The objective of this calculation is to evaluate fabrication stresses in NUHOMS<sup>®</sup>-MP197 cask due to lead pouring and the subsequent cool down to room temperature. The differential contraction induced stresses are also evaluated for both normal and hypothetical accident condition load cases.

The NUHOMS<sup>®</sup>-MP197 cask containment boundary is defined as the cask body inner shell (both cylinder and head), the closure flange and lid. The subject of this analysis is the cylindrical portion of the inner shell. The length of this cylinder is 193.5 in., the inside diameter is 68.00 in. and the thickness is 1.25 in. The cylinder is welded to and supported by the closure flange at the lid end and by the bottom plate at its closed end. The cylindrical region around the inner containment cylinder, within the outer shell, is filled with lead.

The inner containment cylinder is subjected to various loads during fabrication and operation. The stresses in the cylinder have been conservatively evaluated and are shown to be acceptable.

### Loading

The inner containment cylinder is subjected to various loads during cask fabrication and operation. The first significant loading during the fabrication process is an external pressurization of the cylinder produced by the hydrostatic head of molten lead created during the pouring process. The column of the molten lead is less than 193.5 in. long. This head causes a maximum hydrostatic pressure of 193.5 in.  $\times$  0.410 lb/in<sup>3</sup> or 79.34 psi on the cylinder. The hoop stress in the cylinder is  $p \times R_o/t$  or  $79.34 \times 35.25 / 1.25$  which equals -2,237 psi. It is shown in Section 2.10.5.5.3 of Appendix 2.10.5 that this stress is well below any cylinder buckling limit.

The next significant loading on the cylinder occurs during cooldown to room temperature after freezing of the molten lead. The assembly of concentric steel-lead-steel cylinders is stress free and void free at the lead freezing temperature (620° F).

This state occurs since the frozen lead had little strength at this temperature and molten lead is added continuously to fill voids that occur as the lead freezes. When the composite steel-lead-steel assembly begins to cool, the lead shrinks radially against the inner steel cylinder (but away from the outer cylinder). This occurs since the thermal contraction of the lead is higher than that of the steel cylinders.

The loads generated by the differential contraction are minimized by cooling the lead very slowly. This allows time for the lead to creep so that residual fabrication stresses relax. The cool down rate is limited by an approved procedure so that the total time for cool down is approximately one week.

During Normal of Transport and Hypothetical Accident Conditions, the inner cylinder is subjected to additional loads caused by thermal expansion. The thermal stresses generated by temperature gradients in the cask are small relative to the thermal stresses generated by the difference in the thermal expansion of the lead and the stainless steel shells.

The analysis below computes the thermal stresses generated by both lead cool down and differential expansion during normal and accident temperature changes.

### Fabrication Stresses

As shown before, the inner containment cylinder is subjected to a relatively mild hoop compressive stress during the lead pouring operation due to the hydrostatic head of 79.34 psi. The hoop stress in the cylinder at that time is -2,237 psi.

During cool down from the lead freezing temperature of 620° F to room temperature, the lead shrinks more than the inner containment cylinder. The differential expansion is equal to:

$$\Delta R_{Lead-Steel} = R \Delta\alpha \Delta T$$

$$\Delta R = (35.25 \text{ in.}) (17.88 - 9.84) 10^{-6} \text{ } ^\circ\text{F}^{-1} (620-70) \text{ } ^\circ\text{F}$$

$$\Delta R = 0.1559 \text{ in.}$$

Therefore the lead cylinder, if it were free, would shrink 0.1559 in. radially more than the inner containment cylinder. If all of this differential contraction is accommodated in lead, the lead strain equals:

$$\epsilon_{\text{lead}} = \Delta R/R = 0.1559/35.25 = 0.00442 \text{ in/in.}$$

This is 0.44% strain in the lead. If the lead remained a linear elastic material, the residual stress in lead would be equal to:

$$\begin{aligned} \sigma_{\text{lead}} &= E_{\text{lead}} \times \epsilon_{\text{lead}} \\ &= (2.49 \times 10^6) (0.00442) = 11,000 \text{ psi} \end{aligned}$$

If the lead cylinder remained elastic at this stress level, significant loads with corresponding high stresses and strains would be applied to the inner containment cylinder. However, the lead is actually quite soft, and the stress level in the lead remains low because of its inelastic behavior. Figure 2.10.1-20 shows typical short-time and low-strain-rate lead stress vs. strain curves for various temperatures obtained by Tietz [9]. Note that the lead stress corresponding to 0.44% strain is of the order of 450 psi for essentially pure lead, even for very rapid straining (curve A strain rate produces 0.44% strain in less than 6 seconds --  $.0044 \times 60/.05 = 5.28$  second).

Additional insight to the possible magnitude of lead stresses for slow loading rates can be obtained from the stress relaxation and creep data (also by Tietz) in Figures 2.10.1-21 and 22. From Figure 2.10.1-21, it can be seen that 0.5% strain rapidly applied (at strain rate of 0.05 in/in per minute) at 100° F produces a stress of about 500 psi which relaxes to 300 psi in 100 hrs., 290 psi in 168 hrs. (one week), and continues to relax. Also note from Figure 2.10.1-22 that indicates a constant stress of 280 psi in the lead for a strain of 0.5% in about 200 hrs. at 100° F.

This data indicates that lead stress will not exceed about 300 psi if the cool down is accomplished slowly (about 1 week). The interface pressure between the lead cylinder and inner containment cylinder required to exert an average hoop stress of 300 psi in lead can be readily determined:

$$\begin{aligned} P_{\text{interface}} &= \sigma_{\text{lead}} \times t_{\text{lead}} / R_{\text{interface}} \\ &= 300 \text{ psi} \times 3.25 \text{ in.} / 35.25 \text{ in.} = 27.7 \text{ psi} \end{aligned}$$

The hoop stress in the inner containment cylinder is then:

$$\begin{aligned} \sigma_{\theta} \text{ inner cylinder} &= p_{\text{interface}} \times R_{\text{interface}} / t_{\text{cylinder}} \\ &= -27.7 \text{ psi} \times 35.25 \text{ in.} / 1.25 \text{ in.} = -781 \text{ psi} \end{aligned}$$

This stress is small and will become negligible with increasing time. It may also be noted that the hydrostatic head stress will become zero when lead is frozen.

### Normal Condition of Transport

As described above, the annulus between the inner containment cylinder and outer shell is filled with lead that has frozen in the annulus, completely filling it at a temperature of about 620° F. The lead contracts more than the volume of the annulus decreases during cool down after the lead pour. Finally, lead creep occurs with time under stress so that the lead cylinder exerts only negligible residual loading on the inner containment cylinder in the "as fabricated" condition.

When the cask body assembly temperature increases to 302° F, as expected during the hot environment normal condition of transport from Chapter 3, the lead cylinder expands away from the inner containment cylinder, but its volume increase will not fill the annulus between the shells. Therefore, differential expansion induced loads on the inner cylinder only occur for the cases where temperature is below room temperature. Consequently, residual fabrication stresses will decrease further during the hot (100° F ambient) normal condition of transport.

If the cask body assembly is subjected to the -40° F cold environment, the lead cylinder will shrink radially more than the inner containment cylinder. The differential expansion is equal to:

$$\Delta R_{Lead-Steel} = R \Delta \alpha \Delta T$$

$$\Delta R = (35.25 \text{ in.}) (15.55 - 8.5) \times 10^{-6} \text{ } ^\circ\text{F}^{-1} (70 + 40) \text{ } ^\circ\text{F}$$

$$\Delta R = 0.02734 \text{ in.}$$

Therefore the lead cylinder, if it were free, would shrink 0.02734 in. radially more than the inner containment cylinder. If all of this differential contraction is accommodated in lead, the lead strain equals:

$$\epsilon_{lead} = \Delta R / R = 0.02734/35.25 = 0.00078 \text{ in/in.}$$

This is 0.078% strain in the lead. If the lead remains a linear elastic material, the residual stress in lead would be roughly  $(2.49 \times 10^6)$  (0.00078) or 1,942 psi. Figure 2.10.1-20 shows that the lead stress will not exceed 300 psi at strain level of 0.078%, and the stress in the inner containment cylinder will be less than -800 psi, even if the strain is rapidly applied. This stress is small and will become negligible with increasing time.



### Hypothetical Accident Condition of Transport

As described above, the annulus between the inner containment cylinder and outer shell is filled with lead that has frozen in the annulus, completely filling it at a temperature of about 620° F. The lead contracts more than the volume of the annulus during cool down after the lead pour. Finally, lead creep occurs with time under stress so that the lead cylinder exerts only negligible residual loading on the inner containment cylinder in the "as fabricated" condition.

When the cask body assembly temperature increases to 535° F, as expected during the thermal accident condition, the lead cylinder expands away from the inner containment cylinder, but its volume increase will not fill the annulus between the shells. The fabrication residual stresses will, therefore, decrease during the hypothetical thermal accident condition.

### Conclusion

From the results of analyses, it is concluded that the cask fabrication stresses due to the molten lead pouring process and the subsequent freezing to room temperature are small. The differential contraction induced stresses, during -40° F normal condition, are negligible. Furthermore, the fabrication stresses remaining in the cask components at the time the cask will be used for transportation will be insignificant.

## 2.10.1.6 Bolt Preload Discussion

### Discussion:

The modeling methodologies of the 2D and 3D differ with respect to the lid. The 2D axisymmetric model assumes a solid lid (i.e. with no counterbores modeled), where as the 3D FEM explicitly models the counterbores (as shown in Figure 1). As a result, the local stiffness of the lid, and thus its response to that loading changes.

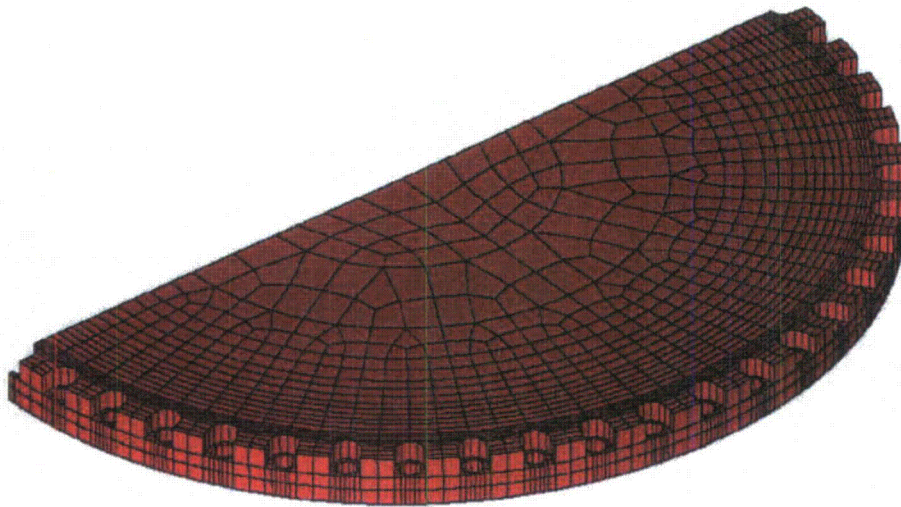


Figure 1: 3D FEM Lid Illustration

Typically, a bolted lid experiences bending stress along the outer surfaces, where the bending stress is greatest. This is clearly visible when viewing a bending stress plot from the FEM results.

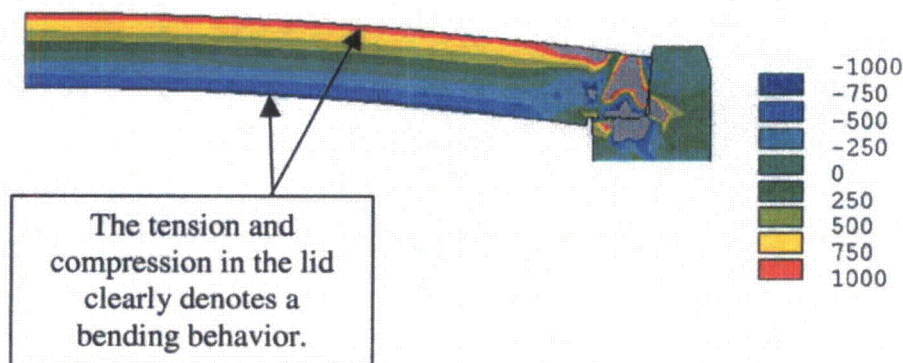


Figure 2: 2D FEM Bending Illustration

Because the 2D FEM assumes an axisymmetric structure, the local stiffness of the lid (at the bolt region) is higher than in the 3D FEM. As such, the sliding behavior of the contact surfaces between the lid and upper cask wall is different in the 2D & 3D models. The less stiff 3D model tends to slide more due to the additional compression of the outer lid surface (at the bolts). This additional sliding creates a larger moment due to the larger perpendicular distance that the bolt load induces in the lid/cask wall. The larger moment produces larger bending stresses.

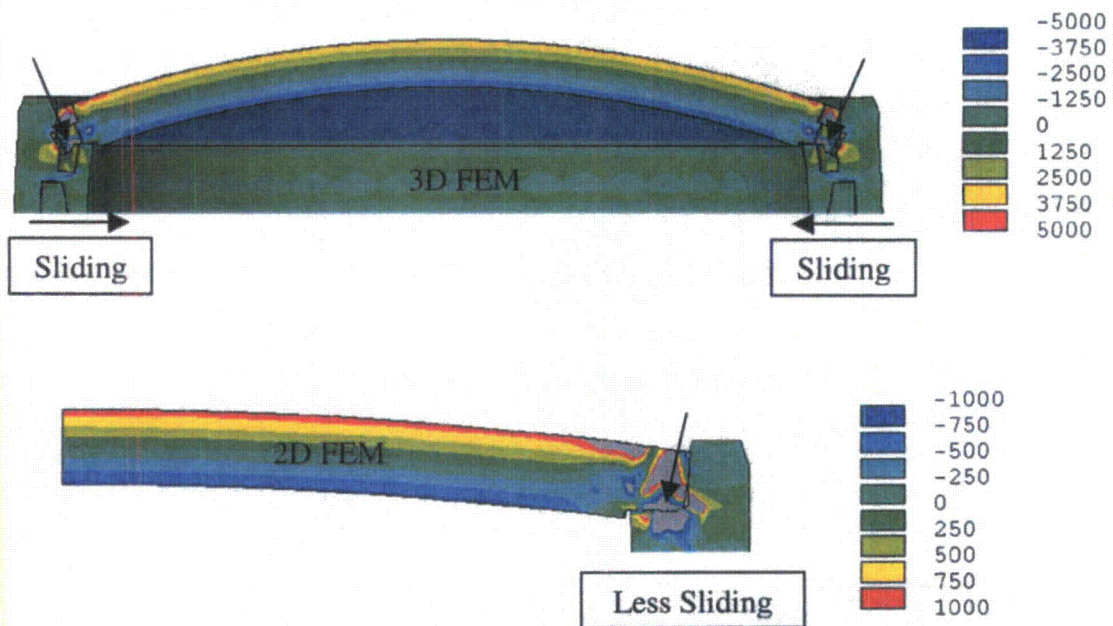


Figure 3: 3D & 2D Bending Stress Illustrations

As a result, the stress intensity fields in the 2D & 3D models will differ for the bolt preload conditions (Tables 2.10.1-4). In the local lid region, the 3D stress intensity reported is approximately 4ksi, whereas the 2D model reports ~1ksi.

Furthermore, tabulated stress results for various loading cases with little or no inertial loading (i.e. railcar shock, railcar vibration, 1g gravity loading, 3g lifting, etc.) using 3D model may report stress results that when compared seem inexplicable. For example, the rail car vibration (0.416g, resultant of vertical & lateral acceleration) load stresses in lid and lid-flange region (Locations 1 to 15 of Table 2.10.1-11) and in the bottom ram closure region (locations 34 and 35 of Table 2.10.1-11) are almost same as for the bolt-preload stresses. The reason being that the preload stresses are hardly overcome by the vibratory load stresses, thus resulting in any significant increase in the stresses. In the case of rail car shock (6.65g, resultant of vertical & lateral acceleration) load, the preload stresses are exceeded. Therefore, the extra vibratory and shock stresses result only after overcoming the preload stresses, and the shock/vibration stress ratio ( $\approx 3$ ) is different than the shock/vibration load ratio ( $\approx 16$ ) in the regions effected by the bolt preloads.

In order to check the validity of the finite element model response, some simple closed-form calculations are conducted. While these simple results are unlikely to duplicate the complex geometry of and loading conditions of the model, they can be used to verify the stresses in simple areas away from discontinuities.

Section 2.10.1.7 verifies the stress results from the 2D finite element model due to the 1-foot end drop on lid end load case.

### 2.10.1.7 Verification of Computer Stress Results due to 1-Foot End Drop on Lid End

The two-dimensional model Bolt Preload Stresses and Bolt Preload plus 1-Foot End Drop on Lid Stresses at locations 1 and 2 (center of lid), and 16, 17, 18 and 19 (cask wall) are compared with hand-calculated stresses. These locations are defined in Figure 2.10.1-19, and are selected because they are located away from geometric discontinuities.

The end drop on lid loading is shown in Figure 2.10.1-11.

$$P_i = 730.2 \text{ psi (axial pressure due to internals)}$$

$$P_{rlm} = 768.4 \text{ psi (axial reaction pressure due to internals and lid)}$$

$$P_{rlo} = 4,592.9 \text{ psi (axial reaction pressure due to cask body and rear impact limiter)}$$

#### Stresses at the Lid Center

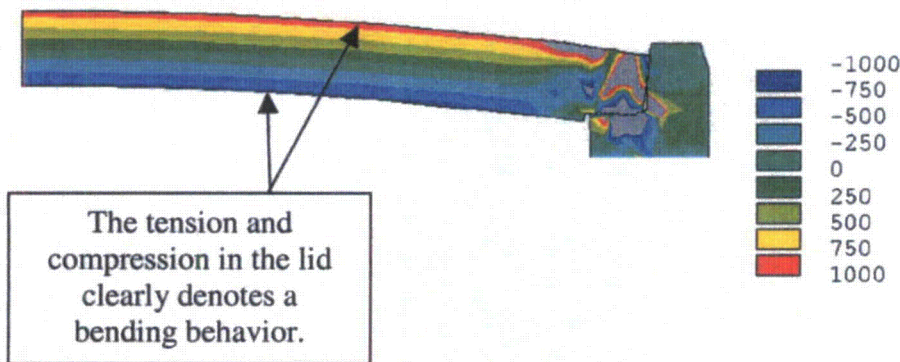
The stresses computed by the 2-dimensional model at locations 1 and 2 are:

##### a) Bolt Preload Stresses:

At Location 1,  $S_x = -840 \text{ psi}$   $S_y = -13 \text{ psi}$   $S_z = -837 \text{ psi}$  S.I. = 829 psi

At Location 2,  $S_x = 875 \text{ psi}$   $S_y = 18 \text{ psi}$   $S_z = 872 \text{ psi}$  S.I. = 861 psi

The deformed lid shape due to bolt preload is shown below. Typically, a bolted lid experiences bending stress ( $S_x$ ) along the outer surfaces, where the bending stress is greatest. This is clearly visible when viewing a bending stress plot from the FEM results.

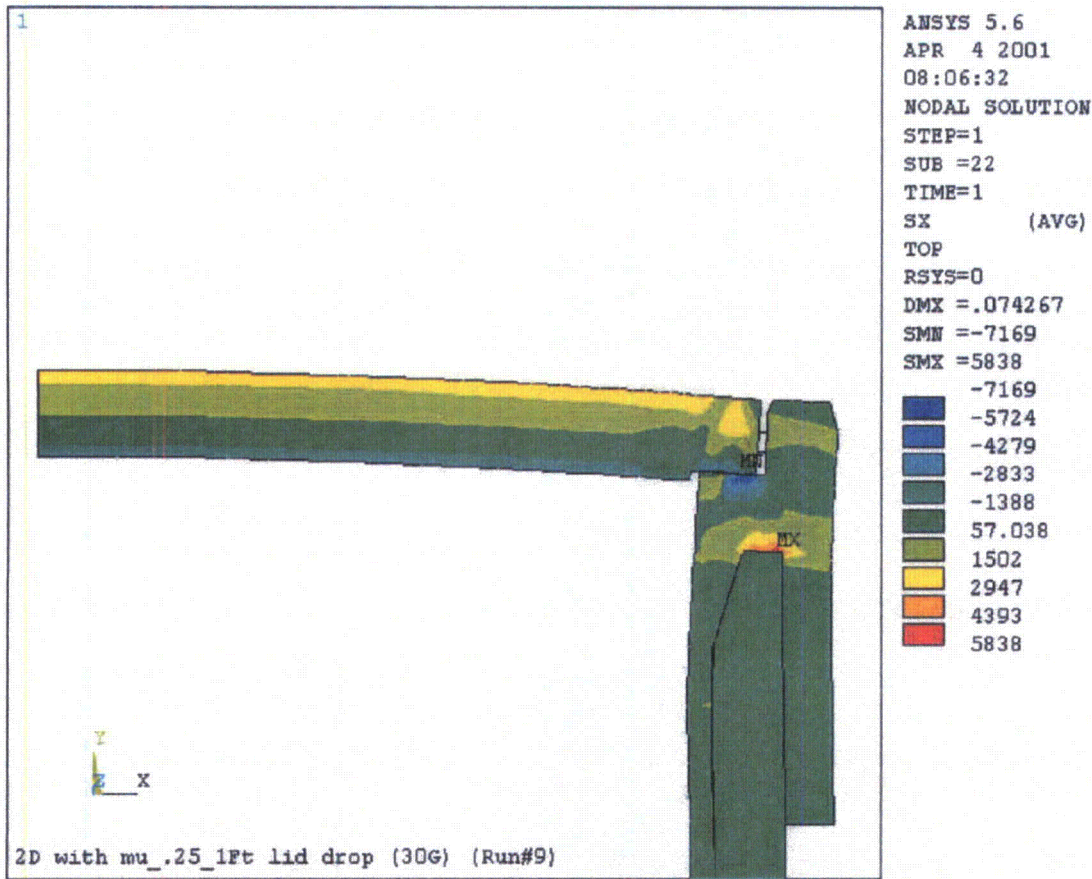


##### b) Bolt Preload plus Lid End Drop Stresses (30g) :

At Location 1,  $S_x = -1956 \text{ psi}$   $S_y = -767 \text{ psi}$   $S_z = -1949 \text{ psi}$  S.I. = 1200 psi

At Location 2,  $S_x = 2095 \text{ psi}$   $S_y = -721 \text{ psi}$   $S_z = 2086 \text{ psi}$  S.I. = 2823 psi

The deformed lid shape and stress distribution due to preload plus lid end drop loads is shown below. This shape is similar to the preload case. The uniform bending stress at lid top and bottom surfaces shows that this stress distribution results also from the bending moment at the bolted-lid location.



Hand – Calculations for Lid stresses due End Drop Pressure:

It is observed that the lid is deformed in similar shape due to bolt preload and preload plus end drop loadings. The stress intensities at the lid center are also similar for the two loadings. Ordinarily, it is expected that the stresses at the lid center will be much higher during the lid end drop. However, the calculations given below show that the lid stresses at center are hardly effected by the direct loads during the end drop.

Pressure  $P_i$ , due to internals = 730.2 psi (Outward)  
 Pressure  $P_{rim}$ , reaction due to internals & lid = 768.4 psi (Inward)

Pressure  $P$ , due to lid inertia for 30g =  $(A \times t \times \text{density} \times 30) / A$   
 =  $(4.5 \times 0.29 \times 30) = 39.15$  psi (Outward)

Net pressure on the central lid region =  $730.2 + 39.15 - 768.4 = 0.95$  psi (Outward)

Stresses due to this net outward pressure are calculated by treating the lid as a circular flat plate with edges supported and uniform load over the surface (from Roark, Ref. 10, Table 10, Case 1):

At Center, Max.  $S_r = 3W(3m + 1) / (8\pi mt^2)$

$a = 72.31/2 = 36.16''$        $t = 4.5''$        $m = 1/\nu = 3.33$        $w = 0.95$  psi

$$W = \pi (36.16)^2 \times 0.95 = 3,902 \text{ lb.}$$

$$S_r = 3 \times 3,902 (3 \times 3.33 + 1) / (8\pi \times 3.33 \times 4.5^2) = 76 \text{ psi}$$

Thus direct central loads on the lid cause negligible stresses. The small increase in lid stresses (beyond the preload condition stresses), during a lid end drop results from the edge moment from lid-flange action due to  $P_{ro} = 4,592.9$  psi (axial reaction pressure due to cask body and rear impact limiter, see Figure 2.10.1-11 for the location of this applied pressure).

The 2-dimensional model stresses at locations 16,17,18 and 19 (see Figure 2.10.1-19) are:

Stresses at locations 16, 17, 18 and 19 from the 2-dimensional model result files are:

a) Bolt Preload Stresses:

At Location 16,	$S_x = 0$ psi	$S_y = -11$ psi	$S_z = -8$ psi	S.I. = 11 psi
At Location 17,	$S_x = -1$ psi	$S_y = -9$ psi	$S_z = -7$ psi	S.I. = 8 psi
At Location 18,	$S_x = 0$ psi	$S_y = 5$ psi	$S_z = -1$ psi	S.I. = 6 psi
At Location 19,	$S_x = 0$ psi	$S_y = 10$ psi	$S_z = 0$ psi	S.I. = 10 psi

As expected, stresses at these locations are negligible due to lid-flange end moment on the cask.

b) Bolt Preload + lid end drop Stresses:

At Location 16,	$S_x = -9$ psi	$S_y = -2879$ psi	$S_z = -1219$ psi	S.I. = 2870 psi
At Location 17,	$S_x = -42$ psi	$S_y = -3095$ psi	$S_z = -1238$ psi	S.I. = 3054 psi
At Location 18,	$S_x = -90$ psi	$S_y = -3391$ psi	$S_z = 1615$ psi	S.I. = 5006 psi
At Location 19,	$S_x = 6$ psi	$S_y = -3281$ psi	$S_z = 1545$ psi	S.I. = 4826psi

As expected, the axial stress component ( $S_y$ ) is the dominant stress component and is used for verification by hand calculation.

Average Stress in the Section =  $-1/4 (2,879 + 3,095 + 3,391 + 3,281) = -3,162$  psi.

c) Hand – Calculated Stresses due Lid End Drop :

Axial Compressive Stress is calculated in the section containing locations 16, 17, 18 and 19 due to a 30g load. The effective weight of this section ( $y = 165.5''$  from the outer surface of the cask bottom) is calculated as follow:

Rear impact limiter and thermal shield	= 14,090 lb.
Bottom End	= 9,954 lb.
Body, Inner Layer $15260 \times (165.5 - 6.5)/193.5$	= 12,539 lb.
Body, Outer Layer $35,037 \times (165.5 - 6.5)/193.5$	= 28,790 lb.
Outer Shell $2,472 \times (165.5 - 24)/158.5$	= 2,207 lb.
Resin $9,975 \times (140.5)/157.5$	= 8,900 lb.
Aluminum Boxes $2,021 \times (140.5)/157.5$	= 1,805 lb.

---

Total Weight = 78,285 lb.

Gamma Shield Lead Weight =  $59,739 \times 159/193.5 = 49,088$  lb.

Weight transferred to cask body by friction =  $0.25 \times 49,088 = 12,272$  lb.

Total downward weight on section =  $78,285 + 12,272 = 90,557$  lb.

Section Area of inner and outer cylinders =  $\pi/4 (70.5^2 - 68.0^2) + \pi/4 (82.0^2 - 77.0^2)$   
=  $271.94 + 624.39 = 896.33$  in<sup>2</sup>

Compressive Axial Stress,  $S_y = -90,557 \times 30g / 896.33 = -3,030$  psi ( $\approx -3,162$  psi calculated from computer).

This stress is quite close (about 4% off) to the computer calculated stress.

Conclusion

There is a good correlation between the computer and hand-calculated stresses at the selected locations for 1-foot lid end drop.



#### 2.10.1.8 References

1. 10CFR 71.71, Normal Conditions of Transport.
2. 10CFR 71.73, Hypothetical Accident Conditions.
3. Regulatory Guide 7.8, "Load Combinations for the Structural Analysis of Shipping casks for Radioactive Material".
4. ASME Code Section III, Subsection NC and Appendices, 1998, including 1999 Addendum.
5. Regulatory Guide 7.6, "Design Criteria for the Structural Analysis of Shipping Cask Containment Vessels".
6. ANSYS Users Manual, Rev. 5.6, 1998.
7. WRC Bulletin 107, March 1979, "Local Stresses in Spherical and Cylindrical Shells Due to External Loadings".
8. NUREG 766510, "Shock and Vibration Environments for Large Shipping Containers on Rail Cars and Trucks".
9. T.E. Tietz, "Mechanical Properties of High Purity Lead and a 0.058 Percent Copper-Lead Alloy", Presented at the Sixty Second Annual Meeting of the ASTM Society, June 1959, ASTM 59, 1052.
10. Roark, Raymond J., "Formulas for Stress and Strain", Fourth Edition, McGraw-Hill Book Company.

**Table 2.10.1-1**  
**Individual Load Conditions**

<b>Run No.</b>	<b>Applicable Individual Loads</b>	<b>Load Used in Run</b>	<b>Stress Result Tables</b>
1	Bolt preload	-	2.10.1-4
2	Internal pressure	50 psig	2.10.1-5
3	External pressure	25 psig	2.10.1-6
4	Thermal stresses at hot environment	-	2.10.1-7
5	Thermal stresses at -20° F cold environment	-	2.10.1-8
6	3G lifting	3G	2.10.1-9
7	Rail Car Shock loads	4.7G – all directions	2.10.1-10
8	Rail car vibration loads	0.37G – vertical 0.19G –lateral 0.19G – longitudinal	2.10.1-11
9	1 foot end drop on lid end	30 G	2.10.1-12
10	1 foot end drop on bottom end	30 G	2.10.1-13
11	1 foot side drop	30 G	2.10.1-14
12	1G gravity loading	1 G	2.10.1-15

**Table 2.10.1-2**  
**Summary of Load Combinations for Normal Condition of Transport**

Run No.	Load Combination	Applicable Individual Loads Applied in the ANSYS Model									
		Bolt Pre-load	Gravity Ig	Int. Pres.	Ext. Pres.	Thermal Hot	Thermal Cold	Thermal -40°F Uniform	Rail Car Vib.	Rail Car shock	Stress Result Table
13	Hot Environment (100° F amb.)	x	x	x		x					2.10.1-16
14	Cold Environment (-40° F amb.)	x	x		x			x			2.10.1-17
15	Increased External Pressure	x	x		x		x				2.10.1-18
16	Min. External Pressure	x	x	x		x					2.10.1-19
17	Rail Car Vibration	x		x		x			x		2.10.1-20
18		x			x		x		x		2.10.1-21
19	Rail Car Shock	x		x		x				x	2.10.1-22
20		x			x		x		x		2.10.1-23

Run No.	Load Combination	Applicable Individual Loads Applied in the ANSYS Model								
		Bolt Pre-load	Internal Pres. (50 psi)	External Pres. (25 psi)	Thermal Hot	Thermal Cold	Lid End Drop	Bottom End Drop	Side drop	Stress Result Table
21	1 Ft End Drop on Lid End	x	x		x		x			2.10.1-24
22		x		x		x	x			2.10.1-25
23	1 Ft End Drop on Bottom End	x	x		x			x		2.10.1-26
24		x		x		x		x		2.10.1-27
25	1 Ft Side Drop	x	x		x				x	2.10.1-28
26		x		x		x			x	2.10.1-29

**Table 2.10.1-3**  
**Summary of Load Combinations for Accident Condition of Transport**

Run No.	Load Combination	Applicable Individual Loads Applied in the ANSYS Model								
		Bolt Pre-Load	Int. Pres. (50 psi)	Ext. Pres. (25 psi)	Thermal Hot	Thermal Cold	Lid End Drop	Bot. End Drop	Side Drop	Stress Result Table
27	30 Ft. End Drop on Bottom End	x	x		x			x		2.10.1-30
28		x		X		x		x		2.10.1-31
29	30 Ft. End Drop on Lid End	x	x		x		x			2.10.1-32
30		x		X		x	x			2.10.1-33
31	30 Ft. Side Drop	x	x		x				x	2.10.1-34
32		x		X		x			x	2.10.1-35

Run No.	Load Combination	Applicable Individual Loads Applied in the ANSYS Model								
		Bolt Pre-Load	Int. Pres. (50 psi)	Ext. Pres. (25 psi)	Thermal Hot	Thermal Cold	Corner Drop Lid End	Corner Drop Bot End	Oblique Drop Lid End	Stress Result Table
33	30 Ft. CG Over Corner Drop on Bottom End	x	x		x			x		2.10.1-36
34		x		x		x		x		2.10.1-37
35	30 Ft. CG Over Corner Drop on Lid End	x	x		x		x			2.10.1-38
36		x		x		x	x			2.10.1-39
37	30 Ft. 20° Oblique Impact on Lid End	x	x		x				x	2.10.1-40
38		x		x		x			x	2.10.1-41

**Table 2.10.1-3**  
**Summary of Load Combinations for Accident Condition of Transport (continued)**

Run No.	Load Combination	Applicable Individual Loads Applied in the ANSYS Model							
		Bolt Pre-load	Int. Pres. (50 psi)	Ext. Pres. (25 psi)	Thermal Hot	Thermal Cold	Oblique Drop Lid End	Oblique Drop Bottom End	Stress Result Table
39	30 Ft. 20° Oblique Impact on Bottom End	x	x		x			x	2.10.1-42
40	30 Ft. 20° Oblique Impact on Bottom End	x		x		x		x	2.10.1-43

Run No.	Load Combination	Applicable Individual Loads Applied in the ANSYS Model								
		Bolt Pre-load	Int. Pres. (50 psi)	Ext. Pres. (25 psi)	Thermal Hot	Thermal Cold	Immersion Ext. Pres. (290 psi)	Fire	Oblique Drop Bottom End	Stress Result Table
41	Immersion (290 psi)	x				x	x			2.10.1-44
42	Fire Accident	x	x					x		2.10.1-45

**Table 2.10.1-4  
Bolt Preload**

<b>Component</b>	<b>location</b>	<b>Max Stress Intensity <math>P_m + P_b</math> (ksi) (2D Model)</b>	<b>Max Stress Intensity <math>P_m + P_b</math> (ksi) (3D Model)</b>
<b>Lid</b>	1	0.83	3.68
	2	0.86	3.58
	3	0.78	3.29
	4	1.91	4.89
<b>Upper Cask Wall</b>	5	4.31	7.01
	6	0.46	1.25
	7	0.82	3.11
	8	0.62	3.07
	9	0.45	0.83
	10	0.36	1.26
	11	0.98	1.77
	12	0.39	1.91
	13	0.32	1.34
	14	0.30	1.14
	15	0.25	1.07
<b>Upper Trunnion</b>	16	0.01	0.20
	17	0.01	0.20
	18	0.01	0.14
	19	0.01	0.08
<b>Mid Cask Wall</b>	20	0.01	0.15
	21	0.01	0.15
	22	0.01	0.05
	23	0.01	0.05
<b>Lower Trunnion</b>	24	0.01	0.14
	25	0.01	0.14
	26	0.01	0.07
<b>Lower Cask wall</b>	27	0.01	0.07
	28	0.01	0.07
	29	0.02	0.20
	30	0.02	0.15
	31	0.01	0.04
<b>Base</b>	32	0.01	0.04
	33	0.02	0.07
	34	0.24	0.41
	35	0.22	0.40

**Table 2.10.1-5**  
**Internal Pressure (50 psi.) only**

<b>Component</b>	<b>location</b>	<b>Max Stress Intensity <math>P_m + P_b</math> (ksi)</b>	<b>Allowable Membrane Stress Intensity (ksi)</b>
<b>Lid</b>	1	3.20	46.70
	2	3.40	46.70
	3	1.82	46.70
	4	1.97	46.70
<b>Upper Cask Wall</b>	5	4.94	31.40
	6	0.46	31.40
	7	0.84	31.40
	8	0.65	31.40
	9	0.54	31.40
	10	0.51	31.40
	11	0.90	31.40
	12	0.56	31.40
	13	0.43	31.40
	14	0.37	31.40
<b>Upper Trunnion</b>	15	0.32	31.40
	16	0.58	31.40
	17	0.54	31.40
	18	0.41	20.00
<b>Mid Cask Wall</b>	19	0.37	20.00
	20	0.57	31.40
	21	0.53	31.40
	22	0.43	20.00
	23	0.38	20.00
<b>Lower Trunnion</b>	24	0.63	31.40
	25	0.59	31.40
	26	0.42	20.00
	27	0.37	20.00
<b>Lower Cask wall</b>	28	1.25	31.40
	29	0.45	31.40
	30	0.71	31.40
<b>Base</b>	31	0.49	31.40
	32	0.94	31.40
	33	0.85	31.40
	34	1.25	31.40
	35	1.37	31.40

**Table 2.10.1-6**  
**External Pressure (25 psi.) only**

<b>Component</b>	<b>location</b>	<b>Max Stress Intensity <math>P_m + P_b</math> (ksf)</b>	<b>Allowable Membrane Stress Intensity (ksf)</b>
<b>Lid</b>	1	0.35	46.70
	2	0.41	46.70
	3	0.44	46.70
	4	2.37	46.70
<b>Upper Cask Wall</b>	5	4.03	31.40
	6	0.55	31.40
	7	1.30	31.40
	8	1.01	31.40
	9	0.62	31.40
	10	0.56	31.40
	11	1.06	31.40
	12	0.54	31.40
	13	0.31	31.40
	14	0.41	31.40
	15	0.27	31.40
<b>Upper Trunnion</b>	16	0.30	31.40
	17	0.28	31.40
	18	0.22	20.00
<b>Mid Cask Wall</b>	19	0.19	20.00
	20	0.28	31.40
	21	0.26	31.40
	22	0.22	20.00
<b>Lower Trunnion</b>	23	0.20	20.00
	24	0.30	31.40
	25	0.28	31.40
	26	0.22	20.00
<b>Lower Cask wall</b>	27	0.19	20.00
	28	0.50	31.40
	29	0.19	31.40
	30	0.31	31.40
<b>Base</b>	31	0.21	31.40
	32	0.46	31.40
	33	0.30	31.40
	34	0.28	31.40
	35	0.57	31.40



**Table 2.10.1-7**  
**Thermal Stresses at hot Environment (100° F)**

<b>Component</b>	<b>location</b>	<b>Max Stress Intensity <math>P_m + P_b</math> (ksi)</b>	<b>Allowable Membrane Stress Intensity (ksi)</b>
<b>Lid</b>	1	2.38	46.70
	2	2.75	46.70
	3	2.31	46.70
	4	3.67	46.70
<b>Upper Cask Wall</b>	5	5.04	31.40
	6	3.22	31.40
	7	6.39	31.40
	8	6.95	31.40
	9	15.63	31.40
	10	5.50	31.40
	11	4.28	31.40
	12	8.54	31.40
	13	7.83	31.40
	14	3.55	31.40
<b>Upper Trunnion</b>	15	3.40	31.40
	16	8.81	31.40
	17	8.03	31.40
	18	6.27	20.00
	19	7.86	20.00
<b>Mid Cask Wall</b>	20	17.19	31.40
	21	14.84	31.40
	22	9.19	20.00
	23	13.26	20.00
<b>Lower Trunnion</b>	24	11.43	31.40
	25	10.01	31.40
	26	7.09	20.00
	27	9.62	20.00
<b>Lower Cask wall</b>	28	6.64	31.40
	29	7.52	31.40
	30	6.74	31.40
	31	3.17	31.40
<b>Base</b>	32	2.99	31.40
	33	2.76	31.40
	34	2.60	31.40
	35	2.97	31.40

**Table 2.10.1-8  
Thermal Stresses at Cold Environment (-20° F)**

<b>Component</b>	<b>location</b>	<b>Max Stress Intensity <math>P_m + P_b</math> (ksi)</b>	<b>Allowable Membrane Stress Intensity (ksi)</b>
<b>Lid</b>	1	2.13	46.70
	2	2.53	46.70
	3	2.08	46.70
	4	3.43	46.70
<b>Upper Cask Wall</b>	5	4.54	31.40
	6	3.21	31.40
	7	0.59	31.40
	8	3.51	31.40
	9	9.35	31.40
	10	1.96	31.40
	11	3.45	31.40
	12	2.92	31.40
	13	7.18	31.40
	14	5.79	31.40
	15	0.99	31.40
<b>Upper Trunnion</b>	16	5.72	31.40
	17	5.12	31.40
	18	4.19	20.00
<b>Mid Cask Wall</b>	19	6.33	20.00
	20	14.04	31.40
	21	11.89	31.40
	22	7.09	20.00
<b>Lower Trunnion</b>	23	11.78	20.00
	24	8.10	31.40
	25	6.84	31.40
	26	5.08	20.00
<b>Lower Cask wall</b>	27	8.23	20.00
	28	4.11	31.40
	29	6.72	31.40
	30	6.14	31.40
<b>Base</b>	31	2.16	31.40
	32	1.82	31.40
	33	2.31	31.40
	34	2.12	31.40
	35	2.31	31.40

Table 2.10.1-9  
3g Lifting

Component	location	Max Stress Intensity $P_m + P_b$ (ksi)	Allowable Membrane Stress Intensity (ksi)
Lid	1	0.12	46.70
	2	0.04	46.70
	3	0.55	46.70
	4	1.87	46.70
Upper Cask Wall	5	4.06	31.40
	6	0.74	31.40
	7	1.57	31.40
	8	1.84	31.40
	9	1.68	31.40
	10	0.79	31.40
	11	0.83	31.40
	12	0.92	31.40
	13	1.42	31.40
	14	1.20	31.40
	15	0.59	31.40
Upper Trunnion	16	0.57	31.40
	17	0.58	31.40
	18	0.13	20.00
Mid Cask Wall	19	0.14	20.00
	20	0.54	31.40
	21	0.54	31.40
	22	0.66	20.00
	23	0.66	20.00
Lower Trunnion	24	0.45	31.40
	25	0.45	31.40
	26	0.54	20.00
	27	0.53	20.00
Lower Cask wall	28	2.61	31.40
	29	1.65	31.40
	30	2.07	31.40
	31	1.00	31.40
Base	32	1.31	31.40
	33	1.31	31.40
	34	2.01	31.40
	35	2.09	31.40

Table 2.10.1-10  
Rail Car Shock Loads

Component	Location	Max Stress Intensity $P_m + P_b$ (ksi) At Contact Side	Max Stress Intensity $P_m + P_b$ (ksi) 90° from Contact Side	Max Stress Intensity $P_m + P_b$ (ksi) 180° from Contact Side	Allowable Membrane Stress Intensity (ksi)
Lid	1	12.71	12.67	12.54	46.70
	2	12.26	12.16	12.19	46.70
	3	7.12	6.97	7.03	46.70
	4	7.46	9.23	7.66	46.70
Upper Cask Wall	5	7.94	5.75	6.83	31.40
	6	1.74	0.84	1.17	31.40
	7	3.63	3.61	2.00	31.40
	8	3.56	1.95	3.24	31.40
	9	2.27	4.96	0.72	31.40
	10	0.93	0.92	0.91	31.40
	11	2.27	2.07	1.67	31.40
	12	2.63	2.82	0.94	31.40
	13	2.45	1.98	2.25	31.40
	14	2.78	3.57	0.92	31.40
	15	0.78	2.04	0.54	31.40
Upper Trunnion	16	6.23	3.64	0.56	31.40
	17	2.02	3.58	1.78	31.40
	18	7.20	5.76	2.29	20.00
	19	1.11	5.76	1.95	20.00
Mid Cask Wall	20	5.67	5.00	2.52	31.40
	21	2.67	3.75	2.44	31.40
	22	3.54	6.28	3.66	20.00
	23	2.81	5.31	3.12	20.00
Lower Trunnion	24	2.72	1.73	1.00	31.40
	25	1.09	1.69	1.32	31.40
	26	6.62	2.68	2.04	20.00
	27	3.61	2.79	1.67	20.00
Lower Cask wall	28	3.54	1.50	2.37	31.40
	29	3.90	1.25	2.19	31.40
	30	4.95	1.94	2.19	31.40
	31	2.09	1.29	1.00	31.40
Base	32	2.15	1.21	1.71	31.40
	33	1.17	0.81	1.42	31.40
	34	0.73	0.53	0.87	31.40
	35	0.66	0.67	0.52	31.40

Table 2.10.1-11  
Rail Car Vibration Loads

Component	Location	Max Stress Intensity $P_m + P_b$ (ksi) At Contact Side	Max Stress Intensity $P_m + P_b$ (ksi) 90° from Contact Side	Max Stress Intensity $P_m + P_b$ (ksi) 180° from Contact Side	Allowable Membrane Stress Intensity (ksi)
Lid	1	4.05	4.03	4.00	46.70
	2	3.91	3.89	3.88	46.70
	3	3.43	3.42	3.43	46.70
	4	4.89	4.89	4.89	46.70
Upper Cask Wall	5	7.06	6.69	7.00	31.40
	6	1.24	1.20	1.24	31.40
	7	3.05	2.98	3.04	31.40
	8	3.17	2.80	3.15	31.40
	9	1.00	0.59	0.90	31.40
	10	1.28	1.21	1.28	31.40
	11	1.78	1.71	1.74	31.40
	12	2.01	1.83	1.92	31.40
	13	1.46	1.27	1.38	31.40
	14	1.30	0.92	1.18	31.40
	15	1.02	1.10	1.01	31.40
Upper Trunnion	16	0.40	0.22	0.15	31.40
	17	0.33	0.16	0.21	31.40
	18	0.40	0.37	0.12	20.00
	19	0.09	0.38	0.09	20.00
Mid Cask Wall	20	0.42	0.24	0.27	31.40
	21	0.31	0.12	0.29	31.40
	22	0.28	0.41	0.21	20.00
	23	0.17	0.35	0.16	20.00
Lower Trunnion	24	0.32	0.14	0.18	31.40
	25	0.20	0.13	0.20	31.40
	26	0.34	0.23	0.10	20.00
	27	0.12	0.24	0.08	20.00
Lower Cask wall	28	0.19	0.16	0.15	31.40
	29	0.08	0.31	0.08	31.40
	30	0.13	0.28	0.03	31.40
	31	0.08	0.11	0.06	31.40
Base	32	0.13	0.08	0.12	31.40
	33	0.07	0.08	0.09	31.40
	34	0.43	0.37	0.43	31.40
	35	0.37	0.35	0.38	31.40

**Table 2.10.1-12**  
**1 Foot End Drop on Lid End**

<b>Component</b>	<b>location</b>	<b>Max Stress Intensity <math>P_m + P_b</math> (ksi)</b>	<b>Allowable Membrane Stress Intensity (ksi)</b>
<b>Lid</b>	1	1.20	46.70
	2	2.82	46.70
	3	1.14	46.70
	4	3.83	46.70
<b>Upper Cask Wall</b>	5	7.34	31.40
	6	5.99	31.40
	7	3.32	31.40
	8	2.07	31.40
	9	2.18	31.40
	10	8.64	31.40
	11	5.93	31.40
	12	1.71	31.40
	13	6.22	31.40
	14	3.28	31.40
<b>Upper Trunnion</b>	15	5.36	31.40
	16	2.87	31.40
	17	3.05	31.40
	18	5.01	20.00
<b>Mid Cask Wall</b>	19	4.83	20.00
	20	2.31	31.40
	21	2.31	31.40
	22	2.59	20.00
<b>Lower Trunnion</b>	23	2.55	20.00
	24	1.73	31.40
	25	1.71	31.40
	26	1.20	20.00
	27	1.18	20.00
<b>Lower Cask wall</b>	28	4.08	31.40
	29	2.13	31.40
	30	2.76	31.40
	31	1.46	31.40
<b>Base</b>	32	2.04	31.40
	33	1.56	31.40
	34	0.50	31.40
	35	3.55	31.40

**Table 2.10.1-13**  
**1 Foot End Drop on Bottom End**

<b>Component</b>	<b>location</b>	<b>Max Stress Intensity <math>P_m + P_s</math> (ksi)</b>	<b>Allowable Membrane Stress Intensity (ksi)</b>
<b>Lid</b>	1	3.30	46.70
	2	3.51	46.70
	3	1.68	46.70
	4	4.04	46.70
<b>Upper Cask Wall</b>	5	3.45	31.40
	6	0.62	31.40
	7	4.23	31.40
	8	2.25	31.40
	9	2.96	31.40
	10	1.89	31.40
	11	1.14	31.40
	12	2.95	31.40
	13	1.84	31.40
	14	1.90	31.40
<b>Upper Trunnion</b>	15	1.15	31.40
	16	2.07	31.40
	17	2.05	31.40
	18	1.08	20.00
<b>Mid Cask Wall</b>	19	1.04	20.00
	20	2.71	31.40
	21	2.70	31.40
	22	2.45	20.00
	23	2.42	20.00
<b>Lower Trunnion</b>	24	3.30	31.40
	25	3.39	31.40
	26	4.61	20.00
<b>Lower Cask wall</b>	27	4.44	20.00
	28	4.74	31.40
	29	2.55	31.40
	30	6.35	31.40
	31	4.14	31.40
<b>Base</b>	32	1.55	31.40
	33	0.71	31.40
	34	2.74	31.40
	35	4.66	31.40

Table 2.10.1-14  
1 Foot Side Drop

Component	Location	Max Stress Intensity $P_m + P_b$ (ksi) At Contact Side	Max Stress Intensity $P_m + P_b$ (ksi) 90° from Contact Side	Allowable Membrane Stress Intensity (ksi)
Lid	1	8.27	7.93	46.70
	2	7.86	7.64	46.70
	3	12.36	2.57	46.70
	4	5.57	6.06	46.70
Upper Cask Wall	5	13.38	6.71	31.40
	6	8.56	3.10	31.40
	7	11.55	9.18	31.40
	8	10.17	4.74	31.40
	9	13.17	8.97	31.40
	10	12.76	4.95	31.40
	11	4.96	5.46	31.40
	12	19.15	8.58	31.40
	13	14.88	6.98	31.40
	14	24.16	8.08	31.40
	15	19.73	7.46	31.40
Upper Trunnion	16	4.69	8.99	31.40
	17	7.54	9.88	31.40
	18	2.61	7.13	20.00
	19	7.55	8.59	20.00
Mid Cask Wall	20	9.67	4.40	31.40
	21	11.53	3.88	31.40
	22	7.39	6.22	20.00
	23	10.90	5.13	20.00
Lower Trunnion	24	3.81	8.54	31.40
	25	7.15	9.21	31.40
	26	2.22	7.96	20.00
	27	8.11	8.83	20.00
Lower Cask wall	28	14.50	8.90	31.40
	29	12.88	6.59	31.40
	30	21.22	8.41	31.40
	31	16.99	5.63	31.40
Base	32	10.82	3.01	31.40
	33	3.70	3.67	31.40
	34	6.02	2.36	31.40
	35	2.95	2.70	31.40



Table 2.10.1-15  
1g Gravity Loading

Component	Location	Max Stress Intensity $P_m + P_b$ (ksi) At Contact Side	Max Stress Intensity $P_m + P_b$ (ksi) 90° from Contact Side	Allowable Membrane Stress Intensity (ksi)
Lid	1	3.81	3.79	46.70
	2	3.58	3.57	46.70
	3	3.31	3.29	46.70
	4	4.89	4.88	46.70
Upper Cask Wall	5	7.16	6.68	31.40
	6	1.30	1.20	31.40
	7	3.26	3.03	31.40
	8	3.49	2.70	31.40
	9	1.39	0.48	31.40
	10	1.38	1.20	31.40
	11	1.84	1.71	31.40
	12	2.21	1.84	31.40
	13	1.67	1.24	31.40
	14	1.65	0.81	31.40
Upper Trunnion	15	1.00	1.15	31.40
	16	0.77	0.35	31.40
	17	0.40	0.30	31.40
	18	0.99	0.66	20.00
Mid Cask Wall	19	0.24	0.66	20.00
	20	0.88	0.52	31.40
	21	0.65	0.33	31.40
	22	0.92	0.87	20.00
Lower Trunnion	23	0.59	0.68	20.00
	24	0.78	0.33	31.40
	25	0.38	0.32	31.40
	26	0.85	0.60	20.00
Lower Cask wall	27	0.24	0.60	20.00
	28	0.46	0.48	31.40
	29	0.27	0.60	31.40
	30	0.42	0.63	31.40
Base	31	0.20	0.26	31.40
	32	0.31	0.26	31.40
	33	0.13	0.20	31.40
	34	0.48	0.39	31.40
	35	0.42	0.38	31.40

Table 2.10.1-16  
1g Side Loading, Hot Environment (100° F Ambient)

Component	Location	Max Stress Intensity $P_m + P_b$ (ksi) At Contact Side	Max Stress Intensity $P_m + P_b$ (ksi) 90° from Contact Side	Allowable Membrane Stress Intensity (ksi)
Lid	1	5.71	5.70	46.70
	2	9.31	9.30	46.70
	3	3.42	3.58	46.70
	4	7.88	8.29	46.70
	5	5.36	5.31	31.40
Upper Cask Wall	6	3.60	3.60	31.40
	7	9.62	9.85	31.40
	8	6.46	6.50	31.40
	9	9.57	10.17	31.40
	10	3.11	2.92	31.40
	11	4.66	4.89	31.40
	12	4.70	5.45	31.40
	13	4.48	4.90	31.40
	14	1.81	2.14	31.40
	15	7.08	7.25	31.40
Upper Trunnion	16	7.16	8.04	31.40
	17	7.14	6.90	31.40
	18	6.72	5.90	20.00
	19	7.88	8.42	20.00
Mid Cask Wall	20	12.88	14.66	31.40
	21	13.67	12.20	31.40
	22	6.79	8.01	20.00
	23	10.56	13.33	20.00
Lower Trunnion	24	9.21	10.02	31.40
	25	8.44	8.32	31.40
	26	7.25	6.40	20.00
	27	9.61	10.06	20.00
Lower Cask wall	28	5.74	6.22	31.40
	29	6.73	7.54	31.40
	30	7.86	8.55	31.40
	31	2.29	2.22	31.40
Base	32	2.44	2.70	31.40
	33	3.23	3.73	31.40
	34	3.95	3.50	31.40
	35	3.56	3.74	31.40

**Table 2.10.1-17**  
**1g Side Loading, Cold Environment (-40° F Ambient)**

<b>Component</b>	<b>Location</b>	<b>Max Stress Intensity <math>P_m + P_b</math> (ksi) At Contact Side</b>	<b>Max Stress Intensity <math>P_m + P_b</math> (ksi) 90° from Contact Side</b>	<b>Allowable Membrane Stress Intensity (ksi)</b>
<b>Lid</b>	1	1.33	1.31	46.70
	2	2.92	2.91	46.70
	3	2.02	2.04	46.70
	4	5.73	5.67	46.70
<b>Upper Cask Wall</b>	5	7.89	7.66	31.40
	6	0.16	0.23	31.40
	7	2.93	3.16	31.40
	8	3.70	4.53	31.40
	9	7.08	7.97	31.40
	10	1.19	1.36	31.40
	11	2.42	2.50	31.40
	12	3.54	3.96	31.40
	13	6.69	7.43	31.40
	14	4.14	4.91	31.40
	15	2.63	2.67	31.40
<b>Upper Trunnion</b>	16	6.24	5.97	31.40
	17	5.88	5.73	31.40
	18	3.63	3.54	20.00
	19	5.41	6.01	20.00
<b>Mid Cask Wall</b>	20	10.87	12.27	31.40
	21	10.65	9.89	31.40
	22	4.35	5.22	20.00
	23	9.30	11.31	20.00
<b>Lower Trunnion</b>	24	7.04	7.70	31.40
	25	6.11	6.10	31.40
	26	4.12	3.54	20.00
	27	7.61	7.86	20.00
<b>Lower Cask wall</b>	28	3.69	4.11	31.40
	29	7.13	7.91	31.40
	30	6.00	6.68	31.40
	31	2.30	2.04	31.40
<b>Base</b>	32	1.93	1.83	31.40
	33	2.46	2.51	31.40
	34	1.81	1.71	31.40
	35	1.93	1.86	31.40

Table 2.10.1-18  
1g Side Loading, Increased External Pressure (25 psig.)

Component	Location	Max Stress Intensity $P_m + P_b$ (ksi) At Contact Side	Max Stress Intensity $P_m + P_b$ (ksi) 90° from Contact Side	Allowable Membrane Stress Intensity (ksi)
Lid	1	1.15	1.13	46.70
	2	2.95	2.93	46.70
	3	1.78	1.83	46.70
	4	5.69	5.76	46.70
Upper Cask Wall	5	7.35	7.00	31.40
	6	0.44	0.48	31.40
	7	3.55	3.59	31.40
	8	2.60	3.18	31.40
	9	7.12	7.94	31.40
	10	1.44	1.53	31.40
	11	2.34	2.44	31.40
	12	3.24	3.86	31.40
	13	6.04	6.69	31.40
	14	3.70	4.15	31.40
	15	3.32	3.41	31.40
Upper Trunnion	16	5.91	5.91	31.40
	17	5.72	5.54	31.40
	18	4.05	3.72	20.00
	19	5.73	6.35	20.00
Mid Cask Wall	20	11.26	12.68	31.40
	21	11.10	10.28	31.40
	22	4.56	5.50	20.00
	23	9.45	11.49	20.00
Lower Trunnion	24	7.31	7.98	31.40
	25	6.38	6.35	31.40
	26	4.44	3.85	20.00
	27	7.86	8.09	20.00
Lower Cask wall	28	3.79	4.18	31.40
	29	6.78	7.58	31.40
	30	6.06	6.70	31.40
	31	2.33	2.15	31.40
Base	32	1.99	1.86	31.40
	33	2.44	2.48	31.40
	34	1.80	1.69	31.40
	35	1.92	1.85	31.40

Table 2.10.1-19  
1g Side Loading, Reduced External Pressure (50 psig.)

Component	Location	Max Stress Intensity $P_m + P_b$ (ksf) At Contact Side	Max Stress Intensity $P_m + P_b$ (ksf) 90° from Contact Side	Allowable Membrane Stress Intensity (ksf)
Lid	1	5.71	5.70	46.70
	2	9.31	9.30	46.70
	3	3.42	3.58	46.70
	4	7.88	8.29	46.70
Upper Cask Wall	5	5.36	5.31	31.40
	6	3.60	3.60	31.40
	7	9.62	9.85	31.40
	8	6.46	6.50	31.40
	9	9.57	10.17	31.40
	10	3.11	2.92	31.40
	11	4.66	4.89	31.40
	12	4.70	5.45	31.40
	13	4.48	4.90	31.40
	14	1.81	2.14	31.40
	15	7.08	7.25	31.40
Upper Trunnion	16	7.16	8.04	31.40
	17	7.14	6.90	31.40
	18	6.72	5.90	20.00
	19	7.88	8.42	20.00
Mid Cask Wall	20	12.88	14.66	31.40
	21	13.67	12.20	31.40
	22	6.79	8.01	20.00
	23	10.56	13.33	20.00
Lower Trunnion	24	9.21	10.02	31.40
	25	8.44	8.32	31.40
	26	7.25	6.40	20.00
	27	9.61	10.06	20.00
Lower Cask wall	28	5.74	6.22	31.40
	29	6.73	7.54	31.40
	30	7.86	8.55	31.40
	31	2.29	2.22	31.40
Base	32	2.44	2.70	31.40
	33	3.23	3.73	31.40
	34	3.95	3.50	31.40
	35	3.56	3.74	31.40

Table 2.10.1-20  
Rail Car Vibration Loads, Internal pressure, Hot Environment

Component	Location	Max Stress Intensity $P_m + P_b$ (ksi) At Contact Side	Max Stress Intensity $P_m + P_b$ (ksi) 90° from Contact Side	Max Stress Intensity $P_m + P_b$ (ksi) 180° from Contact Side	Allowable Membrane Stress Intensity (ksi)
Lid	1	6.02	6.01	5.94	46.70
	2	9.67	9.65	9.58	46.70
	3	3.63	3.73	3.65	46.70
	4	8.15	8.39	8.18	46.70
	5	5.40	5.27	5.40	31.40
Upper Cask Wall	6	3.62	3.56	3.65	31.40
	7	9.64	9.71	9.60	31.40
	8	6.50	6.43	6.49	31.40
	9	9.77	10.15	9.90	31.40
	10	3.15	2.91	3.23	31.40
	11	4.73	4.80	4.79	31.40
	12	4.91	5.33	5.01	31.40
	13	4.62	4.89	4.77	31.40
	14	1.93	2.15	2.00	31.40
	15	7.12	7.17	7.04	31.40
Upper Trunnion	16	7.40	7.90	7.53	31.40
	17	7.17	6.93	7.09	31.40
	18	6.49	6.05	6.38	20.00
	19	7.93	8.29	7.92	20.00
Mid Cask Wall	20	13.13	14.38	14.00	31.40
	21	13.72	12.25	12.33	31.40
	22	6.39	8.24	8.55	20.00
	23	10.64	13.07	12.68	20.00
Lower Trunnion	24	9.38	9.84	9.60	31.40
	25	8.54	8.38	8.59	31.40
	26	7.11	6.58	6.97	20.00
	27	9.53	9.83	9.53	20.00
Lower Cask wall	28	5.86	6.09	5.95	31.40
	29	6.89	7.38	7.17	31.40
	30	8.01	8.36	8.00	31.40
Base	31	2.24	2.26	2.37	31.40
	32	2.50	2.64	2.57	31.40
	33	3.24	3.68	3.54	31.40
	34	3.89	3.49	3.59	31.40
	35	3.54	3.73	3.80	31.40

Table 2.10.1-21  
Rail Car Vibration Loads, External pressure, Cold Environment

Component	Location	Max Stress Intensity $P_m + P_b$ (ksi) At Contact Side	Max Stress Intensity $P_m + P_b$ (ksi) 90° from Contact Side	Max Stress Intensity $P_m + P_b$ (ksi) 180° from Contact Side	Allowable Membrane Stress Intensity (ksi)
Lid	1	1.43	1.41	1.40	46.70
	2	3.29	3.27	3.26	46.70
	3	1.92	1.98	1.94	46.70
	4	5.72	5.75	5.72	46.70
Upper Cask Wall	5	7.30	7.03	7.28	31.40
	6	0.48	0.45	0.52	31.40
	7	3.49	3.47	3.48	31.40
	8	2.78	3.16	2.84	31.40
	9	7.38	7.91	7.45	31.40
	10	1.51	1.52	1.57	31.40
	11	2.36	2.41	2.30	31.40
	12	3.39	3.78	3.49	31.40
	13	6.20	6.63	6.27	31.40
	14	3.86	4.14	3.90	31.40
	15	3.32	3.35	3.27	31.40
Upper Trunnion	16	5.80	5.79	5.62	31.40
	17	5.64	5.57	5.73	31.40
	18	3.83	3.67	3.68	20.00
	19	5.78	6.21	5.83	20.00
Mid Cask Wall	20	11.49	12.47	11.86	31.40
	21	11.16	10.31	10.39	31.40
	22	4.24	5.67	6.11	20.00
	23	9.52	11.30	10.72	20.00
Lower Trunnion	24	7.36	7.80	7.39	31.40
	25	6.55	6.42	6.67	31.40
	26	4.48	4.04	4.58	20.00
	27	7.68	7.87	7.40	20.00
Lower Cask wall	28	3.87	4.11	3.94	31.40
	29	6.84	7.42	6.92	31.40
	30	6.12	6.57	6.11	31.40
	31	2.30	2.21	2.41	31.40
Base	32	1.99	1.82	1.82	31.40
	33	2.44	2.43	2.34	31.40
	34	1.76	1.68	1.77	31.40
	35	1.90	1.84	1.91	31.40

Table 2.10.1-22  
 Rail Car Shock Loads, Internal pressure, Hot Environment

Component	Location	Max Stress Intensity $P_m + P_b$ (ksi) At Contact Side	Max Stress Intensity $P_m + P_b$ (ksi) 90° from Contact Side	Max Stress Intensity $P_m + P_b$ (ksi) 180° from Contact Side	Allowable Membrane Stress Intensity (ksi)
Lid	1	15.77	15.77	15.59	46.70
	2	18.27	18.31	18.11	46.70
	3	7.88	8.72	7.89	46.70
	4	10.90	14.09	11.31	46.70
Upper Cask Wall	5	5.34	5.93	4.80	31.40
	6	1.77	2.42	3.10	31.40
	7	6.27	9.37	6.68	31.40
	8	4.88	5.80	5.72	31.40
	9	9.45	13.98	9.96	31.40
	10	3.03	3.79	3.74	31.40
	11	2.29	4.91	3.61	31.40
	12	1.96	7.93	3.68	31.40
	13	3.43	6.76	4.95	31.40
	14	3.18	4.60	2.71	31.40
	15	5.28	7.64	5.24	31.40
Upper Trunnion	16	7.54	10.62	6.12	31.40
	17	6.57	6.07	7.74	31.40
	18	9.62	6.25	7.60	20.00
	19	7.33	12.09	6.09	20.00
Mid Cask Wall	20	9.17	17.94	11.44	31.40
	21	12.67	11.64	12.85	31.40
	22	8.64	6.22	10.36	20.00
	23	8.00	16.51	9.96	20.00
Lower Trunnion	24	6.69	10.91	8.61	31.40
	25	8.56	7.86	9.08	31.40
	26	9.89	5.61	7.77	20.00
	27	8.32	11.42	8.13	20.00
Lower Cask wall	28	4.17	6.91	5.63	31.40
	29	4.41	8.27	6.24	31.40
	30	5.51	9.35	6.54	31.40
	31	3.57	2.38	2.88	31.40
Base	32	2.33	2.83	2.68	31.40
	33	2.51	3.65	2.82	31.40
	34	3.31	2.76	3.39	31.40
	35	3.35	3.03	3.59	31.40



Table 2.10.1-23  
 Rail Car Shock Loads, External pressure, Cold Environment

Component	Location	Max Stress Intensity $P_m + P_b$ (ksi) At Contact Side	Max Stress Intensity $P_m + P_b$ (ksi) 90° from Contact Side	Max Stress Intensity $P_m + P_b$ (ksi) 180° from Contact Side	Allowable Membrane Stress Intensity (ksi)
Lid	1	10.23	10.20	10.09	46.70
	2	11.38	11.31	11.33	46.70
	3	5.75	5.86	5.66	46.70
	4	7.26	9.39	7.48	46.70
Upper Cask Wall	5	8.19	6.65	7.25	31.40
	6	1.19	0.41	0.55	31.40
	7	1.07	5.83	1.70	31.40
	8	2.71	6.53	3.22	31.40
	9	7.10	12.55	7.78	31.40
	10	1.23	2.72	2.22	31.40
	11	1.75	2.92	1.70	31.40
	12	1.34	6.37	2.86	31.40
	13	4.89	8.75	5.44	31.40
	14	3.91	7.96	4.51	31.40
	15	1.99	3.98	2.86	31.40
Upper Trunnion	16	8.22	8.33	4.77	31.40
	17	6.17	4.51	5.72	31.40
	18	7.44	5.36	4.75	20.00
	19	5.42	10.46	4.36	20.00
Mid Cask Wall	20	9.04	16.01	9.26	31.40
	21	10.12	9.97	10.69	31.40
	22	6.51	5.05	7.71	20.00
	23	7.31	14.73	8.08	20.00
Lower Trunnion	24	6.81	8.94	6.45	31.40
	25	6.49	6.13	7.09	31.40
	26	7.18	3.98	5.34	20.00
	27	6.48	9.77	6.09	20.00
Lower Cask wall	28	2.95	4.62	3.52	31.40
	29	4.20	8.59	5.31	31.40
	30	3.49	7.41	4.50	31.40
	31	3.42	2.00	3.07	31.40
Base	32	2.66	1.95	2.76	31.40
	33	2.64	2.38	2.77	31.40
	34	1.44	0.96	1.51	31.40
	35	1.40	1.09	1.64	31.40

Table 2.10.1-24  
1 Foot End Drop on Lid End, Internal Pressure, Hot Environment

Component	location	Max Stress Intensity $P_m + P_b$ (ksi)	Allowable Membrane Stress Intensity (ksi)
Lid	1	5.00	46.70
	2	6.84	46.70
	3	3.33	46.70
	4	5.35	46.70
Upper Cask Wall	5	10.49	31.40
	6	8.11	31.40
	7	6.74	31.40
	8	4.04	31.40
	9	13.15	31.40
	10	13.51	31.40
	11	7.58	31.40
	12	8.28	31.40
	13	13.81	31.40
	14	2.99	31.40
Upper Trunnion	15	5.47	31.40
	16	8.12	31.40
	17	7.53	31.40
	18	7.65	20.00
Mid Cask Wall	19	8.25	20.00
	20	16.63	31.40
	21	14.32	31.40
	22	9.67	20.00
Lower Trunnion	23	13.68	20.00
	24	10.95	31.40
	25	9.55	31.40
	26	7.62	20.00
Lower Cask wall	27	10.08	20.00
	28	5.80	31.40
	29	6.36	31.40
	30	5.45	31.40
Base	31	4.18	31.40
	32	3.77	31.40
	33	2.69	31.40
	34	1.09	31.40
	35	1.55	31.40

**Table 2.10.1-25**  
**1 Foot End Drop on Lid End, External Pressure, Cold Environment**

<b>Component</b>	<b>location</b>	<b>Max Stress Intensity <math>P_m + P_b</math> (ksi)</b>	<b>Allowable Membrane Stress Intensity (ksi)</b>
<b>Lid</b>	1	1.27	46.70
	2	3.10	46.70
	3	2.32	46.70
	4	5.69	46.70
<b>Upper Cask Wall</b>	5	10.19	31.40
	6	7.70	31.40
	7	2.39	31.40
	8	7.07	31.40
	9	7.41	31.40
	10	10.04	31.40
	11	8.17	31.40
	12	4.24	31.40
	13	15.03	31.40
	14	2.31	31.40
<b>Upper Trunnion</b>	15	5.39	31.40
	16	8.51	31.40
	17	8.64	31.40
	18	5.18	20.00
<b>Mid Cask Wall</b>	19	6.13	20.00
	20	14.34	31.40
	21	12.17	31.40
	22	6.81	20.00
<b>Lower Trunnion</b>	23	11.54	20.00
	24	8.73	31.40
	25	7.46	31.40
	26	4.92	20.00
<b>Lower Cask wall</b>	27	8.09	20.00
	28	5.00	31.40
	29	6.31	31.40
	30	3.30	31.40
<b>Base</b>	31	3.45	31.40
	32	3.46	31.40
	33	2.84	31.40
	34	0.82	31.40
	35	1.34	31.40

**Table 2.10.1-26**  
**1 Foot End Drop on Bottom End, Internal Pressure, Hot Environment**

<b>Component</b>	<b>location</b>	<b>Max Stress Intensity <math>P_m + P_r</math> (ksi)</b>	<b>Allowable Membrane Stress Intensity (ksi)</b>
<b>Lid</b>	1	0.13	46.70
	2	1.06	46.70
	3	1.40	46.70
	4	4.61	46.70
<b>Upper Cask Wall</b>	5	4.34	31.40
	6	2.90	31.40
	7	8.34	31.40
	8	7.87	31.40
	9	14.09	31.40
	10	4.61	31.40
	11	3.87	31.40
	12	6.22	31.40
	13	8.03	31.40
	14	3.29	31.40
	15	4.01	31.40
<b>Upper Trunnion</b>	16	8.32	31.40
	17	7.53	31.40
	18	6.81	20.00
<b>Mid Cask Wall</b>	19	8.35	20.00
	20	16.69	31.40
	21	14.38	31.40
	22	9.75	20.00
	23	13.76	20.00
<b>Lower Trunnion</b>	24	10.92	31.40
	25	9.59	31.40
	26	8.25	20.00
	27	10.12	20.00
<b>Lower Cask wall</b>	28	6.28	31.40
	29	9.11	31.40
	30	4.02	31.40
	31	4.76	31.40
<b>Base</b>	32	1.48	31.40
	33	2.77	31.40
	34	2.40	31.40
	35	2.67	31.40

**Table 2.10.1-27**  
**1 Foot End Drop on Bottom End, External Pressure, Cold Environment**

<b>Component</b>	<b>location</b>	<b>Max Stress Intensity <math>P_m + P_b</math> (ksi)</b>	<b>Allowable Membrane Stress Intensity (ksi)</b>
<b>Lid</b>	1	3.21	46.70
	2	2.56	46.70
	3	1.72	46.70
	4	5.45	46.70
<b>Upper Cask Wall</b>	5	3.82	31.40
	6	1.90	31.40
	7	4.27	31.40
	8	1.98	31.40
	9	5.01	31.40
	10	1.15	31.40
	11	2.45	31.40
	12	3.30	31.40
	13	7.25	31.40
	14	3.25	31.40
	15	1.72	31.40
<b>Upper Trunnion</b>	16	6.92	31.40
	17	6.83	31.40
	18	4.01	20.00
	19	6.20	20.00
<b>Mid Cask Wall</b>	20	14.48	31.40
	21	12.29	31.40
	22	6.96	20.00
	23	11.66	20.00
<b>Lower Trunnion</b>	24	10.67	31.40
	25	9.78	31.40
	26	5.86	20.00
<b>Lower Cask wall</b>	27	8.08	20.00
	28	7.07	31.40
	29	10.06	31.40
	30	2.11	31.40
<b>Base</b>	31	2.93	31.40
	32	1.45	31.40
	33	3.01	31.40
	34	3.23	31.40
	35	3.48	31.40

Table 2.10.1-28  
1 Foot Side Drop, Hot Environment, Internal Pressure

Component	Location	Max Stress Intensity $P_m + P_s$ (ksi) At Contact Side	Max Stress Intensity $P_m + P_s$ (ksi) 90° from Contact Side	Allowable Membrane Stress Intensity (ksi)
Lid	1	10.10	9.79	46.70
	2	12.59	12.39	46.70
	3	11.40	4.03	46.70
	4	7.38	11.22	46.70
Upper Cask Wall	5	9.52	9.07	31.40
	6	12.16	4.92	31.40
	7	13.57	19.92	31.40
	8	14.37	12.55	31.40
	9	21.97	16.09	31.40
	10	15.01	6.43	31.40
	11	8.02	10.07	31.40
	12	23.94	15.70	31.40
	13	21.53	8.60	31.40
	14	27.06	8.94	31.40
	15	19.15	14.76	31.40
Upper Trunnion	16	4.02	11.23	31.40
	17	5.09	11.55	31.40
	18	9.56	9.24	20.00
	19	13.45	11.00	20.00
Mid Cask Wall	20	14.16	10.52	31.40
	21	14.67	12.48	31.40
	22	7.48	10.99	20.00
	23	18.41	9.61	20.00
Lower Trunnion	24	6.20	11.13	31.40
	25	5.72	11.28	31.40
	26	9.13	10.19	20.00
	27	16.24	12.04	20.00
Lower Cask wall	28	20.05	12.74	31.40
	29	19.49	11.08	31.40
	30	26.07	12.90	31.40
Base	31	15.51	6.38	31.40
	32	12.70	4.96	31.40
	33	6.01	3.69	31.40
	34	6.18	5.56	31.40
	35	5.72	5.76	31.40

**Table 2.10.1-29**  
**1 Foot Side Drop, Cold Environment, External Pressure**

<b>Component</b>	<b>Location</b>	<b>Max Stress Intensity <math>P_m + P_b</math> (ksl) At Contact Side</b>	<b>Max Stress Intensity <math>P_m + P_b</math> (ksl) 90° from Contact Side</b>	<b>Allowable Membrane Stress Intensity (ksl)</b>
<b>Lid</b>	1	6.48	6.13	46.70
	2	7.76	7.56	46.70
	3	11.97	2.16	46.70
	4	7.15	7.46	46.70
<b>Upper Cask Wall</b>	5	12.96	7.66	31.40
	6	9.36	2.27	31.40
	7	12.99	12.85	31.40
	8	13.64	5.81	31.40
	9	18.39	14.37	31.40
	10	13.27	5.04	31.40
	11	5.63	6.59	31.40
	12	20.41	12.23	31.40
	13	19.75	8.17	31.40
	14	27.99	10.32	31.40
	15	19.67	9.44	31.40
<b>Upper Trunnion</b>	16	1.76	9.86	31.40
	17	2.10	10.58	31.40
	18	6.15	7.43	20.00
	19	12.62	9.14	20.00
<b>Mid Cask Wall</b>	20	11.70	9.23	31.40
	21	11.49	10.46	31.40
	22	7.40	8.44	20.00
	23	18.43	7.65	20.00
<b>Lower Trunnion</b>	24	4.05	10.17	31.40
	25	2.48	10.43	31.40
	26	6.41	8.44	20.00
	27	14.58	10.77	20.00
<b>Lower Cask wall</b>	28	16.16	10.14	31.40
	29	17.61	10.52	31.40
	30	25.45	12.65	31.40
<b>Base</b>	31	15.99	6.45	31.40
	32	12.68	4.19	31.40
	33	6.10	3.57	31.40
	34	5.60	3.81	31.40
	35	4.36	4.00	31.40

**Table 2.10.1-30**  
**30 Foot End Drop on Bottom End, Internal Pressure, Hot Environment**

<b>Component</b>	<b>location</b>	<b>Max Stress Intensity <math>P_m + P_b</math> (ksi)</b>	<b>Allowable Membrane Stress Intensity (ksi)</b>
<b>Lid</b>	1	7.17	98.00
	2	6.20	98.00
	3	3.80	98.00
	4	7.43	98.00
<b>Upper Cask Wall</b>	5	2.14	65.94
	6	1.74	65.94
	7	13.79	65.94
	8	10.80	65.94
	9	10.46	65.94
	10	3.85	65.94
	11	2.33	65.94
	12	3.93	65.94
	13	8.38	65.94
	14	3.78	65.94
	15	5.48	65.94
<b>Upper Trunnion</b>	16	8.62	65.94
	17	8.41	65.94
	18	6.95	48.00
	19	8.47	48.00
<b>Mid Cask Wall</b>	20	16.81	65.94
	21	14.60	65.94
	22	12.49	48.00
	23	13.83	48.00
<b>Lower Trunnion</b>	24	16.82	65.94
	25	16.19	65.94
	26	14.54	48.00
	27	14.27	48.00
<b>Lower Cask wall</b>	28	13.06	65.94
	29	15.67	65.94
	30	12.59	65.94
	31	10.04	65.94
<b>Base</b>	32	1.78	65.94
	33	3.95	65.94
	34	7.35	65.94
	35	8.36	65.94



**Table 2.10.1-31**  
**30 Foot End Drop on Bottom End, External Pressure, Cold Environment**

<b>Component</b>	<b>location</b>	<b>Max Stress Intensity <math>P_m + P_b</math> (ksl)</b>	<b>Allowable Membrane Stress Intensity (ksl)</b>
<b>Lid</b>	1	10.41	98.00
	2	9.45	98.00
	3	5.34	98.00
	4	9.08	98.00
<b>Upper Cask Wall</b>	5	4.45	65.94
	6	1.07	65.94
	7	9.04	65.94
	8	2.58	65.94
	9	2.01	65.94
	10	3.09	65.94
	11	3.12	65.94
	12	7.04	65.94
	13	8.06	65.94
	14	1.52	65.94
	15	2.89	65.94
<b>Upper Trunnion</b>	16	9.89	65.94
	17	9.95	65.94
	18	4.13	48.00
	19	6.30	48.00
<b>Mid Cask Wall</b>	20	17.20	65.94
	21	15.25	65.94
	22	10.18	48.00
	23	11.72	48.00
<b>Lower Trunnion</b>	24	17.82	65.94
	25	17.32	65.94
	26	12.22	48.00
<b>Lower Cask wall</b>	27	11.96	48.00
	28	15.92	65.94
	29	16.74	65.94
	30	11.18	65.94
	31	8.73	65.94
<b>Base</b>	32	2.50	65.94
	33	4.27	65.94
	34	7.54	65.94
	35	10.06	65.94

**Table 2.10.1-32**  
**30 Foot End Drop on Lid End, Internal Pressure, Hot Environment**

<b>Component</b>	<b>location</b>	<b>Max Stress Intensity <math>P_m + P_s</math> (ksi)</b>	<b>Allowable Membrane Stress Intensity (ksi)</b>
<b>Lid</b>	1	5.56	98.00
	2	9.56	98.00
	3	4.17	98.00
	4	8.21	98.00
<b>Upper Cask Wall</b>	5	19.91	65.94
	6	16.69	65.94
	7	9.66	65.94
	8	6.43	65.94
	9	10.17	65.94
	10	25.81	65.94
	11	15.78	65.94
	12	8.47	65.94
	13	25.61	65.94
	14	6.76	65.94
	15	13.42	65.94
<b>Upper Trunnion</b>	16	13.59	65.94
	17	13.92	65.94
	18	14.40	48.00
<b>Mid Cask Wall</b>	19	14.66	48.00
	20	16.56	65.94
	21	14.30	65.94
	22	12.79	48.00
<b>Lower Trunnion</b>	23	13.57	48.00
	24	11.23	65.94
	25	9.83	65.94
<b>Lower Cask wall</b>	26	7.72	48.00
	27	10.16	48.00
	28	7.31	65.94
	29	5.77	65.94
	30	4.83	65.94
<b>Base</b>	31	6.35	65.94
	32	5.99	65.94
	33	3.47	65.94
	34	1.07	65.94
	35	3.65	65.94

**Table 2.10.1-33**  
**30 Foot End Drop on Lid End, External Pressure, Cold Environment**

<b>Component</b>	<b>location</b>	<b>Max Stress Intensity <math>P_m + P_b</math> (ksi)</b>	<b>Allowable Membrane Stress Intensity (ksi)</b>
<b>Lid</b>	1	2.08	98.00
	2	6.08	98.00
	3	3.42	98.00
	4	8.64	98.00
<b>Upper Cask Wall</b>	5	20.39	65.94
	6	16.45	65.94
	7	5.77	65.94
	8	13.05	65.94
	9	6.89	65.94
	10	23.97	65.94
	11	16.59	65.94
	12	7.14	65.94
	13	27.97	65.94
	14	3.26	65.94
	15	14.78	65.94
<b>Upper Trunnion</b>	16	15.34	65.94
	17	15.47	65.94
	18	11.43	48.00
	19	12.19	48.00
<b>Mid Cask Wall</b>	20	15.40	65.94
	21	13.44	65.94
	22	11.03	48.00
	23	11.53	48.00
<b>Lower Trunnion</b>	24	10.58	65.94
	25	9.71	65.94
	26	5.09	48.00
	27	8.12	48.00
<b>Lower Cask wall</b>	28	8.95	65.94
	29	6.77	65.94
	30	2.59	65.94
	31	5.04	65.94
<b>Base</b>	32	6.04	65.94
	33	4.59	65.94
	34	1.14	65.94
	35	6.98	65.94

Table 2.10.1-34  
30 Foot Side Drop, Hot Environment, Internal Pressure

Component	Location	Max Stress Intensity $P_m + P_b$ (ksi) At Contact Side	Max Stress Intensity $P_m + P_b$ (ksi) 90° from Contact Side	Allowable Membrane Stress Intensity (ksi)
Lid	1	13.73	13.35	98.00
	2	15.83	15.68	98.00
	3	18.38	4.73	98.00
	4	9.30	11.94	98.00
Upper Cask Wall	5	15.01	16.44	65.94
	6	30.89	7.84	65.94
	7	42.10	31.92	65.94
	8	38.24	20.30	65.94
	9	49.24	21.53	65.94
	10	33.75	13.45	65.94
	11	20.15	14.91	65.94
	12	55.77	25.89	65.94
	13	46.55	19.14	65.94
	14	68.093*	16.92	65.94
	15	44.99	21.42	65.94
Upper Trunnion	16	8.58	23.97	65.94
	17	15.83	23.87	65.94
	18	10.77	23.93	48.00
	19	29.26	24.21	48.00
Mid Cask Wall	20	30.23	10.04	65.94
	21	27.00	17.04	65.94
	22	17.35	21.07	48.00
	23	36.06	6.91	48.00
Lower Trunnion	24	9.91	23.33	65.94
	25	16.58	23.74	65.94
	26	9.21	25.53	48.00
	27	31.36	24.89	48.00
Lower Cask wall	28	47.42	20.31	65.94
	29	40.57	16.91	65.94
	30	63.19	20.80	65.94
Base	31	40.78	19.26	65.94
	32	26.87	8.60	65.94
	33	9.90	8.17	65.94
	34	11.25	8.62	65.94
	35	9.00	8.90	65.94

\*Linearized stress intensities  $S_m=47.80$ ksi,  $S_{m+b}=68.09$ ksi, are under the 65.94 & 94.2ksi

Table 2.10.1-35  
30 Foot Side Drop, Cold Environment, External Pressure

Component	Location	Max Stress Intensity $P_m + P_b$ (ksi) At Contact Side	Max Stress Intensity $P_m + P_b$ (ksi) 90° from Contact Side	Allowable Membrane Stress Intensity (ksi)
Lid	1	10.92	10.43	98.00
	2	12.76	12.84	98.00
	3	19.28	2.90	98.00
	4	8.27	8.27	98.00
Upper Cask Wall	5	14.48	11.15	65.94
	6	27.94	6.05	65.94
	7	41.19	22.88	65.94
	8	37.36	12.85	65.94
	9	45.37	19.92	65.94
	10	32.80	12.99	65.94
	11	16.83	11.13	65.94
	12	51.70	20.95	65.94
	13	44.35	16.40	65.94
	14	69.156*	18.98	65.94
	15	46.42	18.44	65.94
Upper Trunnion	16	5.72	24.24	65.94
	17	14.89	23.91	65.94
	18	10.00	22.91	48.00
	19	28.91	23.39	48.00
Mid Cask Wall	20	27.67	10.68	65.94
	21	23.49	15.84	65.94
	22	17.93	19.54	48.00
	23	35.83	6.16	48.00
Lower Trunnion	24	6.36	23.41	65.94
	25	15.55	23.23	65.94
	26	8.24	24.53	48.00
	27	30.82	24.21	48.00
Lower Cask wall	28	43.86	17.10	65.94
	29	38.91	16.35	65.94
	30	62.54	20.26	65.94
	31	41.39	19.23	65.94
Base	32	26.11	7.81	65.94
	33	9.88	8.55	65.94
	34	11.08	7.07	65.94
	35	7.71	7.38	65.94

\* Linearized stress intensities  $S_m=47.60$ ksi,  $S_{m+b}=69.16$ ksi, are under the 65.94 & 94.2ksi

**Table 2.10.1-36**  
**30 Foot CG Over Corner Drop on Bottom End, Hot Environment, Internal Pressure**

<b>Component</b>	<b>Location</b>	<b>Max Stress Intensity <math>P_m + P_b</math> (ksi) At Contact Side</b>	<b>Max Stress Intensity <math>P_m + P_b</math> (ksi) 90° from Contact Side</b>	<b>Allowable Membrane Stress Intensity (ksi)</b>
Lid	1	8.93	8.37	98.00
	2	8.75	6.47	98.00
	3	3.97	3.54	98.00
	4	5.98	6.45	98.00
Upper Cask Wall	5	9.36	5.40	65.94
	6	4.35	4.38	65.94
	7	12.23	12.98	65.94
	8	5.47	7.64	65.94
	9	8.75	5.92	65.94
	10	2.94	2.79	65.94
	11	6.30	5.07	65.94
	12	7.42	6.65	65.94
	13	5.11	3.73	65.94
	14	1.88	2.85	65.94
	15	8.22	7.01	65.94
Upper Trunnion	16	7.77	8.43	65.94
	17	6.87	9.31	65.94
	18	6.19	7.88	48.00
	19	10.99	6.64	48.00
Mid Cask Wall	20	14.30	15.25	65.94
	21	11.90	15.21	65.94
	22	8.55	12.28	48.00
	23	15.29	11.28	48.00
Lower Trunnion	24	24.83	20.38	65.94
	25	21.11	19.15	65.94
	26	17.87	13.76	48.00
	27	16.12	13.11	48.00
Lower Cask wall	28	51.50	29.83	65.94
	29	14.95	19.30	65.94
	30	25.95	15.12	65.94
	31	9.72	17.98	65.94
Base	32	24.09	27.67	65.94
	33	23.67	22.89	65.94
	34	36.90	20.19	65.94
	35	59.45	39.23	65.94

**Table 2.10.1-37**  
**30 Foot CG Over Corner Drop on Bottom End, Cold Environment, External Pressure**

<b>Component</b>	<b>Location</b>	<b>Max Stress Intensity <math>P_m + P_b</math> (ksi) At Contact Side</b>	<b>Max Stress Intensity <math>P_m + P_b</math> (ksi) 90° from Contact Side</b>	<b>Allowable Membrane Stress Intensity (ksi)</b>
<b>Lid</b>	1	9.78	9.26	98.00
	2	13.31	10.53	98.00
	3	2.95	3.62	98.00
	4	6.67	8.58	98.00
<b>Upper Cask Wall</b>	5	15.44	8.68	65.94
	6	0.73	0.78	65.94
	7	6.08	8.41	65.94
	8	2.95	1.88	65.94
	9	5.49	2.03	65.94
	10	1.70	2.89	65.94
	11	4.08	2.70	65.94
	12	6.23	6.35	65.94
	13	8.00	6.52	65.94
	14	3.02	1.77	65.94
	15	3.70	3.20	65.94
<b>Upper Trunnion</b>	16	8.12	9.15	65.94
	17	7.23	10.01	65.94
	18	3.39	5.08	48.00
	19	8.61	4.57	48.00
<b>Mid Cask Wall</b>	20	14.85	15.05	65.94
	21	12.25	14.68	65.94
	22	6.52	10.38	48.00
	23	13.95	9.52	48.00
	24	25.67	20.36	65.94
<b>Lower Trunnion</b>	25	22.02	19.12	65.94
	26	15.68	12.39	48.00
	27	13.99	11.83	48.00
	28	51.89	30.74	65.94
<b>Lower Cask wall</b>	29	17.26	20.17	65.94
	30	28.14	15.46	65.94
	31	10.38	17.69	65.94
<b>Base</b>	32	25.10	28.04	65.94
	33	24.77	23.50	65.94
	34	36.71	20.24	65.94
	35	61.84	41.72	65.94

Table 2.10.1-38  
30 Foot CG Over Corner Drop on Lid End, Hot Environment, Internal Pressure

Component	Location	Max Stress Intensity $P_m + P_b$ (ksi) At Contact Side	Max Stress Intensity $P_m + P_b$ (ksi) 90° from Contact Side	Allowable Membrane Stress Intensity (ksi)
Lid	1	*101.63	61.64	98.00
	2	*107.80	65.82	98.00
	3	36.13	35.84	98.00
	4	47.89	40.17	98.00
Upper Cask Wall	5	14.93	25.22	65.94
	6	17.09	3.97	65.94
	7	48.08	36.36	65.94
	8	21.25	20.35	65.94
	9	27.38	20.70	65.94
	10	17.75	12.04	65.94
	11	17.00	10.64	65.94
	12	27.88	25.87	65.94
	13	21.33	23.14	65.94
	14	4.48	17.34	65.94
	15	8.66	16.32	65.94
Upper Trunnion	16	20.99	19.38	65.94
	17	20.22	19.91	65.94
	18	12.99	12.55	48.00
	19	15.06	12.95	48.00
Mid Cask Wall	20	15.17	15.13	65.94
	21	9.99	15.22	65.94
	22	7.76	12.93	48.00
	23	17.69	10.81	48.00
Lower Trunnion	24	9.97	8.97	65.94
	25	6.55	9.24	65.94
	26	6.58	8.23	48.00
	27	12.70	8.17	48.00
Lower Cask wall	28	4.87	7.14	65.94
	29	7.24	4.61	65.94
	30	6.54	3.95	65.94
	31	4.10	5.07	65.94
Base	32	1.48	3.39	65.94
	33	2.03	3.03	65.94
	34	1.36	1.09	65.94
	35	1.15	1.66	65.94

\* Linearized stress intensities  $S_m=9.36$ ksi,  $S_{m+b}=107.8$ ksi, are under the 98.0 & 140.0ksi



**Table 2.10.1-39**  
**30 Foot CG Over Corner Drop on Lid End, Cold Environment, External Pressure**

<b>Component</b>	<b>Location</b>	<b>Max Stress Intensity <math>P_m + P_b</math> (ksi) At Contact Side</b>	<b>Max Stress Intensity <math>P_m + P_b</math> (ksi) 90° from Contact Side</b>	<b>Allowable Membrane Stress Intensity (ksi)</b>
<b>Lid</b>	1	95.93	54.27	98.00
	2	*105.97	63.41	98.00
	3	30.94	33.43	98.00
	4	49.04	40.26	98.00
<b>Upper Cask Wall</b>	5	16.69	28.66	65.94
	6	13.87	5.35	65.94
	7	46.39	33.77	65.94
	8	18.91	18.05	65.94
	9	34.41	24.80	65.94
	10	20.96	15.50	65.94
	11	15.03	11.85	65.94
	12	28.32	27.89	65.94
	13	23.19	25.30	65.94
	14	5.24	16.85	65.94
	15	9.63	14.99	65.94
<b>Upper Trunnion</b>	16	21.70	19.59	65.94
	17	20.84	19.93	65.94
	18	10.79	10.68	48.00
	19	12.70	11.16	48.00
<b>Mid Cask Wall</b>	20	14.04	15.34	65.94
	21	11.09	15.05	65.94
	22	5.81	10.63	48.00
	23	15.60	9.11	48.00
<b>Lower Trunnion</b>	24	8.54	9.65	65.94
	25	6.73	9.64	65.94
	26	4.11	5.61	48.00
	27	10.69	6.32	48.00
<b>Lower Cask wall</b>	28	5.40	8.05	65.94
	29	7.93	5.43	65.94
	30	4.45	2.01	65.94
<b>Base</b>	31	3.44	4.69	65.94
	32	1.51	3.87	65.94
	33	2.30	3.47	65.94
	34	1.77	1.17	65.94
	35	3.32	3.73	65.94

**Table 2.10.1-40**  
**30 Foot 20° Oblique Drop on Lid End, Hot Environment, Internal Pressure**

<b>Component</b>	<b>Location</b>	<b>Max Stress Intensity <math>P_m + P_b</math> (ksi) At Contact Side</b>	<b>Max Stress Intensity <math>P_m + P_b</math> (ksi) 90° from Contact Side</b>	<b>Allowable Membrane Stress Intensity (ksi)</b>
Lid	1	35.48	32.44	98.00
	2	46.41	46.48	98.00
	3	15.92	13.08	98.00
	4	21.10	22.47	98.00
Upper Cask Wall	5	50.91	20.89	65.94
	6	58.88	9.51	65.94
	7	57.27	32.44	65.94
	8	47.41	31.24	65.94
	9	50.49	15.79	65.94
	10	51.97	21.68	65.94
	11	46.70	17.20	65.94
	12	54.48	31.28	65.94
	13	47.67	30.18	65.94
	14	*69.31	19.65	65.94
	15	41.60	29.68	65.94
Upper Trunnion	16	2.43	35.25	65.94
	17	18.33	32.67	65.94
	18	10.45	33.55	48.00
	19	37.14	30.66	48.00
Mid Cask Wall	20	25.82	14.13	65.94
	21	17.03	19.66	65.94
	22	21.85	22.45	48.00
	23	36.90	10.64	48.00
Lower Trunnion	24	13.84	11.94	65.94
	25	7.34	15.01	65.94
	26	9.13	14.21	48.00
	27	16.19	11.35	48.00
Lower Cask wall	28	10.97	7.45	65.94
	29	12.81	5.34	65.94
	30	13.17	5.27	65.94
	31	2.43	8.25	65.94
Base	32	4.50	4.29	65.94
	33	2.69	4.09	65.94
	34	0.70	1.23	65.94
	35	1.51	1.54	65.94

\* Linearized stress intensities  $S_m=55.19$ ksi,  $S_{m+b}=69.31$ ksi, are under the 65.94 & 94.2ksi

Table 2.10.1-41  
30 Foot 20° Oblique Drop on Lid End, Cold Environment, External Pressure

Component	Location	Max Stress Intensity $P_m + P_b$ (ksi) At Contact Side	Max Stress Intensity $P_m + P_b$ (ksi) 90° from Contact Side	Allowable Membrane Stress Intensity (ksi)
Lid	1	35.10	31.78	98.00
	2	49.55	49.54	98.00
	3	19.96	14.17	98.00
	4	22.55	24.68	98.00
Upper Cask Wall	5	43.72	16.48	65.94
	6	53.40	7.64	65.94
	7	51.40	26.81	65.94
	8	46.27	27.17	65.94
	9	48.35	12.29	65.94
	10	49.57	20.73	65.94
	11	40.19	12.32	65.94
	12	51.52	18.54	65.94
	13	45.37	35.72	65.94
	14	*71.84	32.44	65.94
	15	41.30	29.09	65.94
Upper Trunnion	16	4.57	29.83	65.94
	17	20.65	30.25	65.94
	18	9.72	32.59	48.00
	19	35.97	28.91	48.00
Mid Cask Wall	20	23.11	8.23	65.94
	21	15.87	5.20	65.94
	22	21.16	4.62	48.00
	23	37.18	8.16	48.00
Lower Trunnion	24	12.19	14.60	65.94
	25	4.58	19.45	65.94
	26	10.03	21.35	48.00
	27	16.16	9.50	48.00
Lower Cask wall	28	8.60	11.75	65.94
	29	14.16	14.85	65.94
	30	14.09	13.05	65.94
	31	3.50	10.69	65.94
Base	32	3.96	5.23	65.94
	33	2.13	4.68	65.94
	34	0.41	0.38	65.94
	35	2.19	1.28	65.94

\* Linearized stress intensities  $S_m=54.95$ ksi,  $S_{m+b}=71.84$ ksi, are under the 65.94 & 94.2ksi

Table 2.10.1-42  
30 Foot 20° Oblique Drop on Bottom End, Hot Environment, Internal Pressure

Component	Location	Max Stress Intensity $P_m + P_b$ (ksi) At Contact Side	Max Stress Intensity $P_m + P_b$ (ksi) 90° from Contact Side	Allowable Membrane Stress Intensity (ksi)
Lid	1	3.13	5.22	98.00
	2	2.27	2.48	98.00
	3	1.52	2.56	98.00
	4	10.21	6.38	98.00
Upper Cask Wall	5	9.04	5.76	65.94
	6	7.77	4.94	65.94
	7	16.29	12.36	65.94
	8	9.67	9.32	65.94
	9	18.75	5.57	65.94
	10	6.23	4.77	65.94
	11	10.82	5.28	65.94
	12	12.87	6.95	65.94
	13	9.83	6.64	65.94
	14	8.20	5.48	65.94
	15	10.31	8.26	65.94
Upper Trunnion	16	12.38	11.74	65.94
	17	3.39	15.78	65.94
	18	10.69	14.16	48.00
	19	16.54	10.54	48.00
Mid Cask Wall	20	27.13	14.62	65.94
	21	17.23	21.49	65.94
	22	21.78	24.13	48.00
	23	37.59	10.42	48.00
Lower Trunnion	24	5.23	31.99	65.94
	25	16.16	30.20	65.94
	26	11.20	33.46	48.00
	27	39.06	30.53	48.00
Lower Cask wall	28	35.97	27.26	65.94
	29	37.11	29.77	65.94
	30	59.47	15.44	65.94
	31	34.02	32.20	65.94
Base	32	24.31	11.05	65.94
	33	22.88	20.05	65.94
	34	6.86	5.92	65.94
	35	23.09	28.59	65.94

**Table 2.10.1-43**  
**30 Foot 20° Oblique Drop on Bottom End, Cold Environment, External Pressure**

<b>Component</b>	<b>Location</b>	<b>Max Stress Intensity <math>P_m + P_b</math> (ksi) At Contact Side</b>	<b>Max Stress Intensity <math>P_m + P_b</math> (ksi) 90° from Contact Side</b>	<b>Allowable Membrane Stress Intensity (ksi)</b>
<b>Lid</b>	1	6.91	12.68	98.00
	2	5.95	10.28	98.00
	3	1.57	15.70	98.00
	4	6.75	12.23	98.00
<b>Upper Cask Wall</b>	5	7.90	5.96	65.94
	6	2.97	6.10	65.94
	7	10.55	4.05	65.94
	8	9.58	5.67	65.94
	9	18.84	8.08	65.94
	10	5.36	32.24	65.94
	11	6.20	16.77	65.94
	12	10.69	29.58	65.94
	13	14.33	28.37	65.94
	14	13.98	30.17	65.94
<b>Upper Trunnion</b>	15	6.74	32.65	65.94
	16	10.68	29.75	65.94
	17	1.66	31.91	65.94
	18	12.97	9.49	48.00
<b>Mid Cask Wall</b>	19	16.12	22.86	48.00
	20	24.69	21.49	65.94
	21	16.95	15.46	65.94
	22	20.84	6.62	48.00
	23	37.90	8.30	48.00
<b>Lower Trunnion</b>	24	2.96	20.95	65.94
	25	17.72	11.24	65.94
	26	10.40	4.41	48.00
	27	37.33	8.17	48.00
<b>Lower Cask wall</b>	28	34.05	4.35	65.94
	29	35.37	8.27	65.94
	30	59.14	1.83	65.94
	31	35.04	2.96	65.94
<b>Base</b>	32	23.32	2.92	65.94
	33	24.10	4.84	65.94
	34	6.77	31.28	65.94
	35	25.75	6.12	65.94

**Table 2.10.1-44**  
**Immersion, Cold Environment, 290psi External Pressure**

<b>Component</b>	<b>location</b>	<b>Max Stress Intensity <math>P_m + P_b</math> (ksi)</b>	<b>Allowable Membrane Stress Intensity (ksi)</b>
<b>Lid</b>	1	12.23	98.00
	2	12.47	98.00
	3	5.35	98.00
	4	9.18	98.00
<b>Upper Cask Wall</b>	5	4.22	65.94
	6	0.36	65.94
	7	8.15	65.94
	8	3.46	65.94
	9	2.01	65.94
	10	3.13	65.94
	11	2.27	65.94
	12	4.61	65.94
	13	5.26	65.94
	14	0.82	65.94
	15	3.17	65.94
<b>Upper Trunnion</b>	16	9.40	65.94
	17	8.60	65.94
	18	2.28	48.00
	19	3.99	48.00
<b>Mid Cask Wall</b>	20	17.81	65.94
	21	15.36	65.94
	22	4.54	48.00
	23	9.57	48.00
<b>Lower Trunnion</b>	24	11.96	65.94
	25	10.47	65.94
	26	2.31	48.00
<b>Lower Cask wall</b>	27	5.78	48.00
	28	6.63	65.94
	29	5.11	65.94
	30	1.07	65.94
	31	4.89	65.94
<b>Base</b>	32	6.56	65.94
	33	4.04	65.94
	34	1.00	65.94
	35	5.91	65.94

Table 2.10.1-45  
Fire Accident

Component	location	Max Stress Intensity $P_m + P_b$ (ksi)	Allowable Membrane Stress Intensity (ksi)
Lid	1	0.46	98.00
	2	0.09	98.00
	3	3.73	98.00
	4	2.82	98.00
Upper Cask Wall	5	12.06	65.94
	6	8.72	65.94
	7	5.94	65.94
	8	23.71	65.94
	9	6.21	65.94
	10	4.95	65.94
	11	8.42	65.94
	12	8.18	65.94
	13	20.32	65.94
	14	11.94	65.94
Upper Trunnion	15	16.68	65.94
	16	16.48	65.94
	17	13.56	65.94
Mid Cask Wall	18	20.09	48.00
	19	23.33	48.00
	20	15.74	65.94
Lower Trunnion	21	13.89	65.94
	22	17.38	48.00
	23	20.78	48.00
	24	15.86	65.94
Lower Cask wall	25	13.83	65.94
	26	18.99	48.00
	27	20.89	48.00
	28	9.46	65.94
	29	17.69	65.94
	30	10.16	65.94
Base	31	15.28	65.94
	32	4.92	65.94
	33	6.16	65.94
	34	0.79	65.94
	35	5.31	65.94

Table 2.10.1-46  
Tie Down Loading

Component	Location	Max Stress Intensity $P_m + P_b$ (ksi) At Contact Side	Max Stress Intensity $P_m + P_b$ (ksi) 90° from Contact Side	Max Stress Intensity $P_m + P_b$ (ksi) 180° from Contact Side	Allowable Membrane Stress Intensity (ksi)
Lid	1	22.97	22.95	22.70	101.80
	2	22.17	21.99	22.02	101.80
	3	11.92	12.14	11.83	101.80
	4	11.86	15.02	12.02	101.80
Upper Cask Wall	5	8.35	6.13	7.14	43.30
	6	2.30	1.06	1.06	43.30
	7	3.30	5.98	1.92	43.30
	8	2.28	4.62	2.34	43.30
	9	1.86	9.12	0.69	43.30
	10	0.93	2.07	0.60	43.30
	11	2.92	2.30	1.56	43.30
	12	2.71	4.93	2.33	43.30
	13	1.88	4.00	2.62	43.30
	14	2.10	6.90	0.92	43.30
	15	0.78	2.20	1.08	43.30
Upper Trunnion	16	8.08	5.32	1.21	43.30
	17	2.73	4.87	2.96	43.30
	18	8.52	8.84	3.85	23.40
	19	2.19	8.31	2.79	23.40
Mid Cask Wall	20	7.93	9.16	4.82	43.30
	21	4.33	6.77	4.42	43.30
	22	7.01	10.74	7.47	23.40
	23	5.44	9.44	6.00	23.40
Lower Trunnion	24	3.10	3.37	3.60	43.30
	25	3.24	2.92	2.45	43.30
	26	10.32	4.64	5.93	23.40
	27	7.62	4.36	3.27	23.40
Lower Cask wall	28	6.07	2.52	5.61	43.30
	29	8.04	1.67	4.89	43.30
	30	9.29	2.91	5.73	43.30
Base	31	3.65	1.72	2.11	43.30
	32	3.75	2.10	3.54	43.30
	33	2.14	1.53	2.45	43.30
	34	1.00	0.96	1.27	43.30
	35	1.78	1.76	1.56	43.30



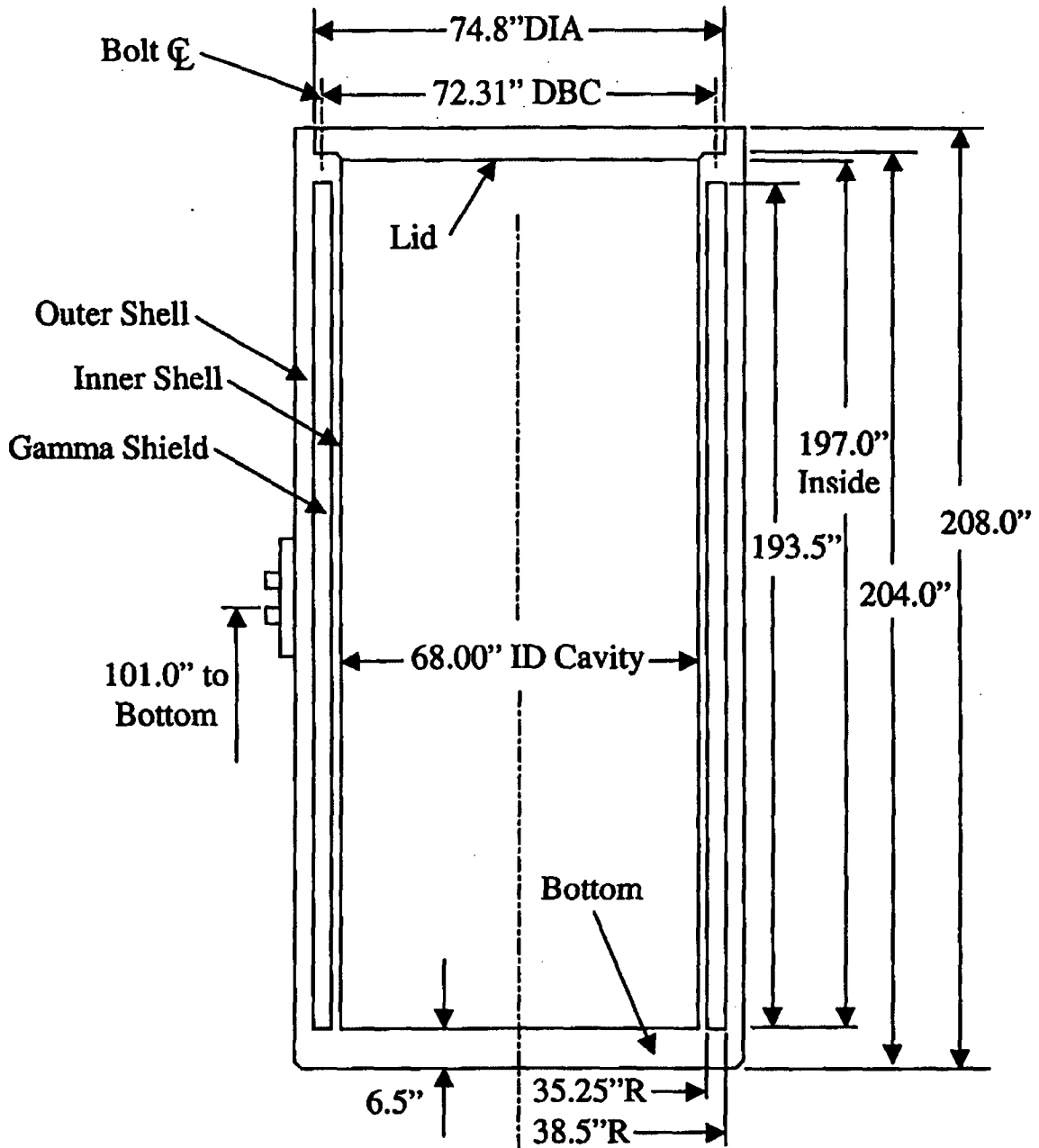
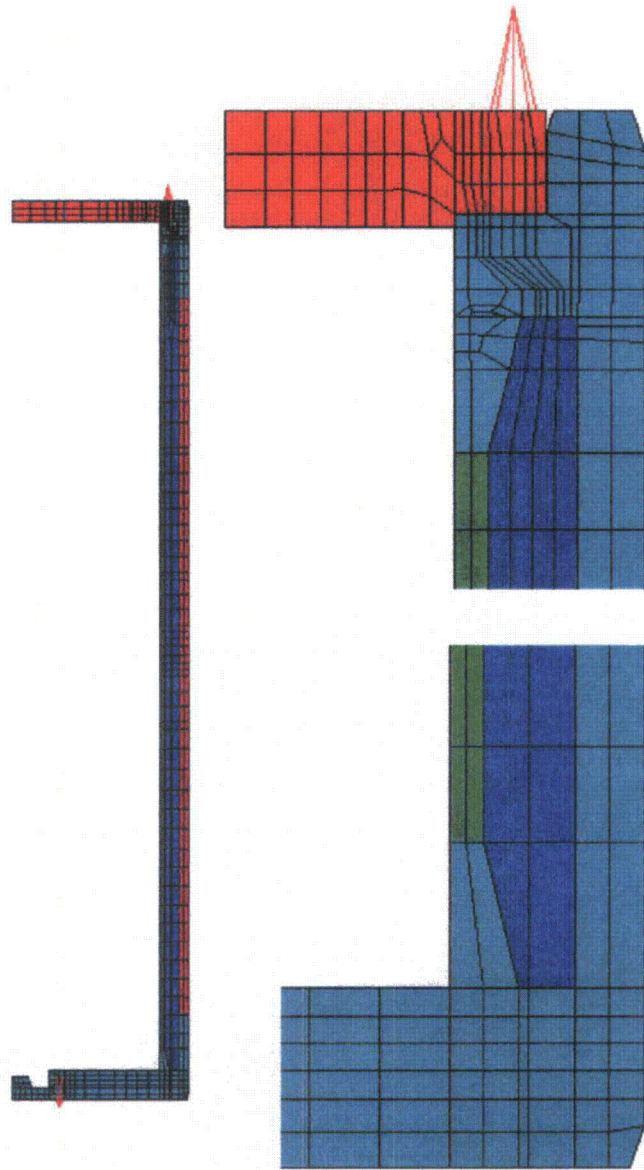
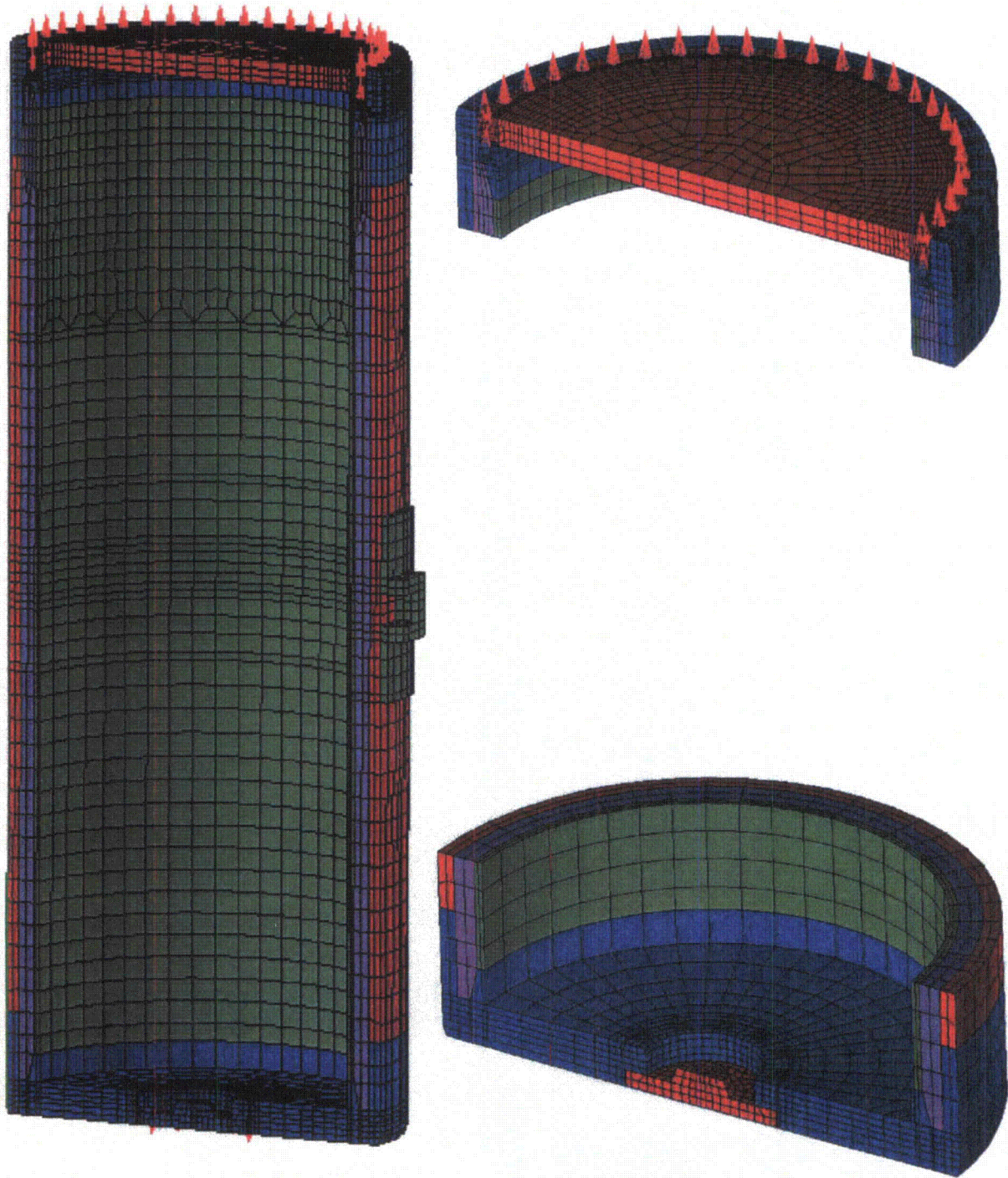


Figure 2.10.1-1: NUHOMS - MP197 Key Dimensions

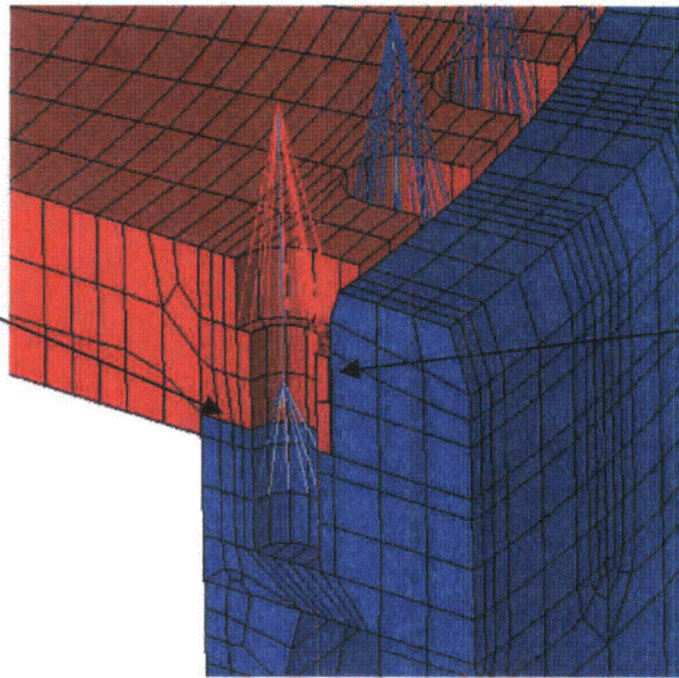


**Figure 2.10.1-2: NUHOMS – MP197 Cask  
2D Finite Element Model**

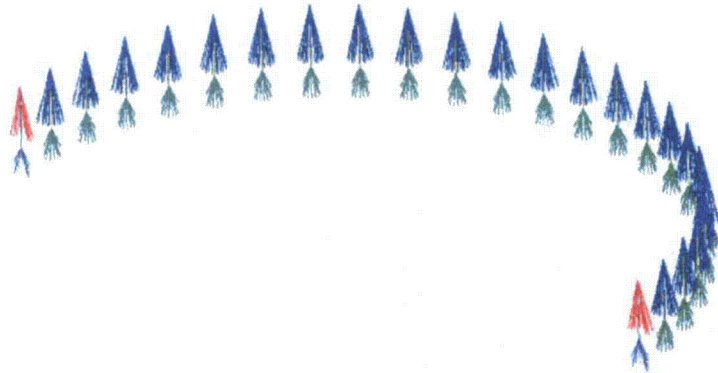
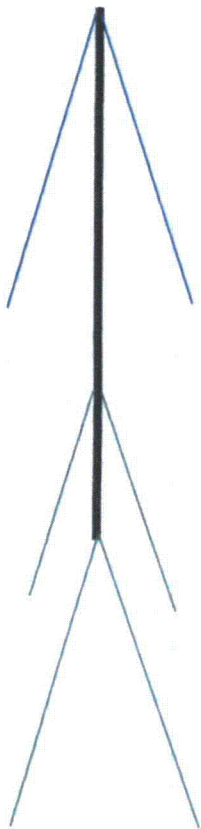


**Figure 2.10.1-3: NUHOMS – MP197 Cask  
3D Finite Element Model**

Axial contact elements are utilized between the lower lid surface and cask.



Radial contact elements are utilized between the outer radial lid surface and cask.



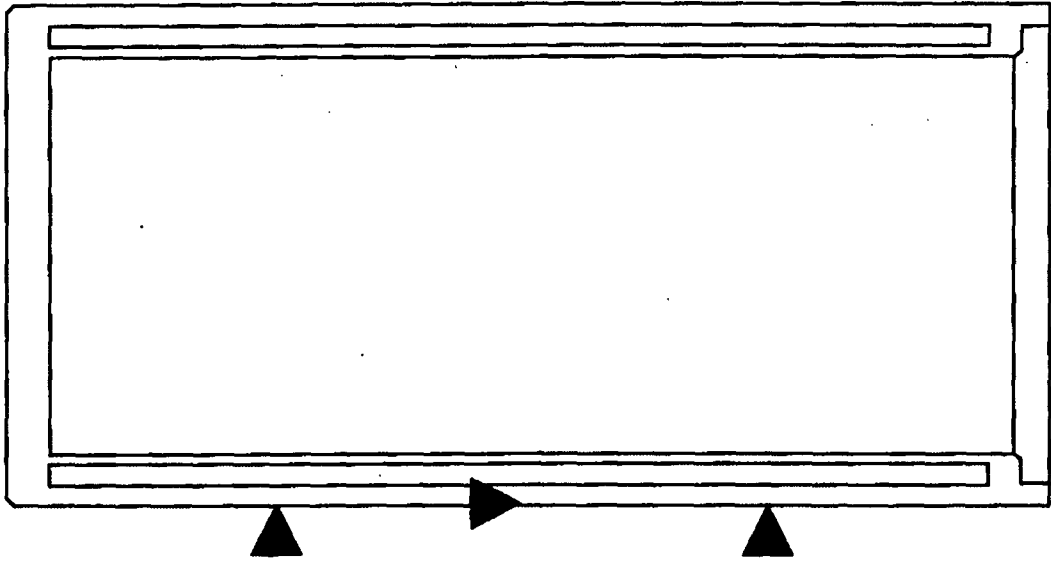
**Figure 2.10.1-4: NUHOMS – MP197 Cask Bolt Representation**



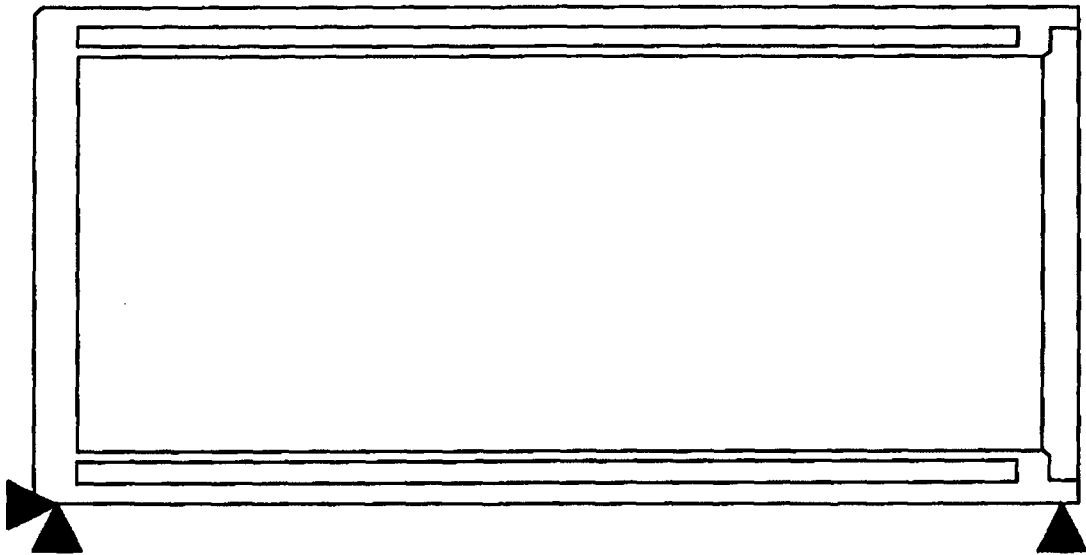
**Figure 2.10.1-5a: 2D Lid End Drop - Boundary Condition**



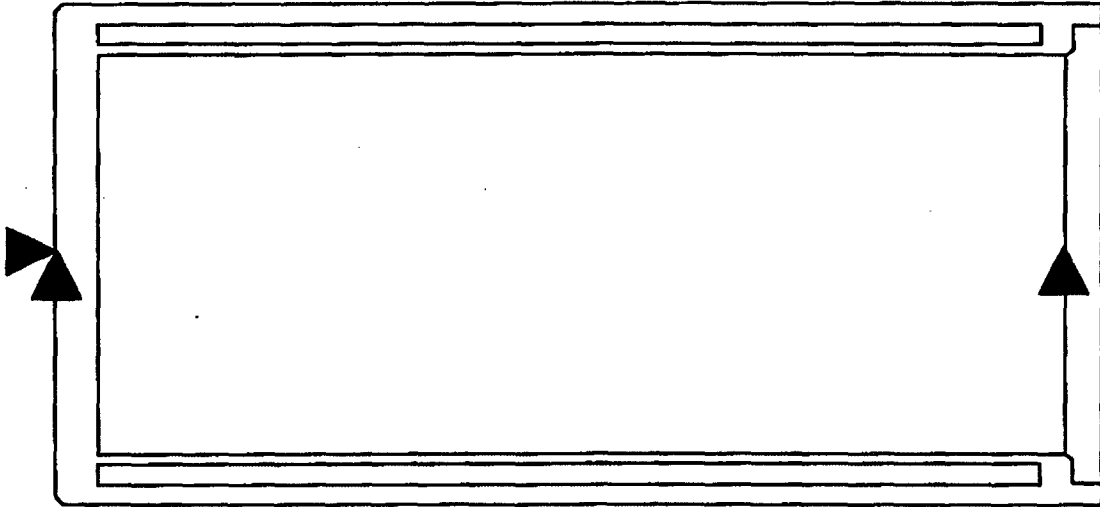
**Figure 2.10.1-5b: 2D Bottom End Drop - Boundary Condition**



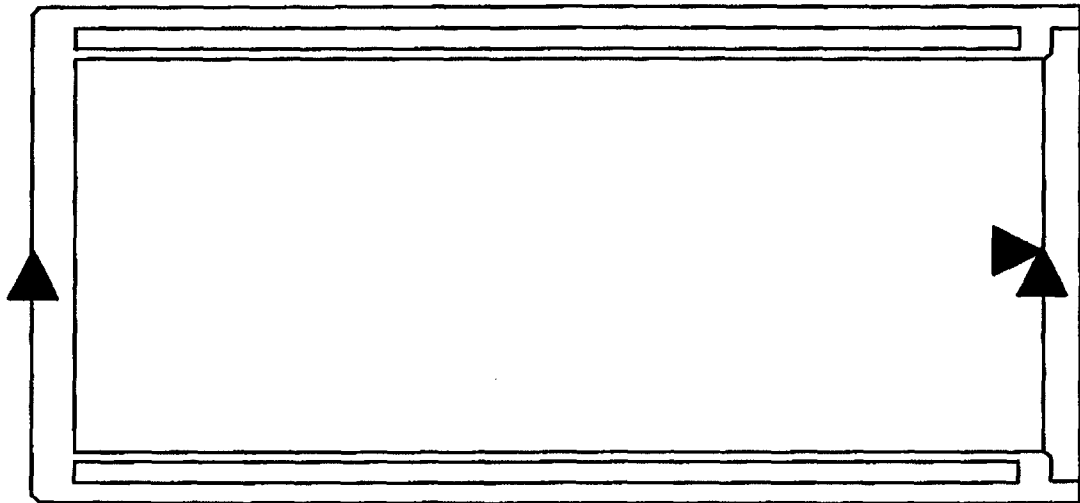
**Figure 2.10.1-5c: 3D Transport Boundary Condition**



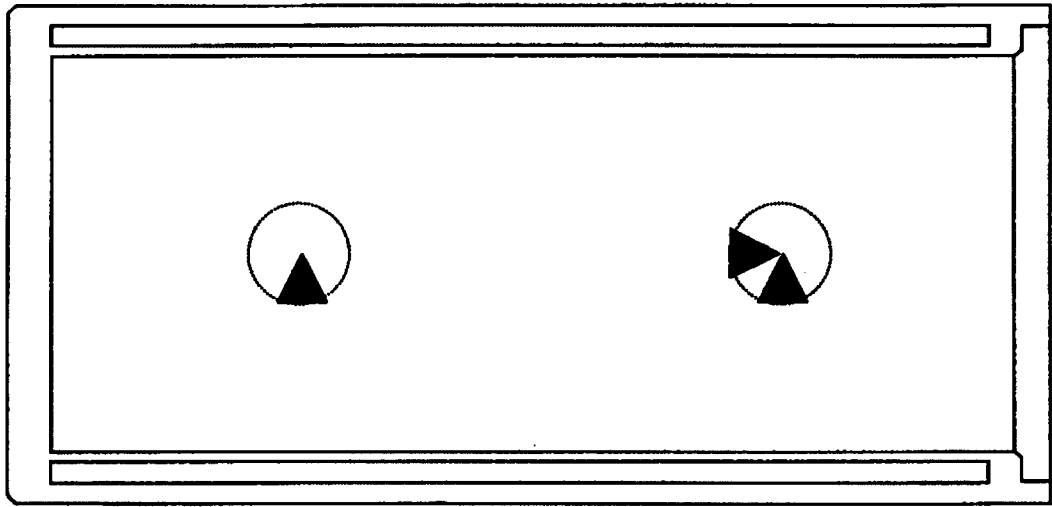
**Figure 2.10.1-5d: 3D Side Drop Boundary Condition**



**Figure 2.10.1-5e: 3D Lid End and Lid Corner Drop Boundary Condition**

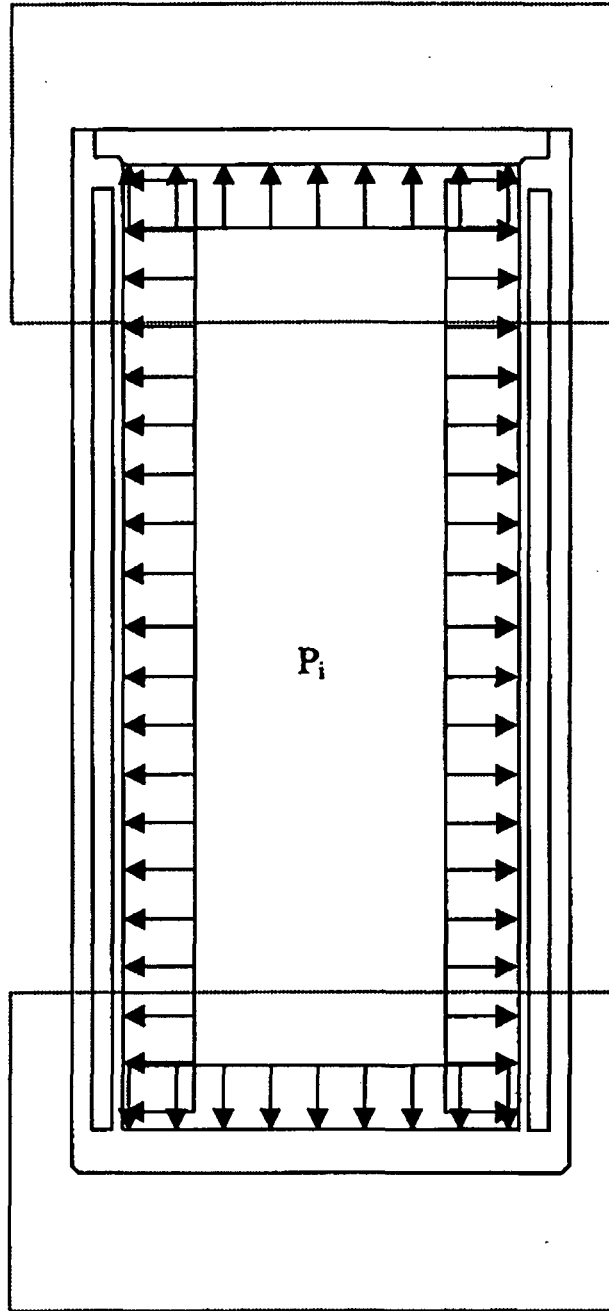


**Figure 2.10.1-5f: 3D Bottom End - Bottom Corner Drop Boundary Condition**

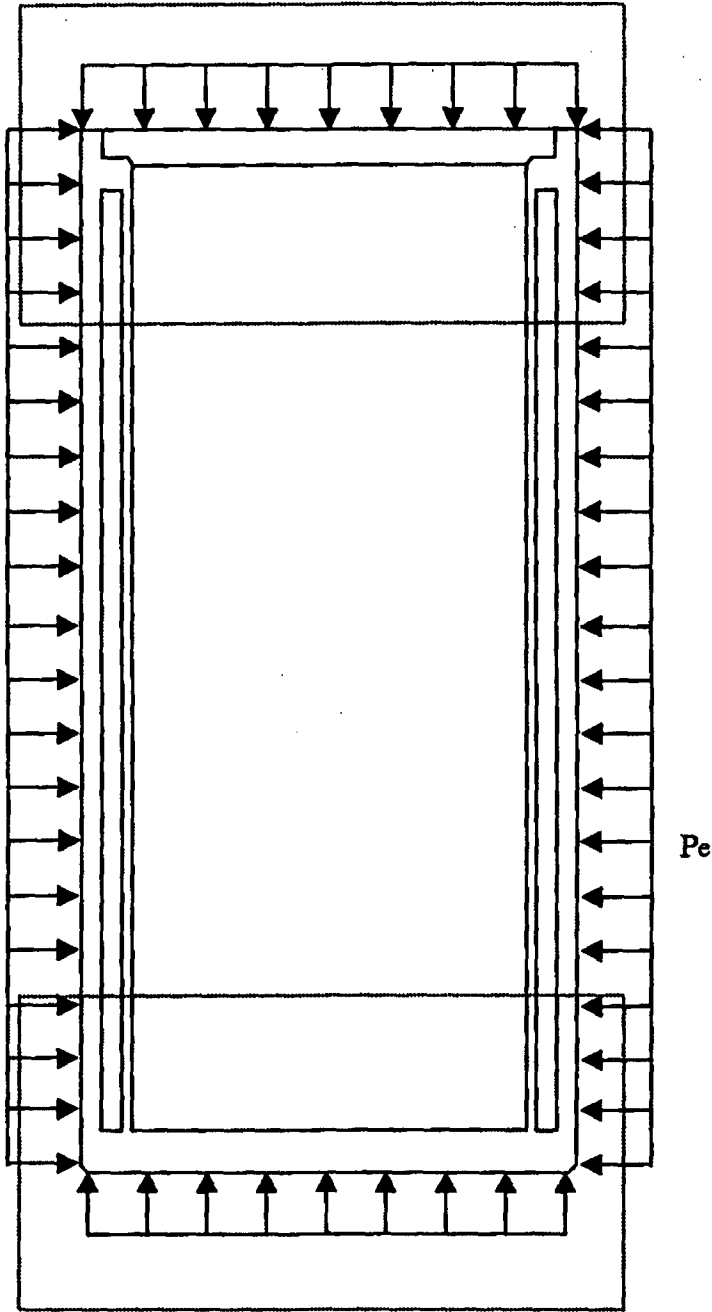


**Figure 2.10.1-5g: 3D 3-G Lift Boundary Condition**





**Figure 2.10.1-6: Internal Pressure Loading**



**Figure 2.10.1-7: External Pressure Loading**

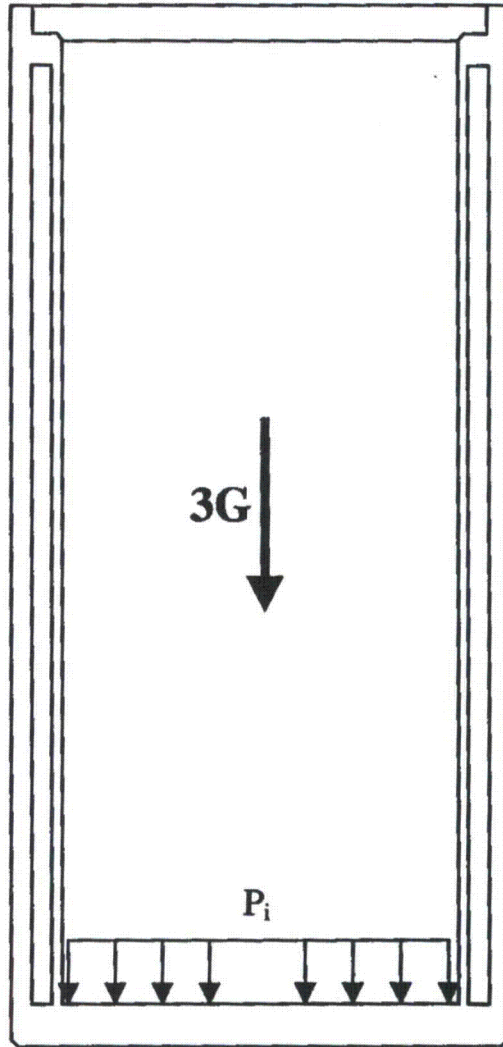


Figure 2.10.1-8: 3G Lift Loading

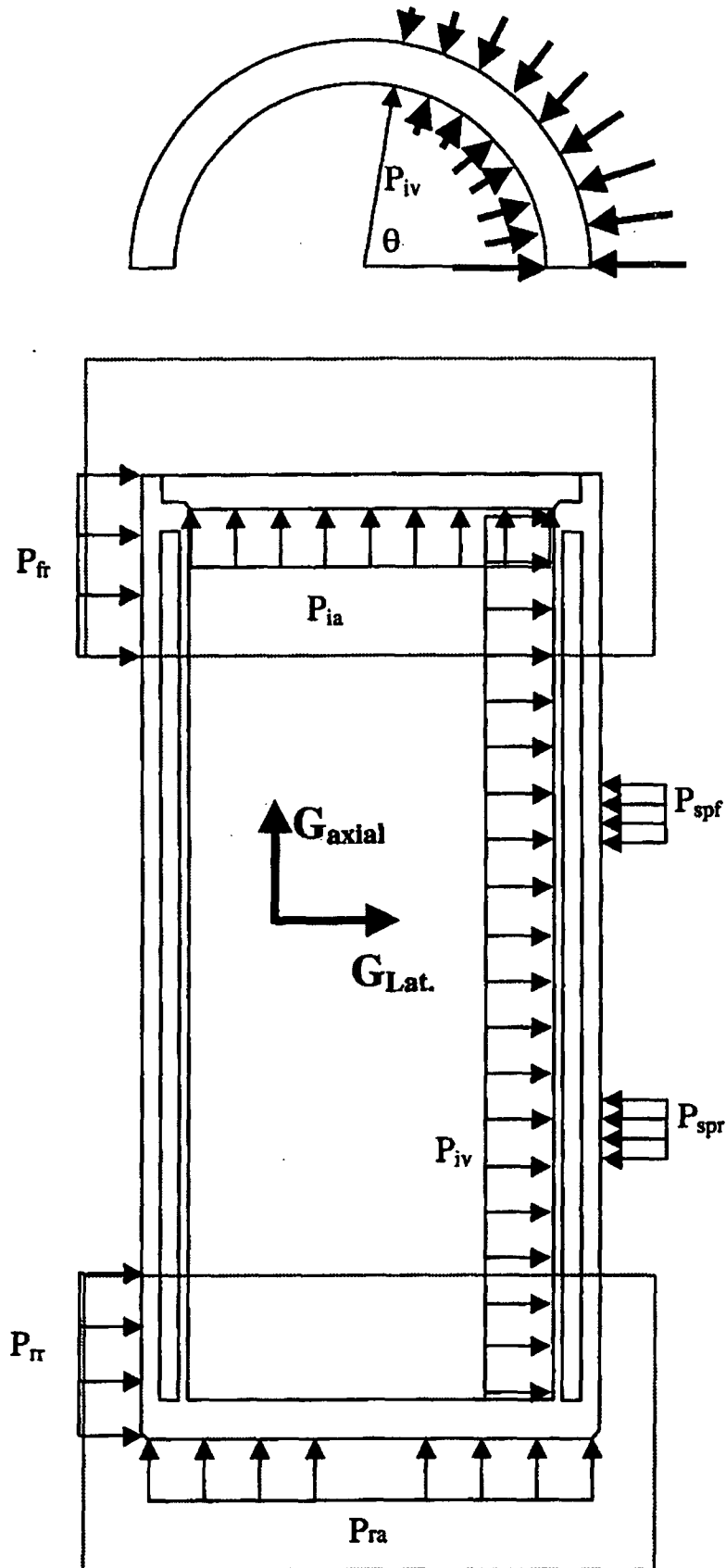


Figure 2.10.1-9: Rail Car Transport Loading

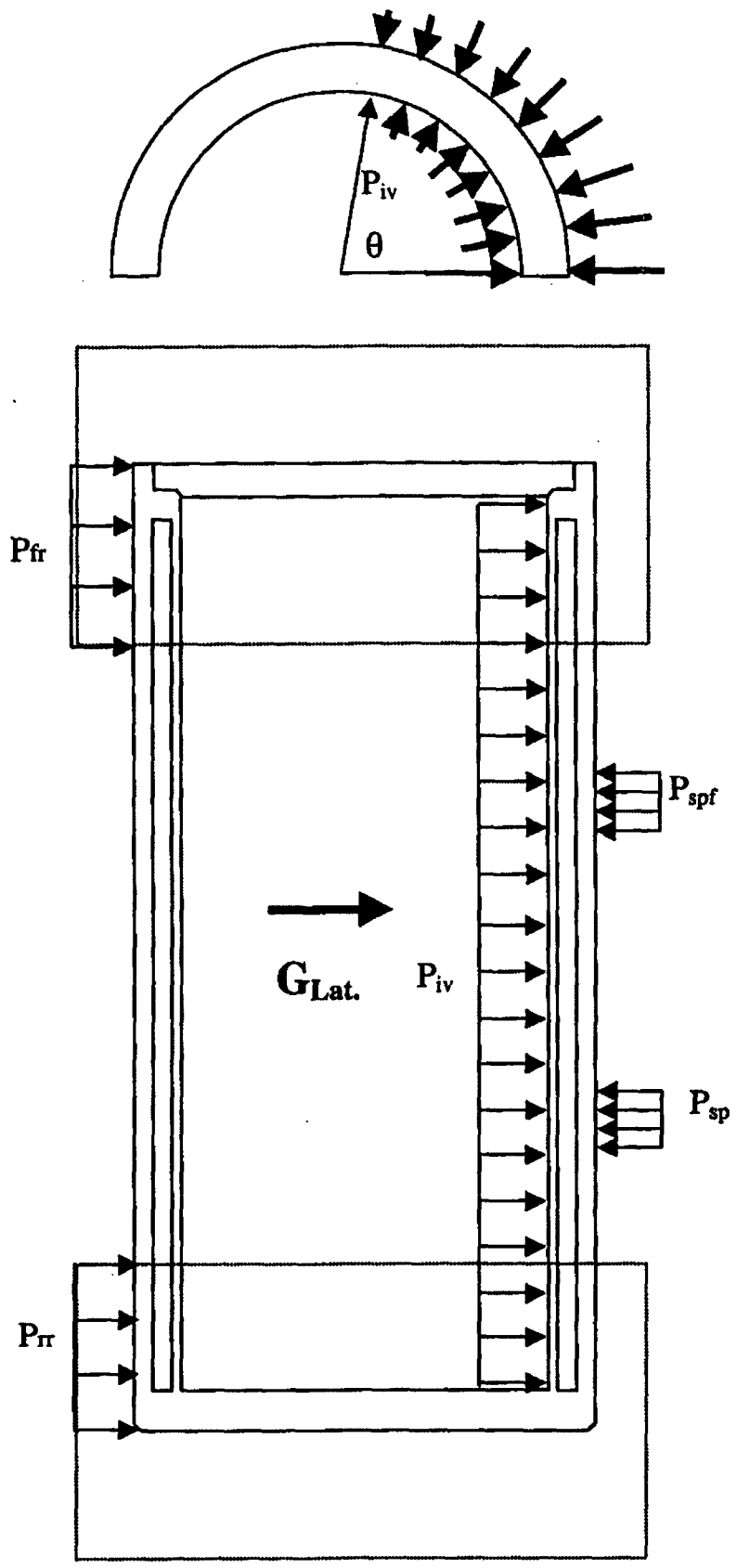


Figure 2.10.1-10: 1G Loading

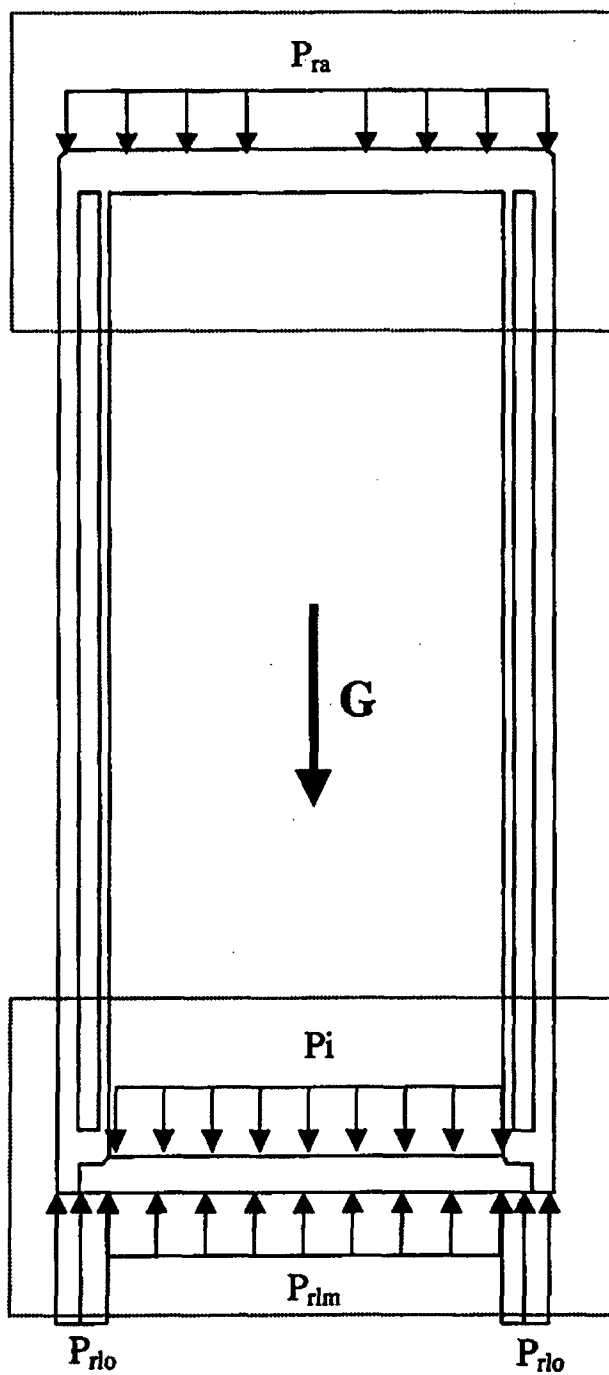


Figure 2.10.1-11: End Drop on Lid Loading

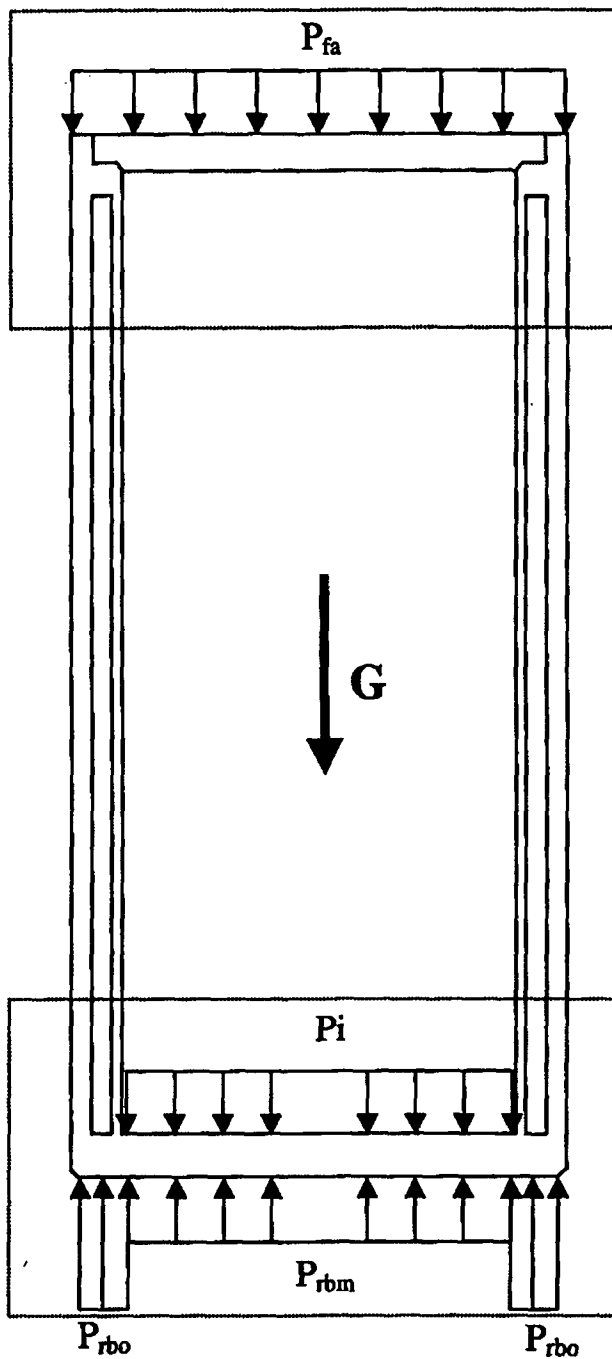


Figure 2.10.1-12: End Drop on Base Loading

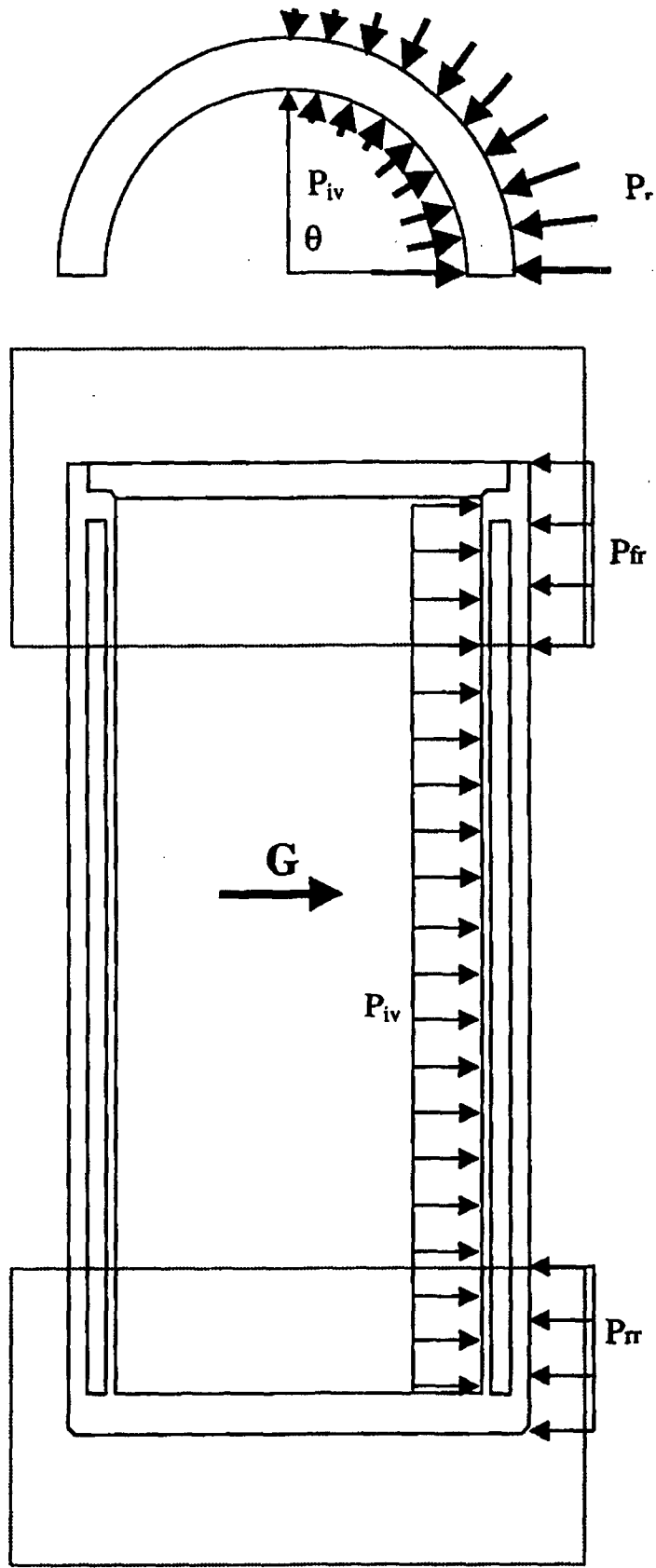


Figure 2.10.1-13: Side Drop Loading



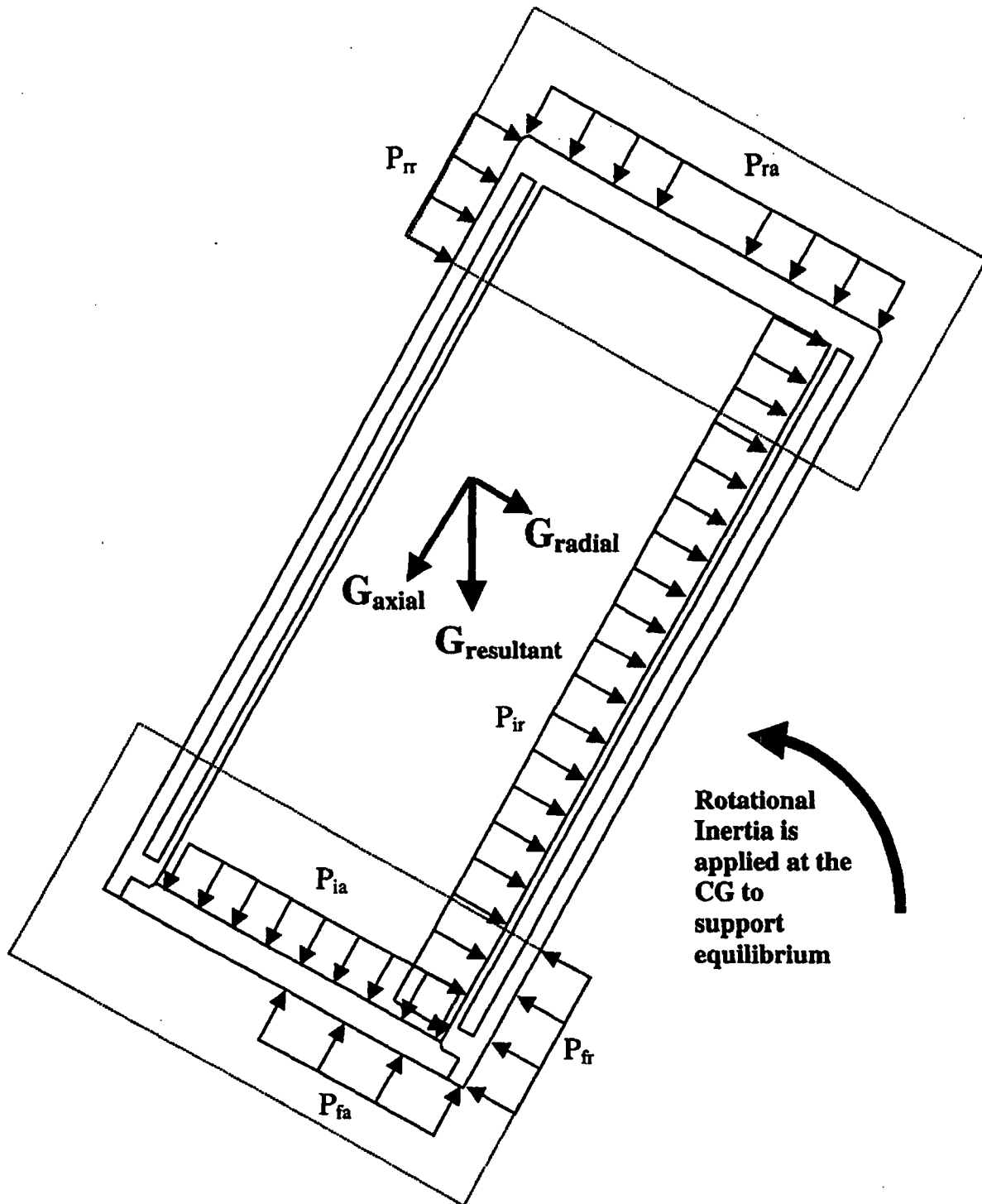


Figure 2.10.1-14: 30 Foot CG Over Corner Drop on Lid End Loading

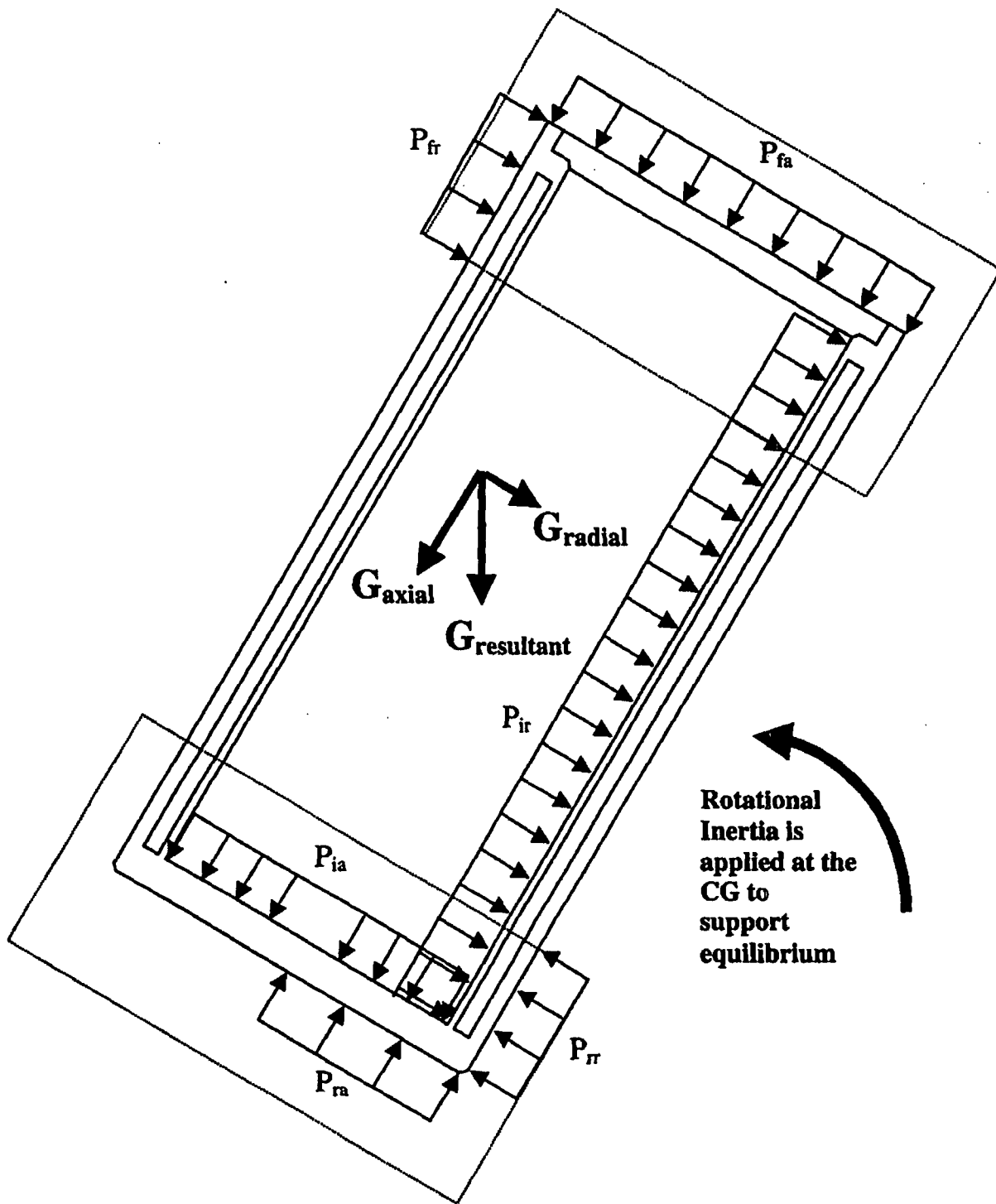


Figure 2.10.1-15: 30 Foot CG Over Corner Drop on Bottom End Loading

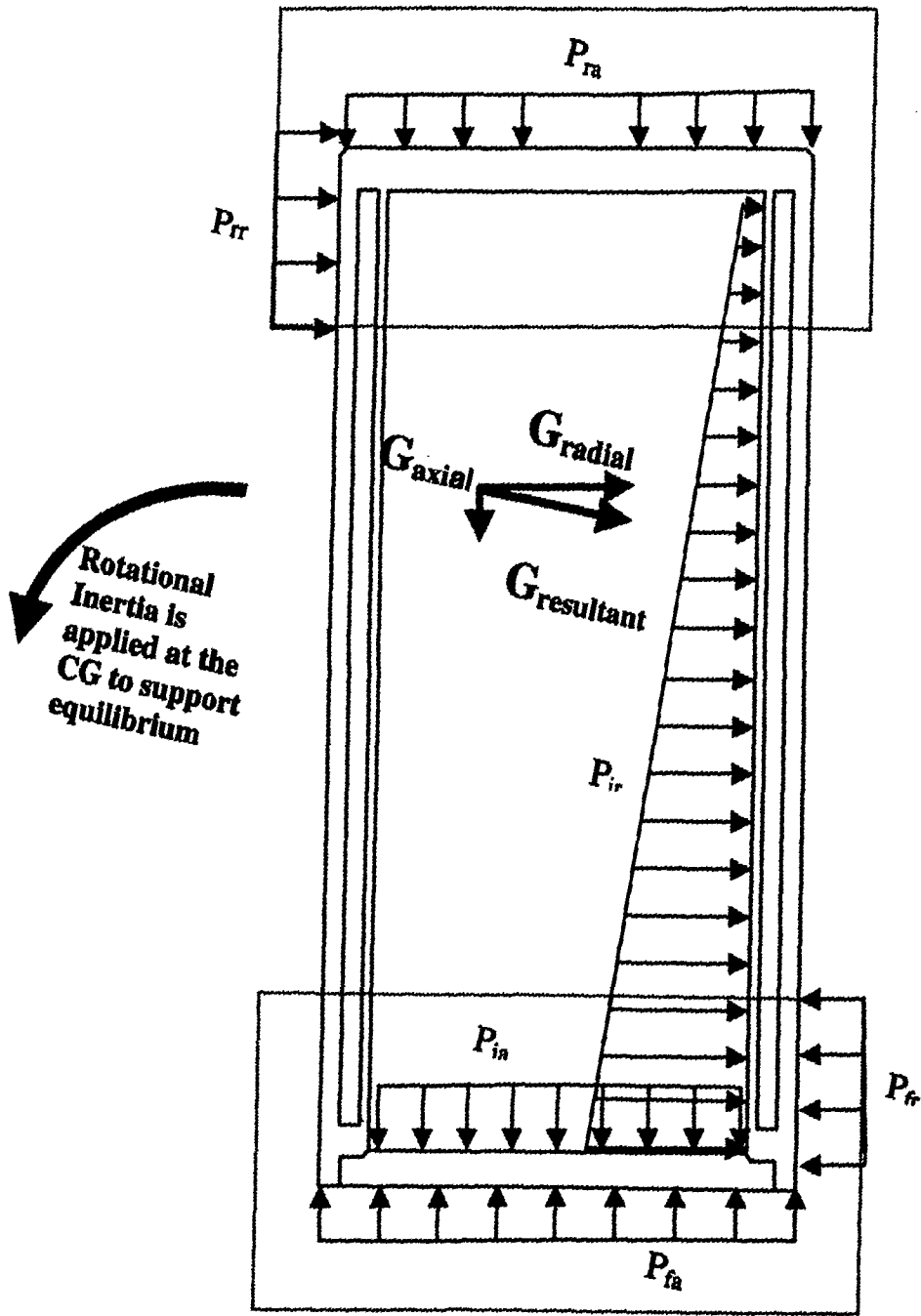


Figure 2.10.1-16: 30 Foot Oblique Impact on Lid End Loading

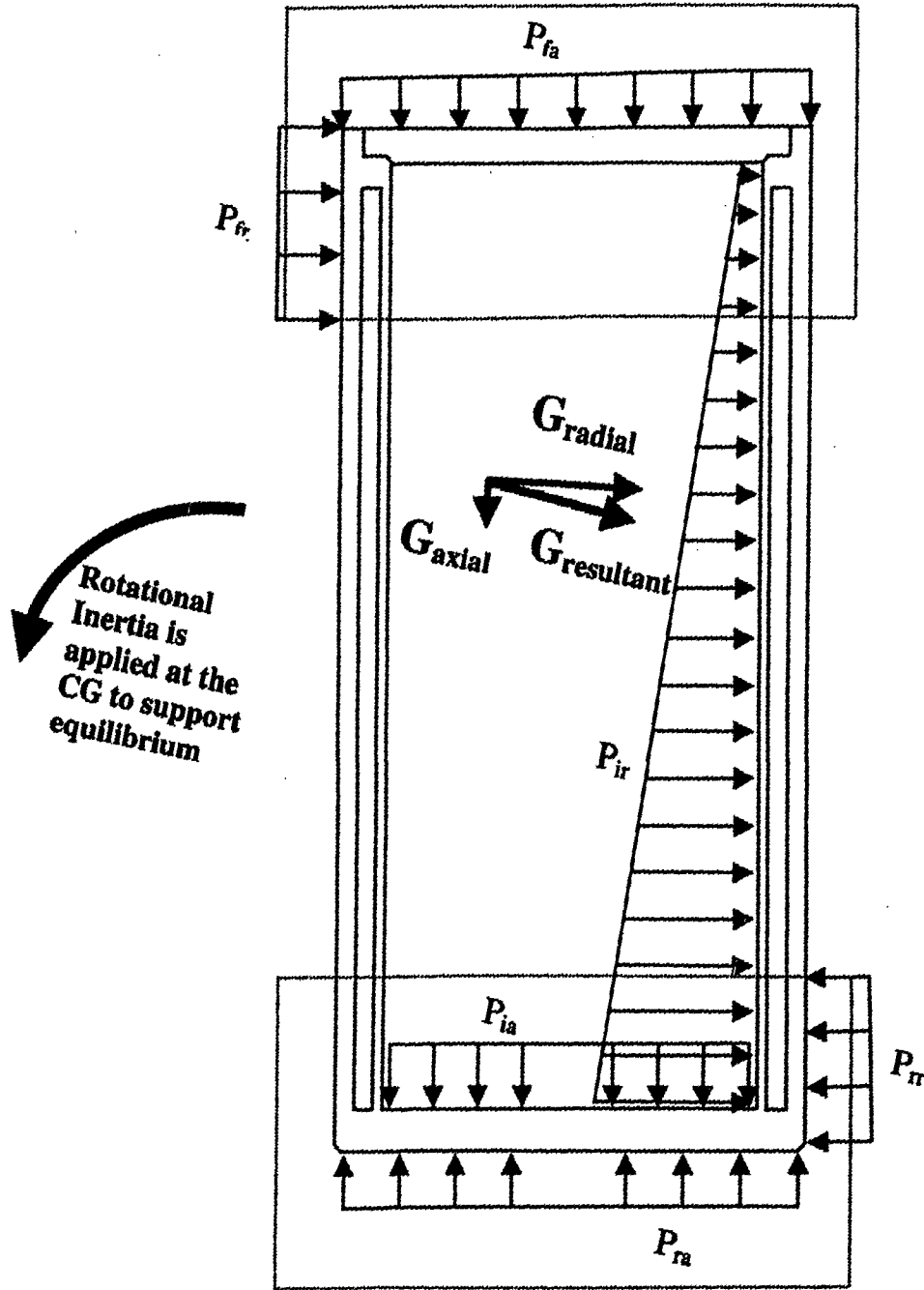
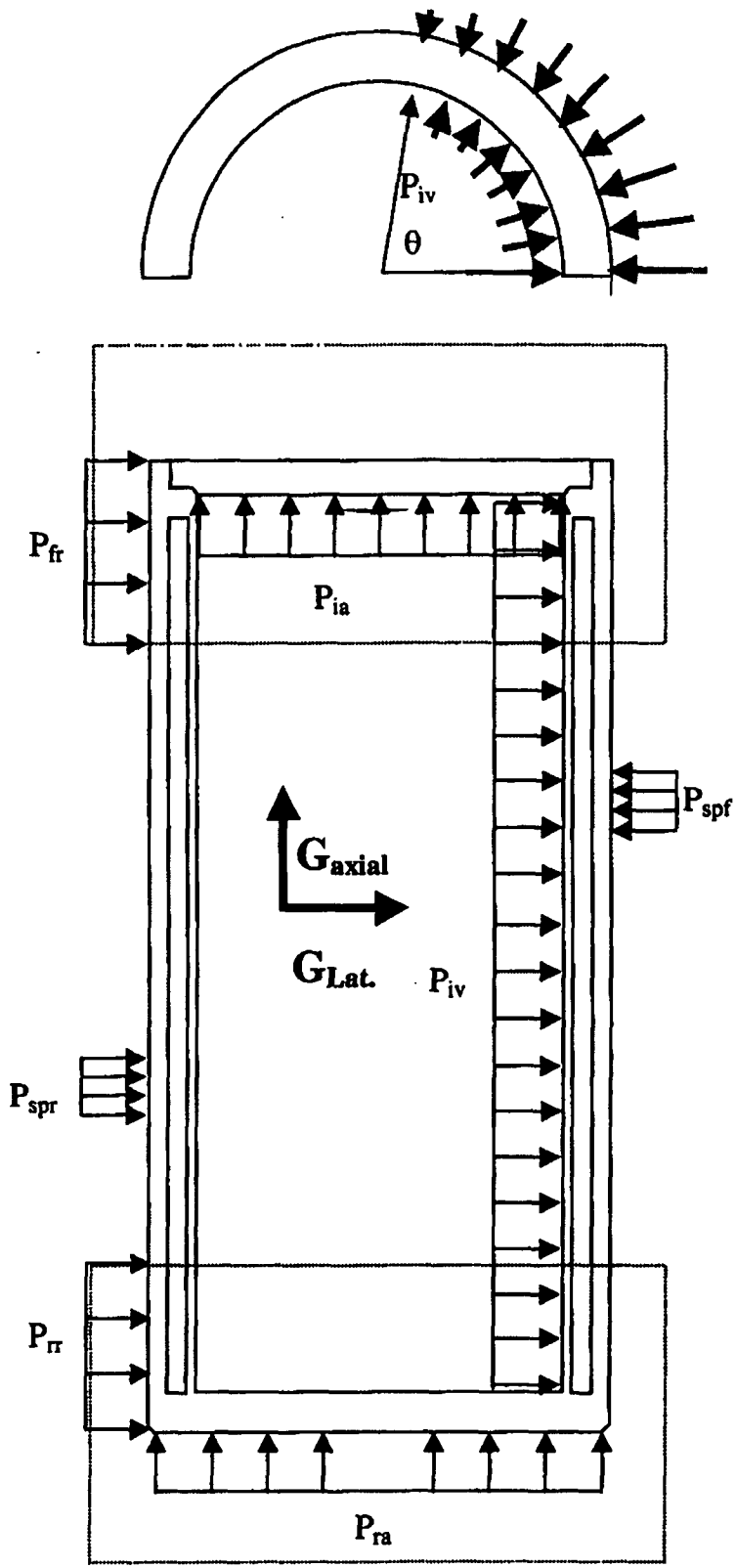
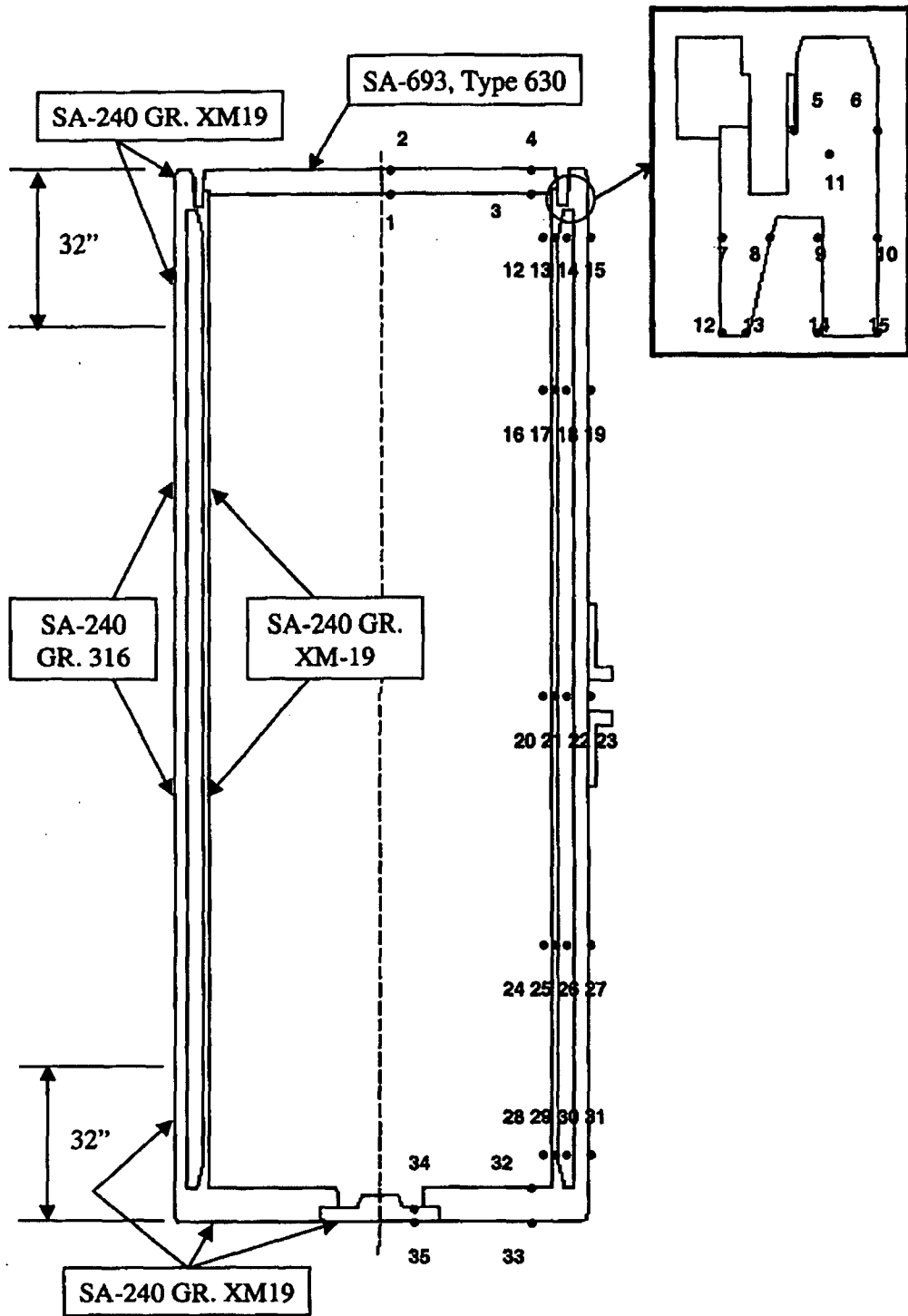


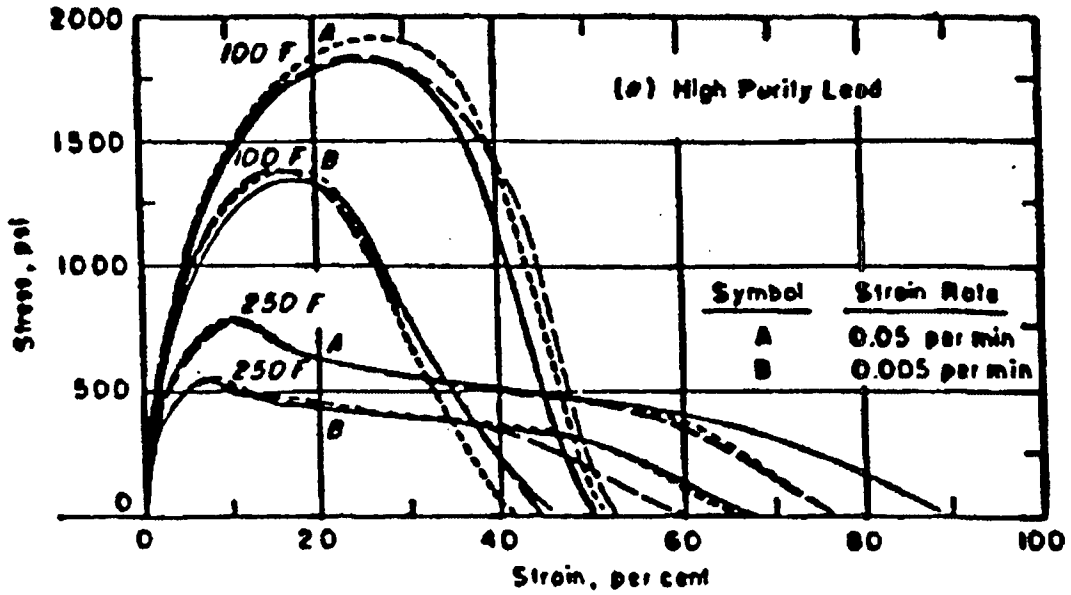
Figure 2.10.1-17: 30 Foot Oblique Impact on Bottom End Loading



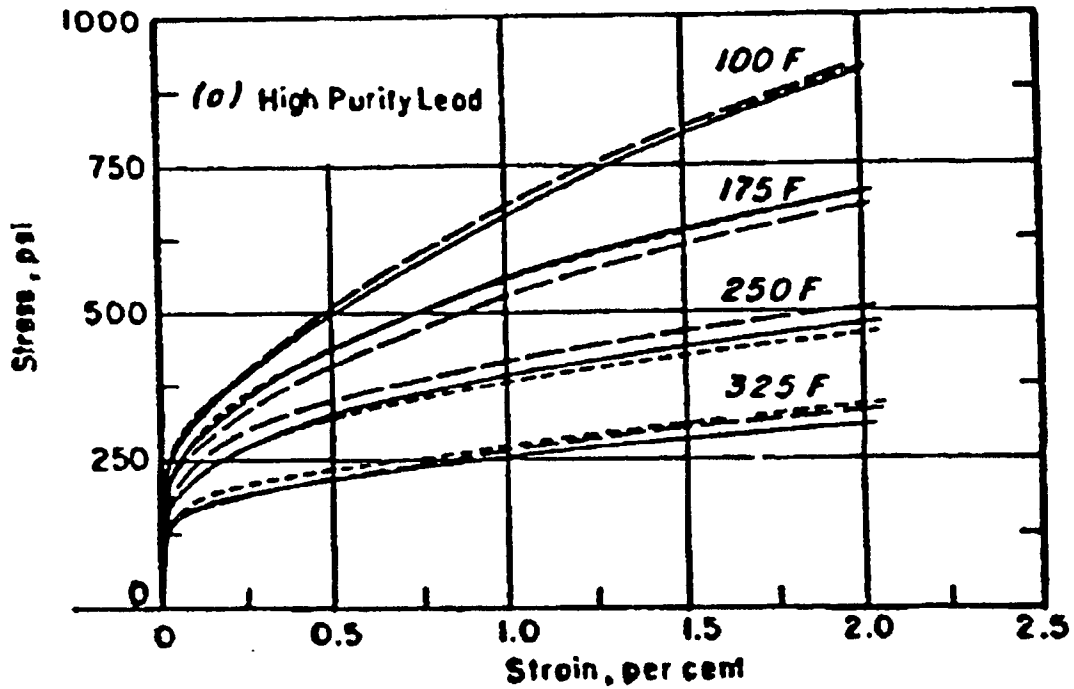
**Figure 2.10.1-18: Tie-Down Loading**



**Figure 2.10.1-19: Standard Stress Report Locations**



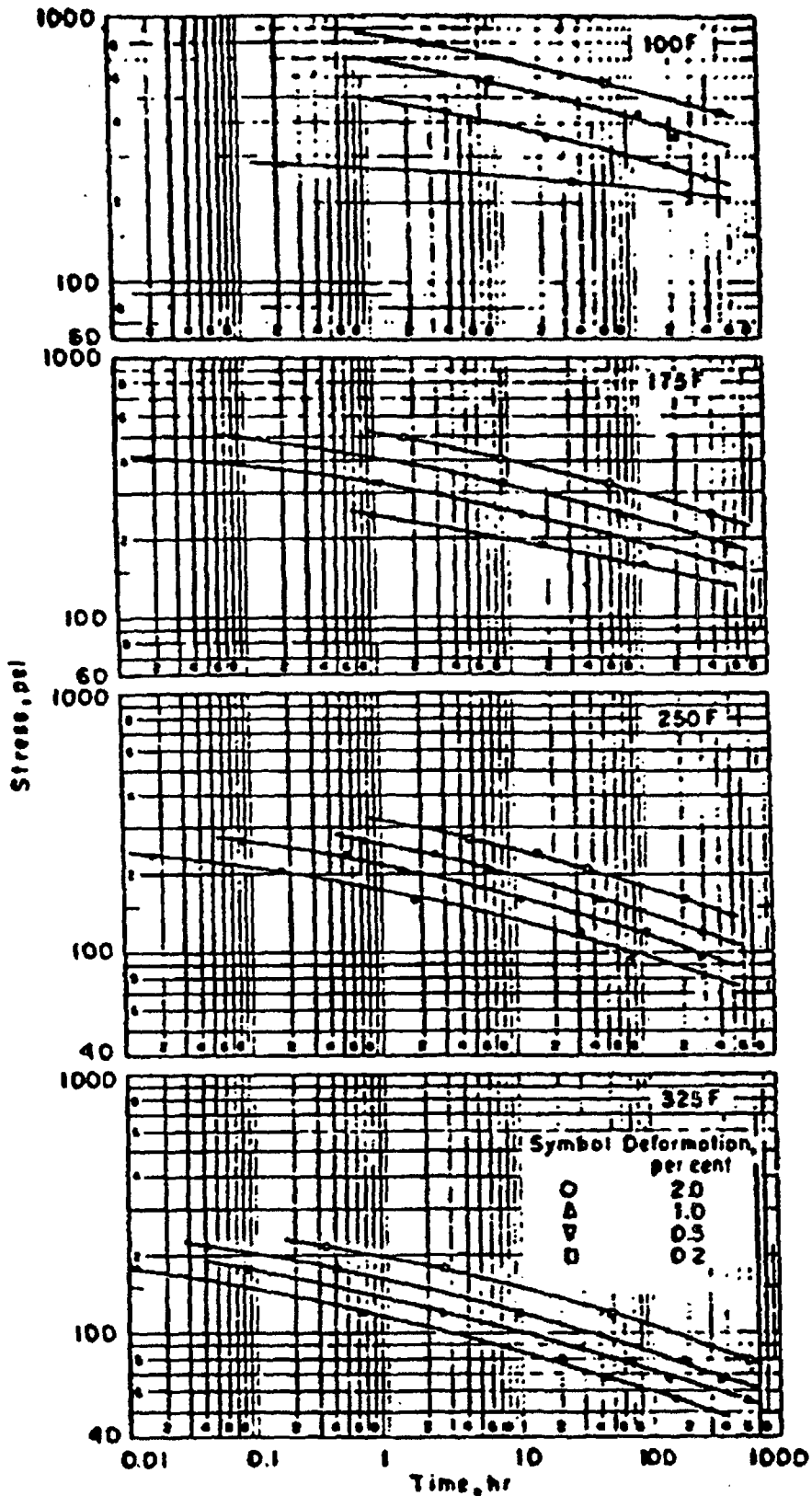
-Effect of Strain Rate on the Tensile Stress-Strain Curves at 100 and 250 F.



-Tensile Stress-Strain Curves to 2 per cent Strain at a Strain Rate of 0.005 per min.

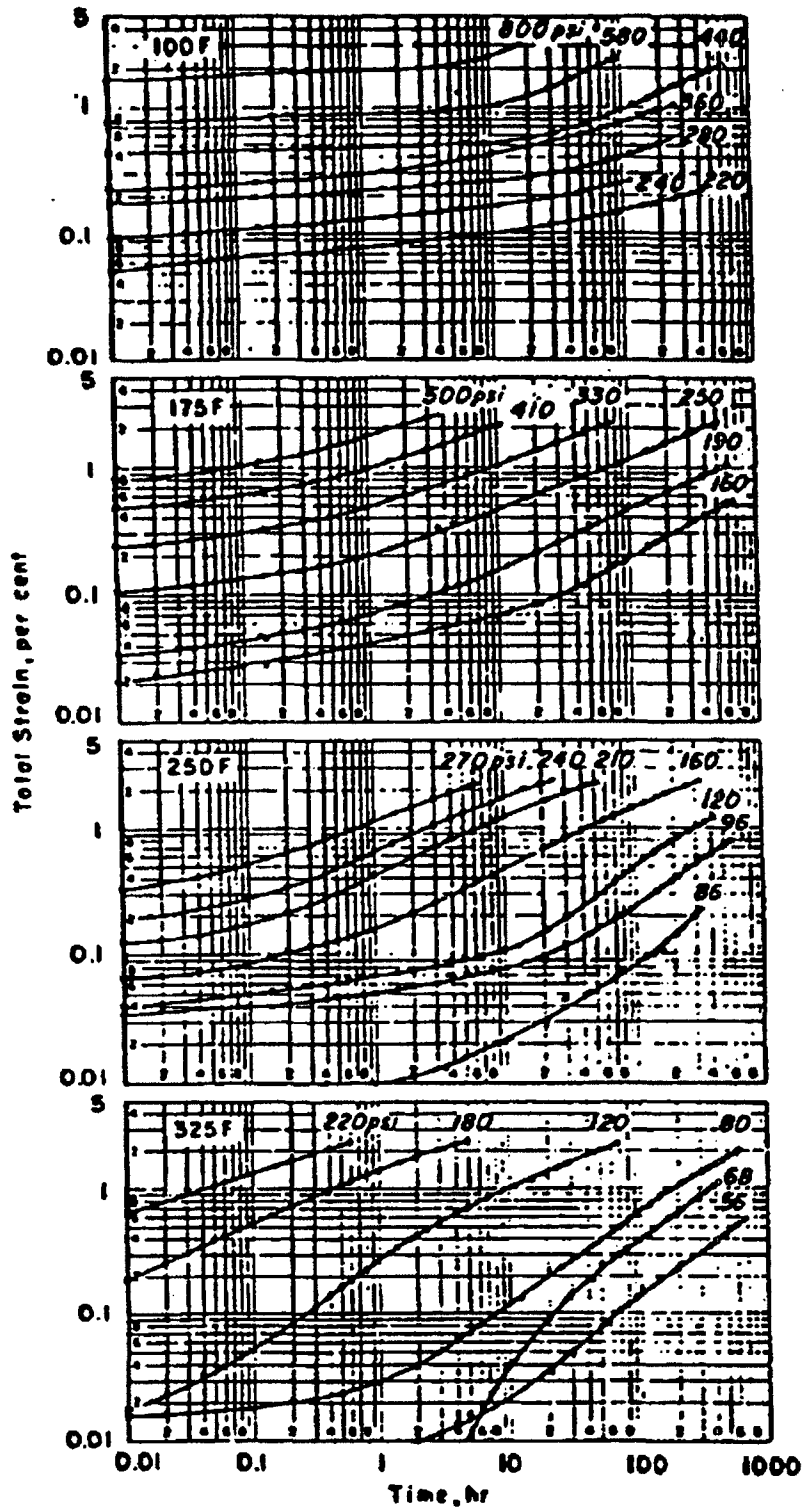
Figure 2.10.1-20  
Typical Stress-Strain Curve for Pure Lead

**Figure 2.10.1-21**  
**Stress Relaxation versus Time at Constant Strain Values of 0.2%, 0.5%, 1.0%, and 2.0% for Pure Lead**





**Figure 2.10.1-22**  
**Total Strain versus Creep Time for Pure Lead**  
**TIETZ ON PROPERTIES OF LEAD AT ELEVATED TEMPERATURES**



—Total Strain versus Creep Time for High-Purity Lead.

## APPENDIX 2.10.2

### TABLE OF CONTENTS

	<u>Page</u>
2.10.2 NUHOMS®-MP197 CASK LID BOLT ANALYSIS .....	2.10.2-1
2.10.2.1 Introduction.....	2.10.2-1
2.10.2.2 Lid Bolt Calculations.....	2.10.2-2
2.10.2.3 Load Combinations.....	2.10.2-9
2.10.2.4 Bolt Stress Calculations .....	2.10.2-12
2.10.2.5 Analysis Results .....	2.10.2-14
2.10.2.6 Fatigue Analysis .....	2.10.2-15
2.10.2-7 Minimum Engagement Length for Bolt and Flange.....	2.10.2-20
2.10.2-8 Ram Port Cover Bolt Analysis.....	2.10.2-22
2.10.2-9 Conclusions.....	2.10.2-33
2.10.2-10 References.....	2.10.2-34

### LIST OF TABLES

2.10.2-1	Design Parameters for Lid Bolt Analysis
2.10.2-2	Bolt Data
2.10.2-3	Allowable Stresses in Closure Bolts For Normal Conditions
2.10.2-4	Allowable Stresses in Closure Bolts For Accident Conditions
2.10.2-5	Design Parameters for Ram Port Cover Bolt Analysis

## APPENDIX 2.10.2

### NUHOMS<sup>®</sup>-MP197 CASK LID BOLT ANALYSIS

#### 2.10.2.1 Introduction

This section evaluates the ability of the transport cask closure to maintain a leak tight seal under normal and accident conditions. Also evaluated in this section, are the bolt thread and internal thread stresses, and lid bolt fatigue. The stress analysis is performed in accordance with NUREG/CR-6007 [1].

The NUHOMS<sup>®</sup>-MP197 cask lid closure arrangement is shown in Appendix 1.4, Drawing 1093-71-7. The 4.5 inch thick lid is bolted directly to the end of the containment vessel flange by 48 high strength alloy steel 1.50 inch diameter bolts. Close fitting alignment pins ensure that the lid is centered in the vessel.

The lid bolt is shown in Appendix 1.4, Drawing 1093-71-7. The bolt material is SA-540 Gr. B24 class 1 which has a minimum yield strength of 150 ksi at room temperature [2].

The following ways to minimize bolt forces and bolt failures for shipping casks are taken directly from NUREG/CR-6007, page xiii [1]. All of the following design methods are employed in the NUHOMS<sup>®</sup>-MP197 cask closure system.

- Protect closure lid from direct impact to minimize bolt forces generated by free drops. (use impact limiters)
- Use materials with similar thermal properties for the closure bolts, the lid, and the cask wall to minimize the bolt forces generated by fire accident
- Apply sufficiently large bolt preload to minimize fatigue and loosening of the bolts by vibration.
- Lubricate bolt threads to reduce required preload torque and to increase the predictability of the achieved preload.
- Use closure lid design which minimizes the prying actions of applied loads.
- When choosing a bolt preload, pay special attention to the interactions between the preload and thermal load and between the preload and the prying action.

The following evaluations are presented in this section:

- Lid bolt torque
- Bolt preload
- Gasket seating load
- Pressure load
- Temperature load
- Impact load
- Puncture load
- Thread engagement length evaluation
- Bearing stress
- Load combinations for normal and accident conditions
- Bolt stresses and allowable stresses
- Lid bolt fatigue

The design parameters of the lid closure are summarized in Table 2.10.2-1. The lid bolt data and material allowables are presented in Tables 2.10.2-2 through 2.10.2-4. A maximum temperature of 200°F is used in the lid bolt region during normal and accident conditions. The following load cases are considered in the analysis.

1. Preload + Temperature Load (normal condition)
2. Pressure Load + 1 Foot Drop (normal condition)
3. Pressure + 30 Foot Corner Drop (accident condition)
4. Pressure + Puncture Load (accident condition)

#### 2.10.2.2 Bolt Load Calculations

Symbols and terminology used in this analysis are taken from NUREG/CR-6007 [1] and are reproduced in Table 2.10.2-1.

##### 2.10.2.2.1 Lid Bolt Torque

A bolt torque range of 1,440 to 1,510 ft. lb. has been selected. Using the minimum torque,

$$F_a = Q/KD_b = 1,440 \times 12 / (0.1 \times 1.500) = 115,200 \text{ lb.}, \text{ and}$$

$$\text{Preload stress} = F_a / \text{Stress Area (Table 2.10.2-2)} = 115,200 / 1.404 = 82,050 \text{ psi.}$$

Using the maximum torque,

$$F_a = Q/KD_b = 1,510 \times 12 / (0.1 \times 1.500) = 120,800 \text{ lb.}, \text{ and}$$

$$\text{Preload stress} = F_a / \text{Stress Area (Table 2.10.2-2)} = 120,800 / 1.404 = 86,040 \text{ psi.}$$

#### 2.10.2.2.2 Bolt Preload ([1], Table 4.1)

For the maximum torque of 1,510 ft. lb.,

$$F_a = 120,800 \text{ lb.}, \text{ and}$$

For the minimum torque of 1,440 ft. lb.,

$$F_a = 115,200 \text{ lb.}, \text{ and}$$

Residual torsional moment for minimum torque of 1,440 ft. lb. is,

$$M_{tr} = 0.5Q = .5(1,440 \times 12) = 8,640 \text{ in. lb.}$$

Residual torsional moment for maximum torque of 1,510 ft. lb. is,

$$M_{tr} = 0.5Q = .5(1,510 \times 12) = 9,060 \text{ in. lb.}$$

Residual tensile bolt force for maximum torque,

$$F_{ar} = F_a = 120,800 \text{ lb.}$$

#### 2.10.2.2.3 Gasket Seating Load

Since an elastomer o-ring is used, the gasket seating load is negligible.

#### 2.10.2.2.4 Pressure Loads ([1], Table 4.3)

Axial force per bolt due to internal pressure is

$$F_a = \frac{\pi D_{ig}^2 (P_{li} - P_{lo})}{4N_b}$$

$D_{ig}$  for outer seal (conservative) = 69.873 in. Then,

$$F_a = \frac{\pi(69.873^2)(50 - 0)}{4(48)} = 3,994 \text{ lb./bolt.}$$

The fixed edge closure lid force is,

$$F_f = \frac{D_{lb}(P_{li} - P_{lo})}{4} = \frac{72.31(50)}{4} = 904 \text{ lb. in.}^{-1}$$

The fixed edge closure lid moment is,

$$M_f = \frac{(P_{ii} - P_{io})D_{lb}^2}{32} = \frac{50(72.31^2)}{32} = 8,170 \text{ in. lb. in.}^{-1}.$$

The shear bolt force per bolt is,

$$F_s = \frac{\pi E_l t_l (P_{ii} - P_{io}) D_{lb}^2}{2 N_b E_c t_c (1 - N_{ul})} = \frac{\pi (27.8 \times 10^6) (4.5) (50) (72.31)^2}{2 (48) (27.6 \times 10^6) (7.0) (1 - 0.305)} = 7,971 \text{ lb./bolt.}$$

The lid shoulder takes this shear force, so that  $F_s = 0$ .

#### 2.10.2.2.5 Temperature Loads

From reference 4, the lid bolt material is SA-540, Type B24, class 1, 2Ni ¼Cr 1/3Mo. The Lid is made of SA-693 Type 630, or SA-705 Type 630, both of which are 17Cr 4Ni 4Cu. The Cask Flange is constructed from SA-182 Type FXM-19, which is 22Cr 13Ni 5Mn. Therefore, the bolts have a coefficient of thermal expansion of  $6.7 \times 10^{-6}$  in./in. °F<sup>-1</sup> at 200° F, the lid has a coefficient of thermal expansion of  $5.90 \times 10^{-6}$  in./in. °F<sup>-1</sup> at 200° F, and the flange has a coefficient of thermal expansion of  $8.5 \times 10^{-6}$  in./in. °F<sup>-1</sup> at 200° F [2].

$$F_a = 0.25 \pi D_b^2 E_b (a_l T_l - a_b T_b)$$

$$F_a = 0.25(\pi)(1.500^2)(27.1 \times 10^6)[(5.90 \times 10^{-6})(130) - (6.7 \times 10^{-6})(130)] = -4,981 \text{ lb.}$$

Even though the lid and flange are constructed from different materials, the shear force per bolt,  $F_s$ , due to a temperature change of 130° F is, 0 psi, since the clearance holes in the lid are oversized (1.69 in. diameter) allowing the lid to grow in the radial direction.

$$F_s = 0.$$

The temperature difference between the inside of the lid and the outside of the lid will always be less than one degree. Consequently, the resulting bending moment is negligible.

$$M_f = 0.$$

### 2.10.2.2.6 Impact Loads ([1], Table 4.5)

The non-prying tensile bolt force per bolt,  $F_a$ , is,

$$F_a = \frac{1.34 \sin(xi)(DLF)(ai)(W_l + W_c)}{N_b} = \frac{1.34 \sin(xi)(1.1)(ai)(96,000)}{48} = 2,948(ai) \sin(xi) \text{ lb./bolt.}$$

Note:  $W_l + W_c$  is conservatively assumed to be 96,000 lbs. [Actual weight from Section 2.2 = 5,611 (lid) + 22,918 (basket and hold down ring) + 22,467 (canister) + 43,005 (fuel assemblies) = 94,001 lbs.]

The shear bolt force is,

$$F_s = \frac{\cos(xi)(ai)(W_l)}{N_b} = \frac{6,000(ai) \cos(xi)}{48} = 125(ai) \cos(xi) \text{ lb./bolt.}$$

The lid shoulder during normal and accident condition drops takes shear force. Therefore,

$$F_s = 0.$$

The fixed-edge closure lid force,  $F_f$ , is,

$$F_f = \frac{1.34 \sin(xi)(DLF)(ai)(W_l + W_c)}{\pi D_{lb}} = \frac{1.34 \sin(xi)(1.1)(ai)(96,000)}{\pi(72.31)} = 622.9 \sin(xi)(ai) \text{ lb. in.}^{-1}$$

The fixed-edge closure lid moment,  $M_f$ , is,

$$M_f = \frac{1.34 \sin(xi)(DLF)(ai)(W_l + W_c)}{8\pi} = \frac{1.34 \sin(xi)(1.1)(ai)(96,000)}{8\pi} = 5,630 \sin(xi)(ai) \text{ in.lb.in}^{-1}$$

### Normal Condition Loads

Even though the 1 foot side drop is the only credible normal condition impact event, all 1 foot drop orientations are conservatively considered for the lid bolt analysis. Since the bolts are protected by the impact limiter during a 90° end drop, the worst case scenario is taken to be roughly a 60° C.G. over corner drop. From the impact limiter 1 foot normal condition analysis (Appendix 2.10.8, Table 2.10.8-13), the maximum axial g load for a 1 foot 60° corner drop is 5 gs. Since the axial acceleration is used,  $\alpha_i$  is taken to be 90°.

$$\alpha_i = 5 \text{ gs, and } \alpha_i = 90^\circ$$

Therefore,

$$\begin{aligned} F_a &= 2,948 \times 5 \times \sin(90^\circ) = 14,740 \text{ lb./bolt,} \\ F_s &= 0 \text{ lb./bolt,} \\ F_f &= 622.9 \times 5 \times \sin(90^\circ) = 3,115 \text{ lb./bolt, and} \\ M_f &= 5,630 \times 5 \times \sin(90^\circ) = 28,150 \text{ lb./bolt.} \end{aligned}$$

### Accident Condition Loads

The accident condition impact load is taken to be the axial acceleration due to a 30 foot, 60° corner drop (Appendix 2.10.8). Since the axial acceleration is used,  $\alpha_i$  is taken to be 90°.

$$\alpha_i = 34 \text{ gs, and } \alpha_i = 90^\circ$$

Therefore,

$$\begin{aligned} F_a &= 2,948 \times 34 \times \sin(90^\circ) = 100,232 \text{ lb./bolt,} \\ F_s &= 0 \text{ lb./bolt,} \\ F_f &= 622.9 \times 34 \times \sin(90^\circ) = 21,179 \text{ lb./bolt, and} \\ M_f &= 5,630 \times 34 \times \sin(90^\circ) = 191,420 \text{ lb./bolt.} \end{aligned}$$

Puncture Loads ([1], Table 4.7):

The non-prying tensile bolt force per bolt,  $F_a$ , is,

$$F_a = \frac{-\sin(\alpha_i) P_{un}}{N_b},$$



where,

$$P_{un} = \text{The smaller of } \begin{cases} 0.75\pi D_{pb}^2 S_{yt} \\ 0.6\pi D_{pb} t_i S_{ul} \\ 0.25\pi D_{pb} S_{fpb}^* \end{cases}$$

\*Flow stress of puncture bar (45 ksi. for mild steel).

$$= \text{The smaller of } \begin{cases} 0.75\pi(6^2)(106,300) = 9.017 \times 10^6 \\ 0.6\pi(6)(9.5)(140,000) = 7.125 \times 10^6 \\ 0.25\pi(6^2)(45,000) = 1.272 \times 10^6 \end{cases}$$

$$\Rightarrow p_{un} = 1.272 \times 10^6 \text{ lb.}$$

The puncture force is greatest when  $xi = 90^\circ$ . Conservatively neglect the protection provided by the impact limiter. Then,

$$F_a = \frac{-\sin(xi)1.272 \times 10^6}{48} = -26,510 \text{ lb.}$$

Since this force is negative (inward acting), the actual resulting bolt force,  $F_a = 0$ , because the applied load is supported by the cask wall and not the lid bolts. The shear bolt force is,

$$F_s = \frac{\cos(90^\circ)P_{un}}{N_b} \text{ lb./bolt.}$$

The lid shoulder during puncture takes shear force. Therefore,

$$F_s = 0.$$

The fixed-edge closure lid force,  $F_f$ , is,

$$F_f = \frac{-\sin(xi)P_{un}}{\pi D_{lb}} = \frac{-\sin(90^\circ)1.272 \times 10^6}{\pi(72.31)} = -5,601 \text{ lb.in}^{-1}.$$

The fixed-edge closure lid moment,  $M_f$ , is,

$$M_f = \frac{-\sin(xi)P_{un}}{4\pi} = \frac{-\sin(90^\circ)1.272 \times 10^6}{4\pi} = -101,250 \text{ lb.in}^{-1}.$$

**LID BOLT INDIVIDUAL LOAD SUMMARY**

Load Case	Applied Load	Non-Prying Tensile Force, $F_a$ (lb.)	Torsional Moment, $M_t$ (in. lb.)	Prying Force, $F_f$ (lb.in. <sup>-1</sup> )	Prying Moment, $M_f$ (in. lb. in. <sup>-1</sup> )	
Preload	Residual	Maximum Torque	120,800	9,060	0	0
		Minimum Torque	115,200	8,640	0	0
Gasket	Seating Load	0	0	0	0	
Pressure	50 psig Internal	3,994	0	904	8,170	
Thermal	300°F	-4,981	0	0	0	
Impact	1 Foot Normal Condition Drop (5 gs)	14,740	0	3,115	28,150	
	30 foot Accident Condition Drop (34 gs)	100,200	0	21,180	191,400	
Puncture	Drop on six inch diameter rod	0	0	-5,601	-101,250	

2.10.2.3 Load Combinations ([1], Table 4.9)

A summary of normal and accident condition load combinations is presented in the following table.

LID BOLT NORMAL AND ACCIDENT LOAD COMBINATIONS

Load Case	Combination Description		Non-Prying Tensile Force, $F_a$ (lb.)	Torsional Moment, $M_t$ (in. lb.)	Prying Force, $F_f$ (lb.in. <sup>-1</sup> )	Prying Moment, $M_f$ (in. lb. in. <sup>-1</sup> )
1.	Preload + Temperature (Normal Condition)	A. Maximum Torque	115,800	9,060	0	0
		B. Minimum Torque	110,200	8,640	0	0
2.	Pressure + Normal Impact (Normal Condition)		18,730	0	4,019	36,320
3.	Pressure + Accident Impact (Accident Condition)		104,200	0	22,080	199,600
4.	Pressure + Puncture (Accident Condition)		3,994	0	-4,697	-93,080

### Additional Prying Bolt Force

Since the prying forces applied in load case 4 (pressure + puncture) acts inward, normal to the cask lid, an additional prying bolt force,  $F_{ap}$ , is generated (Ref. 1, Table 2.1). No additional force is generated for the outward loadings however (load cases 1, 2, and 3), because of the gap between the lid and flange at the outer edge.  $F_{ap}$  is calculated in the following way.

$$F_{ap} = \left( \frac{\pi D_{lb}}{N_b} \right) \left[ \frac{\frac{2M_f}{(D_{lo}^* - D_{lb})} - C_1(B - F_f) - C_2(B - P)}{C_1 + C_2} \right],$$

where,

$$C_1 = 1, C_2 = \left( \frac{8}{3(D_{lo}^* - D_{lb})^2} \right) \left[ \frac{E_l t_l^3}{1 - N_{ul}} + \frac{(D_{lo} - D_{li}) E_f t_f^3}{D_{lb}} \right] \left( \frac{L_b}{N_b D_b^2 E_b} \right)$$

\* Applicable for outward load only, for negative  $M_f$ , replace  $D_{lo}$  with  $D_{li}$ .

$$= \left( \frac{8}{3(68.42 - 72.31)^2} \right) \left[ \frac{27.8 \times 10^6 (4.5^3)}{1 - 0.3} + \frac{(74.68 - 68.42)(27.6 \times 10^6)(7.0)^3}{72.31} \right] \left( \frac{2.27}{(48)(1.500^2)(27.1 \times 10^6)} \right)$$

$$= 0.607,$$

$B$  is the non-prying tensile bolt force, and  $P$  is the bolt preload. Since  $F_s = 0$ ,  $F_s < P$ , and therefore  $B = P$ . Parameters  $B$ ,  $P$ ,  $F_f$ , and  $M_f$  are quantities per unit length of bolt circle. For the applied inward force,

$$P = B = \frac{F_a N_b}{\pi D_{lb}} = \frac{(110,200)(48)}{\pi(72.31)} = 23,280 \text{ lb. in.}^{-1},$$

$$M_f = -101,250 \text{ in.lb. in.}^{-1}, \text{ and } F_f = 0 \text{ lb. in.}^{-1}.$$

Therefore,

$$F_{ap} = \left( \frac{\pi(72.31)}{48} \right) \left[ \frac{\frac{2(-101,250)}{(68.42 - 72.31)} - 1(23,280 - 0) - 0.607(23,280 - 23,280)}{1 + 0.607} \right]$$

$$= 84,750 \text{ lb./bolt.}$$

It is observed that the additional tensile bolt force due to prying for the puncture is less than the accident impact force. The puncture is therefore not critical for bolt stress evaluation.

Bolt Bending Moment ([1], Table 2.2)

The maximum bending bolt moment,  $M_{bb}$ , generated by the applied load is evaluated as follows:

$$M_{bb} = \left( \frac{\pi D_{lb}}{N_b} \right) \left[ \frac{K_b}{K_b + K_l} \right] M_f$$

The  $K_b$  and  $K_l$  are based on geometry and material properties and are defined in NUREG/CR-6007 [1], Table 2.2. By substituting the values given above,

$$K_b = \left( \frac{N_b}{L_b} \right) \left( \frac{E_b}{D_{lb}} \right) \left( \frac{D_b^4}{64} \right) = \left( \frac{48}{4.0} \right) \left( \frac{27.1 \times 10^6}{72.31} \right) \left( \frac{1.500^4}{64} \right) = 3.557 \times 10^5, \text{ and}$$

$$K_l = \frac{E_l t_l^3}{3 \left[ (1 - N_{ul}^2) + (1 - N_{ul})^2 \left( \frac{D_{lb}}{D_{lo}} \right)^2 \right] D_{lb}} = \frac{27.8 \times 10^6 (4.5^3)}{3 \left[ (1 - 0.305^2) + (1 - 0.305)^2 \left( \frac{72.31}{74.68} \right)^2 \right] 72.31}$$

$$= 8.588 \times 10^6$$

Therefore,

$$M_{bb} = \left( \frac{\pi 72.31}{48} \right) \left[ \frac{3.557 \times 10^5}{3.557 \times 10^5 + 8.588 \times 10^6} \right] M_f = 0.1882 M_f$$

For load case 2,  $M_f = 36,320$  in. lb. Substituting this value into the equation above gives,

$$M_{bb} = 6,836 \text{ in. lb. / bolt.}$$

## 2.10.2.4 Bolt Stress Calculations ([1], Table 5.1)

### 2.10.2.4.1 Average Tensile Stress

The bolt preload is calculated to withstand the worst case load combination and to maintain a clamping (compressive) force on the closure joint, under both normal and accident conditions. Based upon the load combination results (see Table LID BOLT NORMAL AND ACCIDENT LOAD COMBINATIONS on page 8), it is shown that a positive (compressive) load is maintained on the clamped joint for all load combinations. Therefore, in both normal and accident load cases, the maximum non-prying tensile force of 120,800 lb., from the maximum torque individual load case, is used. The temperature load is conservatively neglected since it tends to decrease the applied bolt load.

#### Normal Condition

$$S_{ba} = 1.2732 \frac{F_a}{D_{ba}^2} = 1.2732 \frac{120,800}{1.337^2} = 86,040 \text{ psi.} = 86.0 \text{ ksi.}$$

#### Accident Condition

$$S_{ba} = 1.2732 \frac{120,800}{1.337^2} = 86,040 \text{ psi.} = 86.0 \text{ ksi.}$$

### 2.10.2.4.2 Bending Stress

#### Normal Condition

$$S_{bb} = 10.186 \frac{M_{bb}}{D_{ba}^3} = 10.186 \frac{6,836}{1.337^3} = 29,340 \text{ psi.} = 29.3 \text{ ksi.}$$

### 2.10.2.4.3 Shear Stress

For both normal and accident conditions, the average shear stress caused by shear bolt force  $F_s$  is,

$$S_{bs} = 0.$$

For normal and accident conditions the maximum shear stress caused by the torsional moment  $M_t$  is,

$$S_{bt} = 5.093 \frac{M_t}{D_{ba}^3} = 5.093 \frac{9,060}{1.337^3} = 19,310 \text{ psi.} = 19.3 \text{ ksi.}$$

#### 2.10.2.4.4 Maximum Combined Stress Intensity

The maximum combined stress intensity is calculated in the following way ([1], Table 5.1).

$$S_{bi} = [(S_{ba} + S_{bb})^2 + 4(S_{bs} + S_{bt})^2]^{0.5}$$

For normal conditions combine tension, shear, bending, and residual torsion.

$$S_{bi} = [(86,040 + 29,130)^2 + 4(0 + 19,310)^2]^{0.5} = 121,500 \text{ psi.} = 121.5 \text{ ksi.}$$

#### 2.10.2.4.5 Stress Ratios

In order to meet the stress ratio requirement, the following relationship must hold for both normal and accident conditions.

$$R_t^2 + R_s^2 < 1$$

Where  $R_t$  is the ratio of average tensile stress to allowable average tensile stress, and  $R_s$  is the ratio of average shear stress to allowable average shear stress.

#### For normal conditions

$$R_t = 86,040/95,600 = 0.931,$$

$$R_s = 19,310/57,400 = 0.349,$$

$$R_t^2 + R_s^2 = (0.900)^2 + (0.336)^2 = 0.923 < 1.$$

#### For accident conditions

$$R_t = 86,040/115,500 = 0.745,$$

$$R_s = 19,310/69,300 = 0.279,$$

$$R_t^2 + R_s^2 = (0.745)^2 + (0.279)^2 = 0.633 < 1.$$

#### 2.10.2.4.6 Bearing Stress (Under Bolt Head)

The maximum axial bolt force is 120,800 lb. The lid bolt head is a 2.25 inch diameter socket head. The diameter of the bolt hole in the NUHOMS<sup>®</sup>-MP197 cask lid is 1.69 inches. Therefore the bearing area, A, under the lid bolt head is,

$$A = (\pi/4)(2.25^2 - 1.69^2) = 1.733 \text{ in}^2.$$

The bearing stress is,

$$\text{Bearing Stress} = 120,800/1.733 = 69,706 \text{ psi.} = 69.7 \text{ ksi.}$$

The allowable bearing stress on the lid is taken to be the yield stress of the lid material at 300° F. The lid may be manufactured out of SA-693 TP630 or SA-705 TP630. The minimum yield strength of both materials at 300° F is 101,800 psi.

#### 2.10.2.5 Analysis Results

A summary of the bolt stresses calculated above is presented in the following table:

SUMMARY OF STRESSES AND ALLOWABLES

Stress Type	Normal Condition		Accident Condition	
	Stress	Allowable	Stress	Allowable
Average Tensile (ksi.)	86.0	95.6	86.0	115.5
Shear (ksi)	19.3	57.4	19.3	69.3
Combined (ksi)	121.5	129.1	Not Required [1]	
Interaction E.Q. $R_t^2 + R_s^2 < 1$	0.923	1	0.633	1
Bearing (ksi) Allowable (ksi) (S <sub>y</sub> of lid material)	69.7	106.3	Not Required [1]	

The calculated bolt stresses are all less than the specified allowable stresses.



### 2.10.2.6 Fatigue Analysis

The purpose of the fatigue analysis is to show quantitatively that the fatigue damage to the bolts during normal conditions of transport is acceptable. This is done by determining the fatigue usage factor for each normal transport event. For this analysis it is assumed that the transport cask lid bolts are replaced after 85 round trip shipments. The total cumulative damage or fatigue usage for all events is conservatively determined by adding the usage factors for the individual events. The sum of the individual usage factors is checked to make certain that for the 85 round trip shipments of the NUHOMS<sup>®</sup>-MP197 cask, the total usage factor is less than one. The following sequence of events is assumed for the fatigue evaluation.

1. Operating Preload
2. Pressure and Temperature Fluctuations
3. Road vibration
4. Shock
5. Test Pressure
6. 1 foot normal condition drop

Since the bolt preload stress applied to the NUHOMS<sup>®</sup>-MP197 cask lid bolts is higher than all of the other normal and accident condition loads, the stress in the bolt will never exceed the bolt preload stress. Consequently, the application and removal of preload is the only real cyclic loading that occurs in the lid bolts. The following analysis is therefore very conservative since it assumes that the usage factor is the sum of all of the individual event usage factors, and not simply the usage factor for bolt preload.

#### 2.10.2.6.1 Operating Preload

Assuming that the bolts are replaced after 85 round trips, the number of preload cycles is two times the number trips or 170 cycles.

The maximum tensile stress due to bolt preload is 86,040 psi, and the maximum shear stress due to residual bolt torsion is 19,310 psi. The corresponding stress intensity is then

$$S.I. = \sqrt{86,040^2 + 4(19,310^2)} = 94,310 \text{ psi.}$$

#### 2.10.2.6.2 Test Pressure

The hydrostatic test pressure, according to Reference 3, is  $1.25 \times 50$  psi. (design pressure), or 62.5 psi., and will only be performed once. Reference 1 provides bolt loads due to 50 psi internal pressure. So for 62.5 psi pressure, the bolt loads are the following.

$$F_a = 3994 \times (62.5/50) = 11,993 \text{ lb./ bolt.}$$

$$F_s = 0 \times (62.5/50) = 0 \text{ lb. / bolt.}$$

$$F_f = 904 \times (62.5/50) = 1,130 \text{ lb.in.}^{-1}$$

$$M_f = 8170 \times (62.5/50) = 10,213 \text{ in.lb.in.}^{-1}$$

$$M_{bb} = 0.1895 M_f \text{ in.lb. / bolt.}$$

The minimum lid bolt diameter is 1.337 in. Therefore from NUREG/CR-6007 [1], we get the following

$$S_{ba} = 1.2732 \frac{F_a}{D_{ba}^2} = 1.2732 \frac{4,993}{1.337^2} = 2,556 \text{ psi.},$$

$$S_{bb} = 10.186 \frac{M_{bb}}{D_{ba}^3} = 10.186 \frac{0.1895(10,213)}{1.337^3} = 8,248 \text{ psi.},$$

Since internal pressure causes no bolt torsion, and all shear loads are taken by the lid shoulder,

$$S_{bs} = 0, \text{ and } S_{bt} = 0.$$

$$S.I. = S_{bt} = [(S_{ba} + S_{bb})^2 + 4(S_{bs} + S_{bt})^2]^{0.5} = [(3,556 + 8,248)^2 + 4(0)^2]^{0.5} = 11,805 \text{ psi.}$$

#### 2.10.2.6.3 Vibration / Shock

Since the NUHOMS<sup>®</sup>-MP197 cask may be shipped either by truck or by rail car, the shock loading for both cases will be considered.

##### Truck Shock

Shock input was obtained from ANSI N14.23 [4]. This standard specifies shock loads that correspond to normal transport over rough roads or minor accidents such as backing into a loading dock. Since the NUHOMS<sup>®</sup>-MP197 cask will be transported on interstate highways or major good roads, the shock loads will not be applied continuously to the normal transport mode for the package. The fatigue calculation assumes an average trip of 3,000 miles averaging 45 miles per hour. The total driving time would then be 3,000 miles / 45 mph. = 67 hours. Assume the driver stops and leaves the interstate every 4 hours and assume that one shock could be experienced during each of these stops. The return trip package behavior is assumed to be the same as the "loaded" trip even though the cargo is no longer present. Therefore shock loading occurs 18 (shocks per trip) × 2 (round trip) × 85 shipments = 3,060 cycles.

ANSI N14.23 [4] specifies a peak shock loading of 2.3 gs in the longitudinal direction. The weight of the lid, basket, canister, and fuel assemblies is conservatively assumed to be 95,000 lb. The actual maximum weight of the lid, basket, and canister is 94,001 lb. (Section 2.2). The bolt force due to truck shock is,

$$(95,000 \text{ lb})(2.3 \text{ gs}) / (48 \text{ bolts})(1.404 \text{ in}^2 \text{ per bolt}) = 3,242 \text{ psi.}$$

### Rail Car Shock

Again, assume 85 round trip shipments, averaging 3,000 miles each way. NUREG 766510 [5] reports that there are roughly 9 shock cycles per 100 miles of rail car transport. Therefore the total number of cycles is  $3,000 \text{ (miles)} \times 2 \text{ (round trip)} \times 85 \text{ (shipments)} \times 0.09 \text{ (Shocks per mile)} = 45,900 \text{ cycles}$ .

NUREG 766510 [5] specifies a peak shock loading of 4.7 gs in the longitudinal direction for rail car transport. Consequently, the bolt force due to rail car shock is

$$(95,000 \text{ lb})(4.7 \text{ gs}) / (48 \text{ bolts})(1.404 \text{ in}^2 \text{ per bolt}) = 6,625 \text{ psi.}$$

### Vibration

Since vibration accelerations are higher on a truck than on a rail car, the truck vibration loads are considered bounding. According to ANSI N14.23 [4], the peak vibration load at the bed of a truck in the longitudinal direction is 0.3 g's. This results in a stress of 423 psi, which is negligible for a high strength bolt.

#### 2.10.2.6.4 Pressure and Temperature Fluctuations

The following bolt loads result from the maximum temperature change of 230° F (Section 2.10.2.2.5)

$$\begin{aligned} F_a &= -10,850 \text{ lb./ bolt.} \\ F_s &= 0 \text{ lb. / bolt.} \\ F_f &= 0 \text{ lb.in.}^{-1} \\ M_f &= 0 \text{ in.lb.in.}^{-1} \end{aligned}$$

Since the temperature load tends to reduce the axial load in the lid bolts, the temperature load is conservatively neglected. The maximum pressure difference between in the inside and the outside of the lid is conservatively taken to be 50 psi. The bolt loads due to this pressure difference are (Section 2.10.2.2.4),

$$\begin{aligned} F_a &= 3,994 \text{ lb./ bolt.} \\ F_s &= 0 \text{ lb./ bolt.} \\ F_f &= 904 \text{ lb.in.}^{-1} \\ M_f &= 8,170 \text{ in.lb.in.}^{-1} \\ M_{bb} &= 0.1895 M_f \text{ in.lb. / bolt.} \end{aligned}$$

The minimum lid bolt diameter is 1.337 in. The tensile and bending stresses in the lid bolts, generated by pressure fluctuations, are the following [1].

$$S_{ba} = 1.2732 \frac{F_a}{D_{ba}^2} = 1.2732 \frac{3,994}{1.337^2} = 2,845 \text{ psi.},$$

$$S_{bb} = 10.186 \frac{M_{bb}}{D_{ba}^3} = 10.186 \frac{0.1895(8,170)}{1.337^3} = 6,598 \text{ psi.}$$

Since internal pressure and temperature loads cause no bolt torsion, and all shear loads are taken by the lid shoulder,

$$S_{bs} = 0, \text{ and } S_{bt} = 0.$$

The stress intensity due the combine temperature and pressure fluctuations is as follows.

$$S.I. = S_{bi} = [(S_{ba} + S_{bb})^2 + 4(S_{bs} + S_{bt})^2]^{0.5} = [(2,845 + 6,598)^2 + 4(0)^2]^{0.5} = 9,443 \text{ psi.}$$

Assuming this cycle occurs once each one way shipment, the total number of pressure and temperature fluctuation cycles is 170.

#### 2.10.2.6.5 1 Foot Normal Condition Drop

The normal condition drop consists of a 1 foot drop in an orientation that results in the most damage. For the side drop the resulting shear load is taken entirely by the lid / flange interface. For the end drop, the load is transferred to the cask body via the impact limiters, protecting the bolts. Therefore the worst case scenario is taken to be roughly a 60° C.G. over corner drop. From Section 2.10.2.2.6, the resulting bolt loading is the following.

$$\begin{aligned} F_a &= 14,740 \text{ lb./bolt,} \\ F_s &= 0 \text{ lb./bolt,} \\ F_f &= 3,115 \text{ lb./bolt, and} \\ M_f &= 28,150 \text{ lb./bolt.} \\ M_{bb} &= 0.1895 M_f \end{aligned}$$

The tensile and bending bolt stresses generated are the following.

$$S_{ba} = 1.2732 \frac{F_a}{D_{ba}^2} = 1.2732 \frac{14,740}{1.337^2} = 10,499 \text{ psi.},$$

$$S_{bb} = 10.186 \frac{M_{bb}}{D_{ba}^3} = 10.186 \frac{0.1896(28,150)}{1.337^3} = 22,747 \text{ psi,}$$

Since the impact load causes no bolt torsion, and all shear loads are taken by the lid shoulder,

$$S_{bs} = 0, \text{ and } S_{bt} = 0.$$

$$S.I. = S_{bl} = [(S_{ba} + S_{bb})^2 + 4(S_{bs} + S_{bt})^2]^{0.5} = [(10,499 + 22,747)^2 + 4(0)^2]^{0.5} = 33,246 \text{ psi.}$$

Conservatively assume that the cask is dropped once per shipment, resulting in 85 normal condition drops before the lid bolts are changed.

#### 2.10.2.6.6 Damage Factor Calculation

The following damage factors are computed based on the stresses and cyclic histories described above, a fatigue strength reduction factor,  $K_F$ , of 4 [6], and the fatigue curve shown in Table I-9.4 of ASME Section III Appendices.

Event	Stress Intensity (psi.)	$S.I. \times K_F$ (psi.)	$S_a$ (psi.)	Cycles		Damage Factor $n/N$
				$n$	$N$	
Operating Preload	94,310	377,240	211,933	170	250	0.68
Test Pressure	11,804	47,216	26,526	85	20,000	0.00
Truck Shock	3,242	12,968	7,285	3,060	$\infty$	0.00
Rail Car Shock	6,625	26,500	14,888	45,900	300,000	0.15
Pressure and Temperature	9,443	37,772	21,220	170	50,000	0.00
1 Foot Drop Impact Load	33,246	132,984	74,710	85	1,500	0.06
$\Sigma$						0.90

Here,  $n$  is the number of cycles,  $N$  is taken from Figure I-9.4 of reference 7, and  $S_a$  is defined in the following way.

If one cycle goes from 0 to  $+S.I.$ , then  $S_a = (1/2) \times S.I. \times K_F \times K_E$ .

If one cycle goes from  $-S.I.$  to  $+S.I.$ , then  $S_a = S.I. \times K_F \times K_E$ .

Where,  $K_E$  is the correction factor for modulus of elasticity. The Modulus of Elasticity of SA-540, Grade B24, Class 1 is  $26.7 \times 10^6$  psi. @ 300° F. Therefore,  $K_E = 30.0 \times 10^6 / 26.7 \times 10^6 = 1.1236$  [7] [2].

### 2.10.2.7 Minimum Engagement Length for Bolt and Flange

For a 1 1/2" – 6UNC – 2A bolt, the material is SA-540 GR. B24 CL.1, with

$$S_u = 165 \text{ ksi.}, \text{ and} \\ S_y = 150 \text{ ksi (at room temperature)}$$

The threaded insert material is constructed from type 304 stainless steel [9] and have the following material properties.

$$S_u = 70 \text{ ksi.}, \text{ and} \\ S_y = 30 \text{ ksi (at room temperature)}$$

The minimum engagement length,  $L_e$ , for the bolt and flange is ([8], Page 1149),

$$L_e = \frac{2A_t}{3.1416 K_{n \max} \left[ \frac{1}{2} + .57735n(E_{s \min} - K_{n \max}) \right]}$$

Where,

$A_t$  = tensile stress area = 1.404 in.<sup>2</sup>,

$n$  = number of threads per inch = 6,

$K_{n \max}$  = maximum minor diameter of internal threads = 1.350 in. ([8], p. 1292)

$E_{s \min}$  = minimum pitch diameter of external threads = 1.3812 in. ([8], p. 1292)

Substituting the values given above,

$$L_e = \frac{2(1.404)}{(3.1416)1.350 \left[ \frac{1}{2} + .57735(6)(1.3812 - 1.350) \right]} = 1.089 \text{ in.}$$

$$J = \frac{A_s \times S_{ue}}{A_n \times S_{ui}} \quad [4]$$

Where,  $J$  is a factor for the relative strength of the external and internal threads,  $S_{ue}$  is the tensile strength of external thread material, and  $S_{ui}$  is the tensile strength of internal thread material.

$A_s$  = shear area of external threads =  $3.1416 n L_e K_{n \max} [1/(2n) + .57735 (E_{s \min} - K_{n \max})]$

$A_n$  = shear area of internal threads =  $3.1416 n L_e D_{s \min} [1/(2n) + .57735(D_{s \min} - E_{n \max})]$

For the bolt / Helicoil insert connection:

$E_{n\ max}$  = maximum pitch diameter of internal threads = 1.4022 in. ([8], p. 1294).

$D_{s\ min}$  = minimum major diameter of external threads = 1.4794 in. ([8], p. 1292)

Therefore,

$$A_s = 3.1416(6)(1.089)(1.350)[1/(2 \times 6) + .57735 (1.3812 - 1.350)] = 2.808 \text{ in.}^2$$

$$A_n = 3.1416(6)(1.089)(1.4794)[1/(2 \times 6) + .57735 (1.4794 - 1.4022)] = 3.883 \text{ in.}^2$$

So,

$$J = \frac{2.808(165.0)}{3.883(70.0)} = 1.705$$

The required length of engagement,  $Q$ , to prevent stripping of the internal threads is,

$$Q = L_e J = (1.089)(1.705) = 1.857 \text{ in.}$$

The actual minimum engagement length = 2.25 in. > 1.857 in. (limited by threaded insert length).

## 2.10.2-8 Ram Port Cover Bolt Analysis

This section evaluates the ability of the ram port closure to maintain a leak tight seal under normal and accident conditions. Also evaluated in this section, are the ram port cover bolt thread and internal thread stresses. The stress analysis is performed in accordance with NUREG/CR-6007 [1].

The NUHOMS<sup>®</sup>-MP197 cask ram port closure arrangement is shown in Appendix 1.4, Drawing 1093-71-6. The ram port cover plate is bolted directly to the end of the containment vessel flange by 12 high strength alloy steel 1.00 inch diameter bolts.

The following evaluations are presented in this section:

- Lid bolt torque
- Bolt preload
- Gasket seating load
- Pressure load
- Temperature load
- Impact load
- Puncture load
- Thread engagement length evaluation
- Bearing stress
- Load combinations for normal and accident conditions
- Bolt stresses and allowable stresses

The design parameters of the ram port cover are summarized in Table 2.10.2-5. The ram port cover bolt data and material allowables are presented in Tables 2.10.2-2 through 2.10.2-4. A maximum temperature of 300°F is used in the lid bolt region during normal and accident conditions. The following load cases are considered in the analysis.

5. Preload + Temperature Load (normal condition)
6. Pressure Load + 1 Foot Drop (normal condition)
7. Pressure + 30 Foot Corner Drop (accident condition)
8. Pressure + Puncture Load (accident condition)



### 2.10.2.8.1 Bolt Load Calculations

Symbols and terminology for this analysis are taken from reference 1 and are reproduced in Table 1.

#### Lid Bolt Torque and Bolt Preload

A bolt torque range of 100 to 125 ft. lb. has been selected. Using the minimum torque,

$$F_a = Q/KD_b = 100 \times 12 / (0.1 \times 1.00) = 12,000 \text{ lb.}, \text{ and}$$

$$\text{Preload stress} = F_a / \text{Stress Area (Table 2)} = 12,000 / 0.606 = 19,800 \text{ psi.}$$

Using the maximum torque,

$$F_a = Q/KD_b = 125 \times 12 / (0.1 \times 1.00) = 15,000 \text{ lb.}, \text{ and}$$

$$\text{Preload stress} = F_a / \text{Stress Area (Table 2)} = 15,000 / 0.606 = 24,750 \text{ psi.}$$

Residual torsional moment for minimum torque of 100 ft. lb. is,

$$M_{tr} = 0.5Q = .5(100 \times 12) = 600 \text{ in. lb.}$$

Residual torsional moment for maximum torque of 125 ft. lb. is,

$$M_{tr} = 0.5Q = .5(125 \times 12) = 750 \text{ in. lb.}$$

Residual tensile bolt force for maximum torque,

$$F_{ar} = F_a = 15,000 \text{ lb.}$$

Gasket Seating Load (Seal – Parker 2-418, Fluorocarbon, Ref 2):

Since an Elastomer o-ring is used, the gasket seating load is negligible.

Pressure Loads (Ref. 1, Table 4.3):

Axial force per bolt due to internal pressure is

$$F_a = \frac{\pi D_{lg}^2 (P_u - P_{lo})}{4N_b}$$

$D_{lg}$  for outer seal (conservative) = 20.02 in. Then,

$$F_a = \frac{\pi(20.02^2)(50-0)}{4(12)} = 1,312 \text{ lb./bolt.}$$

The fixed edge closure lid force is,

$$F_f = \frac{D_{lb}(P_u - P_{lo})}{4} = \frac{22.00(50)}{4} = 275 \text{ lb. in.}^{-1}.$$

The fixed edge closure lid moment is,

$$M_f = \frac{(P_u - P_{lo})D_{lb}^2}{32} = \frac{50(22.00^2)}{32} = 756 \text{ in. lb. in.}^{-1}.$$

The cask bottom flange shoulder takes the shear force, so that  $F_s = 0$ .

#### Temperature Loads:

From reference 3, the lid bolt material is SA-540, Type B24, class 1, 2Ni 3/4Cr 1/3Mo. The ram port cover and the cask bottom plate is made of SA-240 Type XM-19, which is 22Cr 13Ni 5Mn. Therefore the bolts have a coefficient of thermal expansion of  $6.9 \times 10^{-6}$  in./in.  $^{\circ}\text{F}^{-1}$  at 300 $^{\circ}$  F, and the flange has a coefficient of thermal expansion of  $8.8 \times 10^{-6}$  in./in.  $^{\circ}\text{F}^{-1}$  at 300 $^{\circ}$  F [2].

$$F_a = 0.25 \pi D_b^2 E_b (a_l T_l - a_b T_b)$$

$$F_a = 0.25(\pi)(1.00^2)(26.7 \times 10^6)[(8.8 \times 10^{-6})(230) - (6.9 \times 10^{-6})(230)] = 9,164 \text{ lb.}$$

Even though the ram port cover and bottom flange are constructed from different materials, the shear force per bolt,  $F_s$ , due to a temperature change of 180 $^{\circ}$  F is, 0 psi, since the clearance holes in the cover are oversized (1.63 in. diameter) allowing the cover to grow in the radial direction.

$$F_s = 0.$$

The temperature difference between the inside of the lid and the outside of the lid will always be less than one degree. Consequently, the resulting bending moment is negligible.

$$M_f = 0.$$

Impact Loads (Ref. 1, Table 4.5):

During a bottom end drop or bottom corner drop, the cask bottom plate will protect the ram port cover from the inertial load of the cask internals (canister, basket, and fuel). Therefore, the ram port cover bolts will not experience any additional loads during an impact event.

Puncture Loads (Ref. 1, Table 4.7):

The non-prying tensile bolt force per bolt,  $F_a$ , is,

$$F_a = \frac{-\sin(xi)P_{un}}{N_b},$$

where,

$$P_{un} = \text{The smaller of } \begin{cases} 0.75\pi D_{pb}^2 S_{yt} \\ 0.6\pi D_{pb} t_l S_{ul} \\ 0.25\pi D_{pb} S_{fpb} \end{cases}$$

\*Flow stress of puncture bar (45 ksi. for mild steel).

$$= \text{The smaller of } \begin{cases} 0.75\pi(6^2)(43,300) = 3.673 \times 10^6 \\ 0.6\pi(6)(2.5)(94,200) = 2.663 \times 10^6 \\ 0.25\pi(6^2)(45,000) = 1.272 \times 10^6 \end{cases}$$

$$\Rightarrow P_{un} = 1.272 \times 10^6 \text{ lb.}$$

The puncture force is greatest when  $xi = 90^\circ$ . Conservatively neglect the protection provided by the impact limiter. Then,

$$F_a = \frac{-\sin(xi)1.272 \times 10^6}{12} = -106,030 \text{ lb.}$$

Since this force is negative (inward acting), the actual resulting bolt force,  $F_a = 0$ , because the applied load is supported by the cask wall and not the lid bolts. The shear bolt force is,

$$F_s = \frac{\cos(90^\circ)P_{un}}{N_b} \text{ lb./bolt.}$$

The lid shoulder during puncture takes shear force. Therefore,

$$F_s = 0.$$

The fixed-edge closure lid force,  $F_f$ , is,

$$F_f = \frac{-\sin(\alpha)Pun}{\pi D_b} = \frac{-\sin(90^\circ)1.272 \times 10^6}{\pi(22.00)} = -18,410 \text{ lb.in}^{-1}.$$

The fixed-edge closure lid moment,  $M_f$ , is,

$$M_f = \frac{-\sin(\alpha)Pun}{4\pi} = \frac{-\sin(90^\circ)1.272 \times 10^6}{4\pi} = -101,250 \text{ in.lb.in}^{-1}.$$

#### RAM PORT COVER BOLT INDIVIDUAL LOAD SUMMARY

Load Case	Applied Load		Non-Prying Tensile Force, $F_a$ (lb.)	Torsional Moment, $M_t$ (in. lb.)	Prying Force, $F_f$ (lb.in. <sup>-1</sup> )	Prying Moment, $M_f$ (in. lb. in. <sup>-1</sup> )
Preload	Residual	Maximum Torque	15,000	750	0	0
		Minimum Torque	12,000	600	0	0
Gasket	Seating Load		0	0	0	0
Pressure	50 psig Internal		1,312	0	275	756
Thermal	250°F		9,164	0	0	0
Impact	1 Foot Normal Condition Drop (5 gs)		0	0	0	0
	30 foot Accident Condition Drop (34 gs)		0	0	0	0
Puncture	Drop on six inch diameter rod		0	0	-18,410	-101,250

2.10.2.8.2 Load Combinations (Ref. 1, Table 4.9):

A summary of normal and accident condition load combinations is presented in the following table.

RAM PORT COVER BOLT NORMAL AND ACCIDENT LOAD COMBINATIONS

Load Case	Combination Description		Non-Prying Tensile Force, $F_a$ (lb.)	Torsional Moment, $M_t$ (in. lb.)	Prying Force, $F_f$ (lb.in. <sup>-1</sup> )	Prying Moment, $M_f$ (in. lb. in. <sup>-1</sup> )
1.	Preload + Temperature (Normal Condition)	A. Maximum Torque	24,164	750	0	0
		B. Minimum Torque	21,164	600	0	0
2.	Pressure + Normal Impact (Normal Condition)		1,312	0	275	756
3.	Pressure + Accident Impact (Accident Condition)		1,312	0	275	756
4.	Pressure + Puncture (Accident Condition)		1,312	0	-18,130	-100,500

### Additional Prying Bolt Force and Bending Bolt Moment (Ref. 1, Table 2.1 and Table 2.2)

Since the prying forces applied in load case 4 (pressure + puncture) acts inward, normal to the cask lid, an additional prying bolt force,  $F_{ap}$ , is generated (Ref. 1, Table 2.1). No additional force is generated for the outward loadings however (load cases 1, 2, and 3), because of the gap between the lid and flange at the outer edge (Ref. 3).

Prying forces for the ram port cover plate bolts are determined from FEM analysis, for the puncture load case. The ram port cover is not a full cover plate extending to the diameter of the cask. Therefore, use of NUREG/CR-6007 methodology for calculating the fixed end moments (which is used to calculate prying loads) due to these load conditions is not appropriate for the ram port cover bolts.

A 2-dimensional finite element model is used to compute the ram port cover bolt prying forces caused by the puncture event. Details of the finite element analysis performed are provided in Reference 7.

A single link element is used to represent the ram port cover bolts. Consequently, the resulting force computed in this link element is the total prying force generated in all of the ram port cover bolts. The ram port cover bolt total prying force, computed in reference 7, is 251,360 lb. Therefore, the ram port cover bolt prying force per bolt,  $F_{ap}$ , is,

$$F_{ap} = \frac{251,360}{12} = 20,950 \text{ lb./bolt}$$

Since this bolt load is less than the load generated by the minimum bolt preload (21,164 lb./bolt from load case 1B.), the prying force generated by the puncture event is not critical with respect to bolt stress, and will not result in loss of the ram port cover seal.

### 2.10.2.8.3 Bolt Stress Calculations (Ref. 1, Table 5.1)

#### Average Tensile Stress:

The bolt preload is calculated to withstand the worst case load combination and to maintain a clamping (compressive) force on the closure joint, under both normal and accident conditions. Based upon the load combination results (see Table RAM PORT COVER BOLT NORMAL AND ACCIDENT LOAD COMBINATIONS), it is shown that a positive (compressive) load is maintained on the clamped joint for all load combinations. Therefore, in both normal and accident load cases, the maximum non-prying tensile force of 24,164 lb., from the maximum torque preload + temperature load case, is used.

Normal Condition:

$$S_{ba} = 1.2732 \frac{F_a}{D_{ba}^2} = 1.2732 \frac{24,164}{0.878^2} = 39,910 \text{ psi.} = 39.9 \text{ ksi.}$$

Accident Condition:

$$S_{ba} = 1.2732 \frac{F_a}{D_{ba}^2} = 1.2732 \frac{24,164}{0.878^2} = 39,910 \text{ psi.} = 39.9 \text{ ksi.}$$

#### Shear Stress:

For normal and accident conditions the maximum shear stress caused by the torsional moment  $M_t$  is,

$$S_{bt} = 5.093 \frac{M_t}{D_{ba}^3} = 5.093 \frac{750}{0.878^3} = 5,644 \text{ psi.} = 5.64 \text{ ksi.}$$

#### Maximum Combined Stress Intensity:

The maximum combined stress intensity is calculated in the following way (Ref. 1, Table 5.1).

$$S_{bi} = [ S_{ba}^2 + 4S_{bt}^2 ]^{0.5}$$

For normal conditions combine tension, shear, bending, and residual torsion.

$$S_{bi} = [ 39,910^2 + 4 (5,644)^2 ]^{0.5} = 41,480 \text{ psi.} = 41.5 \text{ ksi.}$$

#### 2.10.8.2.4 Bearing Stress (Under Bolt Head)

The maximum axial bolt force is 24,164 lb. The ram port cover bolt head is a 1.50 inch diameter socket head. The diameter of the bolt hole in the NUHOMS<sup>®</sup>-MP197 Cask lid is 1.12 inches. Therefore the bearing area, A, under the lid bolt head is,

$$A = (\pi/4)(1.50^2 - 1.12^2) = 0.782 \text{ in}^2.$$

The bearing stress is,

$$\text{Bearing Stress} = 24,164/0.782 = 30,900 \text{ psi.} = 30.9 \text{ ksi.}$$

The allowable bearing stress on the ram port cover is taken to be the yield stress of the cover material at 300° F. The ram port cover is manufactured from SA-240 Type-XM-19 or SA-183 Type FXM-19, which has a yield strength 43.3 psi. @ 300° F.

#### 2.10.2.8.5 Results

A summary of the stresses calculated above is listed in the following table:

**SUMMARY OF STRESSES AND ALLOWABLES**

Stress Type	Normal Condition		Accident Condition	
	Stress	Allowable	Stress	Allowable
Average Tensile (ksi.)	39.9	92.4	39.9	115.5
Shear (ksi)	5.64	55.4	5.64	69.3
Combined (ksi)	41.5	124.7	Not Required (Reference 1)	
Bearing (ksi) Allowable (ksi) (S <sub>y</sub> of lid material)	30.9	43.3	Not Required (Reference 1)	



### 2.10.2.8.6 Minimum Engagement Length for Bolt and Flange

For a 1"- 8UNC - 2A bolt, the material is SA-540 GR. B24 CL.1, with

$$S_u = 165 \text{ ksi.}, \text{ and}$$

$$S_y = 150 \text{ ksi (at room temperature)}$$

The ram port cover threaded insert material (Helicoil #1185-16CN-2500) is constructed from type 304 stainless steel and has the following material properties.

$$S_u = 75 \text{ ksi.}, \text{ and}$$

$$S_y = 30 \text{ ksi (at room temperature)}$$

The minimum engagement length,  $L_e$ , for the bolt and flange is ([8], Page 1149),

$$L_e = \frac{2A_t}{3.1416K_{n \max} \left[ \frac{1}{2} + .57735n(E_{s \min} - K_{n \max}) \right]}$$

Where,

$A_t$  = tensile stress area = 0.606 in.<sup>2</sup>,

$n$  = number of threads per inch = 8

$K_{n \max}$  = maximum minor diameter of internal threads = 0.890 in. ([8], p. 1287)

$E_{s \min}$  = minimum pitch diameter of external threads = 0.9100 in. ([8], p. 1287)

Substituting the values given above,

$$L_e = \frac{2(0.606)}{(3.1416)0.890 \left[ \frac{1}{2} + .57735(8)(0.9100 - 0.890) \right]} = 0.732 \text{ in.}$$

$$J = \frac{A_s \times S_{ue}}{A_n \times S_{ui}} \cdot [8]$$

Where,  $S_{ue}$  is the tensile strength of external thread material, and  $S_{ui}$  is the tensile strength of internal thread material.

$A_s$  = shear area of external threads =  $3.1416 n L_e K_{n \max} [1/(2n) + .57735 (E_{s \min} - K_{n \max})]$

$A_n$  = shear area of internal threads =  $3.1416 n L_e D_{s \min} [1/(2n) + .57735(D_{s \min} - E_{n \max})]$

For the bolt / Helicoil insert connection:

$E_{n\ max}$  = maximum pitch diameter of internal threads = 0.9276 in. ([8], p. 1287).

$D_{s\ min}$  = minimum major diameter of external threads = 0.9830 in. ([8], p. 1287)

Therefore,

$$A_s = 3.1416(8)(0.732)(0.890)[1/(2 \times 8) + .57735 (0.9100 - 0.890)] = 1.212 \text{ in.}^2$$

$$A_n = 3.1416(8)(0.732)(0.9830)[1/(2 \times 8) + .57735 (0.9830 - 0.9276)] = 1.710 \text{ in.}^2$$

So,

$$J = \frac{1.212(165.0)}{1.710(75.0)} = 1.559$$

$$Q = L_e J = (0.732)(1.559) = 1.141 \text{ in.}$$

The actual minimum engagement length = 2.50 in. > 1.141 in. (limited by threaded insert length).

### **2.10.2.9 Conclusions**

- 1. Bolt stresses meet the acceptance criteria of NUREG/CR-6007 "Stress Analysis of Closure Bolts for Shipping Casks".**
- 2. A positive (compressive) load is maintained during normal and accident condition loads since bolt preload is higher than all applied loads.**
- 3. If the NUHOMS<sup>®</sup>-MP197 cask lid bolts are replaced after every 85 round trip shipments, they will not fail due to fatigue during transport.**
- 4. The bolt, insert, and flange thread engagement length is acceptable.**
- 5. The ram port cover bolts are acceptable with respect to bolt stress, seal compression, and engagement length.**

2.10.2.10

References

1. Stress Analysis of Closure Bolts for Shipping Cask, NUREG/CR-6007, 1992.
2. American Society of Mechanical Engineers, ASME Boiler and Pressure Vessel Code, Section II, Part D, 1998 with 1999 addenda.
3. American Society of Mechanical Engineers, ASME Boiler and Pressure Vessel Code Section III, Division 1, Subsection NB, 1998 with 1999 addenda.
4. Draft American Standard Design Basis for Resistance to Shock and Vibration of Radioactive Material Packages Greater than One Ton in Truck Transport, ANSI N14.23, 1980.
5. Shock and Vibration Environments for Large Shipping Containers on Rail Cars and Trucks, NUREG 766510, 1977.
6. Design Criteria for the Structural Analysis of Shipping Cask Containment Vessels, U. S. Nuclear Regulatory Commission, Regulatory Guide 7.6, Revision 1, March 1978.
7. American Society of Mechanical Engineers, ASME Boiler and Pressure Vessel Code Section III, Division 1, Appendix, 1998 with 1999 addenda.
8. Machinery Handbook, 21<sup>st</sup> Ed, Industrial Press, 1979.
9. Helicoil Catalog, Heli-Coil 8-Pitch Inserts, Bulletin 913B.
10. Baumeister, T., Marks, L. S., *Standard Handbook for Mechanical Engineers*, 7<sup>th</sup> Edition, McGraw-Hill, 1967.

Table 2.10.2-1  
Design Parameters for Lid Bolt Analysis

- $D_b$  Nominal diameter of closure bolt; 1.500 in.
- $K$  Nut factor for empirical relation between the applied torque and achieved preload is 0.1 for neolube
- $Q$  Applied torque for the preload (in.-lb.)
- $D_{lb}$  Closure lid diameter at bolt circle, 72.31 in.
- $D_{lg}$  Closure lid diameter at the seal (outer) = 69.873 in.
- $E_c$  Young's modulus of cask wall material,  $27.6 \times 10^6$  psi. @ 200° F. [2]
- $E_l$  Young's modulus of lid material,  $27.8 \times 10^6$  psi. @ 200° F. [2]
- $N_b$  Total number of closure bolts, 48
- $N_{ul}$  Poisson's ratio of closure lid, 0.305, ([10], p. 5-6).
- $P_{ei}$  Inside pressure of cask, 50 psig.
- $D_{lo}$  Closure lid diameter at outer edge, 74.68 in.
- $P_{li}$  Pressure inside the closure lid, 50 psig.
- $t_c$  Thickness of cask wall, 7.00 in.
- $t_l$  Thickness of lid, 4.5, 4.0 in.
- $l_b$  Thermal coefficient of expansion, bolt material,  $6.7 \times 10^{-6}$  in. in.<sup>-1</sup> °F<sup>-1</sup> at 200°F [2]
- $l_c$  Thermal coefficient of expansion, cask,  $8.5 \times 10^{-6}$  in. in.<sup>-1</sup> °F<sup>-1</sup> at 200°F [2]
- $l_l$  Thermal coefficient of expansion, lid,  $5.90 \times 10^{-6}$  in. in.<sup>-1</sup> °F<sup>-1</sup> at 200°F [2]
- $E_b$  Young's modulus of bolt material,  $27.1 \times 10^6$  psi. at 200°F [2]
- $a_i$  Maximum rigid-body impact acceleration (g) of the cask
- $DLF$  Dynamic load factor to account for any difference between the rigid body acceleration and the acceleration of the contents and closure lid = 1.1
- $W_c$  weight of contents = 43,005 lb. (fuel) + 22,918 lb. (basket) + 22,467 lb. (canister) = 88,390 lbs., conservatively use 90,000 lb. (Section 2.2)
- $W_l$  weight of lid = 5,611 lbs., say 6,000 lbs.
- $W_c+W_l$  90,000 + 6,000 = 96,000 lbs.
- $x_i$  Impact angle between the cask axis and target surface
- $S_{yl}$  Yield strength of closure lid material, 106.3 ksi. @ 200° F. [2]
- $S_{ul}$  Ultimate strength of closure lid, 140,000 psi.
- $S_{yb}$  Yield strength of bolt material (see Table 2.10.2-3).
- $S_{ub}$  Ultimate strength of bolt material (see Table 2.10.2-4).
- $P_{lo}$  Pressure outside the lid.
- $L_b$  Bolt length between the top and bottom surfaces of closure, 2.27 in.
- $P_{un}$  Maximum impact force that can be generated by the puncture bar during a normal impact.
- $D_{pb}$  Puncture bar diameter, 6 inches as per 10 CFR 71.73 (c) (3).

Table 2.10.2-2

Bolt Data ([1], Table 5.1)

Lid Bolts:

Bolt: 1 1/2" - 6UNC - 2A

$N$ : no of threads per inch = 6

$p$ : Pitch =  $1/6'' = .167$  in.

$D_b$ : Nominal Diameter = 1.50 in.

$D_{ba}$ : Bolt diameter for stress calculations =  $D_b - .9743p = 1.50 - .9743(.167) = 1.337$  in

Stress Area =  $\pi/4 (1.337)^2 = 1.404$  in<sup>2</sup>

Ram Closure Bolts:

Bolt: 1" - 8UNC - 2A

$N$ : no of threads per inch = 8

$p$ : Pitch =  $1/8'' = .125$  in.

$D_b$ : Nominal Diameter = 1.00 in.

$D_{ba}$ : Bolt diameter for stress calculations =  $D_b - .9743p = 1.00 - .9743(.125) = 0.878$  in

Stress Area =  $\pi/4 (0.878)^2 = 0.606$  in<sup>2</sup>

Table 2.10.2-3

Allowable Stresses in Closure Bolts for Normal Conditions of Transport

(MATERIAL: SA-540 Gr. B24 CL.1)

Temperature (°F)	Yield Stress <sup>(1)</sup> (ksi)	Normal Condition Allowables		
		$F_{tb}$ <sup>(2,4)</sup> (ksi)	$F_{vb}$ <sup>(3,4)</sup> (ksi)	$S.I.$ <sup>(5)</sup> (ksi)
100	150	100.0	60.0	135.0
200	143.4	95.6	57.4	129.1
300	138.6	92.4	55.4	124.7
400	134.4	89.6	53.8	121.0
500	130.2	86.8	52.1	117.2
600	124.2	82.8	49.7	111.8

Notes:

1. Yield stress values are from ASME Code, Section II, Table Y-1 [2]
2. Allowable Tensile stress,  $F_{tb} = 2/3 S_y$  ([1], Table 6.1)
3. Allowable shear stress,  $F_{vb} = 0.4 S_y$  ([1], Table 6.1)
4. Tension and shear stresses must be combined using the following interaction equation:

$$\frac{\sigma_{tb}^2}{F_{tb}^2} + \frac{\tau_{yb}^2}{F_{yb}^2} \leq 1.0 \quad [1]$$

5. Stress intensity from combined tensile, shear and residual torsion loads,  $S.I. \leq 0.9 S_y$  ([1], Table 6.1)

Table 2.10.2-4

Allowable Stresses in Closure Bolts for Hypothetical Accident Conditions

(MATERIAL: SA-540 Gr. B24 Cl.1)

Temperature (°F)	Yield Stress <sup>(1)</sup> (ksi)	Accident Condition Allowables		
		0.6 S <sub>y</sub> <sup>(3)</sup> (ksi)	F <sub>tb</sub> <sup>(2,4)</sup> (ksi)	F <sub>vb</sub> <sup>(3,4)</sup> (ksi)
100	150.0	90.0	115.5	69.3
200	143.4	86.0	115.5	69.3
300	138.6	83.2	115.5	69.3
400	134.4	80.6	115.5	69.3
500	130.2	78.1	115.5	69.3
600	124.2	74.5	115.5	69.3

Notes:

1. Yield and tensile stress values are from ASME Code, [2] Table Y-1, Note that S<sub>u</sub> is 165 ksi at all temperatures of interest.
2. Allowable Tensile stress, F<sub>tb</sub> = MINIMUM(0.7 S<sub>u</sub>, S<sub>y</sub>), where 0.7 S<sub>u</sub> = 0.7 (165) = 115.5 ksi. ([1], Table 6.3)
3. Allowable shear stress, F<sub>vb</sub> = MINIMUM(0.42 S<sub>u</sub>, 0.6 S<sub>y</sub>), where 0.42 S<sub>u</sub> = 0.42 (165.) = 69.3 ksi. ([1], Table 6.3)
4. Tension and shear stresses must be combined using the following interaction equation:

$$\frac{\sigma_{tb}^2}{F_{tb}^2} + \frac{\tau_{yb}^2}{F_{yb}^2} \leq 1.0 \quad [1]$$



**Table 2.10.2-5**  
**Design Parameters for Ram Port Cover Bolt Analysis**

- $D_b$  Nominal diameter of closure bolt; 1.00 in.
- $K$  Nut factor for empirical relation between the applied torque and achieved preload is 0.1 for neolube
- $Q$  Applied torque for the preload (in.-lb.)
- $D_{lb}$  Closure lid diameter at bolt circle, 22.00 in.
- $D_{lg}$  Closure lid diameter at the seal (outer) = 20.02 in.
- $E_c$  Young's modulus of cask flange material,  $27.0 \times 10^6$  psi. @ 300° F.
- $N_b$  Total number of closure bolts, 12
- $N_{ul}$  Poisson's ratio of closure material, 0.305, (Ref. 6, p. 5-6).
- $P_{ei}$  Inside pressure of cask, 50 psig.
- $D_{lo}$  RAM Port Cover diameter at outer edge, 23.88 in.
- $D_{li}$  Closure lid diameter at inner edge, 17.26 in.
- $P_{li}$  Pressure inside the closure lid, 50 psig.
- $t_l$  Thickness of lid, 2.5 in.
- $l_b$  Thermal coefficient of expansion, bolt material,  $6.9 \times 10^{-6}$  in. in.<sup>-1</sup> °F<sup>-1</sup> at 300°F
- $l_c$  Thermal coefficient of expansion, cask,  $8.8 \times 10^{-6}$  in. in.<sup>-1</sup> °F<sup>-1</sup> at 300°F
- $l_l$  Thermal coefficient of expansion, cover,  $8.8 \times 10^{-6}$  in. in.<sup>-1</sup> °F<sup>-1</sup> at 300°F
- $E_b$  Young's modulus of bolt material,  $26.7 \times 10^6$  psi. at 300°F
- $E_l$  Young's modulus of cover material,  $27.0 \times 10^6$  psi. @ 300° F.
- $S_{yl}$  Yield strength of cover material, 43.3 ksi. @ 300° F.
- $S_{ul}$  Ultimate strength of cover, 94.2 ksi.
- $S_{yb}$  Yield strength of bolt material (see Table 3).
- $S_{ub}$  Ultimate strength of bolt material (see Table 4).
- $P_{lo}$  Pressure outside the lid, 0 psi.