

Figure 2.5.4-1—Emergency Diesel Generator Fuel Oil Storage and Transfer System Functional Arrangement
Sheet 1 of 4

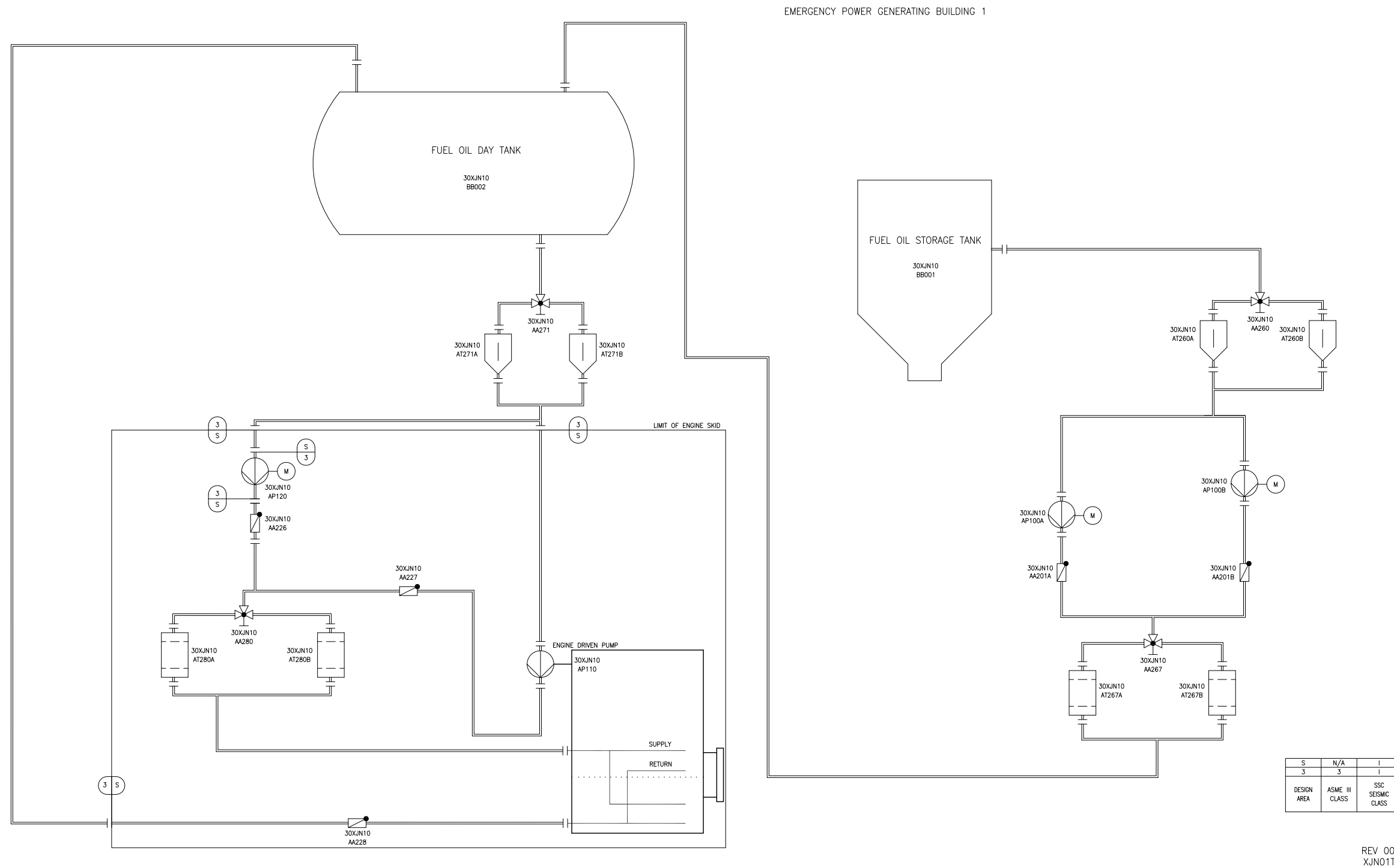

Figure 2.5.4-1—Emergency Diesel Generator Fuel Oil Storage and Transfer System Functional Arrangement
Sheet 2 of 4

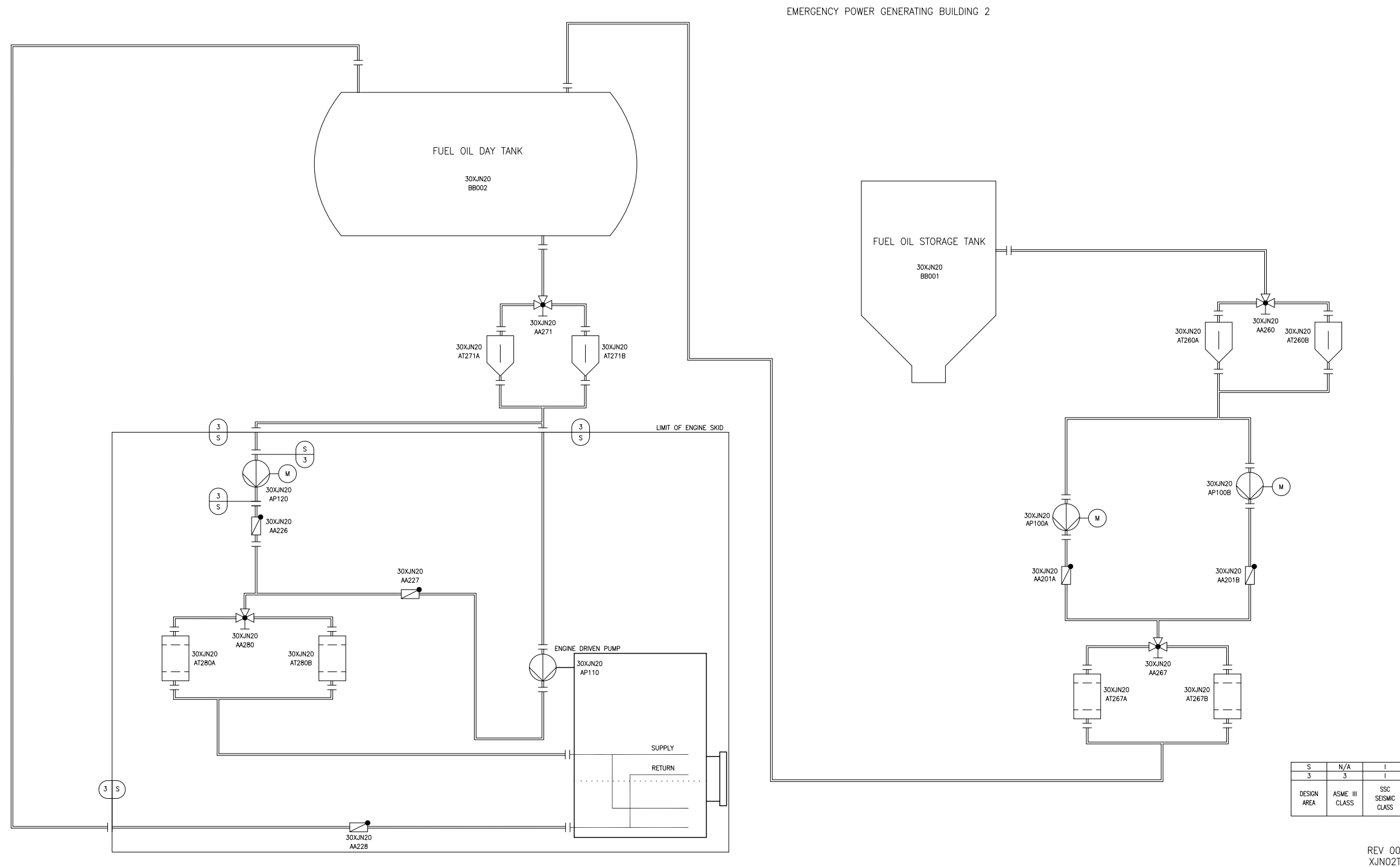

Figure 2.5.4-1—Emergency Diesel Generator Fuel Oil Storage and Transfer System Functional Arrangement
Sheet 3 of 4

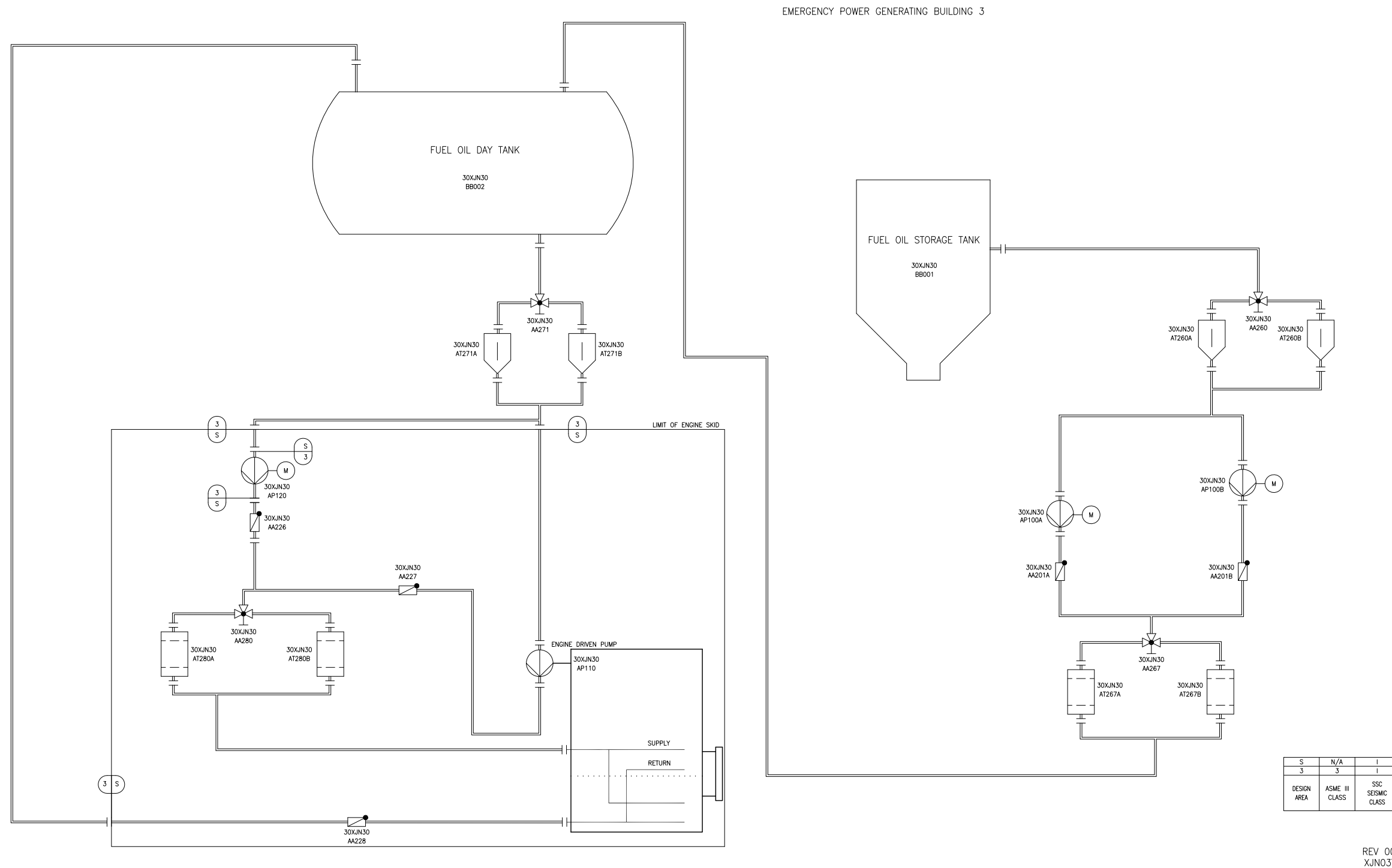

Figure 2.5.4-1—Emergency Diesel Generator Fuel Oil Storage and Transfer System Functional Arrangement
Sheet 4 of 4

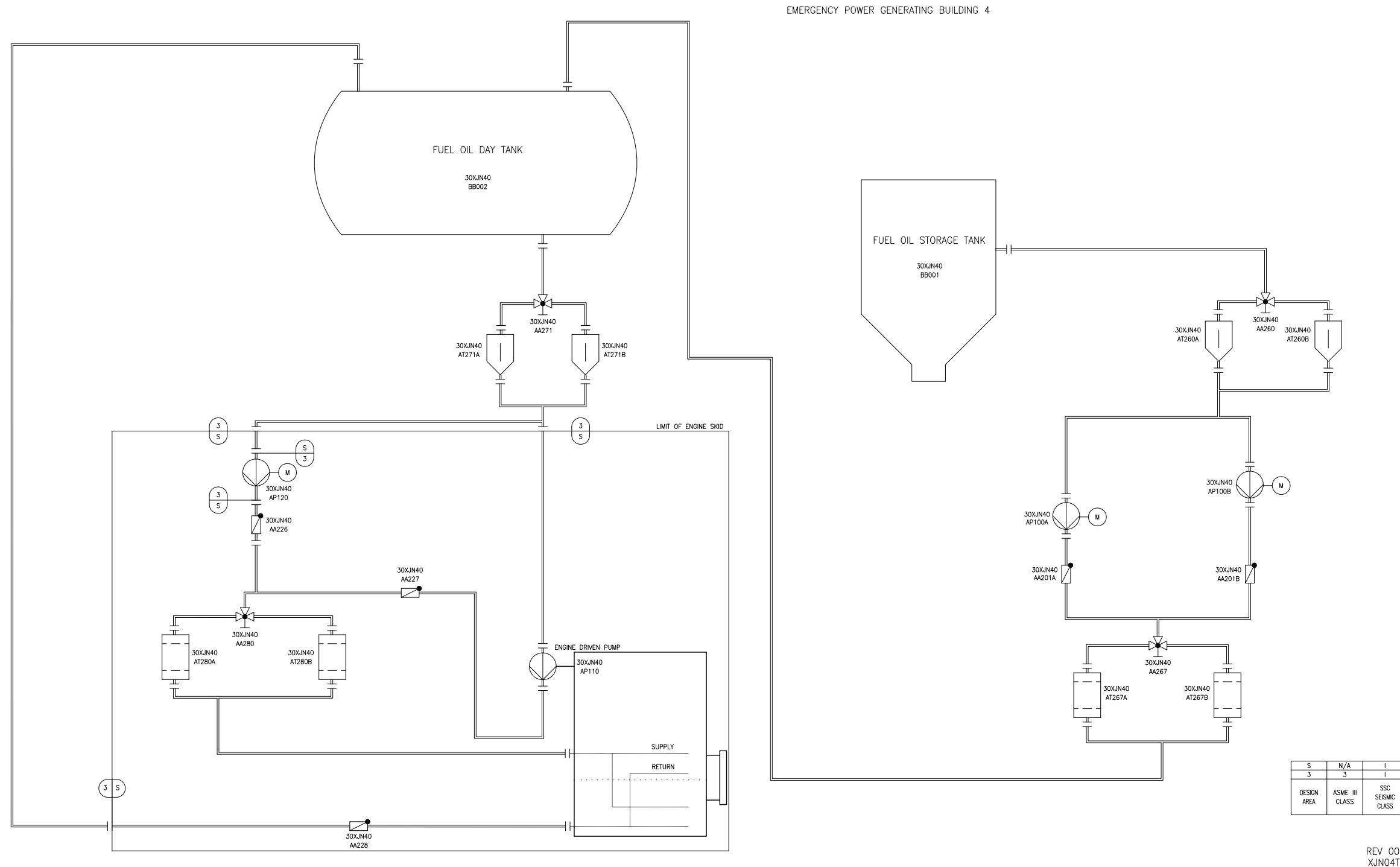
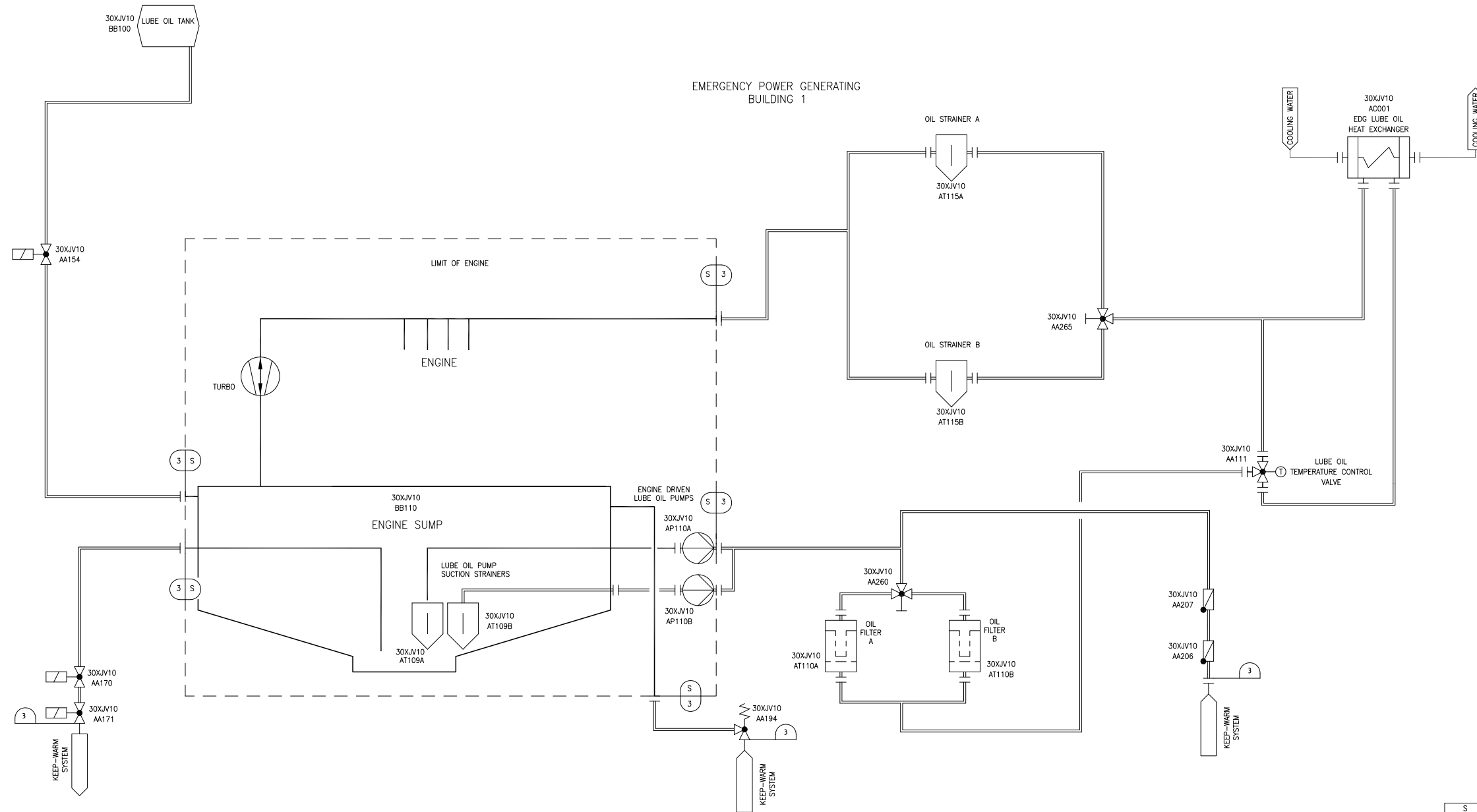

Figure 2.5.4-2—Emergency Diesel Generator Lubricating Oil System Functional Arrangement
Sheet 1 of 4



S	N/A	I
3	3	1
DESIGN AREA	ASME III CLASS	SSC SEISMIC CLASS

REV 003
XJV01T1

Figure 2.5.4-2—Emergency Diesel Generator Lubricating Oil System Functional Arrangement
Sheet 2 of 4

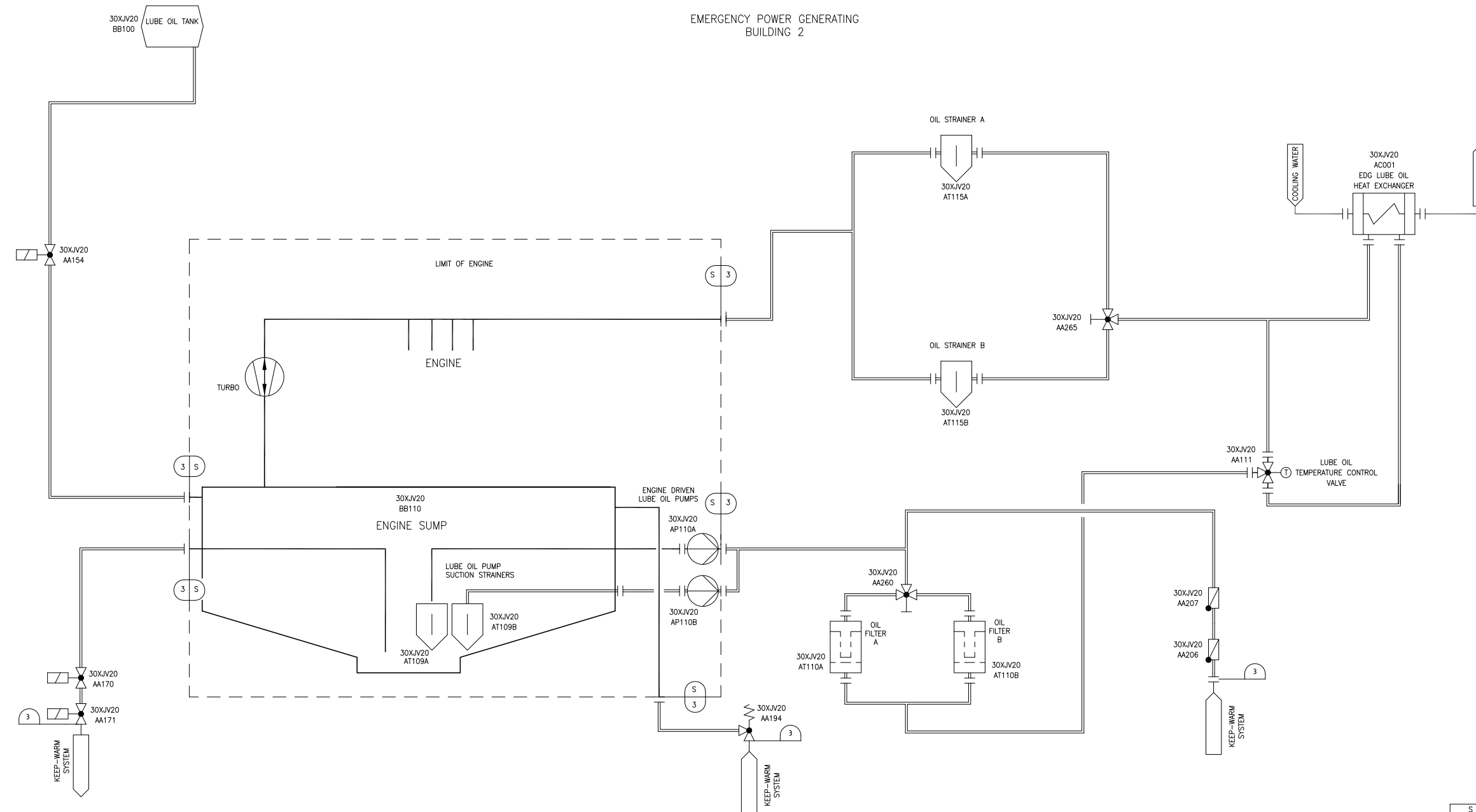

S	N/A	I
3	3	I
DESIGN AREA	ASME III CLASS	SSC SEISMIC CLASS

REV 003
XJV02T1

Figure 2.5.4-2—Emergency Diesel Generator Lubricating Oil System Functional Arrangement
Sheet 3 of 4

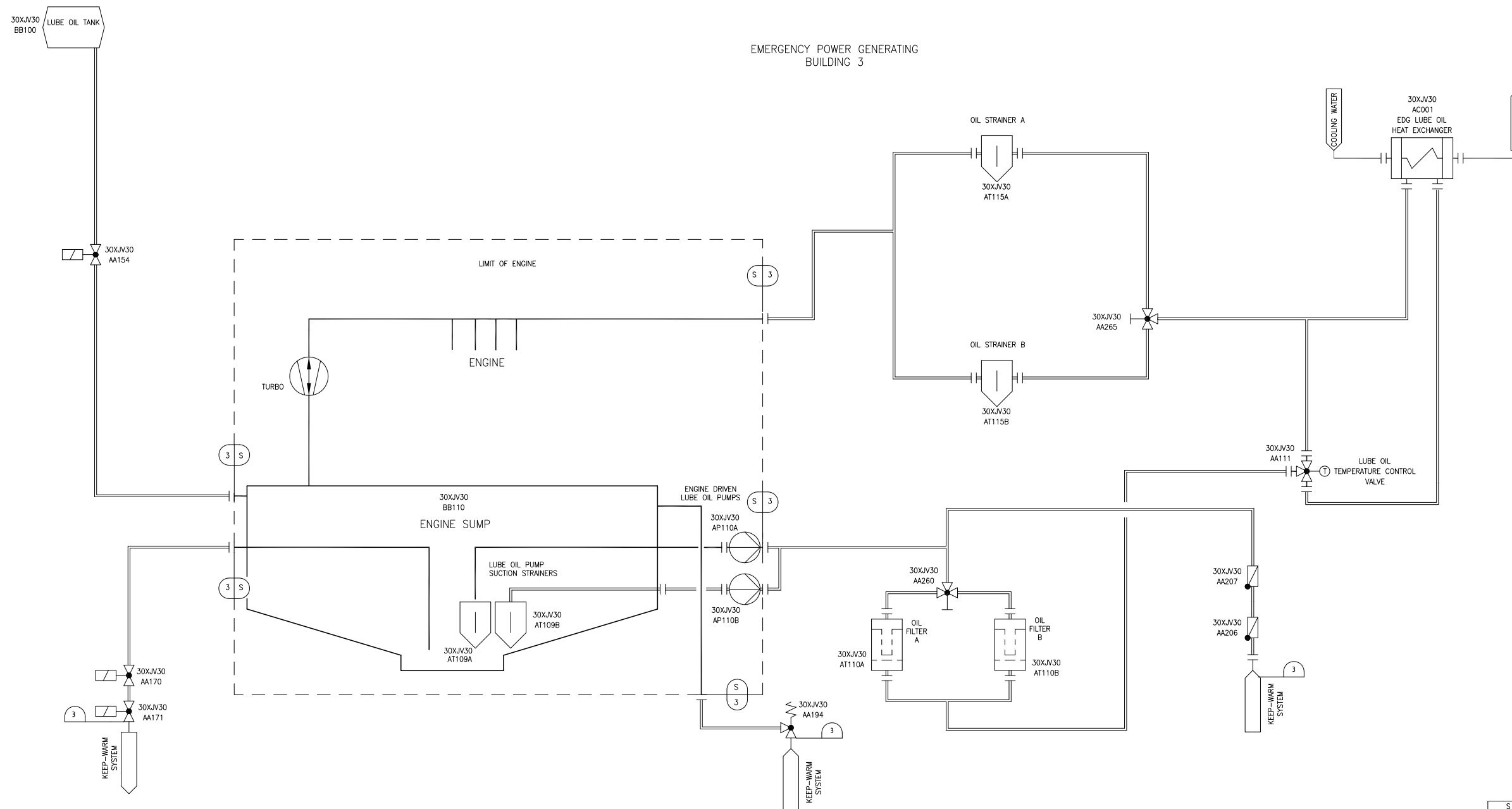

S	N/A	I
3	3	I
DESIGN AREA	ASME III CLASS	SSC SEISMIC CLASS

REV 003
XJV03T1

Figure 2.5.4-2—Emergency Diesel Generator Lubricating Oil System Functional Arrangement
Sheet 4 of 4

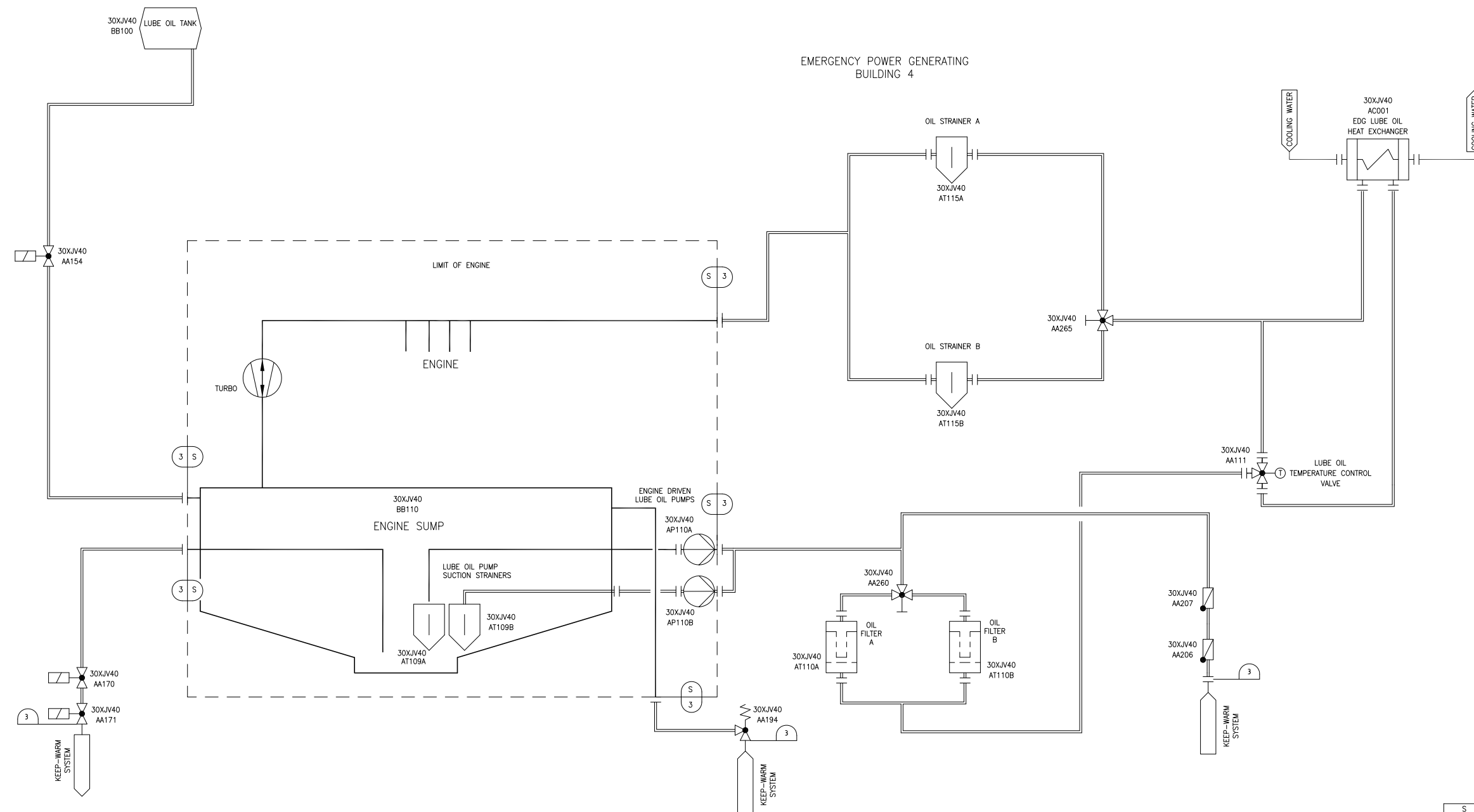

S	N/A	I
3	3	I
DESIGN AREA	ASME III CLASS	SSC SEISMIC CLASS

REV 003
XJV04T1

Figure 2.5.4-3—Emergency Diesel Generator Air Intake and Exhaust System Functional Arrangement
Sheet 1 of 4

EMERGENCY POWER GENERATING BUILDING 1

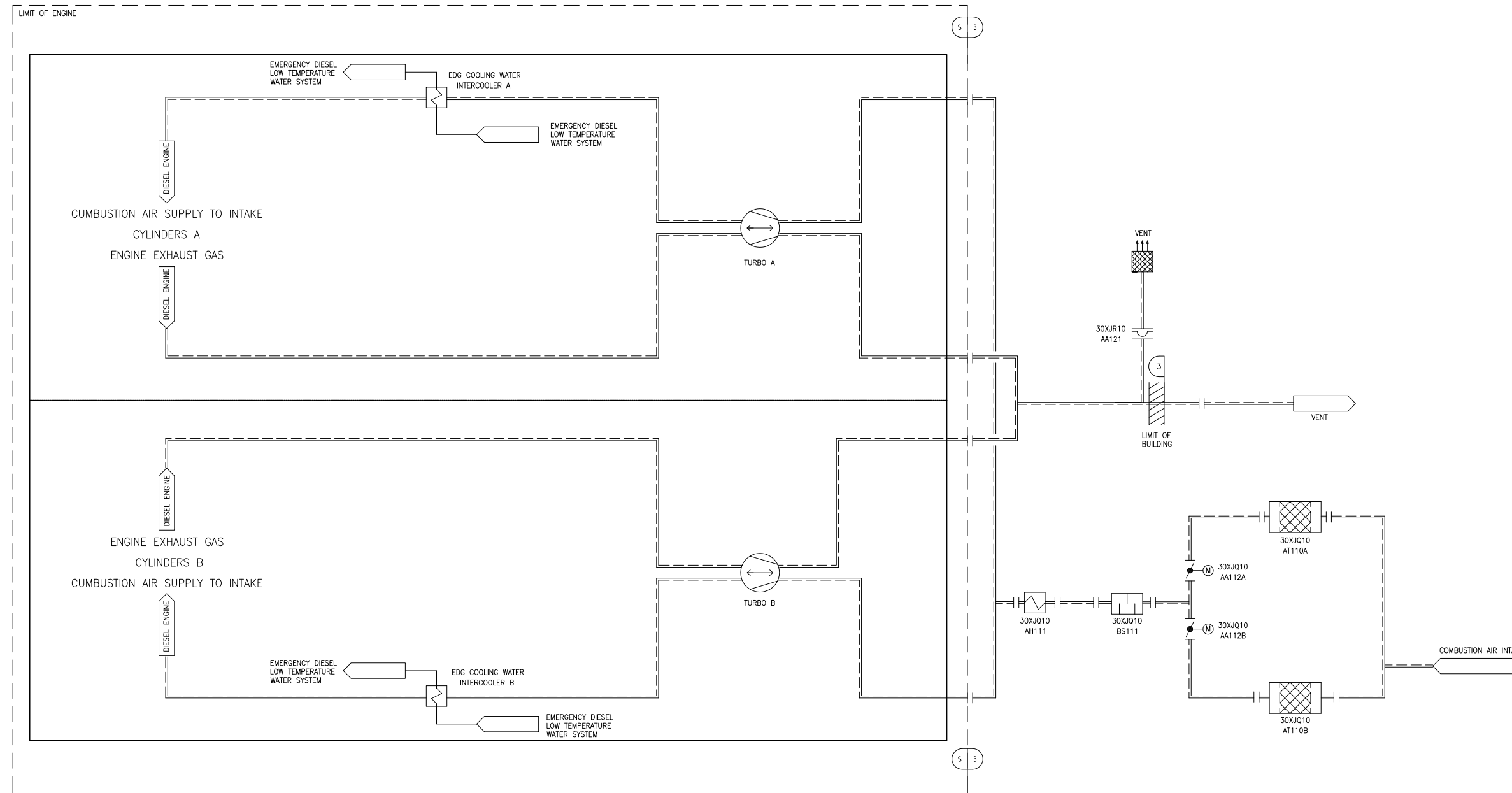

S	N/A	I
3	3	I
DESIGN AREA	ASME III CLASS	SSC SEISMIC CLASS

REV 003
XJQ01T1

Figure 2.5.4-3—Emergency Diesel Generator Air Intake and Exhaust System Functional Arrangement
Sheet 2 of 4

EMERGENCY POWER GENERATING BUILDING 2

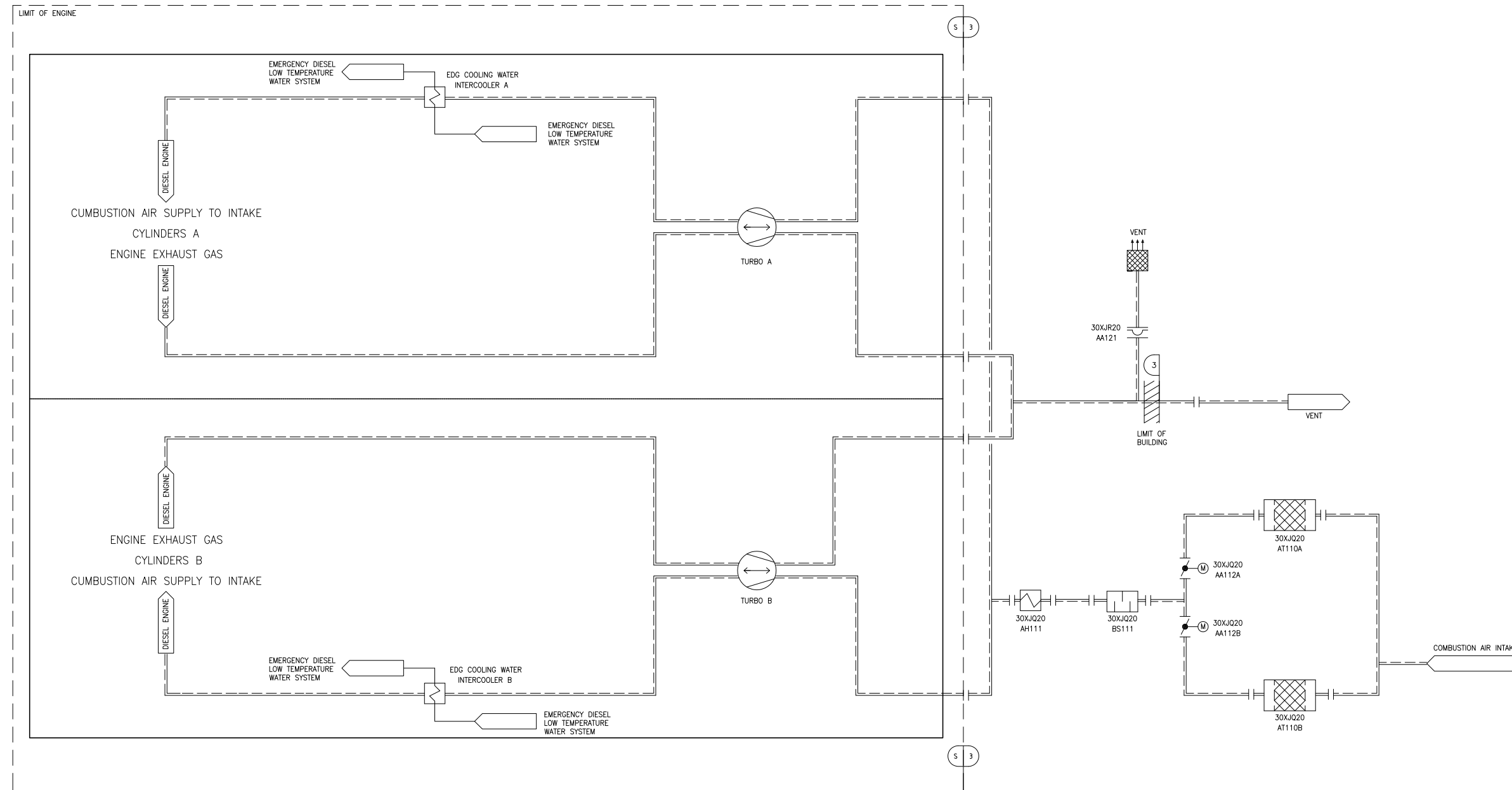

S	N/A	I
3	3	I
DESIGN AREA	ASME III CLASS	SSC SEISMIC CLASS

REV 003
XJQ02T1

Figure 2.5.4-3—Emergency Diesel Generator Air Intake and Exhaust System Functional Arrangement
Sheet 3 of 4

EMERGENCY POWER GENERATING BUILDING 3

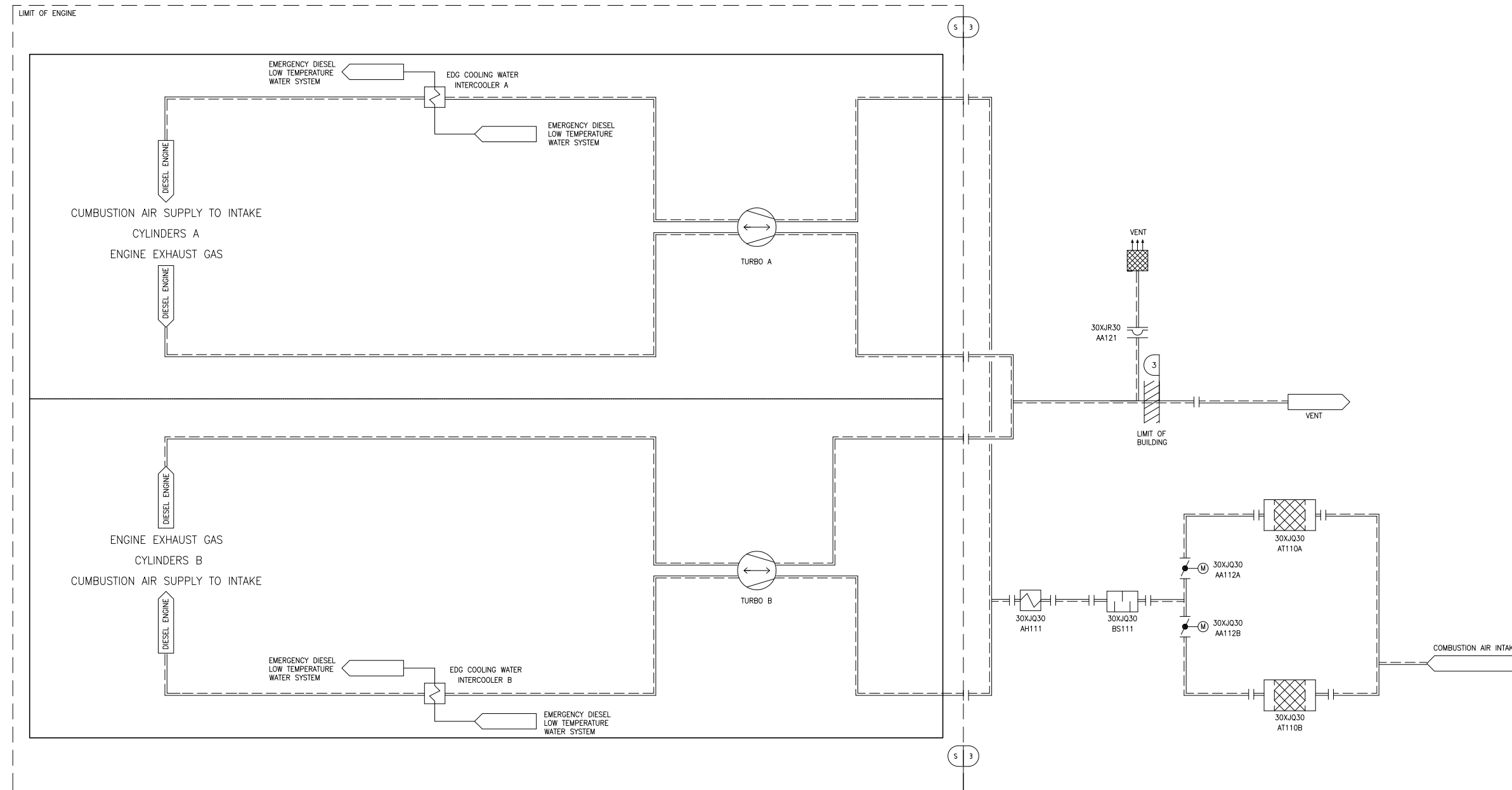

S	N/A	I
3	3	I
DESIGN AREA	ASME III CLASS	SSC SEISMIC CLASS

REV 003
XJQ03T1

Figure 2.5.4-3—Emergency Diesel Generator Air Intake and Exhaust System Functional Arrangement
Sheet 4 of 4

EMERGENCY POWER GENERATING BUILDING 4

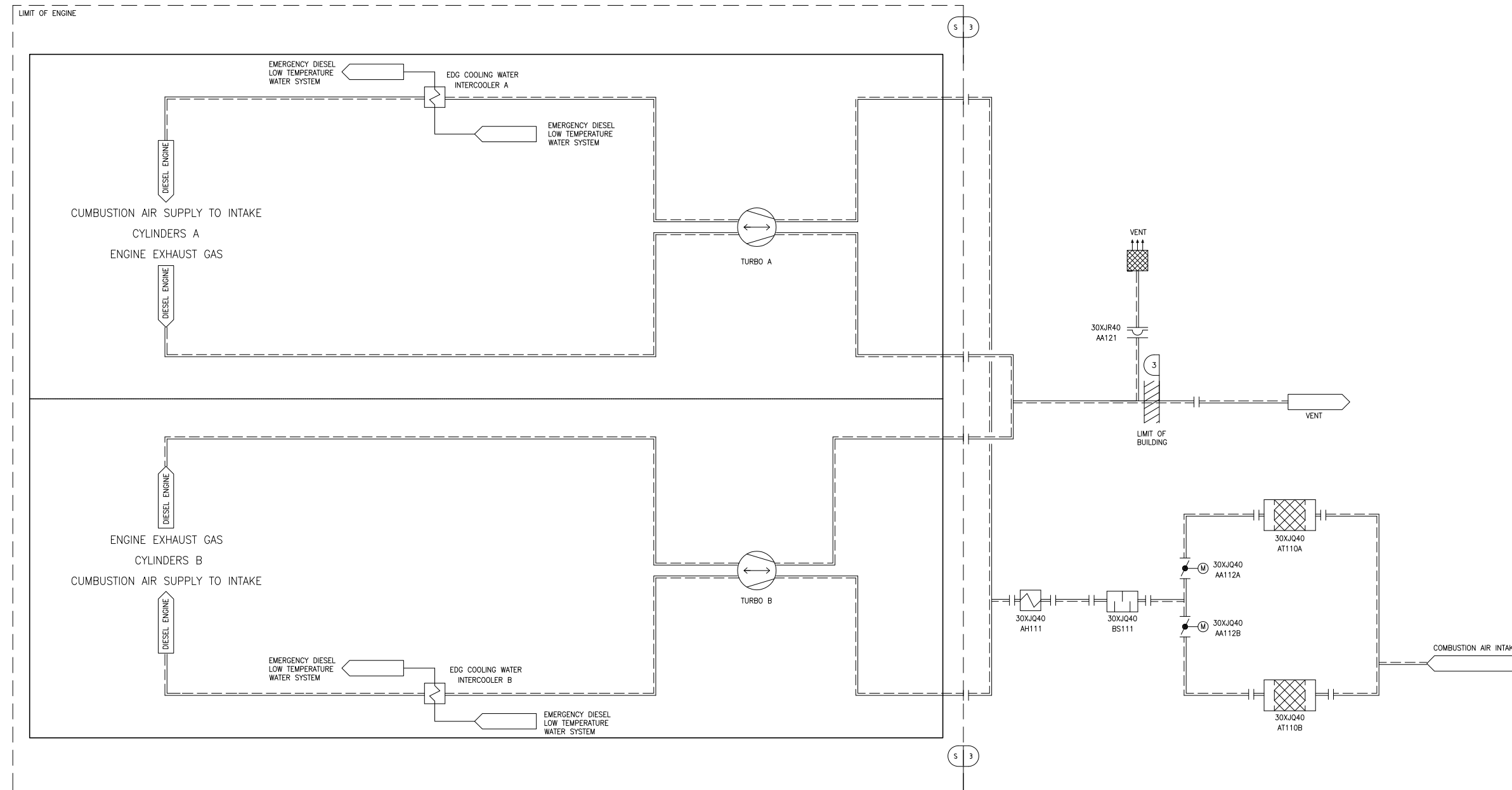

S	N/A	I
3	3	I
DESIGN AREA	ASME III CLASS	SSC SEISMIC CLASS

REV 003
XJQ04T1

Figure 2.5.4-4—Emergency Diesel Generator Cooling Water System Functional Arrangement
Sheet 2 of 8

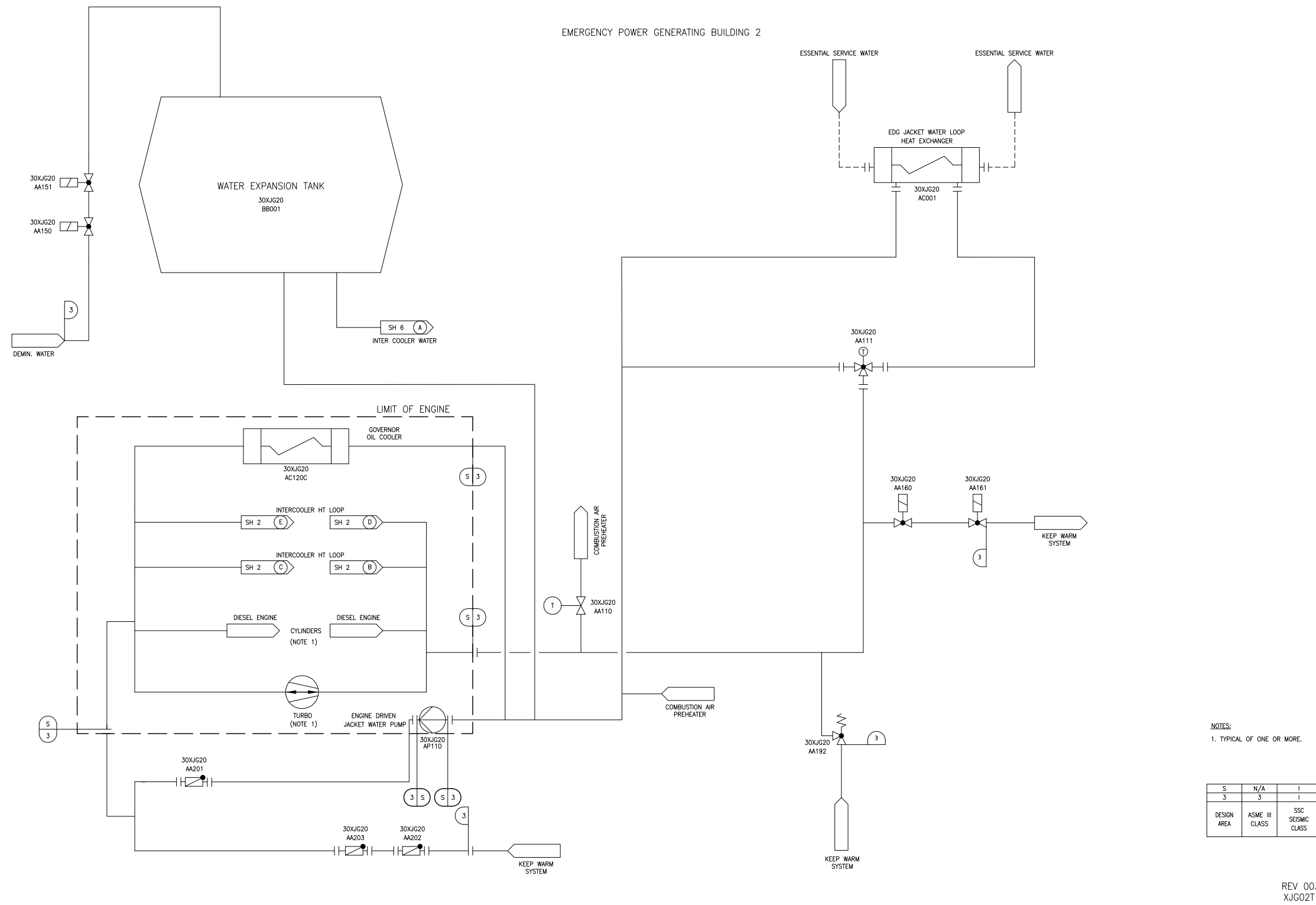

Figure 2.5.4-4—Emergency Diesel Generator Cooling Water System Functional Arrangement
Sheet 3 of 8

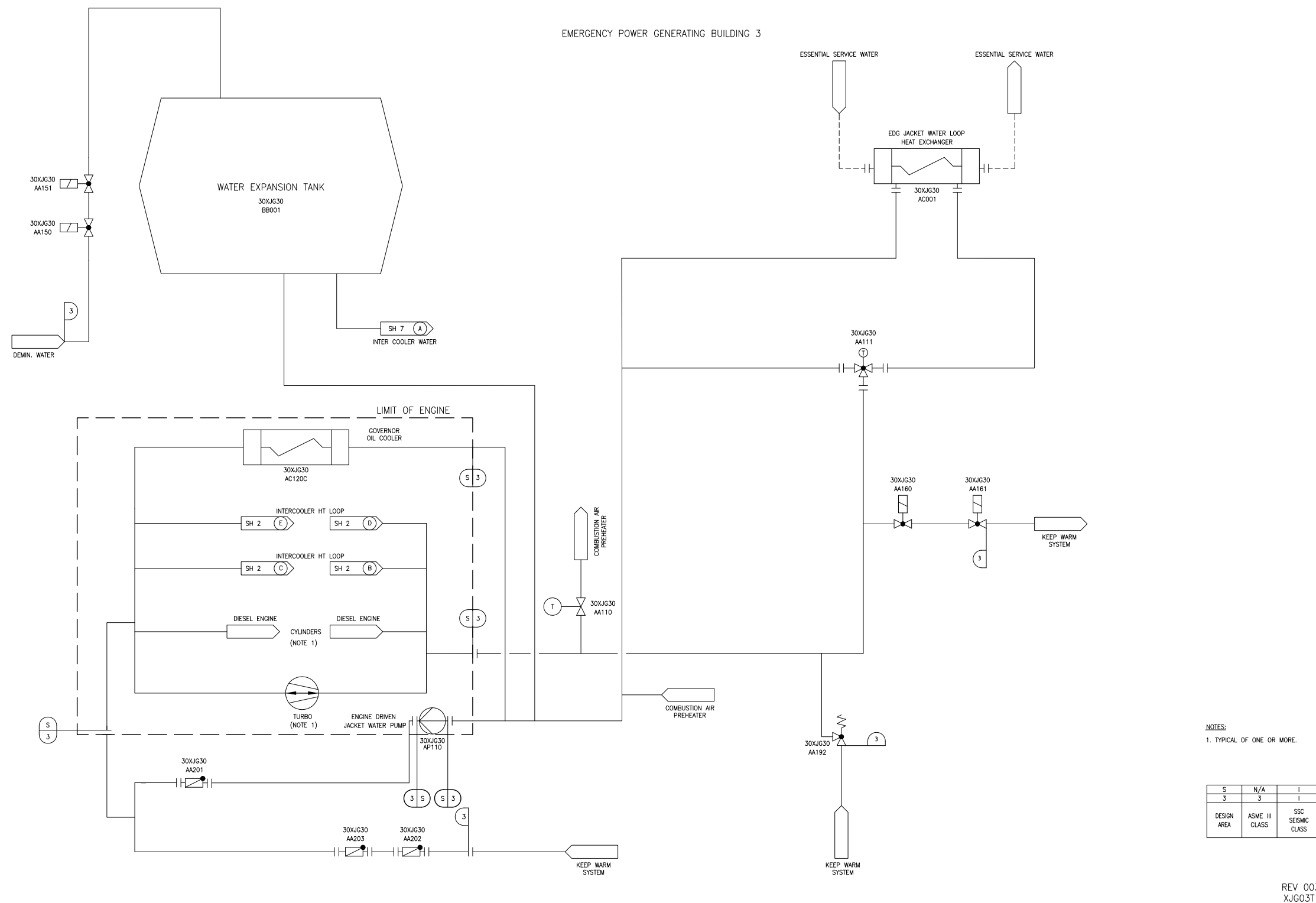

Figure 2.5.4-4—Emergency Diesel Generator Cooling Water System Functional Arrangement
Sheet 4 of 8

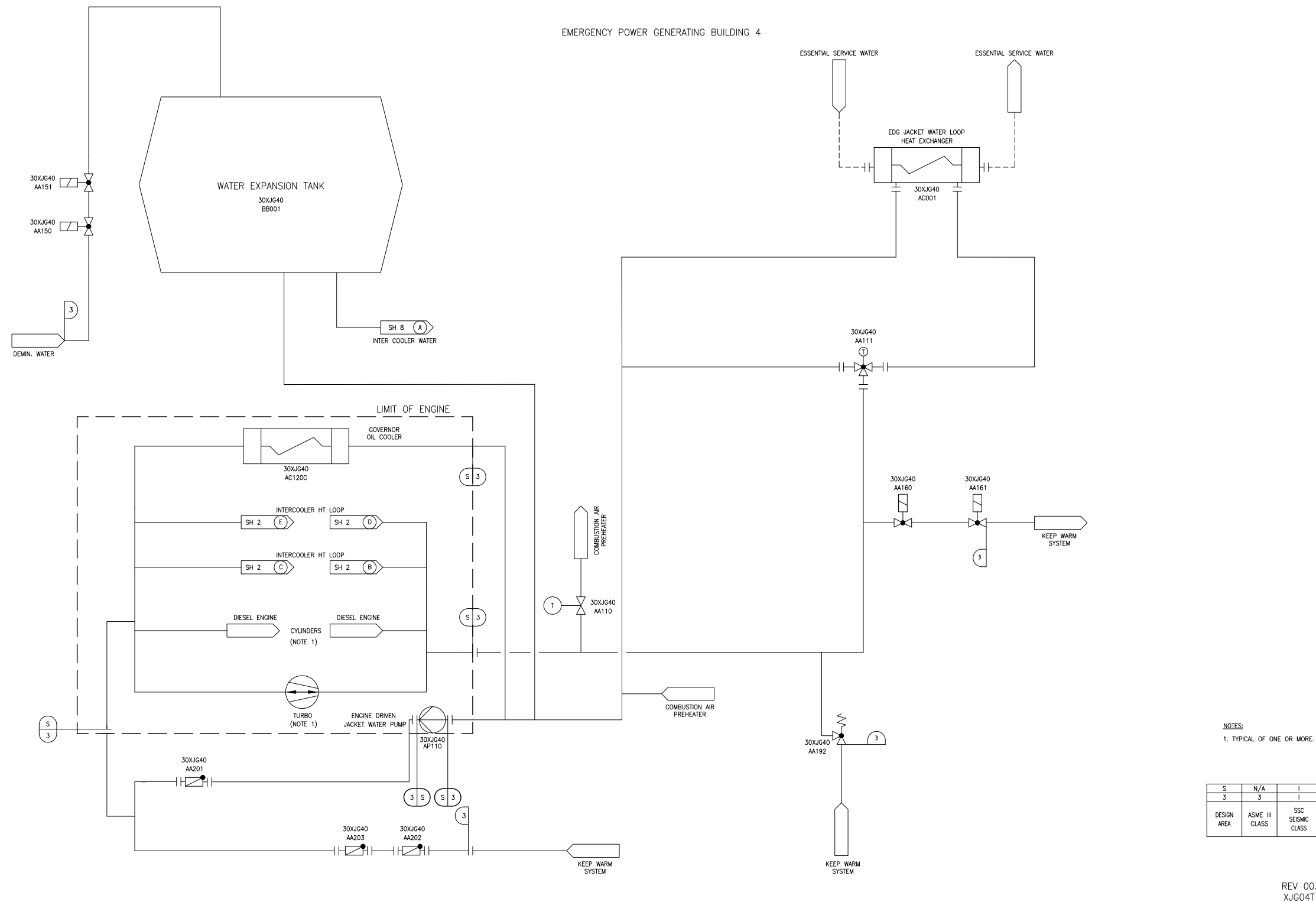
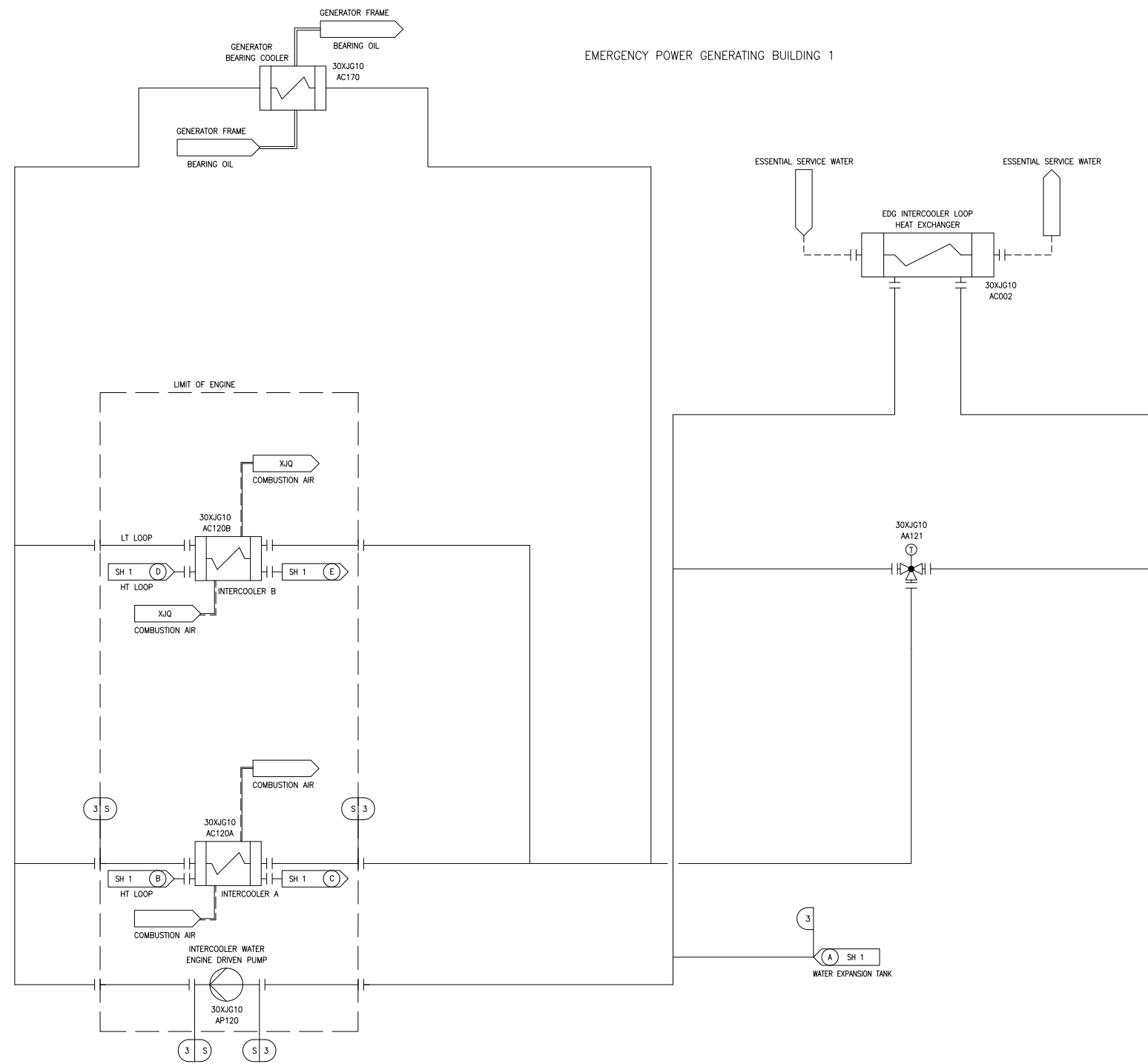

Figure 2.5.4-4—Emergency Diesel Generator Cooling Water System Functional Arrangement
Sheet 5 of 8



S	N/A	I
3	3	1
DESIGN AREA	ASME III CLASS	SSC SEISMIC CLASS

REV 003
XJG05T1

Figure 2.5.4-4—Emergency Diesel Generator Cooling Water System Functional Arrangement
Sheet 6 of 8

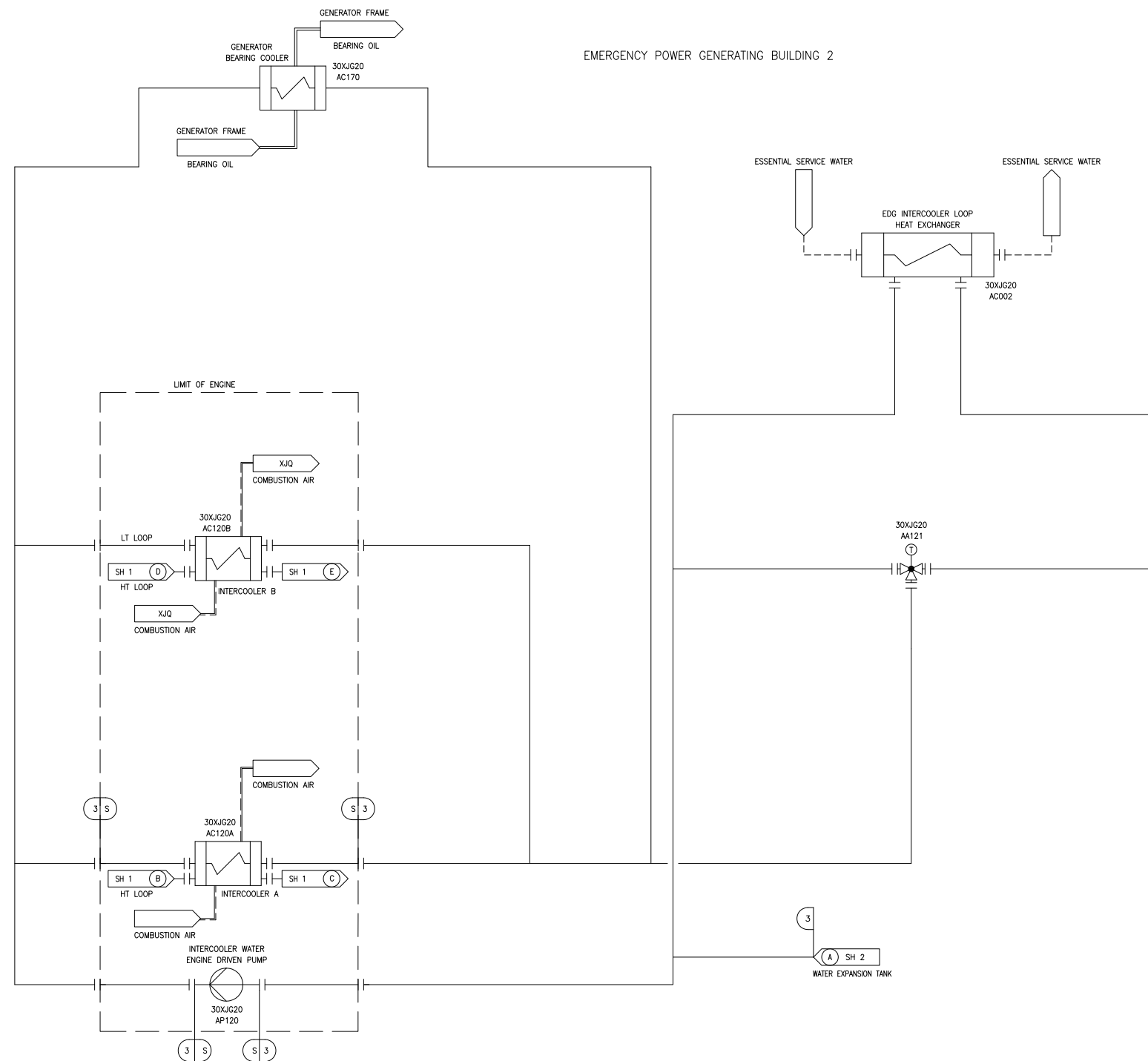

S	N/A	I
3	3	I
DESIGN AREA	ASME III CLASS	SSC SEISMIC CLASS

REV 003
XJG06T1

Figure 2.5.4-4—Emergency Diesel Generator Cooling Water System Functional Arrangement
Sheet 7 of 8

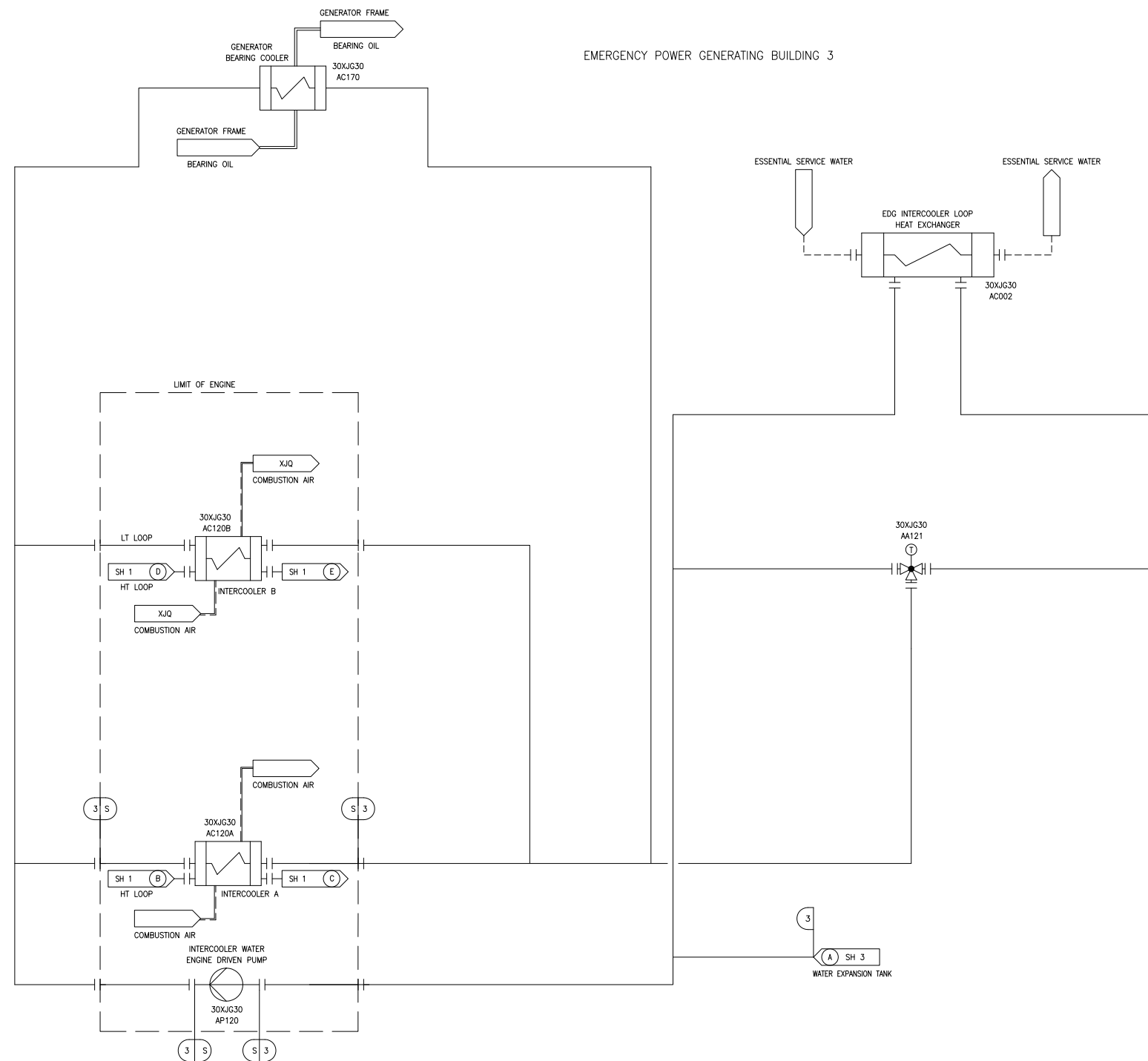

S	N/A	I
3	3	I
DESIGN AREA	ASME III CLASS	SSC SEISMIC CLASS

REV 003
XJG07T1

Figure 2.5.4-4—Emergency Diesel Generator Cooling Water System Functional Arrangement
Sheet 8 of 8

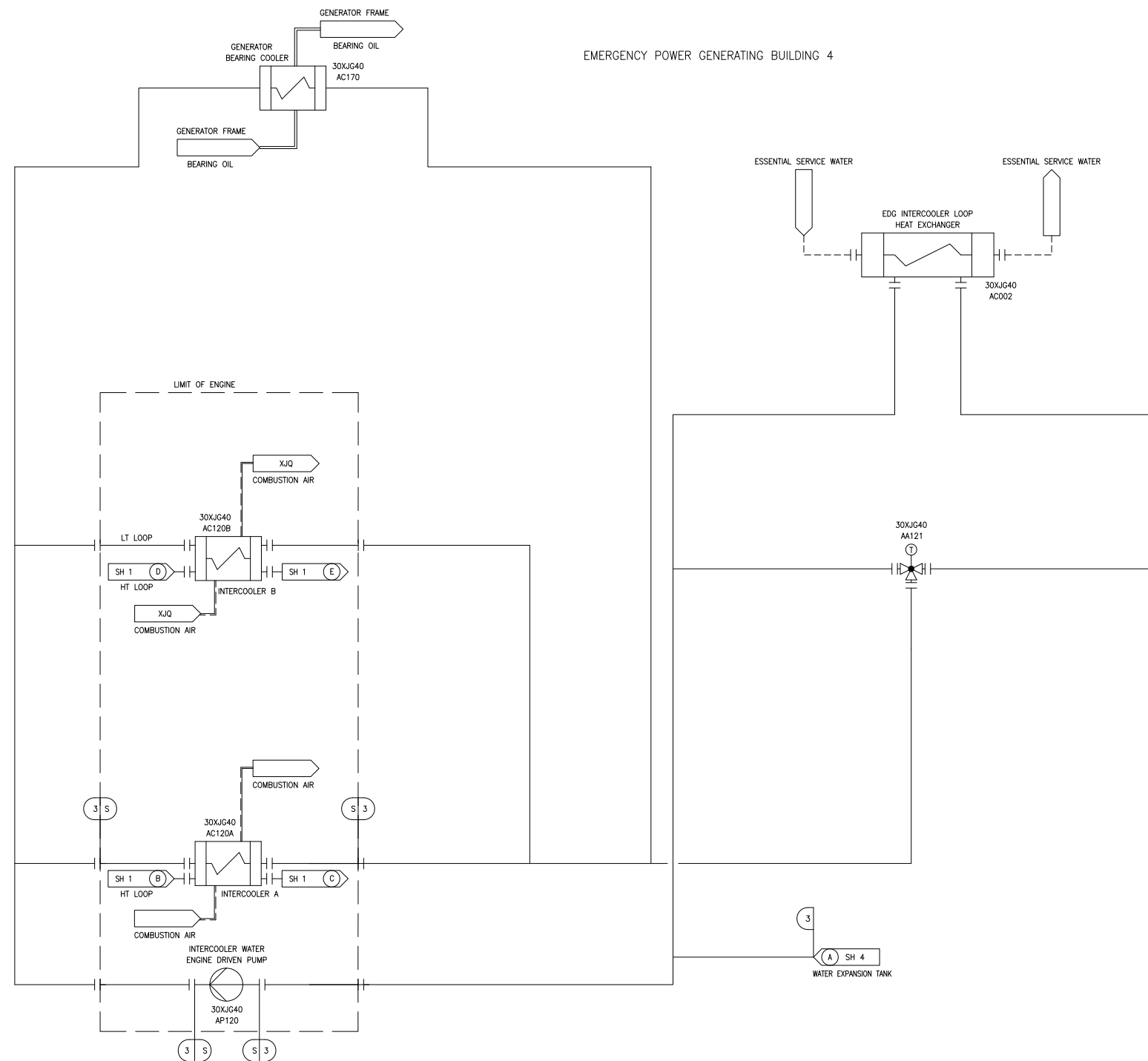

S	N/A	I
3	3	I
DESIGN AREA	ASME III CLASS	SSC SEISMIC CLASS

REV 003
XJG08T1

Figure 2.5.4-5—Emergency Diesel Generator Starting Air System Functional Arrangement
Sheet 1 of 4

EMERGENCY POWER GENERATING BUILDING 1

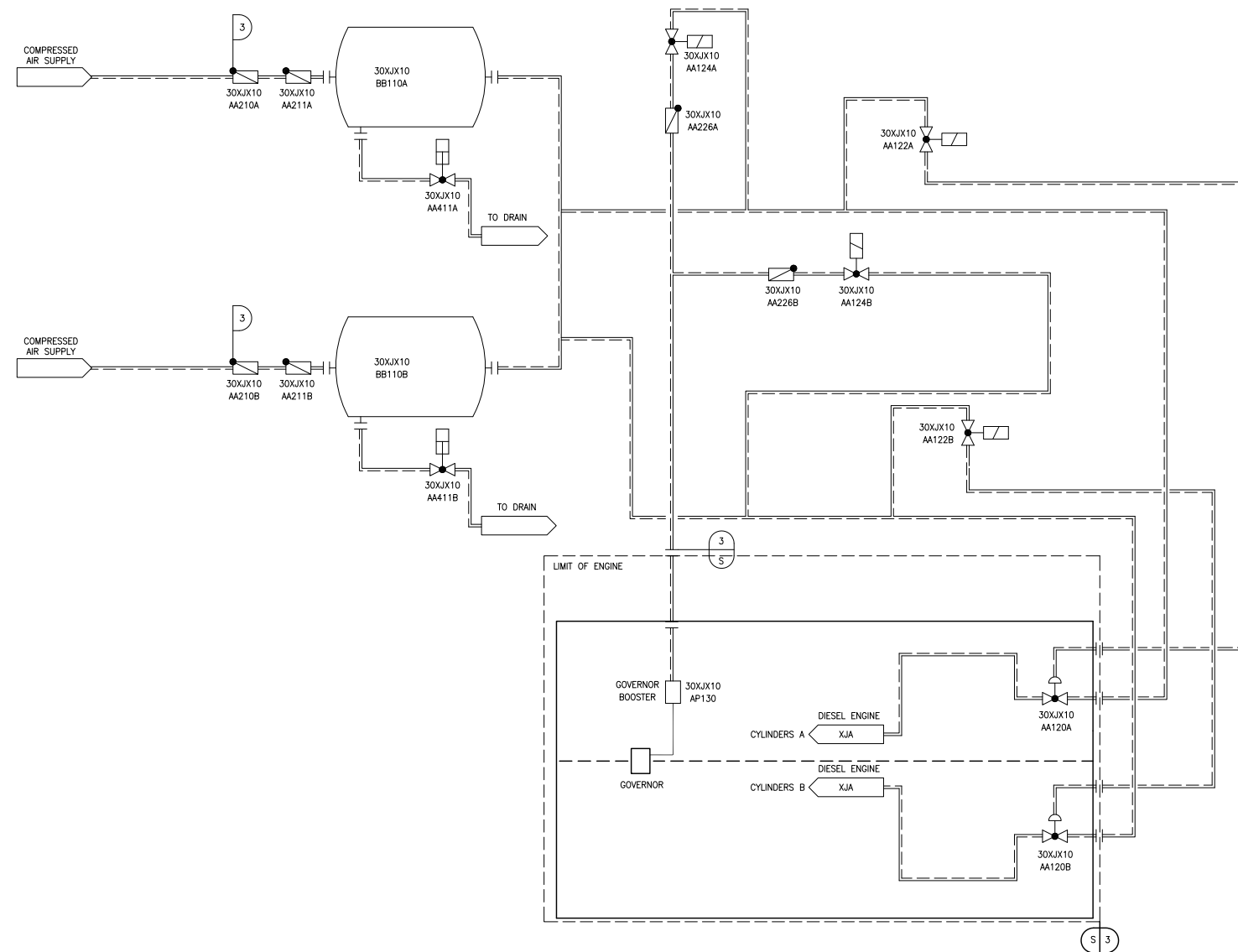

S	N/A	I
3	3	I
DESIGN AREA	ASME III CLASS	SSC SEISMIC CLASS

REV 003
XJX01T1

Figure 2.5.4-5—Emergency Diesel Generator Starting Air System Functional Arrangement
Sheet 2 of 4

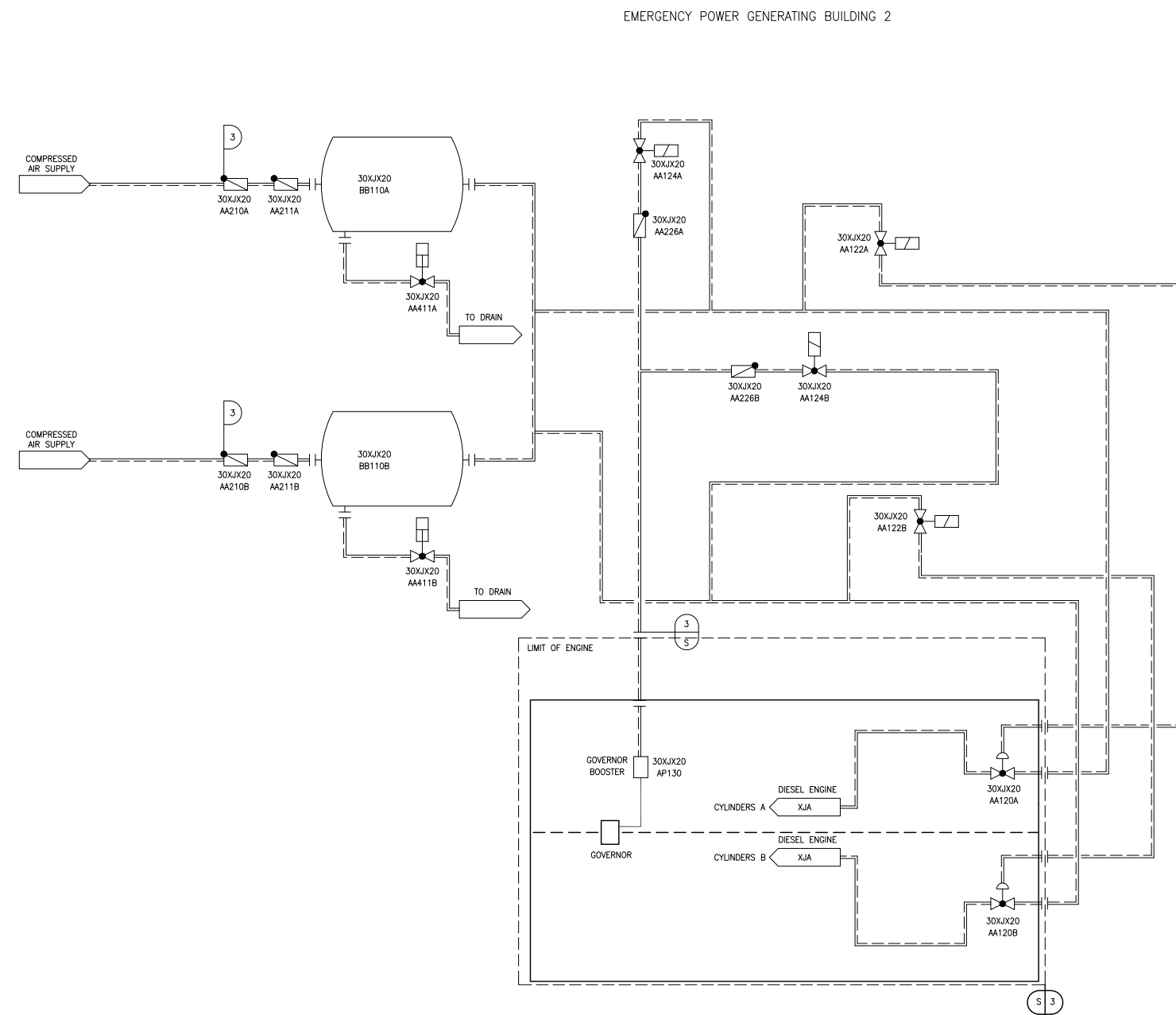

S	N/A	I
3	3	I
DESIGN AREA	ASME III CLASS	SSC SEISMIC CLASS

REV 003
XJX02T1

Figure 2.5.4-5—Emergency Diesel Generator Starting Air System Functional Arrangement
Sheet 3 of 4

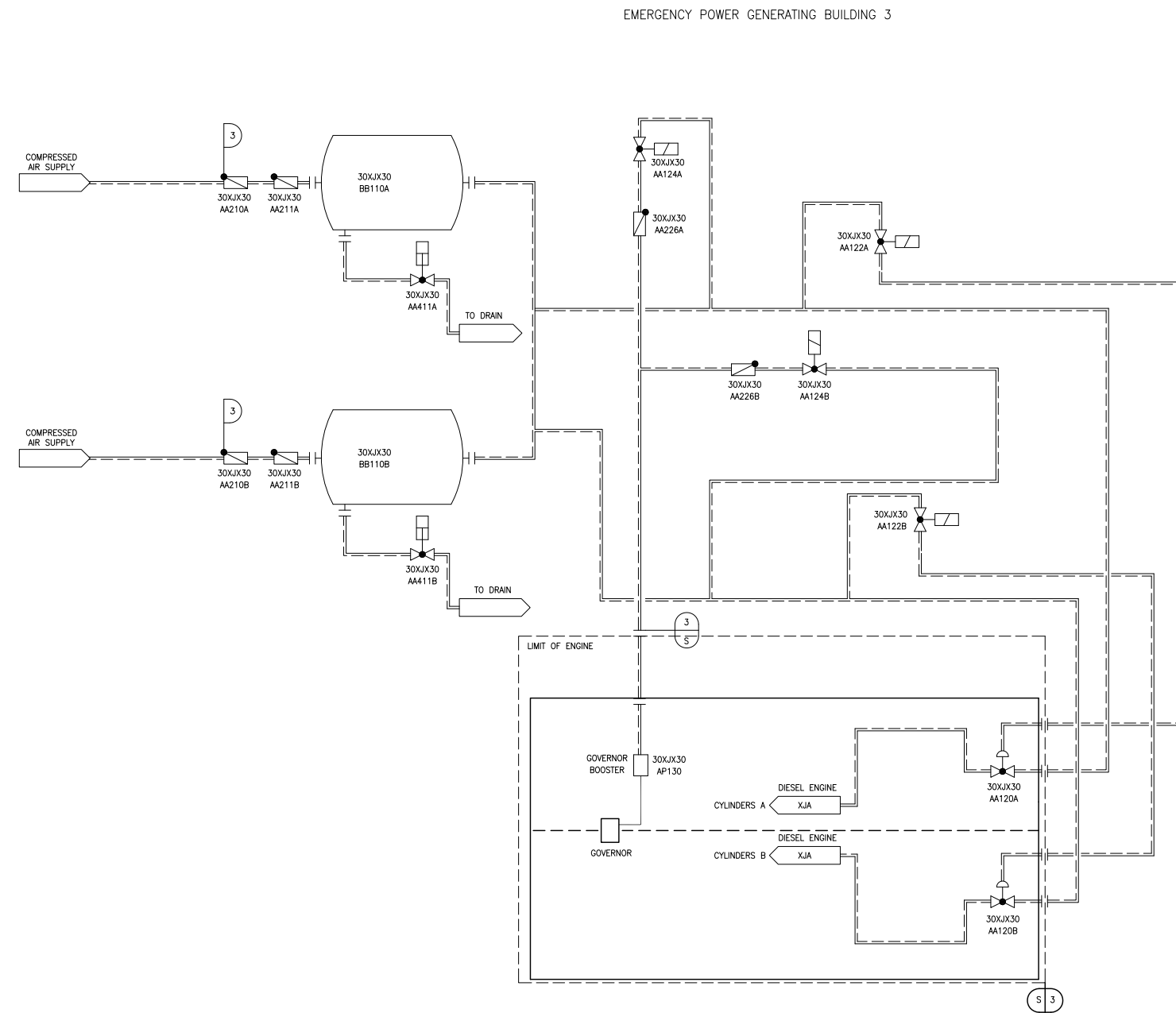

S	N/A	I
3	3	I
DESIGN AREA	ASME III CLASS	SSC SEISMIC CLASS

REV 003
XJX03T1

Figure 2.5.4-5—Emergency Diesel Generator Starting Air System Functional Arrangement
Sheet 4 of 4

EMERGENCY POWER GENERATING BUILDING 4

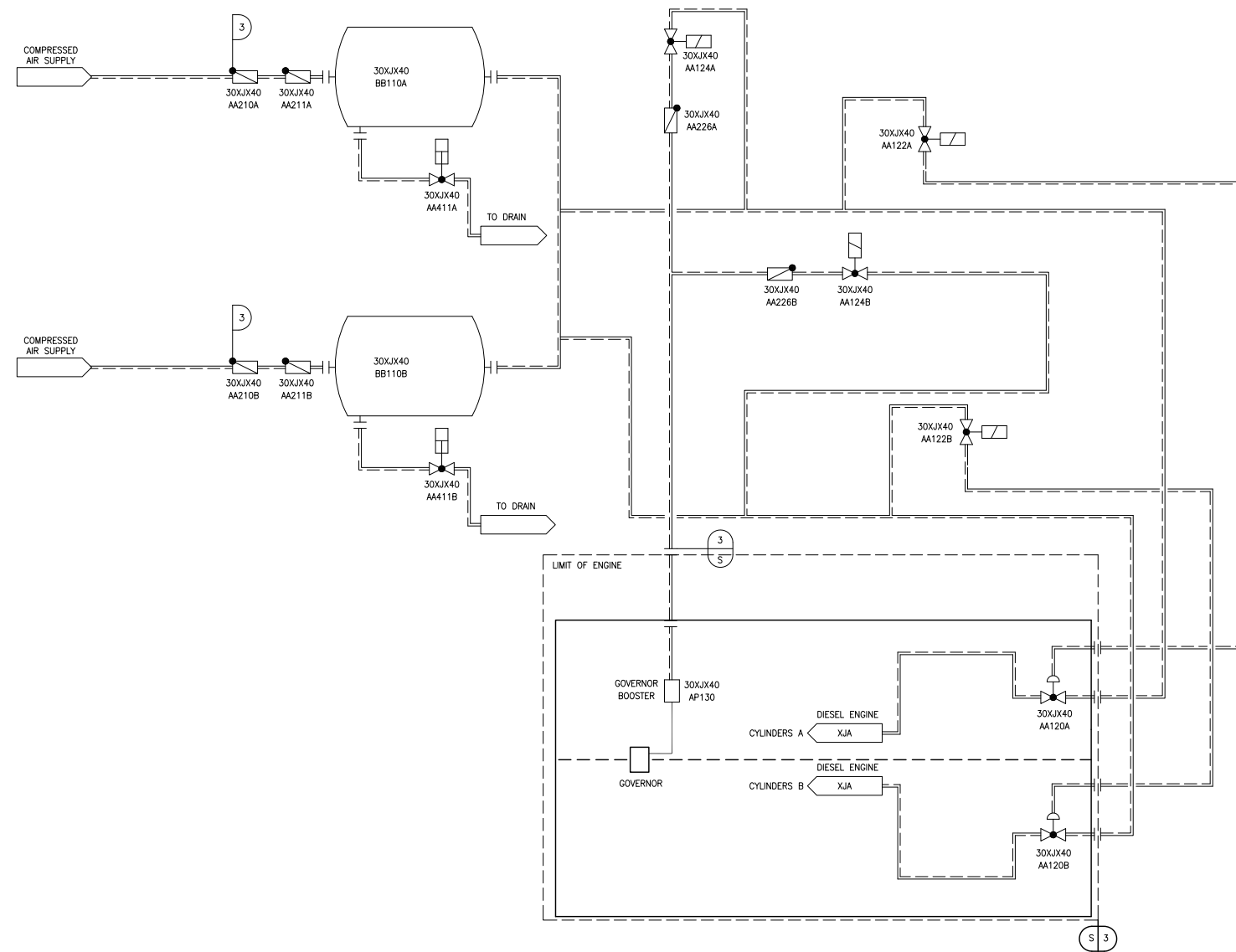

S	N/A	I
3	3	I
DESIGN AREA	ASME III CLASS	SSC SEISMIC CLASS

REV 003
XJX04T1