



River Bend Station
5485 U.S. Highway 61N
St. Francisville, LA 70775
Tel 225-381-4157

Joseph A Clark
Manager, Licensing

RBG-47166

August 3, 2011

U. S. Nuclear Regulatory Commission
Attn.: Document Control Desk
Washington, DC 20555-0001

SUBJECT: River Bend Station, Unit 1 - Requests for Relief
RBS-ISI-016 and RBS-ISI-017
Requests for Relief from ASME Code Section XI Inservice Inspection
Requirements for Pressure Retaining Welds in Control Rod Housings
and Pressure Retaining Welds in Pumps and Valves
Docket No. 50-458
License No. NPF-47

REFERENCES: 1. NUREG-0989; "Safety Evaluation Report Related to the Operation
of River Bend Station," Supplement 3, Appendix L, Dated May
1984.
2. NRC Letter; "River Bend Station Unit 1- Evaluation of Relief
Requests For Second Ten-Year Interval Pum and Valve Inservice
Testing," Dated March 9, 2000 (TAC No. MA4546)

Dear Sir or Madam:

Pursuant to 10 CFR 50.55a, "Codes and Standards," paragraph (g)(5)(iii), Entergy requests relief from certain American Society of Mechanical Engineers (ASME) Boiler and Pressure Vessel Code (BPV), Section XI, Sub Article IWB-2500 Inservice Inspection (ISI) requirements for Examination Category B-O, Pressure Retaining Welds in Control Rod Housings and Examination Category C-G, Pressure Retaining Welds in Pumps and Valves. This relief is requested for the second 10-year interval of the Inservice Inspection Program for the River Bend Station (RBS).

These requests for relief are being submitted beyond the 12 month timeframe following the second 120 month interval as specified under 10 CFR 50.55a(g)(5)(iv). This condition has been addressed in Entergy's Corrective Action Process.

In accordance with 10 CFR 50.55a(g)(6)(i), the proposed relief to the referenced requirements may be approved by the NRC giving due consideration to the burden upon the licensee that could result if the requirements were imposed on the facility. Entergy believes full compliance with the ASME Code, Section XI requirements is not practical. The specific details of the requested relief are enclosed in Attachment 1 and Attachment 2.

A047
NRR

The NRC previously granted relief for these examinations in the Safety Evaluations listed as References 1 and 2 above.

There are no new commitments in this letter.

If you have any questions concerning this letter, please contact me at (225) 381-4177.

Respectfully,

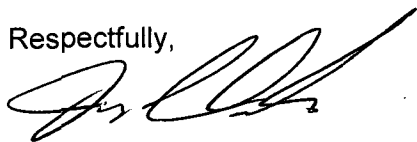

Manager, Licensing
River Bend Station - Unit 1

JAC/bmb

Attachments:

1. Attachment 1 - Second 10 Year Interval Inservice Inspection Program Request For Relief - RBS-ISI-016
2. Attachment 2 - Second 10 Year Interval Inservice Inspection Program Request For Relief - RBS-ISI-017

cc: Regional Administrator
U. S. Nuclear Regulatory Commission
Region IV
612 E. Lamar Blvd., Suite 400
Arlington, TX 76011-4125

NRC Senior Resident Inspector
P. O. Box 1050
St. Francisville, LA 70775

U. S. Nuclear Regulatory Commission
Attn: Mr. Alan B. Wang
MS O-8 B1
Washington, DC 20555-0001

Department of Environmental Quality
Office of Environmental Compliance
Radiological Emergency Planning and Response Section
JiYoung Wiley
P.O. Box 4312
Baton Rouge, LA 70821-4312

RBG-47166
Page 1 of 1

RBG-47166
RBF1-11-0104
File codes; G9.5,

ATTACHMENT 1 TO

RBG-47166

**RIVER BEND STATION – UNIT 1
SECOND 10 YEAR INTERVAL INSERVICE INSPECTION PROGRAM**

REQUEST FOR RELIEF

RBS-ISI-016

**RIVER BEND STATION – UNIT 1
SECOND 10 YEAR INTERVAL INSERVICE INSPECTION PROGRAM
REQUEST FOR RELIEF
RBS-ISI-016**

Component(s) Affected:	See Table 1 below
Code Class:	ASME Code Class 1
References:	ASME Section XI 1992 Edition, 1993 Addenda, Table IWB-2500-1 Inspection Program B
Examination Category:	B-O, Pressure Retaining Welds in Control Rod Housings
Item Number(s):	B14.10, Welds in CRD Housing
Unit / Inspection Interval Applicability:	River Bend Station (RBS), Second (2nd) 10-year interval December 1, 1997 through May 31, 2008

I. Applicable Code Requirement(s)

ASME Code, Section XI, 1992 Edition, 1993 Addenda, Table IWB-2500-1, Examination Category B-O, Pressure Retaining Welds in Control Rod Housings, Item B14.10 requires volumetric or surface examination of 10% of peripheral CRD housing welds.

II. Impracticality of Compliance

The as-installed configuration of the 36 peripheral CRD housings makes performance of the eight required examinations impractical for the following reasons. The housings are laterally proximate to the reactor vessel support pedestal, which limits access to the upper and lower welds on the outer circumference of the housings. Next, the subject welds are below the lower reactor insulation support structure where the housings pass through a series of closely-spaced CRD housing support beams and associated hanger rods, which further limit access to the welds in the upper portion of the housings. Access to both the upper and lower welds from below is further limited by a series of CRD housing support bars, grid plates and grid clamps. Access to the lower welds from the housing ID requires removal of the CRD mechanisms and sleeves. See Diagrams 1 – 5 on pages 5-9 of this relief request.

III. Proposed Alternatives and Basis of Use

Relief is requested from performing the volumetric or surface examinations on 10% of the peripheral CRD housing welds. The subject welds will continue to receive VT-2 examination with the Reactor Coolant Pressure Boundary (RCPB) system leakage test conducted prior to startup from each refueling outage. Under-vessel Drywell leakage is also monitored during each operational cycle.

IV. Duration of Requested Relief

Relief is requested for the second ISI Interval from December 1, 1997 through May 31, 2008.

V. Precedents

Relief from the subject examinations was previously approved by the NRC Staff for the first ISI Interval as documented in NRC SSER 3, Appendix L following the preservice examination.

**RIVER BEND STATION – UNIT 1
SECOND 10 YEAR INTERVAL INSERVICE INSPECTION PROGRAM
REQUEST FOR RELIEF
RBS-ISI-016**

TABLE 1 - AFFECTED COMPONENTS

COMPONENT NO	CATEGORY	ITEM NUMBER	DESCRIPTION
B13-D008-04/17-WELD-1	B-O	B14.10	Welds in CRD Housing
B13-D008-04/17-WELD-2	B-O	B14.10	Welds in CRD Housing
B13-D008-04/21-WELD-1	B-O	B14.10	Welds in CRD Housing
B13-D008-04/21-WELD-2	B-O	B14.10	Welds in CRD Housing
B13-D008-04/25-WELD-1	B-O	B14.10	Welds in CRD Housing
B13-D008-04/25-WELD-2	B-O	B14.10	Welds in CRD Housing
B13-D008-04/29-WELD-1	B-O	B14.10	Welds in CRD Housing
B13-D008-04/29-WELD-2	B-O	B14.10	Welds in CRD Housing
B13-D008-04/33-WELD-1	B-O	B14.10	Welds in CRD Housing
B13-D008-04/33-WELD-2	B-O	B14.10	Welds in CRD Housing
B13-D008-04/41-WELD-1	B-O	B14.10	Welds in CRD Housing
B13-D008-04/41-WELD-2	B-O	B14.10	Welds in CRD Housing
B13-D008-08/13-WELD-1	B-O	B14.10	Welds in CRD Housing
B13-D008-08/13-WELD-2	B-O	B14.10	Welds in CRD Housing
B13-D008-08/45-WELD-1	B-O	B14.10	Welds in CRD Housing
B13-D008-08/45-WELD-2	B-O	B14.10	Welds in CRD Housing
B13-D008-12/09-WELD-1	B-O	B14.10	Welds in CRD Housing
B13-D008-12/09-WELD-2	B-O	B14.10	Welds in CRD Housing
B13-D008-12/49-WELD-1	B-O	B14.10	Welds in CRD Housing
B13-D008-12/49-WELD-2	B-O	B14.10	Welds in CRD Housing
B13-D008-16/05-WELD-1	B-O	B14.10	Welds in CRD Housing
B13-D008-16/05-WELD-2	B-O	B14.10	Welds in CRD Housing
B13-D008-16/53-WELD-1	B-O	B14.10	Welds in CRD Housing
B13-D008-16/53-WELD-2	B-O	B14.10	Welds in CRD Housing
B13-D008-20/05-WELD-1	B-O	B14.10	Welds in CRD Housing
B13-D008-20/05-WELD-2	B-O	B14.10	Welds in CRD Housing
B13-D008-20/53-WELD-1	B-O	B14.10	Welds in CRD Housing
B13-D008-20/53-WELD-2	B-O	B14.10	Welds in CRD Housing
B13-D008-24/05-WELD-1	B-O	B14.10	Welds in CRD Housing
B13-D008-24/05-WELD-2	B-O	B14.10	Welds in CRD Housing
B13-D008-24/53-WELD-1	B-O	B14.10	Welds in CRD Housing
B13-D008-24/53-WELD-2	B-O	B14.10	Welds in CRD Housing
B13-D008-28/05-WELD-1	B-O	B14.10	Welds in CRD Housing
B13-D008-28/05-WELD-2	B-O	B14.10	Welds in CRD Housing
B13-D008-28/53-WELD-1	B-O	B14.10	Welds in CRD Housing
B13-D008-28/53-WELD-2	B-O	B14.10	Welds in CRD Housing
B13-D008-32/05-WELD-1	B-O	B14.10	Welds in CRD Housing
B13-D008-32/05-WELD-2	B-O	B14.10	Welds in CRD Housing

**RIVER BEND STATION – UNIT 1
SECOND 10 YEAR INTERVAL INSERVICE INSPECTION PROGRAM
REQUEST FOR RELIEF
RBS-ISI-016**

TABLE 1 - AFFECTED COMPONENTS

B13-D008-32/53-WELD-1	B-O	B14.10	Welds in CRD Housing
B13-D008-32/53-WELD-2	B-O	B14.10	Welds in CRD Housing
B13-D008-36/05-WELD-1	B-O	B14.10	Welds in CRD Housing
B13-D008-36/05-WELD-2	B-O	B14.10	Welds in CRD Housing
B13-D008-36/53-WELD-1	B-O	B14.10	Welds in CRD Housing
B13-D008-36/53-WELD-2	B-O	B14.10	Welds in CRD Housing
B13-D008-40/05-WELD-1	B-O	B14.10	Welds in CRD Housing
B13-D008-40/05-WELD-2	B-O	B14.10	Welds in CRD Housing
B13-D008-40/53-WELD-1	B-O	B14.10	Welds in CRD Housing
B13-D008-40/53-WELD-2	B-O	B14.10	Welds in CRD Housing
B13-D008-44/09-WELD-1	B-O	B14.10	Welds in CRD Housing
B13-D008-44/09-WELD-2	B-O	B14.10	Welds in CRD Housing
B13-D008-44/49-WELD-1	B-O	B14.10	Welds in CRD Housing
B13-D008-44/49-WELD-2	B-O	B14.10	Welds in CRD Housing
B13-D008-48/13-WELD-1	B-O	B14.10	Welds in CRD Housing
B13-D008-48/13-WELD-2	B-O	B14.10	Welds in CRD Housing
B13-D008-48/45-WELD-1	B-O	B14.10	Welds in CRD Housing
B13-D008-48/45-WELD-2	B-O	B14.10	Welds in CRD Housing
B13-D008-52/17-WELD-1	B-O	B14.10	Welds in CRD Housing
B13-D008-52/17-WELD-2	B-O	B14.10	Welds in CRD Housing
B13-D008-52/21-WELD-1	B-O	B14.10	Welds in CRD Housing
B13-D008-52/21-WELD-2	B-O	B14.10	Welds in CRD Housing
B13-D008-52/25-WELD-1	B-O	B14.10	Welds in CRD Housing
B13-D008-52/25-WELD-2	B-O	B14.10	Welds in CRD Housing
B13-D008-52/29-WELD-1	B-O	B14.10	Welds in CRD Housing
B13-D008-52/29-WELD-2	B-O	B14.10	Welds in CRD Housing
B13-D008-52/33-WELD-1	B-O	B14.10	Welds in CRD Housing
B13-D008-52/33-WELD-2	B-O	B14.10	Welds in CRD Housing
B13-D008-52/37-WELD-1	B-O	B14.10	Welds in CRD Housing
B13-D008-52/37-WELD-2	B-O	B14.10	Welds in CRD Housing
B13-D008-52/41-WELD-1	B-O	B14.10	Welds in CRD Housing
B13-D008-52/41-WELD-2	B-O	B14.10	Welds in CRD Housing

DIAGRAM 1
General Configuration

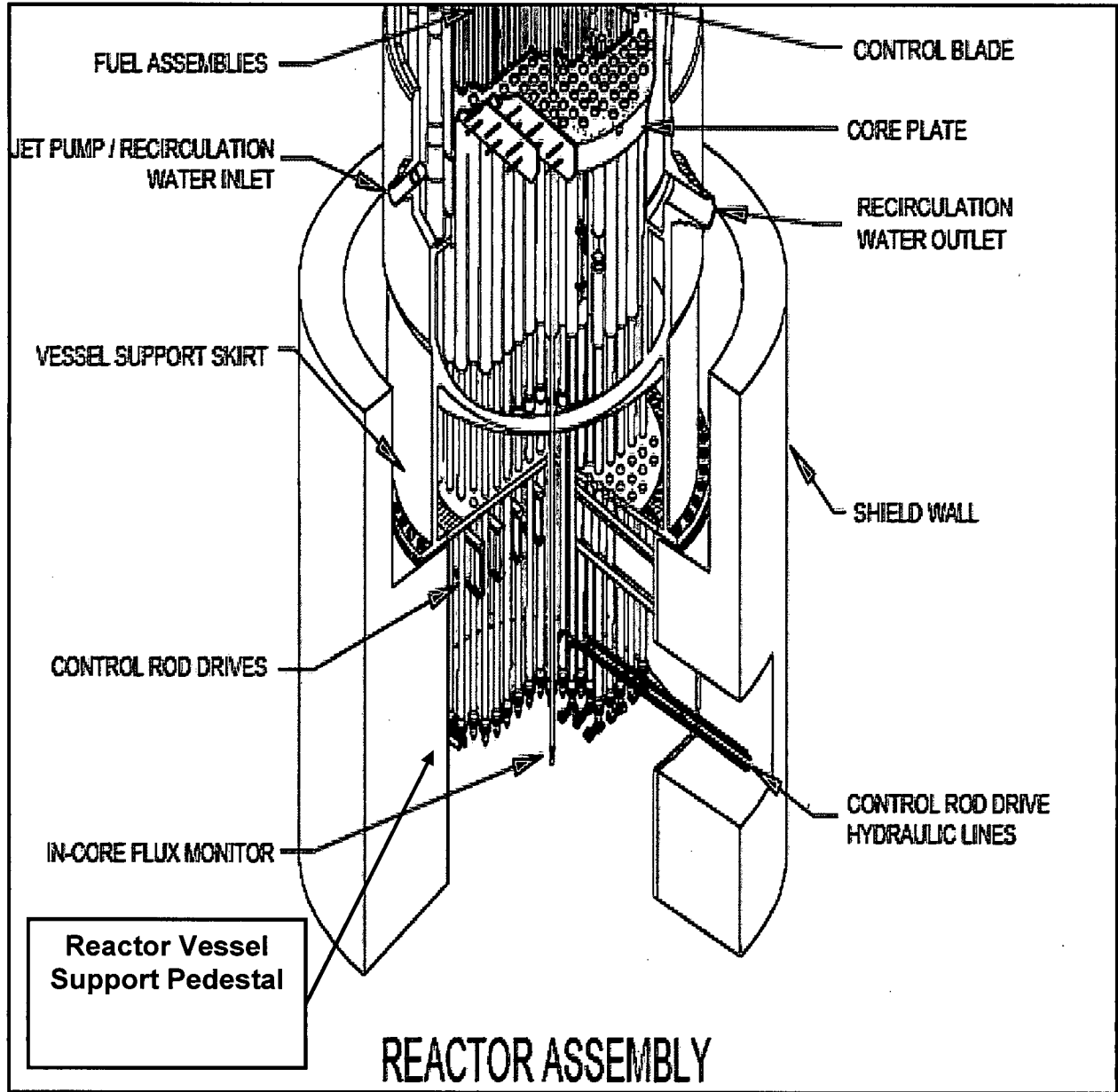

DIAGRAM 2
Elevation View

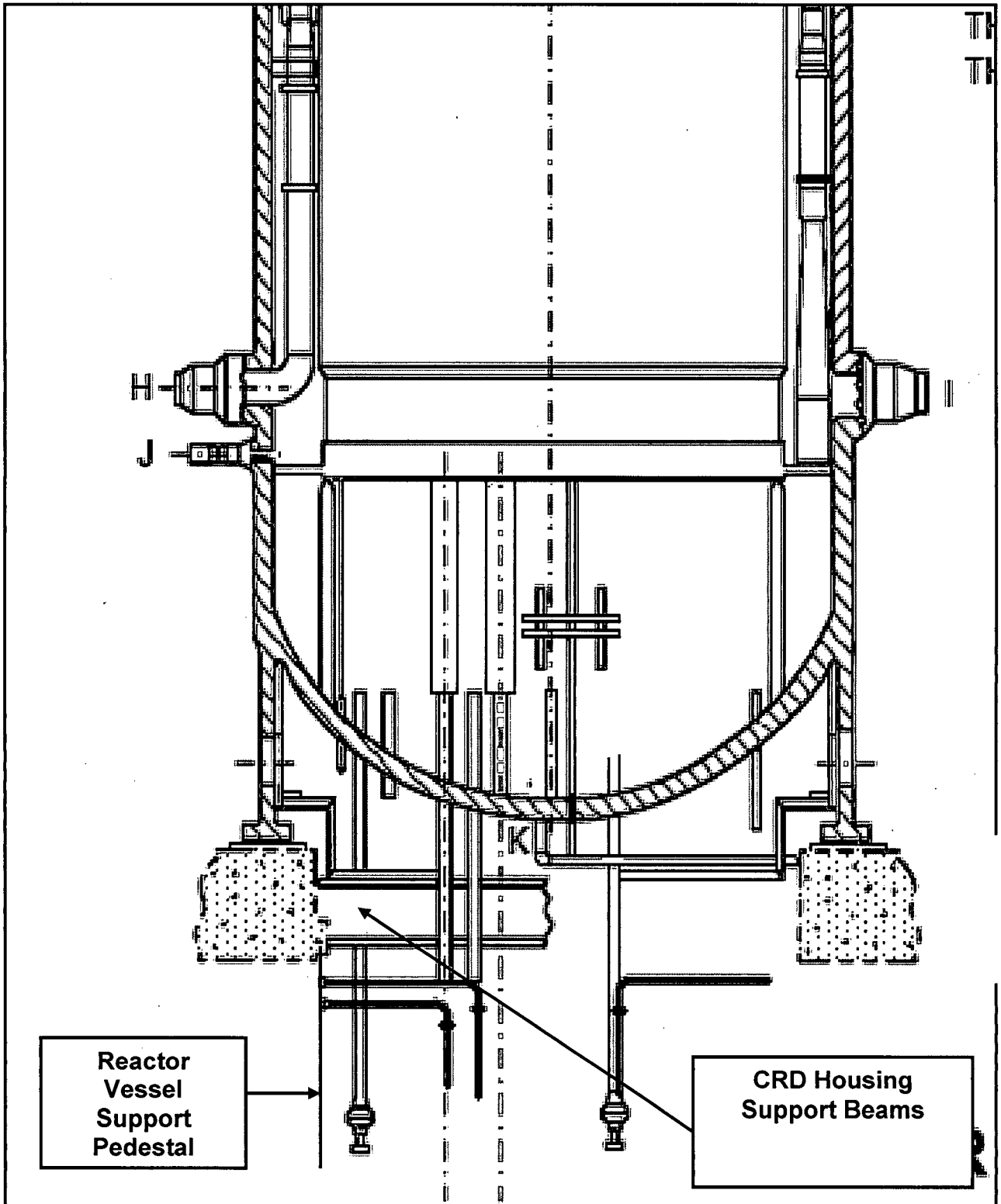
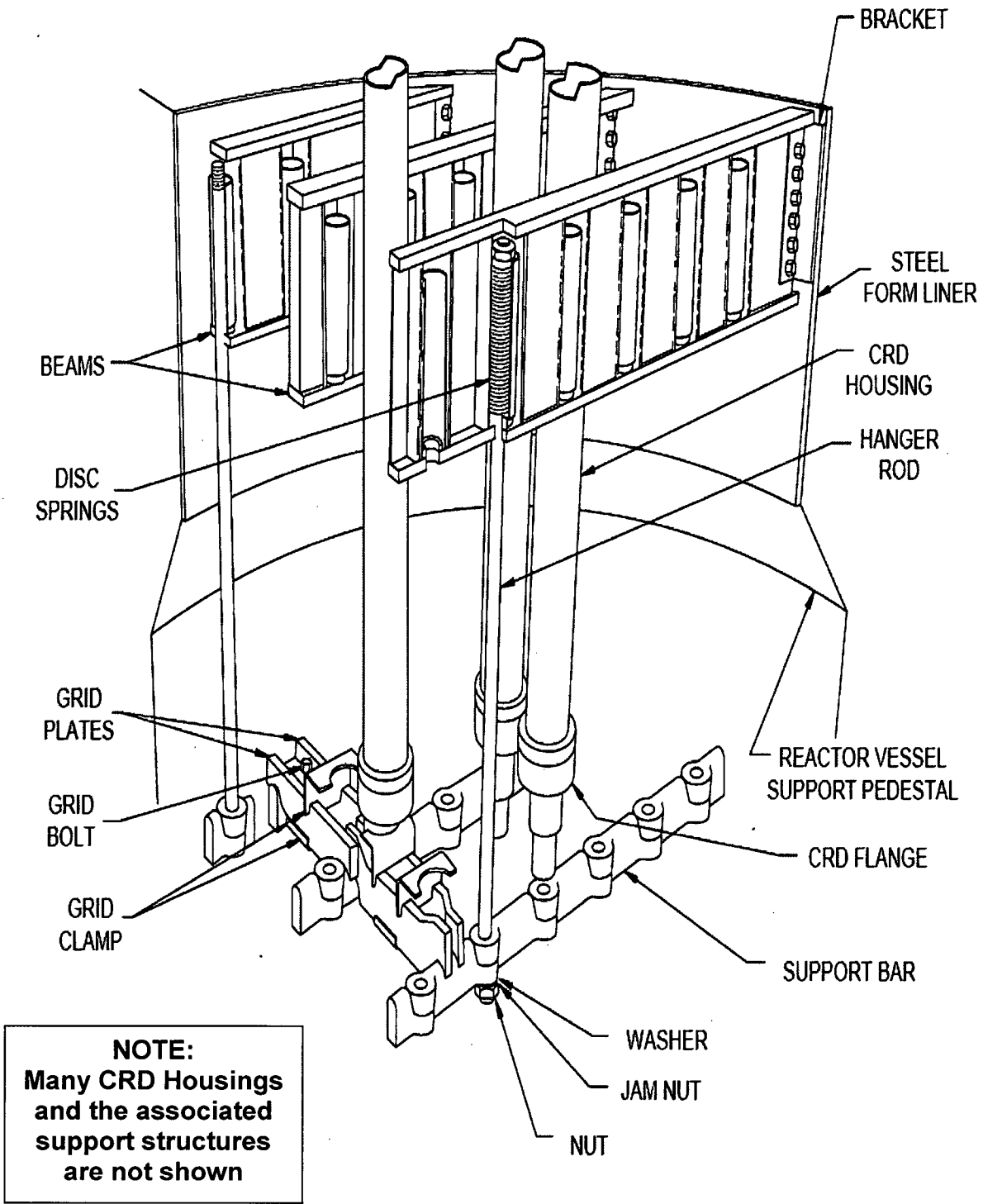

DIAGRAM 3
CRD Housing Support Structures



CONTROL ROD DRIVING HOUSING SUPPORT STRUCTURES

DIAGRAM 4 CRD Housing Coordinates

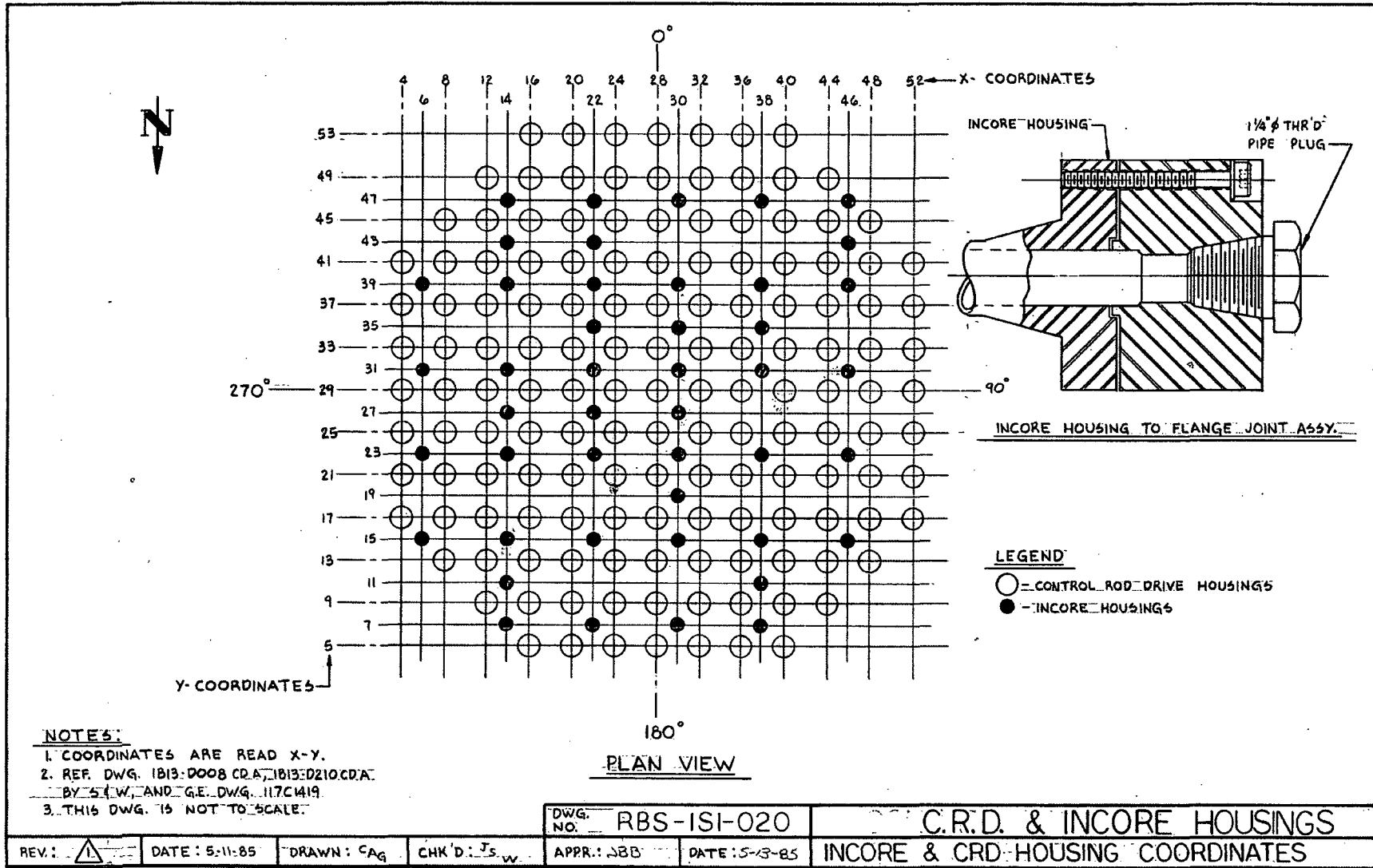
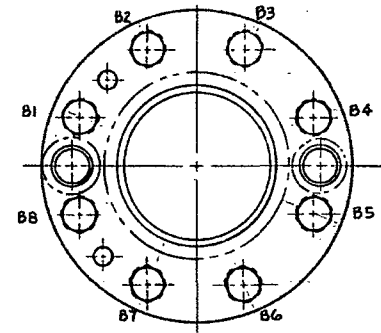

DIAGRAM 5 CRD Housing Weld Map

NOTES:

1. ALL WELDS TO BE PREFIXED BY RDS-B-
2. REF. DWG. NO. 10505424 BY G.E.
3. THIS DWG. IS NOT TO SCALE.



SECTION "A-A"

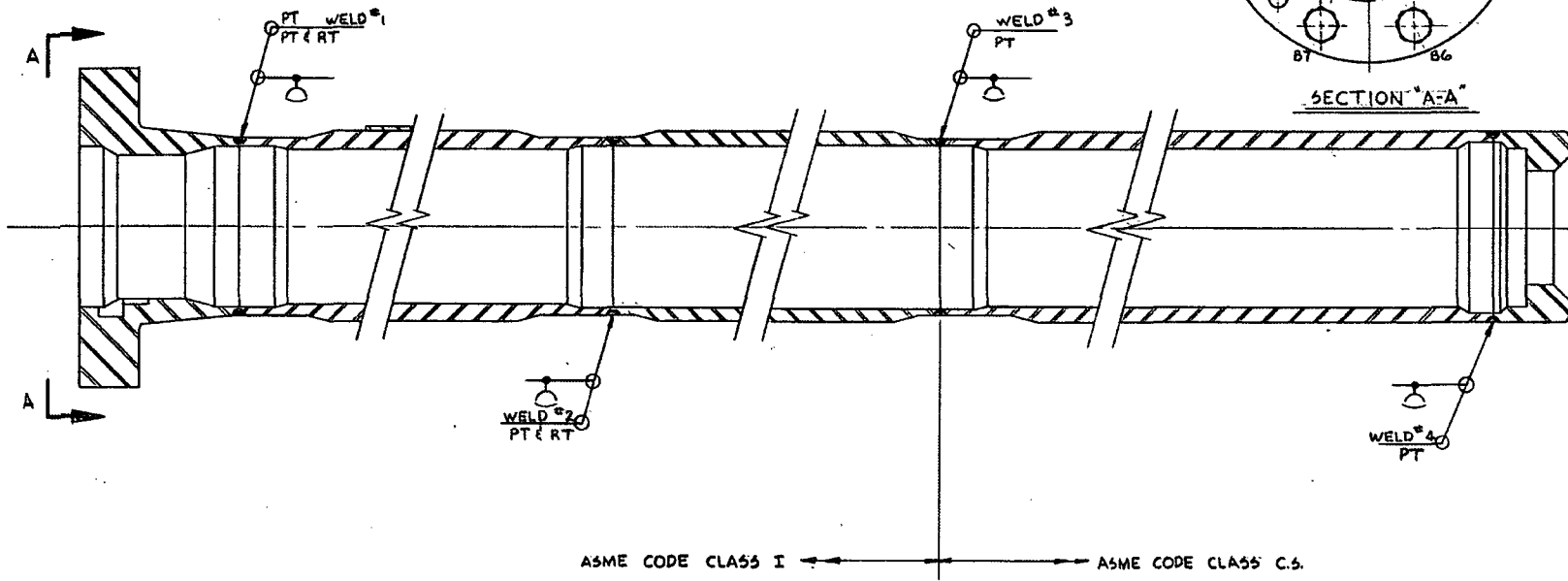

REV:	DATE: 5-11-85	DRAWN: CAG	CHK'D: J.S.W.	APPR: JBB	DATE: 5-13-85	DWG. NO. RBS-ISI-021 CONTROL ROD DRIVE HOUSING JOINT IDENTIFICATION & WELD MAP
------	---------------	------------	---------------	-----------	---------------	--

ATTACHMENT 2 TO

RBG-47166

**RIVER BEND STATION – UNIT 1
SECOND 10 YEAR INTERVAL INSERVICE INSPECTION PROGRAM**

REQUEST FOR RELIEF

RBS-ISI-017

**RIVER BEND STATION – UNIT 1
SECOND 10 YEAR INTERVAL INSERVICE INSPECTION PROGRAM
REQUEST FOR RELIEF
RBS-ISI-017**

Component(s) Affected See Table 1 below
Code Class: ASME Code Class 2
References: ASME Section XI 1992 Edition, 1993 Addenda, Table IWC-2500-1
Inspection Program B
Examination Category: C-G, Pressure Retaining Welds in Pumps and Valves
Item Number(s): C6.10, Pump Casing Welds
Unit / Inspection River Bend Station (RBS), Second (2nd)10-year interval
Interval Applicability: December 1, 1997 through May 31, 2008

I. Applicable Code Requirement(s)

ASME Code, Section XI, 1992 Edition, 1993 Addenda, Table IWC-2500-1, Examination Category C-G, Pressure Retaining Welds in Pumps and Valves – Inspection Program B. Item C6.10 requires surface examination of 100% of welds in all components in each piping run examined under Examination Category C-F each inspection interval. For extent of examination, Note 1 applies, where in the case of multiple pumps and valves of similar design, size, function and service in a system, the examination of only one pump and one valve among each group of multiple pumps and valves is required.

II. Impracticality of Compliance

Insufficient access exists to perform the required examination of the subject welds due to the close proximity of twenty-four adjacent nuts/washers that fasten each upper pump casing to the lower (embedded) casing.

III. Proposed Alternatives and Basis for Use

Relief is requested from performing the surface examination of the DH-1 weld as depicted in Diagrams 1-6 for the pumps listed in Table 1 – Affected Components.

The required examinations will be performed if the subject pumps are disassembled for maintenance to the point where the subject welds are accessible. The subject welds will continue to receive VT-2 examinations with the associated system leakage tests. The remaining weld examinations for the subject pumps were either performed or prior relief was approved.

IV. Duration of Requested Relief

Relief is requested for the second ISI Interval from December 1, 1997 through May 31, 2008.

V. Precedents

Relief from the subject examinations was approved by the NRC Staff for the first ISI Interval as documented in NRC SER dated March 9, 2000, which included RR1-0003 revision 3 (TAC No. MA4546).

**RIVER BEND STATION – UNIT 1
SECOND 10 YEAR INTERVAL INSERVICE INSPECTION PROGRAM
REQUEST FOR RELIEF
RBS-ISI-017**

TABLE 1 - AFFECTED COMPONENTS

COMPONENT NO	CATEGORY	ITEM NUMBER	DESCRIPTION
E12-PC002A-DH-01	C-G	C6.10	Pump Casing Welds
E21-PC001-DH-01	C-G	C6.10	Pump Casing Welds
E22-PC001-DH-01	C-G	C6.10	Pump Casing Welds

DIAGRAM 1
 Pump E12-PC002A

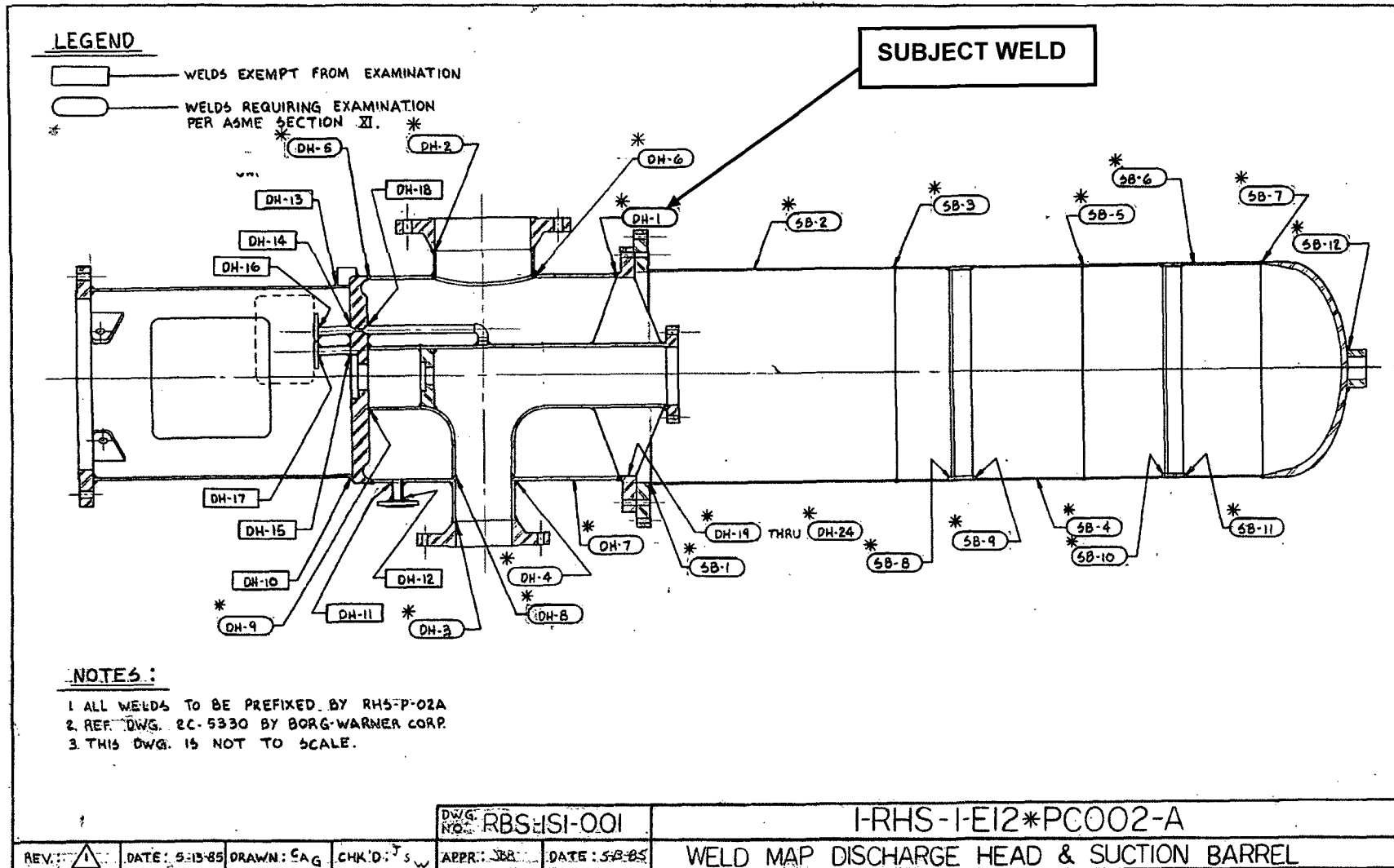

DIAGRAM 2
 Pump E21-PC001

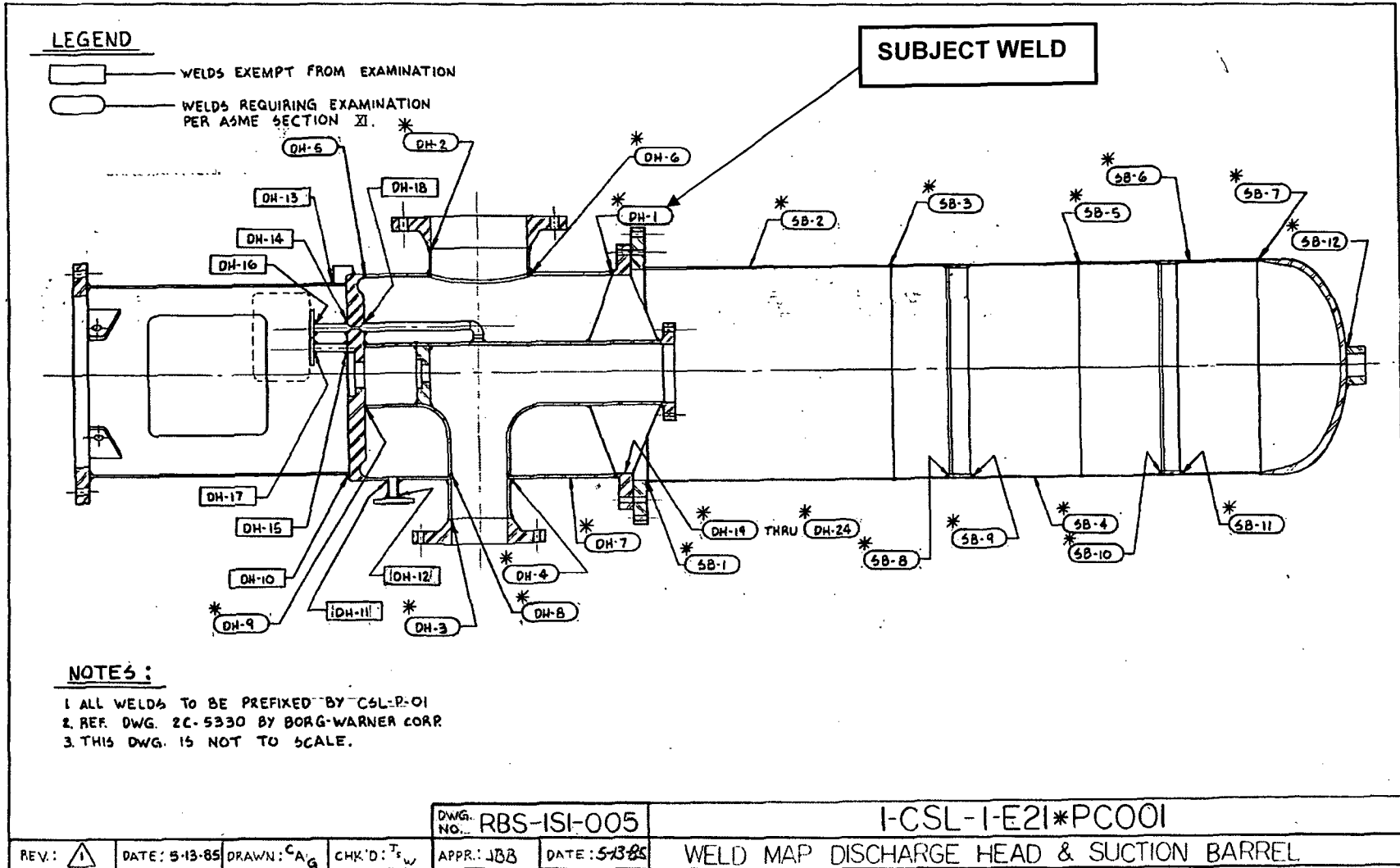

DIAGRAM 3
Pump E22-PC001

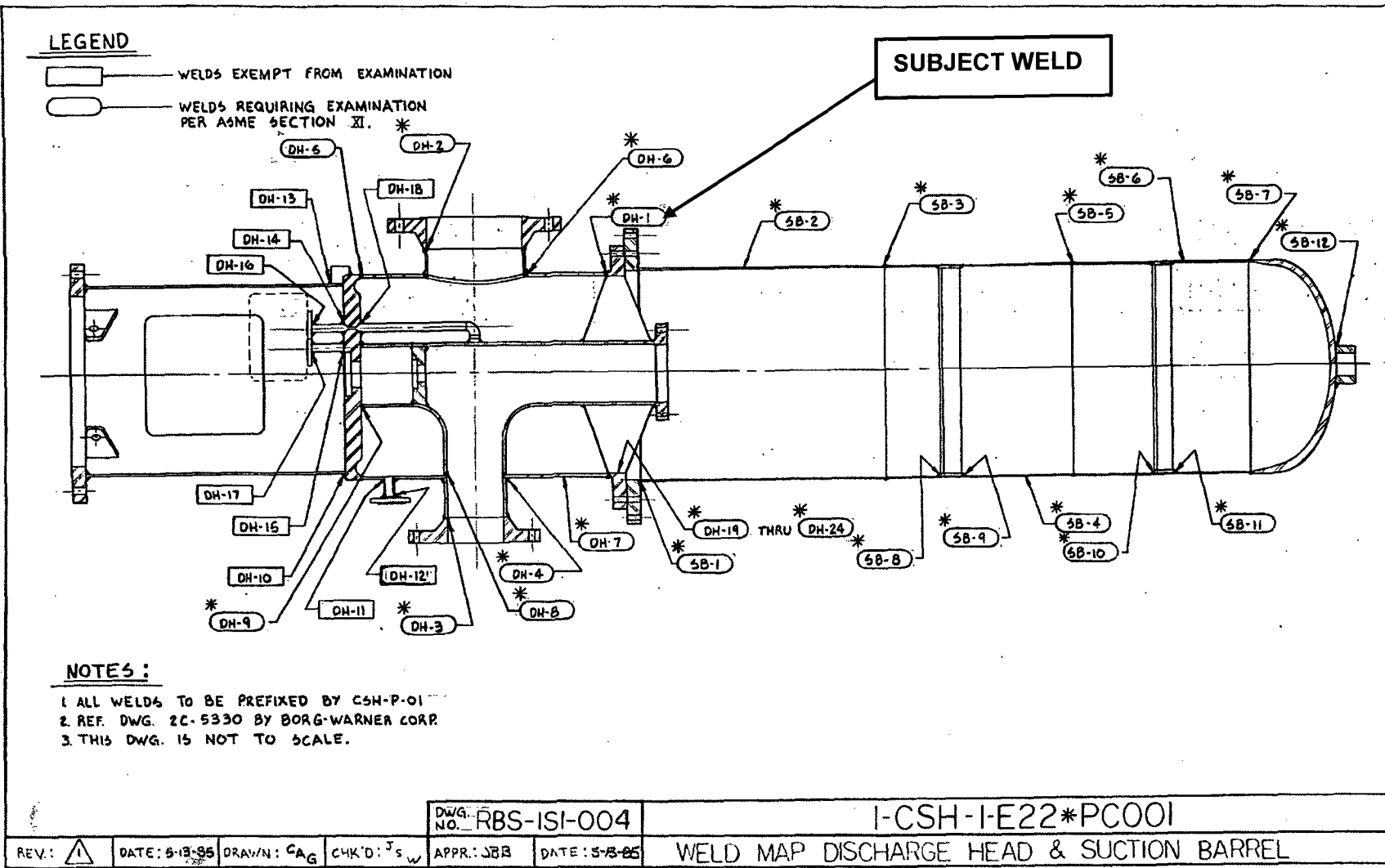
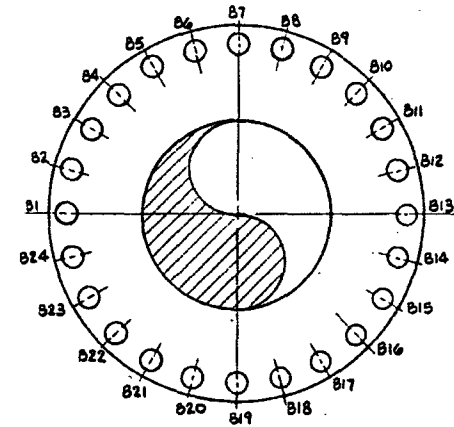
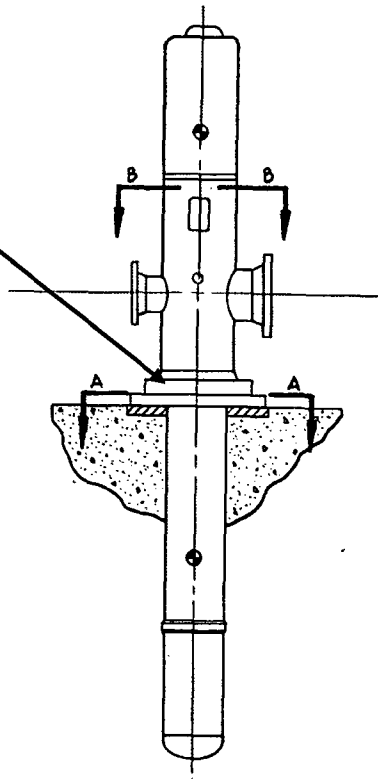
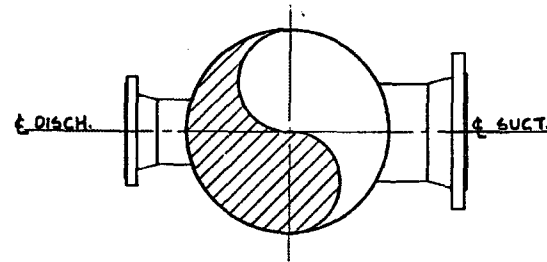

DIAGRAM 4 Pump Bolting Configuration (Typical)

WELD DH-1



SECTION "A-A"



SECTION "B-B"

- NOTES:**
1. THE BOLTING SEQUENCE BEGINS WITH THE BOLT PARALLEL TO THE DISCH. NOZZLE.
 2. REF. DWG. NO. 2C-9308 BY G.E.
 3. THIS DWG. IS NOT TO SCALE.

REV.:	DATE: 5-24-85	DRAWN: SA G	CHK'D: HAZ	APPR: M.W.A	DATE: 5-24-85	1-RHS-1-E12*PC002-A BOLTING ARRANGEMENT
DWG. NO. RBS-ISI-008						

DIAGRAM 5 Pump Bolting Configuration (Typical)

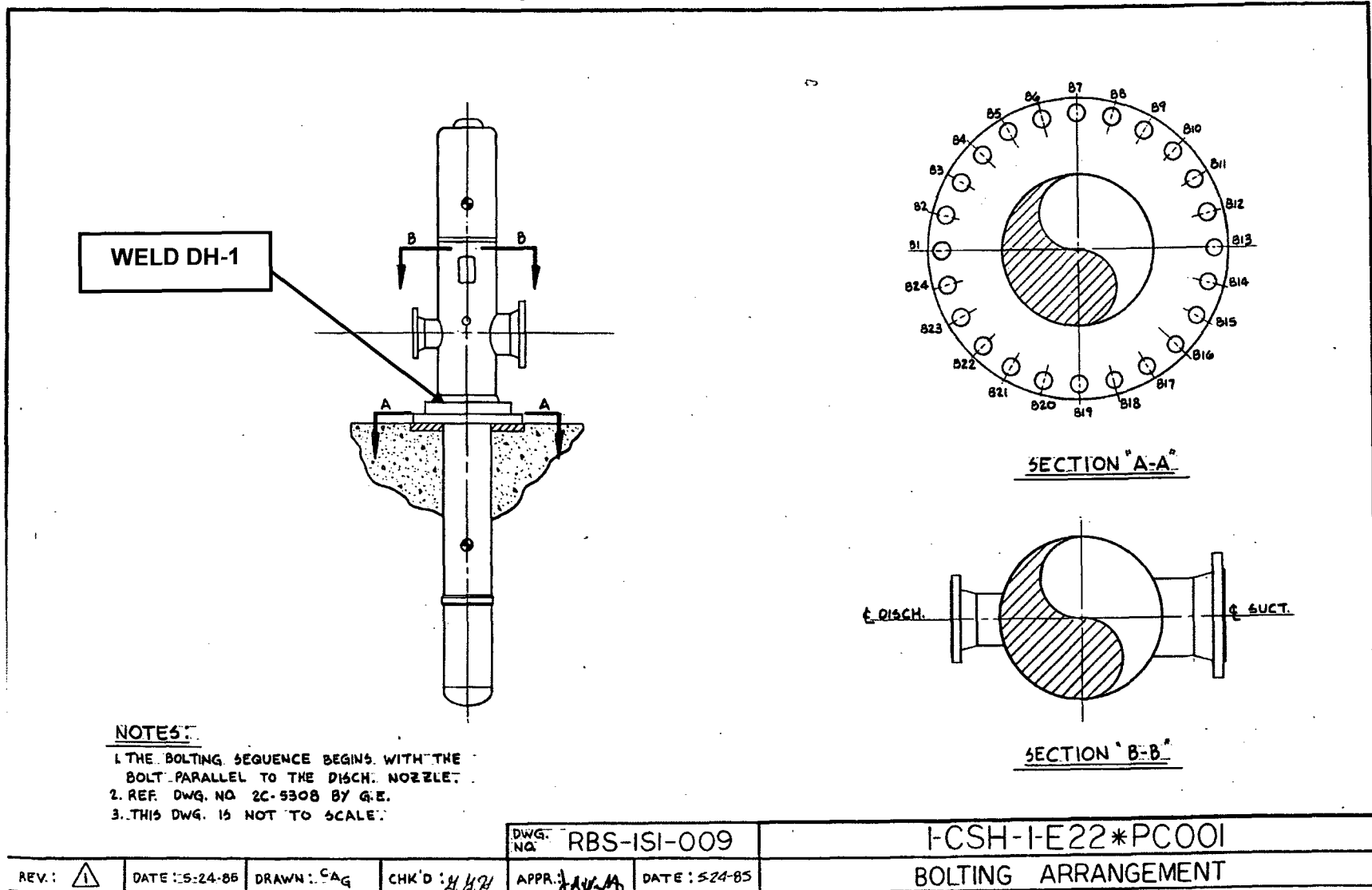
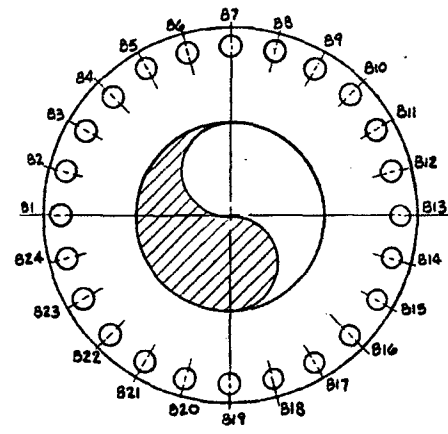
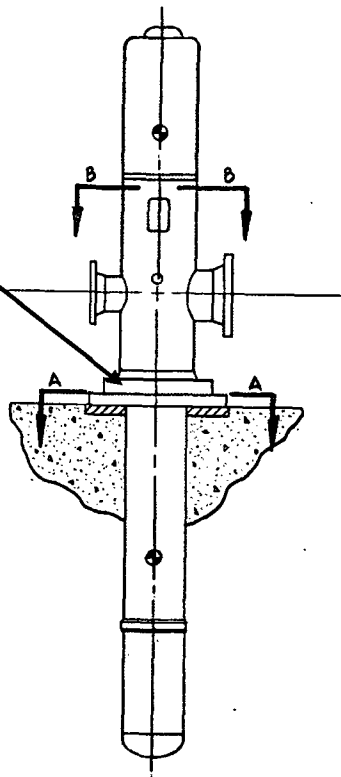
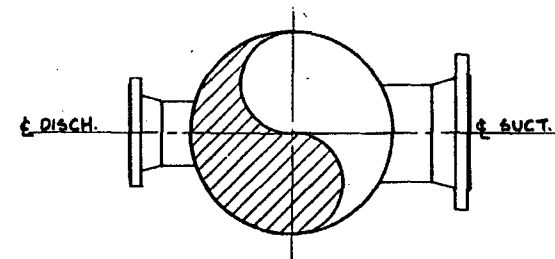

DIAGRAM 6 Pump Bolting Configuration (Typical)

WELD DH-1



SECTION "A-A"



SECTION "B-B"

- NOTES:**
1. THE BOLTING SEQUENCE BEGINS WITH THE BOLT PARALLEL TO THE DISCH. NOZZLE.
 2. REF. DWG. NO. 2C-9308 BY G.E.
 3. THIS DWG. IS NOT TO SCALE.

REV.:	1	DATE: 5-24-85	DRAWN: C.A.G.	CHK'D: <i>[Signature]</i>	APPR.: <i>[Signature]</i>	DATE: 5-24-85	RBS-ISI-010 I-C SL-I-E21*PC001 BOLTING ARRANGEMENT
-------	---	---------------	---------------	---------------------------	---------------------------	---------------	--