



Chemical & Volume Control System

AP1000 Technology Section 6.3

Learning Objectives:

1. State the purposes of the Chemical and Volume Control System (CVCS).
2. Describe the major differences between the AP1000 and current operating Westinghouse plants Chemical and Volume Control Systems.

Purposes

Chemical – Maintains RCS Chemistry

Volume – Maintains coolant inventory in RCS

Control – Controls RCS inventory & chemistry

System – The components required to perform these activities.

CVCS maintains RCS Chemistry within limits and maintains water inventory in the RCS with the assistance of the Pressurizer Level Control System.

Purposes

- **Purification** - Maintains RCS fluid purity and activity levels.
- **RCS inventory control and makeup** - Maintains the required coolant inventory in the RCS; maintains the programmed pressurizer water level during normal plant operations.
- **Chemical shim and chemical control** – Maintains RCS chemistry conditions by controlling the concentration of boron in the coolant and provide the means for controlling the RCS pH and dissolved oxygen levels.
- **Filling and pressure testing the RCS** - Provides the means for filling and pressure testing the RCS. Provides connections for a temporary hydrostatic test pump.
- **Borated makeup to auxiliary equipment** - Provides makeup to the primary side systems that require borated reactor grade water.
- **Pressurizer Auxiliary Spray** - Provides auxiliary spray water for depressurization.

Purification

- No charging pumps!!
 - motive force for the purification loop is the reactor coolant pump head
- The purification loop is located inside containment and operates at RCS pressure
- When the RCPs are stopped during shutdown, the RNS provides the motive force for CVCS purification

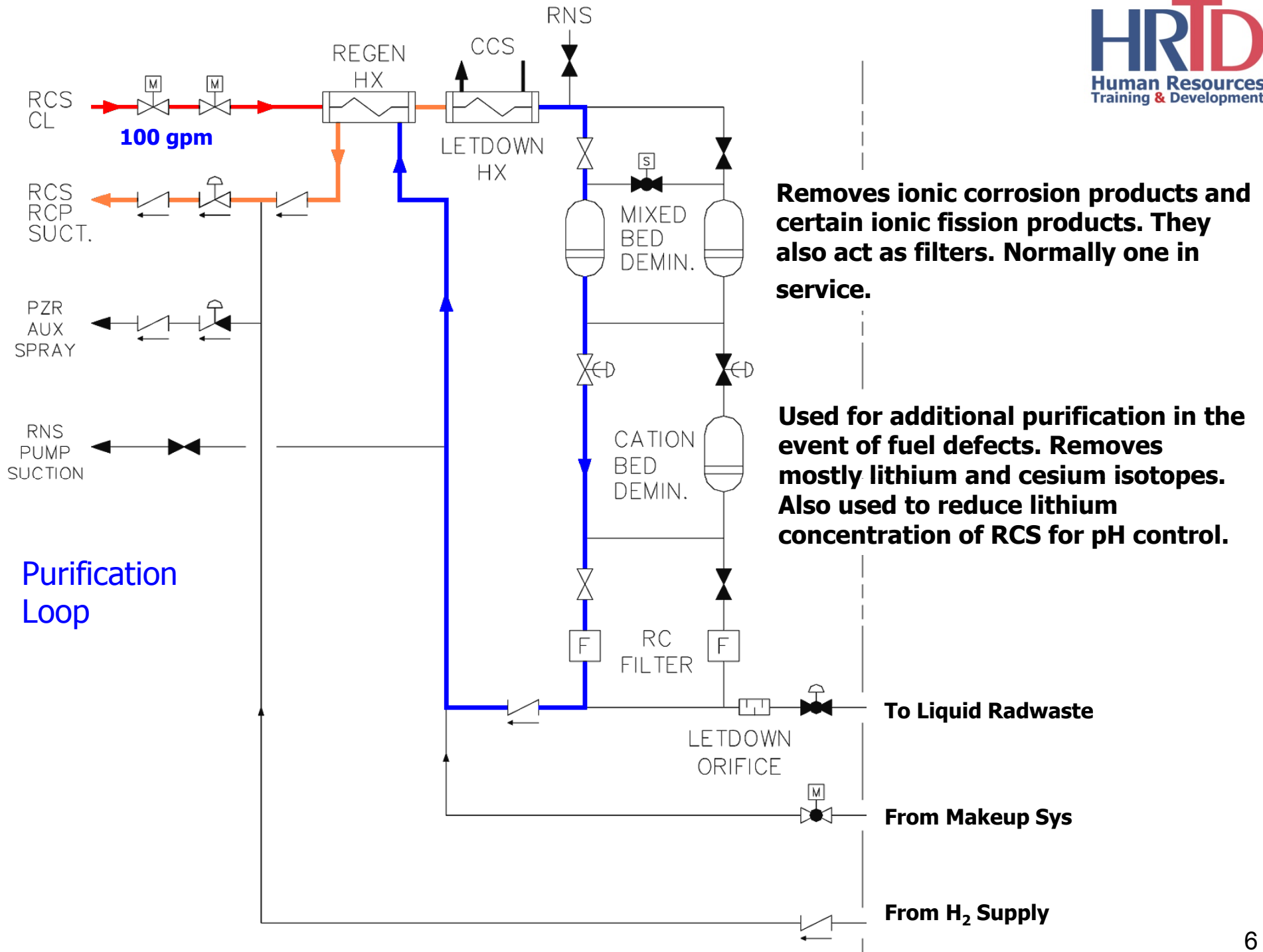

Gaseous Purification

- If radiogas removal is required the CVCS can be operated by routing flow to the liquid radwaste system degassifier via the letdown line.
- In current Westinghouse designs the VCT is utilized for gas removal.

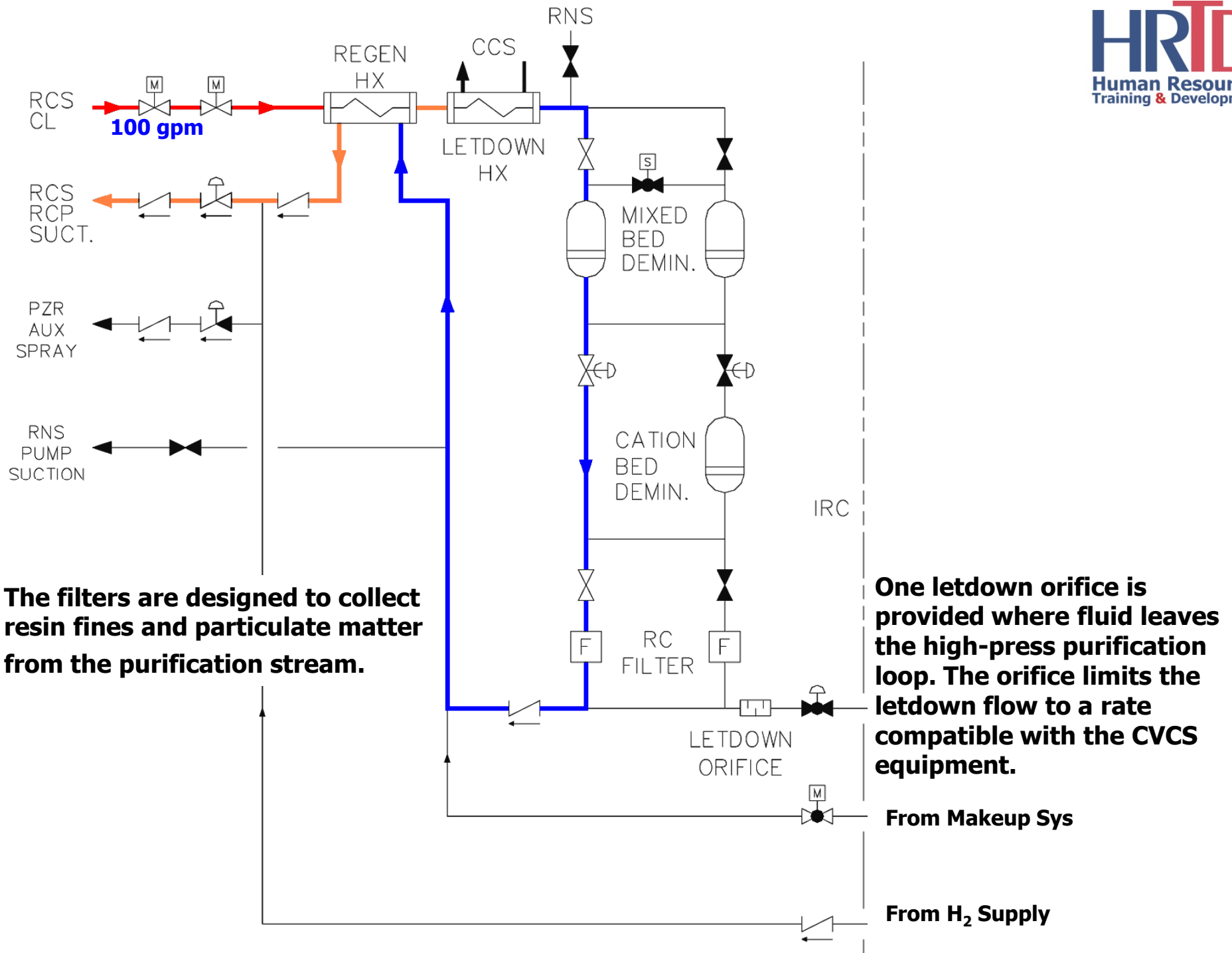

The filters are designed to collect resin fines and particulate matter from the purification stream.

One letdown orifice is provided where fluid leaves the high-press purification loop. The orifice limits the letdown flow to a rate compatible with the CVCS equipment.

Auto close on low pressurizer level. The valves fail "as is" on loss of power. Manual control is provided in the main control room and at the remote shutdown workstation.

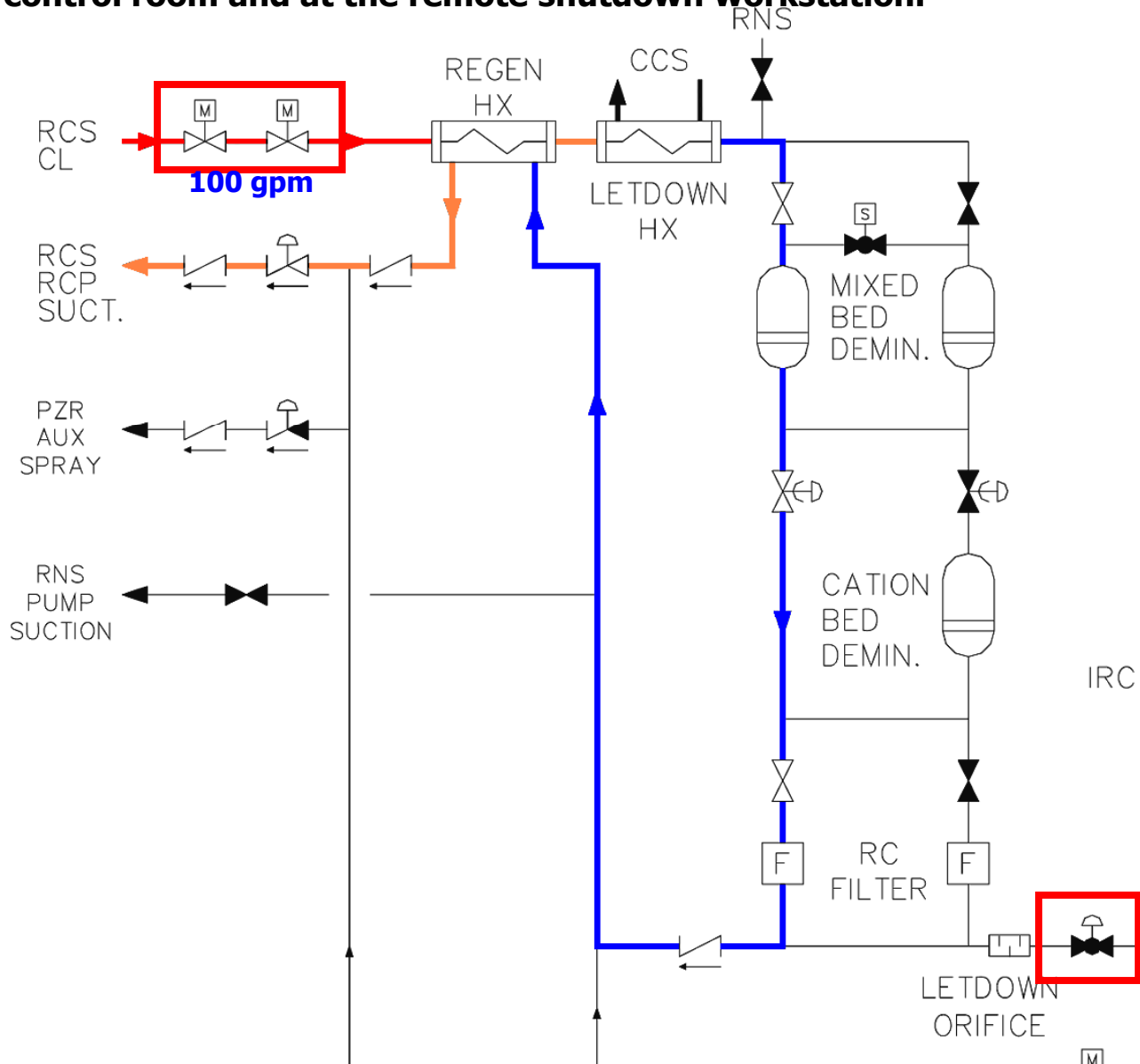

Auto opens and closes on a signal from pressurizer level control. Closes on a containment isolation signal.

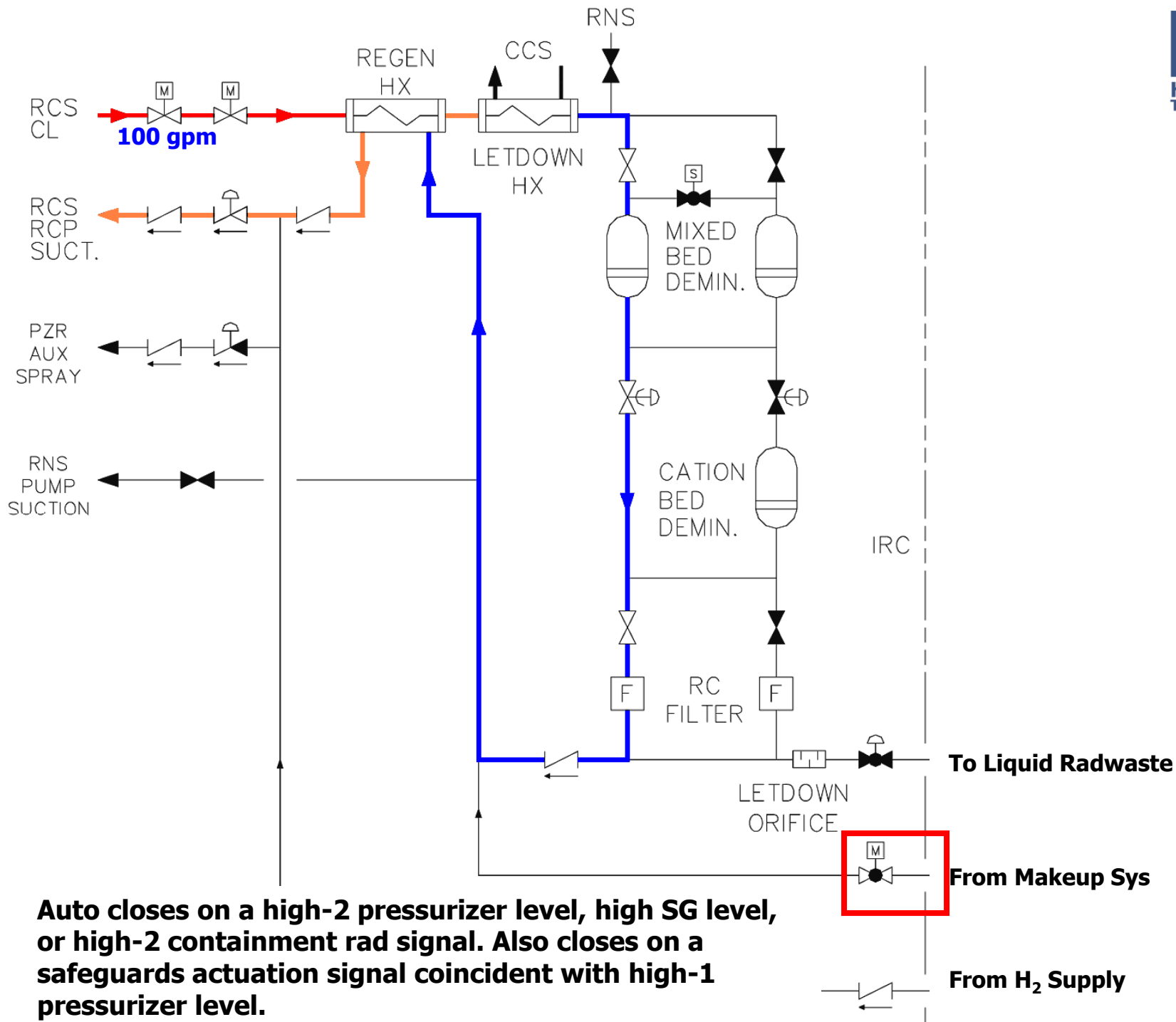

INVENTORY CONTROL

- Acceptable operating band for PZR level is programmed with T_{avg} . No control action if level is within band.
- If PZR level exceeds high end of band, letdown initiates: letdown containment isolation valves open.
- At low end of band, makeup initiates: makeup pumps start.

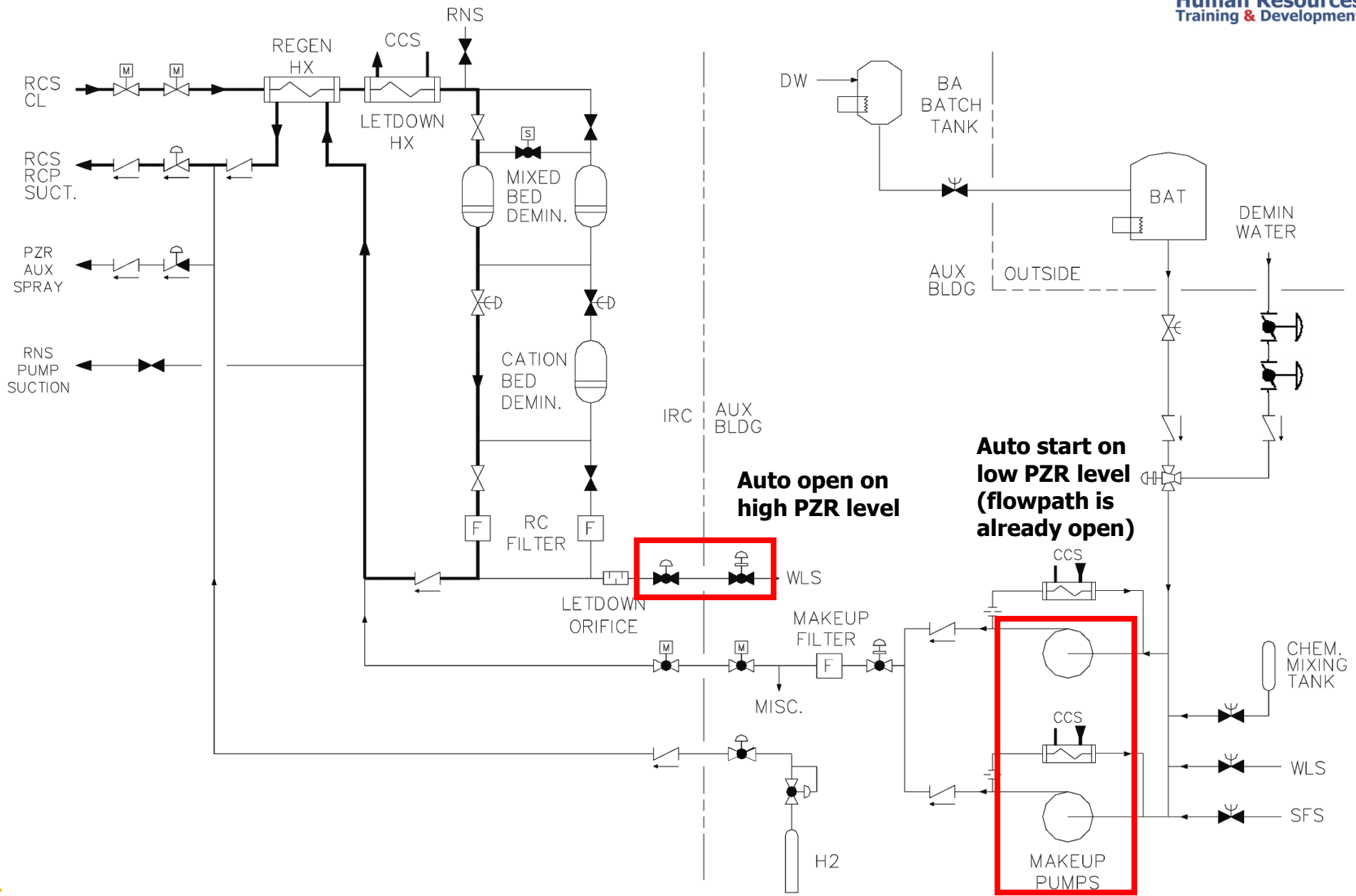

Auto start on low PZR level (flowpath is already open)

Auto open on high PZR level

PRESSURIZER LEVEL CONTROL PROGRAM

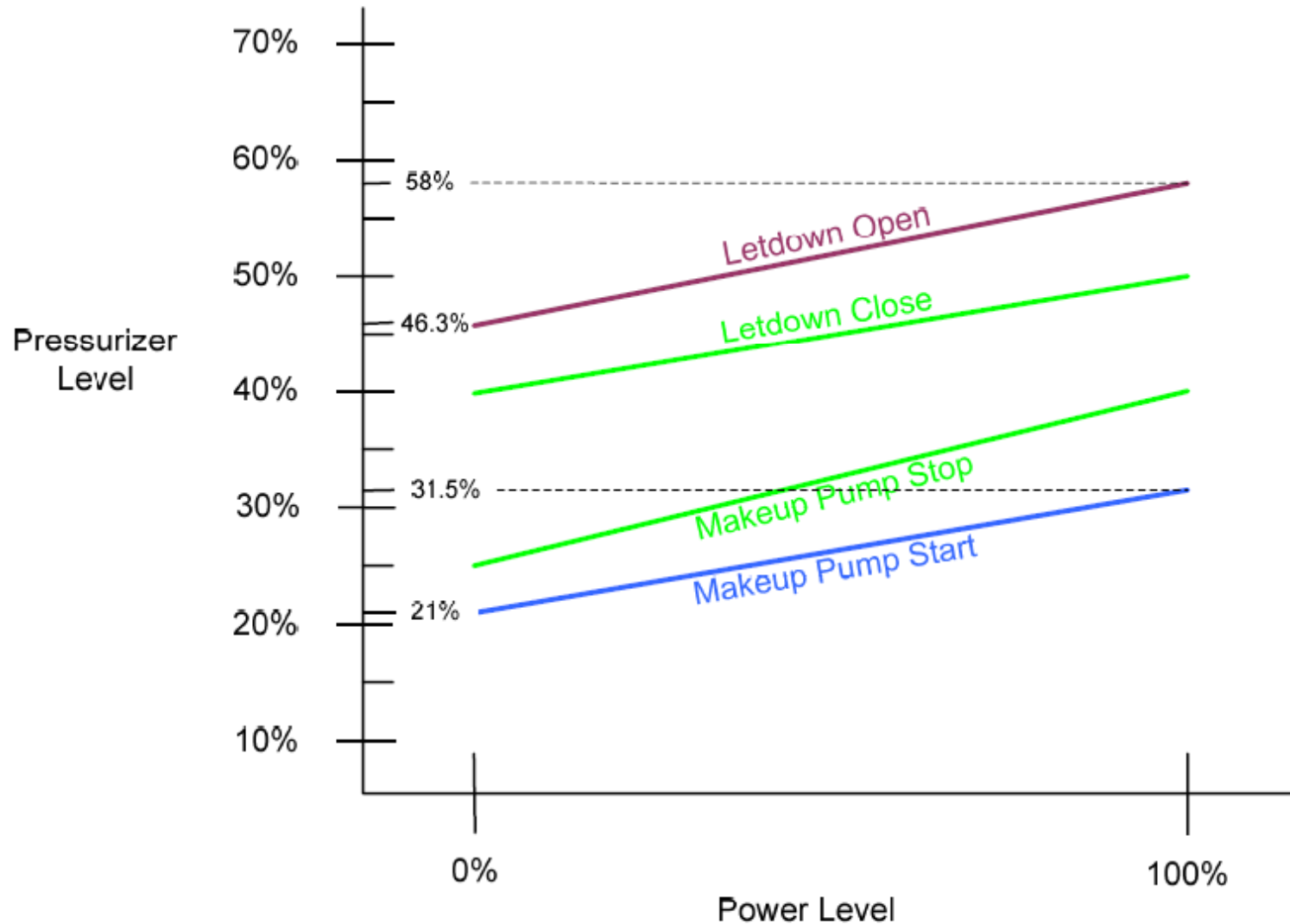

REACTOR MAKEUP SYSTEM

- Provides a method of supplying concentrated boric acid, demineralized water, or a mixture of both to the RCS.
- In combination with letdown is used to maintain pressurizer level at program.
- Consists of storage tanks, transfer pumps, and associated pipes and valves.

Boron Dilution Block Signals:

- 1. Source range flux doubling signal**
- 2. Loss of AC power sources**
- 3. Reactor trip**

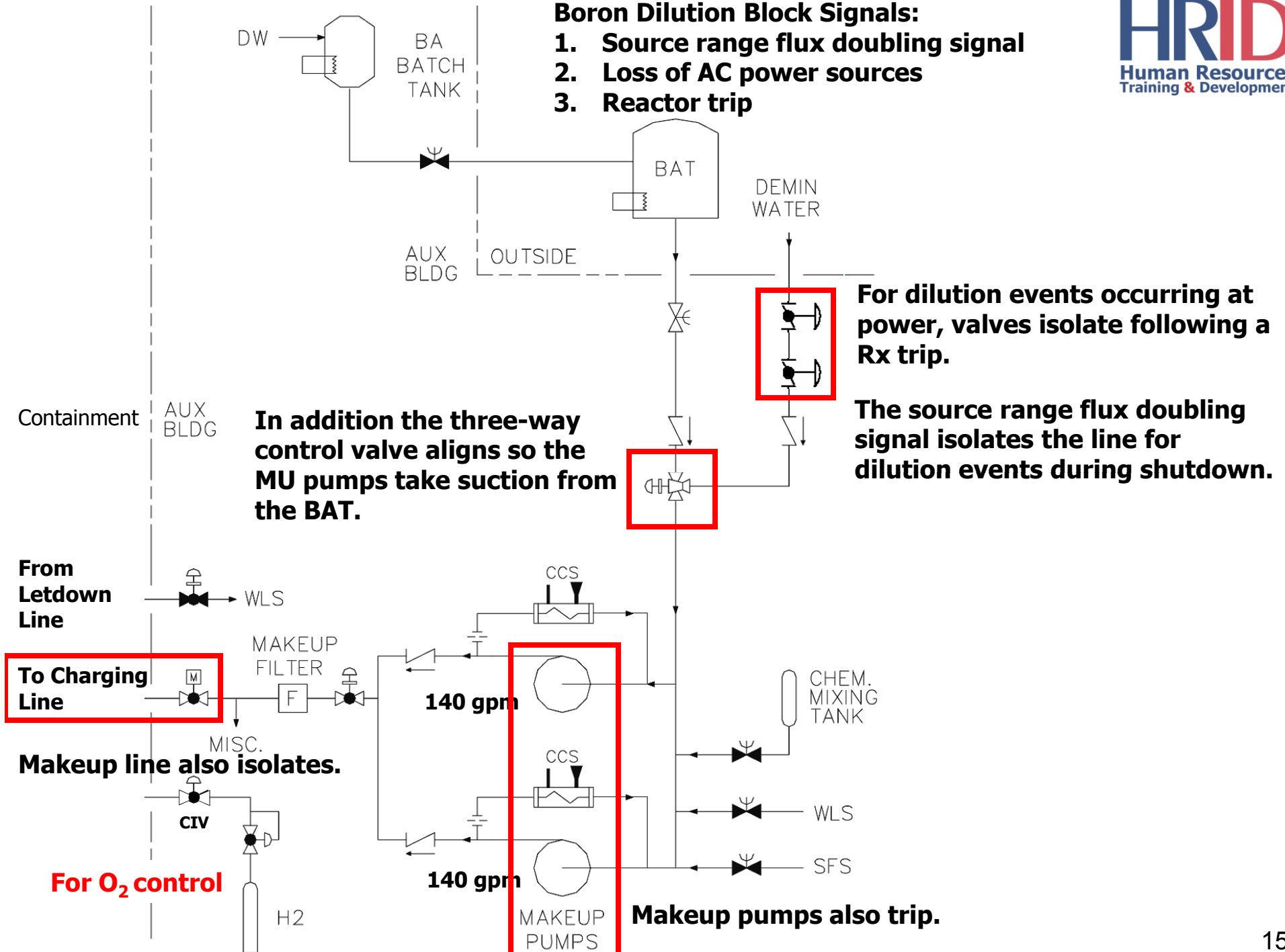

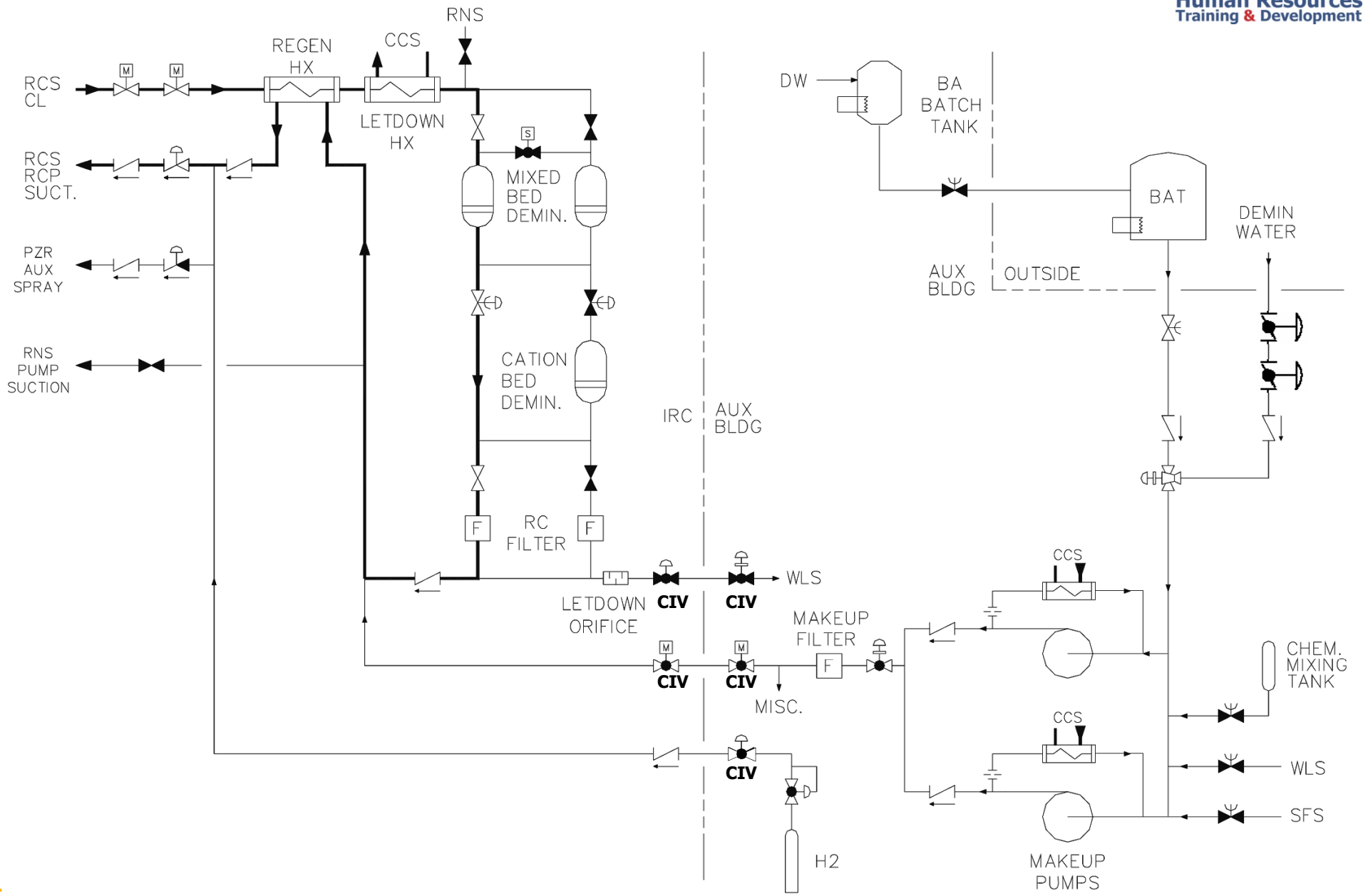

Questions?



Review Question # 1

- One purpose of the CVCS is:
 - a. To maintain proper water inventory in the feedwater system.
 - b. To adjust the boron concentration of the RCS when required.
 - c. To provide cooling water to the letdown heat exchangers.
 - d. To provide pump seal cooling for RNS pumps.

Review Question # 2

- The plant is operating at 50% power & Chemistry reports that the RCS O_2 concentration is high. Which action would the operators take?
 - a. Have Chemistry add hydrogen peroxide to the RCS using the chemical mixing tank.
 - b. Increase the H_2 concentration in the RCS.
 - c. Have Chemistry add lithium hydroxide to the RCS using the chemical mixing tank.
 - d. Increase the hydrogen pressure in the volume control tank.

Review Question # 3

- One big difference between current operating plants and the AP1000 is that the CVCS purification loop is located entirely in:
 - a. The Auxiliary Building
 - b. The Containment
 - c. The Turbine Building
 - d. The Nuclear Annex Building