

**PRIORITY 1**  
ACCELERATED RIDS PROCESSING

REGULATORY INFORMATION DISTRIBUTION SYSTEM (RIDS)

ACCESSION NBR: 9505050077      DOC. DATE: 94/12/31      NOTARIZED: NO      DOCKET #  
 FACIL: 50-305 Kewaunee Nuclear Power Plant, Wisconsin Public Service      05000305  
 AUTH. NAME      AUTHOR AFFILIATION  
 MARCHI, M.L.      Wisconsin Public Service Corp.  
 RECIP. NAME      RECIPIENT AFFILIATION

*See Rpts*

SUBJECT: "Kewaunee Nuclear Power Plant Radioactive Effluent Release Rept Jan-Dec 1994."

DISTRIBUTION CODE: IE48D      COPIES RECEIVED: LTR 1 ENCL 1      SIZE: 300  
 TITLE: 50.36a(a)(2) Semiannual Effluent Release Reports

NOTES:

	RECIPIENT ID CODE/NAME	COPIES LTTR ENCL	RECIPIENT ID CODE/NAME	COPIES LTTR ENCL
	PD3-3 LA LAUFER, R	2 2 1 1	PD3-3 PD	1 1
INTERNAL:	ACRS	1 1	<u>FILE CENTER 01</u>	1 1
	NRR/DOTS/TERB/B	1 1	RGN3 DRSS/RPB	2 2
	RGN3 FILE	1 1		
EXTERNAL:	BNL TICHLER, J	1 1	LITCO AKERS, D	1 1
	NRC PDR	1 1		

NOTE TO ALL "RIDS" RECIPIENTS:  
 PLEASE HELP US TO REDUCE WASTE! CONTACT THE DOCUMENT CONTROL  
 DESK, ROOM P1-37 (EXT. 504-2083) TO ELIMINATE YOUR NAME FROM  
 DISTRIBUTION LISTS FOR DOCUMENTS YOU DON'T NEED!

TOTAL NUMBER OF COPIES REQUIRED: LTTR 13 ENCL 13

P  
R  
I  
O  
R  
I  
T  
Y  
  
1  
  
D  
O  
C  
U  
M  
E  
N  
T

WPSC (414) 433-1598  
TELECOPIER (414) 433-5544



**WISCONSIN PUBLIC SERVICE CORPORATION**

600 North Adams • P.O. Box 19002 • Green Bay, WI 54307-9002

May 1, 1995

10 CFR 50.36a(a)(2)

U. S. Nuclear Regulatory Commission  
ATTN: Document Control Desk  
Washington, D.C. 20555

Ladies/Gentlemen:

Docket 50-305  
Operating License DPR-43  
Kewaunee Nuclear Power Plant  
Radioactive Effluent Release Report January - December, 1994

Enclosed please find a copy of the Kewaunee Nuclear Power Plant Radioactive Effluent Release Report for January through December, 1994. This report is submitted to meet the requirements of Technical Specification 6.9.b.2.

Sincerely,

M. L. Marchi  
Manager - Nuclear Business Group

BJD/jmf

Enc.

cc - US NRC Senior Resident Inspector  
US NRC Region III

LIC\NRC\EFFLUENT.WP

040021

9505050077 941231  
PDR ADOCK 05000305  
R PDR

*JE48*

50-305

WPSC

KEWAUNEE

RADIOACTIVE EFFLUENT RELEASE REPORT 1994

REC'D W/LTR DTD 05/01/95....9505050077

**- NOTICE -**

THE ATTACHED FILES ARE OFFICIAL RECORDS OF THE INFORMATION & RECORDS MANAGEMENT BRANCH. THEY HAVE BEEN CHARGED TO YOU FOR A LIMITED TIME PERIOD AND MUST BE RETURNED TO THE RECORDS & ARCHIVES SERVICES SECTION, T5 C3. PLEASE DO NOT SEND DOCUMENTS CHARGED OUT THROUGH THE MAIL. REMOVAL OF ANY PAGE(S) FROM DOCUMENT FOR REPRODUCTION MUST BE REFERRED TO FILE PERSONNEL.

**- NOTICE -**

**KEWAUNEE NUCLEAR POWER PLANT**

**RADIOACTIVE  
EFFLUENT RELEASE REPORT  
JANUARY - DECEMBER 1994**

---

**WISCONSIN PUBLIC SERVICE CORPORATION  
WISCONSIN POWER & LIGHT COMPANY  
MADISON GAS & ELECTRIC COMPANY**

---

DOCKET 50-305

**KEWAUNEE NUCLEAR POWER PLANT**

**ANNUAL RADIOACTIVE  
EFFLUENT RELEASE REPORT**

January 1 - December 31, 1994

Wisconsin Public Service Corporation  
Green Bay, Wisconsin  
April 12, 1995

## Table of Contents

Section	Description	
0.0	Summary.....	3
1.0	Introduction.....	3
1.1	Effluent Dose.....	3
2.0	Gaseous Effluents.....	4
2.1	Lower Limits of Detection (LLD) for Gaseous Effluents.....	4
2.2	Gaseous Batch Release Statistics.....	6
2.3	Gaseous Effluent Data.....	6
	Table 2.1 Gaseous Effluents - Summation of all Releases.....	7
	Table 2.2 Gaseous Effluents - Elevated Releases.....	8
	Table 2.3 Gaseous Release Total.....	9
	Table 2.4 Dose From Gaseous Effluents.....	17
3.0	Liquid Effluents.....	19
3.1	Lower Limits of Detection (LLD) for Liquid Effluents.....	19
3.2	Liquid Batch Release Statistics.....	21
3.3	Liquid Effluent Data.....	21
	Table 3.1 Liquid Effluents - Summation of all Releases.....	22
	Table 3.2A Liquid Effluents - Batch Releases 1st Quarter.....	23
	Table 3.2B Liquid Effluents - Batch Releases 2nd Quarter.....	25
	Table 3.2C Liquid Effluents - Batch Releases 3rd Quarter.....	27
	Table 3.2D Liquid Effluents - Batch Releases 4th Quarter.....	29
	Table 3.3A Liquid Effluents - Continuous Releases 1st Quarter.....	31
	Table 3.3B Liquid Effluents - Continuous Releases 2nd Quarter.....	33
	Table 3.3C Liquid Effluents - Continuous Releases 3rd Quarter.....	35
	Table 3.3D Liquid Effluents - Continuous Releases 4th Quarter.....	37
	Table 3.4 Dose From Liquid Effluents.....	39
4.0	Unplanned Releases.....	41
5.0	Meteorological Data.....	41
6.0	Solid Waste Disposal.....	42
	Table 6.1 Solid Waste and Irradiated Fuel Shipments.....	43
7.0	Program Revisions.....	45
7.1	Offsite Dose Calculation Manual.....	45
7.2	Major Changes to the Radioactive Waste Treatment Systems.....	45
8.0	Reportable Occurrences.....	45
Appendix A	Meteorological Data	
Appendix B	Offsite Dose Calculation Manual	

## 0 SUMMARY

During 1994 all solid, liquid, and gaseous radioactive effluents from the Kewaunee Nuclear Plant were well below regulatory limits. For individual effluent streams, the limit most closely approached was:

<u>GASEOUS:</u>	Ingestion Pathway-Organ-Liver	
	Specification (mRems)	15
	Actual Dose (mRems)	0.0001444
	% of Specification	0.0009626
<u>LIQUID:</u>	Organ-GI-LLI	
	Quarterly Limit (mRems)	10
	Actual Dose (mRems)	0.02926
	% of Limit	0.29
<u>SOLID:</u>	No upper limit for solid radioactive waste applies.	
	Cubic Meters Shipped	50.6

## 1.0 INTRODUCTION

This report is being submitted in accordance with the requirements of Kewaunee Technical Specifications, Section 6.9.b.2 and the Offsite Dose Calculation Manual, Section 3/4.7. It includes data from all effluent releases made from January 1 - December 31, 1994. The report contains summaries of the gaseous and liquid releases made to the environment including the quantity, characterization, time duration and calculated radiation dose at the site boundary resulting from these releases. The report also includes a summation of solid waste disposal, revisions to the Process Control Program and the Offsite Dose Calculation Manual, and addresses the cumulative meteorological data.

### 1.1 Effluent Dose Limits

Specifications are set to insure that offsite doses are maintained as low as reasonably achievable while still allowing for practical and dependable operation of the Kewaunee Plant.

The Kewaunee Offsite Dose Calculation Manual (ODCM) describes the methodology and parameters used in:

1. The calculation of radioactive liquid and gaseous effluent monitoring instrumentation alarm/trip setpoints.
2. The calculation of radioactive liquid and gaseous concentrations, dose rates and cumulative quarterly and annual doses. The ODCM methodology is acceptable for use in demonstrating compliance with 10 CFR 20.106; 10 CFR 50, Appendix I, and 40 CFR 190.

## 2.0 GASEOUS EFFLUENTS

### 2.1 Lower Limits of Detection (LLD) for Gaseous Effluents

Gaseous radioactive effluents are released in both the continuous mode and the batch mode. The auxiliary building stack is sampled continuously for particulates, halogens and Strontium by redundant "off-line" sample trains. This stack is also grab-sampled daily for gaseous gamma emitters. Batch releases are sampled prior to release for principal gaseous and particulate gamma emitters, halogens and tritium.

The LLD's for gaseous radioanalyses, as listed in Table 4.4 of the Kewaunee ODCM are:

Analysis	LLD ( $\mu\text{Ci/ml}$ )
Gaseous Gamma Emitters	1.00 E-04
Iodine 131	3.00 E-12
Particulate Gamma Emitters	1.00 E-11
Particulate Gross Alpha	1.00 E-11
Strontium 89, 90	1.00 E-11
Noble Gases, Gross Beta or Gamma	1.00 E-06

The nominal "a priori" LLD values are shown below.

Isotope	a priori LLD ( $\mu\text{Ci/ml}$ )
---------	------------------------------------

a. Gaseous emissions:

Kr-87	5.84 E-8
Kr-88	8.27 E-8
Xe-133	6.01 E-8
Xe-133m	2.28 E-7
Xe-135	2.39 E-8
Xe-138	1.03 E-7

b. Particulate emissions:

Mn-54	5.34 E-14
Fe-59	1.33 E-13
Co-58	1.04 E-13
Co-60	1.87 E-13
Zn-65	2.98 E-13
Mo-99	5.01 E-14
Cs-134	1.02 E-13
Cs-137	6.70 E-14
Ce-141	6.15 E-14
Ce-144	3.50 E-13



c. Other identifiable gamma emitters:

Ar-41	4.96 E-8
Kr-85	6.37 E-6
Kr-85m	2.59 E-8
Kr-89	1.21 E-6
Xe-127	2.92 E-8
Xe-131m	9.24 E-7
Xe-135m	3.48 E-8
Xe-137	3.82 E-7
I-131	1.09 E-13

d. Composite particulate samples:

Sr-89	1 E-14
Sr-90	1 E-14
Gross Alpha	1.00 E-14

These "a priori" LLDs represent the capabilities of the counting systems in use, not an after the fact "a posteriori" limit for a particular measurement.

## 2.2 Gaseous Batch Release Statistics

The following is a summation of all gaseous batch releases made during 1994.

Number of batch releases.....	27
Total time for all batch releases (min).....	17800
Maximum time for a batch release (min).....	4063
Average time for a batch release (min).....	659.5
Minimum time for a batch release (min).....	11

## 2.3 Gaseous Effluent Data

The following table 2.1 presents a quarterly summation of the total activity released and average release rates of four categories of gaseous effluents. Table 2.2 lists the quarterly sums of individual gaseous radionuclides released by continuous and batch modes. Table 2.3 is essentially the same data, but is presented as monthly summations. Table 2.4 presents the dose limits for gaseous effluents, and the calculated doses for the year due to gaseous effluents.

**Table 2.1**  
**Annual Radioactive Effluent Release Report 1994**  
**Gaseous Effluents - Summation of all Releases**

Fission and Activation Gases	1st Quarter	2nd Quarter	3rd Quarter	4th Quarter
Total Activity Released (Ci)	3.419E-001	9.618E-002	1.139E-003	0.000E+000
Average Release Rate ( $\mu$ Ci/sec)	4.349E-002	1.223E-002	1.448E-004	0.000E+000
<b>Iodines</b>				
Total Activity Released (Ci)	0.000E+000	0.000E+000	0.000E+000	0.000E+000
Average Release Rate ( $\mu$ Ci/sec)	0.000E+000	0.000E+000	0.000E+000	0.000E+000
<b>Particulates</b>				
Total Activity Released (Ci)	2.885E-009	4.597E-005	4.302E-007	0.000E+000
Average Release Rate ( $\mu$ Ci/sec)	3.670E-010	5.847E-006	5.472E-008	0.000E+000
Gross Alpha Released (Ci)	1.155E-003	8.259E-004	3.528E-004	1.189E-007
<b>Tritium</b>				
Total Activity Released (Ci)	2.019E-001	6.135E-001	1.345E+000	2.181E+000
Average Release Rate ( $\mu$ Ci/sec)	2.569E-002	7.803E-002	1.711E-001	2.775E-001

**Table 2.2**  
**Annual Radioactive Effluent Release Report 1994**  
**Gaseous Effluents**

	Nuclides Released (Ci)			
	Continuous Mode			
	1st Quarter	2nd Quarter	3rd Quarter	4th Quarter
<b>Fission Gases</b>				
Total	0.000E+000	0.000E+000	0.000E+000	0.000E+000
<b>Iodines</b>				
Total	0.000E+000	0.000E+000	0.000E+000	0.000E+000
<b>Particulates</b>				
Co-58	0.000E+000	3.110E-005	0.000E+000	0.000E+000
Co-60	0.000E+000	1.042E-005	0.000E+000	0.000E+000
Sr-89	2.885E-009	4.861E-007	4.302E-007	0.000E+000
Nb-95	0.000E+000	2.527E-006	0.000E+000	0.000E+000
Cs-137	0.000E+000	1.440E-006	0.000E+000	0.000E+000
Total	2.885E-009	4.597E-005	4.302E-007	0.000E+000

	Nuclides Released (Ci)			
	Batch Mode			
<b>Fission Gases</b>				
Ar-41	3.661E-002	1.993E-002	0.000E+000	0.000E+000
Xe-131m	6.327E-005	1.682E-004	0.000E+000	0.000E+000
Xe-133m	1.064E-004	2.043E-004	0.000E+000	0.000E+000
Xe-133	2.300E-001	7.293E-002	1.139E-003	0.000E+000
Xe-135	7.515E-002	2.948E-003	0.000E+000	0.000E+000
Total	3.419E-001	9.618E-002	1.139E-003	0.000E+000
<b>Iodines</b>				
Total	0.000E+000	0.000E+000	0.000E+000	0.000E+000
<b>Particulates</b>				
Total	0.000E+000	0.000E+000	0.000E+000	0.000E+000

**Table 2.3**  
**Annual Radioactive Effluent Release Report 1994**  
**1st Quarter Gaseous Release**  
**Total of all Releases**

Noble Gases (Curies)

Isotope	January	February	March	Total
Ar-41	3.661E-002	0.000E+000	0.000E+000	3.661E-002
Xe-131m	6.327E-005	0.000E+000	0.000E+000	6.327E-005
Xe-133m	1.064E-004	0.000E+000	0.000E+000	1.064E-004
Xe-133	2.300E-001	0.000E+000	0.000E+000	2.300E-001
Xe-135	7.515E-002	0.000E+000	0.000E+000	7.515E-002
Total	3.419E-001	0.000E+000	0.000E+000	3.419E-001

Particulates (Curies)

Isotope	January	February	March	Total
Sr-89	0.000E+000	0.000E+000	2.885E-009	2.885E-009
Total	0.000E+000	0.000E+000	2.885E-009	2.885E-009

Halogens (Curies)

Isotope	January	February	March	Total
Total	0.000E+000	0.000E+000	0.000E+000	0.000E+000

**Table 2.3(con't)**  
**Annual Radioactive Effluent Release Report 1994**  
**1st Quarter Gaseous Release**  
**Total of all Releases**

Summary	January	February	March	<u>Total</u>
Total Noble Gases (Ci)	3.419E-001	0.000E+000	0.000E+000	3.419E-001
Total Halogens (Ci)	0.000E+000	0.000E+000	0.000E+000	0.000E+000
Total Particulate Gross Beta-Gamma Half-Lives>8 Days (Ci)	0.000E+000	0.000E+000	2.885E-009	2.885E-009
Total Tritium (Ci)	4.566E-002	0.000E+000	1.563E-001	2.019E-001
Total Particulate Gross Alpha (Ci)	8.673E-004	1.858E-004	1.016E-004	1.155E-003

**Table 2.3(con't)**  
**Annual Radioactive Effluent Release Report 1994**  
**2nd Quarter Gaseous Release**  
**Total of all Releases**

**Noble Gases (Curies)**

Isotope	April	May	June	Total
Ar-41	1.993E-002	0.000E+000	0.000E+000	1.993E-002
Xe-131m	1.682E-004	0.000E+000	0.000E+000	1.682E-004
Xe-133m	2.043E-004	0.000E+000	0.000E+000	2.043E-004
Xe-133	7.279E-002	1.407E-004	0.000E+000	7.293E-002
Xe-135	2.948E-003	0.000E+000	0.000E+000	2.948E-003
Total	9.604E-002	1.407E-004	0.000E+000	9.618E-002

**Particulates (Curies)**

Isotope	April	May	June	Total
Co-58	3.110E-005	0.000E+000	0.000E+000	3.110E-005
Co-60	1.042E-005	0.000E+000	0.000E+000	1.042E-005
Sr-89	4.861E-007	0.000E+000	0.000E+000	4.861E-007
Nb-95	2.527E-006	0.000E+000	0.000E+000	2.527E-006
Cs-137	1.440E-006	0.000E+000	0.000E+000	1.440E-006
Total	4.597E-005	0.000E+000	0.000E+000	4.597E-005

**Halogens (Curies)**

Isotope	April	May	June	Total
Total	0.000E+000	0.000E+000	0.000E+000	0.000E+000

**Table 2.3(con't)**  
**Annual Radioactive Effluent Release Report 1994**  
**2nd Quarter Gaseous Release**  
**Total of all Releases**

Summary	April	May	June	<u>Total</u>
Total Noble Gases (Ci)	9.604E-002	1.407E-004	0.000E+000	9.618E-002
Total Halogens (Ci)	0.000E+000	0.000E+000	0.000E+000	0.000E+000
Total Particulate Gross Beta-Gamma Half-Lives>8 Days (Ci)	4.597E-005	0.000E+000	0.000E+000	4.597E-005
Total Tritium (Ci)	1.253E-001	1.034E-002	4.779E-001	6.135E-001
Total Particulate Gross Alpha (Ci)	4.432E-004	2.338E-004	1.489E-004	8.259E-004



**Table 2.3(con't)**  
**Annual Radioactive Effluent Release Report 1994**  
**3rd Quarter Gaseous Release**  
**Total of all Releases**

Noble Gases (Curies)

Isotope	July	August	September	Total
Xe-133	1.139E-003	0.000E+000	0.000E+000	1.139E-003
Total	1.139E-003	0.000E+000	0.000E+000	1.139E-003

Particulates (Curies)

Isotope	July	August	September	Total
Sr-89	0.000E+000	0.000E+000	4.302E-007	4.302E-007
Total	0.000E+000	0.000E+000	4.302E-007	4.302E-007

Halogens (Curies)

Isotope	July	August	September	Total
Total	0.000E+000	0.000E+000	0.000E+000	0.000E+000

Table 2.3(con't)  
 Annual Radioactive Effluent Release Report 1994  
 3rd Quarter Gaseous Release  
 Total of all Releases

Summary	July	August	September	<u>Total</u>
Total Noble Gases (Ci)	1.139E-003	0.000E+000	0.000E+000	1.139E-003
Total Halogens (Ci)	0.000E+000	0.000E+000	0.000E+000	0.000E+000
Total Particulate Gross Beta-Gamma Half-Lives>8 Days (Ci)	0.000E+000	0.000E+000	4.302E-007	4.302E-007
Total Tritium (Ci)	2.783E-004	9.128E-001	4.320E-001	1.345E+000
Total Particulate Gross Alpha (Ci)	1.780E-004	8.501E-005	8.979E-005	3.528E-004

**Table 2.3(con't)**  
**Annual Radioactive Effluent Release Report 1994**  
**4th Quarter Gaseous Release**  
**Total of all Releases**

**Noble Gases (Curies)**

Isotope	October	November	December	Total
Total	0.000E+000	0.000E+000	0.000E+000	0.000E+000

**Particulates (Curies)**

Isotope	October	November	December	Total
Total	0.000E+000	0.000E+000	0.000E+000	0.000E+000

**Halogens (Curies)**

Isotope	October	November	December	Total
Total	0.000E+000	0.000E+000	0.000E+000	0.000E+000

**Table 2.3(con't)**  
**Annual Radioactive Effluent Release Report 1994**  
**4th Quarter Gaseous Release**  
**Total of all Releases**

Summary	October	November	December	<u>Total</u>
Total Noble Gases (Ci)	0.000E+000	0.000E+000	0.000E+000	0.000E+000
Total Halogens (Ci)	0.000E+000	0.000E+000	0.000E+000	0.000E+000
Total Particulate Gross Beta-Gamma Half-Lives>8 Days (Ci)	0.000E+000	0.000E+000	0.000E+000	0.000E+000
Total Tritium (Ci)	6.997E-001	2.631E-001	1.219E+000	2.181E+000
Total Particulate Gross Alpha (Ci)	9.452E-008	2.440E-008	0.000E+000	1.189E-007

**Table 2.4**  
**Annual Radioactive Effluent Release Report 1994**  
**Dose From Gaseous Effluents**

The offsite dose limits from radioactive materials in gaseous effluents are specified in Section 3/4.4 of the Kewaunee ODCM and can be summarized as follows:

	Whole Body Gamma	Skin Beta	Organ
Quarterly	5.0 mRad	10.0 mRad	7.5 mRem
Annual	10.0 mRad	20.0 mRad	15.0 mRem

The total release of gaseous effluents during 1994 was within limits. The following offsite doses were calculated using equations 2.7, 2.8, and 2.11 from the Kewaunee ODCM. Calculated offsite doses versus quarterly limits are shown below:

	1st Qtr	2nd Qtr	3rd Qtr	4th Qtr
<b>1. Gamma-Whole Body</b>				
Specification (mRads)	5.000E+000	5.000E+000	5.000E+000	5.000E+000
Actual Dose (mRads)	6.459E-005	2.474E-005	4.588E-008	0.000E+000
% of Specification	1.292E-003	4.949E-004	9.175E-007	0.000E+000
<b>2. Beta-Skin</b>				
Specification (mRads)	1.000E+001	1.000E+001	1.000E+001	1.000E+001
Actual Dose (mRads)	6.239E-005	1.708E-005	1.365E-007	0.000E+000
% of Specification	6.239E-004	1.708E-004	1.365E-006	0.000E+000
<b>3. Ingestion Pathway-Organ</b>				
Specification (mRems)	7.500E+000	7.500E+000	7.500E+000	7.500E+000
Actual Dose (mRems)	4.324E-006	6.557E-005	2.843E-005	6.144E-004
% of Specification	5.765E-005	8.743E-004	3.790E-004	4.608E-005
	TBody	Liver	TBody	Liver

**Table 2.4 (con't)**  
**Annual Radioactive Effluent Release Report 1994**  
**Dose From Gaseous Effluents**

In addition, the cumulative annual offsite doses for the period January 1 - December 31, 1994 versus the ODCM annual limits were:

	Annual
1. Gamma-Whole Body	
Specification (mRads)	1.000E+001
Actual Dose (mRads)	8.938E-005
% of Specification	8.938E-004
2. Beta-Skin	
Specification (mRads)	2.000E+001
Actual Dose (mRads)	7.960E-005
% of Specification	3.980E-004
3. Ingestion Pathway-Organ	
Specification (mRems)	1.500E+001
Actual Dose (mRems)	1.444E-004
% of Specification	9.626E-004
	Liver

### 3.0 LIQUID EFFLUENTS

#### 3.1 Lower Limits of Detection (LLD) for Liquid Effluents

Liquid radioactive effluents are released as both batch releases and continuous releases. Each batch is sampled prior to release and analyzed for gamma emitters and tritium. A fraction of each sample is retained for a monthly proportional composite which is then analyzed for Gross Alpha, Strontium 89, Strontium 90 and Iron 55.

The LLD's for liquid batch release radioanalyses, as listed in Table 4.3 of the ODCM, are:

Analysis	LLD ( $\mu\text{Ci/ml}$ )
Principal Gamma Emitters	1.00 E-06
Iodine 131	1.00 E-06
Tritium	1.00 E-05
Gross Alpha	5.00 E-07
Strontium 89, 90	5.00 E-08
Iron 55	1.00 E-06

The actual obtained "a priori" LLD values for batch releases are shown below.

Isotope	1st Qtr	2nd Qtr	3rd Qtr	4th Qtr	Average a priori LLD ( $\mu\text{Ci/ml}$ )
Mn-54	8.57E-10	8.12E-10	8.12E-10	8.12E-10	8.23E-10
F-59	1.86E-09	1.77E-09	1.77E-09	1.77E-09	1.79E-09
Co-58	8.44E-08	7.99E-10	7.99E-10	7.99E-08	4.15E-08
Co-60	1.22E-09	1.05E-07	1.16E-09	1.16E-09	2.71E-08
Zn-65	2.10E-09	1.99E-09	1.99E-09	1.99E-09	2.02E-09
Mo-99	1.34E-07	5.79E-09	5.82E-07	5.79E-09	1.82E-07
Cs-134	1.35E-07	6.52E-10	2.02E-07	6.52E-10	8.46E-08
Cs-137	8.45E-08	2.20E-07	8.00E-10	8.00E-10	7.65E-08
Ce-141	1.55E-07	5.93E-08	9.29E-08	9.29E-08	1.00E-07
Ce-144	3.22E-07	3.92E-07	1.37E-06	2.45E-07	5.82E-07
I-131	5.52E-08	1.19E-07	5.26E-08	5.26E-08	6.99E-08
H-3	3.60E-06	3.45E-06	3.58E-06	3.74E-06	3.59E-06
Sr-89	8.60E-09	9.27E-09	7.97E-09	8.30E-09	8.54E-09
Sr-90	7.93E-09	7.20E-09	6.63E-09	5.83E-09	6.90E-09
Gross Alpha	8.27E-09	7.03E-09	7.83E-09	1.00E-08	8.28E-09
Fe-55	6.07E-07	7.63E-07	6.73E-07	5.60E-07	6.51E-07

Continuous liquid releases are grab sampled weekly and analyzed for principal gamma emitters. A fraction of each weekly sample is retained for a monthly proportional composite which is then analyzed for Tritium, Gross Alpha, Strontium 89, Strontium 90 and Iron 55.

The LLD's for liquid continuous release radioanalyses, as listed in Table 4.3 of the Kewaunee ODCM, are:

Analysis	LLD ( $\mu\text{Ci/ml}$ )
Principal Gamma Emitters	5.00 E-07
Iodine 131	1.00 E-06
Tritium	1.00 E-05
Gross Alpha	5.00 E-07
Strontium 89, 90	5.00 E-08
Iron 55	1.00 E-06

The actual obtained "a priori" LLD values for continuous releases are shown below.

Isotope	1st Qtr	2nd Qtr	3rd Qtr	4th Qtr	Average a priori LLD ( $\mu\text{Ci/ml}$ )
Mn-54	1.43E-08	2.05E-08	1.91E-08	1.35E-08	1.69E-08
F-59	3.11E-10	2.95E-08	2.95E-08	5.74E-08	2.92E-08
Co-58	5.20E-08	4.18E-08	1.33E-08	1.36E-08	3.02E-08
Co-60	2.61E-08	5.25E-08	3.50E-08	2.48E-08	3.46E-08
Zn-65	3.36E-08	3.75E-08	8.13E-08	5.75E-08	5.25E-08
Mo-99	5.86E-08	4.64E-07	9.75E-10	1.57E-07	1.70E-07
Cs-134	3.78E-07	2.65E-08	4.56E-08	2.17E-08	1.18E-07
Cs-137	5.72E-08	6.50E-08	6.90E-08	7.16E-08	6.57E-08
Ce-141	1.52E-07	2.36E-08	4.10E-08	3.34E-08	6.25E-08
Ce-144	2.83E-07	2.34E-07	2.28E-07	1.83E-07	2.32E-07
I-131	2.45E-08	2.82E-08	1.92E-08	3.91E-08	2.78E-08
H-3	3.60E-06	3.45E-06	3.58E-06	3.74E-06	3.59E-06
Sr-89	6.37E-09	8.03E-09	6.50E-09	8.13E-09	7.26E-09
Sr-90	6.05E-09	5.97E-09	4.37E-09	5.30E-09	5.42E-09
Gross Alpha	5.92E-09	6.13E-09	6.38E-09	8.00E-09	6.61E-09
Fe-55	5.98E-07	7.65E-07	6.63E-07	5.50E-07	6.44E-07



### 3.2 Liquid Batch Release Statistics

The following is a summation of all liquid batch releases made during 1994.

<u>Release Type</u>	<u>Number</u>	<u>Gallons Released</u>
A SGBT Monitor Tk.	7	58533.0
B SGBT Monitor Tk.	15	129360.0
A Waste Condensate	134	124925.0
B Waste Condensate	135	124050.0
A CVC Monitor	24	154045.0
B CVC Monitor	24	156300.0

Total time for all batch releases..... 29291.0 Min.

Maximum time for a batch release..... 969.0 Min.

Minimum time for a batch release..... 5.0 Min.

Average time for a batch release..... 86.4 Min.

### 3.3 Liquid Effluent Data

The following Table 3.1 presents a quarterly summation of the total activity released and average concentration for all liquid effluents. It also presents the gross alpha activity released, volume of waste released and volume of dilution water used. Tables 3.2 and 3.3 are monthly summations of the same information in Table 3.1. Table 3.2 contains the quantity of the individual isotopes released to the unrestricted area for batch releases. Table 3.3 presents a monthly summation of gross radioactivity, tritium, gross alpha and isotopic activity for the secondary blowdown and leakage releases. It also presents the monthly total volume for these releases and dilution volumes. Table 3.4 presents the doses from liquid effluents for each quarter and the calculated doses this year from liquid effluents.

**TABLE 3-1**  
**Annual Radioactive Effluent Release Report 1994**  
**Liquid Effluents - Summation of all Releases**

	1st Qtr	2nd Qtr	3rd Qtr	4th Qtr
<b>Fission and Activation Products</b>				
Total Release Excluding H <sup>3</sup> and Dissolved Gases (Ci)	4.065E-002	3.555E-002	1.057E-002	2.668E-003
Average Concentration (μCi/ml)	3.255E-010	2.558E-010	5.129E-011	2.006E-011
<b>Tritium</b>				
Total Release (Ci)	5.584E+001	2.035E+001	2.974E+001	5.808E+001
Average Concentration (μCi/ml)	4.472E-007	1.464E-007	1.443E-007	4.368E-007
% of Tech. Spec. Limit(3.0E-3 μCi/ml)	1.491E-002	4.880E-003	4.809E-003	1.456E-002
<b>Dissolved Gases</b>				
Total Release (Ci)	0.000E+000	0.000E+000	6.996E-005	2.362E-004
Average Concentration (μCi/ml)	0.000E+000	0.000E+000	3.394E-013	1.776E-012
% of Tech. Spec. Limit(2.0E-4 μCi/ml)	0.000E+000	0.000E+000	1.697E-007	8.881E-007
<b>Gross Alpha Activity</b>				
Total Release (Ci)	0.000E+000	0.000E+000	0.000E+000	0.000E+000
<b>Volume of Waste Released</b>				
Batch (liters)	1.116E+006	1.152E+006	2.966E+005	2.644E+005
Continuous (liters)	4.623E+007	2.509E+007	2.873E+007	3.556E+007
Total (liters)	4.734E+007	2.624E+007	2.903E+007	3.582E+007
<b>Volume of Dilution Water</b>				
Batch (liters)	9.947E+009	8.793E+009	5.516E+009	3.292E+009
Continuous (liters)	1.149E+011	1.302E+011	2.006E+011	1.297E+011
Total (liters)	1.249E+011	1.390E+011	2.061E+011	1.330E+011

**TABLE 3.2A**  
**Annual Radioactive Effluent Release Report 1994**  
**Liquid Effluents - Batch Releases**

	January	February	March	Total
<b>Gross Radioactivity</b>				
<b>Total Release Excluding H<sup>3</sup> and Dissolved Gases (Ci)</b>				
	1.348E-003	1.751E-003	3.952E-003	7.051E-003
<b>Avg. Conc. (μCi/ml)</b>				
	2.976E-010	1.041E-009	1.058E-009	
<b>Tritium</b>				
<b>Total Release (Ci)</b>				
	3.674E+001	6.539E+000	1.256E+001	5.584E+001
<b>Avg. Conc. (μCi/ml)</b>				
	8.111E-006	3.889E-006	3.362E-006	
<b>Dissolved Gases</b>				
<b>Total Release (Ci)</b>				
	0.000E+000	0.000E+000	0.000E+000	0.000E+000
<b>Avg. Conc. (μCi/ml)</b>				
	0.000E+000	0.000E+000	0.000E+000	
<b>Gross Alpha Activity</b>				
<b>Total Release (Ci)</b>				
	0.000E+000	0.000E+000	0.000E+000	0.000E+000
<b>Avg. Conc. (μCi/ml)</b>				
	0.000E+000	0.000E+000	0.000E+000	
<b>Volume of Waste Released</b>				
(liters)	5.488E+005	2.029E+005	3.642E+005	1.116E+006
<b>Volume of Dilution Water</b>				
(liters)	4.530E+009	1.681E+009	3.736E+009	9.947E+009

**TABLE 3.2A (con't)**  
**Annual Radioactive Effluent Release Report 1994**  
**Liquid Effluents - Batch Releases**

Isotope (Ci)	January	February	March	Total
H-3	3.674E+001	6.539E+000	1.256E+001	5.584E+001
Fe-55	9.330E-004	2.840E-004	1.784E-003	3.002E-003
Co-58	4.587E-005	9.402E-004	1.587E-003	2.573E-003
Co-60	4.145E-005	8.932E-005	5.810E-004	7.117E-004
Ag-110m	9.579E-005	5.424E-005	0.000E+000	1.500E-004
Sb-125	2.318E-004	3.833E-004	0.000E+000	6.151E-004
Total	3.674E+001	6.541E+000	1.257E+001	5.585E+001

**TABLE 3.2B**  
**Annual Radioactive Effluent Release Report 1994**  
**Liquid Effluents - Batch Releases**

	April	May	June	<u>Total</u>
<b>Gross Radioactivity</b>				
<b>Total Release Excluding H<sup>3</sup> and Dissolved Gases (Ci)</b>				
	3.137E-003	7.875E-003	2.147E-002	3.248E-002
<b>Avg. Conc. (μCi/ml)</b>				
	8.576E-010	3.163E-009	8.117E-009	
<b>Tritium</b>				
<b>Total Release (Ci)</b>				
	9.551E+000	7.995E+000	2.801E+000	2.035E+001
<b>Avg. Conc. (μCi/ml)</b>				
	2.611E-006	3.211E-006	1.059E-006	
<b>Dissolved Gases</b>				
<b>Total Release (Ci)</b>				
	0.000E+000	0.000E+000	0.000E+000	0.000E+000
<b>Avg. Conc. (μCi/ml)</b>				
	0.000E+000	0.000E+000	0.000E+000	
<b>Gross Alpha Activity</b>				
<b>Total Release (Ci)</b>				
	0.000E+000	0.000E+000	0.000E+000	0.000E+000
<b>Avg. Conc. (μCi/ml)</b>				
	0.000E+000	0.000E+000	0.000E+000	
<b>Volume of Waste Released</b>				
(liters)	6.842E+005	3.248E+005	1.426E+005	1.152E+006
<b>Volume of Dilution Water</b>				
(liters)	3.658E+009	2.490E+009	2.645E+009	8.793E+009

**TABLE 3.2B (con't)**  
**Annual Radioactive Effluent Release Report 1994**  
**Liquid Effluents - Batch Releases**

Isotope (Ci)	April	May	June	Total
H-3	9.551E+000	7.995E+000	2.801E+000	2.035E+001
Cr-51	5.308E-004	9.129E-004	3.945E-004	1.838E-003
Mn-54	0.000E+000	4.290E-005	1.058E-004	1.487E-004
Fe-55	0.000E+000	3.572E-003	1.711E-003	5.284E-003
Co-58	1.855E-003	2.149E-003	1.063E-002	1.463E-002
Fe-59	0.000E+000	7.979E-005	2.584E-004	3.382E-004
Co-60	3.923E-004	3.477E-004	3.230E-003	3.970E-003
Nb-95	5.996E-005	2.442E-004	7.035E-004	1.008E-003
Zr-95	3.884E-005	2.188E-004	4.361E-004	6.938E-004
Ag-110m	1.650E-004	2.552E-004	4.006E-003	4.427E-003
Sn-113	5.932E-005	5.156E-005	1.141E-006	1.120E-004
Sn-117m	2.612E-005	0.000E+000	0.000E+000	2.612E-005
Sb-124	9.412E-006	0.000E+000	0.000E+000	9.412E-006
Total	9.554E+000	8.003E+000	2.823E+000	2.038E+001

**TABLE 3.2C**  
**Annual Radioactive Effluent Release Report 1994**  
**Liquid Effluents - Batch Releases**

	July	August	September	Total
<b>Gross Radioactivity</b>				
<b>Total Release Excluding H<sup>3</sup> and Dissolved Gases (Ci)</b>				
	4.148E-003	3.683E-003	1.842E-003	9.672E-003
<b>Avg. Conc. (μCi/ml)</b>				
	2.704E-009	5.736E-009	5.514E-010	
<b>Tritium</b>				
<b>Total Release (Ci)</b>				
	6.802E+000	7.092E-001	2.222E+001	2.974E+001
<b>Avg. Conc. (μCi/ml)</b>				
	4.435E-006	1.105E-006	6.654E-006	
<b>Dissolved Gases</b>				
<b>Total Release (Ci)</b>				
	0.000E+000	0.000E+000	0.000E+000	0.000E+000
<b>Avg. Conc. (μCi/ml)</b>				
	0.000E+000	0.000E+000	0.000E+000	
<b>Gross Alpha Activity</b>				
<b>Total Release (Ci)</b>				
	0.000E+000	0.000E+000	0.000E+000	0.000E+000
<b>Avg. Conc. (μCi/ml)</b>				
	0.000E+000	0.000E+000	0.000E+000	
<b>Volume of Waste Released</b>				
(liters)	1.048E+005	5.637E+004	1.355E+005	2.966E+005
<b>Volume of Dilution Water</b>				
(liters)	1.534E+009	6.420E+008	3.340E+009	5.516E+009

TABLE 3.2C (con't)  
Annual Radioactive Effluent Release Report 1994  
Liquid Effluents - Batch Releases

Isotope (Ci)	July	August	September	Total
H-3	6.802E+000	7.092E-001	2.222E+001	2.974E+001
Fe-55	6.285E-004	4.510E-004	2.575E-004	1.337E-003
Co-58	1.615E-003	2.734E-003	1.264E-003	5.613E-003
Co-60	8.010E-004	2.637E-004	1.937E-004	1.258E-003
Nb-95	1.009E-004	0.000E+000	0.000E+000	1.009E-004
Ag-110m	1.002E-003	2.341E-004	1.269E-004	1.363E-003
Total	6.806E+000	7.129E-001	2.223E+001	2.975E+001



**TABLE 3.2D**  
**Annual Radioactive Effluent Release Report 1994**  
**Liquid Effluents - Batch Releases**

	October	November	December	Total
<b>Gross Radioactivity</b>				
<b>Total Release Excluding H<sup>3</sup> and Dissolved Gases (Ci)</b>				
	1.726E-006	5.216E-004	1.212E-003	1.735E-003
<b>Avg. Conc. (μCi/ml)</b>				
	1.494E-012	1.003E-009	7.497E-010	
<b>Tritium</b>				
<b>Total Release (Ci)</b>				
	2.447E+001	2.624E+000	3.099E+001	5.808E+001
<b>Avg. Conc. (μCi/ml)</b>				
	2.118E-005	5.046E-006	1.917E-005	
<b>Dissolved Gases</b>				
<b>Total Release (Ci)</b>				
	0.000E+000	0.000E+000	0.000E+000	0.000E+000
<b>Avg. Conc. (μCi/ml)</b>				
	0.000E+000	0.000E+000	0.000E+000	
<b>Gross Alpha Activity</b>				
<b>Total Release (Ci)</b>				
	0.000E+000	0.000E+000	0.000E+000	0.000E+000
<b>Avg. Conc. (μCi/ml)</b>				
	0.000E+000	0.000E+000	0.000E+000	
<b>Volume of Waste Released</b>				
(liters)	6.199E+004	5.713E+004	1.453E+005	2.644E+005
<b>Volume of Dilution Water</b>				
(liters)	1.155E+009	5.201E+008	1.616E+009	3.292E+009

**TABLE 3.2D (con't)**  
**Annual Radioactive Effluent Release Report 1994**  
**Liquid Effluents - Batch Releases**

Isotope (Ci)	October	November	December	Total
H-3	2.447E+001	2.624E+000	3.099E+001	5.808E+001
Fe-55	0.000E+000	1.828E-004	4.650E-004	6.478E-004
Co-58	1.726E-006	2.095E-004	3.925E-004	6.038E-004
Co-60	0.000E+000	6.755E-005	1.111E-004	1.786E-004
Sr-89	0.000E+000	7.426E-007	0.000E+000	7.426E-007
Ag-110m	0.000E+000	6.096E-005	5.992E-005	1.209E-004
Sb-125	0.000E+000	0.000E+000	1.832E-004	1.832E-004
Total	2.447E+001	2.625E+000	3.099E+001	5.809E+001

**TABLE 3.3A**  
**Annual Radioactive Effluent Release Report 1994**  
**Liquid Effluents - Continuous Releases**

	January	February	March	Total
<b>Gross Radioactivity</b>				
<b>Total Release Excluding H<sup>3</sup> and Dissolved Gases (Ci)</b>				
	1.809E-002	1.454E-002	9.681E-004	3.360E-002
<b>Avg. Conc. (μCi/ml)</b>				
	5.353E-010	4.762E-010	1.913E-011	
<b>Tritium</b>				
<b>Total Release (Ci)</b>				
	0.000E+000	0.000E+000	0.000E+000	0.000E+000
<b>Avg. Conc. (μCi/ml)</b>				
	0.000E+000	0.000E+000	0.000E+000	
<b>Dissolved Gases</b>				
<b>Total Release (Ci)</b>				
	0.000E+000	0.000E+000	0.000E+000	0.000E+000
<b>Avg. Conc. (μCi/ml)</b>				
	0.000E+000	0.000E+000	0.000E+000	
<b>Gross Alpha Activity</b>				
<b>Total Release (Ci)</b>				
	0.000E+000	0.000E+000	0.000E+000	0.000E+000
<b>Avg. Conc. (μCi/ml)</b>				
	0.000E+000	0.000E+000	0.000E+000	
<b>Volume of Waste Released</b>				
(liters)	1.655E+007	1.682E+007	1.285E+007	4.623E+007
<b>Volume of Dilution Water</b>				
(liters)	3.380E+010	3.053E+010	5.060E+010	1.149E+011

TABLE 3.3A (con't)  
Annual Radioactive Effluent Release Report 1994  
Liquid Effluents - Continuous Releases

Isotope (Ci)	January	February	March	Total
Na-24	5.926E-004	1.089E-003	5.497E-004	2.231E-003
Fe-55	1.717E-002	1.325E-002	0.000E+000	3.042E-002
Co-58	2.320E-005	0.000E+000	0.000E+000	2.320E-005
Co-60	1.623E-005	0.000E+000	0.000E+000	1.623E-005
Zr-95	5.023E-006	0.000E+000	1.212E-005	1.714E-005
I-133	2.849E-004	1.981E-004	4.063E-004	8.892E-004
Total	1.809E-002	1.454E-002	9.681E-004	3.360E-002

**TABLE 3.3B**  
**Annual Radioactive Effluent Release Report 1994**  
**Liquid Effluents - Continuous Releases**

	April	May	June	Total
<b>Gross Radioactivity</b>				
<b>Total Release Excluding H<sup>3</sup> and Dissolved Gases (Ci)</b>				
	2.863E-003	1.951E-004	5.315E-006	3.064E-003
<b>Avg. Conc. (μCi/ml)</b>				
	1.221E-010	4.719E-012	8.126E-014	
<b>Tritium</b>				
<b>Total Release (Ci)</b>				
	0.000E+000	0.000E+000	0.000E+000	0.000E+000
<b>Avg. Conc. (μCi/ml)</b>				
	0.000E+000	0.000E+000	0.000E+000	
<b>Dissolved Gases</b>				
<b>Total Release (Ci)</b>				
	0.000E+000	0.000E+000	0.000E+000	0.000E+000
<b>Avg. Conc. (μCi/ml)</b>				
	0.000E+000	0.000E+000	0.000E+000	
<b>Gross Alpha Activity</b>				
<b>Total Release (Ci)</b>				
	0.000E+000	0.000E+000	0.000E+000	0.000E+000
<b>Avg. Conc. (μCi/ml)</b>				
	0.000E+000	0.000E+000	0.000E+000	
<b>Volume of Waste Released</b>				
(liters)	2.842E+006	1.104E+007	1.121E+007	2.509E+007
<b>Volume of Dilution Water</b>				
(liters)	2.345E+010	4.134E+010	6.541E+010	1.302E+011

**TABLE 3.3B (con't)**  
**Annual Radioactive Effluent Release Report 1994**  
**Liquid Effluents - Continuous Releases**

Isotope (Ci)	April	May	June	Total
Mn-54	1.394E-005	0.000E+000	0.000E+000	1.394E-005
Fe-55	2.703E-003	0.000E+000	0.000E+000	2.703E-003
Co-58	1.230E-004	8.965E-005	0.000E+000	2.127E-004
Fe-59	2.002E-006	0.000E+000	0.000E+000	2.002E-006
Co-60	2.172E-005	9.015E-005	0.000E+000	1.119E-004
Sb-125	0.000E+000	1.303E-005	0.000E+000	1.303E-005
I-133	0.000E+000	2.242E-006	5.315E-006	7.557E-006
Total	2.863E-003	1.951E-004	5.315E-006	3.064E-003

**TABLE 3.3C**  
**Annual Radioactive Effluent Release Report 1994**  
**Liquid Effluents - Continuous Releases**

	July	August	September	Total
<b>Gross Radioactivity</b>				
<b>Total Release Excluding H<sup>3</sup> and Dissolved Gases (Ci)</b>				
	3.053E-005	0.000E+000	8.684E-004	8.990E-004
<b>Avg. Conc. (μCi/ml)</b>				
	4.517E-013	0.000E+000	1.328E-011	
<b>Tritium</b>				
<b>Total Release (Ci)</b>				
	0.000E+000	0.000E+000	0.000E+000	0.000E+000
<b>Avg. Conc. (μCi/ml)</b>				
	0.000E+000	0.000E+000	0.000E+000	
<b>Dissolved Gases</b>				
<b>Total Release (Ci)</b>				
	0.000E+000	1.852E-005	5.144E-005	6.996E-005
<b>Avg. Conc. (μCi/ml)</b>				
	0.000E+000	2.740E-013	7.864E-013	
<b>Gross Alpha Activity</b>				
<b>Total Release (Ci)</b>				
	0.000E+000	0.000E+000	0.000E+000	0.000E+000
<b>Avg. Conc. (μCi/ml)</b>				
	0.000E+000	0.000E+000	0.000E+000	
<b>Volume of Waste Released</b>				
(liters)	7.657E+006	1.103E+007	1.005E+007	2.873E+007
<b>Volume of Dilution Water</b>				
(liters)	6.759E+010	6.759E+010	6.541E+010	2.006E+011

**TABLE 3.3C (con't)**  
**Annual Radioactive Effluent Release Report 1994**  
**Liquid Effluents - Continuous Releases**

Isotope (Ci)	July	August	September	Total
Mn-54	0.000E+000	0.000E+000	7.354E-005	7.354E-005
Sr-89	0.000E+000	0.000E+000	4.403E-004	4.403E-004
Sr-90	0.000E+000	0.000E+000	7.091E-005	7.091E-005
I-133	3.053E-005	0.000E+000	2.837E-004	3.143E-004
Xe-135	0.000E+000	1.852E-005	5.144E-005	6.996E-005
Total	3.053E-005	1.852E-005	9.199E-004	9.689E-004



**TABLE 3.3D**  
**Annual Radioactive Effluent Release Report 1994**  
**Liquid Effluents - Continuous Releases**

	October	November	December	Total
<b>Gross Radioactivity</b>				
<b>Total Release Excluding H<sup>3</sup> and Dissolved Gases (Ci)</b>				
	1.542E-004	2.571E-004	5.219E-004	9.331E-004
<b>Avg. Conc. (μCi/ml)</b>				
	2.523E-012	7.389E-012	1.544E-011	
<b>Tritium</b>				
<b>Total Release (Ci)</b>				
	0.000E+000	0.000E+000	0.000E+000	0.000E+000
<b>Avg. Conc. (μCi/ml)</b>				
	0.000E+000	0.000E+000	0.000E+000	
<b>Dissolved Gases</b>				
<b>Total Release (Ci)</b>				
	6.761E-005	0.000E+000	1.686E-004	2.362E-004
<b>Avg. Conc. (μCi/ml)</b>				
	1.107E-012	0.000E+000	4.989E-012	
<b>Gross Alpha Activity</b>				
<b>Total Release (Ci)</b>				
	0.000E+000	0.000E+000	0.000E+000	0.000E+000
<b>Avg. Conc. (μCi/ml)</b>				
	0.000E+000	0.000E+000	0.000E+000	
<b>Volume of Waste Released</b>				
(liters)	9.429E+006	9.894E+006	1.624E+007	3.556E+007
<b>Volume of Dilution Water</b>				
(liters)	6.110E+010	3.480E+010	3.380E+010	1.297E+011

**TABLE 3.3D (con't)**  
**Annual Radioactive Effluent Release Report 1994**  
**Liquid Effluents - Continuous Releases**

Isotope (Ci)	October	November	December	Total
Co-60	0.000E+000	4.736E-005	0.000E+000	4.736E-005
Sr-89	0.000E+000	0.000E+000	7.890E-005	7.890E-005
Sr-90	1.434E-005	6.715E-005	0.000E+000	8.149E-005
I-133	1.398E-004	1.426E-004	4.430E-004	7.254E-004
Xe-135	6.761E-005	0.000E+000	1.686E-004	2.362E-004
Total	2.218E-004	2.571E-004	6.905E-004	1.169E-003

**Table 3.4**  
**Annual Radioactive Effluent Report 1994**  
**Dose From Liquid Effluents**

The dose to a member of the public from total liquid radioactive release for each quarter was well below the ODCM limits of 1.5 mRem to the body and less than or equal to 5 mRem to any organ.

Instantaneous release concentrations are limited by the individual radionuclide concentrations established in 10 CFR 20, Appendix B, for unrestricted areas. During the report period, none of the isotopes released exceeded the concentrations specified in Appendix B. The following offsite doses were calculated using equation 1.5 from the Kewaunee ODCM.

Organ 1st Qtr Dose	Dose Total mRem	Quarterly Limit mRem	Percent of Limit
Total Body	4.901E-004	1.5	0.03
Bone	4.978E-004	5.0	0.01
Liver	7.339E-004	5.0	0.01
Thyroid	6.162E-004	5.0	0.01
Kidney	3.952E-004	5.0	0.01
Lung	5.771E-004	5.0	0.01
GI-LLI	7.647E-004	5.0	0.02

Organ 2nd Qtr Dose	Dose Total mRem	Quarterly Limit mRem	Percent of Limit
Total Body	2.470E-004	1.5	0.02
Bone	1.193E-004	5.0	0.00
Liver	2.711E-004	5.0	0.01
Thyroid	1.304E-004	5.0	0.00
Kidney	1.365E-004	5.0	0.00
Lung	1.735E-004	5.0	0.00
GI-LLI	2.606E-002	5.0	0.52

**Table 3.4 (con't)**  
**Annual Radioactive Effluent Report 1994**  
**Dose From Liquid Effluents**

Organ 3rd Qtr Dose	Dose Total mRem	Quarterly Limit mRem	Percent of Limit
Total Body	2.393E-004	1.5	0.02
Bone	5.497E-004	5.0	0.01
Liver	1.280E-004	5.0	0.00
Thyroid	1.544E-004	5.0	0.00
Kidney	1.099E-004	5.0	0.00
Lung	1.118E-004	5.0	0.00
GI-LLI	2.015E-003	5.0	0.04

Organ 4th Qtr Dose	Dose Total mRem	Quarterly Limit mRem	Percent of Limit
Total Body	5.643E-004	1.5	0.04
Bone	9.600E-004	5.0	0.02
Liver	3.433E-004	5.0	0.01
Thyroid	5.263E-004	5.0	0.01
Kidney	3.353E-004	5.0	0.01
Lung	3.367E-004	5.0	0.01
GI-LLI	4.199E-004	5.0	0.01

Calculated Dose This Year

Organ	Dose Total mRem	Quarterly Limit mRem	Percent of Limit
Total Body	1.541E-003	3.0	0.05
Bone	2.127E-003	10.0	0.02
Liver	1.476E-003	10.0	0.01
Thyroid	1.427E-003	10.0	0.01
Kidney	9.770E-004	10.0	0.01
Lung	1.199E-003	10.0	0.01
GI-LLI	2.926E-002	10.0	0.29

#### 4.0 UNPLANNED RELEASES

One unplanned release occurred on April 26, 1994. At about 1830, the Nuclear Auxiliary Operator discovered that the pressure in the B Waste Gas Decay Tank had decreased by about 28 PSIG from what it was at 0700 that morning.

Upon discovery, grab samples were taken in the containment building and in the auxiliary building. No airborne gaseous isotopes were detectable in any of these samples. Radiation detectors monitoring both the containment and the auxiliary building ventilation exhaust stacks were checked for abnormal or increasing trends, but all data was normal.

The cause of the release is indeterminant. Earlier that day, a tagout was cleared following maintenance work on the B Reactor Coolant Pump seals, and during the time of the release Operations personnel were establishing system conditions and valve lineups in preparation for a containment Integrated Leak Rate Test (ILRT). However, follow-up investigations could not conclusively determine exact cause for the pressure decrease nor identify the area or building into which the pressure was released.

Based on a sample of the tank taken at 2108 the same day, a total of  $1.43 \text{ E}+02$  microcuries of Xenon-133 and  $1.67 \text{ E}+02$  microcuries of tritium were calculated as being inadvertently released. This amount of activity relates to the following at the site boundary:

Total Body Dose Rate	$5.18 \text{ E}-06$ mrem/yr.	Limit = 500 mrem/yr.
Skin Dose Rate	$1.22 \text{ E}-05$ mrem/yr.	Limit = 3000 mrem/yr.
Max. Organ Dose Rate	$2.31 \text{ E}-5$ mrem/yr.	Limit = 1500 mrem/yr.
Gamma Air Dose	$5.77 \text{ E}-09$ mrad	Limit = 5 mrad/qtr, 10 mrad/yr.
Beta Air Dose	$1.72 \text{ E}-08$ mrad	Limit = 10 mrad/qtr, 20 mrad/yr.

All calculated doses resulting from this unplanned release were well below all established limits stated in the Offsite Dose Calculation Manual.

#### 5.0 METEOROLOGICAL DATA

Meteorological data for 1994 is retained on file at the Kewaunee Nuclear Power Plant. The data on file includes a continuous strip chart recording and a 15-minute interval listing of wind speed, wind direction and atmospheric stability. This is more conservative than the requirements of ODCM Section 3/4.7. See Appendix A for missing meteorological data times and joint frequency distribution tables.

## 6.0 SOLID WASTE DISPOSAL

Table 6.1 is a summation of solid wastes shipped during 1994. Presented are the types of wastes, major nuclide composition, disposition of the wastes and shipping containers used.

The containers utilized have the following volumes:

High Integrity Container (HIC)	158 ft <sup>3</sup>	4.47 Cu.M
LSA Box (B-25)	98 ft <sup>3</sup>	2.77 Cu.M
LSA Box	50 ft <sup>3</sup>	1.41 Cu.M
DOT-17H Drum	7.5 ft <sup>3</sup>	0.21 Cu.M

A composite sample from the 1994 dewatered resin shipments was analyzed by a contractor for transuranic nuclides. The results showed an average transuranic concentration of 8.85 E-06 nCi/g, well within the disposal site limit of 10 nCi/g.

Table 6.1 contains the radionuclide content (curies) and percent abundance for each type of waste.

Isotopes denoted by an asterisk (\*) in Table 6.1 are correlated values.

**Table 6.1**  
**Annual Radioactive Effluent Report 1994**  
**Solid Waste and Irradiated Fuel Shipments**

A. Solid Waste Shipped Off-Site for Burial or Disposal  
 (Not Irradiated Fuel - Cu.M is actual waste volume not burial volume)

1. Type of Waste	Unit	Quantity
a Dewatered resin	Cu.M	1.79E+01
Container: HIC	Ci	5.01E+02
b Dry Active Waste (Compactible DAW)	Cu.M	3.27E+01
	Ci	5.30E-01

2. Estimate of Major Nuclide by Composition  
 (By Type of Waste)

a. Dewatered Resin

	<u>%</u>	<u>Ci</u>
Cr-51	1.64 E+00	8.23 E+00
Co-58	2.13 E+01	1.07 E+02
Co-60	5.48 E+00	2.75 E+01
Zr-95	1.71 E+00	8.56 E+00
Nb-95	2.63 E+00	1.32 E+01
*Fe-55	4.21 E+01	2.11 E+02
*C-14	5.74 E-01	2.87 E+00
Ni-63	2.27 E+01	1.14 E+02
Sn-117m	1.89 E+00	9.45 E+00
TOTALS	1.00 E+02	5.01 E+02

b. Dry Active Waste (Compactible DAW)

	<u>%</u>	<u>Ci</u>
Mn-54	2.07 E+00	1.10 E-02
Co-58	1.28 E+01	6.78 E-02
Co-60	3.46 E+01	1.83 E-01
Zr-95	4.39 E+00	2.33 E-02
Nb-95	5.61 E+00	2.97 E-02
Cs-137	1.36 E+01	7.23 E-02
Sb-125	4.15 E+00	2.20 E-02
Sn-113	5.46 E-01	2.90 E-03
Sr-90	1.88 E+01	9.97 E-02
Sn-117m	3.44 E+00	1.83 E-02
TOTAL	1.00 E+02	5.30 E-01

3. Solid Waste Disposition

<u>Date of Shipment</u>	<u>Mode of Transportation</u>	<u>Destination</u>
5-22-94	CNSI 14-190H Cask	Barnwell, SC
6-9-94	CNSI 14-190H Cask	Barnwell, SC
6-15-94	VAN	Barnwell, SC
6-16-94	CNSI 14-190H Cask	Barnwell, SC
6-20-94	VAN	Barnwell, SC
6-23-94	CNSI 14-190H Cask	Barnwell, SC

B. Irradiated Fuel Shipments

No irradiated fuel shipments were made from the Kewaunee Nuclear Power Plant during 1994.



## **7.0 PROGRAM REVISIONS**

In accordance with Technical Specifications 6.18.b.3 and 6.19.a, the revisions to the Offsite Dose Calculation Manual and radioactive waste treatment systems are listed below.

### **7.1 Offsite Dose Calculation Manual**

The Offsite Dose Calculation Manual (ODCM) was revised during this reporting period. In accordance with Technical Specification 6.18.b, a copy of the revised ODCM is attached as Appendix B to this report.

The revisions to the ODCM do not reduce the accuracy or reliability of dose calculations or setpoint determinations. All revisions were reviewed and found acceptable by the Plant Operations Review Committee (PORC). The specific changes are discussed below.

ODCM, Revision 7 Changes:

Due to replacement of the Radiation Monitoring System per Design Change 2172, new default setpoints were calculated and incorporated into the ODCM. Table 1.1 (Parameters for Liquid Alarm Setpoint Determinations) and Table 2.2 (Parameters for Gaseous Alarm Setpoint Determinations) were revised to include new default Sensitivity values and new default Setpoint values for the listed channels along with a new reference to Calculation #C10690 which documented these calculations.

### **7.2 Major Changes to the Radioactive Liquid, Gaseous and Solid Waste Treatment Systems**

Major changes to the radioactive liquid, gaseous or solid waste systems are submitted in the annual Updated Final Safety Analysis Report consistent with Technical Specification 6.19.

## **8.0 REPORTABLE OCCURRENCES**

None.

Appendix A  
Kewaunee Nuclear Power Plant  
1994 Meteorological Data  
January 1, 1994 - December 31, 1994

Missing Data Totals

First Quarter 1994:	57
Second Quarter 1994:	75
Third Quarter 1994:	168
Fourth Quarter 1994:	148

**Kewaunee Nuclear Power Plant  
1994 Meteorological Data  
Missing Meteorological Data**

Start and End Date and Time	Wind Speed @ 10 m M0308G	Delta T M0304G	Wind Dir. @ 10 m M0309G	Wind Dir. @ .60 m M0302G	Hours OOS
1/31/94 14:30 to 23:30	X	X	X	X	10
2/24/94 07:30 to 08:30	X	X	X	X	2
2/28/94 10:30 to 23:30	X	X	X	X	14
3/3/94 12:30	X	X	X	X	1
3/4/94 13:30	X	X	X	X	1
3/7/94 09:30 to 14:30	X	X	X	X	6
3/9/94 13:30 to 16:30	X	X	X	X	4
3/14/94 09:30 to 10:30	X	X	X	X	2
3/29/94 14:30 to 15:30	X	X	X	X	2
3/31/94 08:30 to 22:30	X	X	X	X	15
4/3/94 02:30	X	X	X	X	1
4/13/94 09:30	X	X	X	X	1
5/16/94 08:30 to 5/17/94 16:30	X	X	X	X	33
5/19/94 08:30 to 12:30	X	X	X	X	5
5/26/94 09:30 to 10:30	X	X	X	X	2
5/31/94 08:30 to 23:30	X	X	X	X	16
6/15/94 09:30 to 10:30	X	X	X	X	2
6/30/94 09:30 to 23:30	X	X	X	X	15
7/19/94 12:30 to 7/22/94 08:30	X	X	X	X	69
8/7/94 12:30 to 8/8/94 14:30	X	X	X	X	27
8/31/94 08:30 to 23:30	X	X	X	X	16
9/17/94 17:30 to 9/19/94 08:30	X	X	X	X	40
9/30/94 08:30 to 23:30	X	X	X	X	16
10/4/94 10:30 to 14:30	X	X	X	X	5
10/5/94 09:30 to 15:30	X	X	X	X	7
10/7/94 08:30	X	X	X	X	1
10/10/94 10:30 to 14:30	X	X	X	X	5
10/22/94 01:30 to 10/24/94 07:30	X	X	X	X	55
10/31/94 07:30 to 23:30	X	X	X	X	17
11/3/94 19:30	X	X	X	X	1
11/28/94 14:30	X	X	X	X	1
11/30/94 09:30 to 23:30	X	X	X	X	15
12/12/94 08:30	X	X	X	X	1
12/30/94 08:30 to 12/31/94 23:30	X	X	X	X	40
Total Time (hours)					448

Kewaunee Nuclear Power Plant  
 1994 Meteorological Data  
 January 1994 - March 1994

Stability Class A

Wind Direction	CALM	1-3	4-7	8-12	13-18	19-24	>24	TOTAL
N	43	0	4	3	4	0	0	54
NNE	1	1	1	6	5	4	1	19
NE	10	0	1	1	11	38	20	81
ENE	5	0	2	3	12	21	0	43
E	22	2	3	6	29	4	0	66
ESE	0	0	0	6	6	6	0	18
SE	19	4	1	4	9	0	0	37
SSE	13	3	5	2	2	2	0	27
S	17	1	1	10	10	4	0	43
SSW	7	1	6	3	0	0	0	17
SW	5	0	2	1	0	0	0	8
WSW	15	2	8	9	5	3	0	42
W	6	0	1	10	15	15	1	48
WNW	3	1	2	7	8	1	0	22
NW	2	0	7	11	7	1	0	28
NNW	27	9	18	15	13	1	0	83
TOTAL	195	24	62	97	136	100	22	636

Kewaunee Nuclear Power Plant  
 1994 Meteorological Data  
 January 1994 - March 1994

Stability Class B

Wind Direction	CALM	1-3	4-7	8-12	13-18	19-24	>24	TOTAL
N	9	1	0	0	1	1	0	12
NNE	0	0	0	0	0	0	1	1
NE	1	0	1	1	2	0	0	5
ENE	1	0	0	0	0	0	0	1
E	1	0	0	0	1	0	0	2
ESE	1	0	1	2	2	0	0	6
SE	4	1	0	2	1	0	0	8
SSE	1	1	1	0	2	0	0	5
S	3	0	2	3	4	0	0	12
SSW	1	0	0	1	1	0	0	3
SW	1	0	0	1	1	0	0	3
WSW	4	2	0	2	9	2	0	19
W	1	0	0	6	8	6	0	21
WNW	1	0	0	3	0	0	0	4
NW	1	1	2	4	0	0	0	8
NNW	2	0	2	6	4	0	0	14
TOTAL	32	6	9	31	36	9	1	124

Kewaunee Nuclear Power Plant  
 1994 Meteorological Data  
 January 1994 - March 1994

Stability Class C

Wind Direction	CALM	1-3	4-7	8-12	13-18	19-24	>24	TOTAL
N	5	0	3	0	0	4	0	12
NNE	0	0	1	1	0	0	0	2
NE	1	0	1	1	0	0	0	3
ENE	0	0	0	2	0	0	0	2
E	4	1	1	2	2	0	0	10
ESE	0	0	0	0	1	0	0	1
SE	4	0	0	0	2	0	0	6
SSE	4	2	1	0	0	0	0	7
S	4	0	0	4	1	0	0	9
SSW	1	0	0	1	1	0	0	3
SW	2	0	2	2	4	1	0	11
WSW	3	3	0	5	6	4	0	21
W	0	0	3	3	11	2	0	19
WNW	0	0	1	4	0	0	0	5
NW	0	0	1	1	0	1	0	3
NNW	3	0	1	5	9	1	0	19
TOTAL	31	6	15	31	37	13	0	133

Kewaunee Nuclear Power Plant  
 1994 Meteorological Data  
 January 1994 - March 1994

Stability Class D

Wind Direction	CALM	1-3	4-7	8-12	13-18	19-24	>24	TOTAL
N	29	1	2	1	3	0	0	36
NNE	1	0	2	1	0	0	0	4
NE	4	0	0	0	1	0	0	5
ENE	0	1	0	2	0	0	0	3
E	11	0	5	0	1	0	0	17
ESE	0	0	1	0	0	0	0	1
SE	4	1	1	0	2	0	0	8
SSE	5	0	4	2	6	0	0	17
S	5	0	3	10	4	0	0	22
SSW	6	0	7	6	1	0	0	20
SW	6	0	3	6	6	2	0	23
WSW	4	0	6	8	18	10	2	48
W	1	0	4	12	42	11	0	70
WNW	1	0	5	2	10	6	0	24
NW	5	0	5	5	13	2	0	30
NNW	9	1	2	13	11	0	0	36
TOTAL	91	4	50	68	118	31	2	364

Kewaunee Nuclear Power Plant  
 1994 Meteorological Data  
 January 1994 - March 1994

Stability Class E

Wind Direction	CALM	1-3	4-7	8-12	13-18	19-24	>24	TOTAL
N	14	1	0	0	0	0	0	15
NNE	1	0	1	0	0	0	0	2
NE	1	2	0	0	0	2	0	5
ENE	0	0	0	0	0	0	0	0
E	8	0	1	3	0	0	0	12
ESE	0	1	0	0	0	0	0	1
SE	3	1	0	0	0	0	0	4
SSE	5	0	3	2	1	0	0	11
S	5	1	6	8	7	0	0	27
SSW	5	2	5	5	0	0	0	17
SW	1	3	5	9	7	1	0	26
WSW	7	0	5	14	10	1	0	37
W	0	2	5	5	18	8	0	38
WNW	0	0	6	9	10	1	0	26
NW	4	4	11	12	17	0	0	48
NNW	10	3	4	7	5	0	0	29
TOTAL	64	20	52	74	75	13	0	298



Kewaunee Nuclear Power Plant  
 1994 Meteorological Data  
 January 1994 - March 1994

Stability Class F

Wind Direction	CALM	1-3	4-7	8-12	13-18	19-24	>24	TOTAL
N	7	0	0	0	0	0	0	7
NNE	0	0	1	0	0	0	0	1
NE	2	0	1	0	0	0	0	3
ENE	1	1	1	0	0	0	0	3
E	4	3	0	1	0	0	0	8
ESE	0	0	0	0	0	0	0	0
SE	1	0	1	0	0	0	0	2
SSE	2	2	0	1	0	0	0	5
S	2	0	2	6	0	0	0	10
SSW	13	2	5	2	0	0	0	22
SW	0	3	2	8	7	0	0	20
WSW	3	3	5	3	12	0	0	26
W	2	3	8	14	3	0	0	30
WNW	0	0	5	5	2	0	0	12
NW	2	2	3	4	1	0	0	12
NNW	10	4	7	3	1	0	0	25
TOTAL	49	23	41	47	26	0	0	186

Kewaunee Nuclear Power Plant  
 1994 Meteorological Data  
 January 1994 - March 1994

Stability Class G

Wind Direction	CALM	1-3	4-7	8-12	13-18	19-24	>24	TOTAL
N	1	0	0	0	0	0	0	1
NNE	0	0	0	0	0	0	0	0
NE	2	0	0	0	0	0	0	2
ENE	0	0	0	0	0	0	0	0
E	3	1	0	2	0	0	0	6
ESE	0	0	0	0	0	0	0	0
SE	2	0	1	0	0	0	0	3
SSE	5	2	1	0	0	0	0	8
S	3	3	5	0	0	0	0	11
SSW	7	3	15	1	0	0	0	26
SW	0	9	12	10	0	0	0	31
WSW	2	4	20	5	3	0	0	34
W	2	6	25	32	13	0	0	78
WNW	0	9	7	7	1	0	0	24
NW	1	2	9	4	0	0	0	16
NNW	14	13	11	5	0	0	0	43
TOTAL	42	52	106	66	17	0	0	283

Kewaunee Nuclear Power Plant  
 1994 Meteorological Data  
 April 1994 - June 1994

Stability Class A

Wind Direction	CALM	1-3	4-7	8-12	13-18	19-24	>24	TOTAL
N	31	0	0	3	4	0	0	38
NNE	0	0	2	26	40	7	0	75
NE	4	0	11	1	7	7	0	30
ENE	2	0	5	2	1	1	0	11
E	12	0	4	1	3	0	0	20
ESE	1	0	6	0	1	0	0	8
SE	4	1	5	0	0	0	0	10
SSE	10	1	4	2	1	0	0	18
S	9	1	1	7	8	0	0	26
SSW	3	0	0	0	1	0	0	4
SW	2	0	1	3	5	11	1	23
WSW	17	0	4	14	17	3	3	58
W	2	0	6	8	7	10	4	37
WNW	1	0	7	11	6	2	2	29
NW	0	0	1	10	8	1	3	23
NNW	7	0	1	8	18	2	0	36
TOTAL	105	3	58	96	127	44	13	446

Kewaunee Nuclear Power Plant  
 1994 Meteorological Data  
 April 1994 - June 1994

Stability Class B

Wind Direction	CALM	1-3	4-7	8-12	13-18	19-24	>24	TOTAL
N	7	0	0	2	1	0	0	10
NNE	0	0	2	5	13	0	0	20
NE	1	0	1	0	0	0	0	2
ENE	2	0	1	0	0	0	0	3
E	1	0	1	0	0	1	0	3
ESE	0	1	0	0	0	0	0	1
SE	1	0	1	0	0	0	0	2
SSE	1	0	1	1	0	1	0	4
S	0	1	0	3	1	0	0	5
SSW	0	0	0	0	0	0	0	0
SW	0	0	0	0	0	0	0	0
WSW	0	0	0	0	1	0	0	1
W	0	0	0	0	1	0	0	1
WNW	0	0	0	0	1	0	0	1
NW	0	0	0	0	0	0	1	1
NNW	2	0	0	1	3	0	0	6
TOTAL	15	2	7	12	21	2	1	60

Kewaunee Nuclear Power Plant  
 1994 Meteorological Data  
 April 1994 - June 1994

Stability Class C

Wind Direction	CALM	1-3	4-7	8-12	13-18	19-24	>24	TOTAL
N	8	0	0	1	2	1	0	12
NNE	0	0	0	5	5	1	0	11
NE	2	0	2	2	0	0	0	6
ENE	0	0	2	0	0	0	0	2
E	0	0	1	2	1	1	0	5
ESE	0	1	0	1	0	0	0	2
SE	2	0	0	1	0	0	0	3
SSE	0	0	1	0	0	0	0	1
S	2	0	0	0	1	0	0	3
SSW	3	0	0	0	0	0	0	3
SW	1	0	0	0	0	0	1	2
WSW	0	0	0	3	0	0	0	3
W	0	0	0	0	0	1	0	1
WNW	0	0	0	3	1	0	0	4
NW	0	0	0	0	0	0	0	0
NNW	0	0	2	0	2	0	0	4
TOTAL	18	1	8	18	12	4	1	62

Kewaunee Nuclear Power Plant  
 1994 Meteorological Data  
 April 1994 - June 1994

Stability Class D

Wind Direction	CALM	1-3	4-7	8-12	13-18	19-24	>24	TOTAL
N	15	0	1	19	6	1	0	42
NNE	0	0	9	12	6	0	0	27
NE	2	1	9	1	1	0	0	14
ENE	0	0	5	1	0	0	0	6
E	8	4	9	4	1	0	0	26
ESE	1	2	1	1	0	0	0	5
SE	2	2	1	3	0	0	0	8
SSE	4	1	2	2	1	0	0	10
S	2	1	3	11	2	0	0	19
SSW	3	2	5	3	1	0	0	14
SW	2	0	1	2	3	2	1	11
WSW	4	0	3	2	1	2	0	12
W	1	1	3	6	6	0	0	17
WNW	0	0	0	7	0	2	0	9
NW	2	0	1	1	3	0	0	7
NNW	1	2	2	5	6	0	0	16
TOTAL	47	16	55	80	37	7	1	243

Kewaunee Nuclear Power Plant  
 1994 Meteorological Data  
 April 1994 - June 1994

Stability Class E

Wind Direction	CALM	1-3	4-7	8-12	13-18	19-24	>24	TOTAL
N	23	0	5	5	0	0	0	33
NNE	0	2	9	8	4	0	0	23
NE	3	1	10	2	2	0	0	18
ENE	4	2	9	1	0	0	0	16
E	6	2	14	1	0	0	0	23
ESE	0	3	11	2	0	0	0	16
SE	5	2	8	0	0	0	0	15
SSE	8	1	9	1	1	0	0	20
S	3	6	22	12	7	0	0	50
SSW	3	1	3	6	1	0	0	14
SW	3	1	4	4	6	5	2	25
WSW	6	2	4	2	2	3	2	21
W	1	0	1	8	4	0	0	14
WNW	0	2	4	3	1	0	0	10
NW	0	2	5	2	2	0	0	11
NNW	3	1	9	5	3	0	0	21
TOTAL	68	28	127	62	33	8	4	330

Kewaunee Nuclear Power Plant  
 1994 Meteorological Data  
 April 1994 - June 1994

Stability Class F

Wind Direction	CALM	1-3	4-7	8-12	13-18	19-24	>24	TOTAL
N	17	0	4	0	0	0	0	21
NNE	0	0	7	7	1	0	0	15
NE	1	2	8	1	0	0	0	12
ENE	1	1	1	0	0	0	0	3
E	8	1	4	0	0	0	0	13
ESE	0	5	3	0	0	0	0	8
SE	7	2	9	0	1	0	0	19
SSE	3	2	12	7	12	1	0	37
S	5	4	18	5	4	0	0	36
SSW	1	3	9	5	0	0	0	18
SW	4	0	2	3	1	1	0	11
WSW	5	4	3	3	1	0	0	16
W	0	2	5	1	1	0	0	9
WNW	1	1	6	8	0	0	0	16
NW	2	1	5	1	0	0	0	9
NNW	7	4	5	1	0	0	0	17
TOTAL	62	32	101	42	21	2	0	260



Kewaunee Nuclear Power Plant  
 1994 Meteorological Data  
 April 1994 - June 1994

Stability Class G

Wind Direction	CALM	1-3	4-7	8-12	13-18	19-24	>24	TOTAL
N	24	0	7	3	0	0	0	34
NNE	0	1	7	5	0	0	0	13
NE	2	1	10	3	2	0	0	18
ENE	2	2	1	0	0	0	0	5
E	9	10	7	2	0	0	0	28
ESE	0	6	5	0	0	0	0	11
SE	4	11	12	1	1	0	0	29
SSE	4	6	73	64	31	3	0	181
S	7	25	48	25	6	0	0	111
SSW	1	31	43	2	0	0	0	77
SW	4	21	21	9	3	0	0	58
WSW	4	4	21	13	10	0	0	52
W	1	4	10	6	0	0	0	21
WNW	0	8	14	7	2	0	0	31
NW	1	8	9	3	0	0	0	21
NNW	7	7	8	2	0	0	0	24
TOTAL	70	145	296	145	55	3	0	714

Kewaunee Nuclear Power Plant  
 1994 Meteorological Data  
 July 1994 - September 1994

Stability Class A

Wind Direction	CALM	1-3	4-7	8-12	13-18	19-24	>24	TOTAL
N	0	0	5	4	2	0	0	11
NNE	0	1	14	19	3	0	0	37
NE	0	1	15	6	1	0	0	23
ENE	0	3	14	3	4	0	0	24
E	0	2	17	4	2	0	0	25
ESE	0	1	12	4	0	0	0	17
SE	0	4	3	1	1	0	0	9
SSE	0	0	4	3	8	0	0	15
S	0	2	6	10	10	0	0	28
SSW	0	1	7	9	9	0	0	26
SW	0	2	8	14	9	1	0	34
WSW	0	2	13	30	17	0	0	62
W	0	0	15	25	20	0	0	60
WNW	0	0	11	15	10	0	0	36
NW	0	2	9	11	5	0	0	27
NNW	0	1	8	6	2	0	0	17
TOTAL	0	22	161	164	103	1	0	451

Kewaunee Nuclear Power Plant  
 1994 Meteorological Data  
 July 1994 - September 1994

Stability Class B

Wind Direction	CALM	1-3	4-7	8-12	13-18	19-24	>24	TOTAL
N	0	0	0	4	2	0	0	6
NNE	0	0	2	0	0	0	0	2
NE	0	0	1	0	1	0	0	2
ENE	0	0	3	1	1	0	0	5
E	0	0	0	4	0	0	0	4
ESE	0	0	3	0	0	0	0	3
SE	0	0	0	0	0	0	0	0
SSE	0	0	2	0	2	0	0	4
S	0	1	2	1	2	0	0	6
SSW	0	0	3	1	1	0	0	5
SW	0	0	5	1	0	0	0	6
WSW	0	0	1	5	3	1	0	10
W	0	0	3	0	0	0	0	3
WNW	0	0	1	1	0	0	0	2
NW	0	1	1	0	0	0	0	2
NNW	0	0	0	2	2	0	0	4
TOTAL	0	2	27	20	14	1	0	64

Kewaunee Nuclear Power Plant  
 1994 Meteorological Data  
 July 1994 - September 1994

Stability Class C

Wind Direction	CALM	1-3	4-7	8-12	13-18	19-24	>24	TOTAL
N	0	0	1	4	1	0	0	6
NNE	0	0	6	0	0	0	0	6
NE	0	1	2	0	1	0	0	4
ENE	0	0	4	1	1	0	0	6
E	0	0	1	1	0	0	0	2
ESE	0	1	0	1	0	0	0	2
SE	0	0	0	0	0	0	0	0
SSE	0	1	1	0	0	0	0	2
S	0	0	2	0	0	0	0	2
SSW	0	0	1	1	0	0	0	2
SW	0	0	1	1	0	0	0	2
WSW	0	0	0	2	1	0	0	3
W	0	0	1	1	1	0	0	3
WNW	0	0	0	0	0	0	0	0
NW	0	0	0	3	0	0	0	3
NNW	0	0	2	1	1	0	0	4
TOTAL	0	3	22	16	6	0	0	47

Kewaunee Nuclear Power Plant  
 1994 Meteorological Data  
 July 1994 - September 1994

Stability Class D

Wind Direction	CALM	1-3	4-7	8-12	13-18	19-24	>24	TOTAL
N	0	0	3	10	1	0	0	14
NNE	0	2	15	9	1	0	0	27
NE	0	3	5	7	1	0	0	16
ENE	0	2	10	4	7	0	0	23
E	0	2	20	7	3	1	0	33
ESE	0	1	7	3	0	0	0	11
SE	0	1	9	1	1	1	0	13
SSE	0	2	7	2	2	0	0	11
S	0	1	9	8	3	0	0	21
SSW	0	6	8	1	2	0	0	17
SW	0	0	5	2	0	0	0	7
WSW	0	1	4	6	4	1	0	16
W	0	1	5	8	2	0	0	16
WNW	0	2	5	10	3	0	0	20
NW	0	0	6	2	0	0	0	8
NNW	0	2	7	6	8	0	0	23
TOTAL	0	26	125	86	38	3	0	278

Kewaunee Nuclear Power Plant  
 1994 Meteorological Data  
 July 1994 - September 1994

Stability Class E

Wind Direction	CALM	1-3	4-7	8-12	13-18	19-24	>24	TOTAL
N	0	0	6	2	1	0	0	9
NNE	0	1	8	5	3	0	0	17
NE	0	3	12	7	0	0	0	22
ENE	0	3	9	11	7	0	0	30
E	0	2	21	10	0	0	0	33
ESE	0	3	14	6	3	0	0	26
SE	0	6	9	5	1	2	1	24
SSE	0	2	16	10	4	0	0	32
S	0	6	37	14	4	1	0	62
SSW	0	4	14	8	0	0	0	26
SW	0	3	11	10	3	0	0	27
WSW	0	2	6	14	2	0	0	24
W	0	6	11	14	3	0	0	34
WNW	0	1	7	3	0	0	0	11
NW	0	1	4	1	0	0	0	6
NNW	0	0	2	2	0	0	0	4
TOTAL	0	43	187	122	31	3	1	387

Kewaunee Nuclear Power Plant  
 1994 Meteorological Data  
 July 1994 - September 1994

Stability Class F

Wind Direction	CALM	1-3	4-7	8-12	13-18	19-24	>24	TOTAL
N	0	0	3	0	0	0	0	3
NNE	0	0	2	1	0	0	0	3
NE	0	2	8	3	0	0	0	13
ENE	0	6	2	6	0	0	0	14
E	0	5	10	3	0	0	0	18
ESE	0	9	17	0	0	0	0	26
SE	0	2	15	6	0	0	0	23
SSE	0	8	15	11	3	0	0	37
S	0	7	32	6	1	0	0	46
SSW	0	5	13	1	0	0	0	19
SW	0	6	8	4	0	0	0	18
WSW	0	3	8	12	0	0	0	23
W	0	2	10	9	2	0	0	23
WNW	0	2	10	1	0	0	0	13
NW	0	2	8	0	0	0	0	10
NNW	0	0	1	1	0	0	0	2
TOTAL	0	59	162	64	6	0	0	291

Kewaunee Nuclear Power Plant  
 1994 Meteorological Data  
 July 1994 - September 1994

Stability Class G

Wind Direction	CALM	1-3	4-7	8-12	13-18	19-24	>24	TOTAL
N	0	0	0	0	1	0	0	1
NNE	0	1	2	0	0	0	0	3
NE	0	0	3	0	0	0	0	3
ENE	0	0	16	3	5	0	0	24
E	0	2	10	1	1	0	0	14
ESE	0	14	9	0	0	0	0	23
SE	0	10	18	4	0	0	0	32
SSE	0	6	39	29	15	0	0	89
S	0	12	55	26	0	0	0	93
SSW	0	38	41	3	0	0	0	82
SW	0	19	48	0	1	0	0	68
WSW	0	13	36	6	0	0	0	55
W	0	4	19	20	0	0	0	43
WNW	0	0	7	0	0	0	0	7
NW	0	2	5	1	0	0	0	8
NNW	0	4	1	0	0	0	0	5
TOTAL	0	125	309	93	23	0	0	550



Kewaunee Nuclear Power Plant  
 1994 Meteorological Data  
 October 1994 - December 1994

Stability Class A

Wind Direction	CALM	1-3	4-7	8-12	13-18	19-24	>24	TOTAL
N	0	0	0	7	2	0	0	9
NNE	0	0	4	8	9	0	0	21
NE	0	0	7	7	1	0	0	15
ENE	0	0	3	10	16	0	0	29
E	0	0	10	8	8	6	3	35
ESE	0	1	10	5	10	9	7	42
SE	0	0	2	6	18	2	0	28
SSE	0	2	2	0	13	13	0	28
S	0	1	4	8	13	1	0	27
SSW	0	1	10	12	2	0	0	25
SW	0	0	8	14	4	0	3	29
WSW	1	0	14	19	14	8	7	63
W	0	0	11	12	9	8	0	40
WNW	0	0	7	14	17	0	0	38
NW	0	0	1	13	5	0	0	19
NNW	1	1	4	14	7	0	1	28
TOTAL	2	6	97	157	148	47	21	478

Kewaunee Nuclear Power Plant  
 1994 Meteorological Data  
 October 1994 - December 1994

Stability Class B

Wind Direction	CALM	1-3	4-7	8-12	13-18	19-24	>24	TOTAL
N	0	0	3	2	0	0	0	5
NNE	0	0	0	1	3	0	0	4
NE	0	0	0	0	3	0	0	3
ENE	0	0	0	1	1	0	0	2
E	0	0	1	1	0	0	0	2
ESE	0	0	0	0	0	0	0	0
SE	0	0	1	2	1	0	0	4
SSE	0	0	0	2	3	1	0	6
S	0	0	2	1	3	0	0	6
SSW	0	0	2	2	1	0	0	5
SW	0	0	1	2	2	0	0	5
WSW	1	0	1	5	3	0	2	12
W	0	1	1	1	1	0	1	5
WNW	0	0	0	1	3	0	0	4
NW	0	0	0	1	1	0	0	2
NNW	0	0	3	5	1	0	0	9
TOTAL	1	1	15	27	26	1	3	74

Kewaunee Nuclear Power Plant  
 1994 Meteorological Data  
 October 1994 - December 1994

Stability Class C

Wind Direction	CALM	1-3	4-7	8-12	13-18	19-24	>24	TOTAL
N	0	0	2	4	4	0	0	10
NNE	0	0	0	1	0	0	0	1
NE	0	0	3	0	0	0	0	3
ENE	0	0	0	0	0	0	0	0
E	0	0	2	2	1	0	0	5
ESE	0	0	1	0	0	0	0	1
SE	0	0	0	1	0	0	0	1
SSE	0	0	0	1	5	0	1	7
S	0	0	3	6	6	1	0	16
SSW	0	0	3	2	0	0	0	5
SW	0	2	0	0	1	1	0	4
WSW	0	0	2	4	3	4	1	14
W	0	0	6	2	2	3	1	14
WNW	0	0	1	2	2	0	0	5
NW	0	0	2	4	0	0	0	6
NNW	0	0	1	1	0	1	0	3
TOTAL	0	2	26	30	24	10	3	95

Kewaunee Nuclear Power Plant  
 1994 Meteorological Data  
 October 1994 - December 1994

Stability Class D

Wind Direction	CALM	1-3	4-7	8-12	13-18	19-24	>24	TOTAL
N	0	0	6	17	12	0	0	35
NNE	0	1	6	5	2	0	0	14
NE	0	0	0	1	0	0	0	1
ENE	0	1	3	0	1	0	0	5
E	0	5	4	5	2	0	0	16
ESE	0	1	1	1	1	0	0	4
SE	0	1	0	0	0	0	0	1
SSE	0	3	3	5	12	7	1	31
S	0	0	32	28	18	0	0	78
SSW	0	1	16	1	1	4	2	25
SW	0	1	8	2	0	1	7	19
WSW	0	0	5	17	14	4	3	43
W	0	1	6	28	7	13	6	61
WNW	0	2	5	9	8	0	0	24
NW	0	1	7	12	7	2	0	29
NNW	0	0	10	11	4	1	0	26
TOTAL	0	18	112	142	89	32	19	412

Kewaunee Nuclear Power Plant  
 1994 Meteorological Data  
 October 1994 - December 1994

Stability Class E

Wind Direction	CALM	1-3	4-7	8-12	13-18	19-24	>24	TOTAL
N	0	0	4	5	3	0	0	12
NNE	0	1	4	3	0	0	0	8
NE	0	3	4	1	0	0	0	8
ENE	0	0	2	0	0	0	0	2
E	0	1	7	0	0	0	0	8
ESE	0	1	4	2	1	0	0	8
SE	0	0	5	3	1	0	0	9
SSE	0	0	9	14	8	5	0	36
S	0	5	44	29	2	0	0	80
SSW	0	6	17	4	3	1	0	31
SW	0	7	11	8	8	4	0	38
WSW	1	1	14	14	8	3	2	43
W	0	0	9	16	11	1	0	37
WNW	0	0	4	5	1	0	0	10
NW	0	4	7	1	2	0	0	14
NNW	0	0	5	10	0	0	0	15
TOTAL	1	29	150	115	48	14	2	359

Kewaunee Nuclear Power Plant  
 1994 Meteorological Data  
 October 1994 - December 1994

Stability Class F

Wind Direction	CALM	1-3	4-7	8-12	13-18	19-24	>24	TOTAL
N	0	0	0	0	0	0	0	0
NNE	0	0	0	0	0	0	0	0
NE	0	2	1	1	0	0	0	4
ENE	0	0	1	0	0	0	0	1
E	0	1	1	0	0	0	0	2
ESE	0	0	1	2	0	0	0	3
SE	0	0	5	7	0	0	0	12
SSE	0	5	9	6	5	2	0	27
S	0	6	37	10	1	0	0	54
SSW	0	9	25	4	3	0	0	41
SW	0	5	10	7	5	0	0	27
WSW	0	1	19	9	0	0	0	29
W	0	1	10	10	3	0	0	24
WNW	0	1	5	3	3	0	0	12
NW	0	1	4	1	0	0	0	6
NNW	0	0	1	0	0	0	0	1
TOTAL	0	32	129	60	20	2	0	243

Kewaunee Nuclear Power Plant  
 1994 Meteorological Data  
 October 1994 - December 1994

Stability Class G

Wind Direction	CALM	1-3	4-7	8-12	13-18	19-24	>24	TOTAL
N	0	0	1	0	0	0	0	1
NNE	0	2	0	0	0	0	0	2
NE	0	0	0	1	0	0	0	1
ENE	0	1	0	0	0	0	0	1
E	0	3	2	0	0	0	0	5
ESE	0	2	2	0	0	0	0	4
SE	1	4	2	0	0	0	0	7
SSE	0	3	11	4	6	0	0	24
S	1	3	16	7	9	0	0	36
SSW	0	8	48	1	0	0	0	57
SW	0	18	21	10	0	0	0	49
WSW	0	12	35	19	0	0	0	66
W	0	5	48	23	5	0	0	81
WNW	0	4	22	9	1	0	0	36
NW	0	3	23	0	0	0	0	26
NNW	0	1	17	0	0	0	0	18
TOTAL	2	69	248	74	21	0	0	414

## Batch Release Meteorological Data

<u>Release Number</u>	<u>Start Date and Time</u>	<u>Stop Date and Time</u>
94-0001	01/06/94 02:52	01/07/94 06:05
94-0002	01/09/94 08:54	01/09/94 09:22
94-0003	01/09/94 15:38	01/09/94 16:47
94-0004	01/12/94 20:00	01/12/94 20:45
94-0005	01/14/94 08:30	01/14/94 22:50
94-0006	02/08/94 10:58	02/08/94 16:07
94-0007	02/15/94 15:28	02/16/94 03:00
94-0008	03/17/94 08:11	03/17/94 18:46
94-0009	03/23/94 08:59	03/23/94 09:32
94-0010	04/02/94 02:54	04/04/94 22:37
94-0011	04/03/94 19:26	04/03/94 20:10
94-0012	04/05/94 19:20	04/05/94 20:02
94-0013	04/29/94 01:52	04/29/94 14:02
94-0014	04/30/94 22:51	05/02/94 16:28
94-0015	05/07/94 14:03	05/07/94 14:42
94-0016	05/13/94 11:25	05/14/94 00:46
94-0017	05/31/94 15:13	05/31/94 15:45
94-0018	06/13/94 14:50	06/14/94 01:46
94-0019	07/02/94 13:23	07/02/94 13:46
94-0020	07/05/94 15:49	07/05/94 16:00
94-0021	07/13/94 10:13	07/13/94 20:35
94-0022	08/12/94 10:53	08/12/94 23:45
94-0023	09/13/94 10:03	09/13/94 20:16
94-0024	10/13/94 08:18	10/13/94 18:34
94-0025	11/14/94 11:15	11/15/94 01:10
94-0026	04/26/94 13:00	04/26/94 21:08
94-0027	12/13/94 08:56	12/13/94 19:16



Kewaunee Nuclear Power Plant  
 1994 Meteorological Data  
 Release Permit: 9401

Stability Class A	Calm	1-3	4-7	8-12	13-18	19-24	>24	Total
Wind Direction (from)								
NE	0	0	0	0	2	0	0	2
ENE	0	0	0	0	16	9	0	25
E	0	0	3	12	39	2	0	56
ESE	0	0	0	15	6	7	0	28
SE	0	0	0	2	0	0	0	2
TOTAL	0	0	3	29	63	18	0	113

Kewaunee Nuclear Power Plant  
 1994 Meteorological Data  
 Release Permit: 9402

Stability Class F		Calm	1-3	4-7	8-12	13-18	19-24	>24	Total
Wind	Direction (from)								
	WNW	0	0	1	0	0	0	0	1
	TOTAL	0	0	1	0	0	0	0	1

Stability Class G		Calm	1-3	4-7	8-12	13-18	19-24	>24	Total
Wind	Direction (from)								
	W	0	0	0	1	0	0	0	1
	WNW	0	0	0	3	0	0	0	3
	TOTAL	0	0	0	4	0	0	0	4

Kewaunee Nuclear Power Plant  
 1994 Meteorological Data  
 Release Permit: 9403

Stability Class E	Calm	1-3	4-7	8-12	13-18	19-24	>24	Total
Wind Direction (from)								
SSW	0	0	1	0	0	0	0	1
WSW	0	1	1	0	0	0	0	2
W	0	0	1	0	0	0	0	1
TOTAL	0	1	3	0	0	0	0	4

Stability Class F	Calm	1-3	4-7	8-12	13-18	19-24	>24	Total
Wind Direction (from)								
WSW	0	0	1	0	0	0	0	1
TOTAL	0	0	1	0	0	0	0	1

Kewaunee Nuclear Power Plant  
 1994 Meteorological Data  
 Release Permit: 9404

Stability Class D	Calm	1-3	4-7	8-12	13-18	19-24	>24	Total
Wind Direction (from)								
WNW	0	0	0	1	0	0	0	1
TOTAL	0	0	0	1	0	0	0	1

**Kewaunee Nuclear Power Plant  
1994 Meteorological Data  
Release Permit: 9405**

Stability Class A		Calm	1-3	4-7	8-12	13-18	19-24	>24	Total
Wind Direction (from)									
W		0	0	0	0	21	5	0	26
TOTAL		0	0	0	0	21	5	0	26

Stability Class B		Calm	1-3	4-7	8-12	13-18	19-24	>24	Total
Wind Direction (from)									
W		0	0	0	0	4	0	0	4
TOTAL		0	0	0	0	4	0	0	4

Stability Class C		Calm	1-3	4-7	8-12	13-18	19-24	>24	Total
Wind Direction (from)									
W		0	0	0	0	3	0	0	3
TOTAL		0	0	0	0	3	0	0	3

Stability Class D		Calm	1-3	4-7	8-12	13-18	19-24	>24	Total
Wind Direction (from)									
W		0	0	0	1	4	0	0	5
WNW		0	0	0	0	14	2	0	16
NW		0	0	0	0	3	0	0	3
TOTAL		0	0	0	1	21	2	0	24

Kewaunee Nuclear Power Plant  
 1994 Meteorological Data  
 Release Permit: 9406

Stability Class A	Calm	1-3	4-7	8-12	13-18	19-24	>24	Total
Wind Direction (from)								
NNE	0	0	0	0	1	3	0	4
NE	0	0	0	0	4	6	3	13
ENE	0	0	0	0	3	4	0	7
E	0	0	0	0	0	1	0	1
TOTAL	0	0	0	0	8	14	3	25

Kewaunee Nuclear Power Plant  
 1994 Meteorological Data  
 Release Permit: 9407

Stability Class C		Calm	1-3	4-7	8-12	13-18	19-24	>24	Total
Wind	Direction (from)								
	NE	0	0	1	0	0	0	0	1
	ENE	0	0	2	5	0	0	0	7
	TOTAL	0	0	3	5	0	0	0	8

Stability Class D		Calm	1-3	4-7	8-12	13-18	19-24	>24	Total
Wind	Direction (from)								
	ENE	0	0	1	3	0	0	0	4
	E	0	0	2	0	0	0	0	2
	SE	0	0	1	0	0	0	0	1
	W	0	0	0	0	0	2	0	2
	TOTAL	0	0	4	3	0	2	0	9

Stability Class E		Calm	1-3	4-7	8-12	13-18	19-24	>24	Total
Wind	Direction (from)								
	ENE	0	0	0	1	0	0	0	1
	W	0	0	0	0	4	9	0	13
	WNW	0	0	0	1	5	0	0	6
	TOTAL	0	0	0	2	9	9	0	20

Kewaunee Nuclear Power Plant  
 1994 Meteorological Data  
 Release Permit: 9407 (continued)

Stability Class F	Calm	1-3	4-7	8-12	13-18	19-24	>24	Total
Wind Direction (from)								
W	0	0	0	1	0	0	0	1
WNW	0	0	0	2	0	0	0	2
NW	0	0	0	1	0	0	0	1
TOTAL	0	0	0	4	0	0	0	4

Stability Class G	Calm	1-3	4-7	8-12	13-18	19-24	>24	Total
Wind Direction (from)								
W	0	0	0	1	0	0	0	1
NW	0	0	1	0	0	0	0	1
NNW	0	0	4	2	0	0	0	6
TOTAL	0	0	5	3	0	0	0	8



Kewaunee Nuclear Power Plant  
 1994 Meteorological Data  
 Release Permit: 9408

Stability Class A	Calm	1-3	4-7	8-12	13-18	19-24	>24	Total
Wind Direction (from)								
N	19	0	0	0	0	0	0	19
S	4	0	0	0	0	0	0	4
SSW	3	0	0	0	0	0	0	3
W	1	0	0	0	0	0	0	1
NW	1	0	0	0	0	0	0	1
NNW	13	0	0	0	0	0	0	13
TOTAL	41	0	0	0	0	0	0	41

Kewaunee Nuclear Power Plant  
1994 Meteorological Data  
Release Permit: 9409

Stability Class A

Wind Direction (from)	Calm	1-3	4-7	8-12	13-18	19-24	>24	Total
NNW	0	0	5	0	0	0	0	5
TOTAL	0	0	5	0	0	0	0	5

Kewaunee Nuclear Power Plant  
 1994 Meteorological Data  
 Release Permit: 9410

Stability Class A		Calm	1-3	4-7	8-12	13-18	19-24	>24	Total
Wind Direction (from)									
N		71	0	0	0	0	0	0	71
NNW		33	0	0	0	0	0	0	33
TOTAL		104	0	0	0	0	0	0	104

Stability Class B		Calm	1-3	4-7	8-12	13-18	19-24	>24	Total
Wind Direction (from)									
N		15	0	0	0	0	0	0	15
NNW		4	0	0	0	0	0	0	4
TOTAL		19	0	0	0	0	0	0	19

Stability Class C		Calm	1-3	4-7	8-12	13-18	19-24	>24	Total
Wind Direction (from)									
N		16	0	0	0	0	0	0	16
NNW		1	0	0	0	0	0	0	1
TOTAL		17	0	0	0	0	0	0	17

Stability Class D		Calm	1-3	4-7	8-12	13-18	19-24	>24	Total
Wind Direction (from)									
N		36	0	0	0	0	0	0	36
NNW		13	0	0	0	0	0	0	13
TOTAL		49	0	0	0	0	0	0	49

Kewaunee Nuclear Power Plant  
 1994 Meteorological Data  
 Release Permit: 9410 (continued)

Stability Class E	Calm	1-3	4-7	8-12	13-18	19-24	>24	Total
Wind Direction (from)								
N	18	0	0	0	0	0	0	18
NNW	12	0	0	0	0	0	0	12
TOTAL	30	0	0	0	0	0	0	30

Stability Class F	Calm	1-3	4-7	8-12	13-18	19-24	>24	Total
Wind Direction (from)								
N	15	0	0	0	0	0	0	15
NNW	10	0	0	0	0	0	0	10
TOTAL	25	0	0	0	0	0	0	25

Stability Class G	Calm	1-3	4-7	8-12	13-18	19-24	>24	Total
Wind Direction (from)								
N	11	0	0	0	0	0	0	11
NNW	14	0	0	0	0	0	0	14
TOTAL	25	0	0	0	0	0	0	25

Kewaunee Nuclear Power Plant  
 1994 Meteorological Data  
 Release Permit: 9411

Stability Class B

Wind Direction (from)	Calm	1-3	4-7	8-12	13-18	19-24	>24	Total
NNW	1	0	0	0	0	0	0	1
TOTAL	1	0	0	0	0	0	0	1

Stability Class D

Wind Direction (from)	Calm	1-3	4-7	8-12	13-18	19-24	>24	Total
N	1	0	0	0	0	0	0	1
NNW	3	0	0	0	0	0	0	3
TOTAL	4	0	0	0	0	0	0	4

**Kewaunee Nuclear Power Plant**  
**1994 Meteorological Data**  
**Release Permit: 9412**

Stability Class A	Calm	1-3	4-7	8-12	13-18	19-24	>24	Total
Wind Direction (from)								
N	5	0	0	0	0	0	0	5
TOTAL	5	0	0	0	0	0	0	5

**Kewaunee Nuclear Power Plant  
1994 Meteorological Data  
Release Permit: 9413**

Stability Class A		Calm	1-3	4-7	8-12	13-18	19-24	>24	Total
Wind Direction (from)									
WSW		0	0	0	0	0	4	0	4
W		0	0	0	0	3	20	1	24
WNW		0	0	0	0	1	0	0	1
TOTAL		0	0	0	0	4	24	1	29

Stability Class B		Calm	1-3	4-7	8-12	13-18	19-24	>24	Total
Wind Direction (from)									
WSW		0	0	0	0	0	1	0	1
TOTAL		0	0	0	0	0	1	0	1

Stability Class C		Calm	1-3	4-7	8-12	13-18	19-24	>24	Total
Wind Direction (from)									
SSE		0	0	0	1	0	0	0	1
WSW		0	0	0	0	0	1	0	1
W		0	0	0	0	0	1	0	1
TOTAL		0	0	0	1	0	2	0	3

Kewaunee Nuclear Power Plant  
 1994 Meteorological Data  
 Release Permit: 9413

Stability Class D	Calm	1-3	4-7	8-12	13-18	19-24	>24	Total
Wind Direction (from)								
S	0	0	1	5	0	0	0	6
SSW	0	0	1	0	0	0	0	1
WSW	0	0	0	0	0	3	0	3
W	0	0	0	0	0	2	1	3
TOTAL	0	0	2	5	0	5	1	13

Stability Class E	Calm	1-3	4-7	8-12	13-18	19-24	>24	Total
Wind Direction (from)								
SSW	0	0	0	2	0	0	0	2
SW	0	0	0	0	2	2	0	4
WSW	0	0	0	0	0	1	0	1
TOTAL	0	0	0	2	2	3	0	7



Kewaunee Nuclear Power Plant  
 1994 Meteorological Data  
 Release Permit: 9414

Stability Class A		Calm	1-3	4-7	8-12	13-18	19-24	>24	Total
Wind	Direction (from)								
	SSE	0	0	1	3	0	0	0	4
	W	0	0	0	11	4	0	0	15
	WNW	0	0	4	4	2	0	0	10
	NW	0	0	1	1	0	0	0	2
	NNW	0	0	2	2	2	0	0	6
	TOTAL	0	0	8	21	8	0	0	37

Stability Class B		Calm	1-3	4-7	8-12	13-18	19-24	>24	Total
Wind	Direction (from)								
	SSE	0	0	1	1	0	0	0	2
	NW	0	0	0	2	0	0	0	2
	TOTAL	0	0	1	3	0	0	0	4

Stability Class C		Calm	1-3	4-7	8-12	13-18	19-24	>24	Total
Wind	Direction (from)								
	WSW	0	1	0	0	0	0	0	1
	W	0	0	0	1	1	0	0	2
	TOTAL	0	1	0	1	1	0	0	3

Kewaunee Nuclear Power Plant  
 1994 Meteorological Data  
 Release Permit: 9414 (continued)

Stability Class D	Calm	1-3	4-7	8-12	13-18	19-24	>24	Total
Wind Direction (from)								
N	0	0	0	0	1	0	0	1
NNE	0	0	0	1	0	0	0	1
SSE	0	0	1	2	0	0	0	3
W	0	0	0	11	3	0	0	14
WNW	0	0	0	3	0	0	0	3
NW	0	0	1	1	0	0	0	2
NNW	0	0	0	12	1	0	0	13
TOTAL	0	0	2	30	5	0	0	37

Stability Class E	Calm	1-3	4-7	8-12	13-18	19-24	>24	Total
Wind Direction (from)								
NNE	0	0	0	0	2	0	0	2
NE	0	1	0	0	0	0	0	1
SSE	0	0	3	0	1	0	0	4
W	0	0	2	2	0	0	0	4
WNW	0	0	3	1	0	0	0	4
NW	0	0	1	2	0	0	0	3
NNW	0	0	0	2	0	0	0	2
TOTAL	0	1	9	7	3	0	0	20

Kewaunee Nuclear Power Plant  
 1994 Meteorological Data  
 Release Permit: 9414 (continued)

Stability Class F	Calm	1-3	4-7	8-12	13-18	19-24	>24	Total
Wind Direction (from)								
N	0	2	0	0	0	0	0	2
NNE	0	2	1	0	0	0	0	3
NE	0	2	1	0	0	0	0	3
ENE	0	0	1	0	0	0	0	1
SE	0	0	2	0	0	0	0	2
SSE	0	0	0	3	2	0	0	5
NW	0	0	1	0	0	0	0	1
NNW	0	1	0	0	0	0	0	1
TOTAL	0	7	6	3	2	0	0	18

Stability Class G	Calm	1-3	4-7	8-12	13-18	19-24	>24	Total
Wind Direction (from)								
N	0	3	1	0	0	0	0	4
NE	0	1	0	0	0	0	0	1
ESE	0	0	2	0	0	0	0	2
SE	0	0	2	0	0	0	0	2
SSE	0	0	0	0	6	0	0	6
WSW	0	3	2	0	0	0	0	5
W	0	3	6	3	0	0	0	12
WNW	0	1	6	1	0	0	0	8
NW	0	2	1	1	0	0	0	4
NNW	0	5	1	0	0	0	0	6
TOTAL	0	18	21	5	6	0	0	50

Kewaunee Nuclear Power Plant  
 1994 Meteorological Data  
 Release Permit: 9415

Stability Class A	Calm	1-3	4-7	8-12	13-18	19-24	>24	Total
Wind Direction (from)								
NE	0	0	1	0	0	0	0	1
TOTAL	0	0	1	0	0	0	0	1

Kewaunee Nuclear Power Plant  
 1994 Meteorological Data  
 Release Permit: 9416

Stability Class E	Calm	1-3	4-7	8-12	13-18	19-24	>24	Total
Wind Direction (from)								
SE	0	0	2	0	0	0	0	2
S	0	0	2	1	0	0	0	3
SSW	0	0	1	0	0	0	0	1
TOTAL	0	0	5	1	0	0	0	6

Stability Class F	Calm	1-3	4-7	8-12	13-18	19-24	>24	Total
Wind Direction (from)								
SSE	0	0	0	1	8	2	0	11
S	0	0	8	1	0	0	0	9
SSW	0	0	1	0	0	0	0	1
TOTAL	0	0	9	2	8	2	0	21

Stability Class G	Calm	1-3	4-7	8-12	13-18	19-24	>24	Total
Wind Direction (from)								
SSE	0	0	3	7	8	6	0	24
S	0	0	1	0	0	0	0	1
SSW	0	0	1	0	0	0	0	1
TOTAL	0	0	5	7	8	6	0	26

Kewaunee Nuclear Power Plant  
1994 Meteorological Data  
Release Permit: 9417

The meteorological tower was not in service for this 32 minute release.

Kewaunee Nuclear Power Plant  
 1994 Meteorological Data  
 Release Permit: 9418

Stability Class A	Calm	1-3	4-7	8-12	13-18	19-24	>24	Total
Wind Direction (from)								
NNE	0	0	1	0	0	0	0	1
NE	0	0	3	0	0	0	0	3
E	0	1	0	0	0	0	0	1
TOTAL	0	1	4	0	0	0	0	5

Stability Class E	Calm	1-3	4-7	8-12	13-18	19-24	>24	Total
Wind Direction (from)								
NE	0	0	2	0	0	0	0	2
TOTAL	0	0	2	0	0	0	0	2

Stability Class D	Calm	1-3	4-7	8-12	13-18	19-24	>24	Total
Wind Direction (from)								
NE	0	1	1	0	0	0	0	2
ENE	0	1	4	0	0	0	0	5
ESE	0	1	0	0	0	0	0	1
SE	0	1	0	0	0	0	0	1
TOTAL	0	4	5	0	0	0	0	9

Kewaunee Nuclear Power Plant  
 1994 Meteorological Data  
 Release Permit: 9418 (continued)

Stability Class E	Calm	1-3	4-7	8-12	13-18	19-24	>24	Total
Wind Direction (from)								
NE	0	0	4	0	0	0	0	4
ENE	0	1	1	0	0	0	0	2
E	0	2	2	0	0	0	0	4
ESE	0	2	0	0	0	0	0	2
TOTAL	0	5	7	0	0	0	0	12

Stability Class F	Calm	1-3	4-7	8-12	13-18	19-24	>24	Total
Wind Direction (from)								
NNE	0	0	1	0	0	0	0	1
NE	0	1	2	0	0	0	0	3
ENE	0	1	3	0	0	0	0	4
E	0	1	0	0	0	0	0	1
SE	0	1	0	0	0	0	0	1
TOTAL	0	4	6	0	0	0	0	10

Stability Class G	Calm	1-3	4-7	8-12	13-18	19-24	>24	Total
Wind Direction (from)								
NE	0	1	6	0	0	0	0	7
TOTAL	0	1	6	0	0	0	0	7



Kewaunee Nuclear Power Plant  
1994 Meteorological Data  
Release Permit: 9419

Stability Class A	Calm	1-3	4-7	8-12	13-18	19-24	>24	Total
Wind Direction (from)								
ENE	0	0	0	1	0	0	0	1
TOTAL	0	0	0	1	0	0	0	1

Kewaunee Nuclear Power Plant  
 1994 Meteorological Data  
 Release Permit: 9420

Stability Class A	Calm	1-3	4-7	8-12	13-18	19-24	>24	Total
Wind Direction (from)								
S	0	0	1	2	0	0	0	3
TOTAL	0	0	1	2	0	0	0	3

Stability Class D	Calm	1-3	4-7	8-12	13-18	19-24	>24	Total
Wind Direction (from)								
S	0	0	1	0	0	0	0	1
WSW	0	0	0	1	0	0	0	1
TOTAL	0	0	1	1	0	0	0	2

**Kewaunee Nuclear Power Plant  
1994 Meteorological Data  
Release Permit: 9421**

Stability Class A		Calm	1-3	4-7	8-12	13-18	19-24	>24	Total
Wind	Direction (from)								
	N	0	0	1	5	2	0	0	8
	NNE	0	0	0	13	2	0	0	15
	NE	0	0	0	6	1	0	0	7
	TOTAL	0	0	1	24	5	0	0	30

Stability Class B		Calm	1-3	4-7	8-12	13-18	19-24	>24	Total
Wind	Direction (from)								
	N	0	0	1	3	1	0	0	5
	NNE	0	0	0	1	0	0	0	1
	TOTAL	0	0	1	4	1	0	0	6

Stability Class C		Calm	1-3	4-7	8-12	13-18	19-24	>24	Total
Wind	Direction (from)								
	N	0	0	1	1	0	0	0	2
	NNE	0	0	1	0	0	0	0	1
	TOTAL	0	0	2	1	0	0	0	3

Stability Class D		Calm	1-3	4-7	8-12	13-18	19-24	>24	Total
Wind	Direction (from)								
	NNE	0	0	2	0	0	0	0	2
	TOTAL	0	0	2	0	0	0	0	2

**Kewaunee Nuclear Power Plant  
1994 Meteorological Data  
Release Permit: 9422**

Stability Class A		Calm	1-3	4-7	8-12	13-18	19-24	>24	Total
Wind Direction (from)									
SSW		0	0	2	3	0	0	0	5
SW		0	0	0	4	2	0	0	6
WSW		0	0	0	2	0	0	0	2
TOTAL		0	0	2	9	2	0	0	13

Stability Class B		Calm	1-3	4-7	8-12	13-18	19-24	>24	Total
Wind Direction (from)									
S		0	0	2	0	0	0	0	2
TOTAL		0	0	2	0	0	0	0	2

Stability Class C		Calm	1-3	4-7	8-12	13-18	19-24	>24	Total
Wind Direction (from)									
SSE		0	0	1	0	0	0	0	1
S		0	0	4	1	0	0	0	5
TOTAL		0	0	5	1	0	0	0	6

Stability Class D		Calm	1-3	4-7	8-12	13-18	19-24	>24	Total
Wind Direction (from)									
SSE		0	0	1	2	0	0	0	3
S		0	0	9	1	0	0	0	10
SSW		0	1	2	0	0	0	0	3
TOTAL		0	1	12	3	0	0	0	16

Kewaunee Nuclear Power Plant  
 1994 Meteorological Data  
 Release Permit: 9422 (continued)

Stability Class E	Calm	1-3	4-7	8-12	13-18	19-24	>24	Total
Wind Direction (from)								
SSE	0	0	0	3	0	0	0	3
S	0	1	5	0	0	0	0	6
SSW	0	3	2	0	0	0	0	5
SW	0	1	0	0	0	0	0	1
TOTAL	0	5	7	3	0	0	0	15

Stability Class F	Calm	1-3	4-7	8-12	13-18	19-24	>24	Total
Wind Direction (from)								
SSE	0	0	0	0	1	0	0	1
TOTAL	0	0	0	0	1	0	0	1

Kewaunee Nuclear Power Plant  
 1994 Meteorological Data  
 Release Permit: 9423

Stability Class A	Calm	1-3	4-7	8-12	13-18	19-24	>24	Total
Wind Direction (from)								
SW	0	0	0	0	1	0	0	1
WSW	0	0	0	4	9	1	0	14
NNW	0	0	0	0	1	0	0	1
TOTAL	0	0	0	4	11	1	0	16

Stability Class B	Calm	1-3	4-7	8-12	13-18	19-24	>24	Total
Wind Direction (from)								
N	0	0	0	1	0	0	0	1
WSW	0	0	0	0	1	0	0	1
NNW	0	0	0	0	1	0	0	1
TOTAL	0	0	0	1	2	0	0	3

Stability Class C	Calm	1-3	4-7	8-12	13-18	19-24	>24	Total
Wind Direction (from)								
NW	0	0	1	0	0	0	0	1
TOTAL	0	0	1	0	0	0	0	1

Stability Class D	Calm	1-3	4-7	8-12	13-18	19-24	>24	Total
Wind Direction (from)								
N	0	0	2	0	0	0	0	2
WSW	0	0	1	2	1	0	0	4
TOTAL	0	0	3	2	1	0	0	6

**Kewaunee Nuclear Power Plant  
1994 Meteorological Data  
Release Permit: 9423 (continued)**

Stability Class E	Calm	1-3	4-7	8-12	13-18	19-24	>24	Total
Wind Direction (from)								
NNE	0	0	1	0	0	0	0	1
NE	0	0	1	0	0	0	0	1
ENE	0	0	1	0	0	0	0	1
SE	0	0	1	0	0	0	0	1
SSE	0	0	1	0	0	0	0	1
SW	0	0	0	2	0	0	0	2
WSW	0	0	1	0	0	0	0	1
TOTAL	0	0	6	2	0	0	0	8

Stability Class F	Calm	1-3	4-7	8-12	13-18	19-24	>24	Total
Wind Direction (from)								
NE	0	0	1	0	0	0	0	1
WSW	0	0	0	1	0	0	0	1
WNW	0	0	0	1	0	0	0	1
TOTAL	0	0	1	2	0	0	0	3

Stability Class G	Calm	1-3	4-7	8-12	13-18	19-24	>24	Total
Wind Direction (from)								
SE	0	0	1	0	0	0	0	1
SSE	0	0	2	0	0	0	0	2
SSW	0	0	1	0	0	0	0	1
TOTAL	0	0	4	0	0	0	0	4

Kewaunee Nuclear Power Plant  
 1994 Meteorological Data  
 Release Permit: 9424

Stability Class A	Calm	1-3	4-7	8-12	13-18	19-24	>24	Total
Wind Direction (from)								
NNE	0	0	2	0	0	0	0	2
NE	0	0	1	0	0	0	0	1
TOTAL	0	0	3	0	0	0	0	3

Stability Class C	Calm	1-3	4-7	8-12	13-18	19-24	>24	Total
Wind Direction (from)								
N	0	0	1	1	0	0	0	2
NNE	0	0	3	0	0	0	0	3
NE	0	0	1	0	0	0	0	1
TOTAL	0	0	5	1	0	0	0	6

Stability Class D	Calm	1-3	4-7	8-12	13-18	19-24	>24	Total
Wind Direction (from)								
N	0	0	2	3	0	0	0	5
NNE	0	0	5	0	0	0	0	5
NE	0	0	1	0	0	0	0	1
TOTAL	0	0	8	3	0	0	0	11

Stability Class E	Calm	1-3	4-7	8-12	13-18	19-24	>24	Total
Wind Direction (from)								
N	0	0	2	3	0	0	0	5
NNE	0	0	12	0	0	0	0	12
TOTAL	0	0	14	3	0	0	0	17



Kewaunee Nuclear Power Plant  
 1994 Meteorological Data  
 Release Permit: 9424 (continued)

Stability Class F		Calm	1-3	4-7	8-12	13-18	19-24	>24	Total
Wind	Direction (from)								
	N	0	0	1	0	0	0	0	1
	NNE	0	0	2	0	0	0	0	2
	TOTAL	0	0	3	0	0	0	0	3

Stability Class G		Calm	1-3	4-7	8-12	13-18	19-24	>24	Total
Wind	Direction (from)								
	NNW	0	0	1	0	0	0	0	1
	TOTAL	0	0	1	0	0	0	0	1

Kewaunee Nuclear Power Plant  
1994 Meteorological Data  
Release Permit: 9425

Stability Class A	Calm	1-3	4-7	8-12	13-18	19-24	>24	Total
Wind Direction (from)								
WSW	0	0	0	0	0	3	1	4
W	0	0	0	0	1	6	1	8
TOTAL	0	0	0	0	1	9	2	12

Stability Class B	Calm	1-3	4-7	8-12	13-18	19-24	>24	Total
Wind Direction (from)								
W	0	0	0	0	1	1	0	2
TOTAL	0	0	0	0	1	1	0	2

Stability Class C	Calm	1-3	4-7	8-12	13-18	19-24	>24	Total
Wind Direction (from)								
W	0	0	0	0	2	4	0	6
TOTAL	0	0	0	0	2	4	0	6

Stability Class D	Calm	1-3	4-7	8-12	13-18	19-24	>24	Total
Wind Direction (from)								
W	0	0	0	0	4	2	0	6
TOTAL	0	0	0	0	4	2	0	6

Stability Class E	Calm	1-3	4-7	8-12	13-18	19-24	>24	Total
Wind Direction (from)								
W	0	0	1	5	0	0	0	6
TOTAL	0	0	1	5	0	0	0	6

Kewaunee Nuclear Power Plant  
 1994 Meteorological Data  
 Release Permit: 9425 (continued)

Stability Class F	Calm	1-3	4-7	8-12	13-18	19-24	>24	Total
Wind Direction (from)								
SW	0	0	2	0	0	0	0	2
WSW	0	0	1	1	0	0	0	2
W	0	0	2	4	0	0	0	6
WNW	0	0	0	5	0	0	0	5
TOTAL	0	0	5	10	0	0	0	15

Stability Class G	Calm	1-3	4-7	8-12	13-18	19-24	>24	Total
Wind Direction (from)								
WSW	0	0	6	0	0	0	0	6
W	0	0	2	2	0	0	0	4
TOTAL	0	0	8	2	0	0	0	10

Kewaunee Nuclear Power Plant  
 1994 Meteorological Data  
 Release Permit: 9426

Stability Class G

Wind Direction (from)	Calm	1-3	4-7	8-12	13-18	19-24	>24	Total
N	0	0	0	11	1	0	0	12
NE	0	0	0	1	0	0	0	1
SSE	0	0	1	0	0	0	0	1
WSW	0	0	0	1	4	0	0	5
NW	0	0	0	1	0	0	0	1
NNW	0	0	1	11	1	0	0	13
TOTAL	0	0	2	25	6	0	0	33

Kewaunee Nuclear Power Plant  
 1994 Meteorological Data  
 Release Permit: 9427

Stability Class A	Calm	1-3	4-7	8-12	13-18	19-24	>24	Total
Wind Direction (from)								
SSW	0	0	8	0	0	0	0	8
SW	0	1	9	0	0	0	0	10
WSW	0	0	4	0	0	0	0	4
TOTAL	0	1	21	0	0	0	0	22

Stability Class B	Calm	1-3	4-7	8-12	13-18	19-24	>24	Total
Wind Direction (from)								
SSW	0	0	1	0	0	0	0	1
TOTAL	0	0	1	0	0	0	0	1

Stability Class D	Calm	1-3	4-7	8-12	13-18	19-24	>24	Total
Wind Direction (from)								
SW	0	0	1	0	0	0	0	1
WSW	0	0	1	0	0	0	0	1
TOTAL	0	0	2	0	0	0	0	2

Stability Class E	Calm	1-3	4-7	8-12	13-18	19-24	>24	Total
Wind Direction (from)								
SW	0	0	2	0	0	0	0	2
WSW	0	0	1	0	0	0	0	1
TOTAL	0	0	3	0	0	0	0	3

Kewaunee Nuclear Power Plant  
 1994 Meteorological Data  
 Release Permit: 9427 (continued)

Stability Class F	Calm	1-3	4-7	8-12	13-18	19-24	>24	Total
Wind Direction (from)								
WSW	0	0	6	0	0	0	0	6
W	0	0	2	0	0	0	0	2
TOTAL	0	0	8	0	0	0	0	8

Stability Class G	Calm	1-3	4-7	8-12	13-18	19-24	>24	Total
Wind Direction (from)								
WSW	0	0	4	1	0	0	0	5
W	0	0	2	1	0	0	0	3
TOTAL	0	0	6	2	0	0	0	8

APPENDIX B

**KEWAUNEE NUCLEAR POWER PLANT  
OFFSITE DOSE CALCULATION MANUAL**

**Revision 7**

**April 7, 1994**

Reviewed By: *M. L. ...* Date: 4-7-94  
Plant Operations Review Committee

Approved By: *[Signature]* Date: 4/12/94  
Superintendent - Plant Radiation Protection

Approved By: *Wally Flint* Date: 4/7/94  
Superintendent - Plant Radiochemistry

Approved By: *[Signature]* Date: 4-7-94  
Superintendent-Nuclear Licensing & Systems

**KEWAUNEE NUCLEAR POWER PLANT  
OFFSITE DOSE CALCULATION MANUAL**

**Revision 7**

**April 7, 1994**



## CURRENT STATUS ODCM PAGES

Page No.	Revision No.	Date	Page No.	Revision No.	Date
Table of Contents	--	--	53 (Table 2.13)	5	02-15-93
1	5	02-15-93	54 (Table 2.14)	5	02-15-93
2	5	02-15-93	55 (Table 2.14)	5	02-15-93
3	5	02-15-93	56 (Table 2.15)	5	02-15-93
4	5	02-15-93	57 (Table 2.15)	5	02-15-93
5	5	02-15-93	58	5	02-15-93
6	5	02-15-93	59	5	02-15-93
7	5	02-15-93	60	5	02-15-93
8	5	02-15-93	61	5	02-15-93
9	5	02-15-93	62	5	02-15-93
10	5	02-15-93	63	5	02-15-93
11	5	02-15-93	64	5	02-15-93
12	5	02-15-93	65	5	02-15-93
12A	6	06-04-93	66	5	02-15-93
13 (Figure 1)	6	06-04-93	67	5	02-15-93
14 (Table 1.1)	7	04-07-94	68	5	02-15-93
15 (Table 1.2)	5	02-15-93	69	5	02-15-93
16 (Table 1.2)	5	02-15-93	70	5	02-15-93
17 (Table 1.3)	5	02-15-93	71	5	02-15-93
18	5	02-15-93	72	5	02-15-93
19	5	02-15-93	73	5	02-15-93
20	5	02-15-93	74	5	02-15-93
21	5	02-15-93	75	5	02-15-93
22	5	02-15-93	76	5	02-15-93
23	5	02-15-93	77	5	02-15-93
24	5	02-15-93	78	5	02-15-93
25	5	02-15-93	79	5	02-15-93
26	5	02-15-93	80	5	02-15-93
27	5	02-15-93	81	5	02-15-93
28	5	02-15-93	82	5	02-15-93
29 (Figure 2)	5	02-15-93	83	5	02-15-93
30 (Figure 3)	5	02-15-93	84	5	02-15-93
31 (Table 2.1)	5	02-15-93	85	5	02-15-93
32 (Table 2.2)	7	04-07-94	86 (Table 3.1)	5	02-15-93
33 (Table 2.3)	5	02-15-93	87 (Table 3.2)	5	02-15-93
34 (Table 2.4)	5	02-15-93	88 (Table 3.2)	5	02-15-93
35 (Table 2.4)	5	02-15-93	89 (Table 3.3)	5	02-15-93
36 (Table 2.5)	5	02-15-93	90 (Table 3.3)	5	02-15-93
37 (Table 2.5)	5	02-15-93	91 (Table 3.4)	5	02-15-93
38 (Table 2.6)	5	02-15-93	92 (Table 4.0)	5	02-15-93
39 (Table 2.6)	5	02-15-93	93 (Table 4.1)	5	02-15-93
40 (Table 2.7)	5	02-15-93	94 (Table 4.2)	5	02-15-93
41 (Table 2.7)	5	02-15-93	95 (Table 4.3)	5	02-15-93
42 (Table 2.8)	5	02-15-93	96 (Table 4.3)	5	02-15-93
43 (Table 2.8)	5	02-15-93	97 (Table 4.4)	5	02-15-93
44 (Table 2.9)	5	02-15-93	98 (Table 4.4)	5	02-15-93
45 (Table 2.9)	5	02-15-93	99 (Table 4.5)	5	02-15-93
46 (Table 2.10)	5	02-15-93	100 (Table 4.5)	5	02-15-93
47 (Table 2.10)	5	02-15-93	A-1	5	02-15-93
48 (Table 2.11)	5	02-15-93	A-2	5	02-15-93
49 (Table 2.11)	5	02-15-93	A-3	5	02-15-93
50 (Table 2.12)	5	02-15-93	A-4	5	02-15-93
51 (Table 2.12)	5	02-15-93	A-5 (Table A-1)	5	02-15-93
52 (Table 2.13)	5	02-15-93	B-1	5	02-15-93
			B-2	5	02-15-93

## CURRENT STATUS ODCM PAGES

Page No.	Revision No.	Date
B-3	5	02-15-93
B-4	5	02-15-93
B-5	5	02-15-93
B-6 (Table B-1)	5	02-15-93
C-1	5	02-15-93
C-2	5	02-15-93
C-3	5	02-15-93
C-4 (Table C-1)	5	02-15-93
C-5 (Table C-1)	5	02-15-93
C-6 (Table C-1)	5	02-15-93
D-1	5	02-15-93
D-2	5	02-15-93
D-3 (Figure D-1)	5	02-15-93
E-1	5	02-15-93
E-2	5	02-15-93
E-3	5	02-15-93
E-4	5	02-15-93
E-5	5	02-15-93
E-6	5	02-15-93
E-7	5	02-15-93
E-8	5	02-15-93
E-9	5	02-15-93

## Abstract

This document has been developed in accordance with the Wisconsin Public Service Corporation (WPSC) commitment made by letter dated August 21, 1984 (from D. C. Hintz to S. A. Varga). It provides the current methodologies and parameters to be used in the calculation of offsite doses due to radioactive gaseous and liquid effluents and gaseous and liquid effluent monitoring alarm/trip setpoints for the Kewaunee Nuclear Power Plant. To develop this document, WPSC contracted the J. Stewart Bland Consultants, Inc. of Maryland; however, rigorous review and final acceptance of this document has been provided by WPSC. Implementation of this document is the responsibility of WPSC.

December 18, 1984

**KEWAUNEE NUCLEAR POWER PLANT  
OFFSITE DOSE CALCULATION MANUAL**

**Table of Contents**

<b>Introduction</b> .....	1
<b>Definitions</b> .....	1
<b>1.0 Liquid Effluents</b> .....	4
1.1 Radiation Monitoring Instrumentation and Controls .....	4
1.2 Liquid Effluent Monitor Setpoint Determination .....	4
1.2.1 Liquid Effluent Monitors (Radwaste, Steam Generator Blowdown and Service Water) .....	5
1.2.2 Conservative Default Values .....	7
1.3 Liquid Effluent Concentration Limits - 10 CFR 20 .....	7
1.4 Liquid Effluent Dose Calculations - 10 CFR 50 .....	8
1.5 Liquid Effluent Dose Projections .....	11
1.6 Onsite Disposal of Low-Level Radioactively Contaminated Waste Streams .....	12
1.7 Heating Boiler Blowdown Operation with Primary-to-Secondary Leak ..	12A
Figure 1 - Liquid Radioactive Effluent Flow Diagram .....	13
Table 1.1 - Parameters for Liquid Alarm Setpoint Determinations .....	14
Table 1.2 - Site Related Ingestion Dose Commitment Factors .....	15
Table 1.3 - Bioaccumulation Factors (BFI) .....	17
<b>2.0 Gaseous Effluents</b> .....	18
2.1 Radiation Monitoring Instrumentation and Controls .....	18
2.2 Gaseous Effluent Monitor Setpoint Determination .....	18
2.2.1 Containment and Auxiliary Building Vent Monitor .....	18
2.2.2 Conservative Default Values .....	20

Table of Contents (Con't)

2.3	Gaseous Effluent Instantaneous Dose Rate Calculations-10 CFR 20 . . . . .	20
2.3.1	Site Boundary Dose Rate - Noble Gas . . . . .	20
2.3.2	Site Boundary Dose Rate - Radioiodine and Particulates . . . . .	21
2.4	Gaseous Effluent Dose Calculations - 10 CFR 50 . . . . .	22
2.4.1	Unrestricted Area Dose - Noble Gases . . . . .	22
2.4.2	Unrestricted Area Dose - Radioiodine and Particulates . . . . .	24
2.5	Gaseous Effluent Dose Projection . . . . .	26
2.6	Environmental Radiation Protection Standards - 40 CFR 190 . . . . .	27
2.7	Incineration of Radioactively Contaminated Oil . . . . .	28
Figure 2	- Gaseous Radioactive Effluent Flow Diagram . . . . .	29
Figure 3	- Simplified Heating Boiler Fuel Oil System Piping . . . . .	30
Table 2.1	- Dose Factors for Noble Gases . . . . .	31
Table 2.2	- Parameters for Gaseous Alarm Setpoint Determinations . . . . .	32
Table 2.3	- Controlling Locations, Pathways and Atmospheric Dispersion for Dose Calculations . . . . .	33
Table 2.4	Inhalation Pathway Dose Factors - ADULT . . . . .	34
Table 2.5	Inhalation Pathway Dose Factors - TEEN . . . . .	36
Table 2.6	Inhalation Pathway Dose Factors - CHILD . . . . .	38
Table 2.7	Inhalation Pathway Dose Factors - INFANT . . . . .	40
Table 2.8	Vegetation Pathway Dose Factors - ADULT . . . . .	42
Table 2.9	Vegetation Pathway Dose Factors - TEEN . . . . .	44
Table 2.10	Vegetation Pathway Dose Factors - CHILD . . . . .	46
Table 2.11	Grass-Cow-Milk Pathway Dose Factors - ADULT . . . . .	48
Table 2.12	Grass-Cow-Milk Pathway Dose Factors - TEEN . . . . .	50
Table 2.13	Grass-Cow-Milk Pathway Dose Factors - CHILD . . . . .	52
Table 2.14	Grass-Cow-Milk Pathway Dose Factors - INFANT . . . . .	54
Table 2.15	Ground Plane Pathway Dose Factors . . . . .	56
<b>3/4</b>	<b>Radiological Effluent Specifications and Surveillance Requirements . . . . .</b>	<b>58</b>
3/4.0	Applicability and Surveillance Requirements . . . . .	58
3/4.1	Radioactive Liquid Effluent Monitoring Instrumentation . . . . .	60
3/4.2	Radioactive Gaseous Effluent Monitoring Instrumentation . . . . .	61

Table of Contents (Con't)

3/4.3	Liquid Effluents	
	Concentration . . . . .	62
	Dose . . . . .	63
	Liquid Radwaste Treatment System . . . . .	64
3/4.4	Gaseous Effluents	
	Dose Rate . . . . .	65
	Dose- Noble Gases . . . . .	66
	Dose- Iodine-131, Iodine-133 and Radionuclides in Particulate Form . . . . .	67
	Gaseous Radwaste Treatment System . . . . .	68
3/4.5	Total Dose . . . . .	69
3/4.6	Radiological Environmental Monitoring Monitoring Program . . . . .	71
	Land Use Census . . . . .	73
	Interlaboratory Comparison Program . . . . .	74
3/4.7	Reporting Requirements . . . . .	75
3/4.8	Basis . . . . .	77
Table 3.1	Radioactive Liquid Effluent Monitoring Instrumentation . . . . .	86
Table 3.2	Radioactive Gaseous Effluent Monitoring Instrumentation . . . . .	87
Table 3.3	Radiological Environmental Monitoring Program . . . . .	89
Table 3.4	Reporting Levels or Radioactivity Concentrations in Environmental Samples . . . . .	91
Table 4.0	Frequency Notation . . . . .	92
Table 4.1	Radioactive Liquid Effluent Monitoring Instrumentation Surveillance Requirements . . . . .	93
Table 4.2	Radioactive Gaseous Effluent Monitoring Instrumentation Surveillance Requirements . . . . .	94
Table 4.3	Radioactive Liquid Waste Sampling and Analysis Program . . . . .	95
Table 4.4	Radioactive Gaseous Waste Sampling and Analysis Program . . . . .	97
Table 4.5	Detection Capabilities for Environmental Sample Analysis Lower Limit of Detection (LLD) . . . . .	99

**Appendices**

Appendix A	Technical Basis for Effective Dose Factors - Liquid Radioactive Effluents . . . . .	A-1
Table A-1	Adult Dose Contributions Fish and Drinking Water Pathways . . . . .	A-5

Table of Contents (Con't)

Appendix B	Technical Basis for Effective Dose Factors - Gaseous Radioactive Effluents . . . . .	B-1
Table B-1	Effective Dose Factors - Noble Gases . . . . .	B-6
Appendix C	Evaluation of Conservative, Default MPC Value for Liquid Effluents . . . . .	C-1
Table C-1	Calculation of Effective MPC . . . . .	C-4
Appendix D	Site Maps . . . . .	D-1
Figure D-1	Gaseous and Liquid Effluent Release Points . . . . .	D-3
Appendix E	Onsite Disposal of Low-Level Radioactively Contaminated Waste Streams . . . . .	E-1

# KEWAUNEE NUCLEAR POWER PLANT OFFSITE DOSE CALCULATION MANUAL

## Introduction

The Kewaunee Offsite Dose Calculation Manual (ODCM) describes the methodology and parameters used in: 1) the calculation of radioactive liquid and gaseous effluent monitoring instrumentation alarm/trip setpoints; and 2) the calculation of radioactive liquid and gaseous concentrations, dose rates and cumulative quarterly and yearly doses. The methodology stated in this manual is acceptable for use in demonstrating compliance with 10 CFR 20.106, 10 CFR 50, Appendix 1 and 40 CFR 190.

More conservative calculational methods and/or conditions (e.g., location and/or exposure pathways) expected to yield higher computed doses than appropriate for the maximally exposed person may be assumed in the dose evaluations.

The ODCM will be maintained at the station for use as a reference guide and training document of accepted methodologies and calculations. Changes will be made to the ODCM calculational methodologies and parameters as is deemed necessary to assure reasonable conservatism in keeping with the principles of 10 CFR 50.36a and Appendix 1 for demonstrating radioactive effluents are ALARA.

## Definitions

### 1. ACTION

ACTION shall be that part of a specification which prescribes remedial measures required under designated conditions.

### 2. GASEOUS RADWASTE TREATMENT SYSTEM

A GASEOUS RADWASTE TREATMENT SYSTEM is any system designed and installed to reduce radioactive gaseous effluents by collecting off-gases from the primary coolant system and providing for delay or holdup for the purpose of reducing the total radioactivity released to the environment.

### 3. INSTRUMENTATION SURVEILLANCE

- a. CHANNEL CHECK
- b. CHANNEL FUNCTIONAL TEST
- c. CHANNEL CALIBRATION



d. **SOURCE CHECK**

As defined in the Technical Specifications.

4. **MEMBER(S) OF THE PUBLIC**

**MEMBER(S) OF THE PUBLIC** shall include all persons who are not occupationally associated with the plant. This category does not include employees of the utility, its contractors or vendors. Also excluded from this category are persons who enter the site to service equipment or to make deliveries. This category does include persons who use portions of the site for recreational, occupational or other purposes not associated with the plant.

5. **OPERABLE-OPERABILITY**

As defined in the Technical Specifications.

6. **PURGE - PURGING**

**PURGE** or **PURGING** is the controlled process of discharging air or gas from a confinement to maintain temperature, pressure, humidity, concentration or other **OPERATING** condition, in such a manner that replacement air or gas is required to purify the confinement.

7. **RADIOLOGICAL ENVIRONMENTAL MONITORING MANUAL (REMM)**

The **REMM** shall contain the current methodology and parameters used in the conduct of the radiological environmental monitoring program.

8. **SITE BOUNDARY**

The **SITE BOUNDARY** shall be that line beyond which the land is neither owned, nor leased, nor otherwise controlled by the licensee.

9. **UNRESTRICTED AREA**

An **UNRESTRICTED AREA** shall be any area at or beyond the **SITE BOUNDARY** access to which is not controlled by the licensee for purposes of protection of individuals from exposure to radiation and radioactive materials, or any area within the **SITE BOUNDARY** used for residential quarters or for industrial, commercial, institutional, and/or recreational purposes.

10. **VENTILATION EXHAUST TREATMENT SYSTEM**

A **VENTILATION EXHAUST TREATMENT SYSTEM** is any system designed and

installed to reduce gaseous radioiodine or radioactive material in particulate form in effluents by passing ventilation or vent exhaust gases through charcoal absorbers and/or HEPA filters for the purpose of removing iodines or particulates from the gaseous exhaust stream prior to the release to the environment. Such a system is not considered to have any effect on noble gas effluents. Engineered Safety Feature atmospheric cleanup systems (i.e., Auxiliary Building special ventilation, Shield Building ventilation, spent fuel pool ventilation) are not considered to be VENTILATION EXHAUST TREATMENT SYSTEM components.

## 1.0 Liquid Effluents

### 1.1 Radiation Monitoring Instrumentation and Controls

The liquid effluent monitoring instrumentation and controls installed at Kewaunee for controlling and monitoring normal radioactive material releases in accordance with 10 CFR 50, Appendix A, Criteria 60 and 64, are summarized as follows:

- 1) Alarm (and Automatic Termination) - R-18 provides this function on the liquid radwaste effluent line, R-19 on the Steam Generator blowdown.
- 2) Alarm (only) - R-20 and R-16 provide alarm functions for the Service Water discharges.
- 3) Composite Samples - Samples are collected weekly from the steam generator blowdown and analyzed by gamma spectroscopy. Samples are collected weekly from the Turbine Building Sump and analyzed by gamma spectroscopy. The weekly samples are composited for monthly tritium and gross alpha analyses and for quarterly Sr-89 and 90 analyses. During periods of identified primary-to-secondary leakage (with the secondary activity  $> 1.0E-05 \mu\text{Ci/ml}$ ), grab samples from the Turbine Building sump are collected daily and analyzed by gamma spectroscopy. These samples are composited for monthly tritium and gross alpha analyses and for quarterly Sr-89 and 90 analyses.
- 4) Liquid Tank Controls - All radioactive liquid tanks are located inside the Auxiliary Building and contain the suitable confinement systems and drains to prevent direct, unmonitored release to the environment. A liquid radioactive waste flow diagram with the applicable, associated radiation monitoring instrumentation and controls is presented as Figure 1.

### 1.2 Liquid Effluent Monitor Setpoint Determination

Per the requirements of Specification 3.1 (Technical Specification 7.1), alarm setpoints shall be established for the liquid effluent monitoring instrumentation to ensure that the release concentration limits of Specification 3.3.1 (7.3.1) are met (i.e., the concentration of radioactive material released in liquid effluents to unrestricted areas shall be limited to the concentrations specified in 10 CFR 20, Appendix B, Table II, Column 2, for radionuclides and  $2.0E-04 \mu\text{Ci/ml}$  for dissolved or entrained noble gases). The following equation<sup>1</sup> must be satisfied

---

<sup>1</sup> Adapted from NUREG-0133

to meet the liquid effluent restrictions:

$$c \leq \frac{C (F+f)}{f}$$

(1.1)

where:

- C = the effluent concentration limit of Specification 3.3.1 (Technical Specification 7.3.1) implementing the 10 CFR 20 MPC for the site, in  $\mu\text{Ci/ml}$
- c = the setpoint, in  $\mu\text{Ci/ml}$ , of the radioactivity monitor measuring the radioactivity concentration in the effluent line prior to dilution and subsequent release; the setpoint, which is inversely proportional to the volumetric flow of the effluent line and proportional to the volumetric flow of the dilution stream plus the effluent stream, represents a value which, if exceeded, would result in concentrations exceeding the limits of 10 CFR 20 in the unrestricted area
- f = the flow rate at the radiation monitor location in volume per unit time, but in the same units as F, below
- F = the dilution water flow rate as measured prior to the release point, in volume per unit time

[Note that if no dilution is provided,  $c \leq C$ . Also, note that when (F) is large compared to (f), then  $(F + f) \approx F$ .]

- 1.2.1 Liquid Effluent Monitors (Radwaste, Steam Generator Blowdown and Service Water). The setpoints for the liquid effluent monitors at the Kewaunee Nuclear Power Plant are determined by the following equations:

$$SP \leq \frac{MPC_e \times SEN \times CW}{RR} + bkg \quad (1.2)$$

and

$$MPC_e = \frac{\sum C_i}{\sum \frac{C_i}{MPC_i}} \quad (1.3)$$

where:

- SP = alarm setpoint corresponding to the maximum allowable release rate (cpm)
- MPC<sub>e</sub> = an effective MPC value for the mixture of radionuclides in the effluent stream (μCi/ml)
- C<sub>i</sub> = the concentration of radionuclide i in the liquid effluent (μCi)
- MPC<sub>i</sub> = the MPC value corresponding to radionuclide i from 10 CFR 20, Appendix B, Table II, Column 2 (μCi/ml)
- SEN = the sensitivity value to which the monitor is calibrated (cpm per μCi/ml)
- CW = the circulating water flow rate (dilution water flow) at the time of release (gal/min)
- RR = the liquid effluent release rate (gal/min)
- bkg = the background of the monitor (cpm)

The radioactivity monitor setpoint equation (1.2) remains valid during outages when the circulating water dilution is at its lowest. Reduction of the waste stream flow (RR) may be necessary during these periods to meet the discharge criteria. At its lowest value, CW will equal RR and equation (1.2) reverts to the following equation:

(1.4)

$$SP \leq MPC_e \times SEN + bkg$$

1.2.2 Conservative Default Values. Conservative alarm setpoints may be determined through the use of generic, default parameters. Table I.1 summarizes all current default values in use for Kewaunee. They are based upon the following:

- a) substitution of the default effective MPC value of 1.0E-05  $\mu\text{Ci/ml}$  (refer to Appendix C for justification);
- b) substitutions of the lowest operational circulating water flow, in gal/min; and,
- c) substitutions of the highest effluent release rate, in gal/min.

1.3 Liquid Effluent Concentration Limits - 10 CFR 20

Specification 3.3.1 (Technical Specification 7.3.1) limits the concentration of radioactive material in liquid effluents (after dilution in the Circulating Water System) to less than the concentrations as specified in 10 CFR 20, Appendix B, Table II, Column 2 for radionuclides other than noble gases. Noble gases are limited to a diluted concentration of 2E-04  $\mu\text{Ci/ml}$ . Release rates are controlled and radiation monitor alarm setpoints are established to ensure that these concentration limits are not exceeded. In the event any liquid release results in an alarm setpoint being exceeded, an evaluation of compliance with the concentration limits of Specification 3.3.1 (Technical Specification 7.3.1) may be performed using the following equation:

$$\sum [(C_i \div MPC_i) \times (RR \div CW)] \leq 1$$

where:

- $C_i$  = concentration of radionuclide i in the undiluted liquid effluent ( $\mu\text{Ci/ml}$ )
- $MPC_i$  = the MPC value corresponding to radionuclide i from 10 CFR 20, Appendix B, Table II, Column 2 ( $\mu\text{Ci/ml}$ )
- = 2E-04  $\mu\text{Ci/ml}$  for dissolved or entrained noble gases
- RR = the liquid effluent release rate (gal/min)

CW = the circulating water flow rate (dilution water flow) at the time of the release (gal/min)

1.4 Liquid Effluent Dose Calculation - 10 CFR 50

Specification 3.3.2 (Technical Specification 7.3.2) limits the dose or dose commitment to members of the public from radioactive materials in liquid effluents from the Kewaunee Nuclear Power Plant to:

- during any calendar quarter;

≤ 1.5 mrem to total body

≤ 5.0 mrem to any organ

- during any calendar year;

≤ 3.0 mrem to total body

≤ 10.0 mrem to any organ.

Per the surveillance requirements of Specification 4.3.2 (Technical Specification 8.3.2), the following calculational methods may be used for determining the dose or dose commitment due to the liquid radioactive effluents from Kewaunee.

$$D_o = \frac{1.67E-02 \times \text{VOL}}{\text{CW}} \times \sum (C_i \times A_{io}) \quad (1.5)$$

where:

$D_o$  = dose or dose commitment to organ o, including total body (mrem)

$A_{io}$  = site-related ingestion dose commitment factor to the total body or any organ o for radionuclide i (mrem/hr per  $\mu\text{Ci/ml}$ ) (Table 1.2)

$C_i$  = average concentration of radionuclide i, in undiluted liquid effluent representative of the volume VOL ( $\mu\text{Ci/ml}$ )

VOL = volume of liquid effluent released (gal)

CW = average circulating water discharge rate during release period (gal/min)

1.67E-02 = conversion factor (hr/inin)

The site-related ingestion dose/dose commitment factors ( $A_{io}$ ) are presented in Table 1.2 and have been derived in accordance with guidance of NUREG-0133 by the equation:

$$A_{io} = 1.14E+05 [(U_w \div D_w) + (U_F \times BF_i)] DF_i \quad (1.6)$$

where:

$A_{io}$  = composite dose parameter for the total body or critical organ o of an adult for radionuclide i, for the fish ingestion and water consumption pathways (mrem/hr per  $\mu\text{Ci}/\text{ml}$ )

1.14E+05 = conversion factor ( $\text{pCi}/\mu\text{Ci} \times \text{ml}/\text{kg} \div \text{hr}/\text{yr}$ )

$U_w$  = adult water consumption (730 kg/yr)

$D_w$  = dilution factor from the near field area within 1/4 mile of the release point to the nearest potable water intake for the adult water consumption ( $84^2$ , unitless)

$U_F$  = adult fish consumption (21 kg/yr)

$BF_i$  = bioaccumulation factor for radionuclide i in fish from Table 1.3 ( $\text{pCi}/\text{kg}$  per  $\text{pCi}/1$ )

$DF_i$  = dose conversion factor for nuclide i for adults in preselected organ, o, from Table E-11 of Regulatory Guide 1.109, 1977 and NUREG 0172, 1977 (mrem/pCi)

The radionuclides included in the periodic dose assessment per the requirements of Specification 3/4.3.2 (Technical Specification 7/8.3.2) are those as identified by gamma spectral analysis of the liquid waste samples collected and analyzed per the requirements of Specification 4.3.1.1 (Technical Specification 8.3.1.1), Table 4.3 (8.3).

---

<sup>2</sup> Adapted from the Kewaunee Final Environmental Statement, Section V.



Radionuclides requiring radiochemical analysis (e.g., Sr-89 and Sr-90) will be added to the dose analysis at a frequency consistent with the required minimum analysis frequency of Table 4.3 (8.3).

In lieu of the individual radionuclide dose assessment as presented above, the following simplified dose calculational equation may be used for demonstrating compliance with the dose limits of Specification 3.3.2 (Technical Specification 7.3.2). (Refer to Appendix A for the derivation and justification for this simplified method.)

Total Body

$$D_{tb} = \frac{9.67E+03 \times VOL}{CW} \times \sum C_i \tag{1.7}$$

Maximum Organ

$$D_{max} = \frac{1.18E+04 \times VOL}{CW} \times \sum C_i \tag{1.8}$$

where:

- $C_i$  = average concentration of radionuclide i, in undiluted liquid effluent representative of the volume VOL ( $\mu\text{Ci/ml}$ )
- VOL = volume of liquid effluent released (gal)
- CW = average circulating water discharge rate during release period (gal/min)
- $D_{tb}$  = conservatively evaluated total body dose (mrem)
- $D_{max}$  = conservatively evaluated maximum organ dose (mrem)
- 9.67E+03 = conversion factor (hr/min) and the conservative total body dose conversion factor (Cs-134, total body -- 5.79E+05 mrem/hr per  $\mu\text{Ci/ml}$ )
- 1.18E+04 = conversion factor (hr/min) and the conservative maximum organ dose conversion factor (Cs-134, liver -- 7.09E+05 mrem/hr per  $\mu\text{Ci/ml}$ )

## 1.5 Liquid Effluent Dose Projections

**Specification 3.3.3** (Technical Specification 7.3.3) requires that the liquid radioactive waste processing system be used to reduce the radioactive material levels in the liquid waste prior to release when the quarterly projected doses exceed:

- 0.18 mrem to the total body, or
- 0.62 mrem to any organ.

The applicable liquid waste streams and processing systems are as delineated in Figure 1.

Dose projections are made at least once per 31 days by the following equations:

$$D_{tbp} = D_{tb} (91 \div d) \tag{1.9}$$

$$D_{maxp} = D_{max} (91 \div d) \tag{1.10}$$

where:

- $D_{tbp}$  = the total body dose projection for current calendar quarter (mrem)
- $D_{tb}$  = the total body dose to date for current calendar quarter as determined by equation (1.5) or (1.7) (mrem)
- $D_{maxp}$  = the inaximum organ dose projection for current calendar quarter (mrem)
- $D_{max}$  = the inaximum organ dose to date for current calendar quarter as determined by equation (1.5) or (1.8) (mrem)
- $d$  = the number of days to date for current calendar quarter
- 91 = the number of days in a calendar quarter

## 1.6 Onsite Disposal of Low-Level Radioactively Contaminated Waste Streams

During the normal operation of Kewaunee, the potential exists for in-plant process streams which are not normally radioactive to become contaminated with very low levels of radioactive materials. These waste streams are normally separated from the radioactive streams. However, due mainly to infrequent, minor system leaks, and anticipated operational occurrences, the potential exists for these systems to become slightly contaminated. At Kewaunee, the secondary system demineralizer resins, the service water pretreatment system sludges, the make-up water system resins, and the sewage treatment plant sludges are waste streams that have the potential to become contaminated at very low levels. During the yearly testing of a batch of pre-treatment sludge, it was found that approximately 15,000 cubic feet of sludge had been contaminated with Cs-137 and Co-60.

The potential radiation doses to members of the public from these onsite disposal methods are well below 1 mrem per year. This dose is in keeping with the guidelines of the National Council on Radiation Protection (NCRP) in their Report No. 91, in which the NCRP established a "negligible individual risk level" at a dose rate of 1 mrem per year.

It is for these type wastes that the NRC acknowledged in Information Notice No. 83-05 and 88-22 that the levels of radioactive material are so low that control and disposal as a radwaste are not warranted. The potential risks to man are negligible and the disposal costs as a radwaste are unwarranted and costly.

This waste material will be monitored and evaluated prior to disposal to ensure its radioactive material content is negligible. It shall then be disposed of in a normal conventional manner with records being maintained of all materials disposed of using these methods.

Approvals for specific alternate disposal methods are listed in Appendix E. Currently only the sewage treatment facility lagoon sludge has been approved for disposal by land spreading.

## 1.7 Heating Boiler Blowdown Operation with Primary-to-Secondary Leak

During operation with a primary-to-secondary leak, the potential exists for nonradioactive systems to become contaminated. One such system is the heating boiler. Activity is transferred from the reactor coolant system into the secondary main steam system through the leak and then into the heating boiler by bleed steam from the main steam system.

When the heating boiler is operated, it must be periodically blown down to remove impurities which collect in the system. This blowdown is normally directed to the steam generator flash tank but can be diverted to circulating water. Either way, the blowdown becomes a release path for radioactivity to the environment. The heating boiler blowdown is sampled, using current plant procedures, whenever the primary-to-secondary leakage exceeds 10 gallons per day and the gross gamma activity or tritium activity exceeds  $1.0E-05$   $\mu\text{Ci/ml}$ . The results of these samples allows for the activity being released to the environment to be quantified. This is similar to the method used for the turbine building sump release path. The radioactive effluent limits of 10 CFR Part 20, 40 CFR 190, and Technical Specifications can therefore be maintained.

Figure 1  
Liquid Radioactive Effluent Flow Diagram

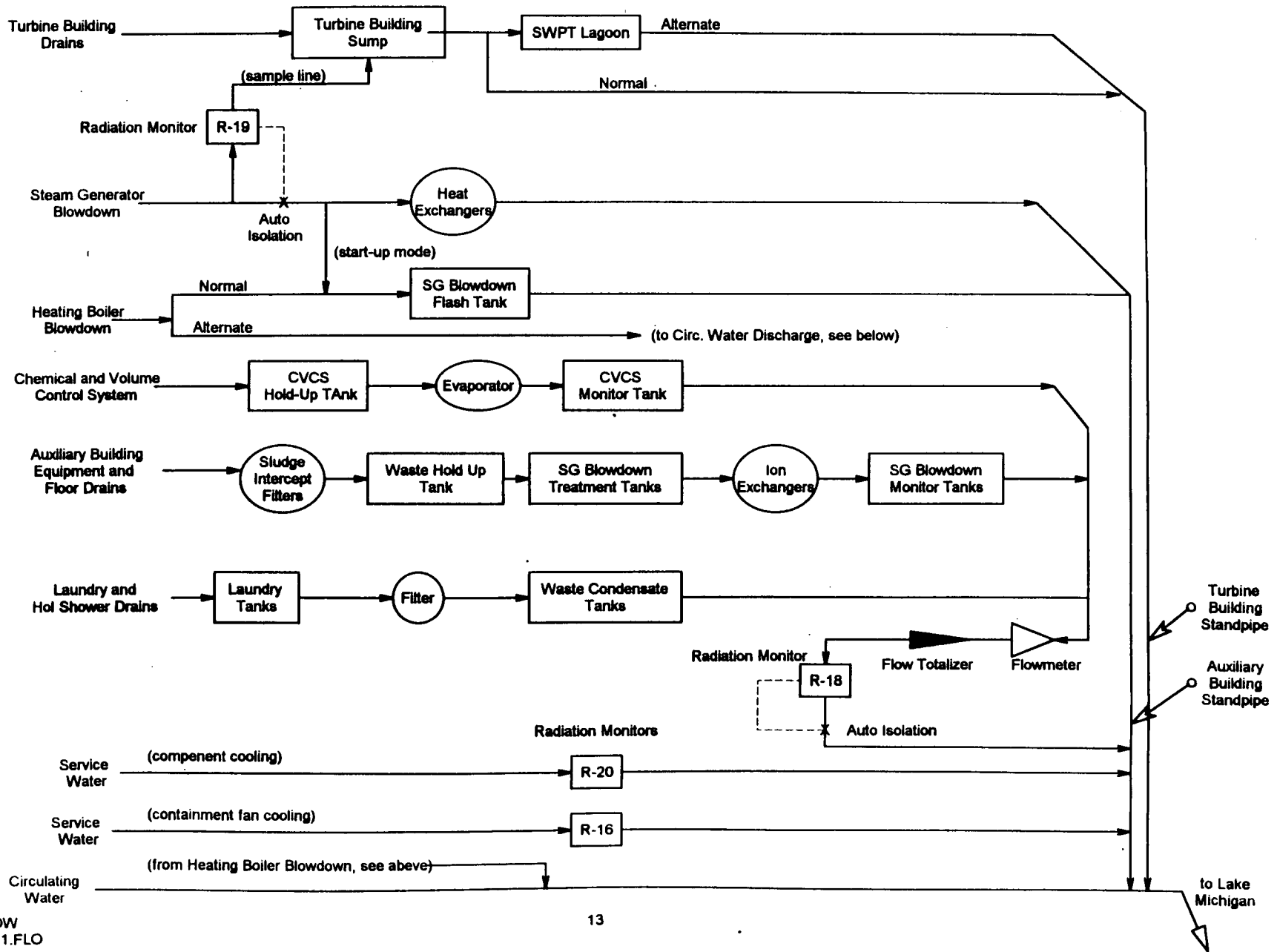

**Table 1.1  
Parameters for Liquid Alarm Setpoint Determinations**

Parameter	Actual Value	Default Value*	Units	Comments
MPC <sub>e</sub>	calculated	1.0E-05**	μCi/ml	Calculate for each batch to be released
C <sub>i</sub>	measured	N/A	μCi/ml	Taken from gamma spectral analysis of liquid effluent
MPC <sub>i</sub>	as determined	N/A	μCi/ml	Taken from 10 CFR 20, Appendix B, Table II, Col. 2
Sensitivity (SEN) R-18 R-19 R-20 R-16	as determined as determined as determined as determined	1.0E+08 1.0E+08 1.0E+08 1.0E+08	cpm per μCi/ml	Radwaste effluent Steam Generator blowdown Service Water - component cooling Service Water - Containment fan cooling
CW	as determined	2.58E+05	gpm	Circulating Water System default = winter, single CW pump
Release Rate (RR) R-18 R-19 R-20 R-16	as determined as determined as determined as determined	8.0E+01 2.0E+02 5.0E+03 1.5E+03	gpm	Determined prior to release; release rate can be adjusted for Technical Specification compliance Steam Generator A and B combined Service Water - component cooling Service Water - Containment fan cooling
background (bkg) R-18 R-19 R-20 R-16	as determined as determined as determined as determined	2.0E+03 8.0E+01 6.0E+01 8.0E+01	cpm	Nominal values only; actual values may be used in lieu of these reference values
Setpoint* (SP) R-18 R-19 R-20 R-16	calculated calculated calculated calculated	3.22E+06 + bkg 1.29E+06 + bkg 5.16E+04 + bkg 1.72E+05 + bkg	cpm	Default alarm setpoints; more conservative values may be used as deem appropriate and desirable for assuring regulatory compliance and for maintaining releases ALARA.
Setpoint* (SP) with no Circulating Water System flow, CW=0				
R-18 R-19 R-20 R-16	calculated calculated calculated calculated	1.25E+05 + bkg 5.00E+04 + bkg 2.00E+03 + bkg 6.67E+03 + bkg	cpm	For outages with no Circulating Water System flow (CW=0) and a dilution flow as provided by the Service Water system of 10,000 gpm total.

\* Refer to Calculation # C10690 for the default setpoint calculation.

\*\* Refer to Appendix C for derivation

Table 1.2

**A<sub>10</sub> Site Related Ingestion Dose Commitment Factors  
(mrem/hr per  $\mu$ Ci/ml)**

<u>Nuclide</u>	<u>Bone</u>	<u>Liver</u>	<u>T.Body</u>	<u>Thyroid</u>	<u>Kidney</u>	<u>Lung</u>	<u>GI-LLI</u>
H-3	-	3.30E-1	3.30E-1	3.30E-1	3.30E-1	3.30E-1	3.30E-1
C-14	3.13E+4	6.26E+3	6.26E+3	6.26E+3	6.26E+3	6.26E+3	6.26E+3
Na-24	4.09E+2	4.09E+2	4.09E+2	4.09E+2	4.09E+2	4.09E+2	4.09E+2
P-32	1.39E+6	8.62E+4	5.36E+4	-	-	-	1.56E+5
Cr-51	-	-	1.28E+0	7.63E-1	2.81E-1	1.69E+0	3.21E+2
Mn-54	-	4.38E+3	8.36E+2	-	1.30E+3	-	1.34E+4
Mn-56	-	1.10E+2	1.96E+1	-	1.40E+2	-	3.52E+3
Fe-55	6.61E+2	4.57E+2	1.06E+2	-	-	2.55E+2	2.62E+2
Fe-59	1.04E+3	2.45E+3	9.40E+2	-	-	6.85E+2	8.17E+3
Co-57	-	2.11E+1	3.51E+1	-	-	-	5.36E+2
Co-58	-	8.99E+1	2.02E+2	-	-	-	1.82E+3
Co-60	-	2.58E+2	5.70E+2	-	-	-	4.85E+3
Ni-63	3.13E+4	2.17E+3	1.05E+3	-	-	-	4.52E+2
Ni-65	1.27E+2	1.65E+1	7.52E+0	-	-	-	4.18E+2
Cu-64	-	1.01E+1	4.72E+0	-	2.53E+1	-	8.57E+2
Zn-65	2.32E+4	7.38E+4	3.33E+4	-	4.93E+4	-	4.65E+4
Zn-69	4.93E+1	9.43E+1	6.56E+0	-	6.13E+1	-	1.42E+1
Br-82	-	-	2.27E+3	-	-	-	2.61E+3
Br-83	-	-	4.05E+1	-	-	-	5.83E+1
Br-84	-	-	5.24E+1	-	-	-	4.12E-4
Br-85	-	-	2.15E+0	-	-	-	-
Rb-86	-	1.01E+5	4.71E+4	-	-	-	1.99E+4
Rb-88	-	2.90E+2	1.54E+2	-	-	-	4.00E-9
Rb-89	-	1.92E+2	1.35E+2	-	-	-	-
Sr-89	2.24E+4	-	6.44E+2	-	-	-	3.60E+3
Sr-90	5.52E+5	-	1.35E+5	-	-	-	1.59E+4
Sr-91	4.13E+2	-	1.67E+1	-	-	-	1.97E+3
Sr-92	1.57E+2	-	6.77E+0	-	-	-	3.10E+3
Y-90	5.85E-1	-	1.57E-2	-	-	-	6.21E+3
Y-91m	5.53E-3	-	2.14E-4	-	-	-	1.62E-2
Y-91	8.58E+0	-	2.29E-1	-	-	-	4.72E+3
Y-92	5.14E-2	-	1.50E-3	-	-	-	9.00E+2
Y-93	1.63E-1	-	4.50E-3	-	-	-	5.17E+3
Zr-95	2.70E-1	8.67E-2	5.87E-2	-	1.36E-1	-	2.75E+2
Zr-97	1.49E-2	3.01E-3	1.38E-3	-	4.55E-3	-	9.34E+2
Nb-95	4.47E+2	2.49E+2	1.34E+2	-	2.46E+2	-	1.51E+6
Nb-97	3.75E+0	9.48E-1	3.46E-1	-	1.11E+0	-	3.50E+3
Mo-99	-	1.07E+2	2.04E+1	-	2.43E+2	-	2.49E+2
Tc-99m	9.11E-3	2.58E-2	3.28E-1	-	3.91E-1	1.26E-2	1.52E+1
Tc-101	9.37E-3	1.35E-2	1.32E-1	-	2.43E-1	6.90E-3	-

Table 1.2 (Continued)

$A_{10}$  Site Related Ingestion Dose Commitment Factors  
(mrem/hr per  $\mu\text{Ci/ml}$ )

Nuclide	Bone	Liver	T.Body	Thyroid	Kidney	Lung	GI-LLI
Ru-103	4.61E+0	-	1.99E+0	-	1.76E+1	-	5.39E+2
Ru-105	3.84E-1	-	1.52E-1	-	4.96E+0	-	2.35E+2
Ru-106	6.86E+1	-	8.68E+0	-	1.32E+2	-	4.44E+3
Rh-103m	-	-	-	-	-	-	-
Rh-106	-	-	-	-	-	-	-
Ag-110m	1.04E+0	9.62E-1	5.71E-1	-	1.89E+0	-	3.92E+2
Sb-124	9.48E+0	1.79E-1	3.76E+0	2.30E-2	-	7.38E+0	2.69E+2
Sb-125	6.06E+0	6.77E-2	1.44E+0	6.16E-3	-	4.67E+0	6.67E+1
Te-125m	2.57E+3	9.31E+2	3.44E+2	7.73E+2	1.04E+4	-	1.03E+4
Te-127m	6.49E+3	2.32E+3	7.91E+2	1.66E+3	2.64E+4	-	2.18E+4
Te-127	1.05E+2	3.79E+1	2.28E+1	7.81E+1	4.29E+2	-	8.32E+3
Te-129m	1.10E+4	4.11E+3	1.74E+3	3.79E+3	4.60E+4	-	5.55E+4
Te-129	3.01E+1	1.13E+1	7.33E+0	2.31E+1	1.27E+2	-	2.27E+1
Te-131m	1.66E+3	8.11E+2	6.76E+2	1.28E+3	8.22E+3	-	8.05E+4
Te-131	1.89E+1	7.89E+0	5.96E+0	1.55E+1	8.27E+1	-	2.67E+0
Te-132	2.42E+3	1.56E+3	1.47E+3	1.73E+3	1.50E+4	-	7.39E+4
I-130	2.79E+1	8.23E+1	3.25E+1	6.97E+3	1.28E+2	-	7.08E+1
I-131	1.54E+2	2.20E+2	1.26E+2	7.20E+4	3.76E+2	-	5.79E+1
I-132	7.49E+0	2.00E+1	7.01E+0	7.01E+2	3.19E+1	-	3.76E+0
I-133	5.24E+1	9.11E+1	2.78E+1	1.34E+4	1.59E+2	-	8.19E+1
I-134	3.91E+0	1.06E+1	3.80E+0	1.84E+2	1.69E+1	-	9.26E-3
I-135	1.63E+1	4.28E+1	1.58E+1	2.82E+3	6.86E+1	-	4.83E+1
Cs-134	2.98E+5	7.09E+5	5.79E+5	-	2.29E+5	7.61E+4	1.24E+4
Cs-136	3.12E+4	1.23E+5	8.86E+4	-	6.85E+4	9.39E+3	1.40E+4
Cs-137	3.82E+5	5.22E+5	3.42E+5	-	1.77E+5	5.89E+4	1.01E+4
Cs-138	2.64E+2	5.22E+2	2.59E+2	-	3.84E+2	3.79E+1	2.23E-3
Ba-139	1.02E+0	7.30E-4	3.00E-2	-	6.83E-4	4.14E-4	1.82E+0
Ba-140	2.15E+2	2.69E-1	1.41E+1	-	9.16E-2	1.54E-1	4.42E+2
Ba-141	4.98E-1	3.76E-4	1.68E-2	-	3.50E-4	2.13E-4	-
Ba-142	2.25E-1	2.31E-4	1.42E-2	-	1.95E-4	1.31E-4	-
La-140	1.52E-1	7.67E-2	2.03E-2	-	-	-	5.63E+3
La-142	7.79E-3	3.54E-3	8.82E-4	-	-	-	2.59E+1
Ce-141	3.17E-2	2.14E-2	2.43E-3	-	9.95E-3	-	8.19E+1
Ce-143	5.58E-3	4.13E+0	4.57E-4	-	1.82E-3	-	1.54E+2
Ce-144	1.65E+0	6.90E-1	8.87E-2	-	4.10E-1	-	5.58E+2
Pr-143	5.60E-1	2.25E-1	2.77E-2	-	1.30E-1	-	2.45E+3
Pr-144	1.83E-3	7.61E-4	9.31E-5	-	4.29E-4	-	-
Nd-147	3.83E-1	4.42E-1	2.65E-2	-	2.59E-1	-	2.12E+3
W-187	2.96E+2	2.47E+2	8.65E+1	-	-	-	8.10E+4
Np-239	2.97E-2	2.92E-3	1.61E-3	-	9.10E-3	-	5.98E+2



**Table 1.3****Bioaccumulation Factors(BF)  
(pCi/kg per pCi/liter)\***

<b>Element</b>	<b>Freshwater Fish</b>
H	9.0E-01
C	4.6E+03
Na	1.0E+02
P	3.0E+03
Cr	2.0E+02
Mn	4.0E+02
Fe	1.0E+02
Co	5.0E+01
Ni	1.0E+02
Cu	5.0E+01
Zn	2.0E+03
Br	4.2E+02
Rb	2.0E+03
Sr	3.0E+01
Y	2.5E+01
Zr	3.3E+00
Nb	3.0E+04
Mo	1.0E+01
Tc	1.5E+01
Ru	1.0E+01
Rh	1.0E+01
Ag	2.3E+00
Sb	1.0E+00
Te	4.0E+02
I	1.5E+01
Cs	2.0E+03
Ba	4.0E+00
La	2.5E+01
Ce	1.0E+00
Pr	2.5E+01
Nd	2.5E+01
W	1.2E+03
Np	1.0E+01

\* Values in this Table are taken from Regulatory Guide 1.109 except for phosphorus which is adapted from NUREG/CR-1336 and silver and antimony which are taken from UCRL 50564, Rev. 1, October 1972.

## 2.0 Gaseous Effluents

### 2.1 Radiation Monitoring Instrumentation and Controls

The gaseous effluent monitoring instrumentation and controls at Kewaunee for controlling and monitoring normal radioactive material releases in accordance with 10 CFR 50, Appendix A, Criteria 60 and 64, are summarized as follows:

- 1) Waste Gas Holdup System - The vent header gases are collected by the waste gas holdup system. Gases may be recycled to provide cover gas for the CVCS hold-up tanks or held in the waste gas tanks for decay prior to release. Waste gas decay tanks are batch released after sampling and analysis. The tanks are discharged via the Auxiliary Building vent. R-13 and/or R-14 provide noble gas monitoring and automatic isolation.
- 2) Condenser Evacuation System - The air ejector discharge is monitored by R-15. Releases from this system are via the Auxiliary Building vent and are monitored by R-13 and/or R-14.
- 3) Containment Purge - Containment purge and ventilation is via the containment stack. The stack radiation monitoring system consists of: a) a noble gas activity monitor providing alarm and automatic termination of release (R-12 and R-21); b) an iodine sampler; and c) a particulate sampler. Effluent flow rates are determined empirically as a function of a fan operation (fan curves). Sampler flow rates are determined by flow rate instrumentation.
- 4) Auxiliary Building Vent - The Auxiliary Building vent receives discharges from the waste gas holdup system, condenser evacuation system, fuel storage area ventilation, Auxiliary Building radwaste processing area ventilation, and Auxiliary Building general area. All effluents pass through: a) a noble gas monitor - (R-13 and/or R-14); b) an iodine sampler (R-13A); and c) a particulate sampler (R-13A). The noble gas monitor (R-13 and/or R-14) provides auto isolation of any waste gas decay tank releases and diverts other releases through the special ventilation system. Effluent flow rates are determined by installed flow measurement equipment or as a function of fan operation (fan curves). Sampler flow rates are determined by flow rate instrumentation.

A gaseous radioactive waste flow diagram with the applicable, associated radiation monitoring instrumentation and controls is presented as Figure 2.

### 2.2 Gaseous Effluent Monitor Setpoint Determination

- 2.2.1 Containment and Auxiliary Building Vent Monitor. Per the requirements of Specification 3.2 (Technical Specification 7.2), alarm setpoints shall be established for the gaseous effluent monitoring instrumentation to ensure that the release rate of noble gases does not exceed corresponding dose

rate at the site boundary of 500 mrem/year to the total body or 3000 mrem/year to the skin. Based on a grab sample analysis of the applicable release (i.e., grab sample of the Containment vent or Auxiliary Building vent), the radiation monitoring alarm setpoints may be established by the following calculational method:

$$\text{FRAC} = [4.72\text{E}+02 \times \text{X/Q} \times \text{VF} \times \sum (\text{C}_i \times \text{K}_i)] \div 500 \quad (2.1)$$

$$\text{FRAC} = [4.72\text{E}+02 \times \text{X/Q} \times \text{VF} \times \sum (\text{C}_i \times (\text{L}_i + 1.1 \text{M}_i))] \div 3000 \quad (2.2)$$

where:

- FRAC = fraction of the allowable release rate based on the identified radionuclide concentrations and the release flow rate
- X/Q = annual average meteorological dispersion to the controlling site boundary location (sec/m<sup>3</sup>)
- VF = ventilation system flow rate for the applicable release point and monitor (ft<sup>3</sup>/min)
- C<sub>i</sub> = concentration of noble gas radionuclide i as determined by radioanalysis of grab sample (μCi/cm<sup>3</sup>)
- K<sub>i</sub> = total body dose conversion factor for noble gas radionuclide i (mrem/yr per μCi/m<sup>3</sup>, from Table 2.1)
- L<sub>i</sub> = beta skin dose conversion factor for noble gas radionuclide i (mrem/yr per μCi/m<sup>3</sup>, from Table 2.1)
- M<sub>i</sub> = gamma air dose conversion factor for noble gas radionuclide i (mrad/yr per μCi/m<sup>3</sup>, from Table 2.1)
- 1.1 = mrem skin dose per mrad gamma air dose (mrem/mrad)
- 4.72E+02 = conversion factor (cm<sup>3</sup>/ft<sup>3</sup> x min/sec)
- 500 = total body dose rate limit (mrem/yr)
- 3000 = skin dose rate limit (mrem/yr)

Based on the more limiting FRAC (i.e., higher value) as determined above, the alarm setpoint for the Containment and Auxiliary Building vent monitors at Kewaunee may be calculated:

$$SP = [ \sum C_i \times SEN \div FRAC ] + bkg \quad (2.3)$$

where:

SP	=	alarm setpoint corresponding to the maximum allowable release rate (cpm)
SEN	=	monitor sensitivity (cpm per $\mu\text{Ci}/\text{cm}^3$ )
bkg	=	background of the monitor (cpm)

2.2.2 Conservative Default Values. A conservative alarm setpoint can be established, in lieu of the individual radionuclide evaluation based on the grab sample analysis, to eliminate the potential of periodically having to adjust the setpoint to reflect minor changes in radionuclide distribution and variations in release flow rate. The alarm setpoint may be conservatively determined by the default values presented in Table 2.2. These values are based upon:

- the maximum ventilation flow rate;
- a radionuclide distribution<sup>3</sup> comprised of 95% Xe-133, 2% Xe-135, 1% Xe-133m, 1% Kr-88 and 1% Kr-85; and
- an administrative multiplier of 0.5 to conservatively assure that any simultaneous releases do not exceed the maximum allowable release rate.

For this radionuclide distribution, the alarm setpoint based on the total body dose rate is more restrictive than the corresponding setpoint based on the skin dose rate. The resulting conservative, default setpoints are presented in Table 2.2.

## 2.3 Gaseous Effluent Instantaneous Dose Rate Calculations - 10 CFR 20

2.3.1 Site Boundary Dose Rate - Noble Gases. Specification 3.4.1.a (Technical Specification 7.4.1.a) limits the dose rate at the site boundary due to noble gas releases to  $\leq 500$  mrem/yr to the total body, and  $\leq 3000$  mrem/yr to the skin. Radiation monitor alarm setpoints are established to ensure that these release limits are not exceeded. In the event any gaseous

---

<sup>3</sup>Adopted from ANSI N237-1976/ANS-18.1, Source Term Specifications, Table 6.

releases from the station results in the alarm setpoints being exceeded, an evaluation of the unrestricted area dose rate resulting from the release may be performed using the following equations:

$$\dot{D}_{tb} = X/Q \times \sum (K_i \times \dot{Q}_i)$$

and

$$\dot{D}_s = X/Q \times \sum ((L_i + 1.1M_i) \times \dot{Q}_i)$$

(2.4)

(2.5)

where:

$\dot{D}_{tb}$  = total body dose rate (mrem/yr)

$\dot{D}_s$  = skin dose rate (mrem/yr)

$X/Q$  = atmospheric dispersion to the controlling site boundary ( $\text{sec}/\text{m}^3$ )

$\dot{Q}_i$  = average release rate of radionuclide  $i$  over the release period under evaluation ( $\mu\text{Ci}/\text{sec}$ )

$K_i$  = total body dose conversion factor for noble gas radionuclide  $i$  (mrem/yr per  $\mu\text{Ci}/\text{m}^3$ , from Table 2.1)

$L_i$  = beta skin dose conversion factor for noble gas radionuclide  $i$  (mrem/yr per  $\mu\text{Ci}/\text{m}^3$ , from Table 2.1)

$M_i$  = gamma air dose conversion factor for noble gas radionuclide  $i$  (mrad/yr per  $\mu\text{Ci}/\text{m}^3$ , from Table 2.1)

1.1 = mrem skin dose per mrad gamma air dose (mrem/mrad)

Actual meteorological conditions concurrent with the release period or the default, annual average dispersion parameters as presented in Table 2.3 may be used for evaluating the gaseous effluent dose rate.

2.3.2 Site Boundary Dose Rate - Radioiodine and Particulates. Specification 3.4.1.b (Technical Specification 7.4.1.b) limits the dose rate to  $\leq 1500$  mrem/yr to any organ for I-131, I-133, tritium and particulates with half-lives greater than 8 days. To demonstrate compliance with this limit, an evaluation is performed at a frequency no greater than that corresponding to the sampling and analysis time period for continuous releases (e.g., nominally once per 7 days) and for batch releases on the

time period over which any batch release is to occur. The following equation may be used for the dose rate evaluation:

$$\dot{D}_o = X/Q \times \sum (R_i \times \dot{Q}_i) \quad (2.6)$$

where:

- $\dot{D}_o$  = average organ dose rate over the sampling time period (mrem/yr)
- $X/Q$  = atmospheric dispersion to the controlling site boundary for the inhalation pathway (sec/m<sup>3</sup>)
- $R_i$  = dose parameter for radionuclide i, (mrem/yr per  $\mu\text{Ci}/\text{m}^3$ ) for the child inhalation pathway from Table 2.6
- $\dot{Q}_i$  = average release rate over the appropriate sampling period and analysis frequency for radionuclide i, I-131, I-133, tritium or other radionuclide in particulate form with half-life greater than 8 days ( $\mu\text{Ci}/\text{sec}$ )

By substituting 1500 mrem/yr for  $\dot{D}_o$ , solving for  $\dot{Q}$ , an allowable release rate for I-131 can be determined. Based on the annual average meteorological dispersion (see Table 2.3) and the most limiting potential pathway, age group and organ (inhalation pathway, child thyroid --  $R_i = 1.62\text{E}+07$  mrem/yr per  $\mu\text{Ci}/\text{m}^3$ ) the allowable release rate for I-131 is 12.8  $\mu\text{Ci}/\text{sec}$ . An added conservatism factor of 0.25 has been included in this calculation to account for any potential dose contribution from other radioactive particulate material. For a 7 day period which is the nominal sampling and analysis frequency for I-131, the cumulative allowable release is 3.9 Ci. Therefore, as long as the I-131 releases in any 7 day period do not exceed 3.9 Ci, no additional analyses are needed to verify compliance with the Specification 3.4.1.b (Technical Specification 7.4.1.b) limits on allowable release rate.

## 2.4 Gaseous Effluent Dose Calculations - 10 CFR 50

2.4.1 Unrestricted Area Dose - Noble Gases. Specification 3.4.2 (Technical Specification 7.4.2) requires a periodic assessment of releases of noble gases to evaluate compliance with the quarterly dose limits of ( $\leq 5$  mrad, gamma-air and  $\leq 10$  mrad, beta-air) and the calendar year limits ( $\leq 10$  mrad, gamma-air and  $\leq 20$  mrad, beta-air). The following equations may be used to calculate the gamma-air and beta-air doses:

$$D_{\gamma} = 3.17E-08 \times X/Q \times \sum (M_i \times Q_i)$$

and

(2.7)

$$D_{\beta} = 3.17E-08 \times X/Q \times \sum (N_i \times Q_i)$$

(2.8)

where:

$D_{\gamma}$  = air dose due to gamma emissions for noble gas radionuclides (mrad)

$D_{\beta}$  = air dose due to beta emissions for noble gas radionuclides (mrad)

$X/Q$  = atmospheric dispersion to the controlling site boundary (sec/m<sup>3</sup>)

$Q_i$  = cumulative release of noble gas radionuclide i over the period of interest ( $\mu$ Ci)

$M_i$  = air dose factor due to gamma emissions from noble gas radionuclide i (mrad/yr per  $\mu$ Ci/m<sup>3</sup> from Table 2.1)

$N_i$  = air dose factor due to beta emissions from noble gas radionuclide i (mrad/yr per  $\mu$ Ci/m<sup>3</sup>, Table 2.1)

3.17E-08 = conversion factor (yr/sec)

In lieu of the individual noble gas radionuclide dose assessment as presented above, the following simplified dose calculational equation may be used for verifying compliance with the dose limits of Specification 3.4.2 (Technical Specification 7.4.2). (Refer to Appendix B for the derivation and justification for this simplified method.)

$$D_{\gamma} = \frac{3.17E-08}{0.50} \times X/Q \times M_{\text{eff}} \times \sum Q_i$$

and

$$D_{\beta} = \frac{3.17E-08}{0.50} \times X/Q \times N_{\text{eff}} \times \sum Q_i$$

(2.9)

(2.10)

where:

$M_{\text{eff}}$  = 5.3E+02 effective gamma-air dose factor (mrad/yr per  $\mu\text{Ci}/\text{m}^3$ )

$N_{\text{eff}}$  = 1.1E+03 effective beta-air dose factor (mrad/yr per  $\mu\text{Ci}/\text{m}^3$ )

0.50 = conservatism factor

Actual meteorological conditions concurrent with the release period or the default, annual average dispersion parameters as presented in Table 2.3, may be used for the evaluation of the gamma-air and beta-air doses.

2.4.2 Unrestricted Area Dose - Radioiodine and Particulates. Per the requirements of Specification 3.4.3 (Technical Specification 7.4.3), a periodic assessment shall be performed to evaluate compliance with the quarterly dose limit ( $\leq 7.5$  mrem) and calendar year limit ( $\leq 15$  mrem) to any organ. The following equation may be used to evaluate the maximum organ dose due to releases of I-131, I-133, tritium and particulates with half-lives greater than 8 days:

$$D_{\text{aop}} = 3.17E-08 \times W \times SF_p \times \sum (R_i \times Q_i)$$

(2.11)

where:

$D_{\text{aop}}$  = dose or dose commitment for age group a to organ o, including the total body, via pathway p from I-131, I-133, tritium and radionuclides in particulate form with half-life greater than eight days (mrem)



W = atmospheric dispersion parameter to the controlling location(s) as identified in Table 2.3

X/Q = atmospheric dispersion for inhalation pathway and H-3 dose contribution via other pathways (sec/m<sup>3</sup>)

D/Q = atmospheric deposition for vegetation, milk and ground plane exposure pathways (l/m<sup>2</sup>)

R<sub>i</sub> = dose factor for radionuclide i, (mrem/yr per μCi/m<sup>3</sup>) or (m<sup>2</sup> - mrem/yr per μCi/sec) from Table 2.4 through 2.15 for each age group a and the applicable pathway p as identified in Table 2.3. Values for R<sub>i</sub> were derived in accordance with the methods described in NUREG-0133.

Q<sub>i</sub> = cumulative release over the period of interest for radionuclide i -- I-131 or radioactive material in particulate form with half-life greater than 8 days (μCi).

SF<sub>p</sub> = seasonal correction factor to account for the fraction of the period that the applicable exposure pathway does exist.

1) For milk and vegetation exposure pathways:

= 
$$\frac{\text{\# of months in the period that grazing occurs}}{\text{total \# of months in period}}$$

= 0.5 for annual calculations

2) For inhalation and ground plane exposure pathways: = 1.0

In lieu of the individual radionuclide (I-131 and particulates) dose assessment as presented above, the following simplified dose calculational equation may be used for verifying compliance with the dose limits of Specification 3.4.3 (Technical Specification 7.4.3).

$$D_{\max} = 3.17E-08 \times W \times SF_p \times R_{I-131} \times \sum Q_i \quad (2.12)$$

where:

- $D_{\max}$  = maximum organ dose (mrem)
- $R_{I-131}$  = I-131 dose parameter for the thyroid for the identified controlling pathway
- = 1.05E+12, infant thyroid dose parameter with the grass-cow-milk pathway controlling ( $m^2$  - mrem/yr per  $\mu\text{Ci/sec}$ )

The ground plane exposure and inhalation pathways need not be considered when the above simplified calculational method is used because of the overall negligible contribution of these pathways to the total thyroid dose. It is recognized that for some particulate radionuclides (e.g. Co-60 and Cs-137), the ground plane exposure pathway may represent a higher dose contribution than either the vegetation or grass-cow-milk pathway. However, use of the I-131 thyroid dose parameter for all radionuclides will maximize the organ dose calculation, especially considering that no other radionuclide has a higher dose parameter for any organ via any pathway than I-131 for the thyroid via the grass-cow-milk pathway.

The location of exposure pathways and the maximum organ dose calculation may be based on the available pathways in the surrounding environment of Kewaunee as identified by the annual land-use census, see Specification 3.6.2 (Technical Specification 7.7.2). Otherwise, the dose will be evaluated based on the predetermined controlling pathways as identified in Table 2.3.

## 2.5 Gaseous Effluent Dose Projection

Specification 3.4.4 (Technical Specification 7.4.4) requires that the Ventilation Exhaust Treatment System be used to reduce radioactive material levels prior to discharge when projected doses exceed one-half the annual design objective rate in any calendar quarter, i.e., exceeding:

- 0.62 mrad/quarter, gamma air;
- 1.25 mrad/quarter, beta air; or
- 0.94 mrem/quarter, maximum organ.

The applicable gaseous release sources and processing systems are as delineated in Figure 2.

Dose projections are performed at least once per 31 days by the following equations:

$$D_{\gamma p} = D_{\gamma} \times (91 \div d) \tag{2.13}$$

$$D_{\beta p} = D_{\beta} \times (91 \div d) \tag{2.14}$$

$$D_{\max p} = D_{\max} \times (91 \div d) \tag{2.15}$$

where:

- $D_{\gamma p}$  = gamma air dose projection for current calendar quarter (mrad)
- $U_{\gamma}$  = gamma air dose to date for current calendar quarter as determined by equation (2.7) or (2.9) (mrad)
- $D_{\beta p}$  = beta air dose projection for current calendar quarter (mrad)
- $D_{\beta}$  = beta air dose to date for current calendar quarter as determined by equation (2.8) or (2.10) (mrad)
- $D_{\max p}$  = maximum organ dose projection for current calendar quarter (mrem)
- $D_{\max}$  = maximum organ dose to date for current calendar quarter as determined by equation (2.11) or (2.12) (mrem)
- $d$  = number of days to date in current calendar quarter
- $91$  = number of days in a calendar quarter

## 2.6 Environmental Radiation Protection Standards 40 CFR 190

For the purpose of implementing **Specification 3.5** (RETS Technical Specification 7.6) on the EPA environmental radiation protection standard and **Technical Specification 6.9.3.b** on reporting requirements, dose calculations may be performed using the above equations with the substitution of average or actual meteorological parameters for the period of interest and actual applicable pathways. Any exposure attributable to on-site sources will be evaluated based on the results

of the environmental monitoring program (TLD measurements) or by calculational methods. NUREG-0543 describes acceptable methods for demonstrating compliance with 40 CFR Part 190 when radioactive effluents exceed the Appendix I portion of the specifications.

## 2.7 Incineration of Radioactively Contaminated Oil

During plant operation, radioactively contaminated oils are generated from various equipment operating in the plant. The largest source of contaminated oil is the reactor coolant pump lubricating oil which is periodically changed for preventive maintenance reasons. 10 CFR Part 20 allows licensees to incinerate radioactively contaminated oils on site provided that the total radioactive effluents from the facility conform to the requirements of 10 CFR Part 50, Appendix I.

Radioactively contaminated oil, which is designated for incineration, will be collected in containers which are uniquely serialized such that the contents can be identified and tracked. Each container will be sampled and analyzed for radioactivity. The isotopic concentrations will be recorded for each container.

The heating boiler will be utilized to incinerate the radioactively contaminated oil collected on site. A gaseous radwaste effluent dose calculation, as prescribed in Section 2.3 of the ODCM, will be performed to insure that the limits established by Specifications 3/4.4.1, 3/4.4.2 and 3/4.4.3 (Technical Specifications 7/8.4.1, 7/8.4.2 and 7/8.4.3) are not exceeded. Release of the activity is assumed to occur at the time the contaminated oil is transferred into the heating boiler fuel oil storage tank and will be accounted for using established plant procedures. This will be valid for an assumed release from the fuel oil storage tank vent, fill piping, or from the boiler exhaust stack. See Figure 3 for a description of the heating boiler fuel oil system.

Figure 2  
Gaseous Radioactive Effluent Flow Diagram

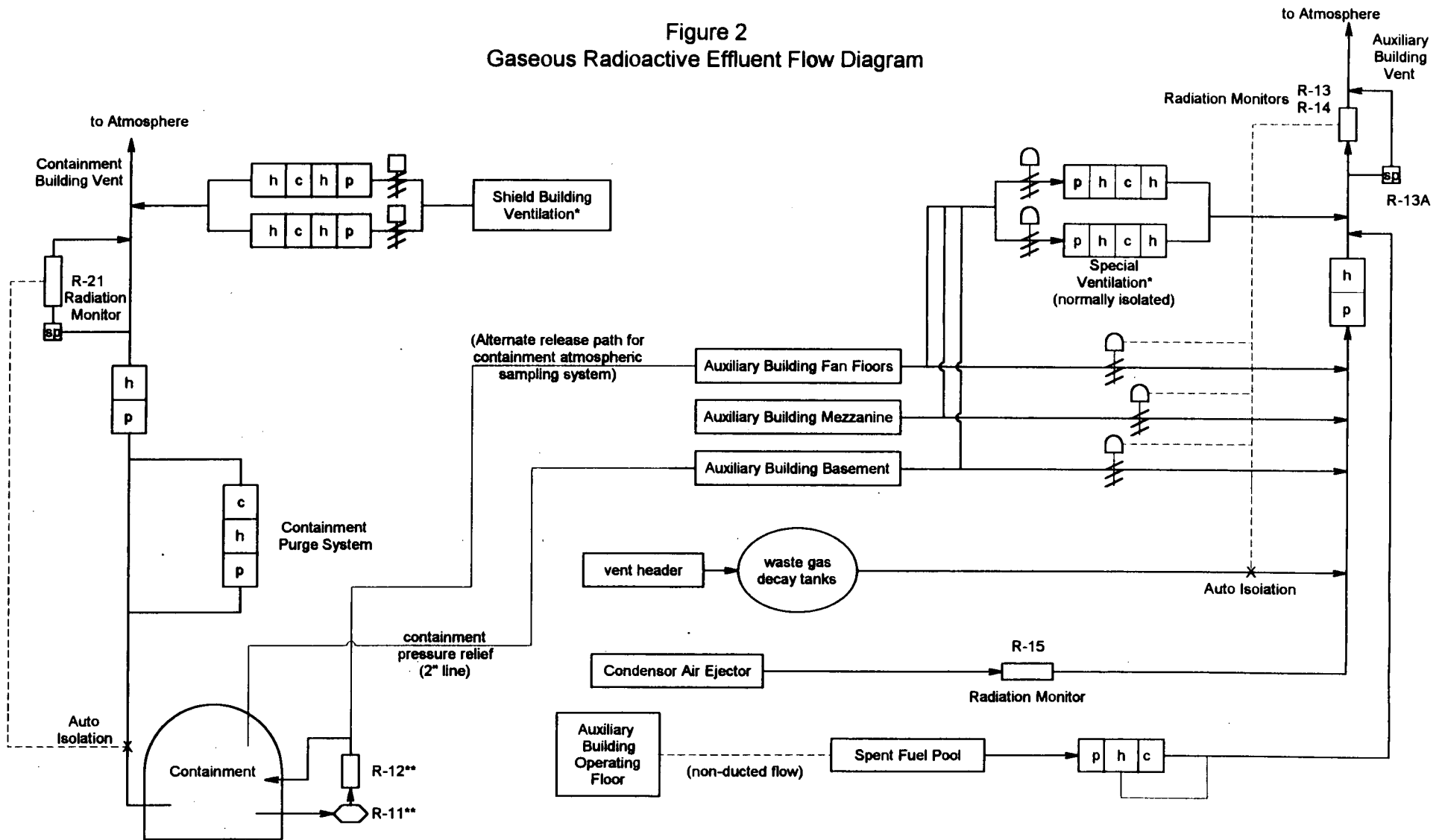

\* The shield building ventilation and special ventilation are ESF systems and are not part of the normal effluent processing system. They are included for completeness only.  
 \*\* The containment air sampler (R-11) and radiation monitor (R-12) can also be aligned as needed for sampling containment vent.

	air operated damper		Sampler/monitor		prefilter
	cylinder operated damper		Sample point		HEPA filter
			Charcoal filter		

**LEGEND**

Figure 3

Simplified Heating Boiler Fuel Oil Piping System

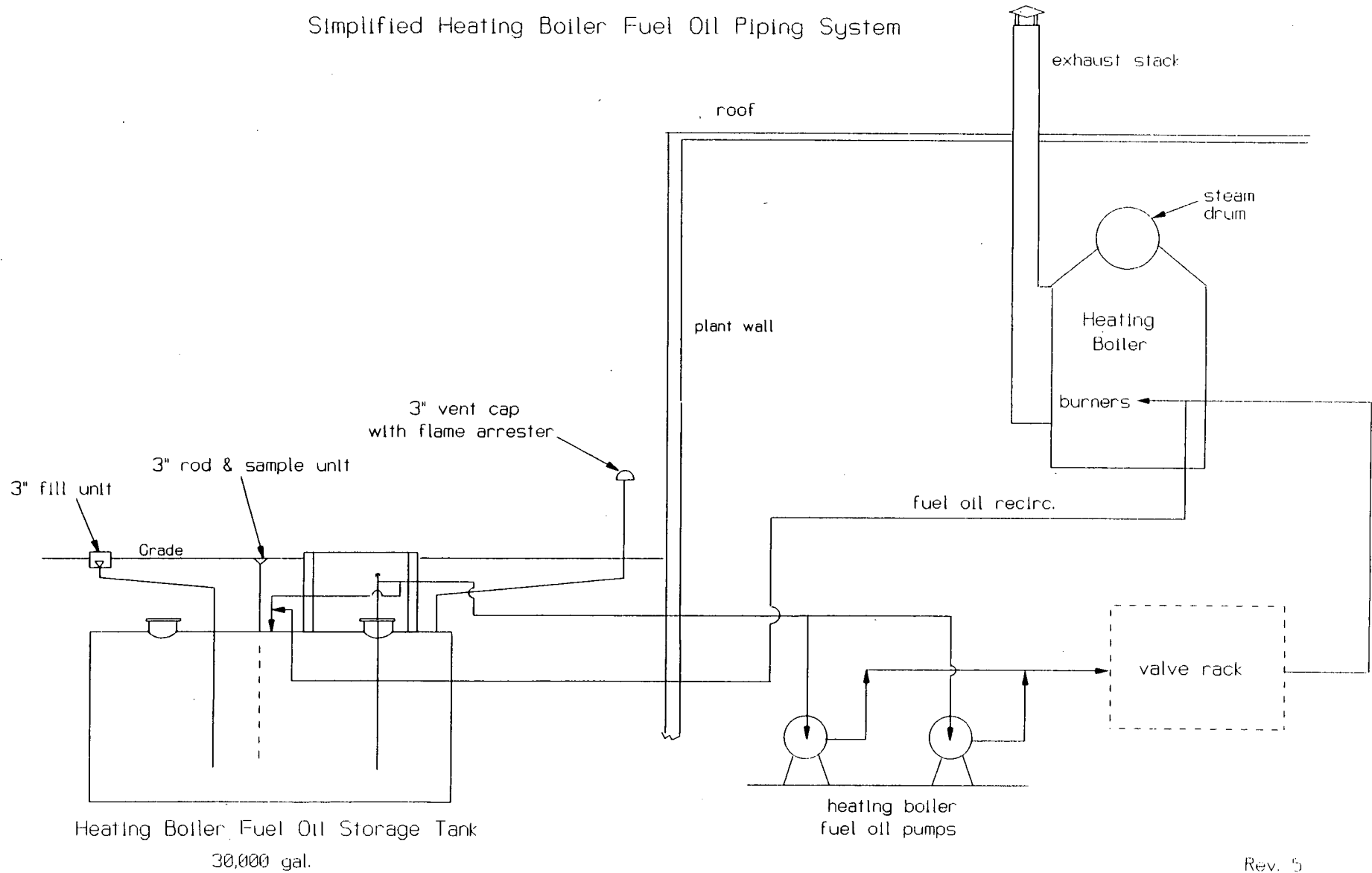

Table 2.1

## Dose Factors for Noble Gases

Radionuclide	Total Body Dose Factor Ki (mrem/yr per $\mu\text{Ci}/\text{m}^3$ )	Skin Dose Factor Li (mrem/yr per $\mu\text{Ci}/\text{m}^3$ )	Gamma Air Dose Factor Mi (mrad/yr per $\mu\text{Ci}/\text{m}^3$ )	Beta Air Dose Factor Ni (mrad/yr per $\mu\text{Ci}/\text{m}^3$ )
Kr-83m	7.56E-02	-----	1.93E+01	2.88E+02
Kr-85m	1.17E+03	1.46E+03	1.23E+03	1.97E+03
Kr-85	1.61E+01	1.34E+03	1.72E+01	1.95E+03
Kr-87	5.92E+03	9.73E+03	6.17E+03	1.03E+04
Kr-88	1.47E+04	2.37E+03	1.52E+04	2.93E+03
Kr-89	1.66E+04	1.01E+04	1.73E+04	1.06E+04
Kr-90	1.56E+04	7.29E+03	1.63E+04	7.83E+03
Xe-131m	9.15E+01	4.76E+02	1.56E+02	1.11E+03
Xe-133m	2.51E+02	9.94E+02	3.27E+02	1.48E+03
Xe-133	2.94E+02	3.06E+02	3.53E+02	1.05E+03
Xe-135m	3.12E+03	7.11E+02	3.36E+03	7.39E+02
Xe-135	1.81E+03	1.86E+03	1.92E+03	2.46E+03
Xe-137	1.42E+03	1.22E+04	1.51E+03	1.27E+04
Xe-138	8.83E+03	4.13E+03	9.21E+03	4.75E+03
Ar-41	8.84E+03	2.69E+03	9.30E+03	3.28E+03

**Table 2.2**  
**Parameters for Gaseous Alarm Setpoint Determinations**

Parameter	Actual Value	Default Value*	Units	Comments
X/Q	calculated	3.6E-06	sec/m <sup>3</sup>	Licensing technical specification value
VF	fan curves	33,000 54,000	cfm	Containment -normal plus purge modes Auxiliary Building - normal operation
C <sub>i</sub>	measured	N/A	μCi/m <sup>3</sup>	
K <sub>i</sub>	nuclide specific	N/A	mrem/yr per μCi/m <sup>3</sup>	Values from Table 2.1
L <sub>i</sub>	nuclide specific	N/A	mrem/yr per μCi/m <sup>3</sup>	Values from Table 2.1
M <sub>i</sub>	nuclide specific	N/A	mrem/yr per μCi/m <sup>3</sup>	Values from Table 2.1
Sensitivity** (SEN) R-12 R-21 R-13 R-14	as determined	2.32E+07 2.32E+07 2.32E+07 2.32E+07	cpm per μCi/cm <sup>3</sup>	Containment Containment Auxiliary Building Auxiliary Building
background (bkg) R-12 R-21 R-13 R-14	as determined	4.0E+02 4.0E+01 6.0E+02 9.0E+02	cpm	Nominal values only; actual values may be used in lieu of these reference values.
Setpoint* (SP) R-12 R-21 R-13 R-14	calculated calculated calculated calculated	2.2E+05 + bkg 2.2E+05 + bkg 1.3E+05 + bkg 1.3E+05 + bkg	cpm	Default alarm setpoints; more conservative values may be used as deemed appropriate and desirable for ensuring regulatory compliance and for maintaining releases ALARA.

\* Refer to Calculation # C10690 for the default setpoint calculation.

\*\* Conservatively based on Xe-133 sensitivity



**Table 2.3**  
**Controlling Locations, Pathways and**  
**Atmospheric Dispersion for Dose Calculations**

<u>(Technical)</u> <u>Specification</u>	<u>Location</u>	<u>Pathway(s)</u>	<u>Atmospheric Dispersion</u>	
			<u>X/Q</u> <u>(sec/m<sup>3</sup>)</u>	<u>D/Q</u> <u>(1/m<sup>2</sup>)</u>
3.4.1.a(7.4.1.a)	site boundary (1300 m, N)	noble gases direct exposure	3.6E-06	N/A
3.4.1.b(7.4.1.b)	site boundary (1300 m, N)	inhalation	3.6E-06	N/A
3.4.2(7.4.2)	site boundary (1300 m, N)	gamma-air beta-air	3.6E-06	N/A
3.4.3(7.4.3)	residence/dairy (1 mile W)	vegetation, milk and ground plane	5.6E-07	5.6E-09

Table 2.4

**R<sub>i</sub> Inhalation Pathway Dose Factors - ADULT**  
 (mrem/yr per  $\mu\text{Ci}/\text{m}^3$ )

<u>Nuclide</u>	<u>Bone</u>	<u>Liver</u>	<u>Thyroid</u>	<u>Kidney</u>	<u>Lung</u>	<u>GI-LLI</u>	<u>T.Body</u>
H-3	-	1.26E+3	1.26E+3	1.26E+3	1.26E+3	1.26E+3	1.26E+3
C-14	1.82E+4	3.41E+3	3.41E+3	3.41E+3	3.41E+3	3.41E+3	3.41E+3
Na-24	1.02E+4	1.02E+4	1.02E+4	1.02E+4	1.02E+4	1.02E+4	1.02E+4
P-32	1.32E+6	7.71E+4	-	-	-	8.64E+4	5.01E+4
Cr-51	-	-	5.95E+1	2.28E+1	1.44E+4	3.32E+3	1.00E+2
Mn-54	-	3.96E+4	-	9.84E+3	1.40E+6	7.74E+4	6.30E+3
Mn-56	-	1.24E+0	-	1.30E+0	9.44E+3	2.02E+4	1.83E-1
Fe-55	2.46E+4	1.70E+4	-	-	7.21E+4	6.03E+3	3.94E+3
Fe-59	1.18E+4	2.78E+4	-	-	1.02E+6	1.88E+5	1.06E+4
Co-57	-	6.92E+2	-	-	3.70E+5	3.14E+4	6.71E+2
Co-58	-	1.58E+3	-	-	9.28E+5	1.06E+5	2.07E+3
Co-60	-	1.15E+4	-	-	5.97E+6	2.85E+5	1.48E+4
Ni-63	4.32E+5	3.14E+4	-	-	1.78E+5	1.34E+4	1.45E+4
Ni-65	1.54E+0	2.10E-1	-	-	5.60E+3	1.23E+4	9.12E-2
Cu-64	-	1.46E+0	-	4.62E+0	6.78E+3	4.90E+4	6.15E-1
Zn-65	3.24E+4	1.03E+5	-	6.90E+4	8.64E+5	5.34E+4	4.66E+4
Zn-69	3.38E-2	6.51E-2	-	4.22E-2	9.20E+2	1.63E+1	4.52E-3
Br-82	-	-	-	-	-	1.04E+4	1.35E+4
Br-83	-	-	-	-	-	2.32E+2	2.41E+2
Br-84	-	-	-	-	-	1.64E-3	3.13E+2
Br-85	-	-	-	-	-	-	1.28E+1
Rb-86	-	1.35E+5	-	-	-	1.66E+4	5.90E+4
Rb-88	-	3.87E+2	-	-	-	3.34E-9	1.93E+2
Rb-89	-	2.56E+2	-	-	-	-	1.70E+2
Sr-89	3.04E+5	-	-	-	1.40E+6	3.50E+5	8.72E+3
Sr-90	9.92E+7	-	-	-	9.60E+6	7.22E+5	6.10E+6
Sr-91	6.19E+1	-	-	-	3.65E+4	1.91E+5	2.50E+0
Sr-92	6.74E+0	-	-	-	1.65E+4	4.30E+4	2.91E-1
Y-90	2.09E+3	-	-	-	1.70E+5	5.06E+5	5.61E+1
Y-91m	2.61E-1	-	-	-	1.92E+3	1.33E+0	1.02E-2
Y-91	4.62E+5	-	-	-	1.70E+6	3.85E+5	1.24E+4
Y-92	1.03E+1	-	-	-	1.57E+4	7.35E+4	3.02E-1
Y-93	9.44E+1	-	-	-	4.85E+4	4.22E+5	2.61E+0
Zr-95	1.07E+5	3.44E+4	-	5.42E+4	1.77E+6	1.50E+5	2.33E+4
Zr-97	9.68E+1	1.96E+1	-	2.97E+1	7.87E+4	5.23E+5	9.04E+0
Nb-95	1.41E+4	7.82E+3	-	7.74E+3	5.05E+5	1.04E+5	4.21E+3
Nb-97	2.22E-1	5.62E-2	-	6.54E-2	2.40E+3	2.42E+2	2.05E-2
Mo-99	-	1.21E+2	-	2.91E+2	9.12E+4	2.48E+5	2.30E+1
Tc-99m	1.03E-3	2.91E-3	-	4.42E-2	7.64E+2	4.16E+3	3.70E-2
Tc-101	4.18E-5	6.02E-5	-	1.08E-3	3.99E+2	-	5.90E-4

Table 2.4 (Continued)

R<sub>i</sub> Inhalation Pathway Dose Factors - ADULT(mrem/yr per  $\mu\text{Ci}/\text{m}^3$ )

<u>Nuclide</u>	<u>Bone</u>	<u>Liver</u>	<u>Thyroid</u>	<u>Kidney</u>	<u>Lung</u>	<u>GI-LLI</u>	<u>T.Body</u>
Ru-103	1.53E+3	-	-	5.83E+3	5.05E+5	1.10E+5	6.58E+2
Ru-105	7.90E-1	-	-	1.02E+0	1.10E+4	4.82E+4	3.11E-1
Ru-106	6.91E+4	-	-	1.34E+5	9.36E+6	9.12E+5	8.72E+3
Rh-103m	-	-	-	-	-	-	-
Rh-106	-	-	-	-	-	-	-
Ag-110m	1.08E+4	1.00E+4	-	1.97E+4	4.63E+6	3.02E+5	5.94E+3
Sb-124	3.12E+4	5.89E+2	7.55E+1	-	2.48E+6	4.06E+5	1.24E+4
Sb-125	5.34E+4	5.95E+2	5.40E+1	-	1.74E+6	1.01E+5	1.26E+4
Te-125m	3.42E+3	1.58E+3	1.05E+3	1.24E+4	3.14E+5	7.06E+4	4.67E+2
Te-127m	1.26E+4	5.77E+3	3.29E+3	4.58E+4	9.60E+5	1.50E+5	1.57E+3
Te-127	1.40E+0	6.42E-1	1.06E+0	5.10E+0	6.51E+3	5.74E+4	3.10E-1
Te-129m	9.76E+3	4.67E+3	3.44E+3	3.66E+4	1.16E+6	3.83E+5	1.58E+3
Te-129	4.98E-2	2.39E-2	3.90E-2	1.87E-1	1.94E+3	1.57E+2	1.24E-2
Te-131m	6.99E+1	4.36E+1	5.50E+1	3.09E+2	1.46E+5	5.56E+5	2.90E+1
Te-131	1.11E-2	5.95E-3	9.36E-3	4.37E-2	1.39E+3	1.84E+1	3.59E-3
Te-132	2.60E+2	2.15E+2	1.90E+2	1.46E+3	2.88E+5	5.10E+5	1.62E+2
I-130	4.58E+3	1.34E+4	1.14E+6	2.09E+4	-	7.69E+3	5.28E+3
I-131	2.52E+4	3.58E+4	1.19E+7	6.13E+4	-	6.28E+3	2.05E+4
I-132	1.16E+3	3.26E+3	1.14E+5	5.18E+3	-	4.06E+2	1.16E+3
I-133	8.64E+3	1.48E+4	2.15E+6	2.58E+4	-	8.88E+3	4.52E+3
I-134	6.44E+2	1.73E+3	2.98E+4	2.75E+3	-	1.01E+0	6.15E+2
I-135	2.68E+3	6.98E+3	4.48E+5	1.11E+4	-	5.25E+3	2.57E+3
Cs-134	3.73E+5	8.48E+5	-	2.87E+5	9.76E+4	1.04E+4	7.28E+5
Cs-136	3.90E+4	1.46E+5	-	8.56E+4	1.20E+4	1.17E+4	1.10E+5
Cs-137	4.78E+5	6.21E+5	-	2.22E+5	7.52E+4	8.40E+3	4.28E+5
Cs-138	3.31E+2	6.21E+2	-	4.80E+2	4.86E+1	1.86E-3	3.24E+2
Ba-139	9.36E-1	6.66E-4	-	6.22E-4	3.76E+3	8.96E+2	2.74E-2
Ba-140	3.90E+4	4.90E+1	-	1.67E+1	1.27E+6	2.18E+5	2.57E+3
Ba-141	1.00E-1	7.53E-5	-	7.00E-5	1.94E+3	1.16E-7	3.36E-3
Ba-142	2.63E-2	2.70E-5	-	2.29E-5	1.19E+3	-	1.66E-3
La-140	3.44E+2	1.74E+2	-	-	1.36E+5	4.58E+5	4.58E+1
La-142	6.83E-1	3.10E-1	-	-	6.33E+3	2.11E+3	7.72E-2
Ce-141	1.99E+4	1.35E+4	-	6.26E+3	3.62E+5	1.20E+5	1.53E+3
Ce-143	1.86E+2	1.38E+2	-	6.08E+1	7.98E+4	2.26E+5	1.53E+1
Ce-144	3.43E+6	1.43E+6	-	8.48E+5	7.78E+6	8.16E+5	1.84E+5
Pr-143	9.36E+3	3.75E+3	-	2.16E+3	2.81E+5	2.00E+5	4.64E+2
Pr-144	3.01E-2	1.25E-2	-	7.05E-3	1.02E+3	2.15E-8	1.53E-3
Nd-147	5.27E+3	6.10E+3	-	3.56E+3	2.21E+5	1.73E+5	3.65E+2
W-187	8.48E+0	7.08E+0	-	-	2.90E+4	1.55E+5	2.48E+0
Np-239	2.30E+2	2.26E+1	-	7.00E+1	3.76E+4	1.19E+5	1.24E+1

Table 2.5

R<sub>i</sub> Inhalation Pathway Dose Factors - TEEN(mrem/yr per  $\mu\text{Ci}/\text{m}^3$ )

Nuclide	Bone	Liver	Thyroid	Kidney	Lung	GI-LLI	T.Body
H-3	-	1.27E+3	1.27E+3	1.27E+3	1.27E+3	1.27E+3	1.27E+3
C-14	2.60E+4	4.87E+3	4.87E+3	4.87E+3	4.87E+3	4.87E+3	4.87E+3
Na-24	1.38E+4	1.38E+4	1.38E+4	1.38E+4	1.38E+4	1.38E+4	1.38E+4
P-32	1.89E+6	1.10E+5	-	-	-	9.28E+4	7.16E+4
Cr-51	-	-	7.50E+1	3.07E+1	2.10E+4	3.00E+3	1.35E+2
Mn-54	-	5.11E+4	-	1.27E+4	1.98E+6	6.68E+4	8.40E+3
Mn-56	-	1.70E+0	-	1.79E+0	1.52E+4	5.74E+4	2.52E-1
Fe-55	3.34E+4	2.38E+4	-	-	1.24E+5	6.39E+3	5.54E+3
Fe-59	1.59E+4	3.70E+4	-	-	1.53E+6	1.78E+5	1.43E+4
Co-57	-	6.92E+2	-	-	5.86E+5	3.14E+4	9.20E+2
Co-58	-	2.07E+3	-	-	1.34E+6	9.52E+4	2.78E+3
Co-60	-	1.51E+4	-	-	8.72E+6	2.59E+5	1.98E+4
Ni-63	5.80E+5	4.34E+4	-	-	3.07E+5	1.42E+4	1.98E+4
Ni-65	2.18E+0	2.93E-1	-	-	9.36E+3	3.67E+4	1.27E-1
Cu-64	-	2.03E+0	-	6.41E+0	1.11E+4	6.14E+4	8.48E-1
Zn-65	3.86E+4	1.34E+5	-	8.64E+4	1.24E+6	4.66E+4	6.24E+4
Zn-69	4.83E-2	9.20E-2	-	6.02E-2	1.58E+3	2.85E+2	6.46E-3
Br-82	-	-	-	-	-	-	1.82E+4
Br-83	-	-	-	-	-	-	3.44E+2
Br-84	-	-	-	-	-	-	4.33E+2
Br-85	-	-	-	-	-	-	1.83E+1
Rb-86	-	1.90E+5	-	-	-	1.77E+4	8.40E+4
Rb-88	-	5.46E+2	-	-	-	2.92E-5	2.72E+2
Rb-89	-	3.52E+2	-	-	-	3.38E-7	2.33E+2
Sr-89	4.34E+5	-	-	-	2.42E+6	3.71E+5	1.25E+4
Sr-90	1.08E+8	-	-	-	1.65E+7	7.65E+5	6.68E+6
Sr-91	8.80E+1	-	-	-	6.07E+4	2.59E+5	3.51E+0
Sr-92	9.52E+0	-	-	-	2.74E+4	1.19E+5	4.06E-1
Y-90	2.98E+3	-	-	-	2.93E+5	5.59E+5	8.00E+1
Y-91m	3.70E-1	-	-	-	3.20E+3	3.02E+1	1.42E-2
Y-91	6.61E+5	-	-	-	2.94E+6	4.09E+5	1.77E+4
Y-92	1.47E+1	-	-	-	2.68E+4	1.65E+5	4.29E-1
Y-93	1.35E+2	-	-	-	8.32E+4	5.79E+5	3.72E+0
Zr-95	1.46E+5	4.58E+4	-	6.74E+4	2.69E+6	1.49E+5	3.15E+4
Zr-97	1.38E+2	2.72E+1	-	4.12E+1	1.30E+5	6.30E+5	1.26E+1
Nb-95	1.86E+4	1.03E+4	-	1.00E+4	7.51E+5	9.68E+4	5.66E+3
Nb-97	3.14E-1	7.78E-2	-	9.12E-2	3.93E+3	2.17E+3	2.84E-2
Mo-99	-	1.69E+2	-	4.11E+2	1.54E+5	2.69E+5	3.22E+1
Tc-99m	1.38E-3	3.86E-3	-	5.76E-2	1.15E+3	6.13E+3	4.99E-2
Tc-101	5.92E-5	8.40E-5	-	1.52E-3	6.67E+2	8.72E-7	8.24E-4

Table 2.5 (Continued)

R<sub>i</sub> Inhalation Pathway Dose Factors - TEEN(mrem/yr per  $\mu\text{Ci}/\text{m}^3$ )

Nuclide	Bone	Liver	Thyroid	Kidney	Luug	GI-LLI	T.Body
Ru-103	2.10E+3	-	-	7.43E+3	7.83E+5	1.09E+5	8.96E+2
Ru-105	1.12E+0	-	-	1.41E+0	1.82E+4	9.04E+4	4.34E-1
Ru-106	9.84E+4	-	-	1.90E+5	1.61E+7	9.60E+5	1.24E+4
Rh-103m	-	-	-	-	-	-	-
Rh-106	-	-	-	-	-	-	-
Ag-110m	1.38E+4	1.31E+4	-	2.50E+4	6.75E+6	2.73E+5	7.99E+3
Sb-124	4.30E+4	7.94E+2	9.76E+1	-	3.85E+6	3.98E+5	1.68E+4
Sb-125	7.38E+4	8.08E+2	7.04E+1	-	2.74E+6	9.92E+4	1.72E+4
Te-125m	4.88E+3	2.24E+3	1.40E+3	-	5.36E+5	7.50E+4	6.67E+2
Te-127m	1.80E+4	8.16E+3	4.38E+3	6.54E+4	1.66E+6	1.59E+5	2.18E+3
Te-127	2.01E+0	9.12E-1	1.42E+0	7.28E+0	1.12E+4	8.08E+4	4.42E-1
Te-129m	1.39E+4	6.58E+3	4.58E+3	5.19E+4	1.98E+6	4.05E+5	2.25E+3
Te-129	7.10E-2	3.38E-2	5.18E-2	2.66E-1	3.30E+3	1.62E+3	1.76E-2
Te-131m	9.84E+1	6.01E+1	7.25E+1	4.39E+2	2.38E+5	6.21E+5	4.02E+1
Te-131	1.58E-2	8.32E-3	1.24E-2	6.18E-2	2.34E+3	1.51E+1	5.04E-3
Te-132	3.60E+2	2.90E+2	2.46E+2	1.95E+3	4.49E+5	4.63E+5	2.19E+2
I-130	6.24E+3	1.79E+4	1.49E+6	2.75E+4	-	9.12E+3	7.17E+3
I-131	3.54E+4	4.91E+4	1.46E+7	8.40E+4	-	6.49E+3	2.64E+4
I-132	1.59E+3	4.38E+3	1.51E+5	6.92E+3	-	1.27E+3	1.58E+3
I-133	1.22E+4	2.05E+4	2.92E+6	3.59E+4	-	1.03E+4	6.22E+3
I-134	8.88E+2	2.32E+3	3.95E+4	3.66E+3	-	2.04E+1	8.40E+2
I-135	3.70E+3	9.44E+3	6.21E+5	1.49E+4	-	6.95E+3	3.49E+3
Cs-134	5.02E+5	1.13E+6	-	3.75E+5	1.46E+5	9.76E+3	5.49E+5
Cs-136	5.15E+4	1.94E+5	-	1.10E+5	1.78E+4	1.09E+4	1.37E+5
Cs-137	6.70E+5	8.48E+5	-	3.04E+5	1.21E+5	8.48E+3	3.11E+5
Cs-138	4.66E+2	8.56E+2	-	6.62E+2	7.87E+1	2.70E-1	4.46E+2
Ba-139	1.34E+0	9.44E-4	-	8.88E-4	6.46E+3	6.45E+3	3.90E-2
Ba-140	5.47E+4	6.70E+1	-	2.28E+1	2.03E+6	2.29E+5	3.52E+3
Ba-141	1.42E-1	1.06E-4	-	9.84E-5	3.29E+3	7.46E-4	4.74E-3
Ba-142	3.70E-2	3.70E-5	-	3.14E-5	1.91E+3	-	2.27E-3
La-140	4.79E+2	2.36E+2	-	-	2.14E+5	4.87E+5	6.26E+1
La-142	9.60E-1	4.25E-1	-	-	1.02E+4	1.20E+4	1.06E-1
Ce-141	2.84E+4	1.90E+4	-	8.88E+3	6.14E+5	1.26E+5	2.17E+3
Ce-143	2.66E+2	1.94E+2	-	8.64E+1	1.30E+5	2.55E+5	2.16E+1
Ce-144	4.89E+6	2.02E+6	-	1.21E+6	1.34E+7	8.64E+5	2.62E+5
Pr-143	1.34E+4	5.31E+3	-	3.09E+3	4.83E+5	2.14E+5	6.62E+2
Pr-144	4.30E-2	1.76E-2	-	1.01E-2	1.75E+3	2.35E-4	2.18E-3
Nd-147	7.86E+3	8.56E+3	-	5.02E+3	3.72E+5	1.82E+5	5.13E+2
W-187	1.20E+1	9.76E+0	-	-	4.74E+4	1.77E+5	3.43E+0
Np-239	3.38E+2	3.19E+1	-	1.00E+2	6.49E+4	1.32E+5	1.77E+1

Table 2.6

R<sub>i</sub> Inhalation Pathway Dose Factors - CHILD(mrem/yr per  $\mu\text{Ci}/\text{m}^3$ )

<u>Nuclide</u>	<u>Bone</u>	<u>Liver</u>	<u>Thyroid</u>	<u>Kidney</u>	<u>Luug</u>	<u>GI-LLI</u>	<u>T.Body</u>
H-3	-	1.12E+3	1.12E+3	1.12E+3	1.12E+3	1.12E+3	1.12E+3
C-14	3.59E+4	6.73E+3	6.73E+3	6.73E+3	6.73E+3	6.73E+3	6.73E+3
Na-24	1.61E+4	1.61E+4	1.61E+4	1.61E+4	1.61E+4	1.61E+4	1.61E+4
P-32	2.60E+6	1.14E+5	-	-	-	4.22E+4	9.88E+4
Cr-51	-	-	8.55E+1	2.43E+1	1.70E+4	1.08E+3	1.54E+2
Mn-54	-	4.29E+4	-	1.00E+4	1.58E+6	2.29E+4	9.51E+3
Mn-56	-	1.66E+0	-	1.67E+0	1.31E+4	1.23E+5	3.12E-1
Fe-55	4.74E+4	2.52E+4	-	-	1.11E+5	2.87E+3	7.77E+3
Fe-59	2.07E+4	3.34E+4	-	-	1.27E+6	7.07E+4	1.67E+4
Co-57	-	9.03E+2	-	-	5.07E+5	1.32E+4	1.07E+3
Co-58	-	1.77E+3	-	-	1.11E+6	3.44E+4	3.16E+3
Co-60	-	1.31E+4	-	-	7.07E+6	9.62E+4	2.26E+4
Ni-63	8.21E+5	4.63E+4	-	-	2.75E+5	6.33E+3	2.80E+4
Ni-65	2.99E+0	2.96E-1	-	-	8.18E+3	8.40E+4	1.64E-1
Cu-64	-	1.99E+0	-	6.03E+0	9.58E+3	3.67E+4	1.07E+0
Zn-65	4.26E+4	1.13E+5	-	7.14E+4	9.95E+5	1.63E+4	7.03E+4
Zn-69	6.70E-2	9.66E-2	-	5.85E-2	1.42E+3	1.02E+4	8.92E-3
Br-82	-	-	-	-	-	-	2.09E+4
Br-83	-	-	-	-	-	-	4.74E+2
Br-84	-	-	-	-	-	-	5.48E+2
Br-85	-	-	-	-	-	-	2.53E+1
Rb-86	-	1.98E+5	-	-	-	7.99E+3	1.14E+5
Rb-88	-	5.62E+2	-	-	-	1.72E+1	3.66E+2
Rb-89	-	3.45E+2	-	-	-	1.89E+0	2.90E+2
Sr-89	5.99E+5	-	-	-	2.16E+6	1.67E+5	1.72E+4
Sr-90	1.01E+8	-	-	-	1.48E+7	3.43E+5	6.44E+6
Sr-91	1.21E+2	-	-	-	5.33E+4	1.74E+5	4.59E+0
Sr-92	1.31E+1	-	-	-	2.40E+4	2.42E+5	5.25E-1
Y-90	4.11E+3	-	-	-	2.62E+5	2.68E+5	1.11E+2
Y-91m	5.07E-1	-	-	-	2.81E+3	1.72E+3	1.84E-2
Y-91	9.14E+5	-	-	-	2.63E+6	1.84E+5	2.44E+4
Y-92	2.04E+1	-	-	-	2.39E+4	2.39E+5	5.81E-1
Y-93	1.86E+2	-	-	-	7.44E+4	3.89E+5	5.11E+0
Zr-95	1.90E+5	4.18E+4	-	5.96E+4	2.23E+6	6.11E+4	3.70E+4
Zr-97	1.88E+2	2.72E+1	-	3.89E+1	1.13E+5	3.51E+5	1.60E+1
Nb-95	2.35E+4	9.18E+3	-	8.62E+3	6.14E+5	3.70E+4	6.55E+3
Nb-97	4.29E-1	7.70E-2	-	8.55E-2	3.42E+3	2.78E+4	3.60E-2
Mo-99	-	1.72E+2	-	3.92E+2	1.35E+5	1.27E+5	4.26E+1
Tc-99m	1.78E-3	3.48E-3	-	5.07E-2	9.51E+2	4.81E+3	5.77E-2
Tc-101	8.10E-5	8.51E-5	-	1.45E-3	5.85E+2	1.63E+1	1.08E-3

Table 2.6 (Continued)

 $R_i$  Inhalation Pathway Dose Factors - CHILD(mrem/yr per  $\mu\text{Ci}/\text{m}^3$ )

<u>Nuclide</u>	<u>Bone</u>	<u>Liver</u>	<u>Thyroid</u>	<u>Kidney</u>	<u>Lung</u>	<u>GI-LLI</u>	<u>T.Body</u>
Ru-103	2.79E+3	-	-	7.03E+3	6.62E+5	4.48E+4	1.07E+3
Ru-105	1.53E+0	-	-	1.34E+0	1.59E+4	9.95E+4	5.55E-1
Ru-106	1.36E+5	-	-	1.84E+5	1.43E+7	4.29E+5	1.69E+4
Rh-103m	-	-	-	-	-	-	-
Rh-106	-	-	-	-	-	-	-
Ag-110m	1.69E+4	1.14E+4	-	2.12E+4	5.48E+6	1.00E+5	9.14E+3
Sb-124	5.74E+4	7.40E+2	1.26E+2	-	3.24E+6	1.64E+5	2.00E+4
Sb-125	9.84E+4	7.59E+2	9.10E+1	-	2.32E+6	4.03E+4	2.07E+4
Te-125m	6.73E+3	2.33E+3	1.92E+3	-	4.77E+5	3.38E+4	9.14E+2
Te-127m	2.49E+4	8.55E+3	6.07E+3	6.36E+4	1.48E+6	7.14E+4	3.02E+3
Te-127	2.77E+0	9.51E-1	1.96E+0	7.07E+0	1.00E+4	5.62E+4	6.11E-1
Te-129m	1.92E+4	6.85E+3	6.33E+3	5.03E+4	1.76E+6	1.82E+5	3.04E+3
Te-129	9.77E-2	3.50E-2	7.14E-2	2.57E-1	2.93E+3	2.55E+4	2.38E-2
Te-131m	1.34E+2	5.92E+1	9.77E+1	4.00E+2	2.06E+5	3.08E+5	5.07E+1
Te-131	2.17E-2	8.44E-3	1.70E-2	5.88E-2	2.05E+3	1.33E+3	6.59E-3
Te-132	4.81E+2	2.72E+2	3.17E+2	1.77E+3	3.77E+5	1.38E+5	2.63E+2
I-130	8.18E+3	1.64E+4	1.85E+6	2.45E+4	-	5.11E+3	8.44E+3
I-131	4.81E+4	4.81E+4	1.62E+7	7.88E+4	-	2.84E+3	2.73E+4
I-132	2.12E+3	4.07E+3	1.94E+5	6.25E+3	-	3.20E+3	1.88E+3
I-133	1.66E+4	2.03E+4	3.85E+6	3.38E+4	-	5.48E+3	7.70E+3
I-134	1.17E+3	2.16E+3	5.07E+4	3.30E+3	-	9.55E+2	9.95E+2
I-135	4.92E+3	8.73E+3	7.92E+5	1.34E+4	-	4.44E+3	4.14E+3
Cs-134	6.51E+5	1.01E+6	-	3.30E+5	1.21E+5	3.85E+3	2.25E+5
Cs-136	6.51E+4	1.71E+5	-	9.55E+4	1.45E+4	4.18E+3	1.16E+5
Cs-137	9.07E+5	8.25E+5	-	2.82E+5	1.04E+5	3.62E+3	1.28E+5
Cs-138	6.33E+2	8.40E+2	-	6.22E+2	6.81E+1	2.70E+2	5.55E+2
Ba-139	1.84E+0	9.84E-4	-	8.62E-4	5.77E+3	5.77E+4	5.37E-2
Ba-140	7.40E+4	6.48E+1	-	2.11E+1	1.74E+6	1.02E+5	4.33E+3
Ba-141	1.96E-1	1.09E-4	-	9.47E-5	2.92E+3	2.75E+2	6.36E-3
Ba-142	5.00E-2	3.60E-5	-	2.91E-5	1.64E+3	2.74E+0	2.79E-3
La-140	6.44E+2	2.25E+2	-	-	1.83E+5	2.26E+5	7.55E+1
La-142	1.30E+0	4.11E-1	-	-	8.70E+3	7.59E+4	1.29E-1
Ce-141	3.92E+4	1.95E+4	-	8.55E+3	5.44E+5	5.66E+4	2.90E+3
Ce-143	3.66E+2	1.99E+2	-	8.36E+1	1.15E+5	1.27E+5	2.87E+1
Ce-144	6.77E+6	2.12E+6	-	1.17E+6	1.20E+7	3.89E+5	3.61E+5
Pr-143	1.85E+4	5.55E+3	-	3.00E+3	4.33E+5	9.73E+4	9.14E+2
Pr-144	5.96E-2	1.85E-2	-	9.77E-3	1.57E+3	1.97E+2	3.00E-3
Nd-147	1.08E+4	8.73E+3	-	4.81E+3	3.28E+5	8.21E+4	6.81E+2
W-187	1.63E+1	9.66E+0	-	-	4.11E+4	9.10E+4	4.33E+0
Np-239	4.66E+2	3.34E+1	-	9.73E+1	5.81E+4	6.40E+4	2.35E+1

Table 2.7

R<sub>i</sub> Inhalation Pathway Dose Factors - INFANT(mrem/yr per  $\mu\text{Ci}/\text{m}^3$ )

<u>Nuclide</u>	<u>Bone</u>	<u>Liver</u>	<u>Thyroid</u>	<u>Kidney</u>	<u>Lung</u>	<u>GI-LLI</u>	<u>T.Body</u>
H-3	-	6.47E+2	6.47E+2	6.47E+2	6.47E+2	6.47E+2	6.47E+2
C-14	2.65E+4	5.31E+3	5.31E+3	5.31E+3	5.31E+3	5.31E+3	5.31E+3
Na-24	1.06E+4	1.06E+4	1.06E+4	1.06E+4	1.06E+4	1.06E+4	1.06E+4
P-32	2.03E+6	1.12E+5	-	-	-	1.61E+4	7.74E+4
Cr-51	-	-	5.75E+1	1.32E+1	1.28E+4	3.57E+2	8.95E+1
Mn-54	-	2.53E+4	-	4.98E+3	1.00E+6	7.06E+3	4.98E+3
Mn-56	-	1.54E+0	-	1.10E+0	1.25E+4	7.17E+4	2.21E-1
Fe-55	1.97E+4	1.17E+4	-	-	8.69E+4	1.09E+3	3.33E+3
Fe-59	1.36E+4	2.35E+4	-	-	1.02E+6	2.48E+4	9.48E+3
Co-57	-	6.51E+2	-	-	3.79E+5	4.86E+3	6.41E+2
Co-58	-	1.22E+3	-	-	7.77E+5	1.11E+4	1.82E+3
Co-60	-	8.02E+3	-	-	4.51E+6	3.19E+4	1.18E+4
Ni-63	3.39E+5	2.04E+4	-	-	2.09E+5	2.42E+3	1.16E+4
Ni-65	2.39E+0	2.84E-1	-	-	8.12E+3	5.01E+4	1.23E-1
Cu-64	-	1.88E+0	-	3.98E+0	9.30E+3	1.50E+4	7.74E-1
Zn-65	1.93E+4	6.26E+4	-	3.25E+4	6.47E+5	5.14E+4	3.11E+4
Zn-69	5.39E-2	9.67E-2	-	4.02E-2	1.47E+3	1.32E+4	7.18E-3
Br-82	-	-	-	-	-	-	1.33E+4
Br-83	-	-	-	-	-	-	3.81E+2
Br-84	-	-	-	-	-	-	4.00E+2
Br-85	-	-	-	-	-	-	2.04E+1
Rb-86	-	1.90E+5	-	-	-	3.04E+3	8.82E+4
Rb-88	-	5.57E+2	-	-	-	3.39E+2	2.87E+2
Rb-89	-	3.21E+2	-	-	-	6.82E+1	2.06E+2
Sr-89	3.98E+5	-	-	-	2.03E+6	6.40E+4	1.14E+4
Sr-90	4.09E+7	-	-	-	1.12E+7	1.31E+5	2.59E+6
Sr-91	9.56E+1	-	-	-	5.26E+4	7.34E+4	3.46E+0
Sr-92	1.05E+1	-	-	-	2.38E+4	1.40E+5	3.91E-1
Y-90	3.29E+3	-	-	-	2.69E+5	1.04E+5	8.82E+1
Y-91m	4.07E-1	-	-	-	2.79E+3	2.35E+3	1.39E-2
Y-91	5.88E+5	-	-	-	2.45E+6	7.03E+4	1.57E+4
Y-92	1.64E+1	-	-	-	2.45E+4	1.27E+5	4.61E-1
Y-93	1.50E+2	-	-	-	7.64E+4	1.67E+5	4.07E+0
Zr-95	1.15E+5	2.79E+4	-	3.11E+4	1.75E+6	2.17E+4	2.03E+4
Zr-97	1.50E+2	2.56E+1	-	2.59E+1	1.10E+5	1.40E+5	1.17E+1
Nb-95	1.57E+4	6.43E+3	-	4.72E+3	4.79E+5	1.27E+4	3.78E+3
Nb-97	3.42E-1	7.29E-2	-	5.70E-2	3.32E+3	2.69E+4	2.63E-2
Mo-99	-	1.65E+2	-	2.65E+2	1.35E+5	4.87E+4	3.23E+1
Tc-99m	1.40E-3	2.88E-3	-	3.11E-2	8.11E+2	2.03E+3	3.72E-2
Tc-101	6.51E-5	8.23E-5	-	9.79E-4	5.84E+2	8.44E+2	8.12E-4



Table 2.7 (Continued)

R<sub>i</sub> Inhalation Pathway Dose Factors - INFANT(mrem/yr per  $\mu\text{Ci}/\text{m}^3$ )

Nuclide	Bone	Liver	Thyroid	Kidney	Lung	GI-LLI	T.Body
Ru-103	2.02E+3	-	-	4.24E+3	5.52E+5	1.61E+4	6.79E+2
Ru-105	1.22E+0	-	-	8.99E-1	1.57E+4	4.84E+4	4.10E-1
Ru-106	8.68E+4	-	-	1.07E+5	1.16E+7	1.64E+5	1.09E+4
Rh-103m	-	-	-	-	-	-	-
Rh-106	-	-	-	-	-	-	-
Ag-110m	9.98E+3	7.22E+3	-	1.09E+4	3.67E+6	3.30E+4	5.00E+3
Sb-124	3.79E+4	5.56E+2	1.01E+2	-	2.65E+6	5.91E+4	1.20E+4
Sb-125	5.17E+4	4.77E+2	6.23E+1	-	1.64E+6	1.47E+4	1.09E+4
Te-125m	4.76E+3	1.99E+3	1.62E+3	-	4.47E+5	1.29E+4	6.58E+2
Te-127m	1.67E+4	6.90E+3	4.87E+3	3.75E+4	1.31E+6	2.73E+4	2.07E+3
Te-127	2.23E+0	9.53E-1	1.85E+0	4.86E+0	1.03E+4	2.44E+4	4.89E-1
Te-129m	1.41E+4	6.09E+3	5.47E+3	3.18E+4	1.68E+6	6.90E+4	2.23E+3
Te-129	7.88E-2	3.47E-2	6.75E-2	1.75E-1	3.00E+3	2.63E+4	1.88E-2
Te-131m	1.07E+2	5.50E+1	8.93E+1	2.65E+2	1.99E+5	1.19E+5	3.63E+1
Te-131	1.74E-2	8.22E-3	1.58E-2	3.99E-2	2.06E+3	8.22E+3	5.00E-3
Te-132	3.72E+2	2.37E+2	2.79E+2	1.03E+3	3.40E+5	4.41E+4	1.76E+2
I-130	6.36E+3	1.39E+4	1.60E+6	1.53E+4	-	1.99E+3	5.57E+3
I-131	3.79E+4	4.44E+4	1.48E+7	5.18E+4	-	1.06E+3	1.96E+4
I-132	1.69E+3	3.54E+3	1.69E+5	3.95E+3	-	1.90E+3	1.26E+3
I-133	1.32E+4	1.92E+4	3.56E+6	2.24E+4	-	2.16E+3	5.60E+3
I-134	9.21E+2	1.88E+3	4.45E+4	2.09E+3	-	1.29E+3	6.65E+2
I-135	3.86E+3	7.60E+3	6.96E+5	8.47E+3	-	1.83E+3	2.77E+3
Cs-134	3.96E+5	7.03E+5	-	1.90E+5	7.97E+4	1.33E+3	7.45E+4
Cs-136	4.83E+4	1.35E+5	-	5.64E+4	1.18E+4	1.43E+3	5.29E+4
Cs-137	5.49E+5	6.12E+5	-	1.72E+5	7.13E+4	1.33E+3	4.55E+4
Cs-138	5.05E+2	7.81E+2	-	4.10E+2	6.54E+1	8.76E+2	3.98E+2
Ba-139	1.48E+0	9.84E-4	-	5.92E-4	5.95E+3	5.10E+4	4.30E-2
Ba-140	5.60E+4	5.60E+1	-	1.34E+1	1.60E+6	3.84E+4	2.90E+3
Ba-141	1.57E-1	1.08E-4	-	6.50E-5	2.97E+3	4.75E+3	4.97E-3
Ba-142	3.98E-2	3.30E-5	-	1.90E-5	1.55E+3	6.93E+2	1.96E-3
La-140	5.05E+2	2.00E+2	-	-	1.68E+5	8.48E+4	5.15E+1
La-142	1.03E+0	3.77E-1	-	-	8.22E+3	5.95E+4	9.04E-2
Ce-141	2.77E+4	1.67E+4	-	5.25E+3	5.17E+5	2.16E+4	1.99E+3
Ce-143	2.93E+2	1.93E+2	-	5.64E+1	1.16E+5	4.97E+4	2.21E+1
Ce-144	3.19E+6	1.21E+6	-	5.38E+5	9.84E+6	1.48E+5	1.76E+5
Pr-143	1.40E+4	5.24E+3	-	1.97E+3	4.33E+5	3.72E+4	6.99E+2
Pr-144	4.79E-2	1.85E-2	-	6.72E-3	1.61E+3	4.28E+3	2.41E-3
Nd-147	7.94E+3	8.13E+3	-	3.15E+3	3.22E+5	3.12E+4	5.00E+2
W-187	1.30E+1	9.02E+0	-	-	3.96E+4	3.56E+4	3.12E+0
Np-239	3.71E+2	3.32E+1	-	6.62E+1	5.95E+4	2.49E+4	1.88E+1

Table 2.8

R<sub>i</sub> Vegetation Pathway Dose Factors - ADULT(mrem/yr per  $\mu\text{Ci}/\text{m}^3$ ) for H-3 and C-14 ( $\text{m}^2 \times \text{mrem}/\text{yr}$  per  $\mu\text{Ci}/\text{sec}$ ) for others

Nuclide	Bone	Liver	Thyroid	Kidney	Lung	GI-LLI	T.Body
H-3	-	2.26E+3	2.26E+3	2.26E+3	2.26E+3	2.26E+3	2.26E+3
C-14	8.97E+5	1.79E+5	1.79E+5	1.79E+5	1.79E+5	1.79E+5	1.79E+5
Na-24	2.76E+5	2.76E+5	2.76E+5	2.76E+5	2.76E+5	2.76E+5	2.76E+5
P-32	1.40E+9	8.73E+7	-	-	-	1.58E+8	5.42E+7
Cr-51	-	-	2.79E+4	1.03E+4	6.19E+4	1.17E+7	4.66E+4
Mn-54	-	3.11E+8	-	9.27E+7	-	9.54E+8	5.94E+7
Mn-56	-	1.61E+1	-	2.04E+1	-	5.13E+2	2.85E+0
Fe-55	2.09E+8	1.45E+8	-	-	8.06E+7	8.29E+7	3.37E+7
Fe-59	1.27E+8	2.99E+8	-	-	8.35E+7	9.96E+8	1.14E+8
Co-57	-	1.17E+7	-	-	-	2.97E+8	1.95E+7
Co-58	-	3.09E+7	-	-	-	6.26E+8	6.92E+7
Co-60	-	1.67E+8	-	-	-	3.14E+9	3.69E+8
Ni-63	1.04E+10	7.21E+8	-	-	-	1.50E+8	3.49E+8
Ni-65	6.15E+1	7.99E+0	-	-	-	2.03E+2	3.65E+0
Cu-64	-	9.27E+3	-	2.34E+4	-	7.90E+5	4.35E+3
Zn-65	3.17E+8	1.01E+9	-	6.75E+8	-	6.36E+8	4.56E+8
Zn-69	8.75E-6	1.67E-5	-	1.09E-5	-	2.51E-6	1.16E-6
Br-82	-	-	-	-	-	1.73E+6	1.51E+6
Br-83	-	-	-	-	-	4.63E+0	3.21E+0
Br-84	-	-	-	-	-	-	-
Br-85	-	-	-	-	-	-	-
Rb-86	-	2.19E+8	-	-	-	4.32E+7	1.02E+8
Rb-88	-	-	-	-	-	-	-
Rb-89	-	-	-	-	-	-	-
Sr-89	9.96E+9	-	-	-	-	1.60E+9	2.86E+8
Sr-90	6.05E+11	-	-	-	-	1.75E+10	1.48E+11
Sr-91	3.20E+5	-	-	-	-	1.52E+6	1.29E+4
Sr-92	4.27E+2	-	-	-	-	8.46E+3	1.85E+1
Y-90	1.33E+4	-	-	-	-	1.41E+8	3.56E+2
Y-91m	5.83E-9	-	-	-	-	1.71E-8	-
Y-91	5.13E+6	-	-	-	-	2.82E+9	1.37E+5
Y-92	9.01E-1	-	-	-	-	1.58E+4	2.63E-2
Y-93	1.74E+2	-	-	-	-	5.52E+6	4.80E+0
Zr-95	1.19E+6	3.81E+5	-	5.97E+5	-	1.21E+9	2.58E+5
Zr-97	3.33E+2	6.73E+1	-	1.02E+2	-	2.08E+7	3.08E+1
Nb-95	1.42E+5	7.91E+4	-	7.81E+4	-	4.80E+8	4.25E+4
Nb-97	2.90E-6	7.34E-7	-	8.56E-7	-	2.71E-3	2.68E-7
Mo-99	-	6.25E+6	-	1.41E+7	-	1.45E+7	1.19E+6
Tc-99m	3.06E+0	8.66E+0	-	1.32E+2	4.24E+0	5.12E+3	1.10E+2
Tc-101	-	-	-	-	-	-	-

Table 2.8 (Continued)

R<sub>i</sub> Vegetation Pathway Dose Factors - ADULT(mrem/yr per  $\mu\text{Ci}/\text{m}^3$ ) for H-3 and C-14 ( $\text{m}^2 \times \text{mrem}/\text{yr}$  per  $\mu\text{Ci}/\text{sec}$ ) for others

Nuclide	Boue	Liver	Thyroid	Kidney	Lung	GI-LLI	T.Body
Ru-103	4.80E+6	-	-	1.83E+7	-	5.61E+8	2.07E+6
Ru-105	5.39E+1	-	-	6.96E+2	-	3.30E+4	2.13E+1
Ru-106	1.93E+8	-	-	3.72E+8	-	1.25E+10	2.44E+7
Rh-103m	-	-	-	-	-	-	-
Rh-106	-	-	-	-	-	-	-
Ag-110m	1.06E+7	9.76E+6	-	1.92E+7	-	3.98E+9	5.80E+6
Sb-124	1.04E+8	1.96E+6	2.52E+5	-	8.08E+7	2.95E+9	4.11E+7
Sb-125	1.36E+8	1.52E+6	1.39E+5	-	1.05E+8	1.50E+9	3.25E+7
Te-125m	9.66E+7	3.50E+7	2.90E+7	3.93E+8	-	3.86E+8	1.29E+7
Te-127m	3.49E+8	1.25E+8	8.92E+7	1.42E+9	-	1.17E+9	4.26E+7
Te-127	5.76E+3	2.07E+3	4.27E+3	2.35E+4	-	4.54E+5	1.25E+3
Te-129m	2.55E+8	9.50E+7	8.75E+7	1.06E+9	-	1.28E+9	4.03E+7
Te-129	6.65E-4	2.50E-4	5.10E-4	2.79E-3	-	5.02E-4	1.62E-4
Te-131m	9.12E+5	4.46E+5	7.06E+5	4.52E+6	-	4.43E+7	3.72E+5
Te-131	-	-	-	-	-	-	-
Te-132	4.29E+6	2.77E+6	3.06E+6	2.67E+7	-	1.31E+8	2.60E+6
I-130	3.96E+5	1.17E+6	9.90E+7	1.82E+6	-	1.01E+6	4.61E+5
I-131	8.09E+7	1.16E+8	3.79E+10	1.98E+8	-	3.05E+7	6.63E+7
I-132	5.74E+1	1.54E+2	5.38E+3	2.45E+2	-	2.89E+1	5.38E+1
I-133	2.12E+6	3.69E+6	5.42E+8	6.44E+6	-	3.31E+6	1.12E+6
I-134	1.06E-4	2.88E-4	5.00E-3	4.59E-4	-	2.51E-7	1.03E-4
I-135	4.08E+4	1.07E+5	7.04E+6	1.71E+5	-	1.21E+5	3.94E+4
Cs-134	4.66E+9	1.11E+10	-	3.59E+9	1.19E+9	1.94E+8	9.07E+9
Cs-136	4.20E+7	1.66E+8	-	9.24E+7	1.27E+7	1.89E+7	1.19E+8
Cs-137	6.36E+9	8.70E+9	-	2.95E+9	9.81E+8	1.68E+8	5.70E+9
Cs-138	-	-	-	-	-	-	-
Ba-139	2.95E-2	2.10E-5	-	1.96E-5	1.19E-5	5.23E-2	8.64E-4
Ba-140	1.29E+8	1.62E+5	-	5.49E+4	9.25E+4	2.65E+8	8.43E+6
Ba-141	-	-	-	-	-	-	-
Ba-142	-	-	-	-	-	-	-
La-140	1.97E+3	9.92E+2	-	-	-	7.28E+7	2.62E+2
La-142	1.40E-4	6.35E-5	-	-	-	4.64E-1	1.58E-5
Ce-141	1.96E+5	1.33E+5	-	6.17E+4	-	5.08E+8	1.51E+4
Ce-143	1.00E+3	7.42E+5	-	3.26E+2	-	2.77E+7	8.21E+1
Ce-144	3.29E+7	1.38E+7	-	8.16E+6	-	1.11E+10	1.77E+6
Pr-143	6.34E+4	2.54E+4	-	1.47E+4	-	2.78E+8	3.14E+3
Pr-144	-	-	-	-	-	-	-
Nd-147	3.34E+4	3.86E+4	-	2.25E+4	-	1.85E+8	2.31E+3
W-187	3.82E+4	3.19E+4	-	-	-	1.05E+7	1.12E+4
Np-239	1.42E+3	1.40E+2	-	4.37E+2	-	2.87E+7	7.72E+1

Table 2.9

R<sub>i</sub> Vegetation Pathway Dose Factors - TEEN(mrem/yr per  $\mu\text{Ci}/\text{m}^3$ ) for H-3 and C-14 ( $\text{m}^2 \times \text{mrem}/\text{yr}$  per  $\mu\text{Ci}/\text{sec}$ ) for others

Nuclide	Bone	Liver	Thyroid	Kidney	Lung	GI-LLI	T.Body
H-3	-	2.59E+3	2.59E+3	2.59E+3	2.59E+3	2.59E+3	2.59E+3
C-14	1.45E+6	2.91E+5	2.91E+5	2.91E+5	2.91E+5	2.91E+5	2.91E+5
Na-24	2.45E+5	2.45E+5	2.45E+5	2.45E+5	2.45E+5	2.45E+5	2.45E+5
P-32	1.61E+9	9.96E+7	-	-	-	1.35E+8	6.23E+7
Cr-51	-	-	3.44E+4	1.36E+4	8.85E+4	1.04E+7	6.20E+4
Mn-54	-	4.52E+8	-	1.35E+8	-	9.27E+8	8.97E+7
Mn-56	-	1.45E+1	-	1.83E+1	-	9.54E+2	2.58E+0
Fe-55	3.25E+8	2.31E+8	-	-	1.46E+8	9.98E+7	5.38E+7
Fe-59	1.81E+8	4.22E+8	-	-	1.33E+8	9.98E+8	1.63E+8
Co-57	-	1.79E+7	-	-	-	3.34E+8	3.00E+7
Co-58	-	4.38E+7	-	-	-	6.04E+8	1.01E+8
Co-60	-	2.49E+8	-	-	-	3.24E+9	5.60E+8
Ni-63	1.61E+10	1.13E+9	-	-	-	1.81E+8	5.45E+8
Ni-65	5.73E+1	7.32E+0	-	-	-	3.97E+2	3.33E+0
Cu-64	-	8.40E+3	-	2.12E+4	-	6.51E+5	3.95E+3
Zn-65	4.24E+8	1.47E+9	-	9.41E+8	-	6.23E+8	6.86E+8
Zn-69	8.19E-6	1.56E-5	-	1.02E-5	-	2.88E-5	1.09E-6
Br-82	-	-	-	-	-	-	1.33E+6
Br-83	-	-	-	-	-	-	3.01E+0
Br-84	-	-	-	-	-	-	-
Br-85	-	-	-	-	-	-	-
Rb-86	-	2.73E+8	-	-	-	4.05E+7	1.28E+8
Rb-88	-	-	-	-	-	-	-
Rb-89	-	-	-	-	-	-	-
Sr-89	1.51E+10	-	-	-	-	1.80E+9	4.33E+8
Sr-90	7.51E+11	-	-	-	-	2.11E+10	1.85E+11
Sr-91	2.99E+5	-	-	-	-	1.36E+6	1.19E+4
Sr-92	3.97E+2	-	-	-	-	1.01E+4	1.69E+1
Y-90	1.24E+4	-	-	-	-	1.02E+8	3.34E+2
Y-91m	5.43E-9	-	-	-	-	2.56E-7	-
Y-91	7.87E+6	-	-	-	-	3.23E+9	2.11E+5
Y-92	8.47E-1	-	-	-	-	2.32E+4	2.45E-2
Y-93	1.63E+2	-	-	-	-	4.98E+6	4.47E+0
Zr-95	1.74E+6	5.49E+5	-	8.07E+5	-	1.27E+9	3.78E+5
Zr-97	3.09E+2	6.11E+1	-	9.26E+1	-	1.65E+7	2.81E+1
Nb-95	1.92E+5	1.06E+5	-	1.03E+5	-	4.55E+8	5.86E+4
Nb-97	2.69E-6	6.67E-7	-	7.80E-7	-	1.59E-2	2.44E-7
Mo-99	-	5.74E+6	-	1.31E+7	-	1.03E+7	1.09E+6
Tc-99m	2.70E+0	7.54E+0	-	1.12E+2	4.19E+0	4.95E+3	9.77E+1
Tc-101	-	-	-	-	-	-	-

Table 2.9 (Continued)

R<sub>1</sub> Vegetation Pathway Dose Factors - TEEN(mrem/yr per  $\mu\text{Ci}/\text{m}^3$ ) for H-3 and C-14 ( $\text{m}^2 \times \text{mrem}/\text{yr}$  per  $\mu\text{Ci}/\text{sec}$ ) for others

<u>Nuclide</u>	<u>Bone</u>	<u>Liver</u>	<u>Thyroid</u>	<u>Kidney</u>	<u>Lung</u>	<u>GI-LLI</u>	<u>T.Body</u>
Ru-103	6.87E+6	-	-	2.42E+7	-	5.74E+8	2.94E+6
Ru-105	5.00E+1	-	-	6.31E+2	-	4.04E+4	1.94E+1
Ru-106	3.09E+8	-	-	5.97E+8	-	1.48E+10	3.90E+7
Rh-103m	-	-	-	-	-	-	-
Rh-106	-	-	-	-	-	-	-
Ag-110m	1.52E+7	1.44E+7	-	2.74E+7	-	4.04E+9	8.74E+6
Sb-124	1.55E+8	2.85E+6	3.51E+5	-	1.35E+8	3.11E+9	6.03E+7
Sb-125	2.14E+8	2.34E+6	2.04E+5	-	1.88E+8	1.66E+9	5.00E+7
Te-125m	1.48E+8	5.34E+7	4.14E+7	-	-	4.37E+8	1.98E+7
Te-127m	5.51E+8	1.96E+8	1.31E+8	2.24E+9	-	1.37E+9	6.56E+7
Te-127	5.43E+3	1.92E+3	3.74E+3	2.20E+4	-	4.19E+5	1.17E+3
Te-129m	3.67E+8	1.36E+8	1.18E+8	1.54E+9	-	1.38E+9	5.81E+7
Te-129	6.22E-4	2.32E-4	4.45E-4	2.61E-3	-	3.40E-3	1.51E-4
Te-131m	8.44E+5	4.05E+5	6.09E+5	4.22E+6	-	3.25E+7	3.38E+5
Te-131	-	-	-	-	-	-	-
Te-132	3.90E+6	2.47E+6	2.60E+6	2.37E+7	-	7.82E+7	2.32E+6
I-130	3.54E+5	1.02E+6	8.35E+7	1.58E+6	-	7.87E+5	4.09E+5
I-131	7.70E+7	1.08E+8	3.14E+10	1.85E+8	-	2.13E+7	5.79E+7
I-132	5.18E+1	1.36E+2	4.57E+3	2.14E+2	-	5.91E+1	4.87E+1
I-133	1.97E+6	3.34E+6	4.66E+8	5.86E+6	-	2.53E+6	1.02E+6
I-134	9.59E-5	2.54E-4	4.24E-3	4.01E-4	-	3.35E-6	9.13E-5
I-135	3.68E+4	9.48E+4	6.10E+6	1.50E+5	-	1.05E+5	3.52E+4
Cs-134	7.09E+9	1.67E+10	-	5.30E+9	2.02E+9	2.08E+8	7.74E+9
Cs-136	4.29E+7	1.69E+8	-	9.19E+7	1.45E+7	1.36E+7	1.13E+8
Cs-137	1.01E+10	1.35E+10	-	4.59E+9	1.78E+9	1.92E+8	4.69E+9
Cs-138	-	-	-	-	-	-	-
Ba-139	2.77E-2	1.95E-5	-	1.84E-5	1.34E-5	2.47E-1	8.08E-4
Ba-140	1.38E+8	1.69E+5	-	5.75E+4	1.14E+5	2.13E+8	8.91E+6
Ba-141	-	-	-	-	-	-	-
Ba-142	-	-	-	-	-	-	-
La-140	1.80E+3	8.84E+2	-	-	-	5.08E+7	2.35E+2
La-142	1.28E-4	5.69E-5	-	-	-	1.73E+0	1.42E-5
Ce-141	2.82E+5	1.88E+5	-	8.86E+4	-	5.38E+8	2.16E+4
Ce-143	9.37E+2	6.82E+5	-	3.06E+2	-	2.05E+7	7.62E+1
Ce-144	5.27E+7	2.18E+7	-	1.30E+7	-	1.33E+10	2.83E+6
Pr-143	7.12E+4	2.84E+4	-	1.65E+4	-	2.34E+8	3.55E+3
Pr-144	-	-	-	-	-	-	-
Nd-147	3.63E+4	3.94E+4	-	2.32E+4	-	1.42E+8	2.36E+3
W-187	3.55E+4	2.90E+4	-	-	-	7.84E+6	1.02E+4
Np-239	1.38E+3	1.30E+2	-	4.09E+2	-	2.10E+7	7.24E+1

Table 2.10

R<sub>i</sub> Vegetation Pathway Dose Factors - CHILD(mrem/yr per  $\mu\text{Ci}/\text{m}^3$ ) for H-3 and C-14( $\text{m}^2 \times \text{mrem}/\text{yr}$  per  $\mu\text{Ci}/\text{sec}$ ) for others

Nuclide	Bone	Liver	Thyroid	Kidney	Lung	GI-LLI	T.Body
H-3	-	4.01E+3	4.01E+3	4.01E+3	4.01E+3	4.01E+3	4.01E+3
C-14	3.50E+6	7.01E+5	7.01E+5	7.01E+5	7.01E+5	7.01E+5	7.01E+5
Na-24	3.83E+5	3.83E+5	3.83E+5	3.83E+5	3.83E+5	3.83E+5	3.83E+5
P-32	3.37E+9	1.58E+8	-	-	-	9.30E+7	1.30E+8
Cr-51	-	-	6.54E+4	1.79E+4	1.19E+5	6.25E+6	1.18E+5
Mn-54	-	6.61E+8	-	1.85E+8	-	5.55E+8	1.76E+8
Mn-56	-	1.90E+1	-	2.29E+1	-	2.75E+3	4.28E+0
Fe-55	8.00E+8	4.24E+8	-	-	2.40E+8	7.86E+7	1.31E+8
Fe-59	4.01E+8	6.49E+8	-	-	1.88E+8	6.76E+8	3.23E+8
Co-57	-	2.99E+7	-	-	-	2.45E+8	6.04E+7
Co-58	-	6.47E+7	-	-	-	3.77E+8	1.98E+8
Co-60	-	3.78E+8	-	-	-	2.10E+9	1.12E+9
Ni-63	3.95E+10	2.11E+9	-	-	-	1.42E+8	1.34E+9
Ni-65	1.05E+2	9.89E+0	-	-	-	1.21E+3	5.77E+0
Cu-64	-	1.11E+4	-	2.68E+4	-	5.20E+5	6.69E+3
Zn-65	8.12E+8	2.16E+9	-	1.36E+9	-	3.80E+8	1.35E+9
Zn-69	1.51E-5	2.18E-5	-	1.32E-5	-	1.38E-3	2.02E-6
Br-82	-	-	-	-	-	-	2.04E+6
Br-83	-	-	-	-	-	-	5.55E+0
Br-84	-	-	-	-	-	-	-
Br-85	-	-	-	-	-	-	-
Rb-86	-	4.52E+8	-	-	-	2.91E+7	2.78E+8
Rb-88	-	-	-	-	-	-	-
Rb-89	-	-	-	-	-	-	-
Sr-89	3.59E+10	-	-	-	-	1.39E+9	1.03E+9
Sr-90	1.24E+12	-	-	-	-	1.67E+10	3.15E+11
Sr-91	5.50E+5	-	-	-	-	1.21E+6	2.08E+4
Sr-92	7.28E+2	-	-	-	-	1.38E+4	2.92E+1
Y-90	2.30E+4	-	-	-	-	6.56E+7	6.17E+2
Y-91m	9.94E-9	-	-	-	-	1.95E-5	-
Y-91	1.87E+7	-	-	-	-	2.49E+9	5.01E+5
Y-92	1.56E+0	-	-	-	-	4.51E+4	4.46E-2
Y-93	3.01E+2	-	-	-	-	4.48E+6	8.25E+0
Zr-95	3.90E+6	8.58E+5	-	1.23E+6	-	8.95E+8	7.64E+5
Zr-97	5.64E+2	8.15E+1	-	1.17E+2	-	1.23E+7	4.81E+1
Nb-95	4.10E+5	1.59E+5	-	1.50E+5	-	2.95E+8	1.14E+5
Nb-97	4.90E-6	8.85E-7	-	9.82E-7	-	2.73E-1	4.13E-7
Mo-99	-	7.83E+6	-	1.67E+7	-	6.48E+6	1.94E+6
Tc-99m	4.65E+0	9.12E+0	-	1.33E+2	4.63E+0	5.19E+3	1.51E+2
Tc-101	-	-	-	-	-	-	-

Table 2.10 (Continued)

R<sub>i</sub> Vegetation Pathway Dose Factors - CHILD(mrem/yr per  $\mu\text{Ci}/\text{m}^3$ ) for H-3 and C-14 ( $\text{m}^2 \times \text{mrem}/\text{yr}$  per  $\mu\text{Ci}/\text{sec}$ ) for others

<u>Nuclide</u>	<u>Bone</u>	<u>Liver</u>	<u>Thyroid</u>	<u>Kidney</u>	<u>Lung</u>	<u>GI-LLI</u>	<u>T.Body</u>
Ru-103	1.55E+7	-	-	3.89E+7	-	3.99E+8	5.94E+6
Ru-105	9.17E+1	-	-	8.06E+2	-	5.98E+4	3.33E+1
Ru-106	7.45E+8	-	-	1.01E+9	-	1.16E+10	9.30E+7
Rh-103m	-	-	-	-	-	-	-
Rh-106	-	-	-	-	-	-	-
Ag-110m	3.22E+7	2.17E+7	-	4.05E+7	-	2.58E+9	1.74E+7
Sb-124	3.52E+8	4.57E+6	7.78E+5	-	1.96E+8	2.20E+9	1.23E+8
Sb-125	4.99E+8	3.85E+6	4.62E+5	-	2.78E+8	1.19E+9	1.05E+8
Te-125m	3.51E+8	9.50E+7	9.84E+7	-	-	3.38E+8	4.67E+7
Te-127m	1.32E+9	3.56E+8	3.16E+8	3.77E+9	-	1.07E+9	1.57E+8
Te-127	1.00E+4	2.70E+3	6.93E+3	2.85E+4	-	3.91E+5	2.15E+3
Te-129m	8.54E+8	2.39E+8	2.75E+8	2.51E+9	-	1.04E+9	1.33E+8
Te-129	1.15E-3	3.22E-4	8.22E-4	3.37E-3	-	7.17E-2	2.74E-4
Te-131m	1.54E+6	5.33E+5	1.10E+6	5.16E+6	-	2.16E+7	5.68E+5
Te-131	-	-	-	-	-	-	-
Te-132	6.98E+6	3.09E+6	4.50E+6	2.87E+7	-	3.11E+7	3.73E+6
I-130	6.21E+5	1.26E+6	1.38E+8	1.88E+6	-	5.87E+5	6.47E+5
I-131	1.43E+8	1.44E+8	4.76E+10	2.36E+8	-	1.28E+7	8.18E+7
I-132	9.20E+1	1.69E+2	7.84E+3	2.59E+2	-	1.99E+2	7.77E+1
I-133	3.59E+6	4.44E+6	8.25E+8	7.40E+6	-	1.79E+6	1.68E+6
I-134	1.70E-4	3.16E-4	7.28E-3	4.84E-4	-	2.10E-4	1.46E-4
I-135	6.54E+4	1.18E+5	1.04E+7	1.81E+5	-	8.98E+4	5.57E+4
Cs-134	1.60E+10	2.63E+10	-	8.14E+9	2.92E+9	1.42E+8	5.54E+9
Cs-136	8.06E+7	2.22E+8	-	1.18E+8	1.76E+7	7.79E+6	1.43E+8
Cs-137	2.39E+10	2.29E+10	-	7.46E+9	2.68E+9	1.43E+8	3.38E+9
Cs-138	-	-	-	-	-	-	-
Ba-139	5.11E-2	2.73E-5	-	2.38E-5	1.61E-5	2.95E+0	1.48E-3
Ba-140	2.77E+8	2.43E+5	-	7.90E+4	1.45E+5	1.40E+8	1.62E+7
Ba-141	-	-	-	-	-	-	-
Ba-142	-	-	-	-	-	-	-
La-140	3.23E+3	1.13E+3	-	-	-	3.15E+7	3.81E+2
La-142	2.32E-4	7.40E-5	-	-	-	1.47E+1	2.32E-5
Ce-141	6.35E+5	3.26E+5	-	1.43E+5	-	4.07E+8	4.84E+4
Ce-143	1.73E+3	9.36E+5	-	3.93E+2	-	1.37E+7	1.36E+2
Ce-144	1.27E+8	3.98E+7	-	2.21E+7	-	1.04E+10	6.78E+6
Pr-143	1.48E+5	4.46E+4	-	2.41E+4	-	1.60E+8	7.37E+3
Pr-144	-	-	-	-	-	-	-
Nd-147	7.16E+4	5.80E+4	-	3.18E+4	-	9.18E+7	4.49E+3
W-187	6.47E+4	3.83E+4	-	-	-	5.38E+6	1.72E+4
Np-239	2.55E+3	1.83E+2	-	5.30E+2	-	1.36E+7	1.29E+2

Table 2.11

$R_1$  Grass-Cow-Milk Pathway Dose Factors - ADULT  
(mrem/yr per  $\mu\text{Ci}/\text{m}^3$ ) for H-3 and C-14 ( $\text{m}^2 \times \text{mrem}/\text{yr}$  per  $\mu\text{Ci}/\text{sec}$ ) for others

<u>Nuclide</u>	<u>Boue</u>	<u>Liver</u>	<u>Thyroid</u>	<u>Kidney</u>	<u>Lung</u>	<u>GI-LLI</u>	<u>T.Body</u>
H-3	-	7.63E+2	7.63E+2	7.63E+2	7.63E+2	7.63E+2	7.63E+2
C-14	3.63E+5	7.26E+4	7.26E+4	7.26E+4	7.26E+4	7.26E+4	7.26E+4
Na-24	2.54E+6	2.54E+6	2.54E+6	2.54E+6	2.54E+6	2.54E+6	2.54E+6
P-32	1.71E+10	1.06E+9	-	-	-	1.92E+9	6.60E+8
Cr-51	-	-	1.71E+4	6.30E+3	3.80E+4	7.20E+6	2.86E+4
Mn-54	-	8.40E+6	-	2.50E+6	-	2.57E+7	1.60E+6
Mn-56	-	4.23E-3	-	5.38E-3	-	1.35E-1	7.51E-4
Fe-55	2.51E+7	1.73E+7	-	-	9.67E+6	9.95E+6	4.04E+6
Fe-59	2.98E+7	7.00E+7	-	-	1.95E+7	2.33E+8	2.68E+7
Co-57	-	1.28E+6	-	-	-	3.25E+7	2.13E+6
Co-58	-	4.72E+6	-	-	-	9.57E+7	1.06E+7
Co-60	-	1.64E+7	-	-	-	3.08E+8	3.62E+7
Ni-63	6.73E+9	4.66E+8	-	-	-	9.73E+7	2.26E+8
Ni-65	3.70E-1	4.81E-2	-	-	-	1.22E+0	2.19E-2
Cu-64	-	2.41E+4	-	6.08E+4	-	2.05E+6	1.13E+4
Zn-65	1.37E+9	4.36E+9	-	2.92E+9	-	2.75E+9	1.97E+9
Zn-69	-	-	-	-	-	-	-
Br-82	-	-	-	-	-	3.72E+7	3.25E+7
Br-83	-	-	-	-	-	1.49E-1	1.03E-1
Br-84	-	-	-	-	-	-	-
Br-85	-	-	-	-	-	-	-
Rb-86	-	2.59E+9	-	-	-	5.11E+8	1.21E+9
Rb-88	-	-	-	-	-	-	-
Rb-89	-	-	-	-	-	-	-
Sr-89	1.45E+9	-	-	-	-	2.33E+8	4.16E+7
Sr-90	4.68E+10	-	-	-	-	1.35E+9	1.15E+10
Sr-91	3.13E+4	-	-	-	-	1.49E+5	1.27E+3
Sr-92	4.89E-1	-	-	-	-	9.68E+0	2.11E-2
Y-90	7.07E+1	-	-	-	-	7.50E+5	1.90E+0
Y-91m	-	-	-	-	-	-	-
Y-91	8.60E+3	-	-	-	-	4.73E+6	2.30E+2
Y-92	5.42E-5	-	-	-	-	9.49E-1	1.58E-6
Y-93	2.33E-1	-	-	-	-	7.39E+3	6.43E-3
Zr-95	9.46E+2	3.03E+2	-	4.76E+2	-	9.62E+5	2.05E+2
Zr-97	4.26E-1	8.59E-2	-	1.30E-1	-	2.66E+4	3.93E-2
Nb-95	8.25E+4	4.59E+4	-	4.54E+4	-	2.79E+8	2.47E+4
Nb-97	-	-	-	-	-	5.47E-9	-
Mo-99	-	2.52E+7	-	5.72E+7	-	5.85E+7	4.80E+6
Tc-99m	3.25E+0	9.19E+0	-	1.40E+2	4.50E+0	5.44E+3	1.17E+2
Tc-101	-	-	-	-	-	-	-



Table 2.11 (Continued)

R<sub>i</sub> Grass-Cow-Milk Pathway Dose Factors - ADULT(mrem/yr per  $\mu\text{Ci}/\text{m}^3$ ) for H-3 and C-14 ( $\text{m}^2 \times \text{mrem}/\text{yr}$  per  $\mu\text{Ci}/\text{sec}$ ) for others

Nuclide	Bone	Liver	Thyroid	Kidney	Lung	GI-LLI	T.Body
Ru-103	1.02E+3	-	-	3.89E+3	-	1.19E+5	4.39E+2
Ru-105	8.57E-4	-	-	1.11E-2	-	5.24E-1	3.38E-4
Ru-106	2.04E+4	-	-	3.94E+4	-	1.32E+6	2.58E+3
Rh-103m	-	-	-	-	-	-	-
Rh-106	-	-	-	-	-	-	-
Ag-110m	5.83E+7	5.39E+7	-	1.06E+8	-	2.20E+10	3.20E+7
Sb-124	2.57E+7	4.86E+5	6.24E+4	-	2.00E+7	7.31E+8	1.02E+7
Sb-125	2.04E+7	2.28E+5	2.08E+4	-	1.58E+7	2.25E+8	4.86E+6
Te-125m	1.63E+7	5.90E+6	4.90E+6	6.63E+7	-	6.50E+7	2.18E+6
Te-127m	4.58E+7	1.64E+7	1.17E+7	1.86E+8	-	1.54E+8	5.58E+6
Te-127	6.72E+2	2.41E+2	4.98E+2	2.74E+3	-	5.30E+4	1.45E+2
Te-129m	6.04E+7	2.25E+7	2.08E+7	2.52E+8	-	3.04E+8	9.57E+6
Te-129	-	-	-	-	-	-	-
Te-131m	3.61E+5	1.77E+5	2.80E+5	1.79E+6	-	1.75E+7	1.47E+5
Te-131	-	-	-	-	-	-	-
Te-132	2.39E+6	1.55E+6	1.71E+6	1.49E+7	-	7.32E+7	1.45E+6
I-130	4.26E+5	1.26E+6	1.07E+8	1.96E+6	-	1.08E+6	4.96E+5
I-131	2.96E+8	4.24E+8	1.39E+11	7.27E+8	-	1.12E+8	2.43E+8
I-132	1.64E-1	4.37E-1	1.53E+1	6.97E-1	-	8.22E-2	1.53E-1
I-133	3.97E+6	6.90E+6	1.01E+9	1.20E+7	-	6.20E+6	2.10E+6
I-134	-	-	-	-	-	-	-
I-135	1.39E+4	3.63E+4	2.40E+6	5.83E+4	-	4.10E+4	1.34E+4
Cs-134	5.65E+9	1.34E+10	-	4.35E+9	1.44E+9	2.35E+8	1.10E+10
Cs-136	2.61E+8	1.03E+9	-	5.74E+8	7.87E+7	1.17E+8	7.42E+8
Cs-137	7.38E+9	1.01E+10	-	3.43E+9	1.14E+9	1.95E+8	6.61E+9
Cs-138	-	-	-	-	-	-	-
Ba-139	4.70E-8	-	-	-	-	8.34E-8	1.38E-9
Ba-140	2.69E+7	3.38E+4	-	1.15E+4	1.93E+4	5.54E+7	1.76E+6
Ba-141	-	-	-	-	-	-	-
Ba-142	-	-	-	-	-	-	-
La-140	4.49E+0	2.26E+0	-	-	-	1.66E+5	5.97E-1
La-142	-	-	-	-	-	3.03E-8	-
Ce-141	4.84E+3	3.27E+3	-	1.52E+3	-	1.25E+7	3.71E+2
Ce-143	4.19E+1	3.09E+4	-	1.36E+1	-	1.16E+6	3.42E+0
Ce-144	3.58E+5	1.50E+5	-	8.87E+4	-	1.21E+8	1.92E+4
Pr-143	1.59E+2	6.37E+1	-	3.68E+1	-	6.96E+5	7.88E+0
Pr-144	-	-	-	-	-	-	-
Nd-147	9.42E+1	1.09E+2	-	6.37E+1	-	5.23E+5	6.52E+0
W-187	6.56E+3	5.48E+3	-	-	-	1.80E+6	1.92E+3
Np-239	3.66E+0	3.60E-1	-	1.12E+0	-	7.39E+4	1.98E-1

Table 2.12

R<sub>1</sub> Grass-Cow-Milk Pathway Dose Factors - TEEN(mrem/yr per  $\mu\text{Ci}/\text{m}^3$ ) for H-3 and C-14 ( $\text{m}^2 \times \text{mrem}/\text{yr}$  per  $\mu\text{Ci}/\text{sec}$ ) for others

<u>Nuclide</u>	<u>Bone</u>	<u>Liver</u>	<u>Thyroid</u>	<u>Kidney</u>	<u>Luug</u>	<u>GI-LLI</u>	<u>T.Body</u>
H-3	-	9.94E+2	9.94E+2	9.94E+2	9.94E+2	9.94E+2	9.94E+2
C-14	6.70E+5	1.34E+5	1.34E+5	1.34E+5	1.34E+5	1.34E+5	1.34E+5
Na-24	4.44E+6	4.44E+6	4.44E+6	4.44E+6	4.44E+6	4.44E+6	4.44E+6
P-32	3.15E+10	1.95E+9	-	-	-	2.65E+9	1.22E+9
Cr-51	-	-	2.78E+4	1.10E+4	7.13E+4	8.40E+6	5.00E+4
Mn-54	-	1.40E+7	-	4.17E+6	-	2.87E+7	2.78E+6
Mn-56	-	7.51E-3	-	9.50E-3	-	4.94E-1	1.33E-3
Fe-55	4.45E+7	3.16E+7	-	-	2.00E+7	1.37E+7	7.36E+6
Fe-59	5.20E+7	1.21E+8	-	-	3.82E+7	2.87E+8	4.68E+7
Co-57	-	2.25E+6	-	-	-	4.19E+7	3.76E+6
Co-58	-	7.95E+6	-	-	-	1.10E+8	1.83E+7
Co-60	-	2.78E+7	-	-	-	3.62E+8	6.26E+7
Ni-63	1.18E+10	8.35E+8	-	-	-	1.33E+8	4.01E+8
Ni-65	6.78E-1	8.66E-2	-	-	-	4.70E+0	3.94E-2
Cu-64	-	4.29E+4	-	1.09E+5	-	3.33E+6	2.02E+4
Zn-65	2.11E+9	7.31E+9	-	4.68E+9	-	3.10E+9	3.41E+9
Zn-69	-	-	-	-	-	-	-
Br-82	-	-	-	-	-	-	5.64E+7
Br-83	-	-	-	-	-	-	1.91E-1
Br-84	-	-	-	-	-	-	-
Br-85	-	-	-	-	-	-	-
Rb-86	-	4.73E+9	-	-	-	7.00E+8	2.22E+9
Rb-88	-	-	-	-	-	-	-
Rb-89	-	-	-	-	-	-	-
Sr-89	2.67E+9	-	-	-	-	3.18E+8	7.66E+7
Sr-90	6.61E+10	-	-	-	-	1.86E+9	1.63E+10
Sr-91	5.75E+4	-	-	-	-	2.61E+5	2.29E+3
Sr-92	8.95E-1	-	-	-	-	2.28E+1	3.81E-2
Y-90	1.30E+2	-	-	-	-	1.07E+6	3.50E+0
Y-91m	-	-	-	-	-	-	-
Y-91	1.58E+4	-	-	-	-	6.48E+6	4.24E+2
Y-92	1.00E-4	-	-	-	-	2.75E+0	2.90E-6
Y-93	4.30E-1	-	-	-	-	1.31E+4	1.18E-2
Zr-95	1.65E+3	5.22E+2	-	7.67E+2	-	1.20E+6	3.59E+2
Zr-97	7.75E-1	1.53E-1	-	2.32E-1	-	4.15E+4	7.06E-2
Nb-95	1.41E+5	7.80E+4	-	7.57E+4	-	3.34E+8	4.30E+4
Nb-97	-	-	-	-	-	6.34E-8	-
Mo-99	-	4.56E+7	-	1.04E+8	-	8.16E+7	8.69E+6
Tc-99m	5.64E+0	1.57E+1	-	2.34E+2	8.73E+0	1.03E+4	2.04E+2
Tc-101	-	-	-	-	-	-	-

Table 2.12 (Continued)

R<sub>1</sub> Grass-Cow-Milk Pathway Dose Factors - TEEN(mrem/yr per  $\mu\text{Ci}/\text{m}^3$ ) for H-3 and C-14 ( $\text{m}^2 \times \text{mrem}/\text{yr}$  per  $\mu\text{Ci}/\text{sec}$ ) for others

Nuclide	Bone	Liver	Thyroid	Kidney	Lung	GI-LLI	T.Body
Ru-103	1.81E+3	-	-	6.40E+3	-	1.52E+5	7.75E+2
Ru-105	1.57E-3	-	-	1.97E-2	-	1.26E+0	6.08E-4
Ru-106	3.75E+4	-	-	7.23E+4	-	1.80E+6	4.73E+3
Rh-103m	-	-	-	-	-	-	-
Rh-106	-	-	-	-	-	-	-
Ag-110m	9.63E+7	9.11E+7	-	1.74E+8	-	2.56E+10	5.54E+7
Sb-124	4.59E+7	8.46E+5	1.04E+5	-	4.01E+7	9.25E+8	1.79E+7
Sb-125	3.65E+7	3.99E+5	3.49E+4	-	3.21E+7	2.84E+8	8.54E+6
Te-125m	3.00E+7	1.08E+7	8.39E+6	-	-	8.86E+7	4.02E+6
Te-127m	8.44E+7	2.99E+7	2.01E+7	3.42E+8	-	2.10E+8	1.00E+7
Te-127	1.24E+3	4.41E+2	8.59E+2	5.04E+3	-	9.61E+4	2.68E+2
Te-129m	1.11E+8	4.10E+7	3.57E+7	4.62E+8	-	4.15E+8	1.75E+7
Te-129	-	-	-	1.67E-9	-	2.18E-9	-
Te-131m	6.57E+5	3.15E+5	4.74E+5	3.29E+6	-	2.53E+7	2.63E+5
Te-131	-	-	-	-	-	-	-
Te-132	4.28E+6	2.71E+6	2.86E+6	2.60E+7	-	8.58E+7	2.55E+6
I-130	7.49E+5	2.17E+6	1.77E+8	3.34E+6	-	1.67E+6	8.66E+5
I-131	5.38E+8	7.53E+8	2.20E+11	1.30E+9	-	1.49E+8	4.04E+8
I-132	2.90E-1	7.59E-1	2.56E+1	1.20E+0	-	3.31E-1	2.72E-1
I-133	7.24E+6	1.23E+7	1.72E+9	2.15E+7	-	9.30E+6	3.75E+6
I-134	-	-	-	-	-	-	-
I-135	2.47E+4	6.35E+4	4.08E+6	1.00E+5	-	7.03E+4	2.35E+4
Cs-134	9.81E+9	2.31E+10	-	7.34E+9	2.80E+9	2.87E+8	1.07E+10
Cs-136	4.45E+8	1.75E+9	-	9.53E+8	1.50E+8	1.41E+8	1.18E+9
Cs-137	1.34E+10	1.78E+10	-	6.06E+9	2.35E+9	2.53E+8	6.20E+9
Cs-138	-	-	-	-	-	-	-
Ba-139	8.69E-8	-	-	-	-	7.75E-7	2.53E-9
Ba-140	4.85E+7	5.95E+4	-	2.02E+4	4.00E+4	7.49E+7	3.13E+6
Ba-141	-	-	-	-	-	-	-
Ba-142	-	-	-	-	-	-	-
La-140	8.06E+0	3.96E+0	-	-	-	2.27E+5	1.05E+0
La-142	-	-	-	-	-	2.23E-7	-
Ce-141	8.87E+3	5.92E+3	-	2.79E+3	-	1.69E+7	6.81E+2
Ce-143	7.69E+1	5.60E+4	-	2.51E+1	-	1.68E+6	6.25E+0
Ce-144	6.58E+5	2.72E+5	-	1.63E+5	-	1.66E+8	3.54E+4
Pr-143	2.92E+2	1.17E+2	-	6.77E+1	-	9.61E+5	1.45E+1
Pr-144	-	-	-	-	-	-	-
Nd-147	1.81E+2	1.97E+2	-	1.16E+2	-	7.11E+5	1.18E+1
W-187	1.20E+4	9.78E+3	-	-	-	2.65E+6	3.43E+3
Np-239	6.99E+0	6.59E-1	-	2.07E+0	-	1.06E+5	3.66E-1

Table 2.13

R<sub>i</sub> Grass-Cow-Milk Pathway Dose Factors - CHILD(mrem/yr per  $\mu\text{Ci}/\text{m}^3$ ) for H-3 and C-14 ( $\text{m}^2 \times \text{mrem}/\text{yr}$  per  $\mu\text{Ci}/\text{sec}$ ) for others

Nuclide	Bone	Liver	Thyroid	Kidney	Lung	GI-LLI	T.Body
H-3	-	1.57E+3	1.57E+3	1.57E+3	1.57E+3	1.57E+3	1.57E+3
C-14	1.65E+6	3.29E+5	3.29E+5	3.29E+5	3.29E+5	3.29E+5	3.29E+5
Na-24	9.23E+6	9.23E+6	9.23E+6	9.23E+6	9.23E+6	9.23E+6	9.23E+6
P-32	7.77E+10	3.64E+9	-	-	-	2.15E+9	3.00E+9
Cr-51	-	-	5.66E+4	1.55E+4	1.03E+5	5.41E+6	1.02E+5
Mn-54	-	2.09E+7	-	5.87E+6	-	1.76E+7	5.58E+6
Mn-56	-	1.31E-2	-	1.58E-2	-	1.90E+0	2.95E-3
Fe-55	1.12E+8	5.93E+7	-	-	3.35E+7	1.10E+7	1.84E+7
Fe-59	1.20E+8	1.95E+8	-	-	5.65E+7	2.03E+8	9.71E+7
Co-57	-	3.84E+6	-	-	-	3.14E+7	7.77E+6
Co-58	-	1.21E+7	-	-	-	7.08E+7	3.72E+7
Co-60	-	4.32E+7	-	-	-	2.39E+8	1.27E+8
Ni-63	2.96E+10	1.59E+9	-	-	-	1.07E+8	1.01E+9
Ni-65	1.66E+0	1.56E-1	-	-	-	1.91E+1	9.11E-2
Cu-64	-	7.55E+4	-	1.82E+5	-	3.54E+6	4.56E+4
Zn-65	4.13E+9	1.10E+10	-	6.94E+9	-	1.93E+9	6.85E+9
Zn-69	-	-	-	-	-	2.14E-9	-
Br-82	-	-	-	-	-	-	1.15E+8
Br-83	-	-	-	-	-	-	4.69E-1
Br-84	-	-	-	-	-	-	-
Br-85	-	-	-	-	-	-	-
Rb-86	-	8.77E+9	-	-	-	5.64E+8	5.39E+9
Rb-88	-	-	-	-	-	-	-
Rb-89	-	-	-	-	-	-	-
Sr-89	6.62E+9	-	-	-	-	2.56E+8	1.89E+8
Sr-90	1.12E+11	-	-	-	-	1.51E+9	2.83E+10
Sr-91	1.41E+5	-	-	-	-	3.12E+5	5.33E+3
Sr-92	2.19E+0	-	-	-	-	4.14E+1	8.76E-2
Y-90	3.22E+2	-	-	-	-	9.15E+5	8.61E+0
Y-91m	-	-	-	-	-	-	-
Y-91	3.91E+4	-	-	-	-	5.21E+6	1.04E+3
Y-92	2.46E-4	-	-	-	-	7.10E+0	7.03E-6
Y-93	1.06E+0	-	-	-	-	1.57E+4	2.90E-2
Zr-95	3.84E+3	8.45E+2	-	1.21E+3	-	8.81E+5	7.52E+2
Zr-97	1.89E+0	2.72E-1	-	3.91E-1	-	4.13E+4	1.61E-1
Nb-95	3.18E+5	1.24E+5	-	1.16E+5	-	2.29E+8	8.84E+4
Nb-97	-	-	-	-	-	1.45E-6	-
Mo-99	-	8.29E+7	-	1.77E+8	-	6.86E+7	2.05E+7
Tc-99m	1.29E+1	2.54E+1	-	3.68E+2	1.29E+1	1.44E+4	4.20E+2
Tc-101	-	-	-	-	-	-	-

Table 2.13 (Continued)

R<sub>i</sub> Grass-Cow-Milk Pathway Dose Factors - CHILD(mrem/yr per  $\mu\text{Ci}/\text{m}^3$ ) for H-3 and C-14 ( $\text{m}^2 \times \text{mrem}/\text{yr}$  per  $\mu\text{Ci}/\text{sec}$ ) for others

Nuclide	Boue	Liver	Thyroid	Kidney	Lung	GI-LLI	T.Body
Ru-103	4.29E+3	-	-	1.08E+4	-	1.11E+5	1.65E+3
Ru-105	3.82E-3	-	-	3.36E-2	-	2.49E+0	1.39E-3
Ru-106	9.24E+4	-	-	1.25E+5	-	1.44E+6	1.15E+4
Rh-103m	-	-	-	-	-	-	-
Rh-106	-	-	-	-	-	-	-
Ag-110m	2.09E+8	1.41E+8	-	2.63E+8	-	1.68E+10	1.13E+8
Sb-124	1.09E+8	1.41E+8	2.40E+5	-	6.03E+7	6.79E+8	3.81E+7
Sb-125	8.70E+7	1.41E+6	8.06E+4	-	4.85E+7	2.08E+8	1.82E+7
Te-125m	7.38E+7	2.00E+7	2.07E+7	-	-	7.12E+7	9.84E+6
Te-127m	2.08E+8	5.60E+7	4.97E+7	5.93E+8	-	1.68E+8	2.47E+7
Te-127	3.06E+3	8.25E+2	2.12E+3	8.71E+3	-	1.20E+5	6.56E+2
Te-129m	2.72E+8	7.61E+7	8.78E+7	8.00E+8	-	3.32E+8	4.23E+7
Te-129	-	-	-	2.87E-9	-	6.12E-8	-
Te-131m	1.60E+6	5.53E+5	1.14E+6	5.35E+6	-	2.24E+7	5.89E+5
Te-131	-	-	-	-	-	-	-
Te-132	1.02E+7	4.52E+6	6.58E+6	4.20E+7	-	4.55E+7	5.46E+6
I-130	1.75E+6	3.54E+6	3.90E+8	5.29E+6	-	1.66E+6	1.82E+6
I-131	1.30E+9	1.31E+9	4.34E+11	2.15E+9	-	1.17E+8	7.46E+8
I-132	6.86E-1	1.26E+0	5.85E+1	1.93E+0	-	1.48E+0	5.80E-1
I-133	1.76E+7	2.18E+7	4.04E+9	3.63E+7	-	8.77E+6	8.23E+6
I-134	-	-	-	-	-	-	-
I-135	5.84E+4	1.05E+5	9.30E+6	1.61E+5	-	8.00E+4	4.97E+4
Cs-134	2.26E+10	3.71E+10	-	1.15E+10	4.13E+9	2.00E+8	7.83E+9
Cs-136	1.00E+9	2.76E+9	-	1.47E+9	2.19E+8	9.70E+7	1.79E+9
Cs-137	3.22E+10	3.09E+10	-	1.01E+10	3.62E+9	1.93E+8	4.55E+9
Cs-138	-	-	-	-	-	-	-
Ba-139	2.14E-7	-	-	-	-	1.23E-5	6.19E-9
Ba-140	1.17E+8	1.03E+5	-	3.34E+4	6.12E+4	5.94E+7	6.84E+6
Ba-141	-	-	-	-	-	-	-
Ba-142	-	-	-	-	-	-	-
La-140	1.93E+1	6.74E+0	-	-	-	1.88E+5	2.27E+0
La-142	-	-	-	-	-	2.51E-6	-
Ce-141	2.19E+4	1.09E+4	-	4.78E+3	-	1.36E+7	1.62E+3
Ce-143	1.89E+2	1.02E+5	-	4.29E+1	-	1.50E+6	1.48E+1
Ce-144	1.62E+6	5.09E+5	-	2.82E+5	-	1.33E+8	8.66E+4
Pr-143	7.23E+2	2.17E+2	-	1.17E+2	-	7.80E+5	3.59E+1
Pr-144	-	-	-	-	-	-	-
Nd-147	4.45E+2	3.60E+2	-	1.98E+2	-	5.71E+5	2.79E+1
W-187	2.91E+4	1.72E+4	-	-	-	2.42E+6	7.73E+3
Np-239	1.72E+1	1.23E+0	-	3.57E+0	-	9.14E+4	8.68E-1

Table 2.14

R<sub>i</sub> Grass-Cow-Milk Pathway Dose Factors - INFANT(mrem/yr per  $\mu\text{Ci}/\text{m}^3$ ) for H-3 and C-14 ( $\text{m}^2 \times \text{mrem}/\text{yr}$  per  $\mu\text{Ci}/\text{sec}$ ) for others

Nuclide	Bone	Liver	Thyroid	Kidney	Lung	GI-LLI	T.Body
H-3	-	2.38E+3	2.38E+3	2.38E+3	2.38E+3	2.38E+3	2.38E+3
C-14	3.23E+6	6.89E+5	6.89E+5	6.89E+5	6.89E+5	6.89E+5	6.89E+5
Na-24	1.61E+7	1.61E+7	1.61E+7	1.61E+7	1.61E+7	1.61E+7	1.61E+7
P-32	1.60E+11	9.42E+9	-	-	-	2.17E+9	6.21E+9
Cr-51	-	-	1.05E+5	2.30E+4	2.05E+5	4.71E+6	1.61E+5
Mn-54	-	3.89E+7	-	8.63E+6	-	1.43E+7	8.83E+6
Mn-56	-	3.21E-2	-	2.76E-2	-	2.91E+0	5.53E-3
Fe-55	1.35E+8	8.72E+7	-	-	4.27E+7	1.11E+7	2.33E+7
Fe-59	2.25E+8	3.93E+8	-	-	1.16E+8	1.88E+8	1.55E+8
Co-57	-	8.95E+6	-	-	-	3.05E+7	1.46E+7
Co-58	-	2.43E+7	-	-	-	6.05E+7	6.06E+7
Co-60	-	8.81E+7	-	-	-	2.10E+8	2.08E+8
Ni-63	3.49E+10	2.16E+9	-	-	-	1.07E+8	1.21E+9
Ni-65	3.51E+0	3.97E-1	-	-	-	3.02E+1	1.81E-1
Cu-64	-	1.88E+5	-	3.17E+5	-	3.85E+6	8.69E+4
Zn-65	5.55E+9	1.90E+10	-	9.23E+9	-	1.61E+10	8.78E+9
Zn-69	-	-	-	-	-	7.36E-9	-
Br-82	-	-	-	-	-	-	1.94E+8
Br-83	-	-	-	-	-	-	9.95E-1
Br-84	-	-	-	-	-	-	-
Br-85	-	-	-	-	-	-	-
Rb-86	-	2.22E+10	-	-	-	5.69E+8	1.10E+10
Rb-88	-	-	-	-	-	-	-
Rb-89	-	-	-	-	-	-	-
Sr-89	1.26E+10	-	-	-	-	2.59E+8	3.61E+8
Sr-90	1.22E+11	-	-	-	-	1.52E+9	3.10E+10
Sr-91	2.94E+5	-	-	-	-	3.48E+5	1.06E+4
Sr-92	4.65E+0	-	-	-	-	5.01E+1	1.73E-1
Y-90	6.80E+2	-	-	-	-	9.39E+5	1.82E+1
Y-91m	-	-	-	-	-	-	-
Y-91	7.33E+4	-	-	-	-	5.26E+6	1.95E+3
Y-92	5.22E-4	-	-	-	-	9.97E+0	1.47E-5
Y-93	2.25E+0	-	-	-	-	1.78E+4	6.13E-2
Zr-95	6.83E+3	1.66E+3	-	1.79E+3	-	8.28E+5	1.18E+3
Zr-97	3.99E+0	6.85E-1	-	6.91E-1	-	4.37E+4	3.13E-1
Nb-95	5.93E+5	2.44E+5	-	1.75E+5	-	2.06E+8	1.41E+5
Nb-97	-	-	-	-	-	3.70E-6	-
Mo-99	-	2.12E+8	-	3.17E+8	-	6.98E+7	4.13E+7
Tc-99m	2.69E+1	5.55E+1	-	5.97E+2	2.90E+1	1.61E+4	7.15E+2
Tc-101	-	-	-	-	-	-	-

Table 2.14 (Continued)

R<sub>1</sub> Grass-Cow-Milk Pathway Dose Factors - INFANT(mrem/yr per  $\mu\text{Ci}/\text{m}^3$ ) for H-3 and C-14 ( $\text{m}^2 \times \text{mrem}/\text{yr}$  per  $\mu\text{Ci}/\text{sec}$ ) for others

Nuclide	Boue	Liver	Thyroid	Kidney	Lung	GI-LLI	T.Body
Ru-103	8.69E+3	-	-	1.81E+4	-	1.06E+5	2.91E+3
Ru-105	8.06E-3	-	-	5.92E-2	-	3.21E+0	2.71E-3
Ru-106	1.90E+5	-	-	2.25E+5	-	1.44E+6	2.38E+4
Rh-103m	-	-	-	-	-	-	-
Rh-106	-	-	-	-	-	-	-
Ag-110m	3.86E+8	2.82E+8	-	4.03E+8	-	1.46E+10	1.86E+8
Sb-124	2.09E+8	3.08E+6	5.56E+5	-	1.31E+8	6.46E+8	6.49E+7
Sb-125	1.49E+8	1.45E+6	1.87E+5	-	9.38E+7	1.99E+8	3.07E+7
Te-125m	1.51E+8	5.04E+7	5.07E+7	-	-	7.18E+7	2.04E+7
Te-127m	4.21E+8	1.40E+8	1.22E+8	1.04E+9	-	1.70E+8	5.10E+7
Te-127	6.50E+3	2.18E+3	5.29E+3	1.59E+4	-	1.36E+5	1.40E+3
Te-129m	5.59E+8	1.92E+8	2.15E+8	1.40E+9	-	3.34E+8	8.62E+7
Te-129	2.08E-9	-	1.75E-9	5.18E-9	-	1.66E-7	-
Te-131m	3.38E+6	1.36E+6	2.76E+6	9.35E+6	-	2.29E+7	1.12E+6
Te-131	-	-	-	-	-	-	-
Te-132	2.10E+7	1.04E+7	1.54E+7	6.51E+7	-	3.85E+7	9.72E+6
I-130	3.60E+6	7.92E+6	8.88E+8	8.70E+6	-	1.70E+6	3.18E+6
I-131	2.72E+9	3.21E+9	1.05E+12	3.75E+9	-	1.15E+8	1.41E+9
I-132	1.42E+0	2.89E+0	1.35E+2	3.22E+0	-	2.34E+0	1.03E+0
I-133	3.72E+7	5.41E+7	9.84E+9	6.36E+7	-	9.16E+6	1.58E+7
I-134	-	-	1.01E-9	-	-	-	-
I-135	1.21E+5	2.41E+5	2.16E+7	2.69E+5	-	8.74E+4	8.80E+4
Cs-134	3.65E+10	6.80E+10	-	1.75E+10	7.18E+9	1.85E+8	6.87E+9
Cs-136	1.96E+9	5.77E+9	-	2.30E+9	4.70E+8	8.76E+7	2.15E+9
Cs-137	5.15E+10	6.02E+10	-	1.62E+10	6.55E+9	1.88E+8	4.27E+9
Cs-138	-	-	-	-	-	-	-
Ba-139	4.55E-7	-	-	-	-	2.88E-5	1.32E-8
Ba-140	2.41E+8	2.41E+5	-	5.73E+4	1.48E+5	5.92E+7	1.24E+7
Ba-141	-	-	-	-	-	-	-
Ba-142	-	-	-	-	-	-	-
La-140	4.03E+1	1.59E+1	-	-	-	1.87E+5	4.09E+0
La-142	-	-	-	-	-	5.21E-6	-
Ce-141	4.33E+4	2.64E+4	-	8.15E+3	-	1.37E+7	3.11E+3
Ce-143	4.00E+2	2.65E+5	-	7.72E+1	-	1.55E+6	3.02E+1
Ce-144	2.33E+6	9.52E+5	-	3.85E+5	-	1.33E+8	1.30E+5
Pr-143	1.49E+3	5.59E+2	-	2.08E+2	-	7.89E+5	7.41E+1
Pr-144	-	-	-	-	-	-	-
Nd-147	8.82E+2	9.06E+2	-	3.49E+2	-	5.74E+5	5.55E+1
W-187	6.12E+4	4.26E+4	-	-	-	2.50E+6	1.47E+4
Np-239	3.64E+1	3.25E+0	-	6.49E+0	-	9.40E+4	1.84E+0

Table 2.15

**R<sub>i</sub> Ground Plane Pathway Dose Factors**  
 (m<sup>2</sup> x mrem/yr per μCi/sec)

<u>Nuclide</u>	<u>Any Organ</u>
H-3	-
C-14	-
Na-24	1.21E+7
P-32	-
Cr-51	4.68E+6
Mn-54	1.34E+9
Mn-56	9.05E+5
Fe-55	-
Fe-59	2.75E+8
Co-57	4.37E+8
Co-58	3.82E+8
Co-60	2.16E+10
Ni-63	-
Ni-65	2.97E+5
Cu-64	6.09E+5
Zn-65	7.45E+8
Zn-69	-
Br-82	4.57E+7
Br-83	4.89E+3
Br-84	2.03E+5
Br-85	-
Rb-86	8.98E+6
Rb-88	3.29E+4
Rb-89	1.21E+5
Sr-89	2.16E+4
Sr-90	-
Sr-91	2.19E+6
Sr-92	7.77E+5
Y-90	4.48E+3
Y-91m	1.01E+5
Y-91	1.08E+6
Y-92	1.80E+5
Y-93	1.85E+5
Zr-95	2.48E+8
Zr-97	2.94E+6
Nb-95	1.36E+8
Nb-97	2.28E+6
Mo-99	4.05E+6
Tc-99m	1.83E+5
Tc-101	2.04E+4
Ru-103	1.09E+8
Ru-105	6.36E+5
Ru-106	4.21E+8



Table 2.15 (Continued)

R<sub>1</sub> Ground Plane Pathway Dose Factors

(m<sup>2</sup> x mrem/yr per μCi/sec)

<u>Nuclide</u>	<u>Any Organ</u>
Rh-103m	-
Rh-106	-
Ag-110m	3.47E+9
Sb-124	2.87E+9
Sb-125	6.49E+9
Te-125m	1.55E+6
Te-127m	9.17E+4
Te-127	3.00E+3
Te-129m	2.00E+7
Te-129	2.60E+4
Te-131m	8.03E+6
Te-131	2.93E+4
Te-132	4.22E+6
I-130	5.53E+6
I-131	1.72E+7
I-132	1.24E+6
I-133	2.47E+6
I-134	4.49E+5
I-135	2.56E+6
Cs-134	6.75E+9
Cs-136	1.49E+8
Cs-137	1.04E+10
Cs-138	3.59E+5
Ba-139	1.06E+5
Ba-140	2.05E+7
Ba-141	4.18E+4
Ba-142	4.49E+4
La-140	1.91E+7
La-142	7.36E+5
Ce-141	1.36E+7
Ce-143	2.32E+6
Ce-144	6.95E+7
Pr-143	-
Pr-144	1.83E+3
Nd-147	8.40E+6
W-187	2.36E+6
Np-239	1.71E+6

## **3/4 RADIOLOGICAL EFFLUENT SPECIFICATIONS AND SURVEILLANCE REQUIREMENTS**

### **3/4.0 APPLICABILITY AND SURVEILLANCE REQUIREMENTS (7/8.0)<sup>4</sup>**

#### **SPECIFICATIONS**

- 3.0.1 (7.0.1)** Compliance with the specifications contained in the succeeding text is required during the conditions specified therein; except that upon failure to meet the specifications, the associated ACTION requirements shall be met.
- 3.0.2 (7.0.2)** Noncompliance with a Specification shall exist when its requirements and associated ACTION requirements are not met within the specified time intervals. If the Specification is restored prior to expiration of the specified time intervals, completion of the Action requirements is not required.
- 3.0.3 (7.0.3)** When a Specification is not met, except as provided in the associated ACTION requirements, reporting pursuant to TS 6.9.3 will be initiated.

#### **SURVEILLANCE REQUIREMENTS**

- 4.0.1 (8.0.1)** Surveillance Requirements shall be met during the conditions specified for individual Specifications unless otherwise stated in an individual Surveillance Requirement.
- 4.0.2 (8.0.2)** Each Surveillance Requirement shall be performed within the specified time interval with:
- a. A maximum allowable extension not to exceed 25% of the surveillance interval, but
  - b. The combined time interval for any 3 consecutive surveillance intervals shall not exceed 3.25 times the specified surveillance interval.

---

<sup>4</sup> The section and table numbers shown in parentheses throughout this section of the ODCM is the 7/8 series numbering system currently used in RETS. RETS is in the process of being removed from the Technical Specifications and incorporated in the ODCM. The new 3/4 series numbering system shown in this ODCM revision will replace the 7/8 series numbers once the TS amendment has been approved. Both numbering systems are currently shown as a cross reference until all TS and procedure changes have been completed.

4  
3.0.3 Failure to perform a Surveillance Requirement within the specified time  
(8.0.3) interval shall constitute a failure to meet the OPERABILITY requirements for a Specification. Exceptions to these requirements are stated in the individual Specification. Surveillance Requirements do not have to be performed on inoperable equipment.

↑ Called Dennis  
to fix!  
Julie U.

3/4.1 RADIOACTIVE LIQUID EFFLUENT MONITORING INSTRUMENTATION  
(7/8.1)

SPECIFICATIONS

- 3.1 The radioactive liquid effluent monitoring instrumentation channels shown in (7.1) Table 3.1 (7.1) shall be OPERABLE with their alarm/trip setpoints set to ensure that the limits of Specification 3.3.1 (7.3.1) are not exceeded. The alarm/trip setpoints of these channels shall be determined in accordance with the methodology in Section 1.0 of the OFFSITE DOSE CALCULATION MANUAL (ODCM).

APPLICABILITY

During release via the monitored pathway.

ACTION

- a. With a radioactive liquid effluent monitoring instrumentation channel alarm/trip setpoint less conservative than required by the above specification, without delay suspend the release of radioactive liquid effluents monitored by the affected channel, or declare the channel inoperable, or change the setpoint so it is acceptably conservative.
- b. With less than the minimum number of radioactive liquid effluent monitoring instrumentation channels OPERABLE, take the ACTION shown in Table 3.1 (7.1). Exert best efforts to return the instruments to OPERABLE status within 30 days and, if unsuccessful, explain in the next Radioactive Effluent Release Report why the inoperability was not corrected in a timely manner.

SURVEILLANCE REQUIREMENTS

- 4.1 Each radioactive liquid effluent monitoring instrumentation channel shall be (8.1) demonstrated OPERABLE by performance of the CHANNEL CHECK, SOURCE CHECK, CHANNEL CALIBRATION and CHANNEL FUNCTIONAL TEST operations at the frequencies shown in Table 4.1 (8.1).

3/4.2 RADIOACTIVE GASEOUS EFFLUENT MONITORING INSTRUMENTATION  
(7/8.2)

SPECIFICATIONS

3.2 The radioactive gaseous effluent monitoring instrumentation channels shown (7.2) in Table 3.2 (7.2) shall be OPERABLE with their alarm/trip setpoints set to ensure that the limits of Specification 3.4.1 (7.4.1) are not exceeded. The alarm/trip setpoints of these channels shall be determined in accordance with the methodology in the ODCM.

APPLICABILITY

As shown in Table 3.2 (7.2).

ACTION

- a. With a radioactive gaseous effluent monitoring instrumentation channel alarm/trip setpoint less conservative than required by the above Specification, without delay suspend the release of radioactive gaseous effluents monitored by the affected channel, or declare the channel inoperable, or change the setpoint so it is acceptably conservative.
- b. With less than the minimum number of radioactive gaseous effluent monitoring instrumentation channels OPERABLE, take the ACTION shown in Table 3.2 (7.2). Exert best efforts to return the instruments to OPERABLE status within 30 days and, if unsuccessful, explain in the next Radioactive Effluent Release Report why the inoperability was not corrected in a timely manner.

SURVEILLANCE REQUIREMENTS

4.2 Each radioactive gaseous effluent monitoring instrumentation channel shall be (8.2) demonstrated OPERABLE by performance of the CHANNEL CHECK, SOURCE CHECK, CHANNEL CALIBRATION and CHANNEL FUNCTIONAL TEST operations at the frequencies shown in Table 4.2 (8.2).

3/4.3 LIQUID EFFLUENTS  
(7/8.3)

CONCENTRATION

SPECIFICATIONS

- 3.3.1 The concentration of radioactive material released in liquid effluents to  
(7.3.1) UNRESTRICTED AREAS shall be limited to the concentrations specified in 10 CFR Part 20, Appendix B, Table II, Column 2 for radionuclides other than dissolved or entrained noble gases. For dissolved or entrained noble gases, the concentration shall be limited to  $2 \times 10^{-4}$  uCi/ml total activity.

APPLICABILITY

During release via the monitored pathway.

ACTION

With the concentration of radioactive material released in liquid effluents to UNRESTRICTED AREAS exceeding the above limits, without delay restore the concentration to within the above limits.

SURVEILLANCE REQUIREMENTS

- 4.3.1.1 Radioactive liquid wastes shall be sampled and analyzed according to the  
(8.3.1.1) sampling and analysis program of Table 4.3 (8.3).
- 4.3.1.2 The results of the radioactivity analyses shall be used in accordance with  
(8.3.1.2) the methodology and parameters in the ODCM to assure that the concentrations at the point of release are maintained within the limits of specification 3.3.1 (7.3.1).

## DOSE

### SPECIFICATIONS

3.3.2 The dose or dose commitment to a MEMBER OF THE PUBLIC from  
(7.3.2) radioactive materials in liquid effluents released to UNRESTRICTED AREAS shall be limited:

- a. During any calendar quarter to less than or equal to 1.5 mrems to the total body and to less than or equal to 5 mrems to any organ, and
- b. During any calendar year to less than or equal to 3 mrems to the total body and to less than or equal to 10 mrems to any organ.

### APPLICABILITY

At all times.

### ACTION

- a. With the calculated dose from the release of radioactive materials in liquid effluents exceeding any of the above limits, in lieu of a Licensee Event Report, prepare and submit to the Commission within 30 days, pursuant to Technical Specification (TS) 6.9.3.c, a Special Report that identifies the cause(s) for exceeding the limit(s) and defines the corrective actions that have been taken to reduce the release and the proposed corrective actions to be taken to assure that subsequent releases will be in compliance with the above limits.

### SURVEILLANCE REQUIREMENTS

4.3.2 Cumulative dose contributions from liquid effluents for the current calendar  
(8.3.2) quarter and the current calendar year shall be determined in accordance with the methodology and parameters in the ODCM once per 31 days.

## LIQUID RADWASTE TREATMENT SYSTEM

### SPECIFICATIONS

- 3.3.3 (7.3.3) The liquid radwaste treatment system as described in the ODCM shall be used to reduce the radioactive materials in liquid wastes prior to their discharge when the projected doses, due to the liquid effluent, to UNRESTRICTED AREAS would exceed 0.18 mrem to the total body or 0.62 mrem to any organ in a calendar quarter.

### APPLICABILITY

At all times.

### ACTION

- a. With radioactive liquid waste being discharged without treatment and in excess of the above limits, in lieu of a Licensee Event Report, prepare and submit to the Commission within 30 days pursuant to TS 6.9.3.c, a Special Report that includes the following information:
1. Explanation of why liquid radwaste was being discharged without treatment, identification of any inoperable equipment or subsystems, and the reason for the inoperability,
  2. Action(s) taken to restore the inoperable equipment to OPERABLE status, and
  3. Summary description of action(s) taken to prevent a recurrence.

### SURVEILLANCE REQUIREMENTS

- 4.3.3 (8.3.3) Doses due to liquid releases from the unit to UNRESTRICTED AREAS shall be projected once per 31 days in accordance with the methodology and parameters in the ODCM.



3/4.4 GASEOUS EFFLUENTS  
(7/8.4)

DOSE RATE

SPECIFICATIONS

3.4.1 (7.4.1) The dose rate due to radioactive materials released in gaseous effluents from the site to areas at and beyond the SITE BOUNDARY shall be limited to the following:

- a. For noble gases: Less than or equal to 500 mrems/yr to the total body and less than or equal to 3000 mrems/yr to the skin, and
- b. For iodine-131, iodine-133, tritium, and for all radionuclides in particulate form with half lives greater than 8 days: Less than or equal to 1500 mrems/yr to any organ.

APPLICABILITY

At all times.

ACTION

- a. With the dose rate(s) exceeding the above limits, without delay restore the release rate to within the above limit(s).

SURVEILLANCE REQUIREMENTS

4.4.1.1 (8.4.1.1) The dose rate due to noble gases in gaseous effluents shall be determined to be within the above limits in accordance with the methodology and parameters in the ODCM.

4.4.1.2 (8.4.1.2) The dose rate due to iodine-131, iodine-133, tritium, and all radionuclides in particulate form with half lives greater than 8 days in gaseous effluents shall be determined to be within the above limits in accordance with the methodology and parameters in the ODCM by obtaining representative samples and performing analyses in accordance with the sampling and analysis program specified in Table 4.4 (8.4).

## DOSE - NOBLE GASES

### SPECIFICATIONS

3.4.2 The air dose due to noble gases released in gaseous effluents, to areas at  
(7.4.2) and beyond the SITE BOUNDARY shall be limited to the following:

- a. During any calendar quarter: Less than or equal to 5 mrad for gamma radiation and less than or equal to 10 mrad for beta radiation and,
- b. During any calendar year: Less than or equal to 10 mrad for gamma radiation and less than or equal to 20 mrad for beta radiation.

### APPLICABILITY

At all times.

### ACTION

- a. With the calculated air dose from radioactive noble gases in gaseous effluents exceeding any of the above limits, in lieu of a Licensee Event Report, prepare and submit to the Commission within 30 days, pursuant to TS 6.9.3.c, a Special Report that identifies the cause(s) for exceeding the limit(s) and defines the corrective actions that have been taken to reduce the releases and the proposed corrective actions to be taken to assure that subsequent releases will be in compliance with the above limits.

### SURVEILLANCE REQUIREMENTS

4.4.2 Cumulative dose contributions for the current calendar quarter and current  
(8.4.2) calendar year for noble gases shall be determined in accordance with the methodology and parameters in the ODCM once per 31 days.

## DOSE - IODINE-131, IODINE-133 AND RADIONUCLIDES IN PARTICULATE FORM

### SPECIFICATIONS

3.4.3 (7.4.3) The dose to a MEMBER OF THE PUBLIC from iodine-131, iodine-133, tritium, and all radionuclides in particulate form with half-lives greater than 8 days in gaseous effluents released to areas at and beyond the SITE BOUNDARY shall be limited to the following:

- a. During any calendar quarter: Less than or equal to 7.5 mrems to any organ and,
- b. During any calendar year: Less than or equal to 15 mrems to any organ.

### APPLICABILITY

At all times.

### ACTION

- a. With the calculated dose from the release of iodine-131, iodine-133, tritium, and radionuclides in particulate form with half lives greater than 8 days, in gaseous effluents exceeding any of the above limits, in lieu of a Licensee Event Report, prepare and submit to the Commission within 30 days, pursuant to TS 6.9.3.c, a Special Report that identifies the cause(s) for exceeding the limit and defines the corrective actions that have been taken to reduce the releases and the proposed corrective actions to be taken to assure that subsequent releases will be in compliance with the above limits.

### SURVEILLANCE REQUIREMENTS

- 4.4.3 (8.4.3) Cumulative dose contributions for the current calendar quarter and current calendar year for iodine-131, iodine-133, tritium, and radionuclides in particulate form with half lives greater than 8 days shall be determined in accordance with the methodology and parameters in the ODCM once per 31 days.

## GASEOUS RADWASTE TREATMENT SYSTEM

### SPECIFICATIONS

3.4.4 The GASEOUS RADWASTE TREATMENT SYSTEM and the  
(7.4.4) VENTILATION EXHAUST TREATMENT SYSTEM shall be used to reduce radioactive materials in gaseous waste prior to their discharge when the projected gaseous effluent air doses due to gaseous effluent releases to areas at and beyond the SITE BOUNDARY would exceed 0.62 mrad for gamma radiation and 1.25 mrad for beta radiation in a calendar quarter. The VENTILATION EXHAUST TREATMENT SYSTEM shall be used to reduce radioactive materials in gaseous waste prior to their discharge when the projected doses due to gaseous effluent releases, to areas at and beyond the SITE BOUNDARY would exceed 0.94 mrem to any organ in a calendar quarter.

### APPLICABILITY

At all times.

### ACTION

- a. With gaseous waste being discharged without treatment and in excess of the above limits, in lieu of a Licensee Event Report, prepare and submit to the Commission within 30 days, pursuant to TS 6.9.3.c, a Special Report that includes the following information:
1. Explanation of why gaseous radwaste was being discharged without treatment, identification of any inoperable equipment or subsystems, and the reason for the inoperability,
  2. Action(s) taken to restore the inoperable equipment to OPERABLE status, and
  3. Summary description of action(s) taken to prevent a recurrence.

### SURVEILLANCE REQUIREMENTS

4.4.4 Doses due to gaseous releases from areas at and beyond the SITE  
(8.4.4) BOUNDARY shall be projected once per 31 days in accordance with the methodology and parameters in the ODCM.

3/4.5 TOTAL DOSE  
(7/8.6)

SPECIFICATIONS

3.5 The annual (calendar year) dose or dose commitment to any MEMBER OF  
(7.6) THE PUBLIC due to releases of radioactivity and to radiation from uranium fuel cycle sources shall be limited to less than or equal to 25 mrems to the total body or any organ, except the thyroid, which shall be limited to less than or equal to 75 mrems.

APPLICABILITY

At all times.

ACTION

a. With the calculated doses from the release of radioactive materials in liquid or gaseous effluents exceeding twice the limits of Specification 3.3.2.a, 3.3.2.b, 3.4.2.a, 3.4.2.b, 3.4.3.a, or 3.4.3.b (7.3.2.a, 7.3.2.b, 7.4.2.a, 7.4.2.b, 7.4.3.a, or 7.4.3.b), calculations should be made including direct radiation contributions from the reactor unit to determine whether the above limits have been exceeded. If such is the case in lieu of a Licensee Event Report, prepare and submit to the Commission within 30 days, pursuant to TS 6.9.3.c, a special report that defines the corrective action to be taken to reduce subsequent releases to prevent recurrence of exceeding the above limits and includes the schedule for achieving conformance with the above limits. This special report as defined in 10 CFR 20.405c, shall include an analysis that estimates the radiation exposure (dose) to a MEMBER OF THE PUBLIC from uranium fuel cycle sources, including all effluent pathways and direct radiation, for the calendar year that includes the release(s) covered by this report. It shall also describe levels of radiation and concentrations of radioactive material involved, and the cause of the exposure levels or concentrations. If the estimated dose(s) exceeds the above limits, and if the release condition resulting in violation of 40 CFR Part 190 has not already been corrected, the special report shall include a request for a variance in accordance with the provisions of 40 CFR Part 190. Submittal of the report is considered a timely request, and a variance is granted until staff action on the request is complete.

## SURVEILLANCE REQUIREMENTS

- 4.5.1 Cumulative dose contributions from liquid and gaseous effluents shall be  
(8.6.1) determined in accordance with Specifications 4.3.2, 4.4.2, and 4.4.3 (8.3.2, 8.4.2, and 8.4.3), and in accordance with the methodology and parameters in the ODCM.
- 4.5.2 Cumulative dose contributions from direct radiation from the reactor unit  
(8.6.2) shall be determined in accordance with the methodology and parameters in the ODCM. This requirement is applicable only under conditions set forth in Specification 3.5.a (7.6.a).

3/4.6 RADIOLICAL ENVIRONMENTAL MONITORING  
(7/8.7)

MONITORING PROGRAM

SPECIFICATIONS

3.6.1 The radiological environmental monitoring program shall be conducted as (7.7.1) specified in Table 3.3 (7.3).

APPLICABILITY

At all times.

ACTION

- a. With the radiological environmental monitoring program not being conducted as specified in Table 3.3 (7.3), in lieu of a Licensee Event Report, prepare and submit to the Commission, in the Annual Radiological Environmental Monitoring Report required by TS 6.9.3.a, a description of the reasons for not conducting the program as required and the plans for preventing a recurrence.
- b. With the level of radioactivity as the result of plant effluents in an environmental sampling medium at a specified location exceeding the reporting levels of Table 3.4 (7.4) when averaged over any calendar quarter in lieu of a Licensee Event Report, prepare and submit to the Commission within 30 days, pursuant to TS 6.9.3.c, a Special Report that identifies the cause(s) for exceeding the limit(s) and defines the corrective actions to be taken to reduce radioactive effluents so that the potential annual dose<sup>5</sup> to A MEMBER OF THE PUBLIC is less than the calendar year limits of Specifications 3.3.2, 3.4.2, and 3.4.3 (7.3.2, 7.4.2, and 7.4.3). When more than one of the radionuclides in Table 3.4 (7.4) are detected in the sampling medium, this report shall be submitted if:

$$\frac{\text{concentration (1)}}{\text{reporting level (1)}} + \frac{\text{concentration (2)}}{\text{reporting level (2)}} + \dots \geq 1.0$$

When radionuclides other than those in Table 3.4 (7.4) are detected and are the result of plant effluents, this report shall be submitted if the potential annual

---

<sup>5</sup>The methodology and parameters used to estimate the potential annual dose to a member of the public shall be indicated in this report.

dose<sup>6</sup> to a MEMBER OF THE PUBLIC is equal to or greater than the calendar year limits of Specifications 3.3.2, 3.4.2 and 3.4.3 (7.3.2, 7.4.2 and 7.4.3). This report is not required if the measured level of radioactivity was not the result of plant effluents; however, in such an event the condition shall be reported and described in the Annual Radiological Environmental Monitoring Report.

- c. With milk or fresh leafy vegetable samples unavailable from one or more of the sample locations required by Table 3.3 (7.3), a sample from an alternative location will be substituted, noting the reason for the unavailability in the Annual Radiological Environmental Monitoring Report. When changes in sampling locations are permanent, the sampling schedule in the RADIOLOGICAL ENVIRONMENTAL MONITORING MANUAL (REMM) will be updated to reflect the new routine and alternative sampling locations and this revision will be described in the Annual Radiological Environmental Monitoring Report.

#### SURVEILLANCE REQUIREMENTS

- 4.6.1 The radiological environmental monitoring samples shall be collected
- (8.7.1) pursuant to Table 3.3 (7.3) from the specific locations given in the table and figure(s) in the REMM, and shall be analyzed pursuant to the requirements of Table 3.3 (7.3) and the detection capabilities required by Table 4.5 (8.5).

---

<sup>6</sup>The methodology and parameters used to estimate the potential annual dose to a member of the public shall be indicated in this report.



## LAND USE CENSUS

### SPECIFICATIONS

- 3.6.2 (7.7.2) A land use census shall be conducted and shall identify within a distance of 8 km (5 miles) the location in each of the 10 meteorological sectors of the nearest milk animal, the nearest residence and the nearest garden<sup>7</sup> of greater than 50 m<sup>2</sup> (500 ft<sup>2</sup>) producing broad leaf vegetation.

### APPLICABILITY

At all times.

### ACTION

- a. With a land use census identifying a location(s) that yields a calculated dose or dose commitment greater than the values currently being calculated in Specification 4.4.3 (8.4.3), in lieu of a Licensee Event Report, identify the new location(s) in the next Annual Radiological Environmental Monitoring Report pursuant to TS 6.9.3.a.
- b. With a land use census identifying a location(s) that yields a calculated dose or dose commitment (via the same exposure pathway) 20 percent greater than at a location from which samples are currently being obtained in accordance with Specification 3.6.1 (7.7.1), add the new location(s) to the radiological environmental monitoring program within 30 days. The sampling location(s), excluding the control station location, having a lower calculated dose or dose commitment(s), via the same exposure pathway, may be deleted from this monitoring program. In lieu of a Licensee Event Report, identify the new location(s) in the next Annual Radiological Environmental Monitoring Report pursuant to TS 6.9.3.a and also include in the report a revised figure(s) and table for the REMM reflecting the new location(s).

### SURVEILLANCE REQUIREMENT

- 4.6.2 (8.7.2) The land use census shall be conducted during the growing season once per 12 months using reasonable survey methods, such as by a door-to-door survey, aerial survey, or by consulting local agriculture authorities. The

---

<sup>7</sup>Sampling of leaf vegetation may be performed at the site boundary in each of two different direction sectors with the highest predicted D/Qs in lieu of the garden census. Specifications for broad leaf vegetation sampling in Table 3.3 (7.3) item 4c, shall be followed, including analysis of control samples.

results of the land use census shall be included in the Annual Radiological Environmental Monitoring Report pursuant to TS 6.9.3.a.

## INTERLABORATORY COMPARISON PROGRAM

### SPECIFICATIONS

3.6.3 Analyses shall be performed on radioactive materials supplied as part of an  
(7.7.3) Interlaboratory Comparison Program that has been approved by the Commission.

### APPLICABILITY

At all times.

### ACTION

a. With analyses not being performed as required above, report corrective actions taken to prevent a recurrence to the Commission in the Annual Radiological Environmental Monitoring Report pursuant to TS 6.9.3.a.

### SURVEILLANCE REQUIREMENTS

4.6.3 The Interlaboratory Comparison Program shall be described in the REMM.  
(8.7.3) A summary of the results obtained as part of the above required Interlaboratory Comparison Program shall be included in the Annual Radiological Environmental Monitoring Report pursuant to TS 6.9.3.a.

3/4.7 REPORTING REQUIREMENTS  
(6.9.3)

3/4.7.1 Annual Radiological Environmental Monitoring Report  
(6.9.3.a)

The Annual Radiological Environmental Monitoring Report shall include:

- a. Summaries, interpretations, and an analysis of trends of the results of the radiological environmental surveillance activities for the report period, including a comparison with preoperational studies, with operational controls as appropriate, and with previous environmental surveillance reports, and an assessment of the observed impacts of the plant operation on the environment. The reports shall also include the results of land use censuses required by Specification 3.6.2 (7.7.2).
- b. The results of analysis of radiological environmental samples and of environmental radiation measurements taken during the period pursuant to the locations specified in the Table and Figures in the Radiological Environmental Monitoring Manual (REMM), as well as summarized and tabulated results of these analyses and measurements in the format of the table in the Radiological Assessment Branch Technical Position, Revision 1, November 1979. In the event that some individual results are not available for inclusion with the report, the report shall be submitted noting and explaining the reasons for the missing results. The missing data shall be submitted as soon as possible in a supplementary report when applicable.
- c. A summary description of the radiological environmental monitoring program; legible maps covering all sampling locations keyed to a table giving distances and directions from the centerline of one reactor; the results of licensee participation in the Interlaboratory Comparison Program, required by Specification 3.6.3 (7.7.3); discussion of all deviations from the sampling schedule of Table 3.3 (7.3); and discussion of all analyses in which the LLD required by Table 4.5 (8.5) was not achievable.

3/4.7.2 Semiannual Radioactive Effluent Release Report  
(6.9.3.b)

The Semiannual Radioactive Effluent Release Report shall include the following:

- a. A summary of the quantities of radioactive liquid and gaseous effluents and solid waste released from the unit following the format of Regulatory Guide 1.21, "Measuring, Evaluating, and Reporting Radioactivity in Solid Wastes and Releases of Radioactive Materials in Liquid and Gaseous Effluents from Light-Water-Cooled Nuclear Power Plants," Revision 1, June 1974.
- b. An annual summary of hourly meteorological data collected over the previous year. This annual summary may be either in the form of an hour-by-hour listing on magnetic tape of wind speed, wind direction, atmospheric stability, and precipitation (if measured), or in the form of joint frequency distributions of wind speed, wind direction, and atmospheric stability.<sup>8</sup> This same report shall include an assessment of the radiation doses due to the radioactive liquid and gaseous effluents released from the unit during the previous calendar year. The assumptions used in making these assessment, i.e., specific activity, exposure time and location, shall be included in these reports. The assessment of radiation doses shall be performed based on the calculational guidance, as presented in the ODCM.
- c. An assessment of radiation doses to the likely most exposed MEMBER OF THE PUBLIC from reactor releases and other nearby uranium fuel cycle sources, including doses from primary effluent pathways and direct radiation, the previous calendar year to show conformance with 40 CFR Part 190, Environmental Radiation Protection Standards for Nuclear Power Operation.
- d. A list and description of unplanned releases from the site to UNRESTRICTED AREAS of radioactive materials in gaseous and liquid effluents made during the reporting period.
- e. Any changes made during the reporting period to the ODCM.

---

<sup>8</sup> In lieu of submission with the second half year Radioactive Effluent Release Report, the licensee has the option of retaining this summary of required meteorological data on site in a file that shall be provided to the NRC upon request.

3/4.8 BASIS  
(7/8.8)

3/4.1 Radioactive Liquid Effluent Monitoring Instrumentation  
(7/8.1)

The radioactive liquid effluent instrumentation is provided to monitor and control, as applicable, the releases of radioactive materials in liquid effluents during actual or potential releases of liquid effluents. The alarm/trip setpoints for these instruments shall be calculated and adjusted in accordance with the methodology and parameters in the ODCM to ensure that the alarm/trip will occur prior to exceeding the limits of 10 CFR Part 20. The operability and use of this instrumentation is consistent with the appropriate requirements of General Design Criteria 60, 63 and 64 of Appendix A to 10 CFR Part 50.

3/4.2 Radioactive Gaseous Effluent Monitoring Instrumentation  
(7/8.2)

The radioactive gaseous effluent instrumentation is provided to monitor and control, as applicable, the releases of radioactive materials in gaseous effluents during actual or potential releases of gaseous effluents. The alarm/trip will occur prior to exceeding the limits of 10 CFR Part 20. The operability and use of this instrumentation is consistent with the appropriate requirements of General Design Criteria 60, 63 and 64 of Appendix A to 10 CFR Part 50.

3/4.3 LIQUID EFFLUENTS  
(7/8.3)

3/4.3.1 CONCENTRATION  
(7/8.3.1)

This specification is provided to ensure that the concentration of radioactive materials released in liquid waste effluents to UNRESTRICTED AREAS will be less than the concentration levels specified in 10 CFR Part 20, Appendix B, Table II, Column 2. This limitation provides additional assurance that the levels of radioactive materials in bodies of water in UNRESTRICTED AREAS will result in exposures within (1) the Section II.A design objectives of Appendix I, 10 CFR Part 50, to a MEMBER OF THE PUBLIC and (2) the limits of 10 CFR Part 20.106(e) to the population. The concentration limit for dissolved or entrained noble gases is based upon the assumption that Xe-135 is the controlling radioisotope and its MPC in air (submersion) was converted to

an equivalent concentration in water using the methods described in International Commission on Radiological Protection (ICRP) Publication 2.

The required detection capabilities for radioactive materials in liquid waste samples are tabulated in terms of the lower limits of detection (LLDs). Detailed discussion of the LLD, and other detection limits can be found in HASL Procedures Manual, HASL-300 (revised annually), Currie, L.A., "Limits for Qualitative Detection and Quantitative Determination - Application to Radiochemistry," Anal. Chem. 40, 586-93 (1968), and Hartwell, J.K., "Detection Limits for Radioanalytical Counting Techniques," Atlantic Richfield Hanford Company Report ARH-SA-215 (June 1975).

**3/4.3.2 DOSE**  
(7/8.3.2)

This specification is provided to implement the requirements of Sections II.A, III.A and IV.A of Appendix I, 10 CFR 50. The Limiting Condition for Operation implements the guides set forth in Section II.A of Appendix I. The ACTION statements provide the required operating flexibility and at the same time implement the guides set forth in Section IV.A of Appendix I to assure that the releases of radioactive material in liquid effluents to UNRESTRICTED AREAS will be kept "as low as is reasonably achievable". The dose calculation methodology and parameters in the ODCM implement the requirements in Section III.A of Appendix I that conformance with the guides of Appendix I be shown by calculational procedures based on models and data, such that the actual exposure of a MEMBER OF THE PUBLIC through appropriate pathways is unlikely to be substantially underestimated. The equations specified in the ODCM for calculating the doses due to the actual release rates of radioactive materials in liquid effluents are consistent with the methodology provided in Regulatory Guide 1.109, "Calculation of Annual Doses to Man from Routine Releases of Reactor Effluents for the Purpose of Evaluating Compliance with 10 CFR Part 50, Appendix I," Revision 1, October 1977 and Regulatory Guide 1.113, "Estimating Aquatic Dispersion of Effluents from Accidental and Routine Reactor Releases for the Purpose of Implementing Appendix I," April 1977.

3/4 3.3 LIQUID RADWASTE TREATMENT SYSTEM  
(7/8.3.3)

The requirement that the appropriate portions of this system be used, when specified, provides assurance that the releases of radioactive materials in liquid effluents will be kept "as low as is reasonably achievable". This specification implements the requirements of 10 CFR Part 50.36a, General Design Criterion 60 of Appendix A to 10 CFR Part 50 and the design objective given in Section II.D of Appendix I to 10 CFR Part 50. The specified limits governing the use of appropriate portions of the liquid radwaste treatment system were specified as a suitable fraction of the dose design objectives set forth in Section II.A of Appendix I, 10 CFR Part 50, for liquid effluents.



### 3/4.4 GASEOUS EFFLUENTS

(7/8.4)

#### 3/4.4.1 DOSE RATE

(7/8.4.1)

This specification is provided to ensure that the dose at any time at and beyond the SITE BOUNDARY from gaseous effluents will be within the annual dose limits of 10 CFR Part 20 to UNRESTRICTED AREAS. The annual dose limits are the doses associated with the concentrations of 10 CFR Part 20, Appendix B, Table II, Column 1. These limits provide reasonable assurance that radioactive material discharged in gaseous effluents will not result in the exposure of a MEMBER OF THE PUBLIC in an UNRESTRICTED AREA, either within or outside the SITE BOUNDARY, to annual average concentrations exceeding the limits specified in Appendix B, Table II of 10 CFR Part 20 (10 CFR Part 20.106(b)). For MEMBERS OF THE PUBLIC who may at times be within the SITE BOUNDARY, the occupancy of that MEMBER OF THE PUBLIC will usually be sufficiently low to compensate for any increase in the atmospheric diffusion factor above that for the SITE BOUNDARY. Examples of calculations for such MEMBERS OF THE PUBLIC, with the appropriate occupancy factors, shall be given in the ODCM. The specified release rate limits restrict, at all times, the corresponding gamma and beta dose rates above background to a MEMBER OF THE PUBLIC at or beyond the SITE BOUNDARY to less than or equal to 500 mrem/yr to the total body or to less than or equal to 3000 mrem/year to the skin. These release rate limits also restrict, at all times, the corresponding thyroid dose rate above background to a child via the inhalation pathway to less than or equal to 1500 mrem/year.

The required detection capabilities for radioactive materials in gaseous waste samples are tabulated in terms of the lower limits of detection (LLDs). Detailed discussion of the LLD, and other detection limits can be found in HASL Procedures Manual, HASL-300 (revised annually), Currie, L.A., "Limits for Qualitative Detection and Quantitative Determination - Application to Radiochemistry," *Anal. Chem.* 40, 586-93 (1968), and Hartwell, J.K., "Detection Limits for Radioanalytical Counting Techniques," Atlantic Richfield Hanford Company Report ARH-SA-215 (June 1975).



3/4.4.2 DOSE - NOBLE GASES  
(7/8.4.2)

This specification is provided to implement the requirements of Sections II.B, III.A and IV.A of Appendix I, 10 CFR Part 50. The Limiting Condition for Operation implements the guides set forth in Section II.B of Appendix I. The ACTION statements provide the required operating flexibility and at the same time implement the guides set forth in Section IV.A of Appendix I to assure that the releases of radioactive material in gaseous effluents to UNRESTRICTED AREAS will be kept "as low as is reasonably achievable." The Surveillance Requirements implement the requirements in Section III.A of Appendix I that conformance with the guides of Appendix I be shown by calculational procedures based on models and data such that the actual exposure of a MEMBER OF THE PUBLIC through appropriate pathways is unlikely to be substantially underestimated. The dose calculation methodology and parameters established in the ODCM for calculating the doses due to the actual release rates of radioactive noble gases in gaseous effluents are consistent with the methodology provided in Regulatory Guide 1.109, "Calculation of Annual Doses to Man from Routine Releases of Reactor Effluents for the Purpose of Evaluating Compliance with 10 CFR Part 50, Appendix I," Revision 1, October 1977 and Regulatory Guide 1.111, "Methods for Estimating Atmospheric Transport and Dispersion of Gaseous Effluents in Routine Releases from Light-Water Cooled Reactors," Revision 1, July 1977. The ODCM equations provided for determining the air doses at and beyond the SITE BOUNDARY are based upon the historical average atmospheric conditions.

3/4.4.3 DOSE - IODINE-131, IODINE-133, TRITIUM, AND  
(7/8.4.3) RADIONUCLIDES IN PARTICULATE FORM

This specification is provided to implement the requirements of Sections II.C, III.A and IV.A of Appendix I, 10 CFR Part 50. The Limiting Conditions for Operation are the guides set forth in Section II.C of Appendix I. The ACTION statements provide the required operating flexibility and at the same time implement the guides set forth in Section IV.A of Appendix I to assure that the releases of radioactive materials in gaseous effluents to UNRESTRICTED AREAS

will be kept "as low as is reasonably achievable". The ODCM calculational methods specified in the Surveillance Requirements implement the requirements in Section III.A of Appendix I that conformance with the guides of Appendix I be shown by calculational procedures based on models and data, such that the actual exposure of a MEMBER OF THE PUBLIC through appropriate pathways is unlikely to be substantially underestimated. The ODCM calculational methodology and parameters for calculating the doses due to the actual release rates of the subject materials are consistent with the methodology provided in Regulatory Guide 1.109, "Calculation of Annual Doses to man from Routine Releases of Reactor Effluents for the Purpose of Evaluating Compliance with 10 CFR Part 50, Appendix I," Revision 1, October 1977 and Regulatory Guide 1.111, "Methods for Estimating Atmospheric Transport and Dispersion of Gaseous Effluents in Routine Releases from Light-Water-Cooled Reactors," Revision 1, July 1977. These equations also provide for determining the actual doses based upon the historical average atmospheric conditions. The release rate specifications for iodine-131, iodine-133, tritium, and radionuclides in particulate form with half lives greater than 8 days are dependent upon the existing radionuclide pathways to man, in areas at and beyond the SITE BOUNDARY. The pathways that were examined in the development of these calculations were: 1) individual inhalation of airborne radionuclides, 2) deposition of radionuclides onto green leafy vegetation with subsequent consumption by man, 3) deposition onto grassy areas where milk animals and meat producing animals graze with consumption of the milk and meat by man, and 4) deposition on the ground with subsequent exposure of man.

#### 3/4.4.4 GASEOUS RADWASTE TREATMENT SYSTEM (7/8.4.4)

The requirement that the appropriate portions of these systems be used, when specified, provides reasonable assurance that the releases of radioactive materials in gaseous effluents will be kept "as low as is reasonably achievable".

This specification implements the requirements of 10 CFR 50.36a, General Design Criterion 60 of Appendix A to 10 CFR Part 50, and the design objectives given in Section II.D of Appendix I to 10 CFR Part 50. The specified limits governing the use of appropriate portions of the systems were specified as a suitable fraction of the dose design objectives set

forth in Sections II.B and II.C of Appendix I, 10 CFR Part 50, for gaseous effluents.

**3/4.5 TOTAL DOSE**  
**(7/8.6)**

This specification is provided to meet the dose limitations of 40 CFR Part 190 that have been incorporated into 10 CFR Part 20 by 46 FR 18525. The specification requires the preparation and submittal of a Special Report whenever the calculated doses from plant generated radioactive effluents and direct radiation exceed 25 mrems to the total body or any organ, except the thyroid, which shall be limited to less than or equal to 75 mrems. It is highly unlikely that the resultant dose to a MEMBER OF THE PUBLIC will exceed the dose limits of 40 CFR Part 190 if the reactor remains within twice the dose design objectives of Appendix I, and if direct radiation doses from the reactor are kept small. The Special Report will describe a course of action that should result in the limitation of the annual dose to a MEMBER OF THE PUBLIC to within the 40 CFR Part 190 limits. For the purposes of the Special Report, it may be assumed that the dose commitment to the MEMBER OF THE PUBLIC from other uranium fuel cycle sources is negligible. If the dose to any MEMBER OF THE PUBLIC is estimated to exceed the requirements of 40 CFR Part 190, the Special Report with a request for a variance (provided the release conditions resulting in violation of 40 CFR Part 190 have not already been corrected), in accordance with the provisions of 40 CFR 190.11 and 10 CFR 20.405c, is considered to be a timely request and fulfills the requirements of 40 CFR Part 190 until NRC staff action is completed. The variance only relates to the limits of 40 CFR Part 190, and does not apply in any way to the other requirements for dose limitation of 10 CFR Part 20, as addressed in Specifications 3.3.1 and 3.4.1 (7.3.1 and 7.4.1). An individual is not considered a MEMBER OF THE PUBLIC during any period in which he/she is engaged in carrying out any operation that is part of the nuclear fuel cycle.

**3/4.6 RADIOLOGICAL ENVIRONMENTAL MONITORING**  
**(7/8.7)**

**3/4.6.1 MONITORING PROGRAM**  
**(7/8.7.1)**

The radiological environmental monitoring program required by this specification provides representative measurements of radiation and of radioactive materials in those exposure pathways and for those radionuclides that lead to the highest

potential radiation exposures of MEMBERS OF THE PUBLIC resulting from the station operation. This monitoring program implements Section IV.B.2 of Appendix I to 10 CFR Part 50 and thereby supplements the radiological effluent monitoring program by verifying that the measurable concentrations of radioactive materials and levels of radiation are not higher than expected on the basis of the effluent measurements and the modeling of the environmental exposure pathways. Guidance for this monitoring program is provided by the Radiological Assessment Branch Technical Position on Environmental Monitoring. Program changes may be initiated based on operational experience.

The required detection capabilities for environmental sample analyses are tabulated in terms of the lower limits of detection (LLDs). The LLDs required by Table 4.5 (8.5) are considered optimum for routine environmental measurements in industrial laboratories. It should be recognized that the LLD is defined as an a priori (before the fact) limit representing the capability of a measurement system and not as an a posteriori (after the fact) limit for a particular measurement.

Detailed discussion of the LLD, and other detection limits, can be found in HASL Procedures Manual, HASL-300 (revised annually), Currie, L.A., "Limits for Qualitative Detection and Quantitative Determination - Application to Radiochemistry," Anal. Chem. 40, 586-93 (1968), and Hartwell, J.K., "Detection Limits for Radioanalytical Counting Techniques," Atlantic Richfield Hanford Company Report ARH-SA-215 (June 1975).

3/4.6.2 LAND USE CENSUS  
(7/8.7.2)

This specification is provided to ensure that changes in the use of areas at and beyond the SITE BOUNDARY are identified and that modifications to the radiological environmental monitoring program are made if required by the door-to-door survey, from aerial survey or from consulting with local agricultural authorities. This census satisfies the requirements of Section IV.B.3 of Appendix I to 10 CFR Part 50. Restricting the census to gardens of greater than 50 m<sup>2</sup> provided assurance that significant exposure pathways via leafy vegetables will be identified and monitored since a garden of this size is the minimum required to produce the quantity (26 kg/yr) of leafy vegetables assumed in Regulatory Guide 1.109 for consumption by a child. To determine this minimum garden size, the following assumptions were made: 1) 20% of the garden was used for growing leafy vegetation (i.e., similar to lettuce and cabbage), and 2) a vegetation yield of 2 kg/m<sup>2</sup>.

3/4.6.3 INTERLABORATORY COMPARISON PROGRAM  
(7/8.7.3)

The requirement for participation in an approved Interlaboratory Comparison Program is provided to ensure that independent checks on the precision and accuracy of measurements of radioactive material in environmental sample matrices are performed as part of the quality assurance program for environmental monitoring in order to demonstrate that the results are valid for the purposes of Section IV.B.2 of Appendix I to 10 CFR Part 50.

**TABLE 3.1 (7.1)  
RADIOACTIVE LIQUID EFFLUENT MONITORING INSTRUMENTATION**

Instrument	Minimum Channels Operable	Action
<b>1. Gross Radioactivity Monitors Providing Alarm and Automatic Termination of Release</b>		
a. Liquid Radwaste Effluent Line (R-18)	1	1
b. Steam Generator Blowdown Effluent Line (R-19)	1	2
<b>2. Gross Beta or Gamma Radioactivity Monitors Providing Alarm But Not Providing Automatic Termination of Release</b>		
a. Service Water System Effluent Line (Component cooling, R-20)	1	3
b. Service Water System Effluent Line (Containment fan cooling, R-16)	1	3

- ACTION 1 -** With the number of channels OPERABLE less than required by the Minimum Channels OPERABLE requirement, effluent releases may continue provided that prior to initiating a release:
- a. At least two independent samples are analyzed in accordance with Specification 4.3.1.1 (8.3.1.1), and
  - b. At least two technically qualified members of the Facility Staff independently verify the release rate calculations and discharge line valving;
- Otherwise, suspend release of radioactive effluents via this pathway.
- ACTION 2 -** With the number of channels OPERABLE less than required by the Minimum Channels OPERABLE requirement, effluent releases via this pathway may continue provided grab samples are analyzed for gross radioactivity (beta or gamma) at a lower limit of detection of 1.0E-6 uCi/ml:
- a. At least once per week with no indication of primary-to-secondary leakage; or
  - b. At least once per 24 hours with identified primary-to-secondary leakage (with secondary side activity > 1.0E-05 uCi/ml)
- ACTION 3 -** With the number of channels OPERABLE less than required by the Minimum Channels OPERABLE requirement, effluent releases via this pathway may continue provided that, at least once per 12 hours, grab samples are collected and analyzed for gross radioactivity (beta or gamma) at a lower limit of detection of 1.0E-6 uCi/ml. (Note: Failure to complete sampling and analysis prior to 12 hours after the monitor is declared O.O.S. is a violation of this specification).

**TABLE 3.2 (7.2)**  
**RADIOACTIVE GASEOUS EFFLUENT MONITORING INSTRUMENTATION**  
**(PAGE 1 OF 2)**

Instrument	Minimum Channels Operable	Applicability	Action
1. Noble Gas Activity Monitor			
a. R-13 or R-14	1	*	
- Waste Gas Holdup System (auto-isolation)			4
- Auxiliary Building Ventilation System			5
- Containment Purge 2" line (auto-isolation)			6
b. R-12 or R-21	1	*	
- Containment purge 36" duct (auto-isolation)			6
c. R-15	1	*	5
- Condenser Evacuation System			
2. Radioiodine & Particulate Samplers			
a. Containment Building vent (R-21)	1	*	7
b. Auxiliary Building vent (R-13A)	1	*	7
3. Sampler flow rate measuring devices			
a. Containment Building vent sampler	1	*	8
b. Auxiliary Building vent sampler	1	*	8

\*At all times

**TABLE 3.2 (7.2)**  
**RADIOACTIVE GASEOUS EFFLUENT MONITORING INSTRUMENTATION**  
**(PAGE 2 OF 2)**

**TABLE NOTATIONS**

- ACTION 4 -** With the number of channels OPERABLE less than required by the Minimum Channels OPERABLE requirement, the contents of the tank(s) may be released to the environment provided that prior to initiating the release:
- a. At least two independent samples of the tank's contents are analyzed, and
  - b. At least two technically qualified members of the Facility Staff independently verify the release rate calculations and discharge valve lineup;
- Otherwise, suspend release of radioactive effluents via this pathway.
- ACTION 5 -** With the number of channels OPERABLE less than required by the Minimum Channels OPERABLE requirement, effluent releases via this pathway may continue provided grab samples are taken at least once per 12 hours and these samples are analyzed for gross activity within 24 hours.
- ACTION 6 -** With the number of channels OPERABLE less than required by the Minimum Channels OPERABLE requirement, immediately suspend PURGING of radioactive effluents via this pathway.
- ACTION 7 -** With the number of channels OPERABLE less than required by the Minimum Channels OPERABLE requirement, effluent releases via the affected pathway may continue provided samples are continuously collected with auxiliary sampling equipment as required in Table 8.4.
- ACTION 8 -** With the number of channels OPERABLE less than required by the Minimum Channels OPERABLE requirement, effluent releases via this pathway may continue provided the flow rate is estimated at least once per 4 hours.



**TABLE 3.3 (7.3)**  
**RADIOLOGICAL ENVIRONMENTAL MONITORING PROGRAM**  
**PAGE 1 OF 2**

Exposure Pathway And/Or Sample	Number of Representative Samples and Sample Locations <sup>a</sup>	Sampling and Collection Frequency	Type and Frequency of Analysis
1. Direct Radiation <sup>b</sup>	TLD, 5 bulbs/packet, 5 Inner Ring locations  6 Outer Ring locations  1 Control location  1 Population center  1 Special interest location  1 Nearby resident	Quarterly	Gamma dose; quarterly
2. Airborne Radioiodine and Particulates	3 samples close to the site boundary in highest average X/Q  1 sample from the closest community having the highest X/Q  1 sample from a control location	Continuous sampler operation  Iodine; semi-monthly  Particulates; weekly or more frequently if required by dust loading.	Iodine; semi-monthly  Particulates; gross beta analysis following filter change. <sup>d</sup> Gamma isotopic of composite (by location) quarterly. <sup>e</sup>
3. Waterborne a. Surface <sup>f</sup>  b. Ground  c. Drinking  d. Sediment from shoreline	1 Upstream sample 1 Downstream sample  1-2 location likely to be affected  1-3 samples of nearest water supply  1 sample from downstream area with potential for recreational value	Monthly grab sample  Quarterly grab sample  Monthly grab sample  Semi-annual grab sample	Gamma isotopic <sup>e</sup> analysis monthly. Composite of grab samples for tritium analysis quarterly.  Gamma isotopic <sup>e</sup> and tritium analysis quarterly.  Monthly gross beta and gamma isotopic <sup>e</sup> analysis. Quarterly tritium analysis of the composite of monthly grab samples.  Gamma isotopic <sup>e</sup> analysis; semiannually.

**TABLE 3.3 (7.3)**  
**RADIOLOGICAL ENVIRONMENTAL MONITORING PROGRAM**  
**PAGE 2 OF 2**

4. Ingestion			
a. Milk	Samples from milking animals in 3 locations within 5 km having the highest dose potential.  1 alternate location 1 control location	Semi-monthly when animals are on pasture. Monthly otherwise.	Gamma isotopic <sup>c</sup> and I-131 analysis semi-monthly when animals are on pasture <sup>d</sup> . Monthly otherwise.
b. Fish	3 random samplings of commercially and recreationally important species in the vicinity of the discharge.	3 times per year	Gamma isotopic <sup>c</sup> on edible portions.
c. Food Products	Samples of leaf vegetables grown nearest each of two different offsite locations within 5 miles of the plant if milk sampling is not performed.	Annually when available	Gamma isotopic <sup>c</sup> and I-131 Analysis.

Table Notations

<sup>a</sup>Specific parameters of distance and direction sector from the centerline of the reactor, and additional descriptions where pertinent, are provided for in Tables 1.1 and 1.2 and Figures 2.1 and 2.2 of the Radiological Environmental Monitoring Manual (REMM) for each and every sample location. Deviations from the required sampling schedule will occur if specimens are unobtainable due to hazardous conditions, seasonal unavailability, malfunction of automatic sampling equipment and other legitimate reasons. If specimens are unobtainable due to sampling equipment malfunction, reasonable efforts shall be made to complete corrective actions prior to the end of the next sampling period. All deviations from the sampling schedule shall be documented in the Annual Radiological Environmental Monitoring Report. It is recognized that, at times, it may not be possible or practicable to continue to obtain samples of the media of choice at the most desired location or time. In these instances suitable alternative media and locations may be chosen for the particular pathway in question and appropriate substitutions made within 30 days in the REMM. The cause of the unavailability of samples for that pathway and the new location(s) for obtaining replacement samples will be identified in the Annual Radiological Environmental Monitoring Report.

<sup>b</sup>For the purposes of this table, a thermoluminescent dosimeter (TLD) is considered to be one phosphor; two or more phosphors in a packet are considered as two or more dosimeters. The NRC guidance of 40 stations is not an absolute number. The number of direct radiation monitoring stations has been reduced according to geographical limitations; e.g., Lake Michigan.

The frequency of analysis or readout for TLD systems depends upon the characteristics of the specific system used and selection is made to obtain optimum dose information with minimal fading.

<sup>c</sup>The purpose of this sample is to obtain background information. If it is not practical to establish control locations in accordance with the distance and wind direction criteria, other sites that provide valid background data may be substituted.

<sup>d</sup>Airborne particulate sample filters shall be analyzed for gross beta radioactivity 24 hours or more after sampling to allow for radon and thoron daughter decay. If gross beta activity in air particulate samples is greater than ten times the yearly mean of control samples, gamma isotopic analysis shall be performed on the individual samples.

<sup>e</sup>Gamma isotopic analysis means the identification and quantification of gamma-emitting radionuclides that may be attributable to the effluents from the facility.

<sup>f</sup>The "upstream sample" shall be taken at a distance beyond significant influence of the discharge. The "downstream" sample shall be taken in an area near the mixing zone.

**TABLE 3.4 (7.4)**  
**REPORTING LEVELS FOR RADIOACTIVITY CONCENTRATIONS**  
**IN ENVIRONMENTAL SAMPLES**

REPORTING LEVELS					
Analysis	Water (pCi/l)	Airborne Particulate or Gases (pCi/m <sup>3</sup> )	Fish (pCi/kg, wet)	Milk (pCi/l)	Food Products (pCi/kg, wet)
H-3	20,000				
Mn-54	1,000		30,000		
Fe-59	400		10,000		
Co-58	1,000		30,000		
Co-60	300		10,000		
Zr-Nb-95	400				
I-131	2	0.9		3	100
Cs-134	30	10	1,000	60	1,000
Cs-137	50	20	2,000	70	2,000
Ba-La-140	200			300	

**TABLE 4.0 (8.0)  
FREQUENCY NOTATION**

Notation	Frequency <sup>1</sup>
S	Once per shift
St	Once per 12 hours
D	Once per 24 hours
W	Once per 7 days
M	Once per 31 days
Q	Once per 92 days
SA	Once per 184 days
R	Once per refueling cycle, not to exceed 18 months
P	Prior to each reactor startup if not done previous week
PR	Completed prior to each release
N.A.	Not applicable

<sup>1</sup>A maximum extension not to exceed 25% of the surveillance interval.

**TABLE 4.1 (8.1)  
RADIOACTIVE LIQUID EFFLUENT MONITORING  
INSTRUMENTATION SURVEILLANCE REQUIREMENTS**

Instrument	Channel Check	Source Check	Channel Calibration	Channel Functional Test
1. Gross Radioactivity Monitors Providing Alarm and Automatic Termination of Release				
a. Liquid Radwaste Effluent Line (R-18)	D	PR	R	Q
b. Steam Generator Blowdown Effluent Line (R-19)	D	M	R	Q
2. Gross Beta or Gamma Radioactivity Monitors Providing Alarm But Not Providing Automatic Termination of Release				
a. Service Water System Effluent Line (Component cooling, R-20)	D	M	R	Q
b. Service Water System Effluent Line (Containment fan cooling, R-16)	D	M	R	Q

**TABLE 4.2 (8.2)  
RADIOACTIVE GASEOUS EFFLUENT MONITORING  
INSTRUMENTATION SURVEILLANCE REQUIREMENTS**

Instrument	Channel Check	Source Check	Channel Calibration	Channel Functional Test	Modes In Which Surveillance Required
1. Noble Gas Activity Monitor					
a. R-13 or R-14					
Waste Gas Holdup System (auto-isolation)	PR	PR	R	Q	*
Auxiliary Building Ventilation System	D	M	R	Q	*
Containment Purge 2" line (auto-isolation)	D	M	R	Q	*
b. R-12 or R-21					
Containment purge 36" duct (auto-isolation)	D	PR	R	Q	*
c. R-15					
Condenser Evacuation System	D	M	R	Q	*
2. Radioiodine Particulate Samplers					
a. Containment Building vent (R-21)	W	N.A.	N.A.	N.A.	*
b. Auxiliary Building vent (R-13A)	W	N.A.	N.A.	N.A.	*
3. Sampler Flow Rate Measuring Devices					
a. Containment Building vent sampler	D	N.A.	R	Q	*
b. Auxiliary Building vent sampler	D	N.A.	R	Q	*

\*At all times other than when the line is valved out and tagged.

**TABLE 4.3 (8.3)**  
**RADIOACTIVE LIQUID WASTE SAMPLING AND ANALYSIS PROGRAM**  
 Page 1 of 2

Liquid Release Type	Sampling Frequency	Minimum Analysis Frequency	Type of Activity Analysis	Lower Limit of Detection (LLD) <sup>a</sup> (uCi/ml)
A. Batch Waste Release Tanks <sup>b</sup>	PR Each Batch	PR Each Batch	Principal Gamma Emitters <sup>c</sup> I-131	1x10 <sup>-6</sup> 1x10 <sup>-6</sup>
	PR Each Batch	M Composite <sup>d</sup>	H-3 Gross Alpha	1x10 <sup>-5</sup> 5x10 <sup>-7</sup>
	PR Each Batch	Q Composite <sup>d</sup>	Sr-89, Sr-90 Fe-55	5x10 <sup>-8</sup> 1x10 <sup>-6</sup>
B. Continuous Releases <sup>e</sup> (SG Blowdown) (TB Sump <sup>g</sup> )	W Grab Sample	W Grab Sample	Principal Gamma Emitters <sup>c</sup>	5x10 <sup>-7</sup>
			I-131	1x10 <sup>-6</sup>
	W Grab Sample	M Composite <sup>f</sup>	H-3 Gross Alpha	1x10 <sup>-5</sup> 5x10 <sup>-7</sup>
W Grab Sample	Q Composite <sup>f</sup>	Sr-89, Sr-90 Fe-55	5x10 <sup>-8</sup> 1x10 <sup>-6</sup>	

TABLE 4.3 (8.3)  
RADIOACTIVE LIQUID WASTE SAMPLING AND ANALYSIS PROGRAM

Page 2 of 2

Table Notations

<sup>a</sup> The LLD is defined, for purposes of these specifications, as the smallest concentration of radioactive material in a sample that will yield a net count, above system background, that will be detected with 95 % probability with only 5 % probability of falsely concluding that a blank observation represents a "real" signal.

For a particular measurement system, which may include radiochemical separation:

$$LLD = \frac{4.66 s_b}{E * V * 2.22 \times 10^6 * Y * \exp(-\lambda \Delta t)}$$

Where:

LLD is the a priori lower limit of detection as defined above, as uCi per unit mass or volume,

$s_b$  is the standard deviation of the background counting rate or of the counting rate of a blank sample as appropriate, as counts per minute,

E is the counting efficiency, as counts per disintegration,

V is the sample size in units of mass or volume,

$2.22 \times 10^6$  is the number of disintegrations per minute per microcurie,

Y is the fractional radiochemical yield, when applicable,

$\lambda$  is the radioactive decay constant for the particular radionuclide, and

$\Delta t$  for plant effluents is the elapsed time between the midpoint of sample collection and time of counting.

Typical values of E, V, Y and  $\Delta t$  should be used in the calculation.

It should be recognized that the LLD is defined as an a priori (before the fact) limit representing the capability of a measurement system and not as an a posteriori (after the fact) limit for a particular measurement.

<sup>b</sup> A batch release is the discharge of liquid wastes of a discrete volume. Prior to sampling for analysis, each batch shall be located, and then thoroughly mixed to ensure representative sampling.

<sup>c</sup> The principal gamma emitters for which the LLD specification applies exclusively are the following radionuclides: Mn-54, Fe-59, Co-58, Co-60, Zn-65, Mo-99, Cs-134, Cs-137, Ce-141, and Ce-144. This list does not mean that only these nuclides are to be considered. Other gamma peaks that are identifiable, together with those of the above nuclides, shall also be analyzed and reported in the Radioactive Effluent Release Report pursuant to TS 6.9.3.b.

<sup>d</sup> A composite sample is one in which the quantity of liquid sampled is proportional to the quantity of liquid waste discharged and in which the method of sampling employed results in a specimen that is representative of the liquids released.

<sup>e</sup> A continuous release is the discharge of liquid wastes of a nondiscrete volume, e.g., from a volume of a system that has an input flow during the continuous release.

<sup>f</sup> As a minimum, the monthly and quarterly composite samples shall be comprised of weekly grab samples.

<sup>g</sup> During periods of identified primary-to-secondary leakage (with the secondary activity > 1.0E-05 uCi/ml), grab samples are collected daily and analyzed by gamma spectroscopy.



**TABLE 4.4 (8.4)**  
**RADIOACTIVE GASEOUS WASTE SAMPLING AND ANALYSIS PROGRAM**  
 Page 1 of 2

Gaseous Release Type	Sampling Frequency	Minimum Analysis Frequency	Type of Activity Analysis	Lower Limit of Detection (LLD) <sup>a</sup> (uCi/ml)
A. Waste Gas Storage Tank	PR Each Tank Grab Sample	PR Each Tank	Principal Gamma Emitters <sup>b</sup>	1x10 <sup>-4</sup>
B. Containment PURGE	PR Each PURGE Grab Sample	PR Each Purge	Principal Gamma Emitters <sup>b</sup>	1x10 <sup>-4</sup>
C. Auxiliary Building and Containment Building Vent	M Grab Sample	M	Principal Gamma Emitters <sup>b</sup>	1x10 <sup>-4</sup>
	Continuous <sup>c</sup>	W Charcoal Sample	I-131	3x10 <sup>-12</sup>
	Continuous <sup>c</sup>	W Particulate Sample	Principal Gamma Emitter <sup>b</sup> (I-131, others)	1x10 <sup>-11</sup>
	Continuous <sup>c</sup>	M Composite Particulate Sample	Gross Alpha	1x10 <sup>-11</sup>
	Continuous <sup>c</sup>	Q Composite Particulate Sample	SR-89, SR-90	1x10 <sup>-11</sup>
	Continuous <sup>c</sup>	Noble Gas Monitor	Noble Gases Gross Beta or Gamma	1x10 <sup>-6</sup>

**TABLE 4.4 (8.4)**  
**RADIOACTIVE GASEOUS WASTE SAMPLING AND ANALYSIS PROGRAM**  
**Page 2 OF 2**

Table Notations

<sup>a</sup> The LLD is defined, for purposes of these specifications, as the smallest concentration of radioactive material in a sample that will yield a net count, above system background, that will be detected with 95% probability with only 5% probability of falsely concluding that a blank observation represents a "real" signal.

For a particular measurement system, which may include radiochemical separation:

$$LLD = \frac{4.66 s_b}{E * V * 2.22 \times 10^6 * Y * \exp(-\lambda \Delta t)}$$

Where:

LLD is the a priori lower limit of detection as defined above, as uCi per unit mass or volume,

$s_b$  is the standard deviation of the background counting rate or of the counting rate of a blank sample as appropriate, as counts per minute,

E is the counting efficiency, as counts per disintegration,

V is the sample size in units of mass or volume,

$2.22 \times 10^6$  is the number of disintegrations per minute per microcurie,

Y is the fractional radiochemical yield, when applicable,

$\lambda$  is the radioactive decay constant for the particular radionuclide, and

$\Delta t$  for plant effluents is the elapsed time between the midpoint of sample collection and time of counting.

Typical values of E, V, Y and  $\Delta t$  should be used in the calculation.

It should be recognized that the LLD is defined as an a priori (before the fact) limit representing the capability of a measurement system and not as an a posteriori (after the fact) limit for a particular measurement.

<sup>b</sup> The principal gamma emitters for which the LLD specification applies exclusively are the following radionuclides: Kr-87, Kr-88, Xe-133, Xe-133m, Xe-135, and Xe-138 for gaseous emissions and Mn-54, Fe-59, Co-58, Co-60, Zn-65, Mo-99, Cs-134, Cs-137, Ce-141, and Ce-144 for particulate emissions. This list does not mean that only these nuclides are to be considered. Other gamma peaks that are identifiable, together with those of the above nuclides, shall also be analyzed and reported in the Radioactive Effluent Release Report pursuant to TS 6.9.3.b.

<sup>c</sup> The ratio of the sample flow rate to the sampled flow stream flow rate shall be known (based on sampler and ventilation system flow measuring devices or periodic flow estimates) for the time period covered by each dose or dose rate calculation made in accordance with Specifications 3.4.1, 3.4.2, and 3.4.3 (7.4.1, 7.4.2 and 7.4.3).

**TABLE 4.5 (8.5)**  
**DETECTION CAPABILITIES FOR ENVIRONMENTAL SAMPLE ANALYSIS<sup>a</sup>**  
**LOWER LIMIT OF DETECTION (LLD)<sup>b,c</sup>**

Page 1 of 2

Analysis	Water (pCi/l)	Airborne Particulate or Gases (pCi/m <sup>3</sup> )	Fish (pCi/kg, wet)	Milk (pCi/l)	Food Products (pCi/kg, wet)	Sediment (pCi/kg, dry)
gross beta	4	0.01				
H-3	2,000					
Mn-54	15		130			
Fe-59	30		260			
Co-58, 60	15		130			
Zr-Nb-95	15					
I-131	1 <sup>d</sup>	0.07		1	60	
Cs-134	15	0.05	130	15	60	150
Cs-137	18	0.06	150	18	80	180
Ba-La-140	15			15		

**TABLE 4.5 (8.5)**  
**DETECTION CAPABILITIES FOR ENVIRONMENTAL SAMPLE ANALYSIS<sup>a</sup>**  
**LOWER LIMIT OF DETECTION (LLD)<sup>b,c</sup>**

Page 2 of 2

Table Notations

<sup>a</sup> This list does not mean that only these nuclides are to be considered. Other peaks that are identifiable, together with those of the above nuclides, shall also be analyzed and reported in the Annual Radiological Environmental Monitoring Report, pursuant to TS 6.9.3.a.

<sup>b</sup> Required detection capabilities for thermoluminescent dosimeters used for environmental measurements are given in RG 4.13.

<sup>c</sup> The LLD is defined, for purposes of these specifications, as the smallest concentration of radioactive material in a sample that will yield a net count, above system background, that will be detected with 95% probability with only 5% probability of falsely concluding that a blank observation represents a "real" signal.

For a particular measurement system, which may include radiochemical separation:

$$LLD = \frac{4.66 s_b}{E * V * 2.22 * Y * \exp(-\lambda \Delta t)}$$

Where:

LLD is the a priori lower limit of detection as defined above, as picocuries per unit mass or volume,  $s_b$  is the standard deviation of the background counting rate or of the counting rate of a blank sample as appropriate, as counts per minute,

E is the counting efficiency, as counts per disintegration,

V is the sample size in units of mass or volume,

2.22 is the number of disintegrations per minute per microcurie,

Y is the fractional radiochemical yield, when applicable,

$\lambda$  is the radioactive decay constant for the particular radionuclide, and

$\Delta t$  for environmental samples is the elapsed time between sample collection, or end of the sample collection period, and time of counting.

Typical values of E, V, Y and  $\Delta t$  should be used in the calculation.

It should be recognized that the LLD is defined as an a priori (before the fact) limit representing the capability of a measurement system and not as an a posteriori (after the fact) limit for a particular measurement. Analyses shall be performed in such a manner that the stated LLDs will be achieved under routine conditions. Occasionally background fluctuations, unavoidable small sample sizes, the presence of interfering nuclides, or other uncontrollable circumstances may render these LLDs unachievable. In such cases, the contributing factors shall be identified and described in the Annual Radiological Environmental Monitoring Report, pursuant to TS 6.9.3.a.

<sup>d</sup> LLD for drinking water samples. If no drinking water pathway exists, the LLD of gamma isotopic analysis may be used.

**APPENDIX A**

**TECHNICAL BASIS FOR EFFECTIVE DOSE FACTORS -**

**LIQUID RADIOACTIVE EFFLUENTS**

## APPENDIX A

### Technical Basis for Effective Dose Factors - Liquid Effluent Releases

The radioactive liquid effluents for the fuel cycle years 1983, 1982 and 1981 were evaluated to determine the dose contribution of the radionuclide distribution. This analysis was performed to evaluate the use of a limited dose analysis for determining environmental doses, providing a simplified method of determining compliance with the dose limits of Specification 3.3.2 (Technical Specification 7.3.2). For the radionuclide distribution of effluents from the Kewaunee Nuclear Power Plant, the controlling organ is either the GI-LLI or the liver. The calculated GI-LLI dose is almost exclusively dictated by the Nb-95 releases; the liver dose is mostly a function of the Cs-134 and Cs-137 releases. The radionuclides, Co-58, Co-60, Sr-90, Cs-134 and Cs-137 contribute essentially all of the calculated total body dose. The results of this evaluation are presented in Table A-1.

For purposes of simplifying the details of the dose calculational process, it is conservative to identify a controlling, dose significant radionuclide and limit the calculational process to the use of the dose conversion factor for this nuclide. Multiplication of the total release (i.e., cumulative activity for all radionuclides) by this dose conversion factor provides for a dose calculational method that is simplified while also being conservative.

For the evaluation of the maximum organ dose, it is conservative to use the Cs-134 dose conversion factor ( $7.09\text{E}+05$  mrem/hr per  $\mu\text{Ci/ml}$ , liver). Only the reactor-generated radionuclide Nb-95 has a higher dose conversion factor ( $1.51\text{E}+06$  mrem/hr per  $\mu\text{Ci/ml}$ , GI-LLI). However, since Nb-95 releases are typically less than 5% of the total releases, it is conservative to use the Cs-134 factor. By this approach, the maximum organ dose will be routinely overestimated. For 1983, using this simplified conservative method would overestimate the maximum organ dose by a factor of 85; for 1982, the conservatism is a factor of 35; and for 1981, a factor of 21.

For the total body calculation, the Cs-134 dose factor ( $5.79\text{E}+05$  mrem/hr per  $\mu\text{Ci/ml}$ , total body) is the highest among the identified dominant nuclides. For 1981, using this simplified conservative dose calculational method would overestimate the total body dose by a factor of 26; for 1982, the conservatism is a factor of 50; and for 1983, a factor of 34.

For evaluating compliance with the dose limits of Specification 3.3.2 (Technical Specification 7.3.2) the following simplified equations may be used:

Total Body

$$D_{tb} = \frac{1.67E-02 \times VOL}{CW} \times A_{Cs-134,TB} \times \sum C_i \quad (A.1)$$

where:

$D_{tb}$  = dose to the total body (mrem)

$A_{Cs-134,TB}$  =  $5.79E+05$ , total body ingestion dose conversion factor for Cs-134 (mrem/hr per  $\mu Ci/ml$ )

VOL = volume of liquid effluent released (gal)

$\sum C_i$  = total concentration of all radionuclides ( $\mu Ci/ml$ )

CW = average circulating water discharge rate during release period (gal/min)

$1.67E-02$  = conversion factor (hr/min)

Substituting the value for the Cs-134 total body dose conversion factor, the equation simplifies to:

$$D_{tb} = \frac{9.67E+03 \times VOL}{CW} \times \sum C_i \quad (A.2)$$

Maximum Organ

$$D_{max} = \frac{1.67E-02 \times VOL \times A_{Cs-134,L}}{CW} \times \sum C_i \quad (A.3)$$

where:

$D_{\max}$  = maximum organ dose (mrem)  
 $A_{\text{Cs-134,L}}$  =  $7.09\text{E}+05$ , liver ingestion dose conversion factor for Cs-134 (mrem/hr per  $\mu\text{Ci/ml}$ )

Substituting the value for  $A_{\text{Cs-134,Liver}}$ , the equation simplifies to:

$$D_{\max} = \frac{1.18\text{E}+04 \times \text{VOL}}{\text{CW}} \times \sum C_i$$

(A.4)

Only the total body dose need be evaluated by this simplified method since it represents the more limiting (compared with the maximum organ dose) for demonstrating compliance with Specification 3.3.2 (Technical Specification 7.3.2).

Tritium is not included in the limited analysis dose assessment for liquid releases, because the potential dose resulting from normal reactor releases is negligible. The average annual tritium release from the Kewaunee Nuclear Plant to Lake Michigan is approximately 300 curies. The calculated total body dose from such a release is  $1.36\text{E}-02$  mrem/yr via the fish ingestion and drinking water pathways. This amounts to 0.45% of the design objective dose of 3 mrem/yr. Furthermore, the release of tritium is a function of operating time and power level and is essentially unrelated to radwaste system operation.



## Appendix A

### Table A-1 Adult Dose Contributions Fisb and Drinking Water Pathways

Radio- Nuelide	1983-84 Fuel Cycle				1982-83 Fuel Cycle				1981-82 Fuel Cycle			
	Release (Ci)	TB Dose Frac.	G1-LL1 Dose Frac.	Liver Dose Frac.	Release (Ci)	TB Dose Frac.	G1-LL1 Dose Frac.	Liver Dose Frac.	Release (Ci)	TB Dose Frac.	G1-LL1 Dose Frac.	Liver Dose Frac.
Co-58	5.91E-01	0.01	0.02	*	2.27E-01	0.01	0.18	*	8.51E-01	0.01	0.37	*
Co-60	1.29E-01	*	0.01	*	2.36E-01	0.02	0.49	0.01	3.66E-01	0.01	0.43	*
Ag-110m	8.41E-02	*	*	*	1.57E-01	*	*	*	2.06E-02	*	*	*
Sb-124	9.46E-02	*	*	*	3.78E-03	*	*	*	2.88E-02	*	*	*
Sb-125	4.60E-02	*	*	*	8.06E-03	*	*	*	2.07E-02	*	*	*
Nb-95	3.91E-02	*	0.96	*	3.67E-04	*	0.24	*	N/D		*	*
Cs-137	3.24E-02	0.64	0.01	0.69	2.08E-02	0.94	0.09	0.96	5.53E-02	0.62	0.14	0.68
Cs-134	1.06E-02	0.35	*	0.31	4.52E-04	0.03	*	0.03	1.93E-02	0.37	0.06	0.32
Total	1.03E+00			6.53E-01				1.36E+00				

\*Less than 0.01

N/D = not detected

**APPENDIX B**

**TECHNICAL BASIS FOR EFFECTIVE DOSE FACTORS -**

**GASEOUS RADIOACTIVE EFFLUENTS**

## APPENDIX B

### Technical Bases for Effective Dose Factors - Gaseous Radioactive Effluents

#### Overview

The evaluation of doses due to releases of radioactive material to the atmosphere can be simplified by the use of effective dose transfer factors instead of using dose factors which are radionuclide specific. These effective factors, which can be based on typical radionuclide distributions of releases, can be applied to the total radioactivity released to approximate the dose in the environment (i.e., instead of having to perform individual radionuclide dose analyses only a single multiplication ( $K_{\text{eff}}$ ,  $M_{\text{eff}}$  or  $N_{\text{eff}}$ ) times the total quantity of radioactive material released would be needed). This approach provides a reasonable estimate of the actual dose while eliminating the need for a detailed calculational technique.

#### Determination of Effective Dose Factors

Effective dose transfer factors are calculated by the following equations:

$$K_{\text{eff}} = \sum (K_i \times f_i) \tag{B.1}$$

where:

- $K_{\text{eff}}$  = the effective total body dose factor due to gamma emissions from all noble gases released
- $K_i$  = the total body dose factor due to gamma emissions from each noble gas radionuclide  $i$  released
- $f_i$  = the fractional abundance of noble gas radionuclide  $i$  relative to the total noble gas activity

$$(L + 1.1 M)_{\text{eff}} = \sum ((L_i + 1.1 M_i) \times f_i) \tag{B.2}$$

where:

$(L + 1.1 M)_{\text{eff}}$  = the effective skin dose factor due to beta and gamma emissions from all noble gases released

$(L_i + 1.1 M_i)$  = the skin dose factor due to beta and gamma emissions from each noble gas radionuclide  $i$  released

$$M_{\text{eff}} = \sum (M_i \times f_i)$$

(B.3)

where:

$M_{\text{eff}}$  = the effective air dose factor due to gamma emissions from all noble gases released

$M_i$  = the air dose factor due to gamma emissions from each noble gas radionuclide  $i$  released

$$N_{\text{eff}} = \sum (N_i \times f_i)$$

(B.4)

where:

$N_{\text{eff}}$  = the effective air dose factor due to beta emissions from all noble gases released

$N_i$  = the air dose factor due to beta emissions from each noble gas radionuclide  $i$  released

Normally, it would be expected that past radioactive effluent data would be used for the determination of the effective dose factors. However, the noble gas releases from Kewaunee have been maintained to such negligible quantities that the inherent variability in the data makes any meaningful evaluations difficult. For the years of 1981, 1982 and 1983, the total noble gas releases have been limited to 6 Ci for 1981, 56 Ci for 1982, and 167 Ci for 1983. Therefore, in order to provide a reasonable basis for the derivation of the effective noble gas dose factors, the primary coolant source term from ANSI N237-1976/ANS-18.1, "Source Term Specifications," has been used as representing a typical distribution. The effective dose factors as derived are presented in Table B-1.

### Application

To provide an additional degree of conservatism, a factor of 0.50 is introduced into the dose calculational process when the effective dose transfer factor is used. This conservatism provides additional assurance that the evaluation of doses by the use of a single effective factor will not significantly underestimate any actual doses in the environment.

For evaluating compliance with the dose limits of Specification 3.4.2 (Technical Specification 7.4.2), the following simplified equations may be used:

$$D_{\gamma} = \frac{3.17E-08}{0.50} \times X/Q \times M_{\text{eff}} \times \sum Q_i$$

(B.5)

$$D_{\beta} = \frac{3.17E-08}{0.50} \times X/Q \times N_{\text{eff}} \times \sum Q_i$$

(B.6)

where:

$D_{\gamma}$	=	air dose due to gamma emissions for the cumulative release of all noble gases (mrad)
$D_{\beta}$	=	air dose due to beta emissions for the cumulative release of all noble gases (mrad)
$X/Q$	=	atmospheric dispersion to the controlling site boundary (sec/m <sup>3</sup> )
$M_{\text{eff}}$	=	5.3E+02, effective gamma-air dose factor (mrad/yr per $\mu\text{Ci}/\text{m}^3$ )
$N_{\text{eff}}$	=	1.1E+03, effective beta-air dose factor (mrad/yr per $\mu\text{Ci}/\text{m}^3$ )
$\sum Q_i$	=	cumulative release for all noble gas radionuclides ( $\mu\text{Ci}$ )
3.17E-08	=	conversion factor (yr/sec)
0.50	=	conservatism factor to account for the variability in the effluent data

Combining the constants, the dose calculational equations simplify to:

$$D_{\gamma} = 3.5E-05 \times X/Q \times \sum Q_i$$

and

(B.7)

$$D_{\beta} = 7.0E-05 \times X/Q \times \sum Q_i$$

(B.8)

The effective dose factors are used on a very limited basis for the purpose of facilitating the timely assessment of radioactive effluent releases, particularly during periods of computer malfunction where a detailed dose assessment may be unavailable. Dose assessments using the detailed, radionuclide dependent calculation are performed at least every six months for preparation of the Semi-Annual Radioactive Effluent Reports. Comparisons can be performed at this time to assure that the use of the effective dose factors does not substantially underestimate actual doses.

## APPENDIX B

### Table B-1

#### Effective Dose Factors - Noble Gases

##### Noble Gases - Total Body and Skin

<u>Radionuclide</u>	$f_i$	<b>Total Body Effective Dose Factor</b> $K_{eff}$ <u>(mrem/yr per <math>\mu\text{Ci}/\text{m}^3</math>)</u>	<b>Skin Effective Dose Factor</b> $(L+1.1 M)_{eff}$ <u>(mrem/yr per <math>\mu\text{Ci}/\text{m}^3</math>)</u>
Kr-85	0.01	--	1.4E+01
Kr-88	0.01	1.5E+02	1.9E+02
Xe-133m	0.01	2.5E+00	1.4E+01
Xe-133	0.95	3.0E+02	6.6E+02
Xe-135	0.02	3.6E+01	7.9E+01
<b>TOTAL</b>		<b>4.8E+02</b>	<b>9.6E+02</b>

##### Noble Gases - Air

<u>Radionuclide</u>	$f_i$	<b>Gamma Air Effective Dose Factor</b> $M_{eff}$ <u>(mrad/yr per <math>\mu\text{Ci}/\text{m}^3</math>)</u>	<b>Beta Air Effective Dose Factor</b> $N_{eff}$ <u>(mrad/yr per <math>\mu\text{Ci}/\text{m}^3</math>)</u>
Kr-85	0.01	--	2.0E+01
Kr-88	0.01	1.5E+02	2.9E+01
Xe-133m	0.01	3.3E+00	1.5E+01
Xe-133	0.95	3.4E+02	1.0E+03
Xe-135	0.02	3.8E+01	4.9E+01
<b>TOTAL</b>		<b>5.3E+02</b>	<b>1.1E+03</b>

**APPENDIX C**  
**EVALUATION OF CONSERVATIVE, DEFAULT MPC VALUE**  
**FOR LIQUID EFFLUENTS**



## Appendix C

### Evaluation of Conservative, Default MPC Value for Liquid Effluents

In accordance with the requirements of Specification 3.1 (Technical Specification 7.1) the radioactive liquid effluent monitors shall be operable with alarm setpoints established to ensure that the concentration of radioactive material at the discharge point does not exceed the MPC value of 10 CFR 20, Appendix B, Table II, Column 2. The determination of allowable radionuclide concentration and corresponding alarm setpoint is a function of the individual radionuclide distribution and corresponding MPC values.

In order to limit the need for routinely having to reestablish the alarm setpoints as a function of changing radionuclide distributions, a default alarm setpoint can be established. This default setpoint can be conservatively based on an evaluation of the radionuclide distribution of the liquid effluents from Kewaunee and the effective MPC value for this distribution.

The effective MPC value for a radionuclide distribution can be calculated by the equation:

$$MPC_e = \frac{\sum C_i}{\sum \frac{C_i}{MPC_i}}$$

(C.1)

where:

$MPC_e$  = an effective MPC value for a mixture of radionuclide ( $\mu\text{Ci/ml}$ )

$C_i$  = concentration of radionuclide i in the mixture

$MPC_i$  = the 10 CFR 20, Appendix B, Table II, Column 2 MPC value for radionuclide i ( $\mu\text{Ci/ml}$ )

Based on the above equation and the radionuclide distribution in the effluents for past years from Kewaunee, an effective MPC value can be determined. Results are presented in Table C-1.

Based on the annual radionuclide distributions, the most limiting effective MPC was for the calendar year 1983, with a calculated value of  $3.8\text{E-}05$   $\mu\text{Ci/ml}$ . For conservatism in establishing the alarm setpoints, a default effective MPC value of  $1.0\text{E-}05$   $\mu\text{Ci/ml}$  was selected. The overall conservatism of this value is reaffirmed for future releases considering that  $1.0\text{E-}05$   $\mu\text{Ci/ml}$  is more restrictive than the individual MPC values for the principal fission and activation products of Co-58, Co-60 and Cs-137 and is only slightly higher than the  $9.0\text{E-}06$   $\mu\text{Ci/ml}$  MPC value for Cs-134.

In 1992, Table C-1 was updated to include data from 1984 through 1991. The default effective MPC value of  $1.0\text{E-}05$   $\mu\text{Ci/ml}$  previously established was reaffirmed as being a conservative value. Note that the 1984 through 1991 data includes more nuclides than previous years data.

## Appendix C

**Table C-1**  
**Calculation of Effective MPC**

Nuclide	MPC ( $\mu\text{Ci/ml}$ )	Activity Released (Ci)		
		1976 - 1981 avg.	1982	1983
Sr-89	3E-06	1.0E-03	3E-05	2E-04
Sr-90	3E-07	2.5E-04	5E-05	1.2E-04
Nb-95	1E-04	5.4E-03	2.4E-03	2.5E-03
I-131	3E-07	1.9E-02	--	3E-05
I-133	1E-06	7.4E-04	--	2E-05
Cs-134	9E-06	7.4E-02	1.1E-02	9.1E-04
Cs-136	6E-05	5.2E-04	--	--
Cs-137	2E-05	5.7E-02	4.7E-02	2.1E-02
Cs-138	--	1.2E-04	--	--
Ba-140	2E-05	4.5E-04	--	6E-06
Mn-54	1E-04	4.5E-02	9E-03	3.6E-03
Co-57	4E-04	3.1E-04	1.7E-04	1.8E-04
Co-58	9E-05	5.5E-01	8.1E-01	2.1E-01
Co-60	3E-05	1.6E-01	3.7E-01	2.0E-01
Sb-124	2E-05	3.4E-02	3E-02	3.8E-03
Sb-125	1E-04	3.4E-02	1.8E-02	8.4E-03
Cr-51	2E-03	4.6E-02	1E-02	2.8E-03
Ag-110m	3E-05	4.3E-02	1.5E-01	7.2E-02
Na-24	3E-05	9.7E-03	1E-05	8.3E-04
Fe-59	5E-05	6.1E-03	4.4E-03	--
Sn-113	8E-05	6.1E-04	1E-04	8E-05
Zr-95	6E-05	2.2E-03	8E-04	4E-04
Total		1.09	1.46	0.53
Ci MPCi		9.2E+04	3.2E+04	1.4E+04
MPC <sub>e</sub> ( $\mu\text{Ci/ml}$ )		1.2E-05	4.6E-05	3.8E-05

**Table C-1 (con't) - Calculation of Effective MPC**

Nuclide	MPC ( $\mu\text{Ci/ml}$ )	Activity Released (Ci)				
		1984	1985	1986	1987	1988
Na-24	3.0E-05	1.42E-03	6.90E-03	5.85E-04	6.16E-04	3.08E-04
Cr-51	2.0E-03	2.57E-03	2.94E-02	4.08E-03	2.02E-02	8.36E-03
Mn-54	1.0E-04	6.06E-03	8.53E-03	1.94E-03	3.37E-03	4.87E-03
Fe-55	8.0E-04	7.45E-03		5.24E-02	1.21E-01	7.23E-02
Mn-56	1.0E-04				8.38E-05	
Co-57	4.0E-04	9.47E-04	2.19E-04	1.01E-04	8.03E-05	3.55E-04
Co-58	9.0E-05	5.78E-01	2.69E-01	1.92E-01	1.86E-01	2.68E-01
Fe-59	5.0E-05	3.62E-04	3.36E-03	1.03E-03	5.02E-03	1.94E-03
Co-60	3.0E-05	1.03E-01	1.41E-01	6.32E-02	4.62E-02	6.22E-02
Ni-63	3.0E-05			2.24E-02		
Sr-89	3.0E-06	2.05E-03	1.40E-04		4.61E-05	6.77E-05
Sr-90	3.0E-07	2.59E-04	3.48E-05		1.54E-05	3.79E-06
Nb-95	1.0E-04	1.23E-03	1.83E-02	2.20E-03	5.32E-03	1.36E-03
Zr-95	6.0E-05	7.30E-04	1.05E-02	6.89E-04	2.36E-03	9.53E-04
Nb-97	1.0E-04	3.91E-02				
Zr-97	2.0E-05	3.55E-04				
Mo-99	4.0E-05					
Ru-103	8.0E-05					
Ag-110m	3.0E-05	8.33E-02	3.82E-02	2.97E-02	8.43E-02	2.32E-02
Sn-113	8.0E-05	1.77E-03	3.85E-03	1.27E-03	1.43E-03	7.88E-04
Sn-117m	3.0E-06					
Sb-122	3.0E-05				1.91E-04	4.48E-04
Sb-124	2.0E-05	9.51E-02	3.95E-02	2.74E-02	2.92E-02	1.52E-02
Sb-125	1.0E-04	4.73E-02	3.07E-02	1.83E-02	2.25E-02	1.15E-02
I-131	3.0E-07	4.44E-05	3.04E-04		1.31E-04	1.33E-03
I-132	8.0E-06			3.44E-05	1.88E-04	
I-133	1.0E-06	4.12E-05		3.64E-05	5.76E-04	2.62E-04
Cs-134	9.0E-06	1.31E-02	5.62E-03	6.51E-04	2.06E-04	1.75E-03
I-134	2.0E-05			1.40E-03		
I-135	4.0E-06				4.31E-04	2.60E-05
Cs-136	6.0E-05					1.92E-04
Cs-137	2.0E-05	2.04E-02	2.24E-02	3.63E-03	2.97E-03	7.91E-03
Cs-138	3.0E-06	8.01E-04				
Ce-139	3.0E-06	3.28E-07				
Ba-140	2.0E-05					
La-140	2.0E-05		7.32E-05	4.07E-05	2.09E-04	2.63E-05
Ce-144	1.0E-05		9.01E-06			
W-187	6.0E-05					
Total Activity (Ci)		1.01E+00	6.28E-01	4.23E-01	5.33E-01	4.83E-01
MPCe ( $\mu\text{Ci/ml}$ )		4.39E-05	4.19E-05	5.24E-05	5.37E-05	3.94E-05

**Table C-1 (cou't) - Calculation of Effective MPC**

Nuclide	MPC ( $\mu\text{Ci/ml}$ )	Activity Released (Ci)		
		1989	1990	1991
Na-24	3.0E-05	5.12E-05	1.53E-05	3.58E-05
Cr-51	2.0E-03	9.59E-04	2.02E-02	1.38E-02
Mn-54	1.0E-04	5.75E-03	2.85E-03	2.34E-03
Fe-55	8.0E-04	1.54E-01	1.53E-02	4.07E-02
Mn-56	1.0E-04			
Co-57	4.0E-04	6.67E-04	4.16E-05	1.97E-04
Co-58	9.0E-05	4.58E-01	8.79E-02	1.01E-01
Fe-59	5.0E-05	4.18E-03	3.05E-03	3.68E-03
Co-60	3.0E-05	9.12E-02	3.36E-02	3.45E-02
Ni-63	3.0E-05			
Sr-89	3.0E-06			2.12E-06
Sr-90	3.0E-07			
Nb-95	1.0E-04	1.43E-02	5.73E-03	4.87E-03
Zr-95	6.0E-05	1.00E-02	3.97E-03	3.07E-03
Nb-97	1.0E-04			
Zr-97	2.0E-05	3.98E-04	1.17E-04	6.21E-05
Mo-99	4.0E-05	3.16E-07		
Ru-103	8.0E-05	6.95E-06		
Ag-110m	3.0E-05	6.12E-02	1.92E-02	1.31E-02
Sn-113	8.0E-05	4.38E-03	2.36E-03	1.93E-03
Sn-117m	3.0E-06			7.21E-05
Sb-122	3.0E-05	5.69E-02	1.53E-05	1.48E-04
Sb-124	2.0E-05	1.22E-02	1.90E-03	2.10E-03
Sb-125	1.0E-04	9.04E-03	2.47E-03	2.61E-03
I-131	3.0E-07	1.45E-03		
I-132	8.0E-06			
I-133	1.0E-06			
Cs-134	9.0E-06	7.47E-03	6.92E-04	1.49E-04
I-134	2.0E-05			
I-135	4.0E-06			
Cs-136	6.0E-05			
Cs-137	2.0E-05	6.25E-03	8.02E-04	1.95E-04
Cs-138	3.0E-06			
Ce-139	3.0E-06			
Ba-140	2.0E-05			
La-140	2.0E-05	2.49E-04		
Ce-144	1.0E-05			
W-187	6.0E-05	9.02E-04	6.87E-04	1.83E-04
<b>Total Activity (Ci)</b>		<b>9.00E-01</b>	<b>2.01E-01</b>	<b>2.25E-01</b>
<b>MPCe (<math>\mu\text{Ci/ml}</math>)</b>		<b>4.62E-05</b>	<b>6.16E-05</b>	<b>7.06E-05</b>

**APPENDIX D**

**Site Maps**

## Appendix D

### Site Maps

Plant drawing A-408, "Radiological Survey Site Map" depicts the site area by illustrating the site boundary and the restricted areas. The area within the site boundary but outside the restricted area is considered the onsite unrestricted area. Plant drawing A-449, "Plan of Plant Area, Fence, Lighting, and CCTV Support Structure" shows the layout of the site buildings. Much of the land located within the unrestricted area is used for recreational or agricultural purposes. The pier, at the liquid discharge of the plant, is often occupied by fishermen. Occupancy factors for this location is estimated to be five fishermen per day. The pier is open to the public from 4 AM to 11 PM. Admittance hours are posted. The school forest is most often visited by the Kewaunee County school system for educational purposes. It is estimated that 250 students visit this area per year.

Figure D-1 presents the locations and elevations of radioactive effluent release points at the plant. The plant drawings referenced above are not included as part of the ODCM but can be found in the plant drawing system.

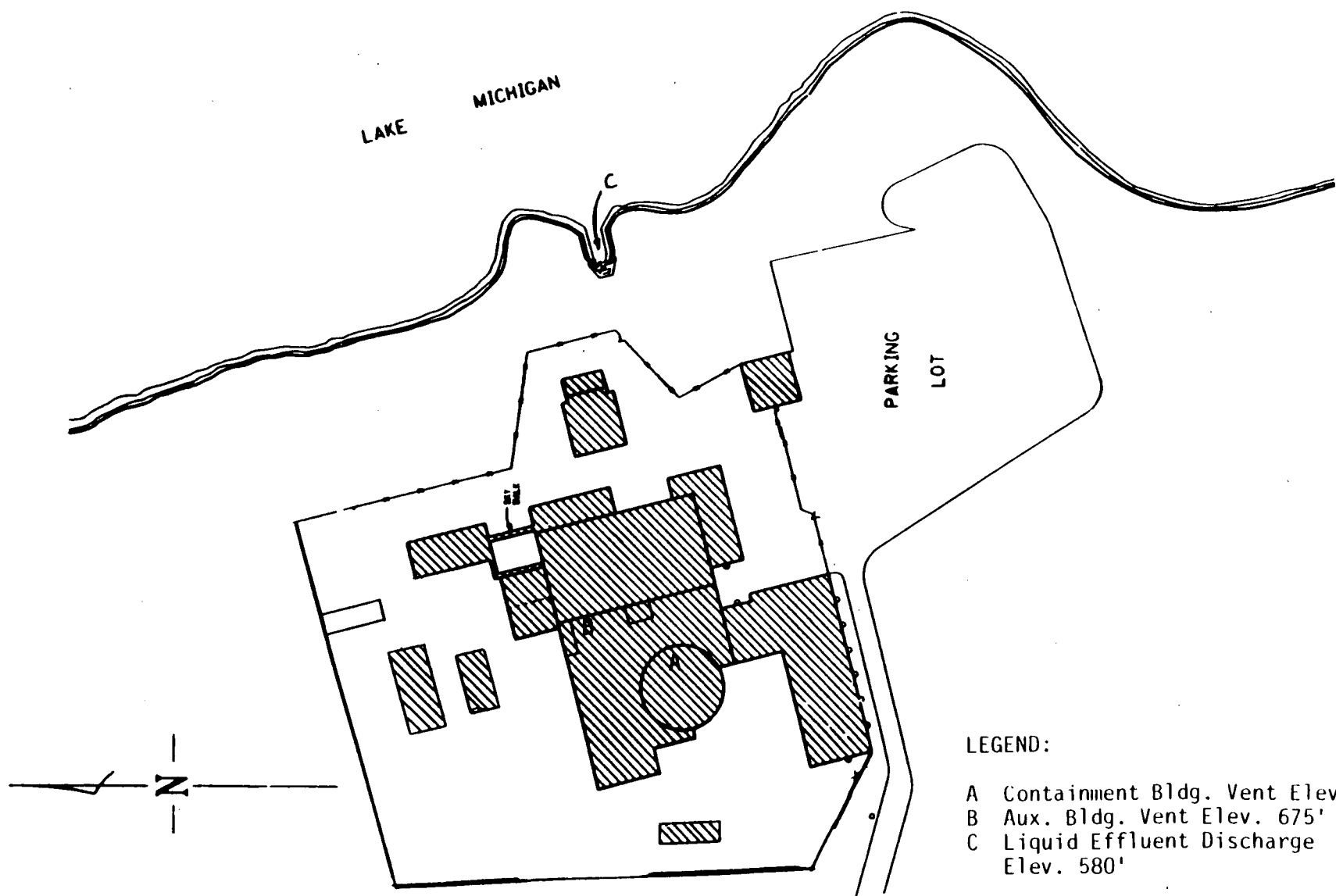

LEGEND:

- A Containment Bldg. Vent Elev. 775'
- B Aux. Bldg. Vent Elev. 675'
- C Liquid Effluent Discharge Elev. 580'

Figure D-1



**APPENDIX E**  
**Onsite Disposal of Low-Level Radioactively**  
**Contaminated Waste Streams**



UNITED STATES  
NUCLEAR REGULATORY COMMISSION  
WASHINGTON, D.C. 20555

K 92-119

Received

6-22-92

June 17, 1992

Docket No. 50-305

Mr. C. A. Schrock  
Manager - Nuclear Engineering  
Wisconsin Public Service  
Corporation  
P. O. Box 19002  
Green Bay, Wisconsin 54037-9002

Dear Mr. Schrock:

SUBJECT: PROPOSED DISPOSAL OF LOW LEVEL RADIOACTIVE WASTE SLUDGE ONSITE AT  
THE KEWAUNEE NUCLEAR POWER PLANT (TAC NO. M75047)

By letters dated September 12, 1989, and October 17, 1991, you submitted a request pursuant to 10 CFR 20.302 for the disposal of waste sludge onsite at the Kewaunee Nuclear Power Plant. We have completed our review of the request and find your procedures, including documented commitments, to be acceptable.

This approval is granted provided that the enclosed safety evaluation is permanently incorporated into your Offsite Dose Calculation Manual (ODCM) as an Appendix, and that future modifications of these commitments are reported to the NRC.

Issuance of this safety evaluation completes all effort on TAC No. M75047.

Sincerely,

Allen G. Hansen, Project Manager  
Project Directorate III-3  
Division of Reactor Projects III/IV/V  
Office of Nuclear Reactor Regulation

Enclosure:  
As stated

cc w/enclosure:  
See next page

NRC LETTER DISTRIBUTION

T A Hanson (MG&E)  
J D Loock (WPL)  
Larry Nielsen (ANFC)  
J L Belant (NSRAC)  
D A Bollom G6  
K H Evers KNP

J P Giesler D2  
M L Marchi KNP  
D L Masarik KNP  
R F Pulec D2 (2)  
D J Ristau D2  
A J Ruege D2

C A Schrock D2  
C R Steinhardt D2  
T J Webb KNP  
S F Wozniak D2  
QA Vault KNP

Mr. C. A. Schrock  
Wisconsin Public Service Corporation

Kewaunee Nuclear Power Plant

cc:

David Baker, Esquire  
Foley and Lardner  
P.O. Box 2193  
Orlando, Florida 32082

Glen Kunesh, Chairman  
Town of Carlton  
Route 1  
Kewaunee, Wisconsin 54216

Mr. Harold Reckelberg, Chairman  
Kewaunee County Board  
Kewaunee County Courthouse  
Kewaunee, Wisconsin 54216

Chairman  
Public Service Commission of Wisconsin  
Hill Farms State Office Building  
Madison, Wisconsin 53702

Attorney General  
114 East, State Capitol  
Madison, Wisconsin 53702

U.S. Nuclear Regulatory Commission  
Resident Inspectors Office  
Route #1, Box 999  
Kewaunee, Wisconsin 54216

Regional Administrator - Region III  
U.S. Nuclear Regulatory Commission  
799 Roosevelt Road  
Glen Ellyn, Illinois 60137

Mr. Robert S. Cullen  
Chief Engineer  
Wisconsin Public Service Commission  
P.O. Box 7854  
Madison, Wisconsin 53707



UNITED STATES  
NUCLEAR REGULATORY COMMISSION  
WASHINGTON, D. C. 20555

SAFETY EVALUATION BY THE OFFICE OF NUCLEAR REACTOR REGULATION  
RELATING TO ONSITE DISPOSAL OF LOW-LEVEL RADIOACTIVELY  
CONTAMINATED WASTE SLUDGE

AT THE KEWAUNEE NUCLEAR POWER PLANT

WISCONSIN PUBLIC SERVICE CORPORATION  
WISCONSIN POWER AND LIGHT COMPANY  
MADISON GAS AND ELECTRIC COMPANY

DOCKET NO. 50-305

1.0 INTRODUCTION

In reference 1, Wisconsin Public Service Corporation (WPSC) requested approval pursuant to Section 20.302 of Title 10 of the Code of Federal Regulations (CFR) for the disposal of licensed material not previously considered in the Kewaunee Final Environmental Statement (FES) dated December 1972. Additional related material from the licensee, from the State of Wisconsin, and from the staff are contained in references 2 through 5.

The WPSC request contains a detailed description of the licensed material (i.e., contaminated sludge) subject to this 10 CFR 20.302 request, based on radioactivity absorbed from liquid discharges of licensed material. The 15,000 cubic feet of contaminated sludge identified in the request contains a total radionuclide inventory of 0.17 mCi of Cesium-137 and Cobalt-60.

In its submittal, the licensee addressed specific information requested in accordance with 10 CFR 20.302(a), provided a detailed description of the licensed material, thoroughly analyzed and evaluated the information pertinent to the effects on the environment of the proposed disposal of licensed material, and committed to follow specific procedures to minimize the risk of unexpected exposures.

2.0 DESCRIPTION OF WASTE

During the normal operation of Kewaunee, the potential exists for in-plant process streams which are not normally radioactive to become contaminated with very low levels of radioactive materials. These waste streams are normally separated from the radioactive streams. However, due mainly to infrequent, minor system leaks, and anticipated operational occurrences, the potential exists for these systems to become slightly contaminated. At Kewaunee, the secondary system demineralizer resins, the service water pre-treatment system sludges, the make-up water system resins, and the sewage treatment plant sludges are waste streams that have the potential to become contaminated at very low levels.

During the yearly testing of a batch of pre-treatment sludge, it was found that approximately 15,000 cubic feet of sludge had been contaminated with Cs-137 and Co-60.

### 3.0 PROPOSED DISPOSAL METHOD

WPSC plans to dispose of the 15,000 cubic feet of contaminated sludge onsite pursuant to 10 CFR 20.302. The sludge is currently contained in an onsite lagoon at the KNPP sewage treatment facility. The disposal of the sludge will be by land application to an area located onsite at KNPP, as shown in Figure 1. The area will be periodically plowed to a depth of 6 inches.

Table 1 lists the principal nuclides identified in the sludge. The activity is based on measurements made in 1989. The radionuclide half-lives, which are dominated by 30-year Cs-137, meet the staff's 10 CFR 20.302 guidelines (reference 6), which apply to radionuclides with half-lives less than 35 years.

Table 1

<u>Nuclide</u>	<u>Total Activity (mCi)</u>
Co-60	0.076
Cs-137	0.094
	-----
	0.170

### 4.0 RADIOLOGICAL IMPACTS

The licensee has evaluated the following potential exposure pathways to members of the general public from the radionuclides in the sludge: (1) external exposure caused by groundshine from the disposal site; (2) internal exposure from inhalation of re-suspended radionuclides; and (3) internal exposure from ingesting ground water. The staff has reviewed the licensee's calculational methods and assumptions and finds that they are consistent with NRC Regulatory Guide 1.109, "Calculation of Annual Doses to Man from Routine Releases of Reactor Effluents for the Purpose of Evaluating Compliance with 10 CFR Part 50, Appendix I," Revision 1, October 1977. The staff finds the assessment methodology acceptable.

Table 2 lists the doses calculated by the licensee for the maximally exposed member of the public based on a total activity of 0.170 mCi disposed of in the current year, as well as the cumulative impact of similar disposals during subsequent years. For any repetitive disposals, the licensee must reapply to the NRC when a particular disposal would exceed the following boundary conditions: (1) the annual disposal must be less than a total activity of 0.2 mCi; (2) the whole body dose to the hypothetical maximally exposed individual must be less than 0.1 mrem/year; and (3) the disposal must be at the same site as described in Figure 1.

TABLE 2

<u>Pathway</u>	<u>Whole Body Dose Received by Maximally Exposed Individual (mrem/year)</u>
Groundshine	0.034
Inhalation	0.008
Groundwater Ingestion	0.007
TOTAL	<u>0.049</u>

As shown in Table 2, the annual dose is expected to be on the order of 0.1 mrem or less. Such a dose is a small fraction of the 300 mrem received annually by members of the general public from sources of natural background radiation.

The guidelines used by the NRC staff for onsite disposal of licensed material are presented in Table 3, along with the staff's evaluation of how each guideline has been satisfied.

The licensee's procedures and commitments as documented in the submittal are acceptable, provided that they are permanently incorporated into the licensee's Offsite Dose Calculation Manual (ODCM) as an Appendix, and that future modifications be reported to NRC in accordance with the applicable ODCM change protocol.

Based on the above findings, the staff finds the licensee's proposal to dispose of the low level radioactive waste sludge onsite in the manner described in the WPSC letter dated September 12, 1989, to be acceptable. The State of Wisconsin has also approved these procedures (reference 5).

TABLE 3

20.302 Guideline  
for Onsite Disposal

1. The radioactive material should be disposed of in a manner that it is unlikely that the material would be recycled.
2. Doses to the total body and any body organ of a maximally exposed individual (a member of the general public or a non-occupationally exposed worker) from the probable pathways of exposure to the disposed material should be less than 1 mrem/year.
3. Doses to the total body and any body organ of an inadvertent intruder from the probable pathways of exposure should be less than 5 mrem/year.
4. Doses to the total body and any body organ of an individual from assumed recycling of the disposed material at the time the disposal site is released from regulatory control from all likely pathways of exposure should be less than 1 mrem.

Staff's Evaluation

1. Due to the nature of the disposed material, recycling to the general public is not considered likely.
2. This guideline is addressed in Table 2.
3. Because the material will be land-spread, the staff considers the maximally exposed individual scenario to also address the intruder scenario.
4. Even if recycling were to occur after release from regulatory control, the dose to the maximally exposed member of the public is not expected to exceed 1 mrem/year, based on the exposure scenarios considered in this analysis.

REFERENCES

- (1) WPSC letter from K. H. Evers to NRC Document Control Desk, September 12, 1989.
- (2) Memorandum from L. J. Cunningham, DREP, to J. N. Hannon, "Request For Additional Information," December 11, 1989.
- (3) NRC letter from M. J. Davis to K. H. Evers of WPSC dated February 13, 1990.
- (4) WPSC letter from K. H. Evers to NRC Document Control Desk, October 17, 1991.
- (5) Letter from L. Sridharan of the State of Wisconsin Department of Natural Resources to M. Vandenbusch of WPSC, dated June 13, 1991.
- (6) E. F. Branagan Jr. and F. J. Congel, "Disposal of Contaminated Radioactive Wastes from Nuclear Power Plants," presented at the Health Physics Society's midyear Symposium on Health Physics Considerations in Decontamination/Decommissioning, Knoxville, TN, February 1986 (CONF-860203).

Principal Contributor: J. Minns

Date: June 17, 1992



Figure 1

Kewaunee Nuclear Power Plant Site Area Map

