

**2.4 Steam and Power Conversion Systems****2.4.1 Main and Startup Feedwater System**

See Section 2.2.4 for information on the main feedwater system.

**Design Description**

The startup feedwater system supplies feedwater to the steam generators during plant startup, hot standby and shutdown conditions, and during transients in the event of main feedwater system unavailability.

1. The functional arrangement of the startup feedwater system is as described in the Design Description of this Section 2.4.1.

2. The FWS provides the following nonsafety-related functions:

The FWS provides startup feedwater flow from the condensate storage tank (CST) to the steam generator system (SGS) for heat removal from the RCS.

3. Controls exist in the main control room (MCR) to cause the components identified in Table 2.4.1-1 to perform the listed function.

4. Displays of the parameters identified in Table 2.4.1-1 can be retrieved in the MCR.

**Inspections, Tests, Analyses, and Acceptance Criteria**

Table 2.4.1-2 specifies the inspections, tests, analyses, and associated acceptance criteria for the FWS.

<b>Table 2.4.1-1</b>			
<b>Equipment Name</b>	<b>Tag No.</b>	<b>Display</b>	<b>Control Function</b>
Startup Feedwater Pump A (Motor)	FWS-MP-03A	Yes (Run Status)	Start
Startup Feedwater Pump B (Motor)	FWS-MP-03B	Yes (Run Status)	Start
Startup Feedwater Pump A Isolation Valve	FWS-PL-V013A	Yes (Valve Position)	Open
Startup Feedwater Pump B Isolation Valve	FWS-PL-V013B	Yes (Valve Position)	Open

<b>Table 2.4.1-2 Inspections, Tests, Analyses, and Acceptance Criteria</b>		
<b>Design Commitment</b>	<b>Inspections, Tests, Analyses</b>	<b>Acceptance Criteria</b>
1. The functional arrangement of the startup feedwater system is as described in the Design Description of this Section 2.4.1.	Inspection of the as-built system will be performed.	The as-built startup feedwater system conforms with the functional arrangement as described in the Design Description of this Section 2.4.1.
2. The FWS provides startup feedwater flow from the CST to the SGS for heat removal from the RCS.	Testing will be performed to confirm that each of the startup feedwater pumps can provide water from the CST to both steam generators.	Each FWS startup feedwater pump provides a flow rate greater than or equal to 260 gpm to each steam generator system at a steam generator secondary side pressure of at least 1106 psia.
3. Controls exist in the MCR to cause the components identified in Table 2.4.1-1 to perform the listed function.	Testing will be performed on the components in Table 2.4.1-1 using controls in the MCR.	Controls in the MCR operate to cause the components listed in Table 2.4.1-1 to perform the listed functions.
4. Displays of the parameters identified in Table 2.4.1-1 can be retrieved in the MCR.	Inspection will be performed for retrievability of parameters in the MCR.	The displays identified in Table 2.4.1-1 can be retrieved in the MCR.

<b>Table 2.4.1-3</b>		
<b>Component Name</b>	<b>Tag No.</b>	<b>Component Location</b>
Startup Feedwater Pump A	FWS-MP-03A	Turbine Building
Startup Feedwater Pump B	FWS-MP-03B	Turbine Building

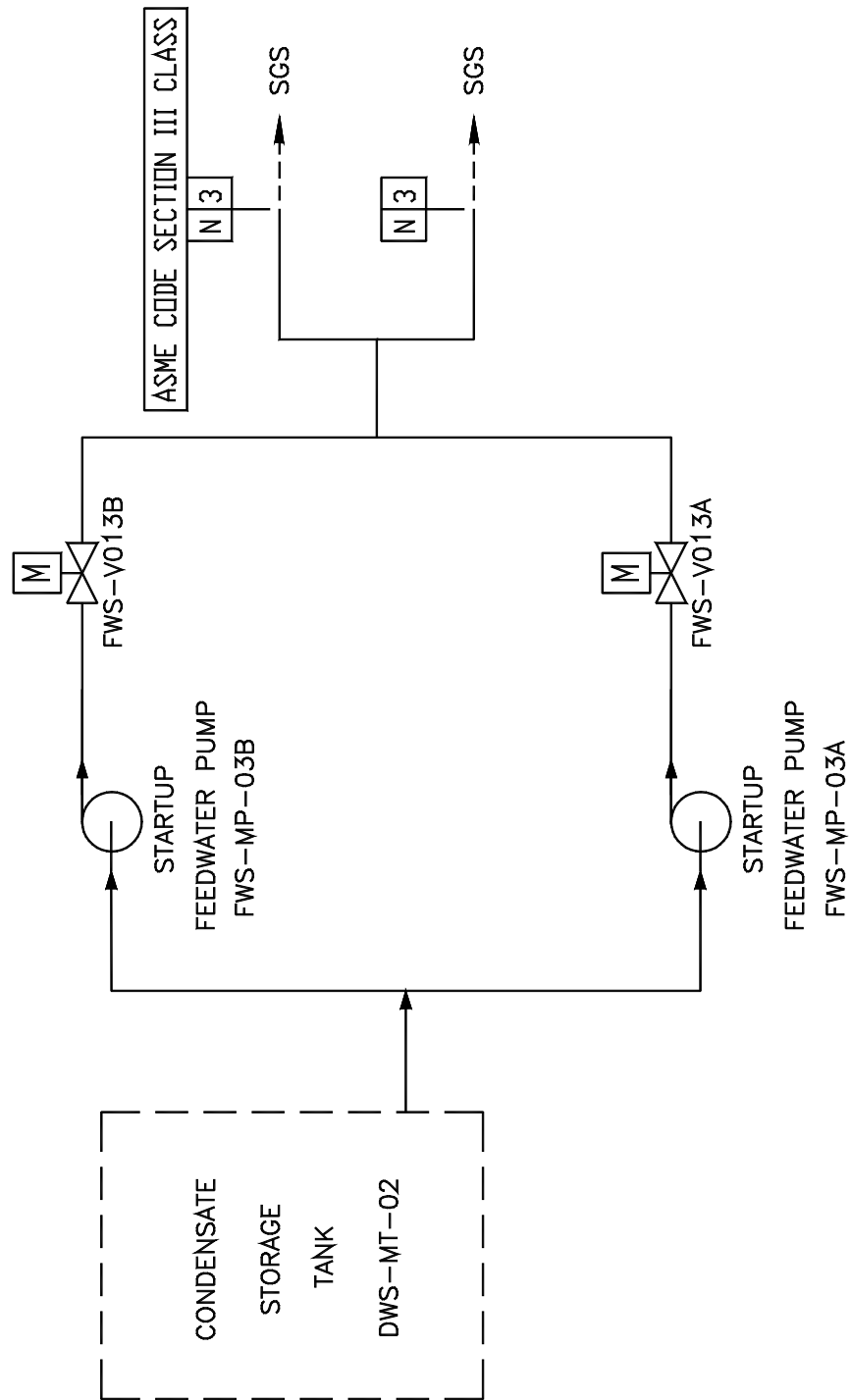

Figure 2.4.1-1  
Main and Startup Feedwater System

**2.4.2 Main Turbine System****Design Description**

The main turbine system (MTS) is designed for electric power production consistent with the capability of the reactor and the reactor coolant system.

The component locations of the MTS are as shown in Table 2.4.2-2.

1. The functional arrangement of the MTS is as described in the Design Description of this Section 2.4.2.
2.
  - a) Controls exist in the MCR to trip the main turbine-generator.
  - b) The main turbine-generator trips after receiving a signal from the PMS.
  - c) The main turbine-generator trips after receiving a signal from the DAS.
3. The overspeed trips for the AP1000 turbine are set for 110% and 111% ( $\pm 1\%$  each). Each trip is initiated electrically in separate systems. The trip signals from the two turbine electrical overspeed protection trip systems are isolated from, and independent of, each other.

**Inspections, Tests, Analyses, and Acceptance Criteria**

Table 2.4.2-1 specifies the inspections, tests, analyses, and associated acceptance criteria for the MTS.

<b>Table 2.4.2-1 Inspections, Tests, Analyses, and Acceptance Criteria</b>		
<b>Design Commitment</b>	<b>Inspections, Test, Analyses</b>	<b>Acceptance Criteria</b>
1. The functional arrangement of the MTS is as described in the Design Description of this Section 2.4.2.	Inspection of the as-built system will be performed.	The as-built MTS conforms with the functional arrangement as described in the Design Description of this Section 2.4.2.
2.a) Controls exist in the MCR to trip the main turbine-generator.	Testing will be performed on the main turbine-generator using controls in the MCR.	Controls in the MCR operate to trip the main turbine-generator.
2.b) The main turbine-generator trips after receiving a signal from the PMS.	Testing will be performed using real or simulated signals into the PMS.	The main turbine-generator trips after receiving a signal from the PMS.
2.c) The main turbine-generator trips after receiving a signal from the DAS.	Testing will be performed using real or simulated signals into the DAS.	The main turbine-generator trips after receiving a signal from the DAS.
3) The trip signals from the two turbine electrical overspeed protection trip systems are isolated from, and independent of, each other.	<p>i) The system design will be reviewed.</p> <p>ii) Testing of the as-built system will be performed using simulated signals from the turbine speed sensors.</p> <p>iii) Inspection will be performed for the existence of a report verifying that the two turbine electrical overspeed protection systems have diverse hardware and software/firmware.</p>	<p>i) The system design review shows that the trip signals of the two electrical overspeed protection trip systems are isolated from, and independent of, each other.</p> <p>ii) The main turbine-generator trips after overspeed signals are received from the speed sensors of the 110% emergency electrical overspeed trip system, and the main turbine-generator trips after overspeed signals are received from the speed sensors of the 111% backup electrical overspeed trip system.</p> <p>iii) A report exists and concludes that the two electrical overspeed protection systems have diverse hardware and software/firmware.</p>

<b>Table 2.4.2-2</b>		
<b>Component Name</b>	<b>Tag No.</b>	<b>Component Location</b>
HP Turbine	MTS-MG-01	Turbine Building
LP Turbine A	MTS-MG-02A	Turbine Building
LP Turbine B	MTS-MG-02B	Turbine Building
LP Turbine C	MTS-MG-02C	Turbine Building
Gland Steam Condenser	GSS-ME-01	Turbine Building
Gland Condenser Vapor Exhauster 1A	GSS-MA-01A	Turbine Building
Gland Condenser Vapor Exhauster 1B	GSS-MA-01B	Turbine Building
Electrical Overspeed Trip Device	--	Turbine Building
Emergency Electrical Overspeed Trip Device	--	Turbine Building

**2.4.3 Main Steam System**

No entry. Covered in Section 2.2.4, Steam Generator System.

**2.4.4 Steam Generator Blowdown System**

No entry. Containment isolation function covered in Section 2.2.1, Containment System and 2.2.4, Steam Generator System.

No entry. Steam generator isolation function covered in Section 2.2.4, Steam Generator System.

**2.4.5 Condenser Air Removal System**

No entry. Covered in Section 3.5, Radiation Monitoring.  
(Note: Monitor is TDS-RE001.)

### 2.4.6 Condensate System

#### Design Description

The condensate system (CDS) provides feedwater at the required temperature, pressure, and flow rate to the deaerator. Condensate is pumped from the main condenser hotwell by the condensate pumps and passes through the low-pressure feedwater heaters to the deaerator. The circulating water system (CWS) removes heat from the condenser and is site specific starting from the interface at the locations where the CWS piping enters and exits the turbine building.

The CDS operates during plant startup and power operations (full and part loads).

The component locations of the CDS are as shown in Table 2.4.6-3.

1. The functional arrangement of the CDS is as described in the Design Description of this Section 2.4.6.
2. Displays of the parameters identified in Table 2.4.6-1 can be retrieved in the main control room (MCR).

#### Inspections, Tests, Analyses, and Acceptance Criteria

Table 2.4.6-2 specifies the inspections, tests, analyses, and associated acceptance criteria for the CDS.

Table 2.4.6-1		
Equipment Name	Tag No.	Display
Condenser Backpressure	CDS-056A	Yes
Condenser Backpressure	CDS-056B	Yes
Condenser Backpressure	CDS-056C	Yes

Table 2.4.6-2 Inspections, Tests, Analyses, and Acceptance Criteria		
Design Commitment	Inspections, Tests, Analyses	Acceptance Criteria
1. The functional arrangement of the CDS is as described in the Design Description of this Section 2.4.6.	Inspection of the as-built system will be performed.	The as-built CDS conforms with the functional arrangement as described in the Design Description of Section 2.4.6.
2. Displays of the parameters identified in Table 2.4.6-1 can be retrieved in the MCR.	Inspection will be performed for retrievability of the parameters in the MCR.	The displays identified in Table 2.4.6-1 can be retrieved in the MCR.

<b>Table 2.4.6-3</b>	
<b>Component Name</b>	<b>Component Location</b>
Low Pressure Feedwater Heaters	Turbine Building
Deaerator Feedwater Heater and Storage Tank	Turbine Building
Main Condenser Shell A	Turbine Building
Main Condenser Shell B	Turbine Building
Main Condenser Shell C	Turbine Building
Condensate Pump A	Turbine Building
Condensate Pump B	Turbine Building
Condensate Pump C	Turbine Building

**2.4.7 Circulating Water System**

No entry for this system.

**2.4.8 Auxiliary Steam Supply System**

No entry for this system.

**2.4.9 Condenser Tube Cleaning System**

No entry for this system.

**2.4.10 Turbine Island Chemical Feed System**

No entry for this system.

**2.4.11 Condensate Polishing System**

No entry for this system.

**2.4.12 Gland Seal System**

No entry. Covered in Section 2.4.2, Main Turbine System.

**2.4.13 Generator Hydrogen and CO<sub>2</sub> System**

No entry for this system.

**2.4.14 Heater Drain System**

No entry for this system.

**2.4.15 Hydrogen Seal Oil System**

No entry for this system.

**2.4.16 Main Turbine and Generator Lube Oil System**

No entry for this system.