

KEYWORDS:

*Groundwater Modeling
Flow and Contaminant Transport
Richard's Equation
Porous Media
Variably Saturated
Code Verification*

RETENTION – Permanent

PORFLOW Testing and Verification Document

Sebastian E. Aleman

Savannah River National Laboratory

Publication Date: June 2007

UNCLASSIFIED
DOES NOT CONTAIN
UNCLASSIFIED CONTROLLED
NUCLEAR INFORMATION

ADC & Reviewing Official: *LaStevan - Meyer*
Date: *6/15/07*

Washington Savannah River Company
Savannah River National Laboratory
Aiken, SC 29808

Prepared for the U.S. Department of Energy

Under Contract No. DE-AC09-96SR18500



SRNL
SAVANNAH RIVER NATIONAL LABORATORY

KEYWORDS:

*Groundwater Modeling
Flow and Contaminant Transport
Richard's Equation
Porous Media
Variably Saturated
Code Verification*

RETENTION – Permanent

PORFLOW Testing and Verification Document

Sebastian E. Aleman

Savannah River National Laboratory

Publication Date: June 2007

Washington Savannah River Company
Savannah River National Laboratory
Aiken, SC 29808

Prepared for the U.S. Department of Energy

Under Contract No. DE-AC09-96SR18500



TM

SRNL
SAVANNAH RIVER NATIONAL LABORATORY

DOCUMENT: WSRC-STI-2007-00150, Rev 0
TITLE: PORFLOW Testing and Verification Document

APPROVALS

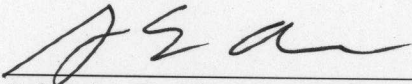
Date: 6/18/07
Sebastian E. Aleman, Author
Engineering, Modeling and Simulation Group, SRNL

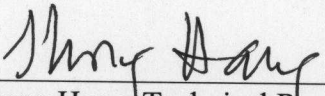

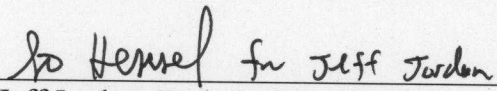
Date: 6/18/07
Thong Hang, Technical Reviewer
Engineering, Modeling and Simulation Group, SRNL

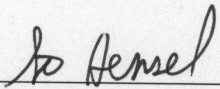
Date: 6/18/07
Jeff Jordan, Technical Reviewer
Engineering, Modeling and Simulation Group, SRNL

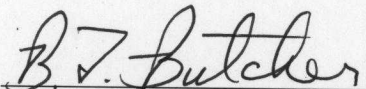
Date: 6/18/07
Steven J. Hensel, Manager
Engineering, Modeling and Simulation Group, SRNL

Date: 6/18/07
B. Tom Butcher, Manager
Environmental Assessment & Performance Modeling Group, SRNL

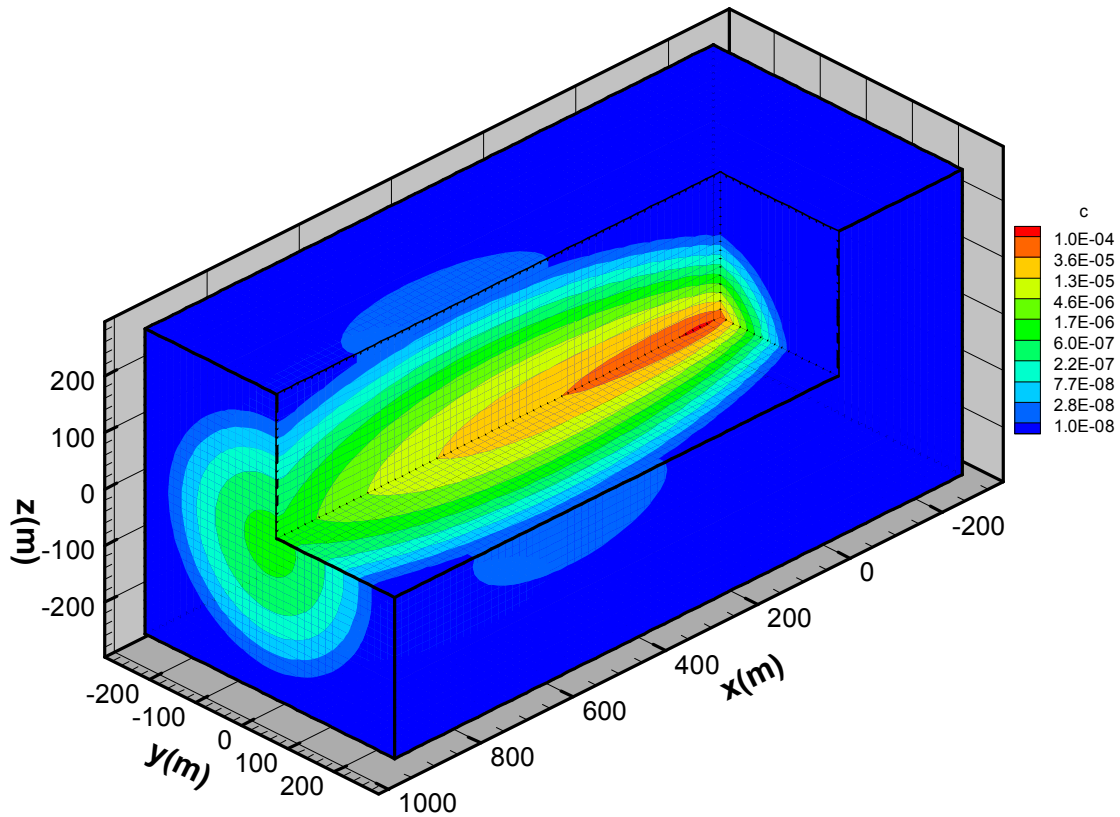
PORFLOW Testing and Verification Document



Washington Savannah River Company
Savannah River National Laboratory
Aiken, SC 29808

Prepared for the U.S. Department of Energy

Under Contract No. DE-AC09-96SR18500



SRNL
SAVANNAH RIVER NATIONAL LABORATORY

DISCLAIMER

This report was prepared by Washington Savannah River Company (WSRC) for the United States Department of Energy under Contract No. DE-AC09-96SR18500 and is an account of work performed under that contract. Neither the United States Department of Energy, nor WSRC, nor any of their employees makes any warranty, expressed or implied, or assumes any legal liability or responsibility for the accuracy, completeness, or usefulness, of any information, apparatus, or product or process disclosed herein or represents that its use will not infringe privately owned rights. Reference herein to any specific commercial product, process, or service by trademark, name, manufacturer or otherwise does not necessarily constitute or imply endorsement, recommendation, or favoring of same by WSRC or by the United States Government or any agency thereof. The views and opinions of the authors expressed herein do not necessarily state or reflect those of the United States Government or any agency thereof.

Printed in the United States of America

Prepared For

U.S. Department of Energy

KEYWORDS:

Groundwater Modeling

Flow and Contaminant Transport

Richard's Equation

Porous Media

Variably Saturated

Code Verification

RETENTION – Permanent

PORFLOW Testing and Verification Document

Sebastian E. Aleman

Savannah River National Laboratory

Publication Date: June 2007

Washington Savannah River Company
Savannah River National Laboratory
Aiken, SC 29808

Prepared for the U.S. Department of Energy



WSRC-STI-2007-00150

Under Contract No. DE-AC09-96SR18500

TABLE OF CONTENTS

ABSTRACT.....1

1 OBJECTIVE AND SOFTWARE DESCRIPTIONS.....2

2 SOFTWARE INSTALLATION AND COMPUTING PLATFORM.....2

3 SCOPE FOR TEST PROBLEMS.....2

4 GROUP 1: GROUNDWATER FLOW PROBLEMS3

4.1 STEADY-STATE, ONE-DIMENSIONAL FLOW IN A CONFINED AQUIFER.....3

4.2 STEADY-STATE, ONE-DIMENSIONAL FLOW IN AN UNCONFINED AQUIFER8

4.3 STEADY-STATE, TWO-DIMENSIONAL FLOW THROUGH A HETEROGENEOUS AQUIFER SYSTEM..... 15

4.4 UNCONFINED AQUIFER SUBJECT TO COMBINED RECHARGE/DRAIN BC20

4.5 TRANSIENT, ONE-DIMENSIONAL FLOW TO A WELL IN A CONFINED AQUIFER (THEIS, 1935)27

4.6 TRANSIENT, TWO-DIMENSIONAL FLOW TO A WELL IN AN ANISOTROPIC CONFINED AQUIFER (HANTUSH AND THOMAS, 1966).....37

4.7 TRANSIENT, ONE-DIMENSIONAL FLOW TO A WELL IN A LEAKY CONFINED AQUIFER (HANTUSH AND JACOB, 1955).....45

4.8 FREE-SURFACE BOUSSINESQ FLOW WITH RECHARGE.....49

4.9 FREE-SURFACE BOUSSINESQ FLOW WITH SEEPAGE.....52

4.10 UNSATURATED VERTICAL SOIL COLUMN.....56

5 GROUP 2: CONTAMINANT TRANSPORT PROBLEMS61

5.1 ONE-DIMENSIONAL SATURATED SOLUTE TRANSPORT IN A UNIFORM FLOW FIELD 61

5.2 TWO-DIMENSIONAL SATURATED SOLUTE TRANSPORT IN A UNIFORM FLOW FIELD 106

5.3 THREE-DIMENSIONAL SATURATED SOLUTE TRANSPORT IN A UNIFORM FLOW FIELD 128

5.4 SLIT AND ENGINEERED TRENCH RADON AIR PATHWAY TRANSPORT SIMULATION 139

5.5 IMPACT OF PORFLOW RETARDATION MODEL ON VARIABLY SATURATED SOLUTE TRANSPORT. 148

6 GROUP 3: NUMERICAL DISPERSION.....153

6.1 NUMERICAL AND MECHANICAL DISPERSION IN A ONE-DIMENSIONAL SATURATED SOIL COLUMN..... 154

7 GROUP 4: KEYWORD COMMANDS.....170

7.1 DECAY AND REGENERATION..... 170

7.2 DISTRIBUTION AND RETARDATION 172

7.3 STATISTICS..... 176

8 REFERENCES179

A HANTUSH AND JACOB NUMERICAL CODE.....180

A.1 FORTRAN LISTING FOR HANTUSHJACOB.F90..... 180

A.2 FORTRAN LISTING FOR F.F90 180

A.3 FORTRAN LISTING FOR COMVAR.F90..... 180

B GROBNER AND HOFREITER NUMERICAL CODE181

B.1 FORTRAN LISTING FOR GH.F90..... 181

B.2 SUPERFILE INPUT FOR 1D TRANSPORT BASE CASE..... 183

B.3 MAIN INPUT FOR 1D TRANSPORT BASE CASE..... 183

C AT123D NUMERICAL CODE.....183

C.1	FORTRAN LISTING FOR AT123D.F90.....	183
C.2	FORTRAN LISTING FOR COMVAR.F90.....	187
C.3	FORTRAN LISTING FOR G.F90.....	187
C.4	FORTRAN LISTING FOR GX.F90	188
C.5	FORTRAN LISTING FOR GY.F90	188
C.6	FORTRAN LISTING FOR GZ.F90.....	188
C.7	SUPERFILE INPUT FOR 2D TRANSPORT BASE CASE (CASE A).....	189
C.8	MAIN INPUT FOR 2D TRANSPORT BASE CASE (CASE A).....	189
D	BATEMAN NUMERICAL CODE	189
D.1	FORTRAN LISTING FOR BATEMAN.F90	189
D.2	FORTRAN LISTING FOR BTERMI.F90	192
D.3	FORTRAN LISTING FOR BTERMIJ.F90.....	192
D.4	FORTRAN LISTING FOR CHKMEM.F90.....	192
D.5	FORTRAN LISTING FOR DECAY_CONSTANTS.F90	193
D.6	SUPERFILE INPUT FOR U-230 DECAY CHAIN.....	193
D.7	MAIN INPUT FOR U-230 DECAY CHAIN.....	193

LIST OF TABLES

TABLE 4.1.1. COMPARISON OF ANALYTICAL SOLUTION AND PORFLOW NUMERICAL RESULTS FOR 4.1 (PROBLEM 1)7

TABLE 4.1.2. PORFLOW DARCY VELOCITY AT NODE 201 FOR 4.1 (PROBLEM 2)7

TABLE 4.1.3. INPUT COMMANDS FOR 4.1 (PROBLEM 1)7

TABLE 4.1.4. INPUT COMMANDS FOR 4.1 (PROBLEM 2)8

TABLE 4.2.1. COMPARISON OF ANALYTICAL SOLUTION AND PORFLOW NUMERICAL RESULTS. 13

TABLE 4.2.2. INPUT COMMANDS FOR 4.2 (PROBLEM 1) 13

TABLE 4.2.3. INPUT COMMANDS FOR 4.2 (PROBLEM 2) 14

TABLE 4.3.1. APPROXIMATE ANALYTICAL AND PORFLOW HYDRAULIC HEAD SOLUTION FOR THE UNCONFINED AND CONFINED AQUIFERS. 18

TABLE 4.3.2. INPUT COMMANDS FOR PROBLEM 4.3 19

TABLE 4.4.1. ANALYTICAL, COMSOL AND PORFLOW WATER TABLE COMPARISON..... 25

TABLE 4.4.2. INPUT COMMANDS FOR PROBLEM 4.4. 25

TABLE 4.4.3. NODAL GRID FOR PROBLEM 4.4. 26

TABLE 4.5.1. COMPARISON OF THEIS, COMSOL AND PORFLOW TRANSIENT DRAWDOWN (0 TO 1 HOUR) 33

TABLE 4.5.2. COMPARISON OF THEIS, COMSOL AND PORFLOW TRANSIENT DRAWDOWN (0 TO 1 DAY) 33

TABLE 4.5.3. INPUT COMMANDS FOR PROBLEM 4.5 (1D) 34

TABLE 4.5.4. INPUT COMMANDS FOR PROBLEM 4.5 (2D) 35

TABLE 4.6.1. COMPARISON OF HANTUSH AND THOMAS, COMSOL AND PORFLOW NUMERICAL RESULTS AT X = 55 M. 41

TABLE 4.6.2. COMPARISON OF HANTUSH AND THOMAS, COMSOL AND PORFLOW NUMERICAL RESULTS AT Y = 55 M. 42

TABLE 4.6.3. COMPARISON OF HANTUSH AND THOMAS, COMSOL AND PORFLOW NUMERICAL RESULTS AT X = Y = 55 M. 42

TABLE 4.6.4. INPUT COMMANDS FOR PROBLEM 4.6. 43

TABLE 4.7.1. COMPARISON OF HANTUSH AND JACOB, COMSOL AND PORFLOW TRANSIENT DRAWDOWN AT R = 60 FEET..... 48

TABLE 4.7.2. INPUT COMMANDS FOR PROBLEM 4.7. 48

TABLE 4.8.1. INPUT COMMANDS FOR PROBLEM 4.8. 52

TABLE 4.9.1. INPUT COMMANDS FOR PROBLEM 4.9. 55

TABLE 4.10.1. INPUT COMMANDS FOR PROBLEM 4.10 (WATER RETENTION PROFILE). 60

TABLE 4.10.2. INPUT COMMANDS FOR PROBLEM 4.10 (CONSTANT SATURATION). 60

TABLE 5.1.1. VALUES OF THE PHYSICAL PARAMETERS, MESH SPACING, TIME STEPS, AND KEY COMPUTED PARAMETERS USED IN THE ONE-DIMENSIONAL TRANSPORT SIMULATIONS..... 65

TABLE 5.1.2. SUMMARY OF SIMULATIONS PERFORMED (BASE CASE AND VARIATIONS) ON THE ONE-DIMENSIONAL TRANSPORT PROBLEM. 66

TABLE 5.1.3. COMPARISON OF ANALYTICAL AND PORFLOW NUMERICAL RESULTS FOR THE TRANSIENT 1D TRANSPORT PROBLEM (BASE CASE)..... 75

TABLE 5.1.4. COMPARISON OF ANALYTICAL AND PORFLOW NUMERICAL RESULTS FOR THE TRANSIENT 1D TRANSPORT PROBLEM (CASE A) 76

TABLE 5.1.5. COMPARISON OF ANALYTICAL AND PORFLOW NUMERICAL RESULTS FOR THE TRANSIENT 1D TRANSPORT PROBLEM (CASE B)..... 77

TABLE 5.1.6. COMPARISON OF ANALYTICAL AND PORFLOW NUMERICAL RESULTS FOR THE TRANSIENT 1D TRANSPORT PROBLEM (CASE C) 78

TABLE 5.1.7. COMPARISON OF ANALYTICAL AND PORFLOW NUMERICAL RESULTS FOR THE TRANSIENT 1D TRANSPORT PROBLEM (CASE D) 79

TABLE 5.1.8. COMPARISON OF ANALYTICAL AND PORFLOW NUMERICAL RESULTS FOR THE TRANSIENT 1D TRANSPORT PROBLEM (CASE E)..... 80

TABLE 5.1.9. COMPARISON OF ANALYTICAL AND PORFLOW NUMERICAL RESULTS FOR THE TRANSIENT 1D TRANSPORT PROBLEM (CASE F)..... 80

TABLE 5.1.10. COMPARISON OF ANALYTICAL AND PORFLOW NUMERICAL RESULTS FOR THE TRANSIENT 1D TRANSPORT PROBLEM (CASE G) 81

TABLE 5.1.11.	COMPARISON OF ANALYTICAL AND PORFLOW NUMERICAL RESULTS FOR THE TRANSIENT 1D TRANSPORT PROBLEM (CASE H)	82
TABLE 5.1.12.	COMPARISON OF ANALYTICAL AND PORFLOW NUMERICAL RESULTS FOR THE TRANSIENT 1D TRANSPORT PROBLEM (CASE I).....	83
TABLE 5.1.13.	COMPARISON OF ANALYTICAL AND PORFLOW NUMERICAL RESULTS FOR THE TRANSIENT 1D TRANSPORT PROBLEM (CASE J).....	84
TABLE 5.1.14.	COMPARISON OF ANALYTICAL AND PORFLOW NUMERICAL RESULTS FOR THE TRANSIENT 1D TRANSPORT PROBLEM (CASE K, TIME = 25 DAYS)	85
TABLE 5.1.15.	COMPARISON OF ANALYTICAL AND PORFLOW NUMERICAL RESULTS FOR THE TRANSIENT 1D TRANSPORT PROBLEM (CASE K, TIME = 50 DAYS)	86
TABLE 5.1.16.	COMPARISON OF ANALYTICAL AND PORFLOW NUMERICAL RESULTS FOR THE TRANSIENT 1D TRANSPORT PROBLEM (CASE L, TIME = 25 DAYS).....	87
TABLE 5.1.17.	COMPARISON OF ANALYTICAL AND PORFLOW NUMERICAL RESULTS FOR THE TRANSIENT 1D TRANSPORT PROBLEM (CASE L, TIME = 50 DAYS).....	88
TABLE 5.1.18.	INPUT COMMANDS FOR 1D TRANSPORT (BASE CASE).....	89
TABLE 5.1.19.	INPUT COMMANDS FOR 1D TRANSPORT (CASE A).....	89
TABLE 5.1.20.	INPUT COMMANDS FOR 1D TRANSPORT (CASE B).....	90
TABLE 5.1.21.	INPUT COMMANDS FOR 1D TRANSPORT (CASE C).....	91
TABLE 5.1.22.	INPUT COMMANDS FOR 1D TRANSPORT (CASE D).....	91
TABLE 5.1.23.	INPUT COMMANDS FOR 1D TRANSPORT (CASE E).....	92
TABLE 5.1.24.	INPUT COMMANDS FOR 1D TRANSPORT (CASE F).....	93
TABLE 5.1.25.	INPUT COMMANDS FOR 1D TRANSPORT (CASE G).....	94
TABLE 5.1.26.	INPUT COMMANDS FOR 1D TRANSPORT (CASE H).....	94
TABLE 5.1.27.	INPUT COMMANDS FOR 1D TRANSPORT (CASE I).....	95
TABLE 5.1.28.	INPUT COMMANDS FOR 1D TRANSPORT (CASE J).....	96
TABLE 5.1.29A.	INPUT COMMANDS FOR 1D TRANSPORT (CASE K, T = 25 DAYS)	96
TABLE 5.1.29B.	INPUT COMMANDS FOR 1D TRANSPORT (CASE K, T = 50 DAYS).....	99
TABLE 5.1.30A.	INPUT COMMANDS FOR 1D TRANSPORT (CASE L, T = 25 DAYS).....	101
TABLE 5.1.30B.	INPUT COMMANDS FOR 1D TRANSPORT (CASE L, T = 50 DAYS).....	103
TABLE 5.2.1.	VALUES OF THE PHYSICAL PARAMETERS, MESH SPACING, TIME STEPS, AND KEY COMPUTED PARAMETERS USED IN THE TWO-DIMENSIONAL TRANSPORT SIMULATIONS.	110
TABLE 5.2.2.	SUMMARY OF SIMULATIONS PERFORMED (BASE CASE AND VARIATIONS) ON THE TWO-DIMENSIONAL TRANSPORT PROBLEM	112
TABLE 5.2.3.	EFFECT GRID ORIENTATION HAS ON THE NUMERICAL CONCENTRATION RESULTS ALONG THE PLUME CENTERLINE FOR THE TRANSIENT 2D TRANSPORT SIMULATION (CASES A AND B, T = 1400 DAYS).	121
TABLE 5.2.4.	EFFECT GRID ORIENTATION HAS ON THE NUMERICAL CONCENTRATION RESULTS TRANSVERSE TO THE PLUME CENTERLINE (424 M DOWNSTREAM OF THE SOURCE) FOR THE TRANSIENT 2D TRANSPORT SIMULATION (CASES A AND B, T = 1400 DAYS).....	123
TABLE 5.2.5.	EFFECT GRID ORIENTATION HAS ON THE NUMERICAL CONCENTRATION RESULTS TRANSVERSE TO THE PLUME CENTERLINE (0 M DOWNSTREAM OF THE SOURCE) FOR THE TRANSIENT 2D TRANSPORT PROBLEM (CASES A AND B, T = 1400 DAYS).	123
TABLE 5.2.6.	EFFECT RETARDATION OR RADIOACTIVE DECAY HAS ON THE NUMERICAL CONCENTRATION ALONG THE PLUME CENTERLINE FOR THE TRANSIENT 2D TRANSPORT PROBLEM (CASES C AND D, T = 1400 DAYS).	123
TABLE 5.2.7.	EFFECT RETARDATION OR RADIOACTIVE DECAY HAS ON THE NUMERICAL CONCENTRATION TRANSVERSE TO THE PLUME CENTERLINE FOR THE TRANSIENT 2D TRANSPORT PROBLEM AT X = 420 METERS (CASES C AND D, T = 1400 DAYS).	125
TABLE 5.2.8.	INPUT COMMANDS FOR 2D TRANSPORT (CASE A).....	125
TABLE 5.2.9.	INPUT COMMANDS FOR 2D TRANSPORT (CASE B).....	126
TABLE 5.2.10.	INPUT COMMANDS FOR 2D TRANSPORT (CASE C).....	126
TABLE 5.2.11.	INPUT COMMANDS FOR 2D TRANSPORT (CASE D).....	127
TABLE 5.3.1.	VALUES OF THE PHYSICAL PARAMETERS, MESH SPACING, TIME STEPS, AND KEY COMPUTED PARAMETERS USED IN THE THREE-DIMENSIONAL TRANSPORT SIMULATIONS.....	133

TABLE 5.3.2.	CONCENTRATION PROFILE FOR 3D TRANSPORT OF THE BASE CASE ALONG THE PLUME CENTERLINE AT 1400 DAYS.	137
TABLE 5.3.3.	CONCENTRATION PROFILES FOR 3D TRANSPORT OF THE BASE CASE TRANSVERSE TO THE PLUME CENTERLINE LOCATED AT X = 120 METERS (1400 DAYS).	138
TABLE 5.3.4.	INPUT COMMANDS FOR PROBLEM 5.3.	138
TABLE 5.4.1.	INPUT COMMANDS FOR PROBLEM 5.4.	145
TABLE 5.4.2.	GEOMETRY SPECIFICATION FOR PROBLEM 5.4.	146
TABLE 5.4.3.	ZONE IDENTIFICATION FOR PROBLEM 5.4.	147
TABLE 5.4.4.	MATERIAL SPECIFICATION FOR PROBLEM 5.4.	147
TABLE 5.5.1.	INPUT COMMANDS FOR PROBLEM 5.5.	151
TABLE 6.1.1.	INPUT COMMANDS FOR PROBLEM 6.1 (NUMERICAL DISPERSION).	156
TABLE 6.1.2.	INPUT COMMANDS FOR PROBLEM 6.1 (MECHANICAL DISPERSION).	163
TABLE 7.1.1.	INPUT COMMANDS FOR PROBLEM 7.1.	171
TABLE 7.2.1.	INPUT COMMANDS FOR PROBLEM 7.2 (DIST COMMAND).	174
TABLE 7.2.2.	INPUT COMMANDS FOR PROBLEM 7.2 (RETA COMMAND).	175
TABLE 7.3.1.	INPUT COMMANDS FOR PROBLEM 7.3.	176
TABLE 7.3.2.	LOCATION OF POINT SOURCE FOR PROBLEM 7.3.	177
TABLE 7.3.3.	STATISTICS FILE SHOWING MAXIMUM VALUE AND ELEMENT FOR DOMAIN.	177
TABLE 7.3.4.	LOCATION OF PLUME CENTERLINE NODES BEYOND X = 700 METERS.	178
TABLE 7.3.5.	STATISTICS FILE SHOWING MAXIMUM VALUE AND ELEMENT BEYOND X = 700 M.	178

LIST OF FIGURES

FIGURE 4.1.1. SCHEMATIC DIAGRAM OF A CONFINED AQUIFER WITH A CONSTANT HEAD BOUNDARY CONDITION AT $x = 0$ AND EITHER A GENERAL HEAD OR RIVER BOUNDARY CONDITION AT $x = 200$3

FIGURE 4.1.2. PORFLOW GRID FOR PROBLEM 4.1.5

FIGURE 4.1.3. COMPARISON OF ANALYTICAL SOLUTION TO PORFLOW NUMERICAL RESULTS FOR 4.1 (PROBLEM 1).6

FIGURE 4.1.4. COMPARISON OF ANALYTICAL SOLUTION TO PORFLOW DARCY VELOCITY FOR 4.1 (PROBLEM 2). .6

FIGURE 4.2.1. SCHEMATIC DIAGRAM OF AN UNCONFINED AQUIFER WITH NO RECHARGE AND CONSTANT HEAD BOUNDARY CONDITIONS (PROBLEM 1).9

FIGURE 4.2.2. SCHEMATIC DIAGRAM OF AN UNCONFINED AQUIFER WITH RECHARGE AND MIXED BOUNDARY CONDITIONS (PROBLEM 2).9

FIGURE 4.2.3. PORFLOW GRID FOR 4.2 (PROBLEM 1).11

FIGURE 4.2.4. PORFLOW GRID FOR 4.2 (PROBLEM 2).11

FIGURE 4.2.5. COMPARISON OF ANALYTICAL SOLUTION AND PORFLOW RESULTS FOR 4.2 (PROBLEM 1).12

FIGURE 4.2.6. COMPARISON OF ANALYTICAL SOLUTION AND PORFLOW RESULTS FOR 4.2 (PROBLEM 2).12

FIGURE 4.3.1. A HETEROGENEOUS SUBSURFACE SYSTEM CONSISTING OF AN UNCONFINED AQUIFER, CONFINING UNIT AND CONFINED AQUIFER.15

FIGURE 4.3.2. PORFLOW GRID FOR PROBLEM 4.3.17

FIGURE 4.3.3. APPROXIMATE ANALYTICAL AND PORFLOW HYDRAULIC HEAD PROFILES FOR THE UNCONFINED AND CONFINED AQUIFERS.19

FIGURE 4.4.1. SCHEMATIC ILLUSTRATION OF AN UNCONFINED AQUIFER EXPERIENCING BOTH RECHARGE AND DRAINAGE AT THE GROUND SURFACE; SEEPLINE UNKNOWN A PRIORI.20

FIGURE 4.4.2. CAUCHY BOUNDARY CONDITION FOR THE SIMULTANEOUS TREATMENT OF GROUNDWATER RECHARGE AND DRAINAGE.21

FIGURE 4.4.3. PORFLOW GRID FOR PROBLEM 4.4.23

FIGURE 4.4.4. COMSOL FINITE-ELEMENT MESH FOR PROBLEM 4.4.24

FIGURE 4.4.5. COMPARISON OF PORFLOW HYDRAULIC HEAD DISTRIBUTION TO ANALYTICAL SOLUTION AND COMSOL SIMULATION ($Y = 0$).24

FIGURE 4.5.1. RADIAL FLOW TO A PUMPING WELL IN A CONFINED AQUIFER.28

FIGURE 4.5.2. 1D PORFLOW RADIAL GRID FOR PROBLEM 4.5.30

FIGURE 4.5.3. 2D PORFLOW CARTESIAN GRID FOR PROBLEM 4.5.31

FIGURE 4.5.4. THEIS, COMSOL AND PORFLOW TRANSIENT DRAWDOWN AT $r = 55$ METERS.31

FIGURE 4.5.5. PORFLOW DRAWDOWN AT 1 DAY FOR 2D CARTESIAN MESH.32

FIGURE 4.6.1. ANISOTROPIC CONFINED AQUIFER WITH $K_x/K_y = 10$37

FIGURE 4.6.2. COMSOL FINITE-ELEMENT MESH FOR PROBLEM 4.6.38

FIGURE 4.6.3. HANTUSH AND THOMAS, COMSOL AND PORFLOW TRANSIENT DRAWDOWN AT $x = 55$ METERS.39

FIGURE 4.6.4. HANTUSH AND THOMAS, COMSOL AND PORFLOW TRANSIENT DRAWDOWN AT $y = 55$ METERS.39

FIGURE 4.6.5. HANTUSH AND THOMAS, COMSOL AND PORFLOW TRANSIENT DRAWDOWN AT $x = y = 55$ METERS.40

FIGURE 4.6.6. PORFLOW DRAWDOWN AT 1 DAY.41

FIGURE 4.7.1. SCHEMATIC DIAGRAM OF A LEAKY CONFINED AQUIFER WITH CONSTANT DISCHARGE FROM A SINGLE, FULLY-PENETRATING WELL.45

FIGURE 4.7.2. 1D PORFLOW RADIAL GRID FOR PROBLEM 4.7.47

FIGURE 4.7.3. HANTUSH AND JACOB, COMSOL AND PORFLOW TRANSIENT DRAWDOWN AT $r = 60$ FEET.47

FIGURE 4.8.1. SCHEMATIC ILLUSTRATION OF PROBLEM 4.8.49

FIGURE 4.8.2. 2D PORFLOW CARTESIAN GRID FOR PROBLEM 4.8.50

FIGURE 4.8.3. COMSOL FINITE-ELEMENT MESH FOR PROBLEM 4.8.51

FIGURE 4.8.4. TIME HISTORY OF PHREATIC SURFACE DUE TO RECHARGE.51

FIGURE 4.9.1. SCHEMATIC ILLUSTRATION OF PROBLEM 4.9.53

FIGURE 4.9.2. 2D PORFLOW CARTESIAN GRID FOR PROBLEM 4.9.54

FIGURE 4.9.3. COMSOL FINITE-ELEMENT MESH FOR PROBLEM 4.9.54

FIGURE 4.9.4.	TIME HISTORY OF PHREATIC SURFACE DUE TO SEEPAGE.	55
FIGURE 4.10.1.	1D PORFLOW GRID FOR PROBLEM 4.10.	57
FIGURE 4.10.2.	COMSOL FINITE-ELEMENT MESH FOR PROBLEM 4.10.	58
FIGURE 4.10.3.	PREDICTED COLUMN SATURATION PROFILE FOR COMSOL AND PORFLOW SIMULATIONS.	59
FIGURE 4.10.4.	PORFLOW SIMULATION OF STEADY-STATE UNSATURATED FLOW AT CONSTANT SATURATION (75%).	59
FIGURE 5.1.1.	SCHEMATIC DIAGRAM FOR 1D SOLUTE TRANSPORT IN A CONFINED AQUIFER.	61
FIGURE 5.1.2.	PORFLOW GRID FOR 1-D BASE CASE TRANSPORT SIMULATION.	68
FIGURE 5.1.3.	CONCENTRATION PROFILES FOR THE 1D TRANSPORT OF THE BASE CASE.	69
FIGURE 5.1.4.	CONCENTRATION PROFILES FOR THE 1D TRANSPORT SHOWING EFFECT OF RETARDATION (CASE A). ..	69
FIGURE 5.1.5.	CONCENTRATION PROFILES FOR THE 1D TRANSPORT SHOWING EFFECT OF RADIOACTIVE DECAY (CASE B).	70
FIGURE 5.1.6.	CONCENTRATION PROFILES FOR THE 1D TRANSPORT SHOWING COMBINED EFFECT OF RETARDATION AND RADIOACTIVE DECAY (CASE C).	70
FIGURE 5.1.7.	CONCENTRATION PROFILES FOR THE 1D TRANSPORT SHOWING EFFECT OF GRID SIZE, $\Delta x = 20$ M (CASE D).	71
FIGURE 5.1.8.	CONCENTRATION PROFILES FOR THE 1D TRANSPORT SHOWING EFFECT OF GRID SIZE, $\Delta x = 40$ M (CASE E).	71
FIGURE 5.1.9.	CONCENTRATION PROFILES FOR THE 1D TRANSPORT SHOWING EFFECT OF GRID SIZE, $\Delta x = 80$ M (CASE F).	72
FIGURE 5.1.10.	CONCENTRATION PROFILES FOR THE 1D TRANSPORT SHOWING EFFECT OF TIME STEP SIZE, $\Delta t = 5$ D (CASE G).	72
FIGURE 5.1.11.	CONCENTRATION PROFILES FOR THE 1D TRANSPORT SHOWING EFFECT OF TIME STEP SIZE, $\Delta t = 10$ D (CASE H).	73
FIGURE 5.1.12.	CONCENTRATION PROFILES FOR THE 1D TRANSPORT SHOWING EFFECT OF TIME STEP SIZE, $\Delta t = 25$ D (CASE I).	73
FIGURE 5.1.13.	CONCENTRATION PROFILES FOR THE 1D TRANSPORT AT HIGH PECELET NUMBER SHOWING EFFECT OF DISPERSION (CASE J).	74
FIGURE 5.1.14.	CONCENTRATION PROFILES FOR THE 1D TRANSPORT AT HIGH PECELET NUMBER SHOWING EFFECT OF NODAL INTEGRATION SCHEMES (CASE K).	74
FIGURE 5.1.15.	CONCENTRATION PROFILES FOR THE 1D TRANSPORT SHOWING EFFECT OF PROPERTY AVERAGING SCHEMES (CASE L).	75
FIGURE 5.2.1.	SCHEMATIC DIAGRAM FOR 2D SOLUTE TRANSPORT IN A CONFINED AQUIFER.	106
FIGURE 5.2.2.	PORFLOW PARALLEL GRID FOR 2D TRANSPORT SIMULATIONS.	114
FIGURE 5.2.3.	PORFLOW DIAGONAL GRID FOR 2D TRANSPORT SIMULATION.	114
FIGURE 5.2.4.	PORFLOW CONCENTRATION PLUME FOR 2D TRANSPORT OF THE BASE CASE ON THE PARALLEL GRID (CASE A).	115
FIGURE 5.2.5.	CONCENTRATION PROFILES FOR 2D TRANSPORT OF THE BASE CASE ALONG THE PLUME CENTERLINE (CASE A).	115
FIGURE 5.2.6.	CONCENTRATION PROFILES FOR 2D TRANSPORT OF THE BASE CASE TRANSVERSE TO THE PLUME CENTERLINE AT $x = 420$ METERS (CASE A).	116
FIGURE 5.2.7.	PORFLOW CONCENTRATION PLUME FOR 2D TRANSPORT OF THE BASE CASE ON THE DIAGONAL GRID (CASE B).	116
FIGURE 5.2.8.	CONCENTRATION PROFILES FOR 2D TRANSPORT OF THE BASE CASE ALONG THE PLUME CENTERLINE (CASE B).	117
FIGURE 5.2.9.	CONCENTRATION PROFILES FOR 2D TRANSPORT OF THE BASE CASE TRANSVERSE TO THE PLUME CENTERLINE AT $x = 424$ METERS (CASE B).	117
FIGURE 5.2.10.	PORFLOW CONCENTRATION PLUME FOR 2D TRANSPORT SHOWING THE EFFECT OF RETARDATION (CASE C).	118
FIGURE 5.2.11.	CONCENTRATION PROFILES FOR 2D TRANSPORT SHOWING THE EFFECT OF RETARDATION ALONG THE PLUME CENTERLINE (CASE C).	118
FIGURE 5.2.12.	CONCENTRATION PROFILES FOR 2D TRANSPORT SHOWING THE EFFECT OF RETARDATION TRANSVERSE TO THE PLUME CENTERLINE AT $x = 420$ METERS (CASE C).	119

FIGURE 5.2.13	PORFLOW CONCENTRATION PLUME FOR 2D TRANSPORT SHOWING THE EFFECT OF RADIOACTIVE DECAY (CASE D).....	119
FIGURE 5.2.14	CONCENTRATION PROFILES FOR 2D TRANSPORT SHOWING THE EFFECT OF RADIOACTIVE DECAY ALONG THE PLUME CENTERLINE (CASE D).....	120
FIGURE 5.2.15	CONCENTRATION PROFILES FOR 2D TRANSPORT SHOWING THE EFFECT OF RADIOACTIVE DECAY TRANSVERSE TO THE PLUME CENTERLINE AT X = 420 METERS (CASE D).....	120
FIGURE 5.3.1.	PORFLOW GRID FOR 3D TRANSPORT SIMULATION.....	135
FIGURE 5.3.2	PORFLOW CONCENTRATION PLUME FOR 3D TRANSPORT OF THE BASE CASE ON A PARALLEL GRID.....	135
FIGURE 5.3.3	CONCENTRATION PROFILE FOR 3D TRANSPORT OF THE BASE CASE ALONG THE PLUME CENTERLINE..	136
FIGURE 5.3.4	CONCENTRATION PROFILES FOR 3D TRANSPORT OF THE BASE CASE TRANSVERSE TO THE PLUME CENTERLINE (IN BOTH Y AND Z DIRECTIONS) LOCATED AT X = 120 METERS.....	136
FIGURE 5.4.1.	RADIOACTIVE DECAY CHAINS LEADING TO RN-222.....	142
FIGURE 5.4.2.	PORFLOW 1D CONCEPTUAL MODEL AND MESH FOR RADON TRANSPORT IN THE SLIT AND ENGINEERED TRENCHES.....	143
FIGURE 5.4.3.	COMPARISON OF COMSOL AND PORFLOW TH-230 CONCENTRATION PROFILES AT 1000 YEARS.....	143
FIGURE 5.4.4.	COMPARISON OF COMSOL AND PORFLOW RA-226 CONCENTRATION PROFILES.....	144
FIGURE 5.4.5.	COMPARISON OF COMSOL AND PORFLOW RN-222 CONCENTRATION PROFILES AT 1000 YEARS.....	144
FIGURE 5.4.6.	COMPARISON OF COMSOL AND PORFLOW RN-222 DISPERSIVE FLUX AT THE LAND SURFACE..	145
FIGURE 5.5.1.	PORFLOW GRID FOR 1D VARIABLY SATURATED TRANSPORT.....	150
FIGURE 5.5.2.	COMPARISON OF COMSOL AND PORFLOW PARENT AND DAUGHTER SOLUTE CONCENTRATION PROFILES AT 25 AND 50 YEARS (PORFLOW USING EQ. 5.5.2).....	150
FIGURE 5.5.3.	COMPARISON OF COMSOL AND PORFLOW PARENT AND DAUGHTER SOLUTE CONCENTRATION PROFILES AT 25 AND 50 YEARS (PORFLOW USING EQ. 5.5.1).....	151
FIGURE 6.1.1.	NORMALIZED SOLUTE CONCENTRATION PROFILES AT 5.5 YEARS FOR VARIABLE MESH SPACING IN PORFLOW WITH NUMERICAL DISPERSION.....	155
FIGURE 6.1.2.	PEAK NORMALIZED SOLUTE CONCENTRATION AS A FUNCTION OF MESH SPACING IN PORFLOW AT 5.5 YEARS WITH NUMERICAL DISPERSION.....	155
FIGURE 6.1.3.	NORMALIZED SOLUTE CONCENTRATION PROFILES AT 5.5 YEARS FOR VARIABLE MESH SPACING IN PORFLOW WITH MECHANICAL DISPERSION.....	156
FIGURE 7.1.1.	COMPARISON OF RADIONUCLIDE CONCENTRATIONS IN THE U-230 DECAY CHAIN TO THE BATEMAN EQUATION.....	171
FIGURE 7.2.1.	IMPLEMENTATION OF SOLUBILITY LIMITED SOURCE BASED ON THE DIST AND RETA COMMAND.....	174

Abstract

The PORFLOW software package is a comprehensive mathematical model for simulation of multi-phase fluid flow, heat transfer and mass transport in variably saturated porous and fractured media. PORFLOW can simulate transient or steady-state problems in Cartesian or cylindrical geometry. The porous medium may be anisotropic and heterogeneous and may contain discrete fractures or boreholes with the porous matrix. The theoretical models within the code provide a unified treatment of concepts relevant to fluid flow and transport.

The main features of PORFLOW that are relevant to Performance Assessment modeling at the Savannah River National Laboratory (SRNL) include variably saturated flow and transport of parent and progeny radionuclides. This document involves testing a relevant sample of problems in PORFLOW and comparing the outcome of the simulations to analytical solutions or other commercial codes. The testing consists of the following four groups.

- Group 1: Groundwater Flow
- Group 2: Contaminant Transport
- Group 3: Numerical Dispersion
- Group 4: Keyword Commands

1 Objective and Software Descriptions

PORFLOW is a commercially developed computer code for use in simulating groundwater flow and contaminant transport in the vadose zone and underlying aquifers. Since the results from calculations performed using PORFLOW are used to comply with regulatory laws, environmental permits and regulations, its software classification is upgraded from the current Level D to Level C

PORFLOW is used in many modeling applications including work for Solid Waste (e.g., waste disposal in Saltstone, Components in Grout, Low Activity Waste Vaults etc.) and High-Level Waste Tank Closures. The results from PORFLOW calculations will form a basis to support many types of analyses such as the Composite Analysis or the Performance Assessment to comply with DOE Orders and environmental regulations. Therefore, PORFLOW is classified as Level C software.

2 Software Installation and Computing Platform

PORFLOW version 5.97.0 has been installed on the IBM PC workstation tegu4. The PORFLOW executable, porflow.exe, is a Windows 2000/XP console program and is located in the network directory \\tegu4\porflow. The testing of PORFLOW was performed on an IBM IntelliStation Z Pro with dual 3.4GHz Xeon processors running Windows 2000.

3 Scope for Test Problems

The test problems were selected based on the fact that analytical solutions (or code-to-code comparisons) exist that definitively establish the code accuracy capability and the resulting impact that mesh and control parameter settings have on accuracy. Four groups of test problems are described to verify the capability of the software to represent the physical phenomena characteristic of groundwater flow and transport applications at the Savannah River Site.

They are:

1. **Group 1:** Saturated and variably saturated groundwater flow in one and two dimensions (steady-state and transient conditions)
2. **Group 2:** Contaminant transport in one, two and three dimensions (transient).
3. **Group 3:** Numerical dispersion.
4. **Group 4:** Keyword Commands (e.g. STATistics)

4 Group 1: Groundwater Flow Problems

4.1 Steady-state, One-Dimensional Flow in a Confined Aquifer

Figure 4.1.1 illustrates two confined aquifers experiencing steady, one-dimensional flow. The test cases are designed to confirm correct implementation of the general head (mixed) and river bed boundary conditions. The problems can be easily solved analytically.

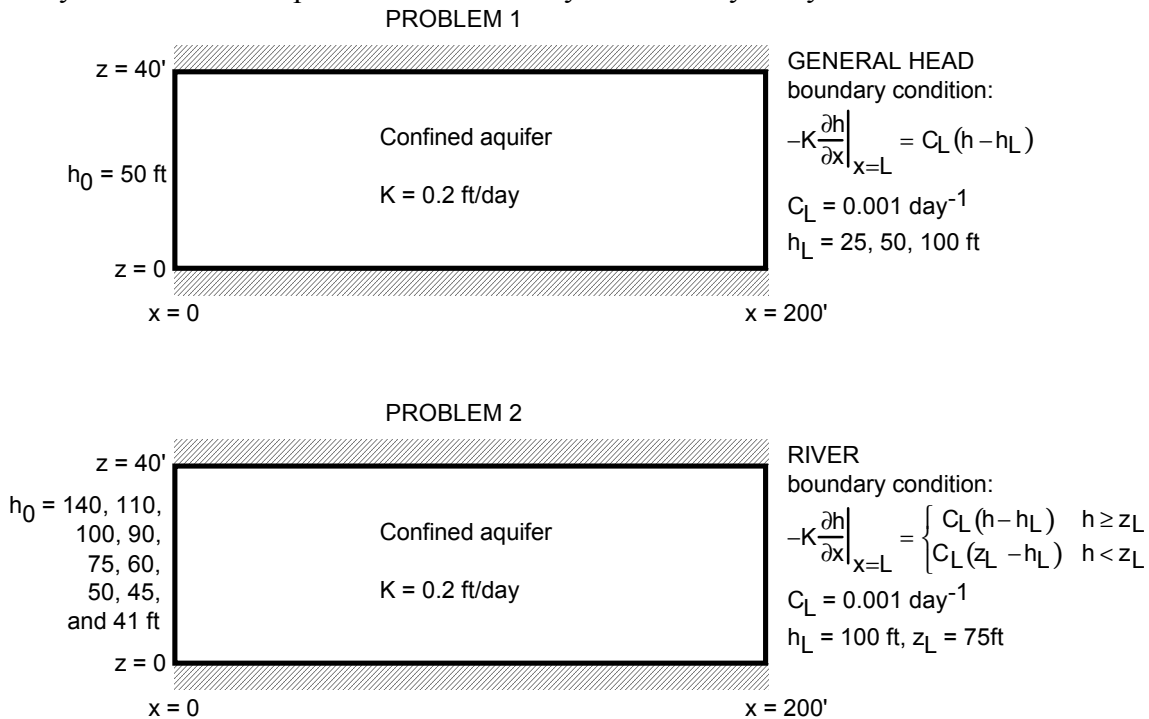

Figure 4.1.1. Schematic Diagram of a Confined Aquifer with a Constant Head Boundary Condition at x = 0 and Either a General Head or River Boundary Condition at x = 200.

Analytical solution: Invoking the Dupuit assumption, the following governing equation can be developed for a confined aquifer (de Marsily, 1986, Eq 5.3.11)

$$\nabla^2 h = \frac{\partial^2 h}{\partial x^2} + \frac{\partial^2 h}{\partial y^2} = \frac{S}{T} \frac{\partial h}{\partial t} + \frac{Q}{T} \tag{4.1.1}$$

where

- h hydraulic head, L
- S storage coefficient of a confined aquifer
- T transmissivity of the aquifer, L²/T
- Q volumetric flow rate per unit surface area withdrawn from the aquifer, L/T

For constant aquifer thickness, constant properties, one-dimensional steady flow and no recharge, Eq. 4.1.1 becomes

$$\frac{d^2h}{dx^2} = 0 \quad (4.1.2)$$

For the boundary conditions of Problem 1

$$h = h_0 \quad @ \quad x = 0 \quad (4.1.3a)$$

$$-K \left. \frac{dh}{dx} \right|_{x=L} = C_L (h - h_L) \quad @ \quad x = L \quad (4.1.3b)$$

the solution can be derived using direct integration as

$$h = h_0 + \frac{h_L - h_0}{1 + \frac{K}{C_L L}} \frac{x}{L} \quad (4.1.4)$$

For the boundary conditions of Problem 2

$$h = h_0 \quad @ \quad x = 0 \quad (4.1.5a)$$

$$U_x = -K \left. \frac{dh}{dx} \right|_{x=L} = \begin{cases} C_L (h - h_L) & h \geq z_L \\ C_L (z_L - h_L) & h < z_L \end{cases} \quad @ \quad x = L \quad (4.1.5b)$$

the solution is

$$h = \begin{cases} h_0 + \frac{h_L - h_0}{1 + \frac{K}{C_L L}} \frac{x}{L} & h \geq z_L \\ h_0 + C_L (h_L - z_L) \frac{x}{L} & h < z_L \end{cases} \quad (4.1.6)$$

PORFLOW simulation and comparison: Figure 4.1.2 illustrates the PORFLOW mesh chosen for both problems. The mesh includes 201 nodes in the x direction and 3 nodes in the y direction. Even though the problem is one-dimensional, PORFLOW requires a minimum of 3 nodes in the y direction. Table 4.1.1 and Figure 4.1.3 present the PORFLOW results for Problem 1 in comparison with the analytical solution. Inspection of Table 4.1.1 shows that PORFLOW sets the pressure at the right boundary node equal to the mixed or Cauchy boundary condition pressure value. In order to test the river boundary condition the Darcy velocity is computed at node 201 ($x = 201, y = 0$) using the volumetric flow and the river boundary condition. The Darcy velocity is given by

$$U_x = \frac{Q}{A} \quad (4.1.7)$$

where the volumetric flow Q at node 201 can be found in the FC array of the PORFLOW archive file and the effective flow area A at node 201 is 40 ft^2 . The Darcy velocity is also given by

$$U_x = \begin{cases} C_L(h - h_L) & h \geq z_L \\ C_L(z_L - h_L) & h < z_L \end{cases} \quad (4.1.8)$$

where h is hydraulic head at node 201 and $h_L = 100 \text{ ft}$, $z_L = 75 \text{ ft}$.

Table 4.1.2 and Figure 4.1.4 present the PORFLOW results for Problem 2 that compares the two calculations of Darcy velocity at node 201. PORFLOW has excellent agreement with the analytic results for both problems.

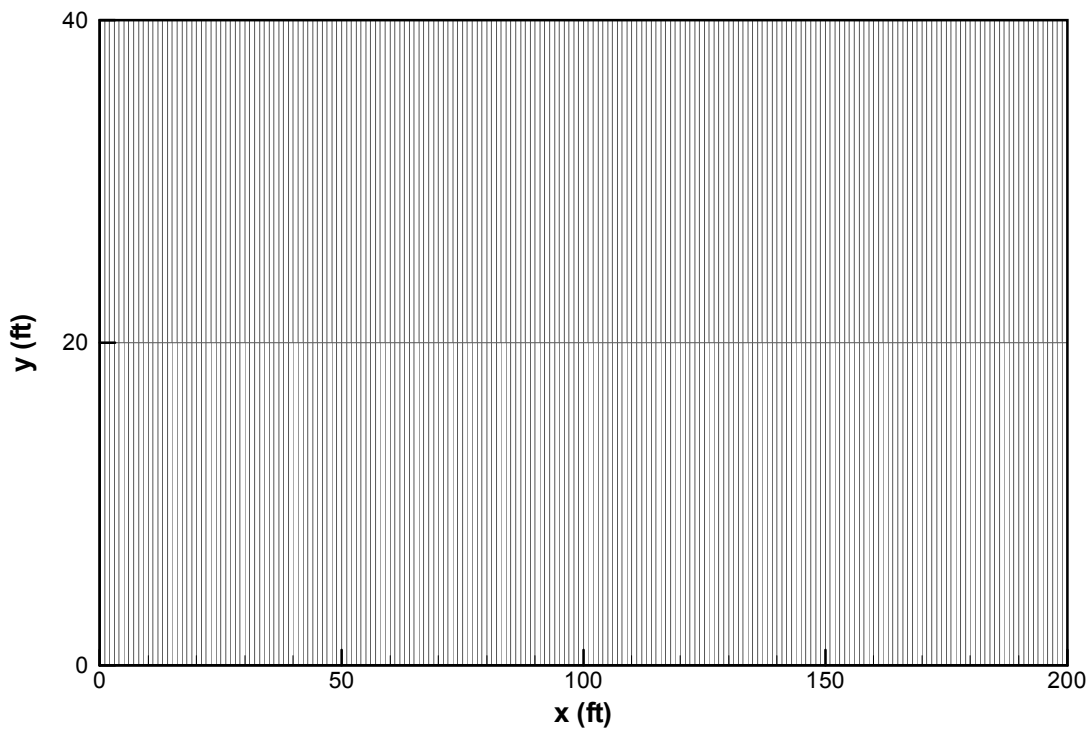

Figure 4.1.2. PORFLOW Grid for Problem 4.1.

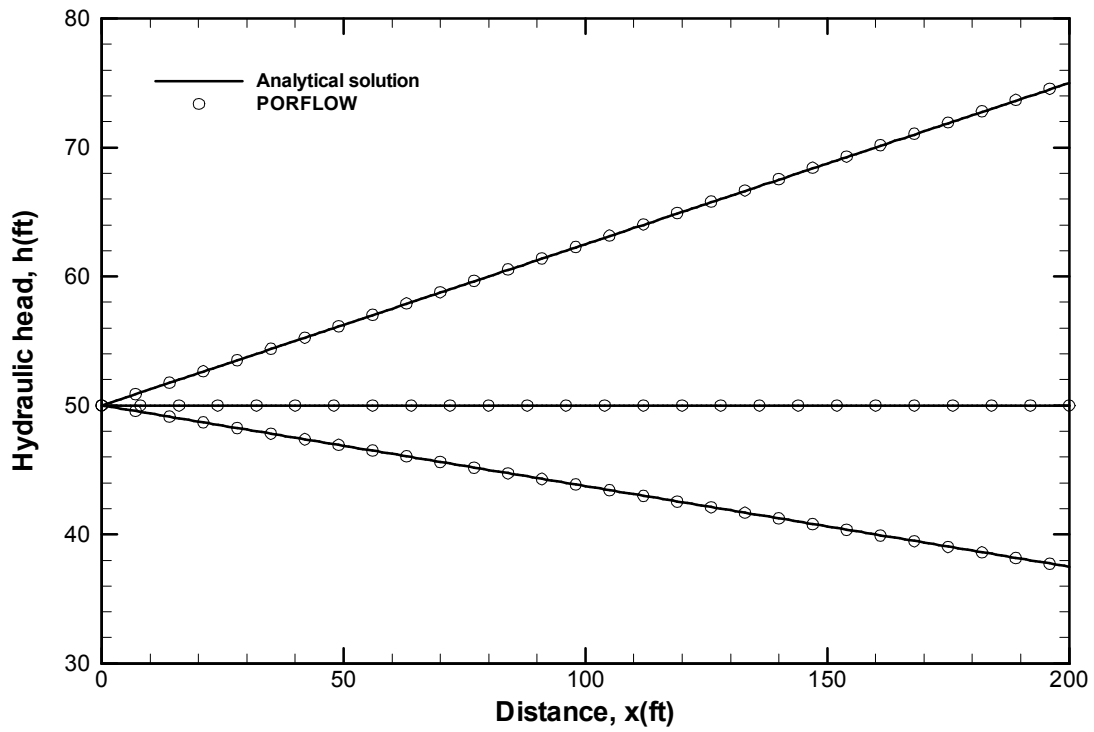

Figure 4.1.3. Comparison of Analytical Solution to PORFLOW Numerical Results for 4.1 (Problem 1).

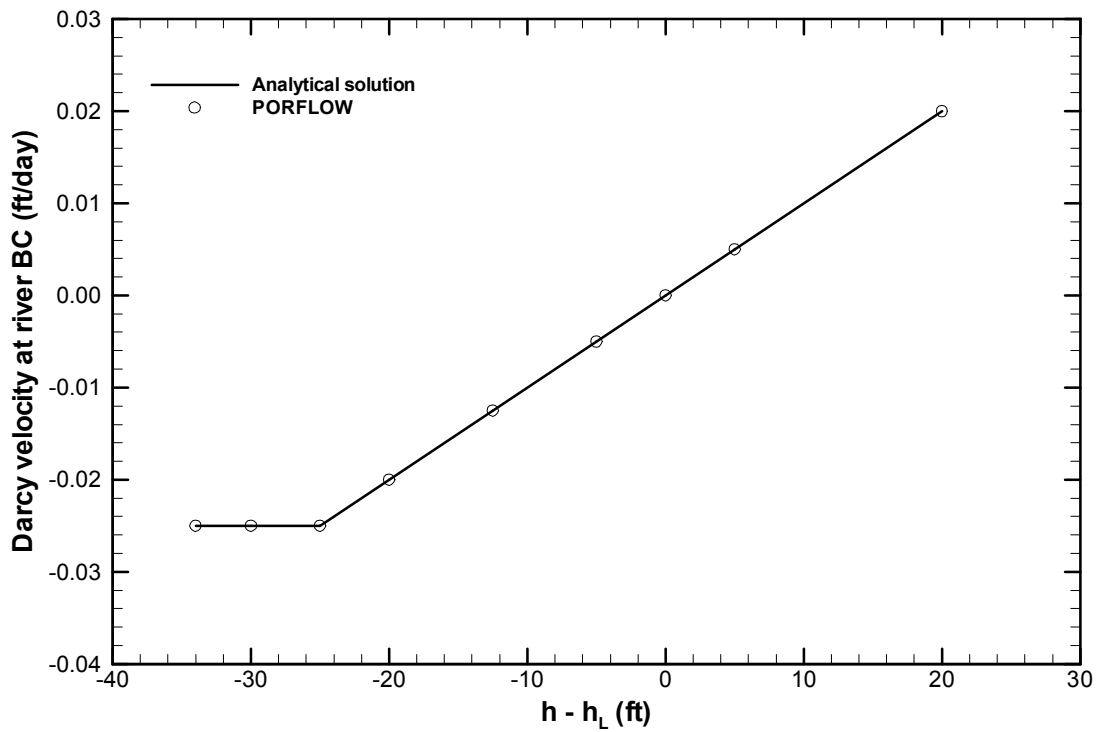

Figure 4.1.4. Comparison of Analytical Solution to PORFLOW Darcy Velocity for 4.1 (Problem 2).

Table 4.1.1. Comparison of Analytical Solution and PORFLOW Numerical Results for 4.1 (Problem 1).

x (ft)	h _L = 25 ft		h _L = 50 ft		h _L = 100 ft	
	Analytic (ft)	PORFLOW (ft)	Analytic (ft)	PORFLOW (ft)	Analytic (ft)	PORFLOW (ft)
0	50.00	50.00	50.0	50.0	50.0	50.0
20	48.75	48.75	50.0	50.0	52.5	52.5
40	47.50	47.49	50.0	50.0	55.0	55.0
60	46.25	46.24	50.0	50.0	57.5	57.5
80	45.00	44.99	50.0	50.0	60.0	60.0
100	43.75	43.73	50.0	50.0	62.5	62.5
120	42.50	42.48	50.0	50.0	65.0	65.0
140	41.25	41.23	50.0	50.0	67.5	67.6
160	40.00	39.98	50.0	50.0	70.0	70.1
180	38.75	38.72	50.0	50.0	72.5	72.6
199	37.56	37.53	50.0	50.0	74.9	74.9
200	37.50	25.00	50.0	50.0	75.0	100.0

Table 4.1.2. PORFLOW Darcy Velocity at Node 201 for 4.1 (Problem 2)

h ₀ (ft)	h _L (ft)	z _L (ft)	PORFLOW		Analytic	
			h _{x=L} (ft)	U (ft/day)	h _{x=L} (ft)	U (ft/day)
140	100	75	120	0.0200	120.0	0.0200
110	100	75	105	0.0050	105.0	0.0050
100	100	75	100	0.0000	100.0	0.0000
90	100	75	95	-0.0050	95.0	-0.0050
75	100	75	87.5	-0.0125	87.5	-0.0125
60	100	75	80	-0.0200	80.0	-0.0200
50	100	75	75	-0.0250	75.0	-0.0250
45	100	75	70	-0.0250	70.0	-0.0250
41	100	75	66	-0.0250	66.0	-0.0250

Table 4.1.3. Input Commands for 4.1 (Problem 1)

```

!*****
TITLE 4.1 Steady-state, 1-D Flow in a Confined Aquifer (Problem 1)
!*****
! General Head boundary condition
!*****

GRID is 201 by 3 NODEs
COORDinate X: NODE values: MINImum=0.0, MAXImum=2.e2
COORDinate Y: 0.,20.,40 at NODEs

GRAVity 0. 0. 0. 0.

HYDRaulic properties S = 0., Kx = 0.2 ft/d, Ky = 0.2 ft/d

SET P = 0 everywhere initially

BOUNDary condition for P: X-, VALUe = 50.
BOUNDary condition for P: X+, MIXEd type: value=100. CL=0.001
BOUNDary condition for P: Y-, FLUX = 0.
BOUNDary condition for P: Y+, FLUX = 0.

! Solution controls
    
```

```
!MATRix NSPC for P precon=CHOL, accel=CONJ, MODI
MATRix ITERation 100
```

```
CONVergence REFERENCE based on ALL: Tolerance = 1.E-8, 100 outer iterations
```

```
DIAGnostic node (201,2) every 1 step
```

```
SOLVE P in STEADy mode: max=500, min=500
SAVE P to '4.1-pl.sav' NOW
```

```
END
```

Table 4.1.4. Input Commands for 4.1 (Problem 2)

```
!*****
TITLe 4.1 Steady-state, 1-D Flow in a Confined Aquifer (Problem 2)
!*****
! River boundary condition
!*****

GRID is 201 by 3 NODES
COORDinate X: NODE values: MINImum=0.0, MAXImum=2.e2
COORDinate Y: 0.,20.,40 at NODES

GRAVity 0. 0. 0. 0.

HYDRAulic properties S = 0., Kx = 0.2 ft/d, Ky = 0.2 ft/d

SET P = 0 everywhere initially

BOUNDary condition for P: X-, VALUe = 41.
BOUNDary condition for P: X+, FLUX: TABLe of values: 3 sets (P,value)
(0.,2.5e-2), (75.,2.5e-2), (300.,-0.2) ! River BC
BOUNDary condition for P: Y-, FLUX = 0.
BOUNDary condition for P: Y+, FLUX = 0.

! Solution controls
MATRix NSPC for P precon=CHOL, accel=CONJ, MODI
MATRix ITERation 100

CONVergence REFERENCE based on ALL: Tolerance = 1.E-8, 100 outer iterations

DIAGnostic node (201,2) every 1 step

SOLVE P in STEADy mode: max=500, min=500
SAVE P U V to '4.1-p2.sav' NOW

END
```

4.2 Steady-state, One-Dimensional Flow in an Unconfined Aquifer

Figures 4.2.1 and 4.2.2 illustrate a pair of unconfined aquifers experiencing steady, one-dimensional flow without and with recharge, respectively. The second problem is essentially FTWORK Problem 4.1.1 (GeoTrans, 1993). Both problems can be easily solved analytically.

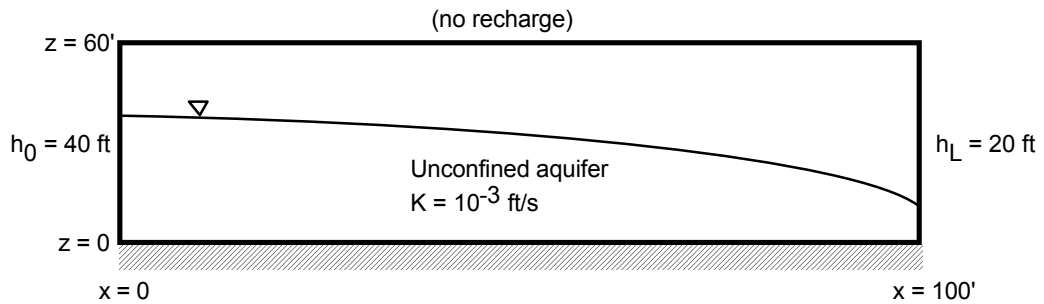

Figure 4.2.1. Schematic Diagram of an Unconfined Aquifer with No Recharge and Constant Head Boundary Conditions (Problem 1).

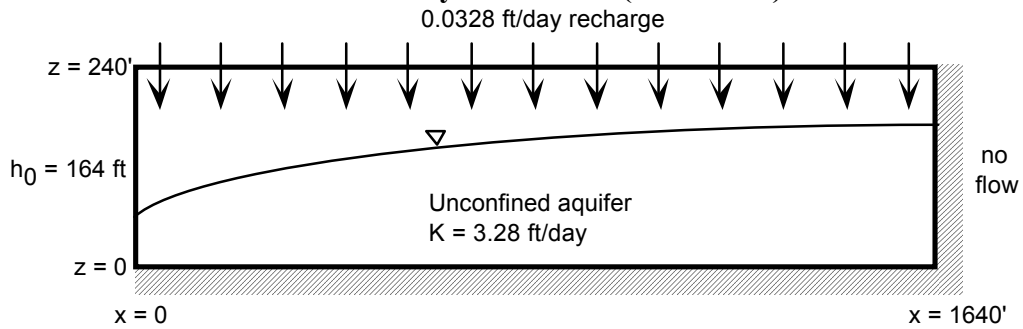

Figure 4.2.2. Schematic Diagram of an unconfined aquifer with recharge and mixed boundary conditions (Problem 2).

Analytical solutions: Invoking the Dupuit assumption (de Marsily, 1986, Eq. (5.1.1)) gives the following general expression for flow in an unconfined aquifer

$$\frac{\partial}{\partial x} \left[\int_{\sigma}^h K_{xx} dz \frac{\partial h}{\partial x} \right] + \frac{\partial}{\partial y} \left[\int_{\sigma}^h K_{yy} dz \frac{\partial h}{\partial y} \right] = \omega_d \frac{\partial h}{\partial t} + Q \tag{4.2.1}$$

where

K saturated hydraulic conductivity tensor, L/T

σ elevation of the aquifer base, L

ω_d specific yield or drainage porosity

If K_{xx} and K_{yy} are constant along the z-axis, we can evaluate the integral to arrive at

$$\frac{\partial}{\partial x} \left[K_{xx} (h - \sigma) \frac{\partial h}{\partial x} \right] + \frac{\partial}{\partial y} \left[K_{yy} (h - \sigma) \frac{\partial h}{\partial y} \right] = \omega_d \frac{\partial h}{\partial t} + Q \tag{4.2.2}$$

For the special case of a horizontal aquifer ($\sigma = 0$), isotropic and uniform medium ($K_{xx} = K_{yy} = K$) and one-dimensional steady-state flow, Eq. 4.2.2 becomes

$$\frac{d^2 h^2}{dx^2} = \frac{2Q}{K} \tag{4.2.3}$$

For the prescribed head boundary conditions for Problem 1

$$h = h_0 \quad @ \quad x = 0 \quad (4.2.4a)$$

$$h = h_L \quad @ \quad x = L \quad (4.2.4b)$$

the solution can be derived using direct integration as

$$h^2 = h_0^2 + (h_L^2 - h_0^2) \frac{x}{L} + \frac{Q_{src} L^2}{K} \left(\frac{x}{L} \right) \left(1 - \frac{x}{L} \right) \quad (4.2.5)$$

where $Q_{src} = -Q$. For the boundary conditions for Problem 2

$$h = h_0 \quad @ \quad x = 0 \quad (4.2.6a)$$

$$h' = 0 \quad @ \quad x = L \quad (4.2.6b)$$

the solution is

$$h^2 = h_0^2 - \frac{Q_{src} L^2}{K} \left(\frac{x}{L} \right) \left(\frac{x}{L} - 2 \right) \quad (4.2.7)$$

PORFLOW simulation and comparison: Figures 4.2.3 and 4.2.4 present the two grids chosen for the PORFLOW simulations. The mesh for Problem 1 contains 101 nodes in the x-direction and 61 nodes in y-direction. The mesh for Problem 2 contains 165 nodes in the x-direction and 25 nodes in the y-direction. Table 4.2.1 and Figures 4.2.5 and 4.2.6 present the analytical solution and PORFLOW results. The agreement is excellent for both problems. The slight differences between the Dupuit assumption and PORFLOW are due to curvature of the phreatic surface (watertable). In reality, the flow is not purely horizontal and the flow near the phreatic surface has small components of velocity in the vertical direction. The PORFLOW input commands for Problem 1 and 2 are shown in Tables 4.2.2 and 4.2.3, respectively.

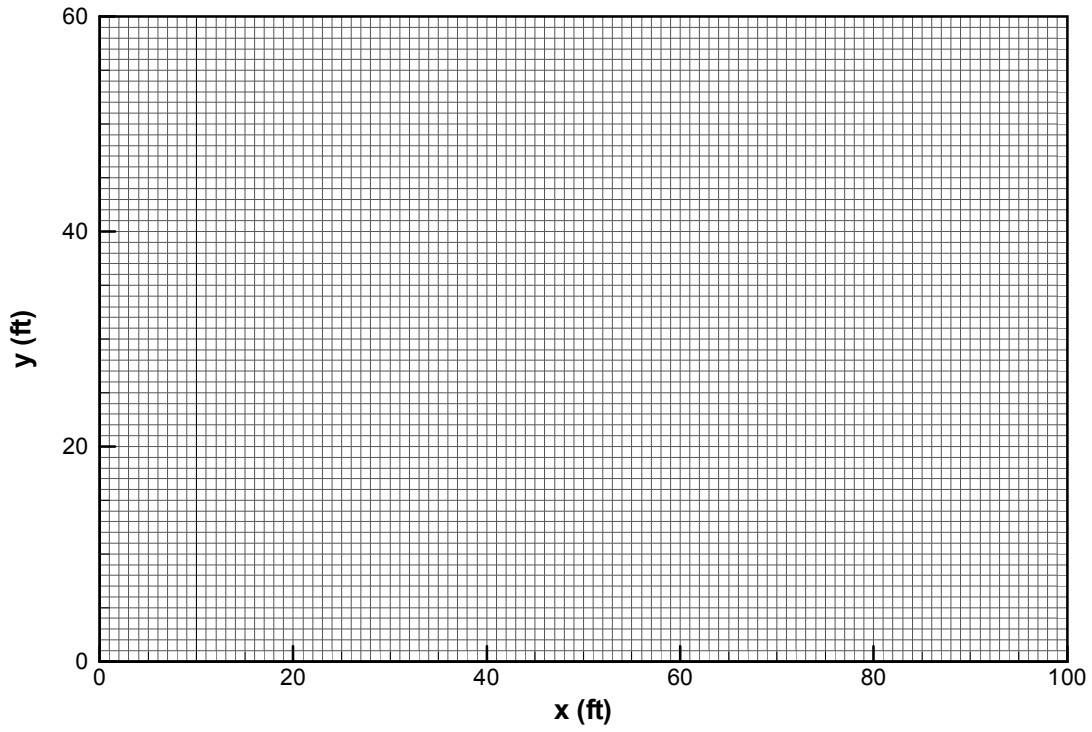

Figure 4.2.3. PORFLOW Grid for 4.2 (Problem 1).

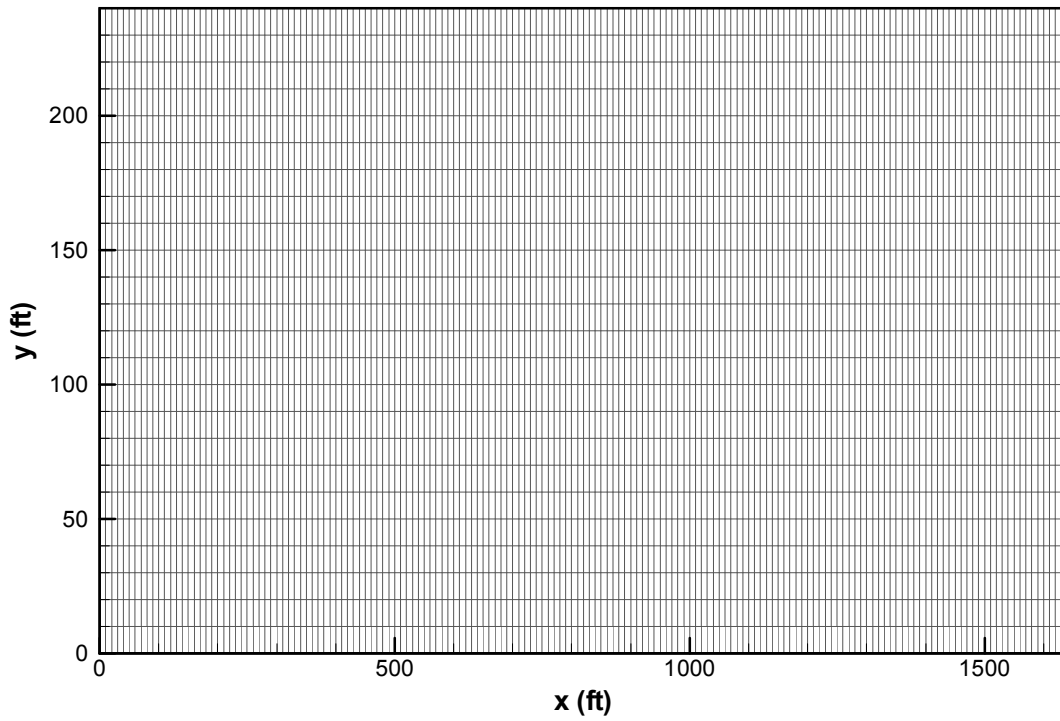

Figure 4.2.4. PORFLOW Grid for 4.2 (Problem 2).

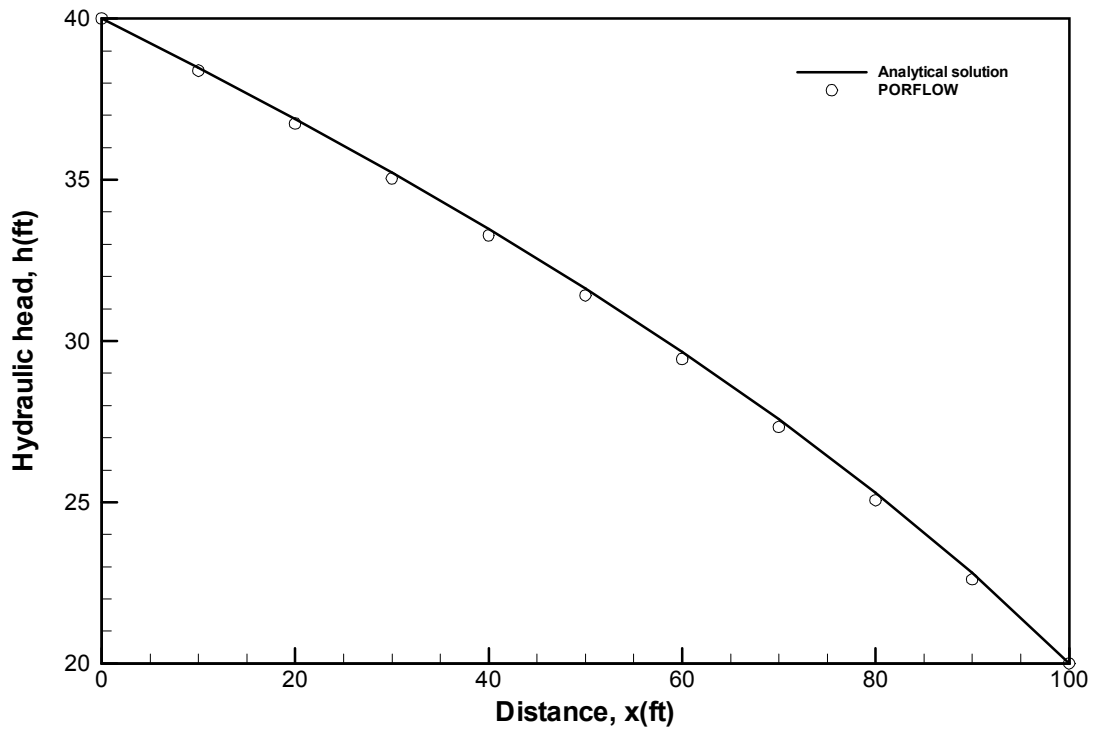

Figure 4.2.5. Comparison of Analytical Solution and PORFLOW Results for 4.2 (Problem 1).

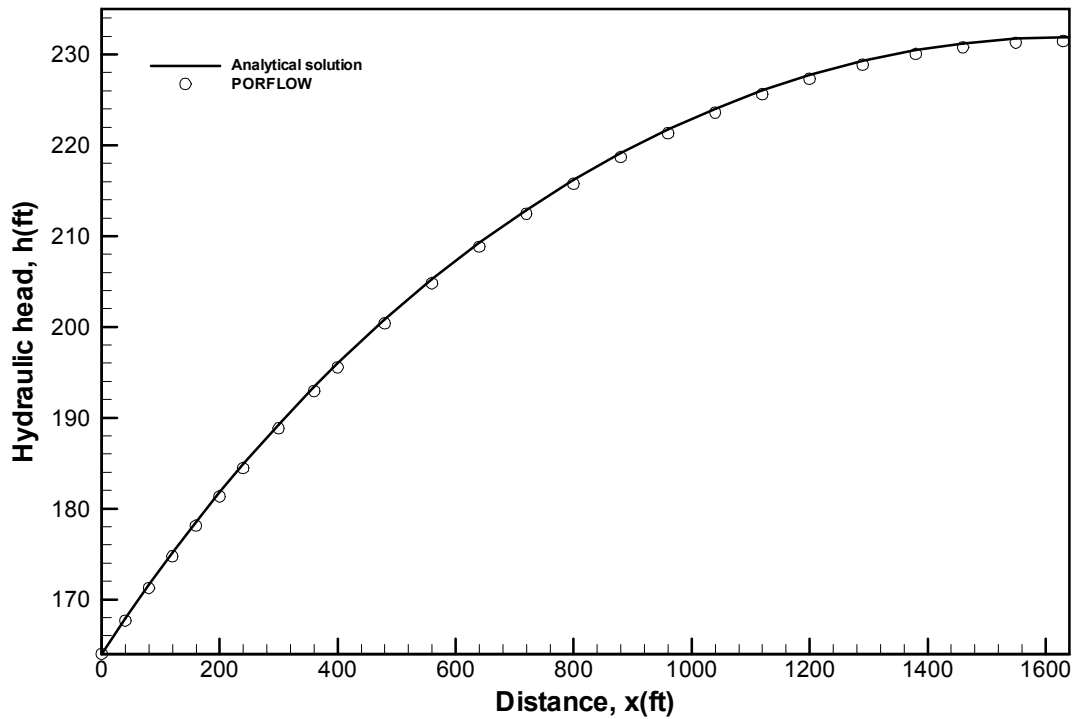

Figure 4.2.6. Comparison of Analytical Solution and PORFLOW Results for 4.2 (Problem 2).

Table 4.2.1. Comparison of Analytical Solution and PORFLOW Numerical Results.

Problem 1			Problem 2		
x (ft)	Analytic (ft)	PORFLOW (ft)	x (ft)	Analytic (ft)	PORFLOW (ft)
0.	40.000	40.000	0	164.000	164.000
10	38.471	38.383	40	167.905	167.660
20	36.878	36.878	80	171.628	171.250
30	35.214	35.041	120	175.180	174.750
40	33.466	33.271	160	178.572	178.110
50	31.623	31.410	200	181.813	181.340
60	29.665	29.438	240	184.911	184.440
70	27.568	27.331	300	189.304	188.830
80	25.298	25.060	360	193.411	192.940
90	22.804	22.605	400	196.000	195.540
100	20.000	20.000	480	200.838	200.380
			560	205.251	204.800
			640	209.265	208.820
			720	212.904	212.460
			800	216.185	215.750
			880	219.126	218.690
			960	221.739	221.310
			1040	224.036	223.600
			1120	226.027	225.600
			1200	227.719	227.300
			1290	229.275	228.850
			1380	230.469	230.030
			1460	231.231	230.780
			1550	231.756	231.290
			1630	231.929	231.460

Table 4.2.2. Input Commands for 4.2 (Problem 1)

```

!*****
TITLe 4.2 Steady-state, 1-D Flow in a an Unconfined Aquifer (Problem 1)
!*****
! No recharge
!*****

GRID is 101 by 61 NODEs
COORDinate NODEs X: MINImum=0.0, MAXImum=1.e+2
COORDinate NODEs Y: MINImum=0.0, MAXImum=6.e+1

GRAVity 0. -1. 0.

!PROPerties: GEOMetric
PROPerties UPWInd
MATERial POROSity 0.43
HYDRauiic properties S = 0., Kx = 1.e-3 ft/s, Ky = 1.e-3 ft/s
MULTiphase VAN Genuchten MUALem: n=3.0, alpha=4.572, Sr=0.104651162 ! Sand Soil

SET P = 0 everywhere initially

LOCate subregion ID=LHEAD for COORDinates (-0.5,-0.5) to (0.5,40.5) select BOUNDary
LOCate subregion ID=LFLUX for COORDinates (-0.5,40.5) to (0.5,60.5) select BOUNDary

LOCate subregion ID=RHEAD for COORDinates (99.5,-0.5,) to (100.5,20.5) select BOUNDary
LOCate subregion ID=RFLUX for COORDinates (99.5,20.5,) to (100.5,60.5) select BOUNDary
    
```

BOUNDary condition for P: VALUe is LINEAr function (40.) (-1)(Y) at ID=LHEAD
 BOUNDary condition for P: FLUX = 0. at ID=LFLUX

BOUNDary condition for P: VALUe is LINEAr function (20.) (-1)(Y) at ID=RHEAD
 BOUNDary condition for P: FLUX = 0. at ID=RFLUX

BOUNDary condition for P: Y-, FLUX = 0.
 BOUNDary condition for P: Y+, FLUX = 0.

! Solution controls
 MATRix NSPC for P precon=CHOL, accel=CONJ, MODI
 MATRix ITERation 100

CONVergence REFERENCE based on ALL: Tolerance = 1.E-6, 100 outer iterations

DIAGnostic P node (100,60) every 1 step

RELAX S 0.01

SOLVE P in STEAdy mode: max=200, min=200
 SAVE P H to '4.2-p1.sav' NOW

END

Table 4.2.3. Input Commands for 4.2 (Problem 2)

```

!*****
TITLe 4.2 Steady-state, 1-D Flow in a an Unconfined Aquifer (Problem 2)
!*****
! recharge and dirichelet BC on right boundary
!*****

!DEFINE VARIABLES
DEFine INIT = 1      ! =0 ==> H SET TO 0, =1 ==> Restart

GRID is 165 by 25 NODEs
COORDinate NODEs X: MINImum=0.0, MAXImum=1.64e+3
COORDinate NODEs Y: MINImum=0.0, MAXImum=2.40e+2

GRAVity 0. -1. 0.

PROPerties: UPWInd
MATERial POROSity 0.43
HYDRaulic properties S = 0., Kx = 3.28 ft/d, Ky = 3.28 ft/d
MULTIphase VAN Genuchten MUALem: n=3.0, alpha=4.572, Sr=0.104651162 ! Sand Soil

! Initial condition
IF(INIT=0) THEN
SET P to 200
ELSE
READ UNFO "RSRT.sav" and make a fresh START !use restart file
ENDIF
RELAX S 0.005

LOCate subregion ID=LHEAD for COORDinates (-0.5,-0.5) to (0.5,164.5) select BOUNDary
LOCate subregion ID=LFLUX for COORDinates (-0.5,164.5) to (0.5,240.5) select BOUNDary

BOUNDary condition for P: VALUe is LINEAr function (164.) (-1)(Y) at ID=LHEAD
BOUNDary condition for P: FLUX = 0. at ID=LFLUX
BOUNDary condition for P: X+, FLUX = 0.

BOUNDary condition for P: Y-, FLUX = 0.
BOUNDary condition for P: Y+, FLUX = 0.0328

! Solution controls
MATRix NSPC for P precon=CHOL, accel=CONJ, MODI
MATRix ITERation 100

CONVergence REFERENCE based on ALL: Tolerance = 1.E-5, 100 outer iterations

DIAGnostic P node (164,60) every 1 step

```

```
SOLVe P in STEAdy mode: max=100, min=100
SAVE P S MOIS to "INIT.sav" UNFormatted using COMpact NOW
SAVE P H to '4.2-p2.sav' NOW
```

END

4.3 Steady-state, Two-Dimensional Flow through a Heterogeneous Aquifer System.

Figure 4.3.1 schematically illustrates a particular problem involving steady-state groundwater flow through a heterogeneous subsurface system. The problem shown in Figure 4.3.1 was chosen as a test case to verify that PORFLOW can correctly solve a groundwater flow problem involving a non-uniform hydraulic conductivity field. Problem parameters were carefully chosen to enable analytic solution. Specifically, the boundary conditions and conductivity field were chosen to create two aquifers with a constant head difference. A constant head difference coupled with a uniform conductivity in the confining unit yields a uniform leakance between the two aquifers. Assuming flow in the aquifers is essentially one-dimensional (Dupuit assumption; typically an excellent assumption), analytical solutions can be derived for both the unconfined and confined aquifers for a constant source/sink term. These analytical solutions are presented below followed by PORFLOW simulation and comparison results.

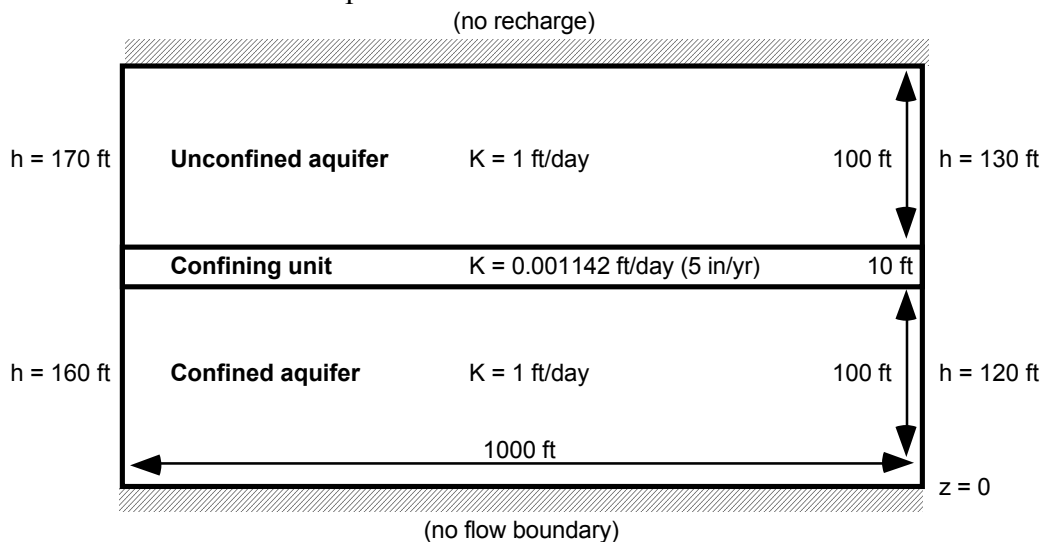

Figure 4.3.1. A Heterogeneous Subsurface System Consisting of an Unconfined Aquifer, Confining Unit and Confined Aquifer.

Unconfined aquifer analytical solution: Invoking the Dupuit assumption (de Marsily, 1986, Eq. (5.1.1)) gives the following general expression for flow in an unconfined aquifer

$$\frac{\partial}{\partial x} \left[\int_{\sigma}^h K_{xx} dz \frac{\partial h}{\partial x} \right] + \frac{\partial}{\partial y} \left[\int_{\sigma}^h K_{yy} dz \frac{\partial h}{\partial y} \right] = \omega_d \frac{\partial h}{\partial t} + Q \quad (4.3.1)$$

If K_{xx} and K_{yy} are constant along the z-axis, we can evaluate the integral to arrive at

$$\frac{\partial}{\partial x} \left[K_{xx} (h - \sigma) \frac{\partial h}{\partial x} \right] + \frac{\partial}{\partial y} \left[K_{yy} (h - \sigma) \frac{\partial h}{\partial y} \right] = \omega_d \frac{\partial h}{\partial t} + Q \quad (4.3.2)$$

For the special case of a horizontal aquifer ($\sigma = 0$), isotropic and uniform medium ($K_{xx} = K_{yy} = K$) and one-dimensional steady-state flow, Eq. 4.3.2 becomes

$$\frac{d^2 h^2}{dx^2} = \frac{2Q}{K} \quad (4.3.3)$$

For the prescribed head boundary conditions

$$h = h_0 \quad @ \quad x = 0 \quad (4.3.4a)$$

$$h = h_L \quad @ \quad x = L \quad (4.3.4b)$$

the solution can be derived using direct integration as

$$h^2 = h_0^2 + (h_L^2 - h_0^2) \frac{x}{L} + \frac{Q_{src} L^2}{K} \left(\frac{x}{L} \right) \left(1 - \frac{x}{L} \right) \quad (4.3.5)$$

where $Q_{src} = -Q$.

Confined aquifer analytical solution: Invoking the Dupuit assumption (de Marsily, 1986, Eq. (5.3.11)) gives the following general expression for flow in an confined aquifer

$$\nabla^2 h = \frac{\partial^2 h}{\partial x^2} + \frac{\partial^2 h}{\partial y^2} = \frac{S}{T} \frac{\partial h}{\partial t} + \frac{Q}{T} \quad (4.3.6)$$

where the ratio T/S is the aquifer diffusivity. For constant aquifer thickness, constant properties and one-dimensional steady flow, Eq. 3.3.6 becomes

$$\frac{d^2 h}{dx^2} = \frac{Q}{Ke} \quad (4.3.7)$$

where e is the thickness of the aquifer. For the prescribed head boundary conditions

$$h = h_0 \quad @ \quad x = 0 \quad (4.3.8a)$$

$$h = h_L \quad @ \quad x = L \quad (4.3.8b)$$

the solution can be derived using direct integration as

$$h = h_0 \left(1 - \frac{x}{L}\right) + h_L \left(\frac{x}{L}\right) + \frac{Q_{\text{src}} L^2}{2Ke} \left(\frac{x}{L}\right) \left(1 - \frac{x}{L}\right) \quad (4.3.9)$$

where $Q_{\text{src}} = -Q$.

PORFLOW numerical simulation and comparison: Figure 4.3.2 illustrates the grid chosen for the PORFLOW simulation. The mesh contains 51 nodes in the x-direction for a mesh spacing of 20 feet and 106 nodes in the y-direction for a mesh spacing of 2 feet. Table 4.3.1 and Figure 4.3.3 present the PORFLOW results alongside the approximate analytical results. As the water flows from the left boundary of the unconfined aquifer, vertical velocity components become evident due to the curvature of the watertable. This impact can be shown by the hydraulic head in the unconfined aquifer falling below the analytical solution and consequently raising the hydraulic head in the confined aquifer. The agreement between the code and analytical solution is excellent. The PORFLOW input commands are shown in Table 4.3.2.

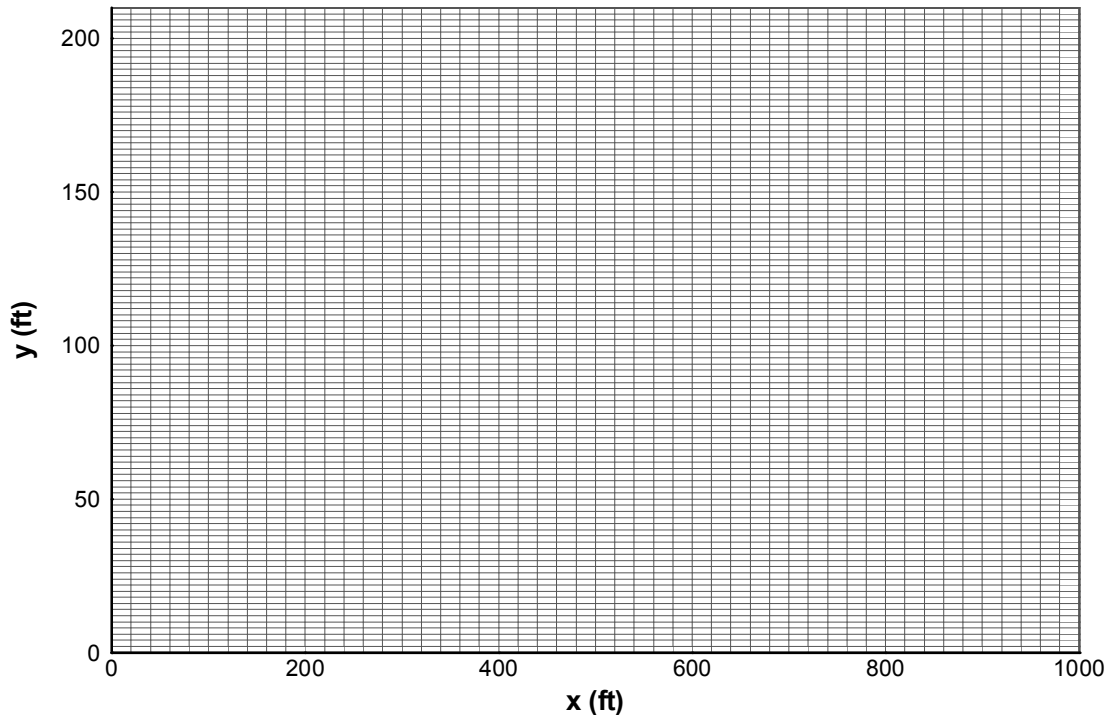

Figure 4.3.2. PORFLOW Grid for Problem 4.3.

Table 4.3.1. Approximate Analytical and PORFLOW Hydraulic Head Solution for the Unconfined and Confined Aquifers.

x/L	x (ft)	Unconfined aquifer head		Confined aquifer head	
		Analytical (ft)	PORFLOW @ y=160' (ft)	Analytical (ft)	PORFLOW @ y=50' (ft)
0.00	0	170.000	170.000	160.000	160.000
0.05	50	168.187	168.093	158.271	158.260
0.10	100	166.367	166.224	156.514	156.498
0.15	150	164.539	164.405	154.728	154.707
0.20	200	162.701	162.631	152.913	152.889
0.25	250	160.852	160.955	151.070	151.044
0.30	300	158.993	159.145	149.199	149.170
0.35	350	157.120	157.011	147.299	147.269
0.40	400	155.233	154.990	145.370	145.340
0.45	450	153.330	153.037	143.413	143.384
0.50	500	151.408	151.146	141.427	141.401
0.55	550	149.465	149.310	139.413	139.389
0.60	600	147.497	147.606	137.370	137.350
0.65	650	145.501	145.779	135.299	135.281
0.70	700	143.470	143.273	133.199	133.184
0.75	750	141.400	141.128	131.070	131.059
0.80	800	139.281	139.028	128.913	128.904
0.85	850	137.101	137.017	126.728	126.721
0.90	900	134.845	135.072	124.514	124.509
0.95	950	132.489	132.870	122.271	122.266
1.00	1000	130.000	130.000	120.000	120.000

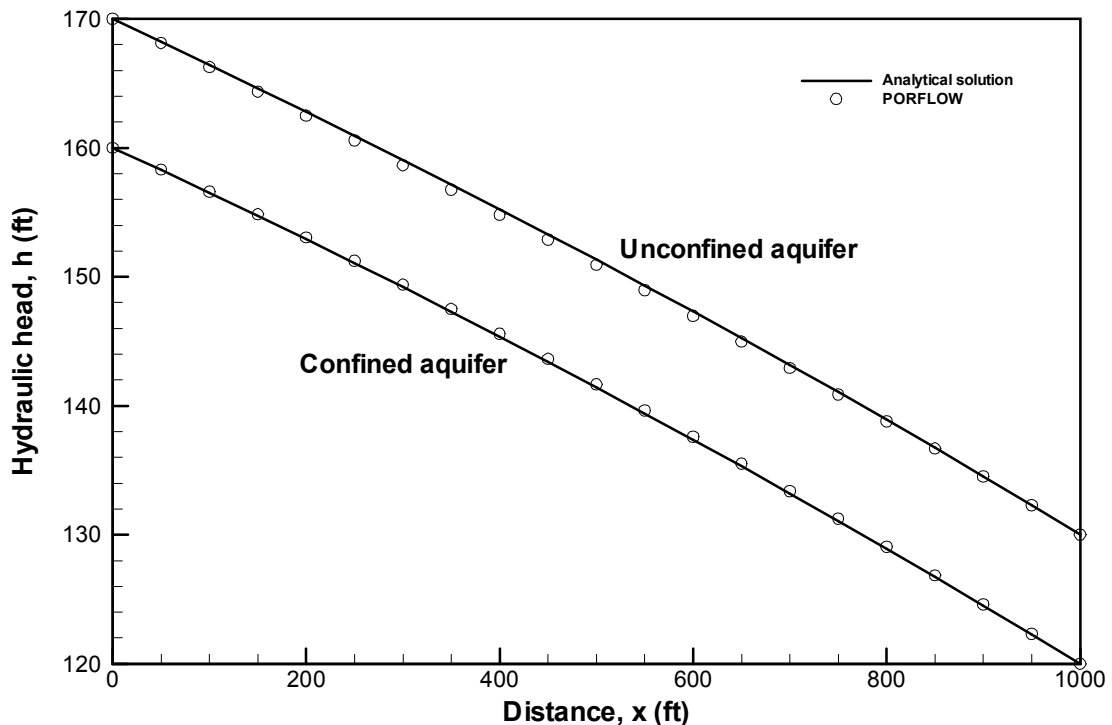

Figure 4.3.3. Approximate Analytical and PORFLOW Hydraulic Head Profiles for the Unconfined and Confined Aquifers.

Table 4.3.2. Input Commands for Problem 4.3

```

*****
TITLE 4.3 Steady-state, 2-D Flow through a heterogenous aquifer system
*****

*****

GRID is 51 by 106 NODEs
COORDinate NODEs X: MINIMUM=0.0, MAXIMUM=1.0e+3
COORDinate NODEs Y: MINIMUM=0.0, MAXIMUM=2.1e+2

GRAVity 0. -1. 0.

!Material Specifications
LOCate subregion ID=MAT1 for COORDinates ( 0.,0.) to (1000.,100.) output to "MAT1.loc"
MATERial type 1 for subregion ID=MAT1
LOCate subregion ID=MAT2 for COORDinates (0.,100.) to (1000.,110.) output to "MAT2.loc"
MATERial type 2 for subregion ID=MAT2
LOCate subregion ID=MAT3 for COORDinates (0.,110.) to (1000.,210.) output to "MAT3.loc"
MATERial type 3 for subregion ID=MAT3

PROPerties: GEOMetric

FOR material type 1
MATERial PORosity 0.3
HYDRaulic properties S = 0., Kx = 1. ft/d, Ky = 1. ft/d
MULTiphase VAN Genuchten MUALem: n=3.0, alpha=4.572, Sr=0.104651162 ! Sand Soil

FOR material type 2
MATERial PORosity 0.3
HYDRaulic properties S = 0., Kx = 1.142e-3 ft/d, Ky = 1.142e-3 ft/d
MULTiphase VAN Genuchten MUALem: n=1.1, alpha=0.3048, Sr=0.250000000 ! Clay Soil

FOR material type 3
MATERial PORosity 0.3
HYDRaulic properties S = 0., Kx = 1. ft/d, Ky = 1. ft/d
MULTiphase VAN Genuchten MUALem: n=3.0, alpha=4.572, Sr=0.104651162 ! Sand Soil

SET P = 0 everywhere initially

BOUNDary condition for P: X-, VALUe is LINEar function (160.) (-1)(Y) at ID=MAT1
BOUNDary condition for P: X-, FLUX = 0. at ID=MAT2
BOUNDary condition for P: X-, VALUe is LINEar function (170.) (-1)(Y) at ID=MAT3

BOUNDary condition for P: X+, VALUe is LINEar function (120.) (-1)(Y) at ID=MAT1
BOUNDary condition for P: X+, FLUX = 0. at ID=MAT2
BOUNDary condition for P: X+, VALUe is LINEar function (130.) (-1)(Y) at ID=MAT3

BOUNDary condition for P: Y-, FLUX = 0.
BOUNDary condition for P: Y+, FLUX = 0.

! Solution controls
MATRix NSPC for P precon=CHOL, accel=CONJ, MODI
MATRix ITERation 500

RELAX S 0.01

CONVergence REFERENCE based on ALL: Tolerance = 1.E-6, 100 outer iterations

DIAGnostic P DP BP RP node (100,210) every 1 step

SOLVe P in STEAdy mode: max=300, min=300
SAVE P H to '4.3.sav' NOW

END

```

4.4 Unconfined Aquifer Subject to Combined Recharge/Drain BC

Figure 4.4.1 schematically illustrates an unconfined aquifer experiencing both recharge and drainage at the ground surface. The position of the seepage line is unknown a priori. This test case is designed to test the implementation of a combined recharge/drain Cauchy boundary condition. The results of the PORFLOW simulation will be compared to an approximate analytical solution and to a finite element simulation of Richard’s equation using the Earth Science Module in COMSOL Multiphysics (COMSOL AB, 2006).

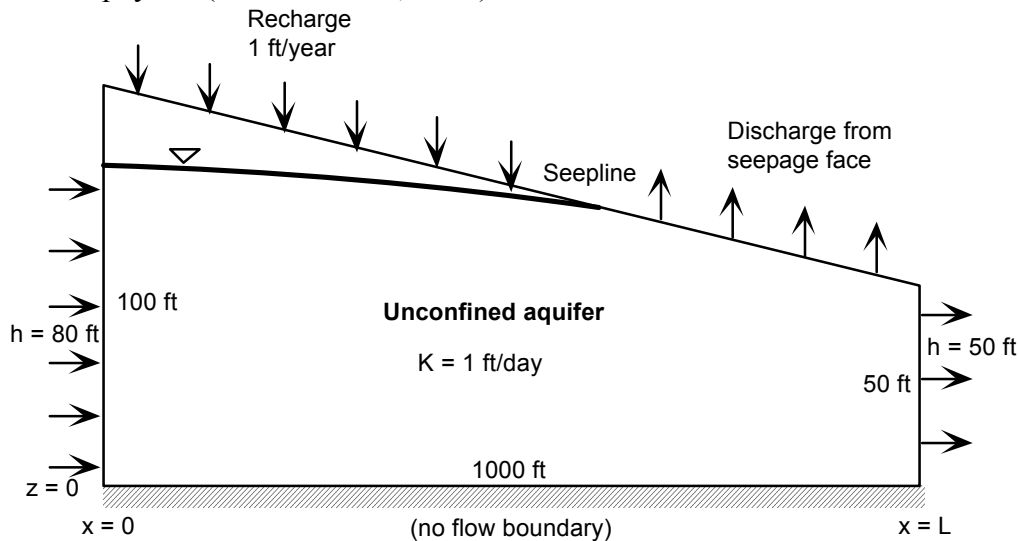

Figure 4.4.1. Schematic Illustration of an Unconfined Aquifer Experiencing both Recharge and Drainage at the Ground Surface; Seepage line unknown a priori.

Analytical solution: With the Dupuit assumption, an analytical solution can be derived for the problem. Between the left boundary and the seepage line, there is an unconfined aquifer subject to a recharge rate of 1 ft/yr. From inspection of Eq. 4.3.5, the analytical solution for hydraulic head is

$$h^2 = h_0^2 + (h_s^2 - h_0^2) \frac{x}{L_s} + \frac{Q_{src} L^2}{K} \left(\frac{x}{L_s} \right) \left(1 - \frac{x}{L_s} \right) \quad 0 \leq x \leq L_s \quad (4.4.1)$$

where the seepage line is positioned at $x = L_s$, the hydraulic head at the seepage line is h_s . The other variables are defined as before. Along the seepage face, the drain coefficient is assumed sufficiently large that the hydraulic head is the same as the ground elevation. That is,

$$h = 50 \left(2 - \frac{x}{L} \right) \quad L_s \leq x \leq L \quad (4.4.2)$$

The location of the seepage line is obtained by simultaneous solution of the following nonlinear equation set:

$$h = 50 \left(2 - \frac{L_s}{L} \right) \tag{4.4.3}$$

$$\left. \frac{dh}{dx} \right|_{x=L_s^-} = \frac{1}{h_s} \left[\frac{h_s^2 - h_0^2}{2L_s} - \frac{Q_{src}L_s}{2K} \right] = \frac{h_L - h_s}{L - L_s} = \left. \frac{dh}{dx} \right|_{x=L_s^+} \tag{4.4.4}$$

For the parameter values indicated in Figure 4.4.1, the location of the seepage is $L_s = 829$ ft.

Implementation of Recharge/Drain Boundary Condition in PORFLOW and COMSOL: A full discussion the head-dependent recharge and drain boundary condition can be found in Section 3.1.7.1 of the FACT Version 2.0 manual (Hamm and Aleman, 2000). In summary, the recharge/drain boundary condition is implemented as shown in Figure 4.4.2.

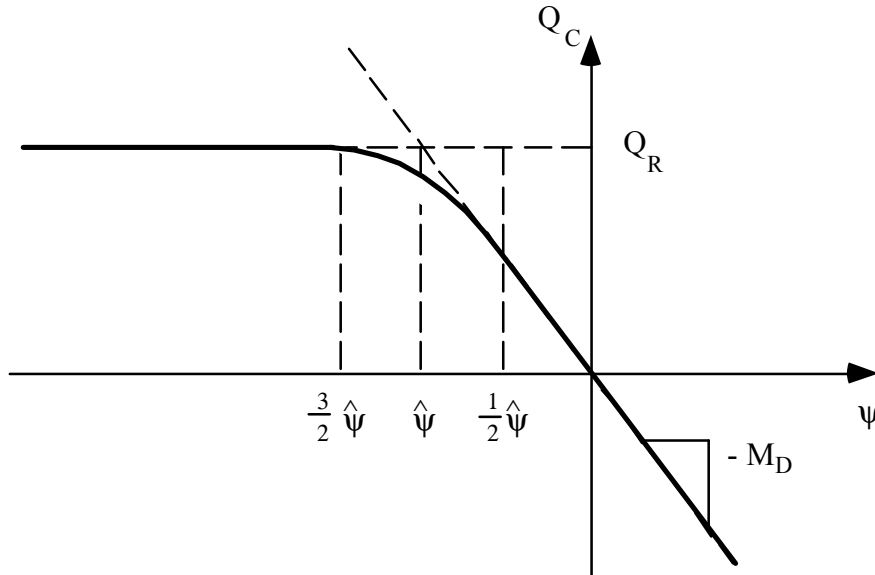

Figure 4.4.2. Cauchy Boundary Condition for the Simultaneous Treatment of Groundwater Recharge and Drainage.

The mathematical formulation chosen for this function, as shown in Figure 4.4.2 is

$$Q_c = \begin{cases} Q_R & \text{for } \psi \leq \frac{3}{2} \hat{\psi} \\ \frac{Q_R}{8} [7 - 2x - x^2] & \text{for } \frac{3}{2} \hat{\psi} < \psi < \frac{1}{2} \hat{\psi} \\ -M_D \psi & \text{for } \frac{1}{2} \hat{\psi} \leq \psi \end{cases} \tag{4.4.5}$$

where

$$\psi = h - y_c \tag{4.4.6a}$$

$$Q_R = A_D R_{max} \tag{4.4.6b}$$

$$M_D = A_D \left(\frac{K}{b} \right)_D \tag{4.4.6c}$$

$$x = 2 \frac{\hat{\psi} - \psi}{\hat{\psi}} \tag{4.4.6d}$$

$$\hat{\psi} = - \frac{Q_R}{M_D} \tag{4.4.6e}$$

and

- y_c nodal surface elevation, ft
- ψ nodal surface pressure head, ft
- Q_c nodal volumetric source or sink flow at surface, ft³/day
- R_{max} maximum recharge, ft/day
- A_D nodal area available for recharge and drainage (computed), ft²
- $(K/b)_D$ surface leakance coefficient, 1/day

Equation 4.4.5 is divided by the nodal area, A_D , to get the expression back to a flux boundary condition, that is required by both PORFLOW and COMSOL as

$$R_c = \begin{cases} R_{max} & \text{for } \psi \leq \frac{3}{2} \hat{\psi} \\ \frac{R_{max}}{8} [7 - 2x - x^2] & \text{for } \frac{3}{2} \hat{\psi} < \psi < \frac{1}{2} \hat{\psi} \\ -(K/b)_D \psi & \text{for } \frac{1}{2} \hat{\psi} \leq \psi \end{cases} \tag{4.4.7}$$

The maximum recharge, R_{max} , is 1 ft/day as shown in Figure 4.4.1. The surface leakance coefficient was set to 1 day⁻¹.

PORFLOW numerical simulation and comparison: The PORFLOW mesh is show in Figure 4.4.3. The mesh contains 21 nodes in the x-direction for a mesh spacing of 50 feet and 21 nodes in the y-direction. The mesh is non-orthogonal in y and has a mesh spacing of 5 feet at the left boundary and a mesh spacing of 2.5 feet at the right boundary. The COMSOL finite-element mesh is shown in Figure 4.4.4 and consists of 9648 triangular elements and 5112 mesh points.

The analytical solution assumes that the recharge is constant at 1 ft/day from the left boundary to the seepline. Figure 4.4.5 and Table 4.4.1 illustrate that the analytical solution (1) predicts higher hydraulic heads than PORFLOW or COMSOL. The implementation of Eq. 4.4.7 in PORFLOW and COMSOL results in the recharge rate varying from a maximum of 1 ft/day to 0 ft/day at the seepline. The effective recharge into the PORFLOW and COMSOL mesh is less than 1 ft/day. An effective recharge rate of 0.67 ft/day in Eq. 4.4.1 provides excellent agreement between the analytical solution (2) and the numerical simulations (Figure 4.4.5). The PORFLOW input commands and grid file are given in Tables 4.4.2 and 4.4.3, respectively.

The drain portion of the recharge/drain boundary condition could not be implemented in PORFLOW due to convergence issues. The Earth Science Module in COMSOL with a fine mesh converged quite rapidly for this problem.

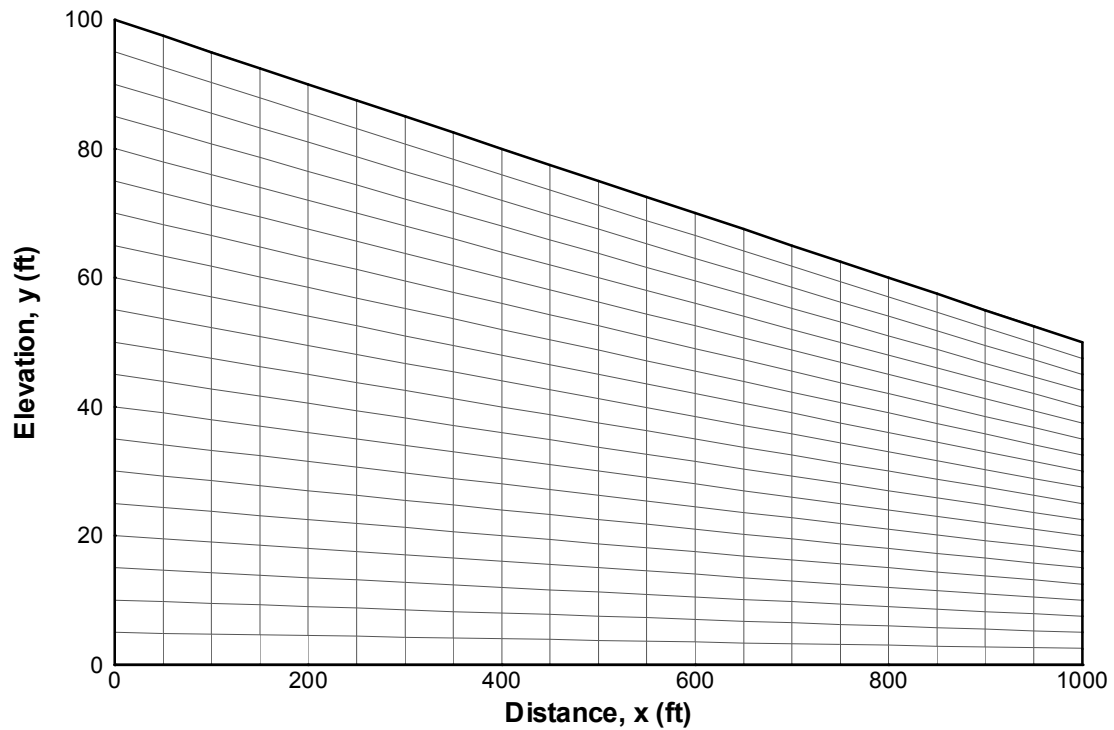

Figure 4.4.3. PORFLOW Grid for Problem 4.4.

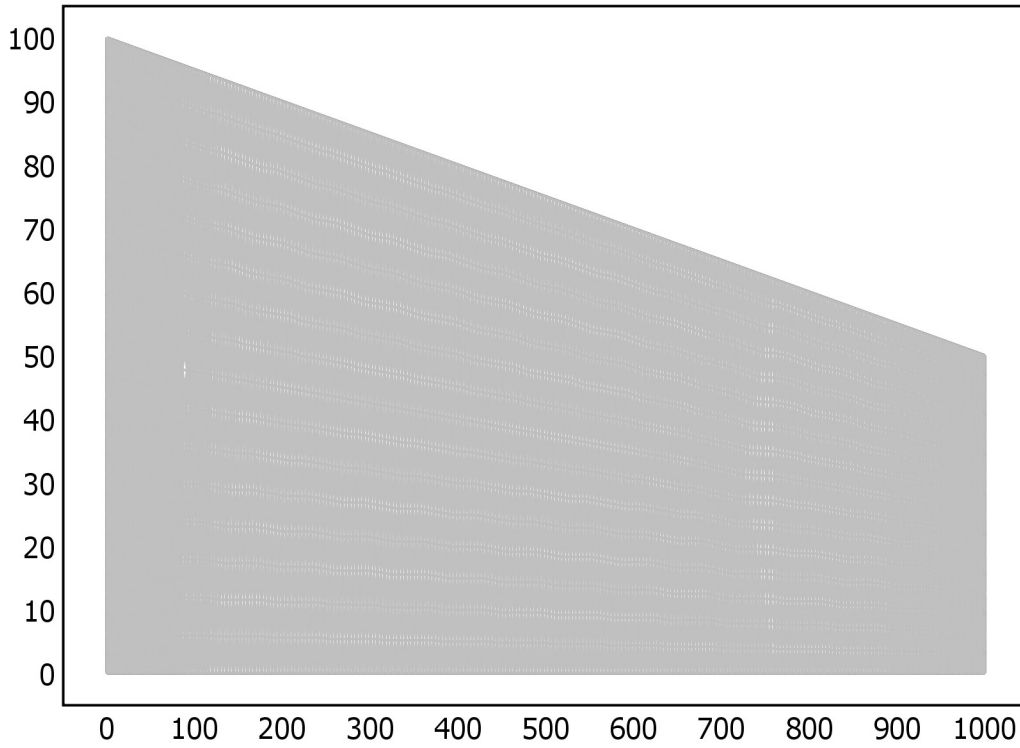

Figure 4.4.4. COMSOL Finite-Element Mesh for Problem 4.4.

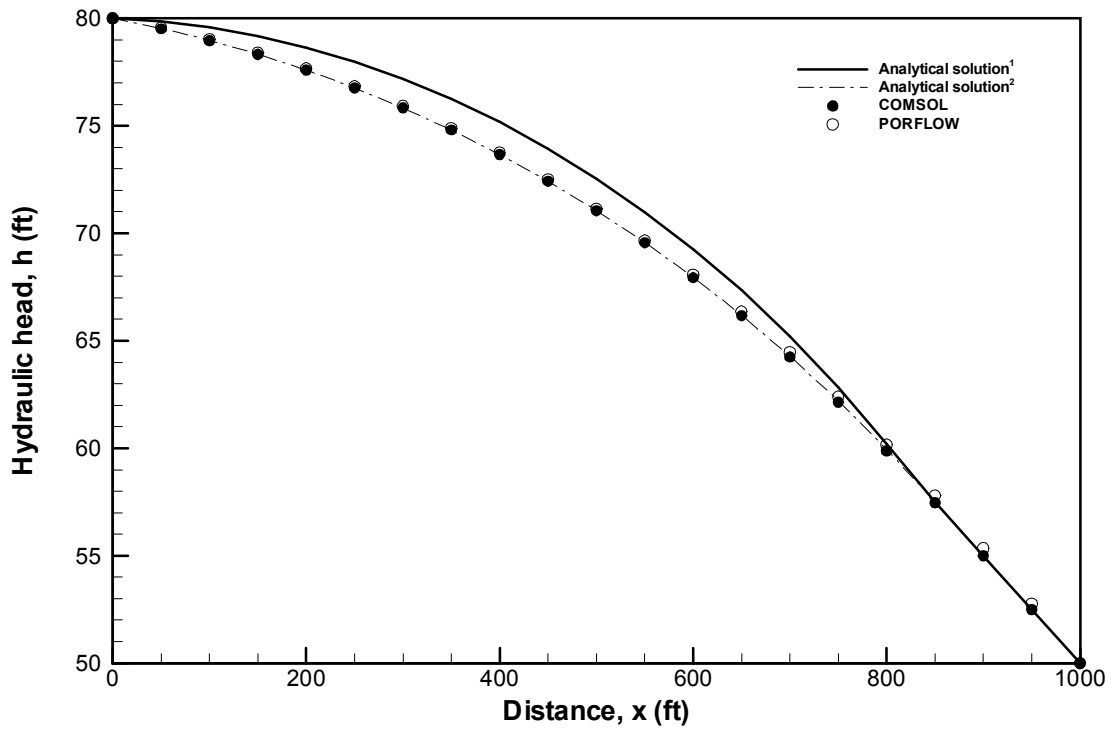

Figure 4.4.5. Comparison of PORFLOW Hydraulic Head Distribution to Analytical Solution and COMSOL Simulation (Y = 0).

Table 4.4.1. Analytical, COMSOL and PORFLOW Water Table Comparison

Horizontal distance, x (ft)	Analytical ¹ head (ft)	Analytical ² head (ft)	COMSOL head (ft)	PORFLOW head (ft)
0	80.000	80.000	80.000	80.000
50	79.850	79.532	79.512	79.574
100	79.575	78.976	78.960	79.031
150	79.173	78.331	78.322	78.394
200	78.642	77.594	77.591	77.661
250	77.980	76.762	76.764	76.839
300	77.184	75.833	75.838	75.912
350	76.248	74.803	74.808	74.880
400	75.168	73.667	73.672	73.753
450	73.938	72.421	72.424	72.507
500	72.550	71.058	71.058	71.136
550	70.994	69.572	69.564	69.654
600	69.259	67.956	67.937	68.075
650	67.333	66.198	66.170	66.352
700	65.196	64.289	64.243	64.463
750	62.829	62.213	62.149	62.397
800	60.204	59.953	59.880	60.157
850	57.500	57.500	57.468	57.804
900	55.000	55.000	54.994	55.344
950	52.500	52.500	52.500	52.768
1000	50.000	50.000	50.000	50.000

Table 4.4.2. Input Commands for Problem 4.4.

```

*****
TITLE 4.4 Unconfined Aquifer Subject to combined recharge/drain BC
*****

*****

DEFine INIT=1

GRID is 21 by 21 NODEs
COORDinate NODEs BLOCK X,Y from file '4.4.xyz'

GRAVity 0. -1. 0.

PROPerties: GEOMetric

MATERial PORosity 0.3
HYDRaulic properties S = 1., Kx = 1. ft/d, Ky = 1. ft/d
MULTiphase VAN Genuchten MUALem: n=1.1, alpha=0.3048, Sr=0.25000000 ! Clay Soil

IF (INIT=0) THEN
SET P = 0
ELSE
READ from archive file '4.4.ini' in UNFormatted mode START
ENDIF

Boundary condition for P: X-, VALUe is LINEar function (80.) (-1)(Y)
Boundary condition for P: X+, VALUe is LINEar function (50.) (-1)(Y)

Boundary condition for P: Y-, FLUX = 0.
Boundary condition for P: Y+, FLUX: TABLE of values: 13 sets (P,value)
(-1.0000E+02, 2.7397E-03), (-4.1096E-03, 2.7397E-03),

```

PORFLOW Testing and Verification Document

(-3.8356E-03, 2.7260E-03), (-3.5616E-03, 2.6849E-03),
 (-3.2877E-03, 2.6164E-03), (-3.0137E-03, 2.5205E-03),
 (-2.7397E-03, 2.3973E-03), (-2.4658E-03, 2.2466E-03),
 (-2.1918E-03, 2.0685E-03), (-1.9178E-03, 1.8630E-03),
 (-1.6438E-03, 1.6301E-03), (-1.3699E-03, 1.3699E-03),
 (0.0000E+00, 0.0000E+00) !Recharge/Drain

! Solution controls
 MATRix NSPC for P precon=CHOL, accel=CONJ, MODI
 MATRix ITERation 100

RELAX P 0.5

CONVergence REFERENCE for ALL: Tolerance = 1.E-4, 200 outer iterations

DIAGnostic H DP BP RP node (20,21) every 1 step

TIME = 0
 SOLV e P in STEAdy mode: max=5000, min=5000
 SAVE P H U V to '4.4.sav' NOW
 SAVE file to '4.4.rst' in UNFORmatted mode

END

Table 4.4.3. Nodal Grid for Problem 4.4.

0.	50.	100.	150.	200.	250.	300.	350.	400.	450.	500.
	550.	600.	650.	700.	750.	800.	850.	900.	950.	1000.
0.	50.	100.	150.	200.	250.	300.	350.	400.	450.	500.
	550.	600.	650.	700.	750.	800.	850.	900.	950.	1000.
0.	50.	100.	150.	200.	250.	300.	350.	400.	450.	500.
	550.	600.	650.	700.	750.	800.	850.	900.	950.	1000.
0.	50.	100.	150.	200.	250.	300.	350.	400.	450.	500.
	550.	600.	650.	700.	750.	800.	850.	900.	950.	1000.
0.	50.	100.	150.	200.	250.	300.	350.	400.	450.	500.
	550.	600.	650.	700.	750.	800.	850.	900.	950.	1000.
0.	50.	100.	150.	200.	250.	300.	350.	400.	450.	500.
	550.	600.	650.	700.	750.	800.	850.	900.	950.	1000.
0.	50.	100.	150.	200.	250.	300.	350.	400.	450.	500.
	550.	600.	650.	700.	750.	800.	850.	900.	950.	1000.
0.	50.	100.	150.	200.	250.	300.	350.	400.	450.	500.
	550.	600.	650.	700.	750.	800.	850.	900.	950.	1000.
0.	50.	100.	150.	200.	250.	300.	350.	400.	450.	500.
	550.	600.	650.	700.	750.	800.	850.	900.	950.	1000.
0.	50.	100.	150.	200.	250.	300.	350.	400.	450.	500.
	550.	600.	650.	700.	750.	800.	850.	900.	950.	1000.
0.	50.	100.	150.	200.	250.	300.	350.	400.	450.	500.
	550.	600.	650.	700.	750.	800.	850.	900.	950.	1000.
0.	50.	100.	150.	200.	250.	300.	350.	400.	450.	500.
	550.	600.	650.	700.	750.	800.	850.	900.	950.	1000.
0.	50.	100.	150.	200.	250.	300.	350.	400.	450.	500.
	550.	600.	650.	700.	750.	800.	850.	900.	950.	1000.
0.0000	0.0000	0.0000	0.0000	0.0000	0.0000	0.0000	0.0000	0.0000	0.0000	0.0000
0.0000	0.0000	0.0000	0.0000	0.0000	0.0000	0.0000	0.0000	0.0000	0.0000	0.0000
0.0000	0.0000	0.0000	0.0000	0.0000	0.0000	0.0000	0.0000	0.0000	0.0000	0.0000
5.0000	4.8750	4.7500	4.6250	4.5000	4.3750	4.2500				

4.1250	4.0000	3.8750	3.7500	3.6250	3.5000	3.3750
3.2500	3.1250	3.0000	2.8750	2.7500	2.6250	2.5000
10.0000	9.7500	9.5000	9.2500	9.0000	8.7500	8.5000
8.2500	8.0000	7.7500	7.5000	7.2500	7.0000	6.7500
6.5000	6.2500	6.0000	5.7500	5.5000	5.2500	5.0000
15.0000	14.6250	14.2500	13.8750	13.5000	13.1250	12.7500
12.3750	12.0000	11.6250	11.2500	10.8750	10.5000	10.1250
9.7500	9.3750	9.0000	8.6250	8.2500	7.8750	7.5000
20.0000	19.5000	19.0000	18.5000	18.0000	17.5000	17.0000
16.5000	16.0000	15.5000	15.0000	14.5000	14.0000	13.5000
13.0000	12.5000	12.0000	11.5000	11.0000	10.5000	10.0000
25.0000	24.3750	23.7500	23.1250	22.5000	21.8750	21.2500
20.6250	20.0000	19.3750	18.7500	18.1250	17.5000	16.8750
16.2500	15.6250	15.0000	14.3750	13.7500	13.1250	12.5000
30.0000	29.2500	28.5000	27.7500	27.0000	26.2500	25.5000
24.7500	24.0000	23.2500	22.5000	21.7500	21.0000	20.2500
19.5000	18.7500	18.0000	17.2500	16.5000	15.7500	15.0000
35.0000	34.1250	33.2500	32.3750	31.5000	30.6250	29.7500
28.8750	28.0000	27.1250	26.2500	25.3750	24.5000	23.6250
22.7500	21.8750	21.0000	20.1250	19.2500	18.3750	17.5000
40.0000	39.0000	38.0000	37.0000	36.0000	35.0000	34.0000
33.0000	32.0000	31.0000	30.0000	29.0000	28.0000	27.0000
26.0000	25.0000	24.0000	23.0000	22.0000	21.0000	20.0000
45.0000	43.8750	42.7500	41.6250	40.5000	39.3750	38.2500
37.1250	36.0000	34.8750	33.7500	32.6250	31.5000	30.3750
29.2500	28.1250	27.0000	25.8750	24.7500	23.6250	22.5000
50.0000	48.7500	47.5000	46.2500	45.0000	43.7500	42.5000
41.2500	40.0000	38.7500	37.5000	36.2500	35.0000	33.7500
32.5000	31.2500	30.0000	28.7500	27.5000	26.2500	25.0000
55.0000	53.6250	52.2500	50.8750	49.5000	48.1250	46.7500
45.3750	44.0000	42.6250	41.2500	39.8750	38.5000	37.1250
35.7500	34.3750	33.0000	31.6250	30.2500	28.8750	27.5000
60.0000	58.5000	57.0000	55.5000	54.0000	52.5000	51.0000
49.5000	48.0000	46.5000	45.0000	43.5000	42.0000	40.5000
39.0000	37.5000	36.0000	34.5000	33.0000	31.5000	30.0000
65.0000	63.3750	61.7500	60.1250	58.5000	56.8750	55.2500
53.6250	52.0000	50.3750	48.7500	47.1250	45.5000	43.8750
42.2500	40.6250	39.0000	37.3750	35.7500	34.1250	32.5000
70.0000	68.2500	66.5000	64.7500	63.0000	61.2500	59.5000
57.7500	56.0000	54.2500	52.5000	50.7500	49.0000	47.2500
45.5000	43.7500	42.0000	40.2500	38.5000	36.7500	35.0000
75.0000	73.1250	71.2500	69.3750	67.5000	65.6250	63.7500
61.8750	60.0000	58.1250	56.2500	54.3750	52.5000	50.6250
48.7500	46.8750	45.0000	43.1250	41.2500	39.3750	37.5000
80.0000	78.0000	76.0000	74.0000	72.0000	70.0000	68.0000
66.0000	64.0000	62.0000	60.0000	58.0000	56.0000	54.0000
52.0000	50.0000	48.0000	46.0000	44.0000	42.0000	40.0000
85.0000	82.8750	80.7500	78.6250	76.5000	74.3750	72.2500
70.1250	68.0000	65.8750	63.7500	61.6250	59.5000	57.3750
55.2500	53.1250	51.0000	48.8750	46.7500	44.6250	42.5000
90.0000	87.7500	85.5000	83.2500	81.0000	78.7500	76.5000
74.2500	72.0000	69.7500	67.5000	65.2500	63.0000	60.7500
58.5000	56.2500	54.0000	51.7500	49.5000	47.2500	45.0000
95.0000	92.6250	90.2500	87.8750	85.5000	83.1250	80.7500
78.3750	76.0000	73.6250	71.2500	68.8750	66.5000	64.1250
61.7500	59.3750	57.0000	54.6250	52.2500	49.8750	47.5000
100.0000	97.5000	95.0000	92.5000	90.0000	87.5000	85.0000
82.5000	80.0000	77.5000	75.0000	72.5000	70.0000	67.5000
65.0000	62.5000	60.0000	57.5000	55.0000	52.5000	50.0000

4.5 Transient, One-Dimensional Flow to a Well in a Confined Aquifer (Theis, 1935)

The problem involves radial flow to a well in a confined aquifer whose classic solution is given by Theis (1935). The problem is illustrated in Figure 4.5.1. Specifically we consider an aquifer with the following attributes:

- homogeneous, isotropic, and of uniform thickness

- fully confined above and below by impervious layers
- infinite in horizontal extent
- water is released instantaneously from storage when hydraulic head decreases
- homogeneous and isotropic properties
- the screen of the pumped well fully penetrates the aquifer
- well diameter is very small, so that storage in the well can be neglected
- water is pumped at a constant rate from the well, and enters uniformly along the well screen
- prior to pumping, the aquifer is in a state of equilibrium

The parameter values chosen for PORFLOW are given in Figure 4.5.1 and are equivalent to those chosen by Anderson (1993, Problem 1) for MODFLOW simulations.

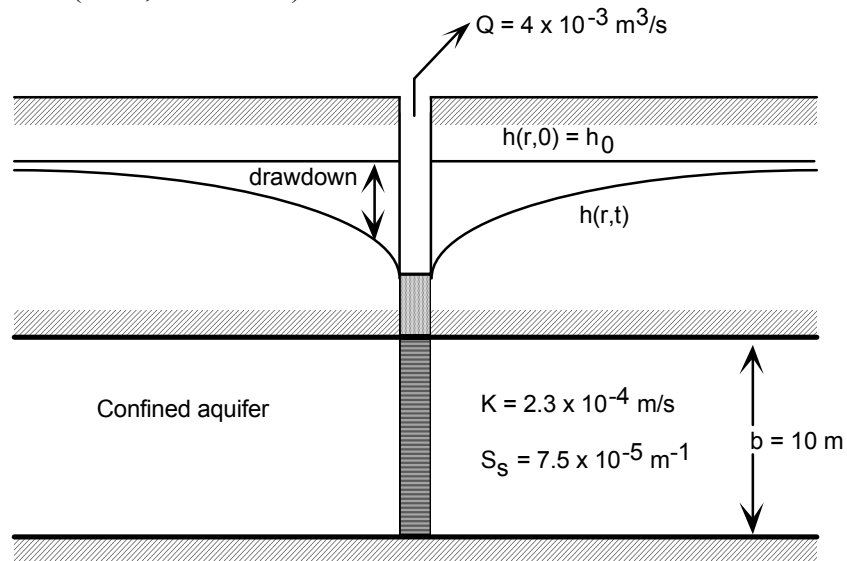

Figure 4.5.1. Radial Flow to a Pumping Well in a Confined Aquifer.

Their analytical solution: The governing equation for the flow problem described above is (Freeze and Cherry, 1979, Section 8.3)

$$\frac{1}{r} \frac{\partial}{\partial r} \left(r \frac{\partial h}{\partial r} \right) = \frac{S}{T} \frac{\partial h}{\partial t} \quad (4.5.1)$$

The initial condition is

$$h(r,0) = h_0 \quad (4.5.2)$$

where h_0 is the constant initial head.

The boundary conditions assume no drawdown in hydraulic head at the infinite boundary

$$h(\infty, t) = h_0 \quad (4.5.3)$$

and a constant pumping rate Q at the well:

$$\lim_{r \rightarrow 0} \left(r \frac{\partial h}{\partial r} \right) = \frac{Q}{2\pi T} \quad \text{for } t > 0 \quad (4.5.4)$$

Because the aquifer properties are homogeneous

$$S = S_s b \quad (4.5.5a)$$

$$T = Kb \quad (4.5.5b)$$

An analytical solution to Equation 4.5.1 subject to the initial and boundary conditions of Eqs. 4.5.2 through 4.5.5 is given by Theis (1935) in terms of drawdown as

$$s = h_0 - h(r, t) = \frac{Q}{4\pi T} \int_u^\infty \frac{e^{-\tau}}{\tau} d\tau = \frac{Q}{4\pi T} W(u) \quad (4.5.6)$$

where

$$u = \frac{r^2 S}{4Tt} \quad (4.5.7)$$

and $W(u)$ is known as the Theis well function. The well function (or the exponential integral) can be evaluated by polynomial and rational approximations given by Abramowitz and Stegun (1970, p. 231).

$$W(u) = \begin{cases} -0.5772 + u - 0.25u^2 + 0.055u^3 - 0.01u^4 + 0.001u^5 - \ln(u) & u < 1 \\ \frac{\exp(-u) u^4 + 8.58u^3 + 18.06u^2 + 8.64u + 0.27}{u^4 + 9.57u^3 + 25.63u^2 + 21.1u + 3.96} & u \geq 1 \end{cases} \quad (4.5.8)$$

Evaluations of the Theis solution for the parameter values specified in Figure 4.5.1 at a radial position of 55 meters from the well are presented in Tables 4.5.1 and 4.5.2 for various times.

PORFLOW simulation and comparison: This problem was solved using PORFLOW in one and two dimensions. Figure 4.5.2 shows the PORFLOW mesh in the radial coordinate system. The mesh consists of 1000 nodes in the radial direction with a finer mesh as you approach the pumping well at the left boundary. The mesh extends from 0.1 meters to 10000 meters in the radial direction. The three nodes in the x-direction are automatically added by PORFLOW for the

1D simulation. Refer to Table 4.5.3 for details of the simulation (material properties, initial and boundary conditions).

The COMSOL mesh, which is not shown, includes 916 finite elements and 917 nodes in the radial direction. The mesh extends from 0 meters to 10000 meters in the radial direction. COMSOL was also used to compute the Theis drawdown using Eqs. 4.5.6 to 4.5.8.

Figure 4.5.3 shows the PORFLOW mesh in the 2D Cartesian coordinate system. The mesh extends from -1200 to +1200 meters in each direction. There are 241 nodes in each direction for a total nodal count of 58081. The mesh is refined locally near the pumping well at the center of the mesh ($x=y=0$) because steep head gradients are expected there. Refer to Table 4.5.4 for details of the simulation.

Figure 4.5.4 illustrates the transient drawdown at a radial distance of 55 meters from the well for the Theis, COMSOL and PORFLOW numerical simulations. There is excellent agreement among the three numerical simulations. Tables 4.5.1 and 4.5.2 show the transient drawdown at short and longer times, respectively.

Figure 4.5.5 shows the PORFLOW drawdown at 1 day for the 2D Cartesian simulation. The near field results show the concentric circles of drawdown as expected while near the boundaries there is distortion of the drawdown contours due to boundary effects.

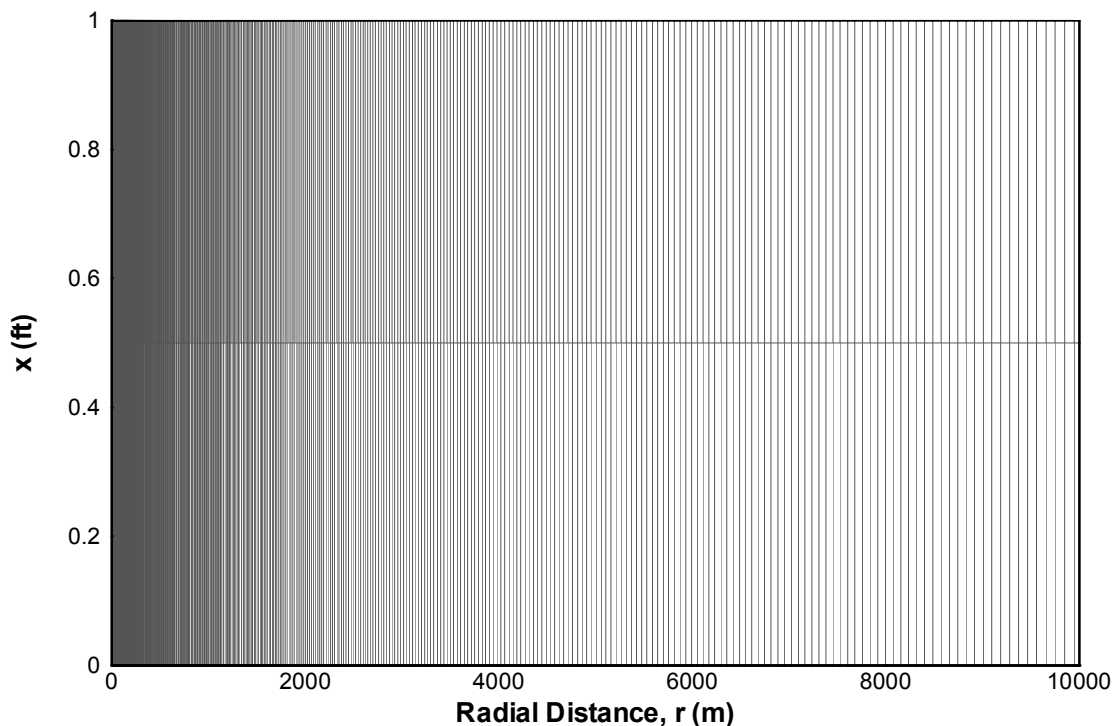

Figure 4.5.2. 1D PORFLOW Radial Grid for Problem 4.5.

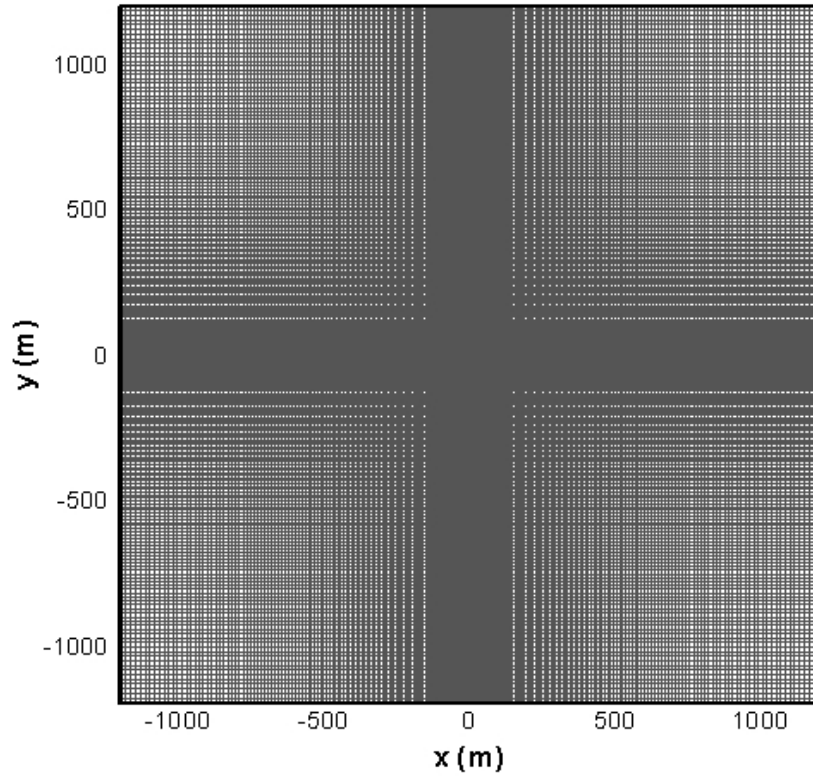

Figure 4.5.3. 2D PORFLOW Cartesian Grid for Problem 4.5.

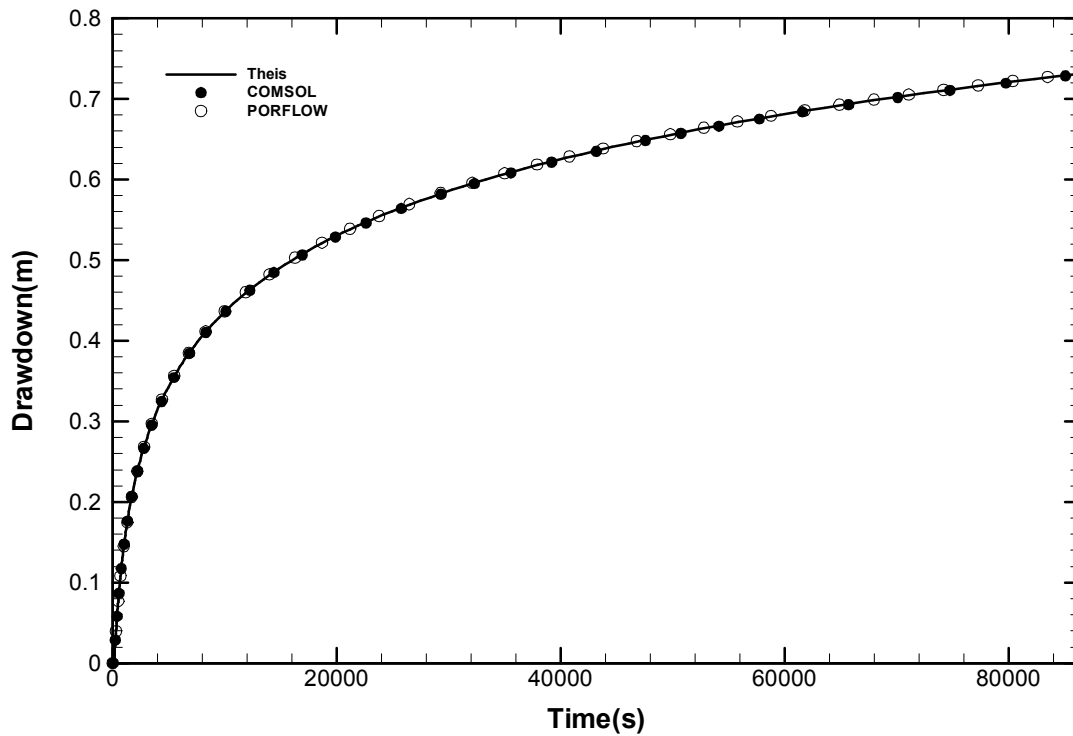

Figure 4.5.4. Theis, COMSOL and PORFLOW Transient Drawdown at $r = 55$ meters.

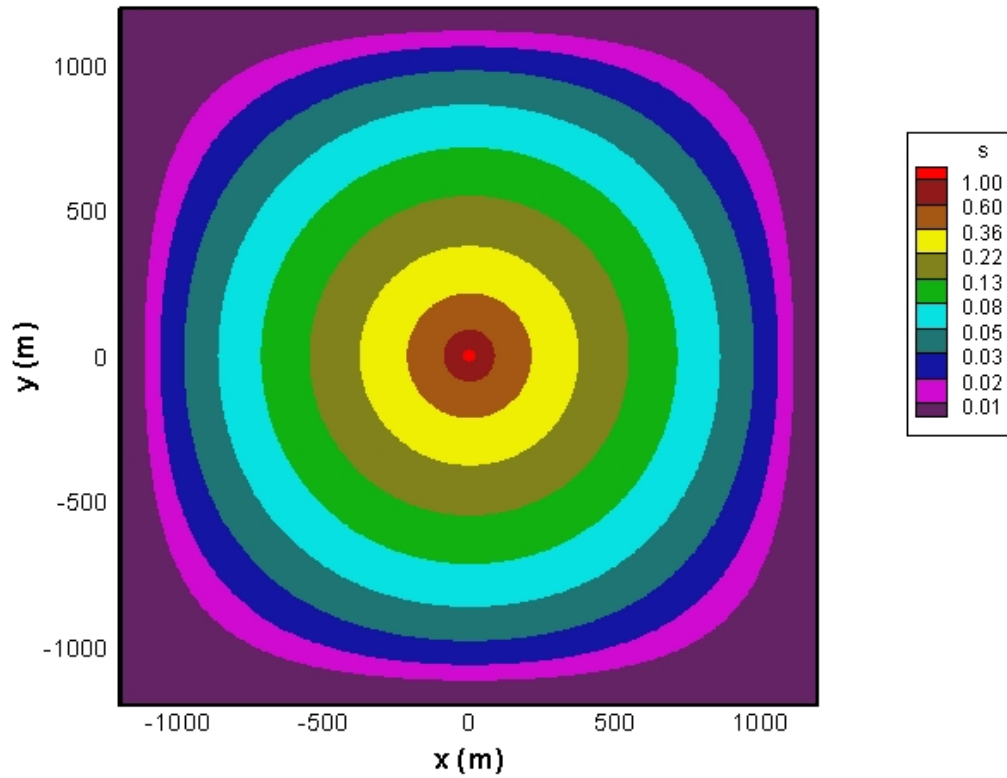

Figure 4.5.5. PORFLOW Drawdown at 1 day for 2D Cartesian Mesh.

Table 4.5.1. Comparison of Theis, COMSOL and PORFLOW Transient Drawdown (0 to 1 hour)

Time (sec)	Theis (m)	COMSOL (m)	PORFLOW (m)
0.00E+00	0.0000E+00	1.1855E-14	0.0000E+00
1.20E+02	6.2764E-03	8.1695E-03	5.6947E-03
2.40E+02	2.9013E-02	2.9221E-02	2.7228E-02
3.60E+02	5.3206E-02	5.1830E-02	5.1300E-02
4.80E+02	7.5200E-02	7.3004E-02	7.3423E-02
6.00E+02	9.4700E-02	9.2141E-02	9.3116E-02
7.20E+02	1.1203E-01	1.0941E-01	1.1064E-01
8.40E+02	1.2757E-01	1.2501E-01	1.2635E-01
9.60E+02	1.4161E-01	1.3886E-01	1.4054E-01
1.08E+03	1.5440E-01	1.5157E-01	1.5346E-01
1.20E+03	1.6614E-01	1.6328E-01	1.6532E-01
1.32E+03	1.7699E-01	1.7445E-01	1.7626E-01
1.44E+03	1.8706E-01	1.8481E-01	1.8641E-01
1.56E+03	1.9645E-01	1.9451E-01	1.9589E-01
1.68E+03	2.0526E-01	2.0357E-01	2.0476E-01
1.80E+03	2.1355E-01	2.1207E-01	2.1311E-01
1.92E+03	2.2137E-01	2.2005E-01	2.2098E-01
2.04E+03	2.2877E-01	2.2759E-01	2.2844E-01
2.16E+03	2.3581E-01	2.3473E-01	2.3552E-01
2.28E+03	2.4250E-01	2.4151E-01	2.4225E-01
2.40E+03	2.4889E-01	2.4798E-01	2.4868E-01
2.52E+03	2.5500E-01	2.5416E-01	2.5482E-01
2.64E+03	2.6085E-01	2.6008E-01	2.6070E-01
2.76E+03	2.6647E-01	2.6575E-01	2.6635E-01
2.88E+03	2.7186E-01	2.7120E-01	2.7177E-01
3.00E+03	2.7706E-01	2.7644E-01	2.7699E-01
3.12E+03	2.8207E-01	2.8149E-01	2.8202E-01
3.24E+03	2.8690E-01	2.8636E-01	2.8688E-01
3.36E+03	2.9157E-01	2.9107E-01	2.9157E-01
3.48E+03	2.9609E-01	2.9562E-01	2.9611E-01
3.60E+03	3.0046E-01	3.0002E-01	3.0050E-01

Table 4.5.2. Comparison of Theis, COMSOL and PORFLOW Transient Drawdown (0 to 1 day)

Time (sec)	Theis (m)	COMSOL (m)	PORFLOW (m)
0.00E+00	0.0000E+00	1.1855E-14	0.0000E+00
3.60E+03	3.0046E-01	2.8601E-01	3.0050E-01
7.20E+03	3.9177E-01	3.7997E-01	3.9208E-01
1.08E+04	4.4633E-01	4.3591E-01	4.4673E-01
1.44E+04	4.8536E-01	4.7708E-01	4.8581E-01
1.80E+04	5.1577E-01	5.0790E-01	5.1626E-01
2.16E+04	5.4069E-01	5.3396E-01	5.4119E-01
2.52E+04	5.6180E-01	5.5606E-01	5.6232E-01
2.88E+04	5.8011E-01	5.7564E-01	5.8064E-01

Time (sec)	Theis (m)	COMSOL (m)	PORFLOW (m)
3.24E+04	5.9628E-01	5.9285E-01	5.9682E-01
3.60E+04	6.1076E-01	6.0809E-01	6.1130E-01
3.96E+04	6.2386E-01	6.2174E-01	6.2441E-01
4.32E+04	6.3583E-01	6.3405E-01	6.3639E-01
4.68E+04	6.4685E-01	6.4530E-01	6.4741E-01
5.04E+04	6.5705E-01	6.5569E-01	6.5762E-01
5.40E+04	6.6656E-01	6.6535E-01	6.6712E-01
5.76E+04	6.7545E-01	6.7437E-01	6.7602E-01
6.12E+04	6.8381E-01	6.8285E-01	6.8438E-01
6.48E+04	6.9168E-01	6.9083E-01	6.9226E-01
6.84E+04	6.9914E-01	6.9838E-01	6.9971E-01
7.20E+04	7.0621E-01	7.0553E-01	7.0679E-01
7.56E+04	7.1294E-01	7.1232E-01	7.1352E-01
7.92E+04	7.1936E-01	7.1879E-01	7.1994E-01
8.28E+04	7.2549E-01	7.2497E-01	7.2608E-01
8.64E+04	7.3137E-01	7.3088E-01	7.3195E-01

Table 4.5.3. Input Commands for Problem 4.5 (1D)

```

*****
TITLe 4.5 Theis Solution for Transient Drawdown
*****
! Theis, C.V., 1935. The Relation Between the Lowering of the
! Piezometric Surface and the Rate and Duration of Discharge of a
! Well Using Groundwater Storage, Trans. Amer. Geophys. Union, 2,
! p. 519-524.
*****

! Allocate space for user-defined variables
ALLOcate DD

GRID is 3 by 1000 NODEs
COORdinate R: MINImum=0.1, MAXImum=1.0e4, RATIo=1.01

HYDRauiic properties S = 7.5e-5, kx = 2.3e-4 m/s, Ky = 2.3e-4 m/s

SET P = 0. everywhere initially

BOUNDary condition for P: Y-, FLUX = -6.366197e-4 !Q/2*pi*rw*b
BOUNDary condition for P: Y+, VALUe = 0.

! Solution controls
MATRix NSPC for P precon=CHOL, accel=CONJ, MODI
MATRix ITERation 100

CONVERgence REFERENCE based on ALL: Tolerance = 1.E-6, 100 outer iterations

DIAGnostic node (2,100) every 100 steps

! Compute auxiliary variables
SET DD by REPLacing by a LINEar function: -1(P) +0(X) ALWAYS !s=-p

HISTory of DD at COORdinate x=0.5,y=55. at TIME interval 100 secs to '4.5-0100.his'
HISTory of DD at COORdinate x=0.5,y=55. at TIME interval 120 secs to '4.5-0120.his'
HISTory of DD at COORdinate x=0.5,y=55. at TIME interval 3600 secs to '4.5-3600.his'

SOLVe P for 1e+5 secs in steps of 1e+1 secs
SAVE P to '4.5.sav' NOW

END

```

Table 4.5.4. Input Commands for Problem 4.5 (2D)

```

*****
TITLe 4.5 Theis Solution for Transient Drawdown
*****
! Theis, C.V., 1935. The Relation Between the Lowering of the
! Piezometric Surface and the Rate and Duration of Discharge of a
! Well Using Groundwater Storage, Trans. Amer. Geophys. Union, 2,
! p. 519-524.
*****

GRID is 241 by 241 NODEs
COORDinate NODEs X:
-1.20000000E+003 -1.18304190E+003 -1.16608380E+003 -1.14929528E+003 -1.13267464E+003
-1.11622022E+003 -1.09993033E+003 -1.08380335E+003 -1.06783763E+003 -1.05203157E+003
-1.03638358E+003 -1.02089206E+003 -1.00555546E+003 -9.90372222E+002 -9.75340818E+002
-9.60459728E+002 -9.45727449E+002 -9.31142493E+002 -9.16703387E+002 -9.02408671E+002
-8.88256903E+002 -8.74246652E+002 -8.60376504E+002 -8.46645057E+002 -8.33050925E+002
-8.19592734E+002 -8.06269125E+002 -7.93078753E+002 -7.80020283E+002 -7.67092399E+002
-7.54293793E+002 -7.41623174E+002 -7.29079261E+002 -7.16660786E+002 -7.04366497E+002
-6.92195150E+002 -6.80145517E+002 -6.68216380E+002 -6.56406535E+002 -6.44714788E+002
-6.33139958E+002 -6.21680877E+002 -6.10336387E+002 -5.99105341E+002 -5.87986606E+002
-5.76979059E+002 -5.66081587E+002 -5.55293089E+002 -5.44612477E+002 -5.34038670E+002
-5.23570602E+002 -5.13207214E+002 -5.02947460E+002 -4.92790304E+002 -4.82734720E+002
-4.72779691E+002 -4.62924212E+002 -4.53167289E+002 -4.43507934E+002 -4.33945173E+002
-4.24478040E+002 -4.15105578E+002 -4.05826840E+002 -3.96640890E+002 -3.87546800E+002
-3.78543650E+002 -3.69630532E+002 -3.60806545E+002 -3.52070798E+002 -3.43422409E+002
-3.34860503E+002 -3.26384216E+002 -3.17992692E+002 -3.09685084E+002 -3.01460551E+002
-2.93318264E+002 -2.85257400E+002 -2.77277144E+002 -2.69376691E+002 -2.61555243E+002
-2.53812009E+002 -2.46146207E+002 -2.38557063E+002 -2.31043811E+002 -2.23605691E+002
-2.16241953E+002 -2.08951852E+002 -2.01734652E+002 -1.94589624E+002 -1.87516046E+002
-1.80513204E+002 -1.73580390E+002 -1.66716904E+002 -1.59922054E+002 -1.53195152E+002
-1.46535519E+002 -1.39942482E+002 -1.33415375E+002 -1.26953540E+002 -1.20556323E+002
-1.14223078E+002 -1.07953166E+002 -1.01745952E+002 -9.56008113E+001 -8.95171216E+001
-8.34942688E+001 -7.75316445E+001 -7.16286464E+001 -6.57846783E+001 -5.99991500E+001
-5.42714768E+001 -4.86010805E+001 -4.29873881E+001 -3.74298326E+001 -3.19278526E+001
-2.64808925E+001 -2.10884020E+001 -1.57498363E+001 -1.04646563E+001 -5.23232817E+000
0.00000000E+000 5.26919097E+000 1.05383819E+001 1.58602648E+001 2.12353665E+001
2.66642193E+001 3.21473605E+001 3.76853332E+001 4.32786856E+001 4.89279715E+001
5.46337503E+001 6.03965868E+001 6.62170517E+001 7.20957213E+001 7.80331776E+001
8.40300084E+001 9.00868076E+001 9.62041747E+001 1.02382716E+002 1.08623042E+002
1.14925771E+002 1.21291528E+002 1.27720942E+002 1.34214651E+002 1.40773296E+002
1.47397528E+002 1.54088003E+002 1.60845382E+002 1.67670335E+002 1.74563537E+002
1.81525672E+002 1.88557427E+002 1.95659501E+002 2.02832595E+002 2.10077420E+002
2.17394693E+002 2.24785139E+002 2.32249489E+002 2.39788483E+002 2.47402867E+002
2.55093395E+002 2.62860828E+002 2.70705935E+002 2.78629494E+002 2.86632288E+002
2.94715110E+002 3.02878760E+002 3.11124047E+002 3.19451786E+002 3.27862803E+002
3.36357930E+002 3.44938008E+002 3.53603888E+002 3.62356425E+002 3.71196489E+002
3.80124953E+002 3.89142701E+002 3.98250627E+002 4.07449633E+002 4.16740628E+002
4.26124533E+002 4.35602278E+002 4.45174800E+002 4.54843047E+002 4.64607976E+002
4.74470555E+002 4.84431760E+002 4.94492576E+002 5.04654001E+002 5.14917040E+002
5.25282710E+002 5.35752036E+002 5.46326055E+002 5.57005815E+002 5.67792372E+002
5.78686795E+002 5.89690162E+002 6.00803563E+002 6.12028097E+002 6.23364877E+002
6.34815025E+002 6.46379674E+002 6.58059970E+002 6.69857069E+002 6.81772139E+002
6.93806359E+002 7.05960922E+002 7.18237030E+002 7.30635900E+002 7.43158758E+002
7.55806844E+002 7.68581412E+002 7.81483725E+002 7.94515061E+002 8.07676711E+002
8.20969977E+002 8.34396176E+002 8.47956637E+002 8.61652702E+002 8.75485728E+002
8.89457085E+002 9.03568154E+002 9.17820335E+002 9.32215038E+002 9.46753687E+002
9.61437723E+002 9.76268599E+002 9.91247784E+002 1.00637676E+003 1.02165703E+003
1.03709010E+003 1.05267750E+003 1.06842077E+003 1.08432148E+003 1.10038119E+003
1.11660150E+003 1.13298402E+003 1.14953036E+003 1.16624216E+003 1.18312108E+003
1.20000000E+003
COORDinate NODEs Y:
-1.20000000E+003 -1.18304190E+003 -1.16608380E+003 -1.14929528E+003 -1.13267464E+003
-1.11622022E+003 -1.09993033E+003 -1.08380335E+003 -1.06783763E+003 -1.05203157E+003
-1.03638358E+003 -1.02089206E+003 -1.00555546E+003 -9.90372222E+002 -9.75340818E+002
-9.60459728E+002 -9.45727449E+002 -9.31142493E+002 -9.16703387E+002 -9.02408671E+002
-8.88256903E+002 -8.74246652E+002 -8.60376504E+002 -8.46645057E+002 -8.33050925E+002
-8.19592734E+002 -8.06269125E+002 -7.93078753E+002 -7.80020283E+002 -7.67092399E+002
-7.54293793E+002 -7.41623174E+002 -7.29079261E+002 -7.16660786E+002 -7.04366497E+002

```

```

-6.92195150E+002 -6.80145517E+002 -6.68216380E+002 -6.56406535E+002 -6.44714788E+002
-6.33139958E+002 -6.21680877E+002 -6.10336387E+002 -5.99105341E+002 -5.87986606E+002
-5.76979059E+002 -5.66081587E+002 -5.55293089E+002 -5.44612477E+002 -5.34038670E+002
-5.23570602E+002 -5.13207214E+002 -5.02947460E+002 -4.92790304E+002 -4.82734720E+002
-4.72779691E+002 -4.62924212E+002 -4.53167289E+002 -4.43507934E+002 -4.33945173E+002
-4.24478040E+002 -4.15105578E+002 -4.05826840E+002 -3.96640890E+002 -3.87546800E+002
-3.78543650E+002 -3.69630532E+002 -3.60806545E+002 -3.52070798E+002 -3.43422409E+002
-3.34860503E+002 -3.26384216E+002 -3.17992692E+002 -3.09685084E+002 -3.01460551E+002
-2.93318264E+002 -2.85257400E+002 -2.77277144E+002 -2.69376691E+002 -2.61555243E+002
-2.53812009E+002 -2.46146207E+002 -2.38557063E+002 -2.31043811E+002 -2.23605691E+002
-2.16241953E+002 -2.08951852E+002 -2.01734652E+002 -1.94589624E+002 -1.87516046E+002
-1.80513204E+002 -1.73580390E+002 -1.66716904E+002 -1.59922054E+002 -1.53195152E+002
-1.46535519E+002 -1.39942482E+002 -1.33415375E+002 -1.26953540E+002 -1.20556323E+002
-1.14223078E+002 -1.07953166E+002 -1.01745952E+002 -9.56008113E+001 -8.95171216E+001
-8.34942688E+001 -7.75316445E+001 -7.16286464E+001 -6.57846783E+001 -5.99991500E+001
-5.42714768E+001 -4.86010805E+001 -4.29873881E+001 -3.74298326E+001 -3.19278526E+001
-2.64808925E+001 -2.10884020E+001 -1.57498363E+001 -1.04646563E+001 -5.23232817E+000
0.00000000E+000 5.26919097E+000 1.05383819E+001 1.58602648E+001 2.12353665E+001
2.66642193E+001 3.21473605E+001 3.76853332E+001 4.32786856E+001 4.89279715E+001
5.46337503E+001 6.03965868E+001 6.62170517E+001 7.20957213E+001 7.80331776E+001
8.40300084E+001 9.00868076E+001 9.62041747E+001 1.02382716E+002 1.08623042E+002
1.14925771E+002 1.21291528E+002 1.27720942E+002 1.34214651E+002 1.40773296E+002
1.47397528E+002 1.54088003E+002 1.60845382E+002 1.67670335E+002 1.74563537E+002
1.81525672E+002 1.88557427E+002 1.95659501E+002 2.02832595E+002 2.10077420E+002
2.17394693E+002 2.24785139E+002 2.32249489E+002 2.39788483E+002 2.47402867E+002
2.55093395E+002 2.62860828E+002 2.70705935E+002 2.78629494E+002 2.86632288E+002
2.94715110E+002 3.02878760E+002 3.11124047E+002 3.19451786E+002 3.27862803E+002
3.36357930E+002 3.44938008E+002 3.53603888E+002 3.62356425E+002 3.71196489E+002
3.80124953E+002 3.89142701E+002 3.98250627E+002 4.07449633E+002 4.16740628E+002
4.26124533E+002 4.35602278E+002 4.45174800E+002 4.54843047E+002 4.64607976E+002
4.74470555E+002 4.84431760E+002 4.94492576E+002 5.04654001E+002 5.14917040E+002
5.25282710E+002 5.35752036E+002 5.46326055E+002 5.57005815E+002 5.67792372E+002
5.78686795E+002 5.89690162E+002 6.00803563E+002 6.12028097E+002 6.23364877E+002
6.34815025E+002 6.46379674E+002 6.58059970E+002 6.69857069E+002 6.81772139E+002
6.93806359E+002 7.05960922E+002 7.18237030E+002 7.30635900E+002 7.43158758E+002
7.55806844E+002 7.68581412E+002 7.81483725E+002 7.94515061E+002 8.07676711E+002
8.20969977E+002 8.34396176E+002 8.47956637E+002 8.61652702E+002 8.75485728E+002
8.89457085E+002 9.03568154E+002 9.17820335E+002 9.32215038E+002 9.46753687E+002
9.61437723E+002 9.76268599E+002 9.91247784E+002 1.00637676E+003 1.02165703E+003
1.03709010E+003 1.05267750E+003 1.06842077E+003 1.08432148E+003 1.10038119E+003
1.11660150E+003 1.13298402E+003 1.14953036E+003 1.16624216E+003 1.18312108E+003
1.20000000E+003

```

HYDRauiic properties S = 7.5e-5, kx = 2.3e-4 m/s, Ky = 2.3e-4 m/s

SET P = 0. everywhere initially

BOUNDary condition for P: X-, VALUe = 0.
BOUNDary condition for P: X+, VALUe = 0.
BOUNDary condition for P: Y-, VALUe = 0.
BOUNDary condition for P: Y+, VALUe = 0.

!Well
LOCAtE (121,121) source for pumping well
SOURce for P = -0.0004 in SELEcted zone

! Solution controls
MATRix NSPC for P precon=CHOL, accel=CONJ, MODI
MATRix ITERation 100

CONVergence REFERENCE based on ALL: Tolerance = 1.E-6, 100 outer iterations

DIAGnostic node (2,18) every 100 steps
SAVE P to '4.5-XY.sav' at TIME interval of 86400 secs
HISToRY of P at COORDinate x=55.,y=55. at TIME interval 100 secs to '4.5-XY.his'

SOLVe P for 1e+5 secs in steps of 86.4 secs

END

4.6 Transient, Two-Dimensional Flow to a Well in an Anisotropic Confined Aquifer (Hantush and Thomas, 1966)

We next consider a confined aquifer identical to Problem 4.5 except that the hydraulic conductivity is anisotropic in the horizontal plane as shown in Figure 4.6.1. The principal axes of the conductivity tensor are assumed to be aligned with the coordinate axes.

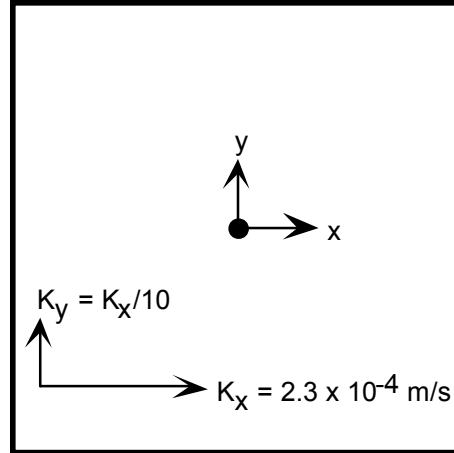

Figure 4.6.1. Anisotropic Confined Aquifer with $K_x/K_y = 10$.

Analytic solution: The governing equation for the flow problem described above can be written as

$$\frac{\partial}{\partial x} \left(T_x \frac{\partial h}{\partial x} \right) + \frac{\partial}{\partial y} \left(T_y \frac{\partial h}{\partial y} \right) = S \frac{\partial h}{\partial t} + Q \delta(x) \delta(y) \quad -\infty < x < \infty, -\infty < y < \infty \quad (4.6.1)$$

The initial condition is

$$h(x, y, 0) = h_0 \quad (4.6.2)$$

Because the aquifer hydraulic conductivity is anisotropic, Eq. 4.5.5b becomes

$$T_x = K_x b \quad \text{and} \quad T_y = K_y b \quad (4.6.3)$$

The solution to the governing equation is given by Hantush and Thomas (1966) as

$$s = h_0 - h(r, t) = \frac{Q}{4\pi\sqrt{T_x T_y}} \int_{u'}^{\infty} \frac{e^{-\tau}}{\tau} d\tau = \frac{Q}{4\pi\sqrt{T_x T_y}} W(u') \quad (4.6.4)$$

where

$$u' = \frac{(x^2 T_y + y^2 T_x) S}{4 T_x T_y t} \quad (4.6.5)$$

and $W(u')$ is the well function. Note that for $T_x = T_y$, the above solution reduces to the Theis solution presented in Section 4.5.

Evaluation of the Hantush and Thomas solution for the parameter values specified in Figures 4.5.1 and 4.6.1 are presented in Tables 4.6.1 through 4.6.3 for various spatial locations and times.

PORFLOW simulation and comparison: The same 2D grid considered in Problem 4.5 was used for the PORFLOW simulation in this problem. The PORFLOW mesh and model settings are given in Table 4.6.4. Figure 4.6.2 shows the COMSOL finite-element mesh which consists of 12440 triangular elements and 6393 nodes.

Due to the anisotropy of the hydraulic conductivity, the spatial contours of drawdown will be elliptical at any point in time. Therefore, we will look at the transient drawdown of a virtual piezometer along the x-axis, y-axis and at a 45 degree angle. Figures 4.6.3, 4.6.4 and 4.6.5 illustrates the Hantush and Thomas, COMSOL and PORFLOW transient drawdown at $x = 55$ m, $y = 55$ m and $x = y = 55$ m, respectively. The agreement between the Hantush and Thomas solution and the numerical simulators is excellent. Figure 4.6.6 shows the PORFLOW drawdown at 1 day. The drawdown contours are elliptical near the well and become distorted near the boundaries. Tables 4.6.1 through 4.6.3 summarize the data shown in Figures 4.6.3 through 4.6.5, respectively.

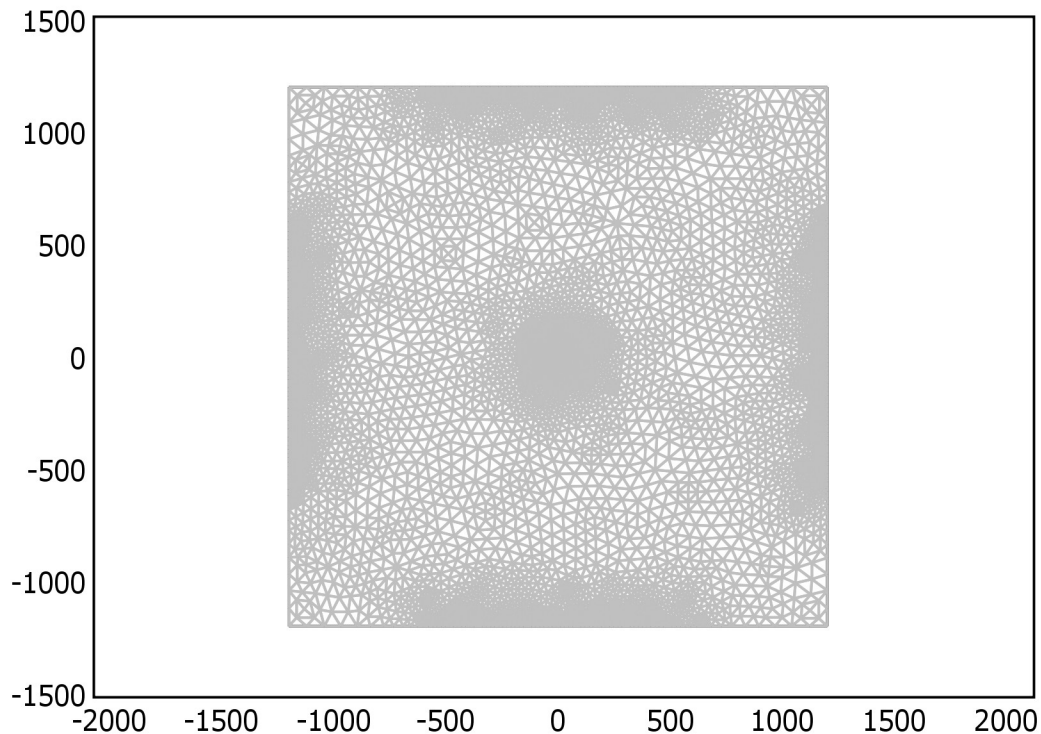

Figure 4.6.2. COMSOL Finite-Element Mesh for Problem 4.6.

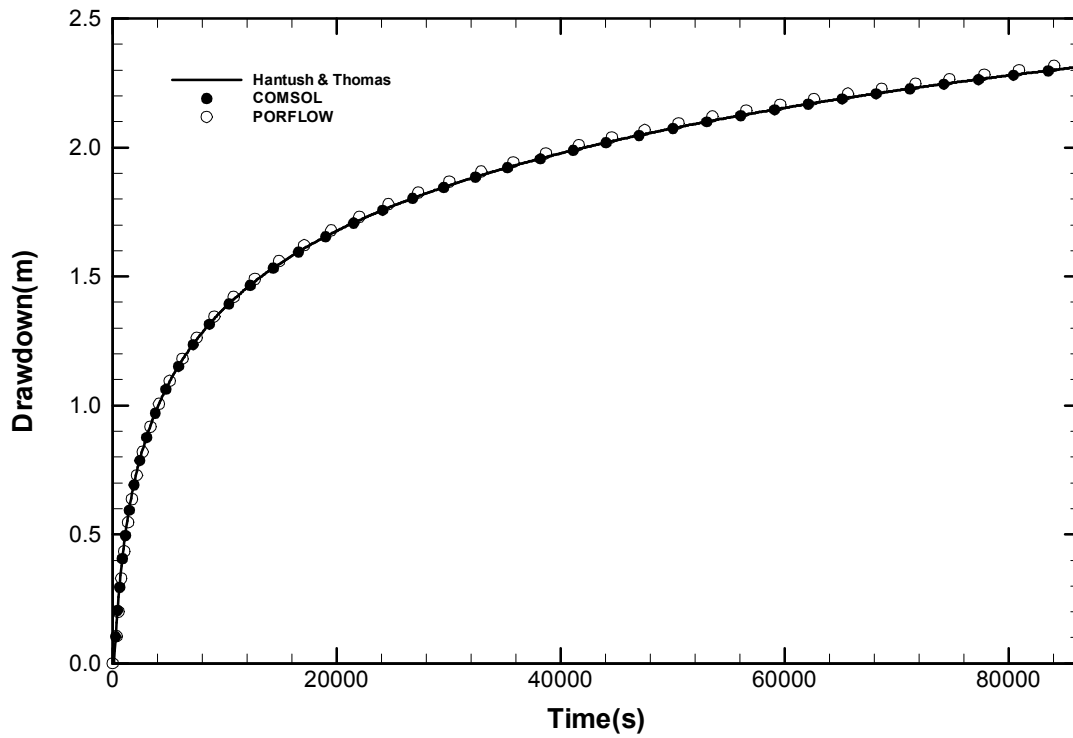

Figure 4.6.3. Hantush and Thomas, COMSOL and PORFLOW Transient Drawdown at $x = 55$ meters.

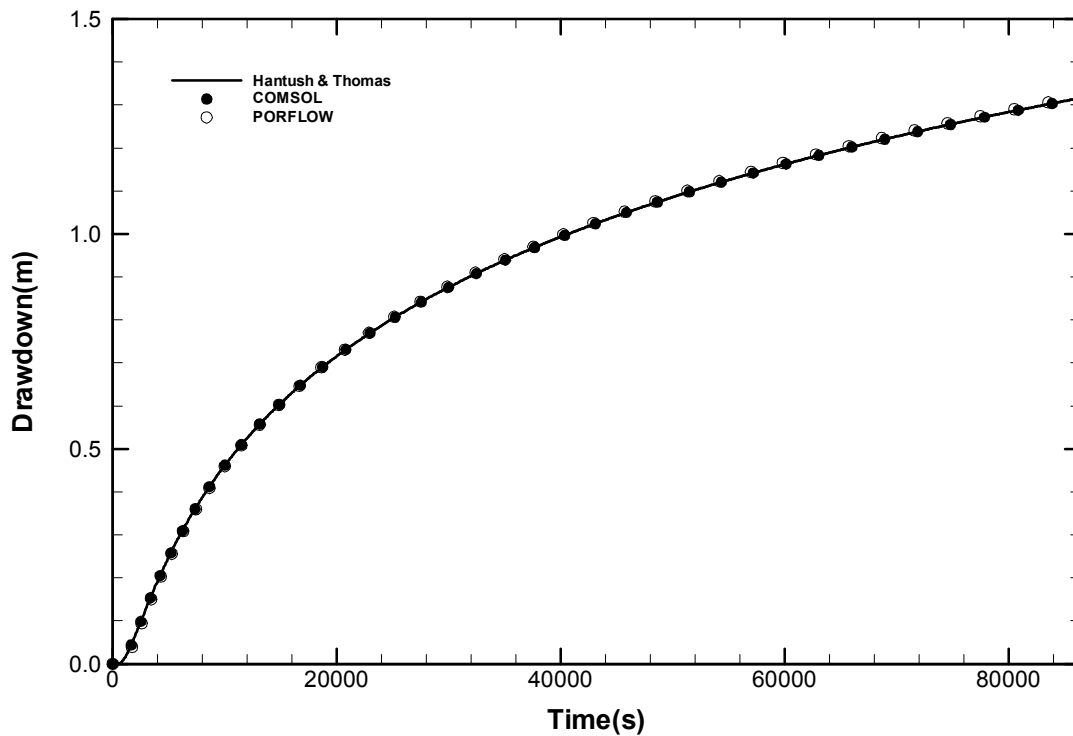

Figure 4.6.4. Hantush and Thomas, COMSOL and PORFLOW Transient Drawdown at $y = 55$ meters.

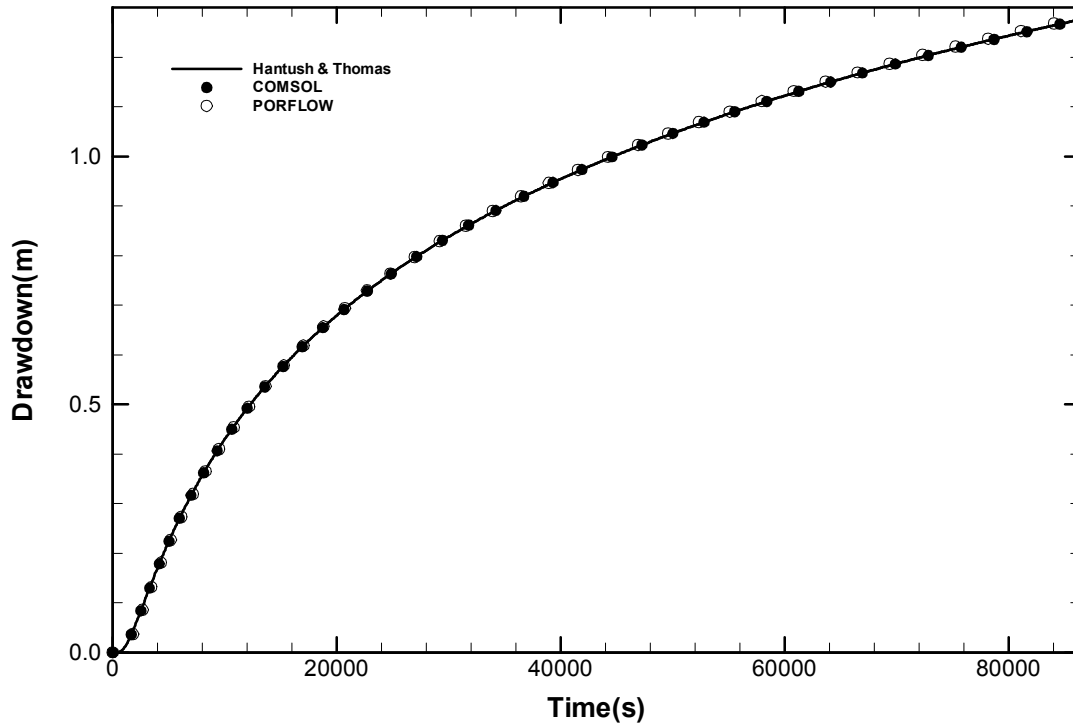

Figure 4.6.5. Hantush and Thomas, COMSOL and PORFLOW Transient Drawdown at $x = y = 55$ meters.

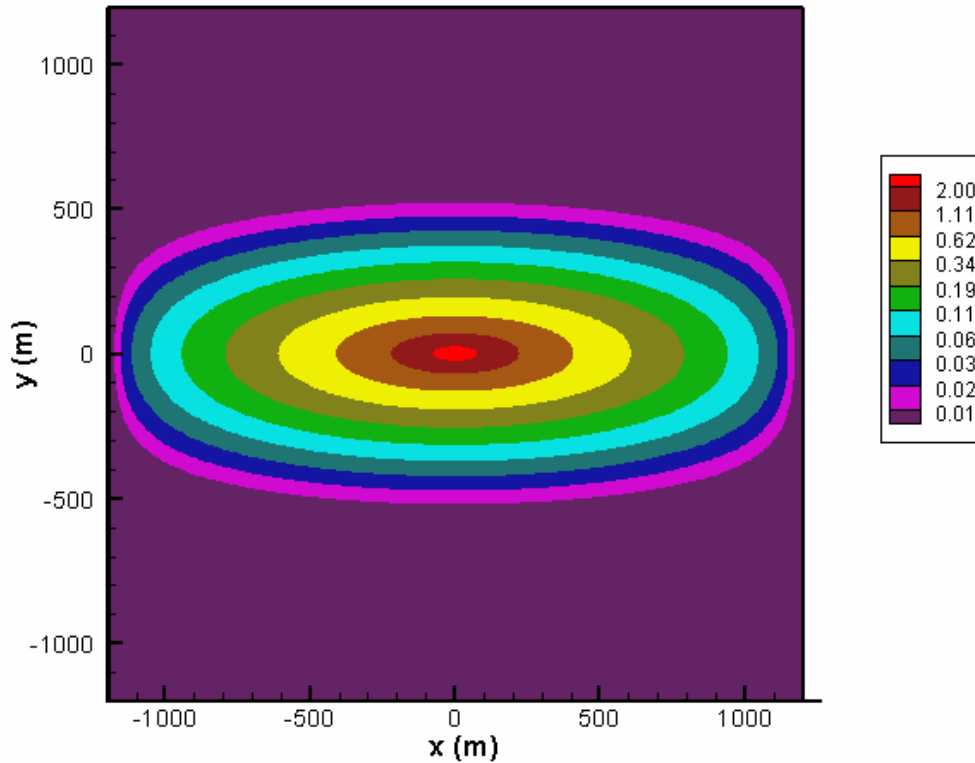

Figure 4.6.6. PORFLOW Drawdown at 1 day.

Table 4.6.1. Comparison of Hantush and Thomas, COMSOL and PORFLOW Numerical Results at x = 55 m.

Time (sec)	Hantush & Thomas (m)	COMSOL (m)	PORFLOW (m)
1.7280E+02	4.8846E-02	5.4038E-02	2.5966E-02
3.4560E+02	1.5936E-01	1.5551E-01	1.0499E-01
5.1840E+02	2.5835E-01	2.5186E-01	2.0017E-01
7.7760E+02	3.7851E-01	3.7191E-01	3.2893E-01
1.2096E+03	5.2824E-01	5.2259E-01	4.9368E-01
1.7280E+03	6.5976E-01	6.5517E-01	6.3681E-01
2.4192E+03	7.9022E-01	7.8654E-01	7.7654E-01
3.1968E+03	9.0181E-01	8.9865E-01	8.9443E-01
4.3200E+03	1.0251E+00	1.0229E+00	1.0232E+00
5.7888E+03	1.1470E+00	1.1455E+00	1.1493E+00
7.6896E+03	1.2667E+00	1.2656E+00	1.2723E+00
1.0022E+04	1.3795E+00	1.3785E+00	1.3874E+00
1.3306E+04	1.5009E+00	1.5000E+00	1.5108E+00
1.7539E+04	1.6198E+00	1.6190E+00	1.6313E+00
2.2896E+04	1.7350E+00	1.7343E+00	1.7477E+00
3.0067E+04	1.8532E+00	1.8524E+00	1.8667E+00
3.9053E+04	1.9668E+00	1.9660E+00	1.9810E+00
5.0026E+04	2.0745E+00	2.0738E+00	2.0893E+00

Time (sec)	Hantush & Thomas (m)	COMSOL (m)	PORFLOW (m)
6.6010E+04	2.1954E+00	2.1945E+00	2.2105E+00
8.6400E+04	2.3128E+00	2.3114E+00	2.3277E+00

Table 4.6.2. Comparison of Hantush and Thomas, COMSOL and PORFLOW Numerical Results at $y = 55$ m.

Time (sec)	Hantush & Thomas (m)	COMSOL (m)	PORFLOW (m)
1.7280E+02	1.8251E-08	2.3841E-05	8.3667E-10
3.4560E+02	4.3407E-05	2.4897E-04	1.2249E-06
5.1840E+02	6.6941E-04	1.3030E-03	6.8076E-05
7.7760E+02	4.6002E-03	5.6579E-03	1.5563E-03
1.2096E+03	2.0298E-02	2.1288E-02	1.2984E-02
1.7280E+03	4.8846E-02	4.9342E-02	3.9031E-02
2.4192E+03	9.3000E-02	9.2968E-02	8.2556E-02
3.1968E+03	1.4309E-01	1.4287E-01	1.3346E-01
4.3200E+03	2.1097E-01	2.1055E-01	2.0278E-01
5.7888E+03	2.8914E-01	2.8878E-01	2.8279E-01
7.6896E+03	3.7495E-01	3.7468E-01	3.7047E-01
1.0022E+04	4.6247E-01	4.6227E-01	4.5963E-01
1.3306E+04	5.6258E-01	5.6245E-01	5.6132E-01
1.7539E+04	6.6541E-01	6.6532E-01	6.6548E-01
2.2896E+04	7.6852E-01	7.6845E-01	7.6965E-01
3.0067E+04	8.7704E-01	8.7699E-01	8.7907E-01
3.9053E+04	9.8351E-01	9.8347E-01	9.8624E-01
5.0026E+04	1.0860E+00	1.0859E+00	1.0892E+00
6.6010E+04	1.2022E+00	1.2021E+00	1.2059E+00
8.6400E+04	1.3162E+00	1.3156E+00	1.3198E+00

Table 4.6.3. Comparison of Hantush and Thomas, COMSOL and PORFLOW Numerical Results at $x = y = 55$ m.

Time (sec)	Hantush & Thomas (m)	COMSOL (m)	PORFLOW (m)
1.7280E+02	4.0034E-09	1.4498E-05	2.0199E-08
3.4560E+02	1.9514E-05	1.5601E-04	4.9338E-06
5.1840E+02	3.8299E-04	8.6546E-04	1.1264E-04
7.7760E+02	3.0962E-03	4.0324E-03	1.4715E-03
1.2096E+03	1.5375E-02	1.6422E-02	1.0586E-02
1.7280E+03	3.9502E-02	4.0179E-02	3.2179E-02
2.4192E+03	7.8673E-02	7.8863E-02	7.0160E-02
3.1968E+03	1.2448E-01	1.2451E-01	1.1626E-01
4.3200E+03	1.8803E-01	1.8779E-01	1.8071E-01
5.7888E+03	2.6246E-01	2.6221E-01	2.5659E-01
7.6896E+03	3.4516E-01	3.4498E-01	3.4091E-01
1.0022E+04	4.3024E-01	4.3013E-01	4.2750E-01
1.3306E+04	5.2824E-01	5.2818E-01	5.2697E-01

Time (sec)	Hantush & Thomas (m)	COMSOL (m)	PORFLOW (m)
1.7539E+04	6.2942E-01	6.2940E-01	6.2943E-01
2.2810E+04	7.2979E-01	7.2980E-01	7.3082E-01
3.0067E+04	8.3876E-01	8.3878E-01	8.4069E-01
3.9053E+04	9.4447E-01	9.4450E-01	9.4709E-01
5.0026E+04	1.0464E+00	1.0464E+00	1.0495E+00
6.6010E+04	1.1621E+00	1.1620E+00	1.1657E+00
8.6400E+04	1.2757E+00	1.2752E+00	1.2791E+00

Table 4.6.4. Input Commands for Problem 4.6.

```

*****
TITLe 4.6 Transient, 2-D Flow to a Well in an Anisotropic Confined Aquifer
*****
! Hantush, M. S., and R. G. Thomas, 1966, "A method for analyzing
! a drawdown test in anisotropic aquifers", Water Resources Res.
! v2 n2, 281-285.
*****

! Allocate space for user-defined variables
ALLocate DD

GRID is 241 by 241 NODEs
COORDinate NODEs X:
-1.20000000E+003 -1.18304190E+003 -1.16608380E+003 -1.14929528E+003 -1.13267464E+003
-1.11622022E+003 -1.09993033E+003 -1.08380335E+003 -1.06783763E+003 -1.05203157E+003
-1.03638358E+003 -1.02089206E+003 -1.00555546E+003 -9.90372222E+002 -9.75340818E+002
-9.60459728E+002 -9.45727449E+002 -9.31142493E+002 -9.16703387E+002 -9.02408671E+002
-8.88256903E+002 -8.74246652E+002 -8.60376504E+002 -8.46645057E+002 -8.33050925E+002
-8.19592734E+002 -8.06269125E+002 -7.93078753E+002 -7.80020283E+002 -7.67092399E+002
-7.54293793E+002 -7.41623174E+002 -7.29079261E+002 -7.16660786E+002 -7.04366497E+002
-6.92195150E+002 -6.80145517E+002 -6.68216380E+002 -6.56406535E+002 -6.44714788E+002
-6.33139958E+002 -6.21680877E+002 -6.10336387E+002 -5.99105341E+002 -5.87986606E+002
-5.76979059E+002 -5.66081587E+002 -5.55293089E+002 -5.44612477E+002 -5.34038670E+002
-5.23570602E+002 -5.13207214E+002 -5.02947460E+002 -4.92790304E+002 -4.82734720E+002
-4.72779691E+002 -4.62924212E+002 -4.53167289E+002 -4.43507934E+002 -4.33945173E+002
-4.24478040E+002 -4.15105578E+002 -4.05826840E+002 -3.96640890E+002 -3.87546800E+002
-3.78543650E+002 -3.69630532E+002 -3.60806545E+002 -3.52070798E+002 -3.43422409E+002
-3.34860503E+002 -3.26384216E+002 -3.17992692E+002 -3.09685084E+002 -3.01460551E+002
-2.93318264E+002 -2.85257400E+002 -2.77277144E+002 -2.69376691E+002 -2.61555243E+002
-2.53812009E+002 -2.46146207E+002 -2.38557063E+002 -2.31043811E+002 -2.23605691E+002
-2.16241953E+002 -2.08951852E+002 -2.01734652E+002 -1.94589624E+002 -1.87516046E+002
-1.80513204E+002 -1.73580390E+002 -1.66716904E+002 -1.59922054E+002 -1.53195152E+002
-1.46535519E+002 -1.39942482E+002 -1.33415375E+002 -1.26953540E+002 -1.20556323E+002
-1.14223078E+002 -1.07953166E+002 -1.01745952E+002 -9.56008113E+001 -8.95171216E+001
-8.34942688E+001 -7.75316445E+001 -7.16286464E+001 -6.57846783E+001 -5.99991500E+001
-5.42714768E+001 -4.86010805E+001 -4.29873881E+001 -3.74298326E+001 -3.19278526E+001
-2.64808925E+001 -2.10884020E+001 -1.57498363E+001 -1.04646563E+001 -5.23232817E+000
0.00000000E+000 5.26919097E+000 1.05383819E+001 1.58602648E+001 2.12353665E+001
2.66642193E+001 3.21473605E+001 3.76853332E+001 4.32786856E+001 4.89279715E+001
5.46337503E+001 6.03965868E+001 6.62170517E+001 7.20957213E+001 7.80331776E+001
8.40300084E+001 9.00868076E+001 9.62041747E+001 1.02382716E+002 1.08623042E+002
1.14925771E+002 1.21291528E+002 1.27720942E+002 1.34214651E+002 1.40773296E+002
1.47397528E+002 1.54088003E+002 1.60845382E+002 1.67670335E+002 1.74563537E+002
1.81525672E+002 1.88557427E+002 1.95659501E+002 2.02832595E+002 2.10077420E+002
2.17394693E+002 2.24785139E+002 2.32249489E+002 2.39788483E+002 2.47402867E+002
2.55093395E+002 2.62860828E+002 2.70705935E+002 2.78629494E+002 2.86632288E+002
2.94715110E+002 3.02878760E+002 3.11124047E+002 3.19451786E+002 3.27862803E+002
3.36357930E+002 3.44938008E+002 3.53603888E+002 3.62356425E+002 3.71196489E+002
3.80124953E+002 3.89142701E+002 3.98250627E+002 4.07449633E+002 4.16740628E+002
4.26124533E+002 4.35602278E+002 4.45174800E+002 4.54843047E+002 4.64607976E+002
4.74470555E+002 4.84431760E+002 4.94492576E+002 5.04654001E+002 5.14917040E+002
5.25282710E+002 5.35752036E+002 5.46326055E+002 5.57005815E+002 5.67792372E+002
5.78686795E+002 5.89690162E+002 6.00803563E+002 6.12028097E+002 6.23364877E+002
6.34815025E+002 6.46379674E+002 6.58059970E+002 6.69857069E+002 6.81772139E+002
6.93806359E+002 7.05960922E+002 7.18237030E+002 7.30635900E+002 7.43158758E+002

```

```

7.55806844E+002 7.68581412E+002 7.81483725E+002 7.94515061E+002 8.07676711E+002
8.20969977E+002 8.34396176E+002 8.47956637E+002 8.61652702E+002 8.75485728E+002
8.89457085E+002 9.03568154E+002 9.17820335E+002 9.32215038E+002 9.46753687E+002
9.61437723E+002 9.76268599E+002 9.91247784E+002 1.00637676E+003 1.02165703E+003
1.03709010E+003 1.05267750E+003 1.06842077E+003 1.08432148E+003 1.10038119E+003
1.11660150E+003 1.13298402E+003 1.14953036E+003 1.16624216E+003 1.18312108E+003
1.20000000E+003
COORdinate NODEs Y:
-1.20000000E+003 -1.18304190E+003 -1.16608380E+003 -1.14929528E+003 -1.13267464E+003
-1.11622022E+003 -1.09993033E+003 -1.08380335E+003 -1.06783763E+003 -1.05203157E+003
-1.03638358E+003 -1.02089206E+003 -1.00555546E+003 -9.90372222E+002 -9.75340818E+002
-9.60459728E+002 -9.45727449E+002 -9.31142493E+002 -9.16703387E+002 -9.02408671E+002
-8.88256903E+002 -8.74246652E+002 -8.60376504E+002 -8.46645057E+002 -8.33050925E+002
-8.19592734E+002 -8.06269125E+002 -7.93078753E+002 -7.80020283E+002 -7.67092399E+002
-7.54293793E+002 -7.41623174E+002 -7.29079261E+002 -7.16660786E+002 -7.04366497E+002
-6.92195150E+002 -6.80145517E+002 -6.68216380E+002 -6.56406535E+002 -6.44714788E+002
-6.33139958E+002 -6.21680877E+002 -6.10336387E+002 -5.99105341E+002 -5.87986606E+002
-5.76979059E+002 -5.66081587E+002 -5.55293089E+002 -5.44612477E+002 -5.34038670E+002
-5.23570602E+002 -5.13207214E+002 -5.02947460E+002 -4.92790304E+002 -4.82734720E+002
-4.72779691E+002 -4.62924212E+002 -4.53167289E+002 -4.43507934E+002 -4.33945173E+002
-4.24478040E+002 -4.15105578E+002 -4.05826840E+002 -3.96640890E+002 -3.87546800E+002
-3.78543650E+002 -3.69630532E+002 -3.60806545E+002 -3.52070798E+002 -3.43422409E+002
-3.34860503E+002 -3.26384216E+002 -3.17992692E+002 -3.09685084E+002 -3.01460551E+002
-2.93318264E+002 -2.85257400E+002 -2.77277144E+002 -2.69376691E+002 -2.61555243E+002
-2.53812009E+002 -2.46146207E+002 -2.38557063E+002 -2.31043811E+002 -2.23605691E+002
-2.16241953E+002 -2.08951852E+002 -2.01734652E+002 -1.94589624E+002 -1.87516046E+002
-1.80513204E+002 -1.73580390E+002 -1.66716904E+002 -1.59922054E+002 -1.53195152E+002
-1.46535199E+002 -1.39942482E+002 -1.33415375E+002 -1.26953540E+002 -1.20556323E+002
-1.14223078E+002 -1.07953166E+002 -1.01745952E+002 -9.56008113E+001 -8.95171216E+001
-8.34942688E+001 -7.75316445E+001 -7.16286464E+001 -6.57846783E+001 -5.99991500E+001
-5.42714768E+001 -4.86010805E+001 -4.29873881E+001 -3.74298326E+001 -3.19278526E+001
-2.64808925E+001 -2.10884020E+001 -1.57498363E+001 -1.04646563E+001 -5.23232817E+000
0.00000000E+000 5.26919097E+000 1.05383819E+001 1.58602648E+001 2.12353665E+001
2.66642193E+001 3.21473605E+001 3.76853332E+001 4.32786856E+001 4.89279715E+001
5.46337503E+001 6.03965868E+001 6.62170517E+001 7.20957213E+001 7.80331776E+001
8.40300084E+001 9.00868076E+001 9.62041747E+001 1.02382716E+002 1.08623042E+002
1.14925771E+002 1.21291528E+002 1.27720942E+002 1.34214651E+002 1.40773296E+002
1.47397528E+002 1.54088003E+002 1.60880382E+002 1.67670335E+002 1.74563537E+002
1.81525672E+002 1.88557427E+002 1.95659501E+002 2.02832595E+002 2.10077420E+002
2.17394693E+002 2.24785139E+002 2.32249489E+002 2.39788483E+002 2.47402867E+002
2.55093395E+002 2.62860828E+002 2.70705935E+002 2.78629494E+002 2.86632288E+002
2.94715110E+002 3.02878760E+002 3.11124047E+002 3.19451786E+002 3.27862803E+002
3.36357930E+002 3.44938008E+002 3.53603888E+002 3.62356425E+002 3.71196489E+002
3.80124953E+002 3.89142701E+002 3.98250627E+002 4.07449633E+002 4.16740628E+002
4.26124533E+002 4.35602278E+002 4.45174800E+002 4.54843047E+002 4.64607976E+002
4.74470555E+002 4.84431760E+002 4.94492576E+002 5.04654001E+002 5.14917040E+002
5.25282710E+002 5.35752036E+002 5.46326055E+002 5.57005815E+002 5.67792372E+002
5.78686795E+002 5.89690162E+002 6.00803563E+002 6.12028097E+002 6.23364877E+002
6.34815025E+002 6.46379674E+002 6.58059970E+002 6.69857069E+002 6.81772139E+002
6.93806359E+002 7.05960922E+002 7.18237030E+002 7.30635900E+002 7.43158758E+002
7.55806844E+002 7.68581412E+002 7.81483725E+002 7.94515061E+002 8.07676711E+002
8.20969977E+002 8.34396176E+002 8.47956637E+002 8.61652702E+002 8.75485728E+002
8.89457085E+002 9.03568154E+002 9.17820335E+002 9.32215038E+002 9.46753687E+002
9.61437723E+002 9.76268599E+002 9.91247784E+002 1.00637676E+003 1.02165703E+003
1.03709010E+003 1.05267750E+003 1.06842077E+003 1.08432148E+003 1.10038119E+003
1.11660150E+003 1.13298402E+003 1.14953036E+003 1.16624216E+003 1.18312108E+003
1.20000000E+003

```

HYDRaulic properties S = 7.5e-5, kx = 2.3e-4 m/s, Ky = 2.3e-5 m/s

SET P = 0. everywhere initially

BOUNDary condition for P: X-, VALUe = 0.
BOUNDary condition for P: X+, VALUe = 0.
BOUNDary condition for P: Y-, VALUe = 0.
BOUNDary condition for P: Y+, VALUe = 0.

!Well
LOCAt (121,121) source for pumping well
SOURce for P = -0.0004 in SELEcted zone

! SolutioN controls
MATRix NSPC for P precon=CHOL, accel=CONJ, MODI

MATRIx ITERation 100

CONVergence REFERENCE based on ALL: Tolerance = 1.E-6, 100 outer iterations

DIAGnostic node (121,121) every 10 steps

! Compute auxiliary variables

SET DD by REPLacing by a LINEar function: $-1(P) + 0(X)$ ALWAYS !s=-p

LOCATE STATION at coordinates (x=55.,y=0.)

HISTory of DD at TIME interval 86.4 secs to '4.6-X55-Y00.his' for SELEcted zone

LOCATE STATION at coordinates (x=0.,y=55.)

HISTory of DD at TIME interval 86.4 secs to '4.6-X00-Y55.his' for SELEcted zone

LOCATE STATION at coordinates (x=55.,y=55.)

HISTory of DD at TIME interval 86.4 secs to '4.6-X55-Y55.his' for SELEcted zone

SOLVe P for 86400 secs in steps of 86.4 secs

SAVE P H DD to '4.6.sav' NOW

END

4.7 Transient, One-Dimensional Flow to a Well in a Leaky Confined Aquifer (Hantush and Jacob, 1955)

We next consider a confined aquifer identical to Problem 4.5 except that the aquifer is recharged from an overlying constant head aquifer through an aquitard separating them, as shown in Figure 4.7.1. The aquitard is assumed to have uniform thickness and vertical conductivity. Flow through the aquitard is assumed to be vertical and proportional to the head difference between the adjoining aquifers (storage capacity assume to be zero). Parameter values are taken from a GeoTrans (1993) problem.

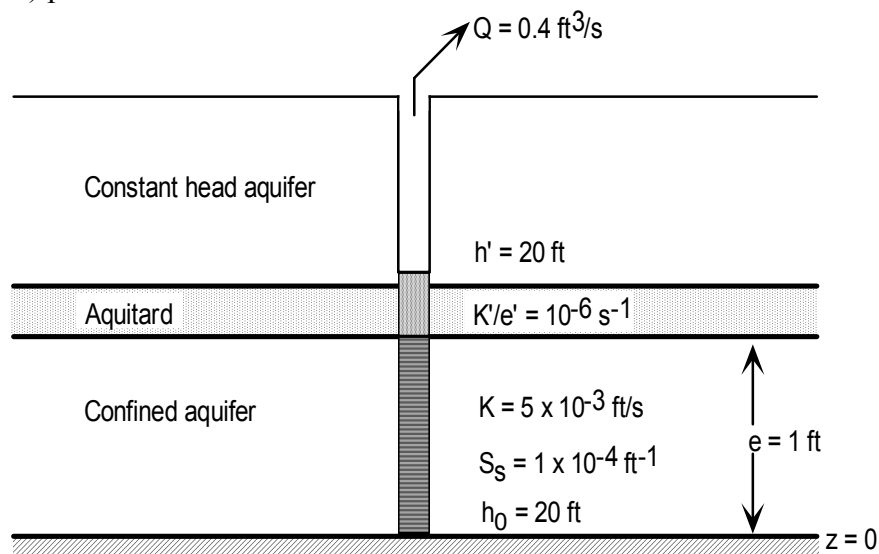

Figure 4.7.1. Schematic Diagram of a Leaky Confined Aquifer with Constant Discharge from a Single, Fully-penetrating Well.

Analytical solution: The governing equation for the flow problem described above is

$$\frac{1}{r} \frac{\partial}{\partial r} \left(r \frac{\partial h}{\partial r} \right) = \frac{S}{T} \frac{\partial h}{\partial t} + F_t \quad (4.7.1)$$

The initial condition is

$$h(r,0) = h_0 \quad (4.7.2)$$

The boundary conditions assume no drawdown in hydraulic head at the infinite boundary:

$$h(\infty, t) = h_0 \quad (4.7.3)$$

and a constant pumping rate Q at the well:

$$\lim_{r \rightarrow 0} \left(r \frac{\partial h}{\partial r} \right) = \frac{Q}{2\pi T} \quad \text{for } t > 0 \quad (4.7.4)$$

where F_t represents leakage from the overlying aquifer. The leakage flux is given by

$$F_t = -\frac{K'}{e'} (h' - h) \quad (4.7.5)$$

where K'/e' is the aquitard leakage coefficient. The solution to Eq. 4.7.1 is given by Hantush and Jacob (1955) as

$$s = h_0 - h(r, t) = \frac{Q}{4\pi T} \int_u^\infty \frac{e^{-\tau - r^2/4B^2\tau}}{\tau} d\tau = \frac{Q}{4\pi T} W \left(u, \frac{r}{B} \right) \quad (4.7.6)$$

where the Hantush leakage factor $B = \sqrt{T e' / K'}$.

Note that for $B = \infty$ (no leakage) the above solution reduces to the Theis solution presented in Section 4.5.

The Hantush and Jacob drawdown shown in Equation 4.7.6 is computed using the HantushJacob numerical code in Section A.

PORFLOW simulation and comparison: Figure 4.7.2 shows the radial mesh used in the PORFLOW simulation. The mesh extends to a radial distance of 10000 feet using 1000 nodes with mesh refinement near the pumping well at $r = 0.1$ feet. The PORFLOW model details are given in Table 4.7.2. A similar COMSOL model was generated with 916 linear radial elements.

Figure 4.7.2 and Table 4.7.1 show a comparison of the Hantush & Jacob solution, COMSOL and PORFLOW transient drawdown at a radial distance of 60 feet. The agreement among the three models is excellent.

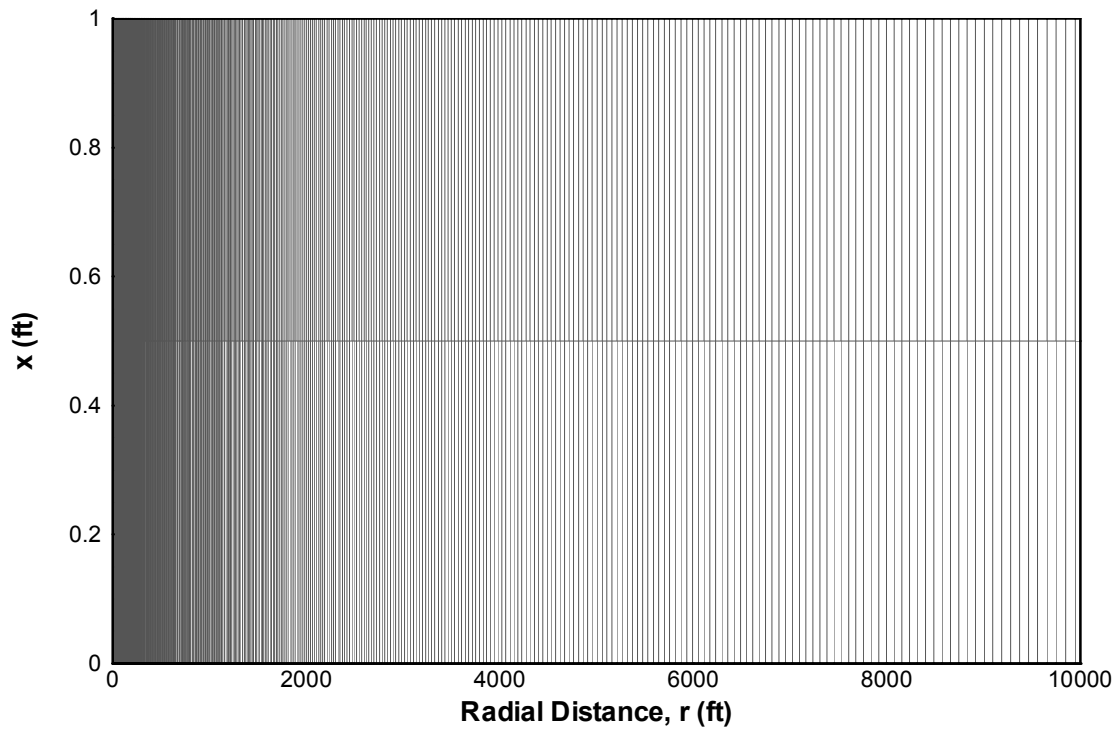

Figure 4.7.2. 1D PORFLOW Radial Grid for Problem 4.7.

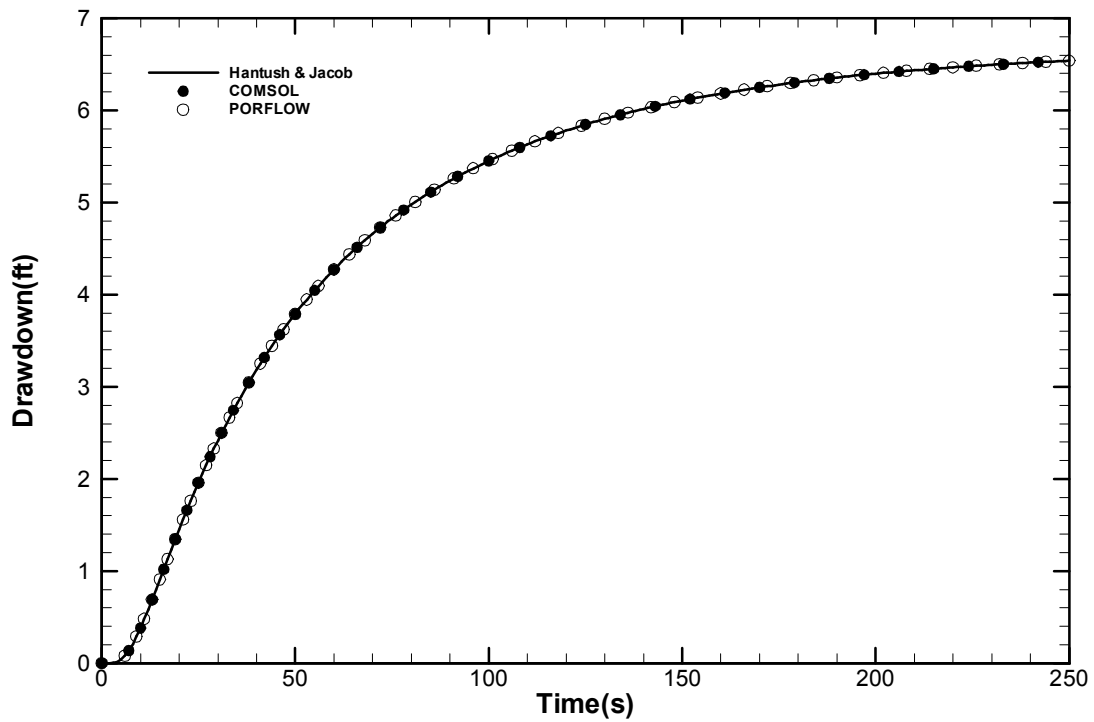

Figure 4.7.3. Hantush and Jacob, COMSOL and PORFLOW Transient Drawdown at $r = 60$ feet.

Table 4.7.1. Comparison of Hantush and Jacob, COMSOL and PORFLOW Transient Drawdown at r = 60 feet

Time (sec)	Hantush & Jacob (ft)	COMSOL (ft)	PORFLOW (ft)
1.00E+00	5.0675E-09	1.4877E-08	1.7054E-08
2.00E+00	7.7806E-05	8.0141E-05	9.0138E-05
3.00E+00	2.2324E-03	2.2312E-03	2.3117E-03
4.00E+00	1.2755E-02	1.2719E-02	1.2884E-02
5.00E+00	3.7615E-02	3.7498E-02	3.7708E-02
6.00E+00	7.9104E-02	7.9019E-02	7.9081E-02
8.00E+00	2.0790E-01	2.0767E-01	2.0753E-01
1.00E+01	3.8210E-01	3.8144E-01	3.8139E-01
1.50E+01	9.0814E-01	9.0757E-01	9.0688E-01
1.60E+01	1.0182E+00	1.0178E+00	1.0169E+00
2.00E+01	1.4521E+00	1.4519E+00	1.4506E+00
2.60E+01	2.0547E+00	2.0548E+00	2.0532E+00
3.50E+01	2.8231E+00	2.8233E+00	2.8216E+00
4.30E+01	3.3813E+00	3.3815E+00	3.3799E+00
5.50E+01	4.0453E+00	4.0455E+00	4.0441E+00
6.70E+01	4.5536E+00	4.5538E+00	4.5525E+00
8.00E+01	4.9778E+00	4.9779E+00	4.9768E+00
1.01E+02	5.4715E+00	5.4716E+00	5.4706E+00
1.20E+02	5.7812E+00	5.7813E+00	5.7805E+00
1.49E+02	6.0975E+00	6.0976E+00	6.0968E+00
1.70E+02	6.2502E+00	6.2502E+00	6.2495E+00
2.00E+02	6.3988E+00	6.3989E+00	6.3982E+00
2.17E+02	6.4582E+00	6.4582E+00	6.4576E+00
2.50E+02	6.5396E+00	6.5396E+00	6.5390E+00

Table 4.7.2. Input Commands for Problem 4.7.

```

*****
TITLE 4.7 Transient, 1-D Flow to a Well in a Leaky Confined Aquifer
*****
! M.S. Hantush and C.E. Jacob, "Nonsteady radial flow in an infinite
! leaky aquifer," EOS Transactions American Geophysical Union, vol. 36,
! no.1, 1955, pp. 95-100.
*****

! Allocate space for user-defined variables
ALLOcate DD

DEFine KL = -1.e-6
DEFine P0 = 0.

GRID is 3 by 1000 NODEs
COORDinate R: MINImum=0.1, MAXImum=1.e4, RATIo=1.01

HYDRaulic properties S = 1.e-4, kx = 5.e-3 ft/s, Ky = 5.e-3 ft/s

SET P = P0 everywhere initially

BOUNDary condition for P: X+ FLUX as LINEar function as (0.) (KL) (P)
BOUNDary condition for P: Y-, FLUX = -6.3661977e-1 !Q/2*pi*rw*e
BOUNDary condition for P: Y+, VALUe = P0

! Solution controls
MATRix NSPC for P precon=CHOL, accel=CONJ, MODI
    
```

 MATRix ITERation 100

CONVergence REFERENCE based on ALL: Tolerance = 1.E-6, 30 outer iterations

DIAGnostic node (2,18) every 100 steps

! Compute auxiliary variables

SET DD by REPLacing by a LINEar function: -1(P) +0(X) ALWAYS !s=-p

HISTory of DD at COORdinate x=0.5,y=60. at TIME interval 1 secs to '4.7.his'

SOLVe P for 250. secs in steps of 1e-2 secs

END

4.8 Free-Surface Boussinesq Flow with Recharge

This test case concerns a semi-infinite, unconfined aquifer. Initially the phreatic surface is at 10 meters everywhere. At time zero, the water level at the left boundary is suddenly raised to 11 meters. The schematic is shown in Figure 4.8.1. The horizontal extent of the computational domain is set at 200 meters and the vertical extent at 11 meters. The objective is to determine the phreatic surface at specified times. This problem is often referred to as the Boussinesq problem. It is described in detail by Polubarinova-Kochina (1962). This problem and description was taken from Problem V10 in the ACRI PORFLOW validation report version 2.50.

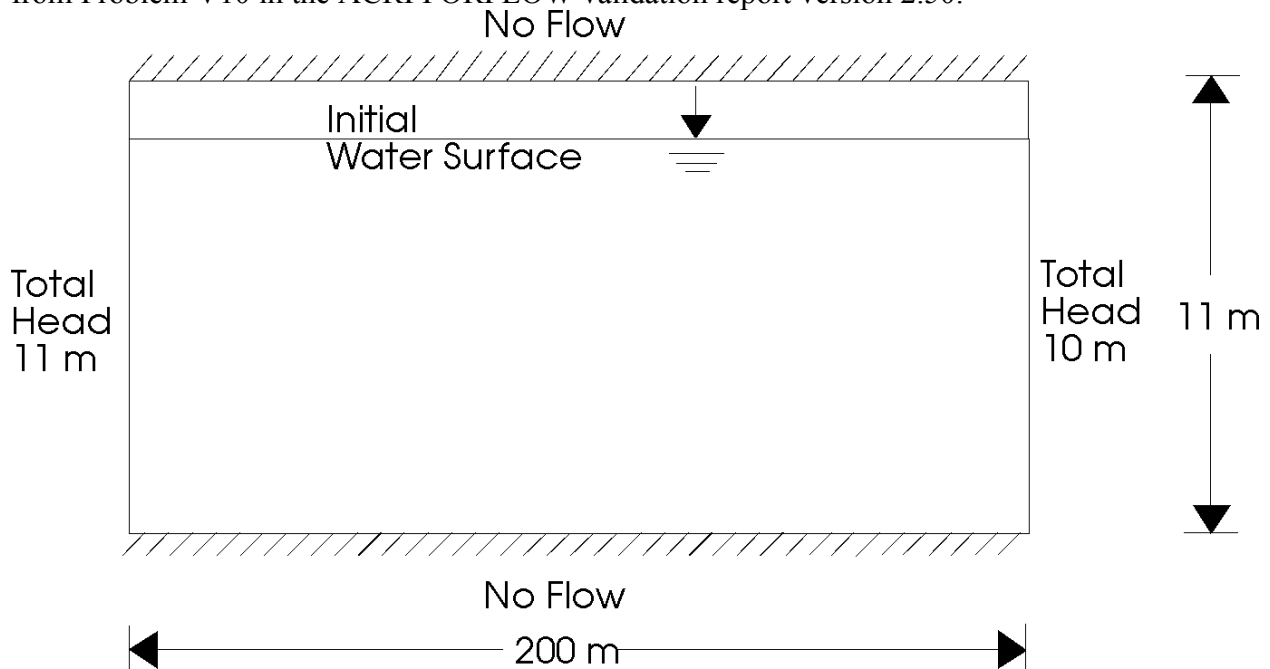

Figure 4.8.1. Schematic Illustration of Problem 4.8.

PORFLOW simulation and comparison: The problem is simulated with a grid of 44 nodes in the horizontal and 23 in the vertical direction. The PORFLOW mesh is shown in Figure 4.8.2. The grid spacing in the horizontal direction increases in a geometric ratio of 1.1. The minimum grid spacing is 0.19 m and the maximum is 17.68 m. The grid spacing in the vertical varies from 0.1 m at the top to 2 m at the bottom. The grid spacing near the top is smaller to allow better resolution near the phreatic surface. The total simulation time is 324 days. In the first 9 days of the simulation, the time step is increased from an initial value of 0.01 days to 1 day in a geometric

ratio of 1.01; thereafter the time step is kept constant at 1 day. The convergence criterion is specified at 10^{-6} and the maximum number of iterations is set to 200 to assure that the transient solution is accurate. The PORFLOW input commands for this problem are shown in Table 4.8.1.

Figure 4.8.3 shows the COMSOL finite-element mesh which consists of 12905 triangular elements and 6858 nodes.

The time history of the phreatic surface due to recharge is shown in Figure 4.8.4 for the PORFLOW and COMSOL numerical simulations for times of 9, 36, 81, 144, 225 and 324 days. Qualitatively the two sets of results are in good agreement. The Polubarinova-Kochina analytical solution was not available for comparison to the numerical results.

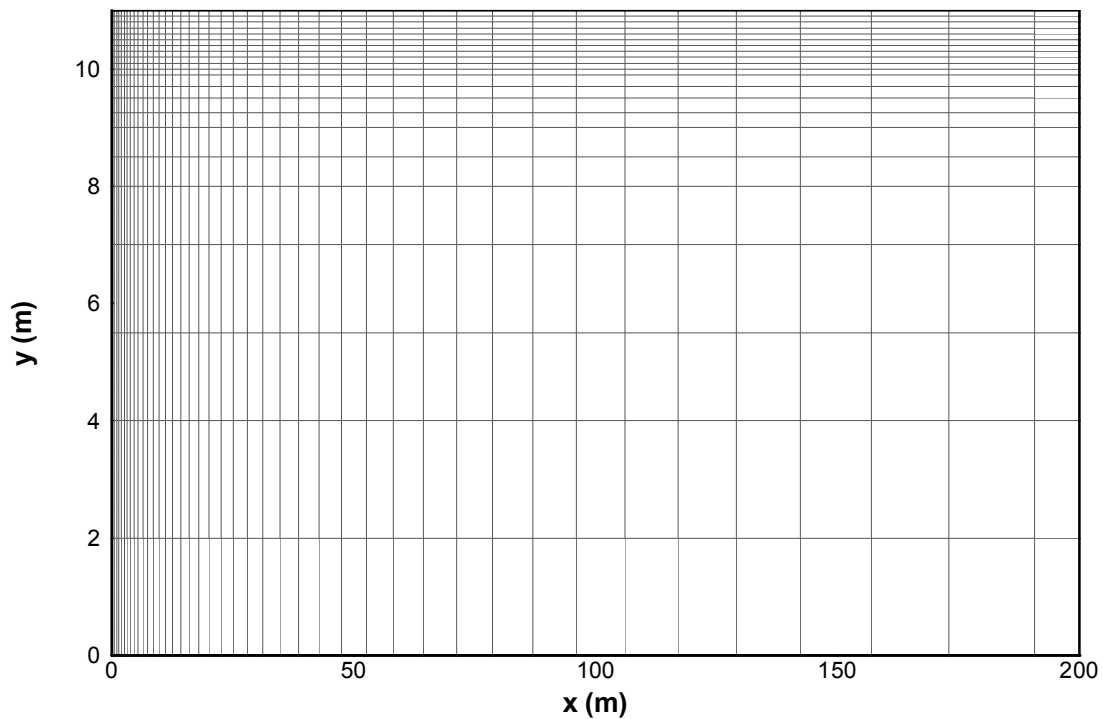

Figure 4.8.2. 2D PORFLOW Cartesian Grid for Problem 4.8

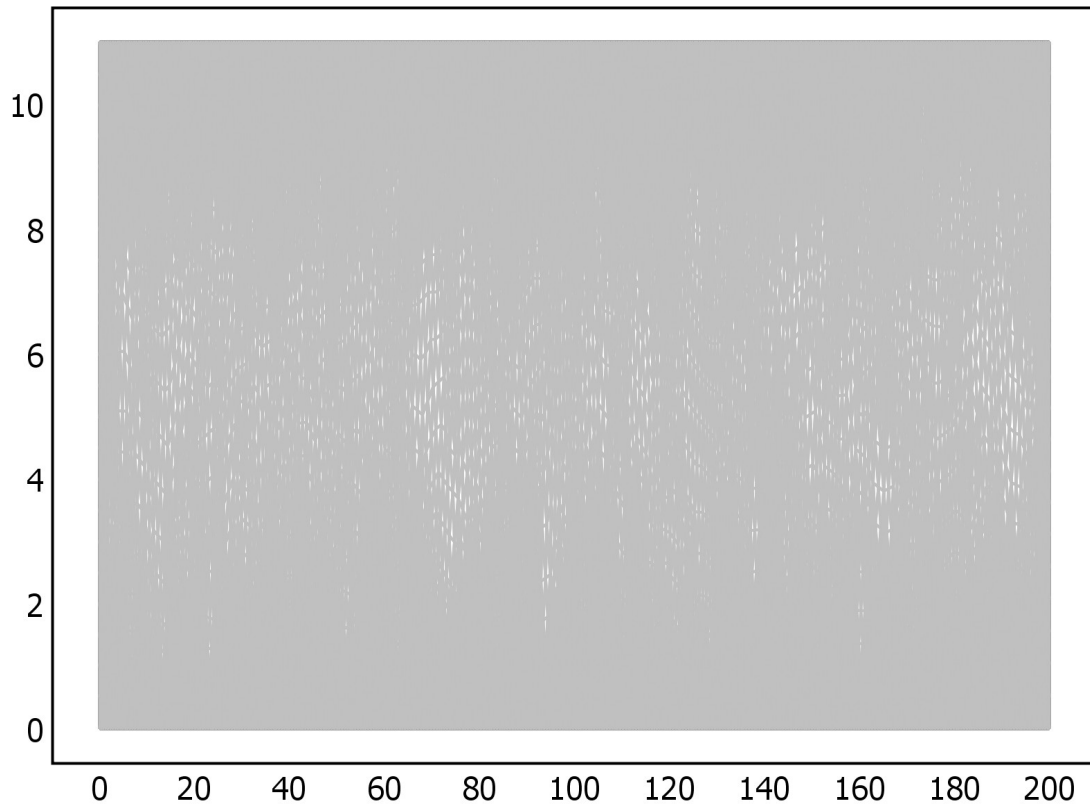

Figure 4.8.3. COMSOL Finite-Element Mesh for Problem 4.8.

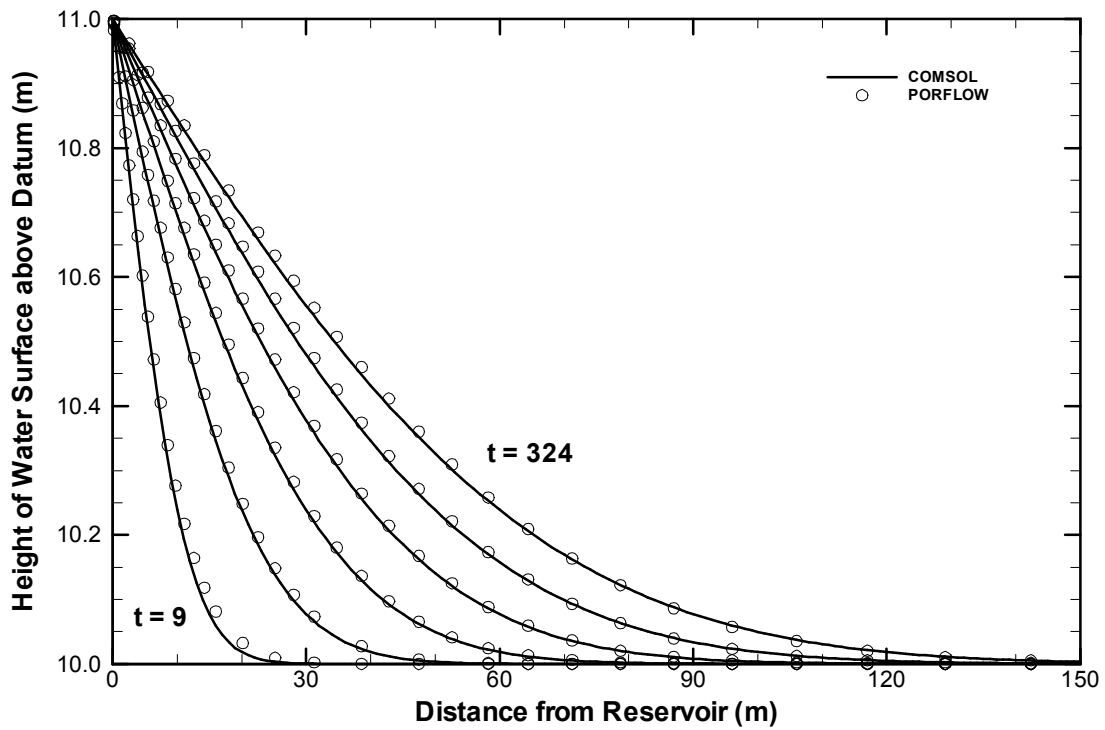

Figure 4.8.4. Time History of Phreatic Surface Due to Recharge.

Table 4.8.1. Input Commands for Problem 4.8.

```

*****
TITLE 4.8 - Transient Free-Surface Boussinesq Flow - Recharge
*****
! Polubarinova-Kochina, P.Ya., 1954. Theory of Groundwater Movement,
! Translated from Russian to English by J.M. Roger de Weist, 1962,
! Princeton University Press, N.J.
*****

PROB WITH FREE SURFACE

GRID NODEs 44 BY 23
COOR X: MIN=0 MAX=200 ratio=1.1
COOR Y values at NODEs are:
0. 2.0 4.0 5.5 7.0 8.0 8.5 9.0 9.25 9.5
9.7 9.9 10.0 10.1 10.2 10.3 10.4 10.5 10.6 10.7
10.8 10.9 11.0

ROCK PORosity = 0.25
HYDRAULIC S=0., Kx=0.1, Ky=1.0

SET H = 10 everywhere
BOUNDary X- for H = 11
BOUNDARY FOR P AT Y- FLUX = 0 $ No-flow bottom boundary
BOUNDARY FOR P AT Y+ FLUX = 0 $ No-flow top boundary

CONVergence for FLOW as a reference: 1.E-6, 200 iter

DIAGNOSITC NODE AT (2,6) every 100 steps
DEBUG GEOMETRY OFF
SAVE H on file '4.8.sav'
SELEct (1,1) to (999,999) interval (2,2)
OUTPut U, V, P H, and S in SELEcted region in NARRow mode

SOLVE for 9 days dt_initiaL=0.01, increase_fac=1.01 dt_max = 1
SAVE NOW
SOLVe for 27 days
SAVE NOW
SOLVe for 45 days
SAVE NOW
SOLVe for 63 days
SAVE NOW
SOLVe for 81 days
SAVE NOW
SOLVe for 99 days

END

```

4.9 Free-Surface Boussinesq Flow with Seepage

This test problem is a variation on the previous Boussinesq problem. In this case, the initial phreatic surface is at 10 meters. At time zero, the water level at the left boundary is suddenly lowered to 9 meters. The schematic is shown in Figure 4.9.1. The horizontal extent of the mesh is 200 meters and the vertical extent is 10 meters. The objective is to determine the phreatic surface at selected times. It is described in detail by Polubarinova-Kochina (1962). This problem and description was taken from Problem V11 in the ACRI PORFLOW validation report version 2.50.

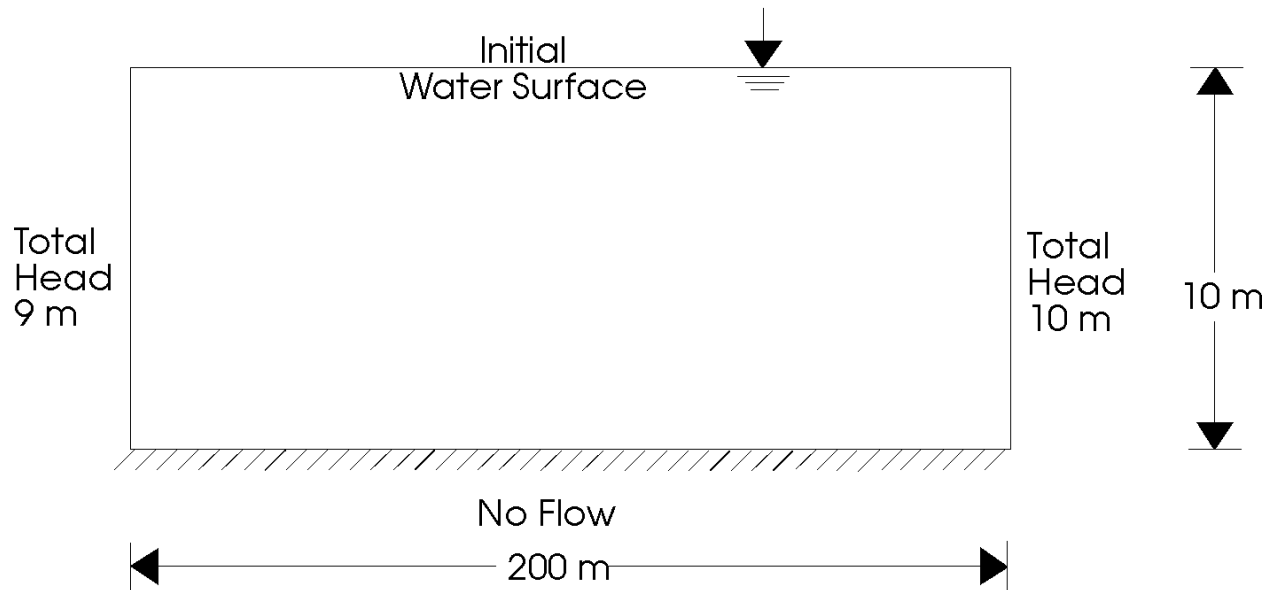

Figure 4.9.1. Schematic Illustration of Problem 4.9.

PORFLOW simulation and comparison: The problem is simulated with a grid of 44 nodes in the horizontal and 23 in the vertical direction. The PORFLOW mesh is shown in Figure 4.9.2. The grid spacing in the horizontal direction increases in a geometric ratio of 1.1. The minimum grid spacing is 0.19 m and the maximum is 17.68 m. The grid spacing in the vertical varies from 0.1 m at the top to 1.5 m at the bottom. The grid spacing near the top is smaller to allow better resolution near the phreatic surface. The total simulation time is 324 days. In the first 9 days of the simulation, the time step is increased from an initial value of 0.01 days to 1 day in a geometric ratio of 1.01; thereafter the time step is kept constant at 1 day. The convergence criterion is specified at 10^{-6} and the maximum number of iterations is set to 200 to assure that the transient solution is accurate. The PORFLOW input commands for this problem are shown in Table 4.9.1.

Figure 4.9.3 shows the COMSOL finite-element mesh which consists of 12616 triangular elements and 6711 nodes.

The time history of the phreatic surface due to seepage is shown in Figure 4.9.4 for the PORFLOW and COMSOL numerical simulations for times of 9, 36, 81, 144, 225 and 324 days. Qualitatively the two sets of results are in good agreement. The Polubarinova-Kochina analytical solution was not available for comparison to the numerical results.

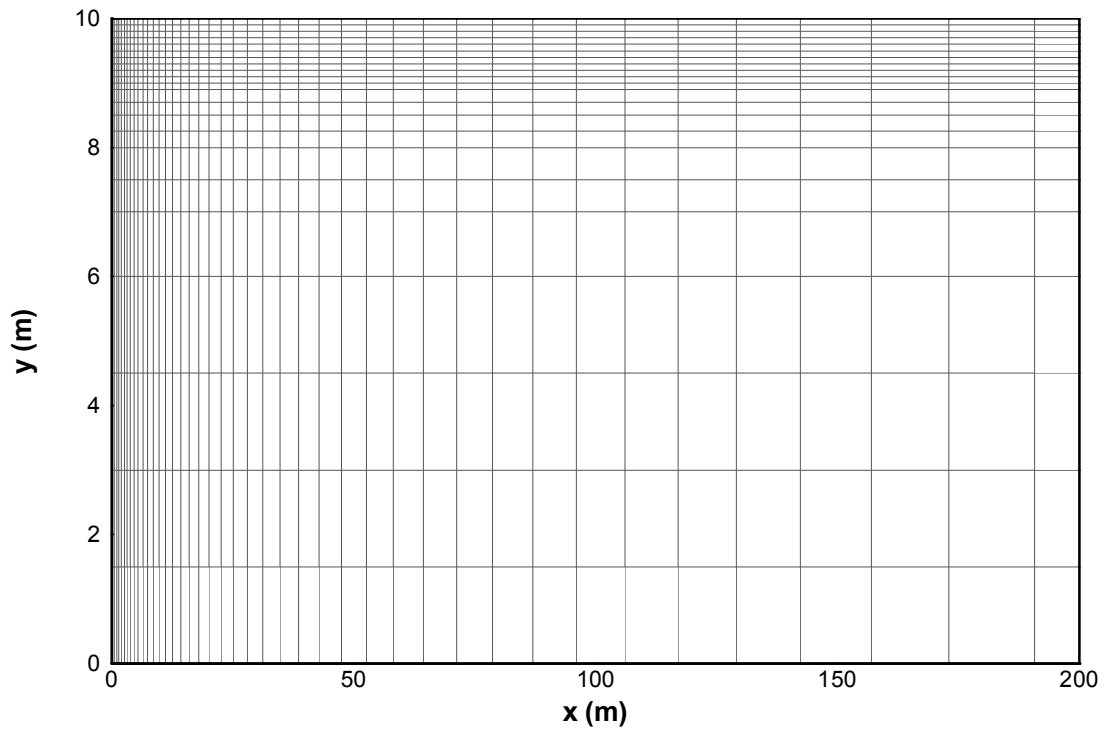

Figure 4.9.2. 2D PORFLOW Cartesian Grid for Problem 4.9.

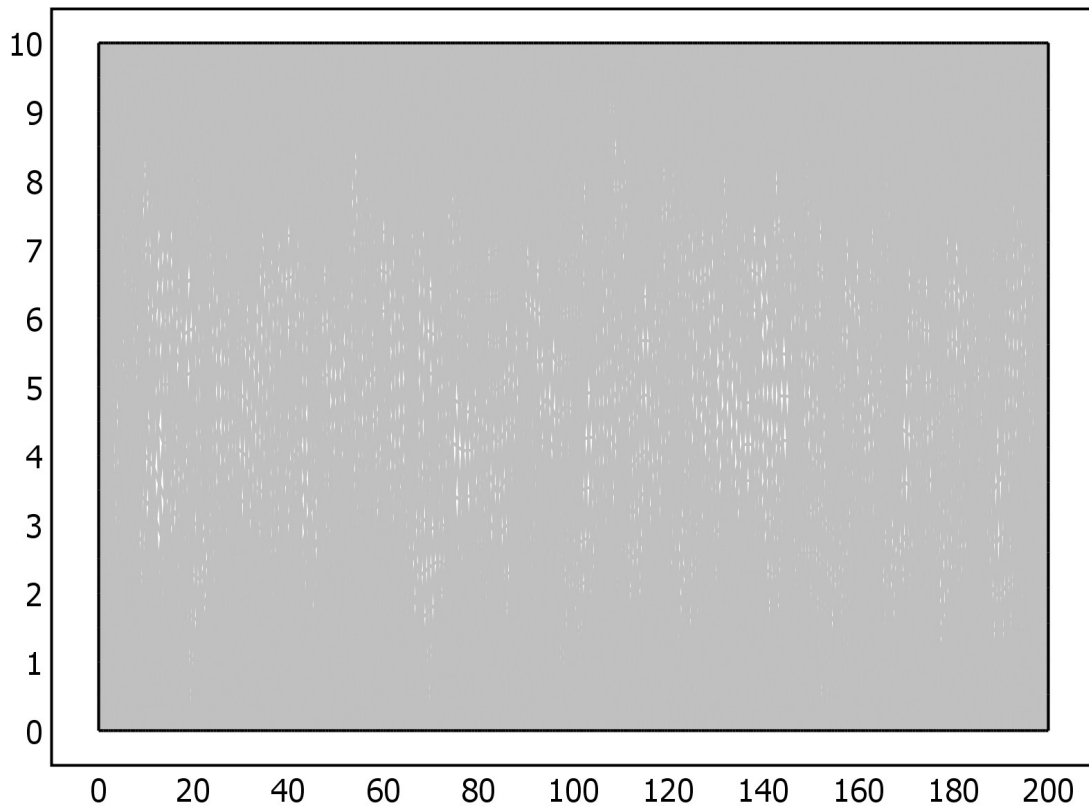

Figure 4.9.3. COMSOL Finite-Element Mesh for Problem 4.9.

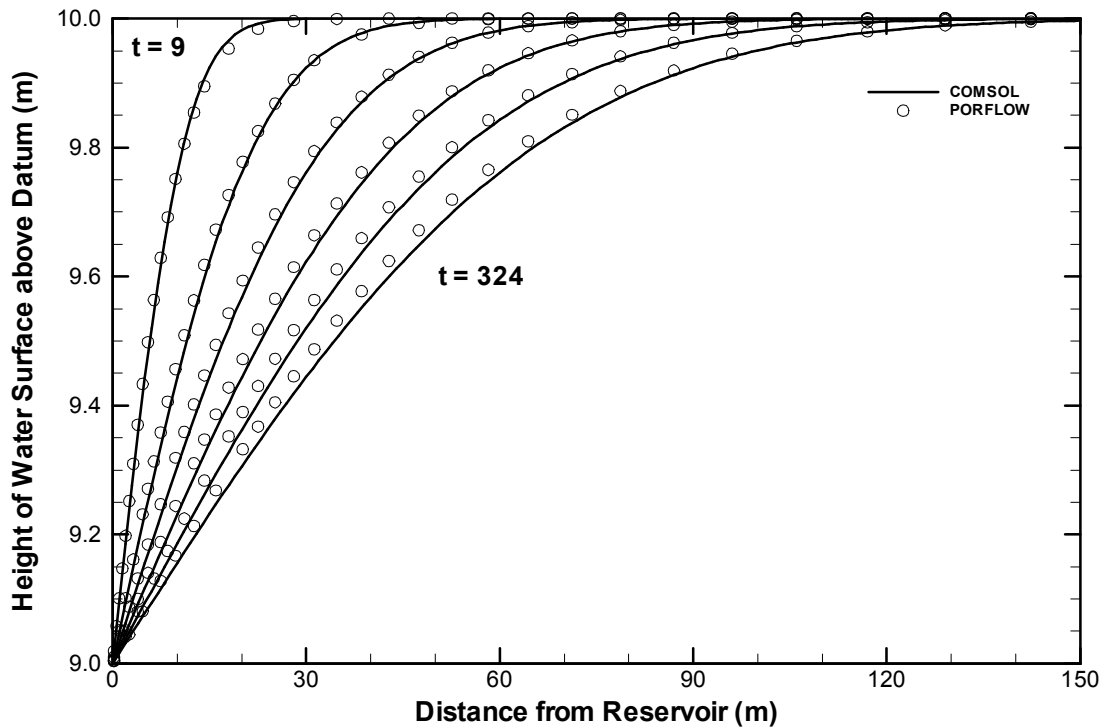

Figure 4.9.4. Time History of Phreatic Surface Due to Seepage.

Table 4.9.1. Input Commands for Problem 4.9.

```

*****
TITLe 4.9 - Transient Free-Surface Boussinesq Flow - Seepage
*****
! Polubarinova-Kochina, P.Ya., 1954. Theory of Groundwater Movement,
! Translated from Russian to English by J.M. Roger de Weist, 1962,
! Princeton University Press, N.J.
*****

Problem with FREE SURFace

GRID NODEs 44 BY 23
COOR X: MIN=0 MAX=200 ratio=1.1
COOR Y values at NODEs are:
 0.  1.5 3.0 4.5 6.0 7.0 7.5 8.0 8.25 8.5
 8.7 8.9 9.0 9.1 9.2 9.3 9.4 9.5 9.6 9.7
 9.8 9.9 10.0

ROCK PORosity = 0.25
HYDRAULIC S=0., Kx=0.1, Ky=1.0

SET H = 10 everywhere
BOUNDary X- for H = 9

BOUNDARY FOR P AT Y- FLUX = 0 $ No-flow bottom boundary

CONVergence for FLOW as a reference: 1.E-6, 200 iter

DIAGNOSITC NODE AT (2,6) every 100 steps
DEBUG GEOMETRY OFF
SAVE H on file '4.9.sav'
SELEct (1,1) to (999,999) interval (2,2)
OUTPut U, V, P H, and S in SELEcted region in NARRow mode

SOLVE for 9 days dt_initia=0.01, increase_fac=1.01 dt_max = 1.0
    
```

SAVE NOW
 SOLVe for 27 days
 SAVE NOW
 SOLVe for 45 days
 SAVE NOW
 SOLVe for 63 days
 SAVE NOW
 SOLVe for 81 days
 SAVE NOW
 SOLVe for 99 days

END

4.10 Unsaturated Vertical Soil Column

Two test cases were designed to confirm correct implementation of soil characteristic curves and Richard's equation. The first test case essentially reproduces the water retention curve under no flow conditions. The second test case involves steady-state unsaturated flow at constant saturation that involves relative permeability. The soil characteristic curves chosen are for "Silt Loam G.E. 3" and are taken from van Genuchten (1980). The van Genuchten models for capillary suction-water retention and relative permeability are

$$S_e = \begin{cases} \frac{1}{\left[1 + (\alpha\psi)^n\right]^m} & \psi > 0 \\ 1 & \psi \leq 0 \end{cases} \quad (4.10.1)$$

$$k_{rw} = S_e^{1/2} \left[1 - \left(1 - S_e^{1/m}\right)^m \right]^2 \quad (4.10.2)$$

where S_e is the "effective saturation" defined by

$$S_e = \frac{S_w - S_{wr}}{1 - S_{wr}} \quad (4.10.3)$$

with empirical parameters α and m .

For Silt Loam G.E. 3 the empirical parameters take on the values

$$S_{wr} = 0.331 \quad (4.10.4a)$$

$$\alpha = 0.129 \text{ ft}^{-1} \quad (4.10.4b)$$

$$m = 0.515 \Rightarrow n = \frac{1}{1 - m} = 2.0619 \quad (4.10.4c)$$

The saturated hydraulic conductivity is $K = 0.163 \text{ ft/day}$ (van Genuchten, 1980).

Figures 4.10.1 and 4.10.2 show the PORFLOW and COMSOL meshes used in the numerical simulation of the test cases, respectively. The 1-D PORFLOW mesh consists of 251 nodes in the x direction and 3 nodes in the y direction. The COMSOL finite-element mesh consists of 3232 triangular elements and 1689 mesh points.

Water retention profile case: The input commands for the PORFLOW simulation are given in Table 4.10.1. Because the steady-state head is zero along the column, there is no flow in the column. Figure 4.10.3 shows the predicted column saturation profile for the COMSOL and PORFLOW numerical simulations. The agreement is excellent.

Steady-state unsaturated flow at constant saturation case: The input commands for the PORFLOW simulation are given in Table 4.10.2. For a saturation of 75%, the capillary pressure is 0.005125952 ft and the relative permeability is 0.043098523. For boundary conditions of -9.377711175 ft applied to both ends of the column, the Darcy velocity throughout the column is constant and equal to:

$$U = k_{rw} K \frac{\Delta h}{\Delta x} = (0.043098523) \left(0.163 \frac{\text{ft}}{\text{day}} \right) \frac{50 \text{ ft}}{50 \text{ ft}} = 0.007025 \frac{\text{ft}}{\text{day}} \quad (4.10.5)$$

The PORFLOW code reproduces the constant saturation of 75% and Darcy velocity in Equation 4.10.5 as shown in Figure 4.10.4.

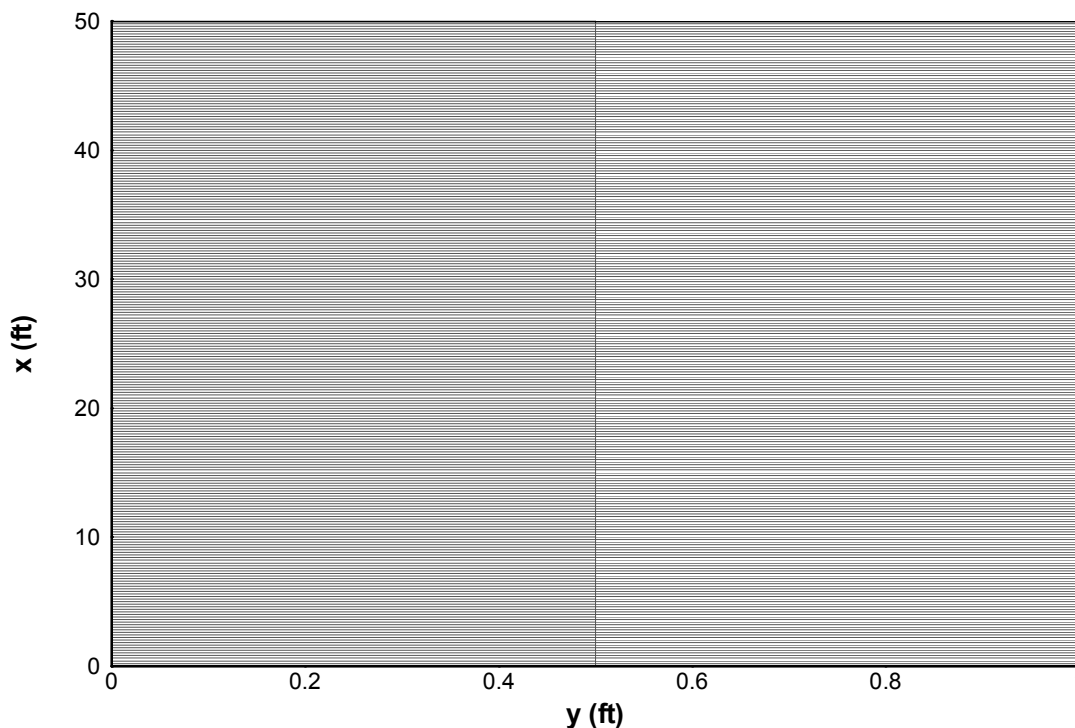

Figure 4.10.1. 1D PORFLOW Grid for Problem 4.10.

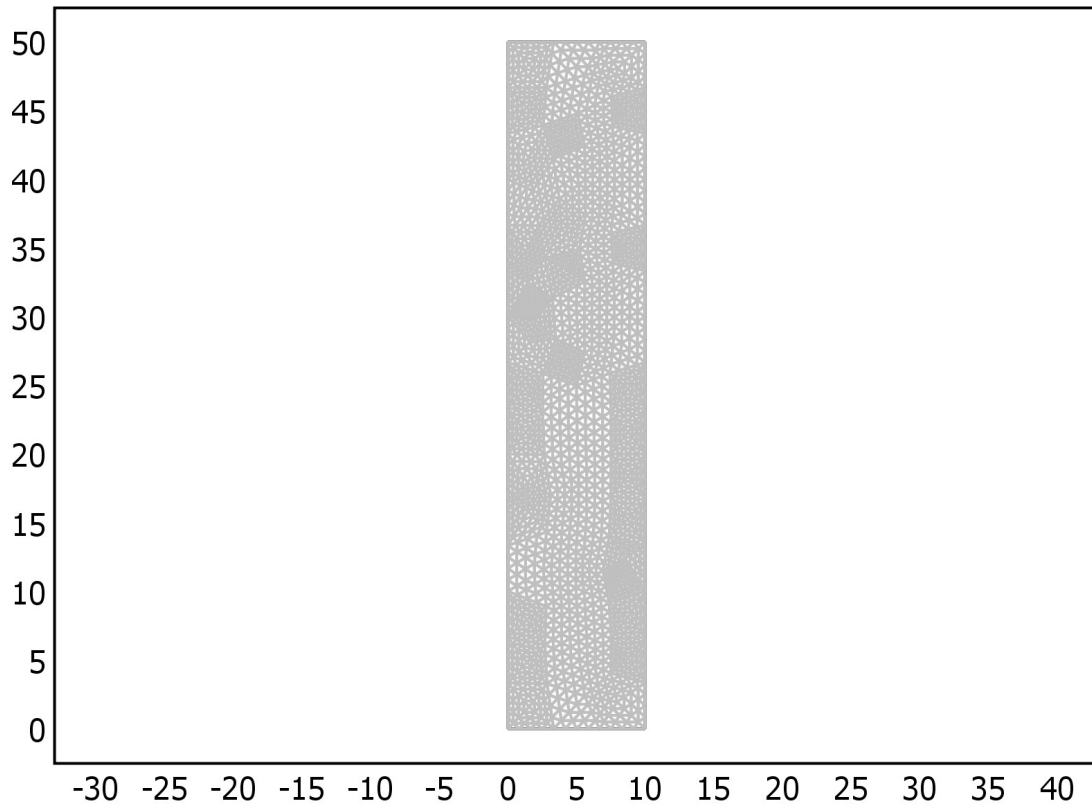

Figure 4.10.2. COMSOL Finite-Element Mesh for Problem 4.10.

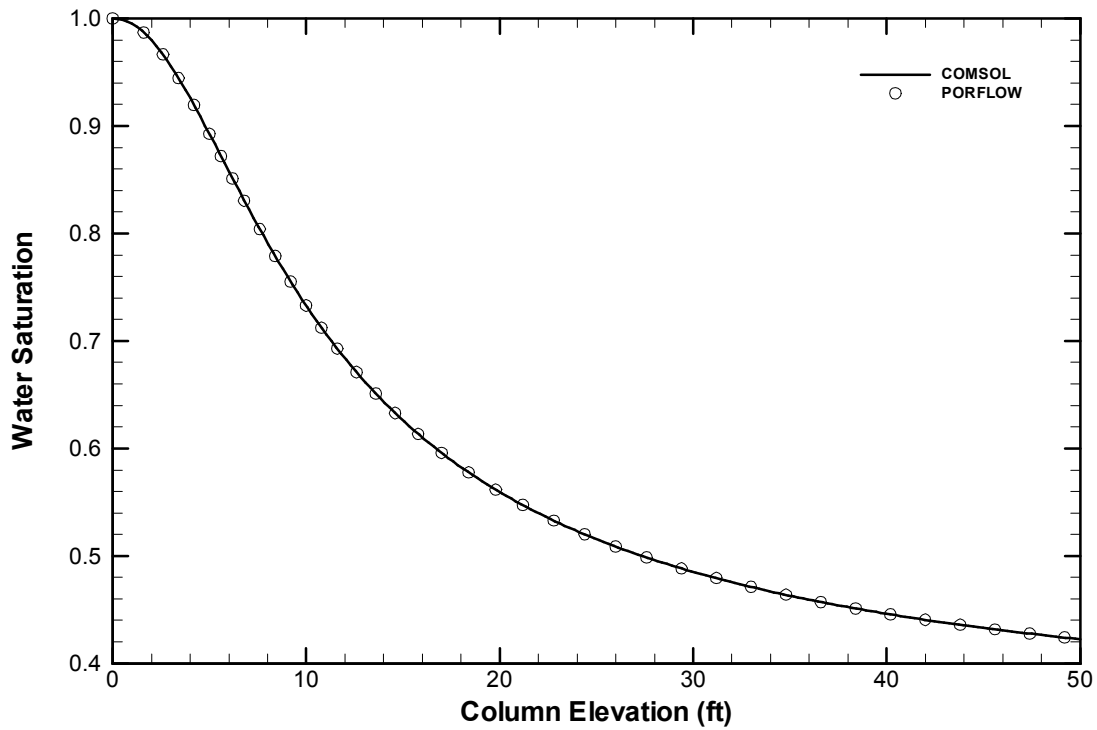

Figure 4.10.3. Predicted Column Saturation Profile for COMSOL and PORFLOW Simulations.

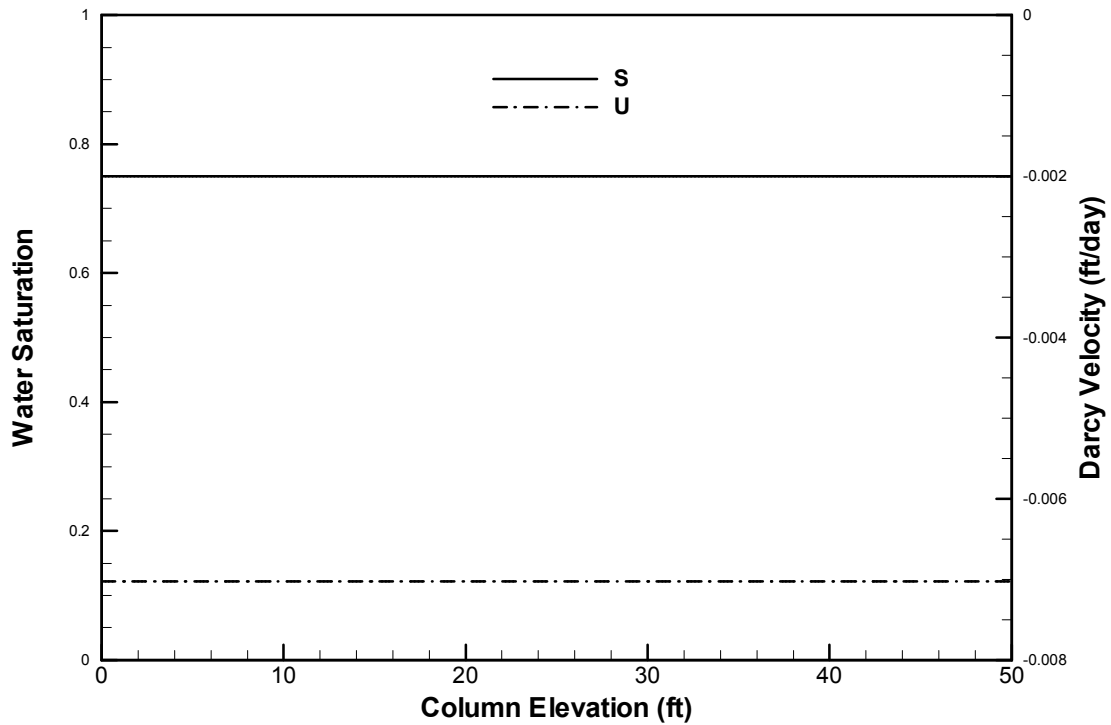

Figure 4.10.4. PORFLOW Simulation of Steady-state Unsaturated Flow at Constant Saturation (75%).

Table 4.10.1. Input Commands for Problem 4.10 (Water Retention Profile).

```

*****
TITLe 4.10 Unsaturated Vertical Soil Column
*****
! Steady-state head is zero, no flow
*****

DEFine h0 = 0.

GRID is 251 NODEs
COORDinate NODEs X: MINImum=0.0, MAXImum=5.e1

GRAVity -1.

ROCK DENsity 1, POROsity = 0.30
HYDRauiic properties S = 0., Kx = 0.163 ft/d, Ky = 0.163 ft/d
MULTiphase VAN Genuchten MUALem: n=2.06185567, alpha=0.129, Sr=0.331 ! Silt Loam G.E. 3

SET H = h0 everywhere initially

BOUNDary condition for H: X-, VALUe = h0
BOUNDary condition for H: X+, VALUe = h0

! Solution controls
!MATRix NSPC for P precon=CHOL, accel=CONJ, MODI
MATRix ITERation 100

CONVergence REFERENCE based on ALL: Tolerance = 1.E-6, 100 outer iterations

DIAGnostic node (126,2) every 10 steps

SOLVe P in STEAdy mode: max=200, min=200
SAVE P H S to '4.10-wrc.sav' NOW

END

```

Table 4.10.2. Input Commands for Problem 4.10 (Constant Saturation).

```

*****
TITLe 4.10 Unsaturated Vertical Soil Column
*****
! Steady-state flow at constant saturation of 75%
*****

GRID is 251 NODEs
COORDinate NODEs X: MINImum=0.0, MAXImum=5.e1

GRAVity -1.

ROCK DENsity 1, POROsity = 0.30
HYDRauiic properties S = 0., Kx = 0.163 ft/d, Ky = 0.163 ft/d
MULTiphase VAN Genuchten MUALem: n=2.06185567, alpha=0.129, Sr=0.331 ! Silt Loam G.E. 3

SET P = -9.377711175 everywhere initially

BOUNDary condition for P: X-, VALUe = -9.377711175
BOUNDary condition for P: X+, VALUe = -9.377711175

! Solution controls
MATRix NSPC for P precon=CHOL, accel=CONJ, MODI
MATRix ITERation 100

CONVergence REFERENCE based on ALL: Tolerance = 1.E-6, 100 outer iterations

DIAGnostic node (126,2) every 10 steps

SOLVe P in STEAdy mode: max=200, min=200
SAVE P H S U to 4.10-csc.sav' NOW

END

```

5 Group 2: Contaminant Transport Problems

In the following three sections, we present one, two, and three dimensional solute transport examples, respectively. They are classical cases ideal for studying the basic behavior of an advection-dispersion equation solver. In the one-dimensional case, we shall test the equation solver in various ways by varying its control parameters over a wide range of values. This enables modelers to see the inherent weaknesses of this solver and help to minimize such weaknesses in their own problems. The majority of behaviors presented below are observed in all advection-dispersion solvers. Ultimately, the users must rely on their own experience and it is highly recommended that several transport simulations of the same problem be performed. Comparisons to these simulations will provide excellent insight into how adequate and optimal their solution is. The test cases selected all have analytic solutions for a clear picture as to how well PORFLOW handles these transport conditions.

5.1 One-Dimensional Saturated Solute Transport in a Uniform Flow Field

This problem deals with one-dimensional advection-dispersion of a non-conservative solute species through a semi-infinite porous medium and is used to demonstrate the impact that various PORFLOW options (i.e., numerical approximations) have on its solution. The 1D advection-dispersion equation is ideal for testing an algorithm's behavior over a wide range of conditions. A physical schematic of this problem is shown in Figure 5.1.1. As illustrated, a non-conservative contaminant is continuously released from a fully penetrating channel into a shallow confined aquifer unit whose groundwater flow is assumed uniform. Both hydrodynamic dispersion and molecular diffusion are allowed, as well as, the possibility of radioactive decay and/or adsorption of the species. It is assumed that the contaminant concentration level in the neighboring reservoir remains constant, the aquifer's flow rate is uniform and constant, and the homogeneous aquifer's properties (such as porosity, soil type, water saturation) are uniform and constant.

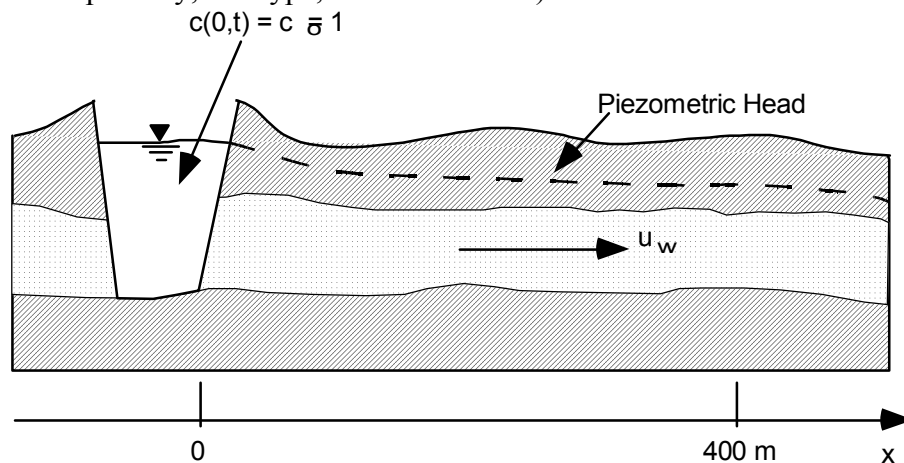

Figure 5.1.1. Schematic Diagram for 1D Solute Transport in a Confined Aquifer.

Analytical solution: The conservative form of the multi-dimensional advection-dispersion equation for solute transport through a variably saturated porous media with radioactive decay and point sources is given as

$$\frac{\partial}{\partial t}(\theta_e R c) + \nabla \cdot (U c) = \nabla \cdot (\Gamma \nabla c) - \theta_e R \lambda c + q c^* \tag{5.1.1}$$

where

- θ_e effective or mobile water content, $S_w \phi$
- R retardation factor, $1 + \rho_b k_d / \theta_e$
- ρ_b bulk soil density, $\rho_s (1 - \phi)$
- ρ_s particle density
- k_d distribution coefficient
- U Darcy velocity vector
- c solute concentration
- Γ apparent hydrodynamic dispersion tensor, $\theta_e D$
- λ radioactive decay constant, $\ln(2)/t_{1/2}$
- q volumetric flow source per unit volume of porous medium
- c^* solute concentration evaluated within source/sink flow term

Equation 5.1.1 is in conservative form and the non-conservative form is considered more amendable to spatial discretization. To accomplish the transformation, use is made of the flow (mixture mass balance) equation in its incompressible form

$$\frac{\partial \theta_e}{\partial t} = -\nabla \cdot U + q \tag{5.1.2}$$

Substituting Equation 5.1.2 into 5.1.1, with expanded advective and mass accumulation terms, yields

$$\theta_e R \frac{\partial c}{\partial t} + c \frac{\partial \theta_e}{\partial t} + c \frac{\partial}{\partial t}(\rho_b k_d) + U \cdot \nabla c - c \frac{\partial \theta_e}{\partial t} + q c = \nabla \cdot (\theta_e D) - \theta_e R \lambda c + q c^* \tag{5.1.3}$$

Assuming that the time derivative of $\rho_b k_d$ is negligible, Equation 5.1.3 reduces to

$$\theta_e R \frac{\partial c}{\partial t} + U \cdot \nabla c = \nabla \cdot (\theta_e D) - \theta_e R \lambda c - q(c - c^*) \tag{5.1.4}$$

Taking the 1D form of Equation 5.1.4 and assuming that no point sources/sinks exist within the domain, constant water saturation level, and that material coefficients are constants, results in

$$\frac{\partial c}{\partial t} = D'_{xx} \frac{\partial^2 c}{\partial x^2} - u'_x \frac{\partial c}{\partial x} - \lambda c \tag{5.1.5}$$

$$u_x = \frac{U_x}{\theta_e} \tag{5.1.5a}$$

$$u'_x = \frac{u_x}{R} \tag{5.1.5b}$$

$$D_{xx} = \alpha_L u_x + \theta_e \tau D_m \tag{5.1.5c}$$

$$D'_{xx} = \frac{D_{xx}}{R} \tag{5.1.5d}$$

where

- α_L longitudinal dispersivity
- τ tortuosity of the porous medium
- D_m bulk molecular diffusion coefficient

For our semi-infinite confined aquifer the initial conditions are:

$$c(x,0) = 0 \tag{5.1.6a}$$

and the boundary conditions are:

$$c(0,t) = c_0 \tag{5.1.6b}$$

$$c(\infty,t) = 0 \tag{5.1.6c}$$

For the first boundary condition we are assuming that at $x = 0$ the contaminant concentration reaches its ultimate value c_0 immediately upon commencement of flow and remains at that value throughout all positive times ($x = 0$ boundary represents an inflow boundary). The second boundary condition is equivalent to assuming that the dispersive flux of solute is zero at plus infinity or

$$\lim_{x \rightarrow \infty} \left(\frac{\partial c}{\partial x} \right) = 0 \tag{5.1.6d}$$

Equation 5.1.5, a linear partial differential equation subject to the initial and boundary conditions given by Eqs. 5.1.6a to 5.1.6d can be solved by applying Laplace and Fourier transforms. The general solution has been derived by Grobner and Hofreiter (1950) and takes the form:

$$c(x,t) = \frac{1}{2} c_0 \exp\left(\frac{u'_x x}{2D'_{xx}}\right) \left[\exp(-x\beta) \operatorname{erfc}\left(\frac{x - \sigma t}{2\sqrt{D'_{xx} t}}\right) + \exp(x\beta) \operatorname{erfc}\left(\frac{x + \sigma t}{2\sqrt{D'_{xx} t}}\right) \right] \tag{5.1.7}$$

where

$$\beta^2 = \left(\frac{u'_x}{2D'_{xx}} \right)^2 + \frac{\lambda}{D'_{xx}} \quad \text{and} \quad \sigma^2 = (u'_x)^2 + 4\lambda D'_{xx} \quad (5.1.7a)$$

When there is no radioactive decay ($\lambda=0$), Equation 5.1.7 reduces to

$$c(x, t) = \frac{1}{2} c_0 \left[\operatorname{erfc} \left(\frac{x - u'_x t}{2\sqrt{D'_{xx} t}} \right) + \exp \left(\frac{u'_x x}{D'_{xx}} \right) \operatorname{erfc} \left(\frac{x + u'_x t}{2\sqrt{D'_{xx} t}} \right) \right] \quad (5.1.8)$$

derived also by Ogata and Banks (1961). The absence of adsorption is achieved by setting the retardation factor to unity ($R = 1$, $k_d = 0$). Note that the original derivation by Grobner and Hofreiter was performed on the limited case of a saturated media in the absence of adsorption. The more general case presented here results in the same solution but is based upon retarded material coefficients. The evaluation of the analytical expression, Equation 5.1.7, for a specific problem is performed numerically using the FORTRAN code GH in Section B.

PORFLOW numerical simulation and comparison: Values of the physical parameters used in the verification simulations are presented in Table 5.1.1. The base case grid chosen for this problem consists of 201 nodes uniformly spaced (2 meters) along the x-axis and 3 nodes in the y direction. Figure 5.1.2 illustrates the PORFLOW mesh chosen. At the channel inlet boundary (left face), the concentration of solute in the incoming water is set to 1.0 kg/m^3 . Due to the finite overall length of our mesh, at the outflow boundary (right face) the dispersive flux is set to zero, while the advective flux is calculated as part of the solution. Since this is a 1D problem, solute concentration gradients do not exist in the transverse directions (y and z directions). The aquifer is assumed to be completely saturated.

Table 5.1.1. Values of the Physical Parameters, Mesh Spacing, Time Steps, and Key Computed Parameters Used in the One-Dimensional Transport Simulations.

Physical parameters	Base Case	Range tested
Darcy velocity, U_x	1.0 m/d	-
Porosity, ϕ	0.25	-
Longitudinal dispersivity, α	5.0 m	0.01,5.0
Apparent molecular dispersion coefficient, $\theta_e \tau D^*$	0.0 m ² /d	-
Water saturation, S_w	1.0	-
Radioactive decay constant, λ	0.0 d ⁻¹	0.0,0.01
Soil density, ρ_s	1.0 kg/m ³	-
Solute distribution coefficient, k_d	0.0 m ³ /kg	0.0,0.3333
Boundary solute concentration, c_0	1.0 kg/m ³	-
Grid specifics		
x grid spacing, Δx	2 m	2,20,40,80
y grid spacing, Δy	0.5 m	-
Number nodes in x-direction	201	201,21,11,6
Number nodes in y-direction	3	-
Longitudinal length	400 m	-
Time steps		
Time duration	50 d	-
number time-steps	500	20,10,5,2
time-step size, Δt	0.1 d	2.5,5,10,25
Key computed parameters		
Retardation factor, R	1.0	1.0,2.0
Bulk soil density, ρ_b	0.75 kg/m ³	-
Phasic velocity, u_x	4.0 m/d	-
Retarded phasic velocity, u'_x	4.0 m/d	4.0,2.0
Retarded longitudinal dispersion coefficient, D'_{xx}	20.0 m ² /d	20.0,10.0
Cell Fourier number, Fo_x	0.5	0.5,0.0078125, 0.03125,0.125,0.5, 1.0,2.0,5.0
Cell Courant number, Co_x	0.2	0.2,0.125,0.25,0.5, 10,20,50
Cell Peclet number, Pe_x	0.4	0.4,4.0,8.0,16.0, 1000.0

For this problem several simulations were performed. As summarized in Table 5.1.2, simulations were performed for a base case and then twelve runs were made varying certain key physical parameters and PORFLOW options to demonstrate their impact on the results. For each simulation, a transient calculation was performed for a 50-day duration and the results from PORFLOW at two points in time (25 and 50 days) are compared to the analytical solution given

by Equation 5.1.7. As shown in Table 5.1.1, a broad range of cell Fourier, cell material Courant and cell Peclet numbers were tested. For understanding behavior, stability and accuracy issues, these are very important quantities to consider.

Table 5.1.2. Summary of Simulations Performed (Base Case and Variations) on the One-Dimensional Transport Problem.

PORFLOW Options	Base Case	A	B	C	D	E	F	G	H	I	J	K	L
Integration scheme HYDRID CONDIF QUICK Central Differencing	x	x	x	x	x	x	x	x	x	x	x	x	x
Property averaging Harmonic Arithmetic Geometric Upwind	x	x	x	x	x	x	x	x	x	x	x	x	x
Mesh Sizes													
Element length, $\Delta x = 2$ m $\Delta x = 20$ m $\Delta x = 40$ m $\Delta x = 80$ m	x	x	x	x				x	x	x	x	x	x
time-step size, $\Delta t = 0.1$ d $\Delta t = 5$ d $\Delta t = 10$ d $\Delta t = 25$ d	x	x	x	x	x	x	x				x	x	x
Physical Parameters													
Longitudinal horizontal dispersivity, $\alpha_L = 5$ m $\alpha_L = 0.01$ m radioactive decay coef., $\lambda = 0.0$ d ⁻¹ $\lambda = 0.01$ d ⁻¹ Solute distribution coef., $k_d = 0.0$ m ³ /kg $k_d = 0.3333$ m ³ /kg	x	x	x	x	x	x	x	x	x	x			x
	x	x			x	x	x	x	x	x	x	x	x
	x		x	x		x	x	x	x	x	x	x	x
		x		x									

The results of all the simulations (both numerical and analytical) are shown in Figures 5.1.3 through 5.1.15. Each figure corresponds to a different combination of parameters (e.g., spatial and temporal approximations). These results are also presented in tabular form for comparison in Tables 5.1.3 through 5.1.17. The analytical results were computed from the computer code GH. The PORFLOW input commands for the 1D transport simulations are given in Tables 5.1.18 through 5.1.30b.

The results presented in Figure 5.1.3 represent our base case. The concentration profiles at both time shots compare very close to the analytical profiles. Once the simulation time has reached 50 days, sufficient time has elapsed such that the concentration profile shape is unaffected by the inlet boundary condition and the mean transport distance (location of 50% of the solute) corresponds to the retarded velocity times elapsed time. For the base case at 50 days, the mean distance is 200 m (i.e., 4.0 m/d x 50 d). Characteristic oscillatory overshoot or undershoot, exhibited by second-order accurate centered spatial differencing, is not observed for the base case because the local cell Peclet number does not exceed 2.

By adjusting the solute distribution coefficient such that the retardation factor becomes 2 (Case A), the retarded dispersion and velocity are halved. These results can be seen in Figure 5.1.4 where (a) the mean transport distance at 50 days is now 100 m and (b) the spread of the plume has been greatly reduced. Compare the results in Figure 5.1.4 to 5.1.3.

By employing a non-zero radioactive decay coefficient such that the solute now becomes a non-conservative transport species (Case B), the solute concentration profiles are reduced especially at the higher concentration levels. These results can be seen in Figure 5.1.5 as compared to Figure 5.1.3.

By applying both retardation and radioactive decay coefficients simultaneously (Case C), we observe the composite effect as shown in Figure 5.1.6. These results show (a) the mean transport distance at 50 days is now less than 100 m and (b) the concentration profile has been reduced at the higher concentration levels.

The effect of varying the grid size spacing (Cases D, E, and F) can be seen in Figures 5.1.7 to 5.1.9. As shown, the "effective", numerical plus mechanical, dispersion coefficient continues to increase as the grid spacing increases. Thus, resolution of the concentration front diminishes. The cell Peclet numbers are 4, 8 and 16 for mesh sizes of $\Delta x = 20$ m, 40 m and 80 m, respectively and we can begin to see significant undershoot and overshoot occurring.

The effect of varying the time-step size (Cases G, H, and I) can be seen in Figures 5.1.10 to 5.1.12. As shown, the "effective", numerical plus mechanical, dispersion coefficient continues to increase as the time-step size increases. Thus, resolution of the concentration front diminishes. At the time-step sizes $\Delta t = 5, 10$ and 25 days, the cell material Courant and Fourier numbers are exceeding unity and we can begin to see significant undershoot and overshoot occurring.

To see a strong effect of oscillation near the concentration front two case runs (Cases J and K) were performed at a cell Peclet number of a thousand. This high of a cell Peclet number results in the transport of nearly square wave (i.e., plug flow) over the time and distance ranges of interest here. Using the central differencing scheme for integration of the transport equation (Case J) we see oscillatory behavior as illustrated in Figure 5.1.13. The central spatial differencing scheme attempt to capture the very steep concentration resulted in upstream oscillations. These oscillations can be minimized or eliminated by refining the grid spacing. We will restrict ourselves to the grid spacing use in the base case. Applying the default HYBRID, CONDIF or Modified

QUICK nodal integration schemes (Case K) eliminates the oscillations but results in a significant increase in artificial dispersion.

PORFLOW offers several options for averaging of material properties from node to node. Figure 5.1.15 (Case L) illustrates the impact of arithmetic, harmonic (default option), geometric and upwind averaging of the dispersion coefficient in the transport equation. Since the dispersion coefficient does not vary spatially in this example, you would expect these various averaging schemes to produce identical results as shown in the figure. A better test would be to have the dispersion coefficient varying spatially and then compare the various averaging options.

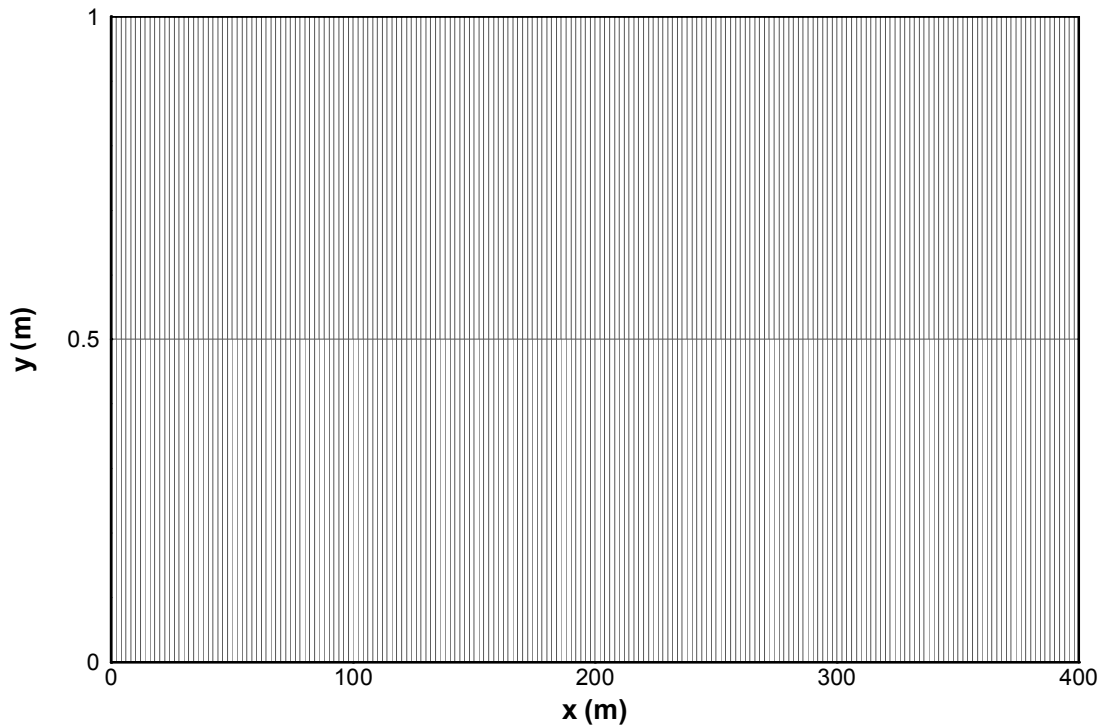

Figure 5.1.2. PORFLOW Grid for 1-D Base Case Transport Simulation.

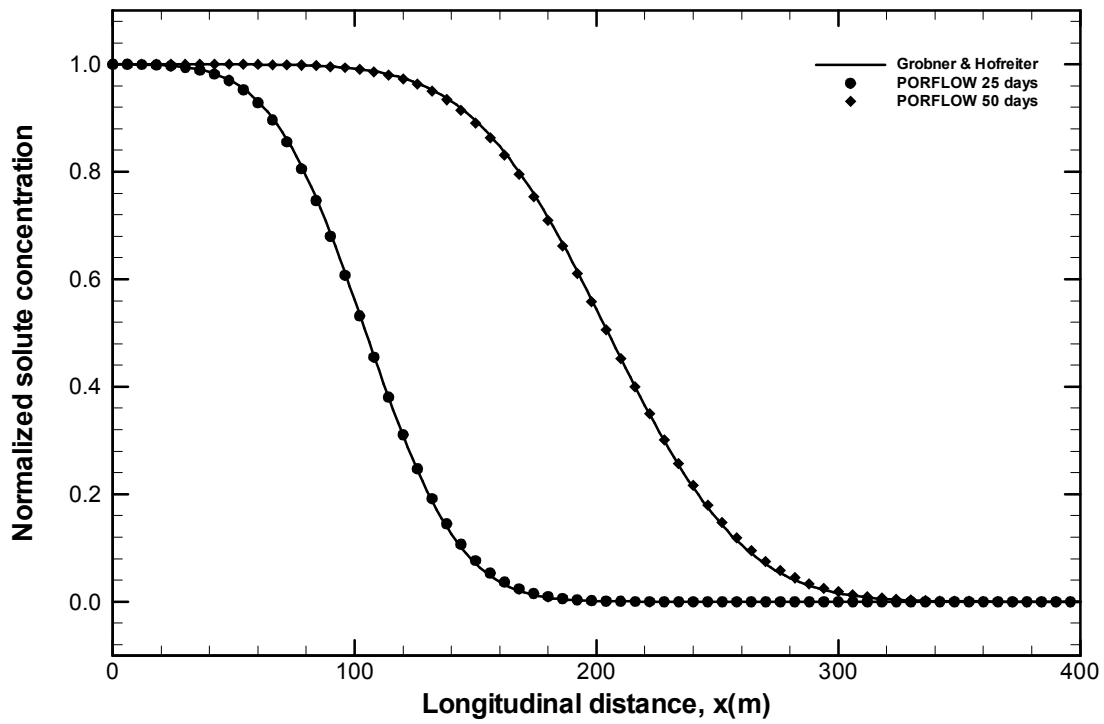

Figure 5.1.3. Concentration Profiles for the 1D Transport of the Base Case.

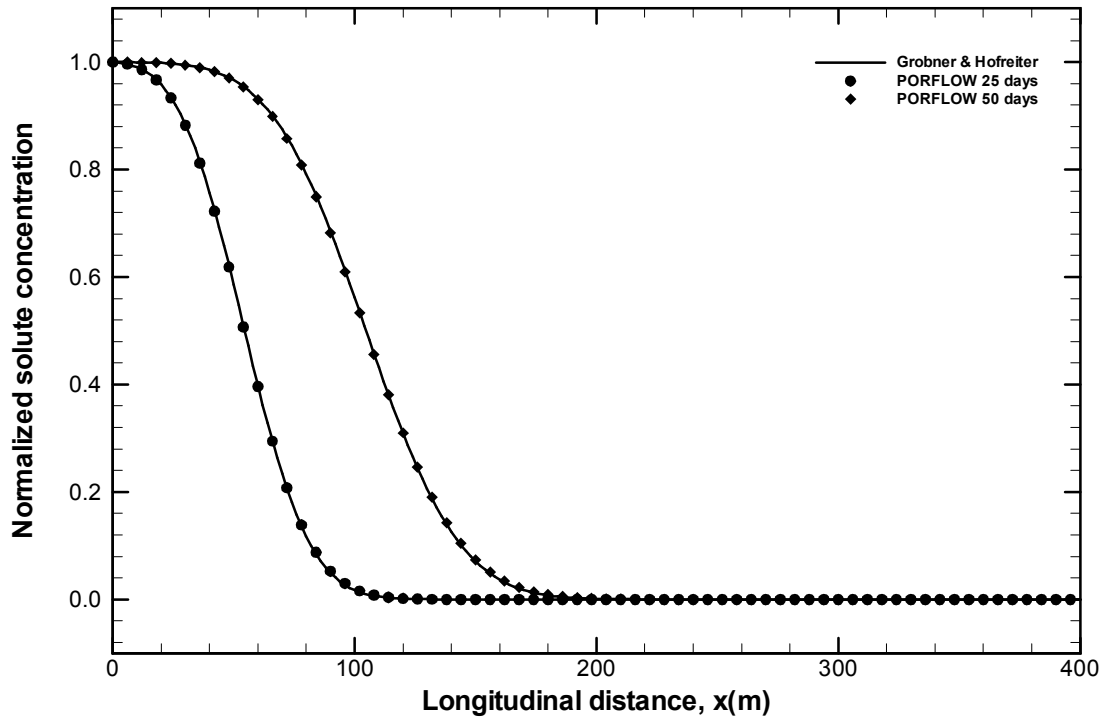

Figure 5.1.4 Concentration Profiles for the 1D Transport Showing Effect of Retardation (Case A).

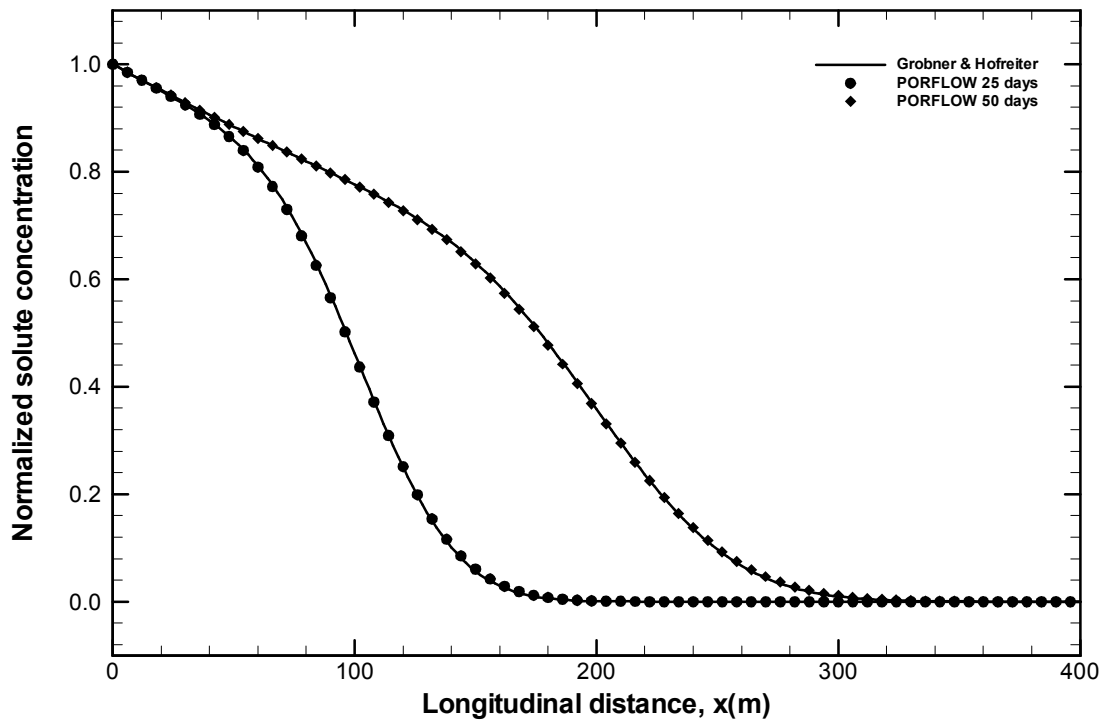

Figure 5.1.5 Concentration Profiles for the 1D Transport Showing Effect of Radioactive Decay (Case B).

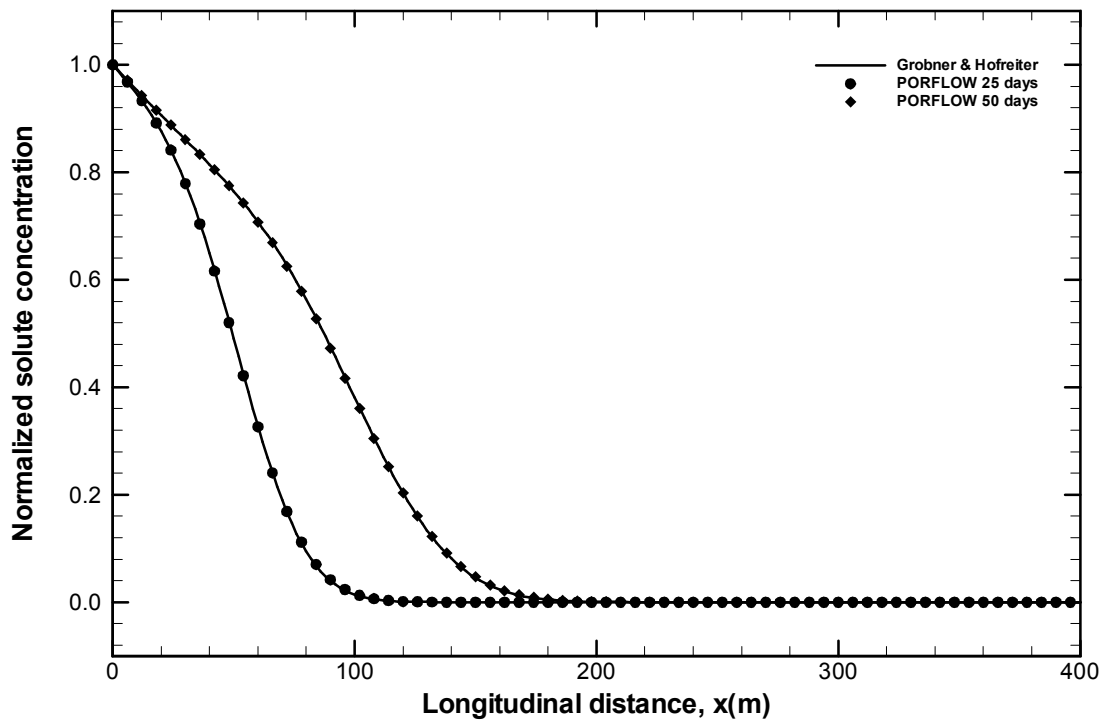

Figure 5.1.6 Concentration Profiles for the 1D Transport Showing Combined Effect of Retardation and Radioactive Decay (Case C).

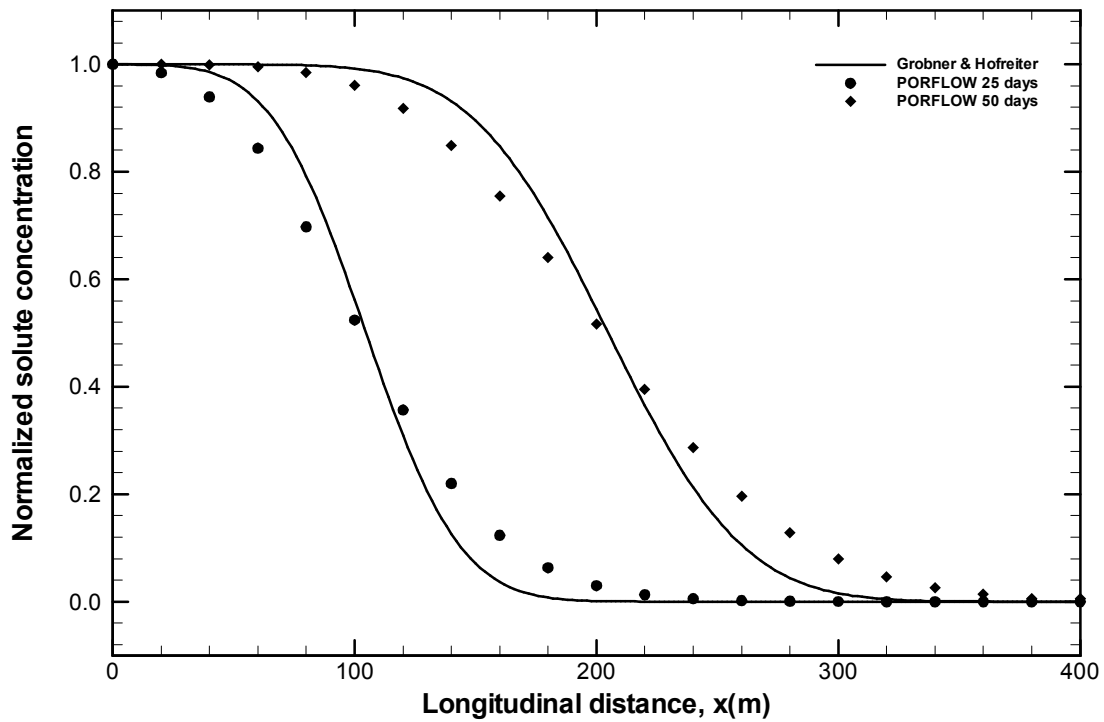

Figure 5.1.7 Concentration Profiles for the 1D Transport Showing Effect of Grid Size, $\Delta x = 20$ m (Case D).

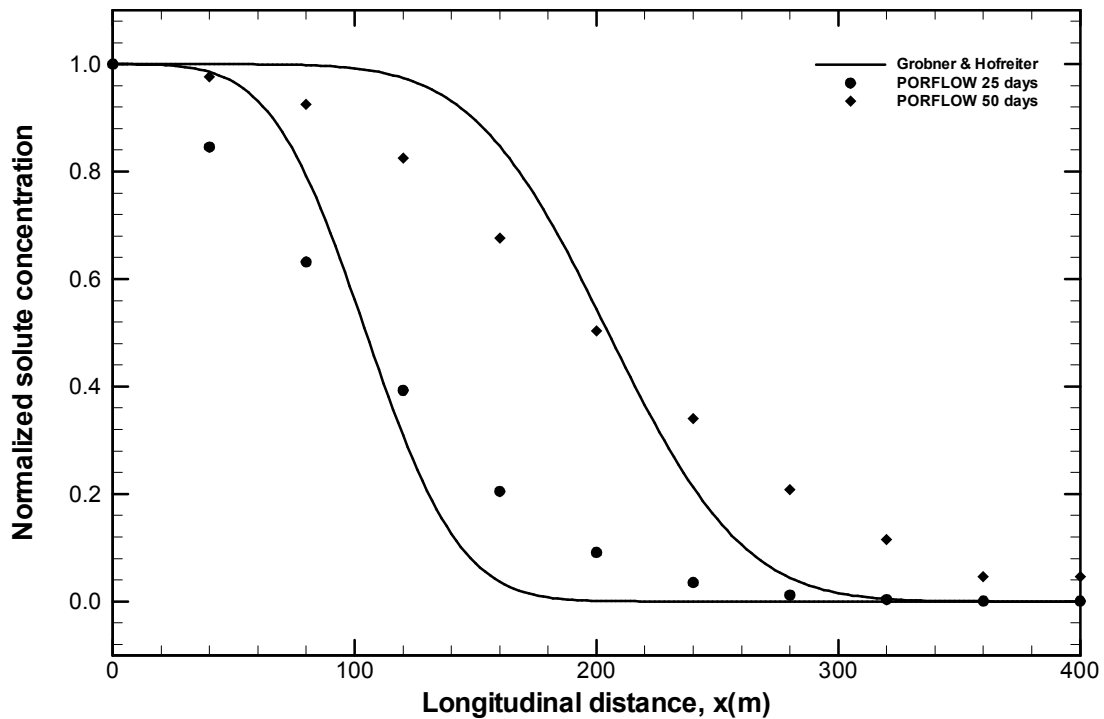

Figure 5.1.8 Concentration Profiles for the 1D Transport Showing Effect of Grid Size, $\Delta x = 40$ m (Case E).

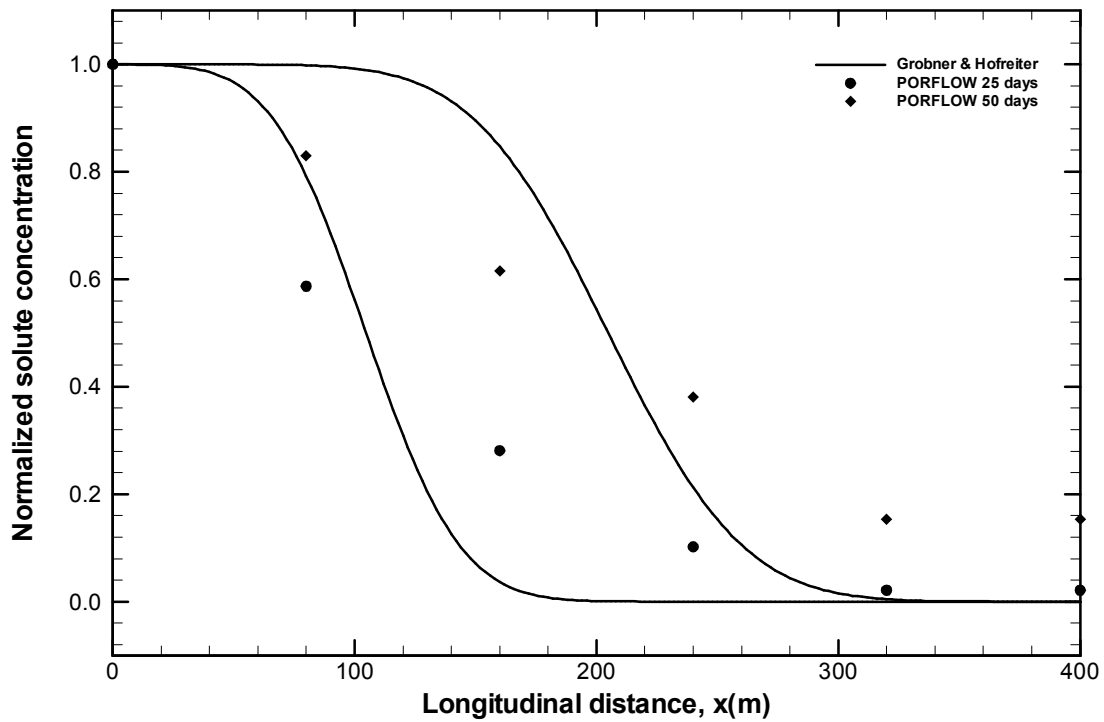

Figure 5.1.9 Concentration Profiles for the 1D Transport Showing Effect of Grid Size, $\Delta x = 80$ m (Case F).

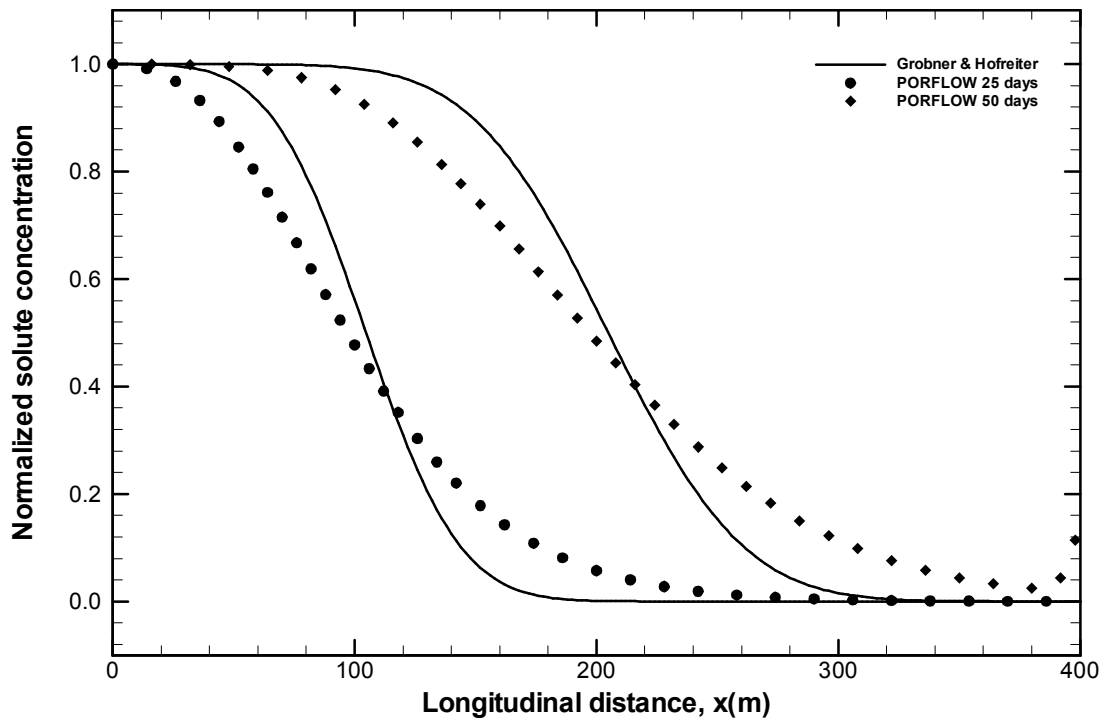

Figure 5.1.10 Concentration Profiles for the 1D Transport Showing Effect of Time Step Size, $\Delta t = 5$ d (Case G).

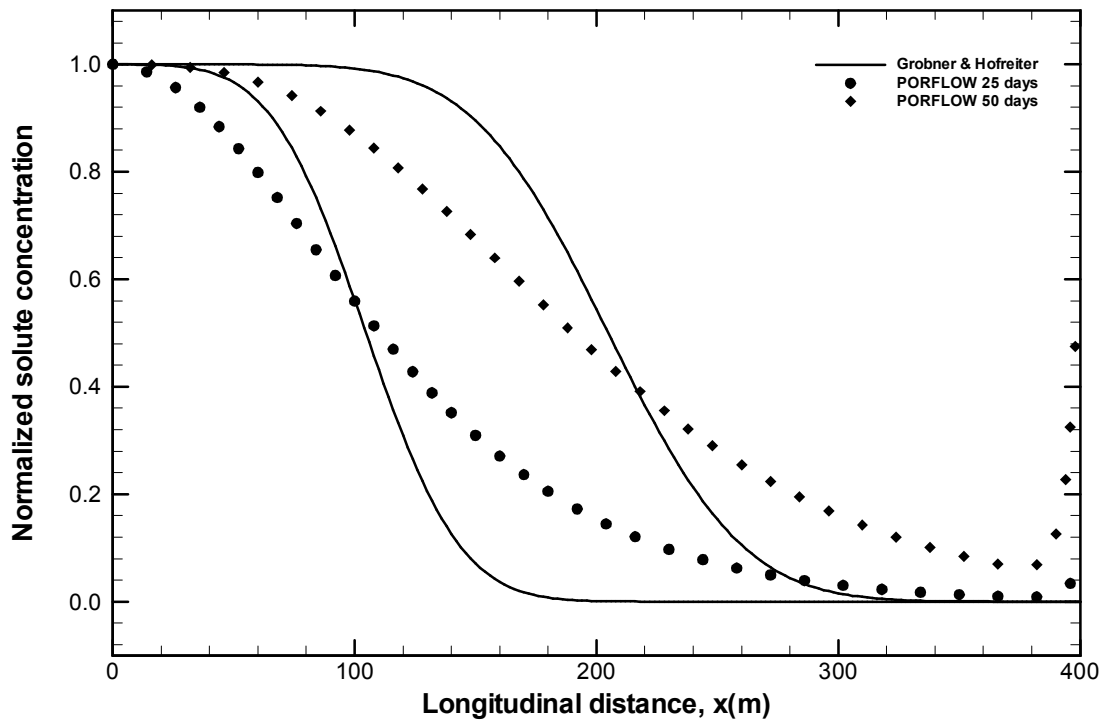

Figure 5.1.11 Concentration Profiles for the 1D Transport Showing Effect of Time Step Size, $\Delta t = 10$ d (Case H).

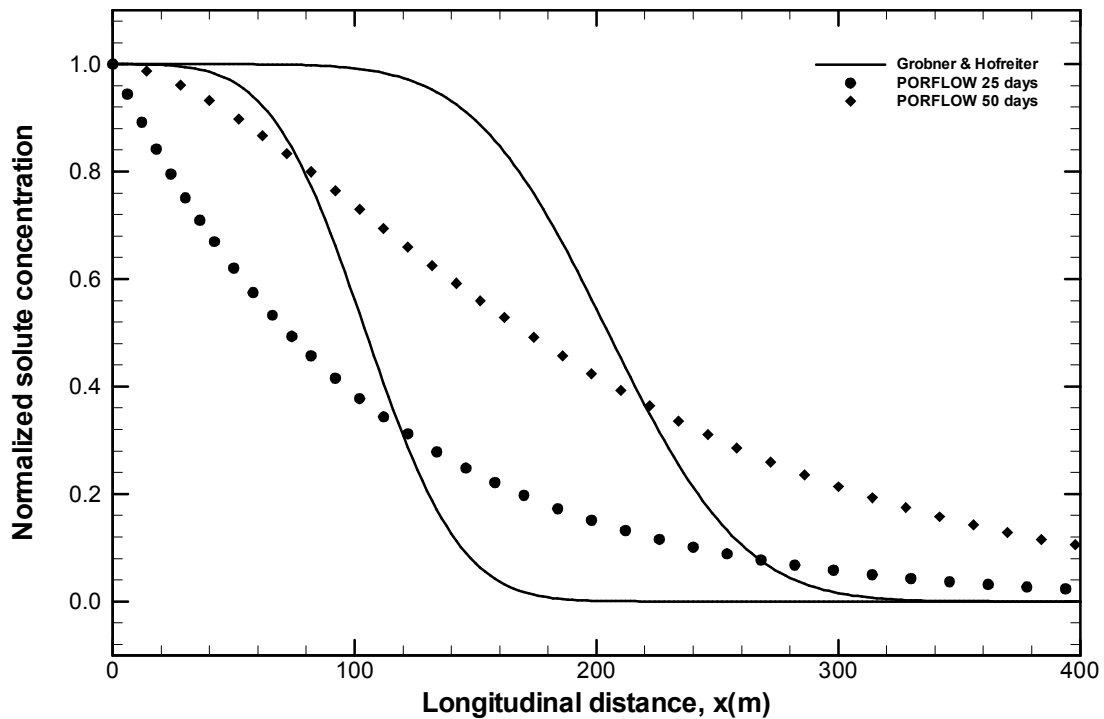

Figure 5.1.12 Concentration Profiles for the 1D Transport Showing Effect of Time Step Size, $\Delta t = 25$ d (Case I).

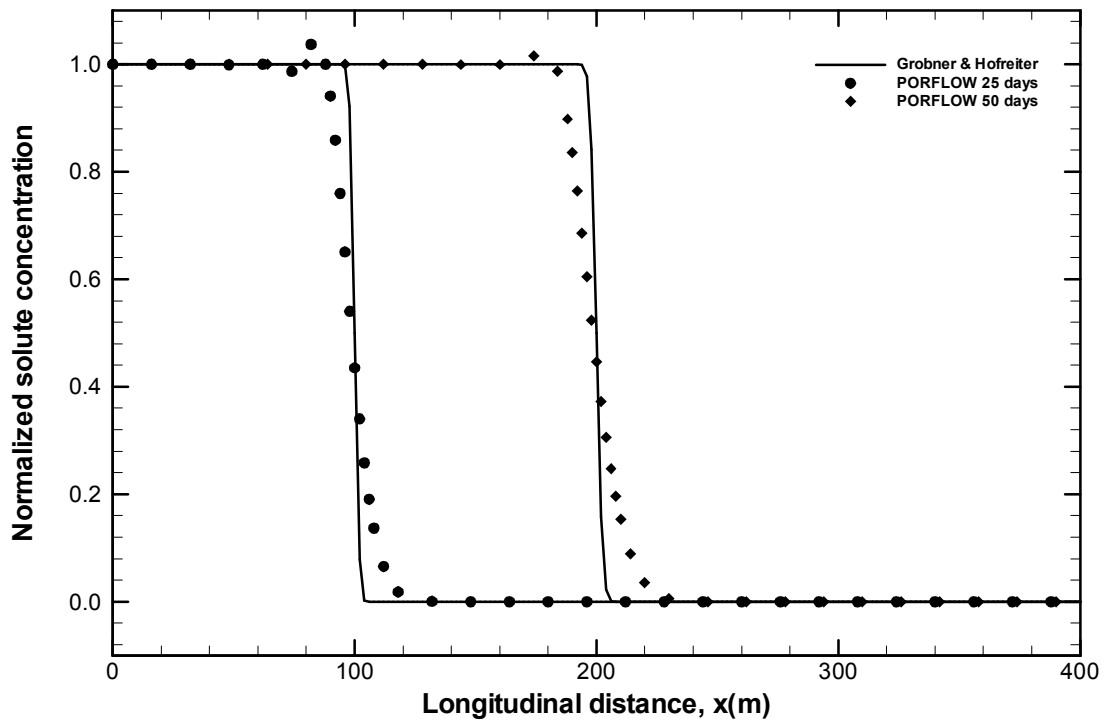

Figure 5.1.13 Concentration Profiles for the 1D Transport at High Peclet Number Showing Effect of Dispersion (Case J).

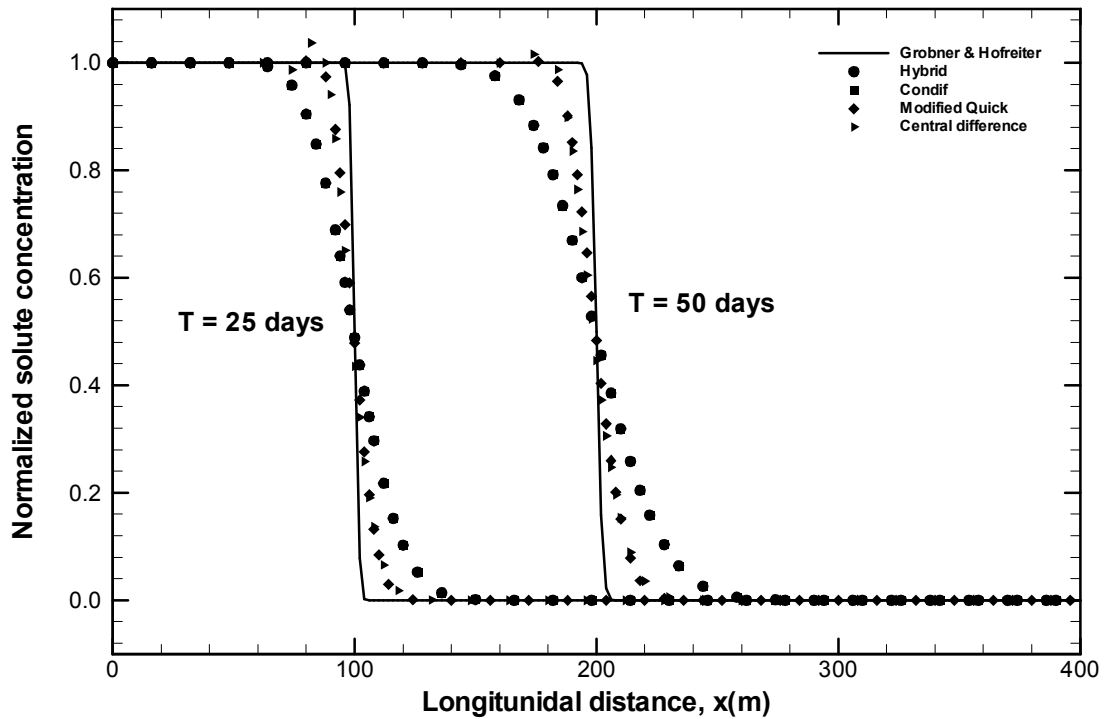

Figure 5.1.14 Concentration Profiles for the 1D Transport at High Peclet Number Showing Effect of Nodal Integration Schemes (Case K).

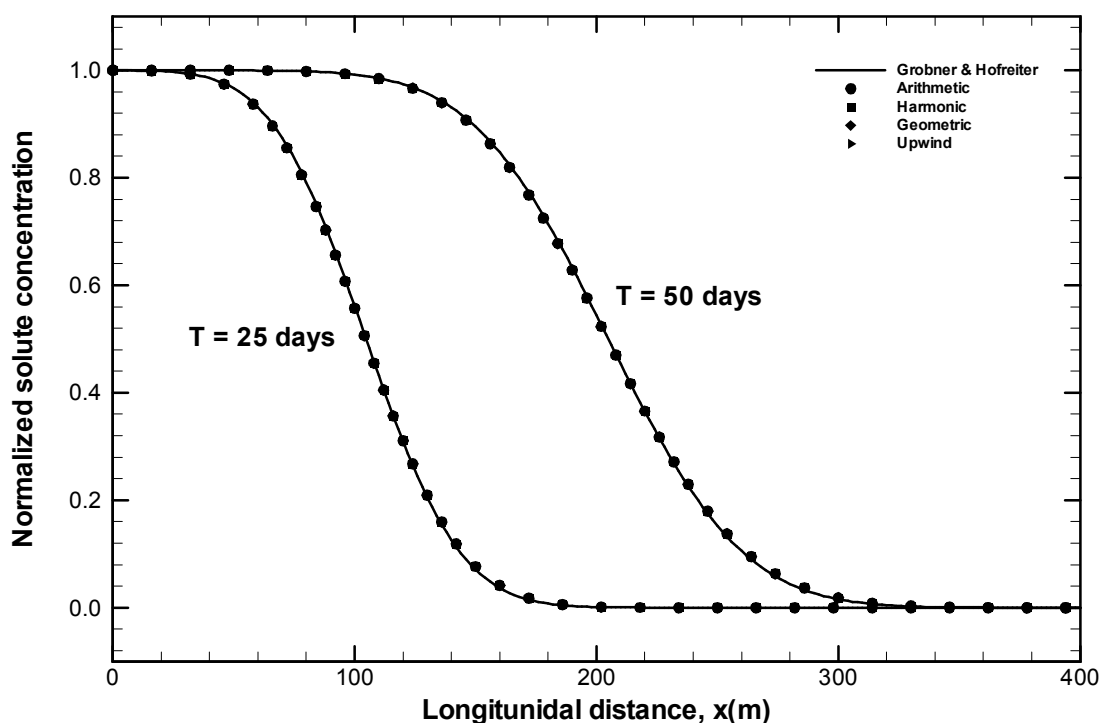

Figure 5.1.15 Concentration Profiles for the 1D Transport Showing Effect of Property Averaging Schemes (Case L).

Table 5.1.3. Comparison of Analytical and PORFLOW Numerical Results for the Transient 1D Transport Problem (Base Case)

Distance downstream x (m)	Analytical (G&H)	Numerical (PORFLOW)	Analytical (G&H)	Numerical (PORFLOW)
	(t = 25 days)	(t = 25 days)	(t = 50 days)	(t = 50 days)
0	1.0000	1.0000	1.0000	1.0000
10	0.9996	0.9996	1.0000	1.0000
20	0.9983	0.9983	1.0000	1.0000
30	0.9945	0.9943	1.0000	1.0000
40	0.9853	0.9846	0.9999	0.9999
50	0.9662	0.9647	0.9999	0.9998
60	0.9312	0.9284	0.9996	0.9996
70	0.8744	0.8701	0.9991	0.9991
80	0.7922	0.7867	0.9981	0.9979
90	0.6856	0.6799	0.9960	0.9957
100	0.5616	0.5572	0.9921	0.9916
120	0.3096	0.3107	0.9742	0.9727
130	0.2057	0.2094	0.9568	0.9546
140	0.1262	0.1313	0.9311	0.9280
150	0.0712	0.0765	0.8951	0.8910
160	0.0368	0.0413	0.8472	0.8424
170	0.0174	0.0207	0.7868	0.7816

Distance downstream x (m)	Analytical (G&H)	Numerical (PORFLOW)	Analytical (G&H)	Numerical (PORFLOW)
	(t = 25 days)	(t = 25 days)	(t = 50 days)	(t = 50 days)
180	0.0075	0.0096	0.7146	0.7094
190	0.0030	0.0041	0.6325	0.6281
200	0.0011	0.0017	0.5441	0.5409
210	0.0003	0.0006	0.4535	0.4521
220	0.0001	0.0002	0.3654	0.3659
230	0.0000	0.0001	0.2840	0.2863
240	0.0000	0.0000	0.2125	0.2163
250	0.0000	0.0000	0.1528	0.1576
260	0.0000	0.0000	0.1055	0.1106
270	0.0000	0.0000	0.0698	0.0747
280	0.0000	0.0000	0.0443	0.0485
290	0.0000	0.0000	0.0269	0.0303
300	0.0000	0.0000	0.0156	0.0182
310	0.0000	0.0000	0.0086	0.0105
320	0.0000	0.0000	0.0046	0.0059
330	0.0000	0.0000	0.0023	0.0031
340	0.0000	0.0000	0.0011	0.0016
350	0.0000	0.0000	0.0005	0.0008
360	0.0000	0.0000	0.0002	0.0004
370	0.0000	0.0000	0.0001	0.0002
380	0.0000	0.0000	0.0000	0.0001
390	0.0000	0.0000	0.0000	0.0000
400	0.0000	0.0000	0.0000	0.0000

Table 5.1.4. Comparison of Analytical and PORFLOW Numerical Results for the Transient 1D Transport Problem (Case A)

Distance downstream x (m)	Analytical (G&H)	Numerical (PORFLOW)	Analytical (G&H)	Numerical (PORFLOW)
	(t = 25 days)	(t = 25 days)	(t = 50 days)	(t = 50 days)
0	1.0000	1.0000	1.0000	1.0000
10	0.9901	0.9902	0.9996	0.9997
20	0.9578	0.9574	0.9983	0.9983
30	0.8844	0.8826	0.9945	0.9945
40	0.7576	0.7542	0.9853	0.9851
50	0.5853	0.5817	0.9662	0.9656
60	0.3981	0.3962	0.9312	0.9300
70	0.2338	0.2347	0.8745	0.8724
80	0.1170	0.1199	0.7923	0.7894
90	0.0494	0.0525	0.6857	0.6826
100	0.0175	0.0197	0.5617	0.5590
120	0.0013	0.0017	0.3096	0.3099
130	0.0003	0.0004	0.2058	0.2075
140	0.0000	0.0001	0.1262	0.1289
150	0.0000	0.0000	0.0712	0.0740

Distance downstream x (m)	Analytical (G&H)	Numerical (PORFLOW)	Analytical (G&H)	Numerical (PORFLOW)
	(t = 25 days)	(t = 25 days)	(t = 50 days)	(t = 50 days)
160	0.0000	0.0000	0.0368	0.0393
170	0.0000	0.0000	0.0174	0.0192
180	0.0000	0.0000	0.0075	0.0087
190	0.0000	0.0000	0.0030	0.0036
200	0.0000	0.0000	0.0011	0.0014
210	0.0000	0.0000	0.0003	0.0005
220	0.0000	0.0000	0.0001	0.0002
230	0.0000	0.0000	0.0000	0.0000
240	0.0000	0.0000	0.0000	0.0000
250	0.0000	0.0000	0.0000	0.0000
260	0.0000	0.0000	0.0000	0.0000
270	0.0000	0.0000	0.0000	0.0000
280	0.0000	0.0000	0.0000	0.0000
290	0.0000	0.0000	0.0000	0.0000
300	0.0000	0.0000	0.0000	0.0000
310	0.0000	0.0000	0.0000	0.0000
320	0.0000	0.0000	0.0000	0.0000
330	0.0000	0.0000	0.0000	0.0000
340	0.0000	0.0000	0.0000	0.0000
350	0.0000	0.0000	0.0000	0.0000
360	0.0000	0.0000	0.0000	0.0000
370	0.0000	0.0000	0.0000	0.0000
380	0.0000	0.0000	0.0000	0.0000
390	0.0000	0.0000	0.0000	0.0000
400	0.0000	0.0000	0.0000	0.0000

Table 5.1.5. Comparison of Analytical and PORFLOW Numerical Results for the Transient 1D Transport Problem (Case B)

Distance downstream x (m)	Analytical (G&H)	Numerical (PORFLOW)	Analytical (G&H)	Numerical (PORFLOW)
	(t = 25 days)	(t = 25 days)	(t = 50 days)	(t = 50 days)
0	1.0000	1.0000	1.0000	1.0000
10	0.9753	0.9753	0.9756	0.9756
20	0.9506	0.9505	0.9518	0.9518
30	0.9245	0.9243	0.9286	0.9286
40	0.8950	0.8944	0.9059	0.9059
50	0.8587	0.8574	0.8838	0.8837
60	0.8112	0.8088	0.8621	0.8620
70	0.7484	0.7447	0.8407	0.8407
80	0.6677	0.6630	0.8196	0.8195
90	0.5705	0.5656	0.7984	0.7982
100	0.4623	0.4584	0.7766	0.7763
120	0.3524	0.3504	0.7537	0.7531
130	0.2508	0.2513	0.7288	0.7278

Distance downstream x (m)	Analytical (G&H)	Numerical (PORFLOW)	Analytical (G&H)	Numerical (PORFLOW)
	(t = 25 days)	(t = 25 days)	(t = 50 days)	(t = 50 days)
140	0.1657	0.1683	0.7007	0.6992
150	0.1012	0.1049	0.6684	0.6663
160	0.0568	0.0608	0.6308	0.6281
170	0.0293	0.0327	0.5871	0.5839
180	0.0138	0.0163	0.5371	0.5335
190	0.0060	0.0075	0.4812	0.4777
200	0.0023	0.0032	0.4210	0.4178
210	0.0008	0.0013	0.3584	0.3559
220	0.0003	0.0005	0.2960	0.2946
230	0.0001	0.0002	0.2366	0.2365
240	0.0000	0.0001	0.1826	0.1836
250	0.0000	0.0000	0.1358	0.1378
260	0.0000	0.0000	0.0972	0.0998
270	0.0000	0.0000	0.0668	0.0696
280	0.0000	0.0000	0.0440	0.0468
290	0.0000	0.0000	0.0278	0.0303
300	0.0000	0.0000	0.0168	0.0189
310	0.0000	0.0000	0.0097	0.0113
320	0.0000	0.0000	0.0054	0.0065
330	0.0000	0.0000	0.0028	0.0036
340	0.0000	0.0000	0.0014	0.0019
350	0.0000	0.0000	0.0007	0.0010
360	0.0000	0.0000	0.0003	0.0005
370	0.0000	0.0000	0.0001	0.0002
380	0.0000	0.0000	0.0001	0.0001
390	0.0000	0.0000	0.0000	0.0000
400	0.0000	0.0000	0.0000	0.0000

Table 5.1.6. Comparison of Analytical and PORFLOW Numerical Results for the Transient 1D Transport Problem (Case C)

Distance downstream x (m)	Analytical (G&H)	Numerical (PORFLOW)	Analytical (G&H)	Numerical (PORFLOW)
	(t = 25 days)	(t = 25 days)	(t = 50 days)	(t = 50 days)
0	1.0000	1.0000	1.0000	1.0000
10	0.9452	0.9452	0.9522	0.9521
20	0.8764	0.8760	0.9061	0.9060
30	0.7805	0.7789	0.8607	0.8607
40	0.6495	0.6465	0.8145	0.8143
50	0.4908	0.4875	0.7647	0.7642
60	0.3283	0.3264	0.7082	0.7073
70	0.1905	0.1909	0.6417	0.6402
80	0.0945	0.0965	0.5638	0.5617
90	0.0396	0.0419	0.4754	0.4731
100	0.0139	0.0156	0.3811	0.3791

Distance downstream x (m)	Analytical (G&H)	Numerical (PORFLOW)	Analytical (G&H)	Numerical (PORFLOW)
	(t = 25 days)	(t = 25 days)	(t = 50 days)	(t = 50 days)
120	0.0041	0.0050	0.2879	0.2867
130	0.0010	0.0014	0.2035	0.2033
140	0.0002	0.0003	0.1336	0.1344
150	0.0000	0.0001	0.0812	0.0826
160	0.0000	0.0000	0.0454	0.0470
170	0.0000	0.0000	0.0233	0.0248
180	0.0000	0.0000	0.0110	0.0120
190	0.0000	0.0000	0.0047	0.0054
200	0.0000	0.0000	0.0019	0.0022
210	0.0000	0.0000	0.0007	0.0009
220	0.0000	0.0000	0.0002	0.0003
230	0.0000	0.0000	0.0001	0.0001
240	0.0000	0.0000	0.0000	0.0000
250	0.0000	0.0000	0.0000	0.0000
260	0.0000	0.0000	0.0000	0.0000
270	0.0000	0.0000	0.0000	0.0000
280	0.0000	0.0000	0.0000	0.0000
290	0.0000	0.0000	0.0000	0.0000
300	0.0000	0.0000	0.0000	0.0000
310	0.0000	0.0000	0.0000	0.0000
320	0.0000	0.0000	0.0000	0.0000
330	0.0000	0.0000	0.0000	0.0000
340	0.0000	0.0000	0.0000	0.0000
350	0.0000	0.0000	0.0000	0.0000
360	0.0000	0.0000	0.0000	0.0000
370	0.0000	0.0000	0.0000	0.0000
380	0.0000	0.0000	0.0000	0.0000
390	0.0000	0.0000	0.0000	0.0000
400	0.0000	0.0000	0.0000	0.0000

Table 5.1.7. Comparison of Analytical and PORFLOW Numerical Results for the Transient 1D Transport Problem (Case D)

Distance downstream x (m)	Analytical (G&H)	Numerical (PORFLOW)	Analytical (G&H)	Numerical (PORFLOW)
	(t = 25 days)	(t = 25 days)	(t = 50 days)	(t = 50 days)
0	1.0000	1.0000	1.0000	1.0000
20	0.9983	0.9840	1.0000	0.9997
40	0.9853	0.9391	0.9999	0.9987
60	0.9312	0.8436	0.9996	0.9949
80	0.7922	0.6975	0.9981	0.9844
100	0.5616	0.5243	0.9921	0.9609
120	0.3096	0.3567	0.9742	0.9173
140	0.1262	0.2199	0.9311	0.8485
160	0.0368	0.1234	0.8472	0.7543

Distance downstream x (m)	Analytical (G&H)	Numerical (PORFLOW)	Analytical (G&H)	Numerical (PORFLOW)
	(t = 25 days)	(t = 25 days)	(t = 50 days)	(t = 50 days)
180	0.0075	0.0634	0.7146	0.6402
200	0.0011	0.0299	0.5441	0.5166
220	0.0001	0.0131	0.3654	0.3952
240	0.0000	0.0053	0.2125	0.2864
260	0.0000	0.0020	0.1055	0.1966
280	0.0000	0.0007	0.0443	0.1279
300	0.0000	0.0002	0.0156	0.0790
320	0.0000	0.0001	0.0046	0.0464
340	0.0000	0.0000	0.0011	0.0259
360	0.0000	0.0000	0.0002	0.0138
380	0.0000	0.0000	0.0000	0.0089
400	0.0000	0.0000	0.0000	0.0089

Table 5.1.8. Comparison of Analytical and PORFLOW Numerical Results for the Transient 1D Transport Problem (Case E)

Distance downstream x (m)	Analytical (G&H)	Numerical (PORFLOW)	Analytical (G&H)	Numerical (PORFLOW)
	(t = 25 days)	(t = 25 days)	(t = 50 days)	(t = 50 days)
0	1.0000	1.0000	1.0000	1.0000
40	0.9853	0.8456	0.9999	0.9762
80	0.7922	0.6316	0.9981	0.9253
120	0.3096	0.3929	0.9742	0.8246
160	0.0368	0.2050	0.8472	0.6762
200	0.0011	0.0911	0.5441	0.5040
240	0.0000	0.0351	0.2125	0.3400
280	0.0000	0.0119	0.0443	0.2078
320	0.0000	0.0036	0.0046	0.1155
360	0.0000	0.0007	0.0002	0.0462
400	0.0000	0.0007	0.0000	0.0462

Table 5.1.9. Comparison of Analytical and PORFLOW Numerical Results for the Transient 1D Transport Problem (Case F)

Distance downstream x (m)	Analytical (G&H)	Numerical (PORFLOW)	Analytical (G&H)	Numerical (PORFLOW)
	(t = 25 days)	(t = 25 days)	(t = 50 days)	(t = 50 days)
0	1.0000	1.0000	1.0000	1.0000
80	0.7922	0.5868	0.9981	0.8293
160	0.0368	0.2813	0.8472	0.6153
240	0.0000	0.1021	0.2125	0.3805
320	0.0000	0.0213	0.0046	0.1537
400	0.0000	0.0213	0.0000	0.1537

Table 5.1.10. Comparison of Analytical and PORFLOW Numerical Results for the Transient 1D Transport Problem (Case G)

Distance downstream x (m)	Analytical (G&H)	Numerical (PORFLOW)	Analytical (G&H)	Numerical (PORFLOW)
	(t = 25 days)	(t = 25 days)	(t = 50 days)	(t = 50 days)
0	1.0000	1.0000	1.0000	1.0000
10	0.9996	0.9954	1.0000	0.9999
20	0.9983	0.9819	1.0000	0.9997
30	0.9945	0.9555	1.0000	0.9992
40	0.9853	0.9141	0.9999	0.9979
50	0.9662	0.8583	0.9999	0.9953
60	0.9312	0.7907	0.9996	0.9907
70	0.8744	0.7150	0.9991	0.9832
80	0.7922	0.6351	0.9981	0.9720
90	0.6856	0.5549	0.9960	0.9563
100	0.5616	0.4775	0.9921	0.9353
120	0.4318	0.4051	0.9854	0.9087
130	0.3096	0.3392	0.9742	0.8764
140	0.2057	0.2807	0.9568	0.8386
150	0.1262	0.2298	0.9311	0.7958
160	0.0712	0.1863	0.8951	0.7487
170	0.0368	0.1496	0.8472	0.6984
180	0.0174	0.1191	0.7868	0.6457
190	0.0075	0.0941	0.7146	0.5919
200	0.0030	0.0738	0.6325	0.5379
210	0.0011	0.0575	0.5441	0.4848
220	0.0003	0.0445	0.4535	0.4334
230	0.0001	0.0343	0.3654	0.3843
240	0.0000	0.0263	0.2840	0.3382
250	0.0000	0.0200	0.2125	0.2955
260	0.0000	0.0152	0.1528	0.2562
270	0.0000	0.0115	0.1055	0.2207
280	0.0000	0.0086	0.0698	0.1888
290	0.0000	0.0064	0.0443	0.1606
300	0.0000	0.0048	0.0269	0.1357
310	0.0000	0.0036	0.0156	0.1140
320	0.0000	0.0027	0.0086	0.0952
330	0.0000	0.0020	0.0046	0.0791
340	0.0000	0.0014	0.0023	0.0654
350	0.0000	0.0011	0.0011	0.0538
360	0.0000	0.0008	0.0005	0.0440
370	0.0000	0.0006	0.0002	0.0359
380	0.0000	0.0004	0.0001	0.0292
390	0.0000	0.0003	0.0000	0.0251
400	0.0000	0.0003	0.0000	0.0349

Table 5.1.11. Comparison of Analytical and PORFLOW Numerical Results for the Transient 1D Transport Problem (Case H)

Distance downstream x (m)	Analytical (G&H)	Numerical (PORFLOW)	Analytical (G&H)	Numerical (PORFLOW)
	(t = 25 days)	(t = 25 days)	(t = 50 days)	(t = 50 days)
0	1.0000	1.0000	1.0000	1.0000
10	0.9996	0.9921	1.0000	0.9996
20	0.9983	0.9734	1.0000	0.9982
30	0.9945	0.9432	1.0000	0.9950
40	0.9853	0.9027	0.9999	0.9893
50	0.9662	0.8538	0.9999	0.9802
60	0.9312	0.7988	0.9996	0.9672
70	0.8744	0.7400	0.9991	0.9498
80	0.7922	0.6794	0.9981	0.9279
90	0.6856	0.6188	0.9960	0.9016
100	0.5616	0.5594	0.9921	0.8711
120	0.4318	0.5024	0.9854	0.8369
130	0.3096	0.4485	0.9742	0.7995
140	0.2057	0.3981	0.9568	0.7596
150	0.1262	0.3517	0.9311	0.7177
160	0.0712	0.3093	0.8951	0.6746
170	0.0368	0.2708	0.8472	0.6309
180	0.0174	0.2362	0.7868	0.5872
190	0.0075	0.2053	0.7146	0.5439
200	0.0030	0.1779	0.6325	0.5016
210	0.0011	0.1536	0.5441	0.4606
220	0.0003	0.1323	0.4535	0.4212
230	0.0001	0.1136	0.3654	0.3837
240	0.0000	0.0973	0.2840	0.3482
250	0.0000	0.0832	0.2125	0.3149
260	0.0000	0.0710	0.1528	0.2838
270	0.0000	0.0604	0.1055	0.2550
280	0.0000	0.0513	0.0698	0.2284
290	0.0000	0.0435	0.0443	0.2039
300	0.0000	0.0369	0.0269	0.1816
310	0.0000	0.0311	0.0156	0.1613
320	0.0000	0.0263	0.0086	0.1429
330	0.0000	0.0222	0.0046	0.1263
340	0.0000	0.0186	0.0023	0.1113
350	0.0000	0.0157	0.0011	0.0979
360	0.0000	0.0132	0.0005	0.0860
370	0.0000	0.0110	0.0002	0.0754
380	0.0000	0.0093	0.0001	0.0668
390	0.0000	0.0085	0.0000	0.0660
400	0.0000	0.0139	0.0000	0.1255

Table 5.1.12. Comparison of Analytical and PORFLOW Numerical Results for the Transient 1D Transport Problem (Case I)

Distance downstream x (m)	Analytical (G&H)	Numerical (PORFLOW)	Analytical (G&H)	Numerical (PORFLOW)
	(t = 25 days)	(t = 25 days)	(t = 50 days)	(t = 50 days)
0	1.0000	1.0000	1.0000	1.0000
10	1.0000	0.9810	1.0000	0.9991
20	0.9999	0.9624	1.0000	0.9978
30	0.9999	0.9442	1.0000	0.9961
40	0.9998	0.9264	1.0000	0.9942
50	0.9996	0.9089	1.0000	0.9920
60	0.9995	0.8917	1.0000	0.9895
70	0.9993	0.8748	1.0000	0.9868
80	0.9990	0.8583	1.0000	0.9838
90	0.9987	0.8421	1.0000	0.9806
100	0.9983	0.8261	1.0000	0.9771
120	0.9978	0.8105	1.0000	0.9734
130	0.9972	0.7952	1.0000	0.9695
140	0.9965	0.7802	1.0000	0.9655
150	0.9956	0.7654	1.0000	0.9612
160	0.9945	0.7509	1.0000	0.9567
170	0.9932	0.7367	1.0000	0.9521
180	0.9917	0.7228	1.0000	0.9473
190	0.9899	0.7092	1.0000	0.9423
200	0.9878	0.6957	1.0000	0.9372
210	0.9853	0.6826	0.9999	0.9319
220	0.9825	0.6697	0.9999	0.9265
230	0.9792	0.6570	0.9999	0.9210
240	0.9754	0.6446	0.9999	0.9154
250	0.9711	0.6324	0.9999	0.9096
260	0.9662	0.6205	0.9999	0.9037
270	0.9607	0.6087	0.9998	0.8978
280	0.9545	0.5972	0.9998	0.8917
290	0.9475	0.5859	0.9997	0.8855
300	0.9398	0.5748	0.9997	0.8793
310	0.9312	0.5640	0.9996	0.8729
320	0.9218	0.5533	0.9996	0.8665
330	0.9114	0.5429	0.9995	0.8601
340	0.9001	0.5326	0.9994	0.8535
350	0.8878	0.5225	0.9993	0.8469
360	0.8744	0.5126	0.9991	0.8403
370	0.8601	0.5029	0.9990	0.8336
380	0.8447	0.4934	0.9988	0.8268
390	0.8282	0.4841	0.9986	0.8200
400	0.8107	0.4750	0.9983	0.8132

Table 5.1.13. Comparison of Analytical and PORFLOW Numerical Results for the Transient 1D Transport Problem (Case J)

Distance downstream x (m)	Analytical (G&H)	Numerical (PORFLOW)	Analytical (G&H)	Numerical (PORFLOW)
	(t = 25 days)	(t = 25 days)	(t = 50 days)	(t = 50 days)
0	1.0000	1.0000	1.0000	1.0000
10	1.0000	1.0000	1.0000	1.0000
20	1.0000	1.0000	1.0000	1.0000
30	1.0000	1.0000	1.0000	1.0000
40	1.0000	1.0000	1.0000	1.0000
50	1.0000	1.0000	1.0000	1.0000
60	1.0000	0.9975	1.0000	1.0000
70	1.0000	0.9979	1.0000	1.0000
80	1.0000	1.0200	1.0000	1.0000
90	1.0000	0.9410	1.0000	1.0000
100	0.5000	0.4350	1.0000	1.0000
120	0.0000	0.0959	1.0000	1.0000
130	0.0000	0.0113	1.0000	1.0000
140	0.0000	0.0008	1.0000	0.9998
150	0.0000	0.0000	1.0000	1.0000
160	0.0000	0.0000	1.0000	0.9999
170	0.0000	0.0000	1.0000	0.9994
180	0.0000	0.0000	1.0000	0.9998
190	0.0000	0.0000	1.0000	1.0250
200	0.0000	0.0000	1.0000	0.8358
210	0.0000	0.0000	0.5000	0.4457
220	0.0000	0.0000	0.0000	0.1531
230	0.0000	0.0000	0.0000	0.0353
240	0.0000	0.0000	0.0000	0.0057
250	0.0000	0.0000	0.0000	0.0007
260	0.0000	0.0000	0.0000	0.0001
270	0.0000	0.0000	0.0000	0.0000
280	0.0000	0.0000	0.0000	0.0000
290	0.0000	0.0000	0.0000	0.0000
300	0.0000	0.0000	0.0000	0.0000
310	0.0000	0.0000	0.0000	0.0000
320	0.0000	0.0000	0.0000	0.0000
330	0.0000	0.0000	0.0000	0.0000
340	0.0000	0.0000	0.0000	0.0000
350	0.0000	0.0000	0.0000	0.0000
360	0.0000	0.0000	0.0000	0.0000
370	0.0000	0.0000	0.0000	0.0000
380	0.0000	0.0000	0.0000	0.0000
390	0.0000	0.0000	0.0000	0.0000
400	0.0000	0.0000	0.0000	0.0000

Table 5.1.14. Comparison of Analytical and PORFLOW Numerical Results for the Transient 1D Transport Problem (Case K, Time = 25 days)

Distance downstream x (m)	Analytical (G&H)	Numerical (PORFLOW)	Numerical (PORFLOW)	Numerical (PORFLOW)	Numerical (PORFLOW)
		(HYBRID)	(CONDIF)	(QUICK)	(CENTRAL)
0.0	1.0000	1.0000	1.0000	1.0000	1.0000
10.0	1.0000	1.0000	1.0000	1.0000	1.0000
20.0	1.0000	1.0000	1.0000	1.0000	1.0000
30.0	1.0000	1.0000	1.0000	1.0000	1.0000
40.0	1.0000	1.0000	1.0000	1.0000	1.0000
50.0	1.0000	0.9998	0.9998	1.0000	1.0000
60.0	1.0000	0.9972	0.9972	1.0000	0.9975
70.0	1.0000	0.9782	0.9782	0.9999	0.9979
80.0	1.0000	0.9044	0.9044	1.0040	1.0200
90.0	1.0000	0.7343	0.7343	0.9353	0.9410
100.0	0.5000	0.4887	0.4887	0.4789	0.4350
110.0	0.0000	0.2552	0.2552	0.0843	0.0959
120.0	0.0000	0.1027	0.1027	0.0034	0.0113
130.0	0.0000	0.0318	0.0318	0.0000	0.0008
140.0	0.0000	0.0076	0.0076	0.0000	0.0000
150.0	0.0000	0.0014	0.0014	0.0000	0.0000
160.0	0.0000	0.0002	0.0002	0.0000	0.0000
170.0	0.0000	0.0000	0.0000	0.0000	0.0000
180.0	0.0000	0.0000	0.0000	0.0000	0.0000
190.0	0.0000	0.0000	0.0000	0.0000	0.0000
200.0	0.0000	0.0000	0.0000	0.0000	0.0000
210.0	0.0000	0.0000	0.0000	0.0000	0.0000
220.0	0.0000	0.0000	0.0000	0.0000	0.0000
230.0	0.0000	0.0000	0.0000	0.0000	0.0000
240.0	0.0000	0.0000	0.0000	0.0000	0.0000
250.0	0.0000	0.0000	0.0000	0.0000	0.0000
260.0	0.0000	0.0000	0.0000	0.0000	0.0000
270.0	0.0000	0.0000	0.0000	0.0000	0.0000
280.0	0.0000	0.0000	0.0000	0.0000	0.0000
290.0	0.0000	0.0000	0.0000	0.0000	0.0000
300.0	0.0000	0.0000	0.0000	0.0000	0.0000
310.0	0.0000	0.0000	0.0000	0.0000	0.0000
320.0	0.0000	0.0000	0.0000	0.0000	0.0000
330.0	0.0000	0.0000	0.0000	0.0000	0.0000
340.0	0.0000	0.0000	0.0000	0.0000	0.0000
350.0	0.0000	0.0000	0.0000	0.0000	0.0000
360.0	0.0000	0.0000	0.0000	0.0000	0.0000
370.0	0.0000	0.0000	0.0000	0.0000	0.0000
380.0	0.0000	0.0000	0.0000	0.0000	0.0000
390.0	0.0000	0.0000	0.0000	0.0000	0.0000
400.0	0.0000	0.0000	0.0000	0.0000	0.0000

Table 5.1.15. Comparison of Analytical and PORFLOW Numerical Results for the Transient 1D Transport Problem (Case K, Time = 50 days)

Distance downstream x (m)	Analytical (G&H)	Numerical (PORFLOW)	Numerical (PORFLOW)	Numerical (PORFLOW)	Numerical (PORFLOW)
		(HYBRID)	(CONDIF)	(QUICK)	(CENTRAL)
0.0	1.0000	1.0000	1.0000	1.0000	1.0000
10.0	1.0000	1.0000	1.0000	1.0000	1.0000
20.0	1.0000	1.0000	1.0000	1.0000	1.0000
30.0	1.0000	1.0000	1.0000	1.0000	1.0000
40.0	1.0000	1.0000	1.0000	1.0000	1.0000
50.0	1.0000	1.0000	1.0000	1.0000	1.0000
60.0	1.0000	1.0000	1.0000	1.0000	1.0000
70.0	1.0000	1.0000	1.0000	1.0000	1.0000
80.0	1.0000	1.0000	1.0000	1.0000	1.0000
90.0	1.0000	1.0000	1.0000	1.0000	1.0000
100.0	1.0000	1.0000	1.0000	1.0000	1.0000
110.0	1.0000	1.0000	1.0000	1.0000	1.0000
120.0	1.0000	1.0000	1.0000	1.0000	1.0000
130.0	1.0000	0.9997	0.9997	1.0000	0.9998
140.0	1.0000	0.9981	0.9981	1.0000	1.0000
150.0	1.0000	0.9912	0.9912	1.0000	0.9999
160.0	1.0000	0.9696	0.9696	0.9999	0.9994
170.0	1.0000	0.9172	0.9172	1.0010	0.9998
180.0	1.0000	0.8180	0.8180	0.9946	1.0250
190.0	1.0000	0.6697	0.6697	0.8517	0.8358
200.0	0.5000	0.4919	0.4919	0.4828	0.4457
210.0	0.0000	0.3188	0.3188	0.1508	0.1531
220.0	0.0000	0.1805	0.1805	0.0232	0.0353
230.0	0.0000	0.0888	0.0888	0.0015	0.0057
240.0	0.0000	0.0379	0.0379	0.0000	0.0007
250.0	0.0000	0.0140	0.0140	0.0000	0.0001
260.0	0.0000	0.0045	0.0045	0.0000	0.0000
270.0	0.0000	0.0013	0.0013	0.0000	0.0000
280.0	0.0000	0.0003	0.0003	0.0000	0.0000
290.0	0.0000	0.0001	0.0001	0.0000	0.0000
300.0	0.0000	0.0000	0.0000	0.0000	0.0000
310.0	0.0000	0.0000	0.0000	0.0000	0.0000
320.0	0.0000	0.0000	0.0000	0.0000	0.0000
330.0	0.0000	0.0000	0.0000	0.0000	0.0000
340.0	0.0000	0.0000	0.0000	0.0000	0.0000
350.0	0.0000	0.0000	0.0000	0.0000	0.0000
360.0	0.0000	0.0000	0.0000	0.0000	0.0000
370.0	0.0000	0.0000	0.0000	0.0000	0.0000
380.0	0.0000	0.0000	0.0000	0.0000	0.0000
390.0	0.0000	0.0000	0.0000	0.0000	0.0000
400.0	0.0000	0.0000	0.0000	0.0000	0.0000

Table 5.1.16. Comparison of Analytical and PORFLOW Numerical Results for the Transient 1D Transport Problem (Case L, Time = 25 days)

Distance downstream x (m)	Analytical (G&H)	Numerical (PORFLOW)	Numerical (PORFLOW)	Numerical (PORFLOW)	Numerical (PORFLOW)
		(Arithmetic)	(Harmonic)	(Geometric)	(Upwind)
0.0	1.0000	1.0000	1.0000	1.0000	1.0000
10.0	0.9996	0.9996	0.9996	0.9996	0.9996
20.0	0.9983	0.9983	0.9983	0.9983	0.9983
30.0	0.9945	0.9943	0.9943	0.9943	0.9943
40.0	0.9853	0.9846	0.9846	0.9846	0.9846
50.0	0.9662	0.9647	0.9647	0.9647	0.9647
60.0	0.9312	0.9284	0.9284	0.9284	0.9284
70.0	0.8744	0.8701	0.8701	0.8701	0.8701
80.0	0.7922	0.7867	0.7867	0.7867	0.7867
90.0	0.6856	0.6799	0.6799	0.6799	0.6799
100.0	0.5616	0.5572	0.5572	0.5572	0.5572
110.0	0.4318	0.4299	0.4299	0.4299	0.4299
120.0	0.3096	0.3107	0.3107	0.3107	0.3107
130.0	0.2057	0.2094	0.2094	0.2094	0.2094
140.0	0.1262	0.1313	0.1313	0.1313	0.1313
150.0	0.0712	0.0765	0.0765	0.0765	0.0765
160.0	0.0368	0.0413	0.0413	0.0413	0.0413
170.0	0.0174	0.0207	0.0207	0.0207	0.0207
180.0	0.0075	0.0096	0.0096	0.0096	0.0096
190.0	0.0030	0.0041	0.0041	0.0041	0.0041
200.0	0.0011	0.0017	0.0017	0.0017	0.0017
210.0	0.0003	0.0006	0.0006	0.0006	0.0006
220.0	0.0001	0.0002	0.0002	0.0002	0.0002
230.0	0.0000	0.0001	0.0001	0.0001	0.0001
240.0	0.0000	0.0000	0.0000	0.0000	0.0000
250.0	0.0000	0.0000	0.0000	0.0000	0.0000
260.0	0.0000	0.0000	0.0000	0.0000	0.0000
270.0	0.0000	0.0000	0.0000	0.0000	0.0000
280.0	0.0000	0.0000	0.0000	0.0000	0.0000
290.0	0.0000	0.0000	0.0000	0.0000	0.0000
300.0	0.0000	0.0000	0.0000	0.0000	0.0000
310.0	0.0000	0.0000	0.0000	0.0000	0.0000
320.0	0.0000	0.0000	0.0000	0.0000	0.0000
330.0	0.0000	0.0000	0.0000	0.0000	0.0000
340.0	0.0000	0.0000	0.0000	0.0000	0.0000
350.0	0.0000	0.0000	0.0000	0.0000	0.0000
360.0	0.0000	0.0000	0.0000	0.0000	0.0000
370.0	0.0000	0.0000	0.0000	0.0000	0.0000
380.0	0.0000	0.0000	0.0000	0.0000	0.0000
390.0	0.0000	0.0000	0.0000	0.0000	0.0000
400.0	0.0000	0.0000	0.0000	0.0000	0.0000

Table 5.1.17. Comparison of Analytical and PORFLOW Numerical Results for the Transient 1D Transport Problem (Case L, Time = 50 days)

Distance downstream x (m)	Analytical (G&H)	Numerical (PORFLOW)	Numerical (PORFLOW)	Numerical (PORFLOW)	Numerical (PORFLOW)
		(Arithmetic)	(Harmonic)	(Geometric)	(Upwind)
0.0	1.0000	1.0000	1.0000	1.0000	1.0000
10.0	1.0000	1.0000	1.0000	1.0000	1.0000
20.0	1.0000	1.0000	1.0000	1.0000	1.0000
30.0	1.0000	1.0000	1.0000	1.0000	1.0000
40.0	0.9999	0.9999	0.9999	0.9999	0.9999
50.0	0.9999	0.9998	0.9998	0.9998	0.9998
60.0	0.9996	0.9996	0.9996	0.9996	0.9996
70.0	0.9991	0.9991	0.9991	0.9991	0.9991
80.0	0.9981	0.9979	0.9979	0.9979	0.9979
90.0	0.9960	0.9957	0.9957	0.9957	0.9957
100.0	0.9921	0.9916	0.9916	0.9916	0.9916
110.0	0.9854	0.9844	0.9844	0.9844	0.9844
120.0	0.9742	0.9727	0.9727	0.9727	0.9727
130.0	0.9568	0.9546	0.9546	0.9546	0.9546
140.0	0.9311	0.9280	0.9280	0.9280	0.9280
150.0	0.8951	0.8910	0.8910	0.8910	0.8910
160.0	0.8472	0.8424	0.8424	0.8424	0.8424
170.0	0.7868	0.7816	0.7816	0.7816	0.7816
180.0	0.7146	0.7094	0.7094	0.7094	0.7094
190.0	0.6325	0.6281	0.6281	0.6281	0.6281
200.0	0.5441	0.5409	0.5409	0.5409	0.5409
210.0	0.4535	0.4521	0.4521	0.4521	0.4521
220.0	0.3654	0.3659	0.3659	0.3659	0.3659
230.0	0.2840	0.2863	0.2863	0.2863	0.2863
240.0	0.2125	0.2163	0.2163	0.2163	0.2163
250.0	0.1528	0.1576	0.1576	0.1576	0.1576
260.0	0.1055	0.1106	0.1106	0.1106	0.1106
270.0	0.0698	0.0747	0.0747	0.0747	0.0747
280.0	0.0443	0.0485	0.0485	0.0485	0.0485
290.0	0.0269	0.0303	0.0303	0.0303	0.0303
300.0	0.0156	0.0182	0.0182	0.0182	0.0182
310.0	0.0086	0.0105	0.0105	0.0105	0.0105
320.0	0.0046	0.0059	0.0059	0.0059	0.0059
330.0	0.0023	0.0031	0.0031	0.0031	0.0031
340.0	0.0011	0.0016	0.0016	0.0016	0.0016
350.0	0.0005	0.0008	0.0008	0.0008	0.0008
360.0	0.0002	0.0004	0.0004	0.0004	0.0004
370.0	0.0001	0.0002	0.0002	0.0002	0.0002
380.0	0.0000	0.0001	0.0001	0.0001	0.0001
390.0	0.0000	0.0000	0.0000	0.0000	0.0000
400.0	0.0000	0.0000	0.0000	0.0000	0.0000

Table 5.1.18. Input Commands for 1D Transport (Base Case)

```

*****
TITLE 5.1 (BC) 1-D saturated solute transport in a uniform flow field
*****
! Basecase
*****

GRID is 201 NODEs
COORDinate NODEs X: MINImum=0.0, MAXImum=4.e2

! Material types and subregions
MATERial type 1 ! total domain

! Material and nuclide properties
PROPerty for C is HARMonic

FOR material type 1:
MATERial DENSITY 1.0
MATERial PORosity 3*0.25
TRANsport for C Kd=0 Da=0 aL=5 aT=0

! Flow conditions
SET S to 1.
SET U to 1. ! m/d

! Boundary conditions
BOUNDary C at X- in VALUe = 1
BOUNDary C at X+ in GRAD = 0

! Diagnostic information
DIAGnostic output: TIME DTIME C for node 200 every 10 steps

! Time history
SAVE for C at TIME every 25 years to '5.1-bc.sav'

! Solution controls
MATRix in X for C 3 sweeps using ADI
LIMIt for C 0.0
CONVergence for C REFERENCE LOCAL 1.e-6, max iterations = 30

! Solve transient transport
! Time period: 0 to 500 years
TIME = 0.

SOLVe C for 50 days in steps of 0.1 days

END
QUIT

```

Table 5.1.19. Input Commands for 1D Transport (Case A)

```

*****
TITLE 5.1 (A) 1-D saturated solute transport in a uniform flow field
*****
! Retardation = 2 (Kd = 0.3333)
*****

GRID is 201 NODEs
COORDinate NODEs X: MINImum=0.0, MAXImum=4.e2

! Material types and subregions
MATERial type 1 ! total domain

! Material and nuclide properties
PROPerty for C is HARMonic

FOR material type 1:
MATERial DENSITY 1.0
MATERial PORosity 3*0.25
TRANsport for C Kd=0.3333 Da=0 aL=5 aT=0

```

```

! Flow conditions
SET S to 1.
SET U to 1. ! m/d

! Boundary conditions
BOUNDary C at X- in VALUe = 1
BOUNDary C at X+ in GRAD = 0

! Diagnostic information
DIAGnostic output: TIME DTIME C for node 200 every 10 steps

! Time history
SAVE for C at TIME every 25 years to '5.1-A.sav'

! Solution controls
MATRix in X for C 3 sweeps using ADI
LIMIt for C 0.0
CONVergence for C REFERENCE LOCAL 1.e-6, max iterations = 30

! Solve transient transport
! Time period: 0 to 50 years
TIME = 0.

SOLVe C for 50 days in steps of 0.1 days

END
QUIT

```

Table 5.1.20. Input Commands for 1D Transport (Case B)

```

*****
TITLE 5.1 (B) 1-D saturated solute transport in a uniform flow field
*****
! Radioactive decay constant = 0.01
*****

GRID is 201 NODEs
COORDinate NODEs X: MINImum=0.0, MAXImum=4.e2

! Material types and subregions
MATERial type 1 ! total domain

! Material and nuclide properties
PROPerty for C is HARMonic

FOR material type 1:
MATERial DENSITY 1.0
MATERial PORosity 3*0.25
TRANSport for C Kd=0 Da=0 aL=5 aT=0

! Nuclide properties
! Decay
DECAy rate for C is 0.01 ! per day

! Flow conditions
SET S to 1.
SET U to 1. ! m/d

! Boundary conditions
BOUNDary C at X- in VALUe = 1
BOUNDary C at X+ in GRAD = 0

! Diagnostic information
DIAGnostic output: TIME DTIME C for node 200 every 10 steps

! Time history
SAVE for C at TIME every 25 days to '5.1-B.sav'

! Solution controls
MATRix in X for C 3 sweeps using ADI
LIMIt for C 0.0

```

CONVergence for C REFERENCE LOCAL 1.e-6, max iterations = 30

! Solve transient transport
 ! Time period: 0 to 50 years
 TIME = 0.

SOLVe C for 50 days in steps of 0.1 days

END
 QUIT

Table 5.1.21. Input Commands for 1D Transport (Case C)

```

*****
TITLE 5.1 (C) 1-D saturated solute transport in a uniform flow field
*****
! Retardation = 2 (Kd = 0.3333), Radioactive decay constant = 0.01
*****

GRID is 201 NODEs
COORDinate NODEs X: MINImum=0.0, MAXImum=4.e2

! Material types and subregions
MATERial type 1 ! total domain

! Material and nuclide properties
PROPerty for C is HARMonic

FOR material type 1:
MATERial DENSITY 1.0
MATERial PORosity 3*0.25
TRANsport for C Kd=0.3333 Da=0 aL=5 aT=0

! Nuclide properties
! Decay
DECAy rate for C is 0.01 ! per day

! Flow conditions
SET S to 1.
SET U to 1. ! m/d

! Boundary conditions
BOUNDary C at X- in VALUe = 1
BOUNDary C at X+ in GRAD = 0

! Diagnostic information
DIAGnostic output: TIME DTIME C for node 200 every 10 steps

! Time history
SAVE for C at TIME every 25 days to '5.1-C.sav'

! Solution controls
MATRix in X for C 3 sweeps using ADI
LIMIt for C 0.0
CONVergence for C REFERENCE LOCAL 1.e-6, max iterations = 30

! Solve transient transport
! Time period: 0 to 50 years
TIME = 0.

SOLVe C for 50 days in steps of 0.1 days

END
QUIT
    
```

Table 5.1.22. Input Commands for 1D Transport (Case D)

```

*****
TITLE 5.1 (D) 1-D saturated solute transport in a uniform flow field
*****
! dx=20
    
```

```

GRID is 21 NODEs
COORDinate NODEs X: MINImum=0.0, MAXImum=4.e2

! Material types and subregions
MATERial type 1 ! total domain

! Material and nuclide properties
PROPerty for C is HARMonic

FOR material type 1:
MATERial DENSITY 1.0
MATERial PORosity 3*0.25
TRANsport for C Kd=0 Da=0 aL=5 aT=0

! Flow conditions
SET S to 1.
SET U to 1. ! m/d

! Boundary conditions
BOUNDary C at X- in VALUe = 1
BOUNDary C at X+ in GRAD = 0

! Diagnostic information
DIAGnostic output: TIME DTIME C for node 200 every 10 steps

! Time history
SAVE for C at TIME every 25 days to '5.1-D.sav'

! Solution controls
MATRix in X for C 3 sweeps using ADI
LIMIt for C 0.0
CONVergence for C REFERENCE LOCAL 1.e-6, max iterations = 30

! Solve transient transport
! Time period: 0 to 50 days
TIME = 0.

SOLVe C for 50 days in steps of 0.1 days

END
QUIT

```

Table 5.1.23. Input Commands for 1D Transport (Case E)

```

*****
TITLe 5.1 (E) 1-D saturated solute transport in a uniform flow field
*****
! dx=40
*****

GRID is 11 NODEs
COORDinate NODEs X: MINImum=0.0, MAXImum=4.e2

! Material types and subregions
MATERial type 1 ! total domain

! Material and nuclide properties
PROPerty for C is HARMonic

FOR material type 1:
MATERial DENSITY 1.0
MATERial PORosity 3*0.25
TRANsport for C Kd=0 Da=0 aL=5 aT=0

! Flow conditions
SET S to 1.
SET U to 1. ! m/d

! Boundary conditions
BOUNDary C at X- in VALUe = 1

```

```

Boundary C at X+ in GRAD = 0

! Diagnostic information
DIAGnostic output: TIME DTIME C for node 200 every 10 steps

! Time history
SAVE for C at TIME every 25 days to '5.1-E.sav'

! Solution controls
MATRix in X for C 3 sweeps using ADI
LIMIt for C 0.0
CONVergence for C REFERENCE LOCAL 1.e-6, max iterations = 30

! Solve transient transport
! Time period: 0 to 50 days
TIME = 0.

SOLVe C for 50 days in steps of 0.1 days

END
QUIT

```

Table 5.1.24. Input Commands for 1D Transport (Case F)

```

*****
TITLE 5.1 (F) 1-D saturated solute transport in a uniform flow field
*****
! dx=80
*****

GRID is 6 NODEs
COORDinate NODEs X: MINImum=0.0, MAXImum=4.e2

! Material types and subregions
MATERial type 1 ! total domain

! Material and nuclide properties
PROPerty for C is HARMonic

FOR material type 1:
MATERial DENSITY 1.0
MATERial PORosity 3*0.25
TRANsport for C Kd=0 Da=0 aL=5 aT=0

! Flow conditions
SET S to 1.
SET U to 1. ! m/d

! Boundary conditions
BOUNDary C at X- in VALUe = 1
BOUNDary C at X+ in GRAD = 0

! Diagnostic information
DIAGnostic output: TIME DTIME C for node 200 every 10 steps

! Time history
SAVE for C at TIME every 25 days to '5.1-F.sav'

! Solution controls
MATRix in X for C 3 sweeps using ADI
LIMIt for C 0.0
CONVergence for C REFERENCE LOCAL 1.e-6, max iterations = 30

! Solve transient transport
! Time period: 0 to 50 days
TIME = 0.

SOLVe C for 50 days in steps of 0.1 days

END
QUIT

```

Table 5.1.25. Input Commands for 1D Transport (Case G)

```

*****
TITLE 5.1 (G) 1-D saturated solute transport in a uniform flow field
*****
! dt=5 days
*****

GRID is 201 NODEs
COORDinate NODEs X: MINImum=0.0, MAXImum=4.e2

! Material types and subregions
MATERial type 1 ! total domain

! Material and nuclide properties
PROPerty for C is HARMonic

FOR material type 1:
MATERial DENSITY 1.0
MATERial PORosity 3*0.25
TRANsport for C Kd=0 Da=0 aL=5 aT=0

! Flow conditions
SET S to 1.
SET U to 1. ! m/d

! Boundary conditions
BOUNDary C at X- in VALUe = 1
BOUNDary C at X+ in FLUX = 0

! Diagnostic information
DIAGnostic output: TIME DTIME C for node 200 every 10 steps

! Time history
SAVE for C at TIME every 25 days to '5.1-G.sav'

! Solution controls
MATRix in X for C 3 sweeps using ADI
LIMIt for C 0.0
CONVergence for C REFERENCE LOCAL 1.e-6, max iterations = 30

! Solve transient transport
! Time period: 0 to 50 days
TIME = 0.

SOLVe C for 50 days in steps of 5. days

END
QUIT

```

Table 5.1.26. Input Commands for 1D Transport (Case H)

```

*****
TITLE 5.1 (H) 1-D saturated solute transport in a uniform flow field
*****
! dt=10 days
*****

GRID is 201 NODEs
COORDinate NODEs X: MINImum=0.0, MAXImum=4.e2

! Material types and subregions
MATERial type 1 ! total domain

! Material and nuclide properties
PROPerty for C is HARMonic

FOR material type 1:
MATERial DENSITY 1.0
MATERial PORosity 3*0.25
TRANsport for C Kd=0 Da=0 aL=5 aT=0

```

```

! Flow conditions
SET S to 1.
SET U to 1. ! m/d

! Boundary conditions
BOUNDary C at X- in VALUe = 1
BOUNDary C at X+ in GRAD = 0

! Diagnostic information
DIAGnostic output: TIME DTIME C for node 200 every 10 steps

! Time history
SAVE for C at TIME every 25 days to '5.1-H.sav'

! Solution controls
MATRix in X for C 3 sweeps using ADI
LIMIt for C 0.0
CONVergence for C REFERENCE LOCAL 1.e-6, max iterations = 30

! Solve transient transport
! Time period: 0 to 50 days
TIME = 0.

SOLVe C for 50 days in steps of 10. days

END
QUIT

```

Table 5.1.27. Input Commands for 1D Transport (Case I)

```

*****
TITLE 5.1 (H) 1-D saturated solute transport in a uniform flow field
*****
! dt=25 days
*****

GRID is 201 NODEs
COORDinate NODEs X: MINImum=0.0, MAXImum=4.e2

! Material types and subregions
MATERial type 1 ! total domain

! Material and nuclide properties
PROPerty for C is HARMonic

FOR material type 1:
MATERial DENSITY 1.0
MATERial PORosity 3*0.25
TRANSport for C Kd=0 Da=0 aL=5 aT=0

! Flow conditions
SET S to 1.
SET U to 1. ! m/d

! Boundary conditions
BOUNDary C at X- in VALUe = 1
BOUNDary C at X+ in GRAD = 0

! Diagnostic information
DIAGnostic output: TIME DTIME C for node 200 every 10 steps

! Time history
SAVE for C at TIME every 25 days to '5.1-I.sav'

! Solution controls
MATRix in X for C 3 sweeps using ADI
LIMIt for C 0.0
CONVergence for C REFERENCE LOCAL 1.e-6, max iterations = 30

! Solve transient transport
! Time period: 0 to 50 days

```

TIME = 0.

SOLVe C for 50 days in steps of 25. days

END
QUIT

Table 5.1.28. Input Commands for 1D Transport (Case J)

```
*****
TITLe 5.1 (J) 1-D saturated solute transport in a uniform flow field
*****
! Longitudinal dispersivity = 0.01 m
*****

GRID is 201 NODEs
COORDinate NODEs X: MINImum=0.0, MAXImum=4.e2

! Material types and subregions
MATERial type 1 ! total domain

! Material and nuclide properties
PROPerty for C is HARMonic

FOR material type 1:
MATERial DENSITy 1.0
MATERial POROSity 3*0.25
TRANsport for C Kd=0 Da=0 aL=0.01 aT=0

! Flow conditions
SET S to 1.
SET U to 1. ! m/d

! Boundary conditions
BOUNDary C at X- in VALUe = 1
BOUNDary C at X+ in GRAD = 0

! Diagnostic information
DIAGnostic output: TIME DTIME C for node 200 every 10 steps

! Time history
SAVE for C at TIME every 25 years to '5.1-J.sav'

! Solution controls
INTEgration for C by CENTral difference scheme
MATRix in X for C 3 sweeps using ADI
LIMIt for C 0.0
CONVergence for C REFERENCE LOCAL 1.e-6, max iterations = 30

! Solve transient transport
! Time period: 0 to 500 years
TIME = 0.

SOLVe C for 50 days in steps of 0.1 days

END
QUIT
```

Table 5.1.29a. Input Commands for 1D Transport (Case K, T = 25 days)

```
*****
TITLe 5.1 (K) 1-D saturated solute transport in a uniform flow field
*****
! integration scheme with high Peclet number (0 to 25 days)
*****

!==== Hybrid profile =====
GRID is 201 NODEs
COORDinate NODEs X: MINImum=0.0, MAXImum=4.e2

! Material types and subregions
```

MATERial type 1 ! total domain

PROPerty for C is HARMonic

FOR material type 1:
MATERial DENSITY 1.0
MATERial PORosity 3*0.25
TRANsport for C Kd=0 Da=0 aL=0.01 aT=0

! Flow conditions
SET S to 1.
SET U to 1. ! m/d

! Boundary conditions
BOUNDary C at X- in VALUe = 1
BOUNDary C at X+ in GRAD = 0

! Diagnostic information
DIAGnostic output: TIME DTIME C for node 200 every 10 steps

! Solution controls
INTEgration for C by HYBRid profile
MATRix in X for C 3 sweeps using ADI
LIMIt for C 0.0
CONVergence for C REFERENCE LOCAL 1.e-6, max iterations = 30

! Solve transient transport
! Time period: 0 to 25 days

TIME = 0.
SOLVe C for 25 days in steps of 0.1 days
SAVE for C NOW to '5.1-K1-25.sav'
END

!===== Hybrid profile =====

!===== CONDif scheme =====
GRID is 201 NODEs
COORDinate NODEs X: MINImum=0.0, MAXImum=4.e2

! Material types and subregions
MATERial type 1 ! total domain

PROPerty for C is HARMonic

FOR material type 1:
MATERial DENSITY 1.0
MATERial PORosity 3*0.25
TRANsport for C Kd=0 Da=0 aL=0.01 aT=0

! Flow conditions
SET S to 1.
SET U to 1. ! m/d

! Boundary conditions
BOUNDary C at X- in VALUe = 1
BOUNDary C at X+ in GRAD = 0

! Diagnostic information
DIAGnostic output: TIME DTIME C for node 200 every 10 steps

! Solution controls
INTEgration for C by CONDif scheme
MATRix in X for C 3 sweeps using ADI
LIMIt for C 0.0
CONVergence for C REFERENCE LOCAL 1.e-6, max iterations = 30

! Solve transient transport
! Time period: 0 to 25 days

TIME = 0.
SOLVe C for 25 days in steps of 0.1 days
SAVE for C NOW to '5.1-K2-25.sav'
END

```
!===== CONDif scheme =====

!===== Modified Quick scheme =====
GRID is 201 NODEs
COORDinate NODEs X: MINImum=0.0, MAXImum=4.e2

! Material types and subregions
MATERial type 1 ! total domain

PROPerty for C is HARMonic

FOR material type 1:
MATERial DENSITY 1.0
MATERial POROSity 3*0.25
TRANsport for C Kd=0 Da=0 aL=0.01 aT=0

! Flow conditions
SET S to 1.
SET U to 1. ! m/d

! Boundary conditions
BOUNDary C at X- in VALUe = 1
BOUNDary C at X+ in GRAD = 0

! Diagnostic information
DIAGnostic output: TIME DTIME C for node 200 every 10 steps

! Solution controls
INTEgration for C by modified QUICk scheme
MATRix in X for C 3 sweeps using ADI
LIMIt for C 0.0
CONVergence for C REFERENCE LOCAL 1.e-6, max iterations = 30

! Solve transient transport
! Time period: 0 to 25 days

TIME = 0.
SOLVe C for 25 days in steps of 0.1 days
SAVE for C NOW to '5.1-K3-25.sav'
END
!===== Modified Quick scheme =====

!===== Central difference scheme =====
GRID is 201 NODEs
COORDinate NODEs X: MINImum=0.0, MAXImum=4.e2

! Material types and subregions
MATERial type 1 ! total domain

PROPerty for C is HARMonic

FOR material type 1:
MATERial DENSITY 1.0
MATERial POROSity 3*0.25
TRANsport for C Kd=0 Da=0 aL=0.01 aT=0

! Flow conditions
SET S to 1.
SET U to 1. ! m/d

! Boundary conditions
BOUNDary C at X- in VALUe = 1
BOUNDary C at X+ in GRAD = 0

! Diagnostic information
DIAGnostic output: TIME DTIME C for node 200 every 10 steps

! Solution controls
INTEgration for C by CENTRAL difference scheme
MATRix in X for C 3 sweeps using ADI
LIMIt for C 0.0
CONVergence for C REFERENCE LOCAL 1.e-6, max iterations = 30
```

```

! Solve transient transport
! Time period: 0 to 25 days

TIME = 0.
SOLVe C for 25 days in steps of 0.1 days
SAVE for C NOW to '5.1-K4-25.sav'
END
!===== Central difference scheme =====

QUIT

```

Table 5.1.29b. Input Commands for 1D Transport (Case K, T = 50 days)

```

*****
TITLE 5.1 (K) 1-D saturated solute transport in a uniform flow field
*****
! integration scheme with high Peclet number (0 to 50 days)
*****

!===== Hybrid profile =====
GRID is 201 NODEs
COORDinate NODEs X: MINImum=0.0, MAXImum=4.e2

! Material types and subregions
MATERial type 1 ! total domain

PROPErty for C is HARMonic

FOR material type 1:
MATERial DENSITY 1.0
MATERial POROSity 3*0.25
TRANSport for C Kd=0 Da=0 aL=0.01 aT=0

! Flow conditions
SET S to 1.
SET U to 1. ! m/d

! Boundary conditions
BOUNDary C at X- in VALUe = 1
BOUNDary C at X+ in GRAD = 0

! Diagnostic information
DIAGnostic output: TIME DTIME C for node 200 every 10 steps

! Solution controls
INTEgration for C by HYBRid profile
MATRix in X for C 3 sweeps using ADI
LIMIt for C 0.0
CONVergence for C REFERENCE LOCAL 1.e-6, max iterations = 30

! Solve transient transport
! Time period: 0 to 50 days

TIME = 0.
SOLVe C for 50 days in steps of 0.1 days
SAVE for C NOW to '5.1-K1-50.sav'
END
!===== Hybrid profile =====

!===== CONDif scheme =====
GRID is 201 NODEs
COORDinate NODEs X: MINImum=0.0, MAXImum=4.e2

! Material types and subregions
MATERial type 1 ! total domain

PROPErty for C is HARMonic

FOR material type 1:
MATERial DENSITY 1.0
MATERial POROSity 3*0.25
TRANSport for C Kd=0 Da=0 aL=0.01 aT=0

```

```
! Flow conditions
SET S to 1.
SET U to 1. ! m/d

! Boundary conditions
BOUNDary C at X- in VALUe = 1
BOUNDary C at X+ in GRAD = 0

! Diagnostic information
DIAGnostic output: TIME DTIME C for node 200 every 10 steps

! Solution controls
INTEgration for C by CONDif scheme
MATRix in X for C 3 sweeps using ADI
LIMIt for C 0.0
CONVergence for C REFERENCE LOCAL 1.e-6, max iterations = 30

! Solve transient transport
! Time period: 0 to 50 days

TIME = 0.
SOLVe C for 50 days in steps of 0.1 days
SAVE for C NOW to '5.1-K2-50.sav'
END
!===== CONDif scheme =====

!===== Modified Quick scheme =====
GRID is 201 NODEs
COORDinate NODEs X: MINImum=0.0, MAXImum=4.e2

! Material types and subregions
MATERial type 1 ! total domain

PROPerty for C is HARMonic

FOR material type 1:
MATERial DENSITY 1.0
MATERial POROSity 3*0.25
TRANSport for C Kd=0 Da=0 aL=0.01 aT=0

! Flow conditions
SET S to 1.
SET U to 1. ! m/d

! Boundary conditions
BOUNDary C at X- in VALUe = 1
BOUNDary C at X+ in GRAD = 0

! Diagnostic information
DIAGnostic output: TIME DTIME C for node 200 every 10 steps

! Solution controls
INTEgration for C by modified QUICk scheme
MATRix in X for C 3 sweeps using ADI
LIMIt for C 0.0
CONVergence for C REFERENCE LOCAL 1.e-6, max iterations = 30

! Solve transient transport
! Time period: 0 to 50 days

TIME = 0.
SOLVe C for 50 days in steps of 0.1 days
SAVE for C NOW to '5.1-K3-50.sav'
END
!===== Modified Quick scheme =====

!===== Central difference scheme =====
GRID is 201 NODEs
COORDinate NODEs X: MINImum=0.0, MAXImum=4.e2

! Material types and subregions
MATERial type 1 ! total domain
```

```

PROPerTy for C is HARMonic

FOR material type 1:
MATERial DENSITy 1.0
MATERial POROSity 3*0.25
TRANSpOrt for C Kd=0 Da=0 aL=0.01 aT=0

! Flow conditions
SET S to 1.
SET U to 1. ! m/d

! Boundary conditions
BOUNDary C at X- in VALUe = 1
BOUNDary C at X+ in GRAD = 0

! Diagnostic information
DIAGnostic output: TIME DTIME C for node 200 every 10 steps

! Solution controls
INTEgration for C by CENTral difference scheme
MATRix in X for C 3 sweeps using ADI
LIMIt for C 0.0
CONVergence for C REFERENCE LOCAL 1.e-6, max iterations = 30

! Solve transient transport
! Time period: 0 to 50 days

TIME = 0.
SOLVe C for 50 days in steps of 0.1 days
SAVE for C NOW to '5.1-K4-50.sav'
END
!===== Central difference scheme =====

QUIT

```

Table 5.1.30a. Input Commands for 1D Transport (Case L, T = 25 days)

```

*****
TITLE 5.1 (L) 1-D saturated solute transport in a uniform flow field
*****
! property averaging (0 to 25 days)
*****

!===== Arithmetic averaging of properties =====
GRID is 201 NODEs
COORDinate NODEs X: MINImum=0.0, MAXImum=4.e2

! Material types and subregions
MATERial type 1 ! total domain

PROPerTy for C is ARITmetic

FOR material type 1:
MATERial DENSITy 1.0
MATERial POROSity 3*0.25
TRANSpOrt for C Kd=0 Da=0 aL=5 aT=0

! Flow conditions
SET S to 1.
SET U to 1. ! m/d

! Boundary conditions
BOUNDary C at X- in VALUe = 1
BOUNDary C at X+ in GRAD = 0

! Diagnostic information
DIAGnostic output: TIME DTIME C for node 200 every 10 steps

! Solution controls
MATRix in X for C 3 sweeps using ADI
LIMIt for C 0.0

```



```
CONVergence for C REFERENCE LOCAL 1.e-6, max iterations = 30

! Solve transient transport
! Time period: 0 to 25 days

TIME = 0.
SOLVe C for 25 days in steps of 0.1 days
SAVE for C NOW to '5.1-L1-25.sav'
END
!===== Arithmetic averaging of properties =====

!===== Harmonic averaging of properties =====
GRID is 201 NODEs
COORDinate NODEs X: MINIMUM=0.0, MAXIMUM=4.e2

! Material types and subregions
MATERIAL type 1 ! total domain

PROPerTy for C is HARMonic

FOR material type 1:
MATERIAL DENSITY 1.0
MATERIAL POROSity 3*0.25
TRANSport for C Kd=0 Da=0 aL=5 aT=0

! Flow conditions
SET S to 1.
SET U to 1. ! m/d

! Boundary conditions
BOUNDary C at X- in VALUe = 1
BOUNDary C at X+ in GRAD = 0

! Diagnostic information
DIAGnostic output: TIME DTIME C for node 200 every 10 steps

! Solution controls
MATRix in X for C 3 sweeps using ADI
LIMIT for C 0.0
CONVergence for C REFERENCE LOCAL 1.e-6, max iterations = 30

! Solve transient transport
! Time period: 0 to 25 days

TIME = 0.
SOLVe C for 25 days in steps of 0.1 days
SAVE for C NOW to '5.1-L2-25.sav'
END
!===== Harmonic averaging of properties =====

!===== Geometric averaging of properties =====
GRID is 201 NODEs
COORDinate NODEs X: MINIMUM=0.0, MAXIMUM=4.e2

! Material types and subregions
MATERIAL type 1 ! total domain

PROPerTy for C is GEOMETric

FOR material type 1:
MATERIAL DENSITY 1.0
MATERIAL POROSity 3*0.25
TRANSport for C Kd=0 Da=0 aL=5 aT=0

! Flow conditions
SET S to 1.
SET U to 1. ! m/d

! Boundary conditions
BOUNDary C at X- in VALUe = 1
BOUNDary C at X+ in GRAD = 0

! Diagnostic information
```

```

DIAGnostic output: TIME DTIME C for node 200 every 10 steps

! Solution controls
MATRix in X for C 3 sweeps using ADI
LIMit for C 0.0
CONVergence for C REFERENCE LOCAL 1.e-6, max iterations = 30

! Solve transient transport
! Time period: 0 to 25 days

TIME = 0.
SOLVe C for 25 days in steps of 0.1 days
SAVE for C NOW to '5.1-L3-25.sav'
END
!===== Geometric averaging of properties =====

!===== Upwind averaging of properties =====
GRID is 201 NODEs
COORDinate NODEs X: MINImum=0.0, MAXImum=4.e2

! Material types and subregions
MATERial type 1 ! total domain

PROPerty for C is UPWInd

FOR material type 1:
MATERial DENSITY 1.0
MATERial PORosity 3*0.25
TRANSport for C Kd=0 Da=0 aL=5 aT=0

! Flow conditions
SET S to 1.
SET U to 1. ! m/d

! Boundary conditions
BOUNDary C at X- in VALUe = 1
BOUNDary C at X+ in GRAD = 0

! Diagnostic information
DIAGnostic output: TIME DTIME C for node 200 every 10 steps

! Solution controls
MATRix in X for C 3 sweeps using ADI
LIMit for C 0.0
CONVergence for C REFERENCE LOCAL 1.e-6, max iterations = 30

! Solve transient transport
! Time period: 0 to 25 days

TIME = 0.
SOLVe C for 25 days in steps of 0.1 days
SAVE for C NOW to '5.1-L4-25.sav'
END
!===== Upwind averaging of properties =====

QUIT
    
```

Table 5.1.30b. Input Commands for 1D Transport (Case L, T = 50 days)

```

*****
TITLE 5.1 (L) 1-D saturated solute transport in a uniform flow field
*****
! property averaging (0 to 50 days)
*****

!===== Arithmetic averaging of properties =====
GRID is 201 NODEs
COORDinate NODEs X: MINImum=0.0, MAXImum=4.e2

! Material types and subregions
MATERial type 1 ! total domain
    
```

PROPerTy for C is ARITmetic

FOR material type 1:
MATERial DENSITy 1.0
MATERial POROSity 3*0.25
TRANSport for C Kd=0 Da=0 aL=5 aT=0

! Flow conditions
SET S to 1.
SET U to 1. ! m/d

! Boundary conditions
BOUNDary C at X- in VALUe = 1
BOUNDary C at X+ in GRAD = 0

! Diagnostic information
DIAGnostic output: TIME DTIME C for node 200 every 10 steps

! Solution controls
MATRix in X for C 3 sweeps using ADI
LIMIt for C 0.0
CONVergence for C REFERENCE LOCAL 1.e-6, max iterations = 30

! Solve transient transport
! Time period: 0 to 50 days

TIME = 0.
SOLVe C for 50 days in steps of 0.1 days
SAVE for C NOW to '5.1-L1-50.sav'
END

!===== Arithmetic averaging of properties =====

!===== Harmonic averaging of properties =====

GRID is 201 NODEs
COORDinate NODEs X: MINImum=0.0, MAXImum=4.e2

! Material types and subregions
MATERial type 1 ! total domain

PROPerTy for C is HARMonic

FOR material type 1:
MATERial DENSITy 1.0
MATERial POROSity 3*0.25
TRANSport for C Kd=0 Da=0 aL=5 aT=0

! Flow conditions
SET S to 1.
SET U to 1. ! m/d

! Boundary conditions
BOUNDary C at X- in VALUe = 1
BOUNDary C at X+ in GRAD = 0

! Diagnostic information
DIAGnostic output: TIME DTIME C for node 200 every 10 steps

! Solution controls
MATRix in X for C 3 sweeps using ADI
LIMIt for C 0.0
CONVergence for C REFERENCE LOCAL 1.e-6, max iterations = 30

! Solve transient transport
! Time period: 0 to 50 days

TIME = 0.
SOLVe C for 50 days in steps of 0.1 days
SAVE for C NOW to '5.1-L2-50.sav'
END

!===== Harmonic averaging of properties =====

!===== Geometric averaging of properties =====

GRID is 201 NODEs

PORFLOW Testing and Verification Document

COORDinate NODEs X: MINImum=0.0, MAXImum=4.e2

! Material types and subregions
MATERial type 1 ! total domain

PROPerTy for C is GEOMetric

FOR material type 1:
MATERial DENSITy 1.0
MATERial POROSity 3*0.25
TRANSport for C Kd=0 Da=0 aL=5 aT=0

! Flow conditions
SET S to 1.
SET U to 1. ! m/d

! Boundary conditions
BOUNDary C at X- in VALUe = 1
BOUNDary C at X+ in GRAD = 0

! Diagnostic information
DIAGnostic output: TIME DTIME C for node 200 every 10 steps

! Solution controls
MATRix in X for C 3 sweeps using ADI
LIMIt for C 0.0
CONVergence for C REFERENCE LOCAL 1.e-6, max iterations = 30

! Solve transient transport
! Time period: 0 to 50 days

TIME = 0.
SOLVe C for 50 days in steps of 0.1 days
SAVE for C NOW to '5.1-L3-50.sav'
END

!===== Geometric averaging of properties =====

!===== Upwind averaging of properties =====
GRID is 201 NODEs
COORDinate NODEs X: MINImum=0.0, MAXImum=4.e2

! Material types and subregions
MATERial type 1 ! total domain

PROPerTy for C is UPWInd

FOR material type 1:
MATERial DENSITy 1.0
MATERial POROSity 3*0.25
TRANSport for C Kd=0 Da=0 aL=5 aT=0

! Flow conditions
SET S to 1.
SET U to 1. ! m/d

! Boundary conditions
BOUNDary C at X- in VALUe = 1
BOUNDary C at X+ in GRAD = 0

! Diagnostic information
DIAGnostic output: TIME DTIME C for node 200 every 10 steps

! Solution controls
MATRix in X for C 3 sweeps using ADI
LIMIt for C 0.0
CONVergence for C REFERENCE LOCAL 1.e-6, max iterations = 30

! Solve transient transport
! Time period: 0 to 50 days

TIME = 0.
SOLVe C for 50 days in steps of 0.1 days
SAVE for C NOW to '5.1-L4-50.sav'

END

!===== Upwind averaging of properties =====

QUIT

5.2 Two-Dimensional Saturated Solute Transport in a Uniform Flow Field

This problem deals with two-dimensional advection-dispersion of a non-conservative solute species from a point source through an infinite porous medium. It is used to demonstrate the impact that grid orientation with transverse dispersion has on the solution from PORFLOW. A physical schematic of this problem is shown in Figure 5.2.1(a). In practice, the idealized conditions are analogous to continual leakage or injection of a contaminant into a shallow confined aquifer from a small leaking landfill or an improperly sealed fully penetrating injection well (gradients in the vertical direction are assumed to be negligible). It is assumed that the total rate of fluid leakage or injection into the aquifer is negligible and does not disturb the ambient groundwater flow regime. Analytically the problem is treated as a point source in the 2-D areal plane.

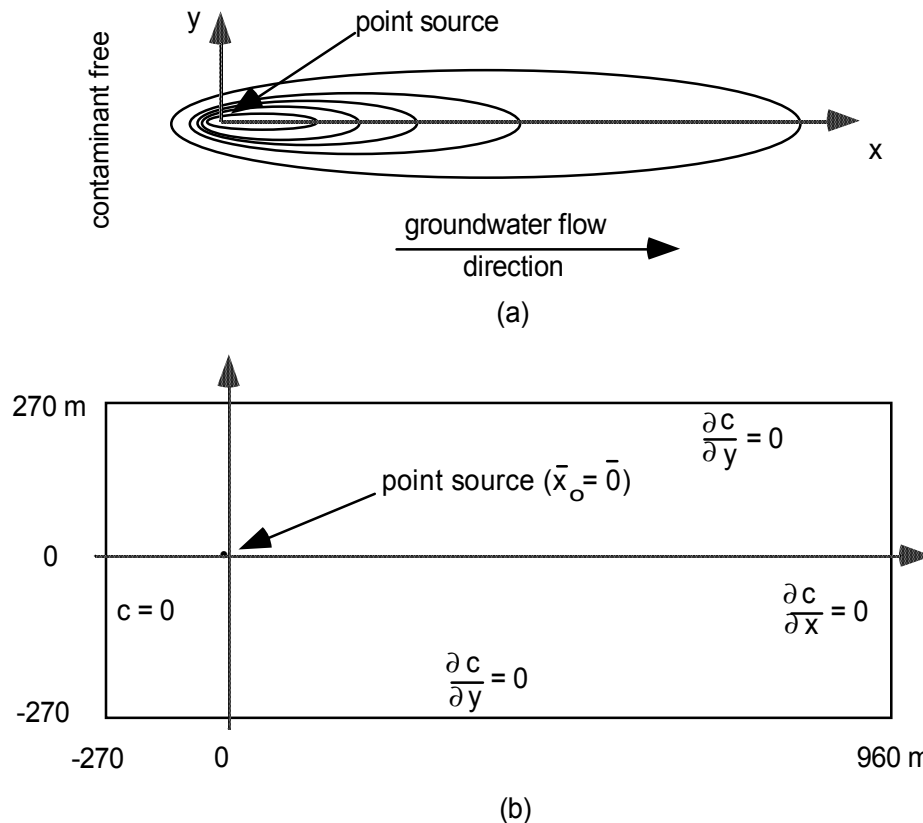

Figure 5.2.1. Schematic Diagram for 2D Solute Transport in a Confined Aquifer

As illustrated in Figure 5.2.1(b), a non-conservative contaminant is continuously released from a point source downstream of an inflow boundary (containing zero contaminant) into a shallow confined aquifer unit whose groundwater flow is assumed to be uniform. Both hydrodynamic dispersion and molecular diffusion are allowed, as well as, the possibility of radioactive decay and/or adsorption of the transported species. It is assumed that the contaminant mass flow rate at

the point source remains constant, the aquifer's flow rate is uniform and constant, and the homogeneous aquifer's properties (such as porosity, soil type, water saturation) are uniform and constant.

Analytical solution: Equation 5.1.4 represents the non-conservative form of the multi-dimensional advection-dispersion equation for solute transport through a variably saturated porous media. Taking the 2-D form of Equation 5.1.4 and assuming that one point exists at the areal location $x = y = 0$, constant water saturation level, and that material coefficients are constants, results in

$$\frac{\partial c}{\partial t} = D'_{xx} \frac{\partial^2 c}{\partial x^2} + D'_{yy} \frac{\partial^2 c}{\partial y^2} + D'_{xy} \frac{\partial^2 c}{\partial x \partial y} + D'_{yx} \frac{\partial^2 c}{\partial y \partial x} - u'_x \frac{\partial c}{\partial x} - u'_y \frac{\partial c}{\partial y} - \lambda c - \frac{q(c - c^*)}{\theta_e R} \quad (5.2.1)$$

where

$$D'_{xx} = \frac{\alpha_L \frac{U_x^2}{|U|} + \alpha_T \frac{U_y^2}{|U|} + \theta_e \tau D_m}{\theta_e R} \quad (5.2.2a)$$

$$D'_{yy} = \frac{\alpha_L \frac{U_y^2}{|U|} + \alpha_T \frac{U_x^2}{|U|} + \theta_e \tau D_m}{\theta_e R} \quad (5.2.2b)$$

$$D'_{xy} = D'_{yx} = \frac{(\alpha_L - \alpha_T) \frac{U_x U_y}{|U|}}{\theta_e R} \quad (5.2.2c)$$

and α_T is the transverse dispersivity.

If the flow field is aligned with the x-axis Equation 5.2.1 reduces to

$$\frac{\partial c}{\partial t} = D'_{xx} \frac{\partial^2 c}{\partial x^2} + D'_{yy} \frac{\partial^2 c}{\partial y^2} - u'_x \frac{\partial c}{\partial x} - \lambda c - \frac{q(c - c^*)}{\theta_e R} \quad (5.2.3)$$

For our infinite confined aquifer the initial conditions are:

$$c(x, y, 0) = 0 \quad (5.2.4a)$$

and the boundary conditions are:

$$c(\pm\infty, y, t) = 0 \quad (5.2.4b)$$

$$c(x, \pm\infty, t) = 0 \quad (5.2.4c)$$

These boundary conditions are equivalent to assuming that the dispersive flux of solute is zero at plus or minus infinity or

$$\lim_{x \rightarrow \pm\infty} \left(\frac{\partial c}{\partial x} \right) = 0 \quad (5.2.4d)$$

$$\lim_{y \rightarrow \pm\infty} \left(\frac{\partial c}{\partial y} \right) = 0 \quad (5.2.4e)$$

For finite times there exists finite values of x and y where Equations 5.2.4d and 5.2.4e remain valid.

As mentioned above, it is assumed that the total rate of fluid flow, q , into the aquifer due to the source is negligible and does not disturb the ambient groundwater flow regime. In order to have a finite mass flow rate of contaminant requires

$$\lim_{q \rightarrow 0} (qc^*) < \infty \Rightarrow \lim_{q \rightarrow 0} (c^*) = \pm\infty \quad (5.2.4f)$$

Equation 5.2.3, a linear partial differential equation subject to the initial and boundary conditions given by Equations 5.2.4a to 5.2.4c, can be solved by applying Laplace and Fourier transforms to derive at the appropriate Green's functions. For details, see Yeh (1981). The general solution for a continuous point source takes the form:

$$c(x, y, t) = \frac{qc^*}{\theta_e R} \int_0^t G(x | \xi; y | \eta; t | \tau) d\tau \quad (5.2.5a)$$

where $G(x | \xi; y | \eta; t | \tau)$ is the Green's function over the domain space. For our analytical problem, we shall limit our flow field to flow parallel to the x -axis only. This results in a dispersion tensor that is diagonal and a separable Green's function. It can be shown that for a simple geometry such as a separable coordinate system, Green's function can be expressed as:

$$G(x | \xi; y | \eta; t | \tau) = G_1(x | \xi; t | \tau) G_2(y | \eta; t | \tau) \quad (5.2.5b)$$

where for a point source in the x -direction (infinite domain, parallel to flow):

$$G_1(x | \xi; t | \tau) = \frac{S(t - \tau)}{\sqrt{4\pi D'_{xx}(t - \tau)}} \exp \left[-\frac{\{(x - \xi) - u'_x(t - \tau)\}^2}{4D'_{xx}(t - \tau)} - \lambda(t - \tau) \right] \quad (5.2.5c)$$

and for a point source in the y -direction (infinite domain, transverse to flow):

$$G_2(y | \eta; t | \tau) = \frac{S(t - \tau)}{\sqrt{4\pi D'_{yy}(t - \tau)}} \exp\left[-\frac{(y - \eta)^2}{4D'_{yy}(t - \tau)}\right] \quad (5.2.5d)$$

where $S(t - \tau)$ is the step function.

The evaluation of the analytical expressions, Equations 5.2.5a to 5.2.5d, for a specific problem is performed numerically using the FORTRAN program AT123D in Section C.

PORFLOW numerical simulation and comparison: The PORFLOW 2-D Cartesian models for this consist of two grids. One grid is a rectangular domain in which the aquifer groundwater flow is in the x-direction only. The other grid is a square domain in which the aquifer groundwater flow is diagonal to the mesh orientation. The point source in both grids is located at $x = y = 0$. Zero diffusive flux boundary conditions are applied at the +X, -Y and +Y faces of the mesh.

Even though we are considering an aquifer unit with infinite extent in the areal directions, our numerical model has finite size. At our inflow boundary (-X) we shall assume that the incoming fluid remains contaminant free (i.e., the contaminant concentration immediately upstream of the source does not extend back up to the inflow boundary). For the parameters chosen (i.e., longitudinal dispersivity, Darcy velocity, and source location), the above assumption remains valid over the time of interest.

In addition, PORFLOW requires input about the total mass flowrate per unit thickness entering the aquifer at the point source. An arbitrarily small but finite value for q_c^* was chosen to maintain computed solute concentration values near the source to acceptable values. Steep concentration gradients near a source can result in oscillatory behavior unless the local grid is sufficiently refined. For demonstration purposes, we have chosen uniform coarse grids and are primarily interested in results away from the source location. The simulations are done by specifying a velocity field and running the solute transport option only. In this way, the flow rate entering the aquifer due to the point source does not alter the aquifer flow field.

Values of the physical parameters used in the verification simulations are presented in Table 5.2.1. For the conservative solute transport cases, the parameters were selected based on data from a field investigation on hexavalent chromium contamination reported by Perlumutter and Lieber (1970) and Wilson and Miller (1978). For the non-conservative solute transport cases, the values of retardation and decay constants were chosen arbitrarily to test the performance of PORFLOW transport modules.

Table 5.2.1. Values of the Physical Parameters, Mesh Spacing, Time Steps, and Key Computed Parameters Used in the Two-Dimensional Transport Simulations.

Physical parameters	Base Case	Range tested
Darcy velocity, U_x	0.161 m/d	-
Porosity, ϕ	0.35	-
Longitudinal dispersivity, α_L	21.3 m	-
Transverse dispersivity, α_T	4.3 m	-
Apparent molecular dispersion coefficient, $\theta_e \tau D_m$	0.0 m ² /d	-
Water saturation, S_w	1.0	-
Radioactive decay constant, λ	0.0 d ⁻¹	0.0,0.005
Soil density, ρ_s	1.23077 kg/m ³	-
Solute distribution coefficient, k_d	0.0 m ³ /kg	0.0,0.4375
Boundary solute concentration, c_0	0.0 kg/m ³	-
Contaminant total mass flowrate per unit aquifer thickness (point source), qc^*	7.040119E-3 kg/d/m	-
Grid specifics		
Grid spacing, $\Delta x = \Delta y$	15 m	-
Number nodes in x-dir	83	-
Number nodes in y-dir	37 (parallel grid) 83 (diagonal grid)	-
Time steps		
Time duration	1400 d	-
number time-steps	1400	-
time-step size, Δt	1 d	-

Key computed parameters		
Retardation factor, R	1.0	2.0
Bulk soil density, ρ_b	0.8 kg/m ³	-
Phasic velocity, u_x	0.46 m/d (P) 0.3253 m/d (D)	-
Retarded phasic velocity, u'_x	0.46 m/d (P) 0.3253 m/d (D)	0.23 m/d (P) 0.1626 m/d (D)
Phasic velocity, u_y	0.0 m/d (P) 0.3253 m/d (D)	-
Retarded phasic velocity, u'_y	0.0 m/d (P) 0.3253 m/d (D)	0.0 m/d (P) 0.1626 m/d (D)
Retarded longitudinal dispersion coefficient, D'_{xx}	9.798 m ² /d (P) 5.888 m ² /d (D)	4.899 m ² /d (P) 2.944 m ² /d (D)
Retarded transverse dispersion coefficient, D'_{yy}	1.978 m ² /d (P) 5.888 m ² /d (D)	0.989 m ² /d (P) 2.944 m ² /d (D)
Retarded cross dispersion coefficient, D'_{xy}	0.0 m ² /d (P) 3.91 m ² /d (D)	0.0 m ² /d (P) 1.955 m ² /d (D)
Cell Fourier number, $Fo_x; Fo_y$	0.0435; 0.0088 (P)	0.0218; 0.0044 (P)
Cell Courant number, $Co_x; Co_y$	0.0307; 0.0 (P)	0.0153; 0.0 (P)
Cell Peclet number, $Pe_x; Pe_y$	0.7042; 3.4883 (P)	0.7042; 3.4883 (P)

In 1D transport, only longitudinal dispersion is active and in a 2D transport problem, both longitudinal and transverse dispersion can occur. In a general 2D transport problem, the off-diagonal terms of the dispersion coefficient tensor are typically non-zero. In PORFLOW the resulting dispersive flux cross-term products such as

$$\frac{\partial}{\partial x} \left[D_{xy} \left(\frac{\partial c}{\partial y} \right) \right] \quad (5.2.6)$$

are handled consistently and are not “lumped”. The lumping approximation is more commonly used in finite difference algorithms (Faust, et. al., 1993) to accommodate their matrix solution requirements. Typically, lumping greatly over estimates transverse dispersion. Also for many algorithms, grid orientation effects occur even though these cross-product dispersion terms are handled in a consistent formulation.

To examine these grid orientation effects in PORFLOW, two base case grids were chosen for this problem: (1) a grid aligned parallel to the aquifer flow direction consisting of 3071 nodes uniformly spaced (15 m in length) with 83 nodes along the x-axis and 37 along the y-axis and (2) a grid aligned at a 45° diagonal to the aquifer flow direction consisting of 6889 nodes uniformly spaced (15 m in length) with 83 nodes along the x-axis and y-axis. Figures 5.2.2 and 5.2.3 illustrate PORFLOW grids chosen. At the channel inlet boundary(s) (-X face; -X face and -Y face), the concentration of solute in the incoming water is set to 0.0 kg/m³. Due to the finite

overall length of our mesh, at the outflow boundary(s) (+X face; +X face and +Y face) the dispersive flux (GRAD) is set to zero, while the advective flux is calculated as part of the solution. In addition, for the parallel grid the dispersive flux is set to zero at the transverse faces (-Y face and +Y face). The nodal spacing for both grid orientations is the same and the results shown should represent grid orientation effects only.

For this problem several simulations were performed. As summarized in Table 5.2.2, simulations were performed for both base cases (parallel and diagonal grids) and then two additional runs were made varying certain key physical parameters and PORFLOW options to demonstrate their impact on the results. For each simulation, a transient calculation was performed for a 1400-day duration and the results from PORFLOW at this end time are compared to the analytical solution given by Equation 5.2.5a. As shown in Table 5.2.1., a range of cell Peclet, cell material Courant, and cell Fourier numbers were tested.

The results of all the simulations (both numerical and analytical) are shown in Figures 5.2.4 through 5.2.15. These results are also presented in tabular form for comparison in Tables 5.2.3 through 5.2.7. The input commands for the 2D transport simulations are given in Tables 5.2.8 through 5.2.11 for Case A through D, respectively. The analytical results were computed from the numerical code AT123D shown in Section C.

Table 5.2.2. Summary of Simulations Performed (Base Case and Variations) on the Two-Dimensional Transport Problem

FACT Options	Base case (parallel)	Base case (diagonal)	A	B	C	D
Mesh Options						
parallel grid	x		x		x	x
diagonal grid		x		x		
Physical Parameters						
radioactive decay coef., $\lambda = 0.0 \text{ d}^{-1}$	x	x	x	x	x	
$\lambda = 0.005 \text{ d}^{-1}$						x
Solute distribution coef., $k_d = 0.0 \text{ m}^3/\text{kg}$	x	x	x	x		x
$k_d = 0.4375 \text{ m}^3/\text{kg}$					x	

The concentration plume presented in Figure 5.2.4 represents our base case parallel grid simulation (Case A). The aquifer flow direction is aligned with the grid and the concentration plume does not exhibit any oscillatory behavior near the continuous point source using the default HYBRID nodal integration scheme. The cell Peclet number, Pe_y , transverse to the plume centerline is greater than 2. Therefore, you would expect to see slight oscillatory behavior in the concentrations transverse to the plume centerline. The HYBRID nodal integration scheme eliminated upstream oscillations in the high Peclet number 1D transport simulation by increasing the artificial dispersion. Similarly, oscillatory behavior transverse to the plume centerline is being suppressed by increased artificial dispersion in that direction.

Figures 5.2.5 and 5.2.6 present concentration profiles for 2D transport of the base case (Case A) along and transverse to the plume centerline at 1400 days, respectively. There is excellent agreement between the PORFLOW numerical results and the results from AT123D. Tables 5.2.3 and 5.2.4 complement the data shown in the figures above. The PORFLOW input commands for Case A are given in Table 5.2.8.

The concentration plume presented in Figure 5.2.7 presents the base case diagonal grid simulation (Case B). The aquifer flow direction is aligned at a 45-degree angle with respect to the grid. The alternating stripes of concentration contours transverse to the plume centerline exhibit oscillatory behavior perhaps due to less diagonal dominance of the dispersion tensor with off diagonal terms. The HYBRID nodal integration scheme was used for this case as well. A point of interest or warning is that PORFLOW by default only computes the diagonal terms of the dispersion tensor. The user must issue the “CONDUCTION with TENSOR diffusivity” command to invoke computation of the off-diagonal dispersion terms.

Figures 5.2.8 and 5.2.9 present concentration profiles for 2D transport of the base case (Case B) along and transverse to the plume centerline at 1400 days, respectively. As shown in Figure 5.2.8, PORFLOW under estimates the concentration upstream of the point source due to increased artificial dispersion in the transverse direction. There is excellent agreement between the PORFLOW numerical results and AT123D away from the source. Tables 5.2.3 and 5.2.4 complement the data shown in the figures above. The PORFLOW input commands for Case B are given in Table 5.2.9.

The concentration plume presented in Figure 5.2.10 shows the effect of retardation on the base case parallel grid simulation (Case C). By adjusting the solute distribution coefficient such that the retardation factor becomes 2, the retarded dispersion coefficient and velocity are halved. These results can be compared to the no retardation base case (Case A) in Figures 5.2.11 and 5.2.12 where the spread of the plume has been greatly reduced. The agreement between the PORFLOW simulation results and AT123D is excellent. Tables 5.2.6 and 5.2.7 summarize the analytical and PORFLOW concentrations along and transverse to the plume centerline at 1400 days, respectively. The PORFLOW input commands for Case C are shown in Table 5.2.10.

The concentration plume presented in Figure 5.2.13 shows the effect of radioactive decay on the base case parallel grid simulation (Case D). By employing a non-zero radioactive decay coefficient, the solute now becomes a non-conservative transport species. These results can be compared to the non-decaying base case (Case A) in Figures 5.2.14 and 5.2.15 where the solute concentration profiles are reduced especially at the higher concentration levels. The agreement between the PORFLOW simulation results and AT123D is excellent. Tables 5.2.6 and 5.2.7 summarize the analytical and PORFLOW concentrations along and transverse to the plume centerline at 1400 days, respectively. The PORFLOW input commands for Case D are shown in Table 5.2.11.

By employing a non-zero radioactive decay coefficient such that the solute now becomes a non-conservative transport species (Cases D), the solute concentration profiles are reduced especially

at the higher concentration levels. These results can be compared to the base case (Case A) in Figure 5.2.14 and 5.2.15.

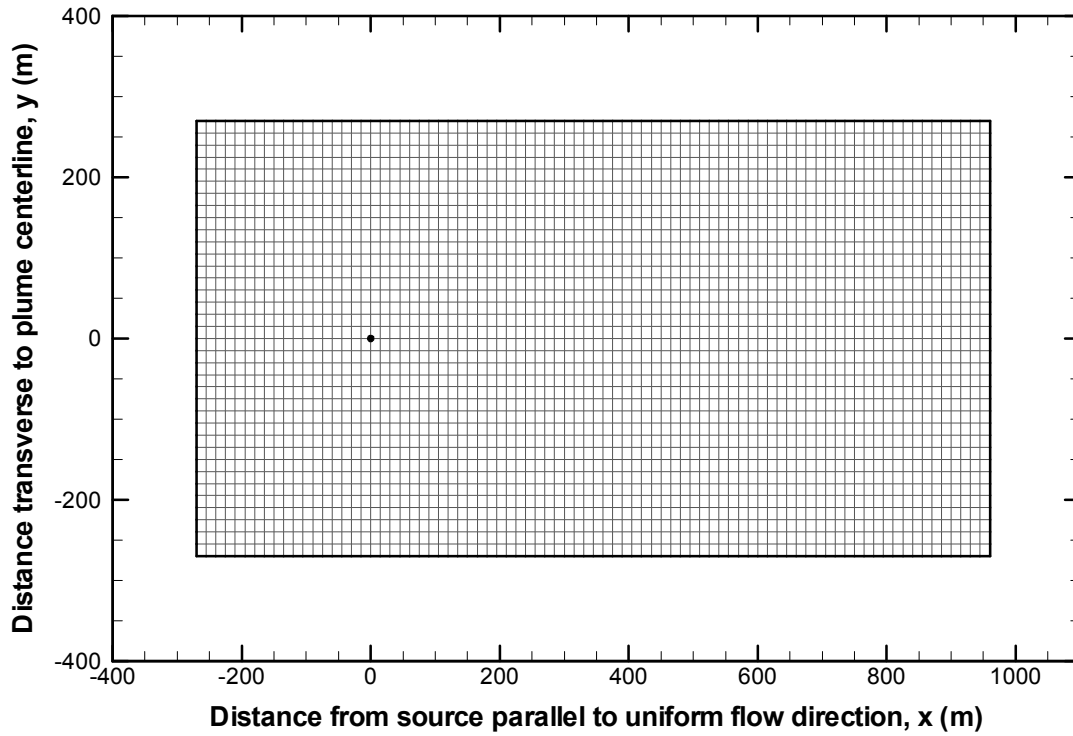

Figure 5.2.2. PORFLOW Parallel Grid for 2D Transport Simulations.

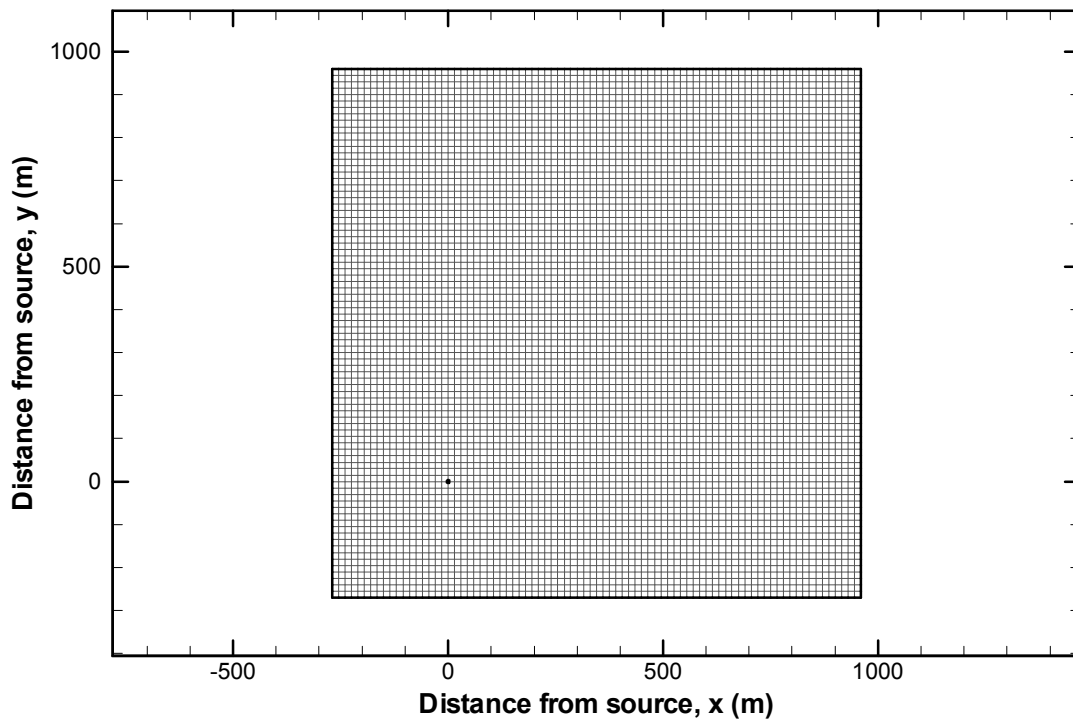

Figure 5.2.3. PORFLOW Diagonal Grid for 2D Transport Simulation.

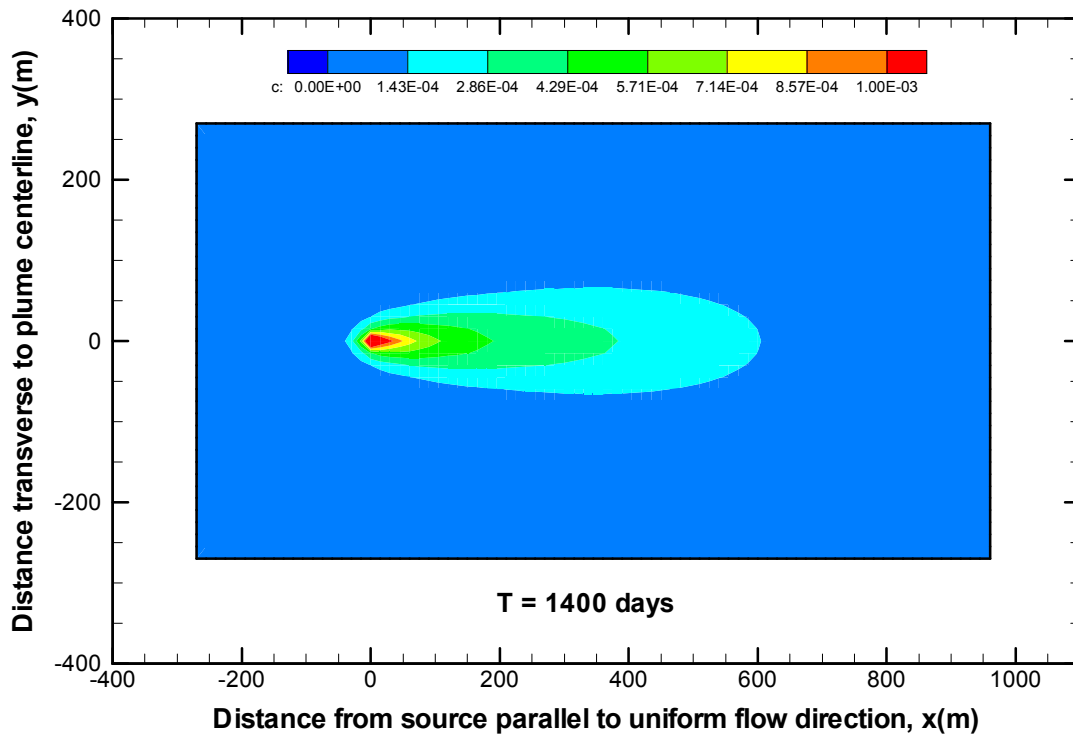

Figure 5.2.4. PORFLOW Concentration Plume for 2D Transport of the Base Case on the Parallel Grid (Case A).

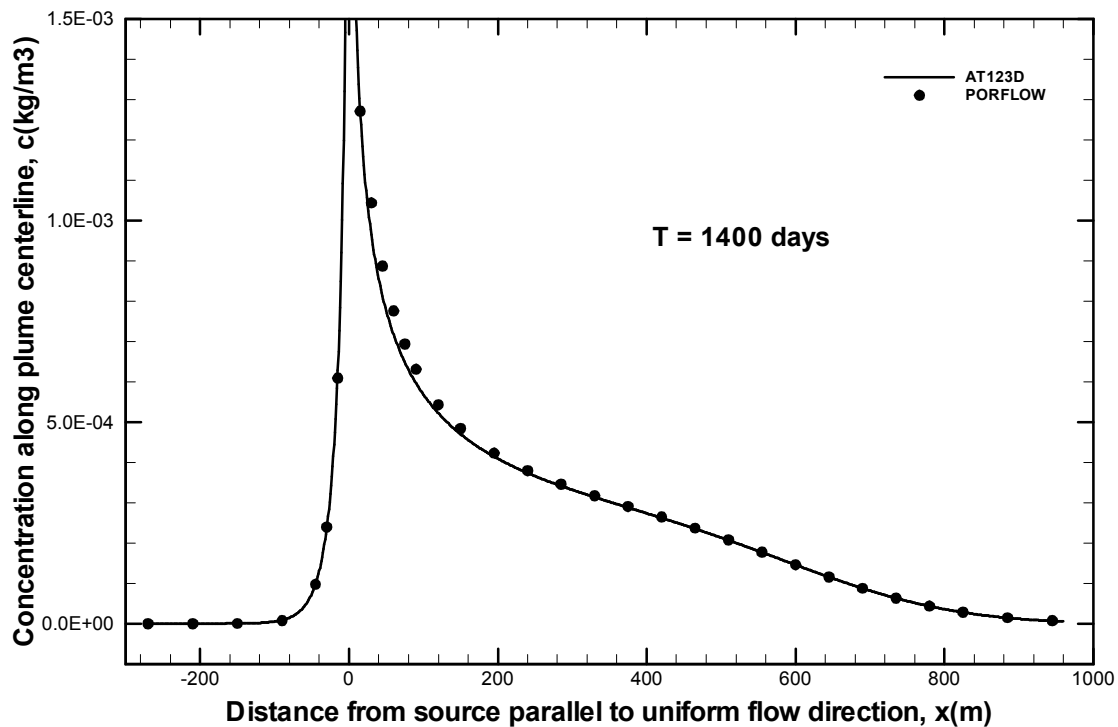

Figure 5.2.5. Concentration Profiles for 2D Transport of the Base Case along the Plume Centerline (Case A).

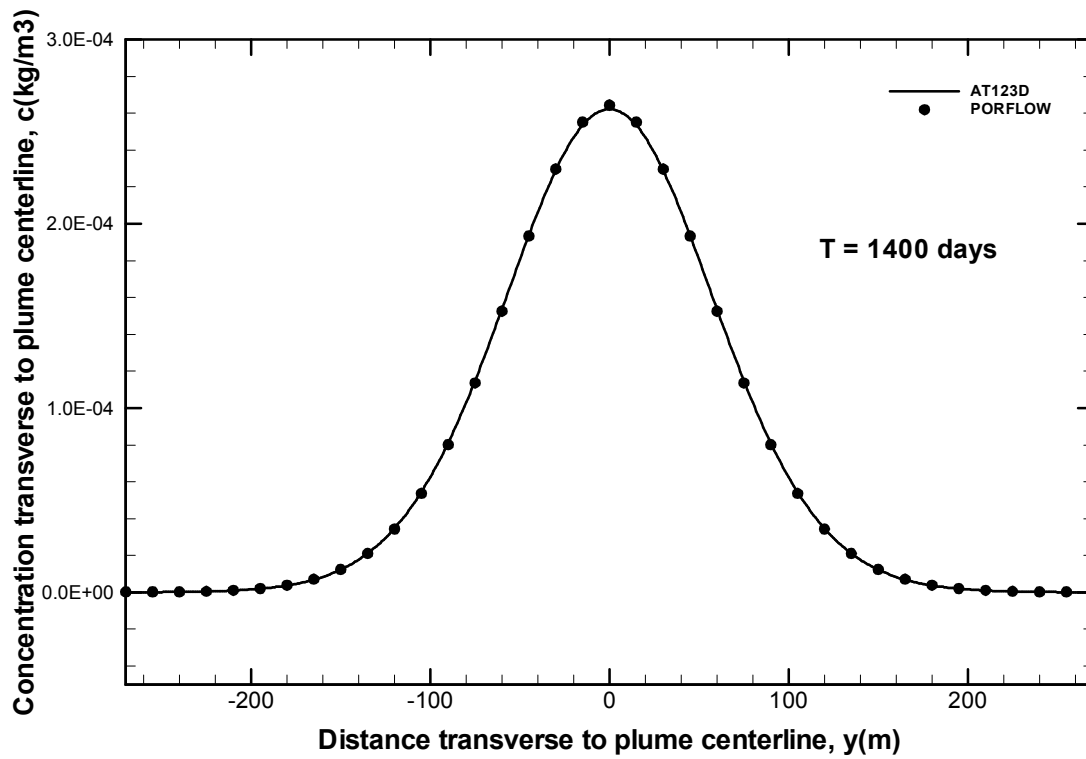

Figure 5.2.6. Concentration Profiles for 2D Transport of the Base Case Transverse to the Plume Centerline at x = 420 meters (Case A).

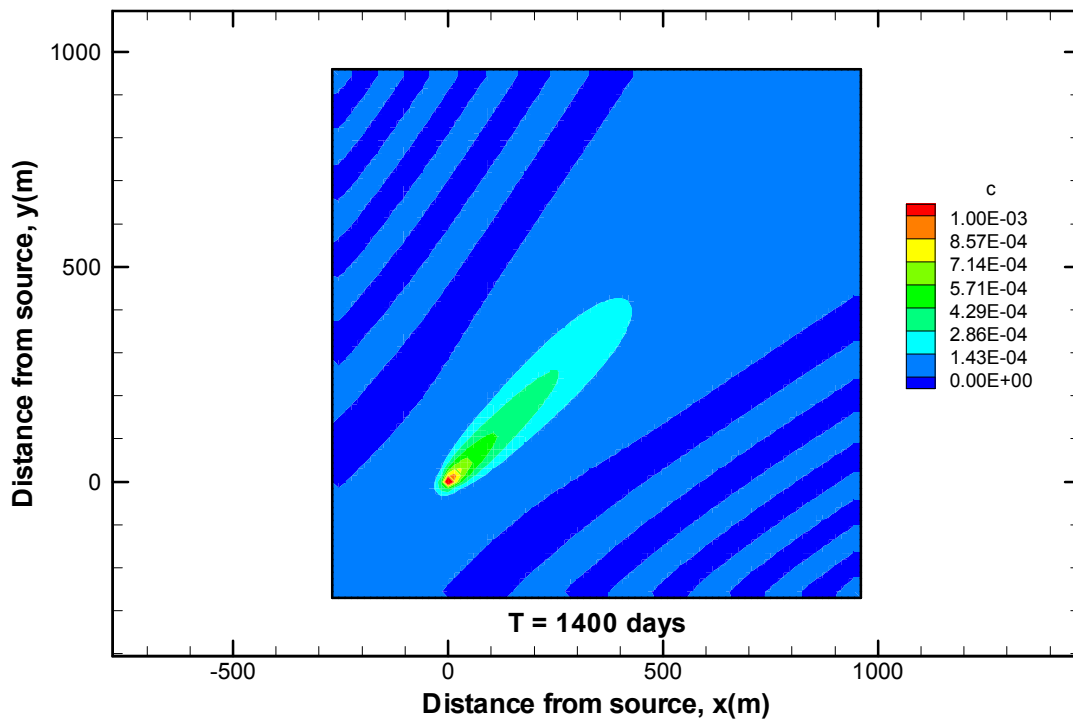

Figure 5.2.7. PORFLOW Concentration Plume for 2D Transport of the Base Case on the Diagonal Grid (Case B).

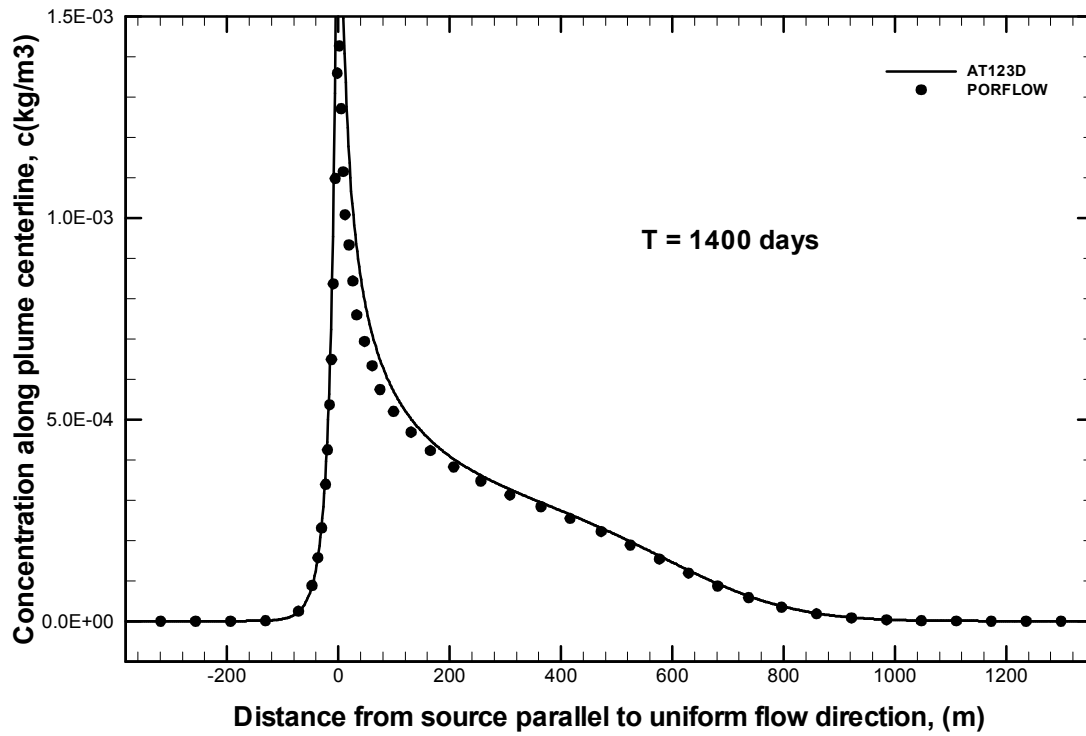

Figure 5.2.8. Concentration Profiles for 2D Transport of the Base Case along the Plume Centerline (Case B).

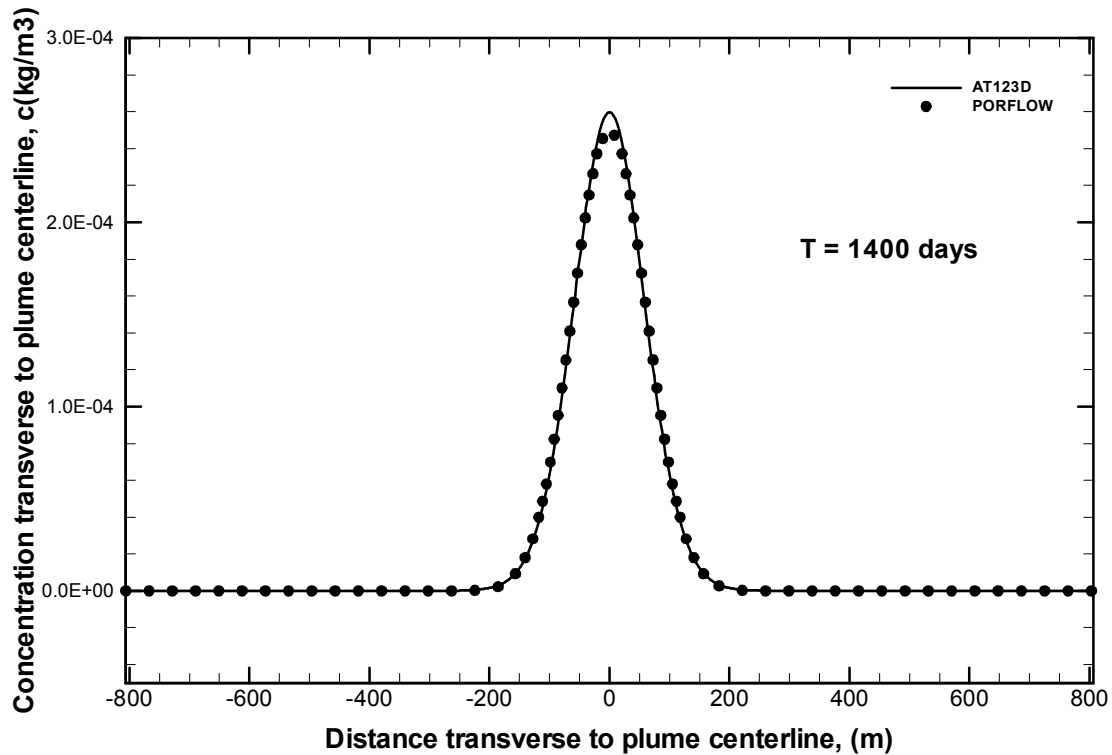

Figure 5.2.9. Concentration Profiles for 2D Transport of the Base Case Transverse to the Plume Centerline at x = 424 meters (Case B).

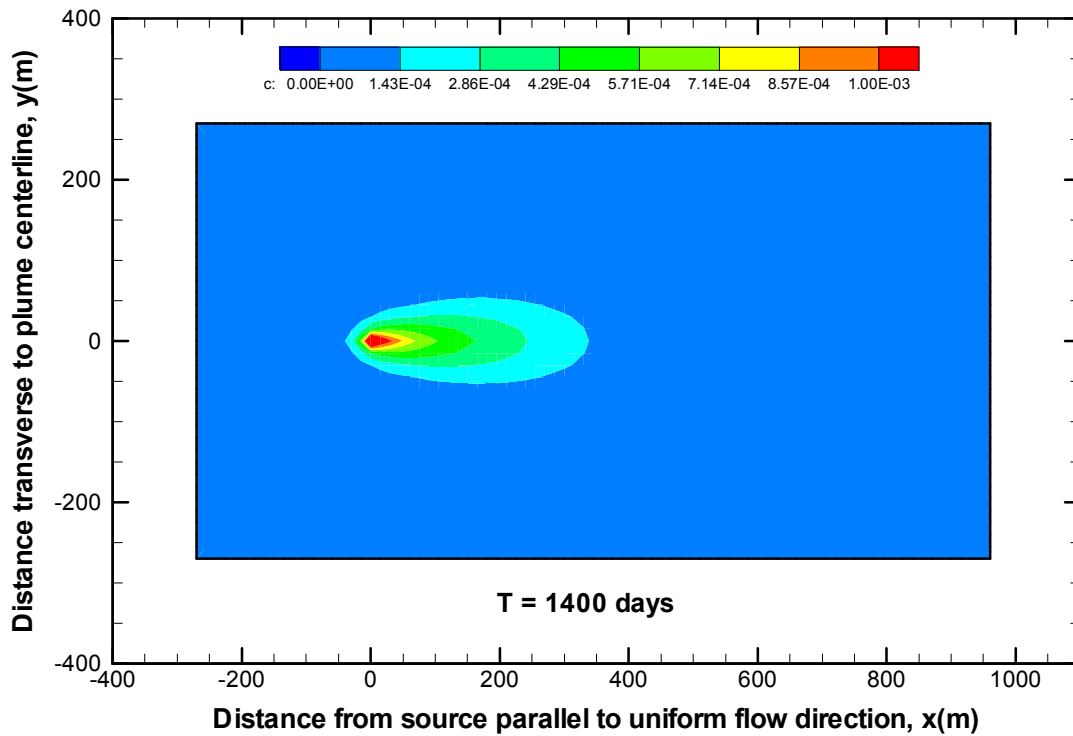

Figure 5.2.10 PORFLOW Concentration Plume for 2D Transport Showing the Effect of Retardation (Case C).

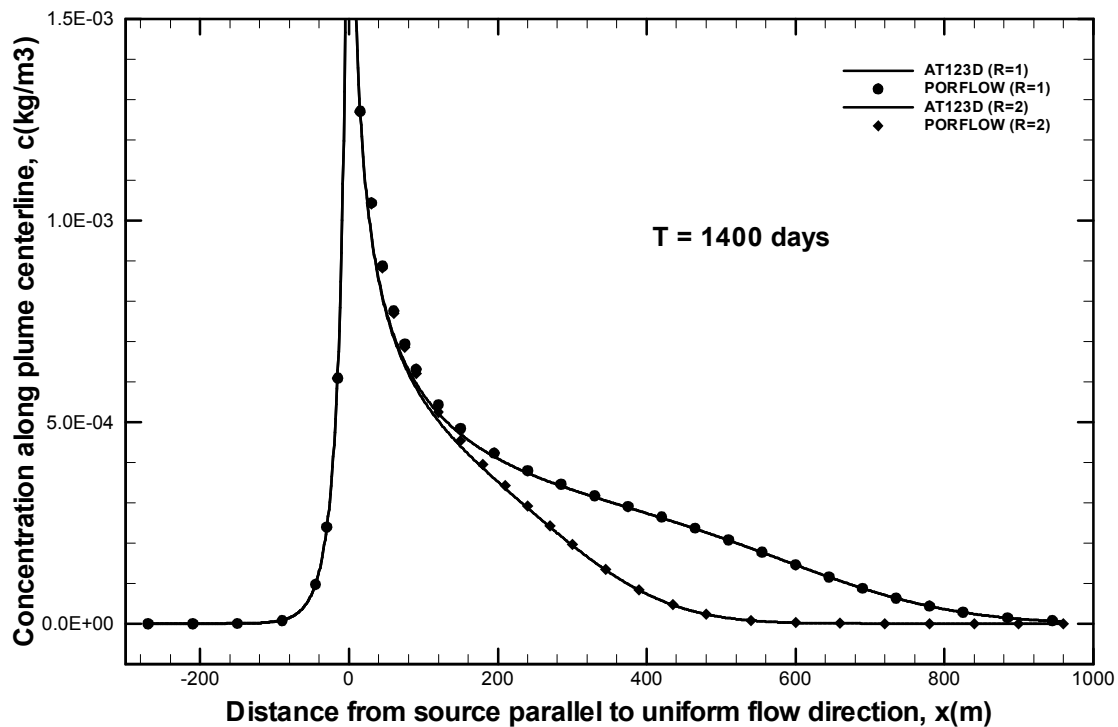

Figure 5.2.11 Concentration Profiles for 2D Transport Showing the Effect of Retardation along the Plume Centerline (Case C).

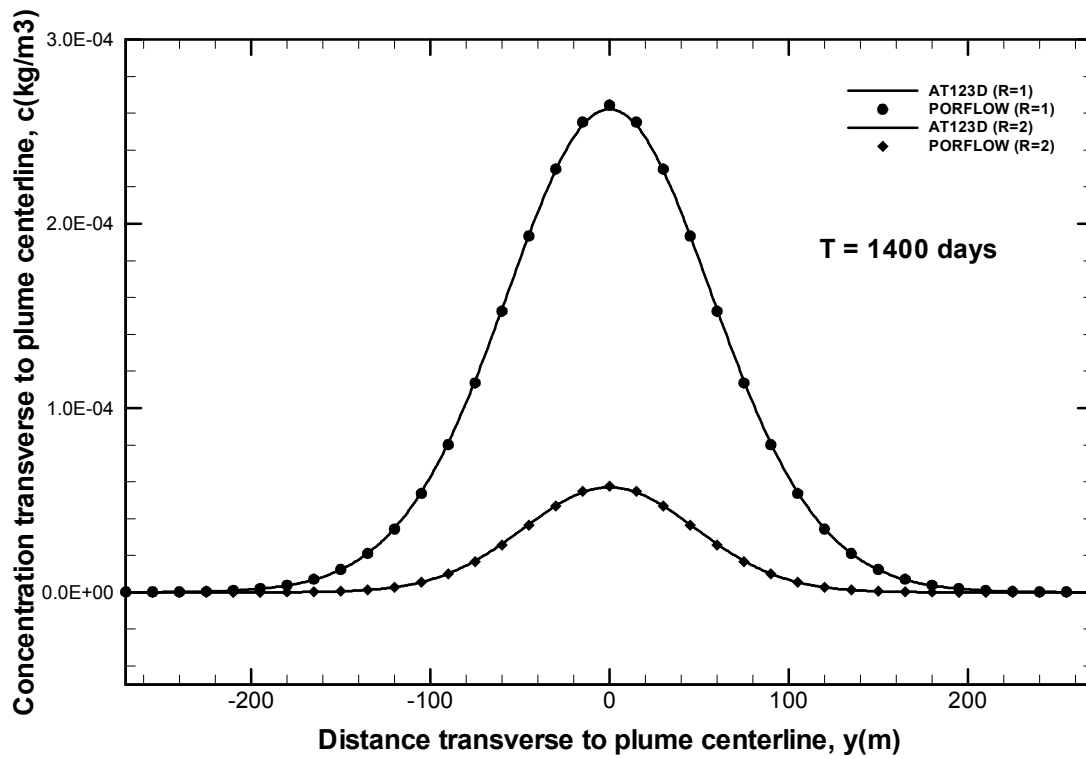

Figure 5.2.12 Concentration Profiles for 2D Transport Showing the Effect of Retardation Transverse to the Plume Centerline at x = 420 meters (Case C).

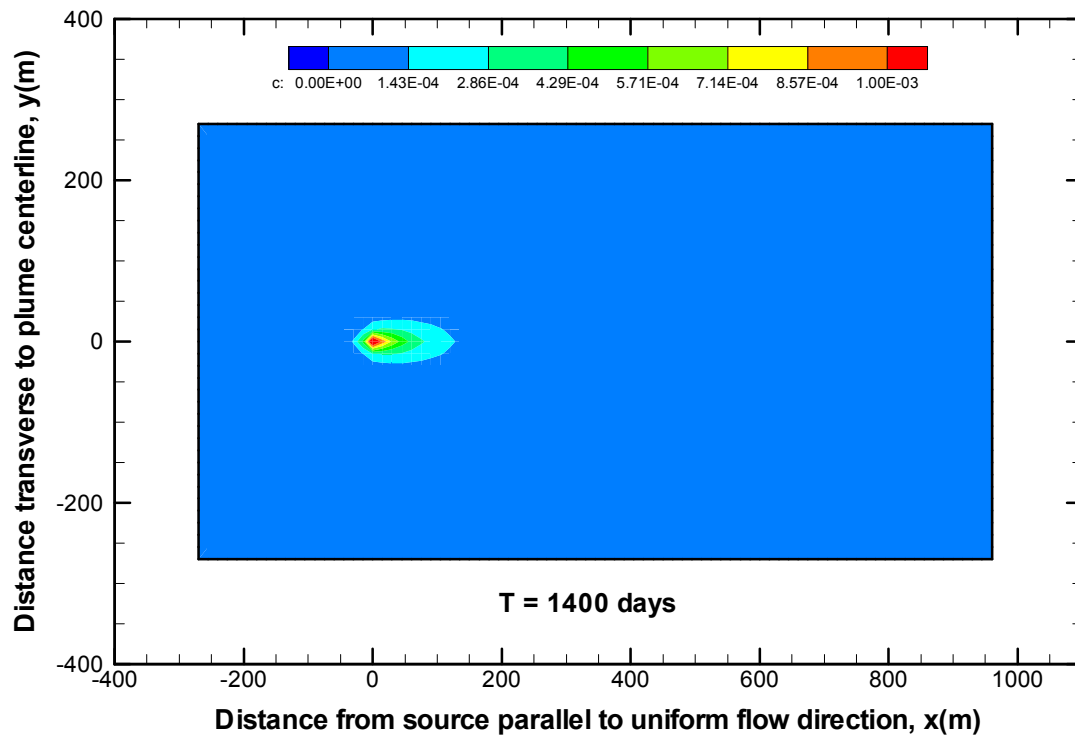

Figure 5.2.13 PORFLOW Concentration Plume for 2D Transport Showing the Effect of Radioactive Decay (Case D).

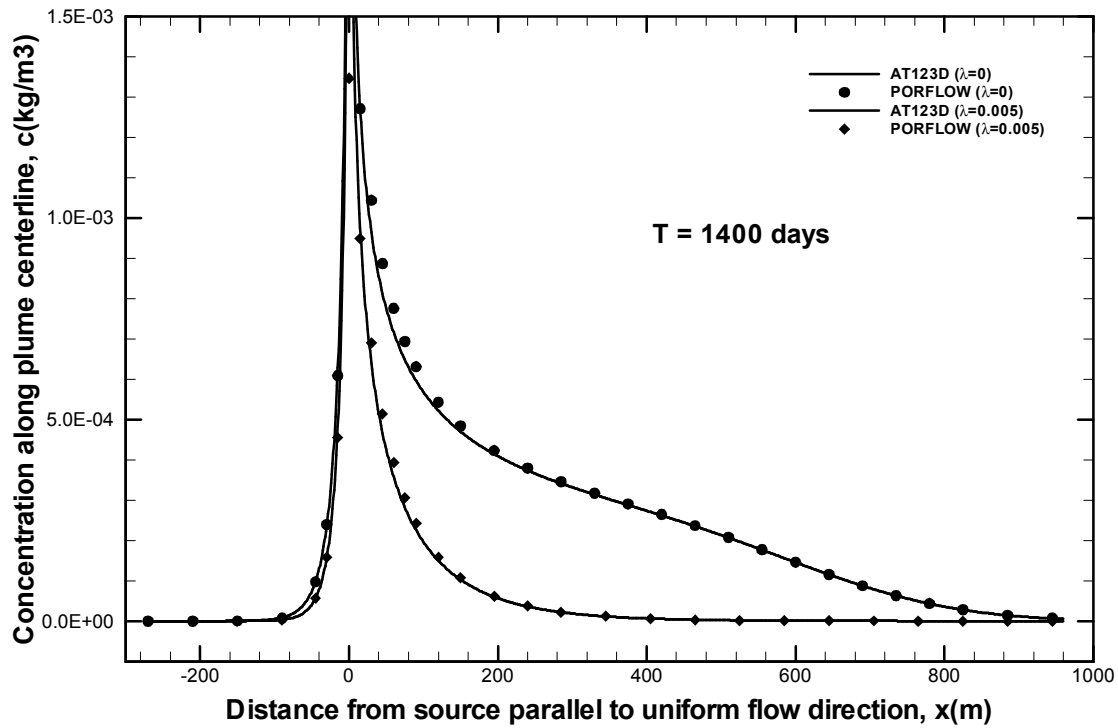

Figure 5.2.14 Concentration Profiles for 2D Transport Showing the Effect of Radioactive Decay along the Plume Centerline (Case D).

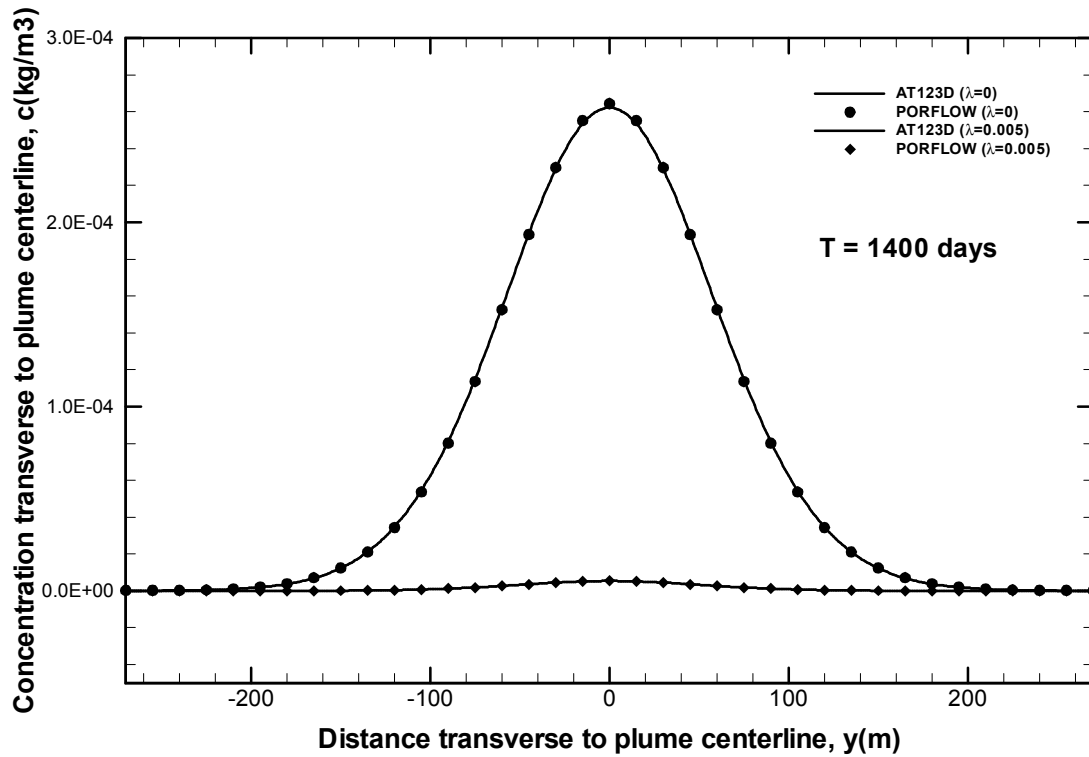

Figure 5.2.15 Concentration Profiles for 2D Transport Showing the Effect of Radioactive Decay Transverse to the Plume Centerline at $x = 420$ meters (Case D).

Table 5.2.3. Effect Grid Orientation has on the Numerical Concentration Results along the Plume Centerline for the Transient 2D Transport Simulation (Cases A and B, T = 1400 days).

Distance down- stream, x (m)	Analytical (AT123D)	Numerical (PORFLOW) (parallel grid)	Distance down- stream, (m)	Analytical (AT123D)	Numerical (PORFLOW) (diagonal grid)
-270.0	1.0987E-09	0.0000E+00	-381.8	4.6641E-12	3.5420E-12
-240.0	4.7766E-09	2.1880E-09	-339.4	3.7091E-11	2.8480E-11
-210.0	2.0884E-08	1.3000E-08	-297.0	2.9432E-10	3.1960E-10
-180.0	9.2081E-08	6.3920E-08	-254.6	2.3433E-09	2.6350E-09
-150.0	4.1095E-07	3.0830E-07	-212.1	1.8828E-08	2.0960E-08
-120.0	1.8670E-06	1.5090E-06	-169.7	1.5381E-07	1.6790E-07
-90.0	8.7236E-06	7.6390E-06	-127.3	1.2921E-06	1.3740E-06
-60.0	4.2841E-05	4.0890E-05	-84.9	1.1426E-05	1.1690E-05
-30.0	2.3592E-04	2.3970E-04	-42.4	1.1389E-04	1.0870E-04
0.0	5.8747E-03	1.6090E-03	0.0	5.5942E-03	1.5000E-03
30.0	9.6481E-04	1.0440E-03	42.4	8.3350E-04	7.2830E-04
60.0	7.1652E-04	7.7560E-04	84.9	6.1293E-04	5.6240E-04
90.0	5.9668E-04	6.3120E-04	127.3	5.0801E-04	4.7650E-04
120.0	5.2226E-04	5.4330E-04	169.7	4.4317E-04	4.2090E-04
150.0	4.7011E-04	4.8410E-04	212.1	3.9757E-04	3.8070E-04
180.0	4.3079E-04	4.4090E-04	254.6	3.6261E-04	3.4920E-04

Distance down- stream, x (m)	Analytical (AT123D)	Numerical (PORFLOW) (parallel grid)	Distance down- stream, (m)	Analytical (AT123D)	Numerical (PORFLOW) (diagonal grid)
210.0	3.9957E-04	4.0730E-04	297.0	3.3377E-04	3.2260E-04
240.0	3.7375E-04	3.7990E-04	339.4	3.0825E-04	2.9850E-04
270.0	3.5158E-04	3.5660E-04	381.8	2.8406E-04	2.7520E-04
300.0	3.3188E-04	3.3610E-04	424.3	2.5975E-04	2.5150E-04
330.0	3.1374E-04	3.1740E-04	466.7	2.3435E-04	2.2640E-04
360.0	2.9645E-04	2.9950E-04	509.1	2.0740E-04	1.9970E-04
390.0	2.7943E-04	2.8210E-04	551.5	1.7904E-04	1.7160E-04
420.0	2.6223E-04	2.6440E-04	594.0	1.4996E-04	1.4300E-04
450.0	2.4451E-04	2.4630E-04	636.4	1.2127E-04	1.1500E-04
480.0	2.2606E-04	2.2750E-04	678.8	9.4293E-05	8.8870E-05
510.0	2.0682E-04	2.0790E-04	721.2	7.0220E-05	6.5810E-05
540.0	1.8686E-04	1.8760E-04	763.7	4.9926E-05	4.6570E-05
570.0	1.6641E-04	1.6690E-04	806.1	3.3797E-05	3.1410E-05
600.0	1.4582E-04	1.4610E-04	848.5	2.1734E-05	2.0170E-05
630.0	1.2552E-04	1.2570E-04	891.0	1.3251E-05	1.2300E-05
660.0	1.0596E-04	1.0610E-04	933.4	7.6472E-06	7.1260E-06
690.0	8.7618E-05	8.7750E-05	975.8	4.1720E-06	3.9150E-06
720.0	7.0870E-05	7.1070E-05	1018.2	2.1491E-06	2.0400E-06
750.0	5.6013E-05	5.6300E-05	1060.7	1.0443E-06	1.0070E-06
780.0	4.3215E-05	4.3590E-05	1103.1	4.7826E-07	4.7110E-07
810.0	3.2518E-05	3.2970E-05	1145.5	2.0631E-07	2.0890E-07
840.0	2.3846E-05	2.4350E-05	1187.9	8.3775E-08	8.7750E-08
870.0	1.7030E-05	1.7540E-05	1230.4	3.2006E-08	3.4940E-08
900.0	1.1837E-05	1.2340E-05	1272.8	1.1499E-08	1.3190E-08
930.0	8.0034E-06	8.5240E-06	1315.2	3.8838E-09	4.7450E-09
960.0	5.2616E-06	7.1230E-06	1357.6	1.2327E-09	2.8200E-09

Table 5.2.4. Effect Grid Orientation has on the Numerical Concentration Results Transverse to the Plume Centerline (424 m downstream of the source) for the Transient 2D Transport Simulation (Cases A and B, T = 1400 days).

Distance transverse, y (m)	Analytical (AT123D)	Numerical (PORFLOW) (parallel grid)	Distance transverse, (m)	Analytical (AT123D)	Numerical (PORFLOW) (diagonal grid)
0.0	2.5975E-04	2.6184E-04	0.0	2.5975E-04	2.5150E-04
30.0	2.2708E-04	2.2777E-04	42.4	1.9880E-04	1.9840E-04
60.0	1.5298E-04	1.5180E-04	84.9	9.1901E-05	9.6740E-05
90.0	8.1128E-05	8.0016E-05	127.3	2.7535E-05	2.8500E-05
120.0	3.4804E-05	3.4501E-05	169.7	5.7418E-06	4.7750E-06
150.0	1.2394E-05	1.2535E-05	212.1	8.7465E-07	3.6950E-07
180.0	3.7386E-06	3.9229E-06	254.6	9.9669E-08	-3.1660E-09
210.0	9.6810E-07	1.0753E-06	297.0	8.5549E-09	-2.0810E-09
240.0	2.1682E-07	2.6725E-07	339.4	5.5217E-10	-7.7560E-12
270.0	4.2133E-08	1.4013E-07	381.8	2.6670E-11	8.9890E-12

Table 5.2.5. Effect Grid Orientation has on the Numerical Concentration Results Transverse to the Plume Centerline (0 m downstream of the source) for the Transient 2D Transport Problem (Cases A and B, T = 1400 days).

Distance transverse, y (m)	Analytical (AT123D)	Numerical (PORFLOW) (parallel grid)	Distance transverse, (m)	Analytical (AT123D)	Numerical (PORFLOW) (diagonal grid)
0.0	5.8747E-03	1.6090E-03	0.0	5.8747E-03	1.5000E-03
30.0	1.4251E-04	1.4270E-04	42.4	6.3611E-05	4.7470E-05
60.0	2.1612E-05	2.1910E-05	84.9	4.9991E-06	1.4400E-06
90.0	3.7120E-06	3.8190E-06	127.3	4.4351E-07	3.8140E-08
120.0	6.6951E-07	6.9970E-07	169.7	4.0405E-08	3.6090E-11
150.0	1.2302E-07	1.3100E-07	212.1	3.5513E-09	-1.4170E-10
180.0	2.2522E-08	2.4600E-08	254.6	2.8281E-10	-1.0280E-11
210.0	4.0198E-09	4.5590E-09	297.0	1.9238E-11	2.7250E-13
240.0	6.8394E-10	8.3160E-10	339.4	1.0659E-12	3.4380E-14
270.0	1.0857E-10	3.7320E-10	381.8	4.6459E-14	0.0000E+00

Table 5.2.6. Effect Retardation or Radioactive Decay has on the Numerical Concentration along the Plume Centerline for the Transient 2D Transport Problem (Cases C and D, T = 1400 days).

Distance downstream, x (m)	Analytical (AT123D)	Numerical (PORFLOW) (R=2.0) (parallel grid)	Analytical (AT123D)	Numerical (PORFLOW) ($\lambda=0.005$) (parallel grid)
-270.0	7.4912E-10	0.0000E+00	8.1095E-11	0.0000E+00

Distance downstream, x (m)	Analytical (AT123D)	Numerical (PORFLOW) (R=2.0) (parallel grid)	Analytical (AT123D)	Numerical (PORFLOW) ($\lambda=0.005$) (parallel grid)
-240.0	3.6661E-09	1.7890E-09	4.6152E-10	2.3820E-10
-210.0	1.7526E-08	1.1140E-08	2.6462E-09	1.7160E-09
-180.0	8.2424E-08	5.7620E-08	1.5319E-08	1.0820E-08
-150.0	3.8459E-07	2.8940E-07	8.9856E-08	6.8310E-08
-120.0	1.7988E-06	1.4570E-06	5.3704E-07	4.4050E-07
-90.0	8.5563E-06	7.5040E-06	3.3046E-06	2.9420E-06
-60.0	4.2453E-05	4.0560E-05	2.1413E-05	2.0740E-05
-30.0	2.3506E-04	2.3900E-04	1.5640E-04	1.5840E-04
0.0	6.1250E-03	1.6080E-03	5.6364E-03	1.3470E-03
30.0	9.6132E-04	1.0410E-03	6.3960E-04	6.8970E-04
60.0	7.1002E-04	7.6940E-04	3.5813E-04	3.9350E-04
90.0	5.8524E-04	6.2000E-04	2.2603E-04	2.4310E-04
120.0	5.0317E-04	5.2440E-04	1.5022E-04	1.5850E-04
150.0	4.3995E-04	4.5390E-04	1.0279E-04	1.0710E-04
180.0	3.8561E-04	3.9520E-04	7.1669E-05	7.4050E-05
210.0	3.3531E-04	3.4200E-04	5.0628E-05	5.2030E-05
240.0	2.8686E-04	2.9140E-04	3.6112E-05	3.6990E-05
270.0	2.3971E-04	2.4260E-04	2.5950E-05	2.6520E-05
300.0	1.9447E-04	1.9630E-04	1.8757E-05	1.9140E-05
330.0	1.5234E-04	1.5340E-04	1.3622E-05	1.3880E-05
360.0	1.1472E-04	1.1550E-04	9.9313E-06	1.0110E-05
390.0	8.2723E-05	8.3370E-05	7.2631E-06	7.3920E-06
420.0	5.6936E-05	5.7620E-05	5.3249E-06	5.4180E-06
450.0	3.7304E-05	3.8040E-05	3.9112E-06	3.9780E-06
480.0	2.3213E-05	2.3960E-05	2.8762E-06	2.9250E-06
510.0	1.3694E-05	1.4390E-05	2.1161E-06	2.1520E-06
540.0	7.6460E-06	8.2300E-06	1.5562E-06	1.5820E-06
570.0	4.0354E-06	4.4830E-06	1.1427E-06	1.1620E-06
600.0	2.0110E-06	2.3250E-06	8.3693E-07	8.5100E-07
630.0	9.4535E-07	1.1480E-06	6.1048E-07	6.2080E-07
660.0	4.1888E-07	5.4030E-07	4.4282E-07	4.5050E-07
690.0	1.7483E-07	2.4220E-07	3.1888E-07	3.2460E-07
720.0	6.8689E-08	1.0350E-07	2.2755E-07	2.3180E-07
750.0	2.5393E-08	4.2170E-08	1.6062E-07	1.6390E-07
780.0	8.8287E-09	1.6400E-08	1.1195E-07	1.1450E-07
810.0	2.8859E-09	6.0890E-09	7.6895E-08	7.8940E-08
840.0	8.8655E-10	2.1600E-09	5.1968E-08	5.3610E-08
870.0	2.5589E-10	7.3230E-10	3.4500E-08	3.5820E-08
900.0	6.9375E-11	2.3750E-10	2.2465E-08	2.3530E-08
930.0	1.7663E-11	7.3150E-11	1.4328E-08	1.5260E-08
960.0	4.2224E-12	3.8240E-11	8.9392E-09	1.2370E-08

Table 5.2.7. Effect Retardation or Radioactive Decay has on the Numerical Concentration Transverse to the Plume Centerline for the Transient 2D Transport Problem at x = 420 meters (Cases C and D, T = 1400 days).

Distance transverse, y (m)	Analytical (AT123D)	Numerical (PORFLOW) (R=2.0) (parallel grid)	Analytical (AT123D)	Numerical (PORFLOW) ($\lambda=0.005$) (parallel grid)
0.0	5.6936E-05	5.7620E-05	5.3249E-06	5.4180E-06
30.0	4.6872E-05	4.6930E-05	4.4559E-06	4.4860E-06
60.0	2.6285E-05	2.5780E-05	2.6453E-06	2.6110E-06
90.0	1.0171E-05	9.9310E-06	1.1536E-06	1.1310E-06
120.0	2.7592E-06	2.7950E-06	3.8698E-07	3.8590E-07
150.0	5.3229E-07	5.9630E-07	1.0464E-07	1.0910E-07
180.0	7.3815E-08	9.9360E-08	2.3748E-08	2.6490E-08
210.0	7.4096E-09	1.3260E-08	4.6656E-09	5.6860E-09
240.0	5.4058E-10	1.4380E-09	8.0986E-10	1.1130E-09
270.0	2.8724E-11	4.2490E-10	1.2558E-10	5.0830E-10

Table 5.2.8. Input Commands for 2D Transport (Case A)

```

*****
TITLE 5.2 (A) 2-D saturated solute transport in a uniform flow field
*****
! Basecase Parallel Grid
*****

GRID is 83 by 37 NODEs
COORDinate NODEs X: MINImum=-2.7e+2, MAXImum=9.6e+2
COORDinate NODEs Y: MINImum=-2.7e+2, MAXImum=2.7e+2

! Material types and subregions
MATERial type 1 ! total domain

! Material and nuclide properties
PROPerty for C is HARMonic

FOR material type 1:
MATERial DENSITY 1.23077
MATERial PORosity 3*0.35
TRANsport for C Kd=0 Da=0 aL=21.3 aT=4.3

! Flow conditions
SET S to 1.
SET U to 0.161 ! m/d

! Boundary conditions
BOUNDary C at X- in VALUe = 0
BOUNDary C at X+ in GRAD = 0
BOUNDary C at Y- in GRAD = 0
BOUNDary C at Y+ in GRAD = 0

LOCate STATION (0.,0.) ! x=0,y=0
SOURce for C is constant at 0.007040119 kg/d/m for SELEcted region

! Diagnostic information
DIAGnostic output: TIME DTIME C for node (0.,0.) every 1 steps

! Time history
SAVE for C at TIME every 100 days to '5.2-A.sav'

! Solution controls
    
```



```

MATRix in X for C 3 sweeps using ADI
!LIMIT for C 0.0
CONVergence for C REFERENCE LOCAL 1.e-6, max iterations = 30

! Solve transient transport
! Time period: 0 to 1400 years
TIME = 0.

SOLVE C for 1400 days in steps of 1 days

END
QUIT

```

Table 5.2.9. Input Commands for 2D Transport (Case B)

```

*****
TITLE 5.2 (B) 2-D saturated solute transport in a uniform flow field
*****
! Diagonal flow with full diffusion tensor
*****

GRID is 83 by 83 NODEs
COORDinate NODEs X: MINIMUM=-2.7e+2, MAXIMUM=9.6e+2
COORDinate NODEs Y: MINIMUM=-2.7e+2, MAXIMUM=9.6e+2

! Material types and subregions
MATERIAL type 1 ! total domain

! Material and nuclide properties
PROPERTY for C is HARMONIC

FOR material type 1:
MATERIAL DENSITY 1.23077
MATERIAL POROSITY 3*0.35
CONDUCTION with TENSOR diffusivity
TRANSPORT for C Kd=0 Da=0 aL=21.3 aT=4.3

! Flow conditions
SET S to 1.
SET U to 0.11384419 ! m/d
SET V to 0.11384419 ! m/d

! Boundary conditions
BOUNDARY C at X- in VALUE = 0
BOUNDARY C at X+ in GRAD = 0
BOUNDARY C at Y- in VALUE = 0
BOUNDARY C at Y+ in GRAD = 0

LOCATE STATION (0.,0.) ! x=0,y=0
SOURCE for C is constant at 0.007040119 kg/d/m for SELEcted region

! Diagnostic information
DIAGNOSTIC output: TIME DTIME C for node (0.,0.) every 10 steps

! Time history
SAVE for C at TIME every 100 days to '5.2-B.sav'

! Solution controls
MATRix in X Y for C 3 sweeps using ADI
!LIMIT for C 0.0
CONVergence for C REFERENCE LOCAL 1.e-6, max iterations = 30

! Solve transient transport
! Time period: 0 to 1400 years
TIME = 0.

SOLVE C 1400 days in steps of 1 days

END
QUIT

```

Table 5.2.10. Input Commands for 2D Transport (Case C)

```

*****
TITLE 5.2 (C) 2-D saturated solute transport in a uniform flow field
*****
! Basecase Parallel Grid, kd = 0.4375 m3/kg
*****

GRID is 83 by 37 NODEs
COORDinate NODEs X: MINImum=-2.7e+2, MAXImum=9.6e+2
COORDinate NODEs Y: MINImum=-2.7e+2, MAXImum=2.7e+2

! Material types and subregions
MATERial type 1 ! total domain

! Material and nuclide properties
PROPerty for C is HARMonic

FOR material type 1:
MATERial DENSITY 1.23077
MATERial PORosity 3*0.35
TRANsport for C Kd=0.4375 Da=0 aL=21.3 aT=4.3

! Flow conditions
SET S to 1.
SET U to 0.161 ! m/d

! Boundary conditions
BOUNDary C at X- in VALUe = 0
BOUNDary C at X+ in GRAD = 0
BOUNDary C at Y- in GRAD = 0
BOUNDary C at Y+ in GRAD = 0

LOCate STATION (0.,0.) ! x=0,y=0
SOURce for C is constant at 0.007040119 kg/d/m for SELEcted region

! Diagnostic information
DIAGnostic output: TIME DTIME C for node (0.,0.) every 1 steps

! Time history
SAVE for C at TIME every 100 days to '5.2-C.sav'

! Solution controls
MATRix in X for C 3 sweeps using ADI
LIMIt for C 0.0
CONVergence for C REFERENCE LOCAL 1.e-6, max iterations = 30

! Solve transient transport
! Time period: 0 to 1400 years
TIME = 0.

SOLVe C for 1400 days in steps of 1 days

END
QUIT

```

Table 5.2.11. Input Commands for 2D Transport (Case D)

```

*****
TITLE 5.2 (D) 2-D saturated solute transport in a uniform flow field
*****
! Basecase Parallel Grid, radioactive decay constant = 0.005 per day
*****

GRID is 83 by 37 NODEs
COORDinate NODEs X: MINImum=-2.7e+2, MAXImum=9.6e+2
COORDinate NODEs Y: MINImum=-2.7e+2, MAXImum=2.7e+2

! Material types and subregions
MATERial type 1 ! total domain

! Material and nuclide properties
PROPerty for C is HARMonic

```

```
FOR material type 1:
MATERial DENSITy 1.23077
MATERial POROSity 3*0.35
TRANsport for C Kd=0 Da=0 aL=21.3 aT=4.3

! Nuclide properties
! Decay
DECAy rate for C is 0.005 per day

! Flow conditions
SET S to 1.
SET U to 0.161 ! m/d

! Boundary conditions
BOUNDary C at X- in VALUe = 0
BOUNDary C at X+ in GRAD = 0
BOUNDary C at Y- in GRAD = 0
BOUNDary C at Y+ in GRAD = 0

LOCAtE STATION (0.,0.) ! x=0,y=0
SOURce for C is constant at 0.007040119 kg/d/m for SELEcted region

! Diagnostic information
DIAGnostic output: TIME DTIME C for node (0.,0.) every 1 steps

! Time history
SAVE for C at TIME every 100 days to '5.2-D.sav'

! Solution controls
MATRix in X for C 3 sweeps using ADI
LIMIT for C 0.0
CONVergence for C REFERENCE LOCAL 1.e-6, max iterations = 30

! Solve transient transport
! Time period: 0 to 1400 years
TIME = 0.

SOLVe C for 1400 days in steps of 1 days

END
QUIT
```

5.3 Three-Dimensional Saturated Solute Transport in a Uniform Flow Field

This problem deals with three-dimensional advection-dispersion of a conservative solute species from a point source through an infinite porous medium. Based upon the problem definition, this problem results in an analytic solution that is axisymmetric in solute concentrations. However, the problem will be solved analytically and numerically in 3D Cartesian coordinates. It is used to demonstrate PORFLOW's capability to solve 3D transport problems and to yield 3D results that are indeed axisymmetric. This problem also tests PORFLOW's formulation of transverse dispersion in more than one dimension. The physical schematic of this problem is essentially the same as for the 2D transport problem discussed in Section 5.2 and shown in Figure 5.2.1(a). In practice, the idealized conditions are analogous to continual leakage, leaching, or injection of a contaminant into a large confined aquifer from buried waste in a landfill or an improperly sealed partially penetrating injection well. It is assumed that the total rate of fluid leakage, leaching, or injection into the aquifer is negligible and does not disturb the ambient groundwater flow regime. Analytically and numerically, the problem is treated as a point source in 3D Cartesian coordinates.

As illustrated in Figure 5.2.1(b), a conservative contaminant is continuously released from a point source downstream of an inflow boundary (containing zero contaminant) into a large aquifer unit whose groundwater flow is assumed to be uniform. The point source is located at a depth such

that end effects at the top and bottom of the aquifer unit are negligible. Both hydrodynamic dispersion and molecular diffusion are allowed for the transported species. It is assumed that the contaminant mass flow rate at the point source remains constant, the aquifer's flow rate is uniform and constant, the aquifer is sufficiently large to neglect end effects, and the homogeneous aquifer's properties (such as porosity, soil type, water saturation) are uniform and constant.

Analytical solution: Equation 5.1.4 represents the non-conservative form of the multi-dimensional advection-dispersion equation for solute transport through a variably saturated porous media. Taking the 3D form of Equation 5.1.4 and assuming that one point exists at the areal location $x = y = z = 0$, constant water saturation level, and that material coefficients are constants, results in

$$\begin{aligned} \frac{\partial c}{\partial t} = & D'_{xx} \frac{\partial^2 c}{\partial x^2} + D'_{xy} \frac{\partial^2 c}{\partial x \partial y} + D'_{xz} \frac{\partial^2 c}{\partial x \partial z} + D'_{yx} \frac{\partial^2 c}{\partial y \partial x} + D'_{yy} \frac{\partial^2 c}{\partial y^2} + D'_{yz} \frac{\partial^2 c}{\partial y \partial z} \\ & + D'_{zx} \frac{\partial^2 c}{\partial z \partial x} + D'_{zy} \frac{\partial^2 c}{\partial z \partial y} + D'_{zz} \frac{\partial^2 c}{\partial z^2} - u'_x \frac{\partial c}{\partial x} - u'_y \frac{\partial c}{\partial y} - u'_z \frac{\partial c}{\partial z} - \lambda c - \frac{q(c - c^*)}{\theta_e R} \end{aligned} \quad (5.3.1)$$

where

$$D'_{xx} = \frac{\alpha_L \frac{U_x^2}{|U|} + \alpha_T \frac{U_y^2 + U_z^2}{|U|} + \theta_e \tau D_m}{\theta_e R} \quad (5.3.2a)$$

$$D'_{yy} = \frac{\alpha_L \frac{U_y^2}{|U|} + \alpha_T \frac{U_x^2 + U_z^2}{|U|} + \theta_e \tau D_m}{\theta_e R} \quad (5.3.2b)$$

$$D'_{zz} = \frac{\alpha_L \frac{U_z^2}{|U|} + \alpha_T \frac{U_x^2 + U_y^2}{|U|} + \theta_e \tau D_m}{\theta_e R} \quad (5.3.2c)$$

$$D'_{xy} = D'_{yx} = \frac{(\alpha_L - \alpha_T) \frac{U_x U_y}{|U|}}{\theta_e R} \quad (5.3.2d)$$

$$D'_{xz} = D'_{zx} = \frac{(\alpha_L - \alpha_T) \frac{U_x U_z}{|U|}}{\theta_e R} \quad (5.3.2e)$$

$$D'_{yz} = D'_{zy} = \frac{(\alpha_L - \alpha_T) \frac{U_y U_z}{|U|}}{\theta_e R} \quad (5.3.2f)$$

If the flow field is aligned with the x-axis, Equation 5.3.1 reduces to

$$\frac{\partial c}{\partial t} = D'_{xx} \frac{\partial^2 c}{\partial x^2} + D'_{yy} \frac{\partial^2 c}{\partial y^2} + D'_{zz} \frac{\partial^2 c}{\partial z^2} - u'_x \frac{\partial c}{\partial x} - \lambda c - \frac{q(c - c^*)}{\theta_e R} \quad (5.3.3)$$

For our infinite confined aquifer the initial conditions are:

$$c(x, y, z, 0) = 0 \quad (5.3.4a)$$

and the boundary conditions are:

$$c(\pm\infty, y, z, t) = 0 \quad (5.3.4b)$$

$$c(x, \pm\infty, z, t) = 0 \quad (5.3.4c)$$

$$c(x, y, \pm\infty, t) = 0 \quad (5.3.4d)$$

These boundary conditions are equivalent to assuming that the dispersive flux of solute is zero at plus or minus infinity or

$$\lim_{x \rightarrow \pm\infty} \left(\frac{\partial c}{\partial x} \right) = 0 \quad (5.3.4e)$$

$$\lim_{y \rightarrow \pm\infty} \left(\frac{\partial c}{\partial y} \right) = 0 \quad (5.3.4f)$$

$$\lim_{z \rightarrow \pm\infty} \left(\frac{\partial c}{\partial z} \right) = 0 \quad (5.3.4g)$$

For finite times there exists finite values of x, y and z where Equations 5.3.4e, 5.3.4f and 5.3.4g remain valid.

As mentioned above, it is assumed that the total rate of fluid flow, q, into the aquifer due to the source is negligible and does not disturb the ambient groundwater flow regime. In order to have a finite mass flow rate of contaminant requires

$$\lim_{q \rightarrow 0} (qc^*) < \infty \Rightarrow \lim_{q \rightarrow 0} (c^*) = \pm\infty \quad (5.3.4h)$$

Equation 5.3.3, a linear partial differential equation subject to the initial and boundary conditions given by Equations 5.3.4a to 5.3.4d, can be solved by applying Laplace and Fourier transforms to derive at the appropriate Green's functions. For details, see Yeh (1981). The general solution for a continuous point source takes the form:

$$c(x, y, z, t) = \frac{qc^*}{\theta_e R} \int_0^t G(x|\xi; y|\eta; z|\zeta; t|\tau) d\tau \quad (5.3.5a)$$

where $G(x|\xi; y|\eta; z|\zeta; t|\tau)$ is the Green's function over the domain space. For our analytical problem, we shall limit our flow field to flow parallel to the x-axis only. This results in a dispersion tensor that is diagonal and a separable Green's function. It can be shown that for a simple geometry such as a separable coordinate system, Green's function can be expressed as:

$$G(x|\xi; y|\eta; z|\zeta; t|\tau) = G_1(x|\xi; t|\tau)G_2(y|\eta; t|\tau)G_3(z|\zeta; t|\tau) \quad (5.3.5b)$$

where for a point source in the x-direction (infinite domain, parallel to flow):

$$G_1(x|\xi; t|\tau) = \frac{S(t-\tau)}{\sqrt{4\pi D'_{xx}(t-\tau)}} \exp\left[-\frac{\{(x-\xi) - u'_x(t-\tau)\}^2}{4D'_{xx}(t-\tau)} - \lambda(t-\tau)\right] \quad (5.3.5c)$$

and for a point source in the y-direction (infinite domain, transverse to flow):

$$G_2(y|\eta; t|\tau) = \frac{S(t-\tau)}{\sqrt{4\pi D'_{yy}(t-\tau)}} \exp\left[-\frac{(y-\eta)^2}{4D'_{yy}(t-\tau)}\right] \quad (5.3.5d)$$

and for a point source in the z-direction (infinite domain, transverse to flow):

$$G_3(z|\zeta; t|\tau) = \frac{S(t-\tau)}{\sqrt{4\pi D'_{zz}(t-\tau)}} \exp\left[-\frac{(z-\zeta)^2}{4D'_{zz}(t-\tau)}\right] \quad (5.3.5e)$$

where $S(t-\tau)$ is the step function.

The evaluation of the analytical expressions, Equations 5.3.5a to 5.2.5e, for a specific problem is performed numerically using the FORTRAN program AT123D in Section C.

PORFLOW numerical simulation and comparison: In PORFLOW, we will model this axisymmetric problem using a 3D mesh containing equally spaced nodes in all three directions. The point source given above will be located at the center of the yz plane, 270 meters from the inflow boundary in the x-direction ($x = y = z = 0$).

Even though we are considering an aquifer unit with infinite extent in the areal and vertical directions, our numerical model has finite size. At our inflow boundary we shall assume that the incoming fluid remains contaminant free (i.e., the contaminant concentration immediately

upstream of the source does not extend back up to the inflow boundary). We also assume that the vertical extent of the top and bottom faces of our mesh from the point source is sufficient distance that negligible amounts of contaminant reaches these boundary faces. For the parameters chosen (i.e., longitudinal dispersivity, Darcy velocity, and source location), the above assumption remains valid over the time of interest.

In addition, PORFLOW requires input about the total mass flowrate entering the aquifer at the point source. An arbitrarily small but finite value for q_c^* was chosen to maintain computed solute concentration values near the source to acceptable values. Steep concentration gradients near a source can result in oscillatory behavior unless the local grid is sufficiently refined. For demonstration purposes, we have chosen uniform coarse grids and are primarily interested in results away from the source location. The simulations are done by specifying a velocity field and running the solute transport option only. In this way, the flow rate entering the aquifer due to the point source does not alter the aquifer flow field.

Values of the physical parameters used in the verification simulations are presented in Table 5.3.1. For the conservative solute transport case the parameters were selected based on data from a field investigation on hexavalent chromium contamination reported by Perlumutter and Lieber (1970) and Wilson and Miller (1978)

In 1D transport, only longitudinal dispersion is active and in a 2D transport problem, both longitudinal and transverse dispersion can occur. In 3D transport, transverse dispersion occurs throughout the plane perpendicular to the flow direction. In a general 3D transport problem, the off-diagonal terms of the dispersion coefficient tensor are typically non-zero. If the grid is aligned parallel to the groundwater flow direction, then only the diagonal terms of the hydrodynamic dispersion tensor are non-zero.

Table 5.3.1. Values of the Physical Parameters, Mesh Spacing, Time Steps, and Key Computed Parameters Used in the Three-Dimensional Transport Simulations

Physical parameters	Base Case
Darcy velocity, U_x	0.161 m/d
Porosity, ϕ	0.35
Longitudinal dispersivity, α_L	21.3 m
Transverse dispersivity, α_T	4.3 m
Apparent molecular dispersion coefficient, $\theta_e \tau D^*$	0.0 m ² /d
Water saturation, S_w	1.0
radioactive decay coef., λ	0.0 d ⁻¹
Soil density, ρ_s	1.23077 kg/m ³
Solute distribution coefficient, k_d	0.0 m ³ /kg
Boundary solute concentration, c_0	0.0 kg/m ³
Contaminant total mass flowrate (point source), qc^*	0.117922 kg/d
Grid specifics	
Mesh spacing, $\Delta x = \Delta y = \Delta z$	15 m
Number nodes in x-dir	83
Number nodes in y-dir	37
Number nodes in z-dir	37
Time steps	
Time duration	1400 d
number time-steps	140
time-step size, Δt	10 d
Key computed parameters	
Retardation factor, R	1.0
Bulk soil density, ρ_b	0.8 kg/m ³
Phasic velocity, u_x	0.46 m/d
Retarded phasic velocity, u'_x	0.46 m/d
Retarded longitudinal dispersion coefficient, D'_{xx}	9.798 m ² /d
Retarded transverse dispersion coefficients, $D'_{yy} = D'_{zz}$	1.978 m ² /d
Retarded cross dispersion coefficients, $D'_{xy} = D'_{xz} = D'_{yz}$	0.0 m ² /d
Cell Fourier number, $Fo_x; Fo_y = Fo_z$	0.4355;0.0879
Cell Courant number, $Co_x; Co_y = Co_z$	0.3067;0.0
Cell Peclet number, $Pe_x; Pe_y = Pe_z$	0.7042;3.4884

To examine in PORFLOW transverse dispersion into a plane perpendicular to groundwater flow without the added complication of cross-term products resulting from the dispersion tensor, a base case grid was chosen for a problem that is aligned parallel to the aquifer flow direction. This

grid consists of 113,627 nodes uniformly sized (15 m in length) with 83 nodes along the x-axis and 37 along the y- and z-axes, respectively. This number of nodes is close to the current license limit of 128,000 nodes.

Figure 5.3.1 illustrates the PORFLOW grid chosen with a chair cut showing the point source location (vertex of chair cut). At the channel inlet boundary (-X face), the concentration of solute in the incoming water is set to 0.0 kg/m³. Due to the finite overall length of our mesh, at the outflow boundary (+X face) the dispersive flux (GRAD) is set to zero, while the advective flux is computed as part of the solution. In addition, the dispersive flux is set to zero at the transverse faces (-Y face, +Y face, -Z face and +Z face). The aquifer is assumed to be completely saturated.

For this problem only the base case simulation was performed. For this simulation, a transient calculation was performed for a 1400-day duration and the results from PORFLOW at this end time were compared to the analytical solution given by Equation 5.3.5.

The results from the simulations, analytical and numerical, are shown in Figures 5.3.2 through 5.3.4. These results are also presented in tabular form in Tables 5.3.2 and 5.3.3. The PORFLOW input commands for the 3D transport simulation are shown in Table 5.3.4. The analytical results were computed using the FORTRAN code AT123D in Section C.

The PORFLOW concentration plume at 1400 days is presented in Figure 5.3.2. A section of the domain has been cut out to highlight the plume centerline and its basic axisymmetric development in the transverse direction.

The concentration profiles for the 3D transport simulation along and transverse to the plume centerline are shown in Figures 5.3.3 and 5.3.4, respectively. Figure 5.3.4 shows computed concentration profiles transverse to the groundwater flow direction and plume centerline (y-axis and z-axis) 120 meters downstream of the point source. The results away from the source show good comparison between the analytical solution and the numerical results for both transverse directions. These results indicate that the concentration plume predicted by PORFLOW is axisymmetric as well.

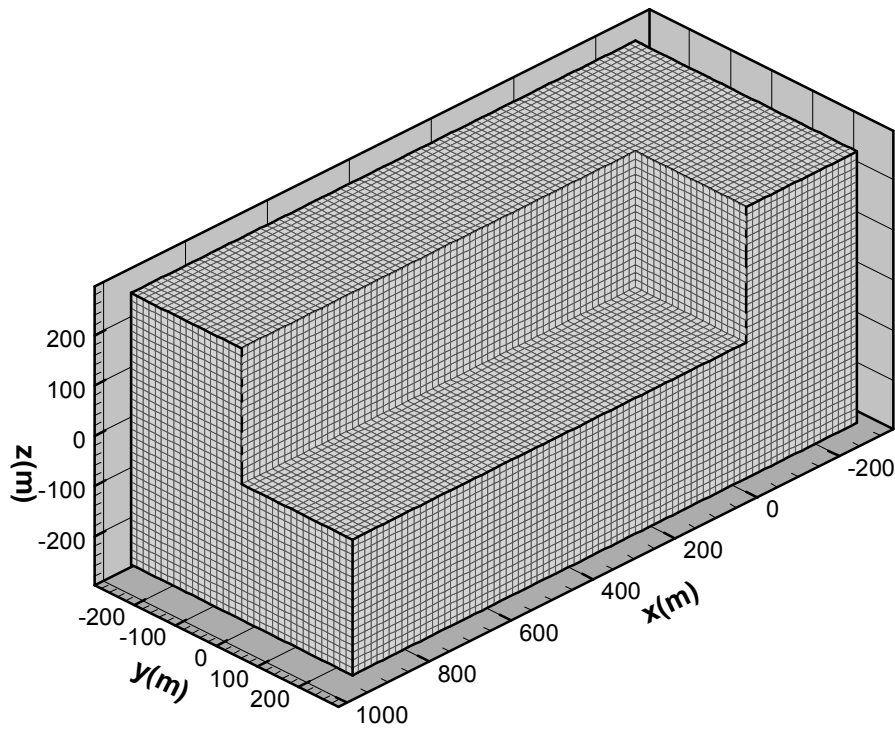

Figure 5.3.1. PORFLOW Grid for 3D Transport Simulation.

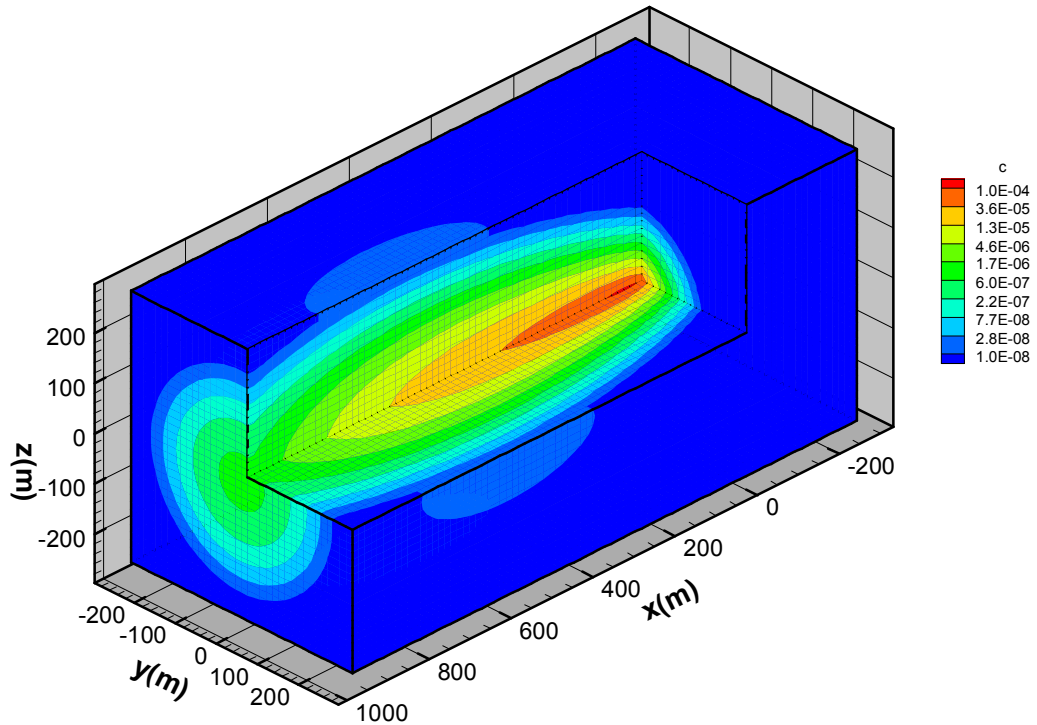

Figure 5.3.2 PORFLOW Concentration Plume for 3D Transport of the Base Case on a Parallel Grid.

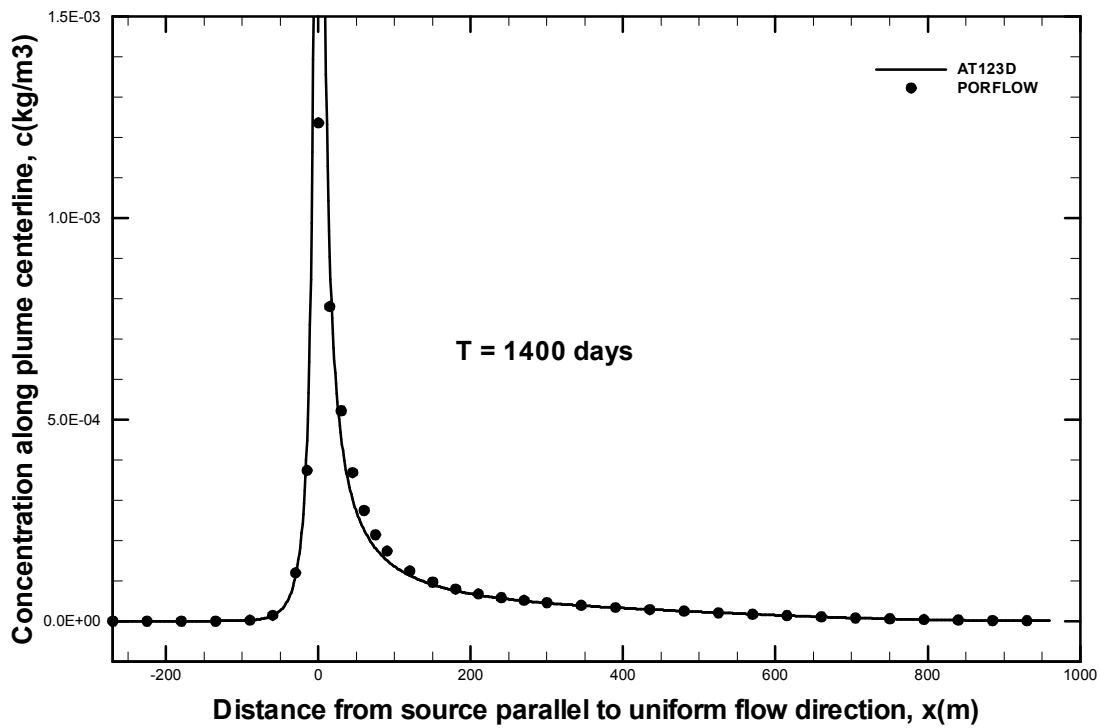

Figure 5.3.3 Concentration Profile for 3D Transport of the Base Case along the Plume Centerline.

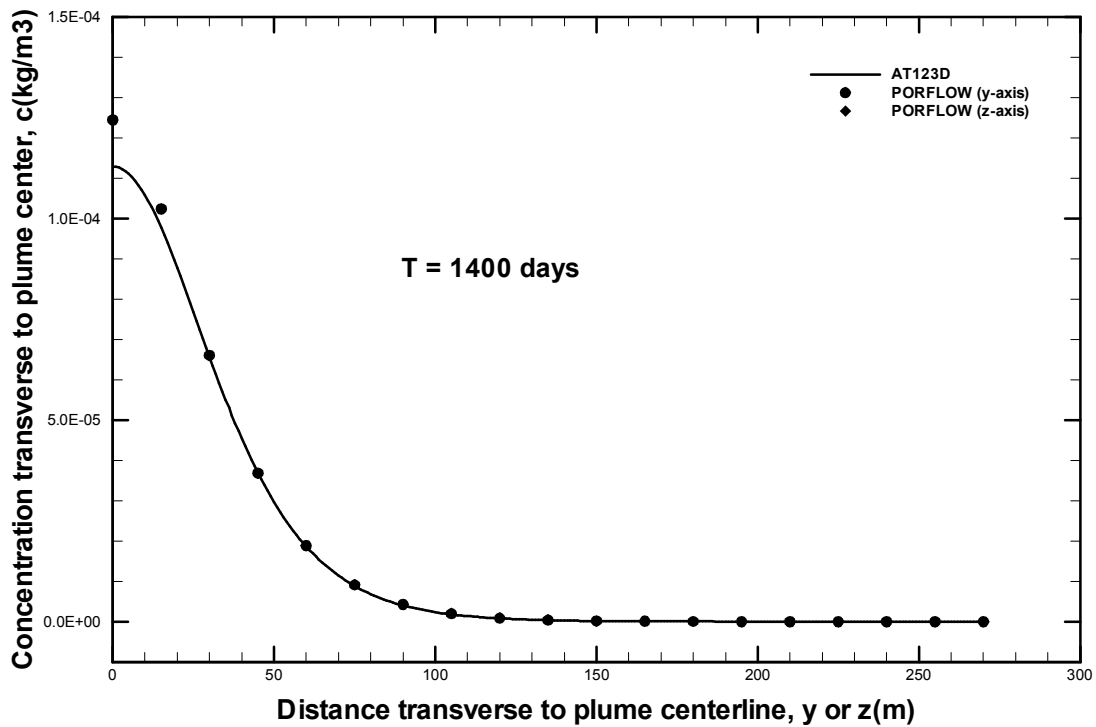

Figure 5.3.4 Concentration Profiles for 3D Transport of the Base Case Transverse to the Plume Centerline (in both y and z directions) located at x = 120 meters.

Table 5.3.2. Concentration Profile for 3D Transport of the Base Case along the Plume Centerline at 1400 days.

Distance downstream, x (m)	Analytical (AT123D)	Numerical (PORFLOW)
-270.0	1.5587E-10	0.0000E+00
-240.0	7.1915E-10	3.4620E-10
-210.0	3.3669E-09	2.1680E-09
-180.0	1.6080E-08	1.1540E-08
-150.0	7.8953E-08	6.1729E-08
-120.0	4.0372E-07	3.4599E-07
-90.0	2.2017E-06	2.0999E-06
-60.0	1.3507E-05	1.4469E-05
-30.0	1.1048E-04	1.1969E-04
0.0	7.7226E-01	1.2359E-03
30.0	4.5181E-04	5.2137E-04
60.0	2.2590E-04	2.7449E-04
90.0	1.5059E-04	1.7350E-04
120.0	1.1293E-04	1.2450E-04
150.0	9.0319E-05	9.6869E-05
180.0	7.5226E-05	7.9329E-05
210.0	6.4417E-05	6.7209E-05
240.0	5.6270E-05	5.8270E-05
270.0	4.9876E-05	5.1370E-05
300.0	4.4683E-05	4.5810E-05
330.0	4.0333E-05	4.1190E-05
360.0	3.6580E-05	3.7220E-05
390.0	3.3249E-05	3.3700E-05
420.0	3.0214E-05	3.0510E-05
450.0	2.7381E-05	2.7540E-05
480.0	2.4687E-05	2.4740E-05
510.0	2.2092E-05	2.2060E-05
540.0	1.9577E-05	1.9490E-05
570.0	1.7142E-05	1.7040E-05
600.0	1.4801E-05	1.4700E-05
630.0	1.2576E-05	1.2510E-05
660.0	1.0498E-05	1.0480E-05
690.0	8.5957E-06	8.6350E-06
720.0	6.8932E-06	6.9950E-06
750.0	5.4073E-06	5.5650E-06
780.0	4.1444E-06	4.3460E-06
810.0	3.1005E-06	3.3300E-06
840.0	2.2620E-06	2.5020E-06
870.0	1.6081E-06	1.8450E-06
900.0	1.1133E-06	1.3340E-06
930.0	7.5006E-07	9.5320E-07
960.0	4.9154E-07	8.1150E-07

Table 5.3.3. Concentration Profiles for 3D Transport of the Base Case Transverse to the Plume Centerline located at x = 120 meters (1400 days).

Distance transverse, y or z (m)	Analytical (AT123D)	Numerical (PORFLOW) (y-axis)	Numerical (PORFLOW) (z-axis)
0.0	1.1293E-04	1.2450E-04	1.2450E-04
30.0	6.5699E-05	6.6050E-05	6.6050E-05
60.0	1.8645E-05	1.8830E-05	1.8830E-05
90.0	4.0297E-06	4.2600E-06	4.2600E-06
120.0	7.9368E-07	8.7710E-07	8.7710E-07
150.0	1.5041E-07	1.7270E-07	1.7270E-07
180.0	2.7710E-08	3.3030E-08	3.3030E-08
210.0	4.9259E-09	6.1340E-09	6.1340E-09
240.0	8.3177E-10	1.1130E-09	1.1130E-09
270.0	1.3098E-10	4.9760E-10	4.9760E-10

Table 5.3.4. Input Commands for Problem 5.3.

```

*****
TITLe 5.3 3-D saturated solute transport in a uniform flow field
*****
! Basecase
*****

GRID is 83 by 37 by 37 NODEs
COORDinate NODEs X: MINImum=-2.7e+2, MAXImum=9.6e+2
COORDinate NODEs Y: MINImum=-2.7e+2, MAXImum=2.7e+2
COORDinate NODEs Z: MINImum=-2.7e+2, MAXImum=2.7e+2

! Material types and subregions
MATERial type 1 ! total domain

! Material and nuclide properties
PROPerty for C is HARMonic

FOR material type 1:
MATERial DENSITy 1.23077
MATERial POROSity 3*0.35
TRANsport for C Kd=0 Da=0 aL=21.3 aT=4.3

! Flow conditions
SET S to 1.
SET U to 0.161 ! m/d

! Boundary conditions
BOUNDary C at X- in VALUe = 0
BOUNDary C at X+ in GRAD = 0
BOUNDary C at Y- in GRAD = 0
BOUNDary C at Y+ in GRAD = 0
BOUNDary C at Z- in GRAD = 0
BOUNDary C at Z+ in GRAD = 0

LOCate STATION (0.,0.,0.) ! x=0,y=0,z=0
SOURce for C is constant at 0.11792 kg/d for SELEcted region

! Diagnostic information
DIAGnostic output: TIME DTIME C for node (0.,0.,0.) every 1 steps

! Time history
SAVE for C at TIME every 1400 days to '5.3.sav'

! Solution controls
    
```

```
MATRix in X Y Z for C 3 sweeps using ADI
!LIMIT for C 0.0
CONVergence for C REFERENCE LOCAL 1.e-6, max iterations = 30

! Solve transient transport
! Time period: 0 to 1400 years
TIME = 0.

SOLVE C for 1400 days in steps of 10 days

END
QUIT
```

5.4 Slit and Engineered Trench Radon Air Pathway Transport Simulation

One-dimensional radon transport models were developed using COMSOL and PORFLOW numerical simulators to compute Rn-222 concentration profiles and fluxes from the Silt and Engineered Trenches over a 1000-year period. The Slit and Engineered Trenches are below grade earthen disposal units, are very similar in design, and foot print. The first time period evaluated, which covers the operational and institutional control periods, was extended from 125 to 1000 years for this verification study. The second time period, which covers the post-closure compliance period (125 to 1125 years), was not modeled.

The potential parent radionuclides that can contribute to the formation of Rn-222 are shown in Figure 5.4.1. The diagram illustrates the decay chains that lead to the creation of Rn-222 and the half-lives for each member of the chain. Since the half-life of U-238 is extremely long (4.5 billion years), members of the decay chain above U-238 can be ignored as potential contributors to the formation of Rn-222 during the time of interest. The Th-230 decay chain (Th-230→Ra-226→Rn-222), which includes three radionuclides, was chosen as the verification candidate.

In the current formulation of the radon air pathway transport model, the following assumptions are utilized:

- Advection for all species is set to zero
- No absorption of species
- No partitioning of radon between gas and liquid phases. Radon is always in the gas phase.
- Molecular diffusion of radon gas only
- Material porosity specified to represent air-filled porosity
- No flux boundary condition specified below the lower waste zone for all species
- Zero concentration boundary condition for radon at the ground surface to maximize flux of radon at the land surface. No flux boundary condition for the remaining species at the land surface.

- The initial activity of Th-230 is set to 0.125 Ci in each of the lower and upper waste zones.

Incorporating the assumptions above and transforming from concentration to activity, the one-dimensional advection-diffusion equation for each species becomes:

$$\frac{\partial \alpha_a}{\partial t} = -\lambda_a \alpha_a \quad (5.4.1)$$

$$\frac{\partial \alpha_b}{\partial t} = \lambda_b \alpha_a - \lambda_b \alpha_b \quad (5.4.2)$$

$$\frac{\partial \alpha_c}{\partial t} = D'_{xx} \frac{\partial^2 \alpha_c}{\partial x^2} + \lambda_c \alpha_b - \lambda_c \alpha_c \quad (5.4.3)$$

$$D'_{xx} = \theta_e \tau D_m \quad (5.4.4)$$

where

a, b, c Th-230, Ra-226 and Rn-222, respectively

α activity of radionuclide, λ_c

PORFLOW numerical simulation and comparison: The COMSOL and PORFLOW material regions are defined as follows: (1) Lower Waste Zone from 0 to 4.16 m; (2) Upper Waste Zone from 4.16 to 4.92 m; (3) Clean Soil from 4.92 to 6.13 m; and (4) Closure Cap from 6.13 to 8.03 m. The PORFLOW 1D mesh consists of 3 nodes in the x-direction and 55 nodes in the y-direction. The material zones and PORFLOW mesh are shown in Figure 5.4.2. The COMSOL 1D finite-element mesh contains 273 nodes and 272 elements. The PORFLOW input commands; geometry specification, zone identification and material specification are shown in Tables 5.4.1 to 5.4.4, respectively.

Figures 5.4.3 and 5.4.4 show a comparison of COMSOL and PORFLOW concentration profiles of Th-230 and Ra-226 at 1000 years, respectively. The agreement is excellent. At 1000 years, the activity of Th-230 is at 99.1% of the original activity. As seen in Figure 5.4.4, the activity of Ra-226 is increasing from 100 to 500 to 1000 years. The two species are immobile within each waste zone as expected.

The radon concentration profile at 1000 years is shown in Figure 5.4.5 as computed by COMSOL and PORFLOW. The short-lived radon is in secular equilibrium with its long-lived parent radium. The radon peak is slightly lower due to molecular diffusion to the land surface over the past 1000 years. The agreement between COMSOL and PORFLOW is excellent.

Figure 5.4.6 represents the radon dispersive flux at the land surface in pCi/m²/sec over a 1000-year period. The radon flux continues to monotonically grow throughout time because of the

rising activity of the radium parent. The agreement is excellent between the COMSOL and PORFLOW numerical results.

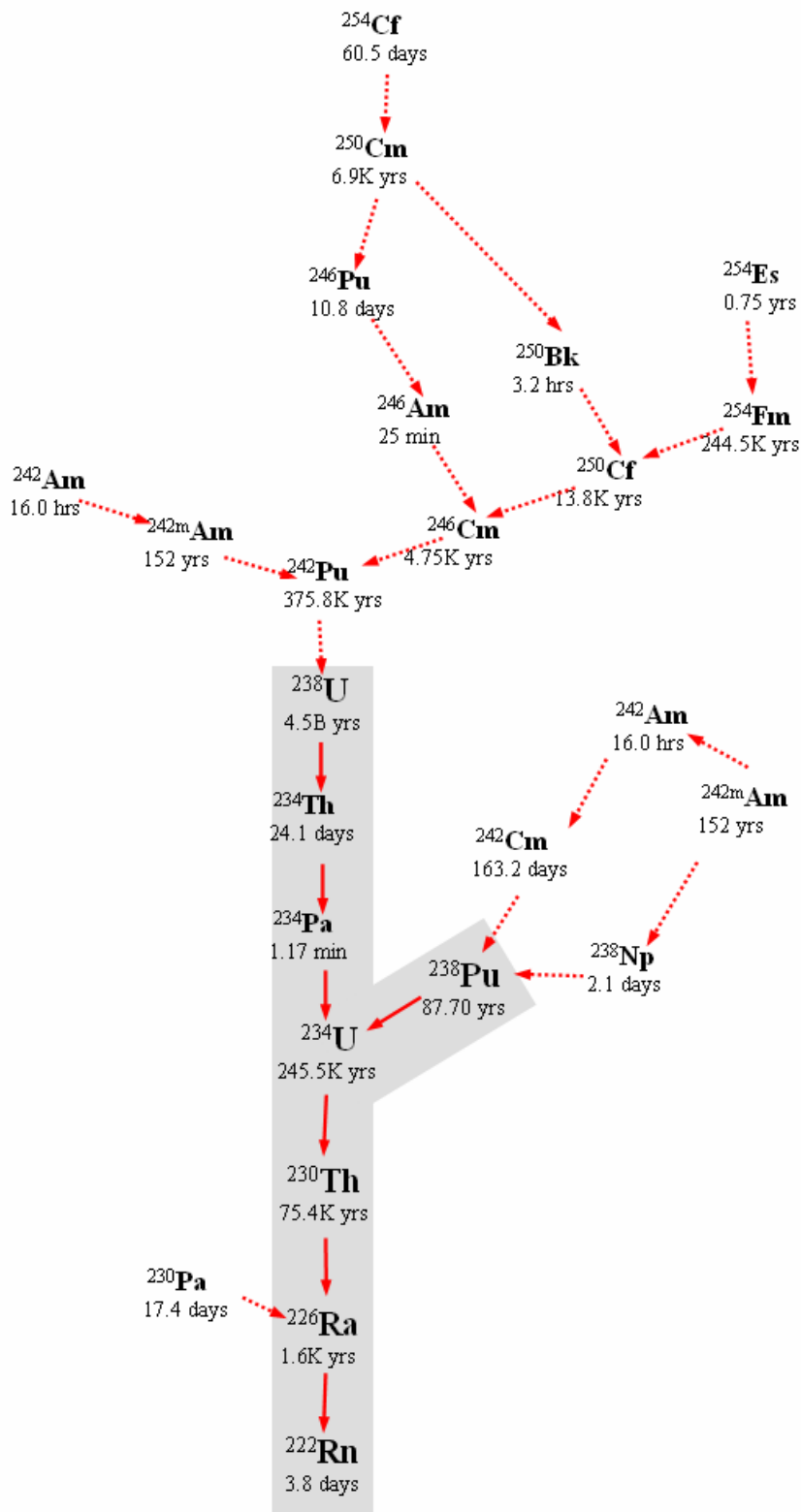

Figure 5.4.1. Radioactive Decay Chains Leading to Rn-222.

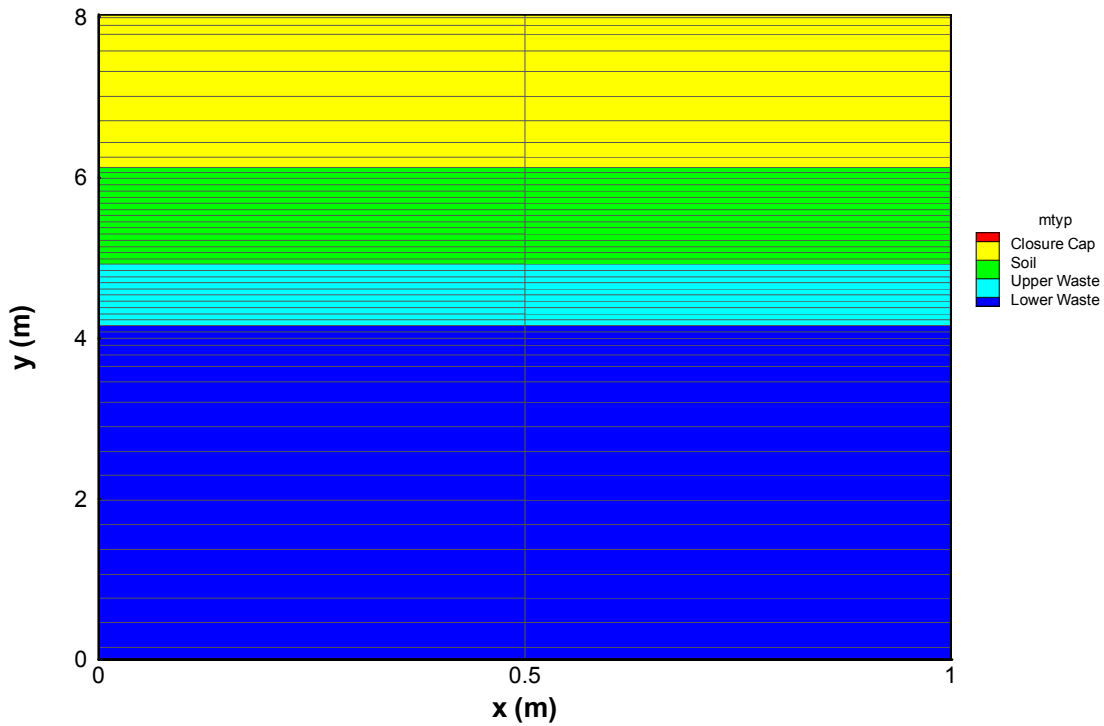

Figure 5.4.2. PORFLOW 1D Conceptual Model and Mesh for Radon Transport in the Slit and Engineered Trenches.

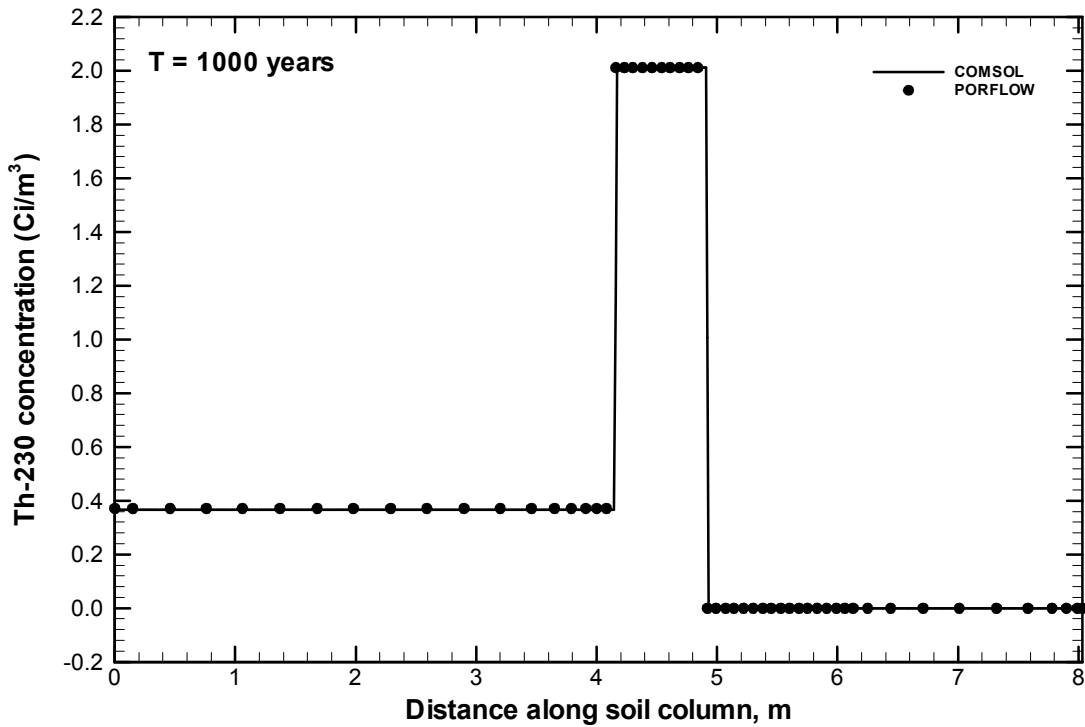

Figure 5.4.3. Comparison of COMSOL and PORFLOW Th-230 Concentration Profiles at 1000 years.

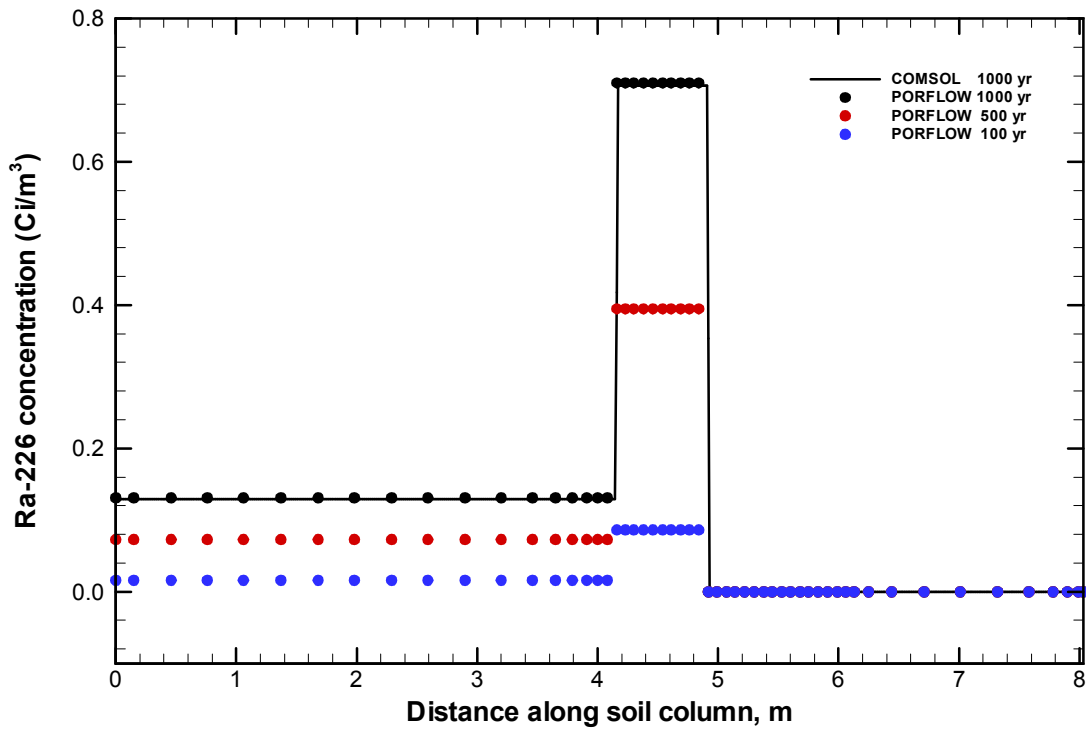

Figure 5.4.4. Comparison of COMSOL and PORFLOW Ra-226 Concentration Profiles.

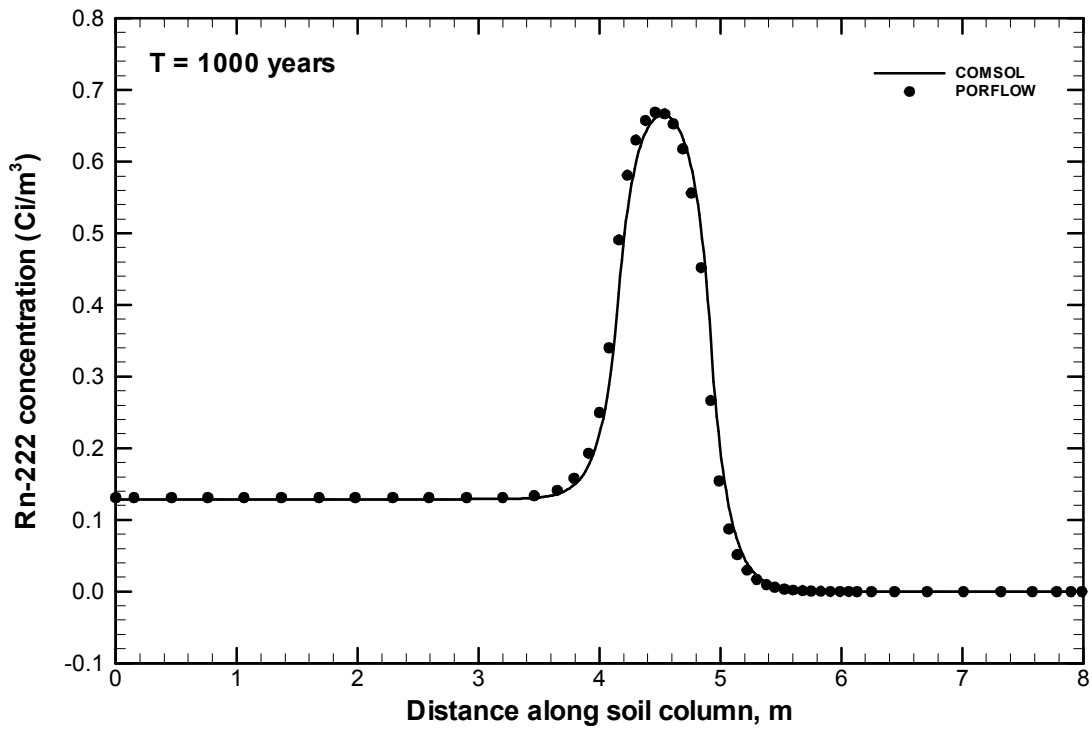

Figure 5.4.5. Comparison of COMSOL and PORFLOW Rn-222 Concentration Profiles at 1000 years.

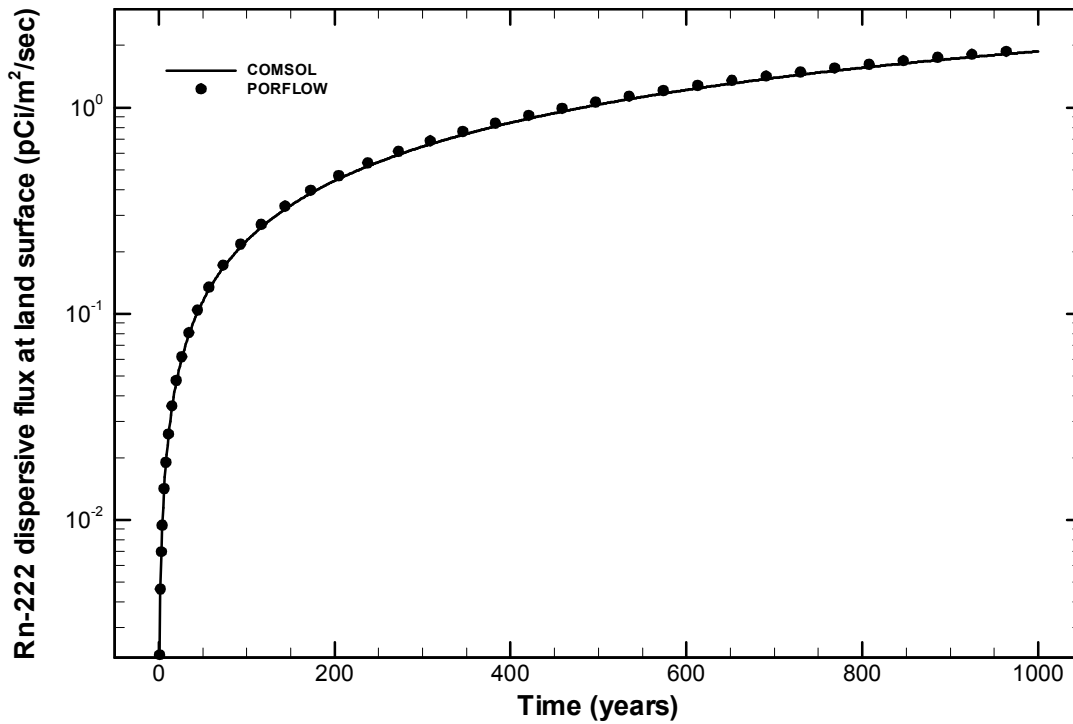

Figure 5.4.6. Comparison of COMSOL and PORFLOW Rn-222 Dispersive Flux at the Land Surface.

Table 5.4.1. Input Commands for Problem 5.4.

```

!Title SLIT Diffusion for Rn-222, 1-D w/ 1 Ci Pu-238 for 1,125Yrs
!1.22 m cover material on top of 4.88 m waste zone prior to collapse
!1.93 m closure cap and 3.15 m cover material on top of 0.76 m waste zone after collapse
!Uniform Distribution in Waste Zone
!SOURCE TERM: Emmanation Factor of 0.25 => 0.25 Ci of Pu-238
!K. L. Dixon
!1/25/2007

!DECAY CHAIN is Th-230-->Ra-226-->Rn-222
!SIMULATION UNITS: length = m, mass = g, time = years
!*****

! Geometry specifications
INCLUDE '../Common/Geom_SLT.dat'

!Zone Information
INCLUDE '../Common/ZoneIni_SLT.dat'
!

!Inventory Information
SET INVENTORY for C to 0.125 in ID=Lower_Waste ! Th-230 ACTIVITY
SET INVENTORY for C to 0.125 in ID=Upper_Waste ! Th-230 ACTIVITY

! Material specific properties
INCLUDE "../COMMON/PROP_SLT_INIT.dat"

! Radionuclide specific transport properties
!This is for first 125 years prior to collapse
FOR material type 1 to 2 !LowerWaste and UpperWaste
TRANSPORT for C3 kd = 0.00, dm = 1.26e+0 ! C3 is Rn-222

FOR material type 3 !Soil
TRANSPORT for C3 kd = 0.00, dm = 1.26e+0 ! C3 is Rn-222
    
```

```

FOR material type 4 !Closure Cap
TRANsport for C3 kd = 0.00, dm = 3.47e+2 ! C3 is Rn-222

BOUN C X- FLUX = 0. ! Th-230
BOUN C X+ FLUX = 0.
BOUN C Y- FLUX = 0.
BOUN C Y+ FLUX = 0.

BOUN C2 X- FLUX = 0. ! Ra-226
BOUN C2 X+ FLUX = 0.
BOUN C2 Y- FLUX = 0.
BOUN C2 Y+ FLUX = 0.

BOUN C3 X- FLUX = 0. ! Rn-222
BOUN C3 X+ FLUX = 0.
BOUN C3 Y- FLUX = 0.
BOUN C3 Y+ VALU = 0.

! Decay Info
DECAY half LIFE for C is 7.538e+04 years ! Th-230 from Nuclear Wallet Cards, BNL
DECAY half LIFE for C2 is 1.600e+03 years ! Ra-226 from Nuclear Wallet Cards, BNL
DECAY half LIFE for C3 is 1.047e-02 years ! Rn-222 from Nuclear Wallet Cards, BNL

REGenerate C2 from C 4.711E+01 ! C/C2
REGenerate C3 from C2 1.528E+05 ! C2/C3

PROPerTy for C C2 C3 is HARMonic !GEOM mean
MATRix in Y direction in 3 sweeps using ADI

DIAGnostic node for TIME C C2 C3 at (2, 26) every 100 steps

FLUX C for ID=DOMAIN by TIME every 1 years to 'FLUX.out'
FLUX C2 for ID=DOMAIN by TIME every 1 years to 'FLUX.out'
FLUX C3 for ID=DOMAIN by TIME every 1 years to 'FLUX.out'

SAVE C C2 C3 for ID=DOMAIN to 'Th-230.sav' at TIME interval of 100 years

TIME = 0.

CONV C REFE GLOBal resid = 1.0e-06, max_iter 10, min_iter 2, F_threshold = 1.e-5
CONV C2 REFE GLOBal resid = 1.0e-06, max_iter 10, min_iter 2, F_threshold = 1.e-5
CONV C3 REFE GLOBal resid = 1.0e-06, max_iter 10, min_iter 2, F_threshold = 1.e-5

DISable FLOW

SOLVe 1000 yrs, init 1.e-5, inc 1.005, max 1. !Pre-collapse

END

```

Table 5.4.2. Geometry Specification for Problem 5.4.

```

GRID 3 by 55
SCALE 1.0000
COORDINATE X:
    0.0 1.0
SCALE 1.0000
COORDINATE Y: !!element interfaces
0.00
0.30
0.61
0.91
1.22
1.52
1.83
2.13
2.44
2.74
3.05
3.35
3.58
3.73
3.86

```

3.96
 4.04
 4.12
 4.19
 4.27
 4.34
 4.42
 4.50
 4.57
 4.65
 4.73
 4.80
 4.88
 4.95
 5.03
 5.11
 5.18
 5.26
 5.34
 5.41
 5.49
 5.56
 5.64
 5.72
 5.79
 5.87
 5.95
 6.02
 6.10
 6.17
 6.33
 6.55
 6.86
 7.16
 7.47
 7.70
 7.85
 7.95
 8.03
 DATUM = 0. 0.

Table 5.4.3. Zone Identification for Problem 5.4.

```

!Porflow constants
DEFINE ZLWaste=1
DEFINE ZUWaste=2
DEFINE ZSoil=3
DEFINE ZCap=4
!
MATERial type ZLWaste from 1 1 to 3 18 !LowerWaste
MATERial type ZUWaste from 1 19 to 3 28 !UpperWaste
MATERial type ZSoil from 1 29 to 3 44 !Soil
MATERial type ZCap from 1 45 to 3 55 !Closure Cap
!
LOCate subregion ( 1, 1) to ( 3, 18) with ID=Lower_Waste
LOCate subregion ( 1, 19) to ( 3, 28) with ID=Upper_Waste
LOCate ID=DOMAIN as nodes ( 1, 1) through (3, 55) !all nodes
  
```

Table 5.4.4. Material Specification for Problem 5.4.

```

FOR material type ZLWaste !Lower_Waste Layer
DENsity = 1.24e+3 ! fluid density (air) in g/m^3
MATERial DENsity = 2.65e+6 ! Particle density in g/m^3
MATERial POROsity = 0.081 0.081 0.081 ! Air-filled porosity
MATERial TORTuosity = 1.00 1.00
!
FOR material type ZUWaste !Upper_Waste Layer
DENsity = 1.24e+3 ! fluid density (air) in g/m^3
MATERial DENsity = 2.65e+6 ! Particle density in g/m^3
MATERial POROsity = 0.081 0.081 0.081 ! Air-filled porosity
MATERial TORTuosity = 1.00 1.00
  
```

```

!
FOR material type ZSoil !Soil Layer
DENsity = 1.24e+3      ! fluid density (air) in g/m^3
MATERial DENsity = 2.65e+6      ! Particle density in g/m^3
MATERial PORosity = 0.081  0.081  0.081      ! Air-filled porosity
MATERial TORTuosity = 1.00 1.00
!
FOR material type ZCap !Closure Cap
DENsity = 1.24e+3      ! fluid density (air) in g/m^3
MATERial DENsity = 2.65e+6      ! Particle density in g/m^3
MATERial PORosity = 1.00  1.00  1.00 ! Air-filled porosity
MATERial TORTuosity = 1.00 1.00

```

5.5 Impact of PORFLOW Retardation Model on Variably Saturated Solute Transport.

The conventional definition of the retardation factor as used by the majority of the groundwater modeling community for a linear adsorption isotherm is shown in Equation 5.1.1 as

$$R = 1 + \rho_s(1 - \phi)k_d/\theta_e \quad (5.5.1)$$

The current conceptual model in PORFLOW for linear sorption assumes that the diffusion in the solid is negligible and that the contact between the fluid and solid is only through the wetted surface (advective or mobile phase fluid). The nonwetted surface in contact with air does not participate in sorption. Therefore, the retardation factor in PORFLOW is computed as

$$R = 1 + \rho_s(S_w - \theta_e)k_d/\theta_e = 1 + \rho_s(1 - \phi)k_d/\phi \quad (5.5.2)$$

Equations 5.5.1 and 5.5.2 are identical under saturated conditions. For variably saturated transport, Equation 5.5.2 always computes a smaller retardation factor than Equation 5.5.1. The impact is less loading to the solid, higher solute concentrations and higher retarded phasic velocities. Is this a conservative approach? Most likely in every case. Obviously, the further conditions are away from saturation, the greater the impact on solute concentrations and transport travel times. This approach is non-standard and should be replaced by the conventional and accepted form of the retardation factor.

PORFLOW numerical simulation and comparison: A one-dimensional solute transport simulation at a constant saturation and Darcy velocity of 50% and 4 meters per year, respectively, was executed in COMSOL and PORFLOW. The COMSOL finite-element grid consists of 240 elements and 241 nodes. The PORFLOW grid is shown in Figure 5.5.1 and contains 201 nodes in the x-direction and 3 nodes in the y-direction. The extent of the mesh is 400 meters. The simulation time was 50 years using time steps of 0.01 year. The solute concentration profiles were written every 25 years.

Two species are tracked in the simulation. A decaying parent with a half-life of 25 years and a non-decaying stable daughter. Each species has a distribution coefficient of 0.5 and a longitudinal dispersivity of 4 meters. The material particle density is 2 with a porosity of 0.5. The bulk density is therefore equal to 1 (water like soil). The retardation factors are computed as 3 and 2 using Equations 5.5.1 and 5.5.2, respectively. The corresponding retarded pore or phasic velocities are 5.333 and 8 meters per year, respectively.

The dispersive flux for each species is set to zero at the outflow boundary (+X). The inflow boundary condition at -X is a unit concentration and zero concentration for the parent and daughter, respectively.

Figure 5.5.2 shows a comparison between the COMSOL and PORFLOW parent and daughter solute concentration profiles at 25 and 50 years. The COMSOL variably saturated transport equation uses the standard form of the retardation factor. As the results show, PORFLOW produces higher solute concentrations than COMSOL. The peak in solute concentration for the daughter species has moved further down the soil column due to a higher retarded pore velocity.

The imbedded construct for computing the retardation factor in PORFLOW can be overridden by use of the RETARDation keyword command with appropriate modifiers. The retardation factor was computed as a function of moisture content using the POWER function

$$R = A(B + C)^D + E \quad (5.5.3)$$
$$A = \rho_s(1 - \phi)k_d, B = \theta_e, C = 0, D = -1, E = 1$$

The RETARDation command is issued for each species and subregion. If no subregion is specified, the command is applied to the whole domain.

Figure 5.5.3 shows the same comparison as in Figure 5.5.2 but where PORFLOW now uses the conventional form of the retardation factor. The comparison is excellent. PORFLOW should be modified to use the conventional form as an option. The input commands for this problem is given in Table 5.5.1.

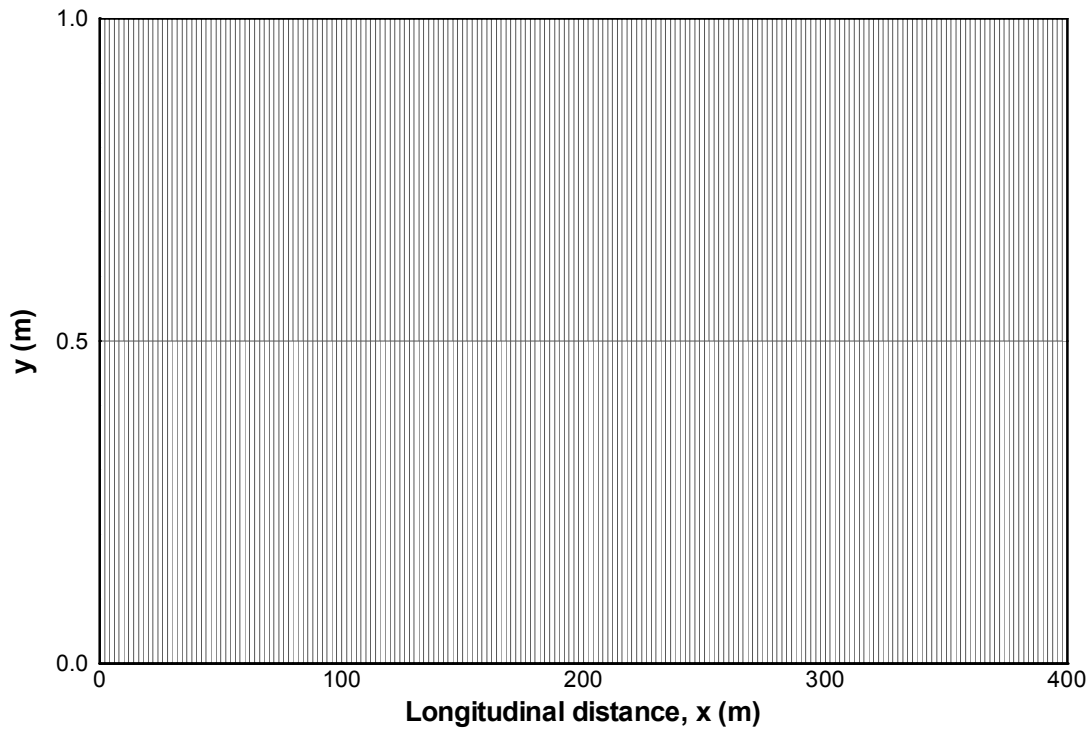

Figure 5.5.1. PORFLOW Grid for 1D Variably Saturated Transport.

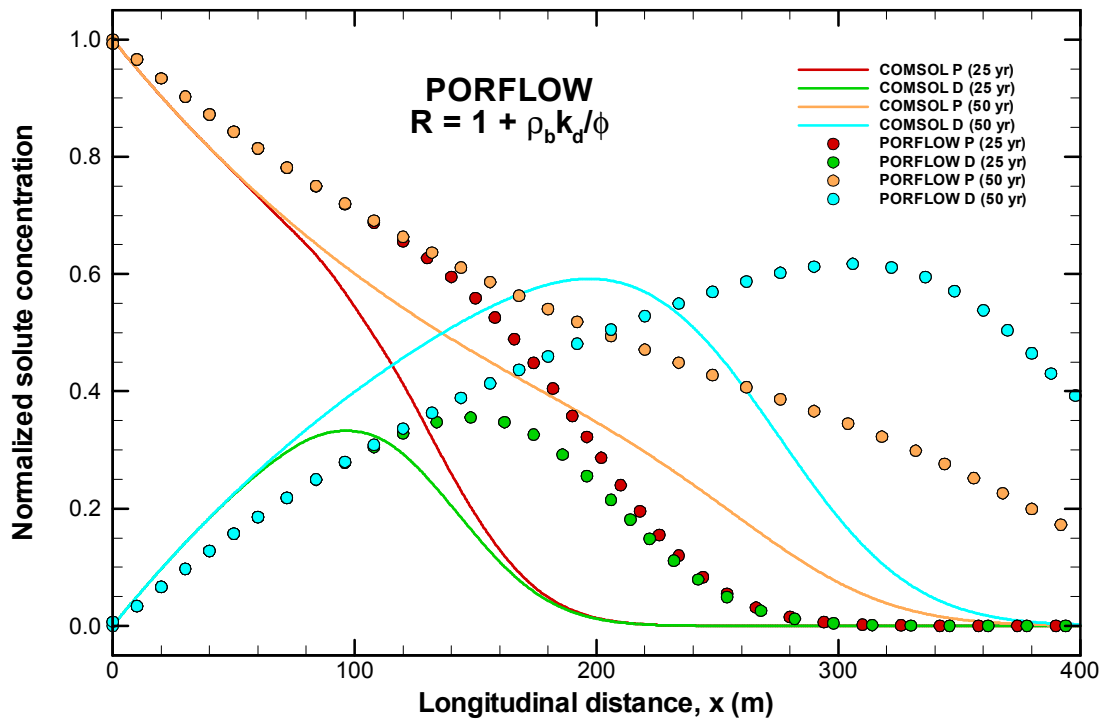

Figure 5.5.2. Comparison of COMSOL and PORFLOW Parent and Daughter Solute Concentration Profiles at 25 and 50 years (PORFLOW using Eq. 5.5.2).

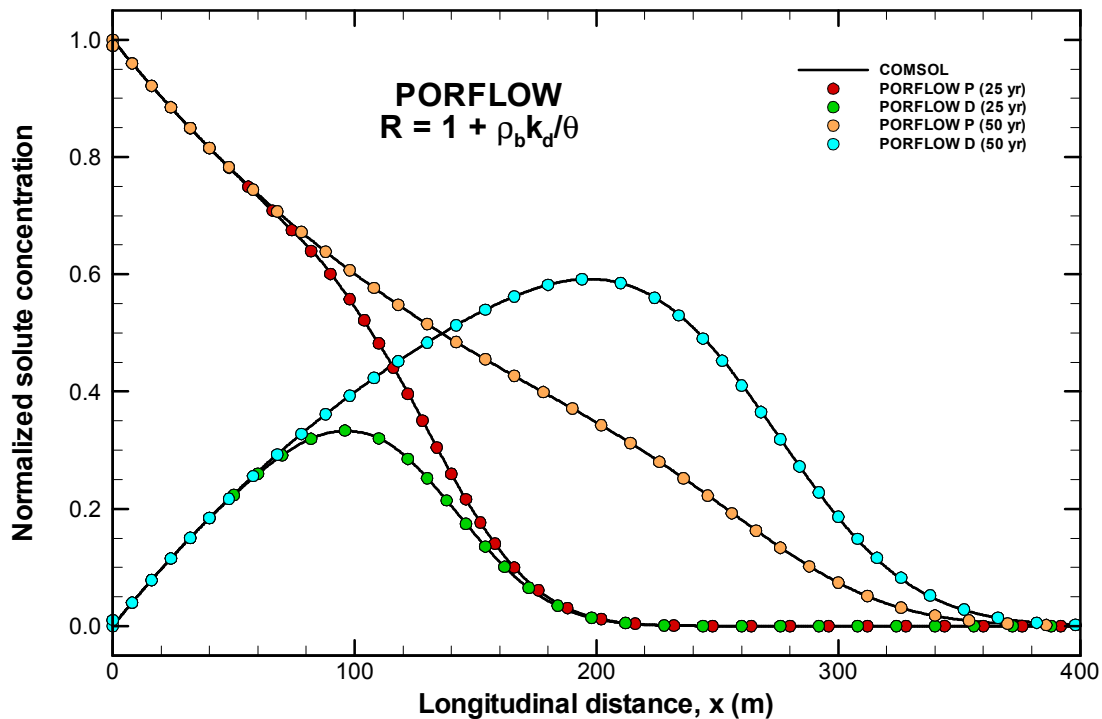

Figure 5.5.3. Comparison of COMSOL and PORFLOW Parent and Daughter Solute Concentration Profiles at 25 and 50 years (PORFLOW using Eq. 5.5.1)

Table 5.5.1. Input Commands for Problem 5.5.

```

*****
TITLE 5.5 1-D unsaturated solute transport in a uniform flow field
*****
! steady-state flow at constant saturation of 50%
*****

!===== retardation factor based on porosity =====
GRID is 201 NODEs
COORDINATE NODEs X: MINIMUM=0.0, MAXIMUM=4.e2

! Material types and subregions
MATERIAL type 1 ! total domain

! Material and nuclide properties
PROPERTY for C is HARMONIC
PROPERTY for C2 is HARMONIC

FOR material type 1:
MATERIAL DENSITY 2.0
MATERIAL POROSITY 3*0.5
TRANSPORT for C Kd=0.5 Da=0 aL=4 aT=0
TRANSPORT for C2 Kd=0.5 Da=0 aL=4 aT=0

! Flow conditions
SET S = 0.5
SET U = 4.0

! Boundary conditions
BOUNDARY C at X- in VALUE = 1
BOUNDARY C at X+ in GRAD = 0
BOUNDARY C2 at X- in VALUE = 0
BOUNDARY C2 at X+ in GRAD = 0
    
```

```
! Decaying species
DECAy half LIFE for C   is 25 years

REGeneration of C2 from C is 1.

SET C2 0.

! Diagnostic information
DIAGnostic output: TIME DTIME C for node 200 every 10 steps

! Time history
SAVE for C C2 at TIME every 25 years to '5.5-phi.sav'

! Solution controls
MATRix in X for C C2 3 3 sweeps using ADI
CONVergence for C REFERENCE LOCAL 1.e-6, max iterations = 30
CONVergence for C2 REFERENCE LOCAL 1.e-6, max iterations = 30

! Solve transient transport
! Time period: 0 to 500 years
TIME = 0.

SOLVe C C2 for 50 days in steps of 0.01 days

END
!===== retardation factor based on porosity =====

!===== retardation factor based on water content =====
GRID is 201 NODEs
COORDinate NODEs X: MINImum=0.0, MAXImum=4.e2

! Material types and subregions
MATERial type 1 ! total domain

! Material and nuclide properties
PROPerty for C is HARMonic
PROPerty for C2 is HARMonic

FOR material type 1:
MATERial DENSITy 2.0
MATERial POROSity 3*0.5
TRANSport for C Kd=0.5 Da=0 aL=4 aT=0
TRANSport for C2 Kd=0.5 Da=0 aL=4 aT=0

! Flow conditions
SET S = 0.5
SET U = 4.0
SET MOIS as LINEar function: 0. + (0.5) (S)

! Boundary conditions
BOUNDary C at X- in VALUe = 1
BOUNDary C at X+ in GRAD = 0
BOUNDary C2 at X- in VALUe = 0
BOUNDary C2 at X+ in GRAD = 0

! Decaying species
DECAy half LIFE for C   is 25 years

REGeneration of C2 from C is 1.

SET C2 0.

!Compute retardation factor based on water content
RETARDation for C as a POWER function: (0.5)*(MOIS + 0)^(-1)+(1) ! Kd = 0.5
RETARDation for C2 as a POWER function: (0.5)*(MOIS + 0)^(-1)+(1) ! Kd = 0.5

! Diagnostic information
DIAGnostic output: TIME DTIME C for node 200 every 10 steps

! Time history
SAVE for C C2 at TIME every 25 years to '5.5-wc.sav'

! Solution controls
```

```
MATRix in X for C C2 3 3 sweeps using ADI
CONVergence for C REFERENCE LOCAL 1.e-6, max iterations = 30
CONVergence for C2 REFERENCE LOCAL 1.e-6, max iterations = 30
```

```
! Solve transient transport
! Time period: 0 to 500 years
TIME = 0.
```

```
SOLVe C C2 for 50 days in steps of 0.01 days
```

```
END
```

```
!===== retardation factor based on water content =====
```

```
QUIT
```

6 Group 3: Numerical Dispersion

The impact of numerical and mechanical dispersion in PORFLOW on peak solute concentrations is addressed in this section with regard to mesh spacing in a one-dimensional pulsed soil column. Numerical dispersion in two and three dimensions is not addressed here but will be addressed in a subsequent study. The node limitation of 128,000 in PORFLOW prohibits the investigation of numerical dispersion in a three-dimensional aquifer model.

Numerical dispersion in one dimension can be minimized by not allowing the solute concentration to advect more than a cell length within a time step. The Courant condition for advective transport is

$$(\delta t)_A \leq \frac{\delta x}{u'_x} \quad (6.1)$$

where $(\delta t)_A$ is the time step for advective transport, δx is the cell length and u'_x is the retarded phasic velocity in the x-direction. Numerical oscillations in the solute concentration due to diffusion and dispersion can be eliminated by invoking the Von Neumann criterion for dispersive transport as

$$(\delta t)_D \leq \frac{(\delta x)^2}{3D'_{xx}} \quad (6.2)$$

where $(\delta t)_D$ is the time step for dispersive and diffusive transport and D'_{xx} is the retarded longitudinal dispersion coefficient. Numerical dispersion can be negligible when $\delta x \leq \alpha_L$, because mechanical dispersion is equally or more important than advective transport. For a refined mesh, the time step for dispersive transport may become more restrictive than the time step for advective transport, due to the quadratic dependence on mesh size in Equation 6.2.

The current engineering judgment for modeling groundwater transport at SRS is not to invoke mechanical dispersion in PORFLOW, only advective and molecular transport. For coarser grids in the aquifer, the idea is that numerical dispersion will be on par with mechanical dispersion based on reasonable values for the longitudinal and transverse dispersivities. This is all conjecture. In

the next section, we will demonstrate the impact of numerical and mechanical dispersion on the peak concentrations of a pulsed one-dimensional soil column.

6.1 Numerical and Mechanical Dispersion in a One-Dimensional Saturated Soil Column.

PORFLOW numerical simulation and comparison: A series of one-dimensional solute transport simulations under saturated conditions and 10 meters per year Darcy velocity were executed in PORFLOW. Ten PORFLOW grids were generated with equally sized mesh spacing ranging from 0.1 to 60 meters. The extent of the PORFLOW grid was from -200 meters to 800 meters. There were adjustments made to the extent of the grid to accommodate a source node at $x = 0$. The number of nodes range from 10001 to 19 for mesh spacing of 0.1 and 60 meters, respectively.

An inflow boundary condition of zero concentration was specified at $-X$ and a dispersive flux of zero was specified at $+X$.

A conservative species was injected at $x = 0$ with a source strength of 10 kg/yr/m for a duration of 1 year and a time step of 0.001 year. This results in a pulse of unit concentration traveling at a phasic velocity of 40 meters per year. The width of the pulse is 40 meters. The transport simulations were executed for an additional 4.5 years at a time step of 0.001 year. The centerline of the pulse arrives at $x = 200$ meters in 5.5 years.

Figure 6.1.1 shows the normalized solute concentration profiles at 5.5 years for mesh spacing ranging for 0.1 to 60 meters. During these simulations, mechanical dispersion and molecular diffusion are set to zero. At a mesh spacing of 0.1 meters, PORFLOW matches the peak concentration of the analytical pulse profile. As the mesh gets coarser, the resulting spread of the pulse is due to numerical dispersion. With increasing mesh spacing, PORFLOW continues to deviate more from the analytical pulse as shown in Figure 6.1.2. Next, we turn on mechanical dispersion to see the impact on the solute concentration profiles.

The centerline of the pulse travels 200 meters in 5.5 years. A rule-of-thumb longitudinal dispersivity equal to one-tenth the travel distance was chosen as 20 meters. Figure 6.1.3 represents the same conditions shown in Figure 6.1.1 except with mechanical dispersion. The peak concentration has dropped from 1 to 0.175. Below a mesh spacing of 20 meters, PORFLOW has excellent agreement with the analytical solution. Numerical dispersion appears to become significant above a mesh spacing of 40 meters.

The input commands for PORFLOW are given in Tables 6.1.1 and 6.1.2.

Fine mesh resolution is needed to capture the peak solute concentration in PORFLOW if no mechanical dispersion is present. If mechanical dispersion is used in PORFLOW, the modeler needs to determine the appropriate mesh spacing and time stepping to mitigate the impact of numerical dispersion especially in multi-dimensional transport.

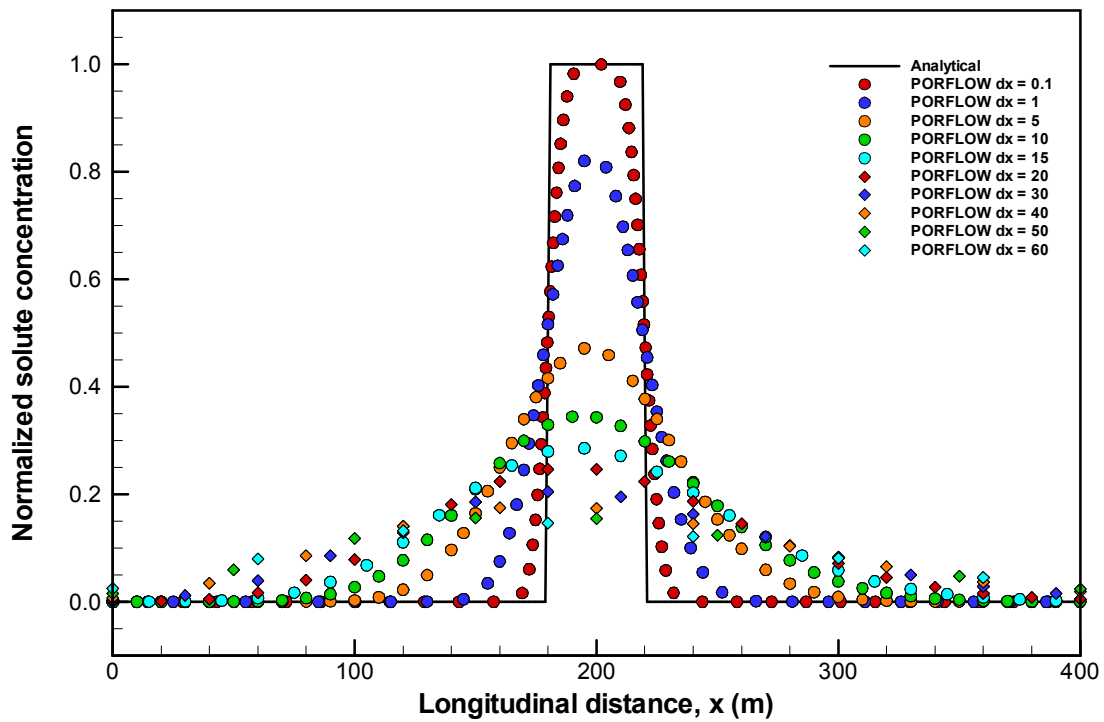

Figure 6.1.1. Normalized Solute Concentration Profiles at 5.5 Years for Variable Mesh Spacing in PORFLOW with Numerical Dispersion.

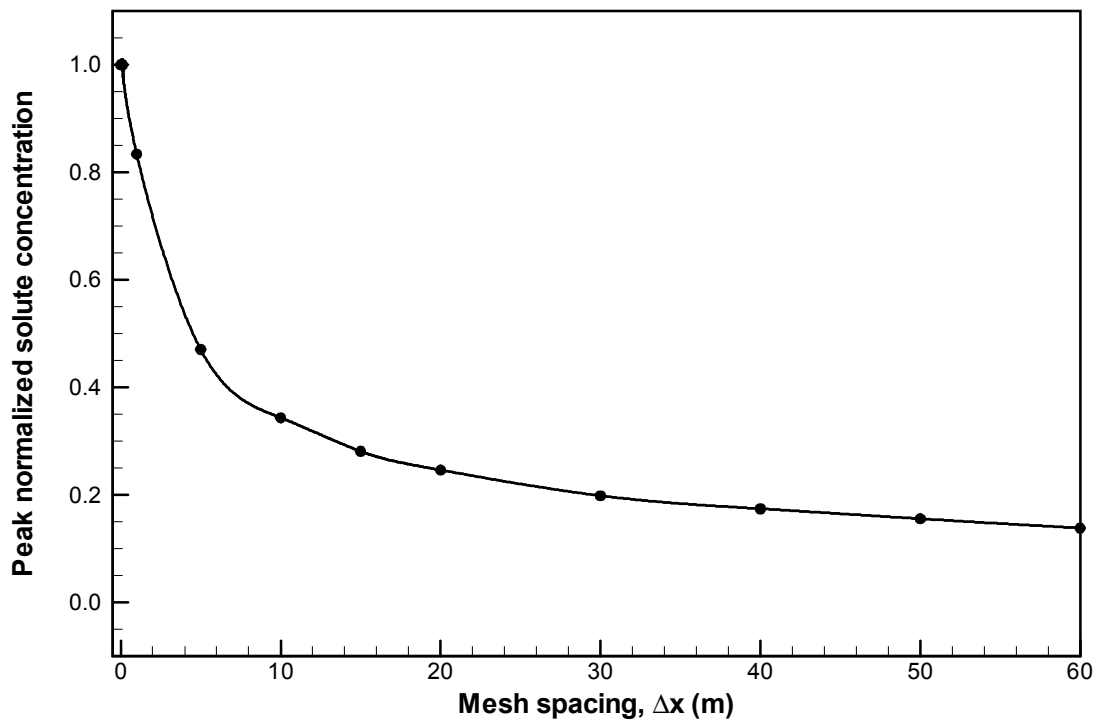

Figure 6.1.2. Peak Normalized Solute Concentration as a Function of Mesh Spacing in PORFLOW at 5.5 Years with Numerical Dispersion.

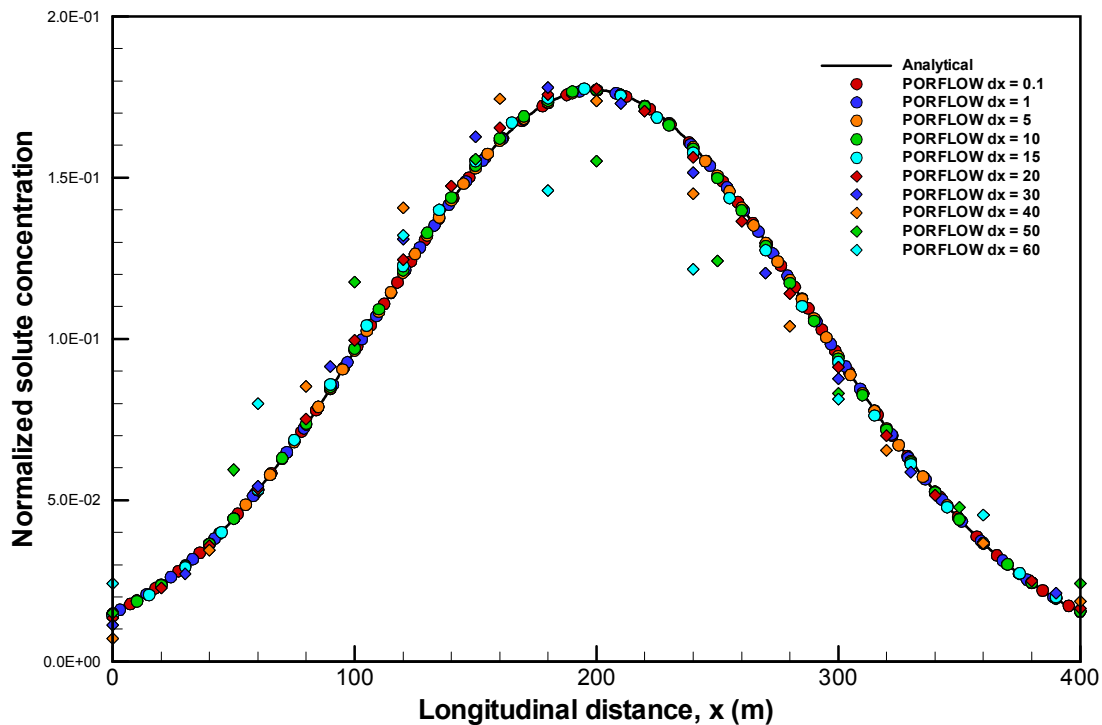

Figure 6.1.3. Normalized Solute Concentration Profiles at 5.5 Years for Variable Mesh Spacing in PORFLOW with Mechanical Dispersion.

Table 6.1.1. Input Commands for Problem 6.1 (Numerical Dispersion).

```

*****
TITLE 1-D saturated solute transport in a uniform flow field
*****
! Numerical Dispersion Study
*****

!===== 0.1 meter mesh spacing =====
GRID is 10001 NODEs
COORDinate NODEs X: MINImum=-2.0e+2, MAXImum=8.0e+2

! Material types and subregions
MATERial type 1 ! total domain

! Material and nuclide properties
PROPerty for C is HARMonic

FOR material type 1:
MATERial DENSITY 1.0
MATERial POROSity 3*0.25
TRANsport for C Kd=0 Da=0 aL=0 aT=0

! Flow conditions
SET S to 1.
SET U to 10. ! m/yr

! Boundary conditions
BOUNDary C at X- in VALUe = 0
BOUNDary C at X+ in GRAD = 0

! Diagnostic information
DIAGnostic output: TIME DTIME C for node (0.,0.5) every 100 steps

! Time history
    
```

```
SAVE for C at TIME every 5.5 years to '6.1-A-L01.sav'

! Solution controls
MATRix in X for C 3 sweeps using ADI
LIMIt for C 0.0
CONVergence for C REFERENCE LOCAL 1.e-6, max iterations = 30

! Solve transient transport
! Time period: 0 to 5.5 years
TIME = 0.

LOCate STATION (0.,0.5) ! x=0,y=0
SOURce for C is constant at 10. kg/y/m for SELEcted region
SOLVe C for 1 years in steps of 0.001 years
SOURce OFF for C for most recently SELEcted region

SOLVe C for 4.5 years in steps of 0.001 years

END
!===== 0.1 meter mesh spacing =====
!===== 1.0 meter mesh spacing =====
GRID is 1001 NODEs
COORdinate NODEs X: MINImum=-2.0e+2, MAXImum=8.0e+2

! Material types and subregions
MATERial type 1 ! total domain

! Material and nuclide properties
PROPerty for C is HARMonic

FOR material type 1:
MATERial DENSITy 1.0
MATERial POROSity 3*0.25
TRANSport for C Kd=0 Da=0 aL=0 aT=0

! Flow conditions
SET S to 1.
SET U to 10. ! m/yr

! Boundary conditions
BOUNDary C at X- in VALUe = 0
BOUNDary C at X+ in GRAD = 0

! Diagnostic information
DIAGnostic output: TIME DTIME C for node (0.,0.5) every 100 steps

! Time history
SAVE for C at TIME every 5.5 years to '6.1-A-L02.sav'

! Solution controls
MATRix in X for C 3 sweeps using ADI
LIMIt for C 0.0
CONVergence for C REFERENCE LOCAL 1.e-6, max iterations = 30

! Solve transient transport
! Time period: 0 to 5.5 years
TIME = 0.

LOCate STATION (0.,0.5) ! x=0,y=0
SOURce for C is constant at 10. kg/y/m for SELEcted region
SOLVe C for 1 years in steps of 0.001 years
SOURce OFF for C for most recently SELEcted region

SOLVe C for 4.5 years in steps of 0.001 years

END
!===== 1 meter mesh spacing =====
!===== 5 meter mesh spacing =====
GRID is 201 NODEs
COORdinate NODEs X: MINImum=-2.0e+2, MAXImum=8.0e+2
```



```
! Material types and subregions
MATERial type 1 ! total domain

! Material and nuclide properties
PROPerty for C is HARMonic

FOR material type 1:
MATERial DENSITY 1.0
MATERial PORosity 3*0.25
TRANsport for C Kd=0 Da=0 aL=0 aT=0

! Flow conditions
SET S to 1.
SET U to 10. ! m/yr

! Boundary conditions
BOUNDary C at X- in VALUe = 0
BOUNDary C at X+ in GRAD = 0

! Diagnostic information
DIAGnostic output: TIME DTIME C for node (0.,0.5) every 100 steps

! Time history
SAVE for C at TIME every 5.5 years to '6.1-A-L03.sav'

! Solution controls
MATRix in X for C 3 sweeps using ADI
LIMIt for C 0.0
CONVergence for C REFERENCE LOCAL 1.e-6, max iterations = 30

! Solve transient transport
! Time period: 0 to 5.5 years
TIME = 0.

LOCate STATION (0.,0.5) ! x=0,y=0
SOURce for C is constant at 10. kg/y/m for SELEcted region
SOLVe C for 1 years in steps of 0.001 years
SOURce OFF for C for most recently SELEcted region

SOLVe C for 4.5 years in steps of 0.001 years

END
!===== 5 meter mesh spacing =====

!===== 10 meter mesh spacing =====
GRID is 101 NODEs
COORDinate NODEs X: MINImum=-2.0e+2, MAXImum=8.0e+2

! Material types and subregions
MATERial type 1 ! total domain

! Material and nuclide properties
PROPerty for C is HARMonic

FOR material type 1:
MATERial DENSITY 1.0
MATERial PORosity 3*0.25
TRANsport for C Kd=0 Da=0 aL=0 aT=0

! Flow conditions
SET S to 1.
SET U to 10. ! m/yr

! Boundary conditions
BOUNDary C at X- in VALUe = 0
BOUNDary C at X+ in GRAD = 0

! Diagnostic information
DIAGnostic output: TIME DTIME C for node (0.,0.5) every 100 steps

! Time history
SAVE for C at TIME every 5.5 years to '6.1-A-L04.sav'
```

```
! Solution controls
MATRix in X for C 3 sweeps using ADI
LIMIt for C 0.0
CONVergence for C REFERENCE LOCAL 1.e-6, max iterations = 30

! Solve transient transport
! Time period: 0 to 5.5 years
TIME = 0.

LOCate STATION (0.,0.5) ! x=0,y=0
SOURce for C is constant at 10. kg/y/m for SELEcted region
SOLVe C for 1 years in steps of 0.001 years
SOURce OFF for C for most recently SELEcted region

SOLVe C for 4.5 years in steps of 0.001 years

END
!===== 10 meter mesh spacing =====

!===== 15 meter mesh spacing =====
GRID is 69 NODEs
COORDinate NODEs X: MINImum=-2.1e+2, MAXImum=8.1e+2

! Material types and subregions
MATERial type 1 ! total domain

! Material and nuclide properties
PROPerty for C is HARMonic

FOR material type 1:
MATERial DENSITY 1.0
MATERial PORosity 3*0.25
TRANsport for C Kd=0 Da=0 aL=0 aT=0

! Flow conditions
SET S to 1.
SET U to 10. ! m/yr

! Boundary conditions
BOUNDary C at X- in VALUe = 0
BOUNDary C at X+ in GRAD = 0

! Diagnostic information
DIAGnostic output: TIME DTIME C for node (0.,0.5) every 100 steps

! Time history
SAVE for C at TIME every 5.5 years to '6.1-A-L05.sav'

! Solution controls
MATRix in X for C 3 sweeps using ADI
LIMIt for C 0.0
CONVergence for C REFERENCE LOCAL 1.e-6, max iterations = 30

! Solve transient transport
! Time period: 0 to 5.5 years
TIME = 0.

LOCate STATION (0.,0.5) ! x=0,y=0
SOURce for C is constant at 10. kg/y/m for SELEcted region
SOLVe C for 1 years in steps of 0.001 years
SOURce OFF for C for most recently SELEcted region

SOLVe C for 4.5 years in steps of 0.001 years

END
!===== 15 meter mesh spacing =====

!===== 20 meter mesh spacing =====
GRID is 51 NODEs
COORDinate NODEs X: MINImum=-2.e+2, MAXImum=8.e+2

! Material types and subregions
MATERial type 1 ! total domain
```

```
! Material and nuclide properties
PROPerty for C is HARMonic

FOR material type 1:
MATERial DENSITY 1.0
MATERial PORosity 3*0.25
TRANsport for C Kd=0 Da=0 aL=0 aT=0

! Flow conditions
SET S to 1.
SET U to 10. ! m/yr

! Boundary conditions
BOUNDary C at X- in VALUe = 0
BOUNDary C at X+ in GRAD = 0

! Diagnostic information
DIAGnostic output: TIME DTIME C for node (0.,0.5) every 100 steps

! Time history
SAVE for C at TIME every 5.5 years to '6.1-A-L06.sav'

! Solution controls
MATRix in X for C 3 sweeps using ADI
LIMIt for C 0.0
CONVergence for C REFERENCE LOCAL 1.e-6, max iterations = 30

! Solve transient transport
! Time period: 0 to 5.5 years
TIME = 0.

LOCate STATION (0.,0.5) ! x=0,y=0
SOURce for C is constant at 10. kg/y/m for SELEcted region
SOLVe C for 1 years in steps of 0.001 years
SOURce OFF for C for most recently SELEcted region

SOLVe C for 4.5 years in steps of 0.001 years

END
!===== 20 meter mesh spacing =====
!===== 30 meter mesh spacing =====
GRID is 35 NODES
COORDinate NODEs X: MINImum=-2.1e+2, MAXImum=8.1e+2

! Material types and subregions
MATERial type 1 ! total domain

! Material and nuclide properties
PROPerty for C is HARMonic

FOR material type 1:
MATERial DENSITY 1.0
MATERial PORosity 3*0.25
TRANsport for C Kd=0 Da=0 aL=0 aT=0

! Flow conditions
SET S to 1.
SET U to 10. ! m/yr

! Boundary conditions
BOUNDary C at X- in VALUe = 0
BOUNDary C at X+ in GRAD = 0

! Diagnostic information
DIAGnostic output: TIME DTIME C for node (0.,0.5) every 100 steps

! Time history
SAVE for C at TIME every 5.5 years to '6.1-A-L07.sav'

! Solution controls
MATRix in X for C 3 sweeps using ADI
```

```
LIMIt for C 0.0
CONVergence for C REFERENCE LOCAL 1.e-6, max iterations = 30

! Solve transient transport
! Time period: 0 to 5.5 years
TIME = 0.

LOCAtE STAtion (0.,0.5) ! x=0,y=0
SOURce for C is constant at 10. kg/y/m for SELEcted region
SOLVe C for 1 years in steps of 0.001 years
SOURce OFF for C for most recently SELEcted region

SOLVe C for 4.5 years in steps of 0.001 years

END
!===== 30 meter mesh spacing =====

!===== 40 meter mesh spacing =====
GRID is 26 NODEs
COORDinate NODEs X: MINImum=-2.e+2, MAXImum=8.e+2

! Material types and subregions
MATERial type 1 ! total domain

! Material and nuclide properties
PROPerty for C is HARMonic

FOR material type 1:
MATERial DENSITY 1.0
MATERial POROSity 3*0.25
TRANSport for C Kd=0 Da=0 aL=0 aT=0

! Flow conditions
SET S to 1.
SET U to 10. ! m/yr

! Boundary conditions
BOUNDary C at X- in VALUe = 0
BOUNDary C at X+ in GRAD = 0

! Diagnostic information
DIAGnostic output: TIME DTIME C for node (0.,0.5) every 100 steps

! Time history
SAVE for C at TIME every 5.5 years to '6.1-A-L08.sav'

! Solution controls
MATRix in X for C 3 sweeps using ADI
LIMIt for C 0.0
CONVergence for C REFERENCE LOCAL 1.e-6, max iterations = 30

! Solve transient transport
! Time period: 0 to 5.5 years
TIME = 0.

LOCAtE STAtion (0.,0.5) ! x=0,y=0
SOURce for C is constant at 10. kg/y/m for SELEcted region
SOLVe C for 1 years in steps of 0.001 years
SOURce OFF for C for most recently SELEcted region

SOLVe C for 4.5 years in steps of 0.001 years

END
!===== 40 meter mesh spacing =====

!===== 50 meter mesh spacing =====
GRID is 21 NODEs
COORDinate NODEs X: MINImum=-2.e+2, MAXImum=8.e+2

! Material types and subregions
MATERial type 1 ! total domain

! Material and nuclide properties
```

PROPerTy for C is HARMonic

FOR material type 1:
MATERial DENSITy 1.0
MATERial POROSity 3*0.25
TRANSport for C Kd=0 Da=0 aL=0 aT=0

! Flow conditions
SET S to 1.
SET U to 10. ! m/yr

! Boundary conditions
BOUNDary C at X- in VALUe = 0
BOUNDary C at X+ in GRAD = 0

! Diagnostic information
DIAGnostic output: TIME DTIME C for node (0.,0.5) every 100 steps

! Time history
SAVE for C at TIME every 5.5 years to '6.1-A-L09.sav'

! Solution controls
MATRix in X for C 3 sweeps using ADI
LIMIt for C 0.0
CONVergence for C REFERENCE LOCAL 1.e-6, max iterations = 30

! Solve transient transport
! Time period: 0 to 5.5 years
TIME = 0.

LOCate STATION (0.,0.5) ! x=0,y=0
SOURce for C is constant at 10. kg/y/m for SELEcted region
SOLVe C for 1 years in steps of 0.001 years
SOURce OFF for C for most recently SELEcted region

SOLVe C for 4.5 years in steps of 0.001 years

END
!===== 50 meter mesh spacing =====

!===== 60 meter mesh spacing =====
GRID is 19 NODEs
COORDinate NODEs X: MINImum=-2.4e+2, MAXImum=8.4e+2

! Material types and subregions
MATERial type 1 ! total domain

! Material and nuclide properties
PROPerTy for C is HARMonic

FOR material type 1:
MATERial DENSITy 1.0
MATERial POROSity 3*0.25
TRANSport for C Kd=0 Da=0 aL=0 aT=0

! Flow conditions
SET S to 1.
SET U to 10. ! m/yr

! Boundary conditions
BOUNDary C at X- in VALUe = 0
BOUNDary C at X+ in GRAD = 0

! Diagnostic information
DIAGnostic output: TIME DTIME C for node (0.,0.5) every 100 steps

! Time history
SAVE for C at TIME every 5.5 years to '6.1-A-L10.sav'

! Solution controls
MATRix in X for C 3 sweeps using ADI
LIMIt for C 0.0
CONVergence for C REFERENCE LOCAL 1.e-6, max iterations = 30

```

! Solve transient transport
! Time period: 0 to 5.5 years
TIME = 0.

LOCate STATION (0.,0.5) ! x=0,y=0
SOURce for C is constant at 10. kg/y/m for SELEcted region
SOLVe C for 1 years in steps of 0.001 years
SOURce OFF for C for most recently SELEcted region

SOLVe C for 4.5 years in steps of 0.001 years

END
!===== 60 meter mesh spacing =====

QUIT

```

Table 6.1.2. Input Commands for Problem 6.1 (Mechanical Dispersion).

```

*****
TITLe 1-D saturated solute transport in a uniform flow field
*****
! Mechanical Dispersion Study
*****

!===== 0.1 meter mesh spacing =====
GRID is 10001 NODEs
COORDinate NODEs X: MINImum=-2.0e+2, MAXImum=8.0e+2

! Material types and subregions
MATERial type 1 ! total domain

! Material and nuclide properties
PROPerty for C is HARMonic

FOR material type 1:
MATERial DENSITy 1.0
MATERial POROSity 3*0.25
TRANSport for C Kd=0 Da=0 aL=20 aT=0

! Flow conditions
SET S to 1.
SET U to 10. ! m/yr

! Boundary conditions
BOUNDary C at X- in VALUe = 0
BOUNDary C at X+ in GRAD = 0

! Diagnostic information
DIAGnostic output: TIME DTIME C for node (0.,0.5) every 100 steps

! Time history
SAVE for C at TIME every 5.5 years to '6.1-B-L01.sav'

! Solution controls
MATRix in X for C 3 sweeps using ADI
LIMIt for C 0.0
CONVergence for C REFERENCE LOCAL 1.e-6, max iterations = 30

! Solve transient transport
! Time period: 0 to 5.5 years
TIME = 0.

LOCate STATION (0.,0.5) ! x=0,y=0
SOURce for C is constant at 10. kg/y/m for SELEcted region
SOLVe C for 1 years in steps of 0.001 years
SOURce OFF for C for most recently SELEcted region

SOLVe C for 4.5 years in steps of 0.001 years

END
!===== 0.1 meter mesh spacing =====

```

```
!===== 1.0 meter mesh spacing =====
GRID is 1001 NODEs
COORDinate NODEs X: MINImum=-2.0e+2, MAXImum=8.0e+2
```

```
! Material types and subregions
MATERial type 1 ! total domain
```

```
! Material and nuclide properties
PROPerty for C is HARMonic
```

```
FOR material type 1:
MATERial DENSITY 1.0
MATERial PORosity 3*0.25
TRANsport for C Kd=0 Da=0 aL=20 aT=0
```

```
! Flow conditions
SET S to 1.
SET U to 10. ! m/yr
```

```
! Boundary conditions
BOUNDary C at X- in VALUe = 0
BOUNDary C at X+ in GRAD = 0
```

```
! Diagnostic information
DIAGnostic output: TIME DTIME C for node (0.,0.5) every 100 steps
```

```
! Time history
SAVE for C at TIME every 5.5 years to '6.1-B-L02.sav'
```

```
! Solution controls
MATRix in X for C 3 sweeps using ADI
LIMIt for C 0.0
CONVergence for C REFERENCE LOCAL 1.e-6, max iterations = 30
```

```
! Solve transient transport
! Time period: 0 to 5.5 years
TIME = 0.
```

```
LOCate STATION (0.,0.5) ! x=0,y=0
SOURce for C is constant at 10. kg/y/m for SELEcted region
SOLVe C for 1 years in steps of 0.001 years
SOURce OFF for C for most recently SELEcted region
```

```
SOLVe C for 4.5 years in steps of 0.001 years
```

```
END
```

```
!===== 1 meter mesh spacing =====
```

```
!===== 5 meter mesh spacing =====
GRID is 201 NODEs
COORDinate NODEs X: MINImum=-2.0e+2, MAXImum=8.0e+2
```

```
! Material types and subregions
MATERial type 1 ! total domain
```

```
! Material and nuclide properties
PROPerty for C is HARMonic
```

```
FOR material type 1:
MATERial DENSITY 1.0
MATERial PORosity 3*0.25
TRANsport for C Kd=0 Da=0 aL=20 aT=0
```

```
! Flow conditions
SET S to 1.
SET U to 10. ! m/yr
```

```
! Boundary conditions
BOUNDary C at X- in VALUe = 0
BOUNDary C at X+ in GRAD = 0
```

```
! Diagnostic information
```

DIAGnostic output: TIME DTIME C for node (0.,0.5) every 100 steps

! Time history

SAVE for C at TIME every 5.5 years to '6.1-B-L03.sav'

! Solution controls

MATRIx in X for C 3 sweeps using ADI

LIMIT for C 0.0

CONVergence for C REFERENCE LOCAL 1.e-6, max iterations = 30

! Solve transient transport

! Time period: 0 to 5.5 years

TIME = 0.

LOCAtE STAtion (0.,0.5) ! x=0,y=0

SOURce for C is constant at 10. kg/y/m for SELEcted region

SOLVe C for 1 years in steps of 0.001 years

SOURce OFF for C for most recently SELEcted region

SOLVe C for 4.5 years in steps of 0.001 years

END

!===== 5 meter mesh spacing =====

!===== 10 meter mesh spacing =====

GRID is 101 NODEs

COORDinate NODEs X: MINImum=-2.0e+2, MAXImum=8.0e+2

! Material types and subregions

MATERial type 1 ! total domain

! Material and nuclide properties

PROPerty for C is HARMonic

FOR material type 1:

MATERial DENSITY 1.0

MATERial PORosity 3*0.25

TRANsport for C Kd=0 Da=0 aL=20 aT=0

! Flow conditions

SET S to 1.

SET U to 10. ! m/yr

! Boundary conditions

BOUNDary C at X- in VALUe = 0

BOUNDary C at X+ in GRAD = 0

! Diagnostic information

DIAGnostic output: TIME DTIME C for node (0.,0.5) every 100 steps

! Time history

SAVE for C at TIME every 5.5 years to '6.1-B-L04.sav'

! Solution controls

MATRIx in X for C 3 sweeps using ADI

LIMIT for C 0.0

CONVergence for C REFERENCE LOCAL 1.e-6, max iterations = 30

! Solve transient transport

! Time period: 0 to 5.5 years

TIME = 0.

LOCAtE STAtion (0.,0.5) ! x=0,y=0

SOURce for C is constant at 10. kg/y/m for SELEcted region

SOLVe C for 1 years in steps of 0.001 years

SOURce OFF for C for most recently SELEcted region

SOLVe C for 4.5 years in steps of 0.001 years

END

!===== 10 meter mesh spacing =====

!===== 15 meter mesh spacing =====

```
GRID is 69 NODES
COORDinate NODEs X: MINImum=-2.1e+2, MAXImum=8.1e+2

! Material types and subregions
MATERial type 1 ! total domain

! Material and nuclide properties
PROPerty for C is HARMonic

FOR material type 1:
MATERial DENSITY 1.0
MATERial PORosity 3*0.25
TRANsport for C Kd=0 Da=0 aL=20 aT=0

! Flow conditions
SET S to 1.
SET U to 10. ! m/yr

! Boundary conditions
BOUNDary C at X- in VALUe = 0
BOUNDary C at X+ in GRAD = 0

! Diagnostic information
DIAGnostic output: TIME DTIME C for node (0.,0.5) every 100 steps

! Time history
SAVE for C at TIME every 5.5 years to '6.1-B-L05.sav'

! Solution controls
MATRix in X for C 3 sweeps using ADI
LIMIt for C 0.0
CONVergence for C REFERENCE LOCAL 1.e-6, max iterations = 30

! Solve transient transport
! Time period: 0 to 5.5 years
TIME = 0.

LOCate STATION (0.,0.5) ! x=0,y=0
SOURce for C is constant at 10. kg/y/m for SELEcted region
SOLVe C for 1 years in steps of 0.001 years
SOURce OFF for C for most recently SELEcted region

SOLVe C for 4.5 years in steps of 0.001 years

END
!===== 15 meter mesh spacing =====

!===== 20 meter mesh spacing =====
GRID is 51 NODES
COORDinate NODEs X: MINImum=-2.e+2, MAXImum=8.e+2

! Material types and subregions
MATERial type 1 ! total domain

! Material and nuclide properties
PROPerty for C is HARMonic

FOR material type 1:
MATERial DENSITY 1.0
MATERial PORosity 3*0.25
TRANsport for C Kd=0 Da=0 aL=20 aT=0

! Flow conditions
SET S to 1.
SET U to 10. ! m/yr

! Boundary conditions
BOUNDary C at X- in VALUe = 0
BOUNDary C at X+ in GRAD = 0

! Diagnostic information
DIAGnostic output: TIME DTIME C for node (0.,0.5) every 100 steps
```

```
! Time history
SAVE for C at TIME every 5.5 years to '6.1-B-L06.sav'

! Solution controls
MATRix in X for C 3 sweeps using ADI
LIMIt for C 0.0
CONVergence for C REFERENCE LOCAL 1.e-6, max iterations = 30

! Solve transient transport
! Time period: 0 to 5.5 years
TIME = 0.

LOCate STATION (0.,0.5) ! x=0,y=0
SOURce for C is constant at 10. kg/y/m for SELEcted region
SOLVe C for 1 years in steps of 0.001 years
SOURce OFF for C for most recently SELEcted region

SOLVe C for 4.5 years in steps of 0.001 years

END
!===== 20 meter mesh spacing =====

!===== 30 meter mesh spacing =====
GRID is 35 NODES
COORDinate NODES X: MINImum=-2.1e+2, MAXImum=8.1e+2

! Material types and subregions
MATERial type 1 ! total domain

! Material and nuclide properties
PROPerty for C is HARMONIC

FOR material type 1:
MATERial DENSITY 1.0
MATERial PORosity 3*0.25
TRANSport for C Kd=0 Da=0 aL=20 aT=0

! Flow conditions
SET S to 1.
SET U to 10. ! m/yr

! Boundary conditions
BOUNDary C at X- in VALUe = 0
BOUNDary C at X+ in GRAD = 0

! Diagnostic information
DIAGnostic output: TIME DTIME C for node (0.,0.5) every 100 steps

! Time history
SAVE for C at TIME every 5.5 years to '6.1-B-L07.sav'

! Solution controls
MATRix in X for C 3 sweeps using ADI
LIMIt for C 0.0
CONVergence for C REFERENCE LOCAL 1.e-6, max iterations = 30

! Solve transient transport
! Time period: 0 to 5.5 years
TIME = 0.

LOCate STATION (0.,0.5) ! x=0,y=0
SOURce for C is constant at 10. kg/y/m for SELEcted region
SOLVe C for 1 years in steps of 0.001 years
SOURce OFF for C for most recently SELEcted region

SOLVe C for 4.5 years in steps of 0.001 years

END
!===== 30 meter mesh spacing =====

!===== 40 meter mesh spacing =====
GRID is 26 NODES
COORDinate NODES X: MINImum=-2.e+2, MAXImum=8.e+2
```

```
! Material types and subregions
MATERial type 1 ! total domain

! Material and nuclide properties
PROPerty for C is HARMonic

FOR material type 1:
MATERial DENSITY 1.0
MATERial PORosity 3*0.25
TRANsport for C Kd=0 Da=0 aL=20 aT=0

! Flow conditions
SET S to 1.
SET U to 10. ! m/yr

! Boundary conditions
BOUNDary C at X- in VALUe = 0
BOUNDary C at X+ in GRAD = 0

! Diagnostic information
DIAGnostic output: TIME DTIME C for node (0.,0.5) every 100 steps

! Time history
SAVE for C at TIME every 5.5 years to '6.1-B-L08.sav'

! Solution controls
MATRix in X for C 3 sweeps using ADI
LIMIt for C 0.0
CONVergence for C REFERENCE LOCAL 1.e-6, max iterations = 30

! Solve transient transport
! Time period: 0 to 5.5 years
TIME = 0.

LOCate STATION (0.,0.5) ! x=0,y=0
SOURce for C is constant at 10. kg/y/m for SELEcted region
SOLVe C for 1 years in steps of 0.001 years
SOURce OFF for C for most recently SELEcted region

SOLVe C for 4.5 years in steps of 0.001 years

END
!===== 40 meter mesh spacing =====

!===== 50 meter mesh spacing =====
GRID is 21 NODEs
COORdinate NODEs X: MINImum=-2.e+2, MAXImum=8.e+2

! Material types and subregions
MATERial type 1 ! total domain

! Material and nuclide properties
PROPerty for C is HARMonic

FOR material type 1:
MATERial DENSITY 1.0
MATERial PORosity 3*0.25
TRANsport for C Kd=0 Da=0 aL=20 aT=0

! Flow conditions
SET S to 1.
SET U to 10. ! m/yr

! Boundary conditions
BOUNDary C at X- in VALUe = 0
BOUNDary C at X+ in GRAD = 0

! Diagnostic information
DIAGnostic output: TIME DTIME C for node (0.,0.5) every 100 steps

! Time history
SAVE for C at TIME every 5.5 years to '6.1-B-L09.sav'
```

```
! Solution controls
MATRix in X for C 3 sweeps using ADI
LIMIt for C 0.0
CONVergence for C REFERENCE LOCAL 1.e-6, max iterations = 30

! Solve transient transport
! Time period: 0 to 5.5 years
TIME = 0.

LOCate STATION (0.,0.5) ! x=0,y=0
SOURce for C is constant at 10. kg/y/m for SELEcted region
SOLVe C for 1 years in steps of 0.001 years
SOURce OFF for C for most recently SELEcted region

SOLVe C for 4.5 years in steps of 0.001 years

END
!===== 50 meter mesh spacing =====

!===== 60 meter mesh spacing =====
GRID is 19 NODEs
COORDinate NODEs X: MINImum=-2.4e+2, MAXImum=8.4e+2

! Material types and subregions
MATERial type 1 ! total domain

! Material and nuclide properties
PROPerty for C is HARMonic

FOR material type 1:
MATERial DENSITY 1.0
MATERial POROSity 3*0.25
TRANSport for C Kd=0 Da=0 aL=20 aT=0

! Flow conditions
SET S to 1.
SET U to 10. ! m/yr

! Boundary conditions
BOUNDary C at X- in VALUe = 0
BOUNDary C at X+ in GRAD = 0

! Diagnostic information
DIAGnostic output: TIME DTIME C for node (0.,0.5) every 100 steps

! Time history
SAVE for C at TIME every 5.5 years to '6.1-B-L10.sav'

! Solution controls
MATRix in X for C 3 sweeps using ADI
LIMIt for C 0.0
CONVergence for C REFERENCE LOCAL 1.e-6, max iterations = 30

! Solve transient transport
! Time period: 0 to 5.5 years
TIME = 0.

LOCate STATION (0.,0.5) ! x=0,y=0
SOURce for C is constant at 10. kg/y/m for SELEcted region
SOLVe C for 1 years in steps of 0.001 years
SOURce OFF for C for most recently SELEcted region

SOLVe C for 4.5 years in steps of 0.001 years

END
!===== 60 meter mesh spacing =====

QUIT
```

7 Group 4: Keyword Commands

This section deals with the testing of several PORFLOW keyword commands that are of interest to the Performance Assessment modelers at SRNL. The list of keywords tested is not exhaustive by any means and will continue to grow as needed by the modeling community.

7.1 DECAy and REGEneration

Mode 1 (Direct Linear Decay) of the DECAy command is used to specify rate constants and mode of decay of a dependent variable due to physical, chemical or radioactive decay. The REGEneration command specifies the regeneration rate of one species from another in the decay chain. The U-230 decay chain, $U-230 \rightarrow Th-226 \rightarrow Ra-222 \rightarrow Rn-218 \rightarrow Po-214 \rightarrow Pb-210 \rightarrow Bi-210 \rightarrow Po-210$, was used to verify that PORFLOW correctly computes transient concentrations of the parent and progeny species undergoing radioactive decay only (no transport). The PORFLOW results were compared to the classical Bateman equation.

Analytical solution: Bateman (1910) developed a general equation for serial decay chains, such as the heavy decay chain of U-238. Assuming that the concentration of all the daughters are initially zero (i.e. $n_i(0) = 0$ for $i > 1$), the concentration of the i -th radionuclide can be determined from

$$n_i(t) = \lambda_1 \lambda_2 \cdots \lambda_{i-1} n_1(0) \sum_{j=1}^i \frac{e^{-\lambda_j t}}{\prod_{\substack{k=1 \\ k \neq j}}^i (\lambda_k - \lambda_j)} \quad (7.1.1)$$

PORFLOW numerical simulation and comparison: A one-element PORFLOW model of unit size was constructed. The initial inventory of U-230 was set equal to one mole. No transport properties were specified for all the species. Zero flux boundary conditions were imposed for all species. A 200-year simulation with a time step of 0.01 years was executed. The history of U-230 and its daughters was recorded every 0.1 years. The PORFLOW input commands are shown in Table 7.1.1.

Figure 7.1.1 shows a comparison of the transient concentrations of the last three daughters in the U-230 decay chain to the Bateman equation. The Bateman and PORFLOW results are shown as lines and circles, respectively. The agreement is excellent. The parent and earlier daughters decay so quickly and are not visible within the scale shown in the figure.

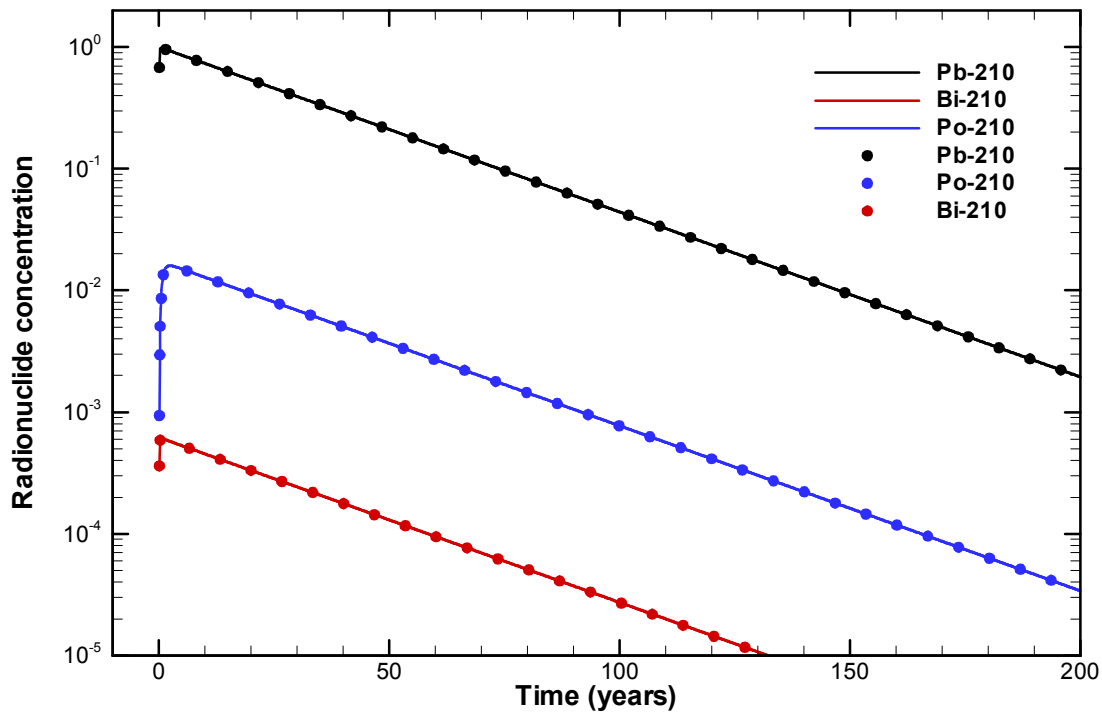

Figure 7.1.1. Comparison of Radionuclide Concentrations in the U-230 Decay Chain to the Bateman Equation.

Table 7.1.1. Input Commands for Problem 7.1.

```

!*****
TITLE: TESTING DEcAY command
!*****
ALLOCATE C5
ALLOCATE C6
ALLOCATE C7
ALLOCATE C8

GRID 3
COORDINATE X RANGE = 1

BOUNDary FOR C: at X- FLUX = 0
BOUNDary FOR C: at X+ FLUX = 0
BOUNDary FOR C2: at X- FLUX = 0
BOUNDary FOR C2: at X+ FLUX = 0
BOUNDary FOR C3: at X- FLUX = 0
BOUNDary FOR C3: at X+ FLUX = 0
BOUNDary FOR C4: at X- FLUX = 0
BOUNDary FOR C4: at X+ FLUX = 0
BOUNDary FOR C5: at X- FLUX = 0
BOUNDary FOR C5: at X+ FLUX = 0
BOUNDary FOR C6: at X- FLUX = 0
BOUNDary FOR C6: at X+ FLUX = 0
BOUNDary FOR C7: at X- FLUX = 0
BOUNDary FOR C7: at X+ FLUX = 0
BOUNDary FOR C8: at X- FLUX = 0
BOUNDary FOR C8: at X+ FLUX = 0

DEcAY half LIFE for C is 5.7100E-02 years ! U-230
DEcAY half LIFE for C2 is 5.8000E-05 years ! Th-226
DEcAY half LIFE for C3 is 1.2000E-06 years ! Ra-222
DEcAY half LIFE for C4 is 1.1100E-09 years ! Rn-218
    
```

```

DECAY half LIFE for C5 is 5.2000E-12 years ! Po-214
DECAY half LIFE for C6 is 2.2200E+01 years ! Pb-210
DECAY half LIFE for C7 is 1.3700E-02 years ! Bi-210
DECAY half LIFE for C8 is 3.8100E-01 years ! Po-210

```

```

REGeneration of C2 from C is 1.00000E+00 ! Th-226 from U-230
REGeneration of C3 from C2 is 1.00000E+00 ! Ra-222 from Th-226
REGeneration of C4 from C3 is 1.00000E+00 ! Rn-218 from Ra-222
REGeneration of C5 from C4 is 1.00000E+00 ! Po-214 from Rn-218
REGeneration of C6 from C5 is 1.00000E+00 ! Pb-210 from Po-214
REGeneration of C7 from C6 is 1.00000E+00 ! Bi-210 from Pb-210
REGeneration of C8 from C7 is 1.00000E+00 ! Po-210 from Bi-210

```

```

SET C2 0
SET C3 0
SET C4 0
SET C5 0
SET C6 0
SET C7 0
SET C8 0

```

```

! Initial condition
SET C INVENTORY to 1 mole with UNIFORM concentration

```

```

DIAGNOSTICS for TIME C at: (2,2) every 10 steps

```

```

! Solution controls
MATRIX in X for C C2 C3 C4 C5 C6 C7 C8 3 3 3 3 3 3 3 3 sweeps using ADI
CONVERGENCE for C C2 C3 C4 C5 C6 C7 C8 REFERENCE LOCAL 1.e-6, max iterations = 30

```

```

SELECT (2,2)
HISTORY for C C2 C3 C4 at TIME interval of 0.1 year to file 'DECAY-1.his' for SELECTED
HISTORY for C5 C6 C7 C8 at TIME interval of 0.1 year to file 'DECAY-2.his' for SELECTED

```

```

SOLVE C C2 C3 C4 C5 C6 C7 C8 200 years in steps of 0.01
SAVE OFF

```

```

END

```

7.2 DISTRIBUTION and RETARDATION

Mode 1 (Distribution Coefficient as a General Function) of the DISTRIBUTION command with the TABLE modifier was used to specify the distribution coefficient, k_d , as a function of fluid concentration in tabular form. The complementary RETARDATION command with the TABLE modifier was used to specify retardation as a function of fluid concentration in tabular form. The table of values was formulated to demonstrate that the DIST or RETA command could be used to limit the solubility of a species. If the fluid concentration is below the solubility limit, the k_d or R remains constant at the nominal value. If the inventory or effective concentration (fluid and solid) of the species exceeds the solubility limit of the species, the k_d or R is adjusted to maintain the fluid concentration at the solubility limit. The fluid concentration is computed in PORFLOW as

$$C = \frac{C_e}{R\theta} \quad (7.2.1)$$

where

C concentration of the species in the fluid phase

C_e inventory or effective concentration of the species in the porous medium

PORFLOW numerical simulation and comparison: A one-element PORFLOW model of unit size was constructed. The dry solid density and the porosity were set to 2 and 0.5, respectively. The fluid phase is saturated. Zero flux boundary conditions were imposed. A 600-year simulation with a time step of 0.1 years was executed. A point source of strength 0.01 per year was turned on for 200 years. A subsequent point sink of strength 0.01 per year was then turned on for the next 100 years. The point source/sink cycle was then repeated.

A table of (C,kd) values with three sets was specified for the DIST command. The kd is set to a constant value of 0.4 ($R = 2$) for fluid concentrations ranging from 0 to 1. Above a fluid concentration of 1 the kd is adjusted so that the product of the retardation factor and water content offsets any increase in the inventory or effective concentration to maintain the solubility limit. This results in a species solubility limit of 1. Once the effective concentration drops below the solubility limit, the kd is constant at 0.4. Similarly, for the RETA command a table of (C,R) values are specified instead.

Figure 7.2.1. shows the implementation of a solubility-limited source based on the DIST and RETA command. During the first 100 years the liquid and solid concentrations are equal ($\rho_s kd = 1$) and track the injection rate of 0.01 per year. At 100 years, the liquid and solid concentrations equal the solubility limit of 1. Between 100 and 200 years, the effective concentration of the species attempts to increase from 1 to 2. Any delta increase in the effective concentration above the solubility limit of 1 is offset by an increase in the product of the retardation factor and water content to keep the fluid concentration at 1. Any mass injected above the solubility limit of the species is discarded by PORFLOW and is reflected by an increase in the flux balance discrepancy in the diagnostic file. Between the time of 200 to 300 years, the solute is extracted at a rate of 0.01 per year. The actual inventory at 200 years is 1 instead of 2 since PORFLOW has discarded the additional mass. This drives the fluid concentration from 1 to 0. The rest of the transient is a repeat of the previous point source/sink cycle. The DIST and RETA commands (Mode 1) function as designed by the developer is nonconservative, due to loss inventory, for implementation as a means to limit the solubility of the species. The fluid concentration should ideally track the solid line in Figure 7.2.1.

The PORFLOW input commands utilizing the DIST and RETA commands are shown in Table 7.2.1 and 7.2.2, respectively.

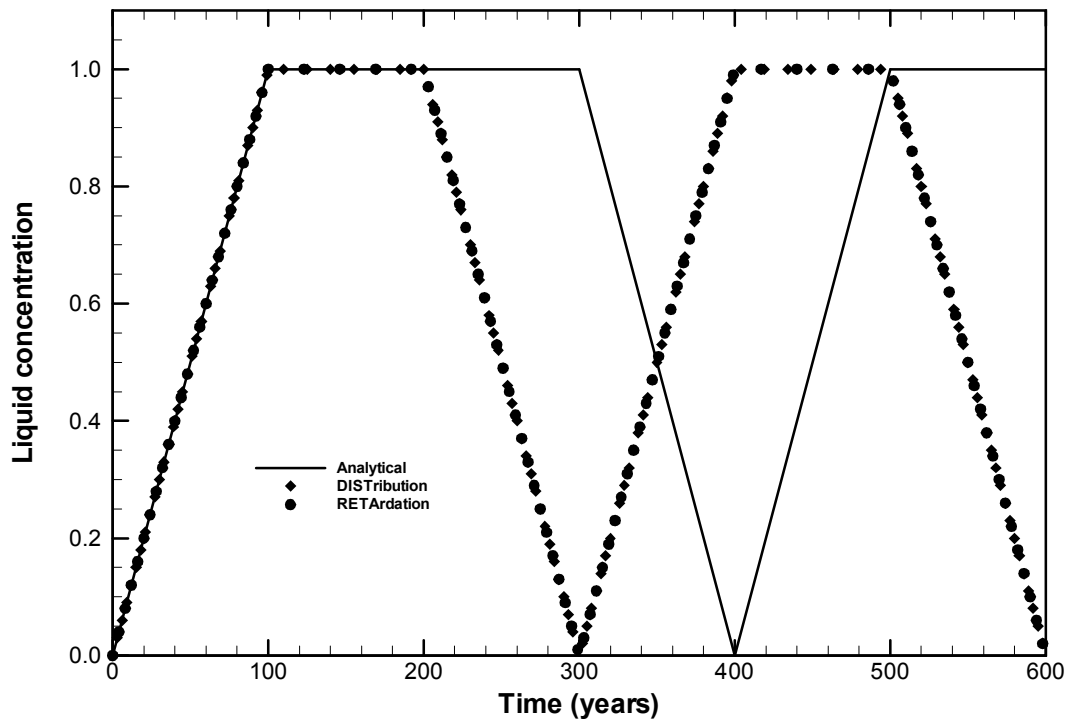

Figure 7.2.1. Implementation of Solubility Limited Source based on the DIST and RETA Command.

Table 7.2.1. Input Commands for Problem 7.2 (DIST command).

```

*****
TITLE: DISTribution command (Mode 1)
! TESTING SOLUBILITY LIMITED SOURCE
*****

GRID 3
COORDINATE X RANGE = 1

MATERIAL dry solid DENSITY = 2.5 !g/cm3
MATERIAL POROSity = 0.5

DENSITY = 1

TRANsport for C Kd=0., Dm=0 !m2/year

BOUNDary FOR C: at X- FLUX = 0
BOUNDary FOR C: at X+ FLUX = 0

SET C to 0
SET S to 1

DISTribution of C as (C,kd) TABLE of values: with 3 sets:
(0., 0.4) (1., 0.4) (2, 1.2)

DIAGnostics for TIME C at: (2,2) every 10 steps

! Solution controls
MATRix in X for C 3 sweeps using ADI
CONVergence for C REFERENCE LOCAL 1.e-6, max iterations = 30

FLUX of C for at TIME interval of 0.1 years to 'DIST.flx'
HISTORY of STORage for C at TIME interval of 0.1 years to 'DIST-STOR.his'
    
```

```
SELEct (2,2)
HISTORY for C at TIME interval of 0.1 years to 'DIST-C.his' for SELEcted
```

```
SELEct (2,2)
SOURce for C by VOLUme: 0.01 per year
SOLVE C 200 years in steps of 0.1
SOURce is OFF for C
```

```
SOURce for C by VOLUme: -0.01 per year
SOLVE C 100 years in steps of 0.1
SOURce is OFF for C
```

```
SOURce for C by VOLUme: 0.01 per year
SOLVE C 200 years in steps of 0.1
SOURce is OFF for C
```

```
SOURce for C by VOLUme: -0.01 per year
SOLVE C 100 years in steps of 0.1
```

```
END
```

Table 7.2.2. Input Commands for Problem 7.2 (RETA command).

```
*****
TITLE: RETardation command (Mode 1)
! TESTING SOLUBILITY LIMITED SOURCE
*****
```

```
GRID 3
COORDINATE X RANGE = 1
```

```
MATERial dry solid DENSity = 2.5 !g/cm3
MATERial POROSity = 0.5
```

```
DENSITY = 1
```

```
TRANSport for C Kd=0., Dm=0 !m2/year
```

```
BOUNDary FOR C: at X- FLUX = 0
BOUNDary FOR C: at X+ FLUX = 0
```

```
SET C to 0
SET S to 1
```

```
RETardation of C as (C,Rvalue) TABLE of values: with 3 sets:
(0., 2.) (1., 2.) (2, 4.)
```

```
DIAGnostics for TIME C at: (2,2) every 10 steps
```

```
! Solution controls
MATRix in X for C 3 sweeps using ADI
CONVergence for C REFERENCE LOCAL 1.e-6, max iterations = 30
```

```
FLUX of C for at TIME interval of 0.1 years to 'RETA.flx'
HISTORY of STORage for C at TIME interval of 0.1 years to 'RETA-STOR.his'
```

```
SELEct (2,2)
HISTORY for C at TIME interval of 0.1 years to 'RETA-C.his' for SELEcted
```

```
SELEct (2,2)
SOURce for C by VOLUme: 0.01 per year
SOLVE C 200 years in steps of 0.1
SOURce is OFF for C
```

```
SOURce for C by VOLUme: -0.01 per year
SOLVE C 100 years in steps of 0.1
SOURce is OFF for C
```

```
SOURce for C by VOLUme: 0.01 per year
SOLVE C 200 years in steps of 0.1
SOURce is OFF for C
```

SOURCE for C by VOLUME: -0.01 per year
 SOLVE C 100 years in steps of 0.1

END

7.3 STATISTICS

The STATISTICS command provides a means to compute and obtain output of the statistics for an independent variable for a selected subregion. The computed statistics consist of the minimum, maximum, mean and standard deviation, and the location of the minimum and the maximum. The statistic of interest for PA modeling at SRNL is the maximum concentration within a subregion or in a subregion beyond a facility or compliance boundary (100 meter well). The STATISTICS command was tested on the 3D saturated solute transport problem in Section 5.3.

The PORFLOW input commands for Problem 5.3 were augmented with two STATISTICS commands as shown in Table 7.3.1. The first command determines the location and maximum concentration within the computational domain every 100 years of the simulation. The second command determines the same information for a subregion beyond $x = 700$ meters.

The maximum concentration for the entire domain exist at the point source located at $x = y = z = 0$. The element number for the point source is 49590 as shown in Table 7.3.2 using the LOCATE command. The STATISTICS command, with no subregion specified, locates the maximum concentration for the entire domain at element 49590 as shown in Table 7.3.3. The command has generated the correct result.

A subregion was selected 700 meters downstream of the point source. The LOCATE EXCLUDE POLYGON command was used to exclude any elements below $x = 700$ meters. The highest concentrations downstream of the point source exist along the plume centerline ($I \geq 20$, $J = 19$, $K = 19$). According to Table 7.3.4, 20825 elements were selected in the subregion. The table was edited to show only the elements along the plume centerline. The STATISTICS command for subregion ID=RECT locates the maximum concentration at element 49637 as shown in Table 7.3.5. This element is along the plume centerline (see Table 7.3.4); therefore, the command has generated the correct result.

Table 7.3.1. Input Commands for Problem 7.3.

```
*****
TITLE STATISTICS command
*****
! 3-D saturated solute transport in a uniform flow field
*****

GRID is 83 by 37 by 37 NODES
COORDINATE NODES X: MINIMUM=-2.7e+2, MAXIMUM=9.6e+2
COORDINATE NODES Y: MINIMUM=-2.7e+2, MAXIMUM=2.7e+2
COORDINATE NODES Z: MINIMUM=-2.7e+2, MAXIMUM=2.7e+2

! Material types and subregions
MATERIAL type 1 ! total domain

! Material and nuclide properties
PROPERTY for C is HARMONIC

FOR material type 1:
```

MATERIAL DENSITY 1.23077
 MATERIAL POROSITY 3*0.35
 TRANSPORT for C Kd=0 Da=0 aL=21.3 aT=4.3

! Flow conditions
 SET S to 1.
 SET U to 0.161 ! m/d

! Boundary conditions
 BOUNDARY C at X- in VALUE = 0
 BOUNDARY C at X+ in GRAD = 0
 BOUNDARY C at Y- in GRAD = 0
 BOUNDARY C at Y+ in GRAD = 0
 BOUNDARY C at Z- in GRAD = 0
 BOUNDARY C at Z+ in GRAD = 0

LOCATE STATION (x=0.,y=0.,z=0.) output to file 'SRCE.loc'
 SOURCE for C is constant at 0.11792 kg/d for SELEcted region

! Diagnostic information
 DIAGNOSTIC output: TIME DTIME C for node (0.,0.,0.) every 1 steps

! STATistics for Domain
 STATISTICS for C at TIME every 100 days to 'DOMAIN-STAT.out'

! STATistics for polygon region beyond x = 700
 LOCATE ID=RECT EXCLUDE POLYGON (x,y,z): to file 'RECT.loc'
 Base: (-280,-280,-280) (700,-280,-280) (700, 280,-280) (-280, 280,-280)
 Top: (-280,-280, 280) (700,-280, 280) (700, 280, 280) (-280, 280, 280)
 STATISTICS for C at TIME every 100 days to 'RECT-STAT.out' for ID=RECT

! Solution controls
 MATRIX in X Y Z for C 3 sweeps using ADI
 !LIMIT for C 0.0
 CONVERGENCE for C REFERENCE LOCAL 1.e-6, max iterations = 30

! Solve transient transport
 ! Time period: 0 to 1400 years
 TIME = 0.

SOLVE C for 1400 days in steps of 10 days
 SAVE OFF

END
 QUIT

Table 7.3.2. Location of Point Source for Problem 7.3.

```
LOCATE LIST of Elements ID=SRCE.loc ! 1
END HEADER
49590
Serial# Element# I J K
1 49590 19 19 19
```

Table 7.3.3. Statistics File Showing Maximum Value and Element for Domain.

```
BEGIN FILE IDENTIFICATION INFORMATION
DATA_TYPE_ID::::: 30
PROBLEM_TITLE::::: Statistics command
ACRi SOFTWARE TOOL: PORFLOW-3D VERSION 5.97.0 /ACRi: DATE: 15 APR 2004
LICENSED USER::::: Len Collard License ID:LENCOLLA00000101
USER NAME::::: ACRi - GEN
DATE::::: 06/01/2007
TIME::::: 21:29:58
END FILE IDENTIFICATION INFORMATION
BEGIN HEADER FOR TABLE COLUMNS
ID# VAR# ZoneID Time:Step# Maximum_Value Element
END HEADER FOR TABLE COLUMNS
1 8 <Domain> 0.0000000E+00 0.0000000E+00 1
1 8 <Domain> 1.0000000E+02 1.1709450E-03 49590
1 8 <Domain> 2.0000000E+02 1.2198963E-03 49590
```

1	8	<Domain>	3.0000000E+02	1.2305669E-03	49590
1	8	<Domain>	4.0000000E+02	1.2340566E-03	49590
1	8	<Domain>	5.0000000E+02	1.2354029E-03	49590
1	8	<Domain>	6.0000000E+02	1.2359710E-03	49590
1	8	<Domain>	7.0000000E+02	1.2362248E-03	49590
1	8	<Domain>	8.0000000E+02	1.2363427E-03	49590
1	8	<Domain>	9.0000000E+02	1.2363992E-03	49590
1	8	<Domain>	1.0000000E+03	1.2364268E-03	49590
1	8	<Domain>	1.1000000E+03	1.2364406E-03	49590
1	8	<Domain>	1.2000000E+03	1.2364475E-03	49590
1	8	<Domain>	1.3000000E+03	1.2364511E-03	49590
1	8	<Domain>	1.4000000E+03	1.2364529E-03	49590

Table 7.3.4. Location of Plume Centerline Nodes Beyond x = 700 meters.

```
LOCATE LIST of Elements ID=RECT.loc      !      20825
END HEADER

          49643  49644  49645  49646  49637  49638  49639  49640  49641  49642
          49653
Serial#  Element#      I      J      K
10405   49637         66     19     19
10406   49638         67     19     19
10407   49639         68     19     19
10408   49640         69     19     19
10409   49641         70     19     19
10410   49642         71     19     19
10411   49643         72     19     19
10412   49644         73     19     19
10413   49645         74     19     19
10414   49646         75     19     19
10415   49647         76     19     19
10416   49648         77     19     19
10417   49649         78     19     19
10418   49650         79     19     19
10419   49651         80     19     19
10420   49652         81     19     19
10421   49653         82     19     19
```

Table 7.3.5. Statistics File Showing Maximum Value and Element Beyond x = 700 m.

```
BEGIN FILE IDENTIFICATION INFORMATION
DATA_TYPE_ID:::::      30
PROBLEM_TITLE:::::  Statistics command
ACRi_SOFTWARE_TOOL:  PORFLOW-3D  VERSION 5.97.0 /ACRi:  DATE: 15 APR 2004
LICENSED_USER:::::  Len Collard
USER_NAME:::::      ACRi - GEN
DATE:::::      06/01/2007
TIME:::::      21:29:58
END FILE IDENTIFICATION INFORMATION
BEGIN HEADER FOR TABLE COLUMNS
ID#  VAR#  ZoneID  Time:Step#  Maximum_Value  Element
END HEADER FOR TABLE COLUMNS
  2   8   RECT    0.0000000E+00  0.0000000E+00    65
  2   8   RECT    1.0000000E+02  4.8580361E-20   49637
  2   8   RECT    2.0000000E+02  9.4585599E-16   49637
  2   8   RECT    3.0000000E+02  4.8345513E-13   49637
  2   8   RECT    4.0000000E+02  3.6034674E-11   49637
  2   8   RECT    5.0000000E+02  8.1758790E-10   49637
  2   8   RECT    6.0000000E+02  8.3690806E-09   49637
  2   8   RECT    7.0000000E+02  4.8936405E-08   49637
  2   8   RECT    8.0000000E+02  1.9030743E-07   49637
  2   8   RECT    9.0000000E+02  5.4566521E-07   49637
  2   8   RECT    1.0000000E+03  1.2404139E-06   49637
  2   8   RECT    1.1000000E+03  2.3563987E-06   49637
  2   8   RECT    1.2000000E+03  3.8903604E-06   49637
  2   8   RECT    1.3000000E+03  5.7507658E-06   49637
  2   8   RECT    1.4000000E+03  7.7888400E-06   49637
```

8 References

- Abramowitz, M. and Stegun, I., 1970. Handbook of Mathematical Functions (Hardcover), National Bureau of Standards (1970).
- ACRI, Inc., 1994. "Validation Version 2.50," Analytical & Computational Research, Inc., 1985-1994.
- ACRI, Inc., 2004. "User's Manual Version 5.0 Rev:5," Analytical & Computational Research, Inc., 1985-2002.
- Anderson, P. F., 1993, "A manual of instructional problems for the U.S.G.S. MODFLOW model", EPA/600/R-93/010, Environmental Protection Agency.
- Bateman, H., 1910. "The solution of a system of differential equations occurring in the theory of radio-active transformations," *Proc. Cambridge Phil. Soc.*, 16, p. 423 (1910).
- COMSOL AB, 2006. "COMSOL Multiphysics: Earth Science Module", Version 3.3, August 2006.
- de Marsily, G., 1986. Quantitative Hydrogeology, Academic Press, Inc.
- Faust, C. R., P. N. Sims, C. P. Spalding, P. F. Anderson, B. H. Lester, M. G. Shupe, and A. Harrover, 1993 (GeoTrans, Inc.). FTWORK: Groundwater Flow and Solute Transport in Three Dimensions, Documentation, Version 12.9, prepared for GeoTrans, Inc., Sterling, Virginia 20166
- Freeze, R. A., and J. A. Cherry, 1979, Groundwater, Prentice-Hall, Englewood Cliffs, New Jersey.
- GeoTrans, 1993, "FTWORK: Groundwater flow and solute transport in three dimensions; Documentation version 2.8".
- Grobner, W., and N. Hofreiter, 1950. Integraltafel, Springer, Vienna, Vol. 2 (Vol. 1, 1949).
- Hamm, L., L. and Aleman, S. E., 2000. "FACT (Version 2.0) Subsurface Flow and Contaminant Transport Documentation and User's Guide (U)," Westinghouse Savannah River Company, March 2000.
- Hantush, M. S. and C. E. Jacob, 1955, "Non-steady radial flow in an infinite leaky aquifer", *Am. Geophys. Union Trans.*, v36, 95-100.
- Hantush, M. S., and R. G. Thomas, 1966, "A method for analyzing a drawdown test in anisotropic aquifers", *Water Resources Res.* v2 n2, 281-285.
- Ogata, A. and R. B. Banks, 1961. A solution of the differential equation of longitudinal dispersion in a porous media, U.S. Geol. Survey, Professional Paper 411-A.
- Permlmutter, N.M. and M. Lieber, 1970. Dispersion of plating wastes and sewage contaminants in groundwater and surface water, South Farmingdale-Massapequa Area, Nassau County, New York, U.S. Geol. Surv. Water Supply Paper 1879-G.
- Polubarinova-Kochina, 1962. "Theory of Ground Water Movement," Translated from the Russian by J. M. Roger De Wiest, Princeton University Press, Princeton, New Jersey, 1962.
- Theis, C. V., 1935, "The relation between the lowering of the piezometric surface and the rate and duration of discharge of a well using groundwater storage", *Trans. Am. Geophys. Union, Ann. Meet.*, 16th, 519-524.
- van Genuchten, M. T., 1980, "A Closed-form Equation for Predicting the Hydraulic Conductivity of Unsaturated Soils", *Soil Sci. Am. J.*, v44, pp. 892-898.

Wilson, J.L. and P.J. Miller, 1978. Two-dimensional plume in uniform ground-water flow, J. of the Hydraulics Div., Amer. Soc. Civ. Engrs., 104, HY4.

Yeh, G.T. 1981. AT123D: Analytical transient one-, two-, and three-dimensional simulation of transport in the aquifer system, Oak Ridge National Lab., Tennessee, Report No. ORNL-5602.

A Hantush and Jacob Numerical Code

A.1 FORTRAN Listing for HantushJacob.f90

```
PROGRAM HantushJacob

! Evaluates the Hantush and Jacob well function and drawdown

USE COMVAR
USE NUMERICAL_LIBRARIES
IMPLICIT NONE
DOUBLE PRECISION x,s,Ss,Q,K,t,pi,L,e
DOUBLE PRECISION F,ERRABS,ERRREL,Wp,ERREST
INTEGER i,INTERV
EXTERNAL F
DATA Ss/1.d-04/,Q/0.4_8/,K/5.d-03/,e/1._8/,L/1.d-06/
pi = dacos(-1._8)
B = dsqrt(K/L)
r = 60._8
INTERV = 1
ERRABS = 0._8
ERRREL = 0.001_8
open(UNIT=9,FILE='HantushJacob.dat',STATUS='UNKNOWN')
write(9,'(a)') 'VARIABLES = "time", "s"'

do i=0,250
  if (i.eq.0) then
    t = 0.5_8
  else
    t = dble(i)
  end if
  x = r**2*Ss/(4._8*K*t)
! IMSL routine DQDAGI: Adaptive general-purpose infinite interval
! univariate quadrature scheme
  call DQDAGI(F,x,INTERV,ERRABS,ERRREL,Wp,ERREST)
  s = Q/(4._8*pi*K*e)*Wp
  write(9,'(1x,e12.6,5x,e12.6)') t,s
end do
stop

END PROGRAM HantushJacob
```

A.2 FORTRAN Listing for F.f90

```
DOUBLE PRECISION FUNCTION F(x)

USE COMVAR
IMPLICIT NONE
DOUBLE PRECISION x
! F is Hantush and Jacob well function integrand
F = DEXP(-x-r**2/(4._8*B**2*x))/x

END FUNCTION F
```

A.3 FORTRAN Listing for Comvar.f90

```
MODULE COMVAR

DOUBLE PRECISION r,B
```

 END MODULE COMVAR

B Grobner and Hofreiter Numerical Code

B.1 FORTRAN Listing for GH.f90

```

PROGRAM GH

!*****
!*
!* Evaluates the general solution derived by Grobner and
!* Hofreiter (1950).
!*
!******

!
  USE numerical_libraries
  IMPLICIT NONE
  CHARACTER*128 commnt,filename,ZoneName
  DOUBLE PRECISION sw,phi,rhos,kd,thalf
  DOUBLE PRECISION wc,rhob,R,lamda
  DOUBLE PRECISION ux,alpha,tau,dm,cent
  DOUBLE PRECISION Dxx,Dxxr,uxp,uxpr,B,sigma
  DOUBLE PRECISION tmin,tmax,delt
  DOUBLE PRECISION xmin,xmax,delx
  DOUBLE PRECISION X,T,F,C
  INTEGER usupr,udiag,umain,uplot,np,I

! INITIALIZE I/O
  usupr = 5
  udiag = 10
  umain = 11
  uplot = 12

  read(usupr,*,err=100) filename
  open(unit=umain,file=filename,status='old',err=100)

  read(usupr,*,err=100) filename
  open(unit=udiag,file=filename,status='unknown',err=100)

  close (unit=usupr)

! sw = water saturation
! phi = porosity
! rhos = soil density
! kd = solute distribution coef
! thalf = radioactive half-life
  read(umain,*,err=200) commnt
  read(umain,*,err=200) sw,phi,rhos,kd,thalf
  write(udiag,1000,err=300) sw,phi,rhos,kd,thalf
! wc = water content
! rhob = bulk density
! R = retardation factor
! lamda = decay constant
  wc = phi*sw
  rhob = rhos*(1._8-phi)
  R = 1._8 + rhob*kd/wc
  if (thalf.eq.0.) then
    lamda = 0._8
  else
    lamda = log(2._8)/thalf
  end if
  write(udiag,1010,err=300) wc,rhob,R,lamda
! ux = darcy x velocity
! alpha = longitudinal dispersivity
! tau = tortuosity
! dm = molecular diffusion coefficient
! cent = inlet concentration
  read(umain,*,err=200) commnt

```



```

    read(umain,*,err=200) ux,alpha,tau,dm,cent
    write(udiag,1020,err=300) ux,alpha,tau,dm,cent
! uxp = phasic velocity
! uxpr = retarded phasic velocity
! Dxx = dispersion coefficient
! Dxxr = retarded dispersion coefficient
    uxp = ux/wc
    uxpr = uxp/R
    Dxx = alpha*uxp + wc*tau*dm
    Dxxr = Dxx/R
    B = dsqrt((0.5_8*uxpr/Dxxr)**2 + lamda/Dxxr)
    sigma = dsqrt(uxpr**2 + 4._8*lamda*Dxxr)
    write(udiag,1030,err=300) uxp,uxpr,Dxx,Dxxr,B,sigma
! tmin = minimum time value
! tmax = maximum time value
! delt = delta time
    read(umain,*,err=200) commnt
    read(umain,*,err=200) tmin,tmax,delt
! xmin = minimum x value
! xmax = maximum x value
! delx = x grid spacing
    read(umain,*,err=200) commnt
    read(umain,*,err=200) xmin,xmax,delx
    np = max(int((xmax-xmin)/delx)+1,1)

    T = tmin
    read(umain,*,err=200) commnt
! Loop over time
    do while (T <= tmax)
        read(umain,*,err=200) filename
        open(unit=uplot,file=filename,status='unknown',err=100)
        read(umain,*,err=200) ZoneName
        write(uplot,'(a)') 'VARIABLES = "x" "y" "c" "mtyp"'
        write(uplot,1500) trim(ZoneName)
        X = xmin
! Loop over x
        do I=1,np
            F = derfc(0.5_8*(X+sigma*T)/dsqrt(Dxxr*T))
            if (F.eq.0._8) then
                C = 0.5_8*cent*dexp(0.5_8*uxpr*X/Dxxr-X*B)*derfc(0.5_8*(X-sigma*T)/dsqrt(Dxxr*T))
            else
                C = 0.5_8*cent*dexp(0.5_8*uxpr*X/Dxxr)*(dexp(-X*B)*derfc(0.5_8*(X-sigma*T)/dsqrt(Dxxr*T))
&
                + dexp(X*B)*derfc(0.5_8*(X+sigma*T)/dsqrt(Dxxr*T))
            end if
            write(uplot,'(2(f10.2),es12.3e3,i7)') X,0.,C,1
            X = X + delx
        end do
        close (unit=uplot)
        T = T + delt
    end do

    close (unit=umain)
    stop 'Normal termination'
    pause
! bail out during open error
    100 stop 'OPEN error'
    pause
! bail out during read error
    200 stop 'READ error'
    pause
! bail out during write error
    300 stop 'WRITE error'
    pause
1000 format(/,'water saturation is ',f5.3, &
    /,'porosity is ',f5.3, &
    /,'soil density is ',f5.3, &
    /,'solute distribution coefficient is ',f5.3, &
    /,'half life is ',es9.3)
1010 format(/,'water content is ',f5.3, &
    /,'bulk density is ',f5.3, &
    /,'retardation factor is ',f5.3, &
    /,'decay constant is ',es9.3)

```

```

1020 format(/,'darcy x velocity is ',f6.3, &
/, 'longitudinal dispersity is ',f5.3, &
/, 'tutuosity is ',f5.3, &
/, 'molecular diffusion coefficient is ',es9.3, &
/, 'inlet concentration is ',f6.3)
1030 format(/,'phasic velocity is ',es9.3, &
/, 'retarded phasic velocity is ',es9.3, &
/, 'dispersion coefficient is ',es9.3, &
/, 'retarded dispersion coefficient is ',es9.3, &
/, 'GH beta is ',es9.3, &
/, 'GH sigma is ',es9.3)
1500 format('ZONE T="'',a,'"')

```

END PROGRAM GH

B.2 Superfile Input for 1D Transport Base Case

GH.inp
GH.log

B.3 Main Input for 1D Transport Base Case

```

/sw,      phi,      rhos,      kd,      thalf/
1.        0.25     1.        0.        0.
/ux,      alpha,    tau,      dm,      cent/
1.        5.        1.        0.        1.
/tmin,    tmax,     delt/
25.       50.      25.
/xmin,    xmax,     delx/
0.        400.    2.
/Tecplot output/
5.1-bc-25.plt
"5.1-bc (25)"
5.1-bc-50.plt
"5.1-bc (50)"

```

C AT123D Numerical Code

C.1 FORTRAN Listing for AT123D.f90

PROGRAM AT123D

```

!*****
!*
!* AT123D: Analytical transient one, two and three dimensional
!* simulation of contaminant transport in an aquifer
!* system with point/line sources. This version is a
!* subset of G. T. Yeh's original 1981 formulation based
!* on Green's functions computed from IMSL subroutines.
!*
!*****

USE comvar
USE numerical_libraries
IMPLICIT NONE
DOUBLE PRECISION, ALLOCATABLE :: alist(:),blist(:),rlist(:), &
                                elist(:)

DOUBLE PRECISION sw,phi,rhos,kd,thalf
DOUBLE PRECISION wc,rhob,R
DOUBLE PRECISION ux,uy,theta
DOUBLE PRECISION uxp,uyp,up
DOUBLE PRECISION DL,DT,tau,Dm
DOUBLE PRECISION Dxx,Dyy,Dzz
DOUBLE PRECISION Qcs,dz,Qcl,src_beg,src_end
DOUBLE PRECISION errabs,errrel,errest
DOUBLE PRECISION cost,sint
DOUBLE PRECISION tmin,tmax,delt

```

```

DOUBLE PRECISION xmin,xmax,delx
DOUBLE PRECISION ymin,ymax,dely
DOUBLE PRECISION zmin,zmax,delz
DOUBLE PRECISION XT,YT,C,INTG
CHARACTER*128 commnt,filename,Zone
CHARACTER*15 timestr
CHARACTER*4 option
INTEGER, ALLOCATABLE :: iord(:)
INTEGER usupr,umain,udiag,uplot,ierr
INTEGER irule,maxsub,neval,nsubin
INTEGER I,J,K,npts
EXTERNAL G

! INITIALIZE I/O
usupr = 5
umain = 10
udiag = 15
uplot = 20

read(usupr,*,err=100) filename
open(unit=umain,file=filename,status='old',err=100)

read(usupr,*,err=100) filename
open(unit=udiag,file=filename,status='unknown',err=100)

read(usupr,*,err=100) filename
open(unit=uplot,file=filename,status='unknown',err=100)
close (unit=usupr)

! ndim = '1D', '2D' or '3D' analytical simulation
! sx = type of source in x-dir ('PS' or 'LS')
! sy = type of source in y-dir ('PS' or 'LS')
! sz = type of source in z-dir ('PS' or 'LS')
! option = 'GRID', 'LINE' or 'PNTS' specified
! Zone = Tecplot zone prefix name
read(umain,*,err=200) commnt
read(umain,*,err=200) ndim,sx,sy,sz,option,Zone
write(udiag,1000,err=300) ndim,sx,sy,sz,option,Zone
! sw = water saturation
! phi = porosity
! rhos = soil density
! kd = solute distribution coef
! thalf = radioactive half-life
read(umain,*,err=200) commnt
read(umain,*,err=200) sw,phi,rhos,kd,thalf
write(udiag,1010,err=300) sw,phi,rhos,kd,thalf
wc = phi*sw
rhob = (1._8-phi)*rhos
R = 1._8 + rhob*kd/wc
if (thalf.eq.0.) then
  lamda = 0._8
else
  lamda = log(2._8)/thalf
end if
write(udiag,1020,err=300) wc,rhob,R,lamda
! ux = Darcy x-dir velocity
! uy = Darcy y-dir velocity
! theta = Rotation angle (degrees counterclockwise from x-axis)
read(umain,*,err=200) commnt
read(umain,*,err=200) ux,uy,theta
write(udiag,1030,err=300) ux,uy,theta
uxp = ux/wc
uxpr = uxp/R
uyp = uy/wc
uypR = uyp/R
up = sqrt(uxp*uxp+uyp*uyp)
! DLh = Longitudinal dispersivity
! DTh = Transverse dispersivity
! tau = tortuosity of porous medium
! Dm = molecular diffusion coefficient
read(umain,*,err=200) commnt
read(umain,*,err=200) DL,DT,tau,Dm
write(udiag,1040,err=300) DL,DT,tau,Dm

```

```

Dxx = DL*uxp**2/up + DT*uyy**2/up + wc*tau*Dm
Dyy = DL*uyy**2/up + DT*uxp**2/up + wc*tau*Dm
Dzz = DT*uxp**2/up + DT*Uyp**2/Up + wc*tau*Dm
Dxxr = Dxx/R
Dyyr = Dyy/R
Dzzr = Dzz/R
write(udiag,1050,err=300) Dxx,Dyy,Dzz,Dxxr,Dyyr,Dzzr
! Qcp = point source mass flowrate
! dz = aquifer thickness
! Xs = x location of point source
! Ys = y location of point source
! Zs = z location of point source
! Ls = start of line source
! Le = end of line source
read(umain,*,err=200) commnt
read(umain,*,err=200) Qcs,dz,Xs,Ys,Zs,Ls,Le
Qcl = Qcs/dz
! src_beg = start time for source
! src_end = end time for source
read(umain,*,err=200) commnt
read(umain,*,err=200) src_beg,src_end
! irule = choice of quadrature rule (Gauss-Kronrod)
!       = 1 ( 7-15 points)
!       = 2 (10-21 points)
!       = 3 (15-31 points)
!       = 4 (20-41 points)
!       = 5 (25-51 points)
!       = 6 (30-61 points)
! maxsub = number of sub intervals allowed
! errabs = absolute error
! errrel = relative error
read(umain,*,err=200) commnt
read(umain,*,err=200) irule,maxsub,errabs,errrel
allocate(alist(maxsub),stat=ierr)
allocate(blist(maxsub),stat=ierr)
allocate(rlist(maxsub),stat=ierr)
allocate(elist(maxsub),stat=ierr)
allocate(iord(maxsub),stat=ierr)
! tmin = minimum time value
! tmax = maximum time value
! delt = delta time
read(umain,*,err=200) commnt
read(umain,*,err=200) tmin,tmax,delt

pi = dacos(-1._8)
theta = theta/1.8d+2*pi
cost = cos(theta)
sint = sin(theta)
select case (option)
case ('GRID')
!   xmin = starting x value for grid
!   xmax = ending x value for grid
!   delx = x grid spacing
read(umain,*,err=200) commnt
read(umain,*,err=200) xmin,xmax,delx
I = max(int((xmax-xmin)/delx)+1,1)
!   ymin = starting y value for grid
!   ymax = ending y value for grid
!   dely = y grid spacing
read(umain,*,err=200) commnt
read(umain,*,err=200) ymin,ymax,dely
J = max(int((ymax-ymin)/dely)+1,1)
!   zmin = starting z value for grid
!   zmax = ending z value for grid
!   delz = z grid spacing
read(umain,*,err=200) commnt
read(umain,*,err=200) zmin,zmax,delz
K = max(int((zmax-zmin)/delz)+1,1)
T = tmin
write(uplot,'(a)',err=300) 'VARIABLES = "x" "y" "z" "c"'
! Loop over time
do while (T <= tmax)
write(timestr,2000,err=300) T

```

```

        write(uplot,2010,err=300) trim(Zone)//trim(timestr),I,J,K
!      Loop over Z
        Z = zmin
        do while (Z <= zmax)
!      Loop over Y
        Y = ymin
        do while (Y <= ymax)
!      Loop over X
        X = xmin
        do while (X <= xmax)
            call DQ2AG(G,src_beg,src_end,errabs,errrel,irule,INTG,errest, &
                maxsub,neval,nsubin,alist,blist,rlist,elist,iord)
            C = Qc1/(wc*R)*INTG
            XT = cost*X - sint*Y
            YT = sint*X + cost*Y
            write(uplot,2020,err=300) XT,YT,Z,C
            X = X + delx
        end do
        Y = Y + dely
    end do
    Z = Z + delz
end do
T = T + delt
end do
case ('LINE')
!   xmin = starting x value for line
!   xmax = ending x value for line
!   delx = x line spacing
    read(umain,*,err=200) commnt
    read(umain,*,err=200) xmin,xmax,delx
    npts = max(int((xmax-xmin)/delx)+1,1)
!   ymin = starting y value for line
!   ymax = ending y value for line
!   dely = y line spacing
    read(umain,*,err=200) commnt
    read(umain,*,err=200) ymin,ymax,dely
    npts = max(int((ymax-ymin)/dely)+1,npts)
!   zmin = starting z value for line
!   zmax = ending z value for line
!   delz = z line spacing
    read(umain,*,err=200) commnt
    read(umain,*,err=200) zmin,zmax,delz
    T = tmin
    write(uplot,'(a)',err=300) 'VARIABLES = "x" "y" "z" "c"'
    do while (T <= tmax)
        write(timestr,2000,err=300) T
        write(uplot,2010,err=300) trim(Zone)//trim(timestr),npts,1,1
        X = xmin
        Y = ymin
        Z = zmin
        do i=1,npts
            call DQ2AG(G,src_beg,src_end,errabs,errrel,irule,INTG,errest, &
                maxsub,neval,nsubin,alist,blist,rlist,elist,iord)
            C = Qc1/(WC*R)*INTG
            XT = cost*X - sint*Y
            YT = sint*X + cost*Y
            write(uplot,2020,err=300) XT,YT,Z,C
            X = X + delx
            Y = Y + dely
            Z = Z + delz
        end do
        T = T + delt
    end do
case ('PNTS')
    stop 'PNTs option not available'
end select
close (unit=umain)
close (unit=uplot)
stop 'Normal termination'
pause
!.... bail out during read error
100 stop 'OPEN error'
pause

```

```

!.... bail out during write error
  200 stop 'READ error'
      pause
!.... bail out during open error
  300 stop 'WRITE error'
      pause
1000 format(/,'simulation type is ',a, &
           /,'type of source in x-dir is ',a, &
           /,'type of source in y-dir is ',a, &
           /,'type of source in z-dir is ',a, &
           /,'option is ',a,' specified', &
           /,'zone name is ',a)
1010 format(/,'water saturation is ',f5.3, &
           /,'porosity is ',f5.3, &
           /,'soil density is ',f5.3, &
           /,'solute distribution coefficient is ',f5.3, &
           /,'half life is ',es9.3)
1020 format(/,'water content is ',f5.3, &
           /,'bulk density is ',f5.3, &
           /,'retardation factor is ',f5.3, &
           /,'decay constant is ',es9.3)
1030 format(/,'darcy x velocity is ',f6.3, &
           /,'darcy y velocity is ',f6.3, &
           /,'rotation angle is ',es9.3,' degrees')
1040 format(/,'longitudinal dispersivity is ',es9.3, &
           /,'transverse dispersivity is ',es9.3, &
           /,'tortuosity of porous medium is ',es9.3, &
           /,'molecular diffusion coefficient is ',es9.3)
1050 format(/,'Dxx dispersion coefficient is ',es9.3, &
           /,'Dyy dispersion coefficient is ',es9.3, &
           /,'Dzz dispersion coefficient is ',es9.3, &
           /,'Dxxr retarded dispersion coefficient is ',es9.3, &
           /,'Dyyr retarded dispersion coefficient is ',es9.3, &
           /,'Dzzr retarded dispersion coefficient is ',es9.3)
2000 format('t =',g12.6)
2010 format('ZONE T="'',a,'"',',I=',i4,'',J=',i4,'',K=',i4, &
           ',DT=(DOUBLE,DOUBLE,DOUBLE,DOUBLE)')
2020 format(3(3x,f12.7),3x,g12.6)
END PROGRAM

```

C.2 FORTRAN Listing for COMVAR.f90

```

MODULE comvar

! Common variables used in the Green's function evaluations.

  IMPLICIT NONE
  DOUBLE PRECISION Dxxr,Dyyr,Dzzr,lamda,uxpr,uypr
  DOUBLE PRECISION X,Xs,Y,Ys,Z,Zs,Ls,Le
  DOUBLE PRECISION pi,T
  CHARACTER*2 ndim,sx,sy,sz

END MODULE comvar

```

C.3 FORTRAN Listing for G.f90

```

DOUBLE PRECISION FUNCTION G(tau)

! Composite Green's function:
! 1D: G = Gx
! 2D: G = Gx*Gy
! 3D: G = Gx*Gy*Gz

  USE comvar
  IMPLICIT NONE
  DOUBLE PRECISION GX,GY,GZ,tau
  EXTERNAL GX,GY,GZ

  SELECT CASE(ndim)
    CASE ('1D')

```

```

      G = GX(tau)
      CASE ('2D')
        G = GX(tau)*GY(tau)
      CASE ('3D')
        G = GX(tau)*GY(tau)*GZ(tau)
      END SELECT

```

END FUNCTION

C.4 FORTRAN Listing for Gx.f90

```
DOUBLE PRECISION FUNCTION GX(tau)
```

```
! Green's function for a point or line source in the x direction
! with uniform flow, dispersion and linear decay.
```

```

      USE comvar
      USE numerical_libraries
      IMPLICIT NONE
      DOUBLE PRECISION tau

      SELECT CASE(sx)
      CASE ('PS')
        GX = 1._8/dsqrt(4._8*pi*Dxxr*(T-tau))*dexp(-((X-Xs)-uxpr*(T-tau))**2 &
          / (4._8*Dxxr*(T-tau))-lamda*(T-tau))
      CASE ('LS')
        GX = 0.5_8*(derf((X-Ls-uxpr*(T-tau))/dsqrt(4._8*Dxxr*(T-tau))) &
          - derf((X-Le-uxpr*(T-tau))/dsqrt(4._8*Dxxr*(T-tau)))) &
          * dexp(-lamda*(T-tau))
      CASE DEFAULT
        write(*,*) "Invalid source in x-direction"
        STOP
      END SELECT

```

END FUNCTION

C.5 FORTRAN Listing for Gy.f90

```
DOUBLE PRECISION FUNCTION GY(tau)
```

```
! Green's function for a point or line source in the y direction
! with uniform flow and dispersion.
```

```

      USE comvar
      USE numerical_libraries
      IMPLICIT NONE
      DOUBLE PRECISION tau
      ! EXTERNAL DERF

      SELECT CASE(sy)
      CASE ('PS')
        GY = 1._8/dsqrt(4._8*pi*Dyyr*(T-tau))*dexp(-((Y-Ys)-uypr*(T-tau))**2 &
          / (4._8*Dyyr*(T-tau)))
      CASE ('LS')
        GY = 0.5_8*(derf((Y-Ls-uypr*(T-tau))/dsqrt(4._8*Dyyr*(T-tau))) &
          - derf((Y-Le-uypr*(T-tau))/dsqrt(4._8*Dyyr*(T-tau))))
      CASE DEFAULT
        write(*,*) "Invalid source in y-direction"
        STOP
      END SELECT

```

END FUNCTION

C.6 FORTRAN Listing for Gz.f90

```
DOUBLE PRECISION FUNCTION GZ(tau)
```

```
! Green's function for a point or line source in the z direction
! with dispersion.
```

```

USE comvar
USE numerical_libraries
IMPLICIT NONE
DOUBLE PRECISION tau
! EXTERNAL DERF

SELECT CASE(sz)
CASE ('PS')
  GZ = 1._8/dsqrt(4._8*pi*Dzrz*(T-tau))*dexp(-((Z-Zs)**2 &
    / (4._8*Dzrz*(T-tau)))
CASE ('LS')
  GZ = 0.5_8*(derf((Z-Ls)/dsqrt(4._8*Dzrz*(T-tau))) &
    - derf((Z-Le)/dsqrt(4._8*Dzrz*(T-tau))))
CASE DEFAULT
  write(*,*) "Invalid source in z-direction"
  STOP
END SELECT

END FUNCTION

```

C.7 Superfile Input for 2D Transport Base Case (Case A)

```

AT123D-Y000.inp
AT123D-Y000.log
AT123D-Y000.plt

```

C.8 Main Input for 2D Transport Base Case (Case A)

```

/ndim,   sx,   sy,   sz,   option,   Zone Name/
'2D'    'PS'  'PS'  'PS'  'LINE'  'AT123D_'
/sw,   phi,   rhos, kd,   thalf/
1.    0.35  1.    0.    0.
/ux,   uy,   theta/
0.161 0.    0.
/DL,   DT,   tau,   Dm/
21.3  4.3  0.    0.
/Qcp,   dz,   xs,   ys,   zs,   Ls,   Le/
0.235844 33.5 0.    0.    0.    0.    0.
/src_beg,   src_end/
0.    1399.99999
/irule,   maxsub,   errabs,   errrel/
1    500    0.    1.e-6
/tmin,   tmax,   delt/
1400. 1400. 1.
/xmin,   xmax,   delx/
-270. 960. 1.
/ymin,   ymax,   dely/
0.    0.    0.
/zmin,   zmax,   delz/
0.    0.    0.

```

D Bateman Numerical Code

D.1 FORTRAN Listing for Bateman.f90

```

PROGRAM Bateman

!.... Computes the ith radionuclide concentration based on
!.... the Bateman Equation (n1-->n2-->n3-->...ni-->). The
!.... concentrations of all the progeny are initially zero
!.... (i.e. ni(0) = 0 for i>1)

USE decay_constants
IMPLICIT DOUBLE PRECISION (a-h,o-z)
INTEGER, PARAMETER :: sor=8,soi=4
CHARACTER*128 commnt,filename

```



```

CHARACTER*10, ALLOCATABLE :: species(:)
ALLOCATABLE :: A(:,:),Aconv(:),thalf(:), t(:)
ALLOCATABLE :: BTerm2(:,:),BTerm1(:)
DOUBLE PRECISION, ALLOCATABLE :: n(:,:)
DOUBLE PRECISION :: n0
DOUBLE PRECISION, EXTERNAL :: BTermi

!.... INITIALIZE I/O
isup = 5
iinp = 10
ilog = 20
icon = 21
iact = 22
iplt = 23

read(isup,*,err=100) filename
open(unit=iinp,file=filename,status='old',err=300)

read(isup,*,err=100) filename
open(unit=ilog,file=filename,status='unknown',err=300)

read(isup,*,err=100) filename
open(unit=icon,file=filename,status='unknown',err=300)

read(isup,*,err=100) filename
open(unit=iact,file=filename,status='unknown',err=300)

read(isup,*,err=100) filename
open(unit=iplt,file=filename,status='unknown',err=300)

!.... PROCESS DECAY CHAIN INFO
!.... nspecies = number of radioactive species
read(iinp,*,err=100) commnt
read(iinp,*,err=100) nspecies
write(ilog,*,err=200) 'nspecies = ',nspecies
!.... species = radioactive species name
!.... thalf = radioactive species half-life
allocate(species(nspecies),stat=ierr)
call chkmem('Bateman','species',10*nspecies,0,ierr)
allocate(thalf(nspecies),stat=ierr)
call chkmem('Bateman','thalf',sor*nspecies,0,ierr)
read(iinp,*,err=100) commnt
do i=1,nspecies
  read(iinp,*,err=100) species(i),thalf(i)
  write(ilog,*,err=200) species(i),thalf(i)
end do
!.... n0 = initial concentration of parent species
!.... tend = end time for transient decay
!.... nint = number of time intervals between 0 and tend
read(iinp,*,err=100) commnt
read(iinp,*,err=100) n0,tend,nint
delt = tend/dble(nint)
!.... lamda = radioactive species decay constant ln(2)/t1/2
!.... Aconv = activity conversion factor for each progeny
allocate(lamda(nspecies),stat=ierr)
call chkmem('Bateman','lamda',sor*nspecies,0,ierr)
allocate(Aconv(nspecies),stat=ierr)
call chkmem('Bateman','Aconv',sor*nspecies,0,ierr)
do i=1,nspecies
  lamda(i) = log(2.0)/thalf(i)
  Aconv(i) = lamda(i)/lamda(1)
  write(ilog,111,err=200) i,lamda(i)
111  format('lamda(',i1,') = ',e12.6)
end do
!.... t = time to evaluate Bateman Eq.
allocate(t(0:nint),stat=ierr)
call chkmem('Bateman','t',sor*nint,0,ierr)
t = 0.08
!.... n(i,j) = radioactive species concentrations (i=species,j=time)
!.... A(i,j) = radioactive species activities
allocate(n(nspecies,0:nint),stat=ierr)
call chkmem('Bateman','n',sor*nspecies*nint,0,ierr)
allocate(A(nspecies,0:nint),stat=ierr)

```

```

      call chkmem('Bateman','A',sor*nspecies*nint,0,ierr)
!.... Initialize concentrations and activities
      n = 0._8
      A = 0._8
      n(1,0) = n0
      A(1,0) = Aconv(1)*n(1,0)
!.... Compute Bateman Eq.time-independent terms for each species
      allocate(BTerm1(nspecies),stat=ierr)
      call chkmem('Bateman','BTerm1',sor*nspecies,0,ierr)
      allocate(BTerm2(nspecies,nspecies),stat=ierr)
      call chkmem('Bateman','BTerm2',sor*nspecies*nspecies,0,ierr)
      do i=1,nspecies
        BTerm1(i) = BTermi(i)*n0
        write(iolog,123,err=200) i,BTerm1(i)
123      format('BTerm1(',i1,') = ',e12.6)
        do j=1,i
          BTerm2(i,j) = 1._8
          do k=1,i
            if (k == j) then
              factor = 1._8
            else
              factor = lamda(k) - lamda(j)
            end if
            BTerm2(i,j) = factor*BTerm2(i,j)
          end do
          write(iolog,124,err=200) i,j,BTerm2(i,j)
124      format('BTerm2(',i1,',',i1,') = ',e12.6)
        end do
      end do
!.... LOOP OVER TIME
      do it=1,nint
        t(it) = dble(it)*delt
        do i=1,nspecies
          do j=1,i
            n(i,it) = n(i,it) + exp(-lamda(j)*t(it))/BTerm2(i,j)
          end do
          n(i,it) = BTerm1(i)*n(i,it)
          A(i,it) = Aconv(i)*n(i,it)
        end do
      end do
!.... WRITE csv FILE of CONCENTRATIONS
      write(icon,*) 'Time',(' ',trim(species(i)),i=1,nspecies)
      do it=0,nint
        write(icon,'(e12.6,12(a,e12.6))') t(it),(' ',n(i,it),i=1,nspecies)
      end do
!.... WRITE csv FILE of ACTIVITIES
      write(iact,*) 'Time',(' ',trim(species(i)),i=1,nspecies)
      do it=0,nint
        write(iact,'(e12.6,12(a,e12.6))') t(it),(' ',A(i,it),i=1,nspecies)
      end do
!.... WRITE TECPLOT FILE OF CONCENTRATIONS AND ACTIVITIES
      write(iplt,*,err=200) 'Title = "Bateman Eqn. for ', &
        species(1)(1:len_trim(species(1))), ' decay chain"'
      write(iplt,*,err=200) 'Variables = '
      write(iplt,*,err=200) '"Time"'
      do i=1,nspecies
        write(iplt,*,err=200) "'//trim(species(i))//'"
      end do
      write(iplt,*,err=200) 'ZONE T = "Concentrations"'
      write(iplt,*,err=200) 'DT=( ',('DOUBLE ',i=1,nspecies+1),)'
      do it=0,nint
        write(iplt,'(7(es13.6,1x))',err=200) t(it),(n(i,it),i=1,nspecies)
      end do
      write(iplt,*,err=200) 'ZONE T = "Activities"'
      write(iplt,*,err=200) 'DT=( ',('DOUBLE ',i=1,nspecies+1),)'
      do it=0,nint
        write(iplt,'(7e13.6)',err=200) t(it),(A(i,it),i=1,nspecies)
      end do
      stop 'Normal termination'
      pause
!.... bail out during read error
100 stop 'READ error'
      pause

```

```

!.... bail out during write error
  200 stop 'WRITE error'
      pause
!.... bail out during open error
  300 stop 'OPEN error'
      pause
      END PROGRAM Bateman

```

D.2 FORTRAN Listing for BTermi.f90

```

RECURSIVE FUNCTION BTermi (i) RESULT (B1)
USE decay_constants
DOUBLE PRECISION B1
INTEGER i
if (i == 1) then
  B1 = 1._8
else
  B1 = lamda(i-1)*BTermi(i-1)
end if
END FUNCTION

```

D.3 FORTRAN Listing for BTermij.f90

```

RECURSIVE FUNCTION BTermij (i,j) RESULT (B2)
USE decay_constants
DOUBLE PRECISION B2
INTEGER i,j
if (i == j) then
  B2 = 1._8*BTermij(i-1,j)
else
  B2 = (lamda(i)-lamda(j))*BTermij(i-1,j)
end if
END FUNCTION

```

D.4 FORTRAN Listing for chkmem.f90

```

SUBROUTINE chkmem(subr,array,nbytes,ialloc,ierr)
IMPLICIT DOUBLE PRECISION (a-h,o-z)
CHARACTER*(*) subr,array
DATA total_memory /0./
SAVE total_memory

array_memory = dble(nbytes)/1.e6
!.... memory allocated
if (ialloc.eq.0) then
  if (ierr.eq.0) then
    total_memory = total_memory + array_memory
    write(*,1000) subr,array,array_memory,total_memory
  else
    write(*,1500) subr,array_memory,array
    stop
  end if
!.... memory deallocated
else
  if (ierr.eq.0) then
    total_memory = total_memory - array_memory
    write(*,1100) subr,array,array_memory
  else
    write(*,1600) subr,array_memory,array
  end if
end if
1000 format(1x,a,': Array ',a,' allocated ',f7.3,' out of ',f7.3,' mbytes')
1100 format(1x,a,': Array ',a,' deallocated ',f7.3,' mbytes')
1500 format(1x,a,': Unable to allocate ',f7.3,' mbytes for array ',a)
1600 format(1x,a,': Unable to deallocate ',f7.3,' mbytes for array ',a)
return
END SUBROUTINE chkmem

```

D.5 FORTRAN Listing for decay_constants.f90

```
MODULE decay_constants
  DOUBLE PRECISION, ALLOCATABLE :: lamda(:)
END MODULE decay_constants
```

D.6 Superfile Input for U-230 Decay Chain

```
U-230.dat
U-230.log
U-230-C.csv
U-230-A.csv
U-230.plt
```

D.7 Main Input for U-230 Decay Chain

```
/nspecies/
8
/species half-life/
'U-230' 5.7100E-02
'Th-226' 5.8000E-05
'Ra-222' 1.2000E-06
'Rn-218' 1.1100E-09
'Po-214' 5.2000E-12
'Pb-210' 2.2200E+01
'Bi-210' 1.3700E-02
'Po-210' 3.8100E-01
/n0 tend npts/
1.d+0 2.d+2 2000
```
