

RECORDS ADMINISTRATION



R0139012

DP - 478

2ND ISSUE

Radioactive Waste

AEC Research and Development Report

**UNDERGROUND STORAGE
OF LOW LEVEL RADIOACTIVE WASTES
AT THE SAVANNAH RIVER PLANT
Engineering Considerations**

by

A. N. Daniel
Design Division
Engineering Department
Wilmington, Delaware

June 1960

RECORDS
COPY
DO NOT REMOVE

Issued by

E. I. du Pont de Nemours & Co.
Explosives Department - Atomic Energy Division
Wilmington, Delaware

This report was prepared as an account of Government sponsored work. Neither the United States, nor the Commission, nor any person acting on behalf of the Commission:

- A. Makes any warranty or representation, expressed or implied, with respect to the accuracy, completeness, or usefulness of the information contained in this report, or that the use of any information, apparatus, method, or process disclosed in this report may not infringe privately owned rights; or
- B. Assumes any liabilities with respect to the use of, or for damages resulting from the use of any information, apparatus, method, or process disclosed in this report.

As used in the above, "person acting on behalf of the Commission" includes any employee or contractor of the Commission, or employee of such contractor, to the extent that such employee or contractor of the Commission, or employee of such contractor prepares, disseminates, or provides access to, any information pursuant to his employment or contract with the Commission, or his employment with such contractor.

Printed in USA. Price \$1.50
Available from the Office of Technical Services
U. S. Department of Commerce
Washington 25, D. C.

255352 ✓

DP - 478

RADIOACTIVE WASTE
(TID-4500, 15th Ed.)

**UNDERGROUND STORAGE OF LOW LEVEL RADIOACTIVE WASTES
AT THE SAVANNAH RIVER PLANT**

Engineering Considerations

by

A. N. Daniel
Design Division
Engineering Department
Wilmington, Delaware

June 1960

Issued by
E. I. du Pont de Nemours & Co.
Explosives Department - Atomic Energy Division
Wilmington, Delaware

Printed by Savannah River Laboratory for
The United States Atomic Energy Commission
Contract AT(07-2)-1

ABSTRACT

This report gives the engineering considerations upon which the design and construction of tanks for the storage of low level radioactive waste solutions were based. The tanks built were 85 feet in diameter, with a wall height of 34 feet 3-3/8 inches and a nominal capacity of 1,300,000 gallons each. While conforming to the principle of total confinement, these tanks were built at a considerably lower cost than the tanks designed for storing high level radioactive wastes. This saving was brought about by the elimination of a number of features such as cooling coils and the annular space and secondary saucer container around the tank.

CONTENTS

	<u>Page</u>
I. Summary	5
A. Storage of Radioactive Waste Material	5
B. Courses Pursued in Study	5
C. Results	5
II. Discussion	7
A. Introduction	7
1. Storage and Types of Radioactive Waste Material	7
2. Objective	7
B. New Waste Storage Tanks	8
1. Factors Influencing Design	8
2. Basic Requirements	8
3. Operating Procedure	9
C. Design Considerations for New Tanks	10
1. Evaluation of Tank Concepts	10
2. Structural Design Criteria	12
3. Steel Tank Liner	15
4. Dome Design	16
5. Walls	19
6. Concrete Floor Slab and Wall Foundation	24
7. Backfill	25
8. Waste Line Supports	25
9. Grading and Surface Treatment - Tank Area	26
D. Construction Procedure	26
1. Construction Sequence	26
2. Excavation	27
3. Floor Slab and Wall Foundation	28
4. Steel Tank Liner	29
5. Walls	31
6. Dome Ring	40
7. Dome Slab and Risers	40
8. Backfilling	41
9. Waste Lines and Services	42
III. References	43

		<u>Page</u>
IV.	Appendix	
Exhibit	I - Alternative Tank Designs	44
Exhibit	II - Waste Storage Tanks - Section and Details	48
Exhibit	III - Waste Storage Tanks and Fill Lines	49
Exhibit	IV - Waste Storage Tanks - Tensioning Elements - Rods and Turnbuckles	50
Exhibit	V - Minimum Approach of Equipment to Tank Wall	51
Exhibit	VI-A - Floor Slabs and Foundations Showing Formwork for Drainage Channels	52
	B - Erection of Steel Liners Showing Raising-Lowering Frame	52
Exhibit	VII-A - Erection of Steel Liners Showing Assembly of Wall Plates	53
	B - Outside of Steel Liner Showing Knuckle Plate, Wall Foundation and Dowels	53
Exhibit	VIII-A - View Showing Wall Scaffold and Dome Form Supports	54
	B - Dome Formwork	54
Exhibit	IX-A - Dome Reinforcing	55
	B - Dome Ring Reinforcing	55
Exhibit	X-A - Extensometer, Turnbuckles in Notch, Clamps, and Safety Chains in Place	56
	B - Tensioning Process with Tensioning Lever at Turnbuckles	56
Exhibit	XI-A - Applying "Shotcrete" to Dome Ring	57
	B - Completed Tank	57
Exhibit	XII-A - Completed Dome Form Deck in Foreground	58
	B - Completed Tanks Showing Piles Near Tank Wall Placed Prior to Backfilling	58
Exhibit	XIII-A - Backfilling in Progress Showing Placement of Vermiculite Bags Around the Wall	59
	B - Backfill Nearing Top of Wall	59

UNDERGROUND STORAGE OF LOW LEVEL RADIOACTIVE WASTES
AT THE SAVANNAH RIVER PLANT

Engineering Considerations

I. SUMMARY

A. STORAGE OF RADIOACTIVE WASTE MATERIAL

At the Savannah River Plant, radioactive wastes from the separations processes are segregated into solutions of high and low level activity and are discharged into two underground tank farms. Although all of the tanks are designed for the containment of high level waste solutions, certain ones are used for storing low level waste solutions not suitable for seepage basin disposal.

In June 1955, it was decided that additional tankage would be required to store low level wastes. By designing these new tanks (total capacity 5,200,000 gallons) to contain only low level wastes, a less expensive structure could be used. Some of the present tanks in use for low level storage could, by waste solution transfer, be released for storing high level wastes.

B. COURSES PURSUED IN STUDY

Existing tank designs at the Hanford Atomic Products Operation and Savannah River Plant were reviewed and variations of these designs were developed. A cost comparison of nine alternative designs was made on a basis of four 1,000,000-gallon tanks.

Initial evaluations were on the basis that the contents of the tank would not exceed 100°F. As the study progressed, the feasibility of concentrating the low activity wastes by evaporation became more evident. This necessitated a review of the design to determine what alterations would be required to accommodate the higher temperatures, or what operating limitations must be imposed so as not to exceed permissible unit stresses.

C. RESULTS

1. The design study indicated that the most practical tank size to meet storage requirements was a tank 85 feet in diameter with a wall height of 34 feet, having a nominal capacity of 1,300,000 gallons.

2. Further analysis showed that the most economical tank structure meeting the design criteria consisted of a steel liner surrounded by a prestressed "Shotcrete" cylindrical shell. The wall and dome ring support a spherical reinforced concrete dome roof - all resting on a wall foundation and a concrete floor slab. See Exhibit II.

3. The upper limits of stress and temperature were established to permit maximum utilization of the completed tank design under additional loads imposed by higher bulk temperatures. This resulted in the following operating limitations: the tanks can be operated with a maximum bulk temperature of 210°F by starting with an 18-inch heel of liquid at a temperature not exceeding 100°F to distribute uniformly the heat resulting from an input no greater than 12 gpm and not exceeding 275°F. It is intended that the 210°F bulk temperature should not be reached sooner than 1800 hours (75.5 days) under 24-hour operation.

4. The tank dome was designed for the possible later installation of an evaporator to concentrate low level waste.

5. A specification was prepared to include detailed procedures for the construction of the concrete tanks to minimize the subsequent development of cracks.

6. Results of stress corrosion studies made by the Du Pont Engineering Research Laboratory were utilized in developing a construction procedure as a measure to minimize residual stresses in the steel tank liner.

7. Construction of several tanks of the design described in this report has been completed.

II. DISCUSSION

A. INTRODUCTION

1. STORAGE AND TYPES OF RADIOACTIVE WASTE MATERIAL

At the Savannah River Plant, the radioactive wastes from the Purex process are segregated into three types: (1) high level or high activity waste, (2) low level or low activity waste, and (3) warm or very low activity waste.

The high level waste is a nitric acid solution that contains the bulk of the fission products from the separations process as well as certain process reagents. This solution is concentrated for recovery of nitric acid by evaporation and then treated with caustic yielding an alkaline solution containing about 35% solids. It requires prolonged heat removal to avoid boiling during storage and is, therefore, stored in tanks that are equipped with cooling coils to remove the fission product decay heat.

The so-called low level waste is perhaps misnamed. It is an aqueous sodium nitrate - sodium aluminate solution resulting primarily from dissolving the aluminum sheaths from the fuel elements; it contains about 35% solids and less than 0.2% of the gross fission products. Although this waste is stored in the same type of tank as is the high activity waste, the rate of heat release from this solution is sufficiently low to permit dissipation of the heat to the surroundings of a buried tank without other cooling facilities. The tanks described in this report were designed for storage of low level wastes (or suitably decayed high level wastes).

The very low activity waste contains laboratory trade wastes, condensates, laundry wastes, and discard water. The radioactivity of this waste is so low that the solution can be discharged to seepage basins where radioactive decay and ion exchange reduce the activity still more so that the amount reaching the water table or surface streams is well below the maximum permissible level published by the National Bureau of Standards*. This report is not concerned with this very low activity waste. It is mentioned only to emphasize the fact that the so-called low activity waste, because of its higher radioactivity, requires storage for an indefinite time.

2. OBJECTIVE

The purpose of this report is to set forth the methods and data used to establish the size, design, construction requirements, and operating limitations for economical and structurally sound tanks to store low level waste solutions.

* Recommendations of the National Committee on Radiation Protection (and Measurements), NBS Handbook No. 69.

B. NEW WASTE STORAGE TANKS

1. FACTORS INFLUENCING DESIGN

As previously stated, the basic principle of liquid waste handling at the Savannah River Plant (SRP) is that of total confinement unless the radioactivity of the waste is so low that the normal background at the site boundaries will not be significantly raised. In applying this principle when additional waste storage tanks were needed, it was agreed that the cost of storage would be considerably reduced if tanks were designed specifically for low level waste. The specifications could be less stringent than those required for fresh high activity waste. The present accumulations of low activity waste could then be transferred from tanks designed for high activity waste into the lower cost tanks.

Factors involved in reaching this conclusion were:

- a. The wide difference in activity level between the two types of waste would permit the adoption of less elaborate means of handling a leak in the steel liner, should one develop.
- b. The low activity waste produces so little heat of decay that it can be dissipated without significantly raising the tank shell temperature.
- c. Performance information of low activity waste tanks at the Hanford Atomic Products Operation appeared favorable for the application of similar units at SRP.
- d. An investigation of low activity waste concentration being conducted simultaneously with the new tank design suggested the likelihood that the tanks would be used for substantially solidified waste.

In view of the foregoing, it was feasible to eliminate certain features incorporated in the tank designs for high activity waste. Such features were the cooling coils, valve house, reflux condenser, dehumidification equipment, annular space and secondary saucer container around tank, external waterproofing, and spare fill lines to each tank.

2. BASIC REQUIREMENTS

Basic requirements established for the new tank design were:

- a. A capacity of at least 1,000,000 gallons for each tank. (The actual capacity of each tank built is 1,300,000 gallons.)

b. An aqueous solution of sodium nitrate - sodium aluminate that contains about 35% dissolved solids and has a specific gravity of 1.25 and a temperature of about 100°F. (In anticipation of the conclusions of the waste concentration study, the design was made on the basis of a specific gravity of 1.8.)

c. A carbon steel tank lining, liquid tight with all seam welds 100% X-ray quality, and of the same quality used for high activity waste storage.

d. The concrete tank surrounding the steel tank liner to be designed and constructed to minimize susceptibility to cracks that would permit significant leakage in the event of failure of the liner.

e. Provision for detection and collection of leakage past the bottom steel liner.

f. The top of the tank to support an earth burden sufficient to reduce the radiation level to an arbitrary 25 mr/hr. (Area seldom occupied)

g. A plugged center opening to support facilities for the possible later installation of an evaporator to concentrate low level waste.

h. Waterproofing only to the extent required to protect the tank structure.

i. Elevation of bottom slab was placed as close as practical to the expected maximum ground water level (230.0 feet).

The study of alternative designs described later in this report proceeded on the above basis.

3. OPERATING PROCEDURE

The initial plan was for each tank to be filled with low activity waste at a maximum rate of 75 gpm at 105-125°F for a period of one hour per eight hours. The tanks were designed to these requirements. However, development of a process to concentrate low activity waste to 65% dissolved solids showed such promise that it appeared desirable to store waste of approximately this concentration in these new tanks. The higher waste temperature associated with this condition imposed additional stresses on the tank structure, which were not contemplated in the original design. A study was made to determine the limiting temperature and filling rate that could be tolerated by the tank designed for the feed conditions previously outlined. Utilization of increased but acceptable unit stresses made it feasible to use these tanks for waste containing 65% dissolved solids under the following conditions:

a. Provide an 18-inch heel of low activity waste at 100°F prior to commencement of filling with concentrated waste.

b. Maximum allowable fill rate to be 12 gpm of 65% concentrate (evaporator bottoms) at 275°F, having negligible heat release from decay. At this filling rate, it would take 1800 hours (75.5 days) of 24-hour operation to reach the 1,300,000-gallon capacity such that the temperature at the end is expected to be about 200°F ±10°F.

c. Each tank to be filled in this manner only once.

It is necessary for the tanks to be kept full of water until they are put into operation in order to help maintain original compression in the prestressed concrete and to protect the bottom slab from any hydrostatic pressure.

C. DESIGN CONSIDERATIONS FOR NEW TANKS

1. EVALUATION OF TANK CONCEPTS

a. Selection of Size

From earlier studies made in connection with high activity storage (HAS) tanks, a diameter of 85 feet and a height of 27 feet were established as the size of the steel container with the fill line at about 25 feet. This size came within the upper limits of an economical height-diameter ratio for a storage capacity of 1,000,000 gallons.

In the design of the new tanks, the 85-foot diameter was retained because of the availability of two raising-lowering frames which had been altered previously for use with the 85-foot-diameter tank bottom of the HAS tanks. The height of the steel container was increased to 34 feet 3-3/8 inches with the liquid depth of waste storage about 2 feet below this height. This size exceeded the most economic height-diameter ratio. However, because of physical conditions noted below, this additional height provided a capacity of 1,300,000 gallons for each tank, exclusive of the 18-inch operating heel, at little additional cost.

The increase in height was influenced by the following:

(1) A proposed diversion box was omitted, which allowed raising the invert elevation of waste line inlet to permit filling by a gravity feed (1-1/2% slope from existing diversion box) and cascade system.

(2) The elevation of the bottom slab was established as close as practical to the expected maximum high ground water level (230.0 feet). This maximum level, which is to be expected once in

100 years, was determined by reviewing available ground water data in the vicinity of the site and climatological records from the Augusta, Georgia weather station.

(3) A minimum uniform earth cover (2 feet-9 inches) over the tank dome was provided for shielding purposes and control of storm drainage.

b. Selection of Type

Alternative tank designs were evaluated to establish the most economical design meeting process requirements. The HAS tanks were used as a basis for cost comparisons as they represented the most economical waste storage at SRP at the time.

Estimates of cost were based on wage rates in effect at SRP in September 1955.

All evaluations were made on the basis of a maximum high water table level (for 100 years) of 230.00 feet and an invert elevation for waste line inlet of 255.76 feet.

Nine tank designs were considered, each having an approximate capacity of 1,000,000 gallons. These designs Cases 1A through 4B, are shown in Exhibit I. They were variations of three tank types - namely: (1) Hanford Atomic Products Operation (HW) for high and low activity, (2) Existing SRP single column HAS tanks, and (3) the original SRP multicolumn HAS tanks modified for low activity.

As a result of these evaluations, Case 4B (Exhibit I), a prestressed design with "Shotcrete" walls, was recommended. The cost was 60% less than that of the basic high temperature HAS tanks and 18% less than that of a typical low activity HW tank installed at SRP, Case 1A.

In an analysis of the prestressed concrete design, a comparison was made between wire winding and the use of rods and turnbuckles. Structurally there was no significant advantage of one over the other and there was little difference in over-all estimated cost. Rods and turnbuckles were chosen for this installation since this method of prestressing was better suited for field conditions and schedule requirements.

The difference in cost between Cases 4A and 4B was not significant. The decision to use the "Shotcrete" for the core wall instead of poured concrete was made in order to get a tighter wall. Shrinkage cracks, if they occur, will not carry through the "Shotcrete" wall, as they will be confined to their respective "Shotcrete" layers.

In the final design phase, construction costs were reduced further by (1) omitting the sand bed under the steel tank bottom, since the cement

topping of the bottom slab was poured at a tolerance of $\pm 1/8$ inch, (2) establishing minimum uniform earth cover over the tank dome to satisfy requirements of both shielding and surface drainage, (3) omitting 3-ply-membrane waterproofing under the steel tank bottom, (4) revising the existing raising-lowering frame for the bottom steel liner installation, (5) venting one tank into a second tank that required only one vent filter for each pair of tanks. Exhibit II shows the tanks as finally designed and constructed.

c. Location (See Exhibit III)

The location selected was based on the following fundamental considerations necessary to meet the established design criteria.

(1) Waste material is to be transported through pipelines by gravity from the existing diversion box to the tanks with the minimum grade for the pipelines established at 1-1/2% as a design requirement.

On this basis, the tanks were located as close to the existing facility as practical, since the gradient and length of the connecting lines established the top elevation of the new tanks.

(2) The limits of the area required for excavation during construction of the tanks were determined by providing sufficient clearance from the existing waste tanks to allow for continuity of operation and at the same time keep the length of the new gravity feed line as short as practical.

Other minor considerations were: proximity to existing service lines such as steam, water, and sewers.

2. STRUCTURAL DESIGN CRITERIA

a. Tank Liner

(1) Material

American Society of Testing Materials (ASTM) A-285 Grade "B" Firebox quality open hearth carbon steel. Minimum tensile strength - 50,000 psi. Minimum yield point - 27,000 psi

(2) Working Stress

17,000 psi maximum

(3) Welded Joints

Submerged arc - where practical. All joints radiographed

(4) Design Loading

Filled with 20 feet of water for leak detection test before encasement

b. Prestressed Concrete Tank

(1) Material

Dome - Class "A" - 5,000-psi concrete

Wall and Dome Ring - 5,000-psi "Shotcrete"

Wall Footing and Floor Slab - Class "C" - 3,000-psi concrete

Reinforcing Steel - ASTM-A15 Intermediate grade billet steel. Minimum tensile strength - 70,000 psi. Minimum yield point - 40,000 psi

Prestressing Rods - 1-inch-diameter rods - American Iron & Steel Institute (AISI) Grade C1060. 7/8-inch-diameter rods AISI Grade C1055. Minimum tensile strength - 105,000 psi. Minimum yield point - 60,000 psi. Roll threaded with oversize threads that will develop full strength of rods. Turnbuckles - AISI Forging Grade C1045 designed to withstand breaking strength of rods

(2) Maximum Working Stresses

Notation

f_c = unit compressive stress in extreme fiber of concrete
in flexure, psi

f_s = unit tensile stress in reinforcing bar, psi

n = ratio of modulus of elasticity of steel to that of
concrete

u = bond stress per unit of surface area of reinforcing bar,
psi

v = unit shearing stress, psi

b = width of concrete section, inch

t = thickness of concrete section, inch

Dome

Membrane stress = 400 psi - compression

Membrane stress = 500 psi - compression, with temperature
stress

Membrane stress = 150 psi - tension, when reinforced with steel

v = 120 psi - vertical shearing stress

n = 6.7

Dome Ring and Wall

$f_c = 2,000$ psi - compression
 $f_c = 2,500$ psi - compression, when normal stresses are
combined with temperature stresses
 $n = 6.7$

Foundation and Floor Slab

$f_c = 1,350$ psi - compression
 $v = 90$ psi
 $u = 300$ psi
 $n = 10$

Reinforcing Steel

$f_s = 20,000$ psi - tension
 $f_s = 25,000$ psi - tension, when normal stresses are
combined with temperature stresses
Minimum - 0.0025 bt each way in dome slab
Minimum - 0.005 bt each way in floor slab
Minimum - 0.005 bt vertically in wall

Prestressing Bands (Rods and Turnbuckles)

Prestress - 50,000 psi
Working stress - 30,000 psi
Losses - 5,000 psi + 6 x concrete prestress

Maximum Allowable Soil Bearing - 10,000 psf

(3) Design Loading

2-foot 9-inch earth cover over dome

Temporary construction load of 22,000-lb bulldozer or 8-ton roller on dome with 12-inch earth cover

Live load of 50 psf all over dome

Equipment load with shielding walls of 365,000 lb concentrated within a 27-ft-diameter circle or the equivalent on the center of the dome.

Six risers with an equipment loading of 3,700 lb each

Tank filled with waste of specific gravity of 1.8

Earth pressure on wall, psf

Before settlement: $32 \times$ depth, ft

After settlement: 80 x depth, ft

Passive resistance to tank expansion: 330 x depth in ft

Surface load of earth-moving equipment on backfill during placing.
See Exhibit V.

Surface load of Loraine MC504W crane (72,000 lb) after backfilling

Temperature of 210°F within tank, which should not be reached before
1800 hours (75.5 days) of 24-hr operation

Thermal gradient of 15°F through dome slab, 7.5°F through wall and 2.6°F
through floor slab

3. STEEL TANK LINER (See Exhibit II)

The steel tank liner has two functions. It is a liquid-tight containment vessel, and it protects the concrete envelope from the waste contents of the tank. The liner is 3/8 inch thick except at the knuckle plates where it is 7/16 inch thick. It is reinforced with four circumferential stiffener angles that help to keep the plates in alignment during erection and maintain proper curvature of the tank while the concrete wall and dome are built. It is anchored to the concrete wall with eight horizontal rows of 3/8-inch hooked Nelson studs, spaced 3 feet apart circumferentially.

The stresses were computed first for the tank wall and knuckle plate under a 20-foot water head for the hydrostatic test. The maximum stress occurs in the knuckle plate. This curved section with 12-inch radius forms an annular ring that cantilevers out from the flat bottom of the tank to support the steel wall of the tank. The steel plate easily carries the 21,200-psi radial bending stress and the maximum circumferential tensile stress is 11,200 psi.

After encasement, the steel tank liner will be compressed circumferentially from prestressing the concrete. The circumferential compressive stress is 15,400 psi at the bottom of the wall.

The effect of the 7-1/2°F thermal gradient through the wall is to add 730 psi compression to the final circumferential stresses or a stress of 11,830 psi at the bottom of the wall, but the stress at the time of prestressing will be the maximum as given above.

The plate is anchored to the concrete with Nelson studs spaced at 36-inch centers. The buckling strength of the plate in a circumferential direction supported on 36-inch centers is 10,700 psi. The circumferential stress will exceed this value in the lower 13 feet of the wall and the plate will buckle away from the wall between the studs a computed distance of 0.6 inch. In doing so, it will place a strain of 1270-lb pull on the Nelson studs which are good for 2200 lb each.

In a vertical direction, the stress from the vertical loads will be 770 psi plus 730 psi additional due to the 7-1/2°F thermal gradient through the wall, or a maximum of 1500-psi compression. The plate will carry the stress safely as the buckling stress is also 10,700 psi in the vertical direction.

It should be noted that, except for the thermal effect, the vertical bending stresses in the concrete wall are not transmitted to the liner which is anchored at only 36-inch intervals. The liner is comparatively free to move and deflect and will conform to infinitesimal changes in the shape of the concrete. The only definite points where it is fixed are at the top and bottom. The thermal effect differs in that it compresses the lining uniformly from top to bottom.

The bottom of the steel liner lies on the concrete floor without anchorage. As the temperature of the tank increases, the steel plate will be hotter than the average temperature of the concrete envelope. This will produce a compression of 250 psi in the plate, but the weight of the plate will be sufficient to hold it down to the concrete slab and prevent buckling.

It is apparent, from the above stresses, that temperature and the gradients established for this job have only a minor effect on the tank lining.

4. DOMES DESIGN

a. Dome (See Exhibit II)

(1) Size and Type

The tank roof consists of a spherical reinforced concrete dome, with an internal radius of curvature of 90 feet-4 inches and a rise of 10 feet-7-1/2 inches above the spring line. This is a ratio of rise to tank diameter of 1 to 8, the usual ratio for a tank dome roof. The maximum slope of 28° permitted the dome to be poured without top forms.

The dome-type roof structure was adopted for the following reasons:

(a) Interior supports and their attendant complexities were eliminated.

(b) A study of other clear-span structures indicated the dome roof to be the most economical type of construction.

(2) Allowable Stresses

The 28-day strength specified for the dome slab was 5000 psi. The actual strength is higher. At 14 days, it tested 5000 psi and at 21 days, the minimum time specified for removal of dome forms, it attained 5500 psi.

Tensile strength using a 6 x 6 inch specimen was 350 psi at 21 days and the modulus of rupture strength (ASTM - Spec. C78) was 1420 psi at 21 days.

A compressive membrane stress of 400 psi was used in the design for normal temperature with an ultimate strength of 3750 psi specified for the concrete. Later it was decided to use 5000-psi concrete because it was obtainable at a very small increase in cost. At the same time the allowable membrane stress was relaxed to 500 psi when the effect of a 210°F temperature was added to the design conditions.

There will be direct tensile stress in the dome due to some types of loading so sufficient reinforcing steel was used to carry the entire tensile stress. Since the concrete would have to crack before the entire stress would be carried by the steel, direct tensile stress is limited to an average value of 150 psi on the concrete section to prevent cracking.

Although shear is not always considered in the design of domes, the vertical shearing stress at any section was limited to 120 psi as an additional safety check.

(3) Design Analysis

The design was based primarily on the membrane theory which assumes that the slab is thin enough that all stresses are of uniform tension or compression at any point in the dome. Local bending effects at the risers and the dome edge, and for equipment loads were investigated.

Analysis therefore required that calculations be made for uniform and concentrated loads, temperature and prestressing forces, and at openings.

The procedure followed was to compute membrane stresses first, then the bending stresses, and finally the combination of the two.

(4) Loadings

The following loads were used in the calculations:

Dome slab, 7 to 10 inches thick, 12.5 lb per inch thickness

2 feet-9 inches earth fill at 110 lb/cu ft, 300 psf

Live load, 50 psf

2-ft-ID Risers -

Equipment	3,700 lb
Concrete	<u>9,300 lb</u>
	13,000 lb (each)

Center opening -

Plug and Evaporator - 140,000 lb

Shielding Walls - 225,000 lb (considered concentrated within a 27-foot-diameter circle)

One 22,000-lb bulldozer (considered concentrated within a 5-foot-diameter circle)

Total Dome Loads -

Dome	710,000 lb
Earth cover	2,050,000 lb
Evaporator plug	140,000 lb
Shielding walls	225,000 lb
Live load	<u>300,000 lb</u>
	3,425,000 lb
Duplications, etc.	<u>32,000 lb</u>
Total	3,393,000 lb

(5) Calculations

(a) General Loading

The maximum stresses for four cases of loading are shown below.

Case	Loads	Membrane Stress, psi	Combined Membrane and Bending Stress,	
			Concrete psi	Steel psi
I	Dome slab and prestressing	-212	-720	+12,400
II	Load in Case I with 12-inch earth cover and 22,000-lb bulldozer at any point	-270	-490	+ 1,060
III	Dome, earth and tank at 210°F	-390	-685	+20,200
IV	Same fully loaded	-440	-675	+ 4,120

Note: Tensile stress = +
Compressive stress = -

Case II includes the membrane stresses due to the weight of the dome slab plus 1 foot of earth fill. The stresses from a 22,000-lb bulldozer operating at any place on the dome were calculated and combined with the foregoing membrane stresses and the moments from prestressing.

Cases III and IV include the moments due to a thermal gradient of 15°F through the dome slab. They are combined with the prestressing moment

and the membrane stresses due to the weight of concrete and full load of earth fill. Case IV is the same as Case III but has the full load on the dome.

(b) Openings

Calculations of the local stresses around the 2-foot riser openings showed a maximum compressive membrane stress in the slab of 460 psi and a maximum tension in the steel of 16,500 psi.

Calculations of the stresses in the center collar showed a tension of 21,900 psi in the circumferential dome slab reinforcing just beyond the collar. The collar sustained a circumferential compression of 1145 psi at the bottom.

b. Dome Ring

The principal function of the dome ring is to carry the ring tension of 1,013,000 lb produced by the maximum load on the dome of 3,393,000 lb.

The dome ring, 24 inches thick x 39 inches high, is built monolithically with the side walls of 5000-psi "Shotcrete". The joint between the dome ring and dome slab was designed so as not to take any moment, but only thrust and shear.

The dome ring was prestressed with 41 one-inch round bands tensioned to 50,000 psi with a total prestress of 1,610,000 lb and an initial compression of 1900 psi in the dome ring. The final circumferential stresses under operating conditions and with allowances for shrinkage, plastic flow, etc., are 615 psi compression in the dome ring and 42,200 psi tension in the tensioning bands.

The dome ring extends out beyond the core wall a maximum of 23 inches. This causes a vertical moment at its juncture with the core wall. Stresses from this moment are low, however, and amount to only 235 psi compression in the outside face and a tension of 3610 psi in the inner layer of vertical wall reinforcing.

5. WALLS

a. Dimensions

The walls form a cylinder 85 feet in diameter and 33 feet high surmounted by the dome ring.

The core wall is 7 inches thick at the top and 11 inches at the bottom. The total wall thickness, including bands and cover, is 10 inches at the top and 15 inches at the bottom.

b. Details

The core wall was constructed of 3/4 to 1-1/2-inch-thick layers of "Shotcrete", which were allowed to set up three days between layers. Tests showed that the bond between layers was so strong that, when cores were broken, they invariably broke at other than the joint between layers. Allowing three days between "Shotcrete" layers had the following advantages:

- (1) Time was allowed for wet curing
- (2) Much of the shrinkage took place before the next layer was added
- (3) The heat usually developed during set was dissipated
- (4) Time was allowed to inspect the layer and repair any weak places
- (5) Most of the shrinkage had taken place when it was prestressed

The dome ring and wall were made monolithic by shooting the layers continually from bottom to top of wall. The vertical reinforcing in the wall was also carried up into the dome ring.

The dome ring and wall act as a unit with a joint between dome ring and dome slab and a joint between the wall and floor. The dowels into the dome slab were placed at the center of the slab, and the dowels from the footing into the wall were placed on the inside to minimize the moment in the footing due to the prestressing. Thus the wall can be considered pin-connected at top and bottom for analysis of restraint at these points.

c. Prestress (See Exhibit IV)

The wall was prestressed circumferentially by 163 7/8-inch round bands roll threaded with a minimum area no smaller than the 7/8-inch rod. The turnbuckles, placed 45° apart on each band, were designed to be stronger than the rods. Rods were tensioned to an average stress of 50,000 psi, which was measured at the quarter point in the individual rod. In order to provide a more uniform distribution of stresses, the turnbuckles on one band were staggered with those on adjacent bands so that points of higher stress would occur next to points of lower stress.

The turnbuckles required a 1-inch-deep notch 18 inches wide the full height of the wall to provide clearance for turning. This reduced the core wall thickness to an effective thickness of 6 inches at the top and 10 inches at the bottom.

The prestressing in the bands was calculated to provide compression in the core wall under all operating conditions after losses from shrinkage, plastic flow, and friction had taken place, without depending on the compression resulting from backfill.

The wall was not prestressed vertically as the load from the dome after adding the earth cover provides a permanent compressive stress of over 100 psi on the wall section and effectively prevents horizontal cracks from opening up.

d. Design Analysis

For the design of the walls, both circumferential and vertical stresses were calculated. The circumferential stresses include prestressing, earth pressure, surcharge from equipment, liquid pressure from contents of the tank, and thermal stresses. The vertical stresses are those due to the roof loads as computed for the dome and to the temperature and bending moments that result from the shear transferred to the top and bottom of the tank from horizontal loads on the walls.

e. Vermiculite Blanket

Calculations showed that the tank wall when heated to 210°F will expand radially 1/2 inch. To preclude overstressing the wall due to the development of passive forces in the surrounding soil, an 8-inch blanket of compressible material consisting of expanded vermiculite was placed against the outside surface of the tank walls. The vermiculite will compress 1 inch at a pressure of 15,000 psf. The use of this material also facilitated the backfill operation by permitting heavier loads adjacent to the tank wall.

f. Calculated Stresses

Note: The "Shotcrete" wall will be referred to by the general term "concrete" in the discussion of stresses that follows.

(1) Prestress

The circumferential stress in the concrete due to the tank being filled with a liquid of 1.8 specific gravity is zero at the top and a tension of 162,500 lb per ft at the bottom, or a stress of 1040 psi on the core wall.

At the working stress of 30,000 psi, the spacing of bands at the bottom using 7/8-inch round rods is 1-5/16 inches center to center. The rods had to be placed in two layers up to the height of 12 feet where the spacing of 2 inches center to center allowed enough clearance between bars to turn the turnbuckles.

These bands, prestressed at 50,000 psi put an initial compression of 275,000 lb on the first foot of core wall. A thickness of 10 inches (minimum at notches) was selected which would be stressed initially to 2290 psi in compression.

A minimum thickness of 6 inches (at the notch) was selected for the top of the wall with a minimum spacing for the 7/8-inch rods on 9-inch centers. The prestress at the top of the wall was 40,000 lb for the top foot, or an initial concrete stress of 555 psi in compression.

(2) Earth Pressure

The stresses in the wall due to earth pressure are shown in the table below for the following cases:

Case 1 - Initial or active pressure

Case 2 - At-rest pressure after settling

Case 3 - Passive pressure, developed by expansion of the tank against the soil as it heats up to 210°F. This is relieved by the 8 inches of expanded vermiculite which takes 1-inch compression at 15,000 psf.

Case	Earth Pressure, psf		Compressive Stress in Wall due to Earth Pressure, psi	
	Top of Wall	Bottom of Wall	Top of Wall	Bottom of Wall
1	265	1,355	90	275
2	640	3,280	220	665
3 (Without vermiculite)	2,640	13,530	915	2,740
3 (With vermiculite)	2,640	5,230	915	1,065

(3) Circumferential Stresses

Case 3 in the preceding table shows a compressive stress at the bottom of the wall of 2740 psi due to passive pressure of earth. Combined with the compressive stress due to prestress less shrinkage, etc., a direct compressive stress of 3335 psi would result with the tank full and 4370 psi with the tank empty.

These are prohibitive design stresses for 5000-psi concrete and require some relief in the form of a permanently loose fill material so expanded vermiculite was used with a final direct stress of 1660 psi.

The thermal gradient of 7.5°F through the wall will add bending stress to the direct stress as shown in the table below.

Summary of Combined Circumferential Stresses

	<u>Concrete, psi</u>		<u>Band Steel, psi</u>	
	<u>Top of Wall</u>	<u>Bottom of Wall</u>	<u>Top of Wall</u>	<u>Bottom of Wall</u>
<u>Direct Stress</u>	-1,320	-1,660	+36,545	+35,460
<u>Combined Stress</u>				
Inside face	-1,430	-1,770		
Outside face	-1,210	-1,550		
Band steel			+37,275	+36,190

The effect of considering the wall free to move instead of pin-connected at the bottom results in the above calculated stresses being higher near the bottom of the tank than is actually the case due to the support received from the floor and foundation. However, by calculating the stresses in this manner, all the circumferential stresses between the top and bottom are proportional within required accuracy. This is on the side of safety and maintains uniform prestressing to the bottom of the tank.

(4) Vertical Stresses in Wall

The vertical stresses in the wall consist of direct compression due to the weight of the dome and superimposed loads and bending due to the cantilever moment of the overhanging dome ring, prestressing of wall and dome ring, thermal gradient through wall, thermal expansion of wall, and changes in loading on wall due to earth pressure and filling the tank.

For convenience, the moment at the bottom of the wall was considered separately from that at the top as one has little effect on the other and they do not occur simultaneously.

The maximum moment occurs during prestressing the wall at a point 3.4 feet from the bottom, causing a compression of 1,440 psi at the outside face and 20,900 psi tension in the inner layer of reinforcing steel. These stresses do not include the effect of vertical loads which are not fully applied until much later. Under operating conditions, these stresses are reduced to 1,270 psi and 11,900 psi, respectively.

The bending moments at the top of the wall were computed for the three following conditions:

1. Prestressing dome ring assuming wall not prestressed
2. Prestressing wall assuming dome ring not prestressed

3. Operating conditions, without thermal gradient

The cantilever moment from the dome ring is combined with these three conditions but not with the thermal gradient that would reduce the maximum moment.

The maximum stress for these conditions occurred during (1) prestressing the dome ring at a point 4.17 feet below the top of the wall when the stress was 920 psi compression on the inside face and 23,700 psi tension in the outer layer of reinforcing steel. Under (3) operating conditions, these stresses are reduced to 500 psi compression on the outside face and 2,420 psi tension in the inner layer of the reinforcing steel.

(5) Equipment Loads

In the preceding calculations, symmetrical loading of the walls was considered and no horizontal bending occurred. When the walls are backfilled, the earth-moving equipment will produce horizontal bending from unsymmetrical loading and if allowed to come too close might overstress the walls.

Calculations were made to determine how far from the wall different pieces of equipment could operate at varying depths of fill. The results are shown on a diagram, which was followed in the backfilling process. (See Exhibit V). Also included in the study was a Lorain crane which will operate on the surface of the ground adjacent to the tanks.

The distances were calculated for the lateral pressure on the wall due to a concentrated load on the surface of the ground using Boussinesq's Equation for earth pressure.

6. CONCRETE FLOOR SLAB AND WALL FOUNDATION

a. Floor Slab

The floor slab is 4 inches thick with No. 4 (1/2-inch) bars 10 inches on centers each way in the lower face. The weight of the liquid, 3600 psf, is carried through the slab to the soil. The 4-inch slab will span about 1.7 feet in case a weak spot should develop in the sub-grade. The cement finish was made 3 inches thick because of the 1-5/8 x 2-5/8 inch notches that form drainage channels to the leak detection pipe below the floor.

The liquid load does not ordinarily cause bending stress in the slab, but the thermal gradient of 2.6°F will produce bending stress of 90 psi compression in the upper surface of the slab and 1795 psi tension in the reinforcing steel in the lower face.

A difference in temperature of 23°F between the center and outside of the floor will stress the concrete to 150 psi beyond which the concrete slab will buckle for the 85-foot-diameter unsupported slab, and a difference of 19°F will stress the reinforcing around the outside to the limiting value of 25,000 psi. This requires an 18-inch-deep heel of water to distribute the heat evenly to the whole floor.

The circular wall footing 4 feet-10 inches wide, is built of 3,000 psi concrete. The maximum pressure of 9,600 psf occurs under the outside edge when the tank is empty.

The footing, which acts as a large ring, restrains the inward movement of the bottom of the wall during prestressing. This produces a circumferential compressive stress of 850 psi in the footing.

7. BACKFILL

The original design consideration was based on placing a loose fill around the tanks. This was not done, since it would have been difficult to place a uniformly loose fill for the entire depth, which would allow the tanks to expand under thermal conditions. Had it been practical to place such a fill, the soil would have consolidated (not necessarily uniformly) due to weathering and its own weight. Hence, full active and passive soil pressures would result.

To minimize these pressure conditions, an 8-inch-thick vermiculite cushion around the tanks was specified. Test results showed that the backfill could be equipment compacted and the vermiculite would deflect the required 0.5 to 1 inch (depending on the dry or wet condition) under a maximum computed 0.5 ton/sq ft active pressure. An additional 1/2-inch deflection due to a computed 8 ton/sq ft outward force (tank expansion) would also be absorbed by the vermiculite.

Standard compaction was specified for the rest of the fill. This minimizes any earth settlement provided complete area coverage is obtained by earth-work equipment as specified.

8. WASTE LINE SUPPORTS

Low level waste is transferred from the separations processes to two of the new tanks through 3-inch stainless steel pipe lines extending from the original diversion box. (See Exhibit III). These tanks are in turn connected to the other new tanks by 4-inch stainless steel cascade lines. In addition a waste line runs from one of the existing tanks to one of the new tanks. This line provides for the transfer of accumulated low level waste. All fill lines are encased with "Transite" pipe for leak-detecting purposes.

The fill lines traverse both unexcavated and previously excavated areas. Because of the type material transported, no structural settlement in the lines could be tolerated.

In areas where the soil has not been disturbed, the fill lines rest on firm earth. Alternative support schemes were evaluated for the lines traversing filled areas. As a result, these lines were supported on 15-ton creosoted wood piles spaced 2 and 5 feet depending on depth of earth cover and size of pile cap.

Piles within 6 feet of the tank wall were placed before backfilling to avoid possible damage to the tank structure during the driving process. (See Exhibit XII-B).

9. GRADING AND SURFACE TREATMENT - TANK AREA

Final grading of the immediate area around the tanks was determined by the amount of earth cover required for shielding over the tank roof. A sewer system with adequate surface inlets was installed to handle the storm drainage.

The area around the tanks received a bituminous surface treatment, a type of pavement that provides the lowest installation and maintenance costs.

D. CONSTRUCTION PROCEDURE

1. CONSTRUCTION SEQUENCE

The sequence given below was followed in the erection of each tank:

- a. Wall foundation
- b. Tank floor slab and cement topping
- c. Construction of steel tank bottom
- d. Radiographic inspection of tank bottom
- e. Vacuum leak testing of tank bottom
- f. Construction of steel tank side plates
- g. Tank water testing
- h. Preparing "Shotcrete" test panels
- i. Placing inner layer of wall reinforcing
- j. Placing "Shotcrete" to line of outer layer of reinforcing
- k. Erecting dome forms and dome ring inside form

- l. Placing outer layer of wall reinforcing and dome ring reinforcing
- m. Finishing shotcreting wall and dome ring
- n. Placing dome reinforcing and riser forms
- o. Tensioning seven bands on wall and four on dome ring to 25,000 psi
- p. Pouring dome slab after core wall and dome ring have reached 5,000 psi and have set a minimum of fourteen days
- q. Tensioning bands in first layer to 50,000 psi after dome slab has reached 5,000 psi and has set a minimum of fourteen days
- r. Removing dome forms after first layer of rods has been fully tensioned and after dome has reached 5,000 psi and has set a minimum of 21 days
- s. Completing outer layers of bands on wall and dome ring, including tensioning to 50,000 psi
- t. Testing tank by filling with water
- u. Applying reinforcing mesh over wall and dome ring and final "Shotcrete" cover
- v. Backfilling and installing piping
- w. Grading and surface treatment

It should be noted that "Shotcrete" operations were in progress on certain completed and accepted steel tanks while construction of the steel liner was still in progress on other tanks.

2. EXCAVATION

Approximately 275,000 cubic yards of earth, including 65,000 cubic yards for two approach ramps were excavated at the tank site to a nominal depth of 59 feet below finished grade. This was about 10 feet above water table (Elevation 217.00) as measured during December 1955. (Note: Water table measured May 15, 1958, was at 218.33.)

The soil was a sandy clay type with sufficient fines to maintain a stable 1:1 maximum slope on all cuts. This soil was reasonably consistent for the full excavation depth. Its permeability characteristics were generally the same at various elevations which explains the

comparative constant elevation of the water table. A berm was constructed at the midpoint of the slope to provide necessary drainage and attendant erosion control. All slopes and berms were treated with emulsified asphalt for stabilization purposes.

Laboratory tests of soil samples from borings made at the site indicated a soil bearing value of 10,000 psf. Test table readings, made upon completion of the excavation, verified the laboratory results.

3. FLOOR SLAB AND WALL FOUNDATION (See Exhibits II and VI)

The wall foundation and the 4-inch floor slab were poured without construction joints on undisturbed soil. Specifications called for the floor slab to have a screeded surface level to $\pm 1/4$ inch from a true horizontal. A 1 foot-6 inch space was provided between the floor slab and wall foundation and filled after seven days with "Embeco" grout mixture.

Because of tolerance requirements for the floor slab, particular attention was given to establishing the correct screed elevation. After the reinforcing steel had been placed, No. 6 reinforcing bars were driven about 3 feet into the ground. Screed chairs, spaced 8 feet in each direction, were welded to the top 2 inches of these bars and set to final elevation of the slab. Straight and true lengths of 1-1/2-inch-diameter screed piping was laid in the screed chairs and the concrete placed and finished to the required tolerance.

A 3-inch cement topping, consisting of a pea gravel mix, was then poured and given a float and trowel finish having a maximum tolerance of $\pm 1/8$ inch from a true level. Drainage channels (3 inches wide x 1-5/8 inches deep) for use in leak detection were formed in this cement topping. See Exhibit VI-A. Their locations coincided with the pattern of bottom plate welds and backup strips. At the center of the base slab, a 3-inch stainless steel drain pipe was set to collect any leakage through the bottom plate welds into the drainage channels. This 3-inch stainless steel line was encased and placed below the 4-inch base slab and run to an 8-inch-diameter by 8-inch-long collection chamber below the footing at the edge of the tank wall. A leak detection probe may be dropped through a riser and tube from the ground surface to this leakage collection chamber.

Dowels in the wall foundation were bent to give a safe clearance for the installation of the steel tank. Afterwards, they were bent back for embedment in the "Shotcrete". See Exhibit VII-B.

4. STEEL TANK LINER

a. General

The construction of the steel tank liner conformed to the ASME Code for Unfired Pressure Vessels. All welds, which might affect the ability of the tank to retain liquids, were radiographed in accordance with procedures and standards of the "ASME Boiler Construction Code, 1952" and du Pont specifications.

A stiff-leg derrick, placed at the center of the four tanks, was used to lift and place the steel plates and assemblies. A steel raising-lowering frame with hydraulic jacks was used to raise the steel bottom, including knuckle plates, for the purpose of radiographic inspection. See Exhibit VI-B.

Attachments welded to the tanks and needed only for erection purposes - such as lugs, brackets, and electrical grounding connections - were kept to a minimum. This reduced locked-up stresses derived from welding.

No access openings were left or holes cut in the tank liner for any purpose. This eliminated weak patch points which, when subjected to thermal shock, might jeopardize the requirement of a sound, liquid-tight tank.

b. Steel Tank Bottom

All plates in the tank bottom were assembled and welded in a manner to ensure minimum variation in elevation. The depth of buckle in any plate could not exceed 1-1/4 inch and the offset on adjoining plates could not exceed 10% of the plate thickness.

The knuckle plates, which joined the bottom and side plates, were placed in assemblies of not less than three pieces. The alignment was controlled by checking the curvature at the top and bottom of the plates holding to a 5/16-inch minimum deviation on the horizontal circumference in a 2-foot-long arc. Care was taken that abutting edges were not offset in excess of 10% of plate thickness.

Upon completion of the tank bottom, the whole assembly was raised 3 feet 6 inches by means of the steel raising-lowering frame and was supported on cribbing. This was done for the purpose of a complete radiographic inspection of the welds and subsequent vacuum leak testing.

After all radiographic work and testing were completed and the tank bottom was accepted, the cribbing was removed and the complete bottom assembly was lowered back to the concrete floor slab by means of the raising-lowering frame. The bottom plates were flattened uniformly against the concrete floor slab by the use of heat and water quenching.

Water was placed on the tank bottom to a depth sufficient to cover the high spots. Working progressively with each high spot, an underwater torch brought these areas to heat treating temperature. Upon removal of the torch, water rushed over the heated area providing a quick quench, which relieved locked-up stresses due to welding and gradually pulled the high spots to the floor.

A horizontal cutting line was established for the welding machine at the top edge of the knuckle plates by a layout crew using optical tooling methods. The resultant horizontal seams were quite accurate. Previously, a water boat was used to establish the cutting line, but this was not precise due to variations caused by the wind.

c. Steel Side Plates

The steel side plates of the tank were assembled and welded in a manner to give the least distortion due to shrinkage and to eliminate kinks at seams and vertical joints. The deviation from true diameter could not exceed 2 inches.

Circumferential stiffener angles were used successfully to control this roundness tolerance. They were located below the horizontal welds of the belt sections at an elevation convenient for welding and were connected to the inside of the tank wall with Nelson stud bolts through slotted holes in the angles. The location of these stud bolts was spotted on the outside surface of plate so that hook anchors on the outside could clear the bolts on the inside by a minimum of 8 inches.

Until the first belt section of side plates was in place, caulking with Sika "Igas" joint sealer at the joint formed by the knuckle plates and bottom concrete slab was done by hand. After that time, caulking was performed with an air gun. One plate edge was left unwelded and wedged out far enough to permit entrance of a 4-inch hose to remove rain and surface waters trapped in the tank shell. Such plates were reformed to proper location, butt welded, inspected, and radiographed as other plate welds.

Hook anchors, attached to the outside surface of steel plates and spaced 3 feet each way except as noted above, were used as points of attachment for reinforcing rods. This provided a means for anchoring the "Shotcrete" core wall to the steel tank.

Sectional ladders were hooked over the top of installed side plates. This precluded welding ladder rungs to the tank wall. Plate welds on the tank wall for grounding welding machines were kept to a minimum. Lifting lugs, welded to the outside surface of the wall plates, were not removed. They were buried in the "Shotcrete" core wall with a minimum cover of 1 inch.

5. WALLS

a. Pneumatic Mortar ("Shotcrete")

(1) General Description

In the processing and placing of "Shotcrete", the following general steps were observed:

(a) Sand and cement were dry mixed in a standard concrete mixer.

(b) The dry mix was unloaded into a bin from which it was gravity-fed into a special mechanical feeder called a "gun". To protect the mix from sun and rain, the bin was kept covered with a tarpaulin.

(c) With the introduction of compressed air into the gun, the pressurized mix was forced out of the gun into the delivery hose by a feed wheel.

(d) The dry mix under pressure passed through the delivery hose to a special nozzle with a special perforated manifold through which water was introduced to the dry mix.

(e) The moistened mixture was jetted from the orifice of the nozzle onto the surface to be shotcreted.

From the foregoing, it was evident that, for a successful job, definite material controls and skilled operators were required to give best results both in structural strength and in appearance.

(2) Preliminary Tests

Therefore, prior to beginning actual shotcreting work on the tanks, it was necessary to devote some time in the field toward developing a mixture to meet specifications with proper sand gradation, cement mix, and water content.

To this end, a 96 x 11-foot-high curved wooden form panel with reinforcing was used for test panel purposes. This panel provided a means to establish certain material standards mentioned above. "Shotcrete" was applied to the panel at an average total thickness of 12 inches which was built up in successive layers.

For this preliminary test, concrete sand and mortar sand were blended to conform as closely as possible to the sieve analysis given in the following table.

<u>Sieve Size</u>	<u>Per Cent Passing</u>
3/8 inch	100.0
4 mesh	99.4
8	91.9
16	76.4
30	50.9
50	25.0
100	10.0

The "Shotcrete" was applied with this analysis for 1:3-1/2 and 1:4 mixes respectively. Resultant tests on core cylinders indicated a lack of fines, particularly those that passed 50 mesh. The bond was good but the quantity of rebound sand caught in the samples showed that too much of the larger size sand was being used. All tests were made by the Pittsburgh Testing Laboratory.

Efforts were made to find a natural sand approximating the above sieve analysis. Finally, a natural mortar sand, secured locally, was found with a moisture content for three separate applications ranging from 3.3 to 3.7%. A 1:4 mix was applied to the test panel and resultant compression tests met the 28-day - 5,000 psi requirement. Samples were taken from the material discharged at the mixer both at the beginning and middle of the run, from the mix as applied to the wall, and from the rebound material in order to determine the moisture and cement contents. These tests resulted in the acceptance of this mortar sand in accordance with the following sieve analysis:

Gradation:

<u>Sieve Size</u>	<u>Per Cent Passing</u>
3/8 inch	100.0
4 mesh	100.0
8	99.9
16	93.8
30	54.3
50	21.2
100	5.3

This sand proved to have the highest compressive strength, the least absorption and the minimum rebound of all the samples tested.

"Shotcrete" was applied to the first tank using mortar sand with the above sieve analysis and a 1:4 mix. After 1-1/2 to 2 inches had been applied, tests indicated that the material did not meet the 28-day - 5,000 psi compression requirement. As a result, gradation and characteristics of the mortar sand used were rerun and sand from another source was secured, tested, and evaluated.

Moisture, rebound, and compression tests were made on 1:3-1/2 and 1:4 mixes using the previously accepted sieve analysis for mortar sand as a base. As a result of these tests, certain requirements were established:

(a) The sand gradation was to conform to the following sieve analysis, which was incorporated in the specifications:

<u>Sieve Size</u>	<u>Required Per Cent Passing</u>	<u>Desired Per Cent Passing</u>
3/8 inch	100	100
4 mesh	98 - 100	99.5
8	95 - 100	97.5
16	60 - 90	85.0
30	40 - 65	54.0
50	10 - 30	18.0
100	2 - 10	4.0
Fineness modulus	2.30 - 2.60	2.42

(b) A dry mix of 1 part of cement to 3-1/2 parts of sand by volume was established which was based on maximum density as determined by specific gravity tests, minimum water content in terms of "Shotcrete" placed, uniformity, and a minimum compressive strength of 5,000 psi in place after 28 days. The 1:4 mix showed some voids behind the reinforcing, while the 1:3-1/2 mix was easier to control with greater consistency and compressive strength.

(c) The water content of sand was set from 3 to 5%. For amounts in excess of this, the water caused hydration of the cement in the gun and nozzle which decreased the flow of material because of hose line clogging.

(d) Although the specifications called for a minimum water content of 4.5 to 7 gallons per bag of cement, 5-1/2 gallons per bag was established for use, which gave a workable mix holding rebound within desired limits. This amount also reduced excessive heat and possible checking when the mortar was cured. With a 1:3-1/2 mix, about a 1:3 mixture was retained in place.

(e) The water pressure was to be held at 20 psi above the air pressure or between 80 and 85 psi for 65-psi air pressure.

(f) Proper controls of all factors affecting final "Shotcrete" product were to be established.

(3) Application

Prior to beginning daily shotcreting operations, "Eye Protection" warning signs were posted in all areas where "Shotcrete" was to be

applied. Unprotected eyes could sustain serious injury from the "Shotcrete" material as it was applied due to the rebound velocity of particles which did not adhere.

The "Shotcrete" over the knuckle plate was shot first and allowed to set up before the wall above was started. If this were not done, there would be the difficulty and extra cost of removing the rebound that would collect at the bottom due to shooting above. The "Shotcrete" was applied to the wall surfaces from five circumferential scaffold platforms. See Exhibit XI. The wall was shot in vertical strips from these platforms which eliminated horizontal "cold" joints around the tank. These vertical joints were staggered in subsequent layers so that planes of weakness could not be formed. The vertical line at which the shotcreting terminated at the end of the working day was trimmed back to good material and tapered to a thin, clean, regular edge with a slope not exceeding 1 to 2.

The "Shotcrete" was applied in successive layers from $3/4$ to $1-1/2$ inches in thickness with a maximum of 2 inches to build up to dimensioned thickness on the drawings. For layers in excess of this, the "Shotcrete" would slough off and/or crack due to its own weight.

Layers were applied on the wall once in three days, which gave sufficient time for the heat in the cement to dissipate. This time also allowed for wet curing, inspection, and removal of unsound material.

The wall surface was wet down thoroughly and scoured with an air jet before applying subsequent layers of "Shotcrete". Always, the surface was given a final check to avoid covering up weak spots in previous layers.

"Shotcrete" dimensions were maintained accurately by means of piano wire suspended vertically at 8-foot intervals around the perimeter of the tank. As each layer of "Shotcrete" was applied, the piano wire was moved outward an additional $1-1/2$ inches from the steel tank liner. This enabled the nozzleman to maintain an even tapered thickness of "Shotcrete" at all times. This method produced a "Shotcrete" surface that was uniformly smooth and free of irregularities to a tolerance of $\pm 1/4$ inch.

After initial curing of "Shotcrete", it was always kept moist over weekends and at night in warm weather by a "soaker" type hose fastened to the top of the tank wall or dome ring and allowed to run until the beginning of the next work day.

No bars or wires were allowed to project completely through the "Shotcrete" wall. When reinforcing tie wires projected beyond the face of the core wall, they were cut back by notching and reshotcreting. Scaffold tie wires to the steel tank were not used. Reinforcing tie

wires were cut neat at the reinforcing bars prior to covering with "Shotcrete" in lieu of bending loose ends back into the core wall space. All of this was done to help ensure a liquid-tight tank.

Cracks and/or voids resulting from sloughing were cut back on a bevel and reshotcreted as soon as possible rather than waiting until the next "Shotcrete" layer was applied.

When reinforcing spacer bars would normally be located opposite the scaffold platform, they were placed approximately 1 foot above or below this level in order to alleviate sloughing and voids mentioned above.

(4) Control Measures

As previously discussed, preliminary tests established such factors as basic material requirements and air and water pressures. Beyond this, and during the preparation and subsequent application of "Shotcrete", certain control measures were necessary to obtain quality results. These were:

(a) The gradation of sand was checked twice a week, and colorimetric tests were made once a week.

(b) The moisture content of sand was checked daily and mix proportions adjusted daily. The batch plant operator was notified of results in writing.

(c) An inspector was assigned at the batch plant to assure that correct quantities were being dry mixed and at a proper rate to provide an uninterrupted flow of material for the "Shotcrete" operation.

(d) Care was taken to conform to the requirements of "ACI Standard Recommended Practice for the Application of Mortar by Pneumatic Pressure" insofar as the time allowed between mixing the material and its application at job site.

(e) On arrival at the job site, three samples of dry mix were checked from each 2-yard load - one at the beginning of discharge, one when the load was half discharged, and one near the end of discharge. These tests were run promptly and the engineer in charge of "Shotcrete" work was advised of any deviation from specified material. If such material was not acceptable, it was rejected and any already applied was removed from the wall.

(f) During the application of the "Shotcrete" material on the tank, a test panel was made by each operator for each day's work.

The test panels, 2 x 2 feet wide and 2 inches thick, were made at or adjacent to the point of placement. They remained undisturbed in shot

location until they had set - at least 4 hours. They were protected from shock, weather conditions, and rebound. After set, the panels were removed from the scaffold, cured, and samples were cut and tested as required for compressive strength at 2, 7, and 28 days.

(g) Samples were taken once daily from each nozzleman's work area to determine the sieve analysis, water, sand, and cement contents. This provided information without undue delay as to the quality of "Shotcrete" material being applied on the tank wall.

The daily sieve analysis on wet samples and rebound for each operator were later eliminated because of the uniformity of test results.

(h) Core cylinders (4-inch) - one for each 150 square feet of wall surface and one for each 25 linear feet of dome ring - were cut from the core wall to verify for record purposes the strength status of the concrete structure. These cores were tested 28 days after final layer was shot. They were taken outside the inner layer of reinforcing and 2 inches minimum from the steel tank liner, so as not to damage the steel tank. These holes in the concrete were filled with a metallic nonshrink grout.

b. Tensioning Elements

(1) Material and Equipment

As noted previously, tensioning elements used to prestress the "Shotcrete" consisted of round carbon steel bars and hexagonal end turnbuckles. On the wall of each tank, 163 7/8-inch round rods were applied with a double layer at the bottom for a height of 12 feet-1 inch. On the dome ring, 41 1-inch round rods were applied in three layers. See Exhibit II.

Eight rod lengths, each about 34 feet-6 inches and connected with turnbuckles, made up one band which encircled the tank. Vertically shaped notches, formed with the final "Shotcrete" layer over reinforcing steel, were located at turnbuckle positions to give the necessary clearance for turning the turnbuckles during stressing process. See Exhibits IV and X.

One vertical bar (1-1/2 x 3/8 inch), containing half-round cuts, was placed in each of these notches to position the rods.

Stressing was accomplished by using a tightening lever inserted into the "eye" of the turnbuckle. For the rod being stressed, clamps were used on each side of the turnbuckle to prevent the rod from turning or riding on the wall. This clamp consisted of two 1-1/4-inch steel plates with two 1-inch bolt connectors and hardened 6-inch steel jaws. See Exhibit X.

Whittemore Strain Gages (10-inch gage length) were used to determine the proper stress in the rods. Each kit consisted of the gage, a standard bar of mild steel having hardened bushings, a double-pointed punch, a wrench, and a reamer. The dial was graduated to 0.0001 inch and one revolution of the long pointer was 0.010 inch. One graduation equaled a deformation of 0.00001 inch per inch or 290 psi.

(2) Preliminary Rod Tests

Representative rods (two 7/8-inch diameter and two 1-inch diameter) from the stock to be used on the tank walls were subjected to certain preliminary tests with results as follows:

(a) Experiments were made with the operation of strain gages to decide whether to use punch marks or drilled holes.

Punch marks gave consistent results under laboratory conditions. However, later experiments in the field proved that drilled holes gave more reliable readings.

(b) Strain gage readings were checked on a testing machine to determine accuracy of reading gage.

Readings were determined to be reliable for an accuracy of less than 1000 psi.

(c) Experiments were made on an 18-inch torque wrench, with 16-inch lever, to determine method of use and the torque necessary to turn turnbuckles.

The torque wrenches tested were too difficult to read accurately. Later use in the field also proved they were out of range and the turnbuckles could not be pulled with sufficient uniformity to get a reading unless the scaffold platforms were made wider.

(d) The pull required on tightening levers to turn turnbuckles was established.

This pull was about 4% higher than that calculated - that is, 167 lb vs. 160 lb. Under field conditions this pull was even higher due to binding of rod threads in turnbuckles and slight variations in the wall surface.

(e) The specified yield point (60,000 psi min.) and ultimate strength (105,000 psi min.) were confirmed by taking elongation readings on the strain gage at 2,000-lb intervals.

(3) Method Assembly

Rods for the first lift were taken directly from the trailer carrying the rods. They were pulled around the tank wall and connected with turnbuckles to form a band of 8 rods. After being placed in the proper position on the tank wall, the closing turnbuckle was attached by bending the two free ends inward with a bar bender to align with and engage the threads of the connecting turnbuckle. Care was taken to merely spring the rod and not put a permanent bend in it. Later, it was agreed that the rods could be prebent if doing so would facilitate placement. No improvement in placement was found, so prebending of the rods was discontinued.

Rods were held in position at proper spacing by 1-1/2 x 3/8-inch spacer bars containing half-round cuts. After "snugging" up the rods, as described in the next section, these bars were removed prior to initial stressing.

For subsequent lifts, a platform was erected at the second scaffold level between tanks and this area was used for storing rods as necessary. The rods were lifted into place, depending on height, by hand or by crane and assembled in a fashion similar to that used for the first lift.

Experience showed that the rods could not be assembled while "Shotcrete" was being applied on upper portions of the wall and dome ring because the waste and rebound that collected on the rods and threads required an unnecessary amount of extra cleaning.

The following system of identifying rods was adopted:

- (a) Bands were numbered from the bottom to top of tank.
- (b) Rods in each band were numbered from 1 to 8 beginning at the turnbuckle notch or slot on the north side and going counter-clockwise.
- (c) Alternate rods that started in the first turnbuckle notch west of north were numbered from 1A to 8A starting with this notch.

(4) Tensioning Procedure

Sufficient stress readings were taken to determine that all bands were stressed uniformly at 50,000 psi as closely as practical. The following minimum readings on designated bands were taken with additional readings as required to obtain proper uniformity and stress.

- (a) Initially, for each of the designated bands noted below, strain gage readings were taken at each end and at the middle

of Rods 1 or 1A. The other seven rods in the designated bands were read at the center. The readings at the center of the rods showed the lowest stress and therefore did not represent the average stress. To give better average readings, stress readings were taken at quarter points on each of the 8 rods in a band. Two readings at the ends of Rod 1 or 1A in a band were taken as before.

(b) The first band designated for stressing was selected 1 foot from the bottom of the tank wall.

(c) Above this, six additional bands were selected at 5-foot intervals up the tank wall.

(d) On the dome ring, two bands were selected - one 12 inches from the top, and the other 12 inches from the bottom of the dome ring.

Before beginning the tensioning process, the bands selected for stress readings were drilled for the strain gages and so marked.

To make sure that all rods were tightened the same degree, care was taken in "snugging" up the bands so that counting the turns would start on each turnbuckle at about the same degree of tightness. To do this, it was decided to loosen the bands and then pull them up enough to just touch the wall. When this was done, zero readings were taken on the bands selected for stress readings. The first turn of the turnbuckle was applied in two half turns with an interval between so that the first half turn on all the turnbuckles in a band was completed before the second half turn was started.

The remaining turns were applied in full turns with an interval between each turn. Although the turning was to be done in unison when possible, this was difficult to achieve because some turnbuckles turned easier than others due to the binding of some of the threads or to obstructions on the threads. Adoption of this procedure gave a more positive check on the initial stages of tightening. A heavy lubricant was also applied to the threads before applying the turnbuckles.

Field experience indicated that if the turnbuckles were tightened two half turns, then four full turns, the desired 50,000 psi for the tank wall would be approximately obtained. For the dome ring, the turnbuckles were generally tightened two half turns, then three full turns to obtain the required 50,000 psi. As noted above, all turnbuckles in a band were tensioned at the same time. This required an 8-man crew and foreman. If the stress readings indicated too low an average stress, additional half turns were taken as required. If stress readings on an individual bar indicated stresses higher than that required, additional half turns were not given this particular rod in that band. When additional turns were applied to rods not designated for testing, no turns were applied to turnbuckles, which obviously were much tighter than others in that band.

6. DOME RING (See Exhibits IX and XI)

It was necessary to install form work for the dome slab prior to shotcreting the dome ring as this provided the necessary "Shotcrete" forms for the dome ring. This made it possible to apply the "Shotcrete" on the dome ring and tank wall in continuous layers horizontally and vertically, giving a monolithic tie-in between the two structural components.

Layers on the dome ring were applied once every two days. A 2-inch-wide shooting strip at the top and bottom of the dome ring was added in 2-inch increments as the "Shotcrete" layers were applied. This facilitated making square edges on the dome ring and eliminated excessive material splashback. The lower part of each layer was shot first in order to preclude the collection of rebound in the lower shooting strip.

7. DOME SLAB AND RISERS (See Exhibits VIII and IX)

The dome forms were erected within the tanks before shotcreting on the walls was completed. The erection of the heavy vertical formwork was facilitated, and labor costs held to a minimum, by using two field construction jigs consisting of two vertical grooved wheels and one horizontal rubber-tired small wheel that ran around the top steel edge of the tank. These jigs were placed 180° apart with a 5/8-inch cable attached between them. A rolling block and tackle attached to the cable allowed the carpenters to erect vertical members of the formwork at any place in the tank.

Starting at the bottom of the tank, vertical form members were braced and secured from scaffolds erected for the safety of the crafts. At the completion of each lift, the scaffold was then raised for another lift. This method was continuous until the top radial pieces were placed. The final lift of scaffold was left in place until dismantling operations were started and the reverse procedure followed. All members were marked and identified as to location in the formwork structure before dismantling, thus making it easier for re-erection in the other tanks.

The dimensional rise of the dome was adhered to by wedging-up of the forms to produce this dimension when the concrete was poured. Differences in elevation at the top of the dome slab due to settlement of forms were held to less than 1 inch.

The dome slab could not be poured until after the core wall and dome ring had reached 5,000 psi, had set a minimum of 14 days, and at the same time had seven bands on the wall and four on the dome ring tensioned to 25,000 psi minimum.

Pouring of the dome slab actually consumed 5 hours. It was poured monolithically, using two cranes working from opposite ends of the dome roof structure. Concrete buckets were dumped starting at the center of the roof and working toward the edge or perimeter of the roof. Each crane worked one-half of the roof and at no time was it necessary for the concrete bucket to swing over an area where craftsmen were working. As the concrete was placed from the center outward, concrete finishers worked closely behind the pouring crew, thus making it possible to expedite the finishing process.

Screed chairs were used to obtain the desired thickness of concrete. Nuts for the chairs were welded to the reinforcing steel which in turn was placed or supported by concrete spacer brick to the clearance specified. As soon as practical, burlap was placed on the dome roof concrete and kept moist for the specified period by means of revolving water sprinklers.

Dome forms were removed after the first layer of rods had been fully tensioned, providing the dome concrete had attained 5,000 psi and 21 days had elapsed since pouring.

8. BACKFILLING (See Exhibit XIII)

The material for backfilling was taken from a spoil pile located during the excavation process for convenient rehaul to the tank site. The downslope of the spoil pile led directly to the south ramp of the excavation.

The quality of the fill material was established as suitable for backfill purposes both during excavation and after the spoil pile had set for several months.

Equipment used for placing and compacting the fill was as follows: power grader, "Tournapulls", "Tornadozer", front end loader, "Tampco" (wobble wheel) rollers, and "Barco" and air-powered hand tampers.

The backfill was placed in layers not exceeding 12 inches with each layer compacted by routing the earthwork equipment in a manner to obtain complete area coverage.

Design considerations required placing bags of vermiculite, 8-inch minimum thickness, around tank walls from the foundation to the under-side of dome ring. These bags weighed about 34 pounds each and contained 4.3 cubic feet of material. They were placed in horizontal layers, brick fashion, stacked on the long edge against the tank wall. As each layer was placed, voids behind and between the bags were filled with earth backfill. When the fill came up to the top of a course of vermiculite bags, additional bags were taken directly from the vendor's trailer, having a 500-bag capacity, and placed against the tank. Deliveries were timed to coincide with backfilling progress.

The general pattern of placing the fill by "Tournapulls" was to deposit the earth in layers with an occasional extra run around the tanks before depositing the load so as to get extra compaction from the heavy vehicle. For a large percentage of the area, there was sufficient width for the "Tournapull" to shift from one side to the other in order to get almost complete coverage. The grader spread the fill out in even layers and the roller made continuous passes over the material. Special routing of the roller near the vermiculite bags provided good compaction close to the tank wall.

Hand tamping equipment was used where obstructions prevented complete equipment coverage, such as around piezometers and the columns supporting the evaporator.

9. WASTE LINES AND SERVICES

Two of the future line stub-outs from the diversion box in the original tank farm were used to convey waste to two of the new tanks and thence by cascade to the other tanks. A waste line was also run from a jet placed in one tank in the original waste tank farm to a tank in the new tank farm in order to transfer suitable accumulated wastes.

The lines consisted of 3-inch stainless steel or carbon steel pipe encased in 6 or 12-inch "Transite" pressure pipe, depending on length of run, so that a proper slope could be provided for leak detection purposes. Where soil had been disturbed by excavation, the "Transite" pipe was supported on piles. Otherwise, it was laid directly on the earth with any soft spots or pockets under the pipe being filled with lean concrete to give an even bearing.

Waste line piles adjacent to the tank walls were placed prior to backfilling. This eliminated possible damage to the tank walls or dome rings due to pile driving. See Exhibit XII-B.

Within the tank backfill area, poles supporting overhead power and electrical lines were pile driven to a depth of 10 feet - 5 blows to the inch. These lines were placed 15 feet above grade so as not to interfere with maintenance and/or operating equipment.

ACKNOWLEDGEMENT

The author is indebted to A. E. Daking and R. J. Endriss of the Design Division and to C. L. Dorsey and E. W. Bolin of the Construction Division of the Engineering Department for their technical assistance in the preparation of this report.

III. REFERENCES

1. American Concrete Institute Building Code 318-56.
2. American Concrete Institute. "ACI Recommended Practice for the Application of Mortar by Pneumatic Pressure, ACI 805-51."
3. U. S. Dept. of Commerce, Bureau of Public Roads. Criteria for Prestressed Concrete Bridges. Washington: U. S. Govt. Print. Off.
4. Portland Cement Association. Design of Circular Domes - R/C #2. Chicago: Portland Cement Association.
5. Portland Cement Association. Circular Concrete Tanks without Prestressing - ST57. Chicago: Portland Cement Association.
6. Salvadori, M. G. "Line Load and Temperature Moments in Shells of Rotation Built into Cylinders". American Concrete Institute Preprint 52-12.
7. Terrington, J. S. "Design of Domes". Concrete and Construction Engineering 32, 460-72 (1937) No. 8, August.
8. Reissner, E. "Stresses and Small Displacements of Shallow Spherical Shells". J. Math. and Physics. 25, 80-85 (1946).
9. Mason, J. L. "Prestressed Circular Concrete Tanks." Portland Cement Association Bulletin R/C 5.
10. Komendant, A. E. Prestressed Concrete Structures. First Edition. New York: McGraw-Hill (1952).
11. Timoshenko, S. Theory of Plates and Shells. First Edition. New York: McGraw-Hill (1940).
12. Den Hartog, J. P. Advanced Strength of Materials. First Edition. New York: McGraw-Hill (1952).
13. Goodier, J. N. "Thermal Stresses". J. Applied Mechanics 4, A-33-36 (1937).

IV. APPENDIX

CASE 1-A

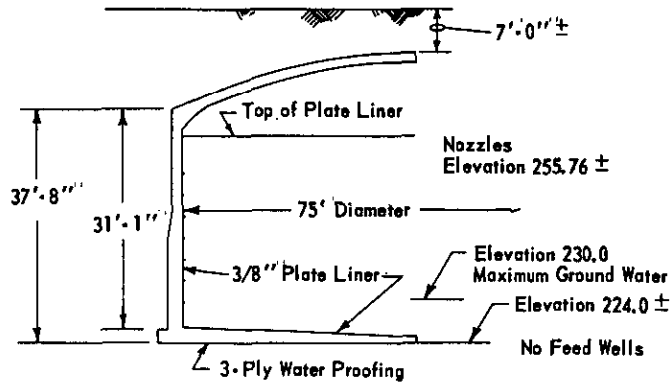

Notes from Hanford Drawings, Specifications, and Facility Description

Storage Period	-	Indefinitely long
Liquid	-	1.25 specific gravity, pH 10, atmospheric pressure
Tank	-	3/8 inch plate liner, open top, slightly dished bottom, spot X-ray check only
Pan	-	None
Annular Space	-	None
Waterproofing	-	Bottom only

CASE 2-AA

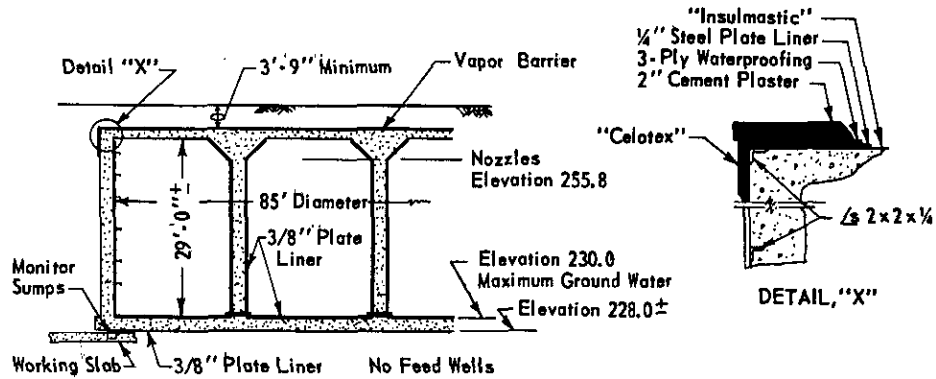

1. Design Conditions

- a) 100° F bulk temperature. No vacuum
- b) Contents - specific gravity 1.25

2. Steel Liner

3/8-inch plate

3. Concrete Walls

Designed for hydraulic pressure

4. Steel Pan

Leak detector only

EXHIBIT I ALTERNATIVE TANK DESIGNS

CASES 2-A & 2-B

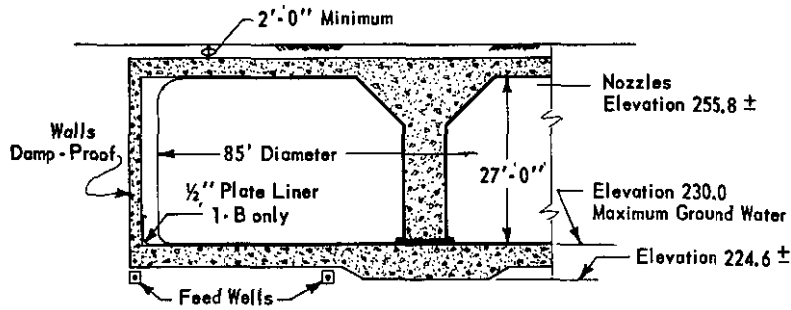

Same as High Activity Tanks except the following Omissions

Case 2-A

- a) No hydraulic pressure on inside wall
- b) Minimum thickness roof slab plus earth
- c) Omit requirement of 1/3 column load transfer to wall to provide for differential settlement

Case 2-B

- Same as Case 2-A except
- a) Omit pan
- b) Provide for 5 ft - 0 in. hydraulic pressure on side walls

CASE 2-C

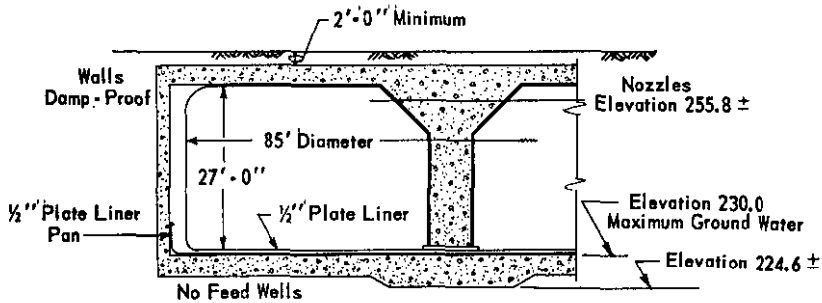

Steel Tank

Same as High Activity Storage Tanks except

- a) 100°F bulk temperature
- b) 1.25 specific gravity
- c) Atmospheric pressure

Concrete Shell

Same as Case 2A except
100°F bulk temperature

CASE 3

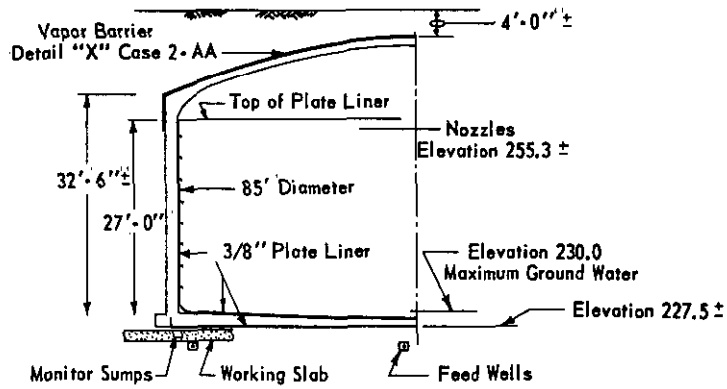

Design Conditions for Elevated Temperature

- Tank - 3/8-inch plate liner
- Concrete Shell - designed for full hydraulic pressure
- Pan - 3/8-inch leak detector only
- Roof Vapor Barrier - 1/4-inch plate

CASE 3-A

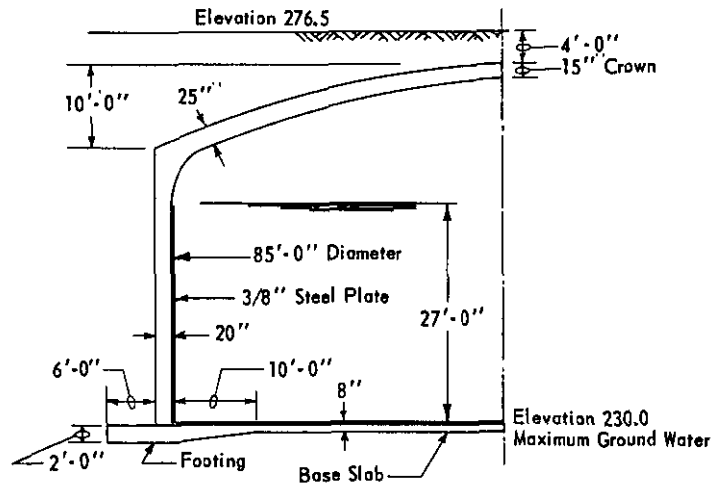

Modified Hanford-Type Conventional Design

- No leak detector pan required
- Partial blast protection
- No 1/4-inch steel plate for vapor seal required

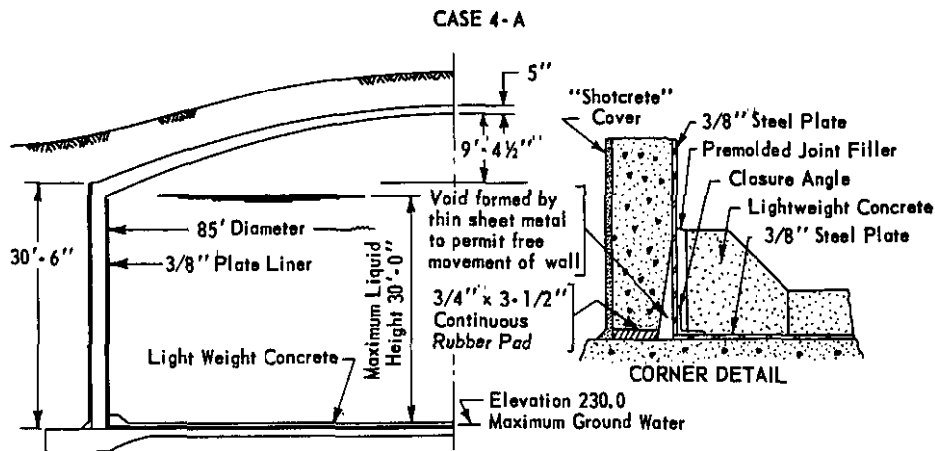

**Prestressed 85-Ft-Diameter Poured Concrete Construction
Modified Hanford Type**

A typical commercial prestress design
No leak detector pan required
No blast provision and no vapor seal

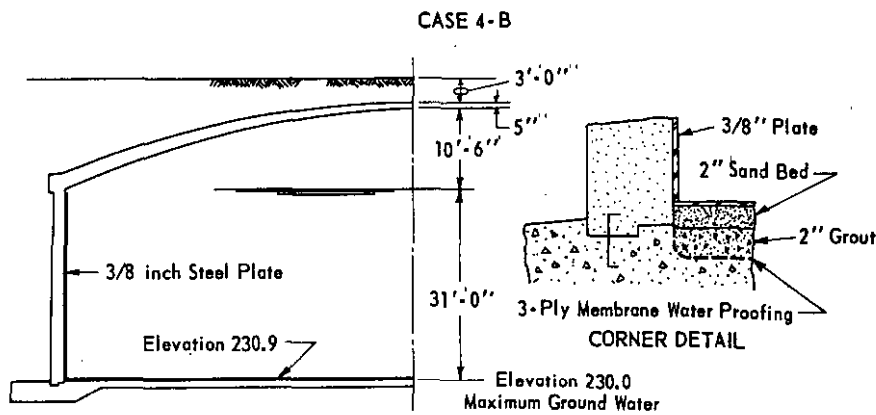

Prestressed 85-Foot-Diameter "Shotcrete" Construction

No blast provision
No leak detector pan required
No steel vapor barrier

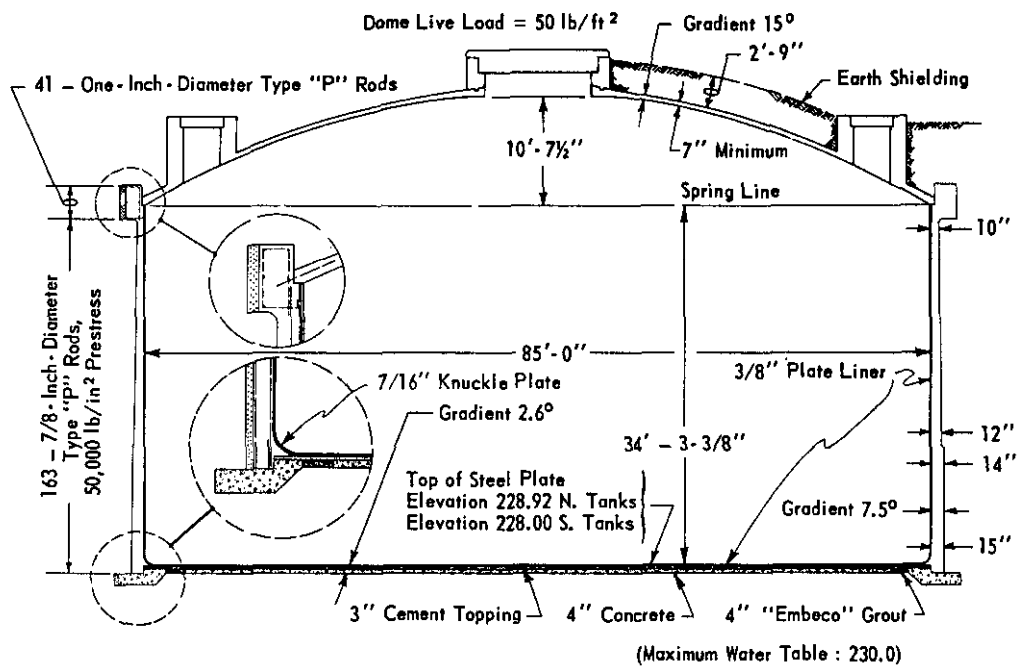

EXHIBIT II WASTE STORAGE TANKS - SECTION AND DETAILS

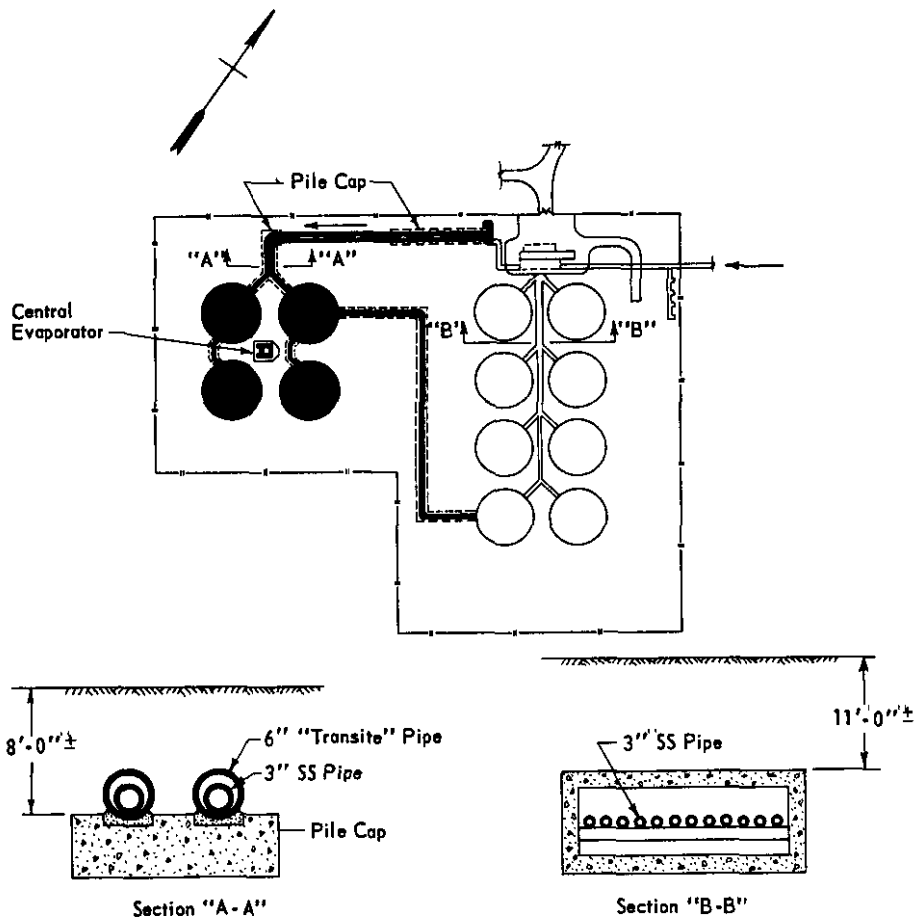
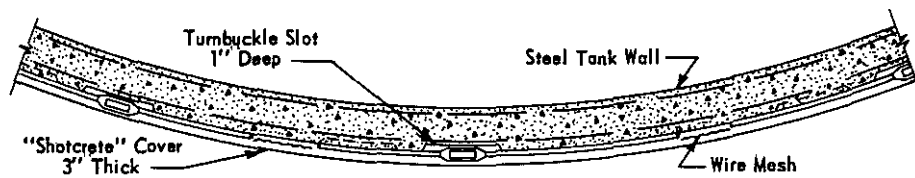
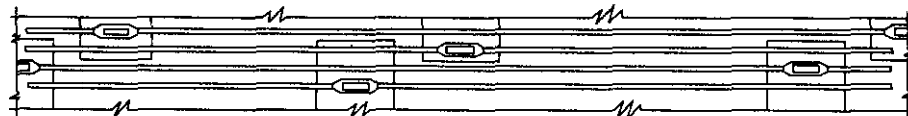

EXHIBIT III WASTE STORAGE TANKS AND FILL LINES



SECTIONAL PLAN



PARTIAL ELEVATION

Rods:

Type "P" rods - 60,000 psi minimum yield
 Prestressed to 50,000 psi
 7/8" diameter - spaced 1-5/16" to 9" on center in wall

EXHIBIT IV WASTE STORAGE TANKS - TENSIONING ELEMENTS - RODS AND TURNBUCKLES

Weights of Loaded Equipment	
Equipment	Lb
MC 504 W Crane	72,000
E 18 "Tournapull"	72,000
D 8 Bulldozer	40,000
White Truck	36,000
Super C Bulldozer	31,700
#12 Grader	22,200
HD 5 + R 13 Roller	30,000
HD 5 Bulldozer	16,000
HD 5 G Endloader	16,200
75A Endloader	15,800
D 2 + X 112 Roller	15,400
D 2 Bulldozer	8,000

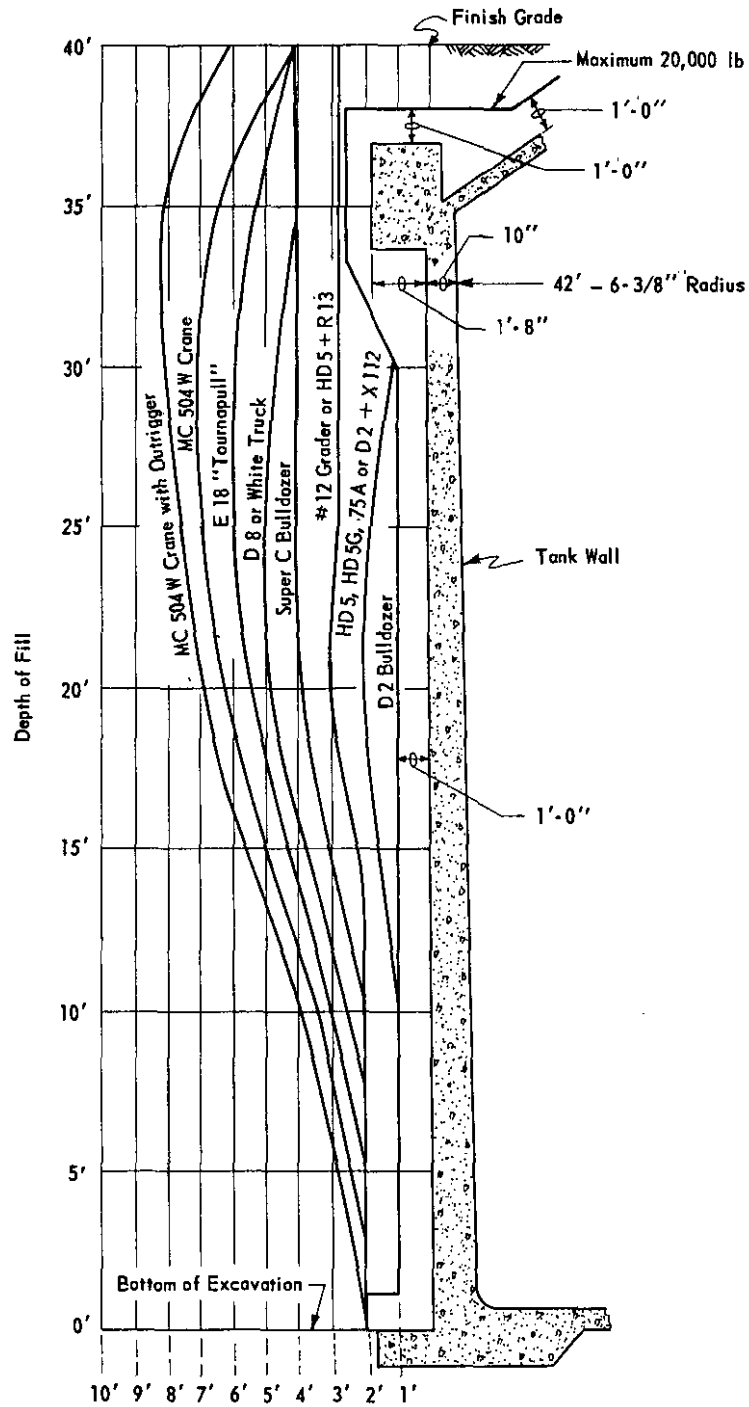

EXHIBIT V MINIMUM APPROACH OF EQUIPMENT TO TANK WALL

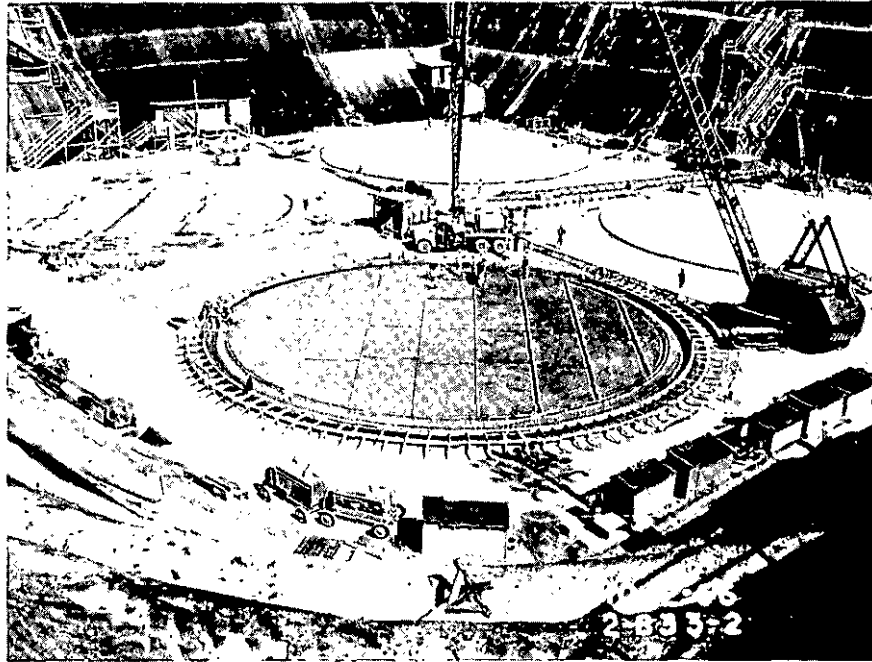

EXHIBIT VI-A FLOOR SLABS AND FOUNDATIONS SHOWING FORMWORK FOR DRAINAGE CHANNELS

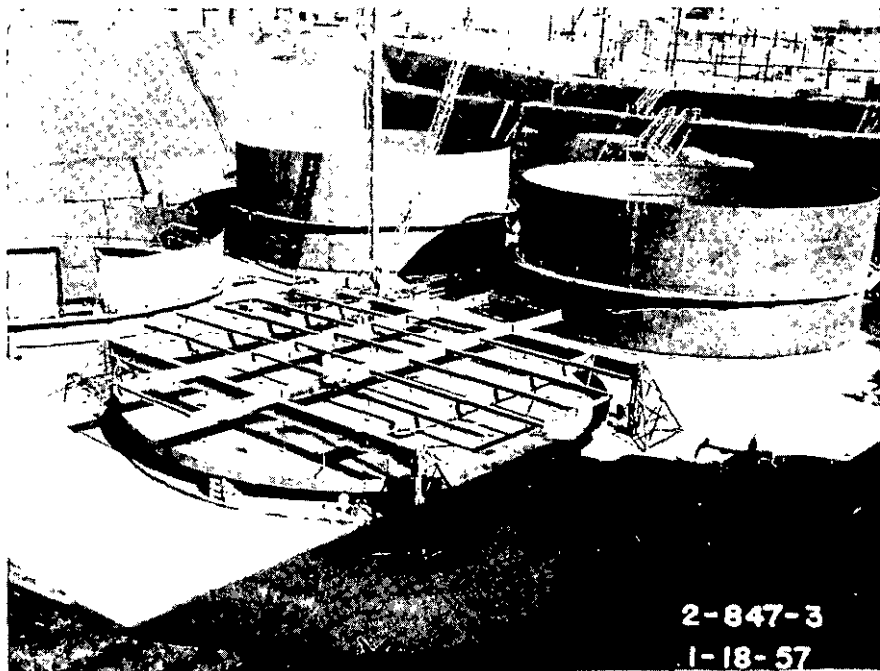

EXHIBIT VI-B ERECTION OF STEEL LINERS SHOWING RAISING-LOWERING FRAME

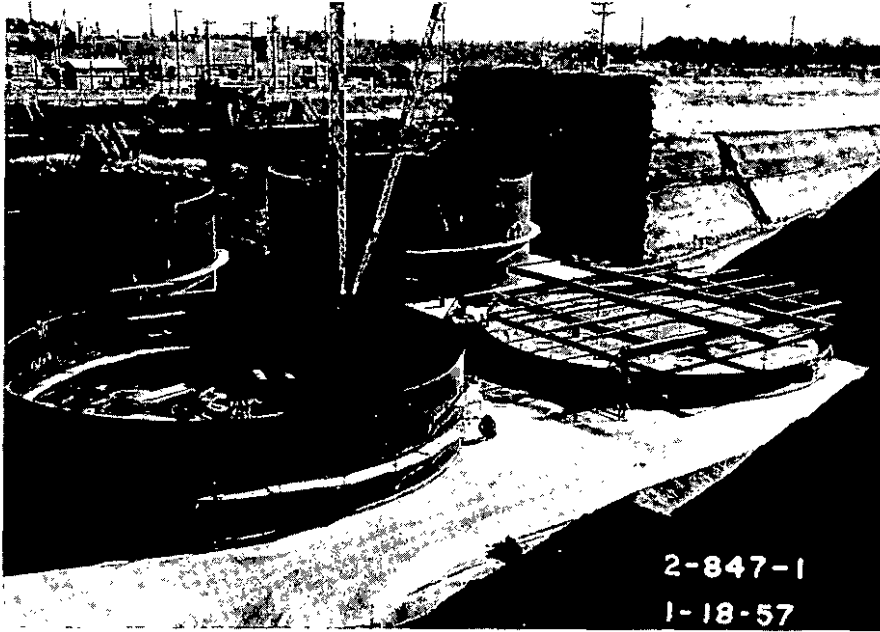

EXHIBIT VII-A ERECTION OF STEEL LINERS SHOWING ASSEMBLY OF WALL PLATES



EXHIBIT VII-B OUTSIDE OF STEEL LINER SHOWING KNUCKLE PLATE,
WALL FOUNDATION AND DOWELS

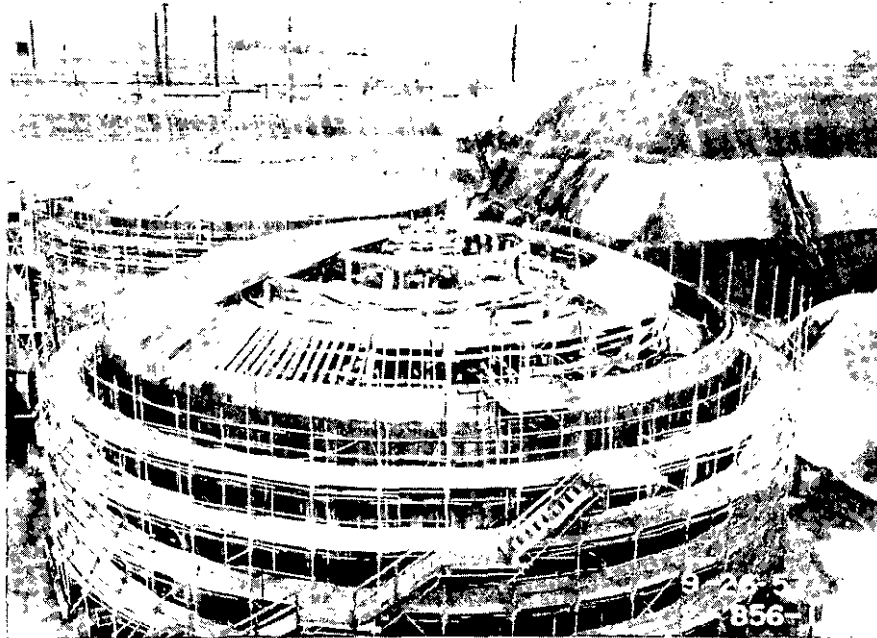

EXHIBIT VIII-A VIEW SHOWING WALL SCAFFOLD AND DOME FORM SUPPORTS

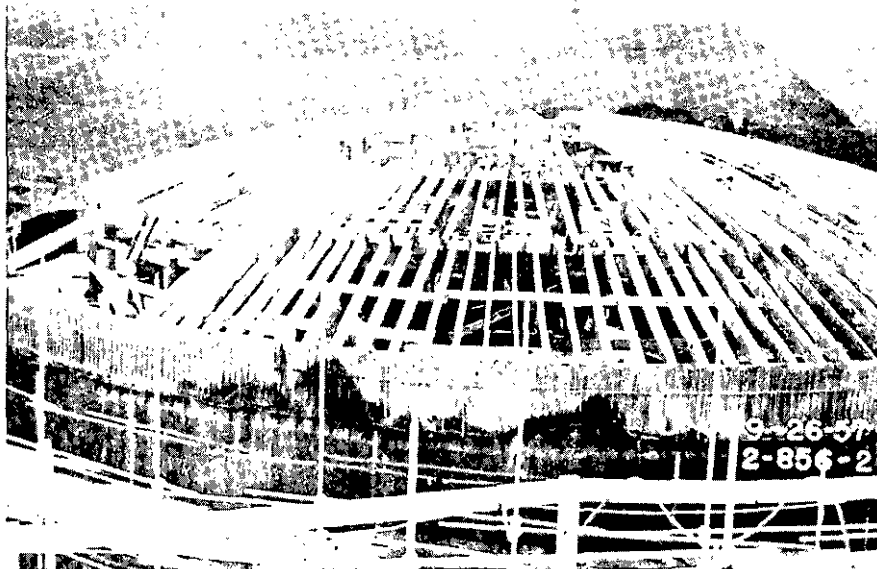

EXHIBIT VIII-B DOME FORMWORK

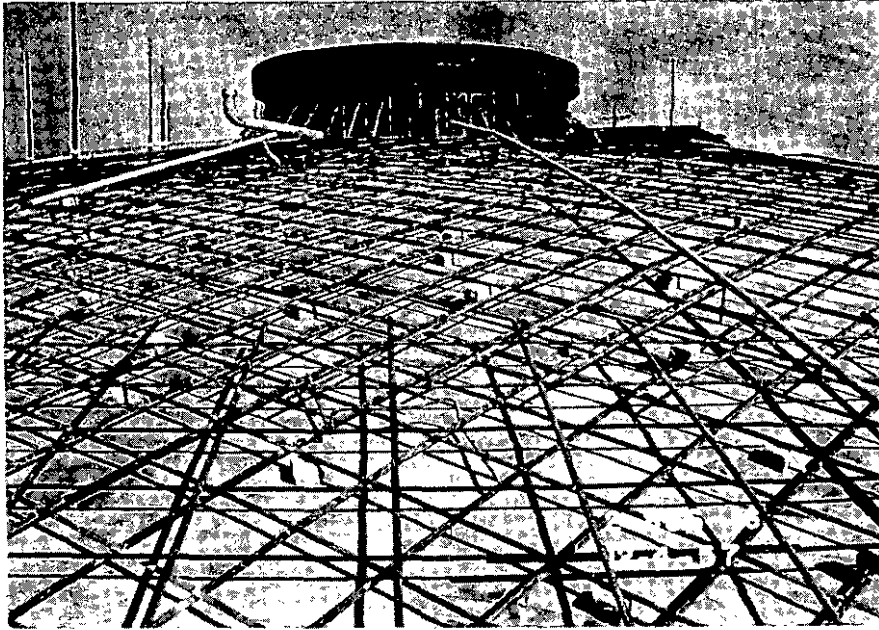

EXHIBIT IX-A DOME REINFORCING

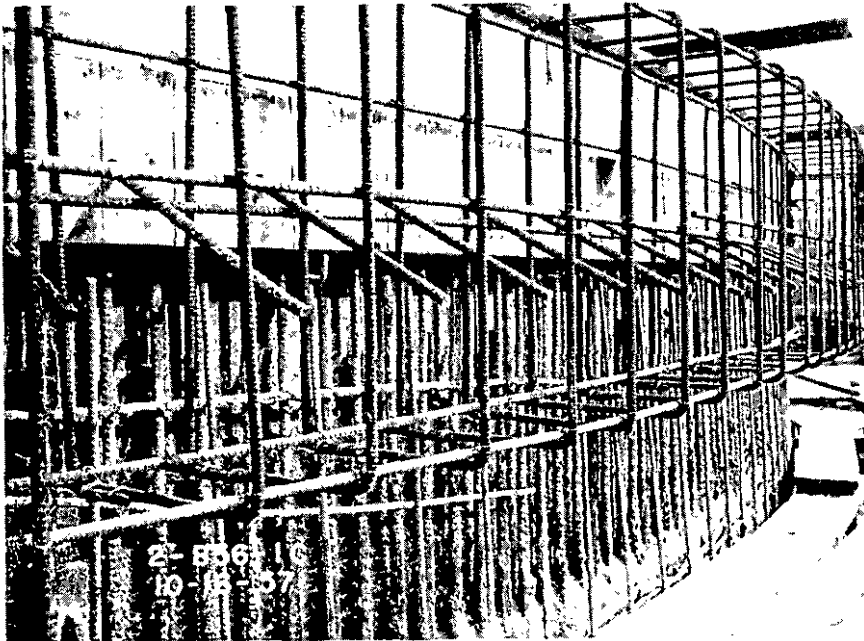

EXHIBIT IX-B DOME RING REINFORCING

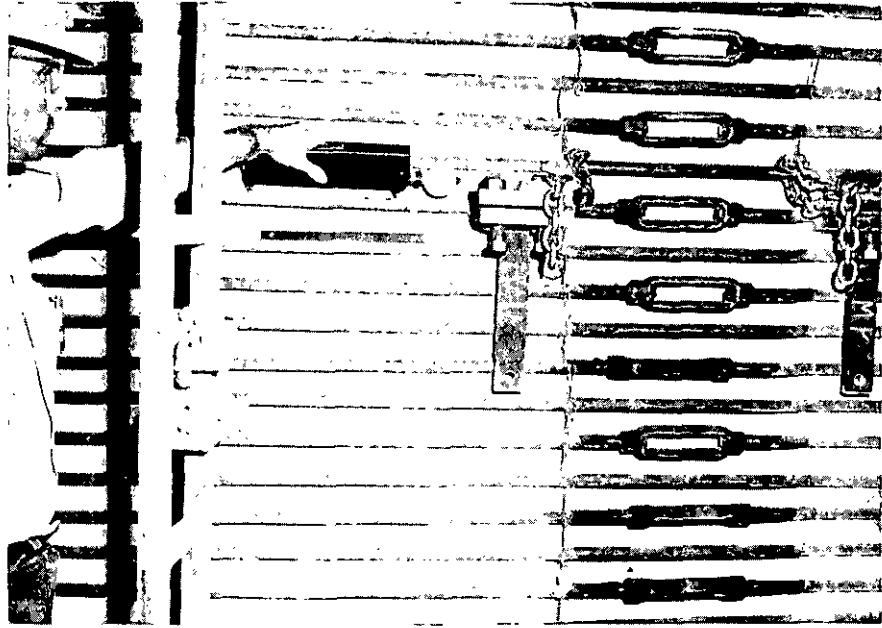

EXHIBIT X-A EXTENSOMETER, TURNBUCKLES IN NOTCH, CLAMPS, AND SAFETY CHAINS IN PLACE



EXHIBIT X-B TENSIONING PROCESS WITH TENSIONING LEVER AT TURNBUCKLES

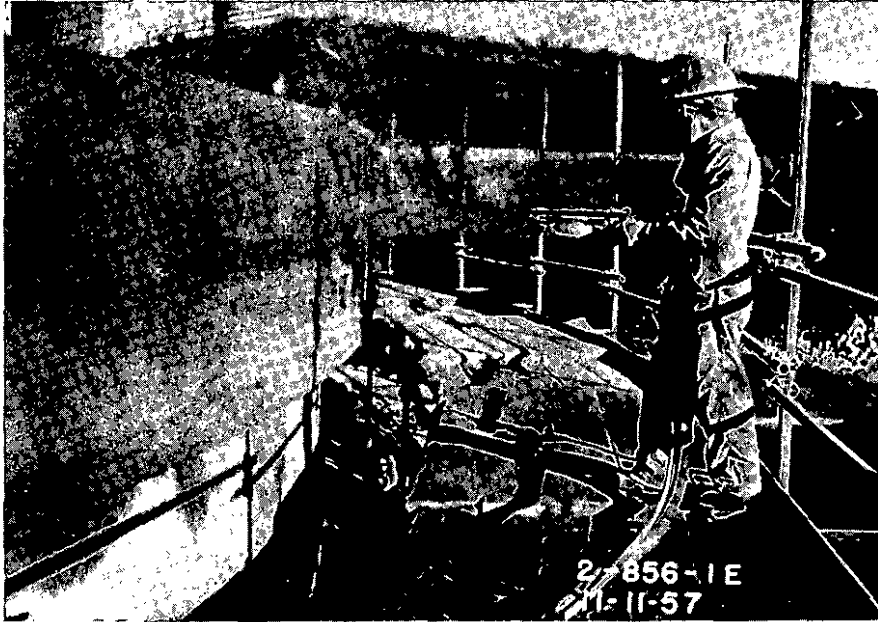

EXHIBIT XI-A APPLYING "SHOTCRETE" TO DOME RING

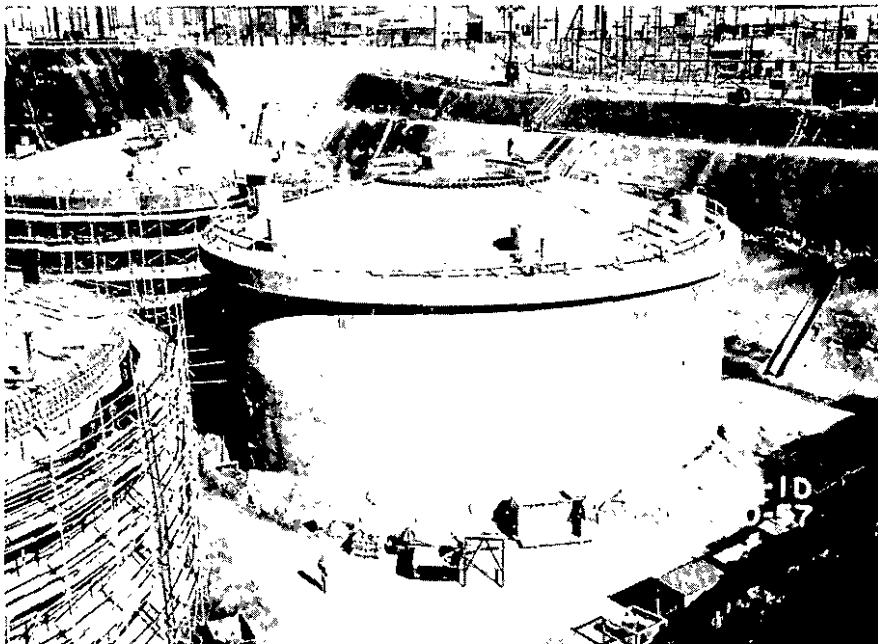

EXHIBIT XI-B COMPLETED TANK

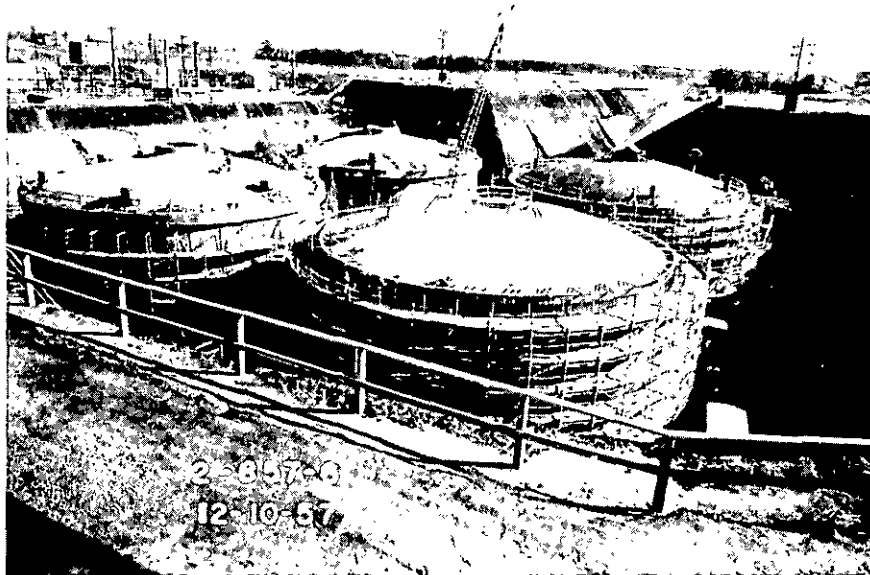

EXHIBIT XII-A COMPLETED DOME FORM DECK IN FOREGROUND



EXHIBIT XII-B COMPLETED TANKS SHOWING PILES NEAR TANK WALL PLACED PRIOR TO BACKFILLING



EXHIBIT XIII-A BACKFILLING IN PROGRESS SHOWING PLACEMENT OF VERMICULITE BAGS AROUND THE WALL

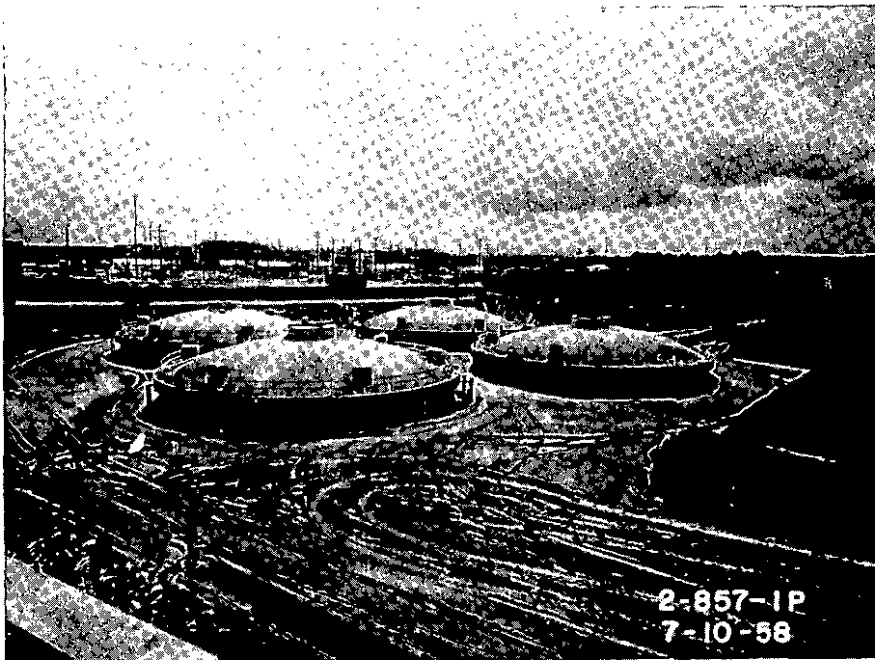

EXHIBIT XIII-B BACKFILL NEARING TOP OF WALL



E. I. DU PONT DE NEMOURS & COMPANY
INCORPORATED

2ND ISSUE

AIKEN, SOUTH CAROLINA

(TEL. & TEL. ADDRESS, AUGUSTA, GA.)

RECORD
COPY

June 28, 1960

EXPLOSIVES DEPARTMENT
SAVANNAH RIVER LABORATORY

H. WORTHINGTON, DIRECTOR
TECHNICAL DIVISION
EXPLOSIVES DEPARTMENT - AED
WILMINGTON

DO NOT RELEASE
FROM FILE

DP-478, UNDERGROUND STORAGE OF LOW LEVEL RADIOACTIVE WASTES
AT THE SAVANNAH RIVER PLANT - ENGINEERING CONSIDERATIONS

by A. N. Daniel

The initial installation of storage tanks to receive radioactive wastes from the Separations Areas at SRP consisted of twelve 750,000-gallon tanks, eight of which were located in the F Area and four in the H Area. Although designed for the containment of high level waste, three of the tanks are used for storage of low level waste solutions not suitable for seepage basin disposal.

In 1954, the need for additional high activity waste storage capacity in H Area led to the construction of four 1,030,000-gallon tanks similar to the original tanks. In June 1955, the need for additional waste storage in F Area led to the design study of tanks to hold 4,000,000 gallons of low activity wastes. Tanks designed specifically for storage of low level wastes could be constructed much more economically than those designed for high activity wastes since certain features incorporated in the latter could be eliminated. These features would include cooling coils, valve house, reflux condenser, dehumidification equipment, annular space and secondary saucer container around the tank, external waterproofing, and spare fill lines to each tank. In addition, accumulated low level wastes and those high level wastes that have decayed sufficiently that cooling is no longer required could be transferred to such tanks, thereby releasing existing tanks for storage of high activity wastes.

This report sets forth the methods and data used to establish the size, design, construction requirements, and operating limitations for economical and structurally sound tanks for storage of low

level waste solutions. It is a revision of DPE-1099, a Confidential report, written by the Design Division of the Engineering Department under Project 981030. DPE-1099 includes design calculations and cost evaluations of the tank designs considered. The present interest in industrial participation in fuel element reprocessing makes it desirable to issue the report in a form suitable for external circulation.

Construction of four tanks of the design described in this report has been completed under Project S8-1030, entitled "Additional Waste Storage Tanks - 200-F Area" authorized for construction December 6, 1956, at a cost of \$0.40/gallon in contrast to \$1.60/gallon for the original tanks. The new tanks have a capacity of 1,300,000 gallons each, instead of the originally planned 1,000,000 gallons, and therefore, increase the total storage capacity in the F area to 11,200,000 gallons.

Currently, four additional tanks, almost identical to the ones described in this report, are under construction in H Area.

R. J. Christl / gmH

R. J. Christl
200 Area Process Supt.

INTERNAL DISTRIBUTION

P. J. Hagelston, SROO (5)	Aiken, S. C.
B. H. Mackey - L. Squires	Wilmington AED
S. A. McNeight	"
M. H. Smith - W. H. Holstein -	"
J. B. Tinker	"
H. Worthington	"
V. R. Thayer	"
R. J. Christl	"
M. G. Buck	"
W File	"
A. D. Duff, Jr.	Engineering Department
A. N. Daniel	" "
J. A. Monier - F. H. Endorf	Savannah River Plant
W. P. Overbeck	"
J. K. Lower	"
W. P. Bebbington	"
R. B. Fenninger	"
C. M. Patterson	"
W. O. Christy	"
PRD File	"
M. H. Wahl - C. W. J. Wende	Savannah River Laboratory
J. O. Morrison	"
J. W. Morris	"
W. E. Winsche	"
C. H. Ice	"
H. M. Kelley	"
TIS File Record Copy	"
TIS File	"

RECORD COPY CHECK LIST

Internal Distribution _____ ✓ - TL
 AEC Approval _____ ✓
 External Distribution _____ ✓
 Date Internal Copies Mailed _____ 8-16-60
 Date External Copies Mailed _____ 9-27-60
 Date (Oak Ridge) (OTS) Copies Mailed _____
 Railway Express (Motor Freight) _____

The following items are to be bound with the Record Copy:

	<u>Secret</u>	<u>Confidential</u>	<u>Unclassified</u>
Approval Sheet	_____	_____	_____ ✓
Internal Distribution	_____	_____	_____ ✓ - TL
External Distribution (M-3679) (TID-4500)	_____	_____	_____ ✓
Proposed Publication Letter	_____	_____	_____ ✓
AEC Approval Letter	_____	_____	_____ ✓
Record Copy Check List	_____	_____	_____ ✓
Publication	_____	_____	_____ ✓

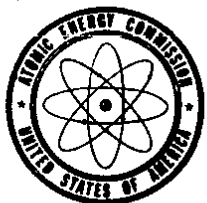

UNITED STATES
ATOMIC ENERGY COMMISSION
SAVANNAH RIVER OPERATIONS OFFICE
P. O. BOX A
AIKEN, SOUTH CAROLINA

TELEPHONE
AUGUSTA, GA.
PARK 4-6311

TELEGRAM ADDRESS
AUGUSTA, GA.

IN REPLY REFER TO:

TI:TEH:mep

July 14, 1960

J W
11 0 2000
173 A

Mr. Hood Worthington, Director
Technical Division, AED
Explosives Department
E. I. du Pont de Nemours and Company
Wilmington 28, Delaware

Dear Mr. Worthington:

We have reviewed for classification and patent considerations the following unclassified documents transmitted by your letters of June 28 and June 29, 1960, and agree that they may be released for standard external distribution:

- DP-478 - "Underground Storage of Low Level Radioactive Wastes at the Savannah River Plant - Engineering Considerations", by A. N. Daniel
- DP-494 - "Precipitation of Radium", by F. E. Butler

Dr. Wahl's office was so notified by telephone this date.

Very truly yours,

Paul J. Hagelston, Director
Technical & Production Division

cc: Dr. M. H. Wahl (2)



E. I. DU PONT DE NEMOURS & COMPANY
 INCORPORATED
 AIKEN, SOUTH CAROLINA
 (TEL. & TEL. ADDRESS, AUGUSTA, GA.)

CC: F. A. Robertson, SROO
 S. A. McNeight
~~XXXXXXXXXX~~ M. H. Smith
 L. C. Evans - H. Worthington
 M. H. Wahl - J. W. Morris -
S. W. O'Rear - TIS File

EXPLOSIVES DEPARTMENT
 SAVANNAH RIVER LABORATORY

June 28, 1960

Mr. P. J. Hagelston, Director (2)
 Technical and Production Division
 Savannah River Operations Office
 U. S. Atomic Energy Commission
 Post Office Box A
 Aiken, South Carolina

Dear Mr. Hagelston:

PROPOSED PUBLICATION - DP-478

Attached for review as to classification and patent matter are five copies of the following report:

Underground Storage of Low Level Radioactive Wastes at the
 Savannah River Plant - Engineering Considerations
 by A. N. Daniel

We propose to release the report for standard external distribution.

To facilitate the release of this report, it would be appreciated if you would telephone your comments to M. H. Wahl's office and send a confirming letter to me with a copy to M. H. Wahl. The report will be released when approval is received, but not until after 14 days from the date shown above.

If any clarification or technical information is needed to aid in your patent review, we suggest you get in touch with

C. W. J. Wende, Assistant Director
Savannah River Laboratory

If you decide to pursue a patent on any development covered in the accompanying material, I shall be happy to supply the additional information required such as appropriate references and the name of the person responsible for the development.

Very truly yours,

Hood Worthington, Director
 Technical Division

HW/
 Enc.
 OSR 24-A148

U. S. Atomic Energy Commission
PUBLICATION FORM

This form, along with documents described herein, should be submitted to USAEC Technical Information Service Extension, P. O. Box 62, Oak Ridge, Tennessee.

Document Title Underground Storage of Low Level Radioactive Wastes
at the Savannah River Plant - Engineering Considerations

Author(s) A. N. Daniel

Contract Number AT(07-2)-1 Date of Document June 1960

I. Research and Development Report Intended for TID-4500 Distribution in Accordance with AEC Manual Chapter 3202

1. Complete TID-4500 distribution has been made, including copies for Office of Technical Services (OTS sale price is \$1.50).
2. Sufficient copies have been printed, but complete TID-4500 distribution has not been made. Copies are enclosed for TIS to:
 - Make complete TID-4500 distribution, including copies to OTS (sale price is _____).
 - Make distribution to OTS only (AEC and other Government agency distribution has been made). (Sale price is _____.)
 - Other. Please specify _____
3. No copies have been printed for TID-4500 and OTS distribution. TIS is requested to reproduce from copy enclosed and to make TID-4500 distribution, including copies for public sale through OTS. Enclosure is:
 - a. Printed copy
 - b. Typed copy
 - c. Reproducible or multilith platesUp to 25 copies will be furnished to authors if desired. Indicate number _____
4. Patent clearance has has not been obtained.

II. Internal and Informal Reports.

AEC Manual Chapter 3202 requires that informal reports generally be given TID-4500 distribution, and that technical information contained in internal reports also appear in a distributable document which receives appropriate distribution.

Chapter 3202 does recognize that issuing organizations may wish to limit distribution of informal reports and internal reports (subsequently distributed externally) under certain conditions. It also provides for negotiation between TIS and the originator, or TIS and the cognizant AEC program division if distribution limitations specified by the originator appear questionable to TIS.

1. Document enclosed is an informal or internal report, which has been considered in light of the above-listed requirements, but which is still not intended for TID-4500 distribution or for publication in a scientific or technical journal. Recommendations are:
- a. TIS is is not to make selected positive distribution to certain AEC contractors as appropriate.
 - b. TIS is is not to fill requests for this document from AEC contractors.
 - c. TIS is is not to selectively distribute and fill requests for this document from other Government agencies.
 - d. TIS is is not to make a single copy available to OTS and announce in NSA.

If distribution limitations are indicated, submit justification or reasons as required by Manual Chapter 3202.

2. Patent clearance has has not been obtained.

III. Document Intended for Publication in Scientific or Technical Journal

1. Document has or will be submitted for publication in the following scientific or technical journal:

	Name of Journal
<hr/>	
	Expected Date of Issuance

2. Copies have been printed and advance project distribution has been made. TIS is is not requested to send a single copy to OTS, announce in NSA, and make domestic depository distribution.

Submitted by J. W. Hill *J. W. Hill*
Organization Savannah River Laboratory
Date 9/27/60

If it is desired that correspondence concerning this document be directed to an individual other than the name above, please indicate. _____

TECHNICAL DIVISION
SAVANNAH RIVER LABORATORY

Report Data Sheet

Report Number DP-478 S C U Approved by [Signature]

Author A. N. Daniel

Title UNDERGROUND STORAGE OF LOW LEVEL RADIOACTIVE WASTES ^{at the} SAVANNAH RIVER PLANT -

Engineering Consideration.

Category RADIOACTIVE WASTE Approved by [Signature]

Abstract _____ Approved by [Signature]

TL - 22 - by SWOR - 5/10/60

Author _____ Supv. _____

Manuscript Approval (See attached notes) _____

Reproduction _____

Copy Approval _____

Printed Copy _____

Approval _____

Recommended for _____

Journal Publication _____

_____ Required _____ Optional

TO BE FILLED OUT BY TIS

Ms:pp Typed _____ Figures _____ Tables _____ Total pp. _____

Direct Master _____ Photo Offset _____ Carbon Ribbon _____ Fabric _____

Paper Stock _____ Cover _____

No. Copies: Internal _____ Int. Extra _____ TID-4500 _____ M-3679 _____

Other () _____ Total Copies _____

FD:pp Typed _____ Figures _____ Tables _____ Total pp. _____

Doc. Date _____ Received _____ Int. Issue _____ Ext. Issue _____

Remarks -1099

Dr: 4/78
 mailed 9/27/60

RADIOACTIVE WASTE

Full Size Copies	TISE Microcard	Standard Distribution
2		Aberdeen Proving Ground
1		Aerojet-General Corporation
1	1	Aerojet-General, San Ramon (IOO-880)
	1	Air Force Cambridge Research Center
	1	Air Force Institute of Technology
2		*AFPR, Boeing, Seattle
3	2	*AFPR, Lockheed, Marietta
2		Air Force Special Weapons Center
2	2	ANP Project Office, Convair, Fort Worth
1	1	Alco Products, Inc.
1		*Allis-Chalmers Manufacturing Company
10	3	Argonne National Laboratory
3		Army Chemical Center
1		*Army Chemical Center (Taras)
1		Army Chemical Corps
1		Army Signal Research and Development Laboratory
1		Atomic Bomb Casualty Commission
	1	AEC Scientific Representative, Argentina,
1		AEC Scientific Representative, Japan -
3	2	*Atomic Energy Commission, Washington
3	1	Atomics International
2		Babcock and Wilcox Company (NYOO-1940)
2	1	Battelle Memorial Institute
2	1	Bettis Plant
4	1	Brookhaven National Laboratory
1		BAR, Goodyear Aircraft, Akron
1		BAR, Grumman Aircraft, Bethpage
1		Bureau of Medicine and Surgery
1		*Bureau of Mines, Albany
1		Bureau of Mines, Salt Lake City
1		Bureau of Ships (Code 1500)
1		Bureau of Yards and Docks
1		Chicago Operations Office
1		Chicago Patent Group
1		Combustion Engineering, Inc.
1		*Committee on the Effects of Atomic Radiation
1		Convair-General Dynamics Corporation, San Diego
1		Defence Research Member
2		Department of the Army, G-2
2		*Division of Raw Materials, Washington
3	1	duPont Company, Alken
1	1	duPont Company, Wilmington
1		Frankford Arsenal
2	1	General Electric Company (ANPD)
4	1	General Electric Company, Richland
1	1	*General Electric Company, St. Petersburg
1		Gibbs and Cox, Inc.
1	1	Goodyear Atomic Corporation
1		Grand Junction Operations Office
1		Hawaii Marine Laboratory
2	1	Iowa State College
1		Jet Propulsion Laboratory
1		Knolls Atomic Power Laboratory
3	1	Los Alamos Scientific Laboratory
1		M & C Nuclear, Inc.

RADIOACTIVE WASTE (Continued)

Full size Copies	TISE Microcard	Standard Distribution
1	1	Mallinckrodt Chemical Works
1		Maritime Administration
1	1	*Martin Company
1		Massachusetts Institute of Technology (Hardy)
1		Mound Laboratory
1		*National Aeronautics and Space Administration, Cleveland
2		National Bureau of Standards
1		National Lead Company, Inc., Winchester
1	1	National Lead Company of Ohio
1	1	*Naval Civil Engineering Laboratory
3		Naval Research Laboratory
1	1	New Brunswick Area Office
2	1	New York Operations Office
1		Nuclear Development Corporation of America
1		Nuclear Metals, Inc.
1	1	Oak Ridge Institute of Nuclear Studies
5		Office of Naval Research
1		Office of Naval Research (Code 422)
1		Office of Ordnance Research
1		*Office of the Chief of Naval Operations
1		Office of the Surgeon General
1		Olin Mathieson Chemical Corporation
1		Ordnance Materials Research Office
1		Patent Branch, Washington
4	2	Phillips Petroleum Company (NRTS)
1		Power Reactor Development Company
2	1	Pratt and Whitney Aircraft Division
2	1	Public Health Service
1	1	Public Health Service, Savannah
1		*Rensselaer Polytechnic Institute
1		Sandia Corporation, Albuquerque
1		Schenectady Naval Reactors Operations Office
1	1	South Dakota School of Mines and Technology
1		Sylvania Electric Products, Inc.
1		Tennessee Valley Authority
3		The Surgeon General
2	1	Union Carbide Nuclear Company (ORGDP)
5	1	Union Carbide Nuclear Company (ORNL)
1	1	Union Carbide Nuclear Company (ORNL-X-12)
1		Union Carbide Nuclear Company (Paducah Plant)
1		U. S. Geological Survey, Albuquerque
1		U. S. Geological Survey, Denver
1		U. S. Geological Survey, Naval Gun Factory
1		U. S. Geological Survey (Nolan)
1		U. S. Geological Survey (Stringfield)
1		U. S. Geological Survey, Washington <i>and Naval Reactors Operations Office</i>
1		U. S. Naval Postgraduate School
2	1	U. S. Naval Radiological Defense Laboratory
1	1	*University of California at Los Angeles
2	1	*University of California, Berkeley
2	1	*University of California, Livermore
1	1	University of Puerto Rico
1	1	University of Rochester
1		Walter Reed Army Medical Center
1		Watertown Arsenal

RADIOACTIVE WASTE (Continued)

Full size Copies	TISE Microcard	Standard Distribution
1	1	Westinghouse Electric Corporation (Schafer)
4	1	Wright Air Development Center
1		Yankee Atomic Electric Company
325		Technical Information Service Extension
<u>75†</u>		Office of Technical Services, Washington
<u>571</u>		
568		
		Deletions from the 14th Edition
1	1	Armed Forces Special Weapons Project, Washington
5		Armed Services Technical Information Agency
1		Vitro Engineering Division

*New listing or change in old listing.

†These copies should be shipped directly to the Office of Technical Services, Department of Commerce, Washington 25, D. C.

JOB RECORD SHEET
(TIME COUNT)

P- 478 S C U ✓

Title _____
 Author _____
 Division _____

Date	TIS Supv.	TIS Edit	TIS Type	TIS Dwg	TIS Make-up	TIS Proof	Author Proof	TIS Corr.	Author Corr.	RC Appr.	TIS Print	Final Rev	TIS Bind
6/28											X	X	
6/29												X	
6/30												X	
7/1												X	X
7/5	Int. Draw.												
7/14	Phone release												
7/14	AEC Phone release 7/14/60												
7/20	AEC letter 7/20/60												
8/16	Review												

INTERNAL ISSUE 7/5/60 AEC PHONE RELEASE 7/14/60 EXTERNAL ISSUE 9/29/60
 WORKING DAYS _____
 TOTAL DAYS _____

JOB RECORD SHEET
(TIME COUNT)

P- 478 S C (U)

Title _____
 Author _____
 Division _____

Date	TIS Supv.	TIS Edit	TIS Type	TIS Dwg	TIS Make-up	TIS Proof	Author Proof	TIS Corr.	Author Corr.	RC Appr.	TIS Print	Final Rev	TIS Bind
5/10			X	X									
5/11			X	X									
5/12			X	X									
5/13			X	X									
5/16			X	X									
5/17			X	X									
5/18			X	X									
5/19			X	X									
5/20			X	X			X						
5/23				X			X ²						
5/24				X			X ¹						
5/25				X			X ¹						
5/26							X						
5/27 XJWH							X						
5/31 "							X						
6/1				X									
6/2			X						X				
6/3					X Mac								
6/6					X								
6/7					X								
6/8					X								
6/9					X kurtz								
6/10					X "								
6/13					X "								
6/14					X "								
6/15					X "								
6/16					X "								
6/17					X "								
6/20					X Janet								
6/21					X "								
6/22					X "							X	
6/23												X	
6/24												X	
6/27												X	

INTERNAL ISSUE _____ AEC PHONE RELEASE _____ EXTERNAL ISSUE _____
 WORKING DAYS _____
 TOTAL DAYS _____

JOB RECORD SHEET
(TIME COUNT)

DP- 478 S C (U)

Title Underground Storage of Low Level Radioactive Wastes - Savannah River Plant

Author A. N. Daniel

Division _____

Date	TIS Supv.	TIS Edit	TIS Type	TIS Dwg	TIS Make-up	TIS Proof	Author Proof	TIS Corr.	Author Corr.	RC Appr.	TIS Print	Final Rev	TIS Bind
3/11	1/0												
3/14													
3/15													
3/16													
3/17													
3/18													
3/21													
3/22	X												
3/23	X												
3/24	X												
3/25	X												
3/28	X												
3/29	X												
3/30	X												
3/31	X												
4/1	X												
4/4	X												
4/5	X												
4/6	X												
4/7	X												
4/8	X												
4/11	X												
4/12	X												
4/20	X												
4/29	X												
5/1	X												
5/2	X												
5/3	X												
5/4	X												
5/5	X												
5/6	X												
5/9	X												
5/10	X												

INTERNAL ISSUE _____ AEC PHONE RELEASE _____ EXTERNAL ISSUE _____
 WORKING DAYS _____
 TOTAL DAYS _____

2nd Issue 8/15/60
Date 6/30/60

Internal Issue of DP-478 and DP-478 TL

TO: Print Shop

→ Note P.I. of TL needs to be reprinted

1. Assemble 30 copies of report
2. Bind 25 copies with TL
3. Bind 5 copies without TL *4 for SROO
1 file Record*
4. Give to document section
5. Retain masters and extra copies of TL in print shop.

TO: Document Section

Issue 30 copies of report. This includes all copies on internal distribution except TIS File and TIS File Record copies.

-Give File Record copy to Editing.

→ Note: Call Katy to make a copy for AEC to show them the changes that were made.

TO: _____

DATE _____

FROM: _____

INTERNAL REFERENCES FOR DP - 47X

Author _____

Title _____

List by number only (Notebooks, DPST's, or any material used in the preparation of this report).

DPE-1099



E. I. DU PONT DE NEMOURS & COMPANY
INCORPORATED
WILMINGTON, DELAWARE

EXPLOSIVES DEPARTMENT

cc: Hood Worthington - L. C. Evans
M. H. Smith
~~J. W. Morris - E. W. O'Rear~~

JW Hall

July 11, 1960

Mr. T. B. Miland, Chief (2)
Classification Branch
Technical & Production Division
Savannah River Operations Office
U. S. Atomic Energy Commission
Aiken, South Carolina

Dear Mr. Miland:

CLASSIFICATION CONSIDERATIONS - DP-478

The above report, "Underground Storage of Low Level Radioactive Wastes at the Savannah River Plant - Engineering Considerations," by A. N. Daniel, which was transmitted to your office by letter of June 28, 1960 from Hood Worthington, has been reviewed for classification.

This report appears to be unclassified by topic 203 of the SRO Classification Guide. The waste storage capacity at SRP has been published previously in pages 826-841, Volume I of the record of the hearings on Industrial Radioactive Waste Disposal held by the J.C.A.B. in January and February of 1959.

Yours very truly,

S. A. McNeight
S. A. McNeight
Technical Assistant
ATOMIC ENERGY DIVISION

SAMcN:r

ES-3277

DON'T SAY IT—WRITE IT

To J. W. Hill - C. R. Tharin

DATE July 26, 1960

At Savannah River Laboratory

FROM M. G. Buck - Wilmington *M.G. Buck*

The following comments and corrections apply to DP-478. Most of them were discussed with C.R. Tharin by telephone.

1. Transmittal letter, 2nd paragraph, 1st line activity is misspelled. Second line, 1,300,000-gallon should be 1,030,000-gallon.

2. Though A. N. Daniel did not object at first to the use of his name as the author, he does now. He will be satisfied to leave his name but include an acknowledgement which I think you can put on page 42. There are a couple of other corrections to be made on that sheet.

Acknowledgement

The author is indebted to A. E. Daking and R. J. Endriss of the Design Division and to C. L. Dorsey and E. W. Bolin of the Construction Division of the Engineering Department for their technical assistance in the preparation of this report.

3. Page 5. Question 1 raised by C. M. Patterson. Since the diameter is given as 85 feet, change wall height to 34 feet. (Note: leave 34 feet 3 3/8 inches on Exhibit II) (~~34 feet 3 3/8 inches~~)

4. Page 7, paragraph 4, line 3; A. N. Daniel suggests that "discharged to" would be better than "disposed of to". Lines 7 and 8, re: Patterson's correction. His statement is o.k. It might require less retyping to change the word "established" to "published", put an asterisk after Bureau of Standards and a footnote: "*Recommendations of the National Committee on Radiation Protection (and Measurements), NBS Handbook No. 69".

Note: The title page of NBS Handbook #69 does not give "and Measurements" but page iii of the Preface gives "National Committee on Radiation Protection" (and later, the National Committee on Radiation Protection and Measurements).

5. Page 9, f. re: Patterson's comment about 25 mr/hr. Christl suggested "to an arbitrary 25 mr/hr since the area is seldom occupied". B. L. Taber and I tried to come up with a correction that would not require retyping the whole page. Move "to" to the line above then have the last line read "reduce the radiation level to an arbitrary 25 mr/hr. (Area seldom occupied.) I counted spaces and think this could be done.

1. We do not agree that the inference made is as Patterson stated. For other reasons, the bottom of the tank must be at the greatest depth possible but it must be kept above the ground water level.

To _____

DATE _____

AT _____

FROM _____

6. Page 10, line 1, activity misspelled.

7. Page 14, third line from bottom. Specific gravity has no dimensions. Delete "feet". Error is in DPE-1099, we should have caught it.

✓ 8. Page 15, 3. Sentence 3 and then Exhibit II. Possibly make arrow for "3/8" Plate Liner" go to right wall, as is, and an additional one to the bottom wall, then make arrow in left hand corner go down to the center of the curved corner and read "7/16" Knuckle Plate". On the original, the knuckle plate was shown as a heavier line but on the scale of the drawing, 1/16" could hardly be shown. Like so.

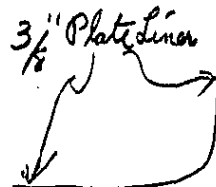
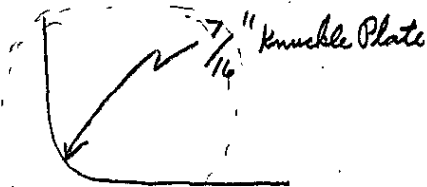

If this is too much to do, delete the 3/8" Plate from lower left hand corner insert.

9. Page 21, e. Line 3. We think it should read an 8-inch blanket, it did in DPE-1099.

10. Page 27, Line above 2. Steel lines should be steel liner.

11. Page 29, b. Line 2. Daniels thought "ensure" should be "insure". I think ensure is correct.

Next to last line, "raising-lowering crane" should read raising-lowering frame, see the paragraph above. (Not your error.)

12. Pages 32-33 - Three Tables.

You moved "inch" from 3/8" to top of column. Only the 3/8 is in inches. The other numbers are mesh size. So it should probably be

Sieve Size
 3/8"
 4 mesh
 8
 .
 .

DON'T SAY IT—WRITE IT

Page 3

To _____

DATE _____

At _____

FROM _____

- ✓ 13. Page 36, 3rd paragraph, line 1, operator misspelled.
14. Page 37, Line 2, another error we should have caught, "~~g~~age" should be "gage" to be consistent.
Line 6, "per inch of 290 psi" should read "per inch or 290 psi".
15. Page 41, 8, Paragraph 3. Delete comma after "Barco", it modifies hand tampers. I guess there should be an "and" before Barco.
16. Page 42, 9, Line 2. "to two of the new two tanks".
Delete second "two".

MGB:apb

CONFIDENTIAL

File with DPE 1099



E. I. DU PONT DE NEMOURS & COMPANY
INCORPORATED
WILMINGTON 98, DELAWARE

CC: A. D. Day, FPM, SRP
R. K. Mason
S. I. Winde
A. E. Daking
Office File
Engg. Dept. AEC File (2)

ENGINEERING DEPARTMENT

January 12, 1959

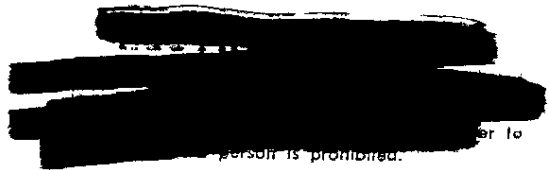

J. B. TINKER, MANAGER (2)
PROCESS SECTION
MANUFACTURING DIVISION
ATOMIC ENERGY DIVISION
EXPLOSIVES DEPARTMENT

PROJECT 981030-24 - UNDERGROUND STORAGE OF LOW LEVEL RADIOACTIVE WASTES - ENGINEERING CONSIDERATIONS
TRANSMITTAL OF CONFIDENTIAL REPORT DPE-1099 DATED DECEMBER, 1958

Transmitted herewith are Copy Nos. 1 through 14 of the subject report.

With copies of this letter, R. K. Mason and A. D. Day are trans-
mitted Copy No. 15 and Copy No. 16 respectively.

DESIGN DIVISION

A. N. Daniel, Jr.

A. N. Daniel, Jr.
Sr. Architectural & Civil Engineer

AND/mcp

Attach.

**WHEN SEPARATED FROM ENCLOSURES,
HANDLE THIS DOCUMENT AS UNCLASSIFIED.**





cc: R. B. Fenninger - W. P. Overbeck
 W. C. Reinig
 R. J. Christl - AED
 File

INTER-OFFICE MEMORANDUM

SAVANNAH RIVER PLANT

July 11, 1960

TO: J. W. HILL

FROM: C. M. PATTERSON

C.M. Patterson
DP-478 - UNDERGROUND STORAGE OF LOW LEVEL
 RADIOACTIVE WASTE AT THE SAVANNAH RIVER PLANT

I have three minor questions concerning the subject report and one correction.

First, the questions -----

1. On page 5 under C. Results, point number one implies that a height of 34 feet 3 3/8 inches is quite critical. I don't think that the height to the 1/8 inch is as important as all this.
2. On page 9, item f. I wonder where the figure 25 mr/hr came from? It is not a Technical Standard. Why not 10 mr/hr or 50 mr/hr?
3. On page 9, item i. Inference is that there was some reason to place the bottom slab at ground water level. I am sure that most installations of this nature prefer to keep as large a soil column between the tank and the ground water as possible.

The following part of the report should be corrected ----

1. Page 7, A. Introduction, paragraph 4 under point one states ----
 "is well below the maximum permissible level established by the National Bureau of Standards."

The National Bureau of Standards sponsors and publishes the recommendations of the National Committee on Radiation Protection and Measurements. It is this Committee who recommends or "establishes" the maximum permissible levels.

Subject statement might read "----- is well below the maximum permissible level recommended by the National Committee on Radiation Protection and Measurements as published in NBS Handbook #69."

CMP:rb

E. I. DU PONT DE NEMOURS & CO.
EXPLOSIVES DEPARTMENT
WILMINGTON, DELAWARE

CC: J. W. HILL, SRP
R. B. FENNINGER/W. P. OVERBECK, SRP
W. C. REINIG, SRP
B. L. TABER
W FILE (2)

August 1, 1960

J. D. ELLETT, MANAGER
SAVANNAH RIVER PLANT
ATTENTION: C. M. PATTERSON (2)

DP-478 - UNDERGROUND STORAGE OF
LOW LEVEL RADIOACTIVE WASTE
AT THE SAVANNAH RIVER PLANT

Your questions and comment contained in memo to J. W. Hill, 7/11/60, relative to the report on low level radioactive waste storage tanks, DP-478, have been considered and resolved in the following manner:

Question 1 concerning the implication that tank height measured to an accuracy of 1/8" is critical - as used on page 5 under C, reporting results of a study on optimum tank size, the nearest foot should be adequate and the report is being changed accordingly.

Question 2 concerning the shielding design basis of a 25 mr/hr field above the tanks - this is an arbitrary number used by giving recognition to the fact that occupancy of the area above the tanks is less than a so-called intermittent occupancy area where the shielding design basis at the time was 10 mr/hr.

Question 3 concerning the placement of the tank bottom slab as near maximum ground water level as practical - as you indicated, normal preference is to keep as large a soil column as possible between tank and water table. However, in this instance, since there is an upper controlling elevation, namely the invert of the inlet pipe which in turn is controlled by line slope from an existing diversion box, it is desirable to go as close as practical (construction tolerance) to the water table to take advantage of as much tank height as is available within the limits of reasonable tank height.

With regard to your comment on that part of this report to be corrected, the reference to limits established by National Bureau of Standards has been re-written to indicate the correct relationship between the National Committee on Radiation Protection and Measurement which recommends limits and the National Bureau of Standards which publishes limits.

ATOMIC ENERGY DIVISION
J. B. TINKER, MANAGER
PROCESS SECTION

BY B. L. Taber
B. L. TABER

BLT/jd

DP-478-4
DP-478-76-4

DP-111 1-8-1-60

COPY NUMBER	DATE LOANED	NAME	DATE RETURNED	COPY NUMBER	DATE LOANED	NAME
5	7-5-60	A.E.G./S.P.O. - G.O. Nagelston	8-3-60			
1	"	A.E.D. Wilson - (B.H. Mackey)	4 240. net. 8-5-60			
1	"	" - S.P.M. Wright	"			
1	"	" - M.H. Smith	"			
1	"	" - H. Washington	"			
1	"	" - D.P. Thayer	"			
1	"	" - G.J. Phibbs	"			
1	"	" - M.G. Buck	will hold - until new one is out			
1	"	" - G.H.	8-9-60			
1	"	Eng. Sgt. - G.D. Duff	"			
1	"	" - G.M. Daniel	"			
1	"	P.R.D. - G.A. Manier	7-15-60			
1	"	" - G.P. Overbeck	7-12-60			
1	"	" - J.H. Lamer	8-11-60			
1	"	" - Mr. E. Redington	8-11-60			
1	"	" - G.B. Ferringer	7-15-60			
1	"	" - C.M. Gardner	9-2-60			
1	"	" - W.D. Christy	8-3-60			
1	"	" - G.H.	8-3-60			
1	"	M.H. Madell	7-15-60			
1	"	G.O. Morrison	8-3-60			
1	"	G.M. Marrie	8-2-60			
1	"	Mr. E. Minisch				
1	"	C.H. Lee	7-15-60			
1	"	H.M. Kelley	8-3-60			
1	"	Printing Shop (Overstock)				