

NOTES:  
1. FOR GENERAL NOTES, REFERENCE DRAWING SYMBOLS SEE DWS 50M1732-EI-01.

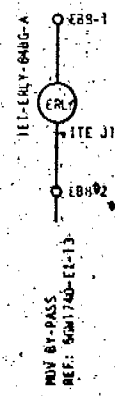
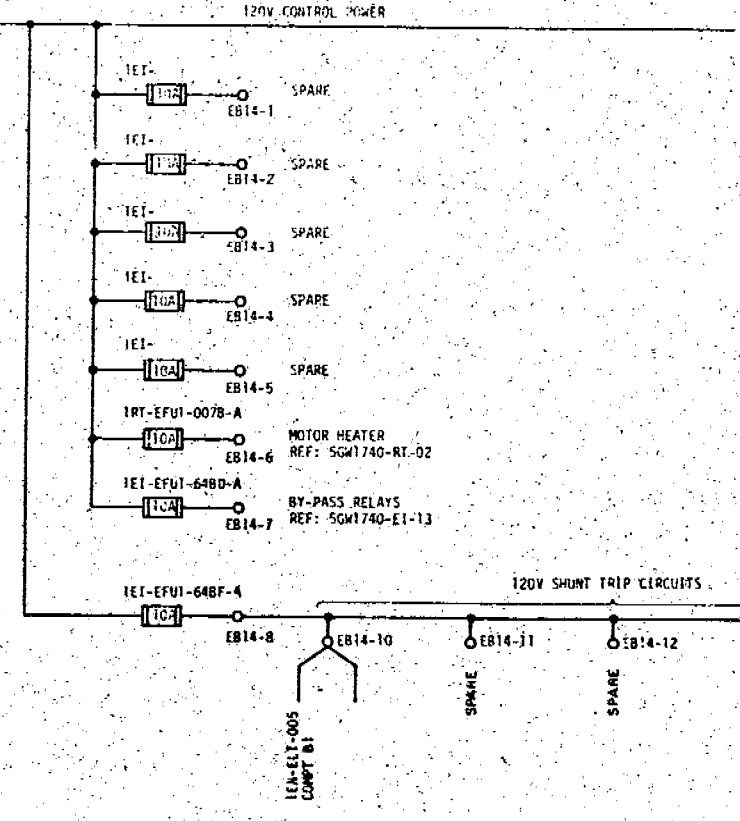
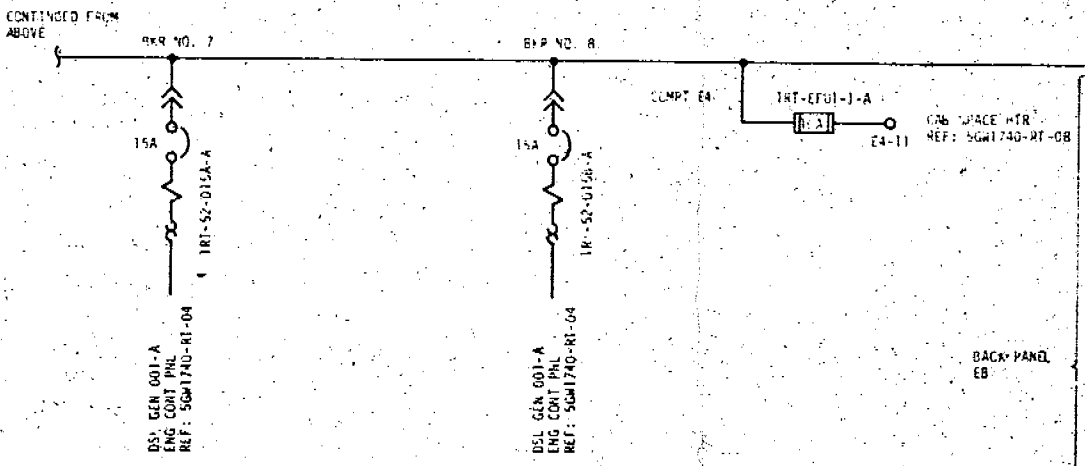
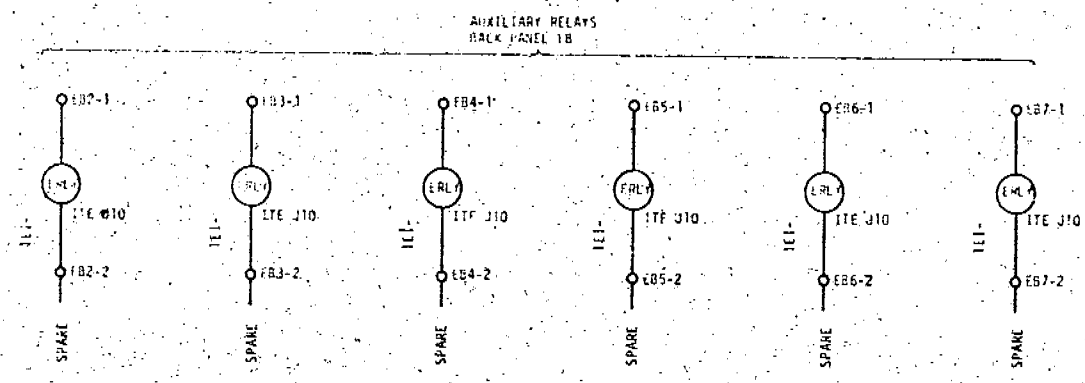
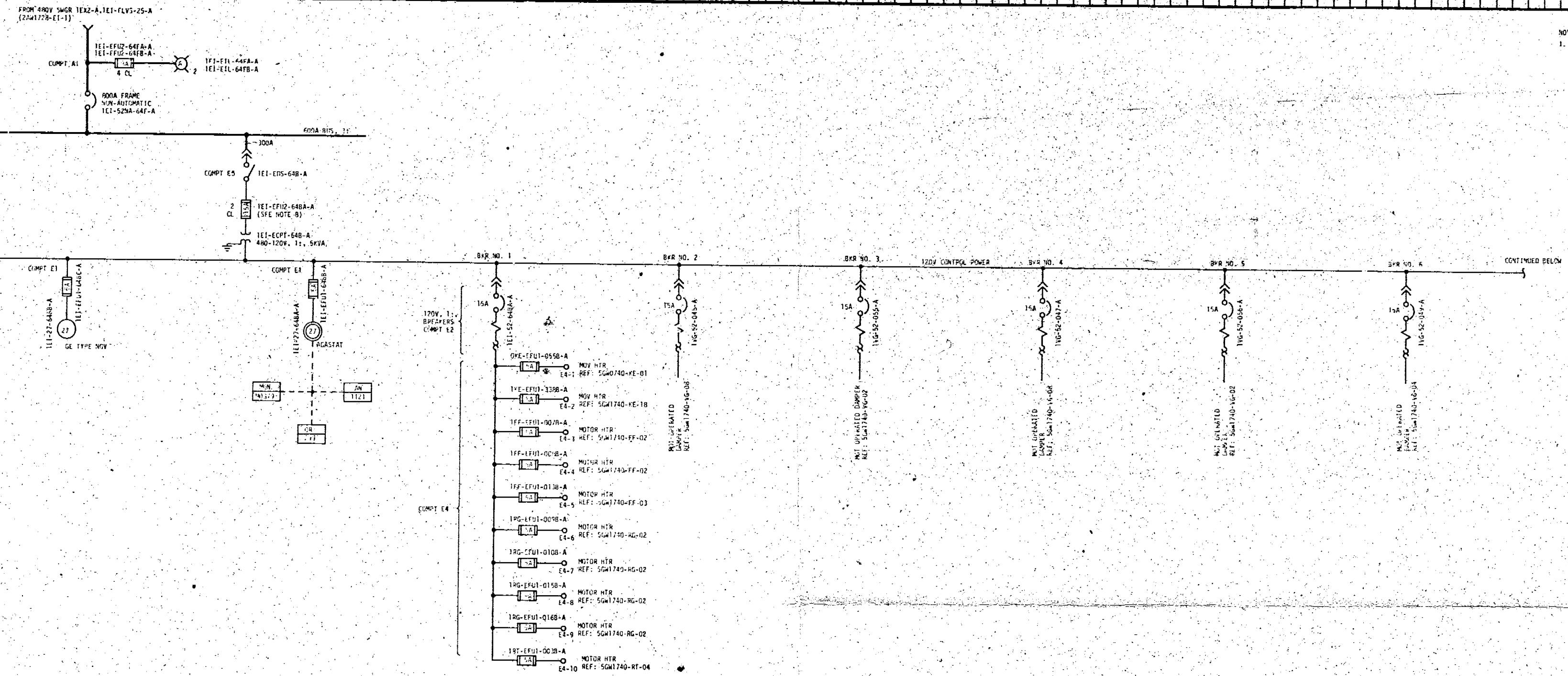

Doc # 50-438  
 Control # 836452536  
 Date 3-25-83 of Document  
 REGULATORY DOCKET FILE

PRC APERTURE CARD

|  |             |      |             |      |       |          |       |       |       |        |        |
|--|-------------|------|-------------|------|-------|----------|-------|-------|-------|--------|--------|
| NO.  | ECN NO.     | DATE | DISC.       | OWN. | CHKD. | SUPV.    | ENGR. | INSP. | SUBM. | REC'D. | APP'D. |
|  |             |      |             |      |       |          |       |       |       |        |        |
| DESIGN   | RE: M. Hope |      |             |      |       |          |       |       |       |        |        |
| CHKD.  |             |      |             |      |       |          |       |       |       |        |        |
| SUPV.  |             |      |             |      |       |          |       |       |       |        |        |
| ENGR.  |             |      |             |      |       |          |       |       |       |        |        |
| INSP.  |             |      |             |      |       |          |       |       |       |        |        |
| SCALE: NTS EXCEPT AS NOTED                           |             |      |             |      |       |          |       |       |       |        |        |
| DIESEL GENERATOR BUILDING UNIT 1                     |             |      |             |      |       |          |       |       |       |        |        |
| SINGLE LINE 480V MCC 1E4-A 1E1-EMCC-64-A             |             |      |             |      |       |          |       |       |       |        |        |
| Bellefonte Nuclear Plant, Tennessee Valley Authority |             |      |             |      |       |          |       |       |       |        |        |
| DIVISION OF ENGINEERING DESIGN                       |             |      |             |      |       |          |       |       |       |        |        |
| SUBMITTED  |             |      | RECOMMENDED |      |       | APPROVED |       |       | Q     |        |        |
| M. R. Hoff   |             |      | A. L. ...   |      |       | R. ...   |       |       |       |        |        |
| INSPECTED AND APPROVED FOR ISSUE                     |             |      |             |      |       |          |       |       |       |        |        |
| KNOXVILLE 3-9-82 88 E SDM1732-EI-03 RD               |             |      |             |      |       |          |       |       |       |        |        |