

**Methodology for Development  
of Emergency Action Levels  
Advanced Passive Light Water Reactors**

September 2007

## **ACKNOWLEDGEMENTS**

NEI acknowledges the valuable input provided, and the extensive technical support provided by the members of the EAL Task Force, Westinghouse Electric Company LLC, General Electric Company, Southern Nuclear Operating Company, EP Consulting, LLC, and Enercon Services, Inc.

## **NOTICE**

This report was prepared as an account of work sponsored by the Nuclear Energy Institute (NEI). Neither NEI nor any of its employees, members, or consultants make any warranty, expressed or implied, or assume any legal liability or responsibility for the accuracy, completeness or usefulness of any information, apparatus, product or process disclosed in this report, or represent that its use would not infringe privately-owned rights.

The opinions, conclusions, and recommendations set forth in this report are those of the authors and do not necessarily represent the views of NEI, its employees, members or consultants.

Because NEI is supported in part by Federal funds, NEI's activities are subject to Title VI of the Civil Rights Act of 1964, which prohibits discrimination based on race, color, or national origin, and other federal laws and regulations, rules, and orders issued thereunder prohibiting discrimination. Written complaints of exclusion, denial of benefits or other discrimination of those bases under this program may be filed with the United States Nuclear Regulatory Commission, Washington, DC 20555 or any other appropriate federal regulatory agency or, among others, the Tennessee Valley Authority (TVA), Office of Equal Employment Opportunity, 400 West Summit Hill Drive, Knoxville, TN 37902.

## **FOREWORD**

The initial version of this document was written based on NEI 99-01, Revision 5 in development in late 2006 as a starting point. The NEI EAL Task Force coordinated with the passive light water reactor vendors to consider each IC/EAL and determine its applicability to the design of the plants and to determine what additional IC/EALs would be required. Those ICs/EALs not applicable due to the design were not included.

The approved Design Certification does not include detailed design data for those items specific to a site location. In many cases this data is necessary to determine EAL thresholds. In these cases this document provides a {site specific} placeholder.

The approved Design Certification does not include some detailed design information such as setpoints and some instrument numbers which are being developed by Westinghouse and General Electric. In many cases this data is necessary to determine EAL thresholds. Appropriately, this document provides a [TBD] placeholder for future inclusion. Development of the site specific EAL scheme may continue using this document.

**EAL Task Force  
2006-2007**

Walter H. Lee	Southern Nuclear Operating Company
David W. Stobaugh	EP Consulting, LLC
Martin Hug	Nuclear Energy Institute
Jay Maisler	Enercon Services, Inc.
Ted Amundson	EP Consulting, LLC
James W. Winters	Westinghouse
Michael M. Corletti	Westinghouse
Stewart W. Long	Westinghouse
Mark G. Williams	Westinghouse
Jesse L. Whiteman	Westinghouse
George E. Wadkins	Hudson Global
Jesse E. Smith	Hudson Global
Mark A. Edmonds	Hudson Global
Joe Walker	General Electric Company
J. Alan Beard	General Electric Company
John Stryhal	General Electric Company
Wayne Marguino	General Electric Company
Gary Miller	General Electric Company
Christopher Bruer	General Electric Company
Mark Paul	Dominion
Tom Gilbert	Dominion
Curtis Buford	Entergy
Greg Sparks	Entergy
Chris Boone	Southern Nuclear Operating Company

## TABLE OF CONTENTS

<b>EXECUTIVE SUMMARY</b> .....	3
<b>ACRONYMS</b> .....	5
<b>1.0 METHODOLOGY FOR DEVELOPMENT OF EMERGENCY ACTION LEVELS</b> .....	7
1.1 Background.....	7
2.0 CHANGES INCORPORATED WITH NEI 07-01 .....	8
3.0 DEVELOPMENT OF BASIS FOR GENERIC APPROACH .....	9
3.1 Definitions Used in Developing EAL Methodology .....	9
3.2 Perspective .....	10
3.3 Recognition Categories.....	10
3.4 Design Differences .....	11
3.5 Required Characteristics .....	11
3.6 Emergency Class Descriptions .....	12
3.7 Emergency Class Thresholds.....	13
3.8 Emergency Action Levels.....	14
3.9 Treatment of Multiple Events and Emergency Class Upgrading.....	15
3.10 Classifying Transient Events.....	15
3.11 Operating Mode Applicability.....	15
3.11.1 ESBWR Operating Modes .....	16
3.11.2 AP1000 Operating Modes .....	16
4.0 HUMAN FACTORS CONSIDERATIONS.....	17
4.1 Level Of Integration Of EALs With Plant Procedures .....	17
4.2 Method Of Presentation.....	17
4.3 Symptom-based, Event-based, Or Barrier-based EALs.....	18
5.0 GENERIC EAL GUIDANCE .....	19
5.1 Generic Arrangement.....	19
5.2 Generic Bases .....	20
5.3 Site-Specific Implementation.....	20
5.4 Definitions .....	21
<b>5.5 ABNORMAL RAD LEVELS/ RADIOLOGICAL EFFLUENT EALs</b> .....	23
AU1 .....	24
AU2 .....	27
AA1 .....	29
AA2 .....	32
AA3 .....	34
AS1.....	35
AG1 .....	37
<b>5.6 COLD SHUTDOWN/REFUELING SYSTEM MALFUNCTION EALs</b> .....	39
CU1 .....	40
CU2 .....	42
CU3 .....	44
CU4 .....	46
CU6 .....	48
CU7 .....	50
CU8 .....	52
CA1 .....	53
CA4 .....	55
CS1 .....	58
CG1 .....	60
<b>5.7 FISSION PRODUCT BARRIER DEGRADATION EALs</b> .....	63
Basis Information For Table 5-F-2.....	67
Basis Information For Table 5-F-4.....	74
<b>5.8 HAZARDS OR OTHER CONDITIONS AFFECTING PLANT SAFETY EALs</b> .....	78
HU1 .....	79
HU2 .....	81

HU3 .....	83
HU4 .....	84
HU5 .....	86
HA1 .....	87
HA2 .....	90
HA3 .....	92
HA5 .....	95
HA6 .....	96
HS2 .....	97
HS3 .....	98
HS4 .....	99
HG1 .....	100
HG2 .....	102
<b>5.9 System Malfunction EALs .....</b>	<b>103</b>
SU1 .....	104
SU2 .....	105
SU3 .....	<b>Error! Bookmark not defined.</b>
SU4 .....	106
SU5 .....	108
SU6 .....	109
SU8 .....	111
SA1 .....	112
SA2 .....	113
SA4 .....	115
SS1 .....	116
SS2 .....	117
SS3 .....	118
SS6 .....	119
SG1 .....	120
SG2 .....	122
<b>Appendix A .....</b>	<b>1</b>
A.1 Purpose of the Effluent ICs/EALs .....	124
A.2 Initiating Conditions .....	125
A.3 Example Emergency Action Levels .....	125
A.3.1 Effluent Monitor Readings .....	126
A.3.2 Perimeter Monitor, Field Survey Results, Dose Projection Results .....	127
A.4 Interface Between ODCM and ICs/EALs .....	128
A.5 Setpoints versus Monitor EALs .....	128
A.7 The Impact of Source Term .....	130

## EXECUTIVE SUMMARY

Nuclear utilities must respond to a formal set of threshold conditions that require plant personnel to take specific actions with regard to notifying state and local governments and the public when certain off-normal indicators or events are recognized. Emergency classes are defined in 10 CFR 50. Levels of response and the conditions leading to those responses are defined in joint NRC/FEMA guidelines contained in Appendix 1 of NUREG-0654/ FEMA-REP-1, Rev. 1, "Criteria for Preparation and Evaluation of Radiological Emergency Response Plans and Preparedness in Support of Nuclear Power Plants," October 1980.

NEI 07-01, Methodology for Development of Emergency Action Levels, Advanced Passive Light Water Reactors, is based on the EAL work accomplished through the NUMARC/NESP 007, NEI 99-01 Revision 4 and Revision 5 development process. The history of the development is contained in 99-01 Revision 4 and continues in Revision 5 of the 99-01 document.

The EAL Task Force identified eight characteristics that were to be incorporated into model EALs. Experience to date has shown these considerations to be valid. These were:

- (1) Consistency (i.e., the EALs would lead to similar decisions under similar circumstances at different plants);
- (2) Human engineering and user friendliness;
- (3) Potential for classification upgrade only when there is an increasing threat to public health and safety;
- (4) Ease of upgrading and downgrading;
- (5) Thoroughness in addressing, and disposing of, the issues of completeness and accuracy raised regarding NUREG-0654, Appendix 1;
- (6) Technical completeness and appropriateness for each classification level;
- (7) A logical progression in classification for combinations of multiple events;
- (8) Objective, observable values.

Based on the information gathered and reviewed, the Task Force has developed generic EAL guidance. Because of the wide variety of presentation methods (formats) used at different utilities, the Task Force believes that specifying guidance as to what each IC and EAL should address, and including sufficient basis information for each EAL will best assure uniformity of approach. The information is presented by Recognition Category:

- A - Abnormal Rad Levels/Radiological Effluent
- C - Cold Shutdown./ Refueling System Malfunction
- F - Fission Product Barrier Degradation
- H - HAZARDS or OTHER Conditions Affecting Plant Safety
- S - System Malfunction

Each of the EAL guides in the Recognition Categories is structured in the following way:

- Recognition Category - As described above.
- Emergency Class – Notice of Unusual Event (NOUE), Alert, Site Area Emergency or General Emergency.
- Initiating Condition - Symptom- or Event-Based, Generic Identification and Title.
- Operating Mode Applicability - Power Operation, Hot Standby, Safe/Stable Shutdown, Cold Shutdown, Refueling, Defueled, All, or Not Applicable.
- Example Emergency Action Level(s) corresponding to the IC.
- Basis information for plant-specific readings and factors that may relate to changing the generic IC or EAL to a different emergency class, such as for Loss of All AC Power.

For Recognition Category F, the EAL information is presented in a matrix format. The presentation method was chosen to clearly show the synergism among the EALs and to support more accurate dynamic assessments. For Recognition Category F, the EALs are arranged by safety function or fission product barrier. Classifications are based on various combinations of safety function or fission product barrier challenges.

The EAL Guidance has the primary threshold for NOUE as operation outside the safety envelope for the plant as defined by plant Technical Specifications, including LCOs and Action Statement Times. In addition, certain precursors of more serious events such as earthquakes are included in NOUE EALs. This provides a clear demarcation between the lowest emergency class and "non-emergency" notifications specified by 10 CFR 50.72.



## ACRONYMS

AC	Alternating Current
ADS	Automatic Depressurization System
AP1000	Advanced Passive 1000 Mw PWR (Westinghouse)
APRM	Average Power Range Monitor
CDE	Committed Dose Equivalent
CET	Core Exit Thermocouple
CFR	Code of Federal Regulations
Ci	Curie
CMT/CNMT	Containment
CSF	Critical Safety Function
CSFST	Critical Safety Function Status Tree
DAS	Diverse Actuation System
DC	Direct Current
DG	Diesel Generator
EAL	Emergency Action Level
EFS	Communication System
EOF	Emergency Operations Facility
EOP	Emergency Operating Procedure
EPA	Environmental Protection Agency
EPG	Emergency Procedure Guideline
EPIP	Emergency Plan Implementing Procedure
EPRI	Electric Power Research Institute
ERG	Emergency Response Guideline
ESBWR	Economic Simplified Boiling Water Reactor (General Electric)
FAA	Federal Aviation Administration
FAQ	Frequently Asked Question
FBI	Federal Bureau of Investigation
FEMA	Federal Emergency Management Agency
FSAR	Final Safety Analysis Report
GE	General Emergency
HCTL	Heat Capacity Temperature Limit
IC	Initiating Condition
IRWST	In Containment Refueling Water Storage Tank
Keff	Effective Neutron Multiplication Factor
LCO	Limiting Condition of Operation
LOCA	Loss of Coolant Accident
LWR	Light Water Reactor
MCR	Main Control Room
MSL	Main Steam Line
MSIV	Main Steam Isolation Valve
mR	milliRoentgen
Mw	Megawatt
NEI	Nuclear Energy Institute
NRC	Nuclear Regulatory Commission
NOUE	Notification Of Unusual Event
OBE	Operating Basis Earthquake
OCA	Owner Controlled Area
ODCM	Off-site Dose Calculation Manual
PA	Protected Area
PAG	Protective Action Guideline
PCS	Primary Containment System
PIP	Plant Investment Protection

## ACRONYMS

PLS	Plant Control System
PMS	Plant Monitoring and Control System
POAH	Point of Adding Heat
PRA/PSA	Probabilistic Risk Assessment / Probabilistic Safety Assessment
PWR	Pressurized Water Reactor
psig	Pounds per Square Inch Gauge
Q-DCIS	Safety Related Distributed Control and Information System
R	Rem
RCS	Reactor Coolant System
RMS	Radiation Monitoring System
RNS	Normal Residual Heat Removal System
RPS	Reactor Protection System
RPV	Reactor Pressure Vessel
RWCU/SDC	Reactor Water Cleanup/Shutdown Cooling System
SAG	Severe Accident Guideline
SCBA	Self Contained Breathing Apparatus
SBGTS	Stand-By Gas Treatment System
SG	Steam Generator
SPDS	Safety Parameter Display System
SRNM	Source Range Neutron Monitor
SRO	Senior Reactor Operator
SSE	Safe Shutdown Earthquake
TEDE	Total Effective Dose Equivalent
TBD	To Be Determined
TOAF/TAF	Top of Active Fuel
TSC	Technical Support Center
TVS	Closed Circuit Television System (AP1000)

## 1.0 METHODOLOGY FOR DEVELOPMENT OF EMERGENCY ACTION LEVELS

### 1.1 Background

NEI 07-01, Methodology for Development of Emergency Action Levels Advanced Passive Light Water Reactors, is based on the EAL work accomplished through the NUMARC/NESP 007, NEI 99-01 Revision 4 and Revision 5 development process. The history of the development is contained in 99-01 Revision 4 and continues in Revision 5 of the 99-01 document.

In 2006 the nuclear power revival of new plants with the advanced passive designs was being planned. The NEI EAL Task Force developed this document to address only the Westinghouse AP1000 and the General Electric ESBWR designs.

## 2.0 CHANGES INCORPORATED WITH NEI 07-01

Changes will be identified in this section for future revisions.

### 3.0 DEVELOPMENT OF BASIS FOR GENERIC APPROACH

The generic guidance provided in this document addresses radiological emergency preparedness. Non-radiological events are included in the classification scheme only to the extent that these events represent challenges to the continued safety of the reactor plant and its operators. There are existing reporting requirements (EPA, OSHA) under which utilities operate. There are also requirements for emergency preparedness involving hazardous chemical releases. While the proposed classification structure could be expanded to include these non-radiological hazards, these events are beyond the scope of this document.

This classification scheme is based on the four classification levels promulgated by the NRC as the standard for the United States. The NRC has determined that US nuclear facilities would continue to classify events using the four classification levels and that the NRC would re-classify the event in any international communication.

#### 3.1 Definitions Used in Developing EAL Methodology

Based on the above review of regulations, review of common utility usage of terms, discussions among Task Force members, and existing published information, the following definitions apply to the generic EAL methodology:

**EMERGENCY CLASS:** One of a minimum set of names or titles, established by the Nuclear Regulatory Commission (NRC), for grouping off-normal nuclear power plant conditions according to (1) their relative radiological seriousness, and (2) the time-sensitive on-site and off-site radiological emergency preparedness actions necessary to respond to such conditions. The existing radiological emergency classes, in ascending order of seriousness, are called:

- Notification of Unusual Event
- Alert
- Site Area Emergency
- General Emergency

**INITIATING CONDITION (IC):** One of a predetermined subset of nuclear power plant conditions where either the potential exists for a radiological emergency, or such an emergency has occurred.

#### **Discussion:**

In NUREG-0654, the NRC introduced, but did not define, the term "initiating condition." Since the term is commonly used in nuclear power plant emergency planning, the definition above has been developed and combines both regulatory intent and the greatest degree of common usage among utilities.

Defined in this manner, an IC is an emergency condition which sets it apart from the broad class of conditions that may or may not have the potential to escalate into a radiological emergency. It can be a continuous, measurable function that is outside Technical Specifications, such as elevated RCS temperature or falling reactor coolant level (a symptom). It also encompasses occurrences such as FIRE (an event) or reactor coolant pipe failure (an event or a barrier breach).

**EMERGENCY ACTION LEVEL (EAL):** A pre-determined, site-specific, observable threshold for a plant Initiating Condition that places the plant in a given emergency class. An EAL can be: an instrument reading; an equipment status indicator; a measurable parameter (on-site or off-site); a discrete, observable event; results of analyses; entry into specific emergency operating procedures; or another phenomenon which, if it occurs, indicates entry into a particular emergency class.

## **Discussion:**

The term "emergency action level" has been defined by example in the regulations, as noted in the above discussion concerning regulatory background. The term had not, however, been defined operationally in a manner to address all contingencies.

There are times when an EAL will be a threshold point on a measurable continuous function, such as a primary system coolant leak that has exceeded Technical Specifications for a specific plant.

At other times, the EAL and the IC will coincide, both identified by a discrete event that places the plant in a particular emergency class. For example, "Train Derailment On-site" is an example of an "NOUE" IC in NUREG-0654 that also can be an event-based EAL.

### 3.2 Perspective

The purpose of this effort is to define a methodology for EAL development that will better assure a consistent emergency classification commensurate with the level of risk. The approach must be easily understood and applied by the individuals responsible for on-site and off-site emergency preparedness and response. In order to achieve consistent application, this recommended methodology must be accepted at all levels of application (e.g., licensed operators, health physics personnel, facility managers, off-site emergency agencies, NRC and FEMA response organizations, etc.).

Commercial nuclear facilities are faced with a range of public service and public acceptance pressures. It is of utmost importance that emergency regulations be based on as accurate an assessment of the risk as possible. There are evident risks to health and safety in understating the potential hazard from an event. However, there are both risks and costs to alerting the public to an emergency that exceeds the true threat. This is true at all levels, but particularly if evacuation is recommended.

### 3.3 Recognition Categories

ICs and EALs can be grouped in one of several schemes. This generic classification scheme incorporates symptom-based, event-based, and barrier-based ICs and EALs.

The symptom-based category for ICs and EALs refers to those indicators that are measurable over some continuous spectrum, such as core temperature, coolant levels, containment pressure, etc. When one or more of these indicators begin to show off-normal readings, reactor operators are trained to identify the probable causes and potential consequences of these "symptoms" and take corrective action. The level of seriousness indicated by these symptoms depends on the degree to which they have exceeded Technical Specifications, the other symptoms or events that are occurring contemporaneously, and the capability of the licensed operators to gain control and bring the indicator back to safe levels.

Event-based EALs and ICs refer to occurrences with potential safety significance. The range of seriousness of these "events" is dependent on the location, number of contemporaneous events, remaining plant safety margin, etc.

Barrier-based EALs and ICs refer to the level of challenge to principal barriers used to assure containment of radioactive materials contained within a nuclear power plant. For radioactive materials that are contained within the reactor core, these barriers are: fuel cladding, reactor coolant system pressure boundary, and containment. The level of challenge to these barriers encompasses the extent of damage (loss or potential loss) and the number of barriers concurrently under challenge. In reality, barrier-based EALs are a subset of symptom-based EALs that deal with symptoms indicating fission product barrier challenges. These barrier-based EALs are primarily derived from Emergency Operating Procedures (EOPs) Critical Safety Function (CSF) Status Tree Monitoring for the AP1000 and Emergency Procedure and Severe Accident

Guidelines (EPGs/SAGs) for the ESBWR. Challenge to one or more barriers generally is initially identified through instrument readings and periodic sampling. The fission product barrier matrix described in Section 5-F is a hybrid approach that recognizes that some events may represent a challenge to more than one barrier, and that the containment barrier is weighted less than the reactor coolant system pressure boundary and the fuel clad barriers.

Symptom-based ICs and EALs are most easily identified when the plant is in a normal startup, operating or safe/stable shutdown mode of operation, with all of the barriers in place and the plant's instrumentation and emergency safeguards features fully operational as required by Technical Specifications. It is under these circumstances that the operations staff has the most direct information of the plant's systems, displayed in the main Control Room. As the plant moves through the decay heat removal process toward cold shutdown and refueling, barriers to fission products are reduced (i.e., reactor coolant system pressure boundary may be open) and fewer of the safety systems required for power operation are required to be fully operational.

It is important to note that in some operating modes there may not be definitive and unambiguous indicators of containment integrity available to Control Room personnel. For this reason, barrier-based EALs should not place undue reliance on assessments of containment integrity in all operating modes. Generally, Technical Specifications relax maintaining containment integrity requirements in cold shutdown and refueling in order to provide flexibility in performance of specific tasks during shutdown conditions. Containment pressure and temperature indications may not increase if there is a pre-existing breach of containment integrity.

Several categories of emergencies have no instrumentation to indicate a developing problem, or the event may be identified before any other indications are recognized. A reactor coolant pipe could break; FIRE alarms could sound; radioactive materials could be released; and any number of other events can occur that would place the plant in an emergency condition with little warning. For emergencies related to the reactor system and safety systems, the ICs shift to an event based scheme as the plant mode moves toward cold shutdown and refueling modes. For non-radiological events, such as FIRE, external floods, wind loads, etc., as described in NUREG-0654 Appendix 1, event-based ICs are the norm.

In many cases, a combination of symptom-, event- and barrier-based ICs will be present as an emergency develops. In a loss of coolant accident (LOCA), for example:

- Coolant level is dropping; (symptom)
- There is a leak of some magnitude in the system (pipe break, safety valve stuck open) that exceeds plant capabilities to make up the loss; (barrier breach or event)
- Core (coolant) temperature is rising; (symptom) and
- At some level, fuel failure begins with indicators such as high off-gas, high coolant activity samples, etc. (barrier breach or symptom)

### 3.4 Design Differences

Although the same basic concerns with barrier integrity and the major safety problems of nuclear power plants are similar, design differences will have a substantial effect on EALs. In these cases, EAL guidelines unique to AP1000 and ESBWR are specified. These passive design plants incorporate the requirements contained in EPRI Advanced Light Water Reactor (ALWR) Requirements Document. Accordingly, many of the plant safety features for both designs are functionally equivalent.

### 3.5 Required Characteristics

Eight characteristics that should be incorporated into model EALs are identified below:

- (1) Consistency (i.e., the EALs would lead to similar decisions under similar circumstances at different plants);
- (2) Human engineering and user friendliness;
- (3) Potential for classification upgrade only when there is an increasing threat to public health and safety;
- (4) Ease of upgrading and downgrading;
- (5) Thoroughness in addressing, and disposing of, the issues of completeness and accuracy raised regarding NUREG-0654 Appendix 1;
- (6) Technical completeness for each classification level;
- (7) A logical progression in classification for multiple events; and
- (8) Objective, observable values.

The EAL development methodology pays careful attention to these eight characteristics to assure that all are addressed in the proposed EALs. The most pervasive and complex of the eight is the first—"consistency." The common denominator that is most appropriate for measuring consistency among ICs and EALs is relative risk. The approach taken in the development of these EALs is based on risk assessment to set the boundaries of the emergency classes and assure that all EALs that trigger that emergency class are in the same range of relative risk. Precursor conditions of more serious emergencies also represent a potential risk to the public and must be appropriately classified.

### 3.6 Emergency Class Descriptions

There are three considerations related to emergency classes. These are:

- (1) The potential impact on radiological safety, either as now known or as can be reasonably projected;
- (2) How far the plant is beyond its predefined design, safety, and operating envelopes; and
- (3) Whether or not conditions that threaten health are expected to be confined to within the site boundary.

The ICs deal explicitly with radiological safety impact by escalating from levels corresponding to releases within regulatory limits to releases beyond EPA Protective Action Guideline (PAG) plume exposure levels. In addition, the "Discussion" sections below include off-site dose consequence considerations which were not included in NUREG-0654 Appendix 1.

**NOTIFICATION OF UNUSUAL EVENT (NOUE):** Events are in progress or have occurred which indicate a potential degradation of the level of safety of the plant or indicate a security threat to facility protection has been initiated. No releases of radioactive material requiring off-site response or monitoring are expected unless further degradation of safety systems occurs.

**Discussion:**

Potential degradation of the level of safety of the plant is indicated primarily by exceeding plant technical specification Limiting Condition of Operation (LCO) allowable Action Statement time for achieving required mode change. Precursors of more serious events should also be included because precursors do represent a potential degradation in the level of safety of the plant. Minor releases of radioactive materials are included. In this emergency class, however, releases do not require monitoring or off-site response.

**ALERT:** Events are in progress or have occurred which involve an actual or potential substantial degradation of the level of safety of the plant or a security event that involves probable life threatening risk to site personnel or damage to site equipment because of HOSTILE ACTION. Any releases are expected to be limited to small fractions of the EPA PAG exposure levels.



**Discussion:**

Rather than discussing the distinguishing features of "potential degradation" and "potential substantial degradation," a comparative approach would be to determine whether increased monitoring of plant functions is warranted at the Alert level as a result of safety system degradation. This addresses the operations staff's need for help, independent of whether an actual decrease in plant safety is determined. This increased monitoring can then be used to better determine the actual plant safety state, whether escalation to a higher emergency class is warranted, or whether de-escalation or termination of the emergency class declaration is warranted. Dose consequences from these events are small fractions of the EPA PAG plume exposure levels.

**SITE AREA EMERGENCY (SAE):** Events are in progress or have occurred which involve actual or likely major failures of plant functions needed for protection of the public or HOSTILE ACTION that results in intentional damage or malicious acts; 1) toward site personnel or equipment that could lead to the likely failure of or; 2) that prevent effective access to, equipment needed for the protection of the public. Any releases are not expected to result in exposure levels which exceed EPA PAG exposure levels beyond the site boundary.

**Discussion:**

The discriminator (threshold) between Site Area Emergency and General Emergency is whether or not the EPA PAG plume exposure levels are expected to be exceeded outside the site boundary. This threshold, in addition to dynamic dose assessment considerations discussed in the EAL guidelines, clearly addresses NRC and off-site emergency response agency concerns as to timely declaration of a General Emergency.

**GENERAL EMERGENCY (GE):** Events are in progress or have occurred which involve actual or IMMINENT substantial core degradation or melting with potential for loss of containment integrity or HOSTILE ACTION that results in an actual loss of physical control of the facility. Releases can be reasonably expected to exceed EPA PAG exposure levels off-site for more than the immediate site area.

**Discussion:**

The bottom line for the General Emergency is whether evacuation or sheltering of the general public is indicated based on EPA PAGs, and therefore should be interpreted to include radionuclide release regardless of cause. In addition, it should address concerns as to uncertainties in systems or structures (e.g. containment) response, and also events such as waste gas tank releases and severe spent fuel pool events postulated to occur at high population density sites. To better assure timely notification, EALs in this category must primarily be expressed in terms of plant function status, with secondary reliance on dose projection. In terms of fission product barriers, loss of two barriers with loss or potential loss of the third barrier constitutes a General Emergency.

### 3.7 Emergency Class Thresholds

The most common bases for establishing these boundaries are the Technical Specifications, bounding conditions and setpoints for each plant that have been developed in the design basis calculations and the Safety Analysis Report (SAR).

For those conditions that are easily measurable and instrumented, the boundary is likely to be the EAL (observable by plant staff, instrument reading, alarm setpoint, etc.) that indicates entry into a particular emergency class. For example, the main steam line radiation monitor may detect high radiation that triggers an alarm. That radiation level also may be the setpoint that closes the main steam isolation valves (MSIV)

and initiates the reactor trip/scram. This same radiation level threshold, depending on plant-specific parameters, also may be the appropriate EAL for a direct entry into an emergency class.

In addition to the continuously measurable indicators, such as coolant temperature, coolant levels, leak rates, containment pressure, etc., the SAR provides indications of the consequences associated with design basis events. Examples would include steam pipe breaks, MSIV malfunctions, and other anticipated events that, upon occurrence, place the plant immediately into an emergency class.

Another approach for defining these boundaries is the use of a plant-specific probabilistic safety assessment (PSA - also known as probabilistic risk analysis, PRA). PRAs have been completed for the designs as part of the licensing process. PRAs can be used as a good first approximation of the relevant ICs and risk associated with emergency conditions.

Another critical element of the analysis to arrive at these threshold (boundary) conditions is the time that the plant might stay in that condition before moving to a higher emergency class. The time dimension is critical to the EAL since the purpose of the emergency class for state and local officials is to notify them of the level of mobilization that may be necessary to handle the emergency. This is particularly true when a "Site Area Emergency" or "General Emergency" is IMMINEENT.

### 3.8 Emergency Action Levels

ICs/EALs are for unplanned events. A planned evolution involves preplanning to address the limitations imposed by the condition, the performance of required surveillance testing, and the implementation of specific controls prior to knowingly entering the condition. Planned evolutions to test, manipulate, repair, or perform maintenance or modifications to systems and equipment that result in an EAL Threshold Value being met or exceeded are not subject to classification and activation requirements as long as the evolution proceeds as planned. However, these conditions may be subject to the reporting requirements of 10 CFR 50.72.

Classifications are based on evaluation of each Unit. All classifications are to be based upon VALID indications, reports or conditions. Indications, reports or conditions are considered VALID when they are verified by (1) an instrument channel check, or (2) indications on related or redundant indications, or (3) by direct observation by plant personnel, such that doubt related to the indication's operability, the condition's existence, or the report's accuracy is removed. Implicit in this definition is the need for timely assessment.

With the emergency classes defined, the thresholds that must be met for each EAL to be placed under the emergency class can be determined. There are two basic approaches to determining these EALs. EALs and emergency class boundaries coincide for those continuously measurable, instrumented ICs, such as radioactivity, core temperature, coolant levels, etc. For these ICs, the EAL will be the threshold reading that most closely corresponds to the emergency class description using the best available information.

The Emergency Director must remain alert to events or conditions that lead to the conclusion that exceeding the EAL threshold is IMMINEENT. Under certain plant conditions, an alternate instrument or a temporary instrument may be installed to facilitate monitoring the parameter. In addition, visual observation may be sufficient to detect that a parameter is approaching or has reached a classifiable threshold. In these cases, the classification of the event is appropriate even if the instrument normally used to monitor the parameter is inoperable or has otherwise failed to detect the threshold. If, in the judgment of the Emergency Director, an IMMINEENT situation is at hand, the classification should be made as if the threshold has been exceeded..

For discrete (discontinuous) events, the approach will have to be somewhat different. Typically, in this category are internal and external hazards such as FIRE or earthquake. The purpose for including hazards in EALs is to assure that station personnel and off-site emergency response organizations are prepared to deal with consequential damage these hazards may cause. If, indeed, hazards have caused damage to safety functions or fission product barriers, this should be confirmed by symptoms or by observation of such

failures. Therefore, it may be appropriate to enter an Alert status for events approaching or exceeding design basis limits such as Operating Basis Earthquake, design basis wind loads, FIRE within VITAL AREAs, etc. This would give the operating staff additional support and improved ability to determine the extent of plant damage. If damage to barriers or challenges to Critical Safety Functions (CSFs) have occurred or are identified, then the additional support can be used to escalate or terminate the Emergency Class based on what has been found. Security events must reflect potential for increasing security threat levels.

The EOPs contain detailed instructions regarding the monitoring of these functions and provides a scheme for classifying the significance of the challenge to the functions. In providing EALs based on these schemes, the emergency classification can flow from the EOP assessment rather than being based on a separate EAL assessment. This is desirable as it reduces ambiguity and reduces the time necessary to classify the event.

Portions of the IC and EAL bases are specifically designated as information necessary for the development of the site-specific thresholds of the EALs. These developer information sections are in [*brackets and italicized*]. The information contained in these portions consists of references, examples, instructions for calculations, etc. These portions of the basis need not be included in the plant specific technical basis document supporting the EALs. In some cases, the information developed from the developer information may be appropriate to include in the plant specific technical basis document. In addition, the appendices are developer information in their entirety.

### 3.9 Treatment of Multiple Events and Emergency Class Upgrading

When multiple simultaneous events occur, the emergency classification level is based on the highest EAL reached. For example, two Alerts remain in the Alert category. Or, an Alert and a Site Area Emergency is a Site Area Emergency. Further guidance is provided in RIS 2007-02, Clarification of NRC Guidance for Emergency Notifications During Quickly Changing Events.

Although the majority of the EALs provide very specific thresholds, the Emergency Director must remain alert to events or conditions that lead to the conclusion that exceeding the EAL threshold is IMMEDIATE. If, in the judgment of the Emergency Director, an IMMEDIATE situation is at hand, the classification should be made as if the threshold has been exceeded. While this is particularly prudent at the higher emergency classes (as the early classification may provide for more effective implementation of protective measures), it is nonetheless applicable to all emergency classes.

### 3.10 Classifying Transient Events

There may be cases in which a plant condition that exceeded an EAL threshold was not recognized at the time of occurrence, but is identified well after the condition has occurred (e.g., as a result of routine log or record review) and the condition no longer exists. In these cases, an emergency should not be declared.

Reporting requirements of 10 CFR 50.72 are applicable and the guidance of NUREG-1022, Event Reporting Guidelines 10 CFR 50.72 and 50.73, should be applied.

Existing guidance for classifying transient events addresses the period of time of event recognition and classification (15 minutes). However, in cases when an EAL declaration criterion may be met momentarily during the normal expected response of the plant, declaration requirements should not be considered to be met when the conditions are a part of the designed plant response or result in appropriate operator actions.

### 3.11 Operating Mode Applicability

The plant operating mode that existed at the time that the event occurred, prior to any protective system or operator action initiated in response to the condition, is compared to the mode applicability of the EALs. If an event occurs, and a lower or higher plant operating mode is reached before the emergency classification can be made, the declaration shall be based on the mode that existed at the time the event occurred.

For events that occur in Cold Shutdown or Refueling, escalation is via EALs that have Cold Shutdown or Refueling for mode applicability, even if Safe/Stable Shutdown (or a higher mode) is entered during any subsequent heatup. In particular, the Fission Product Barrier Matrix EALs are applicable only to events that initiate in Safe/Stable Shutdown or higher.

### 3.11.1 ESBWR Operating Modes

Power Operations (1):	Mode Switch in Run
Startup (2):	Mode Switch in Startup or Refuel
Hot Shutdown (3):	Mode Switch in Shutdown, Average Reactor Coolant Temperature greater than 420 °F
Stable Shutdown (4)	Mode Switch in Shutdown, Average Reactor Coolant Temperature less than or equal to 420 °F and greater than 200 °F
Cold Shutdown (5):	Mode Switch in Shutdown, Average Reactor Coolant Temperature less than or equal to 200 °F
Refueling (6):	Mode Switch in Shutdown or Refuel, and one or more vessel head bolts less than fully tensioned.
Defueled (None)	All reactor fuel removed from reactor pressure vessel

### 3.11.2 AP1000 Operating Modes

Power Operations (1):	Reactor Power greater than 5%, Keff greater than or equal to 0.99
Startup (2):	Reactor Power less than or equal to 5%, Keff greater than or equal to 0.99
Hot Standby (3):	RCS greater than 420 °F, Keff less than 0.99
Safe Shutdown (4):	RCS less than or equal to 420°F, but greater than 200°F , Keff less than 0.99
Cold Shutdown (5):	RCS less than or equal to 200 °F, Keff less than 0.99
Refueling (6):	One or more vessel head closure bolts less than fully tensioned
Defueled (None)	All reactor fuel removed from reactor pressure vessel.

## 4.0 HUMAN FACTORS CONSIDERATIONS

Some factors that should be considered in determining the method of presentation of EALs:

- Who is the audience (user) for this information? A senior utility executive would likely want information presented differently than a licensed operator. Off-site agencies and the NRC may have entirely different information needs.
- The conditions under which the information must be read, understood, and acted upon. Since the subject matter here is *emergency* actions, it is highly likely that the user of the EALs will be under high stress during the conditions where they are required to be used, particularly under conditions corresponding to Site Area Emergency and General Emergency.
- What is the user's perception as to the importance of the EALs compared to other actions and decisions that may be needed at the same time? To allow a licensed operator to discharge his responsibilities for dealing with the situation and also provide prompt notification to outside agencies, the emergency classification and notification process must be rapid and concise.
- Is the EAL consistent with the user's knowledge of what constitutes an *emergency* situation?
- How much help does the user receive in deciding which EAL and emergency class is involved? An Emergency Director with a staffed TSC and EOF has many more resources immediately at his disposal than the licensed operator (typically, the Shift Supervisor) who has to make the initial decisions and take first actions.

Based on review of a number of plants' EALs and associated information, interviews with utility personnel, and a review of drill experience some recommendations follow.

### 4.1 Level Of Integration Of EALs With Plant Procedures

A rigorous integration of EALs and emergency class determinations into the plant procedure set, although having some benefits, is probably unnecessary. Such a rigorous integration could well make it more difficult to keep documentation up-to-date. However, keeping EALs totally separated from plant procedures and relying on licensed operator or other utility Emergency Director memory during infrequent, high stress periods is insufficient.

#### **RECOMMENDATION:**

**Visual cues in the plant procedures that it is appropriate to consult the EALs is a method currently used by several utilities. This method can be effective when it is tied to appropriate training. Notes in the appropriate plant procedures to consult the EALs can also be used. It should be noted that this discussion is not restricted to only the emergency procedures; alarm recognition procedures, abnormal operating procedures, and normal operating procedures that apply to cold shutdown and refueling modes should also be included. In addition, EALs can be referenced on entry into particular procedures or existence of particular Critical Safety Function conditions.**

### 4.2 Method Of Presentation

A variety of presentation methods are presently in use. Methods range from directly copying NUREG-0654 Appendix 1 language, adding plant-specific indications to clarify NUREG-0654, use of procedure language including specific tag numbers for instrument readings and alarms, deliberate omission of instrument tag numbers, flow charts, critical safety function status trees, checklists, and combinations of the above.

What is clear, however, is that the licensed operator (typically the Shift Supervisor) is the first user of this information, has the least amount of help in interpreting the EALs, and also has other significant responsibilities to fulfill while dealing with the EALs. Emergency Directors outside the Control Room to whom responsibilities are turned over have other resources and advisors available to them that a licensed operator may not have when first faced with an emergency situation. In addition, as an emergency situation evolves, the operating staff and the health physics staff are the personnel who must first deal with information that is germane to changing the emergency classification (up, down, or out of the emergency class).

**RECOMMENDATION:**

**The method of presentation should be one with which the operations and health physics staff are comfortable. As is the case for emergency procedures, bases for steps should be in a separate (or separable) document suitable for training and for reference by emergency response personnel and off-site agencies. Each nuclear plant should already have presentation and human factors standards as part of its procedure writing guidance. EALs that are consistent with those procedure writing standards (in particular, emergency operating procedures which most closely correspond to the conditions under which EALs must be used) should be the norm for each utility.**

4.3 Symptom-based, Event-based, Or Barrier-based EALs

A review of the emergency class descriptions provided elsewhere in this document shows that NOUEs and Alerts deal primarily with sequences that are precursors to more serious emergencies or that may have taken a plant outside of its intended operating envelope, but currently pose no danger to the public. Observable indications in these classes can be events (e.g. natural phenomena), symptoms (e.g., high temperature, low water level), or barrier-related (e.g., challenge to fission product barrier). As one escalates to Site Area Emergency and General Emergency, potential radiological impact to people (both on-site and off-site) rise. However, at this point the root cause event(s) leading to the emergency class escalation matter far less than the increased (potential for) radiological releases. Thus, EALs for these emergency classes should be primarily symptom- and barrier-based. It should be noted again, as stated in Section 3.4, that barrier monitoring is a subset of symptom monitoring, i.e., what readings (symptoms) indicate a challenge to a fission product barrier.

**RECOMMENDATION:**

**A combination approach that ranges from primarily event-based for NOUEs to primarily symptom- or barrier-based for General Emergencies is recommended. This is to better assure that timely recognition and notification occurs, that events occurring during refueling and cold shutdown are appropriately covered, and that multiple events can be effectively treated in the EALs.**

## 5.0 GENERIC EAL GUIDANCE

This section provides generic EAL guidance based on the information gathered and reviewed by the Task Force. Because of the wide variety of presentation methods used at different utilities, this document specifies guidance as to what each IC and EAL should address, and including sufficient basis information for each will best assure uniformity of approach. This approach is analogous to reactor vendors' owners groups developing generic emergency procedure guidelines which are converted by each utility into plant-specific emergency operating procedures. Each utility is reminded, however, to review the "Human Factors Considerations" section of this document as part of implementation of the attached Generic EAL Guidance.

### 5.1 Generic Arrangement

The information is presented by Recognition Categories:

- A - Abnormal Rad Levels / Radiological Effluent
- C - Cold Shutdown./ Refueling System Malfunction
- F - Fission Product Barrier Degradation
- H - HAZARDS or OTHER Conditions Affecting Plant Safety
- S - System Malfunction

EALs for permanently defueled plants and Independent Spent Fuel Storage Installations are contained in NEI 99-01, current revision and are not addressed in this document.

The Initiating Conditions for each of the above Recognition Categories are in the order of NOUE, Alert, Site Area Emergency, and General Emergency. For all Recognition Categories, an Initiating Condition matrix versus Emergency Class is first shown. For Recognition Category F, the barrier-based EALs are presented in Tables 5-F-2 and 5-F-3 for ESBWR and AP1000 respectively.

With the exception of Recognition Category F, each of the EAL guides in Recognition Categories is structured in the following way:

- **Recognition Category** - As described above.
- **Emergency Class** - NOUE, Alert, Site Area Emergency or General Emergency.
- **Initiating Condition** – Symptom- or Event-Based, Generic Identification and Title.
- **Operating Mode Applicability** - These modes are defined in each licensee's Technical Specifications. The mode classifications and terminology appropriate to the specific facility should be used.
- **Example Emergency Action Level(s)** – These EALs are examples of conditions and indications that were considered to meet the criteria of the IC. For site specific implementation, the examples are Threshold Values that become an Emergency Action Level that can be classified based on the relative threat the condition represents.
- **Basis** – Provides information that explains the IC and example EALs. The bases are written to assist the personnel implementing the generic guidance into site-specific procedures. Some bases provide information intended to assist with establishing site-specific instrumentation values. Appendices A and C provide detailed guidance on implementing their corresponding Recognition Categories.

For Recognition Category F, basis information is presented in a format consistent with Tables 5-F-1, 2 and 3. The presentation method shown for Fission Product Barrier Function Matrix was chosen to clearly show the synergism among the EALs and to support more accurate dynamic assessments.

## 5.2 Generic Bases

The generic guidance has the primary threshold for NOUEs as operation outside the safety envelope for the plant as defined by plant Technical Specifications, including LCOs and Action Statement Times. In addition, certain precursors of more serious events are included in NOUE IC/EALs. This provides a clear demarcation between the lowest emergency class and "non-emergency" notifications specified by 10 CFR 50.72.

For a number of Alerts, IC/EALs are chosen based on hazards which may cause damage to plant safety functions (i.e., tornadoes, hurricanes, FIRE in plant VITAL AREAs) or require additional help directly (Control Room evacuation) and thus increased monitoring of the plant is warranted. The symptom-based and barrier-based IC/EALs are sufficiently anticipatory to address the results of multiple failures, regardless of whether there is or is not a common cause. Declaration of the Alert will already result in the staffing of the TSC for assistance and additional monitoring. Thus, direct escalation to the Site Area Emergency is unnecessary. Other Alerts, that have been specified, correspond to conditions which are consistent with the emergency class description.

The basis for declaring a Site Area Emergency and General Emergency is primarily the extent and severity of fission product barrier challenges, based on plant conditions as presently known or as can be reasonably projected.

With regard to the Hazards Recognition Category, the existence of a hazard that represents a potential degradation in the level of safety of the plant is the basis of NOUE classification. If the hazard results in VISIBLE DAMAGE to plant structures or equipment associated with safety systems or if system performance is affected, the event may be escalated to an Alert. The reference to "duration" or to "damage" to safety systems is intended only to size the event. Consequential damage from such hazards, if observed, would be the basis for escalation to Site Area Emergency or General Emergency, by entry to System Malfunction or Fission Product Barrier IC/EALs.

## 5.3 Site-Specific Implementation

The guidance presented here is not intended to be applied to plants as-is. However, the benefits of aligning with the guidance as closely as possible may be realized in: improved interface with the NRC; improved interface with other utilities; and better positioning to adopt future enhancements, such as "Frequently Asked Questions" (FAQs). The generic guidance is intended to provide the logic for developing site-specific IC/EALs using site-specific IC/EAL presentation methods. Each utility will need to implement the IC/EALs using site-specific needs with regard to instrumentation, nomenclature, plant arrangement, and method of presentation, etc. When plant design prevents use of ICs/EALs prescribed in NEI 07-01, other indications that address the subject condition should be implemented. Such revision is expected and encouraged provided that the intent of the generic guidance is retained. Deviations from the intent may be acceptable, but will need to be justified during regulatory review. Items associated with presentation, e.g., format, sequencing of IC/EALs, IC numbering, recognition categories are at the option of the utility. RIS 2003-18 and its supplements 1 and 2 clarify the expectations for alignment with the guidance document and the associated regulatory review requirements.

The generic guidance includes both ICs and example EALs. It is the intent of this guidance that both be included in the site-specific implementation. Each serves a specific purpose. The IC is intended to be the fundamental criteria for the declaration, whereas, the EALs are intended to represent unambiguous examples of conditions, Threshold Values, that may meet the IC. There may be unforeseen events, or combinations of events, for which the EALs may not be exceeded, but in the judgment of the Emergency Director, the intent of the IC may be met. While the generic guidance does include Emergency Director judgment ICs, the additional detail in the individual ICs will facilitate classifications over the broad guidance of the Emergency Director judgment ICs.



State and local requirements have not been reflected in the generic guidance and should be considered on a case-by-case basis with appropriate state and local emergency response organizations.

Although not a requirement, utilities should consider either preparing a basis document or including basis information with the IC/EALs. The bases provided for each IC/EAL will provide a starting point for developing these site-specific bases. This information may assist the Emergency Director in making classifications, particularly those involving judgment or multiple events. The basis information may be useful in training, for explaining event classifications to off-site officials, and would facilitate regulatory review and approval of the classification scheme.

#### 5.4 Definitions

In the IC/EALs, selected words have been set in all capital letters. These words are defined terms having specific meanings as they relate to this procedure. Definitions of these terms are provided below.

**BOMB:** An explosive device suspected of having sufficient force to damage plant systems or structures.

**CIVIL DISTURBANCE:** A group of persons violently protesting station operations or activities at the site.

**CONTAINMENT CLOSURE:** (AP1000) The site specific procedurally defined action taken to secure primary containment. (ESBWR) The Tech. Spec. Section 3.6 required and site-specific procedurally defined action taken to secure primary or the Reactor Building and the associated structures, systems, and components as a functional barrier to fission product release under existing plant conditions.

**EXPLOSION:** A rapid, violent, unconfined combustion, or catastrophic failure of pressurized equipment that imparts energy of sufficient force to potentially damage permanent structures, systems, or components.

**FAULTED:** (AP1000) in a steam generator, the existence of secondary side leakage that results in an uncontrolled drop in steam generator pressure or the steam generator being completely depressurized.

**FIRE:** Combustion characterized by heat and light. Sources of smoke, such as slipping drive belts or overheated electrical equipment do not constitute FIRES. Observation of flame is preferred but is NOT required if large quantities of smoke and heat are observed.

**HOSTAGE:** A person(s) held as leverage against the station to ensure that demands will be met by the station.

**HOSTILE ACTION:** An act toward a NPP or its personnel that includes the use of violent force to destroy equipment, take HOSTAGES, and/or intimidates the licensee to achieve an end. This includes attack by air, land, or water using guns, explosives, projectiles, vehicles, or other devices used to deliver destructive force. Other acts that satisfy the overall intent may be included. HOSTILE ACTION should not be construed to include acts of civil disobedience or felonious acts that are not part of a concerted attack on the NPP. Non-terrorism-based EALs should be used to address such activities, (i.e., violent acts between individuals in the OWNER CONTROLLED AREA).

**HOSTILE FORCE:** One or more individuals who are engaged in a determined assault, overtly or by stealth and deception, equipped with suitable weapons capable of killing, maiming, or causing destruction.

**IMMINENT:** Mitigation actions have been ineffective, additional actions are not expected to be successful, and trended information indicates that the event or condition will occur. Where "IMMINENT" timeframes are specified, they shall apply.

**NORMAL PLANT OPERATIONS:** Activities at the plant site associated with routine testing, maintenance, or equipment operations, in accordance with normal operating or administrative procedures. Entry into

abnormal or emergency operating procedures, or deviation from normal security or radiological controls posture, is a departure from NORMAL PLANT OPERATIONS.

**POINT OF ADDING HEAT:** A Unit specific reactor power level at which sufficient energy is being added to the reactor coolant from the reactor to result in a bulk coolant temperature increase. [This value may vary slightly based on plant core loading and time of life. For purposes of identifying the Unit specific reactor power level, a typical value may be chosen to prevent having to recalculate this setpoint. Sites may choose to operationally have their staff identify that the reactor is at the POAH and not develop a specific power level equivalent to the POAH.]

**PROJECTILE:** An object directed toward a Nuclear Power Plant that could have an effect sufficient to cause concern for its continued operability, reliability, or safety of personnel.

**PROTECTED AREA:** (site-specific) Typically, the area which normally encompasses all controlled areas within the security PROTECTED AREA fence.

**REACTOR BUILDING ISOLATION:** (ESBWR) See CONTAINMENT CLOSURE.

**RUPTURED:** (AP1000) in a steam generator, existence of primary-to-secondary leakage of a magnitude sufficient to require or cause a reactor trip and automatic depressurization.

**SECURITY CONDITION:** Any Security Event as listed in the approved security contingency plan that constitutes a threat/compromise to site security, threat/risk to site personnel, or a potential degradation to the level of safety of the plant. A SECURITY CONDITION does not involve a HOSTILE ACTION.

**SIGNIFICANT TRANSIENT:** (AP1000) An UNPLANNED event involving one or more of the following: (1) automatic turbine runback greater than 25% thermal reactor power, (2) electrical load rejection greater than 25% full electrical load, (3) Reactor Trip, (4) Safety Injection Actuation, or (5) thermal power oscillations greater than 10%. (ESBWR) [TBD].

**STRIKE ACTION:** A work stoppage within the PROTECTED AREA by a body of workers to enforce compliance with demands made on (site-specific). The STRIKE ACTION must threaten to interrupt NORMAL PLANT OPERATIONS.

**UNISOLABLE:** A breach or leak that cannot be promptly isolated.

**UNPLANNED:** A parameter change or an event that is not the result of an intended evolution and requires corrective or mitigative actions.

**VALID:** An indication, report, or condition, is considered to be VALID when it is verified by (1) an instrument channel check, or (2) indications on related or redundant indicators, or (3) by direct observation by plant personnel, such that doubt related to the indicator's operability, the condition's existence, or the report's accuracy is removed. Implicit in this definition is the need for timely assessment.

**VISIBLE DAMAGE:** Damage to equipment or structure that is readily observable without measurements, testing, or analysis. Damage is sufficient to cause concern regarding the continued operability or reliability of affected structure, system, or component. Example damage includes: deformation due to heat or impact, denting, penetration, rupture, cracking, paint blistering. Surface blemishes (e.g., paint chipping, scratches) should not be included.

**VITAL AREA:** (site-specific) Typically, any area, normally within the PROTECTED AREA, which contains equipment, systems, components, or material, the failure, destruction, or release of which could directly or indirectly endanger the public health and safety by exposure to radiation.

## 5.5 ABNORMAL RAD LEVELS/ RADIOLOGICAL EFFLUENT EALs

**Table 5-A-1: Recognition Category “A” Initiating Condition Matrix**

GENERAL EMERGENCY	SITE AREA EMERGENCY	ALERT	NOUE
<p><b>AG1</b> Off-site Dose Resulting from an Actual or IMMEDIATE Release of Gaseous Radioactivity Greater Than 1000 mrem TEDE or 5000 mrem Thyroid CDE for the Actual or Projected Duration of the Release Using Actual Meteorology. <i>Op. Modes: All</i></p>	<p><b>AS1</b> Off-site Dose Resulting from an Actual or IMMEDIATE Release of Gaseous Radioactivity Greater Than 100 mrem TEDE or 500 mrem Thyroid CDE for the Actual or Projected Duration of the Release. <i>Op. Modes: All</i></p>	<p><b>AA1</b> Any Release of Gaseous or Liquid Radioactivity to the Environment Greater Than 200 Times the Off-site Dose Calculation Manual for 15 Minutes or Longer. <i>Op. Modes: All</i></p>	<p><b>AU1</b> Any Release of Gaseous or Liquid Radio-activity to the Environment Greater Than Two Times the Off-site Dose Calculation Manual for 60 Minutes or Longer. <i>Op. Modes: All</i></p>
		<p><b>AA3</b> Rise in Radiation Levels Within the Facility that Impedes Operation of Systems Required to Maintain Safe Operations or to Establish or Maintain Cold Shutdown <i>Op. Modes: All</i></p>	<p><b>AU2</b> UNPLANNED Rise in Plant Radiation Levels. <i>Op. Modes: All</i></p>
		<p><b>AA2</b> Damage to Irradiated Fuel or Loss of Water Level that Has Resulted or Will Result in the Uncovering of Irradiated Fuel Outside the Reactor Vessel. <i>Op. Modes: All</i></p>	

Initiating Condition -- NOTIFICATION OF UNUSUAL EVENT

Any Release of Gaseous or Liquid Radioactivity to the Environment Greater Than 2 Times the Off-site Dose Calculation Manual for 60 Minutes or Longer.

Operating Mode Applicability: All

Example Emergency Action Levels: (1 or 2 or 3 or 4 or 5)

*Note: The Emergency Director should not wait until the applicable time has elapsed, but should declare the event as soon as it is determined that the release duration has exceeded, or will likely exceed, the applicable time. In the absence of data to the contrary, assume that the release duration has exceeded the applicable time if an ongoing release is detected and the release start time is unknown.*

1. VALID reading on any of the following radiation monitors greater than 2 times the alarm setpoint established by a current radioactivity discharge permit for 60 minutes or longer.

AP1000

Plant Vent	VFS-RICA-103	[TBD]
Turbine Island Vent	TDS-JE-RE001	[TBD]
Gaseous Radwaste Discharge	WGS-RICA-017	[TBD]
Liquid Radwaste discharge	WLS-RIA-229	[TBD]
Wastewater Discharge	WWS-JE-RE021	[TBD]

ESBWR

Plant Stack	D11-PRM-RMS-13	[TBD]
Liquid Radwaste Discharge	D11-PRM-RMS-11	[TBD]
Isolation Condenser Vent Exhaust	D11-PRM-RMS-19	[TBD]

2. VALID reading on any of the following radiation monitors greater than the reading shown for 60 minutes or longer:

AP1000

Steam Generator Blowdown	BDS-RE-010	[TBD]
	BDS-RE-011	[TBD]
Main Steam Line	SGS-RIA-026, RIA-027	[TBD]
Service Water Blowdown	SWS-RIA-008	[TBD]
Containment Air Filtration Exhaust	VFS-MA-02A, MA-02B	[TBD]

ESBWR

Main Steamline	D11-PRM-RMS-01	[TBD]
Containment Purge Exhaust	D11-PRM-RMS-23	[TBD]
Drywell Sump LCW/HCW Discharge	D11-PRM-RMS-16	[TBD]
Turbine Bldg. Combined Ventilation Exhaust	D11-PRM-RMS-10	[TBD]
Radwaste Bldg. Ventilation Exhaust	D11-PRM-RMS-17	[TBD]

3. Confirmed sample analyses for gaseous or liquid releases indicates concentrations or release rates greater than 2 times (site-specific ODCM) for 60 minutes or longer.

## ABNORMAL RAD LEVELS/RADIOLOGICAL EFFLUENT

4. VALID reading on perimeter radiation monitoring system greater than 0.10 mR/hr above normal\* background for 60 minutes or longer [*for sites having telemetered perimeter monitors*].  
\*Normal can be considered as the highest reading in the past twenty-four hours excluding the current peak value.
5. VALID indication on automatic real-time dose assessment capability indicating greater than (site-specific value) for 60 minutes or longer [*for sites having such capability*].

### **Basis:**

[Refer to Appendix A for a detailed basis of the radiological effluent IC/EALs.]

This IC addresses a potential or actual decrease in the level of safety of the plant as indicated by a radiological release that exceeds regulatory commitments for an extended period of time. [*Nuclear power plants incorporate features intended to control the release of radioactive effluents to the environment. Further, there are administrative controls established to prevent unintentional releases, or control and monitor intentional releases. These controls are located in the Off-site Dose Calculation Manual (ODCM).*] The occurrence of extended, uncontrolled radioactive releases to the environment is indicative of a degradation in these features and/or controls. [*Some sites may find it advantageous to address gaseous and liquid releases with separate initiating conditions and EALs.*]

The ODCM multiples are specified in ICs AU1 and AA1 only to distinguish between non-emergency conditions, and from each other. While these multiples obviously correspond to an off-site dose or dose rate, the emphasis in classifying these events is the degradation in the level of safety of the plant, NOT the magnitude of the associated dose or dose rate. [*Releases should not be prorated or averaged. For example, a release exceeding 4x ODCM for 30 minutes does not meet the threshold for this IC.*]

This EAL includes any release for which a radioactivity discharge permit was not prepared, or a release that exceeds the conditions (e.g., minimum dilution flow, maximum discharge flow, alarm setpoints, etc.) on the applicable permit. The Emergency Director should not wait until 60 minutes has elapsed, but should declare the event as soon as it is determined that the release duration has or will likely exceed 60 minutes. Also, if an ongoing release is detected and the starting time for that release is unknown, the Emergency Director should, in the absence of data to the contrary, assume that the release has exceeded 60 minutes.

Threshold #1 addresses radioactivity releases, that for whatever reason, cause effluent radiation monitor readings to exceed two times the Technical Specification limit and releases are not terminated within 60 minutes. [*This alarm setpoint may be associated with a planned batch release, or a continuous release path. In either case, the setpoint is established by the ODCM to warn of a release. Indexing the EAL threshold to the ODCM setpoints in this manner ensures that the EAL threshold will never be less than the setpoint established by a specific discharge permit.*]

Threshold #2 addresses effluent or accident radiation monitors on non-routine release pathways (i.e., for which a discharge permit would not normally be prepared). [*The setpoint will be based on radiation monitor readings to exceed two times the Technical Specification limit and releases are not terminated within 60 minutes. The ODCM establishes a methodology for determining effluent radiation monitor setpoints. The ODCM specifies default source terms and, for gaseous releases, prescribes the use of pre-determined annual average meteorology in the most limiting downwind sector for showing compliance with the regulatory commitments. These monitor reading Thresholds should be determined using this methodology.*]

Threshold #3 addresses uncontrolled releases that are detected by sample analyses, particularly on unmonitored pathways, e.g., spills of radioactive liquids into storm drains, heat exchanger leakage in river water systems, etc.

ABNORMAL RAD LEVELS/RADIOLOGICAL EFFLUENT

The 0.10 mR/hr value in Threshold #4 is based on a release rate not exceeding 500 mrem per year, [as provided in the ODCM, prorated over 8766 hours, multiplied by two, and rounded. ( $500 \div 8766 \times 2 = 0.114$ ). This is also the basis of the site specific value in Threshold #5].

[Thresholds #1 and #2 directly correlate with the IC since annual average meteorology is required to be used in showing compliance with the ODCM and is used in calculating the alarm setpoints. Thresholds #4 and #5 are a function of actual meteorology, which will likely be different from the limiting annual average value. Thus, there will likely be a numerical inconsistency. However,] the fundamental basis of this IC is NOT a dose or dose rate, but rather the degradation in the level of safety of the plant implied by the uncontrolled release. Exceeding Threshold #4 or Threshold #5 is an indication of an uncontrolled release meeting the fundamental basis for this IC.

AP1000 References:

VFS-M3C-101  
WGS-M3C-101  
WLS-M3C-101  
WWS-M3C-100  
BDS-M3C-101  
SGS-M3C-101  
SWS-M3C-101  
RMS-J7-001

ESBWR References:

DCD Tier 2, Figure 11.5-1, Rev. 3  
DCD Tier 2, Section 5.5.1, Rev. 3

Initiating Condition -- NOTIFICATION OF UNUSUAL EVENT

UNPLANNED Rise in Plant Radiation Levels.

Operating Mode Applicability: All

Example Emergency Action Levels: (1 or 2)

1. a. UNPLANNED water level drop in a refueling pathway as indicated by:

AP1000

Spent Fuel Pool Low-Low Alarm 22.75 ft. on SFS-LICA-19A/B/C  
Visual observation

ESBWR

Rx Well Cavity	G21-FAPCS-LS-N020-Low [TBD]
Buffer Pool	G21-FAPCS-LS-N019-Low [TBD]
Upper Fuel Transfer Pool	G21-FAPCS-LS-N018-Low [TBD]
Skimmer Surge Tank A/B Level	G21-FAPCS-LS-R621-Low, [TBD] G21-LS-R622-Low-Low [23 feet]
Spent Fuel Storage Pool	G21-FAPCS-LS-R634-Low, [TBD] G21-LS-R632 [TBD], G21-LS-R633[TBD]
Lower Fuel Transfer Pool	G21-FAPCS-LS-N026-Low [TBD]
Visual observation	

**AND**

- b. VALID rise in area radiation reading indicated by:

AP1000

Fuel Handling Area Exhaust Radiation Monitor	VAS-RE 001
Containment High Range	PXS-RICA-160, 161, 162, 163
Refueling Bridge Portable Monitor	[site specific]

ESBWR

Refueling Floor Area #1, EL 34000 (Reactor Building)	D21-ARM-RMS-01
Refueling Floor Area #2, EL 34000 (Reactor Building)	D21-ARM-RMS-02
New Fuel Buffer Pool, EL 27000 (Reactor Building)	D21-ARM-RMS-03
New Fuel Buffer Pool, EL 27000 (Reactor Building)	D21-ARM-RMS-04
Fuel Handling Machine (IFTS), EL 34000 (Reactor Building)	D21-ARM-RMS-40
Spent Fuel Floor, EL 4650 (Fuel Building)	D21-ARM-RMS-01
Fuel Handling Machine, EL 4650, (Fuel Building)	D21-ARM-RMS-02
Fuel Transfer Cask Area, EL 4650 (Fuel Building)	D21-ARM-RMS-03
IFTS Fuel Building Isolation Valve Room (Inside), EL 4600	D21-ARM-RMS-12

2. VALID Area Radiation Monitor readings or survey results indicate a rise by a factor of 1000 over normal\* levels.

## ABNORMAL RAD LEVELS/RADIOLOGICAL EFFLUENT

\*Normal levels can be considered as the highest reading in the past twenty-four hours excluding the current peak value.

### **Basis:**

This IC addresses elevated radiation levels as a result of water level lowering but above the RPV flange or events that have resulted, or may result, in unexpected rise in radiation dose rates within plant buildings. These radiation levels represent a loss of control over radioactive material and may represent a potential degradation in the level of safety of the plant.

*[In light of Reactor Cavity Seal failure incidents at two different PWRs and loss of water in the Spent Fuel Pit/Fuel Transfer Canal at a BWR, explicit coverage of these types of events via EAL #1 is appropriate given their potential for increased doses to plant staff.]* Classification as a NOUE is warranted as a precursor to a more serious event. The refueling pathway is a site specific combination of cavities, tubes, canals and pools. *[Site-specific indications may include instrumentation such as water level and local area radiation monitors, and personnel (e.g., refueling crew) reports. If available, video cameras may allow remote observation. Depending on available level instrumentation, the declaration threshold may need to be based on indications of water makeup rate or decrease in refueling water storage tank level.]*

While a radiation monitor could detect a rise in dose rate due to a drop in the water level, it might not be a reliable indication of whether or not the fuel is covered. *[For example, the reading on an area radiation monitor located on the refueling bridge may rise due to planned evolutions such as head lift, or even a fuel assembly being raised in the manipulator mast. Generally, elevated radiation monitor indications will need to combined with another indicator (or personnel report) of water loss.]* For refueling events where the water level drops below the RPV flange classification would be via CU2. This event escalates to an Alert per IC AA2 if irradiated fuel outside the reactor vessel is uncovered. For events involving irradiated fuel in the reactor vessel, escalation would be via the Fission Product Barrier Matrix for events in operating modes 1-4.

*[The ESBWR fuel pool cooling function is also provided in the event that a recently unloaded fuel batch requires continued cooling during the post-accident period. The spent fuel pool contains sufficient inventory to ensure no operator action is required during the first 72 hours. After that period, either makeup water must be supplied to the spent fuel pool or the FAPCS must be initiated. The FAPCS equipment is environmentally qualified, so access is not required and redundancy is included in system components.]*

Threshold #2 addresses elevated in-plant radiation levels encountered during operation of plant processes that represent a degradation in the control of radioactive material, and represent a potential degradation in the level of safety of the plant. This EAL excludes in-plant radiation levels that may result from use of radiographic sources. A specific list of ARMs is not required as it would restrict the applicability of the Threshold. The intent is to identify loss of control of radioactive material in any monitored area. This event escalates to an Alert per IC AA3 if the increase in dose rates impedes personnel access necessary for safe operation.

### AP1000 References:

SFS-M3C-101  
RCS-M3C-101  
VAS-M3C-101  
PXS-M3C-101  
RMS-J7-001

### ESBWR References

DCD Tier 2, Table 3.3.5.1-1, Rev. 3  
DCD Tier 2, Table 12.3-2, Rev. 3  
DCD Tier, Sec. 9.1.3  
NEDO-33319



Initiating Condition -- ALERT

Any Release of Gaseous or Liquid Radioactivity to the Environment Greater Than 200 Times the Off-site Dose Calculation Manual for 15 Minutes or Longer.

Operating Mode Applicability: All

Example Emergency Action Levels: (1 or 2 or 3 or 4 or 5)

*Note: The Emergency Director should not wait until the applicable time has elapsed, but should declare the event as soon as it is determined that the release duration has exceeded, or will likely exceed, the applicable time. In the absence of data to the contrary, assume that the release duration has exceeded the applicable time if an ongoing release is detected and the release start time is unknown.*

1. VALID reading on any effluent monitor that exceeds 200 times the alarm setpoint established by a current radioactivity discharge permit for 15 minutes or longer.

AP1000

Plant Vent	VFS-RICA-103	[TBD]
Turbine Island Vent	TDS-JE-RE001	[TBD]
Gaseous Radwaste Discharge	WGS-RICA-017	[TBD]
Liquid Radwaste discharge	WLS-RIA-229	[TBD]
Wastewater Discharge	WWS-JE-RE021	[TBD]

ESBWR

Plant Stack	D11-PRM-RMS-13	[TBD]
Liquid Radwaste Discharge	D11-PRM-RMS-11	[TBD]
Isolation Condenser Vent Exhaust	D11-PRM-RMS-19	[TBD]

2. VALID reading on any of the following radiation monitors greater than the reading shown for 15 minutes or longer:

AP1000

Steam Generator Blowdown	BDS-RE-011	[TBD]
	BDS-RE-010	[TBD]
Main Steam Line	SGS-RIA-026, RIA-027	[TBD]
Service Water Blowdown	SWS-RIA-008	[TBD]
Containment Air Filtration Exhaust	VFS-MA-02A, MA-02B	[TBD]

ESBWR

Main Steamline	D11-PRM-RMS-01	[TBD]
Containment Purge Exhaust	D11-PRM-RMS-23	[TBD]
Drywell Sump LCW/HCW Discharge	D11-PRM-RMS-16	[TBD]
Turbine Bldg. Combined Ventilation Exhaust	D11-PRM-RMS-10	[TBD]
Radwaste Bldg. Ventilation Exhaust	D11-PRM-RMS-17	[TBD]

3. Confirmed sample analyses for gaseous or liquid releases indicates concentrations or release rates, greater than 200 times {site specific ODCM value} for 15 minutes or longer.

## ABNORMAL RAD LEVELS/RADIOLOGICAL EFFLUENT

4. VALID reading on perimeter radiation monitoring system greater than 10.0 mR/hr above normal\* background for 15 minutes or longer [*for sites having telemetered perimeter monitors*].  
*\*Normal can be considered as the highest reading in the past twenty-four hours excluding the current peak value.*
5. VALID indication on automatic real-time dose assessment capability indicating greater than (site-specific value) for 15 minutes or longer [*for sites having such capability*].

Basis:

[*Refer to Appendix A for a detailed basis of the radiological effluent IC/EALs.*]

The Emergency Director should not wait until the applicable time has elapsed, but should declare the event as soon as it is determined that the condition will likely exceed the applicable time.

This IC addresses a potential or actual decrease in the level of safety of the plant as indicated by a radiological release that exceeds regulatory commitments for an extended period of time. [*Nuclear power plants incorporate features intended to control the release of radioactive effluents to the environment. Further, there are administrative controls established to prevent unintentional releases, or control and monitor intentional releases. These controls are located in the Off-site Dose Calculation Manual (ODCM).*] The occurrence of extended, uncontrolled radioactive releases to the environment is indicative of a degradation in the features and/or controls established to prevent unintentional releases, or control and monitor intentional releases. [*Some sites may find it advantageous to address gaseous and liquid releases with separate initiating conditions and EALs.*]

The ODCM multiples are specified in ICs AU1 and AA1 only to distinguish between non-emergency conditions, and from each other. While these multiples obviously correspond to an off-site dose or dose rate, the emphasis in classifying these events is the degradation in the level of safety of the plant, NOT the magnitude of the associated dose or dose rate.

[*To ensure a realistic near-linear escalation path, a value should be selected roughly half-way between the AU1 value and the value calculated for AS1 value. The value will be based on radiation monitor readings to exceed 200 times the Technical Specification limit and releases are not terminated within 15 minutes. The ODCM establishes a methodology for determining effluent radiation monitor setpoints. The ODCM specifies default source terms and, for gaseous releases, prescribes the use of pre-determined annual average meteorology in the most limiting downwind sector for showing compliance with the regulatory commitments. This EAL can be determined using this methodology if appropriate.*]

[*Releases should not be prorated or averaged.*]

This EAL includes any release for which a radioactivity discharge permit was not prepared, or a release that exceeds the conditions (e.g., minimum dilution flow, maximum discharge flow, alarm setpoints, etc.) on the applicable permit.

The Emergency Director should not wait until 15 minutes has elapsed, but should declare the event as soon as it is determined that the release duration has or will likely exceed 15 minutes. Also, if an ongoing release is detected and the starting time for that release is unknown, the Emergency Director should, in the absence of data to the contrary, assume that the release has exceeded 15 minutes.

Threshold #1 addresses radioactivity releases that for whatever reason cause effluent radiation monitor readings that exceed two hundred times the alarm setpoint established by the radioactivity discharge permit. This alarm setpoint may be associated with a planned batch release, or a continuous release path. [*In either*

## ABNORMAL RAD LEVELS/RADIOLOGICAL EFFLUENT

*case, the setpoint is established by the ODCM to warn of a release that is not in compliance. Indexing the EAL threshold to the ODCM setpoints in this manner ensures that the EAL threshold will never be less than the setpoint established by a specific discharge permit.]*

Threshold #2 addresses effluent or accident radiation monitors on non-routine release pathways (i.e., for which a discharge permit would not normally be prepared). *[To ensure a realistic near-linear escalation path, a setpoint should be selected roughly half-way between the AU1 EAL #2 value and the value calculated for AS1 rad monitor value. The setpoint will be based on radiation monitor readings to exceed two hundred times the Technical Specification limit and releases are not terminated within 15 minutes. The ODCM establishes a methodology for determining effluent radiation monitor setpoints. The ODCM specifies default source terms and, for gaseous releases, prescribes the use of pre-determined annual average meteorology in the most limiting downwind sector for showing compliance with the regulatory commitments. These monitor reading EALs should be determined using this methodology.]*

Threshold #3 addresses uncontrolled releases that are detected by sample analyses, particularly on unmonitored pathways, e.g., spills of radioactive liquids into storm drains, heat exchanger leakage in river water systems, etc.

The 10.0 mR/hr value in Threshold #4 is based on a release rate not exceeding 500 mrem per year, *as provided in the ODCM, prorated over 8766 hours, multiplied by 200, and rounded. (500 ÷ 8766 × 200 = 11.4)*. This is also the basis of the site specific value in EAL #5.

Thresholds #1 and #2 directly correlate with the IC since annual average meteorology is *[required to be]* used *[in showing compliance with the ODCM and is used in calculating the alarm setpoints]*. Thresholds #4 and #5 are a function of actual meteorology, which will likely be different from the limiting annual average value. *[Thus, there will likely be a numerical inconsistency. However,]* the fundamental basis of this IC is NOT a dose or dose rate, but rather the degradation in the level of safety of the plant implied by the uncontrolled release. Exceeding Threshold #4 or #5 is an indication of an uncontrolled release meeting the fundamental basis for this IC.

*[Due to the uncertainty associated with meteorology, emergency implementing procedures should call for the timely performance of dose assessments using actual (real-time) meteorology in the event of a gaseous radioactivity release of this magnitude. The results of these assessments should be compared to the ICs AS1 and AG1 to determine if the event classification should be escalated.]*

### AP1000 References:

VFS-M3C-101  
WGS-M3C-101  
WLS-M3C-101  
WWS-M3C-100  
BDS-M3C-101  
SGS-M3C-101  
SWS-M3C-101  
RMS-J7-001

### ESBWR References:

DCD Tier 2, Figure 11.5-1, Rev. 3  
DCD Tier 2, Sec. 5.5.1, Rev. 3

Initiating Condition -- ALERT

Damage to Irradiated Fuel or Loss of Water Level that Has or Will Result in the Uncovering of Irradiated Fuel Outside the Reactor Vessel.

Operating Mode Applicability: All

Example Emergency Action Levels: (1 or 2)

- 1. A VALID alarm or elevated reading on any of the following due to damage to irradiated fuel or loss of water level

AP1000

Fuel Handling Area Exhaust Radiation Monitor	VAS-RE-001
Containment High Range	PXS-RICA-160, 161, 162, 163
Refueling Bridge Portable Monitor	[site specific]

ESBWR

Refueling Floor Area #1, EL 34000 (Reactor Building)	D21-ARM-RMS-01
Refueling Floor Area #2, EL34000 (Reactor Building)	D21-ARM-RMS-02
New Fuel Buffer Pool, EL 27000 (Reactor Building)	D21 -ARM-RMS -03
New Fuel Buffer Pool, EL 27000 (Reactor Building)	D21 -ARM-RMS -04
Fuel Handling Machine (IFTS), EL 34000 (Reactor Building)	D21-ARM-RMS-40
Spent Fuel Floor, EL 4650 (Fuel Building)	D21-ARM-RMS-01
Fuel Handling Machine, EL 4650 (Fuel Building)	D21-ARM-RMS-02
Fuel Transfer Cask Area, EL 4650 (Fuel Building)	D21-ARM-RMS-03
IFTS Fuel Building Isolation Valve Room (Inside), EL 4650	D21-ARM-RMS-12

- 2. A water level drop in the reactor refueling pathway resulting in irradiated fuel becoming uncovered as indicated by:

AP1000

Spent Fuel Pool Low-Low Alarm XXXX ft.	SFS-LICA-19A/B/C
Visual observation	

ESBWR

Rx Well Cavity	G21-FAPCS-LS-N020-Low [TBD]
Buffer Pool	G21-FAPCS-LS-N019-Low [TBD]
Upper Fuel Transfer Pool	G21- FAPCS-LS-N018-Low [TBD]
Skimmer Surge Tank A/B Level	G21-FAPCS-LS-R621-Low, [TBD]
	G21-FAPCS-LS-R622-Low-Low [23 feet]
Spent Fuel Storage Pool	G21-FAPCS-LS-R634-Low [TBD],
	G21-FAPCS-LS-R632 [TBD],
	G21-FAPCS-LS-R633 [TBD]
Lower Fuel Transfer Pool	G21-FAPCS-LS-N026-Low [TBD]
Visual observation	

**Basis:**

This IC addresses specific events that have resulted, or may result, in unexpected rise in radiation dose rates within plant buildings, and may be a precursor to a radioactivity release to the environment. These events

## ABNORMAL RAD LEVELS/RADIOLOGICAL EFFLUENT

represent a loss of control over radioactive material and represent degradation in the level of safety of the plant. [*These events escalate from IC AU2 in that fuel activity has been released, or is anticipated due to fuel heatup.*].

Threshold #1 addresses radiation monitor indications of fuel uncover and/or fuel damage. Elevated readings on ventilation monitors may be indication of a radioactivity release from the fuel, confirming that damage has occurred. Raised background at the monitor due to water level lowering may mask raised ventilation exhaust airborne activity and needs to be considered. [*While a radiation monitor could detect a rise in dose rate due to a drop in the water level, it might not be a reliable indication of whether or not the fuel is covered. For example, the monitor could in fact be properly responding to a known event involving transfer or relocation of a source, stored in or near the fuel pool or responding to a planned evolution such as removal of the reactor head.*] Application of this threshold requires understanding of the actual radiological conditions present in the vicinity of the monitor.

In Threshold #2, site-specific indications may include instrumentation such as water level and local area radiation monitors, and personnel (e.g., refueling crew) reports. The refueling pathway is a site specific combination of cavities, tubes, canals and pools. [*If available, video cameras may allow remote observation. Depending on available level indication, the declaration threshold may need to be based on indications of water makeup rate.*]

Escalation, if appropriate, would occur via IC AS1 or AG1 or Emergency Director judgment.

### AP1000 References:

SFS-M3C-101  
VAS-M3C-101  
PXS-M3C-101  
RMS-J7-001

### ESBWR References:

DCD Tier 2, Table 3.3.5.1-1, Rev. 3  
DCD Tier 2, Table 12.3-2, Rev. 3  
DCD Tier, Sec. 9.1.3  
NEDO-33319

Initiating Condition -- ALERT

Rise in Radiation Levels Within the Facility That Impedes Operation of Systems Required to Maintain Safe Operations or to Establish or Maintain Cold Shutdown

Operating Mode Applicability: All

Example Emergency Action Levels:

1. Dose rate greater than 15 mR/hr in the following areas requiring continuous occupancy to maintain plant safety functions:

AP1000

Main Control Room Area Monitor	RMS-JE-RE010
Technical Support Center Area Monitor	RMS-JE-RE016
Central Alarm Station	RMS-JE-RE009

ESBWR

Main Control Room	D11-PRM-RMS-04A, B
Technical Support Center	D11-PRM-RMS-20
Central Alarm Station	D11-PRM-RMS-TBD
Secondary Alarm Station	D11-PRM-RMS-TBD

Basis:

The cause and/or magnitude of the increase in radiation levels is not a concern of this IC. The Emergency Director must consider the source or cause of the increased radiation levels and determine if any other IC may be involved. *[For example, a dose rate of 15 mR/hr in the Control Room may be a problem in itself. However, the increase may also be indicative of high dose rates in the containment due to a LOCA. In this latter case, an SAE or GE may be indicated by the fission product barrier matrix ICs.]*

*[At multiple-unit sites, the example EALs could result in declaration of an Alert at one unit due to a radioactivity release or radiation shine resulting from a major accident at the other unit. This is appropriate if the increase impairs operations at the operating unit.]*

Areas requiring continuous occupancy includes the Control Room and *[, as appropriate to the site, any other control stations that are staffed continuously. The value of 15mR/hr is derived from the GDC 19 value of 5 rem in 30 days with adjustment for expected occupancy times. Although Section III.D.3 of NUREG-0737, "Clarification of TMI Action Plan Requirements", provides that the 15 mR/hr value can be averaged over the 30 days, the value is used here without averaging, as a 30 day duration implies an event potentially more significant than an Alert.]*

*[The AP1000 Containment Area–Personnel Hatch radiation monitor, RMS-JE-RE009, monitors the area in immediate proximity to Rooms 12451, 12452 and 12454. This monitor would be used to alert Security personnel associated with the Central Alarm Station (CAS).]*

AP1000 References:

ESBWR References

RMS-J7-001

DCD Tier 2, Figure 11.5-1, Rev. 3

Initiating Condition -- SITE AREA EMERGENCY

Off-site Dose Resulting from an Actual or IMMINENT Release of Gaseous Radioactivity Greater Than 100 mrem TEDE or 500 mrem Thyroid CDE for the Actual or Projected Duration of the Release.

Operating Mode Applicability: All

Example Emergency Action Levels: (1 or 2 or 3 or 4)

*Note: If dose assessment results are available at the time of declaration, the classification should be based on dose assessment instead of radiation monitor values. While necessary declarations should not be delayed awaiting results, the dose assessment should be initiated / completed in order to determine if the classification should be subsequently escalated.*

*Note: The Emergency Director should not wait until the applicable time has elapsed, but should declare the event as soon as it is determined that the release duration has exceeded, or will likely exceed, the applicable time.*

1. VALID reading on any of the following radiation monitors greater than the reading shown for 15 minutes or longer:

AP1000

Plant Vent (Mid Range Gas)	VFS-RIA-104A	[Setpoint TBD]
Plant Vent (High Range Gas)	VFS-RIA-104B	[Setpoint TBD]
Gaseous Radwaste discharge	WGS-RICA-017	[Setpoint TBD]

ESBWR

Plant Stack	D11-PRM-RMS-13	[Setpoint TBD]
Isolation Condenser Vent Exhaust	D11-PRM-RMS-19	[Setpoint TBD]

2. Dose assessment using actual meteorology indicates doses greater than 100 mrem TEDE or 500 mrem thyroid CDE at or beyond the site boundary.
3. A VALID perimeter radiation monitoring system reading greater than 100 mR/hr. for 15 minutes or longer. [for sites having telemetered perimeter monitors]
4. Field survey results indicate closed window dose rates greater than 100 mR/hr expected to continue for 60 minutes or longer; or analyses of field survey samples indicate thyroid CDE greater than 500 mrem for one hour of inhalation, at or beyond the site boundary.

**Basis:**

[Refer to Appendix A for a detailed basis of the radiological effluent IC/EALs.]

This IC addresses radioactivity releases that result in doses at or beyond the site boundary that exceed a small fraction of the EPA Protective Action Guides (PAGs). Releases of this magnitude are associated with the failure of plant systems needed for the protection of the public. [While these failures are addressed by other ICs, this IC provides appropriate diversity and addresses events which may not be able to be classified on the basis of plant status alone, e.g., fuel handling accident in spent fuel building.]

ABNORMAL RAD LEVELS/RADIOLOGICAL EFFLUENT

*The TEDE dose is set at 10% of the EPA PAG, while the 500 mrem thyroid CDE was established in consideration of the 1:5 ratio of the EPA PAG for TEDE and thyroid CDE.]*

The Emergency Director should not wait until 15 minutes has elapsed, but should declare the event as soon as it is determined that the release duration has or will likely exceed 15 minutes.

*[The (site specific) monitor list in EAL #1 should include monitors on all potential release pathways.]*

*[The EPA PAGs are expressed in terms of the sum of the effective dose equivalent (EDE) and the committed effective dose equivalent (CEDE), or as the thyroid committed dose equivalent (CDE). For the purpose of these IC/EALs, the dose quantity total effective dose equivalent (TEDE), as defined in 10 CFR 20, is used in lieu of "...sum of EDE and CEDE...." The EPA PAG guidance provides for the use of adult thyroid dose conversion factors. However, some states have decided to calculate child thyroid CDE. Utility IC/EALs need to be consistent with those of the states involved in the facility's emergency planning zone.]*

*[The monitor reading EALs should be determined using a dose assessment method that back calculates from the dose values specified in the IC. The meteorology used should be the same as those used for determining the monitor reading EALs in ICs AUI and AAI. The same source term (noble gases, particulates, and halogens) may also be used as long as it maintains a realistic and near linear escalation between the EALs for the four classifications. Since doses are generally not monitored in real-time, it is suggested that a release duration of one hour be assumed, and that the EALs be based on a site specific boundary (or beyond) dose of 100 mrem whole body or 500 mrem thyroid, whichever is more limiting (as was done for EALs #3 and #4). If individual site analyses indicate a longer or shorter duration for the period in which the substantial portion of the activity is released, the longer duration should be used.]*

*If proper escalations do not result from the use of the same source term, if the calculated values are unrealistically high, or if correlation between the values and dose assessment values does not exist, then consider using an accident source term for ASI and AGI calculations.*

*[Since dose assessment is based on actual meteorology, whereas the monitor reading EALs are not, the results from these assessments may indicate that the classification is not warranted, or may indicate that a higher classification is warranted. For this reason, emergency implementing procedures should call for the timely performance of dose assessments using actual meteorology and release information. If the results of these dose assessments are available when the classification is made (e.g., initiated at a lower classification level), the dose assessment results override the monitor reading EALs.]*

AP1000 References:

VFS-M3C-101  
WGS-M3C-101  
RMS-J7-001

ESBWR References:

DCD Tier 2, Table 11.5-1, Rev. 3



Initiating Condition -- GENERAL EMERGENCY

Off-site Dose Resulting from an Actual or IMMEDIATE Release of Gaseous Radioactivity Greater Than 1000 mrem TEDE or 5000 mrem Thyroid CDE for the Actual or Projected Duration of the Release Using Actual Meteorology.

Operating Mode Applicability: All

Example Emergency Action Levels: (1 or 2 or 3 or 4)

*Note: If dose assessment results are available at the time of declaration, the classification should be based on dose assessment instead of radiation monitor values. Do not delay declaration awaiting dose assessment results.*

*Note: The Emergency Director should not wait until the applicable time has elapsed, but should declare the event as soon as it is determined that the release duration has exceeded, or will likely exceed, the applicable time.*

1. VALID reading on any of the following radiation monitors greater than the reading shown for 15 minutes or longer:

AP1000

Plant Vent (Mid Range Gas)	VFS-RIA-104A	[Setpoint TBD]
Plant Vent (High Range Gas)	VFS-RIA-104B	[Setpoint TBD]
Gaseous Radwaste discharge	WGS-RICA-017	[Setpoint TBD]

ESBWR

Plant Stack	D11-PRM-RMS-13	[Setpoint TBD]
Isolation Condenser Vent Exhaust	D11-PRM-RMS-19	[Setpoint TBD]

2. Dose assessment using actual meteorology indicates doses greater than 1000 mrem TEDE or 5000 mrem thyroid CDE at or beyond the site boundary.
3. VALID perimeter radiation monitoring system reading greater than 1000 mR/hr. for 15 minutes or longer. [for sites having telemetered perimeter monitors]
4. Field survey results indicate closed window dose rates greater than 1000 mR/hr expected to continue for 60 minutes or longer; or analyses of field survey samples indicate thyroid CDE greater than 5000 mrem for one hour of inhalation, at or beyond site boundary.

**Basis:**

[Refer to Appendix A for a detailed basis of the radiological effluent IC/EALs.]

This IC addresses radioactivity releases that result in doses at or beyond the site boundary that exceed the EPA Protective Action Guides (PAGs). Public protective actions will be necessary. Releases of this magnitude are associated with the failure of plant systems needed for the protection of the public and likely involve fuel damage. [While these failures are addressed by other ICs, this IC provides appropriate diversity and addresses events which may not be able to be classified on the basis of plant status alone. It is

ABNORMAL RAD LEVELS/RADIOLOGICAL EFFLUENT

*important to note that, for the more severe accidents, the release may be unmonitored or there may be large uncertainties associated with the source term and/or meteorology.]*

The Emergency Director should not wait until 15 minutes has elapsed, but should declare the event as soon as it is determined that the release duration has or will likely exceed 15 minutes.

*[The (site specific) monitor list in EAL #1 should include monitors on all potential release pathways.]*

*[The EPA PAGs are expressed in terms of the sum of the effective dose equivalent (EDE) and the committed effective dose equivalent (CEDE), or as the thyroid committed dose equivalent (CDE). For the purpose of these IC/EALs, the dose quantity total effective dose equivalent (TEDE), as defined in 10 CFR 20, is used in lieu of "...sum of EDE and CEDE..." The EPA PAG guidance provides for the use of adult thyroid dose conversion factors. However, some states have decided to calculate child thyroid CDE. Utility IC/EALs need to be consistent with those of the states involved in the facilities emergency planning zone.]*

*[The monitor reading EALs should be determined using a dose assessment method that backcalculates from the dose values specified in the IC. The meteorology and source term (noble gases, particulates, and halogens) used should be the same as those used for determining the monitor reading EALs in ICs AU1 and AA1. This protocol will maintain intervals between the EALs for the four classifications. Since doses are generally not monitored in real-time, it is suggested that a release duration of one hour be assumed, and that the EALs be based on a site specific boundary (or beyond) dose of 1000 mrem whole body or 5000 mrem thyroid, whichever is more limiting (as was done for EALs #3 and #4). If individual site analyses indicate a longer or shorter duration for the period in which the substantial portion of the activity is released, the longer duration should be used.]*

*[Since dose assessment is based on actual meteorology, whereas the monitor reading EALs are not, the results from these assessments may indicate that the classification is not warranted. For this reason, emergency implementing procedures should call for the timely performance of dose assessments using actual meteorology and release information. If the results of these dose assessments are available when the classification is made (e.g., initiated at a lower classification level), the dose assessment results override the monitor reading EALs.]*

AP1000 References:

VFS-M3C-101  
WGS-M3C-101  
RMS-J7-001

ESBWR References:

DCD Tier 2, Table 11.5-1, Rev. 3

COLD SHUTDOWN/REFUELING SYSTEM MALFUNCTION

**5.6 COLD SHUTDOWN/REFUELING SYSTEM MALFUNCTION EALS**

**Table 5-C-1: Recognition Category “C” Initiating Condition Matrix**

<b>GENERAL EMERGENCY</b>	<b>SITE AREA EMERGENCY</b>	<b>ALERT</b>	<b>NOUE</b>
<b>CG1</b> Loss of RPV Inventory Affecting Fuel Clad Integrity with Containment Challenged. <i>Op. Modes: Cold Shutdown, Refueling</i>	<b>CS1</b> Loss of RPV Inventory Affecting Core Decay Heat Removal Capability. <i>Op. Modes: Cold Shutdown, Refueling</i>	<b>CA1</b> Loss of RCS/RPV Inventory. <i>Op. Modes: Cold Shutdown, Refueling</i>	<b>CU1</b> RCS Leakage. (ESBWR) <i>Op. Mode: Cold Shutdown</i>
			<b>CU2</b> UNPLANNED Loss of RCS/RPV Inventory <i>Op. Mode: Refueling</i>
			<b>CU3</b> All Safety Related DC Batteries Not Being Charged for Greater Than 30 Minutes Due to Loss of Power to PIP Busses. <i>Op. Modes: Cold Shutdown, Refueling, Defueled</i>
		<b>CA4</b> Inability to Maintain Plant in Cold Shutdown. <i>Op. Modes: Cold Shutdown, Refueling</i>	<b>CU4</b> UNPLANNED Loss of Decay Heat Removal Capability. <i>Op. Modes: Cold Shutdown, Refueling</i>
			<b>CU6</b> UNPLANNED Loss of All On-site or Off-site Communications Capabilities. <i>Op. Modes: Cold Shutdown, Refueling, Defueled</i>
			<b>CU7</b> UNPLANNED Loss of Required DC Power for 15 Minutes or longer. <i>Op. Modes: Cold Shutdown, Refueling</i>
			<b>CU8</b> Inadvertent Criticality. <i>Op Modes:, Cold Shutdown, Refueling</i>

Initiating Condition -- NOTIFICATION OF UNUSUAL EVENT

RCS Leakage.

Operating Mode Applicability: Cold Shutdown

Example Emergency Action Levels:

*Note: The Emergency Director should not wait until the applicable time has elapsed, but should declare the event as soon as it is determined that the condition will likely exceed the applicable time.*

AP1000

1. Not applicable

ESBWR

1. RCS leakage results in the inability to maintain or restore RPV level greater than Level 2 setpoint [338.5 inches (8597 mm)] on B21-NBS-LI R604A-D Wide Range for 15 minutes or longer.

**Basis:**

This IC is included as a NOUE because it is considered to be a potential degradation of the level of safety of the plant. The inability to establish and maintain level is indicative of loss of RCS inventory. Prolonged loss of RCS Inventory may result in escalation to the Alert level via either IC CA1 (Loss of RCS/RPV Inventory with Irradiated Fuel in the RPV) or CA4 (Inability to Maintain Plant in Cold Shutdown with Irradiated Fuel in the RPV).

*[For AP1000, this IC and associated EALs are deleted, as the IC and EALs for CA1 adequately address the precursor events intended by CU1 for the AP1000 when in Cold Shutdown, and because of the significant design differences between the AP1000 and current pressurized water reactors (PWRs) that form the original basis for CU1. The AP1000 design does not include "containment bypass" as a credible scenario in the Cold Shutdown mode, and the passive Emergency Core Cooling System (ECCS) and passive Residual Heat Removal (RHR) System are still available in Mode 5. The large amount of water inventory maintained in the passive ECCS and in the passive RHR System would be sufficient for much larger RCS leakage rates than for current PWRs. Because of these design differences, the AP1000 design does not include Technical Specifications for RCS leakage limits in Mode 5. The availability of the passive ECCS and RHR System for makeup, and the lack of a credible threat to the environment due to containment bypass or RCS leakage in the AP1000 design, preclude the need for monitoring of the RCS inventory by leakage rate in Mode 5. RCS leakage of a much larger magnitude than that of current PWRs is required to affect decay heat removal, and initiating conditions that indicate a precursor to loss of decay heat removal based on loss of RCS inventory are adequately addressed in IC and EALs for CA1. Waiting until the CA1 IC is met provides sufficient time for operator to take necessary actions to prevent loss of decay heat removal, and placing lower limits on RCS leakage for notification is not necessary as a precursor initiating condition because of this long operator response time involved. Therefore, this IC is not applicable to AP1000, and should be deleted.]*

AP1000 References:

Tech Spec 3.4.7

Tech Spec 3.5

RCS-M3-001

PXS-M3-001

RNS-M3-001

GW-GL-022

## COLD SHUTDOWN/REFUELING SYSTEM MALFUNCTION

ESBWR References:

DCD Tier 2, Chap 16, Sec. 3.4.2 Rev. 3

DCD Tier 2, Chap. 5, Sec. 5.2.5.1.1, Rev. 3

Initiating Condition -- NOTIFICATION OF UNUSUAL EVENT

UNPLANNED Loss of RCS/RPV Inventory.

Operating Mode Applicability: Refueling

Example Emergency Action Levels: (1 or 2)

*Note: The Emergency Director should not wait until the applicable time has elapsed, but should declare the event as soon as it is determined that the condition will likely exceed the applicable time.*

AP1000

1. UNPLANNED RCS level drop below the top of the RPV flange either visually or as indicated by RCS Hot Leg level at 9.7% and lowering as indicated on RCS-LT-160A or -160B for 15 minutes or longer.
2. RCS level cannot be monitored with a loss of RCS inventory as indicated by:
  - Visual observations inside containment
  - Unexplained rise in Containment sump level on WLS-LICR-034, WLS-LICR-035, OR WLS-LICR-036.

ESBWR

1. RPV level drop below the RPV flange for 15 minutes or longer.
2. RPV level cannot be determined with a loss of RPV inventory as indicated by unexplained Drywell Equipment or Floor Drain Sumps level rise on Drywell K10-HCW Sump LE-[TBD] OR Drywell K10-LCW Sump LE-[TBD]

**Basis:**

This IC is included as a NOUE because it may be a precursor of more serious conditions and, as result, is considered to be a potential degradation of the level of safety of the plant. Refueling evolutions that decrease RCS water level below the RPV flange are carefully planned and procedurally controlled. An UNPLANNED event that results in water level decreasing below the RPV flange warrants declaration of a NOUE due to the reduced RCS inventory that is available to keep the core covered. The allowance of 15 minutes was chosen because it is reasonable to assume that level can be restored within this time frame using one or more of the redundant means of refill that should be available. If level cannot be restored in this time frame then it may indicate a more serious condition exists. Continued loss of RCS Inventory will result in escalation to the Alert level via either IC CA1 (Loss of RCS/RPV Inventory with Irradiated Fuel in the RPV) or CA4 (Inability to Maintain Plant in Cold Shutdown with Irradiated Fuel in the RPV).

*[In the refueling mode, normal means of core temperature indication and RCS level indication may not be available. Redundant means of RPV level indication are permanently installed (including the ability to monitor level visually) to assure that the ability to monitor level will not be interrupted. However, if all level indication were to be lost during a loss of RCS inventory event, the operators would need to determine that RPV inventory loss was occurring by observing sump or tank level changes. Sump or tank level rise must be evaluated against other potential sources of leakage such as cooling water sources inside the containment to ensure they are indicative of RCS leakage. Escalation to Alert would be RCS heatup via CA1.]*

## COLD SHUTDOWN/REFUELING SYSTEM MALFUNCTION

### AP1000 References:

RCS-M3C-101  
WLS-M3C-101  
WLS-M3-001  
RCS-M3-001  
PXS-M3-001

### ESBWR References:

DCD Tier 2, Chap. 7, Sect. 7.3.3.2  
DCD Tier 2, Chap. 7, Table 7.3-5  
NEDO-33319

Initiating Condition -- NOTIFICATION OF UNUSUAL EVENT

All Safety Related DC Batteries Not Being Charged for 30 Minutes or Longer Due to Loss of Power to PIP Busses.

Operating Mode Applicability: Cold Shutdown  
Refueling  
Defueled

Example Emergency Action Level:

*Note: The Emergency Director should not wait until the applicable time has elapsed, but should declare the event as soon as it is determined that the condition will likely exceed the applicable time.*

AP1000

1. Loss of all AC power capability to Busses ECS-ES-1 and ECS-ES-2 busses for 30 minutes or longer.

ESBWR

1. Loss of all AC power capability to PIP busses 1000A3 AND 1000B3 for 30 minutes or longer.

**Basis:**

The off-site AC power system supplies power for the unit in cold shutdown, refueling, and defueled conditions. Both the normal off-site and standby on-site AC power systems are non-Class 1E with no Technical Specification requirements. All safety-related functions associated with the unit in cold shutdown and refueling are provided by the safety-related on-site Class 1E DC power systems. *[The Passive ALWRs do not have safety-related standby diesel generators. Storage batteries are the standby power source for Class 1E electric power.]*

*[In cold shutdown, the decay heat available to raise RCS temperature during a loss of RCS water inventory or loss of decay heat removal event may be significantly greater than in the refueling mode. Entry into cold shutdown conditions may be attained within hours of operating at power or hours after refueling is completed. Technical Specification 3.9 requires the reactor to be subcritical for greater than {100 hours – AP1000}{24 hours ESBWR} prior to the movement of irradiated fuel. The heatup threat and therefore the threat to damaging the fuel clad may be lower for events that occur in the refueling mode with irradiated fuel in the RPV. The heatup threat could be lower for cold shutdown conditions if the entry into cold shutdown was following a refueling.]*

*[AP1000 - The loss of normal off-site AC power and standby on-site AC power systems de-energizes the RNS pumps. However, the on-site safety-related Class 1E DC power systems are rated for 24 hours and 72 hours of service based on the most-limiting post-accident electrical load requirements for powering the passive, safety-related systems, and thus remain available for a significant time following a loss of all off-site AC power and on-site AC power. Therefore, the progression of events after a loss of RNS cooling at mid-loop caused by a loss of AC power results in a heatup to saturation, a boiling off of coolant to the IRWST, reduction of hot leg level, and actuation of passive IRWST injection. This restores RCS water inventory using only the passive cooling systems and the on-site safety-related Class 1E DC power systems.]*

*[ESBWR The loss of normal off-site AC power and standby AC power systems de-energizes the RWCU/SDC pumps. The on-site safety related DC power system is rated for 72 hours of service based on the*



## COLD SHUTDOWN/REFUELING SYSTEM MALFUNCTION

*instrumentation and control power for systems required for safe shutdown, and thus remains available for a significant time following a loss of all offsite AC power and on-site. Beyond 72 hours the Fire Protection System (FPS) is available to provide makeup water to the upper pools, Passive Containment Cooling, Isolation Condenser, and Spent Fuel pools. The Fire Protection System enables the upper pools to be filled with water from FPS, which provides makeup water to extend the cooling period from 72 hours to 7 days.]*

Loss of DC power potentially compromises all safety related plant systems requiring electric power. *[When in cold shutdown, refueling, or defueled mode the event can be classified as an Unusual Event, because of the significantly reduced decay heat and lower temperatures and pressures, increasing the time to restore one of the normal off-site AC power and standby on-site AC power systems. In addition, the passive design affords additional and redundant means to remove heat passively or restore power to active components. The selection of 30 minutes was arbitrary. It was chosen for allowing sufficient time for plant personnel to attempt to establish a viable diesel generator AC power supply to the PIP busses.]*

Escalation to an Alert, if appropriate, is by Abnormal Radiation Levels / Radiological Effluent, or Emergency Director Judgment ICs. Thirty minutes was selected as a threshold to exclude transient or momentary power losses, and is appropriate because of the passive cooling systems and the on-site safety-related Class 1E DC power systems.

### AP1000 References:

APP-ECS-E8-001  
APP-RCS-M3-001  
APP-PXS-M3-001  
APP-RNS-M3-001  
APP-ZOS-E8-001  
Technical Specification 3.9.7

### ESBWR References:

DCD Tier 2, Chap. 8, Figure 8.1-1, Rev. 3  
DCD Tier 2, Chap. 19, Sec. 19.A.3 and Table  
19.2-2 Rev. 1

Initiating Condition -- NOTIFICATION OF UNUSUAL EVENT

UNPLANNED Loss of Decay Heat Removal Capability.

Operating Mode Applicability: Cold Shutdown  
Refueling

Example Emergency Action Levels: (1 or 2)

*Note: The Emergency Director should not wait until the applicable time has elapsed, but should declare the event as soon as it is determined that the condition will likely exceed the applicable time.*

AP1000

1. An event results in RCS temperature exceeding 200 F on RCS-TI-135A or -135B
2. Loss of all RCS temperature and RPV level indication for 15 minutes or longer.

ESBWR

1. An event results in RCS temperature exceeding 200 F on C51-TC-[TBD]
2. Loss of all RCS temperature and RPV level indication for 15 minutes or longer.

**Basis:**

This IC is included as a NOUE because it may be a precursor of more serious conditions and, as a result, is considered to be a potential degradation of the level of safety of the plant. *[In cold shutdown, the decay heat available to raise RCS temperature during a loss of RCS water inventory or loss of decay heat removal event may be significantly greater than in the refueling mode. Entry into cold shutdown conditions may be attained within hours of operating at power or hours after refueling is completed. Technical Specification 3.9 requires the reactor to be subcritical for greater than {100 hours –AP1000}{24 hours ESBWR} prior to the movement of irradiated fuel. The heatup threat and therefore the threat to damaging the fuel clad may be lower for events that occur in the refueling mode with irradiated fuel in the RPV.]* Monitoring RCS temperature and RPV level will determine if escalation to the Alert level via CA4 or CA1 will occur if required.

*[AP1000 - Decay heat removal is normally performed by the non-safety related RNS pumps and heat exchangers. The progression of events after a loss of RNS cooling at mid-loop results in a heatup to saturation, a boiling off of coolant to the IRWST, reduction of hot leg level, and actuation of passive IRWST injection. This restores RCS water inventory using only the safety-related passive cooling systems. However, if an unplanned event causes the both normal decay heat removal and the passive cooling systems to be lost, then RCS temperature can exceed 200°F. In addition, even though RNS may be operating and initial RCS/RPV inventory is available, a loss of all RCS temperature and RPV level indication prevents the operator from ensuring adequate RNS decay heat removal is occurring.]*

*[ESBWR Decay heat removal is normally performed by both trains of the nonsafety-related RWCUS/SDC, which transfers sensible heat and core decay heat load produced when the reactor is being shutdown, or is in the shutdown condition, to the Reactor Component Cooling Water System. In the PRA it is assumed that both trains of RWCUS/SDC are running, because the time periods in which only one train is running occurs when the reactor well is flooded. Failure of one of the trains is not considered an initiating event.]*

## COLD SHUTDOWN/REFUELING SYSTEM MALFUNCTION

Any reduction of RCS inventory to the predetermined setpoint will result in an Alert based on CA1 or CA4.

AP1000 References:

APP-RCS-M3-001  
APP-PXS-M3-001  
APP-RNS-M3-001  
APP-GW-GL-022  
Tech Spec 3.4.7  
Tech Spec 3.5

ESBWR References: [TBD]

Initiating Condition -- NOTIFICATION OF UNUSUAL EVENT

UNPLANNED Loss of All On-site or Off-site Communications Capabilities.

Operating Mode Applicability: Cold Shutdown  
Refueling  
Defueled

Example Emergency Action Levels: (1 or 2)

1. Loss of all of the following on-site communications capability affecting the ability to perform routine operations:

AP1000

- EFS
- TVS
- (Site specific)

ESBWR

- Plant Page/party Line
- PABX
- Sound Powered Phones
- Plant Radios
- (Site specific)

2. Loss of all of the following off-site communication methods affecting the ability to perform offsite notifications:

(site-specific list of communications methods)

**Basis:**

The purpose of this IC and its associated EALs is to recognize a loss of communications capability that either defeats the plant operations staff ability to perform routine tasks necessary for plant operations or the ability to communicate problems with off-site authorities. The loss of off-site communications ability is expected to be significantly more comprehensive than the condition addressed by 10 CFR 50.72.

The availability of one method of ordinary off-site communications is sufficient to inform state and local authorities of plant conditions. [*This EAL is to be used only when extraordinary means (e.g., relaying of information from radio transmissions, individuals being sent to off-site locations, etc.) are being utilized to make communications possible.*]

[*Site-specific list for on-site communications loss must encompass the loss of all means of routine communications (e.g., commercial telephones, sound powered phone systems, page party system and radios / walkie talkies).*] EFS and TVS are comprised of the following:

- Wireless Telephone System
- Telephone-Page System
- Sound Powered System
- Security Communication System
- Closed Circuit Television System

## COLD SHUTDOWN/REFUELING SYSTEM MALFUNCTION

*[Site-specific list for off-site communications loss must encompass the loss of all means of communications with off-site authorities. This should include the ENS, commercial telephone lines, teletype transmissions, and dedicated phone systems.]*

AP1000 References:

EFS-E8-001  
TVS-J7-001

ESBWR References: [TBD]



## COLD SHUTDOWN/REFUELING SYSTEM MALFUNCTION

*loss results in the inability to maintain cold shutdown, the escalation to an Alert will be per CA4 - Inability to Maintain Plant in Cold Shutdown with Irradiated Fuel in the RPV.]*

Bus voltage of [TBD] VAC is the minimum bus voltage necessary for the operation of safety-related instrumentation and controls. This voltage value incorporates a margin significantly longer than the allowed 15 minutes of operation before the onset of inability to operate those loads.

AP1000 References:

IDS-E8-001

ESBWR References:

DCD Tier 2, Chap. 8, Rev. 3, Section 8.3.2.1

Initiating Condition -- NOTIFICATION OF UNUSUAL EVENT

Inadvertent Criticality.

Operating Mode Applicability:

Cold Shutdown  
Refueling

Example Emergency Action Levels:

AP1000

1. An UNPLANNED sustained positive startup rate.

ESBWR

1. An UNPLANNED SRNM sustained positive period.

**Basis:**

This IC addresses criticality events that occur in Cold Shutdown or Refueling modes such as fuel assembly loading errors (mis-located and mis-oriented). This IC indicates a potential degradation of the level of safety of the plant, warranting a NOUE classification.

Escalation would be by Emergency Director judgment.

*[This condition can be identified using period monitors/startup rate monitor. The term "sustained" is used in order to allow exclusion of expected short term positive periods/startup rates from planned fuel bundle or control rod movements during core alteration. These short term positive periods/startup rates are the result of the increase in neutron population due to subcritical multiplication.]*

AP1000 Reference:

ESBWR References: [TBD]

PMS-J4-020

PMS-J1-003



Initiating Condition -- ALERT

Loss of RCS/RPV Inventory.

Operating Mode Applicability: Cold Shutdown  
Refueling

Example Emergency Action Levels: (1 or 2)

*Note: The Emergency Director should not wait until the applicable time has elapsed, but should declare the event as soon as it is determined that the condition will likely exceed the applicable time.*

AP1000

1. a. Pressurizer level at 12% and lowering on RCS-LT-200

**OR**

- b. RCS Hot Leg level is at 9.7% and lowering as indicated on RCS-LT-160A OR -160B
2. RCS level cannot be monitored for 30 minutes or longer with a loss of RCS/RPV inventory as indicated by unexplained rise in Containment sump level on WLS-LICR-034, WLS-LICR-035, OR WLS-LICR-036.

ESBWR

1. RCS inventory reduced below Level 1 setpoint [218.4 inches (5547 mm) above TAF] on RPV Water Level B21-NBS-LI R604A-D Wide Range for 15 minutes or longer.
2. RCS/RPV level cannot be determined for 30 minutes or longer with a loss of RCS/RPV inventory as indicated by unexplained Drywell Equipment or Floor Drain Sumps level rise on Drywell K10-HCW Sump LE-[TBD] OR Drywell K10-LCW Sump LE-[TBD]

**Basis:**

These thresholds serve as precursors to a loss of ability to adequately cool the fuel. The magnitude of this loss of water indicates that makeup systems have not been effective and may not be capable of preventing further RPV level lowering and potential core uncovering. This condition will result in a minimum classification of Alert. The inability to restore and maintain level after reaching this setpoint would therefore be indicative of a failure of the RCS barrier.

{AP1000 - The RCS Pressurizer level and Hot Leg level setpoints were chosen to indicate that actions must be taken to prevent reaching a level that would cause a loss of RNS cooling. The inability to restore and maintain level after reaching this setpoint would therefore be indicative of a failure of the RCS barrier. The pressurizer level setpoint is 12%, which is the pressurizer level low-2 setpoint. This provides CMT actuation for Core Heat Removal. The hot leg level setpoint is 9.7%, which is the hot leg level low-2 setpoint. This activates ADS 4 and IRWST injection for Core Heat Removal.}

{ESBWR – The Level 1 actuation setpoint was chosen to indicate that those makeup efforts are failing. The inability to restore and maintain level after reaching this setpoint would therefore be indicative of a failure of the RCS barrier.}

## COLD SHUTDOWN/REFUELING SYSTEM MALFUNCTION

*[In cold shutdown the decay heat available to raise RCS temperature during a loss of inventory or heat removal event may be significantly greater than in the refueling mode. Entry into cold shutdown conditions may be attained within hours of operating at power or hours after refueling is completed. Technical Specification 3.9 requires the reactor to be subcritical for greater than {100 hours –AP1000}{24 hours ESBWR} prior to the movement of irradiated fuel.. Thus the heatup threat and therefore the threat to damaging the fuel clad may be lower for events that occur in the refueling mode with irradiated fuel in the RPV].*

If all level indication were to be lost during a loss of RCS inventory event, the operators would need to determine that RPV inventory loss was occurring by observing sump or tank level changes. *[Sump or tank level rise must be evaluated against other potential sources of leakage such as cooling water sources inside the containment to ensure they are indicative of RCS leakage.]*

The 30-minute duration for the loss of level indication was chosen to allow CA1 to be an effective precursor to CS1. This provides time to increase makeup and isolate leakage prior to core uncover. Whether or not the actions in progress will be effective should be apparent within 30 minutes. *[When in Cold Shutdown or Refueling the event can be classified as an Alert due to the significantly reduced decay heat and lower temperature and pressure. This increases the time available to resolve the problem. Significant fuel damage is not expected to occur until after core uncover has occurred as addressed IC CS1. Therefore this EAL meets the definition for an Alert emergency.]*

*[Significant fuel damage is not expected to occur until the core has been uncovered for greater than 1 hour per the analysis referenced in the CGI basis. Therefore this EAL meets the definition for an Alert emergency.]*

If RPV level continues to decrease then escalation to Site Area Emergency will be via CS1 (Loss of RPV Inventory Affecting Core Decay Heat Removal Capability).

AP1000 References:

ESBWR References: [TBD]

RCS-M3 -101  
WLS-M3C-101  
WLS-M3-001  
RCS-M3-001  
PXS-M3-001

Initiating Condition -- ALERT

Inability to Maintain Plant in Cold Shutdown with Irradiated Fuel in the RPV.

Operating Mode Applicability: Cold Shutdown  
Refueling

Example Emergency Action Levels: (1 or 2 or 3)

*Note: The Emergency Director should not wait until the applicable time has elapsed, but should declare the event as soon as it is determined that the condition will likely exceed the applicable time.*

AP1000

1. An UNPLANNED event results in RCS Temperature greater than 200°F as indicated on RCS-TI-135A OR -135B for greater than the specified duration on table.

<b>Table: RCS Reheat Duration Thresholds</b>		
<b>RCS</b>	<b>Containment Closure</b>	<b>Duration</b>
Intact	N/A	60 minutes*
Open	Established	20 minutes*
	Not Established	0 minutes

\* If an RCS heat removal system is in operation within this time frame and RCS temperature is being reduced, the EAL is not applicable.

2. An UNPLANNED event results in RCS Pressure increase greater than 10 psi due to a loss of RCS cooling. (This does not apply in Solid Plant conditions.)

ESBWR

1. An UNPLANNED event results in RCS temperature exceeding 200 degrees F as indicated by any of the following for greater than the specified duration on table:
  - Core Inlet Temperature, C51-TC-[TBD],
  - RWCU Bottom Head Suction Temperature G31-RWCU-SDC-TT-N005, -N006, A-1,B-1 through A-4, B-4
  - RWCU Suction Temperature G31-RWCU-SDC-TT-N001, -N002, A-1, B-1 through A-4, B-4

<b>Table: RCS Reheat Duration Thresholds</b>		
<b>RCS</b>	<b>REACTOR BUILDING ISOLATION</b>	<b>Duration</b>
Intact	N/A	60 minutes*
Open	Established	20 minutes*
	Not Established	0 minutes

\* If an RCS heat removal system is in operation within this time frame and RCS temperature is being reduced, the EAL is not applicable.

2. An UNPLANNED event results in RCS Pressure increase greater than 10 psi due to a loss of RCS cooling.

## COLD SHUTDOWN/REFUELING SYSTEM MALFUNCTION

Basis:

For Threshold 1, the RCS Reheat Duration Threshold table addresses complete loss of functions required for core cooling for greater than 60 minutes during refueling and cold shutdown modes when RCS integrity is established. *[RCS integrity should be considered to be in place when the RCS pressure boundary is in its normal condition for the cold shutdown mode of operation (e.g., no freeze seals or nozzle dams). The status of CONTAINMENT CLOSURE in this condition is immaterial given that the RCS is providing a high pressure barrier to fission product release to the environment.]* The 60 minute time frame should allow sufficient time to restore cooling without there being a substantial degradation in plant safety.

The RCS Reheat Duration Threshold table also addresses the complete loss of functions required for core cooling for greater than 20 minutes during refueling and cold shutdown modes when CONTAINMENT CLOSURE is established but RCS integrity is not established. *[As discussed above, RCS integrity should be assumed to be in place when the RCS pressure boundary is in its normal condition for the cold shutdown mode of operation (e.g., no freeze seals or nozzle dams).]* The allowed 20 minute time frame was included to allow operator action to restore the heat removal function, if possible. *[The allowed time frame is consistent with the guidance provided by Generic Letter 88-17, "Loss of Decay Heat Removal" (discussed later in this basis) and is believed to be conservative given that a low pressure Containment barrier to fission product release is established.]*

Finally, complete loss of functions required for core cooling during refueling and cold shutdown modes when neither CONTAINMENT CLOSURE nor RCS integrity are established. *[RCS integrity is in place when the RCS pressure boundary is in its normal condition for the cold shutdown mode of operation (e.g., no freeze seals or nozzle dams). No delay time is allowed because the evaporated reactor coolant that may be released into the Containment during this heatup condition could also be directly released to the environment.]*

The note (\*) indicates that this EAL is not applicable if actions are successful in restoring an RCS heat removal system to operation and RCS temperature is being reduced within the specified time frame.

In Threshold 2, the 10 psi pressure increase covers situations where, due to high decay heat loads, the time provided to restore temperature control, should be less than 60 minutes. The RCS pressure setpoint chosen should be 10 psi or the lowest pressure that the site can read on installed Control Board instrumentation that is equal to or greater than 10 psi.

Escalation to Site Area would be via CS1 should boiling result in significant RPV level loss leading to core uncover.

*[AP1000 - this IC and its associated EALs are based on concerns raised by Generic Letter 88-17, "Loss of Decay Heat Removal." A number of phenomena such as pressurization, vortexing, steam generator U-tube draining, RCS level differences when operating at a mid-loop condition, decay heat removal system design, and level instrumentation problems can lead to conditions where decay heat removal is lost and core uncover can occur. NRC analyses show that there are sequences that can cause core uncover in 15 to 20 minutes and severe core damage within an hour after decay heat removal is lost.]*

A loss of Technical Specification components alone is not intended to constitute an Alert. The same is true of a momentary UNPLANNED excursion above the Technical Specification cold shutdown temperature limit when the heat removal function is available.

The Emergency Director must remain alert to events or conditions that lead to the conclusion that exceeding the EAL threshold is IMMINENT. If, in the judgment of the Emergency Director, an IMMINENT situation is at hand, the classification should be made as if the threshold has been exceeded.

## COLD SHUTDOWN/REFUELING SYSTEM MALFUNCTION

AP1000 References:

RCS-M3C-101

RCS-M3-001

PXS-M3-001

RNS-M3-001

ESBWR References: [TBD]

COLD SHUTDOWN/REFUELING SYSTEM MALFUNCTION

**CS1**

Initiating Condition -- SITE AREA EMERGENCY

Loss of RCS/RPV Inventory Affecting Core Decay Heat Removal Capability.

Operating Mode Applicability: Cold Shutdown  
Refueling

Example Emergency Action Levels: (1 or 2 or 3)

*Note: The Emergency Director should not wait until the applicable time has elapsed, but should declare the event as soon as it is determined that the condition will likely exceed the applicable time.*

AP1000

1. WITH CONTAINMENT CLOSURE NOT established:

RPV level less than Lo-2 (3 inches above the inside surface of the bottom of the Hot Leg) on RCS LT-160A or -160B

**OR**

2. With CONTAINMENT CLOSURE established

RCS LT-160A or LT-160B Offscale low

**OR**

3. RPV level cannot be monitored for 60 minutes or longer with a loss of RPV inventory as indicated by:

- Containment radiation monitor reading GREATER THAN [TBD] rad/hr on PXS-JE-RE-160, -161, -162, OR -163
- Unexplained containment sump level rise on WLS-LICR-034, WLS-LICR-035, OR WLS-LICR-036
- Erratic Source Range Monitor Indication

## COLD SHUTDOWN/REFUELING SYSTEM MALFUNCTION

### ESBWR

1. WITH REACTOR BUILDING ISOLATION NOT established:

RPV level less than Level 0.5 Setpoint [39.4 inches (1000 mm) above TAF] on B21-NBS-LI-R615A-D

### OR

2. With REACTOR BUILDING ISOLATION established

RPV level less than Level 0 Setpoint [0 inches (0 mm)] on B21-NBS-LI-R615A-D

### OR

3. RPV level cannot be monitored for 60 minutes or longer with a loss of RPV inventory as indicated by unexplained Drywell Equipment or Floor Drain Sumps level rise on Drywell K10-HCW Sump LE-[TBD] OR Drywell K10-LCW Sump LE-[TBD]

### Basis:

Under the conditions specified by this IC, continued lowering in RPV level is indicative of a loss of inventory control. Inventory loss may be due to an RPV breach, pressure boundary leakage, or continued boiling in the RPV.

*[In cold shutdown the decay heat available to raise RCS temperature during a loss of inventory or heat removal event may be significantly greater than in the refueling mode. Entry into cold shutdown conditions may be attained within hours of operating at power or hours after refueling is completed. Technical Specification 3.9 requires the reactor to be subcritical for greater than {100 hours –AP1000}{24 hours ESBWR} prior to the movement of irradiated fuel. Thus the heatup threat and therefore the threat to damaging the fuel clad may be lower for events that occur in the refueling mode with irradiated fuel in the RPV.]*

*{AP1000 – For 1.a, the lowest observable level is used. ESBWR – For 1.a, the lowest level above the fuel is used.}*

The 60-minute duration allows sufficient time for actions to be performed to recover needed cooling equipment and is considered to be conservative.

Declaration of a Site Area Emergency is warranted under the conditions specified by the IC. Escalation to a General Emergency is via CG1 (Loss of RPV Inventory Affecting Fuel Clad Integrity with Containment Challenged with Irradiated Fuel in the RPV) or radiological effluent IC AG1 (Off-site Dose Resulting from an Actual or IMMINENT Release of Gaseous Radioactivity Exceeds 1000 mrem TEDE or 5000 mrem Thyroid CDE for the Actual or Projected Duration of the Release Using Actual Meteorology).

AP1000 References:

ESBWR References: [TBD]

APP-RCS-M3C-101

Tech Specs 3.4.12, 3.4.13, 3.5.3,  
3.5.5 and 3.5.7

## COLD SHUTDOWN/REFUELING SYSTEM MALFUNCTION

**CG1**

Initiating Condition -- GENERAL EMERGENCY

Loss of RPV Inventory Affecting Fuel Clad Integrity with Containment Challenged.

Operating Mode Applicability: Cold Shutdown  
Refueling

Example Emergency Action Level:

*Note: The Emergency Director should not wait until the applicable time has elapsed, but should declare the event as soon as it is determined that the condition will likely exceed the applicable time.*

AP1000

1. a. CONTAINMENT challenged as indicated by one or more of the following:
  - CONTAINMENT CLOSURE not established
  - Explosive mixture inside containment
  - Pressure above [TBD] psig value

**AND**

- b. Core uncover 30 minutes or longer as indicated by **EITHER**:
  - RCS LT-160A or LT-160B Offscale low.

**OR**

- CANNOT be monitored with indication of core uncover by ANY of the following:
  - PXS-JE-RE160, -161, -162, -163 radiation monitor reading greater than [TBD] (Hi2 setpoint).
  - Core Exit Thermocouple temperature equal to or greater than [700°F] on [TBD].
  - Erratic Source Range Monitor Indication
  - Unexplained containment sump level rise on WLS-LICR-034, WLS-LICR-035, OR WLS-LICR-036

ESBWR

1. a. CONTAINMENT challenged as indicated by one or more of the following:
  - Explosive mixture inside containment
  - Pressure above [TBD value]
  - REACTOR BUILDING ISOLATION not established
  - Reactor Building radiation monitors above [TBD value]

**AND**

- b. Core uncover for 30 minutes or longer as indicated by **EITHER**:
  - Less than Level 0 Setpoint [0 inches (0 mm)] on B21-NBS-LI-R615A-D.
  - RPV level cannot be monitored with core uncover indicated by EITHER of the following:
    - Drywell Radiation Monitors T62-RMS-RDT-[TBD] reading greater than {site-specific} high setpoint
    - Unexplained Drywell Equipment or Floor Drain Sumps level rise on Drywell K10-HCW Sump LE-[TBD] OR Drywell K10-LCW Sump LE-[TBD]



## COLD SHUTDOWN/REFUELING SYSTEM MALFUNCTION

Basis:

*[In the cold shutdown mode, normal RCS level and RPV level instrumentation systems will normally be available to detect inventory loss. However, if all level indication were to be lost during a loss of RCS inventory event, the operators would need to determine that RPV inventory loss was occurring by observing other indications.]*

These conditions represent the inability to restore and maintain RPV level to above the top of active fuel. Fuel damage is probable if RPV level cannot be restored, as available decay heat will cause boiling, further reducing the RPV level. With the CONTAINMENT breached or challenged then the potential for unmonitored fission product release to the environment is high. This represents a direct path for radioactive inventory to be released to the environment. This is consistent with the definition of a GE. The GE is declared on the occurrence of the loss or IMMEDIATE loss of function of all three barriers.

*[These conditions are based on concerns raised by Generic Letter 88-17, Loss of Decay Heat Removal, SECY 91-283, Evaluation of Shutdown and Low Power Risk Issues, NUREG-1449, Shutdown and Low-Power Operation at Commercial Nuclear Power Plants in the United States, and, NUMARC 91-06, Guidelines for Industry Actions to Assess Shutdown Management.]*

Analysis indicates that core damage may occur within an hour following continued core uncovering therefore, conservatively, 30 minutes was chosen.

If CONTAINMENT CLOSURE is re-established prior to exceeding the 30 minute core uncovering time limit then escalation to GE would not occur.

*[In the cold shutdown mode, normal RCS level and RPV level instrumentation systems will normally be available to detect decreasing RPV water level. However, if all level indication were to be lost during a loss of RCS inventory event, the operators would need to determine that RPV inventory loss was occurring by observing sump or tank level changes.]*

*[In the refueling mode, normal means of RPV level indication may not be available. Redundant means of RPV level indication will be normally installed (including the ability to monitor level visually) to assure that the ability to monitor level will not be interrupted. However, if all level indication were to be lost during a loss of RCS inventory event, the operators would need to determine that RPV inventory loss was occurring by observing sump or tank level changes.]*

Sump or tank level rise must be evaluated against other potential sources of leakage such as cooling water sources inside the containment to ensure they are indicative of RCS leakage.

As water level in the RPV lowers, the dose rate above the core will increase. The dose rate due to this core shine should result in up-scaled radiation monitor indication and possible alarm. *[Calculations should be performed to conservatively estimate a site-specific dose rate setpoint indicative of core uncovering (ie...level at TOAF)].* Additionally, post-TMI studies indicated that the installed nuclear instrumentation will operate erratically when the core is uncovered *[and that this should be used as a tool for making such determinations].*

The GE is declared on the occurrence of the loss or IMMEDIATE loss of function of all three barriers. *[Based on the above discussion, ]*RCS barrier failure resulting in core uncovering for 30 minutes or more may cause fuel clad failure. With the CONTAINMENT breached or challenged then the potential for unmonitored fission product release to the environment is high. This represents a direct path for radioactive inventory to be released to the environment. This is consistent with the definition of a GE.

## COLD SHUTDOWN/REFUELING SYSTEM MALFUNCTION

*[CONTAINMENT CLOSURE/REACTOR BUILDING ISOLATION is the action taken to secure containment and its associated structures, systems, and components as a functional barrier to fission product release under existing plant conditions. CONTAINMENT CLOSURE/REACTOR BUILDING ISOLATION should not be confused with containment integrity as defined in Technical Specifications. Site shutdown contingency plans typically provide for re-establishing CONTAINMENT CLOSURE/REACTOR BUILDING ISOLATION following a loss of heat removal or RCS inventory functions.]*

### AP1000 References:

APP-PXS-M3C-101  
APP-PXS-M3-001  
Tech Specs 3.4.12, 3.4.13, 3.5.3,  
3.5.5, 3.5.7 and 3.5.8

### ESBWR References: [TBD]

DCD Tier 2, Chapter 7, Sect. 7.3.3.2, Table 7.3-5  
Rev. 3  
DCD Tier 2, Chapter 16, Sections 3.1.2, 3.3.1.6,  
3.4.3, 3.6.3.1, Rev. 3  
DCD Tier 2, Chapter 16, Sect. B.3.6.1.1, Rev. 3

## FISSION PRODUCT BARRIERS

### 5.7 FISSION PRODUCT BARRIER DEGRADATION EALs

**Table 5-F-1: Recognition Category “F” Initiating Condition Matrix**

See Table 5-F-2 for BWR Thresholds

See Table 5-F-3 for PWR Thresholds

<b>GENERAL EMERGENCY</b>	<b>SITE AREA EMERGENCY</b>	<b>ALERT</b>	<b>NOUE</b>
<b>FG1</b> Loss of ANY Two Barriers <u>AND</u> Loss or Potential Loss of Third Barrier <i>Op. Modes: Power Operation, Hot                      Standby, Startup, Safe/Stable                      Shutdown</i>	<b>FS1</b> Loss or Potential Loss of ANY Two Barriers <i>Op. Modes: Power Operation, Hot                      Standby, Startup, Safe/Stable                      Shutdown</i>	<b>FA1</b> ANY Loss or ANY Potential Loss of EITHER Fuel Clad <u>OR</u> RCS <i>Op. Modes: Power Operation, Hot                      Standby, Startup, Safe/Stable                      Shutdown</i>	<b>FU1</b> ANY Loss or ANY Potential Loss of Containment <i>Op. Modes: Power Operation, Hot                      Standby, Startup, Safe/Stable                      Shutdown</i>

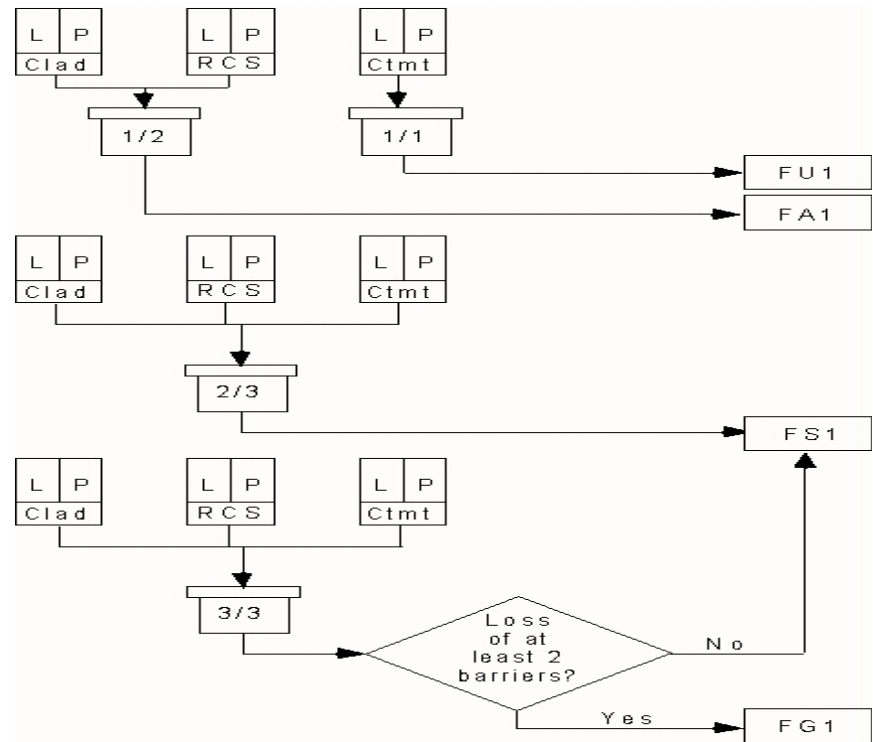

Note: The logic flow diagram is for use by developers and is not required for site specific implementation.

## FISSION PRODUCT BARRIERS

### NOTES

1. The logic used for these initiating conditions reflects the following considerations:
  - The Fuel Clad Barrier and the RCS Barrier are weighted more heavily than the Containment Barrier (See Sections 3.4 and 3.8). NOUE ICs associated with RCS and Fuel Clad Barriers are addressed under System Malfunction ICs.
  - At the Site Area Emergency level, there must be some ability to dynamically assess how far present conditions are from the threshold for a General Emergency. For example, if Fuel Clad and RCS Barrier “Loss” EALs existed, that, in addition to off-site dose assessments, would require continual assessments of radioactive inventory and containment integrity. Alternatively, if both Fuel Clad and RCS Barrier “Potential Loss” EALs existed, the Emergency Director would have more assurance that there was no immediate need to escalate to a General Emergency.
  - The ability to escalate to higher emergency classes as an event deteriorates must be maintained. For example, RCS leakage steadily increasing would represent an increasing risk to public health and safety.
  - The Containment Barrier should not be declared lost or potentially lost based on exceeding Technical Specification action statement criteria, unless there is an event in progress requiring mitigation by the Containment barrier. When no event is in progress (Loss or Potential Loss of either Fuel Clad and/or RCS) the Containment Barrier status is addressed by Technical Specifications.

**Table 5-F-2: BWR EAL Fission Product Barrier Table  
Thresholds For LOSS or POTENTIAL LOSS of Barriers\***

\*Determine which combination of the three barriers are lost or have a potential loss and use the following key to classify the event. Also, multiple events could occur which result in the conclusion that exceeding the loss or Potential loss thresholds is IMMIDENT. In this IMMIDENT loss situation use judgment and classify as if the thresholds are exceeded.

<b>GENERAL EMERGENCY</b>	<b>SITE AREA EMERGENCY</b>	<b>ALERT</b>	<b>UNUSUAL EVENT</b>
Loss of ANY two Barriers AND Loss or Potential Loss of Third Barrier	Loss or Potential Loss of ANY two Barriers	ANY loss or ANY Potential Loss of EITHER Fuel Clad or RCS	ANY loss or ANY Potential Loss of Containment

<u>Fuel Clad Barrier Threshold Values</u>		<u>RCS Barrier Threshold Values</u>		<u>Containment Barrier Threshold Values</u>	
LOSS	POTENTIAL LOSS	LOSS	POTENTIAL LOSS	LOSS	POTENTIAL LOSS

<u><b>1. Primary Coolant Activity Level</b></u> 1. Primary coolant activity greater than [300 uCi/gm]		<u><b>1. Primary Containment Pressure</b></u> 1. Primary containment pressure greater than 1.85 psig on T62-CMS-PI-[TDB]-A-D due to RCS leakage		<u><b>1. Primary Containment Conditions</b></u> 1. Primary containment pressure rise followed by a rapid unexplained drop in primary containment pressure <b>OR</b> 2. Primary containment pressure response not consistent with LOCA conditions	
<b>OR</b>		<b>OR</b>		<b>OR</b>	
<u><b>2. Reactor Vessel Water Level</b></u> 1. RPV water level cannot be restored and maintained above Post Accident Monitor Fuel Zone Range 0 inches (0 mm) B21-LI-R615A-D		<u><b>2. Reactor Vessel Water Level</b></u> 1. RPV water level cannot be restored and maintained above Level 0.5 Setpoint Post Accident Monitor Fuel Zone Range 39.4 inches (1000 mm) B21- LI-R615A-D		<u><b>2. Reactor Vessel Water Level</b></u> Not Applicable	
<b>OR</b>		<b>OR</b>		<b>OR</b>	
<u><b>3. Not Applicable</b></u> Not applicable		<u><b>3. RCS Leak Rate</b></u> 1. Unisolable Main Steamline Break as indicated by: Failure of both valves in any one line to close <b>AND</b> 1a. Steamline High Flow greater than 140% rated <b>OR</b> 1b. Main Steam Line Low Pressure less than 750 psig <b>OR</b> 1c. Main Steam Tunnel Ambient Temperature greater than [TBD]		1. RCS leak greater than 100 gpm in the drywell. <b>OR</b> 2. Unisolable primary system leakage outside primary containment as indicated by exceeding EITHER of the following: 2a. Max Safe Operating Temperature. <b>OR</b> 2b. Max Safe Area Radiation.	
<b>OR</b>		<b>OR</b>		<b>OR</b>	
Not applicable		<u><b>2. Automatic Depressurization System automatically OR manually initiated.</b></u>		<u><b>3. Primary Containment Isolation Failure or Bypass</b></u> 1. Failure of all valves in any one line to close <b>AND</b> direct downstream pathway to the environment exists after a primary containment isolation signal <b>OR</b> 2. Intentional primary containment venting per EOPs <b>OR</b> 3. Unisolable primary system leakage outside Containment as indicated by exceeding EITHER of the following: 3a. Max Safe Operating Temperature. <b>OR</b> 3b. Max Safe Area Radiation.	
<b>OR</b>		<b>OR</b>		<b>OR</b>	
Not applicable		Not applicable		1. Feedline break as indicated by: [TBD]	

**Table 5-F-2: BWR EAL Fission Product Barrier Table  
Thresholds For LOSS or POTENTIAL LOSS of Barriers\***

\*Determine which combination of the three barriers are lost or have a potential loss and use the following key to classify the event. Also, multiple events could occur which result in the conclusion that exceeding the loss or Potential loss thresholds is IMMEDIATE. In this IMMEDIATE loss situation use judgment and classify as if the thresholds are exceeded.

<b>GENERAL EMERGENCY</b> Loss of ANY two Barriers AND Loss or Potential Loss of Third Barrier	<b>SITE AREA EMERGENCY</b> Loss or Potential Loss of ANY two Barriers	<b>ALERT</b> ANY loss or ANY Potential Loss of EITHER Fuel Clad or RCS	<b>UNUSUAL EVENT</b> ANY loss or ANY Potential Loss of Containment
---	--	--	---

<u>Fuel Clad Barrier Threshold Values</u>		<u>RCS Barrier Threshold Values</u>		<u>Containment Barrier Threshold Values</u>	
LOSS	POTENTIAL LOSS	LOSS	POTENTIAL LOSS	LOSS	POTENTIAL LOSS
<b><u>4. Primary Containment Radiation Monitoring</u></b>		<b><u>4. Primary Containment Radiation Monitoring</u></b>		<b><u>4. Primary Containment Radiation Monitoring</u></b>	
1. Primary containment radiation monitor reading greater than (5% clad failure dispersed in the drywell) R/hr on [TBD]	Not Applicable	1. Primary containment radiation monitor reading greater than (normal operating chemistry dispersed in the drywell) R/hr on [TBD]	Not Applicable	Not applicable	1. Primary containment radiation monitor reading greater than (20% clad failure dispersed in the drywell) R/hr on [TBD]
OR		OR		OR	
<b><u>5. Other (Site-Specific) Indications</u></b>		<b><u>5. Other (Site-Specific) Indications</u></b>		<b><u>5. Other (site-specific) Indications</u></b>	
1. [MSL Rad Monitors Drywell Fission Product Monitor – TBD]	(Site specific) as applicable	(Site specific) as applicable	(Site specific) as applicable	(Site specific) as applicable	(Site specific) as applicable
OR		OR		OR	
<b><u>6. Emergency Director Judgment</u></b>		<b><u>6. Emergency Director Judgment</u></b>		<b><u>6. Emergency Director Judgment</u></b>	
1. Any condition in the judgment of the Emergency Director that indicates Loss or Potential Loss of the Fuel Clad Barrier		1. Any condition in the judgment of the Emergency Director that indicates Loss or Potential Loss of the RCS Barrier		1. Any condition in the judgment of the Emergency Director that indicates Loss or Potential Loss of the Containment barrier	

## FISSION PRODUCT BARRIERS

### Basis Information For Table 5-F-2 ESBWR Emergency Action Level Fission Product Barrier Reference Table

#### **FUEL CLAD BARRIER THRESHOLDS:** (1 or 2 or 3 or 4 or 5 or 6)

##### **1. Primary Coolant Activity Level**

This (site-specific) value corresponds to 300  $\mu\text{Ci/gm}$  I-131 equivalents. Assessment by the EAL Task Force indicates that this amount of coolant activity is well above that expected for iodine spikes and corresponds to less than 5% fuel clad damage. [*This amount of radioactivity indicates significant clad damage and thus the Fuel Clad Barrier is considered lost. The value expressed can be either in mR/hr observed on the sample or as uCi/gm results from analysis.*]

There is no potential loss associated with this condition.

##### **2. Reactor Vessel Water Level**

The "Loss" value is the top of active fuel which is used in EOPs to indicate challenge of core cooling. This is the minimum value to assure core cooling without further degradation of the clad.

Level 0.5 corresponds to a water level 39.4 inches above the top of the active fuel. The "Potential Loss" Threshold is the same as the RCS barrier "Loss" Threshold #2. Thus, this Threshold indicates a "Loss" of RCS barrier and a "Potential Loss" of the Fuel Clad Barrier. This Threshold appropriately escalates the emergency class to a Site Area Emergency.

##### **3. Not applicable**

##### **4. Primary Containment Radiation Monitoring**

The (site-specific) reading is a value which indicates the release of reactor coolant, with elevated activity indicative of fuel damage, into the drywell. [*The reading should be calculated assuming the instantaneous release and dispersal of the reactor coolant noble gas and iodine inventory associated with a concentration of 300  $\mu\text{Ci/gm}$  dose equivalent I-131 or the calculated concentration equivalent to the clad damage used in Threshold #1 into the drywell atmosphere. Reactor coolant concentrations of this magnitude are several times larger than the maximum concentrations (including iodine spiking) allowed within Technical Specifications and are therefore indicative of fuel damage. This value is greater than that specified for RCS barrier Loss Threshold #4. Thus, this Threshold indicates a loss of both Fuel Clad barrier and RCS barrier that appropriately escalates the emergency classification level to a Site Area Emergency..*]

[**Caution:** *it is important to recognize that in the event the radiation monitor is sensitive to shine from the reactor vessel or piping, spurious readings will be present and another indicator of fuel clad damage is necessary or compensated for in the threshold value.*]

There is no potential loss associated with this condition.

##### **5. Other (Site-Specific) Indications**

Main Steam Line Monitors and the Drywell Fission Product Monitor at the specified values are indicative of fuel clad failure.

##### **6. Emergency Director Judgment**

## FISSION PRODUCT BARRIERS

This Threshold addresses any other factors that are to be used by the Emergency Director in determining whether the Fuel Clad barrier is lost or potentially lost. In addition, the inability to monitor the barrier should also be incorporated in this Threshold as a factor in Emergency Director judgment that the barrier may be considered lost or potentially lost. (See also IC SG1, " Prolonged Loss of All Off-site and On-site AC Power for greater than 72 hours.", for additional information.)

### **RCS BARRIER THRESHOLDS: (1 or 2 or 3 or 4 or 5 or 6)**

The RCS Barrier is the reactor coolant system pressure boundary and includes the reactor vessel and all reactor coolant system piping up to the isolation valves.

#### **1. Primary Containment Conditions**

1.85 psig drywell pressure is based on the drywell high pressure set point which indicates a LOCA.

There is no potential loss associated with this condition.

#### **2. Reactor Vessel Water Level**

*[This "Loss" Threshold is the same as "Potential Loss" Fuel Clad Barrier Threshold #2. The water level corresponds to the level which is used in EOPs to indicate challenge of core cooling.]* Level 0.5 corresponds to a water level 39.4 inches above the top of the active fuel. *[This Threshold appropriately escalates the emergency class to a Site Area Emergency. Thus, this Threshold indicates a loss of the RCS barrier and a Potential Loss of the Fuel Clad Barrier.]*

There is no potential loss associated with this condition.

#### **3. RCS Leak Rate**

An unisolable MSL break is a breach of the RCS barrier. Thus, this Threshold is included for consistency with the Alert emergency classification. Automatic Depressurization System automatically or manually initiated indicates a breach of the RCS.

The potential loss of RCS based on leakage is set at a level indicative of a breach of the RCS but which is well within the makeup capability of the CRD high pressure injection. Core uncover is not a significant concern for a 100 gpm leak, however, break propagation leading to significantly larger loss of inventory is possible.

Potential loss of RCS based on primary system leakage outside the drywell is determined from site-specific temperature or area radiation Max Normal setpoints in the areas of the plant which indicate a direct path from the RCS to areas outside primary containment. The indicators should be confirmed to be caused by RCS leakage. *[An unisolable leak which is indicated by a high alarm setpoint escalates to a Site Area Emergency when combined with Containment Barrier Threshold 3 (after a containment isolation) and a General Emergency when the Fuel Clad Barrier criteria is also exceeded.]*

#### **4. Primary Containment Radiation Monitoring**

The (site-specific) reading is a value which indicates the release of reactor coolant to the drywell. *[The reading should be calculated assuming the instantaneous release and dispersal of the reactor coolant noble gas and iodine inventory associated with normal operating concentrations (i.e., within T/S) into the drywell atmosphere. This reading will be less than that specified for Fuel Clad Barrier Threshold #4. Thus, this*



## FISSION PRODUCT BARRIERS

*Threshold would be indicative of a RCS leak only. If the radiation monitor reading increased to that value specified by Fuel Clad Barrier Threshold #4, fuel damage would also be indicated.]*

There is no potential loss associated with this condition.

### **5. Other (Site-Specific) Indications**

This Threshold addresses other (site-specific) indications that may indicate loss or potential loss of the RCS barrier.

### **6. Emergency Director Judgment**

This Threshold addresses any other factors that are to be used by the Emergency Director in determining whether the RCS barrier is lost or potentially lost. In addition, the inability to monitor the barrier should also be incorporated in this Threshold as a factor in Emergency Director judgment that the barrier may be considered lost or potentially lost. (See also IC SG1, " Prolonged Loss of All Off-site and On-site AC Power for greater than 72 hours.", for additional information.)

### **PRIMARY CONTAINMENT BARRIER THRESHOLDS: (1 or 2 or 3 or 4 or 5 or 6)**

The Primary Containment Barrier includes the drywell, the wetwell, their respective interconnecting paths, and other connections up to and including the outermost containment isolation valves. Containment Barrier Thresholds are used primarily as discriminators for escalation from an Alert to a Site Area Emergency or a General Emergency.

#### **1. Primary Containment Conditions**

Rapid unexplained loss of pressure (i.e., not attributable to drywell spray or condensation effects) following an initial pressure increase indicates a loss of containment integrity. [*Drywell pressure should increase as a result of mass and energy release into containment from a LOCA. Thus, drywell pressure not increasing under these conditions indicates a loss of containment integrity. This indicator relies on the operator's recognition of an unexpected response for the condition and therefore does not have a specific value associated. The unexpected response is important because it is the indicator for a containment bypass condition.*] The 45 psig for potential loss of containment is based on the primary containment design pressure. Existence of an explosive mixture means hydrogen and oxygen concentration of at least the lower deflagration limit curve exists.

The Heat Capacity Temperature Limit (HCTL) is the highest suppression pool temperature from which Emergency RPV Depressurization will not raise:

- Suppression chamber temperature above the maximum temperature capability of the suppression chamber and equipment within the suppression chamber which may be required to operate when the RPV is pressurized,
- Suppression chamber pressure above Primary Containment Pressure Limit A, while the rate of energy transfer from the RPV to the containment is greater than the capacity of the containment vent.

The HCTL is a function of RPV pressure and suppression pool water level. It is utilized to preclude failure of the containment and equipment in the containment necessary for the safe shutdown of the plant and therefore, the inability to maintain plant parameters below the limit constitutes a potential loss of containment.

#### **2. Reactor Vessel Water Level**

## FISSION PRODUCT BARRIERS

There is no loss threshold associated with this condition.

The entry into the Primary Containment Flooding emergency procedure indicates reactor vessel water level can not be restored and that a core melt sequence is in progress. [*Severe Accident Guidelines (SAG)s direct the operators to enter Containment Flooding when Reactor Vessel Level cannot be restored to greater than TAF or is unknown.*] Entry into Containment Flooding procedures is a logical escalation in response to the inability to maintain reactor vessel level.

The conditions in this potential loss Threshold represent a potential core melt sequences which, if not corrected, could lead to vessel failure and increased potential for containment failure. [*In conjunction with and an escalation of the level Thresholds in the Fuel and RCS barrier columns, this Threshold will result in the declaration of a General Emergency -- loss of two barriers and the potential loss of a third.*]

### **3. Containment Isolation Failure or Bypass**

This Threshold addresses the inability to isolate the containment when containment isolation is required. Also, an intentional venting of primary containment for pressure control per EOPs to the environment is considered a loss of containment. Containment venting for temperature or pressure when not in an accident situation should not be considered. In addition, the presence of area radiation or temperature alarms high setpoint indicating unisolable primary system leakage outside the drywell are covered after a containment isolation. The indicators should be confirmed to be caused by RCS leakage.

The use of the modifier “direct” in defining the release path discriminates against release paths through interfacing liquid systems. The existence of an in-line charcoal filter does not make a release path indirect since the filter is not effective at removing fission noble gases. [*Typical filters have an efficiency of 95-99% removal of iodine. Given the magnitude of the core inventory of iodine, significant releases could still occur. In addition, since the fission product release would be driven by boiling in the reactor vessel, the high humidity in the release stream can be expected to render the filters ineffective in a short period.*]

### **4. Containment Radiation Monitoring**

There is no loss associated with this condition.

The (site-specific) reading is a value which indicates significant fuel damage well in excess of that required for loss of RCS and Fuel Clad. A major release of radioactivity requiring off-site protective actions from core damage is not possible unless a major failure of fuel cladding allows radioactive material to be released from the core into the reactor coolant. Regardless of whether containment is challenged, this amount of activity in containment, if released, could have such severe consequences that it is prudent to treat this as a potential loss of containment, such that a General Emergency declaration is warranted. [*NUREG-1228, "Source Estimations During Incident Response to Severe Nuclear Power Plant Accidents," indicates that such conditions do not exist when the amount of clad damage is less than 20%. Unless there is a (site-specific) analysis justifying a higher value, it is recommended that a radiation monitor reading corresponding to 20% fuel clad damage be specified here.*]

### **5. Other (Site-Specific) Indications**

This Threshold addresses other (site-specific) indications that may indicate loss or potential loss of the containment barrier.

### **6. Emergency Director Judgment**

This Threshold addresses any other factors that are to be used by the Emergency Director in determining whether the Containment barrier is lost or potentially lost. In addition, the inability to monitor the barrier

## FISSION PRODUCT BARRIERS

should also be incorporated in this Threshold as a factor in Emergency Director judgment that the barrier may be considered lost or potentially lost. The Containment Barrier should not be declared lost or potentially lost based on exceeding Technical Specification Action Statement criteria, unless there is an event in progress requiring mitigation by the Containment barrier. When no event is in progress (Loss or Potential Loss of either Fuel Clad and/or RCS) the Containment Barrier status is addressed by Technical Specifications. (See also IC SG1, " Prolonged Loss of All Off-site and On-site AC Power for greater than 72 hours.", for additional information.)

**Table 5-F-3: PWR EAL Fission Product Barrier Reference Table  
Thresholds For LOSS or POTENTIAL LOSS of Barriers\***

\*Determine which combination of the three barriers are lost or have a potential loss and use the following key to classify the event. Also, multiple events could occur which result in the conclusion that exceeding the loss or Potential loss thresholds is IMMEDIATE. In this IMMEDIATE loss situation use judgment and classify as if the thresholds are exceeded.

<b>GENERAL EMERGENCY</b> Loss of ANY two Barriers AND Loss or Potential Loss of Third Barrier	<b>SITE AREA EMERGENCY</b> Loss or Potential Loss of ANY two Barriers	<b>ALERT</b> ANY loss or ANY Potential Loss of EITHER Fuel Clad or RCS	<b>UNUSUAL EVENT</b> ANY loss or ANY Potential Loss of Containment
---	--	--	---

<b>Fuel Clad Barrier Threshold Values</b>		<b>RCS Barrier Threshold Values</b>		<b>Containment Barrier Threshold Values</b>	
<b>LOSS</b>	<b>POTENTIAL LOSS</b>	<b>LOSS</b>	<b>POTENTIAL LOSS</b>	<b>LOSS</b>	<b>POTENTIAL LOSS</b>
<b><u>1. Critical Safety Function Status</u></b>		<b><u>1. Critical Safety Function Status</u></b>		<b><u>1. Critical Safety Function Status</u></b>	
Core-Cooling Red Entry Conditions Met	Core Cooling-Orange Entry Conditions Met <u>OR</u> Heat Sink-Red Entry Conditions Met	Not Applicable	RCS Integrity-Red Entry Conditions Met <u>OR</u> Heat Sink-Red Entry Conditions Met	Not Applicable	Containment-Red Entry Conditions Met
<b>OR</b>		<b>OR</b>		<b>OR</b>	
<b><u>2. Primary Coolant Activity Level</u></b>		<b><u>2. RCS Leak Rate</u></b>		<b><u>2. Containment Pressure</u></b>	
Dose Equivalent [300 μCi/gm I-131 <u>OR</u> 280 μCi/gm XE-133] as indicated on [Instrument TBD]	Not Applicable	RCS leak rate greater than available makeup capacity as indicated by RCS subcooling less than 30 degrees on [TBD]	RCS leak rate greater than 135 gpm on [TBD] with Letdown isolated	A containment pressure rise followed by a rapid unexplained drop in containment pressure. <u>OR</u> Containment pressure or sump level response not consistent with LOCA or MSL break conditions	59 psig and rising on PCS-PI- 012, PCS-PI-013 or PCS-PI- 014 <u>OR</u> 4% H <sub>2</sub> on VLS-AE001, 002 or 003 <u>OR</u> Containment Pressure Hi/Hi Alarm on PCS-P005, PCS-006 or PCS-007 <u>AND</u> PCS does NOT actuate.
<b>OR</b>		<b>OR</b>		<b>OR</b>	
<b><u>3. Core Exit Thermocouple Readings</u></b>		<b><u>3. Not Applicable</u></b>		<b><u>3. Core Exit Themocouple Reading</u></b>	
Greater than 1200°F	Greater than 700°F	Not applicable	Not applicable	Not applicable	Core exit thermocouples in excess of 1200 °F <u>AND</u> Restoration procedures not effective within 15 minutes <u>AND</u> Stage 4 ADS actuated.
<b>OR</b>		<b>OR</b>		<b>OR</b>	

**Table 5-F-3: PWR EAL Fission Product Barrier Reference Table  
Thresholds For LOSS or POTENTIAL LOSS of Barriers\***

\*Determine which combination of the three barriers are lost or have a potential loss and use the following key to classify the event. Also, multiple events could occur which result in the conclusion that exceeding the loss or Potential loss thresholds is IMMEDIATE. In this IMMEDIATE loss situation use judgment and classify as if the thresholds are exceeded.

<b>GENERAL EMERGENCY</b> Loss of ANY two Barriers AND Loss or Potential Loss of Third Barrier	<b>SITE AREA EMERGENCY</b> Loss or Potential Loss of ANY two Barriers	<b>ALERT</b> ANY loss or ANY Potential Loss of EITHER Fuel Clad or RCS	<b>UNUSUAL EVENT</b> ANY loss or ANY Potential Loss of Containment
---	--	--	---

<u>Fuel Clad Barrier Threshold Values</u>		<u>RCS Barrier Threshold Values</u>		<u>Containment Barrier Threshold Values</u>	
LOSS	POTENTIAL LOSS	LOSS	POTENTIAL LOSS	LOSS	POTENTIAL LOSS
<b><u>4. Reactor Vessel Water Level</u></b>		<b><u>4. SG Tube Rupture</u></b>		<b><u>4. SG Secondary Side Release with P-to-S Leakage</u></b>	
Not Applicable	RCS Hot Leg Level LESS than [9.7%] on RCS-LT-160A or RCS-LT-160B. <b>OR</b> Inventory CSF – Yellow Entry Conditions met	Ruptured S/G results in a CMT/PRHR Actuation	Not Applicable	RUPTURED S/G is also FAULTED outside of containment <b>OR</b> Primary-to-Secondary leakrate greater than 10 gpm with UNISOLABLE steam release from affected S/G to the environment	Not applicable
<b>OR</b>		<b>OR</b>		<b>OR</b>	
<b><u>5. Not Applicable</u></b>		<b><u>5. Not Applicable</u></b>		<b><u>5. CNMT Isolation Failure or Bypass</u></b>	
Not Applicable	Not Applicable	Not Applicable	Not Applicable	Failure of all valves in any one line to close <u>AND</u> direct downstream pathway to the environment exists after CTMT isolation signal	Not Applicable
<b>OR</b>		<b>OR</b>		<b>OR</b>	
<b><u>6. Containment Radiation Monitoring</u></b>		<b><u>6. Containment Radiation Monitoring</u></b>		<b><u>6. Containment Radiation Monitoring</u></b>	
Containment radiation monitor reading greater than [TBD] rad/hr on PXS-JE-RE-160, -161, -162, OR -163	Not Applicable	Containment radiation monitor reading greater than 2 rad/hr on PXS-JE-RE-160, -161, -162, <u>OR</u> -163	Not Applicable	Not Applicable	Containment radiation monitor reading GREATER THAN [TBD] rad/hr on PXS-JE-RE-160, -161, -162, <u>OR</u> -163
<b>OR</b>		<b>OR</b>		<b>OR</b>	
<b><u>7 Other (Site-Specific) Indications</u></b>		<b><u>7. Other (Site-Specific) Indications</u></b>		<b><u>7. Other (site-specific) Indications</u></b>	
(Site specific ) as applicable	(Site specific) as applicable	(Site-specific) as applicable	(Site-specific) as applicable	(Site specific) as applicable	(Site specific) as applicable
<b>OR</b>		<b>OR</b>		<b>OR</b>	
<b><u>8. Emergency Director Judgment</u></b>		<b><u>8. Emergency Director Judgment</u></b>		<b><u>8. Emergency Director Judgment</u></b>	
Any condition in the judgment of the Emergency Director that indicates Loss or Potential Loss of the Fuel Clad Barrier		Any condition in the judgment of the Emergency Director that indicate Loss or Potential Loss of the RCS Barrier		Any condition in the judgment of the Emergency Director that indicates Loss or Potential Loss of the Containment barrier	

## FISSION PRODUCT BARRIERS

### Basis Information For Table 5-F-4 PWR Emergency Action Level Fission Product Barrier Reference Table

#### **FUEL CLAD BARRIER THRESHOLDS:** (1 or 2 or 3 or 4 or 5 or 6 or 7 or 8)

1. Critical Safety Function Status

These Thresholds serve as precursors to a loss of fuel clad. Core cooling orange path indicates subcooling has been lost and that some clad damage may occur. Core cooling red path indicated significant superheating and core uncover and is considered to indicate a loss of the fuel clad. Heat Sink RED when heat sink is required indicates the steam generator heat sink function is under extreme challenge and provides the potential for loss of the fuel clad. Meeting the entry conditions satisfies these thresholds.

2. Primary Coolant Activity Level

This is a site specific value corresponding to 300  $\mu\text{Ci/gm}$  I-131 equivalent or 280  $\mu\text{Ci/gm}$  Xe-133. This amount of radioactivity indicates significant clad damage and the fuel barrier is considered lost.

There is no equivalent Potential Loss for this item.

3. Core Exit Thermocouple Readings

The core exit thermocouples (CETs) provide an adequate measure of core temperatures to estimate temperatures at which potential cladding damage and core over temperature may be occurring. CETs with readings greater than 700 °F indicate the onset of inadequate core cooling. Continued operation in this state can lead to a core damage sequence if Emergency Operating Procedures are not effective in restoring core cooling.

CETs with readings above 1200 °F indicate significant clad heating and the loss of the fuel clad barrier. Core exit thermocouples are included in addition to the Critical Safety Functions to include conditions when the status trees may not be in use.

4. Reactor Vessel Water Level

There is no Loss Threshold corresponding to this item.

The potential loss corresponds to a level 3 inches above the bottom of the Hot Leg. This is defined by the CSFSTs as an Inventory YELLOW path. Meeting the entry conditions satisfies this threshold.

The value for the Potential Loss Threshold corresponds to the 3 inches above the bottom of the Hot Leg. This Potential Loss Threshold is defined by the Inventory YELLOW path.

5. Not Applicable

6. Containment Radiation Monitoring

The reading of 100 rad/hr on PXS-JE-RE160, RE161, RE162 or RE163 is a value which indicates the release of reactor coolant, with elevated activity indicative of fuel damage, into the containment. Use of a confirmed radiation monitoring reading can lead to an earlier Alert classification. A reactivity excursion or mechanical damage may cause fuel damage that is first detected by radiation monitors.

Reactor coolant concentrations of this magnitude are several times larger than the maximum concentrations (including iodine spiking) allowed within Technical Specifications and are therefore indicative of fuel damage.

There is no Potential Loss Threshold associated with this item.

7. Other (Site-Specific) Indications – Not Applicable

## FISSION PRODUCT BARRIERS

### 8. Emergency Director Judgment

The Emergency Director can declare an Alert based on the judgment that conditions exist which indicate the Loss or Potential Loss of the Fuel Cladding barrier. This can take any other factors into consideration including the inability to monitor the barrier.

### **RCS BARRIER THRESHOLDS:** (1 or 2 or 3 or 4 or 5 or 6 or 7 or 8)

#### 1. Critical Safety Function Status

There is no Loss Threshold associated with this item.

These Thresholds serve as precursors to a loss of fuel clad. Heat Sink RED when heat sink is required indicates the steam generator heat sink function is under extreme challenge and provides the potential for loss of the fuel clad. An Integrity RED path indicates an extreme challenge to the safety function and a potential loss of the RCS barrier. Meeting the entry conditions satisfies these thresholds.

#### 2. RCS Leak Rate

The Loss Threshold addresses conditions where leakage from the RCS is greater than available inventory control capacity such that a loss of subcooling has occurred. The loss of subcooling is the fundamental indication that the inventory control systems are inadequate in maintaining RCS pressure and inventory against the mass loss through the leak.

The potential loss is based on the inability to maintain normal liquid inventory within the reactor coolant system by the Chemical and Volume Control System (CVS). Where leakage is greater than available inventory control a loss of subcooling can occur. Isolating letdown is a standard abnormal operating procedure action and may prevent unnecessary classifications when a non-RCS leakage path such as a CVS leak exists. The intent of this condition is met if attempts to isolate Letdown are NOT successful.

#### 3. Not Applicable

#### 4. Steam Generator Tube Rupture (SGTR)

A SGTR is based on the inability to maintain normal liquid inventory within the RCS by normal operation of the CVS system. The loss of the RCS barrier is based on leakage large enough to cause CMT/PRHR actuation.

There is no Potential Loss Threshold for this condition.

#### 5. Not Applicable

#### 6. Containment Radiation Monitoring

The reading of 100 rad/hr on PXS-JE-RE160, RE161, RE162 or RE163 is a value which indicates the release of reactor coolant to the containment. Reactor coolant concentrations of this magnitude are several times larger than the maximum concentrations (including iodine spiking) allowed within Technical Specifications and are therefore indicative of fuel damage.

There is no Potential Loss Threshold associated with this item.

#### 7. Other (Site-Specific) Indications – Not Applicable

#### 8. Emergency Director Judgment

The Emergency Director can declare an Alert based on the judgment that conditions exist which indicate the Loss or Potential Loss of the RCS Barrier. This can take any other factors into consideration including the inability to monitor the barrier.

### **CONTAINMENT BARRIER THRESHOLDS:** (1 or 2 or 3 or 4 or 5 or 6 or 7 or 8)

#### 1. Critical Safety Function Status

## FISSION PRODUCT BARRIERS

There is no Loss Threshold associated with this item.

A Containment RED path indicates an extreme challenge to the safety function derived from appropriate instrument readings and/or sampling results, and thus represents a potential loss of containment. Meeting the entry condition satisfies this threshold.

### 2. Containment Pressure

Rapid unexplained loss of pressure following an initial pressure rise indicates a loss of containment integrity. Containment pressure should increase as a result of mass and energy release into the containment. In addition, containment pressure or sump level response not consistent with design basis accident conditions can also be an indicator of a Loss of containment integrity.

This indicator relies on operator recognition of an unexpected response for the condition and therefore does not have a specific value associated with it. The unexpected response is important because it is the indicator for a containment bypass condition.

Containment Pressure at 45 psig (design pressure) and the existence of an explosive mixture of hydrogen means there is potential for damage to containment. Containment pressure at 6.2 psig or greater indicates the pressure has reached the PCS actuation setpoint. Should the PCS system not actuate at this point, this condition would represent a Potential Loss of Containment. This represents a challenge to containment that requires operation of the containment isolation and pressure suppression systems.

### 3. Core Exit Thermocouples (CETs)

The Core Cooling RED path represents an imminent core melt sequence, which if not corrected, could lead to RPV failure and an increased potential for containment failure. It is appropriate to allow 15 minutes for functional restoration procedures to address the core melt sequence. Whether or not the procedures will be effective should be apparent in 15 minutes. In addition, if the CETs continue to be at or greater than 1200°F for 15 minutes after the ADS Valves have actuated, the conditions in this Potential Loss Threshold represent IMMEDIATE core melt sequences which, if not corrected, could lead to vessel failure and increased potential for containment failure. If the Emergency Operating Procedures have been ineffective in restoring reactor vessel level above the RCS and Fuel Clad barriers, there is not a success path and a core melt sequence is in progress.

### 4. SG Secondary Side Release With Primary To Secondary Leakage

Steam generator tube leakage can represent the bypass of containment and the loss of the RCS barrier. This recognizes the non-isolable release path directly to the environment. The first Loss Threshold addresses the condition in which a RUPTURED steam generator is also FAULTED.

The second loss Threshold addresses SG tube leaks that exceed 10 gpm in conjunction with a UNISOLABLE release path to the environment.

### 5. Containment Isolation Failure or Bypass

The failure of the isolation of a containment penetration allows a direct path to the environment and represents failure of the Containment barrier. The Containment barrier must be considered breached if isolation fails.

### 6. Containment Radiation Monitoring

There is no Loss Threshold associated with this item.

The 100 rad/hr reading is a value which indicates significant fuel damage well in excess of the Thresholds associated with both loss of Fuel Clad and loss of RCS barriers. A major release of radioactivity requiring off-site protective actions from core damage is not possible unless a major failure of fuel cladding allows radioactive material to be released from the core into the reactor coolant.



## FISSION PRODUCT BARRIERS

Regardless of whether containment is challenged, this amount of activity in containment, if released, could have such severe consequences that it is prudent to treat this as a potential loss of containment, such that a General Emergency declaration is warranted. [NUREG-1228, "Source Estimations During Incident Response to Severe Nuclear Power Plant Accidents," indicates that such conditions do not exist when the amount of clad damage is less than 20%. Unless there is a (site-specific) analysis justifying a higher value, it is recommended that a radiation monitor reading corresponding to 20% fuel clad damage be specified here.

7. Other (Site-Specific) Indications – Not Applicable
8. Emergency Director Judgment

The Emergency Director can declare an Alert based on the judgment that conditions exist which indicate the Loss or Potential Loss of the Containment Barrier. This can take any other factors into consideration including the inability to monitor the barrier. The Containment Barrier should not be declared lost or potentially lost based on exceeding Technical Specification Action Statement criteria, unless there is an event in progress requiring mitigation by the Containment barrier. When no event is in progress (Loss or Potential Loss of either Fuel Clad and/or RCS) the Containment Barrier status is addressed by Technical Specifications.

## 5.8 HAZARDS OR OTHER CONDITIONS AFFECTING PLANT SAFETY EALS

**Table 5-H-1: Recognition Category “H” Initiating Condition Matrix**

GENERAL EMERGENCY	SITE AREA EMERGENCY	ALERT	NOUE
		<b>HA1</b> Natural or Destructive Phenomena Affecting VITAL AREAS. <i>Op. Modes: All</i>	<b>HU1</b> Natural or Destructive Phenomena Affecting the PROTECTED AREA. <i>Op. Modes: All</i>
		<b>HA2</b> FIRE or EXPLOSION Affecting the Operability of Plant Safety Systems Required to Establish or Maintain Safe/Stable Shutdown. <i>Op. Modes: All</i>	<b>HU2</b> FIRE Within PROTECTED AREA Boundary Not Extinguished Within 15 Minutes of Detection <u>OR</u> EXPLOSION within the Protected Area Boundary <i>Op. Modes: All</i>
		<b>HA3</b> Access To a VITAL AREA Is Prohibited Due To Release of Toxic, Corrosive, Asphyxiant or Flammable Gases Which Jeopardizes Operation of Systems Required to Maintain Safe Operations or Safely Shutdown the Reactor <i>Op. Modes: All</i>	<b>HU3</b> Release of Toxic, Corrosive, Asphyxiant, or Flammable Gases Deemed Detrimental to NORMAL PLANT OPERATIONS. <i>Op. Modes: All</i>
	<b>HS2</b> Control Room Evacuation Has Been Initiated and Plant Control Cannot Be Established. <i>Op. Modes: All</i>	<b>HA5</b> Control Room Evacuation Has Been Initiated. <i>Op. Modes: All</i>	
<b>HG1</b> HOSTILE ACTION Resulting in Loss Of Physical Control of the Facility. <i>Op. Modes: All</i>	<b>HS4</b> HOSTILE ACTION within the PROTECTED AREA <i>Op. Modes: All</i>	<b>HA4</b> HOSTILE ACTION within the OWNER CONTROLLED AREA or Airborne Attack Threat. <i>Op. Modes: All</i>	<b>HU4</b> Confirmed SECURITY CONDITION or Threat Which Indicates a Potential Degradation in the Level of Safety of the Plant. <i>Op. Modes: All</i>
<b>HG2</b> Other Conditions Existing Which in the Judgment of the Emergency Director Warrant Declaration of a General Emergency. <i>Op. Modes: All</i>	<b>HS3</b> Other Conditions Existing Which in the Judgment of the Emergency Director Warrant Declaration of a Site Area Emergency. <i>Op. Modes: All</i>	<b>HA6</b> Other Conditions Existing Which in the Judgment of the Emergency Director Warrant Declaration of an Alert. <i>Op. Modes: All</i>	<b>HU5</b> Other Conditions Existing Which in the Judgment of the Emergency Director Warrant Declaration of a NOUE. <i>Op. Modes: All</i>

HAZARDS OR OTHER CONDITIONS  
AFFECTING PLANT SAFETY

**HU1**

Initiating Condition -- NOTIFICATION OF UNUSUAL EVENT

Natural or Destructive Phenomena Affecting the PROTECTED AREA.

Operating Mode Applicability: All

Example Emergency Action Level: (1 or 2 or 3 or 4)

1. Seismic event identified by any 2 of the following:
  - Earthquake felt in plant.
  - Seismic event confirmed by [site-specific indication or method TBD].
  - National Earthquake Center.
2. Tornado striking within PROTECTED AREA boundary or high wind gust greater than ([TBD] mph AP1000 JE-MES-[TBD]) (ESBWR – [TBD]).
3. Turbine failure resulting in casing penetration or damage to turbine or generator seals.
4. (Site-Specific) occurrences affecting the PROTECTED AREA.

Basis:

These Thresholds are categorized on the basis of the occurrence of an event of sufficient magnitude to be of concern to plant operators. *[Areas identified define the location of the event based on the potential for damage to equipment contained therein. Escalation of the event to an Alert occurs when the magnitude of the event is sufficient to result in damage to equipment contained in the specified location.]*

Threshold #1:*[should be developed on site-specific basis.]* Damage may be caused to some portions of the site, but should not affect ability of safety functions to operate. *[Method of detection can be based on instrumentation, validated by a reliable source, or operator assessment. As defined in the EPRI-sponsored "Guidelines for Nuclear Plant Response to an Earthquake", dated October 1989, a "felt earthquake" is:*

*An earthquake of sufficient intensity such that: (a) the vibratory ground motion is felt at the nuclear plant site and recognized as an earthquake based on a consensus of Control Room operators on duty at the time, and (b) for plants with operable seismic instrumentation, the seismic switches of the plant are activated. For most plants with seismic instrumentation, the seismic switches are set at an acceleration of about 0.01g.]*

*[The AP1000 is designed for a safe shutdown earthquake (SSE) defined by a peak ground acceleration of 0.30g. Operating Basis Earthquake (OBE) is not considered in the design basis. For the purpose of shutdown criteria the operating basis earthquake is considered to be one-third of the safe shutdown earthquake. The seismic equipment is designed to remain functional after a SSE. The time-history analyzer receives input from the triaxial acceleration sensors. It provides for initiation of audible and visual alarms in the main Control Room. Alarms are initiated when a seismic event exceeds a predetermined value or the calculated cumulative absolute velocity (CAV).]*

*[The ESBWR peak ground acceleration (PGA) of the SSE at the foundation level is 0.3g in the horizontal direction. The PGA in the vertical direction is equal to the horizontal PGA. The Operating Basis Earthquake (OBE) is not an ESBWR design requirement. Consistent with the Appendix S to 10 CFR 50, the design*

HAZARDS OR OTHER CONDITIONS  
AFFECTING PLANT SAFETY

*requirements associated with the OBE, when the level of OBE ground motion is chosen to be one-third of the SSE ground motion, are satisfied without performing explicit response or design analyses. The ESBWR OBE ground motion is one-third of the SSE ground motion.]*

The National Earthquake Center can confirm that an earthquake has occurred in the area of the plant.

Threshold #2 is based on the assumption that a tornado striking (touching down) or high winds within the PROTECTED AREA may have potentially damaged plant structures containing functions or systems required for safe shutdown of the plant. [*The high wind site specific value should be based on site-specific FSAR design basis as long as it is within the range of the instrumentation available for wind speed.*] If such damage is confirmed visually or by other in-plant indications, the event may be escalated to Alert.

Threshold #3 addresses main turbine rotating component failures of sufficient magnitude to cause observable damage to the turbine casing or to the seals of the turbine generator. [*Of major concern is the potential for leakage of combustible fluids (lubricating oils) and gases (hydrogen cooling) to the plant environs. Actual FIRES and flammable gas build up are appropriately classified via HU2 and HU3. Generator seal damage observed after generator purge does not meet the intent of this Threshold because it did not impact normal operation of the plant.*] This Threshold is consistent with the definition of a NOUE while maintaining the anticipatory nature desired and recognizing the risk to non-safety related equipment. Escalation of the emergency classification is based on potential damage done by projectiles generated by the failure. These events would be classified by the radiological ICs or Fission Product Barrier ICs.

Threshold #4 is other site-specific phenomena [*such as hurricane, flood, or seiche*] that can also be precursors of more serious events. [*In particular, sites subject to severe weather as defined in the NUMARC station blackout initiatives, should include an Threshold based on activation of the severe weather mitigation procedures (e.g., precautionary shutdowns, diesel testing, staff call-outs, etc.).*]

AP1000 References:

APP-SJS-J7-001  
APP-RCS-M3-001  
APP-CNS-M3-001

ESBWR References:

DCD Tier 2 Table 3G.1-2, Rev. 3

HAZARDS OR OTHER CONDITIONS  
AFFECTING PLANT SAFETY

**HU2**

Initiating Condition -- NOTIFICATION OF UNUSUAL EVENT

FIRE Within the PROTECTED AREA Boundary Not Extinguished Within 15 Minutes of  
Detection OR EXPLOSION within the PROTECTED AREA Boundary.

Operating Mode Applicability: All

Example Emergency Action Level:

1. FIRE not extinguished in less than 15 minutes of Control Room notification or receipt of a Control Room FIRE alarm in any of the following areas:

AP1000

- Containment
- Shield Building
- Aux Building
- Annex Building
- Turbine Building
- Radwaste Building

ESBWR

- Containment
- Reactor Building
- Fuel Building
- Control Building
- Turbine Building
- Electrical Building
- Radwaste Building

2. EXPLOSION within the Protected Area boundary.

Basis:

The purpose of Threshold #1 is to address the magnitude and extent of FIRES that may be potentially significant precursors to damage to safety systems. As used here, *Detection* is visual observation and report by plant personnel or sensor alarm indication. The 15 minute time period begins with a credible notification that a FIRE is occurring, or indication of a VALID fire detection system alarm. Validation of a fire detection system alarm includes actions that can be taken with the Control Room or other nearby site-specific location to ensure that the alarm is not spurious. An alarm is assumed to be an indication of a FIRE unless it is disproved within the 15 minute period by personnel dispatched to the scene. *[In other words, a personnel report from the scene may be used to disprove a sensor alarm if received within 15 minutes of the alarm, but shall not be required to verify the alarm.]*

*[Only the protected area is considered. All safety-related structures, systems, and components are located on the nuclear island. The nuclear island includes the containment building, shield building, and auxiliary building. This site specific list is limited to buildings and areas contiguous to plant vital areas or other significant buildings or areas.]*

HAZARDS OR OTHER CONDITIONS  
AFFECTING PLANT SAFETY

The 15 minute duration is to size the FIRE and to discriminate against small FIREs that are readily extinguished [(e.g., smoldering waste paper basket). *The site-specific list should be limited and applies to buildings and areas contiguous (in actual contact with or immediately adjacent) to plant VITAL AREAs or other significant buildings or areas. The intent of this IC is not to include buildings (i.e., warehouses) or areas that are not contiguous (in actual contact with or immediately adjacent) to plant VITAL AREAs. This excludes FIREs within administration buildings, waste-basket FIREs, and other small FIREs of no safety consequence*]. Fires inside the protected area, located near equipment, that last 15 minutes or longer can result in a challenge to the site fire brigade. This represents a degradation in plant operational status. [*Immediately adjacent implies that the area immediately adjacent contains or may contain equipment or cabling that could impact equipment located in the vital area or the fire could damage equipment inside the vital area or that precludes access to vital areas.*]

For Threshold #2 only those EXPLOSIONS of sufficient force to damage permanent structures or equipment within the PROTECTED AREA should be considered. [*No attempt is made in this Threshold to assess the actual magnitude of the damage. The occurrence of the EXPLOSION is sufficient for declaration.*] The Emergency Director also needs to consider any security aspects of the EXPLOSION, if applicable.

Escalation to a higher emergency class is by IC HA2, "FIRE Affecting the Operability of Plant Safety Systems Required for the Current Operating Mode".

AP1000 References:

FPS-M3-001  
CNS-M3-001  
Technical Specification 5.4

ESBWR References: [TBD]

DCD Tier 2 Chap 9, Sect. 9.5.1 Rev. 3, FPS-U43  
DCD Tier 2 Chap. 16, Sect. 5.4.1

HAZARDS OR OTHER CONDITIONS  
AFFECTING PLANT SAFETY

**HU3**

Initiating Condition – NOTIFICATION OF UNUSUAL EVENT

Release of Toxic, Corrosive, Asphyxiant, or Flammable Gases Deemed Detrimental to  
NORMAL PLANT OPERATIONS.

Operating Mode Applicability: All

Example Emergency Action Levels: (1 or 2)

1. Toxic, corrosive, asphyxiant or flammable gases in amounts that have or could adversely affect NORMAL PLANT OPERATIONS.
2. Report by Local, County or State Officials for evacuation or sheltering of site personnel based on an off-site event.

Basis:

This IC is based on the existence of uncontrolled releases of toxic or flammable gas that may enter the site boundary and affect NORMAL PLANT OPERATIONS.

During the initial stages of a potential gas release, actions that are taken as precautions (such as precautionary evacuation of a room or area while conditions are assessed) do not constitute an adverse affect on NORMAL PLANT OPERATIONS.

The fact that SCBA may be worn does not eliminate the need to declare the event.

It is intended that releases of toxic, corrosive, asphyxiant or flammable gases are of sufficient quantity, and the release point of such gases is such that NORMAL PLANT OPERATIONS would be affected. *[This would preclude small or incidental releases, or releases that do not impact structures needed for plant operation. The Thresholds are intended to not require significant assessment or quantification. The IC assumes an uncontrolled process that has the potential to affect NORMAL PLANT OPERATIONS.]*

An Asphyxiant is a gas capable of reducing the level of oxygen in the body to dangerous levels. Most commonly, asphyxiants work by merely displacing air in an enclosed environment. This reduces the concentration of oxygen below the normal level of around 19%, which can lead to breathing difficulties, unconsciousness or even death.

Escalation of this Threshold is via HA3, which involves a quantified a release of toxic or flammable gas affecting access to VITAL AREAS.

AP1000 References:

ESBWR References: [TBD]

HAZARDS OR OTHER CONDITIONS  
AFFECTING PLANT SAFETY

**HU4**

Initiating Condition – NOTIFICATION OF UNUSUAL EVENT

Confirmed SECURITY CONDITION or Threat Which Indicates a Potential Degradation in the Level of Safety of the Plant.

Operating Mode Applicability: All

Example Emergency Action Levels:

1. A SECURITY CONDITION that does NOT constitute a HOSTILE ACTION as reported by the (site-specific) security shift supervision.
2. A credible site specific security threat notification.
3. A validated notification from NRC providing information of an aircraft threat.

Basis:

Reference is made to (site-specific) security shift supervision because these individuals are the designated personnel on-site qualified and trained to confirm that a security event is occurring or has occurred. Training on security event classification confirmation is closely controlled due to the strict secrecy controls placed on the plant Safeguards Contingency Plan.

Threshold #1 is based on (site-specific) Site Security Plans. Security events which do not represent a potential degradation in the level of safety of the plant, are reported under 10 CFR 73.71 or in some cases under 10 CFR 50.72. *[Examples of security events that indicate Potential Degradation in the Level of Safety of the Plant are provided below for consideration.]* Security events assessed as HOSTILE ACTIONS are classifiable under HA4, HS4 and HG1.

This threshold is based on site specific security plans. Site specific Safeguards Contingency Plans are based on guidance provided by NEI 03-12.

Threshold #2 is to ensure that appropriate notifications for the security threat are made in a timely manner. This includes information of a credible threat. *[Only the plant to which the specific threat is made need declare the Notification of Unusual Event.]*

Threshold #3 is to ensure that notifications for the security threat are made in a timely manner and that Off-site Response Organizations and plant personnel are at a state of heightened awareness regarding the credible threat. Only the plant to which the specific threat is made need declare the Notification of Unusual Event. *[This Threshold is met when a plant receives information regarding an aircraft threat from NRC. Validation is performed by calling the NRC or by other approved methods of authentication. Should the threat involve an airliner (airliner is meant to be a large aircraft with the potential for causing significant damage to the plant) then escalation to Alert via HA4 would be appropriate if the airliner is less than 30 minutes away from the plant. The NRC Headquarters Operations Officer (HOO) will communicate to the licensee if the threat involves an airliner. The status of the plane may be provided by NORAD through the NRC. It is not the intent of this Threshold to replace existing non-hostile related Thresholds involving aircraft.]*



HAZARDS OR OTHER CONDITIONS  
AFFECTING PLANT SAFETY

*[The determination of “credible” is made through use of information found in the (site-specific) Safeguards Contingency Plan.]*

A higher initial classification could be made based upon the nature and timing of the threat and potential consequences. *[The licensee shall consider upgrading the emergency response status and emergency classification in accordance with the [site security specific] Safeguards Contingency Plan and Emergency Plans.]*

AP1000 References:

ESBWR References: [TBD]

HAZARDS OR OTHER CONDITIONS  
AFFECTING PLANT SAFETY

**HU5**

Initiating Condition – NOTIFICATION OF UNUSUAL EVENT

Other Conditions Existing Which in the Judgment of the Emergency Director Warrant  
Declaration of a NOUE.

Operating Mode Applicability: All

Example Emergency Action Level:

1. Other conditions exist which in the judgment of the Emergency Director indicate that events are in progress or have occurred which indicate a potential degradation of the level of safety of the plant or indicate a security threat to facility protection has been initiated. No releases of radioactive material requiring off-site response or monitoring are expected unless further degradation of safety systems occurs.

Basis:

This EAL addresses unanticipated conditions not addressed explicitly elsewhere but that warrant declaration of an emergency because conditions exist which are believed by the Emergency Director to fall under the NOUE emergency class.

AP1000 References:

ESBWR References: [TBD]

HAZARDS OR OTHER CONDITIONS  
AFFECTING PLANT SAFETY

**HA1**

Initiating Condition -- ALERT

Natural or Destructive Phenomena Affecting the Plant VITAL AREAS.

Operating Mode Applicability: All

Example Emergency Action Levels: (1 or 2 or 3 or 4 or 5 or 6)

1. Seismic event greater than Operating Basis Earthquake (OBE) {AP1000 - 0.10g} as indicated by the time history analyzer initiation of the Control Room alarm. {ESBWR – 0.10g} as indicated by seismic instrumentation.

**AND**

Confirmed by **EITHER**:

- Earthquake felt in plant
- National Earthquake Center

2. Tornado striking or high winds greater than {AP1000 – [TBD]} {ESBWR – [TBD]} mph resulting in **VISIBLE DAMAGE** to any of the following structures containing safety systems or components OR Control Room indication of degraded performance of those systems.

AP1000

- Containment Building
- Shield Building
- Aux Building

ESBWR

- Containment Building
- Reactor Building
- Control Building
- Electrical Building

3. Vehicle crash within **PROTECTED AREA** boundary and resulting in **VISIBLE DAMAGE** to any of the following structures containing safety systems or components OR Control Room indication of degraded performance of those safety systems:

AP1000

- Containment
- Shield Building
- Aux Building

ESBWR

- Containment
- Reactor building
- Fuel Building
- Control Building
- Turbine Building
- Electrical Building

HAZARDS OR OTHER CONDITIONS  
AFFECTING PLANT SAFETY

- Radwaste Building
4. (ESBWR) Turbine failure-generated projectiles result in any VISIBLE DAMAGE to or penetration of the Electrical Building.  
  
(AP1000) Not applicable
  5. Internal flooding in any areas of the plant that creates an industrial safety hazard (e.g., electric shock) that precludes access necessary to operate or monitor equipment.
  6. (Site-Specific) occurrences within PROTECTED AREA boundary and resulting in VISIBLE DAMAGE to plant structures containing equipment necessary for safe shutdown, or has caused damage as evidenced by Control Room indication of degraded performance of those systems.

Basis:

These Thresholds escalate from HU1 in that the occurrence of the event has resulted in VISIBLE DAMAGE to plant structures or areas containing equipment necessary for a safe shutdown, or has caused damage to the safety systems in those structures evidenced by control indications of degraded system response or performance. The occurrence of VISIBLE DAMAGE and/or degraded system response is intended to discriminate against lesser events. The initial "report" should not be interpreted as mandating a lengthy damage assessment prior to classification. No attempt is made in this Threshold to assess the actual magnitude of the damage. The significance here is not that a particular system or structure was damaged, but rather, that the event was of sufficient magnitude to cause this degradation. Escalation to higher classifications occur on the basis of System Malfunctions.

*[Threshold #1 should be based on site-specific FSAR design basis.]* Seismic events of this magnitude can result in a plant VITAL AREA being subjected to forces beyond design limits, and thus damage may be assumed to have occurred to plant safety systems. *[See EPRI-sponsored "Guidelines for Nuclear Plant Response to an Earthquake", dated October 1989, for information on seismic event categories.]*

*[Threshold #2 should be based on site-specific FSAR design basis as it is within the range of the instrumentation available for wind speed.]* Wind loads of this magnitude can cause damage to safety functions.

*[Threshold #s 2, 3, and 4 should specify site-specific safety structure, system, or component and functions required for safe shutdown of the plant.]*

*[Threshold #3 addresses crashes of vehicle types large enough to cause significant damage to safety structure, system, or component containing functions and systems required for safe shutdown of the plant.]*

Threshold #4 addresses the threat to safety related equipment imposed by projectiles generated by main turbine rotating component failures. This list of areas includes all areas containing safety structure, system, or component, their controls, and their power supplies.

Note that this Threshold would not normally be applicable in cold shutdown, refueling, or defueled modes since steam is not normally available to rotate the main turbine in these plant conditions. If steam from alternate sources is being used to rotate the main turbine for testing, then this EAL would be applicable in these shutdown modes.

HAZARDS OR OTHER CONDITIONS  
AFFECTING PLANT SAFETY

This Threshold is, therefore, consistent with the definition of an ALERT in that if projectiles have damaged or penetrated areas containing safety structure, system, or component the potential exists for substantial degradation of the level of safety of the plant.

Threshold #5 addresses the effect of internal flooding that has created industrial safety hazards (e.g., electrical shock) that preclude necessary access to operate or monitor safety equipment.

Threshold #6 is other site-specific phenomena [*such as hurricane, flood, or seiche*] that can also be precursors of more serious events. [*In particular, sites subject to severe weather as defined in the NUMARC station blackout initiatives, should include an Threshold based on activation of the severe weather mitigation procedures (e.g., precautionary shutdowns, diesel testing, staff call-outs, etc.).*]

AP1000 References:

APP-SJS-J7-001  
APP-RCS-M3-001  
APP-CNS-M3-001

ESBWR References: [TBD]

DCD Tier 2 Chapter 3, Sect. 3.7, Rev. 3  
DCD Tier 2 3.7.1.1, Rev. 3  
DCD Tier 2 Table 3G.1-2, Rev. 3

HAZARDS OR OTHER CONDITIONS  
AFFECTING PLANT SAFETY

**HA2**

Initiating Condition -- ALERT

FIRE or EXPLOSION Affecting the Operability of Plant Safety Systems Required to Establish or Maintain Safe/Stable Shutdown.

Operating Mode Applicability: All

Example Emergency Action Level:

1. FIRE or EXPLOSION resulting in VISIBLE DAMAGE to any of the following structures containing safety systems, or components **OR** Control Room indication of degraded performance of those safety systems:

AP1000

- Containment
- Shield Building
- Aux Building

ESBWR

- Containment
- Reactor building
- Fuel Building
- Control Building
- Turbine Building
- Electrical Building
- Radwaste Building

Basis:

*[Site-specific areas containing functions and systems required for the safe shutdown of the plant should be specified. Site-Specific Safe Shutdown Analysis should be consulted for equipment and plant areas required to establish or maintain safe shutdown. This will make it easier to determine if the FIRE or EXPLOSION is potentially affecting one or more redundant trains of safety systems.]*

The reference to damage of systems is used to identify the magnitude of the FIRE / EXPLOSION and to discriminate against minor FIRES / EXPLOSIONs. The reference to safety systems is included to discriminate against FIRES / EXPLOSIONs in areas having a low probability of affecting safe operation. The significance here is not that a safety system was degraded but the fact that the FIRE / EXPLOSION was large enough to cause damage to these systems.

The inclusion of a "VISIBLE DAMAGE" should not be interpreted as mandating a lengthy damage assessment prior to classification. No attempt is made in this Threshold to assess the actual magnitude of the damage. The occurrence of the EXPLOSION with reports of evidence of damage is sufficient for declaration. *[The declaration of an Alert and the activation of the Technical Support Center will provide the Emergency Director with the resources needed to perform these damage assessments.]* The Emergency Director also needs to consider any security aspects of the EXPLOSIONs.

HAZARDS OR OTHER CONDITIONS  
AFFECTING PLANT SAFETY

Escalation to a higher emergency class, if appropriate, will be based on System Malfunction, Fission Product Barrier Degradation, Abnormal Rad Levels / Radiological Effluent, or Emergency Director Judgment ICs.

AP1000 References:

APP-RCS-M3-001  
APP-CNS-M3-001  
APP-FPS-M3-001  
APP-GW-GJP-305

ESBWR References: [TBD]

DCD Tier 2 Chapter 9, Section 9.5.1, Rev. 3

HAZARDS OR OTHER CONDITIONS  
AFFECTING PLANT SAFETY

**HA3**

Initiating Condition -- ALERT

Access to a VITAL AREA Is Prohibited Due To Release of Toxic, Corrosive, Asphyxiant or Flammable Gases Which Jeopardizes Operation of Systems Required to Maintain Safe Operations or Safely Shutdown the Reactor.

Operating Mode Applicability: All

Example Emergency Action Levels:

1. Access to a VITAL AREA is prohibited due to toxic, corrosive, asphyxiant, or flammable gases which jeopardizes operation of systems required to maintain safe operations or safely shutdown the reactor.

Basis:

Gases in a Plant Vital Area can affect the ability to safely operate or safely shutdown the reactor.

Escalation to a higher emergency class, if appropriate, will be based on System Malfunction, Fission Product Barrier Degradation, Abnormal Rad Levels / Radioactive Effluent, or Emergency Director Judgment ICs.

During the initial stages of a potential gas release, actions that are taken as precautions (such as pre-cautionary evacuation of a room or area while conditions are assessed) do not constitute jeopardizing operation of systems required to maintain safe operations or safely shutdown the reactor.

The fact that self contained breathing apparatus (SCBA) may be worn does not eliminate the need to declare the event

An Asphyxiant is a gas capable of reducing the level of oxygen in the body to dangerous levels. Most commonly, asphyxiants work by merely displacing air in an enclosed environment. This reduces the concentration of oxygen below the normal level of around 19%, which can lead to breathing difficulties, unconsciousness or even death.

*[Flammable gasses, such as hydrogen and acetylene, are routinely used to maintain plant systems (hydrogen) or to repair equipment/components (acetylene - used in welding).]* This Threshold addresses concentrations at which gases can ignite/support combustion. An uncontrolled release of flammable gasses within a facility structure has the potential to affect safe operation of the plant by limiting either operator or equipment operations due to the potential for ignition and resulting equipment damage/personnel injury.

AP1000 References:

ESBWR References: [TBD]



HAZARDS OR OTHER CONDITIONS  
AFFECTING PLANT SAFETY

**HA4**

Initiating Condition - ALERT

HOSTILE ACTION Within the OWNER CONTROLLED AREA or Airborne Attack Threat.

Operating Mode Applicability: All

Example Emergency Action Level: (1 or 2)

1. A HOSTILE ACTION is occurring or has occurred within the OWNER CONTROLLED AREA as reported by the (site specific security shift supervision).
2. A validated notification from NRC of an airliner attack threat within 30 minutes of the site.

Basis:

These EALs address the contingency for a very rapid progression of events, such as that experienced on September 11, 2001. They are not premised solely on the potential for a radiological release. Rather the issue includes the need for rapid assistance due to the possibility for significant and indeterminate damage from additional air, land or water attack elements.

The fact that the site is under serious attack or is an identified attack target with minimal time available for further preparation or additional assistance to arrive requires a heightened state of readiness and implementation of protective measures that can be effective (such as on-site evacuation, dispersal or sheltering).

Threshold #1 addresses the potential for a very rapid progression of events due to a HOSTILE ACTION. It is not intended to address incidents that are accidental events or acts of civil disobedience, such as small aircraft impact, hunters, or physical disputes between employees within the OCA. Those events are adequately addressed by other EALs.

*[Although nuclear plant security officers are well trained and prepared to protect against HOSTILE ACTION, it is appropriate for OROs to be notified and encouraged to begin activation (if they do not normally) to be better prepared should it be necessary to consider further actions.]*

*[If not previously notified by the NRC that the airborne HOSTILE ACTION was intentional, then it would be expected, although not certain, that notification by an appropriate Federal agency would follow. In this case, appropriate federal agency is intended to be NORAD, FBI, FAA or NRC. However, the declaration should not be unduly delayed awaiting Federal notification.]*

Threshold #2 addresses the immediacy of an expected threat arrival or impact on the site within a relatively short time.

The intent of this EAL is to ensure that notifications for the airliner attack threat are made in a timely manner and that OROs and plant personnel are at a state of heightened awareness regarding the credible threat. Airliner is meant to be a large aircraft with the potential for causing significant damage to the plant.

This EAL is met when a plant receives information regarding an airliner attack threat from NRC and the airliner is within 30 minutes of the plant. Validation is performed by calling the NRC or by other approved methods of authentication. Only the plant to which the specific threat is made need declare the Alert.

HAZARDS OR OTHER CONDITIONS  
AFFECTING PLANT SAFETY

The NRC Headquarters Operations Officer (HOO) will communicate to the licensee if the threat involves an airliner (airliner is meant to be a large aircraft with the potential for causing significant damage to the plant). The status and size of the plane may be provided by NORAD through the NRC.

AP1000 References:

ESBWR References: [TBD]

HAZARDS OR OTHER CONDITIONS  
AFFECTING PLANT SAFETY

**HA5**

Initiating Condition -- ALERT

Control Room Evacuation Has Been Initiated.

Operating Mode Applicability: All

Example Emergency Action Level:

AP1000

1. GW-GJP-306, Evacuation of Control Room, requires Control Room evacuation.

ESBWR

1. Abnormal Operating Procedure [TBD] Forced Control Room Evacuation, requires Control Room evacuation.

Basis:

With the Control Room evacuated, additional support, monitoring and direction through the Technical Support Center and/or other emergency response facilities is necessary. Inability to establish plant control from outside the Control Room will escalate this event to a Site Area Emergency.

AP1000 References:

ESBWR References: AOP-[TBD]

APP-GW-GJP-306

HAZARDS OR OTHER CONDITIONS  
AFFECTING PLANT SAFETY

**HA6**

Initiating Condition -- ALERT

Other Conditions Existing Which in the Judgment of the Emergency Director Warrant  
Declaration of an Alert.

Operating Mode Applicability: All

Example Emergency Action Level:

1. Other conditions exist which in the judgment of the Emergency Director indicate that events are in progress or have occurred which involve an actual or potential substantial degradation of the level of safety of the plant or a security event that involves probable life threatening risk to site personnel or damage to site equipment because of HOSTILE ACTION. Any releases are expected to be limited to small fractions of the EPA Protective Action Guideline exposure levels.

Basis:

This Threshold addresses unanticipated conditions not addressed explicitly elsewhere but that warrant declaration of an emergency because conditions exist which are believed by the Emergency Director to fall under the Alert emergency class.

AP1000 References:

ESBWR References: [TBD]

HAZARDS OR OTHER CONDITIONS  
AFFECTING PLANT SAFETY

**HS2**

Initiating Condition – - SITE AREA EMERGENCY

Control Room Evacuation Has Been Initiated and Plant Control Cannot Be Established.

Operating Mode Applicability: All

Example Emergency Action Level:

AP1000

1. a. Control room evacuation has been initiated.

**AND**

- 
- b. Control of the plant cannot be established per [procedure TBD] within [TBD] minutes.

ESBWR

1. a. Control room evacuation has been initiated.

**AND**

- 
- b. Control of the plant cannot be established per [procedure TBD] in less than [TBD] minutes.

Basis:

Expeditious transfer of safety systems has not occurred but fission product barrier damage may not yet be indicated. The intent of this IC is to capture those events where control of the plant cannot be reestablished in a timely manner. *[Site-specific time for transfer based on analysis or assessments as to how quickly control must be reestablished without core uncovering and/or core damage. This time should not exceed [TBD] minutes without additional justification.]* The determination of whether or not control is established at the remote shutdown panel is based on Emergency Director (ED) judgment. The ED is expected to make a reasonable, informed judgment within the site-specific time for transfer that control of the plant from the remote shutdown panel has been achieved.

The intent of the EAL is to establish control of important plant equipment and knowledge of important plant parameters in a timely manner. Primary emphasis should be placed on those components and instruments that supply protection for and information about safety functions. These safety functions are reactivity control (ability to shutdown the reactor and maintain it shutdown), reactor water level (ability to cool the core), and decay heat removal (ability to maintain a heat sink) for a ESBWR. The equivalent functions for AP1000 are reactivity control, RCS inventory, and secondary heat removal.

Escalation of this event, if appropriate, would be by Fission Product Barrier Degradation, Abnormal Rad Levels/Radiological Effluent, or Emergency Director Judgment ICs.

AP1000 References:  
APP-GW-GJP-306

ESBWR References: [TBD]

HAZARDS OR OTHER CONDITIONS  
AFFECTING PLANT SAFETY

HAZARDS OR OTHER CONDITIONS  
AFFECTING PLANT SAFETY

HS3

Initiating Condition – -SITE AREA EMERGENCY

Other Conditions Existing Which in the Judgment of the Emergency Director Warrant Declaration of a Site Area Emergency.

Operating Mode Applicability: All

Example Emergency Action Level:

1. Other conditions exist which in the judgment of the Emergency Director indicate that events are in progress or have occurred which involve actual or likely major failures of plant functions needed for protection of the public or HOSTILE ACTION that results in intentional damage or malicious acts: (1) toward site personnel or equipment that could lead to the likely failure of; or (2) that prevent effective access to equipment needed for the protection of the public. Any releases are not expected to result in exposure levels which exceed EPA Protective Action Guideline exposure levels beyond the site boundary.

Basis:

This EAL addresses unanticipated conditions not addressed explicitly elsewhere but that warrant declaration of an emergency because conditions exist which are believed by the Emergency Director to fall under the emergency class description for Site Area Emergency.

AP1000 References:

ESBWR References: [TBD]

HAZARDS OR OTHER CONDITIONS  
AFFECTING PLANT SAFETY

**HS4**

Initiating Condition – - SITE AREA EMERGENCY

HOSTILE ACTION Within the PROTECTED AREA.

Operating Mode Applicability: All

Example Emergency Action Level:

1. A HOSTILE ACTION is occurring or has occurred within the PROTECTED AREA as reported by the (site security shift supervision).

**Basis:**

This condition represents an escalated threat to plant safety above that contained in the Alert in that a HOSTILE FORCE has progressed from the OWNER CONTROLLED AREA to the PROTECTED AREA.

This EAL addresses the contingency for a very rapid progression of events, such as that experienced on September 11, 2001. It is not premised solely on the potential for a radiological release. Rather the issue includes the need for rapid assistance due to the possibility for significant and indeterminate damage from additional air, land or water attack elements.

The fact that the site is under serious attack with minimal time available for further preparation or additional assistance to arrive requires ORO readiness and preparation for the implementation of protective measures.

This EAL addresses the potential for a very rapid progression of events due to a HOSTILE ACTION. It is not intended to address incidents that are accidental events or acts of civil disobedience, such as small aircraft impact, hunters, or physical disputes between employees within the PROTECTED AREA. Those events are adequately addressed by other EALs.

*[Although nuclear plant security officers are well trained and prepared to protect against HOSTILE ACTION, it is appropriate for OROs to be notified and encouraged to begin preparations for public protective actions (if they do not normally) to be better prepared should it be necessary to consider further actions.]*

*[If not previously notified by NRC that the airborne HOSTILE ACTION was intentional, then it would be expected, although not certain, that notification by an appropriate Federal agency would follow. In this case, appropriate federal agency is intended to be NORAD, FBI, FAA or NRC. However, the declaration should not be unduly delayed awaiting Federal notification.]*

Escalation of this emergency classification level, if appropriate, would be based on actual plant status after impact or progression of attack.

AP1000 References:

ESBWR References: [TBD]

HAZARDS OR OTHER CONDITIONS  
AFFECTING PLANT SAFETY

**HG1**

Initiating Condition – GENERAL EMERGENCY

HOSTILE ACTION Resulting in Loss of Physical Control of the Facility.

Operating Mode Applicability: All

Example Emergency Action Level: (1 or 2)

1. A HOSTILE ACTION has occurred such that plant personnel are unable to operate equipment required to maintain safety functions.
2. A HOSTILE ACTION has caused failure of Spent Fuel Cooling Systems and IMMEDIATE fuel damage is likely for a freshly off-loaded reactor core in pool.

Basis:

This IC encompasses conditions under which a HOSTILE ACTION has resulted in a loss of physical control of VITAL AREAS (containing vital equipment or controls of vital equipment) required to maintain safety functions and control of that equipment cannot be transferred to and operated from another location.

*[Typically, these safety functions are reactivity control (ability to shut down the reactor and keep it shutdown) reactor water level (ability to cool the core), and decay heat removal (ability to maintain a heat sink) for a BWR. The equivalent functions for a PWR are reactivity control, RCS inventory, and secondary heat removal.]*

If control of the plant equipment necessary to maintain safety functions can be transferred to another location, then the above initiating condition is not met.

*[The ESBWR fuel pool cooling function is also provided in the event that a recently unloaded fuel batch requires continued cooling during the post-accident period. The spent fuel pool contains sufficient inventory to ensure no operator action is required during the first 72 hours. After that period, either makeup water must be supplied to the spent fuel pool or the FAPCS must be initiated. The FAPCS equipment is environmentally qualified, so access is not required and redundancy is included in system components.]*

This EAL also addresses failure of spent fuel cooling systems as a result of HOSTILE ACTION if IMMEDIATE fuel damage is likely [ (e.g., freshly off-loaded reactor core in pool). “Freshly” is defined by site-specific requirements.]

*[Loss of physical control of the Control Room or remote shutdown capability alone may not prevent the ability to maintain safety functions per se. Design of the remote shutdown capability and the location of the transfer switches should be taken into account. The intent of the EAL is to establish control of important plant equipment and knowledge of important plant parameters in a timely manner. Primary emphasis should be placed on those components and instruments that supply protection for and information about safety functions. Typically, these safety functions are reactivity control (ability to shutdown the reactor and maintain it shutdown), reactor water level (ability to cool the core), and decay heat removal (ability to maintain a heat sink) for a BWR. The equivalent functions for a PWR are reactivity control, RCS inventory, and secondary heat removal.]*

AP1000 References:



HAZARDS OR OTHER CONDITIONS  
AFFECTING PLANT SAFETY

ESBWR References: [TBD]

HAZARDS OR OTHER CONDITIONS  
AFFECTING PLANT SAFETY

**HG2**

Initiating Condition – GENERAL EMERGENCY

Other Conditions Existing Which in the Judgment of the Emergency Director Warrant  
Declaration of a General Emergency.

Operating Mode Applicability: All

Example Emergency Action Level:

1. Other conditions exist which in the judgment of the Emergency Director indicate that events are in progress or have occurred which involve actual or IMMEDIATE substantial core degradation or melting with potential for loss of containment integrity or HOSTILE ACTION that results in an actual loss of physical control of the facility. Releases can be reasonably expected to exceed EPA Protective Action Guideline exposure levels at or beyond, the site boundary.

Basis:

This EAL addresses unanticipated conditions not addressed explicitly elsewhere but that warrant declaration of an emergency because conditions exist which are believed by the Emergency Director to fall under the General Emergency class.

AP1000 References:

ESBWR References: [TBD]

## SYSTEM MALFUNCTIONS

### 5.9 System Malfunction EALs

**Table 5-S-1: Recognition Category “S” Initiating Condition Matrix**

GENERAL EMERGENCY	SITE AREA EMERGENCY	ALERT	NOUE
<p><b>SG1</b> All Safety Related DC Batteries Not Being Charged for Greater Than 72 Hours Due to Loss of Power to PIP Busses. <i>Op. Modes: Power Operation, Startup, Hot Standby, Safe/Stable Shutdown</i></p>	<p><b>SS1</b> All Safety Related DC Batteries Not Being Charged for 24 Hours or Longer Due to Loss of Power to PIP Busses. <i>Op. Modes: Power Operation, Startup, Hot Standby, Safe/Stable Shutdown</i></p>	<p><b>SA1</b> All Safety Related DC Batteries Not Being Charged for 60 Minutes or Longer Due to Loss of Power to PIP Busses. <i>Op. Modes: Power Operation, Startup, Hot Standby, Safe/Stable Shutdown</i></p>	<p><b>SU1</b> All Safety Related DC Batteries Not Being Charged for 30 Minutes or Longer Due to Loss of Power to PIP Busses. <i>Op. Modes: Power Operation, Startup, Hot Standby, Safe/Stable Shutdown</i></p>
<p><b>SG2</b> Automatic Scram (Trip) and All Manual Actions Fail to Shutdown the Reactor and Indication of an Extreme Challenge to the Ability to Cool the Core Exists. <i>Op. Modes: Power Operation, Startup</i></p>	<p><b>SS2</b> Automatic Scram (Trip) Fails to Shutdown the Reactor and Manual Actions Taken From the Reactor control Console are NOT Successful in Shutting Down the Reactor <i>Op. Modes: Power Operation, Startup</i></p>	<p><b>SA2</b> Automatic Scram (Trip) Fails to Shutdown the Reactor and the Manual Actions Taken From the Reactor Control Console are Successful in Shutting Down the Reactor <i>Op. Modes: Power Operation, Startup</i></p>	<p><b>SU2</b> Inability to Reach Required Shutdown Mode Within Technical Specification Limits. <i>Op. Modes: Power Operation, Startup, Hot Standby, Safe/Stable Shutdown</i></p>
	<p><b>SS6</b> Inability to Monitor a SIGNIFICANT TRANSIENT in Progress. <i>Op. Modes: Power Operation, Startup, Hot Standby, Safe/Stable Shutdown</i></p>	<p><b>SA4</b> Loss of Indicating and Monitoring Functions <i>Op. Modes: Power Operation, Startup, Hot Standby, Safe/Stable Shutdown</i></p>	
	<p><b>SS3</b> Loss of All Vital DC Power for 15 Minutes or Longer. <i>Op. Modes: Power Operation, Startup, Hot Standby, Safe/Stable Shutdown</i></p>		<p><b>SU4</b> Fuel Clad Degradation. <i>Op. Modes: Power Operation, Startup, Hot Standby</i></p>
			<p><b>SU5</b> RCS Leakage. <i>Op. Modes: Power Operation, Startup, Hot Standby, Safe/Stable Shutdown</i></p>
			<p><b>SU6</b> UNPLANNED Loss of All On-site <u>OR</u> Off-site Communications Capabilities. <i>Op. Modes: Power Operation, Startup, Hot Standby, Safe/Stable Shutdown</i></p>
			<p><b>SU8</b> Inadvertent Criticality. <i>Op. Modes: Hot Standby, Safe/Stable Shutdown</i></p>

## SYSTEM MALFUNCTION

**SU1**

### Initiating Condition -- NOTIFICATION OF UNUSUAL EVENT

All Safety Related DC Batteries Not Being Charged for 30 Minutes or Longer Due to Loss of Power to PIP Busses.

Operating Mode Applicability:

Power Operation  
Startup  
Hot Standby  
Safe/Stable Shutdown

Example Emergency Action Level:

*Note: The Emergency Director should not wait until the applicable time has elapsed, but should declare the event as soon as it is determined that the condition will likely exceed the applicable time.*

AP1000

1. PIP Busses ECS-ES-1 and ECS-ES-2 de-energized for 30 minutes or longer.

ESBWR

1. PIP Busses 1000A3 and 1000B3 de-energized for 30 minutes or longer.

Basis:

Prolonged de-energization of the PIP busses reduces required redundancy and potentially degrades the level of safety of the plant by rendering the plant more vulnerable to a complete loss of DC Power. 30 minutes was selected as a threshold to exclude transient or momentary losses of AC power.

*[The Passive ALWRs do not need/have safety-related standby diesel generators. Storage batteries are the standby power source for Class 1E electric power.]*

AP1000 References:

APP-ECS-E8-001  
APP-ZOS-E8-001  
Technical Specification 3.8

ESBWR References: [TBD]

DCD Tier 2 Chapter 8, Sect. 8.1.5.1 Rev 3  
DCD Tier 2 Chapter 8, Sect. 8.1.5.2 Rev. 3  
DCD Tier 2, Chap. 8, Figure 8.1-1, Rev. 3  
DCD Tier 2 Chapter 16, Sect. 3.8 Rev. 3

## SYSTEM MALFUNCTION

**SU2**

Initiating Condition -- NOTIFICATION OF UNUSUAL EVENT

Inability to Reach Required Shutdown Mode Within Technical Specification Limits.

Operating Mode Applicability:	Power Operation
	Startup
	Hot Standby
	Safe/Stable Shutdown

Example Emergency Action Level:

1. Plant is not brought to required operating mode within Technical Specifications LCO Action Statement Time.

Basis:

Limiting Conditions of Operation (LCOs) require the plant to be brought to a required shutdown mode when the Technical Specification required configuration cannot be restored. Depending on the circumstances, this may or may not be an emergency or precursor to a more severe condition. *[In any case, the initiation of plant shutdown required by the site Technical Specifications requires a four hour report under 10 CFR 50.72 (b) Non-emergency events. The plant is within its safety envelope when being shut down within the allowable Action Statement time in the Technical Specifications.]* An immediate NOUE is required when the plant is not brought to the required operating mode within the allowable Action Statement time in the Technical Specifications. Declaration of a NOUE is based on the time at which the LCO-specified Action Statement time period elapses under the site Technical Specifications and is not related to how long a condition may have existed. *[Other required Technical Specification shutdowns that involve precursors to more serious events are addressed by other System Malfunction, Hazards, or Fission Product Barrier Degradation ICs.]*

AP1000 Reference:

ESBWR References: [TBD]

Technical Specification 3.0.3

## SYSTEM MALFUNCTION

**SU4**

Initiating Condition -- NOTIFICATION OF UNUSUAL EVENT

Fuel Clad Degradation.

Operating Mode Applicability:	Power Operation Startup Hot Standby
-------------------------------	---

Example Emergency Action Levels: (1 or 2)

AP1000

1. Liquid Sample Radiation Monitor PSS-RICA-050 High Alarm Setpoint [TBD]  $\mu\text{Ci/cc}$  indicating fuel clad degradation greater than Technical Specification 3.4.10 allowable limits.

**OR**

2. Dose equivalent I-131 greater than  $60 \mu\text{Ci/gm}$  **OR** dose equivalent Xe-133 greater than  $280 \mu\text{Ci/gm}$  for more than 6 hours from sampling and analysis.

ESBWR

1. [TBD] radiation monitor readings indicating fuel clad degradation greater than Technical Specification 3.4.3 allowable limits.
2. [TBD] coolant sample activity value indicating fuel clad degradation greater than Technical Specification 3.4.3 allowable limits.

Basis:

This IC is included as a NOUE because it is considered to be a potential degradation in the level of safety of the plant and a potential precursor of more serious problems. EAL #1 addresses site-specific radiation monitor readings such as BWR air ejector monitors, PWR failed fuel monitors, etc., that provide indication of fuel clad integrity. EAL #2 addresses coolant samples exceeding coolant Technical Specifications for iodine spike. Escalation of this IC to the Alert level is via the Fission Product Barrier Degradation Monitoring ICs.

*[AP1000 - PSS-RICA-050, provides early indication of significant increase in radioactivity of the reactor coolant, indicating a possible fuel cladding breach. On high alarm, the primary sampling system liquid sample radiation monitor isolates the sample flow by closing the outside containment isolation valve (PSS-PL-V011) and initiates an alarm in the main Control Room and locally to alert the operator. At that time, sampling and analysis would be performed to verify compliance with the Technical Specification 3.4.10 RCS Specific Activity limits.*

*Technical Specification 3.4.10 limits the allowable concentration of iodines and noble gases, such as xenon, in the reactor coolant. Limiting Condition for Operation (LCO) limits are established to be consistent with fuel defect level of 0.25 percent and to ensure that plant operation remains within conditions assumed for shielding and DBA release analyses.*

*Technical Specification Surveillance Requirement (SR) 3.4.10.1 requires performing a measure of the noble gas specific activity of the reactor coolant once every 7 days, which provides an indication of any increase in*

## SYSTEM MALFUNCTION

*the release of noble gas activity from fuel rods containing cladding defects. SR 3.4.10.2 requires performing a measure of the iodine specific activity of the reactor coolant once every 14 days, and between 2 to 6 hours after a reactor power increase of greater than or equal to 15% of Rated Thermal Power within a 1 hour period. Trending the results of these surveillances allows proper remedial action to be taken PRIOR to reaching the LCO upper limits under normal operating conditions.]*

AP1000 References:

APP-PSS-M3C-101  
Tech Spec 3.4.10

ESBWR References: [TBD]

NEDO-33319  
DCD Tier 2, Chapter 16, Sect. 3.4.3 Rev. 3

## SYSTEM MALFUNCTION

**SU5**

Initiating Condition -- NOTIFICATION OF UNUSUAL EVENT

RCS Leakage.

Operating Mode Applicability:	Power Operation Startup Hot Standby Safe/Stable Shutdown
-------------------------------	---

Example Emergency Action Levels:	(1 or 2)
----------------------------------	----------

AP1000

1. Unidentified leakage greater than 5 gpm.
2. Identified leakage greater than 25 gpm.

ESBWR

1. Unidentified or pressure boundary leakage greater than 50 gpm.
2. Total leakage greater than 75 gpm.

Basis:

This IC is included as a NOUE because it may be a precursor of more serious conditions and, as result, is considered to be a potential degradation of the level of safety of the plant. The value for the unidentified leakage (including the pressure boundary) was selected as it is observable with normal Control Room indications and is 10 times the Technical Specification limit. Lesser values must generally be determined through time-consuming surveillance tests (e.g., mass balances).

Relief valve normal operation should be excluded from this IC. However, a relief valve that operates and fails to close per design should be considered applicable to this IC if the relief valve cannot be isolated.

The EAL for identified leakage is set at a higher value due to the lesser significance of identified leakage in comparison to unidentified or pressure boundary leakage and is 2.5 times the Technical Specification limit. In either case, escalation of this IC to the Alert level is via Fission Product Barrier Degradation ICs.

AP1000 References:

ESBWR References: [TBD]

Technical Specification 3.4.7



## SYSTEM MALFUNCTION

**SU6**

Initiating Condition -- NOTIFICATION OF UNUSUAL EVENT

UNPLANNED Loss of All On-site or Off-site Communications Capabilities.

Operating Mode Applicability:	Power Operation Startup Hot Standby Safe/Stable Shutdown
-------------------------------	---

Example Emergency Action Levels:	(1 or 2)
----------------------------------	----------

1. Loss of all of the following on-site communication methods affecting the ability to perform routine operations:

AP1000

- EFS
- TVS
- (Site specific)

ESBWR

- Plant Page/Party Line
- PABX
- Sound Powered Phones
- Plant Radios
- (Site specific)

2. Loss of all of the following off-site communication methods affecting the ability to perform offsite notifications:

(site-specific list of communications methods)

Basis:

The purpose of this IC and its associated EALs is to recognize a loss of communications capability that either defeats the plant operations staff ability to perform routine tasks necessary for plant operations or the ability to communicate problems with off-site authorities. The loss of off-site communications ability is expected to be significantly more comprehensive than the condition addressed by 10 CFR 50.72.

The availability of one method of ordinary off-site communications is sufficient to inform state and local authorities of plant conditions. [*This EAL is to be used only when extraordinary means (e.g., relaying of information from radio transmissions, individuals being sent to off-site locations, etc.) are being utilized to make communications possible.*] EFS and TVS are comprised of the following:

- Wireless Telephone System
- Telephone-Page System
- Sound Powered System
- Security Communication System
- Closed Circuit Television System

## SYSTEM MALFUNCTION

*[Site-specific list for on-site communications loss must encompass the loss of all means of routine communications (e.g., commercial telephones, sound powered phone systems, page party system and radios / walkie talkies).]*

*[Site-specific list for off-site communications loss must encompass the loss of all means of communications with off-site authorities. This should include the ENS, commercial telephone lines, telecopy transmissions, and dedicated phone systems.]*

AP1000 References:

ESBWR References: [TBD]

APP-EFS-J7-001

APP-TVS-J7-001

## SYSTEM MALFUNCTION

**SU8**

Initiating Condition -- NOTIFICATION OF UNUSUAL EVENT

Inadvertent Criticality.

OPERATING MODE APPLICABILITY

Hot Standby  
Safe/Stable Shutdown

Example Emergency Action Level:

AP1000

1. UNPLANNED sustained positive startup rate.

ESBWR

1. UNPLANNED SRNM Short Period Alarm.

Basis:

This IC addresses inadvertent criticality events. This IC indicates a potential degradation of the level of safety of the plant, warranting a NOUE classification. This IC excludes inadvertent criticalities that occur during planned reactivity changes associated with reactor startups[ *(e.g., criticality earlier than estimated). The Cold Shutdown/Refueling IC is CU8*].

*[This condition can be identified using period monitors/startup rate monitor. The term "sustained" is used in order to allow exclusion of expected short term positive periods/startup rates from planned fuel bundle or control rod movements during core alteration. These short term positive periods/startup rates are the result of the increase in neutron population due to subcritical multiplication.]*

Escalation would be by the Fission Product Barrier Matrix, as appropriate to the operating mode at the time of the event, or by Emergency Director judgment.

AP1000 References:

ESBWR References: [TBD]

APP-PMS-J1-003

## SYSTEM MALFUNCTION

**SA1**

Initiating Condition -- ALERT

All Safety Related DC Batteries Not Being Charged for Greater Than 60 Minutes Due to Loss of Power to PIP Busses.

Operating Mode Applicability:

Power Operation  
Startup  
Hot Standby  
Safe/Stable Shutdown

Example Emergency Action Level:

AP1000

1. PIP Busses ECS-ES-1 and ECS-ES-2 de-energized for greater than 60 minutes.

ESBWR

1. PIP Busses 1000A3 and 1000B3 de-energized for greater than 60 minutes.

Basis:

This IC and the associated EALs are intended to provide an escalation from IC SU1. Prolonged de-energization of the PIP busses reduces required redundancy and potentially degrades the level of safety of the plant by rendering the plant more vulnerable to a complete loss of DC Power. 60 minutes was selected as an escalation to ensure augmented support is available to the operating crew.

The condition indicated by this IC is the degradation of the AC power systems.

*[There are no safety-related functions with respect to Off-site or On-site AC power in the advanced passive plant design that are required for the protection of any of the fission product barriers. All electrical power requirements that are necessary to protect the health and safety of the public and the fission product barriers are part of the DC power system design which is completely independent of the off-site or on-site AC power systems.]*

AP1000 References:

APP-ECS-E8-001  
APP-EDS-E8-001  
APP-IDS-E8-001  
Tech Spec 3.8

ESBWR References: [TBD]

DCD Tier 2, Chap. 8, Figure 8.1-1, Rev. 3



## SYSTEM MALFUNCTION

Technical Specification 3.3.1

ESBWR References: [TBD]

## SYSTEM MALFUNCTION

**SA4**

Initiating Condition -- ALERT

Loss of Indicating and Monitoring Functions.

Operating Mode Applicability:	Power Operation Startup Hot Standby Safe/Stable Shutdown
-------------------------------	---

Example Emergency Action Level:

*Note: The Emergency Director should not wait until the applicable time has elapsed, but should declare the event as soon as it is determined that the condition will likely exceed the applicable time.*

AP1000

1. Loss of All PLS and PMS Indicating and Monitoring Functions for 15 minutes or longer.

ESBWR

1. Loss of any three Q-DCIS Indicating and Monitoring Functions for 15 minutes or longer.

Basis:

This IC recognizes the difficulty associated with monitoring changing plant conditions without the use of a major portion of the control and indication systems.

*[The Protection and Safety Monitoring System (PMS) provides the functions necessary to protect the plant during normal operations, to shutdown the plant, and to maintain the plant in a safe shutdown condition. The Plant Control System (PLS) includes the control functions that provide for the control of the nuclear process, conversion of nuclear energy into heat energy, and transport of the heat energy from the nuclear reactor to the main steam turbine.]*

[ESBWR TBD]

This Alert will be escalated to a Site Area Emergency if the operating crew cannot monitor the transient in progress.

AP1000 References:

APP-PMS-J7-001  
APP-DAS-J7-001  
APP-PLS-J7-001  
APP-DDS-J7-001

ESBWR References: [TBD]

## SYSTEM MALFUNCTION

**SS1**

Initiating Condition -- SITE AREA EMERGENCY

All Safety Related DC Batteries Not Being Charged for 24 Hours or Longer Due to Loss of Power to PIP Busses.

Operating Mode Applicability:

Power Operation  
Startup  
Hot Standby  
Safe/Stable Shutdown

Example Emergency Action Level:

*Note: The Emergency Director should not wait until the applicable time has elapsed, but should declare the event as soon as it is determined that the condition will likely exceed the applicable time.*

AP1000

1. PIP Busses ECS-ES-1 and ECS-ES-2 de-energized for 24 hours or longer.

ESBWR

1. PIP Busses 1000A3 and 1000B3 de-energized for 24 hours or longer.

Basis:

Prolonged de-energization of the PIP busses reduces required redundancy and potentially degrades the level of safety of the plant by rendering the plant more vulnerable to a complete loss of DC Power. 24 hours was selected as a threshold to escalate for recognition of the seriousness of the issue in that power has been unable to be restored through normal and abnormal operating procedures.

*[There are no safety-related functions with respect to Off-site or On-site AC power in the Passive ALWR plant designs that are required for the protection of any of the fission product barriers. All electrical power requirements that are necessary to protect the health and safety of the public and the fission product barriers are part of the DC power system design which is completely independent of the off-site or on-site AC power systems.]*

Escalation to General Emergency is via Fission Product Barrier Degradation or IC SG1, "Prolonged Loss of All Off-site and On-site AC Power for greater than 72 hours."

AP1000 References:

APP-ECS-E8-001  
APP-EDS-E8-001  
APP-IDS-E8-001  
Tech Spec 3.8

ESBWR References: [TBD]

DCD Tier 2, Chap. 8, Figure 8.1-1, Rev. 3





## SYSTEM MALFUNCTION

**SS3**

Initiating Condition -- SITE AREA EMERGENCY

Loss of All Vital DC Power for 15 Minutes or Longer.

Operating Mode Applicability:	Power Operation Startup Hot Standby Safe/Stable Shutdown
-------------------------------	---

Example Emergency Action Level:

*Note: The Emergency Director should not wait until the applicable time has elapsed, but should declare the event as soon as it is determined that the condition will likely exceed the applicable time.*

### AP1000

1. Less than [TBD] bus voltage on all of the following IE DC Busses for 15 minutes or longer.

IDSA-EA-1	IDSC-EA-1
IDSA-EA-2	IDSC-EA-2
IDSB-EA-1	IDSC-EA-3
IDSB-EA-2	IDSD-EA-1
IDSB-EA-3	IDSD-EA-2

### ESBWR

1. Less than 210V on all Vital DC Busses 11, 12, 21, 22, 31, 32, 41, and 42 for 15 minutes or longer.

Basis:

Loss of all DC power compromises ability to monitor and control plant safety functions. Prolonged loss of all DC power will cause core uncovering and loss of containment integrity when there is significant decay heat and sensible heat in the reactor system. Fifteen minutes for the initiating condition was selected as a threshold to exclude transient or momentary power losses.

*[(Site-specific) bus voltage should be based on the minimum bus voltage necessary for the operation of safety related equipment. This voltage value should incorporate a margin of at least 15 minutes of operation before the onset of inability to operate those loads. This voltage is usually near the minimum voltage selected when battery sizing is performed. Typically the value for the entire battery set is approximately 105 VDC. For a 60 cell string of batteries the cell voltage 1.75 Volts per cell. For a 58 string battery set the minimum voltage is typically 1.81 Volts per cell.]*

Escalation to a General Emergency would occur by Abnormal Rad Levels/Radiological Effluent, Fission Product Barrier Degradation, or Emergency Director judgment ICs.

AP1000 References:  
APP-ECS-E8-001  
APP-EDS-E8-001  
APP-IDS-E8-001  
Tech Spec 3.8

ESBWR References: [TBD]

SYSTEM MALFUNCTION

**SS6**

Initiating Condition -- SITE AREA EMERGENCY

Inability to Monitor a SIGNIFICANT TRANSIENT in Progress.

Operating Mode Applicability:	Power Operation Startup Hot Standby Safe/Stable Shutdown
-------------------------------	---

Example Emergency Action Level:

AP1000

- 1. a. Loss of all PLS, PMS and DAS Indication and Monitoring capability

**AND**

- b. A SIGNIFICANT TRANSIENT in progress.

ESBWR

- 1. a. UNPLANNED Loss of all Q-DCIS Indicating and Monitoring Functions

**AND**

- b. A SIGNIFICANT TRANSIENT [as indicated by – TBD] in progress.

Basis:

This IC recognizes the inability of the Control Room staff to monitor the plant response to a transient. A Site Area Emergency is considered to exist if the Control Room staff cannot monitor safety functions needed for protection of the public.

AP1000 References:

ESBWR References: [TBD]

APP-PMS-J7-001  
APP-DAS-J7-001  
APP-PLS-J7-001  
APP-DDS-J7-001

## SYSTEM MALFUNCTION

**SG1**

### Initiating Condition -- GENERAL EMERGENCY

All Safety Related DC Batteries Not Being Charged for Greater Than 72 Hours Due to Loss of Power to PIP Busses.

Operating Mode Applicability:	Power Operation
	Startup
	Hot Standby
	Safe/Stable Shutdown

### Example Emergency Action Level:

#### AP1000

1. PIP Busses ECS-ES-1 and ECS-ES-2 de-energized for greater than 72 hours.

#### ESBWR

1. PIP Busses 1000A3 and 1000B3 de-energized for greater than 72 hours.

### Basis:

*[There are no safety-related functions with respect to off-site or on-site AC power in the Passive ALWRs plant design that are required for the protection of any of the fission product barriers. However, a Loss of all AC power compromises the ability to charge the IE batteries and the ability to recover from an accident condition. Prolonged loss of all AC power and other failures could lead to loss of fuel clad, RCS, and containment. The 72 hours to restore AC power is based on Technical Specification Bases B 3.8. Appropriate allowance for off-site emergency response including evacuation of surrounding areas should be considered. Although this IC may be viewed as redundant to the Fission Product Barrier Degradation IC, its inclusion is necessary to better assure timely recognition and emergency response.]*

{AP1000 - The DC Battery design is for at least 72 hours of safety related power. If the DC busses have been de-energized, then the reactor is being maintained in a safe shutdown condition by gravity and natural circulation. This reduces the fission product barrier protection for the plant to being dependent on the non-safety related ancillary diesels to ensure safety, creating a potential threat to all three fission product barriers. As the batteries would be beyond their design capability, operators would also be dependent upon indications powered by the ancillary diesels for monitoring plant status and other functions.}

{ESBWR - The DC Battery design is for at least 72 hours of safety related power. If the DC busses have been de-energized, then the reactor is being maintained in a safe shutdown condition by gravity and natural circulation by refilling the Isolation Condenser and PCC Pools using the on-site Fire Protection System.}

This IC is specified to assure that in the unlikely event of a prolonged station blackout, timely recognition of the seriousness of the event occurs and that declaration of a General Emergency occurs as early as is appropriate, based on a reasonable assessment of the event trajectory.

The likelihood of restoring at least one bus should be based on a realistic appraisal of the situation since a delay in an upgrade decision based on only a chance of mitigating the event could result in a loss of valuable time in preparing and implementing public protective actions.

## SYSTEM MALFUNCTION

Under these conditions, fission product barrier monitoring capability may be degraded. Although it may be difficult to predict when power can be restored, it is necessary to give the Emergency Director a reasonable idea of how quickly to declare a General Emergency based on two major considerations:

1. Are there any present indications that core cooling is already degraded to the point that Loss or Potential Loss of Fission Product Barriers is IMMEDIATE?
2. If there are no present indications of such core cooling degradation, how likely is it that power can be restored in time to assure that a loss of two barriers with a potential loss of the third barrier can be prevented?

Thus, indication of continuing core cooling degradation must be based on Fission Product Barrier monitoring with particular emphasis on Emergency Director judgment as it relates to IMMEDIATE Loss or Potential Loss of fission product barriers and degraded ability to monitor fission product barriers.

### AP1000 References:

APP-ECS-E8-001  
APP-EDS-E8-001  
APP-IDS-E8-001  
Tech Spec 3.8  
Tech Spec Basis B 3.8.1

### ESBWR References:

DCD Tier 2, Chap. 8, Figure 8.1-1, Rev. 3



## SYSTEM MALFUNCTION

*[For PWRs, the extreme challenge to the ability to cool the core is intended to mean that the core exit temperatures are at or approaching 1200 degrees F or that the reactor vessel water level is below the top of active fuel. For plants using CSFSTs, this EAL equates to a Core Cooling RED condition combined with a Subcriticality RED condition. For BWRs, the extreme challenge to the ability to cool the core is intended to mean that the reactor vessel water level cannot be restored and maintained above the Top of Active Fuel (TAF) as described in the EOP bases.]*

*[Another consideration is the inability to initially remove heat during the early stages of this sequence. For PWRs, if emergency feedwater flow is insufficient to remove the amount of heat required by design from at least one steam generator, an extreme challenge should be considered to exist. For plants using CSFSTs, this EAL equates to a Heat Sink RED condition combined with a Subcriticality RED condition. For BWRs, considerations include inability to remove heat via the main condenser, or via the suppression pool.]*

In the event either of these challenges exists at a time that the reactor has not been brought below the power associated with the Safety System Design [*typically 3 to 6% power*], a core melt sequence exists. In this situation, core degradation can occur rapidly. For this reason, the General Emergency declaration is intended to be anticipatory of the fission product barrier matrix declaration to permit maximum off-site intervention time.

### AP1000 References:

APP-PMS-J4-020  
APP-PMS-J7-001  
APP-DAS-J7-001  
APP-PLS-J7-001

### ESBWR References:

DCD Tier 2, Sec 15.5 (Rev 3)

## Appendix A

### Basis for Radiological Effluent Initiating Conditions

#### Introduction

This appendix supplements the basis information provided in Section 5 for initiating conditions AU1, AA1, AS1, and AG1.

This appendix will be structured into seven major sections. They are:

1. Purpose of the effluent ICs/EALs and their relationship to other ICs/EALs
2. Explanation of the ICs
3. Explanation of the example EALs and their relationship to the ICs
4. Interface between the ICs/EALs and the Off-site Dose Calculation Manual (ODCM)
5. Monitor setpoints versus EAL thresholds.
6. The impact of meteorology
7. The impact of source term

#### A.1 Purpose of the Effluent ICs/EALs

ICs AU1, AA1, AS1, and AG1 provide classification thresholds for UNPLANNED and/or uncontrolled releases of radioactivity to the environment. In as much as the purpose of emergency planning at nuclear power plants is to minimize the consequences of radioactivity releases to the environment, these ICs would appear to be controlling. However, classification of emergencies on the basis of radioactivity releases is not optimum, particularly those classifications based on radiation monitor indications. Such classifications can be deficient for several reasons, including:

- In significant emergency events, a radioactivity release is seldom the initiating event, but rather, is the consequence of some other condition. Relying on an indication of a release may not be sufficiently anticipatory.
- The relationship between an effluent monitor indication caused by a release and the off-site conditions that result is a function of several parameters (e.g., meteorology, source term) which can change in value by orders of magnitude between normal and emergency conditions and from event to event. The appropriateness of these classifications is dependent on how well the parameter values assumed in pre-established classification thresholds match those that are present at the time of the incident.

Section 3.3 of NEI 07-01 emphasizes the need for accurate assessment and classification of events, recognizing that over-classification, as well as under-classification, is to be avoided. Primary emphasis is intended to be placed on plant conditions in classifying emergency events. Effluent ICs were included, however, to provide a basis for classifying events that cannot be readily classified on the basis of plant condition alone. Plant condition ICs are included to address the precursors to radioactivity release in order to ensure anticipatory action. The effluent ICs do not stand alone, nor do the plant condition ICs. The inclusion of both categories more fully addresses the potential event spectrum and compensates for potential deficiencies in either. This is a case in which the whole is greater than the sum of the parts.

From the discussion that follows, it should become clear how the various aspects of the NEI 07-01 effluent ICs/EALs work together to provide for reasonably accurate and timely emergency classifications. While some aspects of the radiological effluent EALs may appear to be potentially unconservative, one also needs to consider IC/EALs in other recognition categories that compensate for this condition. During site-specific implementation of these ICs/EALs, changes to some of these aspects might appear advantageous. While site-specific changes are anticipated, caution must be used to ensure that these changes do not impact the overall effectiveness of the ICs / EALs.



## Appendix A

### Basis for Radiological Effluent Initiating Conditions

#### A.2. Initiating Conditions

There are four radiological effluent ICs provided in NEI 99-01. The IC and the fundamental basis for the ultimate classification for the four classifications are:

General (AG1)	Off-site Dose Resulting from an Actual or IMMEDIATE Release of Gaseous Radioactivity Exceeds 1000 mR TEDE or 5000 mR Thyroid CDE for the Actual or Projected Duration of the Release Using Actual Meteorology.
Site Area (AS1)	Off-site Dose Resulting from an Actual or IMMEDIATE Release of Gaseous Radioactivity Exceeds 100 mR TEDE or 500 mR Thyroid CDE for the Actual or Projected Duration of the Release.
Alert (AA1)	Any UNPLANNED Release of Gaseous or Liquid Radioactivity to the Environment that Exceeds 200 Times Off-site Dose Calculation Manual for 15 Minutes or Longer.
NOUE (AU1)	Any UNPLANNED Release of Gaseous or Liquid Radioactivity to the Environment that Exceeds Two Times Off-site Dose Calculation Manual for 60 Minutes or Longer.

The fundamental basis of AU1 and AA1 ICs differs from that for AS1 and AG1 ICs. It is important to understand the differences.

- Off-site Dose Calculation Manuals (ODCM) establish methodologies for establishing effluent monitor alarm setpoints, based on defined source term and meteorology assumptions.
- AU1 and AA1 are **NOT** based on these particular values of off-site dose or dose rate but, rather, on the loss of plant control implied by a radiological release that exceeds a specified multiple of the ODCM release limits for a specified period of time.
- The ODCM multiples are specified only to distinguish AU1 and AA1 from non-emergency conditions and from each other. While these multiples obviously correspond to an off-site dose, the classification emphasis is on a release that does not comply with a license commitment for an extended period of time.
- While some of the example EALs for AU1 and AA1 use indications of off-site dose rates as **symptoms** that the ODCM limits may be exceeded, the IC, and the classification, are **NOT** concerned with the particular value of off-site dose. While there may be quantitative inconsistencies involved with this protocol, the qualitative basis of the EAL, i.e., loss of plant control, is not affected.
- The basis of the AS1 and AG1 ICs **IS** a particular value of off-site dose for the event duration. AG1 is set to the value of the EPA PAG. AS1 is a fraction (10%) of the EPA PAG. As such, these ICs are consistent with the fundamental definitions of a Site Area Emergency and General Emergency.

#### A.3 Example Emergency Action Levels

For each of the classifications, NEI 07-01 provides some example emergency action levels and bases. Ideally, the example EALs would correspond numerically with the thresholds expressed in the respective IC. Two cases are applicable to the effluent EALs:

1. The EAL corresponds numerically to the threshold in the respective IC. For example, a field survey result of 1000 mrem/hr for a projected release duration of one hour corresponds directly to AG1.
2. The EAL corresponds numerically to the threshold in the respective IC under certain assumed conditions. For example, an effluent monitor reading that equates to 100 mrem for the

## **Appendix A**

### **Basis for Radiological Effluent Initiating Conditions**

projected duration of the release corresponds numerically to AS1 *if* the actual meteorology, source term, and release duration matches that used in establishing the monitor thresholds.

There are four typical example EALs:

- Effluent Monitor Readings: These EALs are pre-calculated values that correspond to the condition identified in the IC for a given set of assumptions.
- Field Survey Results: These example EALs are included to provide a means to address classifications based on results from field surveys.
- Perimeter Monitor Indications: For sites having them, perimeter monitors can provide a direct indication of the off-site consequences of a release.
- Dose Assessment Results: These example EALs are included to provide a means to address classifications based on dose assessments.

#### A.3.1 Effluent Monitor Readings

As noted above, these EALs are pre-calculated values that correspond to the condition identified in the IC for a given set of assumptions. The degree of correlation is dependent on how well the assumed parameters (e.g., meteorology, source term, etc.) represent the actual parameters at the time of the emergency.

#### **AS1 and AG1**

Classifications should be made under these EALs if VALID (e.g., channel check, comparison to redundant/diverse indication, etc.) effluent radiation monitor readings exceed the pre-calculated thresholds. In a change from previous versions of this methodology, confirmation by dose assessments is no longer required as a prerequisite to the classification. Nonetheless, dose assessments are important components of the overall accident assessment activities when significant radioactivity releases have occurred or are projected. Dose assessment results, when they become available, may serve to confirm the validity of the effluent radiation monitor EAL, may indicate that an escalation to a higher classification is necessary, or may indicate that the classification wasn't warranted. AS1 and AG1 both provide that, if dose assessment results are available, the classification should be based on the basis of the dose assessment result rather than the effluent radiation monitor EAL.

#### **AU1 and AA1**

ODCMs provide a methodology for determining default and batch-specific effluent monitor alarm setpoints pursuant to Standard Technical Specification (STS) 3.3.3.9. These setpoints are intended to show that releases are within Technical Specifications. The applicable limits are 500 mrem/year whole body or 3000 mrem/year skin from noble gases. (Inhalation dose rate limits are not addressed here since the specified surveillance involves collection and analysis of composite samples. This after-the-fact assessment could not be made in a timely manner conducive to accident classification.) These setpoints are calculated using default source terms or batch-specific sample isotopic results and annual average X/Q. Since the meteorology data is pre-defined, there is a direct correlation between the monitor setpoints and the ODCM limits. Although the actual X/Q may be different, NUREG-1022, Event Reporting Guidelines 10 CFR 50.72 and 50.73, provided "...Annual average meteorological data should be used for determining off-site airborne concentrations of radioactivity to maintain consistency with the Technical Specifications (TS) for reportability thresholds." The ODCM methodology is based on long term continuous releases. However, its use here in a short term release situation is appropriate. Remember that the AU1 and AA1 ICs are based on a loss of plant control indicated by the failure to comply with a multiple of the ODCM release limits for an extended period and that the ODCM provides the methodology for showing compliance with these limits.

To obtain the EAL thresholds, multiply the ODCM setpoint for each monitor by 2 (AU1) or 200 (AA1). It would be preferable to reference "2 x ODCM Setpoint" or "200 x ODCM Setpoint" as the EAL threshold. In this manner, the EAL would always change in step with changes in the ODCM setpoint (e.g., for a batch or special release). In actual practice, there may be a "warning" and a "high" alarm setpoint. The setpoint that

## Appendix A

### Basis for Radiological Effluent Initiating Conditions

is closest in value to the ODCM limit should be used. Facility ODCMs may lower the actual setpoint to provide an administrative "safety margin". Also, if there is more than one unit or release stack on the site, the ODCM limits may be apportioned. Two possible approaches to obtain the EAL thresholds are:

- The "2x" and "200x" multiples could be increased to address the reduced setpoints. For example, if the stack monitor were set to 50% of the ODCM limit, the EAL threshold could be set to "4x" and "400x" the setpoint on that monitor.
- The reduced setpoints could be ignored and the "2x" and "200x" multiples used as specified. While numerically conservative, using a single set of multipliers would probably be desirable from a human engineering standpoint.

In a change from previous versions of this methodology, confirmation by dose assessments is no longer required as a prerequisite to the classification. While assessments with real meteorology may have provided a basis for escalating to AS1 (or AG1), the assessments could not confirm the AU1 or AA1 classifications since compliance with the ODCM limit is demonstrated using *annual average* meteorology – not – actual meteorology.

Nonetheless, dose assessments are important components of the overall accident assessment activities when significant radioactivity releases have occurred or are projected. Dose assessment results, when they become available, may indicate that an escalation to a higher classification is necessary. AS1 and AG1 both provide that, if dose assessment results are available, the classification should be based on the basis of the dose assessment result rather than the effluent radiation monitor EAL.

In typical practice, the radiological effluent monitor alarms would have been set, on the basis of ODCM requirements, to indicate a release that could exceed the ODCM limits. Alarm response procedures call for an assessment of the alarm to determine whether or not these limits have been exceeded. Utilities typically have methods for rapidly assessing an abnormal release in order to determine whether or not the situation is reportable under 10 CFR 50.72. Since a radioactivity release of a magnitude comparable to the ODCM limits will not create a need for off-site protective measures, it would be reasonable to use these abnormal release assessment methods to initiate dose assessment techniques using actual meteorology and projected source term and release duration.

#### A.3.2 Perimeter Monitor, Field Survey Results, Dose Projection Results

##### **AS1 and AG1**

The perimeter monitor and field survey results are included to provide a means for classification based on actual measurements. There is a 1:1 correlation (with consideration of release duration) between these EALs and the IC since all are dependent on actual meteorology.

Dose projection result EALs are included to provide a basis for classification based on results from assessments triggered at lower emergency classifications. If the dose assessment results are available at the time that the classification is made, the results should be used in conjunction with this EAL for classifying the event rather than the effluent radiation monitor EAL.

Although the IC references TEDE and thyroid CDE as criteria, field survey results and perimeter monitor indications will generally not be reported in these dose quantities, but rather in terms of a dose rate. For this reason, the field survey EALs are based on a  $\beta$ - $\gamma$  dose rate and a thyroid CDE value, both assuming one hour of exposure (or inhalation). If individual site analyses indicate a longer or shorter duration for the period in which the substantial portion of the activity is released, the longer duration should be used for the field survey and/or perimeter monitor EALs.

##### **AU1 and AA1**

As discussed previously, the threshold in these ICs is based on exceeding a multiple of the ODCM for an extended period. The applicable ODCM limit is the instantaneous dose rate provided in Standard Technical

## Appendix A

### Basis for Radiological Effluent Initiating Conditions

Specification (STS) 3.11.2.1. While these three EALs are also expressed in dose rate, they are dependent on *actual* meteorology. However, compliance with the ODCM is demonstrated using *annual average* meteorology. Due to this, the only time that there would be a 1:1 correlation between the IC and these EALs is when the value of the actual meteorology matched the annual average -- an unlikely situation. For this reason, these EALs can only be indirect indicators that the ODCM limits may be exceeded. The three example EALs are consistent with the fundamental basis of AU1 and AA1, that of a uncontrolled radioactivity release that indicates a loss of plant control. A dose rate, at or beyond the site boundary, greater than 0.1 mR/hr for 60 minutes or 10.0 mR/hr for 15 minutes is consistent with this fundamental basis, regardless of the lack of numerical correlation to the ODCM. The time periods chosen for the NOUE AU1 (60 minutes) and Alert AA1 (15 minutes) are indicative of the relative risks based on the loss of ability to terminate a release.

The numeric values shown in AU1 and AA1 are based on a release rate not exceeding 500 mrem per year, converted to a rate of:  $500 \div 8766 = 0.057$  mR/hr. If we take a multiple of 2, as specified in the NOUE threshold, this equates to a dose rate of about 0.11 mR/hr, which rounds to the 0.1 mR/hr specified in AU1. Similarly for the AA1 EALs, we obtain 10 mR/hr.

In AU1 and AA1, reference is made to *automatic real-time dose assessment capability*. In AS1 and AG1, the reference is to *dose assessment*. This distinction was made since it is unlikely that a dose assessment using manual methods would be initiated without some prior indication, e.g., an effluent monitor EAL.

#### A.4 Interface Between ODCM and ICs/EALs

For AU1 and AA1, a strong link was established with the facility's ODCM. It was the intent of the NUMARC/NESP EAL Task Force to have the AU1 and AA1 EALs indexed to the ODCM alarm setpoints. This was done for several reasons:

- To allow the EALs to use the monitor setpoints already in place in the facility ODCM, thus eliminating the need for a second set of values as the EALs. The EAL could reference "2x ODCM Setpoint" or "200x ODCM Setpoint" for the monitors addressed in the ODCM. Extensive calculations would only be necessary for monitors not addressed in the ODCM.
- To take advantage of the alarm setpoint calculational methodology already documented in the facility ODCM.
- To ensure that the operators had an alarm to indicate the abnormal condition. If the monitor EAL threshold was less than the default ODCM setpoint, the operators could be in the position of having exceeded an EAL and not knowing it.
- To simplify the IC/EAL by eliminating the need to address planned and UNPLANNED releases, continuous or batch releases, monitored or unmonitored releases. Any release that complies with the ODCM controls would not exceed a monitor EAL threshold.
- To eliminate the possibility of a planned release (e.g., containment / drywell purge) resulting in effluent radiation monitor readings that exceed an classification threshold that was based on a different calculation method. ODCMs typically require specific alarm setpoints for such releases. If the release can be authorized under the provisions of the ODCM, an emergency classification is not warranted. If the monitor EAL threshold is indexed to the ODCM setpoint (e.g., "...2 x ODCM setpoint...") the monitor EAL will always change in step with the ODCM setpoint.

#### A.5 Setpoints versus Monitor EALs

Effluent monitors typically have provision for two separate alarm setpoints associated with the level of measured radioactivity. (There may be other alarms for parameters such as low sample flow.) These

## Appendix A

### Basis for Radiological Effluent Initiating Conditions

setpoints are typically established by the facility ODCM. As such, at most sites the values of the monitor EAL thresholds will not be implemented as actual alarm setpoints, but would be tabulated in the classification procedure. If the monitor EAL thresholds are calculated as suggested herein they will be higher than the ODCM alarm setpoints by at least a factor of two (i.e., AU1). This alarm alerts the operator to compare the monitor indication to the EAL thresholds. The NEI 07-01 effluent EALs do NOT require alarm setpoints based on the monitor EALs. However, if spare alarm channels are available (e.g., high range channels), the monitor EAL threshold could be used as the alarm setpoint.

#### A.6 The Impact of Meteorology

The existence of uncertainty between actual event meteorology and the meteorology assumed in establishing the EALs was identified above. It is important to note that uncertainty is present regardless of the meteorology data set assumed. The magnitude of the potential difference and, hence, the degree of conservatism will depend on the data set selected. Data sets that are intended to ensure low probability of under-conservative assessments have a high probability of being over-conservative. For nuclear power plants, there are different sets of meteorological data used for different purposes. The two primary sets are:

- For accident analyses purposes, sector X/Q values are set at that value that is exceeded only 0.5% of the hours wind blows into the sector. The highest of the 16 sector values is the maximum sector X/Q value. The site X/Q value is set at that value that is exceeded only 5% of the hours for all sectors. The higher of the sector or site X/Q values is used in accident analyses.
- For routine release situations, annual average X/Q values are calculated for specified receptor locations and at standard distances in each of the 16 radial sectors. In setting ODCM alarm set points, the annual average X/Q value for the most restrictive receptor at or beyond the site boundary is used. The sector annual average X/Q value is normalized for the percentage of time that the wind blows into that sector. In an actual event, the wind direction may be into the affected sector for the entire release duration. Many sites experience typical sector X/Qs that are 10-20 times higher than the calculated annual average for the sector.

In developing the effluent EALs, the NEI EAL Task Force elected to use annual average meteorology for establishing effluent monitor EAL thresholds. This decision was based on the following considerations.

- Use of the accident X/Qs, may be too conservative. For some sites, the difference between the accident X/Q and the annual average X/Q can be a factor of 100-1000. With this difference in magnitude, the calculated monitor EALs for AS1 or AG1 might actually be less than the ODCM alarm setpoints, resulting in unwarranted classifications for releases that might be in compliance with ODCM limits.
- The ODCM is based in part on annual average X/Q (non-normalized). ODCMs already provide alarm setpoints based on annual average X/Q that could be used for AU1 and AA1.
- Use of a X/Q more restrictive than the X/Q used to establish ODCM alarm setpoints could create a situation in which the EAL value would be less than the ODCM setpoint. In this case, the operators would have no alarm indication to alert them of the emergency condition.
- Use of one X/Q value for AU1 and AA1 and another for AS1 and AG1 might result in monitor EALs that would not progress from low to high classifications. Instead, the AS1 and AA1 EALs might overlap.

Plant specific consideration must be made to determine if annual average meteorology is adequately conservative for site-specific use. If not one of the two more conservative techniques described above should be selected. It is incumbent upon the licensee to ensure that the selection is properly implemented to provide consistent classification escalation.

## Appendix A

### Basis for Radiological Effluent Initiating Conditions

The impact of the differences between the assumed annual average meteorology and the actual meteorology depends on the particular EAL.

- For the AU1 and AA1 effluent monitor EALs, there is no impact since the IC and the EALs are based on annual average meteorology by definition.
- For the field survey, perimeter monitor, and dose assessment results EALs in AS1 and AG1, there is no impact since the IC and these EALs are based on actual meteorology.
- For the AS1 and AG1 effluent monitor EALs, there may be differences since the IC is based on actual meteorology and the monitor EALs are calculated on the basis of annual average meteorology or, on a site-specific basis, one of the more conservative derivatives of annual average meteorology. This is considered as acceptable in that dose assessments using actual meteorology will be initiated for significant radioactivity releases. Needed escalations can be based on the results of these assessments. As discussed previously, this delay was deemed to be acceptable since in significant release situations, the plant condition EALs should provide the anticipatory classifications necessary for the implementation of off-site protective measures.
- For the field survey, perimeter monitor, and dose assessment results EALs in AU1 and AA1, there is an impact. These three EALs are dependent on actual meteorology. However, the threshold values for all of the AU1 and AA1 EALs are based on the assumption of annual average meteorology. If the actual and annual average meteorology were equal, the IC and all of the EALs would correlate. Since it is likely that the actual meteorology will exceed the annual average meteorology, there will be numerical inconsistencies between these EALs and the IC. The three example EALs are consistent with the fundamental basis of AU1 and AA1, that of an uncontrolled radioactivity release that indicates a loss of plant control. A dose rate, at or beyond the site boundary, greater than 0.1 mR/hr for 60 minutes or 10.0 mR/hr for 15 minutes is consistent with this fundamental basis, regardless of the lack of numerical correlation to the ODCM.

#### A.7 The Impact of Source Term

The ODCM methodology should be used for establishing the monitor EAL thresholds for these ICs. The ODCM provides a default source term based on expected releases. In many cases, the ODCM source term is derived from expected and/or design releases tabulated in the FSAR.

For AS1 and AG1, the bases suggests the use of the same source terms used for establishing monitor EAL thresholds for AU1 and AA1, or an accident source term if deemed appropriate. This guidance is provided to promote proper escalations, use realistic values, and correlation between rad monitor values and dose assessment results. This guidance is provided to avoid potential overlaps between effluent monitor EALs for AA1 and AS1. Other source terms may be appropriate to achieve these goals. In any case, efforts should be made to obtain and use best estimate (For Example: NUREG 1465), as opposed to conservative, source terms for all four ICs.

Even if the same source term is used for all four ICs, the analyst must consider the impact of overly conservative iodine to noble gas ratios. The AU1 and AA1 IC thresholds are based on external noble gas exposure. The AS1 and AG1 ICs are based on either TEDE or thyroid CDE. TEDE includes a contribution from inhalation exposure (i.e., CEDE) while the thyroid CDE is due solely to inhalation exposure. The inhalation exposure is sensitive to the iodine concentration in the source term. Since AU1 and AA1 are based on noble gases, and AS1 and AG1 are dependent on noble gases and iodine, an over conservative iodine to noble gas ratio could result in AS1 and AG1 monitor EAL thresholds that either overlap or are too close to the AA1 monitor EAL thresholds.

**Appendix A**  
Basis for Radiological Effluent Initiating Conditions

As with meteorology, assessment of source terms has uncertainty. This uncertainty is compensated for by the anticipatory classifications provided by ICs in other recognition categories.