

CENG

a joint venture of



Constellation
Energy



EDF

CALVERT CLIFFS
NUCLEAR POWER PLANT

January 31, 2011

U. S. Nuclear Regulatory Commission
Washington, DC 20555

ATTENTION: Document Control Desk

SUBJECT: Calvert Cliffs Nuclear Power Plant
Unit No. 1; Docket No. 50-317
Relief Request for Modifications to Pressurizer Heater Sleeve and Lower Level
Nozzle Penetrations (RR-PZR-01)

Pursuant to 10 CFR 50.55a(a)(3)(i), Calvert Cliffs Nuclear Power Plant, LLC (Calvert Cliffs) hereby requests Nuclear Regulatory Commission approval to perform modifications to Calvert Cliffs Unit 1 pressurizer heater sleeve and lower level nozzle penetrations in order to mitigate the propensity for primary water stress corrosion cracking occurring. The modifications will be performed as an alternative to the pressurizer American Society of Mechanical Engineers Code requirements. Performance of these modifications, as detailed in Attachment (1), will maintain an acceptable level of quality and safety.

Calvert Cliffs requests approval of this alternative be completed by January 1, 2012 in order to allow this alternative to be performed during Unit 1's 2012 Refueling Outage which is scheduled to commence in February 2012. This relief request is effective for Calvert Cliffs Fourth Ten-Year Inservice Inspection Interval.

Should you have questions regarding this matter, please contact Mr. Douglas E. Lauver at (410) 495-5219.

Very truly yours,

James J. Stanley

Manager – Engineering Services

JJS/KLG/bjd

Attachment: (1) Relief Request for Alternative Modifications to Unit 1 Pressurizer Heater Sleeve and Lower Level Nozzle Penetrations (RR-PZR-01)

A047
NRR

Document Control Desk
January 31, 2011
Page 2

cc: D. V. Pickett, NRC
W. M. Dean, NRC

Resident Inspector, NRC
S. Gray, DNR

ATTACHMENT (1)

**RELIEF REQUEST FOR ALTERNATIVE MODIFICATIONS TO UNIT 1
PRESSURIZER HEATER SLEEVE AND LOWER LEVEL NOZZLE
PENETRATIONS (RR-PZR-01)**

ATTACHMENT (1)

**RELIEF REQUEST FOR ALTERNATIVE MODIFICATIONS TO UNIT 1 PRESSURIZER
HEATER SLEEVE AND LOWER LEVEL NOZZLE PENETRATIONS (RR-PZR-01)**

**Calvert Cliffs Nuclear Power Plant, Unit 1
10 CFR 50.55a Request Number RR-PZR-01**

**Proposed Alternative
in Accordance with 10 CFR 50.55a(a)(3)(i)**

-- Alternative Provides Acceptable Level of Quality and Safety--

1. American Society of Mechanical Engineers (ASME) Code Components Affected

Components:	Pressurizer heater and lower level nozzle penetrations
Code Class:	Class 1
Examination Category:	B-P
Code Item Number:	B15.10
Description:	Pressurizer Heater Sleeve and Lower Level (Instrument) Nozzle Penetrations (Qty 119)
Size:	Heater Sleeves 1.156 Inch Nominal Outside Diameter Instrument Nozzles 1.315 Inch Nominal Outside Diameter
Material:	Stainless Steel Type 316/316L

2. Applicable Code Edition and Addenda

ASME Boiler and Pressure Vessel Code (ASME Code) Section XI – 2004 Edition, no Addenda

Code Case N-638-1, Similar and Dissimilar Metal Welding Using Ambient Temperature Machine GTAW Temper Bead Technique, Section XI, Division 1

ASME Code Section III, 1965 Edition, including Addenda through Winter 1967

3. Applicable Code Requirement

The 2004 Edition, no Addenda of ASME Code Section XI, IWA-4221(a) states:

“An item to be used for repair/replacement activities shall meet the Owner’s Requirements. Owner’s Requirements may be revised, provided they are reconciled in accordance with IWA-4222. Reconciliation documentation shall be prepared.”

The 2004 Edition, no Addenda of ASME Code Section XI, IWA-4221(b) states:

“An item to be used for repair/replacement activities shall meet the Construction Code specified in accordance with (1), (2), or (3) below.”

The 2004 Edition, no Addenda of ASME Code Section XI, IWA-4221(c) states in part:

“As an alternative to (b) above, the item may meet all or portions of the requirements of different Editions and Addenda of the Construction Code, or Section III... provided the requirements of IWA-4222 through IWA-4226, as applicable, are met. ...”

The 2004 Edition, no Addenda of ASME Code Section XI, IWA-4400 provides welding, brazing, metal removal, and installation requirements related to repair/replacement activities.

ATTACHMENT (1)

**RELIEF REQUEST FOR ALTERNATIVE MODIFICATIONS TO UNIT 1 PRESSURIZER
HEATER SLEEVE AND LOWER LEVEL NOZZLE PENETRATIONS (RR-PZR-01)**

The 2004 Edition, no Addenda of ASME Code Section XI, IWA-4411 states:

“Welding, brazing, and installation shall be performed in accordance with the Owner’s Requirements and, except as modified below, in accordance with the Construction Code of the item.”

The 2004 Edition, no Addenda of ASME Code Section XI, IWA-4411(a) states in part:

“Later editions and addenda of the Construction Code, or a later different Construction Code, either in its entirety or portions thereof, and Code Cases may be used provided the substitution is as listed in IWA-4221(c). ...”

The 2004 Edition, no Addenda of ASME Code Section XI, IWA-4610(a) states in part:

“... Thermocouples and recording instruments shall be used to monitor the process temperatures.
...”

Code Case N-638-1, *Similar and Dissimilar Metal Welding Using Ambient Temperature Machine GTAW Temper Bead Technique*, provides requirements for automatic or machine Gas Tungsten Arc Welding (GTAW) of Class 1 components without the use of preheat or postweld heat treatment.

Code Case N-638-1, paragraph 3.0(d) states:

“The maximum interpass temperature for field applications shall be 350°F regardless of the interpass temperature during qualification.”

Code Case N-638-1, last sentence in the “*Reply*” states:

“The nondestructive examination requirements of the Construction Code need not be met, provided the requirements of paragraphs 1.0 through 5.0, and all other requirements of IWA-4000 are met.”

Code Case N-638-1, paragraph 4.0(b) states:

“The final weld surface and the band around the area defined in paragraph 1.0(d) shall be examined using a surface and ultrasonic methods when the completed weld has been at ambient temperature for at least 48 hours. The ultrasonic examination shall be in accordance with Appendix I.”

The 2004 Edition, no Addenda of ASME Code Section XI, IWA-4611.1(a) states:

“Defects shall be removed in accordance with IWA-4422.1. A defect is considered removed when it has been reduced to an acceptable size.”

The 2004 Edition, no Addenda of ASME Code Section XI, IWA-4422.1 states in part:

“A defect is considered removed when it has been reduced to an acceptable size... ”

The 2004 Edition, no Addenda of ASME Code Section XI, IWA-4422.1(b) states:

“Alternatively, the defect removal area and any remaining portion of the defect may be evaluated and the component accepted in accordance with the appropriate flaw evaluation provisions of Section XI, or the design provisions of the Owner’s Requirements and either the Construction Code or Section III.”

ATTACHMENT (1)

**RELIEF REQUEST FOR ALTERNATIVE MODIFICATIONS TO UNIT 1 PRESSURIZER
HEATER SLEEVE AND LOWER LEVEL NOZZLE PENETRATIONS (RR-PZR-01)**

The 2004 Edition, no Addenda of ASME Code Section XI, IWB-3420 states:

“Each detected flaw or group of flaws shall be characterized by the rules of IWA-3300 to establish the dimensions of the flaws. These dimensions shall be used in conjunction with the acceptance standards of IWB-3500.”

The 2004 Edition, no Addenda, of ASME Code Section XI, IWA-3300(a) states in part:

“Flaws detected by the preservice and inservice examinations shall be sized...”

The 2004 Edition, no Addenda, of ASME Code Section XI, IWA-3300(b) states in part:

“Flaws shall be characterized in accordance with IWA-3310 through IWA-3390, as applicable...”

The 2004 Edition, no Addenda of ASME Code Section XI, IWB-3142.4 states:

“A component containing relevant conditions is acceptable for continued service if an analytical evaluation demonstrates the component’s acceptability. The evaluation analysis and evaluation acceptance criteria shall be specified by the Owner. A component accepted for continued service based on analytical evaluation shall be subsequently examined in accordance with IWB-2420(b) and (c).”

The 2004 Edition, no Addenda of ASME Code Section XI, IWB-2420(b) states in part:

“If a component is accepted for continued service in accordance with IWB-3132.3 or IWB-3142.4, the areas containing flaws or relevant conditions shall be reexamined during the next three inspection periods listed in the schedule of the inspection program of IWB-2400...”

The 2004 Edition, no Addenda of ASME Code Section XI, IWB-2420(c) states:

“If the reexaminations required by IWB-2420(b) reveal that the flaws or relevant conditions remain essentially unchanged for three successive inspection periods, the component examination schedule may revert to the original schedule of successive inspections.”

The 2004 Edition, no Addenda of ASME Code Section III, NB-5331 states:

“All imperfections which produce a response greater than 20% of the reference level shall be investigated to the extent that the operator can determine the shape, identity, and location of all such imperfections and evaluate them in terms of acceptance standards given in (a) and (b) below.”

The 2004 Edition, no Addenda of ASME Code Section III, NB-5331(b) states:

“Indications characterized as cracks, lack of fusion, or incomplete penetration are unacceptable regardless of length.”

4. Reason for Request

Relief is requested in accordance with 10 CFR 50.55a (a)(3)(i).

Since the heater sleeve/lower level nozzles are constructed of Alloy 600 and their welds to the pressurizer lower head are Alloy 82/182, and these materials are susceptible to primary water stress corrosion cracking (PWSCC) in the pressurizer environment, flaws may exist in the Calvert Cliffs Nuclear Power Plant (Calvert Cliffs), Unit 1 pressurizer heater sleeves/lower level nozzles and/or heater sleeve/lower level nozzle to bottom head welds.

ATTACHMENT (1)

RELIEF REQUEST FOR ALTERNATIVE MODIFICATIONS TO UNIT 1 PRESSURIZER HEATER SLEEVE AND LOWER LEVEL NOZZLE PENETRATIONS (RR-PZR-01)

As an alternative to the requirements of pressurizer Code of Construction, ASME Section III, 1965 Edition/Winter 67 Addenda, and the pressurizer modification Construction Code, ASME Section III, 2004 Edition, no Addenda, Calvert Cliffs Unit 1, operated by Calvert Cliffs Nuclear Power Plant, LLC (Calvert Cliffs), proposes to perform modification of the pressurizer heater sleeve and lower level nozzle penetrations, to mitigate the propensity for PWSCC degradation. The ambient temperature inside diameter temper bead (IDTB) welding method to restore the pressure boundary of the penetrations will be used. The IDTB welding method is performed with a remotely operated weld tool, utilizing the machine Gas Tungsten-Arc Welding (GTAW) process and the ambient temperature bead method with 50°F minimum preheat temperature and no post weld heat treatment. The modifications will be conducted in accordance with the 2004 Edition, no Addenda of ASME Section XI, Code Case N-638-1, and the alternative requirements discussed below.

Stainless steel 316 base material with less than 0.03% maximum carbon content, and ER309 weld material with 0.03% maximum carbon content, both of which are resistant to PWSCC, will be used for the modifications. The stainless steel material to be used is dual certified as it meets both the low carbon content requirement of the "T" grade and the mechanical properties of the "non-L" grade material.

Basic steps for the modification are:

1. Machining to remove the lower portion of the sleeve/nozzle to approximately mid-wall thickness in the pressurizer bottom head. This machining is performed from the outside of the pressurizer and increases the penetration bore diameter and also establishes the weld preparation. (Refer to Figure 1)
2. Liquid penetrant (PT) examination of the machined area that is to be welded.
3. Welding the replacement stainless steel lower sleeve/nozzle to the pressurizer bottom head using stainless steel weld material. (Refer to Figure 2)
4. Machining the weld inner surface and adjacent area to provide a surface suitable for nondestructive examination. (NDE)
5. PT and ultrasonic (UT) examination of the weld and adjacent area. (Refer to Figure 2)

Calvert Cliffs has determined that modified pressurizer heater sleeve and lower level nozzle penetrations utilizing the requirements specified in this request will provide an acceptable level of quality and safety.

5. Proposed Alternatives and Bases for Use

5.1 Interpass Temperature Monitoring

Code Case N-638-1, paragraph 3.0(d) requires a maximum interpass temperature of 350°F for field applications.

Code Case N-638-1, last sentence in the "*Reply*" requires compliance with IWA-4000 unless specific requirements in Code Case N-638-1 specify alternatives thereto.

The 2004 Edition, no Addenda of ASME Code Section XI, IWA-4610(a) requires that thermocouples and recording instruments be used to monitor process temperatures.

ATTACHMENT (1)

RELIEF REQUEST FOR ALTERNATIVE MODIFICATIONS TO UNIT 1 PRESSURIZER HEATER SLEEVE AND LOWER LEVEL NOZZLE PENETRATIONS (RR-PZR-01)

However, direct interpass temperature measurement is impractical to perform during welding operations from inside the heater and lower level nozzle penetration bores.

For this modification the maximum interpass temperature will be determined by both of the following methods:

- (1) heat-flow calculations, using at least the variables listed below
 - (a) welding heat input
 - (b) initial base material temperature
 - (c) configuration, thickness, and mass of the item being welded
 - (d) thermal conductivity and diffusivity of the materials being welded
 - (e) arc time per weld pass and delay time between each pass
 - (f) arc time to complete the weld

- (2) measurement of the maximum interpass temperature on a test coupon that is no thicker than the item to be welded. The maximum allowed heat input of the welding procedure shall be used in welding the test coupon.

Although ASME Section IX, QW-290 requires hardness testing, QW-290 also permits the individual code sections to substitute impact testing when it is more appropriate to the section's constituencies. Hardness testing is more appropriate to vessels within the petrochemical industry where hydrogen damage from the process fluids is the prevalent concern. Impact testing is more appropriate to nuclear applications where ASME Sections III and XI always have and continue to require impact testing for temperbead welding qualification. Calvert Cliffs intends to qualify this temperbead welding procedure using impact testing in lieu of hardness testing as permitted by ASME Section XI.

This methodology is consistent with the associated requirements specified in Code Case N-638-2 and subsequent versions. Regulatory Guide 1.147, Revision 16 (Reference 1), lists ASME Code Case N-638-4 as a conditionally accepted ASME Code Section XI code case. The approval conditions noted in the regulatory guide do not impact requirements for performing maximum interpass temperature verification as described in Code Case N-638-4 and herein.

Calvert Cliffs requests relief from using thermocouples to monitor and verify process temperatures.

5.2 Acceptance Examination Area

Code Case N-638-1 paragraph 4.0(b) requires the final weld surface and the preheated band around the area defined in paragraph 1.0(d) to be examined using surface and ultrasonic methods.

Code Case N-638-1 paragraph 1.0(d) requires the area to be welded and the band around the welded area (defined as at least 1½ times the component thickness or 5 in., whichever is less), to be preheated.

The band includes an annular area extending five inches around the penetration bore on the outside surface of the pressurizer bottom head. The purpose for the examination of this area is to ensure all flaws associated with an area with flaws requiring subsequent weld repair have been removed or addressed since these flaws may have been associated with the original flaw and may have been overlooked. In this case, the new weld is performed remote from the sleeve/nozzle to pressurizer weld which are postulated to contain flaw(s).

ATTACHMENT (1)

RELIEF REQUEST FOR ALTERNATIVE MODIFICATIONS TO UNIT 1 PRESSURIZER HEATER SLEEVE AND LOWER LEVEL NOZZLE PENETRATIONS (RR-PZR-01)

It is unnecessary to examine the band around the weld area defined in Code Case N-638-1 paragraph 1.0(d).

The final examination of the new weld and immediate surrounding area within the bore will be sufficient to verify that defects have not been induced in the low alloy steel bottom head material due to the welding process and will assure the integrity of the sleeve/nozzle and the new weld. Figure 2 depicts the areas for PT and UT of the modified heater sleeve/lower level nozzle penetration.

The PT area includes the new weld surface and the ½ inch minimum distance above and below the weld.

Ultrasonic examination will be performed by scanning from the inner diameter surface of the sleeve/nozzle and weld. The UT is qualified to detect flaws in the new weld and base metal interface beneath the new weld. Ultrasonic examination acceptance criteria are in accordance with 2004 Edition, no Addenda, Section III, NB-5331. The extent of the examination is consistent with Construction Code requirements.

The volume of interest for UT includes the new weld, the bottom head low alloy steel base material heat affected zone, and the sleeve/nozzle to weld interface and will be covered to the maximum extent practical.

This methodology is consistent with the associated requirements specified in Code Case N-638-2 and subsequent versions. Regulatory Guide 1.147, Revision 16 (Reference 1) lists ASME Code Case N-638-4 as a conditionally accepted ASME Code Section XI code case. The approval conditions noted in the regulatory guide do not impact requirements for performing final NDE on the weld region only as described in Code Case N-638-4 and herein.

Calvert Cliffs requests relief from examination of the area defined in Code Case N-638-1 paragraph 4.0(b).

5.3 Acceptance NDE

Code Case N-638-1, Paragraph 4.0(b) requires that the specified volumetric examination be in accordance with Section XI, Appendix I. Paragraph 4.0(e) specifies the acceptance criteria to be in accordance with IWB-3000.

However, IWB-3000 does not have any acceptance criteria that directly apply to the partial penetration weld configuration. Regulatory Guide 1.147, Revision 15 (Reference 2) has conditionally approved Case N-638-1 with the condition that UT volumetric examinations be performed with personnel and procedures qualified for the new weld volume and qualified by demonstration using representative samples which contain construction type flaws.

The acceptance criteria of NB-5331 in the 2004 Edition, no Addenda, Section III, will apply to all flaws identified within the new weld volume, except for triple point anomaly occurrences as discussed later herein.

Section III, NB-5245 requires incremental and final surface examination of partial penetration welds. Due to the welding layer disposition sequence (i.e., each layer is deposited parallel to the penetration

ATTACHMENT (1)

RELIEF REQUEST FOR ALTERNATIVE MODIFICATIONS TO UNIT 1 PRESSURIZER HEATER SLEEVE AND LOWER LEVEL NOZZLE PENETRATIONS (RR-PZR-01)

centerline), the specific requirements of NB-5245 cannot be met. The Construction Code requirement for progressive surface examination is because volumetric examination is not practical for conventional partial penetration weld configurations.

In this case, the new weld to be applied is suitable for ultrasonic examination. As a result a UT and a final surface PT examination will be performed.

Ultrasonic examination will be performed by scanning from the inner diameter surface of the sleeve/nozzle and weld. The UT is qualified to detect flaws in the new weld and base metal interface beneath the new weld. Ultrasonic examination acceptance criteria are in accordance with NB-5331. The extent of the examination is consistent with Construction Code requirements.

The volume of interest for UT includes the new weld, the bottom head low alloy steel base material heat affected zone, and the sleeve/nozzle to weld interface. These areas will be covered to the maximum extent practical.

The final UT examination of the new weld and immediate surrounding area will be sufficient to verify that defects have not been induced in the ferritic low alloy pressurizer lower head due to the welding process. The UT will be performed by scanning from the ID surface of the weld and adjacent portion of the heater sleeve/lower level nozzle bore. The UT is qualified to detect flaws in the new weld and base metal interface in the modified configuration, to the maximum extent practical.

The UT transducers and delivery tooling are capable of scanning from the bore of the nozzles with inside diameters near 1.20 inches. The scanning is performed using a probe that contains 0° L-wave, 45° L-wave in two axial and two circumferential beam directions, and 70° L-wave in one axial beam direction. 100% of the weld volume is examined with all beam angles. The weld configuration precludes examination of a small portion of the ferritic steel heat affected zone that is shadowed by the interface of the OD of the nozzle. The UT coverage obtained with each transducer is shown in Figures 3 through 7.

This methodology is consistent with the associated requirements specified in Code Case N-638-2 and subsequent versions. Reference 1 lists ASME Code Case N-638-4 as a conditionally accepted ASME Code Section XI code case. The conditions noted in the regulatory guide do not impact requirements for final UT and PT examination of the weld as described in Code Case N-638-4 and herein.

Calvert Cliffs requests relief from NDE acceptance examination requirements as specified in Code Case N-638-1 paragraphs 4.0(b) and 4.0(e).

5.4 Triple Point Anomaly

The 2004 Edition, no Addenda, of ASME Code Section III NB-5331(b) requires indications producing responses greater than 20% reference level that are characterized as cracks, lack of fusion, or incomplete penetration, to be considered unacceptable regardless of their length.

A result of the ambient temperature temper bead modification weld is the occurrence of an anomaly in the weld at the triple point. The triple point is the point in the weld where the low alloy steel head, the stainless steel sleeve/nozzle, and the stainless steel weld intersect. The location of the triple point

ATTACHMENT (1)

RELIEF REQUEST FOR ALTERNATIVE MODIFICATIONS TO UNIT 1 PRESSURIZER HEATER SLEEVE AND LOWER LEVEL NOZZLE PENETRATIONS (RR-PZR-01)

anomaly is shown in Figure 2. This anomaly consists of an irregularly shaped, very small void. Mock-up testing has verified that the anomalies may exist and do not exceed 0.05 inches in length. For purposes of analysis, the anomalies are assumed to exist around the entire bore circumference (360°), at the triple point elevation.

A fracture mechanics analysis was performed to provide justification, in accordance with Section XI, for operating with the postulated triple point anomaly. The anomaly is modeled as a 0.05 inch, semi-circular "crack like" defect, extending 360° around the circumference at the triple point location.

For the heater sleeves and lower level nozzles, postulated flaws could be oriented within the anomaly such that there are two possible flaw propagation paths, as discussed below.

Horizontal Direction, Path 1:

Flaw propagation path 1 occurs across the heater sleeve/instrument nozzle wall thickness from the OD of the nozzle to the ID of the nozzle. This is the shortest path through the component wall that passes through the new stainless steel weld.

For completeness, two types of flaws are postulated at the outside surface of the nozzle. A 360° continuous circumferential flaw, lying in a horizontal plane, is considered to be a conservative representation of crack-like defects that may exist in the weld. This flaw would be subjected to axial stresses in the nozzle. An axially oriented semi-circular outside surface flaw is also considered since it would lie in a plane that is normal to the higher circumferential stresses. Both of these flaws would propagate toward the inside surface of the nozzle.

Vertical Direction, Path 2:

Flaw propagation path 2 occurs up the outside surface of the new weld between the weld and pressurizer lower head. A continuous surface flaw is postulated to lie along this cylindrical interface between the weld and head. This flaw, driven by radial stresses, may propagate along either the new stainless steel weld or the low alloy steel head.

Based on evaluation procedures and acceptance criteria contained in Article IWB-3612 and Appendix C of ASME Section XI, results of fracture mechanics analyses demonstrate that a 0.05 inch weld anomaly in either a repaired heater sleeve or instrumentation nozzle is acceptable for a 40-year design life. The fracture toughness margins are greater than those required by Article IWB-3612 of ASME Section XI. Final flaw sizes after fatigue crack growth are less than the allowable flaws sizes from Appendix C of the ASME Code. Limit load analysis, performed for the ductile stainless steel weld material, and showed limit load margins greater than those required by Appendix C of ASME Section XI.

The results of this evaluation will be submitted to the NRC in accordance with the requirements of IWB-3144.

Calvert Cliffs requests relief to permit anomalies, as described herein, at the triple point.

ATTACHMENT (1)

RELIEF REQUEST FOR ALTERNATIVE MODIFICATIONS TO UNIT 1 PRESSURIZER HEATER SLEEVE AND LOWER LEVEL NOZZLE PENETRATIONS (RR-PZR-01)

5.5 Flaw Characterization and Successive Examinations - Heater Sleeve and Lower Level Nozzle J-Groove Weld

IWA-3300(a) and (b) specify that flaws are to be characterized so that the evaluations necessary to determine acceptability in accordance with IWB-3500 or IWB-3600 as applicable, can be performed. However, the original sleeve/nozzle to bottom head J-groove weld is extremely difficult to examine with UT due to the geometry. These conditions preclude ultrasonic coupling and control of the sound beam needed to perform flaw sizing with reasonable confidence in the measured flaw dimensions. Therefore, it is impractical to characterize the flaw geometry that may exist therein. As these J-groove welds have not been examined, they are assumed to have worst-case unacceptable flaws.

The J-groove weld flaws have been evaluated for acceptance in accordance with the analytical evaluation requirements of IWB-3142.4 using worst-case postulated flaw sizes and orientations. Fracture mechanics evaluation is performed to determine if degraded J-groove weld material could remain in the pressurizer, since no examination is feasible to size any flaws that might remain following the modification. It is postulated that a radial crack in the Alloy 82/182 weld metal would propagate via PWSCC, through the weld and butter, to the interface with the low alloy steel bottom head. It is fully expected that such a crack would then blunt and be arrested at the butter-to-head interface.

Crack growth through the original Alloy 82/182 weld would tend to relieve the residual stresses in the weld as the crack grew to its final size until its growth is arrested at the low alloy steel interface. Although residual stresses in the head material are low, it is assumed that a small flaw could initiate in the low alloy steel head and grow by fatigue. It is postulated that a small flaw in the head would combine with a large PWSCC flaw in the weld to form a radial corner flaw.

Based on a combination of linear elastic and elastic plastic fracture mechanics analysis of a postulated remaining flaw in the original Alloy 82/182 J-groove weld and butter material, as applicable, a repaired heater sleeve is acceptable for a 35-year design life, while a repaired instrumentation nozzle would be acceptable for 32 years of fatigue crack growth into the low alloy steel head. In both cases, the applied tearing modulus was shown to be less than the tearing modulus of the low alloy steel head material. Furthermore, it was demonstrated that the applied J-integral, or crack driving force, is less than the value of the J-integral resistance curve of the material at a crack extension of 0.1 inch.

Successive examinations required by IWB-3142.4 will not be performed because analytical evaluation of the worst-case postulated flaw was performed to demonstrate the acceptability of continued operation. A reasonable assurance of the pressurizer bottom head structural integrity is maintained without the successive examination by the fact that evaluation has shown the worst-case flaw to be acceptable for continued operation.

Calvert Cliffs requests relief from flaw characterization requirements of IWB-3300(a) and (b) and subsequent examination requirements as specified in IWB-3142.4.

6. Conclusions

Implementation of the modification to the pressurizer heater sleeves and lower level nozzle penetrations will produce an effective modification that will restore and maintain the pressure boundary structural integrity of the Calvert Cliffs Unit 1 pressurizer. Similar modifications to reactor vessel closure head

ATTACHMENT (1)

RELIEF REQUEST FOR ALTERNATIVE MODIFICATIONS TO UNIT 1 PRESSURIZER HEATER SLEEVE AND LOWER LEVEL NOZZLE PENETRATIONS (RR-PZR-01)

control rod drive mechanism penetrations have been performed successfully and have been in service for several years without any known degradation. The alternative provides improved structural integrity and reduced likelihood of leakage for the primary system. Accordingly, the use of the alternative provides an acceptable level of quality and safety in accordance with 10 CFR 50.55a(a)(3)(i).

7. Duration of Proposed Alternative

The provisions of this alternative are applicable to the fourth ten-year in-service inspection interval for Calvert Cliffs which commenced on October 10, 2009 and will end on June 30, 2019.

The modifications performed in accordance with the provisions of this alternative shall remain in place for the design life of the modifications.

8. References

1. NRC Regulatory Guide 1.147, Revision 16, Inservice Inspection Code Case Acceptability ASME Section XI, Division 1, October 2010
2. NRC Regulatory Guide 1.147, Revision 15, Inservice Inspection Code Case Acceptability, ASME Section XI, Division 1, October 2007

ATTACHMENT (1)

RELIEF REQUEST FOR ALTERNATIVE MODIFICATIONS TO UNIT 1 PRESSURIZER
HEATER SLEEVE AND LOWER LEVEL NOZZLE PENETRATIONS (RR-PZR-01)

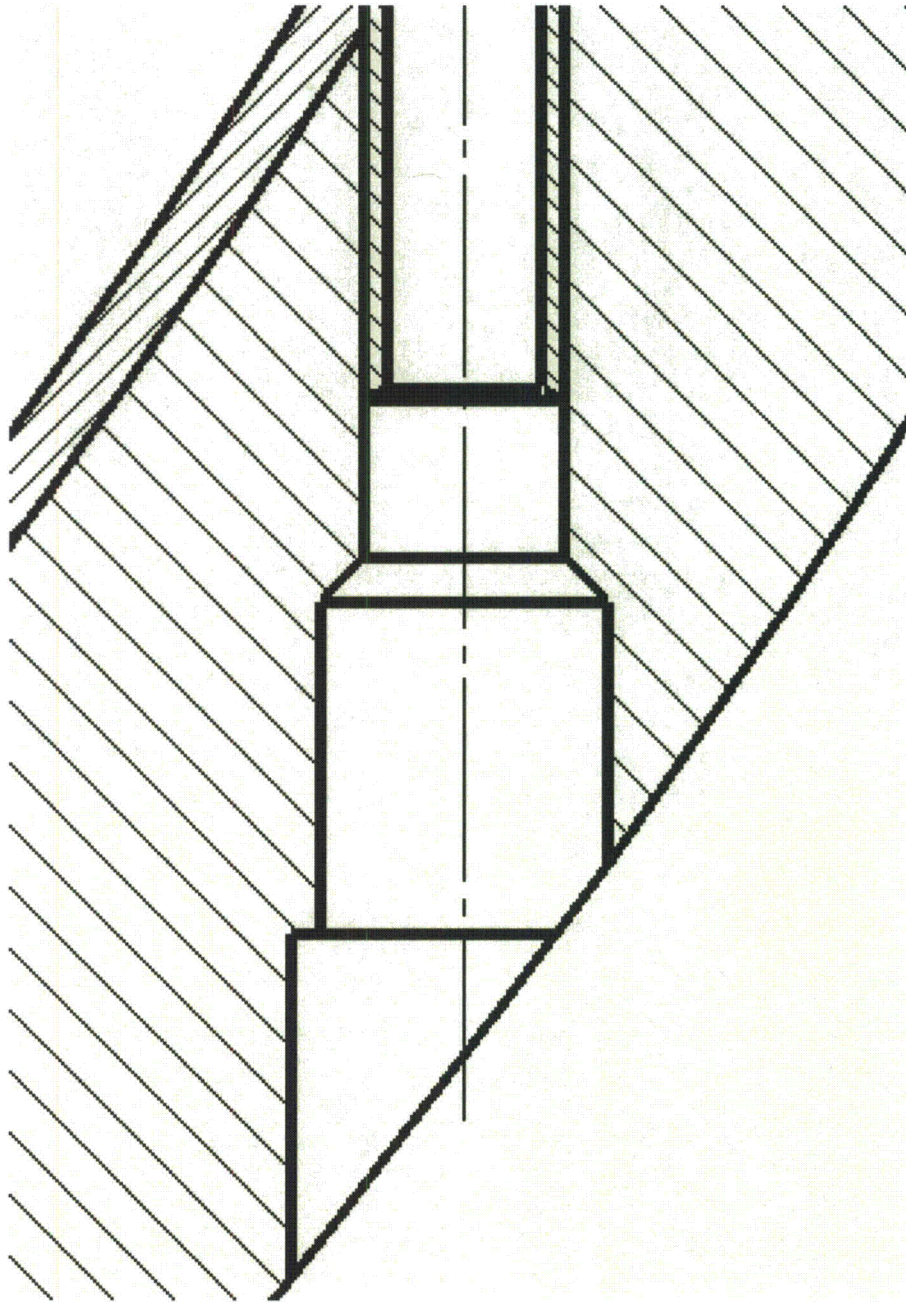

Figure 1: Machining

ATTACHMENT (1)

RELIEF REQUEST FOR ALTERNATIVE MODIFICATIONS TO UNIT 1 PRESSURIZER
HEATER SLEEVE AND LOWER LEVEL NOZZLE PENETRATIONS (RR-PZR-01)

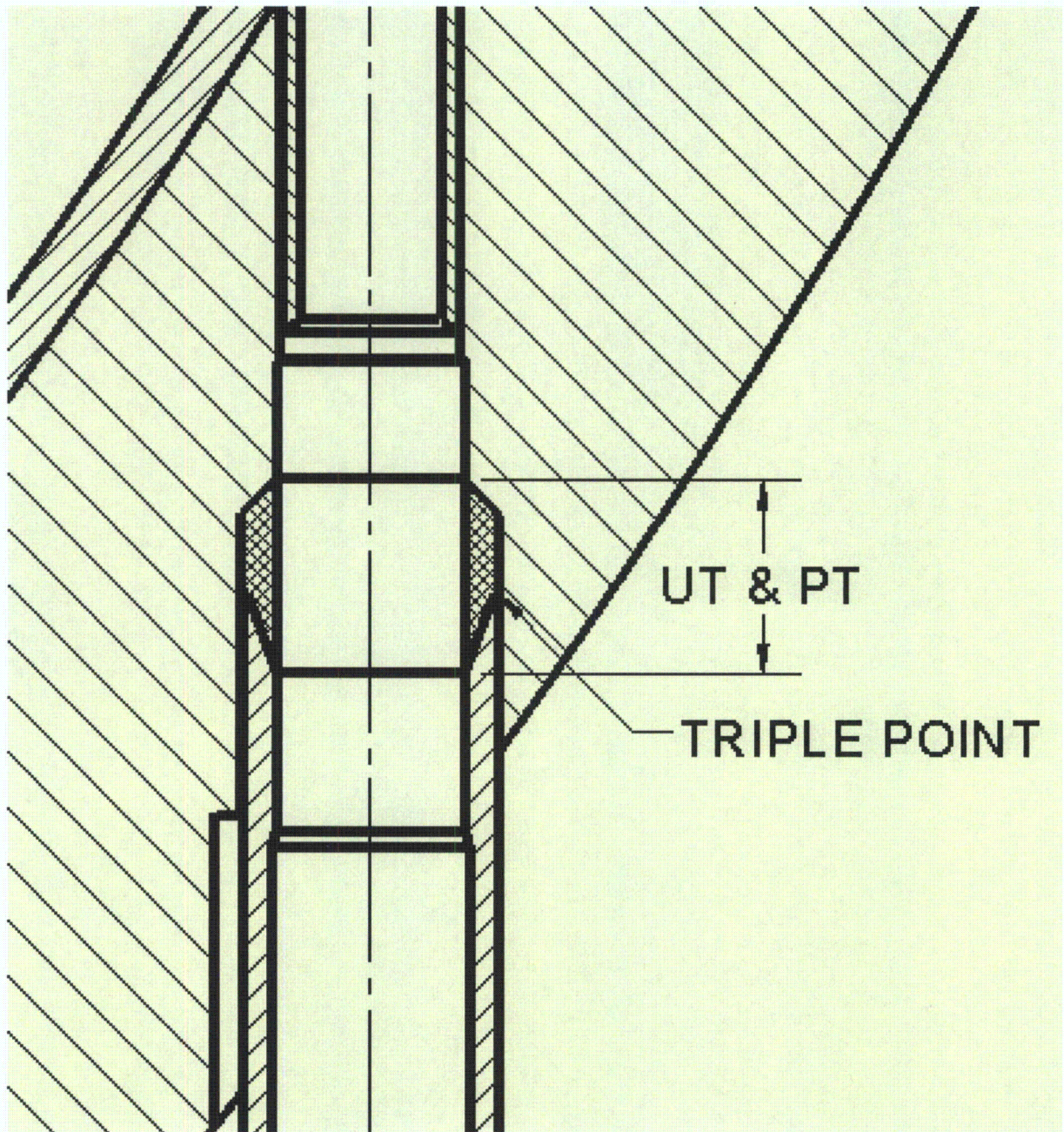

Figure 2: Welding and Examination

ATTACHMENT (1)

RELIEF REQUEST FOR ALTERNATIVE MODIFICATIONS TO UNIT 1 PRESSURIZER
HEATER SLEEVE AND LOWER LEVEL NOZZLE PENETRATIONS (RR-PZR-01)

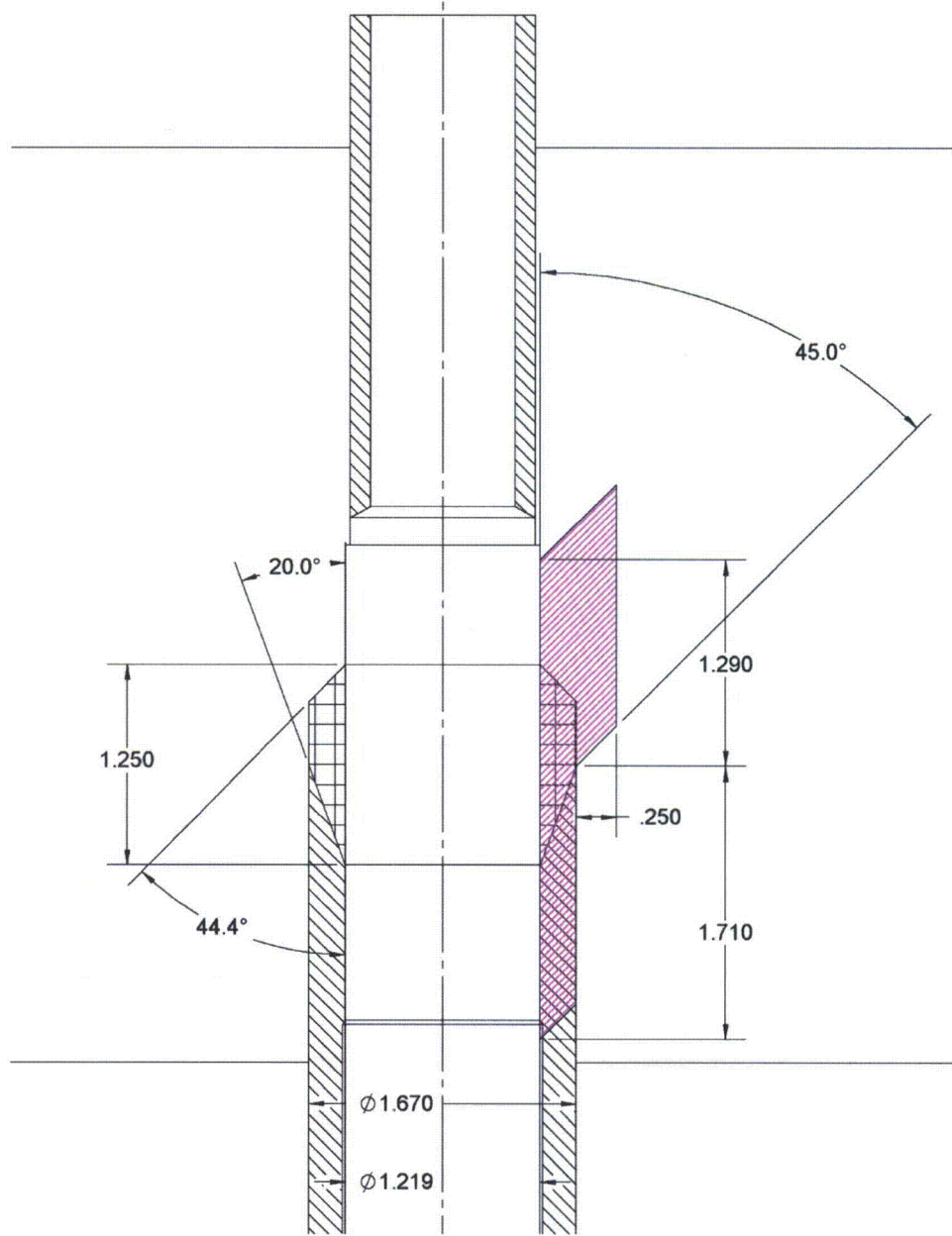

Figure 3: UT 45-Degree Up

ATTACHMENT (1)

RELIEF REQUEST FOR ALTERNATIVE MODIFICATIONS TO UNIT 1 PRESSURIZER
HEATER SLEEVE AND LOWER LEVEL NOZZLE PENETRATIONS (RR-PZR-01)

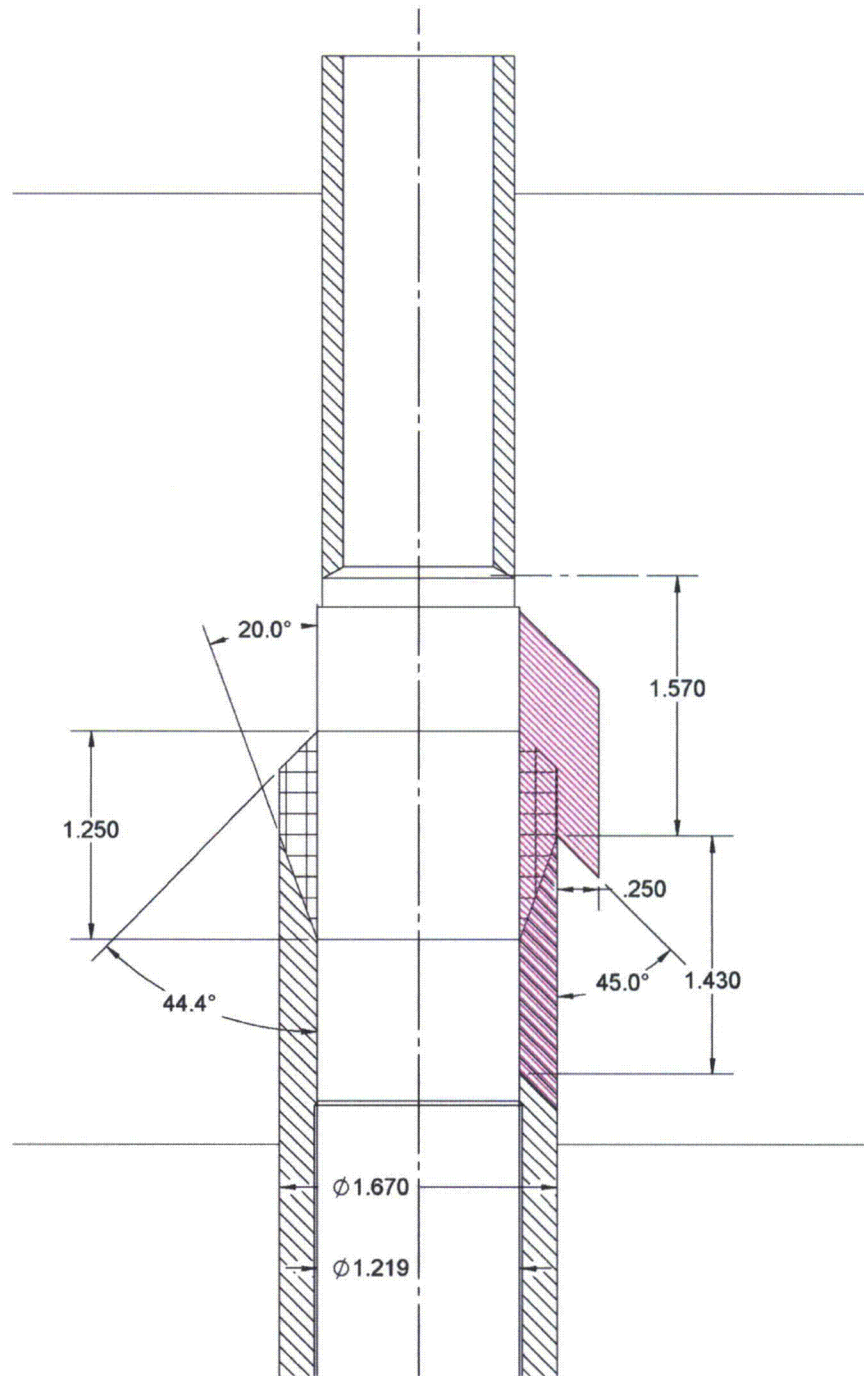

Figure 4: UT 45-Degree Down

ATTACHMENT (1)

RELIEF REQUEST FOR ALTERNATIVE MODIFICATIONS TO UNIT 1 PRESSURIZER
HEATER SLEEVE AND LOWER LEVEL NOZZLE PENETRATIONS (RR-PZR-01)

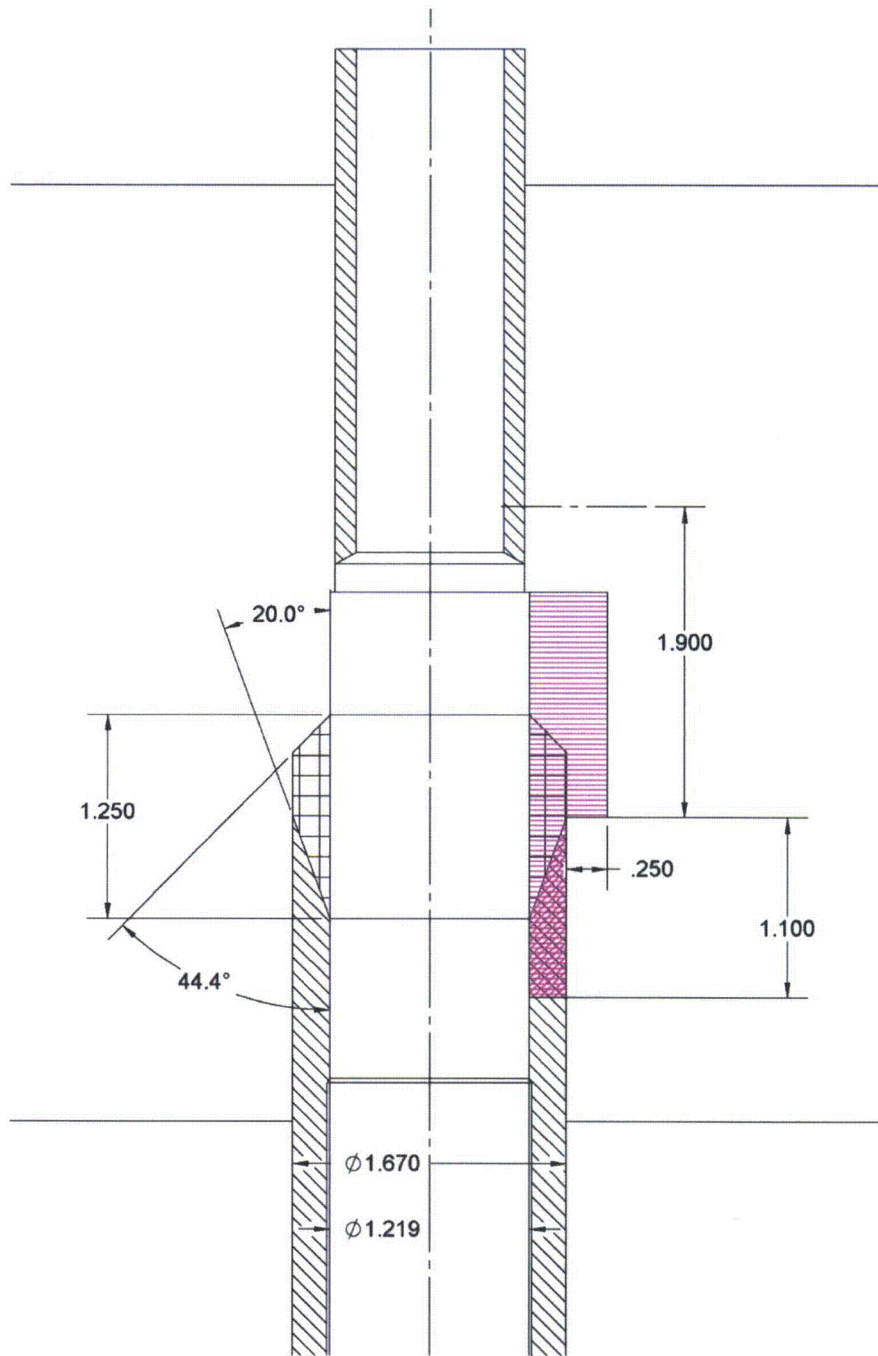

Figure 5: UT 45-Degree Looking Clockwise and Counter-Clockwise

ATTACHMENT (1)

RELIEF REQUEST FOR ALTERNATIVE MODIFICATIONS TO UNIT 1 PRESSURIZER
HEATER SLEEVE AND LOWER LEVEL NOZZLE PENETRATIONS (RR-PZR-01)

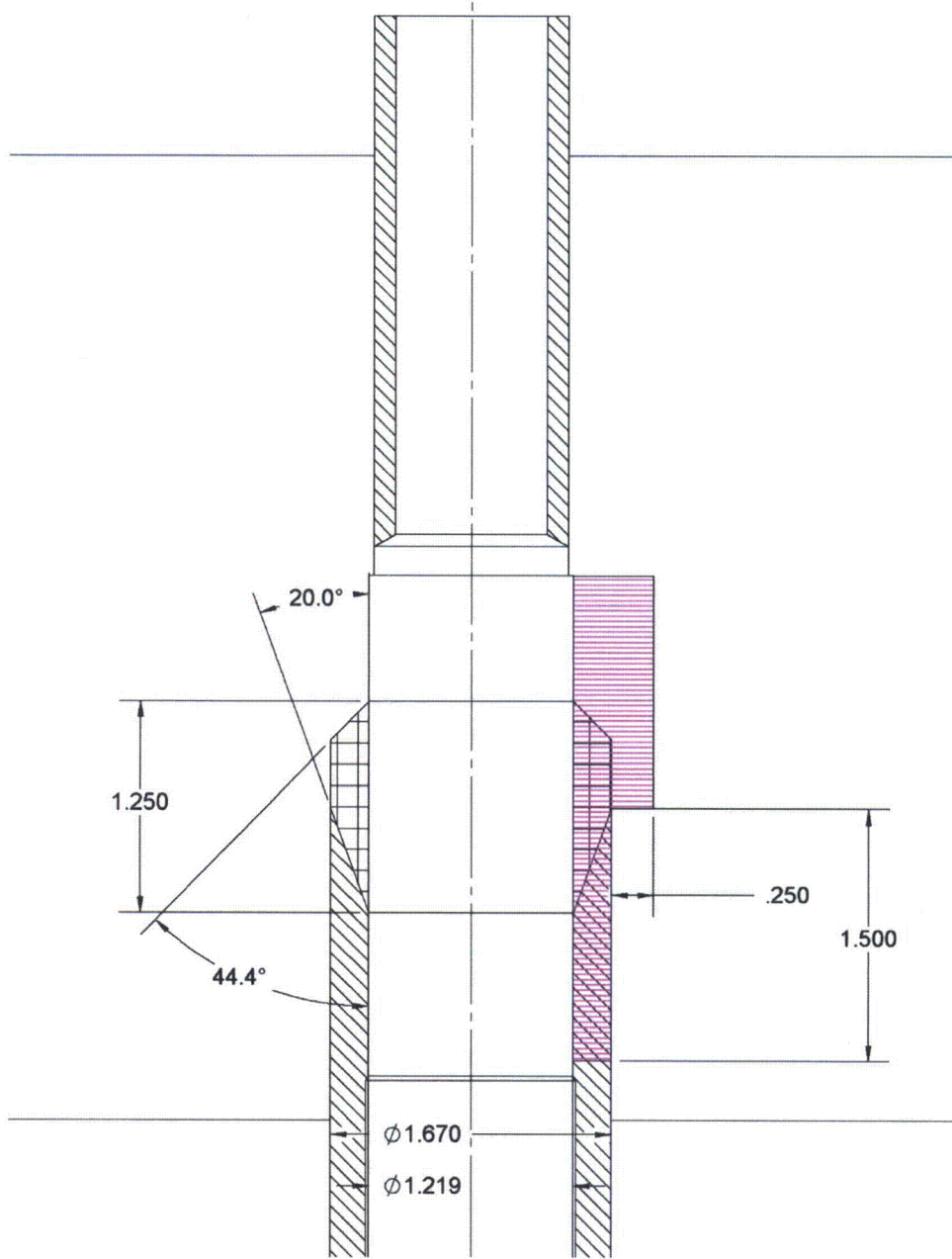

Figure 6: UT 0-Degree

ATTACHMENT (1)

RELIEF REQUEST FOR ALTERNATIVE MODIFICATIONS TO UNIT 1 PRESSURIZER
HEATER SLEEVE AND LOWER LEVEL NOZZLE PENETRATIONS (RR-PZR-01)

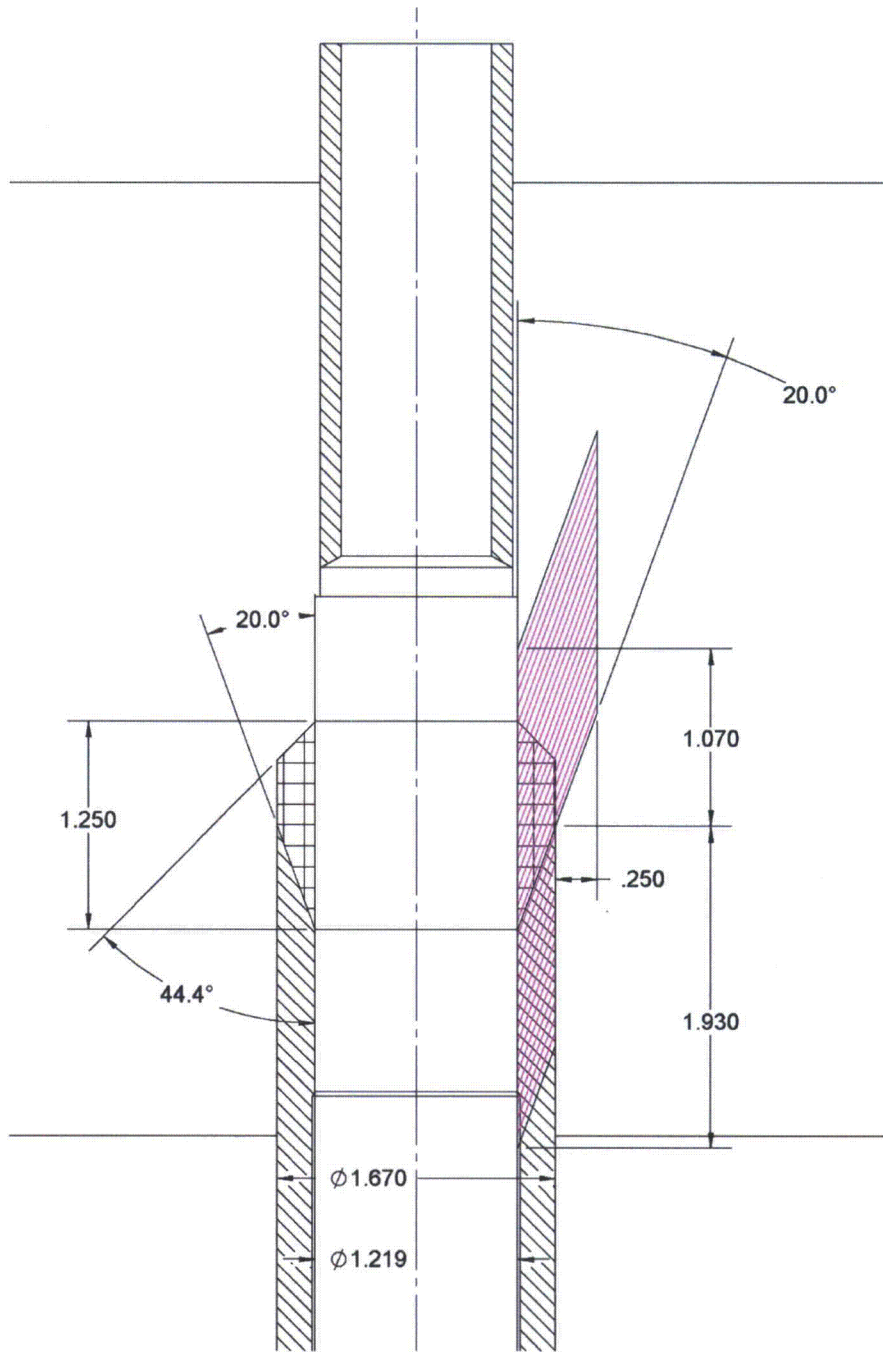

Figure 7: UT 70 Degree Up