

ENVIRONMENTAL REPORT SUPPLEMENT No. 1

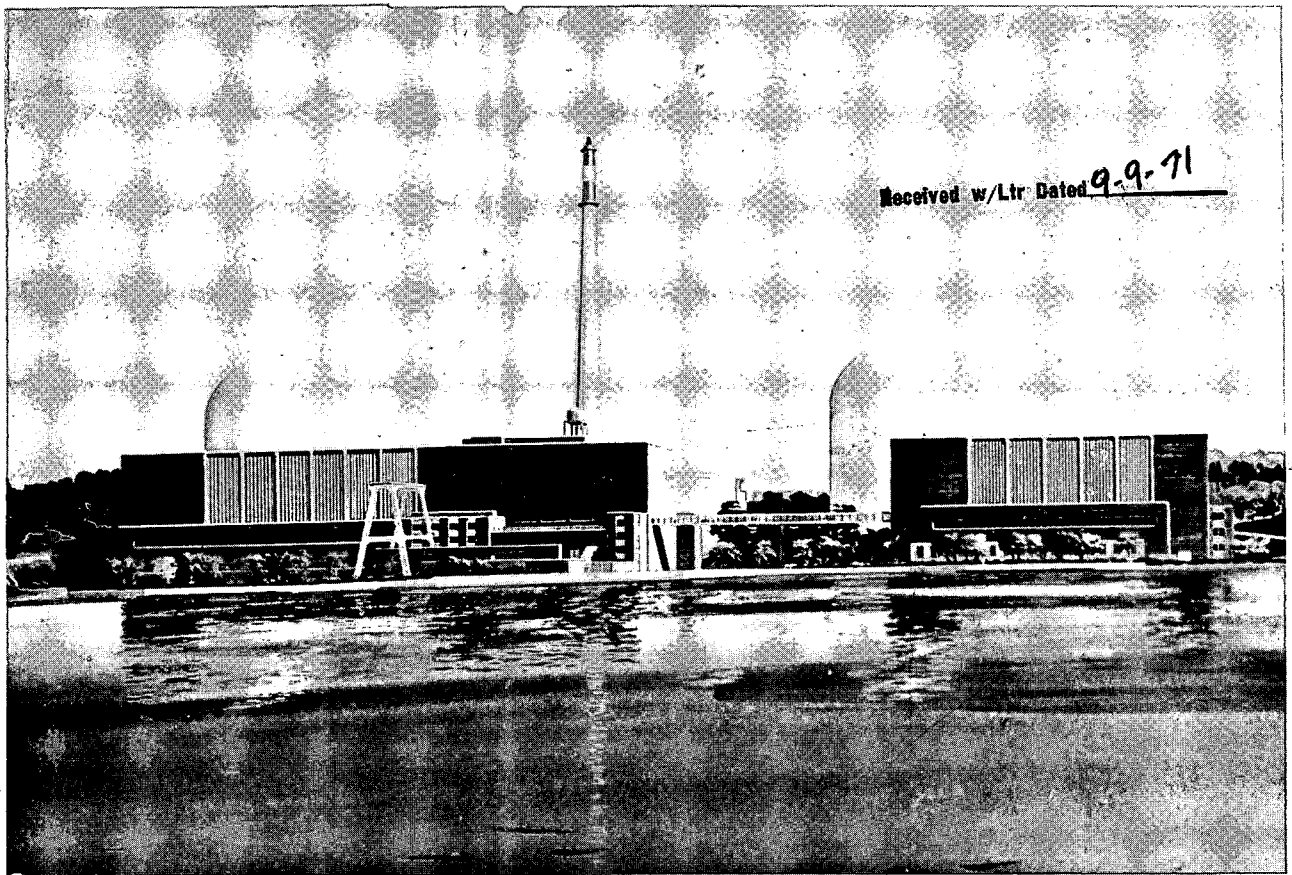

APPENDICES - VOLUME No. 1

SEPTEMBER 1971

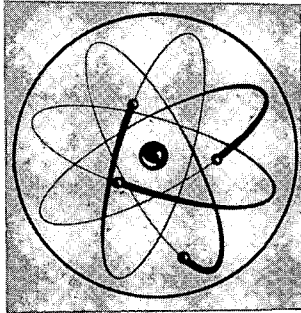
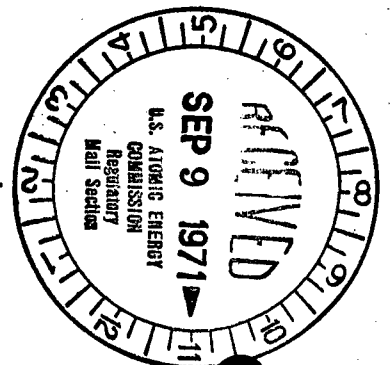

INDIAN POINT UNIT NO. 2

Con Edison

3967

8110296 284

TABLE OF APPENDICES.

- APPENDIX - A: TRANSPORT OF CONTAMINANTS IN THE HUDSON RIVER ABOVE
INDIAN POINT STATION
Quirk, Lawler and Matusky Engineers
May 1966
- APPENDIX - B: HYDROLOGY OF INDIAN POINT SITE AND SURROUNDING AREA
Metcalf and Eddy Engineers
October 1965
- APPENDIX - C: A MICROMETEOROLOGICAL SURVEY OF THE BUCHANAN, NEW
YORK AREA
New York University - College of Engineering
November 1965
- APPENDIX - D: EVALUATION OF POTENTIAL RADIATION HAZARD RESULTING
FROM ASSUMED RELEASE OR RADIOACTIVE WASTES
TO ATMOSPHERE FROM PROPOSED BUCHANAN NUCLEAR
POWER PLANT
New York University - College of Engineering
April 1957
- APPENDIX - E: SUMMARY OF CLIMATOLOGICAL DATA AT BUCHANAN, NEW YORK
New York University - College of Engineering
March 1958
- APPENDIX - F: 1980 PROJECTIONS OF POPULATION AND LAND USE FOR AN AREA
CIRCUMSCRIBED BY A 55 - MILE RADIUS FROM
BUCHANAN, NEW YORK
Regional Economic Development Institute, Incorporated
November 1965
- APPENDIX - G: WIND OBSERVATIONS AT INDIAN POINT
26 November 1969 - 1 October 1970
New York University - School of Engineering and Science
May 1971
- APPENDIX - H: LETTER FROM WESTCHESTER COUNTY DEPARTMENT OF
PLANNING
November 1970
- APPENDIX - I: PERMITS RELATING TO INDIAN POINT UNIT NO. 2
- APPENDIX - J: EFFECT OF INDIAN POINT COOLING WATER DISCHARGE ON HUD-
SON RIVER TEMPERATURE DISTRIBUTION
Quirk, Lawler and Matusky Engineers
January 1968

TABLE OF APPENDICES (Continued)

- APPENDIX - K: EFFECT OF INDIAN POINT COOLING WATER DISCHARGE ON HUDSON RIVER TEMPERATURE DISTRIBUTION
Quirk, Lawler and Matusky Engineers
February 1969
- APPENDIX - L: INDIAN POINT MODEL STUDIES
Alden Research Laboratories
March 1969
- APPENDIX - M: EFFECT OF SUBMERGED DISCHARGE OF INDIAN POINT COOLING WATER ON HUDSON RIVER TEMPERATURE DISTRIBUTION
Quirk, Lawler and Matusky Engineers
October 1969
- APPENDIX - N: INFLUENCE OF HUDSON RIVER NET NON-TIDAL FLOW ON TEMPERATURE DISTRIBUTION
Quirk, Lawler and Matusky Engineers
October 1969
- APPENDIX - O: INDIAN POINT COOLING WATER STUDIES: MODEL NO. 2
Alden Research Laboratories
May 1969
- APPENDIX - P: INDIAN POINT ECOLOGICAL SURVEY: REPORT I
Raytheon Company
June - December 1969
- APPENDIX - Q: INDIAN POINT ECOLOGICAL SURVEY: REPORT II
Raytheon Company
January - June 1970
- APPENDIX - R: HUDSON RIVER AT INDIAN POINT
New York University Medical Center - Institute
of Environmental Medicine
- APPENDIX - S: FISH PROTECTION AT INDIAN POINT UNIT NO. 1
Consolidated Edison Co. of New York
November 1970
- APPENDIX - T: COST EXPENDITURES ON ENVIRONMENTAL STUDIES
- APPENDIX - U: ENVIRONMENTAL MONITORING SURVEY
- APPENDIX - V: CONSOLIDATED EDISON INDIAN POINT REACTOR
POST OPERATIONAL SURVEY: AUGUST 1965
Division of Environmental Health Services
New York State Department of Health

TABLE OF APPENDICES (Continued)

- APPENDIX - W:** **CONSOLIDATED EDISON INDIAN POINT REACTOR
ENVIRONMENTAL AND POST OPERATION SURVEY: JULY 1966**
 **Division of Environmental Health Services
 New York State Department of Health**
- APPENDIX - X:** **TECHNICAL SPECIFICATION - INDIAN POINT UNIT NO. 2**
 Section 3.9: Effluent Release
- APPENDIX - Y:** **MANMADE RADIONUCLIDES IN THE HUDSON RIVER ESTUARY**
 **New York University Medical Center - Institute
 of Environmental Medicine**
 November 1970

TRANSPORT OF CONTAMINANTS
IN THE HUDSON RIVER
ABOVE INDIAN POINT STATION

QUIRK, LAWLER AND MATUSKY ENGINEERS
Environmental Science and Engineering Consultants
New York, New York

I. BASIS FOR ANALYSIS

Transport of any substance in a tidal estuary is governed by the Law of Conservation of Mass. Figure 1 illustrates the application of this law in an estuary. After discharge to the estuary, waste particles are carried downstream, in the movement of upland runoff toward the ocean. This phenomenon is known as convection. The rate of convective mass transport across any river section is equal to the product of fresh water runoff, Q , and contaminant concentration, c .

Besides convection, particles are transported in an estuary by longitudinal mixing. Longitudinal mixing, or dispersion, is a complex function of reversing tidal currents and salinity-induced circulation. Dispersive transport occurs only in the presence of a concentration gradient of the material being transported. The rate of dispersive transport is equal to the product of the dispersion coefficient, E , and the negative of the longitudinal concentration gradient, dc/dx . The dispersion coefficient, E , is a measure of the estuary's ability to transport material in the presence of a concentration gradient, and is a quantitative function of tidal current and salinity-induced circulation.

The concentration profile in Figure 1 indicates how convection and dispersion distribute estuarine contaminants. Since only contaminants that decay or, at best, are conserved, are being considered, the maximum containment concentration must occur at the point of introduction of the contaminant to the estuary. In the case of saline contamination, the salt is introduced at the mouth of the estuary so that the maximum salinity occurs here; in the case of discharge of radioactive contaminants at Indian Point, the maximum concentration of radioactivity will exist in this vicinity, as shown on Figure 1.

The concentration in the region downstream of the point of discharge, ($x = 0$), decays less rapidly than does its counterpart in the upstream region. This is so because in the downstream region, dispersion, in moving material in the direction of decreasing concentration, aids convection. More material is transported downstream than upstream, so, at the same absolute distance from the point of discharge, the upstream concentration is lower than the downstream concentration.

A mass balance over the incremental volume, $A\Delta x$, in Figures 1 is written:

$$\text{Inflow} - \text{Outflow} + \text{Production} = \text{Accumulation} \quad \dots \dots \dots (1)$$

CONTAMINANT DISTRIBUTION IN AN ESTUARY MASS TRANSPORT RELATIONSHIPS

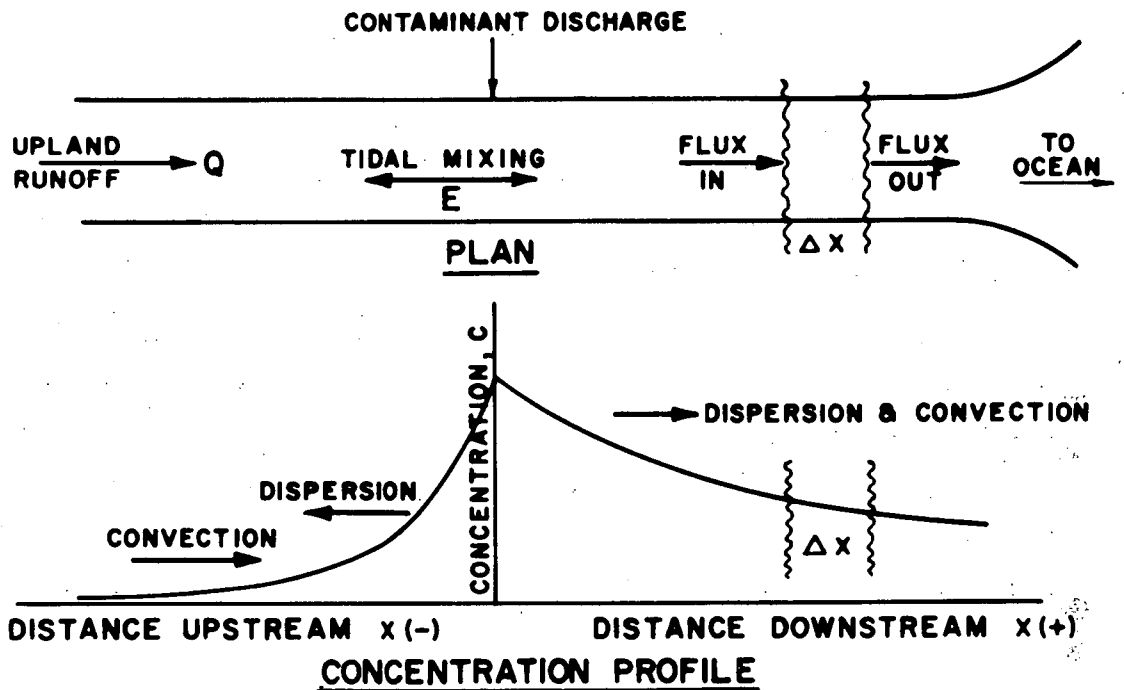

MASS BALANCE OVER VOLUME ELEMENT, $A \Delta x$

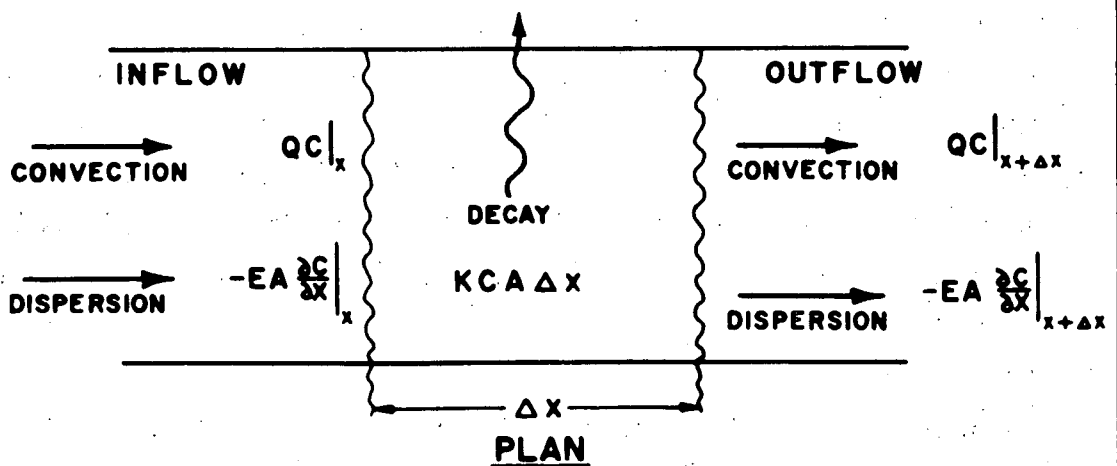

Figure 1

Algebraic summation of the individual contributions; shown in Figure 1 to Equation 1 gives:

$$\left[Qc - EA \frac{dc}{dx} \right]_x - \left[Qc - EA \frac{dc}{dx} \right]_{x + \Delta x} - KCA\Delta x = \frac{d}{dt} [CA\Delta x] \dots \dots \dots (2)$$

in which:

- c = contaminant concentration, ML⁻³
- x = distance along longitudinal axis of the estuary, L
- t = time, T
- A = cross-sectional area of the estuary, L²
- Q = fresh water flow (upland runoff), L³T⁻¹
- E = longitudinal dispersion coefficient, L²T⁻¹
- K = first order decay constant, T⁻¹

The production, or in this case, decay, term is the rate at which material is produced or consumed by physical, chemical, biochemical or nuclear reaction within the volume element.

For decay according to first order kinetics, the usual kinetics of radioactive decay, this rate of consumption of contaminant is equal to the product of the unit rate, Kc, times the volume, AΔx, within which the reaction is taking place.

The accumulation term completes the inventory by accounting for the net rate of increase or decrease of material upon summation of the rates of inflow, outflow and production. This is equal to the time rate of change of total contamination mass within the reactor volume, AΔx.

The parameters, Q, A, E and K, in most estuaries are functions of space and time. To avoid tenuous mathematical complexity, these parameters are often considered to be constants. This approach, justification of which appears in a later section of the report, has been selected for the analysis used in this report. For the case of constant Q, E, A and K, Equation 2 rearranges to:

$$E \left[\frac{dc}{dx} \Big|_{x + \Delta x} - \frac{dc}{dx} \Big|_x \right] - \frac{Q}{A} \left[\frac{c|_{x + \Delta x} - c|_x}{\Delta x} \right] - Kc = \frac{dc}{dt} \dots \dots \dots (3)$$

The bracketed terms are average rates of change with respect to x. The limit of Equation 3, as Δx approaches zero, is as follows:

$$E \frac{d^2c}{dx^2} - U \frac{dc}{dx} - Kc = \frac{dc}{dt} \dots \dots \dots (4)$$

U is equal to Q/A and is the average fresh water velocity. Equation 4 is a linear partial differential equation in x and t and is often referred to as the convection-diffusion equation for non-conservative substances. It has been selected as the defining equation for all subsequent analyses presented in this report.

At this juncture, it is important to note that the concentration, c, is actually a tidal smoothed, area averaged concentration. This means that rather than attempt to define local behavior at any point within a cross-section and during a tidal cycle, the analyst looks at the average concentration over an entire cross-section over a full tidal cycle. Justification of this procedure is given by Kent (1), Harleman and Holley (2), and Lawler (3).

This justification proceeds by starting with the equation of continuity of a single chemical specie (4), in which contaminant concentration is a function of three space dimensions and real time. Dependence on the lateral and vertical space coordinates is replaced by dependence on total cross-sectional area by integrating over the total width and depth. The resulting equation is then integrated over a tidal cycle and change with respect to real time replaced by change with respect to tidal cycle units of time.

In the course of these integrations, several new terms are generated, all of which contribute to the dispersion phenomenon. These are eventually replaced by the overall dispersion flux, $E \frac{dc}{dx}$.

Once contaminants are dispersed over the river channel, the various concentrations at specific points within the cross-section and tidal cycle can be expected to be less than 20% of the tidal smoothed, area averaged value. Figures 2 through 7 illustrate this for salt. The actual variation of salinity across various cross-sections within the reach between Indian Point and Chelsea is shown on Figures 2, 4 and 6. Figures 3, 5 and 7 show the sinusoidal variation of the area averaged salinity at these sections over a tidal cycle, as well as a linearized plot of this variation.

STATION - INDIAN POINT
 SALINITY MEASUREMENTS
 LOCATION - LAT. 41°-16.5'
 MILE POINT - 42.635
 DATE - NOV. 22-23, 1964
 AVERAGE SALINITY - 6730ppm

DEPTH IN FT.

	EAST B.	MID. S.	WEST B.
O	1	1	1
Δ	14	30	28
X	24	50	45

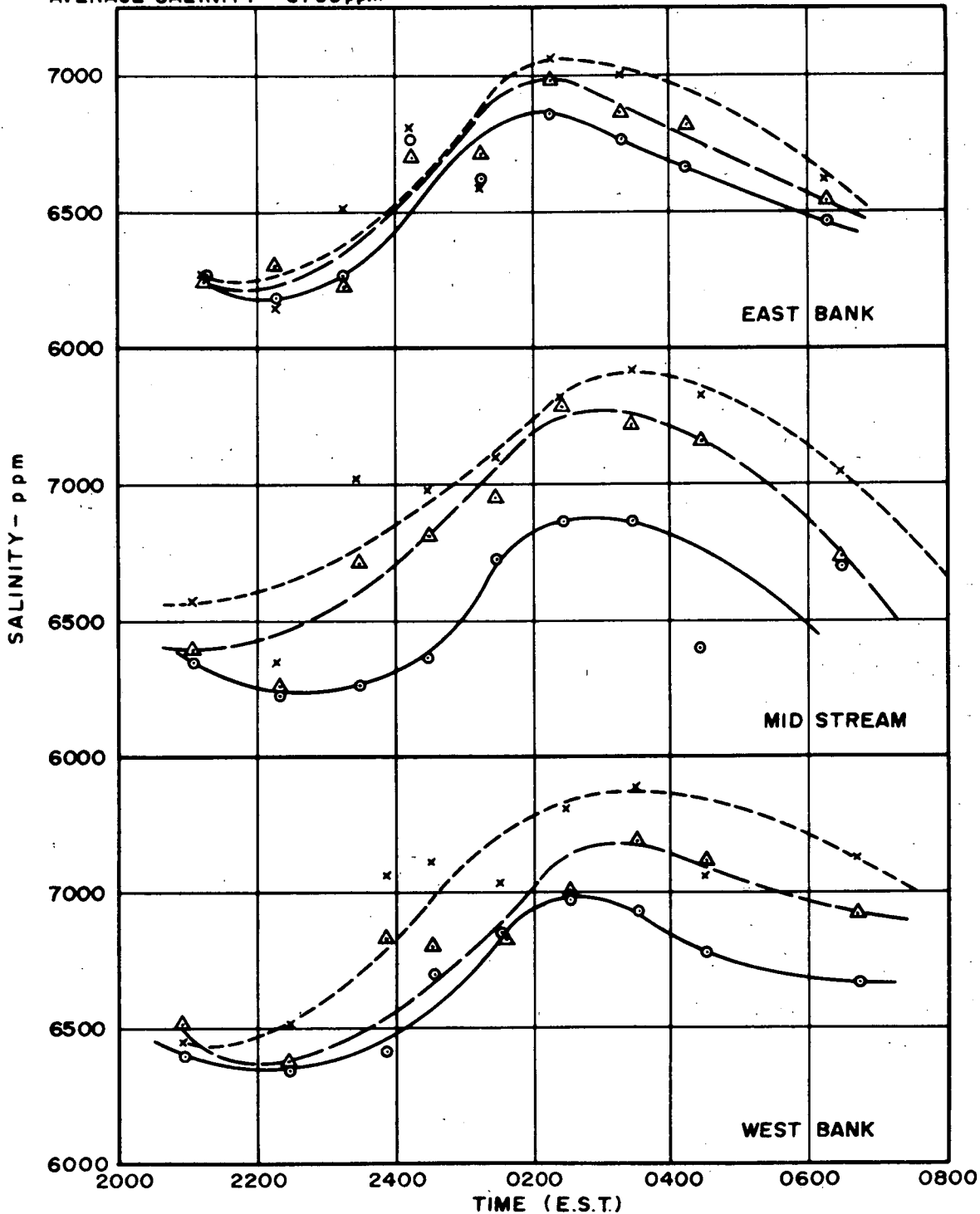
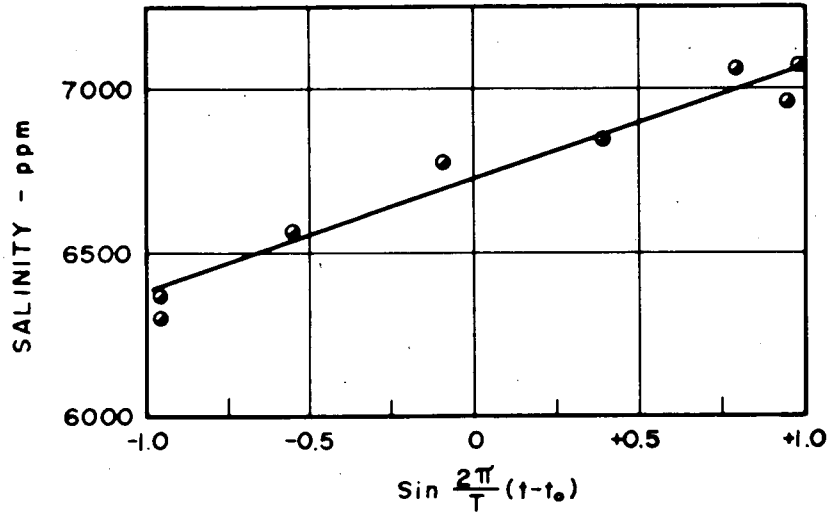
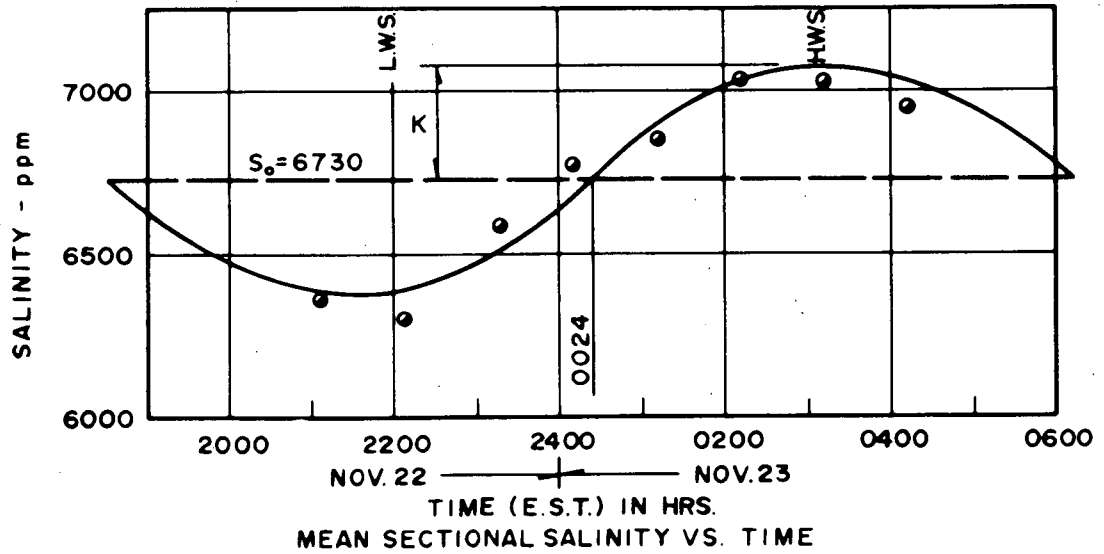

Figure 2

STATION - INDIAN POINT
 LOCATION - LAT. 41° - 16.5'
 MILE POINT 42.635
 DATE NOV. 22 - 23, 1964



MEAN SECTIONAL SALINITY VS. PHASE ANGLE



MEAN SECTIONAL SALINITY VS. TIME

Figure 3

STATION - WEST POINT

SALINITY MEASUREMENTS

LOCATION - LAT. 41°-23'

MILE POINT 51.570

DATE NOV. 22, 1964

AVERAGE SALINITY - 4900 ppm

DEPTH IN FT.

	E. BANK	MID. S.	W. BANK
○	1	1	1
△	10.5	30	34
x	17.4	50	56

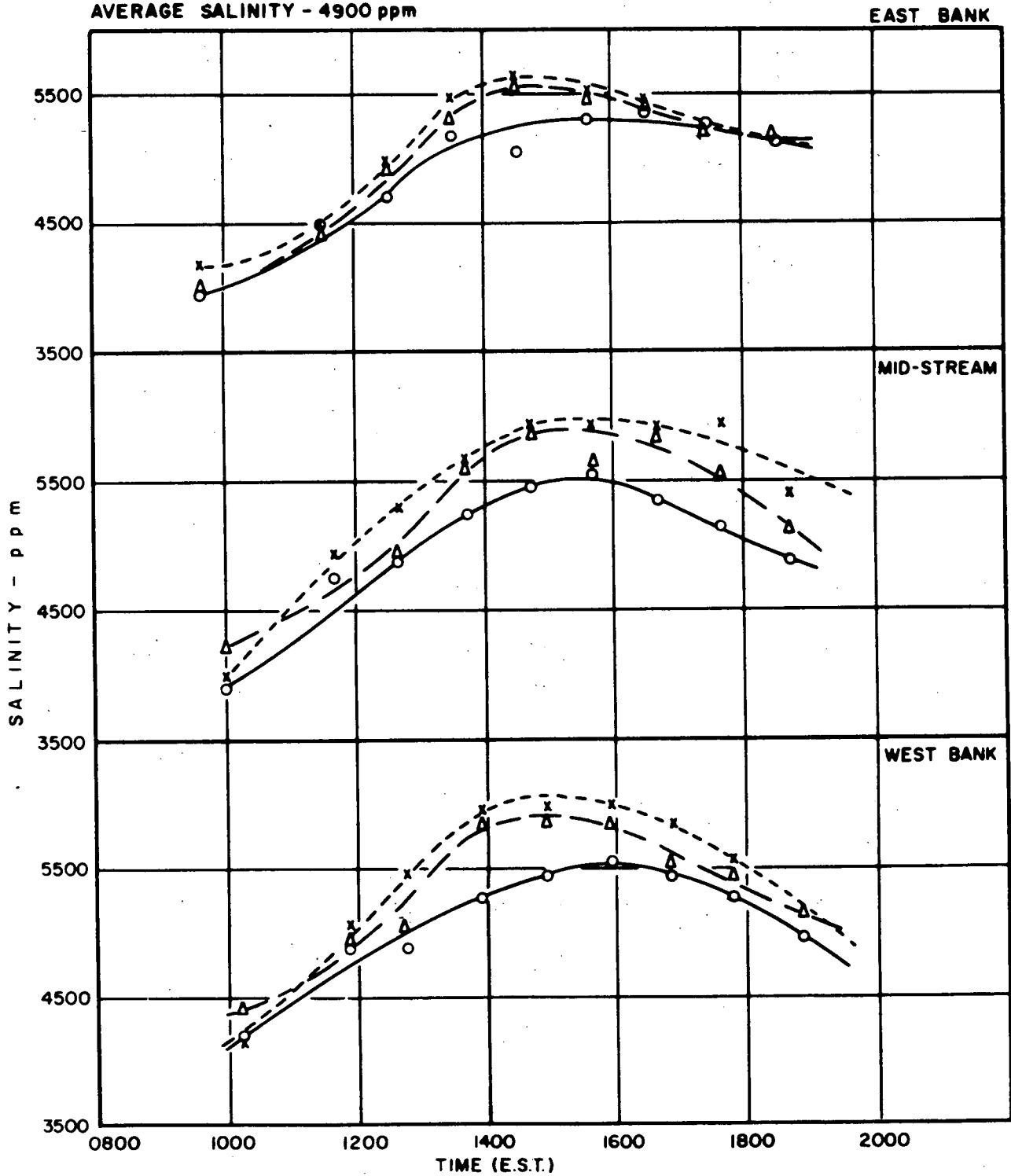

Figure 4

STATION - WEST POINT
 LOCATION - LAT. 41°-23'
 MILE POINT 51.570
 DATE NOV. 22, 1964

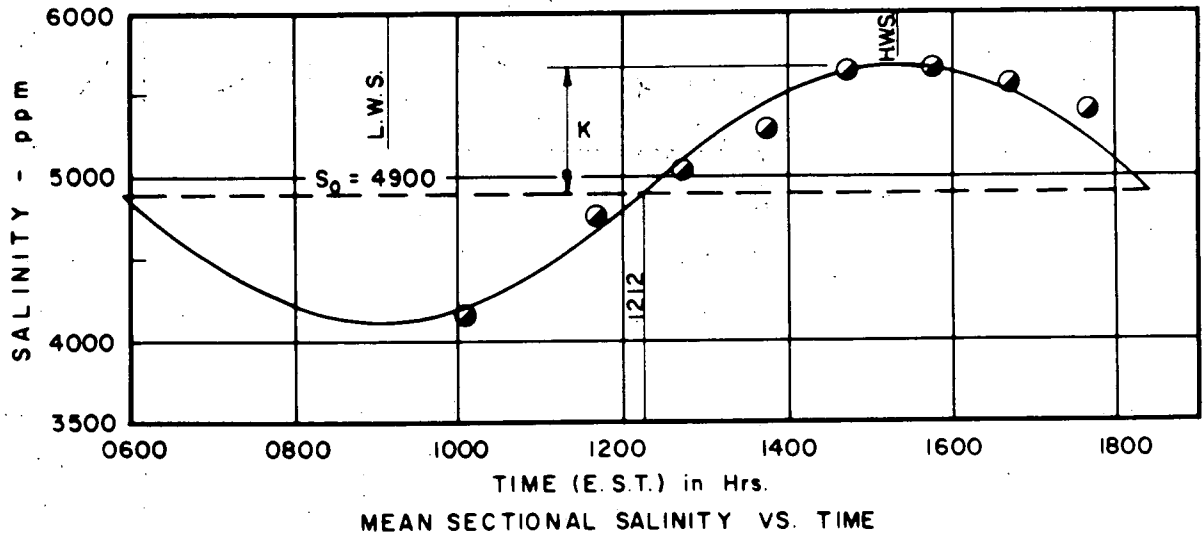
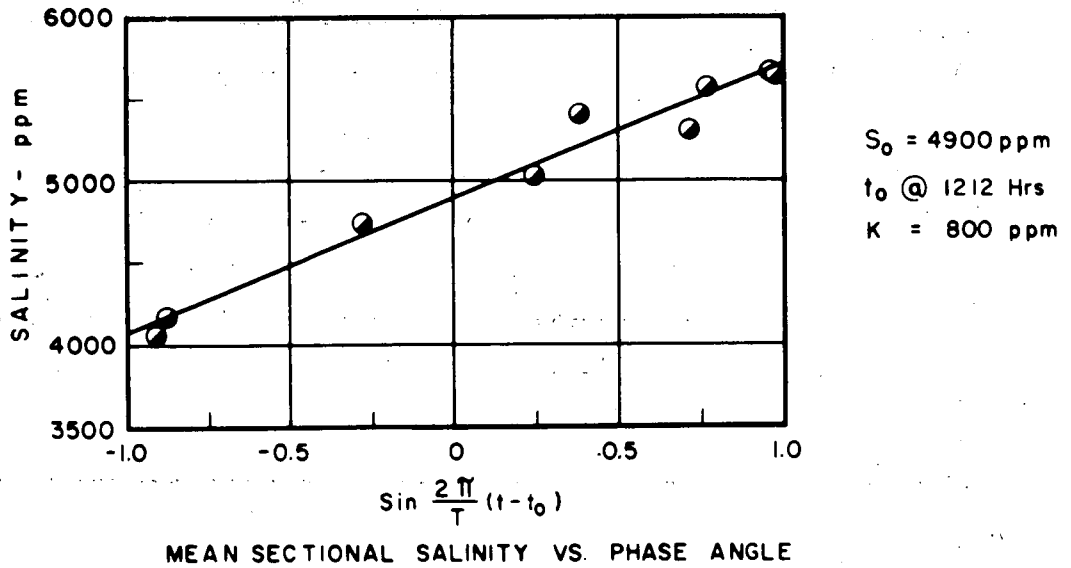

Figure 5

STATION - NEWBURGH

SALINITY MEASUREMENTS

LOCATION - LAT. 41°-30'

MILE POINT 60.645

DATE NOV. 20-21, 1964

AVERAGE SALINITY - 3060 ppm

DEPTH IN FT.

	E. BANK	MID. S.	W. BANK
○	1.5	1.5	1.5
△	16.5	17.5	23
x	26	29	38

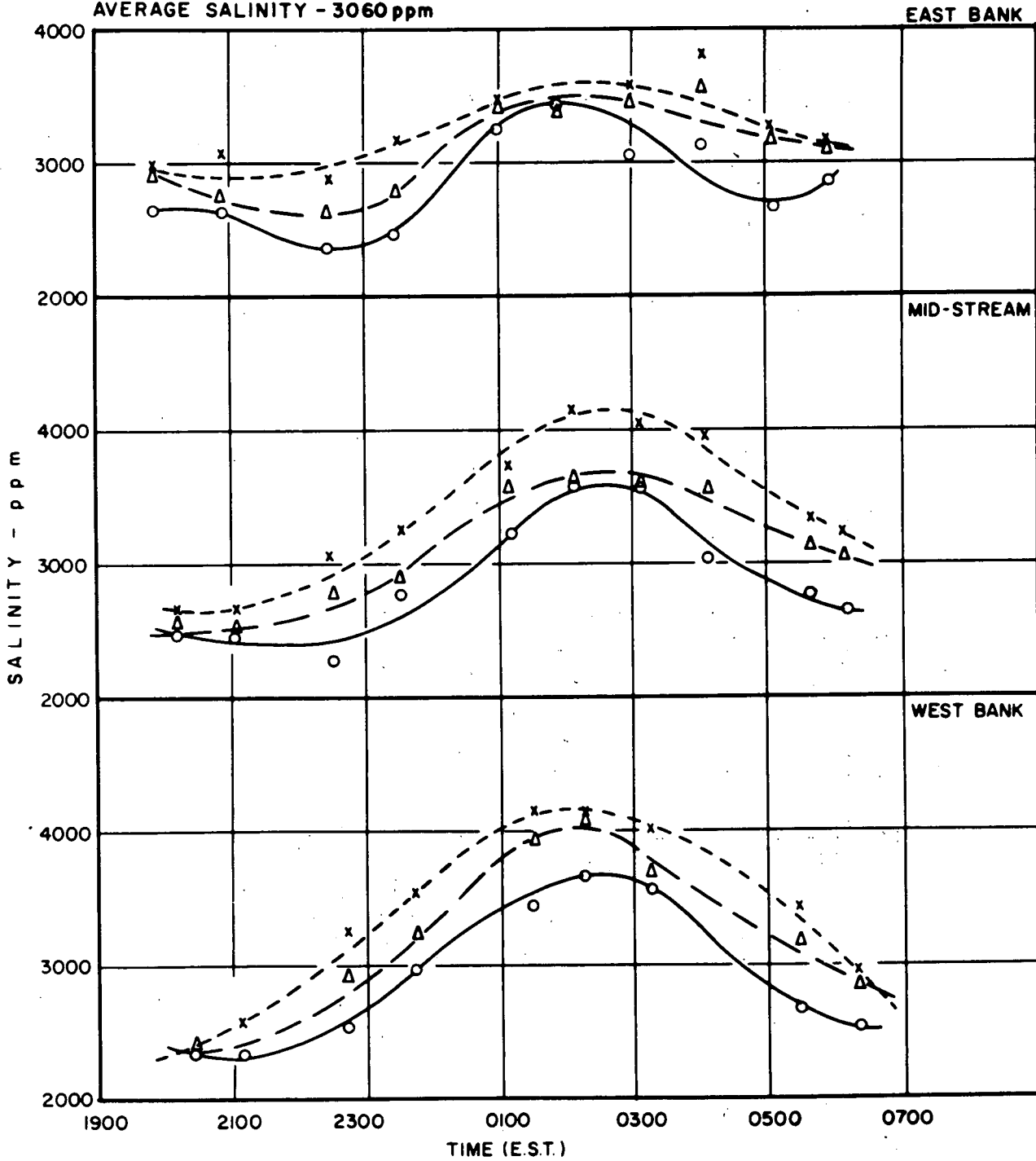
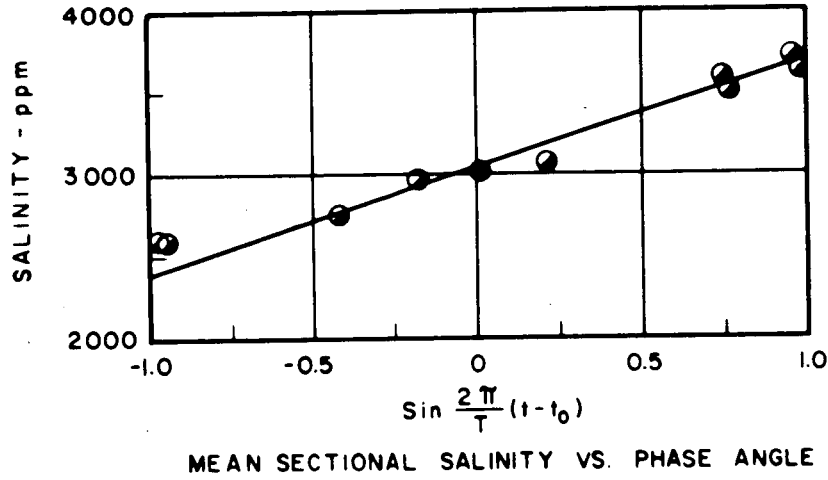

Figure 6

STATION - NEWBURGH
 LOCATION - LAT. 41°-30'
 MILE POINT 60.645
 DATE NOV. 20-21, 1964



$S_0 = 3060$ ppm
 $t_0 @ 2336$ Hrs
 $K = 650$ ppm

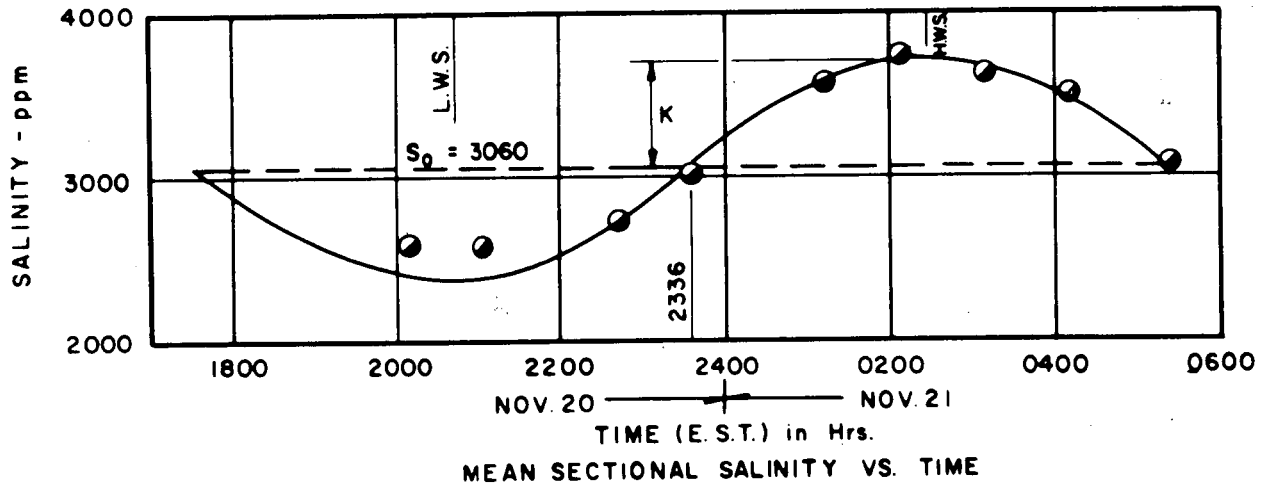

Figure 7

II. SELECTION OF NUMERICAL VALUES OF PARAMETERS

Numerical values of the parameters E, U and K, which appear in the defining differential equation and therefore control the distribution of any contamination in the estuary, must be chosen for the Hudson River.

1. FRESH WATER DISCHARGE

Fresh water velocity, U, is obtained by dividing fresh water discharge by the river cross-sectional area, A. Fresh water flow into the Hudson is measured at Green Island, at mile point 152, where the tributary drainage area totals 8090 square miles. The drainage area of the Hudson Basin, tributary to the entire River, is approximately 13,370 square miles. Over 95% of this area is located north of Indian Point. Because of the inability to measure directly fresh water flow in tidal waters, the Green Island gage is used to establish lower River discharges. The ratio of tributary drainage areas between Indian Point and the gage is 1.57. Analysis of data developed by the United States Geological Survey (USGS) indicates a most probable value for yield factor of 1.22. All values of lower River flow referred to in this report were established using this ratio, i.e., lower River flow is equal to Green Island gaged flow times 1.22.

The pattern of the long-term monthly flows, shown in Figure 8, is indicative of the general variation of River discharge. During the months of March through May, the flow averaged 29,000 cfs or almost 3.5 times the average discharge during the months from June through October. This is equivalent to the statement that the volume of fresh water discharged during the spring months is in excess of twice the volume discharged during the subsequent five-month period.

Figure 1 and Equation 4 indicate that as fresh water velocity decreases, given a fixed value of the longitudinal dispersion coefficient, the dispersion effect increases. Therefore, contaminant concentration values in the region above Indian Point can be expected to increase as flow decreases. Furthermore, due to increased salinity intrusion during periods of low fresh water flow, the longitudinal dispersion coefficient, which is strongly dependent on salinity-induced circulation, can be expected to increase in the upper region of the River. For these reasons, analysis of the effect of pollutants on the River require that drought flows be selected in assigning values of U.

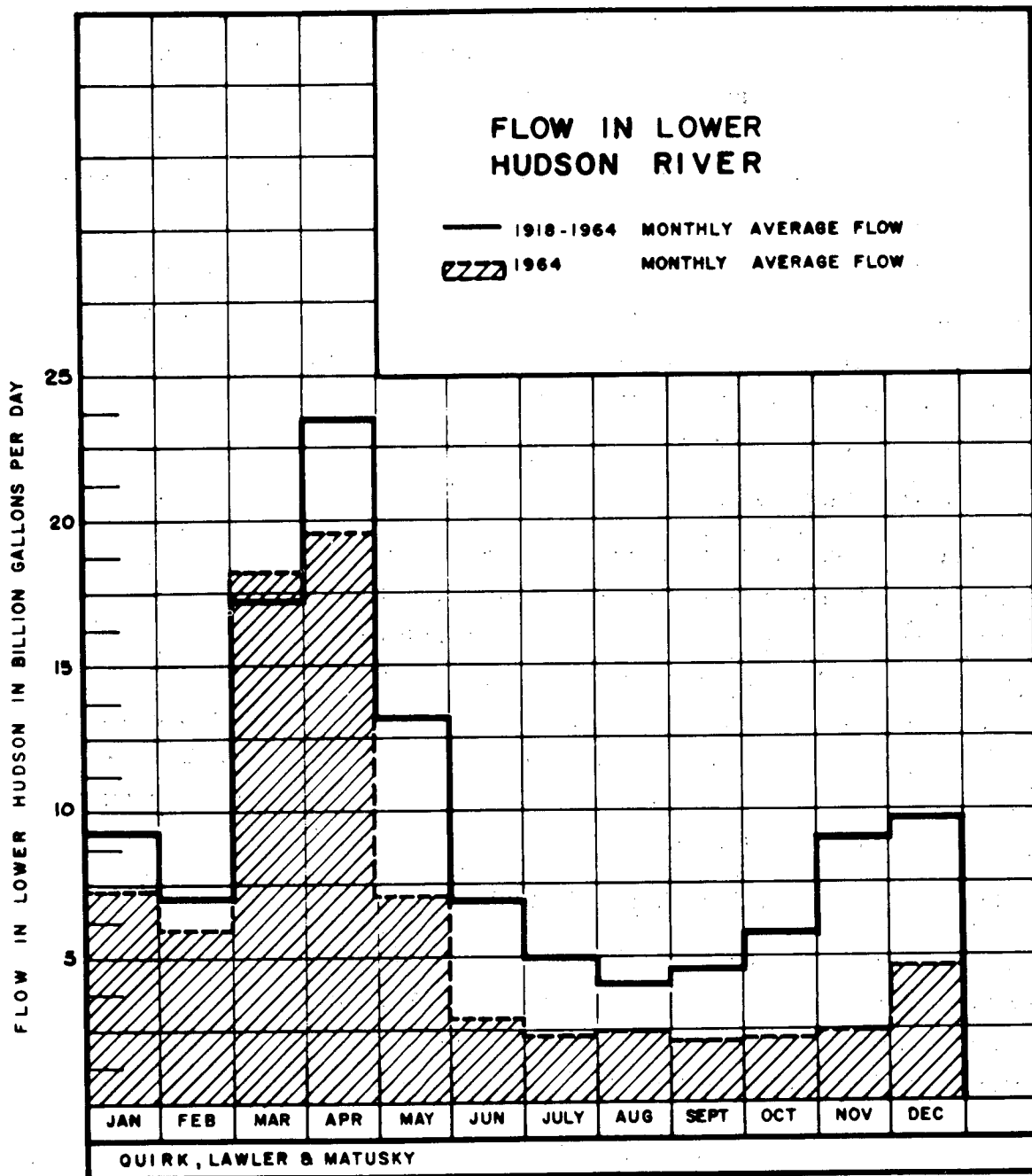

Figure 8

Figure 9 shows a statistical analysis of Hudson River drought flows for the years 1918 through 1964. For drought durations of one week (seven consecutive days), and one month, a plot of flow versus the percent of the time such flow can be expected to occur is given. For example, Figure 9 indicates, for a duration of one week, a flow of 2630 cfs can be expected to occur 5% of the time or once in 20 years.

It should be noted that the response of the Hudson to area-wide droughts is significantly different from that of individual, smaller-sized basins in the region. The difference can be attributed to the size and number of sub-drainage areas within the overall basin and the degree of regulation obtained from up-River storage facilities, such as the Sacandaga and Indian Lake reservoirs.

2. CROSS-SECTIONAL AREA

Figure 10 shows the variation of cross-sectional area with distance above the Battery. Variation is erratic and as such is not amenable to simple mathematical description; i.e., as an elementary function of distance. Between Indian Point and Chelsea, the area varies from a minimum of 120,000 square feet just north of Bear Mountain Bridge to a maximum of 175,000 square feet at the mouth of Newburgh Bay. The average area over this 22 mile river reach is 140,000 square feet; this number has been selected as the value of the constant parameter, A, in Equation 3.

3. LONGITUDINAL DISPERSION COEFFICIENT

The value of the longitudinal dispersion coefficient at any point within the salt-intruded reach of the River can be conveniently obtained by analysis of salinity profiles. The limiting form of Equation 2 for the case of a conservative substance such as salt, and non-constant values of Q, A and E, is:

$$\frac{1}{A} \frac{d}{dx} \left[EA \frac{dc}{dx} - Qc \right] = \frac{dc}{dt} \quad \dots \dots \dots (5)$$

If the variation of salinity with x and t is known, the derivatives $\frac{\partial c}{\partial x}$ and $\frac{\partial c}{\partial t}$ may be obtained graphically or numerically. Equation 5 can then be used to compute the value of E at any point within the saline reach of the River.

This procedure requires that a number of profiles be available so that the time derivative, $\frac{\partial c}{\partial t}$, can be computed and also requires that the value of Q, now a time and distance dependent function, controlling the intrusion, be known. This

HUDSON RIVER FLOW, THOUSAND CUBIC FEET PER SECOND

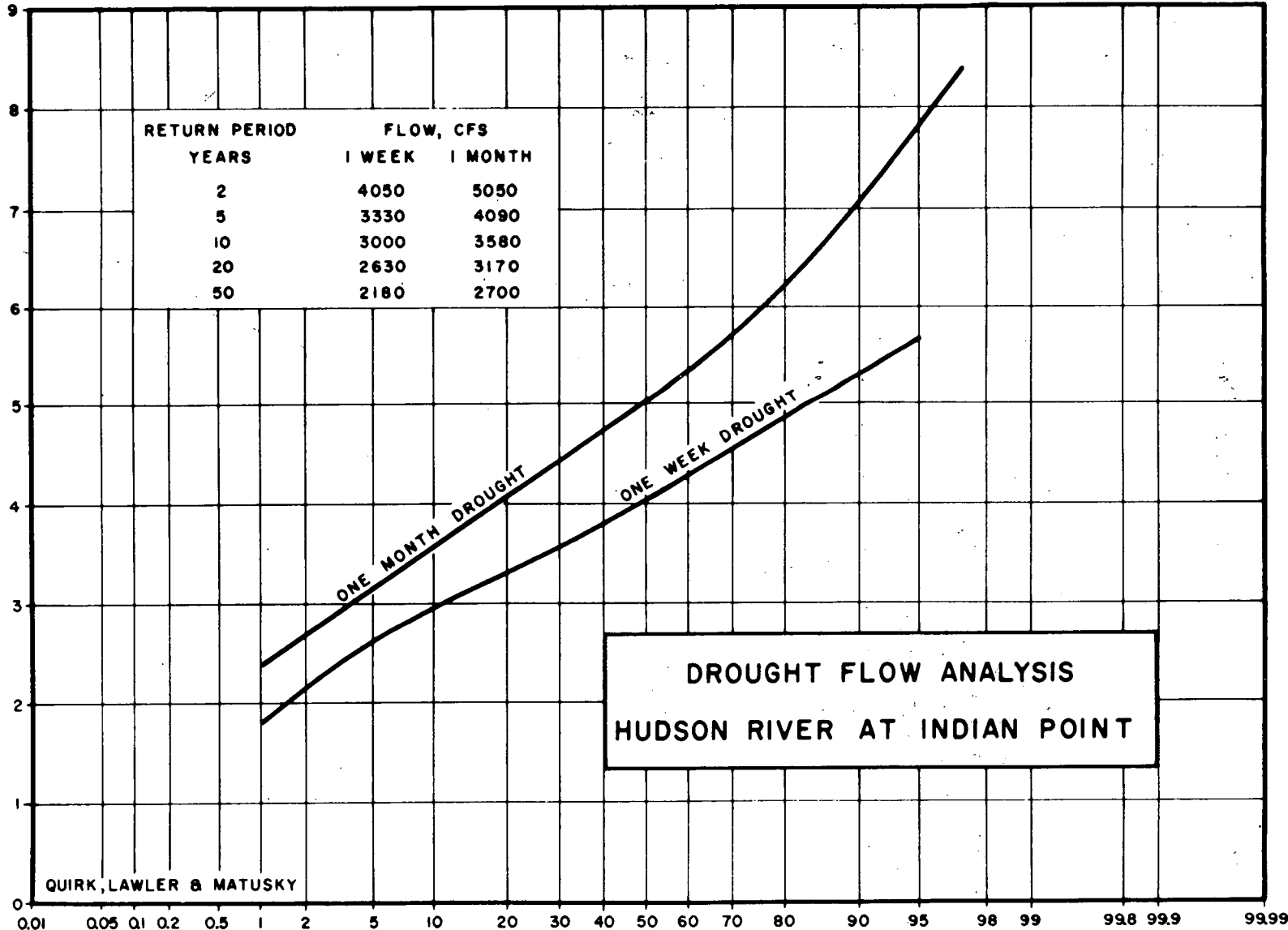

DROUGHT FLOW ANALYSIS
HUDSON RIVER AT INDIAN POINT

QUIRK, LAWLER & MATUSKY

PERCENT OF YEARS FLOW IS EQUAL TO OR LESS THAN THE STATED VALUE

Figure 9

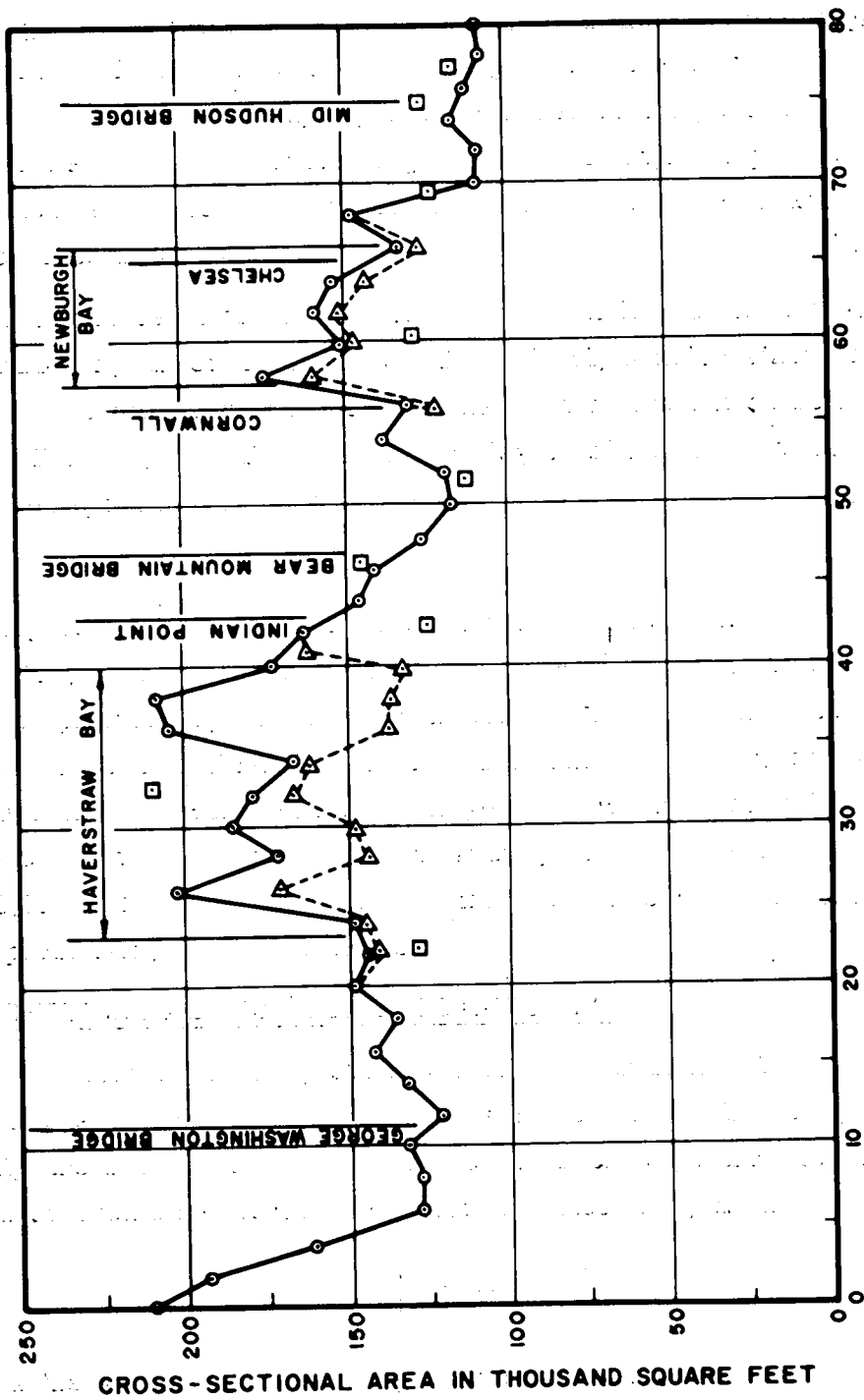

- TOTAL CROSS-SECTIONAL AREA, USC & GS SOUNDINGS
- △ CHANNEL AREA, USC & GS SOUNDINGS
- TOTAL AREA, Q L & M FATHOMETER SURVEY, 1964

**HUDSON RIVER
CROSS-SECTIONAL AREA
MEAN LOW WATER**

Figure 10

latter requirement poses some difficulty in evaluating Hudson River dispersion. Fresh water flow can only be measured at Green Island, above the tidal region, and the attenuating effect of tidal mixing on time-variable flows is not known.

These difficulties have been avoided by recognizing that drought flows in the Hudson remain relatively constant for extended periods of time; Q , and therefore U , are known and the steady Q gives rise to steady salinity profiles during these periods. Under these conditions, the net flux of salt in the River must be zero since there is no sink or source of salt within the estuary. Equation 5 then reduces to:

$$E \frac{dc}{dx} - Uc = 0 \quad \dots \dots \dots (6)$$

Rearrangement of Equation 6 yields a solution for the dispersion coefficient.

$$E = U \left[2.303 \frac{d \log c}{dx} \right]^{-1} \quad \dots \dots \dots (7)$$

Numerical values of $\frac{d \log c}{dx}$ may be obtained by graphical differentiation of a semi-logarithmic plot of salinity versus distance. $U(x)$ is equal to the flow associated with that profile, divided by the area, $A(x)$, at the point in question. Typical steady state salinity profiles are shown in Figure 11. Values of E , computed as described above, are shown in Figure 12 for these and several other drought profiles.

Figure 12 indicates that the dispersion coefficient at some points may increase as flow decreases whereas, at other points, the reverse may occur. For example, at mile point 20, the value of E , during the 1964 drought flow of 4100 cfs, was 12,000 sf/sec and, during the 1959 drought flow of 8700 cfs, was 6000 sf/sec. On the other hand, at mile point 50, E in 1964 was 4200 sf/sec and, in 1959, was 5000 sf/sec.

These phenomena can be explained in terms of the mechanisms contributing to longitudinal dispersion. In the lower part of the saline region, under drought conditions (less than 12,000 cfs), salinity-induced circulation, which depends strongly on the salt concentration, is the predominating mechanism, whereas, toward the end of the intrusion, this saline effect is less predominant and also less variable. The relative contribution of fresh water flow to the dispersion characteristics of the River increase as the absolute contribution of the salinity

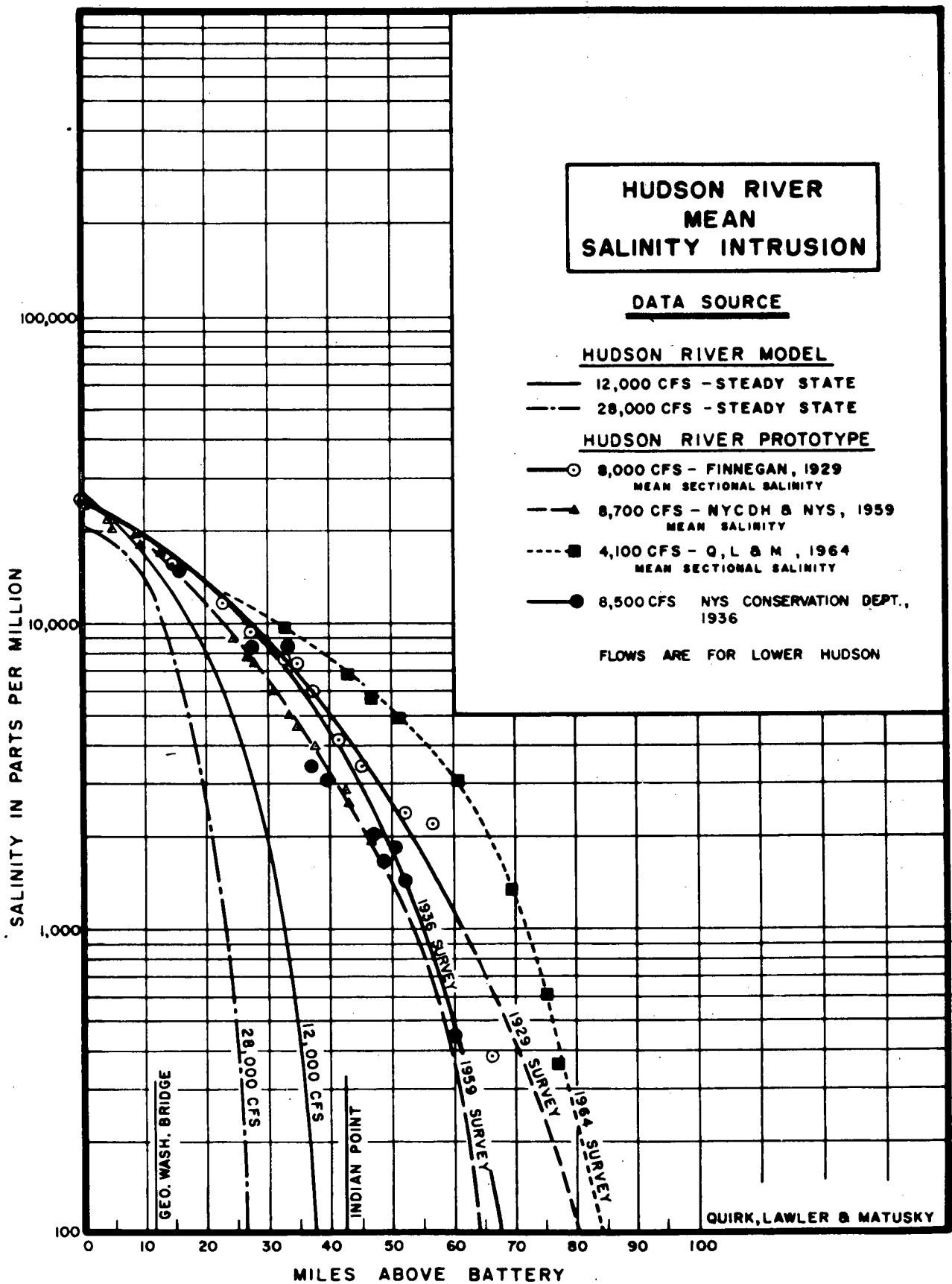

Figure 11

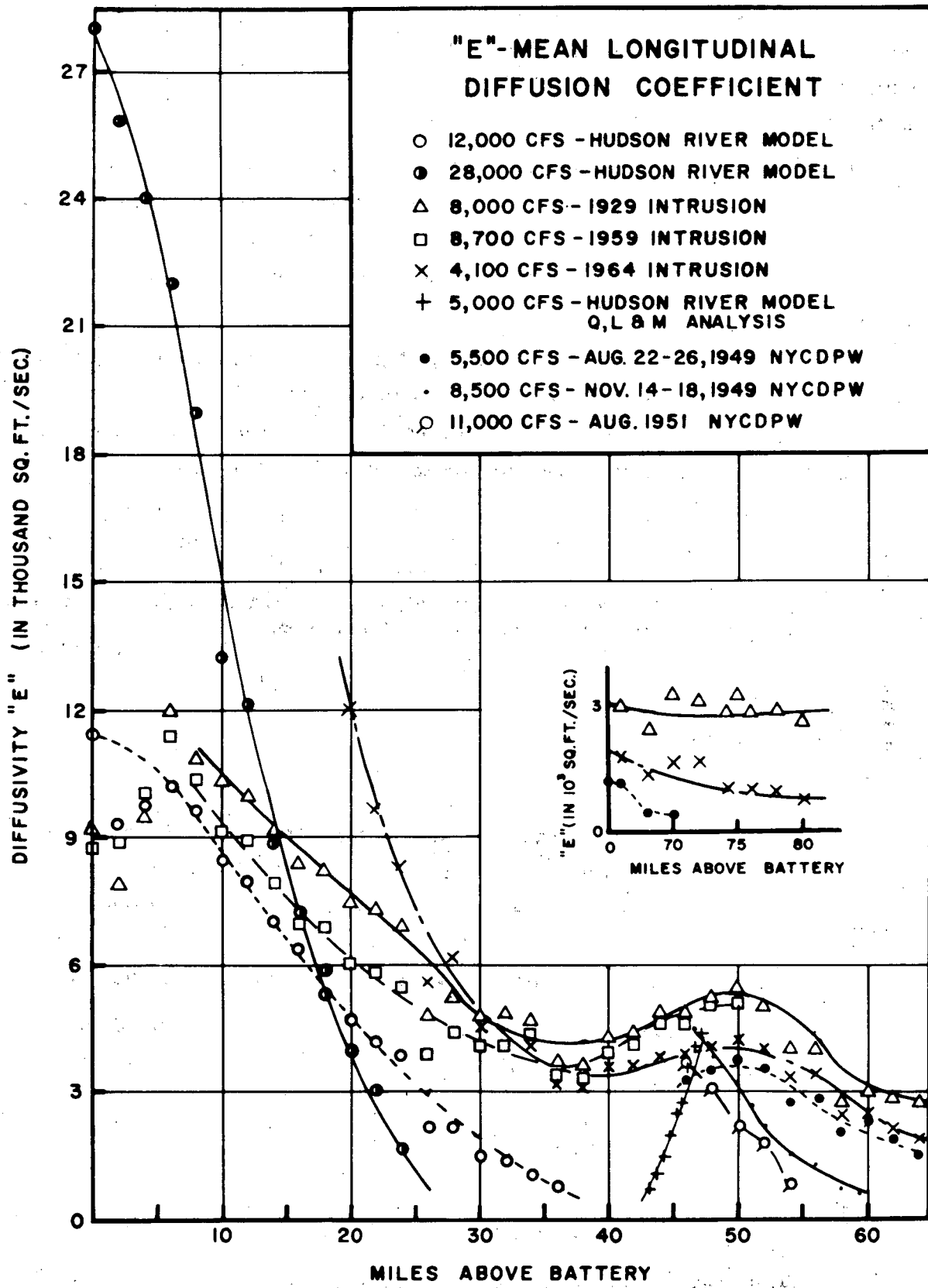

Figure 12

decreases. Thus, increases in fresh water flow can, under some conditions, outweigh the corresponding decrease in salinity, the net effect being an increase in the dispersion coefficient.

Under other conditions, the reverse is true and a decrease in the dispersion coefficient in the presence of an increased flow will be observed. Details for these phenomena and a quantitative method for the prediction of $E(x)$ in the Hudson River as a function of flow are more fully discussed in previous reports (5), (6).

The determination of E as a function of x has been presented to justify the use and selection of constant values of E in this report. A choice of E equal to the maximum value of $E(x)$ within the reach between Indian Point and Chelsea will result in a conservative analysis for the following reasons:

- (1) As Chelsea is approached, the true value of E will fall below this maximum, causing the actual contaminant concentration to be lower than that predicted by constant parameter analysis.
- (2) The predicted downstream flux will be less than the actual downstream flux because the true E values, in this region, are larger than the constant E . Thus, the predicted value of the fraction of total contamination discharge moving upstream will be greater than the actual value of this fraction.

These qualitative statements can be seen more clearly by reference to Figure 1.

Figure 12 indicates that maximum E in the reach between Indian Point and Chelsea occurs between mile points 45 and 50. Accordingly, the values of E for this analysis have been selected by obtaining the average E between mile points 45 and 50 for any given flow. A second choice of E has been made by obtaining the average between mile points 43 and 65 (Indian Point and Chelsea).

The average value of E over a finite length of River is obtained by application of the mean value theorem for derivatives to Equation 7. This yields:

$$\left[\frac{E}{U} \right]_{AVG} = \left[2.303 \frac{\Delta \log c}{\Delta x} \right]^{-1} \dots \dots \dots (8)$$

$$E_{AVG} = U_{AVG} \left[2.303 \frac{\Delta \log c}{\Delta k} \right]^{-1} \dots \dots \dots (9)$$

A correlation of all available Hudson River salinity and flow data is shown on Figure 13. Values of E used in this report have been computed by application

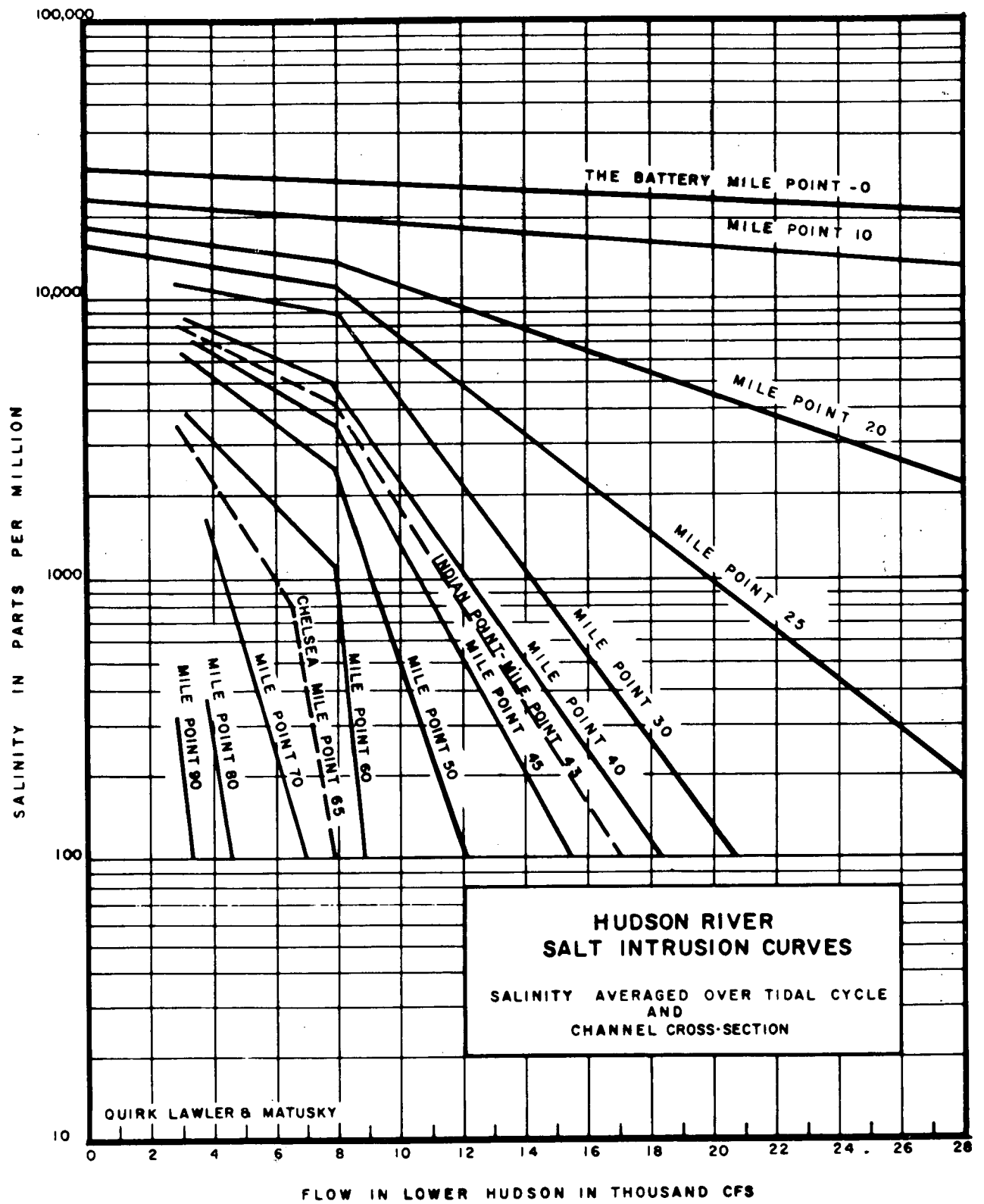

Figure 13

of Equation 9 to these data. For example, at a flow of 4000 cfs, the computation for average E between mile points 43 and 65 is:

$$\begin{aligned}
 E &= \left[\frac{4000}{141,300} \right] \cdot \left[\frac{2.303 (\log 7000 - \log 2200)}{[-43 - (-65)] 5280} \right]^{-1} \\
 &= 2830 \text{ sq. ft./sec} \\
 &= 8.74 \text{ sq. mile/day}
 \end{aligned}$$

Correspondingly, for the same flow, the average E between mile points 45 and 50 is:

$$\begin{aligned}
 E &= \left[\frac{4000}{123,500} \right] \cdot \left[\frac{2.303 (\log 6500 - \log 5400)}{-45 - (-50)} \right]^{-1} \\
 &= 4640 \text{ sq. ft./sec} \\
 &= 14.3 \text{ sq. mile/day}
 \end{aligned}$$

Figure 14 shows the variation, with flow, of average E, computed by Equation 9 as shown above.

III. EFFECT OF CONTINUOUS DISCHARGE ON CHELSEA INTAKE

This section analyzes the effect of a continuous discharge from Indian Point on water drawoff at Chelsea and is subdivided as follows:

1. A steady state of equilibrium analysis
2. A transient analysis or approach to steady state

1. ANALYTICAL DEVELOPMENT FOR STEADY STATE CONDITION

Figure 15 depicts the problem. The defining differential equation is given by Equation 4. Since this equation does not include discharge at Indian Point or drawoff at Chelsea, it will not define behavior across these two planes. For these reasons, the Hudson is divided into three regions, one above Chelsea, one between Chelsea and Indian Point and one below Indian Point. A solution for each region is obtained by application of proper boundary conditions to the general solution of Equation 4.

The steady state form of Equation 4 is:

$$\frac{Ed^2c}{dx^2} - \frac{Udc}{dx} - Kc = 0 \quad \dots \dots \dots (10)$$

The general solution of this second order, linear, ordinary differential equation is:

$$c = C_1 e^{jx} + C_2 e^{kx} \quad \dots \dots \dots (11)$$

in which

$$j = \frac{U + \sqrt{U^2 + 4KE}}{2E}$$

$$k = \frac{U - \sqrt{U^2 + 4KE}}{2E}$$

$C_1, C_2 =$ arbitrary constants

Equation 11 is the form of the general solution for each of the three regions. Designating River velocity above Chelsea as U_1 and below Chelsea as U_2 , the general solution in each of the three reaches is written:

$$c_I = C_1 e^{j_1 x} + C_2 e^{k_1 x} \quad \dots \dots \dots (11a)$$

$$c_{II} = C_3 e^{j_2 x} + C_4 e^{k_2 x} \quad \dots \dots \dots (11b)$$

$$c_{III} = C_5 e^{j_2 x} + C_6 e^{k_2 x} \quad \dots \dots \dots (11c)$$

Figure 14

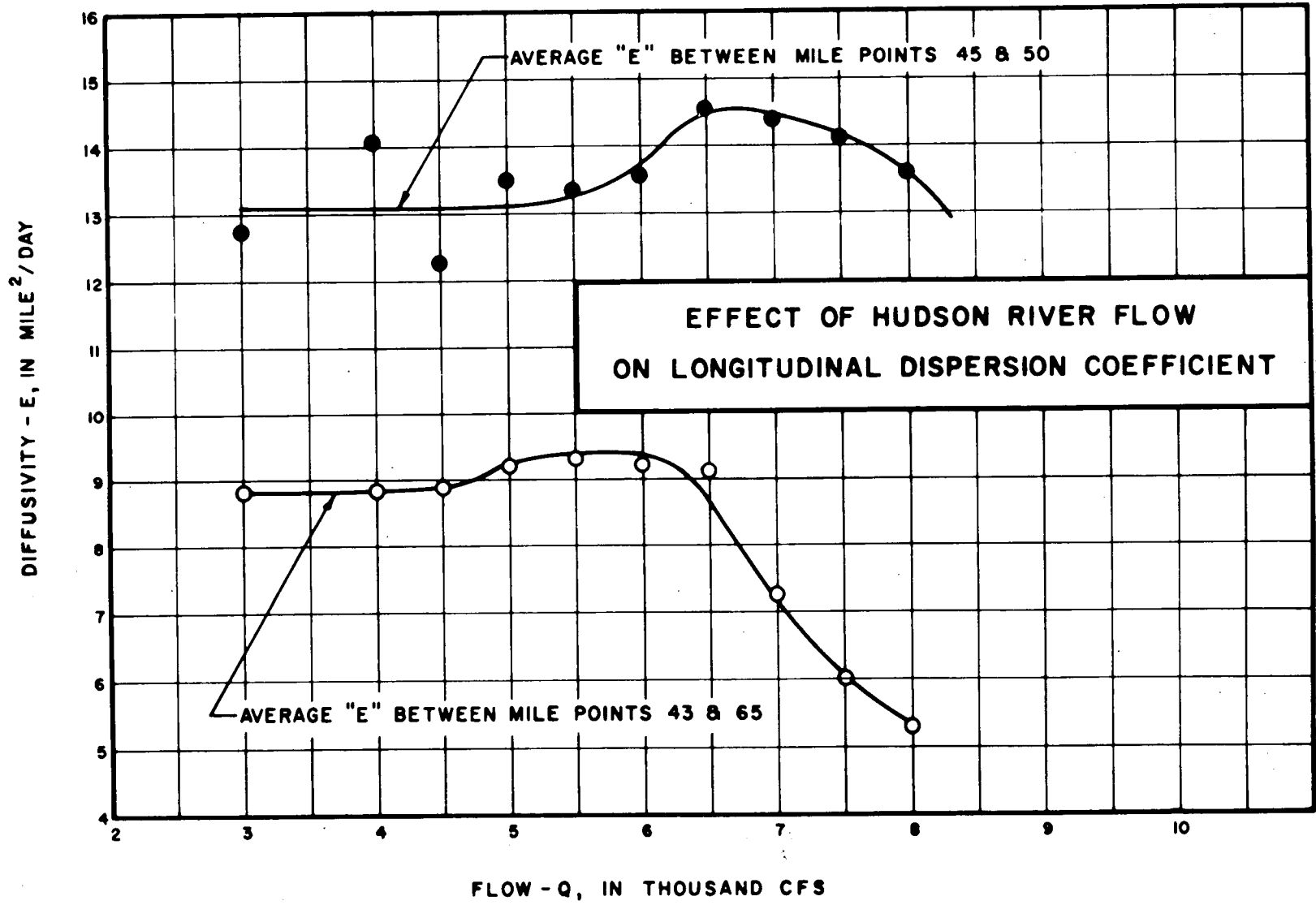

CONTINUOUS DISCHARGE OF RADIOACTIVE CONTAMINANT EFFECT ON UPRIVER WATER INTAKE

I. THE THREE REGION SYSTEM

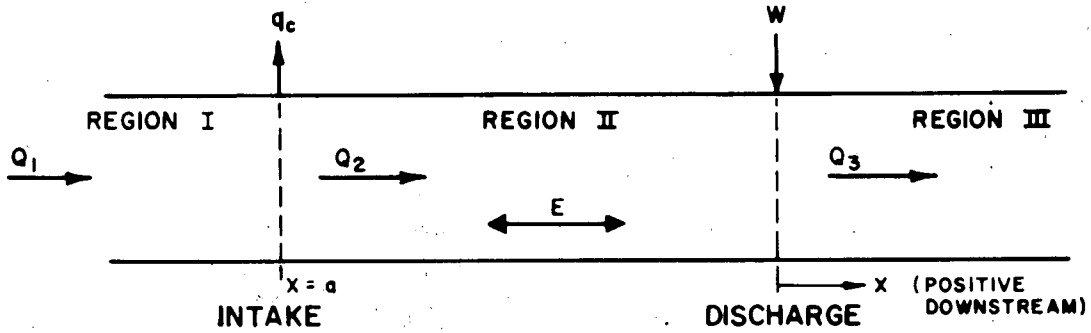

2. MATERIAL BALANCE ABOUT POINT OF DISCHARGE

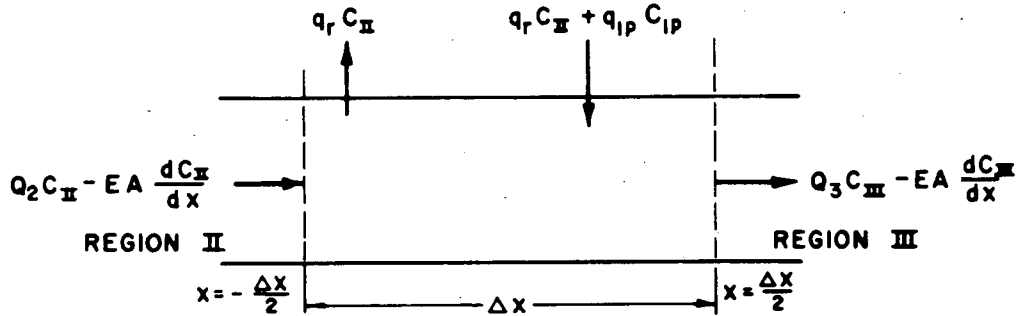

3. MATERIAL BALANCE ABOUT POINT OF INTAKE

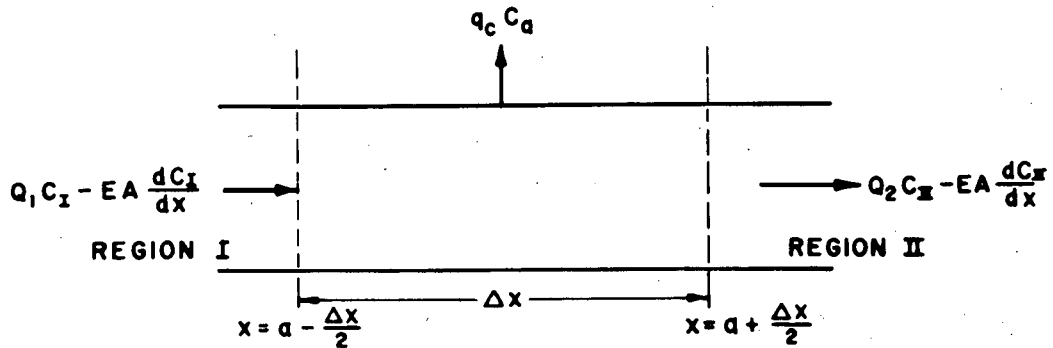

Figure 15

in which

$$\left. \frac{j_1}{k_1} \right\} = \frac{U_1 \pm \sqrt{U_1^2 + 4KE}}{2E}$$

$$\left. \frac{j_2}{k_2} \right\} = \frac{U_2 \pm \sqrt{U_2^2 + 4KE}}{2E}$$

To evaluate the six arbitrary constants, six boundary conditions are necessary. These are developed as follows:

1. The contaminant can be expected to reach negligible concentrations before passing out of the estuary into the ocean. This is not due to any diluting effect of the ocean, but rather because the distance between Indian Point and New York Harbor is sufficiently long to permit virtually complete disappearance of contaminant originating at Indian Point by the time this contaminant reaches the Harbor. This means that the downstream end of the estuary has no influence on contaminant distribution in the estuary. The estuary may therefore be considered to be infinitely long and the first boundary condition may be written:

$$C_{III} \Big|_{x = \infty} = 0 \quad \text{BC \#1}$$

2. In the upstream region, convection opposes dispersion and the distance from Indian Point to the upper end of the estuary is even greater than the distance from Indian Point to the lower end. For these reasons, the statements concerning BC #1 are even more applicable here and the second boundary condition is written:

$$C_I \Big|_{x = -\infty} = 0 \quad \text{BC \#2}$$

3. Although Equation 10 does not define behavior across sections at Indian Point and Chelsea, and discontinuity in some derivatives will occur at these points, the contaminant concentration itself is continuous, and therefore single-valued at all points. This fact gives rise to the third and fourth boundary conditions:

$$C_I \Big|_{x = a} = C_{II} \Big|_{x = a} \quad \text{BC \#3}$$

$$C_{II} \Big|_{x = 0} = C_{III} \Big|_{x = 0} \quad \text{BC \#4}$$

4. To describe the behavior at the boundary between regions II and III, a material balance about the plane of discharge is constructed as shown on Figure 15. The steady state material balance is written:

$$\left[Q_2 c_{II} - EA \frac{dc_{II}}{dx} \right]_{x = \frac{\Delta x}{2}} + q_r c_{II} + q_{IP} c_{IP} - q_r c_{II} - \left[Q_3 c_{III} - EA \frac{dc_{III}}{dx} \right]_{x = \frac{\Delta x}{2}} = K \bar{c} A \Delta x \quad \dots \dots \dots (12)$$

- in which Q_2 = River flow above Indian Point
- q_{IP} = volumetric discharge from plant
- Q_3 = $Q_2 + q_{IP}$ = net River flow below Indian Point
- c_{IP} = concentration of plant contaminants prior to introduction to recirculating flow
- q_r = recirculating River flow through plant

Simplifying Equation 12 and taking the limit as $\Delta x \rightarrow 0$ yields:

$$q_{IP} [c_{IP} - c_{II}]_{x=0} = EA \left[\frac{dc_{II}}{dx} - \frac{dc_{III}}{dx} \right]_{x=0} \quad \dots \dots \dots (13)$$

In reality, virtually all of the flow from Indian Point is recirculated from the River. Therefore $q_{IP} \ll Q_2$, and for all practical purposes $Q_2 = Q_3$. Call $(q_{IP} \cdot c_{IP})$, W , the continuous load on the River, take the limit of Equation 12 and obtain for the fifth boundary condition:

$$W = EA \left[\frac{dc_{II}}{dx} - \frac{dc_{III}}{dx} \right] \quad \text{BC \#5}$$

Notice that the first derivatives of the contaminant concentration are discontinuous at the point of discharge. This behavior is shown clearly by the contaminant profile in Figure 1.

5. The behavior at the boundary between regions I and II is developed similarly. A material balance about the plane of drawoff is constructed in Figure 15 and is written:

$$\left[Q_1 c_I - EA \frac{dc_I}{dx} \right]_{a - \frac{\Delta x}{2}} - q_c c_a - \left[Q_2 c_{II} - EA \frac{dc_{II}}{dx} \right]_{a + \frac{\Delta x}{2}} - K \bar{c} A \Delta x = 0 \quad \dots \dots (14)$$

- in which Q_1 = River flow above Chelsea
- q_c = drawoff at Chelsea
- Q_2 = $Q_1 - q_c$ River flow below Chelsea
- c_a = contaminant concentration at Chelsea

As Δx approaches zero, $c_I = c_{II} = c_a$ and Equation 14 becomes:

$$\left. \frac{dc_I}{dx} \right|_{x=a} = \left. \frac{dc_{II}}{dx} \right|_{x=a} \quad \text{BC \#6}$$

Notice, in the case of drawoff from the River, the concentration of contaminant in the withdrawn flow is identical to the concentration of contaminant in the River at the point of drawoff. In the case of discharge to the River, the contaminant concentration in the discharged flow is much larger than in the River at this point. Thus, in the case of drawoff, the defining differential equation does not hold across the point of drawoff because the River flow is changed, while in the case of discharge, it does not hold because of the imposition of a net load on the River.

Substitution of Equations 11a, b, c into these six boundary conditions yields values for the six arbitrary constants. The explicit solutions for contaminant concentration becomes:

$$c_I = \frac{W e^{(j_2 - j_1) a} + j_1 x}{AE (j_1 - k_2)} \quad \dots \dots \dots (15)$$

$$c_{II} = \frac{W}{AE} \left[\frac{e^{j_2 x}}{j_2 - k_2} + \frac{(j_2 - j_1) e^{(j_2 - k_2) a} + k_2 x}{(j_2 - k_2) (j_1 - k_2)} \right] \quad \dots \dots \dots (16)$$

$$c_{III} = \frac{W}{AE} \left[\frac{(j_1 - k_2) + (j_2 - j_1) e^{(j_2 - k_2) a}}{(j_2 - k_2) (j_1 - k_2)} \right] e^{k_2 x} \quad \dots \dots \dots (17)$$

For the case of no decay, $K = 0$, and:

$$j_1 = \frac{U_1}{E}$$

$$j_2 = \frac{U_2}{E}$$

$$k_2 = 0$$

For this case, the concentrations at $x = 0$ (Indian Point) and at $x = a$ (Chelsea) are, respectively:

$$C_0 = \frac{W}{Q_1} \left[\frac{U_1}{U_2} \left(1 - e^{-\frac{U_2 \cdot a}{E}} \right) + e^{-\frac{U_2 \cdot a}{E}} \right] \quad \dots \dots \dots (18)$$

$$C_a = \frac{W}{Q_1} e^{-\frac{U_2 \cdot a}{E}} \quad \dots \dots \dots (19)$$

For no drawoff at Chelsea, Equation 18 and 19 reduce to the simple case of discharge of a conservative contaminant at $x = 0$; i.e., $U_1 = U_2$, $Q_1 = Q_2 = Q$ and:

$$C_o = \frac{W}{Q} \dots \dots \dots (20)$$

$$C_a = \frac{W}{Q} e^{-\frac{U}{E} a} \dots \dots \dots (21)$$

The ratio of concentration at Chelsea to concentration at Indian Point is:

$$\frac{C_{\text{Chelsea}}}{C_{\text{Indian Point}}} = \frac{C_a}{C_o} = \frac{1}{1 + \frac{U_1}{U_2} \left(e^{-\frac{U_2 \cdot a}{E}} - 1 \right)} \dots \dots \dots (22)$$

For the case of no drawoff at Chelsea, this reduces to $e^{-\frac{U_a}{E}}$.

2. TRANSIENT CONDITION

Subsequent to commencement of a steady, continuous discharge, a time lag occurs before steady state profiles, described by Equation 15 through 21, are established. To determine concentration build-up as a function of time as well as of space, an unsteady state analysis of Equation 4 must be made. Such an analysis has been judged necessary in this study, not only to establish the rapidity of approach to steady state, but also to serve as a basis for a computer solution of the maximum permissible continuous release when radioactive decay is taken into account (7).

Analysis shows that the 100 mgd Chelsea draw has only a slight effect on equilibrium concentration at Chelsea. The same can be expected during the approach to equilibrium so that transient analysis without consideration of draw-off was used. This has been developed previously in considerable detail (8). The final equation for the distribution of contaminant upstream of the point of waste discharge is:

$$c_I(x,t) = \frac{W}{2Q\sqrt{1 + \frac{4KE}{U^2}}} \left[E \times P \left[\frac{U}{2E} \left(1 + \sqrt{1 + \frac{4KE}{U^2}} \right) x \right] \cdot \text{ERFC} \left(\frac{-x}{\sqrt{4Et}} - \sqrt{\frac{U^2 + 4KE}{4E}} t \right) - \text{EXP} \left[\frac{U}{2E} \left(1 - \sqrt{1 + \frac{4KE}{U^2}} \right) x \right] \cdot \text{ERFC} \left(\frac{-x}{\sqrt{4Et}} + \sqrt{\frac{U^2 + 4KE}{4E}} t \right) \right] \dots \dots \dots (23)$$

The corresponding steady state solution, given by Equation 16 when $j_1 = j_2$ (no drawoff, $U_1 = U_2$), is:

$$c_I(x) = \frac{W}{Q \sqrt{1 + \frac{4KE}{U^2}}} e^{\frac{U}{2E} \left[1 + \sqrt{1 + \frac{4KE}{U^2}} \right] x} \dots \dots \dots (24)$$

The ratio of the transient response to the equilibrium response is:

$$\frac{c_I(x,t)}{c_I(x,\infty)} = \frac{1}{2} \left[\text{ERFC} \left[\frac{-x}{\sqrt{4Et}} - \sqrt{\frac{U^2 + 4KE}{4E}} t \right] - \text{EXP} \left[-\frac{U}{E} \sqrt{1 + \frac{4KE}{U^2}} x \right] \cdot \text{ERFC} \left[\frac{-x}{\sqrt{4Et}} + \sqrt{\frac{U^2 + 4KE}{4E}} t \right] \right] \dots \dots \dots (25)$$

For the case of no decay, Equation 25 reduces to:

$$\frac{c_I(x,t)}{c_I(x,\infty)} = \frac{1}{2} \left[\text{ERFC} \left[\frac{-x}{\sqrt{4Et}} - \sqrt{\frac{U^2 t}{4E}} \right] - \text{EXP} \left[-\frac{U}{E} x \right] \cdot \text{ERFC} \left[\frac{-x}{\sqrt{4Et}} + \sqrt{\frac{U^2 t}{4E}} \right] \right] \dots \dots \dots (26)$$

IV. INSTANTANEOUS RELEASE

This case represents the condition of an accidental spill of radioactive contaminant to the River. A slug of material is released over a short time interval, which for practical purposes can be assumed to be instantaneous. The object is to determine the time of appearance of and the value of maximum concentration at Chelsea.

1. PREVIOUS STUDIES

Studies of the effect of instantaneous release of conservative substances at Indian Point were conducted on the Hudson River Model at the Waterways Experiment Station, Vicksburg, Mississippi, circa 1962 (9). Figure 16 is a reproduction of Plate 30, reference 9, and shows the distribution of conservative dye, released over a single tidal cycle at Indian Point, for a River flow of 12,000 cfs. Notice that the spread is asymmetrical, favoring the downstream direction. This documents the variable nature of the dispersion coefficient and the fact that it increases in the downstream direction, as shown previously in Figure 12. A more detailed analysis of these data, in terms of the mechanisms which cause E to vary, may be found in references 5 and 6.

The occurrence of maximum upstream E values between mile points 45 and 50 is demonstrated by Figure 16. Within this reach a decreasing slope, particularly for tidal cycles 15 through 30, can be seen, indicative of greater spreading or longitudinal dispersion. For a flow of 12,000 cfs, salinity is well below mile point 55, the approximate location of the mouth of Newburgh Bay, and therefore not available to induce circulation, i.e., increase E . Below this point the channel narrows, the velocity is higher, and the downstream-directed convection strong. However, the rate of tidal energy dissipation, besides salinity-induced circulation, the other major cause of dispersion, is relatively high and dispersion is enhanced and the dye moves up this far.

Tidal energy dissipation in the larger expanse of the bay is relatively low; without salinity-induced circulation present, dispersion becomes negligible and is overpowered by downstream-directed convection. Thus, at the flow of 12,000 cfs, dye does not appear above mile point 55.

At drought flows, of course, salinity is present for north of this point; significant dispersion, at these times, can be expected in the vicinity of Chelsea.

Figure 16

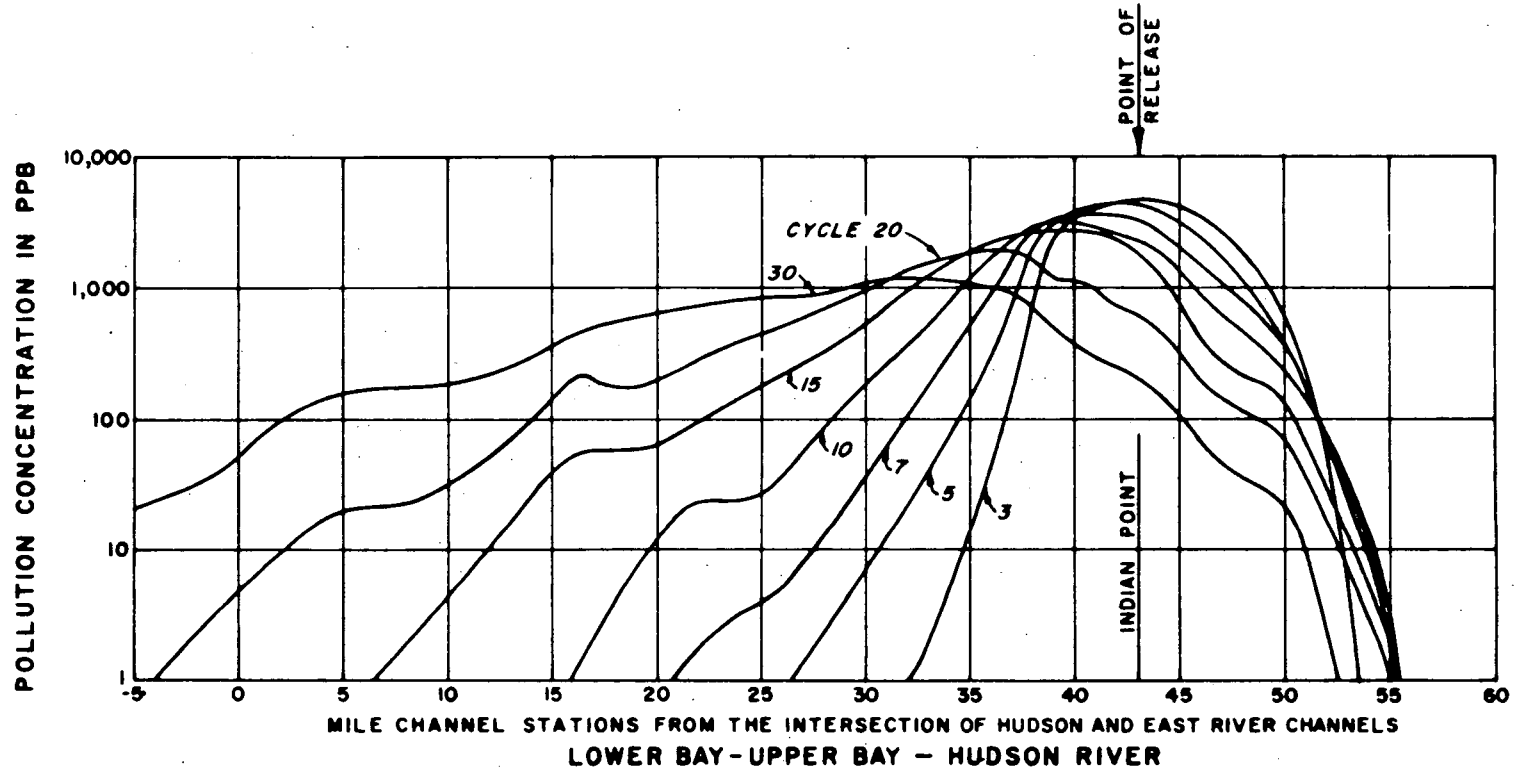

NOTE: A TOTAL OF 6 LITERS OF DYE WAS RELEASED
 AT A UNIFORM RATE DURING 1 TIDAL CYCLE.
 THE INITIAL DYE CONCENTRATION WAS 1,000,000 PPB.
 HUDSON RIVER AND RARITAN RIVER INFLOWS
 = 12,000 CFS AND 1770 CFS RESPECTIVELY.

INTERSTATE SANITATION COMMISSION
 POLLUTION STUDIES
 PLATE 30
**DISTRIBUTION OF POLLUTION
 AT HIGH-WATER SLACK**
 CONSOLIDATED EDISON CO. TREATMENT PLANT
 LOWER BAY-UPPER BAY - HUDSON RIVER

2. CONSTANT PARAMETER ANALYSIS

Drawoff at Chelsea is not considered; the results of the continuous analysis indicate this is not a serious omission. Detailed analysis of the instantaneous release for constant River characteristics has been developed previously (8); a brief outline of the development is given here.

The defining differential equation is Equation 4. The initial and boundary conditions are developed as shown on Page 9 and are:

$$\text{Initial Condition: } C|_{t=0} = 0, \quad -\infty \leq x \leq \infty$$

$$\text{Boundary Conditions \#1, \#2: } C|_{x=\pm\infty} = 0, \quad \text{all } t$$

$$\text{Boundary Conditions \#3: } C|_{x_- \rightarrow 0} = C|_{x_+ \rightarrow 0} \quad \text{all } t$$

$$\text{Boundary Conditions \#4: } A E \left[\frac{dc}{dx} \Big|_{x_- \rightarrow 0} - \frac{dc}{dx} \Big|_{x_+ \rightarrow 0} \right] = f(t), \quad t > 0$$

$f(t)$ in B. C. #4 is the delta function and is written:

$$f(t) = \begin{cases} \frac{M}{\Delta t}, & 0 < t < \Delta t \\ 0, & \Delta t < t \leq \infty \end{cases}$$

in which M = Mass of contaminant released

The Laplace Transform Solution of Equation 4, subject to the above conditions, yields:

$$C(x, t) = \frac{M}{2A \sqrt{\pi E t}} e^{-\frac{(x - Ut)^2}{4Et} - Kt} \quad \dots \dots \dots (27)$$

To compute the dilution effect only, set $K = 0$. Equation 27 becomes:

$$c(x, t) = \frac{M}{2A \sqrt{\pi E t}} e^{-\frac{(x - Ut)^2}{4Et}} \quad \dots \dots \dots (28)$$

The maximum value of $C(x, t)$ at a given x is desired. Differentiate Equation 28 with respect to t and equate the results to zero to determine the time at which the maximum concentration occurs. This procedure yields:

$$t_{\text{critical}} = \frac{E}{U^2} \left[-1 + \sqrt{1 + \frac{U^2 x^2}{E^2}} \right] \quad \dots \dots \dots (29)$$

VIII. REFERENCES

1. Kent, R. "Diffusion in a Sectionally Homogeneous Estuary." Paper No. 3392, Transactions, American Society of Civil Engineers, Vol. 128, Part III (1963).
2. Holley, E. R., Jr. and Harleman, D. R. F. "Dispersion of Pollutants in Estuary Type Flows." Report No. 74, Hydrodynamics Laboratory, Massachusetts Institute of Technology, Cambridge, Mass. (January 1965).
3. Lawler, J. P. "Mathematical Analysis of Estuarine Pollution," in "Engineering Aspects of Marine Waste Disposal." Environmental Health Sciences and Engineering Training Course Manual, R. A. Taft Sanitary Engineering Center, Cincinnati, Ohio (1965).
4. Bird, R. B., Stewart, W. E. and Lightfoot, E. N. "Transport Phenomena." John Wiley and Sons, New York, N. Y. (1960).
5. "Evaluation of Waste Diffusion in the Hudson River at Peekskill." Report to Standard Brands, Incorporated by Quirk, Lawler and Matusky, Water Resources Engineers, New York, N. Y. (December 1964).
6. "Hudson River Dispersion Characteristics." Progress Report to Consolidated Edison Company of New York, Incorporated by Quirk, Lawler and Matusky, Water Resources Engineers, New York, N. Y. (October 1965)
7. "Indian Point Station - River Diffusion Study." Consolidated Edison Company of New York, Incorporated - Memorandum from C. A. Larson to W. J. Cahill, Jr. (April 26, 1966).
8. Lawler, J. P. "Differential Equations" in "Stream and Estuarine Analysis." Training Manual, Tenth Summer Institute in Water Pollution Control, Manhattan College, New York, N. Y. (June 1965).
9. "Joint Pollution Studies in the New York Harbor Model." Miscellaneous Paper No. 2-558, U. S. Army Engineer Waterways Experiment Station, Vicksburg, Miss. (February 1963).

**HYDROLOGY OF INDIAN POINT SITE
AND SURROUNDING AREA**

METCALF & EDDY ENGINEERS

OCTOBER, 1965

**REPORT PREPARED BY GEORGE P. FULTON
UNDER DIRECTION OF HARRY L. KINSEL, P. E.**

ACKNOWLEDGEMENTS

We acknowledge with thanks the assistance of many public officials, including the following, in furnishing data for this report:

Mr. Alfred Morgan, Chief Engineer
Palisades Interstate Park Commission

Mr. George O'Keefe, Director, Division
of Environmental Sanitation, Rockland
County Health Department

Mr. George Natt, Director,
Westchester County Water Agency

Mr. Michael Frimpter, U. S.
Geological Survey, Middletown, New York

INTRODUCTION

The hydrological features of the Indian Point site have been studied in three categories; the Hudson River, ground water and surface water reservoirs. Flow data and the flood history of the Hudson River in the vicinity of the Indian Point plant are discussed. Ground water sources within the area are generally used for industrial or commercial purposes with some limited residential usage on the west side of the river. The surface water reservoirs in the surrounding area that are used for water supplies and sources of alternate water supplies are also described.

HUDSON RIVER

General

The Consolidated Edison Indian Point plant is situated on the east bank of the Hudson River below Peekskill, just above Verplancks Point. In the general area of the plant, water from the Hudson River is used only for industrial cooling purposes. The nearest community utilizing the Hudson River for a public water supply at the present time is Poughkeepsie, some 30 miles upstream from the plant site.

Flow

Flow data for the Hudson River were abstracted from a previous report of Mr. K. Kennison, submitted to Consolidated Edison on November 18, 1958 (included as an appendix to the section on hydrology). Flood data were obtained from the Survey Division of the Corps of Engineers in New York City.

In the vicinity of Indian Point, the width of the Hudson River ranges from 4,500 to 5,000 feet with maximum depths of from 55 to 75 feet. Cross sectional areas of the river from a point three quarters of a mile upstream from the plant site to a mile downstream are in the order of from 165,000 to 170,000 square feet.

Flow duration records of the Hudson River for a 17-year period preceding 1930 show the following:

<u>Rate of Flow</u> <u>c.f.s.</u>	<u>Percent of Time</u> <u>Exceeded</u>
26,000	20%
15,250	40%
10,500	60%
7,000	80%
4,000	98%

It is evident that even the highest rates of flow expected will influence depth of flow in the river to only a small degree in the vicinity of the plant. This is due to the relatively high available flow section and the width of the river. River depth is affected more by the tidal influence than it can be by any anticipated flood flows.

The Hudson River is tidal as far upstream as Troy, some 100 miles from Indian Point. The elevation of the water surface in the vicinity of the plant is so responsive to the tidal cycle that average rate of flow has little effect on depth of flow or velocity of flow.

Flood History

Tide elevations vary both daily and seasonally and, in addition, can be affected by atmospheric conditions such as can exist during extreme storms or hurricanes. The atmospheric conditions can cause a surge which, added to the normal tide, establishes water elevation.

The highest water elevation at the U.S.G.S. station at Verplancks Point, one-half mile below Indian Point, was 7.4 feet above MSL (mean sea level) recorded in the year 1950. A higher surge occurred in 1960, but the normal tide stage was such that actual water elevation was somewhat less than the 1950 record. In an earlier period, before 1935, the highest recorded elevation was 4.75 ft. above MSL at Verplancks Point on August 24, 1933.

Mean water elevations at Verplancks Point are just below 1.0 (MSL). The mean range of water depth stages is about 3.0 ft.. With high runoff in the Hudson River Basin, the mean range at times averages a half a foot higher during the spring period.

The highest river elevation, recorded in 1950, was about 6.5 feet higher than average river levels, or some 5.0 feet higher than average high river stages. Considering past flood history and the fact that flood stages are primarily the effect of tidal influence, flooding of the Indian Point plant site appears to be a highly unlikely possibility.

Contamination Potential

The hazards of contamination of water supplies by discharge of water borne wastes from the Consolidated Edison Indian Point plant are almost minimal. In the reach of the Hudson River that could be affected, river water is used only for industrial cooling.

It should be mentioned that the City of New York is now in the process of constructing a river water pumping station at Chelsea in Putnam County below Poughkeepsie. The intent is to pump Hudson River water into the City system.

WELLS AND GROUND WATER

General

Within a five-mile radius of the plant the only public water supply using ground water is the Stony Point system of Utilities and Industries located in Rockland County across the river from Indian Point. Reports on ground water resources within this five-mile radius indicate the existence of numerous other wells. These wells are for industrial and commercial usage and for individual water supplies for private residences. Residential usage, however, is almost entirely confined to the area on the west side of the Hudson River.

Ground Water Geology

Water bearing strata in the area within a five-mile radius of Indian Point can be divided into unconsolidated surface deposits and consolidated bedrock. Unconsolidated deposits cover most of the bedrock in this area and range in thickness from a few feet in the hills to several hundred feet in the larger valleys. Unconsolidated deposits range from clays, which produce only meager quantities of water, to coarse sand and gravel capable of yielding several hundred gallons per minute to a well.

The bedrock underlies the unconsolidated deposits and, where these are absent, crops out at the surface. Ground water in bedrock occurs principally in fractures and solution channels.

Thus, the water bearing characteristics are generally similar, although the rocks differ widely in mineral composition and water yield.

Bedrock in Westchester County is, for the most part, metamorphic in character and includes schist and gneiss, with smaller amounts of limestone, quartzite and slate. Small injections of granite can also be found. Only minimal yields of ground water can be obtained from bedrock formations in Westchester County.

Consolidated rocks are the chief source of water in Rockland County. Principal rock units include the following:

- a) Newark Group - sandstone, shale and conglomerate.
- b) Palisade Diabase - diabase with some basalt.
- c) Cambrian and Ordovician Rocks - quartzite, limestone and dolomite.
- d) Precambrian Rocks - granite, gneiss, with some schist and diorite.

The Newark group provides the greatest source of ground water supply in Rockland County. The other units of bedrock yield only minimal quantities, as in Westchester County.

A small area of Orange County lies within the 5-mile radius being considered. Wells in this area have been drilled in bedrock formations similar to those in Westchester County where the water yield is small.

Well Supplies

As mentioned before, the only public water supply served by wells in the 5-mile radius of Indian Point is the Stony Point System. This system serves the Villages of Haverstraw and West Haverstraw as well as portions of the Towns of Haverstraw and Stony Point. The Stony Point supply wells are located in stratified drift, an unconsolidated formation. These wells are relatively shallow, the greatest depth about 35 ft. Total yield of the wells to the system averages about 550 gpm.

Other wells in Rockland County, in the area being considered, include some wells for commercial and industrial use and many private wells serving individual residences. These wells are located in bedrock for the most part and range from 100 to 300 ft. in depth. Consumption of water from wells serving private homes will vary from 100 to 1,000 gpd (gallons per day), depending on the number of persons using the supply and the facilities using water.

There are only a few wells still in use in Westchester County within the 5-mile radius. Almost all the wells within 2 to 3 miles of Indian Point have been abandoned and connections have been made to public water systems for supply. At the fringes of the area a few private wells are used for individual residences. These wells are mostly in unconsolidated deposits with depths less than 50 ft. Some wells exist in bedrock with depths varying up to several hundred feet.

A small portion of the community of Fort Montgomery in Orange County lies within 5 miles of the plant. Homes in this community are served entirely by individual private wells in bedrock. Depth of the wells vary up to several hundreds of feet.

Contamination Potential

The bedrock formation is such that it is highly unlikely that wastes percolating into the ground from the Indian Point site will reach the water bearing formations used for water supply on the west side of the river in Rockland and Orange Counties. Most of the wells in Westchester County are shallow, in unconsolidated formations with ground surface elevations considerably higher than at the plant site. This situation would preclude the possibility of contamination of the supply through ground water flow. Bedrock wells in Westchester County are similarly at higher elevations and, for the most part, are drilled in different rock formations than exists at the plant site.

SURFACE WATER RESERVOIRS

General

The major sources of water supply in the Indian Point area are lakes and surface water reservoirs. The reservoirs within a 15-mile radius of the plant site are tabulated in Tables 1-7 along with the users, capacities and distances from Indian Point. A detailed analysis of the reservoirs within 5 miles of the plant describes alternate sources of supply to those communities served by the reservoirs.

City of Peekskill-Camp Field Reservoir

The 54-million gallon Camp Field Reservoir of the City of Peekskill system, located 2.9 miles from Indian Point, is a raw-water receiving basin for the water treatment plant. Water is pumped into this basin from Peekskill Hollow Brook. For the most part, the water supply is the continuous flow of this brook. At times of low flow the supply can be supplemented by releasing water into the stream from holding reservoirs in Wicopee (Putnam County) some 11.7 miles from Indian Point or from the Catskill Aqueduct of the City of New York, located a short distance upstream from the pump intake.

The City of Peekskill system is divided into two service pressure areas. Water for the low-pressure area flows by gravity from Camp Field Reservoir through a bank of slow-sand filters

into the system. No additional storage is provided for this section of the system. Water for the high-service area flows from the reservoir through two diatomaceous earth filters by gravity and then is pumped to a pair of elevated storage tanks with a total capacity of 800,000 gallons. The high-service system serves approximately 25 percent of the Peekskill area. The remaining area, including Standard Brands and most of the other industrial consumers, is served by the low-pressure system.

Total water consumption in Peekskill averages about 5 mgd. The largest single user is Standard Brands, at an average rate of 1.5 mgd. All water is supplied from Peekskill Hollow Brook. Two connections to other systems are available for emergency conditions. One is the above-mentioned Catskill Aqueduct connection which discharges into Peekskill Hollow Brook. This flow must be processed through the two treatment facilities for use. The other emergency connection is to the Montrose Water District system which can supply between 1.0 and 1.25 mgd from the Catskill Aqueduct to the low-service section of the Peekskill system.

Since no piping is installed to bypass Camp Field Reservoir, contamination of this basin would deprive Peekskill of its normal source of supply. Installation of a bypass would involve some 800 lin. ft. of 24-in. pipe between the inlet force mains and the outlet lines to the two filter facilities. With such a

bypass, it would be possible to take water directly to the filters from Peekskill Hollow Brook after the passage of contaminated water in the event of prolonged contamination of Camp Field Reservoir. It might be necessary to accelerate flushing out of the brook and the impoundment at the pumping station in such a situation by releasing water from either the Catskill Aqueduct or the Wicopee reservoirs.

Peekskill most likely could not depend on the Montrose connection alone. This can supply less than one-half the normal demands of the low-service system even with the assumption that Standard Brands would not operate during the emergency. The high-service system has only 800,000-gallon storage, which would last less than 24 hours after shutting down the Peekskill Hollow Brook supply.

As presently arranged, the City of Peekskill would be practically deprived of a water supply with elimination of Peekskill Hollow Brook as a source. A study will soon be made under the auspices of the Westchester County Water Agency and the State of New York to determine the feasibility of connecting the Peekskill system to a proposed transmission main crossing northern Westchester County from the Delaware Aqueduct of the City of New York. This proposal could furnish an independent source of water in sufficient supply to serve all the needs of the City of Peekskill in the event of an emergency.

Palisades Interstate Park Commission - Queensboro Lake

Queensboro Lake, some 5 miles from Indian Point, serves as the year-round water supply for Bear Mountain Inn. The inn facilities include the offices of the Palisades Interstate Park Commission as well as a hotel and restaurant. Three other lakes feed into Queensboro Lake through stream flow or by pipe connection. Only Queensboro Lake is connected directly to the water system and no bypass is available to route water around the lake from a more distant location.

In case of contamination of Queensboro Lake, Bear Mountain Inn would be deprived of its water supply. A neighboring community, Fort Montgomery, is served entirely by individual private wells. This would seem to indicate that installation of an emergency well supply for Bear Mountain Inn would be feasible.

Stony Point Water System - Utilities and Industries

The Stony Point supply of Utilities and Industries, an investor-owned water company, serves the towns of Stony Point and Haverstraw as well as the villages of Haverstraw and West Haverstraw. Total average consumption is about 1.8 mgd with 1.0 mgd from a surface supply and 0.8 mgd from wells.

The impounding reservoir of the surface supply of 4.5 million gallon capacity is located some 3.5 miles from Indian Point. With contamination of this supply, the system would be left with only the wells which furnish about 45 percent of total consumption.

Negotiations are now under way for purchase of the Stony Point supply by the Spring Valley Water Company, an investor-owned utility serving most of the remaining areas of Rockland County. This company derives water from a well system of 13 to 15 mgd capacity and up to 7 mgd from De Forest Lake outflow some 10.8 miles from Indian Point. Plans have been completed for construction this fall of a connection between the Spring Valley Water Company system and the Stony Point system. This connection will furnish well water from the Spring Valley supply to the Stony Point network.

As far as can be ascertained from public records, the above three systems comprise the only surface water usage within a 5-mile radius of the Indian Point power plant except for industrial cooling water usage of the Hudson River. All other supplies are reported as originating in wells or from surface storage outside the 5-mile limit.

WATER STORAGE RESERVOIRS
WITHIN 15 MILE RADIUS OF INDIAN POINT

TABLE 1

WESTCHESTER COUNTY

<u>Code</u>	<u>Reservoir</u>	<u>User</u>	<u>Capacity Million Gallons</u>	<u>Distance Surface</u>	
				<u>Miles</u>	<u>Acres</u>
W-8	Indian Brook	Ossining WB.	101	6.5	17
W-18	Pocantico Lake	New Rochelle Wat. Co.	200	11.9	63
W-14	Fergusons Lake	Pocantico Hills Est.	40 *	13.5	28
W-13	Tarrytown Res.	Tarrytown	313	14.0	85
W-13	Open Res. - 2	Tarrytown	1.75 & 1.10	14.0	1
W-1	Croton Res.	New York City (See List)	65,300 (Inside 15 mi.)		4059
W-10	Whippoorwill La.	New Castle Wat. Co.	25 *	13.3	8
W-11	Byram Lake	Mt. Kisco	950	15.0	133
W-11	Open Res.	Mt. Kisco	10 *	14.0	2
W-5	Lake Shenorock	Amawalk-Shenorock WD.	90 *	11.1	16
W-6	Open Res.	Lincoln Hall School	25 *	11.9	6
W-1A	Amawalk	NYC (See List)	10,000 (Included in W-1)	11.6	588
W-4	Camp Field Res.	Peekskill	54	2.9	11

* Estimated

WATER STORAGE RESERVOIRS
WITHIN 15 MILE RADIUS OF INDIAN POINT

TABLE 2

PUTNAM COUNTY

<u>Code</u>	<u>Reservoir</u>	<u>User</u>	<u>Capacity Million Gallons</u>	<u>Distance Miles</u>	<u>Surface Acres</u>
P-20	Lake Mahopac	See List	5,000 *	12.7	577
P-10	Oscawanna Lake	See List	3,500 *	9.5	362
P-21	Pelton Pond	N.Y.S. Fahnestock Park	125 *	14.0	11
P-6	Cold Spring	Cold Spring	150 *	13.0	25
B-3	Cargill Res.	Beacon	160	15.0	22
B-2	Mt. Beacon Res.	Beacon	180	14.5	17
B-1	Melzingah Res.	Beacon	60	13.3	8
W-4	Wicopee	Peekskill	1,200	11.7	166
P-5	Lake Secor	Carmel WD #5	350 *	10.8	50

* Estimated

WATER STORAGE RESERVOIRS
WITHIN 15 MILE RADIUS OF INDIAN POINT

TABLE 3

ORANGE COUNTY

<u>Code</u>	<u>Reservoir</u>	<u>User</u>	<u>Capacity Million Gallons</u>	<u>Distance Miles</u>	<u>Surface Acres</u>
0-11	Lusk Res.	U.S. M.A.	50 *	7.5	16
0-4	Intake Res.	Highland Falls	2.5	6.5	
	Bog Meadow	" "	80	8.3	43
	Little Bog	" "	4.5	7.5	2
	Jims Pond	" "	40	8.4	16
0-12	Turkey Hill La.	Palisades Int. Park	150	5.9	58
	Nawahunta La.	" " "	22	6.7	16
0-20	Silvermine La.	Palisades Int. Park	465	6.0	84
	Queensboro La.	" " "	56	5.0	37
0-16	Lake Stahahe	Palisades Int. Park	230	11.1	90
0-16	Summit Lake	Palisades Int. Park	110	8.3	34
	Barnes La.	Pal.Int.Pk. & U.S.M.A.	24	8.0	18
	Te'ata La.	Pal. Int. Pk.	77	7.7	32
	Upper Twin La.	" " "	105	7.7	24
	Lower Twin La.	" " "	88	7.6	26
	Massawiepa La.	" " "	104	7.7	29
0-17	Lake Tiorati	Pal.Int. Pk., Tiorati & Cohasset	1,500	6.7	296
0-10	Cromwell Lake	Woodbury	80	11.2	55
0-2	Walton Lake	Chester	300	14.6	129
0-5	Lake Mombasha	Monroe	1,750	13.0	324
0-1	Echo Lake	Arden Farms	40 *	9.5	30
0-7	Of Res.	Sterling Forest	60 *	13.7	42

ORANGE COUNTY (CONT'D.)

TABLE 3 (CONT'D)

<u>Code</u>	<u>Reservoir</u>	<u>User</u>	<u>Capacity Million Gallons</u>	<u>Distance Miles</u>	<u>Surface Acres</u>
0-8&9	Tuxedo Lake	Tuxedo & Tuxedo Pk.	2,500	14.5	294
0-3	Aleck Meadow	Cornwall	23	9.2	9
	Arthur's Pond	Cornwall	115	9.2	20

* Estimated

WATER STORAGE RESERVOIRS

TABLE 4

WITHIN 15 MILE RADIUS OF INDIAN POINT

ROCKLAND COUNTY

<u>Code</u>	<u>Reservoir</u>	<u>User</u>	<u>Capacity Million Gallons</u>	<u>Distance Miles</u>	<u>Surface Acres</u>
R-14	Lake Sebago	Sebago Lake, Pal. Int. Pk.	1,100	10.8	300
R-18	Lake Welch	Welch Lake	1,000	7.2	209
R-13	Breakneck Pond	Breakneck Lake, Pal. Int. Pk.	100	9.2	63
R-3	Sec. & Third Res.	Letchworth Vill.	100	8.5	40
R-1	Open Res.	Utilities & Ind.	4.5	3.5	5
R-7	Hillburn Res.	Hillburn	1.0	14.7	4
R-6	DeForest Lake	Hackensack Wat. Co. Spring Val. Wat. Co.	5,500	10.8	960

TABLE 5

MULTIPLE USERS OF WATER SUPPLY SYSTEMS
WITHIN 15 MILE RADIUS OF INDIAN POINT
WESTCHESTER COUNTY

New Croton Aqueduct (New York City)

Ossining Water Board

Sing Sing Prison

Village of North Tarrytown

New Rochelle Water Company

Village of Bronxville

Town of Eastchester

Village of North Pelham

Village of Pelham

Village of Pelham Manor

Village of Tuckahoe

Village of Irvington

Village of Briarcliff Manor

New Castle Water District #1

Village of Tarrytown

Old Croton Aqueduct (New York City)

Ossining Water Board

Village of Ossining

Town of Ossining

Sing Sing Prison

TABLE 5 (CONT'D.)

Kensico Reservoir (New York City)

City of White Plains

North Castle District #1

Westchester Joint Water Works No. 1

Village of Mamaroneck

Town of Harrison

Town of Mamaroneck

City of Rye

City of New Rochelle

Village of Larchmont

Village of Scarsdale

Village of Pelham Manor

Harrison District #1

Catskill Aqueduct (New York City)

Grasslands (Westchester Co.)

Hawthorne Improvement District

Hawthorne

Town of Mt. Pleasant

Valhalla W D

Valhalla

Town of Mt. Pleasant

City of Yonkers

Village of Scarsdale

New Rochelle Wat. Co. (same as Pocantico Lake)

TABLE 5 (CONT'D.)

Amawalk Reservoir (New York City)

Yorktown W S D D

Amawalk Heights W D

Town of Somers

Town of Yorktown (13 Water Districts)

Peekskill System (City of Peekskill)

City of Peekskill

Village of Buchanan

Town of Cortlandt

Indian Brook Reservoir (Ossining Water Board)

Village of Ossining

Town of Ossining

Sing Sing Prison

Whippoorwill Lake (New Castle Water Co.)

Town of New Castle (Part)

Town of North Castle (Part)

Pocantico Lake (New Rochelle Water Co.)

Village of Ardsley

Village of Dobbs Ferry

Town of Greenburgh

Village of Hastings

Village of Scarsdale

Village of Eastchester

TABLE 5 (CONT'D.)

Tarrytown Reservoir

Village of Tarrytown

Glenville W D

Town of Greenburgh

Eastview

Town of Mount Pleasant

Village of North Tarrytown

TABLE 6

MULTIPLE USERS OF WATER SUPPLY SYSTEMS
WITHIN 15 MILE RADIUS OF INDIAN POINT
PUTNAM COUNTY

Lake Oscawanna

Hiawatha Improvement Co.
Hilltop W D
Wildwood Knolls W D
Oscawanna Lake (Private Homes)

Lake Mahopac

Lake Gardens
Lake Mahopac Woods
Mahopac Hills
Mahopac Old Village
Lake Mahopac (Private Homes)
Lake Mahopac Ridge
Lake View Park
Mahopac School

TABLE 7

MULTIPLE USERS OF WATER SUPPLY SYSTEMS
WITHIN 15 MILE RADIUS OF INDIAN POINT
ROCKLAND COUNTY

De Forest Lake

Hackensack Water Co.

Spring Valley Water Co.

Town of Clarkstown (Part)

Town of Ramapo

Town of Orangetown

Nyack

Village of Nyack

Village of South Nyack

Upper Nyack

Town of Clarkstown (Part)

Stony Point Supply (Utilities and Industries)

Town of Stony Point

Town of Haverstraw

Village of Haverstraw

Village of West Haverstraw

KARL R. KENNISON
CIVIL AND HYDRAULIC ENGINEER
361 CLINTON AVE., BROOKLYN, N. Y.

Nov. 18, 1955

Mr. G. R. Milne
Mechanical Engineer
Cons. Edison Co. of N. Y.
4 Irving Place
New York 3, N. Y.

Dear Sir :

You have described to me the general features of the atomic-energy power plant which you are planning to construct on the east bank of the Hudson River below Peekskill. I understand that you wish me to report on such hydrologic features of the site as may affect your plans.

From the information that you have made available to me I conclude that the most useful information I can give you is that which relates to the amount and character of the flow in the river. At the proposed site the river has a width of about 4500 to 5000 feet, a maximum depth of 55 to 75 feet at less than 1000 feet off shore, and a cross-sectional area of about 165,000 to 170,000 square feet. Sheet 1 shows a number of cross sections of the river, plotted from the U.S.C.&G.S. charts, at intervals of 1500 feet, from 3750 feet upstream to 5250 feet downstream from the proposed plant.

At this site the effect of the tides is all important and so far outweighs any other consideration that, at least for present purposes, the information already available on the day-by-day variation of the runoff from the tributary watershed is adequate.

On Sheet 2 I have plotted an approximate flow-duration curve from data I had already calculated covering a period of

17 years.

An average rate of about 26000 cfs may be expected to be exceeded 20 % of the time

"	"	"	"	"	15250	"	"	"	40 %	"	"	"
"	"	"	"	"	10500	"	"	"	60 %	"	"	"
"	"	"	"	"	7000	"	"	"	80 %	"	"	"

For say 2 % of the time the rate may be as low as 4000 cfs

However as above indicated the ebb and flow of the tide is the all important consideration. The river is tidal to as far upstream as Troy. Its hourly behavior in the tidal range varies throughout its length. The U. S. Coast & Geodetic Survey has tabulated a great deal of information from which a general picture of conditions off the shore at the proposed site can be obtained.

On Sheet 3 I have plotted the data, as they are applicable to this particular site. This indicates that the elevation of the water surface is so responsive to the tidal cycle that the average rate of flow, or runoff from the tributary watershed, has relatively little effect on the velocity past the site. I conclude that it is this velocity and the resulting volume of flow available for mixing and dilution in which you are primarily interested. In the limited time at my disposal I can only draw general conclusions. These may be adequate for present purposes. You could obtain better information by running a series of tests on surface and sub-surface floats, at varying distances off shore, throughout the tidal cycle.

The velocity recorded by the U.S.C.&G.S. is that in midstream at or near the surface. In order to be on the safe side in drawing conclusions, I have assumed that 80 % of this velocity represents the average vertically from surface to bottom, and that 80 % also represents the average horizontally from side to

side, hence that roughly 64 % represents the average over the entire cross section. I have also assumed that 15 % of the total cross section, or a stretch about five or six hundred feet wide off shore, is all that should be used in considering the initial mixing or diluting effect. In making this assumption I am governed to some extent by Hazen's studies relative to the off-shore distance of Poughkeepsie's water intake to avoid direct contamination by its sewage. I have further assumed that the velocity in this off-shore stretch is only 60% of the midstream velocity, hence that roughly 48% represents the average over the cross section of this off-shore stretch.

On Sheet 4 I have shown the result of these assumptions, which, as above stated, are believed to be on the safe side in considering the direct effect of mixing or dilution of your wastes. This emphasizes the all-important effect of the tides, the quantity available for dilution varying in about three hours from a maximum of eight or ten million gallons per minute to nothing.

Although you will have to put up with this variation as far as your continuous cooling water circulation is concerned, it does point to the desirability of incorporating in your design a method of controlling the time for the discharge into the cooling water outlet of any and all waste that is to any extent radioactive. I would say that this should be done in any event for the drainage from your routine and emergency demineralizers, and it might well be done also for drainage from all areas liable to accidental contamination.

From your estimate of the extent of dilution already

accomplished in the demineralizer waste overflow, I trust you can get an approximate figure for the dilution that may result in the river off shore, and can compare this with what you may find necessary or desirable for adequate protection of fish life or of the fish eating public.

As far as the effect on public water supplies is concerned, the use of the Hudson River for water supply, other than condenser cooling, is very limited. The nearest municipality involved is Poughkeepsie, 30 miles or more upstream, and even at that distance threatened at times with the problem of salinity. There is no likelihood that in the future any nearer municipality will take its domestic water supply from the Hudson. In fact the tendency is the other way, and the more remote municipalities of Catskill and Hudson have abandoned earlier supplies taken from the river.

As far as the effect on ground water is concerned, you have acquired an ample area of surrounding land. I can see no possibility of any deleterious effect.

I trust that this information which I have assembled in the limited time available will be helpful to you. If from these approximate figures there appears to be any question as to the adequacy of the safety factor in dilution, you may, as above stated, require additional information from float tests.

From what you have told me about your proposed designs and methods of operation, I suspect that there is no real question of safety but only one of public relations - the avoidance of even the appearance of danger.

Very truly yours,

Karl R. Korman
Consulting Engineer

KARL R. KENNISON
CIVIL AND HYDRAULIC ENGINEER
361 CLINTON AVE., BROOKLYN, N. Y.

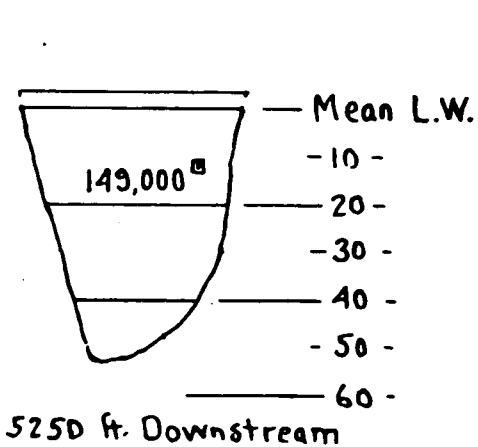
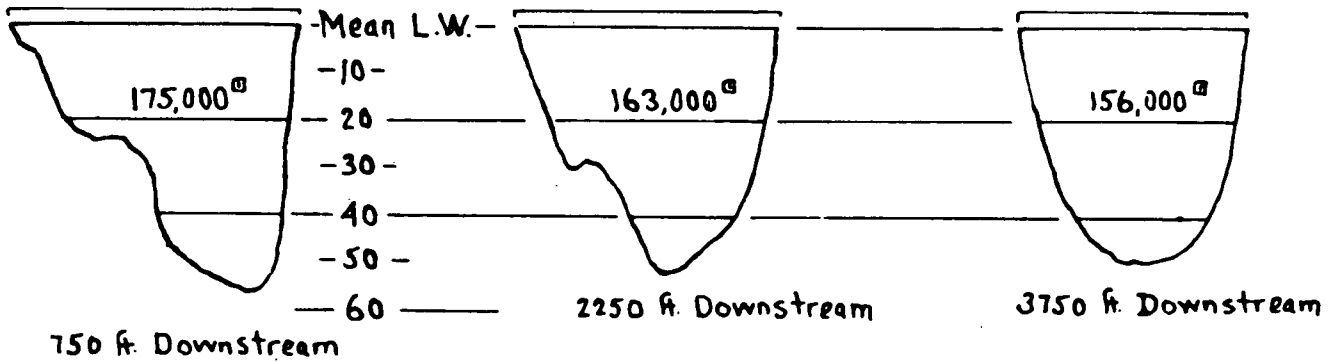
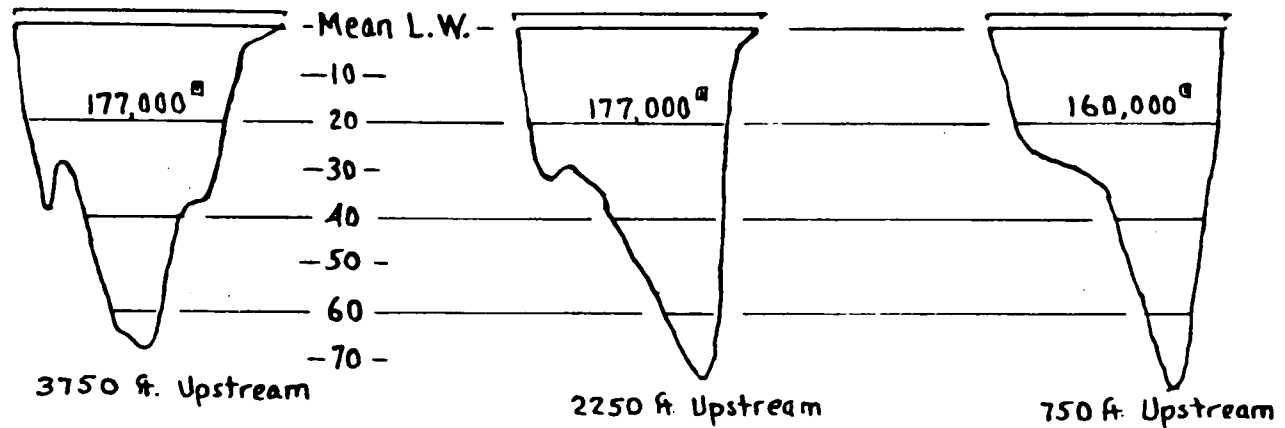

CROSS SECTIONS OF THE
HUDSON RIVER
(Looking Upstream)
Spaced 1500 ft. apart past the
PROPOSED CONS. EDISON PLANT
BELOW PEEKSKILL

K.R.K.

Hudson River at Location of Proposed Cons. Edison Plant below Peekskill

2

11-8-51

-Karl R. Kennison
Cons. Eng.

APPROX. FLOW-DURATION CURVE
(Subsequent to Sacandaga - 1930)

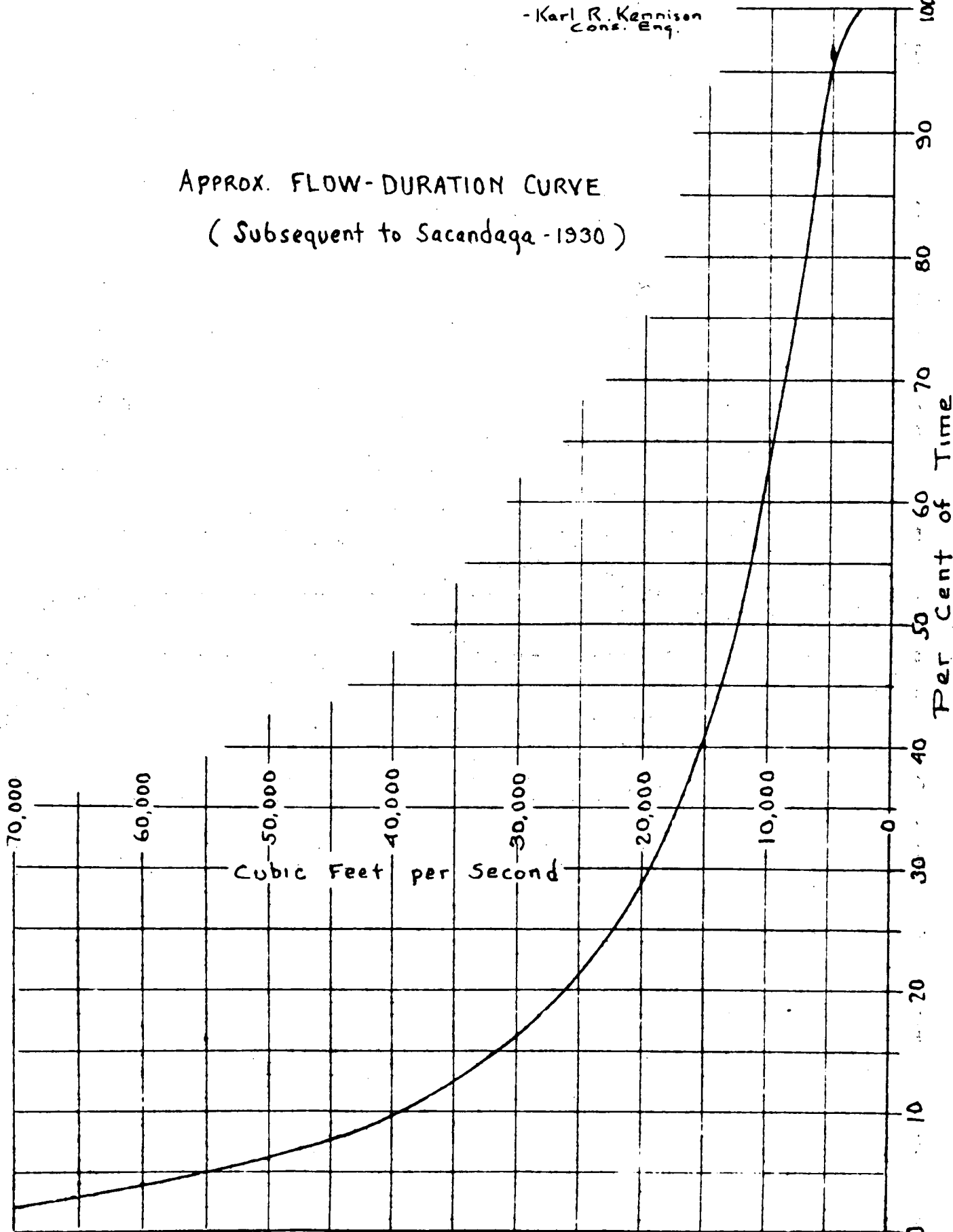

K.R.K.

Hudson River at Location of Proposed Cons. Edison Plant below Peekskill

3

9-13

- Karl R. Kennison
Cons. Eng.

Data from Coast & Geodetic Survey

"Average conditions in the axis of the main channel
during the summer months"

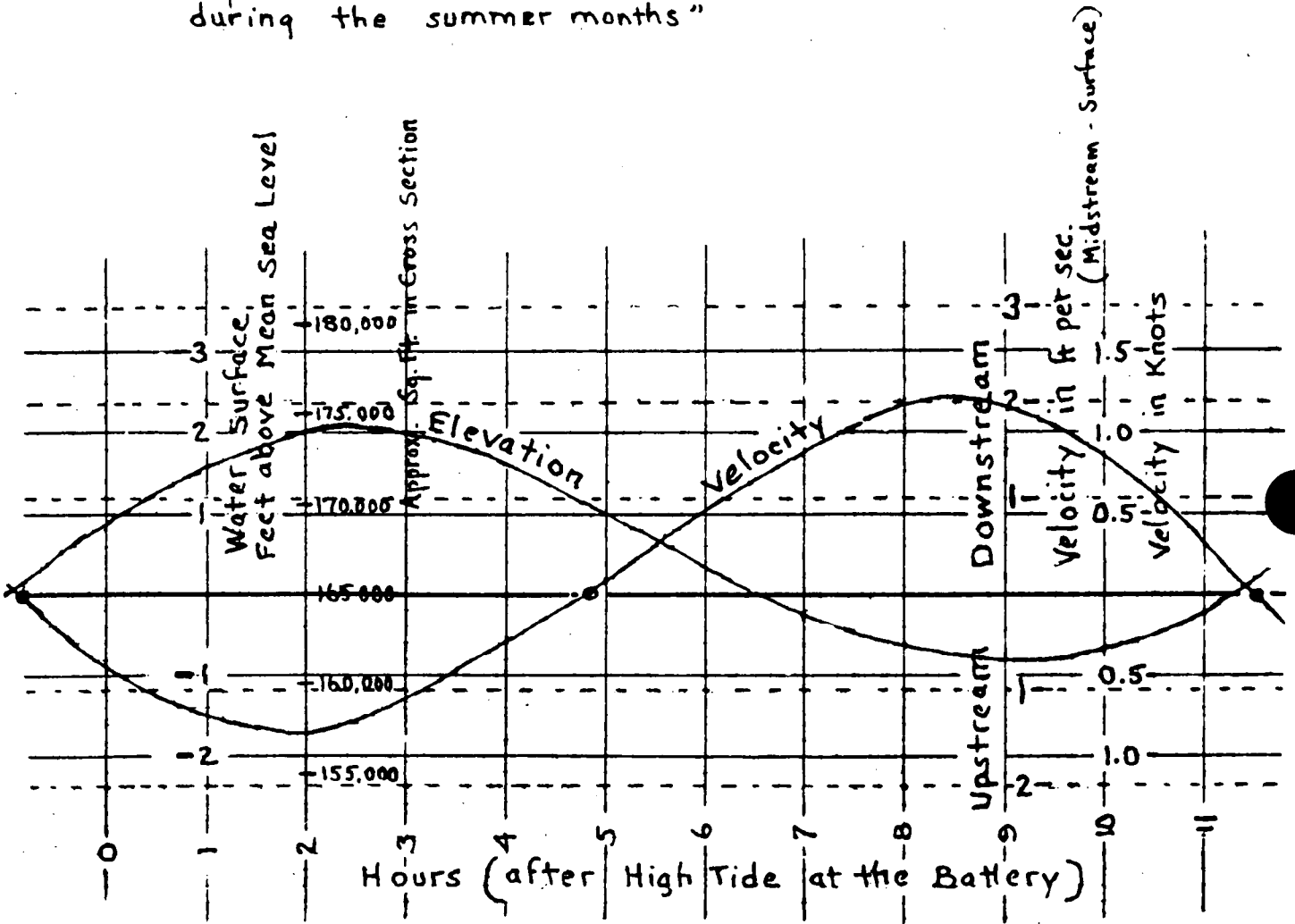

K.R.K.

Hudson River at Location of Proposed Cons. Edison Plant below Peekskill

4

11-8 55

- Karl R. Kennison
Cons. Eng.

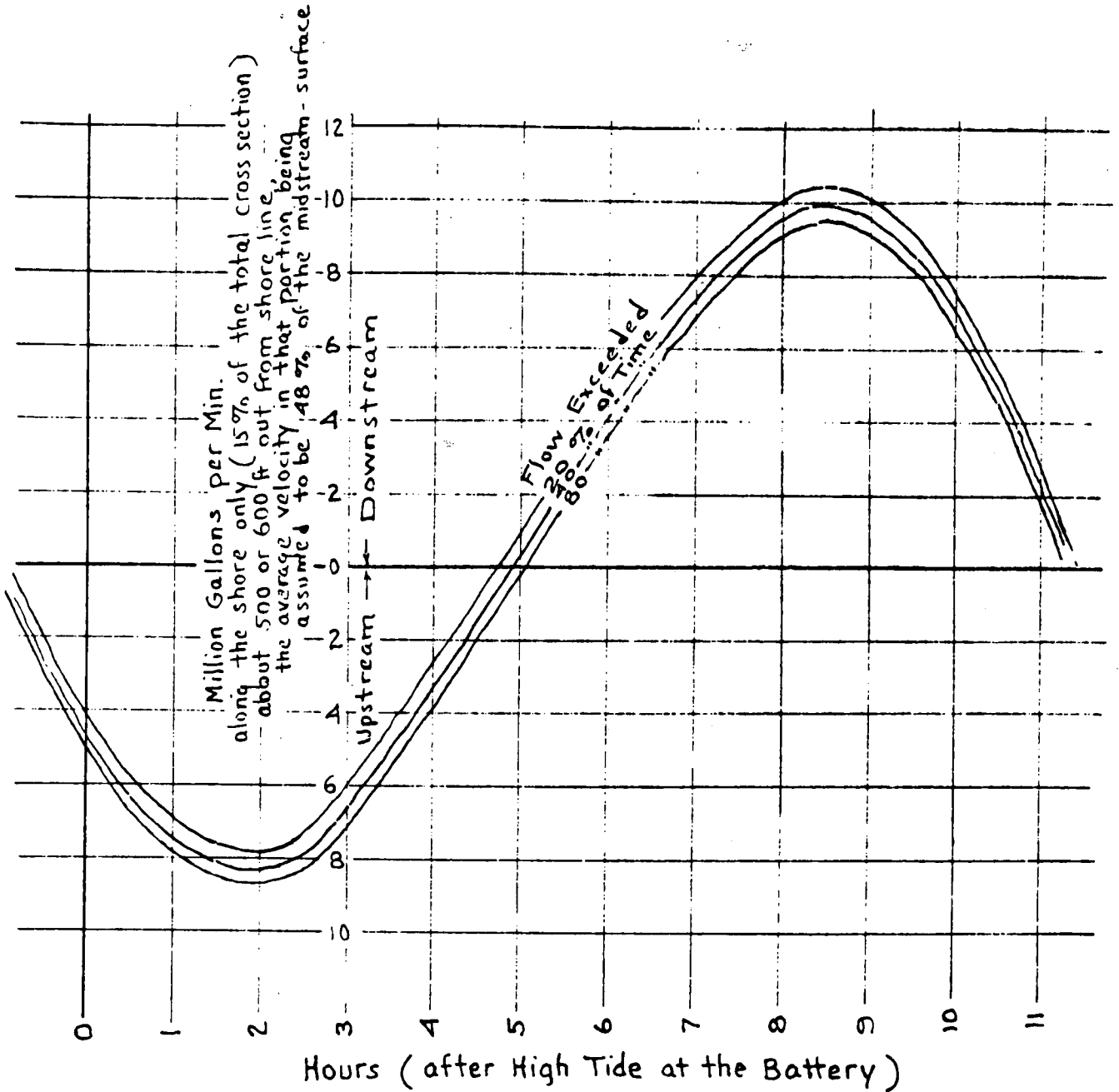



NEW YORK UNIVERSITY

College of Engineering

RESEARCH DIVISION

University Heights, New York 53, N. Y.

Technical Report No. 372.1

**A MICROMETEOROLOGICAL SURVEY OF THE
BUCHANAN, NEW YORK AREA
SUMMARY OF PROGRESS TO 1 DECEMBER 1955**

**Prepared for
Consolidated Edison Co. of N. Y., Inc.
November, 1955**

NEW YORK UNIVERSITY
ENGINEERING RESEARCH DIVISION

REPORT NO. 372.1

A MICROMETEOROLOGICAL SURVEY OF
THE BUCHANAN, NY AREA

SUMMARY OF PROGRESS TO 1 DEC. 1955

Prepared by Ben Davidson
B. Davidson
Project Director

Approved by Harold K. Work /p.p.
H. K. Work
Director, Research Division

Prepared for
Consolidated Edison Company of New York
November 1955

TABLE OF CONTENTS

	<u>Page</u>
LIST OF TABLES AND FIGURES.	3
<u>1. INTRODUCTION</u>	
1.1 Description of Topography	4
1.2 Meteorological Effects of Topography.	4
1.3 Objectives of Project.	6
<u>2. EQUIPMENT</u>	
2.1 Wind Measuring Equipment.	6
2.2 Temperature Measuring Equipment	6
2.3 Smoke Generating Equipment.	7
<u>3. OBSERVATION SITES</u>	
3.1 Meteorological Tower.	7
3.2 Off-Tower Anemometer Sites.	8
3.3 Chronology of Available Observations.	8
<u>4. DISCUSSION OF DATA</u>	
4.1 Diurnal Variation of Wind Direction ,	9
4.2 Distribution of Wind with Height and Across-Valley.	11
4.3 Seasonal Dependence of Down-Valley Winds.	12
4.4 Presentation of Climatological Data	12
<u>5. CONCLUSIONS AND FUTURE PLANS</u>	
5.1 Conclusions	13
5.2 Future Plans.	14

LIST OF TABLES AND FIGURES

Tables

- 1 - Frequency distribution of wind speed for Winter months (by day and night) as observed at Peekskill Military Academy, 1932-34.
- 2 - Frequency distribution of wind speed for Spring months (by day and night) as observed at Peekskill Military Academy, 1932-34.
- 3 - Frequency distribution of wind speed for Summer months (by day and night) as observed at Peekskill Military Academy, 1932-34.
- 4 - Frequency distribution of wind speeds for Fall months (by day and night) as observed at Peekskill Military Academy, 1932-33.

Figures

- 1 - Map of area surrounding meteorological tower. Underlined areas (Hall, Jones, Dock, Peekskill Military Academy) are sites of anemometer locations or sources of previous data.
- 2 - Photograph of tower. Note aerovanes at 100, 200 and 300 ft. levels.
- 3 - Showing bivane in Trailer office before installation.
- 4 - Photograph showing base of tower, smoke producing apparatus, and trailer housing recorders. Note Dunderberg in background.
- 5 - Diurnal variation of wind component along axis of valley (040°= Down Valley, 220°= Up-Valley), median values for indicated hours. (Data from Jones, 70 ft above river, Sept, Oct. 1955)
- 6 - Frequency distribution of wind components along axis of valley, (040°= Down Valley, 220°= Up-Valley) and in the cross valley direction (120°= +, 310°= -) by day and night. (Data from Jones, Sept. Oct. 1955)
- 7 - Illustrating the seasonal dependence of the diurnal variation of NERly wind direction.

1. Introduction

1.1 Description of Topography

Indian Point Park, site of the proposed power plant, is located some two miles SW of the town of Peekskill which is the most densely populated area in the immediate vicinity of the site. Indian Point, itself, is on the east bank of the Hudson River which runs NE-SW at this point but makes a sharp right angled turn some 2 miles NE of the Point (see Fig. 1). The west bank of the Hudson is flanked by the steep, heavily wooded slopes of the Dunderberg and Ramapo peaks (heights close to 1,000 ft.) which extend further to the west by other names and gradually rise to slightly higher peaks.

The general orientation of this mass of high ground is NE to SW. One mile NW of the site, Dunderberg bulges to the east, and north of Dunderberg and the site, high ground reaching 900 ft. forms the east bank of the Hudson as the river makes a sharp turn to the northwest. To the NE of the site, the narrow beds of the Canopus and Peekskill creeks lie generally in a NNE to NE orientation. To the east of the site peaks are generally lower than those to the north and west. Spitzenberg and Blue Mts average about 600 ft. in height and there is a weak, poorly defined series of ridges which again seem to run in a NNE direction. The river south of the site makes another sharp bend to the southeast and then widens as it flows past Croton and Haverstraw.

1.2 Meteorological Effects of Topography

The site then lies in a bowl surrounded on almost all sides by high ground ranging from 600 to 1000 ft. Although the heights of the orographic features are relatively small when compared to classical Alpine or western United States valley studies, the topography surrounding the present

site is nevertheless pronounced enough to decisively influence the meteorology of the valley. We may expect the topography to exert its influence in the following ways.

a) The orientation of the ridges serves to channel the air flow in the valley into preferred directions. We would therefore expect the frequency distribution of wind direction to be more peaked than it would be over level terrain.

b) The ridges act as a barrier to the descent of faster moving air to ground levels and for this reason wind speeds in the valley should be lower than over level terrain.

c) The differing radiational characteristics of the valley, valley sides and plain at the mouth of the valley combined with the sheltering effect of the ridges give rise to thermally induced local air circulations. These circulations, if present, should have a well marked diurnal period and should be seasonally dependent. When present in a pure and highly developed form, the thermally induced currents have well-defined vertical branches with systematic ascending or descending currents along the valley sides and center.

d) When prevailing winds are strong and normal to the ridges some sort of quasi-stationary eddy wind system may develop in the valley. This type of wind system may be very turbulent and in a rough statistical sense may also have preferred regions of sustained positive or negative vertical currents.

e) The effect of these valley systems on diffusion rates are largely unknown. Moreover, the vertical circulation branches - if they exist - can redistribute diffusing material in the vertical in a manner which is quite inconsistent with values of the traditional vertical diffusion coefficients derived from studies over level terrain.

1.3 Objectives of Project

The objectives of the present study are to evaluate the effect of topography on the diffusion climatology of the site. This involves collection of data describing the wind distribution in the vertical and horizontal, temperature gradients and interpretation of this data in terms of diffusion from a ground and elevated source.

2. Equipment

2.1 Wind Measuring Equipment

The project has on hand now five Bendix-Friez Aerovanes, the outputs of which are recorded continuously on twin chart recorders and are the primary source of our climatological wind data. Two highly sensitive Beckman Whitley anemometers are used for low level wind determinations and for special studies. Two very sensitive bivanes developed at M.I.T. (see Fig. 2) are used to determine the three dimensional wind direction. The bivanes when used with the Beckman Whitleys form a compatible system for quantitative determination of vertical currents. The output of both the Beckman and bivane can be recorded continuously (but not regularly) on standard 0-1 ma Esterline Angus recorders, four of which are in our possession now.

Also available to the project are two theodolites for use in double theodolite /pibal ascents. It is hoped that the angular readings of the theodolites when following balloons can be recorded photographically at discrete intervals, thus making possible regularly scheduled ascents despite manpower limitations.

2.2 Temperature Measuring Equipment

Temperature is measured by Type A - Brown Resistance Thermometers. When placed in specially designed wells, the time constant of these thermometers

is about 3 minutes in a wind of 20 fps. The bulbs are placed in shielded, gold leafed cylinders and are aspirated at about 20 fps. The output of the resistance bulbs is recorded on a 4 channel Brown Elektronik Recorder, while differences in the output of matched bulbs are recorded on a 6 channel Brown Elektronik recorder. The recording cycle is 2 minutes for the four channel recorder (channels sampled at 30 second intervals) and 3 minutes for the six channel temperature difference recorder. Four of these bulbs are now in our possession. Ten others are still on order with delivery now expected by mid-December.

2.3 Smoke Generating Equipment

The Chemical Corps has kindly loaned the project an M2A1 smoke generator. The generator operates at a capacity of 50 gallons per hour and should enable us to collect smoke trajectory observations in all but the strongest wind conditions. For use with the generator, the project has acquired a 700 cfm blower (at 1.5 psi) powered by a 7-1/2 hp 220 V. motor.

3. Observation Sites

3.1 Meteorological Tower

Figure 1 is a map of the area showing the principal observation points. The underlined names are sites of more or less contiguous observations. The meteorological tower is the focal point of all observations made in the valley. The tower is a 310 ft guyed trylon type (sides about 42 inches) with an inside ladder. The base of the tower is about 110 ft above river level. Seven 10 ft booms are mounted horizontally at 50 ft intervals for support of the meteorological instruments. Aerovanes are mounted on alternate booms at heights of 210, 310 and 410 ft above river level while Brown resistance bulbs will be mounted at 50 ft intervals, (see Fig. 2). A five inch galvanized pipe runs up one corner of the tower.

The smoke generator and blower are mounted at the foot of the tower and during operations the smoke is forced up the pipe by the blower. Ports are provided at about 300, 350 and 410 ft above river level enabling us to vary the height of emission of the smoke trail as conditions warrant. The output of the meteorological instruments are recorded in the Trailer, shown in Fig. 4.

3.2 Off-Tower Anemometer Sites

The U. S. Maritime Commission has kindly granted us permission to use several of the Reserve Fleet ships anchored in the Hudson off Stony Pt. as anemometer sites. Usable observations have been continuously recorded on the Hall and Jones (see Fig. 1) since 1 Sept. The anemometer on the Hall was removed 1 Nov. for installation on the tower. The Jones anemometer will operate continuously for the remainder of the project. It has a good exposure, close to the middle of the river, and presumably removed from the slope currents of the Dunderberg peak to the west.

A Beckman-Whitley anemometer began operation 15 Nov. on the roof of a dock on the east side of the river. The Jones and Dock observations (at about 70 ft above river) will fill in the details of the flow close to the valley.

An aerovane will shortly be mounted on the roof of the main building of the Peekskill Military Academy (elevation about 200 ft). This is the approximate site of a USWB station which made regular hourly observations during 1932, 1933 and part of 1934. Reactivation of the station will enable us to get the maximum information from the old records.

3.3 Chronology of Available Observations:

In summary, pertinent data available to the project for climatological purposes as of 1 Dec. follow:

<u>Site</u>	<u>Ht.(above river)</u>	<u>Type</u>	<u>Dates of Availability</u>
Hall	70	Wind	1 Sept - 30 Oct.
Jones	70	Wind	1 Sept on
Dock	50	Wind	15 Nov. on
Tower	210	Wind	1 Nov.
"	310	Wind	1 Nov.
"	410	Wind	1 Nov.*
"	T(410)-T(260)	Temp. diff.	8 Dec.*
"	T(160)-T(260)	Temp. diff.	8 Dec.*
"	at 50 ft intervals	" "	10 Jan.*
Water	0	Temp.	10 Jan.*
Peekskill Military Academy	200	Wind	Jan. 1932-Sept.1934
	200	Wind	8 Dec.*

* Estimated date of installation.

4. Discussion of Data

4.1 Diurnal Variation of Wind Direction

The most striking feature of the two months of Jones data which have been analyzed thus far is the diurnal variation of wind direction. At sunset there is a pronounced tendency for the wind to shift to NE. At sunrise there is again a tendency for the winds to shift to SW. On some days the shift is very abrupt and occurs just about at sunrise and sunset. On other days the shift is not so abrupt and may not take place till after midnight and then only after an hour or two of calm winds. NE winds, on occasion, persist until noon before southwesterly flow begins. On still other days, of course, the prevailing winds are so strong as to swamp any possible valley effect, and on those days there is no diurnal shift in wind direction.

A northeast wind parallels the valley orientation at the plant site and is directed down river towards the mouth of the Hudson. If we define the axis of the valley as a line running 040° - 220° , and compute wind components along the axis of the valley and in the cross-valley direction, the diurnal variation of wind direction becomes quite apparent. Figure 5 is a plot of the median values of the up and down valley component of the wind as a function of

time of day. The down valley component reaches its peak median value at about 0600 while the up-valley component reaches its peak median value at about 1600. The peak median value of the nocturnal down wind component is 5 mph while the peak value of the daytime median wind is about 3 mph. These peak values merely reflect the fact that statistically the night time northeasterly flow occurs more frequently than does its/southwesterly/daytime counterpart.

This is clearly seen in Figure 6 where the frequency distribution (calms omitted) of wind components along the axis of the valley (6a) and in the cross valley direction (6b) is shown for night (solid line) and day (dashed line). The distribution of the axial component is strongly bimodal for both night and day. At night the most frequent component is down valley (northeast) about 6 mph. A secondary mode is up-valley at about 5 mph but its frequency is about 1/3 the down valley frequency. In the daytime the principal mode becomes up-valley but a substantial down valley frequency is still observed. It is evident that two regimes are operating, one associated with the valley influence under relatively weak synoptic flow conditions, and one associated with rather strong synoptic flow which alternately swamps the day and nighttime valley influences. A third and weaker regime also operates, namely, a tendency for persistence of northeasterly winds until about noon on some days and a tendency for northeasterly winds to begin rather late at night on still other days. The latter regime is undoubtedly associated with cloudiness and other air mass radiational conditions.

The distribution of the cross-valley component (Fig. 6b) is very sharply peaked around zero at night indicating that during a great many nights the flow is substantially along the axis of the valley. In the daytime the zero peak is considerably reduced and the distribution broadens indicating a considerable cross-valley component which is generally superimposed on the up-valley daytime flow. All in all, comparison of the two

distributions indicate that night time stability conditions have the effect of channeling the flow along the axis of the valley, while in the daytime the channeling effect of the valley sides is not as evident, being partially overcome by descent of air from above the valley ridge lines. This can be clearly seen when we compare the r.m.s. wind component along the axis of the valley with the r.m.s. wind component in the cross-valley direction. At night the r.m.s. along-valley component is about twice the cross-valley r.m.s. value. During the day, the r.m.s. value of both components are about the same.

4.2. Distribution of Wind With Height and Across-Valley.

The observations discussed above were made on board the Jones anchored in midriver where presumably the down valley wind should exist in its purest form. There are two months of simultaneous data available from the Hall, anchored close to the west shoreline of the Hudson. Although not yet ready for presentation, preliminary analysis of the differences between the Jones and Hall indicate very little difference in the broad features of the flow pattern.

The project was fortunate in being able to acquire (from the U.S. Weather Bureau) a 2-3/4 year series of data made at the Peekskill Military Academy, Jan. 1932-Sept. 1934. As nearly as can be ascertained at the present time, these observations were made at a point at least 200 ft. above river level and about 2 miles NE of the site. Essentially the same diurnal variation of wind direction as discussed above was found with the old data. In addition to this, preliminary examination of tower winds for Nov. indicate that on at least some occasions the diurnal trend in wind direction is in evidence up to 420 ft. above river level. The tentative conclusion is that the down valley wind fills the breadth of the valley and on at least some occasions extends to over 400 ft. above river level.

4.3. Seasonal Dependence of Down-Valley Winds

To illustrate the seasonal dependence of night time northeasterly flow we have calculated the percent frequency that NNE to ENE winds were observed at Peekskill Military Academy, 1932-1934 as a function of time of day for the various seasons. The results are shown in Figure 7. As was to be expected, the diurnal variation of northeasterly winds reaches a maximum amplitude during summer and a minimum amplitude during winter. This result can be explained as due principally to the generally stronger synoptic flow during winter than during summer. A secondary reason is perhaps the change in cloudiness and radiational conditions from summer to winter. The dashed line plot of Fig. 7 represents the percent frequency of occurrence of both calm and NNE to ENE winds. The reason for this presentation is that calm is an arbitrary designation depending on instrumental and observer thresholds. Considering the equipment in use in 1932 we believe that a large number of the recorded night time calms were characterized by a slow drift of air from the NE. This supposition is strengthened by the fact that a similar count for the Jones Sept - Oct. data indicates a maximum night time incidence of about 70% for NNE to ENE flow.

4.4. Presentation of Climatological Data

The frequency distribution of wind speed and direction by wind speed class and by night and day for the various seasons is presented in Tables 1 thru 4. The data is from the U.S. Weather Bureau station at Peekskill Military Academy (1932-1934). Day and night were arbitrarily defined with respect to sunrise and sunset of the middle of each month. It is believed that in this form the interpretation of the frequency distribution of wind in terms of diffusion parameters is facilitated. For example, the night time class of wind from any direction with speed 1-4 mph is undoubtedly

characterized by a strong inversion. To assist in this kind of interpretation we have also available (but not presented in this report) the distribution of cloudiness for each class in Tables 1-4. Before making definite interpretations, however, we prefer to correlate the tower temperature measurements with the wind data we will shortly begin receiving from the Peekskill Military Academy.

5. Conclusions and Future Plans

5.1. Conclusions

We now have a fairly good idea of the general flow patterns at our observation points. Still unknown, is the distribution with height of the flow patterns we have discussed in the previous section. The meteorologically unique feature of the valley is, of course, the substantial night time incidence of northeasterly winds. This valley phenomenon is of great importance to our study primarily because low wind speed and presumably stable thermal stratification are associated with the night time winds. These conditions usually result in a narrow plume of relatively high concentration. However, because of the possibility - still unexplored - of sustained up or down vertical velocities it is still too early to make statements about ground concentrations.

In many ways it is fortunate that the night time winds are usually directed down valley away from Peekskill. On the other hand, it becomes of paramount importance to evaluate the effect of the bend of the river south of the site on the trajectories of sources emanating from Indian Point Park. It is also of great importance to evaluate the diffusive conditions associated with the day time up-valley winds which have a tendency to carry diffusing materials to Peekskill. This procedure must also be carried out for the occasions when night time flow associated with general weather conditions is directed up-valley.

5.2. Future Plans

Our future plans follow directly from our tentative conclusions and these are generally to evaluate trajectories and diffusive conditions under critical wind condition regimes. This will be done with the aid of our smoke installation, and as far as is consistent with horizontal visibility conditions, with quasi constant level balloon trajectories.

As winter draws on, it is apparent that our opportunity for studying the up and down valley winds will be curtailed. However, the generally stronger winter winds will afford us opportunity to examine the structure of possible eddy winds in the neighborhood of the site. These winds - if they exist at the proper height - may be instrumental in carrying smoke to the ground.

In the meanwhile we must complete our instrumental installation, iron out the bugs in the smoke system, and continue with the accumulation and analysis of climatological data.

TABLE I - Frequency distribution of wind speed for winter months
(by day and night) as observed at Peekskill Military Academy, 1932-34.

<u>Direction</u>	<u>DAY</u>				<u>NIGHT</u>			
	<u>Speed (mph)</u>			<u>Total</u>	<u>Speed (mph)</u>			<u>Total</u>
	<u>1-4</u>	<u>5-10</u>	<u>>10</u>		<u>1-4</u>	<u>5-10</u>	<u>>10</u>	
N	.020	.031	.029	.080	.009	.019	.021	.049
NNE	.004	.003	.003	.010	.004	.004	.003	.011
NE	.048	.047	.035	.130	.077	.085	.029	.191
ENE	.006	.020	.031	.057	.006	.028	.022	.056
E	.017	.009	.001	.027	.038	.006	.001	.045
ESE	.002	.002	-	.004	.004	.002	-	.006
SE	.021	.006	.001	.028	.016	.005	-	.021
SSE	-	.005	.002	.007	.002	.004	-	.006
S	.022	.020	.003	.045	.028	.016	.001	.045
SSW	.005	.028	.011	.044	.005	.026	.011	.042
SW	.048	.051	.021	.120	.043	.045	.011	.099
WSW	.002	.015	.012	.029	.002	.001	.005	.008
W	.031	.028	.019	.078	.017	.020	.007	.044
WNW	.001	.028	.034	.063	.003	.017	.025	.045
NW	.014	.048	.103	.165	.013	.077	.094	.184
NNW	.002	.021	.034	.057	.004	.021	.035	.060
TOTAL	.243	.362	.339	.944	.271	.376	.215	.912
Calm				.056				.088
		Total		1.000		Total		1.000

TABLE II - Frequency distribution of wind speed for Spring months
(by day and night) as observed at Peekskill Military Academy 1932-34.

<u>Direction</u>	<u>DAY</u>				<u>NIGHT</u>			
	<u>Speed (mph)</u>			<u>Total</u>	<u>Speed (mph)</u>			<u>Total</u>
	<u>1-4</u>	<u>5-10</u>	<u>>10</u>		<u>1-4</u>	<u>5-10</u>	<u>>10</u>	
N	.018	.029	.020	.067	.021	.023	.012	.056
NNE	.003	.014	.003	.020	.004	.009	.001	.014
NE	.035	.055	.007	.097	.127	.065	.010	.202
ENE	.004	.030	.026	.060	.010	.032	.015	.057
E	.012	.013	.002	.027	.041	.016	.004	.061
ESE	.002	.007	.002	.011	.004	.006	-	.010
SE	.018	.019	.003	.040	.029	.014	.002	.045
SSE	.007	.014	.006	.027	.008	.019	.002	.029
S	.036	.039	.014	.089	.040	.036	.002	.078
SSW	.012	.048	.021	.081	.010	.044	.010	.064
SW	.049	.074	.010	.133	.042	.037	.007	.086
WSW	.007	.008	.005	.020	.002	.001	.002	.005
W	.040	.026	.006	.072	.019	.011	.002	.032
WNW	.005	.028	.024	.057	.002	.010	.021	.033
NW	.022	.046	.045	.113	.012	.023	.014	.049
NNW	.002	.016	.012	.030	.002	.014	.012	.028
TOTAL	.272	.466	.206	.944	.373	.360	.116	.849
Calm				.056				.151
		Total		1.000		Total		1.000

TABLE III - Frequency distribution of wind speeds for Summer months
(by day and night) as observed at Peekskill Military Academy, 1932-34.

<u>Direction</u>	<u>DAY</u>				<u>NIGHT</u>			
	<u>Speed (mph)</u>			<u>Total</u>	<u>Speed (mph)</u>			<u>Total</u>
	<u>1-4</u>	<u>5-10</u>	<u>>10</u>		<u>1-4</u>	<u>5-10</u>	<u>>10</u>	
N	.022	.030	.011	.063	.025	.017	.006	.048
NNE	.003	.008	-	.011	.002	.007	-	.009
NE	.064	.080	.013	.157	.200	.078	.006	.284
ENE	.008	.034	.016	.058	.010	.021	.009	.040
E	.014	.007	.001	.022	.051	.011	.001	.063
ESE	.002	.004	.001	.007	.004	.003	-	.007
SE	.017	.010	-	.027	.026	.015	.002	.043
SSE	.003	.009	.003	.015	.009	.007	.001	.017
S	.036	.040	.008	.084	.060	.031	.002	.093
SSW	.010	.060	.019	.089	.014	.030	.005	.049
SW	.069	.078	.006	.153	.042	.041	.002	.085
WSW	.006	.013	-	.019	.004	.001	-	.005
W	.026	.019	-	.045	.018	.005	-	.023
WNW	.005	.026	.008	.039	.001	.007	.001	.009
NW	.026	.063	.025	.114	.014	.041	.012	.067
NNW	<u>.005</u>	<u>.014</u>	<u>.013</u>	<u>.032</u>	<u>.003</u>	<u>.009</u>	<u>.009</u>	<u>.021</u>
TOTAL	.316	.495	.124	.935	.483	.324	.056	.863
Calm				<u>.065</u>				<u>.137</u>
		Total		1.000		Total		1.000

TABLE IV - Frequency distribution of wind speeds for Fall months
(by day and night) as observed at Peekskill Military Academy, 1932-33.

Direction	DAY				NIGHT			
	Speed (mph)			Total	Speed (mph)			Total
	1-4	5-10	>10		1-4	5-10	>10	
N	.023	.038	.022	.083	.018	.024	.008	.050
NNE	.001	-	.001	.002	.001	.003	.005	.009
NE	.049	.073	.031	.153	.102	.092	.039	.233
ENE	.005	.037	.024	.066	.008	.038	.029	.075
E	.020	.010	-	.030	.052	.004	-	.056
ESE	.004	.004	.001	.009	.002	.004	-	.006
SE	.014	.004	.002	.020	.028	-	-	.028
SSE	.001	.013	.002	.016	.003	.006	.002	.011
S	.028	.031	.010	.059	.042	.024	.010	.076
SSW	.014	.034	.015	.063	.015	.028	.011	.054
SW	.052	.070	.014	.136	.039	.032	.005	.076
WSW	.001	.008	-	.009	.001	.007	.002	.010
W	.036	.025	.004	.065	.011	.020	.005	.036
WNW	.009	.026	.026	.061	.006	.018	.016	.040
NW	.013	.044	.063	.120	.021	.055	.044	.120
NNW	-	.012	.023	.035	.005	.009	.006	.020
TOTAL	.260	.429	.238	.927	.354	.364	.182	.900
Calm				.073				.100
		Total		1.000		Total		1.000

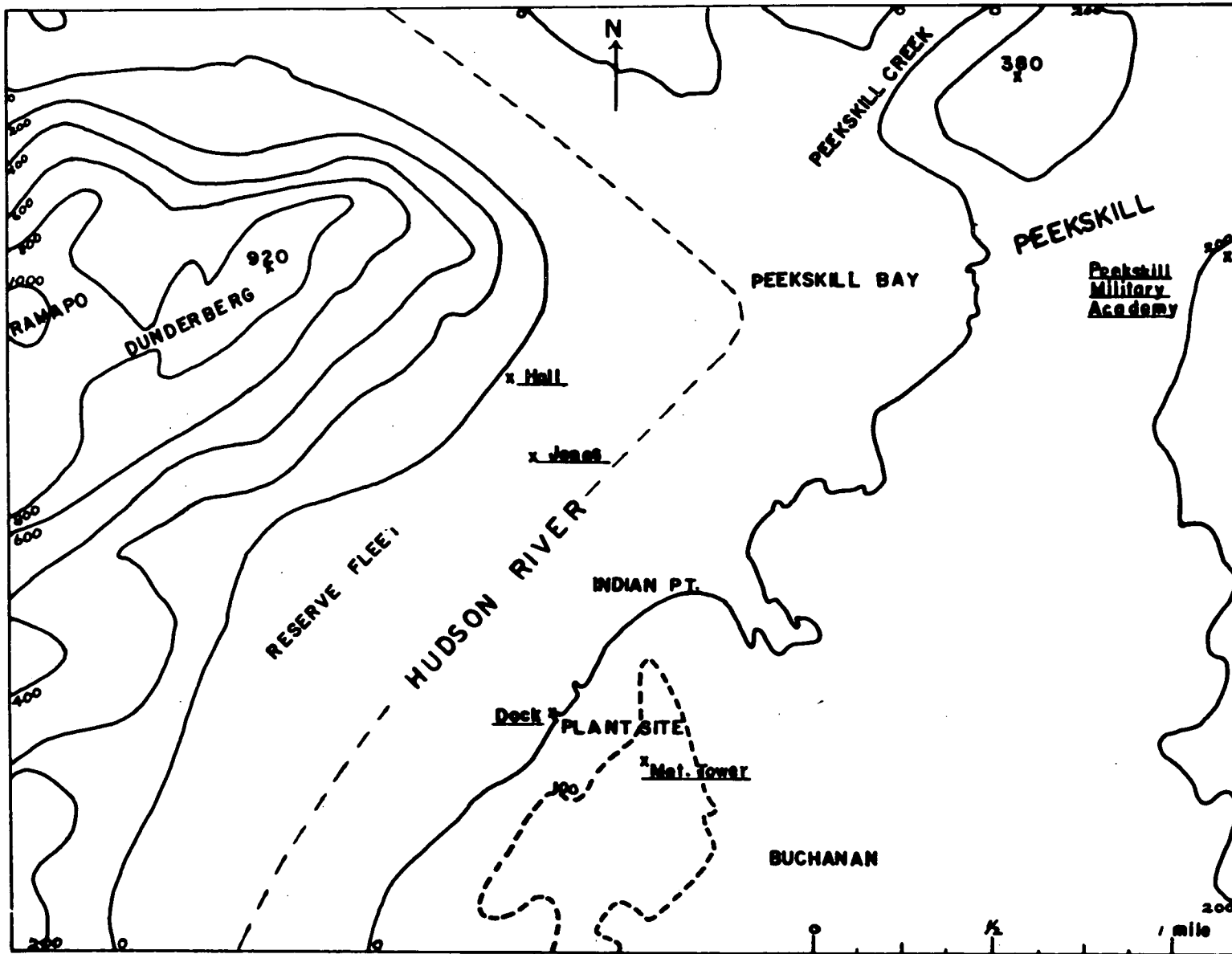

Fig. 1 Map of area surrounding meteorological tower. Underlined areas (Hall, Jones, Dock, Peekskill Military Academy) are sites of anemometer locations or sources of previous data.

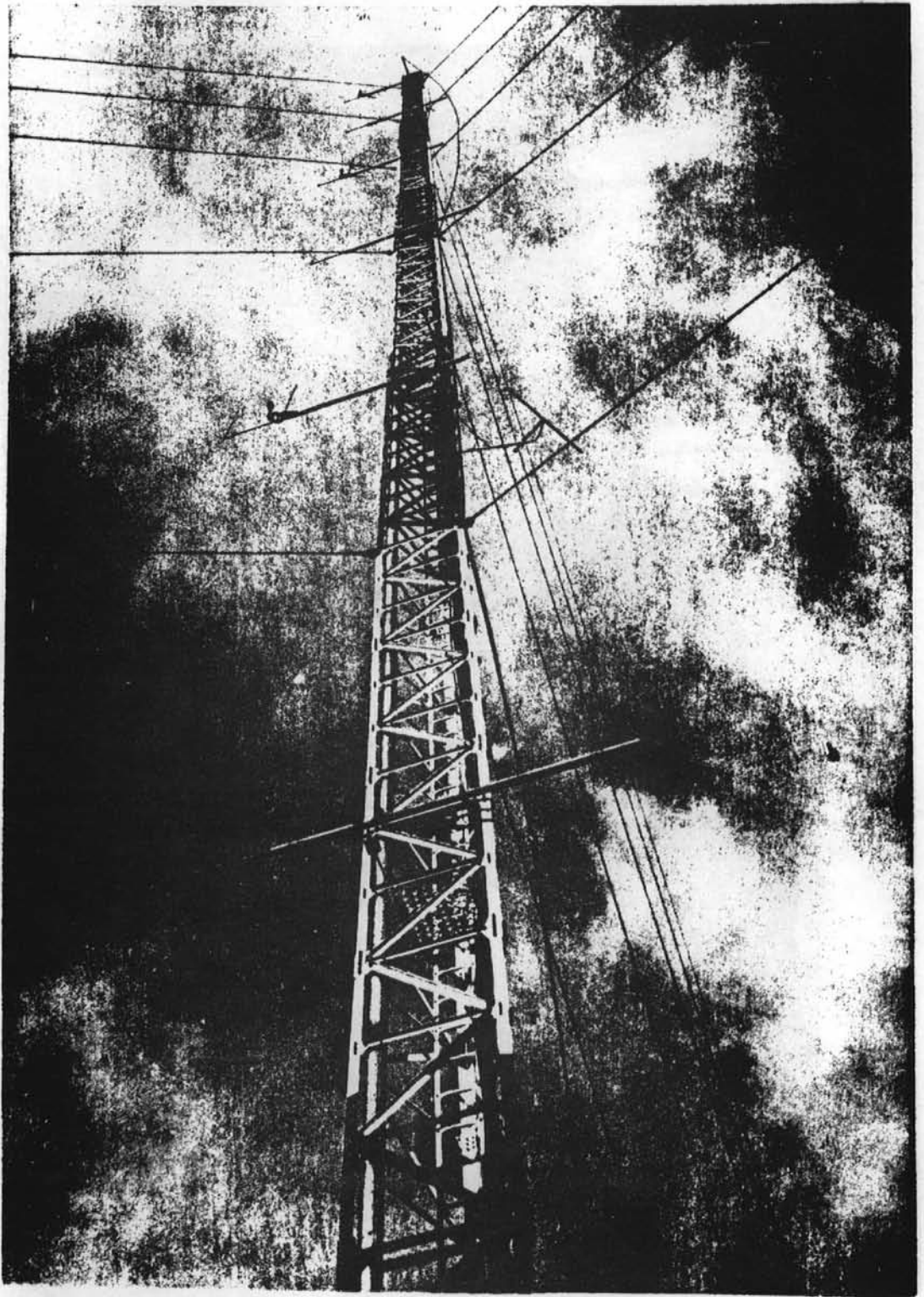

Fig. 2 Photograph of tower. Note Aerovanes at 100, 200 and 300 ft. levels.



Fig. 3 Showing bivane in Trailer office before installation.

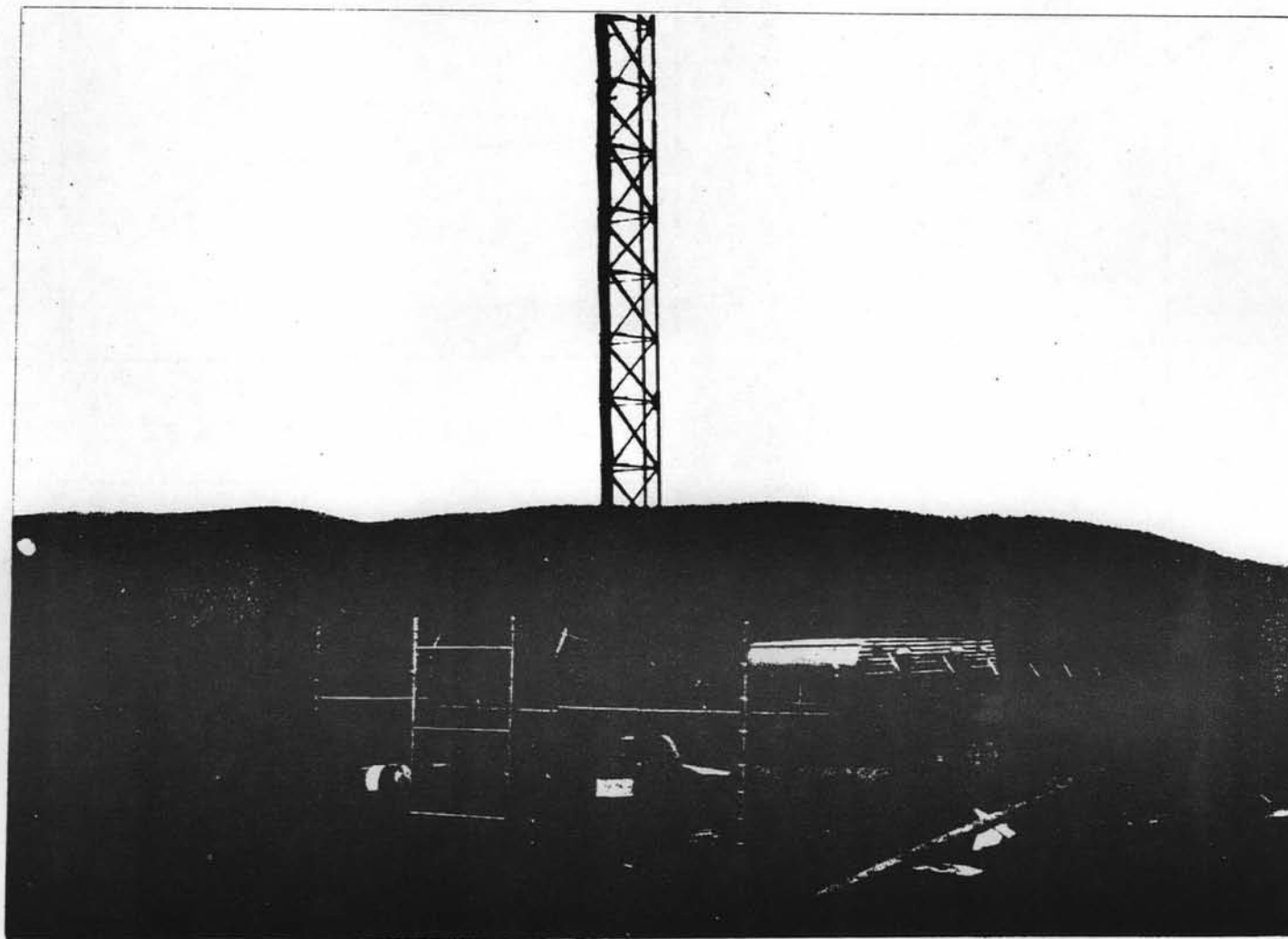

Fig. 4 Photograph showing base of tower, smoke producing apparatus, and trailer housing recorders. Note Dunderberg in background.

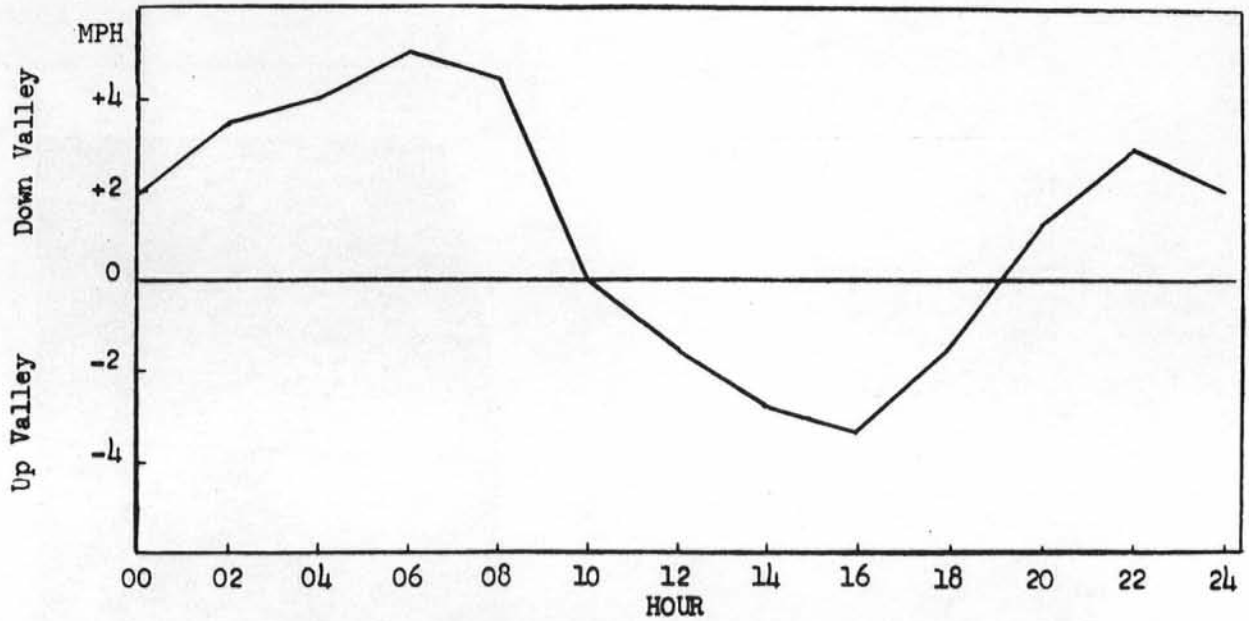

Fig. 5 - Diurnal Variation of wind component along axis of valley (040°= Down Valley, 220°= Up Valley), median values for indicated hours. (Data from Jones, 70 ft. above river, Sept., Oct. 1955)

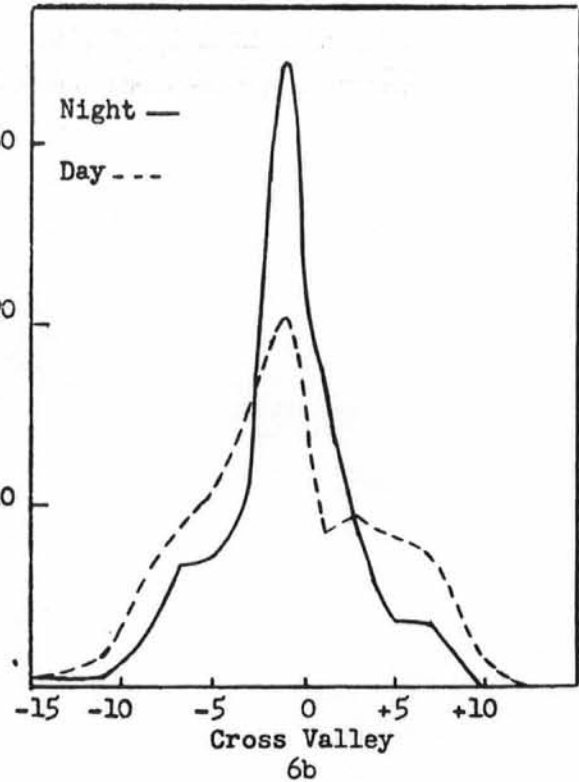
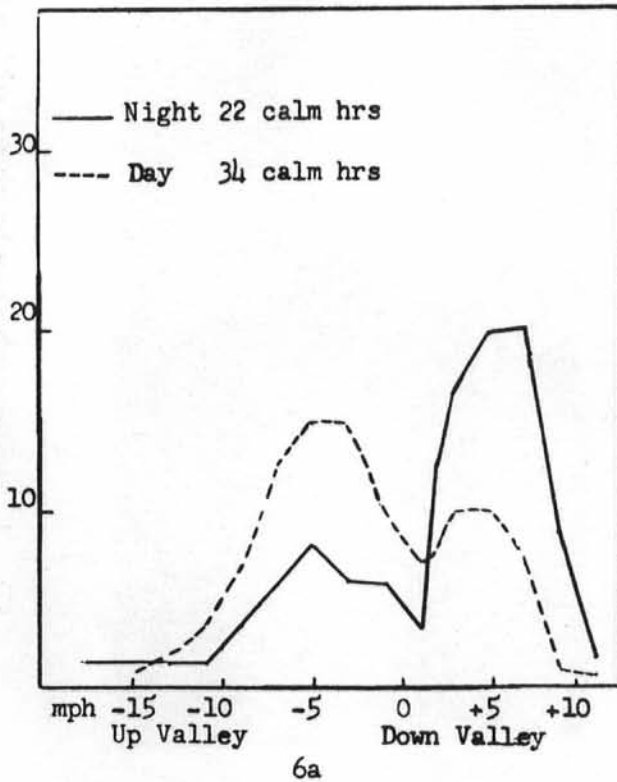

Fig. 6 - Frequency distribution of wind components along axis of valley, (040°= Down Valley, 220°= Up Valley) and in the cross valley direction (120°= +, 310°= -) by day and night (Data from Jones, Sept. Oct. 1955)

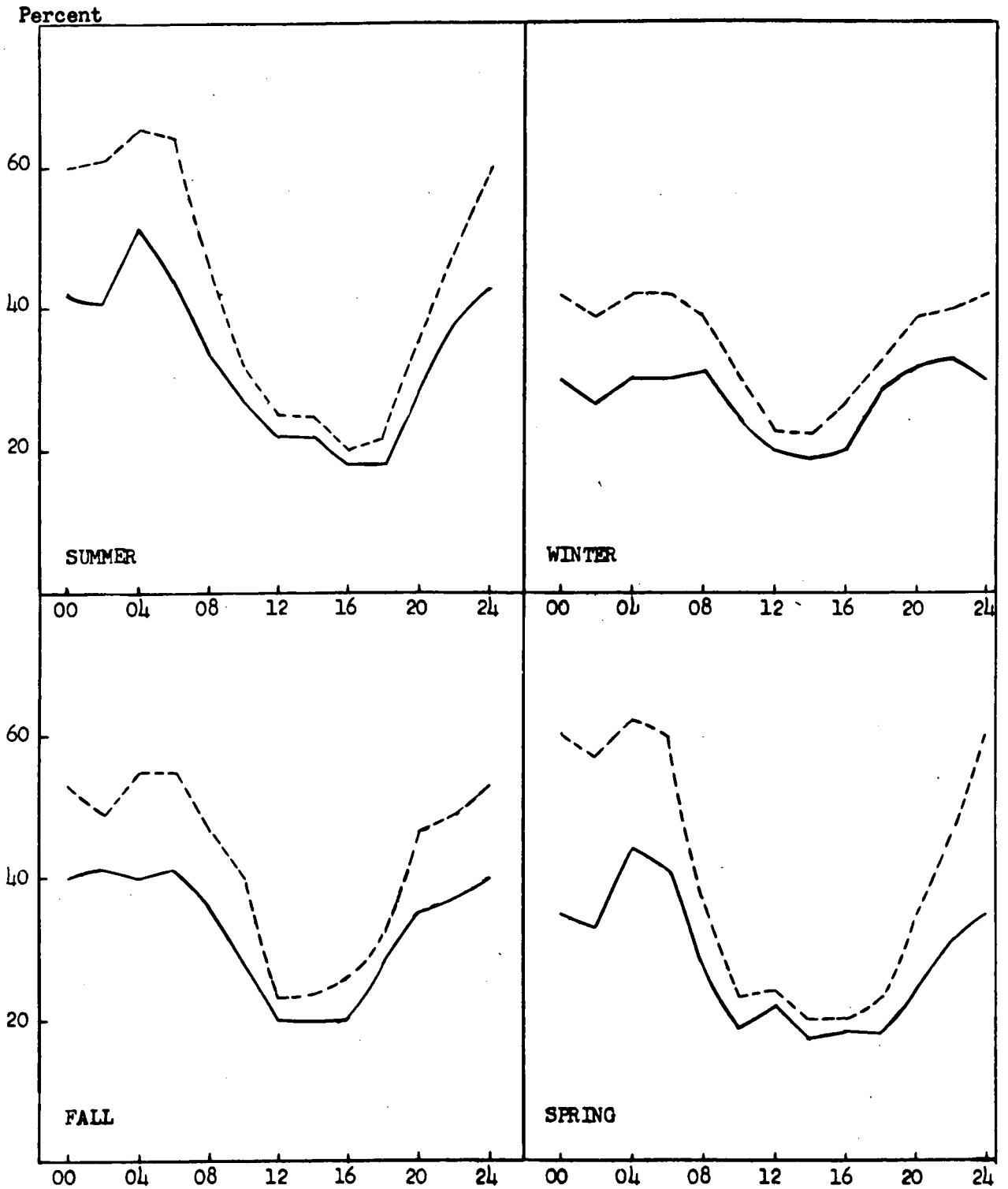

Fig. 7 - Illustrating the seasonal dependence of the diurnal variation of northerly wind direction. Solid line represents percent time wind was from NNE-ENE at the indicated hour. Dashed line represents percent time wind was either calm or from NNE-ENE. (Data from Peekskill Military Academy, Jan. 1932-Sept. 1934.)

NEW YORK UNIVERSITY

COLLEGE OF ENGINEERING
RESEARCH DIVISION

University Heights, New York 53, N.Y.

Technical Report No. 372.3

EVALUATION OF POTENTIAL RADIATION HAZARD
RESULTING FROM ASSUMED RELEASE OF RADIOACTIVE WASTES TO
ATMOSPHERE FROM PROPOSED BUCHANAN NUCLEAR POWER PLANT

(Section 2 & 3 only)

Prepared for
Consolidated Edison Co. of N. Y., Inc.
April, 1957

2. Diffusive conditions at site

2.1. Eddy wind structure in the valley

Meteorological conditions investigated were cases of daytime strong NW flow breaking over the Dunderberg peak. Data sources include instrumented aircraft runs (through cooperation of Cornell Aeronautical Laboratory), and (through the cooperation of the Meteorology Group at Brookhaven) comparison of three-dimensional wind vector distributions taken simultaneously at Buchanan and Brookhaven National Laboratory.

Unfortunately, the aircraft runs are not yet completely reduced,*but sufficient information is available to serve our purpose here. Following is a schematic sketch of the envelope of turbulent fluctuations measured by the airplane on a run at 1000 ft, starting just over the Dunderberg peak and proceeding southeast over the meteorology tower.

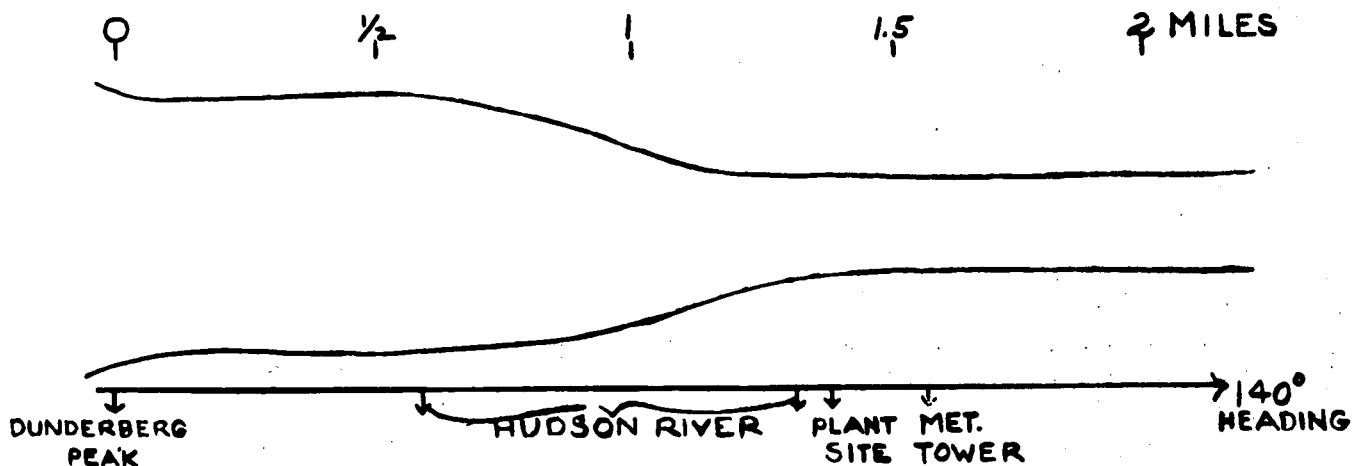

*The data have since been published in full in Lappe, V.O., and B. Davidson, 1960: The power spectral analysis of concurrent airplane and tower measurements of Atmospheric Turbulence, Final Report, Contract No. NOAS 58-517-d, College of Engineering, New York University.

(footnote added October 1965)

The very large amount of turbulence associated with the breaking of air flow over the Dunderberg decays rather quickly downstream and the turbulent field settles down to a steady rms level at the east bank of the Hudson River. This uniform level is maintained for approximately five miles east of the site.

Comparison of an airplane run made at 400 ft elevation following the east bank of the Hudson with a run made the same day over the Brookhaven tower indicates that the rms turbulence at Buchanan is about 1.5 times greater than that observed at Brookhaven. The larger Buchanan rms value was due to the contribution of relatively strong, but highly intermittent gusts. Our conclusions are that the plant site is safely out of the very strong field of turbulence associated with the Dunderberg range, but that the site will be subject to occasional incursions of extreme gusts under strong northwest flow conditions.

This conclusion is further borne out by comparison of 10 second mean azimuth and elevation angle fluctuations at Brookhaven and Buchanan shown in fig. 2.1. The distributions cover about 3 hours of data taken under daytime strong northwest flow conditions. The azimuth angle distributions are directly comparable and indicate an rms azimuth fluctuation at Buchanan about 1.5 times that at Brookhaven. This ratio is consistent from hour to hour.

The elevation angles were measured by dissimilar instruments (ours having the faster response), but the 10 second mean should make

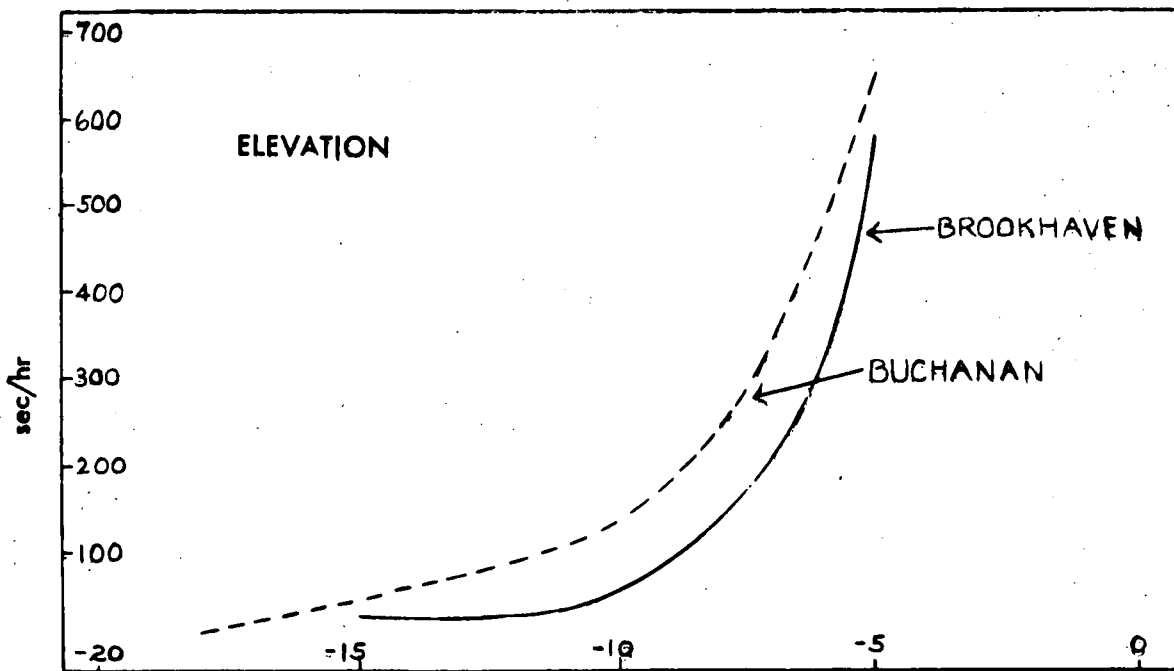
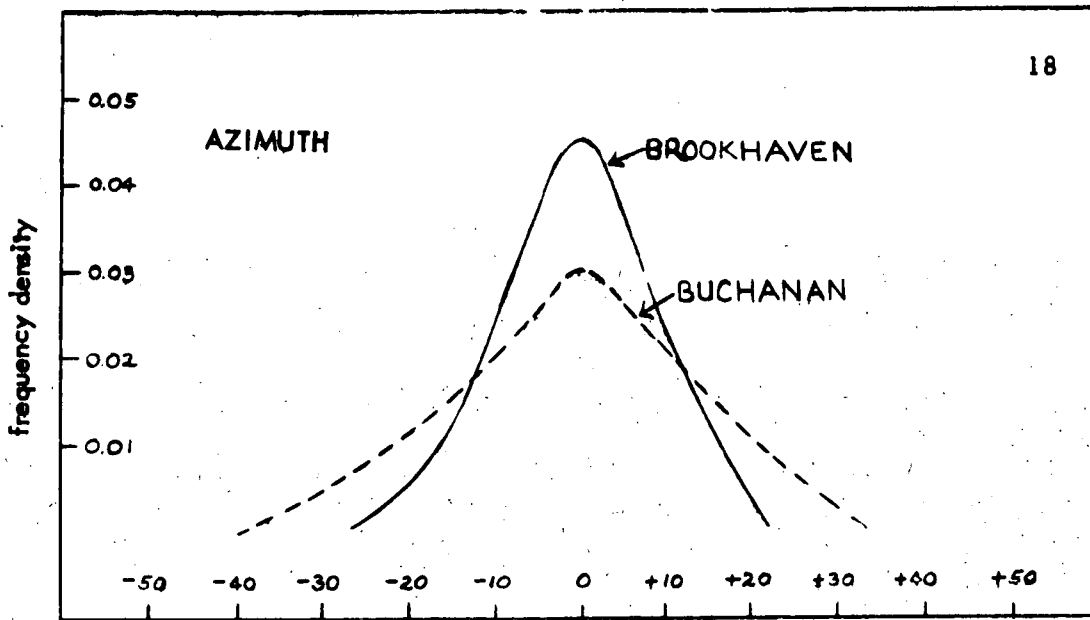

Fig. 2.1. Comparison of Brookhaven and Buchanan azimuth and elevation angle fluctuation traces.

the instrument readings comparable. There is a definite tendency toward more extreme downward directed vertical angles at Buchanan. However, this difference is not consistent from hour to hour, the major contribution to the difference coming from one hour of data; the other two hours showed but minor differences.

2.2. Diffusion coefficients

Smoke experiments were conducted at irregular intervals with a smoke generator source located 91 meters above ground. The behavior of the smoke for a distance of 1000 m from the source was documented by photographs usually made at 20 second intervals. The quantities abstracted from the film included the rate of expansion of the instantaneous plume, and a simple count of the number of times smoke was on the ground at given distances downwind. By assuming an inverse square law for concentrations, i. e., dividing smoke frequency by distance squared, we were able to estimate the point of maximum ground concentration.

For radiation calculations, it is desirable to find coefficients to fit a Sutton type concentration equation. This type of equation involves three parameters, C_y , C_z , and n . The diffusion coefficients at Buchanan were evaluated in a number of different ways. All of these approaches gave essentially the same answer. Since diffusion coefficients are fairly well known at Brookhaven, the simplest method was to use the relationship (see Ref. 8)

$$\text{Buch } C_y^2 = \frac{\left[\frac{4}{(1-n)(2-n)} \left(\frac{N}{u} \right)^n (\overline{a'^2})^{1-n} \right]}{\left[\frac{4}{(1-n)(2-n)} \left(\frac{N}{u} \right)^n (\overline{a'^2})^{1-n} \right]} \text{Buch } C_y^2 \text{ Brook} \quad (2.1)$$

Brook

where $\overline{a'^2}$ is the variance of the azimuth angle fluctuation, and N is the macroviscosity. Here a small angle approximation has been made for $\sin \alpha$, and the correlation between u and α has been assumed zero.

Brookhaven fluctuation data were available for their B condition.

Under identical wind speed and stability conditions, the Reynolds stress ($\overline{u'w'}$) was about the same for both sites. Similar stress values under identical large scale conditions imply similar roughness (z_0) values

Since

$$N = (\overline{u'w'})^{1/2} z_0$$

the above indicates similar N values for both sites. As a first approximation n is assumed to be the same and equation (2.1) can be solved for Buch C_y^2 in terms of the known Brookhaven coefficient. The process is repeated using new values of n , until the solution converges.

A similar equation can be solved for C_z^2 (here only the variance in downward directed elevation angles was considered). Knowing the distance of maximum concentration from observation, the remaining parameter, n , can be determined from

$$d_{\max} = \left(\frac{h^2}{C_z^2} \right)^{\frac{1}{2-n}}$$

For other meteorological conditions the same procedure was followed this time using the coefficients established at Buchanan for the previous case as known values. In summary we find:

Table 2.1. Summary of diffusion coefficients at Buchanan.

<u>Condition</u>	<u>$C_y(m)^{n/2}$</u>	<u>$C_z(m)^{n/2}$</u>	<u>n</u>
L ₁ Lapse (light winds 1-3 m/sec)	0.60	0.48	0.20
L ₂ Lapse (strong winds > 4 m/sec)	0.53	0.43	0.30
N Adiabatic to isothermal temperature gradients	0.47	0.39	0.40

There was a great deal of variability in the coefficients determined for the the A case mostly because of large aperiodic changes in the mean wind direction.

The hourly lateral vertical diffusion coefficients (C_y) in Table 2.1 are large compared to the established Brookhaven values. The primary reason for this is the large azimuth oscillations which are due to the hills and rugged country surrounding the site. On an hourly basis, therefore, smoke plumes would diffuse more quickly at Buchanan than at most other flat terrain sites. On an annual basis, however, the restrictive influence of the valley channels the flow so that the long term annual spread is probably less at the Buchanan site.

2.3. Inversion plume

A few smoke runs were made under inversion conditions. These runs were documented by photographs from below and from an aircraft flying at

3000 ft. The results indicate a half-angle expansion of the instantaneous plume of about .05 radians with wind speeds of 4 mph. With wind speeds less than 2 mph the instantaneous half-angle expansion increases to about .09 radians. Under steady wind conditions azimuth angles fluctuate with a σ of about .065 radians.

The plume holds together as a compact mass for several miles. The ratio of width to height of the plume is on the order of 5 to 10. In general the inversion plume trajectory tends to follow the river around the bends north and south of the site.

3. Climatological Data and Diffusion Classes

Tables 3.1 and 3.2 summarize the wind and temperature gradient data taken at the 300 ft tower level (410 ft above river) for the winter and summer seasons. A similar yearly summary for the 100 ft tower level (210 ft above river) is presented in Table 3.3. The temperature gradient classification is defined as follows:

For 300 ft level:

I = Inversion class	$T_{300} - T_7 \geq 0$
N = Isothermal-Adiabatic class	$0 > T_{300} - T_7 \geq -1.8^\circ\text{F}$
L = Lapse (unstable class)	$-1.8^\circ\text{F} > T_{300} - T_7$

For 100 ft level:

I = Inversion class	$T_{150} - T_7 \geq 0$
N = Isothermal-Adiabatic class	$0 > T_{150} - T_7 \geq 0.9^\circ\text{F}$
L = Lapse condition	$-0.9^\circ\text{F} > T_{150} - T_7$

For visual purposes these data are summarized in Figs. 3.1 and 3.2. (Arrows are flying with the wind.) There is a tendency for winds to be along the axis of the valley for both the summer and winter seasons. With respect to populated areas, wind trajectories are towards Buchanan and Verplank for a substantial portion of the time. Wind trajectories towards Peekskill (the major population center in the area) are relatively infrequent.

The diurnal wind regime in the valley at low levels was discussed in some detail in NYU Report 372.1. The height variation of the diurnal wind regime in the valley is extremely complicated and quite variable. Most frequently, the 030° night-time flow extends to about 2 to 3 hundred ft above river with a slow southerly drift above the down river

TABLE 3.1. Frequency Distribution of Wind Speed
and Direction at 300 Ft. Tower Level for Winter Season (Nov-April)
According to Temperature Gradient Class.

I = inversion,
N = isothermal-adiabatic
L = lapse condition

$0 > T_{300}-T_7 \geq 0$
 $-1.8^{\circ}\text{F} > T_{300}-T_7 \geq -1.8^{\circ}\text{F}$

Wind Direction		Wind Speed (mph)						Total
		1-4	5-8	9-13	14-19	20-27	>27	
205-220	I	.0053	.0058	.0086	.0017	.0005	-	.0219
	N	.0053	.0034	.0024	.0010	.0007	.0002	.0130
	L	.0017	.0005	.0012	.0007	.0002	-	.0043
225-240	I	.0053	.0043	.0067	.0007	-	-	.0170
	N	.0010	.0017	.0034	.0007	.0010	-	.0078
	L	.0005	.0005	.0014	.0007	-	-	.0031
245-260	I	.0041	.0048	.0038	.0012	.0002	-	.0141
	N	.0005	.0007	.0034	.0077	.0019	.0002	.0144
	L	.0012	.0012	.0012	.0024	.0002	-	.0062
265-280	I	.0034	.0029	.0038	.0017	.0005	.0007	.0130
	N	.0014	.0022	.0053	.0048	.0029	.0017	.0183
	L	.0012	.0002	.0022	.0017	.0007	.0002	.0060
285-300	I	.0019	.0038	.0050	.0017	.0005	-	.0129
	N	.0010	.0038	.0168	.0170	.0089	.0014	.0489
	L	.0002	-	.0048	.0093	.0038	-	.0181
305-320	I	.0022	.0038	.0031	.0019	.0002	-	.0112
	N	.0014	.0074	.0201	.0321	.0122	.0026	.0758
	L	.0017	.0007	.0086	.0127	.0062	-	.0299
325-340	I	.0029	.0026	.0034	.0005	-	-	.0094
	N	.0007	.0034	.0173	.0206	.0103	.0034	.0557
	L	.0019	.0019	.0036	.0081	.0034	.0012	.0201
345-360	I	.0026	.0060	.0024	.0012	-	-	.0122
	N	.0026	.0065	.0216	.0168	.0185	.0031	.0691
	L	.0017	.0043	.0141	.0065	.0059	.0022	.0347

(continued on next page)

TABLE 3.1(Continued)

Wind Direction		Wind Speed (mph)						Total
		1-4	5-8	9-13	14-19	20-27	>27	
005-020	I	.0060	.0096	.0067	.0007	-	-	.0230
	N	.0058	.0175	.0302	.0115	.0134	.0002	.0786
	L	.0024	.0060	.0079	.0038	.0012	-	.0213
025-040	I	.0031	.0050	.0026	-	-	-	.0107
	N	.0050	.0077	.0105	.0048	.0024	-	.0304
	L	.0017	.0024	.0022	.0002	.0002	-	.0067
045-060	I	.0026	.0026	.0002	.0002	-	-	.0056
	N	.0034	.0036	.0053	.0036	.0002	-	.0161
	L	.0005	.0010	.0005	-	-	-	.0020
065-140	I	.0070	.0034	.0002	-	-	-	.0106
	N	.0103	.0080	.0048	.0012	-	-	.0243
	L	.0010	.0012	.0012	-	-	-	.0034
145-160	I	.0048	.0046	.0024	.0007	.0002	-	.0127
	N	.0026	.0053	.0024	.0014	.0002	.0005	.0124
	L	.0014	.0017	.0031	.0014	-	-	.0076
165-180	I	.0091	.0144	.0122	.0019	-	-	.0376
	N	.0098	.0089	.0091	.0079	.0029	.0017	.0403
	L	.0002	.0060	.0065	.0024	.0007	-	.0158
185-200	I	.0117	.0108	.0151	.0038	.0007	-	.0421
	N	.0070	.0086	.0115	.0038	.0007	.0005	.0321
	L	.0010	.0041	.0026	.0005	.0002	-	.0084
Calm	I							.0005
	N							.0084
	L							.0115
Total	I	.0719	.0846	.0764	.0180	.0029	.0007	.2550
	N	.0580	.0884	.1639	.1349	.0762	.0156	.5454
	L	.0182	.0316	.0611	.0506	.0230	.0036	.1996

TABLE 3.2. Frequency Distribution of Wind Speed
and Direction at 300 Ft. Tower Level for Summer Season (May-October)
According to Temperature Gradient Class.

I = inversion, $T_{300-T7} \geq 0$
 N = isothermal-adiabatic $0 > T_{300-T7} \geq -1.8^\circ\text{F}$
 L = lapse condition $-1.8^\circ\text{F} > T_{300-T7}$

Wind Direction	Wind Speed (mph)						Total
	1 - 4	5 - 8	9-13	14-19	20-27	>27	
205-220	I	.0074	.0122	.0053	.0005	-	.0254
	N	.0023	.0038	.0058	.0015	.0003	.0137
	L	.0066	.0048	.0033	.0005	-	.0152
225-240	I	.0084	.0071	.0043	.0003	-	.0201
	N	.0010	.0041	.0038	-	-	.0089
	L	.0018	.0038	.0038	.0003	-	.0097
245-260	I	.0064	.0056	.0031	.0003	-	.0154
	N	.0013	.0018	.0033	.0005	.0003	.0072
	L	.0028	.0028	.0038	-	-	.0094
265-280	I	.0036	.0025	.0025	.0008	-	.0094
	N	.0019	.0005	.0031	.0033	.0010	.0098
	L	.0024	.0048	.0048	.0005	.0003	.0128
285-300	I	.0043	.0028	.0048	.0008	.0008	.0135
	N	.0003	.0013	.0053	.0048	.0038	.0155
	L	.0028	.0031	.0071	.0023	.0010	.0163
305-320	I	.0056	.0038	.0051	.0015	.0005	.0165
	N	.0010	.0028	.0064	.0046	.0031	.0179
	L	.0033	.0041	.0061	.0043	.0036	.0214
325-340	I	.0069	.0076	.0028	.0010	-	.0183
	N	.0008	.0015	.0074	.0038	.0018	.0153
	L	.0036	.0025	.0092	.0023	.0013	.1889
345-360	I	.0076	.0186	.0140	.0010	-	.0412
	N	.0013	.0031	.0125	.0064	.0023	.0261
	L	.0074	.0081	.0135	.0043	.0013	.0346

(continued on next page)

TABLE 3.2(Continued)

Wind Direction		Wind Speed (mph)					Total	
		1 - 4	5 - 8	9-13	14-19	20-27		>27
005-020	I	.0094	.0244	.0196	.0005	-	-	.0539
	N	.0025	.0086	.0191	.0046	.0023	-	.0371
	L	.0053	.0122	.0099	.0028	-	-	.0303
025-040	I	.0122	.0089	.0036	.0005	-	-	.0252
	N	.0074	.0064	.0094	.0033	.0003	-	.0268
	L	.0064	.0056	.0031	.0012	-	-	.0164
045-060	I	.0043	.0015	.0003	-	-	-	.0061
	N	.0023	.0043	.0043	.0005	-	-	.0014
	L	.0018	.0015	.0020	.0010	-	-	.0063
065-110	I	.0076	.0038	.0031	-	-	-	.0115
	N	.0104	.0102	.0074	.0005	-	-	.0285
	L	.0043	.0046	.0028	.0003	-	-	.0120
115-160	I	.0079	.0038	.0071	.0010	.0003	-	.0201
	N	.0033	.0056	.0058	.0056	.0025	-	.0228
	L	.0025	.0053	.0074	.0043	.0015	-	.0210
165-180	I	.0084	.0117	.0117	.0018	-	-	.0336
	N	.0043	.0059	.0145	.0081	.0008	-	.0336
	L	.0076	.0160	.0142	.0074	.0003	-	.0455
185-200	I	.0109	.0165	.0140	.0010	-	-	.0424
	N	.0041	.0069	.0107	.0076	.0010	-	.0303
	L	.0081	.0173	.0084	.0020	.0020	-	.0378
Calm	I							.0244
	N							.0061
	L							.0020
Total	I	.1109	.1310	.1012	.0109	.0015	-	.3799
	N	.0440	.0666	.1188	.0551	.0193	.0005	.3104
	L	.0666	.0966	.0994	.0336	.0112	-	.3094

TABLE 3.3 Frequency Distribution of Wind Speed and Direction
at 100 Ft. Tower Level for Entire Year According
to Temperature Gradient Class.

I = inversion $T_{150}-T_7 \geq 0$
 N = isothermal-adiabatic $0 > T_{150}-T_7 \geq -0.9^\circ\text{F}$
 L = lapse condition $-0.9^\circ\text{F} > T_{150}-T_7$

Wind Direction	Wind Speed (mph)						Total
	1-4	5-8	9-13	14-19	20-27	>27	
205-220	I	.0111	.0138	.0034	-	-	.0283
	N	.0044	.0031	.0014	.0001	-	.0090
	L	.0039	.0047	.0017	.0005	-	.0108
225-240	I	.0108	.0061	.0016	-	-	.0185
	N	.0027	.0014	.0012	.0001	-	.0054
	L	.0034	.0041	.0024	.0001	-	.0100
245-260	I	.0061	.0059	.0030	.0001	-	.0151
	N	.0019	.0016	.0026	.0011	.0001	.0073
	L	.0016	.0027	.0014	.0001	-	.0058
265-280	I	.0056	.0060	.0042	.0009	.0004	.0171
	N	.0022	.0012	.0030	.0012	.0002	.0078
	L	.0017	.0036	.0037	.0022	.0006	.0119
285-300	I	.0035	.0050	.0076	.0041	.0017	.0224
	N	.0017	.0015	.0087	.0052	.0022	.0194
	L	.0044	.0036	.0088	.0061	.0009	.0238
305-320	I	.0036	.0047	.0088	.0049	.0016	.0237
	N	.0007	.0030	.0128	.0108	.0022	.0295
	L	.0032	.0021	.0092	.0070	.0014	.0229
325-340	I	.0039	.0062	.0067	.0022	-	.0190
	N	.0019	.0044	.0105	.0092	.0021	.0283
	L	.0035	.0051	.0075	.0022	.0007	.0191
345-360	I	.0100	.0074	.0034	.0005	.0001	.0216
	N	.0031	.0081	.0158	.0100	.0025	.0397
	L	.0056	.0132	.0120	.0030	.0007	.0345

(continued on next page)

TABLE 3.3(Continued)

Wind Direction	Wind Speed (mph)						Total	
	1 - 4	5 - 8	9-13	14-19	20-27	>27		
005-020	I	.0173	.0324	.0113	.0008	-	-	.0618
	N	.0083	.0199	.0192	.0078	-	.0001	.0553
	L	.0072	.0128	.0078	.0011	-	-	.0289
025-040	I	.0176	.0303	.0095	-	-	-	.0574
	N	.0041	.0095	.0052	.0010	-	-	.0198
	L	.0046	.0051	.0017	.0002	-	-	.0116
045-060	I	.0100	.0055	.0010	-	-	-	.0165
	N	.0021	.0049	.0027	-	-	-	.0097
	L	.0024	.0031	.0014	.0004	-	-	.0073
065-110	I	.0156	.0030	.0010	-	-	-	.0196
	N	.0106	.0052	.0007	.0001	-	-	.0166
	L	.0047	.0034	.0021	-	-	-	.0102
115-160	I	.0049	.0047	.0006	.0004	-	-	.0106
	N	.0036	.0050	.0040	.0010	.0002	-	.0138
	L	.0014	.0056	.0072	.0024	.0002	-	.0168
165-180	I	.0105	.0122	.0044	-	-	-	.0271
	N	.0059	.0082	.0118	.0012	.0006	-	.0277
	L	.0071	.0138	.0128	.0026	-	-	.0363
185-200	I	.0111	.0172	.0060	.0004	-	-	.0347
	N	.0049	.0054	.0050	.0001	.0002	-	.0156
	L	.0067	.0111	.0047	.0011	-	-	.0236
Calm	I							.0188
	N							.0052
	L							.0024
Total	I	.1414	.1603	.0725	.0143	.0036	.0006	.4115
	N	.0583	.0821	.1053	.0492	.0106	.0007	.3114
	L	.0614	.0939	.0848	.0293	.0046	.0004	.2768

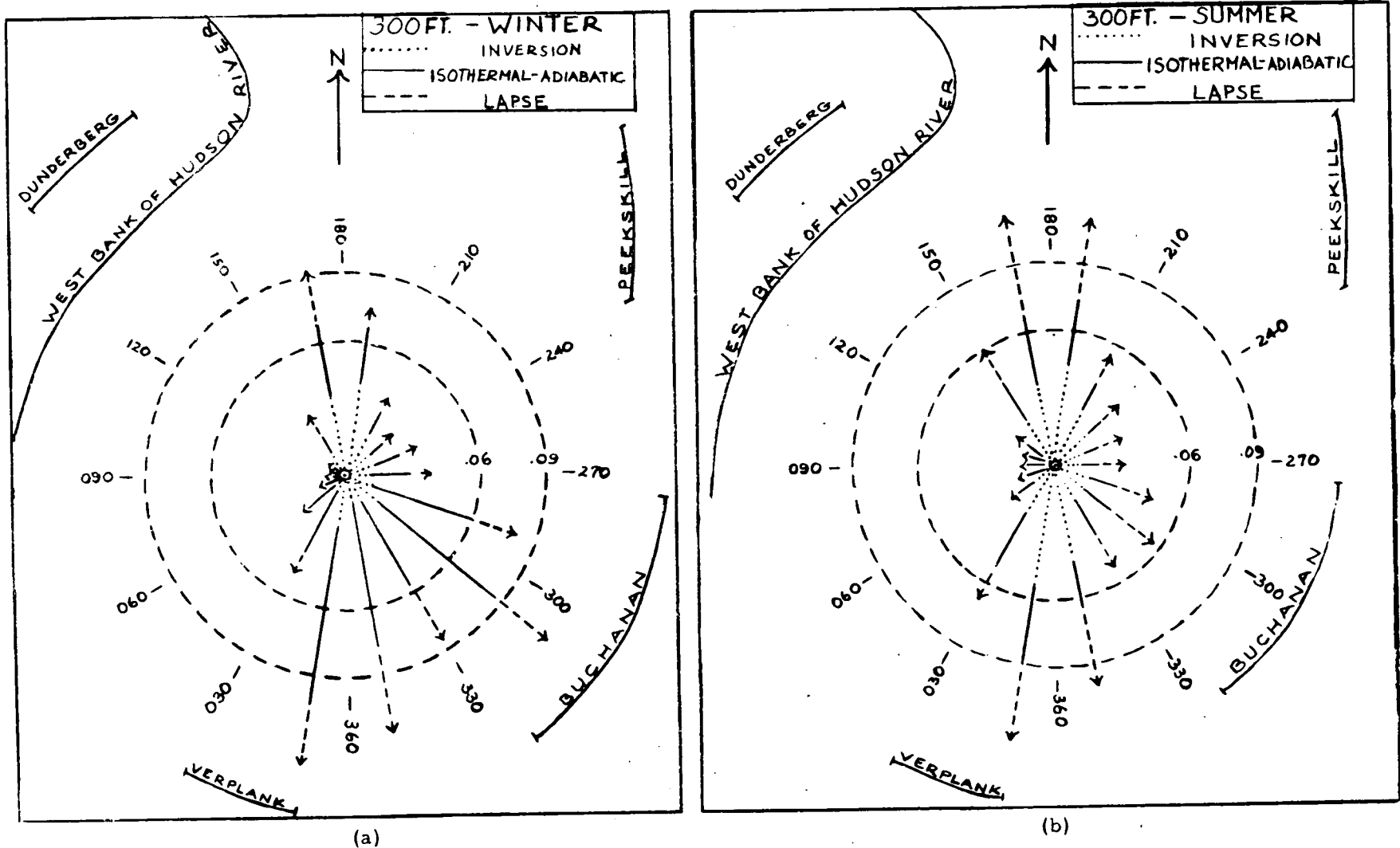
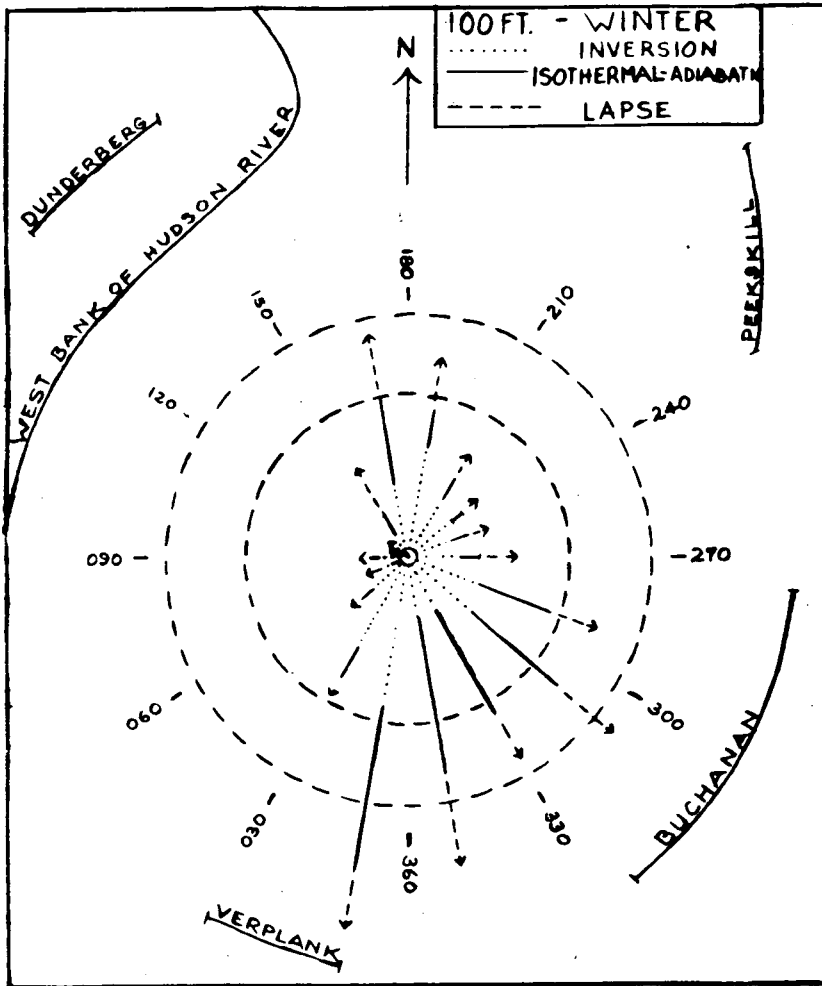
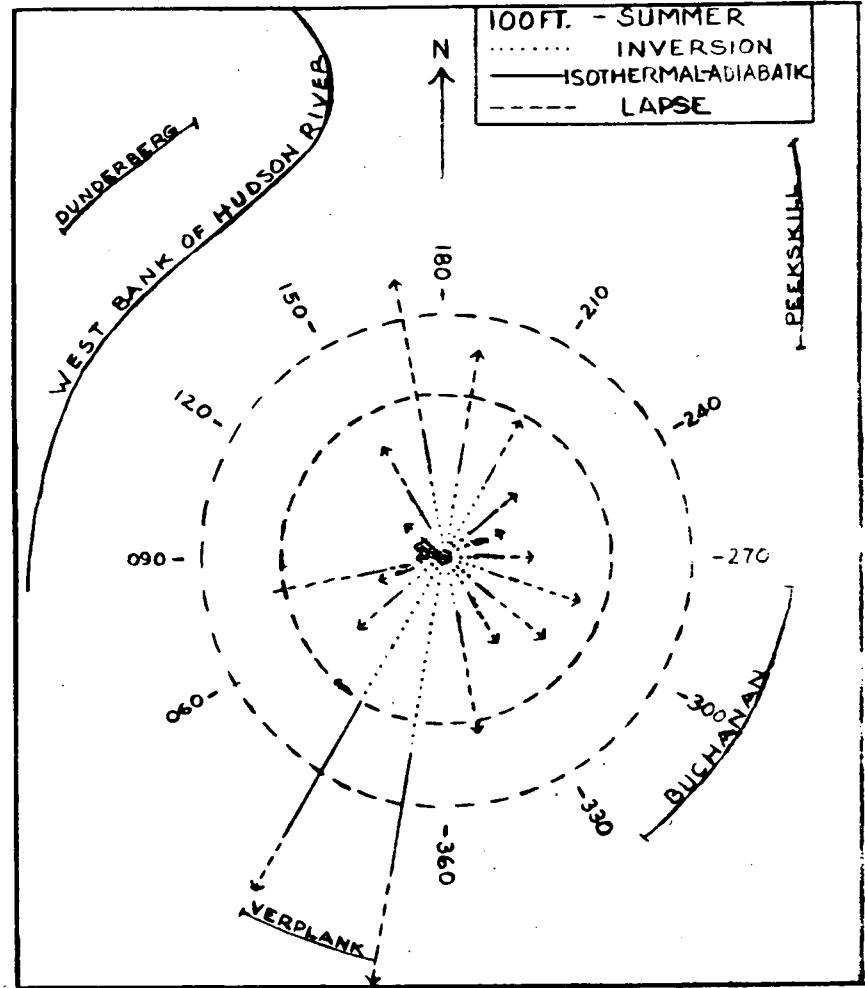

Fig. 3.1. Wind rose (300 ft) according to temperature gradient (a) winter, (b) summer.



(a)



(b)

Fig. 3.2. Wind rose (100 ft) according to temperature gradient classes (a) winter, (b) summer.

flow. On occasion the 030° flow does extend to above 400 ft. (There is a lag of 2 to 4 hours in the onset of the 030 flow from 70 ft to 400 ft on these occasions.) The height to which the down valley flow extends does not appear to depend on the height or intensity of the inversion, but is probably related to very weak and unmeasurable prevailing pressure gradients.

For diffusion estimates, the following classes were defined:

- L₁ - Unstable Temperature gradient, winds < 8 mph
- L₂ - Unstable Temperature gradient, winds > 8 mph
- N - Adiabatic-Isothermal class
- I - Inversion class

The percent frequency of occurrence of each of these classes follow:

(300 ft data)

	<u>Winter</u>	<u>Summer</u>
L ₁	5	17
L ₂	15	15
N	54	30
I	26	38

A substantial portion of all hours fall into the adiabatic-isothermal class. As it happens, it is this class which is the most difficult to interpret as far as diffusion behavior is concerned. Some hours which fall into this class are characterized by relatively shallow inversions up to 50 or 100 ft with adiabatic gradients above. Under these circumstances, it is difficult to state whether or not smoke will descend to the ground. However, this will not affect the radiation calculations seriously. In view of the heated source calculations, the N class will

not enter seriously into the calculations until wind speeds of the order of 10-12 mph are attained. Study of our fluctuation traces at all levels indicate to us that smoke will descend to the ground under strong wind speed conditions.

Department of Meteorology and Oceanography

NEW YORK UNIVERSITY

COLLEGE OF ENGINEERING

•
RESEARCH DIVISION

**SUMMARY OF CLIMATOLOGICAL DATA AT BUCHANAN, NEW YORK
1956-1957**

By
Ben Davidson



Technical Report No. 372.4

Prepared for
Consolidated Edison Co. of N. Y., Inc.

March, 1958

**RESEARCH DIVISION
COLLEGE OF ENGINEERING
NEW YORK UNIVERSITY**

Department of Meteorology and Oceanography

Technical Report No. 372.4

**SUMMARY OF CLIMATOLOGICAL DATA AT BUCHANAN, NEW YORK
1956-1957**

Prepared by

**Ben Davidson
Project Director**

**Prepared for
Consolidated Edison Co. of N. Y., Inc.
March 1958**

Table of Contents

	Page
1. Introduction	1
2. Comparison of 1956-1957 data	2
3. Variation of wind direction with height	4
4. Wind rose presentation	6
References	8

List of Figures

Fig. 1. Comparison of wind direction distribution for all stability classes	3
Fig. 2. Comparison of wind direction distribution for all stability classes, summer 1956	4
Fig. 3. Wind rose at 300 ft tower level for inversion, neutral and lapse conditions, based upon 1956-1957 data . . .	7

1. Introduction

A detailed summary of climatological data collected during 1956 is contained in Technical Report No. 372.3 - Evaluation of Potential Radiation Hazard, April 1957. The tower was run on a skeleton basis during 1957. Wind observations were made at 100 and 300 feet (200 and 400 feet above river level), while temperature was observed at 7, 150, and 300 feet above ground. Because of the relative infrequency of calibration and general maintenance during 1957 the 1956 data are considered far more accurate. The 300 ft 1957 data were processed in the same manner as the 1956 data. In the present report we summarize:

- (a) The effect of climatological differences between 1956 and 1957 on the radiation calculations of Report 372.3.
- (b) The local wind rose as a function of height above river, and
- (c) The combined 1956-1957 wind rose at 300 feet as a function of stability and wind speed.

2. Comparison of 1956-1957 data

In Table I the essential features of the 1956 and 1957 300 ft data are summarized as a function of stability class. All definitions remain the same as in the previous report. In particular, Inversion conditions (I) are defined to occur when $T_{300} - T_7 \geq 0$; Isothermal-adiabatic conditions (N) when $0 > T_{300} - T_7 \geq -1.8^\circ\text{F}$; and Lapse conditions (L) when $T_{300} - T_7 < 1.8^\circ\text{F}$.

Table I. Frequency of Inversion (I), Neutral (N), and Lapse (L) conditions with associated mean wind speeds, \bar{V} (mph) for 1956 and 1957.

	I	\bar{V}	N	\bar{V}	L	\bar{V}
Summer						
1956	0.38	6.5	0.31	10.4	0.31	11.6
1957	0.35	6.2	0.33	12.8	0.32	9.7
Winter						
1956	0.25	7.6	0.54	12.6	0.20	8.5
1957	0.33	7.1	0.48	13.1	0.19	9.0
All seasons						
1956	0.315	6.9	0.425	11.8	0.255	10.4
1957	0.340	6.6	0.405	13.0	0.255	9.4

There are minor differences, but on the whole, the data seem compatible. There were slightly more inversion hours in 1957 than in 1956 with a slightly lower wind speed. The yearly frequency for each temperature gradient condition does not vary more than 10 percent whilst the mean wind speed for each class is also within 10 percent of the 1956 figure. Almost all of the radiation calculations are inversely proportional to the mean wind speed or to the harmonic mean. There is not too great a difference between the two years and for this reason the total integrated dosage for the area should not vary too greatly, say within 10 to 20 percent,

which is well within the range of uncertainty of the original calculations.

The areal distribution of radiation contained in Figs. 1.1 and 1.2 of the earlier report depends in the mean on the distribution of wind direction. Fig. 1 is a comparison of the annual distribution of wind direction for 1956 and 1957. Again the differences are not great; the 1957 distribution seems a bit more peaked than the 1956 data. This may be due in part to systematic individual differences in reading the charts. Whatever the cause, the differences in the distribution are well within the limits of accuracy of the initial calculations.

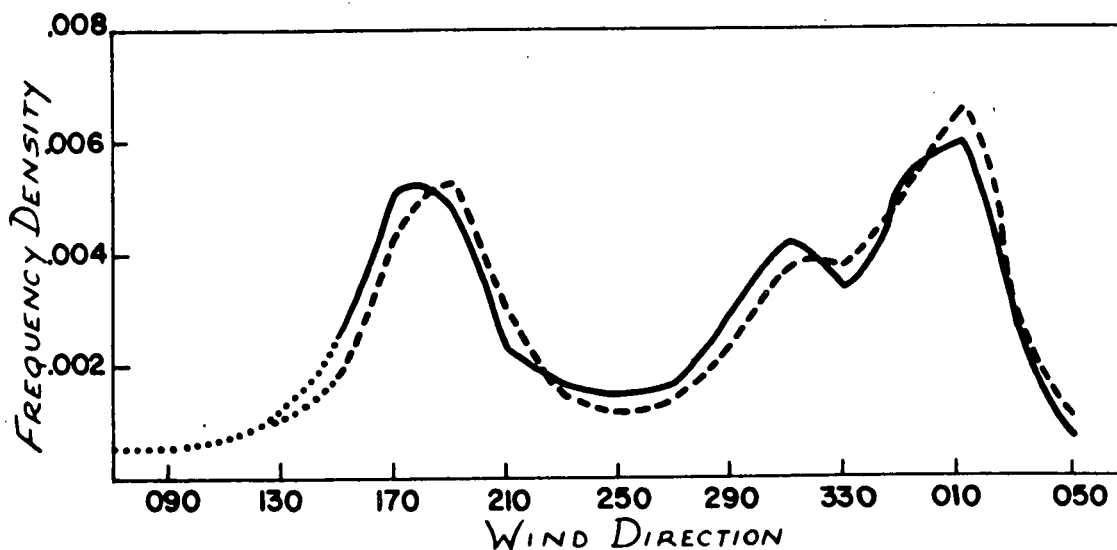

Fig. 1. Comparison of wind direction distribution for all stability classes (1956, solid line; 1957, dashed line).

3. Variation of wind direction with height

Some idea of the variation of wind direction with height may be gained from the 100 and 300 ft summer wind rose (Figs. 3.1 and 3.2 of the original report). To supplement this information, we compare in Fig. 2 the distribution of wind direction for the 1956 summer season at 400 ft (300 ft tower level), 200 ft (100 ft tower level) and 70 ft above river. The 70 ft data were obtained from an anemometer mounted on the "Jones", a ship anchored in mid-river. The ship site is about 0.8 mile northwest of the tower (see map in Report 372.1). It is evident that there are systematic differences in the three distributions. The most obvious is the build-up of southerly winds with height. The Jones distribution is flat from 150° to 250°, while the 100 and 300 ft tower

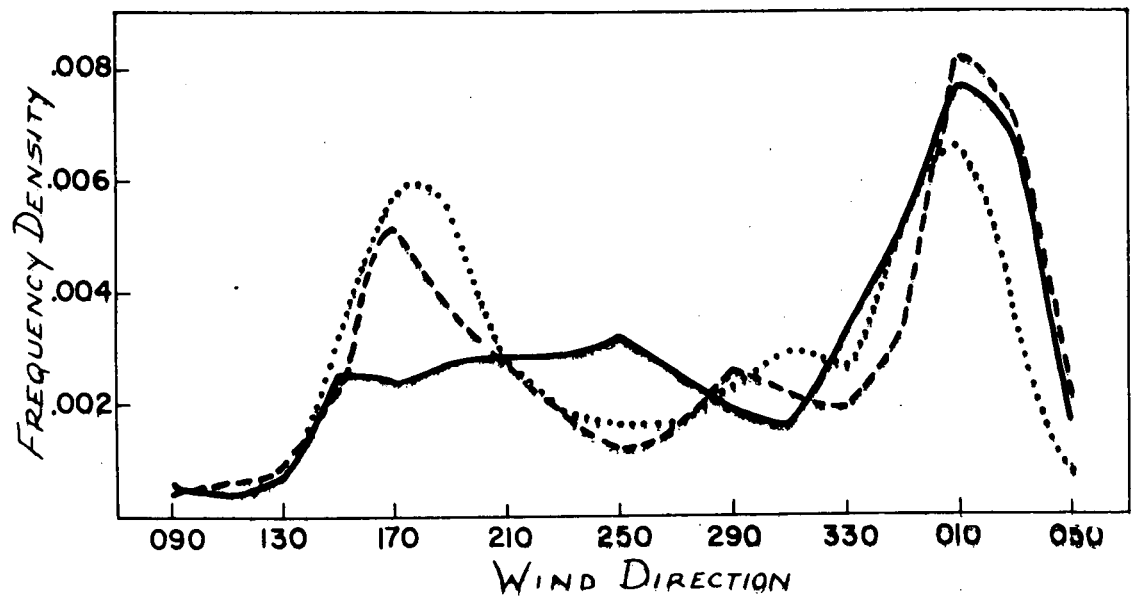

Fig. 2. Comparison of wind direction distribution for all stability classes, summer 1956. (Jones, solid line; 100 ft tower, dashed line; 300 ft tower, dotted line).

distributions peak fairly well at 170°. On the down valley side of the distribution (about 020°), The Jones and 100 ft tower level distributions are fairly well matched. The 300 ft tower level distribution does not reach nearly the same frequency at 030° as do the other two distributions. Some of the essential differences in the two distributions are summarized in the following table.

Percent time indicated wind direction ranges were observed at

<u>Direction Range</u>	<u>Jones</u>	<u>100 ft Tower</u>	<u>300 ft Tower</u>
340-040	38	37	30
360-040	28	30	19
160-220	16	23	27
160-200	10	18	22

Part of the difference between the distributions can be explained by the tendency for light southerly winds to be observed at the 300 ft tower level when the nocturnal NNE winds have set in at the Jones and 100 ft tower locations. The remainder appears to be a daytime phenomenon and indicates that The Jones distribution is affected by the proximity of the valley walls in a rather complicated fashion.

4. Wind rose presentation

In Fig. 3 we present wind roses based upon two years of data for inversion, neutral, and lapse conditions at the 300 ft level. The bars here are flying with the wind and pointing to the indicated meteorological wind direction. The length of the bar is proportional to the average frequency of occurrence per year of the appropriate wind direction and stability condition. For convenience in interpretation we indicate the general location of populated areas surrounding the site.

An interesting feature of the wind rose is the elongation along the axis of the valley during inversion hours. Wind trajectories towards Peekskill, the most densely populated area near the site, are relatively infrequent during neutral and lapse conditions. There is a sizeable frequency of 210° winds during inversion hours. This trajectory would just about brush the northern outskirts of Peekskill, but it is probable that terrain effects would tend to curve the trajectory so that it follows the river. In general, the inversion wind rose shows a high frequency of up and down valley wind directions.

During lapse and neutral conditions, the wind rose indicates a substantial frequency of northwest winds which are the prevailing winds over flat land in this area. Under these temperature gradient conditions, one may expect effluent concentrations on the ground. There are a substantial number of wind trajectories toward the villages of Buchanan, Montrose and Verplank during neutral and lapse conditions, and towards the village of Verplank during inversion conditions.

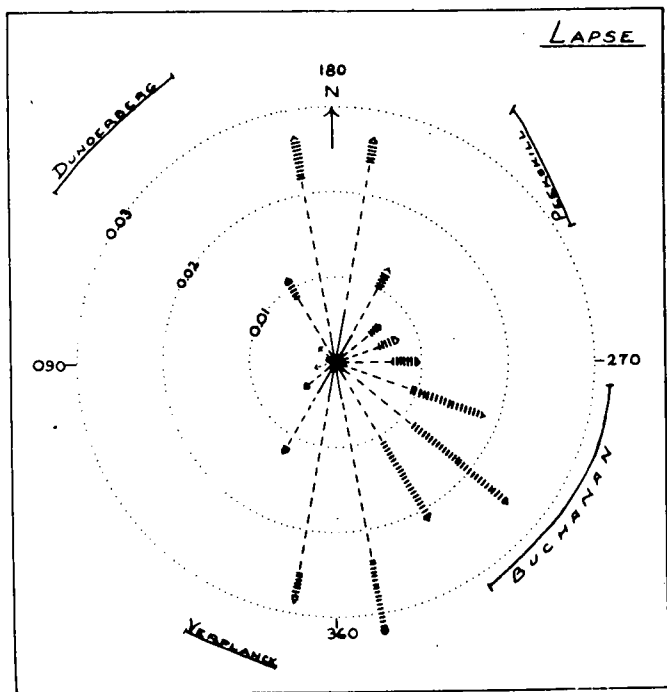
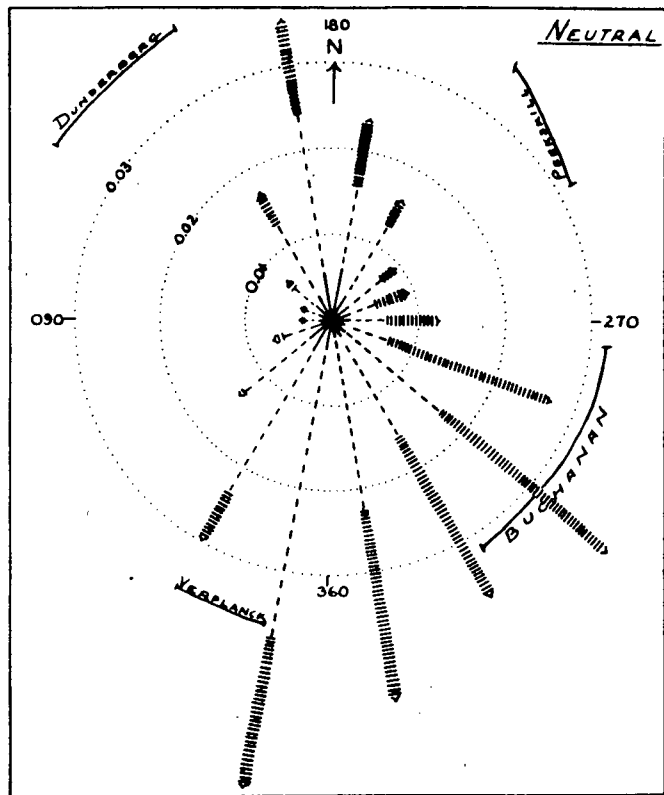
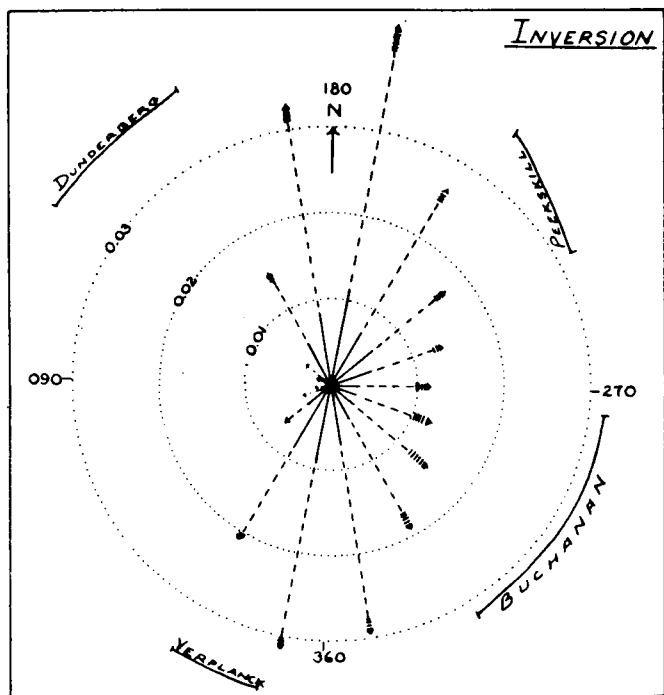

Legend: — less than 5 mph
 --- 5-13 mph
 ||| > 13 mph

Fig. 3. Wind rose at 300 ft tower level for inversion, neutral and lapse conditions, based upon 1956-1957 data. (Bars are flying with the wind). Calm: Inversion .026; Neutral .0107; Lapse .0052.

References

Davidson, B., and J. Halitsky, 1955: A micrometeorological survey of the Buchanan, N. Y. area. - Summary of progress to 1 December 1955. Technical Report No. 372.1, Research Division, New York University, College of Engineering.

Davidson, B., and J. Halitsky, 1957: Evaluation of potential radiation hazard resulting from assumed release of radioactive wastes to atmosphere from the proposed Buchanan nuclear power plant. Technical Report No. 372.3, Research Division, New York University, College of Engineering.

U. S. DEPARTMENT OF COMMERCE

SINCLAIR WEEKS, *Secretary*

WEATHER BUREAU

F. W. REICHELDERFER, *Chief*

TECHNICAL PAPER NO. 15

Maximum Station Precipitation for
1, 2, 3, 6, 12, and 24 Hours

Part X: New York

DIVISION OF HYDROLOGIC SERVICES

HYDROMETEOROLOGICAL SECTION

In cooperation with

CORPS OF ENGINEERS, U. S. ARMY



WASHINGTON, D. C.

December 1954

Station: BEAR MOUNTAIN, NEW YORK

Drainage basin: HUDSON

County: ORANGE

Lat. 41° 19'N Long. 74° 00'W

Elev.(ft.) 1301

Period of record: 1941-1950

Month		Duration (hours)					
		1	2	3	6	12	24
Jan.	Amt. Date	0.38 7/1946	0.60 31/1942	0.85 31/1942	1.29 1/1945	1.49 31/1942	1.51 5-6/1949
Feb.	Amt. Date	0.26 14/1944	0.41 14/1944	0.56 14/1944	0.80 14-15/1944	1.12 20-21/1947	1.42 20-21/1947
Mar.	Amt. Date	0.35 ^a 21/1948	0.57 3/1942	0.78 3/1942	0.99 3/1942	1.19 6-7/1944	1.41 2-3/1947
Apr.	Amt. Date	0.61 30/1947	0.89 30/1947	1.06 1/1948	1.51 1/1948	1.71 1/1948	2.08 18-19/1949
May	Amt. Date	0.70 6/1949	1.21 20/1949	1.35 30/1948	1.77 27/1946	2.51 27/1946	2.87 27/1946
Jun.	Amt. Date	0.67 21/1945	0.83 21/1945	0.88 21/1945	1.01 23/1942	1.50 2/1946	1.82 1-2/1946
Jul.	Amt. Date	1.57 20/1945	1.72 22/1946	1.85 22/1946	2.47 22-23/1945	2.74 22-23/1945	3.98 18-19/1945
Aug.	Amt. Date	1.25 26/1947	1.44 16/1942	1.71 16/1942	1.93 16/1942	2.30 9/1942	2.47 24-25/1945
Sep.	Amt. Date	0.81 30/1946	1.21 24/1946	1.71 24/1946	2.08 24/1946	2.28 24/1946	2.80 26-27/1942
Oct.	Amt. Date	0.59 10/1950	0.86 26/1943	1.03 26/1942	1.53 ^b 26/1942	2.83 26-27/1943	3.95 26-27/1943
Nov.	Amt. Date	1.18 8/1947	1.97 8/1947	2.22 8/1947	3.14 8/1947	3.65 8/1947	3.65 8/1947
Dec.	Amt. Date	0.63 25/1945	1.17 25/1945	1.48 25/1945	1.99 25/1945	2.09 25-26/1945	3.33 30-31/1948
Annual	Amt. Date	1.57 7/20/45	1.97 11/8/47	2.22 11/8/47	3.14 11/8/47	3.65 11/8/47	3.98 7/18-19/45

^aAlso 23/1949.

^bAlso 26/1943.

U. S. DEPARTMENT OF COMMERCE, WEATHER BUREAU

Station, Bear Mountain County, Orange State, New York

Latitude 41.19 Longitude, 74.00 Elevation, 1300 feet.

Data, Precipitation, Monthly and Annuals

Year.	January.	February.	March.	April.	May.	June.	July.	August.	September.	October.	November.	December.	Annual.
1939	3.81	3.62	3.16	5.90	1.30	5.32	3.04	3.36	3.04	4.20	1.69	3.39	41.83
1940	5.58	3.87	5.72	6.68	6.53	3.12	3.68	4.05	2.82	3.38	4.48	3.87	53.78
1941	2.77	2.87	2.22	2.00	1.79	4.46	6.31	3.33	0.25	2.35	3.18	4.47	36.00
1942	3.98	1.85	5.67	0.92	3.20	3.80	5.79	5.51	4.44	3.61	4.79	4.62	48.18
1943	2.36	1.19	2.00	3.47	4.56	3.80	3.73	2.56	2.99	12.64	4.18	2 1.01	44.49
1944	1.93	2.05	5.60	5.30	2.54	3.06	2.03	2.42	5.99	2.12	5.09	2.37	40.50
1945	2.97	2.46	1.79	3.79	7.18	4.28	16.87	4.73	5.36	2.13	6.53	4.46	62.55
1946	1.79	1.65	2.97	1.97	8.91	3.11	8.10	4.93	6.24	2.13	1.03	2.18	45.31
1947	2.85	3.39	3.48	4.76	9.49	6.55	7.38	2.78	2 1.90	2.69	8.51	3.68	57.46
1948	3.05	1.21	3.29	5.28	7.30	4.84	3.52	2.76	0.68	1.92	4.90	6.14	44.89
1949	5.08	2.27	1.88	5.47	6.53	0.96	3.45	2.94	5.60	2.52	1.91	2.79	41.40
1950	2.81	4.46	3.40	2.97	6.02	3.77	5.16	2.94	2.26	2.45	5.39	6.24	47.87
1951	4.60	4.14	8.40	2.94	4.11	3.87	5.07	5.19	2.06	5.13	2.55	5.96	59.02
1952	4.53	3.22	5.46	8.54	5.29	5.92	5.13	8.13	5.01	0.52	7.48	5.84	62.07
1953	6.75	1.89	5.71	4.72									
Sums													
Means													

REMARKS

U. S. DEPARTMENT OF COMMERCE
WEATHER BUREAU
NATIONAL WEATHER RECORDS CENTER

JOB NO. 6729

SURFACE WIND SPEEDS VERSUS
DIRECTION WHEN SOME FORM OF
PRECIPITATION IS OCCURRING
(ANNUAL AND MONTHLY)

STATION: BEAR MOUNTAIN, NEW YORK

PERIOD: JANUARY 1944 - DECEMBER 1948

Sponsored by: Consolidated Edison Company of New York, Inc.

DATE OCTOBER 28, 1965

FEDERAL BUILDING
ASHEVILLE, N.C.

Book 2 of 2

USCOMM-WB-ASHEVILLE

SURFACE WIND SPEEDS VERSUS DIRECTION
WHEN SOME FORM OF PRECIPITATION IS OCCURRING

BEAR MOUNTAIN, NEW YORK

ANNUAL

JANUARY 1944 - DECEMBER 1948

MILES PER HOUR														
Speed Dir.		1-3	4-7	8-12	13-18	19-24	25-31	32-38	39-46	47 Over		Total		
N		16	61	106	71	54	41	17	1	1		368		
NNE		4	28	58	57	24	14	0	1	4		190		
NE		7	24	72	79	29	10	0	0	0		221		
ENE		7	45	109	74	23	12	1	0	0		271		
E		17	103	314	316	101	20	1	0	0		872		
ESE		8	65	150	183	48	10	4	0	0		468		
SE		8	67	147	104	16	13	3	0	0		358		
SSE		1	30	97	82	36	16	3	4	0		269		
S		19	78	181	162	98	43	17	8	3		609		
SSW		2	27	82	86	69	40	5	11	0		322		
SW		8	31	93	97	51	27	6	2	1		316		
WSW		4	21	51	53	35	17	8	6	1		196		
W		7	32	34	41	26	16	8	7	4		175		
WNW		4	19	45	46	66	43	26	7	3		259		
NW		9	33	67	52	42	35	12	10	1		261		
NNW		15	43	65	71	49	22	5	0	0		270		
CALM	55											55		
TOTAL	55	136	707	1671	1574	767	379	116	57	18		5,480		

5,480 occurrences out of a possible 43,848.

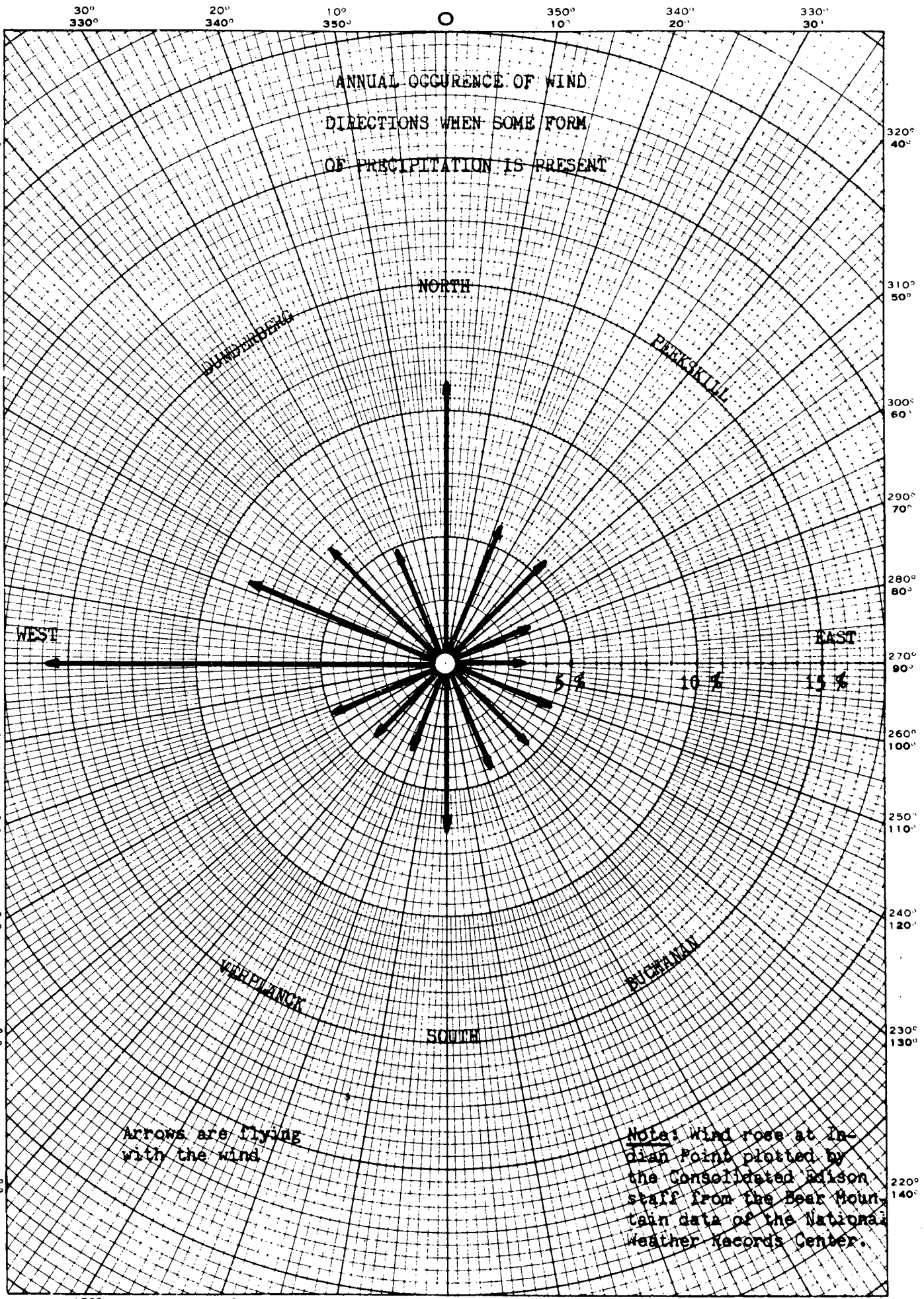

Arrows are flying with the wind

Note: Wind rose at Indian Point plotted by the Consolidated Edison staff from the Bear Mountain data of the National Weather Records Center.

U. S. DEPARTMENT OF COMMERCE
WEATHER BUREAU
NATIONAL WEATHER RECORDS CENTER

JOB NO. 6729

OCCURRENCE OF WIND SPEED
AND DIRECTION DURING THUNDERSTORMS
(ANNUAL ONLY)

STATION: BEAR MOUNTAIN, NEW YORK

PERIOD: JANUARY 1944 - DECEMBER 1948

Sponsored by: Consolidated Edison Company of New York, Inc.

DATE OCTOBER 28, 1965

FEDERAL BUILDING
ASHEVILLE, N.C.

Book 1 of 2

USCOMM-WB-ASHEVILLE

OCCURRENCE OF WIND SPEED AND DIRECTION DURING THUNDERSTORMS

BEAR MOUNTAIN, NEW YORK

ANNUAL 1944 - 1948

MILES PER HOUR														
Speed Dir.		1-3	4-7	8-12	13-18	19-24	25-31	32-38	39-46	47 Over		Total		
N		2	5	10	6	2	1	1				27		
NNE			2	2	4	1						9		
NE		2	1	3	4	2	1					13		
ENE			3	7	4	2						16		
E			8	10	7							25		
ESE			5	11	3							19		
SE		2	10	16	16	3						47		
SSE			1	26	19	5						51		
S		4	24	57	47	11	1					144		
SSW			4	23	26	12	1	1				67		
SW		3	6	22	24	11	4	1	1			72		
WSW		1	8	12	34	15	5	4		1		80		
W		3	11	12	27	10	6	3	1	4		77		
WNW			3	18	11	10	12	2	2	3		61		
NW			6	17	4	9	6	2	2	1		47		
NNW			5	12	4	8	1	2	2			34		
CALM	7											7		
TOTAL	7	17	102	258	240	101	38	16	8	9		796		

There were no thunderstorms observed for the months November, December, January & February during this period (1944-1948).

30° 20° 10° 350° 340° 330°
330° 340° 350° 10° 20° 30°

ANNUAL OCCURENCE OF WIND DIRECTIONS DURING THUNDERSTORMS

NORTH

DUNDEBERG

PERKINSVILLE

WEST

EAST

SOUTH

VERMILION

BUCHANA

Arrows are flying
with the wind

Note: Wind rose at Indian
Point plotted by the Con-
solidated Edison staff from
the Bear Mountain data of
the National Weather Records
Center.

150° 160° 170° 180° 190° 200° 210°
210° 200° 190° 180° 170° 160° 150°

REGIONAL ECONOMIC DEVELOPMENT INSTITUTE, INCORPORATED

1980 PROJECTIONS
OF
POPULATION AND LAND USE
FOR AN
AREA CIRCUMSCRIBED BY A 55-MILE RADIUS
FROM
BUCHANAN, NEW YORK

PREPARED FOR
CONSOLIDATED EDISON COMPANY OF NEW YORK, INC.

NOVEMBER 3, 1965

REGIONAL ECONOMIC DEVELOPMENT INSTITUTE, INCORPORATED

PART I

INTRODUCTION

The following two parts of this report present the results and methodology of projecting 1980 population and land use for an area circumscribed by a 55-mile radius from Buchanan, New York.

Due to the short time available to produce the projections, complete reliance was placed on the aggregate population and land use estimates produced by the Regional Plan Association of New York. These were obtained as the result of an intensive four days' perusal of their frequently revised projections, and by making extensive use of their counsel and advice.

RPA estimates for 1980 population by county were used as the limits to population growth by municipalities for the period 1960 to 1980. The 55-mile radius from Buchanan, New York, circumscribed an area which was segregated into rings-and-sectors as the following "Key to Numbering of Zones" indicates. The projections of population by municipalities constrained by RPA county estimates were then fitted to the area and totals by zones and rings-and-sectors were produced. These results appear in the following section and the methodology in the third section.

Estimates for land use in 1960 as well as projections for land use in 1980 were not available at all in county or municipal detail. Consequently, detailed land use for 1960 and projected land use in 1980 could only be controlled by average figures for land use derived from RPA estimates for some fifty

REGIONAL ECONOMIC DEVELOPMENT INSTITUTE, INCORPORATED

KEY TO NUMBERING OF ZONES

<u>Direction</u>	<u>Miles from Buchanan, New York</u>				
	<u>0 - 15</u>	<u>15 - 25</u>	<u>25 - 35</u>	<u>35 - 45</u>	<u>45 - 55</u>
N to NE	1	9	17	25	33
NE to E	2	10	18	26	34
E to SE	3	11	19	27	35
SE to S	4	12	20	28	36
S to SW	5	13	21	29	37
SW to W	6	14	22	30	38
W to NW	7	15	23	31	39
NW to N	8	16	24	32	40

REGIONAL ECONOMIC DEVELOPMENT INSTITUTE, INCORPORATED

-2-

municipalities, all or part of only five counties and New York City. ¹

The land use values by counties are of necessity then likely to contain error. It is believed, however, that the possible error is small and that all the values are of the correct magnitude. The results of the detailed land use estimates for 1960 and the projections for 1980 appear in the following section and the methodology appears in the third section.

Basic work sheets and data processing "print-outs," and cards, including the itemization and splitting of municipalities and subsidiary projections of municipality population, have been retained by Regional Economic Development Institute, Incorporated, and are available.

This report was directed by Professor Edgar M. Hoover and produced by the research staff of the Regional Economic Development Institute, Incorporated.

REGIONAL ECONOMIC DEVELOPMENT INSTITUTE, INCORPORATED

PART II

RESULTS

The following tables contain 1980 projections of population for forty zones and ring-and-sector totals as well as 1980 projections of land use by county.

REGIONAL ECONOMIC DEVELOPMENT INSTITUTE, INCORPORATED

1980 POPULATION PROJECTIONS

<u>Zone</u>	<u>Population 1960</u>	<u>"Extrapolative" Projection 1980</u>	<u>"Density" Projection 1980</u>	<u>"Compromise" Projection 1980</u>	<u>Area Square Miles</u>
1	18,323	39,898	43,809	41,735	88.0
2	40,834	73,427	72,607	72,675	73.7
3	35,566	71,378	70,322	70,688	74.8
4	90,143	161,448	165,633	163,637	65.4
5	91,660	200,223	190,255	196,263	83.0
6	9,311	41,361	50,645	44,614	94.4
7	13,682	29,164	28,159	28,541	92.2
8	27,321	53,115	50,587	52,110	77.1
9	34,117	80,065	68,931	74,678	164.8
10	28,146	70,500	74,326	72,221	145.4
11	140,695	233,058	240,843	237,278	162.8
12	699,673	986,875	980,462	984,442	211.0
13	357,097	599,794	543,170	571,367	148.1
14	30,028	58,733	67,709	63,052	150.5
15	18,441	32,471	33,116	33,156	151.6
16	84,925	141,310	135,638	138,432	130.6
17	86,252	139,785	136,592	138,252	237.4
18	54,946	99,186	104,718	101,987	186.6
19	190,677	348,846	328,943	339,140	183.9
20	2,404,766	2,311,656	2,352,125	2,329,609	120.3
21	1,778,513	2,002,018	2,007,352	2,004,810	244.5
22	43,359	110,373	116,864	113,629	243.6
23	41,430	62,763	69,242	66,569	259.1
24	23,788	37,677	38,858	38,387	246.7
25	32,826	56,608	61,401	58,775	331.7
26	66,942	129,540	133,990	131,587	312.0
27	321,128	527,513	536,210	531,602	133.2
28	3,261,122	3,485,870	3,478,298	3,483,747	333.5
29	3,153,690	3,240,678	3,273,470	3,257,437	294.2
30	89,690	237,359	232,037	235,001	316.6
31	25,461	34,124	38,459	36,363	305.3
32	33,718	50,132	52,668	51,427	321.7
33	25,915	38,780	46,254	42,473	364.5
34	433,876	672,402	716,147	694,861	380.9
35	224,934	546,199	534,771	540,497	202.9
36	1,055,784	1,439,316	1,365,059	1,402,590	181.9
37	930,905	1,517,627	1,496,222	1,506,849	304.9
38	36,768	83,814	97,434	90,389	353.8
39	12,862	15,407	15,502	15,451	335.4
40	52,084	75,837	73,789	74,673	380.3

REGIONAL ECONOMIC DEVELOPMENT INSTITUTE, INCORPORATED

1980 "COMPROMISE" PROJECTION OF POPULATION

by Ring-and-Sector Zones

	<u>N to NE</u>	<u>NE to E</u>	<u>E to SE</u>	<u>SE to S</u>	<u>S to SW</u>	<u>SW to W</u>	<u>W to NW</u>	<u>NW to N</u>	<u>Ring Totals</u>
0 to 15	41,735	72,675	70,688	163,637	196,263	44,614	28,541	52,110	670,263
15 to 25	74,678	72,221	237,278	984,442	571,367	63,052	33,156	138,432	2,174,626
25 to 35	138,252	101,987	339,140	2,329,609	2,004,810	113,629	66,569	38,387	5,132,383
35 to 45	58,775	131,587	531,602	3,483,747	3,257,437	235,001	36,363	51,427	7,785,939
45 to 55	42,473	694,861	540,497	1,402,590	1,506,849	90,389	15,451	74,673	4,367,783
Sector Totals	355,913	1,073,331	1,719,205	8,364,025	7,536,726	546,685	180,080	355,029	20,130,994

REGIONAL ECONOMIC DEVELOPMENT INSTITUTE, INCORPORATED

1960 POPULATION

by Ring-and-Sector Zones

	<u>N to NE</u>	<u>NE to E</u>	<u>E to SE</u>	<u>SE to S</u>	<u>S to SW</u>	<u>SW to W</u>	<u>W to NW</u>	<u>NW to N</u>	<u>Ring Totals</u>
0 to 15	18,323	40,834	35,566	90,143	91,660	9,311	13,682	27,321	326,840
15 to 25	34,117	28,146	140,695	699,673	357,097	30,028	18,441	84,925	1,393,122
25 to 35	86,252	54,946	190,677	2,404,766	1,778,513	43,359	41,430	23,788	4,623,731
35 to 45	32,826	66,942	321,128	3,261,122	3,153,690	85,690	25,461	33,718	6,980,577
45 to 55	25,915	433,876	224,934	1,055,784	930,905	36,768	12,862	52,084	2,773,128
Sector Totals	197,433	624,744	913,000	7,511,488	6,311,865	205,156	111,876	221,836	16,097,398

REGIONAL ECONOMIC DEVELOPMENT INSTITUTE, INCORPORATED

TABLE 1

Counties in Con Ed Study Area			1	2	3	4	5	6	7	8	9		
State	In RPA Region	Outside RPA Region	Percent In Con Ed Area	Averaging		D 1980 RPA Population Estimate	From I 1980 Projection	Equation 2 I 1980 Projection	Best Estimate From Equations 1 & 2	Adjusted to Best Estimate I 1980 RPA Total	Square Miles Total Area		
				Equation 1 I 1960 Projection	From I 1960 RPA Total Estimate								
Conn.	Fairfield		100	109	131	96	1666	141	126	141	216	633	
		Litchfield	52			[29]	[201]	[36]			[36]	938 (49)	
		New Haven	71			[77]	[1997]	[107]			[107]	610 (433)	
N. J.	Bergen		100	75	68	75	4635	90	92	92	140	233	
	Essex		100	62	48	73	7812	65	59	65	99	128	
	Hudson		100	31	15	31	12222-	29	18	31*	31*	45	
	Middlesex		46	63	59	59	3067	97	83	97	148 (68)	313 (150)	
	Morris		100	58	73	53	1538	100	87	100	153	468	
	Passaic		100	49	43	49	2861	58	41	58	89	194	
	Somerset		33	35	44	35	1091	55	44	55	84 (28)	307 (101)	
			Sussex	100			[26]	[216]	[42]			[42]	528
		Union		100	41	41	50	5825	45	49	49	75	103
		Warren	13			[3]	[287]	[4]			[4]	361 (47)	
N. Y.	Dutchess		100	61	37	55	368	82	57	82	125	816	
	Nassau		100	110	113	133	5119	119	177	177	271	293	
	Orange		100	63	69	63	374	85	45	85	130	829	
	Putnam		100	14	24	18	471	27	28	28	43	234	
	Rockland		100	27	46	34	1899	43	26	43	65	179	
	Suffolk		71	133	146	133	1830	216	161	216	329 (234)	921 (654)	
			Sullivan	56			[18]	[62]	[22]			[22]	986 (552)
			Ulster	88			[51]	[161]	[65]			[65]	1143 (1006)
		Westchester		100	101	99	101	2690	126	104	126	193	435
		Bronx		100	38	20	29	32143-	29*	29*	29*	29*	42
		Kings		100	68	33	49	35870-	49*	49*	49*	49*	69
	New York		100	20	11	16	68182-	16*	16*	16*	16*	22	

REGIONAL ECONOMIC DEVELOPMENT INSTITUTE, INCORPORATED

TABLE 1 continued...

<u>Counties in Con Ed Study Area</u>			1	2	3	4	5	6	8	9		
<u>State</u>	<u>In RPA Region</u>	<u>Outside RPA Region</u>	<u>Percent In Con Ed Area</u>	<u>Equation 1 I 1960 Projection Sq. Miles</u>	<u>Averaging From I 1960 RPA Total Estimate</u>	<u>Best Estimate I 1960</u>	<u>D 1980 From RPA Population Estimate</u>	<u>Equation 1 I 1980 Projection Sq. Miles</u>	<u>Equation 2 I 1980 Projection Sq. Miles</u>	<u>Best Estimate I 1980 From Equations 1 & 2</u>	<u>Adjusted to Best Estimate I 1980 RPA Total</u>	<u>Square Miles Total Area</u>
N. Y.	Queens		100	80	52	76	17661	93	102	76*	76*	109
	Richmond		100	20	20	20	7759	30	30	30	46	58
Pa.		Pike	65			[7]	[22]	[8]			[8]	545 (354)
TOTAL RPA REGION				1258	1192	1248		1595	1423	1645	2408	
CONTROL TOTALS				1248	1248	1248		2408	2408	2408	2408	
TOTAL INTENSIVE LAND USE IN CONSOLIDATED EDISON AREA						1459					2461	

NOTES: Figures in [] are for counties outside RPA's Region and are only added in Column 8.

Figures with * are for counties whose population density declined or projection produced over 100 percent of land used intensively. In such cases, 1960 estimates of land use intensity were used for 1980.

Figures in () in Column 8 are square miles of intensively used land in the Consolidated Edison Area for those counties which are not 100 percent within that area. Those in () in Column 9 are the total square miles of the county in the Consolidated Edison Area.

REGIONAL ECONOMIC DEVELOPMENT INSTITUTE, INCORPORATED

TABLE 2

ESTIMATED LAND USE 1960 AND PROJECTED LAND USE 1980¹

	INTENSIVE 1960 & 1980			NON-INTENSIVE 1960			NON-INTENSIVE 1980			11	12	
	1	2	3	4	5	6	7	8	9			10
	<u>Residential</u>	<u>Industrial/ Commercial</u>	<u>Total</u>	<u>Institutional and Park</u>	<u>Public Rights of Way</u>	<u>Total</u>	<u>Community Facilities & Institutions</u>	<u>Parks & Recreation</u>	<u>Public Rights of Way</u>	<u>Total</u>	<u>Open</u>	<u>Grand Totals</u>
1960												
Square Miles	1032	216	1248	696	418	1114					4062	6424
Percentage of Total Developed Land	43	9	52	29	19	48						
High	58	12		45	22							
Low	32	2		15	13							
1980												
Square Miles	2040	368	2408				876	784	682	2342	1674	6424
Percentage of Total Developed Land	43	8	51				19	16	14	49		
1960 - 1980												
Square Miles of Land to be Developed	1400	220	1620							1228		
Percentage of Total Land to be Developed			58							42		

1. The averages were derived from the data in "Table 3. The Use of Developed Land in Selected Areas of the Region." RPA Bulletin Number 100, Page 21, September, 1962. The data for square miles excludes Monmouth County from the original RPA totals.

REGIONAL ECONOMIC DEVELOPMENT INSTITUTE, INCORPORATED

TABLE 3

LAND USE BY COUNTY 1954 AND 1960 IN SQUARE MILES

Counties in Con Ed Study Area			1954			1960				
			Intensive	Low Intensive	Open Land	INTENSIVE		LOW INTENSIVE		
State	In RPA Region	Outside RPA Region				Residential	Industrial/ Commercial	Institutional and Park	Public Rights of Way	Open
Conn.	Fairfield		90	13	530	80	16	64	43	430
		Litchfield				[24]	[5]	[2]	[3]	[15]
		New Haven				[64]	[13]	[43]	[28]	[285]
N. J.	Bergen		70	18	145	62	13	19	13	126
	Essex		57	19	57	61	12	7	4	44
	Hudson		21	6	18	26	5	2	1	11
	Middlesex		49	16	248	49	10	31	20	203
	Morris		46	23	399	44	9	50	33	332
	Passaic		33	43	118	41	8	17	12	116
	Somerset		23	7	277	29	6	33	22	217
		Sussex				[22]	[4]	[60]	[40]	[402]
	Union		43	15	45	43	7	6	4	43
	Warren				[2]	[1]	[5]	[3]	[34]	
N. Y.	Dutchess		39	5	772	46	9	92	61	608
	Nassau		136	38	119	114	19	78	13	69
	Orange		23	66	740	52	11	92	61	613
	Putnam		14	1	219	15	3	26	17	173
	Rockland		14	51	114	28	6	30	12	103
	Suffolk		119	79	723	110	23	95	63	630
		Sullivan				[15]	[3]	[64]	[43]	[427]
		Ulster				[42]	[9]	[115]	[76]	[764]
	Westchester		79	79	277	83	18	40	27	267

REGIONAL ECONOMIC DEVELOPMENT INSTITUTE, INCORPORATED

TABLE 3 continued...

LAND USE BY COUNTY 1954 AND 1960 IN SQUARE MILES

<u>Counties in Con Ed Study Area</u>			<u>1954</u>			<u>1960</u>				
			<u>Intensive</u>	<u>Low Intensive</u>	<u>Open Land</u>	<u>INTENSIVE</u>		<u>LOW INTENSIVE</u>		
<u>State</u>	<u>In RPA Region</u>	<u>Outside RPA Region</u>				<u>Residential</u>	<u>Industrial/Commercial</u>	<u>Institutional and Park</u>	<u>Public Rights of Way</u>	<u>Open</u>
N. Y.	Bronx		31*	7	4	25	4	2	1	10
	Kings		34	4	31	42	7	2	2	16
	New York		20*	2	0	14	2	2	3	1
	Queens		98*	10	1	65	11	4	3	26
	Richmond		29*	8	21	17	3	5	3	30
Pa.		Pike				[6]	[1]	[42]	[28]	[277]
TOTAL RPA REGION						1046	202	697	418	4068
CONTROL TOTALS						1032	216	696	418	4062
TOTAL CONSOLIDATED EDISON AREA						1221	238	1028	639	6272

NOTES: Figures with * are for 1954 land use in New York City. They were not used for 1960 and 1980 because the data for 1960 was assumed to be more discrete.

Figures in [] are for those counties outside RPA's Region. They are added in to the total for Con Ed's area.

REGIONAL ECONOMIC DEVELOPMENT INSTITUTE, INCORPORATED

TABLE 3, PART TWO

LAND USE PROJECTION BY COUNTY FOR 1980 IN SQUARE MILES

<u>Counties in Con Ed Study Area</u>			<u>INTENSIVE</u>		<u>LOW INTENSIVE</u>				
<u>State</u>	<u>In RPA Region</u>	<u>Outside RPA Region</u>	<u>Residential</u>	<u>Industrial/Commercial</u>	<u>Community Facilities & Institutions</u>	<u>Parks & Recreation</u>	<u>Public Rights of Way</u>	<u>Open</u>	
Conn.	Fairfield		183	33	92	83	71	171	
		Litchfield	[30]	[6]	[3]	[3]	[2]	[5]	
		New Haven	[88]	[19]	[72]	[65]	[55]	[134]	
N. J.	Bergen		118	22	20	19	16	38	
	Essex		83	16	6	6	5	12	
	Hudson		26	5	3	3	2	6	
	Middlesex		126 (58)	22 (10)	18	16	14	34	
	Morris		130	23	69	63	54	129	
	Passaic		75	14	23	21	18	43	
	Somerset		71 (24)	13 (4)	16	15	12	30	
		Sussex		[34]	[8]	[107]	[97]	[83]	[199]
	Union		63	12	6	6	5	11	
	Warren		[3]	[1]	[9]	[9]	[7]	[18]	
N. Y.	Dutchess		106	19	152	138	117	283	
	Nassau		230	41	5	4	4	9	
	Orange		110	20	154	140	119	286	
	Putnam		37	6	42	38	32	79	
	Rockland		56	10	25	23	19	46	
	Suffolk		279 (199)	50 (35)	92	84	72	172	
		Sullivan		[18]	[4]	[117]	[106]	[90]	[217]
		Ulster		[53]	[12]	[207]	[188]	[160]	[386]
	Westchester		162	31	53	48	42	99	
	Bronx		25	4	3	3	2	5	

REGIONAL ECONOMIC DEVELOPMENT INSTITUTE, INCORPORATED

TABLE 3, PART TWO continued...

LAND USE PROJECTION BY COUNTY FOR 1980 IN SQUARE MILES

<u>Counties in Con Ed Study Area</u>			<u>INTENSIVE</u>		<u>LOW INTENSIVE</u>			
<u>State</u>	<u>In RPA Region</u>	<u>Outside RPA Region</u>	<u>Residential</u>	<u>Industrial/Commercial</u>	<u>Community Facilities & Institutions</u>	<u>Parks & Recreation</u>	<u>Public Rights of Way</u>	<u>Open</u>
N. Y.	Kings		42	7	4	4	4	8
	New York		14	2	1	1	1	3
	Queens		65	11	7	7	6	13
	Richmond		39	7	3	2	2	5
Pa.		Pike	[7]	[1]	[76]	[69]	[59]	[142]
	TOTAL RPA REGION		2040	368	794#	724#	617#	1482#
	CONTROL TOTALS		2040	368	876	784	682	1674
	TOTAL CONSOLIDATED EDISON AREA		2078	383	1385	1261	1073	2583

NOTES: Total RPA Region figures followed by # indicate that only the portion of the counties in Con Ed's area are included. This explains why these figures are further from the control total figures than in previous cases.

Figures in [] are for those counties outside RPA's Region. They are added in to the total for Con Ed's area.

REGIONAL ECONOMIC DEVELOPMENT INSTITUTE, INCORPORATED

PART III A

PROJECTIONS OF POPULATION, AND DISTRIBUTION BY ZONES

Our summary tables show the distribution by 40 zones (eight sectors in each of five concentric rings) of the 1960 population and of the 1980 population projected according to three different techniques. In this section we explain (1) how the projections were made, and (2) how both the 1960 and the projected 1980 populations were allocated among the 40 prescribed zones.

1. The Projections

We started from projected totals for each of the twenty-nine counties that lie wholly or partially within the 55-mile circle. All three of our projections agree in the total for each county. This starting-point was adopted because of the availability of a rather recent set of county population projections for 1980, prepared by the Regional Plan Association of New York and representing the outcome of extended and intensive study of the New York metropolitan region and its growth patterns. The RPA projections represent a careful revision and improvement of earlier projections made by Harvard University's New York Metropolitan Region Study in 1958-1959; the revisions take into account the findings of the 1960 Census and other subsequent materials. They are also tied in closely with the RPA's analysis of present and prospective land use in the area.

Consequently, we adopted the Regional Plan Association's county total for 1980, for each of the counties in which such an RPA figure is available. Our projections for individual municipalities were controlled so as to add up to the RPA total in each county.

REGIONAL ECONOMIC DEVELOPMENT INSTITUTE, INCORPORATED

-2-

The 55-mile circle includes some territory beyond RPA's sphere of analysis: Warren and Sussex Counties in New Jersey, and fractions of a half-dozen other counties in Connecticut, New York State, and Pennsylvania. For these additional counties and part-counties, we prepared our own projections--based on relative growth rates in 1950-1960 and 1960-1965, the projected 1960-1980 growth rates available from RPA for adjoining and roughly similar counties, and RPA's broad indications of the directions of most rapid outward spread of metropolitan growth in the next decade or two. These projections are of course crude compared with RPA's; but even fairly substantial errors in them will not be likely to distort the final results very greatly, since the population involved is only about five percent of the total within the 55-mile circle.

The next step was to disaggregate the twenty-nine counties into their 500-odd component municipalities. As simple rules for deciding how fast individual municipalities would grow relative to their counties, we used two different principles in separate projections, and then combined them in a third projection.

A. Extrapolative Projection. Our first set of projections is based on the assumption that places which grew faster than their counties in the 1950's will continue to do so, and that those which lagged behind their counties' growth in the 1950's will continue to lag in the 1960's and 1970's. Specifically, each municipality's population was first projected linearly to 1980, simply extending the 1950-1960 growth rate for another twenty years. This extrapolation was done both on a geometric basis (using the 1950-1960 percentage increase per annum) and

REGIONAL ECONOMIC DEVELOPMENT INSTITUTE, INCORPORATED

-3-

an arithmetic basis (using the 1950-1960 increase rate in persons per annum). The latter was adopted after inspection of the results, since it produced fewer cases that were obviously absurd¹ and also because the projected growth for the area as a whole involves a somewhat smaller percentage rate per annum between 1960 and 1980 than was registered in the 1950's.

The extrapolated figures for all the municipalities in each county were then totaled, and adjusted up or down pro rata to make the total conform to the RPA or other total already established for the county.

B. Density-based Projection. One quite obvious shortcoming of the extrapolative technique just described is that it takes no account of restraints upon growth arising from the filling-up of developable space. We sought, therefore, to develop an alternative set of projections which would incorporate the hypothesis that percentage rates of growth of individual communities slacken off with higher population densities per square mile.

Some preliminary investigations into data for selected counties were made to see if the posited inverse relation of growth rate to density is actually present to a sufficiently significant degree to make it a useful projection guide. These investigations disclosed a marked relationship of the expected sort in the 1950-1960 growth and density rate for municipalities. It appeared also that a straight-line regression relation between the logarithms of (1) the growth ratio and (2)

1. For example, take the not unrealistic case of a small, suburban community that grew from 100 in 1950 to 2,000 in 1960. Extending that rate of percentage increase would give a projected 1980 population of 800,000! The less-exuberant arithmetic extrapolation, in the same instance, would give only 5,800 for 1980.

REGIONAL ECONOMIC DEVELOPMENT INSTITUTE, INCORPORATED

-4-

the density of population at the beginning of the time interval provided a more appropriate formulation than a simple linear relation.

Accordingly, the data on 1950 and 1960 population and land area for all municipalities were processed so as to yield a statistically-fitted regression formula for municipalities in each county, relating rate of population growth to density of population. In fitting the equation, the data for individual municipalities were weighted according to population, giving larger places a proportionately greater influence on the formula.

These regression formulas were, in all but a few counties, associated with a high enough degree of correlation to leave no doubt about the usefulness of this approach as a guide to relative rates of expected population growth. With one unimportant exception (Sullivan County), the relationships were consistently inverse in direction as would be expected (i. e., higher density was associated with lower growth rates in any given county). In the Sullivan County case, the correlation was too small to make its size or direction significant.

The projections produced by this method for individual municipalities were then totaled for each county and adjusted to make the county totals conform to the RPA or other total already established for that county, just as was done with the first or extrapolative set of projections.

C. Compromise Projection. The two alternative sets of projections just described rest on entirely different principles, each of which (the continuity of growth differentials, and the inverse relation of growth rate to density) has demonstrable validity but falls short of complete adequacy. Consequently, it

REGIONAL ECONOMIC DEVELOPMENT INSTITUTE, INCORPORATED

-5-

seemed appropriate to combine the two types of projection into a third, incorporating both the continuity and the density effects.

To get this third set, labeled "compromise" projections, we took for each municipality the geometric mean between the adjusted extrapolative and the adjusted density-based projection. Then the "compromise" projections for the municipalities of each county were added up and adjusted to make the county total conform, as in the two previous cases, to the RPA or other total already established for the county.

The averaging procedure allows each of the two effects (growth-continuity and density) to exert an effect on the compromise projections. Where the extrapolative and the density-based projections were in close agreement, they reinforce each other in projecting differentiation of growth rates in different parts of a county; where the extrapolative and density-based projections give sharply differing answers, they tend to cancel one another out in terms of such differentiation, leading to compromise projections which show relatively little dissimilarity in growth rates among the parts of a county. This seems appropriate--where the two approaches we have tried give very different results, we are well advised to take both of them less seriously and have less occasion for diverging very far from the simple assumption that all parts of any given county will grow at equal rates.

The geometric mean was chosen in preference to the arithmetic as a way of still further toning-down the most extreme variations of growth rates.

It seems to us that the compromise projections are the "best" of the three so far as anyone can judge in advance. However, all three sets of projections are

REGIONAL ECONOMIC DEVELOPMENT INSTITUTE, INCORPORATED

-6-

presented in equal detail so that users of these reported results may make their own evaluations and decisions.

2. ALLOCATION TO RING AND SECTOR ZONES

Each of the three sets of projections by municipalities (and also the actual 1960 populations of municipalities then had to be translated into population totals for the 40 ring-and-sector zones stipulated.

A little more than half of the municipalities were found to lie wholly within one of the 40 zones. Each of the rest had to be split, with portions allocated to anywhere from two to six different zones. In view of the large number of cases involved (more than 250 municipalities,) to be split into more than 600 fractional parts, the splitting was done by inspection of a map showing the municipalities and zone boundaries, the proportional division of the municipality's area among contiguous zones ^{was} ~~were~~ estimated visually, and in most cases it was assumed that the same proportionate split would also apply to that municipality's population. Whenever feasible, however, and particularly where places of significant size were concerned, account was taken of the location of major concentrations of population within the municipality boundaries.

It was assumed that the same split-up of a municipality would apply in the case of each of the three projections, and also for the 1960 population.

The derivation of 1960 and projected population totals for each of the 40 zones was carried on in an electronic computer, which also provided totals in each case for each ring and each sector of the grid.

REGIONAL ECONOMIC DEVELOPMENT INSTITUTE, INCORPORATED

PART III B

PROJECTIONS OF LAND USE BY COUNTY, 1980

The basic theory of the projection technique used to disaggregate RPA gross estimates of land use is that in each county the "intensive use ratio" (I) defined as the percentage of total land area used for residential, commercial, and industrial purposes,¹ is a function of the population density (D) for that county. This relationship is demonstrated in the following Graph which plots the logarithms of I 1954 (percentage of land in intensive use in 1954) against the logarithms of D, where D is the average of 1950 and 1960 population densities for each of twenty-one counties in the RPA Region.²

A statistical test of the relationship between I and D was then produced by fitting a regression equation of the form $\log Y = a + b \log X$ to the scatter of points in the Graph. The fitted equation,³ $\log I \text{ 1954} = -.361 + .531 \log D$ (Equation 1) has an R^2 , or coefficient of determination, equal to .931. This means that 93.1 percent of the variation in the percentage of land used intensively is explained by population density. Equation 1 is the basis for disaggregating by

-
1. This definition of intensive land development is the one used by the Regional Plan Association to describe "Table 20. Land Development by County in 1954, RPA Bulletin Number 87, page 31, June, 1957.
 2. Sources of Data: "Table 20. Land Development by County 1964," RPA Bulletin Number 87, page 31, June, 1957, and "Table 4. The Region's Population, 1860 to 1960, by County, RPA Bulletin Number 100, page 36 (Appendix), September, 1962.
 3. An explanation of the regression technique used may be found in most general statistical research text books, such as Ferber and Verdoorn, "Research Methods in Economics and Business," New York, 1962.

GRAPH

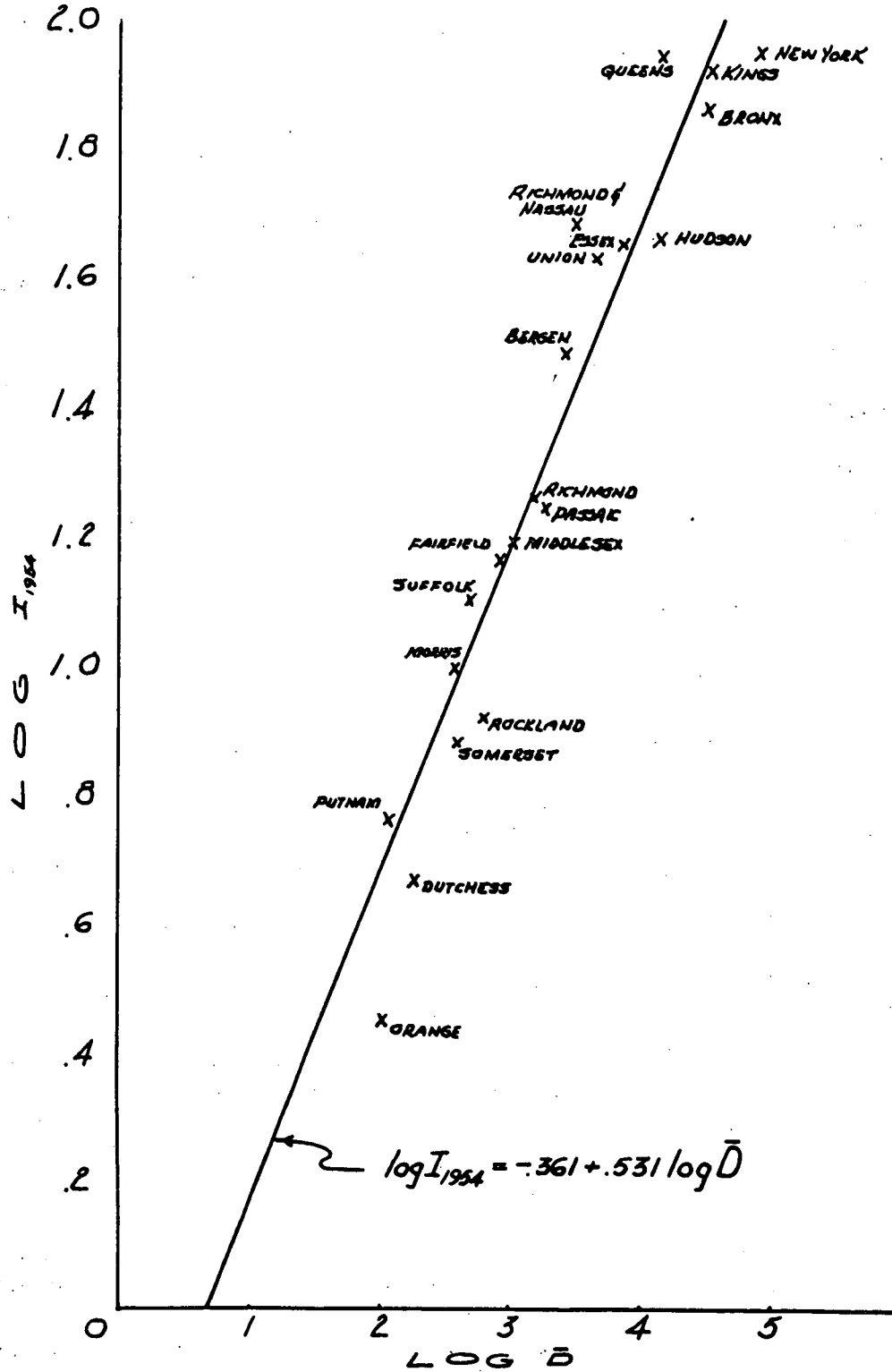

REGIONAL ECONOMIC DEVELOPMENT INSTITUTE, INCORPORATED

-2-

counties RPA's gross land use estimates for its region. Land use values for counties not in RPA's Region were also obtained from Equation 1, but no control or scale factor was available.

Application of this relationship yielded the estimates of square miles of intensively used land by county in 1960, in Column 1 of Table 1. A second estimate of intensive land use by county in 1960 was obtained by applying an average value of 52 percent for intensive land use to RPA estimates of 1960 "committed" land.⁴ This second set of estimates (Column 2 in Table 1) permits the projection estimates from Equation 1 to be judged against a control total derived from the RPA estimates for committed land. Of the total 2,400 square miles of committed land in RPA estimates for 1960, 1,248 square miles were developed intensively. The 1,258 square miles of intensively used land projected by Equation 1 is within one percent of this control total. Column 3 represents the results of an adjustment in intensively used land for those counties in Column 2 which suffered most from averaging. The adjustment was made by applying the high (low) intensity percentage for counties closer to (farther from) the core of RPA's Region.⁵ This correction brought the total for the second estimate to that of the control total. The best estimates of square miles of intensively used land by counties in Column 3, Table 1. were then

-
4. The average value of 52 percent was derived from 1960 RPA estimates of committed land used intensively in selected areas of the region. See Table 2, Column 3.
 5. See Table 2 for high and low values of intensive land use ratio. Also "The Region's Rings of Development," RPA Bulletin Number 100, page 6, September, 1962.

REGIONAL ECONOMIC DEVELOPMENT INSTITUTE, INCORPORATED

-3-

disaggregated into residential and commercial/industrial uses by applying average figures of 83 and 17 percent, respectively, which were derived from RPA aggregate estimates. The results appear in Table 3.

With this foundation, the next step was the projection of land-use intensity in 1980 by means of Equation 1. The population density for 1980 used in the projection came from RPA estimates of 1980 population by county for those counties in RPA's region.⁶ (Population density for 1980 for counties not covered by RPA were obtained by extrapolating population for 1980 from that in 1950 and 1960.)⁷ The results in square miles of this projection appear in Column 5 of Table 1.

Projecting by Equation 1 requires that points in the Graph far from the regression line will be on the regression line twenty years hence. Thus, an alternative form of this projecting technique embodying the same relationship was also used. These alternative-form projections, which appear in Column 6 of Table 1 were produced by

$$\log I_{1980} = \log I_{1954} + .531 (\log D_{1980} - \log D) \quad (\text{Equation 2})$$

which uses the difference in population density between 1980 and the average of 1950-1960 to project the difference in the intensive land use ratio between 1980 and 1954. While it is felt that neither set of the projected intensive land use

-
6. "Table 5. The Region's Projected Population, 1965 to 1985, by County," RPA Bulletin Number 100, page 36 (Appendix), September, 1962.
 7. County and Data Book, 1962, United States Department of Commerce, Bureau of the Census, Washington, 1962.

REGIONAL ECONOMIC DEVELOPMENT INSTITUTE, INCORPORATED

-4-

figures are any better than could possibly be obtained from the existing data, they can be viewed with some assurance that they are of the correct magnitude.

The Regional Plan Association estimated that 2,500 more square miles of land will be developed between 1960 and 1985.⁸ Assuming that this is done at an even rate over the 25-year period, about 2,000 square miles will be developed between 1960 and 1980. RPA estimates that 58 percent of this land will be developed in intensive uses.⁹ Thus, 1,160 square miles of intensively developed land could be added by 1980 according to the estimate derived from RPA data. Total land used intensively in the region could reach 2,408 square miles as shown in Table 2.

With this new control total for total intensively used land in 1980, the "best" disaggregated projection from Equations 1 and 2 was adjusted by a factor of 1.529 to coincide with RPA estimates. The "best" disaggregated projected value for intensively used land in each county is given in Column 7 of Table 1. Selection of the value for this column from the values produced by Equations 1 and 2 in Columns 5 and 6, respectively, was made by taking the larger value in all cases except Hudson County and New York City. In the cases of Hudson County and New York City, Equations 1 and 2 gave smaller projected values because population is expected to decline; but, even with slight population decline, it is reasonable to assume that the percentage of land used intensively should remain

8. "Chart 14. Extent of Land Development in the Region, 1960 and 1985." RPA Bulletin Number 100, page 20. An adjustment has been made for excluding Monmouth County in our projections.

9. Ibid.

REGIONAL ECONOMIC DEVELOPMENT INSTITUTE, INCORPORATED

-5-

at least as high as in 1960, so the 1960 figure is retained for 1980.

The further disaggregation of intensive land use in 1980 by county was produced by applying to the difference in land use intensity between 1960 and 1980 average values of 83 percent for residential and 17 percent for commercial/industrial uses, which were derived from RPA estimated values for the region as a whole. The resultant increment in residential and commercial/industrial usage was added to the values obtained in similar fashion for 1960; and the totals for 1980 are given in Table 3, Part Two.

TABLE 1.4-1

1960 POPULATION
BY RING AND SECTOR ZONES
FOR 15 MILE RADIUS

	<u>0 to 1/2</u>	<u>1/2 to 1</u>	<u>1 to 2</u>	<u>2 to 3</u>	<u>3 to 4</u>	<u>4 to 5</u>	<u>5 to 10</u>	<u>10 to 15</u>
N to 15°	0	0	0	60	60	0	1210	
15° to 30°	0	0	50	130	120	710	610	
30° to NE	0	0	280	5650	1000	890	4070	
N to NE								3490
NE to 60°	0	0	2930	7460	630	1100	2770	
60° to 75°	0	10	2050	1610	1470	1460	3690	
75° to E	0	10	270	180	140	250	5080	
NE to E								9720
E to 105°	0	300	130	50	330	90	2170	
105° to 120°	46	54	270	70	540	540	1720	
120° to SE	0	80	330	50	270	320	2270	
E to SE								25940
SE to 150°	0	320	630	310	410	300	23740	
150° to 165°	0	50	760	1900	20	0	1810	
165° to S	0	30	350	50	0	0	8300	
SE to S								51160
S to 195°	0	160	250	0	50	300	19200	
195° to 210°	0	0	1000	20	300	3800	6300	
210° to SW	0	0	50	530	3200	1000	8500	
S to SW								47000
SW to 240°	0	0	20	350	160	50	1000	
240° to 255°	0	0	150	120	40	100	0	
255° to W	0	0	20	150	120	0	0	
SW to W								7030
W to 285°	0	0	20	30	0	0	90	
285° to 300°	0	0	40	0	0	0	1030	
300° to NW	0	0	60	50	120	0	150	
W to NW								12090
NW to 330°	0	0	20	0	40	260	100	
330° to 345°	0	20	0	50	80	3100	780	
345° to N	0	0	50	0	0	40	7880	
NW to N								14990

NOTE: The populations above refer to Fig. No. 1.4-2

TABLE 1.4-2

1980 "COMPROMISE" PROJECTION OF POPULATION
 BY RING AND SECTOR ZONES
 FOR 15 MILE RADIUS

	<u>0 to 1/2</u>	<u>1/2 to 1</u>	<u>1 to 2</u>	<u>2 to 3</u>	<u>3 to 4</u>	<u>4 to 5</u>	<u>5 to 10</u>	<u>10 to 15</u>
N to 15°	0	0	0	140	140	0	2750	
15° to 30°	0	0	110	300	270	1620	1390	
30° to NE	0	0	640	12860	2280	2030	9270	
N to NE								7940
NE to 60°	0	0	5210	13280	1120	1960	4930	
60° to 75°	0	20	3650	2860	2620	2600	6570	
75° to E	0	20	480	320	250	440	9040	
NE to E								17300
E to 105°	0	600	260	100	650	180	4310	
105° to 120°	100	100	540	140	1070	1070	3420	
120° to SE	0	160	650	100	540	640	4510	
E to SE								51500
SE to 150°	0	580	1140	560	740	540	43100	
150° to 165°	0	90	1380	3450	40	0	3290	
165° to S	0	60	640	90	0	0	15070	
SE to S								92870
S to 195°	0	340	540	0	110	640	41110	
195° to 210°	0	0	2140	40	640	8140	13490	
210° to SW	0	0	110	1130	6850	2140	18200	
S to SW								100640
SW to 240°	0	0	100	1680	770	240	4790	
240° to 255°	0	0	720	570	190	480	0	
255° to W	0	0	100	720	570	0	0	
SW to W								33680
W to 285°	0	0	40	60	0	0	190	
285° to 300°	0	0	80	0	0	0	2140	
300° to NW	0	0	130	110	260	0	310	
W to NW								25220
NW to 330°	0	0	40	0	80	490	190	
330° to 345°	0	40	0	100	150	5910	1480	
345° to N	0	0	100	0	0	80	15030	
NW to N								28420

NOTE: The populations above refer to Fig. No. 1.4-2

New York University
School of Engineering and Science
Department of Meteorology and Oceanography
Geophysical Sciences Laboratory
Technical Report No. TR 71-3

Wind Observations at Indian Point
26 November 1969-1 October 1970

Prepared by

James Halitsky, Project Director
Edward J. Kaplin
Joseph Laznow

for

Consolidated Edison Co. of N. Y., Inc.
4 Irving Place, New York, N. Y. 10003

17 May 1971

Summary

Wind observations made at a 100 ft meteorological tower at Indian Point and at a ship anchored in the Hudson River northwest of Indian Point in 1969-70 were compared with observations made at similar installations in 1955-56. It was found that

- 1) Annual average statistics of wind speed, direction and vertical temperature difference were substantially the same for 1956 and 1970. Points of difference were increased frequencies of lapses and low wind speeds and a shift in the southerly frequency maximum to the southeast in 1969-70. The low-speed inversion frequency was unchanged.
- 2) Average wind hodographs at the ships exhibited the same diurnal reversal pattern and the same 2.5 m/sec nighttime downvalley speed in both years. The average wind hodograph at the tower showed a similar pattern of reversal but the nighttime downvalley speed was about 2m/sec.
- 3) All sixteen daily wind hodographs used for calculating the average hodograph at the tower showed the diurnal reversal and exhibited considerable variability in speed and direction from day to day through a complete cycle.
- 4) Maximum persistences of low-speed inversion winds in the critical 005° - 020° sector were 2 hrs, 4 hrs and 3 hrs for 1, 1.5 and 2 m/s speeds, respectively, during the entire 10-month data record.

Table of Contents

	<u>Page</u>
Summary	ii
List of Tables	iv
List of Figures	iv
1. Introduction	1
2. Data Log	2
3. Annual Average Wind Statistics at the I P 1 and I P 3 Stations	4
4. Valley Wind Hodographs During Virtually-Zero Pressure Gradient Conditions	7
4.1 Average Hodographs	7
4.2 Daily Hodographs	9
5. Persistence of Low-Speed Winds	10
References	12

List of Tables

	<u>Page</u>
1. Wind Persistence at I P 3 under Inversion Conditions	11

List of Figures

1. Local Topography at Indian Point and Trap Rock
2. Ground Contours at el. 100 ft
3. Ground Contours at el. 200 ft
4. Data Log
5. (a-d) Comparison of Wind Direction Frequency Distributions for 1956 and 1970 by Temperature Gradient Class
5. (e-h) Comparison of Wind Direction Frequency Distributions for 1956 and 1970 by Speed Class
6. Comparison of Wind Speed Cumulative Frequencies for 1956 and 1970
7. Corrected Wind Speed Cumulative Frequencies at I P 3 for 1970
8. Average Wind Hodographs at Ships, 15 Years Apart
9. Average Wind Hodograph at 100 ft Elevation at I P 3 Tower Site, 1970
10. (a-d) Individual Wind Hodographs at Indian Point Tower I P 3
11. Low Speed Wind Behavior During Night Hours at Indian Point Tower in 1970

List of Tables

	<u>Page</u>
1. Wind Persistence at I P 3 under Inversion Conditions	11

List of Figures

1. Local Topography at Indian Point and Trap Rock
2. Ground Contours at el. 100 ft
3. Ground Contours at el. 200 ft
4. Data Log
5. (a-d) Comparison of Wind Direction Frequency Distributions for 1956 and 1970 by Temperature Gradient Class
5. (e-h) Comparison of Wind Direction Frequency Distributions for 1956 and 1970 by Speed Class
6. Comparison of Wind Speed Cumulative Frequencies for 1956 and 1970
7. Corrected Wind Speed Cumulative Frequencies at I P 3 for 1970
8. Average Wind Hodographs at Ships, 15 Years Apart
9. Average Wind Hodograph at 100 ft Elevation at I P 3 Tower Site, 1970
10. (a-d) Individual Wind Hodographs at Indian Point Tower I P 3
11. Low Speed Wind Behavior During Night hours at Indian Point Tower in 1970

1. Introduction

This is the second of two progress reports covering meteorological investigations in the Hudson River valley near Indian Point from August 1968 to the present.

The first report [Halitsky, Laznow and Leahey (1970)] described wind measurements at Indian Point, Bowline Point and Montrose until 30 June 1969, and provided details of changes in tower location and instrumentation introduced during the period July-November 1969.

This report presents an analysis of measurements taken at the present tower at Indian Point (IP 3) and at a ship, the Cape Charles (CC) anchored in the Hudson River, and compares them with similar measurements taken in 1955-1957 at approximately the same locations. The focus of this report is to evaluate whether site meteorology has changed significantly during the intervening years, and to elucidate aspects of the meteorology not reported previously.

In order to clarify the various tower locations and periods of operation, the following nomenclature was established in the first report and will be continued.

<u>Data Period</u>	<u>Station Symbol</u>	<u>Station Location</u>
1955	J	Ship "Jones" in Hudson River
1956-1957	I P 1	Indian Point, southeast of plant
1968-1969	I P 2	Indian Point, southwest of plant
1968-	B P	Bowline Point
1968-	M P	Montrose Point
1969-	I P 3	Indian Point (close to I P 1)
1970	C C	Cape Charles (close to J)

Figs 1, 2 and 3 show the station locations and local topography.

2. Data Log

Fig 4 shows the periods of data acquisition for all of the stations which were in operation in 1970. Station B P is included, even though its operation is now being funded by Orange and Rockland Utilities, Inc. in order to show the total store of data for the region. The net radiometer (R) and ambient temperature (T) at I P 3, and the Aerovane (A) at the Cape Charles are supplementary instruments provided by N. Y. University.

All of the instruments except the bivariate produced continuous records on slow-speed strip charts (1 inch, 2 inch or 3 inch per hour). The bivariate chart drive was modified to run 50 minutes at 3 inch per hour followed by 10 minutes at 3 inches per minute and repeat. Thus, each chart (indicated by a dot in Fig 3) contained a 36-hr record of fast-and slow-speed data for each hour.

The statistical data presented in this report represent periods when simultaneous wind speed, wind direction and temperature difference were available at I P 3. The overall period selected for analysis was 26 November 1969-1 October 1970. The degree of completeness of record is as follows:

	<u>Hours all data present</u>	<u>Total Hours in period</u>	<u>% completeness</u>
Climet	5989	7440	80.5
Aerovane	6164	7440	82.8

3. Annual Average Wind Statistics at the I P 1 and I P 3 Stations

The annual average wind statistics at I P 3 for the 10-month measurement period in 1969-1970 are shown in graphical form in Figs 5 (a-h), 6 and 7. Also included in these figures, for comparison purposes, are the equivalent I P 1 statistics originally reported by Davidson and Halitsky (1957), Table 3.3 and subsequently incorporated into Sec 2.6 of the Unit 2 FSAR.

The two sets of Aerovane statistics represent observations taken about 13 years apart with similar or identical instruments at almost the same locations. As seen in Fig 1, the two towers are about 200 ft apart, and the base of the I P 3 tower is about 15 ft lower in elevation. The present site topography has fewer trees, more pavement, and new steel and concrete structures in the quadrant northwest of the tower.

Wind speed and direction were measured at the 100 ft elevation on each tower; therefore the absolute elevation of the I P 3 instrument is about 15 ft lower than that of the I P 1 instruments.

Temperature differences were measured between 95 ft and 7 ft on the 100 ft high I P 3 tower whereas 150 ft and 7 ft were used on the 310 ft high I P 1 tower. However, the isothermal and adiabatic lapse rates were used to separate the lapse, neutral and inversion categories in both cases. This was accomplished by using an adiabatic ΔT of -0.5 F for I P 3 in place of the -0.9 F used for I P 1.

Fig 5 shows the frequency distribution of wind directions as measured by the Aerovanes in 1956 and 1970.

Fig 5a represents all winds irrespective of speed and temperature gradient class. The shapes of the curves are quite similar, the most important difference being a shift of the 1956 southerly maximum toward the southeast in 1970.

Fig 5 (b-d) shows the dependence on temperature gradient class. No major change is apparent in the neutral class, but the 1970 data show more frequent lapses and less frequent inversions in all directions.

Fig 5 (e-h) shows the dependence on speed class. The southeasterly shift observed in Fig 5a is seen to occur in the 5-8 mph and 9-13 mph speed classes. Low-speed winds in the 1-4 mph class were more frequent in 1970, especially for the 000°-045° direction range.

None of the above differences are sufficiently large to invalidate the 1956 wind statistics reported in Davidson and Halitsky (1957). Of the three noticeable differences, the decrease in frequency of inversions and the increase in southeasterly winds both contribute to reducing the concentrations in inhabited regions contiguous to the site. However, the increased frequency of low-speed winds from the northeasterly sector bears further examination.

Fig 6 shows a comparison of cumulative frequencies of wind speed for the two years. The 1956 curves can not be extended below 2 m/s because the published data show only two categories below that speed, i.e., calm and 1-4 mph, covering speeds from 0 to 4.5 mph. The cumulative frequency shown at a speed of 2 m/s is the sum of these two categories. The 1970 data were classified in finer groupings and yielded well-defined curves in the low speed range. The 1970 data in Fig 6 were uncorrected for speed calibration. It is not known if corrections were applied to the 1956 data.

The upper curves, representing all temperature gradients and directions, show good agreement for the two years. The inversion curves show good agreement during calms and near 2-3 m/s, but the 1970 inversion frequencies were smaller than the 1956 frequencies at the higher speeds. This discrepancy in high speed inversions is in the direction of enhancing the atmospheric diffusion potential over that which was postulated on the basis of the 1956 data. It is not known how much of the difference between the two years is due to the absence of October and November data in 1970.

Because of the high starting speed of the Aerovane, the curves of Fig 6 show spuriously high frequencies of low wind speeds. When the 1970 data are corrected for speed calibration (see Fig 6 of Halitsky et al (1970)), the data appear as in Fig 7.

In order to check the Aerovane data, we have included in Fig 7 the corresponding curves obtained from the more sensitive Climet instrument at the same location during the same period, corrected for speed calibration.

The difference between the Aerovane and Climet curves may be attributed to the poor behavior of the Aerovane at low speeds. A true speed of 1 m/s is near the starting threshold of the Aerovane. The corresponding indicated speed may be anything in the range 0-2 mph or one division of the chart. At the same time, a one-division indication may be simply a zero-setting error. For these reasons, it is believed that the Climet data should be regarded as more reliable.

4. Valley Wind Hodographs During Virtually-Zero Pressure Gradient Conditions

4.1 Average Hodographs

Average wind hodographs taken during the months of September and October 1955 are presented in FSAR Sec 2.6, Figs 2.6-1 and 2.6-2, to demonstrate that the wind reverses diurnally when the upper air (geostrophic) wind is zero or weak, thereby precluding the occurrence of protracted periods of calm or light wind.

The 1955 data were taken with an Aerovane mounted 70 ft above river elevation on the mast of a ship, the Jones, anchored in the Hudson River about one mile northwest of the tower (see Fig 2). Thirty-five days, during which weak pressure gradient conditions existed over the area, were selected for study. Of these 35 days, 12 days had virtually zero pressure gradient. The two Figures represent the average of wind vectors over the 12 or 35 day period, for each even-numbered hour during the day.

Both of the 1955 hodographs show a well-defined steady flow toward the SSW (030° winds) during the night (2000-0800 hrs), and a somewhat less steady flow toward the NNE (210° winds) during the day (1200-1600). During the transition hours (1000 and 1800 hrs) the flow was weak and variable. The average wind speeds during the night were about 2.5 m/s.

On the basis of these data, it was concluded that the accident meteorology model calling for a wind sequence of 1 m/s steady for two hours followed by 2 m/s steady in the same direction for 24 hrs was conservative since the hodograph showed a wind reversal after 12 hours. However, it has been pointed out that individual hodographs for each of the days may have exhibited lower wind speeds and may have failed to show the diurnal reversal.

To explore this aspect, an Aerovane was installed 100 ft above river level on the mast of another ship, the Cape Charles, anchored in the Hudson River close to the former location of the Jones. The instrument was in operation from March 17, 1970 to Sept. 17, 1970. It had been hoped that the period could be extended to the end of October to gather test data for the same months that were used in the 1955 study, but the instrument had to be removed prematurely because the ship was being prepared for removal.

Using the available record, we selected the two-month period July 15-Sept. 15 as having the closest seasonal correspondence to the 1955 study, and found 17 days during which virtually-zero pressure gradient conditions existed, as determined from surface weather maps for 0700 EST. The hourly wind velocity vector was determined for each even-numbered hour and a vector average was taken over the 17 days for those hours. The average hodograph is shown in Fig 8, together with the 1955 Jones hodograph.

The important characteristics of the 1955 hodograph were confirmed by the 1970 data. A predominant, diurnally-reversing circulation exists along the 030° - 210° axis. The nighttime down-valley flow was slightly weaker (~ 2.0 m/s vs ~ 2.4 m/s) and began about an hour later (2100 vs 2000 hrs) in 1970 but both terminated at ~ 0900 hrs. The up-valley daytime flow was also somewhat weaker (~ 1.5 m/s vs ~ 2 m/s), and did not show the strong southerly wind at 1400 and 1600 hrs. The latter effect may be due to the more northerly location of the Jones, near the nose of Dunderberg Mtn., where the flow direction changes rapidly (see Fig 2).

Before analyzing the individual hodographs for each day, it should be noted that the Jones and Cape Charles are located very close to the steep southerly side of Dunderberg Mtn. (peak el. 1120 ft), and are therefore exposed to air currents which tend to flow parallel to the hillside. This topographic influence is not present at the plant site.

To determine what differences, if any, exist between the winds at the ships and the plant site, an average hodograph for 16 of the 17 days was calculated from the records of the Climet speed and direction instrument at the 100 ft elevation on the I P 3 tower (Fig 9). The Climet instrument was inoperative on 1 of the 17 days). The most significant change from the Cape Charles hodograph is the appearance of a southeasterly wind component during the afternoon and evening hours. This component also appeared at the Jones in 1955. Apparently this is an integral part of the valley circulation, causing the hodograph vector to rotate counterclockwise with increasing time, and was not experienced at the Cape Charles due to the deflecting influence of the hillside. A northwesterly down-slope wind may also have been present during the afternoon and evening at the Cape Charles, since the hillside is in shadow at that time.

4.2 Daily Hodographs

Fig 10 (a-d) shows the 16 daily hodographs from which the average hodograph at the I P 3 tower, shown in Fig 9, was calculated. The nighttime down-valley flow appears in all 16 cases. The daytime up-valley flow is quite variable in both speed and direction, and is characterized by generally higher wind speeds and wider direction swings.

5. Persistence of Low-Speed Winds

Fig 11 contains a time history of each of the wind conditions during the night hours of the days corresponding to the hodographs of Fig 10 (a-d). The graphs are the variation of the wind speed with time for those hours when the wind direction was between 000° and 045°. We shall assume that the wind direction was steady if it remained in this 45° sector. (This is quite conservative, since a wind which meanders uniformly in a 45° sector of 500 m radius under inversion conditions produces an average concentration about 8 times smaller than the steady wind axial concentration.)

The observed wind angle θ and temperature differences $\Delta T = T_{95} - T_7$ are noted under each observation. Positive values of ΔT indicate inversions. ΔT values between - 0.5 and 0 indicate neutral. ΔT values smaller than - 0.5 designate lapses.

The longest period of direction persistence was 8 hrs, occurring on July 25-26, Aug. 8-9, Aug. 13-14, Sept. 12-13 and Sept. 13-14. The average wind speed in each case was at least 2 m/s. ΔT was recorded on only 3 of these days, and an inversion occurred only during the first two hours of one of the days.

The period of poorest dispersion potential occurred on July 24-25. It lasted 6 hours with a gradual increase of wind speed from 0.2 to 2.0 m/s, a gradual decrease of temperature gradient from $\Delta T = + 1.7$ to - 0.8, and a gradual direction change from 007° to 043°. The occurrence of the strongest inversion during the early part of the night and its subsequent weakening and change to neutral or lapse beyond 0200 hrs seems to be a common phenomenon at the site.

Wind persistence may also be examined by listing the number of occurrences that wind of specified characteristics persisted for a specified number of consecutive hours during the entire 10 month test period in 1969-70. The following table shows these data for inversion conditions only.

Table 1. Wind Persistence at I P 3 Under Inversion Conditions (1969-1970)

Wind Sector	No. of Consec. Hrs.	Maximum speed in sequence (mph)							
		0.3	0.5	1.0	1.5	2.0	3.0	4.0	6.0
005°-020°	1	1	2	22	41	64	115	141	151
	2			1	3	2	7	5	2
	3				3		2	2	3
	4				1				
	10								1
025°-040°	1			16	42	75	155	189	198
	2			1	2	5	16	7	3
	3					1	2	2	1
	4						2	3	
	5							2	1
	6							1	
	7						1		

It is seen that very light winds do not persist beyond one hour, and high persistences begin to appear at about 3 m/s. For both sectors combined, the longest persistences for 1.0, 1.5 and 2.0 m/s winds were 2 hrs, 4 hrs and 3 hrs, respectively.

References

- Davidson, B. and J. Halitsky (1957): Evaluation of Potential Radiation Hazard Resulting from Assumed Release of Radioactive Wastes to Atmosphere from Proposed Buchanan Nuclear Power Plant. N. Y. University Dep't. of Meteorology and Oceanography Tech. Rep't. No. 372.3.
- Halitsky, J., J. Laznow and D. Leahey (1970): Wind Observations at Indian Point, Montrose and Bowline Point. 31 August 1968 to 30 June 1969. N. Y. University Dep't. of Meteorology and Oceanography Tech. Rep't. TR-70-3.
- FSAR: Final Facility Description and Safety Analysis Report. Consolidated Edison Co. of N. Y., Inc. Nuclear Generating Unit No. 2. Exhibit B-8.

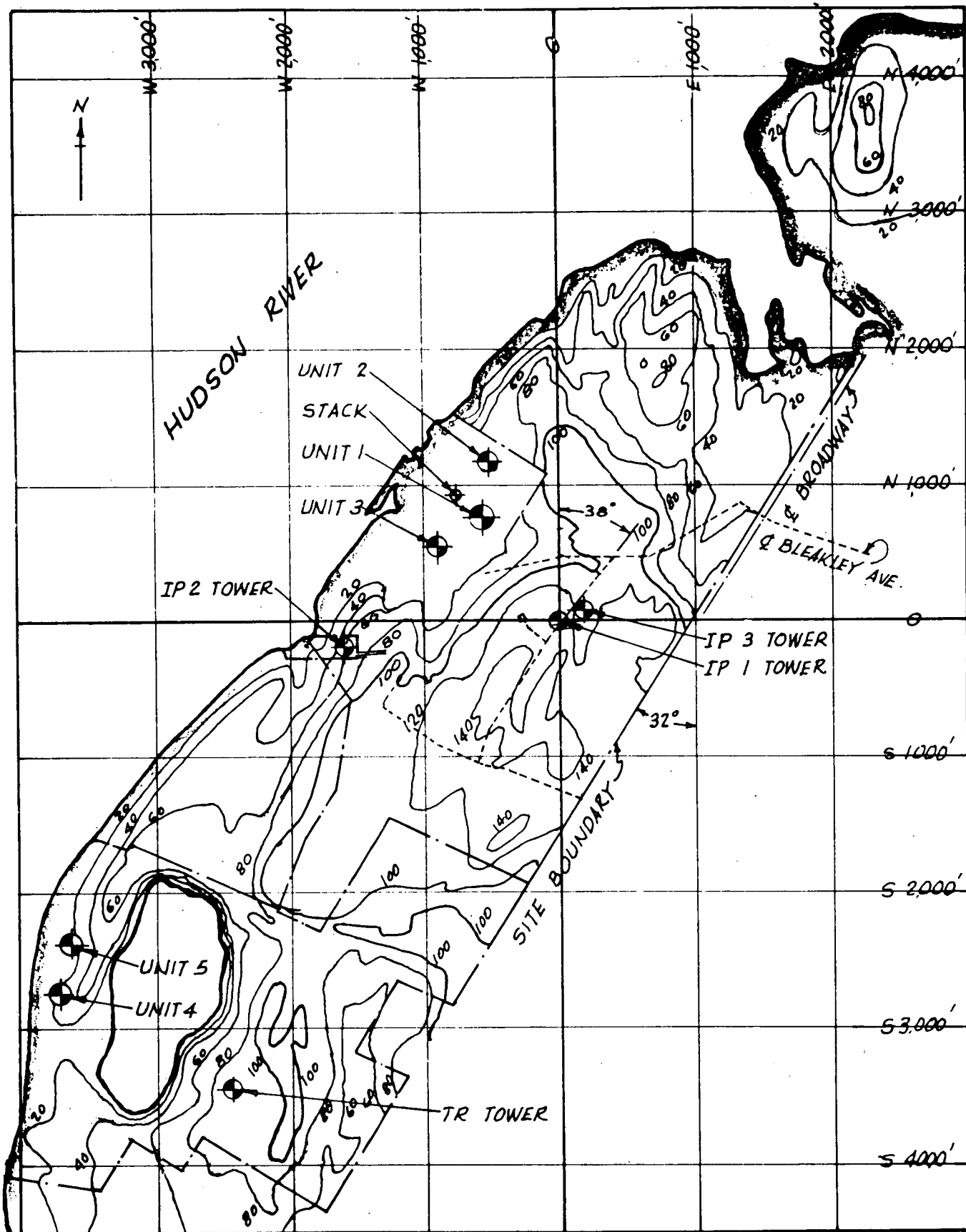

FIG. 1. LOCAL TOPOGRAPHY AT INDIAN POINT AND TRAP ROCK

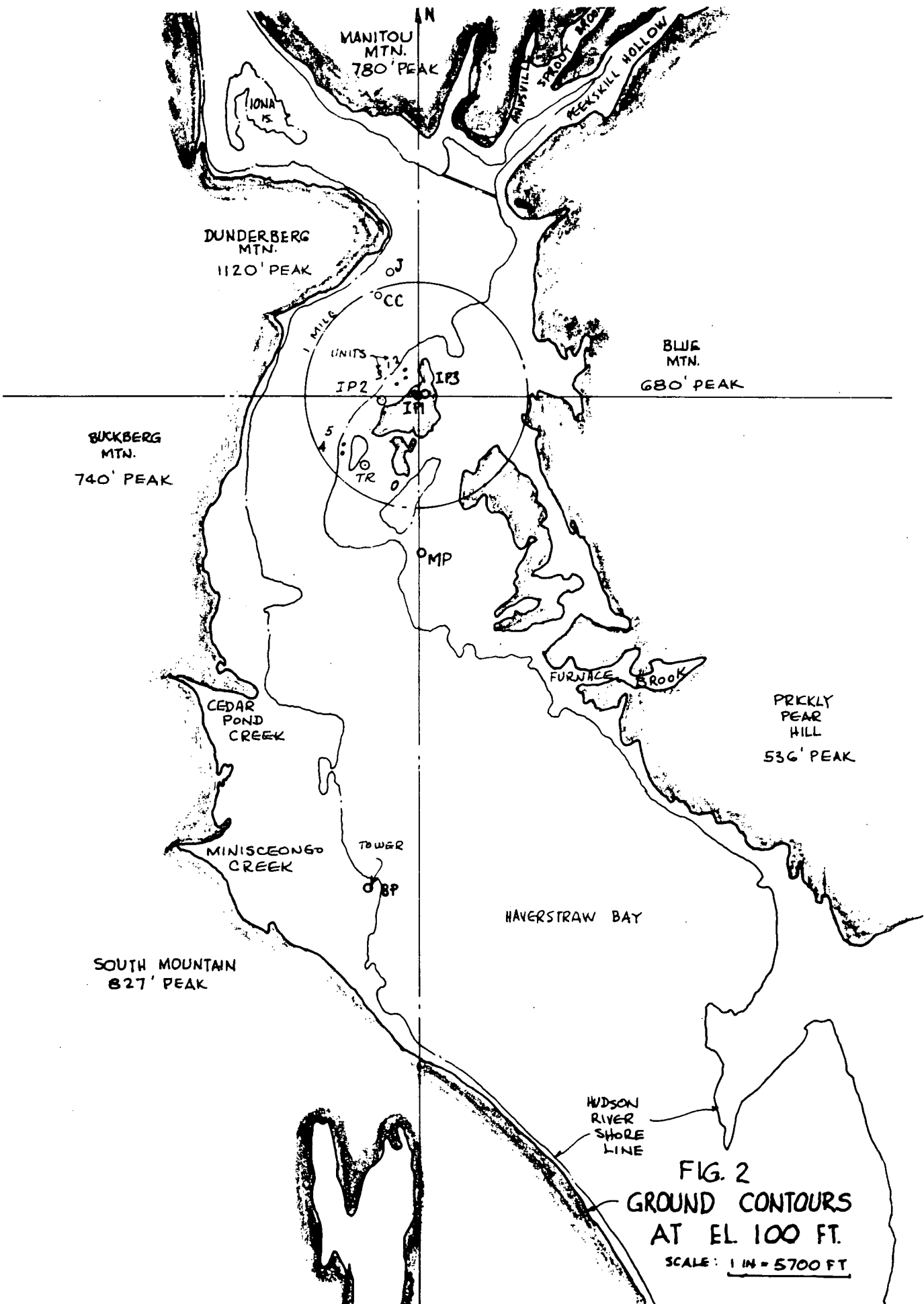

FIG. 2
 GROUND CONTOURS
 AT EL 100 FT.
 SCALE: 1 IN = 5700 FT

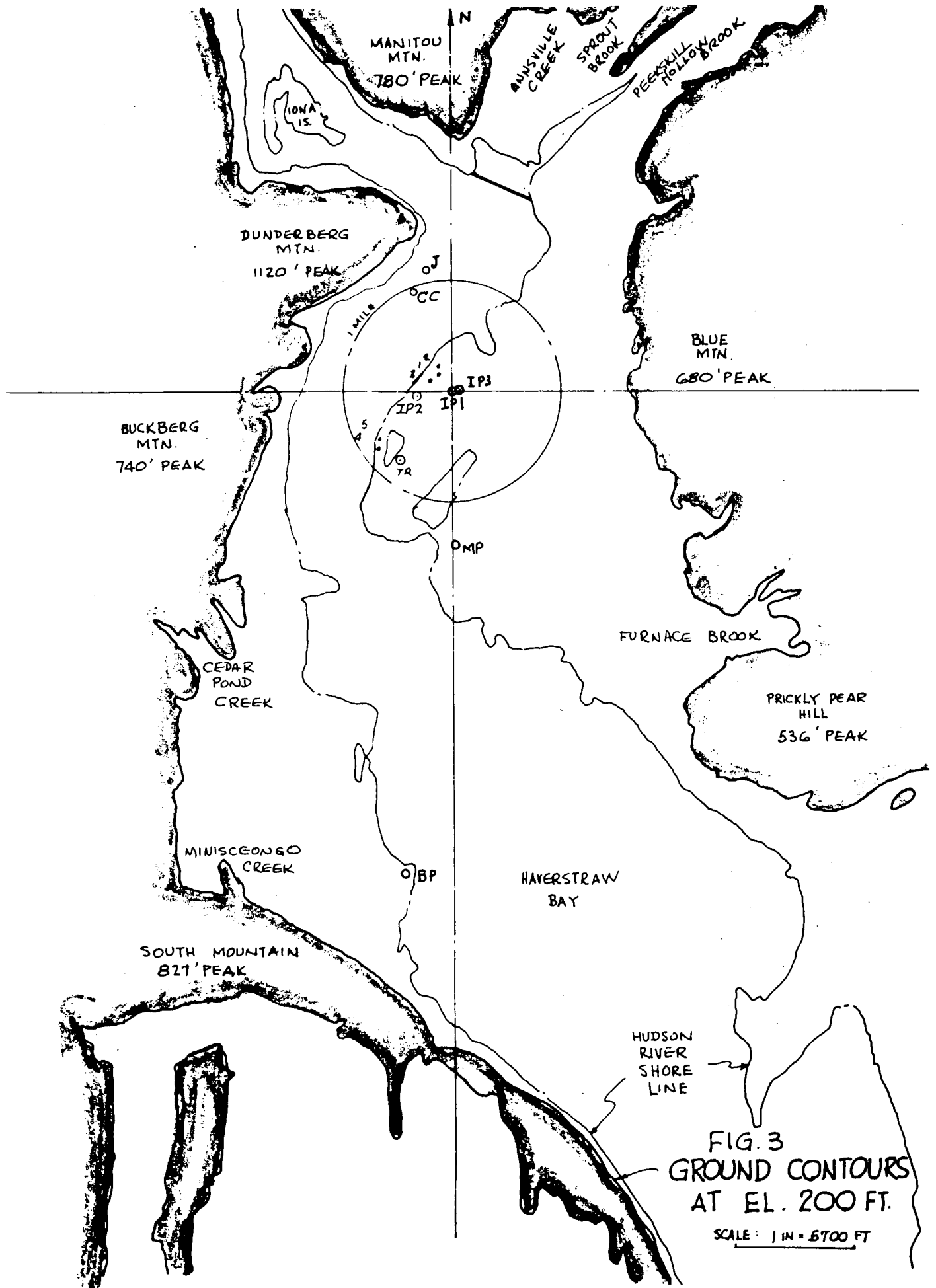

FIG. 3
 GROUND CONTOURS
 AT EL. 200 FT.
 SCALE: 1 IN = 5700 FT

YEAR		1969					1970											
MONTH		AUGUST	SEPTEMBER	OCTOBER	NOVEMBER	DECEMBER	JANUARY	FEBRUARY	MARCH	APRIL	MAY	JUNE	JULY	AUGUST	SEPTEMBER	OCTOBER	NOVEMBER	DECEMBER
BP	A { S D																	
	5 ΔT																	
MP	C { S D																	
IP 3	A { S D																	
	C { S D																	
	40 ΔT																	
	17 ΔT																	
	7 ΔT																	
	G { θ φ																	
TR	C { S D																	
CC	A { S D																	

S = SPEED, D = DIRECTION, ΔT = TEMPERATURE DIFFERENCE
 A = AEROVANE, C = CLIMET, G = BIVANE, R = NET RADIOMETER, T = AMBIENT TEMPERATURE
 θ = AZIMUTH ANGLE, φ = VERTICAL ANGLE
 5, 7, 17, 40 = ELEVATION OF LOWER SENSOR ABOVE GROUND (FT)
 ELEVATION OF UPPER ΔT SENSOR = 95 FT ABOVE GROUND
 ELEVATION OF S, D, θ, φ SENSORS = 100 FT ABOVE GROUND (~70 FT FOR CC)

————— DATA TABULATED FOR ANALYSIS
 DATA ON FAST SPEED CHARTS

FIG. 4. DATA LOG

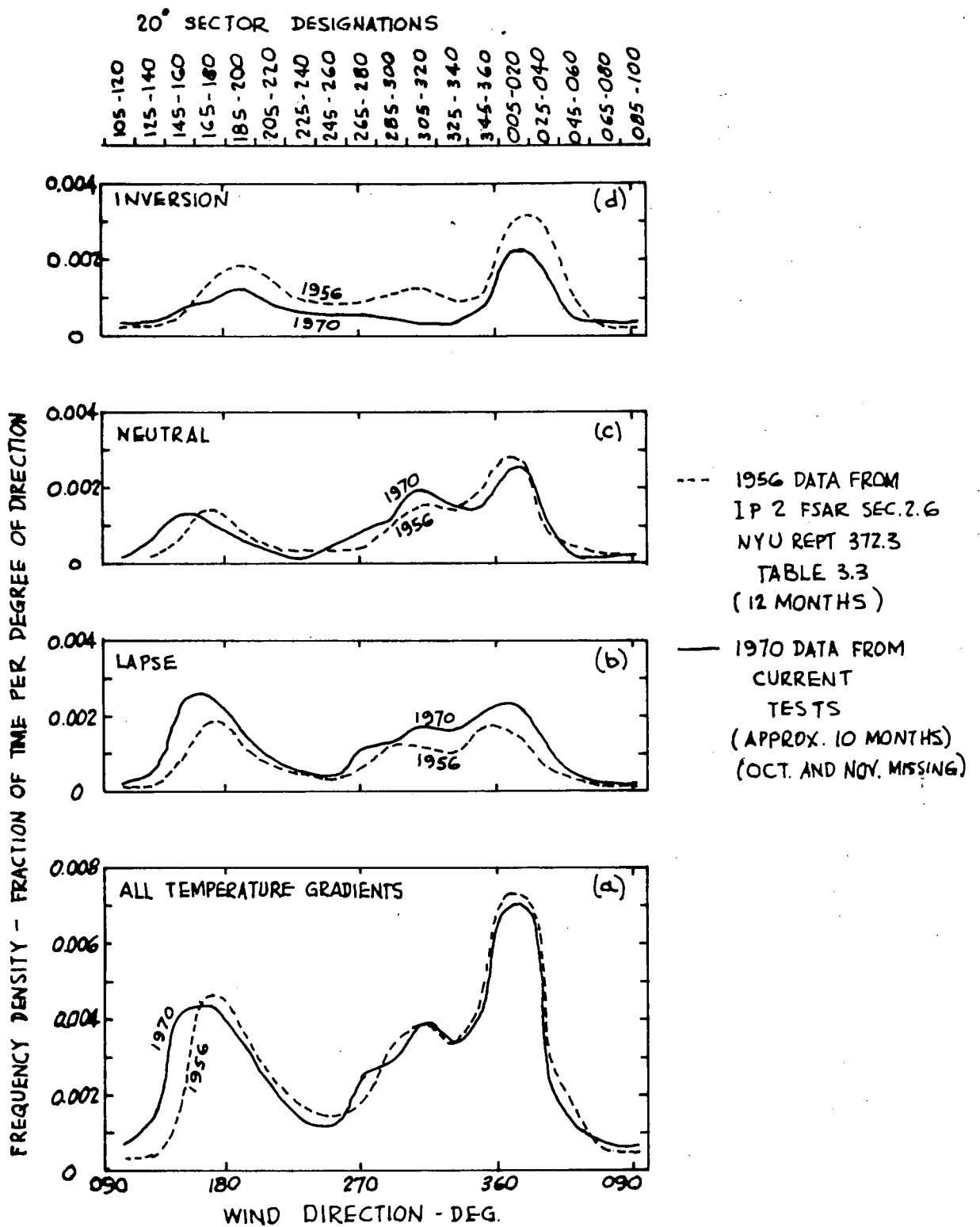
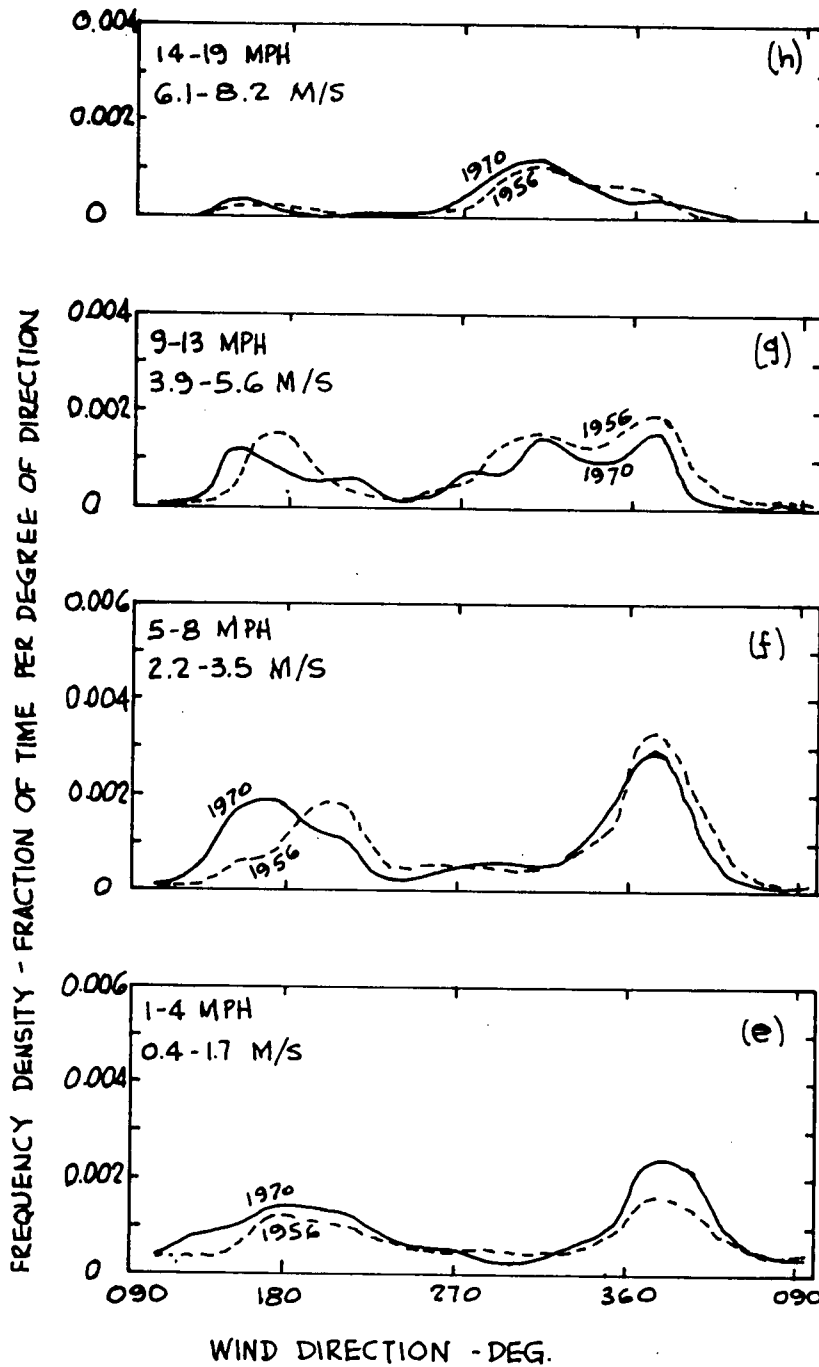

FIG. 5 (a-d)

COMPARISON OF WIND DIRECTION FREQUENCY DISTRIBUTIONS
FOR 1956 AND 1970

20° SECTOR DESIGNATIONS

105-120	125-140	145-160	165-180	185-200	205-220	225-240	245-260	265-280	285-300	305-320	325-340	345-360	005-020	025-040	045-060	065-080	085-100
---------	---------	---------	---------	---------	---------	---------	---------	---------	---------	---------	---------	---------	---------	---------	---------	---------	---------



--- 1956 DATA FROM
IP 2 FSAR SEC. 2.6
NYU REPT. 372.3
TABLE 3.3
(12 MONTHS)

— 1970 DATA FROM
CURRENT TESTS
(APPROX. 10 MONTHS)
(OCT. AND NOV. MISSING)

FIG. 5 (e-h)

COMPARISON OF WIND DIRECTION FREQUENCY DISTRIBUTIONS
FOR 1956 AND 1970

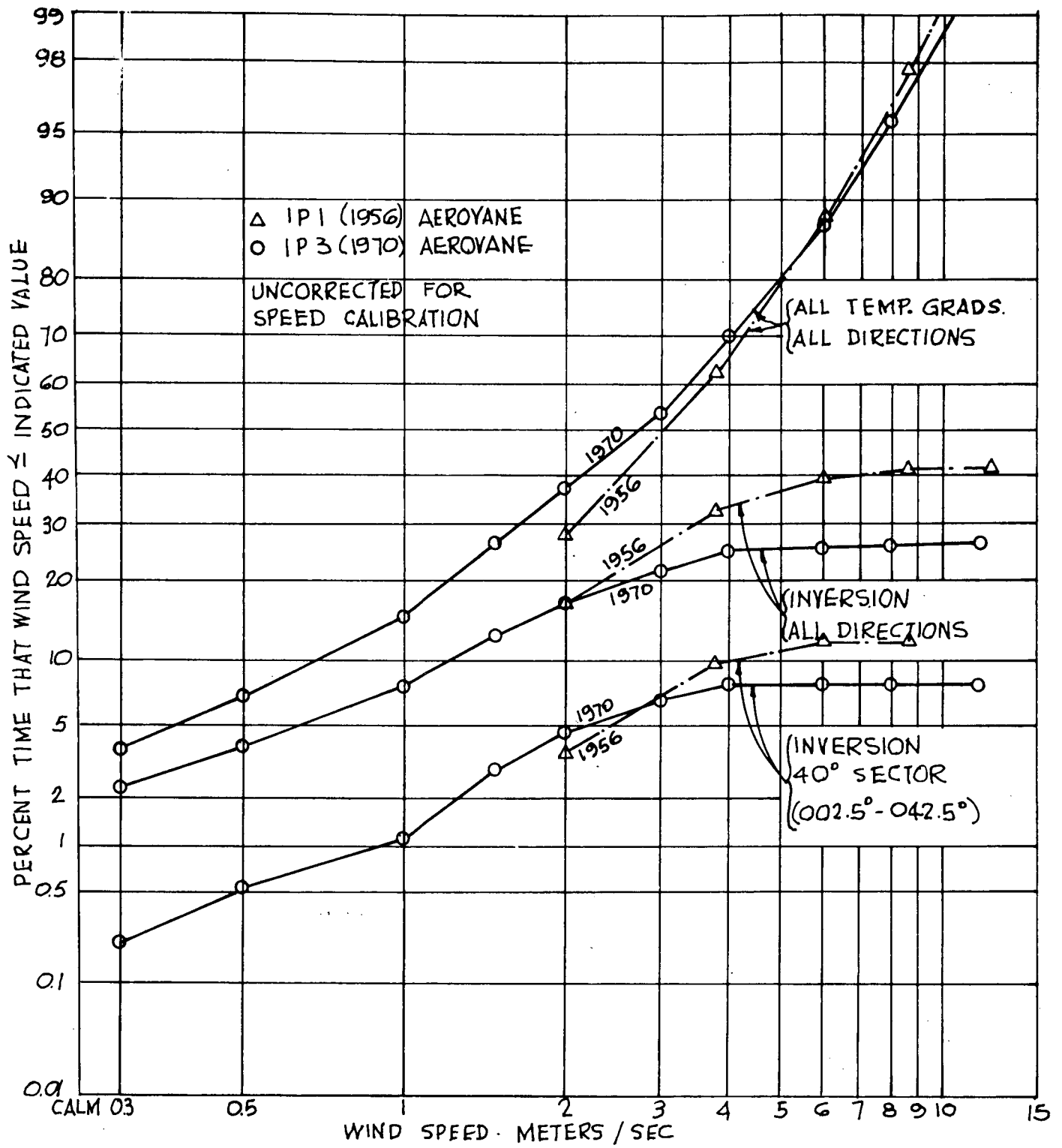

FIG. 6

COMPARISON OF WIND SPEED CUMULATIVE FREQUENCIES
 IN 1956 AND 1970

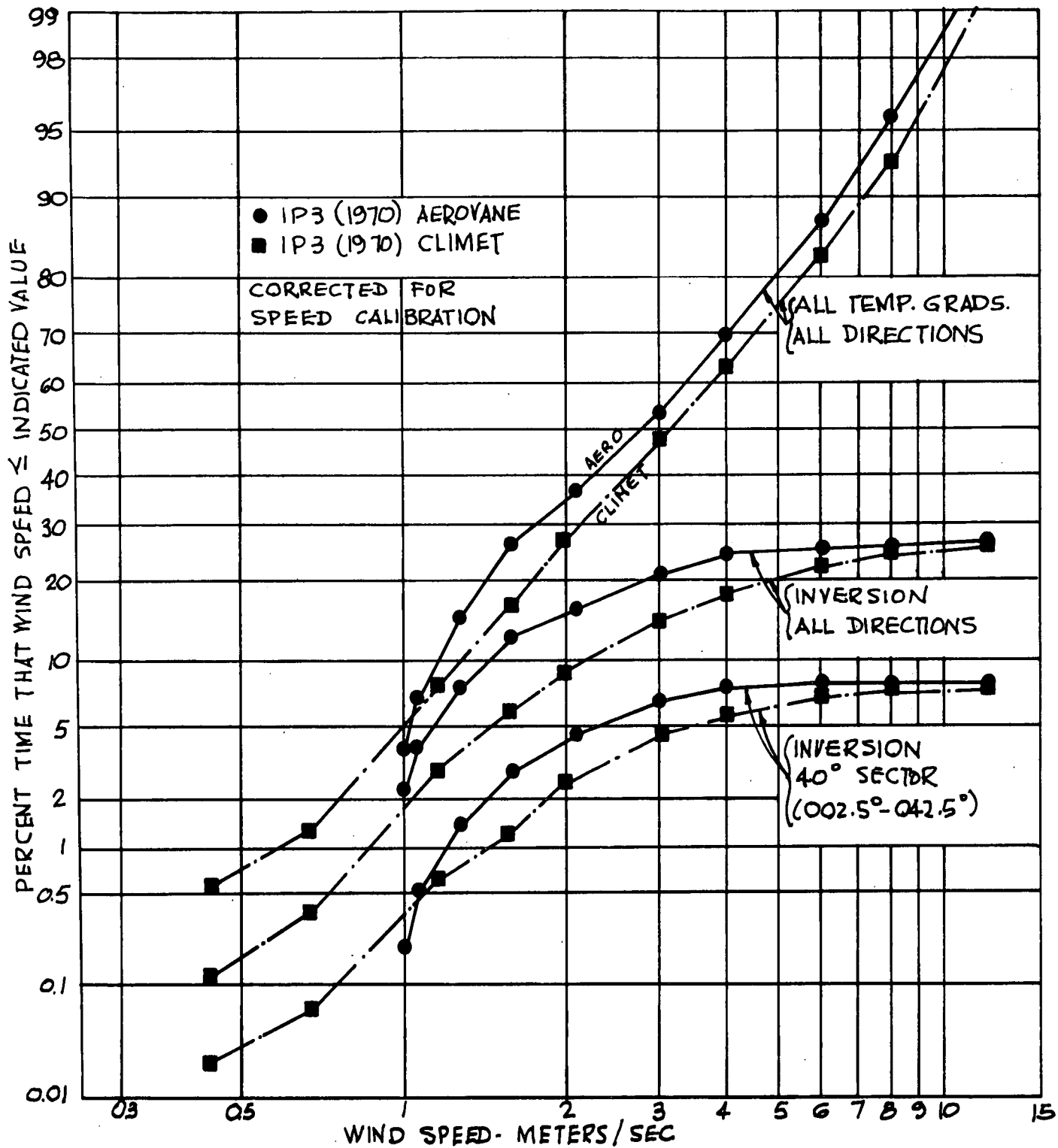
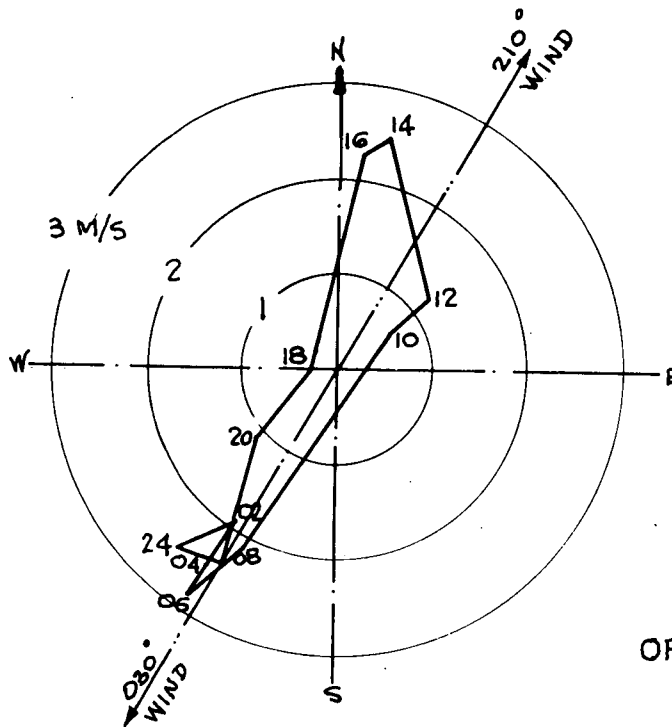
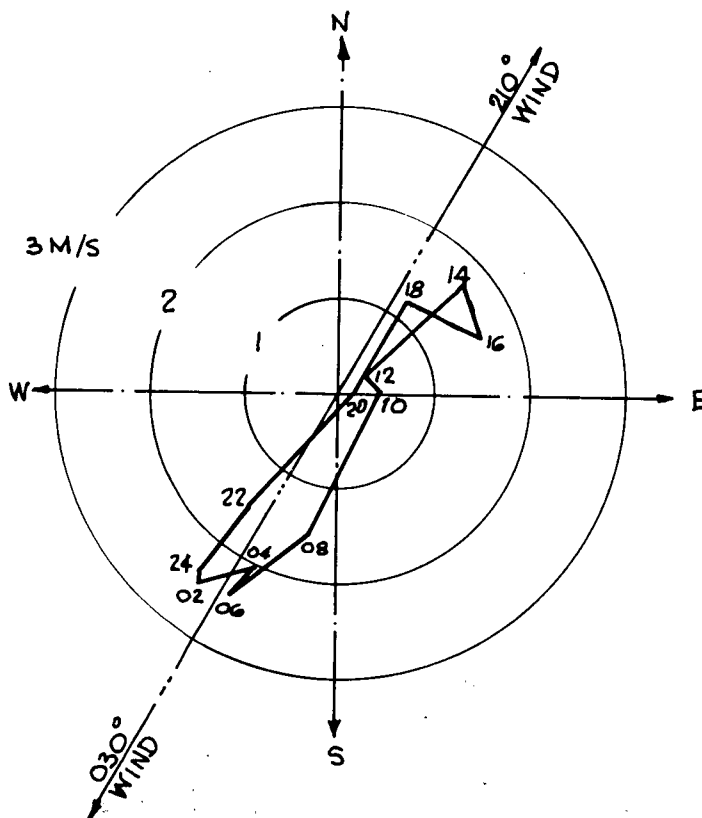

FIG. 7
 CORRECTED WIND SPEED CUMULATIVE FREQUENCIES
 FOR AEROVANE AND CLIMET IN 1970



JONES
AEROVANE
12-DAY
AVERAGE
SEPT. - OCT.
1955

(FROM FIG. 2.6-1
OF I.P. UNIT 2 FSAR)



CAPE
CHARLES
AEROVANE
17-DAY
AVERAGE
JULY 15-SEPT. 15
1970

FIG. 8
AVERAGE WIND HODOGRAPHS
AT SHIPS, 15 YEARS APART

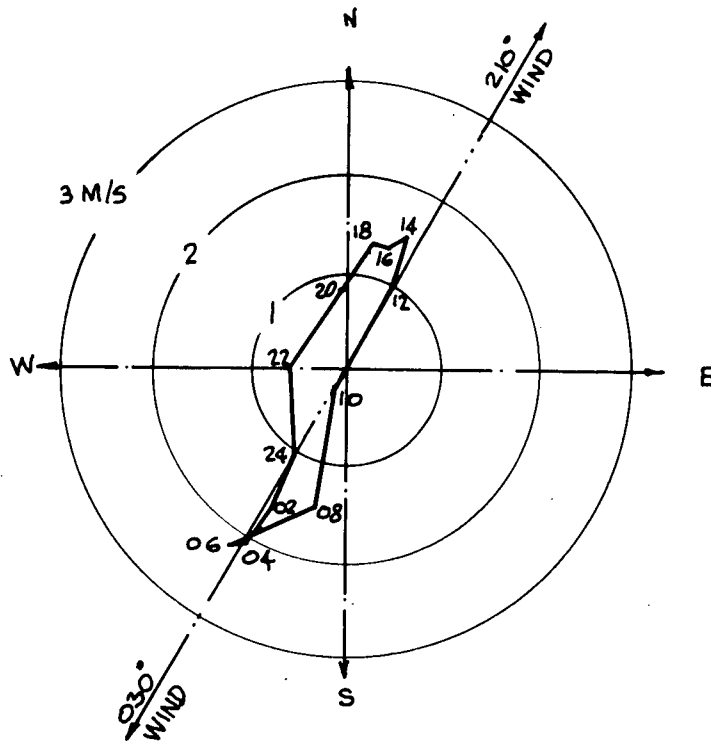

IP3 TOWER
 CLIMET
 16-DAY
 AVERAGE
 JULY 15 - SEPT. 15
 1970

FIG. 9

AVERAGE WIND HODOGRAPH
 AT 100 FT. ELEVATION
 AT IP 3 TOWER SITE
 1970

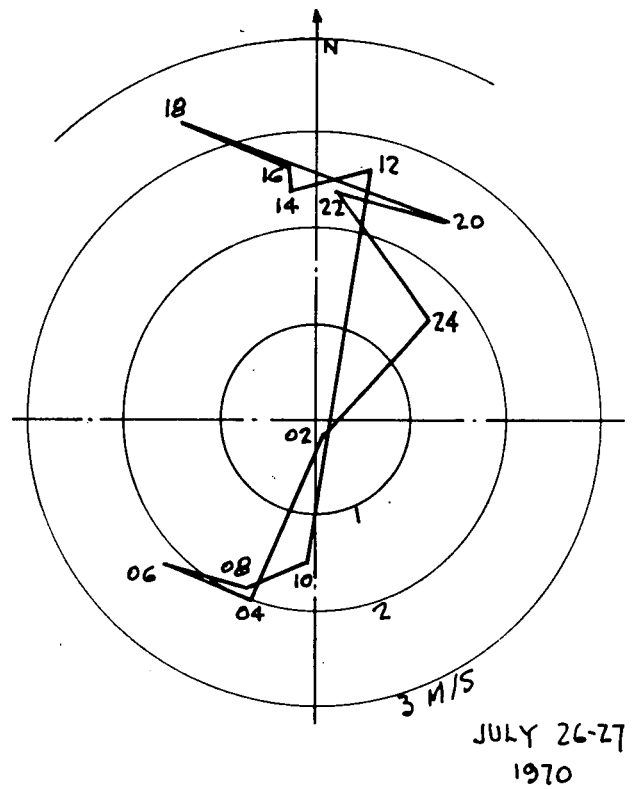
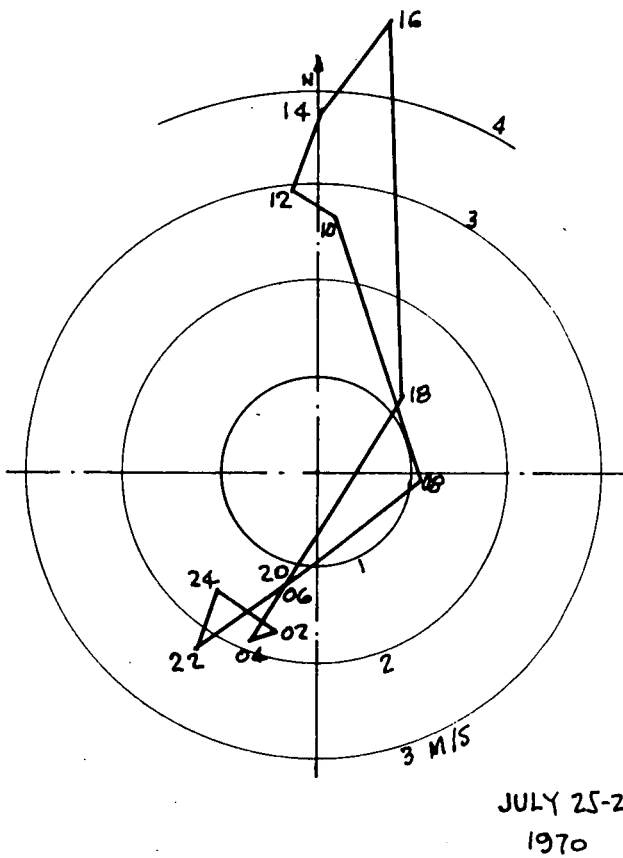
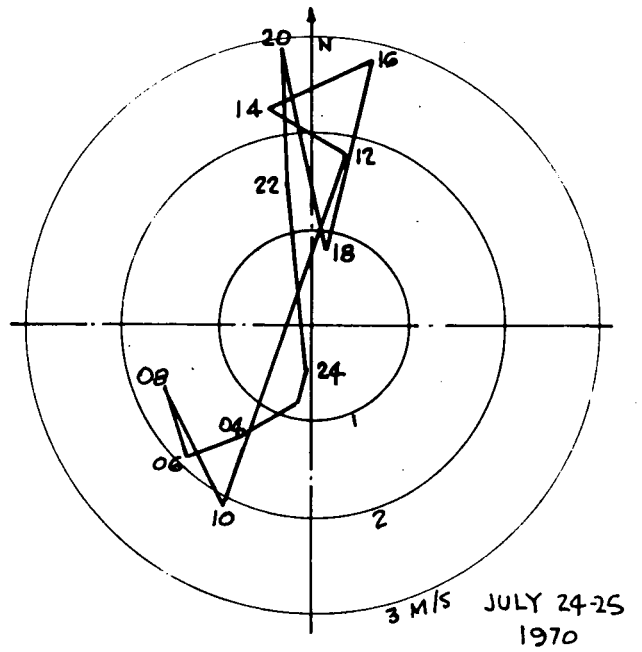
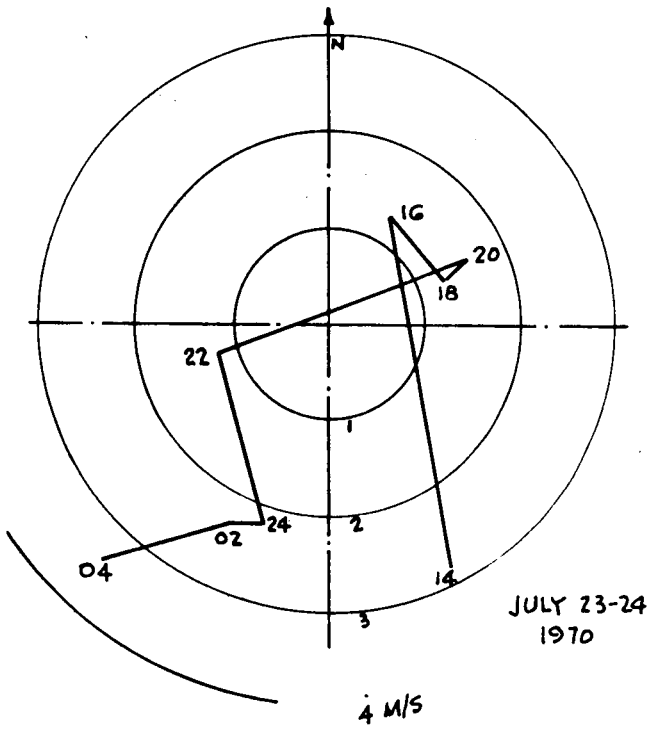
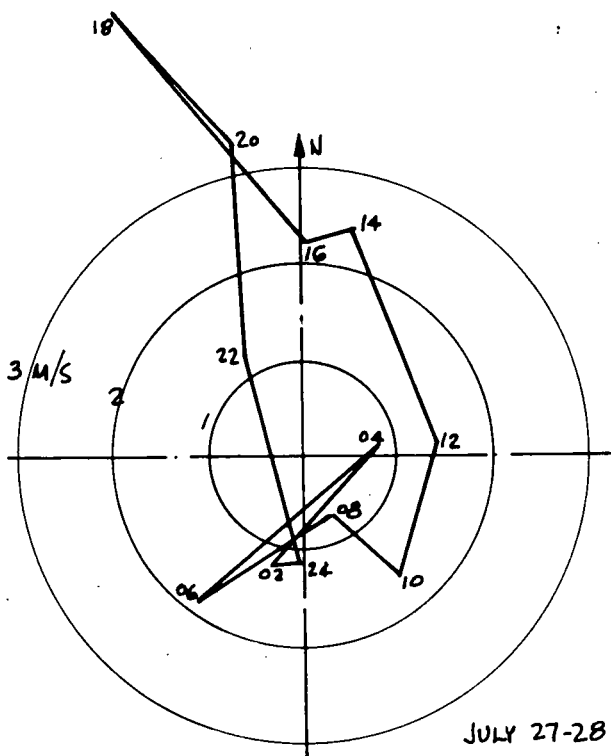
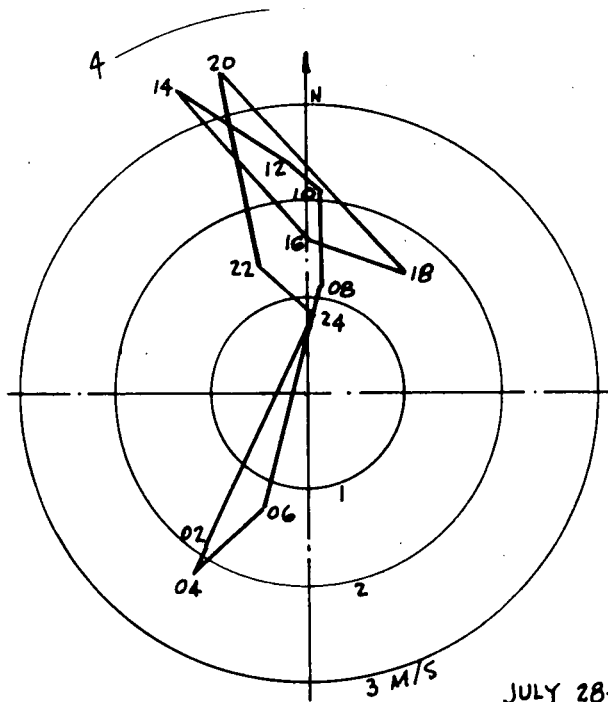

FIG. 10 a
INDIVIDUAL WIND HODOGRAPHS AT
INDIAN POINT TOWER IP 3



JULY 27-28
1970



JULY 28-29
1970

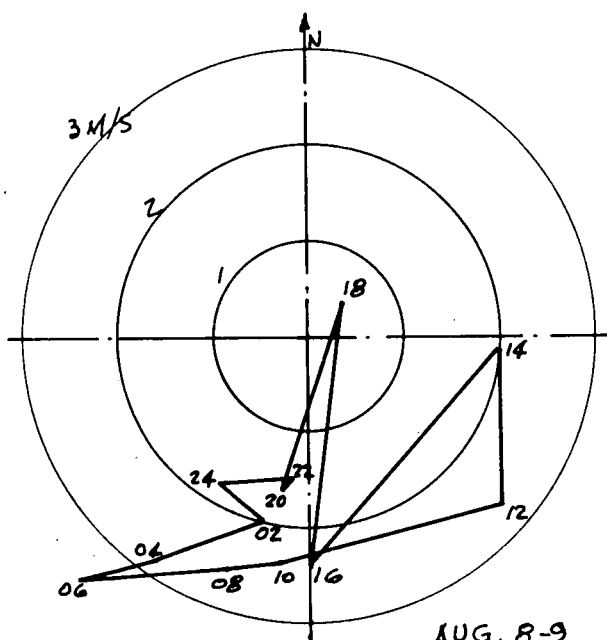

AUG. 8-9
1970

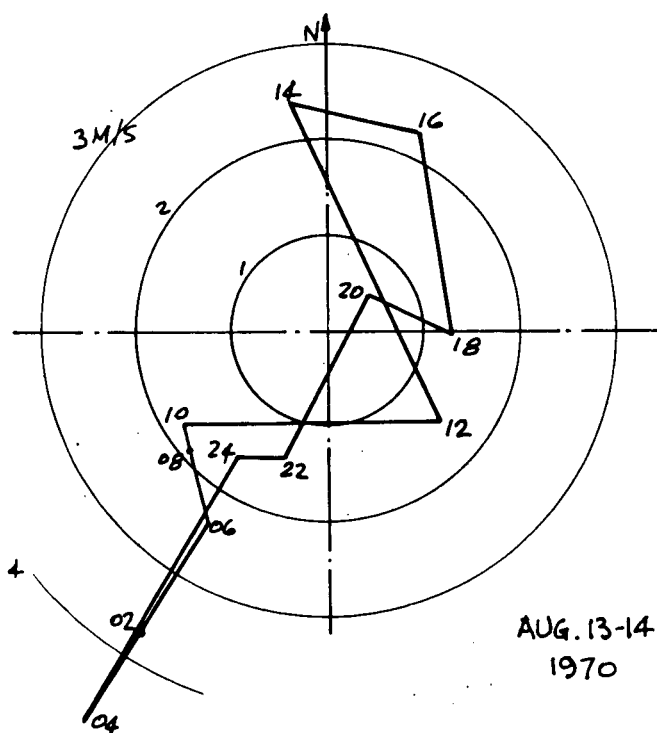

AUG. 13-14
1970

FIG. 10b
INDIVIDUAL WIND HODOGRAPHS AT
INDIAN POINT TOWER IP 3

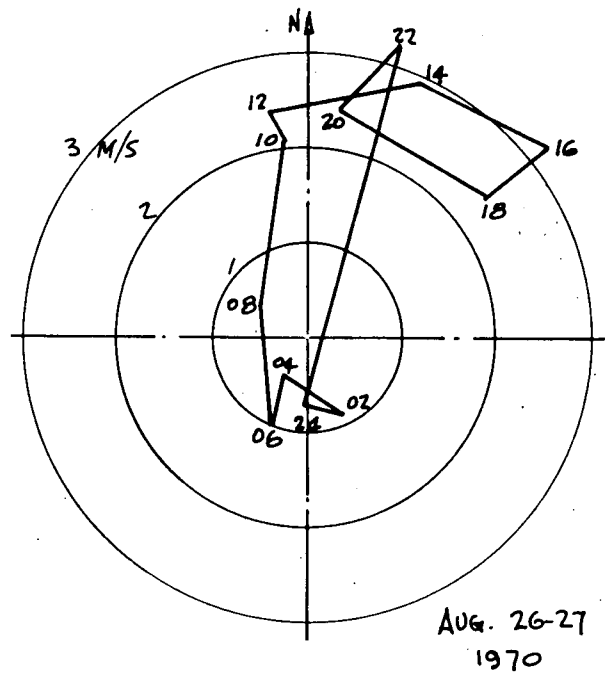
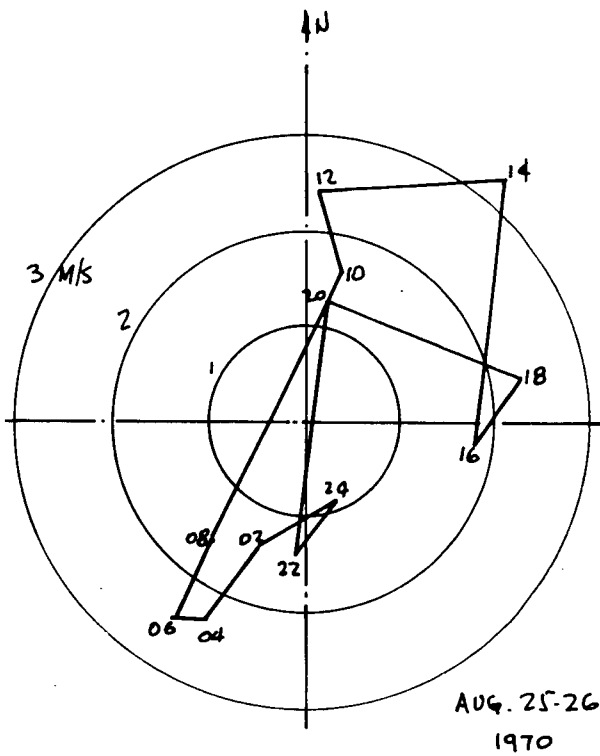
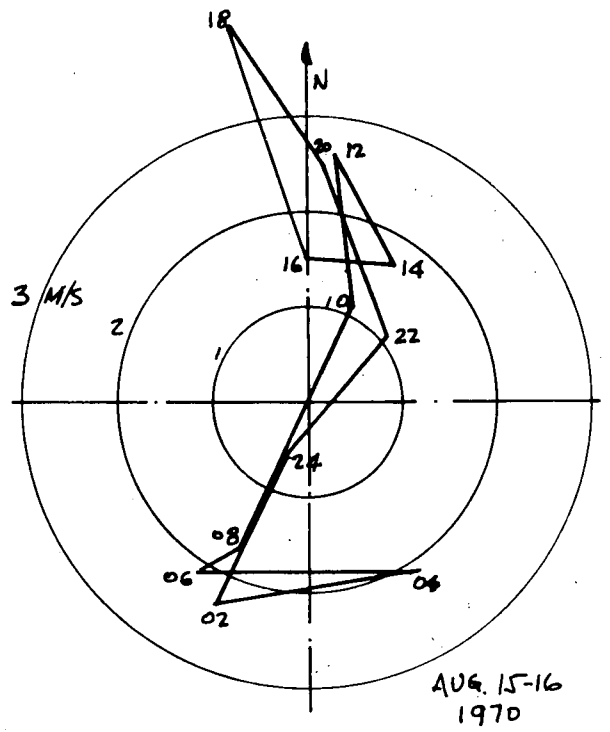
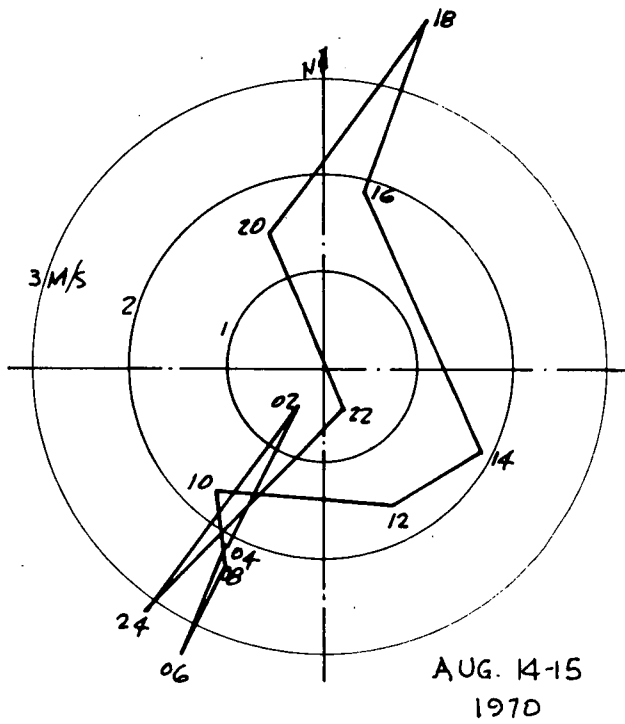

FIG. 10c
INDIVIDUAL WIND HODOGRAPHS AT
INDIAN POINT TOWER 1P3

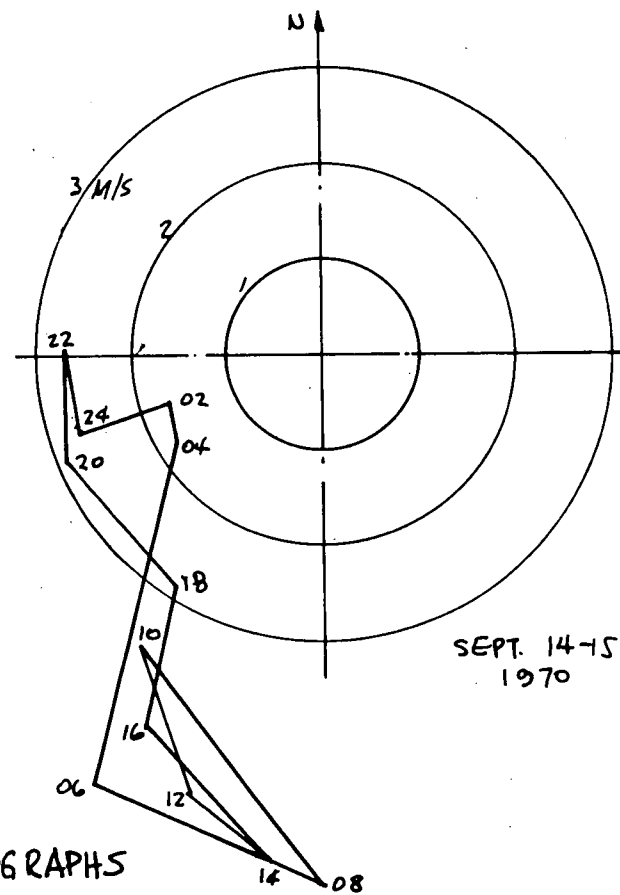
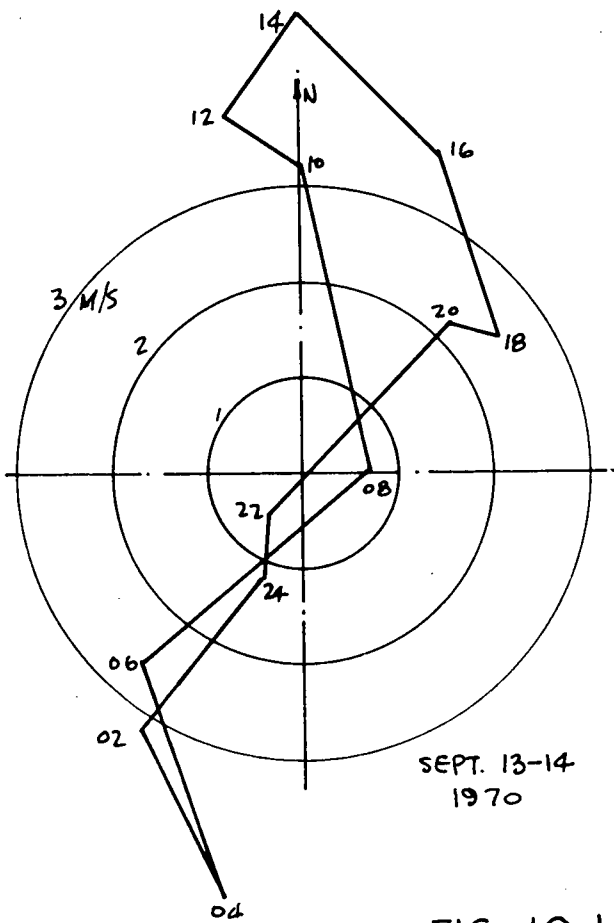
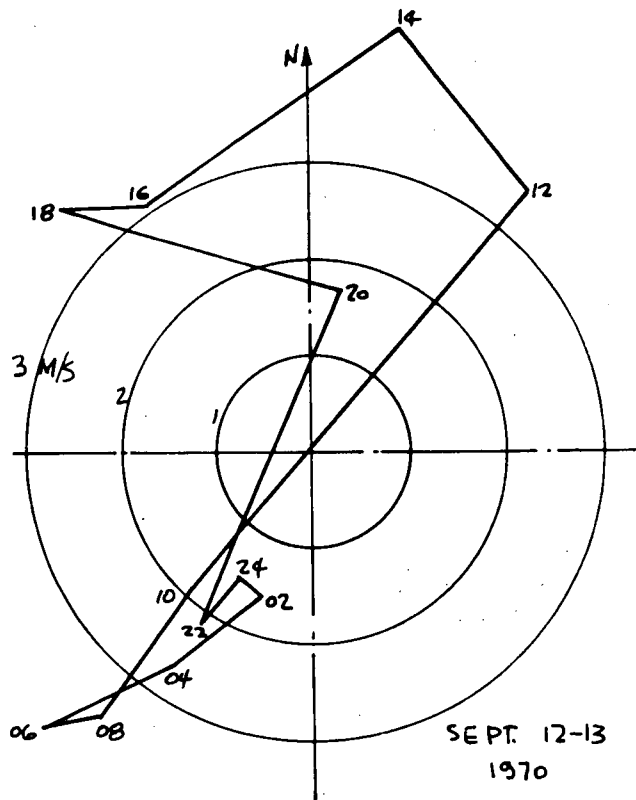
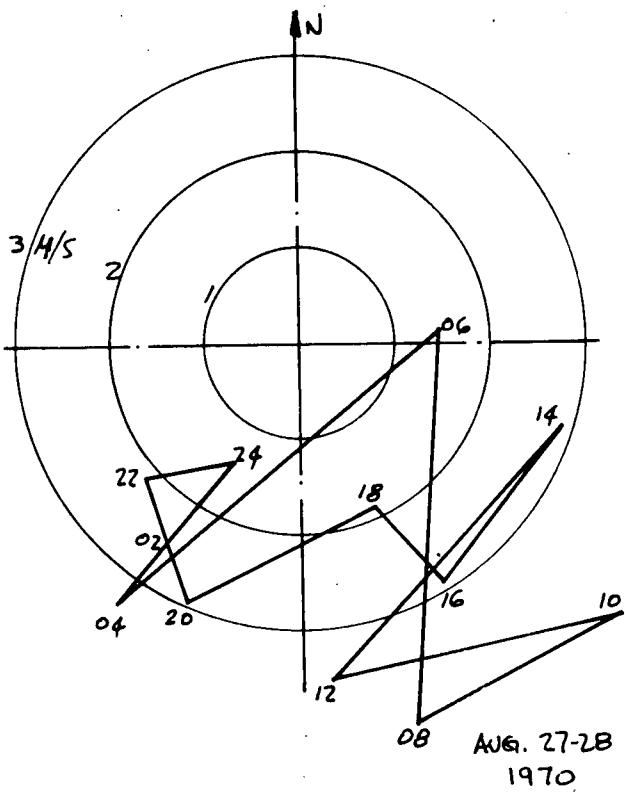

FIG. 10d
INDIVIDUAL WIND HODOGRAPHS
AT INDIAN POINT TOWER IP3

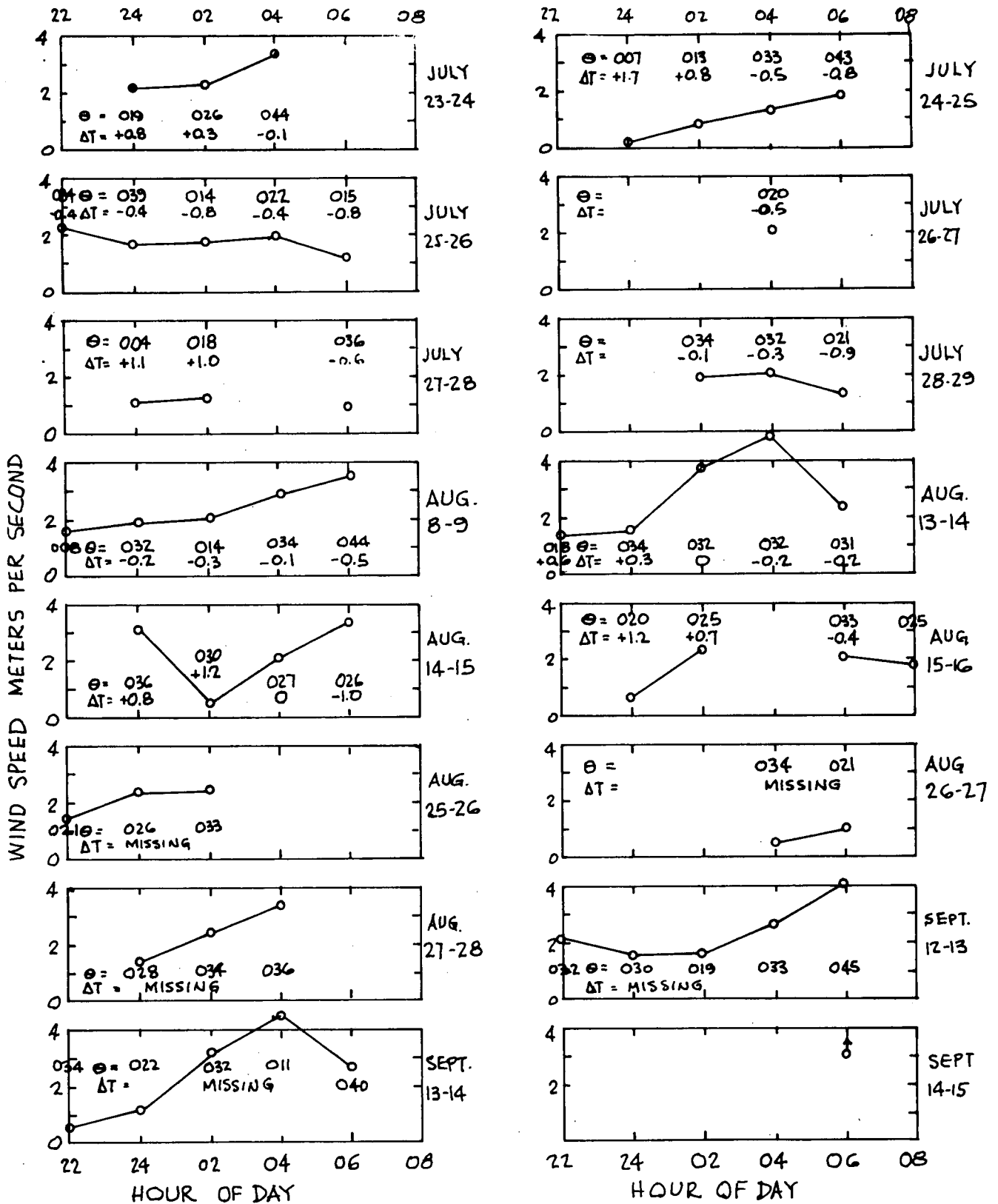

FIG. 11 LOW-SPEED WIND BEHAVIOR DURING NIGHT HOURS AT INDIAN POINT TOWER IN 1970

SPEED AND DIRECTION MEASURED WITH CLIMET AT 100FT TEMPERATURE DIFFERENCE (ΔT) BETWEEN 95FT AND 7FT

EDWARD FLIZOLE CHAIRMAN	YONKERS	WILLIAM H. CASABELLA, JR. VICE CHAIRMAN	DOUGLASS FERRY
P. M. FREEMAN	BEDFORD	WARREN T. LINDQUIST	NORTH CASTLE
EDWARD M. CIGOS	PEERSKILL	MRS. THOMAS M. WALLER	BEDFORD
J. EDWARD HENSON	WHITE PLAINS	EDWARD S. MORICCA	NEW ROSELLE
EDWARD J. DEEHANTY COMR. OF PUBLIC WORKS	EX OFFICIO	CHARLES E. FOUND COMR. OF PARKS, RECREATION & CONSERVATION	EX OFFICIO

WESTCHESTER COUNTY DEPARTMENT OF PLANNING

PETER Q. ESCHWEILER, A.I.P.
COMMISSIONER
JOSEPH R. POTENZA, Assoc. A.I.P.
CHIEF PLANNER

910 COUNTY OFFICE BUILDING WHITE PLAINS, N. Y. 10601 914 WHITE PLAINS 9-1300

November 9, 1970

Mr. Harold L. Price
Director of Regulation
U.S. Atomic Energy Commission
Washington, D. C. 20545

Re: Indian Point Nuclear Generating Station

Dear Mr. Price:

The Consolidated Edison Company of New York, Inc., had advised us that you have received a letter from the Department of Housing and Urban Development stating that the "Westchester County Planning Agency" should be contacted with respect to the relationship of the planning of the nuclear power generating station at Indian Point (Units 1, 2, and 3) in Westchester County, New York to overall county planning concepts.

This is to advise you that this Department is the official planning agency for the County of Westchester. We have consulted with Con Edison on numerous occasions over the years and have been kept informed of the development at the Indian Point site. The site is zoned for industrial use, and the use of this site for nuclear power generation is consistent with the over-all land use and development plan of the Department for Westchester County.

We note that the present proceeding relates to Indian Point No. 2. Since Unit No. 1 was already in existence at this site when Unit No. 2 was planned, we believe that proper planning favored the location of additional units at the same site, since the area was already committed to industrial use, and since any modifications of development patterns in the immediate area because of the presence of the reactor, for whatever reasons, have already taken place and the community has adjusted to this new industrial use.

Maintenance of access to the Hudson River shore for public recreational purposes has been encouraged by the Planning Department wherever possible. It is our understanding that Consolidated Edison has provided and intends to provide such recreation areas on suitable portions of lands owned as part of these generating facility locations. This policy is strongly endorsed for its consistency with both County and local planning objectives.

Very truly yours,

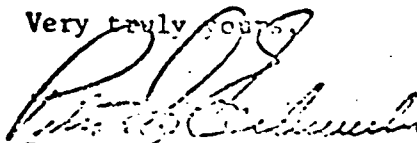
Peter Q. Eschweiler
Commissioner

PQE:hw

cc: Mr. Joseph C. Swidler, Chairman
New York Public Service Commission

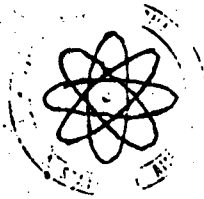

UNITED STATES
ATOMIC ENERGY COMMISSION
WASHINGTON, D.C. 20545

PROJECT No. 50-247

OCT 14 1966

Consolidated Edison Company
of New York, Inc.
4 Irving Place
New York, New York 10003

Attention: Mr. W. C. Beattie
Vice President

Gentlemen:

Enclosed is Construction Permit No. CPPR-21 which has been issued pursuant to the Atomic Safety and Licensing Board's Initial Decision dated October 3, 1956. The construction permit authorizes Consolidated Edison Company of New York, Inc., to construct the Indian Point Station Unit No. 2 at its Indian Point site in the Town of Buchanan, Westchester County, New York.

Also enclosed is a copy of a related notice which has been transmitted to the Office of the Federal Register for publication.

Sincerely yours,

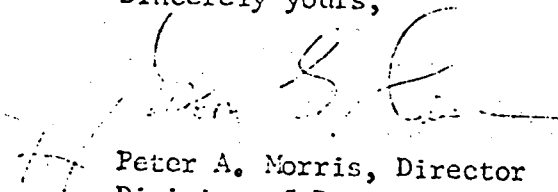
Peter A. Morris, Director
Division of Reactor Licensing

Enclosures:
As stated above

cc: Arvin E. Upton, Esquire
Messrs. LeBoeuf, Lamb & Leiby
1821 Jefferson Place, N. W.
Washington, D. C. 20036

UNITED STATES ATOMIC ENERGY COMMISSION

DOCKET NO. 50-247

CONSOLIDATED EDISON COMPANY OF NEW YORK, INC.

NOTICE OF ISSUANCE OF PROVISIONAL CONSTRUCTION PERMIT

Please take notice that, pursuant to the Initial Decision of the Atomic Safety and Licensing Board, dated October 3, 1966, the Director of the Division of Reactor Licensing has issued Provisional Construction Permit No. CPPR-21 to Consolidated Edison Company of New York, Inc., for the construction of a pressurized water nuclear reactor, designated as Indian Point Station Unit No. 2, to be located at Consolidated Edison Company's Indian Point site on the Hudson River in the Town of Buchanan, Westchester County, New York.

The construction permit is in the form set forth in Attachment "B" to the Initial Decision except that the allocation figure specified in paragraph 4 has been increased to reflect the greatest quantity of special nuclear material (24,325 kilograms of uranium 235) outstanding during the term of the license, and a typographical error in line 1 of subparagraph 2.B. has been corrected to change the work "operated" to "located".

A copy of the Initial Decision is on file in the Commission's Public Document Room, 1717 H Street, N. W., Washington, D. C.

FOR THE ATOMIC ENERGY COMMISSION

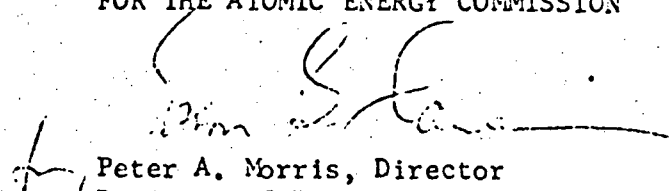
Peter A. Morris, Director
Division of Reactor Licensing

Dated at Bethesda, Maryland
this 14th of October, 1966.



UNITED STATES
ATOMIC ENERGY COMMISSION
WASHINGTON, D.C. 20545

CONSOLIDATED EDISON COMPANY OF NEW YORK, INC.

DOCKET NO. 50-247

PROVISIONAL CONSTRUCTION PERMIT

Construction Permit No. CPPR-21

1. Pursuant to Section 104b of the Atomic Energy Act of 1954, as amended (the Act), and Title 10, Chapter 1, Code of Federal Regulations, Part 50, Licensing of Production and Utilization Facilities, and pursuant to the order of the Atomic Safety and Licensing Board, the Atomic Energy Commission (the Commission) hereby issues a provisional construction permit to Consolidated Edison Company of New York, Inc. (Consolidated Edison) for a utilization facility (being a part of an electric generating plant designated as Indian Point Station Unit No. 2) described in the application and amendments thereto filed in this matter by Consolidated Edison and as also described in the evidence received at the public hearing upon that application. The utilization facility is a pressurized water reactor having a thermal capacity of and designated to operate at 2758 megawatts. The plant of which the facility is a part will be located on the Hudson River in the Village of Buchanan, Westchester County, New York.
2. This permit shall be deemed to contain and is subject to the conditions specified in Sections 50.54 and 50.55 of said regulations; is subject to all applicable provisions of the Act, and rules, regulations and orders of the Commission now or hereafter in effect; and is subject to the conditions specified or incorporated below:
 - A. The earliest date for completion of the facility is January 1, 1969 and the latest date for completion of the facility is June 1, 1969.
 - B. The facility shall be constructed and located at the site as described in the application as amended in the Village of Buchanan, Westchester County, New York.
 - C. This construction permit authorizes Consolidated Edison to construct the facility described in the application and the hearing record in accordance with the principal architectural and engineering criteria set forth therein.

3. This permit is provisional to the extent that a license authorizing operation of the facility will not be issued by the Commission unless:
(A) Consolidated Edison submits to the Commission, by amendment to the application, the complete final hazards summary report, portions of which may be submitted and evaluated from time to time; (B) the Commission finds that the final design provides reasonable assurance that the health and safety of the public will not be endangered by the operation of the facility in accordance with procedures approved by it in connection with the issuance of said license; and (C) Consolidated Edison submits proof of financial protection and the execution of an indemnity agreement as required by Section 170 of the Act.
4. Pursuant to Section 50.60 of the regulations in Title 10, Chapter 1, CFR, Part 50, the Commission has allocated to Consolidated Edison for use in the operation of the reactor 24,325 kilograms of uranium 235 contained in uranium in the isotopic ratios specified in the application. Estimated schedules of special nuclear material transfers to Consolidated Edison and returns to the Commission are contained in Appendix A which is attached hereto. Transfers by the Commission to Consolidated Edison in accordance with the column entitled "AEC to Con Ed" in Appendix A will be conditioned upon Consolidated Edison's return to the Commission of material substantially in accordance with the column entitled "Con Ed to AEC" in Appendix A.

FOR THE ATOMIC ENERGY COMMISSION

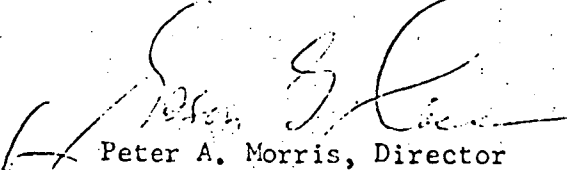

Peter A. Morris, Director
Division of Reactor Licensing

Attachment:
Appendix A

Date of Issuance: OCT 14 1966

ALLOCATION OF SPECIAL NUCLEAR MATERIALS
TO CONSOLIDATED EDISON COMPANY
INDIAN POINT #2
(KG U-235)

FY	AEC to Con Ed <u>1/</u>	Con Ed to AEC		Year Net	Cumulative Net
		Cold <u>1/</u>	Irrad. <u>4/</u>		
1968	2,378 <u>2/</u>	-0-	-0-	2,378	2,378
1969	-0-	238 <u>3/</u>	-0-	(238)	2,140
1970	1,904	-0-	-0-	1,904	4,044
1971	952	190	295 <u>5/</u>	467	4,511
1972	952	95	206 <u>6/</u>	651	5,162
1973	952	95	197 <u>7/</u>	660	5,822
1974	952	95	252	605	6,427
1975	952	95	504	353	6,780
1976	952	95	252	605	7,385
1977	952	95	252	605	7,990
1978	952	95	252	605	8,595
1979	952	95	252	605	9,200
1980	952	95	252	605	9,805
1981	952	95	252	605	10,410
1982	952	95	252	605	11,015
1983	952	95	252	605	11,620
1984	952	95	252	605	12,225
1985	952	95	252	605	12,830
1986	952	95	252	605	13,435
1987	952	95	252	605	14,040
1988	952	95	252	605	14,645
1989	952	95	252	605	15,250
1990	952	95	252	605	15,855
1991	952	95	252	605	16,460
1992	952	95	252	605	17,065
1993	952	95	252	605	17,670
1994	952	95	252	605	18,275
1995	952	95	252	605	18,880
1996	952	95	252	605	19,485

(continued)

- 1/ 2.92% unless otherwise indicated.
2/ 727 kg at 2.23%; 776 kg at 2.38; 875 kg at 2.68.
3/ 73 kg at 2.23%; 77 kg at 2.38; 88 kg at 2.68.
4/ 0.92% unless otherwise indicated
5/ 1.05%
6/ 0.75%
7/ 0.72%

Allocation of Special Nuclear Materials to
 Consolidated Edison Company, Indian Point #2
 (Kg U-235)

pg. 2

FY	AEC to Con Ed	Con Ed to AEC		Year Net	Cumulative Net
		Cold	Irrad.		
1997	952	95	252	605	20,090
1998	952	95	252	605	20,695
1999	952	95	252	605	21,300
2000	952	95	252	605	21,905
2001	952	95	252	605	22,510
2002	952	95	252	605	23,115
2003	952	95	252	605	23,720
2004	952	95	252	605	24,325
2005	-0-	95	252	(347)	23,978
2006	-0-	-0-	252	(252)	23,726
2007	-0-	-0-	252	(252)	23,474
2008	-0-	-0-	252	(252)	23,222
TOTAL	36,650	3,658	9,770	23,222	---

DEPARTMENT OF THE ARMY

NOTE.—It is to be understood that this instrument does not give any property rights either in real estate or material, or any exclusive privileges; and that it does not authorize any injury to private property or invasion of private rights, or any infringement of Federal, State, or local laws or regulations, nor does it obviate the necessity of obtaining State assent to the work authorized. IT MERELY EXPRESSES THE ASSENT OF THE FEDERAL GOVERNMENT SO FAR AS CONCERNS THE PUBLIC RIGHTS OF NAVIGATION. (See *Cummings v. Chicago*, 188 U. S., 410.)

16-13162-2

NANOP-E

PERMIT
Department of the Army, New York District
Corps of Engineers,
111 East 16th Street, New York, N. Y. 10003
23 February, 1966

Consolidated Edison Company of New York, Inc.
4 Irving Place
New York, N. Y. 10003

Gentlemen:

Referring to written request dated 10 January 1966, signed by Mr. E. G. Watkins, - - - - -

I have to inform you that, upon the recommendation of the Chief of Engineers, and under the provisions of Section 10 of the Act of Congress approved March 3, 1899, entitled "An act making appropriations for the construction, repair, and preservation of certain public works on rivers and harbors, and for other purposes," you are hereby authorized by the Secretary of the Army.

to place fill, - - - - -
(Here describe the proposed structure or work.)

in Hudson River, - - - - -
(Here to be named the river, harbor, or waterway concerned.)

at Indian Point, Westchester County, N. Y., - - - - -
(Here to be named the nearest well-known locality—preferably a town or city—and the distance in miles and tenths from some definite point in the same, stating whether above or below or other direction by points of compass.)

in accordance with the plans shown on the drawing attached hereto and marked:
(Or drawings; give file number or other definite identification marks.)

1507-24 (Hudson River-Consolidated Edison Co. of N.Y. - fill at Indian Point), -

subject to the following conditions:

(a) That the work shall be subject to the supervision and approval of District Engineer, Corps of Engineers, in charge of the locality, who may temporarily suspend the work at any time if in his judgment the interests of navigation so require.

(b) That any material dredged in the prosecution of the work herein authorized shall be removed evenly and no large refuse piles, ridges across the bed of the waterway, or deep holes that may have a tendency to cause injury to navigable channels or to the banks of the waterway shall be left. If any pipe, wire, or cable hereby authorized is laid in a trench, the formation of permanent ridges across the bed of the waterway shall be avoided and the back filling shall be so done as not to increase the cost of future dredging for navigation. Any material to be deposited or dumped under this authorization, either in the waterway or on shore above high-water mark, shall be deposited or dumped at the locality shown on the drawing hereto attached, and, if so prescribed thereon, within or behind a good and substantial bulkhead or bulkheads, such as will prevent escape of the material in the waterway. If the material is to be deposited in the harbor of New York, or in its adjacent or tributary waters, or in Long Island Sound, a permit therefor must be previously obtained from the Supervisor of New York Harbor, New York City.

(c) That there shall be no unreasonable interference with navigation by the work herein authorized.

(d) That if inspections or any other operations by the United States are necessary in the interest of navigation, all expenses connected therewith shall be borne by the permittee.

(e) That no attempt shall be made by the permittee or the owner to forbid the full and free use by the public of all navigable waters at or adjacent to the work or structure.

(f) That if future operations by the United States require an alteration in the position of the structure or work herein authorized, or if, in the opinion of the Secretary of the Army, it shall cause unreasonable obstruction to the free navigation of said water, the owner will be required upon due notice from the Secretary of the Army, to remove or alter the structural work or obstructions caused thereby without expense to the United States, so as to render navigation reasonably free, easy, and unobstructed; and if, upon the expiration or revocation of this permit, the structure, fill, excavation, or other modification of the watercourse hereby authorized shall not be completed, the owners shall, without expense to the United States, and to such extent and in such time and manner as the Secretary of the Army may require, remove all or any portion of the uncompleted structure or fill and restore to its former condition the navigable capacity of the watercourse. No claim shall be made against the United States on account of any such removal or alteration.

(g) That the United States shall in no case be liable for any damage or injury to the structure or work herein authorized which may be caused by or result from future operations undertaken by the Government for the conservation or improvement of navigation, or for other purposes, and no claim or right to compensation shall accrue from any such damage.

(h) That if the display of lights and signals on any work hereby authorized is not otherwise provided for by law, such lights and signals as may be prescribed by the U. S. Coast Guard, shall be installed and maintained by and at the expense of the owner.

(i) That the permittee shall notify the said district engineer at what time the work will be commenced, and as far in advance of the time of commencement as the said district engineer may specify, and shall also notify him promptly, in writing, of the commencement of work, suspension of work, if for a period of more than one week, resumption of work, and its completion.

(j) That if the structure or work herein authorized is not completed on or before the 31st day of December, 1962, this permit, if not previously revoked or specifically extended, shall cease and be null and void.

By authority of the Secretary of the Army:

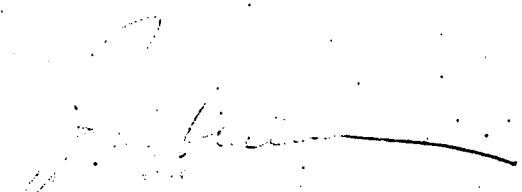
R. T. BATSON
Colonel, Corps of Engineers
District Engineer

213
~~MS~~

DEPARTMENT OF THE ARMY
NEW YORK DISTRICT, CORPS OF ENGINEERS
111 EAST 16TH STREET
NEW YORK, N. Y. 10003

IN REPLY REFER TO

NANOP=E

15 March 1966

Consolidated Edison Company of New York, Inc.
4 Irving Place
New York, N. Y. 10003

Gentlemen:

In accordance with written request dated 17 February 1966, signed by Mr. E. G. Watkins, the revised plans hereto attached are approved to supersede the plans approved by the Secretary of the Army in Department of the Army permit dated 23 February 1966, to place fill in Hudson River, at Indian Point, Westchester County, N. Y. The said authorization is hereby specifically modified to read as follows:

"....to construct a discharge channel extension wall, a screen well structure, to place fill and to dredge to depths of twenty-six feet below mean low water at the screen well and twenty-one feet below mean low water in the discharge channel, in accordance with the plans shown on the drawings attached hereto...."

The conditions to which the work is made subject remain in full force and effect.

BY AUTHORITY OF THE SECRETARY OF THE ARMY:

1 Incl
Revised plans
(5 sheets)

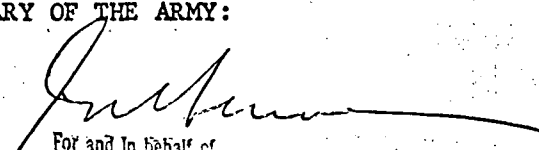
For and in behalf of
R. T. BATSON
Colonel, Corps of Engineers
District Engineer

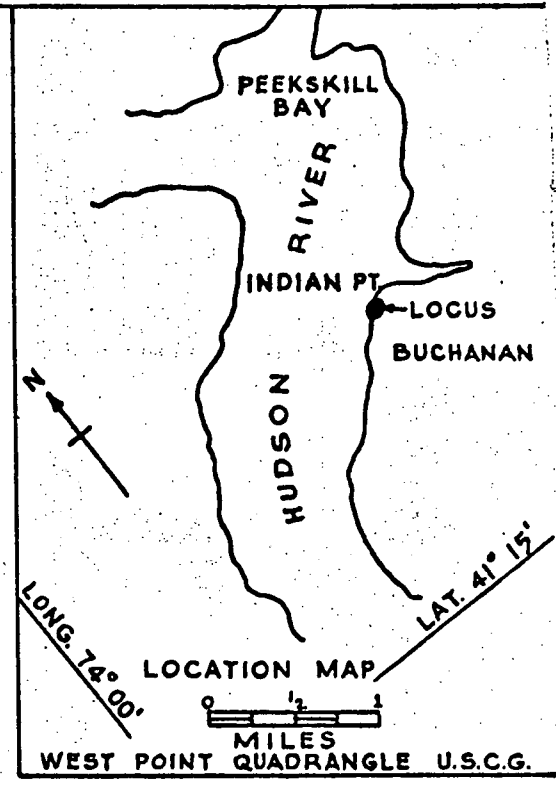
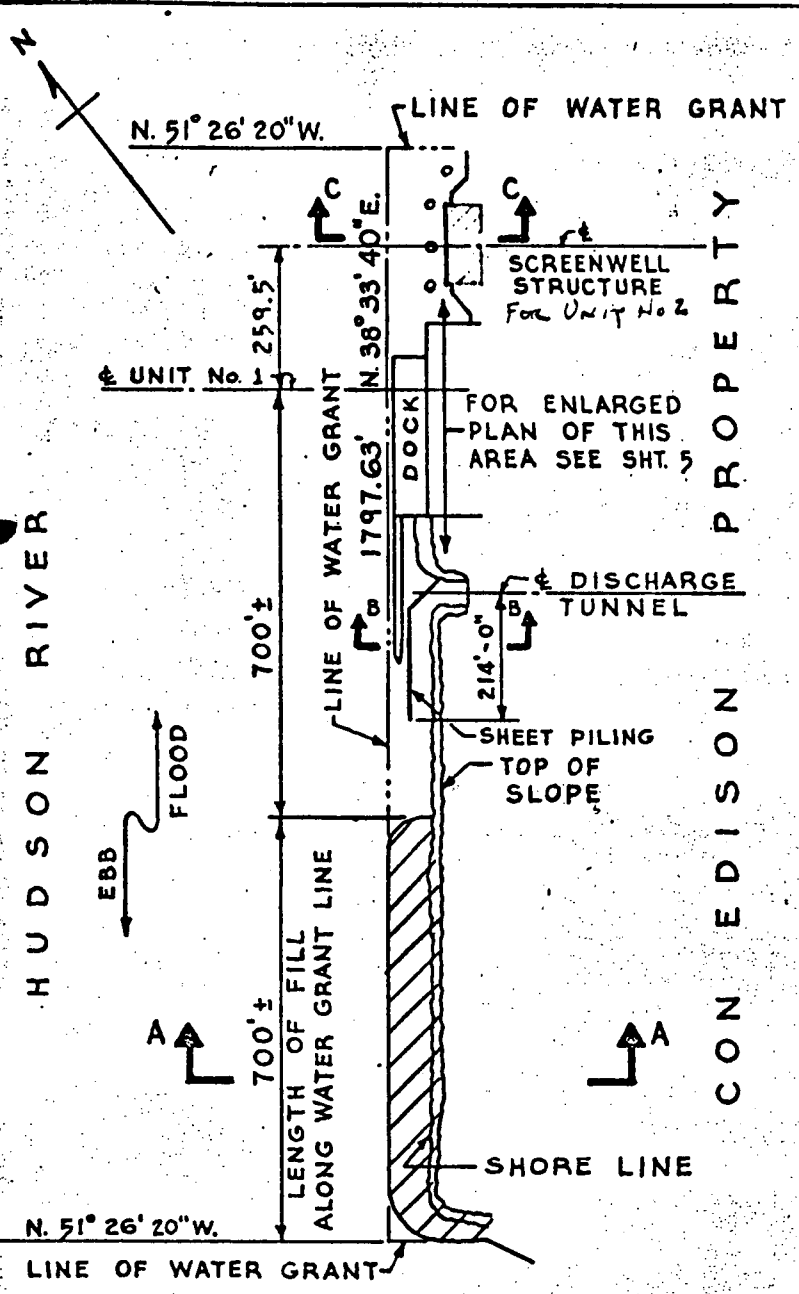

PLAN

SCALE: 1" = 300'-0"
 300 0 300

PROPOSED DISCHARGE CHANNEL
 EXTENSION, SCREENWELL STRUCTURE,
 EXCAVATION & DREDGING

PROPOSED FILL
 IN HUDSON RIVER
 AT INDIAN POINT

REVISED DATE: FEBRUARY 16, 1966

COUNTY OF WESTCHESTER, STATE OF NEW YORK
 APPLICATION BY CONSOLIDATED EDISON CO.
 OF NEW YORK, INC.

SHEET 1 OF 5

JANUARY 10, 1965

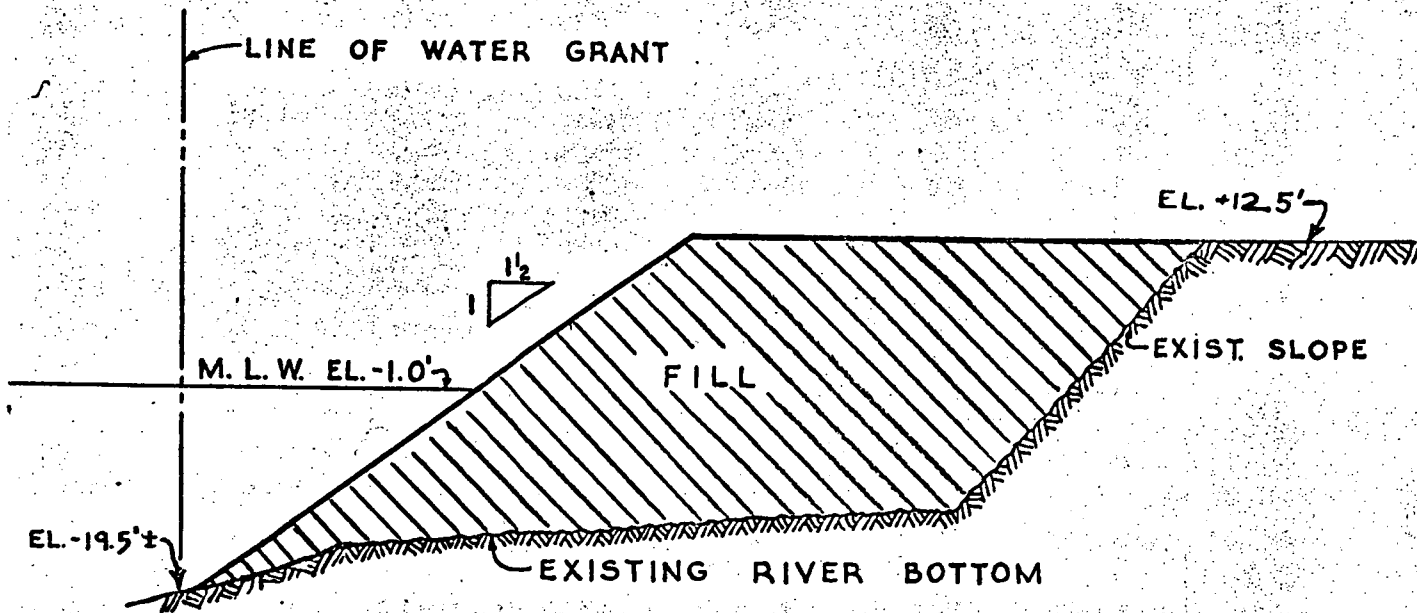

SECTION A-A

SCALE: $\frac{1}{16}'' = 1'-0''$

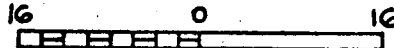

NOTE:

ALL ELEVATIONS REFER
TO STANDARD DATUM
AT SANDY HOOK.

REVISED DATE: FEBRUARY 16, 1966

PROPOSED FILL
IN HUDSON RIVER
AT INDIAN POINT
COUNTY OF WESTCHESTER, STATE OF NEW YORK
APPLICATION BY CONSOLIDATED EDISON CO.
OF NEW YORK, INC.

SHEET 2 OF 5

JANUARY 10, 1966

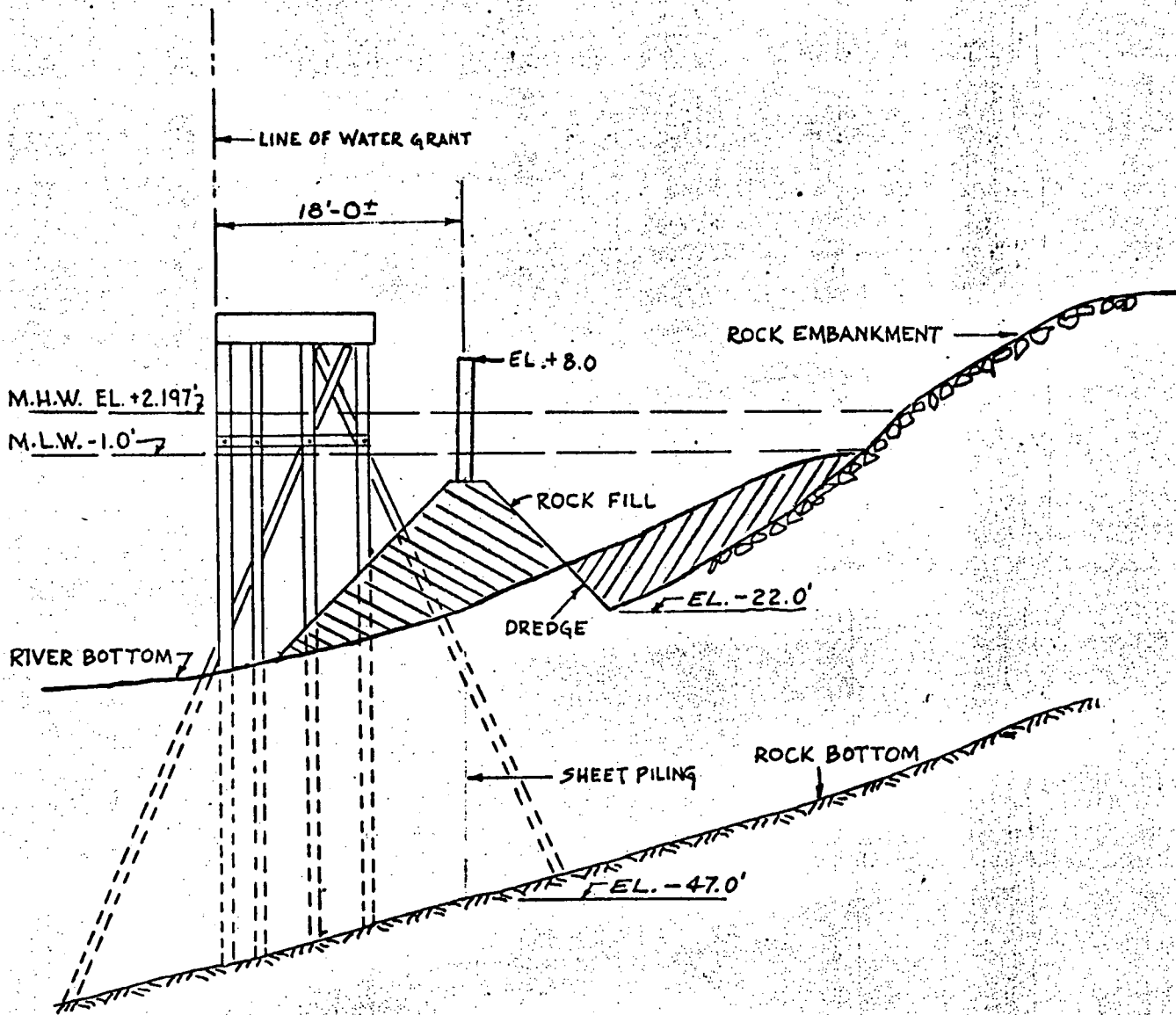

SECTION B - B

SCALE IN FEET

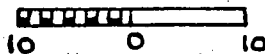

PROPOSED DISCHARGE
CHANNEL EXTENSION
IN HUDSON RIVER
AT INDIAN POINT

COUNTY OF WESTCHESTER, STATE OF NEW YORK
APPLICATION BY CONSOLIDATED EDISON CO.
OF NEW YORK, INC.

SHEET 3 OF 5

FEBRUARY 16, 1966

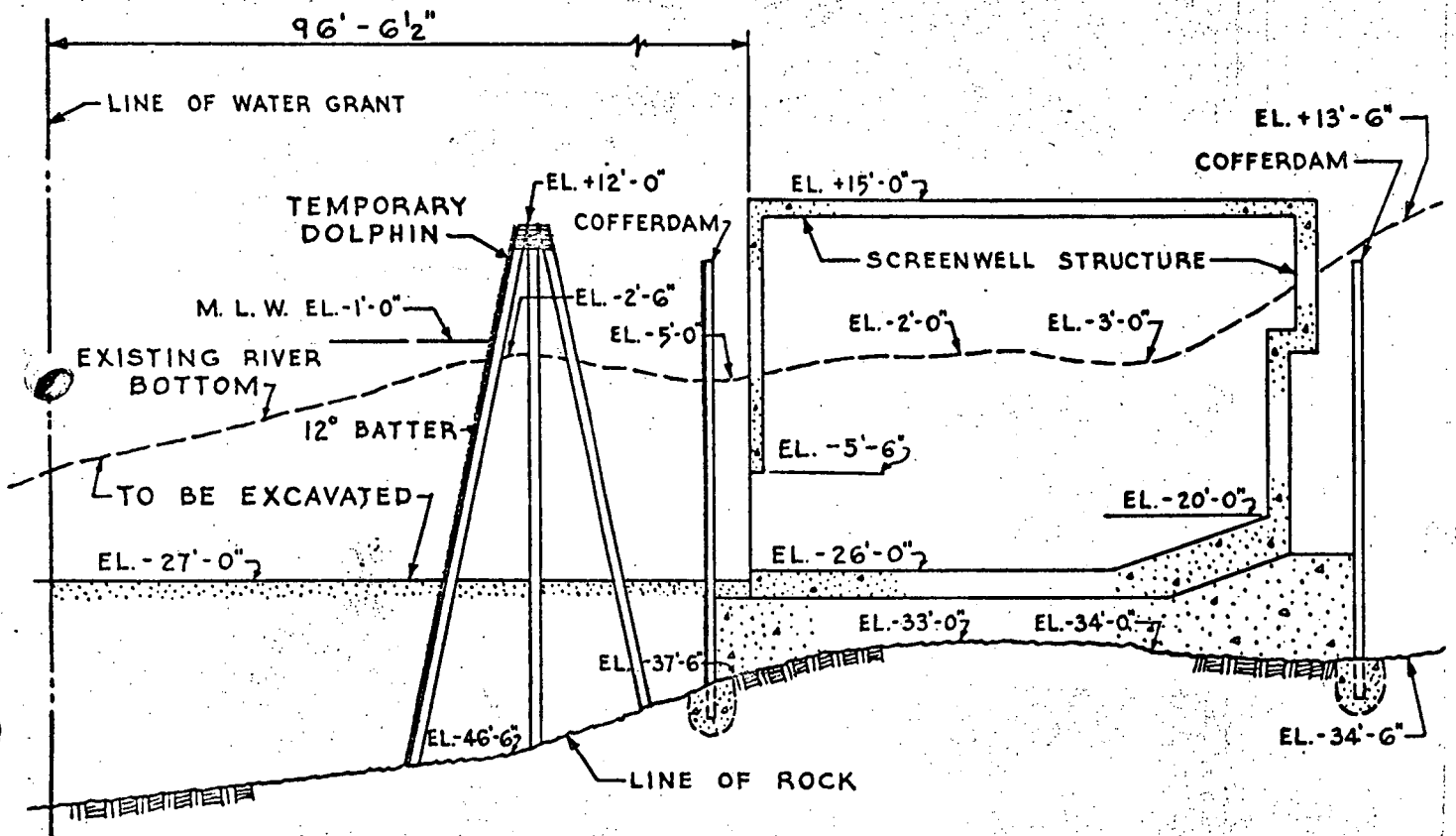

SECTION C - C

SCALE: 1" = 20'

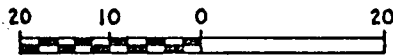

UNIT No 2

PROPOSED SCREENWELL STRUCTURE,
 DOLPHINS & DREDGING
 IN HUDSON RIVER
 AT INDIAN POINT

COUNTY OF WESTCHESTER, STATE OF NEW YORK
 APPLICATION BY CONSOLIDATED EDISON CO.
 OF NEW YORK

SHEET 4 OF 5

FEB. 16, 1966

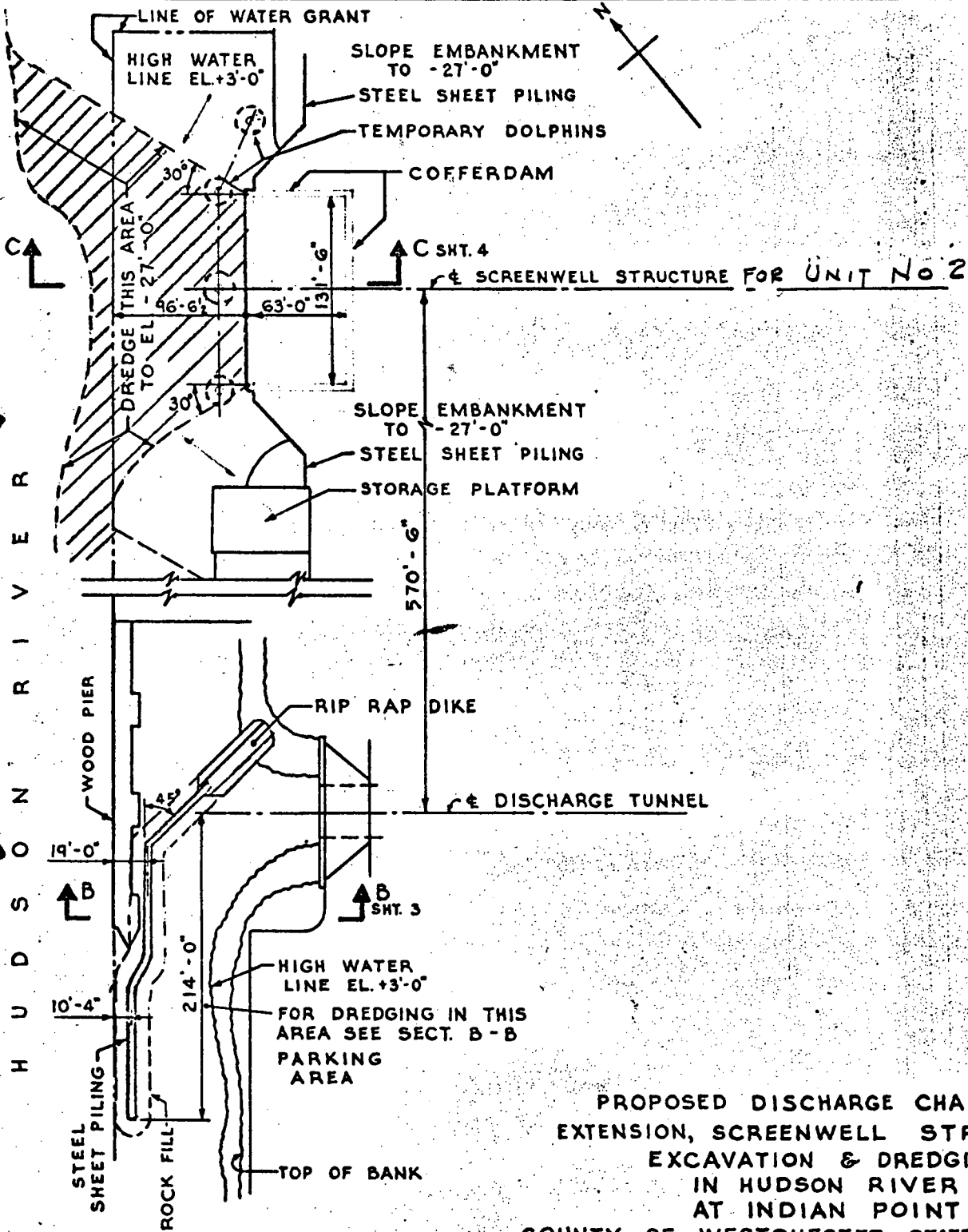

ENLARGED PLAN OF
DISCHARGE TUNNEL &
SCREENWELL STRUCTURE AREA

PROPOSED DISCHARGE CHANNEL
EXTENSION, SCREENWELL STRUCTURE,
EXCAVATION & DREDGING
IN HUDSON RIVER
AT INDIAN POINT
COUNTY OF WESTCHESTER, STATE OF NEW YORK
APPLICATION BY CONSOLIDATED EDISON CO.
OF NEW YORK, INC.

SHEET 5 OF 5

FEBRUARY 16, 1966

SCALE: 1" = 100'



DEPARTMENT OF THE ARMY
NEW YORK DISTRICT, CORPS OF ENGINEERS
111 EAST 16TH STREET
NEW YORK, N. Y. 10003

IN REPLY REFER TO

NANOP-E

19 January 1967

Consolidated Edison Company of New York, Inc.
4 Irving Place
New York, N.Y. 10003

Gentlemen:

In accordance with written request dated 30 December 1966, signed by Mr. E. G. Watkins, the revised plans hereto attached are approved to supersede the plans approved by the Secretary of the Army in Department of the Army permit dated 23 February 1966, and revised plans approved on 15 March 1966, to place fill in Hudson River at Indian Point, Westchester County, New York.

The conditions to which the work is made subject remain in full force and effect.

BY AUTHORITY OF THE SECRETARY OF THE ARMY:

1 Incl
Drawing
(Sheets 1,4&5)

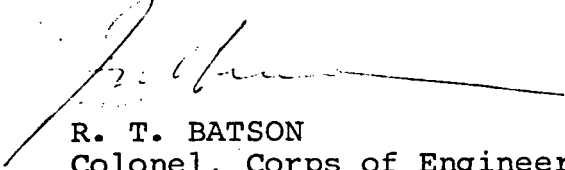
R. T. BATSON
Colonel, Corps of Engineers
District Engineer

DEPARTMENT OF THE ARMY

NOTE.—It is to be understood that this instrument does not give any property rights either in real estate or material, or any exclusive privileges; and that it does not authorize any injury to private property or invasion of private rights, or any infringement of Federal, State, or local laws or regulations, nor does it obviate the necessity of obtaining State assent to the work authorized.

(See Cummings v. Chicago, 188 U. S., 410.)

16-13168-6

NANOP-E

PERMIT

Department of the Army, New York District
Corps of Engineers
111 East 16th Street, New York, N.Y. 10003
29 September, 1967

Consolidated Edison Company of New York, Inc.
4 Irving Place
New York, N. Y. 10003

Gentlemen:

Referring to written request dated 22 May 1967, signed by Mr. E. G. Watkins,
Structural Engineer, - - - - -

I have to inform you that, upon the recommendation of the Chief of Engineers,
and under the provisions of Section 10 of the Act of Congress approved March 3,
1899, entitled "An act making appropriations for the construction, repair, and
preservation of certain public works on rivers and harbors, and for other pur-
poses," you are hereby authorized by the Secretary of the Army.

to construct a screenwell, bulkheads, a discharge channel, to dredge to a depth
(Here describe the proposed structure or work.)
of twenty-six (26) feet below mean low water; dredged material to be placed behind
the bulkheads, and to install temporary dolphins; - - - - -
in Hudson River, - - - - -
(Here to be named the river, harbor, or waterway concerned.)

at Indian Point, Westchester County, N. Y., - - - - -
(Here to be named the nearest well-known locality—preferably a town or city—and the distance in miles and tenths from some definite point in
the same, stating whether above or below or giving direction by points of compass.)

5
in accordance with the plans shown on the sheets attached hereto and marked:
(Or drawings; give file number or other definite identification marks.)
1507-24 (Hudson River-Consolidated Edison Co. of N.Y., Inc-screenwell, bulkheads,
and discharge channel, dredge and fill at Indian Point), - - - - -
subject to the following conditions:

① E. G. Watkins

(m) That the permittee shall make modifications of project structures and of the operation of the Indian Point Nuclear Power Station as necessary to comply with the applicable State or Federal water quality standards.

(n) That the permittee shall comply with any regulation, condition, or instruction affecting the work hereby authorized if and when issued by the State or Interstate water pollution control agency having jurisdiction to abate or prevent water pollution, or by the Federal Water Pollution Control Administration.

BY AUTHORITY OF THE SECRETARY OF THE ARMY:



FOR AND IN BEHALF OF

R. T. BATSON

Colonel, Corps of Engineers
District Engineer



(6)

DEPARTMENT OF THE ARMY
NEW YORK DISTRICT, CORPS OF ENGINEERS
26 FEDERAL PLAZA
NEW YORK, N. Y. 10007

IN REPLY REFER TO

NANOP-E

24 November 1970

Consolidated Edison Company
of New York, Inc.
4 Irving Place
New York, N.Y. 10003

Gentlemen:

In accordance with written request dated 3 August 1970, signed by Mr. Joseph A. Marubbio, the revised plans hereto attached are approved to supersede the plans approved by the Secretary of the Army in Department of the Army permit dated 29 September 1967, to construct a screenwell, bulkheads, a discharge channel, to dredge to a depth of twenty-six (26) feet below mean low water; dredged material to be placed behind the bulkheads, and to install temporary dolphins, in Hudson River, at Indian Point, Westchester County, N.Y.

The revised plans, submitted in accordance with condition (m) of the permit, provide for the installation of a steel outfall section consisting of 12 submerged openings. The dredging area and the construction of the mooring dolphins have also been modified.

The conditions to which the work is made subject remain in full force and effect.

BY AUTHORITY OF THE SECRETARY OF THE ARMY:

A handwritten signature in cursive script, appearing to read "James W. Barnett".

For and in behalf of

JAMES W. BARNETT
Colonel, Corps of Engineers
District Engineer

1 Incl
Drawing

7589

FILE COPY

VINCENTI/ip/226



DEPARTMENT OF THE ARMY
NEW YORK DISTRICT, CORPS OF ENGINEERS
111 EAST 16TH STREET
NEW YORK, N. Y. 10003

IN REPLY REFER TO

NANOP-E

11 December 1967

Consolidated Edison Company of
New York, Inc.
4 Irving Place
New York, N.Y. 10003

Gentlemen:

With reference to written request dated 23 October 1967, upon the recommendation of the Chief of Engineers and under the provisions of Section 10 of the Act of Congress approved 3 March 1899 (30 Stat. 1151; 33 U.S.C. 403), you are hereby authorized by the Secretary of the Army to dredge a flotation channel to a depth of ten (10) feet below mean sea level and construct a ramp in Lents Cove, Hudson River at Village of Buchanan, County of Westchester, New York, in accordance with the attached plans. The dredged material is to be deposited at an approved Government dumping ground under a permit to be obtained from the Supervisor of New York Harbor.

This permission, if not previously revoked or specifically extended shall cease and be null and void if the work authorized is not completed on or before 31 December 1970.

It is to be understood that the authorization does not give any property rights either in real estate or material, or any exclusive privileges, and that it does not authorize any injury to private property or invasion of private rights, or any infringement of Federal, State, or local laws or regulations, nor does it obviate the necessity of obtaining State assent to the work authorized. (See Cummings v. Chicago, 188 U.S., 410.)

BY AUTHORITY OF THE SECRETARY OF THE ARMY:

Dallas L. Knoll, Jr.
For and in behalf of

DALLAS L. KNOLL, JR.
Colonel, Corps of Engineers
Acting District Engineer

1 Incl
Drawings, Sheet 1 & 2

POLL/OP-E
Wuestefeld
WUESTEFELD/OP

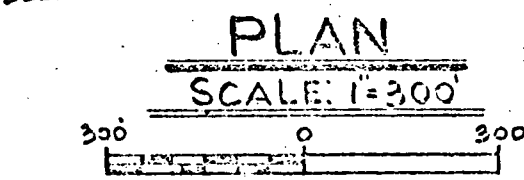
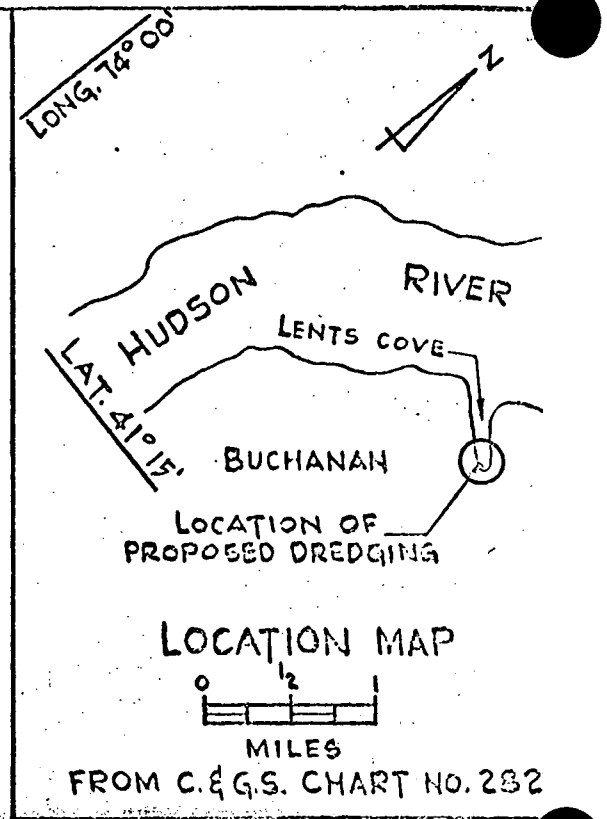
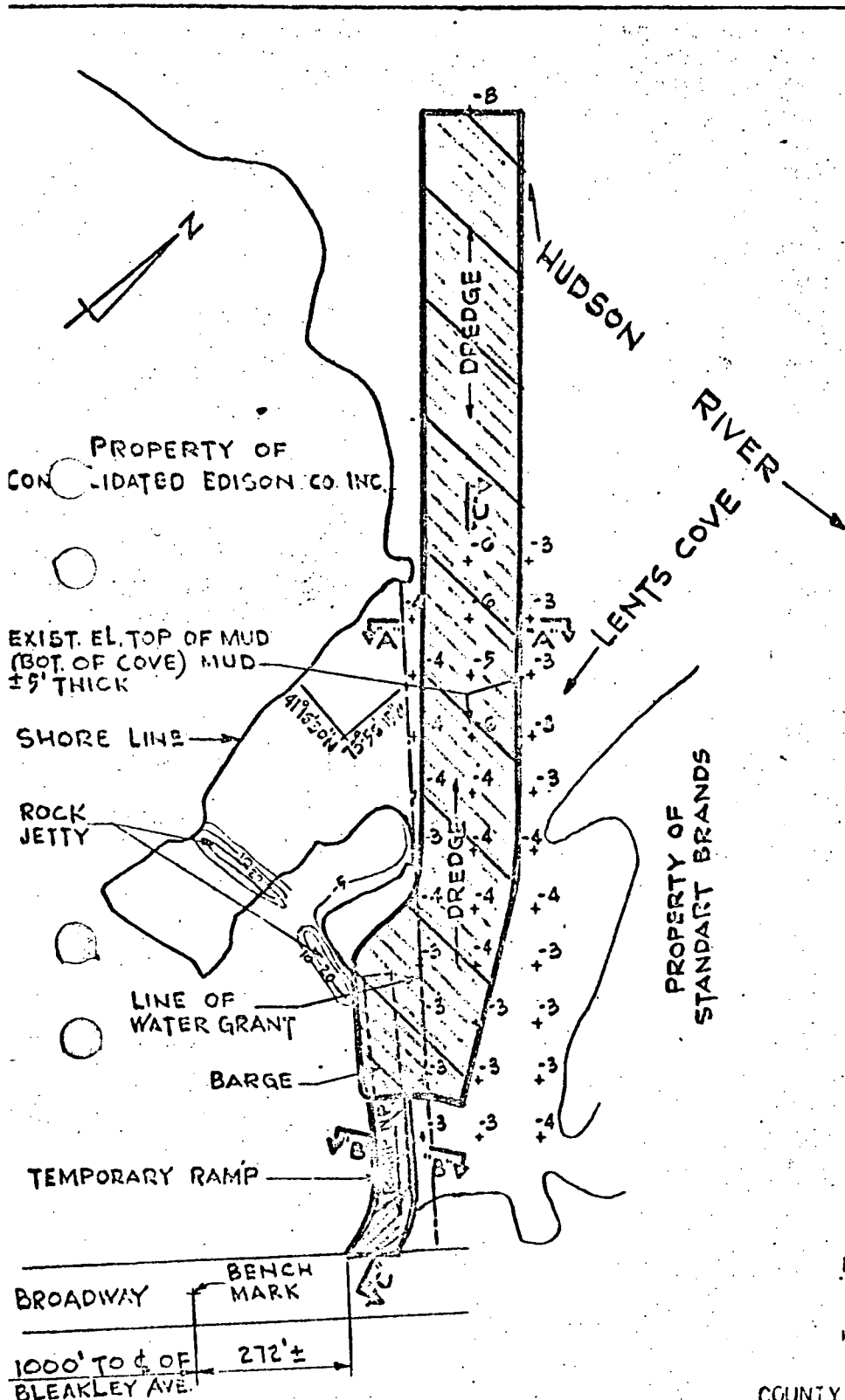

PROPOSED DREDGING AND RAMP
AT LENTS COVE

HUDSON RIVER AND BROADWAY
VILLAGE OF BUCHANAN
COUNTY OF WESTCHESTER, STATE OF NEW YORK

APPLICATION BY
CONSOLIDATED EDISON CO OF NEW YORK, INC

SHEET 1 OF 2 OCTOBER 23, 1967

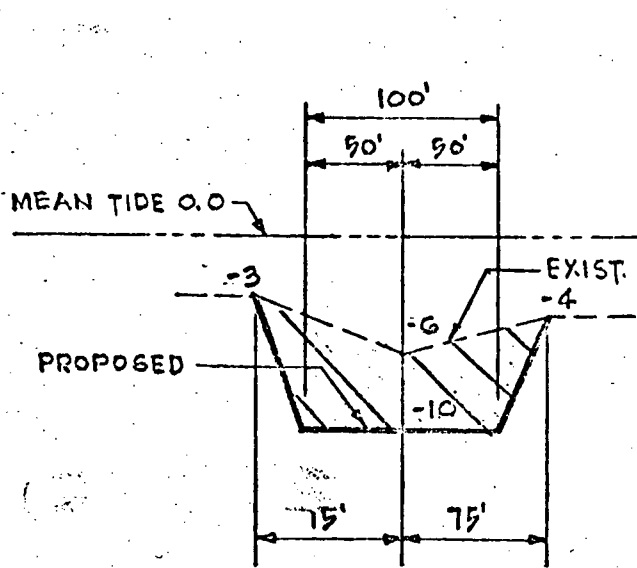

SECTION "A-A"

HORIZ. SCALE: 1"=100'-0"
VERT. SCALE: 1"=10'-0"

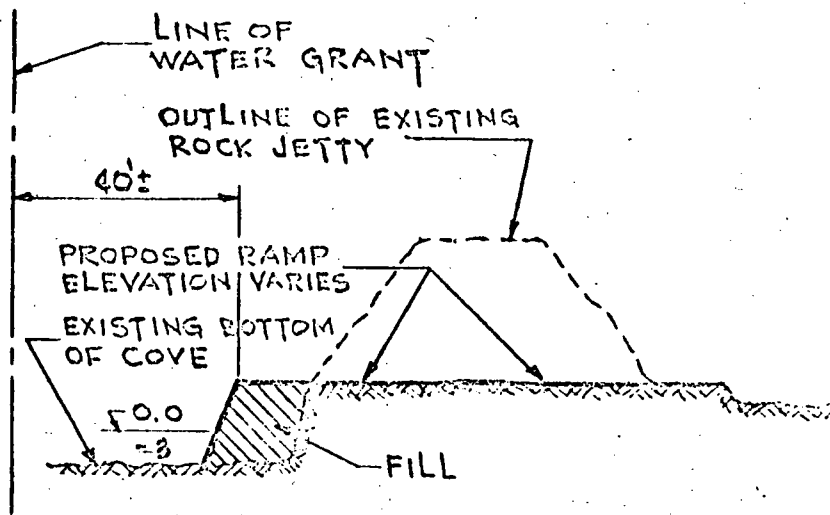

SECTION "B-B"

SCALE: 1"=20'-0"

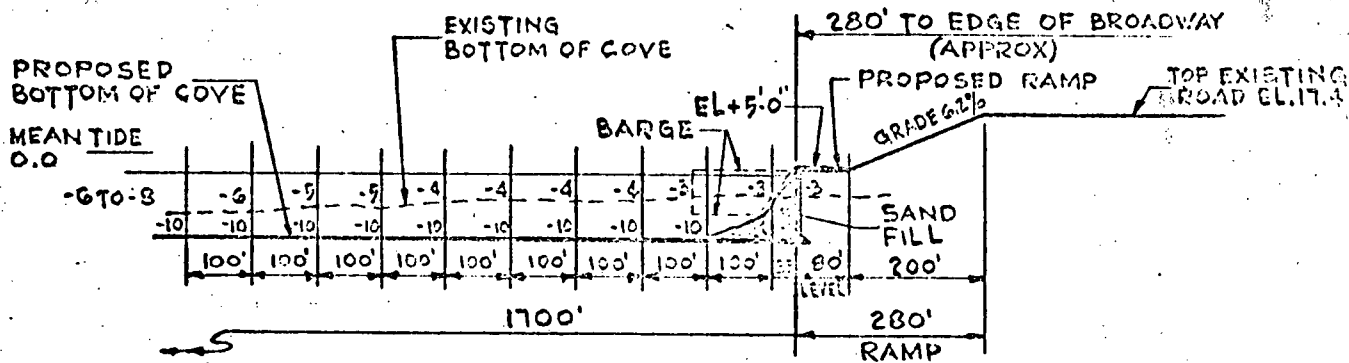

SECTION "C-C"

HORIZ. SCALE: 1"=300'-0"
VERT. SCALE: 1"=30'-0"

NOTE:

SOUNDINGS ARE IN FEET AND REFER TO MEAN TIDE LEVEL AT LENT'S COVE WHICH IS 1.7' ABOVE HUDSON RIVER DATUM

PROPOSED DREDGING AND RAMP AT LENTS COVE

HUDSON RIVER AND BROADWAY VILLAGE OF BUCHANAN COUNTY OF WESTCHESTER, STATE OF NEW YORK

APPLICATION BY CONSOLIDATED EDISON CO OF NEW YORK, INC

STATE OF NEW YORK
DEPARTMENT OF HEALTH

HOLLIS S. INGRAHAM, M. D.
COMMISSIONER

84 HOLLAND AVENUE
ALBANY, N. Y. 12208

MEREDITH H. THOMPSON, D. ENG.
ASSISTANT COMMISSIONER

BUREAU OF

WATER RESOURCE SERVICES
ROBERT D. HENNIGAN, P.E.
DIRECTOR

August 22, 1966

Superseded May 1970

SEP 6 1966
INDIAN PT 2
5B

Handwritten notes:
The attached
plans for the
discharge of the
effluent from
the plant.

Consolidated Edison Company of New York
4 Irving Place
New York, New York

Attention: H. W. Dierman, Chief Engineer

Gentlemen:

Re: Approval of Final Plans
Cooling Water Discharge Facilities
Indian Point Generating Station
Buchanan (V), Westchester County

Transmittal

The permit for this project, dated August 22, 1966, is attached.

One approved copy of the design report and specifications are being forwarded.

This permit supersedes and voids the permit issued for Unit #1, on August 1, 1961.

This permit carries qualifying conditions:

1. Revocability and modification
2. Construction conformance with approved plans
3. Construction time limitations
4. Start of operation
5. Satisfactory operation
6. Volume and type of waste limitation
7. Renewal provisions
8. Submission of monthly operating reports
9. Radioactive concentrations in the effluent
10. Temperature effects on receiving waters
11. Facilities modification
12. Chlorine concentrations in the effluent

Operation Responsibility

It is the permittee's responsibility to insure that this facility is operated at all times in conformity to the Public Health Law and State Health Department regulations.

Required Analyses

The minimum measurements and analyses of influent water and final discharge are:

1. Flow
2. Temperature
3. Chlorine residual, demand and feed rate

The receiving waters shall also be measured for temperature.

Assistance

Information can be obtained from the Westchester County Health Department regarding:

1. Details, frequency, and requirements for laboratory analyses.
2. Certificate of construction compliance.
3. Submission of monthly operational reports.

Facilities Approved

Approved plans call for the installation of 214 foot cooling water discharge channel.

Performance

The facility is approved on the basis that it shall maintain a receiving water quality of Class SB standards and shall discharge an effluent that will not produce a deleterious effect on fish life or propagation.

August 22, 1966

Additional Facilities

Because of the nature of the discharge it is recognized by Consolidated Edison, that additional works may be needed to correct unforeseen deficiencies uncovered during operational surveillance. Such modifications may be in the nature of the addition of de-chlorination facilities and the provision of a sub-aqueous multi-port diffuser.

Very truly yours,

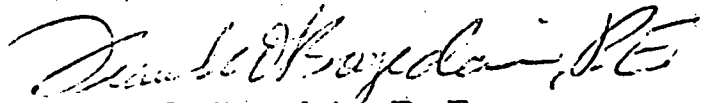

Frank O. Bogedain, P. E.
Chief, Municipal-Industrial
Wastes Section

Attachment

cc: Westchester County Health Department
White Plains Regional Office

PERMIT TO CONSTRUCT AND OPERATE WASTE TREATMENT WORKS AND TO DISCHARGE WASTES INTO WATERS OF THE STATE

This permit is issued under the provisions of Article 12 of the Public Health Law for the project described below:

Consolidated Edison Co. of N.Y.		<input checked="" type="checkbox"/> Surface Water Discharge <input type="checkbox"/> Ground Water Discharge	<input type="checkbox"/> Sewers <input type="checkbox"/> Pumping Station	<input type="checkbox"/> Treatment Works <input checked="" type="checkbox"/> Additions or Alterations
Name of receiving water course, if surface waters; if subsurface, name of water course to which ground water is tributary Hudson River		Name of City, Village or Town in which point of discharge is located. Buchanan	Name & Location of Works (city, village or town) Indian Point Gen. Sta.	<input type="checkbox"/> Municipal <input type="checkbox"/> Institutional <input type="checkbox"/> Private (individual) <input type="checkbox"/> Private (other) <input checked="" type="checkbox"/> Industrial Waste
Class: SB	Name of major drainage basin in which point of discharge is located Lower Hudson	County: Westchester		
Estimated cost of works \$200,000	Design flow gals. per day 1.8 BGD	Design equivalent population BOD basis N/A	Grade of Certified Supervising Plant Operator required N/A	Degree of Treatment <input type="checkbox"/> Primary <input type="checkbox"/> Intermediate <input type="checkbox"/> Secondary <input type="checkbox"/> Tertiary

Description of works such as number, name and capacity of units. If sewer construction or pumping station, name the tributary plant.

214 foot cooling water discharge channel

Permission to discharge wastes is granted upon and subject to the following conditions which, by initiating construction of the approved works, the permittee accepts and agrees to abide by and conform with the following:

1. THAT the permit shall be revocable at any time or subject to modifications or change pursuant to Article 12 of the Public Health Law, when in the judgment of the Commissioner such revocation, modification, or change shall become necessary or desirable.
2. THAT the proposed works shown on the approved plans and approved specifications shall be fully constructed in complete conformity with such plans and specifications, or approved amendments thereto (under the supervision of a New York State licensed Professional Engineer).
3. THAT this permit shall be deemed null and void unless construction of the works for which this permit is issued is commenced by Dec. 31, 1966 and fully completed by Dec. 31, 1969.
4. THAT the works shall not be placed in operation until they have been completed in accordance with the approved plans, unless permission is received for the temporary use of a portion of the works from the local health office having jurisdiction.
5. THAT the works and appurtenances shall be operated and maintained for their intended use at all times so as to comply with the provisions of the Public Health Law and the Sanitary Code of the State of New York and all other laws, statutes, codes and rules and regulations applicable.

SEE REVERSE SIDE

ISSUED FOR THE STATE COMMISSIONER OF HEALTH | DATE
Thomas C. Brogden, Jr. | 8/22/66
 Designated Representative

6. THAT only the volume and type of waste described in the engineer's project report dated April 8, 1966 and approved on August 22, 1966, and no additional waste, storm water, surface water or any other source of extraneous liquid or solids shall be admitted to the discharge works.
7. THAT this permit shall terminate in five years from the date of issuance. An application for renewal shall be made on forms supplied by the Department of Health and accompanied by such supporting information as the Department of Health may request.
8. THAT reports of the daily operation of the cooling water facilities including laboratory tests and results shall be submitted monthly to the Department of Health on forms furnished by or satisfactory to the Department of Health.
9. THAT quantities or concentrations in the effluent at site boundaries are subject to the requirements of the United States Atomic Energy Commission as specified in Title 10, Code of Federal Regulations, Part 20, or as otherwise specified in applicable licenses issued by the United States Atomic Energy Commission.
10. THAT at all times the temperature of the effluent shall not exceed a level that will produce a deleterious effect on fish life and propagation thereof in the receiving water.
11. THAT whenever required by the Department of Health the proposed works shall be modified in accordance to plans first submitted to and approved by the Department of Health.
12. THAT at all times the chlorine residual in the effluent shall not exceed five-tenths milligram per liter (0.5mg/l).

MAR 7 9 17 AM '66

PERMIT NO. 8-4-66
DAM NO. _____STATE OF NEW YORK
WATER RESOURCES COMMISSION
CONSERVATION DEPARTMENTConsolidated Edison Co. of New York, Inc.4 Irving Place, New York, N.Y.

residing at

is hereby permitted to: (construct) (reconstruct) (repair) (alter the bed or banks of) (dredge) (place fill in) _____
Hudson RiverLocated in County Westchester Town Cortlandtcarrying out the following works: Construct Discharge Extension bySection of stream to which this permit applies That section on property of Consolidated Edison Co.,
Indian Point, N.Y.

Note: (a) This permit does not relieve the permittee of responsibility for damages to riparian owners or others.

(b) If the structure or work herein authorized is not completed on or before the 30th day of
June, 1966, this permit, if not specifically extended, shall cease and be null and void.

CONDITIONS

1. The permitted work shall be subject to inspection by an authorized representative of the Water Resources Commission who may order the work suspended if the public interest so requires.

2. The permittee shall file in the office of the Local Permit Agent a notice of intention to commence work at least 48 hours in advance of the time of commencement and shall also notify him promptly in writing of the completion of the work.

3. As a condition of the issuance of this permit, the applicant has accepted expressly, by the execution of the application, the full legal responsibility for all damages, direct or indirect, of whatever nature, and by whomever suffered, arising out of the project described herein and has agreed to indemnify and save harmless the State from suits, actions, damages and costs of every name and description resulting from the said project.

4. Any material dredged in the prosecution of the work herein permitted shall be removed evenly, without leaving large refuse piles, ridges across the bed of the waterway, or deep holes that may have a tendency to cause injury to navigable channels or to the banks of the waterway.

5. Any material to be deposited or dumped under this permit, either in the waterway or on shore above high-water mark, shall be deposited or dumped at the locality shown on the drawing hereto attached, and, if so prescribed thereon, within or behind a good and substantial bulkhead or bulkheads, such as will prevent escape of the material into the waterway.

6. There shall be no unreasonable interference with navigation by the work herein authorized.

7. That if future operations by the State of New York require an alteration in the position of the structure or work herein authorized, or if, in the opinion of the Water Resources Commission it shall cause unreasonable obstruction to the free navigation of said waters or endanger the health, safety or welfare of the people of the State, or loss

or destruction of the natural resources of the State, the owner may be ordered by the Commission to remove or alter the structural work, obstructions, or hazards caused thereby without expense to the State; and if, upon the expiration or revocation of this permit, the structure, fill, excavation, or other modification of the watercourse hereby authorized shall not be completed, the owners shall, without expense to the State, and to such extent and in such time and manner as the Water Resources Commission may require, remove all or any portion of the uncompleted structure or fill and restore to its former condition the navigable capacity of the watercourse. No claim shall be made against the State of New York on account of any such removal or alteration.

8. That the State of New York shall in no case be liable for any damage or injury to the structure or work herein authorized which may be caused by or result from future operations undertaken by the State for the conservation or improvement of navigation, or for other purposes, and no claim or right to compensation shall accrue from any such damage.

9. That if the display of lights and signals on any work hereby authorized is not otherwise provided for by law, such lights and signals as may be prescribed by the United States Coast Guard shall be installed and maintained by and at the expense of the owner.

10. All work carried out under this permit shall be performed in accordance with established engineering practice and in a workmanlike manner.

11. This permit shall not be construed as conveying to the applicant any right to trespass upon the lands of others to perform the permitted work or as authorizing the impairment of any right, title or interest in real or personal property held or vested in a person not a party to the permit.

12. Nothing in this permit shall be deemed to affect the responsibility of the permittee to comply with any applicable Rules and Regulations of the U.S. Army Corps of Engineers or any other governmental agency having jurisdiction.

Other Conditions:

None

The issuance of this permit certifies that it is not contrary to the public interest that the proposed works be done.
The applicant in accepting this permit signifies his agreement to abide by the conditions set forth above.

Application Date 2/1/66 Expiration Date 6/30/66
Permit Issued 3/2/66

By Warren H. McKeon
(Permit Agent) **Supv.,** (Name and Address)

Warren H. McKeon, Regl. ~~Supv.~~ Region 8
NYS Conservation Department, 105 Dutchess Turnpike, Poughkeepsie, N.Y.

cc: Robert Cook (1)
George Odell (2)

PERMIT NO. 8-22-70
DAM NO. _____

STATE OF NEW YORK
WATER RESOURCES COMMISSION
~~XX~~

Consolidated Edison Company of New York, Inc. residing at
4 Irving Place, New York City, New York 10003

is hereby permitted to: ~~XX~~
Construct discharge channel

Located in County Westchester Town Buchanan by
carrying out the following works: Extend discharge canal 98 feet down river and protect with
sheetpiling at Indian Point Generating Station as described in sketches 1-5 submitted
with application.

Section of stream to which this permit applies Hudson River

Note: (a) This permit does not relieve the permittee of responsibility for damages to riparian owners or others.
(b) If the structure or work herein authorized is not completed on or before 31 day of
December, 1970, this permit, if not specifically extended, shall cease and be null and void.

CONDITIONS

1. The permitted work shall be subject to inspection by an authorized representative of the Water Resources Commission who may order the work suspended if the public interest so requires.
2. The permittee shall file in the office of the Local Permit Agent a notice of intention to commence work at least 48 hours in advance of the time of commencement and shall also notify him promptly in writing of the completion of the work.
3. As a condition of the issuance of this permit, the applicant has accepted expressly, by the execution of the application, the full legal responsibility for all damages, direct or indirect, of whatever nature, and by whomever suffered, arising out of the project described herein and has agreed to indemnify and save harmless the State from suits, actions, damages and costs of every name and description resulting from the said project.
4. Any material dredged in the prosecution of the work herein permitted shall be removed evenly, without leaving large refuse piles, ridges across the bed of the waterway, or deep holes that may have a tendency to cause injury to navigable channels or to the banks of the waterway.
5. Any material to be deposited or dumped under this permit, either in the waterway or on shore above high-water mark, shall be deposited or dumped at the locality shown on the drawing hereto attached, and, if so prescribed thereon, within or behind a good and substantial bulkhead or bulkheads, such as will prevent escape of the material into the waterway.
6. There shall be no unreasonable interference with navigation by the work herein authorized.
7. That if future operations by the State of New York require an alteration in the position of the structure or work herein authorized, or if, in the opinion of the Water Resources Commission it shall cause unreasonable obstruction to the free navigation of said waters or endanger the health, safety or welfare of the people of the State, or loss

- or destruction of the natural resources of the State, the owner may be ordered by the Commission to remove or alter the structural work, obstructions, or hazards caused thereby without expense to the State; and if, upon the expiration or revocation of this permit, the structure, fill, excavation, or other modification of the watercourse hereby authorized shall not be completed, the owners shall, without expense to the State, and to such extent and in such time and manner as the Water Resources Commission may require, remove all or any portion of the uncompleted structure or fill and restore to its former condition the navigable capacity of the watercourse. No claim shall be made against the State of New York on account of any such removal or alteration.
8. That the State of New York shall in no case be liable for any damage or injury to the structure or work herein authorized which may be caused by or result from future operations undertaken by the State for the conservation or improvement of navigation, or for other purposes, and no claim or right to compensation shall accrue from any such damage.
9. That if the display of lights and signals on any work hereby authorized is not otherwise provided for by law, such lights and signals as may be prescribed by the United States Coast Guard shall be installed and maintained by and at the expense of the owner.
10. All work carried out under this permit shall be performed in accordance with established engineering practice and in a workmanlike manner.
11. This permit shall not be construed as conveying to the applicant any right to trespass upon the lands of others to perform the permitted work or as authorizing the impairment of any right, title or interest in real or personal property held or vested in a person not a party to the permit.
12. Nothing in this permit shall be deemed to affect the responsibility of the permittee to comply with any applicable Rules and Regulations of the U.S. Army Corps of Engineers or any other governmental agency having jurisdiction.

The issuance of this permit certifies that it is not contrary to the public interest that the proposed works be done.
The applicant in accepting this permit signifies his agreement to abide by the conditions set forth above.

Application Date March 16, 1970 Expiration Date December 31, 1970

Permit Issued June 30, 1970

By *[Signature]* State of New York, Conservation Dept., Albany, N.Y.
Central (Permit Agent) (Name and Address) 12201

cc: Warren McKeon (2)
Eli Dietsch
Corps of Engineers - New York

P E R M I T

No. 8-22-70

(TO ALTER OR CHANGE A STREAM OR WATERCOURSE)

has been issued to CON. EDISON
NEW YORK, N.Y.

DISCHARGE CANAL AT INDIAN POINT STA.

under the Conservation Law, Part III A, Art. 5

New York State Water Resources Commission

Robert W. Kilborne, Chairman

T. P. CURRAN

Permit Agent

12-31-70

Expiration Date

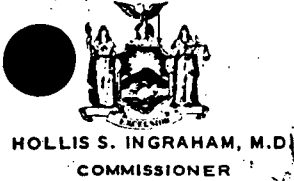

copy to ENE file 5/25/70

CERTIFIED MAIL
Return Receipt Requested

STATE OF NEW YORK
DEPARTMENT OF HEALTH

84 HOLLAND AVENUE
ALBANY, NEW YORK 12208

May 19, 1970

ENVIRONMENTAL HEALTH SERVICES

DWIGHT F. METZLER, P.E.
DEPUTY COMMISSIONER

DIVISION OF PURE WATERS
PAUL W. EASTMAN, P.E.
ASSISTANT COMMISSIONER

Mr. Charles F. Luce
Chairman of the Board
Consolidated Edison Company of New York, Inc.
4 Irving Place
New York, New York 10003

Dear Sir:

Re: Outfall Construction
Indian Point Nuclear Station
Buchanan (V), Westchester County

Transmittal

The construction permit for this project, dated May 19, 1970, is attached.

One approved copy of the plans is being forwarded separately.

Permit to Construct

This permit carries qualifying conditions:

1. Permit filing
2. Revocability and modification
3. Construction conformance
4. Start of operation
5. Construction supervision
6. Construction certification
7. Construction time limitations
8. Additional restrictions and response

The attached construction permit does not constitute authority to operate the approved facilities. Please note instructions below regarding operation permit.

Mr. Charles F. Luce
Page 2
May 19, 1970

Permit to Operate

Pursuant to provisions of Part 73 of Title 10 of the official compilation of Codes, Rules and Regulations of the State of New York, a permit to operate the constructed facilities is required.

Upon completion of the facilities, application for the permit to operate should be submitted to the Bureau of Industrial Wastes of the New York State Department of Health, 84 Holland Avenue, Albany, New York, accompanied by a certificate of construction compliance, executed by the New York State licensed professional engineer supervising construction.

The Bureau of Industrial Wastes will contact you in the near future to provide application forms and instructions for the operating permit.

The attached permit authorizes construction of an effluent channel and diffuser whose hydraulic capacity is rated at 3,020,000,000 gallons per day. It shall not be inferred that this authority to construct commits the Department to allow operation at the rated capacity. Serious questions concerning the acceptability of discharges of heated waters from the operation of all three units at Indian Point remain unanswered.

Destruction of the previously approved outfalls for units one and two to facilitate construction of the intake and outfall for unit three is noted. The urgency to obtain approval to construct this outfall for the current discharge from unit one and the near-future discharge from unit two is recognized. The Department will, upon completion of these facilities, and receipt of your application, issue an operating permit for unit one.

To obtain operating permits for units two and three, it must be conclusively demonstrated by Consolidated Edison Company that the thermal criteria relating to limits and distribution of temperature and the thermal standard relating to conditions non-injurious to fish life will be satisfied. It is also necessary to define and verify predictions made from mathematical and hydraulic models to correlate actual operati

Mr. Charles F. Luce
Page 3
May 19, 1970

of units one and two to conditions postulated for unit three. The conclusions drawn by your consultants from studies done to date cannot be accepted as representative of conditions that will prevail after operation is established. Field work to assess actual conditions and effects of unit one, and units one and two, to supplement theoretical projections is essential. To this end, it is required that extensive temperature and ecological studies, on a program to be agreed to by the company and the various agencies involved, be conducted and reported to establish the basis for unit two and three operating permits.

An analysis of existing and projected thermal loadings on the Hudson River estuary portion, which includes your existing Indian Point site and the proposed Verplanck site, have indicated a future heat load which would be unacceptable. Therefore, you are formally advised that any further units proposed for Indian Point or for Verplanck will require cooling facilities to reduce cooling water temperature to essentially intake ambient temperature.

Acceptance of the enclosed permit and initiation of construction will constitute agreement by Consolidated Edison Company to the conditions of approval, including the restrictions intended to be imposed on its future operations. If these restrictions cannot be accepted, the permit should be rejected. If that course of action is selected by Consolidated Edison Company, the Department will schedule a public hearing for denial of the permit application for unit number three on the grounds that it has not been conclusively demonstrated that the water resource will be protected or the water quality standards will not be contravened by the proposed operations of the Company.

A reply at your earliest convenience will be appreciated.

Very truly yours,

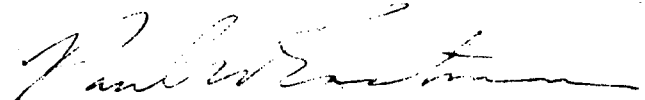

Paul W. Eastman, P.E.
Assistant Commissioner

Attachment

cc: Westchester County Health Dept.
White Plains Regional Office
Quirk, Lawler, Matusky
Interstate Sanitation Commission
Hudson River Valley Commission

NEW YORK STATE DEPARTMENT OF HEALTH

PERMIT TO CONSTRUCT A WASTE DISPOSAL SYSTEM

Permit is issued under the provisions of Article 12 of the Public Health Law and 10 NYCRR 73.

1. Name of Permittee: Consolidated Edison Company of New York, Inc.	2. Location of Works (C,V,T): Buchanan (V)	3. County: Westchester	4. Entity or Area Served: Indian Point Nuclear Power Plant
--	---	-------------------------------	---

By initiating construction of the approved works, the permittee accepts and agrees to abide by and conform with the following:

1. THAT the construction permit shall be maintained on file by the permittee.
2. THAT the permit is revocable or subject to modification or change pursuant to Article 12 of the Public Health Law.
3. THAT the facilities shall be fully constructed and completed in compliance with the engineering report, plans and specifications as approved.
4. THAT the facilities shall not be placed in operation until construction has been completed and an operation permit has been issued, or unless ordered to be operated by the Commissioner or by a Court.
5. THAT the construction of the facilities shall be under the supervision of a person or firm qualified to practice professional engineering in the State of New York under the Education Law of the State of New York, whenever engineering services are required by such law for such purposes.
6. THAT where such facilities are under the supervision of a professional engineer, he shall certify to the Department and to the permittee that the constructed facilities have been under his supervision and that the works have been fully completed in accordance with the approved engineering reports, plans, specifications and permit.
7. THAT the construction of the facilities shall commence by June 1, 1970 and be fully completed by September 1, 1970.
8. THAT this permit shall not be effective until Consolidated Edison Company of New York Inc. shall respond in writing to agree to conditions contained in the letter which transmits the permit.

(SEE REVERSE SIDE)

ISSUED FOR THE STATE COMMISSIONER OF HEALTH | DATE
Alvin J. [Signature] | 5/19/70
 Designated Representative

Distribution: White - Applicant
 Pink - Central Office (BED) Yellow - File (LHO or DHO)
 Green - Other

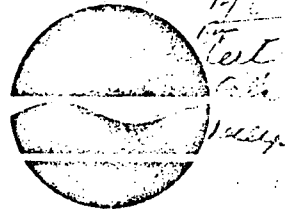

New York State Department of Environmental Conservation
Albany, N. Y. 12201
Division of Pure Waters

Henry L. Diamond
Commissioner

December 10, 1970

Mr. Harry G. Woodbury
Executive Vice President
Consolidated Edison Company of New York, Inc.
4 Irving Place
New York, New York 10003

Re: Outfall Construction
Indian Point Nuclear
Station
Buchanan (V), Westchester Co.

Dear Sir:

Transmittal

The construction permit for this project, dated December 10, 1970, is attached. This permit shall supercede all previous permits and the instructions below for operating permit issuance provide the basis for future discharge control.

One approved copy of the plans is enclosed.

Permit to Construct

This permit carries qualifying conditions:

1. Permit filing
2. Revocability and modification
3. Construction conformance
4. Start of operation
5. Construction supervision
6. Construction certification
7. Construction time limitations

The attached construction permit does not constitute authority to operate the approved facilities. Please note instructions below regarding operation permit.

Permit to Operate

Pursuant to provisions of Part 73 of Title 10 of the official compilation of Codes, Rules and Regulations of the State of New York, a permit to operate the constructed facilities is required.

Upon completion of the facilities, application for the permit to operate should be submitted to the Bureau of Industrial Wastes of the New York State Department of Environmental Conservation, 50 Wolf Road, Albany, New York 12201, accompanied by a certificate of construction compliance, executed by the New York State licensed professional engineer supervising construction.

The Bureau of Industrial Wastes will contact you in the near future to provide application forms and instructions for the operating permit.

The attached permit authorizes construction of an effluent channel and diffuser whose hydraulic capacity is rated at 3,020,000,000 gallons per day. It shall not be inferred that this authority to construct commits the Department to allow operation at the rated capacity. Serious questions concerning the acceptability of discharges of heated waters from the operation of all three units at Indian Point remain unanswered.

Destruction of the previously approved outfalls for units one and two to facilitate construction of the intake and outfall for unit three is noted. The Department will, upon completion of these facilities, and receipt of your application, issue an operating permit for units one and two.

To obtain an operating permit for unit three, it must be conclusively demonstrated by Consolidated Edison Company that the thermal criteria relating to limits and distribution of temperature and the thermal standard relating to conditions non-injurious to fish life will be satisfied. It is also necessary to define and verify predictions made from mathematical and hydraulic models to correlate actual operations of units one and two to conditions postulated for unit three. The conclusions drawn by your consultants from studies done to date cannot be accepted as representative of conditions that will prevail after operation is established.

Field work to assess actual conditions and effects of units one and two, to supplement theoretical projections is essential. To this end, it is required that extensive temperature and ecological studies, on a program to be agreed to by the company and the various agencies involved, be conducted and reported to establish the basis for the unit three operating permit. The Department of Environmental Conservation's Bureau of Water Quality Management in the Division of Pure Waters, and the Division of Fish and Wildlife, will provide details of surveillance to satisfy the Department on physical/chemical and ecological parameters respectively.

An analysis of existing and projected thermal loadings on the Hudson River estuary portion, which includes your existing Indian Point site and the proposed Verplanck site, have indicated a future heat load which would be unacceptable. Therefore, you are formally advised that any further units proposed for Indian Point or for Verplanck will require cooling facilities to reduce cooling water temperature to essentially intake ambient temperature.

The above portions contain that material from the May 19, 1970 approval letter which is considered pertinent and applicable, adjusted as necessary to reflect accommodation of unit two in the approval and the basis of operating permit therefor. The following material relates to updated considerations now applicable.

The basis of approval at this time is the commitment by Consolidated Edison to:

1. Provide installation of adjustable gates, prior to unit two operation, which will be controlled to maintain, under all sequences of unit one and/or two operation an average discharge velocity of not less than ten feet per second, and
2. Investigate, design and construct a new intake structure for all units, with intake screens upstream of all units, as proposed in the environmental report, as expeditiously as possible.

Mr. Harry G. Woodbury

-4-

December 10, 1970

Number one is incorporated in plans approved herewith, and the construction completion date reflects Con-Ed information that commercial operations could not take place for unit two before the date noted. Number two completing date is unknown at this time, but the intake completion and a demonstration of its efficiency must precede commercial operation of unit three in any case. The instream verification studies required above to support a unit three operating permit application must include data on the new intake structure.

The requirements for followup, testing, and measurement programs are consistant with those which have been and will be imposed on other utilities to determine compliance with criteria and standards and verification and refinement of mathematical and hydraulic model studies. Consolidated Edison has not been singled for any special restrictions nor is any more expected from the company than of any other discharger, which is, compliance with all applicable laws, standards, criteria and rules and regulations officially adopted by New York State.

Acceptance of the enclosed permit and initiation of construction will constitute agreement by Consolidated Edison Company to the conditions of approval, including the restrictions intended to be imposed on its future operations. If these restrictions cannot be accepted, the permit should be rejected. If that course of action is selected by Consolidated Edison Company, the Department will schedule a public hearing for denial of the permit application for unit number three on the grounds that it has not been conclusively demonstrated that the water resource will be protected or the water quality standards will not be contravened by the proposed operations of the Company.

Very truly yours,

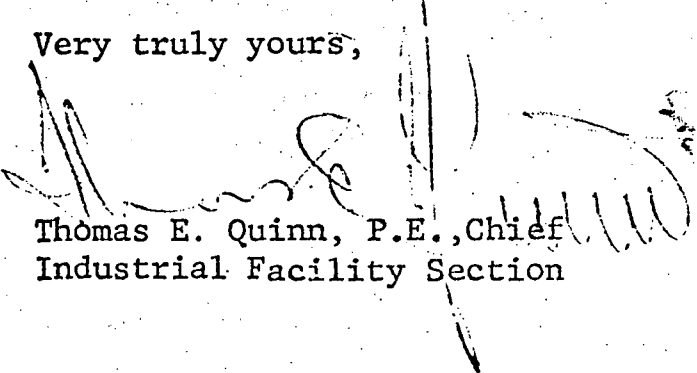

Thomas E. Quinn, P.E., Chief
Industrial Facility Section

TEQ:sp
Attach.

cc: Westchester Co. Health Dept.
cc: White Plains Regional Office
cc: Bureau of Water Quality Management

NEW YORK STATE DEPARTMENT OF ENVIRONMENTAL CONSERVATION

PERMIT TO CONSTRUCT A WASTE DISPOSAL SYSTEM

This permit is issued under the provisions of Article 12 of the Public Health Law and 10 NYCRR 73.

1. Name of Permittee: Consolidated Edison Company of New York, Inc.	2. Location of Works (C.V.T.): Buchanan (V)	3. County: Westchester	4. Entity or Area Served: Indian Point Nuclear Power Plant
--	--	---------------------------	---

By initiating construction of the approved works, the permittee accepts and agrees to abide by and conform with the following:

1. THAT the construction permit shall be maintained on file by the permittee.
2. THAT the permit is revocable or subject to modification or change pursuant to Article 12 of the Public Health Law.
3. THAT the facilities shall be fully constructed and completed in compliance with the engineering report, plans and specifications as approved.
4. THAT the facilities shall not be placed in operation until construction has been completed and an operation permit has been issued, or unless ordered to be operated by the Commissioner or by a Court.
5. THAT the construction of the facilities shall be under the supervision of a person or firm qualified to practice professional engineering in the State of New York under the Education Law of the State of New York, whenever engineering services are required by such law for such purposes.
6. THAT where such facilities are under the supervision of a professional engineer, he shall certify to the Department and to the permittee that the constructed facilities have been under his supervision and that the works have been fully completed in accordance with the approved engineering reports, plans, specifications and permit.
7. THAT the construction of the facilities shall commence by April 1, 1971 and be fully completed by June 30, 1971

ISSUED FOR THE STATE COMMISSIONER OF
Environmental Conservation

DATE

Designated Representative

12/10/70

Description:

5. Type of Ownership:				
<input type="checkbox"/> Municipal	<input type="checkbox"/> Commercial	<input type="checkbox"/> 68 Private-Other	<input type="checkbox"/> 1 Authority	<input type="checkbox"/> 30 Interstate
<input checked="" type="checkbox"/> Industrial 4911	<input type="checkbox"/> 6 Sewage Works Corp.	<input type="checkbox"/> Private-Institutional	<input type="checkbox"/> 19 Federal	<input type="checkbox"/> 40 International
<input type="checkbox"/> 67 Private-Home	<input type="checkbox"/> 26 Board of Education	<input type="checkbox"/> 20 State	<input type="checkbox"/> 18 Indian Reservation	
6. Type & Nature of Construction:		Collection	Treatment and/or Disposal	
		<input type="checkbox"/> 1 New	<input checked="" type="checkbox"/> 1 New	
		<input type="checkbox"/> 2 Additions or Alterations	<input type="checkbox"/> 2 Additions or Alterations	
7. Estimated Cost of Construction:				
Collection System		Treatment and/or Disposal		
8. Type of Waste:				
<input type="checkbox"/> 1 Sewage	<input type="checkbox"/> Industrial	<input checked="" type="checkbox"/> Other		
Specify		Specify <u>Cooling Water</u>		
9. Degree of Treatment:				
<input type="checkbox"/> 1 None	<input type="checkbox"/> 3 Primary	<input type="checkbox"/> 5 Secondary	<input type="checkbox"/> 7 Complete	
<input type="checkbox"/> 2 Septic Tank	<input type="checkbox"/> 4 Intermediate	<input type="checkbox"/> 6 Tertiary	<input checked="" type="checkbox"/> 8 Not Applicable	
10. Point of Discharge:				
Location (C,V,T) <u>Buchanan (V)</u>		Major Drainage Basin <u>Lower Hudson</u>		
Surface Water: Name of Watercourse <u>Hudson River</u>		Surface Water Class <u>SB</u>		
Ground Water: Name of Watercourse to which ground water is tributary		Ground Water Class		
11. Name of Receiving Treatment Works:		12. Grade of Plant Operator Required:	13. Disinfection Required:	
N/A		N/A	<input type="checkbox"/> 1 Continuous <input type="checkbox"/> 2 Seasonal <input checked="" type="checkbox"/> 3 None	
14. Design Flow (Gals./day):	15. Design Equivalent Population (BOD Basis):	16. Design Plant Efficiency (% BOD Removal):		
3,020,000,000	N/A	N/A		

Description of works, such as number, name and capacity of units:

one - effluent channel with submerged diffuser:

252' side open channel with twelve (12) submerged openings, four (4) by fifteen (15) feet each, with eighteen (18) foot centerline depth submergence, including eleven (11) adjustable ports, as detailed on drawings #A1080436-2 and C182661-0 of Consolidated Edison Company.

BUCHANAN (V) ...

NEW YORK STATE DEPARTMENT OF HEALTH
BUREAU OF ENVIRONMENTAL SANITATION
AND
WATER POLLUTION CONTROL BOARD

"LIBER 28-263

PERMIT TO DISCHARGE SEWAGE OR WASTES
INTO THE WATERS OF THE STATE

Application having been duly made as provided by the Public Health Law, permission is hereby given to the Consolidated Edison Company of New York Incorporated, its successors and assigns, to discharge sewage effluent from the proposed sewage disposal works to serve the Indian Point Generating Station in the Village of Buchanan, as shown on the plans approved this day, into the ground waters of the State tributary to the Hudson River at the points on the property indicated on the approved plans

within the VILLAGE of BUCHANAN, WESTCHESTER COUNTY, NEW YORK

under the following conditions:

- I. THAT this permit shall be revocable at any time or subject to modification or change when in the judgment of the Water Pollution Control Board such revocation, modification or change shall become necessary.
- II. THAT the proposed sewage disposal works shown on the plans approved this day shall be fully constructed in complete conformity with such plans or approved amendments thereto.
- III. THAT only sewage and no ground water, storm water or surface water from streets, foundations, roofs or other areas shall be admitted to the proposed sewage disposal works.
- IV. THAT the sludge and scum shall be removed from any settling tank whenever they shall have accumulated so as to occupy one-fourth the capacity of the tank below the flow line.
- V. THAT whenever sludge or scum is removed from a settling tank or any part of the system, it shall be done in such a manner as to cause no nuisance and the sludge or scum disposed of by burying in some remote place at least 250 feet from any house, road, well, spring, stream or other body of water and covered with not less than 6 inches of earth in such a manner that it will not flow or be washed by rain or melted snow or other means over the surface of the ground or into any well, spring, stream or other body of water.
- VI. THAT whenever any seepage of sewage to the surface of the ground is detected, the Water Pollution Control Board shall be notified immediately and prompt action shall be taken by the owner to correct this condition satisfactorily.
- VII. THAT whenever required by the Water Pollution Control Board, additional or more adequate works for the collection or disposal of sewage shall be installed and put in operation, plans for which shall first be submitted to and receive the approval of the said Board.

Dated June 10, 1959

DEPARTMENT OF HEALTH

By: John C. Hebert
Chief, Sewerage and Wastes Section, Bureau
Environmental Sanitation

By: Angela T. Dwyer
Executive Secretary, Water Pollution Control Bd.

NOTE - This permit before being operative shall be recorded in

the County Clerk's office of WESTCHESTER County.

STATE OF NEW YORK }
COUNTY OF ALBANY } SS.

On the 10TH day of JUNE in the year 1957,
before me personally came JOHN C. HABERER residing in Delmar, N. Y.,
to me known, who being by me duly sworn, did depose and say, that
he is Chief, Sewerage and Wastes Section of the Department of Health
of the State of New York, the Department named in and which executed the
above instrument; that said instrument was so executed pursuant to
the authority vested in him by law and that he signed his name thereto
pursuant to like authority.

Katherine H. Campion

KATHERINE H. CAMPION
Notary Public in the State of New York
Residing in Albany County
My Commission Expires March 31, 1957

STATE OF NEW YORK }
COUNTY OF ALBANY } SS.

On the 10TH day of JUNE in the year 1957,
before me personally came ANSELMO F. DAPPERT residing in Delmar, N. Y.,
to me known, who being by me duly sworn, did depose and say, that he is
Executive Secretary of the Water Pollution Control Board of the Depart-
ment of Health of the State of New York, the Department named in and
which executed the above instrument; that said instrument was so executed
pursuant to the authority vested in him by law and that he signed his name
thereto pursuant to like authority.

Katherine H. Campion

KATHERINE H. CAMPION
Notary Public in the State of New York
Residing in Albany County
My Commission Expires March 31, 1957

Recorded in the office of the Clerk of the
County of Westchester, in Liber 28, at Page
263 of Miscellaneous Records, on July 9, 1959,
and returned to Mr. H.B. Guckel, Room 1500,
4 Irving Place, New York 3, N.Y.

RECORD
Sewer Permit

Clerk

JUL 9 1959 00105
PAGE \$ 3.50
NAME'S

1 cent

DEPUTY
BY *[Signature]*

TOTAL \$ 3.50

3.50

EDWARD L. WARREN
COUNTY CLERK

OFFICE



New York State Department of Environmental Conservation
Albany, N. Y. 12201

Henry L. Diamond
Commissioner

November 13, 1970

✓ Res. Const. Mgr. _____

Asst. Res. Const. Mgr./Proj. Supt. _____

Q. A. _____

Supt. I.P. #2 _____

Supt. I.P. _____

Supt. I.P.P. _____

Mr. Frank D. McElwee, P.E.
Resident Construction Manager
Consolidated Edison Company
Indian Point
Buchanan, New York 10511

Dear Mr. McElwee:

As requested in your letter of September 14, 1970 and in accord with our telephone conversation of September 11, 1970, the New York State Department of Environmental Conservation hereby grants permission to discharge the chemical solution outlined in the September 14, 1970 letter on the following conditions:

1. The rate of discharge of the chemical solution to the 450,000 gpm of service water and circulating water flow shall not exceed 58 gallons per minute.
2. The concentration of the chemical solution shall not exceed the following:
 - a. phosphate ion - 10 ppm
 - b. morpholine - 2 ppm
 - c. hydrozine - 0.01 ppm
 - d. silica - 5 ppm
 - e. total dissolved solids - 125 ppm
 - f. pH, up to 11.0
3. Permission granted is based upon conditions existing as reported to the Department of Environmental Conservation by Consolidated Edison Company.
4. All conditions of the March 11, 1970, letter from Eugene F. Seebald to Harry G. Woodbury shall apply to this discharge as well as all chemical discharges.

Mr. Frank D. McElwee

-2-

November 13, 1970

This authorization shall remain in effect only until completion of the discharge of the chemicals. The Consolidated Edison Company will advise the New York State Department of Environmental Conservation upon completion, of the actual times of discharge, rate of discharge, and constituents and concentration of discharge.

Very truly yours,

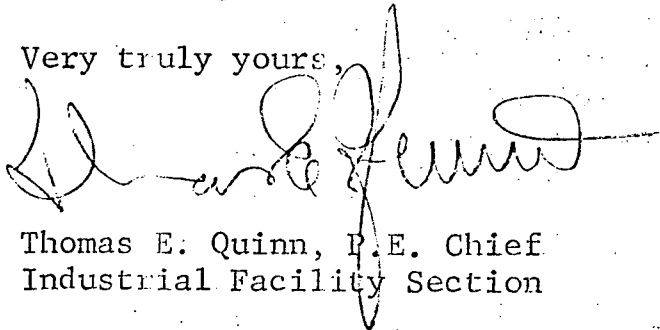

Thomas E. Quinn, P.E. Chief
Industrial Facility Section

TEQ:WEL/sp

cc: White Plains Regional Office
cc: Westchester County Health Dept.
cc: Mr. G. Burdick

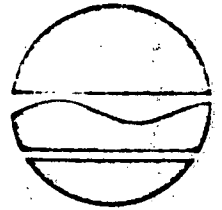

New York State Department of Environmental Conservation
Albany, N. Y. 12201
Division of Pure Waters

Henry L. Diamond
Commissioner

February 10, 1971

Mr. Frank D. McElwee, P.E.
Resident Construction Manager
Consolidated Edison Company
Indian Point
Buchanan, New York 10511

Re: Chemical Discharge
Indian Point
Buchanan (V), Westchester Co.

Dear Mr. McElwee:

As requested in conference on February 10, 1971, the New York State Department of Environmental Conservation hereby grants permission to discharge the chemical solutions as stated below:

1. The rate of discharge of the chemical solution to a minimum 100,000 gpm of service water, and circulating water flow shall be at a rate such that the following concentrations as noted are not exceeded at any point at the confluence of the outfall and the Hudson River:
 - a. Hexavalent chromium 0.05 mg/l
 - b. Morpholine 0.1 mg/l
 - c. Hydrazine 0.1 mg/l
 - d. Lithium hydroxide 0.01 mg/l
2. Permission granted is based upon conditions existing as reported to the Department of Environmental Conservation by Consolidated Edison Company.
3. All conditions of the March 11, 1970, letter from Eugene F. Seebald to Harry G. Woodbury shall apply to this discharge as well as all chemical discharges.

Mr. Frank D. McElwee

-2-

February 10, 1971

This authorization shall remain in effect only until completion of the discharge of the presently stored chemicals. The Consolidated Edison Company will advise the New York State Department of Environmental Conservation upon completion, of the actual times of discharge, rate of discharge, and constituents and concentration of discharge.

Very truly yours,

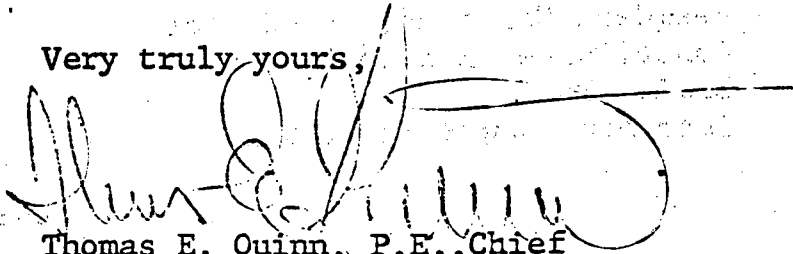

Thomas E. Quinn, P.E., Chief
Industrial Facility Section

TEQ:sp

- cc: White Plains Regional Office
- cc: Westchester County Health Dept.
- cc: Mr. G. Burdick

PERMIT NO. 8-1-66

WATER RESOURCES COMMISSION
CONSERVATION PERMITConsolidated Edison Co., of
4 Irving Place, New York City, N.Y.is hereby permitted to: (construct) (reconstruct) (repair) (alter the bed or banks of) (dredge) (place fill in)
Hudson RiverLocated in County of Westchester Town Buchanan by
carrying out the following works: deposit 50,000 cu. yards of rock spoil as indicated on
attached sheets (2).Section of stream to which this permit applies on property of Con. Edison Indian Point Generating
Station, Buchanan, N.Y.Note: (a) This permit does not relieve the permittee of responsibility for damages to riparian owners or others.
(b) If the structure or work herein authorized is not completed on or before 31st
March, 1966, this permit, if not specifically extended, shall cease and be null and void.

CONDITIONS

1. The permitted work shall be subject to inspection by an authorized representative of the Water Resources Commission who may order the work suspended if the public interest so requires.
2. The permittee shall file in the office of the Local Permit Agent a notice of intention to commence work at least 48 hours in advance of the time of commencement and shall also notify him promptly in writing of the completion of the work.
3. As a condition of the issuance of this permit, the applicant has accepted expressly, by the execution of the application, the full legal responsibility for all damages, direct or indirect, of whatever nature, and by whomever suffered, arising out of the project described herein and has agreed to indemnify and save harmless the State from suits, actions, damages and costs of every name and description resulting from the said project.
4. Any material dredged in the prosecution of the work herein permitted shall be removed evenly, without leaving large refuse piles, ridges across the bed of the waterway, or deep holes that may have a tendency to cause injury to navigable channels or to the banks of the waterway.
5. Any material to be deposited or dumped under this permit, either in the waterway or on shore above high-water mark, shall be deposited or dumped at the locality shown on the drawing hereto attached, and, if so prescribed thereon, within or behind a good and substantial bulkhead or bulkheads, such as will prevent escape of the material into the waterway.
6. There shall be no unreasonable interference with navigation by the work herein authorized.
7. That if future operations by the State of New York require an alteration in the position of the structure or work herein authorized, or if, in the opinion of the Water Resources Commission it shall cause unreasonable obstruction to the free navigation of said waters or endanger the health, safety or welfare of the people of the State, or loss or destruction of the natural resources of the State, the owner may be ordered by the Commission to remove or alter the structural work, obstructions, or hazards caused thereby without expense to the State; and if, upon the expiration or revocation of this permit, the structure, fill, excavation, or other modification of the watercourse hereby authorized shall not be completed, the owners shall, without expense to the State, and to such extent and in such time and manner as the Water Resources Commission may require, remove all or any portion of the uncompleted structure or fill and restore to its former condition the navigable capacity of the watercourse. No claim shall be made against the State of New York on account of any such removal or alteration.
8. That the State of New York shall in no case be liable for any damage or injury to the structure or work herein authorized which may be caused by or result from future operations undertaken by the State for the conservation or improvement of navigation, or for other purposes, and no claim or right to compensation shall accrue from any such damage.
9. That if the display of lights and signals on any work hereby authorized is not otherwise provided for by law, such lights and signals as may be prescribed by the United States Coast Guard shall be installed and maintained by and at the expense of the owner.
10. All work carried out under this permit shall be performed in accordance with established engineering practice and in a workmanlike manner.
11. This permit shall not be construed as conveying to the applicant any right to trespass upon the lands of others to perform the permitted work or as authorizing the impairment of any right, title or interest in real or personal property held or vested in a person not a party to the permit.
12. Nothing in this permit shall be deemed to affect the responsibility of the permittee to comply with any applicable Rules and Regulations of the U.S. Army Corps of Engineers or any other governmental agency having jurisdiction.

Other Conditions:

If the fill consists of rock and other materials of a size small enough to be washed away by river or tidal action, then the rock slope shall be protected by 78C heavy stone fill or equivalent.

The issuance of this permit certifies that it is not contrary to the provisions of the State Water Pollution Control Law.

The applicant in accepting this permit signifies his agreement to abide by the conditions of the permit.

Application Date Jan. 11, 1966

Permit Issued Feb. 4, 1966

By Warren H. McKeon

(Permit Agent)

(Name and Address)

Warren H. McKeon, Regl. Supervisor
Region 8
105 Dutchess Turnpike
Poughkeepsie, N.Y.

PERMIT NO. 8-11-66 ←
 DAM NO. _____

STATE OF NEW YORK
 WATER RESOURCES COMMISSION
 CONSERVATION DEPARTMENT

Consolidated Edison Co. of New York, Inc.

4 Irving Place, New York City, N.Y. residing at _____

is hereby permitted to: (construct) (reconstruct) (repair) (alter the bed or banks of) (dredge) (place fill in) _____
Hudson River

Located in County Westchester Town Buchanan by _____

carrying out the following works: Dredge an area of 135' by 63' by 22' deep. Dredged area to be used for concrete screenwell construction. ←

Section of stream to which this permit applies at Indian Point Generating Station

Note: (a) This permit does not relieve the permittee of responsibility for damages to riparian owners or others.
 (b) If the structure or work herein authorized is not completed on or before 30th day of April, 19 66, this permit, if not specifically extended, shall cease and be null and void.

CONDITIONS

1. The permitted work shall be subject to inspection by an authorized representative of the Water Resources Commission who may order the work suspended if the public interest so requires.

2. The permittee shall file in the office of the Local Permit Agent a notice of intention to commence work at least 48 hours in advance of the time of commencement and shall also notify him promptly in writing of the completion of the work.

3. As a condition of the issuance of this permit, the applicant has accepted expressly, by the execution of the application, the full legal responsibility for all damages, direct or indirect, of whatever nature, and by whomever suffered, arising out of the project described herein and has agreed to indemnify and save harmless the State from suits, actions, damages and costs of every name and description resulting from the said project.

4. Any material dredged in the prosecution of the work herein permitted shall be removed evenly, without leaving large refuse piles, ridges across the bed of the waterway, or deep holes that may have a tendency to cause injury to navigable channels or to the banks of the waterway.

5. Any material to be deposited or dumped under this permit, either in the waterway or on shore above high-water mark, shall be deposited or dumped at the locality shown on

or destruction of the natural resources of the State, the owner may be ordered by the Commission to remove or alter the structural work, obstructions, or hazards caused thereby without expense to the State; and if, upon the expiration or revocation of this permit, the structure, fill, excavation, or other modification of the watercourse hereby authorized shall not be completed, the owners shall, without expense to the State, and to such extent and in such time and manner as the Water Resources Commission may require, remove all or any portion of the uncompleted structure or fill and restore to its former condition the navigable capacity of the watercourse. No claim shall be made against the State of New York on account of any such removal or alteration.

8. That the State of New York shall in no case be liable for any damage or injury to the structure or work herein authorized which may be caused by or result from future operations undertaken by the State for the conservation or improvement of navigation, or for other purposes, and no claim or right to compensation shall accrue from any such damage.

9. That if the display of lights and signals on any work hereby authorized is not otherwise provided for by law, such lights and signals as may be prescribed by the United States Coast Guard shall be installed and maintained by and at the expense of the owner.

Other Conditions:

Nothing } the issuance of this permit shall be construed as
approval of the construction of Atomic Energy Unit #2 and its associated structures,
nor shall it be construed as relieving the applicant from taking such steps in
the future as may be necessary to reduce or mitigate losses of fish which may
occur as a result of operations of this project

The issuance of this permit certifies that it is not contrary to the public interest that the proposed works be done.

The applicant in accepting this permit signifies his agreement to abide by the conditions set forth above.

Application Date 2-17-66

Expiration Date 4-30-67

Permit Issued 4-13-66

By Warren H. McKeon

(Name and Address)

(Permit Agent)

Warren H. McKeon-Regl. Supv.
NYS Conservation Dept.
105 Dutchess Turnpike
Poughkeepsie, N.Y.

cc: Robert Cook (1)
Geo. Odell (2)

Jul 7 4 10 PM '67

PERMIT NO. 8-31067
DAM NO. _____STATE OF NEW YORK
WATER RESOURCES COMMISSION
CONSERVATION DEPARTMENTConsolidated Edison Company of New York, Inc., residing at
4 Irving Place, New York, N.Y.is hereby permitted to: (construct) (reconstruct) (repair) (alter the bed or banks of) (dredge) (place fill in) _____
and dredge Hudson River.Located in County Westchester Town Buchanan by
carrying out the following works: Construct a new screen wall and relocate discharged
channel as indicated on attached plans entitled "Proposed Screerwell Structure,
Discharge Channel, Excavation, Dredging and Fill in Hudson River at Indian Point.
Section of stream to which this permit applies At Indian Point Generating Plant, Buchanan.

Note: (a) This permit does not relieve the permittee of responsibility for damages to riparian owners or others.

(b) If the structure or work herein authorized is not completed on or before 31st day of
December, 19 68, this permit, if not specifically extended, shall cease and be null and void.

CONDITIONS

1. The permitted work shall be subject to inspection by an authorized representative of the Water Resources Commission who may order the work suspended if the public interest so requires.

2. The permittee shall file in the office of the Local Permit Agent a notice of intention to commence work at least 48 hours in advance of the time of commencement and shall also notify him promptly in writing of the completion of the work.

3. As a condition of the issuance of this permit, the applicant has accepted expressly, by the execution of the application, the full legal responsibility for all damages, direct or indirect, of whatever nature, and by whomsoever suffered, arising out of the project described herein and has agreed to indemnify and save harmless the State from suits, actions, damages and costs of every name and description resulting from the said project.

4. Any material dredged in the prosecution of the work herein permitted shall be removed evenly, without leaving large refuse piles, ridges across the bed of the waterway, or deep holes that may have a tendency to cause injury to navigable channels or to the banks of the waterway.

5. Any material to be deposited or dumped under this permit, either in the waterway or on shore above high-water mark, shall be deposited or dumped at the locality shown on the drawing hereto attached, and, if so prescribed thereon, within or behind a good and substantial bulkhead or bulkheads, such as will prevent escape of the material into the waterway.

6. There shall be no unreasonable interference with navigation by the work herein authorized.

7. That if future operations by the State of New York require an alteration in the position of the structure or work herein authorized, or if, in the opinion of the Water Resources Commission it shall cause unreasonable obstruction to the free navigation of said waters or endanger the health, safety or welfare of the people of the State, or loss

or destruction of the natural resources of the State, the owner may be ordered by the Commission to remove or alter the structural work, obstructions, or hazards caused thereby without expense to the State; and if, upon the expiration or revocation of this permit, the structure, fill, excavation, or other modification of the watercourse hereby authorized shall not be completed, the owners shall, without expense to the State, and to such extent and in such time and manner as the Water Resources Commission may require, remove all or any portion of the uncompleted structure or fill and restore to its former condition the navigable capacity of the watercourse. No claim shall be made against the State of New York on account of any such removal or alteration.

8. That the State of New York shall in no case be liable for any damage or injury to the structure or work herein authorized which may be caused by or result from future operations undertaken by the State for the conservation or improvement of navigation, or for other purposes, and no claim or right to compensation shall accrue from any such damage.

9. That if the display of lights and signals on any work hereby authorized is not otherwise provided for by law, such lights and signals as may be prescribed by the United States Coast Guard shall be installed and maintained by and at the expense of the owner.

10. All work carried out under this permit shall be performed in accordance with established engineering practice and in a workmanlike manner.

11. This permit shall not be construed as conveying to the applicant any right to trespass upon the lands of others to perform the permitted work or as authorizing the impairment of any right, title or interest in real or personal property held or vested in a person not a party to the permit.

12. Nothing in this permit shall be deemed to affect the responsibility of the permittee to comply with any applicable Rules and Regulations of the U.S. Army Corps of Engineers or any other governmental agency having jurisdiction.

XERO
COPYXERO
COPY

Other Conditions:

The Division of Fish & Game, Region 8 Office will be notified 48 hours prior to any blasting operations.

The issuance of this permit certifies that it is not contrary to the public interest that the proposed works be done.

The applicant in accepting this permit signifies his agreement to abide by the conditions set forth above.

Application Date 5/22/67

Expiration Date December 31, 1968

Permit Issued 6/22/67

By Warren H. McKeon
(Permit Agent)

(Name and Address)

Warren H. McKeon, Regional Supervisor
Region 8
N.Y.S. Conservation Dept.
105 Dutchess Turnpike
Poughkeepsie, N.Y.

- cc: Robert A. Cook (1)
- George A. Odell (1)
- Robert Mahon (1)

PERMIT NO. 8-78-67
 DAM NO. _____

STATE OF NEW YORK
 WATER RESOURCES COMMISSION
 CONSERVATION DEPARTMENT

Edgar G. Watkins c/o Consolidated Edison Company residing at
4 Irving Place, New York 10003

is hereby permitted to: (construct) (reconstruct) (repair) (alter the bed or banks of) (dredge) (place fill in) _____
Hudson River in Lents Cove

Located in County Westchester Town Peekskill by
 carrying out the following work: Dredge a channel approximately 150 feet wide by 1800

feet long in Lents Cove of Hudson River adjacent to Consolidated Edison Co.
generating station at Indian Point. Channel will be used for beaching heavy equipment barges
 Section of stream to which this permit applies on property of permittee

- Note: (a) This permit does not relieve the permittee of responsibility for damages to riparian owners or others.
 (b) If the structure or work herein authorized is not completed on or before 31st day of
January, 1968, this permit, if not specifically extended, shall cease and be null and void.

CONDITIONS

1. The permitted work shall be subject to inspection by an authorized representative of the Water Resources Commission who may order the work suspended if the public interest so requires.

2. The permittee shall file in the office of the Local Permit Agent a notice of intention to commence work at least 48 hours in advance of the time of commencement and shall promptly advise the Local Permit Agent of the completion of the work.

3. As a condition of the issuance of this permit, the applicant has accepted expressly, by the execution of the application, the full legal responsibility for all damages, direct or indirect, of whatever nature, and by whomever suffered, arising out of the project described herein and has agreed to indemnify and save harmless the State from suits, actions, damages and costs of every kind and description resulting from the said project.

4. Any material dredged in the prosecution of the work herein permitted shall be removed evenly, without leaving large refuse piles, rickety across the bed of the waterway, or deep holes that may have a tendency to cause injury to navigable channels or to the banks of the waterway.

5. Any material to be deposited or dumped under this permit, either in the waterway or on shore above high-water mark, shall be deposited or dumped at the locality shown on the drawing hereto attached, and, if so prescribed thereon, within or behind a good and substantial bulkhead or bulkheads, such as will prevent escape of the material into the waterway.

6. There shall be no unreasonable interference with navigation by the work herein authorized.

7. That if future operations by the State of New York require an alteration in the position of the structure or work herein authorized, or if, in the opinion of the Water Resources Commission it shall cause unreasonable obstruction to the free navigation of said waters or endanger the health, safety or welfare of the people of the State, or loss

or destruction of the natural resources of the State, the owner may be ordered by the Commission to remove or alter the structural work, obstructions, or hazards caused thereby without expense to the State; and if, upon the expiration or revocation of this permit, the structure, fill, excavation, or other modification of the watercourse hereby authorized shall not be completed, the owners shall, without expense to the State, and to such extent and in such time and manner as the Water Resources Commission may require, remove all or any portion of the uncompleted structure or fill and restore to its former condition the navigable capacity of the watercourse. No claim shall be made against the State of New York on account of any such removal or alteration.

8. That the State of New York shall in no case be liable for any damage or injury to the structure or work herein authorized which may be caused by or result from future operations undertaken by the State for the conservation or improvement of navigation, or for other purposes, and no claim or right to compensation shall accrue from any such damage.

9. That if the display of lights and signals on any work hereby authorized is not otherwise provided for by law, such lights and signals as may be prescribed by the United States Coast Guard shall be installed and maintained by and at the expense of the owner.

10. All work carried out under this permit shall be performed in accordance with established engineering practice and in a workmanlike manner.

11. This permit shall not be construed as conveying to the applicant any right to trespass upon the lands of others to perform the permitted work or as authorizing the impairment of any right, title or interest in real or personal property held or vested in a person not a party to the permit.

12. Nothing in this permit shall be deemed to affect the responsibility of the permittee to comply with any applicable Rules and Regulations of the U.S. Army Corps of Engineers or any other governmental agency having jurisdiction.

NEW YORK STATE DEPARTMENT OF HEALTH

Number: HA680101

RECEIVED

DIVISION OF AIR RESOURCES

APR 22 1968

PERMIT TO CONSTRUCT AN AIR POLLUTION FACILITY

Date: April 12, 1968

E. G. WATKINS

This permit is issued under the provision of Article 12-A of the Public Health Law for the project described below:

<p>Issued to:</p> <p>Consolidated Edison Company of New York, Inc. 4 Irving Place New York, New York 10003</p> <p>Attention: Mr. E. G. Watkins</p>	<p>Facility and Name of City, Village or Town and County, in which the point of emission is located:</p> <p>Fuel Burning Equipment Indian Point Generating Station Buchanan (V) - Westchester County</p>
<p><u>Type of Facility</u></p> <p><input type="checkbox"/> New Installation</p> <p><input checked="" type="checkbox"/> Modification</p> <p><input type="checkbox"/> Air Cleaning Device Included</p> <p><input type="checkbox"/> Relocation</p>	<p><u>Type of Installation</u></p> <p><input checked="" type="checkbox"/> Permanent</p> <p><input type="checkbox"/> Secret</p> <p><input type="checkbox"/> Trial</p> <p><input type="checkbox"/> Waived (Sec. 176.2)</p>

Complete description of facilities such as number, name and capacity of units:

2 Babcock and Wilcox integral furnace boilers Type FM with steam atomizing burner and forced draft consuming a total of 6940 pounds No. 6 fuel oil per hour.

Permission to construct this air pollution facility is granted upon and subject to the following conditions which by initiating the construction of these facilities, the permittee accepts and agrees to abide by and conform with the following:

That this permit shall be deemed null and void unless construction of these facilities for which this permit is issued is commenced by July 12, 1968 and is fully completed by April 12, 1969.

the proposed facilities shown on the approved plans and approved specifications shall be fully constructed in complete conformity with such plans and specifications, or approved amendments thereto.

That the proposed facilities shall not be placed in operation until they have been completed in accordance with the approved plans, or approved amendments thereto.

- 4) That the Permit to Construct is not a Certificate to Operate and operation prior to the issuance of a Certificate to Operate shall be confined to these operations needed to test the facilities and the firms shall notify the designated representative at least 15 days before any temporary operation is started or any tests are made.
- 5) That the permit shall be revocable at any time or subject to modifications or change when in the judgement of the Commissioner such revocation, modification or change shall become necessary or desirable.
- 6) That tests shall or may be required in accordance with Part 178. Additional air pollution control equipment may be required prior to the issuance of a Certificate to Operate if stack emission tests, acceptable to the Commissioner of Health, show that the installation does not conform to rules established by the Air Pollution Control Board.

THIS PERMIT TO CONSTRUCT IS NOT TRANSFERABLE EITHER FROM ONE LOCATION TO ANOTHER OR FROM ONE FACILITY TO ANOTHER.

A COPY OF THIS PERMIT MUST BE DISPLAYED IN A CONSPICUOUS PLACE NEAR THE FACILITY FOR WHICH THE PERMIT IS ISSUED.

Date: April 12, 1968

Issued for the State Commissioner of Health

Eric A. Seiffer

Eric A. Seiffer
Chief, Engineering Plans Review Section

Name and Title
Designated Representative

RECEIVED

SEP 18 1967

HUDSON
RIVER
VALLEY
COMMISSION

E. G. WATKINS

STATE OF NEW YORK

FRANK WELLS McCABE
Chairman
PETER J. BRENNAN
R. STEWART KILBORNE
CHARLES T. LANIGAN

HELEN HAYES MACARTHUR
CARL J. MAYS
FERGUS REID III
DR. ALAN SIMPSON
WILLIAM H. WHYTE

ALEXANDER ALDRICH, *Executive Director*
BRUCE HOWLETT, *Associate Executive Director*

105 WHITE PLAINS ROAD TARRYTOWN, N. Y. 10591
TELEPHONE: 914-631-8800
488 BROADWAY ALBANY, N. Y. 12207
TELEPHONE: 518-474-2200

Tarrytown September 14, 1967

Consolidated Edison of New York
4 Irving Place
New York, New York

ATTENTION: Mr. E. G. Watkins

Gentlemen:

On September 13th, 1967, in accordance with its special review authority, the Hudson River Valley Commission took action on your proposed project for the screenwell and discharge line at Indian Point in the Village of Buchanan. The Commission gave its unanimous approval to the project while noting that future development at Indian Point in connection with the third unit will require additional review in detail before the screenwell and discharge line are put into operation.

The Commission appreciates your cooperation in supplying the information necessary for the review of this project.

Sincerely,

Alexander Aldrich

Executive Director

DEC 11 1967

E. G. WATKINS

HUDSON
RIVER
VALLEY
COMMISSION

STATE OF NEW YORK

FRANK WELLS McCABE
Chairman

PETER J. BRENNAN
R. STEWART KILBORNE
CHARLES T. LANIGAN

HELEN HAYES MACARTHUR
CARL J. MAYS
FERGUS REID III
DR. ALAN SIMPSON
WILLIAM H. WHYTE

ALEXANDER ALDRICH, *Executive Director*
BRUCE HOWLETT, *Associate Executive Director*

105 WHITE PLAINS ROAD TARRYTOWN, N. Y. 10591
TELEPHONE: 914-631-8800
488 BROADWAY ALBANY, N. Y. 12207
TELEPHONE: 518-474-2200

Tarrytown, New York
December 7, 1967

Consolidated Edison
4 Irving Place
New York, New York

ATTENTION: Mr. Edgar Watkins

Gentlemen:

On December 6th, 1967, in accordance with its special review authority, the Hudson River Valley Commission took action on your proposed project for a dredging operation in Lent's Cove in the Village of Buchanan. The Commission gave its unanimous approval to the project while noting that every attempt should be made to eventually restore the ramp area where practicable with planting to reduce to a minimum the effects of clearing.

Sincerely,

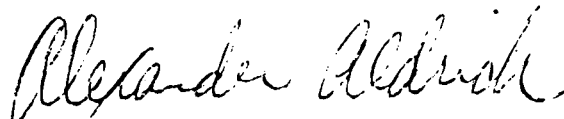

Executive Director

CC: Hon. William J. Burke
Mayor of the Village of Buchanan



CONFIDENTIAL
 DEPARTMENT OF THE ARMY
 NEW YORK DISTRICT, CORPS OF ENGINEERS
 111 EAST 16TH STREET
 NEW YORK, N. Y. 10003

VERIFIED BY
 (S)

NAHOP-E

11 December 1967

Consolidated Edison Company of
 New York, Inc.
 4 Irving Place
 New York, N.Y. 10003

General:

With reference to written request dated 23 October 1967,
 upon the recommendation of the Chief of Engineers and under the
 provisions of Section 10 of the Act of Congress approved 3 March
 1899 (30 Stat. 1151; 33 U.S.C. 403), you are hereby authorized
 by the Secretary of the Army to dredge a flotation channel to
 a depth of ten (10) feet below mean sea level and construct a
 ramp in Lents Cove, Hudson River at Village of Buchanan, County
 of Westchester, New York, in accordance with the attached plans.
 The dredged material is to be deposited at an approved Government
 dumping ground under a permit to be obtained from the Supervisor
 of New York Harbor.

This permission, if not previously revoked or specifically
 extended shall cease and be null and void if the work authorized
 is not completed on or before 31 December 1970.

It is to be understood that the authorization does not give
 any property rights either in real estate or material, or any
 exclusive privileges, and that it does not authorize any injury
 to private property or invasion of private rights, or any infringe-
 ment of Federal, State, or local laws or regulations, nor does it
 obviate the necessity of obtaining State assent to the work author-
 ized. (See Cummings v. Chicago, 188 U.S., 410.)

BY AUTHORITY OF THE SECRETARY OF THE ARMY:

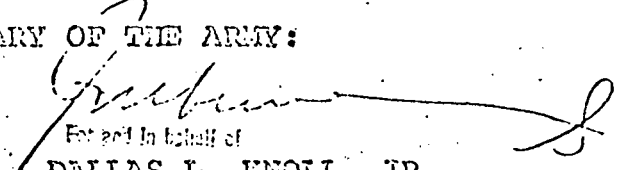
 For and in behalf of
 DALLAS L. KNOLL, JR.
 Colonel, Corps of Engineers
 Acting District Engineer

1 Incl
 Drawings, Sheet 1 & 2

POLL/OP-E
 WUESTEFELD/OP

HUDSON
RIVER
VALLEY
COMMISSION

Mv. [Signature]
STATE OF NEW YORK

105 WHITE PLAINS ROAD
TARRYTOWN NEW YORK 10591

RECEIVED

MAR 31 1971

C. A. MULLER
914-631-8800

FERGUS REID III Chairman
CARL J. MAYS Executive Director

CAm
3/31/71

March 26, 1971

Mr. Charles A. Muller
Plant Structures Engineer
Consolidated Edison Company
of New York, Inc.
4 Irving Place
New York, New York 10003

1/G
How art
truly beams?
WSB
4/14/71

Dear Mr. Muller:

The Hudson River Valley Commission staff has reviewed the plans you provided on February 5, 1971. Although the plans do indicate a discrepancy from those reviewed by the Commission on September 13, 1967, we do not feel that they indicated a project subject to review.

Thank you for submitting your revised plans.

Very truly yours,

Eleanor G. Ashby

(Mrs.) Eleanor G. Ashby
Project Review Administrator

20012
(Special Manager)

[Handwritten signature]



New York State Department of Environmental Conservation
Albany, N. Y. 12201

Henry L. Diamond
Commissioner

December 7, 1970

Mr. Harry G. Woodbury
Senior Vice President
Consolidated Edison Company of
New York, Inc.
4 Irving Place
New York, New York 10003

Dear Mr. Woodbury:

Water Quality Certification
Indian Point Generating Station

In response to your letter of September 2, 1970 and in accordance with Section 21-b of the Water Quality Improvement Act of 1970 (P.L. 91-224), reasonable assurance is hereby given by the State of New York that the effluent from Generating Station Units #1 and #2 to be discharged through the submerged jet outlet will not contravene the applicable water quality standards for the Hudson River at the point of discharge. This letter supercedes our letter of September 29, 1970.

Accordingly, an operating permit will be issued upon receipt of the required application under provisions of Part 73, Title 10 of the Official Compilation of Codes, Rules and Regulations of the State of New York. However, prior to the granting of operating permits for the discharge of effluents from Unit 3, the applicant must demonstrate that thermal criteria relating to limits and distribution of temperature and the thermal standard relating to conditions noninjurious to fish life will be satisfied.

Very truly yours,

[Handwritten signature]

T. P. Curran
For Department of Environmental
Conservation

cc: Mr. D. Stevens
Mr. I. Grossman
Mr. W. McKeon
Mr. R. Mt. Pleasant
Mr. T. Quinn
Corps of Engineers - New York
Federal Water Quality Administration
U.S. Department of the Interior

XERO COPY

XERO COPY

To be kept on the work

Village of Buchanan
BUILDING PERMIT

No 373

Date Dec. 1, 1965

Permission is hereby granted *Gen. Edison Co.*

4 Irving Place New York N.Y.

Location *Indian Point, Buchanan N.Y.*

Sec. *9* Bl. *33* Lot *1* Tax Map

Owner *same* Address

Contractor Address

Dimensions (over all) *Excavation*

Stories High

Use *Nuclear Steam Electric Gen. Station*

Date of Issue *Dec. 1, 1965*

Fee *4.05.50*

Lehas White
Building Inspector

To be kept on the work

Village of Buchanan
BUILDING PERMIT

Nº 381

Date *May 16, 1966*

Permission is hereby granted *Gen. Edison Co.*

4 Irving Place New York

Location *Indian Point Buchanan N.Y.*

Sec. *9*..... Bl. *33*... Lot *1*..... Tax Map

Owner *Gen. Edison Co.* Address *4 Irving Place New York*

Contractor Address

Dimensions (over all) *124' x 57' 11"*

Stories High *none*

Use *Intake well structure for electric gen. plant #2*

Date of Issue *May 16, 1966*

Fee *1,235.00*

Charles White
Building Inspector

To be kept the work

Village of Buchanan
BUILDING PERMIT

Nº 387 Date May 24, 1966

Permission is hereby granted *Gen. Edison Co*
of New York Inc

Location ... *Indian Point*

Sec. *9* Bl. *33* Lot *1* Tax Map

Owner ... *same* Address

Contractor Address

Dimensions (over all) *FRONT, REAR DEP D*
275' 255' 151'4 106'4

Stories High

Use *Nuclear Steam Elect. Gen. Unit #2 addition*

Date of Issue *May 24, 1966*

Fee *2,535.50*

Chas. White
Building Inspector

Turbine Room, Heater Bay & Discharge Water Turbine

To be kept on the work

Village of Buchanan
BUILDING PERMIT

Nº 404

Date *Sept, 27, 1966*

Permission is hereby granted *to* *Ed. Co. of*

New York & Irving Place

Location *Indian Point*

Sec. *9* Bl. *33* Lot *1* Tax Map

Owner *same* Address

Contractor Address

Dimensions (over all) *70' x 127' x 23'*

Stories High *2*

Use *Business, Auto, Bldg. & Water Holdup Tank*

Date of Issue *Sept*

Fee *1354.50*

Alan White

Building Inspector

To be kept on the work

Village of Buchanan
BUILDING PERMIT

Nº 405

Date Sept. 22, 1966

Permission is hereby granted *Long Island Co. of*

New York Location *Indian Point*

Sec. *9* Bl. *33* Lot *1* Tax Map

Owner *Same* Address

Contractor Address

Dimensions (over all) *93' x 30' x 37'*

Stories High

Use *Fuel Storage Bldg.*

Date of Issue

Fee *933.50*

Alvin White
Building Inspector

10000

10000

111

To be kept on the work

Village of Buchanan
BUILDING PERMIT

No 406

Date Sept 22, 1966

Permission is hereby granted *Edison Co. of*

New York.....*to*.....*install*.....*Power*.....
Location .. *Clinton Rd*

Sec. *9*..... Bl. *33*..... Lot *1*..... Tax Map

Owner .. *Edison*..... Address

Contractor .. Address

Dimensions (over all) *115' x 220' Ht.*

Stories High

Use .. *Maintenance Bldg*

Date of Issue .. *Sept. 22, 1966*

Fee *1,035.50*

Chas White
.....
Building Inspector

10000-50000

To be kept on the work

Village of Buchanan
BUILDING PERMIT

No. 411

Date Feb. 18, 1967

Permission is hereby granted Am. Edison Co.

of New York

Location Indian Point, Buchanan, N.Y.

Sec. 9 Bl. 93 Lot 1 Tax Map

Owner same Address

Contractor Address

Dimensions (over all) 121'6" x 22'4" - 37'11"

Stories High

Use Control Room - Station #2

Date of Issue Feb. 18, 1967

Fee 235.50

Wm. J. White
Building Inspector

255,000.00

GENERAL RECEIPT Feb. 18 1967 No. 2918

VILLAGE OF BUCHANAN, Buchanan, N. Y.

Received of Am. Edison Co. \$ 235.50

Two hundred thirty five + 50/100 DOLLARS

For Build. Permit No. 411

DISTRIBUTION:

FUND	CODE	AMOUNT

Wm. J. White
(Title)
By Wm. J. White

EFFECT OF INDIAN POINT
COOLING WATER DISCHARGE
ON
HUDSON RIVER TEMPERATURE DISTRIBUTION

JANUARY, 1968

CONSOLIDATED EDISON COMPANY OF NEW YORK, INCORPORATED
NEW YORK, NEW YORK

EFFECT OF INDIAN POINT COOLING WATER DISCHARGE
ON
HUDSON RIVER TEMPERATURE DISTRIBUTION

JANUARY, 1968

QUIRK, LAWLER & MATUSKY ENGINEERS
ENVIRONMENTAL SCIENCE & ENGINEERING CONSULTANTS
505 FIFTH AVENUE
NEW YORK, NEW YORK 10017

QUIRK, LAWLER & MATUSKY ENGINEERS
ENVIRONMENTAL SCIENCE & ENGINEERING CONSULTANTS

505 FIFTH AVENUE
NEW YORK, NEW YORK 10017

212 867-0080

WATER RESOURCES PLANNING
WATER SUPPLY & TREATMENT
INDUSTRIAL WASTE TREATMENT
SEWERAGE & SEWAGE TREATMENT
RIVER & MARINE STUDIES
SOLID WASTE DISPOSAL
AIR POLLUTION ANALYSIS

COMPUTER FACILITIES

THOMAS P. QUIRK, P. E.
JOHN P. LAWLER, P. E.
FELIX E. MATUSKY, P. E.

File: 115-5

January 15, 1968

Mr. E. G. Watkins
Structural Engineer
Consolidated Edison Company of
New York, Incorporated
4 Irving Place
New York, New York 10003

Dear Mr. Watkins:

In accordance with your authorization, we are pleased to submit our report on the evaluation of the effect of Indian Point thermal discharge on Hudson River temperatures.

Expected seasonal temperature variation, for all three nuclear units at full power, has been developed and is evaluated against recently proposed New York State Department of Health criteria on thermal discharges.

Field studies conducted at Indian Point in recent years have been utilized in the study. Hydraulic model studies have been employed to evaluate various effluent channel outlet designs.

A summary of our findings, conclusions and recommendations precedes the report on pages S-1 to S-2 inclusive.

Very truly yours,

John P. Lawler

JPL/ck

Table of Contents

	<u>Page</u>
<u>Letter of Transmittal</u>	ii
<u>Summary of Findings, Conclusions and Recommendations</u>	S-1 to S-4
I. <u>Events Leading to the Report</u>	1
II. <u>New York State Department of Health Requirements</u>	2
III. <u>Purpose and Scope</u>	6
IV. <u>River Temperature Profiles and Delineation of Mixing Zones</u>	7
One-Dimensional Analysis - General	7
One-Dimensional Analysis Predictions - July 1966 and April 1967	9
1. Surface Heat Transfer	10
2. Dilution by Circulatory Flow	11
One-Dimensional Analysis Prediction - Future Loading	12
Establishment of the Mixing Zone at Indian Point	14
Extent of the Mixing Zone	21
V. <u>Hydraulic Model Studies and Effluent Channel Outlet Selection</u>	22
Application to Overall River Behavior	22
Effluent Channel Outlet Evaluation	22
Effect of Outlet Design on Intake Temperatures	26
Recommendations for Model Expansion	27
VI. <u>Transient Effects Due to Startup or Shutdown</u>	29
VII. <u>Effect on River Dissolved Oxygen</u>	31
Loss of Oxygen During Passage through Plant	32
Loss of Oxygen in the Receiving Waterway	33
<u>References</u>	35
<u>Appendix A - Development of the One-Dimensional Mathematical Model</u>	A-1 to A-15
<u>Appendix B - Selection of Parameters</u>	B-1 to B-13

Summary of Findings, Conclusions and Recommendations

1. Consolidated Edison plans to build a third nuclear reactor at Indian Point. The effect of the combined cooling water discharge from all three units on the temperature distribution in the Hudson River near Indian Point is estimated in this report.
2. Application will be made by Edison to the New York State Health Department for a permit to discharge warmed water to the Hudson River. Temperature effects due to the Indian Point Plant have been evaluated against criteria currently proposed by this agency for the control of thermal discharges.
3. New York State Health Department criteria follow recommendations made by the National Technical Advisory Committee to the Department of the Interior. These criteria were developed to protect all important marine and estuarial species, even the most sensitive, from adverse temperature effects. Preliminary evaluation shows that some of these criteria, when applied to the region around Indian Point, may be overly conservative. Edison biologists should review these standards in the light of Hudson River ecology in the vicinity of Indian Point.
4. Expected capacity operation of all three units at Indian Point will result in a 16.4°F rise in the 2,040,000 gpm cooling water flow. All results presented in this report are based on continuous, year round operation at rounded values of 17°F and 2,100,000 gpm and represent a maximum loading condition.
5. Health Department criteria include division of the River's cross-section at any point along its length into a mixing zone and a passage zone. The mixing zone is established to provide capacity for diluting the heated effluent with cooler River water. No specific criteria are affixed to this zone but it should not exceed 50% of the total cross-sectional area.

The remaining portion of the cross-section is called a passage zone; its purpose is to provide a passage way for migratory fish and other life. Criteria in this zone include a maximum temperature of 86°F , a maximum summer (June through September) rise in temperature of 1.5°F , a maximum non-summer rise of 4°F , and a change rate of no more than 1°F in any hour, or 7°F in 24 hours.

6. Mathematical analyses have been developed to estimate the expected cross-sectional area average temperature rise along the longitudinal axis of the River and the departure from this average at any point within a cross-section. These analyses yield computed temperatures which, for the same loading condition, are higher than field temperature measurements made during Indian Point No. 1 operation. Computer results, therefore, are considered to represent a conservative estimate of the effect of Indian Point thermal discharges on the River.
7. The distribution of temperature across a River cross-section has been represented by two different mathematical expressions. Throughout the report, these have been designated "the exponential decay model" and "the reciprocal decay model."

The exponential decay model represents temperature as an exponentially decreasing function of River cross-sectional area. The reciprocal decay model represents temperature as being approximately inversely proportional to River area. Reciprocal model results are more conservative but the exponential model is more theoretically sound.

8. Maximum temperatures will occur at Indian Point. Temperatures will steadily decrease as distance above or below Indian Point increases.

Analysis shows that the non-summer rise standard of 4°F , the absolute temperature of 86°F , and the temperature change criteria will not be exceeded.

The summer rise standard of 1.5°F is not exceeded, provided the decay follows the exponential behavior. Reciprocal decay behavior yields a maximum temperature outside the mixing zone of 1.9°F .

These results, which delineate the maximum size of the mixing zone at Indian Point, are summarized below:

	<u>Exponential Decay</u>	<u>Reciprocal Decay</u>	<u>Proposed Standard</u>
<u>Non-Summer Conditions</u>			
Maximum Area, $\Delta T=4^{\circ}\text{F}$	30%	25%	50%
Maximum ΔT , at 50% Area	1.5°F	2.3°F	4°F
<u>Summer Conditions</u>			
Maximum Area, $\Delta T=1.5^{\circ}\text{F}$	44%	64%	50%
Maximum ΔT , at 50% Area	1.1°F	1.9°F	1.5°F

9. These summer results represent conditions during the latter part of September, after three months of a sustained low River flow of 4000 cfs. This drought condition, i.e., flows lower than 4000 cfs, for a duration of three months, is not expected to occur more than once in 20 years.

Variation of the maximum temperature outside the mixing zone at Indian Point, throughout a severe drought year, is shown in Figure S-1.

10. The mixing zone will extend above and below Indian Point. Four miles from the plane of discharge, during the critical period of September, the 1.5°F isotherm is expected to bound about 25% of the River's cross-section; eight miles away, this will be reduced to about 15%.

Delineation of the extent of the mixing zone, for the critical period of September, and a sustained low flow of 4000 cfs, are tabulated as follows:

<u>Miles Above or Below Indian Point</u>	<u>Area Average Temperature Rise, °F</u>	<u>Surface Area Temperature Rise, °F</u>	<u>Percentage of Cross- Section Bounded by 1.5°F Isotherm</u>
0	3.0	9.0	50
2	2.3	6.9	38
4	1.75	5.2	27
6	1.35	4.0	20
8	1.0	3.0	15
10	0.75	2.2	10

These values are mean values taken between model extremes given on Figure S-2. Figure S-2 shows the extent of this zone for each decay model, as well as the average temperature across each River section.

11. The frequency of occurrence of maximum temperature rise outside the mixing zone is shown in Figure S-3. This figure shows that the maximum temperature rise outside the mixing zone, for less than 5% of all summers, is expected to be between 1.3 and 2.1°F. For 50% of all summer periods, this range can be expected to be 0.9° to 1.8°F.
12. Alden hydraulic model studies, conducted for the three unit operation, were analyzed. These studies were made for evaluation of intake and effluent structures and are not suitable for prediction of absolute values of River temperature rise at three unit operation. Results are suitable for evaluation of the relative effects of various effluent

50 % AREA TEMPERATURE ISOTHERM ΔT_{50}

HUDSON RIVER AT INDIAN POINT

EXPONENTIAL DECAY MODEL

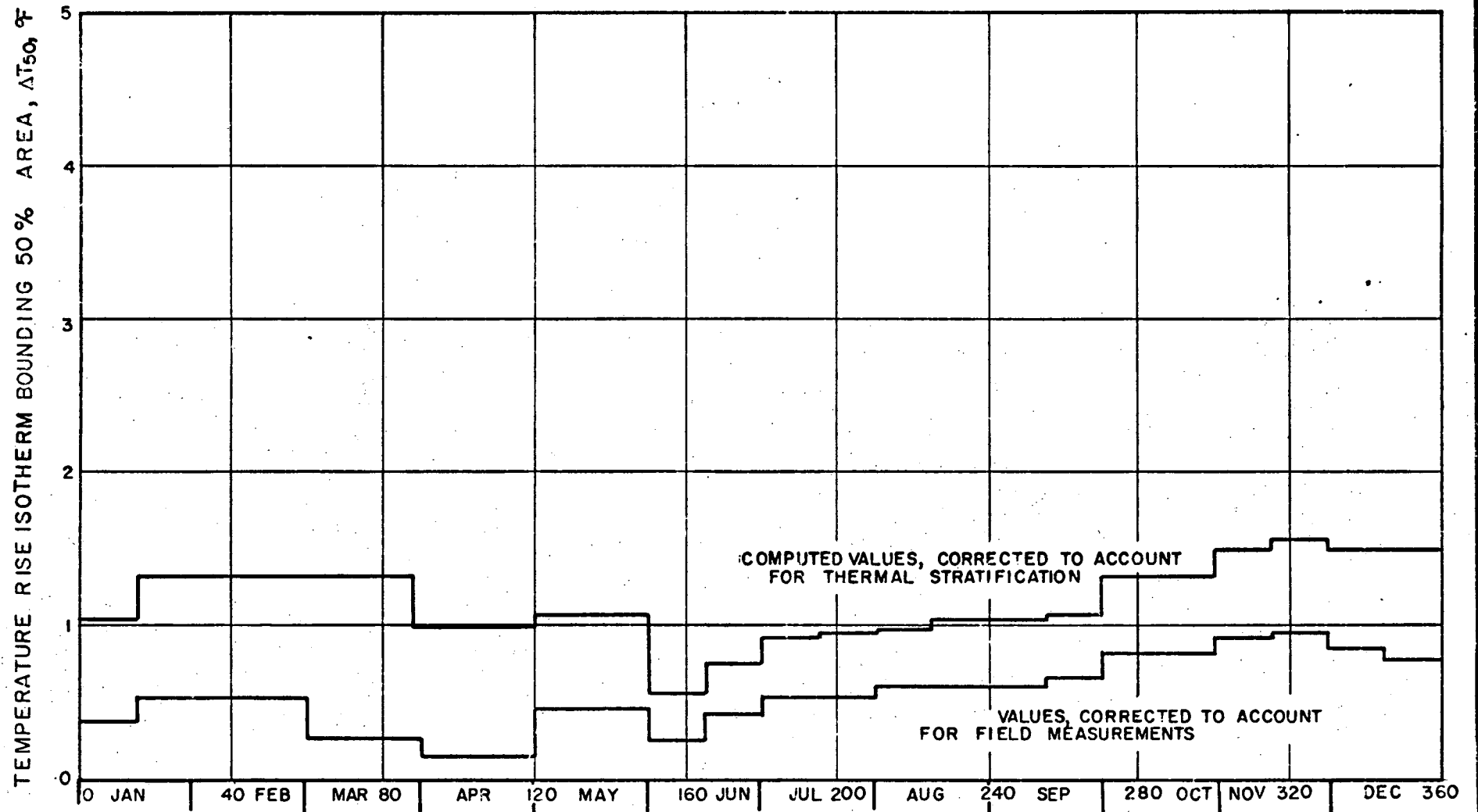

EXTENT OF MIXING ZONE

AREA AVERAGE TEMP. RISE
VS

PERCENTAGE AREA WITH 1.5°F CONTOUR
VS

DISTANCE FROM INDIAN POINT

DISTANCE FROM INDIAN POINT

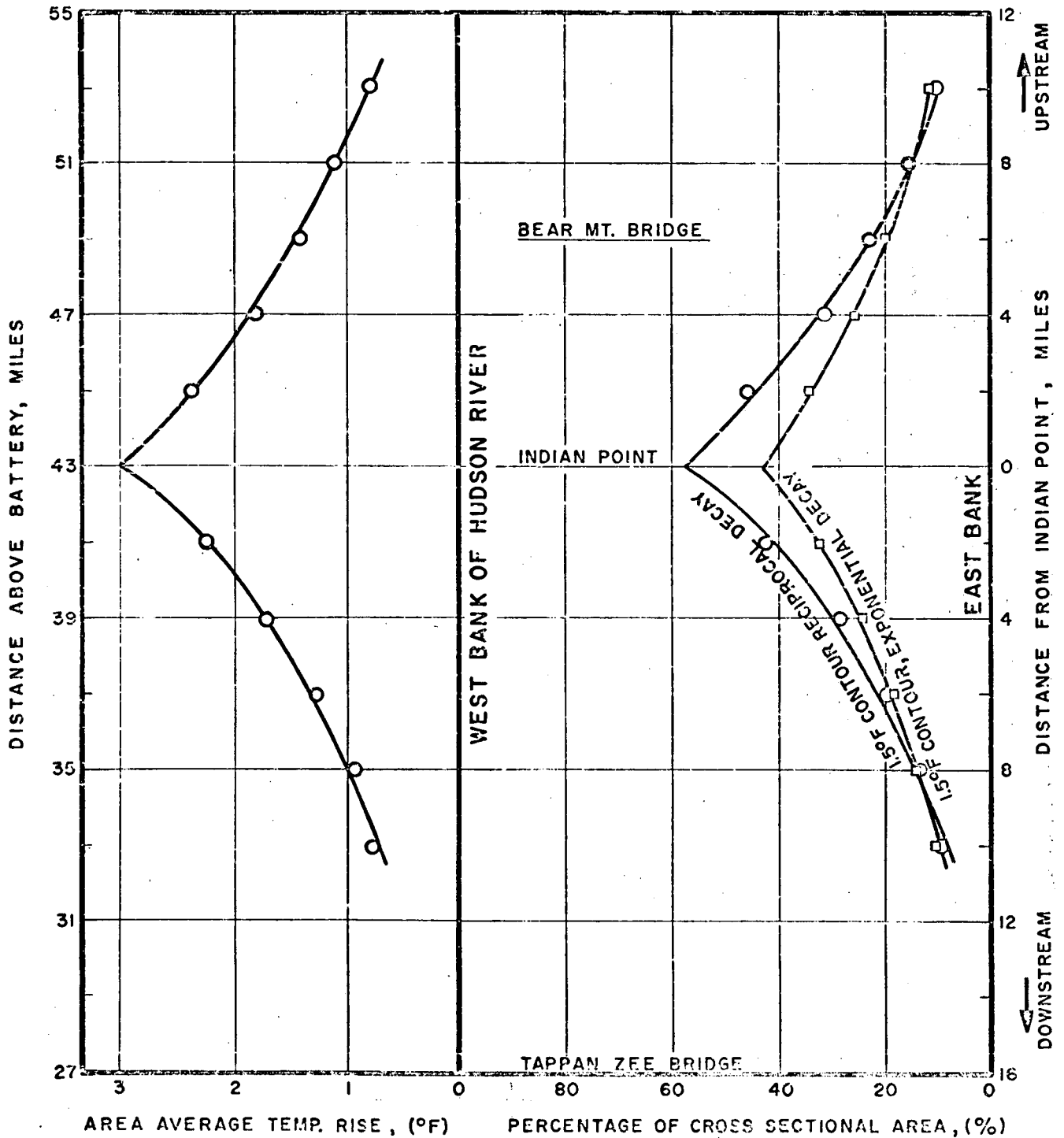

FREQUENCY OF OCCURRENCE OF SUMMER AVERAGE TEMPERATURE RISE AT INDIAN POINT FOR CAPACITY OPERATION OF THREE NUCLEAR UNITS

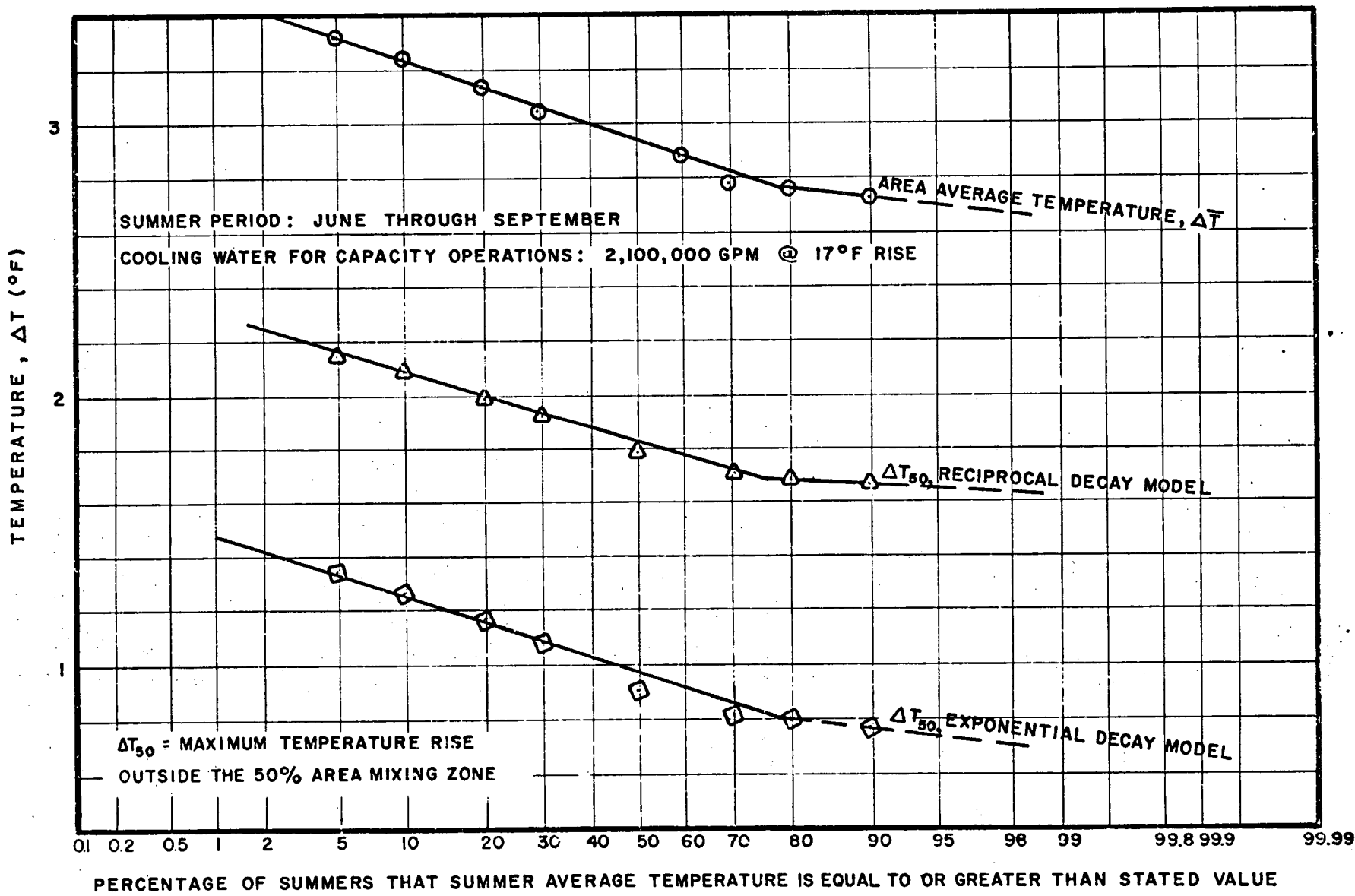

FIGURE S-3

channel outlet configurations.

These results show that effluent water can be directed along the east shore or at any angle toward mid-River. Directing the effluent downstream, and at an angle 45° from the east shore, results in markedly lower temperatures along the east shore, by comparison with directing this effluent downstream, but parallel with and adjacent to this shore. The latter configuration, however, provides better protection of the plant intake water.

13. The effect of the expected River temperature rise on River dissolved oxygen concentration has been evaluated. The addition of heat is not expected to cause any significant change in the dissolved oxygen content of the water as it passes through the plant.

Some decrease in the dissolved oxygen saturation concentration, C_s , will occur in the general vicinity of Indian Point. An increase in the average surface temperature in this vicinity from about 78°F to about 83°F may occur. This will decrease the C_s value from about 8.0 ppm to about 7.7 ppm.

Depletion of oxygen due to increased biological activity in the presence of higher temperatures will be offset by increased rate of replenishment of dissolved oxygen from the atmosphere. Thus, lowering the dissolved oxygen saturation is expected to be the only significant effect of the heated effluent on River DO resources.

The dissolved oxygen standard in this reach of the River is 5 ppm; the oxygen available for organic waste assimilation, therefore, is approximately 3 ppm. The expected maximum reduction of about 0.3 ppm in the saturation concentration represents a utilization of about 10% of the available assimilation capacity.

This does not appear to create an objectionable situation. DO levels in this vicinity at present are usually well above the 5.0 ppm standard. Upon completion of construction of required waste treatment facilities, the DO level should be maintained well above the 5 ppm criterion.

I. Events Leading to the Report

Consolidated Edison Company of New York, Inc. is planning to build a third nuclear reactor at Indian Point. Similar in design to Unit No. 2, which is currently under construction at Indian Point, Unit No. 3 will require 870,000 gpm of cooling water to carry some 7.4 billion BTU per hour of waste heat from this reactor to the Hudson River. On completion of Unit No. 3, total installed generating capacity of Unit Nos. 1, 2 and 3 is expected to be 2,351 megawatts and will require 2,040,000 gpm cooling water to remove 17 billion BTU per hour of waste heat.

Various regulatory agencies, including the Fish and Wild Life Service and the Federal Water Pollution Control Administration of the Department of the Interior, the United States Army Corps of Engineers, the Interstate Sanitation Commission, the Hudson River Valley Commission, and the New York State Departments of Conservation and Health, as well as the Atomic Energy Commission, either have requested or may request information on the effect of this thermal load on the Hudson River. The New York State Department of Health will require this information to establish conditions for the construction and operation of facilities to discharge wastes before issuing permits for (1) construction and (2) operation of these works. This two permit system replaces the previous single "Permit to Discharge Wastes to Waters of the State."

Field measurements of the temperature distribution in the Hudson River, resulting from discharge of heated effluent from Unit No. 1, have been performed and reported on by Northeastern Biologists Incorporated (1), (2).¹ Studies of the present and future Indian Point thermal discharge have been made on a Hudson River hydraulic model by the Alden Hydraulic Laboratory, Worcester, Massachusetts (3), (4). Studies of the hydraulic characteristics of the Hudson River, and of its ability to disperse wastes, have been made by Quirk, Lawler and Matusky Engineers for Consolidated Edison (5), (6), (7).

Quirk, Lawler and Matusky Engineers were retained by Consolidated Edison to correlate the results of these studies in order to predict the effect of operation of all three units on the River. This report documents results of that study.

¹A list of references follows this report on pages 35 and 36.

II. New York State Department of Health Requirements

The purpose and scope of this study have been developed in the light of New York State Department of Health requirements with respect to thermal discharges. Current NYSDH policy is presented in this section; specific study objectives and scope are presented in Section III. Although the project may be reviewed by the other agencies mentioned, conclusions are likely to be submitted to the NYSDH for its consideration in reviewing the application for the aforementioned permits. Policies of these agencies are not discussed.

Under Article 12, Public Health Law of New York State, the New York State Water Pollution Control Board¹ adopted² "Rules and Classifications and Standards of Quality and Purity for Waters of New York State." Primary administration of the provisions of these rules is the responsibility of the New York State Department of Health. Control is exercised through conditions on the permits to construct and operate facilities to discharge to waters of the State.

The Hudson River at Indian Point is classified "SB" by the New York State Water Resources Commission.³ Under this classification, best usage of the waters is "bathing and any other usages except shell fishing for market purposes." Quality standards for Class SB waters include specifications on heated liquids and on dissolved oxygen, a parameter which is partially controlled by water temperature. On heated liquids, the specification reads:

"None alone or in combination with other wastes in

¹Abolished on January 1, 1962. Functions were transferred to the New York State Water Resources Commission.

²By order made and entered October 23, 1950, effective October 25, 1950 (as amended on December 6, 1954, December 11, 1956, and April 20, 1959). "Rules and Classifications and Standards of Quality and Purity for Waters of New York State" are filed under the Administrative Codes & Regulations of the New York State Department of Conservation.

³"Official Classifications - Lower Hudson River Drainage Basin from Mouth to Northern Westchester - Rockland County Lines." Report prepared and published for Water Resources Commission by New York State Department of Health.

sufficient amounts or at such temperatures as to be injurious to edible fish or shellfish or the culture or propagation thereof, -----; and otherwise none in sufficient amounts to make the waters unsafe or unsuitable for bathing or impair the waters for any other best usage as determined for the specific waters which are assigned to this class."

Although this specification is largely qualitative, some quantitative criteria are applied by the Health Department in considering specific applications for permission to discharge heated effluents. Due to an FWPCA request to upgrade its temperature standards, an extensive revision of these criteria has been under study by the Health Department in recent weeks. Earlier criteria are detailed in a preliminary report on this study (8). Suggested new criteria are in the development stage and have not yet been officially accepted or released by the Health Department.

These criteria are being developed in line with recent recommendations made by the National Technical Advisory Committee on Water Quality Criteria (9). The recommendation of NTAC on both fish and estuarine and marine organisms are found in the Committee report "Water Quality Criteria for Fish, Other Aquatic Life, and Wild Life." Although there are some differences, the new Health Department criteria are expected to follow these recommendations closely.

New criteria applicable to the evaluation of Indian Point thermal discharge include the provision of a zone for mixing and dilution of the thermal effluent with the receiving waters, and temperature specifications on the tidal salt water receiver outside the mixing zone.

The mixing zone is established to permit use of a portion of the River for dilution of high temperature effluents, while at the same time preserving the remainder for passage of fish and aquatic organisms. No particular temperature criterion must be met in the mixing zone, but its extent is generally considered to be limited to 50% of the cross-sectional area of the estuary. The length of the mixing zone is unspecified.

In estuaries, temperature criteria outside the mixing zone include a maximum temperature of 86°F, a maximum temperature rise of 1.5°F from June through September and a 4°F rise during the remainder of the year. Temperature change rates are not to exceed 1°F per hour or 7°F in any 24 hour period, excepting, of course, emergency shut-down and startup.

The ability to meet each of these criteria requires a determination of the extent of the mixing zone; i.e., delineation of the boundaries of the zone within which all temperatures exceed the particular criterion under consideration. Since the naturally occurring River temperature rarely, if ever, exceeds 80°F, the 1.5°F and 4°F temperature rise criteria are more restrictive than the 86°F maximum for the case of thermal discharge at Indian Point. Rise rate criteria, when applied to the zone outside the boundaries of the 1.5°F or 4°F mixing zones, will not be exceeded.

The salt water criteria were selected since previous studies (5), (7) show that generally the River is salty at Indian Point. These criteria are more stringent than the fresh water criteria, particularly during the summer months. For example, by comparison to the allowable rise of 1.5°F (June through September) in the tidal salt water regime, a 5°F rise is permitted in the fresh water regime.

The National Technical Advisory Committee interim report (9) implies that the recommended water quality criteria on temperature have been written to protect all important species, including the most sensitive.

"Temperature requirements of marine and estuarine organisms in the biota of a given region may vary widely. Therefore, if we are to maintain temperature favorable to the biota, all important species, including the most sensitive, must be protected." (p. 199)

The applicability of a 1.5°F maximum rise as a measure of the upper limit of non-injurious temperature effects on Hudson River ecology in the Indian Point vicinity should be evaluated by Edison aquatic biologists.

In this regard, consideration should be given to the closeness of Indian Point to the upstream boundary of the salt intrusion; aquatic organisms indigent to this vicinity may be less sensitive to temperature changes than biota which are found in marine (sea) waters or close to the estuary's mouth. This probability is recognized in the NTAC report.

"It has been found that [marine and estuarine] organisms in the intertidal zone vary considerably in their ability to withstand high temperatures. Those in the uppermost areas of the tidal zone can generally withstand higher temperatures than those in the lower portions of the tidal zone, and these in turn can generally withstand higher temperatures than the same species of animals living in the sub-tidal zones." (p. 199)

Furthermore, the recommended maximums were also based on the lack of variation in marine water temperature.

"In general, temperatures in the marine waters do not change as rapidly and do not have the overall range from extreme to extreme that they do in fresh waters. The marine and estuarial fishes, therefore, can withstand less variation in temperature. There is some acclimatization allowable, but overall temperature range and rate of change are even more important than they are in fresh waters."

These statements may not apply to the upper waters of the Hudson estuary. Temperature ranges appear to be similar to the range recorded in the fresh water portion of the Hudson and in other fresh water Rivers in the State.

III. Purpose and Scope

The purpose of this study is to develop the Hudson River temperature distribution which can be expected in the vicinity of Indian Point upon operation of all three nuclear power units. Temperature rises are computed for the seasonally varying meteorology and hydrology and are presented in terms of frequency of occurrence. Recommendations for evaluation of a thermal discharge, included in the proposed new criteria, are considered.

Scope of work required to achieve delineation of expected temperature profiles and the boundaries of the mixing zone includes:

1. Development of the one-dimensional temperature profile along the longitudinal axis of the River for various loading conditions. These temperatures are averages over the tidal cycle and over the River cross-section. Results are obtained via a time dependent mathematical model and include the variation of the average temperature at any section throughout the year.
2. Evaluation of model results using River temperature profiles obtained by field measurement during the operation of Indian Point No. 1.
3. Determination of the shape of the temperature profile across a cross-section from the field measurements and relation of the sectional average temperature to this profile.
4. Determination, for the condition of future loading, of the temperature distribution across a section, using the sectional average temperature obtained via the one-dimensional model and the relation of the sectional average to the profile across the section developed from field measurements.
5. Construction, from these results, of zones of mixing corresponding to the various temperature criteria outlined in the Health Department Guidelines.

In addition, this study also includes evaluation of the effect of the heated discharge on the waste assimilation capacity of the River, and evaluation of the merits of various effluent channel outlet configurations from data obtained on the Alden hydraulic model.

IV. River Temperature Profiles and Delineation of Mixing Zones

This section follows the procedure outlined under scope of work. One-dimensional model results are given first, followed by evaluation of these in light of available field measurements. Construction of profiles across the River sections are then presented for the case of Unit No. 1. These results are then combined with the one-dimensional results for future loading conditions to delineate expected mixing and passage zone temperatures.

One-Dimensional Analysis - General

The Hudson River drainage basin is shown in Figure 1. The River is tidal from its mouth at the Battery in New York City (Mile Point 0) to the Federal Dam at Troy (MP 154). Heat introduced at Indian Point, MP 43, will be subject to reversing tidal currents as well as salinity induced circulatory currents, and will be distributed above and below the zone of discharge.

Details of the development of a mathematical model to describe distribution of temperature from a heated effluent are given in Appendix A. The model is the application of the Law of Conservation of Energy over a series of segments of the Hudson Estuary between the Battery and Troy. The energy mechanisms considered include movement by fresh water flow, dispersion by tidal turbulence and density induced circulating currents, and heat transfer across the water surface by convection, evaporation, and radiation.

Parameters required to quantize these mechanisms include River geometry, fresh water runoff, longitudinal dispersion coefficients, and surface heat transfer coefficients. Procedures employed to evaluate these parameters are given in Appendix B and in previous reports (5), (6), (7), (8).

Although the effect is mitigated to some extent in an estuary due to high levels of longitudinal dispersion, flow is a controlling parameter in the evaluation of dilution of waste effluents by the receiving waterway. For a given thermal load, the temperature of the River after mixture with the thermal effluent increases as River flow decreases. For this reason, drought flows were given particular attention in this study.

Figure 2 shows monthly average lower Hudson River flows during 1964 and for the 47 year period ending in 1964. Flows during the year 1964 were among the lowest sustained flows of record in the Hudson River. With the exception of March, the 1964 flows are seen to be

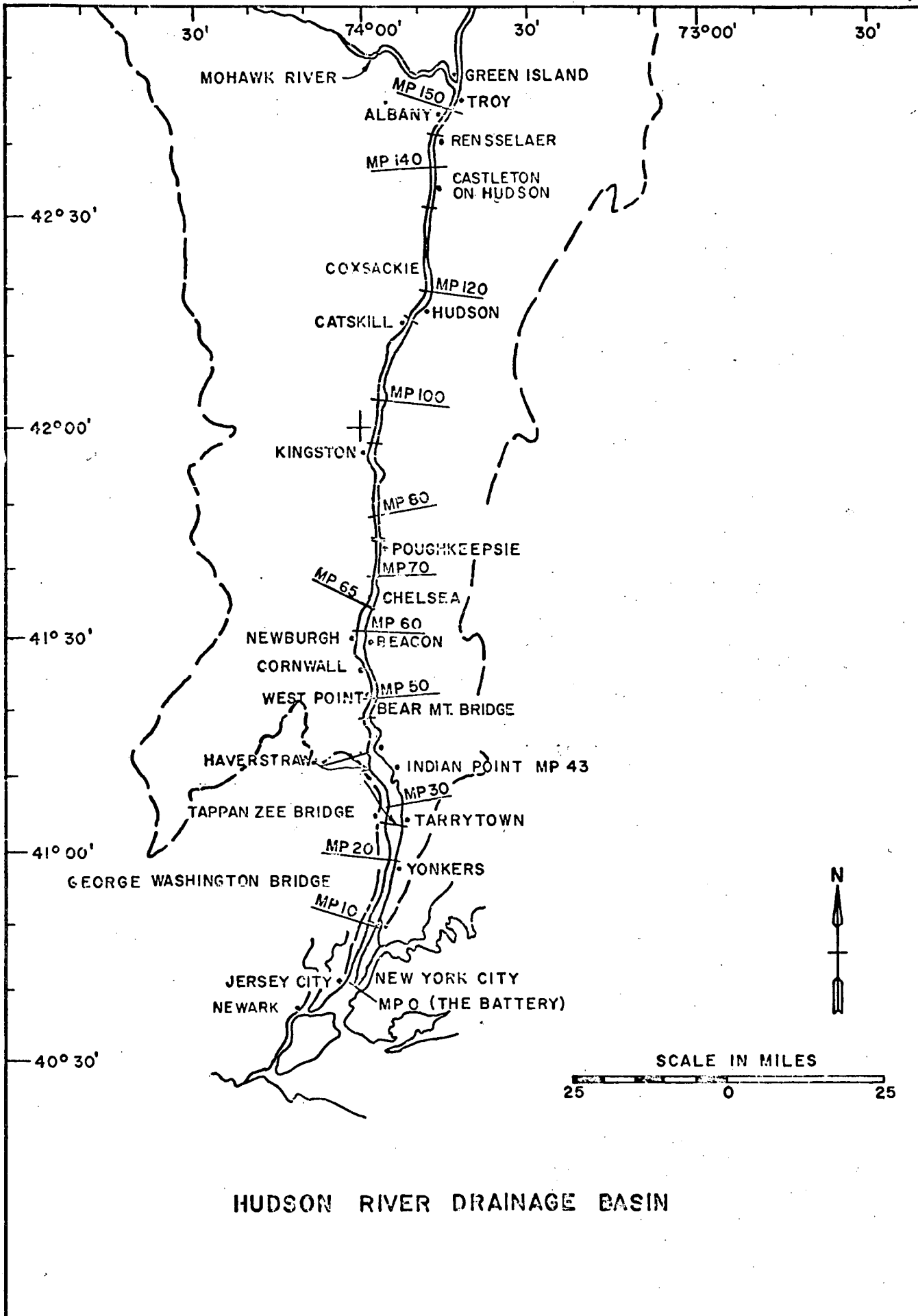
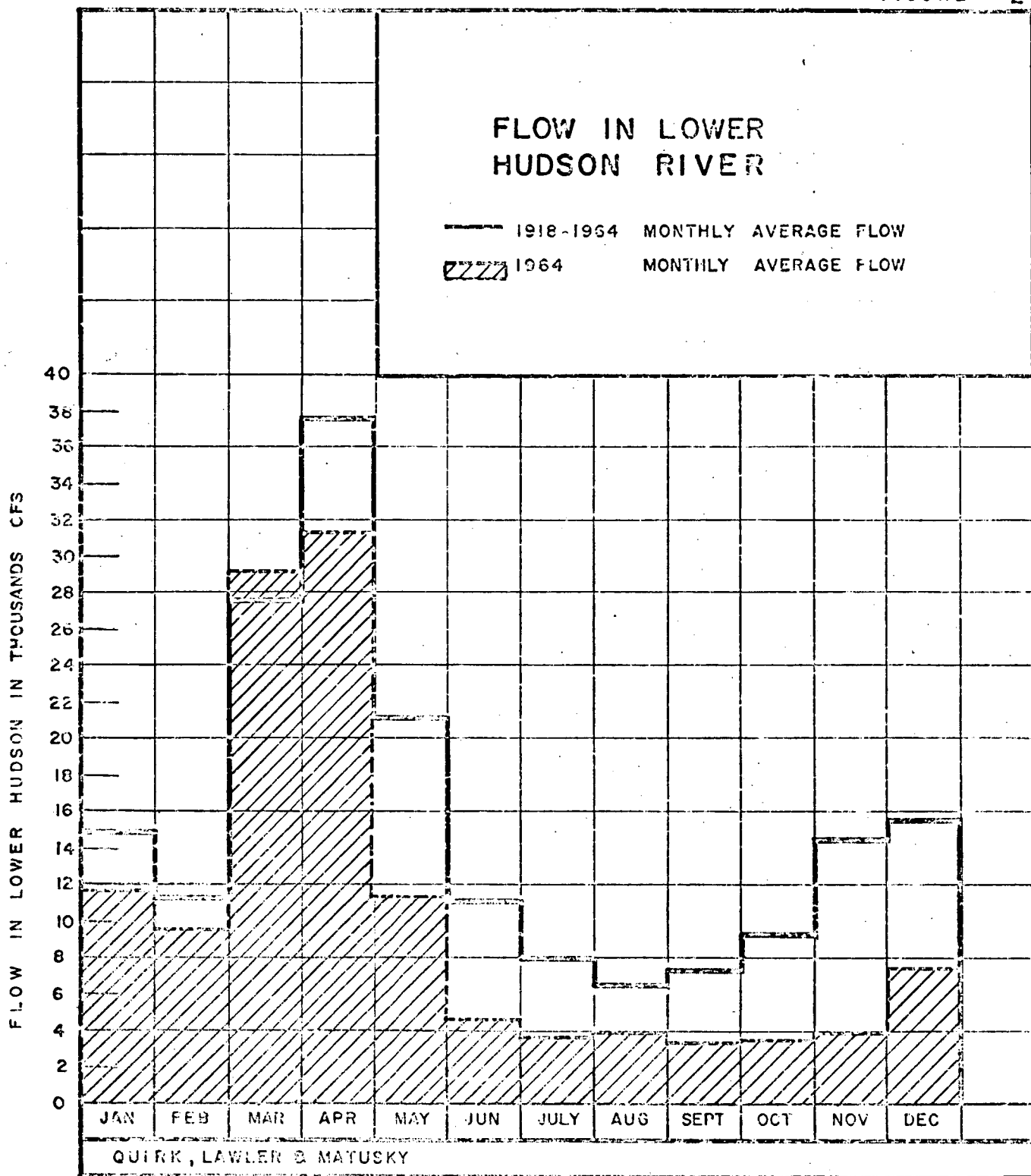

FIGURE 2



substantially less than the average condition. Flows from June through December, 1964 were generally 50% or less of the average condition for each of those months.

Surface heat transfer coefficients were computed from the prevailing meteorology for each month, and checked by comparison with heat transfer calculations based on naturally occurring water temperature changes during each month. The surface heat transfer coefficient has the dimensions of BTU/sf/day/°F and, when multiplied by the difference between the actual water surface temperature and the equilibrium water surface temperature, yields the heat transfer in BTU/day per square foot of water surface area. Monthly average heat transfer coefficients, computed using 1964 Weather Bureau data applicable to the Indian Point vicinity, are given in Figure 3. Yearly variation in each monthly surface heat transfer coefficient is not great; the monthly coefficients shown in Figure 3 have been used for predictive purposes throughout this report.

The equilibrium water surface temperature is that temperature at the water surface which will yield a zero net heat transfer across the surface. The ambient, or naturally occurring, water temperature generally lags the equilibrium temperature between February and July; during this period, the water body is warming. Between August and January, the ambient temperature exceeds the equilibrium temperature and the River is cooling. Figure 4 shows this phenomena in the Hudson River at Indian Point for the meteorological conditions of 1964.

River cross-sectional area, depth and surface width vary with distance along the longitudinal axis of the River and have a variable effect on the temperature profiles. For example, Haverstraw Bay, where the surface area to volume ratio is large, heats and cools faster than the gorge between this Bay and Newburg Bay to the north. Charts showing the variable geometric pattern and tables of the values used in the model are given in Appendix B.

Longitudinal dispersion in the Hudson River varies with fresh water flow and distance along the River's axis. The upstream movement of salt during periods of low flow increases the dispersion effect in the Indian Point area, and smoothes the otherwise strong influence of River flow. Values of the dispersion coefficient used in this model are given in Appendix B. Details of the effect of dispersion on contaminant intensity are given in Appendix A.

WATER SURFACE HEAT TRANSFER

HUDSON RIVER NEAR INDIAN POINT

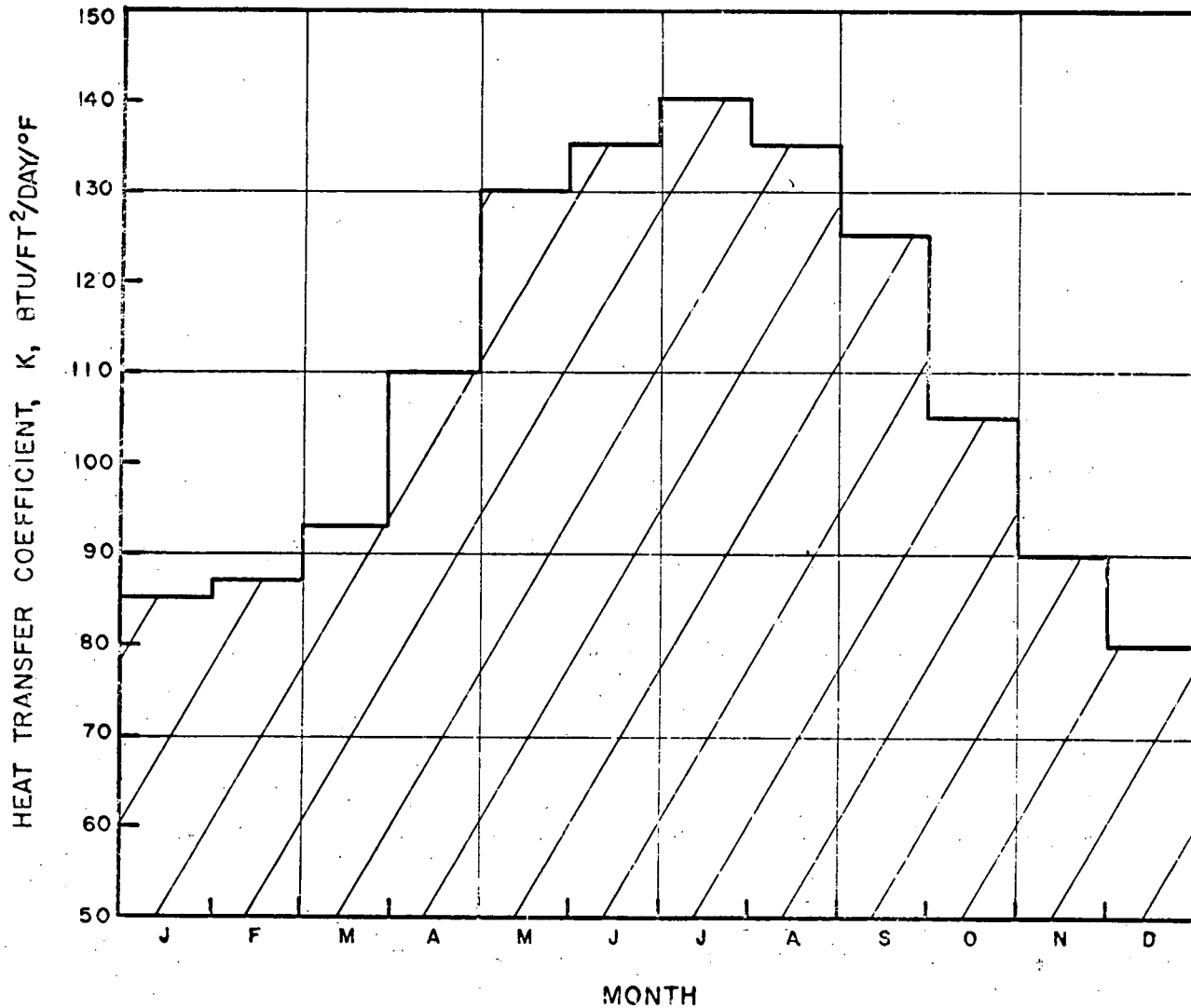

K IS A FUNCTION OF:

- AIR TEMPERATURE, T_a
- SOLAR RADIATION, H_s
- ATMOSPHERIC RADIATION, H_a
- WIND SPEED, w
- RELATIVE HUMIDITY, R_H
- AIR VAPOR PRESSURE, e_a

SOURCE OF DATA:

AGENCY	YEAR
U.S. WEATHER BUREAU	1951 TO 1964
U.S. AIR FORCE AIR WEATHER SERVICE	1942 TO 1965

FIGURE 3

EQUILIBRIUM SURFACE TEMPERATURE
 & RIVER AMBIENT TEMPERATURE
 HUDSON RIVER NEAR INDIAN POINT

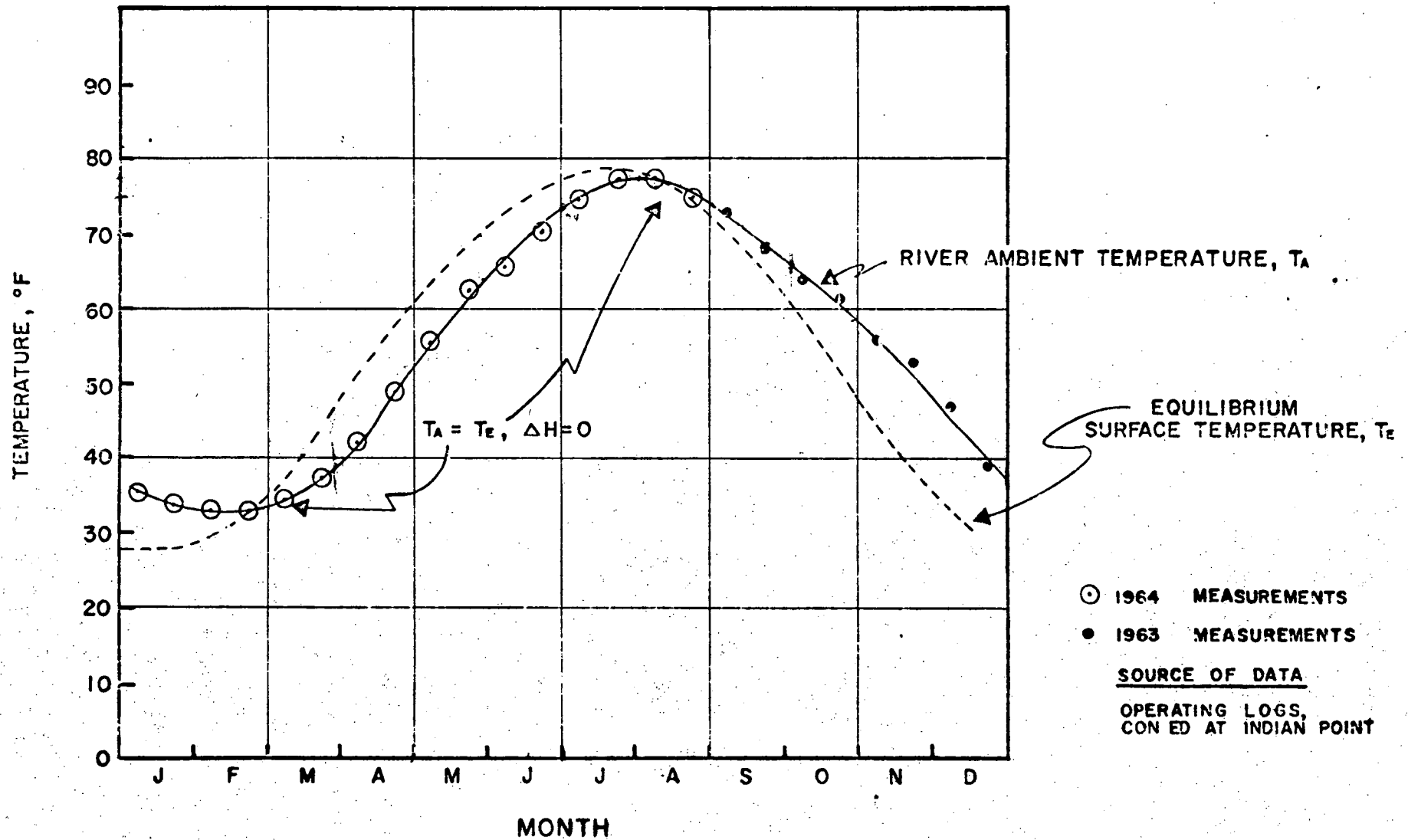

FIGURE 4

One-Dimensional Analysis Predictions - July 1966 and April 1967

Extensive field measurements of Hudson River temperatures were made by Northeastern Biologists Inc. during the months of July, 1966 (1) and April, 1967(2) to establish temperature rises in the River caused by Indian Point Unit No. 1. These data provide the only means of testing the applicability of the one-dimensional model to the analysis of Indian Point thermal discharge.

River flow and prevailing meteorology for these periods were used to predict the average temperature at Indian Point for comparison with the NBI data. Table 1 shows the values selected for the model parameters and the model-computed and field measured temperature values.

Table 1 shows that the model-computed temperatures at Indian Point are 100% and 80% higher than the measured values for July and April, respectively. The reasons for these differences are discussed below.

Field measurements during April, 1967 were made on approximately eight different phases of the tidal cycle. Temperature rise isotherms across the section at Indian Point were constructed for each of these phases. Typical plots for the flood and ebb cycles are shown in Figures 5 and 6. The tidal cycle average plot of the rise isotherms versus cross-sectional area contained within each isotherm is shown in Figure 7. The average temperature over the entire cross-section was obtained by computing the area under the curve in Figure 7 and dividing this result by the total River cross-sectional area at Indian Point of 160,000 square feet.

Similar procedures were used to analyze the July data. Temperature measurements during this survey were made at the surface, middle and bottom only, rather than at every integral degree Fahrenheit; the results, therefore, should be considered less reliable. Figure 8 shows the average position of the isotherms throughout the tidal cycle and Figure 9 shows the given isotherms plotted against the area contained within that isotherm. The average temperature over the entire cross-section was computed as described above for Figure 7.

These values represent the difference between temperature measurements made within the zone of the River that is measurably influenced by the thermal discharge, and the River ambient temperature. Although several measurements of River ambient temperature were made, these were recorded to the nearest whole degree so it is possible that the recorded ambient temperature was high by 0.5°F.

TABLE 1
 COMPARISON OF MODEL-COMPUTED
 AND
 FIELD-MEASURED TEMPERATURE RISES AT INDIAN POINT

	<u>July 1966</u>	<u>April 1967</u>
River flow, cfs	7,300	40,000
Dispersion coefficient, mile ² /day	10	2
Heat transfer coefficient, BTU/ft ² /day/°F	140	110
Cross sectional area, ft ²	160,000	160,000
Mean depth, ft.	40	40
River ambient temperature, °F	75	45
Temperature rise across reactor, °F	10	11
Circulating water flow, gpm	300,000	300,000
Heat loss to River, BTU/day	36 X 10 ⁹	40 X 10 ⁹
Model-computed River temperature rise, °F	0.40	0.18
Field-measured River temperature rise, °F	0.2	0.1

UNIT No. 1 OUTLET

TEMPERATURE RISE ISOTHERMS, °F

HUDSON RIVER AT INDIAN POINT

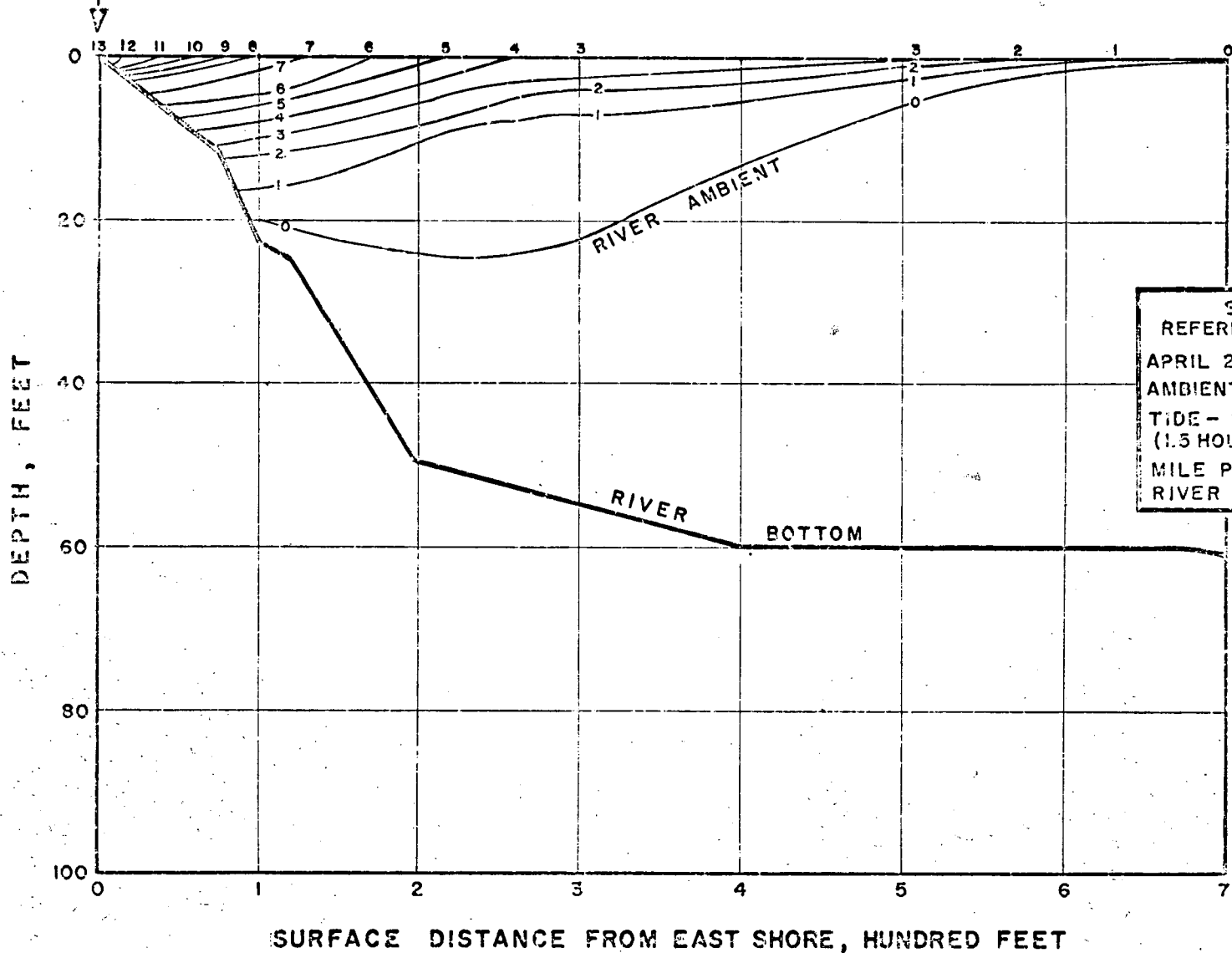

SOURCE OF DATA
REFERENCE 2, STATION 56
APRIL 26, 1967
AMBIENT RIVER TEMP. 45°F
TIDE - EARLY FLOOD
(1.5 HOURS AFTER LW₅)
MILE POINT: 43
RIVER FLOW - 40,000 CFS

FIGURE 5

UNIT No. 1 OUTLET

TEMPERATURE RISE ISOTHERMS

HUDSON RIVER AT INDIAN POINT

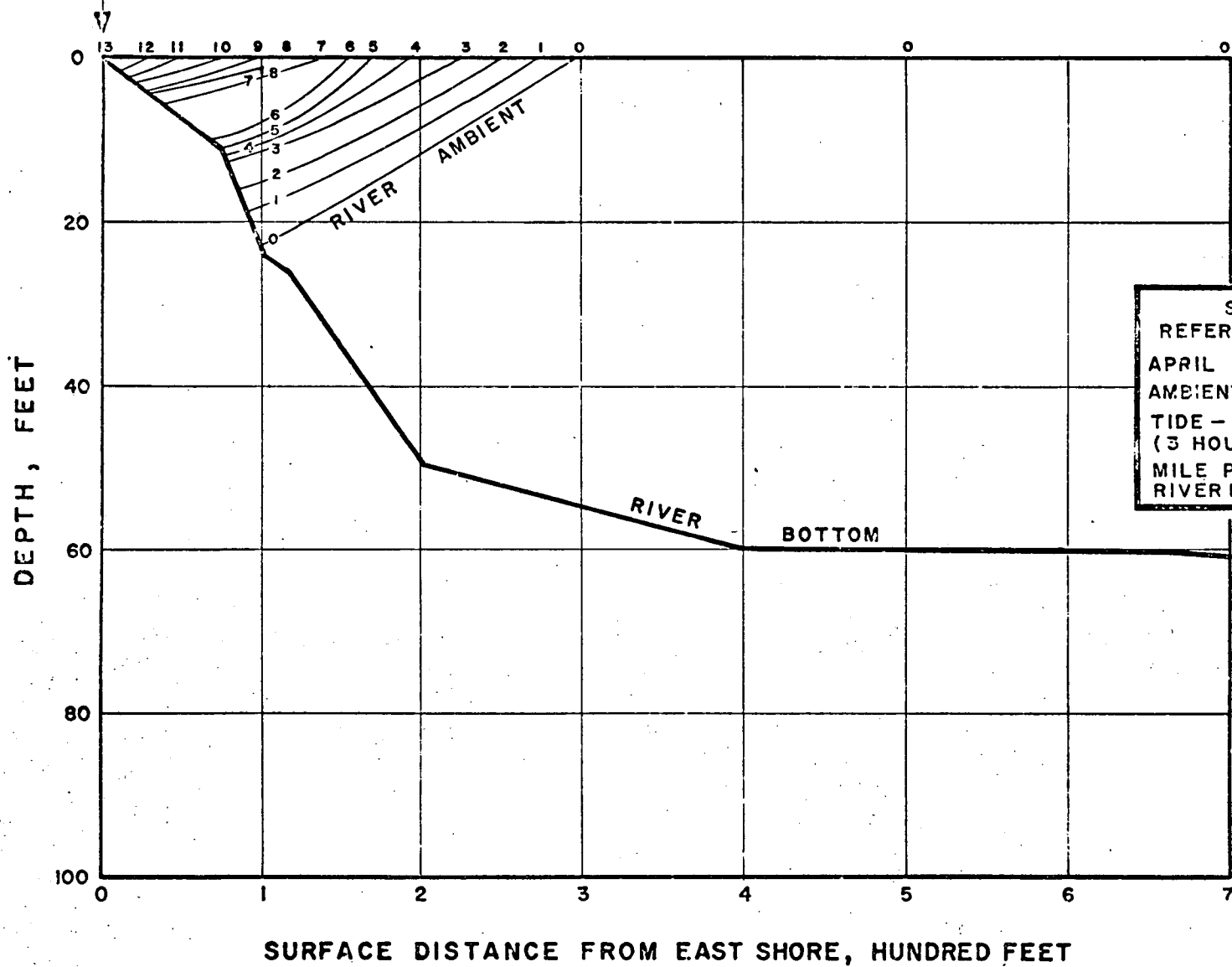

SOURCE OF DATA
REFERENCE 2, STATION 56
APRIL 17, 1967
AMBIENT RIVER TEMP. 45°F
TIDE - MAXIMUM EBB
(3 HOURS AFTER HWS)
MILE POINT: 43
RIVER FLOW - 40,000 CFS

FIGURE 6

TIDAL AVERAGE TEMPERATURE RISE DISTRIBUTION
FOR
HUDSON RIVER AT INDIAN POINT

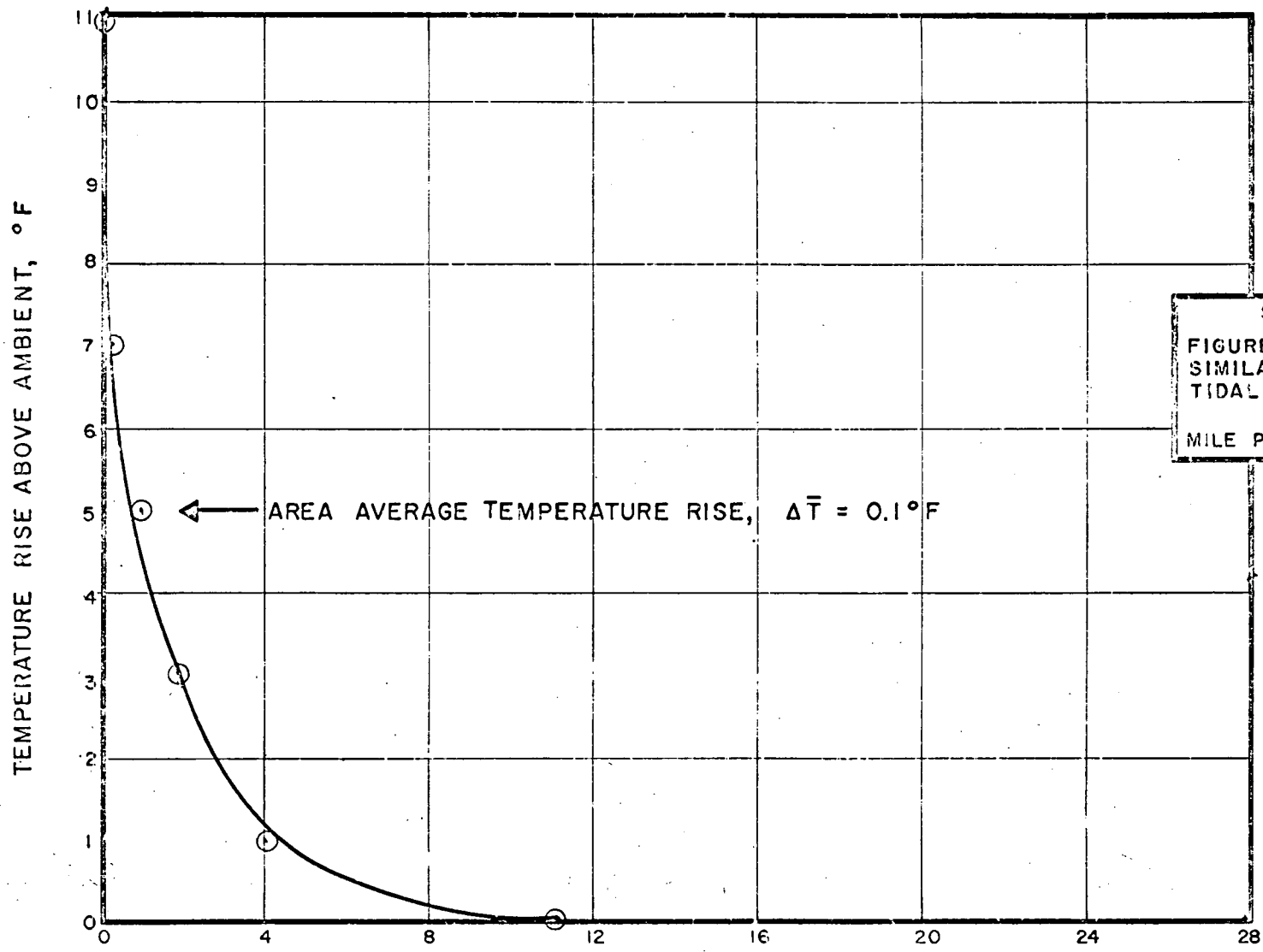

← AREA AVERAGE TEMPERATURE RISE, $\Delta \bar{T} = 0.1^\circ \text{F}$

SOURCE OF DATA
FIGURES 5 & 6 AND
SIMILAR PLOTS FOR OTHER
TIDAL PHASES
MILE POINT: 43

FIGURE 7

TEMPERATURE RISE ISOTHERMS, °F

HUDSON RIVER AT INDIAN POINT

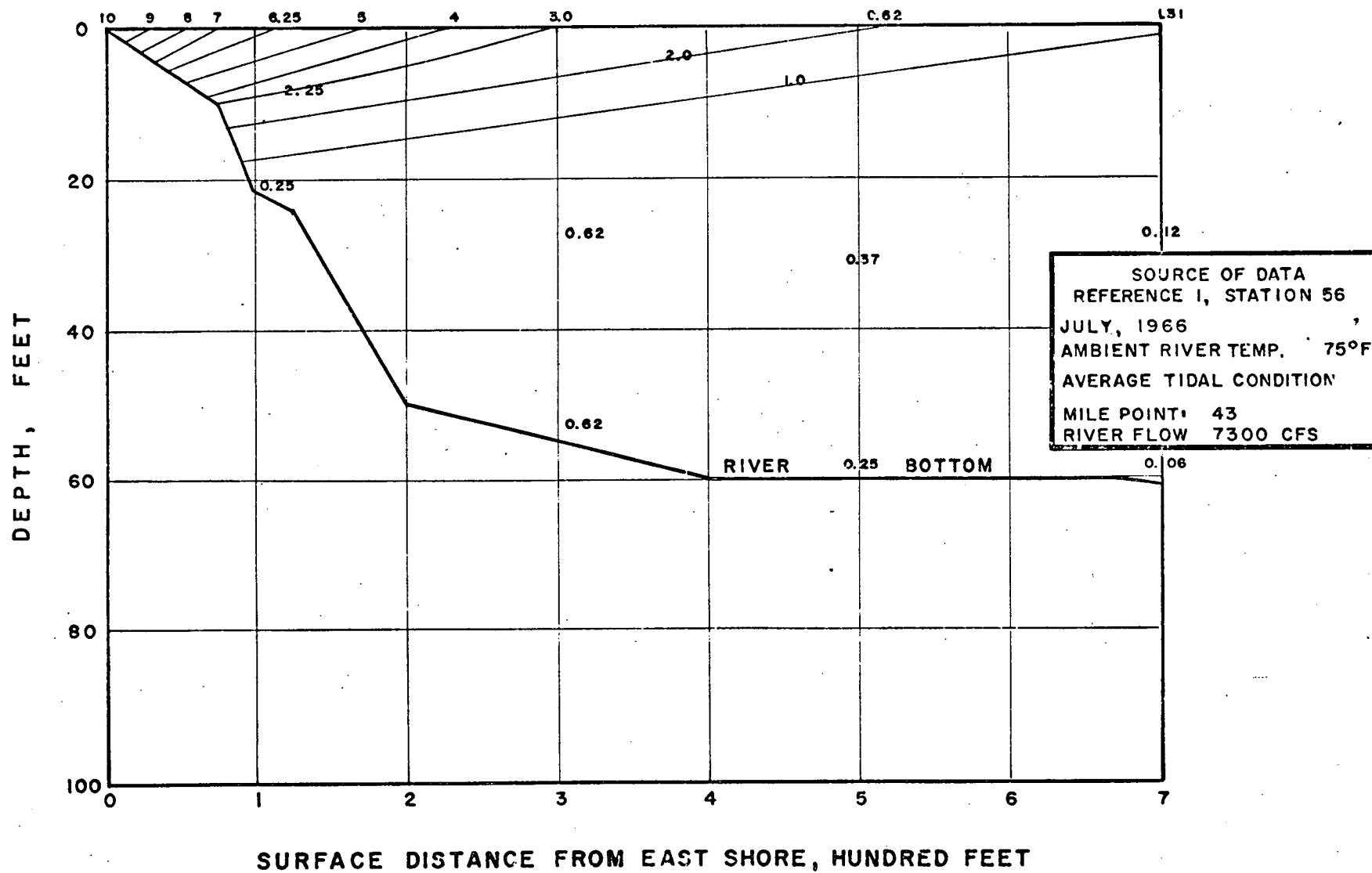
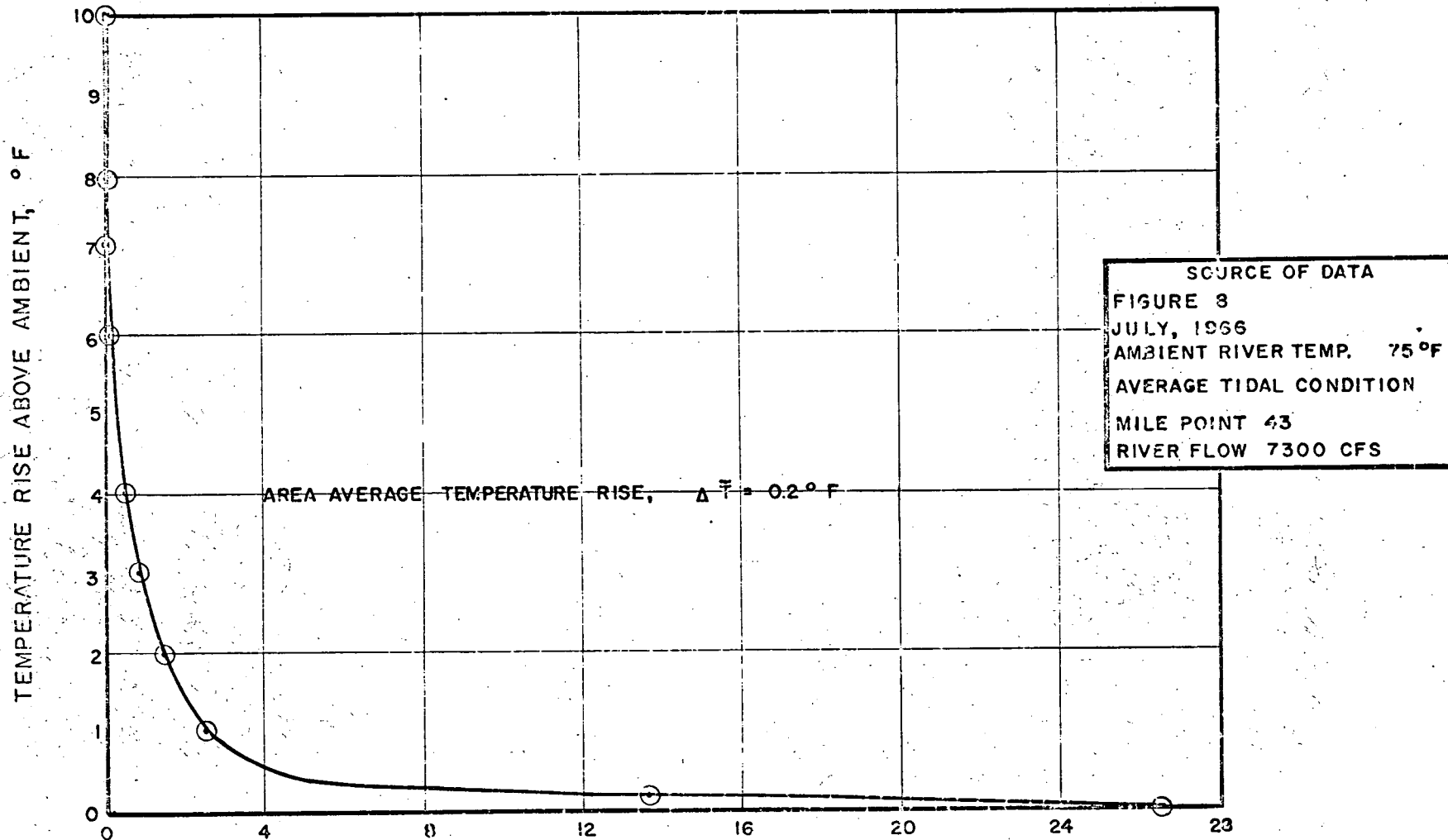

FIGURE 8

TIDAL AVERAGE TEMPERATURE RISE DISTRIBUTION
 FOR
 HUDSON RIVER AT INDIAN POINT



AREA BOUNDED BY THE GIVEN TEMPERATURE RISE ISOTHERM, THOUSAND SQUARE FEET
 (AREA WITHIN WHICH THE TEMPERATURE RISE \geq THE RISE ISOTHERM)

FIGURE 9

A maximum possible average temperature can be computed by assuming the true ambient is 0.5°F lower than recorded, that all measurements within the zone of influence were precise, and that ambient conditions were not reached nearer the east shore or surface than recorded. This computation was done by dropping the abscissa's¹ on Figures 7 and 9 by 0.5°F , extrapolating the temperature curve to zero, and repeating the averaging procedure. Maximum possible average temperatures of 0.3 for the July, 1966 data and 0.17 for the April, 1967 data were obtained. The above assumptions favor elevated values; it is unlikely the true averages are this high.

An alternative averaging technique was also employed. Rather than constructing isotherms, the arithmetic average temperature was computed over a section extending a given distance from the east shore and from surface to bottom. Curves of average temperature versus area for July, 1966 and April, 1967, using this method, are shown in Figures 10 and 11, respectively. Average temperatures across the full cross-section were 0.21°F and 0.12°F for July and August, by comparison to 0.2°F and 0.1°F , respectively, for the isotherm method. The close agreement of the two methods supports these results as good estimates of the true averages.

The above comparison of measured and model-computed temperatures shows that the one-dimensional model may be expected to yield, for a given thermal loading, River temperatures that are higher than those which will actually occur. The following considerations suggest reasons for this behavior.

1. Surface Heat Transfer - Model calculations were made using heat transfer coefficients obtained by analysis of the meteorological data. Appendix A shows that unless the vertical temperature gradient is flat, a correction factor must be applied to the heat transfer coefficient when it is employed in the one-dimensional model. This factor is equal to the ratio of the average surface temperature to the area averaged temperature.

This correction was not applied to the original model because it could not be obtained without recourse to measured temperature profiles near Indian Point. Use of the measured profiles for this purpose was avoided to maintain independence between model and measurement. Furthermore, this ratio may vary with the longitudinal distance coordinate; data to define the ratio some distance from the source were not available.

1. i. e., the measured temperature rises were each increased by 0.5°F .

TIDAL AVERAGE TEMPERATURE RISE DISTRIBUTION

FOR

HUDSON RIVER AT INDIAN POINT

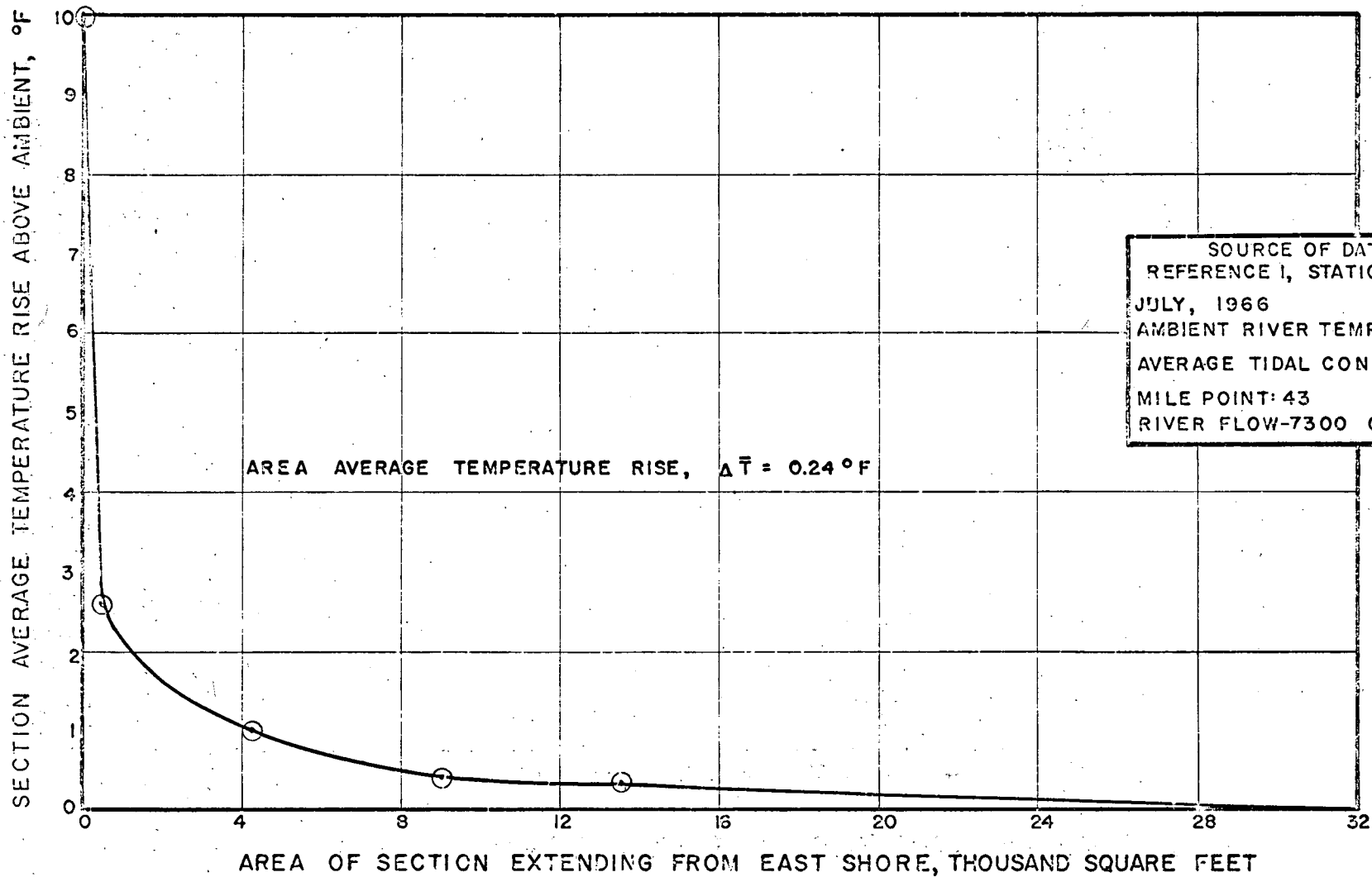

FIGURE 10

TIDAL AVERAGE TEMPERATURE RISE DISTRIBUTION

FOR
HUDSON RIVER AT INDIAN POINT

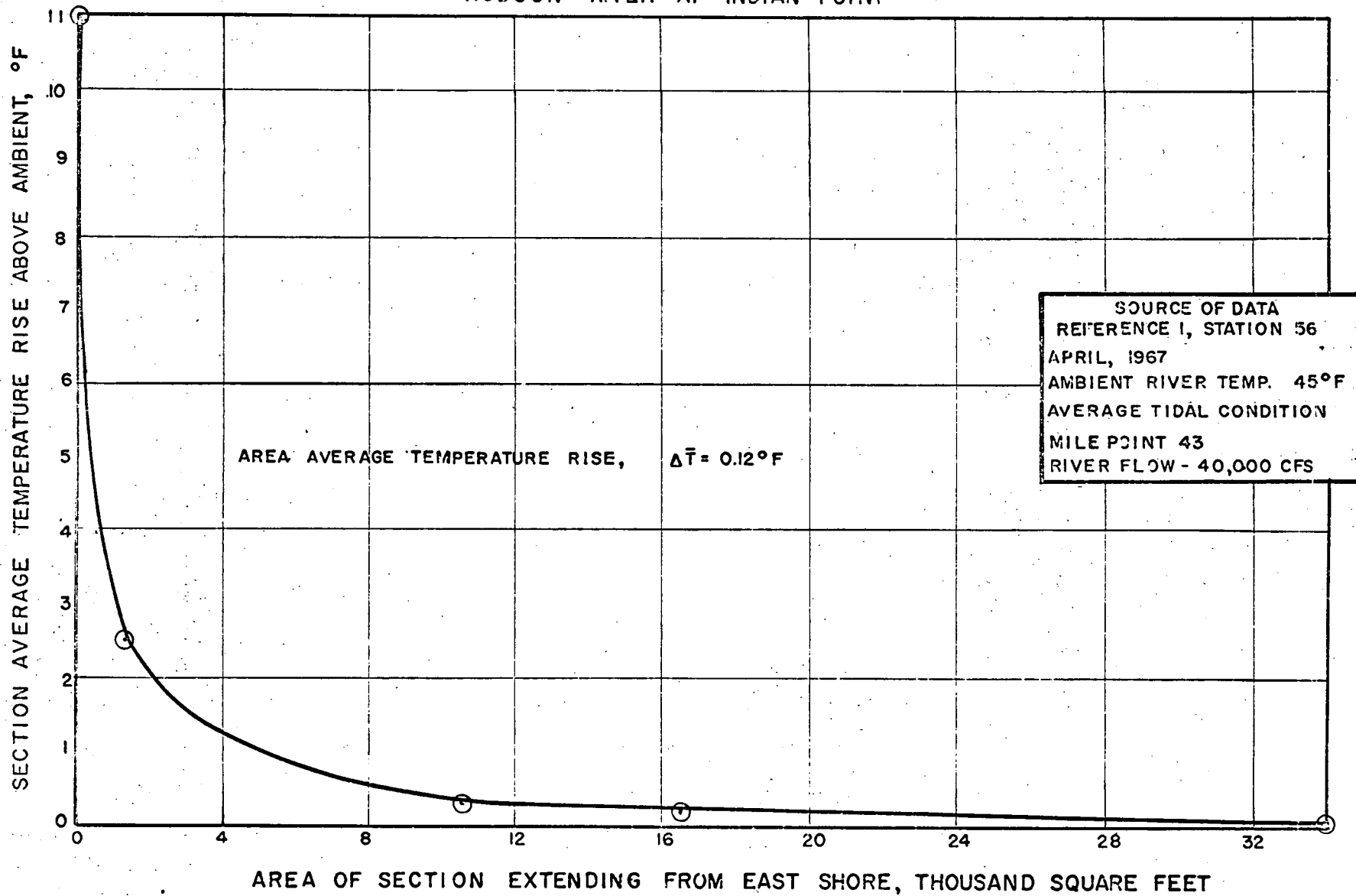

FIGURE 11

The ratio of the measured surface average temperature to the measured area average temperature at Indian Point is 3.0 for the July data and 6.0 for the April data. Adjustment of the model to account for increased surface heat transfer yields revised model-computed averages of 0.25°F for July, 1966 and 0.17°F for April, 1967, by comparison to the original values of 0.40 and 0.18, respectively.

This correction has a much greater influence on the average temperature at Indian Point for the drought flow condition (July) than for the high flow condition (April). Heat transfer will occur over whatever surface is influenced by elevated temperatures. In the presence of drought flows, salinity intrusion causes the longitudinal dispersion to increase sharply. Waste heat is carried upstream as well as downstream of the point of discharge and surface heat transfer at the plane of discharge is fully developed. During high spring flows, virtually all the heat is carried downstream and surface heat transfer only begins as one moves below the plane of discharge.

2. Dilution by Circulatory Flow - The Hudson is a partially stratified estuary and, at any section within the saline intrusion, is characterized by a net, non-tidal upstream movement of sea water in its lower layer and a similar downstream movement in its upper layer (10).

The fresh water runoff into the estuary is generally small by comparison to this circulating flow. The ratio of the net non-tidal circulation to the fresh water runoff has been observed in other partially stratified estuaries to vary from 9 to 40. The circulation increases in the downstream direction as greater volumes of sea water are lifted, via momentum exchange, into the upper layer (11). This ratio will vary with distance from the estuary's mouth.

This phenomena suggests that a non-conservative contaminant, such as heat, if released and held in the upper layer, should be diluted by the net non-tidal flow in the upper layer. Decay of this contaminant would be expected to be zero before the circulation was complete and the flow returned.

The net non-tidal flow has never been measured in the Hudson. Extensive field current measurements, at various depths throughout cross-sections within the salt intruded reach, and over a full tidal cycle, are necessary to obtain this quantity. Measurements meeting these requirements are not available for the Hudson.

Net non-tidal flow will disperse contaminants throughout the estuary. This effect is generally considered to be accounted for by the longitudinal dispersion coefficient. However, this parameter is measured by analysis of longitudinal profiles of the area averaged salinity. Salinity does not decay, and in a partially mixed estuary, does not vary markedly in the vertical direction so that the concentration in the lower layer is only slightly larger than that in the upper layer. Artificially induced temperature, on the other hand, does decay and is characterized by significant vertical gradients. The dispersion coefficient is a function of density differences. Thermal stratification, therefore, could increase the dispersion coefficient and account for lower measured temperatures.

Surface heat transfer corrections, to account for surface temperatures that are higher than sectional average temperatures, are applied to the one-dimensional model to yield results which, although still conservative, conform more closely to field measurements. The correction procedure is outlined in Appendix A. Although density-induced circulation, and therefore the longitudinal dispersion coefficient, should increase in the presence of thermal stratification, sufficient data are not available to warrant increasing the values of the salinity-determined dispersion coefficients.

One-Dimensional Model Prediction -- Future Loading

This section presents results obtained using the one-dimensional model, a thermal loading computed for maximum output of all three nuclear units, and 1964 hydrology, dispersion, and meteorology.

Figure 12 shows model computed Indian Point temperatures and a temperature range based on corrections discussed in the previous section. Results appear as constant values over 15 or 30 day periods.

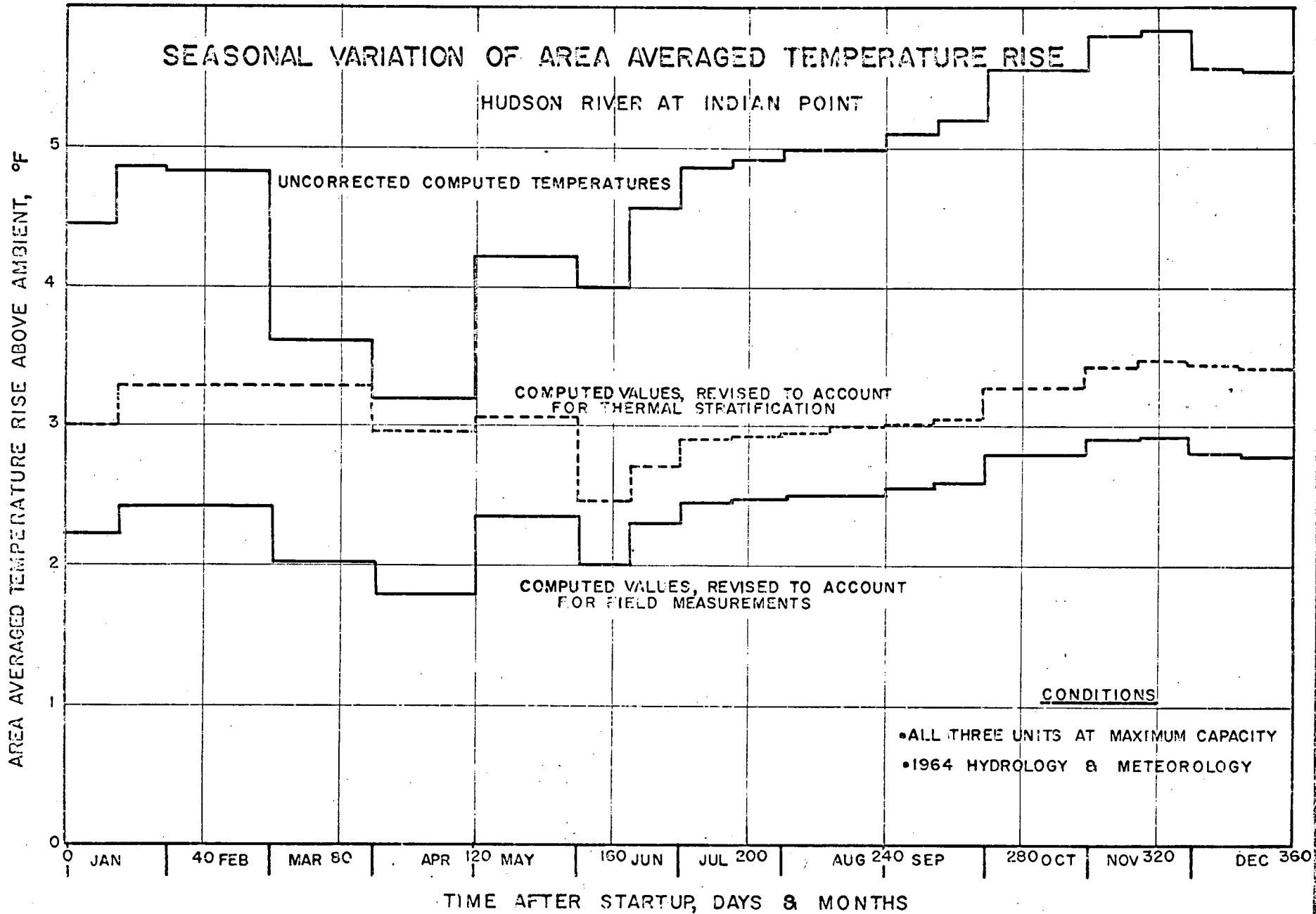

FIGURE 12

Flows and dispersion coefficients represent 15 day averages. These data were inputted to the computer on the first and sixteenth of each month. Output temperature was read on the fifteenth and thirtieth of each month; these values were employed to represent behavior during the two halves of the month.

Temperatures for some months, e.g. April, October, are constant over the month. This means that steady state conditions were reached during the first 15 day period of that month and the input data for the second period was equal to that for the first.

Temperature rises follow the expected trend. The sharp rise during the first 15 days of January is the result of starting the model from a zero condition on January 1. The March flow of 24,000 cfs is significantly higher than the January and February flows and a rapid drop in temperature rise, due to dilution by the higher flow, occurs. The April flow of 30,000 cfs furthered the drop. Flows begin to drop in May and from the middle of June through November, were essentially constant at 4000 cfs. Surface heat transfer coefficients dropped steadily after July due to decreasing equilibrium temperatures (Figures 3 and 4). This combination caused temperatures to increase gradually until December when flow again rose.

The upper boundary of the range shown on Figure 12 represents the uncorrected model-computed temperature rises. The lower boundary represents the model-computed temperatures, corrected by the ratios observed between Unit No. 1 measured and computed values. Months during which the flow exceeded the yearly average of 12,000 cfs were reduced by the April ratio of 0.1/0.18. The July ratio of 0.2/0.4 was used to correct months in which the flow was less than 12,000 cfs.

The middle curve shown in Figure 12 represents the model-computed temperatures, corrected for the observed surface to area average temperature ratio for Unit No. 1 operation. For months in which the flow exceeded 12,000 cfs, the April ratio of 6.0 was used. The July ratio of 3.0 was used for the remaining months. These corrections were applied to the heat transfer coefficients, rather than the temperature themselves. As shown previously, this effect has little influence on temperatures associated with high flow months.

Establishment of the Mixing Zone at Indian Point

The one-dimensional model results described above can be used in conjunction with the three dimensional observations made during April 1967 and July 1966 to establish the boundaries of the mixing zone.

Establishing this zone begins by taking the average temperature at Indian Point for future conditions and the qualitative shape of the temperature profile across this section, as delineated by measurement, to establish the expected quantitative profile across this section. This will permit computation of the area within which temperatures exceed 1.5°F during the summer months and 4.0° during the winter.

Figure 9 shows that temperature across the plane of discharge drops rapidly as the area influenced by the discharge increases. This temperature-area relationship can be written:

$$\Delta T = \Delta T_R \left[\frac{C}{C+A} \right] \quad (1)$$

in which: ΔT = tidal average temperature rise contour, °F
 ΔT_R = temperature rise across the reactor, °F
 A = area within plane of discharge and bounded by ΔT , ft²
 C = empirically determined constant

Equation 1 provides a convenient empirical method of correlating the temperature rise data. This expression yields correct behavior at the point of discharge, i.e., at the channel outlet, $A=0$, T is the effluent channel temperature, and ΔT is equal to ΔT_R , the rise across the plant. Rapid decay as the zone of influence widens is taken into account by the inverse relation of ΔT to A .

To obtain C for a given condition, Equation 1 is written in reciprocal form:

$$\frac{1}{\Delta T} = \frac{1}{\Delta T_R} + \left(\frac{1}{C \cdot \Delta T_R} \right) A \quad (2)$$

The reciprocal of the temperature rise, $1/\Delta T$, is plotted against the area, A . If the temperature decay follows the functional form of Equation 1, this plot should yield a straight line with intercept equal to $1/\Delta T_R$. The slope will equal $1/C \cdot \Delta T_R$, and, since ΔT_R is known, C can be determined.

The July, 1966 data, shown on Figure 9, have been correlated according to Equation 2, as shown in Figure 13. The fit is good and Equation 1 is considered to provide one practical method of describing the mode of temperature decay across the plane of discharge.

The April, 1967 data, shown in Figure 7, decayed more rapidly than Equation 1 will account for. Better correlation of these measurements was obtained using Equation 3.

$$\Delta T = \Delta T_R e^{-KA}$$

(3)

Equation 3 delineates exponential decay of temperature with area. K is another empirically determined decay coefficient. Data which follow this functional relationship will plot as a straight line on semi-logarithmic coordinates. Figure 14 shows that the April, 1967 data of Figure 7 is correlated well by Equation 3.

Equations 1 and 3 both provide practical means of describing the temperature decay across the plane of discharge. Rather than associate Equation 1 with low flow conditions and Equation 3 with high flows, both models will be used, in conjunction with the one-dimensional area average results, to predict temperature distribution across the plane of discharge over the whole flow range. For a given ΔT_R and $\Delta \bar{T}$ (the total area average temperature), Equation 1 will yield a more rapid initial decay but will tail off at a higher value than Equation 3.

To distinguish these two models in the ensuing, Equation 1 is designated the reciprocal decay model (decay is roughly proportional to the reciprocal of area) and Equation 3, the exponential decay model.

The area average temperature rise across the plane of discharge, $\Delta \bar{T}$, can be computed by integrating these equations over the entire cross-section and dividing the result by the total cross-sectional area, A_T .

TEMPERATURE DECAY CORRELATION

HUDSON RIVER AT INDIAN POINT

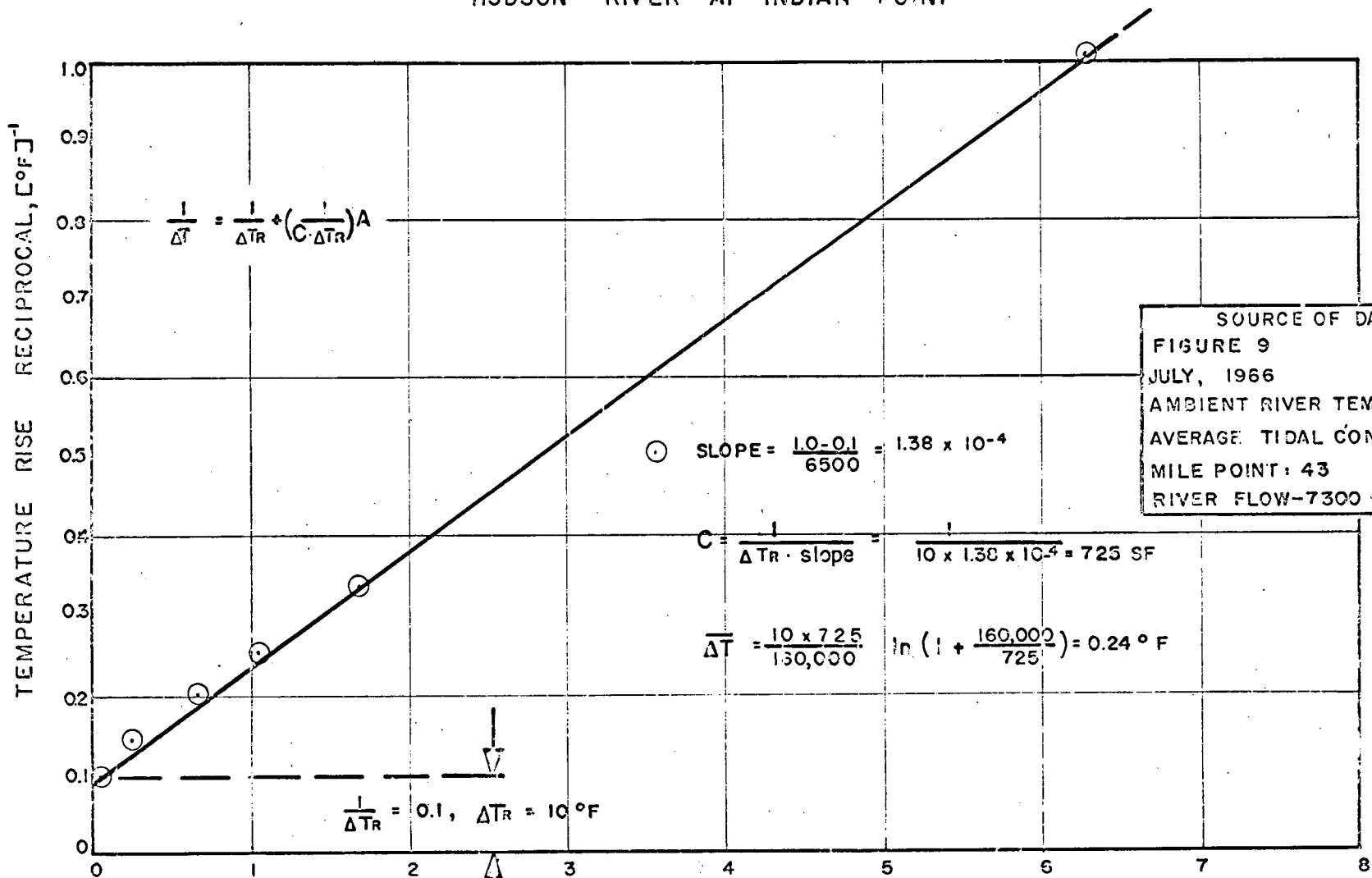

AREA BOUNDED BY THE GIVEN TEMPERATURE RISE ISOTHERM, THOUSAND SQUARE FEET

TEMPERATURE DECAY CORRELATION

HUDSON RIVER AT INDIAN POINT

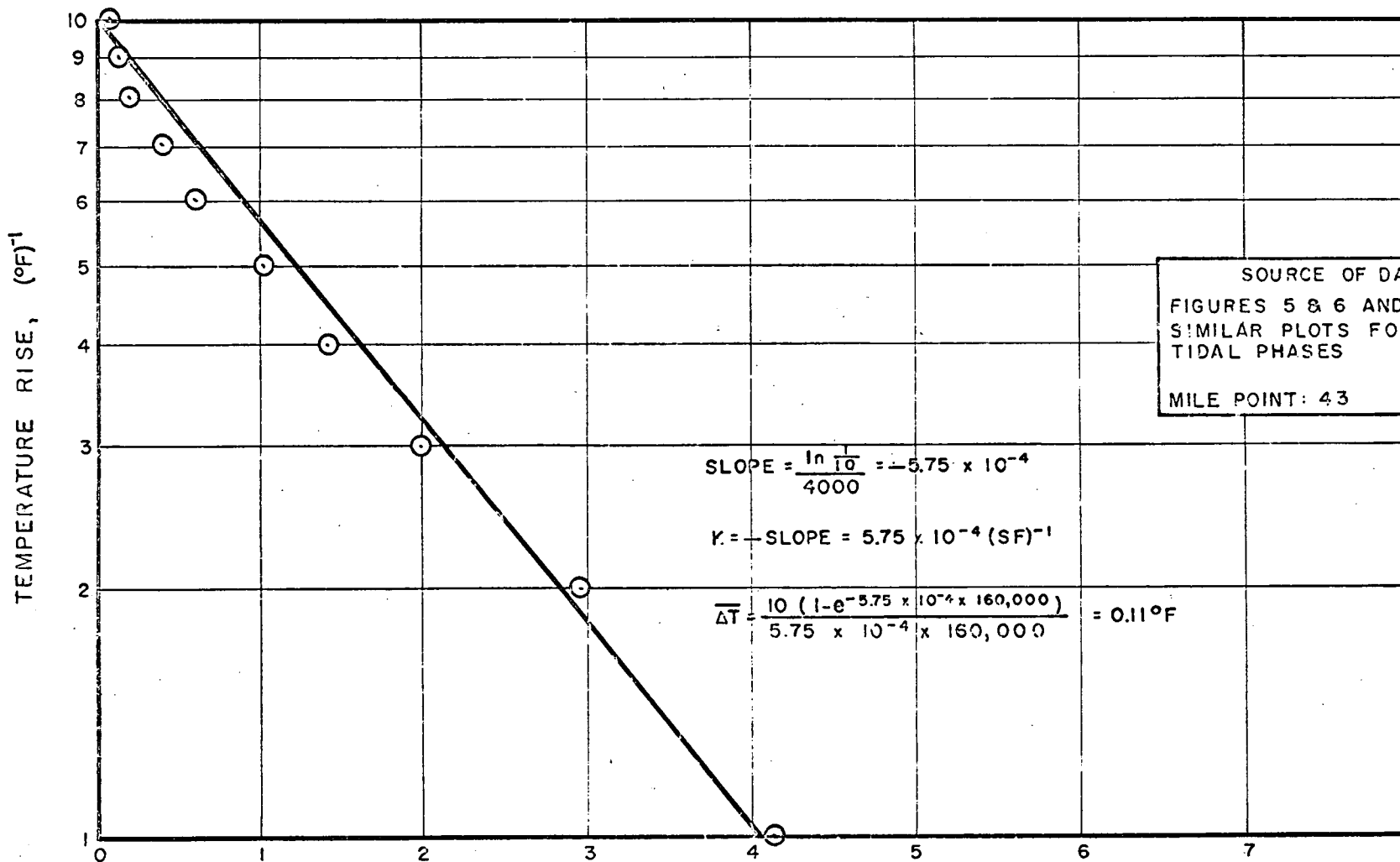

AREA BOUNDED BY THE GIVEN TEMPERATURE RISE ISOTHERM THOUSAND SQUARE FEET

Reciprocal Decay:

$$\overline{\Delta T} = \frac{1}{A_T} \int_0^{A_T} \left(\frac{C}{C+A} \right) \Delta T_R dA \quad (4)$$

Exponential Decay:

$$\overline{\Delta T} = \frac{1}{A_T} \int_0^{A_T} \Delta T_R e^{-KA} dA \quad (5)$$

This procedure yields the average temperature rise, $\overline{\Delta T}$, in terms of the maximum rise across the plant, ΔT_R , the total River cross-section at the plane of discharge, A , and a decay parameter, C or K .

Reciprocal Decay:

$$\overline{\Delta T} = \Delta T_R \frac{C}{A_T} \ln \left(1 + \frac{A_T}{C} \right) \quad (6)$$

Exponential Decay:

$$\overline{\Delta T} = \Delta T_R \left(\frac{1}{KA_T} \right) \left(1 - e^{-KA_T} \right) \quad (7)$$

Computation of $\overline{\Delta T}$ for the data shown in Figure 9 is made via Equation 6 and is given on Figure 13. The computed value of 0.24 agrees reasonably well with the graphically determined averages of 0.2 and 0.21 for Figures 9 and 10, respectively.

Computation of $\overline{\Delta T}$ for the data in Figure 7 is made using Equation 7 and is given on Figure 14. The computed value of 0.12°F agrees with the graphically determined averages of 0.1 and 0.12 for Figures 7 and 11, respectively.

These equations provide a method for establishing the boundary of the mixing zone at the plane of discharge. This method is described below using the reciprocal decay model. Results are given for both models and probable limits of the zone established.

Assume the decay profile across this plane will have the functional form of Equation 1 for the increased future loading. $\overline{\Delta T}$ is the area averaged, tidal smoothed temperature rise and is obtained for the future condition from the one-dimensional model. ΔT_R is the rise

across the plant for the same condition.

Since A_T is also known, the decay coefficient, C , can be computed from Equation 6. This value may then be used in conjunction with Equation 1 to establish either the temperature rise at any selected value of A , or the value of A bounded by a given temperature contour.

The value of the decay coefficient, C , for the case of a 17°F rise across the plant and the Indian Point cross-sectional area of 160,000 square feet, is obtained for any $\Delta\bar{T}$ from the graphical representation of Equation 6, given on Figure 15.

For these conditions, solution of Equation 1 to obtain the temperature value bounding 50% of the total cross-section yields:

$$\Delta T_{0.5A_T} = 17 \left[\frac{C}{C + 80,000} \right] \quad (8)$$

Rearrangement of Equation 1 to solve for area bounded by a given contour yields:

$$A = \left(\frac{\Delta T_R}{\Delta T} - 1 \right) C \quad (9)$$

For the 1.5°F and 4°F criteria, Equation 9 gives:

$$A_{1.5^\circ\text{F}} = 10.3C \quad (10)$$

$$A_{4^\circ\text{F}} = 3.25C \quad (11)$$

Figures 16 and 17 show the results of applying the reciprocal decay model to the model generated area average temperature distributions shown in Figure 12. Figure 16 gives the percentage of area within

RECIPROCAL DECAY MODEL

HUDSON RIVER AT INDIAN POINT

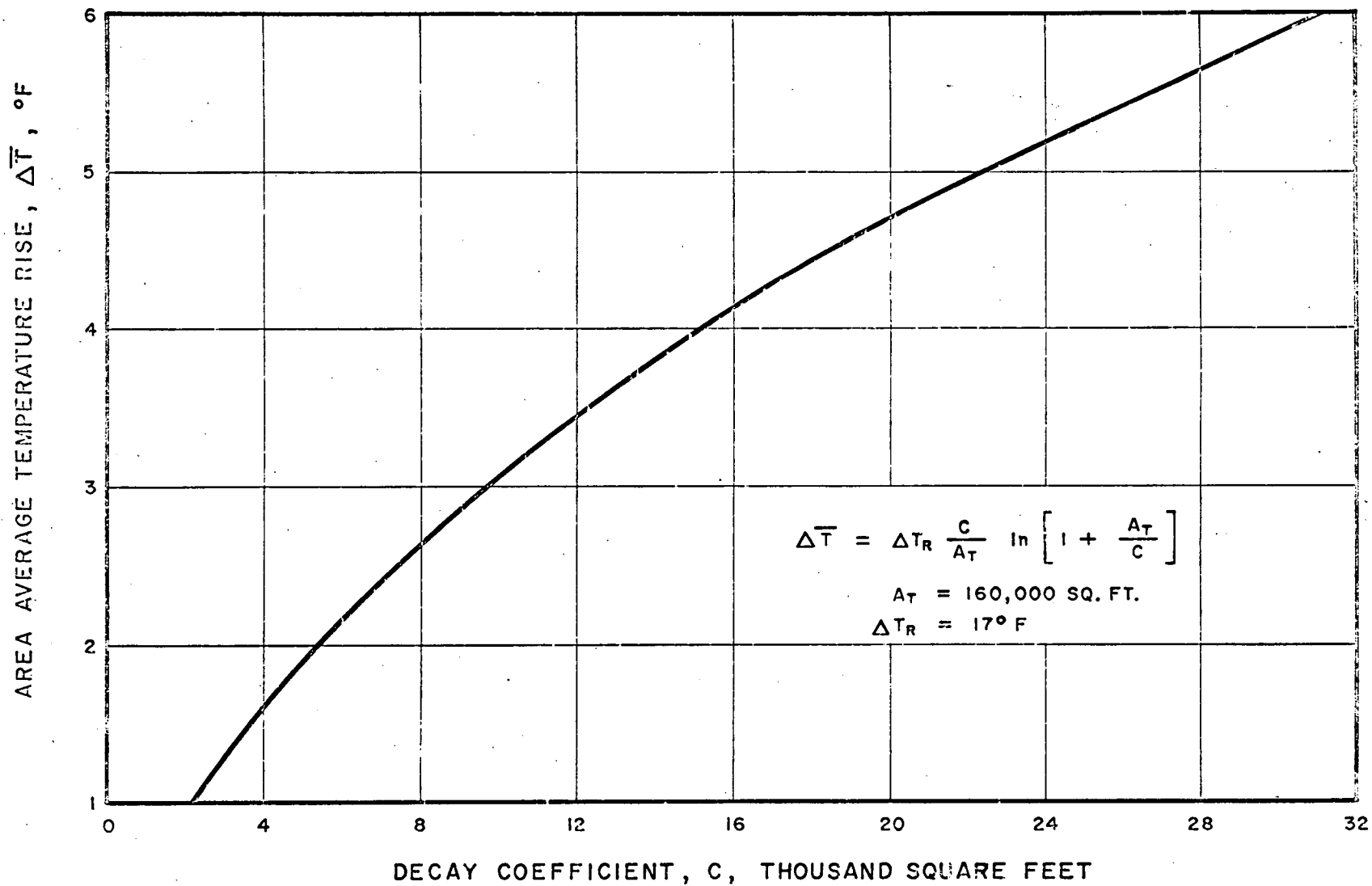

FIGURE 15

PERCENTAGE AREA WITHIN MIXING ZONE

HUDSON RIVER AT INDIAN POINT

MIXING ZONE CRITERION:

RECIPROCAL DECAY MODEL

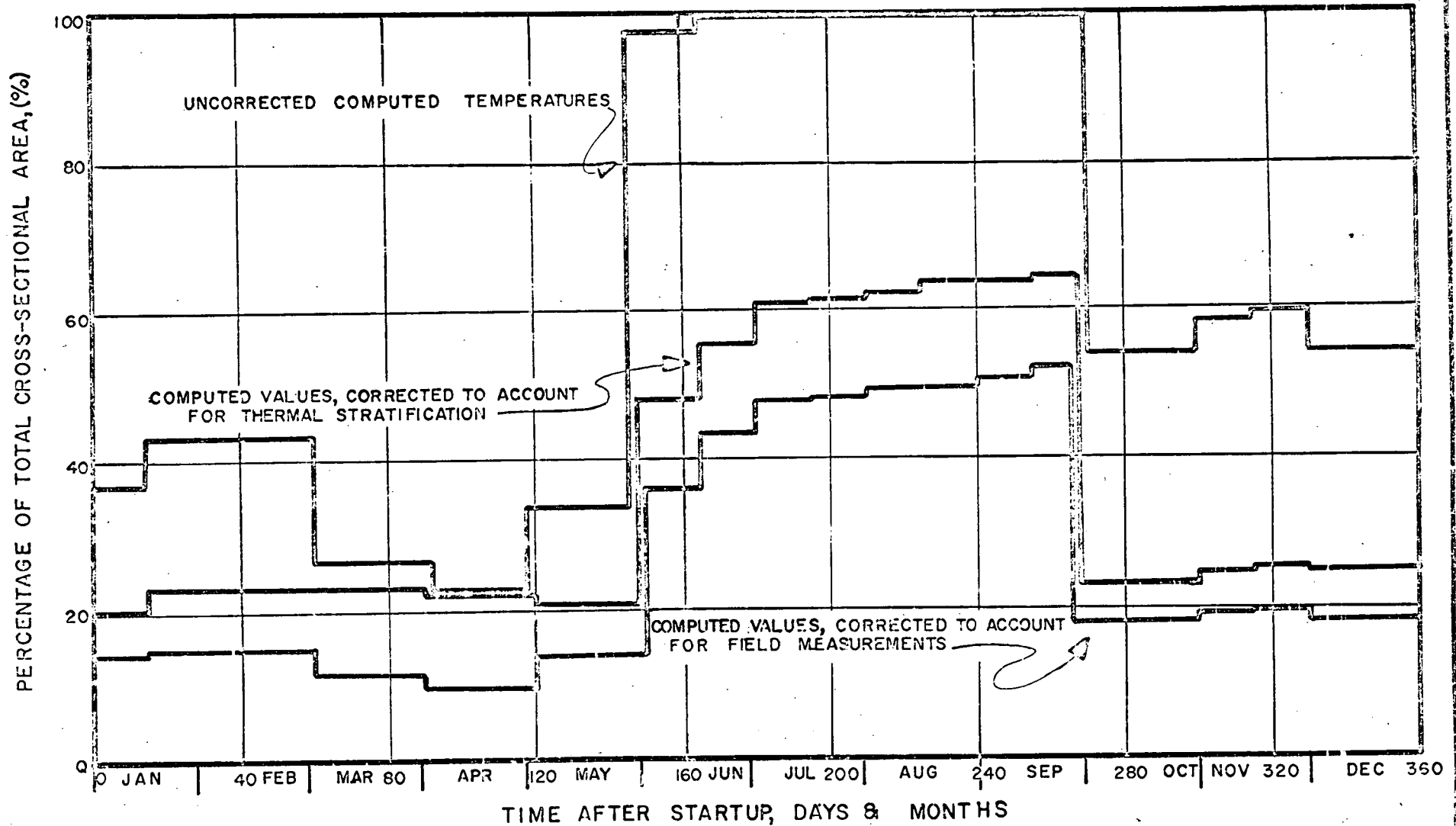
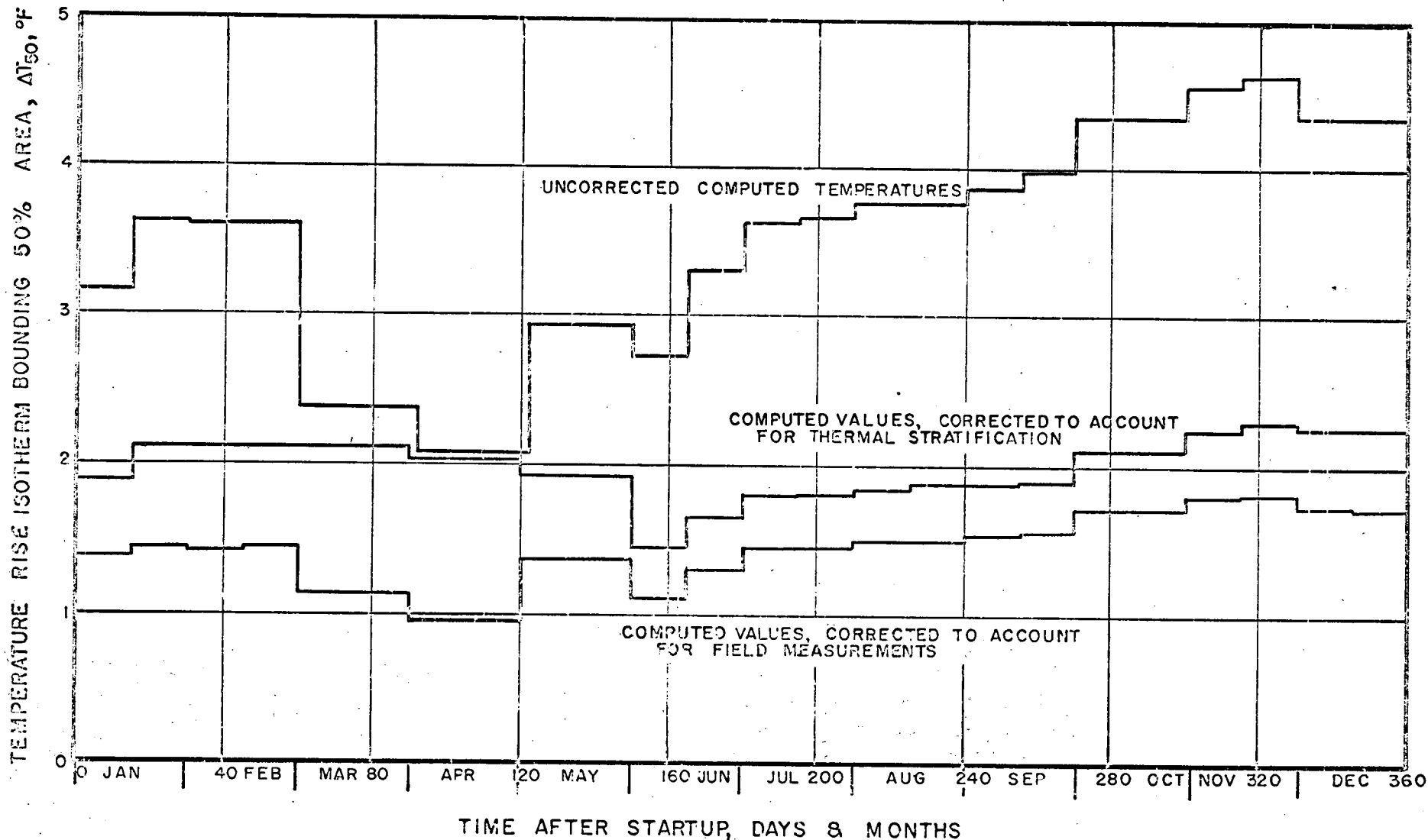

FIGURE 16

50% AREA TEMPERATURE ISOTHERM, ΔT_{50}
 HUDSON RIVER AT INDIAN POINT
 RECIPROCAL DECAY MODEL



which temperatures will exceed the summer criterion of 1.5°F and the winter criterion of 4.0°F. Figure 17 gives the temperature contour bounding 50% of the cross-section. Sample calculations are given in Table 2.

Similar computations were made using the exponential decay model. Given $\Delta\bar{T}$, ΔT_R and A_T , the decay coefficient K is obtained from Figure 18, the graphical representation of Equation 7. Temperature bounding 50% of the cross-section at Indian Point is obtained from Equation 3 for the prescribed ΔT_R and A_T as follows:

$$\Delta T_{0.5A_T} = 17 \exp(-80,000 K) \quad (12)$$

Areas bounded by the summer and winter temperature criteria are given, respectively, by:

$$A_{1.5^\circ F} = \frac{2.42}{K} \quad (13)$$

$$A_{4^\circ F} = \frac{1.45}{K} \quad (14)$$

Figures 19 and 20 show the results of applying the exponential decay model to the data in Figure 12. Figure 19 gives the percentage of area within which temperatures will exceed the summer and winter temperature criteria. Figure 20 gives the temperature contour bounding 50% of the cross-section. Sample calculations are given in Table 3.

The ranges of values at any time on Figures 16, 17, 19 and 20 were developed from the ranges shown on Figure 12. The uncorrected values represent an uncorrected model estimate and should not be applied to delineation of the mixing zone. The values corrected for thermal stratification represent a good estimate of the future behavior and are used to establish mixing zone boundaries.

TABLE 2

SAMPLE CALCULATIONS
RECIPROCAL DECAY MODEL

Source of $\bar{\Delta T}$ data: Figure 12, curve revised for thermal stratification

Period selected: July 1 - 15

Area average temperature, $\bar{\Delta T}$: 2.9°F

Decay coefficient, C, Figure 15: 9,460 SF

ΔT bounding 50% of cross section, Equation 8: 1.8°F

Area bounded by 1.5°F contour, Equation 10: 97,000 SF

Percentage area bounded by 1.5°F contour: $97,000/160,000$ or 60%

EXPONENTIAL DECAY MODEL

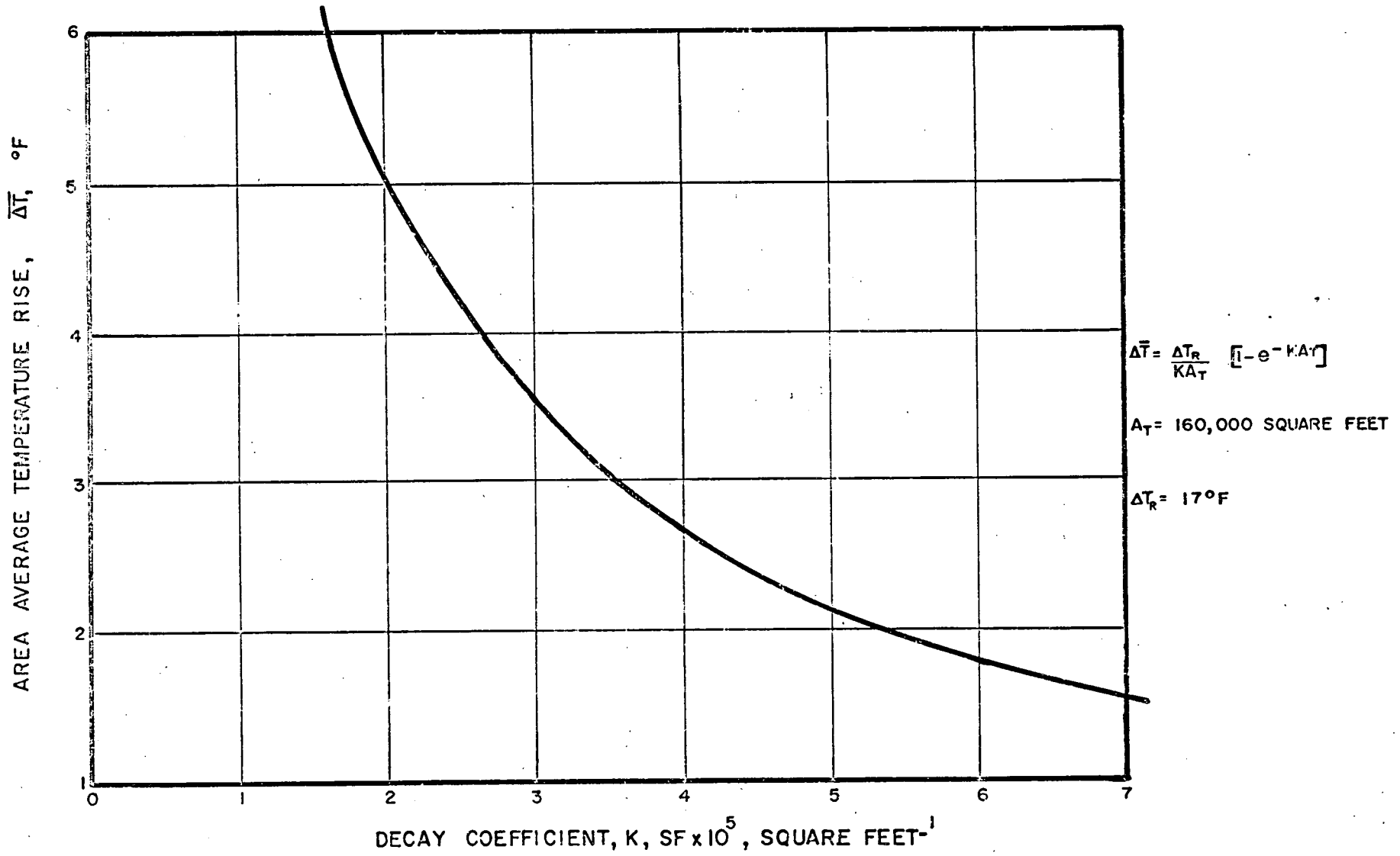

FIGURE 18

PERCENTAGE AREA WITHIN MIXING ZONE

HUDSON RIVER AT INDIAN POINT

MIXING ZONE CRITERION:

EXPONENTIAL DECAY MODEL

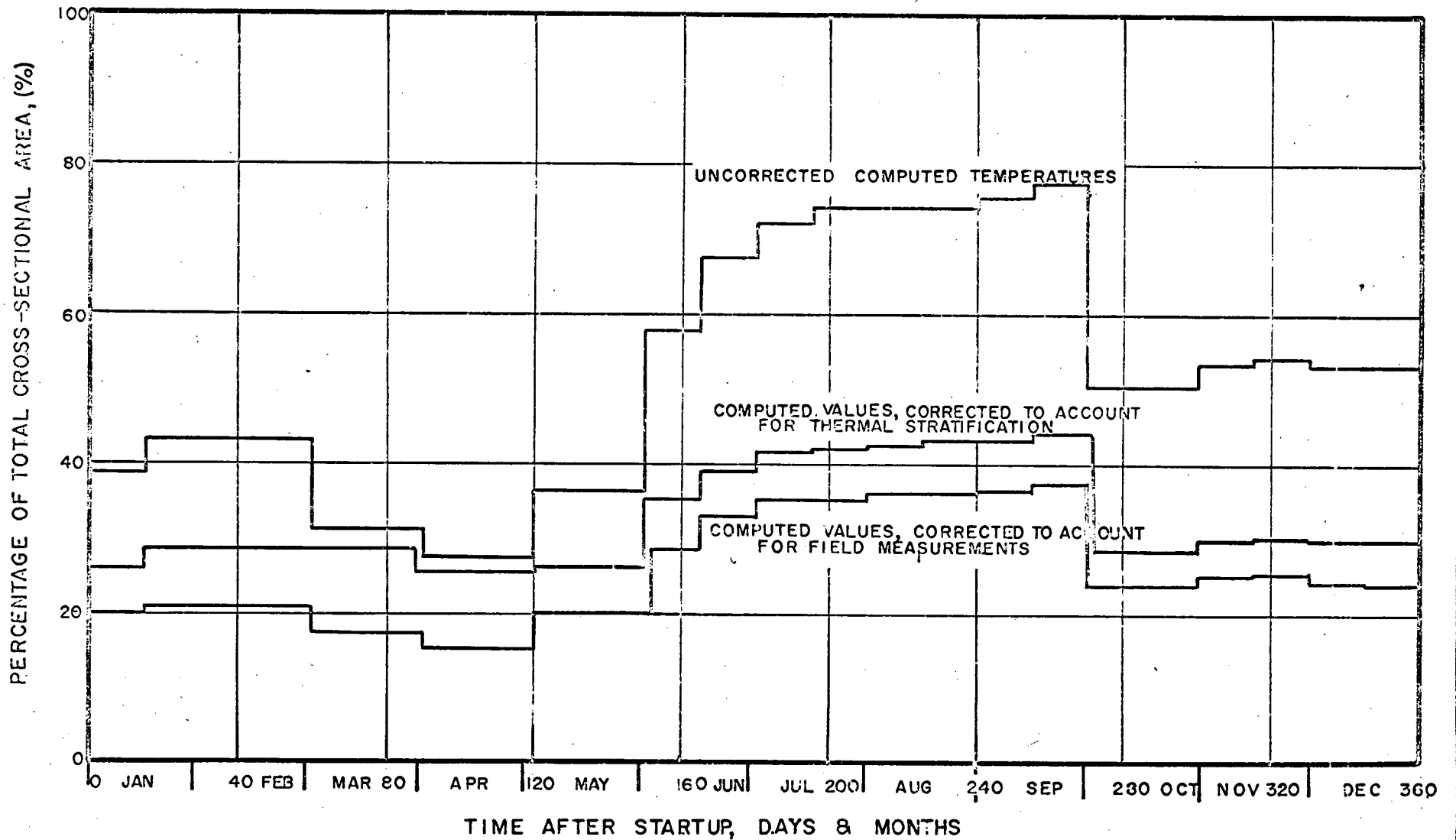

50% AREA TEMPERATURE ISOTHERM ΔT_{50}
 HUDSON RIVER AT INDIAN POINT
 EXPONENTIAL DECAY MODEL

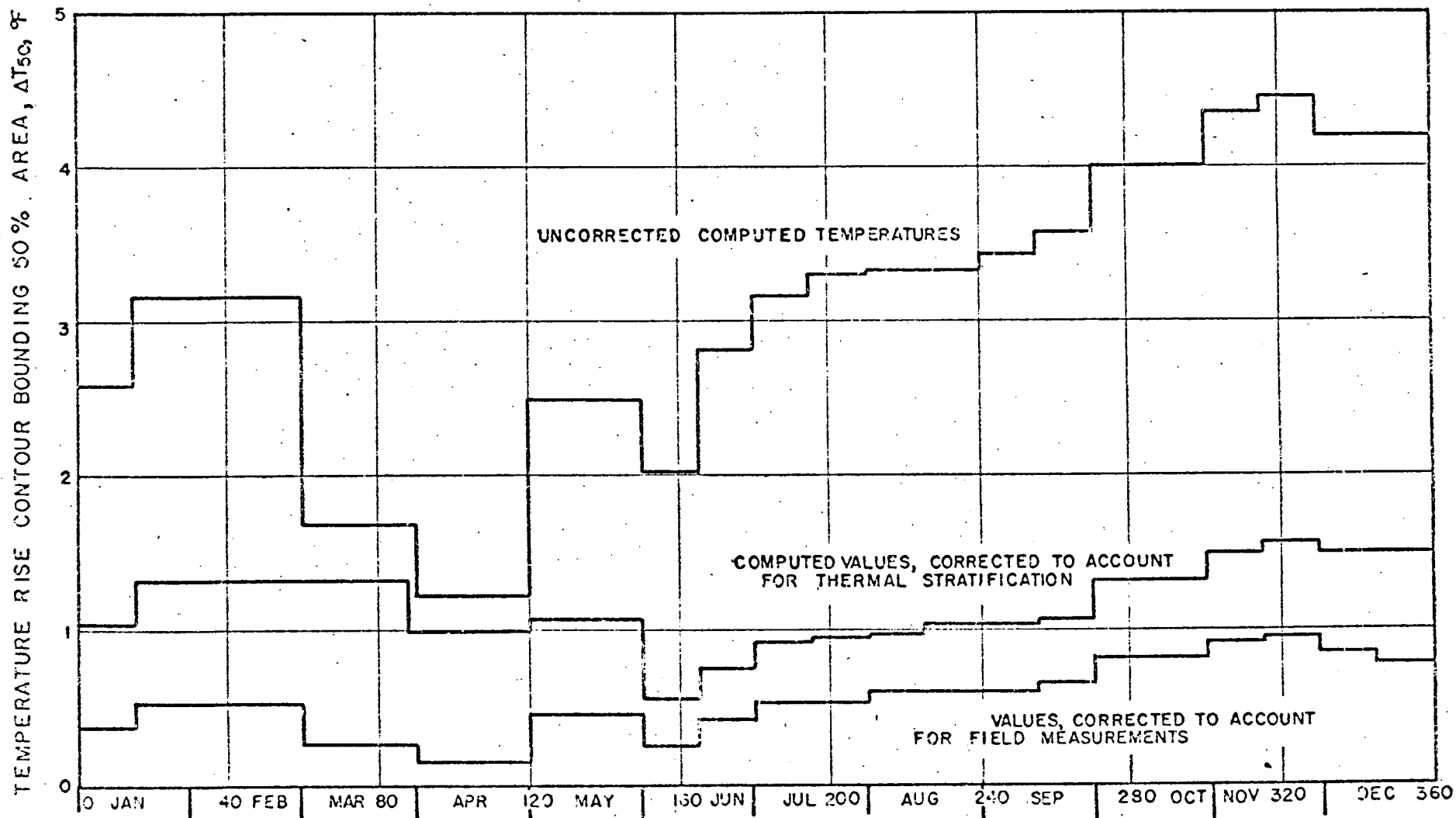

FIGURE 20

TABLE 3

SAMPLE CALCULATIONS
EXPONENTIAL DECAY MODEL

Source of data: Figure 12, curve revised for thermal stratification

Period selected: July 1 - 15

Area average temperature, $\bar{\Delta T}$: 2.9°F

Decay coefficient, K, Figure 18: $3.65 \times 10^{-5} \text{SF}^{-1}$

ΔT bounding 50% of cross section, Equation 12: 0.92°F

Area bounded by 1.5°F contour, Equation 13: 66,000 SF

Percentage area bounded by 1.5°F contour: 66,000/160,000 or 41%

Although the predictions on the basis of field measurements are somewhat lower than the thermally stratified results, the curve fitting of temperatures below 1°F is questionable; i.e., a flatter tail on the decay curves of April, 1967 and July, 1966 would have caused closer agreement between the lower two estimates in Figures 16, 17, 19 and 20.

Specifics below refer to the curves corrected for thermal stratification.

The 4°F non-summer criterion was met for either model at all times. For the reciprocal decay model, the maximum mixing zone cross-section was 25%; for exponential decay, this value was 30%. Correspondingly, the maximum temperatures reached during the non-summer months at the 50% area were 2.3°F and 1.5°F, respectively, for these two models.

These non-summer period results show clearly the behavior of the two models. Reciprocal decay model temperatures drop rapidly but tail off to higher values. The 4°F value was reached more rapidly by the reciprocal model as evidenced by the smaller area (25% versus 30%) bounded by it. The approach toward ambient conditions is slower, however, as lower temperatures are reached, and the exponential model exhibited a lower temperature at the 50% point (1.5°F versus 2.3°F).

The 1.5°F summer criterion required a bounding area of 64% using the reciprocal model and a 44% area using the exponential area. Correspondingly, temperatures at the 50% point were 1.9°F and 1.1°F, respectively.

These results are summarized in Table 4.

Non-summer temperature criteria can be expected to be met at all times at Indian Point. At flows above 15,000 cfs, the salt front will not pass Indian Point (Appendix B, Figure B-3). During these periods (usually February through May), the fresh criterion of 5°F will apply and will yield an even smaller mixing zone.

Although Figure 13 shows the July, 1966 data were correlated well by the reciprocal decay model, two considerations favor selection of the exponential decay model as more representative of expected future behavior:

1. Theoretical models of two and three dimensional distribution of contaminants discharged continuously from a single source in an estuary have been developed (12).

TABLE 4
MIXING ZONE DELINEATION
AT INDIAN POINT

	<u>Exponential Decay</u>	<u>Reciprocal Decay</u>
<u>Non-Summer Conditions:</u>		
Maximum Area, $\Delta T = 4^{\circ}\text{F}$	30%	25%
Maximum ΔT , at 50% Area	1.5°F	2.3°F
<u>Summer Conditions:</u>		
Maximum Area, $\Delta T = 1.5^{\circ}\text{F}$	44%	64%
Maximum ΔT , at 50% Area	1.1°F	1.9°F

These show exponential decay of concentration with distance in any direction from the source.

These models were not utilized in this study because boundary conditions are not the same. However, the exponential functional form is generated not by the boundary conditions but by the form of the defining differential equations. These equations are analogous to the two and three dimensional heat transfer equations which define local behavior of Indian Point thermal discharge.

2. Survey procedures followed during the April, 1967 survey represent a revision of procedures during the original survey conducted in July, 1966. At any station, temperatures were read at each integral Fahrenheit degree between the effluent channel temperature and the ambient temperature, rather than at only three depths. This yielded much more information, particularly at the near surface and, as a result, contour construction was more accurate.

It should be noted that, although the April surface temperature data is considered to be more accurate than that of July, the surface to area average temperature ratio of 3.0, obtained in July, was used to make the thermal stratification correction in the summer data. Had the April value of 6.0 been used, the summer values for the thermally stratified curves would have been significantly lower.

Use of the exponential decay model yields results which meet the summer criteria at all times. Use of the reciprocal decay model yields results which exceed these criteria slightly (area excess: 15% or less, temperature excess: 0.5°F or less) when flows are less than 4000 cfs.

The summer temperature rises have been translated to a temperature frequency distribution in Figure 21. This relation has been developed using an average summer heat transfer coefficient of $135 \text{ BTU/sf/day}/^{\circ}\text{F}$ and the four month summer average flows and corresponding dispersion coefficients. This relationship gives the percentage of summers for which the Indian Point temperatures can be expected to be equal to or less than any given value.

FREQUENCY OF OCCURRENCE OF SUMMER AVERAGE TEMPERATURE RISE AT INDIAN POINT FOR CAPACITY OPERATION OF THREE NUCLEAR UNITS

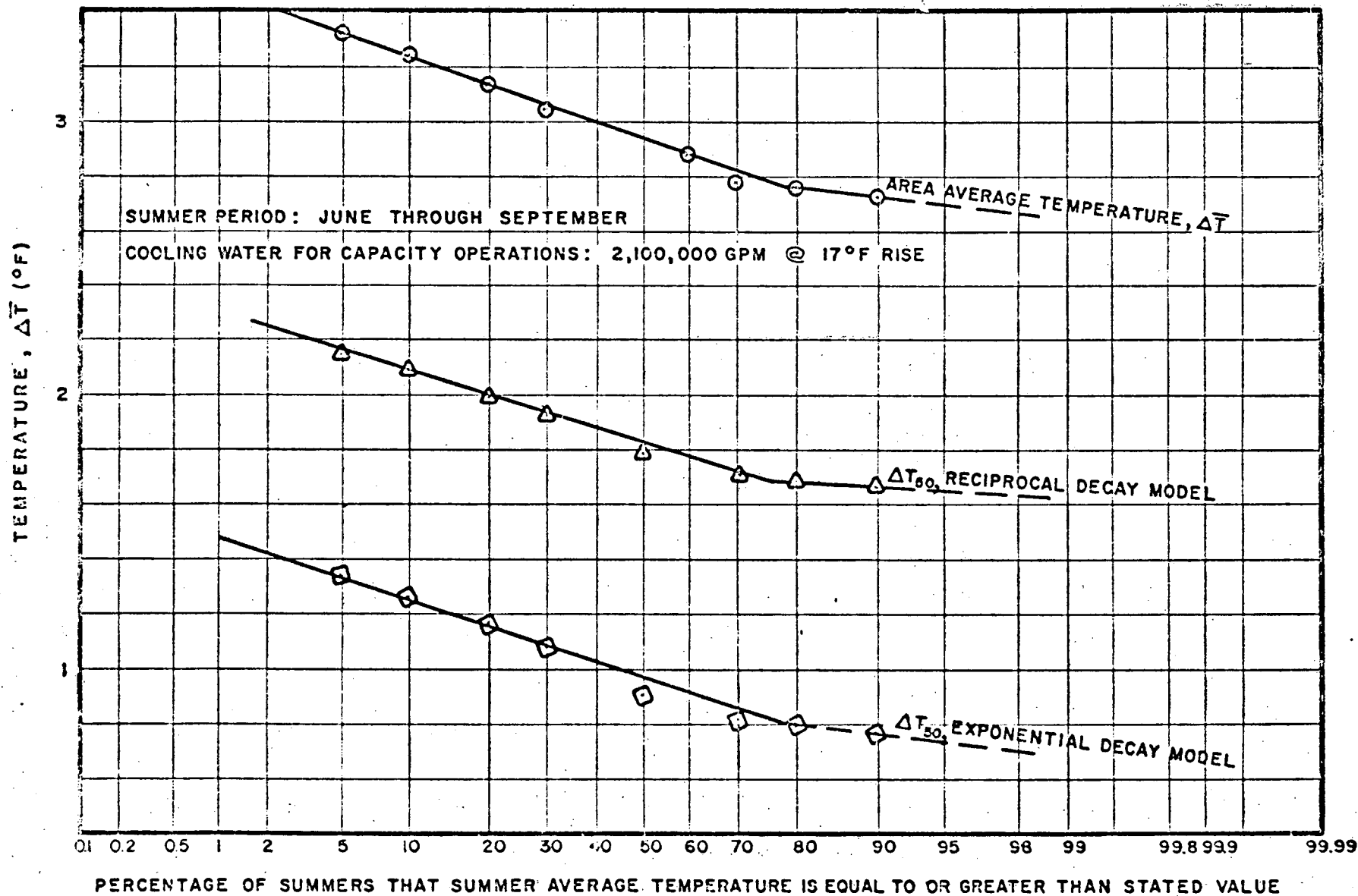

FIGURE 21

Extent of the Mixing Zone

In this section, an estimate of the longitudinal extent of the mixing zone is made. Field measurements made during Indian Point No. 1 operation did not extend more than 800 feet below the plane of discharge, but do show that relatively rapid decay of elevated temperatures can be expected.

Figure 22 shows the temperature distribution observed at high water slack, 800 feet below the plane of discharge, during the April, 1967 survey. Similar plots were constructed during seven other phases of the tidal cycle. Tidal cycle average results are shown in Figure 23.

These data show a rapid decay of temperature. The area average temperature was 0.0825°F , by comparison to an average of 0.093°F at the plane of discharge (the 0.093°F is rounded to 0.1°F in Figure 7). The measured surface to area average temperature ratio, or thermal stratification factor, was 8.5.

The value of 0.0825°F indicates a decay much more rapid than that predicted by the model, even where corrected by the observed stratification factor. The length of the mixing zone under future conditions is computed using a thermal stratification factor of 3.0 and, on the basis of the above observations, represents a conservative estimate.

The reciprocal and exponential decay models are used to delineate decay across any section, in the same manner as used previously to delineate decay across the plane of discharge. No information is available on the decay of ΔT_{max} at any section. Therefore, the values of C and K, the decay coefficients for the two models, have been obtained using Figures 15 and 18, respectively. This procedure will yield mixing zone areas that are higher than actual for the reciprocal decay model, but may be lower than the actual for the exponential model.

Figure 24 shows the percentage cross-sectional area contained by the 1.5°F contour and the tidal area average temperature rise at various points above and below Indian Point. These results were obtained for the severe drought condition of 4000 cfs and the September heat transfer rate of $125 \text{ BTU/sf/day}/^{\circ}\text{F}$. Sample calculations are given in Table 5.

These results show that the area average temperature rise drops below 1.5°F about five miles above and below the discharge point. Percentage cross-sectional area contained by the 1.5°F contour drops below 15% of the total area some eight miles above and below the discharge point. These results are summarized in Table 6.

TEMPERATURE RISE ISOTHERMS, °F
HUDSON RIVER AT INDIAN POINT

800 FT. BELOW PLANE OF DISCHARGE

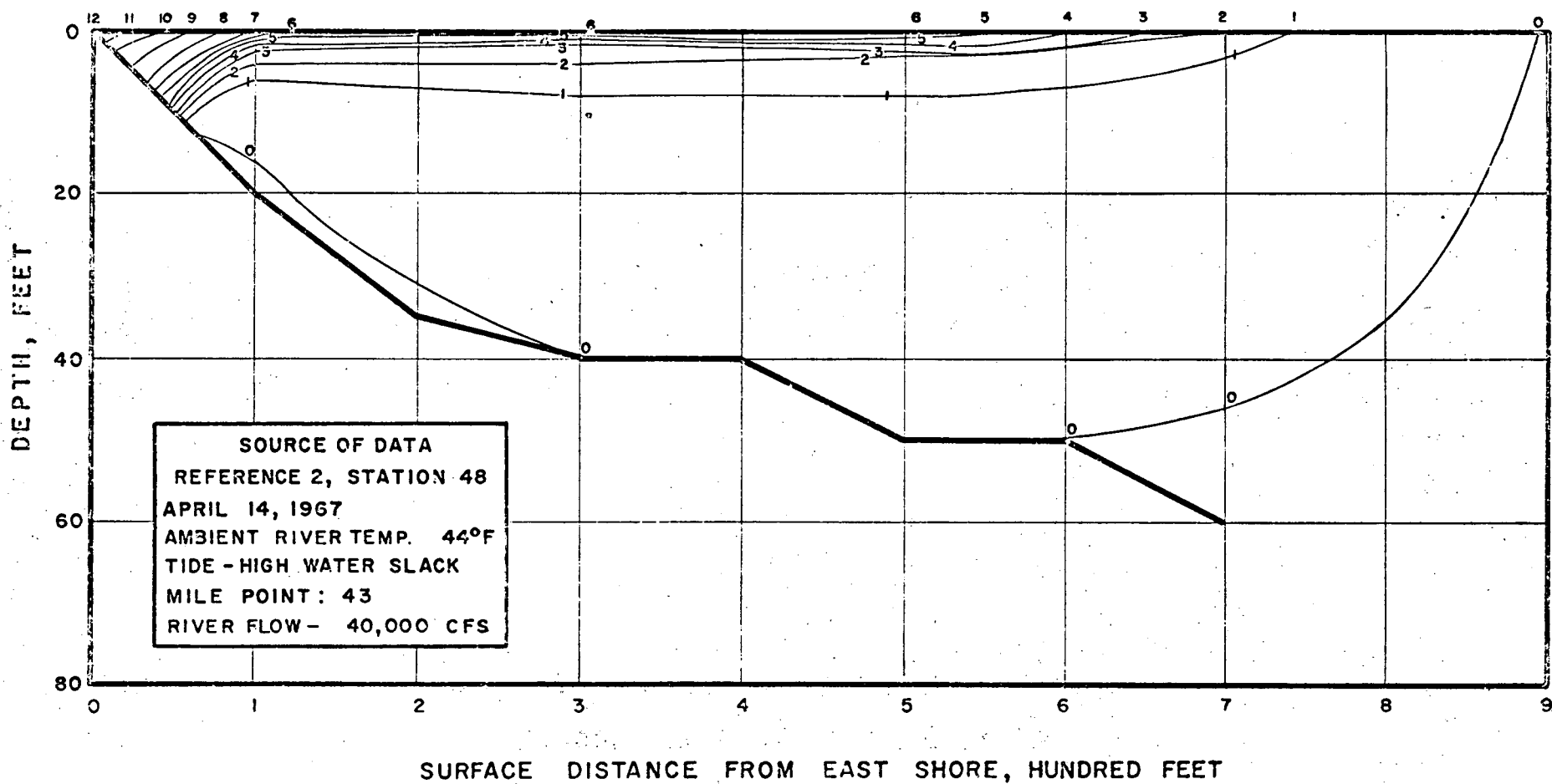

TIDAL AVERAGE TEMPERATURE RISE DISTRIBUTION

HUDSON RIVER AT INDIAN POINT

800 FT. BELOW PLANE OF DISCHARGE

APRIL, 1967

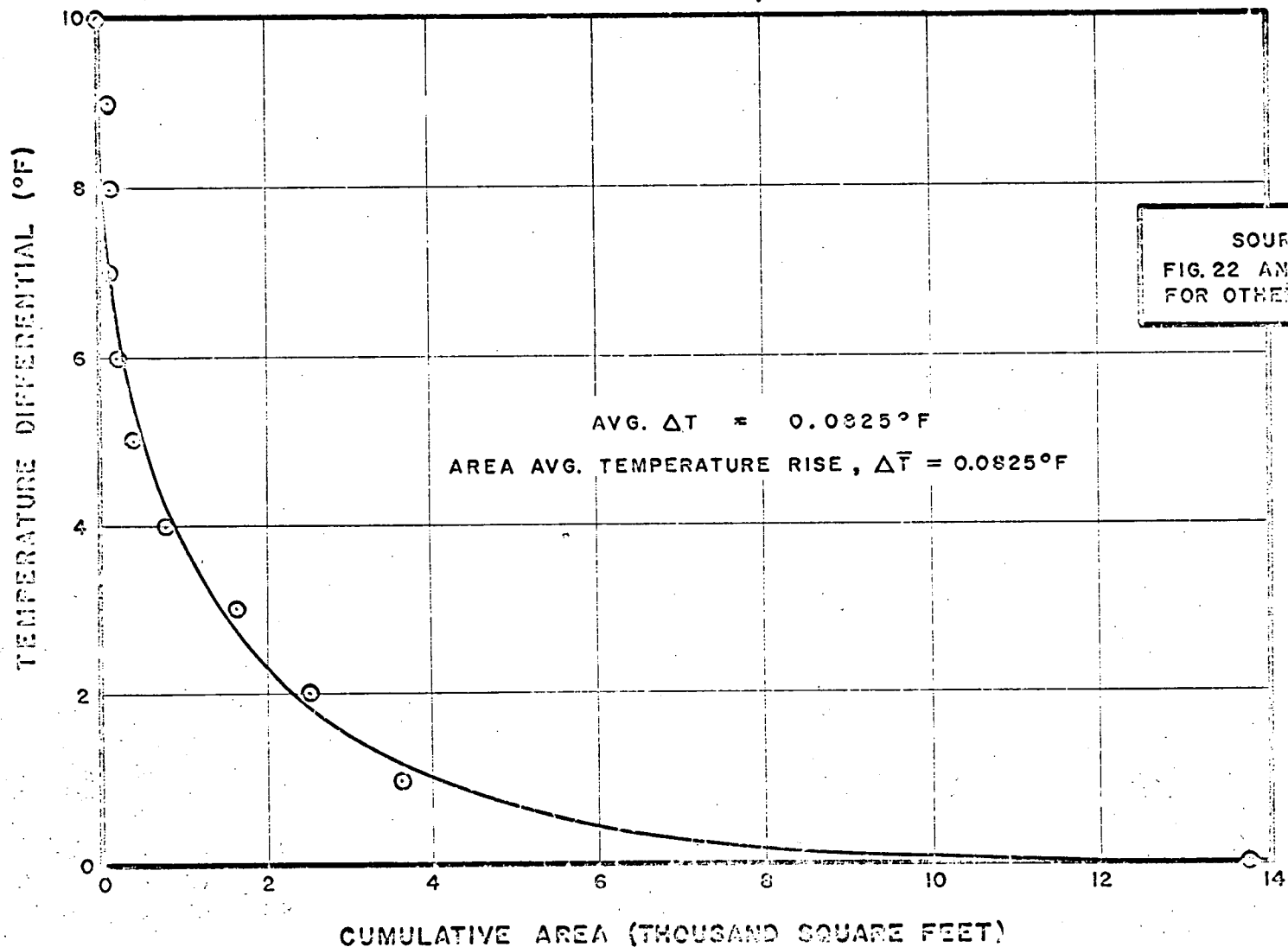

EXTENT OF MIXING ZONE

AREA AVERAGE TEMP. RISE
VS
DISTANCE FROM INDIAN POINT

PERCENTAGE AREA WITH 1.5°F CONTOUR
VS
DISTANCE FROM INDIAN POINT

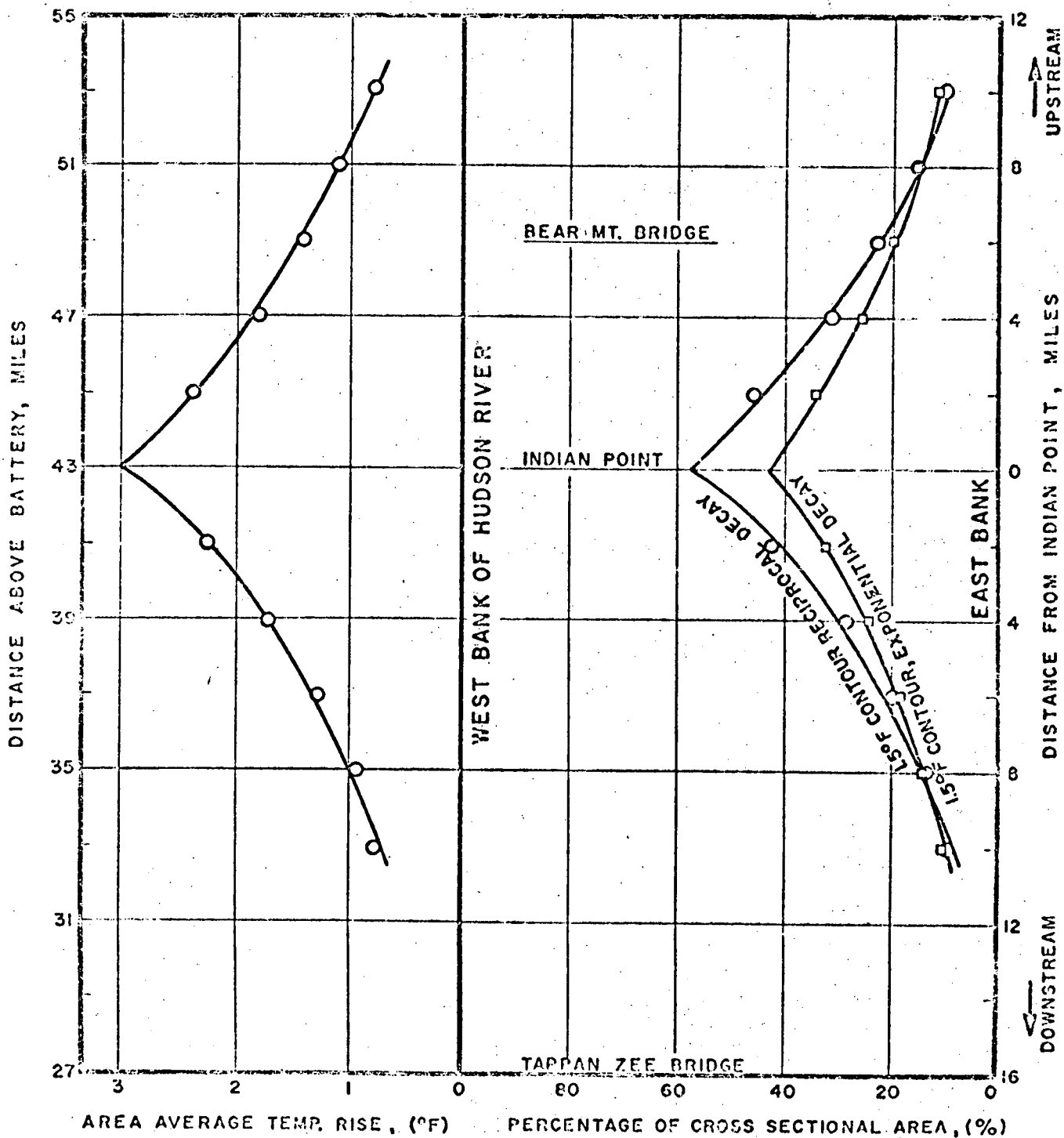

TABLE 5

SAMPLE CALCULATION
DETERMINATION OF EXTENT OF MIXING ZONE

Area Average Temperature Model: steady state, longitudinally
variable parameters

Month: September

Flow, Q: 4,000 cfs

Heat Exchange Coefficient, \bar{K} : 125 BTU/SF/day/ $^{\circ}$ F.

Thermal Stratification Factor (TSF): 3.0

Area Average Temperature, $\bar{\Delta T}$, 4 miles below Indian Point: 1.7 $^{\circ}$ F.

Equations for determination of area bounded by 1.5 $^{\circ}$ F. profile:

Reciprocal decay: $A_{1.5^{\circ}F} = 10.3C$

Exponential decay: $A_{1.5^{\circ}F} = \frac{2.42}{K}$

For

$$C = 4,300 \text{ ft.}^2 \text{ (Figure 15)}$$

$$K = 6.25 \times 10^{-5} \text{ ft.}^2 \text{ (Figure 18)}$$

Substitution of these data in above equations yields:

$$A = 46,000 \text{ SF or 29\% (Reciprocal Model)}$$

$$A = 39,000 \text{ SF or 24\% (Exponential Model)}$$

TABLE 6

EXTENT OF MIXING ZONE
UNDER CONDITIONS OF MAXIMUM SEVERITY¹

<u>Miles above or below Indian Point</u>	<u>Area Average Temperature Rise, °F</u>	<u>Surface Area Temperature Rise, °F</u>	<u>Percentage of Cross Section bounded by 1.5°F Isotherm²</u>
0	3.0	9.0	50
2	2.3	6.9	38
4	1.75	5.2	27
6	1.35	4.0	20
8	1.0	3.0	15
10	0.75	2.2	10

¹ Conditions employed: Month = September

$Q = 4,000$ cfs, steady state

$\bar{K} = 125$ BTU/SF/day/°F

² Mean values taken between model extremes given on Figure 24

V. Hydraulic Model Studies and Effluent Channel Outlet Selection

The initial study conducted on the Indian Point generating station model by Alden Hydraulic Laboratories evaluated the effect of one and two unit operation on the intake cooling water (3). Additional studies, (4), performed from April to August 1967, investigated the effect of one, two and three unit operation on the River temperature distribution. Original boundaries were too restricted for proper evaluation of the effect of all three units so that the model was expanded prior to 1967 testing.

Expanded model dimensions were 75 feet long by 25 feet wide. For the prototype to model ratio of 60, this was equivalent to a River length of 4500 feet and a River width of 1500 feet. Prototype to model depth ratio was 40. River depths were determined from soundings and scaled for model application.

Application to Overall River Behavior

Model results were not utilized in making the analysis of overall River behavior and mixing zone determinations discussed in the previous section.

Even with the expansion, the model covers only one half the River width and considerably less than a tidal excursion above and below the plant. Since the mixing zone itself may be larger than the segment of the River represented by the model, the model data were not applicable to the overall River analysis.

Plans for construction of a new model are currently being made by Consolidated Edison. Suggested improvements to make this model more useful in the overall analysis are given on pages 27 and 28.

Effluent Channel Outlet Evaluation

The model was used to evaluate the relative effects of several different modes of release of cooling water from the effluent channel to the River. These studies were made under a continuously varying tidal flow procedure. Objections outlined above to use of the model to predict overall River temperature rises do not apply here; the relative local effect of three different outlet structures is evaluated. Effects studied include intake temperatures, shore-line temperatures and jet behavior.

Figures 26 through 28 illustrate the three effluent channel outlets studied.

Outlet No. 1, shown in Figure 26, closely resembles both the current outlet works (located upstream of the planned location for the future channel) and original Con Edison thinking for the required works for all three units. The south end of the channel is fully open and the discharge flow is directed along the east shore of the River. The side channel weir shown in Figure 26 is an addition, not comparable to the existing works or planned design; i.e., the west wall of the current River channel extends the full River depth along its entire length.

Previous model tests for Units No. 1 and No. 2 operation showed Outlet No. 1 configuration is effective in keeping intake cooling water temperatures at a minimum.

Outlets No. 2 and No. 3 block the south end of the effluent channel and divert the discharge toward the center of the River. The effluent is discharged over a weir to aid in keeping the heated water close to the surface. Outlet No. 2 consists of several vertical slats which divide the side channel weir into a series of ports and insure uniform discharge over the whole length of the weir. No slats were provided for Outlet No. 3.

Dispersion of heated effluent in the River was obtained visibly in the model by use of dye. Figures 29 through 32 show the dye distribution created by Outlet No. 1. Figures 29 through 31 show progressive movement of the dye patch during an ebb tide condition and Figure 32 shows behavior during flood tide.

The effluent flows along the east shore in the form of a jet. The jet disperses slightly with distance from the plant but does not display any significant mixing with the River within the model boundaries.

For one unit operation, photographs (not shown here) during flood tide showed the jet turned toward the center of the River before reaching the downstream model boundary. The greater momentum of the three unit effluent (flow is seven times that of Unit No. 1) explains the lack of reversal of the jet in flood tide for this loading. These results imply that use of this outlet for three unit operation will result in relatively high temperatures for considerable distances along the east shore.

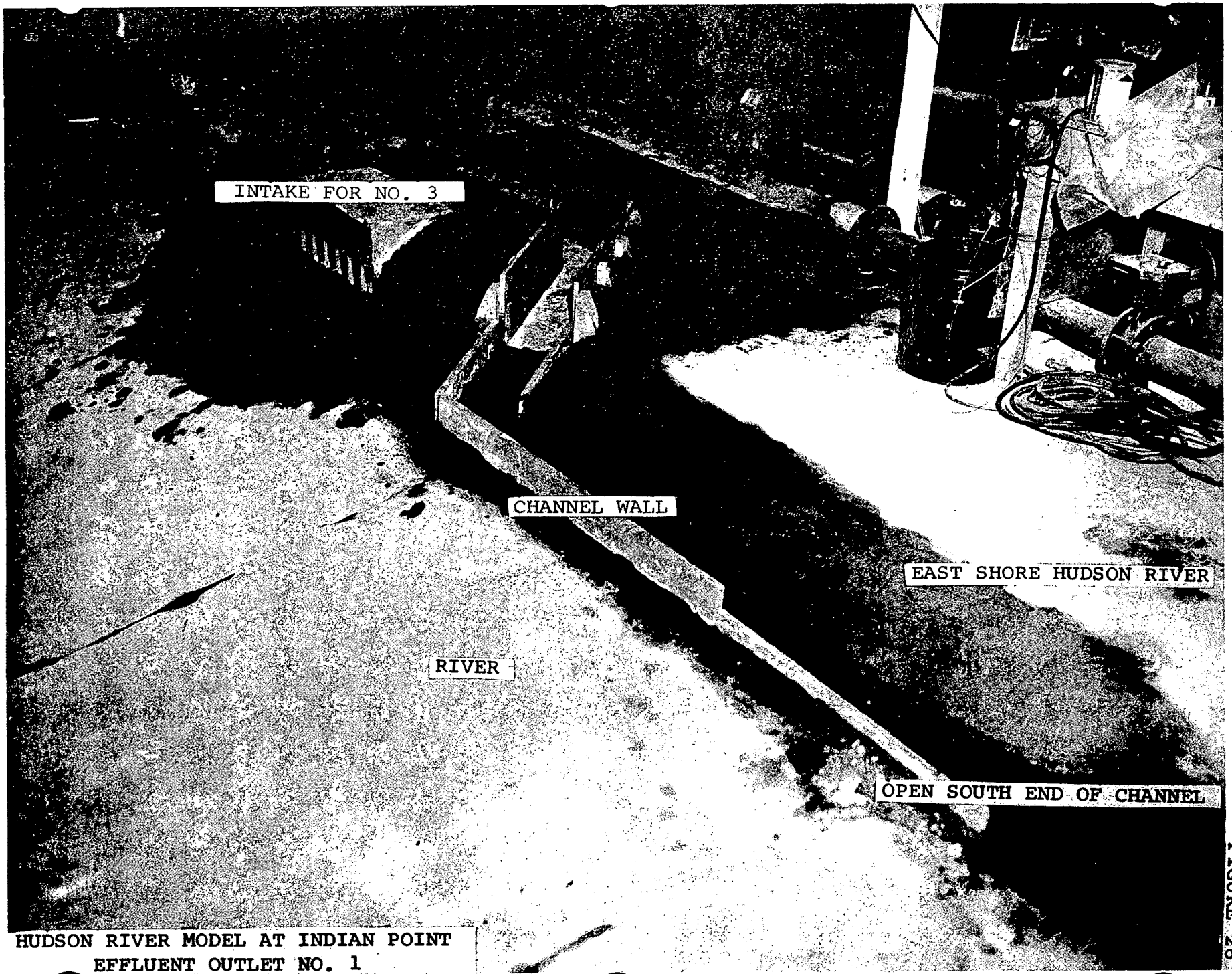

INTAKE FOR NO. 3

CHANNEL WALL

RIVER

EAST SHORE HUDSON RIVER

OPEN SOUTH END OF CHANNEL

HUDSON RIVER MODEL AT INDIAN POINT
EFFLUENT OUTLET NO. 1

FIGURE 26

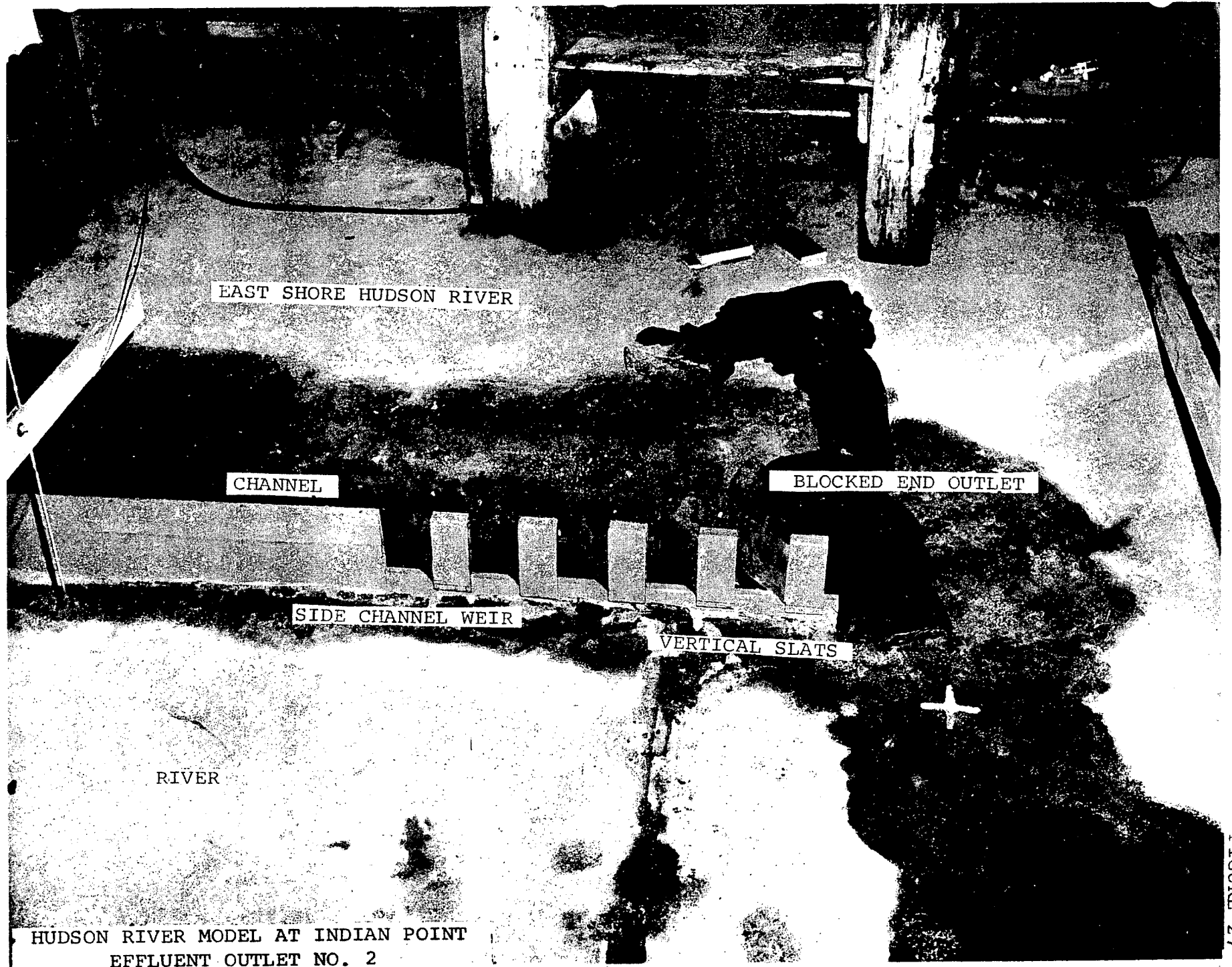

EAST SHORE HUDSON RIVER

CHANNEL

BLOCKED END OUTLET

SIDE CHANNEL WEIR

VERTICAL SLATS

RIVER

HUDSON RIVER MODEL AT INDIAN POINT
EFFLUENT OUTLET NO. 2

FIGURE 27

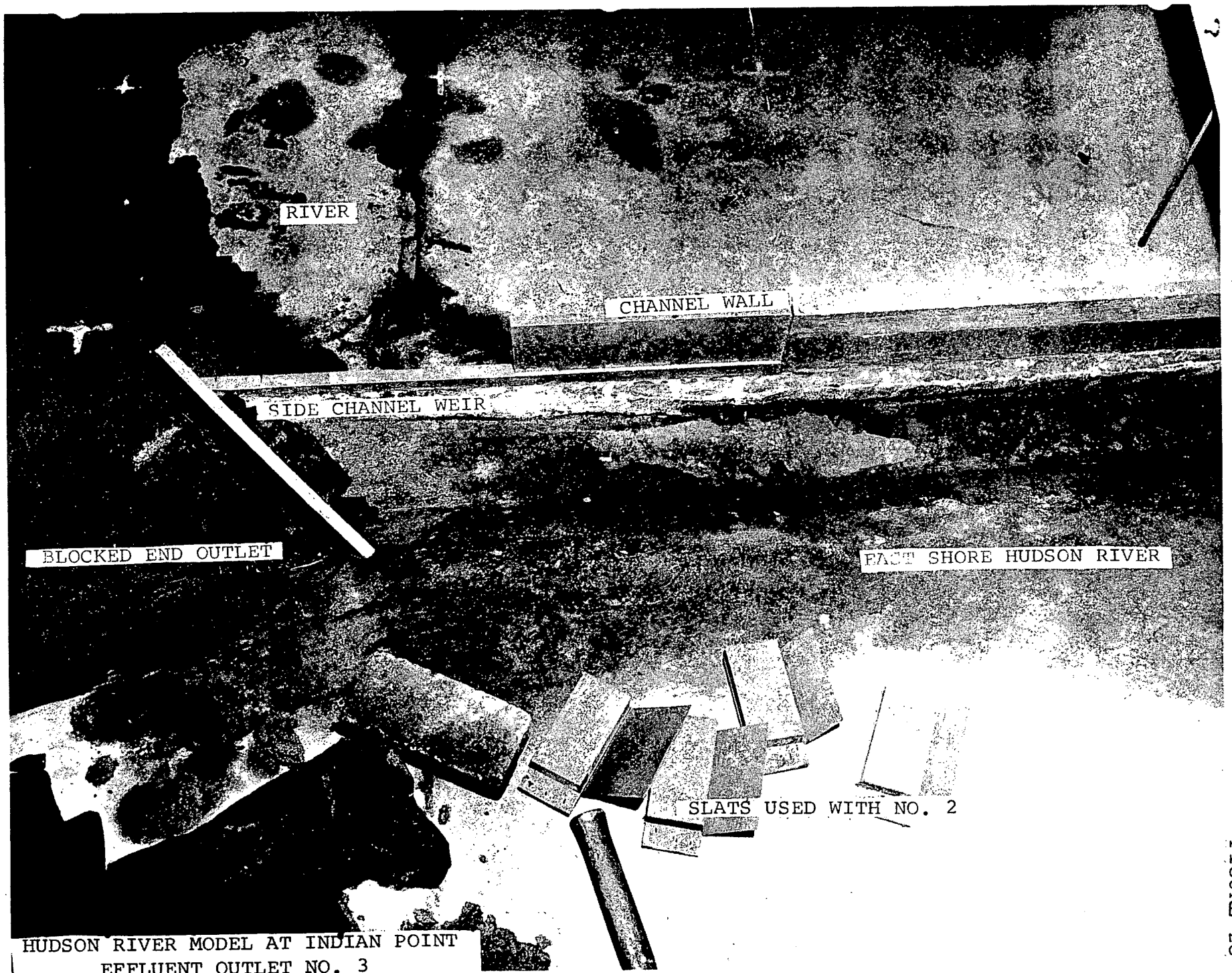

RIVER

CHANNEL WALL

SIDE CHANNEL WEIR

BLOCKED END OUTLET

FACT SHORE HUDSON RIVER

SLATS USED WITH NO. 2

HUDSON RIVER MODEL AT INDIAN POINT
EFFLUENT OUTLET NO. 3

FIGURE 28

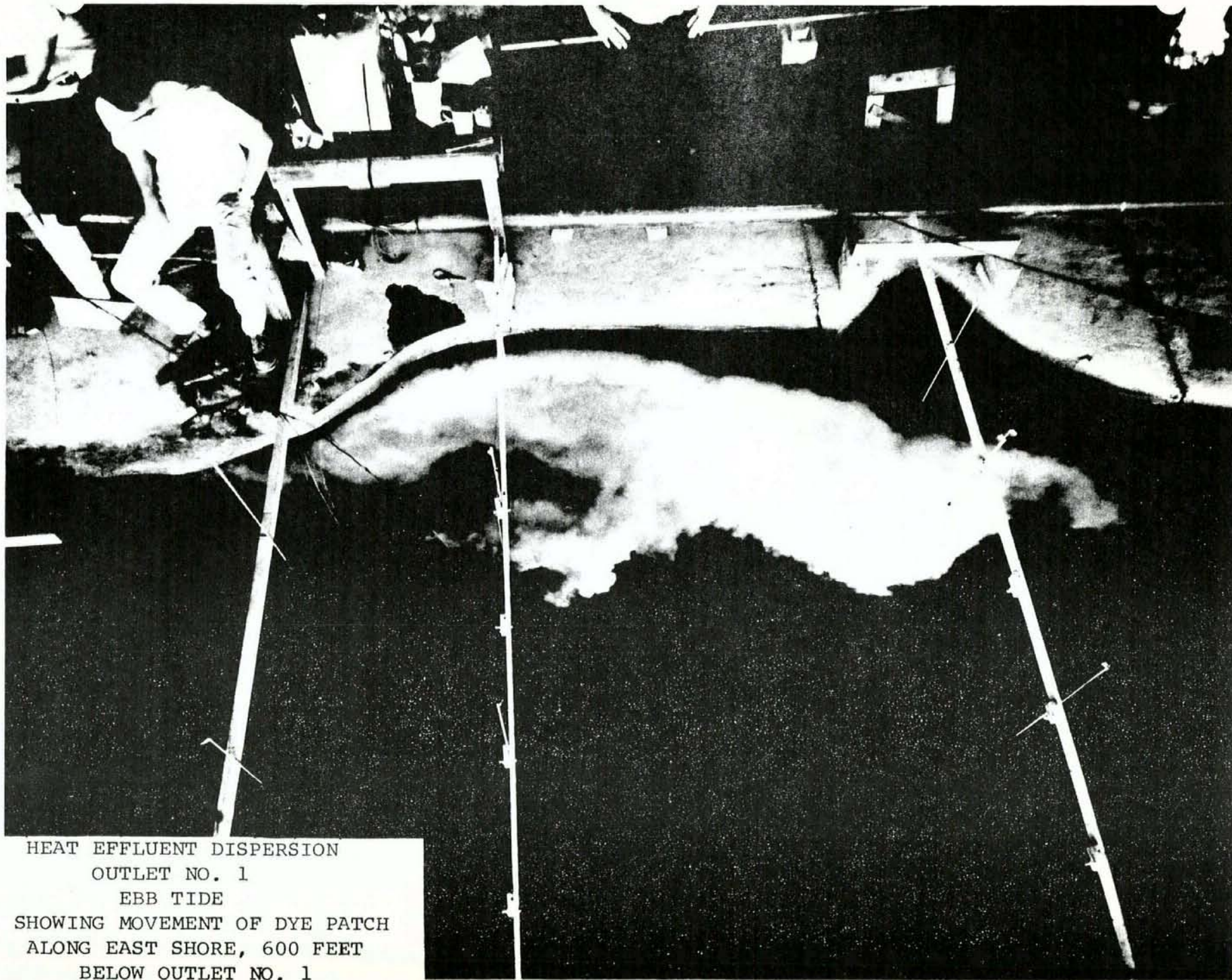

HEAT EFFLUENT DISPERSION
OUTLET NO. 1
EBB TIDE
SHOWING MOVEMENT OF DYE PATCH
ALONG EAST SHORE, 600 FEET
BELOW OUTLET NO. 1

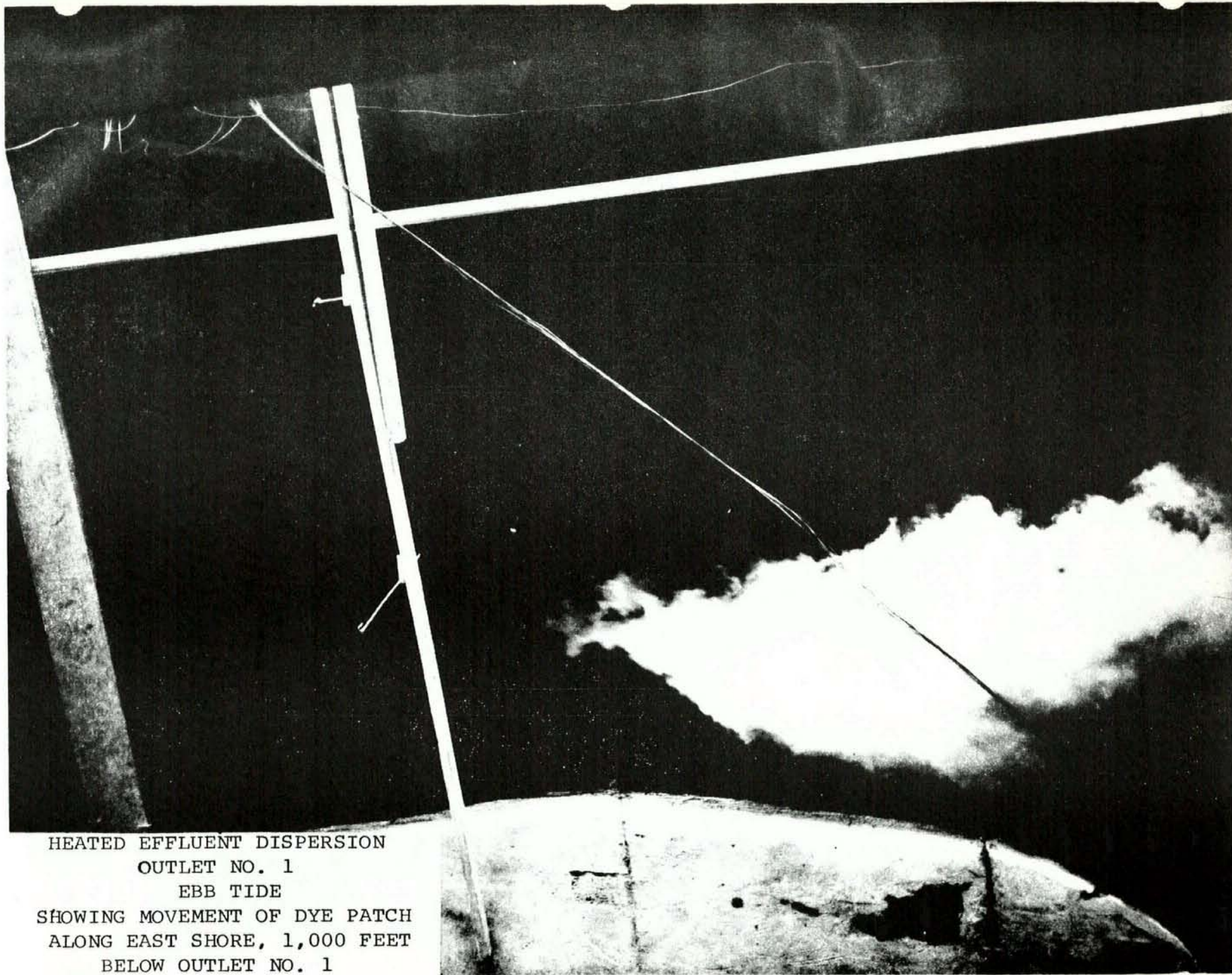

HEATED EFFLUENT DISPERSION
OUTLET NO. 1
EBB TIDE
SHOWING MOVEMENT OF DYE PATCH
ALONG EAST SHORE, 1,000 FEET
BELOW OUTLET NO. 1

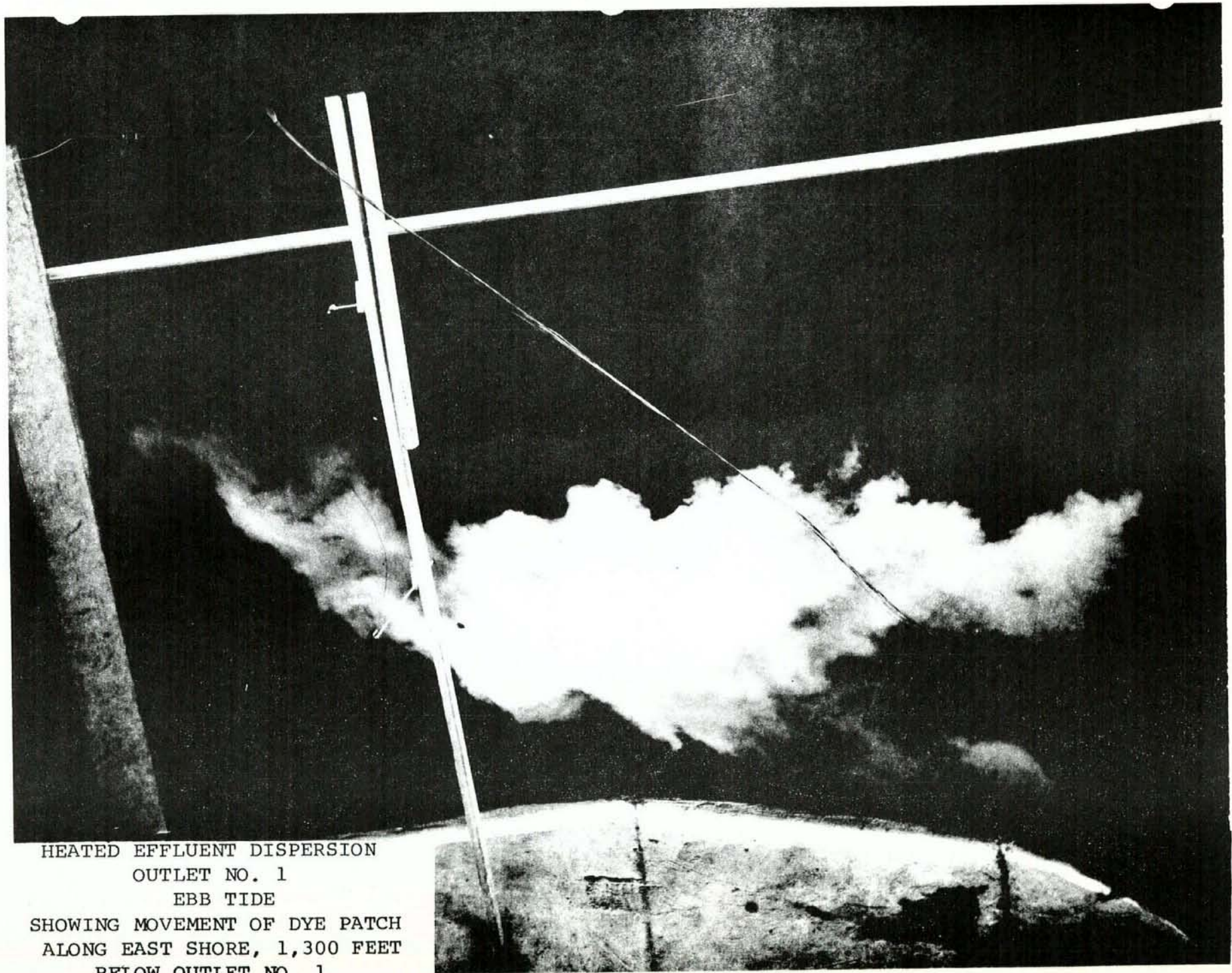

HEATED EFFLUENT DISPERSION
OUTLET NO. 1
EBB TIDE
SHOWING MOVEMENT OF DYE PATCH
ALONG EAST SHORE, 1,300 FEET
BELOW OUTLET NO. 1

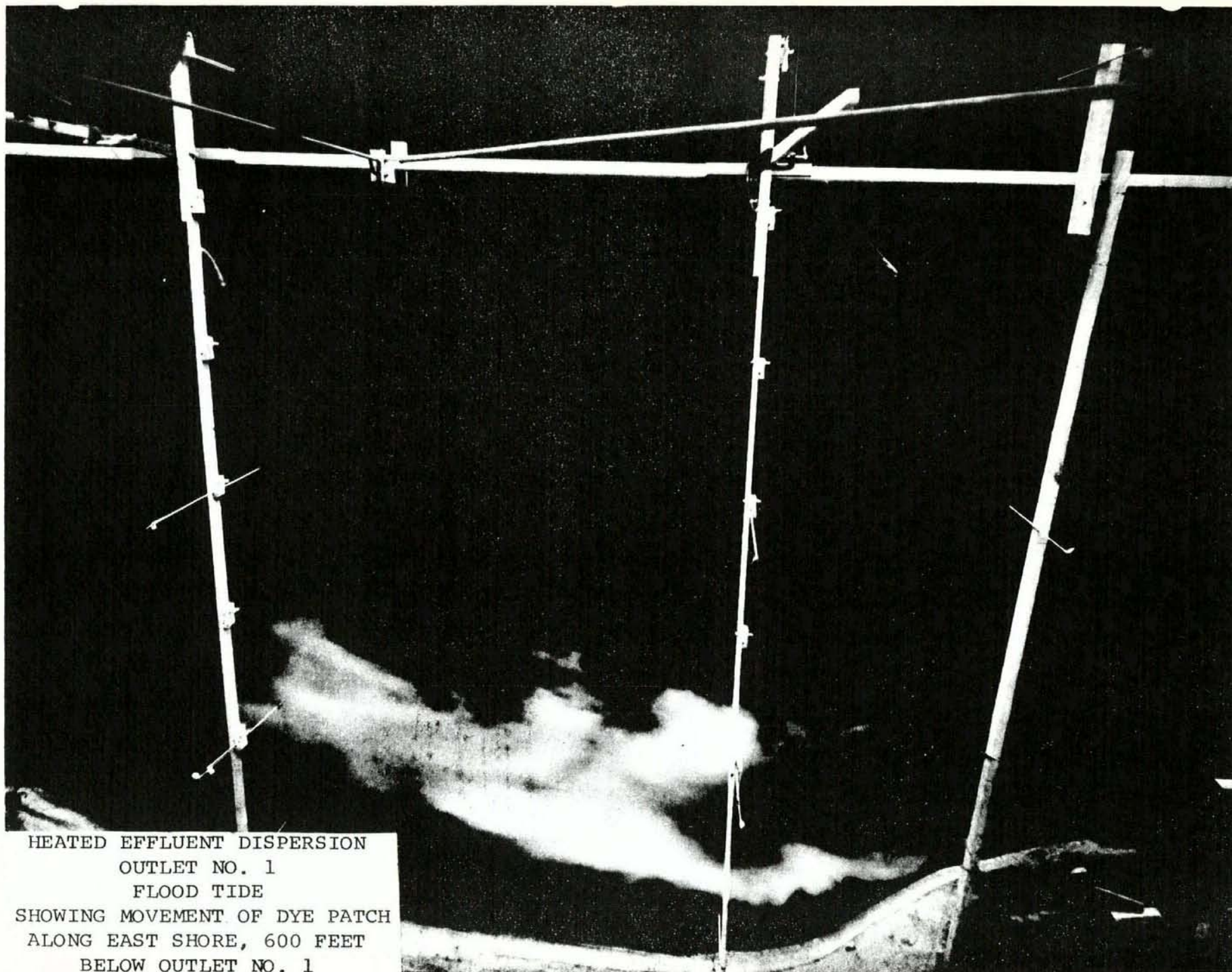

HEATED EFFLUENT DISPERSION
OUTLET NO. 1
FLOOD TIDE
SHOWING MOVEMENT OF DYE PATCH
ALONG EAST SHORE, 600 FEET
BELOW OUTLET NO. 1

Dye patterns resulting from discharge through Outlet No. 2 are illustrated for ebb and flood conditions in Figures 33 and 34, respectively. The effluent flows between the vertical slats, and the heated effluent discharges to the River in separate streams. The direction of each stream depends on the orientation of the vertical slats with respect to the longitudinal axis of the River. Virtually any angle of deflection can be obtained by this outlet configuration.

Figures 33 and 34 show that the momentum of the three unit effluent flow is sufficient to bring the heated liquid well out into the River during the entire tidal cycle.

Dye patterns observed using Outlet No. 3 are shown in Figures 35 and 36. These patterns are similar to those associated with Outlet No. 2. Mixing with the River is considered to be somewhat less complete, due to the absence of deflectors. The dye jet leaving Outlet No. 3 extended over the southern half of the side channel weir, whereas that leaving Outlet No. 2, extended over the entire length of this weir. In addition, the deflectors provide the flexibility of directing the jet at any angle to the River.

Model temperature measurements were also made to compare the effects of these three outlet designs. These were made over the full tidal cycle. Simulation of the continuously varying tidal condition occurred for at least four cycles before measurement and analysis of temperature changes between cycles showed that this was sufficient to insure steady state conditions. Model temperature rise across the reactor varied between 13 and 15°F, with an average of 14 F, throughout these runs.

Figure 37 shows the location of stations at which temperature measurements are reported in Figures 38 through 46. Temperatures shown in these figures have been adjusted for a temperature rise across the plant of 17°F. Interpretation of these measurements is given below. Prediction of absolute prototype temperatures from these results has not been made. These results, however, are reliable for comparison of relative effects of the three different outlet designs.

Station 50-11 is close to the shore at the north end of the cove just below the south line of Edison's Indian Point property. Temperature differences observed at this point were greater than at any other analyzed. Figure 38 shows these results. The slatted side channel weir gave the lowest temperatures, as would be expected, since the discharge from Outlet No. 1 moved directly past this point in a relatively undiluted state, and less spreading is created by Outlet No. 3 than by Outlet No. 2.

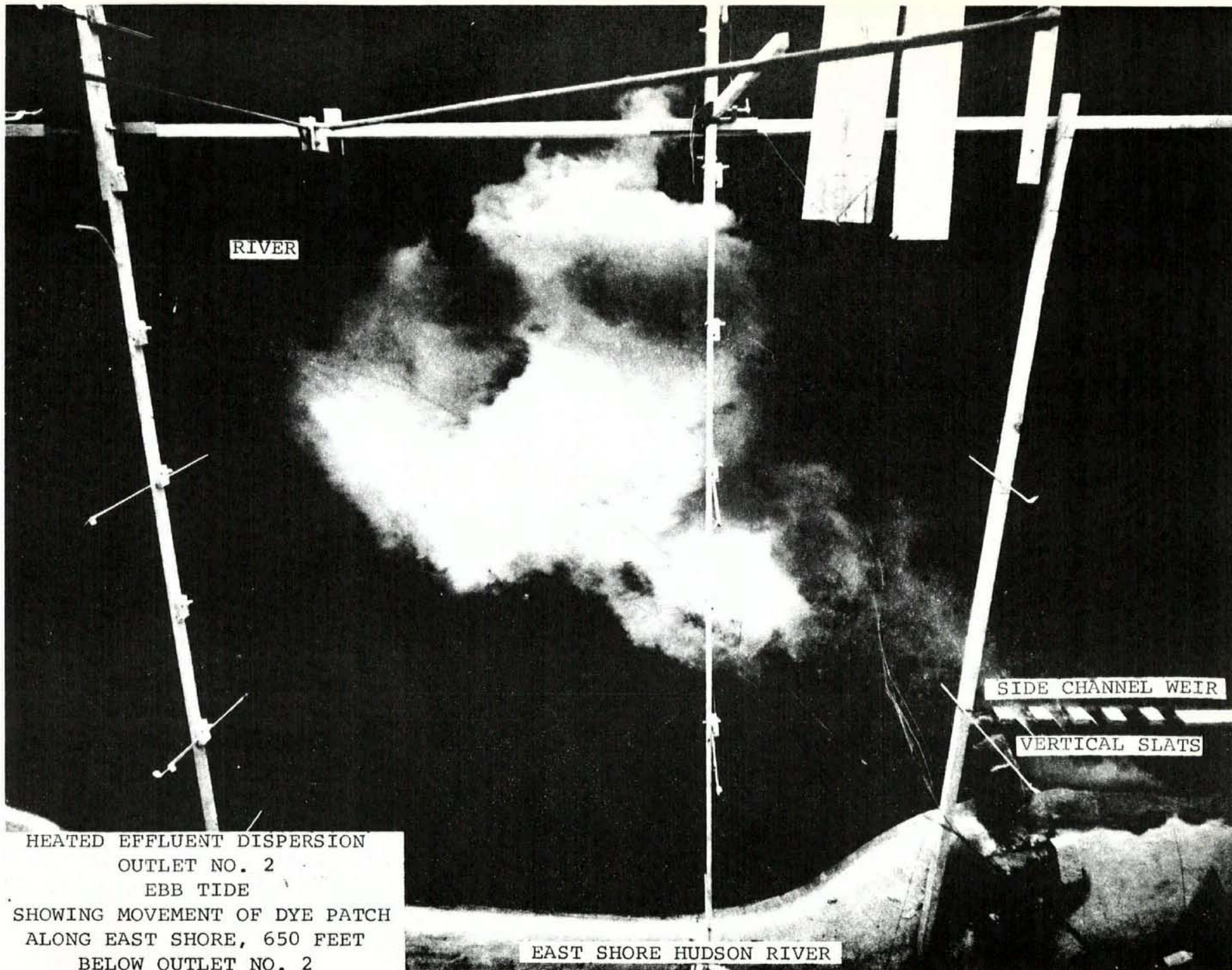

RIVER

SIDE CHANNEL WEIR

VERTICAL SLATS

HEATED EFFLUENT DISPERSION
OUTLET NO. 2
EBB TIDE
SHOWING MOVEMENT OF DYE PATCH
ALONG EAST SHORE, 650 FEET
BELOW OUTLET NO. 2

EAST SHORE HUDSON RIVER

FIGURE 33

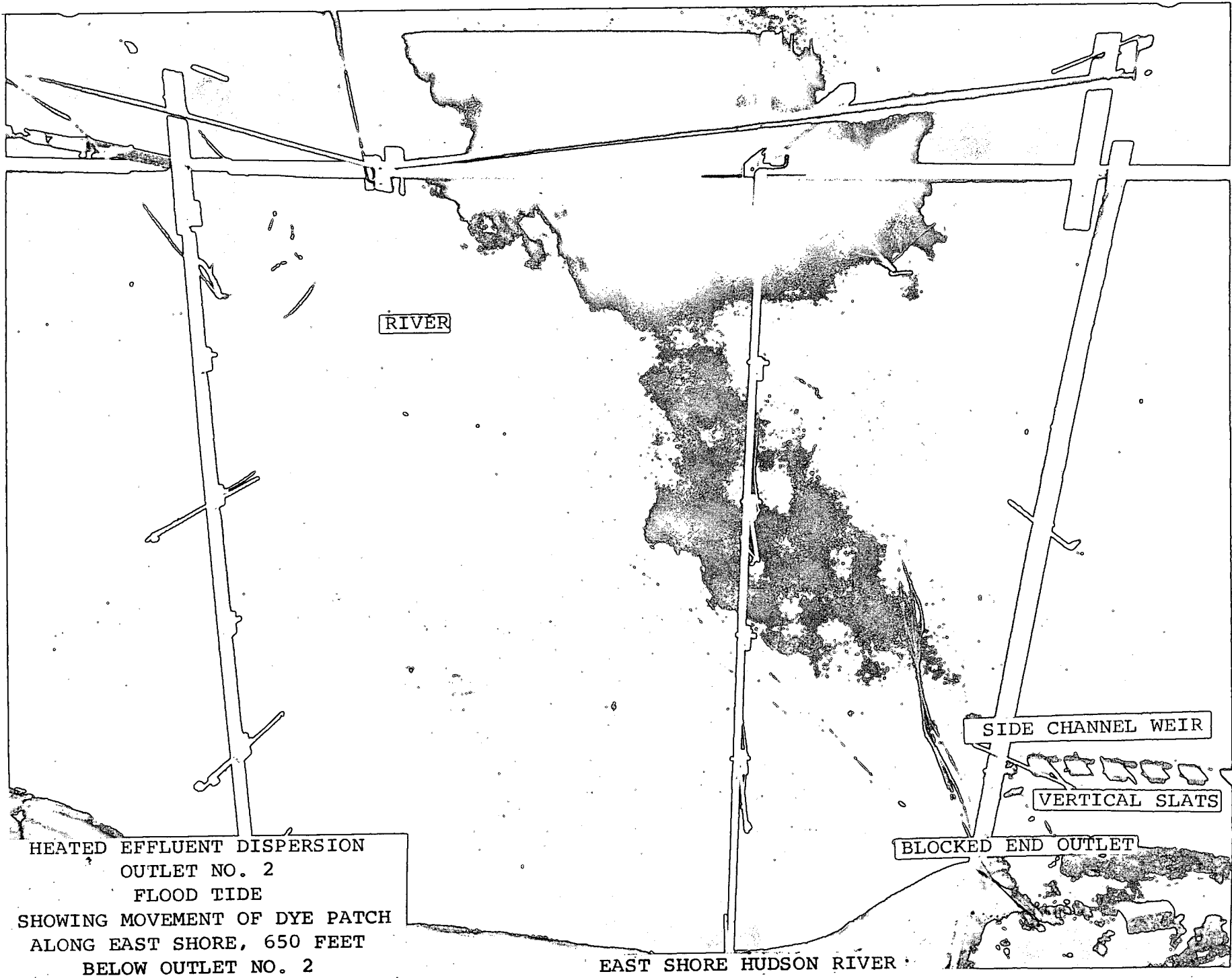

FIGURE 34



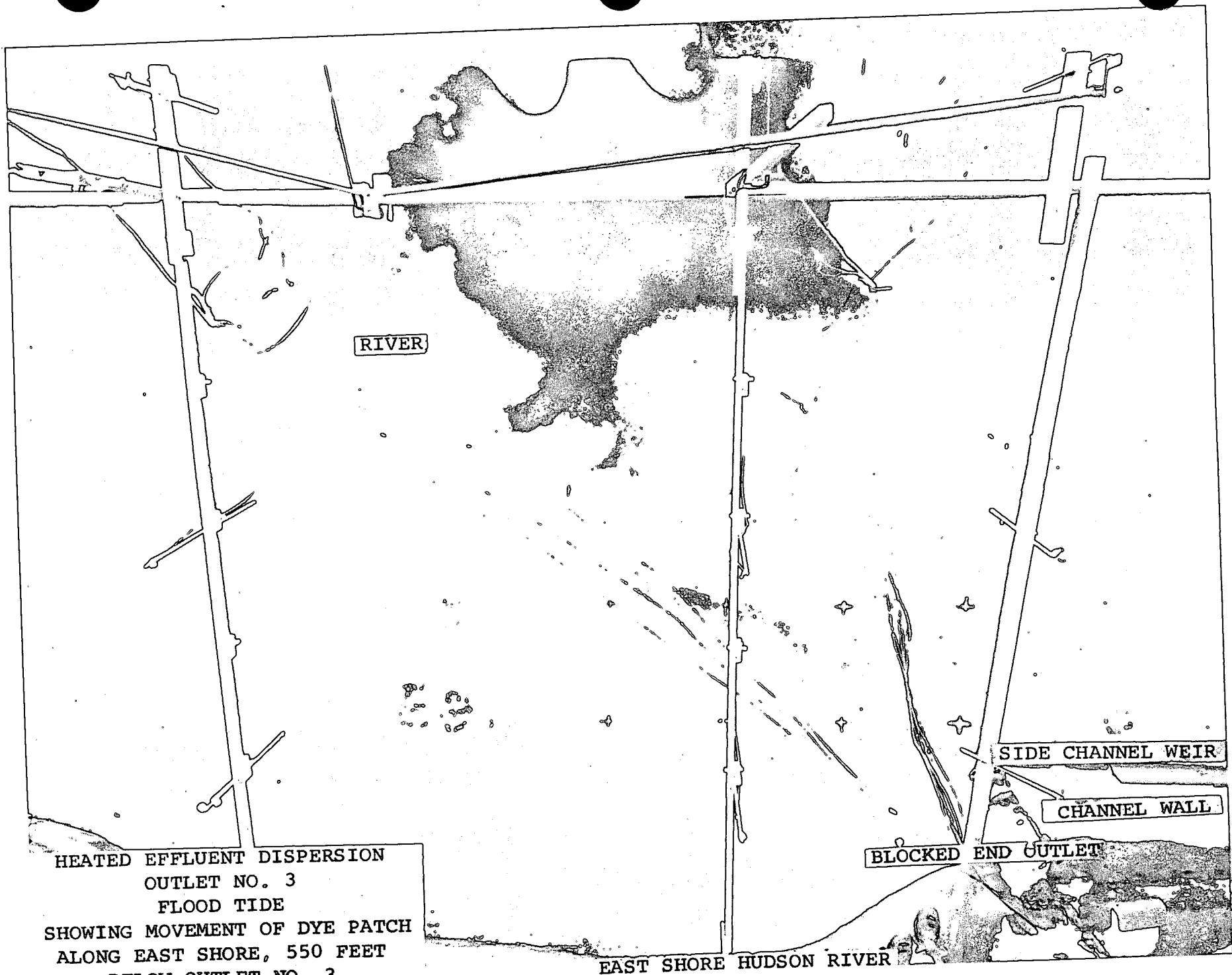
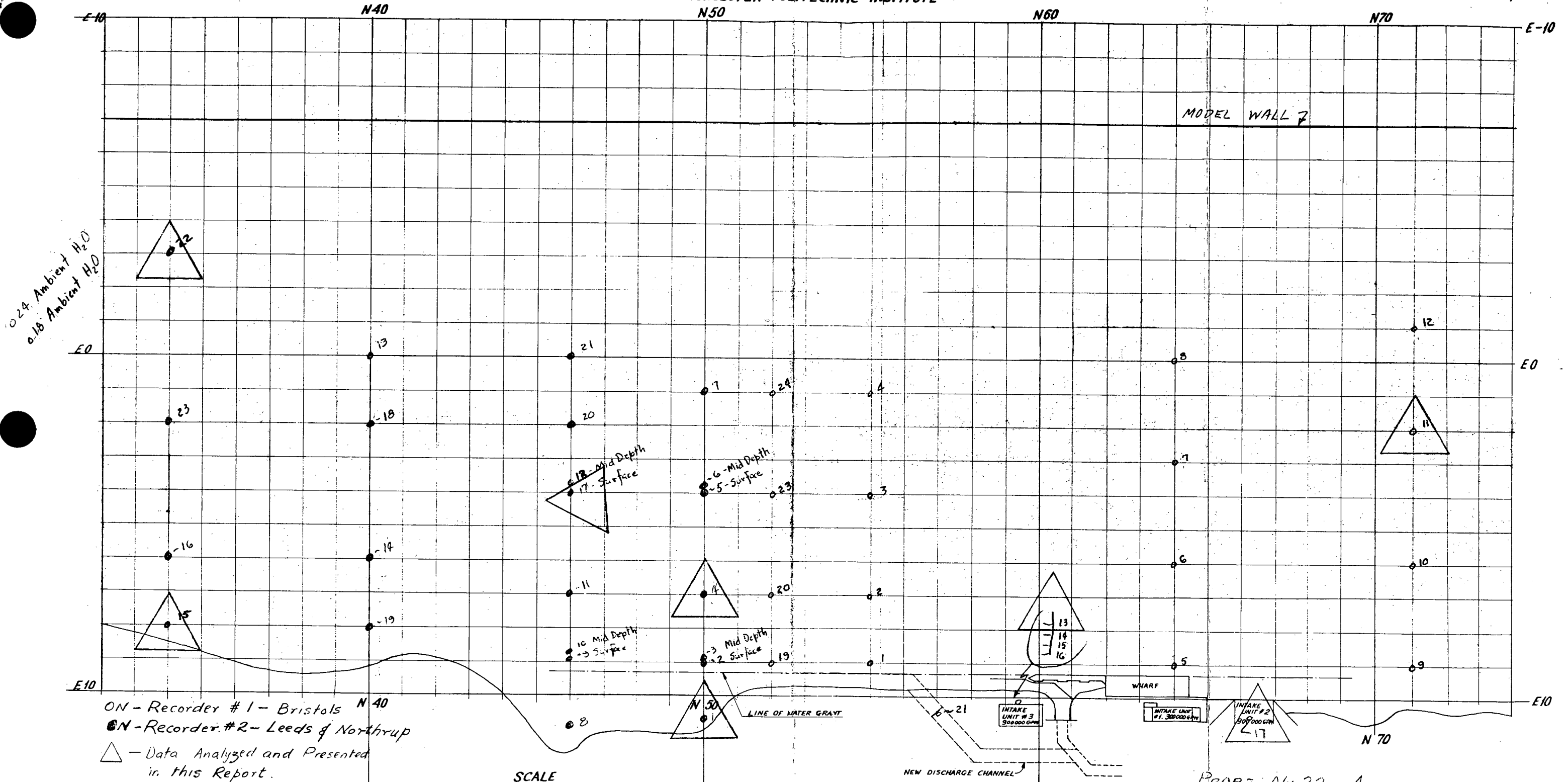

FIGURE 36

INDIAN POINT GENERATING STATION
 CONSOLIDATED EDISON COMPANY
 HYDRAULIC MODEL STUDIES BY ALDEN RESEARCH LABORATORIES
 WORCESTER POLYTECHNIC INSTITUTE

FIGURE 37



o 24 Ambient H₂O
 o 18 Ambient H₂O

ON - Recorder #1 - Bristols N 40
 ●N - Recorder #2 - Leeds & Northrup
 △ - Data Analyzed and Presented
 in this Report.

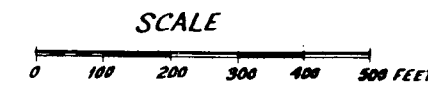

TEST CONDITIONS

START - STOP OF TEST
 AMBIENT WATER TEMP. PROBES 18, 24
 DISCHARGE --- --- PROBE 21
 INTAKE --- --- PROBES 13 thru 17
 AMBIENT AIR --- --- PROBE 22

STAGE, TIME
 TIDE CONDITIONS CONTINUOUSLY VARYING TIDE AND STAGE
 DISCHARGE 2,100,000 GPM FROM UNITS #1, 2 & 3 (4,690CFS)
 TEST CONDUCTED 8-18-67 1967 BY
 APPROVED BY

COMPARISON OF EFFLUENT CHANNEL OUTLET DESIGNS
 TIDAL TEMPERATURE VARIATION AT STATION 50-11

AUGUST 18, 1967

- — OUTLET No 1 — Discharge Parallel to Shore
- △ — OUTLET No 2 — Discharge Toward River Channel, Multiple Deflectors
- — OUTLET No 3 — Discharge Toward River Channel, No Deflectors

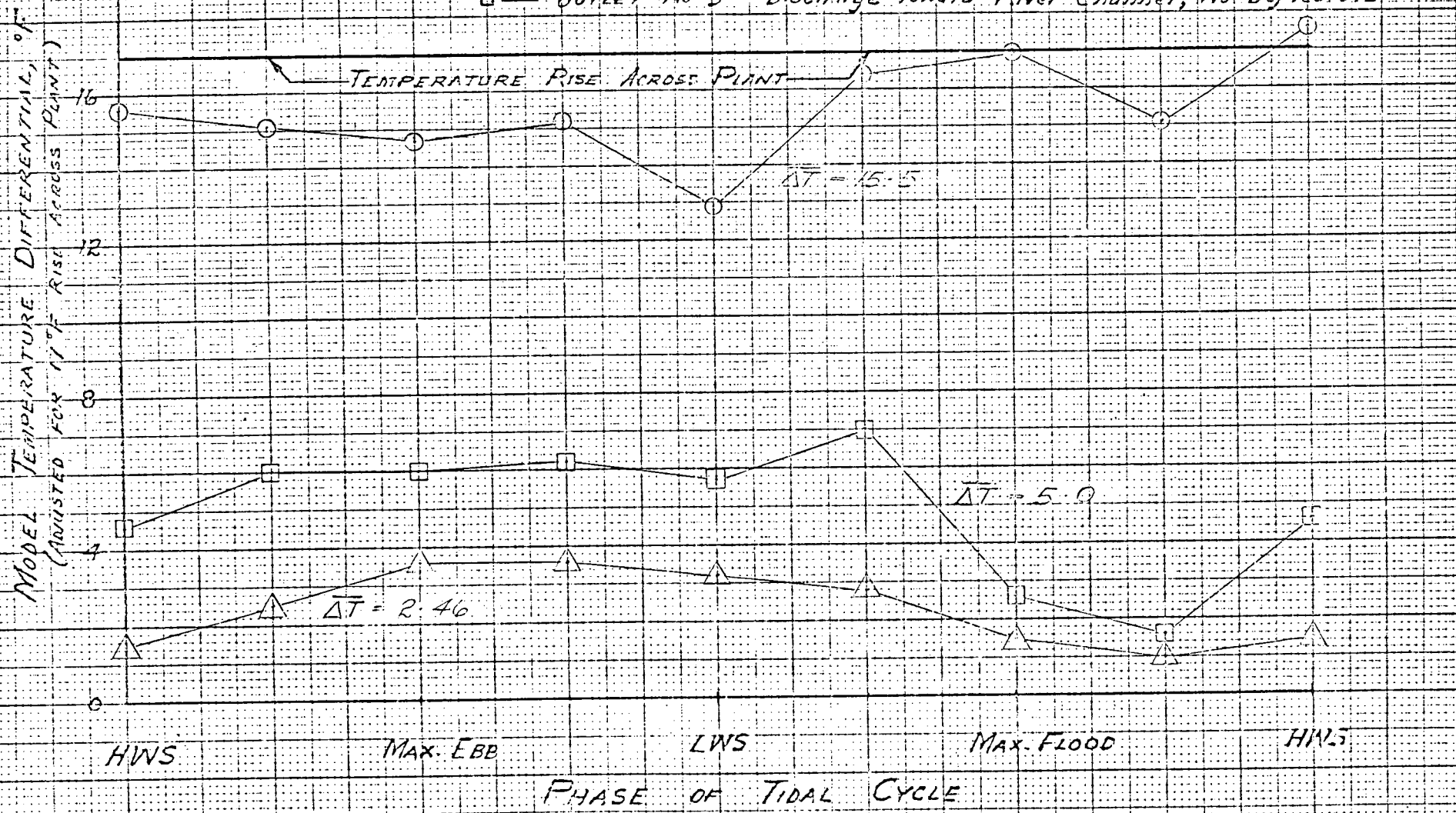

Figure 38 shows the temperature rise close to shore for the shore line directed discharge (Outlet No. 1) may increase during flood or will at least not show a marked drop by comparison to behavior during ebb. The River channel directed discharge (Outlets No. 2 and No. 3) may exhibit a decrease in temperature close to shore during flood.

Comparison of the average temperatures over the full tidal cycle shows that shore line temperatures just below Indian Point may be reduced by a factor of approximately seven or three by employing Outlet No. 2 or No. 3, respectively, rather than Outlet No. 1.

Figures 39 and 40 show behavior at Stations 34-8 and 34-(-3). These points are 1800 feet downstream of the effluent channel outlet and 200 and 1300 feet off shore, respectively. Temperatures 200 feet off shore (Figure 38) are still highest for Outlet No. 1 and lowest for Outlet No. 2. Eleven hundred feet out the trend is the same, although the differential is much less significant.

Figures 41 and 42 show results at Stations 50-7 and 46-4, points in the vicinity of the dye patches shown on Figures 33 through 36 for Outlets No. 2 and No. 3. Station 50-7 is about 200 feet below the outlet and 400 feet off shore, and Station 46-4 is 600 feet downstream, 700 feet off shore. Again, the fact that the discharge from Outlet No. 3 does not distribute itself over the entire length of the weir, but rather at its southern end, is responsible for the higher temperatures associated with this outlet by comparison to Outlet No. 2.

These figures also show that, although Outlet No. 1 will cause lower temperatures during ebb by comparison to Outlet No. 2, the reverse will be true during flood. The average temperature rise over the full cycle is approximately equal for the two.

Figures 43 and 44 show results at two points upstream of the plane of discharge. Station 55-4 is 300 feet upstream of the outlet and 600 feet off shore; Station 71-2 is 1900 feet upstream and 800 feet off shore. Tidal cycle average temperatures show little difference between the three modes of discharge. Temperatures are significantly lower than the rise across the plant.

Results of the effect of these three modes of discharge on River temperatures are summarized in Table 7.

COMPARISON OF EFFLUENT CHANNEL OUTLET DESIGNS
 TIDAL TEMPERATURE VARIATION AT STATION 34-8

AUGUST 18, 1967

- — OUTLET No. 1 — Discharge Parallel to Shore
- △ — OUTLET No. 2 — Discharge Toward River Channel, Multiple Deflectors
- — OUTLET No. 3 — Discharge Toward River Channel, No Deflectors

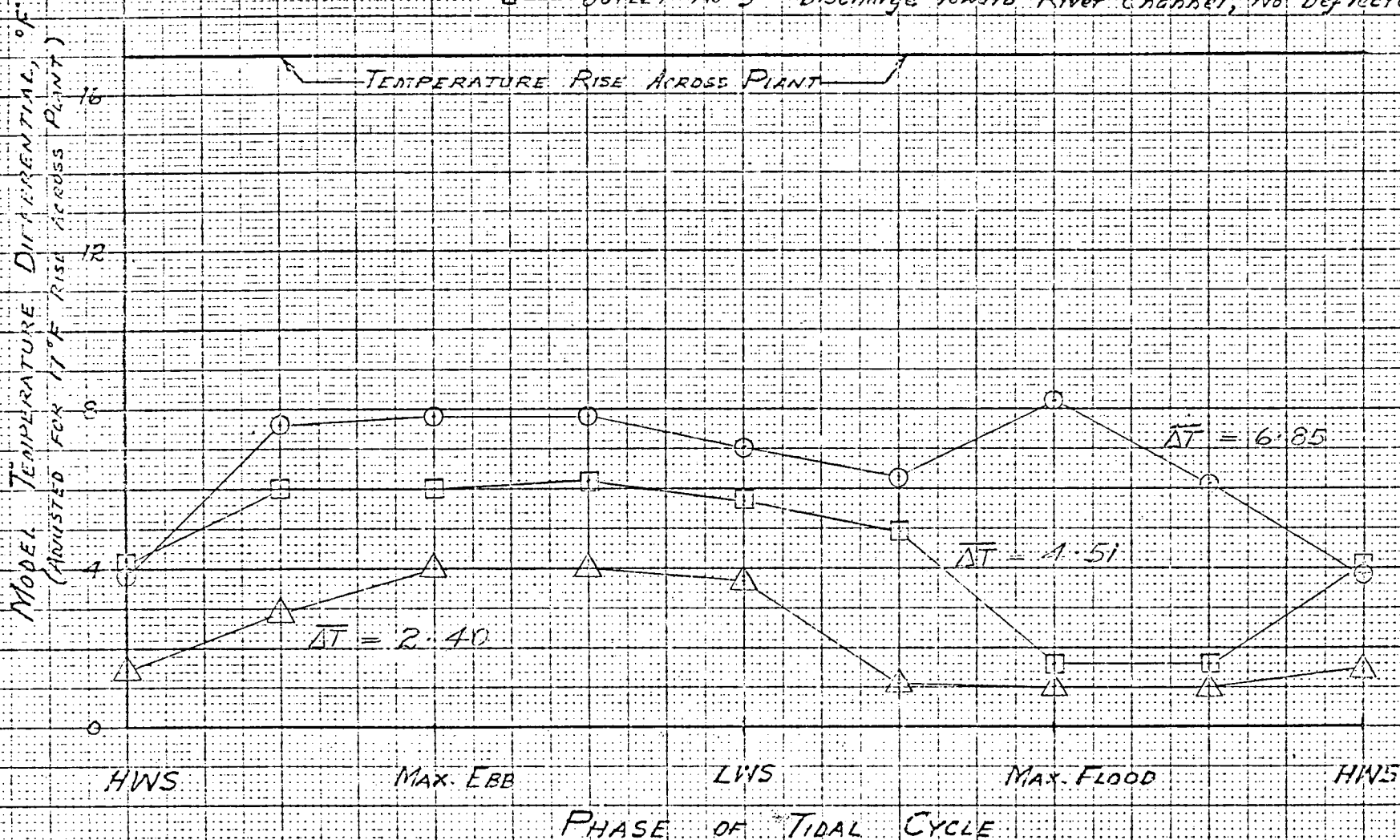

FIGURE 39

COMPARISON OF EFFLUENT CHANNEL OUTLET DESIGNS
TIDAL TEMPERATURE VARIATION AT STATION 34-3

AUGUST 18, 1967

- — OUTLET No. 1 — Discharge Parallel to Shore
- △ — OUTLET No. 2 — Discharge Toward River Channel, Multiple Deflectors
- — OUTLET No. 3 — Discharge Toward River Channel, No Deflectors

MODEL TEMPERATURE DIFFERENTIAL, °F
(ADJUSTED FOR 17°F RISE ACROSS PLANT)

TEMPERATURE RISE ACROSS PLANT

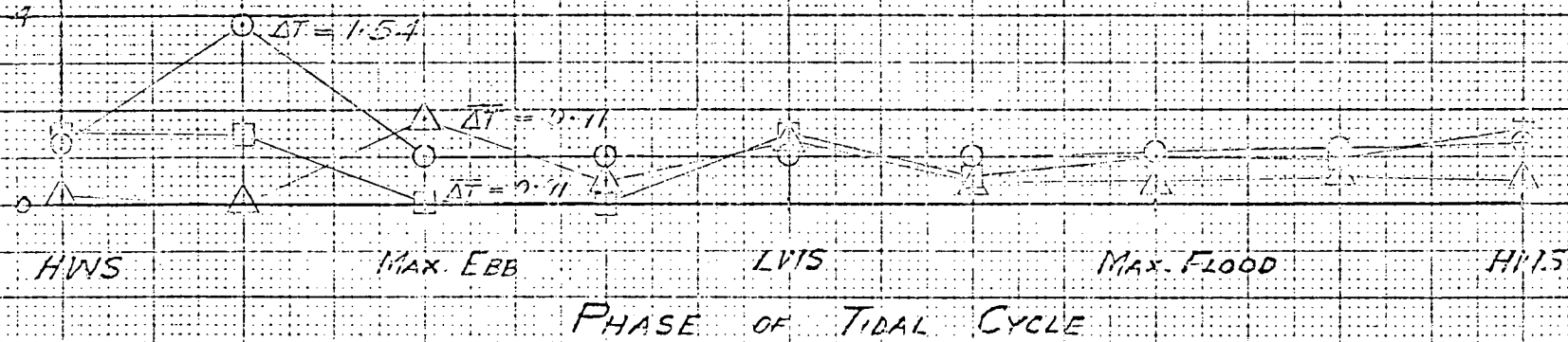

FIGURE 10

COMPARISON OF EFFLUENT CHANNEL OUTLET DESIGNS
 TIDAL TEMPERATURE VARIATION AT STATION 50-7

AUGUST 18, 1967

- — OUTLET No. 1 — Discharge Parallel to Shore
- △ — OUTLET No. 2 — Discharge Toward River Channel, Multiple Deflectors
- — OUTLET No. 3 — Discharge Toward River Channel, No Deflectors

MODEL TEMPERATURE DIFFERENTIAL, °F
 (ADJUSTED FOR 1°F RISE ACROSS PLANT)

TEMPERATURE RISE ACROSS PLANT

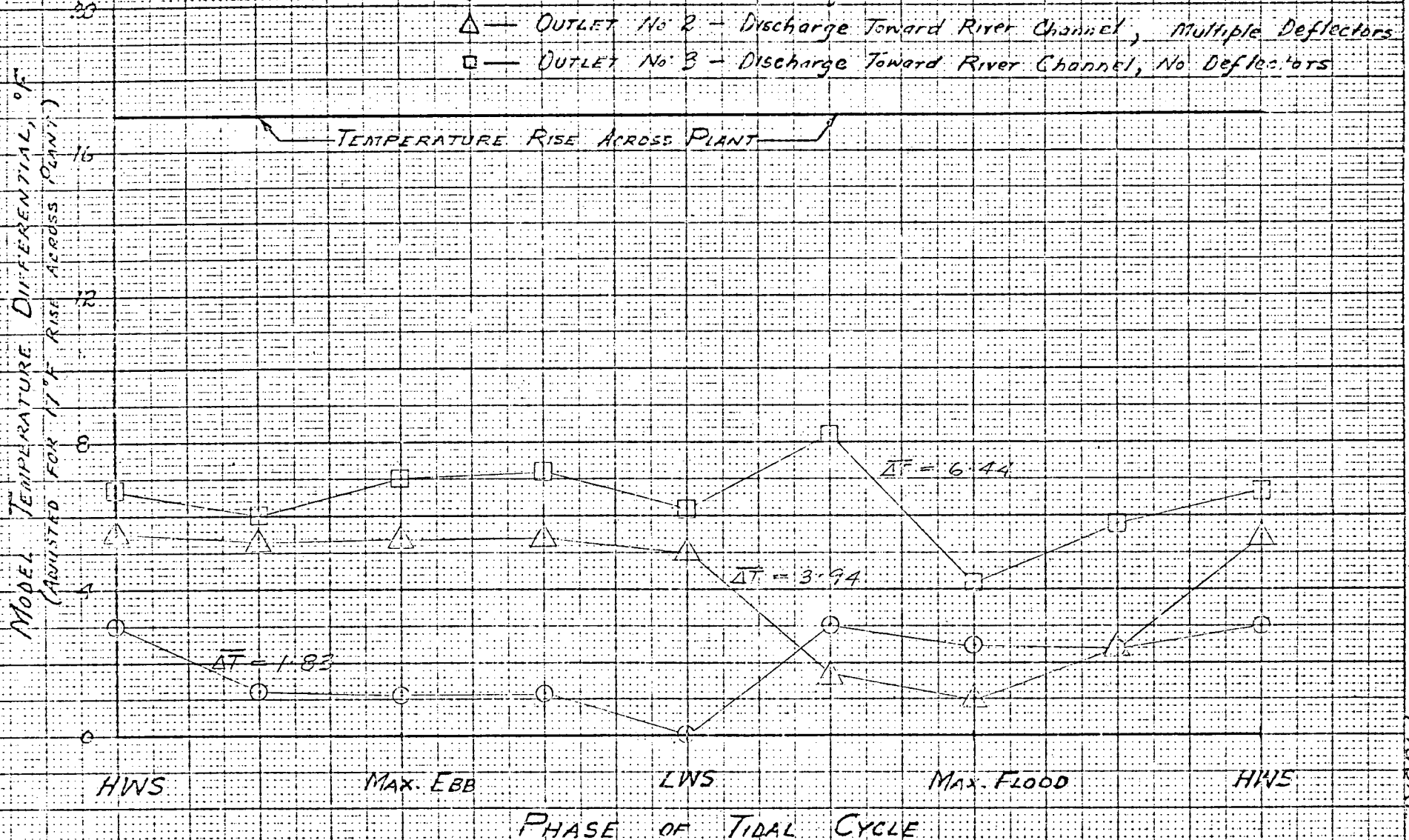

FIGURE 41

COMPARISON OF EFFLUENT CHANNEL OUTLET DESIGNS
TIDAL TEMPERATURE VARIATION AT STATION 412-1

AUGUST 18, 1967

- — OUTLET No 1 - Discharge Parallel to Shore
- △ — OUTLET No 2 - Discharge Toward River Channel, Multiple Deflectors
- — OUTLET No 3 - Discharge Toward River Channel, No Deflectors

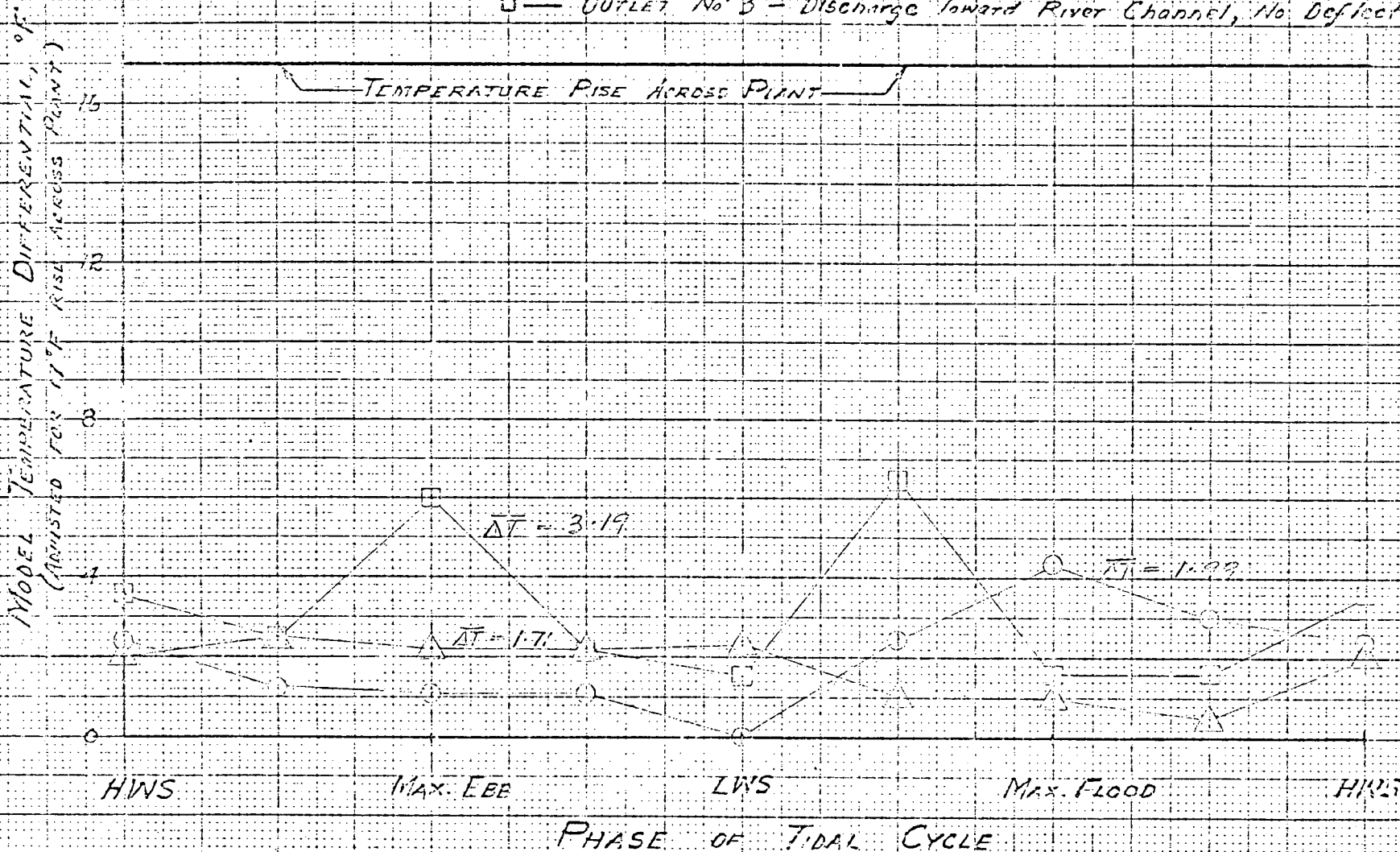

FIGURE 2-11

COMPARISON OF EFFLUENT CHANNEL OUTLET DESIGNS
 TIDAL TEMPERATURE VARIATION AT STATION 55-4

AUGUST 18, 1967

- — OUTLET No. 1 — Discharge Parallel to Shore
- △ — OUTLET No. 2 — Discharge Toward River Channel, Multiple Deflectors
- — OUTLET No. 3 — Discharge Toward River Channel, No Deflectors

MODEL TEMPERATURE DIFFERENTIAL, °F
 (ADJUSTED FOR 17°F RISE ACROSS PLANT)

TEMPERATURE RISE ACROSS PLANT

20

16

12

8

4

HWS

MAX. EBB

LWS

MAX. FLOOD

HWS

PHASE OF TIDAL CYCLE

$\Delta T = 1.48$

$\Delta T = 1.04$

$\Delta T = 1.51$

FIGURE 4.5

COMPARISON OF EFFLUENT CHANNEL OUTLET DESIGNS

TIDAL TEMPERATURE VARIATION AT STATION 71-12

AUGUST 18, 1967

- — OUTLET No 1 — Discharge Parallel to Shore
- △ — OUTLET No 2 — Discharge Toward River Channel, Multiple Deflectors
- — OUTLET No 3 — Discharge Toward River Channel, No Deflectors

MODEL TEMPERATURE DIFFERENTIAL, °F
(CORRECTED FOR 17°F RISE ACROSS PLANT)

TEMPERATURE RISE ACROSS PLANT

30
20
16
12
8
4
0

HWS MAX. EBB LWS MAX. FLOOD HWS

PHASE OF TIDAL CYCLE

$\Delta T = 0.95$

$\Delta T = 1.25$

$\Delta T = 1.075$

FIGURE 4.1

TABLE 7

COMPARISON OF TIDAL CYCLE AVERAGE TEMPERATURES
DUE TO VARIOUS EFFLUENT CHANNEL OUTLET DESIGNS

<u>Station</u>	<u>Distance Offshore (Feet)</u>	<u>Distance Below Outlet (Feet)</u>	Tidal Cycle Average Temperatures °F		
			<u>No. 1</u>	<u>No. 2</u>	<u>No. 3</u>
50-11	25	220	15.5	2.46	5.0
34-8	50	1820	6.85	2.40	4.51
34-(-3)	550	1820	1.54	0.713	0.906
50-7	400	220	1.83	3.94	6.44
46-4	750	620	1.99	1.71	3.19
55-4	600	-280	1.48	1.51	1.04
71-2	800	-1880	0.95	1.075	1.05
Intake of Unit No. 2	0	-1300	0.64	0.875	0.74
Intake of Unit No. 3	0	-780	0.95	1.025	0.99

Effect of Outlet Design on Intake Temperatures

Figures 45 and 46 show the relative effects of the three outlets on the temperatures of the intakes for Unit No. 2 and Unit No. 3, respectively. In the model, as shown on Figure 37, Unit No. 2 is located 1400 feet upstream of the outlet, and Unit No. 3, 700 feet. Temperature of Unit No. 1 intake water was not recorded. Since this intake is about two thirds the distance from the No. 3 intake to the No. 2 intake, results from this unit have been obtained by interpolation between the results for the other two.

Table 8 shows the comparison for the tidal cycle average temperature. Tidal cycle average temperatures have been used for comparison because the effect of intake temperature rise on condenser design is probably best judged by the expected long-term value, and because the differences observed in the averages are probably more reliable than differences of individual values.

Table 8 shows that intake temperatures at Units 2 and 3, occurring with Outlet No. 2, were about 60% and 30% higher, respectively, than those occurring with Outlet No. 1. Intake temperatures associated with Outlet No. 3 were about 20% higher than Outlet No. 1 associated values.

The selection of an outlet design must weigh the relative advantages of each possibility. While Outlet No. 1 will produce the lowest intake temperatures, it will also produce the highest downstream shoreline temperatures. On the other hand, Outlet No. 2 avoids the effect of high shoreline temperatures that are produced by Outlet No. 1 but exhibits an intake temperature that is, on the average for all intakes, 40% higher than that of Outlet No. 1. Outlet No. 3 produces an intermediate result.

The temperature profiles in Figures 45 and 46 and the results shown on Table 8 would appear to indicate that, while the percentage differences are significant, absolute intake temperature differences for the three designs are insignificant. On the basis of the reduced shoreline and shoal area temperatures which would accrue, it would appear that outlet design should be similar to Outlet No. 2. However, as suggested above at the beginning of this section, no means are available at this time for accurately predicting the absolute value of prototype temperature rises from these model results.

Should the prototype Unit No. 3 intake average temperature be as high as 2°F for the Outlet No. 1 design, the results shown above indicate that this temperature would exceed 3°F for the Outlet No. 2 design. If condenser capital and operating costs depend

COMPARISON OF EFFLUENT CHANNEL OUTLET DESIGNS

TIDAL TEMPERATURE VARIATION AT INTAKE OF UNIT 2

AUGUST 18, 1967

- — OUTLET No. 1 — Discharge Parallel to Shore
- △ — OUTLET No. 2 — Discharge Toward River Channel, Multiple Deflectors
- — OUTLET No. 3 — Discharge Toward River Channel, No Deflectors

TEMPERATURE RISE ACROSS PLANT

MODEL TEMPERATURE DIFFERENTIAL, °F
 (CONSTANT FOR 17°F RISE ACROSS PLANT)

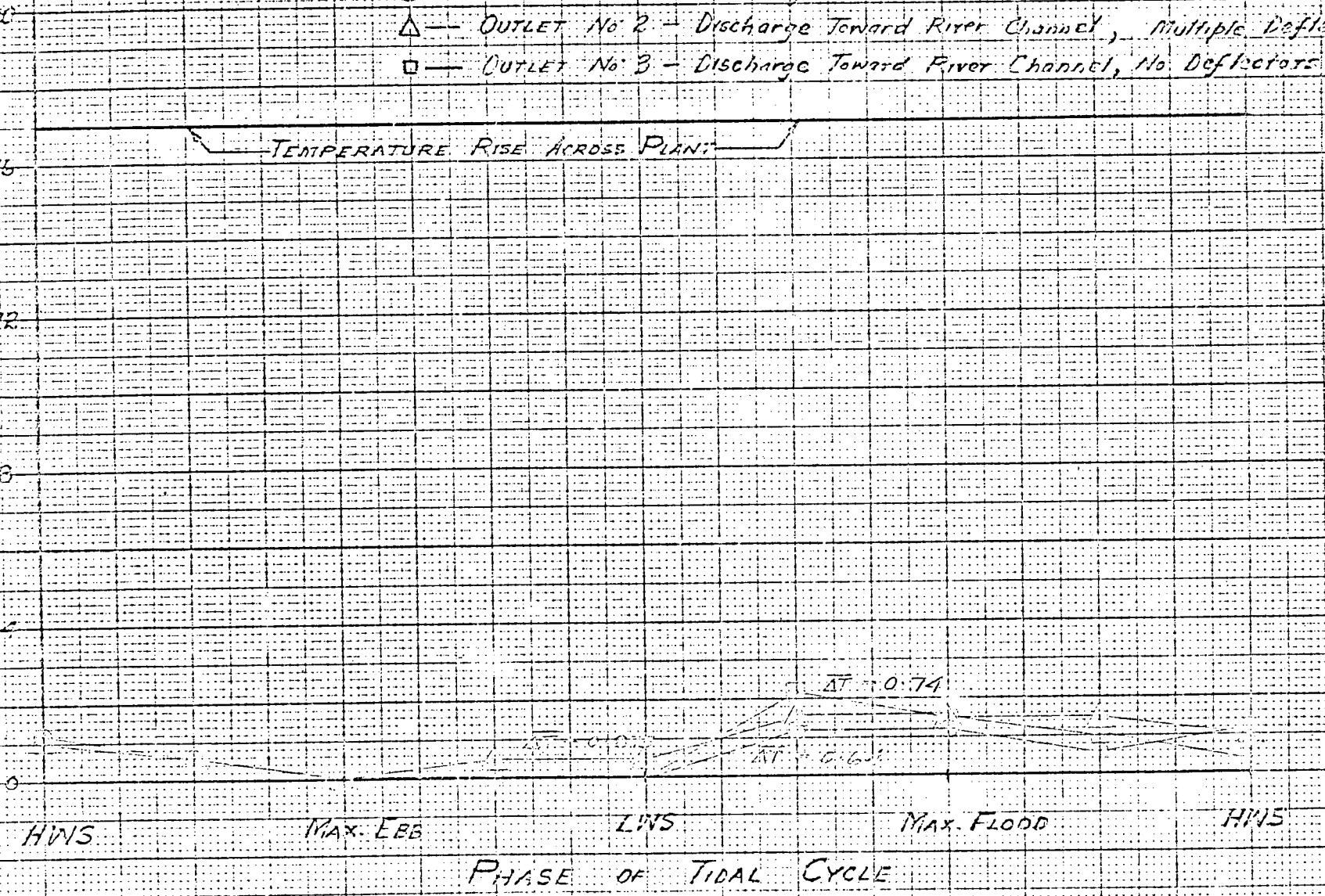

FIGURE 47

COMPARISON OF EFFLUENT CHANNEL OUTLET DESIGNS
 TIDAL TEMPERATURE VARIATION AT INTAKE OF UNIT 2

AUGUST 18, 1967

- — OUTLET No. 1 — Discharge Parallel to Shore
- △ — OUTLET No. 2 — Discharge Toward River Channel, Multiple Deflectors
- — OUTLET No. 3 — Discharge Toward River Channel, No Deflectors

Model Temperature Differential, of (Adjusted For 1" R Rise Across Plant)

TEMPERATURE RISE ACROSS PLANT

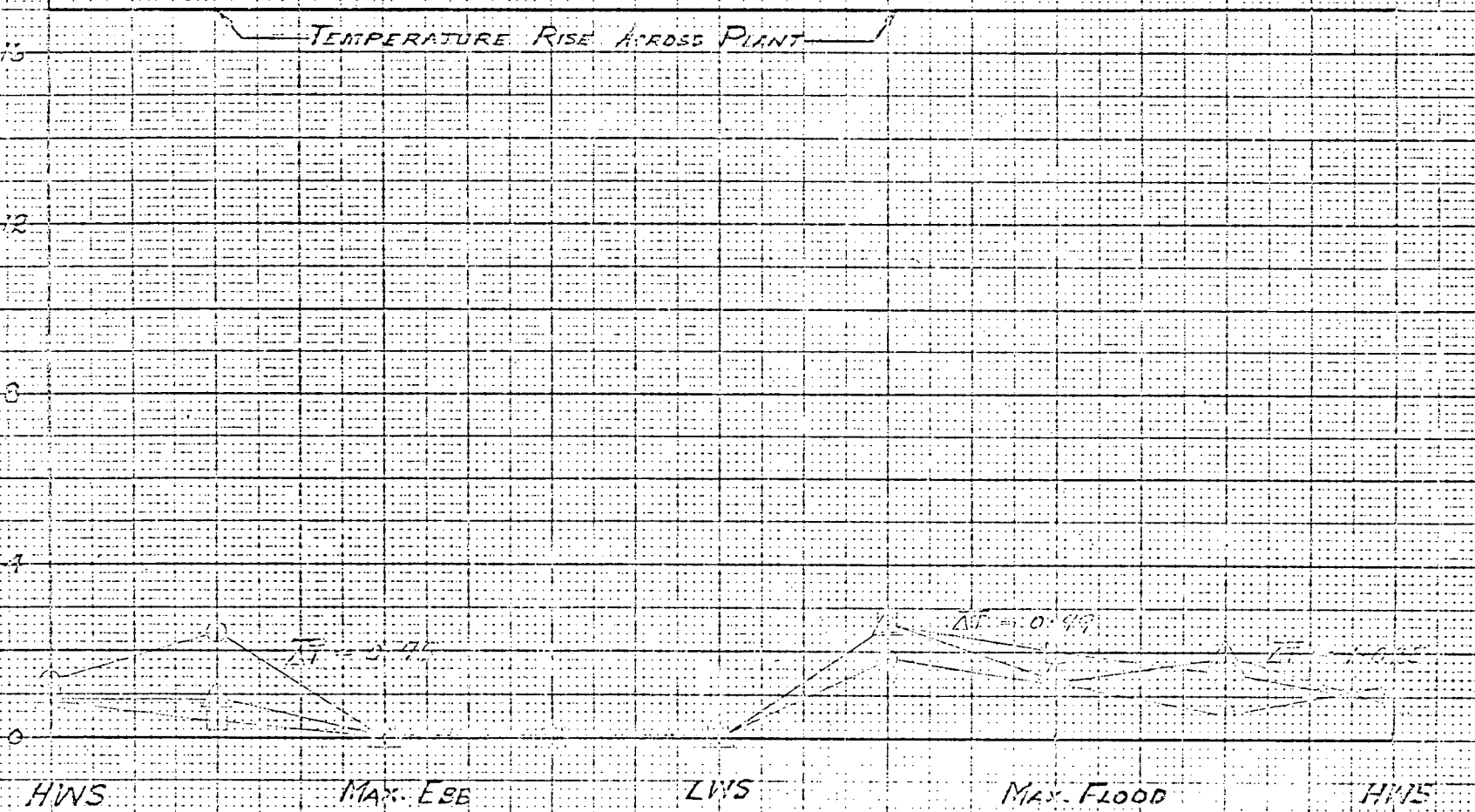

PHASE OF TIDAL CYCLE

FIGURE 41

TABLE 8

COMPARISON OF VARIOUS OUTLET DESIGNS ON
INTAKE WATER TEMPERATURES

<u>Channel</u>	<u>Unit No. 1</u>		<u>Unit No. 2</u>		<u>Unit No. 3</u>	
	<u>°F</u>	<u>%</u>	<u>°F</u>	<u>%</u>	<u>°F</u>	<u>%</u>
1	0.63	100	0.56	100	0.78	100
2	0.93	148	0.89	159	1.00	128
3	0.76	121	0.67	120	0.95	122

strongly on the absolute value of intake temperature rise, then expansion of the model and additional analysis may be warranted. At the same time, evaluation of the effect of shoreline and shoal area temperature rises on the ecology of those areas should be made.

In any event, outlets should be designed to keep the heated effluent as close to the surface as possible, for both rapid heat transfer to the atmosphere and for protection of intakes, which, in turn, should be designed to draw water as far below the surface as practical.

Recommendations for Model Expansion

Consideration has been given by Edison to expansion of the Alden model. With due regard to the physical limitations, the following suggestions are made:

1. An undistorted geometric scale should be considered. If it is impossible to decrease the horizontal scale from 1:60 to 1:40, the present vertical scale, the possibility of increasing the vertical scale to 1:60 should be evaluated.
2. The model should extend at least 4000 feet downstream of the downstream-most potential future outlet location. The present model only extended 2000 feet below this point; for three unit operation significant temperature rises were observed in some of the waters spilling over the model downstream weir and the jet was not observed to turn prior to reaching this point. This increased distance represents a minimum; it is only 20% of the tidal excursion in this vicinity.
3. The present upstream boundary is about 750 feet above the upstream-most intake. Although expansion of this distance should be secondary to the downstream expansion (on the basis that the intakes will remain above the outlets), this distance is only 7% of a tidal excursion and an increased upstream length is also recommended.
4. The model should extend the width of the River.
5. Present potential future effects of the Orange and Rockland Utilities' Lovett Plant at Tomkins Cove should be evaluated and accounted for in the model if significant.

6. Temperature probes should be located at several depths so that better comparison of model results to prototype field data can be made. For fixed probe depths, calibration charts should be prepared so that the actual depth at which a "surface" or other probe is reading is known for any point on the tidal cycle.
7. Intake and outlet structures should be removable. This should include provision for inserting the present Indian Point intake and effluent structure, since model operation for this condition is necessary for comparison with prototype field results.
8. Intake water should be recirculated to a heater, raised the necessary temperature and discharged, rather than wasted as currently done. This would permit evaluation of the buildup in temperature which will occur if a fraction of the heated water reaches the intake structure.
9. Evaluation of the effect of saline induced vertical density gradients on the thermal stratification should be made. If this appears to be of the same order as the density gradients induced by the heated liquid, its effect should be included in the model.
10. Model operation should be on a continuously varying River flow basis, to simulate the tidal conditions. Stage and flow regulation during a continuously varying run is currently done manually. An improved method of adjusting flows and stage throughout the tidal cycle is recommended.
11. Consideration should be given to the use of fluorescent dyes as tracers. Measurement of the concentration of a conservative dye would avoid the problem of temperature losses via heat transfer across the model surface; results would delineate the hydraulic phenomena more reliably. Dye measurements made in conjunction with temperature measurements on both model and prototype may provide sufficient information to make the model to prototype scaleup.

VI. Transient Effects Due to Startup or Shutdown

Temperature change rate criteria in Technical Bulletin No. 36 include temperature changes of no more than 1°F in any hour and no more than 7°F in a 24 hour period, outside of the mixing zone.

Consideration of the effect of startup or shutdown has been based on instantaneous change from no load to full load or vice-versa. This will yield conservative results since startup or shutdown of the plant would always occur over a few hours.

Calculations are made using a model which traces the transient effect from no load to full load. These results are applicable to the reverse case of shutdown also, since the transient mechanism will be the same.

The 7°F rise in a 24 hour period will never be exceeded. Results presented in Figure 12, Section IV, show that the area average temperature at Indian Point for the most conservative model, i.e., the model uncorrected for thermal stratification, never reaches 6°F . The plant is a base load plant, rather than a peaking station, and the maximum heat load has been used in these calculations. Furthermore, Figures 17 and 20 show that the maximum temperature in the passage zone, i.e., the temperature contour bounding the mixing zone, is less than the area average temperature. Therefore, the criterion of no more than a 7°F rise in 24 hours will always be met.

A transient model, useful for treatment of the 1°F change in one hour criterion, has been developed in a previous report (6). This model gives the variation in time and space of the tidal smoothed, area averaged concentration of any conservative or non-conservative contaminant, which is released continuously, at a constant rate, from a single plane source in the estuary. Full release begins at time zero and continues to steady state at time infinity. Prior to zero, the estuary is free of waste.

The application in reference (6) is for the continuous low level release of radioactivity in the cooling water flow at Indian Point. However, the development of the differential equation of mass transport underlying this result, and the accompanying initial and boundary conditions, is completely analogous to the energy transport development in Appendix A. Therefore, by making the minor modification of changing the concentration, C , to the temperature, T , the waste load, W , to the thermal load, $H/\rho C_p$, and the first order radioactivity

decay rate constant, K , to the temperature exchange coefficient, K_T , Equations 37 and 38 in the appendix to reference (6) may be employed to evaluate the transient condition.

The results given in Section IV show that the most severe temperature rise occurs at the plane of discharge. Modification, as described, of the equations referred to in reference (6), and simplification for the case of the temperature at the plane of discharge, i.e., at $x=0$, gives for the area averaged Indian Point temperature at any time after commencing discharge of heated effluent:

$$\Delta T_{IP} = \left[\frac{H}{\rho C_p Q \sqrt{1 + \frac{4K_T E}{U^2}}} \right] \text{ERF} \left[\left(\frac{U^2 + 4K_T E}{4E} \right) t \right]^{\frac{1}{2}} \quad (15)$$

For severe drought conditions, Figure 47 shows the change from zero temperature rise to steady state conditions in the area average temperature differential. The maximum rise rate occurs immediately; the rate decreases continuously as time goes on. The rise reaches 1°F after 10 hours. This is the shortest period over which any 1°F rise occurs, and shows that the rise rate criterion of 1°F in an hour is not exceeded. Furthermore, this is the area average condition; the maximum passage zone rise rate will be even less.

CHANGE IN TEMPERATURE DIFFERENTIAL AT INDIAN POINT WITH
TIME AFTER COMMENCING CONTINUOUS DISCHARGE

STEADY STATE TEMPERATURE DIFFERENTIAL

TEMPERATURE DIFFERENTIAL, °F

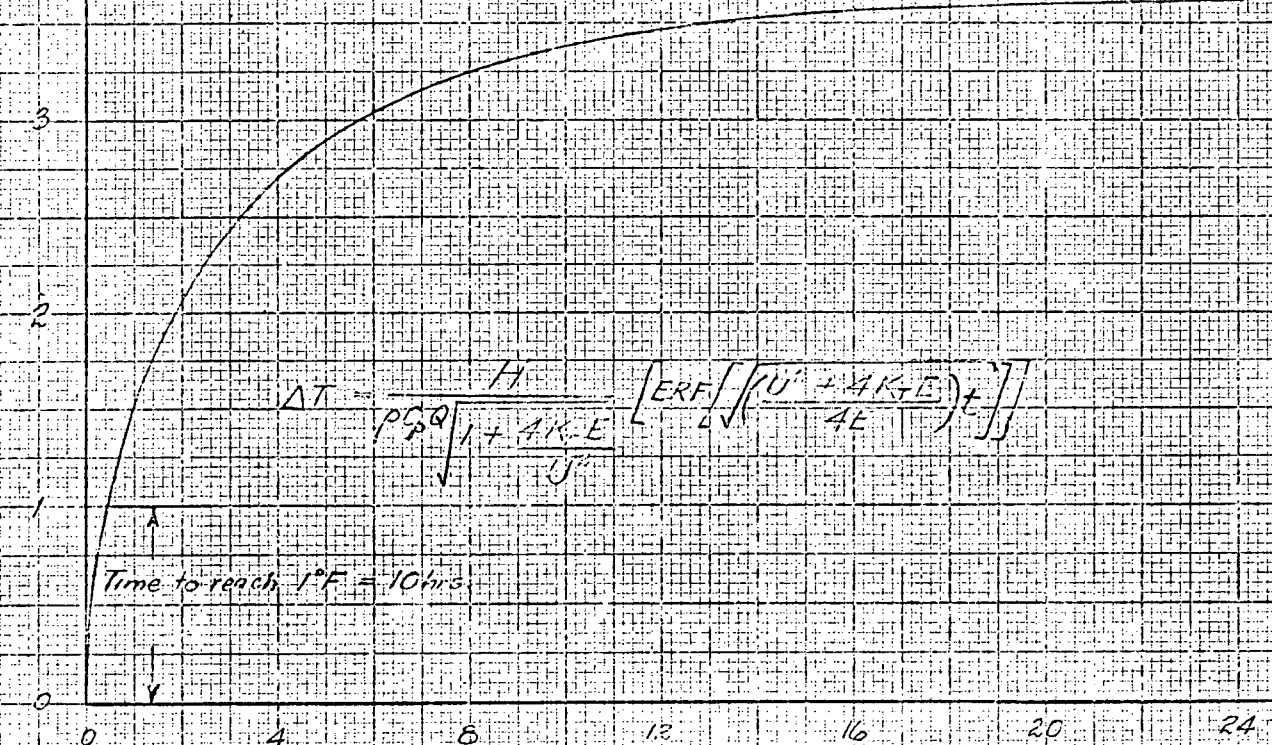

- $H = 430 \times 10^9 \text{ BTU/CAS}$
- $E = 10 \text{ SQ. MILE/DAY}$
- $Q = 4,000 \text{ CFS}$
- $U = 0.1 \text{ FT MILE/DAY}$
- $\rho = 62.4 \text{ #/CF}$
- $C_p = 1 \text{ BTU/#/°F}$
- $R = 140 \text{ BTU/SQ. FT/DAY}$
- $D = 13 \text{ FT}$
- $T = 3 \text{ °F}$
- $K_T = 0.16 \text{ DAY}^{-1}$

TIME, DAYS

FIGURE 27

VII. Effect on River Dissolved Oxygen

New York State Standards for Class SB waters require that a dissolved oxygen concentration of 5.0 ppm or better be held at all times. This standard has particular significance for sewage and organic industrial wastes, since the decomposition and stabilization of organic effluents, in the dissolved oxygen bearing waters, is accomplished by bacteria which utilize this dissolved oxygen during the stabilization process.

Oxygen is only slightly soluble in water; the saturation value usually ranges between 7.0 and 11.0 ppm and depends on temperature and salinity content. Since the standard is 5 ppm, the permissible departure from saturation, or dissolved oxygen deficit, is rather small. It is this phenomenon that is largely responsible for current requirements of high levels of sewage and industrial waste treatment; excessive waste loads on a waterway will deplete its oxygen tension below the 5.0 ppm level.

The actual level of River dissolved oxygen will depend on the rates of consumption of oxygen for waste stabilization and of replenishment of oxygen from the atmosphere. These rates are both temperature dependent. The rate of consumption is expressed by the product of the waste concentration and a reaction velocity constant, K_1 . This constant is a measure of bacterial activity and is therefore temperature dependent. The rate of reaeration is equal to the product of the oxygen deficit and a reaeration coefficient, K_2 . The oxygen deficit is a function of the oxygen saturation concentration, which is temperature dependent. K_2 varies with the coefficient of molecular diffusion, and is therefore also temperature dependent.

Thus the oxygen concentration in a waterway receiving wastes is a function of at least three temperature dependent parameters. Algae, bottom deposits and waste nitrification also affect the oxygen level and are temperature dependent. These do not appear, currently, to contribute significantly to the oxygen balance in the Indian Point area, and are not considered.

The net effect of the expected future temperature rise near Indian Point on River dissolved oxygen levels is discussed below. The effect of raising large volumes of River water 17°F as this water passes through the plant, and the effect of causing a long term net rise of somewhat lower temperatures in the River, are both considered.

Loss of Oxygen During Passage through Plant

Loss of dissolved oxygen in the cooling water itself due to the 17°F temperature rise could occur by three mechanisms:

1. Reduction of the saturation coefficient
2. Increased biological activity
3. Reduced reaeration due to confined flow.

None of these potential sources of oxygen reduction will be significant at Indian Point.

Loss of oxygen due to reduced saturation would only occur if the oxygen concentration in the intake water were higher than the saturation concentration of oxygen for the effluent water temperature. If this occurred, a supersaturated condition would exist after heating and oxygen would begin to be driven off to the atmosphere.

Conditions of maximum severity on oxygen usually occur in the summer at high temperatures. Maximum River ambient temperature at Indian Point is approximately 78°F, at which the oxygen saturation is about 8.0 ppm. A 17°F rise to 95°F would yield an oxygen saturation of about 7.0 ppm for the effluent channel water. Oxygen levels in the River, near Indian Point, during August 1967, ranged between 5.0 and 6.0 ppm, showing that the 95°F saturation concentration is higher than actual River levels and no oxygen will be lost via this mechanism.

Somewhat higher oxygen levels may result when required treatment levels are eventually met. However the time of passage through the plant is in the order of a few minutes, and, even if supersaturated conditions did develop, there is not sufficient time for significant oxygen loss by gassing to the atmosphere.

Time of passage through the plant, from intake to outlet, is 2.5 minutes. Calculations show that the increased oxygen loss, due to either increased biological activity or reduced reaeration, is insignificant in this amount of time.

Therefore, no significant loss of oxygen is expected during passage of the cooling water through the plant. Grab samples of inlet and outlet water, taken on August 30, 1967, showed a reduction of 0.25 ppm. This is significantly higher than is expected (less than 0.1 ppm). Since the 0.25 ppm figure is a difference between two values,

each of which is accurate to ± 0.05 ppm, the precision is only of the order of ± 0.1 , and may explain the somewhat higher value.

Loss of Oxygen in the Receiving Waterway

Previous studies (19) have shown that the maximum steady state oxygen deficit associated with the continuous discharge of a single plane source of waste is given by:

$$DOD_{max} = \frac{W}{Q} \left(\frac{K_1}{K_1 - K_2} \right) \left[\frac{\left(\frac{K_2 \sqrt{1+4P}}{j_2 \sqrt{1+4N}} \right)^{\frac{j_2}{j_2 - k_2}}}{\sqrt{1+4P}} - \frac{\left(\frac{K_2 \sqrt{1+4P}}{j_2 \sqrt{1+4N}} \right)^{\frac{k_2}{j_2 - k_2}}}{\sqrt{1+4N}} \right] \quad (16)$$

- in which:
- DOD = dissolved oxygen deficit, $C_s - C$
 - C = dissolved oxygen (DO) concentration, ppm
 - C_s = saturated DO concentration, ppm
 - W = waste load, # ultimate BOD/day
 - Q = river flow, cfs
 - K_1 = deoxygenation coefficient, day^{-1}
 - K_2 = reaeration coefficient, day^{-1}
 - $N = K_1 E / U^2$
 - $P = K_2 E / U^2$
 - E = dispersion coefficient, $mile^2/day$
 - U = fresh water velocity, $mile/day$
 - $k_2 = 0.5 [1 - \sqrt{1+4N}]$
 - $j_2 = 0.5 [1 - \sqrt{1+4P}]$

Total known waste loading between the Tappan Zee Bridge and Bear Mountain Bridge is about 60,000 #/day. Of this, about 50,000 #/day are discharged within about a mile of Indian Point. The model yielding Equation 16 appears to provide a reasonably accurate simulation of DO behavior in the vicinity of Indian Point. Equation 16 has been used to estimate the effect of Indian Point thermal discharge on Hudson River DO levels.

Figure 24 shows that the area average temperature averaged $1.67^{\circ}F$ over the reach between Mile Points 33 and 53. For the thermal stratification factor of 3.0, this corresponds to a surface average of $5^{\circ}F$. River ambient temperature does not appear to exceed $80^{\circ}F$ at Indian Point. Maximum temperatures observed were $78^{\circ}F$ and usually occur in August. The effect on River DO of a $1.67^{\circ}F$ area average

temperature rise and a 5°F surface temperature rise over an ambient condition of 80°F is given below.

Selection of values for K_1 and K_2 for the Hudson River is discussed in reference (19). Selection of River flow and dispersion coefficient for summer drought conditions is discussed in Appendix B of this report. Table 9 summarizes the numerical value of parameters used with Equation 16 and the resultant concentrations of DO for the artificially heated and ambient conditions.

The results in Table 9 show that a relatively small change in River dissolved oxygen will occur upon heating. Virtually no change will occur in the dissolved oxygen deficit, because the increased reaeration and deoxygenation effects tend to balance each other. The dissolved oxygen saturation, however, decreases by almost 0.4 ppm, as the surface temperature increases from 80 to 85°F.

These results are somewhat higher than the present levels of DO in the River. DO measurements made during August, 1967 show that the DO between Mile Points 35 and 50 ranges between 5.4 and 6.4 ppm. Additional effects, including unknown loads in the study area, transport of contaminants from areas above or below this study area into the study area, and waste nitrification, may explain the difference.

In any event, the above calculations show the dissolved oxygen concentration for the heated condition can be expected to be approximately 0.3 ppm lower than that for the unheated condition. Since the maximum permissible deficit at the maximum observed summer temperature of 77 to 78°F is about 3 ppm, the 0.3 ppm corresponds to a reduction of 10% of the deficit available for other uses.

The waste assimilation capacity of the River is defined as the amount of organic material which may be discharged to the River without dropping the DO below some prescribed minimum. Such discharge constitutes a permitted "use" of the River. The reduction of 10% of the deficit available for consumption corresponds to a similar reduction in the waste assimilation capacity.

This reduction will not create an undesirable condition in the River. Present DO levels in this vicinity generally exceed the 5.0 ppm criterion. Upon completion of required waste treatment facilities by present and future users, the 5.0 ppm criterion is expected to be met at all times.

TABLE 9

EFFECT OF TEMPERATURE RISE ON RIVER DISSOLVED OXYGEN,
AS COMPUTED USING EQUATION 16

<u>Parameter</u>	<u>Summer Ambient Condition</u>	<u>Heated Condition</u>
Area Average Temperature, °F	80	82
Coefficient of Temperature Dependency for K_1	1.04	1.04
Deoxygenation Coefficient, K_1 , Day ⁻¹		
Base Value at 68°F	0.25	0.25
Value at Given Area Average Temperature	0.325	0.34
Surface Temperature, °F	80	85
Coefficient of Temperature Dependency for K_2	1.02	1.02
Reaeration Coefficient, K_2 , Day ⁻¹		
Base Value at 68°C	0.052	0.052
Value at Given Surface Temperature	0.0595	0.0625
Saturation DO Concentration, C_s , ppm	7.73	7.36
Total Known Ultimate BOD Load, MP 33 to 53, #/Day	62,000	62,000
Flow, cfs	4,000	4,000
Dispersion Coefficient, Square Mile/Day	9	9
Dissolved Oxygen Deficit, ppm	0.62	0.60
Dissolved Oxygen, ppm	7.11	6.76

References

1. Northeastern Biologists, Incorporated, "Investigation of the Effects of Cooling Water Upon Hudson River Water Temperatures." Report to Consolidated Edison Company of New York, Incorporated, New York, N. Y. (August 3, 1966).
2. Northeastern Biologists, Incorporated, "1967 Temperature Study Hudson River - Indian Point." Report to Consolidated Edison Company of New York, Incorporated, New York, N. Y. (May 5, 1967).
3. Alden Hydraulic Laboratory, "Hydraulic Model Study Indian Point Generating Station, Parts I and II." Report to Consolidated Edison Company of New York, Incorporated, New York, N. Y. (April 1965 and March 1966).
4. Alden Hydraulic Laboratory, "Indian Point Progress Report." Report to Consolidated Edison Company of New York, Incorporated, New York, N. Y. (August 1967).
5. Quirk, Lawler & Matusky Engineers, "Hudson River Dispersion Characteristics." Progress Report to Consolidated Edison Company of New York, Incorporated, New York, N. Y. (October 1965).
6. Quirk, Lawler & Matusky Engineers, "Effect of Contaminant Discharge at Indian Point on Hudson River Water Intake at Chelsea, New York." Report to Consolidated Edison Company of New York, Incorporated, New York, N. Y. (May 1966).
7. Quirk, Lawler & Matusky Engineers, "Fresh Water Availability at Cornwall." Memorandum Report to Consolidated Edison Company of New York, Incorporated, New York, N. Y. (January 1966).
8. Quirk, Lawler & Matusky Engineers, "Effect of Cooling Water Discharge on Hudson River Temperature Distribution." Preliminary Report to Consolidated Edison Company of New York, Incorporated, New York, N. Y. (August 1967).
9. National Technical Advisory Committee on Water Quality Criteria, "Water Quality Criteria for Fish, Other Aquatic Life, and Wildlife." Interim Report to the Secretary of the Interior, Federal Water Pollution Control Administration, Washington, D. C. (June 30, 1967).

10. Quirk, Lawler & Matusky Engineers, "Effect of Pneumatic Barriers on the Intrusion of Salt in the Delaware and Hudson River Models." Report to Delaware River Basin Commission, Trenton, N. J. (January 1966).
11. Pritchard, D. W., "Observations of Circulation in Coastal Plain Estuaries." Publication No. 83, American Association for the Advancement of Science, Washington, D. C. (1967).
12. Quirk, Lawler & Matusky Engineers, "Evaluation of Proposed Waste Disposal System - Georgetown, Prince Edward Island." Report to Laurie A. Coles Associates, Charlottetown, P. E. I. (February 1967).
13. Edinger, J. E. and Geyer, J. C., "Heat Exchange in the Environment." Research Project RP-49, Cooling Water Studies for Edison Electric Institute, The John Hopkins University, Baltimore, Md. (June 1, 1965).
14. Kent, R., "Diffusion in a Sectionally Homogeneous Estuary." Paper No. 3392, Transactions, American Society of Civil Engineers, Volume 128, Part III (1963).
15. Holley, E. R., Jr. and Harleman, D. R. F., "Dispersion of Pollutants in Estuary Type Flows." Report No. 74, Hydrodynamics Laboratory, Massachusetts Institute of Technology, Cambridge, Mass. (January 1965).
16. Lawler, J. P., "Mathematical Analysis of Estuarine Pollution," in "Engineering Aspects of Marine Waste Disposal." Environmental Health Sciences and Engineering Training Course Manual, R. A. Taft Sanitary Engineering Center, Cincinnati, Ohio (1965).
17. Edinger, J. E., Geyer, J. C. and Graves, W. L., "The Variation of Water Temperatures Due to Steam Electric Cooling Operations." Presented at the Research Symposium of the 1964 Water Pollution Control Federation New York Conference (October 8-13, 1967).
18. Quirk, Lawler & Matusky Engineers, "Blending of Desalinated and Hudson River Water at Indian Point, New York." Report to Consolidated Edison Company of New York, Incorporated, New York, N. Y. (September 1965).
19. Quirk, Lawler & Matusky Engineers, "Study of Estuarine Pollutant and Water Quality Distribution in the New York City - New Jersey Metropolitan Area." Report to Interstate Sanitation Commission, New York, N. Y. (September 1967).

Appendix ADevelopment of the One-Dimensional Mathematical Model

Temperature distribution in a tidal estuary is governed by the Law of Conservation of Energy. This law states that the rate of change of energy within a region of fluid must equal the net rate of energy transfer across the region plus the total rate of energy produced within the region. An energy balance for a tidal estuary, written in terms of a fluid temperature differential, $T-T_E$, is shown in Figure A-1. T_E , the equilibrium temperature, is the water temperature at which the net rate of surface heat transfer is zero. $T-T_E$, or ΔT , is the temperature rise above the equilibrium temperature due to the heated effluent.

After discharge, heated particles are carried downstream toward the ocean by the movement of upland runoff. This phenomenon is known as convection. The rate of convective temperature transport across any river section is equal to the product of fresh water runoff, Q , the water temperature differential, $(T-T_E)$, density, ρ , and heat capacity, C_p .

Temperature is also transported in an estuary by longitudinal mixing. Mixing, or dispersion, is a complex function of reversing tidal currents and salinity-induced circulation patterns. Dispersive transport occurs only in the presence of a longitudinal temperature gradient in the waterway. The rate of dispersive transport is equal to the product of a dispersion coefficient, E , and the negative of the longitudinal temperature gradient, dT/dX .

The energy production term is the rate at which heat is either absorbed by or dissipated from the tidal waters. This term includes the effect of short wave solar radiation, long wave atmospheric radiation, evaporation, conduction and back radiation.

The rate of temperature dissipation in an estuary is shown by Edinger and Geyer (13) to be proportional to the departure of the liquid from the equilibrium temperature, T_E , i.e. the temperature at which the net rate of heat transfer across the water surface is zero. The energy dissipation term, therefore, is equal to the product of an overall heat transfer coefficient, \bar{K} , the temperature differential, $T-T_E$, and the fluid volume, $A\Delta X$, within which the transfer is taking place.

The energy inventory is completed by accounting for the time rate of change of energy within the fluid volume, $A\Delta X$. This is called the accumulation term and is equal to the time derivative of the

product $\rho C_p \Delta T A \Delta X$.

The temperature profile in Figure A-1 illustrates how convection, dispersion and dissipation distribute the thermal energy received from a single heated effluent. Since the source of heat raises the temperature at the discharge point above the equilibrium temperature, energy is lost to the atmosphere, and the maximum temperature occurs at the point of discharge.

An energy balance over the incremental volume, $A \Delta X$, in Figure A-1 is written:

$$\text{INPUT} - \text{OUTPUT} + \text{PRODUCTION} = \text{ACCUMULATION} \dots \dots (1)$$

Algebraic summation of the individual terms shown in Figure A-1 gives:

$$\left[\rho C_p Q (T - T_E) - \rho C_p E A \frac{d(T - T_E)}{dx} \right]_{x+\Delta x} - \bar{K} (T - T_E) B \Delta x = \frac{d}{dt} \left[\rho C_p (T - T_E) A \Delta x \right] \quad (2)$$

in which: T = water temperature, $^{\circ}\text{F}$
 T_E = equilibrium water temperature, $^{\circ}\text{F}$
 X = distance along longitudinal axis of the estuary, miles
 t = time, days
 A = cross-sectional area of the estuary, sq. ft.
 B = surface width, ft.
 Q = fresh water flow (upland runoff), cfs
 E = longitudinal dispersion coefficient, sf/second
 \bar{K} = heat transfer coefficient, BTU/sf/hour/ $^{\circ}\text{F}$
 ρ = water density, #/cf
 C_p = heat capacity of water, BTU/#/ $^{\circ}\text{F}$

The units given are those commonly associated with each parameter. All calculations, of course, are performed within a consistent set of units.

The limit of Equation 2, as ΔX , Δt both approach zero, is:

$$\frac{d}{dx} \left[\rho C_p \left(E A \frac{d(T - T_E)}{dx} - Q (T - T_E) \right) \right] - \bar{K} B (T - T_E) = \frac{d}{dt} \left(\rho C_p A (T - T_E) \right) \quad (3)$$

TEMPERATURE DISTRIBUTION IN AN ESTUARY ENERGY TRANSPORT RELATIONSHIPS

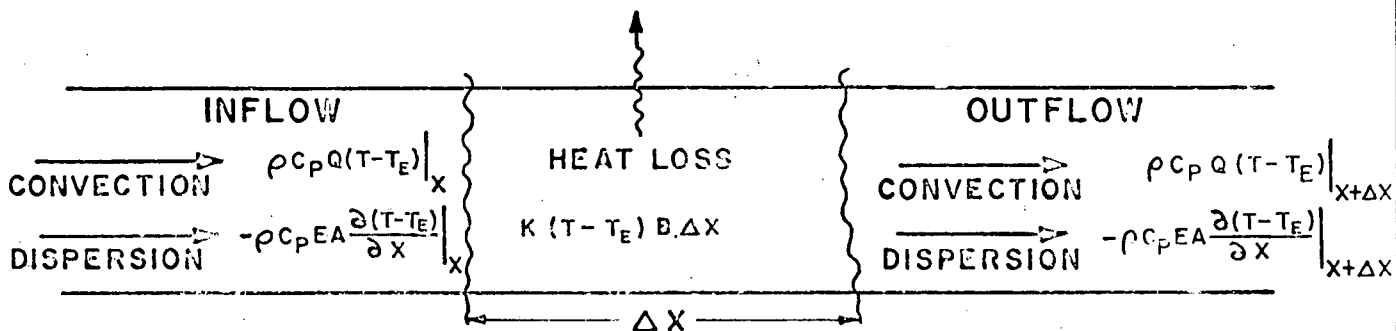
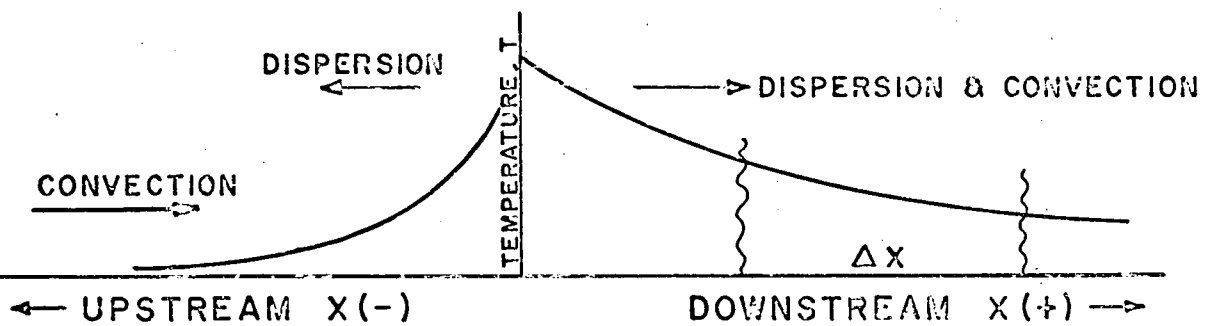
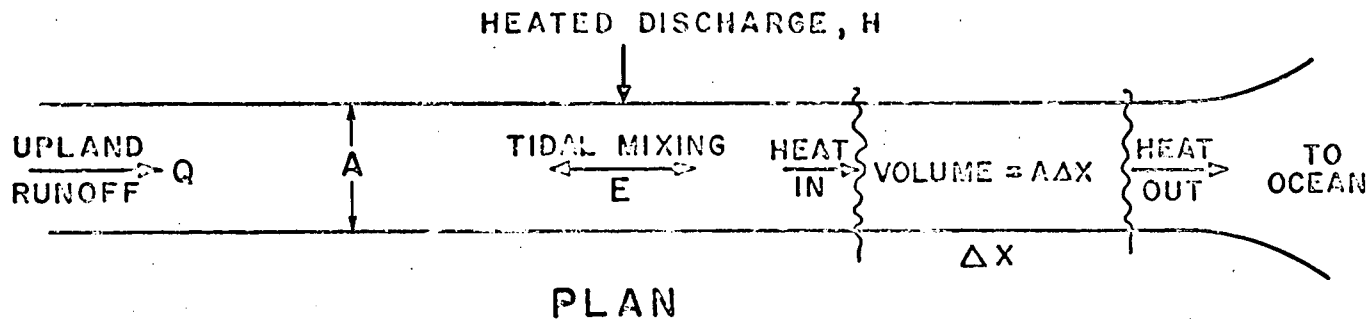

Steady State, Constant Space Parameter Model

Equation 3 recognizes that the system parameters, ρ , C_p , T_E , E , A , Q and \bar{K} may vary with distance and time. The objective of this first model is to predict maximum temperatures which would accrue in the presence of sustained warm weather and low flow. For this purpose, the system parameters in Equation 3 may be considered to be independent of time and the time derivative, zero. The salinity range within the region under consideration will yield variations in density and heat capacity of about 1%; ρ and C_p are therefore considered to be constants. Changes in weather conditions and fresh water flow over a ten mile reach on either side of Indian Point are negligible; Q , K_T and T_E may also be treated as constants. Cross-section area, A , and dispersion coefficient, E , vary $\pm 30\%$ and $\pm 15\%$ respectively, about their averages over the twenty mile reach. For the first model, A and E in Equation 3 have been assumed constant. Following this model, a more flexible model, with most parameters time and distance variable, is developed for ultimate study use.

For the set of constant system parameters and the steady state condition, Equation 3 simplifies to:

$$E \frac{d^2 \tilde{T}}{dx^2} - U \frac{d \tilde{T}}{dx} - K_T \tilde{T} = 0 \quad (4)$$

in which: \tilde{T} = the temperature differential, $T - T_E$, $^{\circ}F$
 U = average fresh water velocity, Q/A , ft/second
 K_T = temperature exchange coefficient, $\frac{\bar{K} B}{\rho C_p A}$, day^{-1}

Equation 4 is a linear ordinary differential equation and represents the average rate of longitudinal energy transport across any cross-section of the estuary. This equation is the basis for the analysis of overall temperature distribution in an estuary.

Tidal parameters of period and amplitude, the tidal time variable t , and the lateral and vertical variables, y and z , do not appear in Equation 4 because this equation represents the average behavior across any section over a full tidal cycle.

Rigorous development of Equation 4 begins with the generalized three-dimensional, time variable equation of energy transport, and employs a series of integrations over the lateral and vertical dimensions, as well as over the tidal period to yield this statement of average behavior. By this procedure, the dispersion

coefficient is shown to be a lumped representation of several mixing mechanisms, which depend on salinity, tidal movement, and geometric parameters. Detailed analysis of this procedure, including development of the dispersion coefficient, is given in the literature (14), (15), (16).

Edinger and Geyer's work (13) shows that the net heat transfer across the water surface is actually given by:

$$\Delta H = \bar{K} (T_s - T_E) \quad (5)$$

in which: ΔH = net water surface heat transfer, BTU/ft²/day
 \bar{K} = heat transfer coefficient, BTU/ft²/day/°F
 T_s = actual water surface temperature, °F
 T_E = equilibrium water surface temperature, °F

In Equation 2, T_s has been replaced by T , the tidal smoothed, area averaged temperature. This procedure is only valid if the vertical mixing across the section is sufficiently intense to cause the vertical temperature profiles to be flat. If the vertical temperature gradient is not zero, then the surface temperature T_s will not equal the area average temperature T , and a correction factor for the decay term in Equation 2 will be necessary if this equation is to be used.

This correction factor is obtained by writing an expression analogous to Equation 5 in terms of the area average temperature, T , rather than the water surface temperature, T_s .

$$\Delta H = \bar{K}' (T - T_E) \quad (6)$$

in which: \bar{K}' = modified surface heat transfer coefficient

Since ΔH in Equations 5 and 6 is still the same value for a given set of conditions, substitution of Equation 5 into Equation 6 and rearrangement will yield the definition of \bar{K}' .

$$\bar{K}' = \frac{\bar{K} (T_s - T_E)}{(T - T_E)} \quad (7)$$

Thus, the modified heat transfer coefficient, \bar{K}^1 , is equal to the meteorological surface heat transfer coefficient, \bar{K} , times the ratio of the surface temperature differential to the area average temperature differential. For flat vertical temperature gradients, this ratio is 1.0. For non-zero gradients, \bar{K} in Equations 2 and 3, and K_T in Equation 4, should be multiplied by the numerical value of this coefficient. This number may be determined either empirically or theoretically.

Temperature rise criteria have been written, and background temperature measurements have been made, on River ambient conditions. Therefore, it is convenient to construct models for temperature rise on the basis of ambient water conditions rather than equilibrium water conditions. Figure 4, following page 8, shows the relation of ambient and equilibrium temperature in the Hudson.

Edinger et al (17) show that Equation 4, or its unsteady state counterpart, can be written on an ambient temperature basis. To show this, the constant space parameter counterparts of Equation 3, for both the naturally occurring and artificially induced water temperature, are written first:

Naturally Occurring Temperature, T_A (Ambient Temperature):

$$E \frac{\partial^2 T_A}{\partial x^2} - U \frac{\partial T_A}{\partial x} - K_T'' (T_A - T_E) = \frac{\partial T_A}{\partial t} \quad (8)$$

Artificially Induced Temperature, T :

$$E \frac{\partial^2 T}{\partial x^2} - U \frac{\partial T}{\partial x} - K_T' (T - T_E) = \frac{\partial T}{\partial t} \quad (9)$$

in which: $K_T'' = K_T \frac{(T_{AS} - T_E)}{(T_A - T_E)}$

$$K_T' = K_T \frac{(T_S - T_E)}{(T - T_E)}$$

Substitute the definitions of K_T' and K_T'' in Equations 9 and 8, subtract Equation 8 from Equation 9, and obtain:

$$E \frac{\partial^2 (T - T_A)}{\partial x^2} - U \frac{\partial (T - T_A)}{\partial x} - K_T (T_s - T_{As}) = \frac{\partial (T - T_A)}{\partial t} \quad (10)$$

Let $\bar{K}_T = \left(\frac{T_s - T_{As}}{T - T_A} \right) K_T$. Substitute for K_T into Equation 10, call $(T - T_A)$, the temperature rise over the ambient condition, ΔT , and obtain:

$$E \frac{\partial^2 \Delta T}{\partial x^2} - U \frac{\partial \Delta T}{\partial x} - \bar{K}_T \Delta T = \frac{\partial \Delta T}{\partial t} \quad (11)$$

\bar{K}_T is obtained by computing the thermal stratification factor, $\frac{T_s - T_{As}}{T - T_A}$, and multiplying the meteorological K_T by this TSF. In the Hudson River near Indian Point, background temperature measurements show that the vertical gradient of the River ambient temperature is flat. Therefore, the TSF for the ambient condition is 1.0 and, $T_A = T_{As}$, and the TSF for the artificially induced condition is simply $\frac{T_s - T_A}{T - T_A}$.

The steady state version of Equation 11 is:

$$E \frac{d^2 \Delta T}{dx^2} - U \frac{d \Delta T}{dx} - \bar{K}_T \Delta T = 0 \quad (12)$$

The solution of Equation 12 for boundary conditions applicable to Indian Point thermal discharge is given below. Although the overbar in \bar{K}_T in the ensuing discussion is dropped, the results may be used for any TSF value.

Longitudinal Temperature Distribution

This section develops the steady state temperature distribution along the longitudinal axis of a tidal river due to a single continuous plane source of heated effluent. Figure A-2 lists the applicable boundary conditions and the resulting solution equations developed from Equation 12.

A. General Solution of Defining Differential Equation

Equation 12 is a second order, linear ordinary differential equation with constant coefficients. The general solution is:

$$\Delta T(x) = C_1 e^{Jx} + C_2 e^{Kx} \quad (13)$$

in which:

$$\left. \begin{matrix} J \\ K \end{matrix} \right\} = \frac{U}{2E} \left[1 \pm \sqrt{1 + \frac{4K_1 E}{U^2}} \right]$$

B. Boundary Conditions

The integration constants, C_1 and C_2 , are evaluated by application of suitable boundary conditions. Since Equation 12 does not include a term for the heat transferred into the River by the heated effluent, it does not describe behavior across the plane of temperature discharge. As a result, the integration constants in Equation 13 must be evaluated independently on either side of the plane of discharge; i.e., the values of C_1 and C_2 above Indian Point are not identical to the values of the constants below Indian Point. Four boundary conditions are required for evaluation of these four integration constants.

Figure A-3 shows the areas above and below the source of heat in the River and the corresponding symbol for temperature differential. The four boundary conditions are developed as follows.

1. Because the distance between Indian Point and New York Harbor is long, the temperature differential will be negligible before reaching the lower end of the estuary. This means that the down-

TEMPERATURE DISTRIBUTION IN AN ESTUARY

MATHEMATICAL DESCRIPTION

CONDITIONS

- SINGLE PLANE SOURCE
- INFINITE RECEIVER
- STEADY STATE
- CONSTANT PARAMETERS

ENERGY TRANSPORT EQUATION

$$E \frac{d^2 \Delta T}{dx^2} - u \frac{d \Delta T}{dx} - K_T \Delta T = 0$$

BOUNDARY CONDITIONS

- $\Delta T_I \Big|_{x=-\infty} = 0$
- $\Delta T_{II} \Big|_{x=\infty} = 0$
- $\Delta T_I \Big|_{x=0} = \Delta T_{II} \Big|_{x=0}$
- $H = \rho C_p E A \left[\frac{d \Delta T_I}{dx} - \frac{d \Delta T_{II}}{dx} \right]_{x=0}$

TEMPERATURE PROFILE EQUATIONS

$$\left. \begin{array}{l} \Delta T_I \\ \Delta T_{II} \end{array} \right\} = \frac{H e^{\frac{u}{2E} \left[1 \pm \sqrt{1 + \frac{4K_T E}{u^2}} \right] x}}{\rho C_p Q \sqrt{1 + \frac{4K_T E}{u^2}}}$$

CONTINUOUS THERMAL DISCHARGES INTO A RECEIVER OF INFINITE EXTENT

MATERIAL BALANCE ABOUT THE POINT OF DISCHARGE

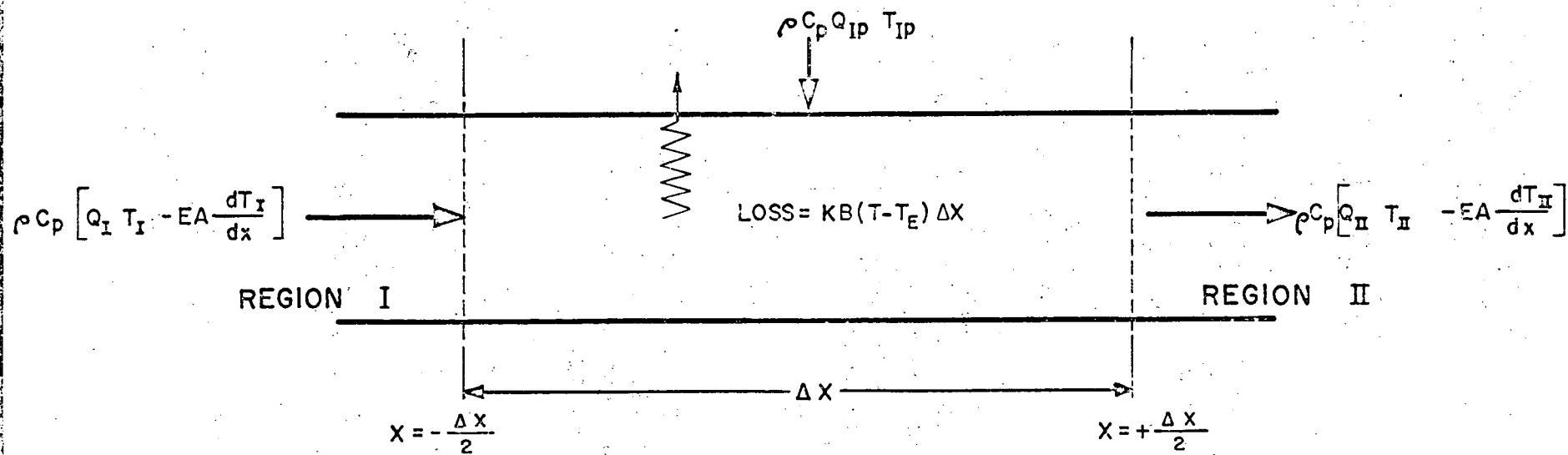

stream end of the estuary has no influence on temperature distribution in the estuary. The estuary may, therefore, be considered to be infinitely long and the first boundary condition may be written:

$$\Delta T_{II} \Big|_{x=\infty} = 0$$

BC#1

2. In the upstream region, convection opposes dispersion and the distance from Indian Point to the upper end of the estuary is even greater than the distance from Indian Point to the lower end. For these reasons, the statements concerning BC#1 are even more applicable here and the second boundary condition is written:

$$\Delta T_I \Big|_{x=-\infty} = 0$$

BC#2

3. Although Equation 12 does not define behavior across the section at Indian Point, and discontinuity in some derivatives will occur at these points, the temperature itself is continuous and single-valued at all points. This fact gives rise to the third boundary condition:

$$\Delta T_I \Big|_{x=0} = \Delta T_{II} \Big|_{x=0}$$

BC#3

4. To describe the behavior at the boundary between regions I and II, a material balance about the plane of discharge is constructed as shown in Figure A-3. The steady state material balance is written:

$$\rho C_p \left[(Q \Delta T_I - EA \frac{d\Delta T_I}{dx}) + q_{IP} \Delta T_p \right]_{x=-\frac{\Delta x}{2}} - \rho C_p \left[(Q \Delta T_{II} - EA \frac{d\Delta T_{II}}{dx}) + q_{IP} \Delta T_I \right]_{x=\frac{\Delta x}{2}} = \bar{K} \Delta T_B \Delta x$$

(14)

in which: Q = river flow
 q_{IP} = recirculated cooling water flow
 T_p = effluent channel temperature

The limit of Equation 14 as $\Delta X \rightarrow 0$ is:

$$\rho C_p Q_{EP} (T_P - T_I)_{x=0} = \rho C_p EA \left[\frac{d\Delta T_I}{dx} - \frac{d\Delta T_{II}}{dx} \right]_{x=0} \quad (15)$$

$\rho C_p Q_{EP} (T_P - T_I)$ is equal to H, the reactor waste heat in BTU/Day. The fourth boundary condition is written:

$$H = \rho C_p EA \left[\frac{d\Delta T_I}{dx} - \frac{d\Delta T_{II}}{dx} \right]_{x=0} \quad \text{BC\#4}$$

C. Particular Solution

Evaluation of the four integration constants is accomplished by substitution of Equation 13 in the four boundary conditions. This procedure yields:

$$\Delta T_I(x) = \frac{H \cdot C}{\rho C_p Q \sqrt{1 + \frac{4KTE}{U^2}}} \frac{U}{2E} (1 + \sqrt{1 + \frac{4KTE}{U^2}})^x, \quad x \leq 0 \quad (16)$$

$$\Delta T_{II}(x) = \frac{H \cdot C}{\rho C_p Q \sqrt{1 + \frac{4KTE}{U^2}}} \frac{U}{2E} (1 - \sqrt{1 + \frac{4KTE}{U^2}})^x, \quad x \geq 0 \quad (17)$$

Equations 16 and 17 have been used in the foregoing report to evaluate conditions close to Indian Point. The River geometry diverges rapidly below the head of Haverstraw Bay, some four miles below Indian Point, and dispersion coefficient decreases for a short distance and then increases. In the upstream direction, depth increases, and area and dispersion coefficient both change. For

these reasons, Equations 16 and 17 are most useful within a region bounded four to five miles above and below Indian Point. Most useful is the expression for the maximum temperature rise, which occurs across the plane of discharge. This is obtained by setting x in either Equation 16 or 17 equal to zero.

$$\Delta T_{IP} = \frac{H}{\rho C_p Q \sqrt{1 + \frac{4K_T E}{U^2}}} \quad (18)$$

One-Dimensional Unsteady State, Variable Parameter Model

In the previous section, the general solution for the steady state constant parameter model was derived. In most estuaries, including the lower Hudson River, parameters are not constant. For the lower Hudson, area, depth and surface width vary along the longitudinal axis; flow, surface heat transfer and thermal loading vary with time, and the longitudinal dispersion is both space and time dependent.

This variable behavior of the loading and system parameters is included in the unsteady state, variable parameter model developed below. For real estuaries, time and space variable analytical solutions are not possible except in simplified cases. A numerical solution technique is developed below for temperature distribution in the lower Hudson River.

The development of this model begins by breaking the estuary into a finite number of sections along its length.

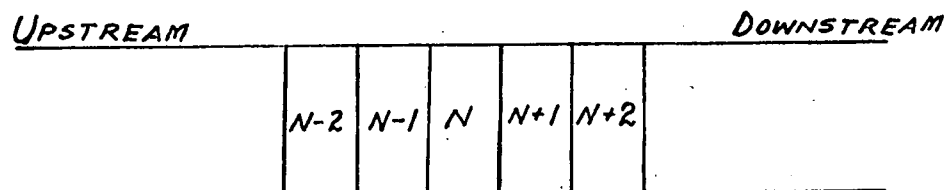

An energy balance written over one of these sections is given by Equation 1, Appendix A.

Energy input into Section N is due to advection, dispersion at the upstream end, and thermal discharge, if any, within the section. Energy output is due to advection and dispersion at the downstream end of Section N. Thermal decay is due to loss of energy to the atmosphere. The difference between the energy input to the section and the energy output (including decay) from the section yields the accumulation of energy within the section over the time interval to which input and output refer.

The inputs to Section N are expressed mathematically as follows:

$$\text{Advective Input} = \rho C_p Q_{N-1,N} \Delta T_{N-1,N}$$

in which: $Q_{N-1,N}$ = the fresh water flow from Section N-1 into Section N
 $\Delta T_{N-1,N}$ = the temperature at the boundary between the Sections N-1, N

$$\text{Dispersion Input} = - \rho C_p E_{N-1,N} A_{N,N+1} \frac{\partial \Delta T_{N-1,N}}{\partial x}$$

in which: $E_{N-1,N}$ = the dispersion coefficient between Sections N-1 and N
 $\frac{\partial \Delta T_{N-1,N}}{\partial x}$ = the temperature gradient between Sections N-1 and N
 $A_{N-1,N}$ = the cross-sectional area between Sections N-1 and N

$$\text{Thermal Discharge Input} = H_N, \text{ BTU/DAY}$$

Output terms are written similarly as follows:

$$\text{Advection Output} = \rho C_p Q_{N,N+1} \Delta T_{N,N+1}$$

$$\text{Dispersion Output} = - E_{N,N+1} A_{N,N+1} \frac{\partial \Delta T_{N,N+1}}{\partial x} \rho C_p$$

Loss due to heat transfer across the water surface is written:

$$\rho C_p K_{TN} V_N \Delta T_N$$

in which: K_{TN} = the temperature exchange coefficient in Section N
 V_N = the volume of Section N
 ΔT_N = the temperature differential in Section N

The accumulation of energy is written:

$$\rho C_p V_N \frac{\partial \Delta T_N}{\partial t}$$

Placing these terms in the general energy balance and dividing by the constant, ρC_p yields:

$$\begin{aligned} & + Q_{N-1,N} \Delta T_{N-1,N} + \left(-E_{N-1,N} A_{N-1,N} \frac{\partial \Delta T_{N-1,N}}{\partial x} \right) \\ & - Q_{N,N+1} \Delta T_{N,N+1} - \left(-E_{N,N+1} A_{N,N+1} \frac{\partial \Delta T_{N,N+1}}{\partial x} \right) \\ & - K_N V_N \Delta T_N = V_N \frac{\partial \Delta T_N}{\partial t} \end{aligned}$$

(19)

This expression is written for the general Section N, is valid for any section, and is identical to Equation 2 above. Departure from the previous development (Equations 3 through 17) begins at this point. Rather than reduce Equation 19 to behavior at a point by shrinking the section length to zero, the section length is kept intact and a method is developed for evaluating ΔT_N , the section average temperature rise.

Consider the section location to be given by the midpoint along its length. The section average temperature rise is defined to delineate section temperature rise behavior. Section lengths are relatively

small and the section average temperature difference (ΔT_{N-1} or ΔT_N) is assumed to vary linearly between section midpoints.

For a linear variation between midpoints, the boundary temperature difference ($\Delta T_{N-1,N}$) is expressed in terms of the section midpoint temperature differences as follows:

$$\Delta T_{N-1,N} = \Delta T_{N-1} \xi_{N-1,N} + (1 - \xi_{N-1,N}) \Delta T_N \quad (20)$$

in which: $\xi_{N-1,N} = \frac{L_{N-1}}{L_{N-1} + L_N}$, L being the section length

The linear assumption on temperature difference requires that the gradient of temperature difference with distance must be constant over the expressed interval between adjacent section midpoints. This yields:

$$\frac{d\Delta T_{N-1,N}}{dx} = - \left(\frac{\Delta T_{N-1} - \Delta T_N}{(L_{N-1} + L_N)/2} \right)$$

$$\frac{d\Delta T_{N,N+1}}{dx} = - \left(\frac{\Delta T_N - \Delta T_{N+1}}{(L_N + L_{N+1})/2} \right)$$

Time increments are chosen sufficiently small so that the temperature difference for any section also may be assumed to vary linearly with time over that time increment. The time derivative of the section average temperature rise therefore is equal to the difference in the section average temperature rises at the beginning and end of the interval, divided by the interval. This is written:

$$\frac{d\Delta T_N}{dt} = \frac{\Delta T_N \Big|_{t_2} - \Delta T_N \Big|_{t_1}}{t_2 - t_1} = \frac{\Delta(\Delta T_N)}{\Delta t}$$

in which: t_1 = time at beginning of interval Δt
 t_2 = time at end of interval Δt

The dispersion term may be rewritten in terms of a tidal exchange coefficient D . This coefficient represents the percentage of contaminant transferred per day between any two adjacent sections via tidal exchange.

$$D_{N-1,N} = \frac{E_{N-1,N} A_{N-1,N}}{(L_{N-1} + L_N)/2}$$

$$D_{N,N+1} = \frac{E_{N,N+1} A_{N,N+1}}{(L_N + L_{N+1})/2}$$

Substituting these modifications into Equation 19 yields an expression in terms of section average temperature rise only:

$$\begin{aligned} & Q_{N-1,N} (\xi_{N-1,N} \Delta T_{N-1} + (1 - \xi_{N-1,N}) \Delta T_N) \\ & - Q_{N,N+1} (\xi_{N,N+1} \Delta T_N + (1 - \xi_{N,N+1}) \Delta T_{N+1}) \\ & + D_{N-1,N} (\Delta T_{N-1} - \Delta T_N) + D_{N,N+1} (\Delta T_{N+1} - \Delta T_N) \\ & - K_N V_N \Delta T_N = V_N \frac{\Delta(\Delta T_N)}{\Delta t} \end{aligned} \quad (21)$$

Equation 21 shows that a balance over any one section requires a knowledge of the section average temperature rises of the two adjacent sections. To find the temperature difference in all sections at any one time, Equation 21 is written for each section and then the set of equations is solved simultaneously for $\Delta(\Delta T_N)$. This is the change in ΔT_N over the time interval Δt . This change is added to the initial ΔT_N at the beginning of the time interval, to yield the ΔT_N at the end of the time interval.

To start the solution, an initial ΔT is required for each section. Thereafter, the ΔT is computed for each section at the end of each time increment. The initial condition may be arbitrary. The solution will rapidly become independent of whatever initial condition is chosen.

The above solution was programmed using the ALGOL language and the General Electric 200 Series Time-Sharing computer system. Stable behavior was obtained by use of a 0.01 day time interval. Segment length was generally two miles. Typical run times were about 100 processor seconds and 15 minutes of printer time.

Typical values of the parameters for a run are shown in Table A-1. Selection of parameters is discussed in Appendix B.

Results using this model for the future thermal loading at Indian Point are given in Section IV of the report. These include profiles of ΔT_N at Indian Point throughout the year (Figure 12) and the longitudinal profile of ΔT_N for conditions of maximum severity (Figure 24).

Figure 24 is shown as a continuous profile; the section average temperature ΔT_N is assumed to vary continuously along the River. This is equivalent to either associating the section average temperature with the section midpoint temperature, or shrinking the section size to zero. Either interpretation is consistent with the linear profile which was assumed to exist between segments.

TABLE A-1

TYPICAL NUMERICAL VALUES OF PARAMETERS ASSOCIATED WITH
SOLUTION OF UNSTEADY STATE, VARIABLE PARAMETER MODEL

<u>Parameter</u>	<u>Symbol</u>	<u>Units</u>	<u>Magnitude</u>
Temperature Exchange Coefficient	K_{TN}	1/Day	.06
Heat Loading	$H/\rho C_p$	$^{\circ}F \cdot \text{Miles}^3/\text{Day}$.046
Length Ratio	ξ	Dimensionless	.5
Section Length	L_N	Miles	2
Section Volume	V_N	Miles^3	.010
Time Interval	Δt	Days	.01
Tidal Exchange Coefficient	$D_{N,N-1}$	$\text{Miles}^3/\text{Day}$.01
Fresh Water Flow	Q	$\text{Miles}^3/\text{Day}$.02
Section Average Temperature Rise	ΔT_N	$^{\circ}F$	0-5
Rise Difference Over Time Interval	$\Delta(\Delta T_N)$	$^{\circ}F$.0001
Section Cross-Sectional Area	A_N	Miles^2	.002

Appendix B
Selection of Parameters

Numerical values of the parameters, E , U , and K_T , which appear in Equation 4 and control the temperature distribution in an estuary, must be chosen for the study area. This area is shown on the location map, Figure 1, and extends from Haverstraw Bay to West Point. A brief description of the methods used to obtain these parameters is given below. More detailed analyses of the data employed to obtain these parameters are given in previous reports to the Consolidated Edison Company (5), (6), (18).

A. Fresh Water Discharge

Fresh water velocity, U , is obtained by dividing fresh water discharge by the river cross-sectional area, A . Fresh water flow into the Hudson is measured at Green Island, at mile point 152, where the tributary drainage area totals 8090 square miles. The drainage area of the Hudson Basin, tributary to the entire River, is approximately 13,370 square miles. Over 95% of this area is located north of Indian Point. Because of the inability to measure directly fresh water flow in tidal waters, the Green Island gage is used to establish lower River discharges. Analysis of data developed by the United States Geological Survey (USGS) indicates that the annual average lower River flow is 22% greater than the Green Island annual average flow. All values of lower River flow referred to in this report were established using this ratio, i.e., lower River flow is equal to Green Island gaged flow times 1.22.

The pattern of the long term monthly flows, shown in Figure 2 is indicative of the variation of River discharge. During the months of March through May, monthly flow averaged 29,000 cfs or almost 3.5 times the average discharge during the months from June through October. This is equivalent to the statement that the volume of fresh water discharged during the spring months is in excess of twice the volume discharged during the subsequent five month period.

Figure A-1 and Equation A-4 indicate that as fresh water velocity decreases, given a fixed value of the longitudinal dispersion coefficient, the dispersion effect increases. Therefore, temperature values in the region above Indian Point can be expected to increase as flow decreases. Furthermore, due to increased salinity intrusion during periods of low fresh water flow, the longitudinal dispersion coefficient, which is strongly dependent on salinity-induced circulation, can be expected to increase in the upper region of the River. Thus, heated effluents will remain in the vicinity of Indian Point

for longer periods of time during drought flows. For this reason, analysis of the effect of heated discharges on the River requires that drought flows be selected in assigning values of U.

Figure B-1 shows a statistical analysis of Hudson River drought flows for the years 1918 through 1964. For drought durations of one week (seven consecutive days), and one month, a plot of flow versus the per cent of the time such flow can be expected to occur is given. For example, Figure B-1 indicates, for a duration of one week per year, a flow of 2630 cfs can be expected to occur 5% of the time or once in 20 years.

B. Cross-Sectional Area

Figure B-2 shows the variation of Hudson River cross-sectional area with distance above the Battery. Variation is erratic and as such is not amenable to simple mathematical description; i.e., as an elementary function of distance. Between the mile points 33 and 53, the channel area varies from a minimum of 120,000 square feet to a maximum of 170,000 square feet. The average area over this 20 mile river reach is 140,000 square feet; this number has been selected as the value of the constant parameter, A, in Equation A-4.

C. Longitudinal Dispersion Coefficient

The value of the longitudinal dispersion coefficient at any point within the salt-intruded reach of the River can be conveniently obtained by analysis of salinity profiles. The limiting form of the mass transport equation analogous to Equation A-2, for the case of a conservative substance such as salt, and non-constant values of Q, A, and E, is:

$$\frac{1}{A} \frac{d}{dx} \left[EA \frac{dc}{dx} - Qc \right] = \frac{dc}{dt}$$

(B-1)

If the variation of salinity with x and t is known, the derivatives $\frac{\partial c}{\partial x}$ and $\frac{\partial c}{\partial t}$ may be obtained graphically or numerically. Equation B-1 can then be used to compute the value of E at any point within the saline reach of the River.

This procedure requires that a number of profiles be available so that the time derivative, $\frac{\partial c}{\partial t}$, can be computed, and also requires that the values of Q, a time and distance dependent function which is controlling the intrusion, be known. This latter require-

HUDSON RIVER FLOW, THOUSAND CUBIC FEET PER SECOND

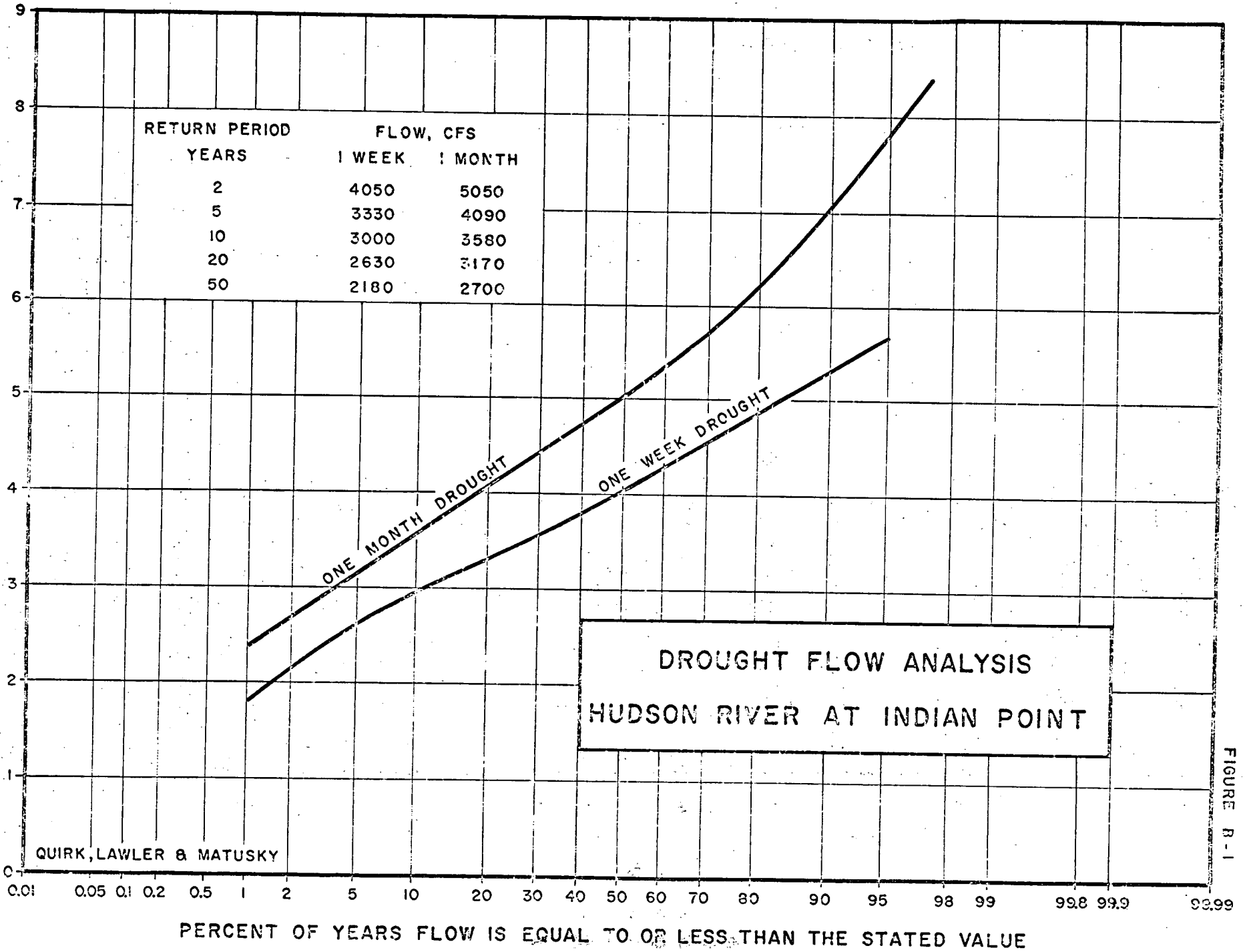
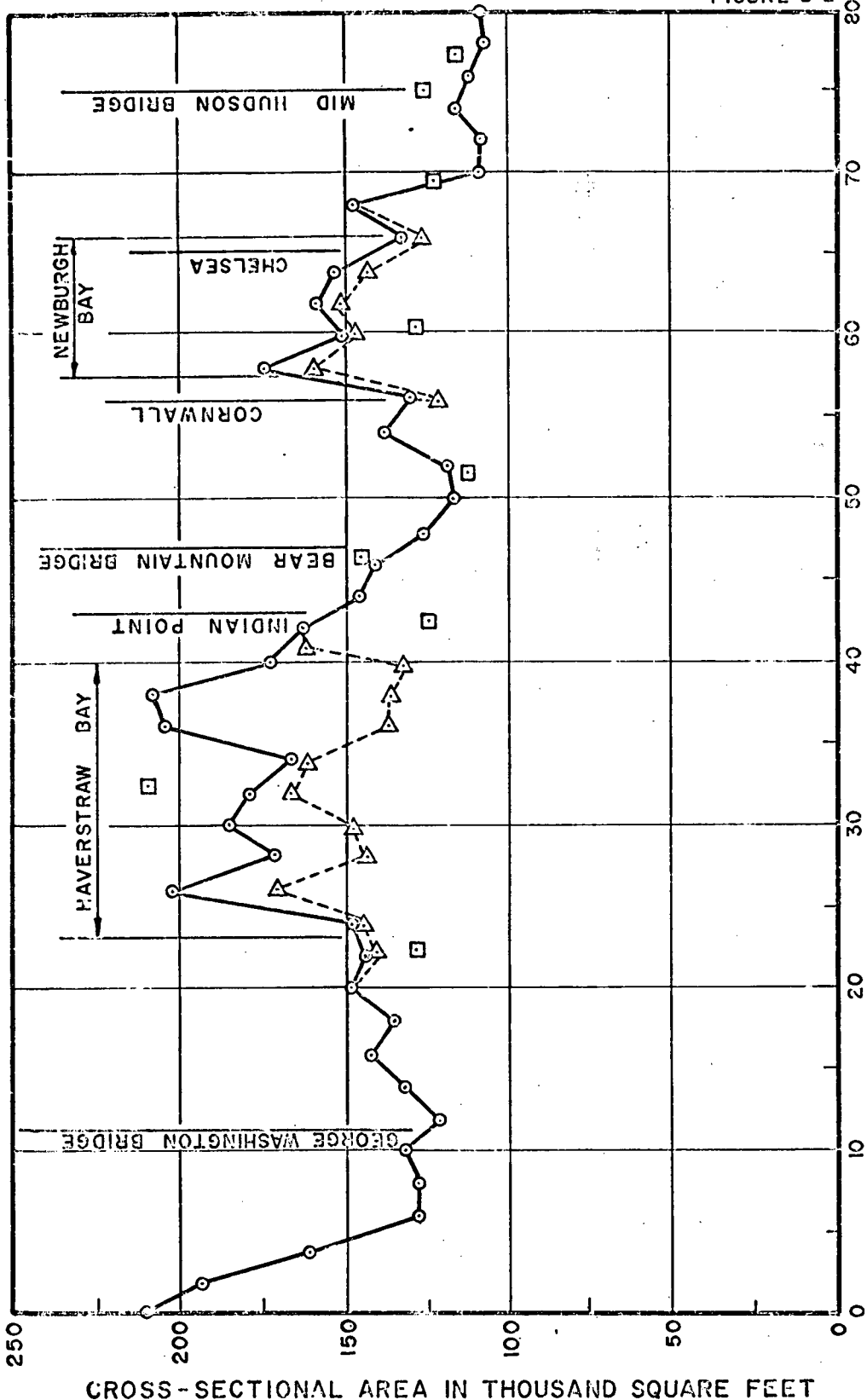

FIGURE B-1

FIGURE B-2



○ TOTAL CROSS-SECTIONAL AREA, USC & GS SOUNDINGS

△ CHANNEL AREA, USC & GS SOUNDINGS

□ TOTAL AREA, QL & M FATHOMETER SURVEY, 1964

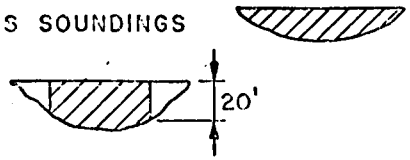

HUDSON RIVER
CROSS-SECTIONAL AREA
MEAN LOW WATER

ment poses some difficulty in evaluating Hudson River dispersion. Fresh water flow can only be measured at Green Island, above the tidal region, and the attenuating effect of tidal mixing on time variable flows is not known.

These difficulties have been avoided by recognizing that drought flows in the Hudson remain relatively constant for extended periods of time; Q , and therefore U , are known and the steady Q gives rise to steady salinity profiles during these periods. Under these conditions, the net flux of the salt in the River must be zero, since there is no sink or source of salt within the estuary. Equation B-1 then reduces to:

$$E \frac{dc}{dx} - Uc = 0 \quad (B-2)$$

Rearrangement of Equation B-2 yields a solution for the dispersion coefficient:

$$E = U \left[2.303 \frac{d \log c}{dx} \right]^{-1} \quad (B-3)$$

Numerical values of $\frac{d \log c}{dx}$ may be obtained by graphical differentiation of a semi-logarithmic plot of salinity versus distance. $U(x)$ is equal to the flow associated with that profile, divided by the area, $A(x)$, at the point in question. Typical steady state salinity profiles are shown in Figure B-3. Values of E , computed as described above, are shown in Figure B-4 for these and several other drought profiles.

Figure B-4 indicates that maximum E in the reach between Haverstraw and West Point occurs between mile points 45 and 50, i.e. just north of Indian Point. The values of E for this analysis have been selected by obtaining the average E between mile points 45 and 50 for any given flow.

The average value of E over a finite length of River is obtained by application of the mean value theorem for derivatives to Equation B-3. This yields:

$$\left[\frac{E}{U} \right]_{\text{avg}} = \left[2.303 \frac{\Delta \log c}{\Delta x} \right]^{-1} \quad (B-4)$$

HUDSON RIVER MEAN SALINITY INTRUSION

DATA SOURCE

HUDSON RIVER MODEL

- 12,000 CFS - STEADY STATE
- - - 28,000 CFS - STEADY STATE

HUDSON RIVER PROTOTYPE

- 8,000 CFS - FINNEGAN, 1929
MEAN SECTIONAL SALINITY
- -△ 8,700 CFS - NYCDH & NYS, 1959
MEAN SALINITY
- -□ 4,100 CFS - Q, L & M, 1964
MEAN SECTIONAL SALINITY
- 8,500 CFS NYS CONSERVATION DEPT.,
1936

FLOWS ARE FOR LOWER HUDSON.

SALINITY IN PARTS PER MILLION

100,000

10,000

1,000

100 0 10 20 30 40 50 60 70 80 90 100

MILES ABOVE BATTERY

GEO. WASH. BRIDGE

28,000 CFS

12,000 CFS

INDIAN POINT

1936 SURVEY

1959 SURVEY

1939 SURVEY

1964 SURVEY

QUIRK, LAWLER & MATUSKY

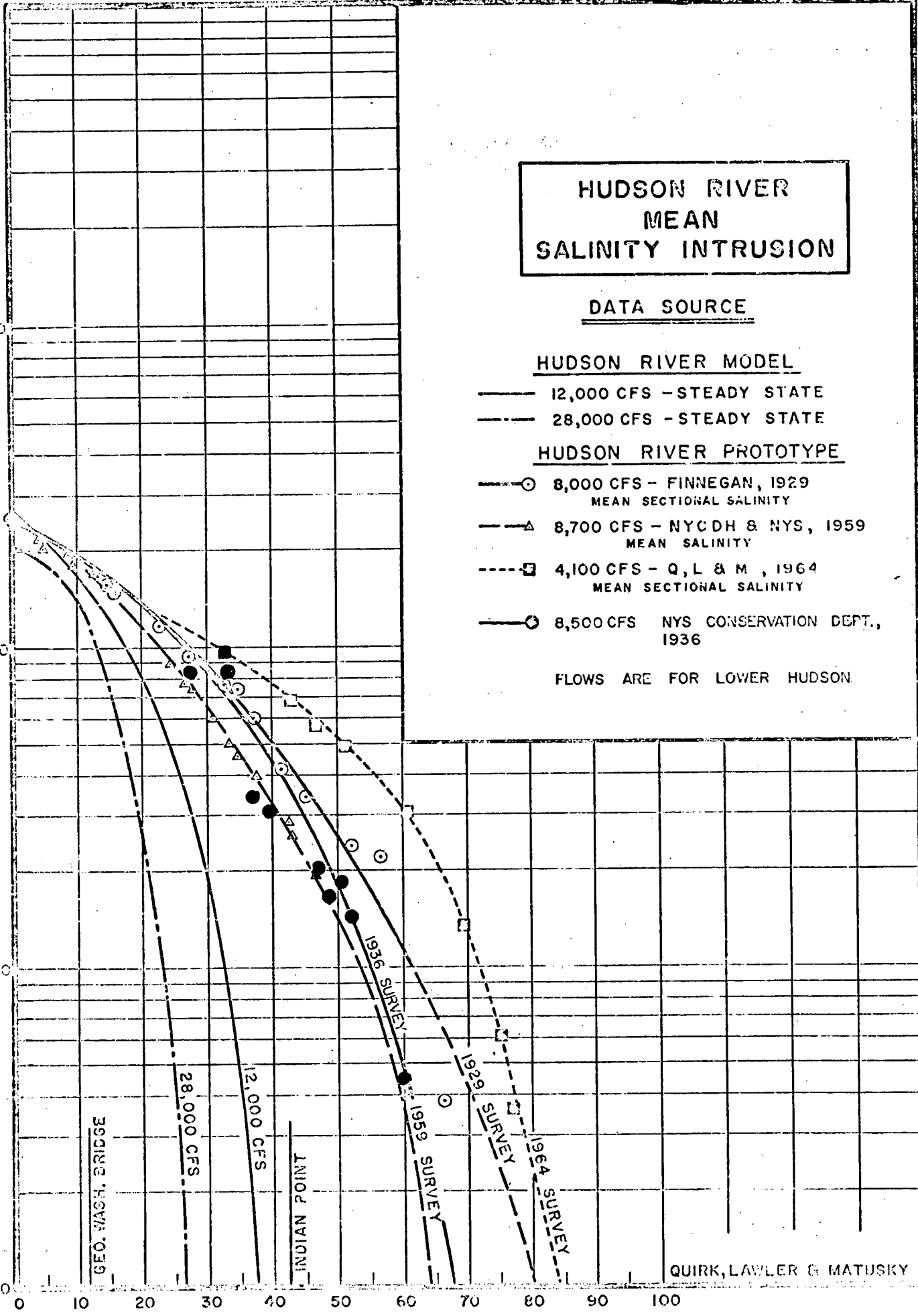

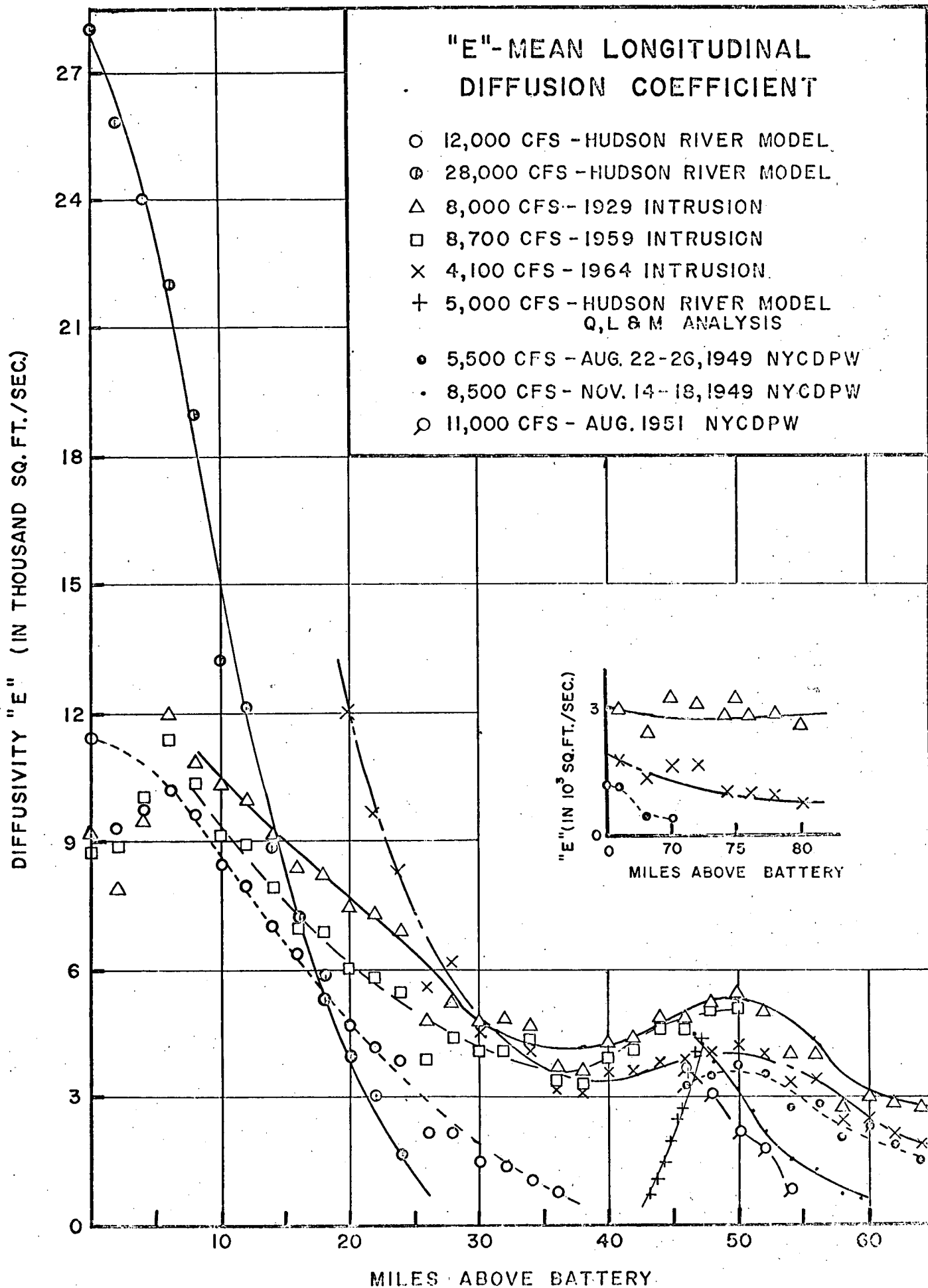

$$E_{AVG} \doteq U_{AVG} \left[2.303 \frac{\Delta \text{LOG } C}{\Delta x} \right]$$

(B-5)

A correlation of all available Hudson River salinity and flow data is shown on Figure B-5. Values of E used in this report have been computed by application of Equation B-5 to these data. For example, at a flow of 4000 cfs, the computation for average E between mile points 45 and 50 is:

$$\begin{aligned} E &= \frac{4,000}{123,500} \cdot \frac{2.303 (\log 6500 - \log 5400)}{-45 - (-50)} \\ &= 4640 \text{ sq. ft./sec.} \\ &= 14.3 \text{ sq. mile/day} \end{aligned}$$

Figure B-6 shows the variation, with flow, of average E, computed by Equation B-5 as shown above.

D. Tidal Exchange Coefficient

The tidal exchange coefficients, D, can be calculated from their definitions, by using dispersion and area data developed above:

$$D_{N,N+1} = \frac{E_{N,N+1} A_{N,N+1}}{(L_N + L_{N+1})/2}$$

(B-6)

In the absence of computed dispersion coefficients, exchange coefficients may be computed from steady state salt profiles. At steady state, the net salt flux across a section is zero; the advective mass flux downstream must equal the dispersive salt flux upstream. Analogous to the development of the unsteady state model in Appendix A, the steady state salt flux between any two segments is written:

$$Q_{N,N+1} (E_{N,N+1} C_N + (1 - E_{N,N+1}) C_{N+1}) - D_{N,N+1} (C_{N+1} - C_N) = 0$$

(B-7)

FIGURE D-5

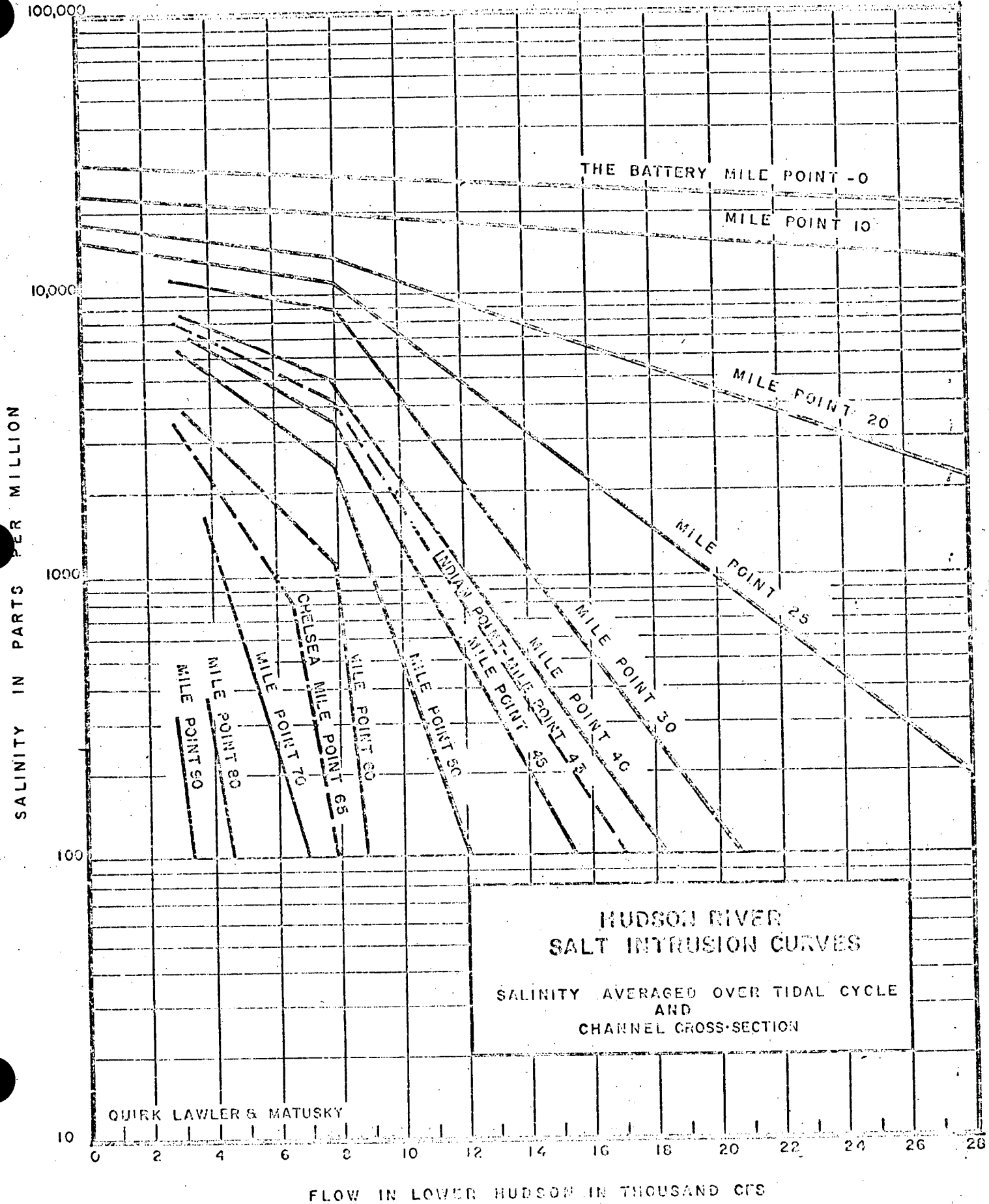

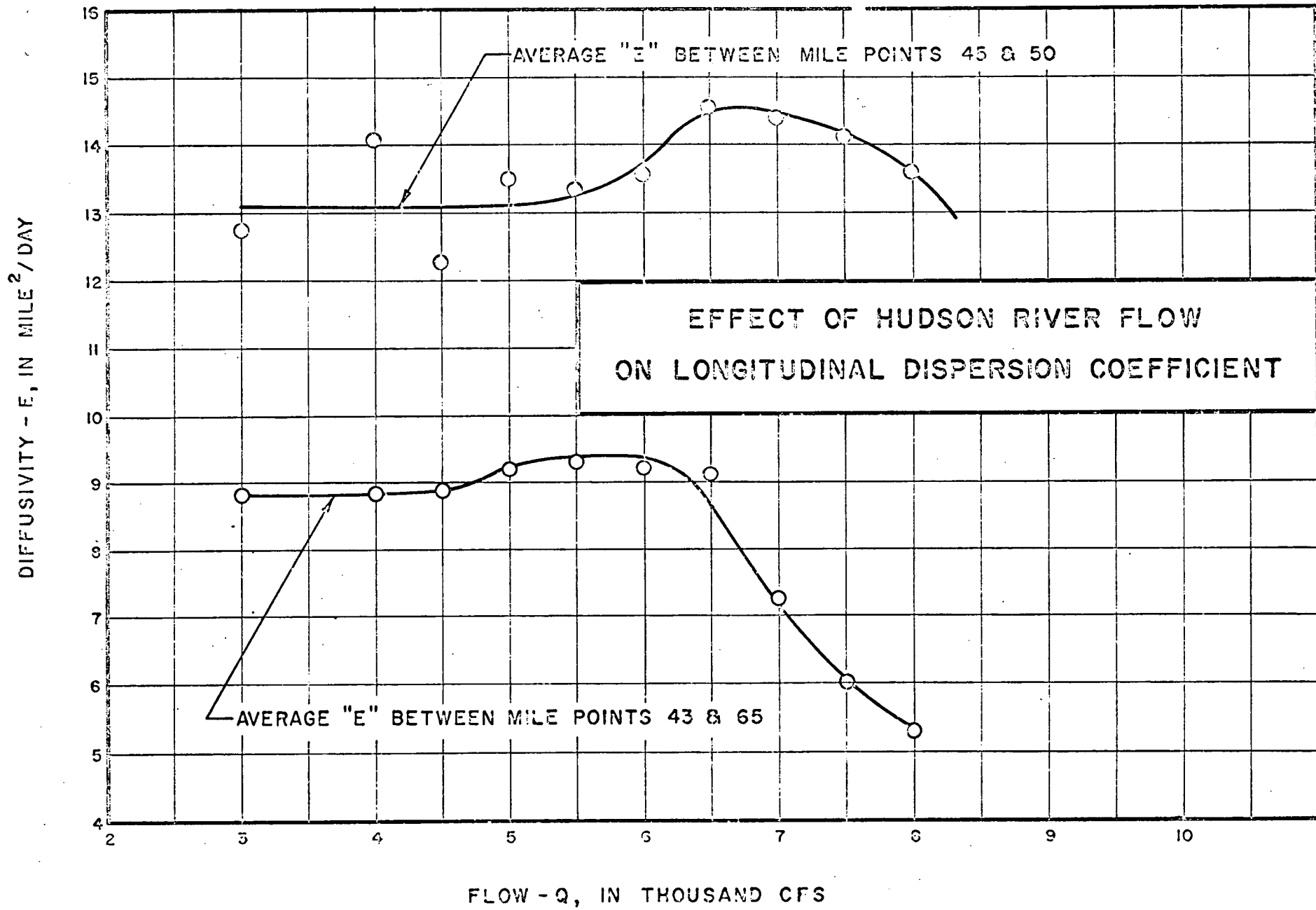

FIGURE B-6

in which C_N is the section average salt concentration.

Solving for $D_{N,N+1}$ yields:

$$D_{N,N+1} = \frac{[Q_{N,N+1} (\xi_{N,N+1} C_N + (1 - \xi_{N,N+1}) C_{N+1})]}{C_{N+1} - C_N}$$

(B-8)

Exchange coefficients within the salt intruded reach were computed directly from salt profiles shown in Figure B-3. To evaluate exchange coefficients past the intrusion, Equation B-6 was used to compute dispersion coefficients, $E_{N,N+1}$, associated with the exchange coefficients computed above for the salt-intruded reach.

These values were plotted against distance up to the end of the intrusion. Dispersion coefficients past the intrusion were estimated by linear extrapolation of this plot to an E value at Troy of 0.5 miles/day. Exchange coefficients above the intrusion were then computed from these dispersion coefficients, using Equation B-6. This procedure, rather than direct extrapolation of exchange coefficients, is necessary because exchange coefficients are a function of section length and do not necessarily decrease smoothly.

Sample values of exchange coefficients and equivalent dispersion coefficients, computed from Figure B-3 profile at 4000 cfs, are shown in Table B-1.

Values in parentheses are the extrapolated dispersion coefficients and computed exchange coefficients for the reach above the intrusion.

E. Temperature Exchange Coefficient

The temperature exchange coefficient, K_T , is the net rate at which heat is lost or gained by a body of water for a unit temperature difference. It depends upon the following heating mechanisms:

1. Short Wave Solar Radiation, H_s

The short-wave solar radiation is the radiant energy which passes directly from the sun to the earth and which ranges in wave length from 0.14 microns to 4.0 microns. The short wave energy reaching the earth's surface is dependent upon scattering and absorption in the upper atmosphere, altitude of the sun and amount of cloud cover. Although empirical formulae are available to compute short wave radiation, it can be measured readily with a pyrheliometer, an instrument which responds only to short wave radiation. The United

States Weather Bureau has made extensive use of the pyrheliometer and has comprehensive records of short wave radiation. In this study, short wave radiation has been estimated from the data of Edinger and Geyer (13), which were developed from Weather Bureau records.

2. Long Wave Atmospheric Radiation, H_a

Atmospheric gases radiate energy in the long wave region. The long wave radiation from the atmosphere ranges in wave length between 4.0 microns and 120 microns and depends primarily on air temperature and humidity. The magnitude of the long wave radiation may be estimated by empirical formulae. Brunt's formula, which gives a value of the atmospheric radiation that is within 10% to 20% of measured values, is written below:

$$H_a = 4.5 \times 10^{-8} (T_a + 460)^4 (C + 0.031 \sqrt{e_a}) \quad (B-9)$$

in which: H_a = long wave atmospheric radiation in BTU ft.⁻² day⁻¹
 T_a = air temperature in °F measured about six feet above the water surface
 e_a = air vapor pressure in mm. of mercury measured about six feet above the water surface
 C = a coefficient determined from the air temperature and ratio of the measured solar radiation to the clear sky solar radiation

Equation B-9 was used for all long wave radiation computations in this study.

3. Back Radiation, H_{br}

Back radiation is the long wave radiation transmitted from the earth's surface to the atmosphere in wave lengths ranging from 4.0 microns to 120 microns. Since water radiates as an almost perfect black body, the rate at which heat is lost by this mechanism can be computed from the Stefan-Boltzmann fourth power radiation law:

$$H_{br} = - \gamma_w \sigma (T_s + 460)^4$$

TABLE B-1

EXCHANGE COEFFICIENTS COMPUTED FROM
STEADY STATE SALT PROFILE AT 4000 CFS

<u>Distance from Battery (Miles)</u>	<u>Between Sections</u>	<u>Exchange Coefficient (Mile³/Day)</u>	<u>Equivalent Dispersion Coefficient (Mile²/Day)</u>
152	1-2	(0)	(.5)
120	2-3	(.0000705)	(1.7)
100	3-4	(.000555)	(2.5)
90	4-5	(.00149)	(2.9)
86	5-6	(.00388)	(3.06)
84	6-7	(.00635)	(3.14)
82	7-8	(.00611)	(3.32)
80	8-9	.006664	3.44
78	9-10	.010584	5.57
76	10-11	.012936	6.44
74	11-12	.015288	7.64
72	12-13	.013524	6.99
70	13-14	.012936	6.69
68	14-15	.012936	4.91
66	15-16	.013272	5.47
64	16-17	.013818	5.03
62	17-18	.018312	6.47
60	18-19	.020664	7.64
58	19-20	.023016	7.34
56	20-21	.022344	9.59
54	21-22	.024696	9.90
52	22-23	.019992	9.30
50	23-24	.027048	12.77
48	24-25	.0294	12.92
46	25-26	.0261927	10.37
44	26-27	.0285447	10.89
42	27-28	.02842	9.71
40	28-29	.03346	10.71
38	29-30	.03293	8.84
36	30-31	.03528	9.64
34	31-32	.0376	11.65
32	32-33	.03444	10.73
30	33-34	.03442	10.37
28	34-35	.03258	10.69
26	35-36	.037044	10.22
24	36-37	.0419	15.80
22	37-38	.0335	12.89
20	38-39	.0205	13.51
15	39-40	.0155	15.48
10	40-41	.0208	21.81
5	41-42	.02646	25.78
0	42-43	.0144	19.13
-15	43-44	.0282	---

in which: H_{br} = rate of back radiation in $\text{BTU ft.}^{-2} \text{ day}^{-1}$

γ_w = emissivity of water, = 0.97

σ = Stefan-Boltzmann Constant - 4.15×10^{-8}
 $\text{BTU ft.}^{-1} \text{ day}^{-1} \text{ } ^\circ\text{F}$

T_s = water surface temperature, $^\circ\text{F}$

Equation B-10, which gives an exact computation of back radiation values, was used exclusively for back radiation computations in this study.

4. Evaporation, H_e

Heat is lost from a body of water to the atmosphere through vaporization of the water. Each pound of water that leaves as water vapor carries its latent heat of vaporization of 970 BTU. Evaporation is dependent on wind speed and the difference in the saturated water vapor pressure at the water surface and the water vapor pressure in the air. There are many empirical equations for estimating evaporation. The most general form for the evaporation equation is:

$$H_e = - (a + bW)(e_s - e_a)$$

(B-11)

in which: H_e = rate of evaporation, $\text{BTU ft.}^{-2} \text{ day}^{-1}$

a, b = coefficients depending on evaporation formula employed

W = wind speed, miles per hour

e_a = air vapor pressure at the air temperature, T_a , and relative humidity, R_h , mm. of mercury

e_s = saturation vapor pressure of water at the water surface temperature, T_s , mm. of mercury.

Edinger and Geyer (13) present several sets of values for the coefficients, a and b . These coefficients vary with altitude of the air temperature measurement, and the time period selected for averaging wind speed. Values of $a=0$ and $b=16.8$, representative of daily average conditions, were selected for this study. Computations using other choices of these coefficients showed less than 10% variation in the heat transferred from the study area by evaporation.

5. Heat Conduction, H_c

Heat conduction across the water surface will occur in the presence of a temperature differential between air and water. The rate at which heat is conducted between two media is equal to the product of the heat transfer coefficient and the temperature differential between these media. The heat transfer coefficient is proportional to the evaporative heat transfer coefficient, $(a + bW)$. The rate of heat conduction is written:

$$H_c = -0.26(a + bW)(T_s - T_a) \quad (B-12)$$

in which: H_c = rate of heat conduction, $\text{BTU ft.}^{-2} \text{ day}^{-1}$

Since the rate of heat conduction is about one-tenth the magnitude of other heat mechanisms, loss of accuracy in heat conduction calculations is generally not significant. Equation B-12 was used for heat conduction calculations throughout the study.

6. Overall Heat Budget, ΔH

The net rate at which heat is added to or lost from a river is determined by the following heat budget:

$$\Delta H = H_s + H_a + H_{br} + H_e + H_c \quad (B-13)$$

Table B-2 summarizes the meteorological data existing during NBI surveys in June and July 1966 and April 1967. ΔH , calculated on the basis of data in Table B-2, indicated that the River was warming at a rate of $720 \frac{\text{BTU}}{\text{Day/Ft}^2}$ in April and $700 \frac{\text{BTU}}{\text{Day/Ft}^2}$ in June.

Calculation of the actual rate of heat exchange during the River surveys was computed on the basis of increase in River ambient temperature (temperature in region unaffected by thermal discharge) as follows:

$$\Delta H = \frac{\Delta T_A}{\Delta t} \rho C_p D$$

(B-14)

in which: ΔT_A = river ambient temperature increase, °F
 Δt = time span of river survey, days
 C_p = specific heat of water, 1 BTU/#/°F
 ρ = density of water, 62.4 #/ft.³
 D = average river depth, 38 ft.

Table B-3 compares ΔH evaluations based on the heat budget, Equation B-13, and the actual River temperature increase, Equation B-14. The variation between computed and measured ΔH for April 1967 conditions was 11% and for June-July 1966 was 3%. The good agreement attests to the applicability of heat budget analysis.

To incorporate the heat exchange rate in the mathematical development, ΔH must be related to temperature. ΔH is proportional to the difference of the actual water temperature, T_S , and the equilibrium water temperature, T_E ; i. e., temperature at which the cooling and heating rates are equal, ΔH equals zero. The proportionality defines the overall heat transfer coefficient, \bar{K} :

$$\bar{K} = \frac{\Delta H}{T_S - T_E} \quad (\text{B-15})$$

Edinger and Geyer (13) have prepared nomographic charts and equations for a trial and error evaluation of equilibrium temperatures and overall heat transfer coefficients. Although this method is approximate, it offers a rapid means of evaluating T_E . The nomographic solution proceeds as follows:

- 1) Assume an equilibrium temperature range
- 2) Find \bar{K} for a given W and temperature range from Figure B-7
- 3) Compute $F(\bar{K})$:

$$F(\bar{K}) = \frac{\bar{K} - 15.7}{\bar{K}}$$

(B-16)

TABLE B-2

METEOROLOGICAL DATA AT INDIAN POINT

	<u>April 1967</u>	<u>June-July 1966</u>
Air Temperature, °F	50	72.5
Water Surface Temperature, °F	46	75
Wind Speed, MPH	11.5	8
Air Vapor Pressure, mm	7	17
Relative Humidity, %	60	70
Saturation Vapor Pressure, mm	7.5	22

TABLE B-3

COMPARISON OF COMPUTED
AND
MEASURED HEAT EXCHANGE RATES

<u>Method of Analysis</u>	Heat Exchange Rate BTU/Day/Ft ²	
	<u>April 1967</u>	<u>June-July 1966</u>
Computed by Equation B-11		
$\Delta H = H_s + H_a - H_{br} - H_e - H_c$	+720	+700
Measured by Equation B-14		
$\Delta H = \frac{\Delta T}{\Delta t} \rho C_p D$	+650	+720

TAKEN FROM REFERENCE (13)

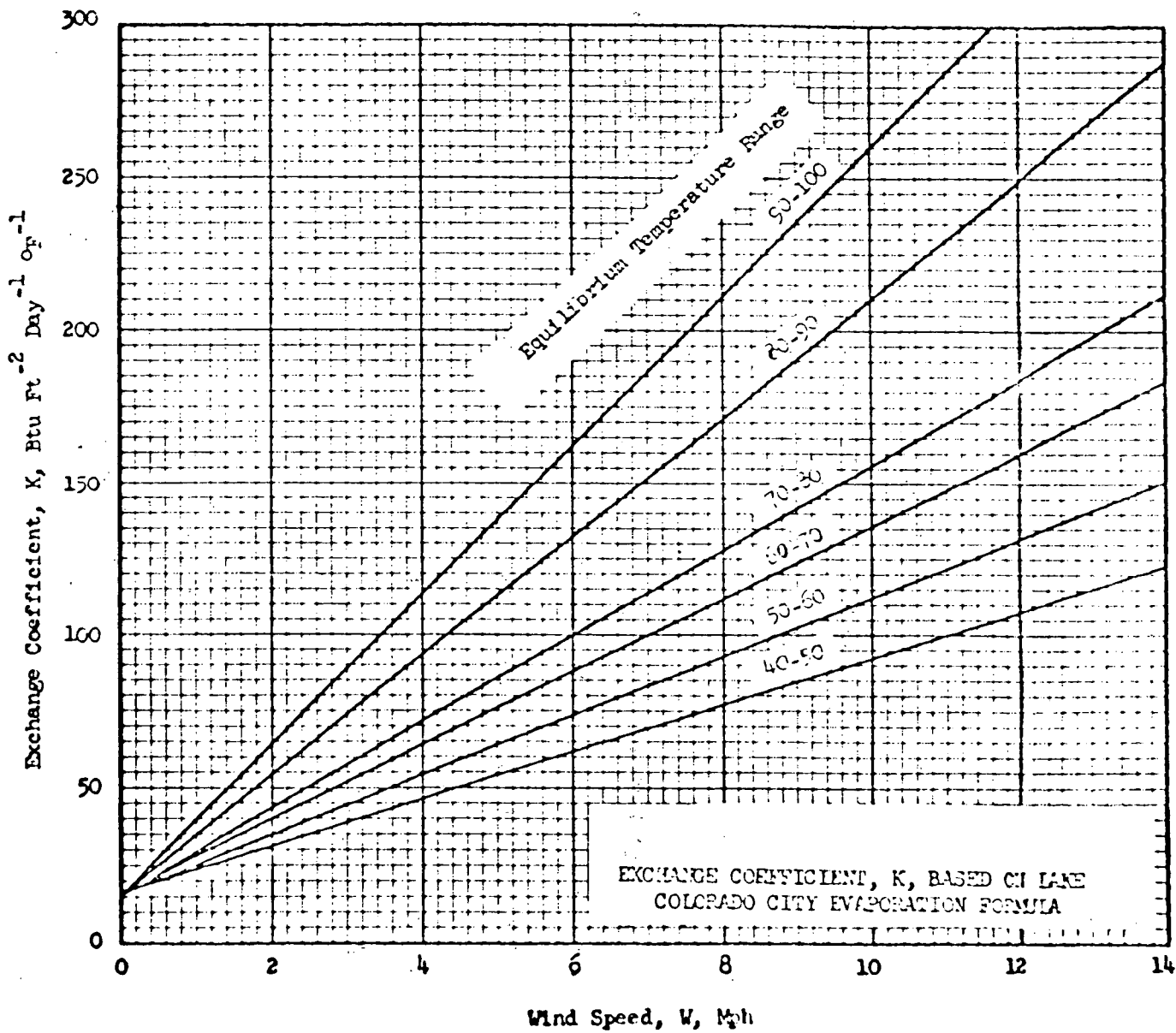

Figure B-7

- 4) For given H_s , H_a and \bar{K} , compute E_1 :

$$E_1 = \frac{H_s + H_a - 1801}{\bar{K}}$$

(B-17)

- 5) Find E_2 for a given T_a and temperature range from Figure B-8

- 6) Find E_3 for a given e_a and temperature range from Figure B-8

- 7) Compute M :

$$M = E_1 + F(\bar{K})(E_2 + E_3)$$

(B-18)

- 8) Find $(M - T_E)$ from Figure B-9

- 9) Compute T_E :

$$T_E = M - (M - T_E)$$

(B-19)

- 10) Check to see that this computed value falls within the selected temperature range. If it does not, choose a new range based on the value of T_E given in Step 9 and repeat the computations.

Upon determination of the equilibrium temperature and the overall heat transfer coefficient for a given set of meteorological data, ΔH may be computed as:

$$\Delta H = -\bar{K}(T_s - T_E)$$

(B-20)

TAKEN FROM REFERENCE (13)

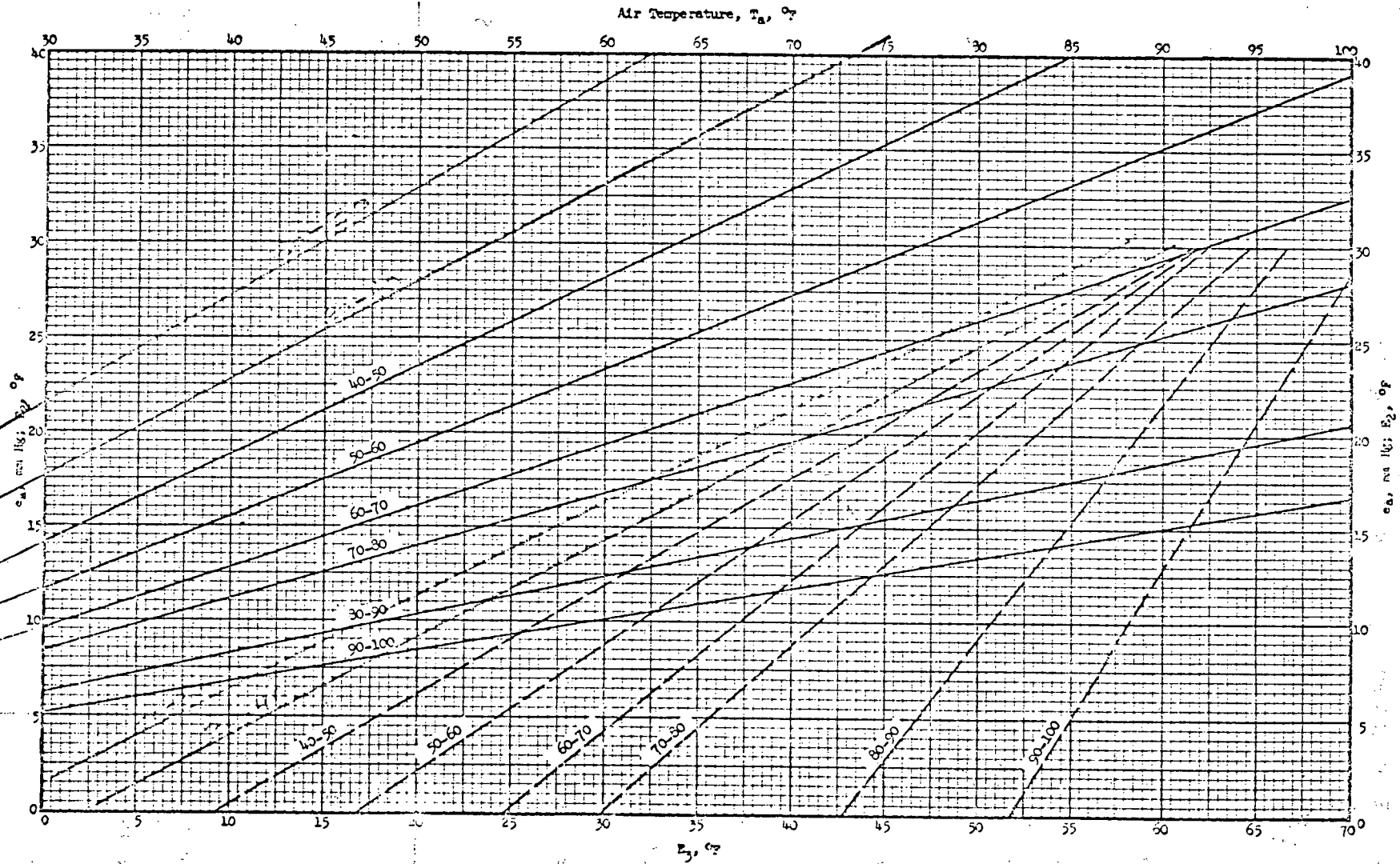

E_s FROM AIR VAPOUR PRESSURE, e_a ; AND E_s FROM AIR TEMPERATURE, T_a
FOR USE IN EQUATION 3-12

Figure B-8

M - E CORRECTION FOR USE IN EQUATION 3-17

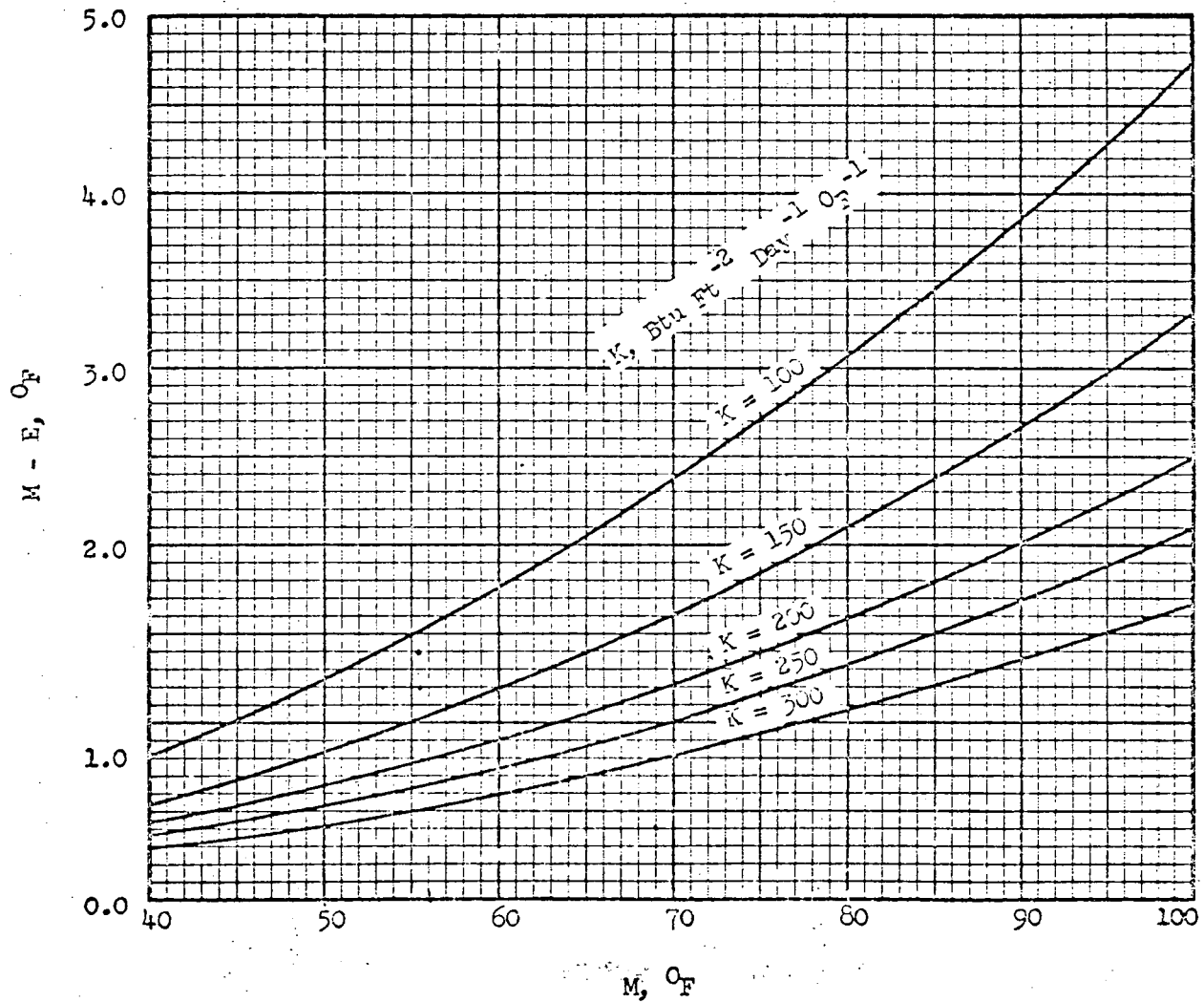

TAKEN FROM REFERENCE (13)

Figure B-9

TABLE B-4

SOURCES OF METEOROLOGICAL DATA

<u>Data</u>	<u>Source</u>
Air Temperature	U.S. Weather Bureau Stations at West Point and Poughkeepsie
Relative Humidity	U.S. Weather Bureau Stations at Central Park, NYC and Albany Airport
Wind Speed	U.S. Weather Bureau Stations and USAF Air Weather Service at Newburgh
Water Temperature	Central Hudson Gas & Electric Corporation Steam Station at Danskammer Point, 1966 Consolidated Edison Company Operating Logs at Indian Point
Air Vapor Pressure	Reference 13
Saturation Vapor Pressure	Reference 13
Solar Radiation	U.S. Weather Bureau Station at Central Park, NYC

ΔH was computed by Equation B-20 for the meteorological conditions of the June and July 1966 and the April 1967 surveys. ΔH for June and July 1966 was +825 BTU/Day/Ft² and for April 1967 was +750 BTU/Day/Ft². Although the estimates computed by Equation B-20 are about 15% higher than the estimates in Table B-3, the variation can be attributed to the approximations made in nomographic analysis.

On the basis of nomographic analysis, the overall heat transfer coefficient, K , used in this study varied between 80 and 140 BTU/ft²/day.

The temperature exchange coefficient (K_T) referred to in Equation 3 is computed as follows:

$$K_T = \frac{\bar{K}}{\rho C_p D} \quad (B-21)$$

Since River depth varies, K_T varied in space as well as with season. Values ranged between 0.015 and 0.15/day.

As described in Appendix A, the effective value of K_T for the one dimensional models was obtained by multiplying Equation B-21 by the thermal stratification factor.

7. Verification of Heat Budget Analysis

Heat budget computations are verified by comparisons to measured heating and cooling rates in the River. This procedure was shown above, using NBI River temperature measurements to verify heat exchange rates computed meteorological conditions which prevailed during the April and July surveys.

Verification of the heat exchange rates was also made by comparison to additional data for different periods.

Table B-4 lists the data and sources used to obtain 1964 and 1966 meteorological conditions.

A complete record of all the meteorological variables is not available for any one specific River location; data from the various locations mentioned in Table B-4 were therefore used. Variations between locations are not great and results are applicable to the River at Indian Point.

Indian Point meteorological data reported in the Preliminary Safety Analysis Report submitted to the U. S. Atomic Energy Commission verified the applicability of the data selected. Indian Point data could not be used for analysis because it was arranged in terms of probability of occurrence, i.e., the data were not amenable for comparison to actual River conditions for a specific period.

Table B-5 summarizes the meteorological data used to compute heat exchange rates for 1964 and 1966. The average wind speed for January and March of 1964 was approximately 10.5 MPH. Wind speeds, for the winter months, measured at Indian Point for the Preliminary Safety Report to the U. S. A. E. C. reported a 38% probability of speeds from 5 to 10 MPH, a 35% probability of speeds less than 5 MPH, and a 27% probability of speeds greater than 10 MPH. An average winter month of 10.5 MPH is not inconsistent with these results.

Additional agreement of PSAR wind speed measurements with U. S. Weather Bureau records is shown in Table B-6.

Table B-6 compares wind speed measurements made by the U. S. Weather Bureau at Central Park and Newburgh, New York to measurements made at Indian Point as reported in the Preliminary Safety Analysis Report. As individual yearly records were not complete, comparisons were made for data taken during different time periods.

Measurements made during winter months show close agreement. Weather Bureau measurements during the summer months were approximately 1 MPH or 10% lower than PSAR measurements. This is not significant to the results of this study.

Table B-7 summarizes the heat exchange rates computed from meteorological conditions and measured by River temperature data for January and March 1964 and for August through November of 1966. Table B-7 demonstrates a reasonably close agreement between measured and computed heat exchange rates. The August 1966 comparison exhibits the most severe variation. During this period River ambient temperatures were close to the equilibrium temperature. The above results, one showing warming, the other cooling, and both near zero rates, confirm this fact.

TABLE B-5

METEOROLOGICAL DATA USED IN HEAT BUDGET ANALYSIS

<u>Parameter</u>	<u>January</u> <u>1964</u>	<u>March</u> <u>1964</u>	<u>August</u> <u>1966</u>	<u>September</u> <u>1966</u>	<u>October</u> <u>1966</u>	<u>November</u> <u>1966</u>
Air Temperature, °F	28	36.6	75.3	63.8	53.4	45.3
Relative Humidity, %	56	55.8	63	74	68	72.5
Wind Speed, MPH	10.8	10.4	7.4	8.0	8.8	8.9
Air Vapor Pressure, mmHg	4.5	4.75	16.5	12.7	7.9	6.7
Saturation Vapor Pressure, mmHg	5	5	24.5	20.8	14.5	9.5
Solar Radiation, BTU/Ft ² /Day	620	1140	1690	1230	1140	577
Water Temperature, °F	34.6	35.7	77.8	73	62.5	51

TABLE B-6

WIND SPEED MEASUREMENTS

Comparison of PSAR Recordings
 at Indian Point to
 Weather Bureau Records at
 Central Park and Newburgh, New York

<u>Season</u>	<u>Wind Speed (MPH)</u>		
	PSAR Indian Point 1956-1957	U. S. Weather Bureau Central Park 1964	U. S. Weather Bureau Newburgh 1942-1964
Winter	10.4	9.8	10.8
Summer	9.4	8.3	8.4

TABLE B-7
 COMPARISON OF MEASURED
 AND
 COMPUTED HEAT EXCHANGE RATES

<u>Period</u>	<u>ΔH River Temperature Increases</u>	<u>BTU/Ft²/Day Computed by Heat Budget Analysis</u>
January 1964	-500	-321
March 1964	+635	+684
August 1966	- 66	+147
September 1966	-617	-623
October 1966	-710	-651
November 1966	-597	-490

F. Indian Point Thermal Loads

Heat loads associated with the maximum expected output capacity (stretch rating) of the units at Indian Point are given in Table B-8. The three unit loading used in calculations in this report was computed for a rounded flow of 2,100,000 gpm and a plant temperature rise of 17°F. For stretch rating conditions, area average and mixing zone temperatures, therefore, are 6% lower than those reported. For the manufacturers guaranteed output, River temperatures will be 16% lower than those reported. Reported values, therefore, reflect a conservative loading condition.

TABLE B-8

INDIAN POINT HEAT LOADS

	<u>Unit</u> <u>No. 1</u>	<u>Unit</u> <u>No. 2</u>	<u>Unit</u> <u>No. 3</u>	<u>Total or</u> <u>Average</u>
Guaranteed Output, MWE	285	873	965	2123
Maximum Expected Output, MWE	285	1033	1033	2351
Maximum Temperature Rise Across Condenser, °F	13	17	17	16.4
Cooling Water Flow, GPM	300	870	870	2040
Heat Load, $\rho C_p q \Delta T$, BTU/Day $\times 10^{-9}$	47	178	178	403
Heat Load, MW	574	2170	2170	4914
Thermal Efficiency ¹	33.2	32.3	32.3	32.4

Rounded Heat Loss @ 17°F and 2,100,000 GPM = 430×10^9 BTU/Day

Stretch Rating Heat Loss @ 16.4°F and 2,040,000 GPM = 403×10^9 BTU/Day

Heat Loss Based on Manufacturer's Guarantee and 32.4% Efficiency = 363×10^9 BTU/Day

¹Computed on basis of maximum expected output and heat load.

CONSOLIDATED EDISON COMPANY OF NEW YORK, INCORPORATED
NEW YORK, NEW YORK

EFFECT OF INDIAN POINT COOLING WATER DISCHARGE
ON
HUDSON RIVER TEMPERATURE DISTRIBUTION

FEBRUARY, 1969

(REVISION OF REPORT OF JANUARY, 1968)

QUIRK, LAWLER & MATUSKY ENGINEERS
ENVIRONMENTAL SCIENCE & ENGINEERING CONSULTANTS
505 FIFTH AVENUE
NEW YORK, NEW YORK 10017

QUIRK, LAWLER & MATUSKY ENGINEERS
ENVIRONMENTAL SCIENCE & ENGINEERING CONSULTANTS

505 FIFTH AVENUE
NEW YORK, NEW YORK 10017
212 867-0080

WATER RESOURCES DEVELOPMENT
WATER POLLUTION CONTROL
AIR POLLUTION CONTROL
SOLID WASTES DISPOSAL

SYSTEMS ANALYSIS & DESIGN

COMPUTER FACILITIES
PILOT PLANT FACILITIES
ANALYTICAL LABORATORIES

THOMAS P. QUIRK
JOHN P. LAWLER
FELIX E. MATUSKY
WILLIAM A. PARSONS
LEONARD J. EDER
ROBERT A. NORRIS
VINCENT J. BOCCCHINO

February 17, 1969

Mr. George T. Cowherd
Environmental Engineer
Consolidated Edison Company
of New York
4 Irving Place
New York, New York 10003

Dear Mr. Cowherd:

We are submitting our report on the expected effect of simultaneous operation of three nuclear units at Indian Point on Hudson River temperatures.

This report is a revision of, and should be considered as superceding, our original report on this subject of January, 1968.

The several changes in the proposed thermal discharge criteria of the New York State Health Department since early 1968 have necessitated this revision. In particular, criteria on water surface temperatures have required replacement of the planned surface discharge by a submerged outfall.

Data made available since our earlier report have been utilized. These include infra-red surveys of surface temperature by Texas Instruments and operation of Indian Point Model II by the Alden Research Laboratory. Our earlier mathematical model has been adjusted to yield better agreement with field data.

A summary of findings, conclusions, and recommendations precedes the report on pages S-1 to S-4 inclusive.

Very truly yours,

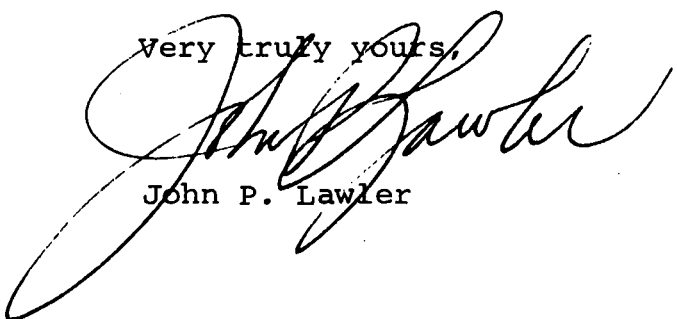

John P. Lawler

JPL/mmn
Enclosure

TABLE OF CONTENTS

	<u>Page</u>
<u>Letter of Transmittal</u>	
<u>Summary of Findings, Conclusions & Recommendations</u>	S-1
I. <u>Events Leading to the Report</u>	1
II. <u>Purpose and Scope</u>	3
III. <u>Indian Point Heat Loads</u>	4
IV. <u>River Data for Present Conditions</u>	
NBI Indian Point Surveys, July, 1966 & April, 1967	6
Texas Instruments, Incorporated, Airborne Infrared	
Surveys, October 28, 1967 and April 6, 1968	8
Comparison of NBI and TXI Data	13
V. <u>Revision of Predictive Model</u>	
Comparison of Predicted and Measured Profiles -	
January '68 Report	14
Rationale for Model Revision	16
Net Non-tidal Flow and Thermal Stratification	16
Surface Heat Transfer	19
Model Adjustment	20
VI. <u>Temperature Distribution for Three Unit Operation</u>	
Generalized Solution - Exponential Decay Model	25
Conditions of Maximum Severity	25
Thermal Stratification Factors	25
Bounding Area-Plane of Discharge	27
Bounding Surface Width - Plane of Discharge	27
Areal and Surface Boundaries - Summer Conditions	27
Behavior Beyond the Plane of Discharge	28
Hydraulic Model Results	29
Correlation of Hydraulic Model with Predictive	
Model	32
Submerged Discharge	36

Appendix

Alden Hydraulic Laboratories - Submerged Discharge Report

SUMMARY OF FINDINGS, CONCLUSIONS & RECOMMENDATIONS

1. In January, 1968, Quirk, Lawler and Matusky Engineers submitted a report entitled "Effect of Indian Point Cooling Water Discharge on Hudson River Temperature Distribution." This report presented a mathematical analysis of the effect of three unit discharge on temperature rises in the River. Results were evaluated against a set of thermal discharge criteria, which were, at the time, proposed by the New York State Department of Health (NYSDH).

The analysis was conservative; computation of temperature rises for one unit operation were significantly higher than field observations for this condition. The analytical results, however, did not contravene the proposed criteria, so the model was submitted as evidence that the three unit discharge would meet the thermal standard.

2. The proposed NYSDH criteria have undergone significant changes since the submission of the January, 1968 report. In particular, surface temperature criteria have been added. These include a maximum surface water temperature of 90°F at any point in the surface, and a requirement that no more than two thirds, or 67%, of the surface width be subject to temperatures greater than 83°F, or artificial temperature rises of 4°F.

These surface temperature criteria have necessitated a revision of the prior work. The 90°F criterion will require a subsurface discharge; the early work was predicated on a surface discharge.

Furthermore, the conservative mathematical model shows only marginal agreement with the 4°F, 67% surface width criterion. The model, therefore, has been adjusted to agree with field measurements, and, as a result, shows clear ability of the three unit discharge to meet these new criteria.

3. The first adjustment in the mathematical model consisted of reducing the heat load to 79% of the value used in prior calculations.

Previously, the heat load used was 6% higher than that associated with the maximum possible three unit electrical output

(stretch rating) of 2351 MW. Planned operation, however, is 90% of this value, or 2114 MW. This latter value is slightly less than the manufacturer's guaranteed rating of 2123 MW, the maximum value at which the station may operate under initial Atomic Energy Commission operating licenses.

These facts, in addition to crediting 5% of the heat generated against in-plant heat losses, lead to a design heat load of 340×10^9 BTU/day, which is 79% of the previous employed loading of 430×10^9 BTU/day.

Circulating water flow is 2,040,000 gpm, rounded previously to 2,100,000 gpm. The three unit effluent channel temperature rise is now 14°F, rather than the 17°F used previously.

4. The maximum River ambient surface water temperature is 78° to 79°F and usually occurs in August. Hydraulic model studies show that the 14°F effluent channel temperature rise can be reduced markedly, before reaching the River's surface, by discharging these waters to the River through a submerged outfall.

Model studies showed that six rectangular ports, each 30 ft. wide by 4 ft. high, and separated by 10 ft. wide partitions, located along the bottom of the west wall of the discharge canal, would yield maximum surface temperatures substantially lower than the 90°F criterion. Results for various submergences are given as follows:

Submergence to Top of Port (ft. below MSL)	Depth to Channel Bottom (ft. below MSL)	Maximum Surface Temperature Rise, °F	
		For $\Delta T_p = 17^\circ\text{F}$	For $\Delta T_p = 14^\circ\text{F}$
16	20	88	86.5
21	25	87	85.5
26	30	85	84

5. Comparison of the values predicted by the unadjusted mathematical model for Unit No. 1 behavior with the field measurements is given in Table 4 in the text. The mathematical model was ad-

justed to yield these observed values when operating at the Unit No. 1 heat load.

This adjusted model showed that the area-average temperature rises across the plane of discharge is some 50 to 75% of the values previously predicted. Furthermore, the decay of temperature above and below the plane of discharge becomes much more rapid, resulting in a substantial reduction of the extent of temperature rises greater than 1°F.

This improved dilution and dispersion is believed to be the result of salinity-induced circulation in the estuary. Detailed explanation of this mechanism, and the unique role it appears to have in dispersing thermal discharges is discussed in Chapter IV under "Rationale for Model Revision."

Results obtained from operation of the Indian Point Hydraulic Model II were also employed to confirm the rapid dispersion of heat given by the adjusted mathematical model.

6. Two critical conditions were studied. The condition of maximum severity was defined as that set of hydrology and meteorology which occurred in November, 1964. A sustained six month drought flow of 4000 cfs and a low heat transfer coefficient of 90 BTU/SF/day/°F, which occurred at that time, were shown, in the January 1968 report, to cause maximum temperature rises.

The critical summer condition consisted of the same flow, but used the August heat transfer coefficient of 135 BTU/SF/day/°F. Although this condition yields lower River temperature rises, it was studied because summer conditions are reported by many to constitute the critical biological condition.

Figure S-1 shows the predictions for the percentage of surface width and cross-sectional area bounded by the 4°F isotherm. These were obtained using the adjusted model.

The maximum percentage of either parameter occurs at the plane of discharge and, in the case of both width and area, is clearly less than the proposed criterion. These plane of discharge results are summarized as follows:

<u>Condition</u>	<u>% Area Bounded by the 4°F Isotherm</u>		<u>% Surface Width Bounded by the 4°F Isotherm</u>	
	<u>Criterion</u>	<u>Prediction</u>	<u>Criterion</u>	<u>Prediction</u>
Maximum Severity	50	26	67	52
Critical Summer	50	21	67	33

7. The percentages of the surface width bounded by other isotherms at various distances above and below Indian Point were also computed using the adjusted model. These results are shown in Figure S-2.

Figure S-2 shows clearly that temperature rises greater than 1°F are limited to the vicinity of Indian Point. The Indian Point heat load is not expected, for instance, to influence the temperature pattern at Orange and Rockland Utilities' Lovett Plant.

In conjunction with Figure S-2, it should be remembered that, for effluent channel temperature rises between 14°F and 17°F, the maximum temperature rise at any point in the surface can be held between 5°F and 9°F, depending on the submergence depth.

BOUNDARIES OF THE 4°F ISOTHERM
FOR
THREE UNIT DISCHARGE AT INDIAN POINT

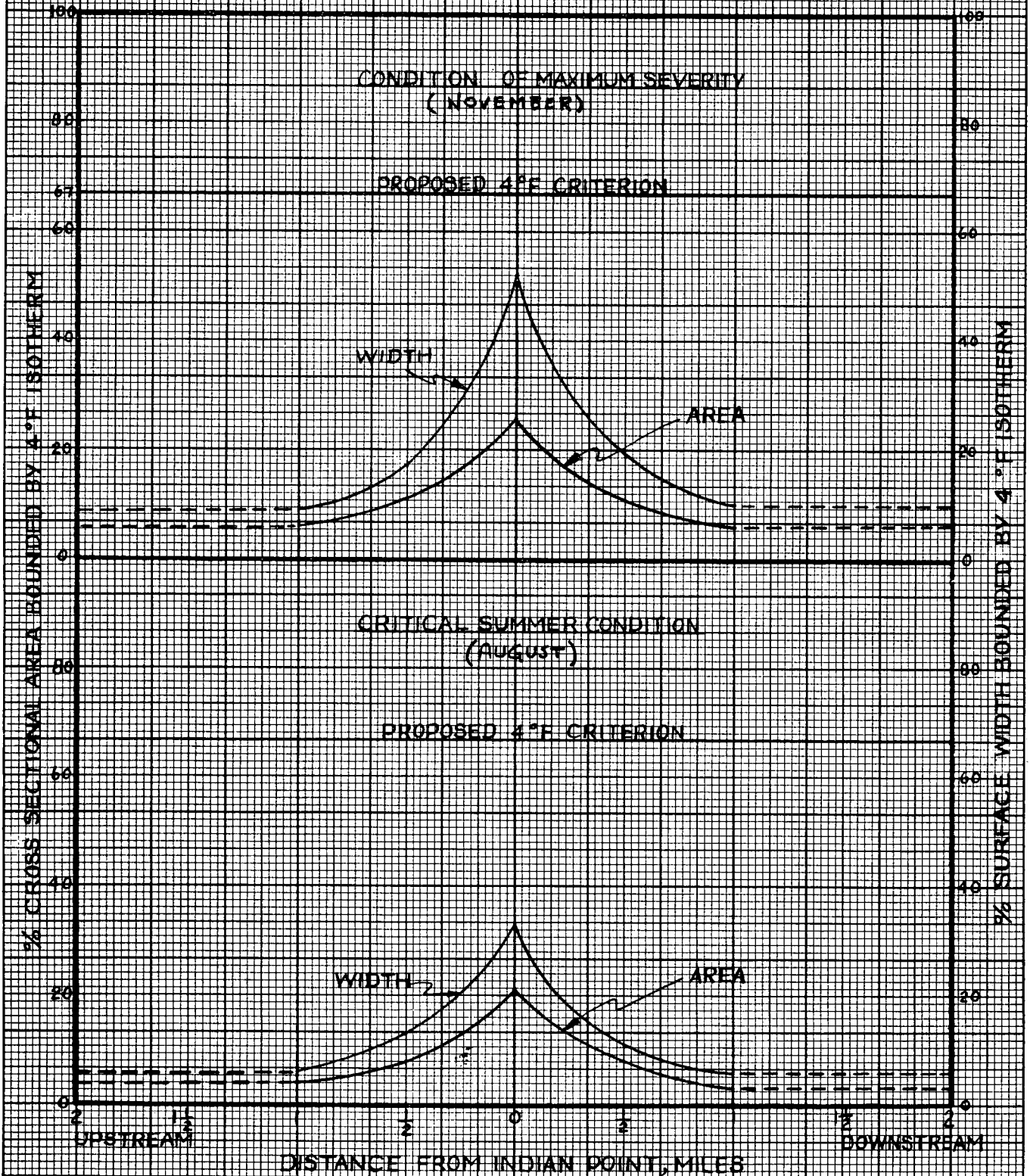

BOUNDARIES OF STATED SURFACE ISOTHERMS
FOR
THREE UNIT DISCHARGE AT INDIAN POINT
SUMMER CRITICAL CONDITION
(AUGUST)

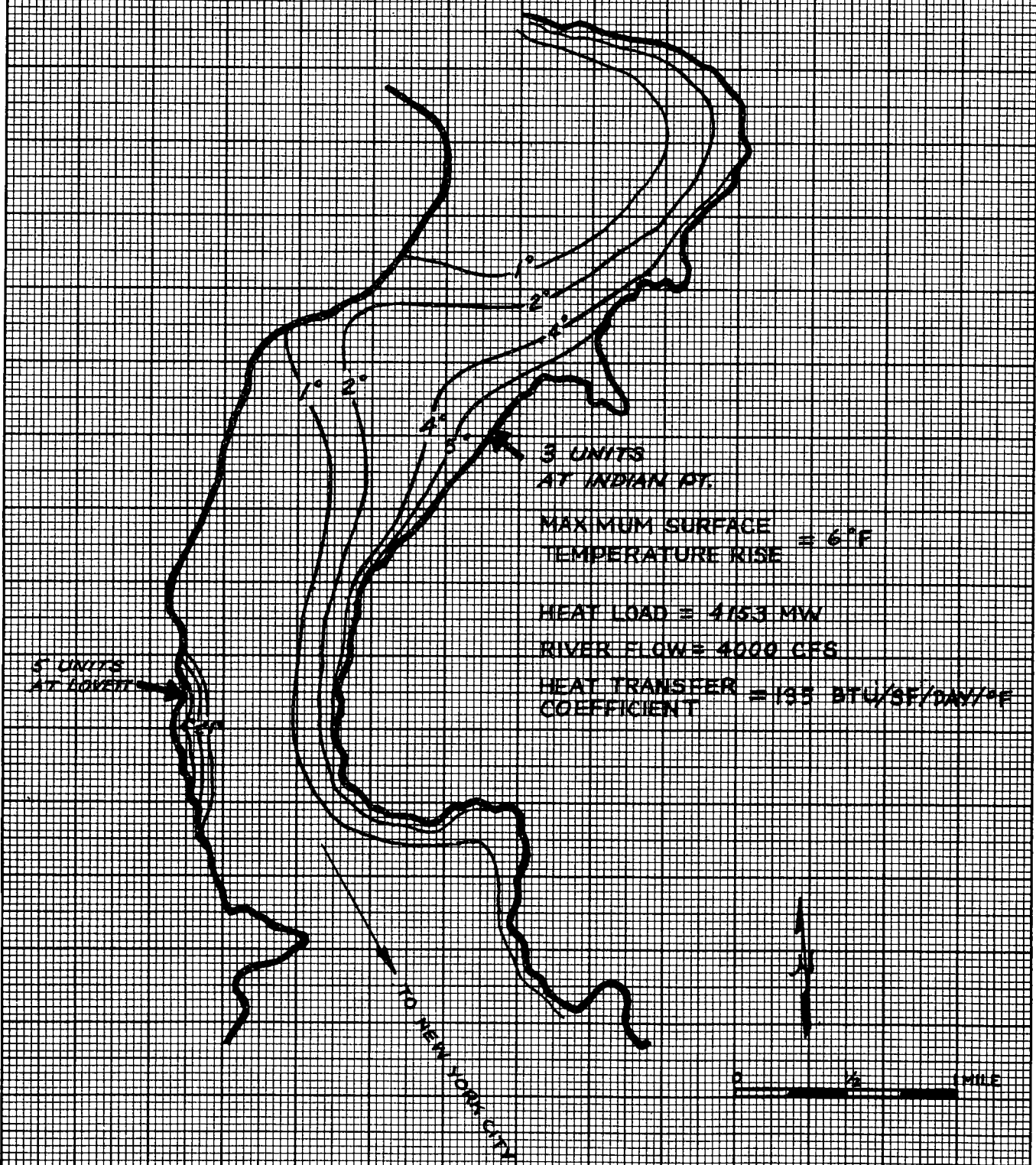

I. EVENTS LEADING TO THE REPORT

On January 15, 1968, Quirk, Lawler & Matusky Engineers submitted a report entitled Effect of Indian Point Cooling Water Discharge on Hudson River Temperature Distribution, to the Consolidated Edison Company of New York, Incorporated.

The purpose of this report was to evaluate River temperatures expected from three unit operations at Indian Point against the thermal discharge criteria of the New York State Department of Health (NYS DH).

These criteria had been developed by NYSDH to provide numerical means of applying the thermal discharge (heated liquids) standard which, for the Class I waters of the Hudson River near Indian Point, reads:¹

"None alone or in combination with other substances or wastes in sufficient amounts to be injurious to edible fish and shellfish, or the culture or propagation thereof, or which shall in any manner affect the flavor, color, odor, or sanitary condition of such fish or shellfish so as to injuriously affect the sale thereof, or which shall cause any injury to the public and private shellfisheries of this State; and otherwise none in sufficient amounts to impair the waters for any other best usage as determined for the specific waters which are assigned to this class."

Since the time of preparation and submission of the January '68 report, the development of means of applying this thermal discharge standard was made the responsibility of the New York State Water Resources Commission (NYSWRC). The original NYSDH criteria have undergone some revision and the NYSWRC is now considering these revisions for adoption, subject to public hearings. This supplementary report presents an evaluation of the three unit discharge in the light of these recently proposed criteria.

The predicted temperature distributions which appear in the January '68 report are the results of a conservative analysis.

¹"Classification and Standards of Quality and Purity for Waters of New York State." (Parts 700-703, Title 6, Official Compilation of Codes, Rules and Regulations.) Prepared and Published for Water Resources Commission by NYSDH (Nov, 1967)

Waste heat loads used exceed the design waste heat load. River Temperature was not permitted to decay as rapidly as it actually does; i.e., as indicated by field measurements made during Unit No. 1 operation.

Using this conservative approach, the January '68 report showed the three unit operation would not contravene the early NYSDH criteria. Further refinement was therefore considered unnecessary.

Evaluation of three unit operation against the new, more restrictive criteria, using the conservative approaches given in the January '68 report, shows only marginal conformity to these criteria.

Therefore the conservative approach has been relaxed in the present report, and the predictions are made recognizing the actual expected heat load and the observed rapid decay behavior.

II. PURPOSE AND SCOPE

The purpose of this report is to redefine the surface and lateral Hudson River temperature distributions which can be expected as a result of three unit operation at Indian Point.

These temperatures will be compared to the allowable degree and extent of elevated temperatures as delineated in the present proposed criteria. These criteria require that temperature rises of 4°F, or absolute temperatures of 83°F, not be exceeded over more than 50% of the River's cross-section nor over more than two thirds of the River's surface width. Furthermore, surface water temperatures should not exceed 90°F at any point.

The work required to achieve this objective includes:

1. Determination of heat loads that can be expected for three unit operation. These heat loads are those which result from planned operation of the three nuclear units.
2. Revision of the predictive model to conform more closely to field experience. This will be done by adjusting the mathematical model to yield results for Unit No. 1 operation similar to the field temperature measurements obtained during operation of Unit No. 1.
3. Prediction of three unit temperature profiles using the revised River model. These results will be correlated with results obtained from a second hydraulic model simulation of Indian Point three unit behavior.
4. Analysis of a planned submerged discharge design.

III. INDIAN POINT HEAT LOADS

The nuclear-fueled electric generating units at Indian Point will operate at an efficiency slightly in excess of 32%. That is, of the total thermal energy produced within the reactor, 32% will be converted to electrical output. The remaining 68% represents the waste heat which is lost within the plant or which is discharged to the river in the cooling water.

Typical in-plant losses are about 5% of the thermal input.² Consequently, approximately 63% (100-32-5) of the total thermal energy is discharged to the river as waste heat in the cooling water.

Table 1 lists the thermal input and its breakdown into electrical output, loss within plant and loss to river for the average summer week, for three unit operation, during 1973. After 1973, Consolidated Edison will have additional power sources and electrical output required from the three units operating at Indian Point will be reduced.

The electrical outputs presented in Table 1 were determined by Consolidated Edison system engineering personnel. These 1973 estimates represent the power that will be needed from the three units at Indian Point in accordance with the projected 1973 power needs and with the most efficient operation of all power sources within the Consolidated Edison system.

Table 1 shows that, during the average summer week in 1973, the weekly average of daily average electrical outputs would be 2114 MW. This agrees with the manufacturer's guaranteed output of 2123 MW and operation of Indian Point as a base load plant.

The maximum possible output stretch rating that the three units are believed to be capable of producing is 2351 MW. Operation at this level is not planned, however, and furthermore, will not be permitted by the Atomic Energy Commission in issuing the original operating permits.

The mode of operating the three unit Indian Point complex given

²"Industrial Waste Guide on Thermal Pollution." U.S. Department of Interior, Federal Water Pollution Control Administration, Pacific Northwest Water Laboratory, Corvallis, Oregon (Sept, 1968)

TABLE 1

ESTIMATE OF THE BREAKDOWN OF HEAT PRODUCED AT INDIAN POINT

Three Unit Operation
Average Summer Week - 1973

<u>Day</u> (MW)	<u>Electrical Output</u> (MW)	<u>Heat Loss within Plant</u> (MW)	<u>Heat Loss to River</u> (MW)	<u>Thermal Input (Heat Produced by Reactor)</u> (MW)
Monday	2195	342	4313	6850
Tuesday	2147	335	4218	6700
Wednesday	2147	335	4218	6700
Thursday	2147	335	4218	6700
Friday	2147	335	4218	6700
Saturday	2080	325	4095	6500
Sunday	1935	320	3795	6050
Weekly Average	2114	333	4153	6600

in Table 1 is the result of efficient operation of the entire Edison system, considering sources of power. If the nuclear units are operated at their maximum output during night hours when the demand is small, less efficient fossil-fueled units might have to be shut down completely. These fossil-fueled units are required to meet the heavy demand during peak hours. They should be kept operational to insure a smooth transition from periods of low demand to periods of high demand.

Furthermore, Consolidated Edison supplies steam to the New York City steam system. This steam is produced in fossil-fueled plants within N.Y.C. Although the steam can be piped directly to the steam system, bypassing the turbines, it becomes economically justifiable to direct the steam through the turbines and obtain electrical output as a by-product.

In Table 1, the weekly average of the daily average heat loads to the river is shown to be 4153 MW. In the January 1968 report, all temperature predictions for three unit operation were based upon operation with a cooling water flow of 2,100,000 GPM and a temperature rise in these cooling waters of 17°F.

This is equivalent to a heat load of 430×10^9 BTU/DAY or 5250 MW. Consequently, all estimates in the January 1968 report are based upon a three unit heat load that is 26% $((5250-4153) \times 100 / 4153)$ greater than the load that can be expected when three units are actually operating at Indian Point.

All subsequent analyses presented in this report, are based on a three unit Indian Point heat load to the River of 4153 MW or 340×10^9 BTU/day. Cooling water flow will remain equal to the design total of 2,040,000 gpm. The temperature rise across the condensers will be 13.9 °F, rather than 17 °F. This value has been rounded to 14°F in calculating areal and surface behavior in this report.

IV. RIVER DATA FOR PRESENT CONDITIONS

The purpose of this section is to present River temperature data measured by Northeastern Biologists, Incorporated (NBI), in July, 1966 and April, 1967, and by Texas Instruments, Incorporated (TXI), in October, 1967 and April, 1968.

These data, which define the temperature effect for one unit operation, will be used as the basis for extrapolations of temperature effects for three unit operation. The accuracy of the measurements is supported by comparisons of the NBI and TXI survey results.

Furthermore, a comparison is included of the measured extent of the surface and lateral temperature effect to the ~~degree~~ allowable as stated in the proposed criteria.

NBI Indian Point Surveys, July, 1966 and April, 1967

The Indian Point plant site is located on the east shore of the Hudson, about 43 river miles above New York Harbor. Consolidated Edison operates one nuclear unit at Indian Point, with a maximum expected electrical output of 285 MW.

Temperature surveys were performed in the vicinity of Indian Point by Northeastern Biologists, Incorporated, in July, 1966 and in April, 1967. There were fourteen and seventeen actual survey days for the July, 1966 and April, 1967 surveys, respectively.

A grid system was established for consistent location of sampling points. The grid system covered an area of two million square feet extending in the north-south direction from a point 1,000 feet downstream of the outfall to a point 1,000 feet upstream of the outfall and extending in the east-west direction from the east shore to a point 1,000 feet **west** of the shore.

Temperature measurements during the July survey were made at the surface, middle and bottom only, rather than at every integral degree Fahrenheit, as was the case with the April survey. Therefore, for purposes of constructing subsurface temperature distributions, the July data is less reliable.

The temperature data reflects different stages of both the ebb and flood tidal phases. The temperature effect on the surface

and across the cross-section was plotted for seven different tidal phases. The seven tidal phases spanned a full tidal cycle and an average tidal condition was constructed by averaging the temperature distributions that existed for the seven tidal phases.

Figures 1 and 2 depict the surface temperature distribution for the average tidal condition for the July and April surveys, respectively. The temperature distributions result from heat loads of 482 MW and 422 MW, respectively, average heat loads for Indian Point Unit No. 1 during each survey period. These heat loads conform to operation at about 85% of the maximum electrical output (285MW), the output during that period approximating 245 MW.

Temperatures are presented in terms of the rise above the ambient temperature, i.e., naturally occurring river temperature prior to discharge of waste heat.

For the April survey, Figure 2 shows that the 4°F temperature rise extends approximately 330 feet off shore. Correspondingly, for the July survey, the 4°F rise extends 360 feet off shore. The width of the river at this point is 4,000 feet.

Figures 3 and 4 depict the temperature distribution across the cross-section for the section at the discharge point for two tidal phases during the April survey, early flood and maximum ebb, respectively. Both Figures 3 and 4 represent only the first 700 feet of width out of a total of 4,000 feet. Temperature rises beyond 700 feet were not measurable and therefore, the remainder of the river cross-section was not plotted. Five figures similar to Figures 3 and 4 were plotted for five other tidal phases and an average tidal condition was determined by averaging the seven temperature distributions.

Figure 5 represents the cross-sectional area enclosed by temperature rises for the April average tidal condition. The 4°F temperature rise encloses approximately 1,700 square feet. As the total cross-sectional area at this point is 160,000 square feet, the 4°F rise encloses 1% of the total cross-sectional area.

The average temperature rise over the entire cross-section was 0.093°F. This value was obtained by computing the area under the curve in Figure 5 and dividing the result by the total River cross-sectional area.

SURFACE ISOTHERMS AT INDIAN POINT
TIDAL AVERAGE CONDITIONS

JULY 1966

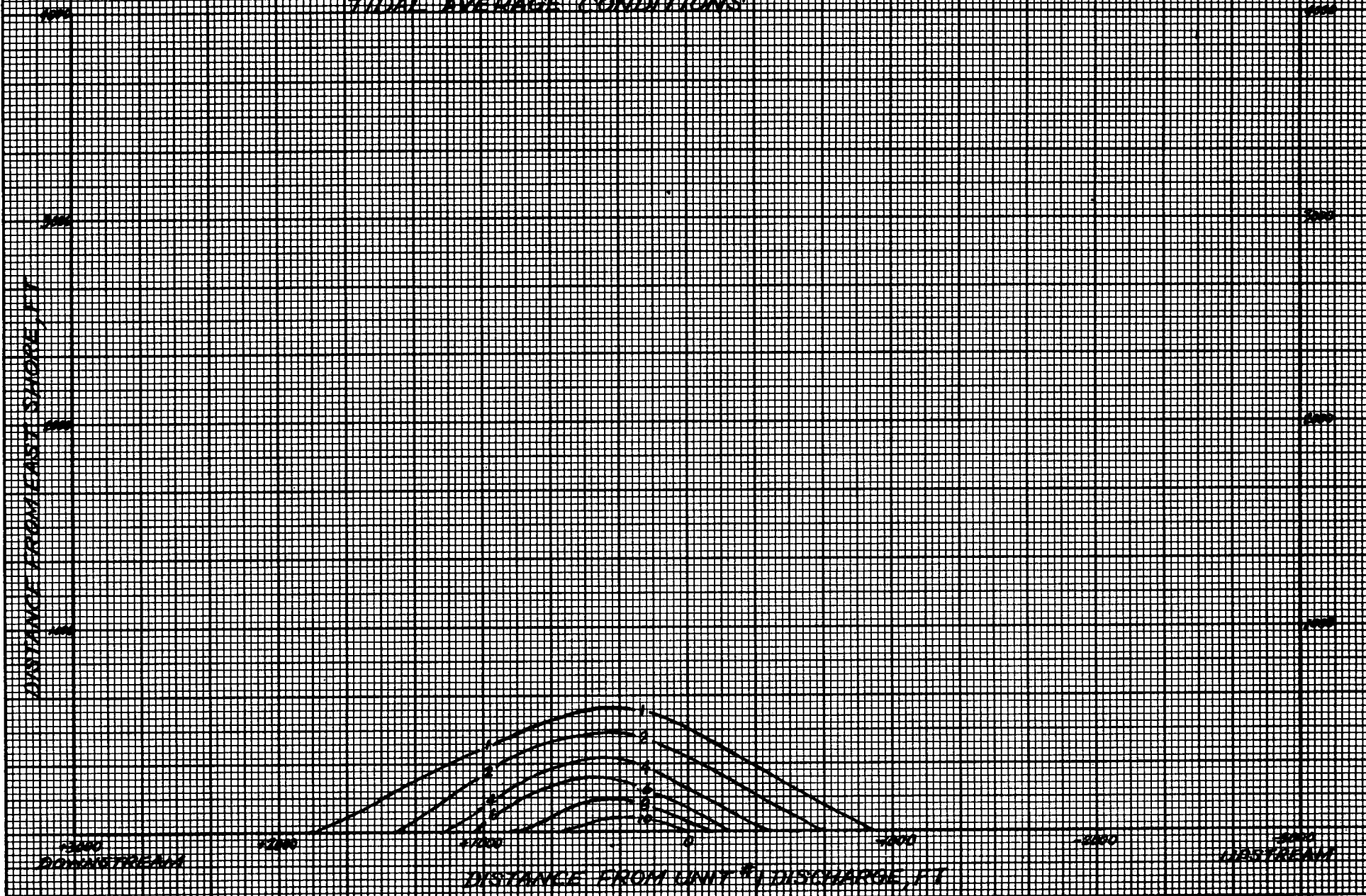
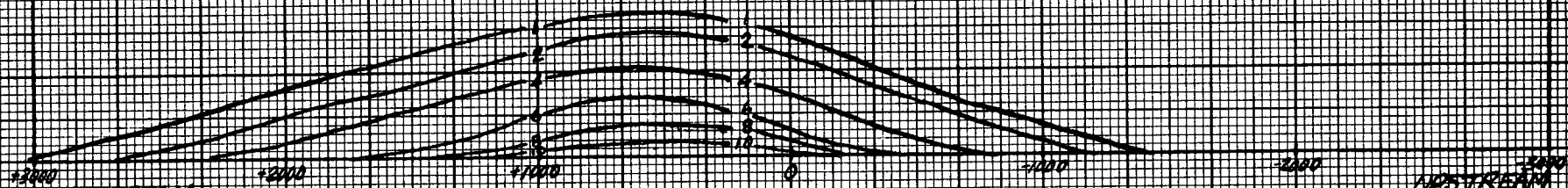

FIGURE 1

SURFACE ISOTHERMS AT INDIAN POINT
TIDAL AVERAGE CONDITION
APRIL, 1967

DISTANCE FROM EAST SHORE FT



DISTANCE FROM UNIT #1 DISCHARGE FT

FIGURE 2

TEMPERATURE RISE ISOTHERMS, °F
HUDSON RIVER AT INDIAN POINT

UNIT No. 1 OUTLET

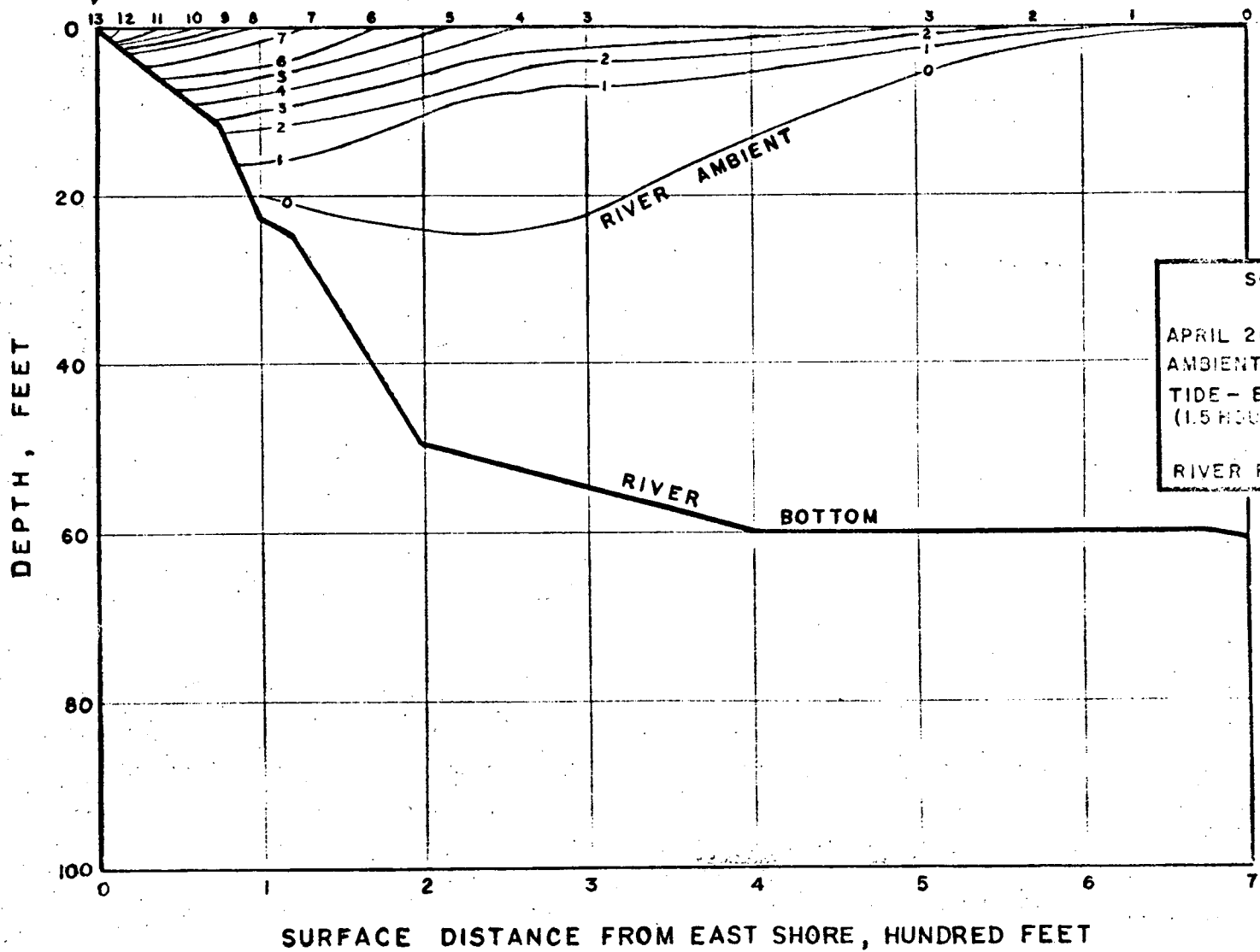

SOURCE OF DATA
APRIL 26, 1967
AMBIENT RIVER TEMP. 45°F
TIDE - EARLY FLOOD
(1.5 HOURS AFTER LW₅)
RIVER FLOW - 40,000 CFS

FIGURE 3

UNIT No. 1 OUTLET

TEMPERATURE RISE ISOTHERMS HUDSON RIVER AT INDIAN POINT

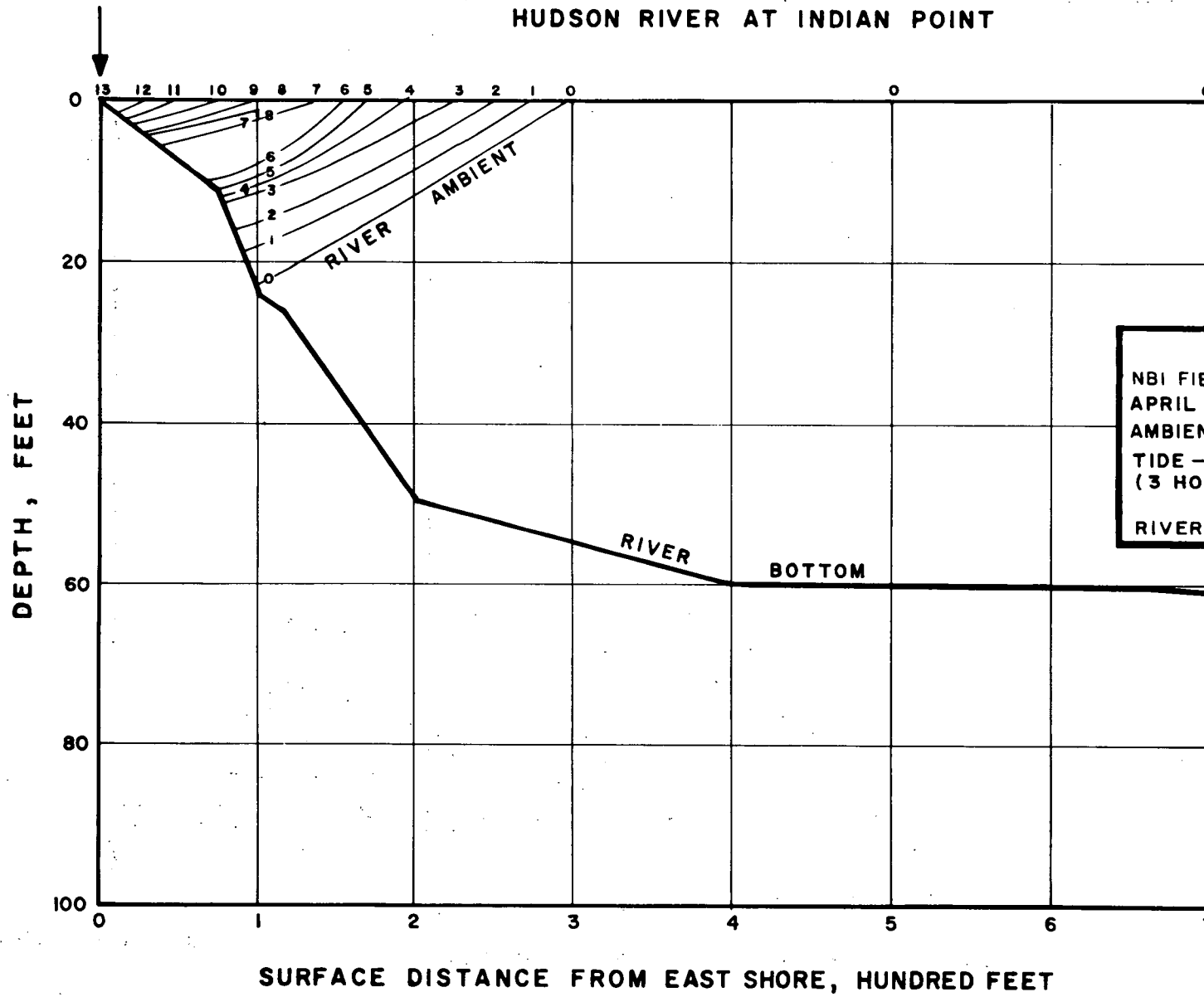

SOURCE OF DATA
NBI FIELD MEASUREMENTS
APRIL 17, 1967
AMBIENT RIVER TEMP. 45°F
TIDE - MAXIMUM EBB
(3 HOURS AFTER HWS)
RIVER FLOW - 40,000 CFS

FIGURE 4

TIDAL AVERAGE TEMPERATURE RISE DISTRIBUTION
HUDSON RIVER AT INDIAN POINT
MEASUREMENTS AT PLANE OF DISCHARGE
APRIL, 1967

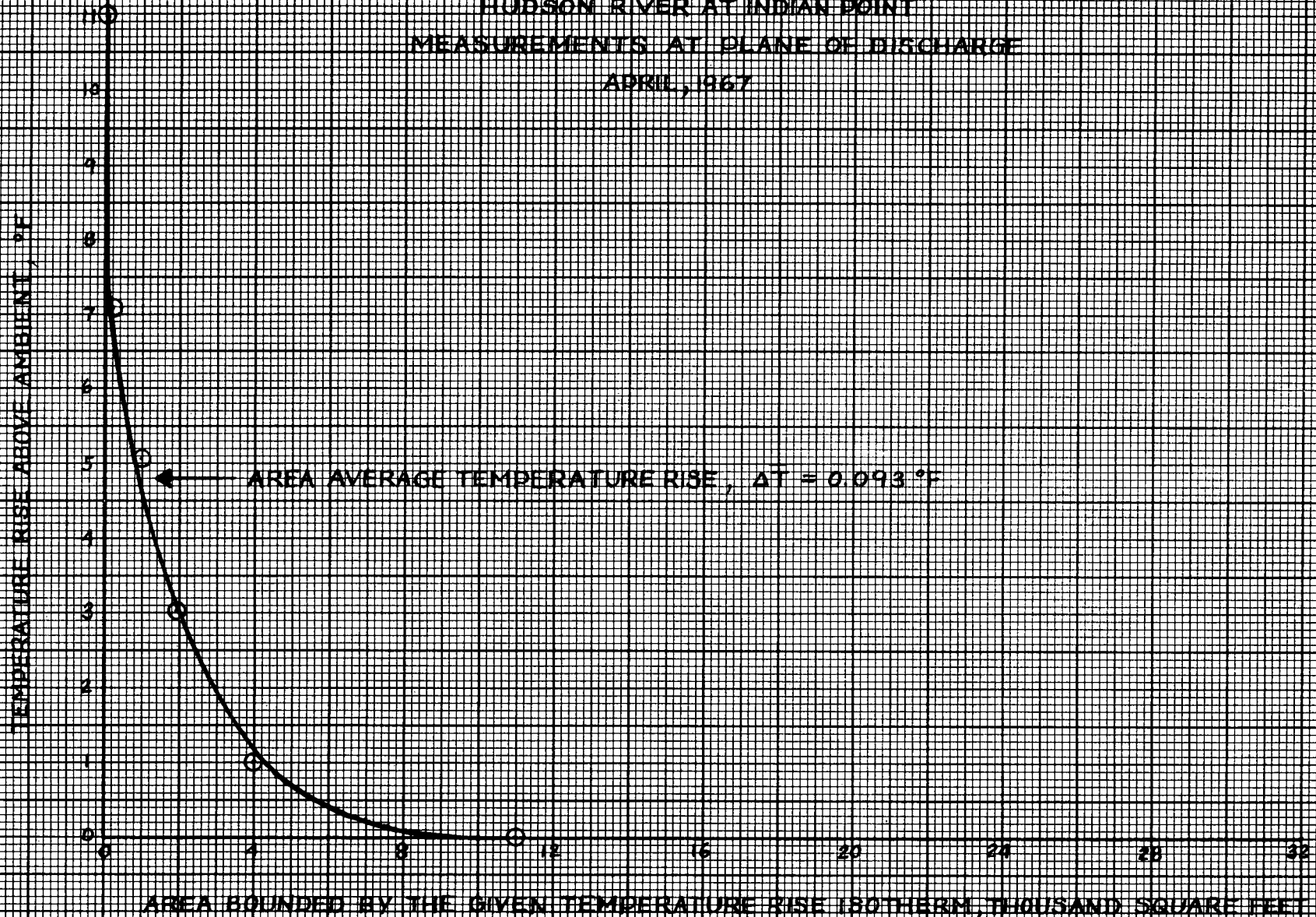

FIGURE 5

Figure 6 represents the cross-sectional area enclosed by temperature rises for an average condition for the July survey.

The average temperature rise over the entire cross-section was 0.2°F and the 4°F temperature rise enclosed approximately 2,000 square feet. This corresponds to 1% of the total cross-sectional area.

Although the average temperature rise in July is twice that of April, the local and surface temperature effects are not proportionately increased. The July average temperature rise is higher because of the retention of a greater amount of heat below the surface of the river.

The higher temperature rises below the surface are the result of the low flow conditions and related high mixing characteristics which occurred during July. The freshwater flow during July was 7,300 cfs as compared to 40,000 cfs during April.

Table 2 summarizes the portion of the river at Indian Point effected by temperature rises in excess of 4°F . The proposed standard requires that a minimum of $1/3$ of the surface and $1/2$ of the cross-sectional area have temperature rises of less than 4°F . The NBI data shows that more than 90% of the surface and approximately 99% of the cross-sectional area will have temperature rises less than 4°F .

Texas Instruments, Incorporated, Airborne Infrared Surveys,
October 28, 1967 and April 6, 1968

Two airborne infrared data surveys of the Hudson River in the Indian Point vicinity were performed for Consolidated Edison by TXI. The surveys were undertaken to collect data for compilation of isothermal maps of the river surface.

The following excerpt from the TXI report, Airborne Infrared Survey, Indian Point Area, Hudson River, New York, December 1968, presents the theory behind infrared imagery and describes the procedure employed for the Hudson River survey.

"Infrared imagery, similar in appearance to strip photography, is produced by a series of scan lines perpendicular to the flight direction. Relative radiometric temperature differences are represented by different gray tones. Light

TIDAL AVERAGE TEMPERATURE RISE DISTRIBUTION ACROSS PLANE OF DISCHARGE

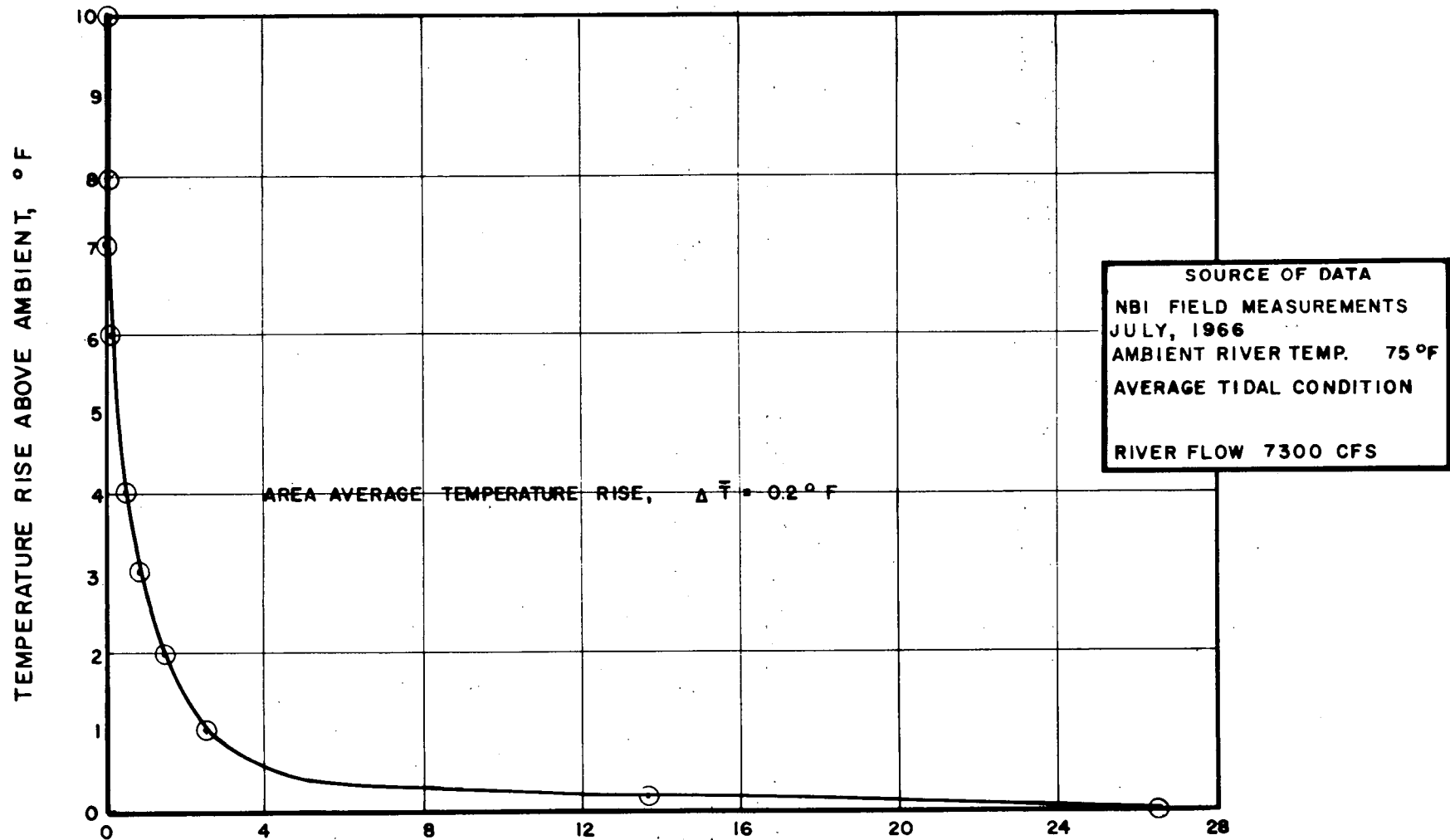

AREA BOUNDED BY THE GIVEN TEMPERATURE RISE ISOTHERM, THOUSAND SQUARE FEET
(AREA WITHIN WHICH THE TEMPERATURE RISE \geq THE RISE ISOTHERM)

TABLE 2

PORTION OF RIVER AT INDIAN POINT EFFECTED
BY TEMPERATURE RISES IN EXCESS OF 4°F

<u>Survey</u>	<u>Lateral Distance</u>		<u>Area</u>	
	<u>FT</u>	<u>% of full width</u>	<u>FT²</u>	<u>% of total cross-sectional area</u>
July	360	9	2000	1
April	330	8	1700	1

tones on a positive print of infrared imagery represent relatively high radiometric temperatures. Dark tones are related to relatively low radiometric temperatures.

The TXI system produces imagery in the 8 to 14 micron wavelength band which is not rectified; i.e., the scale along the flight direction is relatively constant, but the scale perpendicular to the flight direction becomes smaller with increased distance away from the centerline.

Infrared mapping systems are designed so that electronic signal displacement between hot and cold objects is controlled within the dynamic range of the recording film. The system's thermal baseline continually adjusts itself to the average between hot and cold temperatures of the scanned area. This compensation occurs in the circuitry prior to the glow-modulator which exposes the recording film. Thus, the imagery contains the effects of thermal baseline adjustment.

The Texas Instruments system also monitors the video signal from the detector at the preamplification stage by a type-A oscilloscope. The oscilloscope presentation of individual sweeps (single scan lines) of the detectors are recorded by a 35-mm camera. These A-Scope profile data, used to compile isothermal maps, are not affected by system compensation and can be considered quantitative.

Radiometric temperature references are provided by temperature-controlled blackbody baffles mounted within the scanning system's field of view. The temperature of each reference baffle is closely monitored during flight. The amplitude difference between the two reference baffles can be converted to a temperature scale from which temperature values can be assigned to individual points along the A-Scope trace. Correlation between A-Scope data and the scanner imagery is supplied by a difucial system which also provides a means of tying airborne data to ground position.

Overflights were made between Croton Point and Bear Mountain Bridge at altitudes of 5000 and 10,000 ft above the river surface. Three straight segments were flown for each tidal coverage because of the meandering configuration of the

river in the survey area. The first segment was flown north-westward from Croton Point to the vicinity of Tomkins Lake. Segment 2 covered the area from the town of Tomkins Cove to Annsville Creek. The third flightline extended from Peekskill Bay to Bear Mountain Bridge."

Survey results are presented as a set of eight isothermal maps. Figures 7 through 10 were compiled from the October, 1967 data while Figures 11 through 14 show the results of the flights in April, 1968.

During the October survey, the unit at Indian Point was shut down.

Orange and Rockland Utilities, Incorporated, which operates four fossil-fueled units at its Lovett plant site, located two miles downstream of Indian Point on the west shore of the Hudson, was operational. The heat load discharged from the four units at Lovett is shown on an hourly basis for October 28, 1967 in Figure 15. The average heat load for the day was approximately 200 MW.

Designated on Figure 15, are the times and tidal phase for the four isothermal maps given in Figures 7 through 10. Although, the hourly heat loads prior to any one particular survey may differ, this does not result in an corresponding change in the temperature distribution of the river. The river does not react instantaneously to changes in heat load, but more accurately reflects the average heat load for several hours prior to an actual measurement. Thus, in analyzing these isothermal maps, each map should be associated with an average loading condition prior to the survey.

The heat loads discharged from the four units at Lovett and for the one unit at Indian Point are shown on an hourly basis for April 6, 1968 in Figures 16 and 17 respectively. The average heat loads for the day were 395 MW and 195 MW for Indian Point and Lovett, respectively.

Figure 17 shows that the surveys at early ebb and late ebb would more accurately reflect a load of 285 MW while the surveys at mid flood and high water slack reflect a load of 487 MW. As the four surveys will be averaged and associated with an average tidal condition, the average daily load of 395 MW will be used as responsible for the average tidal effect.

The following discussion of Figures 7 through 14 is taken from the the TXI, December 1968 report.

FIGURE 7

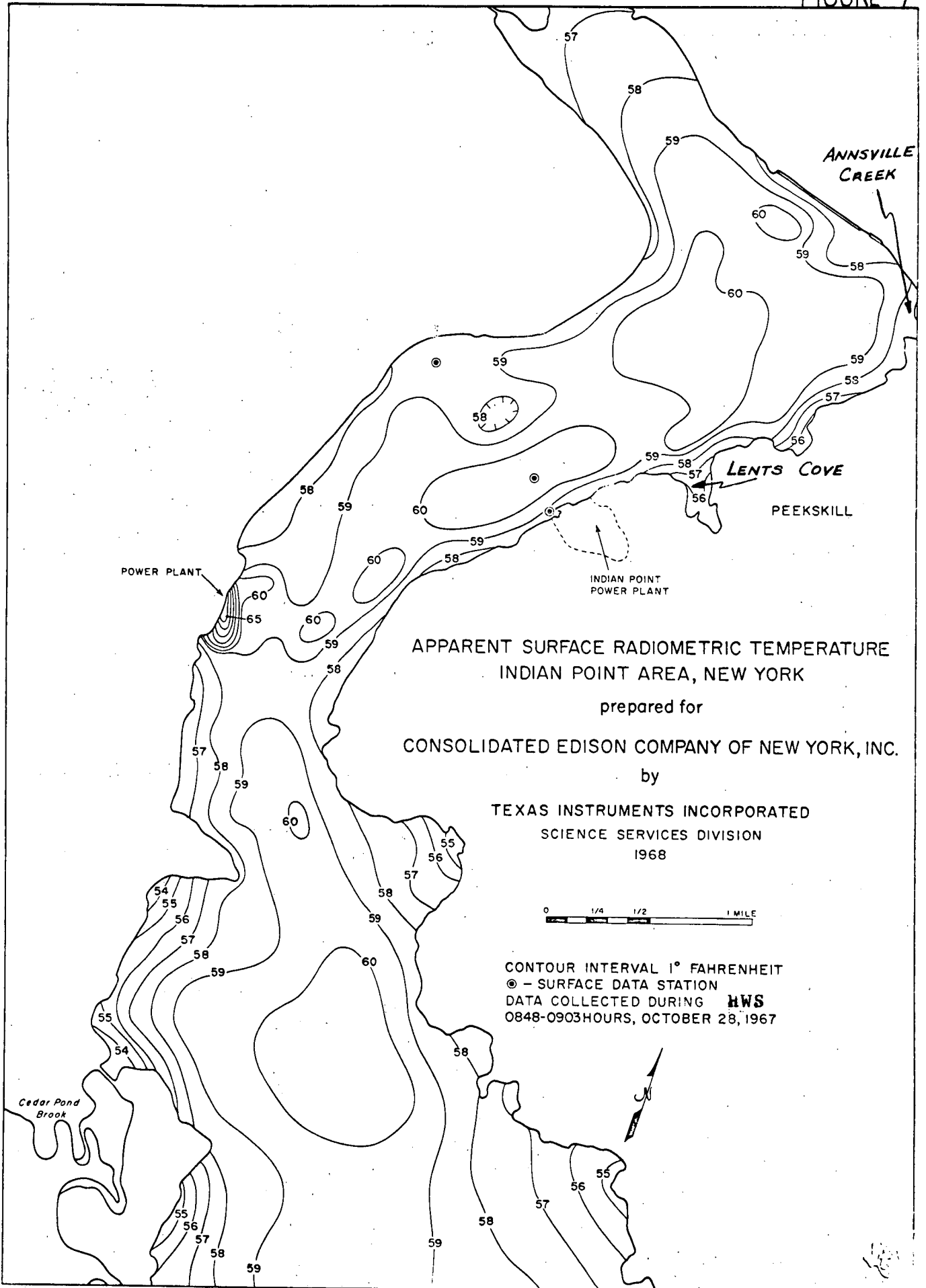
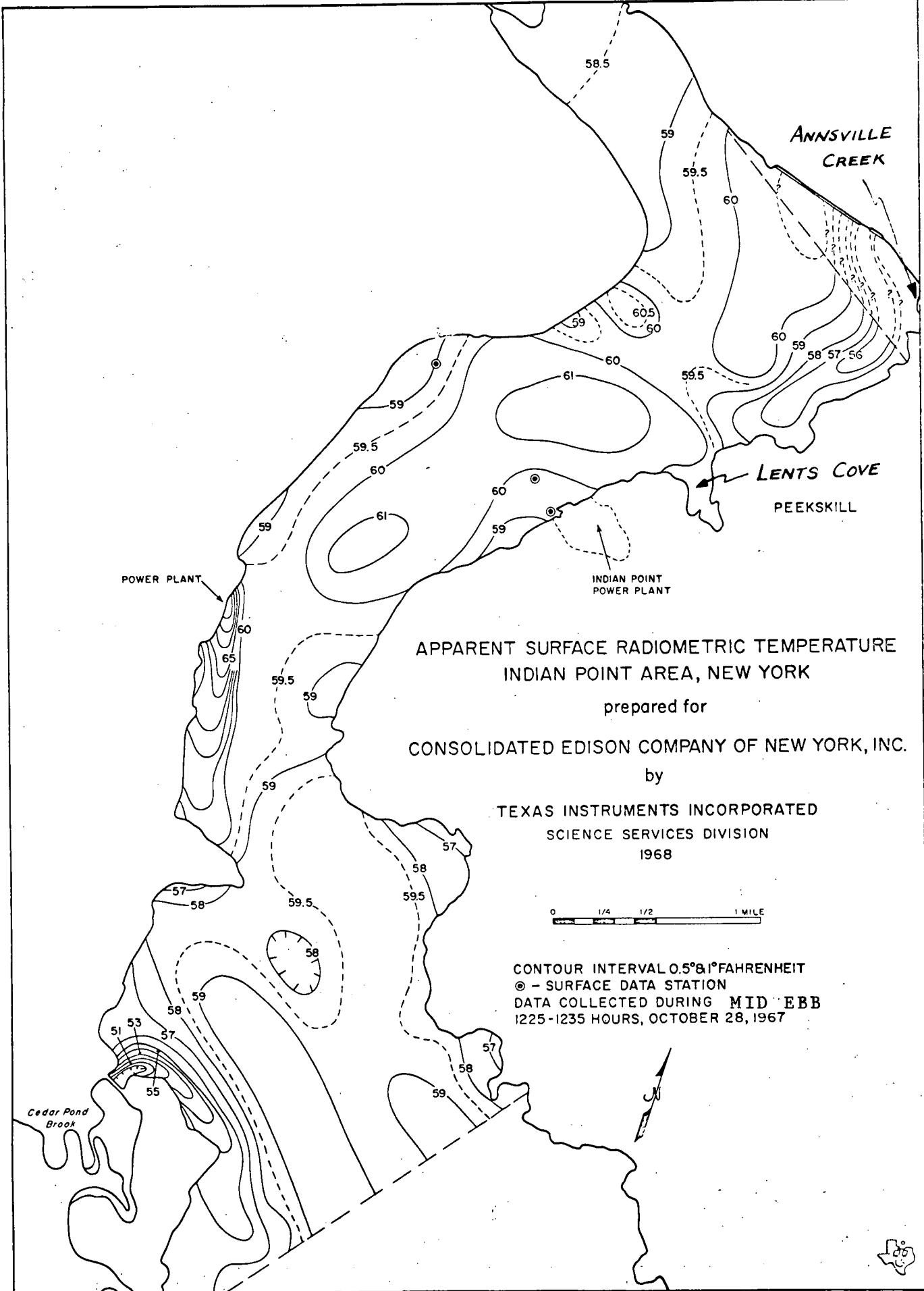
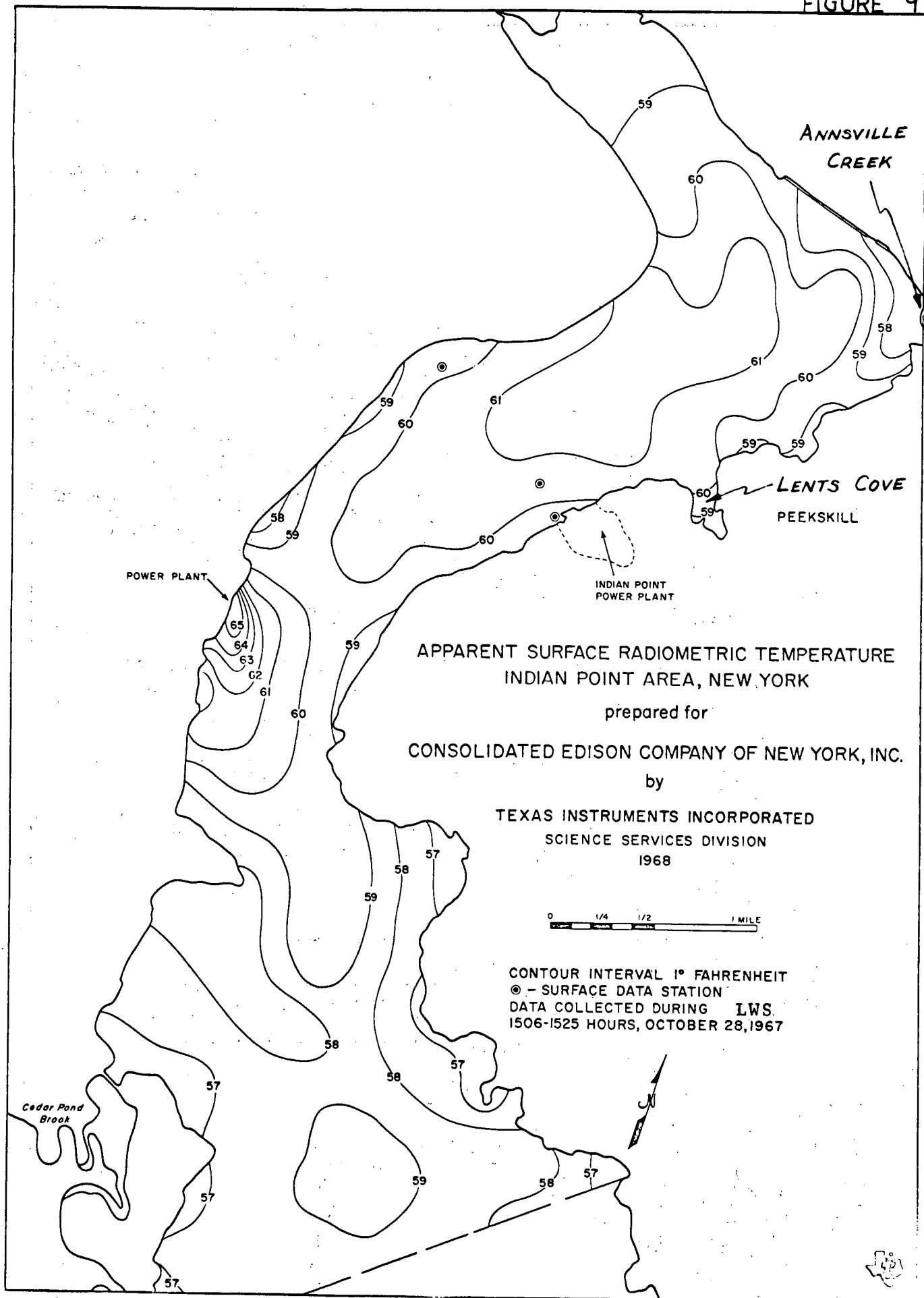

FIGURE 8





APPARENT SURFACE RADIOMETRIC TEMPERATURE
INDIAN POINT AREA, NEW YORK
prepared for
CONSOLIDATED EDISON COMPANY OF NEW YORK, INC.

by
TEXAS INSTRUMENTS INCORPORATED
SCIENCE SERVICES DIVISION
1968

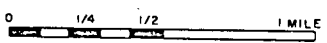

CONTOUR INTERVAL 1° FAHRENHEIT
● - SURFACE DATA STATION
DATA COLLECTED DURING IWS
1506-1525 HOURS, OCTOBER 28, 1967



FIGURE 10

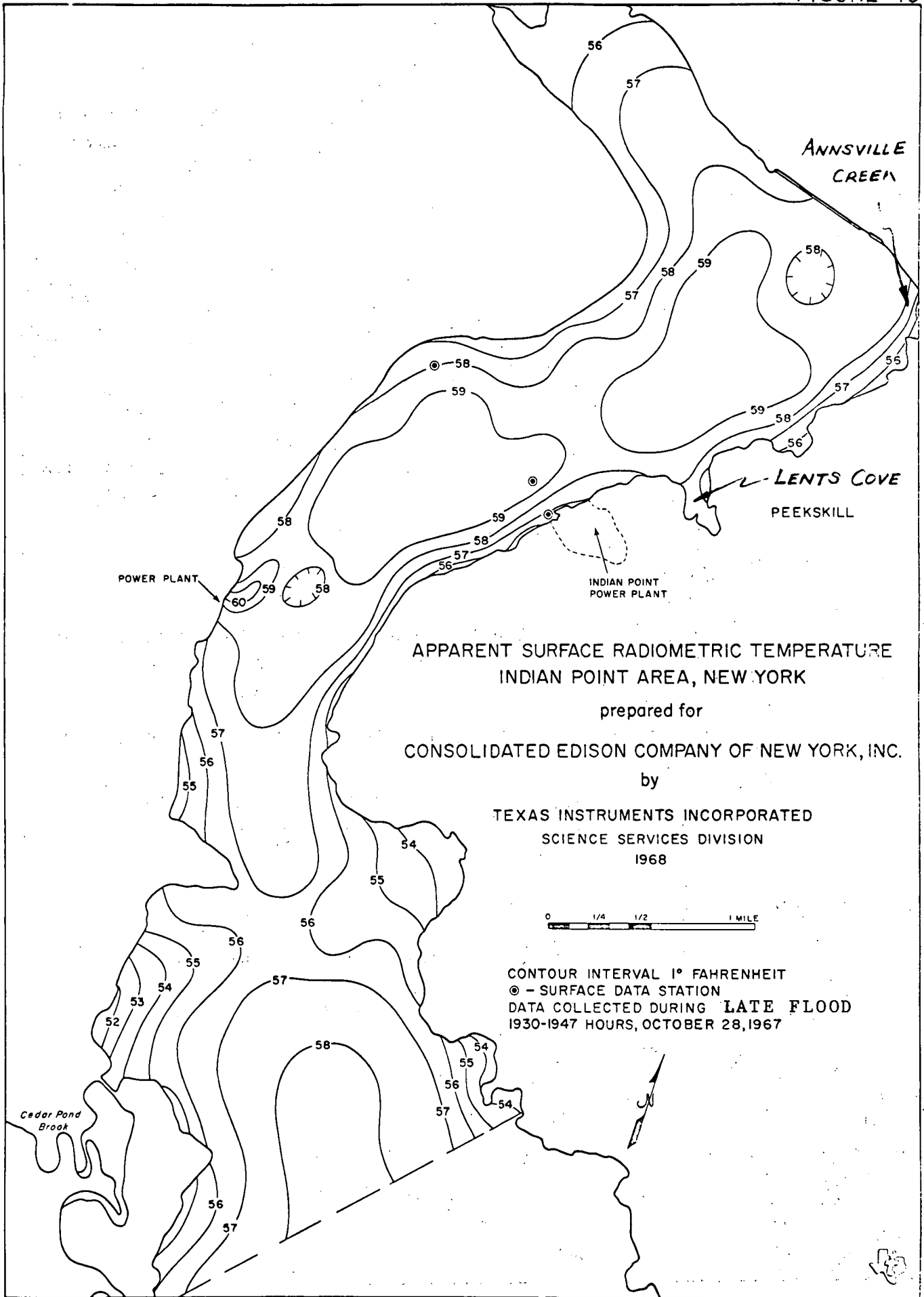
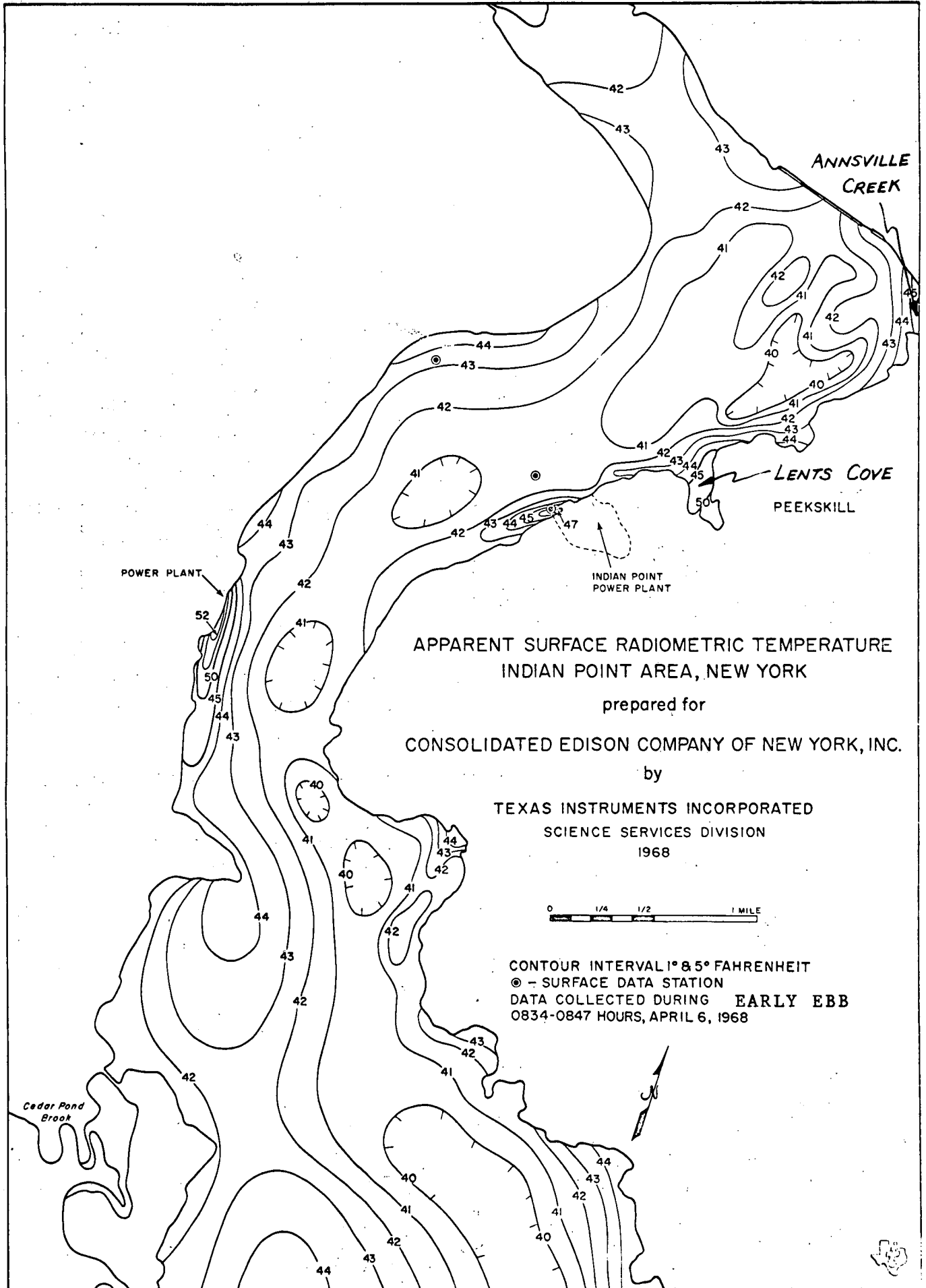

FIGURE 11



APPARENT SURFACE RADIOMETRIC TEMPERATURE
INDIAN POINT AREA, NEW YORK
prepared for
CONSOLIDATED EDISON COMPANY OF NEW YORK, INC.

by
TEXAS INSTRUMENTS INCORPORATED
SCIENCE SERVICES DIVISION
1968

CONTOUR INTERVAL 1° & 5° FAHRENHEIT
● - SURFACE DATA STATION
DATA COLLECTED DURING EARLY EBB
0834-0847 HOURS, APRIL 6, 1968

FIGURE 12

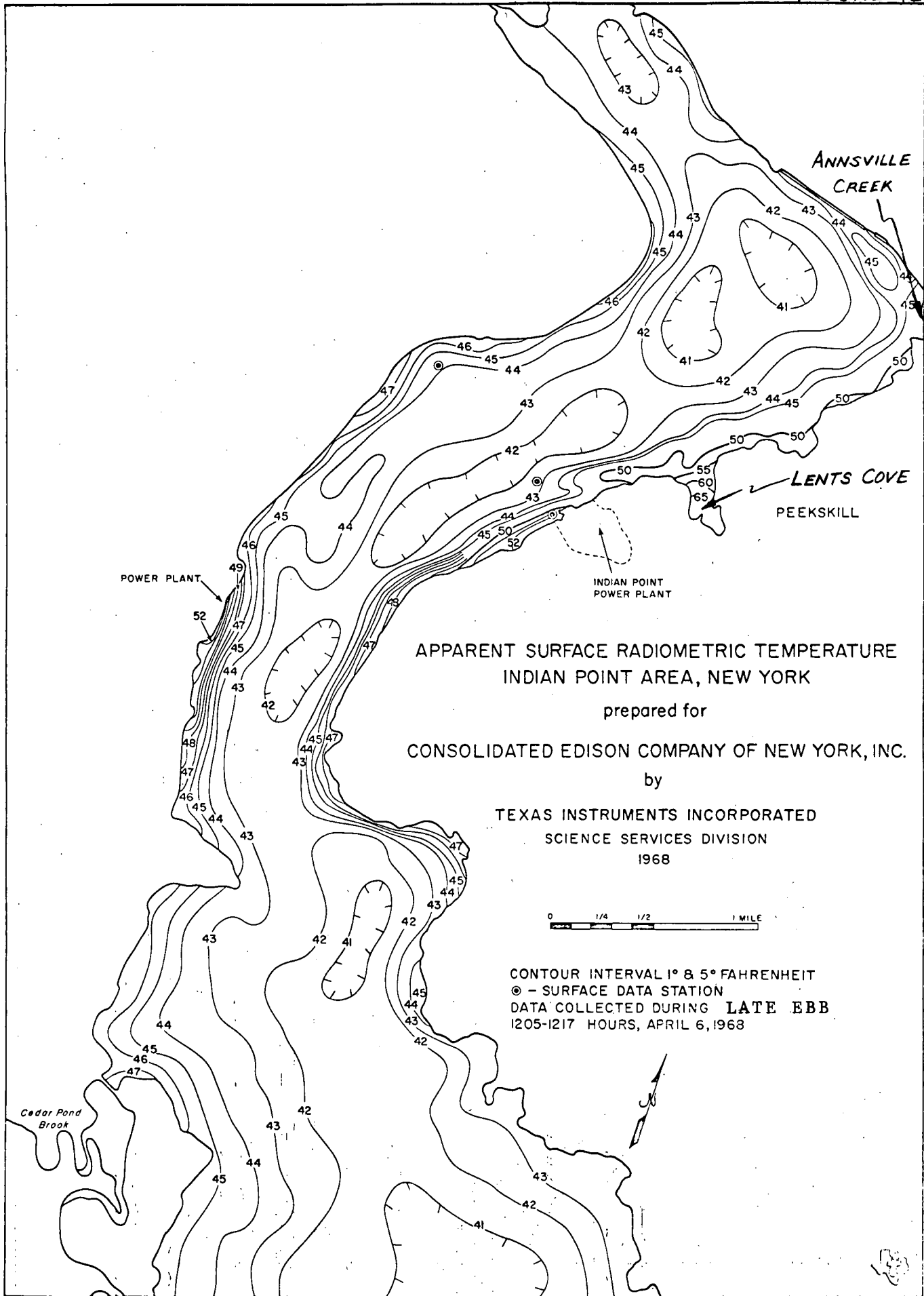

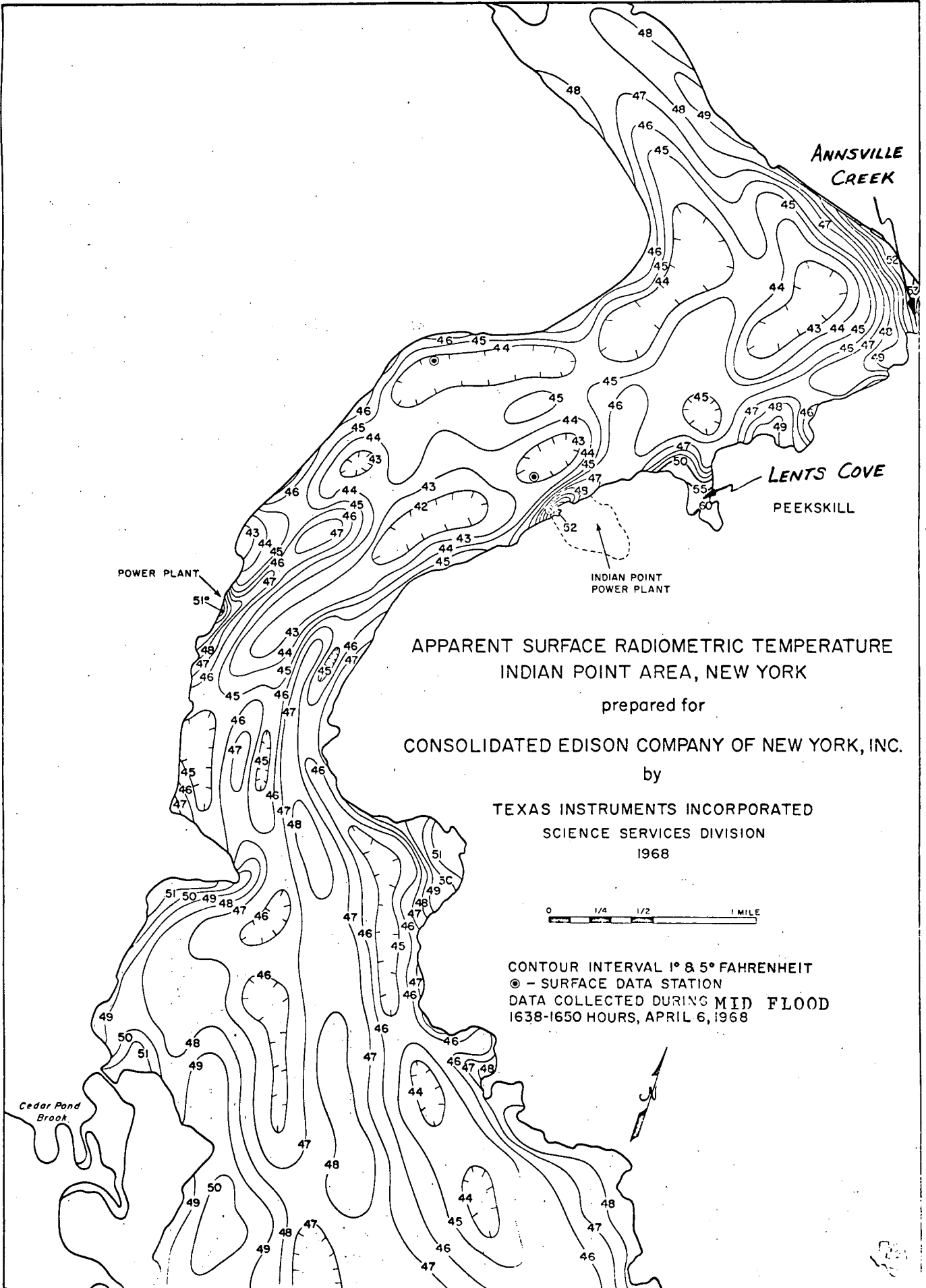
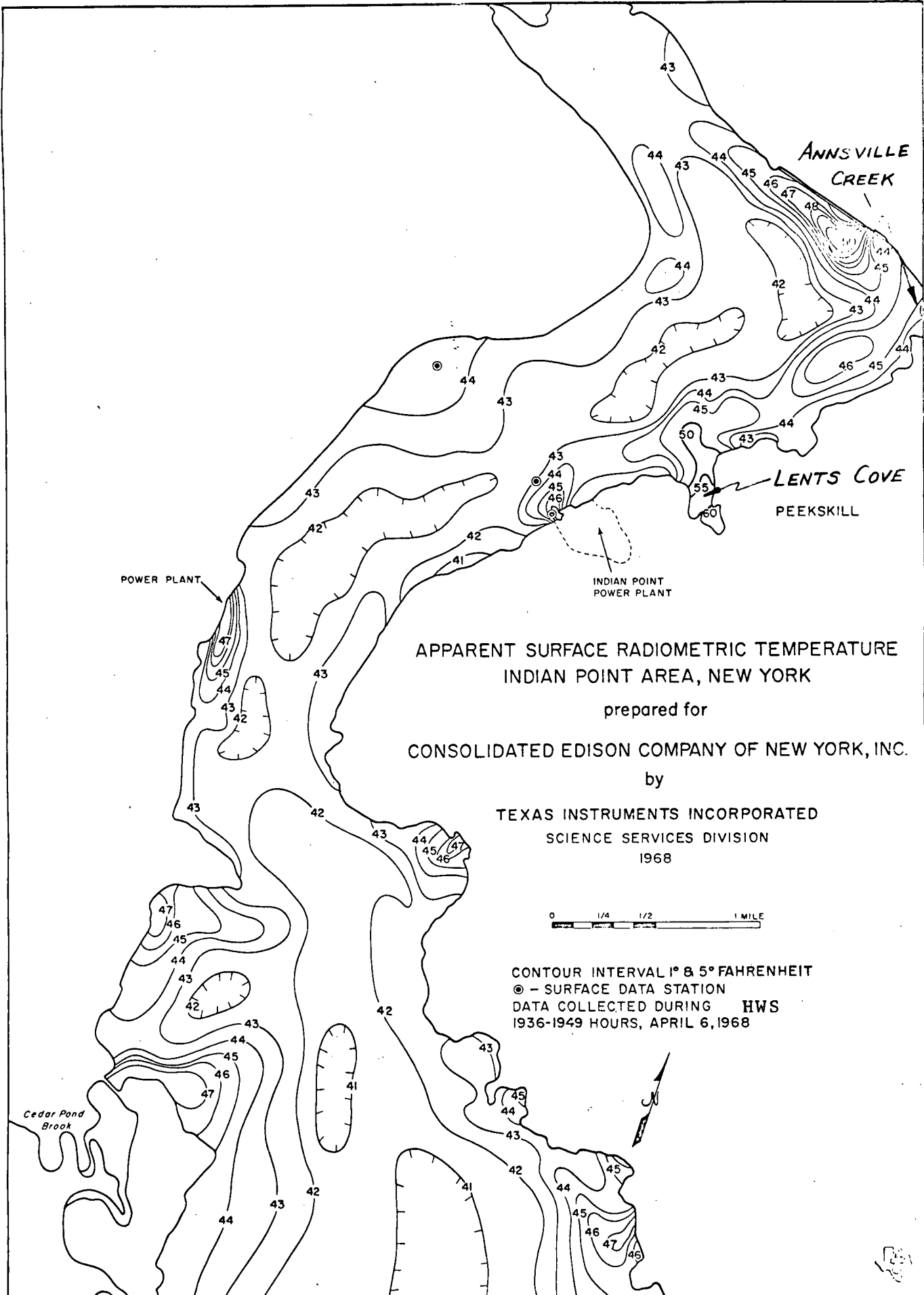

FIGURE 14



VARIATION IN HOURLY HEAT LOAD AT LOVETT
OCT. 28, 1967

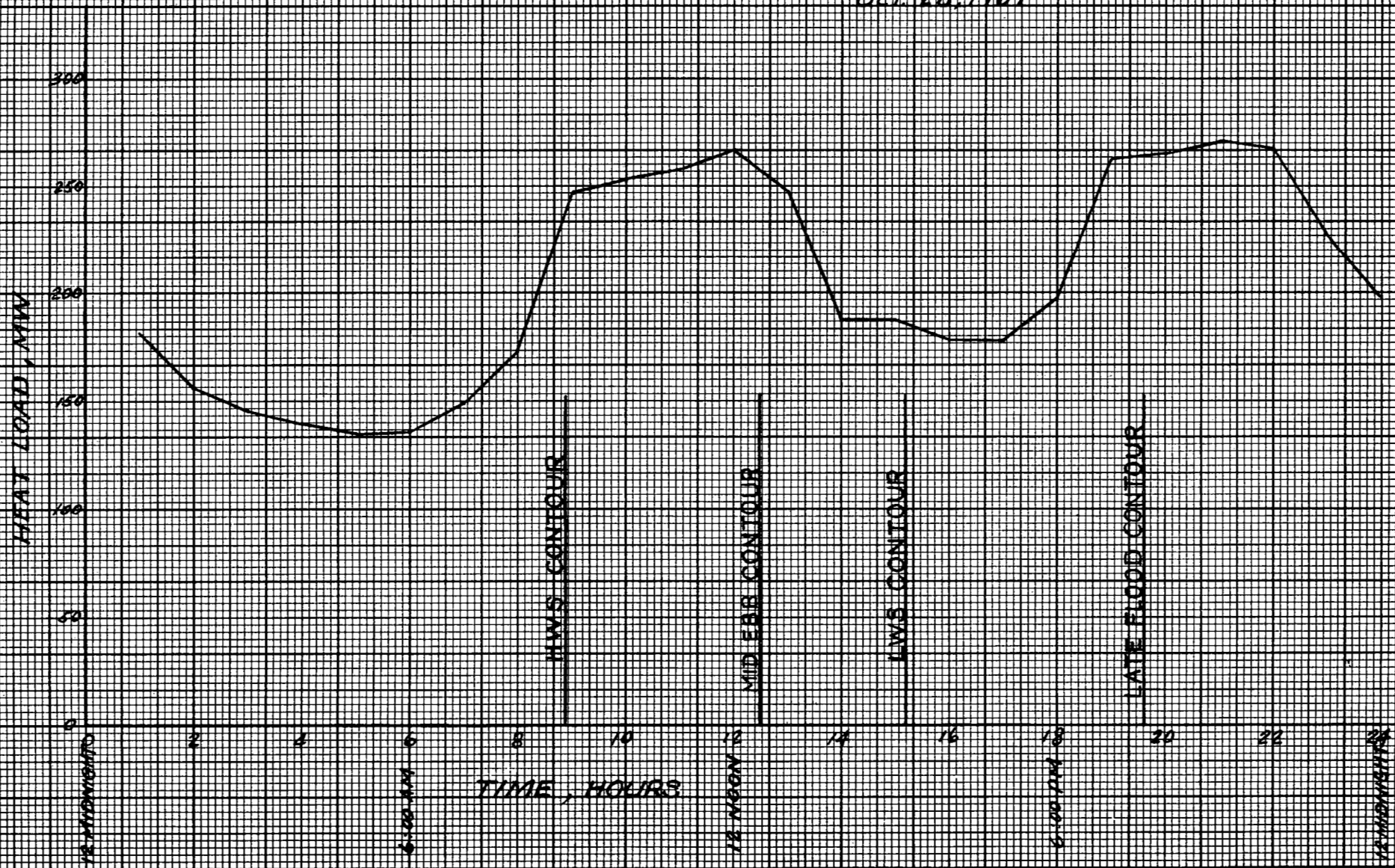

FIGURE 15

REVISED 10/28/67

VARIATION IN HOURLY HEAT LOAD AT LOVETT
Apr. 6, 1968



FIGURE 16

VARIATION IN HOURLY HEAT LOAD AT INDIAN POINT
APR 6, 1968

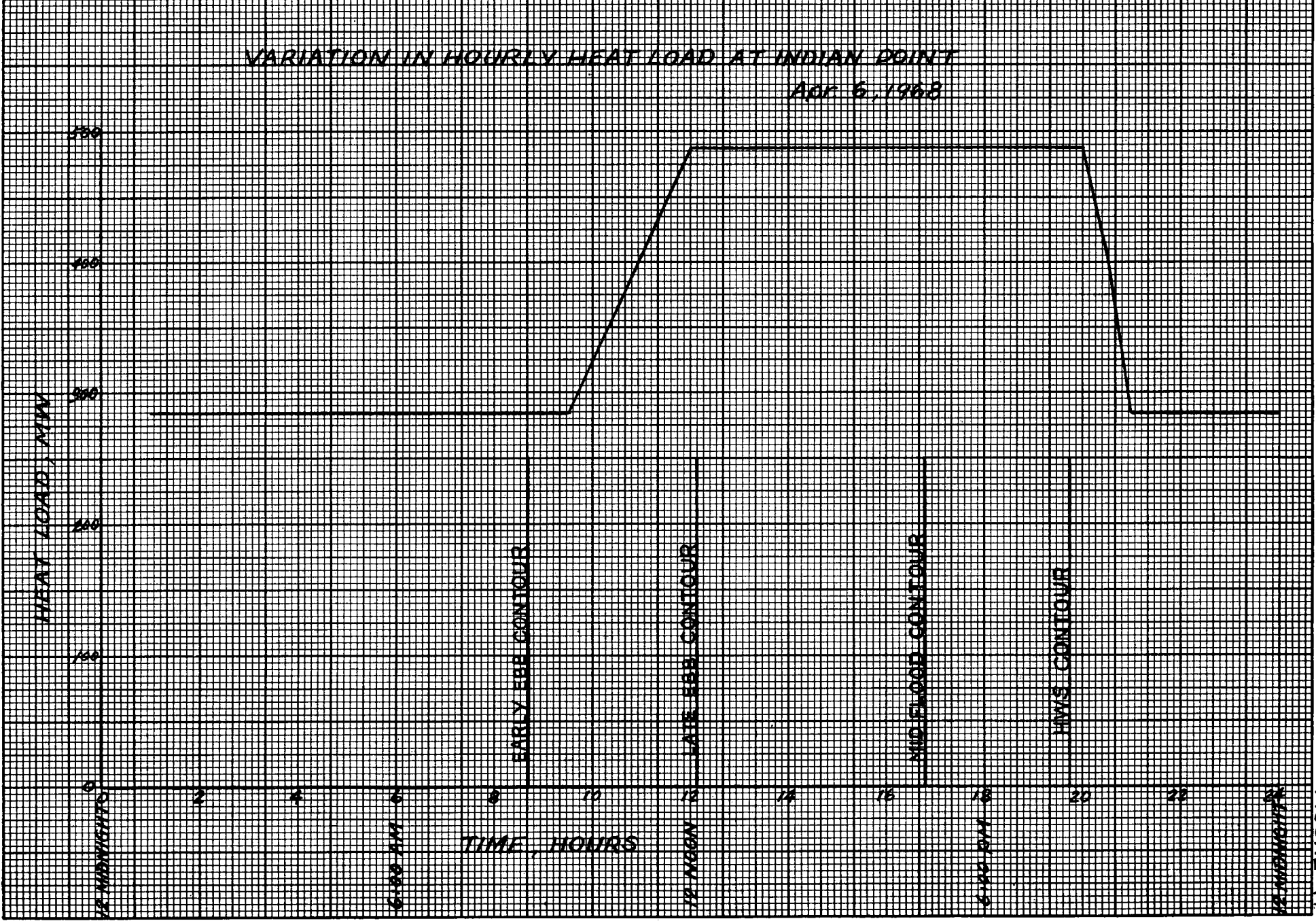

FIGURE 17

The isothermal maps indicate that during October survey the Hudson River was warm relative to the temperature of the small lakes, ponds, and tributary streams. This is particularly well illustrated on Figure 8. The discharge from Annsville Creek and Cedar Pond Brook is several degrees cooler than the main part of the Hudson River. The relatively cool surface runoff appears to keep the river surface cool along the shoreline, compared to the relatively warm midstream area.

The change in the surface thermal pattern during each tidal condition is indicated by the contours. The thermal discharge from the Lovett power plant on the west side of the river varies considerable in shape and direction from one map to the next. The highest temperature (about 8°F above river temperature) is indicated on Figure 8. The mapped amplitude variations of this thermal discharge are related to the interval at which quantitative data were collected, approximately 1.5 sec or about 300 ft on the ground at normal flight speeds. This interval is suitable for mapping general surface thermal variations but is not adequate to observe on each overflight a small target such as a discharge channel. On Figure 10, for example, the effluent from the Lovett power plant is not only restricted in area because of the current/tide situation but is mapped as only a 2°F thermal anomaly. During this overflight the discharge channel falls between two A-Scope profiles; thus, the true temperature of the thermal discharge was not measured.

During the April survey the surface runoff from the tributary streams was warm relative to the Hudson River. All of the maps of the second set show that the central portion of the river is cool relative to the warm marginal zones.

The mapped thermal effluent from the Lovett power plant also varies in amplitude on the second set due to the data collection interval. However, a maximum temperature of 52°F was recorded on two of the maps, indicating that the water temperature at the discharge channel was about 9°F above the river temperature.

The Indian Point power plant thermal discharge varies in temperature, but the maximum value of 52°F on Figures 12 and

13 agrees well with the observed surface data.

"It is significant that the highest temperatures recorded in the second set of data are related to the discharge from Annsville Creek and from Dickey Brook, which enters the Hudson River at Lents Cove. Industrial or sewage disposal plants may contribute to the relatively high temperature of these creeks. However, the imagery and A-Scope data during some of the overflights indicate that the small lakes and ponds in the area have a high surface temperature, probably due to solar heating. Thus, the airborne data suggest that at certain parts of the year a considerable volume of warm water entering the Hudson River may be due to solar heating of shallow surface water."

Table 3 shows the surface at Indian Point with temperature rises in excess of 4°F for the April survey. The 4°F rises were computed for three different ambient conditions, 42°F, 43°F and 44°F. Three different ambient conditions were assumed because a single ambient temperature applied over the full surface would not be appropriate.

The isothermal maps demonstrate the marked temperature variation on the surface. To evaluate the added temperature caused by the power plant heat load at any time, the naturally occurring temperature at that point, prior to power plant heat load, would have to be known. However, this can not be done because addition of heat artificially has changed the surface temperature contours and it would only be possible to approximate what the surface temperature might have been, had there been no artificial heating.

In any event, temperature rises computed for several different ambient temperatures provides a method of establishing a range from which the true effect of the power plant heat load may be selected.

Table 3 shows that for the average of the four tidal phases, the surface width at Indian Point effected by temperature rises in excess of 4°F ranged from 200 feet to 360 feet, corresponding to a range of from 5% to 9% of the total width.

TABLE 3

WIDTH AT INDIAN POINT SUBJECTED TO
TEMPERATURE RISES IN EXCESS OF 4°F

APRIL 6, 1968

<u>Time</u>	<u>Tidal Phase</u>	<u>W I D T H</u>					
		<u>T_A=42</u>		<u>T_A=43</u>		<u>T_A=44</u>	
		<u>FT</u>	<u>%</u>	<u>FT</u>	<u>%</u>	<u>FT</u>	<u>%</u>
0834-0847	Early Ebb	240	6	150	4	-	-
1205-1217	Late Ebb	550	14	500	12.5	450	11
1638-1650	Mid Flood	300	7.5	270	7	240	6
1936-1949	High Water Slack	360	9	150	4	-	-
Average		360	9	270	7	200	4.5

Comparison of NBI and TXI Data

The TXI data represents surface temperatures only. Consequently, all comparisons will be for surface effects.

Also, comparison will only be made for the April surveys. This is reasonable because surveys, taking place during the same month of the year, would be subject to similar meteorological and freshwater runoff conditions.

The TXI results for the 42°F and 43°F ambient temperatures demonstrated good agreement with the results reported by NBI for their April, 1967 survey. The NBI April, 1967 survey showed that on a tidal average basis temperature rises in excess of 4°F consumed 330 feet or 8% of the total width at Indian Point. The TXI April, 1968 survey showed for the 42°F ambient temperature that 360 feet or 9% of the width was consumed. Correspondingly, for the 43°F ambient temperature, 270 feet or 7% of the width was consumed.

The average heat load discharged at Indian Point during the April, 1967 survey was 472 MW, almost 20% higher than the 395 MW that was discharged on April 6, 1968. Therefore, it might be more appropriate to associate the April 6, 1968 temperature rise result with the 43°F ambient temperature; the temperature effect for April, 1968, associated with a smaller heat load, should be less than the temperature effect for April, 1967.

In any event, the NBI and TXI survey results are in agreement. This gives support for their use as a basis for extrapolating to temperature effects resulting from future heat loads. Also, from the results of these surveys, it can be concluded that at the present time the surface width at Indian Point effected by temperatures in excess of 4°F is less than 10% of the total width. Correspondingly, the area consumed by a 4°F rise is in the order of 1%.

V. REVISION OF PREDICTIVE MODEL

This chapter first compares the predictions of River temperature profiles for Unit No. 1 operation using the January '68 report model, to field observations of River temperature in the vicinity of Indian Point during several periods of Unit No. 1 operation in 1966 and 1967.

Reasons for differences are suggested, and the model is then adjusted empirically to yield results compatible with field measurements.

Use of this adjusted model to predict temperature profiles for three unit operation is given in Chapter VI.

Comparison of Predicted and Measured Profiles - January '68 Report.

To determine the temperature effect caused by operation at Indian Point, QL&M Engineers developed an unsteady-state mathematical model, which generated the longitudinal profile of area-average temperature rises. Model results for one unit operation were compared to river temperature measurements made in the vicinity of the Indian Point Unit No. 1 discharge by Northeastern Biologists, Incorporated (NBI), in July, 1966 and April, 1967.

Table 4 presents this comparison. For July 1966, the predicted temperature rise was 25% higher than the actual temperature rise at the plane of discharge and 69% higher than the actual temperature rise at the cross-section 800 feet downstream of the plane of discharge. Correspondingly, for April 1967, the predicted temperature rises were 85% and 100% higher than the measured temperature rises.

These area-average values are extremely small and the validity of the comparison could be questioned; i.e., should a reviewer consider temperature rises of 0.1 to 0.2°F negligible, he might conclude comparison of such results is unacceptable.

This potential objection is answered by pointing out that these area-averages represent the weighted effect of significant temperature rises near the east shore of each cross-section considered, and zero temperature rises over most of the remainder of the cross-section. The very small area-averages are merely the result of measurable temperature rises over less than 10% of the cross-section, reduced by the ratio of the affected area to the total area of some 160,000 sq. ft.

TABLE 4

COMPARISON OF PREDICTED AND MEASURED AREA-AVERAGE TEMPERATURE RISES
HUDSON RIVER NEAR INDIAN POINT

Location	Area-Average Temperature Rise ¹					
	July 1966			April 1967		
	Measured °F	Predicted °F	<u>Predicted</u> Measured	Measured °F	Predicted °F	<u>Predicted</u> Measured
Across Plane of Discharge	0.2 ¹	0.25 ¹	1.25	0.093 ¹	0.172 ¹	1.85
Across Plane 800 Ft. Below Discharge	0.145 ²	0.245 ³	1.69	0.0825 ¹	0.17 ³	2.06

1- Data taken from January, 1968 Report, Table 1 and pages 9, 11 and 21.

2- Obtained from field data by same procedures outlined in January 1968 report to obtain plane of discharge averages.

3- Computed using unrevised one-dimensional mathematical models.

The methods used to compute the measured area-average temperature rise are given in detail in the January '68 report. These are summarized below to clarify the answer to the potential objections stated above.

Figure 18 depicts the temperature rise distribution at the plane of discharge for an early flood tidal condition during the April 1967 survey. Seven figures similar to Figure 18 were constructed for different tidal phases and the areas enveloped by each isotherm were averaged. For a given isotherm, the average of the eight different areas, corresponding to the eight tidal phases, equally spaced in time, was considered representative of the average tidal condition.

Figure 5 (following page 7) shows the cross-sectional areas enveloped by different temperature rises for the average tidal condition. Figure 5 shows that, while the temperature effect averaged over the full 160,000 square feet may be negligible ($<0.1^{\circ}\text{F}$), temperature rises in the immediate vicinity of the discharge are significant. Temperature rises of greater than 1°F existed for 4,000 square feet.

Spreading the effect that exists within the first 11,000 square feet (boundary of the 0°F isotherm) over the full 160,000 square feet area results in the apparent negligible average effect. Averaging the temperature rise over the local area effected (the first 11,000 square feet) would have resulted in higher temperatures that might be considered more meaningful. However, as the area-average model predicts area-averages only, field measurements had to be converted to area averages for purposes of comparison.

A more valid objection would be to question the point at which the measured temperature versus area curves are extrapolated to zero. This objection is considered and answered in the January '68 report (pages 9 and 10). This question can be answered further by plotting the temperature rise isotherm versus area of influence of the isotherm for both the measured and predicted area-average temperature rises. Such a comparison is made in Figure 19.

Figure 19 is a comparison of exponential model predicted areas enveloping different temperature rises to actual measurements made during the April 1967 survey (see Figure 5). Figure 19

TEMPERATURE RISE DISTRIBUTION ACROSS SECTION AT INDIAN POINT
MEASUREMENTS AT PLANE OF DISCHARGE
TIDE - EARLY FLOOD
APRIL 26, 1967

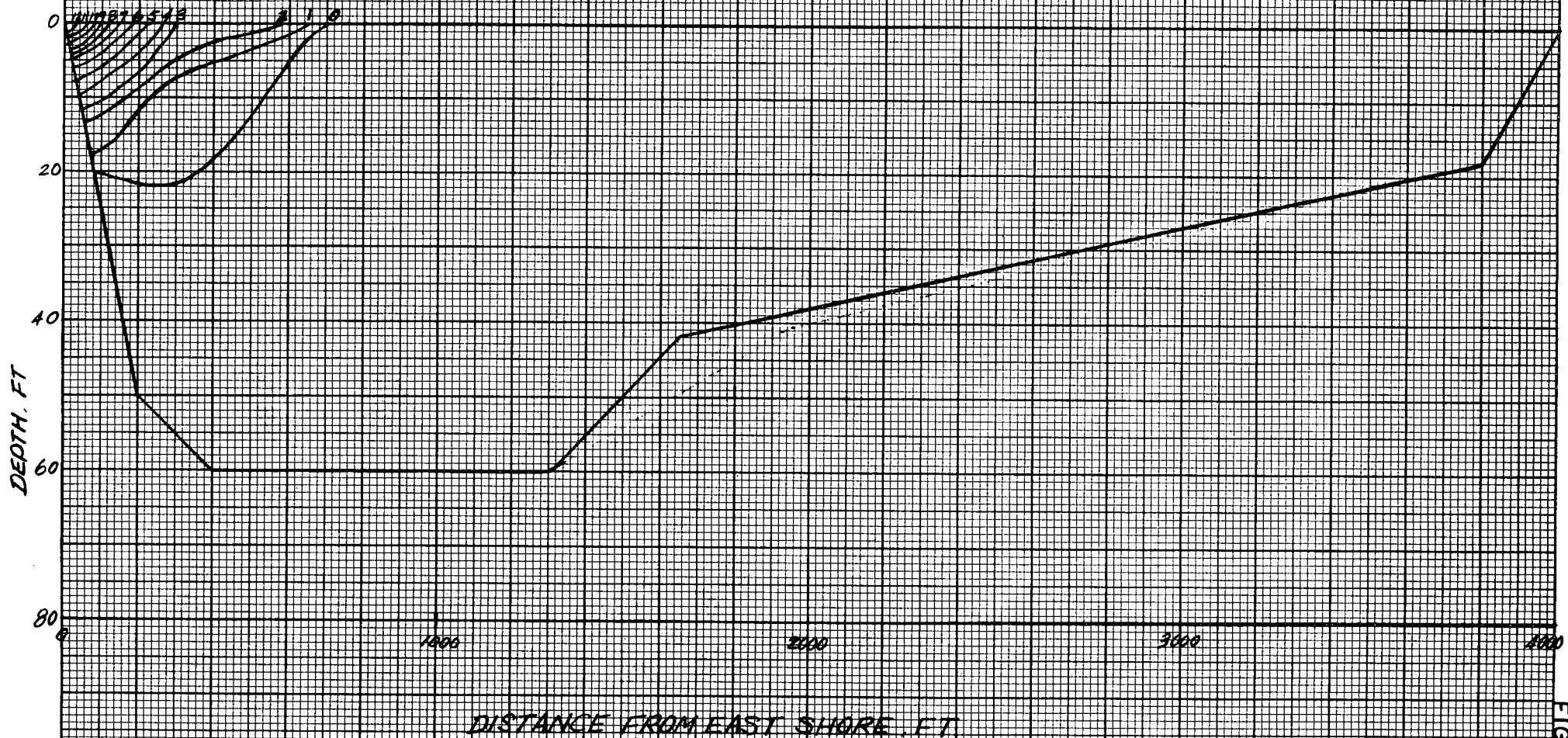

FIGURE 18

TIDAL AVERAGE TEMPERATURE RISE DISTRIBUTION
 HUDSON RIVER AT INDIAN POINT
 MEASUREMENTS AT PLANE OF DISCHARGE

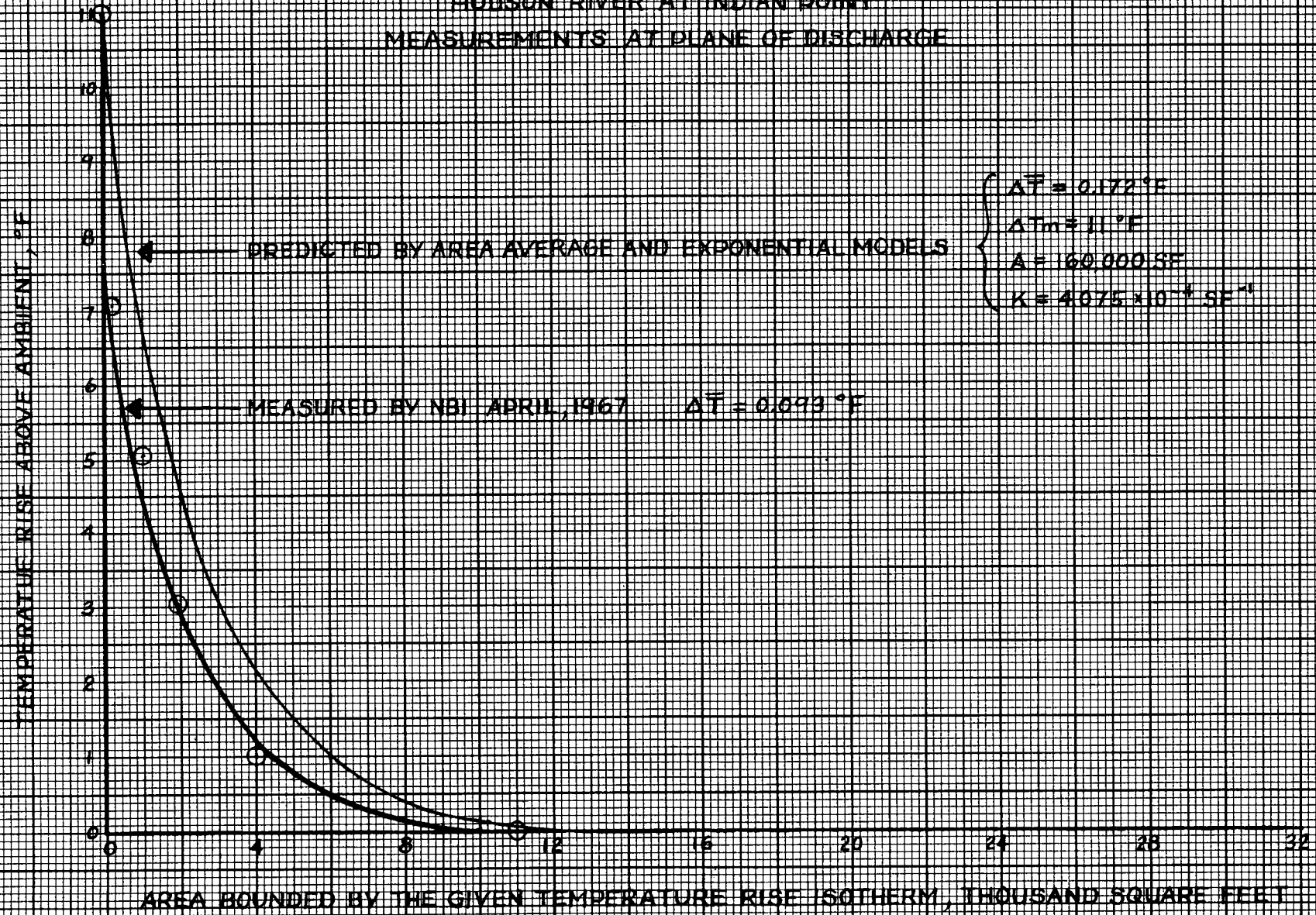

FIGURE 19

demonstrates more clearly the extent to which model computed temperature rises exceed the measured temperature rises.

Rationale for Model Revision

Table 4 shows clearly that the observed area-average temperature, a good parameter of the effect of the thermal discharge on the River, is substantially lower than its predicted counterpart at the plane of discharge, and here more so at a plane a short (800 ft) distance away from the discharge plane. Before adjusting the model to conform to these observations, reasons for these differences are discussed.

Net non-tidal Flow and Thermal Stratification

Partially stratified estuaries, such as the Hudson, are subject to a net upstream movement of sea water in their lower layers and a downstream movement in their upper layers. This movement is induced by density differences which exist on account of the vertical and longitudinal distribution of salinity. This effect is often called the net non-tidal flow, but must be distinguished from the freshwater runoff, which is the actual difference between total upstream and downstream tidal movement.

The net non-tidal flow has never been measured in the Hudson but has been shown to exist.³ Extensive field current measurements, at various depths throughout cross-sections within the salt intruded reach, and over a full tidal cycle, are necessary to obtain this quantity. Measurements meeting these requirements are not available for the Hudson.

Measurements of net non-tidal flow in other estuaries, such as the James River in Virginia, have been made. Values of ten to forty times the freshwater runoff have been observed. The actual value increases in the seaward direction of the estuary due to entrainment of the lower layer water by the flow in the upper layer.

³ Quirk, Lawler & Matusky Engineers - Hudson River Report files

⁴ Pritchard, D.W., "Observations of Circulation in Coastal Plain Estuaries." Chapter in "Estuaries", G.H. Lauff, Editor, Publication No. 83, American Association for the Advancement of Science, Washington, D.C. 1967

In any event, this phenomenon provides substantially more capacity for diluting waste discharges than the fresh water runoff. The net effect is, of course, less than straight dilution by the magnitude of the net non-tidal movement, because this effect is partially offset by vertical mixing due to tidal turbulence. Vertical mixing causes contaminants, originally diluted and washed downstream in the upper layer's flow, to return in the lower layer's upstream movement.

This net dilution effect is generally considered to be accounted for by the longitudinal dispersion coefficient. The longitudinal dispersion coefficient, however, is measured by analysis of longitudinal profiles of the area-averaged salinity. In the case of dilution of non stratifying discharges such as sewage or most industrial wastes, the vertical distribution of these contaminants in the estuary is roughly the same as that of the ocean generated salt, and the net dilution effect is estimated fairly well by using longitudinal dispersion coefficients obtained from salinity profiles. There is reason to believe that the combined net non-tidal flow, vertical mixing dilution effect is greater for an inherently stratifying discharge, such as is a thermal discharge, than that which is obtained using dispersion coefficients generated from salinity profiles.

The reason for this belief lies in the balance of energy which exists between the tendency of tidal turbulence to force complete vertical mixing, and the tendency of the landward directed flow of highly saline ocean water to ride underneath the seaward directed flow of non-saline fresh water. This balance and which mechanism is stronger can be observed by the relative steepness of the vertical salinity profile at any cross section of the estuary.

For rivers like the Mississippi, the fresh water flow is large, the Gulf tides relatively weak, and the net result is a very stratified estuary. In a river like the Delaware, particularly in the summer, just the reverse is true, the vertical salinity profiles are quite flat, and the estuary is classified as completely mixed.

The Hudson more closely approximates the conditions in the Delaware, but due to the attenuating influence of New York Harbor on tidal power, and larger fresh water flows, the vertical salinity gradients are not quite as flat as those of the Delaware. The Hudson estuary is usually classified as partially mixed.

Now the introduction of a discharge, which will tend to stratify of itself, effectively superimposes a condition on the estuary's existing energy balance, which it is not equipped to alter. In other words, the heated liquid, being lighter, will rise to the surface, and tend to stay there, since there is little excess turbulent energy available to cause vertical mixing. Vertical mixing is present, of course, but is counteracted by the tendency of the estuary itself to stratify. Before introduction of the heated effluent these opposing mechanisms are already in a state of balance. An effluent, whose stable state is to locate near the surface, will not be subject to the same extent of vertical mixing as are the natural waters of the estuary.

If the heated effluent is not as strongly subject to vertical mixing as a non-stratifying discharge, then the net dilution effect of the estuary on this discharge should be greater than the usual dilution effect as measured by the magnitude of the longitudinal dispersion coefficient. In other words, the salinity induced circulatory flow is still present, the heated effluent finds its way into the upper seaward directed portion of the circulatory flow, and is diluted by it. The net dilution is greater than it would be for the non-stratifying discharge, because there is insufficient excess tidal turbulence to break up the lighter and therefore stable upper layer. Little of the heated water, therefore, is transferred to the lower, upstream moving layer, and the diluting effect of net non-tidal flow is offset to a lesser degree by vertical mixing than in the case of a non-stratifying discharge.

Vertical mixing, of course, will eventually occur, but the point is that such an effect may take a lot longer than usual. Since the temperature decay is primarily at the surface, the heat has every opportunity to dissipate to the atmosphere, and by the time the water in the upper layer is exchanged with lower layer's water, much of the heat may be gone. Thus the return of this water in the lower layer past the original plane of discharge will be at a time when this water possesses relatively little heat.

The improved dilution will therefore tend not to be seriously offset. Were the material conservative, it would not be lost from the estuary until it was exchanged with the ocean, and the net dilution would not be as great.

The January '68 report shows clearly that the heat from Indian Point is concentrated in the upper layers of the estuary. The profiles for the section some 800 ft. below the discharge show that

the elevated temperatures remain in the surface layer longer than in the layers below. This is to be expected since the thickness of the heated layer would tend to decrease as heat is transferred to the atmosphere, the upper most layer being the last to retain elevated temperature.

Thus it appears that one reason for the marked differences between predicted and measured values is in the improved dilution by net non-tidal flow, available to the thermal discharge since it stabilizes in the surface layers of the estuary, where it can decay to the atmosphere.

This mechanism should not have as strong an influence in April, when fresh water flow is high and Indian Point salinity correspondingly very low, as during the summer, when the reverse is true, since the net non-tidal flow decreases as salinity decreases. The differences in the April data may be due in part to this effect and in part to a significant longitudinal dispersion accompanying the high fresh water flows. (Model calculations in the January '68 report for the high spring flows considered longitudinal dispersion to be very small.)

Surface Heat Transfer

Area-average model calculations were made using heat transfer coefficients that related the difference between the actual surface water temperature and the ambient surface water temperature to the rate at which heat was dissipated to the atmosphere.

Since the area-average model does not differentiate between average temperature and surface temperature, a correction factor was employed to account for differences between these two. This factor was termed the thermal stratification factor (TSF) and is equal to the ratio of the average surface temperature to the area average temperature.

This factor computed at Indian Point plane of discharge was equal to 3.0 for the July 1966 data and 6.0 for the April 1967 data. Results presented in the January '68 report include the above corrections.

Observation of the temperature distribution in planes some distance from the plane of discharge shows that the elevated temperatures tend to concentrate at the surface as the heated water moves away from the plane of discharge. Determination of the correction factor at sections both upstream and downstream of Indian Point showed higher factors existed at these planes by comparison to that at the plane of discharge.

For example, at the section 800 feet downstream of Indian Point, this factor was twice the Indian Point value in July 1, 1966.

Had increased TSF values been used in computing temperature behavior above and below the plane of discharge, in accordance with what measured data showed, the total heat given off to the atmosphere would be greater and resulting predicted river temperature lower.

Model Adjustment

In this section the area-averaged model is adjusted to yield agreement with the measured area-averages of 1966 and 1967. The exponential model is then used to show that the model generated rise isotherm versus bounded area and surface width curves agree reasonably well with the corresponding measured curves.

The area-averaged model used in the January '68 report consisted of equilibrium behavior of a transient, variable space parameter, one dimensional energy transport equation. For the sake of relation simplicity in illustration, this model is replaced by an equivalent, infinite receiver model as shown in Table 5.

The factors f_1 and f_2 were computed by determining the ratios of the exponential decay rates exhibited by the variable parameter model to those of the infinite receiver model. The low flow conditions summarized in Table 5 of the January '68 report were used to obtain the following numerical values.

upstream $f_1 = 0.90$

downstream: $f_2 = 1.44$

In other words, the more precise variable parameter model decays quite a bit more rapidly in the downstream direction (due primarily to the rapidly expanding area) and slightly less rapidly in the upstream direction, than does the infinite receiver model. For high flow conditions, the predicted area averages in Table 4 were obtained using the infinite receiver model, so the f_1 , f_2 values for high flows are unity. For this condition, the segmented, variable parameter model gave even higher area average temperatures and is less precise than the infinite receiver.

Table 4 shows a far more rapid decay in the observed data occurs than is predicted by the area-average model. The observed decay data is rather limited, but can safely be presumed to decay expo-

TABLE 5

EQUIVALENT AREA AVERAGE MODEL

The form of the infinite receiver model, modified to yield the variable parameter model results is:

$$\left. \begin{array}{l} \Delta \bar{T}_I \\ \Delta \bar{T}_{II} \end{array} \right\} = \frac{H e^{\left(\frac{f_1}{f_2}\right) \frac{U}{2E} \left(1 \pm \sqrt{1 + \frac{4K'E}{U^2}}\right) X}}{\rho C_p Q \sqrt{1 + \frac{4K'E}{U^2}}}$$

in which: $\Delta \bar{T}$ = area-average temperature rises, °F
 I - designates behavior above Indian Point
 II - designates behavior below Indian Point

H = thermal discharge, BTU/day

ρ = water density, #/ft.³

C_p = heat capacity, BTU/#/°F

Q = River freshwater flow, ft.³/day

K' = temperature decay coefficient, day⁻¹

U = freshwater velocity, Q/A, miles/day

E = longitudinal dispersion coefficient, sq. miles/day

f_1, f_2 = upstream & downstream model conversion factors

X = distance from plane of discharge (positive direction downstream), miles

nentially in the longitudinal direction. This presumption is based on theory and observed lateral decay behavior. The adjusted area-average model is then written:

$$\left. \begin{matrix} \Delta \bar{T}_I \\ \Delta \bar{T}_II \end{matrix} \right\} = \frac{f_5 H e^{\left(\frac{f_1}{f_2}\right)\left(\frac{f_3}{f_4}\right)} \frac{U}{2E} \left(1 + \sqrt{1 + \frac{4K'E}{U^2}}\right) \times}{\rho C_P Q \sqrt{1 + \frac{4K'E}{U^2}}} \dots\dots\dots (1)$$

The coefficient f_5 adjusts the model to agree with observed area-averages at Indian Point. The coefficients f_3 and f_4 , in conjunction with f_5 , adjust the model to agree with observed area-averages upstream and downstream of Indian Point, respectively.

Table 4 shows the actual differences between field data and model predictions of Unit No. 1 behavior, as given in the January '68 report. Before computing the f_3 , f_4 and f_5 values, the estimates of H for Unit No. 1 operation were corrected to account for the actual electrical energy output during the survey periods.

The estimate used in the January '68 report for July, 1966 was based on effluent channel flow and River temperature measurements taken in the near vicinity of the discharge and for this reason can be expected to be slightly lower than the true effluent channel heat load. Table 6 shows that it was 91% of the correct value.

Table 6 shows excellent agreement between the April heat load, as estimated using April electrical energy output, 32% thermal efficiency, and, 5% in-plant heat loss, and the effluent channel flow and temperature rise values. Temperature measurements in April were made in the channel; hence the better agreement.

Table 7 summarizes the correction factors to be employed in using Equation 1. The upstream factor f_3 has been assumed to be equal to the downstream factor f_4 . Temperature rises in the upstream direction in April were virtually zero due to the high freshwater flow, and correspondingly negligible back mixing. July upstream data were very sparse and were not analyzed for this purpose.

TABLE 6

ESTIMATES OF HEAT LOSS TO RIVER
DURING OPERATION OF INDIAN POINT UNIT NO. 1

<u>Item</u>	<u>July, 1966</u>	<u>April, 1967</u>
<u>On Basis of Average Monthly Plant Output</u>		
Average Output, MWE	245	240
Heat Generated, MW	765	750
In-plant Loss, MW	38	38
Waste Heat Load	482	472
<u>On Basis of Effluent Channel Characteristics</u>		
Channel Flow, gpm	300,000	300,000
Outlet Temperature, °F	10	11
Waste Heat Load, MW	440	480
<u>Waste Heat Load Comparison</u>		
<u>On Basis of Channel Values</u>		
<u>On Basis of Average Output</u>	0.91	1.02

TABLE 7

SUMMARY OF MODEL ADJUSTMENT FACTORS

<u>Factor</u>	<u>Location</u>	<u>Adjustment</u>	<u>Flow Regime</u>	
			<u>12000 CFS</u>	<u>12000 CFS</u>
f ₁	Upstream	Convert upstream and downstream decay rates of infinite receiver to agree with segmented model	1.0	0.90
f ₂	Downstream	Convert upstream and downstream decay rates of segmented model to agree with observed data	1.0	1.44
f ₃	Upstream	Convert maximum area average value of either model to agree with observed data	12.9	15
f ₄	Downstream	Convert maximum area average value of either model to agree with observed data	12.9	15
f ₅	Plane of Discharge	Convert maximum area average value of either model to agree with observed data	0.54	0.73

This adjusted area-average model is used in conjunction with the exponential decay model (pages 15 and 16, January '68 Report) to obtain the areas and surface widths bounded by a given temperature rise isotherm. The exponential model for area is:

$$\Delta T = \Delta T_m e^{-KA} \dots\dots\dots (2)$$

in which:

- ΔT = temperature rise isotherm, °F
- ΔT_m = maximum temperature at any point in the cross-section, °F
- A = that portion of the cross-section within which the temperature rises equal or exceed $\Delta T, SF.$
- K = exponential decay coefficient for area, SF^{-1}

The exponential model for surface width is:

$$\Delta T_s = \Delta T_{sm} e^{-kb} \dots\dots\dots (3)$$

in which:

- ΔT_s = surface temperature rise isotherm, °F
- ΔT_{sm} = maximum surface temperature
- b = that portion of the surface width within which the surface temperature rises equal or exceed $\Delta T_s, FT.$
- k = exponential decay coefficient for surface width, FT^{-1}

The exponential decay coefficients, K and k, are found by recognizing that the curves given by equations 2 and 3 can be uniquely defined if the maximum and average temperatures and the total cross-sectional area, ΔT , and surface width, B, are known. The area-average and surface average temperatures are respectively:

$$\bar{\Delta T} = \Delta T_m \left(\frac{1}{KA_T} \right) \left(1 - e^{-KA_T} \right) \quad \dots\dots (4)$$

$$\bar{\Delta T}_s = \Delta T_{sm} \left(\frac{1}{kB} \right) \left(1 - e^{-kB} \right) \quad \dots\dots (5)$$

The adjusted one dimensional area-averaged model is used to compute ΔT . The surface average temperature, $\bar{\Delta T}_s$, is equal to $\bar{\Delta T}$ multiplied by the thermal stratification factor (TSF). Equation 4 and 5 are solved to obtain K and k. Equations 2 and 3 are then used to obtain the percentages of cross-sectional area ($100 \frac{A_T}{A}$) and surface width ($100 \frac{b}{B}$) corresponding to selected temperature rises, ΔT and ΔT_s .

This procedure is illustrated using the July, 1966 and April, 1967 NBI data to show the reasonably good behavior which is obtained using the adjusted model.

Figure 20 shows the areas bounded by a given rise isotherm as observed in April, 1967 and as obtained using both the unadjusted and adjusted models. The shape of the curve obtained using the adjusted model does not agree perfectly with the observed data, although it can be seen that the area-average value, $\bar{\Delta T}$, for the two curves will be the same. The unadjusted curve is seen to heat significantly more area, as described above in discussing Figure 19.

Figure 21 shows a comparison of the measured surface width behavior to that computed using equations 3 and 5 for the April, 1967 data. The agreement is quite good, particularly between 1 and 4°F, the contours of interest in considering zones of passage. Better agreement between the higher values would have been obtained had 12°F maximum been used. This would not be justified by the discharge channel temperatures. Furthermore, to preserve the average, the computed exponential would have tailed off more rapidly than did the observed data.

Table 8 summarizes the calculation procedure employed to obtain the computed curves shown in Figures 20 and 21.

Figure 22 shows the computed and measured curves for decay of surface temperature with surface width for the April, 1967 conditions at the surface of a plane 800 ft below the discharge plane. The exponential model does not yield precise agreement with the measured data (the actual decay being more linear in nature,) but the

TIDAL AVERAGE TEMPERATURE RISE DISTRIBUTION
 HUDSON RIVER AT INDIAN POINT
 MEASUREMENTS AT PLANE OF DISCHARGE

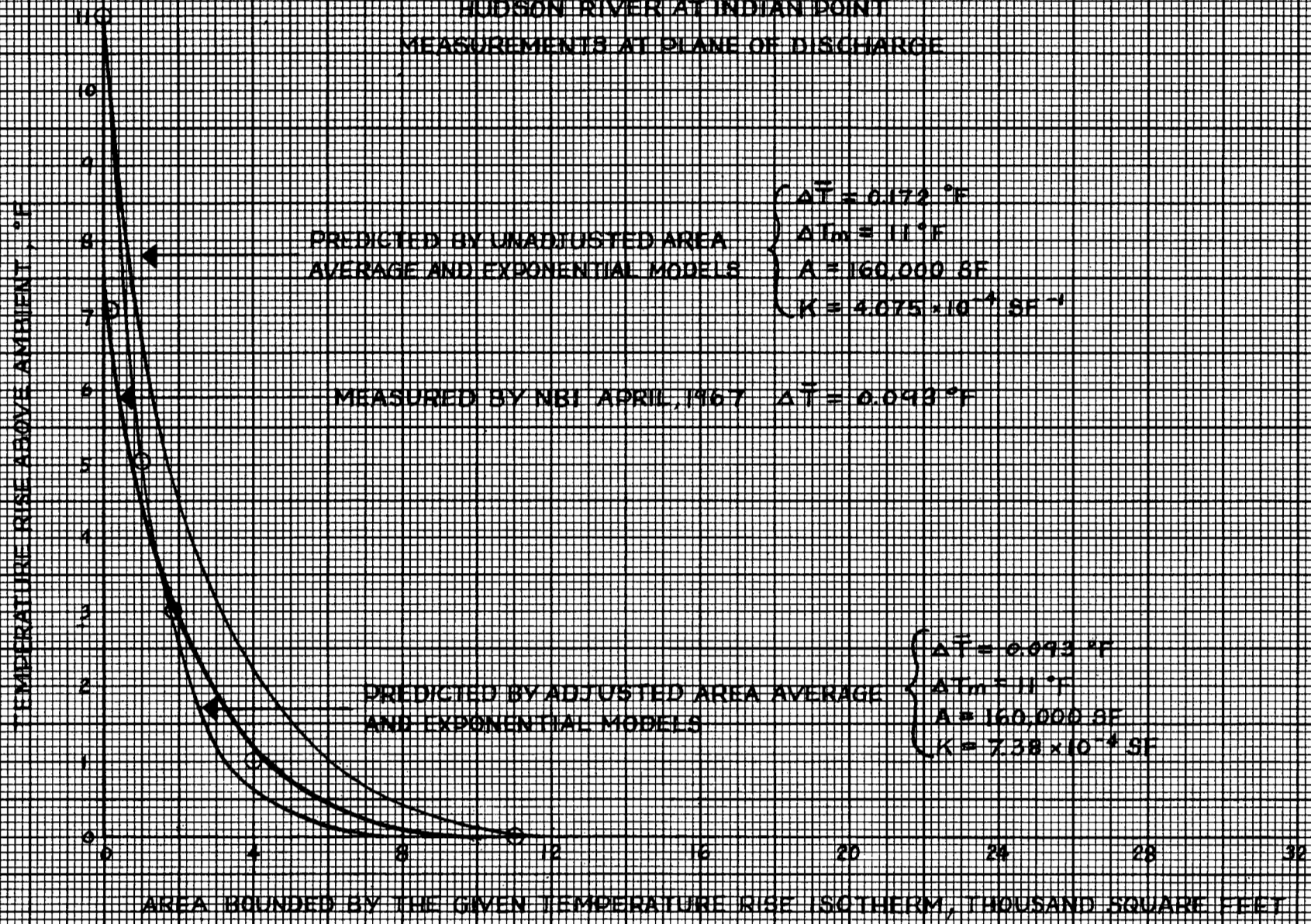

FIGURE 20

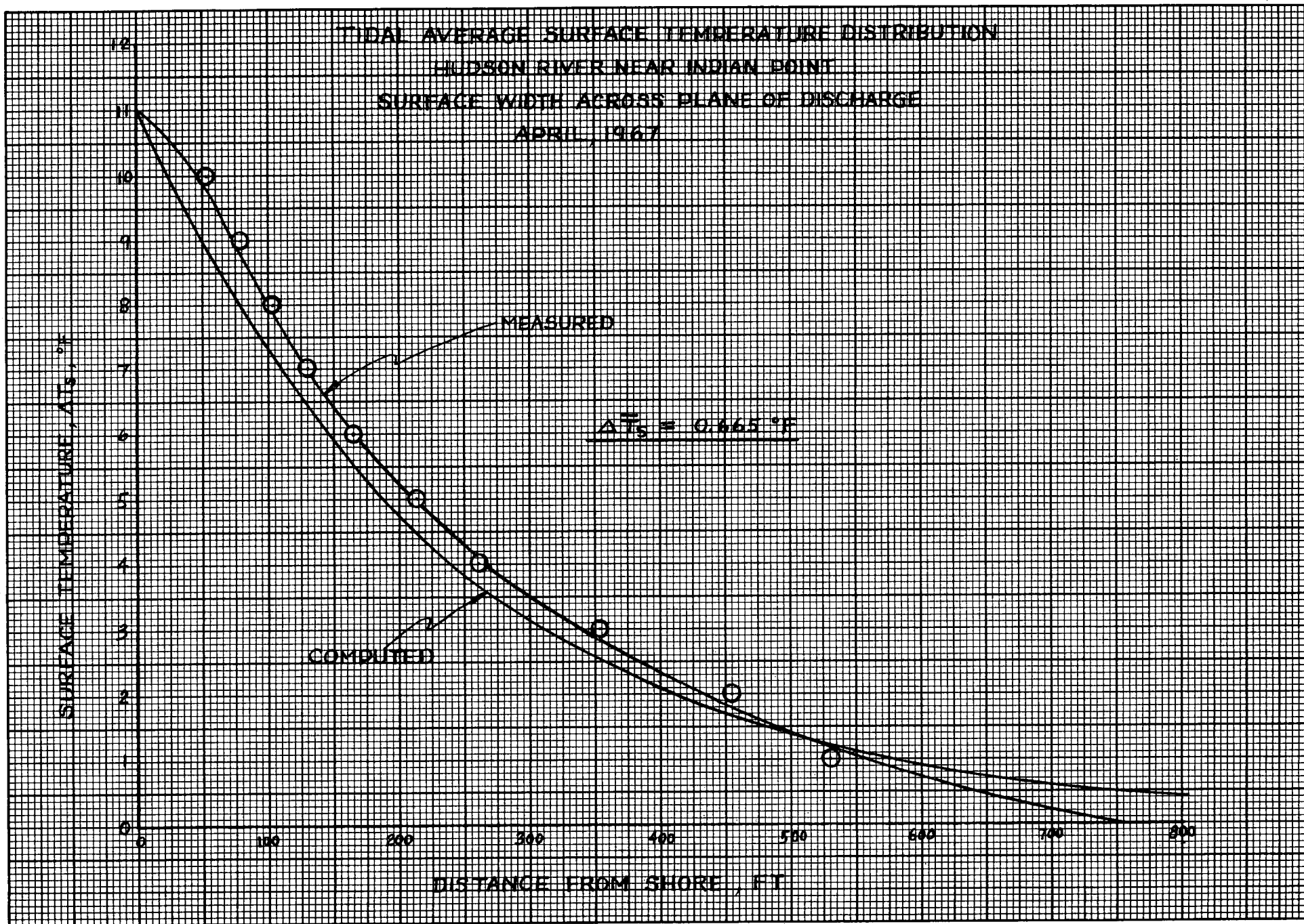

FIGURE 21

TABLE 8

CALCULATIONS REQUIRED TO OBTAIN COMPUTED CURVES
OR FIGURES 20 AND 21

Conditions for April, 1967

$$H = 39.3 \times 10^9 \text{ BTU/day}$$

$$Q = 40,000 \text{ CFS}$$

$$E = 2 \text{ sq. miles/day}$$

$$K' = 0.264 \text{ Day}^{-1} \text{ (} K = 110 \text{ BTU/SF/day/}^\circ\text{F, TSF} = 6, D = 6\text{)}$$

$$U = 4.1 \text{ miles/day (} A = 160,000 \text{ SF)}$$

Calculation of Area--Average Temperature Rise

$$\text{From Table 5, } \Delta\bar{T} = 0.172 \text{ }^\circ\text{F (unadjusted)}$$

$$\begin{aligned} \text{From Equation 1 and Table 7, } \Delta\bar{T} &= 0.54 \times 0.172 \\ &= 0.093 \text{ (adjusted)} \end{aligned}$$

Calculation of Exponential Decay Behavior for Area (Figure 20)

$$\Delta T_m = 11^\circ\text{F, } \Delta T = 0.093, A_T = 160,000 \text{ SF}$$

$$\text{From Equation 4, } K = 7.38 \times 10^{-4} \text{ SF}^{-1}$$

$$\text{From Equation 2, } \Delta T = 11 \text{ Exp } (-7.38 \times 10^{-4} A)$$

Calculation of Exponential Decay Behavior for Surface Width
(Figure 20)

$$\Delta T_{sm} = 11^\circ\text{F, } \Delta\bar{T} = 0.665 \text{ }^\circ\text{F, } B = 4000 \text{ ft}$$

$$\text{From Equation 5, } k = 4.13 \times 10^{-3} \text{ ft}^{-1}$$

$$\text{From Equation 3, } \Delta T_s = 11 \text{ Exp } (-4.13 \times 10^{-3} b)$$

TIDAL AVERAGE SURFACE TEMPERATURE DISTRIBUTION
HUDSON RIVER NEAR INDIAN POINT
SECTION 800 FT BELOW PLANE OF DISCHARGE
APRIL, 1967

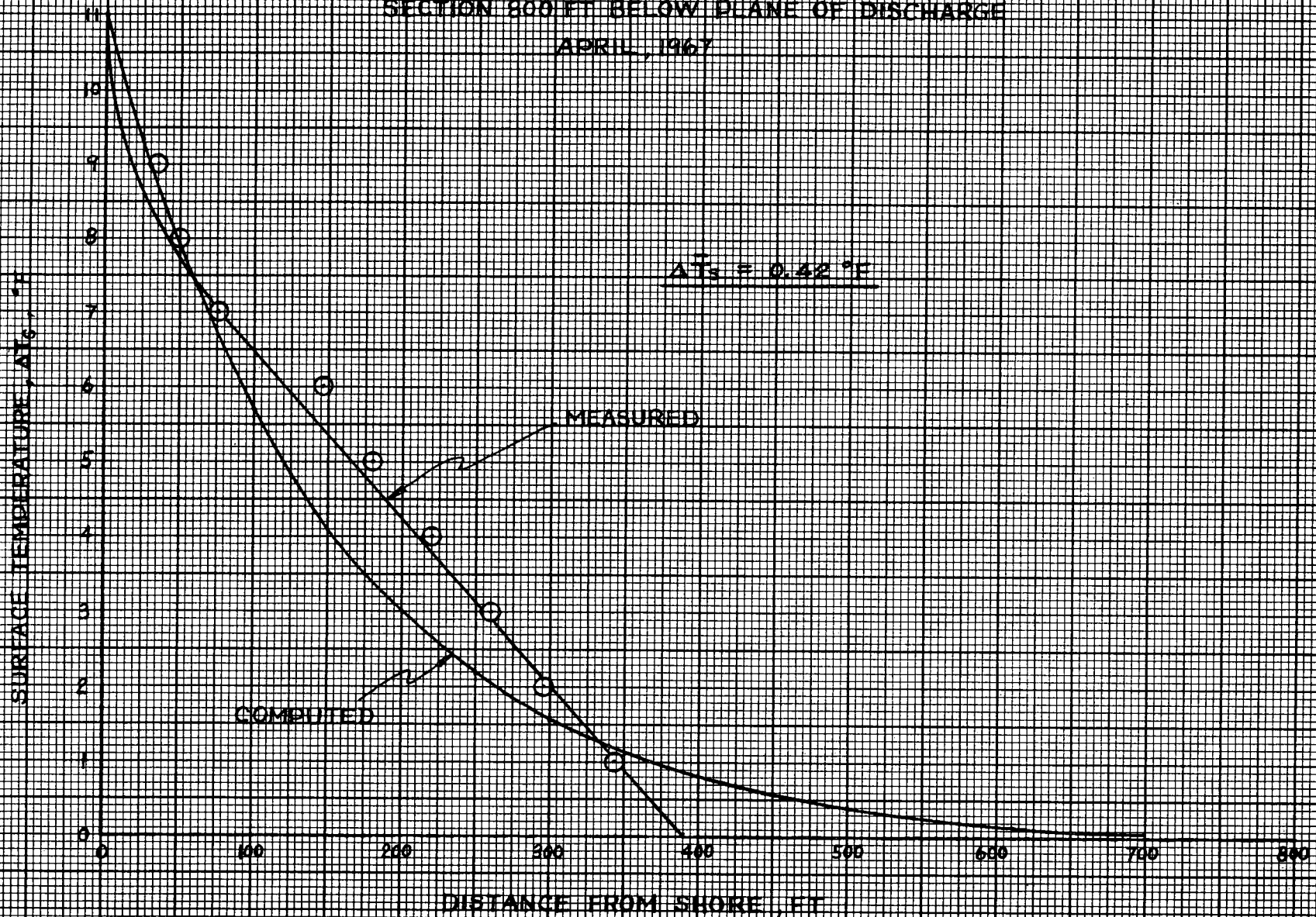

FIGURE 22

surface average temperature, $\bar{\Delta T}_s$, is the same for both curves.

Figure 23 shows the computed and measured surface behavior at the discharge plane for the July, 1966 conditions. The exponential curve, with a maximum temperature of 11°F, diverges somewhat from the measured curve, but opposite to the departure seen in Figure 21. Again, control is maintained by the fact that the surface average temperature rise, $\bar{\Delta T}_s$, is the same for both curves.

These results show that exponential decay behavior of both the area and surface temperature rises, across planes perpendicular to the longitudinal areas of the River, gives a reasonably accurate description of the actual behavior of these parameters, provided the area-average model is adjusted to yield the measured area-average values.

These models and the procedures for using them are employed in the next chapter to predict the effect of three unit operation at Indian Point on the temperature rise pattern in the Hudson River.

TIDAL AVERAGE SURFACE TEMPERATURE DISTRIBUTION
HUDSON RIVER NEAR INDIAN POINT
SURFACE WIDTH ACROSS PLANE OF DISCHARGE
JULY, 1966

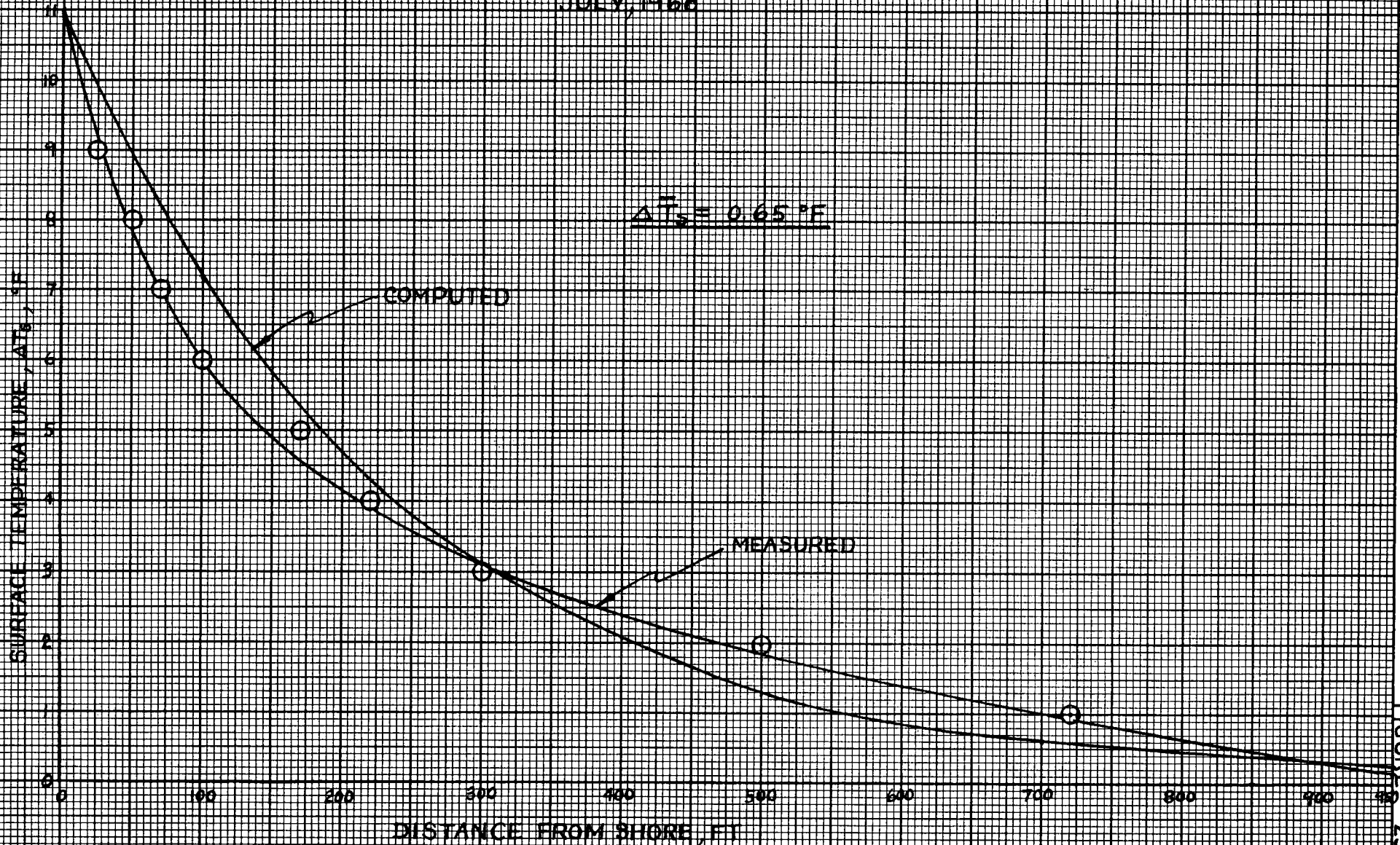

FIGURE 23

VI. TEMPERATURE DISTRIBUTION FOR THREE UNIT OPERATION

This chapter utilizes the adjusted mathematical model to predict the Hudson River temperature rise distribution which can be expected in the presence of a 4153 MW waste heat load from Indian Point. Results obtained by the Alden Hydraulic Laboratory for three unit operation of Indian Point Hydraulic Model II are presented to support these predictions.

Generalized Solution - Exponential Decay Model

Figure 24 is a generalized solution of the exponential decay models given by Equations 2 through 5 in the previous chapter. The curves are valid for both area and surface width calculations because the upper abscissa is presented as a fraction of the total cross-sectional area or surface width. Use of Figure 24 is described in Table 9.

Conditions of Maximum Severity

The January '68 report shows that conditions of maximum severity were reached in November, 1964. A sustained six month low flow of 4000 CFS, and a relatively low heat transfer coefficient of 90 BTU/SF/day/°F combined to create the maximum computed area-average temperature rises. These conditions are employed below to compute a probable extreme condition.

Thermal Stratification Factors

Since a submerged discharge is planned, the thermal stratification factor for the low flow condition has been reduced from 3.0 to values between 1.5 and 2.5. The value of 1.0 represents a minimum which can only be approached. In addition to the influence of submerged discharge, the increased heat load is expected to drive the stratification factor down, because, by comparison to Unit No. 1 behavior, the increased flow of heated water into the River will have a greater effect on the subsurface temperatures.

A thermal stratification factor of 1.0 would be obtained if the heated discharge were completely mixed across the plane of discharge. For this case, Table 10 (following page 27) shows that the area-average temperature rise would be 3.4°F. Since complete mixing is assumed, the temperature at every point would be 3.4°F and nowhere would the 4°F criterion be exceeded.

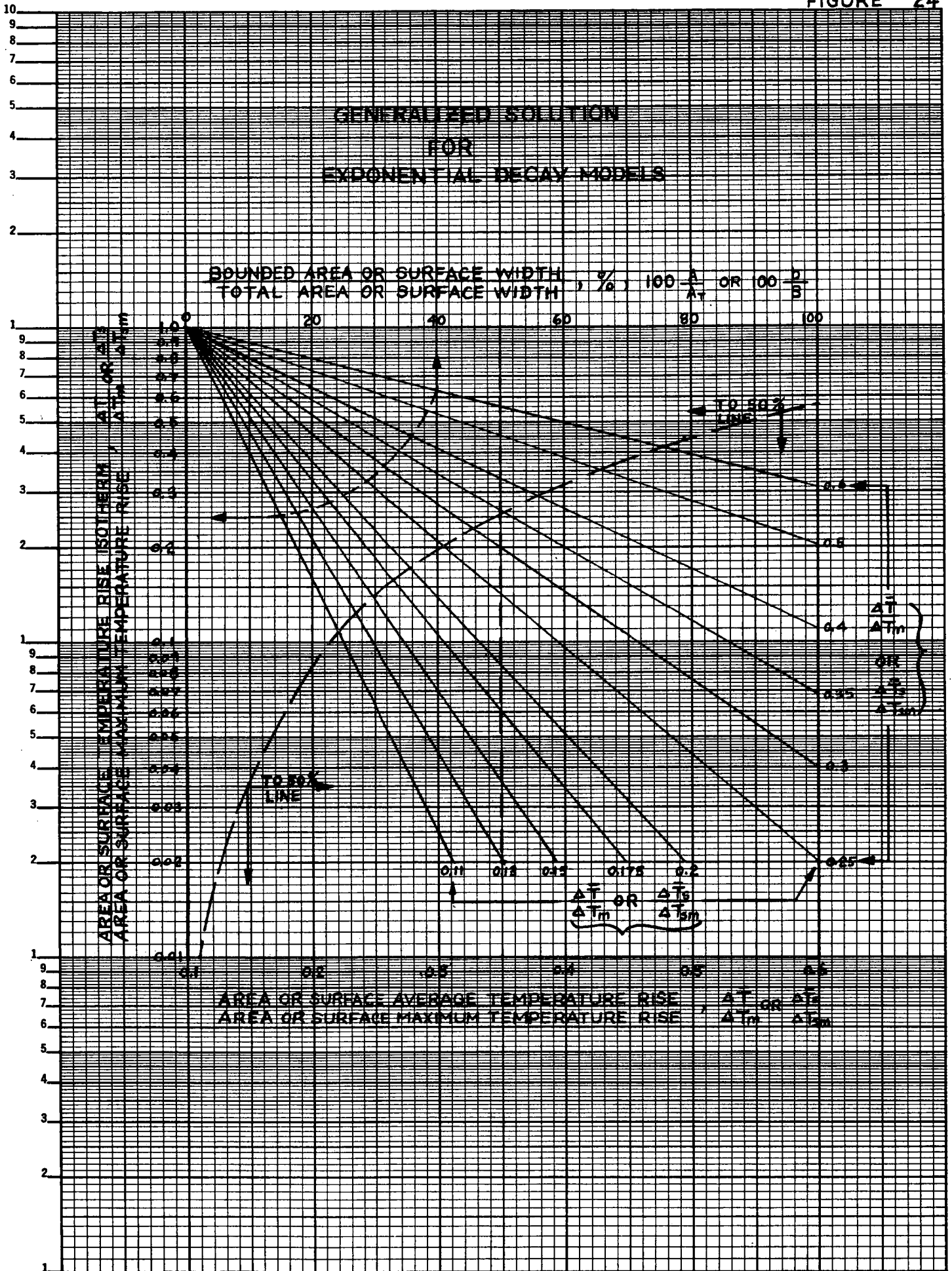

TABLE 9

APPLICATION OF GENERALIZED SOLUTION FOR
EXPONENTIAL DECAY MODELS (FIGURE 24)

GIVEN: Area or Surface Average Behavior

OBJECT: Find Percentage of Area or Width
Enveloped by a Given Temperature Use.

1. Select maximum temperature value
2. Compute ratio of average to maximum temperature
3. Enter bottom abscissa at value computed in 2.
4. Move vertically upward to dashed curve
5. Value on left ordinate is the temperature ratio at 50% of the cross-section or surface width
6. Move horizontally left or right and intersect dashed vertical line (the 50% vertical)
7. Dimensionless temperature profile is obtained by drawing straight line between intersection in 6 and upper right corner.
8. Select desired temperature. Divide by maximum temperature in 1 to obtain dimensionless counterpart. Enter line drawn in 7 at this ordinate and obtain desired percentage of area or width.

For the reverse case of finding the average behavior, given the profile, compute and plot the dimensionless profile, intersect the 50% vertical with this profile, move horizontally from this point to the dashed curve, and then vertically down to the bottom abscissa to find the dimensionless average.

A thermal stratification factor of 3.0 was obtained for the surface discharge conditions of July, 1966. Were a surface discharge planned for the three unit operation, the maximum surface temperature, for the planned waste heat load of 4153 MW, would be 14°F. Assume that under these conditions, the thermal stratification factor would reach 3.0.

These concepts suggest that the thermal stratification factor increases with an increase in the maximum surface water temperature. In this analysis of low flow, River temperature behavior, the thermal stratification factor has been assumed to vary linearly with the maximum surface water temperature, from a minimum value of 1.0 at the completely mixed temperature of 3.4°F, to a maximum of 3.0 at the effluent channel temperature of 14°F.

Assuming a maximum ambient temperature of 78°F, the maximum surface temperature rise must not be more than 12°F to avoid contravening the 90°F surface water temperature standard. Submerged discharge studies⁵ show that maximum surface water temperatures between 6 and 9°F can be expected if the heated effluent is discharged through ports along the bottom of the west wall of the discharge channel. The actual value which will occur depends on the effluent channel temperature and the depth of submergence. More details on the submerged discharge are given in a later section in this chapter.

For purposes of establishing the areal and surface bounds of the 4°F contour, maximum surface water temperatures of 6, 9 and 12°F were considered. The thermal stratification factor to be used with each of these temperatures was determined using the linear assumption described above and yielded:

<u>Maximum Surface Temperature, °F</u>	<u>Thermal Stratification Factor</u>	
	<u>Linear Model</u>	<u>Rounded Value</u>
3.4	1.0	1.0
6	1.5	1.5
9	2.05	2.0
12	2.6	2.5
14	3.0	3.0

-
5. Progress Report on Indian Point II Studies for Consolidated Edison Company of New York. Alden Research Laboratory (1968)
This report is appended to the present QL&M report.

Thus the TSF values of 1.5, 2.0 and 2.5 correspond to ΔT_{sm} values of 6, 9 and 12°F, respectively.

Bounding Area-Plane of Discharge

Table 10 summarizes the computation of the area-average temperature rises across the plane of discharge for the low flow condition and several TSF, and of the corresponding percentages of the total cross-section, within which the temperature rise equals or exceeds the 4°F criterion. Table 10 indicates the area bounded by the 4°F isotherm can be expected to range between 20 and 26% of the total Indian Point cross-section. Notice that the temperature bounding 50% of the cross-section, the maximum percentage permitted by the proposed criteria as a bound on the 4°F isotherm, ranges between 0.6 and 1.3°F, considerably lower than the 4°F upper limit.

Bounding Surface Width-Plane of Discharge

Table 11 summarizes the computation of the percentage of surface width bounded by the 4°F surface water temperature rise at the plane of discharge. Table 11 shows that some 50 to 60% of the surface width will have temperatures equal to or greater than 4°F. The proposed standard permits up to 67% of the surface width to have surface temperatures greater than 4°F. This criterion, therefore, will not be contravened.

Table 11 shows clearly the value of the submerged discharge. The 6°F maximum surface water temperature rise condition can be obtained by submerging the discharge. Not only does this case yield the lowest surface width percentage (52%), but the temperatures within that 52% will have to range between 4 and 6°F.

By comparison, the condition of a ΔT_{sm} of 12°F, which is more representative of a surface discharge, has the highest surface width percentage (60%), and the temperatures with that 60% will range between 4 and 12°F.

Areal and Surface Boundaries - Summer Conditions

The foregoing represent what are considered to be extreme conditions from the standpoint of low flows and low heat transfer coefficients. From a biological standpoint, conditions which occur in August, when low flows and high ambient water temperatures prevail, probably represent the critical condition.

TABLE 10

COMPUTATION OF AREA-AVERAGE TEMPERATURE RISE
AND AREA BOUNDED BY THE 4°F ISOTHERM FOR
THE DISCHARGE PLANE AT INDIAN POINT FOR
CONDITIONS OF MAXIMUM SEVERITY

Conditions

H = 340 X 10⁹ BTU/day, ΔT_m = 14°F
 Q = 4000 CFS, U = 0.41 mile/day, E = 12 sq miles/day
 K̄ = 90 BTU/SF/day/°F, K' = [0.0361 X TSF]day⁻¹
 f₅ = 0.73

Area Average Temperature Calculation

$$f_5 H / \rho C_p Q = \frac{0.73 \times 340 \times 10^9}{54 \times 10^5 \times 4 \times 10^3} = 11.5^\circ\text{F}$$

$$4K'E/U^2 = \frac{4 \times 0.036 \times 12}{0.41 \times 0.41} \text{ (TSF)} = 10.3 \text{ TSF}$$

<u>TSF</u>	<u>10.3TSF</u>	<u>√1 + 10.3TSF</u>	<u>ΔT̄</u> (By Equation 1)
1.0	10.3	3.36	3.42
1.5	15.4	4.05	2.84
2.0	20.6	4.64	2.47
2.5	25.7	5.16	2.23
3.0	30.9	5.64	2.04

Percentage of Cross-Section Bounded by 4°F Isotherm

<u>ΔT̄</u>	<u>$\frac{\Delta T}{\Delta T_m}$</u> (For 14°F Condenser rise)	<u>$\frac{\Delta T}{\Delta T_m} @ 100 \frac{A}{A_T} = 50$</u>	<u>$\frac{100 \frac{A}{A_T} @ \frac{\Delta T}{\Delta T_m} = 0.286}{(\% \text{ Area } @ 4^\circ\text{F})}$</u>	<u>Isotherm Bounding 50% of Area (For 14°F Condenser rise)</u>
2.84	0.203	0.090	26	1.26
2.47	0.176	0.060	22	0.84
2.23	0.159	0.044	20	0.62

TABLE 11

COMPUTATION OF AREA AVERAGE TEMPERATURE RISE
AND AREA BOUNDED BY THE 4°F ISOTHERM FOR
THE DISCHARGE PLANE AT INDIAN POINT FOR
CONDITIONS OF MAXIMUM SEVERITY

CONDITIONS: SAME AS TABLE 10

SURFACE WIDTH CALCULATIONS

<u>Item</u>	<u>Source</u>	<u>Value Corresponding to a ΔT_{sm} of:</u>		
		<u>6°F</u>	<u>9°F</u>	<u>12°F</u>
TSF	Page 26	1.5	2.0	2.5
$\bar{\Delta T}$, °F	Table 10	2.84	2.47	2.23
$\Delta \bar{T}_s$, °F	$\bar{\Delta T} \times \text{TSF}$	4.26	4.94	5.57
$\bar{\Delta T}_s / \Delta T_{sm}$	Calculate	0.71	0.550	0.463
$\frac{\Delta T_s}{\Delta T_{sm}}$ @ $\frac{100b}{B} = 50$	Figure 24	0.68	0.51	0.40
$\frac{\Delta T_s}{\Delta T_{sm}}$ @ $\Delta T_s = 4^\circ\text{F}$	Calculate	0.667	0.444	0.333
$\frac{100b}{B}$ @ $\Delta T_s = 4^\circ\text{F}$	Figure 24	52	60	60

Table 12 summarizes calculations for this condition. Parameters include a 6°F maximum surface water temperature rise, a sustained low flow of 4000 CFS and an August heat transfer coefficient of 135 BTU/SF/day/°F (Figure 3, January '68 Report).

Table 12 shows that 21% of the cross-section and 33% of the surface width are bounded by the 4°F isotherm. These are significantly lower than the 26 and 52% values obtained for similar discharge conditions in Tables 10 and 11, respectively, in which the 90 BTU/SF/day/°F November heat transfer coefficient was used.

Behavior Beyond the Plane of Discharge

Table 13 shows the decay of the area-average temperature rise with distance above and below the plane of discharge at Indian Point. Both August and November conditions are presented; ΔT_{sm} is assumed to be held to 6°F in both cases and the TSF is held constant at 1.5. Adjustment coefficients are those developed in Table 7 for low flow conditions.

Table 13 shows a very rapid decay of the area-average temperature with distance away from Indian Point. This rapid decay is caused by the large values obtained for the adjustment factors, f_3 and f_4 .

The adjusted model is presumed to apply within the first mile above and below the plane of discharge. The model cannot be applied over an infinite distance because the adjusted decay rates, by comparison to the area-averaged rise at the plane of discharge, will not permit all the heat to be rejected.

The adjusted model is considered to represent the rapid dispersal and dilution of the heated effluent by the net non-tidal flow mechanism. Average temperature will be reduced to about 1°F within the first mile above and below the plant.

Most of the heat (BTU) introduced to the River still remains at this point. This residual heat dissipates slowly to the atmosphere as the water particles move up and down the estuary. Whatever residual heat still remains is eventually exchanged with incoming ocean waters.

This loss of residual heat is similar to the way in which other residual pollutants are lost from the estuary. The difference is that the intensity of the heat, i.e., the temperature rise, is

TABLE 12

COMPUTATION OF 4° F AREA/AND SURFACE BOUNDARIES
AT THE PLANE OF DISCHARGE FOR SUMMER CONDITIONS

Conditions

$$\begin{aligned}
 H &= 340 \times 10^9 \text{ BTU/day, } \Delta T_m = 14^\circ\text{F, } \Delta T_{sm} = 6^\circ\text{F} \\
 Q &= 4,000 \text{ CFS, } U = 0.41 \text{ mile/day, } E = 12 \text{ sq. miles/day} \\
 \bar{K} &= 135 \text{ BTU/SF/Day/}^\circ\text{F, } \text{TSF} = 1.5, \text{K}' = 0.08/\text{day}^{-1} \\
 f_5 &= 0.73
 \end{aligned}$$

Area Average Temperature Rise

$$\begin{aligned}
 \Delta \bar{T} &= f_5 H [pCpQ]^{-1} [1 + 4K'E/U^2]^{-1/2} \\
 &= 11.5 \times [1 + 23.1]^{-1/2} = \underline{\underline{2.34}}^\circ\text{F}
 \end{aligned}$$

Percentage of Cross-Sectional Area Bounded by 4° F Isotherm

$$\begin{aligned}
 \Delta \bar{T} / \Delta T_m &= 2.34 / 14 = 0.167 \\
 \Delta T / \Delta T_m \text{ at } \Delta T = 4^\circ\text{F} &\text{ is } 0.286 \\
 100 A / A_T \text{ (at } \Delta T / \Delta T_m = 0.286) &= \underline{\underline{21\%}} \text{ Figure 24}
 \end{aligned}$$

Percentage of Surface Width Bounded by 4° F Isotherm

$$\begin{aligned}
 \Delta \bar{T}_s &= \text{TSF} \times \Delta \bar{T} = 3.5^\circ\text{F} \\
 \Delta \bar{T}_s / \Delta T_{sm} &= 3.5 / 6.0 = 0.583 \\
 \Delta T_s / \Delta T_{sm} \text{ at } \Delta T = 4^\circ\text{F} &\text{ is } 0.67 \\
 100b/B \text{ (at } \Delta T_s / \Delta T_{sm} = 0.67) &= 33\% \text{ Figure 24}
 \end{aligned}$$

TABLE 13

CALCULATION OF AREA-AVERAGE TEMPERATURE
RISES ABOVE AND BELOW INDIAN POINT FOR
THE CRITICAL SUMMER AND MAXIMUM SEVERE
CONDITIONS

Calculation of Longitudinal Exponential Decay Rate

$$J_1 = f_1 f_3 \frac{U}{2E} \left[1 + \sqrt{1 + \frac{4K'E}{U^2}} \right] \quad \text{upstream}$$

$$J_2 = f_2 f_4 \frac{U}{2E} \left[1 - \sqrt{1 - \frac{4K'E}{U^2}} \right] \quad \text{downstream}$$

Critical Summer Condition (August) (See Tables 7 & 12 for Parameters)

$$J_1 = 0.90 \times 15 \times \frac{0.41}{2 \times 12} \left[1 + \sqrt{24.1} \right] = 1.36 \text{ Miles}^{-1}$$

$$J_2 = 1.44 \times 15 \times \frac{0.41}{2 \times 12} \left[1 - \sqrt{24.1} \right] = 1.44 \text{ Miles}^{-1}$$

Condition of Maximum Severity (November) (See Tables 7 & 10 for Parameters)

$$J_1 = 0.9 \times 15 \times 0.0171 \left[1 + 4.05 \right] = 1.17 \text{ Miles}^{-1}$$

$$J_2 = 1.44 \times 15 \times 0.0171 \left[1 - 4.05 \right] = -1.125 \text{ Miles}^{-1}$$

Calculation of Area-Average Temperatures

<u>Distance</u> (Miles)	<u>Area Average Temperature, $\Delta\bar{T}$, °F</u>	
	<u>August</u>	<u>November</u>
-1.0	0.60	0.88
-0.5	1.19	1.58
0	2.34	2.84
0.5	1.14	1.62
1.0	0.55	0.92

reduced much more quickly than is the intensity of particulate pollutants, i.e., the concentration, since the inherent stratification enhances dilution by net non-tidal flow. Correspondingly, this improved dilution effect will result in a greater portion of the residual heat being flushed from the estuary, as opposed to dissipation from the estuary's surface, by comparison to the relative proportions of the soluble organic pollutant, which are flushed out of or decay within the estuarine waters.

Figures 25 and 26 show the boundaries of the 4°F and 2°F surface and area isotherm. Additional decay will occur beyond the one mile limit. The exact behavior of this decay is not known, but is presumed to be slow, in accordance with the loss of residual heat mechanism described above. A horizontal dash line is shown in Figure 25 and represents the upper limit of the isotherms' boundaries beyond this point.

The surface curves in these Figures were developed using a ΔT_{sm} value of 6°F. This value was also used for ΔT_m , in constructing the area curves, beyond the plane of discharge, since this will be the maximum expected temperature at any point beyond the zone of initial dilution of the 14°F effluent. Figure 27 shows the expected surface isotherm pattern.

Hydraulic Model Results

During the period of the foregoing analysis, a hydraulic model of the Indian Point three unit operation was built and operated by the Alden Hydraulic Laboratory of the Westchester Polytechnic Institute, Worcester, Massachusetts. This model is designated Indian Point Model II and extends two miles above and below the plane of discharge at Indian Point and over the River's full width and depth.

Model scale is 1 to 250 in the horizontal plane and 1 to 60 in the vertical. Tidal action is simulated by varying the flow introduced or withdrawn at each end of the model. Heated effluent is discharged through a series of submerged ports and directed toward the River's channel.

Figures A-1 through A-7 are reproductions of results received from the Alden Hydraulic Laboratory and represent surface temperature rises during different phases of the tidal cycle for three units discharging 2,100,000 gpm at a 17°F temperature rise. Figure A-8 is a map showing the highest instantaneous temperature measured at any point in the surface for these operating conditions.

BOUNDARIES OF THE 4°F ISOTHERM
FOR
THREE UNIT DISCHARGE AT INDIAN POINT

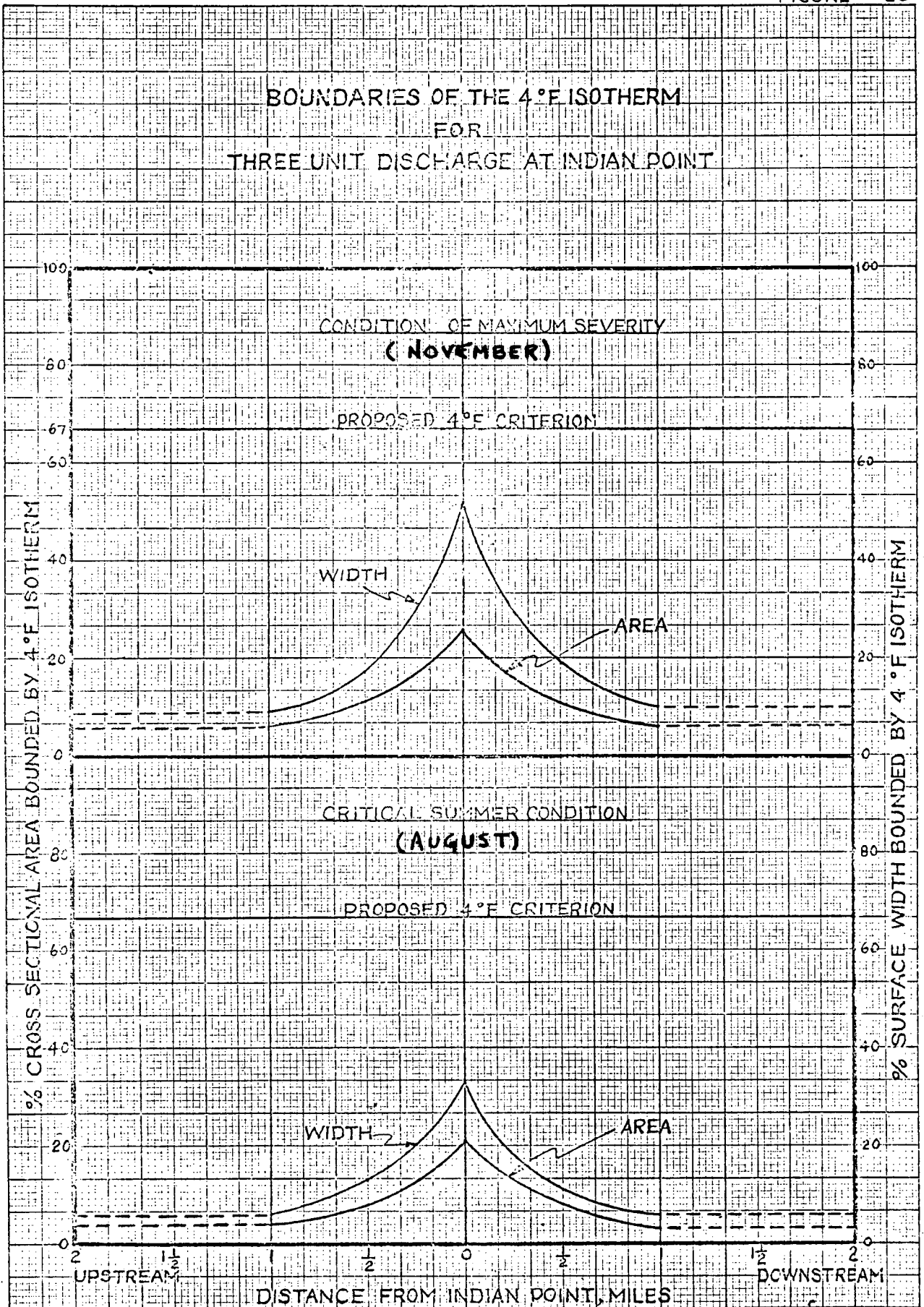

BOUNDARIES OF THE 2°F ISOTHERM
FOR
THREE UNIT DISCHARGE AT INDIAN POINT

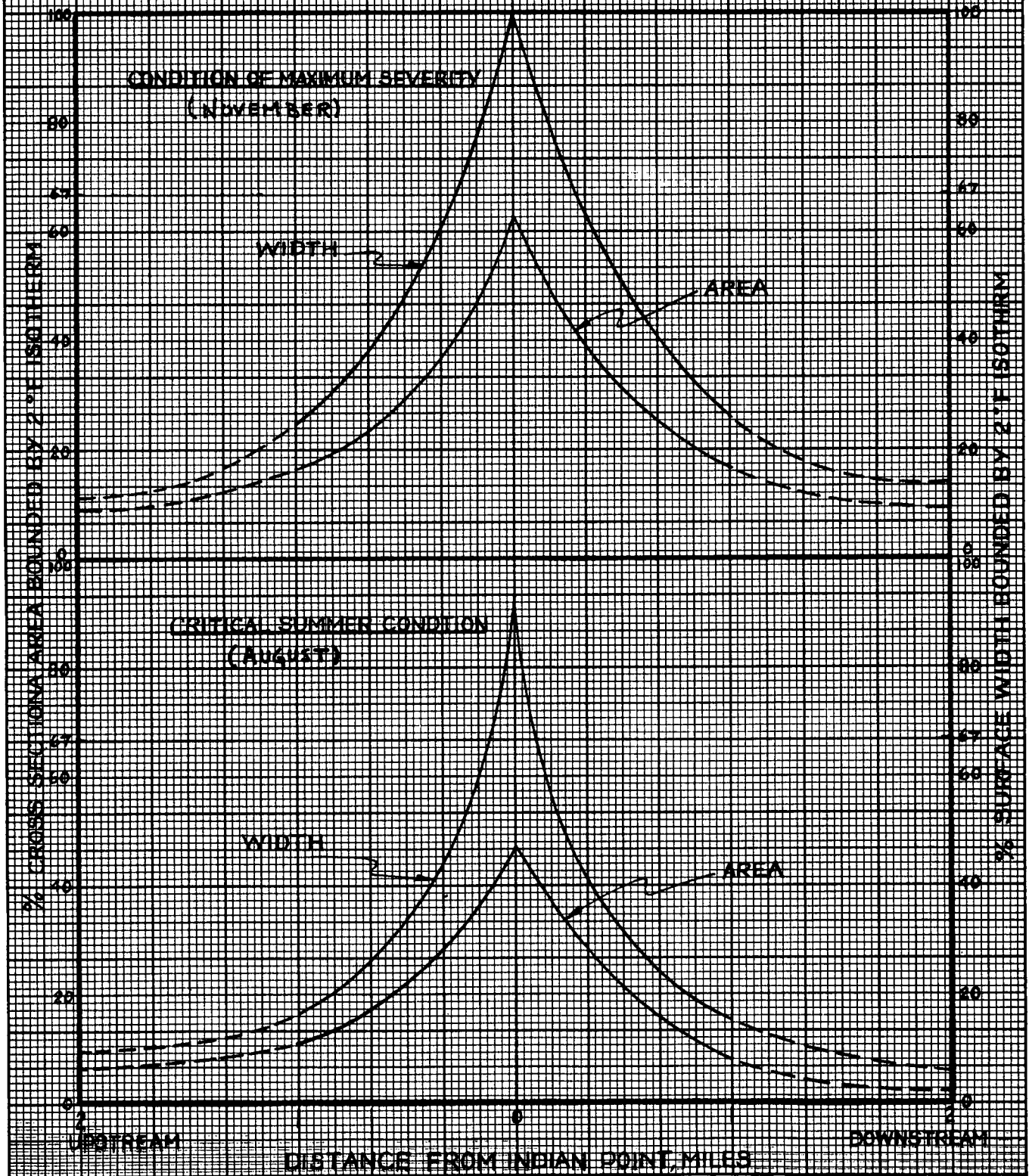

BOUNDARIES OF STATED SURFACE ISOTHERMS
FOR
THREE UNIT DISCHARGE AT INDIAN POINT

SUMMER CRITICAL CONDITION
(AUGUST)

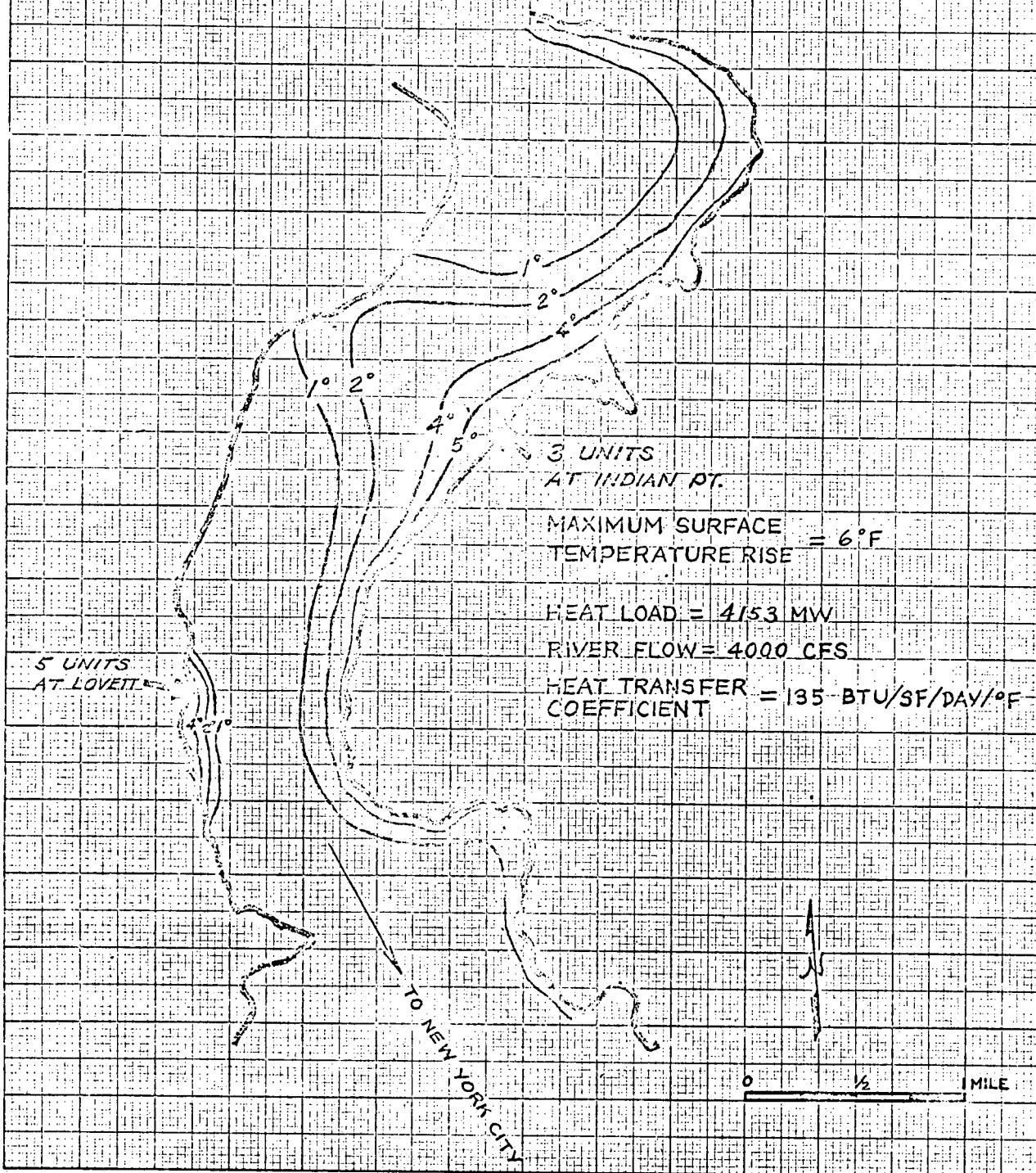

FIG A-1

Fig 1

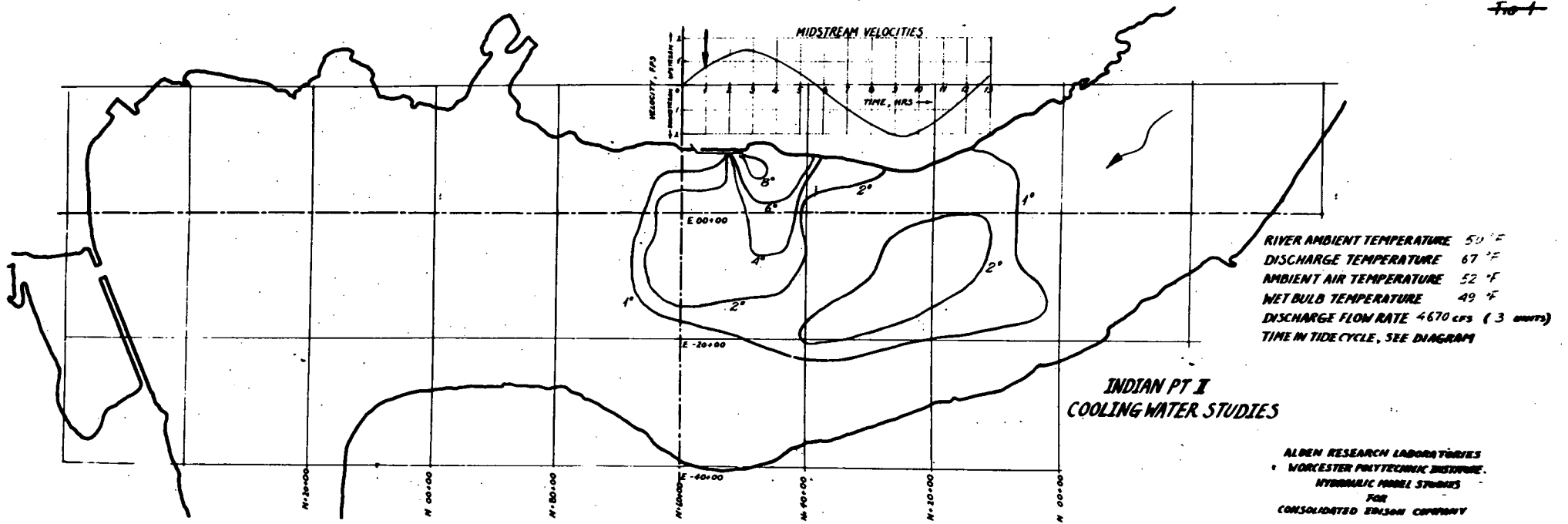

FIG A-2

Fig 2

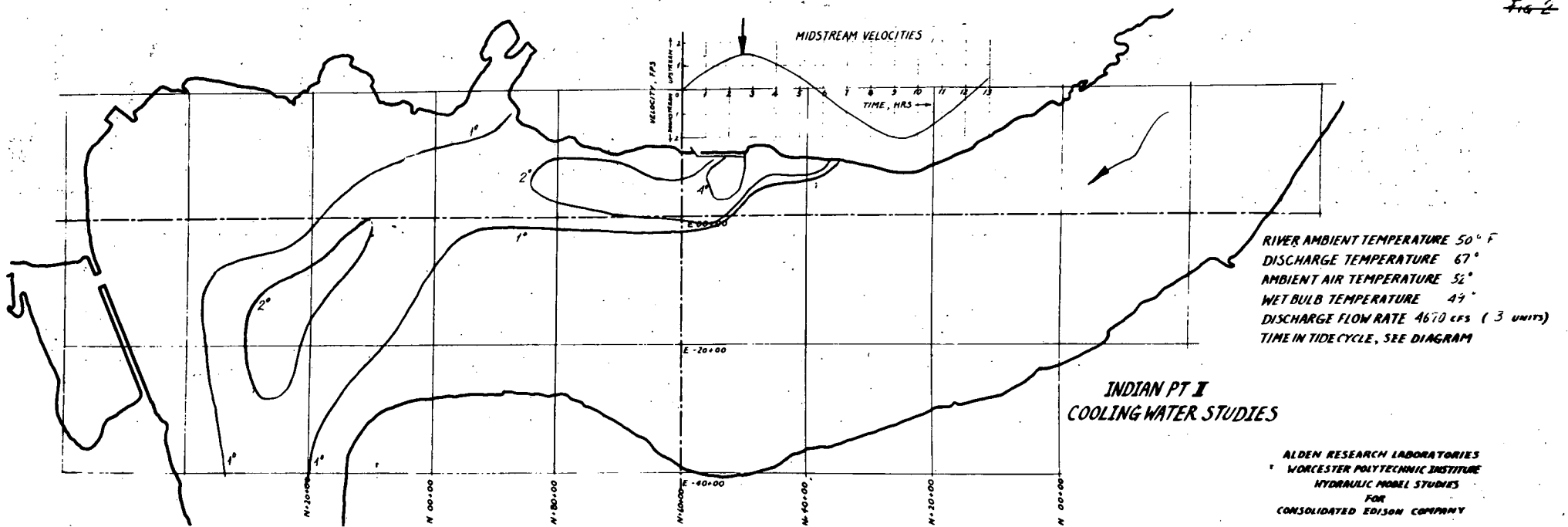

FIG A-3

Fig 3.

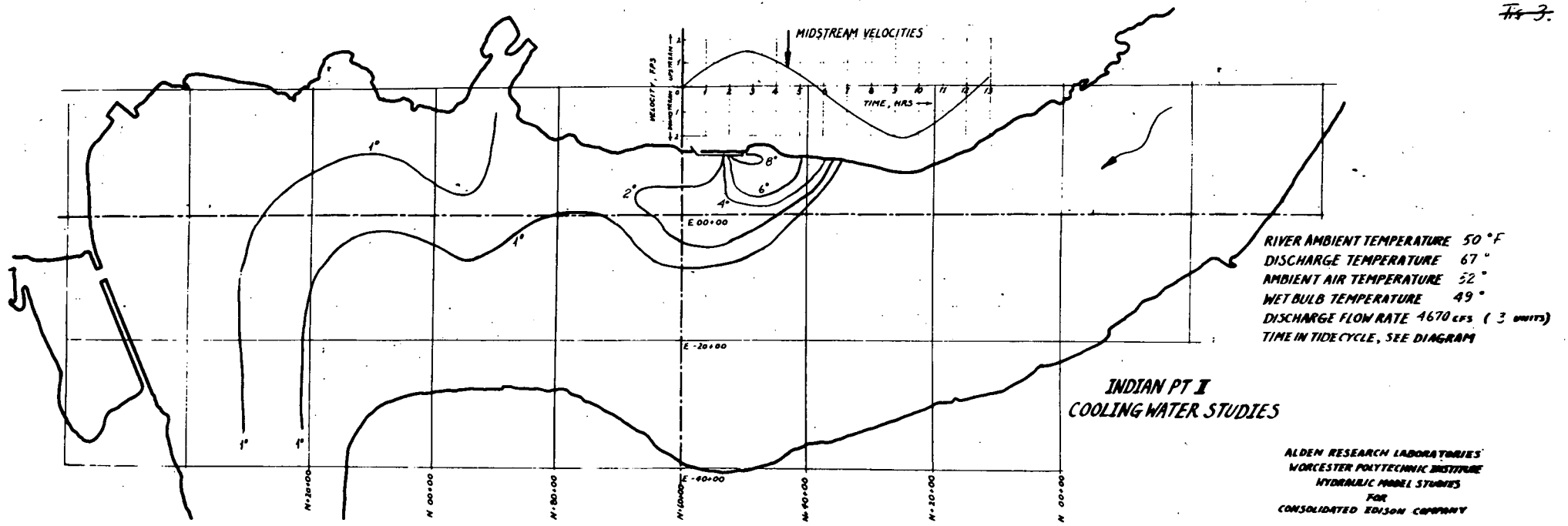

FIG A-4

FIG 4

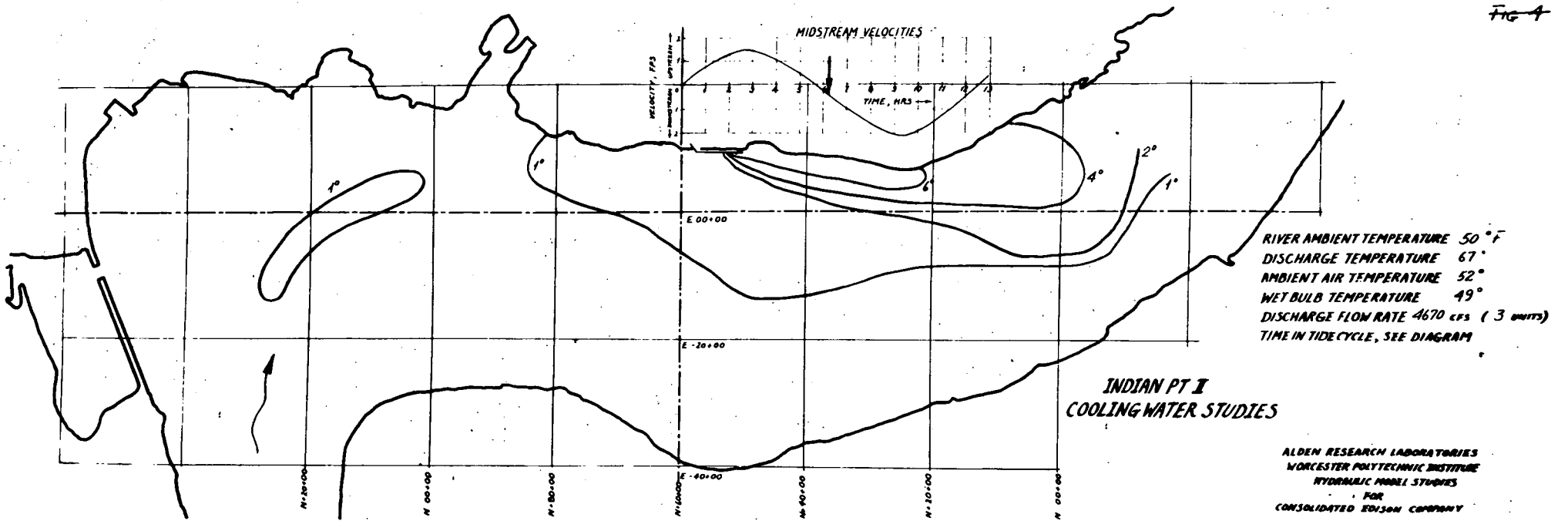

FIG A-5

Fig 5

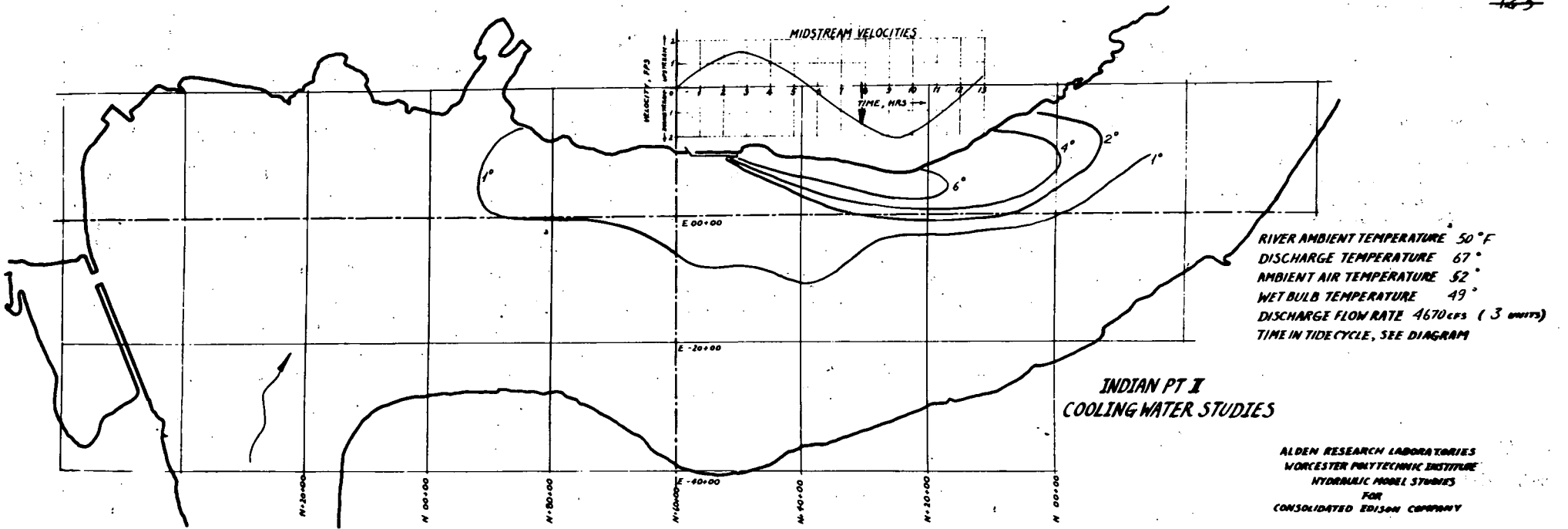

FIG A-6

Fig 6.

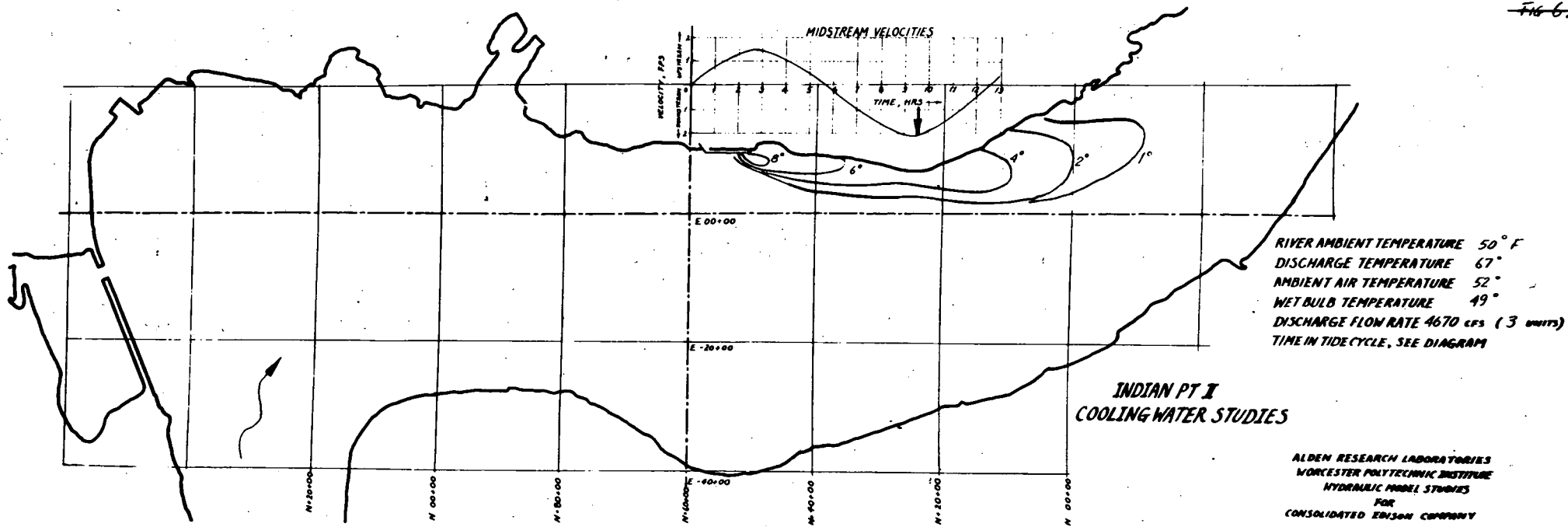
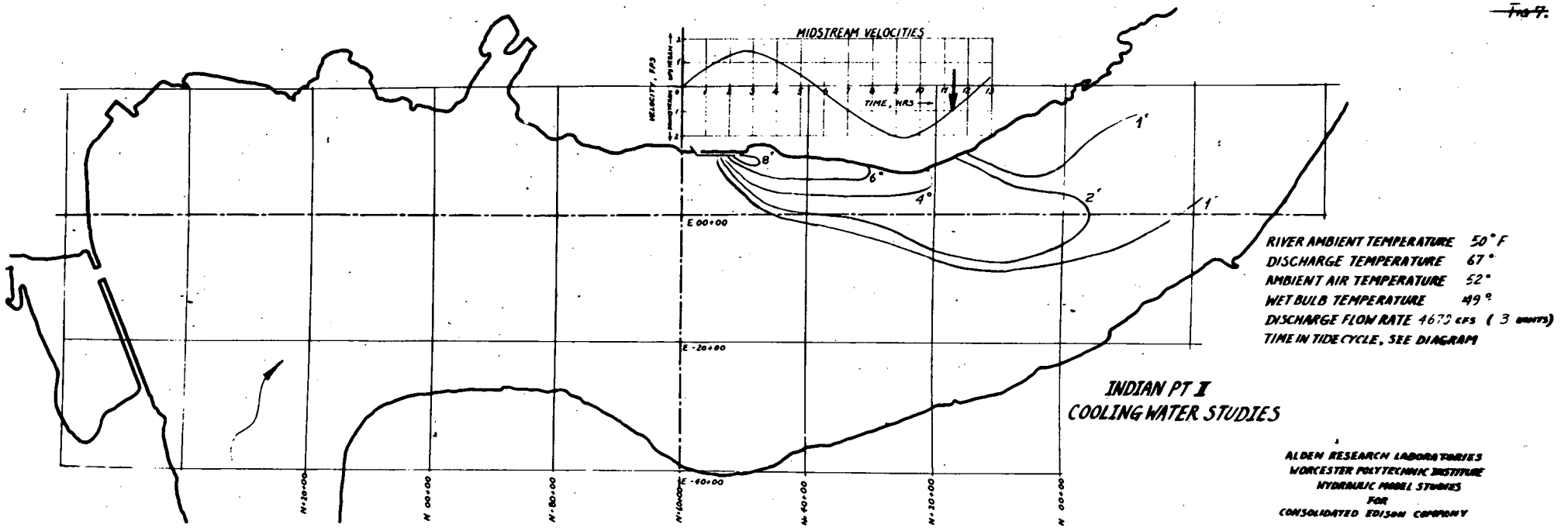

FIG A-7

Fig 7.



RIVER AMBIENT TEMPERATURE 50° F
DISCHARGE TEMPERATURE 67°
AMBIENT AIR TEMPERATURE 52°
WET BULB TEMPERATURE 49°
DISCHARGE FLOW RATE 4670 cfs (3 units)
TIME IN TIDE CYCLE, SEE DIAGRAM

**INDIAN PT II
COOLING WATER STUDIES**

ALDEN RESEARCH LABORATORIES
WORCESTER POLYTECHNIC INSTITUTE
HYDRAULIC MODEL STUDIES
FOR
CONSOLIDATED EDISON COMPANY

FIG A-8

Fig. 8.

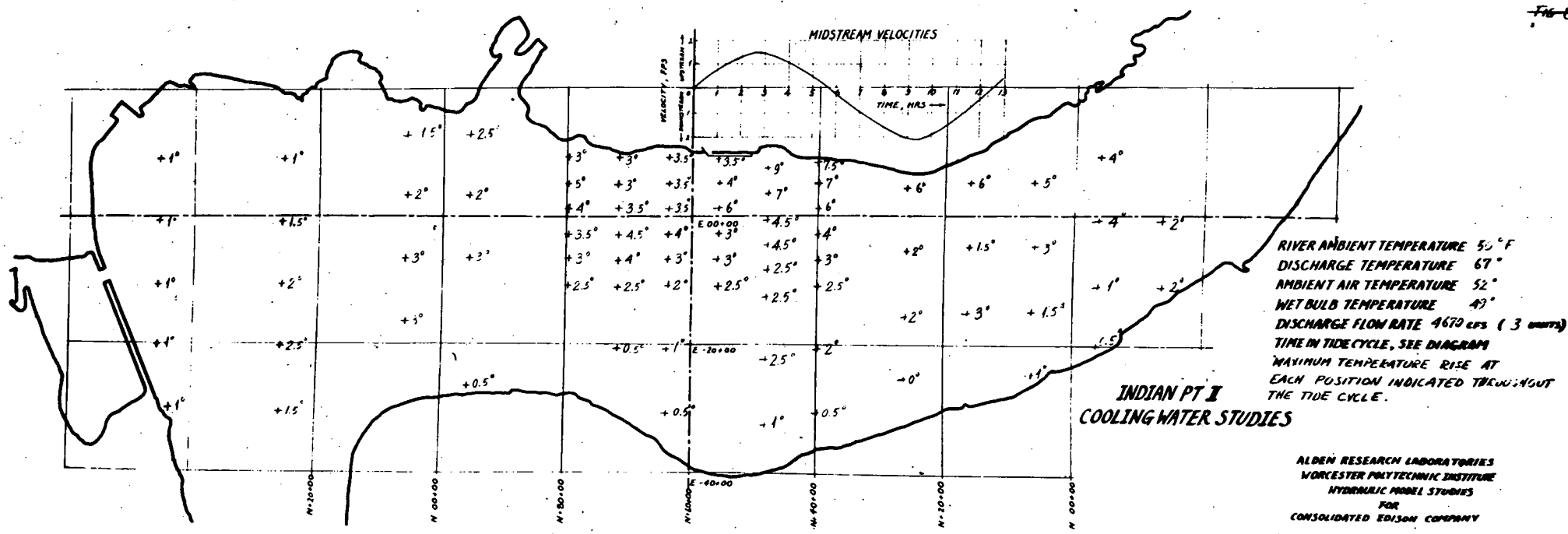

Note that Figure A-8 does not represent a pattern that can occur at any one time in the River. Each maximum value occurs at a different time during the tidal cycle. This figure merely reflects the fact that all the water particles, including the warmest, oscillate back and forth. At any given point in time these warmest particles will locate in a certain limited area. Figure A-8 shows the locus of this area throughout the tidal cycle.

The behavior of the heated discharge, as it mixes with River water, is described by the Alden Laboratory in correspondence accompanying the submission of Figures A-1 through A-8 to Consolidated Edison. These remarks are as follows:

"1. The maps are produced to show the distribution at the surface with time of the heated cooling water. The conditions of the test represented an ambient river temperature of 50°F and a discharge temperature of 67°F from Units #1, 2 and 3 (4670 cfs). $T = 0$ is arbitrarily taken as the time when flow starts being fed into the model at its downstream end (Verplanck Point.) The isotherms are based on the recording of 78 thermocouples in different positions in the model from which has been subtracted the ambient river temperature. The ambient temperature was evaluated from two thermocouples placed in the incoming flow to the model.

Figure A-1 shows the conditions at $T = 1$ hour. During the slack preceeding flood a build-up of warm water takes place and in this period of time the width of the river being affected by warm water assumes a maximum for this section of the river.

Figure A-2 indicates the conditions 1-1/2 hours later ($t = 2.6$ hrs). The cooling water is now forced with the river flow in an upstream direction. The build-up shown on Figure 1 has produced an "island" of warmer water, 2°, which is on its way to leave the model. It is also noted that the maximum temperature rise in the vicinity of the plant is reduced due to the higher flow velocities and following more efficient mixing.

Letter from Alden Research Laboratories (C.C. Neale), dated December 30, 1968 to Mr. Edward G. Watkins, Structural Engineer - Consolidated Edison Company of New York, Inc. 4 Irving Place, New York, N.Y. 10003.

Figure A-3 at 4.5 hours is towards the end of the flood tide. As a result of the reducing flood current the isotherms indicate a trend towards swelling. Also due to less efficient mixing the isotherms in the plant vicinity assume higher values.

Figure A-4 shows the conditions shortly after slack before ebb. An "island" of 1° warm water is left behind upstream of the plant and there is seen to be an accumulation of cooling water in the river section adjacent to the plant. However, the build-up of cooling water is not so extensive at slack preceeding ebb as with slack preceeding flood since the change from flood to ebb takes place more swiftly than the change from ebb to flood.

Figure A-5 shows the conditions towards maximum ebb strength. The cooling water is now swept downstream along the east shore. Some cooling water is still left behind upstream of the plant.

Figure A-6 indicates the situation at maximum ebb. The cooling water is swept downstream in a relatively narrow position of the river along the east shore. Due to the efficient mixing at the rather high current velocities the isotherms are closed curves -i.e., even the 1° isotherm terminates within the model.

Figure A-7 shows the conditions towards the end of the ebb tide. Compared to Figure 6 the current velocities are reduced and the isotherms tend to spread out and also to extend further downstream. This isotherm pattern eventually transforms itself into the pattern shown on Figure 1, thereby completing a cycle.

2. Figure A-8 shows the maximum temperatures at each of the 78 probe locations as recorded at any time within the tide cycle. It should be noted that the picture presented in this way tends to give a pessimistic impression of the temperature effect on the river."

The following section considers these results in the context of the mathematical analyses presented previously, and relates the model behavior to the prototype.

Correlation of Hydraulic Model With Predictive Model

The net flow in the hydraulic model for the conditions shown in Figures A-1 through A-8 was 33,000 cfs. This represents a high runoff condition, similar to that which existed during the April, 1967 field survey.

This high flow is necessary for correlation with the prototype. The model contains no salt, and, therefore, the normal estuarine net non-tidal flow pattern is not reproduced in the model. However, this effect is weakest where salt is not present, which is the case at Indian Point when the freshwater runoff exceeds 20,000 cfs.

On Page 19, in discussing the net non-tidal flow mechanism, it is noted that it is unlikely that this effect explains the rapid temperature decay observed in the River during the April, 1967 high flow condition. The observed high dilution and rapid decay is presumed to be caused by relatively high longitudinal dispersion coefficients accompanying the high runoffs.

During low flow conditions in the Hudson River, longitudinal dispersion has been shown, in previous studies, to be primarily a function of salinity induced circulation and tidal turbulence. Since the runoff is small, the contribution of fresh water velocity gradients to the overall dispersion effect is small, and beyond the salt front, dispersion becomes negligible. A discussion of why this is not the case in the presence of high freshwater flows follows.

In the presence of these salt and tide mechanisms, back-mixing or dispersion of salt or a pollutant upstream of its source occurs, and is explained in terms of a longitudinal dispersion coefficient which permits upstream as well as downstream movement. Hence the location of the salt front is generally considered to be the point where the contribution of salt to the dispersion is small.

During low flows, the salt intrudes relatively far up into the estuary and, since tidal power also decreases with distance upstream, the tidal contribution to the dispersion is also small at this point. Thus, beyond the salt front in the presence of low runoff, the longitudinal dispersion coefficient is small and is often neglected.

In the presence of high flows, however, the runoff is the predominant mechanism, and forces the salt well downstream. The longitudinal dispersion effect accompanying these high flows may be quite high, but may only be utilized to describe downstream pollutant movement.

Some back-mixing will occur since tidal power is still relatively high but this will generally be limited to a tidal excursion. Upstream pollutant movement, therefore, can be considered to be negligible beyond a tidal excursion.

Thus, for high flow conditions, the model simulates the prototype and the adjusted mathematical model may be employed to show correlation between model and prototype behavior.

Table 14 summarizes calculations, for model conditions, for the area-average and surface width temperature rises at the plane of discharge in the model, using the adjusted mathematical model. Note that the usual low dispersion coefficient of the unadjusted model is employed. The improved effect, described above, must be considered as being contained in the adjusted coefficient.

With respect to this adjusted mathematical model, it should be noted that it is now primarily an empirical formulation. It is not likely that the parameters which appear in Equation 1 will appear in the same order in the correct theoretical description of these thermal phenomena. For this reason, there seems to be little value in converting the adjustment factors in Table 7 into improved flows, dispersion coefficients, etc.

The value of the adjusted model is that it represents correctly the observed exponential behavior. The functional form, which the physical parameters in the unadjusted model take, has been maintained because it provides a convenient means of considering seasonal changes in the hydrological and meteorological mechanisms that control the temperature distributions. The major extrapolation from observed data is in the heat load itself. The temperature response is believed to remain linearly dependent on this parameter, so that use of Equation 1 is presumed to be valid.

The model heat transfer coefficients are not well defined. The value of \bar{K} used in Table 14 is roughly equal to the average of available data on this parameter. Observation of Equation 1, however, shows this value plays a relatively small role in the rapid decay of temperature in the vicinity of Indian Point. As described previously, mixing, dispersion and dilution are the primary reasons for the observed temperature behavior, and, for high flow conditions, the model effects these.

TABLE 14

CALCULATIONS FOR AREA-AVERAGE TEMPERATURE RISE
AND SURFACE WIDTH ISOTHERMS AT PLANE OF DISCHARGE
HYDRAULIC MODEL CONDITIONS

Conditions

$$H = 430 \times 10^9 \text{ BTU/day, } \Delta T_{sm} = 8.4^\circ\text{F}$$

$$Q = 33,000 \text{ CFS, } U = 3.38 \text{ miles/day, } E = 2 \text{ sq. miles/day}$$

$$\bar{K} = 110 \text{ BTU/SF/Day/}^\circ\text{F, } \text{TSF} = 1.2, \text{K}' = 0.053 \text{ day}^{-1}$$

$$f_5 = 0.54$$

Area Average and Surface Average Temperature Calculations

$$\frac{f_5 H}{\rho C_p Q} = \frac{0.54 \times 430 \times 10^9}{54 \times 10^5 \times 3.3 \times 10^4} = 1.31^\circ\text{F}$$

$$\frac{4K' E}{U^2} = \frac{4 \times 0.053 \times 2}{3.38 \times 3.38} = 0.037$$

$$\Delta \bar{T} = 1.31 \times \sqrt[3]{1 + 0.037} = 1.28^\circ\text{F}$$

$$\Delta \bar{T}_s = 1.2 \times 1.28 = 1.53^\circ\text{F}$$

Percentage of Surface Width Bounded by Given Isotherm

$$\Delta \bar{T}_s / \Delta T_{sm} = 1.53 / 8.4 = 0.18$$

<u>% Surface Width</u>	<u>$\Delta T_s / \Delta T_{sm}$ (Fig. 24)</u>	<u>$\Delta T_s, ^\circ\text{F}$</u>
10	0.58	4.9
20	0.33	2.8
30	0.19	1.6
40	0.11	0.9

The maximum tidal average surface temperature across the plane of discharge is 8.4°F, as will be shown shortly in Figure 28. This is higher than the 6°F which the submerged discharge will be able to effect, due to a smaller submergence in the distorted model.

The thermal stratification factor employed in this model analysis is 1.2, considerably smaller than the values used previously in projecting actual River performance under critical conditions. This value was chosen because the distorted vertical scale is believed to create conditions closer to complete mixing than will occur in the prototype.

Table 14 shows exponential decay of surface temperature with surface width across the discharge plane. These results agree very well with the plane of discharge tidal average surface temperature rise isotherms shown in Figure 28.

The curves in Figure 28 were constructed by first constructing similar curves at each station for each of the seven tidal phases represented in Figures A-1 through A-7. For each station, the seven sets of data, which consist of surface rise isotherms versus percentage of surface width bounded by a given isotherm, were then averaged to yield average surface width bounded by a given isotherm, and the curves of Figure 28 drawn.

Figure 28 shows that the exponential decay model is followed closely at the plane of discharge (Station 0 + 0 in Figure 28) and immediately above and below the plane of discharge.

The agreement between the results obtained in Table 14, analyzing the hydraulic model conditions with the adjusted mathematical model, and those in Figure 28, obtained directly from hydraulic model surface isotherms, is shown below:

<u>% of Surface Width</u>	<u>Hydraulic Model Surface Temperature Rise, $\Delta \bar{T}_s$, °F</u>	
	<u>Using Math. Model</u> (Table 14)	<u>Averaging Measured</u> <u>Surface Isotherms</u> (Figure 27)
10	4.9	4.5
20	2.8	2.4
30	1.6	1.3
40	0.9	0.7

FIGURE 28

TEMPERATURE RISE ISOTHERM
 VS
 PERCENTAGE SURFACE WIDTH
 TIDAL AVERAGE CONDITION
 INDIAN POINT MODEL II

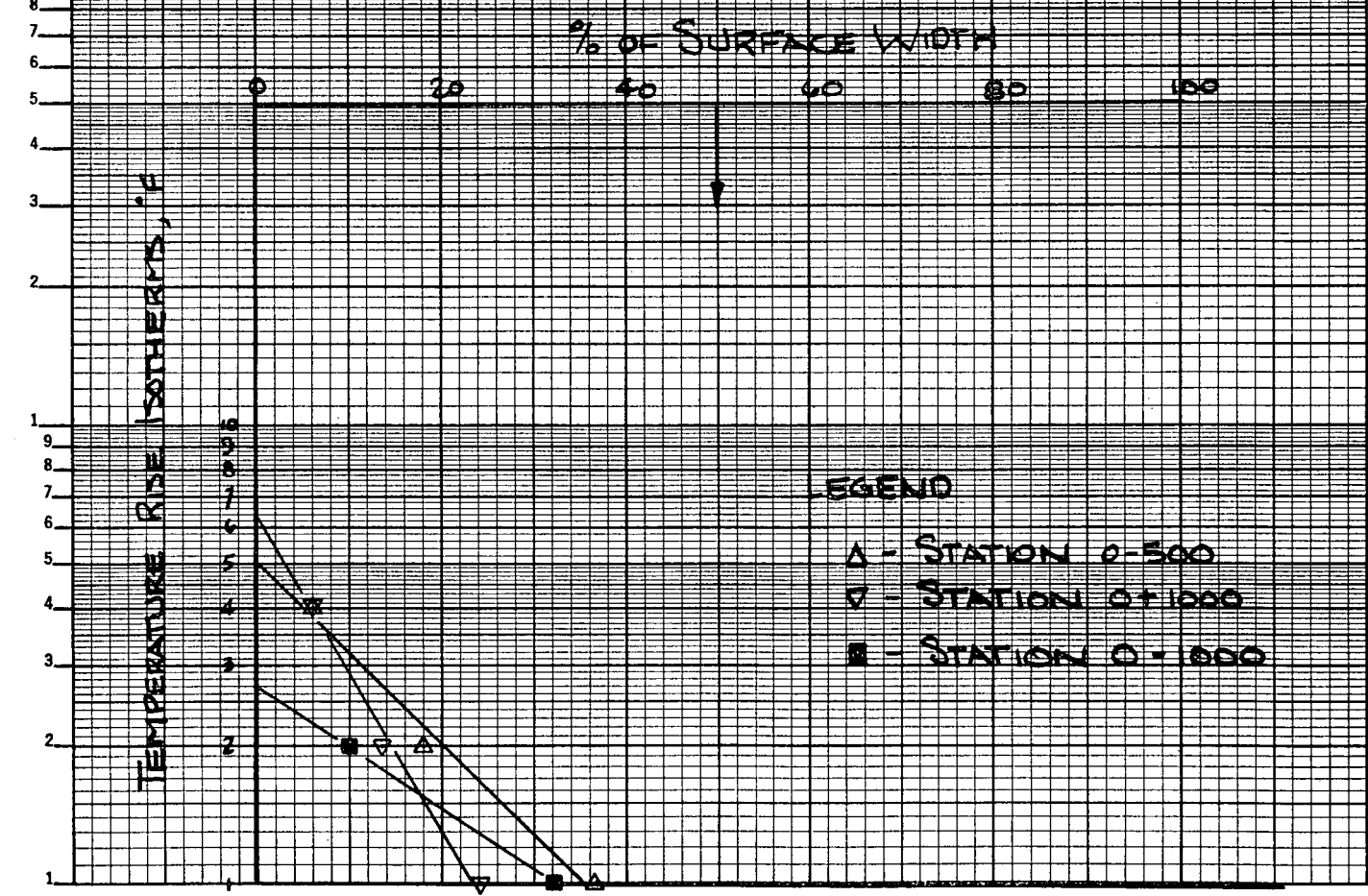
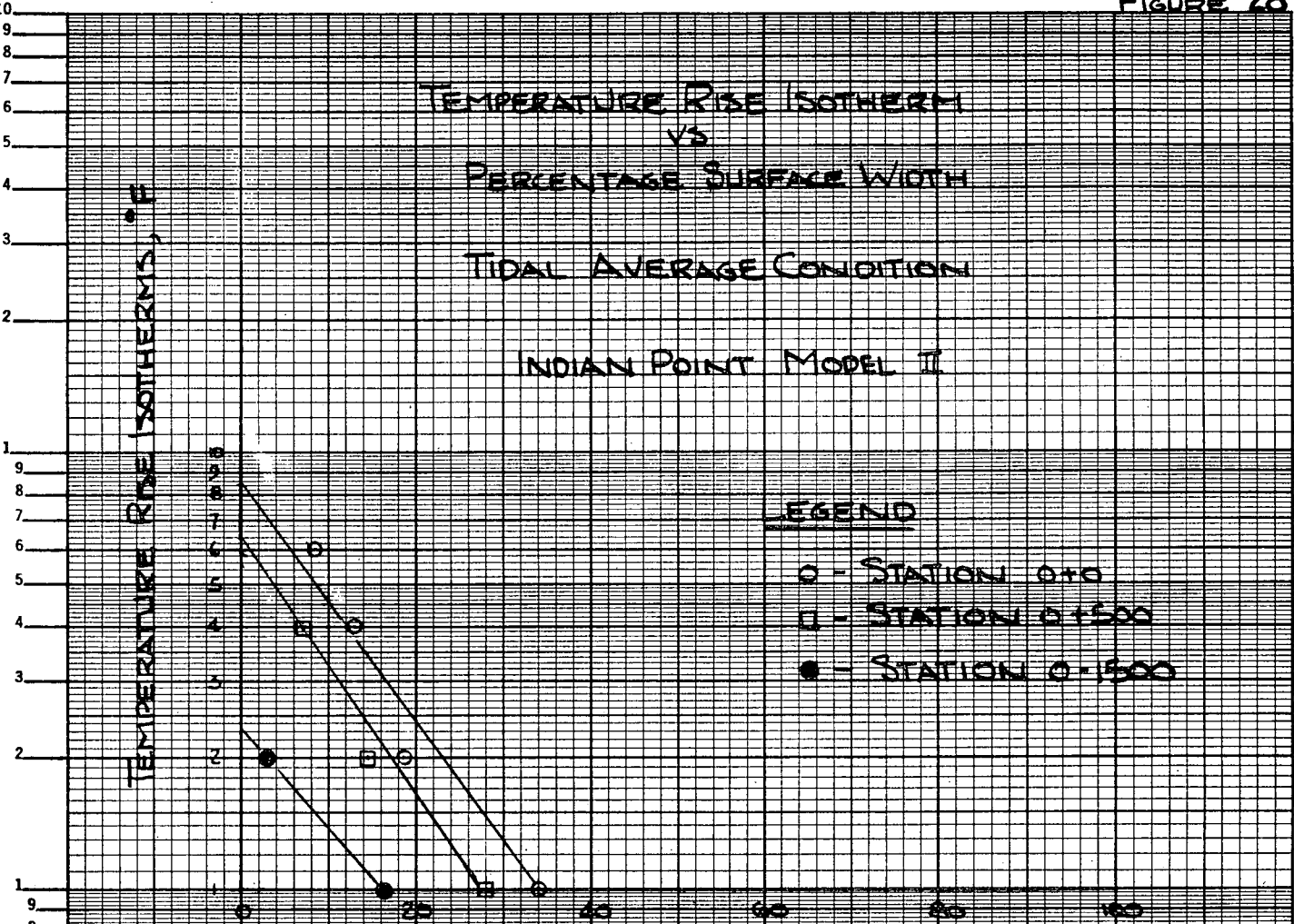

This agreement is quite good and further confirms the validity of using the adjusted model to predict three unit behavior. The average surface temperature rise, ΔT_s , for the plane of discharge curve in Figure 28 was 1.35°F by comparison to the 1.53°F obtained in Table 14. Of course, latitude in the selection of the thermal stratification factor affords some control over these results; the value chosen however, is believed to be approximately correct for the reason given.

The surface average temperature rise, ΔT_s , of each curve in Figure 28 was also computed. These results are given below:

<u>Station</u>	<u>Location</u>	<u>ΔT_s, °F</u>
0-1,500	1,500 ft. upstream	0.44
0-1,000	1,000 ft. upstream	0.81
0- 500	500 ft. upstream	1.00
0+0	Plane of discharge	1.35
0- 500	500 ft. downstream	0.94
0+1,000	1,000 ft. downstream	0.77

Area average temperature rises should be slightly less than these values. The TSF values for the station above and below the plane of discharge are probably closer to unity than is the value for the plane of discharge, as evidenced by the rapid decay of the maximum surface temperature shown in Figure 28.

The rapid decay shown above was compared to decay according to Equation 1 for the hydraulic model conditions given in Table 14. The procedures shown in Table 13 were used with the parameters in Table 14 to compute the decay coefficients j_1 and j_2 .

The decay coefficients j_1 and j_2 , using the model adjustment factor given in Table 7, were 22 and 0.22 miles⁻¹, respectively. The upstream value of 22 mile⁻¹ is for more rapid than that observed in the Alden model and is probably due to the fact that the f_4 factor for April, 1967 of 12.9, representing observations below Indian Point at that time, was arbitrarily applied to the upstream region as well.

In light of the discussion above of the longitudinal dispersion effect in the presence of high flows, this procedure effectively does not credit the upstream region with back-mixing. The f_3 factor is probably actually substantially lower than f_4 , rather than equal to it. This would yield surface average values substantially in agreement with those given above.

The downstream decay coefficient of 0.22 mile^{-1} yields $\Delta \bar{T}$, and therefore $\Delta \bar{T}_s$, values which are larger than those given above. This is probably due to the fact that the term $(1 - \sqrt{1+N})$ is very sensitive for small values of N . The value obtained, (-0.02) , may not be extremely accurate.

Submerged Discharge

A submerged outlet in the effluent channel is planned for discharging the heated effluent to the River. This type outfall was selected to insure that the proposed criterion of a 90°F maximum surface water temperature at any point in the River's surface be met at all times. The submerged outfall, by comparison to a surface discharge, will also reduce the percentage of the surface width subject to temperature rises greater than 4°F .

The effect of various submerged outfall designs and depths of submergence was studied in detail in an undistorted model of the River in the near vicinity of Indian Point by the Alden Hydraulic Laboratory. A copy of Alden's report on this study is appended to this present report. A summary of the major findings is given in Table 15.

Reduction in temperature occurs by entrainment of the surrounding ambient water as the jet of heated liquid works its way toward the surface. This phenomenon is called initial jet dilution and has been the subject of numerous theoretical analyses.

A simplified analysis of this mechanism was attempted to permit evaluation of submerged discharge under conditions of submergence and effluent channel temperature rise other than those studied in the Alden model.

This approach first obtained the path of the jet by assuming it follows the kinematics of projectile motion, employing the acceleration due to the buoyancy of the lighter warmer water, and the average horizontal velocity of the jet. The normal dilution formulae for jet entrainment were then employed to determine the extent of the dilution by the time the jetted fluid reached the River's surface.

TABLE 15

SUMMARY OF ALDEN HYDRAULIC LABORATORY FINDINGS FOR
DISCHARGE OF THREE UNIT HEATED WATER THROUGH A
SUBMERGED OUTFALL

Test Conditions

Model Scale: 1:50 undistorted

Three Unit Flow: 4,660 CFS (2,100,000 GPM)

Effluent Channel Temperature Rise: 17°F

Total Length of Discharge Canal from First Through
Last Port: 230 Ft.

Port Design: 6 Rectangular Ports, each 30 Ft. Long,
4 Ft. High

Port Spacing: 10 Ft.

River Flow: Approximately 25% of Average Ebb Tide

Port Velocity: 10Ft/Sec

Summary of Maximum Surface Temperature Rises

<u>Submergence to Top of Port (Ft. below MSL)</u>	<u>Depth to Channel Bottom (Ft. below MSL)</u>	<u>Maximum Surface Temperature Rise (°F)</u>	<u>Location of Maximum Rise (Ft. of Shore)</u>
16	20	9	200
21	25	8	200
26	30	6	200

This approach yielded results which showed substantially greater dilution than was obtained in the model. The fact that buoyant acceleration, which appears in the calculations, is extremely sensitive to small density changes is the probable reason for the lack of good agreement.

Since the model results were more conservative, they were used, in conjunction with an extremely simple but very conservative view of jet dilution, to predict behavior at the planned discharge temperature of 14°F.

The second approach begins by assuming the jet rises to the surface in a straight vertical direction. The formula for dilution of a jet into a fluid of equal density is used. This is written:

$$S_o = 0.32 X/D_o \quad (6)$$

in which: S_o = ratio of River water entrained in the jet to the discharge channel flow

X = distance from the port at which the dilution, S_o , is measured

D_o = effective port diameter, or better, the effective diameter of the jet's vena contracta

The value of S_o is computed at X equal to the submergence of the port center line. A computed maximum surface temperature rise, ΔT_{sm} , is then obtained as follows:

$$\Delta T_{sm} = \frac{\Delta T_p}{1+S_o} \quad (7)$$

in which: ΔT_p = effluent channel temperature rise

Table 16 shows values of ΔT_{sm} , obtained by using Equations 6 & 7, for the model conditions given in Table 15. The values of ΔT_{sm} observed in the model are smaller, as expected, since Equations 6 & 7 ignore the horizontal nature of the initial jet velocity and the resultant curvilinear path, as well as the additional entrainment due to the relative motion induced by the buoyancy effect.

The ratio of the observed to computed values of ΔT_{sm} is computed in Table 16 for each of the three model submergence conditions.

TABLE 16

COMPARISON OF COMPUTED AND OBSERVED MAXIMUM SURFACE TEMPERATURE RISES FOR $\Delta T_p = 17^\circ\text{F}$, AND PREDICTIONS FOR $\Delta T_p = 14^\circ\text{F}$

Computed Surface Temperature Rise for $\Delta T_p = 17^\circ\text{F}$

$$\Delta T_{sm} = \frac{\Delta T_p}{1 + \frac{0.32x}{D_o}}$$

$$D_o = \frac{120 \times 0.65}{0.785} = 10 \text{ FT.}$$

<u>Centerline Submergence, FT</u> (x)	ΔT_{sm}	
	<u>Computed From Equations 6 & 7</u>	<u>Measured in Model (See Table 15)</u>
18	10.8	9
23	9.8	8
28	8.9	6

Computed Surface Temperature Rise for $\Delta T_p = 14^\circ\text{F}$

<u>Centerline Submergence</u>	<u>ΔT_{sm}, Computed</u>	<u>$\frac{\Delta T_{sm, \text{observed}}}{\Delta T_{sm, \text{computed}}}$</u>	<u>ΔT_{sm}, Adjusted</u>
18	8.9	0.833	7.4
23	8.1	0.817	6.6
28	7.4	0.675	5.0

Equation 7 is then adjusted by these ratios, and used to compute expected temperatures for the planned effluent channel temperature rise of 14°F. Results are given in Table 16.

These results show that, in the presence of a 14°F effluent channel temperature rise, a maximum River surface temperature rise of 6°F can be expected at a center line submergence of about 26 ft., corresponding to a total depth of 28 ft. Model results, of course, show the 6°F surface rise can be obtained for the 17°F channel rise with a center line submergence of 28 ft., or total depth of 30 ft.

APPENDIX A

PROGRESS REPORT
on
INDIAN POINT II STUDIES
for
CONSOLIDATED EDISON COMPANY OF NEW YORK

at

ALDEN RESEARCH LABORATORIES
WORCESTER POLYTECHNIC INSTITUTE
WORCESTER, MASSACHUSETTS, 01609

INTRODUCTION

Different outfall configurations for the cooling water from the Indian Point Power Plant have been studied in the existing Indian Point II model. During the course of these studies it was found desirable to discharge the cooling water from submerged outfall openings facing toward the river. Preliminary studies in the Indian Point II model, which has a distortion of 4.16, indicated that the testing of submerged outlets would yield local results not corresponding to equivalent prototype outlets. The reason was that a jet formed by an outlet, is a specific hydraulic phenomenon, which develops without regard to the model distortion. A free jet, issuing into an infinite ambient recipient, has an angle of divergence of about 11.3° . Therefore in the distorted model the spread of the jet would appear to occur at too low a rate. The cooling water jet would entrain excessive ambient water at the point where the river surface was reached and would therefore indicate a resulting temperature on the low side. Since the results thus would be on the optimistic side, rather than on the conservative side, it was decided to carry out the detailed investigation of the outfall configuration in an undistorted model. The aim of these tests was two-fold: 1) To determine the geometry of the outfalls so as to meet specified requirements with respect to river surface temperatures. 2) To determine the boundary condition to be imposed on the distorted model so as to obtain correct results from this model outside the area directly affected by the outfalls.

THE MODEL

It was decided to construct the undistorted outfall model utilizing the heat capacity of the boiler supplying the distorted model. Part of the sump area for the distorted model was found to be a convenient site for the undistorted model, providing river ambient water for the model without any extra effort in terms of piping, installing of pump capacity, etc. Based on the above conditions a model scale ratio of 1:50 was chosen. Photos #1 and #2 show the model and Figure #1 shows the extent of the modeled area in comparison with the equivalent area of the distorted model. The river bottom topography was modeled on the basis of the data used for the distorted model. The lateral slope of the river bottom outside the outfall is relatively gentle and constitutes an almost plane sloping surface within the nearest 300 to 400 feet off shore. Therefore the increased submergence of the outfalls could be modeled by increasing the depth of water in the model rather than by actually excavating to greater depth of the outfall. This saved considerable time in testing and also gave the advantage of more direct comparison of different amounts of submergence.

Part of the discharge channel and the sheet piling along the river shore, containing the outfall openings, was modeled in sheet metal to an elevation such that a water depth in the discharge channel of up to 32 feet could be modeled. A regulating gate was installed at the downstream end of the model to regulate the depth of water. A 4" warm water pipeline containing an orifice meter and valves for adjusting the temperature as well as the flow rate was installed.

The model was equipped with 22 thermocouples already connected to one of the recorders of the distorted model. These were placed with reference to a grid system for which N60 and the grant of water line were base lines. For detailed measurements a thermistor set with 12 probes was used which provided more flexibility than the more stationary thermocouples.

TEST PERFORMED

The advantage of subsurface discharge is that the cooling water issuing from the discharge openings becomes mixed with ambient water which is entrained from essentially 4 directions. The forced mixing increases with increasing momentum of the discharge flow. However, the force required to produce the momentum must be supplied from the cooling water pumps. It was indicated by the Consolidated Edison Company that an increase of the discharge head of 1.5 feet could probably be tolerated. This was used as a guide for the testing.

An elevation difference of 1.5 feet between the water level in the channel and that of the river corresponds in terms of velocity head to a velocity of about 10 fps. This would theoretically be the velocity of the discharge at the vena contracta of the jet. It was found experimentally that an outfall opening area of about 720 feet² was the minimum area for discharging 4660 cfs from units 1, 2 and 3 and not exceeding 1.5 feet water surface elevation difference. (The corresponding coefficient of contraction was 0.65 which was compatible with the configuration of the discharge structure.) It was reasoned that the lower the height of the discharge openings the greater the submergence and thus the more efficient the mixing. Based on the above considerations six discharge openings 4 feet high and 30 feet wide were chosen, separated by 10 foot-wide partitions. The total length of the discharge structure thus was 235 feet including 5 feet of wall downstream from the last opening. The end of the channel was blanked off.

The degree of mixing and thus the drop in effluent temperature depends on the degree of submergence of the outfall openings. This is particularly the case for the temperature at the river surface in the area where the effluent reaches the surface. Therefore three different degrees of submergence of the above described outfall openings were tested.

A test series was performed using a continuous, low slot, again based on 1.5 feet back-up of the water in the discharge channel. Temperature measurements did not reveal any advantage of this design over that consisting of separate openings.

Vanes were tested to help deflect the water at a greater angle to the direction of the discharge channel. Although this visually seemed to indicate an improvement, temperature measurements did not bear this out.

For all tests the discharge temperature was elevated about 17°F above ambient river temperature. Evidently no tidal action was attempted in testing but a slight downstream flow through the model was maintained to prevent heat from building up due to the warm water discharge from the outfall.

TEST RESULTS

Figures 1, 2 and 3 show the test results in terms of surface isotherms. Figure 1 is for a submergence of the outfall openings of 16 feet, ie. the channel bottom was 20 feet below mean sea level. It is seen that the maximum surface temperature above ambient river temperature was 9°F. The highest temperatures occurred downstream from the outfall about 200 feet off shore.

Figure 2 shows the results with a submergence of 21-foot or 25-foot channel depth. The maximum surface temperature was reduced to 8°, again occurring about 200 feet off shore and downstream from the outfalls.

Figure 3 indicates the effect of 26-foot submergence. The maximum temperature rise was found to be 6°F approximately 200 feet off shore, slightly downstream from the end of the channel. Thus an assumed ambient river water temperature of 79° would be expected to yield a maximum surface temperature of 85°F. The channel bottom elevation with this design corresponded to 30 feet below mean sea water level.

Temperature distribution in vertical direction was measured at a couple of points in the area of maximum surface temperature. The temperatures were found to be essentially constant with depth as indicated in the temperature profile shown in Figure 4.

Since the highest temperatures were found at rather close proximity to the model back wall the temperature results did not convince that the model yielded the maximum surface temperature. Tests were therefore conducted to scale 1:75 by changing the outfall model structure and adjusting the flow rate. It was found that the 6°

isotherm was not exceeded. Temperatures, however, stayed constant to about 350' off shore, the maximum distance that could be measured for this model scale ratio without interference with the model back wall. This result was compatible with the finding that the vertical temperature distribution was constant.

Also with the 1:75 model good agreement was found with results from the 1:50 model when corresponding points were compared.

Finally, to verify that the trend towards temperature concentration downstream from the outfall structure would not be accentuated by a downstream river flow, tests were performed with an ambient river flow in the downstream direction. The flow velocities corresponded roughly to an average ebb condition. It was found that the cooling water was deflected so that the maximum temperature would occur close to the shore line. However, the maximum temperatures were not higher than for the condition of no river flow.

CONCLUSIONS

Model tests in an undistorted scale model of ratio 1:50 indicated that an outfall structure consisting of a vertical wall along the grant of water line, containing six openings 4 feet high and 30 feet wide with partitions of 10 feet and submerged 26 feet to the top of the openings would yield river surface temperature increases not exceeding 6°F. The discharged water had a temperature of 17°F above ambient river temperature.

For constructional reasons it may be desirable to limit the width of the openings. It is felt that as long as the overall length of the outfall structure is maintained the results of this investigation will still be valid. (For example, 12 openings with 5 foot wide partitions.) *[Each opening would be 15 FT. WIDE*

The model tests yielded information for reproducing the temperature conditions in a boundary in the vicinity of the distorted Indian Point II model outfall area.

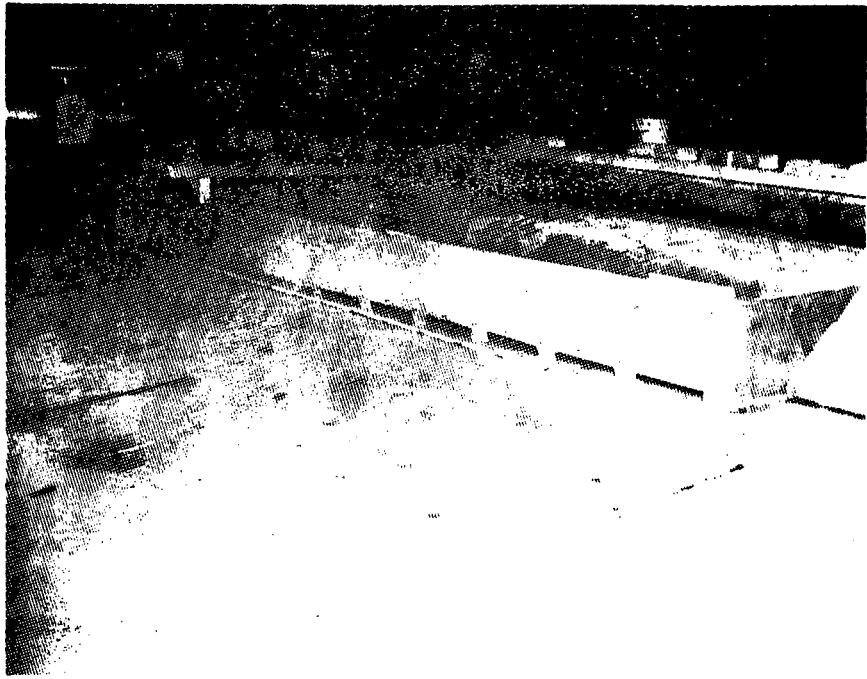
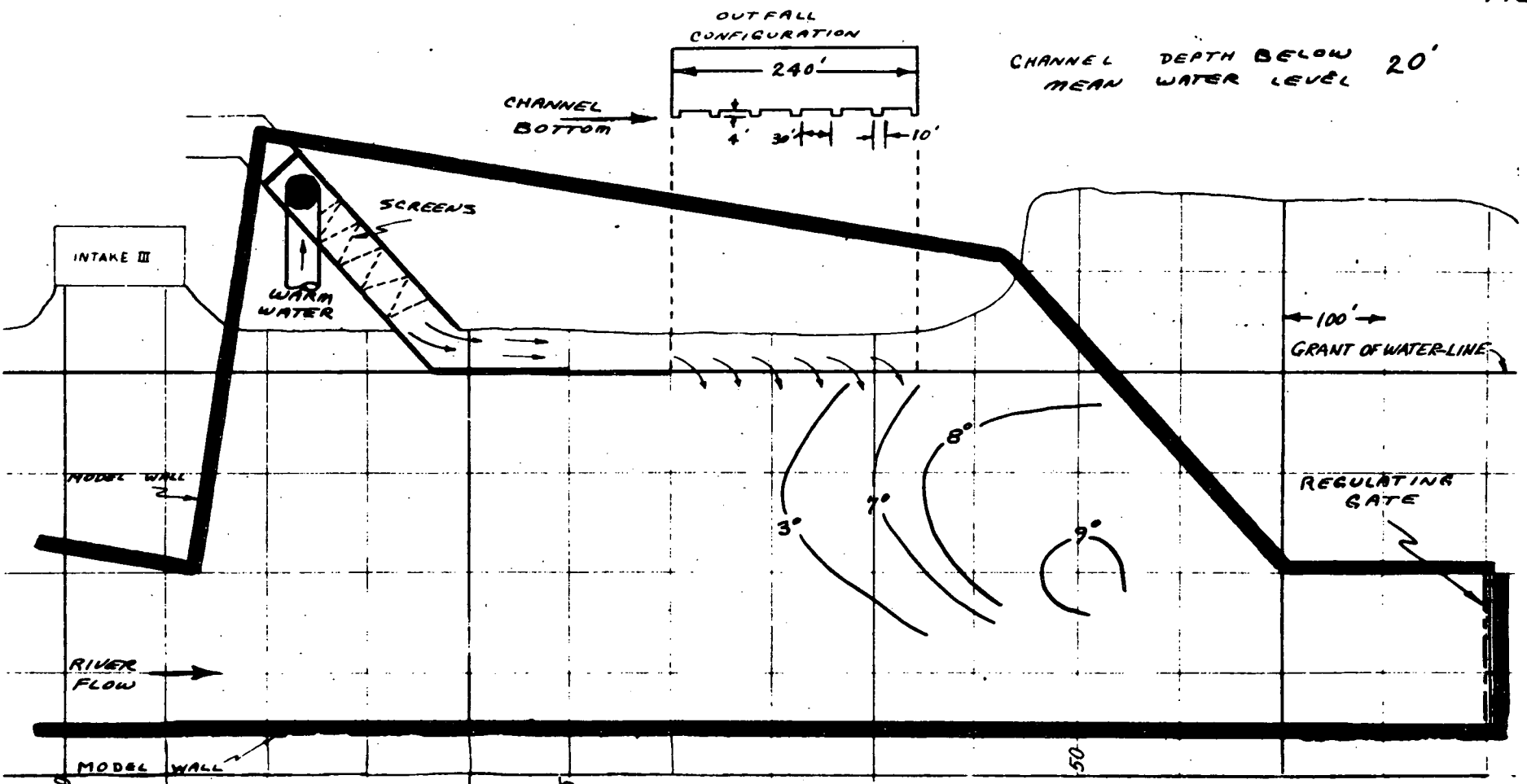

Figure 1



Figure 2

FIG 1



CHANNEL DEPTH BELOW MEAN WATER LEVEL 20'

ISOTHERMS ARE SURFACE TEMPERATURES ABOVE AMBIENT RIVER TEMPERATURE.

WARM WATER IS 17°F ABOVE AMBIENT RIVER TEMPERATURE.

ALDEN RESEARCH LABORATORIES
WORCESTER POLYTECHNIC INSTITUTE

HYDRAULIC MODEL STUDIES FOR
CONSOLIDATED EDISON COMPANY NY

INDIAN POINT II MODEL *

MODEL SCALE: 1' = 50'
*(UNDISTORTED) SUB MODEL

FIG 2

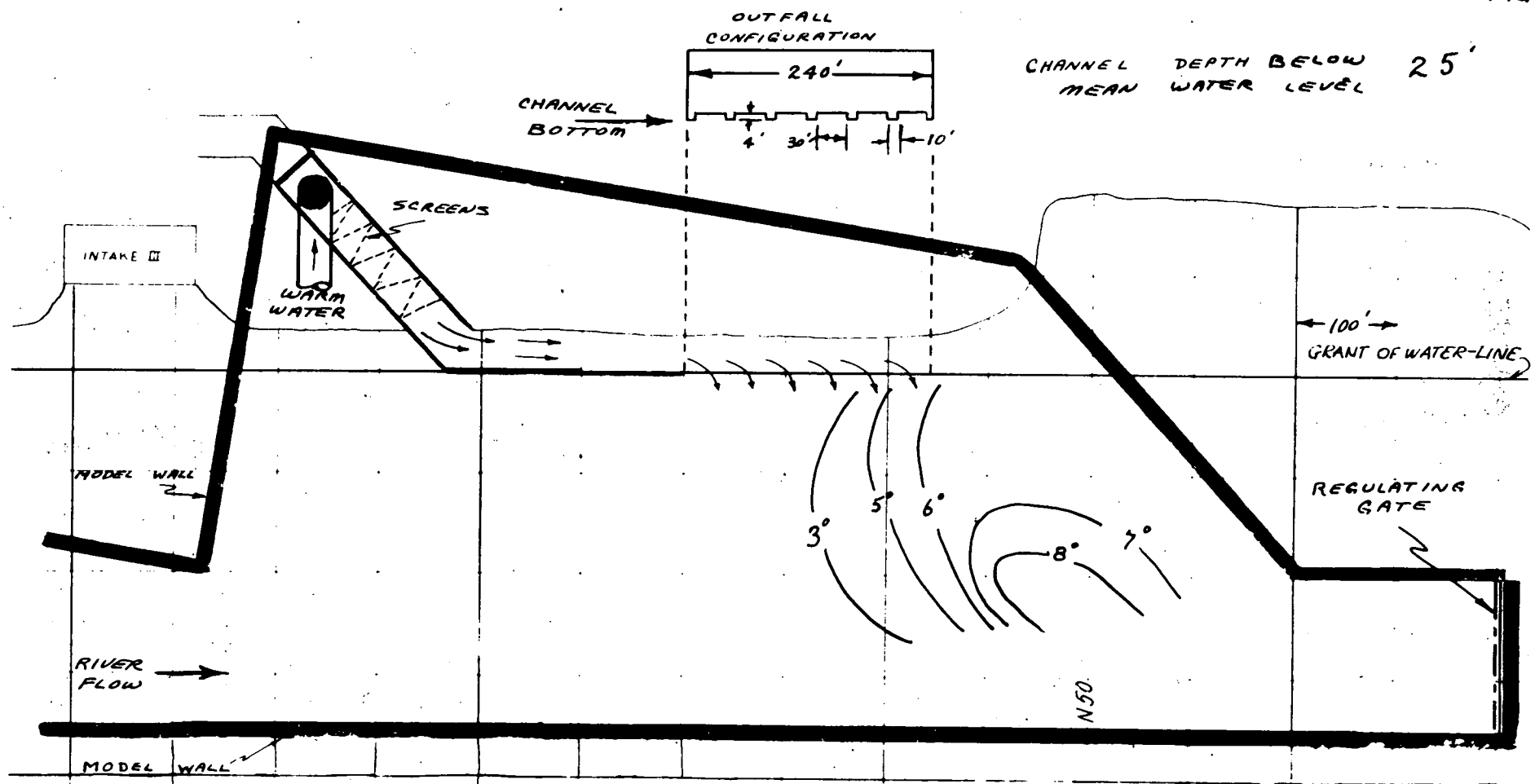

ISOTHERMS ARE SURFACE TEMPERATURES
 ABOVE AMBIENT RIVER TEMPERATURE.
 WARM WATER IS 17°F ABOVE
 AMBIENT RIVER TEMPERATURE.

ALDEN RESEARCH LABORATORIES

WORCESTER POLYTECHNIC INSTITUTE

HYDRAULIC MODEL STUDIES FOR
 CONSOLIDATED EDISON COMPANY NY

INDIAN POINT II MODEL *

MODEL SCALE: 1' = 50'
 * (UNDISTORTED) SUB-MODEL

FIG 3

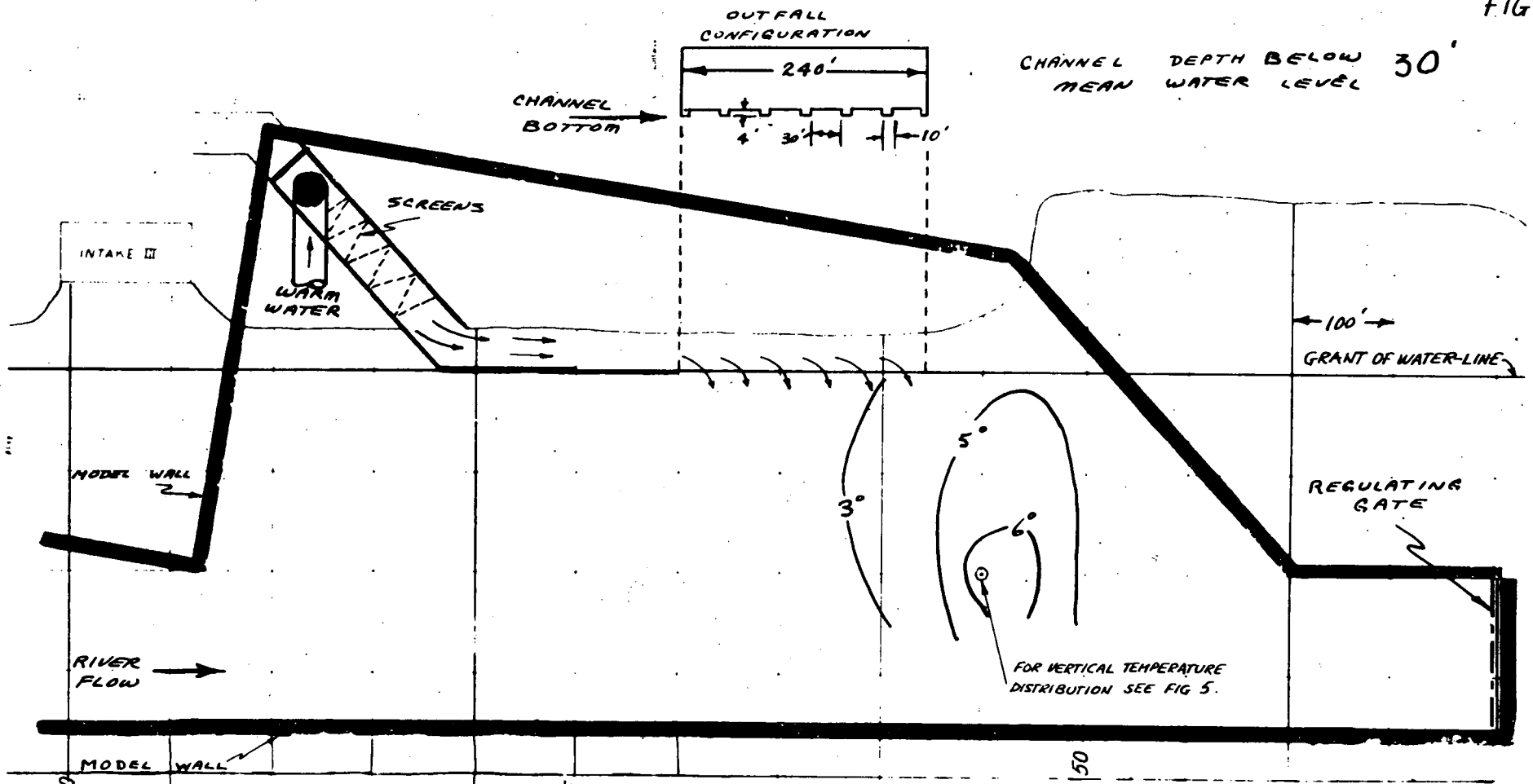

ISOTHERMS ARE SURFACE TEMPERATURES ABOVE AMBIENT RIVER TEMPERATURE.

WARM WATER IS 17° ABOVE AMBIENT RIVER TEMPERATURE.

ALDEN RESEARCH LABORATORIES

WORCESTER POLYTECHNIC INSTITUTE

HYDRAULIC MODEL STUDIES FOR
CONSOLIDATED EDISON COMPANY NY

INDIAN POINT II MODEL *

MODEL SCALE: 1' = 50'

* (UNDISTORTED) SUB-MODEL

TYPICAL CROSS-SECTION

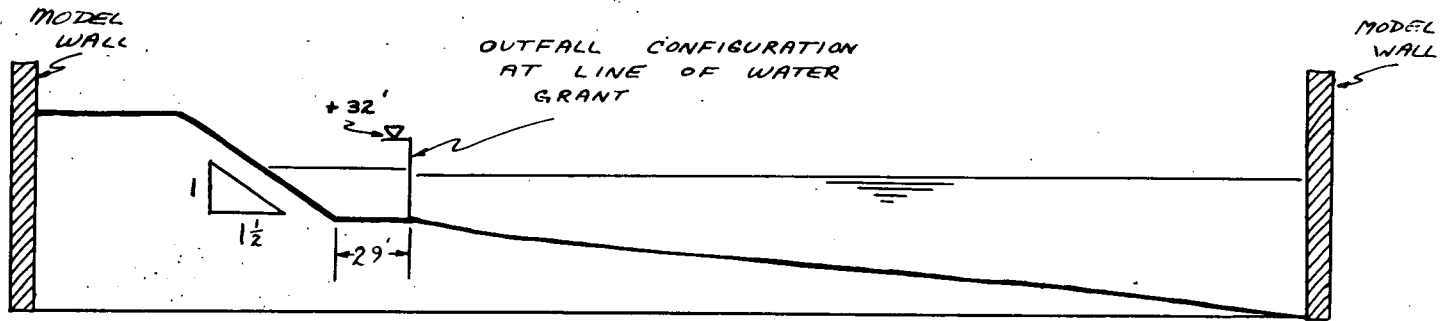

SCALE : 1" = 50'

ALDEN RESEARCH LABORATORIES
WORCESTER POLYTECHNIC INSTITUTE
HYDRAULIC MODEL STUDIES FOR
CONSOLIDATED EDISON COMPANY NY
INDIAN POINT II MODEL*

* UNDISTORTED SUB-MODEL
SCALE 1:50

TEMPERATURE VS DEPTH
AT

(N 51, 200' FROM LINE of
WATER GRANT)

DISCHARGE WATER 17° ABOVE AMBIENT

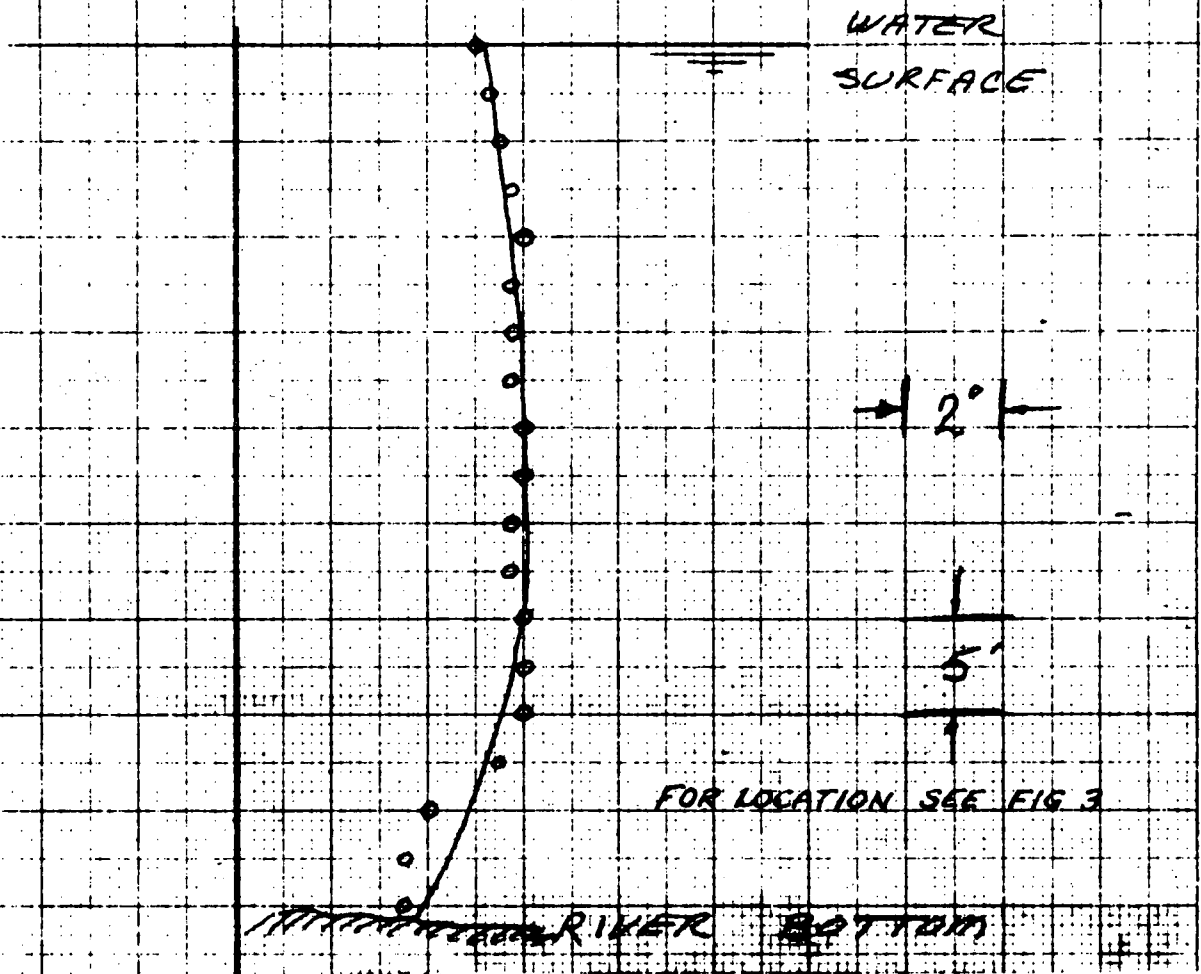

AMBIENT
RIVER
TEMPERATURE

ALDEN RESEARCH LABORATORIES

WORCESTER POLYTECHNIC INSTITUTE

HYDRAULIC MODEL STUDIES FOR
CONSOLIDATED EDISON COMPANY N.Y.

INDIAN POINT II MODEL

*UNDISTORTED SUB-MODEL
SCALE 1:50

ALDEN RESEARCH LABORATORIES
WORCESTER POLYTECHNIC INSTITUTE

INDIAN POINT MODEL STUDIES

CONSOLIDATED EDISON COMPANY,
NEW YORK, N. Y.

March, 1969

THE ALDEN RESEARCH LABORATORIES

In 1894, Professor George I. Alden, head of the Mechanical Engineering Department of Worcester Polytechnic Institute, foresaw a need for research in hydraulics and fluid mechanics. He selected a 240-acre site in Holden on a power privilege which had flowage rights to a 150-acre pond. Through his efforts the site was given to the Institute and a laboratory constructed.

The laboratory was formally named the Alden Hydraulic Laboratory in 1915 when George Alden financed a meter station. Although he was not long in direct contact with the Laboratory, Professor Alden never lost interest in its progress. Through gifts or grants from his trust fund after his death additions to the facility were made in 1925, 1930, 1936 and 1937. Further generosity from his trust fund made possible the construction of the present main building in 1968.

For nearly fifty years the Laboratory was directed by Charles M. Allen, a student of Professor Alden. His interests, personality and creative ability gave the Laboratory its character and reputation in the area of hydraulics.

He was succeeded as Director in 1952 by Professor Leslie J. Hooper. Through his efforts the scope of the research work and size of the facility was expanded. To reflect the broader scope of the Laboratories' graduate study program the name was officially changed to the Alden Research Laboratories in 1965. In 1968, Professor Lawrence C. Neale became the third Director of the Laboratory.

The Alden Research Laboratories are operated as a separate research facility of the Worcester Polytechnic Institute. Presently, its efforts are divided into four main work areas. The facility must first provide research facilities and instruction for graduate and undergraduate students studying at W. P. I. Second, the Laboratory provides services to industry in the area of flow calibration or flow studies of numerous devices used in pipe lines ranging in size from a fraction of an inch in diameter to 48 inches in diameter. The third area is concerned with naval ballistic studies associated with water entry, water exit or underwater studies.

Lastly, the Laboratory has acquired a national and an international reputation in the area of model studies of rivers, dams, spillways, intakes, pumps, etc. In addition to a pump test facility there are currently 30 models in existence or under construction at the Laboratory. Of these models ten are in the area of flow through structures, eight for pump storage projects, ten for heat rejection studies and two miscellaneous studies.

In addition to the model studies, members of the staff are active participants on numerous national and international committees dealing in areas of fluid mechanics. This, in addition to consulting on numerous full scale projects, helps the Laboratory staff stay abreast of current work in its field.

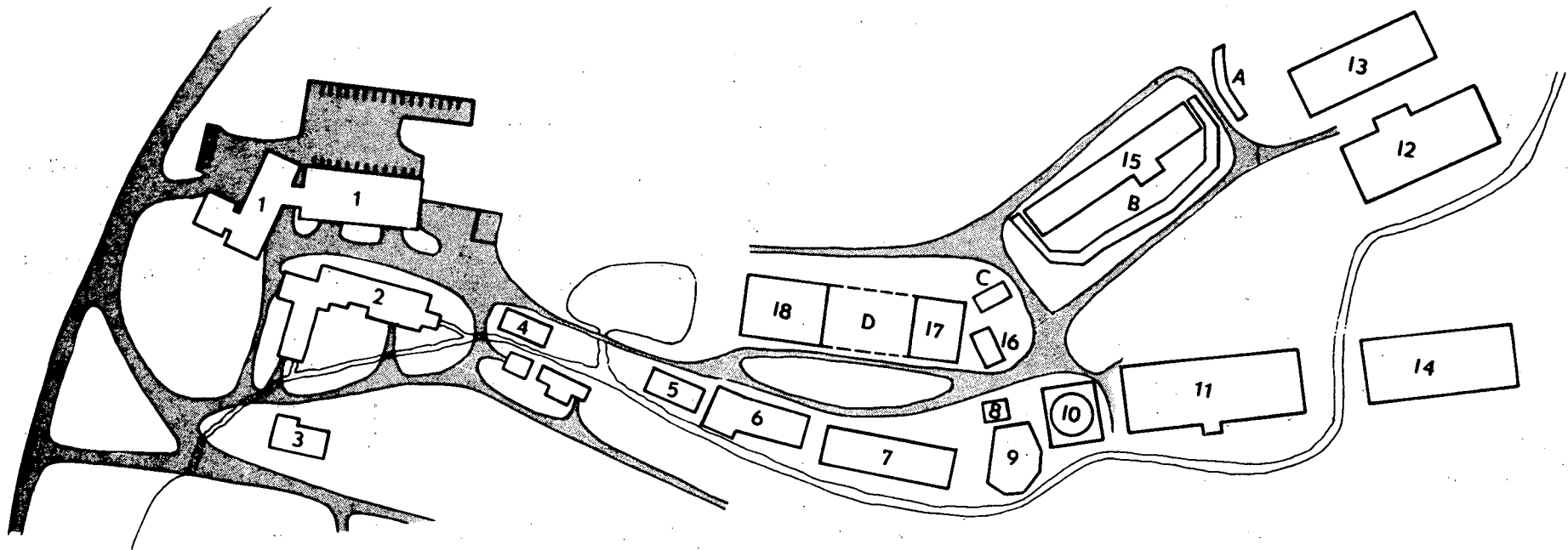

ALDEN RESEARCH LABORATORIES

- | | | | | |
|-------------------------------|-----------------------|----------------------|---|-------------------------------|
| 1- NEW LAB BUILDING | 6- FOSTER WHEELER | 11- MORGANTOWN | 16- JOCASSEE | AREA A- OYSTER CREEK |
| 2- OLD LAB BUILDING | 7- CHALK POINT | 12- CALVERT CLIFFS | 17- BEAVER VALLEY | AREA B- NORTHFIELD RIVER |
| 3- LOW HEAD LAB | 8- RILEY STOKER | 13- INDIAN POINT III | 18- INDIAN POINT II
VT. YANKEE DISCHARGE | AREA C- EASTON |
| 4- TECH OFFICE | 9- PILGRIM WAVE BASIN | 14- GILBOA | NORTHFIELD INTAKE
CORNWALL II | AREA D- LUDINGTON
CORNWALL |
| 5- SAMMIS I
VERMONT YANKEE | 10- BEAR SWAMP | 15- PEACH BOTTOM | | |

INDIAN POINT II MODEL

GENERAL ARRANGEMENT

MODEL RATIO

1:250

FROM POND

0 10 20 FT.

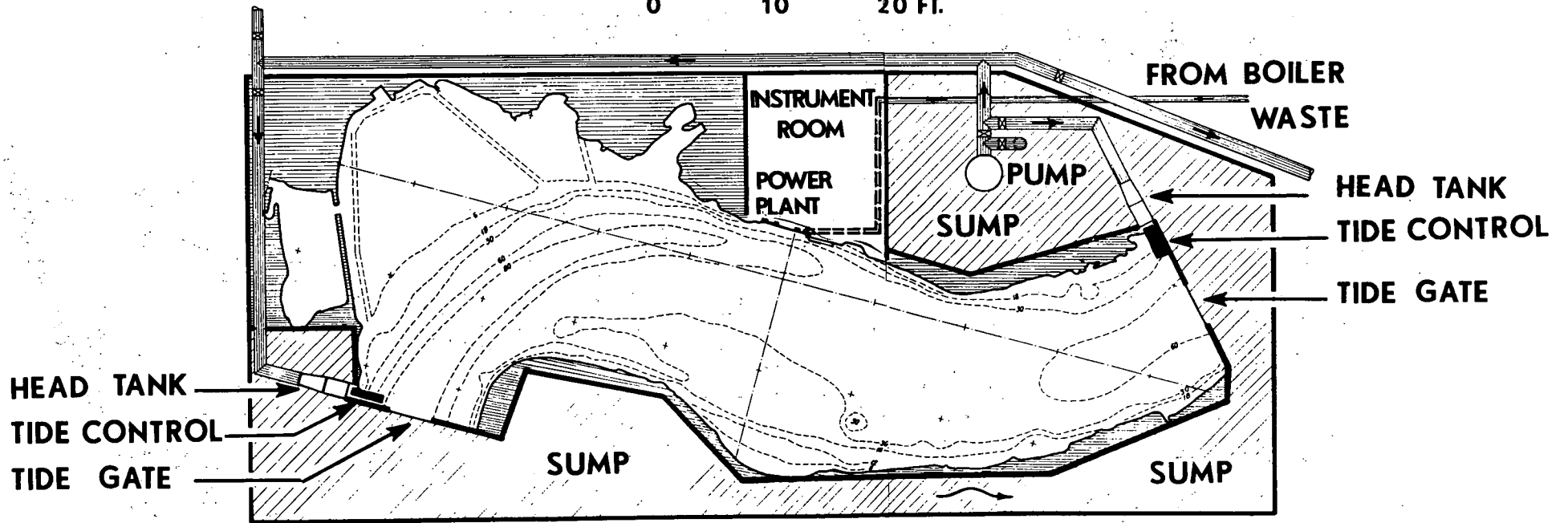

INDIAN POINT III MODEL

GENERAL ARRANGEMENT

0 10 20 30 40 50 FT.

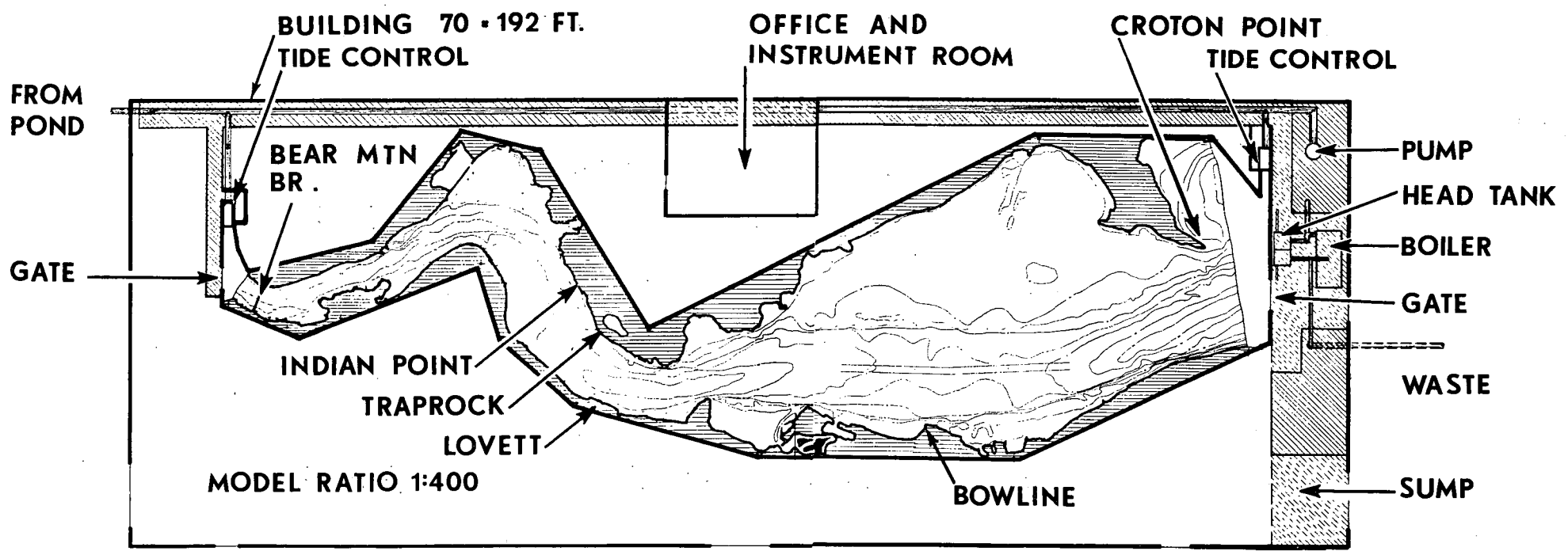

RELATIONS BETWEEN PROTOTYPE AND MODEL PROPERTIES

	<u>INDIAN POINT II MODEL</u>	<u>PROTOTYPE</u>	
<u>GEOMETRIC</u>	Length	1 Foot	250 Feet
	Width	1 Foot	250 Feet
	Depth	1 Foot	60 Feet
	Volume	1 Foot ³	375,000 Feet ³
<u>KINEMATIC</u>	Time	1 Second	32.2 Seconds
	Velocity	1 FPS	7.74 FPS
	Flow Rate	1 CFS	116,000 CFS
<u>DYNAMIC</u>	Pressure	1 PSI	60 PSI
	Gravity Force	1 Pound	375,000 Pounds
<u>TEMPERATURE</u>		1°F	1°F

The Kinematic-Dynamic-and Temperature Ratios are based on Froud Scaling i.e. Gravity and Inertia Forces are considered dominant forces.

RELATIONS BETWEEN PROTOTYPE AND MODEL PROPERTIES

	<u>INDIAN POINT III MODEL</u>	<u>PROTOTYPE</u>
<u>GEOMETRIC</u>	Length	1 Foot 400 Feet
	Width	1 Foot 400 Feet
	Depth	1 Foot 80 Feet
	Volume	1 Foot ³ 12,800,000 Feet ³
<u>KINEMATIC</u>	Time	1 Second 44.7 Seconds
	Velocity	1 FPS 8.9 FPS
	Flow Rate	1 CFS 286,000 CFS
<u>DYNAMIC</u>	Pressure	1 PSI 80 PSI
	Gravity Force	1 Pound 12,800,000 Pounds
<u>TEMPERATURE</u>		1° F 1° F

The Kinematic-Dynamic-and Temperature Ratios are based on Froud Scaling i.e. Gravity and Inertia Forces are considered dominant forces.

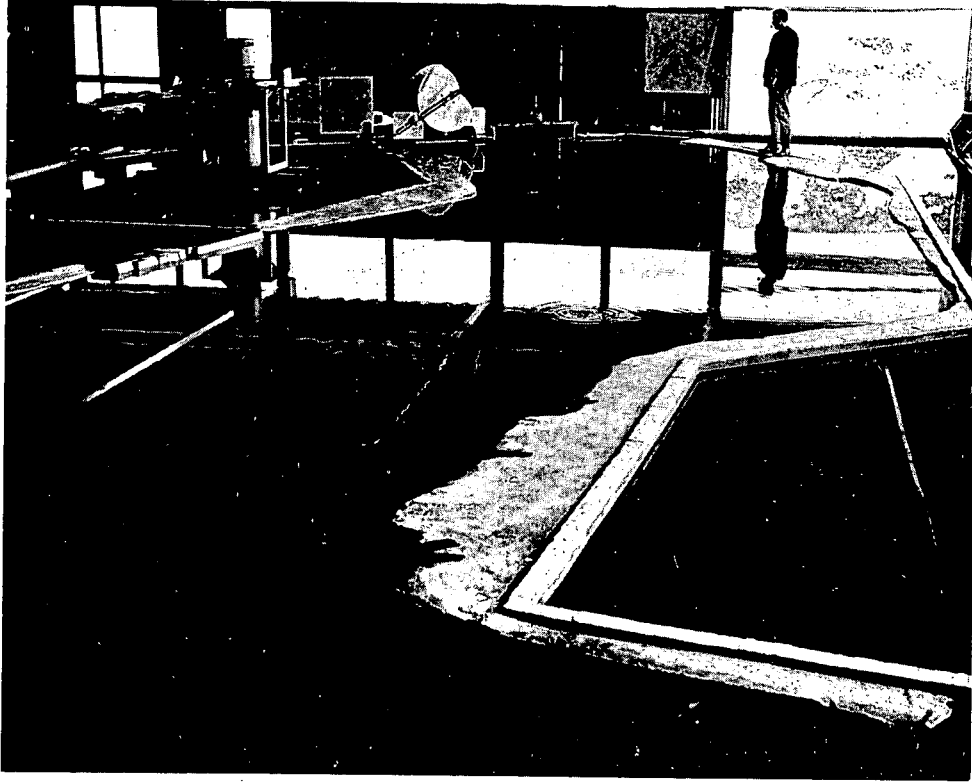

INDIAN POINT II MODEL

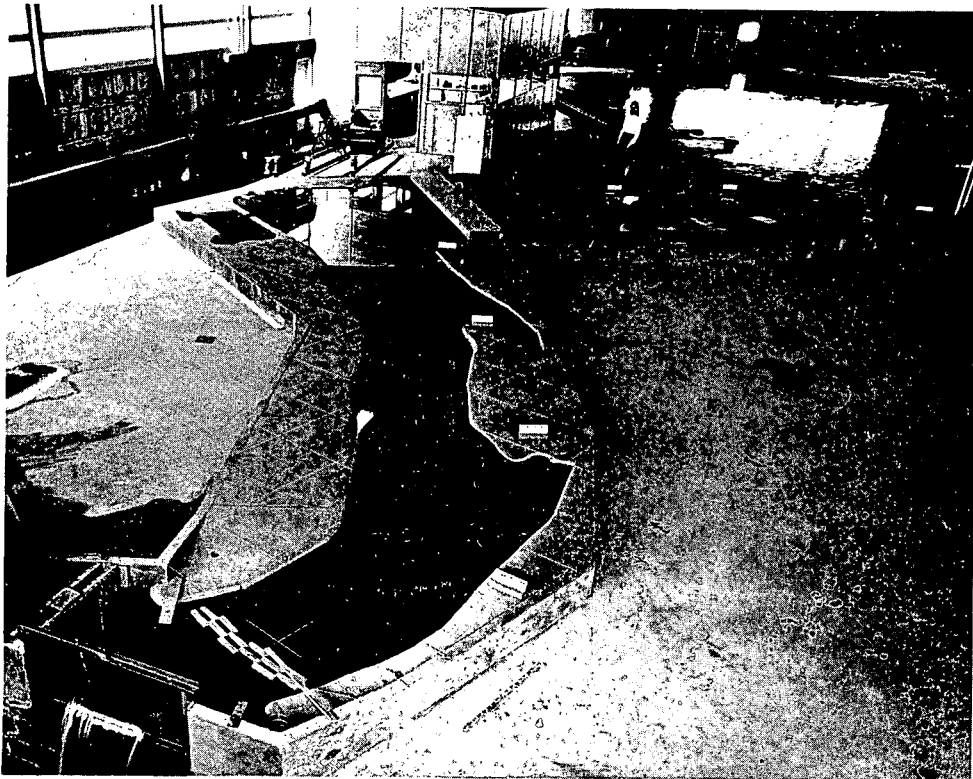

INDIAN POINT III MODEL

THE USE OF RIVER MODELS IN POWER PLANT HEAT EFFECT STUDIES

Lawrence C. Neale^{*}

INTRODUCTION

The use of hydraulic models in the study of various hydraulic phenomena such as flow over spillways, flow around bridge piers, and flow in canals has been known and applied for centuries. Numerous examples of this type of model can be found in the history of science. However, the widespread use of such models has waited until the twentieth century. It is now the rare hydraulic project of significant size or scope that is not modelled for some detail during its design.

The use of river models for heat effect studies has been of more recent origin. Such studies have been conducted over the past 15 years at the Alden Research Laboratories of Worcester Polytechnic Institute. Six such studies involving cooling water for thermal plants have been completed during this period. Similar studies have been carried out in other laboratories such as the laboratories of the Army Engineer Corps at Vicksburg and at the TVA laboratories at Norris. In addition, there has been a considerable effort devoted to the development of the theoretical aspects, both of the prototype problem and the modelling of these problems. The rest of this discussion will be concerned with how this effort has developed at the Alden Research Laboratories. It should be pointed out that the Alden Research

^{*} Lawrence C. Neale
Professor of Hydraulic Engineering
Alden Research Laboratories
Worcester Polytechnic Institute
Worcester, Mass.

Laboratories development has resulted from the support and confidence of a number of clients. These include the Philadelphia Electric Company, Potomac Electric Power Company, Consolidated Edison Company, Duquesne Power Company, American Electric Power Company and Stone and Webster Engineering Corporation.

The river models at the Alden Research Laboratories have tended to be rather large, in terms of the usual river model, with model ratios ranging from 1/10 to 1/200. There are several reasons for this trend. First, a relatively large model tends to provide greater accuracy of any measurements made on the model. Second, a larger model allows a better reproduction of the details of topography and structures which tends to produce a better reproduction of the prototype flow patterns. Third, the turbulence level in the larger models tends to be greater and therefore more nearly duplicates the prototype.

There are several features of the Alden Research Laboratories' plant that have made the use of large models possible. The laboratory is situated on a natural water site with a reservoir of approximately 100 acres draining an area of 4-1/2 square miles, which affords a dependable and relatively large water supply for experimental use. Also, a large portion of the 200 acres of land at the laboratory is available for river model studies.

CONSTRUCTION

It has been found that for model heat studies, the model must be completely enclosed. This allows the atmospheric conditions over the model to be stabilized and to eliminate the solar effects which can vary widely. Therefore the first step

in the construction of a model is to provide a suitable enclosure. Photograph No. 1 shows such a building under construction.

A concrete slab is first placed as a base in preparing a model site and then the limits of the model are defined by placing reinforced concrete walls. These walls are usually 4" thick and vary in height from several inches to several feet. Thus, the model is provided with permanent boundaries that can be used for instrument placement and measurement control, as well as a water tight basin.

Wooden templates are cut in the carpenter shop to the profile of the topography of the river bottom. These templates may be as long as 80 or 90 feet and vary in height according to the topography being reproduced. These templates are located on the model from a control such as a grid that is usually etched on the slab and also on the concrete walls. This grid can be used to locate model structures that may be required and can be used to locate instruments. This grid, depending upon the model scales, is usually developed with an interval of between 3 and 5 feet.

After the templates have been placed and are set on grade with an engineer's level, the space between the templates is filled with sand and gravel, which is tamped in place to within approximately one inch of the upper edge or contoured surface of the templates. A coating of topping concrete is then placed to reproduce the topography and to provide an impervious coating on the model. Photograph No. 2 shows a model under construction and Photograph No. 3 shows a completed model. The model does not need to be completely water tight, since the water will be confined within the concrete walls. Usually, the models are painted to allow better observation of tracers and to facilitate photography of dye,

paper chips or floates which are used to trace flow patterns, and to determine the velocity distribution. The structures such as bridges, plant inlets, and outlets, and other pertinent features usually are wooden, but fiberglass, steel or other appropriate materials may be used.

The flow is usually provided from an outside sump and pumped to the model inlets and structures through appropriate pipe lines installed around the outside of the model. Adjacent to the sump, an oil fired or electrically operated heater for the water is set up to provide a variation of the water temperatures in the sump and river, as required to duplicate prototype conditions, as well as the temperature differentials planned for the cooling water flow. A boiler to perform this task may be rated as high as 100 HP and burn up to 25 gallons of oil per hour.

INSTRUMENTATION

Calibrated flow meters are installed in each of the supply pipe lines for flow measurement and valves for flow regulation. Point gages and staff gages are used to determine water surface elevations. The temperature measurements are made with either thermister type or thermocouple temperature sensors. These sensors are located at the critical locations such as the inlet and outlet sections of the model and the inlet and outlet of the model plant. In addition, the sensors are placed in various sections of the model to provide data which will allow a development of temperature distribution and flow patterns of the warm water. Temperature records at a variety of depths are needed in many instances in order to obtain data on the possible stratification in the model. It is usually desirable to record all temperature

indications continuously. The number of temperature sensors have varied for the models which have been studied at the laboratory, the smallest number in some of the early studies was ten and the largest number utilized to date is 250. In addition, there is usually a need for portable probes. The temperature indicators or recorders may or may not be portable but the sensor coverage must be sufficient to allow determination of temperature in any area that is not covered by the permanently installed temperature sensors.

The apparatus necessary for a tidal model is more involved since the water surface elevation and flow rate must be controlled at each end of the model to reproduce the complete tide cycle continuously and automatically. It was learned in some of the earlier studies that steady state model operation could not be used to study the tidal effects. It was apparent in these cases that completely valid data was not obtained until the model was operated manually through a number of tide cycles. Therefore, the automatic model can be run through many tide cycles without stopping, thus allowing a development of residual temperatures as may be expected in a long estuary.

Sometimes regulated rivers can present just as complicated flow requirements as a tidal model. Since hydro-electric plants are more and more being used for peak loads, the resulting flow in a river can be anything but stable. In a recent model it was necessary to study the operation of two hydro-electric plants and a pump storage plant all operating in conjunction with a nuclear plant on the same reservoir. The optimum loading of the system was determined by a computer program for a number of average river flows. It was necessary to operate the model on a weekly cycle.

TEST PROCEDURE

A period of model adjustment must be carried out in operating all river models before actual testing can begin. During this period the model is studied and modified until it performs as the prototype. Thus it is important to have data from the field, not only on the physical features but on flow phenomena, such as water surface elevations, velocity, flow patterns and flow rates. In some cases, where this data is not available it is necessary to go into the field and obtain sufficient information to adjust the model. Data is also obtained on model performance during the period of adjustment that serves as a basis of comparison with later tests and modifications. However, in all cases, photographic data is taken to supplement recorded temperatures, elevations, flows and the like. The photographic data takes the form of both motion pictures and stills and usually involves tracers in the form of dyes, paper chips and floats. The detailed operating procedure for these models differs widely with respect to the type of model and type of plant operation that is planned.

The simplest form of model which has been tested at the Alden Research Laboratories is the river model with the heat effect superimposed. In this type of model, the testing involves setting a variety of river flows and river stages on the model and then superimposing the steam plant cooling water flows at the proper locations. At the model steam plant, this means withdrawing the correct flow from the river at the plant intake location and introducing the heated flow at the selected discharge or outlet point. The flow patterns developed by the hot water and the changes in the flow pattern of the river, with the hot water being introduced and the cooling flow withdrawn, are then documented. It has been desirable to reproduce river temper-

ature over the range from summer to winter operation. In the extremes this has required a river temperature variation from 32° to 85°F., representing extreme winter and summer conditions. This requirement means that there must be a large amount of water heated and available.

In the case of rivers where the hydro-electric development is complete, large quantities of water at various temperatures must be available to allow the model to be operated over some cyclical program, such as a weekly cycle. In most cases, the operation of such a model is carried out for at least two weeks of operation. The first week is run to develop the proper distribution in the reservoir and the second week is run as the test of record. This system allows the model to start and run through a typical week for the record.

The operation of the tidal models also involves some time in developing a quasi-steady state. The model must be run through a number of tide cycles, with the cooling water being withdrawn, heated and re-introduced, in order for the heat distribution to develop over the whole section being modelled. The number of tide cycles necessary to produce this state must be determined for each model by monitoring its operation after adjustment. Data on the temperatures is recorded versus time and the time is usually developed in portions of the tide cycle.

In all of the model studies data reduction has been an increasing problem. Thus it has been necessary to turn to computer techniques of data reduction as well as data recording compatible with the computer. At the present time, data is being read and transferred to punched cards directly. All the latest model data will go directly onto magnetic tape for data processing.

SCALING

The Reynolds Number (ratio of inertia and viscous forces in all modelling work must be greater than certain minimum limits in order for the model to perform in a turbulent manner similar to the prototype. Also in river model work the Froude number (ratio of gravitational and inertia forces) must be maintained for both model and prototype. The normal Froude relationship is applied to the various quantities to be scaled such as distances, flows, velocity and time. On this basis, for a model scale of 1/1000 horizontal and 1/100 vertical, which happens to be those for a model under construction at the moment, the following ratios developed:

$$\text{Length} \quad \frac{L_m}{L_p} = 1/1000$$

$$\text{Height} \quad \frac{H_m}{H_p} = 1/100$$

$$\text{Flow} \quad \frac{Q_m}{Q_p} = \frac{L_m H_m^{3/2}}{L_p H_p^{3/2}} = 1,000,000$$

$$\text{Velocity} \quad \frac{V_m}{V_p} = \frac{\sqrt{H_m}}{\sqrt{H_p}} = 1/10$$

$$\text{Time} \quad \frac{T_m}{T_p} = \frac{V_m/L_m}{V_p/L_p} = 1/10$$

Also involved with the warm water flow into the reservoir or river is the densimetric Froude number which is normally written as:

$$F = \frac{V_o}{\sqrt{\frac{\Delta \rho}{\rho} g D_o}}$$

where V_o = jet velocity
 ρ = mass density of jet
 g = acc. gravity
 D_o = dia. jet

This special form of the Froude number is used in determining the density difference of the warm water and the receiving water for correct modelling. This relationship reduces to the form:

$$\left(\frac{\Delta \rho}{\rho}\right) \text{ for Prototype} = \frac{\Delta \rho}{\rho} \text{ for Model}$$

which means that if the temperatures of warm water and the receiving water are the same model and prototype, then the mixing characteristics will be the same.

Finally, a distorted model has certain advantages in addition to the R_n limit, namely that certain combinations of scales allow the model to theoretically scale the heat transfer phenomena.

Since the amount of heat added to the reservoir is the flow rate in pounds per second multiplied by the temperature rise, the ratio of model and prototype is given as the following relationship:

$$\frac{\gamma_m Q_m (\Delta t_m)}{\gamma_p Q_p (\Delta t_p)} = \text{Ratio of heat added}$$

where γ = specific weight of water
 Q = volume flow rate
 t = temperature

Since in the Froude scaling above

$$\frac{Q_m}{Q_p} = \frac{L_m H_m^{3/2}}{L_p H_p^{3/2}}$$

and $\gamma_p = \gamma_m$

$$\Delta t_p = \Delta t_m$$

The heat transfer in both model and prototype is dependent upon a surface area so the

$$\frac{(\text{Heat Trans})_m}{(\text{Heat Trans})_p} = \left(\frac{L_m}{L_p}\right)^2$$

Then in order to have these terms modelled properly from the prototype, the scale ratios must be such that

$$\left(\frac{L_m}{L_p}\right)^2 = \frac{L_m H_m^{3/2}}{L_p H_p^{3/2}}$$

or $\frac{L_m}{L_p} = \left(\frac{H_m}{H_p}\right)^{3/2}$

as, for example, the ratio of

$$\frac{L_m}{L_p} = 1/1000 \text{ and } \frac{H_m}{H_p} = 1/100$$

does satisfy this relationship.

RESULTS

The results from the model studies can be presented in a number of ways in order to make maximum utilization of the tests. The various methods are all aimed at showing how the flow patterns of the warm water have developed and predicting the extent of the effects in the prototype. All of the studies have indicated that the basic patterns developed in the model are similar to those of the prototype. This means that with the pattern defined by the model, the transfer from model to prototype is involved with evaluating the temperature difference intensity. This basically is what has been done for model studies where receiving water has ranged in temperature from 32° to 85°F. and temperature differentials produced by condenser cooling have varied from 0° to 45°F.

Thus, once the basic patterns have been established, it is possible to use these patterns and the prototype operating conditions, including atmospheric conditions, to predict the resulting warm water distribution. In addition, this allows an evaluation of such things as, the amount of re-circulation that will be experienced at the power plant and the overall effect on the body of receiving water. Temperature gradients, both in terms of time and depth, can be established at specific locations.

It is important to note that in going from the model to the prototype, there are a number of basic parameters that must be taken into account. First, in the model tests, within the building the wind velocities are maintained practically at zero; second, because of the closed building and the lack of circulation and changing of air, the relative humidity over the model is extremely high; finally, because of the

completely enclosed structure, the solar effects are eliminated from the model. Experience has shown that the net result of these various differences between prototype and model, tend to produce a heat loss from the model to the atmosphere that is considerably less than a normal situation in the prototype. It has been found, in all cases to date, from data taken in the field, that the temperatures tend to be a bit higher for a given set of operating conditions in the model than the prototype.

Figure 1 shows the model layout of a heat study for a relatively simple run of the river situation. There are peculiarities to each particular study and the details will bring this out, even in this more or less typical case. It will be noted that there is a water supply and distributor box at the upper end of the model to provide a controlled, measured and variable river flow. In addition, at the plant location, there is provision for taking water from the river, at the intake for each unit of the plant, and provision for heated water, at the proper temperature and amount, to be re-introduced to the model through the outlets on the individual units as designed. The individual features that make this model study a bit different is the fact that there is an existing unit and that its intake and outlet are not rearranged in the light of additional future units downstream. It will also be noted that the fuel barges moored offshore from the plant are in place during the studies. This was necessary in order to duplicate the flow patterns that would take place with fuel barges in the moored positions, as they will be for a major portion of the time that the plant is in operation.

In this particular study, a number of thermistors were used for sensing temperatures at different locations and at different depths in the model. These sensors were placed on a frame that could be moved up and downstream and across the model. A minimum

of 24 individual readings could be taken at a particular time, and over the period of about one hour, a survey of well over 200 test points could be obtained.

Because of the steady state condition of a particular river flow and plant operating condition, it was not necessary to get simultaneous readings over a large area of the model. In most instances, it was found that the model for a particular operating condition and river stage would stabilize in five to ten minutes. However, in most cases, the model was not subjected to a data survey for at least one half hour after all the flows and temperatures had been set and operating in a constant or stable manner.

Figures 2 through 5 indicate the type of data and results obtained from this model work. These take the form of isotherms of excess temperature, based on ambient river water temperature, plotted on a plan view of the model. Figures 2 and 3 are with the old plant, plus units one and two of the new plant, operating with a river flow of 7000 cfs. This means the river flow exceeds the total plant flow by a factor of a little over three to one. Figure 2 is an indication of isotherms for the water surface obtained in the general area of the plant. It should be noted that the guide wall at the outlet for Units 1 and 2, as well as the fuel barges, have an apparent effect on the flow patterns of the warm water. Figure 3 is a similar plot of conditions 2 feet (prototype) below the surface. Figures 4 and 5 are similar plots but for a larger river flow, but the same plant conditions. The river flow in this case, about 25 times the total plant flow. It is now seen from the isotherms plotted for the surface and for a depth of two feet, how a much larger river flow tends to moderate the excess temperature in the area of the plant. An added aspect

in this particular model study, was a study of the sedimentation or bed load motion that occurred in the general vicinity of the plant and a prediction of the dredging requirements that would be necessary to maintain the intake.

The second study to be reviewed is that of the completely developed river and a thermal plant located on the reservoir. The flow in this reservoir is, to a large extent, controlled by the operation of these plants and by a pump storage plant, which uses the reservoir as the lower basin of its two basin system. The weekly cycle was found to vary with the predicted flow of the undeveloped river. Because of this schedule, the model has been required to operate on the weekly time schedule. The scales of the model are such that a weekly prototype time period consumes a model test time of roughly three hours and forty minutes. As indicated previously, in order to properly duplicate this time cycle and the flow patterns in it, at least two weekly cycles are run in succession, in order to obtain meaningful data. The temperature probes are spotted at the critical locations over the model, as well as in other areas that are considered important, and for basically three different elevations, one at the surface, and five feet below the surface and one ten feet below the surface. There are 240 sensors taking data at a rate of better than every 50 seconds. The general arrangement of the model is shown in Figure 6. The supply lines to the various hydro-electric plants should be noted as well as the direction of the flow at each plant. The sump is necessary to supply the water at the required basic reservoir temperatures and the boiler and appropriate pipe lines provide heated water as required.

Figures 7, 8, 9, and 10 are isotherms of excess temperature at the reservoir surface and at a depth of ten feet for two times in the weekly cycle. Figures 7 and 8

show the isotherms for a Thursday afternoon situation. While Figures 9 and 10 show the isotherms for Sunday morning conditions. It is apparent from an inspection of these figures that the time of the day and week are significant to the temperature effects in specific sections of the model. The differences noted, in reviewing the isotherms, point up the influence of the hydro-electric station's flows on the reservoir. After a weekend when pumping has been most active at the pump storage plant, the excess temperatures are moving well upstream in the reservoir, due to the draw down and the draft of the pump storage plant and its location relatively far up the reservoir on the opposite bank from the thermal plant.

It is apparent that the type of outlet structure can influence the flow patterns of the warm water effluent from the plant. There is a possibility of varying the influence of the cooling water flow on the reservoir by the structural arrangement at the thermal plant outlet.

Figure 11 shows a general layout for one of the tidal models studied at Alden Research Laboratories. The location of the controls and water supply necessary to vary the water level and the flow into and out of the model at either end are shown. The sump, oil-fired water heater and pumping supply necessary to produce these tidal flows at any temperature between 40° and 90°F. are indicated. It should be pointed out that in most tidal studies the cooling water flows are small relative to the maximum flow. The cyclical variation of tidal flow with the smaller heated flow thus becomes the critical aspect in the study. In addition, to the permanent sensors, a portable probe with eight thermocouple sensors in a vertical array is provided to probe any area throughout the model. This probe provides information to develop the vertical profiles of temperature. The operation of the model, with

the scales that were chosen, requires that the complete tidal cycle take about thirty minutes. Usually it is found necessary to operate the model for about four hours or about eight tide cycles before taking data for as many tidal cycles as required. The data being taken was always referenced to the tide phase so that any specific point or bit of data could be considered in its proper time sequence. Figures 12, 13 and 14 are plots of surface isotherms of the middle section of the model showing the results of structural changes to the outlet canal. Figure 12 is for the longest structure while the other two show the results of different amounts of shortening. These are all for the same phase of the tide. Additional data was developed for other tide phases and model arrangements.

The results presented in this report have been taken directly from the model studies and no attempt has been made to make any of the necessary adjustments to the prototype. Also, in all cases, the arrangements shown have been subject to further revision so that final conclusions can not be drawn from the data shown.

ACKNOWLEDGEMENT

The entire staff of the Alden Research Laboratories have participated in developing the techniques and results discussed in this paper. Much of the technical material used has been the work of Mr. A. G. Ferron while Professor L. J. Hooper and Mr. F. P. Colon have also reviewed the text.

SUMMARY

A number of river model studies have been undertaken at the Alden Research Laboratories to determine the influence of heated water effluent on bodies of water. The flow patterns developed from these model studies have been used to predict the flow patterns and temperature patterns in the prototype. This type of study, using similar techniques, has been applied to rivers, reservoirs and estuaries. Although it is difficult to obtain detailed data from the field after completion of projects, the results that have been obtained indicate good agreement with those of the model study. It is hoped that the future will see a further improvement in the modelling techniques and instrumentation and that the theoretical development will allow more complete analytical treatment of the problem. It is also apparent that more detailed data on accomplished projects are necessary to the whole process.

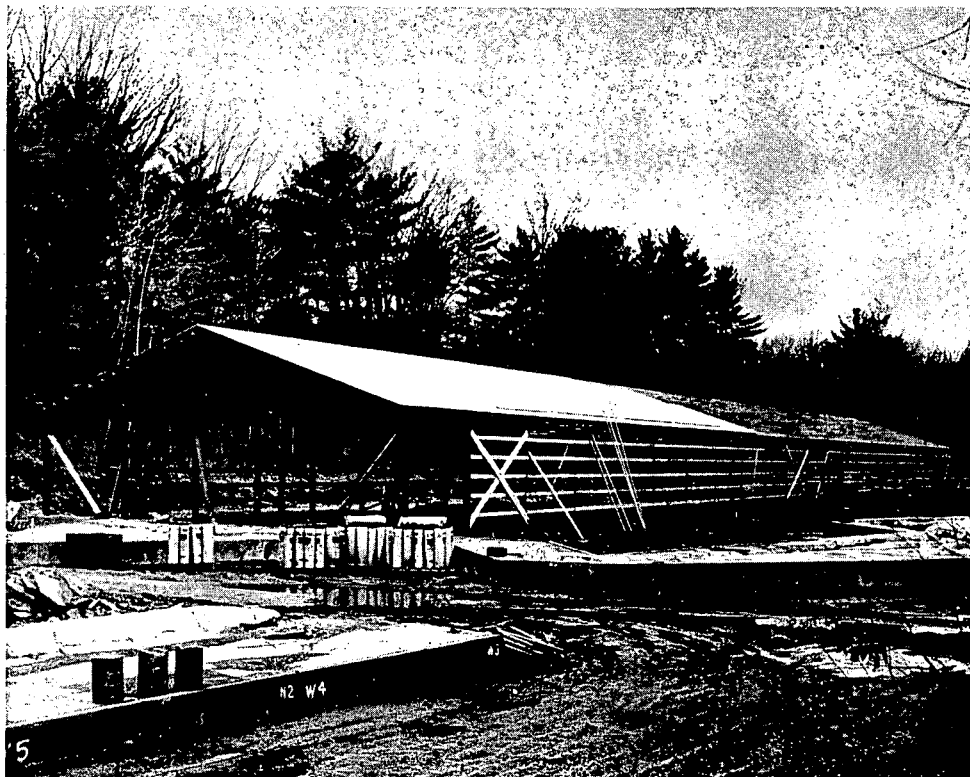

Photo 1

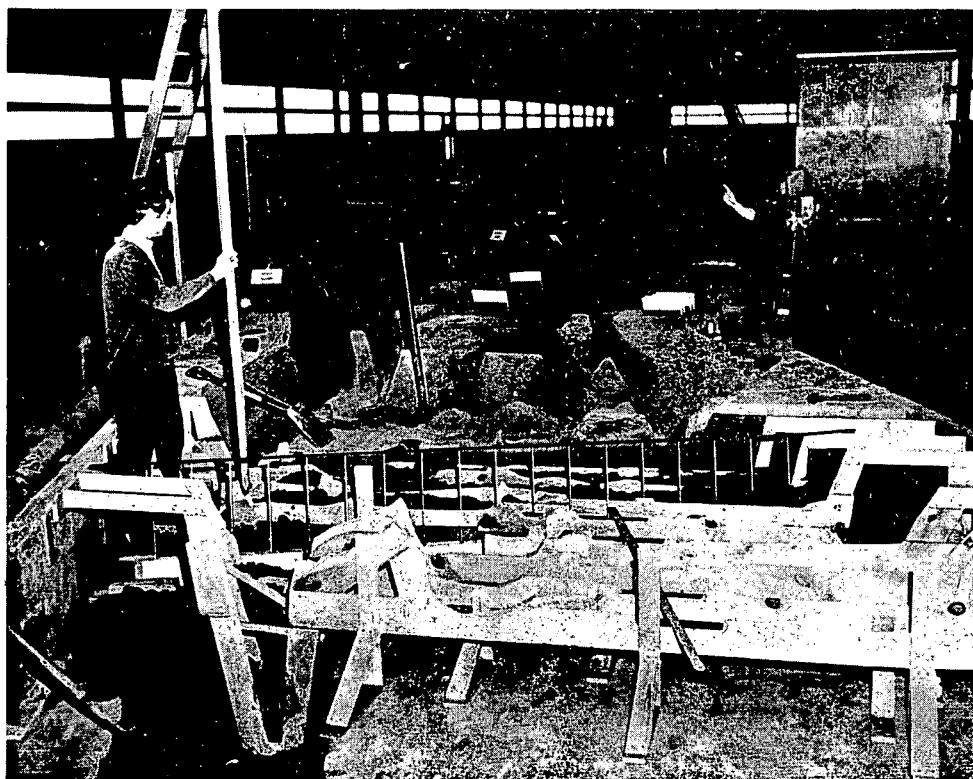

Photo 2

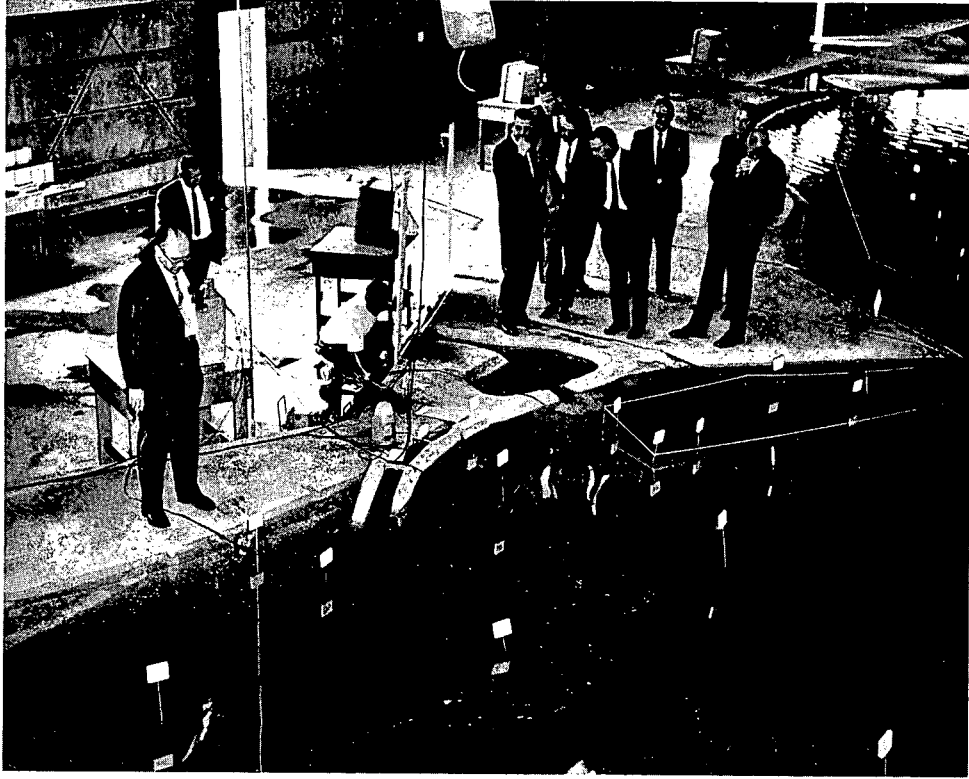

Photo 3

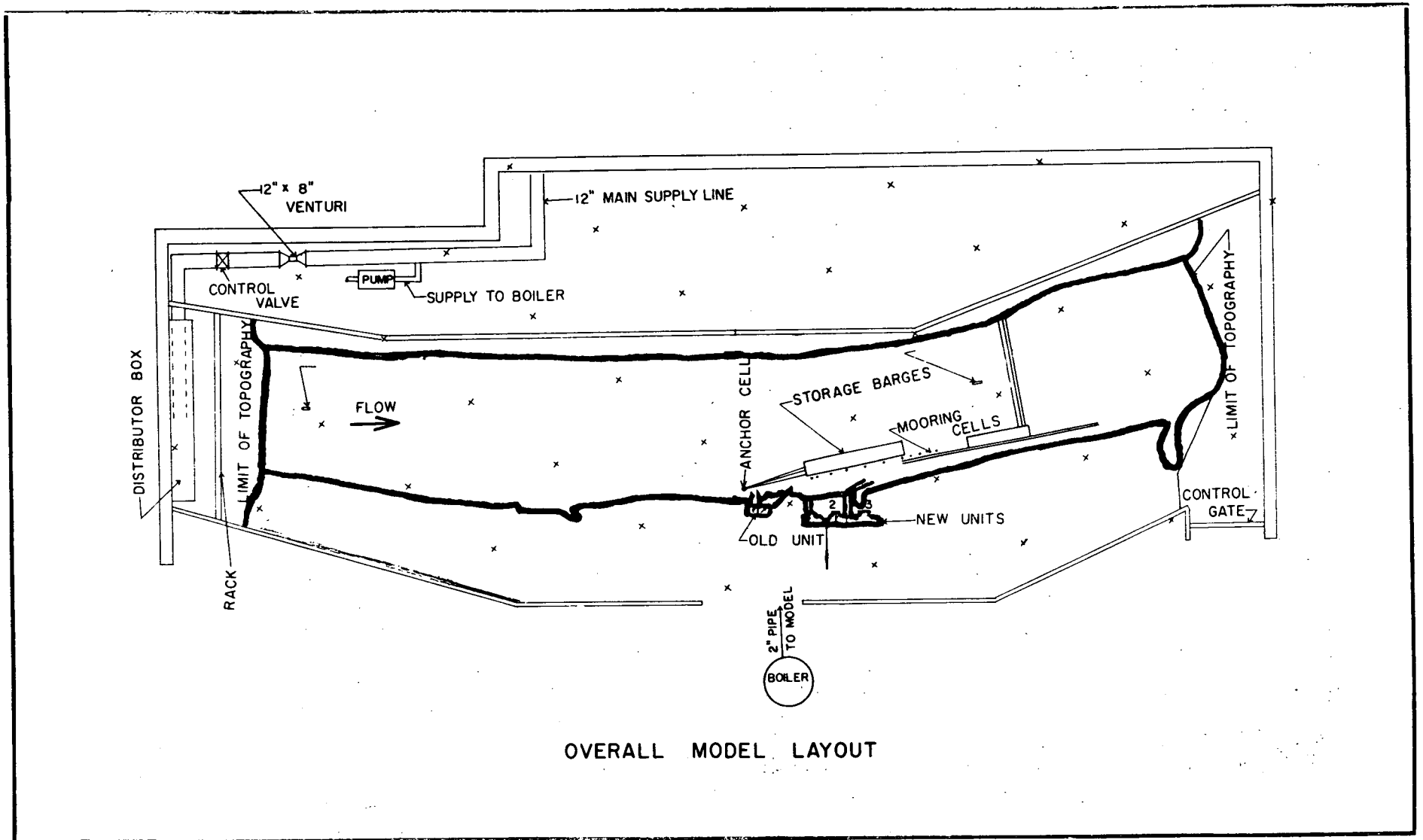

FIG. 1

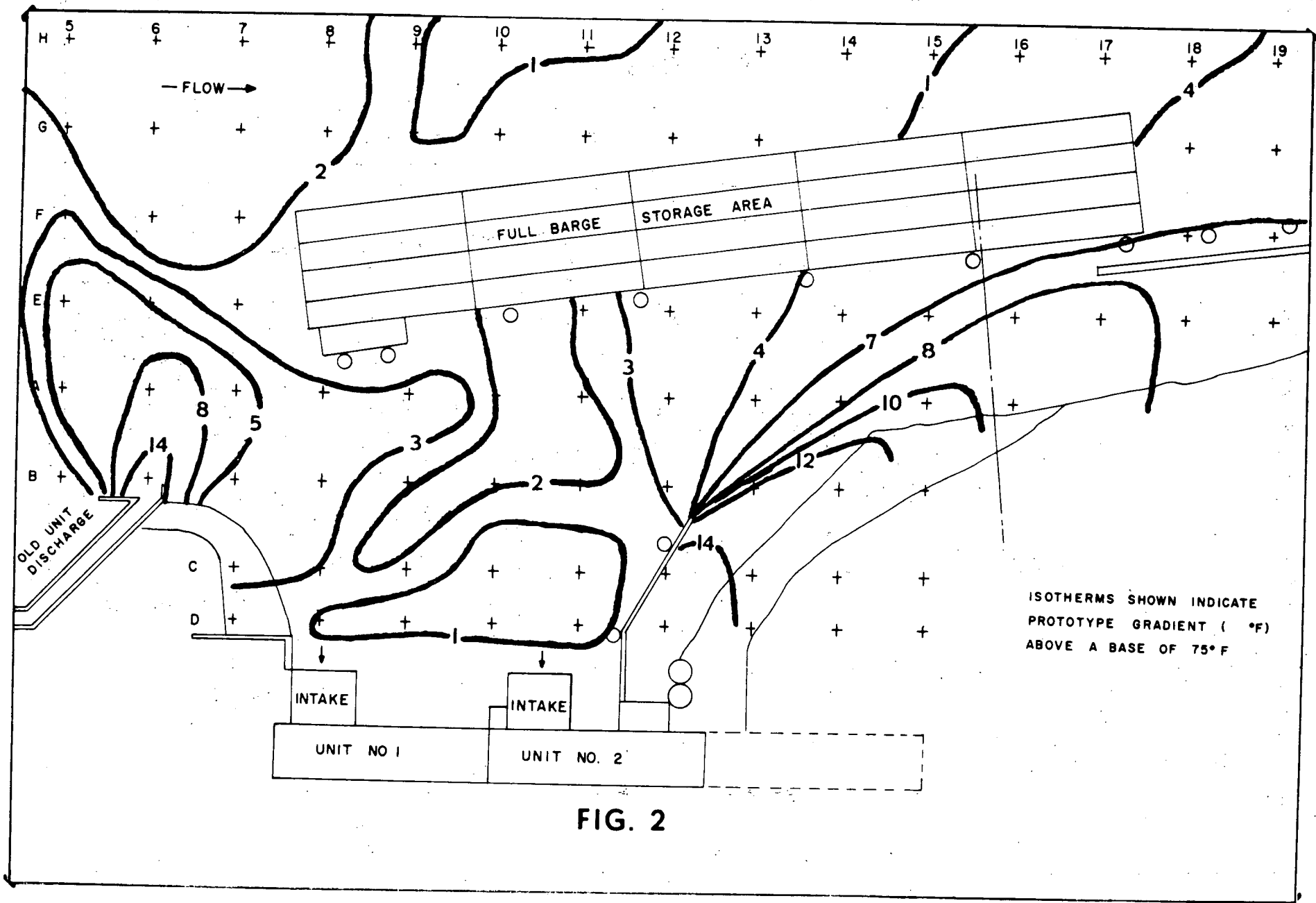

FIG. 2

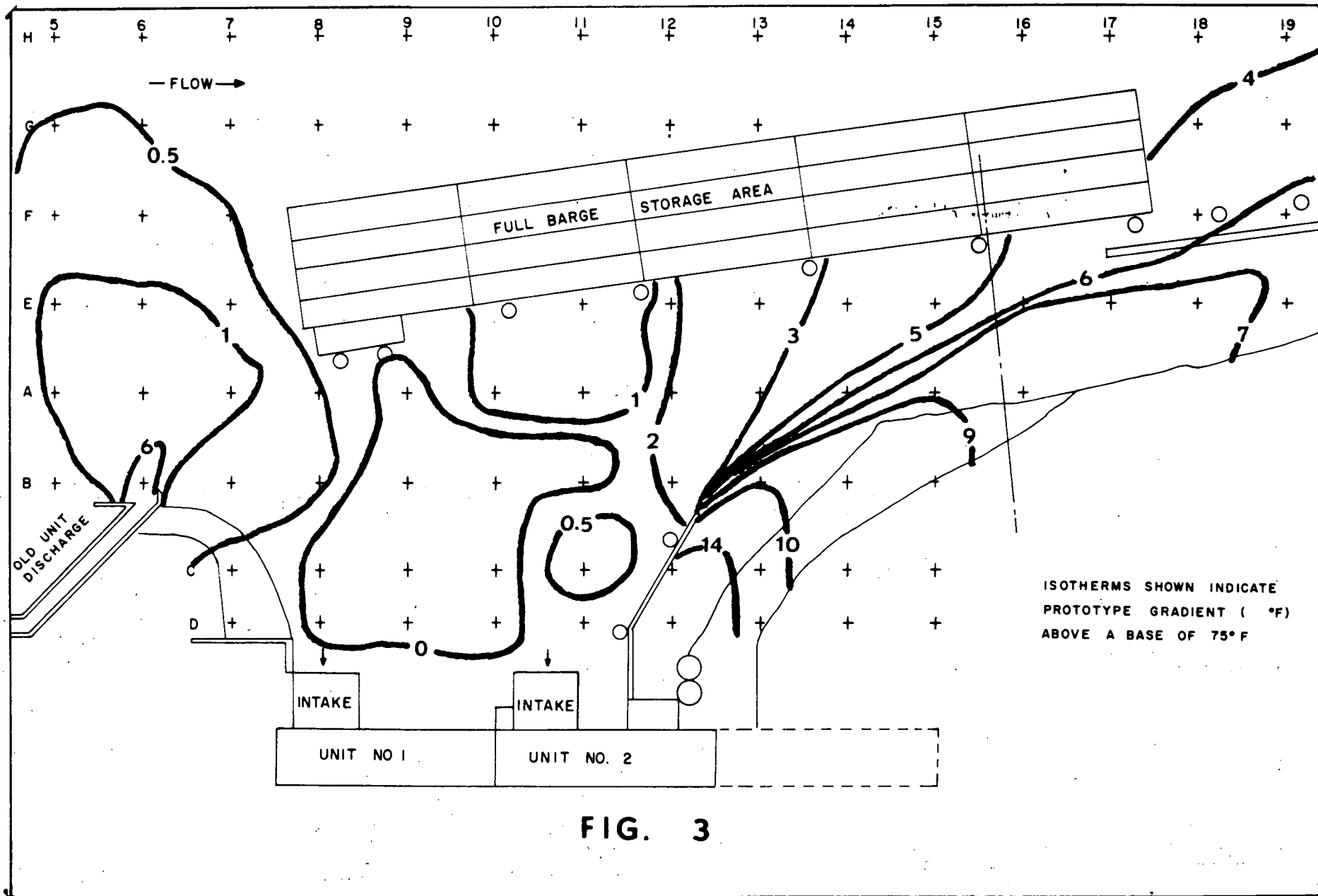

FIG. 3

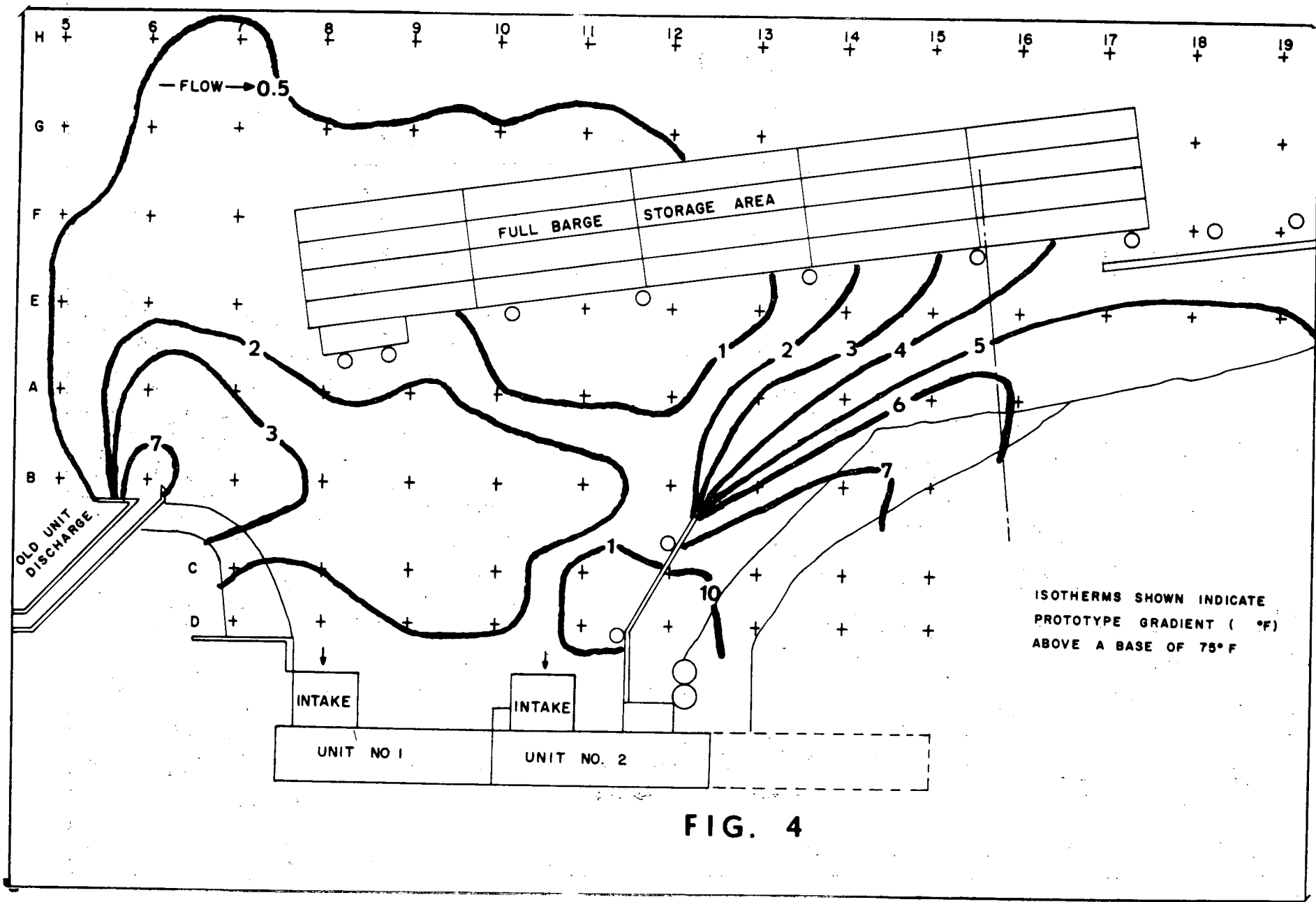

FIG. 4

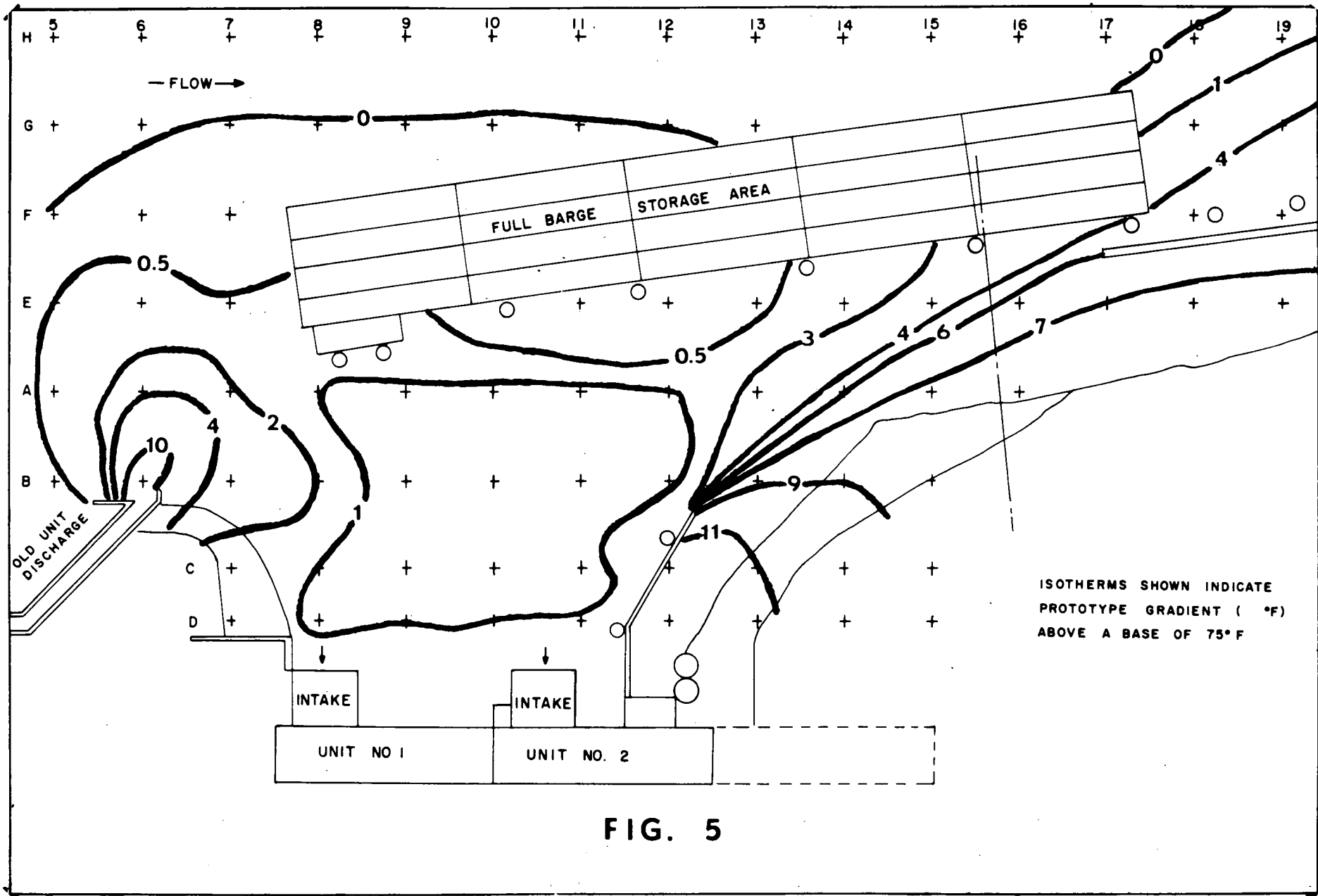

FIG. 5

0 1000 2000 3000 4000 5000 6000 7000 8000 9000 10000
PROTOTYPE SCALE - FT.

0 5 10 15 20 25 30 35 40 45 50 55 60
MODEL SCALE - FT.

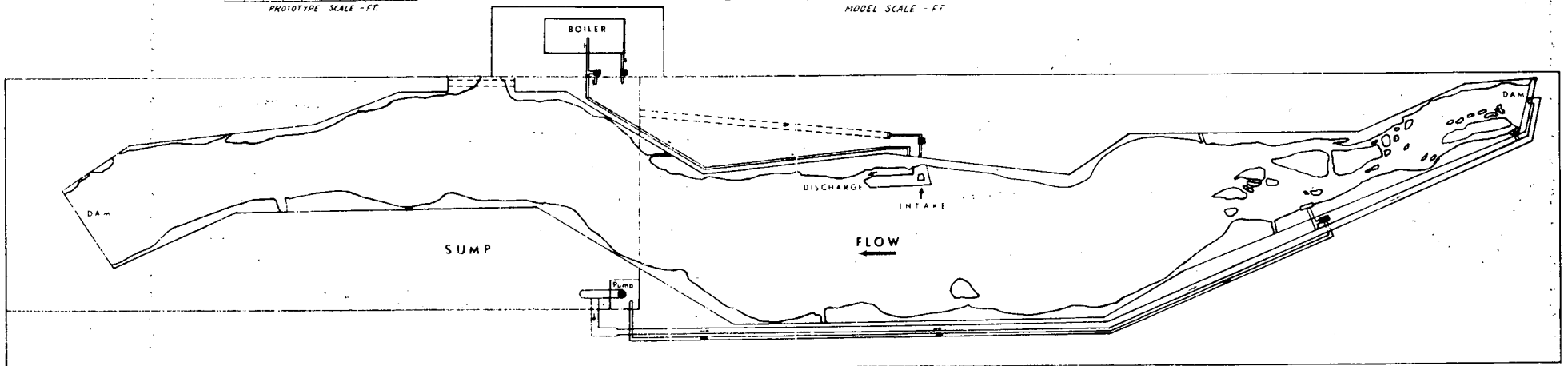
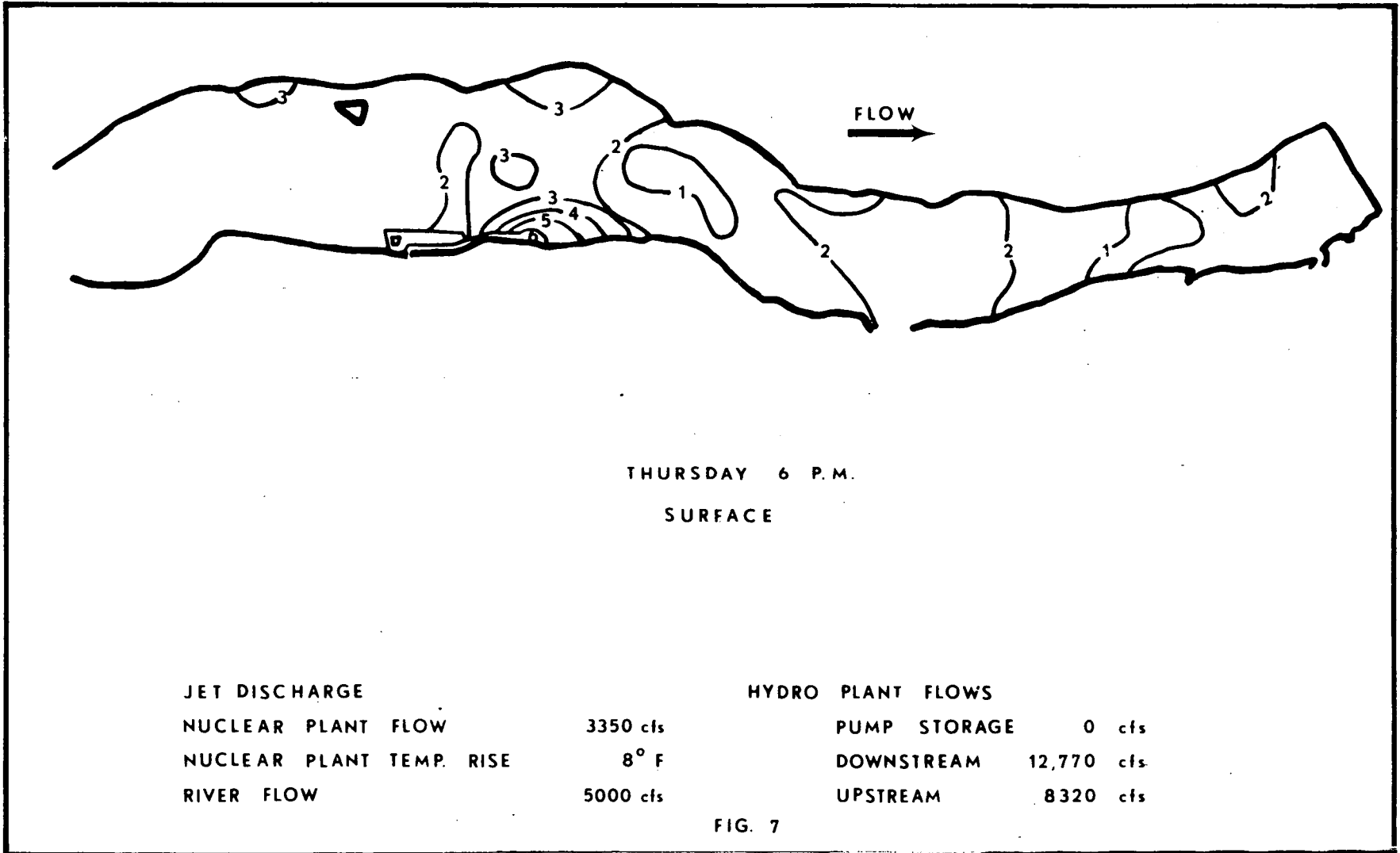
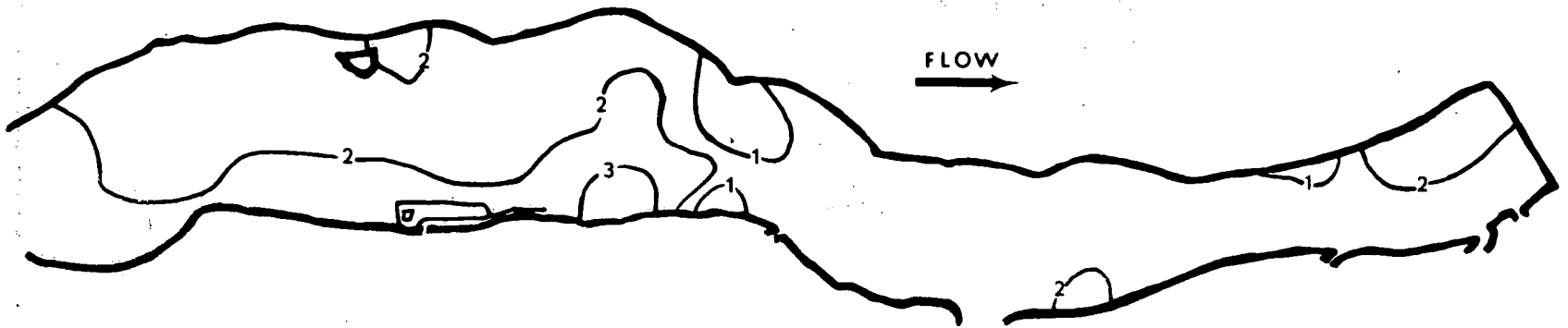

FIG 6





THURSDAY 6 P.M.

10 FT. DEPTH

JET DISCHARGE

NUCLEAR PLANT FLOW 3360 cfs

NUCLEAR PLANT TEMP. RISE 8° F

RIVER FLOW 5000 cfs

HYDRO PLANT FLOWS

PUMP STORAGE 0 cfs

DOWNSTREAM 12,770 cfs

UPSTREAM 8320 cfs

FIG. 8

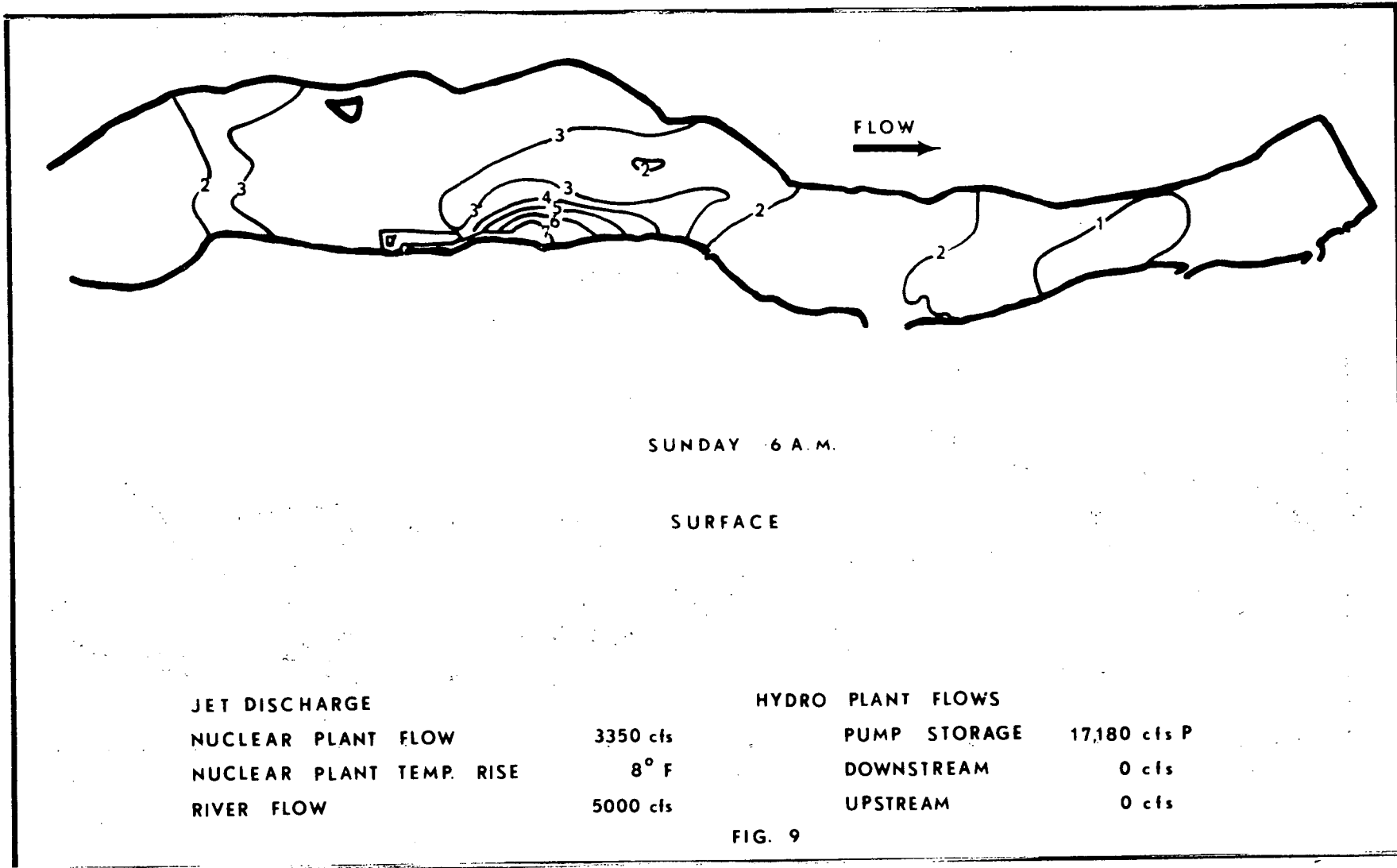

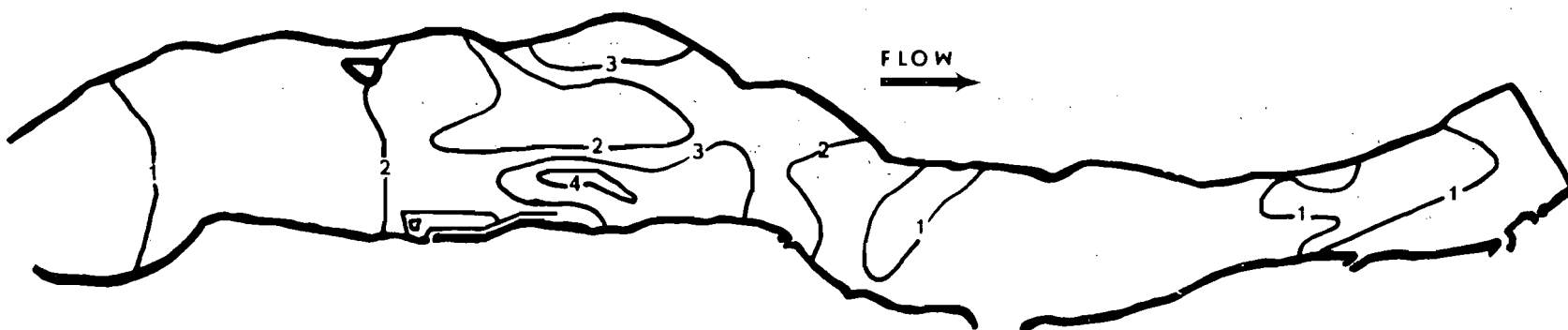

SUNDAY 6 A.M.

10 FT. DEPTH

JET DISCHARGE
 NUCLEAR PLANT FLOW 3350 cfs
 NUCLEAR PLANT TEMP. RISE 8° F
 RIVER FLOW 5000 cfs

HYDRO PLANT FLOWS
 PUMP STORAGE 17,180 cfs P
 DOWNSTREAM 0 cfs
 UPSTREAM 0 cfs

FIG. 10

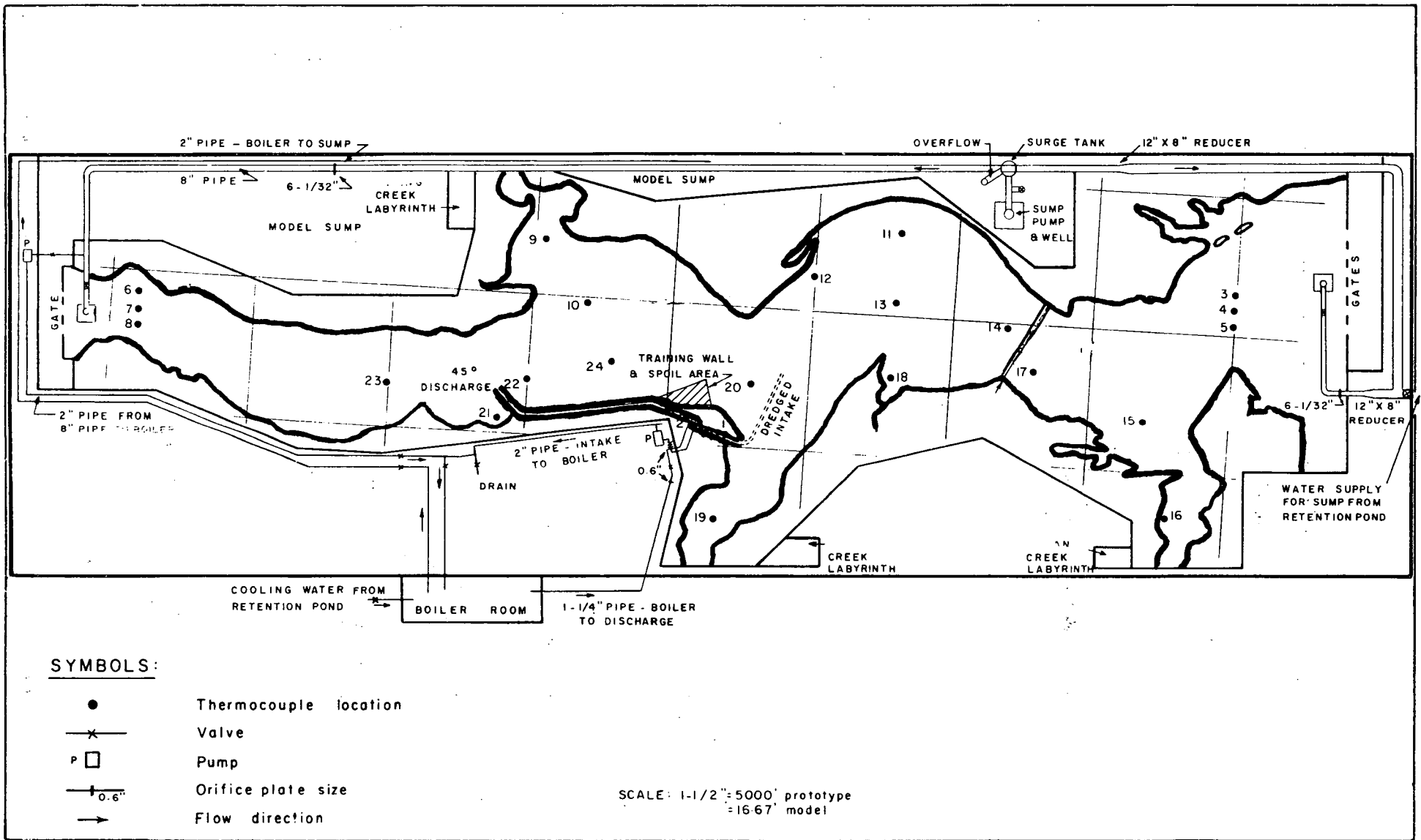

FIG. 11

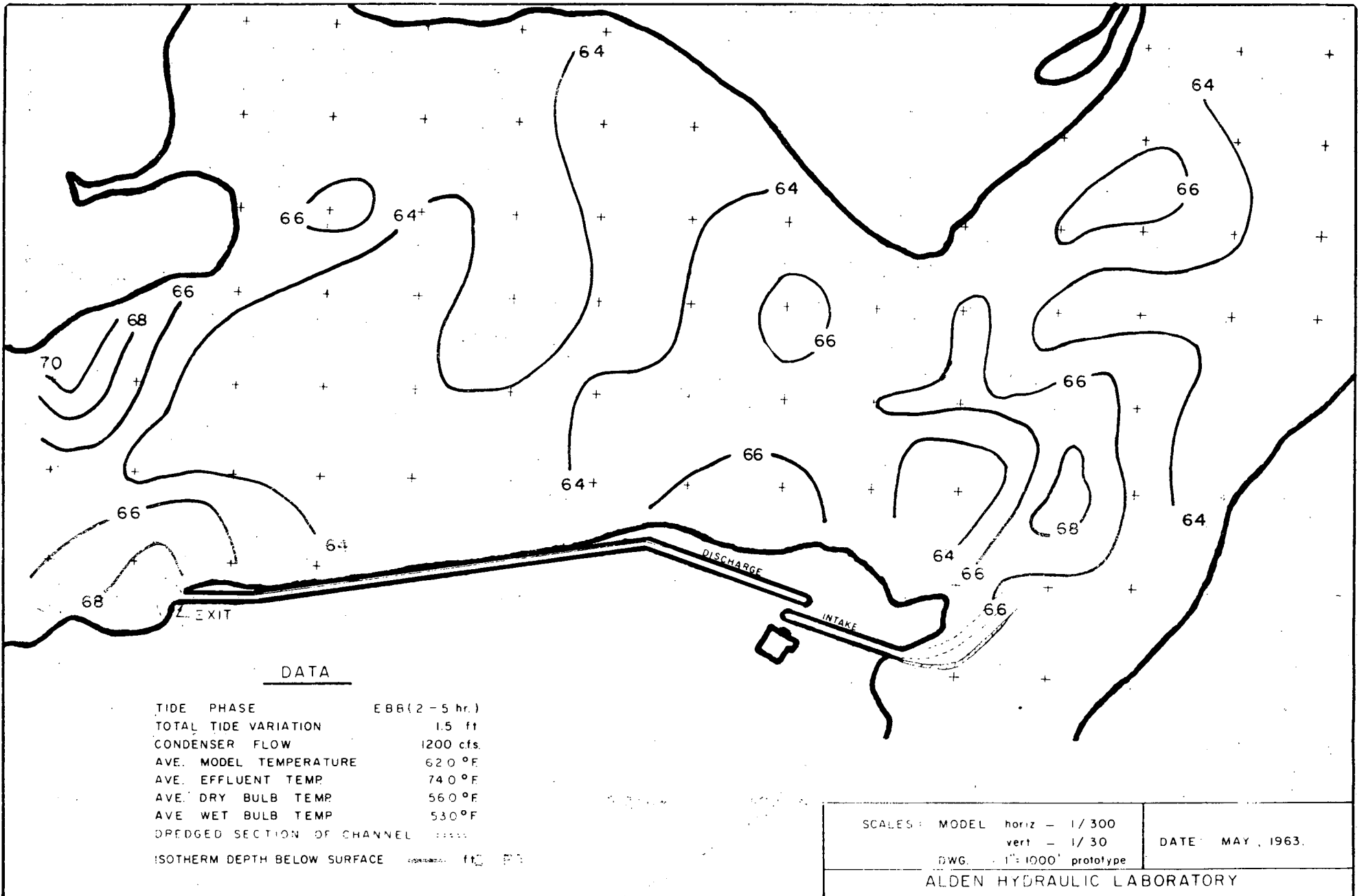

FIG. 12

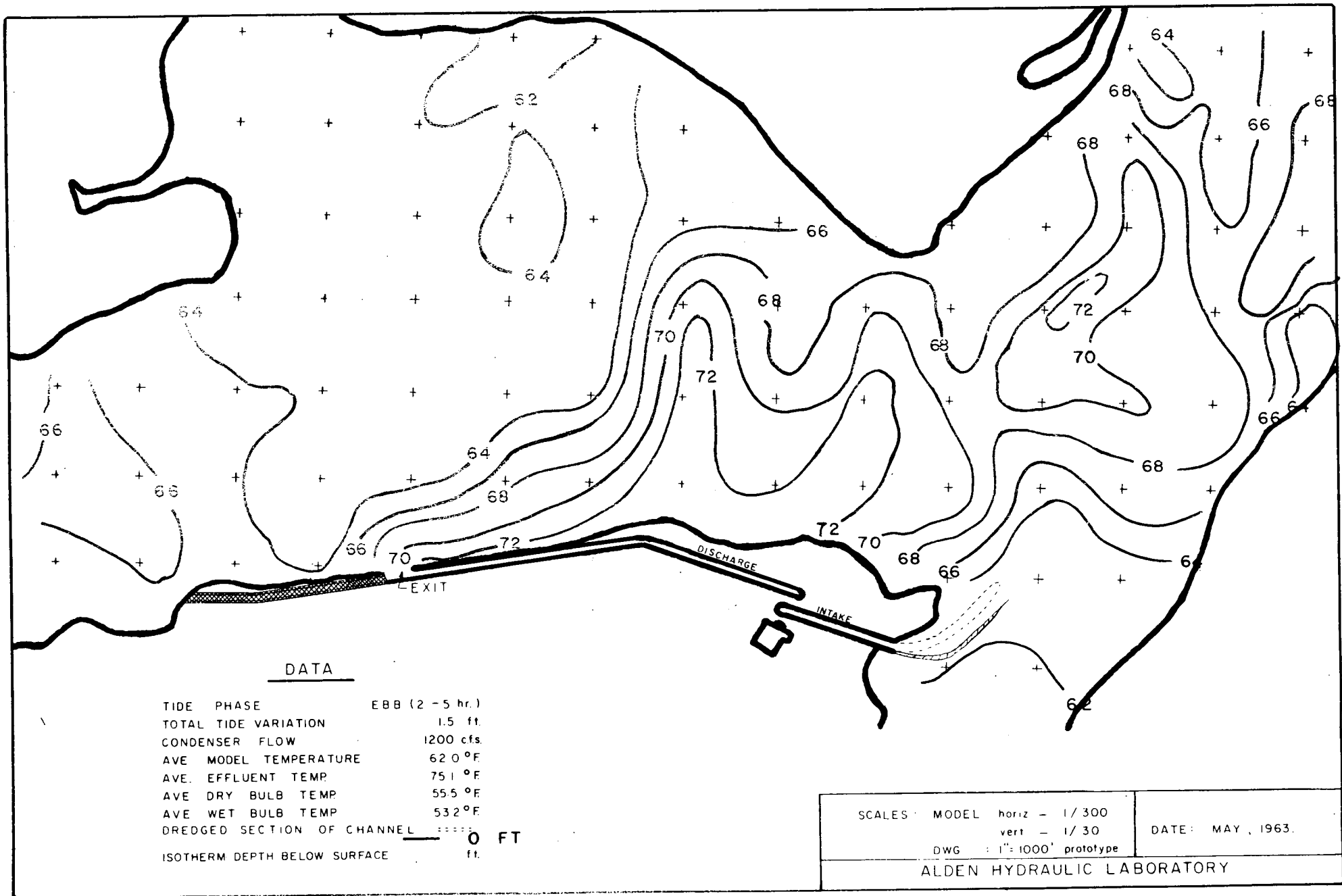

FIG. 13

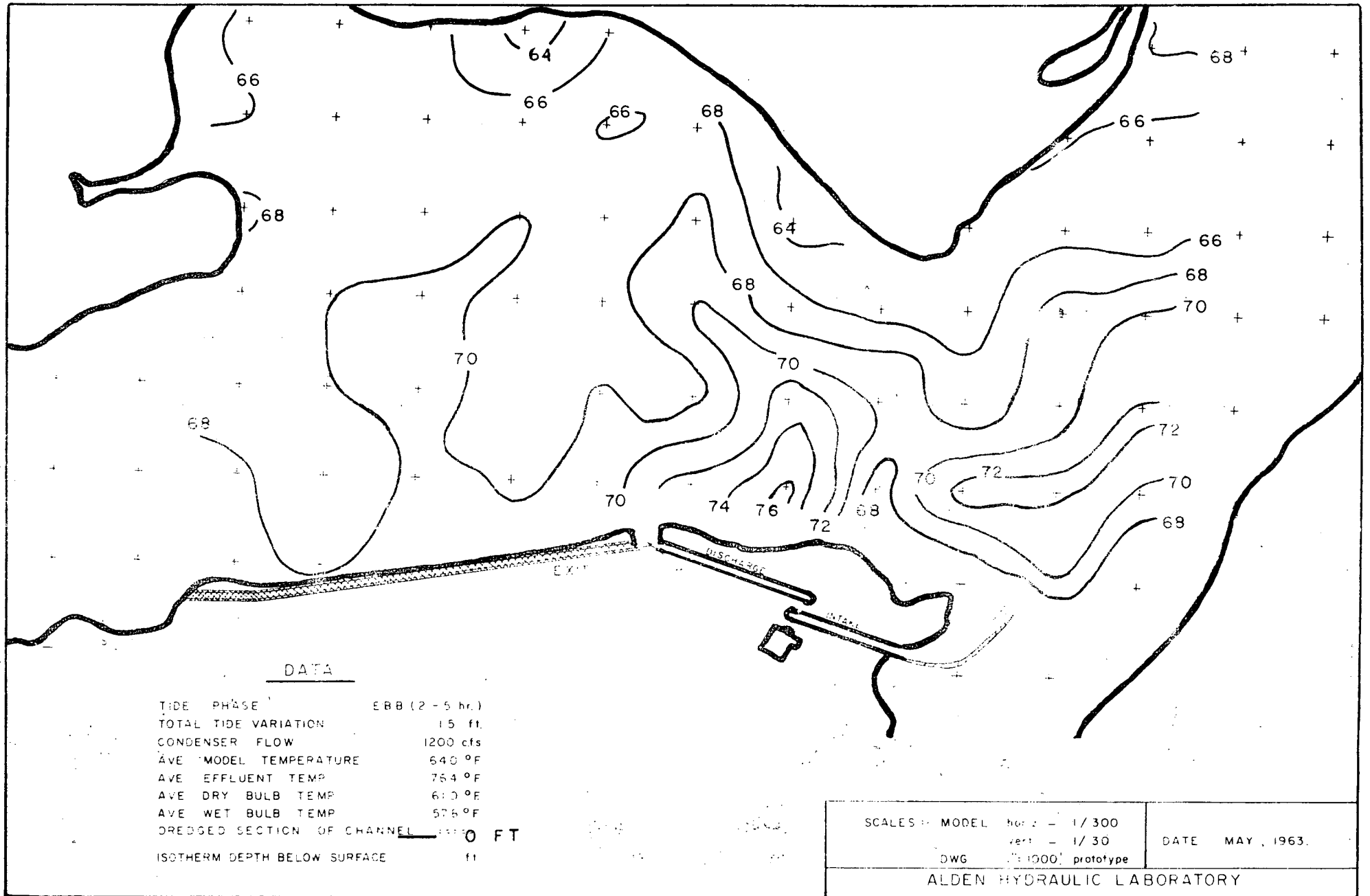

FIG. 14

MODEL STUDIES OF RECIRCULATION IN POWER PLANTS

L. J. Hopper, Director
Alden Hydraulic Laboratory
Worcester Polytechnic Institute
Worcester, Massachusetts

Presented at

WASHINGTON STATE UNIVERSITY, PULLMAN, WASHINGTON

October 29-30, 1959

MODEL STUDIES OF RECIRCULATION IN POWER PLANTS

L. J. Hooper, Director
Alden Hydraulic Laboratory
Worcester Polytechnic Institute
Worcester, Massachusetts

The factors to be taken into account in the design of the model for this type of work have been described in a previous paper. In brief, the effects may be summarized by pointing out that inasmuch as the problem is associated with low flow in the river, it follows that the depth and velocity in the field will both probably be small. These facts lead to large physical models in order to keep the flow conditions in the model above laminar. This naturally leads further to distorted models for economic reasons. We have always used heated water in our model studies to provide the effect of the heating by condensers in the power plant since this duplicated the density conditions as well as all of the other properties of the water. Furthermore, it allows the analysis of the performance of the model to be made by the heat balance.

Model experience

It is proposed in the following paper to describe some of the difficulties that have been experienced with model testing of re-circulation of condenser cooling water in power plants and to discuss further some of the types of results that can be obtained from such studies.

The greatest problem that was encountered in this type of model study is the establishing of standard conditions for test or even maintaining control of all of the conditions that affect the heat balance in the model. All models of this type at the Alden Hydraulic Laboratory have been constructed outdoors because of their size. It was quickly found that the sun and the wind both had a tremendous effect on the heat radiated into and out of the model. When time is not pressing and the work can be done in the summertime, it is usually best to wait until late in the afternoon when the sun is low and there is no heat coming in; the breeze that has stirred during the day has died away and the evening flow of air has not commenced. This naturally means that there will be a large number of days when the model will be fired up but the weather conditions will not become satisfactory and the model will be shut down to wait for a favorable situation.

The best possible solution is a model located indoors or completely covered in. This may add considerable to the expense, but it is definitely desirable to provide for covering in the model. It not only makes the work go faster, but it also provides better control so that the results are apt to be more accurate.

Where work must continue into colder weather with an outdoor model, it has been found desirable to provide two boilers so that the river water could be heated as well as the circulating water. Although some study was given to heating both the river water and the condenser flow, with one boiler, it seemed to produce a very complex arrangement of controls with a good possibility of interaction. For this reason, the simpler method of using two boilers was adopted. In the first case, there was found a condemned 100 hp boiler which was vented to the atmosphere so that it worked under no steam pressure. For the second boiler, a simple insulated box with expanded metal

tubes and an oil burner was used to provide the necessary heating effect. This made it possible to control the temperature coming into the model as well as the temperature rise provided by the condensers and made the operation of the model considerably simpler.

Most of these models for studying re-circulation are difficult to operate because of the pondage effects. Naturally the bed of the river is large compared to the flow and the very low velocities make control difficult. Work with these models have also indicated that it is very desirable to take much more temperature data than one would at first think necessary. It is obvious that the river temperature, the condenser inlet temperature, the condenser discharge temperature and the river discharge temperature will all be necessary in making the heat balance. It will quickly be found in experience that many more readings can be taken of the surface temperature in order to arrive at an average figure of surface temperature of the pool surface to be used in computing the heat transfer coefficient "U". Further, readings may also be desirable at various spots along the bottom so that the temperature profile can also be estimated.

On one of the model studies, there was made available a multipoint recording resistance thermometer which took temperatures in twelve different locations in succession. The calibration of the instrument was modified in order to make the temperature range of the model extend across the full scale of the instrument. This was found very desirable in controlling the model, inasmuch as variations in flow and temperature became apparent more quickly and it was found valuable thereafter in providing information that was needed in the analysis of the results.

TEST RESULTS

All of these re-circulating water studies have the effects of density and consequent stratification to a greater or less degree. Unfortunately, the density effect is not the only one acting, but there are also the velocity effects which can modify the pattern of flow considerably. It is obvious that where there is a deep pool the density effects will predominate, but where the depths are shallow, the flow and velocity effects may be the dominant factor in establishing the pattern.

One of the interesting facts found on an early model was the pattern of flow at the intake to a proposed steam power plant. In this case, the tests were being made with approximately 50% re-circulation and there was a pool, although quite shallow. As will be noted in Figure 1, the relatively cool water coming from upstream, was on the left bank of the river and the re-circulating water returning to the intake was also on the left and convex bank of the river. Whereas one might have expected that each of these flow would have gone into the nearest intakes, the reverse was found to be true. As will be seen in Figure 1, the hot water flowed beyond the center line of the intake and entered the upstream entrance, whereas the cold water flowed underneath and beyond the centerline of the intake and for the most part, entered the downstream intake opening. The temperature of the incoming water of each section of the intake was recorded throughout the tests and differences between the two intakes as great as 10 were found. It was not known whether this would constitute a problem in the operation of the plant, so that steps were taken to mix this flow should it be necessary in the field. Although a means was found of doing this, it proved to be more

difficult than anticipated. The corrective work consisted of a wall extending out into the stream and this was not put in until actual experience with the plant indicated its need. So far as is known, no trouble has been experienced with the variation in temperature between the cooling water to the two units and the wall to provide mixing has not been installed.

Another effect that may be a little surprising is the matter of discharging the discharge, where possible, parallel to a bank of the river. The velocity along the bank will present a lower pressure than is present in the main stream, so that the moving stream will be held on contact with the bank until its kinetic energy is dissipated (Figure 2). Reference to Figure 3 will show the relative increase in cooling area of the pool at a given river flow that could be secured by taking advantage of this velocity effect. Naturally the effect is easier to maintain on the concave bank of the stream than on the convex, but it will work in both cases.

An interesting indication of the interplay between velocity and density effects, is seen in Figure 4, which shows the velocity patterns at river discharges of 1500 and 600 cfs, with a condenser re-circulating flow of 800 cfs. This pattern was found in a river where the depths were varying between a minimum of approximately 5 feet to a maximum of about 15 feet, so that the pool effects were becoming more prominent as the river discharge decreased. It will be noted that at 1500 cfs the surface water flow pattern is showing signs of instability with areas where the water is apparently sinking or stagnant rather than flowing. On the other hand, the bottom flow for this condition is completely definite and stable as is shown by dye indications. At 600 cfs, however, the reverse is true. It will be seen by this time that the surface flow is completely stable, whereas the bottom flow has now the unstable characteristics that were seen before in the surface flow. Needless to say, when a model is being operated in a transition range of this sort, it is much more difficult to secure consistent heat data.

As an indication of the type of result that is normally found from this study, there is included the test result of one of the model studies, Figure 4. This is for a river where there is a considerable pool effect at the low river discharges. It will be seen that the model indicates a temperature rise of 16 degrees at the intake due to re-circulation when the river flow drops to 500 cfs. The condenser flow for this condition was taken at 800 cfs, with a 14 degrees Fahrenheit rise. At 800 cfs the temperature rise at the intake is still 9.3 degrees, and even at 1500 cfs, which is nearly twice the cooling water flow to the condensers, it is found that there is re-circulation causing a temperature rise of 3.7 degrees.

From this model curve, there is predicted immediately below it, another curve which indicates the expected temperature rise in the field. Experience has indicated that the minimum heat transfer obtained in the model for conditions of little heat transfer to the air, is 3 BTU per square foot per degree F. per hour. Experience in the field, however, indicates a minimum value of 6 or 7 BTU per degree, per square foot, per hour. The predicted curve, therefore, reflects the difference of 3 and 6 in the heat transfer coefficient. Beyond this, the use of a distorted model results in a smaller area, in proportion to the volume of water, than will be found in the field. Even further, in this particular model, more area of the pool will be affected by higher temperatures than was represented in the model. In predicting the field result, therefore, a heat balance calculation was made at several

discharges by a method of arithmetic integration to evaluate properly the increased area and the increased heat transfer coefficient that will be found in the field. As shown in the curve, this amounted to 4.5 degrees at the low flow. The modification of temperature was only 1.4 degrees at a discharge of 1500 cfs. In the latter case, the increased velocity of the stream prevented the warm water from traveling very far upstream so that the modification of area as between the model and the field was very small.

There is an interesting possibility in the re-circulation problem of using a heat storage effect of a pool to tide over the period of worst operating conditions during the day. Briefly the highest daily temperature comes between 12 and 6 o'clock in the afternoon; the humidity and a lack of wind are apt to go along with this high temperature as it is the maximum peak load due to air condition. On the other hand, after 6 o'clock the temperatures drop as a rule, and during the night a modest breeze may spring up to give a much better operating condition. Obviously, if the pool is large enough, there can be an averaging effect between the night operating conditions and those found during the worst part of the day. Unfortunately, in none of the models that we have tested, has this pondage effect been adequate to be of any economic interest.

The possibility of reducing load and dropping the pool temperature was studied on one of the projects. It was assumed that reduced load on the plant would be maintained until noontime and then full load would be carried from noon until 6 o'clock. In this study, it was found that only four degree-hours of storage could be secured by operating the plant at 50% load for six hours in advance of the desired maximum load condition. The re-circulating time in the pool was three hours and the study showed again that most of the benefit obtainable was secured in one re-circulating period.

However, where a steam plant is located on a deep pool and where density stratification is possible, it should be entirely feasible to secure considerable benefit from storage effects.

There is one further item that is shown from the studies made at the Alden Hydraulic Laboratory, concerning the re-circulating problem of a steam power plant located on a river. This is the fact that the power plant should preferably be located on the outside or concave bank of the bend. In the first place, this will be effective in bringing the deepest water to the intake of the power plant and at the same time minimizing any trouble that may occur from silting. As the depth of the pool increases, the location on a concave bank is still important since to secure the maximum benefit of stratification, the intake must be located as deep as possible and with very low velocity of inflow if the stratification is not to be disturbed.

In conclusion, it is felt that some of the results found from tests indicate that the model test of a steam power plant to determine the factors of temperature, re-circulation, time, silting and stratification at steam power plant inlets may well be of value in indicating the design of such intakes. With the increasing size of steam power plants, the problem of securing adequate supplies of cooling water is becoming more serious. In some locations, there is a further complication that States are beginning to talk of considering heat in a stream under the same category as acid, and other industrial wastes; in other words, an undesirable pollution. In one instance, it is known that a committee on legislation is toying with the idea of

considering that any single steam power plant must not raise the total temperature of the river water by more than 2 degrees. It is obvious that if such thinking is expressed in the regulation of steam power plants, there are many plants now in operation which will find themselves in difficulty during severe warm weather operating conditions.

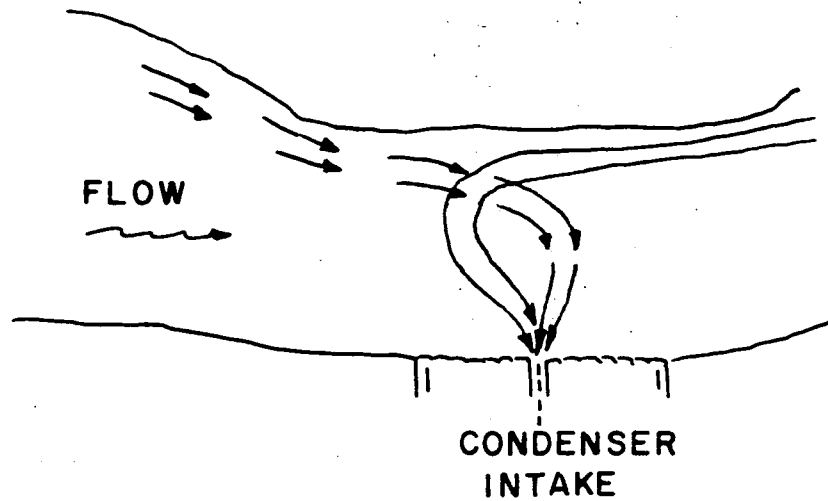

PATTERN OF FLOW AT INTAKE
WITH 50% RECIRCULATION

ALDEN HYDRAULIC LABORATORY
WORCESTER POLYTECHNIC INSTITUTE
WORCESTER, MASS.

Fig. 1



FIGURE 2. Effect of Condenser Flow Directed Along River Bank.

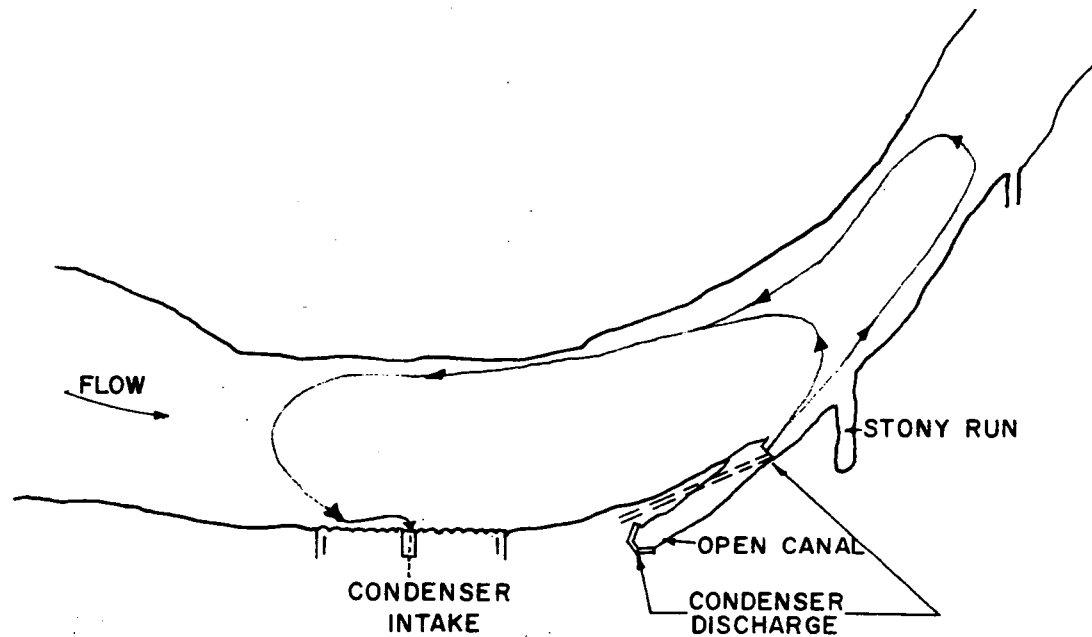

ORIGINAL POOL
AREA 567,000 sq. ft.

MODIFIED POOL
AREA 785,000 sq. ft.

COMPARISON OF COOLING POOL AREAS
ALDEN HYDRAULIC LABORATORY
WORCESTER POLYTECHNIC INSTITUTE
WORCESTER, MASS.

FIGURE 3

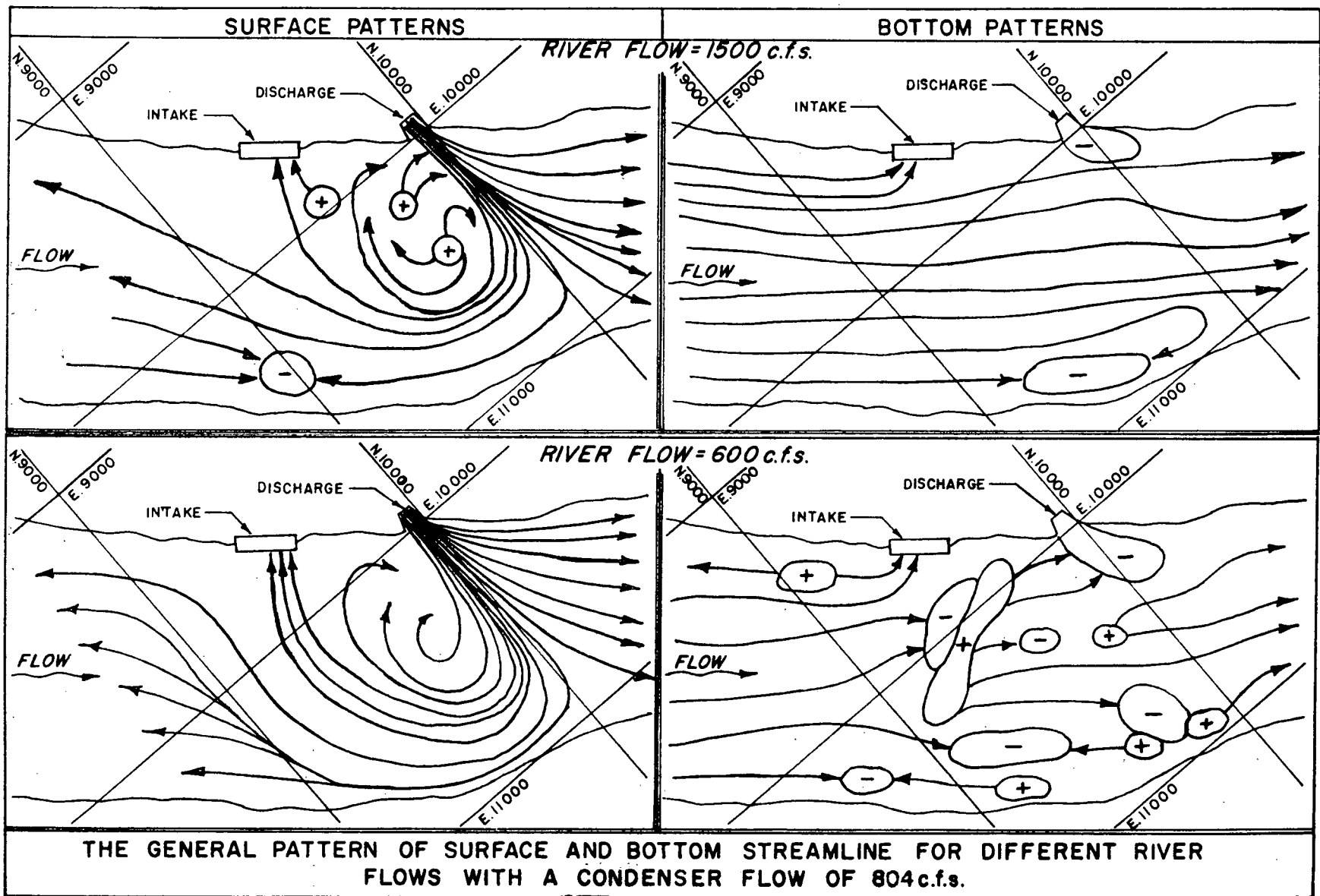
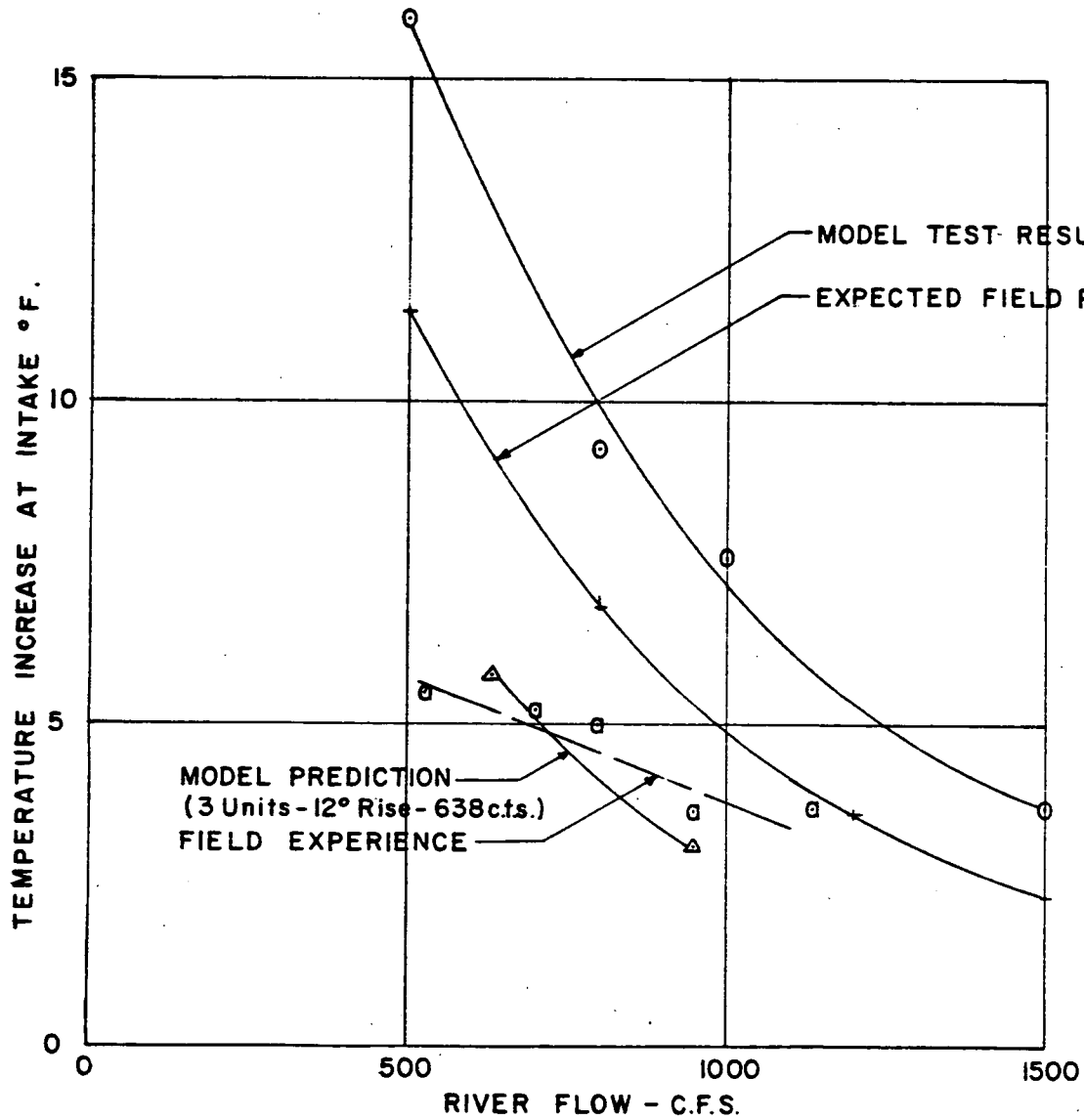

Fig. 4



STUDY OF RECIRCULATION
 ALDEN HYDRAULIC LABORATORY
 WORCESTER POLYTECHNIC INSTITUTE
 WORCESTER, MASS.

FIGURE 5

Consolidated Edison Company of New York, Inc.

EFFECT OF SUBMERGED DISCHARGE OF
INDIAN POINT COOLING WATER ON
HUDSON RIVER TEMPERATURE
DISTRIBUTION

October, 1969

Quirk, Lawler & Matusky Engineers
Environmental Science & Engineering Consultants
505 Fifth Avenue
New York, New York 10017

QUIRK, LAWLER & MATUSKY ENGINEERS
ENVIRONMENTAL SCIENCE & ENGINEERING CONSULTANTS

505 FIFTH AVENUE
NEW YORK, NEW YORK 10017

212 867-0080

WATER RESOURCES DEVELOPMENT
WATER POLLUTION CONTROL
AIR POLLUTION CONTROL
SOLID WASTES DISPOSAL

SYSTEMS ANALYSIS & DESIGN

COMPUTER FACILITIES
PILOT PLANT FACILITIES
ANALYTICAL LABORATORIES

THOMAS P. QUIRK
JOHN P. LAWLER
FELIX E. MATUSKY
WILLIAM A. PARSONS
LEONARD J. EDER
ROBERT A. NORRIS
VINCENT J. BOCCHINO

October 13, 1969

File: 115-5

Mr. George T. Cowherd, Jr.
Environmental Engineer
Consolidated Edison Company
of New York, Inc.
4 Irving Place
New York, New York 10003

Dear Mr. Cowherd:

The accompanying report has been written to provide theoretical support for the planned submerged outfall design for efficient discharge of heated waters from Indian Point Unit Nos. 1, 2 and 3.

As you know, the proposed outfall, which will consist of twelve 4 X 15' slots, spaced on 20' centers, submerged 18 feet below the water's surface, and discharging at 10ft/sec normal to the River's longitudinal axis, was selected after extensive testing in an undistorted hydraulic model of the outfall site at the Alden Research Laboratory. Alden's results showed that the maximum surface temperature rise would not exceed 50% of the plant temperature rise, and that the surface area encompassing temperature rises greater than 4°F would be rather small.

This study consists of the development of a mathematical model which is based on a consideration of the fluid mechanics of submerged jets (Chapter I), a comparison of the theoretical model to observations of actual submerged jet behavior made in the Alden model and in the Hudson River (Chapter II), and a prediction of behavior at Indian Point under a different and more severe set of conditions than those studied in the hydraulic model (Chapter III).

Study results are summarized as follows:

Mr. George T. Cowherd, Jr.
October 13, 1969

-2-

1. A mathematical model describing the behavior of a submerged jet in the Hudson River was developed and successfully programmed for computer solution.

This model consists of a set of twelve simultaneous equations, and incorporates the effects of plant intake temperature density and salinity, plant outfall temperature, density, salinity and flow, outfall geometry, including port size, shape, edging, orientation, and submergence, and river velocity (both runoff and tidal), tidal phase, and ambient temperature, density and salinity.

Initial jet momentum, induced buoyancy, and entrained river flow and momentum are the major controlling mechanisms accounted for. Drag force and the influence of the river surface and bottom on the expanding jet are not included.

Computer output includes the path of the expanding jet, and, at any port along this path, the jet diameter, velocity, density, temperature and dilution factor. Stops are included to indicate when the jet boundary reaches the river surface or bottom.

2. Computed results agree reasonably well with measurements made in the undistorted hydraulic model, and in the vicinity of the submerged outfall of Orange and Rockland Utilities' Lovett Unit #4, located at Tomkins Cove on the Hudson River's west bank, less than two miles south of Indian Point.

Improved agreement is obtained by adjusting computed results to account for the boundary and drag effects not included in the mathematical model, and for interference between adjacent jets in the multiple-port design.

3. Computed results for a condition of a maximum ambient temperature of 79°F, and a maximum condenser rise of 17°F, showed that the maximum surface temperature can be expected to be 9°F. The surface area bounded by the 4°F isotherm, and the lateral distance from shore, bounded by this isotherm, can be expected to be on the order of the values given for these parameters in our report to Con Edison of February, 1969.

Mr. George T. Cowherd, Jr.
October 13, 1969

-3-

These results show that the submerged outfall will perform as previously estimated, and that this design should meet the Thermal Discharge Criteria of the New York State Water Resources Commission.

Very truly yours,



John P. Lawler

JPL:kk

TABLE OF CONTENTS

	<u>Page</u>
Letter of Transmittal	
I. Theoretical Analysis of Submerged Jet Discharge	1
II. Comparison of Theoretical Results and Field Tests	33
1. Hudson River Model Tests	33
2. Lovett Plant Submerged Discharge Surveys	44
III. Evaluation of Indian Point Submerged Discharge	48
References	57
<u>Appendix</u>	
Alden Hydraulic Laboratories-Submerged Discharge Report	

I. THEORETICAL ANALYSIS OF SUBMERGED JET DISCHARGE

A. Introduction

The characteristics of any hydraulic phenomenon, such as a hydraulic jump or a submerged jet, may be analyzed by application of the fundamentals of fluid flow. The applicable principles of fluid flow include:

1. The principle of conservation of mass, from which the equation of continuity is developed;
2. The principle of kinetic energy, from which certain flow equations are derived; and
3. The principle of momentum, from which equations describing dynamic forces exerted by flowing fluids may be established.

In the case of a jet submerged in a quiescent body of liquid of the same density, the pressure distribution is assumed to be hydrostatic, and, if drag forces are neglected, the momentum flux in the direction of the expanding jet remains constant. Assumption of a particular velocity function (such as the Gaussian frequency distribution) then permits evaluation of the rate of jet expansion

and the accompanying distribution of the turbulence characteristics.

The following description of the fate of a submerged jet of heated effluent may help to clarify the complex inter-relationship between the different principles outlined above.

B. Description of the Problem

When a jet of heated effluent is discharged into a receiving water body at some depth below its surface, it rises, as a plume, to the surface, and then spreads laterally and longitudinally at the free surface. This rising behavior is caused by both initial vertical momentum flux (which is present unless the jet is directed horizontally), and the net buoyant force due to the lower density of the jet. The initial vertical momentum flux is due to the fact that the jet has a higher vertical velocity than the surrounding river water. The buoyant force is caused by the difference in density between the heated effluent and the surrounding ambient river water.

Reduction in temperature occurs by entrainment of the river water into the jet as the jet of heated liquid works its way toward the surface. This dilution proceeds until the relative velocity

between the jet and surrounding water is reduced to zero. This phenomenon is called initial jet dilution. Further dilution occurs by turbulent transport mechanisms.

The relative motion between the plume and the river water develops shear stresses. Turbulence is generated and mixing takes place first around the periphery of the column and finally throughout the whole column. This results in a continual growth in jet size, a decrease in jet temperature, and an increase in density of the heated jet as it nears the surface.

Entrainment of horizontal momentum possessed by the river itself, as the jet entrains the river water, causes the plume to move upstream or downstream depending upon river flow direction.

In estuaries, the introduced heat is ultimately lost to the atmosphere and flushed from the estuary in the seaward directed flow of the surface layers.

The purpose of this theoretical analysis was to develop a mathematical model and computer program, suitable for the prediction of the coordinates of the axis of the jet, and, at any point on this axis, for the prediction of jet size, velocity, dilution, density

and temperature. Model inputs include port size, initial jet velocity, jet orientation, discharge water salinity, maximum plant temperature rise, river ambient temperature, river water salinity and river runoff and/or tidal velocity.

C. Formulation of the Mathematical Model

In this section the basic equations for a circular jet discharging into a river are developed in terms of the known above mentioned design parameters.

The problem is formulated based upon the following assumptions:

1. Initial jet momentum is conserved, i.e., dragforce is neglected and the jet, at any point, will contain this momentum as originally distributed in the three dimensional system, as well as any momentum picked up from the river itself.
2. The jet is axially symmetric along its entire length.
3. Jet expansion continues indefinitely.
4. Boundary effects are neglected and an infinite source of water is available for dilution.

The first assumption has been adopted in submerged discharge analysis by many investigators. Field and laboratory measurements have shown the second assumption is valid in most practical cases, at least until the river bottom or surface begins to interfere. The effects of drag force and boundary interference are discussed in Chapters III and IV, under verification and application of the model.

Figure 1 shows the coordinate system chosen for the analysis. The "x" axis is horizontal, perpendicular to the longitudinal axis of the river (this is the "z" axis), and values of "x" increase positively as one moves away from the outfall ($x=0$) laterally into the river.

The "y" axis begins at the outfall ($y=0$) and moves vertically upward toward the river's surface. Values of "y" increase positively as one moves vertically upward.

The "z" axis begins at the outfall ($z=0$). Values of "z" increase positively as one moves downstream along the river's longitudinal axis, which, of course, is normal to the lateral, or "x" axis, of the river. In tidal rivers, the river itself possesses a positive "z" momentum during ebb, and a negative "z" momentum during flood.

The momentum in the lateral or "x" direction is considered to be constant. This implies that the buoyant forces, produced by differences in the mass density of the effluent and the receiving waters, will cause the plume of diluted effluent to surface before the lateral momentum is diminished by the effect of viscous or frictional resistance.

Vertical or "y" momentum, at any reference point in the plume, is equal to any initial vertical momentum from the outfall, plus the total buoyant force occurring at the point. Notice that this recognizes the addition of momentum to the system, as the jet becomes exposed to the influence of the river.

Momentum in the longitudinal direction is equal to the component of initial momentum in this direction, plus the added amount due to the exchange of momentum from the receiving waters entrained into the jet plume. This recognizes that the entrained river water is part of the river's flow and, as such, possesses a "z" velocity and, therefore, a "z" momentum.

The origin of this coordinate system ($x=0, y=0, z=0$) is actually the vena contracta of the jet as it emerges from the submerged

FIGURE 1

SUBMERGED DISCHARGE MODEL DEVELOPMENT

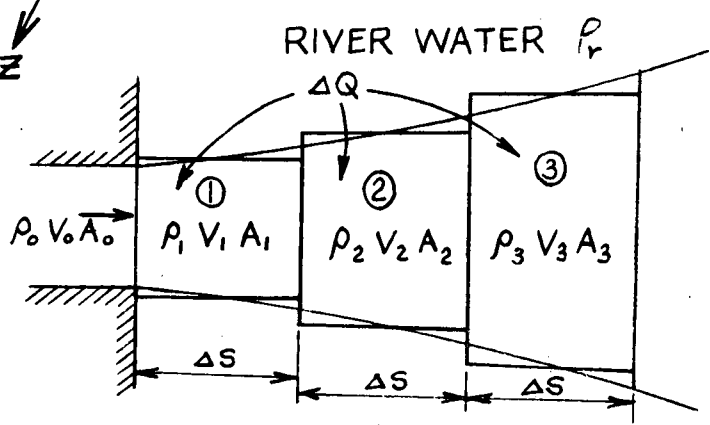
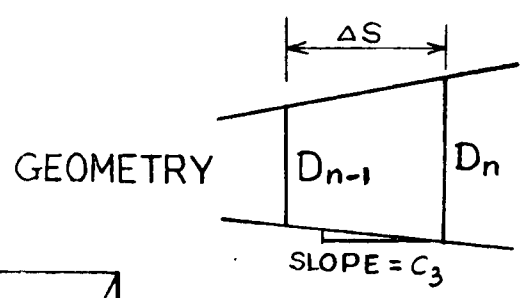
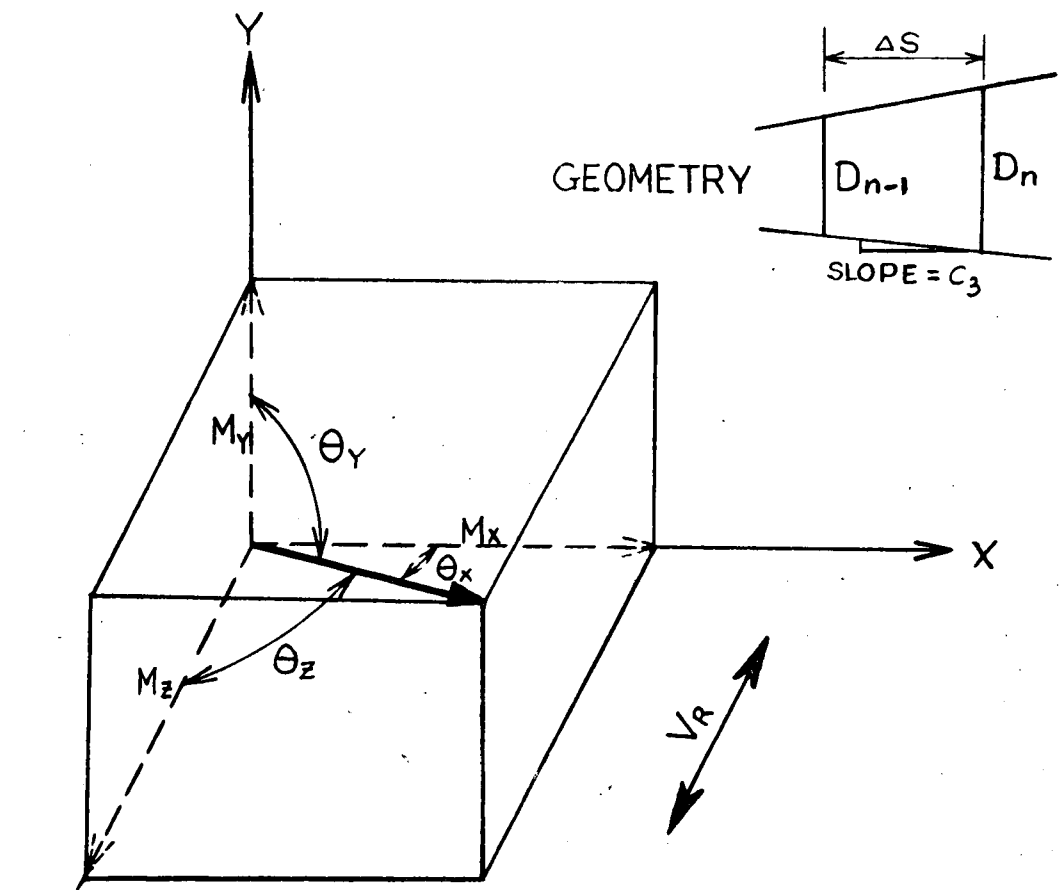

CONSERVATION OF MASS

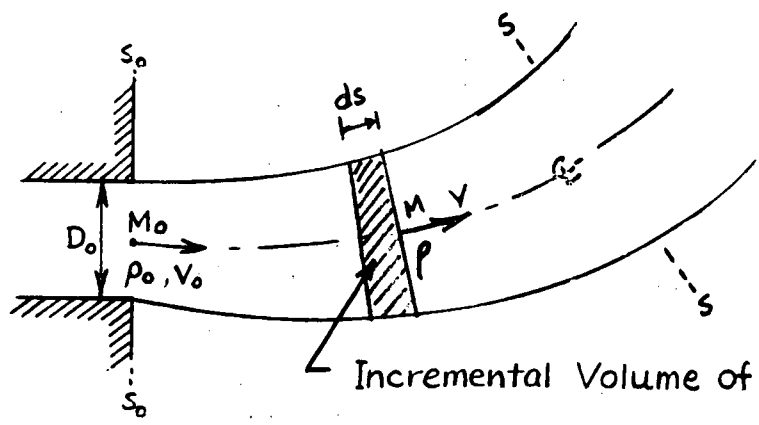

CONSERVATION OF MOMENTUM

outfall. For sharp edged ports or slots, this will be slightly beyond the opening itself (and slightly below, if the jet is directed downward at some angle from the horizontal). For rounded openings, the center of the opening is the origin of the coordinate system.

1. Development of the Momentum Equations

Consider the flow path shown in Figure 1 in which sections s_0 and s are normal to the centerline of the jet at the outfall and at any arbitrary section beyond the outfall, respectively.

Adopt the following nomenclature:

- A_0 = Cross-sectional area of the vena contracta
- A = Cross-sectional area of the jet at any point x, y, z
- C_3 = Slope of the jet boundary
- x = Lateral distance from point of discharge
- y = Vertical distance from point of discharge
- z = Longitudinal distance from point of discharge
- s = Length along centerline of jet from point of discharge
- D_0 = Diameter of the jet's vena contracta
- D = Diameter of the jet at any point x, y, z

- v_o = Initial average jet velocity = Q_o/A_o
 v = Average jet velocity at any point $x, y, z = Q/A$
 v_r = Average river or tidal velocity (positive = downstream)
 ρ_o = Mass density of effluent
 ρ = Jet mass density at any point x, y, z
 ρ_r = River mass density
 M_o = Initial jet momentum = $\rho_o A_o v_o^2$
 M = Total jet momentum at any point x, y, z
 $M_x, M_y, M_z = M \cos \theta_x, \theta_y, \theta_z$
 $\theta_x, \theta_y, \theta_z$ = Direction of angles between a tangent to the center-line of the jet at any point x, y, z and the x, y, z axes
 Q_o = Effluent flow rate
 Q = Flow rate of the jet at any point
 V_n = Incremental volume of jet over an incremental distance Δs

Momentum balances are written for the three directions using the control volume approach. This is particularly suitable for the system under study, since the discharge is continuous, and for this study, assumed to be operating at steady state.

We are dealing, therefore, with rates of momentum flow, i.e., the

momentum per unit time flowing past an inlet or outlet section of the jet volume chosen for analysis, and the basic equation is developed by inventorying the momentum as it flows in and out of this volume, and is produced by development of buoyant forces, lost due to viscous drag, or added along the length of the volume element due to entrainment of river water possessing a momentum of its own.

This inventory equation is written on each of x,y, and z momentum over the jet volume between the sections s_0 and s as follows:

$$\begin{aligned}
 &\text{Rate of Momentum Input} - \text{Rate of Momentum Output} + \text{Forces Acting on Jet and Momentum Flow Gained or Lost} \\
 &= \text{Time Rate of Accumulation of Momentum within Jet} \dots\dots\dots(1)
 \end{aligned}$$

For the steady state condition, the only one investigated here, the right side of Equation 1 is identically zero.

Consider "x" momentum. Since drag is neglected, the third term in Equation 1 is zero and the momentum equation in the "x" direction is written as follows:

$$M_{x_0} - M_x \Big|_s = 0$$

or

$$\rho v^2 A \cos \theta_x = \rho_0 v_0^2 A_0 \cos \theta_0 \quad \dots\dots\dots (2)$$

Consider "y" direction. In the "y" direction, the vertical momentum flux (flow) increases due to the net buoyant effect. Application of Equation 1 to "y" momentum over the volume between 0 and s yields:

$$M_0 \cos \theta_{y_0} - M \cos \theta_y + \int_0^s (\rho - \rho_r) g A ds = 0$$

or

$$M \cos \theta_y = M_0 \cos \theta_{y_0} + \int_0^s (\rho - \rho_r) g A ds \quad \dots\dots\dots (3)$$

Consider "z" momentum. In the "z" direction, the rate of change of momentum flux along the jet is equal to the rate of entrainment of river momentum flux, which is inherently "z" directed. Since the jet entrains river water, and since this water has a "z" velocity, which we assume will not be lost or decreased, the "z" balance must include the introduction of river "z" momentum into the jet.

The magnitude of this rate of momentum introduction will be the product of the entrained mass flow, $\rho_r dQ$, times the river velocity, v_r . Application of Equation 1 to "z" momentum, over the jet

volume between s_0 and s then yields:

$$M_0 \cos \theta_{z_0} - M \cos \theta_z + \int_0^s \rho_r v_r \frac{dQ}{ds} ds$$

$$\underline{or}$$

$$M \cos \theta_z = M_0 \cos \theta_{z_0} + \int_0^s \rho_r v_r \frac{dQ}{ds} ds \quad \dots\dots\dots (4)$$

We are in the process of developing a system of simultaneous equations to provide a unique solution for a number of unknowns ($\rho, v, A, \theta_x, \theta_y, \theta_z$). The unknown ρ , which appears in the integral in Equation 3, and dQ/ds , or $\frac{d(vA)}{ds}$, which appears in the integral in Equation 4, are complex functions of s , i.e., of location. Analytical solutions of this eventual system of equations, therefore, will be virtually impossible to obtain.

A numerical technique, suitable for high speed digital computation, will be used to solve the equations. The development of this solution begins by breaking the jet plume into a finite number of sections, each of length Δs , along its centerline (see Figure 1).

Equations 3 and 4, describing the balance of "y" and "z" momentum over the jet lengths, are rewritten for incorporation into the numerical solution technique as follows:

$$M_n \cos \theta_{y_n} = M_0 \cos \theta_{y_0} + \sum_{i=1}^n (\rho_r - \bar{\rho}_i) g V_i$$

or

$$M_n \cos \theta_{y_n} = M_{n-1} \cos \theta_{y_{n-1}} + (\rho_r - \bar{\rho}_n) g V_n \dots \dots \dots (5)$$

$$M_n \cos \theta_{z_n} = M_0 \cos \theta_{z_0} + \sum_{i=1}^n \rho_r V_r \Delta Q_i$$

or

$$M_n \cos \theta_{z_n} = M_{n-1} \cos \theta_{z_{n-1}} + \rho_r V_r \Delta Q_n \dots \dots \dots (6)$$

The following definitions apply:

M_n = the momentum flowing out of the segment n. This is equal to the product of the density, velocity and cross-sectional area of the jet at the downstream end of the volume segment V_n .

$\cos \theta_{y_n}$ = the "y" direction cosine of the tangent to the jet centerline at the downstream end of the segment V_n . $\cos \theta_{z_n}$ is defined similarly.

V_n = the volume of any jet segment n. This is equal to the average cross-sectional area of the segment, A_n , times the segment length Δs .

ΔQ_n = the incremental river flow entrained into the segment n. The total jet flow leaving the segment at its downstream end includes this flow, all previously entrained river flows, $\sum_{i=1}^n \Delta Q_i$, and the jet flow, Q_0 .

The final momentum relationship, which will be necessary to provide sufficient equations to obtain a unique solution, is written by recognizing that the total momentum at any point is the vector sum of the momentum in the x, y and z directions. This is written:

$$\bar{M} = \bar{M}_x + \bar{M}_y + \bar{M}_z \quad \dots\dots\dots(7)$$

or, in terms of the scalars which appear in the individual component equations:

$$M^2 = M_x^2 + M_y^2 + M_z^2 \quad \dots\dots\dots(8)$$

Since each component momentum scalar can be written in terms of the product of M and the pertinent direction cosine, Equation 8 just requires that the sum of the direction cosines equal unity. Thus, we have:

$$M_n = \rho_n v_n A_n \quad \dots\dots\dots(9)$$

and

$$\cos^2 \theta_{x_n} + \cos^2 \theta_{y_n} + \cos^2 \theta_{z_n} = 1 \quad \dots\dots\dots(10)$$

The following definitions apply:

ρ_n = mass density of the jet, at the downstream end of
the segment V_n

v_n = average jet velocity, at the downstream end of
the segment V_n

A_n = cross-sectional area of the jet, at the downstream
end of the segment V_n

Note that the average segment density and area, $\bar{\rho}_n, \bar{A}_n$, which appear in the previous set of definitions, are hatted to distinguish them from ρ_n and A_n .

We have now developed five independent equations, namely equations 2, 5, 6, 9 and 10. Observation of these equations show that ten unknown variables have been generated, namely the total momentum M_n , the three direction cosines $\theta_x, \theta_y, \theta_z$, the geometric quantities A_n and V_n , the mass quantities ρ_n and $\bar{\rho}_n$, and the flow quantities v_n and ΔQ_n .

Thus, we will have to develop at least five more equations, and more if any new unknown variables are introduced. The following

sections consider the geometric and flow relationships available to do this.

2. Development of Geometric Relationships

Extensive literature on the expansion of submerged jets shows that the slope of the jet boundary generally is in the range of 1 to 4 to 1 to 6. Actually, most authors recognize a core flow, or zone of establishment, in which the boundary increases at a slower rate, say 1 to 6 to 1 to 10, for a distance of about six port diameters, followed by a zone of established flow where the expansion rate is of the order of 1 to 5. (1), (2), (3)

This fact has been utilized as a key element in the solution of the present problem. We have insufficient field data to establish empirical expansion coefficients for the Hudson River, but have recognized that any jet will show a volume expansion. The expansion coefficients, or slopes, used, therefore, have been taken from the literature. Evaluation of the sensitivity of the results to choice of slope has been made and shows that this approach is an acceptable one.

The slope of the jet cone, relative to the jet centerline, is assumed to be fixed and is given by the coefficient C_3 . The

diameter of the downstream end of any jet segment V_n is written:

$$D_n = D_{n-1} + 2C_3 \Delta S \quad \dots\dots\dots(11)$$

In the programmed solution of this problem, the existence of two zones of different slopes is recognized. C_3 is replaced by C_1 in the zone of establishment, which is stated to exist for a total distance S_2 . In the established zone, instead of using the value of C_1 , C_3 in Equation 11, is replaced by a larger constant, designated C_2 .

Equation 11 introduces one more equation, but at the same time one more unknown variable. D_n , of course, can be computed directly from Equation 11 without recourse to other equations, but this calculation removes Equation 11 from further use and we still need five more equations (11 variables, 6 equations at this point).

Once the jet diameter D_n is known, however, geometric relationships for A_n and V_n can be introduced, and we will have two more equations without introducing any addition unknowns.

The area A_n , is given simply:

$$A_n = \frac{\pi}{4} D_n^2 \dots\dots\dots (12)$$

Each segment of the expanding jet is the frustum of a cone, the volume of which is written:

$$V_n = \frac{\pi}{12} \Delta S \left[D_n^2 + (D_n - 2C_3 \Delta S) D_n + (D_n - 2C_3 \Delta S)^2 \right] \dots\dots\dots (13)$$

We now have 11 variables and eight independent equations. One additional geometric relationship can be developed.

If we consider the case of a constant density, constant temperature system, relative velocity is the only difference between the jet and the surrounding medium. In this case the volume of any segment V_n is equal to the volume of the preceding segment plus the volume of river water introduced by entrainment. This is written:

$$V_n = V_{n-1} + (V_n - V_{n-1}) \dots\dots\dots (14)$$

This, of course, is trivial for the constant density case and new information is not provided. For the case of discharge of a fluid of one density into a fluid of another density, but at the same temperature, the mass occupied by the volume segment V_n , can

be obtained in terms of the mass occupied by the previous volume, V_{n-1} , and the mass introduced by entrainment of river water. This is written:

$$\bar{\rho}_n V_n = \bar{\rho}_{n-1} V_{n-1} + \rho_r (V_n - V_{n-1}) \quad \dots\dots\dots (15)$$

In other words, the mass in the segment n is equal to whatever is in segment n-1 plus that which is added by entrainment of river water. This incremental mass, of course, must equal the river density times the volume increment, $V_n - V_{n-1}$. This equation provides additional information for a constant temperature system.

For our case, since temperature and density both vary, the mass relationship will still hold, but it cannot be expressed as simply as is done in Equation 15. V_n must reflect a certain shrinkage, due to the fact that the average temperature within V_n is not as high as that within V_{n-1} . In other words, were a volume of average density $\bar{\rho}_{n-1}$ and average temperature \bar{T}_{n-1} mixed with a volume of average density ρ_r and average temperature \bar{T}_r , which is cooler than \bar{T}_{n-1} , the resultant volume would be smaller and the density larger than would occur if both temperatures were equal. Thus, Equation 15 is incorrect since $(V_n - V_{n-1})$ no longer represents the exact volume of entrained water.

Recognizing the temperature effect on the density, the equation of state for water is then introduced to provide additional information on density. This is written:

$$\bar{\rho}_n = f(\bar{T}_n) \dots\dots\dots(16)$$

This function appears in the programmed solution as a least squares polynomial fit of tabulated density-temperature relationships for waters of various salinities. Actually, the program incorporates the entire density-temperature-salinity relationship, as well as an equation of continuity on salinity, so that it may be used in situations in which the effluent salinity is different than the river salinity.

Equation 16 introduces one more unknown variable, \bar{T}_n , as well as one more equation, so that three equations are still needed. We know, however, that a heat balance will eventually be introduced, even if the equation of state had not been, since a knowledge of T_n is one of the solution objectives.

Equation 16 was introduced at this point because an alternative approach, and in fact our original approach, is to use Equation 15.

This approach, however, introduces substantial error in the location of the surface boil, because the buoyant forces, which control the upward movement of the jet, are, of course, strongly influenced by the jet density.

Actually, Equation 15 is quite useful and does appear in the programmed solution. A trial and error solution technique has been used and Equation 15 is employed to obtain an initial estimate of jet density. This estimate then becomes the point of departure into the trial and error solution.

It should be noted that there is a slight anomaly in the solution, since the jet slope is held constant and was originally defined as a measure of the entrained water. The incremental volume in segment V_n , i.e., $V_n - V_{n-1}$, now represents the entrained volume less the temperature-induced shrinkage which has occurred. The volume change due to the temperature effect is insignificant, however, and there need be no further concern on this point.

Recognition of the temperature-induced effect was necessary because of its effect on density. Although equally small, the change appears in the $(\rho_r - \rho)$ buoyancy term, where small changes in ρ cause large changes in $(\rho_r - \rho)$, since ρ is numerically very

close to ρ_r .

We now have nine equations and twelve unknown variables. Continuity and energy relationships are now developed to provide additional information.

3. Development of the Continuity Relationship

Application of the inventory equation for mass, similar to that given by Equation 1 for momentum, gives:

$$\rho_0 v_0 A_0 - \rho v A \Big|_s + \int_0^s \rho_r \frac{dQ}{ds} ds = 0$$

or

$$\rho v A \Big|_s = \rho_0 v_0 A_0 + \int_0^s \rho_r \frac{dQ}{ds} ds \quad \dots\dots\dots(17)$$

Using the segmented approach, Equation 17 is rewritten:

$$\rho_n v_n A_n = \rho_0 v_0 A_0 + \sum_{i=1}^n \rho_r \Delta Q_i$$

or, since the river density is usually assumed to be constant,

$$\rho_n v_n A_n = \rho_0 v_0 A_0 + \rho_r Q_r$$

or, in terms of the characteristics of the previous segment

$$\rho_n v_n A_n = \rho_{n-1} v_{n-1} A_{n-1} + \rho_r \Delta Q_n \quad \dots\dots\dots(18)$$

No new unknown variables have been introduced, so we now have a total of ten equations and twelve unknown variables. A heat balance over the jet will provide an eleventh equation, as shown next.

4. Development of the Heat Balance

An inventory of thermal energy over the jet is written in accordance with the principles of Equation 1 as follows:

$$\rho_0 v_0 A_0 C_p \Delta T_0 - \rho v A C_p \Delta T \Big|_s + \int_0^s \rho_r C_p \Delta T_r \frac{dQ}{ds} ds = 0$$

or

$$\rho v A C_p \Delta T \Big|_s = \rho_0 v_0 A_0 C_p \Delta T_0 + \int_0^s \rho_r C_p \Delta T_r \frac{dQ}{ds} ds \dots \dots \dots (19)$$

In Equation 19, C_{p_0} , C_{p_r} and C_p are the heat capacities of the effluent, river and diluted jet waters, respectively. These vary only slightly with temperature, and from this point forward are considered to be constant and equal, with a value of 1.0 BTU/#/°F.

Heat losses have been neglected. Previous work has shown that only negligible losses occur in the near vicinity of a heated discharge. Loss along the submerged boundary of the jet is totally insignificant, and even at the surface, significant heat

transfer to the atmosphere does not occur until the surface area affected by the heated water is much larger than that associated with the jet. In other words, atmospheric heat transfer does not become significant within the zone of initial dilution.

In segmented form, Equation 19 may be written:

$$\rho_n V_n A_n \Delta T_n = \rho_o V_o A_o \Delta T_o + \sum_{i=1}^n \rho_r \Delta T_r \Delta Q_i$$

or

$$\rho_n V_n A_n \Delta T_n = \rho_o V_o A_o \Delta T_o + \rho_r \Delta T_r Q_r$$

or

$$\rho_n V_n A_n \Delta T_n = \rho_{n-1} V_{n-1} A_{n-1} \Delta T_{n-1} + \rho_r \Delta T_r \Delta Q_n \dots \dots \dots (20)$$

Any reference temperature may be chosen to define the datum for the various ΔT . In this work, T_r , the river ambient temperature, has always been held constant. If T_r is chosen as the datum, the terms in Equations 19 and 20 containing ΔT_r vanish, and the heat balance becomes simply:

or

$$\rho_n V_n A_n \Delta T_n = \rho_o V_o A_o \Delta T_o$$

$$\rho_n V_n A_n \Delta T_n = \rho_{n-1} V_{n-1} A_{n-1} \Delta T_{n-1} \dots \dots \dots (21)$$

Notice that the ratio, $\Delta T_n / \Delta T_o$, is just equal to the flow dilution factor, $\rho_n v_n A_n / \rho_o v_o A_o$. This factor is included in the computer output printout and, as will be shown, is used as a primary control in the interpretation of results.

Equation 21 introduces a new unknown variable, T_n (ΔT_n , of course, is just equal to $T_n - T_r$), so we now have eleven equations and thirteen unknowns.

5. Nature of Average Density and Temperature, ρ_n and \bar{T}_n

Two of these unknown quantities are \bar{T}_n and $\bar{\rho}_n$, the average temperature and density in the jet segment V_n . These must bear some relation to the segment outlet temperature and density, T_n and ρ_n . These quantities only arise because the numerical solution technique requires that the segment volume be finite.

As this volume becomes increasingly small, $\bar{\rho}_n \rightarrow \rho_n$, and $\bar{T}_n \rightarrow T_n$; in the limit, the defining equations are differential equations, not difference equations, and $\bar{\rho}_n$, which appears in the equation for "y" momentum, does not appear at all, being, for point behavior, identical to ρ . The average temperature \bar{T}_n , of course, appeared upon introduction of the equation of state for $\bar{\rho}_n$. The point temperature value, T , would be required to evaluate the point

density, ρ .

The computer solution employed is an iterative technique and requires relatively small segment lengths for rapid convergence. For small segment lengths, $\bar{\rho}_n \approx \rho_n$ and $\bar{T}_n \approx T_n$, and, for this model, have been set identically equal to the segment outlet density and temperature, ρ_n and T_n .

6. Model Development Summary

At this point, we have succeeded in introducing sufficient equations to permit a unique solution, given numerical values of the input parameters ($\rho_0, T_0, v_0, A_0, \theta x_0, \theta y_0, \theta z_0, \rho_r, v_r, T_r$).

The eleven unknown variables are $D_n, A_n, V_n, \rho_n, v_n, T_n, \Delta Q_n, M_n, \theta x_n, \theta y_n, \theta z_n$.

The solution proceeds by solving for the various outlet section variables for the first segment, $n=1$, in which the inlet section variables (the $n-1$ subscripted variables in the various equations) are the known parameters in the jet's vena contracta ($\rho_0, T_0, v_0, D_0, A_0, \theta x_0, \theta y_0, \theta z_0$). These results then become input for segment 2 and the equations are now solved for the outlet variables $\rho_2, T_2,$

v_2 , etc. This procedure is usually continued until $v_n = v_r$, although, in interpreting results, a number of controls have been instituted, as will be discussed in latter sections.

In the actual solution technique, D_n, A_n and V_n are obtained immediately from Equations 11, 12 and 13. The remaining eight variables, $\rho_n, v_n, T_n, \Delta Q_n, M_n, \theta x_n, \theta y_n$ and θz_n , are obtained by a trial and error solution of the eight simultaneous equations, 2, 5, 6, 9, 10, 16, 18 and 21.

D. Submerged Discharge Computer Program

The foregoing procedure has been programed in Fortran IV for solution on RAPIDATA time-sharing facilities. Chart I is a schematic diagram of the relation of the model, the solution technique, the program and computer input and output.

Plate I is a listing of the input or data file for the program, and includes a description of each item of input data and its location in the data file. This facilitates use of the program by personnel previously unfamiliar with it. The main program is THOUT3, standing for the third modification of our thermal out-fall routine. The data file is designated THOUTA.

SUBMERGED DISCHARGE ANALYSIS
FLOW SHEET

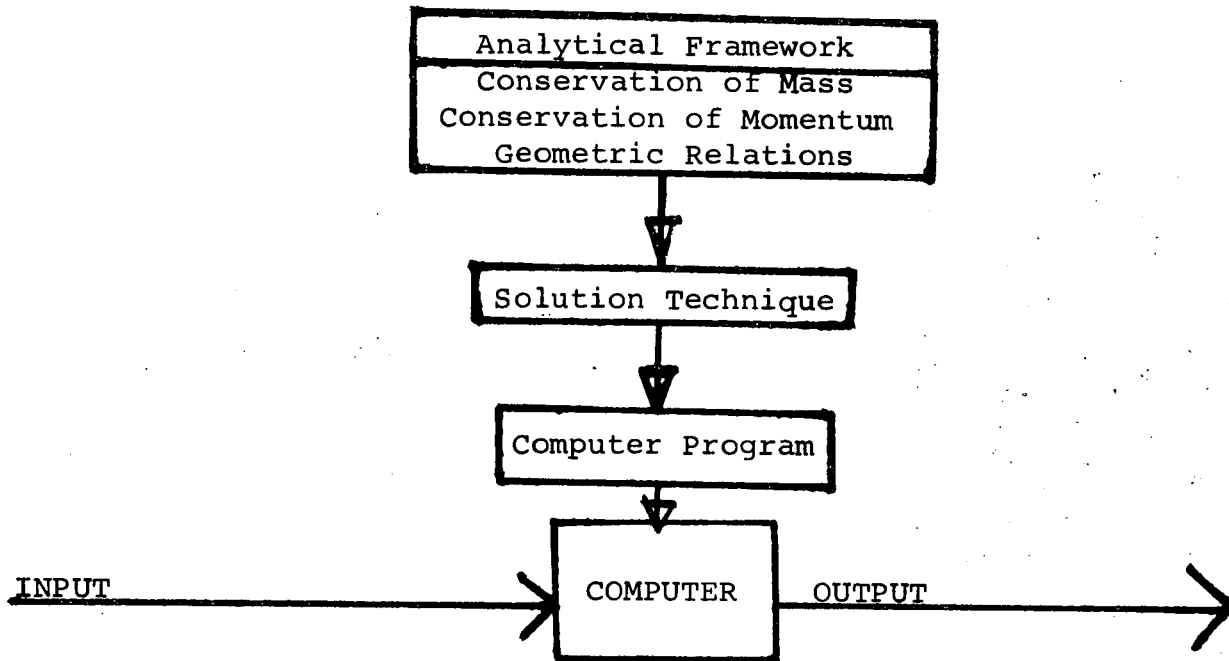

- .Port size
- .Jet initial velocity
- .Depth of submergence
- .Orientation of port
- .Maximum temperature of heated liquid
- .Mass density of effluent
- .Port coefficients
- .Ambient temperature
- .River velocity
- .Mass density of river water

- .Path of jet
- .Jet velocity
- .Jet size
- .Mass density of jet
- .Dilution ratio
- .Jet temperature

SUBMERGED OUTFALL INPUT DATA FILE

OLD
NAME: THOUTA

READY
LIST

THOUTA 13:58 RDS2 OCTOBER 10, 1969

1000 1,100
 3000 .1, .16, .2, 62, .12, .05
 4000 10, .2, 9, .7071, .0, .7071
 5000 .96, .04, 90, .90.
 6000 92, .72, .2, .2.
 10000 THE SEQUENCE OF PARAMETER DEFINITIONS WHICH FOLLOWS IS THE
 10100 SAME AS THE SEQUENCE OF DATA WHICH APPEARS ABOVE.
 10200 NRUNS (# OF INDEPENDENT RUNS), KT(KT*DS=PRINTOUT INTERVAL)
 10300 DS (INCREMENT ALONG JET CENTERLINE)(FT)
 10400 C1 JET SLOPE WITHIN CORE FLOW
 10500 C2 JET SLOPE BEYOND CORE FLOW (AFTER S2)
 10600 S2 LENGTH OVER WHICH C1 IS APPLICABLE (FT)
 10700 YLIM DISTANCE OF SURFACE FROM INITIAL JET CENTERLINE (FT)
 10800 DDQ1 INITIAL INCREMENT OF FLOW ADDED TO JET
 10900 DO INITIAL DIAMETER OR JET (PORT DIAMETER)(FT)
 11000 VO INITIAL JET VELOCITY (FT/SEC)
 11100 COSX ANGLE THE JET CENTERLINE MAKES WITH +XAXIS (LATERAL)
 11200 COSY ANGLE THE JET CENTERLINE MAKES WITH +YAXIS (VERTICAL)
 11300 COSZ ANGLE THE JET CENTERLINE MAKES WITH +ZAXIS (LONGITUDINAL)
 11400 VTMAX MAXIMUM VELOCITY (TIDAL)(FT/SEC)
 11500 VRIV RIVER VELOCITY (FT/SEC)
 11600 ANGT ANGLE INCREMENT ADDED TO INITIAL ANGLE FOR MULTI-ANGLE RUNS
 11700 ANG INITIAL STARTING ANGLE (SINE CURVE)(DEG)
 11800 TO INITIAL JET TEMPERATURE (F)
 11900 TRIV INITIAL RIVER TEMPERATURE (F)
 12000 SALO INITIAL SALINITY OF JET (PPT)
 12100 SALR INITIAL SALINITY OF RIVER (PPT)

BYE
OFF AT 14:01

Numerical values of the jet slope and port coefficients(1) used in the program (line 3000 in THOUTA) are summarized below:

<u>Coefficient</u>	<u>Circular Port</u>	<u>Slot</u>
Diameter, D_0	D_0	$4A_0/\pi$
Jet Slope, C_3		
Zone of flow establishment, C_1	0.16	0.15
Zone of established flow, C_2	0.20	0.25
Length of zone of flow establishment, S_2	$6.2 D_0$	$5.3 X \text{ width}$

Plate II is a listing of the main program THOUT3. This program is reasonably general and can be used to evaluate a large number of submerged outfall situations.

For example, between lines 1440C and 1680C, the river velocity at any phase of the tide is computed, given the runoff velocity and the maximum tidal velocity. The computer is then directed to print results at any desired number of equally spaced time increments over the full tidal cycle.

Between lines 1800C and 2102C, the density is given as a function of temperature and salinity. Coefficients employed were obtained previously by a least squares polynomial fit of density-temperature-

OLD
NAME: THOUT3

SUBMERGED OUTFALL PROGRAM

READY
LIST

LISTING

```

THOUT3      13:41      RDS2      OCTOBER 10, 1969

1000      INTEGER OF1,OF2,DENCT
1020      CALL OPENF(1,"THOUTA")
1022      CALL OPENF(2,"THOUTO")
1040      IF1=1
1060      OF1=66
1062      OF2=2
1080      102  FORMAT(1H ,5F10.2,F10.4//)
1100      111  FORMAT(1H ,8X,2HDS,8X,2HC1,8X,2HC2,8X,2HS2,
1120&      6X,4HYLIM,6X,4HDDQI/)
1140      112  FORMAT(1H ,8X,2HDO,8X,2HVO,6X,4HCOSX,
1160&      6X,4HCOSY,6X,4HCOSZ/)
1180      192  FORMAT(1H ,17HTOO MANY CUTS.....,14,3X,6HDDQ = ,F10.5)
1200      READ(IF1,) NRUNS,KT
1220      NR=0
1230      DTOL=1.E-05
1240      PI=3.14159265
1260      PI1=PI/180.
1280      TOL=0.3
1281      ITOLI=1000
1282      CUT=2.
1283      NCUTS=50
1284      JRHO=1
1286      RHOAL=1.E-2
1288      TBOUND=10.
1292      JSURFT=0
1300      200  READ(IF1,)DS,C1,C2,S2,YLIM,DDQI
1320      READ(IF1,)DO,VO,COSX,COSY,COSZ
1340      READ(IF1,)VTMAX,VRIV,ANGT,ANG
1360      READ(IF1,)TO,TRIV,SALO,SALR
1380      TANG=360.
1420C
1440C      TIDAL RIVER VELOCITY FUNCTION
1460C
1480      1091 VR=VRIV+VTMAX*SIN(ANG*PI1)
1500      WRITE(OF1,312)
1520      312  FORMAT(1H ,7X,3HANG,8X,2HVR/)
1540      311  FORMAT(1H ,2F10.2//)
1560      WRITE(OF1,311)ANG,VR
1580      DQ=0.
1600      DDQ=DDQI
1620      ITOL=ITOLI
1640      I=0
1660      J=0
1680C
1700C      TEMPERATURE CONVERSION
1720C
1740      CO=(5./9.)*(TO-32.)
1760      CR=(5./9.)*(TRIV-32.)
1780C
1800C      LEAST-SQUARES EVALUATION OF MASS DENSITY FROM TEMP.
1820C
1840      COF1=9.991638E-01
1860      COF2=7.7364515E-04
1880      COF3=-7.6762273E-07

```

```

1900 DROS=COF1+COF2*SALO+COF3*SALO**2.
1920 DROSR=COF1+COF2*SALR+COF3*SALR**2.
1940 F1=1.0000512
1960 F2=3.5764685E-05
2000 F3=-6.8972574E-06
2020 F4=2.8117132E-08
2040 DENO=F1+F2*CO +F3*CO**2. +F4*CO**3.
2060 DENR=F1 +F2*CR +F3*CR**2. +F4*CR**3.
2080 RHOO=1.93869627*(DENO+DROSO-.9991)
2100 RHOOR=1.93869627*(DENR+DROSR-.9991)
2101C
2102C END OF MASS DENSITY EVALUATION
2103C
2104C
2105C VARIOUS INITIAL VALUES
2106C
2120 AU=.7854*DO*DO
2121 VOL=AU*DS
2140 OMENO=RHO0*AU*VO*VO
2160 XMO=OMENO*COSX
2180 YMO=OMENO*COSY
2200 ZMO=OMENO*COSZ
2220 DMOM=0.
2240 RMOM=ZMO
2260 BOUY=0.
2280 B=0.
2300 S=0.
2320 X=0.
2340 Y=0.
2360 K=0
2380 Z=0.
2400 D=DO
2420 V=VO
2440 A=AO
2460 RHO=RHO0
2470 TEMP2=TO
2472 SAL2=SALO
2480 113 FORMAT(1H ,8X,2HTO,6X,4HTRIV,6X,4HSALO,6X,4HSALR/)
2500C
2520C PRINT OUT INPUT DATA
2540C
2560 WRITE(OF1,111)
2580 WRITE(OF1,102)DS,C1,C2,S2,YLIM,DDQI
2600 WRITE(OF1,112)
2620 WRITE(OF1,155)DO,VO,COSX,COSY,COSZ
2640 155 FORMAT(1H ,5F10.2//)
2660 WRITE(OF1,113)
2680 WRITE(OF1,158)TO,TRIV,SALO,SALR
2700 158 FORMAT(1H ,4F10.2/////)
2710 WRITE(OF1,500)
2720 WRITE(OF1,501)
2722 WRITE(OF2,816)
2724 816 FORMAT(////)1H ,7X,1HS,6X,1HD,4X,9HDIRECTION,
2726& 8H COSINES,4X,21HRADIUS PROJECTIONS ON)
2728 WRITE(OF2,817)
2730 817 FORMAT(1H ,15X,2(2X,6HX-AXIS,2X,6HY-AXIS,2X,6HZ-AXIS)//)
2740C
2760C MAJOR LOOP TO INCREMENT JET CENTER LINE DISTANCE
2780C
2800 1 S=S+DS
2802 TEMP1=TEMP2
2804 SAL1=SAL2
2820 A1=A
2840 RHO1=RHO
2860 V1=V
2880 D1=D

```

```

2900      VOL1=VOL
2920      IF(S-S2)20,21,21
2940      20 C3=C1
2960      GO TO 23
2980      21 C3=C2
3000      23 DD=C3*2.*DS
3020      D=D+DD
3040      A=.7854*D*D
3060      VOL=.2618*DS*(D*D+D1*D+D1*D1)
3080      RMOM=RMOM+DMOM
3100      B=32.2*(RHOR-RH1)*VOL
3120      BOUY=BOUY+B
3140      RHO=(RHO1*VOL1+RHOR*(VOL-VOL1))/VOL
3160      YM=YMO+BOUY
3180      XM=XMO
3200C
3220C      TRIAL AND ERROR SOLUTION FOR ENTRAINED FLOW RATE INCR.
3240C
3260      70 DQ=DQ+DDQ
3280      I=I+1
3281      JJ=1
3282      2050 TEMP2=(RHO1*TEMP1*V1*A1+RHOR*DQ*TRIV)/((V1*A1+DQ)*RHO)
3283      TC2=(5./9.)*(TEMP2-32.)
3284      SAL2=(SAL1*V1*A1*RHO1+SALR*DQ*RHOR)/((V1*A1+DQ)*RHO)
3285      RHOC=F1+F2*TC2+F3*TC2**2+F4*TC2**3
3286      DRO=COF1+COF2*SAL2+COF3*SAL2**2
3287      RHOC=1.9386927*(RHOC+DRO-.9991)
3288      IF(ABS(RHOC-RHO)-RHOTL)2000,2000,2010
3289      2010 IF(JJ-JRHO)2030,2020,2020
3290      2030 JJ=JJ+1
3291      RHO=RHOC
3292      GO TO 2050
3293      2020 WRITE(OF1,2021)RHO,RHOC,TEMP2
3294      2021 FORMAT(1H ,5HRHO= ,E15.9,6HRHOC= ,E15.9,8HTEMP2 = ,E15.9,///)
3295      GO TO 910
3296      2000 RHO=RHOC
3300      DMOM=RHOR*VR*DQ
3320      ZM=RMOM+DMOM
3340      TM=SQRT(XM*XM+YM*YM+ZM*ZM)
3360      V=SQRT(TM/(RHO*A))
3380      DQC=(RHO*V*A-RHO1*V1*A1)/RHOR
3400      T=ABS(DQ-DQC)
3420      IF(T-TOL)40,40,50
3440      50 IF(I-ITOL)70,70,51
3460      51 IF(J-NCUTS)52,191,191
3480      52 DQ=0.
3500      DDQ=DDQ/CUT
3520      ITOL=ITOLI*DDQI/DDQ
3540      I=0
3560      J=J+1
3580      GO TO 70
3660      40 I=0
3680      DDQ=DDQ*CUT
3700      J=J-1
3720      ITOL=ITOLI*DDQI/DDQ
3721C
3722C      END OF TRIAL AND ERROR LOOP
3723C
3740C
3760C      COMPUTATION OF ANGLES AND DIST. FOR JET CENTERLINE.
3780C
3782C      ANGX,ANGY,ANGZ..ARE DIRECTIONAL COSINES OF MOMENTUM
3784C      VECTOR AND POSITIVE (+) X,Y AND Z AXIS RESPECTIVELY.
3786C
3800      ANGX=XM/TM
3820      ANGY=YM/TM

```



```

3840     ANGZ=ZM/DM
3842     SANGX=SQRT(1.-ANGX**2)
3844     SANGY=SQRT(1.-ANGY**2)
3846     SANGZ=SQRT(1.-ANGZ**2)
3860     DX=ANGX*DS
3880     DY=ANGY*DS
3900     DZ=ANGZ*DS
3902     PROJRX=SANGX*(D/2.)
3904     PROJRY=SANGY*(D/2.)
3906     PROJRZ=SANGZ*(D/2.)
3920     X=X +DX
3940     Y=Y+DY
3960     Z=Z+DZ
3980     K=K+1
4000     DIL=A*V*RHO/(A0*V0*RHO0)
4001C
4002C     EVALUATION OF AVERAGE JET TEMPERATURE
4003C
4020     TDIL=TO/DIL+(1.-(1./DIL))*TRIV
4040     F5=-1.5383679E+05
4060     F6=3.1249029E+05
4080     F7=-1.5864127E+05
4110     SALJ=(SALR*(A*V -A0*V0) +SALO*A0*V0)/(A*V)
4111     DEN=RHO/1.93869627
4115     TEST=F5+F6*DEN+F7*DEN**2.
4116     DTEST=1.E-02
4120     TEST1=TEST-TBOUND
4125     DENCT=1
4130     DEN1=COF1+COF2*SALJ +COF3*SALJ**2.
4140     410 DEN2=F1+F2*TEST1 +F3*TEST1**2. +F4*TEST1**3.
4150     RHOT=1.93869627*(DEN2 +DEN1 -0.9991)
4160     DIF=ABS(RHOT-RHO)
4170     IF(DIF -DTOL)400,400,401
4180     401 IF(TEST1-TEST-TBOUND)405,405,406
4190     405 TEST1=TEST1 +DTEST
4200     GO TO 410
4210     406 DTEST=DTEST/2.
4212     DENCT=DENCT+1
4214     IF(DENCT-10)422,422,972
4220     422 TEST1=TEST-1.
4230     GO TO 410
4240     400 TRHOF=(9./5.)*TEST1 +32.
4241     IF(JSURFT)800,800,810
4242     800 YTEMP=Y+(D/2.)*SANGY
4244     IF(YLIM-YTEMP)802,802,810
4246     802 JSURFT=1
4248     WRITE(OF1,803)
4249     WRITE(OF2,803)
4250     803 FORMAT(/,1H ,26HAT NEXT LINE OF OUTPUT JET,
4251&     20H INTERSECTED SURFACE//)
4252     WRITE(OF1,100)S,X,Y,Z,D,V,TDIL,TRHOF,DIL
4254     WRITE(OF2,815)S,D,ANGX,ANGY,ANGZ,PROJRX,PROJRY,PROJRZ
4256     815 FORMAT(1H ,F8.1,F7.1,3F8.5,3F8.1/)
4258     810 CONTINUE
4460     IF(K-KT)622,623,910
4480     623 CONTINUE
4500     500 FORMAT(1H ,7X,1HS,7X,1HX,7X,1HY,7X,1HZ,6X,1HD,5X,1HV,
4520&     2X,4HTEMP,2X,4HTEMP,6X,3HDIL/1H ,49X,2HBY,4X,2HBY)
4540     501 FORMAT(1H ,48X,3HDIL,3X,3HDEN/)
4600     WRITE(OF1,100)S,X,Y,Z,D,V,TDIL,TRHOF,DIL
4605     WRITE(OF1,101)TEMP2,AL2,RHO
4606     WRITE(OF2,815)S,D,ANGX,ANGY,ANGZ,PROJRX,PROJRY,PROJRZ
4610     101 FORMAT(/,3HT= ,F12.3,3HS= ,F12.2,5HRHO= ,F12.3)
4620     100 FORMAT(1H ,4F8.1,1F7.1,3F6.1,F9.2/)
4640     K=0
4660     622 CONTINUE

```

```
4680      IF(Y-YLIM)1,1,901
4700  901  ANG=ANG+ANGT
4720      IF(ANG-TANG)1091,900,900
4740  191  WRITE(OF1,192)J,DDQ
4760  900  NR=NR+1
4780      IF(NR-NRUNS)200,910,910
4790  972  WRITE(OF1,973)DENCT
4795  973  FORMAT(1H ,///15H DENCT > LIMIT ,110)
4800  910  CALL EXIT
4820      END
```

PLATE II 5 OF 5

salinity tables. These relationships are used later on in the program in solving for density.

Between lines 2520C and 2730 the computer is instructed to print-out basic input data, so that output can be readily interpreted by the engineer, in terms of the input or controlling system parameters.

The program then proceeds through an iterative solution of the previously developed equations, segment by segment.

Plates III and IV are typical solution printouts. Plate III includes the input data, identified in Plate I, and basic output information. The first four output items, s, x, y and z , locate the position of any point on the jet centerline, which is a distance s from the origin along the centerline, in terms of its x, y and z coordinates. Units, which will be included in a print-out revision, are FT. for each of these four variables.

"D" is jet diameter in FT., measured normal to a tangent to the centerline at the point x, y, z . "v" is average jet velocity, across the jet section, normal to the centerline tangent at x, y, z .

RUN

SUBMERGED OUTFALL PROGRAM PRINTOUT

THOUT3 12:49 RDS2 OCTOBER 2, 1969

PLATE III

ANG	VR					
90.00	1.00					
DS	C1	C2	S2	YLIM	DDQI	
0.10	0.15	0.25	79.50	20.00	0.0500	
DO	VO	COSX	COSY	COSZ		
8.75	10.00	1.00	0.00	0.00		
TO	TRIV	SALO	SALR			
96.00	79.00	2.00	2.00			

	S (FT.)	X (FT.)	Y (FT.)	Z (FT.)	D (FT)	V FT/SEC	TEMP BY DIL	TEMP BY DEN	DIL
	10.0	10.0	0.1	0.2	11.7	7.4	91.7	91.8	1.34
T=	91.770S=		2.00RHO=			1.931			
	20.0	20.0	0.2	0.7	14.7	5.9	89.1	89.2	1.69
T=	89.243S=		2.00RHO=			1.932			
	30.0	29.9	0.6	1.5	17.7	4.9	87.3	87.6	2.04
T=	87.561S=		2.00RHO=			1.933			
	40.0	39.9	1.1	2.7	20.7	4.2	86.1	86.3	2.39
T=	86.362S=		2.00RHO=			1.933			
	50.0	49.7	1.8	4.1	23.7	3.7	85.2	85.5	2.74
T=	85.464S=		2.00RHO=			1.934			
	60.0	59.5	2.7	5.9	26.7	3.3	84.5	84.8	3.10
T=	84.767S=		2.00RHO=			1.934			
	70.0	69.2	3.9	8.0	29.7	3.0	83.9	84.2	3.46
T=	84.210S=		2.00RHO=			1.934			
	80.0	78.8	5.4	10.4	32.8	2.7	83.4	83.7	3.85
T=	83.736S=		2.00RHO=			1.934			
	90.0	88.2	7.2	13.3	37.8	2.4	82.8	83.0	4.49

LIST

SUBMERGED OUTFALL PROGRAM PRINTOUT (ADDITIONAL)

THOUTO 17:07 RDS2 OCTOBER 13, 1969

PLATE IV

	S	D	DIRECTION COSINES			RADIUS PROJECTIONS ON		
			X-AXIS	Y-AXIS	Z-AXIS	X-AXIS	Y-AXIS	Z-AXIS
00010								
00020								
00030								
00040								
00050								
00060								
00070								
00080	10.0	11.7	0.99994	0.01092	0.00000	0.1	5.9	5.9
00090								
00100	20.0	14.7	0.99969	0.02478	0.00000	0.2	7.4	7.4
00110								
00120	30.0	17.7	0.99914	0.04157	0.00000	0.4	8.9	8.9
00130								
00140	40.0	20.7	0.99812	0.06128	0.00000	0.6	10.4	10.4
00150								
00160	50.0	23.7	0.99648	0.08387	0.00000	1.0	11.8	11.9
00170								
00180	60.0	26.7	0.99401	0.10927	0.00000	1.5	13.3	13.4
00190								
00200								
00210								
00220	AT NEXT LINE OF OUTPUT JET INTERSECTED SURFACE							
00230								
00240								
00250	67.4	29.0	0.99154	0.12983	0.00000	1.9	14.4	14.5
00260								
00270	70.0	29.7	0.99052	0.13740	0.00000	2.0	14.7	14.9
00280								
00290	80.0	32.8	0.98577	0.16809	0.00000	2.8	16.2	16.4
00300								
00310	90.0	37.8	0.97938	0.20202	0.00000	3.8	18.5	18.9
00320								
00330	100.0	42.8	0.97090	0.23950	0.00000	5.1	20.8	21.4
00340								
00350	110.0	47.8	0.95998	0.28008	0.00000	6.7	23.0	23.9
00360								
00370	120.0	52.8	0.94634	0.32319	0.00000	8.5	25.0	26.4
00380								

PPP

"TEMP BY DIL" is the calculation of the jet temperature using Equation 21. To check the numerical consistency of the program, temperature is also computed (after the solution is complete) using Equation 18 and the program solution value of ρ . This value is "TEMP BY DEN". Differences are virtually always less than 1°F apart.

"TEMP BY DIL" is the correct value of jet temperature at any point. There will generally be a small difference between the two values, due to the trial and error nature of the solution. Temperature computed by Equation 21, which computes "TEMP BY DIL", is less sensitive to density errors than is temperature computed by Equation 18, and is the choice to set the jet temperature value.

"DIL" is the jet dilution factor, $\rho Q / \rho_0 Q_0$. The second line of output data includes jet temperature, salinity and density for the x, y, z above it. Temperature is merely a repeat of "TEMP BY DEN" to greater precision and is included to identify the line with the line above.

Plate IV is additional printout, which includes the "S" and "D" for identification with output data on Plate III, and gives the direction cosines and the projection of the radius on each

of the three coordinate axes. This information is used in computing the size of the jet isotherms, particularly as they appear at the surface.

E. Limitations and Uses of the Theoretical Solution

The mathematical model developed above deals with an ideal submerged discharge case. Due to the complexity of the inter-relationship between the different fluid mechanical principles, which control the submerged discharge phenomenon, assumptions were necessary in formulating the model.

These assumptions consider that axial symmetry is maintained throughout the jet expansion, and that drag is negligible. In most of the situations under study, depths of submergence are not great, and the outfall, in general, is located near the river bottom. In such situations, drag is probably not totally negligible, and the jet will not continue axially symmetric once river surface or bottom interferes with its boundaries. The program results, in cases where these effects are present, must be interpreted carefully.

This program is being used to evaluate the merits of several

submerged discharge schemes along the Hudson and East Rivers. In the course of its development, several modifications, such as the use of the equation of state, have already been adopted to improve the program's applicability. Further improvements are planned as the work on these projects progresses.

The Indian Point submerged discharge design, however, has been based on several hydraulic model tests. In this case, the program is used to provide theoretical support for the hydraulic model results, and to evaluate seasonal variations in the behavior of the Indian Point submerged discharge.

In the next chapter, model computed temperature results are compared to results obtained in the undistorted Indian Point submerged discharge hydraulic model at Alden, and to field temperature measurements on the submerged outfall of Orange and Rockland Utilities' Lovett Unit #4 at Tompkins Cove. This station is located less than 2 miles south of the Indian Point Plant, on the opposite shore of the Hudson River.

Adjustments in computer model results are made, and recognize boundary effects at both of these locations. Comparison of the adjusted results with field and hydraulic model measurements,

shows reasonably good agreement, and supports use of the computer model to predict jet temperature distributions under other sets of conditions. The computer model is so used in Chapter III, to predict behavior at Indian Point under sets of conditions not studied in the hydraulic model.

II. COMPARISON OF THEORETICAL RESULTS AND FIELD TESTS

A. Introduction

The effect of various submerged outfall designs and depths of submergence was studied in detail in an undistorted model of the River in the near vicinity of Indian Point by the Alden Hydraulic Laboratory. A copy of Alden's report on this study is appended to this report. A summary of the various designs is given in Table III in the Appendix.

In addition, several prototype temperature surveys were conducted this summer in the vicinity of Orange and Rockland's submerged discharge effluent at Lovett.

A comparison between these measurements and the corresponding computed results is summarized below.

B. Hudson River Model Tests

Hydraulic model tests in an undistorted model of ratio 1:50 indicated that an initial temperature reduction of about 50% may be achieved in several submerged discharge schemes. A comparison of the effectiveness of these outfall configurations favoured the selection of a 240 foot long structure with twelve 4'X15' openings.

A summary of the design parameters and major model findings of the selected outfall design is given in Table 1.

Hydraulic model results showing the temperature distribution for these conditions are presented in Figure 2 (Figure 6 of Appendix).

1. Computed Results

Computer printout for the conditions of the hydraulic model run is given in Plate V. The input data included the design parameters outlined in Table 1, as well as the proper port coefficients (C_1 , C_2 and S_2 , see page 27, Chapter I) and a diameter of an equivalent circular port of 8.75'. Stable behavior was obtained using an incremental segment length ΔS , or DS , of 10 ft. Typical run time was about 1500 seconds.

Definition of the different parameters used in the program is given in Plate I.

Figures 3 and 4 show the computed lateral, vertical and longitudinal location of any one of the 12 jets. The boundaries of the plume shown in these figures represent the vertical and longitudinal projections of the computed jet size at different locations.

TABLE 1

SUMMARY OF ALDEN HYDRAULIC LABORATORY FINDINGS
FOR SUBMERGED DISCHARGE OF INDIAN POINT HEATED WATER

Test Conditions

Model Scale - 1:50 undistorted
Total Length of Discharge Canal - 240 ft.
Depth of Submergence below MSL - 20 ft.
Submergence to Centerline of Port - 18 ft.
Number of ports - 12
Port Dimensions - 4 ft. high and 15 ft. long
Orientation of Ports - 0°, 90°, 90° with lateral, longitudinal and
vertical axes, respectively
Port Spacing - 20 ft.
Initial Jet Velocity - 10 fps
Effluent Channel Temperature Rise - 14°F
Ambient Temperature - 40°F
River Velocity - 0.4 fps (Ebb)

Summary of Findings

Maximum Surface Temperature Rise - 7°F
Location of Maximum Surface Temperature Rise - 150' off shore and
350' downstream of
discharge channel

$$\text{Dilution} = \frac{\text{Effluent Channel Temperature Rise}}{\text{Maximum Surface Temperature Rise}} = \frac{14^{\circ}}{7^{\circ}} = 2$$

OUTFALL CONFIGURATION

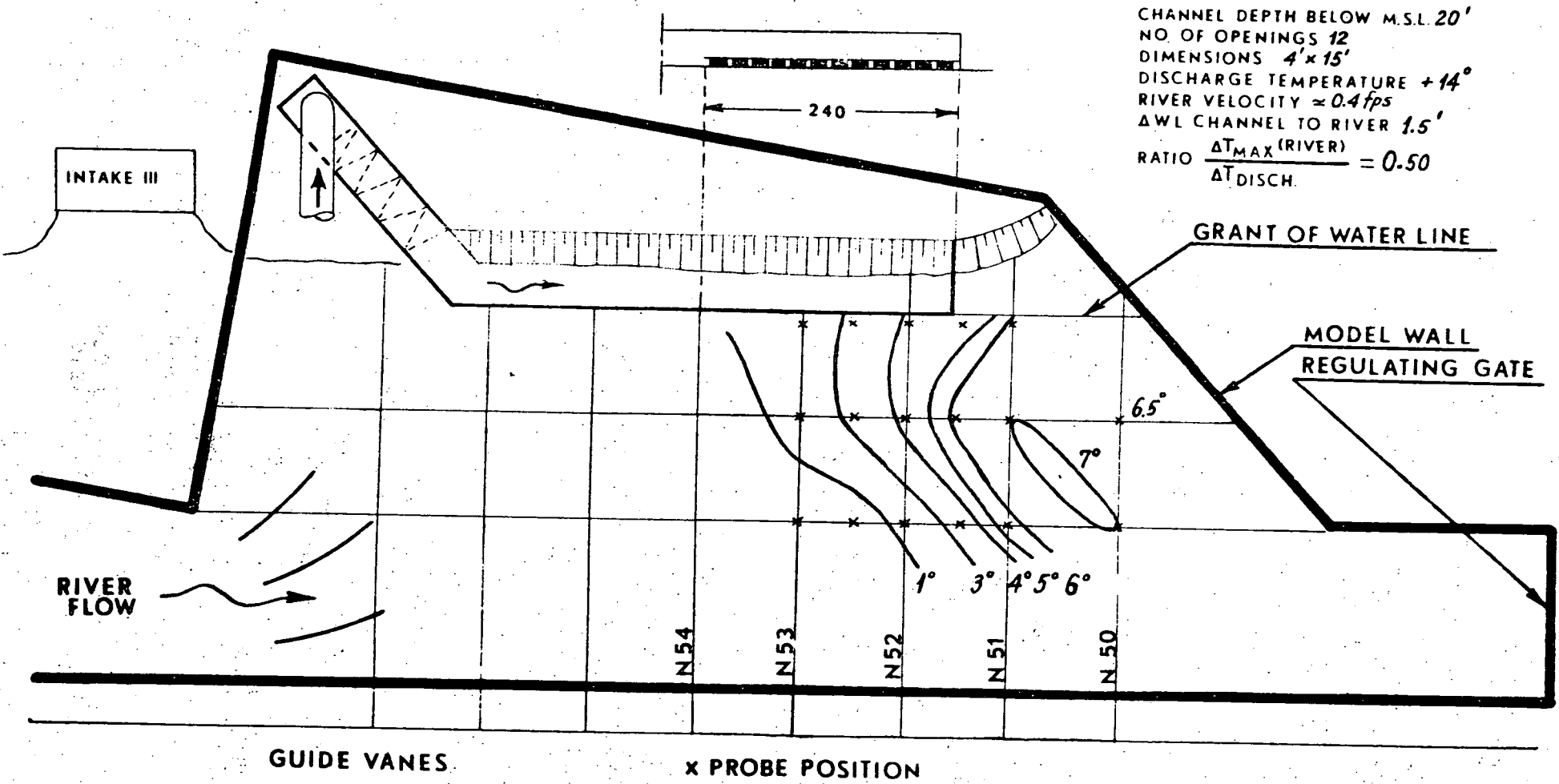

ALDEN RESEARCH LABORATORIES
 WORCESTER POLYTECHNIC INSTITUTE
 INDIAN POINT-II SUB-MODEL
 MODEL SCALE 1:50 (UNDISTORTED)
 SURFACE ISOTHERMS
 TEST DATE MAR '69

INDIAN POINT SUBMERGED DISCHARGE

PLATE V

RUN

HYDRAULIC MODEL TEST CONDITIONS

SHEET 1 OF 1

THOUT3 12:16 RDS2 OCTOBER 6, 1969

ANG VR
90.00 0.40

DS C1 C2 S2 YLIM DDQI
0.10 0.15 0.25 79.50 18.00 0.0500

DO VO COSX COSY COSZ
8.75 10.00 1.00 0.00 0.00

TO TRIV SALO SALR
54.00 40.00 0.00 0.00

S	X	Y	Z	D	V	TEMP BY DIL	TEMP BY DEN	DIL
10.0	10.0	0.0	0.1	11.7	7.4	50.4	50.5	1.34

T= 50.518S= 0.00RHO= 1.938
20.0 20.0 0.0 0.3 14.7 5.9 48.3 48.4 1.69

T= 48.434S= 0.00RHO= 1.938
30.0 30.0 0.1 0.6 17.7 4.9 46.9 47.0 2.03

At next line of output, jet interference occurs

T= 47.047S= 0.00RHO= 1.939
40.0 40.0 0.2 1.1 20.7 4.2 45.9 46.0 2.37

T= 46.057S= 0.00RHO= 1.939
50.0 50.0 0.3 1.7 23.7 3.7 45.2 45.2 2.72

T= 45.313S= 0.00RHO= 1.939
60.0 59.9 0.4 2.4 26.7 3.3 44.6 44.6 3.06

T= 44.735S= 0.00RHO= 1.939
70.0 69.9 0.6 3.3 29.7 2.9 44.1 44.2 3.41

T= 44.271S= 0.00RHO= 1.939

80.0 79.8 0.8 4.3 32.8 2.7 43.7 43.8 3.77

T= 43.881S= 0.00RHO= 1.939

PLATE V

Sheet 2 of 5

AT NEXT LINE OF OUTPUT JET INTERSECTED SURFACE

i.e., upper boundary of jet reached surface

82.9 82.7 0.9 4.6 34.3 2.6 43.6 43.6 3.93

90.0 89.8 1.0 5.4 37.8 2.3 43.2 43.3 4.35

T= 43.403S= 0.00RHO= 1.939
100.0 99.7 1.3 6.8 42.8 2.1 42.8 42.9 4.93

T= 43.026S= 0.00RHO= 1.939
110.0 109.5 1.7 8.4 47.8 1.8 42.5 42.6 5.51

T= 42.697S= 0.00RHO= 1.939
120.0 119.4 2.0 10.2 52.8 1.7 42.3 42.3 6.10

T= 42.433S= 0.00RHO= 1.939
130.0 129.1 2.5 12.3 57.8 1.5 42.1 42.1 6.70

T= 42.215S= 0.00RHO= 1.939
140.0 138.9 2.9 14.6 62.8 1.4 41.9 41.9 7.30

T= 42.033S= 0.00RHO= 1.939
150.0 148.5 3.5 17.0 67.8 1.3 41.8 41.7 7.90

T= 41.879S= 0.00RHO= 1.939
160.0 158.1 4.1 19.8 72.8 1.2 41.6 41.6 8.51

T= 41.747S= 0.00RHO= 1.939
170.0 167.7 4.7 22.7 77.8 1.2 41.5 41.5 9.13

T= 41.632S= 0.00RHO= 1.939
180.0 177.2 5.5 25.8 82.8 1.1 41.4 41.4 9.75

At next line of output, lower boundary of jet hits bottom

T= 41.531S= 0.00RHO= 1.939
190.0 186.6 6.3 29.1 87.8 1.0 41.3 41.3 10.38

T= 41.443S= 0.00RHO= 1.939
200.0 195.9 7.1 32.6 92.8 1.0 41.3 41.2 11.02

T= 41.364S= 0.00RHO= 1.939
210.0 205.1 8.1 36.4 97.8 0.9 41.2 41.1 11.66

T= 41.294S= 0.00RHO= 1.939
220.0 214.3 9.1 40.3 102.8 0.9 41.1 41.0 12.32

T= 41.224S= 0.00RHO= 1.939
230.0 223.3 10.1 44.4 107.8 0.9 41.1 41.0 12.99

PLATE V

T= 41.161S= 0.00RHO= 1.939
240.0 232.3 11.3 48.7 112.8 0.8 41.0 40.9 13.67

Sheet 3 of 5

T= 41.104S= 0.00RHO= 1.939
250.0 241.1 12.5 53.2 117.8 0.8 41.0 40.9 14.36

T= 41.053S= 0.00RHO= 1.939
260.0 249.9 13.8 57.8 122.8 0.8 40.9 40.8 15.06

T= 41.007S= 0.00RHO= 1.939
270.0 258.5 15.2 62.7 127.8 0.7 40.9 40.8 15.77

T= 40.964S= 0.00RHO= 1.939
280.0 267.0 16.7 67.7 132.8 0.7 40.8 40.7 16.51

Center line of jet plume reaches surface

T= 40.921S= 0.00RHO= 1.939

USED: CPU 1414.7 I/O 54.8

READY

READY
LISTNH

00010
00020
00030
00040
00050
00060
00070
00080
00090
00100
00110
00120
00130
00140
00150
00160
00170
00180
00190
00200
00210
00220
00230
00240
00250

	S	D	DIRECTION COSINES			RADIUS PROJECTIONS ON		
			X-AXIS	Y-AXIS	Z-AXIS	X-AXIS	Y-AXIS	Z-AXIS
	10.0	11.7	0.99991	0.00196	0.01330	0.1	5.9	5.9
	20.0	14.7	0.99964	0.00417	0.02660	0.2	7.4	7.4
	30.0	17.7	0.99918	0.00662	0.03989	0.4	8.9	8.9
	40.0	20.7	0.99854	0.00930	0.05316	0.6	10.4	10.4
	50.0	23.7	0.99772	0.01221	0.06639	0.8	11.9	11.8
	60.0	26.7	0.99671	0.01536	0.07959	1.1	13.4	13.3
	70.0	29.7	0.99551	0.01874	0.09275	1.4	14.9	14.8
	80.0	32.8	0.99409	0.02235	0.10627	1.8	16.4	16.3

at next line of output, jet interference occurs

AT NEXT LINE OF OUTPUT JET INTERSECTED SURFACE

i.e., upper boundary of jet reaches surface

00260	82.9	34.3	0.99339	0.02344	0.11233	2.0	17.1	17.0
00270	90.0	37.8	0.99154	0.02627	0.12712	2.5	18.9	18.8
00280	100.0	42.8	0.98848	0.03058	0.14825	3.2	21.4	21.2
00290	110.0	47.8	0.98460	0.03523	0.17126	4.2	23.9	23.6
00300	120.0	52.8	0.98018	0.04019	0.19398	5.2	26.4	25.9
00310	130.0	57.8	0.97525	0.04544	0.21637	6.4	28.9	28.2
00320	140.0	62.8	0.96983	0.05098	0.23841	7.7	31.4	30.5
00330	150.0	67.8	0.96392	0.05681	0.26005	9.0	33.9	32.8
00340	160.0	72.8	0.95756	0.06290	0.28128	10.5	36.4	35.0
00350	170.0	77.8	0.95077	0.06926	0.30207	12.1	38.8	37.1
00360	180.0	82.8	0.94356	0.07586	0.32239	13.7	41.3	39.2
00370	190.0	87.8	0.93597	0.08271	0.34222	15.5	43.8	41.3
00380	200.0	92.8	0.92802	0.08978	0.36155	17.3	46.2	43.3
00390	210.0	97.8	0.91966	0.09707	0.38052	19.2	48.7	45.2
00400	220.0	102.8	0.91018	0.10444	0.40083	21.3	51.1	47.1
00410	230.0	107.8	0.90037	0.11193	0.42048	23.5	53.6	48.9
00420	240.0	112.8	0.89027	0.11954	0.43947	25.7	56.0	50.7

at next line of output lower boundary of jet hits bottom of river

PLATE V
Sheet 5 of 5

00620								
00630	250.0	117.8	0.87991	0.12726	0.45778	28.0	58.4	52.4
00640								
00650	260.0	122.8	0.86933	0.13507	0.47542	30.4	60.9	54.0
00660								
00670	270.0	127.8	0.85846	0.14295	0.49256	32.8	63.3	55.6
00680								
00690	280.0	132.8	0.84655	0.15072	0.51052	35.4	65.7	57.1
00700								

Center line of jet reaches surface

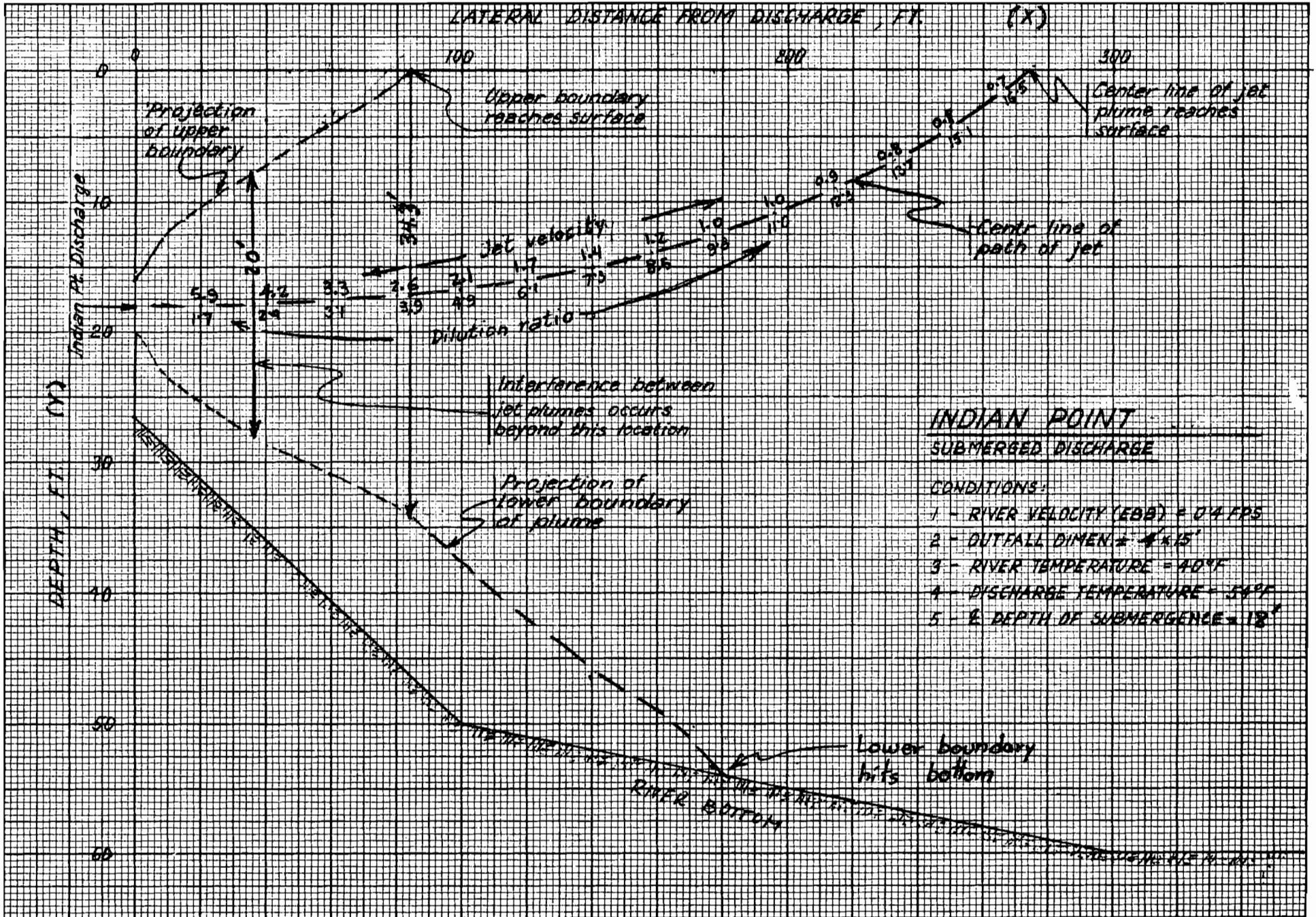

FIGURE (3)

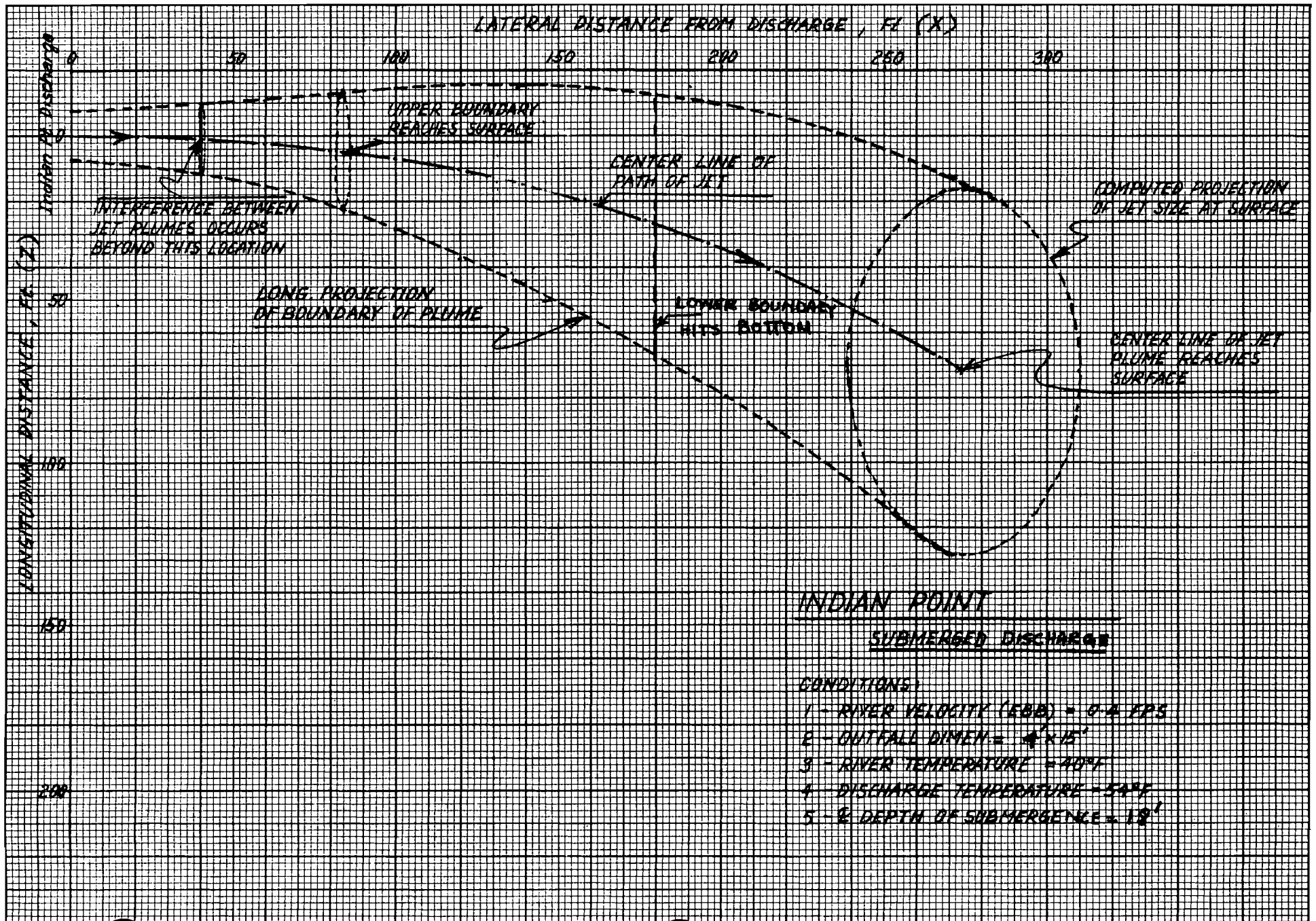

FIGURE - 4

The computed jet velocity and dilution ratio along the centerline of the path of the jet are also shown in Figure 3.

Four important points on the jet path are indicated in Figures 3 and 4, as well as on the computer printout. These are designated as control points because they represent points at which boundary interference occurs. These three points are the point beyond which the boundaries of any two adjacent jets in the multiple port system touch, the points where the upper boundary and centerline of the jet reach the surface, and the point where the lower boundary of the jet touches bottom.

Jet interference between adjacent jets occurs when the plume diameter exceeds center to center port spacing, which, in this design, is 20 feet. The upper boundary reaches the surface when the vertical projection of the jet's radius exceeds the difference between the depth of submergence and the vertical location of the jet. The lower boundary hits the river's bottom, when the vertical projection of the jet's radius is greater than the difference between the water depth and the vertical elevation of the jet's centerline. The centerline of the plume reaches the surface when the vertical location of the plume is equal to the depth of submergence to the port centerline.

The significance of these four locations will be discussed later. For convenience, these four locations will be referred to, in this report, as the interference, boundary and centerline surface controls, and boundary bottom control.

Major jet characteristics for this run, associated with these four controls, are summarized in Table 2.

2. Interpretation of Computed Results

a- Boundary Control

The assumption of unlimited jet expansion, outlined in the previous chapter, requires that the amount of river water available for dilution is infinite. Therefore, if the computations are allowed to proceed beyond a certain limit, where river water is not available, i.e., beyond the boundary surface and/or bottom control locations, the program will give dilution ratios greater than the expected values.

In other words, beyond the points where either the upper boundary reaches the surface, and/or the lower boundary hits the river bottom, before the computed centerline location of the jet reaches the surface, only part of the rising plume will experience entrainment

TABLE 2

SUMMARY OF INDIAN POINT MAJOR JET CHARACTERISTICS* ASSOCIATED
WITH CONTROL LOCATIONS

Parameter	Interference ⁽¹⁾ Control	Boundary Control		Centerline ⁽⁴⁾ Surface Control
		Upper ⁽²⁾	Lower ⁽³⁾	
1. Location of Centerline of Jet Measured from Discharge Channel, Ft. (Lateral, Vertical and Longitudinal)	40,0.2,1.1	82.7,0.9,4.6	186.6,6.3,29.1	274,18,71
2. Jet Diameter, Ft.	20.7	34.3	87.8	140.0
3. Average Jet Velocity, Ft/Sec	4.2	2.6	1.0	0.7
4. Average Dilution Ratio	2.37	3.93	10.38	17.0
5. Average Temperature Rise, °F	6.0	3.6	1.3	0.8
6. Jet's Radius Projections on:				
x - axis	0.6	2.0	15.5	38.0
y - axis	10.4	17.1	43.8	68.0
z - axis	10.4	17.0	41.3	60.0

*Test conditions are summarized in Table 1.

- (1) Location where jet interference occurs.
(2) Location where upper boundary reaches the surface.
(3) Location where lower boundary hits the River's bottom.
(4) Location where jet centerline reaches the surface.

of the river water into the jet.

Thus, the computed dilution ratios beyond a boundary control location, must be adjusted on the basis of actual to computed jet size. A weighted average of the jet size may result in a more practical dilution ratio. Considering only one jet, i.e., no interference in the run discussed previously, the boundary control dilution is 3.93. The computed centerline surface control dilution is 17. Therefore, these two values represent the lower and upper limits of dilution. Actual dilution may be obtained using these limits and available water for dilution beyond the boundary control location

b- Interference Control

When the submerged discharge scheme consists of several ports, interference between the individual jets will occur when the jet size exceeds port spacing. This effect will reduce the amount of river water available for dilution.

Comparison of computed results to the hydraulic model results also shows that the surface plume is located farther downstream, but nearer to shore in the hydraulic model than it is in the computer model. Possible reasons for these differences follow.

Consider horizontal jet expansion in a quiescent fluid. As the jet expands, velocity normal to the jet centerline, initially zero, grows ever larger. This is particularly true at the jet boundary, since the streamlines continue to diverge away from the centerline at an increasing rate. This normal velocity must arise at the expense of momentum in the direction of the jet centerline.

Thus, in our orientation, some lateral momentum must be lost, in developing these "z" or longitudinal directed velocities. Between this and drag, the actual available lateral momentum at any point must be less than the computed amount. Since the buoyant forces would be unaffected, the actual location of the surface boil should be closer to shore, as, in fact, does occur in the hydraulic model.

The fact that the boil is located farther downstream in the hydraulic model than the computations predict also follows from the above supposition. In the presence of a downstream river flow, which is the case studied in the model, the jet is bent downstream as river water, with a downstream velocity is entrained. Longitudinal components of velocity all around the jet boundary are directed downstream, so that additional "z" directed velocity, arising at the expense of lateral momentum, will add to the river velocity. The net effect will be to pull the jet farther downstream than computed.

These observations do not appear to be a function of interference. The explanations offered should be valid for single jets as well, and in fact, the surface boil at Lovett #4 is actually closer to the shore than the computer model predicts. At slack conditions, the location in the longitudinal direction is roughly the same, but during ebb, the actual boil is farther upstream, rather than downstream, than the predicted boil. The Lovett boil, however, is influenced by many things, including physical obstructions, relatively rough location estimates, and surface interference from adjacent surface outfalls.

In the case of the hydraulic model run, the interference control dilution ratio is 2.37 and the centerline surface control location of the plume is 274', 18' and 71' in the lateral, vertical and longitudinal directions, respectively.

c- Comparison of the Computed and Observed Results

A discussion of the interference effect on dilution is considered below, followed by the effect on the location of the centerline of the plume.

The effective lower limit of dilution ratio, when interference is present, is now somewhere between 2.37 and 3.93, (the dilution

for boundary surface control). The lower limit of the dilution ratio represents the absolute minimum expected dilution and was used in this study.

Figure 5 compares the temperature distribution measured in the hydraulic model with the computed results using the conservative lower dilution limit without location adjustment.

The theoretical isotherms were computed on the assumption that the temperature distribution, across any plane perpendicular to the path, follows a cosine function between a maximum value and a boundary value of 3°F. The location of the boundary temperature was taken at the location where the upper boundary reaches the surface. The behavior of the Lovett plant submerged discharge also agrees reasonably well with this assumption.

The maximum surface temperature rise is then computed as follows:

$$\begin{aligned} \text{Average surface temperature rise} &= \frac{\text{Maximum plant temperature rise}}{\text{Dilution Ratio}} \\ &= \frac{14}{2.37} = 5.9^{\circ} \end{aligned}$$

$$\begin{aligned} \text{Average temperature rise above boundary temperature (3}^{\circ}\text{F)} &= 5.9 - 3 = \\ &2.9^{\circ}\text{F} \end{aligned}$$

OUTFALL CONFIGURATION

CHANNEL DEPTH BELOW M.S.L. 20'
 NO. OF OPENINGS 12
 DIMENSIONS 4' x 15'
 DISCHARGE TEMPERATURE + 14°
 RIVER VELOCITY ≈ 0.4 fps
 AWL CHANNEL TO RIVER 1.5'
 RATIO $\frac{\Delta T_{MAX} (RIVER)}{\Delta T_{DISCH.}} = 0.50$

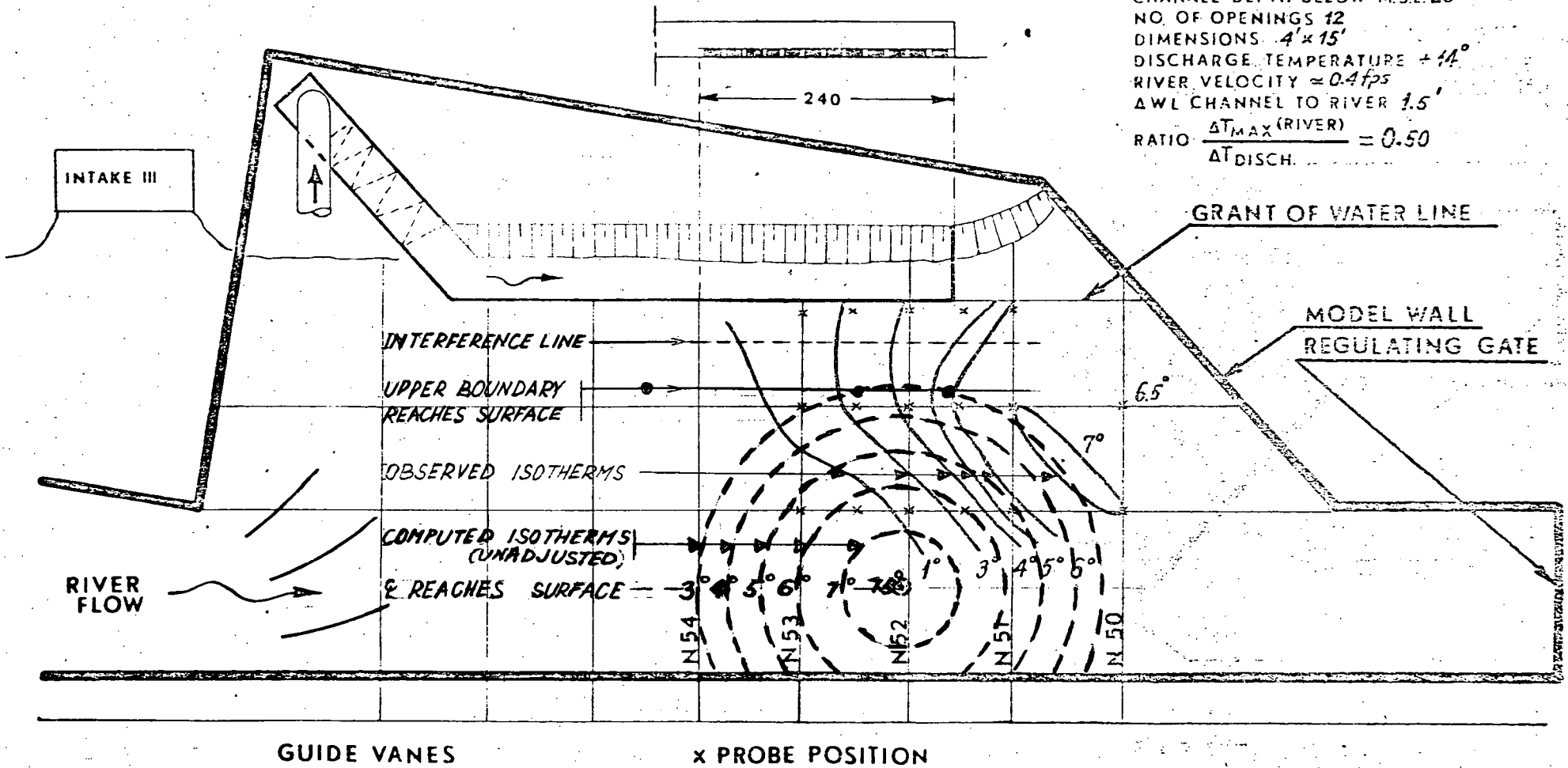

ALDEN RESEARCH LABORATORIES
 WORCESTER POLYTECHNIC INSTITUTE
 INDIAN POINT II SUB-MODEL
 MODEL SCALE 1:50 (UNDISTORTED)
 SURFACE ISOTHERMS
 TEST DATE MAR '69

Maximum temperature rise above boundary temperature (3°F) = $-\frac{\pi}{2}$
 $\times 2.9 = 4.55^{\circ}\text{F}$

Maximum surface temperature rise = maximum temperature rise above
 boundary temperature + $3^{\circ} = 4.55 + 3 = 7.55^{\circ}\text{F}$

The temperature distribution between 7.55° and 3°F may be obtained
 by using the following cosine function:

$$T = k \sin \frac{\pi d}{D/2} + 3$$

where

k = maximum temperature rise above boundary temperature

$\frac{d}{D/2}$ = ratio of the distance from the location of
 boundary temperature of any temperature rise
 and maximum temperature rise.

The agreement between the measured and computed temperatures is reasonable. Notice that the modified program result is more conservative (yields a higher maximum surface temperature) since it credits the heated effluent with an absolute minimum dilution. The computed location and shape of the individual isotherms is also conservative since it distributes the temperature over a very wide range (between the unadjusted locations of the centerline and upper boundary).

A closer agreement between the theoretical and observed location of the isotherms may be obtained by taking into account the effect of jet interference and drag on the lateral and longitudinal momentum.

Additional lateral and longitudinal displacements of the surface location of the plume's centerline, equivalent to the uncorrected longitudinal displacement and half the lateral displacement of an individual jet, have been arbitrarily selected in this study (140' and 70' respectively, in this case). The selection of the adjustment was guided by the discussion above under "interference" as well as by consideration of a hypothetical case of twelve solid jets, i.e., no mixing. If the jets were solid, the maximum displacement that could occur would be twelve times their size (1440' in this case). However, the fluid jets are well mixed upon interfering, and the displacement must be far less than the hypothetical case.

This selection of one uncorrected longitudinal displacement may be interpreted as doubling the river flow effect on the location of the path. The new location of the centerline will cause a shift of all the points along the path. The magnitude of the shift is shown in Figure 6. The steps required to effect the shift are

OUTFALL CONFIGURATION

CHANNEL DEPTH BELOW M.S.L. 20'
 NO. OF OPENINGS 12
 DIMENSIONS 4' x 15'
 DISCHARGE TEMPERATURE +14°
 RIVER VELOCITY ≈ 0.4 fps
 ΔWL CHANNEL TO RIVER 1.5'
 RATIO $\frac{\Delta T_{MAX} (RIVER)}{\Delta T_{DISCH.}} = 0.50$

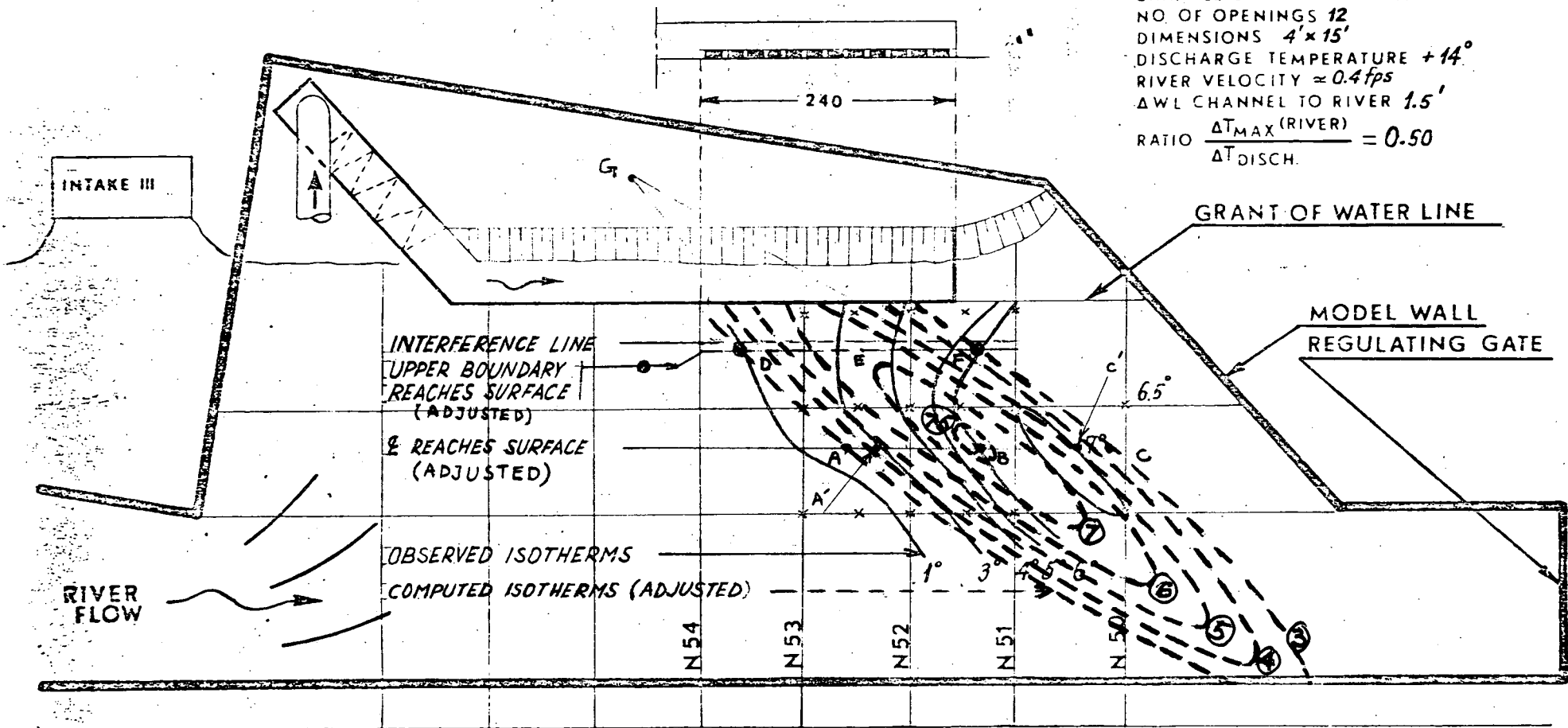

GUIDE VANES x PROBE POSITION

ALDEN RESEARCH LABORATORIES
 WORCESTER POLYTECHNIC INSTITUTE
 INDIAN POINT II SUB-MODEL
 MODEL SCALE 1:50 (UNDISTORTED)
 SURFACE ISOTHERMS
 TEST DATE MAR '69

described in detail below.

1. Shift the computed surface location of the centerline of the first, middle and last jet, a distance equivalent to $\frac{1}{2}$ lateral ($\frac{X}{2}$) and one longitudinal displacement (Z) of one jet, i.e., $\frac{274}{2} = 137'$ towards the discharge in the lateral direction and 71' downstream of the discharge. The new locations are represented by points A', B and C' in Figure 6.

2. Shift the location of the upper boundary surface location of these 3 jets by their relative displacement $(\frac{S_2}{S_1} \sqrt{Z^2 + \frac{X^2}{4}}$ where $\frac{S_2}{S_1}$ = ratio of the distance from the discharge measured along the path of the original surface location of the centerline and the upper boundary). This corresponds to 25' and 40' in the longitudinal and lateral directions, respectively. Designate the new locations by D, E, F.

3. Apply the maximum uncorrected jet radius projection (60') on the longitudinal axis to the new surface location of the centerline of the first and last jets. Designate A, B, C to these new locations.

4. Connect the points A,D and C,F by straight lines. Call the point of intersection of these lines G.
5. Distribute the temperature between point B and G, A and C using the cosine function mentioned earlier.

The points D and F represent the new locations of the upper boundary. Point B is the new location of the center of the plume. Point G represents the extent of the boundary temperature. The adoption of these new locations is still conservative since the procedure extends the location of the boundary temperature even beyond the location where the upper boundary first reaches the surface.

Figure 6 compares the measured temperature distribution and computed values obtained using the above described procedure. The computed results agree reasonably well with the observed values and are on the conservative side.

C. Lovett Plant Submerged Discharge Surveys

Extensive field measurements of the temperature distribution in the Hudson River resulting from the submerged discharge of existing Lovett Unit #4 effluent, were performed throughout the daylight

hours of 7/3/69, 9/23/69 and 10/2/69. These data were converted to temperature isotherms in the surface and across the cross-section at 1 ft. intervals. Figures 7 and 8 show two surface temperature isotherms corresponding to two different tidal conditions (maximum ebb and high water slack). Temperature rises downstream of the submerged pipe include the effect of the surface discharge from Units # 1,2 and 3, which are located about 25' downstream of Unit #4.

Unit #4 design and operating characteristics, in effect during the surveys, as well as major survey findings, are presented in Table 3. The measured dilution ratios vary with tidal current conditions, tidal elevation and variation in plant output. The values shown in Table 3 represent upper and lower limits of measured dilution ratios.

Figure 9 shows the variation in dilution ratios with depth of submergence throughout a tidal cycle for one of the surveys. The measured dilution values varied between 1.5 and 3.

Computer printouts for two tidal conditions (maximum ebb and slack) for 9/23/69 operating characteristics are given in Plates 4 and 5.

HUDSON RIVER - LOVETT

9/23/69

TIDE - MAX. EBB

AMBIENT TEMP. = 72.7 °F

GENERATING CAPACITY = 176 MW

DISCHARGE TEMP. = 92 °F

INTAKE TEMP. = 72 °F

DISCHARGE FLOW = 104,000 GPM

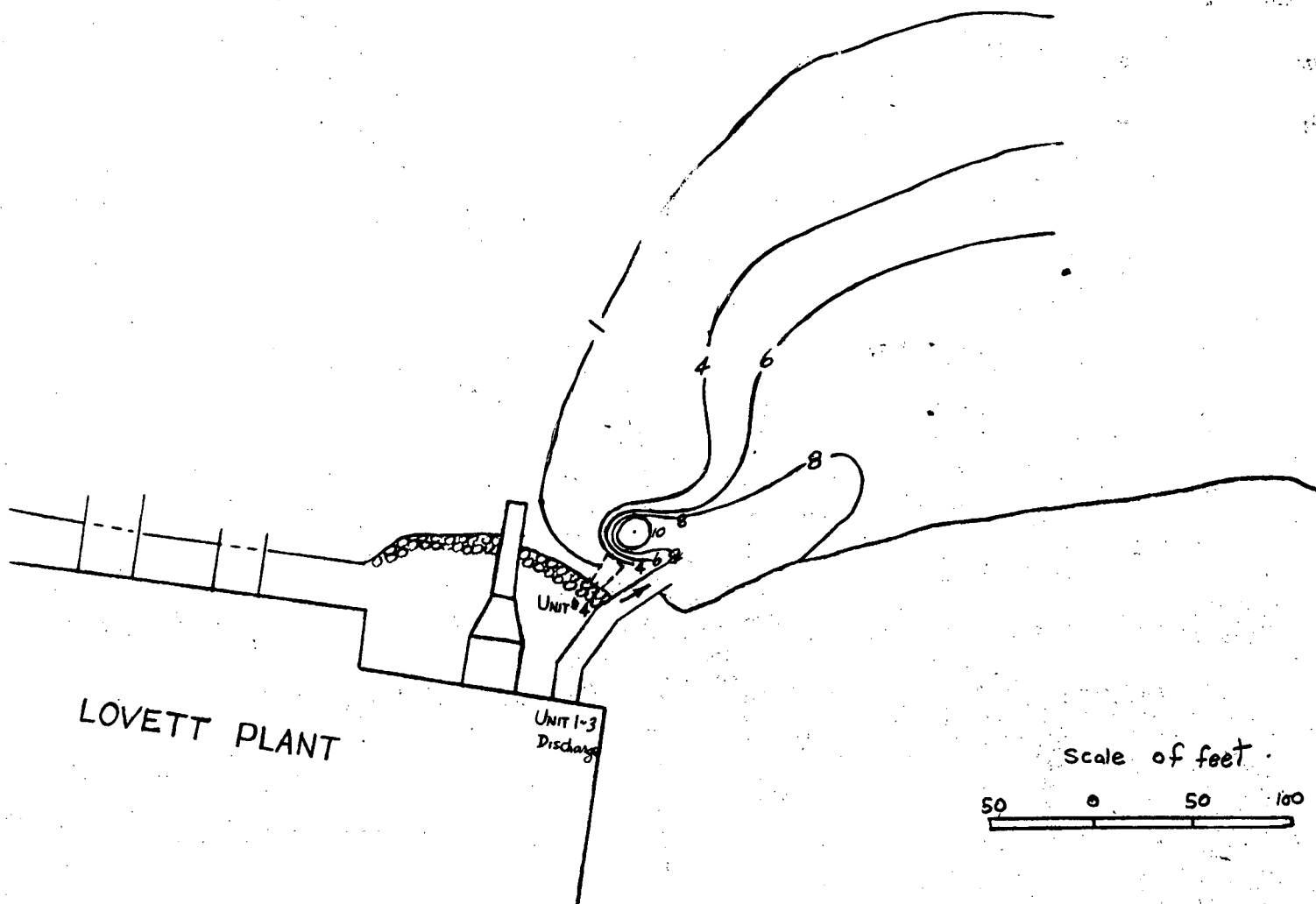

HUDSON RIVER - LOVETT

9/23/69

TIDE - HWS

AMBIENT TEMP. = 71.8 °F

GENERATING CAPACITY = 176 MW

DISCHARGE TEMP. = 90 °F

INTAKE TEMP. = 72 °F

DISCHARGE FLOW = 104,000 GPM

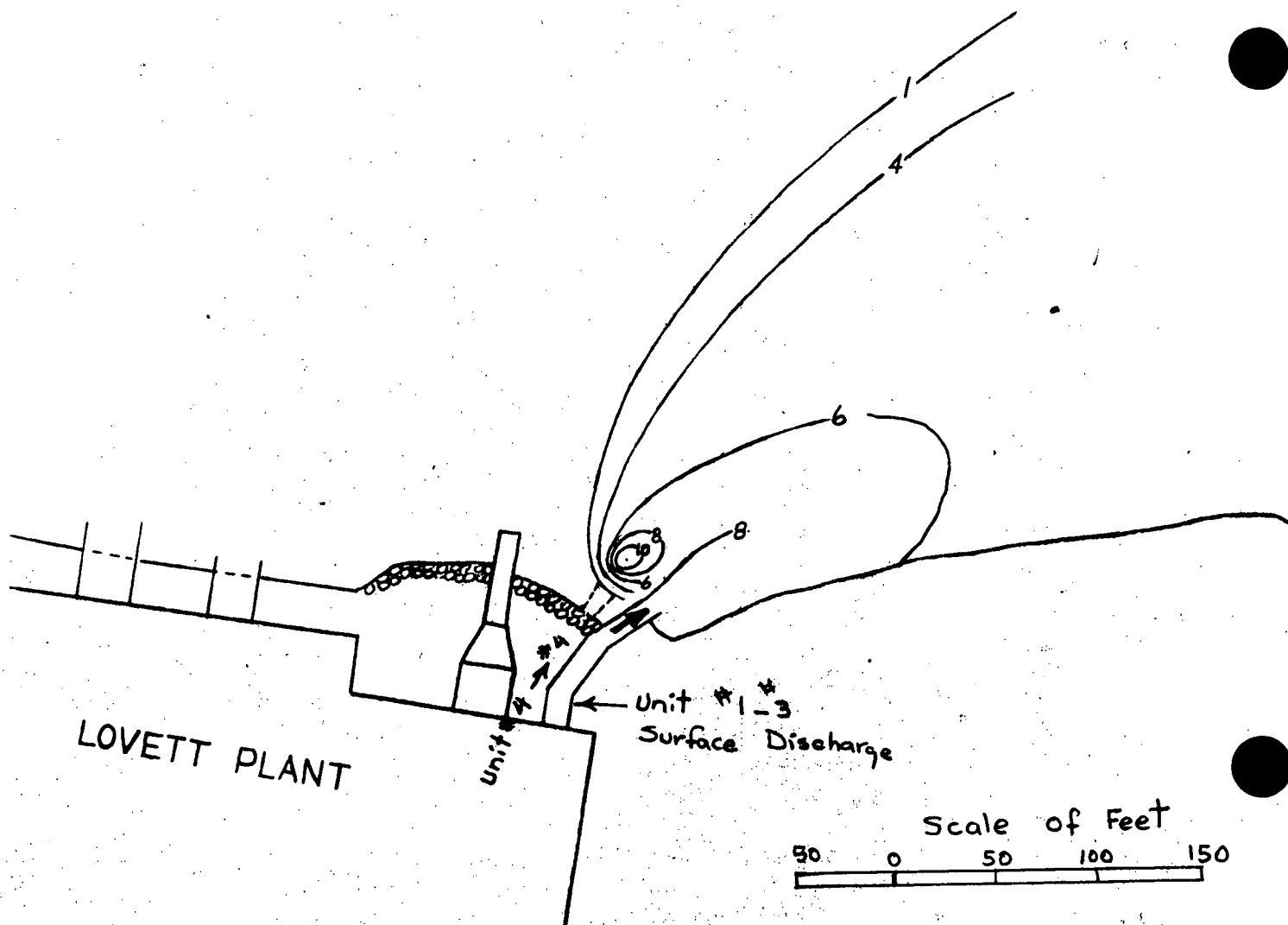

TABLE 3

SUMMARY OF LOVETT PLANT UNIT #4 CHARACTERISTICS
AND MAJOR SURVEY FINDINGS

<u>Unit Characteristics</u>	<u>Design</u>	<u>7/3/69</u>	<u>9/23/69</u>	<u>10/2/69</u>
Rated Capacity (MW)	198.5	170	175	170
Maximum Cooling Water Flow (gpm)	104,000	104,000	104,000	104,000
Maximum Condenser Temperature Rise (°F)	17	17 - 18	18 - 19	17
Intake Temperature (°F)	-	75 - 76	72 - 73	71
Discharge Temperature (°F)	-	92 - 94	90 - 92	88
Ambient River Temperature (°F)	-	74.3	71.8-72.5	68.2
Diameter of Port (Ft.)	10	10	10	10
Centerline Depth of Submergence Below MHW (Ft.)	11.3	11.3	11.3	11.5
Jet Velocity (fps)	2.9	2.9	2.9	2.9
Orientation of the Jet Cosθ _x , Cosθ _y , Cosθ _z	0.7071, 0, 0.7071	-	-	-
<u>Summary of Findings</u>				
Maximum Surface Temperature Rise (°F)		12	9 - 13	6 - 9
Location of Maximum Surface Temperature Rise				
Lateral (measured from		15	15	20
Longitudinal discharge pipe) (ft)		20	20	15
Dilution = $\frac{\text{Effluent Temperature Rise}}{\text{Maximum Surface Temperature Rise}}$		1.4 - 1.5	2.1 - 1.5	2.8 - 1.9

Figure '9'
7/3/69 SURVEY

HUDSON RIVER AT LOVETT
UNIT #4 SUBMERGED DISCHARGE

DILUTION RATIO

10 5 3 2.5 2 1.67 1.5 1.25 1

Depth Above Top of Pipe, ft

Depth Above Centerline of Pipe, ft

Variation in Dilution Ratio
with Depth of Submergence
7/3/69 Survey

Max. Surface Temp. RISE / Plant Temp. RISE, %

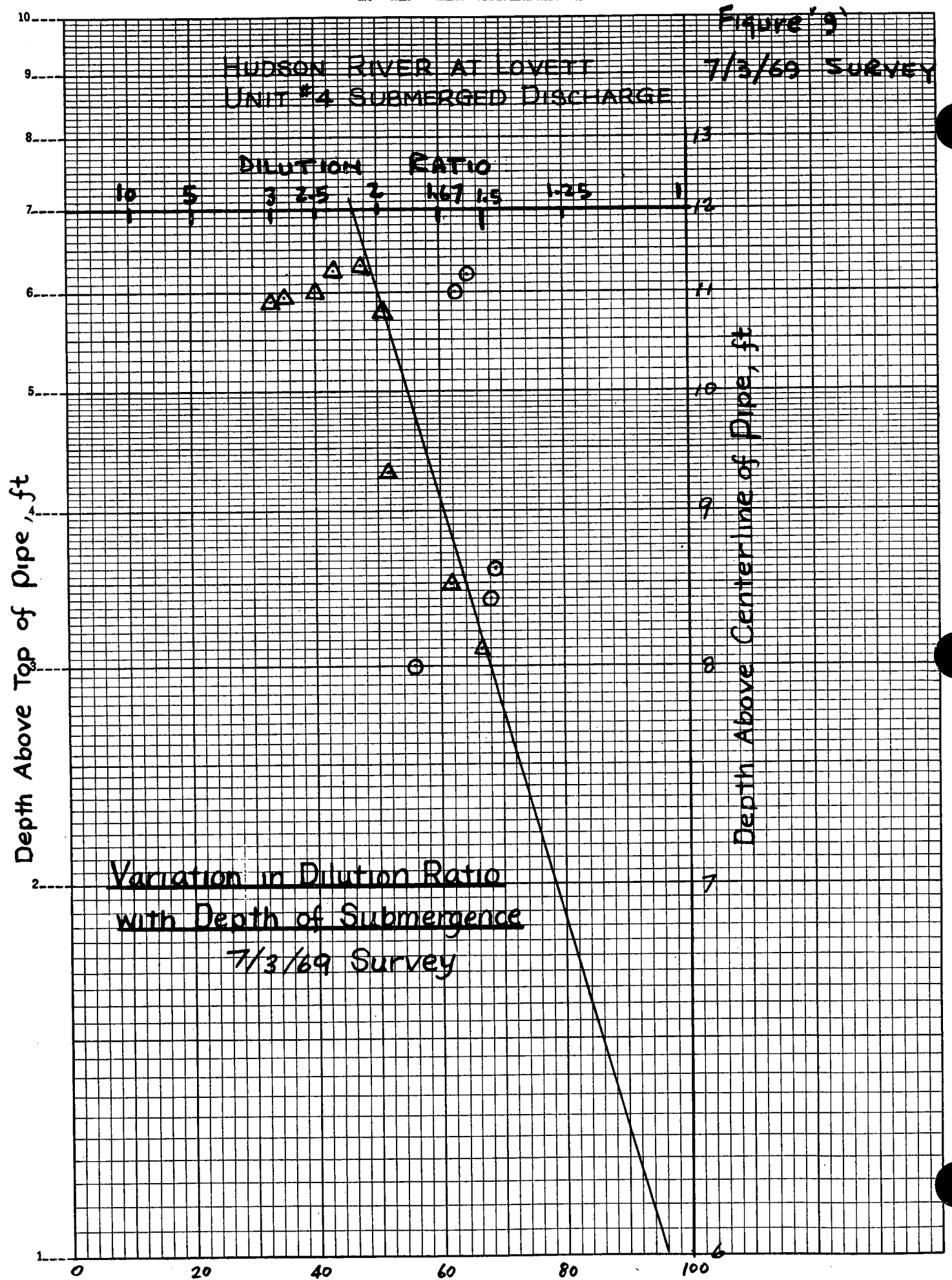

ANG VR

90.00 1.00

LOVETT #4 SUBMERGED DISCHARGE
CONDITIONS OF MAX. EBB ON SEPT. 23, 1969

DS	C1	C2	S2	YLIM	DDQI
0.10	0.16	0.20	62.00	12.00	0.0500
DO	VO	COSX	COSY	COSZ	
10.00	2.90	0.71	0.00	0.71	
TO	TRIV	SALO	SALR		
92.00	72.00	2.00	2.00		

THOUT 3 OUTPUT

S	X	Y	Z	D	V	TEMP BY DIL	TEMP BY DEN	DIL
10.0	6.8	0.6	7.3	13.2	2.3	86.5	86.8	1.38
T=	86.8345=		2.00RHO=		1.933			
20.0	12.9	2.5	15.0	16.4	2.0	83.0	83.9	1.81
T=	83.8635=		2.00RHO=		1.934			

AT NEXT LINE OF OUTPUT JET INTERSECTED SURFACE

24.1	15.2	3.6	18.2	17.7	1.9	82.0	83.0	2.01
30.0	18.3	5.5	22.8	19.6	1.7	80.6	81.6	2.32
T=	81.5675=		2.00RHO=		1.935			
40.0	23.0	9.4	30.8	22.8	1.6	78.9	79.8	2.91

THOUTO OUTPUT

S	D	DIRECTION COSINES			RADIUS PROJECTIONS ON			
		X-AXIS	Y-AXIS	Z-AXIS	X-AXIS	Y-AXIS	Z-AXIS	
00040								
00050								
00060								
00070								
00080	10.0	13.2	0.64458	0.12267	0.75464	5.0	6.6	4.3
00090								
00100	20.0	16.4	0.57929	0.24400	0.77774	6.7	8.0	5.2
00110								
00120								
00130								

AT NEXT LINE OF OUTPUT JET INTERSECTED SURFACE

00140								
00150								
00160								
00170	24.1	17.7	0.55252	0.29187	0.78073	7.4	8.5	5.5
00180								
00190	30.0	19.6	0.50557	0.34987	0.78866	8.5	9.2	6.0
00200								
00210	40.0	22.8	0.43523	0.42981	0.79110	10.3	10.3	7.0

The computed jet characteristics for the maximum ebb run, associated with the boundary surface control, and the centerline surface control locations are summarized in Table 4.

The computed dilution ratio and surface location of the jet, for this condition, are compared to actual observations in Table 5.

The computed dilution ratio used in this comparison (1.81) is the boundary surface control value introduced in the previous section. Since there is no jet interference in this case, the governing parameter is this boundary control. This value (1.81) compares favorably to the range of the observed values of 2.1 to 1.5.

The computed lateral, vertical and longitudinal locations of the centerline of the jet for the two tidal conditions are compared with the observed values in Figures 10 through 13. The agreement between the observed and computed lateral and longitudinal locations is quite good. In the vertical direction, the measurements show a faster plume rise. This, however, is to be expected, since the program neglects the effect of the drag forces which tend to decrease the lateral momentum.

The computed temperature isotherms using the procedure outlined in

TABLE 4

SUMMARY OF LOVETT UNIT #4 JET CHARACTERISTICS* ASSOCIATED
WITH CONTROL LOCATIONS

<u>Parameter</u>	<u>Boundary[⊗] Control</u>	<u>Centerline[⊗] Surface Control</u>
1- Location of Centerline of Jet Measured from Discharge Channel, Ft. (Lateral, Vertical and Longitudinal)	12.9, 2.5, 15	23, 9.4, 30.8
2. Jet Diameter, Ft.	16.4	22.8
3. Average Jet Velocity, Ft/Sec	2.0	1.6
4. Average Dilution Ratio	1.81	2.91
5. Average Temperature Rise, °F	11.0	7.0
6. Jet's Radius Projections on:		
x - axis	6.7	10.3
y - axis	8.0	10.3
z - axis	5.2	7.0

*Test conditions are for 9/23/69 maximum ebb survey as summarized in Table 3.

⊗Taken from computer printout values close to control locations.

TABLE 5

COMPARISON OF COMPUTED AND MEASURED LOVETT PLANT
SUBMERGED DISCHARGE SURVEY FINDINGS

	<u>Computed</u>	<u>Observed</u>
1. Maximum Surface Temperature Rise, °F	15.5	9-13
2. Location of Maximum Surface Temperature Rise (Measured from Discharge Pipe)		
Lateral, ft.	23	15
Longitudinal, ft.	31	20
3. Dilution Ratio	1.81	2.1-1.5

HUDSON RIVER AT LOVETT UNIT 4 SUBMERGED DISCHARGE

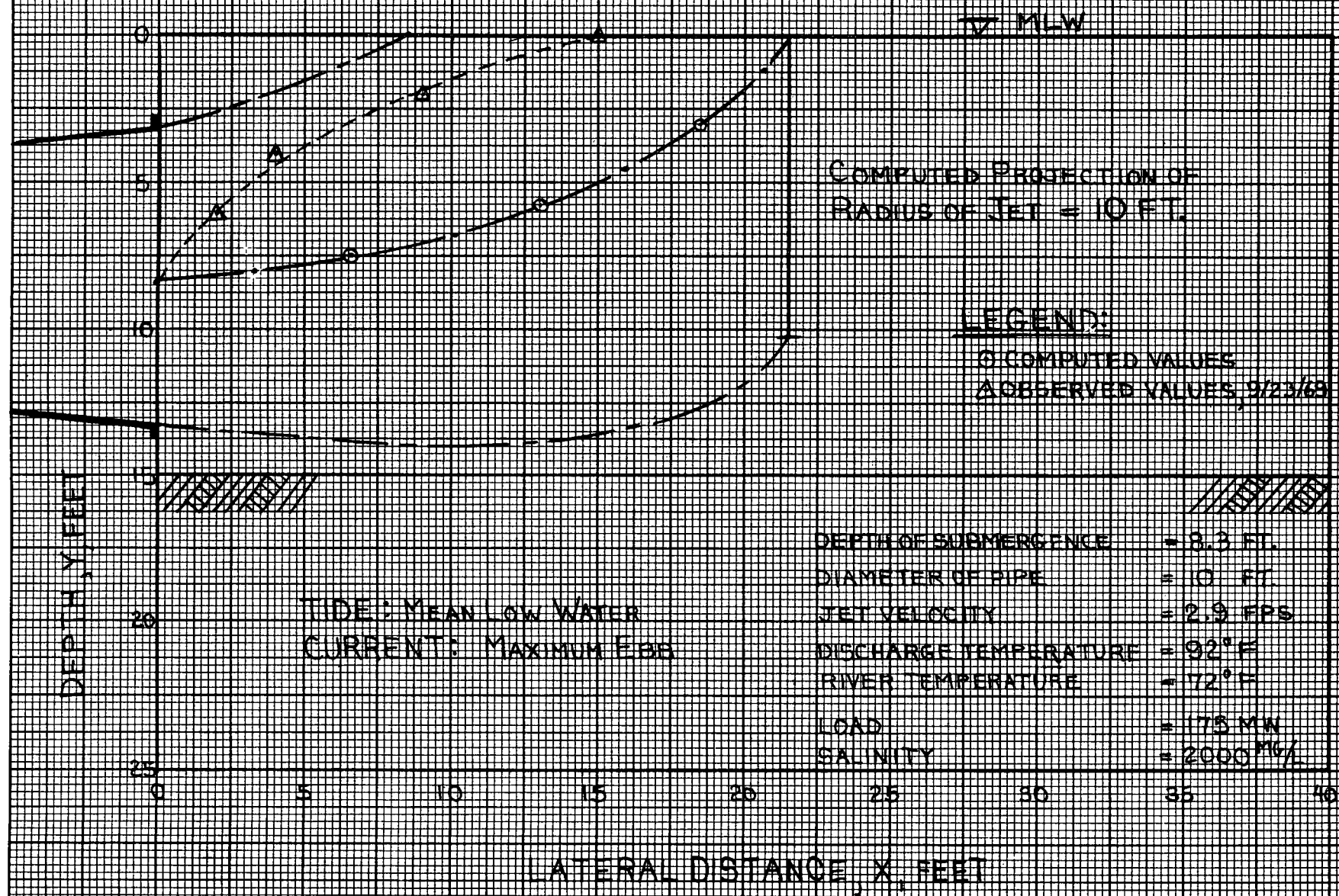
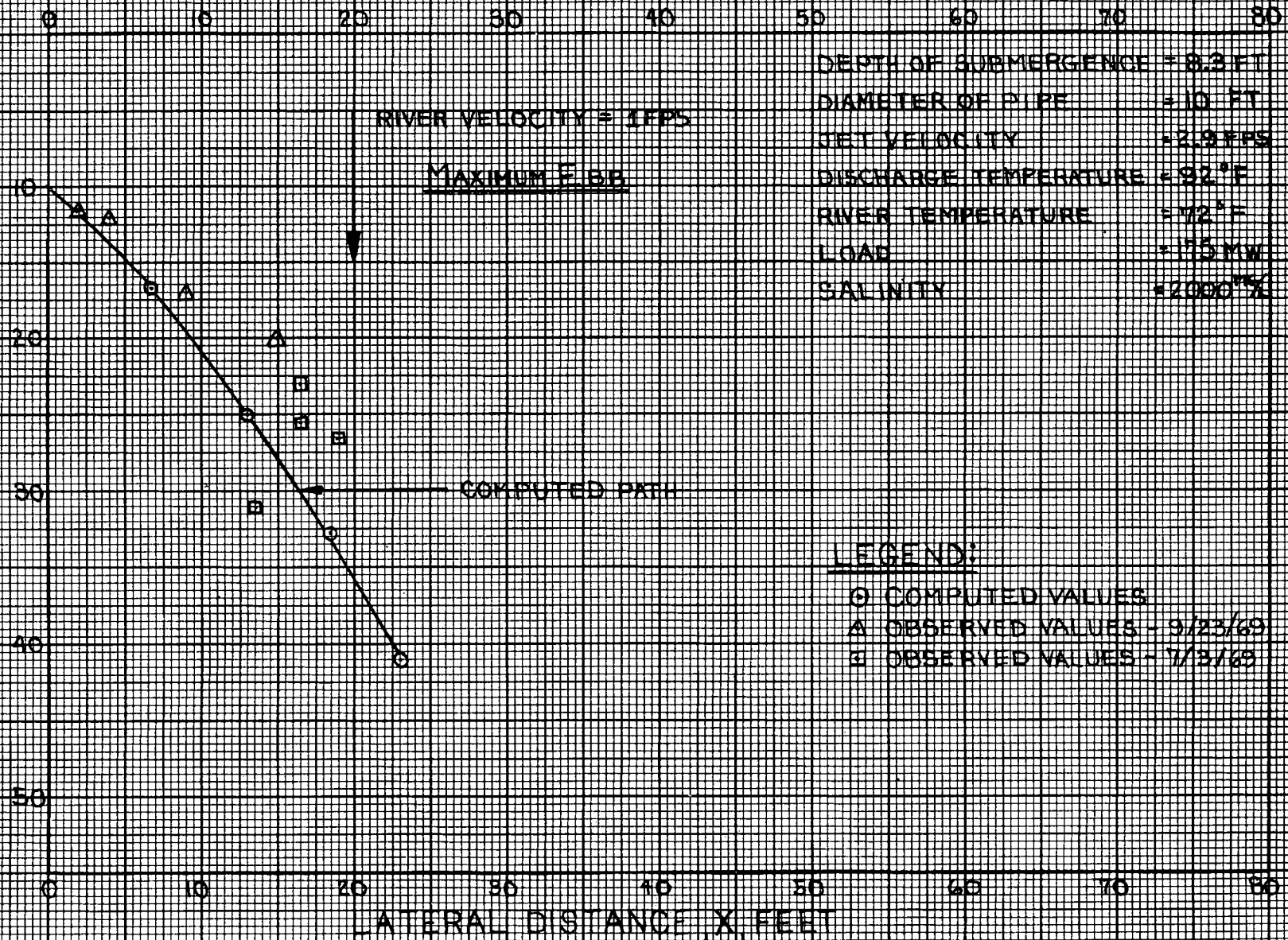

Figure No. 1

HUDSON RIVER AT LOVETT UNIT 4 SUBMERGED DISCHARGE

LONGITUDINAL DISTANCE, Z, FEET



DEPTH OF SUBMERGENCE = 8.3 FT
 DIAMETER OF PIPE = 10 FT
 JET VELOCITY = 21.9 FPS
 DISCHARGE TEMPERATURE = 92°F
 RIVER TEMPERATURE = 72°F
 LOAD = 175 MW
 SALINITY = 2000‰

LEGEND:

- O COMPUTED VALUES
- A OBSERVED VALUES - 9/23/69
- E OBSERVED VALUES - 7/3/68

FIGURE 117

HUDSON RIVER AT LOVETT
UNIT 4 SUBMERGED DISCHARGE

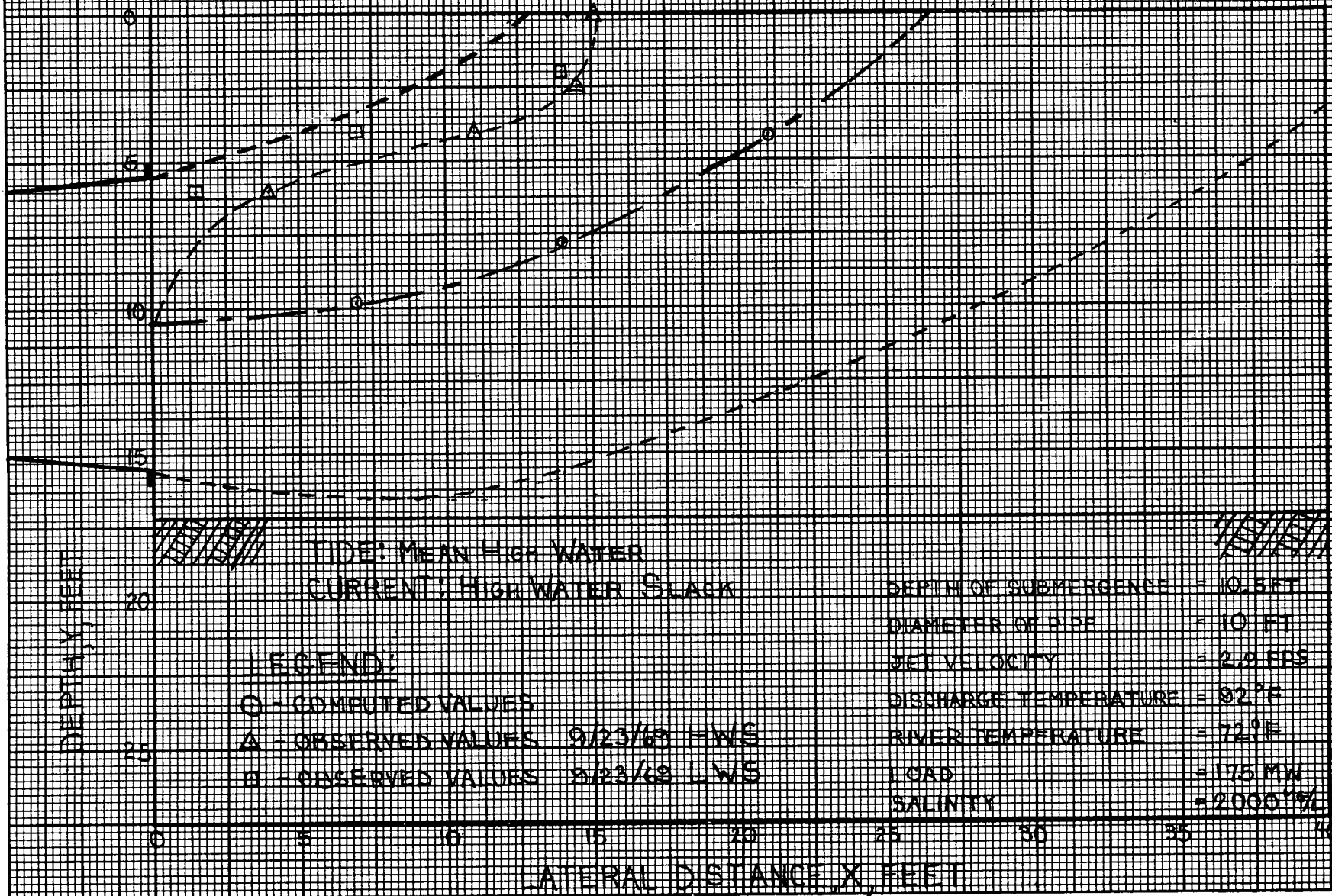
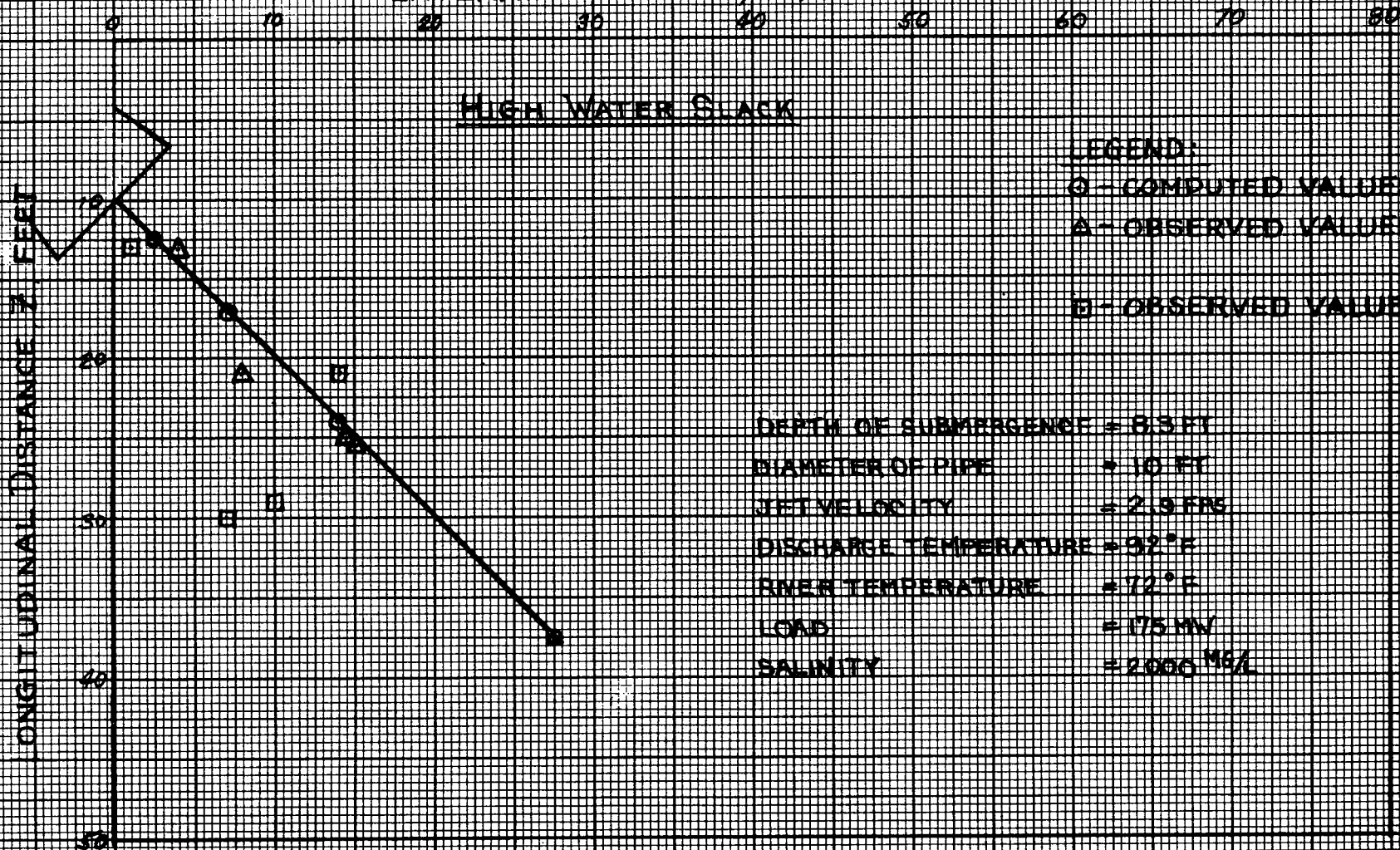

FIGURE 4-10

HUDSON RIVER AT LOVETT
 UNIT #4 SUBMERGED DISCHARGE
 LATERAL DISTANCE, X, FEET



DEPTH OF SUBMERGENCE = 8.3 FT
 DIAMETER OF PIPE = 10 FT
 JET VELOCITY = 2.9 FRS
 DISCHARGE TEMPERATURE = 92°F
 RIVER TEMPERATURE = 72°F
 LOAD = 175 MW
 SALINITY = 2000 MG/L

Figure 13

the last section (i.e., boundary control dilution and no location adjustment) are compared with the measured temperature distribution in Figures 14 and 15. The overall agreement between the results are considered to be reasonable. The deviations may be due to the effect of the surface discharge of Units 1 through 3 on the shape and location of the measured isotherms as well as errors in estimating distances smaller than 50 feet.

An adjustment of the plume's location, similar to the one adopted earlier, will result in a closer agreement.

FIGURE '14'

HUDSON RIVER - LOVETT PLANT
SEPT. 23, 1969
RUN 3 MAXIMUM EBB
AMBIENT 72.7°F
SURFACE

DEPTH OF SUBMERGENCE - 8.3 FT.
DIAMETER OF PIPE - 10 FT
JET VELOCITY - 2.9 FPS
DISCHARGE TEMPERATURE - 92°F
RIVER TEMPERATURE - 72°F
LOAD - 175 MW
SALINITY - 2000 mg/L

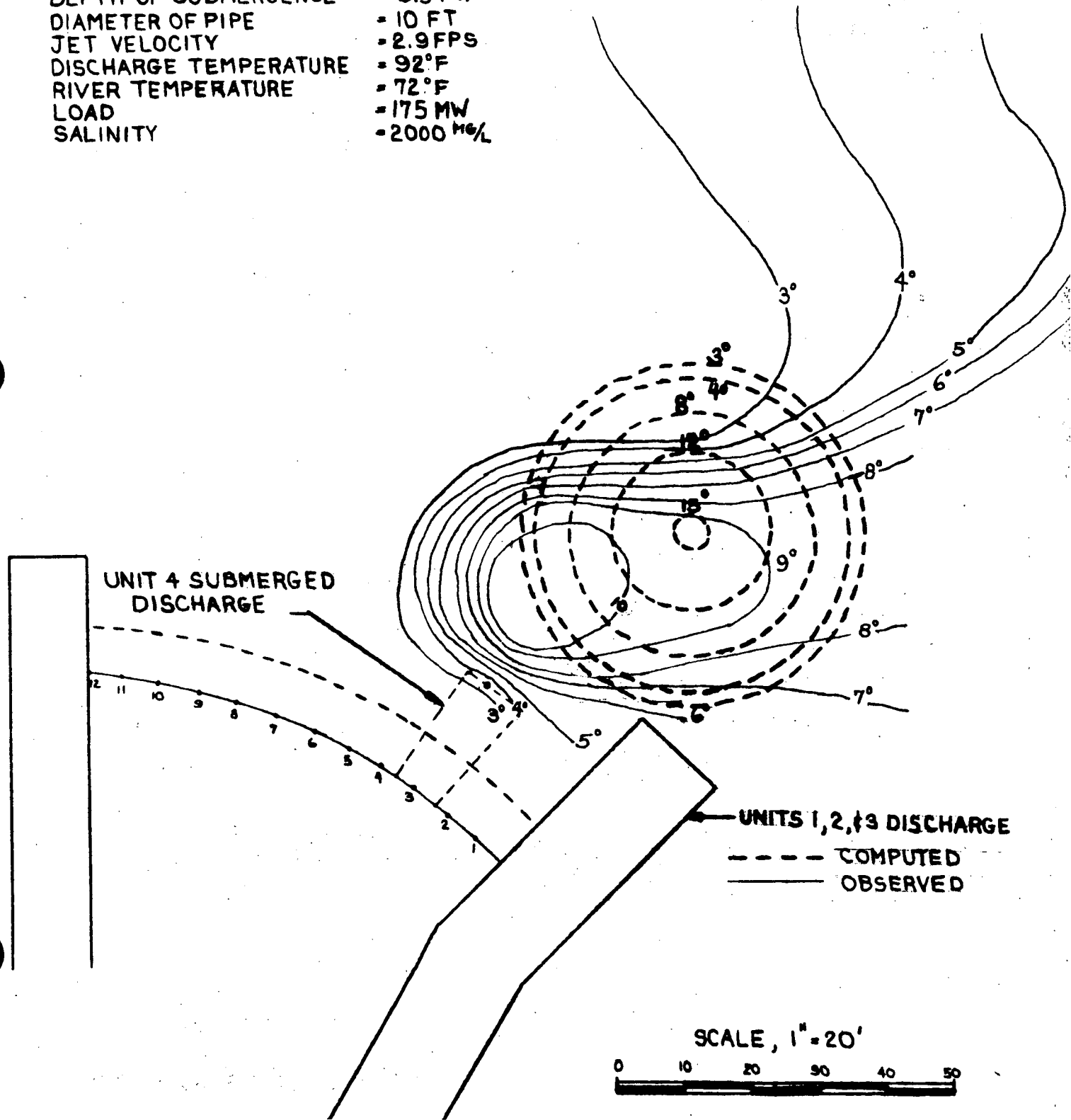
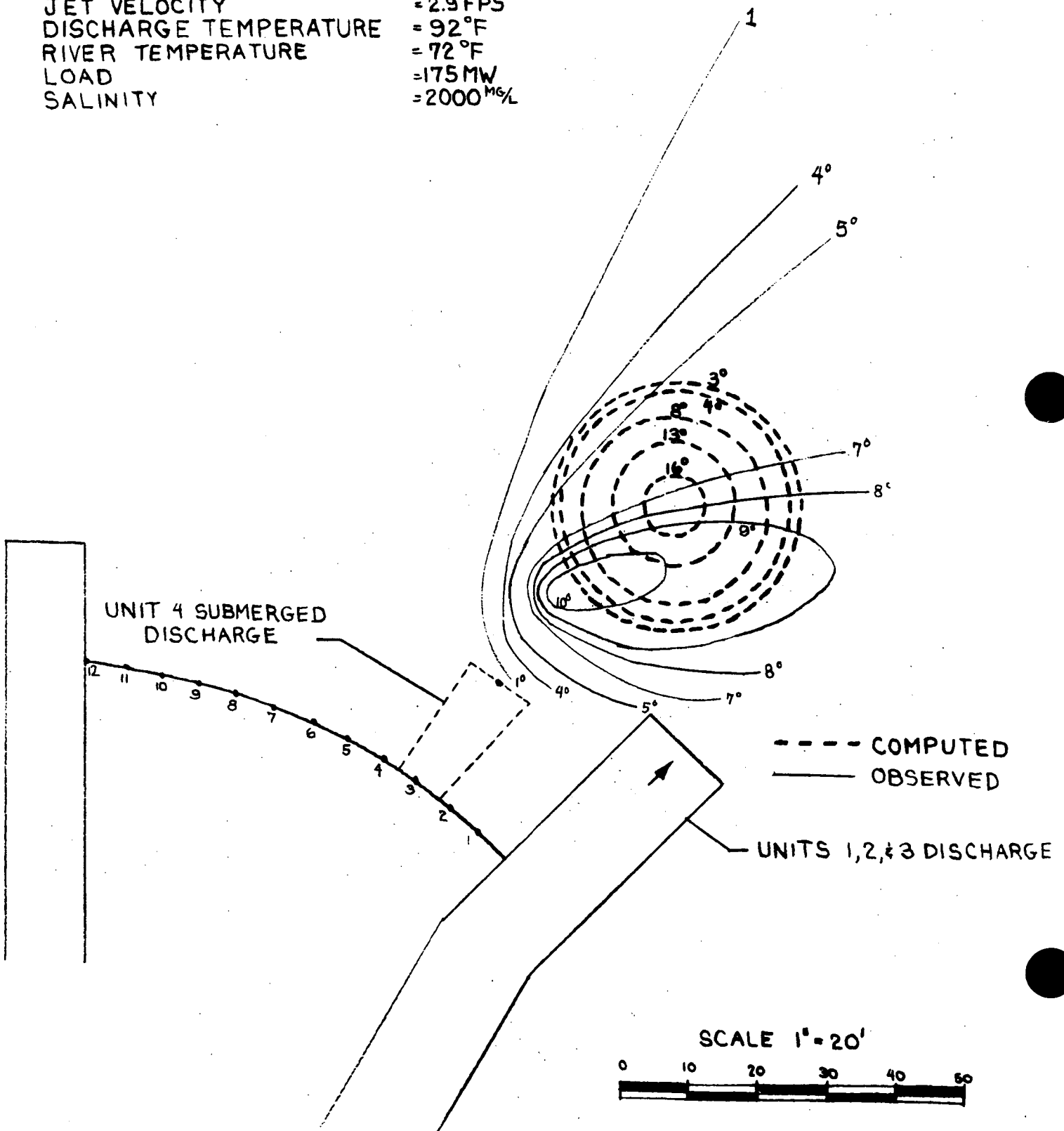

FIGURE '15'

HUDSON RIVER - LOVETT PLANT
SEPT 23, 1969
RUN 2 HIGH WATER SLACK
AMBIENT 71.8°F
SURFACE

DEPTH OF SUBMERGENCE = 10.5 FT
DIAMETER OF PIPE = 10 FT
JET VELOCITY = 2.9 FPS
DISCHARGE TEMPERATURE = 92°F
RIVER TEMPERATURE = 72°F
LOAD = 175 MW
SALINITY = 2000 MG/L



III. EVALUATION OF INDIAN POINT SUBMERGED DISCHARGE

The proposed Indian Point submerged discharge was studied in detail in an undistorted hydraulic model of the River. Those results agreed reasonably well with the theoretical solution as outlined in Chapter II. For the port configuration selected, however, those studies were based upon an effluent channel temperature rise of 14°F, an ambient temperature of 40°F, and a River ebb velocity of 0.4 fps.

The same design was theoretically evaluated under a different set of conditions. The mathematical model used for this purpose is the adjusted and verified theoretical solution presented in Chapter II. Results of this evaluation follow.

The new condition represents a more critical case. It differs from the hydraulic model run condition, summarized in Table 1, in the following manner:

Effluent channel temperature rise	= 17°F
Ambient temperature	= 79°F
Maximum discharge temperature	= 96°F
River velocity	= 1 fps
River salinity	= 2000 ppm

This condition was regarded as the summer condition of maximum severity and was studied because summer conditions are considered by many to constitute the critical biological condition.

Expected capacity operation of all three units at Indian Point will result in a 16.4°F rise in the 2,040,000 gpm cooling water flow. All results presented in this chapter are based on continuous, year round operation at rounded values of 17°F and 2,100,000 gpm and represent a maximum loading condition.

This heat load is 6% higher than that associated with the maximum possible 3 unit electrical output (stretch rating) of 2351 MW. Planned operation, however, is 90% of this value, or 2114 MW. This latter value is slightly less than the manufacturer's guaranteed rating of 2123 MW, the maximum value at which the station may operate under initial Atomic Energy Commission operating licenses. These latter facts lead to a design heat load of 340×10^9 BTU/day, which corresponds to a temperature rise of 14°F rather than 17°F.

The use of temperature rise of 17°F, therefore, represents the most severe condition expected.

The maximum River ambient surface water temperature used in this

evaluation is 79°F. This is considered to be the highest ambient water temperature that will be seen by the intake at any time. Ambient water temperature does not reach this value every year. For example, the maximum ambient water temperature observed in the vicinity of Indian Point this year occurred in August and was 77.5°F.

A River ebb velocity of 1 fps was used in this run rather than .4 fps. This velocity represents an average tidal velocity in the vicinity of Indian Point.

Computer printout for the critical summer condition is given in Plate 8. Computed submerged discharge characteristics, for this run, corresponding to the controls described in Chapter II, i.e., interference, and boundary and centerline surface controls, are summarized in Table 6.

Figures 16 and 17 depict the computed lateral, vertical and longitudinal location of any one of the twelve jets. The jet boundaries shown in these figures represent the vertical and longitudinal projections of the computed jet size at different locations. The computed jet velocity and dilution ratio are also shown in Figure 16. The three controls are also located on Figures 16 and 17.

OLD: THOUT3

READY
RUN

INDIAN POINT SUBMERGED DISCHARGE, MAX. EBB
CRITICAL SUMMER CONDITION

THOUT3 11:13 RDS2 OCTOBER 6, 1969

ANG	Vk					
90.00	1.00					
DS	C1	C2	S2	YLIM	DDGI	
0.10	0.15	0.25	79.50	18.00	0.0500	
DO	VO	COSX	COSY	COSZ		
8.75	10.00	1.00	0.00	0.00		
TO	TRIV	SALO	SALR			
96.00	79.00	2.00	2.00			

	S	X	Y	Z	D	V	TEMP BY DIL	TEMP BY DEN	DIL
	10.0	10.0	0.1	0.2	11.7	7.4	91.7	91.8	1.34
T=	91.770S=		2.00RHO=			1.931			
	20.0	20.0	0.2	0.7	14.7	5.9	89.1	89.2	1.69
T=	89.243S=		2.00RHO=			1.932			
	30.0	29.9	0.6	1.5	17.7	4.9	87.3	87.6	2.04
T=	87.561S=		2.00RHO=			1.933			
	40.0	39.9	1.1	2.7	20.7	4.2	86.1	86.3	2.39
T=	86.362S=		2.00RHO=			1.933			
	50.0	49.7	1.8	4.1	23.7	3.7	85.2	85.5	2.74
T=	85.464S=		2.00RHO=			1.934			
	60.0	59.5	2.7	5.9	26.7	3.3	84.5	84.8	3.10
T=	84.767S=		2.00RHO=			1.934			
	70.0	69.2	3.9	8.0	29.7	3.0	83.9	84.2	3.46
T=	84.210S=		2.00RHO=			1.934			
	80.0	78.8	5.4	10.4	32.8	2.7	83.4	83.7	3.85

T= 83.736S= 2.00RHO= 1.934
 90.0 88.2 7.2 13.3 37.8 2.4 82.8 83.0 4.49

T= 83.035S= 2.00RHO= 1.934
 100.0 97.4 9.3 16.7 42.8 2.1 82.3 82.5 5.16

T= 82.514S= 2.00RHO= 1.935
 110.0 106.3 11.7 20.5 47.8 2.0 81.9 82.1 5.85

T= 82.113S= 2.00RHO= 1.935

AT NEXT LINE OF OUTPUT JET INTERSECTED SURFACE

110.7 106.9 11.8 20.8 48.2 1.9 81.9 82.1 5.90
 120.0 114.9 14.4 24.9 52.8 1.8 81.6 81.8 6.59

T= 81.771S= 2.00RHO= 1.935
 130.0 123.2 17.4 29.7 57.8 1.7 81.3 81.5 7.37

T= 81.488S= 2.00RHO= 1.935

END of THOUT 3 Run

ANG VR
 180.00 0.02

DS C1 C2 S2 YLIM DD&I
 0.10 0.15 0.25 79.50 18.00 0.0500

DO VO COSX COSY COSZ
 8.75 10.00 1.00 0.00 0.00

TO TRIV SALO SALR
 96.00 79.00 2.00 2.00

S X Y Z D V TEMP BY DIL
 TEMP BY DEN

STOP

USED: CPU 1591.8 I/O 38.0

READY
 OLD: THOUTO

READY
 LENGTH

1440 CHAR.

LEST

LIST

THOUTO 11:57 RDS2 OCTOBER 6, 1969

00010
00020
00030
00040

	S	D	DIRECTION COSINES			RADIUS PROJECTIONS ON		
			X-AXIS	Y-AXIS	Z-AXIS	X-AXIS	Y-AXIS	Z-AXIS
00050								
00060								
00070								
00080	10.0	11.7	0.99939	0.01092	0.03330	0.2	5.9	5.9
00090								
00100	20.0	14.7	0.99748	0.02473	0.06651	0.5	7.4	7.4
00110								
00120	30.0	17.7	0.99418	0.04137	0.09946	1.0	8.9	8.8
00130								
00140	40.0	20.7	0.98939	0.06077	0.13198	1.5	10.4	10.3
00150								
00160	50.0	23.7	0.98299	0.08279	0.16392	2.2	11.8	11.7
00170								
00180	60.0	26.7	0.97490	0.10728	0.19509	3.0	13.3	13.1
00190								
00200	70.0	29.7	0.96502	0.13406	0.22530	3.9	14.7	14.5
00210								
00220	80.0	32.8	0.95292	0.16283	0.25579	5.0	16.2	15.9
00230								
00240	90.0	37.8	0.93049	0.19219	0.31185	6.9	18.6	18.0
00250								
00260	100.0	42.8	0.90454	0.22288	0.36350	9.1	20.9	20.0
00270								
00280	110.0	47.8	0.87574	0.25437	0.41035	11.6	23.1	21.8
00290								

00300
00310

AT NEXT LINE OF OUTPUT JET INTERSECTED SURFACE

00320
00330
00340

00350	110.7	48.2	0.87363	0.25659	0.41344	11.7	23.3	21.9
00360								
00370	120.0	52.8	0.84299	0.28543	0.45596	14.2	25.3	23.5
00380								
00390	130.0	57.8	0.80787	0.31547	0.49782	17.0	27.4	25.5

END of THOUT O RUN

OLD:THPUT3

NO SUCH PROGRAM: THPUT3
OLD:THOUT3

READY

LISTNH:3720

3720

ITOL=ITOLI*DDQI/DBQ

3721C

TABLE 6

SUMMARY OF INDIAN POINT JET CHARACTERISTICS ASSOCIATED
WITH CONTROL LOCATIONS
(CRITICAL SUMMER CONDITION)

<u>Parameter</u>	<u>Interference Control</u>	<u>Boundary Control</u>	<u>Centerline Surface Control</u>
1. Location of Centerline of Jet Measured from Discharge Channel, Ft. (Lateral, Vertical and Longitudinal)	39.9, 1.1, 2.7	69.2, 3.9, 8	125, 18, 30
2. Jet Diameter, Ft.	20.7	29.7	58
3. Average Jet Velocity, Ft/Sec	4.2	3.0	1.7
4. Average Dilution Ratio	2.39	3.46	7.50
5. Average Temperature Rise, °F	7.1	4.92	2.26
6. Jet's Radius Projections on:			
x - axis	1.5	3.9	17.0
y - axis	10.4	14.7	27.4
z - axis	10.3	14.5	25.5

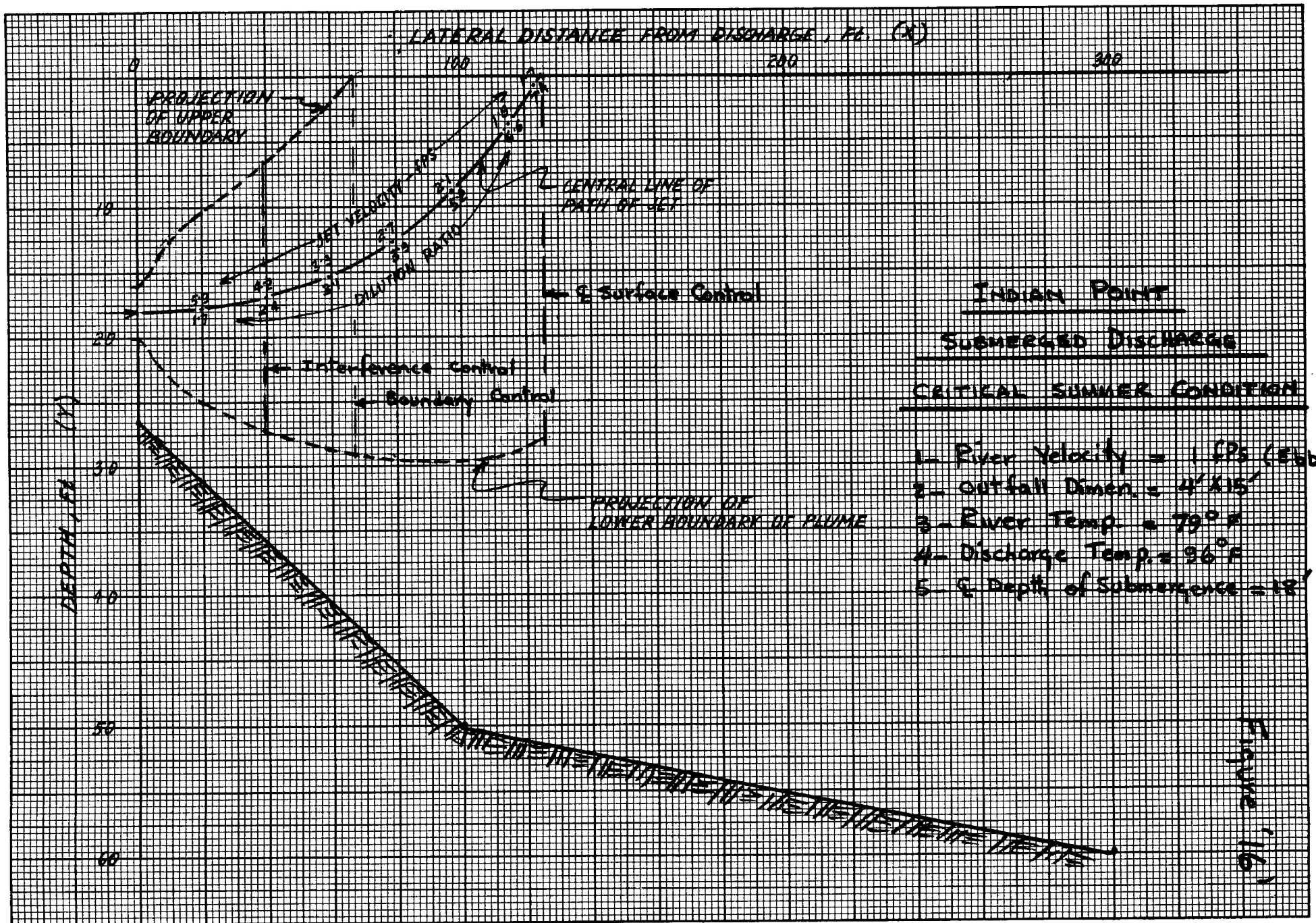
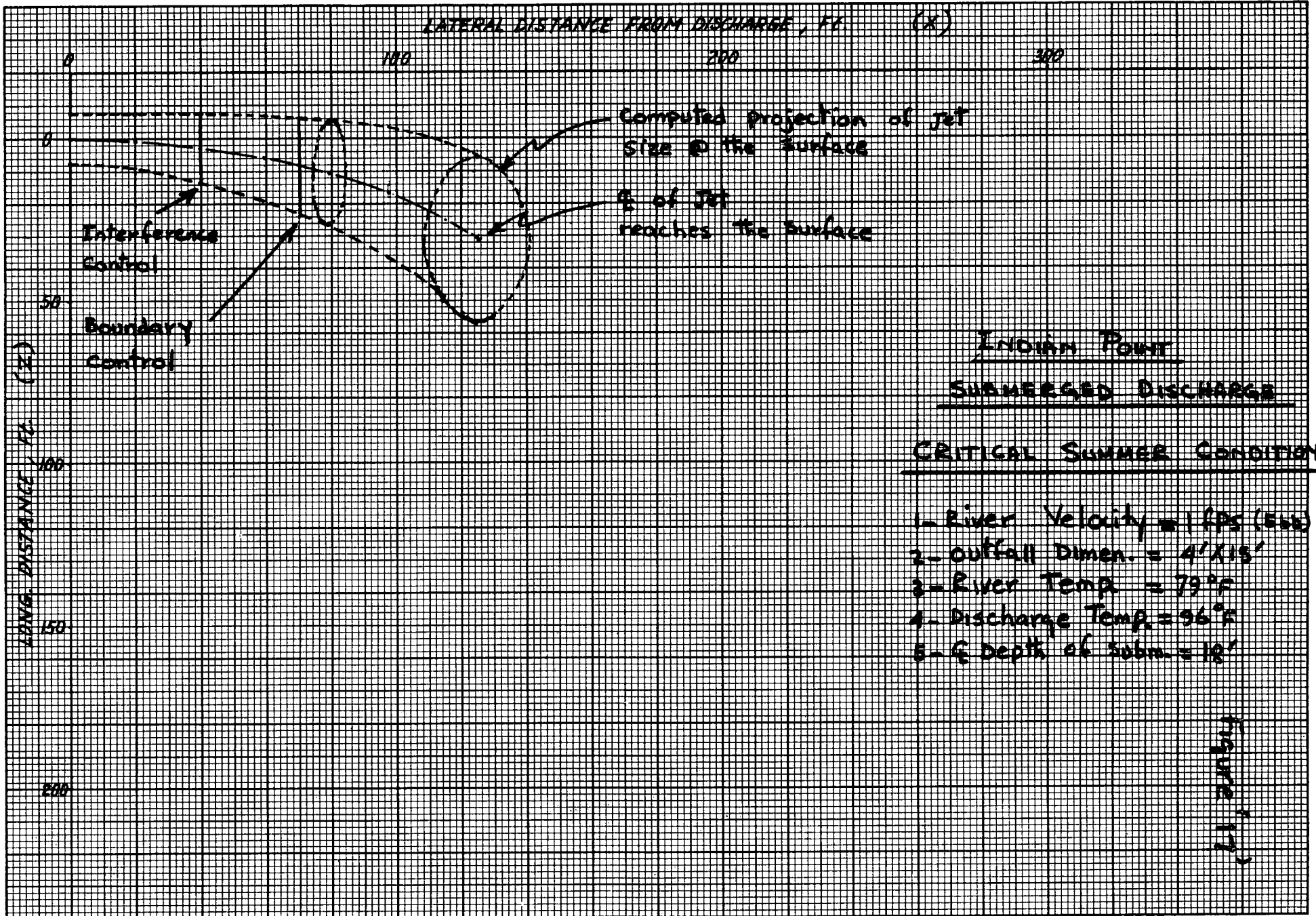

Figure (16)



INFORM POINT

SUBMERGED DISCHARGE

CRITICAL SUMMER CONDITION

- 1 - River Velocity = 1 f/s (EWS)
- 2 - outfall Dimen. = 4' X 15'
- 3 - River Temp = 79°F
- 4 - Discharge Temp = 96°F
- 5 - Q depth of subm. = 10'

Figure (17)

Figure 18 shows the relative locations of the centerline of the twelve jets. The three critical locations are also shown.

The procedures outlined in Chapter II, i.e., boundary control dilution and longitudinal and lateral centerline adjustment, were used to predict the temperature distribution resulting from a temperature rise of 17°F in ambient waters of 79°F . The predicted isotherms, for this condition, are shown in Figure 19.

By comparison to the hydraulic model run, the critical summer jet reaches the surface faster, even with a higher river velocity. In other words, the jet does not see as much water as it rises in the summer. This, of course, results in a smaller jet size and a lesser control location dilution.

Interestingly, the dilution ratio at a given distance along the centerline of the jet is somewhat greater in the present run, than it was for the hydraulic model conditions. Appearance of the jet at the surface, however, controls the available dilution, and the dilution ratio associated with boundary surface control was used for the prediction of the temperature distribution.

The faster jet rise, in this case, is caused by a higher buoyancy

LATERAL DISTANCE, FT. (X)

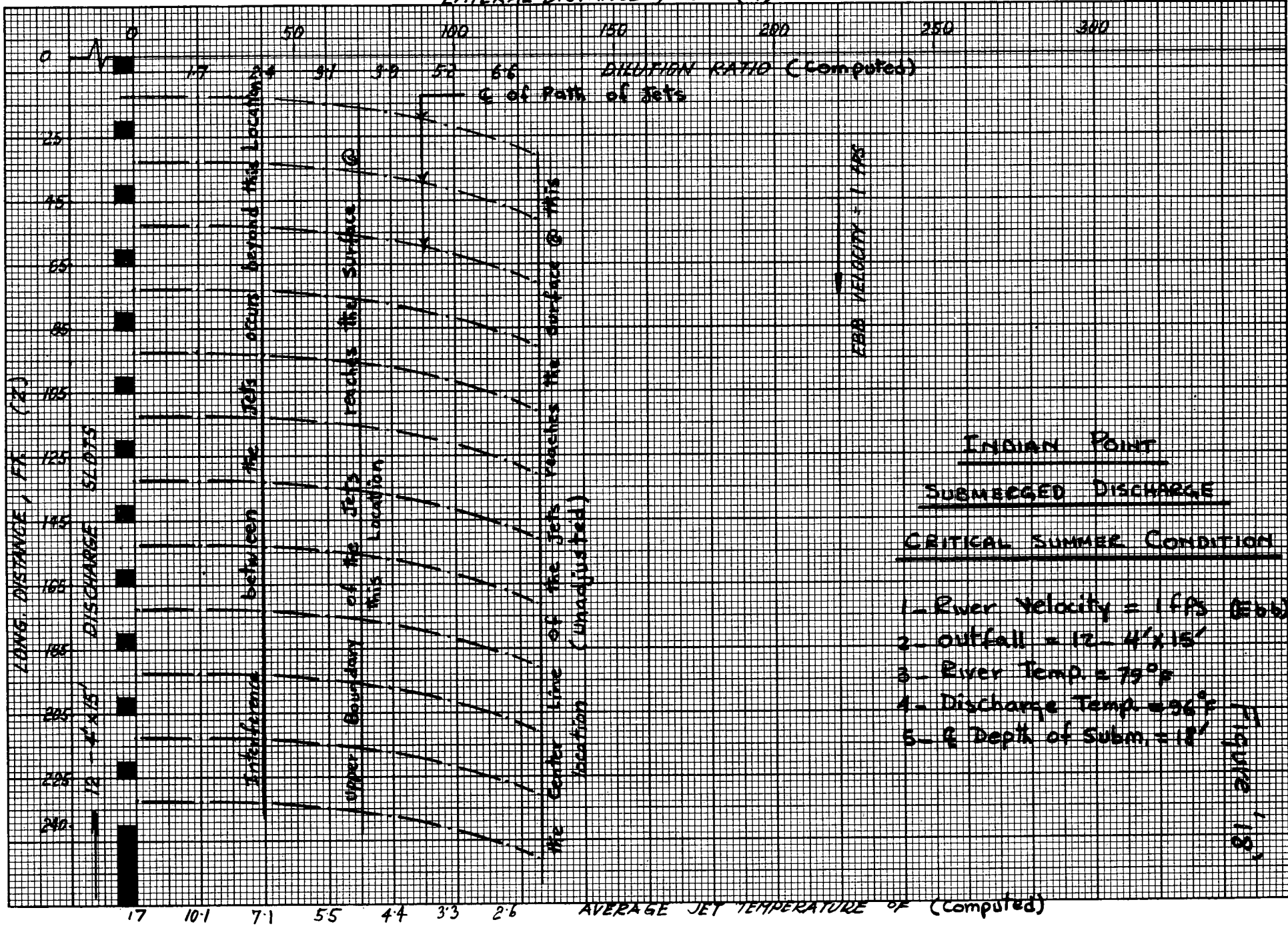

INDIAN POINT

SUBMERGED DISCHARGE

CRITICAL SUMMER CONDITION

- 1 - River Velocity = 1 FPS (666)
- 2 - outfall = 12 - 4' x 15'
- 3 - River Temp. = 79° F
- 4 - Discharge Temp. = 96° F
- 5 - Depth of subm. = 18'

Figure 18'

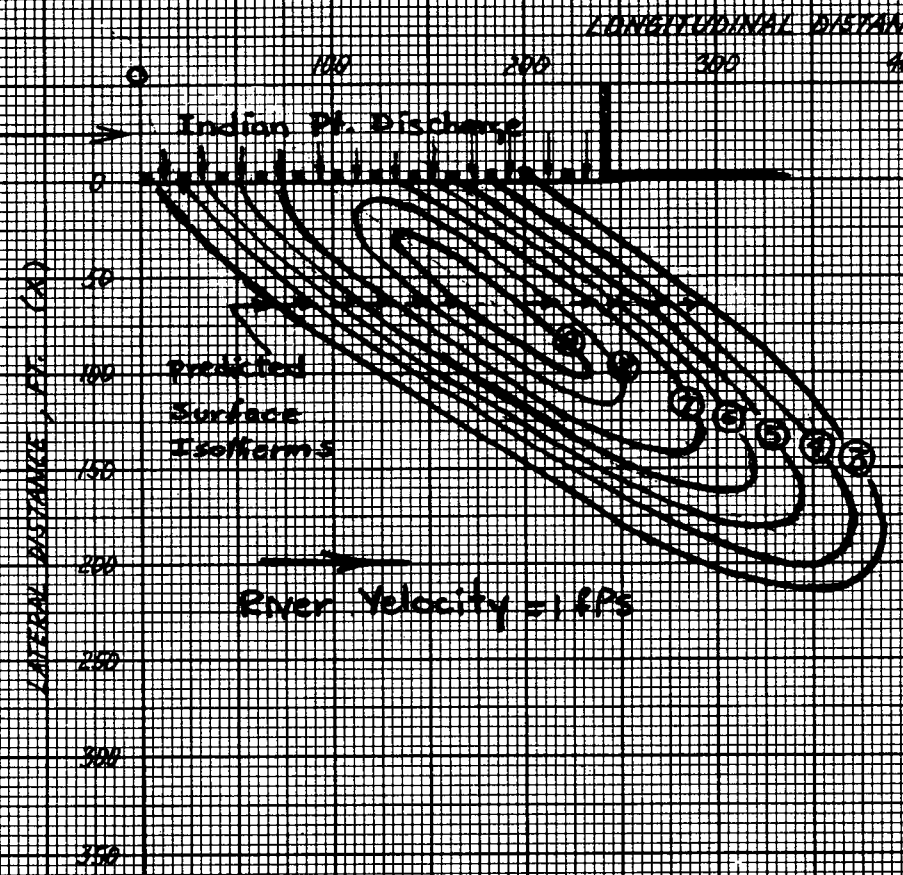

INDIAN POINT
SUBMERGED DISCHARGE
CRITICAL SUMMER CONDITION

- 1. River Velocity = 1 FPS (cell)
- 2. outfall = 12 - 4' x 15'
- 3. Ambient Temp. = 79°F
- 4. Discharge Temp. = 96°F
- 5. Depth of submergence = 10'

Figure (19)

flux, which is due to a greater difference between river and jet densities as a result of 17°F instead of 14°F temperature rise. This difference, which represents the driving force in the vertical direction, is even greater than the effect of an increase in the river velocity from 0.4 to 1 fps. A maximum surface temperature rise of 9.45°F $\left(\left(\frac{17}{2.39} - 3 \right) \frac{\pi}{2} + 3 \right)$ is expected at the surface. This may be compared with 7.55°F temperature rise computed in Chapter II for a temperature rise of 14°F and an ambient river temperature of 40°F.

The predicted maximum surface temperature rises for this condition, as well as the hydraulic model condition agree reasonably well with the previously computed values summarized in Table 16 in QL&M's Feb., 1969 report to Con Edison on Indian Point Thermal Discharge, (4).

In interpreting the computed results, however, the following points should be taken into account:

1. The computed results are probably conservative. The actual maximum temperature rises may be lower than those shown in Figure 19. This results from the fact that the computations ignore any dilution beyond the location where the jets start to interfere.

In reality, however, entrainment of the river water into the individual jets will occur beyond this location, due to the availability of large volumes of ambient water in comparison to the total discharge flow. This can be best appreciated by realizing that the interference between the centerlines and upper boundaries of adjacent jets occurs some 16 and 17', respectively, below the water surface. The water contained in this part of the river above these elevations has an ambient temperature. The computation neglects any entrainment of this water.

2. The procedure puts the location of the jet boundary at the surface farther from the surface centerline location, than the unadjusted model result, i.e., the projection of the jet area on the surface is greater after adjustment than before. Water is still entrained, and, even if not at ambient temperature, still requires the jet to expand at approximately the same rate.

Figure 19 shows that the area bounded by the 4^oF isotherm is considerably lower than the estimate made previously in QL&M's February, 1969 report (4) on this question. At that time, however, the submerged discharge dynamics were not fully understood and the estimates were made using temperature decay functions obtained during studies of the existing surface discharge.

These field results showed that temperature decay across the River's cross-section and surface width vary exponentially with percentage of these parameters. When applied to the submerged discharge, a correction was made to account for an expected lesser degree of stratification between the surface and the section as a whole, but no change was made in the exponential nature of the surface and area decay functions.

Consideration of the computed submerged discharge results shows clearly that the temperature decay is not exponential in this case, i.e., at least not exponential from the point of discharge down through temperature rises less than 1°F .

The exponential behavior is replaced by a sharp drop in the immediate vicinity of the discharge down to about 3°F . This is then followed by a much slower movement down through the lower ΔT values.

This behavior is consistent with known fluid mechanical behavior upon introduction of an effluent into a receiving waterway. In the case of a low velocity, top to bottom discharge, heated effluent will rise quickly to the surface and then move away under the influence of turbulent transport mechanisms.

Analytical solutions of simple turbulent transport problems usually result in exponential or similar type functions describing the decay behavior of introduced contaminants. Thus, the observed exponential behavior of the low velocity discharges was not unexpected. These concepts have been pointed out in early reports to Con Edison on Indian Point behavior, in January, 1968 (5) and in February, 1969 (4).

In the case of the submerged discharge, initial dilution mechanisms have been shown to control dilution of the plant effluent, down to the 3 to 5°F temperature rise range. Beyond this point, turbulent transport mechanisms (6) and overall dispersion and dissipation mechanisms (4), (5) begin to control.

The submerged discharge results shown in Figure 19 indicate that the surface areas bounded by the 4°F isotherm are on the order of a few acres, and the lateral distance bounded by this isotherm will be on the order of a few hundred feet, rather than on the order of 2000 feet, as estimated previously.

The submerged discharge model, however, does not predict what will happen to the plume as it moves away from the point where it breaks the surface. A flattening out will occur and the heated water will move along the surface, gradually mixing via turbulence with cooler water. We know that this will occur at a point a few degrees above ambient, but to guarantee that such movement will occur at 3°F rather

than at 4°F is not possible with this model. To be conservative, therefore, the extent of the 4°F isotherm should be considered to be on the order of the values presented in our February, 1969 report.

The effect of the critical summer condition submerged discharge during tidal slack conditions was investigated. Computer printout for this condition is given in Plate IX. The interference control dilution ratio and centerline surface location of the plume in the lateral direction were essentially the same as those used in the maximum ebb computations.

Therefore, the computed isotherms for slack conditions are essentially the same as the maximum ebb isotherms in magnitude and lateral location. No longitudinal displacement of the plume occurs at this condition.

OLD:THOUT3

INDIAN POINT SUBMERGED DISCHARGE CRITICAL SUMMER CONDITION SLACK TIDE

PLATE IX
1 of 3

READY
S-RUNNH

ANG	VR				
180.00	0.00				
DS	C1	C2	S2	YLIM	DDQI
0.10	0.15	0.25	79.50	18.00	0.0500
DO	VO	COSX	COSY	COSZ	
8.75	10.00	1.00	0.00	0.00	
TO	TRIV	SALO	SALR		
96.00	79.00	2.00	2.00		

	S	X	Y	Z	D	V	TEMP BY DIL	TEMP BY DEN	DIL
	10.0	10.0	0.1	0.0	11.7	7.4	91.7	91.8	1.34
T=	91.770S=		2.00RHO=			1.931			
	20.0	20.0	0.2	0.0	14.7	5.9	89.1	89.2	1.69
T=	89.241S=		2.00RHO=			1.932			
	30.0	30.0	0.6	0.0	17.7	4.9	87.4	87.6	2.03
T=	87.557S=		2.00RHO=			1.933			
	40.0	40.0	1.1	0.0	20.7	4.2	86.2	86.3	2.38
T=	86.355S=		2.00RHO=			1.933			
	50.0	50.0	1.8	0.0	23.7	3.7	85.2	85.4	2.72
T=	85.453S=		2.00RHO=			1.934			
	60.0	59.9	2.8	0.0	26.7	3.3	84.5	84.7	3.07
T=	84.752S=		2.00RHO=			1.934			

AT NEXT LINE OF OUTPUT JET INTERSECTED SURFACE

67.4	67.3	3.6	0.0	29.0	3.0	84.1	84.3	3.33
70.0	69.8	4.0	0.0	29.7	3.0	84.0	84.2	3.42

T= 84.190S= 2.00RHO= 1.934
80.0 79.7 5.5 0.0 32.8 2.7 83.5 83.7 3.79

T= 83.714S= 2.00RHO= 1.934
90.0 89.5 7.4 0.0 37.8 2.3 82.9 83.1 4.38

T= 83.069S= 2.00RHO= 1.934
100.0 99.3 9.6 0.0 42.8 2.1 82.4 82.6 4.98

T= 82.578S= 2.00RHO= 1.935
110.0 108.9 12.2 0.0 47.8 1.9 82.0 82.2 5.59

T= 82.194S= 2.00RHO= 1.935
120.0 118.5 15.2 0.0 52.8 1.7 81.7 81.9 6.22

T= 81.885S= 2.00RHO= 1.935
USED: CPU 1586.6 I/O 122.0

READY

OFF AT 11:29

THOUTO 11:59 RDS2 OCTOBER 13, 1969

00010

00020

00030

00040

00050

00060

00070

00080

00090

00100

00110

00120

00130

00140

00150

00160

00170

00180

00190

00200

00210

00220

AT NEXT LINE OF OUTPUT JET INTERSECTED SURFACE

00230

00240

00250

00260

00270

00280

00290

00300

00310

00320

00330

00340

00350

00360

00370

00380

S	D	DIRECTION COSINES			RADIUS PROJECTIONS ON		
		X-AXIS	Y-AXIS	Z-AXIS	X-AXIS	Y-AXIS	Z-AXIS
10.0	11.7	0.99994	0.01092	0.00000	0.1	5.9	5.9
20.0	14.7	0.99969	0.02478	0.00000	0.2	7.4	7.4
30.0	17.7	0.99914	0.04157	0.00000	0.4	8.9	8.9
40.0	20.7	0.99812	0.06128	0.00000	0.6	10.4	10.4
50.0	23.7	0.99648	0.08387	0.00000	1.0	11.8	11.9
60.0	26.7	0.99401	0.10927	0.00000	1.5	13.3	13.4

67.4	29.0	0.99154	0.12983	0.00000	1.9	14.4	14.5
70.0	29.7	0.99052	0.13740	0.00000	2.0	14.7	14.9
80.0	32.8	0.98577	0.16809	0.00000	2.8	16.2	16.4
90.0	37.8	0.97938	0.20202	0.00000	3.8	18.5	18.9
100.0	42.8	0.97090	0.23950	0.00000	5.1	20.8	21.4
110.0	47.8	0.95998	0.28008	0.00000	6.7	23.0	23.9
120.0	52.8	0.94634	0.32319	0.00000	8.5	25.0	26.4

REFERENCES

- (1) Camp, T.R., "Water and its Impurities", Reinhold Publishing Corporation, New York, 1963.
- (2) Rouse, Hunter, "Engineering Hydraulics," proceedings of the 4th Hydraulic Conference, Iowa Institute Conference, Iowa Institute of Hydraulic Research, John Wiley & Sons, Inc., New York, 1950.
- (3) Imandi, C. and Rouse, H., "Jet-Induced Circulation and Diffusion," Journal of the Hydraulics Division, March, 1969.
- (4) Quirk, Lawler & Matusky Engineers, "Effect of Indian Point Cooling Water Discharge on Hudson River Temperature Distribution," study prepared for Consolidated Edison Company of New York, Inc., February, 1969.
- (5) Quirk, Lawler & Matusky Engineers, "Effect of Indian Point Cooling Water Discharge on Hudson River Temperature Distribution," study prepared for Consolidated Edison Company of New York, Inc., January, 1968.
- (6) Brooks, N.H., "Diffusion of Sewage Effluent in an Ocean Current," proceedings, International Conference on Waste Disposal in the Marine Environment, Pergamon Press, New York (Circa 1960).

APPENDIX "A"

PROGRESS REPORT
on
INDIAN POINT II STUDIES
for
CONSOLIDATED EDISON COMPANY OF NEW YORK

at

ALDEN RESEARCH LABORATORIES
WORCESTER POLYTECHNIC INSTITUTE
HOLDEN, MASSACHUSETTS, 01520

April, 1969

INTRODUCTION

Consolidated Edison Company in a letter of March 7, 1969 requested that additional tests be carried out in the undistorted 1:50 scale model of the outfall and its near portion of the Hudson River. Tests according to the specified conditions were performed between March 23 and March 28 and preliminary results from these tests were verbally reported in conjunction with the data evaluation.

This progress report gives the test results in terms of isotherms plotted in the vicinity of the outfall structure as covered by the undistorted model. Also, the results of some computations have been included indicating an "efficiency" of each particular outfall configuration in terms of the ratio of the highest observed river surface temperature to the temperature of the cooling water effluent. In order to give a more complete picture of the variation of "efficiency" with outfall configuration pertinent results from the previous tests (August and November 1968) have also been included.

It is felt that a rather complete survey of possible outfall designs, possible within the limits of topography and available space for construction, has been accomplished.

4.3 Test Results

The outfall configurations tested and reported herein are summarized in the following Table III and detailed results are presented in Figures 5 - 14:

Test Data	Length of Outfall Structure	Depth of Channel Below MSL	Number of Openings	Dimensions of Openings	Water Level Difference Between Channel and River	Effluent Temperature ΔT_E Above River Ambient	Ratio of Max. Observed Surface Temp. ΔT_S to ΔT_E	Figure Number for Details
	feet	feet		feet	F	F		
March 1969	340	20	17	2.4 x 15	1.5	13.8	0.48	5
March 1969	240	20	12	4 x 15	1.5	14.0	0.50	6
Aug. 1969	240	20	6	4 x 30	1.5	17	0.53	7
March 1969	340	20	17	2.8 x 15	1.25	13.9	0.54	8
Oct. 1968	240	20	6	8 x 30	0.3	17	0.59	9
March 1969	240	20	12	6.5 x 15	0.5	13.7	0.61	10
Oct. 1968	240	20	6	7 x 30	0.4	17	0.67	11
March 1969	340	20	224	2.5 DIA.	0.6	12.9	0.67	12
Oct. 1968	240	25	6	7 x 30	0.4	17	0.70	13
Oct. 1968	240	30	6	7 x 30	0.4	17	0.65	14

TABLE III DATA OF TESTED OUTFALL CONFIGURATIONS

In general the tests results have been arranged as to decreasing efficiency. It is noted that the smaller the ratio between maximum observed river temperature and effluent temperature the more effective is the outfall structure in providing dilution.

The general trend indicated by the table values is that dilution primarily increased with discharge velocity. It is also seen that within the range tested the length of the outfall structure does not have a significant influence on the dilution. Submergence of the outfall openings does have an effect on dilution, increasing submergence improves the dilution, however, this effect is not as marked as that due to exit velocity.

It should be noted that the efficiency values shown for the tests of August and October, 1968 are not as accurate as those shown for the tests performed in March, 1969. For two reasons the latter are more accurate. The ambient temperature was more stable due to more uniform temperature of the water and the flow pattern of the water representing river flow was improved by better designed guide vanes in the upstream part of the model.

One of the tests seems to fall outside of the general efficiency pattern namely the test with six 8 by 30 foot openings, Figure 9. It is felt that the relatively favorable efficiency value indicated for this test is in error. A probable explanation is that the highest surface temperature escaped measurement due to the particular flow pattern produced by this outfall configuration.

The test with 224 circular openings, 2.5' diameter in two rows, spaced 3 feet center to center distance both horizontally and vertically, indicates a relatively low efficiency. Despite the higher exit velocity this design is equivalent to 6 openings 7

by 30 feet in terms of dilution.

The effective exit velocity is indicated by the water level difference between the outfall channel and the river. The exit velocity is approximately equal to $\sqrt{2gh}$ where h is the water level difference, g is the gravity constant. The exit velocity determined this way is higher than the nominal velocity computed as $\frac{Q}{A}$ where Q is the effluent flow rate and A is the total area of the outfall openings. The reason is that the flow is contracted by passing through the sharp cornered openings. A coefficient of contraction was computed for several of the tests and found to have a value of between 0.6 and 0.7. It was found that the coefficient increased slightly with the longer outfall structure presumably due to the relatively lower channel velocities. This is reflected in the fact that the height of the openings could be somewhat reduced without exceeding ^a water level difference of 1.5 feet between channel and river. The nominal area with the 240 foot long channel was 720 feet² while the nominal area with the 340 foot channel was 612 feet² for 1.5 feet water level difference. The 720 feet² opening area yields an opening height of 2.8 feet with the 340 foot long channel. A test with these conditions was performed, see Figure 8.

Tests were performed to determine the effect on water level difference of adjustable openings at the downstream end of the outfall channel. These tests were conducted with the outfall configuration consisting of a 340 foot long structure containing 17 openings 2.4 feet high and with 5 foot partitions between the openings. Figure 15 shows the results. It is seen that the "head loss" decreased rapidly when the last opening was extended up to the water surface, one free opening reduced the water

level difference by 50%. A plot on semilogarithmic paper indicated that the gain in "head loss" varied exponentially with the number of free openings. It is seen from Figure 15 that the additional gain, when more than 3 openings were free, was insignificant.

CONCLUSIONS

Model tests in an undistorted model of ratio 1:50 simulating a variety of outfall configurations indicated that an initial reduction of the effluent cooling water temperature of approximately 50% may be achieved in one of several ways:

- 1) a 340 foot long structure with 17 openings 2.4' x 15' reduced the maximum surface temperature to 48% of the effluent temperature.
- 2) a 240 foot long structure, 12 openings 4' x 15'; reduction to 50%
- 3) a 240 foot long structure, 6 openings 4' x 30'; reduction to 53%
- 4) a 340 foot long structure, 17 openings 2.8' x 30'; reduction to 54%

While structures 1), 2) and 3) produced a water level difference between the channel and the river of 1.5 feet, structure 4) caused a difference of 1.25 feet.

It was found that the water level difference between channel and river may be reduced by 50% by extending the furthestmost downstream opening of ~~the~~ structure ¹ to the water surface. The gain with additional free openings decreased exponentially. Adjustable outfall openings would be used at times when the need for initial dilution is reduced.

It is interesting to note that the rather well developed theoretical approach to the dilution problem applied to the flow conditions of structure 1) indicates a temperature reduction to approximately 25% of the effluent temperature. The theoretical approach assumes an infinite depth above and below the outfall "slot" and is therefore not applicable to the boundary conditions of this outfall. The model results indicating only about 50% reduction reflect the reduced entrainment of ambient water due to the boundary conditions.

OUTFALL CONFIGURATION

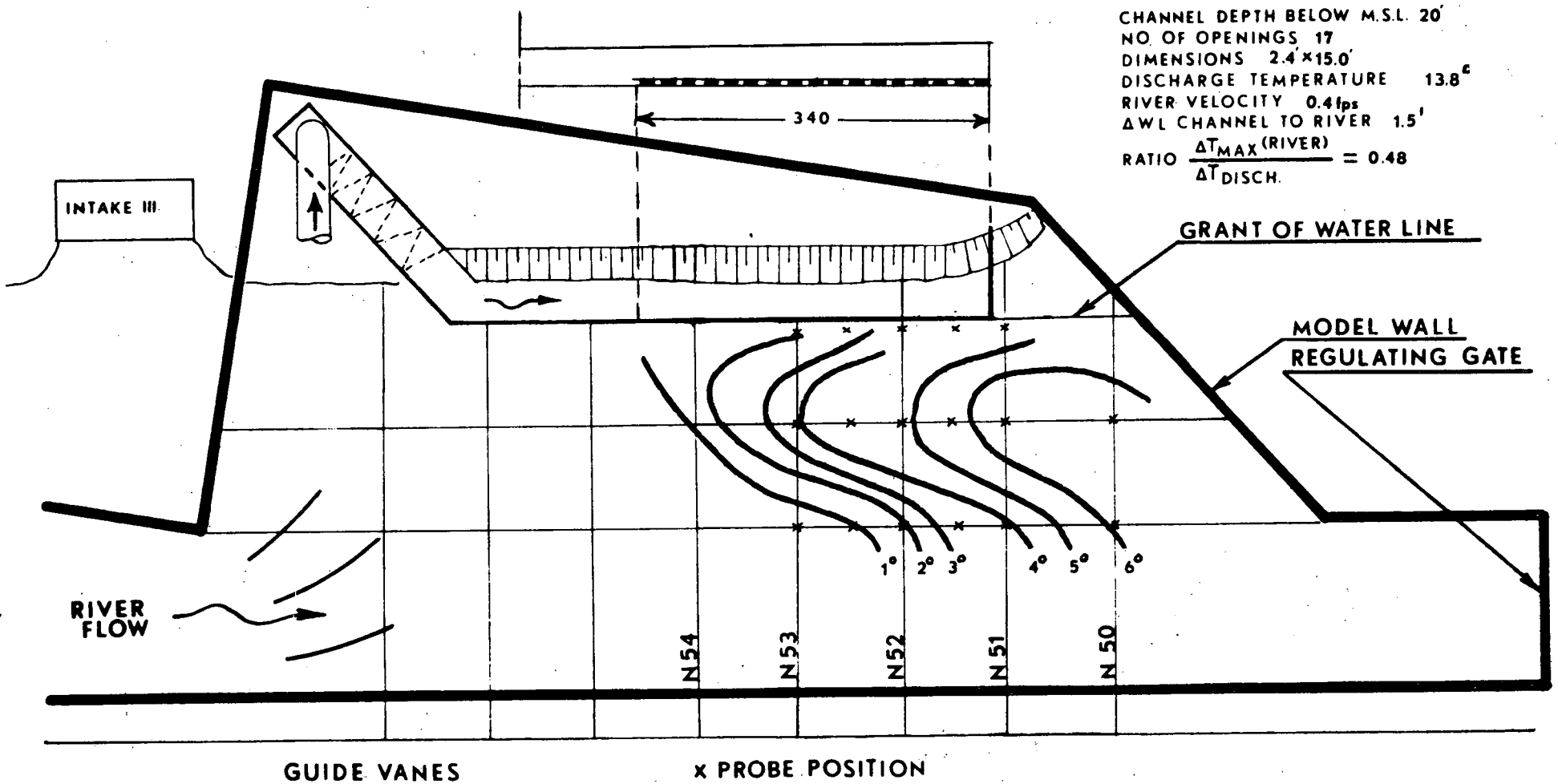

CHANNEL DEPTH BELOW M.S.L. 20'
 NO. OF OPENINGS 17
 DIMENSIONS 2.4 x 15.0'
 DISCHARGE TEMPERATURE 13.8°
 RIVER VELOCITY 0.4 fps
 ΔWL CHANNEL TO RIVER 1.5'
 RATIO $\frac{\Delta T_{MAX}(RIVER)}{\Delta T_{DISCH.}} = 0.48$

ALDEN RESEARCH LABORATORIES
 WORCESTER POLYTECHNIC INSTITUTE
 INDIAN POINT II SUB-MODEL
 MODEL SCALE 1:50 (UNDISTORTED)
 SURFACE ISOTHERMS
 TEST DATE MAR '69

OUTFALL CONFIGURATION

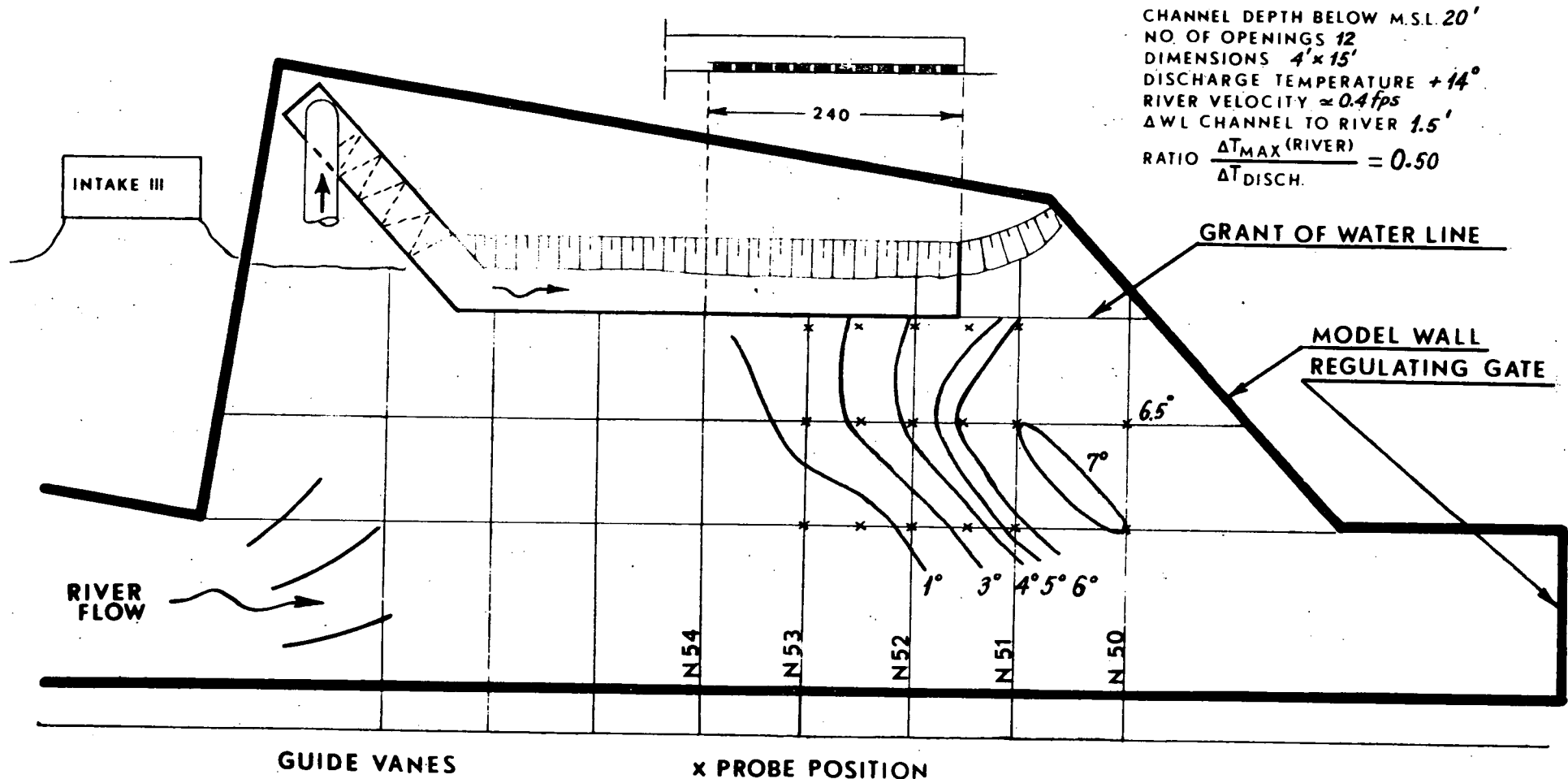

CHANNEL DEPTH BELOW M.S.L. 20'
 NO. OF OPENINGS 12
 DIMENSIONS 4' x 15'
 DISCHARGE TEMPERATURE +14°
 RIVER VELOCITY ≈ 0.4 fps
 ΔWL CHANNEL TO RIVER 1.5'
 RATIO $\frac{\Delta T_{MAX}(RIVER)}{\Delta T_{DISCH.}} = 0.50$

ALDEN RESEARCH LABORATORIES
 WORCESTER POLYTECHNIC INSTITUTE
 INDIAN POINT II SUB-MODEL
 MODEL SCALE 1:50 (UNDISTORTED)
 SURFACE ISOTHERMS
 TEST DATE MAR '69

FIG. 6

OUTFALL CONFIGURATION

CHANNEL DEPTH BELOW M.S.L. 20'
 NO. OF OPENINGS 6
 DIMENSIONS 4x30'
 DISCHARGE TEMPERATURE 17°
 RIVER VELOCITY 0.4 fps
 ΔWL CHANNEL TO RIVER 1.5'
 RATIO $\frac{\Delta T_{MAX}(RIVER)}{\Delta T_{DISCH.}} = 0.53$

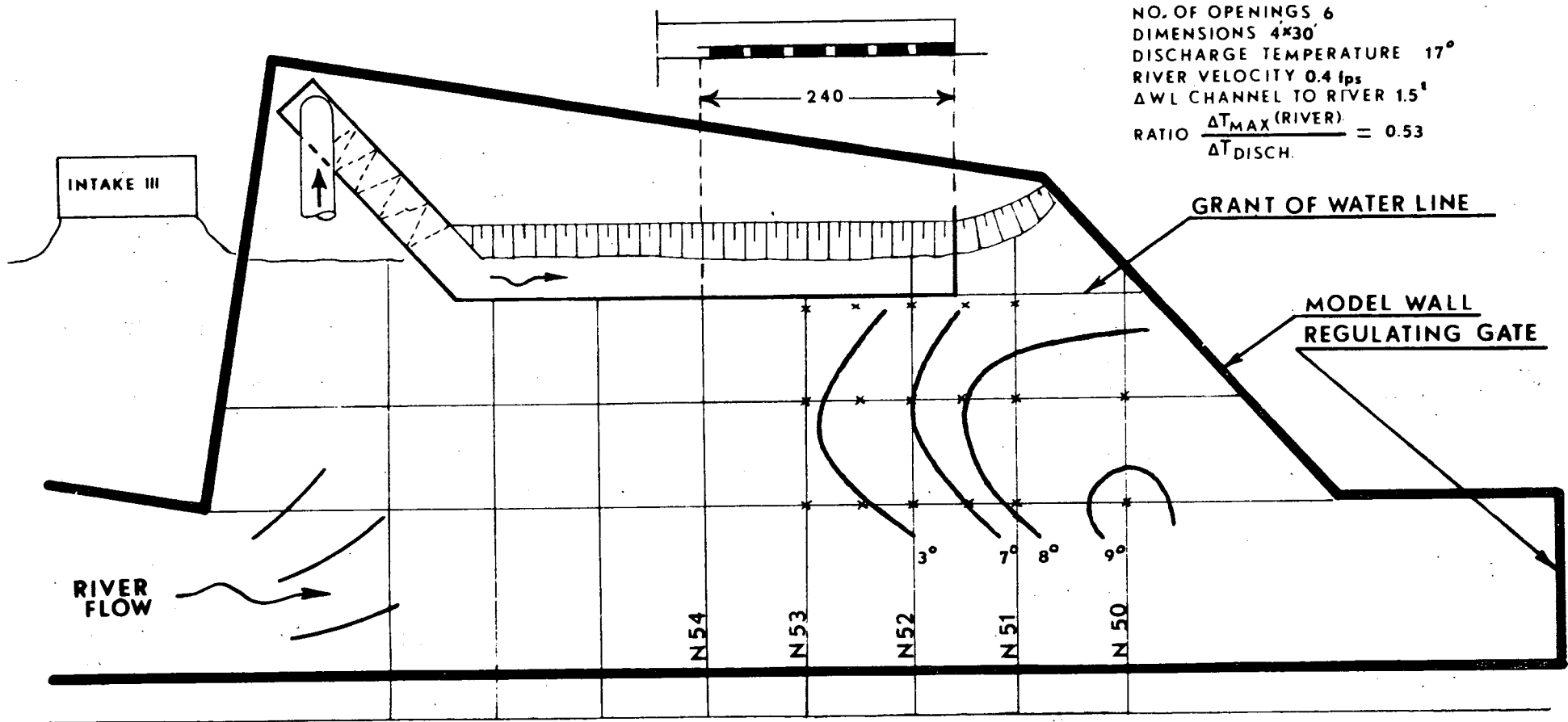

GUIDE VANES

x PROBE POSITION

ALDEN RESEARCH LABORATORIES
 WORCESTER POLYTECHNIC INSTITUTE
 INDIAN POINT II SUB-MODEL
 MODEL SCALE 1:50 (UNDISTORTED)
 SURFACE ISOTHERMS
 TEST DATE AUG. '68

OUTFALL CONFIGURATION

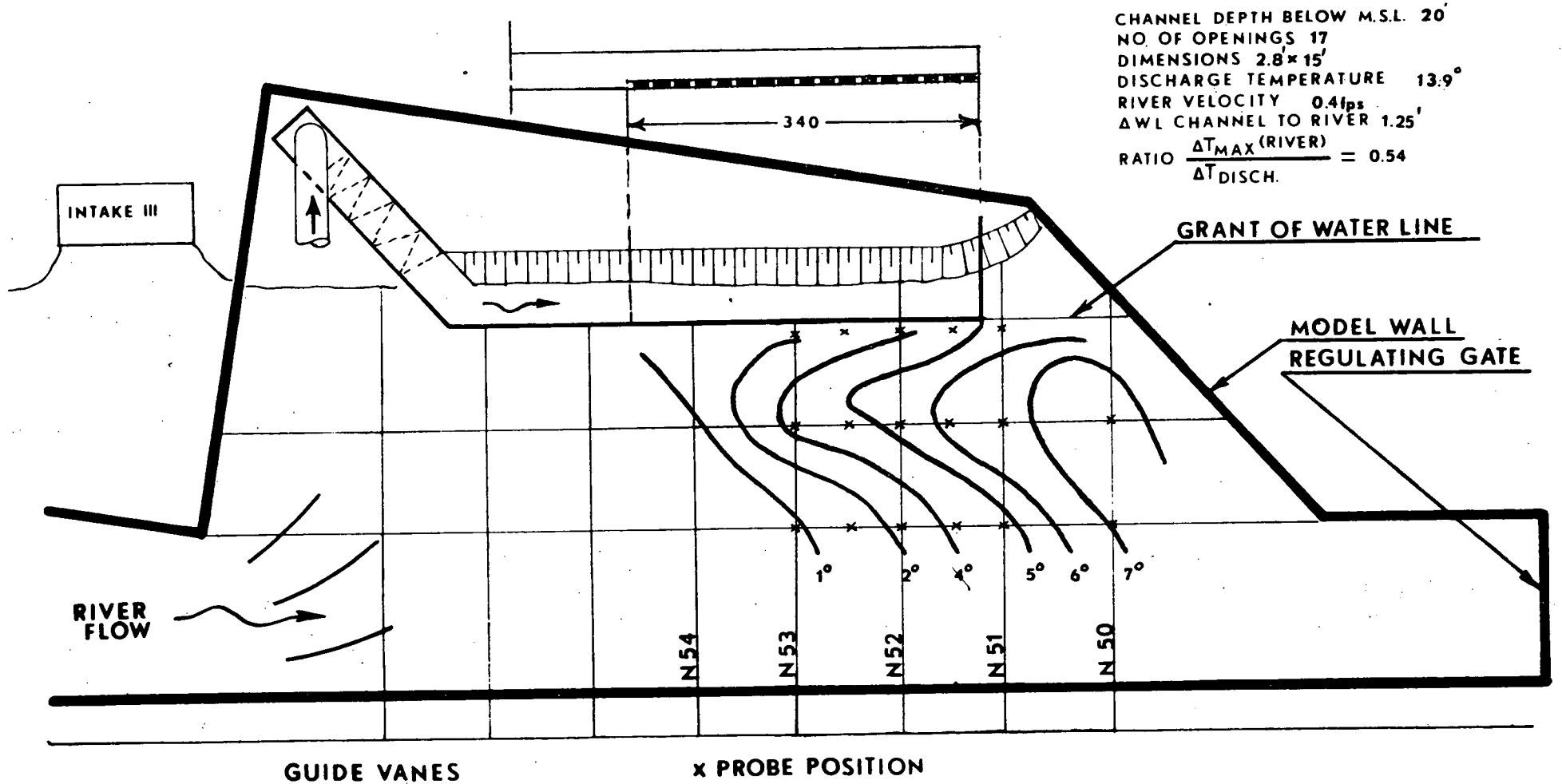

ALDEN RESEARCH LABORATORIES
 WORCESTER POLYTECHNIC INSTITUTE
 INDIAN POINT II SUB-MODEL
 MODEL SCALE 1:50 (UNDISTORTED)
 SURFACE ISOTHERMS
 TEST DATE MAR '69

OUTFALL CONFIGURATION

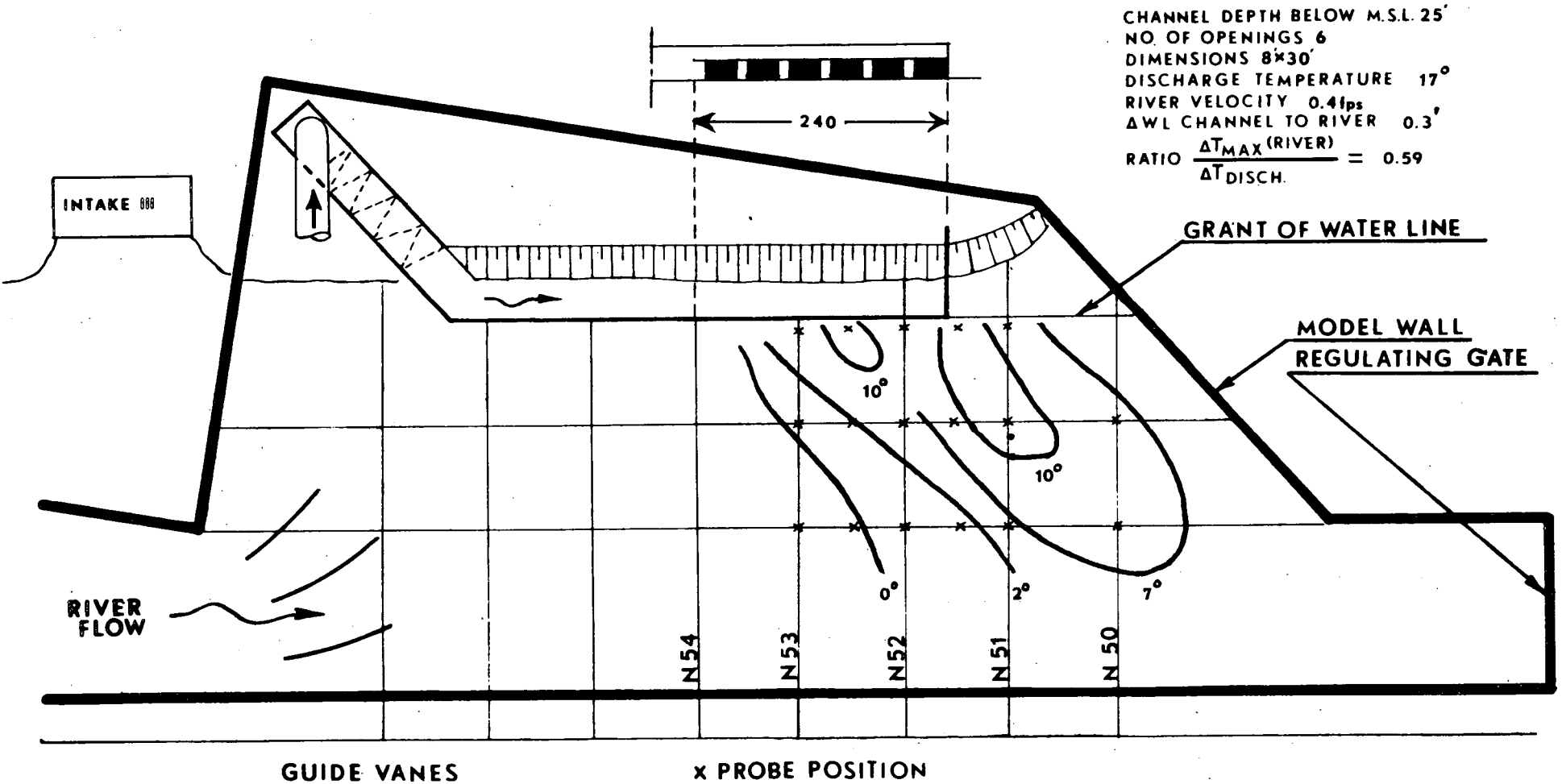

CHANNEL DEPTH BELOW M.S.L. 25'
 NO. OF OPENINGS 6
 DIMENSIONS 8x30'
 DISCHARGE TEMPERATURE 17°
 RIVER VELOCITY 0.4fps
 ΔWL CHANNEL TO RIVER 0.3'
 RATIO $\frac{\Delta T_{MAX} (RIVER)}{\Delta T_{DISCH.}} = 0.59$

GUIDE VANES

x PROBE POSITION

ALDEN RESEARCH LABORATORIES
 WORCESTER POLYTECHNIC INSTITUTE
 INDIAN POINT II SUB-MODEL
 MODEL SCALE 1:50 (UNDISTORTED)
 SURFACE ISOTHERMS
 TEST DATE OCT. '68

OUTFALL CONFIGURATION

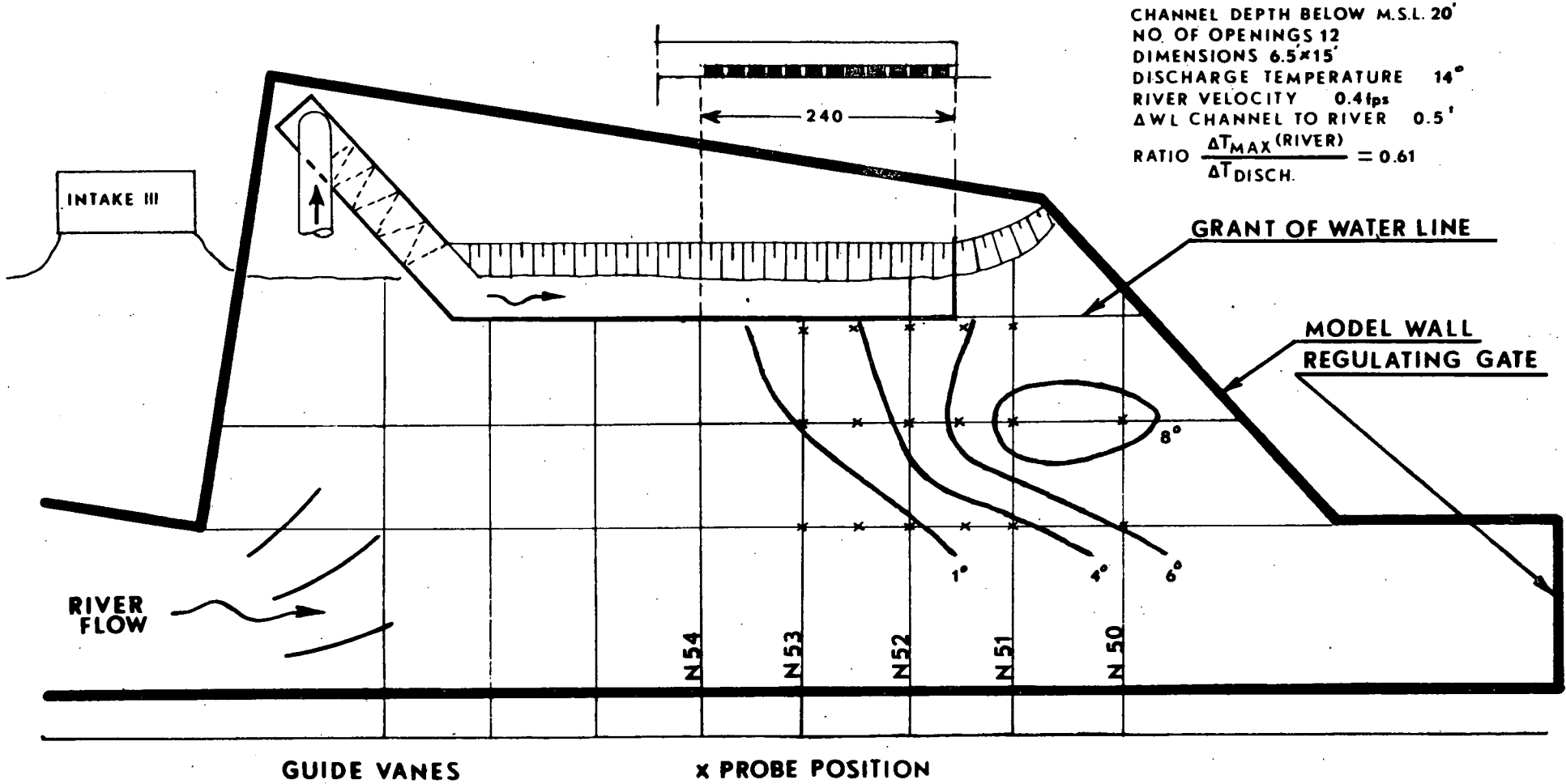

CHANNEL DEPTH BELOW M.S.L. 20'
 NO. OF OPENINGS 12
 DIMENSIONS 6.5x15'
 DISCHARGE TEMPERATURE 14°
 RIVER VELOCITY 0.4fps
 ΔWL CHANNEL TO RIVER 0.5'
 RATIO $\frac{\Delta T_{MAX}(RIVER)}{\Delta T_{DISCH.}} = 0.61$

ALDEN RESEARCH LABORATORIES
 WORCESTER POLYTECHNIC INSTITUTE
 INDIAN POINT II SUB-MODEL
 MODEL SCALE 1:50 (UNDISTORTED)
 SURFACE ISOTHERMS
 TEST DATE MAR '69

OUTFALL CONFIGURATION

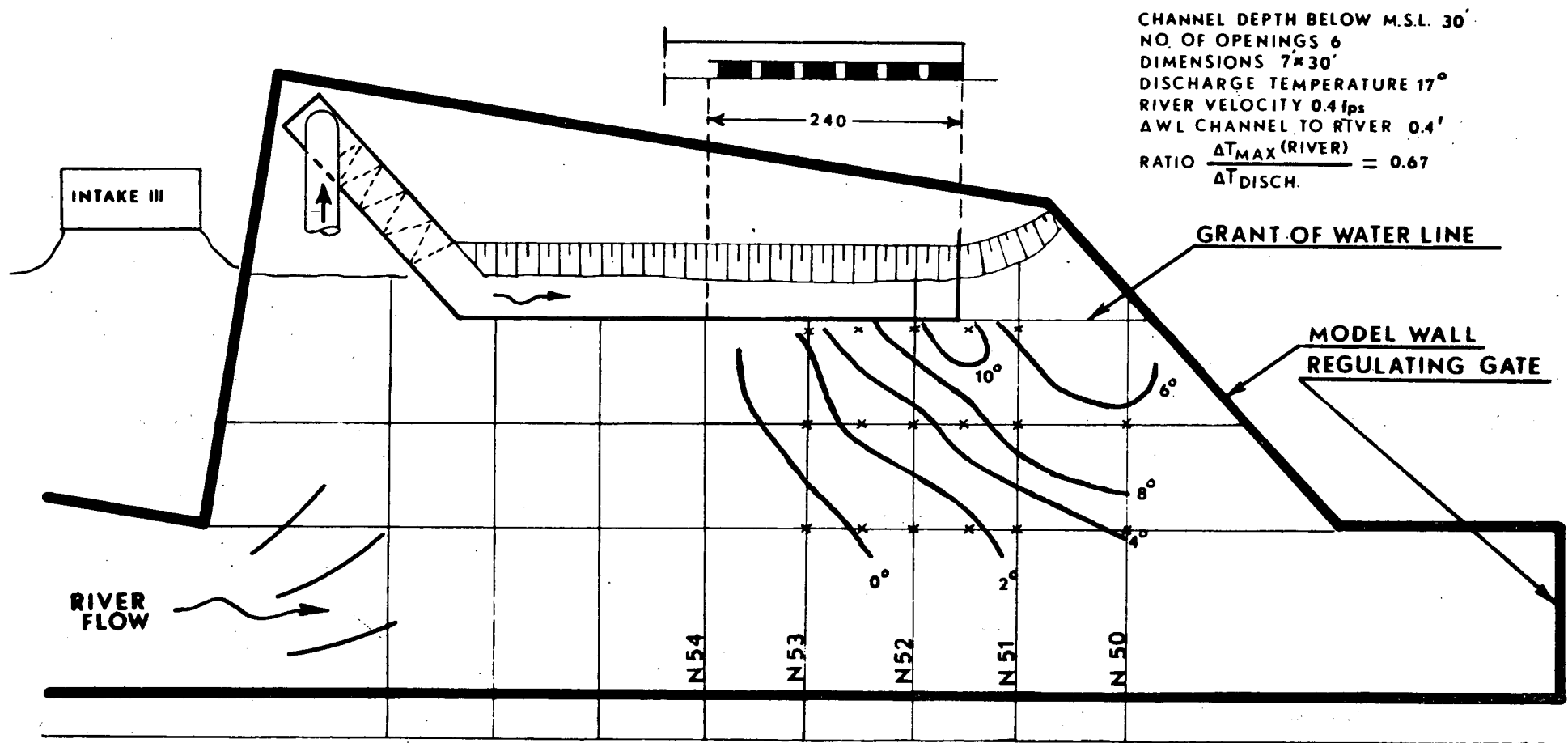

CHANNEL DEPTH BELOW M.S.L. 30'
 NO. OF OPENINGS 6
 DIMENSIONS 7x30'
 DISCHARGE TEMPERATURE 17°
 RIVER VELOCITY 0.4 fps
 ΔWL CHANNEL TO RIVER 0.4'
 RATIO $\frac{\Delta T_{MAX} (RIVER)}{\Delta T_{DISCH.}} = 0.67$

GUIDE VANES

x PROBE POSITION

ALDEN RESEARCH LABORATORIES
 WORCESTER POLYTECHNIC INSTITUTE
 INDIAN POINT II SUB-MODEL
 MODEL SCALE 1:50 (UNDISTORTED)
 SURFACE ISOTHERMS
 TEST DATE OCT. '68

OUTFALL CONFIGURATION

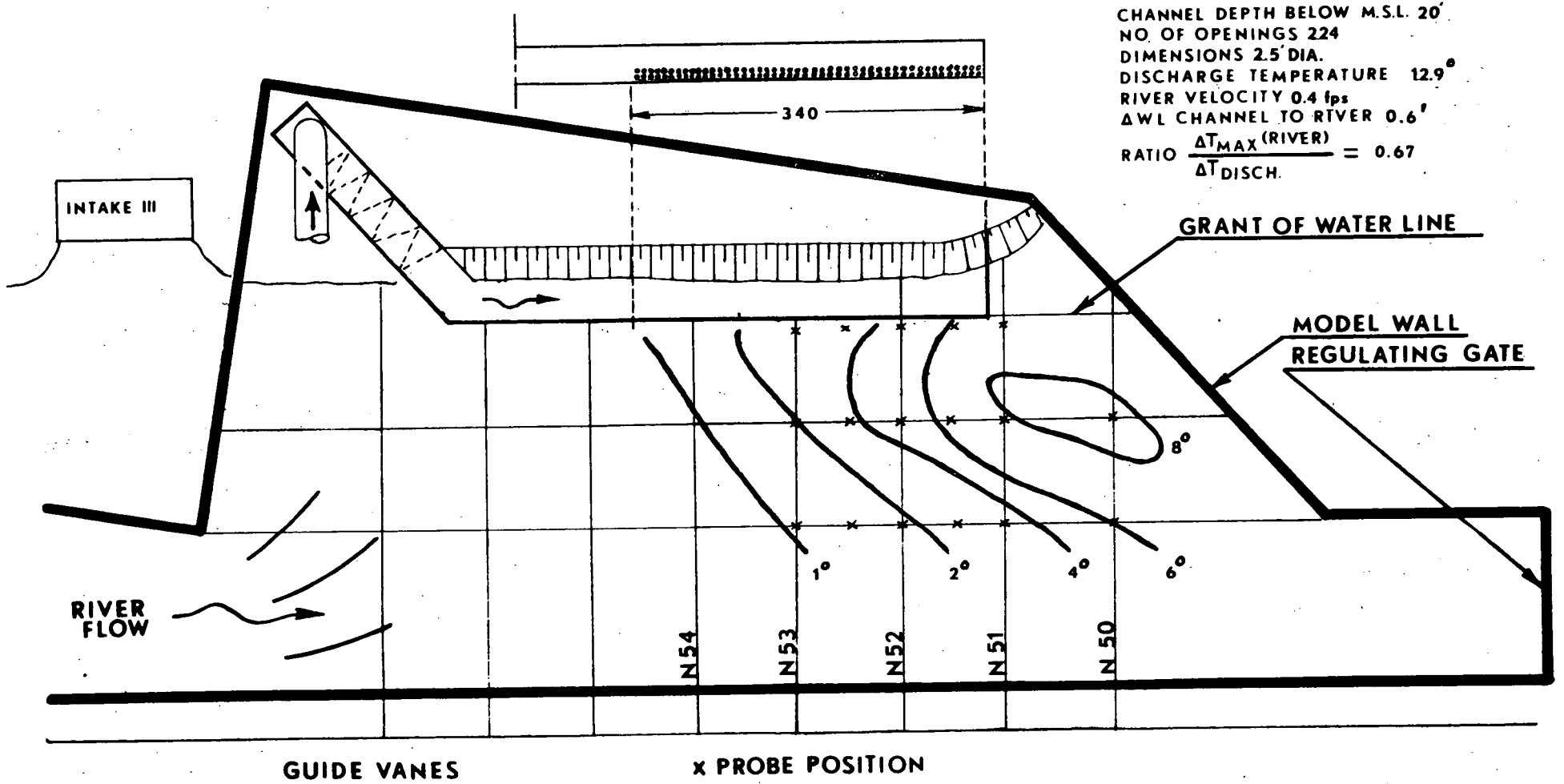

ALDEN RESEARCH LABORATORIES
 WORCESTER POLYTECHNIC INSTITUTE
 INDIAN POINT II SUB-MODEL
 MODEL SCALE 1:50 (UNDISTORTED),
 SURFACE ISOTHERMS
 TEST DATE MAR '69

FIG. 12

OUTFALL CONFIGURATION

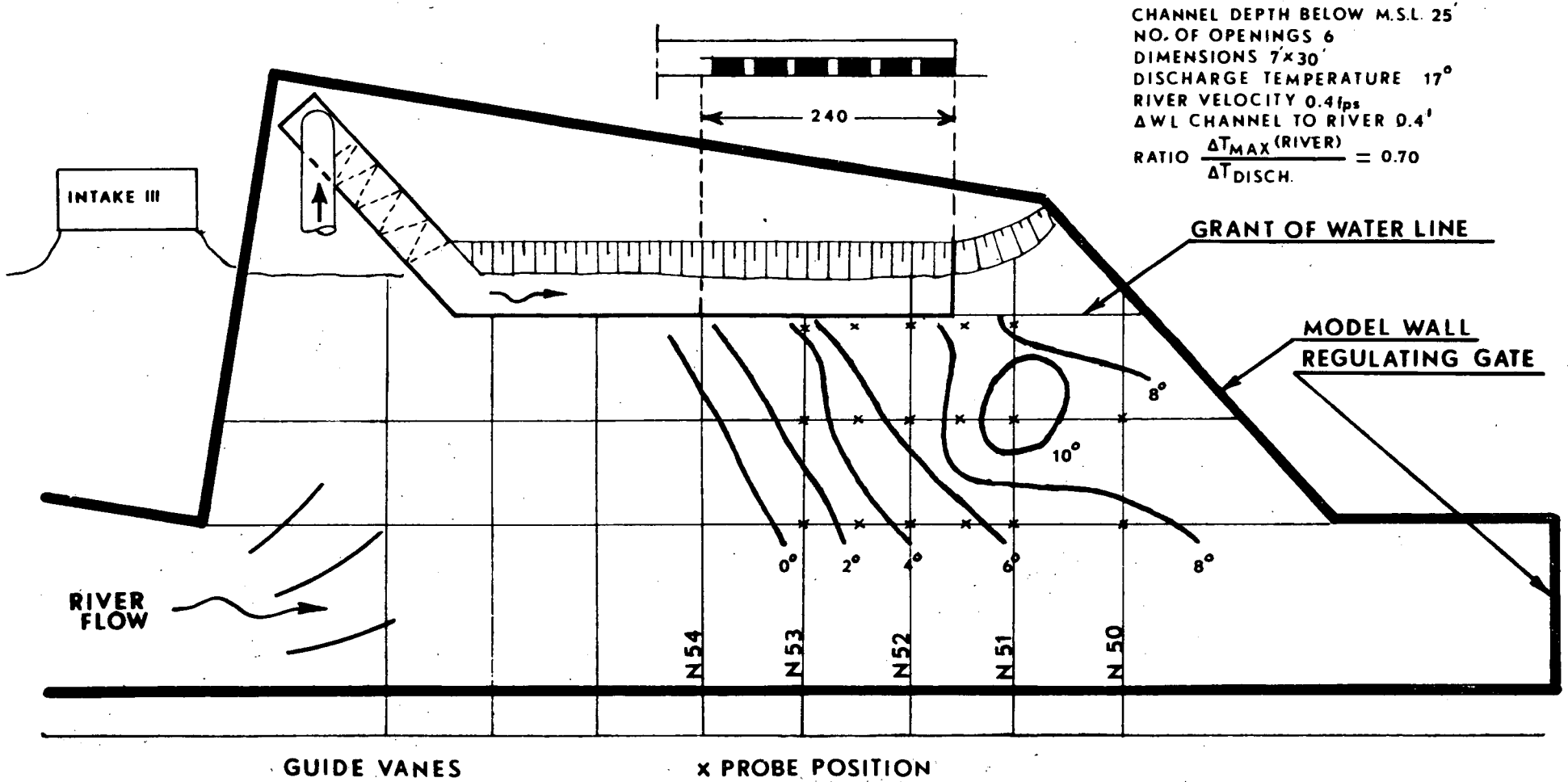

CHANNEL DEPTH BELOW M.S.L. 25'
 NO. OF OPENINGS 6
 DIMENSIONS 7x30'
 DISCHARGE TEMPERATURE 17°
 RIVER VELOCITY 0.4fps
 ΔWL CHANNEL TO RIVER 0.4'
 RATIO $\frac{\Delta T_{MAX} (RIVER)}{\Delta T_{DISCH.}} = 0.70$

ALDEN RESEARCH LABORATORIES
 WORCESTER POLYTECHNIC INSTITUTE
 INDIAN POINT II SUB-MODEL
 MODEL SCALE 1:50 (UNDISTORTED)
 SURFACE ISOTHERMS
 TEST DATE OCT. '68

OUTFALL CONFIGURATION

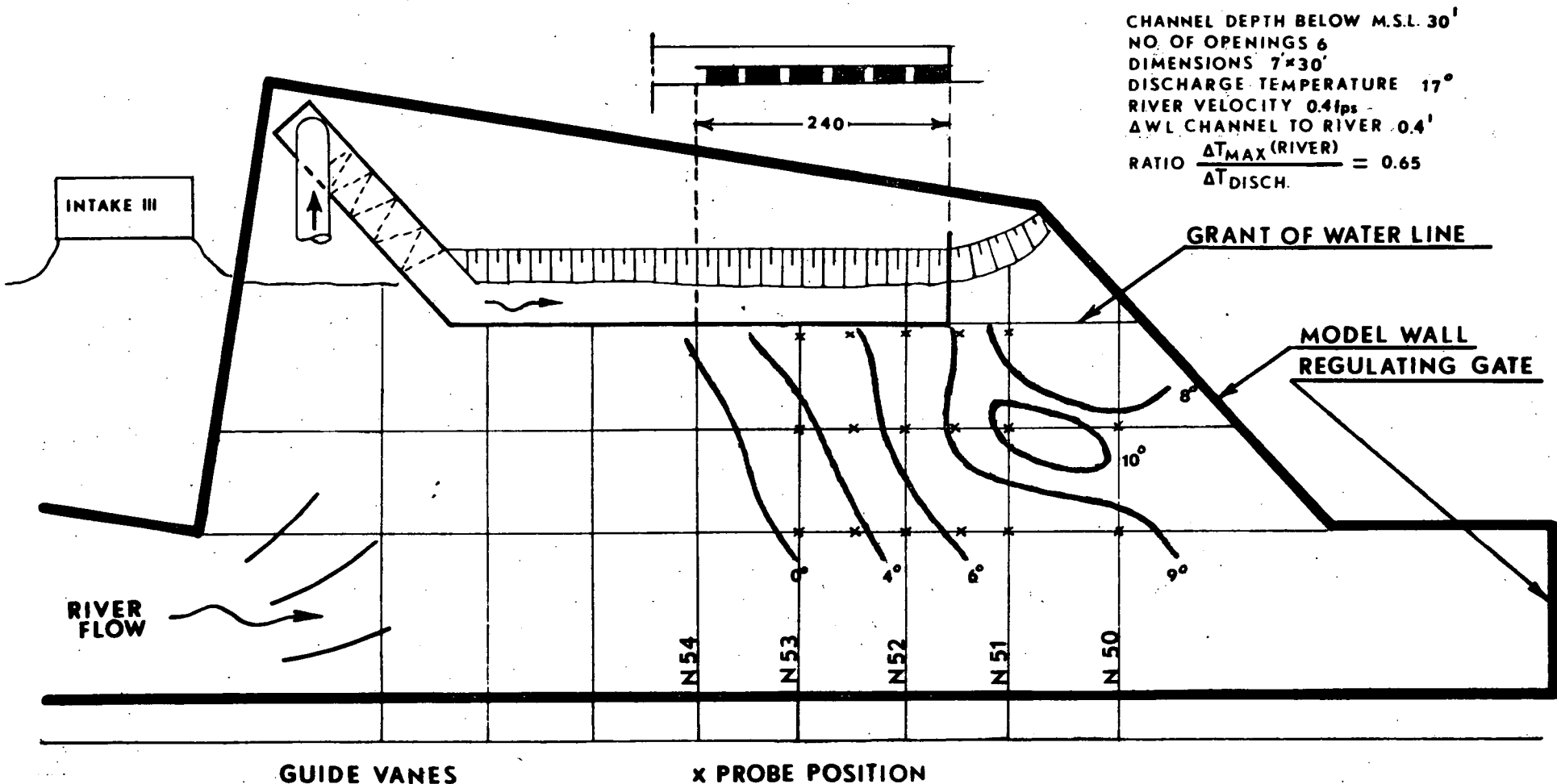

CHANNEL DEPTH BELOW M.S.L. 30'
 NO. OF OPENINGS 6
 DIMENSIONS 7x30'
 DISCHARGE TEMPERATURE 17°
 RIVER VELOCITY 0.4fps
 ΔWL CHANNEL TO RIVER .04'
 RATIO $\frac{\Delta T_{MAX}(RIVER)}{\Delta T_{DISCH.}} = 0.65$

ALDEN RESEARCH LABORATORIES
 WORCESTER POLYTECHNIC INSTITUTE
 INDIAN POINT II SUB-MODEL
 MODEL SCALE 1:50 (UNDISTORTED)
 SURFACE ISOTHERMS
 TEST DATE OCT. '68

FIG. 14

FIG. 15

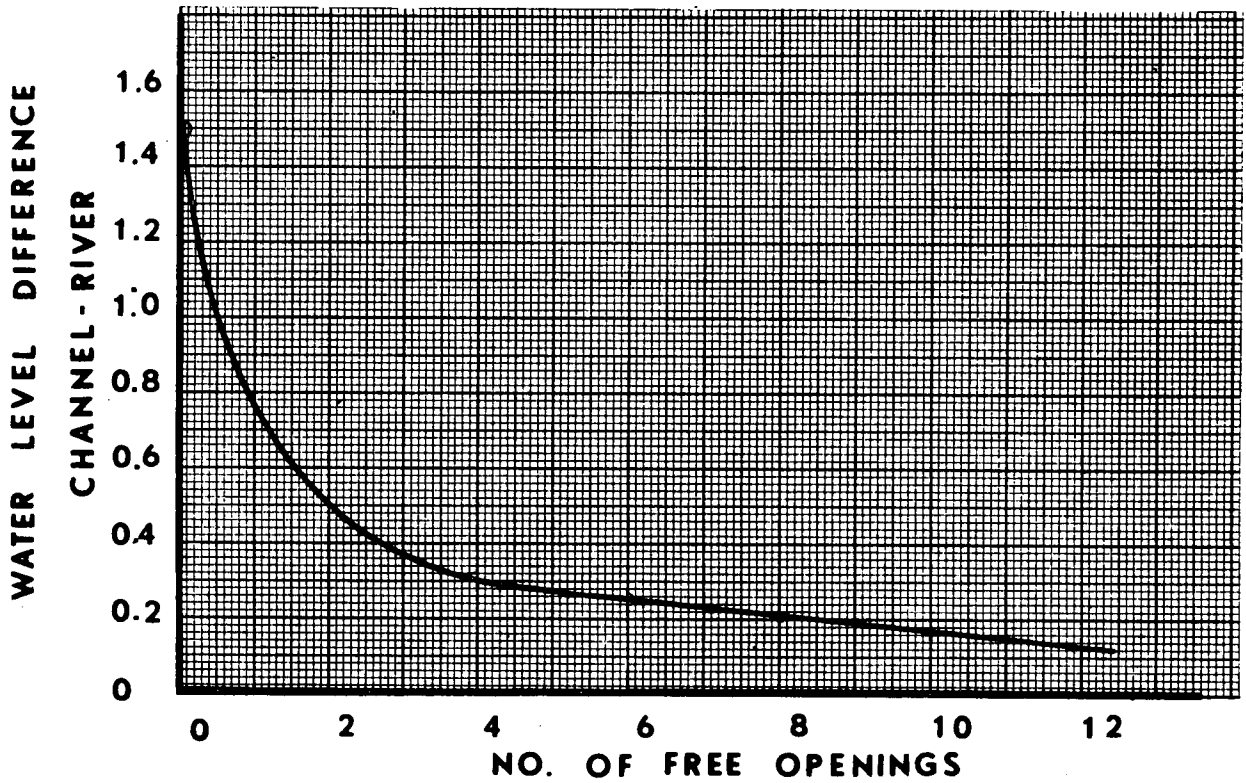
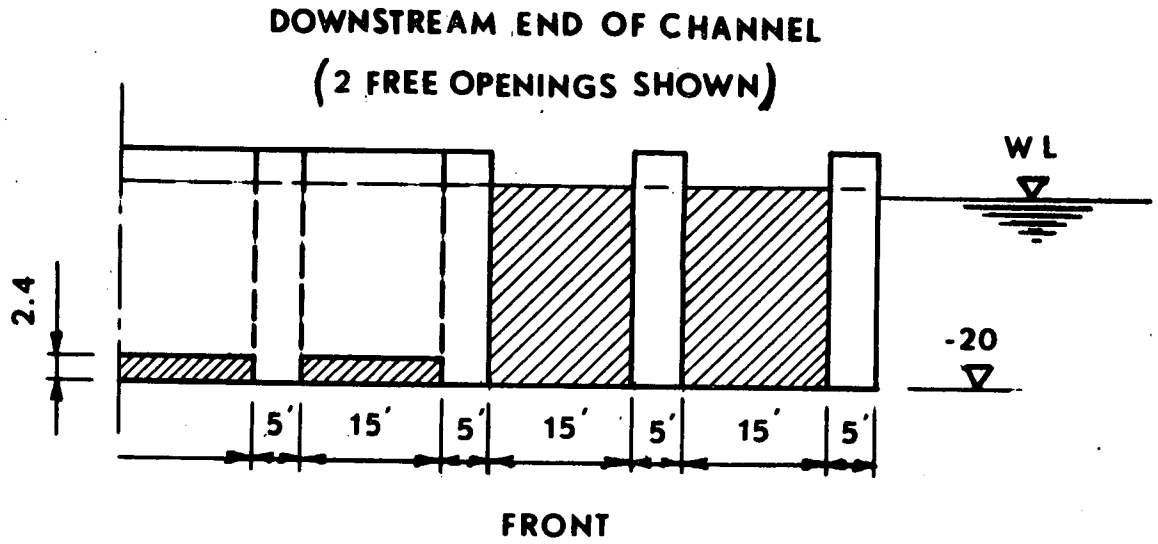

ALDEN RESEARCH LABORATORIES
WORCESTER POLYTECHNIC INSTITUTE
INDIAN POINT II SUB-MODEL

MODEL SCALE 1:50 (UNDISTORED)
WATER LEVEL DIFFERENCE CHANNEL - RIVER

Consolidated Edison Company of New York, Inc.

INFLUENCE OF HUDSON RIVER
NET NON-TIDAL FLOW
ON
TEMPERATURE DISTRIBUTION

October, 1969

Quirk, Lawler & Matusky Engineers
Environmental Science & Engineering Consultants
505 Fifth Avenue
New York, New York 10017

QUIRK, LAWLER & MATUSKY ENGINEERS
ENVIRONMENTAL SCIENCE & ENGINEERING CONSULTANTS

505 FIFTH AVENUE
NEW YORK, NEW YORK 10017
212 867-0080

WATER RESOURCES DEVELOPMENT
WATER POLLUTION CONTROL
AIR POLLUTION CONTROL
SOLID WASTES DISPOSAL

SYSTEMS ANALYSIS & DESIGN

COMPUTER FACILITIES
PILOT PLANT FACILITIES
ANALYTICAL LABORATORIES

THOMAS P. QUIRK
JOHN P. LAWLER
FELIX E. MATUSKY

WILLIAM A. PARSONS
LEONARD J. EDER
ROBERT A. NORRIS
VINCENT J. BOCCHINO

October 28, 1969

File: 115-5

Mr. George T. Cowherd, Jr.
Environmental Engineer
Consolidated Edison Company
of New York, Inc.
4 Irving Place
New York, New York 10003

Dear Mr. Cowherd:

Pursuant to your request, we are pleased to submit our report on the evaluation of the influence of Hudson River net non-tidal flow on temperature distribution in the vicinity of Indian Point.

This report provides an additional theoretical support of the reduced temperature effect arrived at empirically in our February, 1969 Report.

Several Hudson River current observations and salinity measurements at various depths throughout several cross-sections have been utilized in the study. These field studies were conducted by the U.S. Coast & Geodetic Survey in 1929, 1958 and 1959 and by our firm in 1964.

Study results are summarized as follows:

1. The salinity and current measurements showed that there is a net upstream movement of sea water in the lower layers and a downstream movement of fresher water in the upper layers of the Lower Hudson River. The surface of no net motion which separates the two layers usually occurs somewhat above mid-depth. This movement is induced by density differences which exist on account of the vertical and longitudinal distribution of salinity. Such movement exists mainly in the saline portion of the estuary. This effect is called the net non-tidal flow.

Mr. George T. Cowherd, Jr.
October 28, 1969

S-2

2. At Indian Point, the net non-tidal flow is present when the fresh water runoff in the Lower Hudson is less than 20,000 cfs. The effect is weakest where salt is not present.
3. Field measurements showed that when the lower Hudson fresh water runoff is about 7,300 cfs, there is a seaward flow of about 22,000 cfs at Indian Point in the upper layer and an upstream flow of some 14,700 cfs in the lower layer. These values indicate that, under such conditions, a total flow of some 36,700 cfs is available for dilution purposes at Indian Point. This flow is about five times the fresh water flow.
4. The U.S. Coast and Geodetic survey observations indicated that during August-September, 1929, the total dilution flow, in both layers, ranged from some 192,000 cfs at the ocean entrance to the fresh water flow value of about 8,000 cfs some 60 miles above Battery. The total dilution flow at Indian Point was about 36,000 cfs.
5. The net non-tidal flow concept succeeded in explaining the measured area-average temperature rise at Indian Point better than all previous attempts. The predicted area-average temperature rise across Indian Point plane of discharge was only 9% less than its observed counterpart measured in July, 1966.
6. The discharge of a three unit Indian Point design heat load of 340 BBTU/day is expected to cause an area-average temperature rise of about 1.7°F when the fresh water runoff is about 7,300 cfs. A maximum value of about 3.2°F may occur when the net non-tidal flow effect is weak and the fresh water runoff is some 20,000 cfs. Therefore, this temperature parameter may be expected to range between 1.7°F and 3.2°F.
7. The net non-tidal mechanism indicated that a substantial reduction in the area-average temperature rise is expected to occur downstream of Indian Point and effectively no temperature movement (other than tidal) in the upstream direction.

QUIRK, LAWLER & MATUSKY ENGINEERS

Mr. George T. Cowherd, Jr.
October 28, 1969

S-3

8. The establishment of the existence of the net non-tidal flow in the Hudson and the conclusions outlined above offer an additional support of the results of our February, 1969 Indian Point Report.

Very truly yours,

QUIRK, LAWLER & MATUSKY ENGINEERS

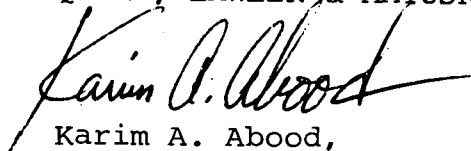

Karim A. Abood,
Project Engineer

KAA/mmn

TABLE OF CONTENTS

	<u>Page</u>
Letter of Transmittal	S-1
I. Purpose and Scope	1
II. Characteristics of Partially Stratified Estuaries	3
III. Hudson River Net Non-Tidal Flow	6
IV. Effect of Net Non-Tidal Flow on Temperature Distribution in the Vicinity of Indian Point	23

I. PURPOSE AND SCOPE

In February, 1969, Quirk, Lawler and Matusky Engineers submitted a report¹ on the expected effect of simultaneous operation of three nuclear units at Indian Point on Hudson River temperature distribution. The results of February, 1969 were arrived at empirically by adjusting our mathematical model to yield better agreement with available Indian Point field data.

Reasons for the differences between the measured and predicted temperatures and rationale for model revision were discussed in the Report. The net non-tidal flow concept was assumed to be the major reason for lower measured temperatures.

After reviewing the February, 1969 Report, the State Department of Health asked for additional information regarding the Hudson River salinity gradients, dispersion and dilution mechanisms at Indian Point during high and low fresh water flow conditions.

The purpose of this report is to supply an additional support of the February, 1969 empirical reduced temperature effect on the basis of the net non-tidal flow concept.

The work required to achieve this objective includes:

1. Establishment of the existence of the net non-tidal flow mechanism in the lower Hudson.
2. Evaluation of the magnitude of this flow and its variation in the vicinity of Indian Point.
3. Comparison of the area-average temperature rise at Indian Point measured in July, 1966 with its predicted counterpart using the net non-tidal flow approach.
4. Prediction of the expected area-average temperature rise resulting from the discharge of a three unit Indian Point design heat load.

II. CHARACTERISTICS OF PARTIALLY STRATIFIED ESTUARIES

In partially stratified estuaries, such as the Hudson, where the mixing of salt and fresh water is incomplete, there is a net upstream movement of sea water in their lower layers and a downstream movement of fresher water in their upper layers. The conditions in such an estuary are represented in Figure 1.

The salinity increases with depth at a less rapid rate of change at the upper and lower layers than at an intermediate layer which experiences a greater rate of change of salinity with depth as in Figure 1-C. The salinity in both layers, however, decreases steadily from the ocean entrance to the head of the estuary (see Figure 1-b).

Because of the greater density of the water in the lower layer, the reversal in flow from ebb to flood occurs earlier at the bottom, i.e., the duration of the bottom flood current exceeds that of the bottom ebb. In the upper layer, where the water is fresher, the reverse is true, i.e., ebb current duration at the surface exceeds that of the surface flood current.

Also, the ebb velocity is a maximum at the surface and decreases

with depth, while the flood velocity is minimum at the surface and increases with depth until near mid-depth, and then, because of bottom friction, decreases as it reaches the bottom as shown in Figure 1-d.

Since the river inflow is in the same direction of the ebb current, the ebb velocity is always greater, in magnitude, than the flood velocity.

There is also a very small net vertical motion of the more saline upstream-moving lower layers towards the surface layers and corresponding downward movement of the downstream-moving upper layers, as in Figure 1-d. The intensity of this motion increases in the upstream direction with almost no vertical mixing at the ocean entrance and a maximum rate of change at the upstream end of the ocean-derived salt intrusion. These mechanisms result in a low vertical salinity gradient at the ocean entrance and a substantial difference between bottom and top salinity at the end of the salt intrusion region.

The net flow pattern, induced by density differences which exist on account of the vertical and longitudinal salinity distribution, may be measured through evaluation of long-term current observations, at various depths throughout cross-sections within the salt intruded

CHARACTERISTICS OF PARTIALLY STRATIFIED ESTUARIES

(a) SECTION ALONG A PARTIALLY STRATIFIED ESTUARY

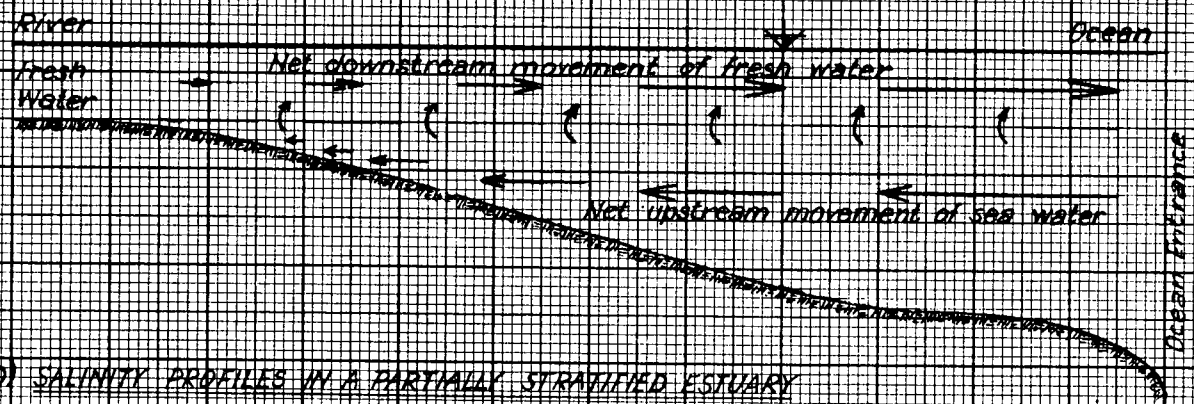

(b) SALINITY PROFILES IN A PARTIALLY STRATIFIED ESTUARY

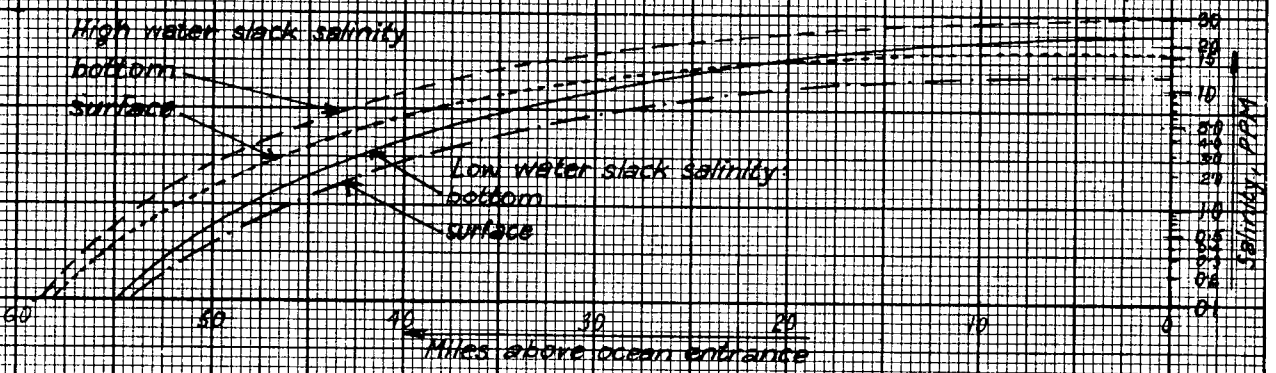

(c) VERTICAL PROFILES OF SALINITY IN A PARTIALLY STRATIFIED ESTUARY

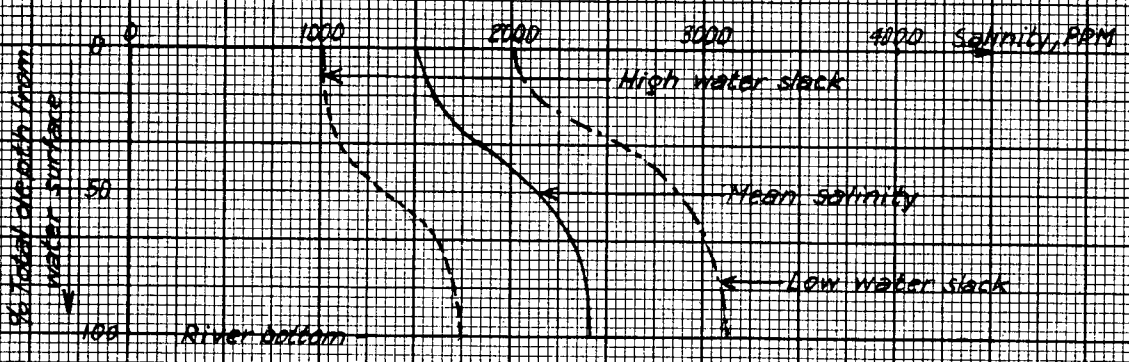

(d) VERTICAL PROFILES OF VELOCITY IN A PARTIALLY STRATIFIED ESTUARY

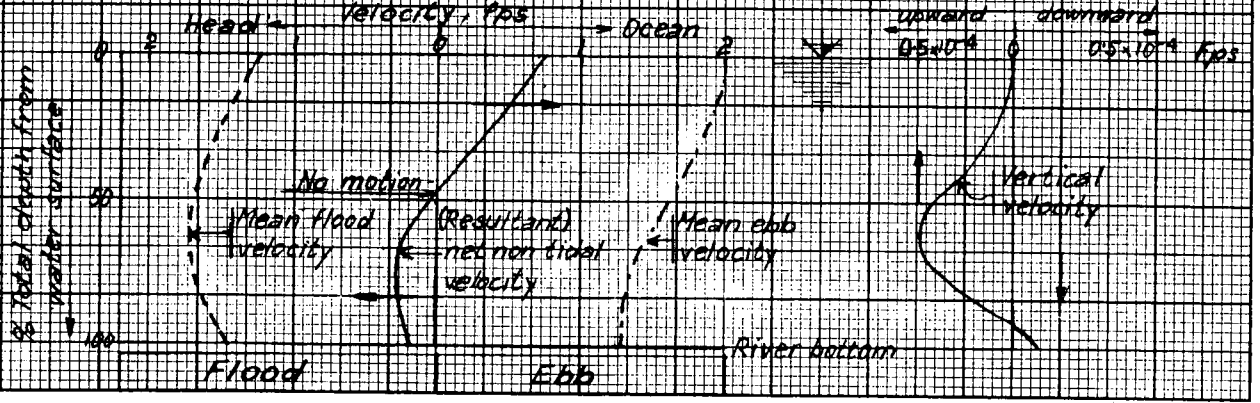

reach, and over a full tidal cycle.

The net circulation pattern described above is often called the net non-tidal flow, but must be distinguished from the fresh water runoff, which is the actual difference between total upstream and downstream tidal movement. Several investigators have evaluated this effect in partially mixed estuaries including the James River in Virginia², the Mersey Estuary³, and the Juan de Fuca Strait, British Columbia.⁴ Values of ten to forty times the fresh water flow have been observed. The actual value increases in the seaward direction of the estuary due to entrainment of the lower layer water by the flow in the upper layer.

III. HUDSON RIVER NET NON-TIDAL FLOW

Extensive long term field current measurements have not been conducted in the Hudson River. However, several Hudson River current and salinity surveys are available and were used to evaluate this phenomenon. Results of this evaluation are presented below.

The surveys used in the evaluation include:

1. QL&M Kyma Salinity Survey, 1964
2. Marmer Current and Salinity Survey, 1958-59
3. Finnegan Current and Density Survey, 1929

The salinity and density measurements were used to show that the net non-tidal flow phenomenon exists in the Hudson. The current measurements were used to compute this effect.

A description of these surveys follows:

A. 1964 Kyma Salinity Survey⁵1. Description of the Survey

This salinity survey was carried out under the direction of QL&M personnel and included the section of the river from mile point 22.825 near Dobbs Ferry to mile point 77.38 in the vicinity of Roosevelt Point.

Data were collected continuously over the 6-day period, November 19-24, 1964.

The locations of the stations sampled during the period are shown on Figure 2.

At each of these stations the following data were collected:

1. Hourly (10 per tidal cycle) salinity measurements at each of three depths (1 or 1.5 ft., $\frac{1}{2}$ depth and $\frac{5}{6}$ depth) and at each of three points across the river (east bank, midchannel, and west bank). A total of some 90 samples were collected at each station. The salinity sampling procedure was dependent on the salt water concentration; for salinities less than 3,000 ppm, Nansen bottles were used in conjunction with a laboratory salinometer. When the salinity exceeded 3,000 ppm, an in-situ salinometer was employed. When using the in-situ instrument, a Nansen sample was taken at the midchannel station at $\frac{5}{6}$ depth for every third run. These samples were titrated as a check on the in-situ readings.
2. Temperature measurements at each of the points described in item #1 above. When the Nansen bottles were used for salinity, the temperature data were obtained using a bathythermograph. When the in-situ salinometer was employed, the thermistor on

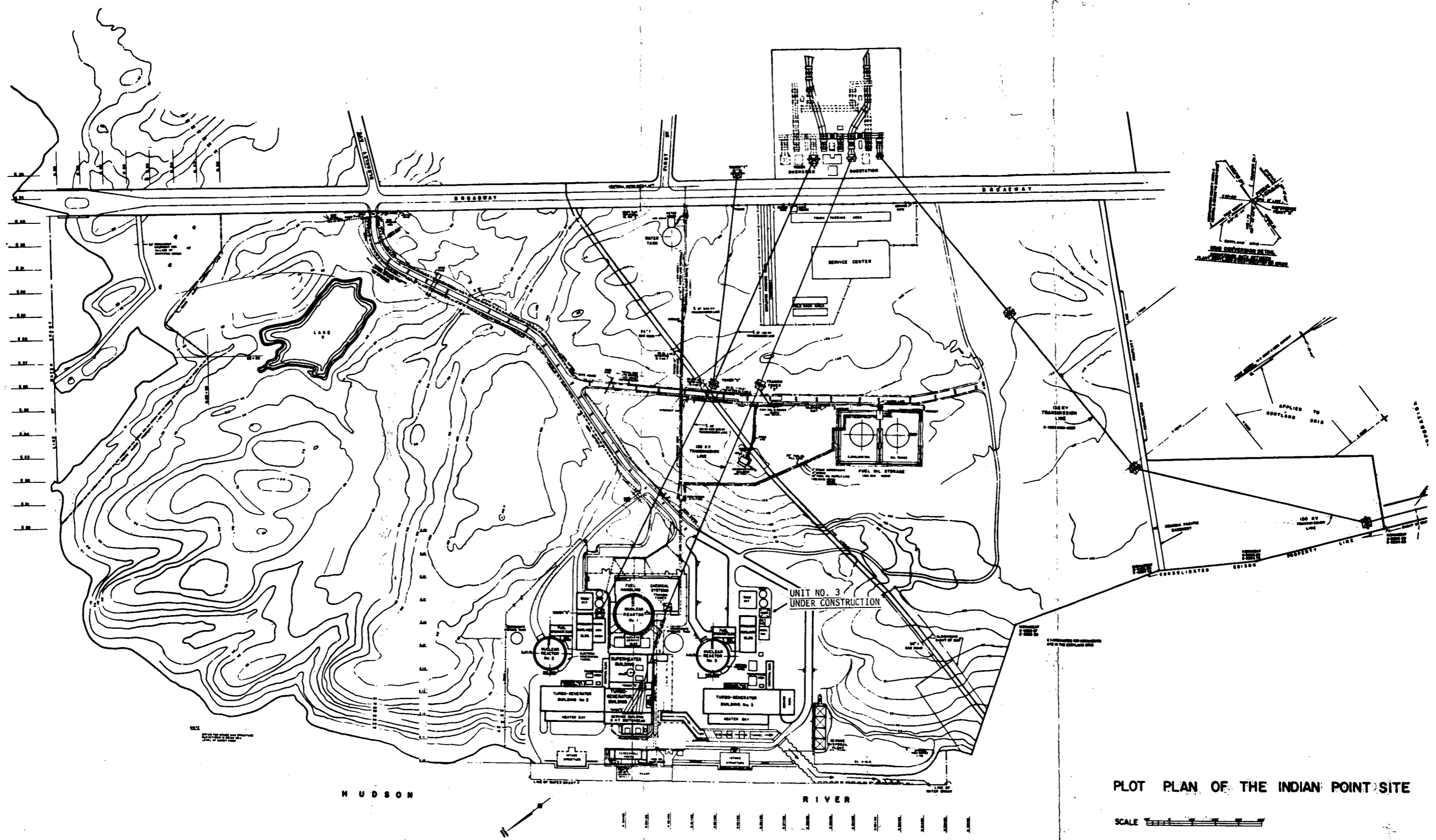

PLOT PLAN OF THE INDIAN POINT SITE

SCALE

GENERAL PLANT PLAN

FIGURE NO. 2

this instrument was used to determine temperature. Supplementary bucket temperatures and bathythermographs were used as checks during the use of the in-situ instrument.

3. River bottom profile across each station, using a recording fathometer.
4. Time, tidal stage and weather conditions were recorded.

Figure 3 shows a typical raw salinity data at three depths at the east bank, midstream, and west bank locations for Indian Point. Salinities were first averaged through the depth, then across the river width. The resultant mean sectional salinity curve is shown on Figure 4 for Indian Point.

Figure 5 shows the mean salinity profile for this survey together with the fresh water histogram at Green Island during and prior to the survey period. The salinities shown are averaged over tidal cycle and River cross-section. The average fresh water flow in the lower Hudson corresponding to the survey period is 4,000 cfs.

2. Interpretation of Survey Results

The vertical mid-channel salinity variation during high water slack

STATION - INDIAN POINT
 SALINITY MEASUREMENTS
 LOCATION - LAT. 41°-16.5'
 MILE POINT - 42.635
 DATE - NOV. 22-23, 1964
 AVERAGE SALINITY - 6730 ppm

DEPTH IN FT.

	EAST B.	MID S.	WEST B.
O	1	1	1
Δ	14	30	28
X	24	50	45

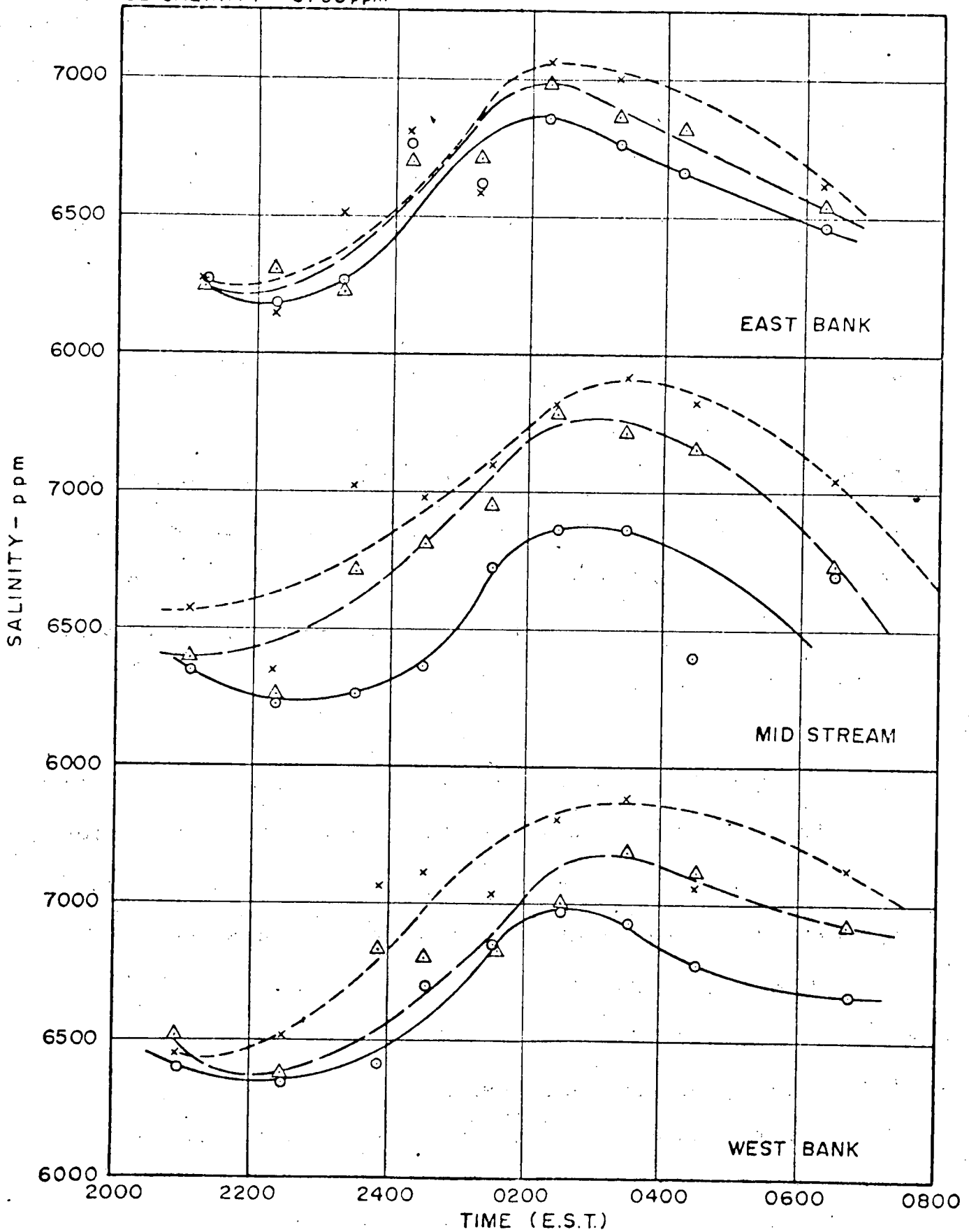

STATION - INDIAN POINT
 LOCATION - LAT. 41° - 16.5'
 MILE POINT 42.635
 DATE NOV. 22 - 23, 1964

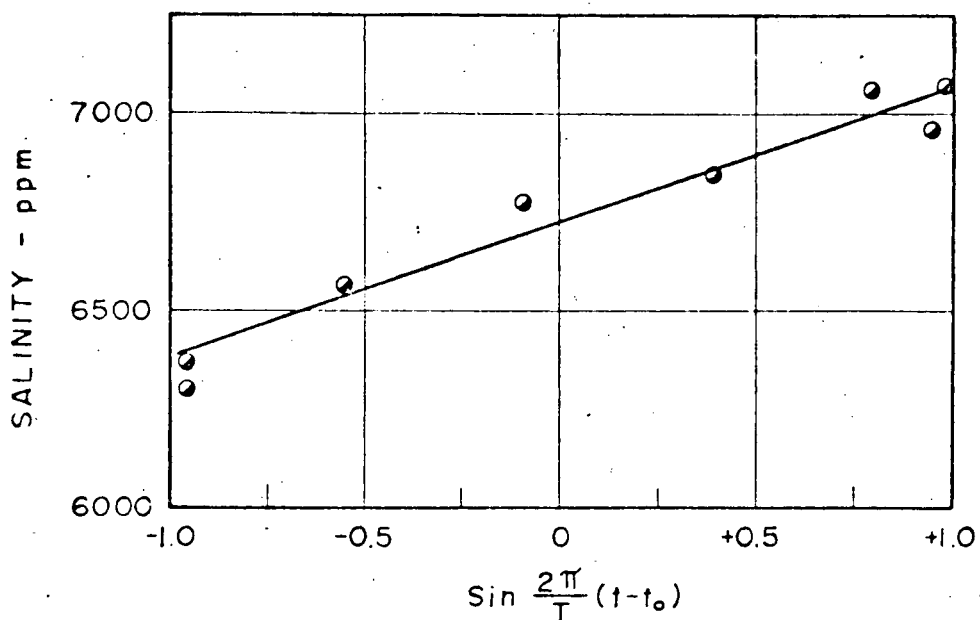

MEAN SECTIONAL SALINITY VS. PHASE ANGLE

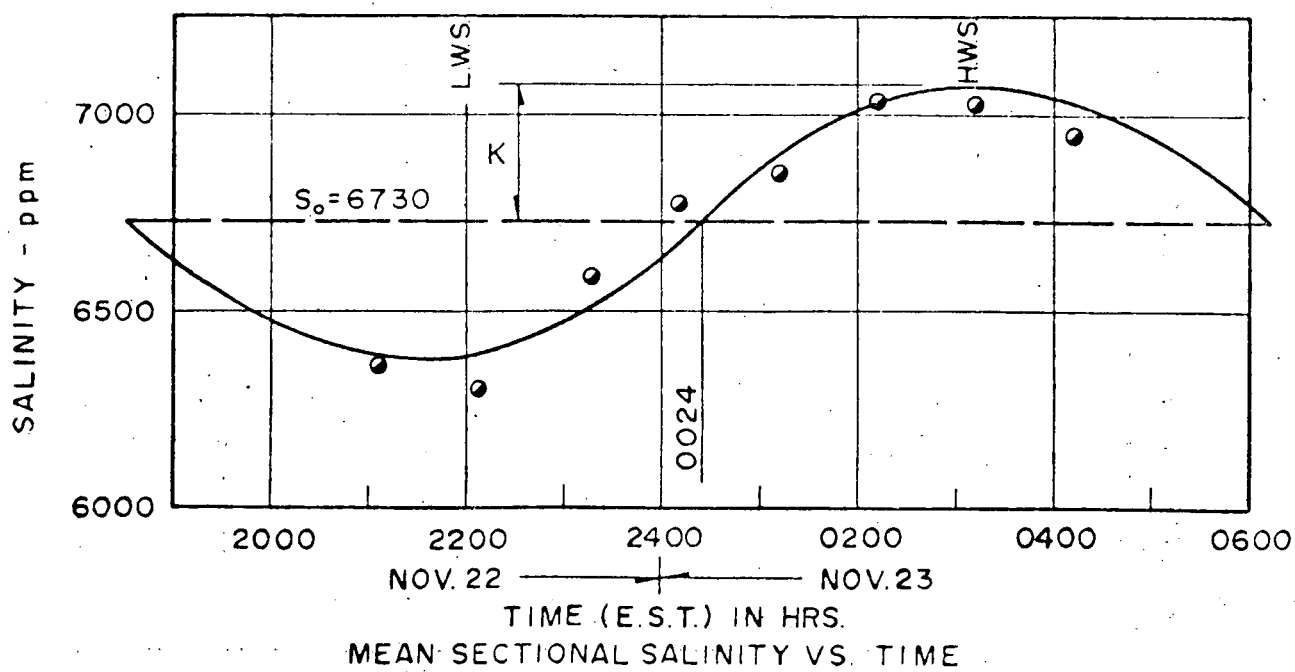

MEAN SECTIONAL SALINITY VS. TIME

FIGURE 5

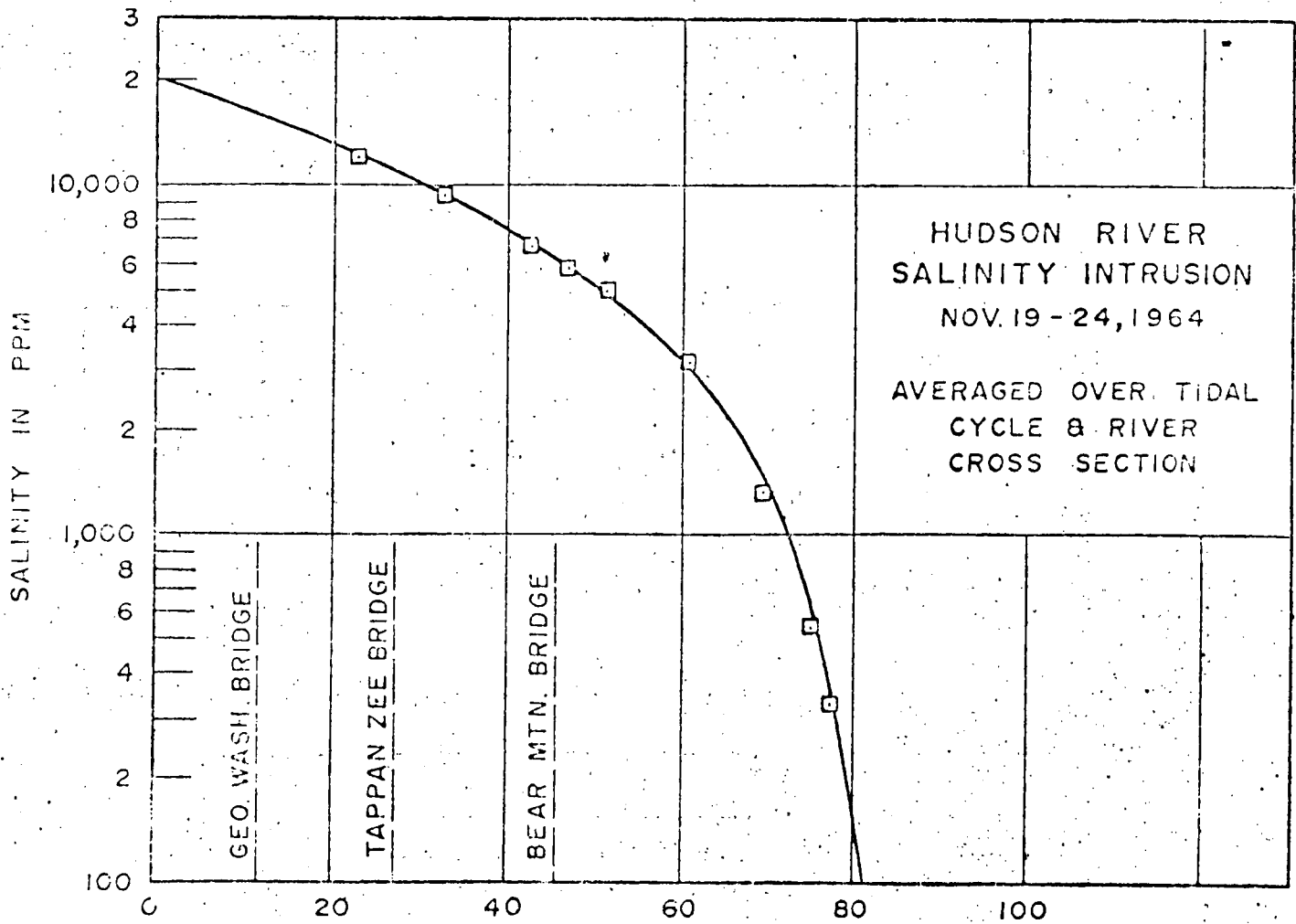
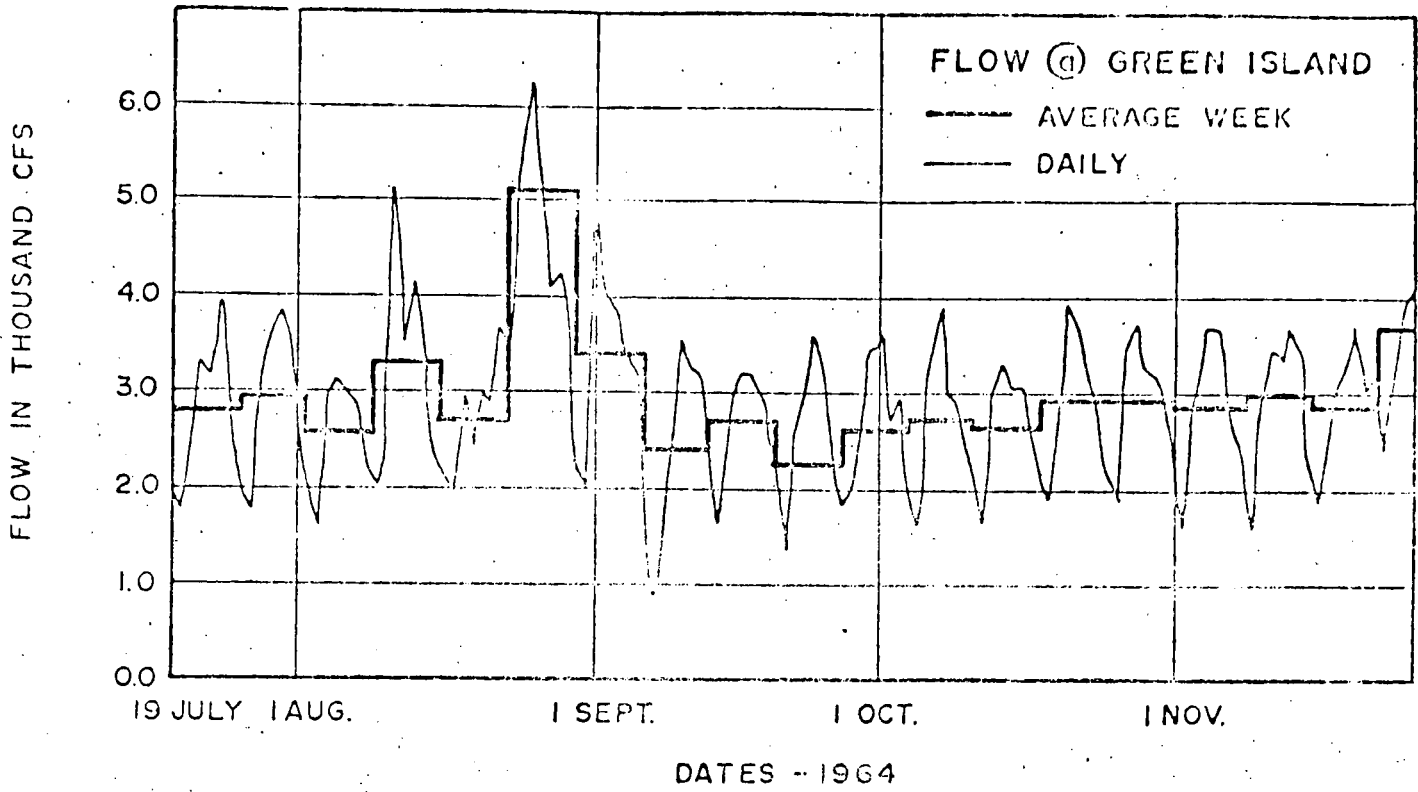

at the nine Kyma stations is shown in Figure 6. Figure 7 depicts the maximum vertical salinity variation, for this condition, as a percent of the mean vertical salinity, with distance.

These two figures indicate the following:

1. The upper layers are always lighter than the bottom layers. (Figure 6).
2. The maximum difference between the surface and bottom salinities ranges between 200 to 500 ppm. This change represents about 5 to 35% of the mean vertical salinity (Figure 6).
3. The surface layer has a weak vertical gradient. The gradient increases with depth and reaches a maximum at about mid-depth then decreases again near the bottom (Figure 6).
4. The increase in the relative vertical salinity change is gradual in the saline part and increases substantially as one approaches the fresh water regimen. (Figure 7).
5. The salinity in both layers decreases steadily from the ocean entrance to the head of the estuary. (Figure 6).

These facts indicate that the net non-tidal flow, described earlier,

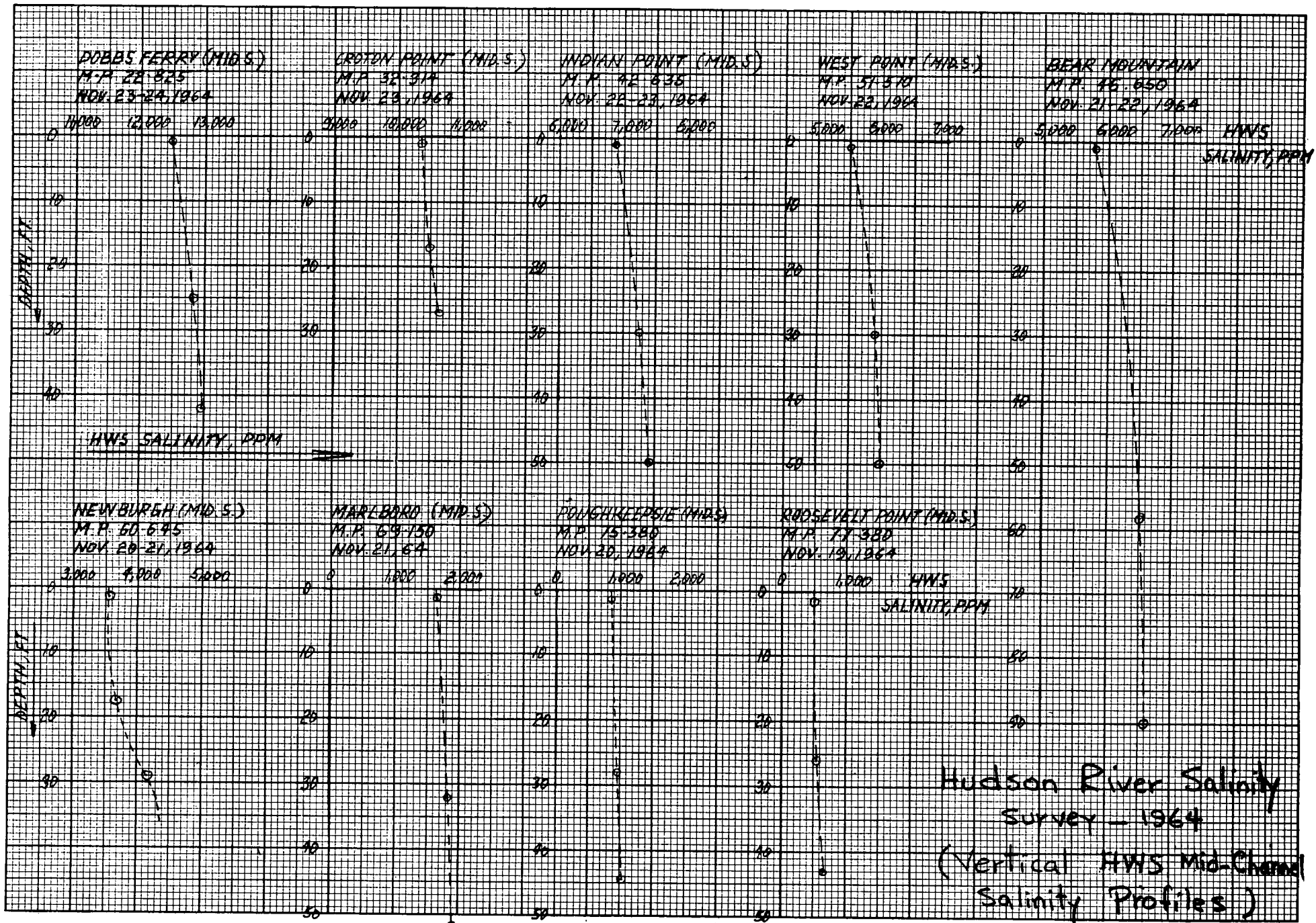
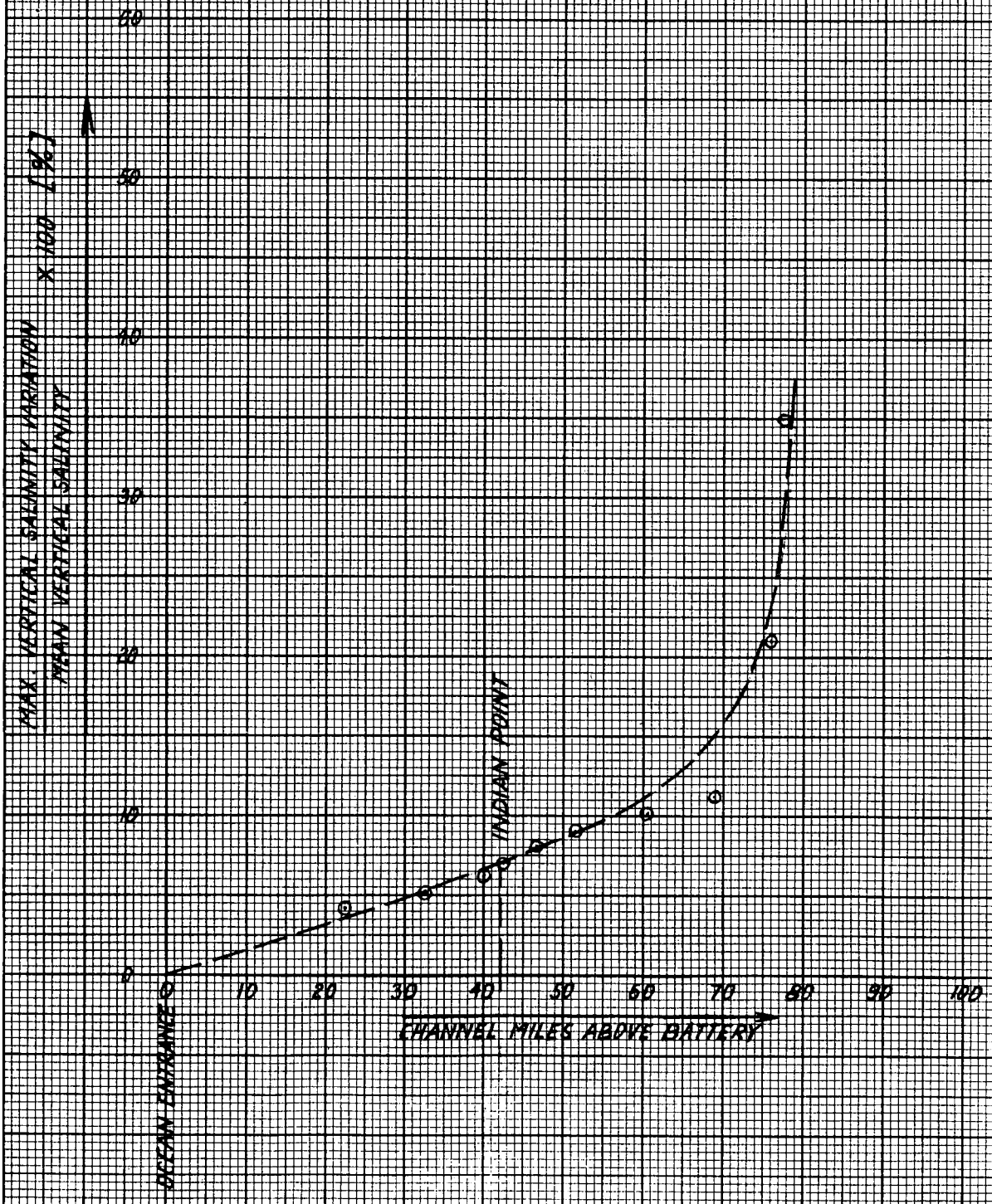

FIGURE 6

HUDSON RIVER
MID CHANNEL, HWS, SALINITY SURVEY, 1964

(VARIATION IN MAX. VERTICAL SALINITY CHANGE WITH DISTANCE ABOVE OCEAN ENTRANCE)



exists in the Hudson. Item #4 also indicates that the vertical circulation intensity increases in the upstream direction with almost zero vertical mixing at the Battery and a maximum rate at the upstream end of salt intrusion.

B. 1958-59 Marmer Survey⁶

1. Description of the Survey

The observations of 1958 and 1959 were conducted by the U.S. Coast and Geodetic Survey, using the survey vessel Marmer. The survey covered the section of the River from New York Harbor to Highland Falls (mile point 51). The locations of four Marmer stations are shown in Figure 2. These stations cover the reach of the Hudson of interest to this study (between mile points 27 and 51).

At each of these stations, Roberts radio current meters were employed to obtain current observations each half hour over a 100-hour period at several depths. At most stations, observations were made at three depths, though at stations in shallow water observations were made at one or two depths, the numbers of points in the vertical depending on the total depth to the bottom. These four stations were occupied twice, once in October 7-16, 1958, and again in June 17-21 and April 20-24, 1969.

During the period of the field study, from February 1958 to November

1959, the Coast and Geodetic Survey also obtained measurements yielding salinity as a function of depth at each of the stations. The observations were made using the CBI induction conductivity temperature indicator (Schiemer and Pritchard, 1961). This instrument gives direct readings of temperature in degrees centigrade and conductivity in millimhos/cm. The observed data were then processed to give the salinity as determined by temperature and conductivity.

2. Interpretation of the Survey Results

The current measurements at stations 45 through 48 were used to compute the net non-tidal flow in the Hudson during the survey periods. The raw data consisted of continuous velocity measurements for several days at three depths. A summary of the measurements during October 13, 1968 at station 48 is reproduced on Figure 8.

The net non-tidal velocity was then computed using the following equation:

$$U = \frac{z}{\pi} \left(\frac{V_e \cdot T_e - V_f \cdot T_f}{T_e + T_f} \right) \quad \dots (1)$$

where:

- U = net non-tidal velocity in ft/sec.
- V_e = maximum ebb velocity in ft/sec.
- V_f = maximum flood velocity in ft/sec.

FIGURE 8

48 New York Harbor Harbor Tide Tables 1958

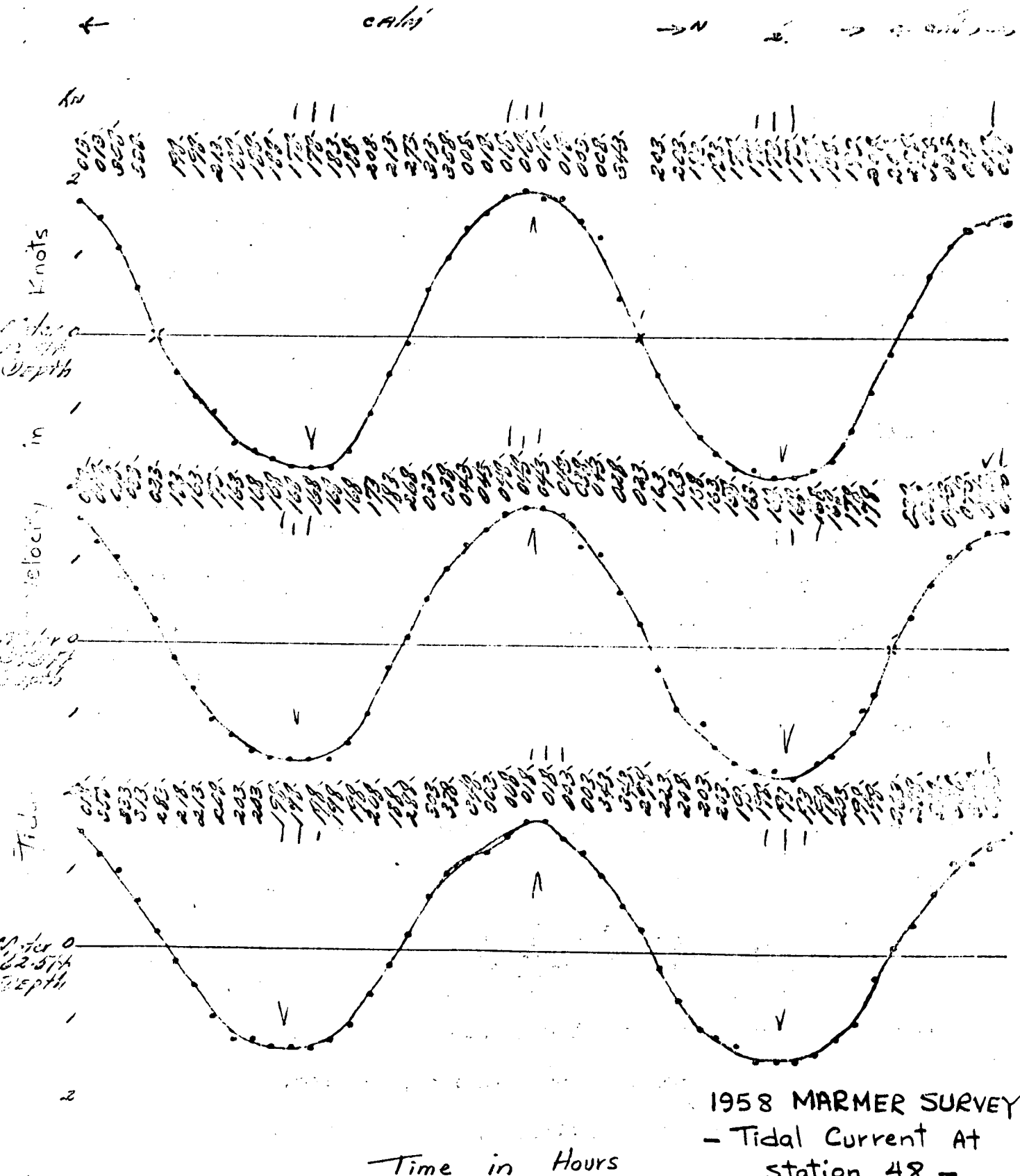

1958 MARMER SURVEY - Tidal Current At station 48 -

FIGURE 9

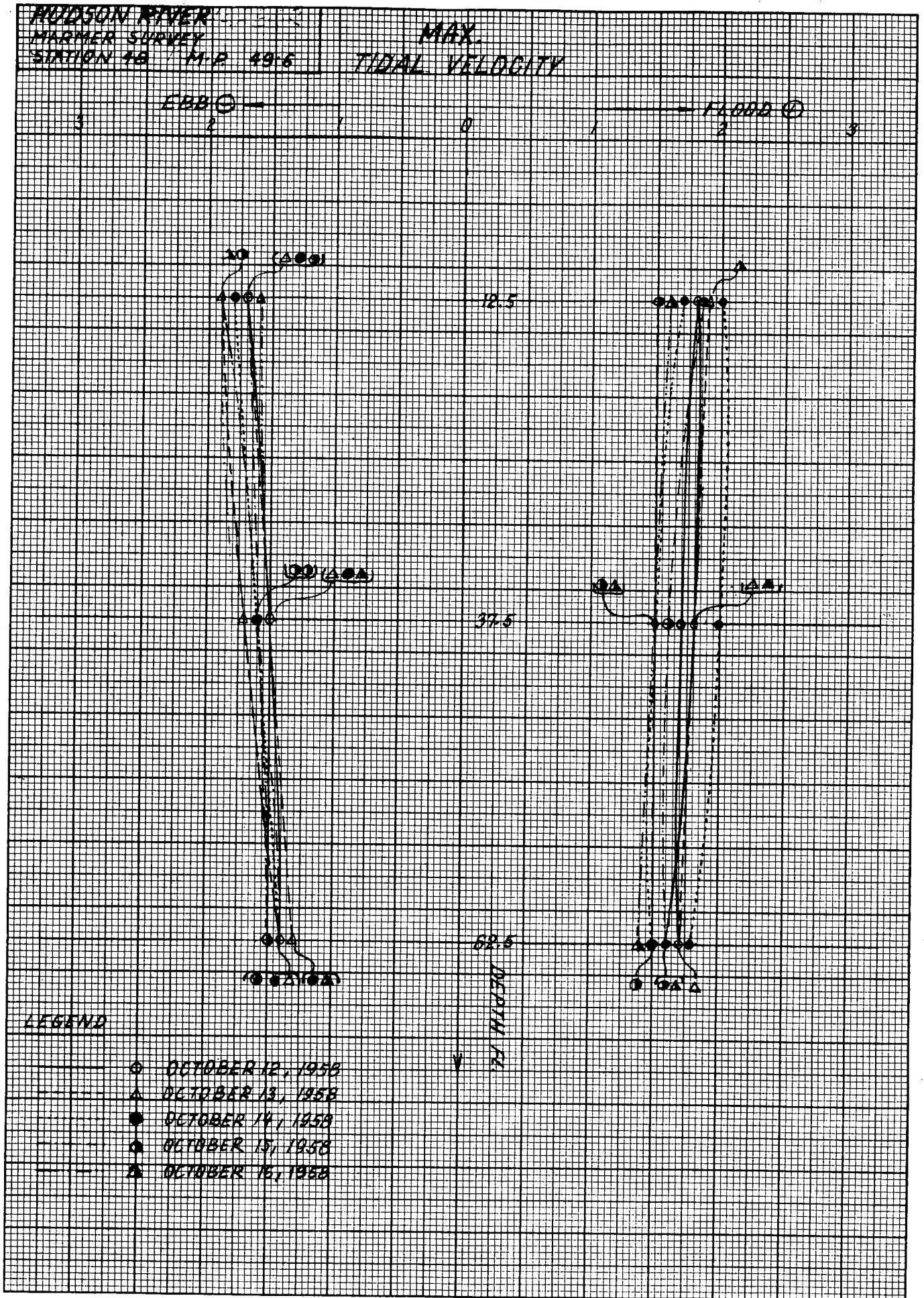
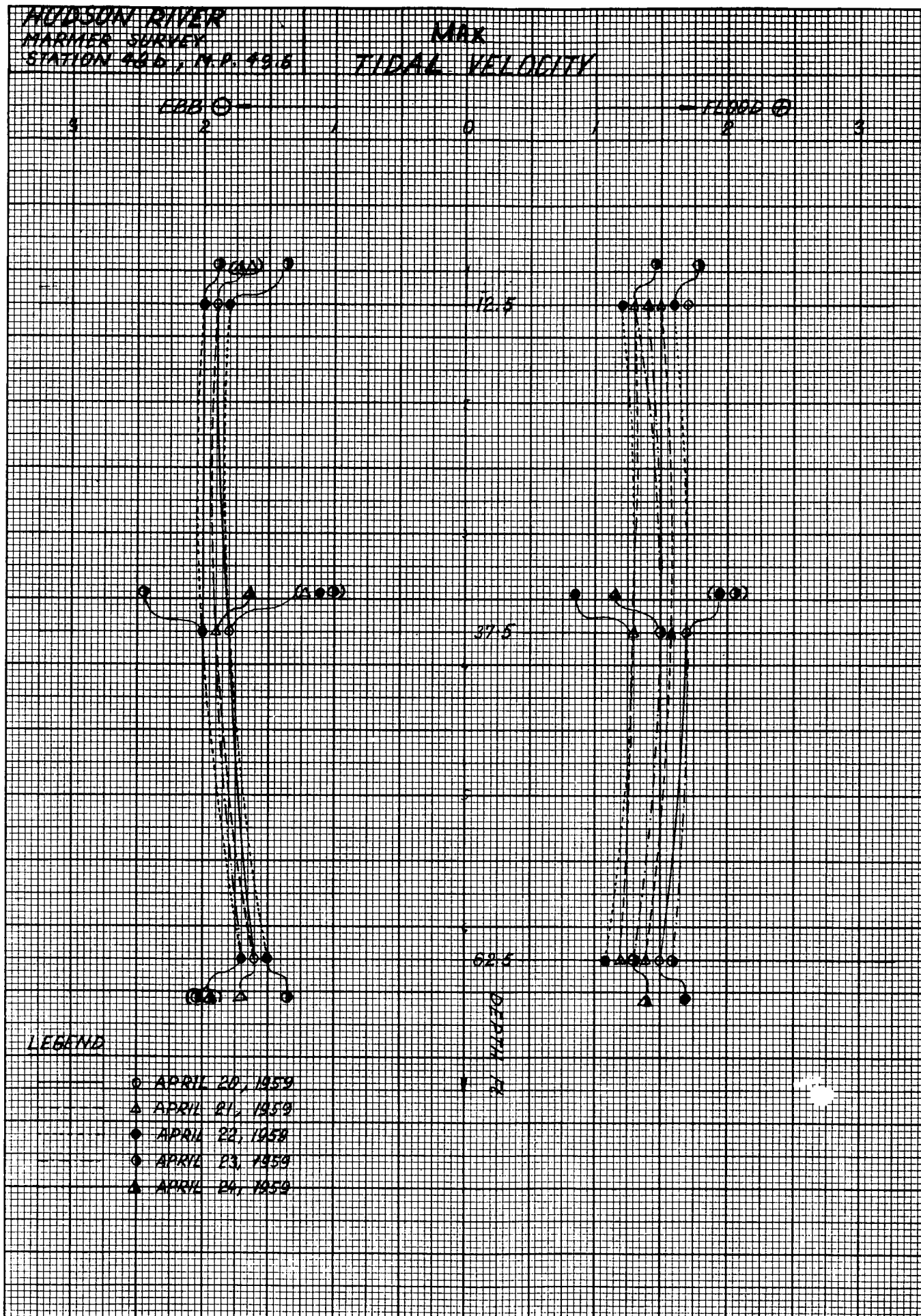

FIGURE 10



MUDSON RIVER, MARMER SURVEY, STATION 48, M.P. 49.6
NET NON-TIDAL VELOCITY

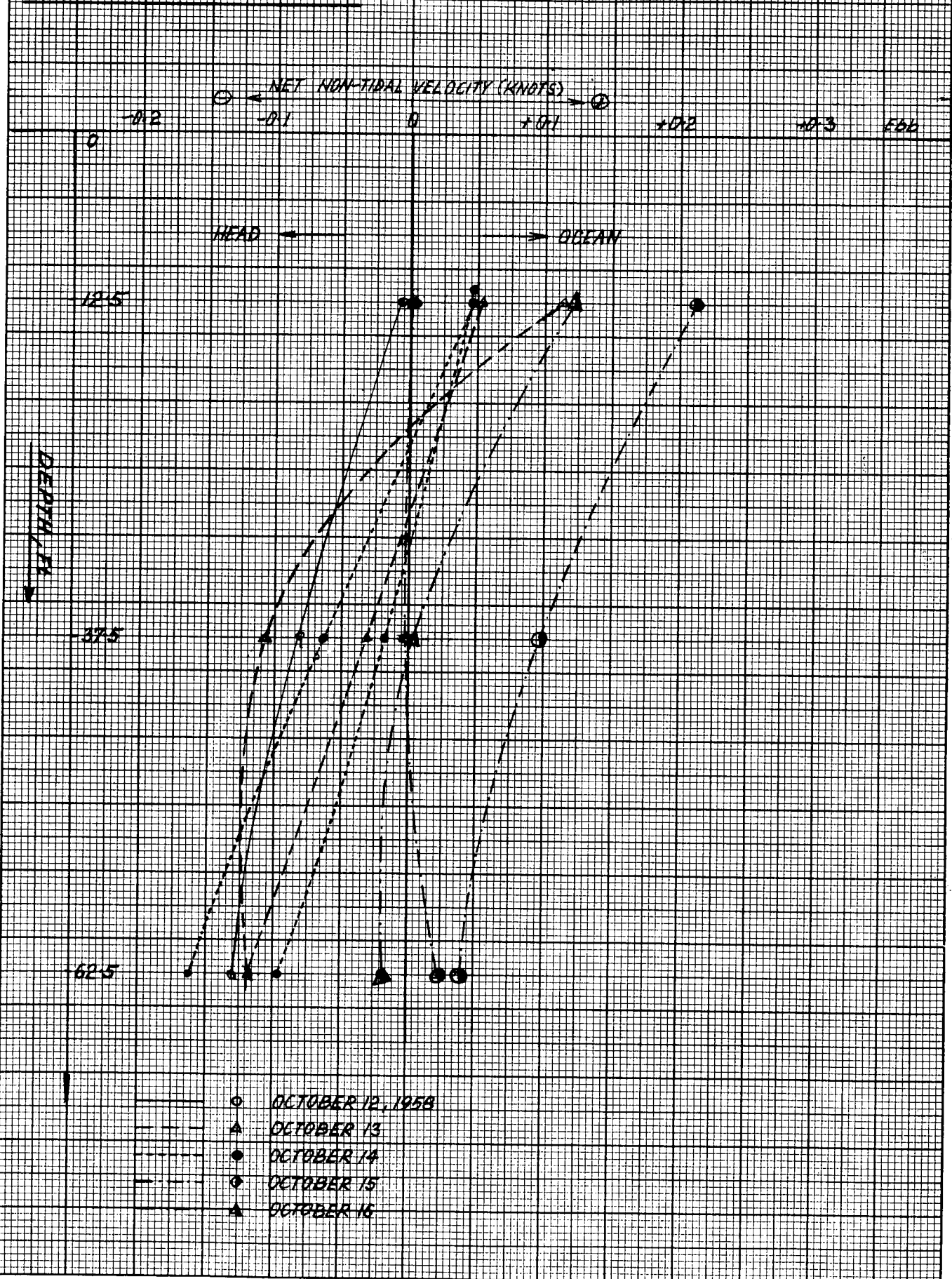
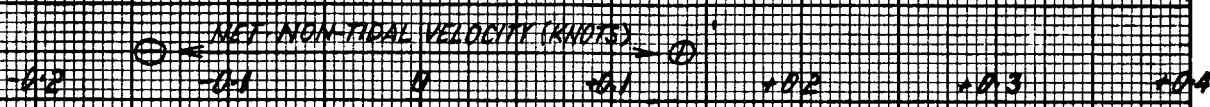

FIGURE 12

HUDSON RIVER, MARPER SURVEY, STATION 484, N.E. 19.6
 NET NON-TIDAL VELOCITY



HEAD ← → OCEAN

12.5

37.5

62.5

DEPTH (FEET)

- LEGEND:
- APRIL 20, 1959
 - △ APRIL 21
 - APRIL 22
 - ⊙ APRIL 23
 - ▲ APRIL 24

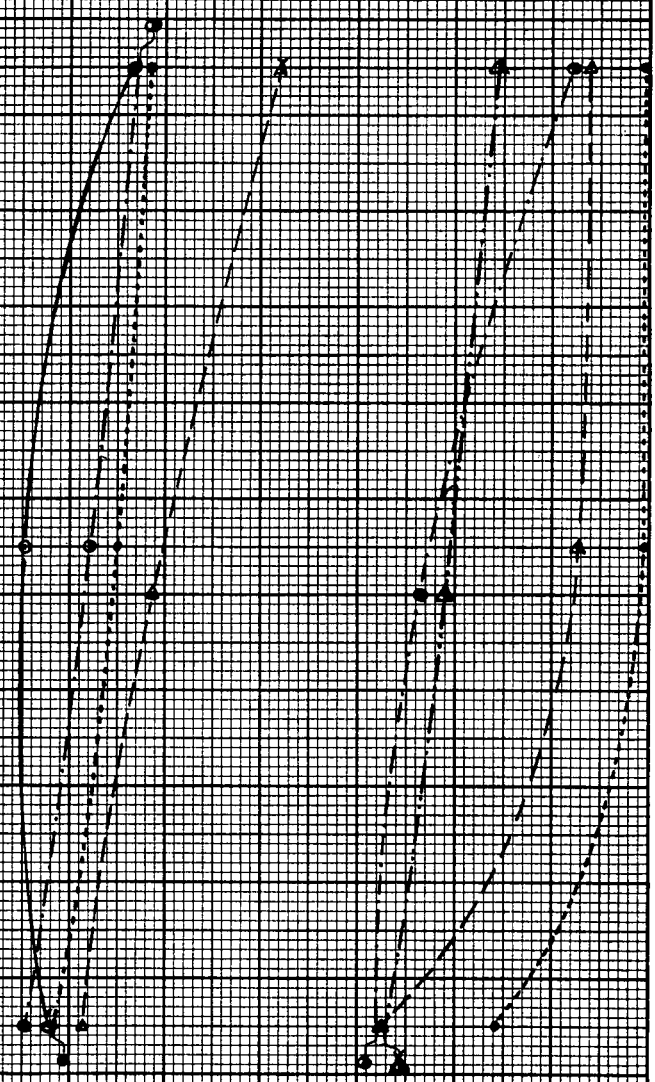

T_e = duration of ebb cycle, in hrs.

T_f = duration of flood cycle, in hrs.

Equation 1 assumes a sinusoidal variation of tidal velocity with time. This assumption is valid in the Hudson River ⁵. Also, both Marmer current observations shown in Figure 8 and Kyma salinity measurements shown in Figure 4 support this assumption. The net non-tidal velocity exists when the product of maximum ebb velocity and ebb duration and the corresponding flood product are not equal.

These products represent the maximum tidal excursion during ebb and flood. Therefore, the net non-tidal velocity in a given layer may also be defined as average net change of the position of a fluid particle, in either layer, over a period of one tidal cycle.

The presence of a net non-tidal flow in a partially mixed estuary may also be shown using Equation 1.

In such estuaries, as described earlier, $V_e > V_f$ and $T_e > T_f$, and therefore $V_e T_e > V_f T_f$ in the upper layers. Therefore, U is always positive (i.e., downstream flow) at the surface. Similarly, since $V_e T_e < V_f T_f$ in the lower layers, U is always negative (i.e., upstream

flow) near the bottom. When both products are equal, there is no net motion. This occurs at about mid-depth.

The vertical profiles of the maximum ebb and flood currents for the October 12-16, 1958 and April 20-24, 1959 periods at station 48 are shown in Figures 9 and 10.

The net non-tidal velocity, computed using Equation 1, for the same periods is plotted as a function of depth in Figures 11 and 12. Positive values indicate, seaward flow and negative values landward flow.

In general, there was a net downstream flow in the upper layers of station 48 and a net upstream flow in the lower layers during the period October 12-16, 1958. Figure 12, on the other hand, indicates the absence of a two layer flow in April, 1959. The reason for this behavior is the magnitude of fresh water flow. The fresh water flow in the lower Hudson in April 1959 was about 44,000 cfs as compared to about 10,000 cfs during October 12-16, 1958. These values indicate that station 48 did not experience any salt intrusion during April, 1959, and some 600 ppm in October, 1958. These values were obtained using a generalized correlation between salt intrusion and fresh water flow.⁶ The actual measurements showed similar results.

The net non-tidal velocity vertical profiles for the periods October 7-16, 1958 and June 17-21, 1959 at the other stations are shown in Figures 13 through 20. Only the weighted average profiles of all tidal cycles are shown.

The net non-tidal flow, Q_n , was then computed using the following equation:

$$Q_n = \bar{U} \times \bar{B} \times \Delta d \quad \dots\dots (2)$$

where: Δd = Depth increment, in ft.

\bar{B} = Average channel width over the depth increment, in ft.

\bar{U} = Average net non-tidal velocity over the same increment in ft./sec.

The River channel was divided into several increments four to five feet in depth, and the flow through each segment was computed using Equation 2. The negative and positive flows through all of the segments were added. The results are summarized in Table 1.

Some of the computed values are not realistic. The difference between the seaward flow and the landward flow, which should be equal to the fresh water flow, is significantly smaller or larger than the actual fresh water flow (600 to 100,000 cfs vs. 10,000 cfs in October 1958).

TABLE 1

NET NON-TIDAL FLOW IN THE HUDSON RIVER

1958-59 MARMER SURVEY

<u>Station</u>	<u>Miles above Battery</u>	<u>Seaward Flow in the Upper Layer, cfs</u>	<u>Landward Flow in the Upper Layer, cfs</u>	<u>Period</u>
45	27	7,823	- 367	October 7-11, 1958
45b	27	8,645	- 437	June 17-21, 1959
46	33.4	114,357	-3117	October 7-11, 1958
46b	33.4	70,486	-2273	June 17-21, 1959
47	33.1	10,235	-6881	October 7-11, 1958
47b	33.1	5,058	-18654	June 17-21, 1959
48	49.6	6,716	-6133	October 10-16, 1958
48b	49.6	39,640	-2377	April 20-24, 1959

HUDSON RIVER
 MARMER SURVEY
 STATION 4-5
 M.R. 27
 OCTOBER 7-11, 1958

AVERAGE NET NON-TIDAL VELOCITY

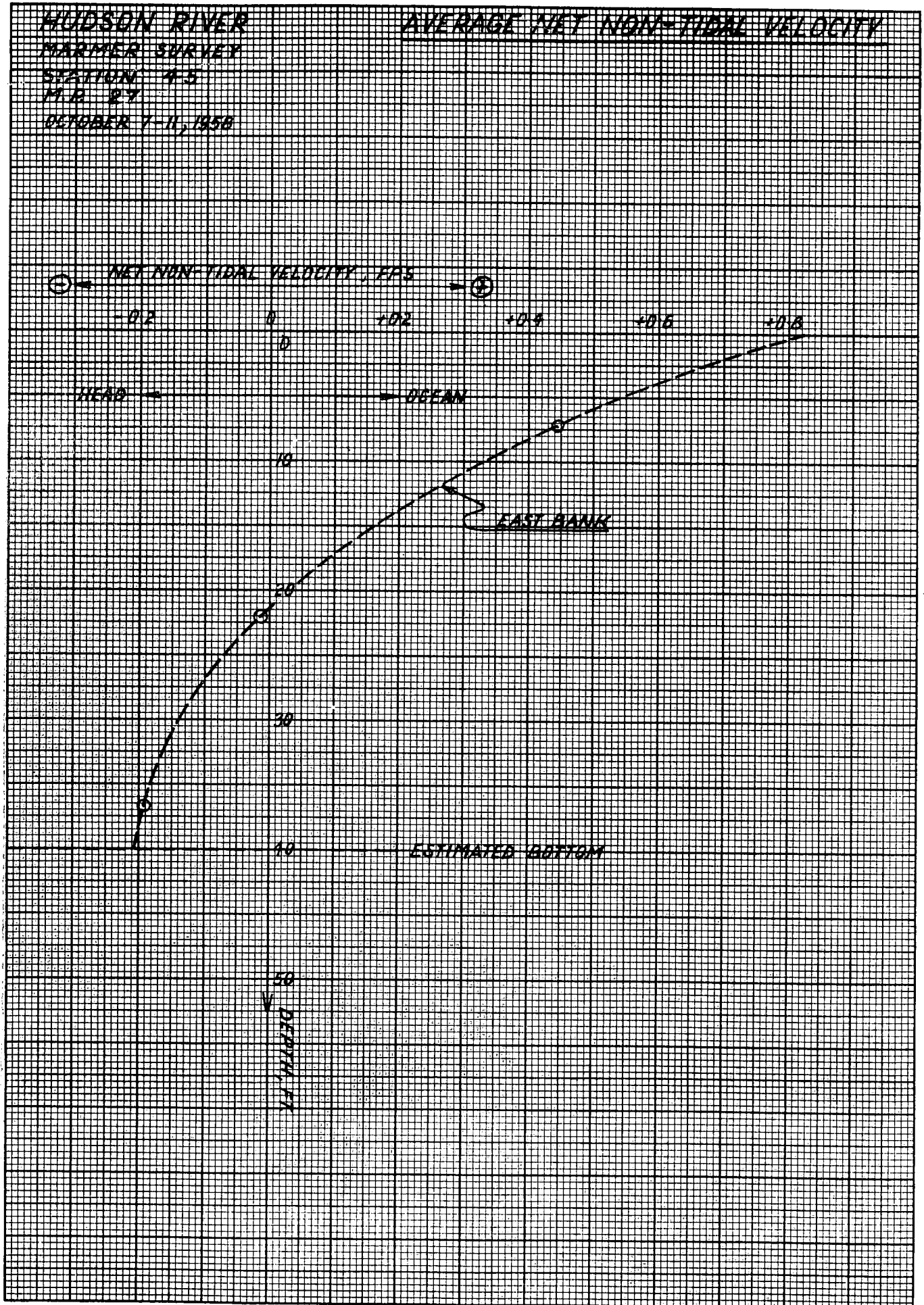

HUDSON RIVER
MARMER SURVEY
STATION #56
M.P. 27
JUNE 17-21, 1959

AVERAGE NET NON-TIDAL VELOCITY

NET NON-TIDAL VELOCITY, FPS
-0.2 0 +0.2 +0.4 +0.6 +0.8

HEAD ←

→ OCEAN

FAST BANK

ESTIMATED BOTTOM

DEPTH, FT

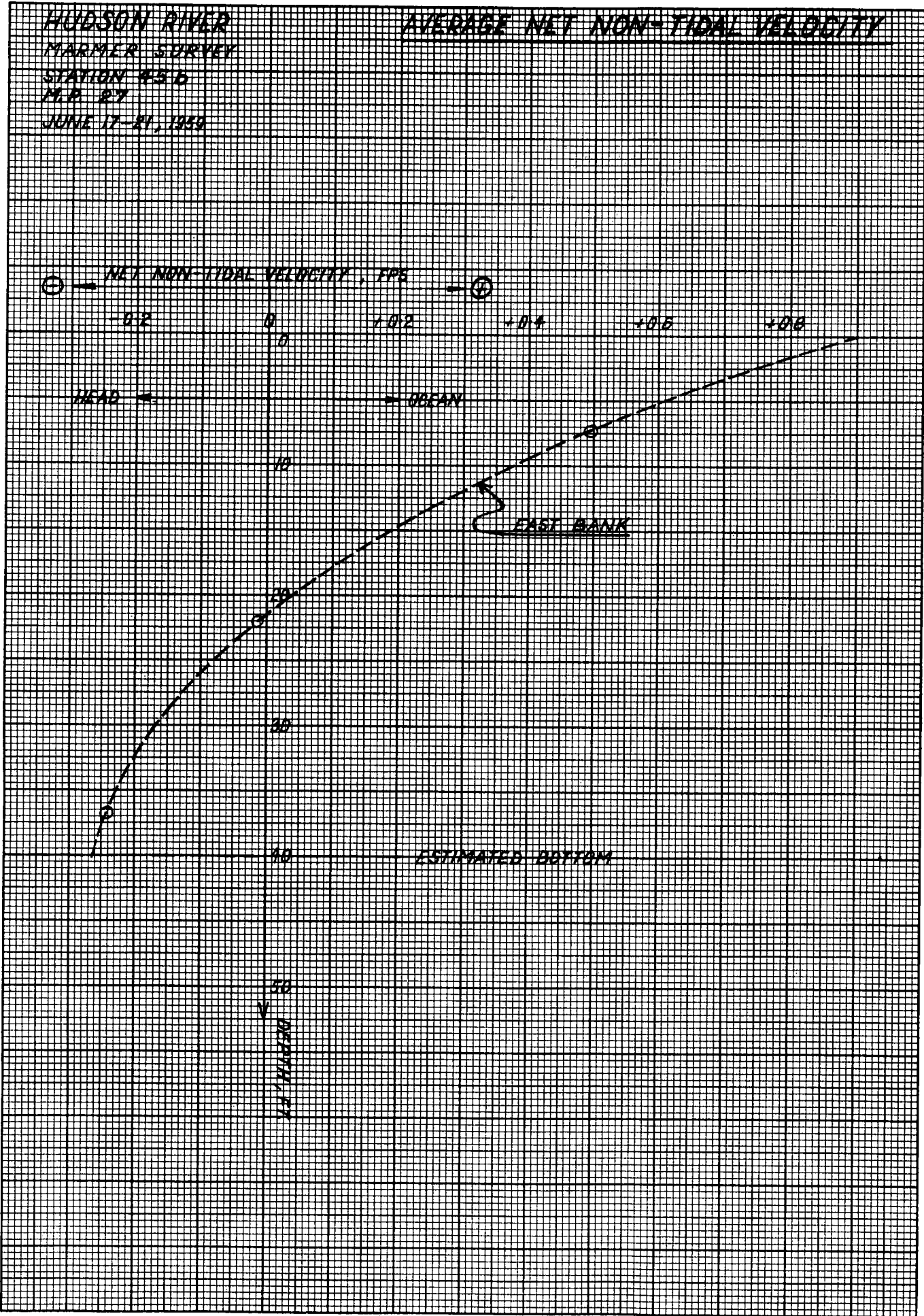

HUDSON RIVER
MARKER SURVEY

AVERAGE NET NON-TIDAL VELOCITY

STATION 75
M.P. 35.4
OCTOBER 7-11, 1958

NET NON-TIDAL VELOCITY, FPS

-0.3 -0.2 -0.1 0 +0.1 +0.2 +0.3 +0.4 +0.5 +0.6

HEAD

OCEAN

10

20

30

40

MID-CHANNEL

ESTIMATED BOTTOM

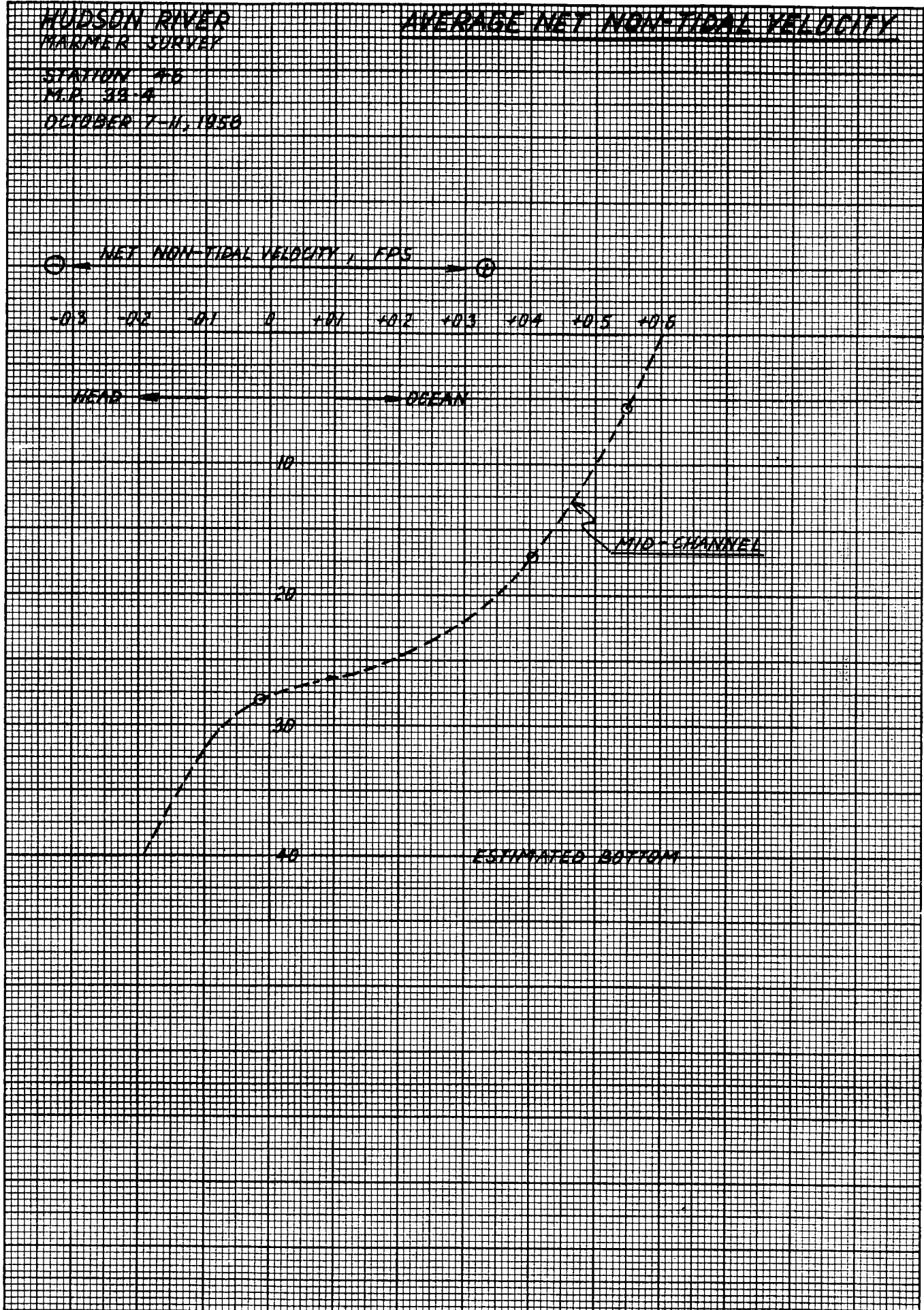

FIGURE 16

HUDSON RIVER

AVERAGE NET NON-TIDAL VELOCITY

MARKER SURVEY

STATION 356

M.P. 93.4

JUNE 17-21, 1959

⊙ NET NON-TIDAL VELOCITY, FPS ⊙

102 101 0 101 102 103 104 105 106 107 108

HEAD ←

→ OCEAN

MID-CHANNEL

ESTIMATED BOTTOM

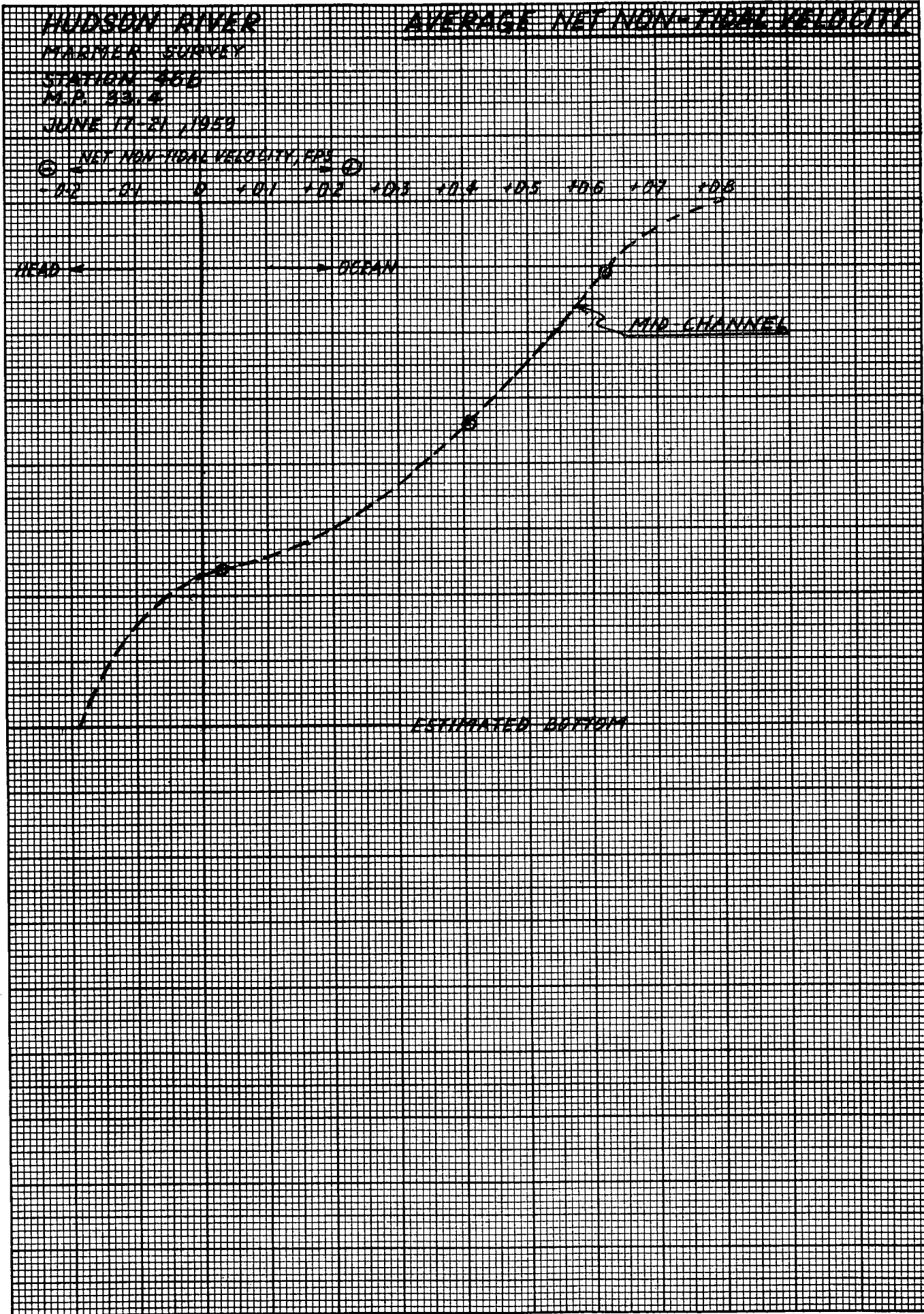
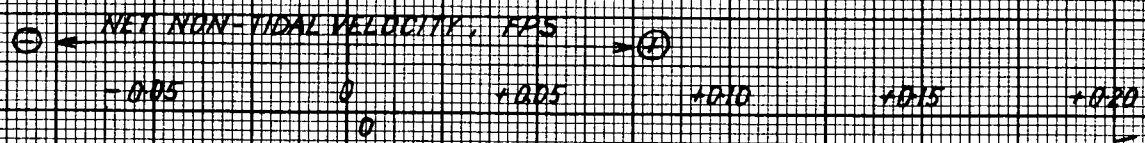

FIGURE 17

HUDSON RIVER
MARKER SURVEY
STATION 47
M.P. 33.1
OCTOBER 7-11, 1958

AVERAGE NET NON-TIDAL VELOCITY



HEAD

OCEAN

EAST BANK

ESTIMATED BOTTOM

DEPTH, FT

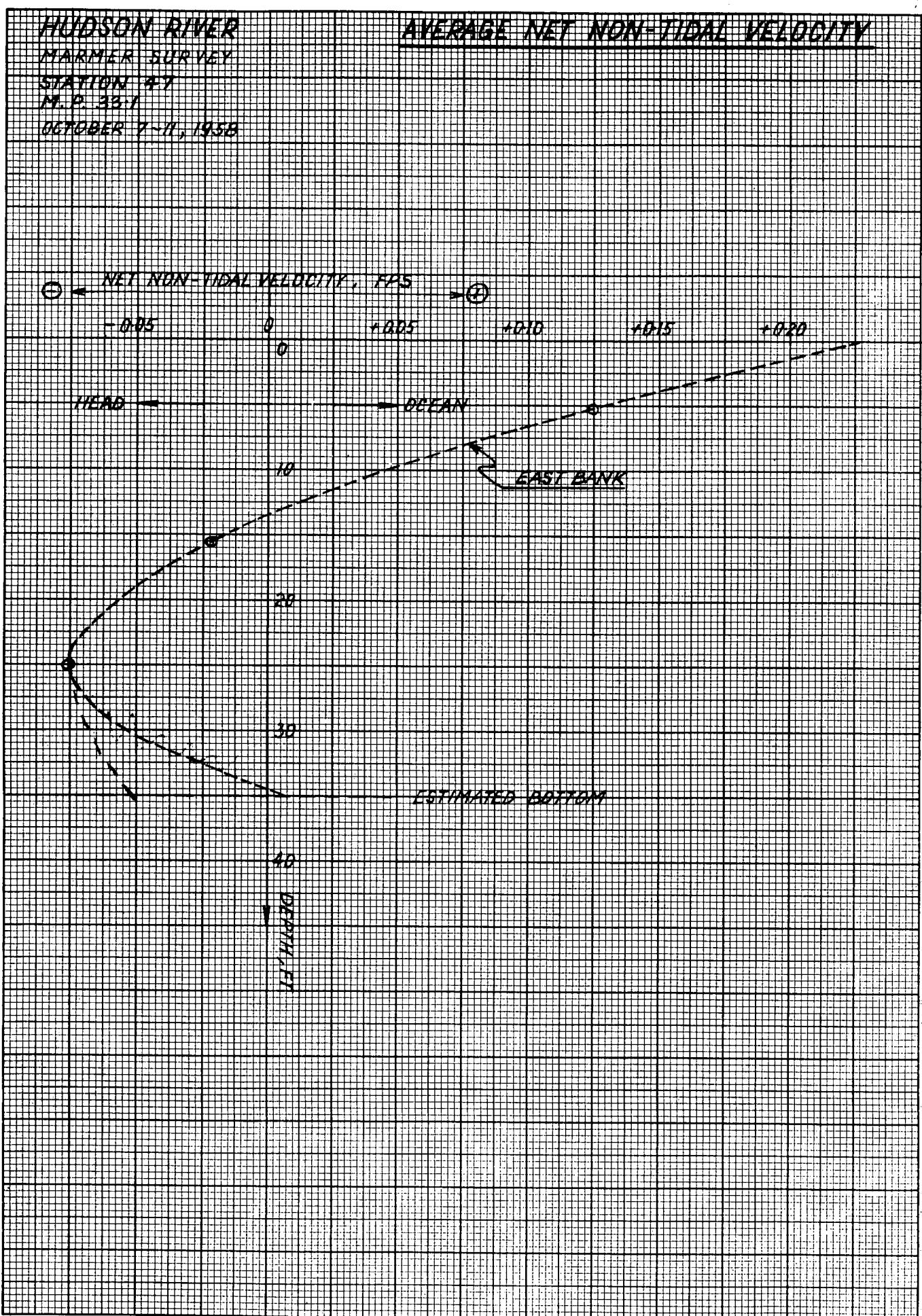

HUDSON RIVER
HARMER SURVEY

AVERAGE NET NON-TIDAL VELOCITY

STATION #75
M.P. 33.1
JUNE 17-21, 1959

NET NON-TIDAL VELOCITY, FPS

-0.30 -0.20 -0.10 0 +0.10 +0.20 +0.30

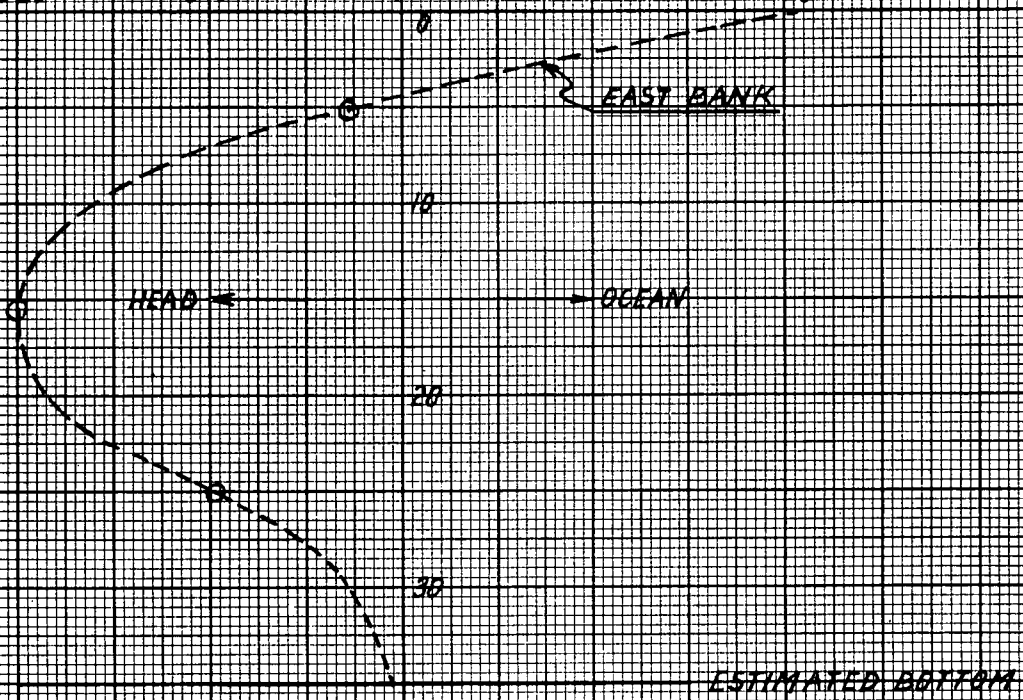

HEAD ←

→ OCEAN

EAST BANK

ESTIMATED BOTTOM

DEPTH, FT

HUDSON RIVER
MARMER SURVEY
STATION 48
M.P. 49.6
OCTOBER 12-16, 1958

AVERAGE NET NON-TIDAL VELOCITY

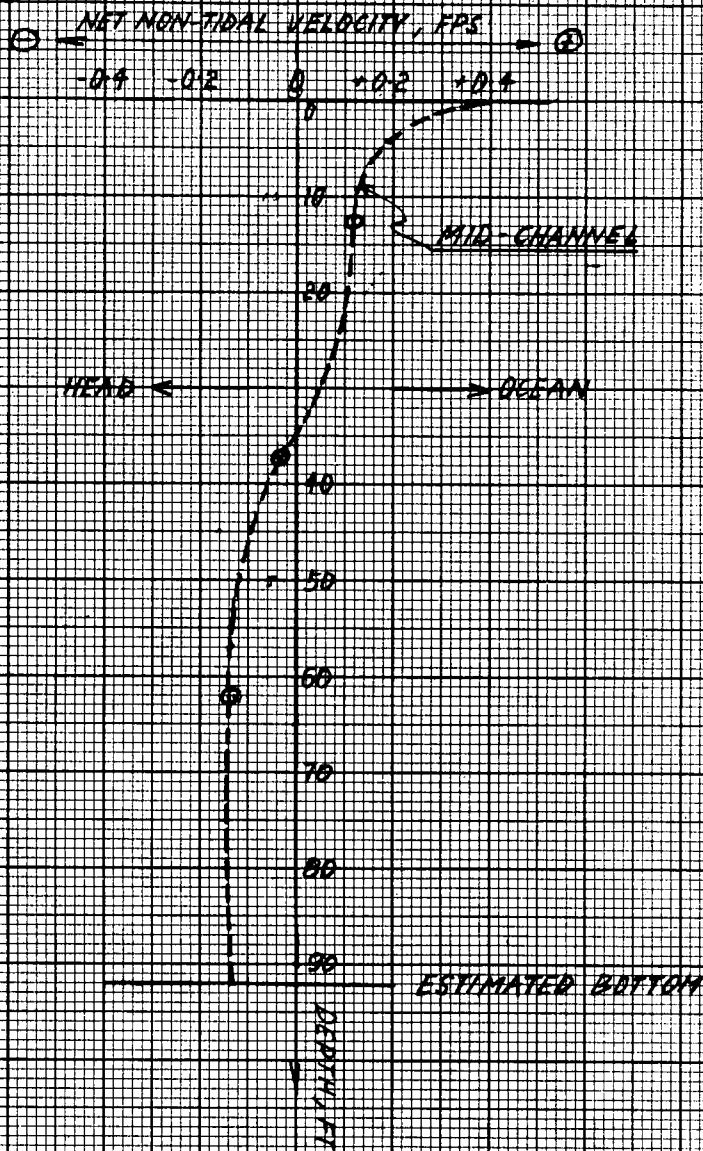
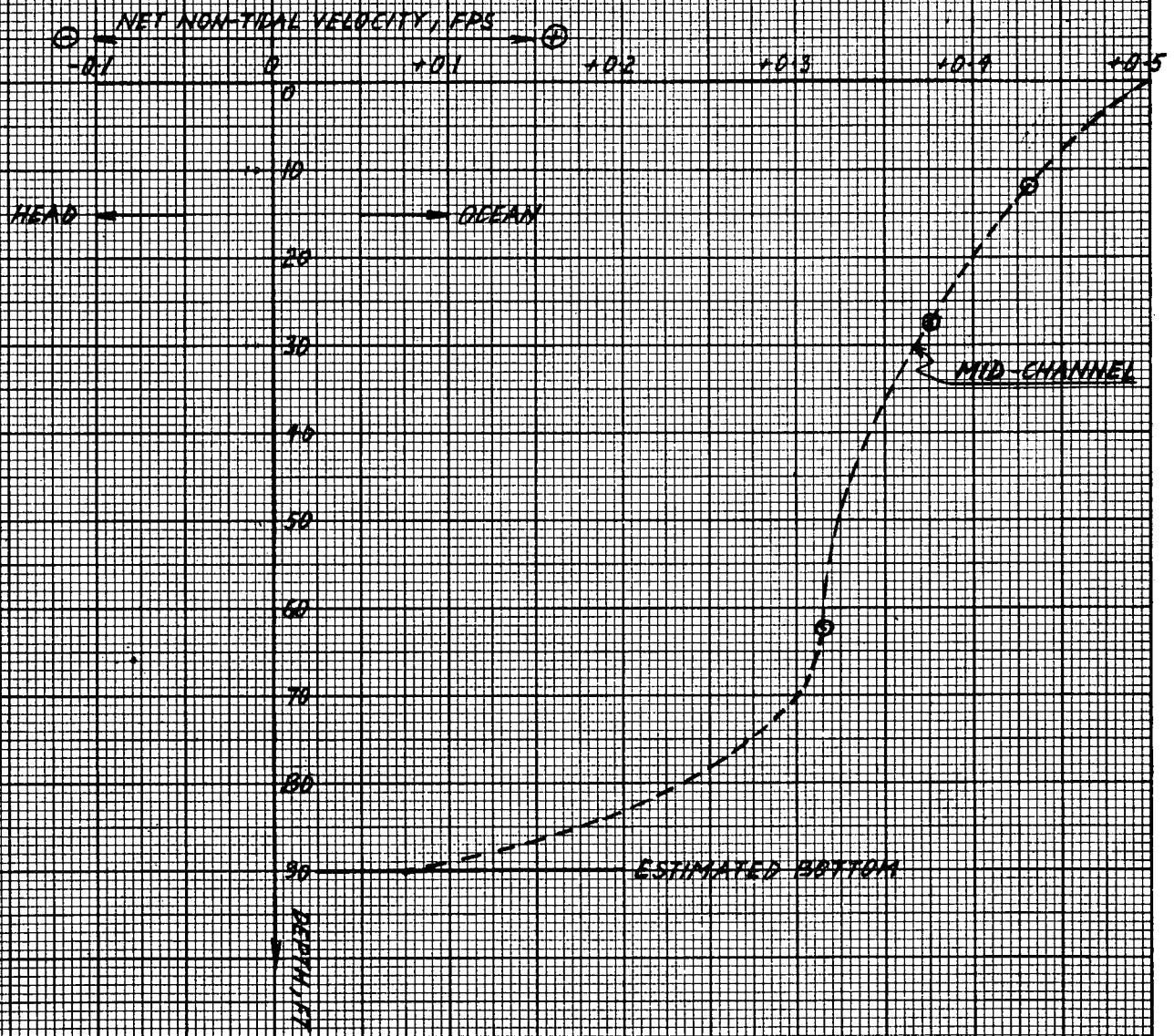

FIGURE 20

HUDSON RIVER
MARKER SURVEY
STATION 486
M.P. 49.6
APRIL 20-24, 1959

AVERAGE NET NON-TIDAL VELOCITY



The reason behind these discrepancies stems from lack of extensive field measurements which necessitated numerous extrapolations of velocity profiles to the surface and bottom. Also, the selected stations represent the velocity behavior in only a part of the channel (either on bank side or mid-channel). These values were assigned to the total river cross-section.

In conclusion, the Marmer data clearly indicate the presence of net non-tidal flow in the Hudson, but are not sufficient enough to be used for the measurement of net non-tidal flow.

C. 1929 Finnegan's Survey⁷

1. Description of the Survey

The observations of 1929 covered the section of the River from Riverdale to Troy. The locations of the first 21 stations (between Riverdale and Danskammer Point) are shown in Figure 2. Data were collected over a 17-day period. Water density, D, temperature, and current velocity were measured generally at several different depths. The survey densities were reduced to the standard temperature of 15°C and converted to salinity concentrations using Equation 3.

$$C = 1.312 \times 10^6 \times \Delta D \quad \dots (3)$$

where: c = Salt concentration in ppm.

ΔD = Increase in fluid density at 15°C

The intrusion profile together with fresh water histogram at Green Island is shown in Figure 21.

The fresh water discharge used for computation of flow characteristics from these data was determined from an analysis of gaging records at Green Island, tributary inflow below Green Island and the detention time requirements of the channel. The average inflow during the survey period was about 8000 cfs along the entire saline water stretch of the river.

A 15-foot current pole was used for the surface currents except where insufficient depths made it necessary to use shorter poles. Price current meters were used to obtain subsurface velocities.

2. Interpretation of Survey Results

The mean vertical salinity profiles at stations F-1 through F-21 are shown in Figures 22 through 24. The shapes of these profiles are similar to those shown in Figures 6 and 1. Therefore, conclusions similar to those of Kyma Survey measurements (see item A-2) may be drawn.

The current data (velocity and duration) are summarized in Table 105 of Reference 7. Current observations included 50 hours at each

FIGURE 21

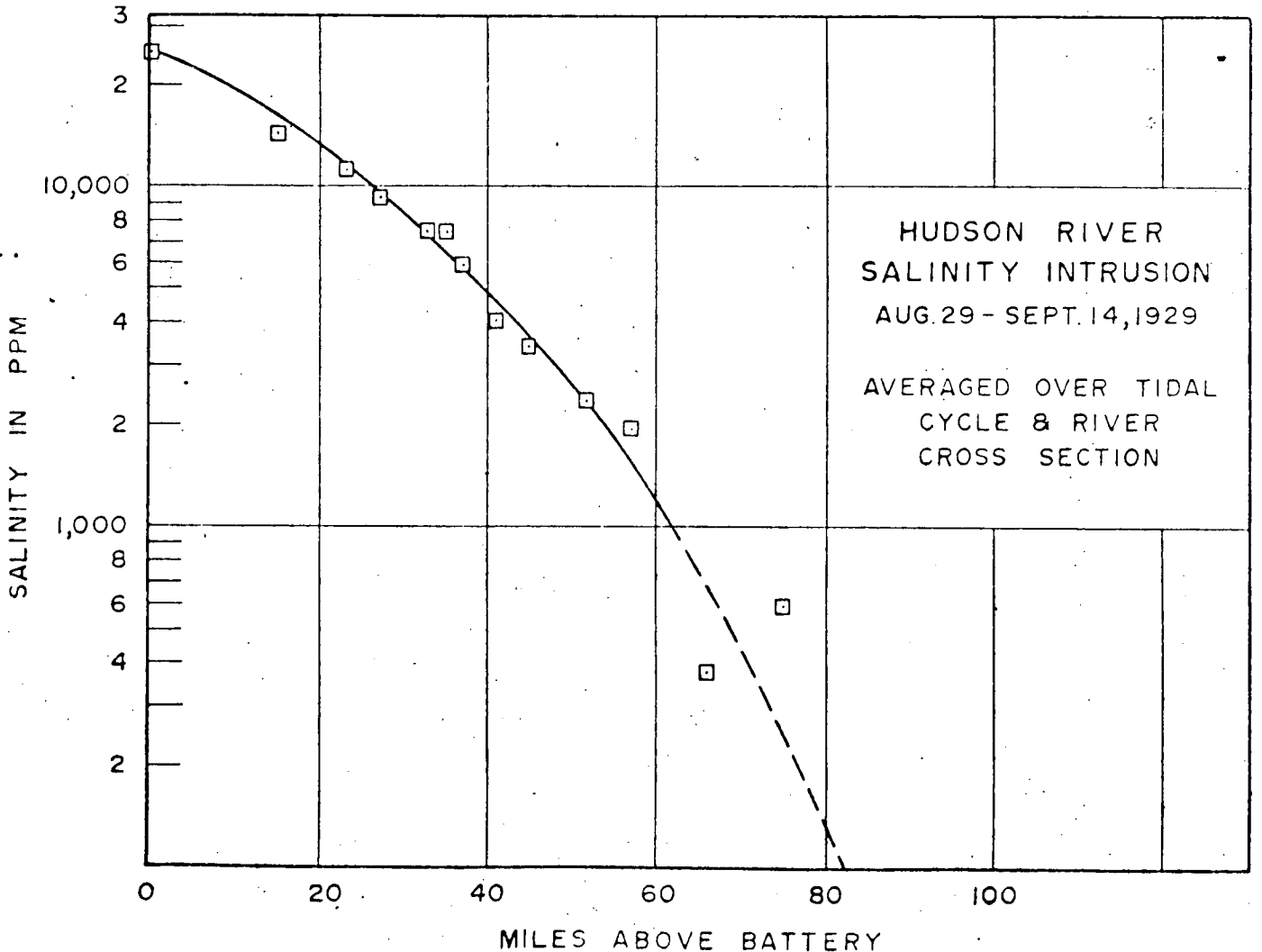
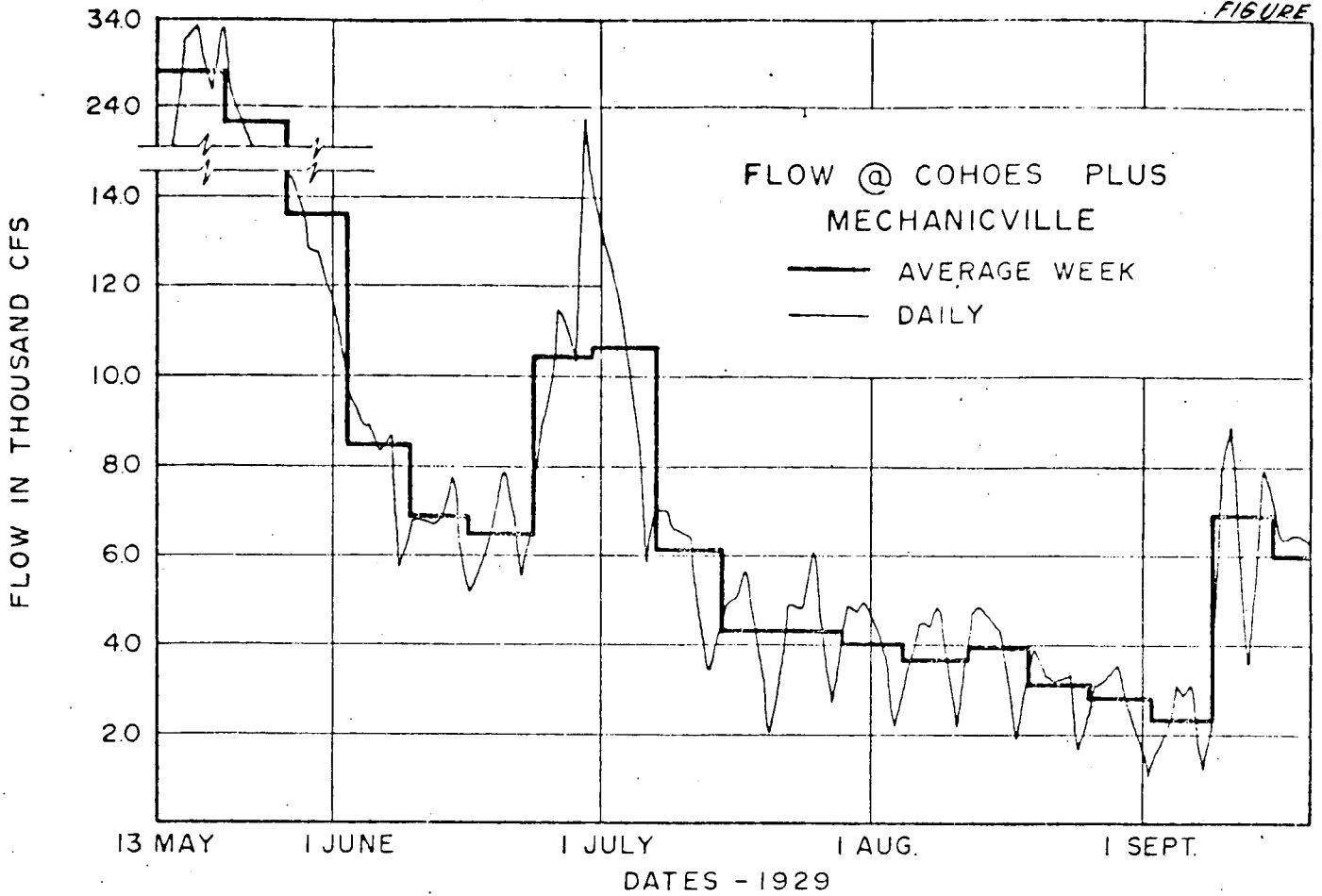

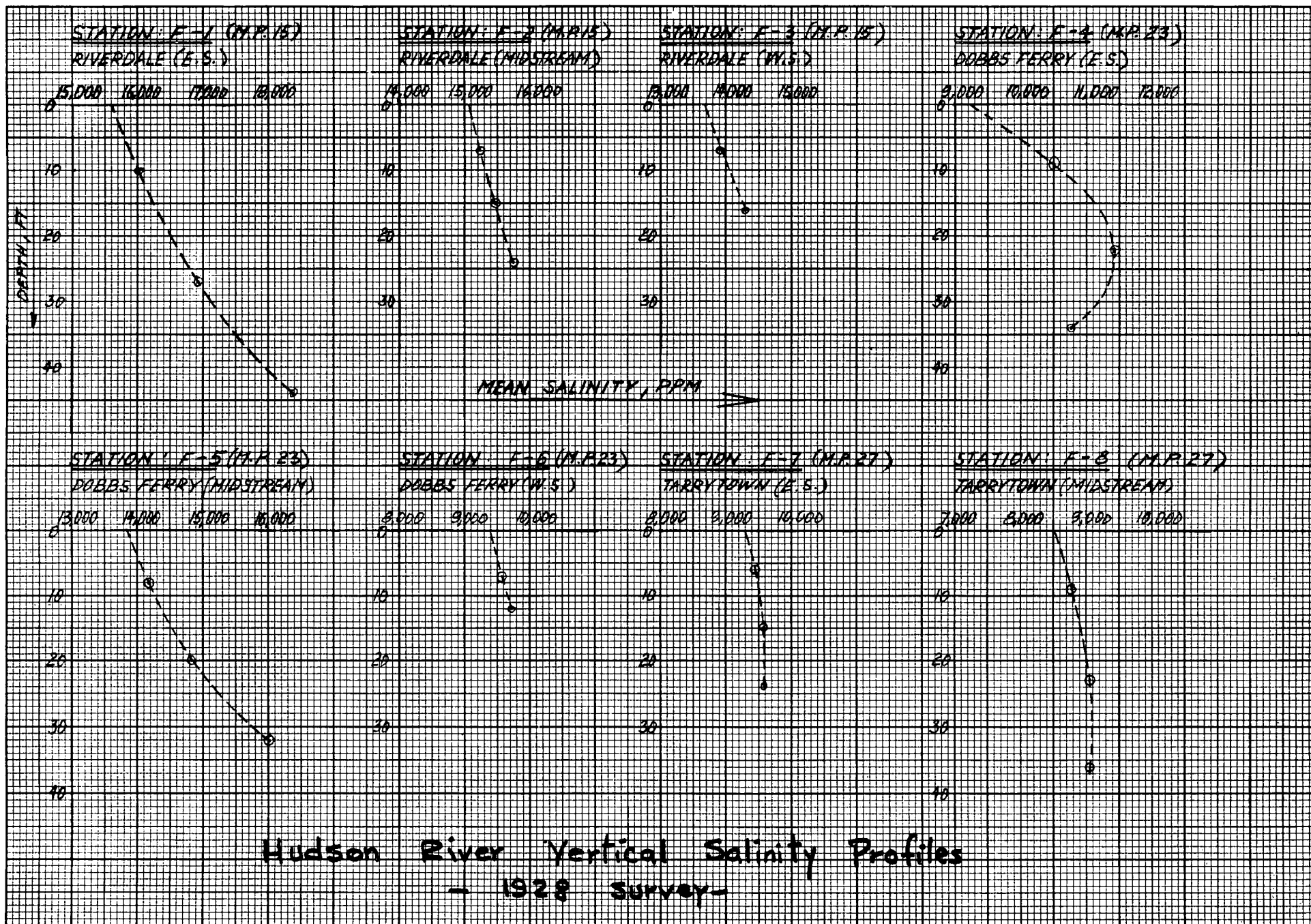

FIGURE 22

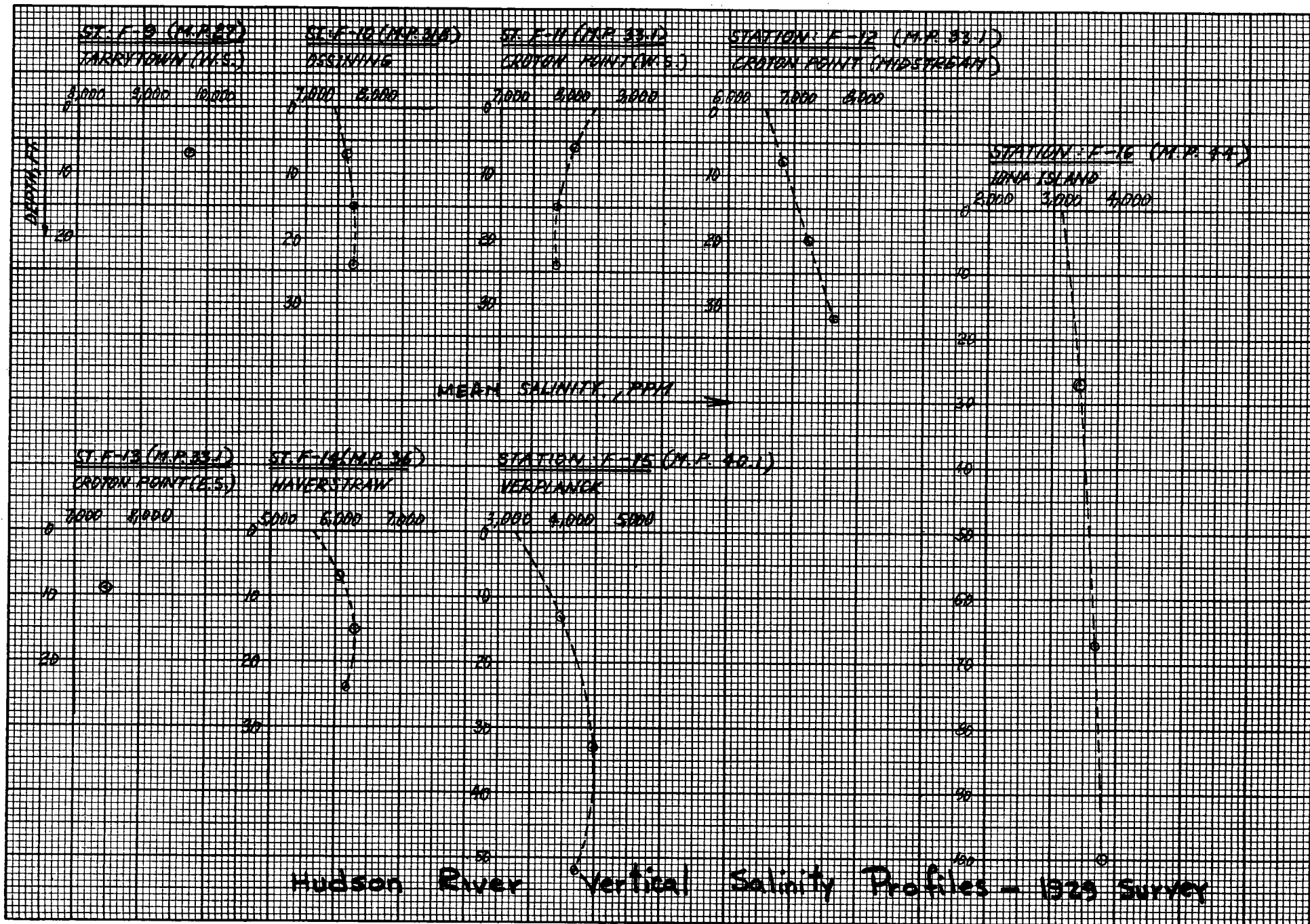

FIGURE 23

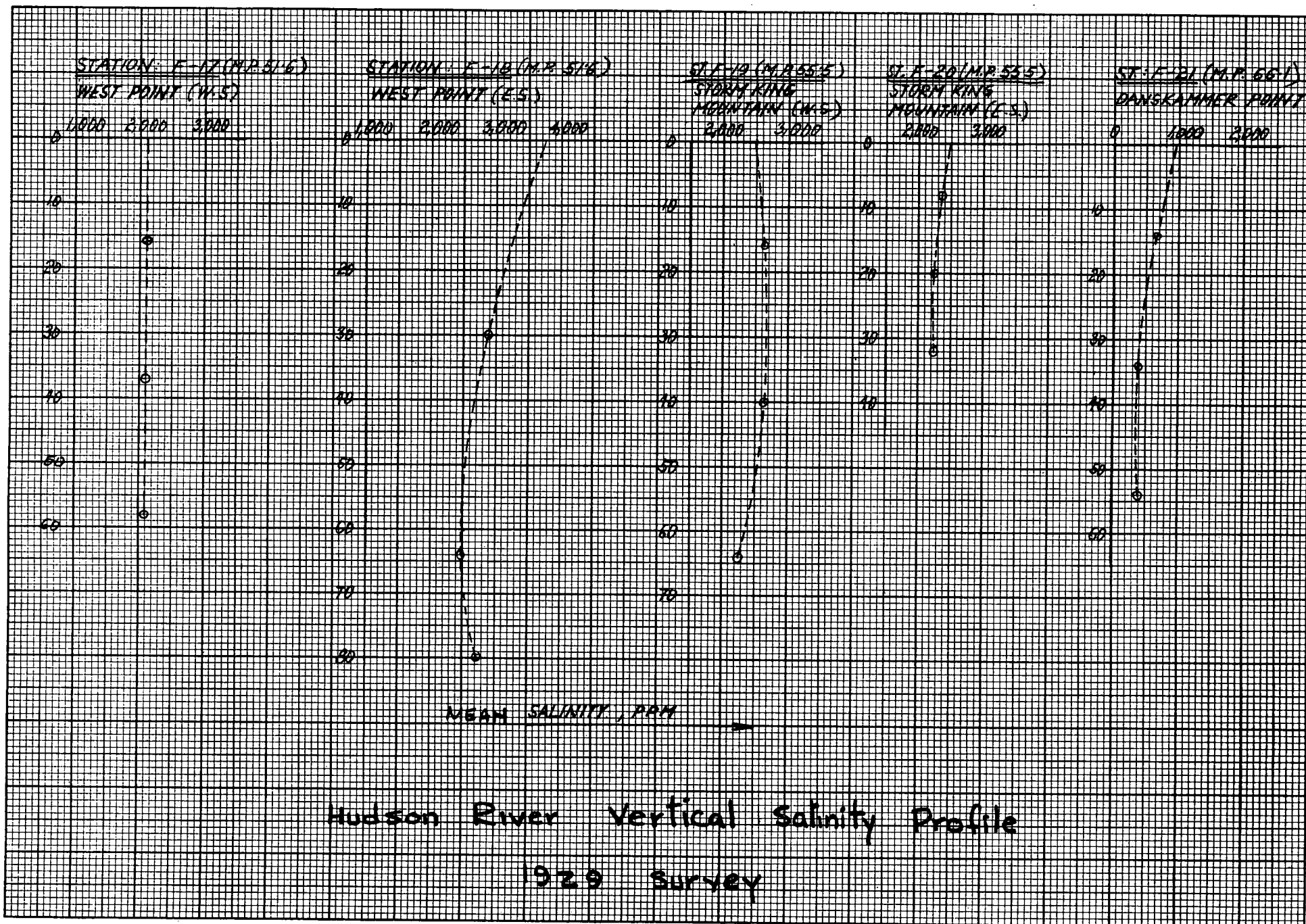

FIGURE 24

station in order to cover complete tidal cycles.

In general, there were three locations for each station (east bank, mid-channel, and west bank) and the tidal velocity was measured at three to six different depths at each location.

Compared with the Marmer Survey, Finnegan's data are more comprehensive.

The net non-tidal velocity and flow at these stations were computed using Equations 1 and 2. The vertical profiles of the net non-tidal velocity at these stations are given in Figures 25 through 35. The shapes of most of these curves are similar to those of other partially mixed estuaries (see Figure 1) and indicate a net flow in the seaward direction in the upper layer (positive values) and up-estuary in the lower layer (negative values).

The surface and bottom net non-tidal velocities were determined by extrapolation. A few of these profiles indicated that there was virtually no net flow in one part of the river. Others showed that the net flow in one half of the channel is in a direction opposite to the other half.

The net non-tidal flow was computed by arbitrarily sectioning the

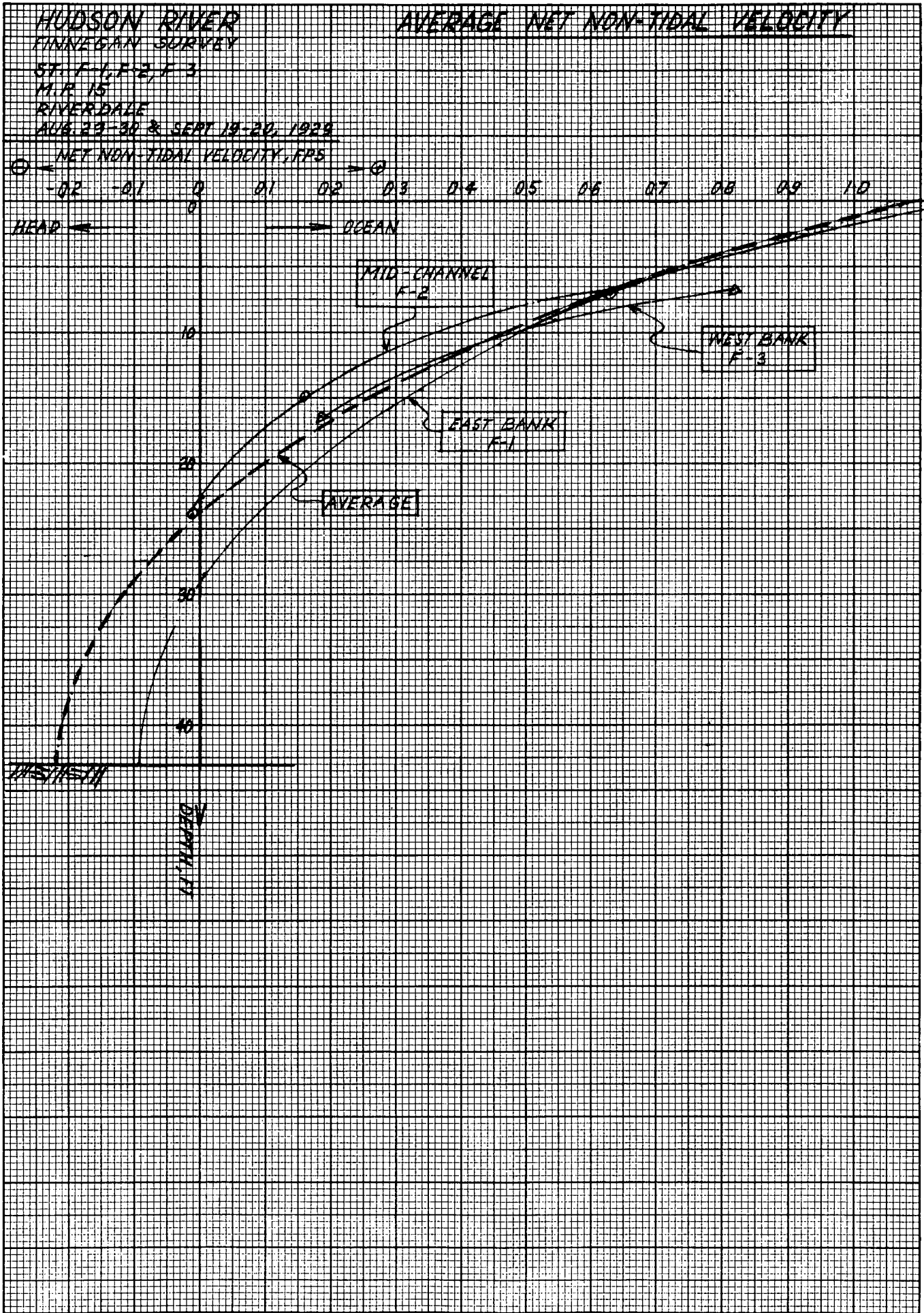

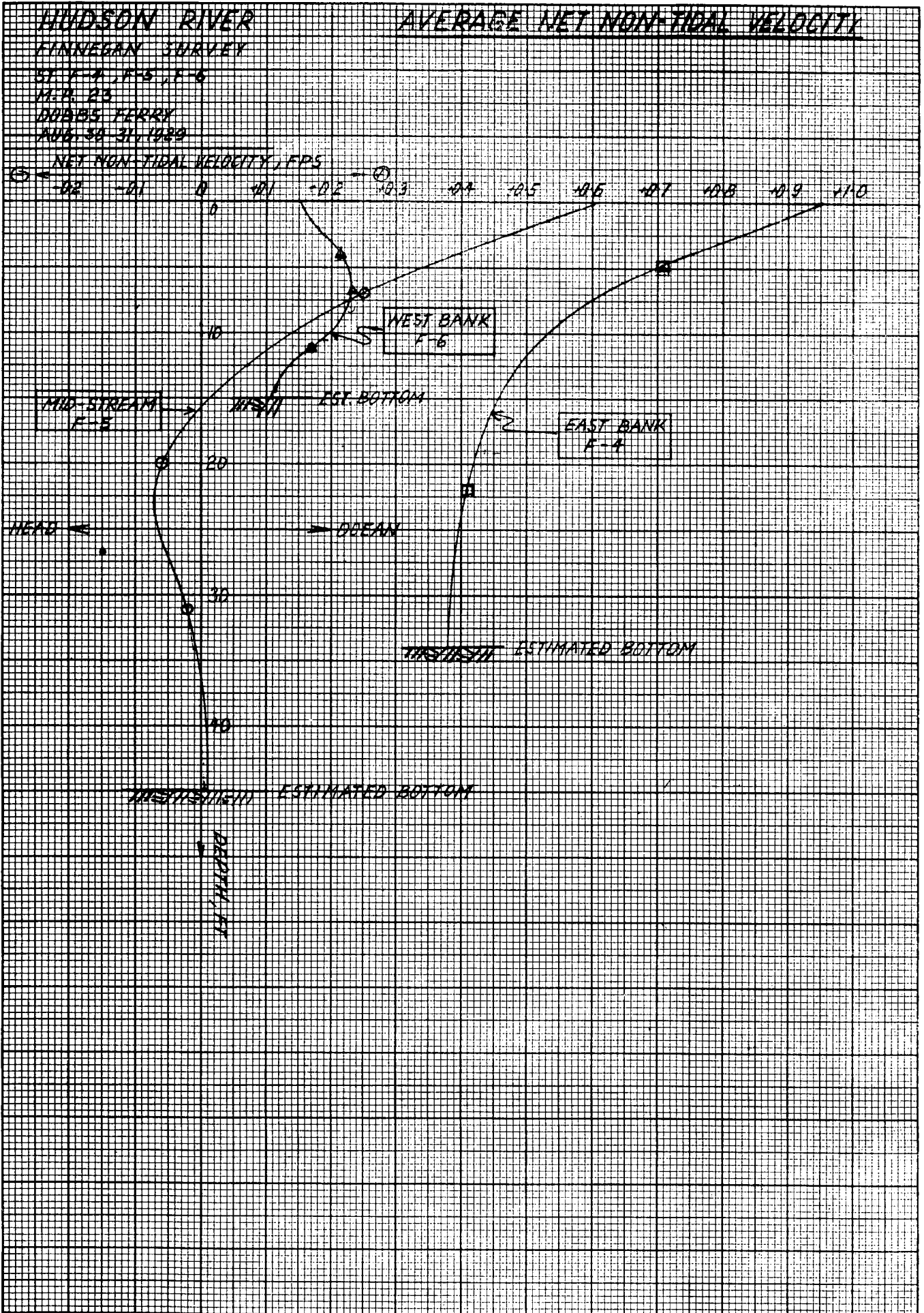

HUDSON RIVER
FINNEGAN SURVEY
ST. F-7, F-8, F-9
M.P. 27
TERRYTOWN
SEPT 3-4, 1929

AVERAGE NET NON-TIDAL VELOCITY

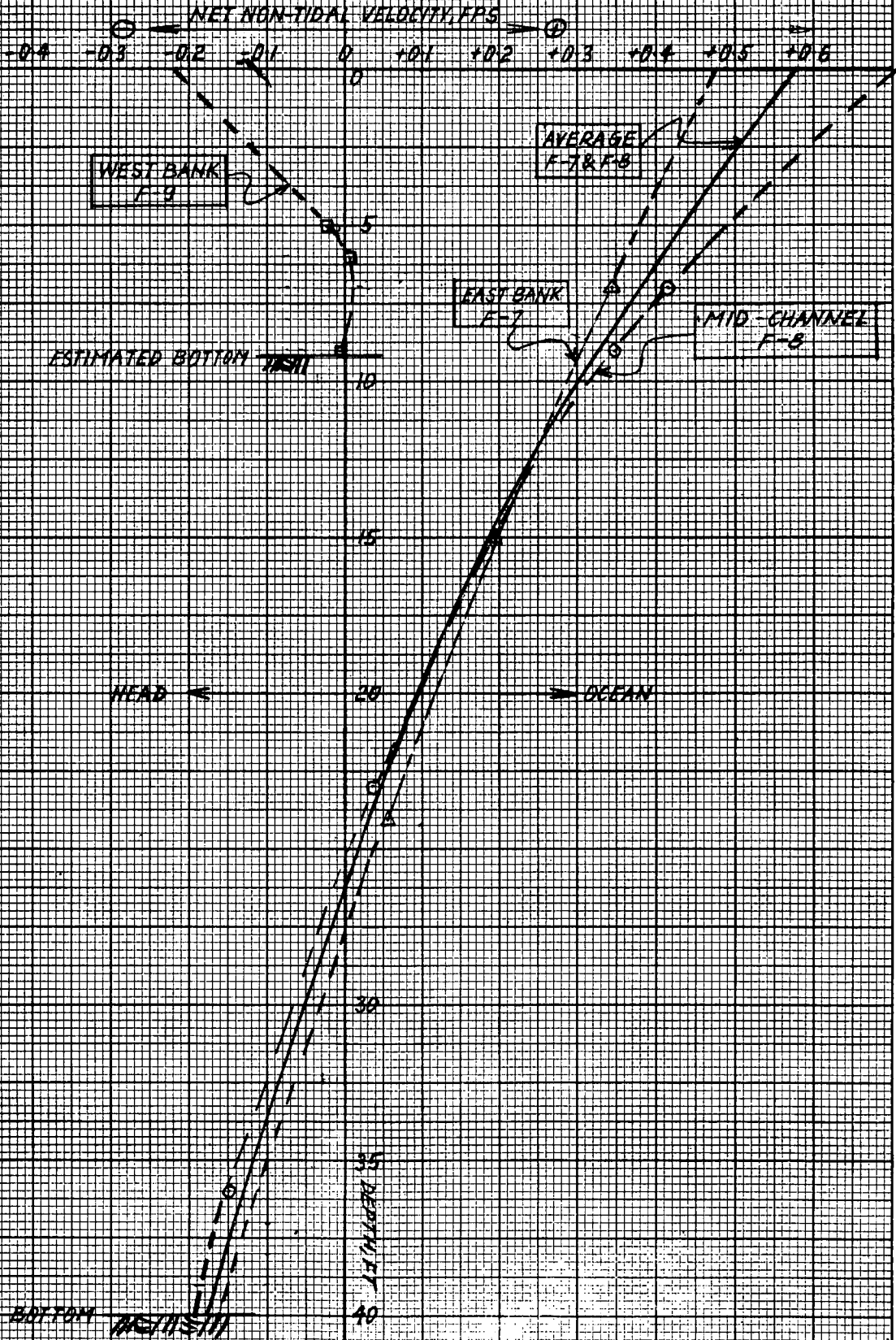

HUDSON RIVER
FINNEGAN SURVEY
ST. F-10
M.P. 31.8
OBSERVING
SEPT. 4-5, 1960

AVERAGE NET NON-TIDAL VELOCITY

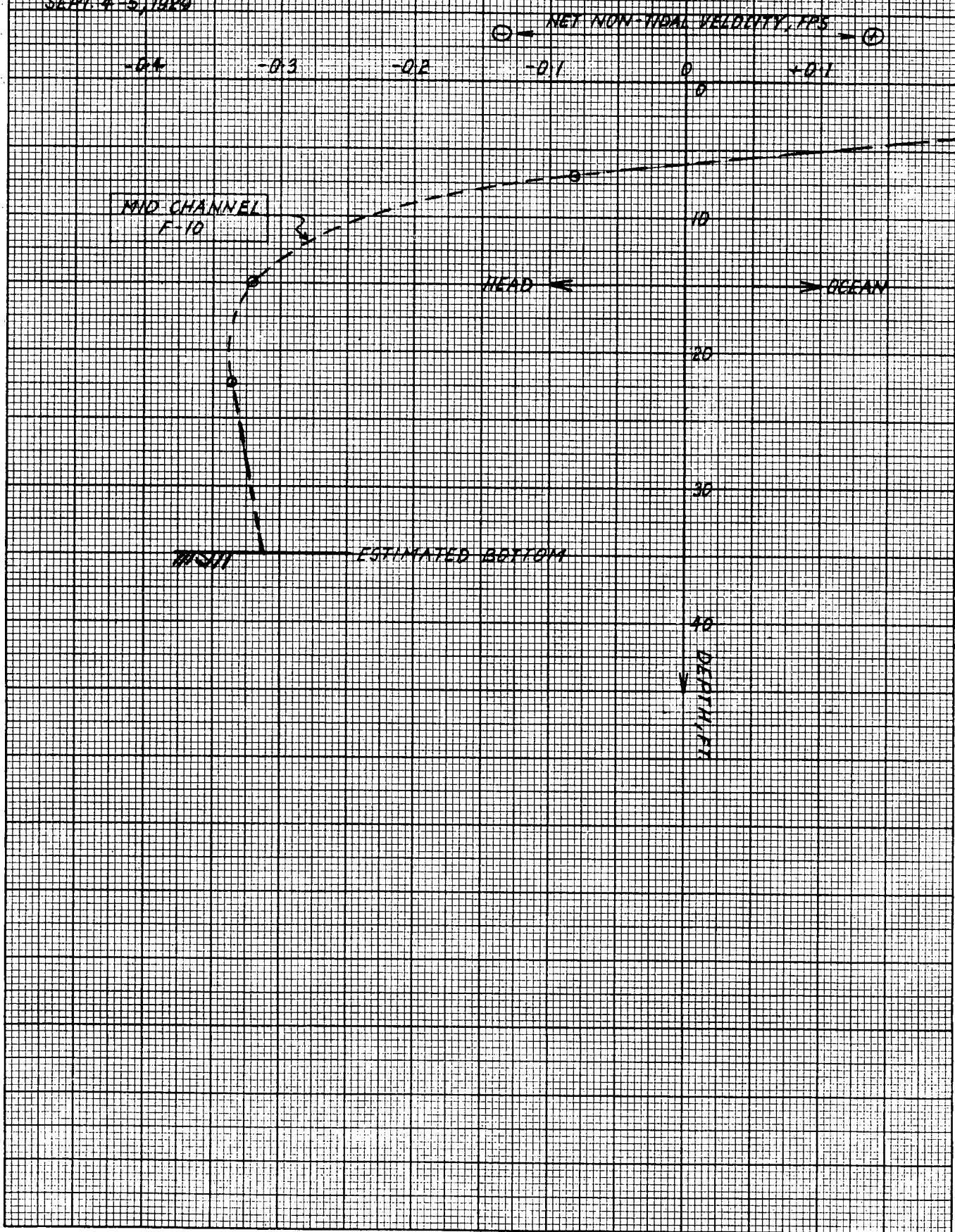

HUDSON RIVER
 FINNEGAN SURVEY
 ST. F-11, F-12, F-13
 M.P. 33.1
 CROTON POINT
 SEPT. 4-5, 1929

AVERAGE NET NON-TIDAL VELOCITY

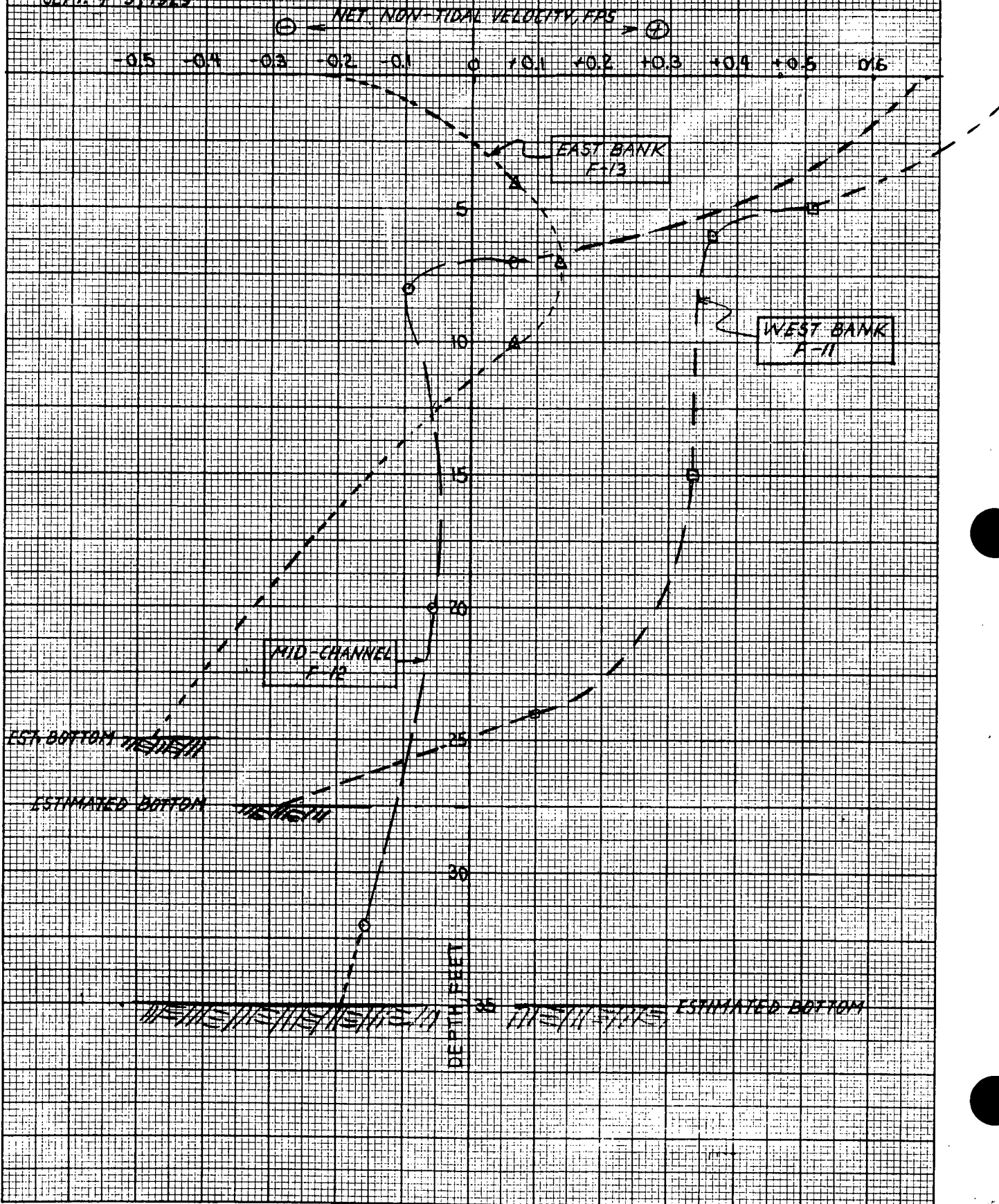

HUDSON RIVER
FINNEGAN SURVEY
ST. F-19
M.P. 36.0
HAVERSTOWN
SEPT 5-6, 10-12, 1929

AVERAGE NET NON-TIDAL VELOCITY

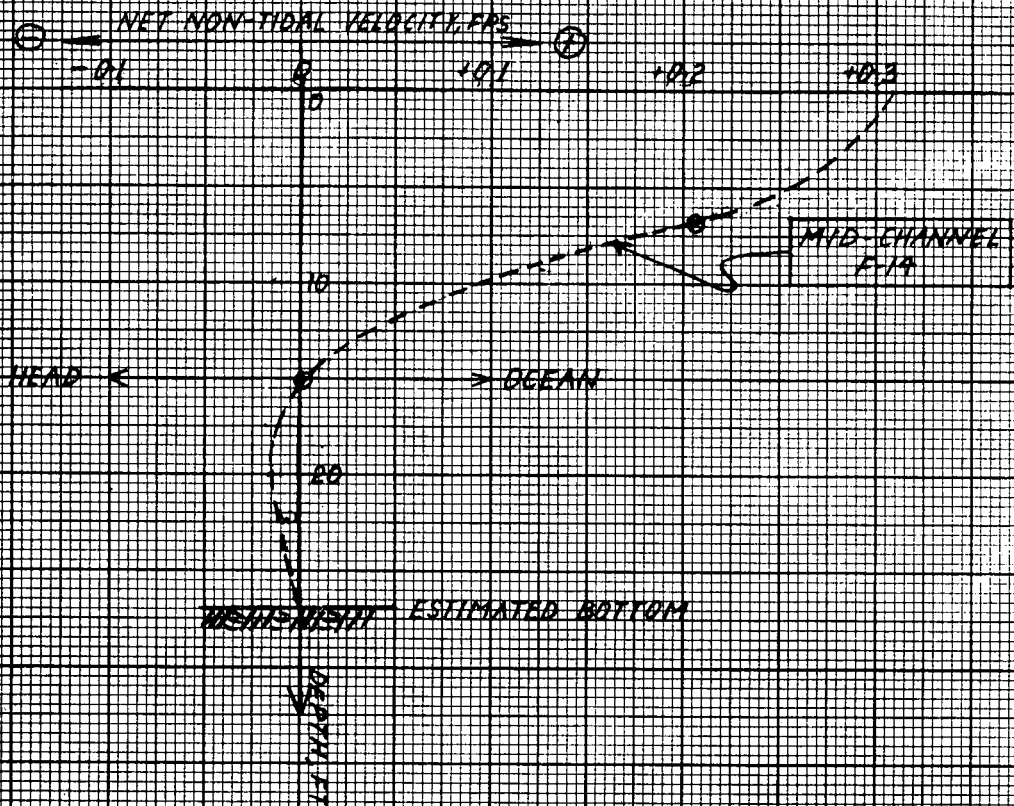

HUDSON RIVER
 TINNEY'S SURVEY
 ST. V. 12
 M. P. 40.1
 VERPLANCK
 SEPT. 5, 8, 10-13, 1929

AVERAGE NET NON-TIDAL VELOCITY

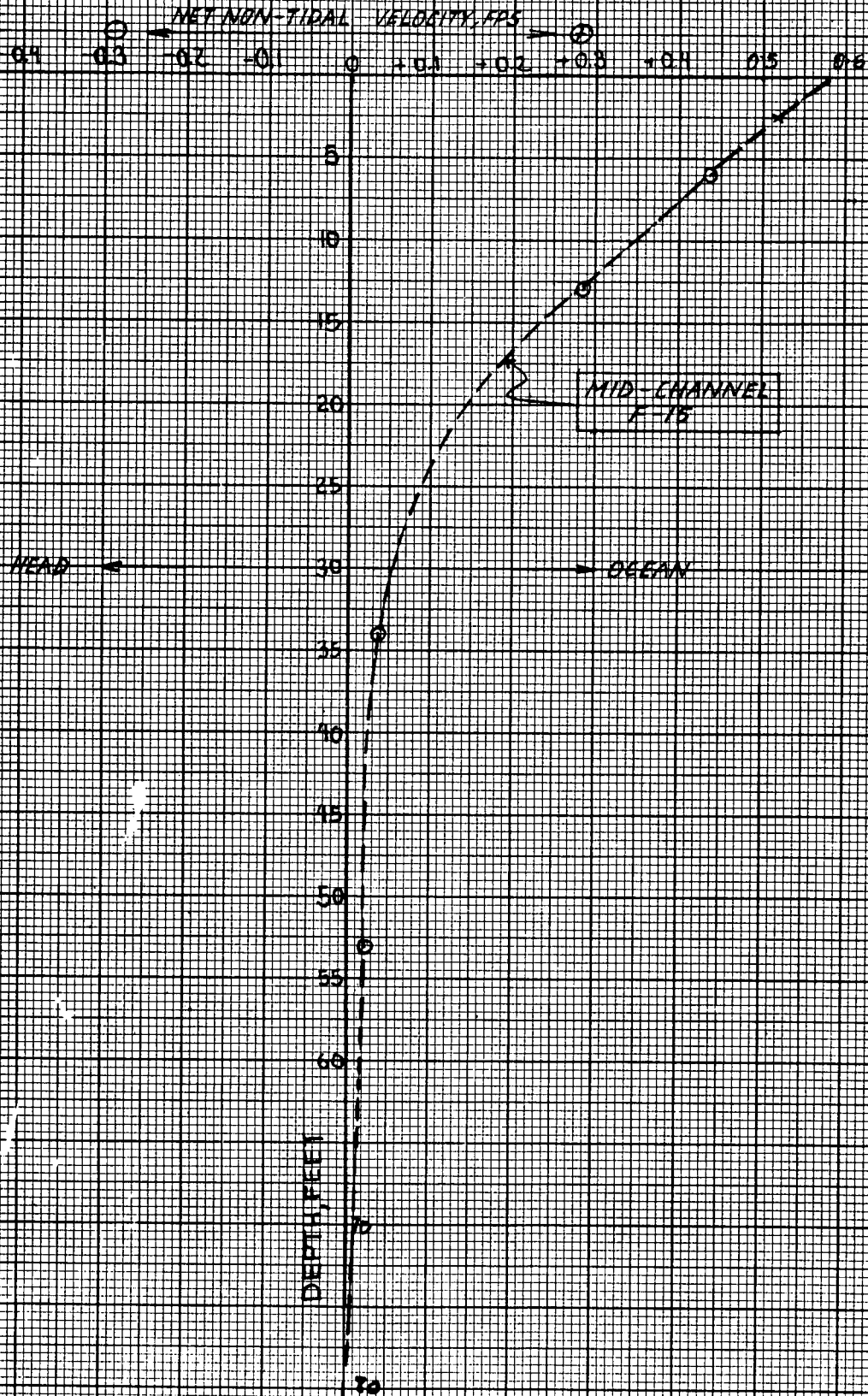

HUDSON RIVER
CINNENDEN SURVEY
STATION: F-16
M.P. 44.0
MONA ISLAND
SEPT. 5-6, 1923

AVERAGE NET NON-TIDAL VELOCITY

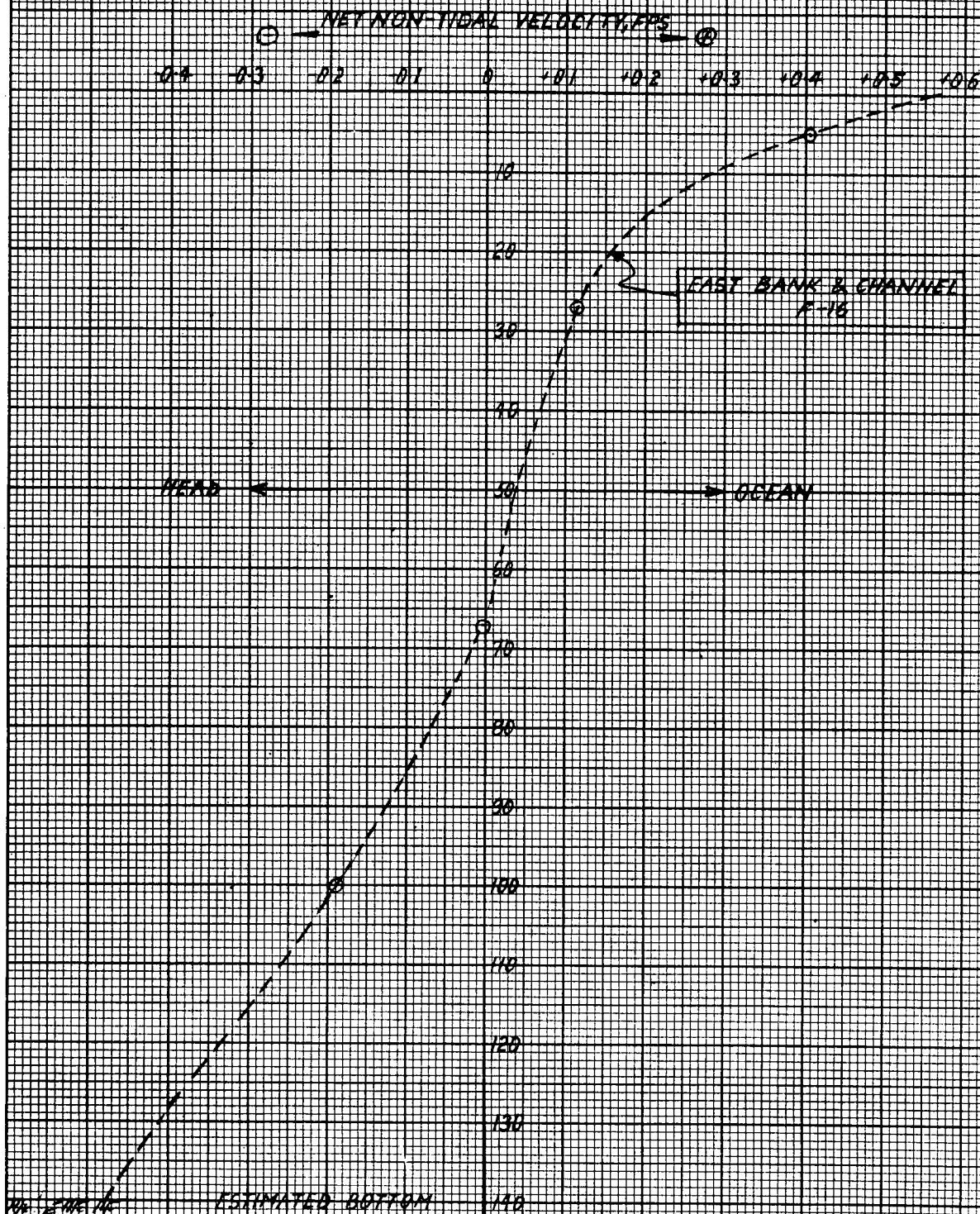

HUDSON RIVER
 FINNEGAN SURVEY
 ST. F-17, F-18
 M.P. 51.4
 WEST POINT
 SEPT. 6, 1929

AVERAGE NET NON-TIDAL VELOCITY

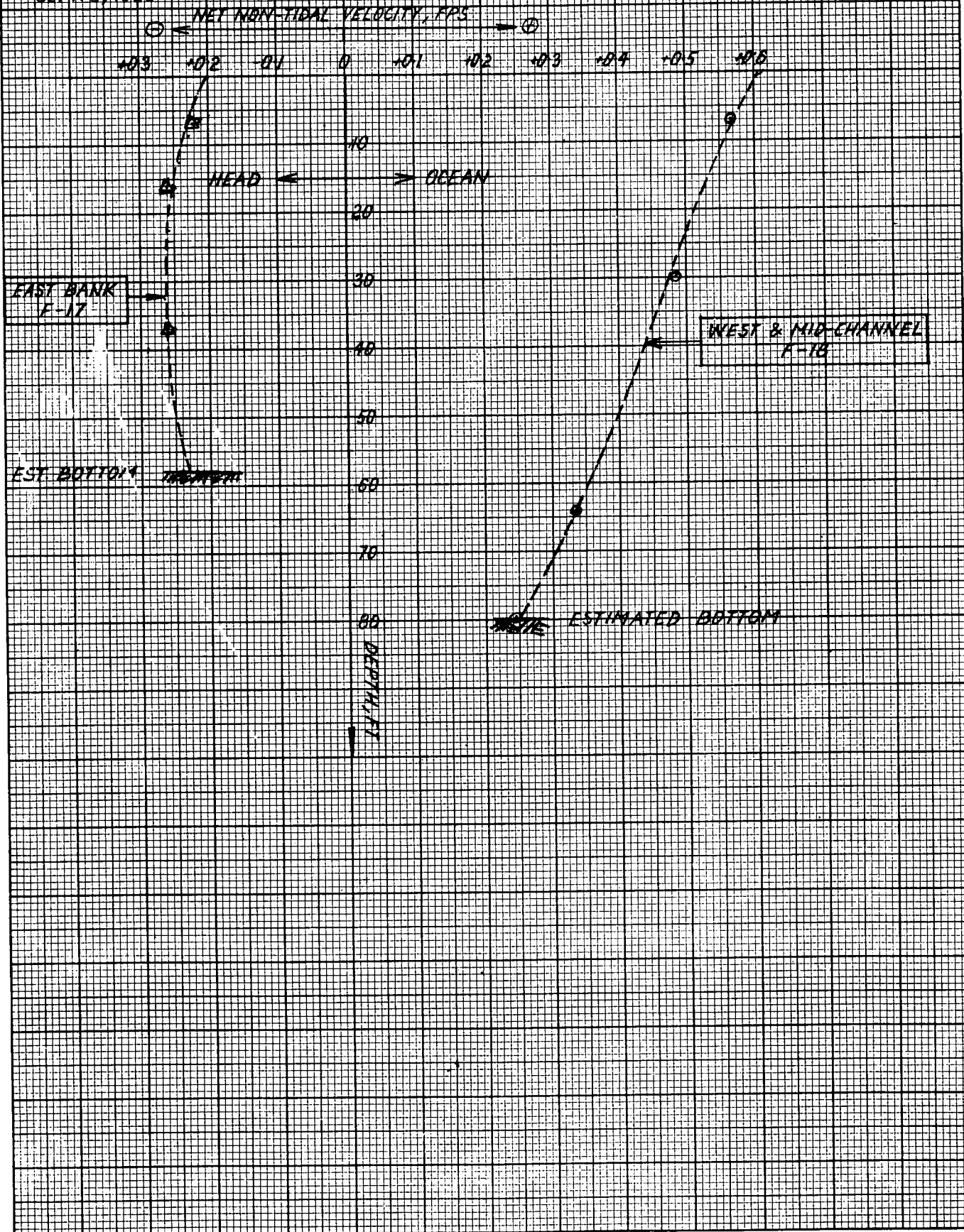

River's cross-section into three segments and assigning them to the corresponding locations of the velocity measurements. The net non-tidal flows for this survey are summarized in Table 2.

The results in the upper layer were generally better than those in the lower layer due to a more complete set of velocity measurements in this layer. A material balance, however, could not be obtained in most cases, i.e., the difference between the net upstream and downstream flows was not equal to the fresh water flow of 8000 cfs.

This could be due to several reasons including: influences of temporary meteorological conditions on current observations covering only a few days, the choice of allocating part of the river's cross-section to a particular velocity measurement location, the use of the only available velocity measurements (mostly mid-channel) as representative of the whole cross-section, and lack of velocity measurements in the upper and/or lower ten feet of the channel.

Figure 36 shows all of the measured points. Those representing either complete or typical of partially mixed estuaries net flow behavior in the upper layer are shown by closed circles. These points were assumed to represent an average condition that existed in September, 1929. Further discussion of this measured function

TABLE 2

NET NON-TIDAL FLOW IN THE HUDSON RIVER
(AUG. 29 - SEPT. 14, 1929) FINNEGAN'S SURVEY

<u>Station</u>	<u>Miles Above Battery</u>	<u>Total Seaward¹ Flow in the Upper Layer, cfs</u>	<u>Total Landward² Flow in the Lower Layer, cfs</u>
F-1,F-2,F-3	15.0	48,742	- 2,945
F-4,F-5,F-6	23.0	24,774	- 1,798
F-7,F-8,F-9	27.0	38,874	- 857
F-10	31.8	15,750 ³	-39,810
F-11,F-12,F-13	33.1	19,600 ⁴	- 9,665
F-14	36.0	33,018 ³	- 440
F-15	40.1	27,408 ³	0
F-16	44.0	17,624 ⁵	-10,863
F-17,F-18	51.4	12,000 ⁵	- 4,592
F-19,F-20	55.5	3,000 ⁴	- 4,013
F-21	66.1	23,673 ³	0

1. Estimated fresh water flow is 8000 cfs.
2. Incomplete measurements. Values are obtained by extrapolation of a few points.
3. Only mid channel net velocities were available.
4. Inconsistent net velocity variation which may be caused by influences of temporary meteorological conditions.
5. Mid channel and one bank net velocities were used.

HUDSON RIVER
FINNEGAN SURVEY
ST. F-19, F-20
M. D. 555
SEPT. 6-7, 1929

AVERAGE NET NON-TIDAL VELOCITY

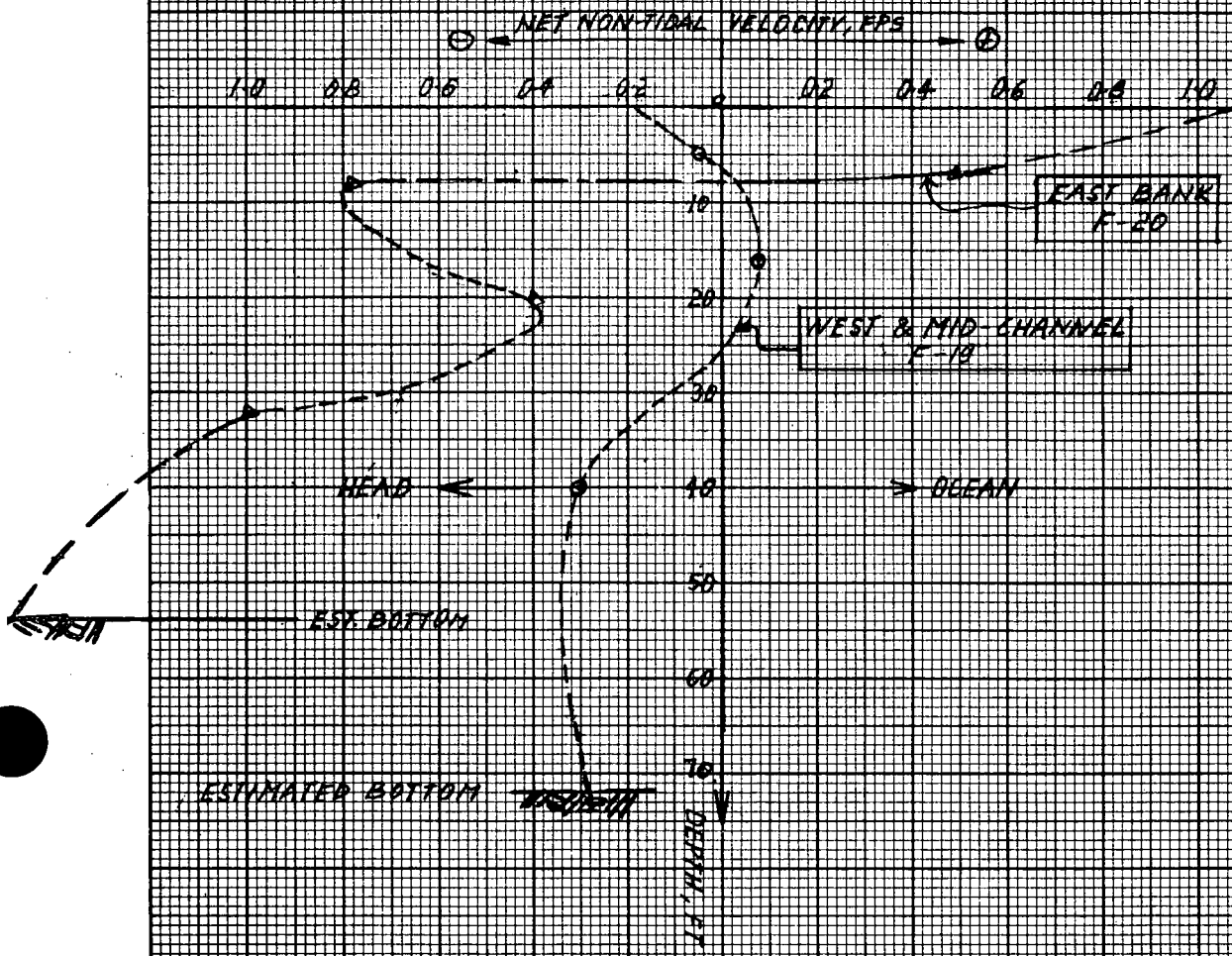

HUDSON RIVER
LYNNELGAN SURVEY
ST. F-21
M. P. 65-1
DANSKAMMER
SEPT. 10-11 & 18-19, 1923

AVERAGE NET NON-TIDAL VELOCITY

NET NON-TIDAL VELOCITY, FPS
0.05 0 0.05 0.10 0.15 0.20 0.25

HEAD ← → OCEAN

10

20

30

40

50

60

70

DEPTH

FAD-CHANNEL
F-21

ESTIMATED BOTTOM

|||||

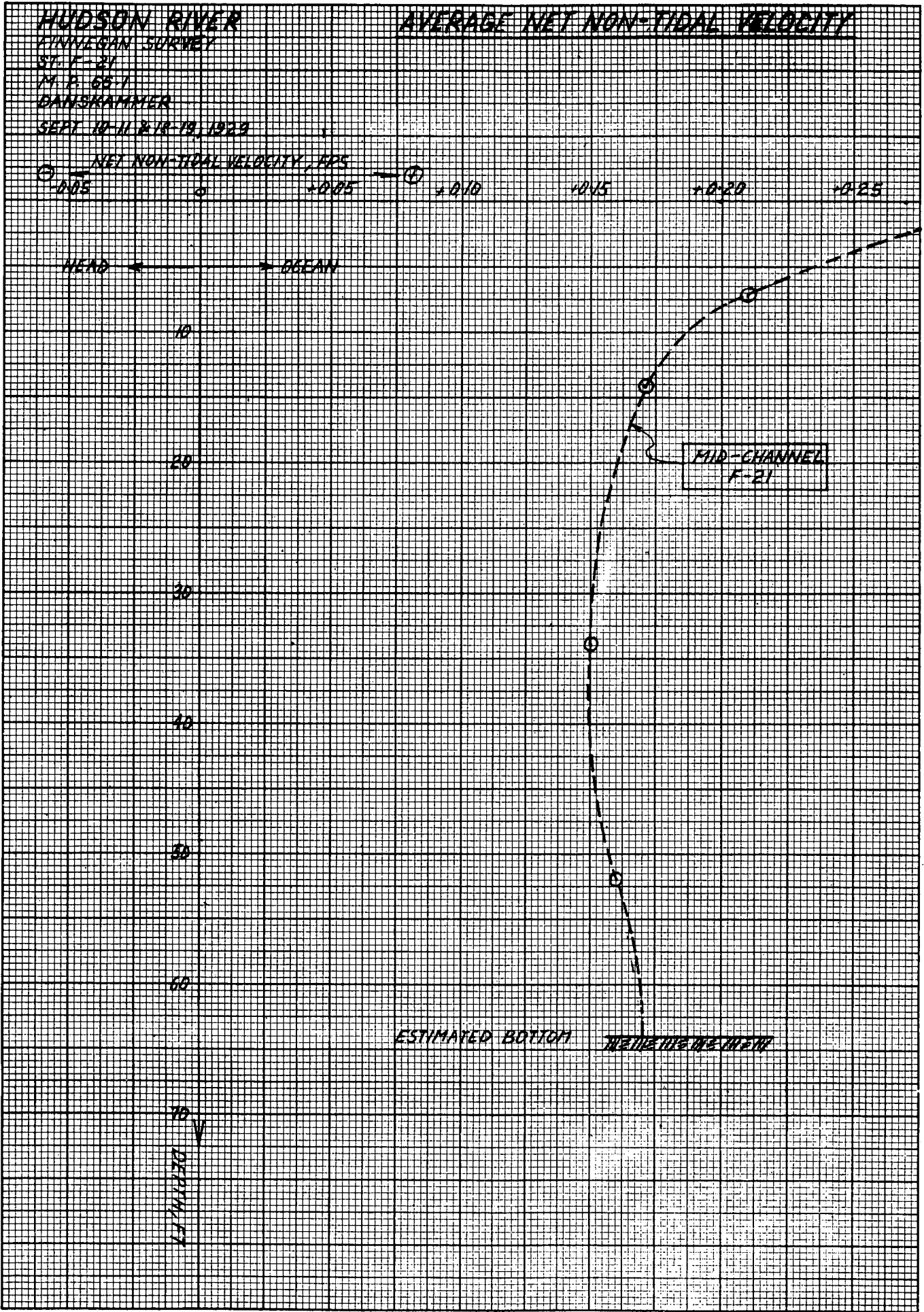

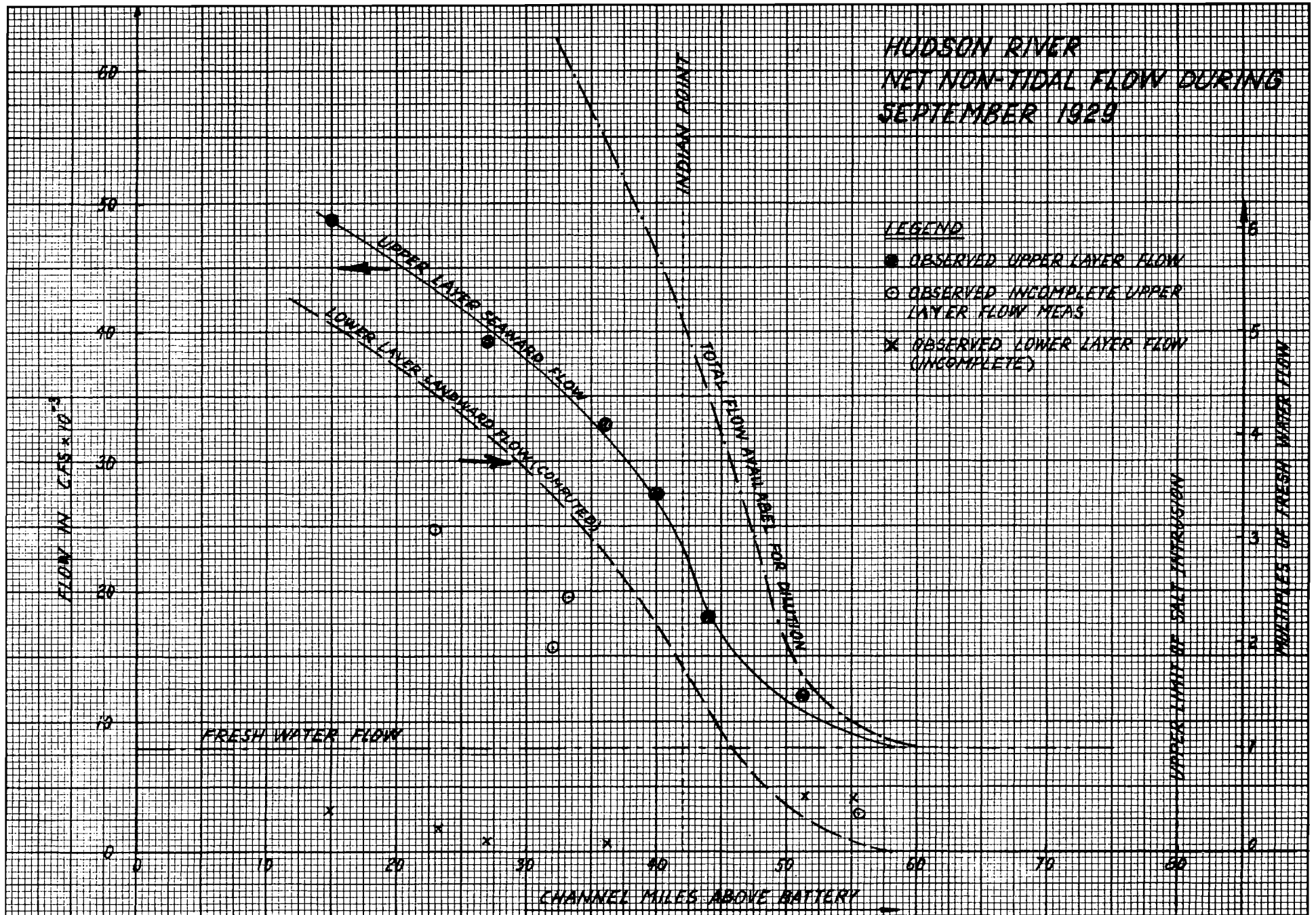

FIGURE 36

is presented in the next section. This curve represents the variation in the upper layer seaward flow with distance above the ocean entrance of the estuary. The selected curve through the measured points in the upper layer indicates that the volume of water flowing toward the ocean increases as one proceeds from the head to the mouth, a mechanism that occurs in all partially stratified estuaries.

The lower layer landward flow was then computed from a material balance between the upper layer net flow and the measured fresh water flow (8000 cfs). This curve is represented by a broken line in Figure 36.

The total river water flow available for dilution throughout the River's cross-section and over a period of a tidal cycle is the sum of the net upper and lower layer flows. This curve is also shown in Figure 36.

Figure 36 also expresses these net flows in terms of fresh water flow. At Indian Point, for example, the upper layer seaward flow is about three times the fresh water flow. The total river flow available for dilution throughout a tidal cycle is, therefore, about five times the fresh water flow. These ratios are small when compared with those of other partially mixed estuaries (20 to 40 times the

fresh water flow).^{1,2} However, the magnitudes of the Hudson River hydrodynamic characteristics are somewhat smaller.

3. Net Seaward Flow in the Upper 15 Feet of the Channel

The results presented in the previous section were obtained using Finnegan's direct results as derived from his current observations. These measurements covered intervals of only a few days and include the effects of local eddies and counter currents which may be created by shoals or other obstructions as well as the influence of temporary meteorological conditions.

The U.S. Coast and Geodetic Survey adjusted these as well as several series of observations in the same general locality. The method of adjustment is described in Reference 7 as follows:

"The adjustment was accomplished by plotting on cross-section paper the observational data, using the distance of each station from the mouth of the river as measured by its latitude as the abscissa and the result to be adjusted as the ordinate, separate adjustments being made for each current phase interval and for flood and ebb velocities. The stations used for the adjustment were those located well out in the stream, stations near the shore being excluded.

Smooth curves were drawn to follow as near as practicable the general trend of the plotted points." The resulting interval curves are reproduced in Figure 37 and the velocity curves in Figure 38.

"The adjusted values were then scaled off from these curves. For convenience in making comparisons between the times of the tide and the current phases, the values were taken for the same localities as those used for the adjusted tidal data in Table 97. A direct comparison in the times may be made through the Greenwich intervals.

The times of slack water and flood and ebb strength are referred also to the times of the high and low water at the Battery, and through the application of these differences to the predicted tides at the latter place, the times of the current phases may be readily estimated. It should be kept in mind, however, that the differences represent average values and are subject to variations depending upon the special conditions which may prevail at the time."

The adjusted current values represent the average velocities at strength of flood and strength of ebb. These velocities refer to

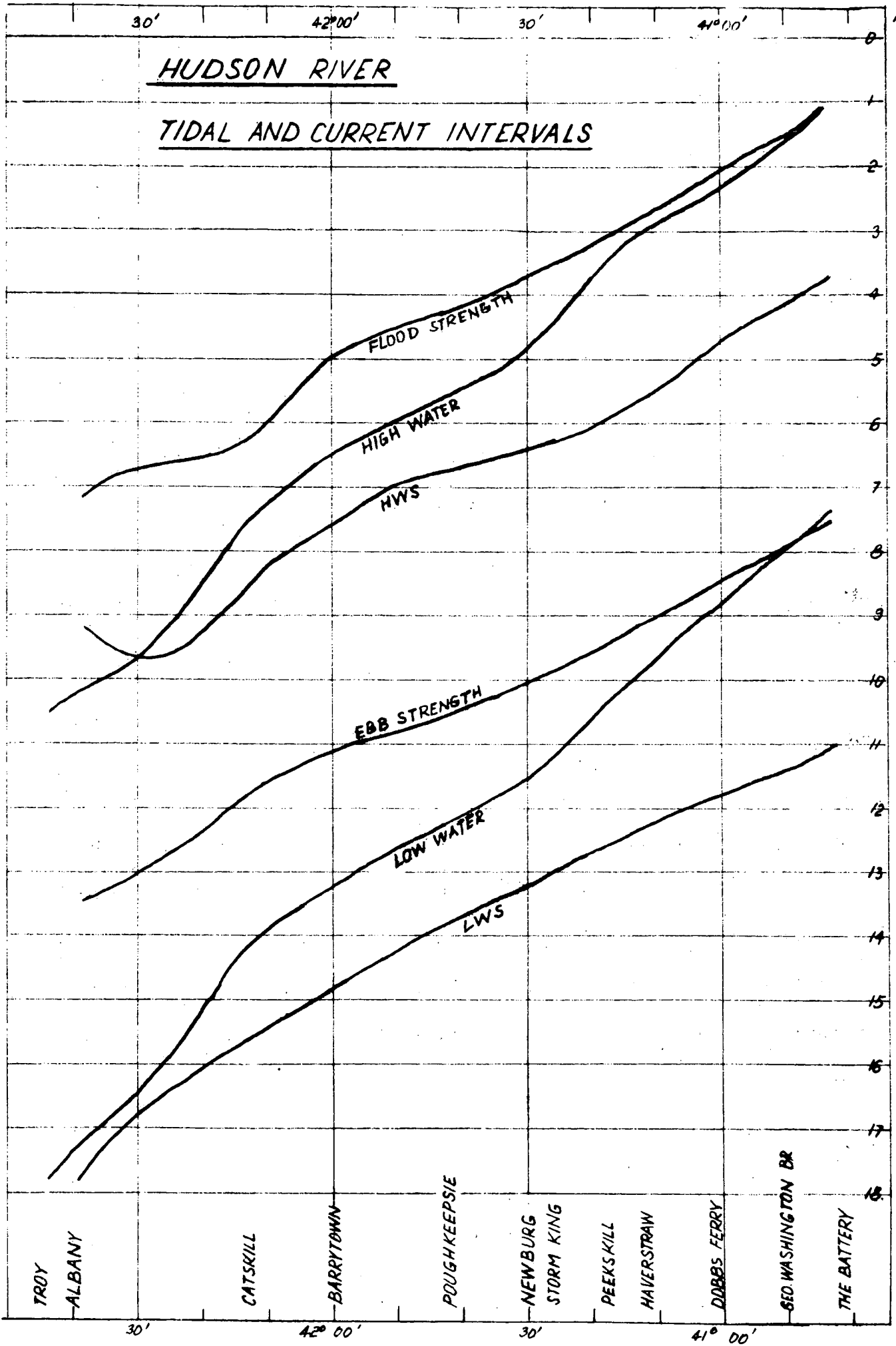
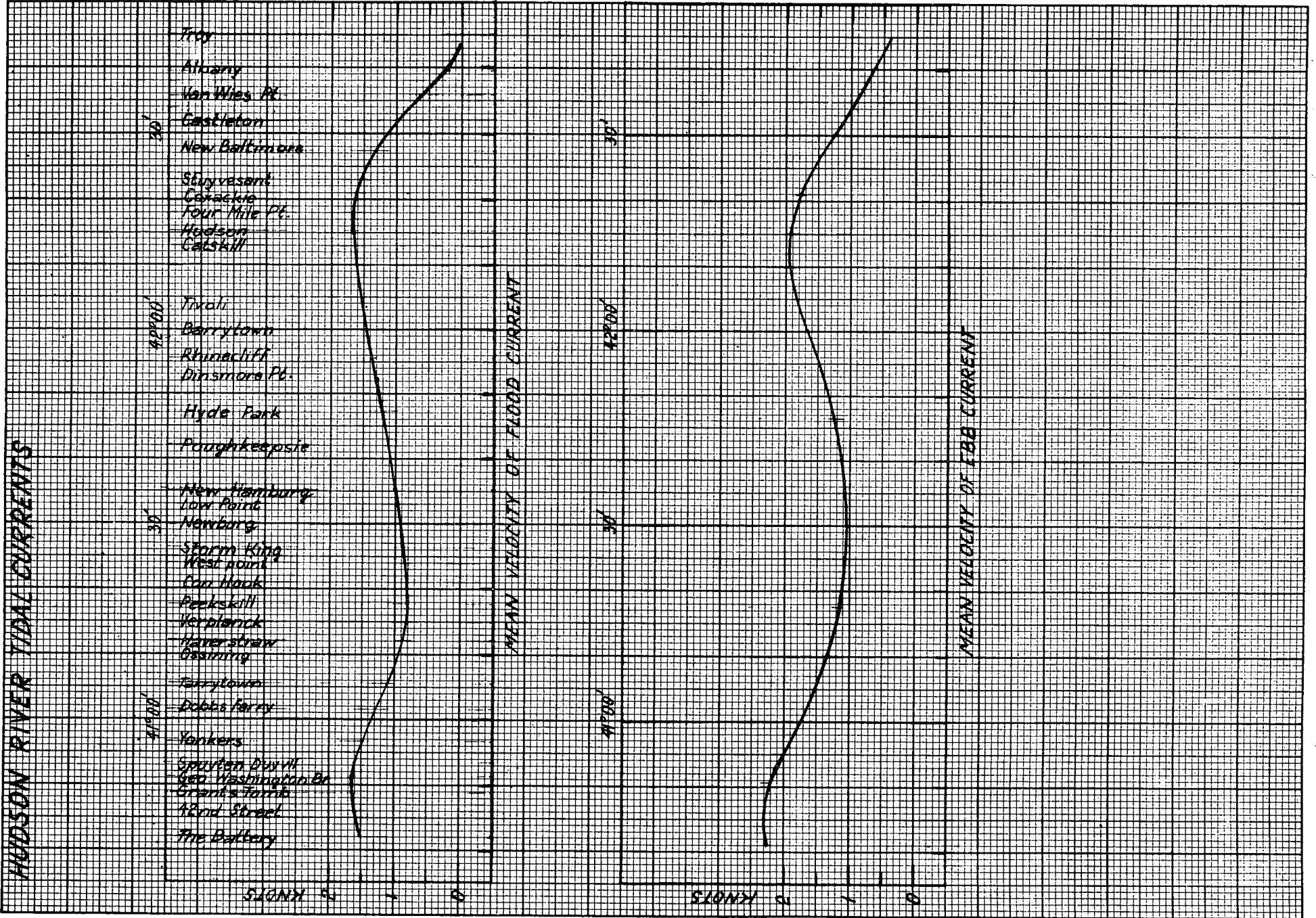

FIGURE 38



the mid-channel of the Hudson River and are taken to include those to a depth of 15 feet.

The computed net non-tidal channel velocity and flow in the upper 15 feet of the lower 82 miles of the Hudson River are summarized in Table 3. Figure 39 depicts the variation in net non-tidal channel flow with distance above the ocean entrance. The total upper layer flow computed using Finnegan's data is also shown in Figure 39 for comparison purposes. Notice that the total flow curve represents the net seaward flow contained in the upper layer, i.e., from the surface to zero net velocity depth which may be more than 15 feet.

TABLE 3

"HUDSON RIVER NET NON-TIDAL FLOW"

USING ADJUSTED CURRENT DATA MID CHANNEL AND TO A DEPTH OF 15 FT.*

Station	(1)	(2)	(3)	(4)	(5)	(6)	(7)	(8)
	Miles Above Battery	Maximum Ebb (Knots)	Ebb Duration (Hours)	Flood Strength (Knots)	Flood Duration (Hours)	Average Net (2X3-4X5) X $\frac{2X1.69}{\pi X12.42}$	Average River Width 0-15' ft.	Upper 15' Flow, cfs 6X7X15'
The Battery	0	2.3	7.71	1.5	4.71	.92	5800	80,000
George Washington Bridge	12	2.2	7.61	1.6	4.81	.78	4165	48,400
Riverdale	15	2.0	7.60	1.6	4.82	.65	4700	45,700
Dobbs Ferry	23	1.7	7.47	1.3	4.95	.554	4600	38,200
Tarrytown	27	1.5	7.32	1.1	5.10	.467	5000	35,000
Ossining	31.8	1.3	7.12	.9	5.30	.385	6750	39,000
Haverstraw	36	1.3	7.07	.8	5.35	.424	6000	38,000
Peekskill	42	1.2	6.57	.8	5.85	.277	3900	16,200
Iona Island	44	1.1	6.58	.8	5.84	.223	2000	6,700
Bear Mountain Bridge	46	1.1	6.58	.8	5.84	.223	2150	7,200
West Point	51.4	1.1	6.64	.9	5.78	.182	1950	5,330

TABLE 3 (CONTINUED)

"HUDSON RIVER NET NON-TIDAL FLOW"

USING ADJUSTED CURRENT DATA MID CHANNEL AND TO A DEPTH OF 15 FT.*

Station	(1)	(2)	(3)	(4)	(5)	(6)	(7)	(8)
	Miles Above Battery	Maximum Ebb (Knots)	Ebb Duration (Hours)	Flood Strength (Knots)	Flood Duration (Hours)	Average Net (2X3-4X5) X $\frac{2 \times 1.69}{\pi \times 12.42}$	Average River Width 0-15' ft.	Upper 15' Flow, cfs 6X7X15'
Storm King	55.5	1.1	6.66	.9	5.76	.183	2600	7,140
Newburgh	66	1.1	6.74	.9	5.68	.197	3000	8,850
Hyde Park	82	1.3	7.16	1.2	5.26	.258	3000	11,600

*Current and duration data were taken from Table 106, Reference 7. These values were obtained using Finnegan's results as well as several series of other observations in the same general locality.

HUDSON RIVER
NET NON-TIDAL CHANNEL FLOW

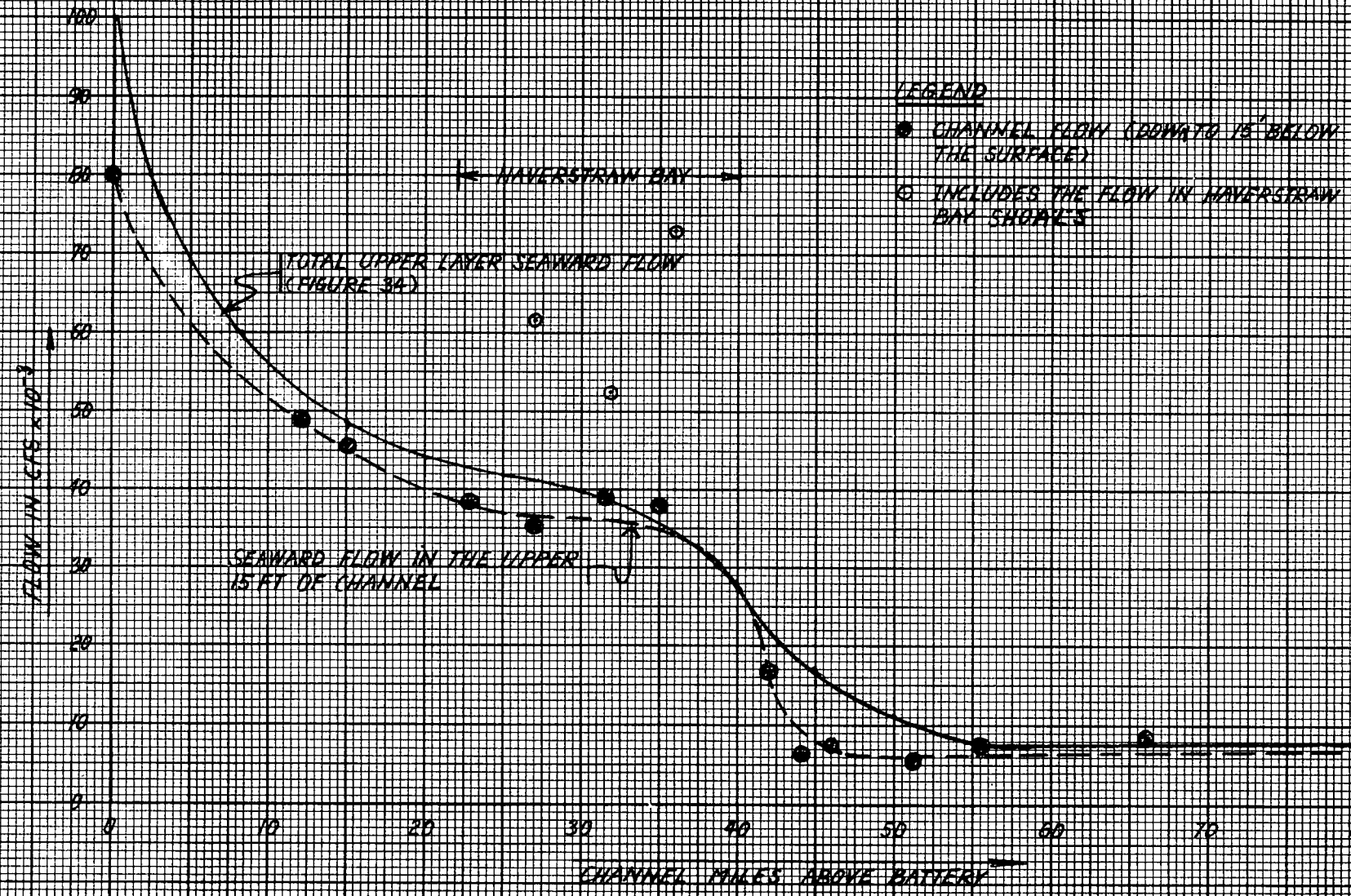

FIGURE 39

IV. EFFECT OF NET NON-TIDAL FLOW ON TEMPERATURE DISTRIBUTION
IN THE VICINITY OF INDIAN POINT.

A. Thermal Discharge in Partially Stratified Estuaries

A lighter effluent, such as a heated liquid, discharged into a partially stratified estuary rises to the surface and tends to remain in the upper layer and be carried with it. Therefore, the hydrodynamic characteristics controlling the fate of such a discharge are those of the upper layer.

Turbulent mixing, however, leads to a horizontal and eventually some vertical dispersion. Vertical mixing, however, is counteracted by the tendency of the estuary itself to stratify. Before introduction of the heated effluent these opposing mechanisms are already in a state of balance. An effluent, whose stable state is to locate near the surface, will be subject to a smaller vertical mixing than the natural waters of the estuary or an effluent having a density equal to the River's density.

Little of the heated effluent water, is transferred to the lower upstream moving layer. However, the temperature decay is primarily at the surface and the heat has every opportunity to dissipate to the atmosphere. Thus, by the time the water in the upper layer is

exchange with lower layer's water, much of the heat may be gone. In other words, the return of this water in the lower layer past the original plane of discharge will be at a time when this water possesses relatively little heat.

The heated liquid is ultimately flushed from the estuary in the seaward directed flow of the surface layers.

In dealing with an area-averaged and tidal-smoothed temperature rises both the upper seaward flow and lower layer landward flow must be taken into consideration.

B. Prediction of Area-Average Temperature Rise Using the Net Non-Tidal Flow Concept

The area-average temperature rise across the plane of discharge may be expressed as follows:

$$\Delta \bar{T} = \frac{H}{\rho \times C_p \times Q_d \times 86,400} \dots\dots (4)$$

where: H = Heat loss to River in BTU/day.
 ρ = Water Density in #/cu.ft.
 C_p = Heat capacity of water in BTU/#/°F.
 Q_d = Total dilution flow in cu.ft./sec.

The total dilution flow, in this case, is the sum of the upper layer seaward flow and the lower layer landward flow. Its magnitude is influenced by the fresh water flow, longitudinal dispersion, channel geometry, tidal characteristics and vertical salinity gradients.

Equation 4 is identical to those expressing the area-average temperature rise in terms of these parameters.⁷

For a water density of 62.4 lb/ft³ and heat capacity of 1 BTU/#/°F, Equation 4 reduces to:

$$\Delta \bar{T} = \frac{H}{5.4 Q_d} \quad \dots (5)$$

where: $\Delta \bar{T}$ = Area-average temperature rise across plane of discharge in °F.

H = Heat load in billion BTU/day.

Q_d = Total dilution flow in thousand cu.ft/sec.

C. Comparison of Indian Point July 1966 Temperature Measurements and Net Non-Tidal Predictions

A comparison of predicted (using the net non-tidal approach) and measured (8) (during July 1966) area-average Hudson River temperature rises in the vicinity of Indian Point follows.

The upper seaward flow at Indian Point may be obtained from Figure 36. The Figure values are valid for fresh water flow conditions of about 8000 cfs. The fresh water flow that prevailed during July 1966 was about 92% of this value (7300 cfs). Therefore, the use of the Figure values in the computation is valid.

Thus, for July 1966 conditions:

1. Indian Point upper layer seaward flow = 22,000 cfs (from Fig. 36)
2. Indian Point lower layer landward flow = 22,000 - 7,300 = 14,700 cfs
(from material balance)

3. Total channel net flow available for dilution $Q_d = 22,000 + 14,700$
 $= 36,700$ cfs
4. Measured area-average temperature rise across the plane of discharge = 0.2°F (see Table 1 of Jan. 1968 Report).
5. The predicted area-average temperature rise across the plane of discharge may be computed from Equation 5.

H = Heat loss to the River during July 1966 survey period
 = 36 BBTU/day (see Table 1 of Jan. 1968 Report).

$$\Delta \bar{T} = \frac{36}{5.4 \times 36.7} = 0.182^\circ\text{F}$$

This value is only 9% less than the actual.

Therefore, the agreement between the measured area-average temperature rise at Indian Point, and that predicted using the net non-tidal concept is better than all previous attempts at explaining this temperature parameter.

D. Prediction of Indian Point Temperature Distribution using the Net Non-Tidal Flow Concept

Indian Point design heat load is 340 BBTU/day.¹ The total dilution flow at Indian Point during fresh water conditions similar to those of July 1966 is 36,700 cfs (see previous section). Therefore, the expected area-average temperature rise across the plane of discharge

is $\frac{340}{5.4 \times 36.7} = 1.71^\circ\text{F}$ (from Equation 5).

For other heat load and/or dilution flow values, the expected area

average temperature rise may be obtained from Figure 40, which represents a graphical solution of Equation 5.

The effect of variation in available dilution flow in both layers on the area-average temperature rise is shown in Figure 41.

An increase of 50% in dilution flow results in a reduction of about 70% in the area average temperature rise. An equivalent decrease in dilution flow, on the other hand, results in a 100% increase in this temperature parameter. However, the total dilution flow at Indian Point is always greater than 20,000 cfs. No ocean derived salt is seen at Indian Point when the fresh water flow in the lower Hudson is 20,000 cfs.⁵ The net non-tidal flow, under these conditions, is all in one layer and in the downstream direction. The minimum total dilution flow, therefore, is equivalent to this value. Higher dilution values result from either fresh water flows in excess of 20,000 cfs or net non-tidal flows caused by salt intrusion.

Thus, the maximum area-average temperature rise at Indian Point is not expected to exceed 3.2°F, which corresponds to dilution flow of 20,000 cfs (see Figure 41). Lower values occur during the summer and fall of dry years, when the fresh water flow is minimum and the salinity gradient is maximum or during very high fresh water flow periods. The variation of this parameter with fresh water flow is shown in Figure 42.

FIGURE 40

HUDSON RIVER AT INDIAN POINT
 EXPECTED AREA AVERAGE TEMPERATURE RISE - GENERALIZED SOLUTION

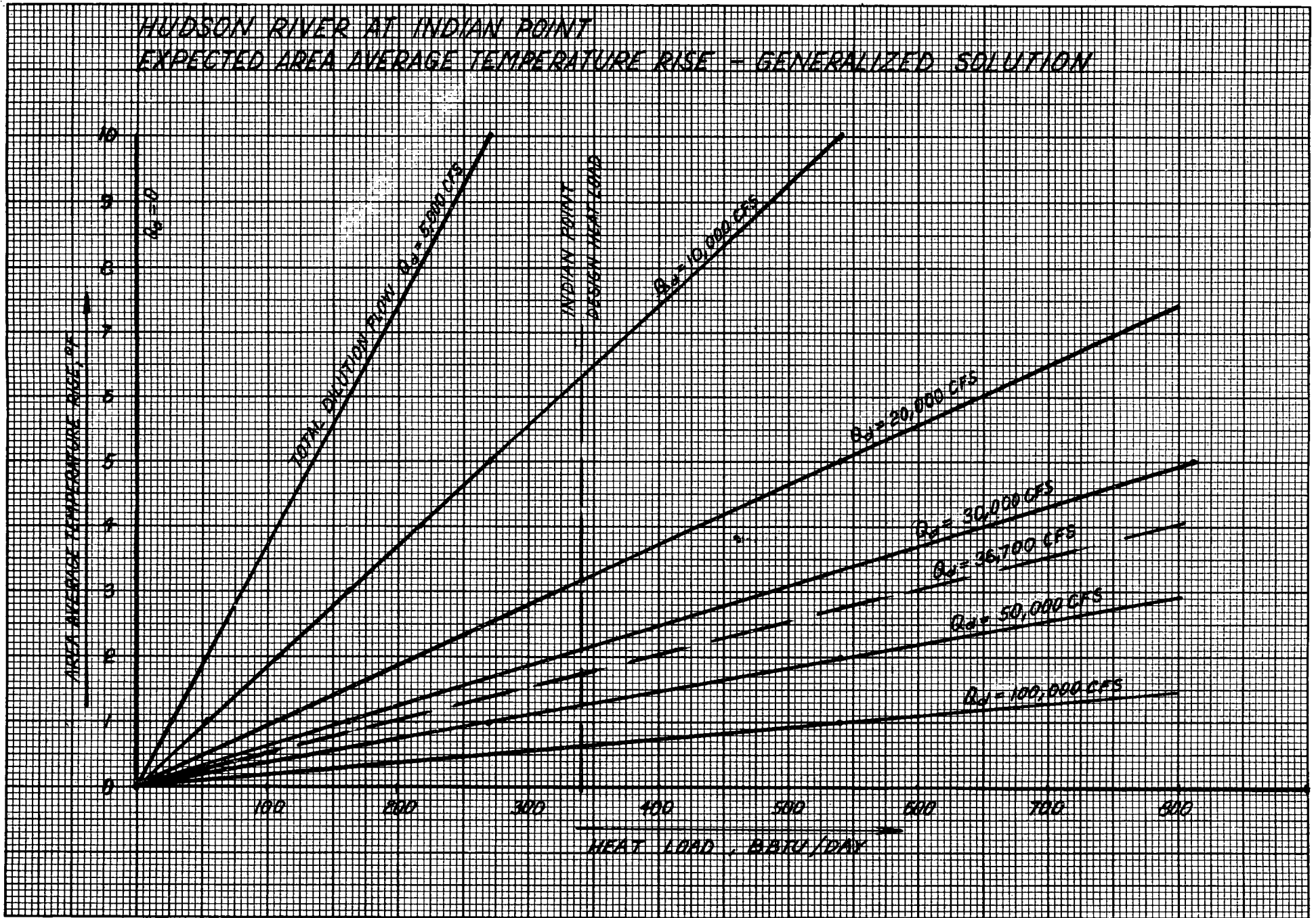

FIGURE 41

HUDSON RIVER AT INDIAN POINT
VARIATION IN EXPECTED AREA TEMPERATURE RISE DUE TO CHANGE IN DILUTION FLOW
DESIGN HEAT LOAD = 340×10^9 BTU/DAY

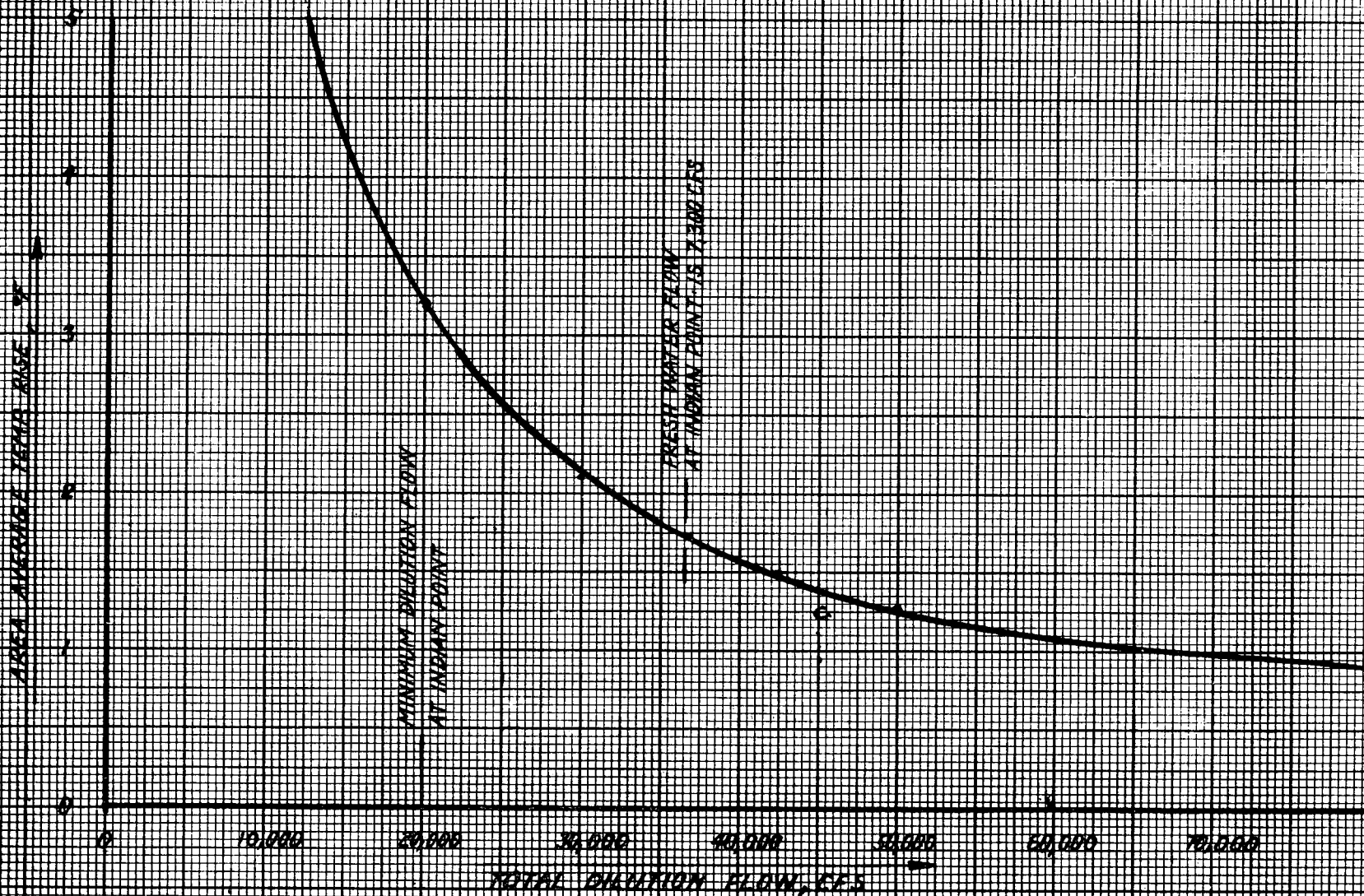
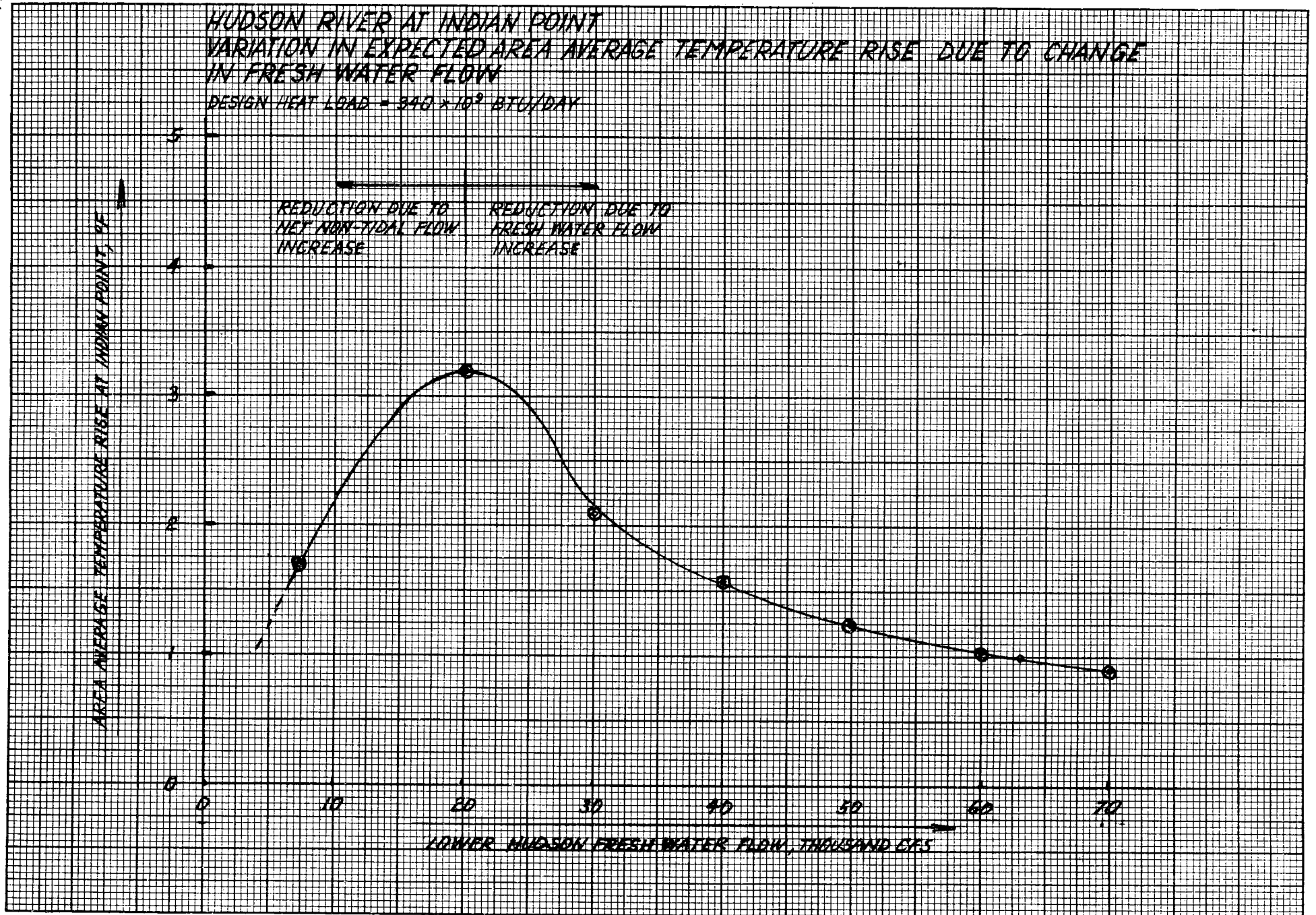

FIGURE 4E



The behavior beyond the plane of discharge is controlled by the variation in the upper layer and total dilution flows at Indian Point. The upper layer flow, which carries the heated effluent, is always in the downstream direction. Figure 36 shows that the magnitude of this flow increases significantly as one proceeds from Indian Point to the Battery. The lower layer landward flow, on the other hand, decreases in the landward direction. The total flow available for dilution is greater downstream of the discharge. Therefore, a substantial reduction in the area-average temperature rise is expected to occur downstream of Indian Point and effectively no temperature movement (other than tidal) in the upstream direction. Indian Point temperature measurements as well as recent thermal surveys along the Hudson River showed similar behavior.

E. Conclusions of February 1969 Indian Point Report

Our February 1969 Indian Point predictions were arrived at empirically by adjusting our mathematical model to yield better agreement with field data.

The net non-tidal flow concept, on the other hand, helped to theoretically explain these measurements better than all previous attempts.

Therefore, the establishment of the existence of the net non-tidal

flow in the Hudson and the conclusions outlined in this Report, may be taken as representing an additional support of the reduced temperature effect model used in our February 1969 Report.

REFERENCES

1. Quirk, Lawler & Matusky Engineers, "EFFECT OF INDIAN POINT COOLING WATER DISCHARGE ON HUDSON RIVER TEMPERATURE DISTRIBUTION", Report to Consolidated Edison Company of New York, Inc., February, 1969.
2. Pritchard, D.W., "OBSERVATIONS OF CIRCULATION IN COASTAL PLAIN ESTUARIES." Chapter in "Estuaries" G.H. Lauff, Editor, Publication No. 83, American Association for the Advancement of Science, Washington, D.C. 1967.
3. Bowden, K.F., "CIRCULATION AND MIXING IN THE MERSEY ESTUARY." I.A.S.H. Comm. of Surface Waters, Publ. 51, pp. 352-360, 1960.
4. Tully, J.P., "ON STRUCTURE, ENTRAINMENT AND TRANSPORT IN ESTUARINE EMBAYMENTS," J. Marine Res., 17:523-535, 1958.
5. Quirk, Lawler & Matusky Engineers, "HUDSON RIVER DISPERSION CHARACTERISTICS," Progress Report to Consolidated Edison Company of New York, Inc., October, 1965.
6. Pritchard, D.W., Okubo, A., and Mehr, E., "A STUDY OF THE MOVEMENT AND DIFFUSION OF AN INTRODUCED CONTAMINANT IN NEW YORK HARBOR WATERS," Technical Report 31, CBI, October, 1962.
7. USC&GS, "TIDES AND CURRENTS IN HUDSON RIVER," Special Publication No. 180, 1934.
8. Quirk, Lawler & Matusky Engineers, "EFFECT OF INDIAN POINT COOLING WATER DISCHARGE ON HUDSON RIVER TEMPERATURE DISTRIBUTION," January, 1968.

INDIAN POINT MODEL NO.2 COOLING WATER STUDIES

for

CONSOLIDATED EDISON COMPANY
NEW YORK, N. Y.

Peter A. Larsen

ALDEN RESEARCH LABORATORIES
WORCESTER POLYTECHNIC INSTITUTE

Lawrence C. Neale, Director

May, 1969

TABLE OF CONTENTS

	PAGE NO.
1. INTRODUCTION	
2. MODEL DESIGN	
2.1 Model Topography	4
2.2 Water Supply, Tide Controls	7
2.3 Instrumentation	8
3. MODEL CRITERIA	
3.1 Model Similitude Relations	13
3.2 Velocity Distribution - Field Measurements	18
3.3 Heat Transfer Conditions	20
3.4 Temperature Conditions for the Model as a Whole	22
3.5 Significance of Model Length as Related to that Accumulation	23
4. UNDISTORTED SUB-MODEL 1:50 OF THE COOLING WATER OUTFALL STRUCTURE	
4.1 Introduction	26
4.2 Model	27
4.3 Test Results	30
4.4 Conclusions of Sub-Model Tests	33
5. TEST RESULTS, MAIN MODEL	
5.1 General	35
5.2 Test Results Reported	38
5.3 Tests With Units 1 + 2 + 3	39
5.4 Tests With Units 1 + 2	41
5.5 Recirculation	42

LIST OF FIGURES

FIGURE	1	INDIAN POINT MODEL II, GENERAL ARRANGEMENT				
	2	SPECIFIC WEIGHT - TEMPERATURE RELATIONSHIP				
	3	VELOCITY VERSUS TIME, STAGE VERSUS TIME				
	4	FIELD MEASUREMENTS				
	5 - 14	UNDISTORTED SUB-MODEL. ISOTHERMS				
	15	"	"	HEAD LOSS		
	16 - 55	ISOTHERMS, 3 UNITS, AMBIENT RIVER TEMPERATURE 50F				
	56 - 77	"	"	"	"	80F
	78 - 85	"	2 UNITS	"	"	65F
	86 - 93	"	"	"	"	56F
	94 - 101	"	"	"	"	80F
	102 - 103	RECIRCULATION				

LIST OF PHOTOGRAPHS

PHOTO NO.		PAGE NO.
1	SAND FILL BEING COMPACTED	5
2	CONCRETING THE TOPOGRAPHY	5
3	INTAKES AND DISCHARGE CHANNEL, UNITS 1 + 2 + 3	6
4	DISCHARGE CHANNEL, UNITS 1 + 2	6
5	HEAD TANK, TIDE MACHINE, DISCHARGE GATE	9
6	RECORDERS AND DATA LOGGER	9
7	THERMOCOUPLE MOUNTING	10
8	DRY BULB-WET BULB INSTRUMENT, DEW POINT INSTRUMENT	10
9	VELOCITY MEASUREMENTS. CANDLE PATH LINES	14
10	ARTIFICIAL ROUGHNESS	14
11	UNDISTORTED MODEL. SIX 4 FOOT HIGH OPENINGS	29
12	UNDISTORTED MODEL IN OPERATION	30

INDIAN POINT MODEL NO. 2 COOLING WATER STUDIES

1. INTRODUCTION

A hydraulic model was designed and constructed for the Consolidated Edison Company of New York at the Alden Research Laboratories of Worcester Polytechnic Institute during the Winter and Spring of 1968. The model was constructed in an existing building in an area which had previously been the site of the Indian Point Model No. 1. The No. 2 model was designed to reproduce a section of the Hudson River from Verplanck Point about 9000 feet downstream from the Indian Point Plant to Roa Hook about 9000 feet upstream from the Plant. A horizontal scale of 1:250 and a vertical scale of 1:60 were selected. The model was designed to simulate the cooling water flow conditions pertaining to generating units No. 1 and No. 2 and those pertaining to generating units Nos. 1, 2 and 3 in which case a changed configuration of the outfall applied.

Since the tidal action of the Hudson River is a dominant hydraulic factor in determining the flow pattern as well as the dispersion of released cooling water the model was designed with automatic tide controls.

The so-called Moth Ball Fleet consisting of some 160 World War II cargo ships, anchored along the western side of the river, opposite the Indian Point Plant, was considered to influence the river hydraulics and was therefore incorporated in the model.

Although of secondary importance in terms of heat effect, the Rockland-Orange Company's Lovett plant situated on the western shore of Hudson River was included in the model.

In order to assure satisfactory hydrodynamic similitude between model and prototype rather comprehensive field measurements were planned by the Alden Research Laboratories and Consolidated Edison Company. The field studies, based on aerial mapping of drogues, were carried out on two occasions, August 14 and September 20, 1968. The model was adjusted on the basis of field data.

Changes in the New York State regulations stating the limiting temperature conditions for the River required radical changes in the design of the cooling water outfall structures on two different occasions during the course of testing. The temperature requirements pertaining to the near vicinity of the outfall were such that a submerged outfall proved necessary in order to accomplish sufficient initial dilution of the cooling water. In order to determine the design and dimensions of adequate outfall structures it was necessary to conduct tests in an undistorted scale model. Such a model was constructed to scale 1:50 and comprehensive testing was carried out with two purposes: 1) to guide Consolidated Edison Company in their design of the outfall structure so as to meet the given temperature requirements; 2) to establish a set of boundary conditions to be imposed on the main model. The results of these tests were reported in a progress report of August, 1968 and, due to renewed changes in state regulations, which invalidated the application of these test results, a progress report of October 1968. Additional tests were carried out in the small model in March of 1969 and results presented in a progress report of April, 1969. Since the outfall test results are essential both in regard to the design of the prototype outfall structure and also to the testing of the main model a summary of these tests and their results are presented herein.

The final testing of the main model was carried out between November 4 and December 6, 1968 and the results of these tests are presented in this report.

2. MODEL DESIGN

2.1 Model Topography

Reproduction of the river bed topography was based on essentially two sources:

A 1:24000 map which shows depth contour lines at 6, 12, 18 and 30 feet below mean low water and in addition a number of point soundings and the Coast and Geodetic Survey map No. 282 to scale 1:40000 which gives a great number of point soundings and information about dredgings. Templates were made based on the above information and placed on the model foundation concrete slab according to an adopted coordinate system, see Photo No. 1. The templates were back filled with sand which was compacted to within about 2 inches from the template edge. The remaining 2 inches were filled with concrete, molded to the shape of the river topography using the templates as guides, see Photo No. 2. Two foot high 4" concrete walls, cast on the concrete slab, provided with the slab a water tight enclosure for the model.

The area containing the cooling water intakes and the outfall channel was molded in fiberglass in order to facilitate changing of these structures to model the configuration pertaining to different construction stages. Photo No. 3 shows the intake-discharge configuration for Units 1, 2 and 3 with connecting piping while Photo No. 4 shows the fiberglass part representing the outfall for Units 1 and 2. Figure 1 shows the general arrangement of the model including the model topography.

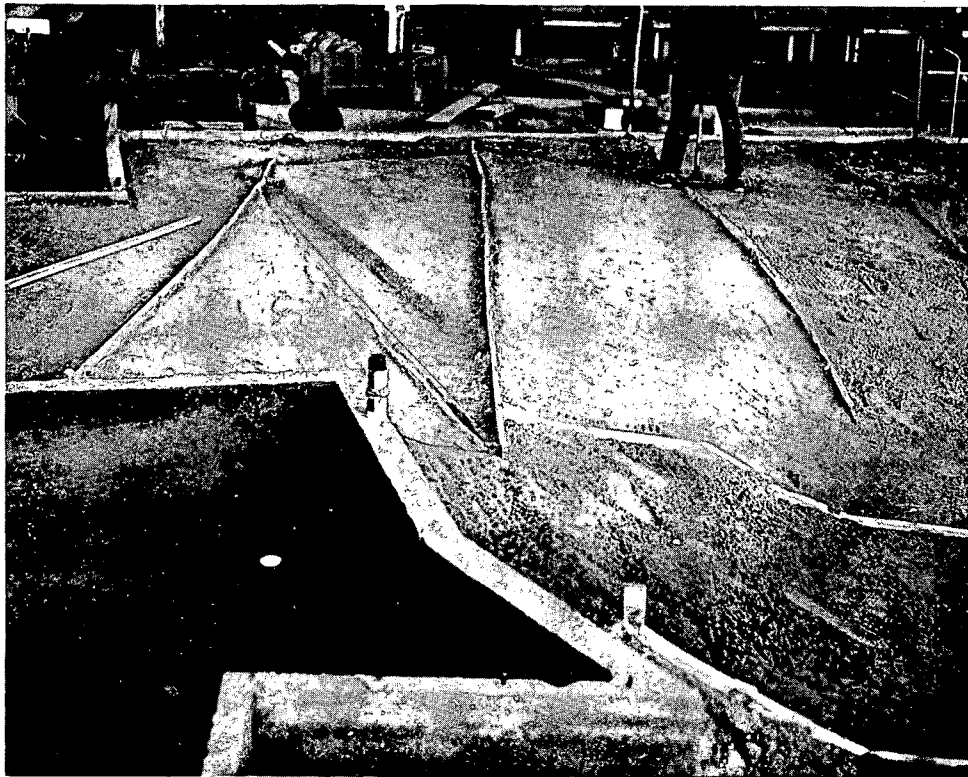

PHOTO NO. 1 SAND FILL BEING COMPACTED

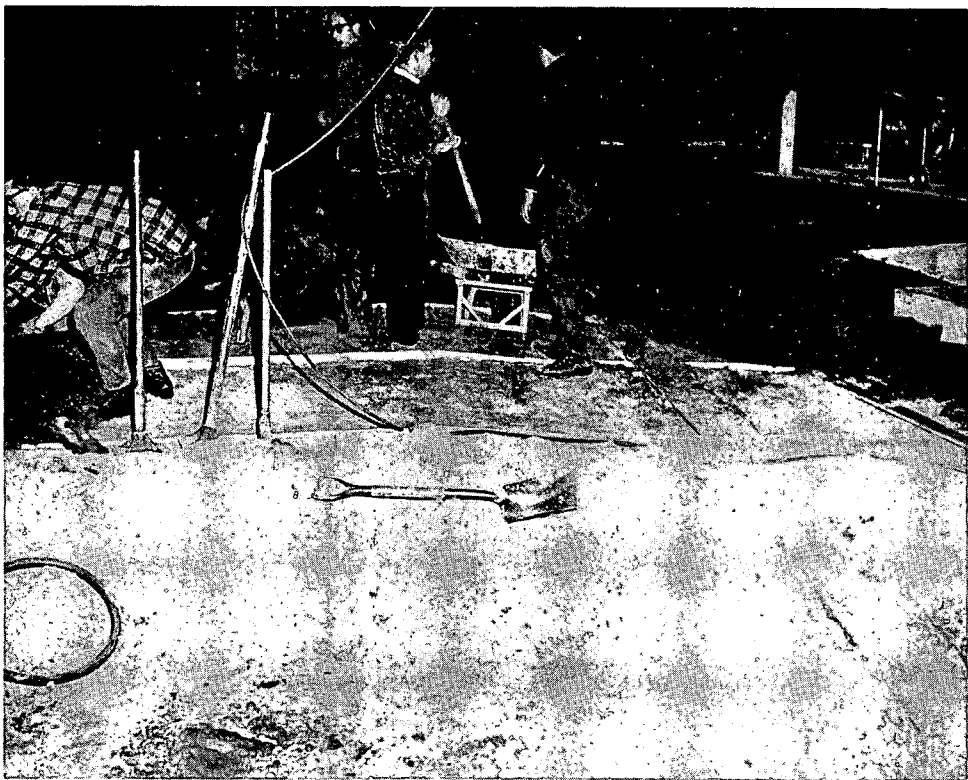

PHOTO NO. 2 CONCRETING THE TOPOGRAPHY

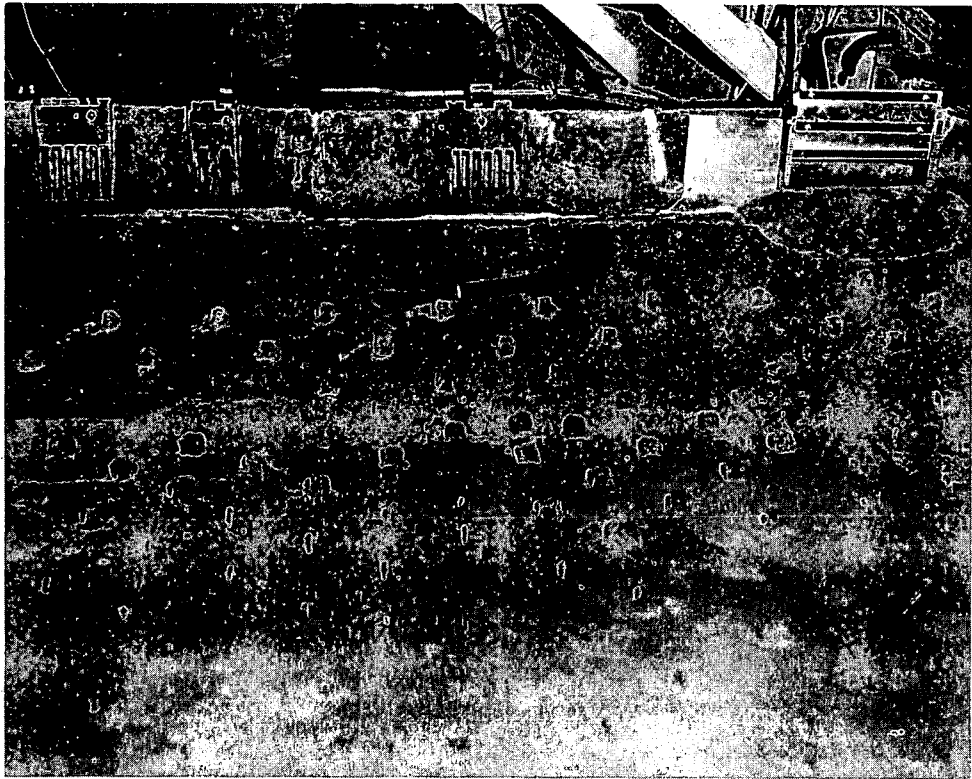

PHOTO NO. 3 INTAKES AND DISCHARGE CHANNEL,
UNITS 1 + 2 + 3

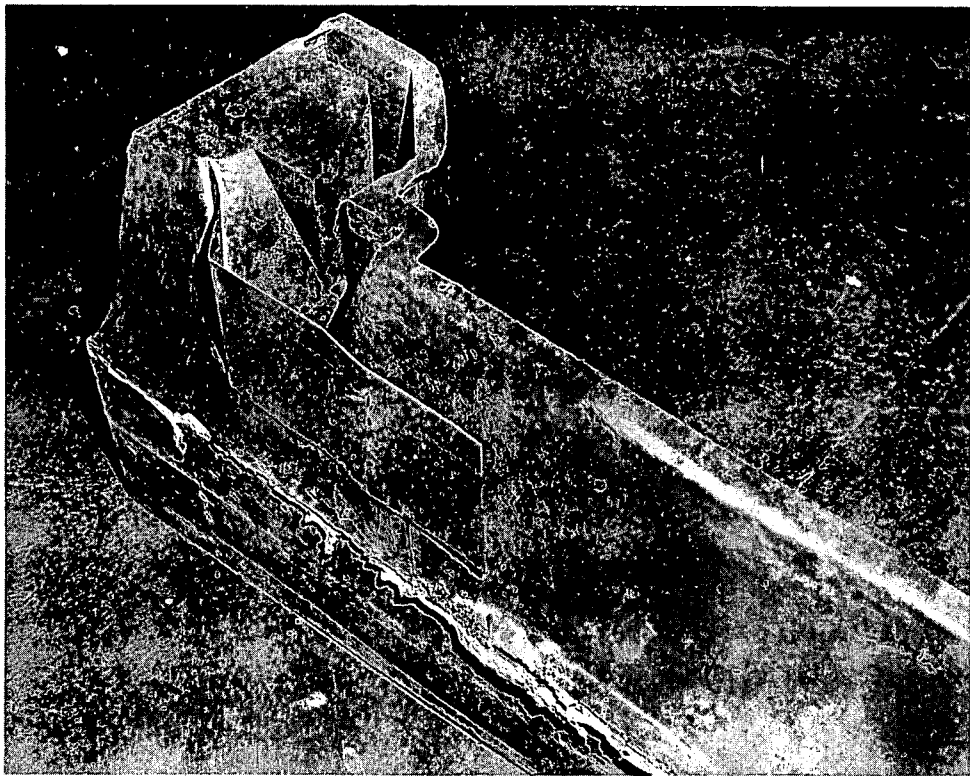

PHOTO NO. 4 DISCHARGE CHANNEL, UNITS 1 + 2

2.2 Water Supply, Tide Controls

The river flow at Indian Point is strongly dependent on the tide action of the Atlantic Ocean. A tide cycle at Indian Point comprises a flood period with an average duration of about 6 hours and an ebb period of about 6.5 hours, flood plus ebb thus making a tide cycle duration of approximately 12.5 hours. The flow associated with the tide action varies from 0 at slack tide to approximately 250,000 cfs. upstream flow at peak flood, back to 0 flow at slack before ebb and approximately 250,000 cfs downstream flow at peak ebb. The tidal flow varies due to variation in the tide as a function of mutual position of moon and sun, wind and barometric conditions. These variations would, in general, be in the order of 20% but may at times be twice this value.

Superimposed on the tidal flow is the Hudson River fresh water flow which varies from about 4000 cfs. associated with a severe drought to in the order of 40,000 cfs due to a high spring run-off.

In order to model the flow variation over a tide cycle control apparatus was designed and fabricated. The tide controls constituted two sets of specially designed discharge valves and overflow weirs, one set for each end of the model. Valves and gates were operated by cams, mechanically driven at a speed such that one revolution was equal to the period of a model tide cycle. Photo 5 shows the downstream control apparatus with its overflow weir and the constant head tank for the discharge valve.

Water for the model was supplied from a 20 HP propeller pump placed in a sump outside the model, see Figure 1. 12" piping connected the pump to each of the constant head tanks. The function of the head tanks was to minimize variations

in flow to the tide valve due to fluctuations of pump discharge. In this way a flow with variations of less than 1% was supplied to the tide valves. The tide valves directed the proper amount of flow, at any instant, to the model while the excess was directed back to the sump.

The tide machine cam design was based on data obtained from "Tides and Currents in Hudson River" by Paul Schureman, U. S. Coast and Geodetic Survey.

Heated water for simulating the cooling water effluent was supplied from a 50 HP boiler. The pipe line delivering the water to the model outfall channel was equipped with a calibrated flow meter and valves for regulating the flow rate. A cold water line supplied water upstream of the meter for adjusting the temperature of the effluent.

Flow from the cooling water intakes was withdrawn by a pump with pipes, containing flow meters and valves, leading from the intakes to the suction side of the pump. Thus the flow from each individual intake could be adjusted and metered.

2.3 Instrumentation

In order to measure temperatures at various points in the model and of water entering the model and leaving it, a system of thermocouples connected to four 24-channel recorders was adopted. The recorders (Esterline Angus) were operated in parallel, each recorder printing the temperature reading from a thermocouple every 2 seconds. With 24 thermocouples per recorder a complete scan of 96 thermocouples would thus be carried out in 48 seconds. Simultaneously a data logger digitalized the recorder outputs and fed this information to an IBM computer tape for data processing. After completing one scan the recorders would automatically

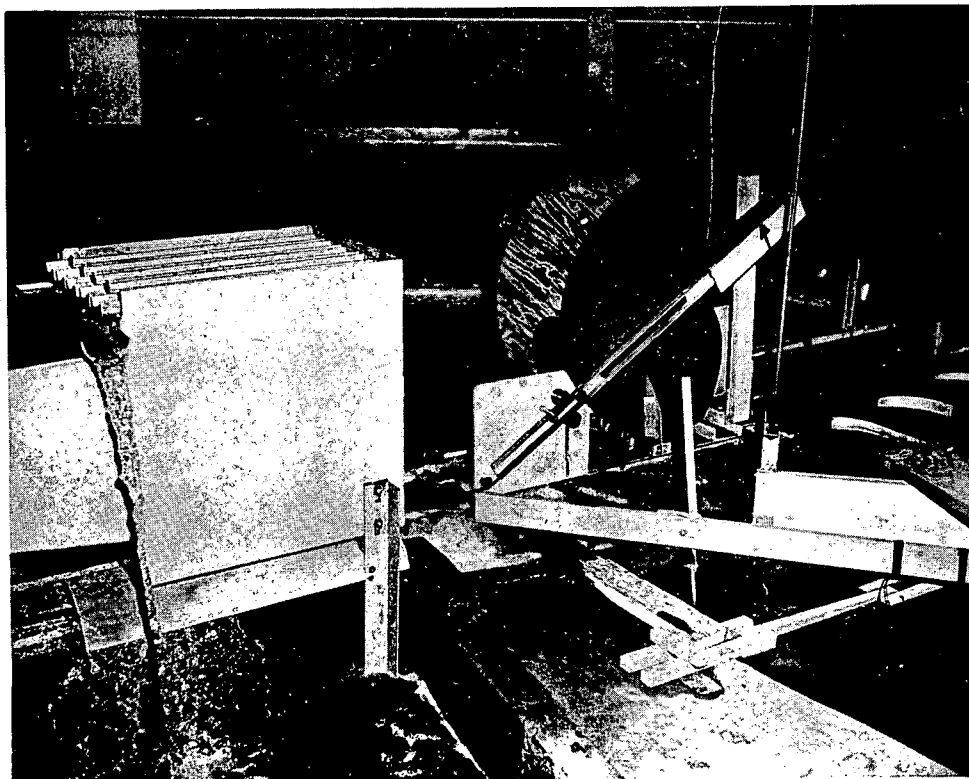

PHOTO NO. 5 HEAD TANK, TIDE MACHINE, DISCHARGE GATE

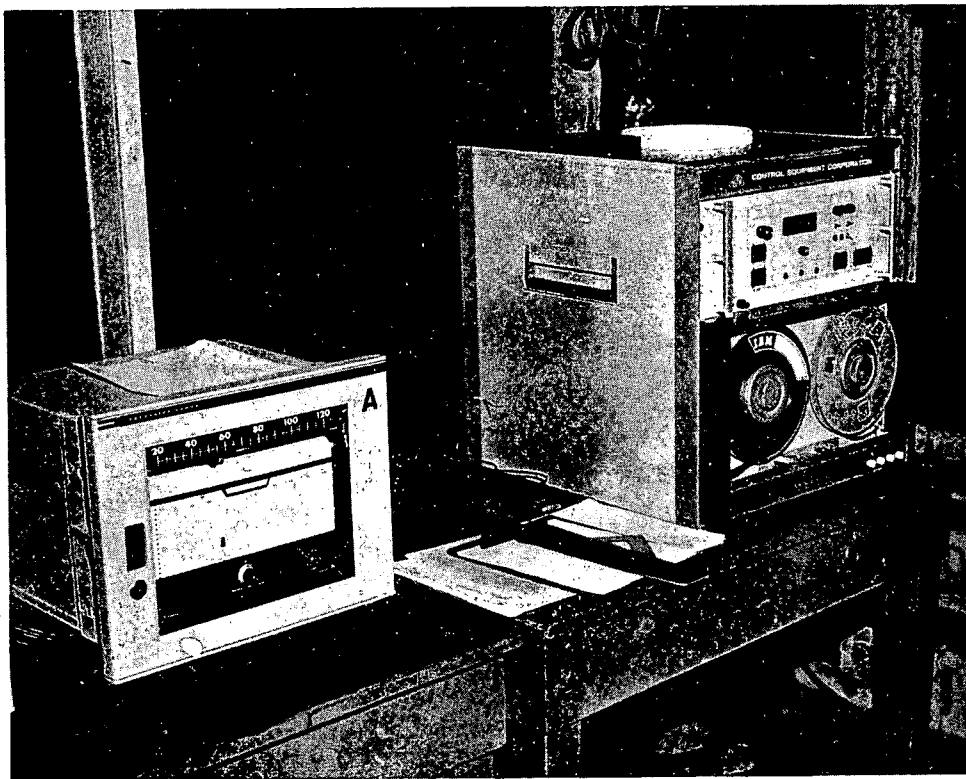

PHOTO NO. 6 RECORDERS AND DATA LOGGER



PHOTO NO. 7 THERMOCOUPLE MOUNTING

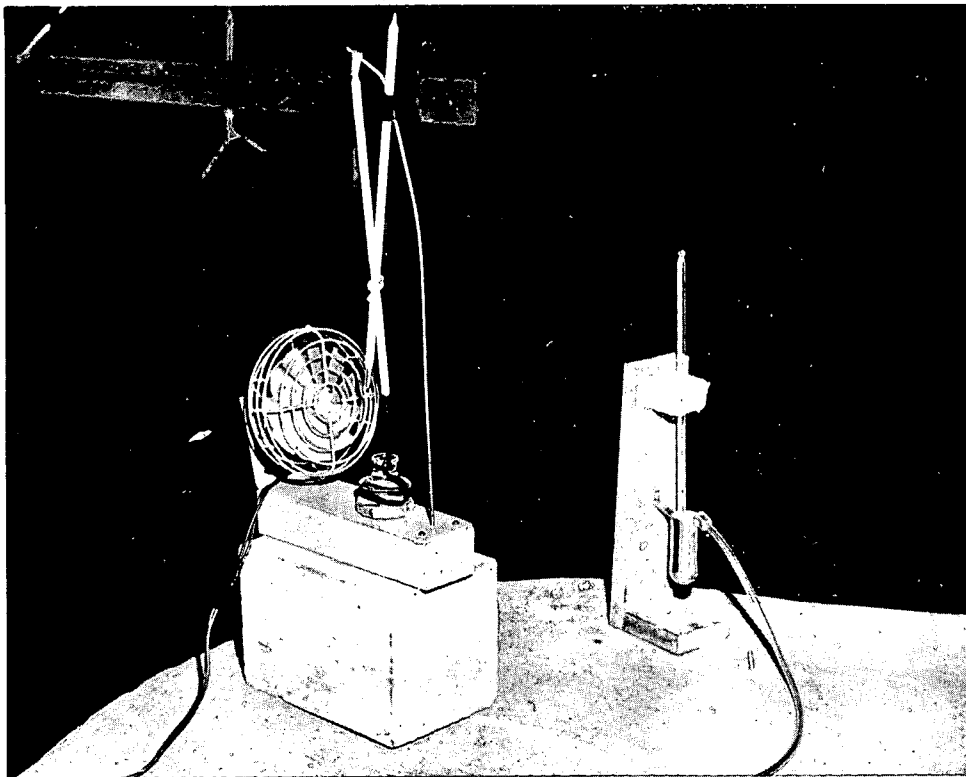

PHOTO NO. 8 DRY BULB - WET BULB INSTRUMENT,
DEW POINT INSTRUMENT

start a new scan. Photo 6 shows one of the recorders and the data logger.

Fixed thermocouples were mounted according to Table I

<u>Position</u>	<u>Number of Thermocouples</u>
Intake Unit No. 1	2) one close to the upper edge
" " 2	2) of the intake opening, one
" " 3	2) near the bottom
Discharge Channel	1
Air Temperature up- stream end of "Moth Ball Fleet"	1
Discharge to and from model, downstream end	2
upstream end	2
Thermos bottle	<u>4</u>
	16

TABLE I POSITION OF FIXED THERMOCOUPLES

The remaining 80 thermocouples were distributed within the model, supported on wooden dowels as shown on Photo No. 7. The boards were movable in horizontal directions and the dowels could be adjusted as to elevation.

As indicated by Table 1, 4 thermocouples were mounted in a thermos bottle. In this way a check was provided on recorder drift. In addition to the 96 recorder registered thermocouples a portable thermistor apparatus was used providing 23 additional temperature probes. The thermistor instrument was manually operated as to switching between probes as well as read-out.

In order to record air temperature and humidity a dry bulb-wet bulb instrument was used, see Photo No. 8. This instrument was calibrated to a dew point instrument in order to achieve the correct compensating air stream provided by a small fan.

Timing with respect to the tide cycle was based on the tide machine cam motion. A set of electrical switches placed at equal time intervals activated a bulb which provided time signals. A zero time was arbitrarily chosen as the time when water started flowing into the model at the downstream end. This would essentially correspond to slack before flood at Verplanck Point.

The velocity distribution in the model was measured by a photographic method. A camera was mounted vertically above the area to be investigated. The camera was equipped with a slowly rotating disk below the lens with "spokes" which intermittently interrupted the exposure. Candles on styrofoam floats supplied with sheet metal cruciforms, adjustable as to depth, were traced by the camera. The candle paths so photographed would show time marks due to the interrupter and would thus yield information both about velocity magnitude and velocity direction. Photo No. 9 shows as an example a photograph obtained this way.

3. MODEL CRITERIA

3.1 Model Similitude Relations

It is the purpose of the model to simulate the hydraulic behaviour of the Hudson River within the modeled area. The dominating forces, governing the flow distribution, are gravity forces and inertia forces. The gravity forces include so-called buoyancy forces caused by differences in specific weight. It is therefore essential that the ratio between inertia and gravity forces be maintained equal in the prototype and the model. The ratio between these forces can be expressed as

$$\frac{F_i}{F_G} = \frac{V^2}{gL}$$

where F_i stands for inertia force, F_G for gravity force, V is the

velocity at a given point in the flow and L is a characteristic length at that point, generally the depth of flow. The square root of this ratio is generally called the Froude number and the model criteria then can be expressed as the requirement that the Froude number for any point in the model be equal to the Froude number of the corresponding point in the prototype.

With this criteria and the chosen length and depth ratios of the model the dynamic and kinematic scale ratios between model and prototype can be computed. These ratios are given in Table 2.

It should be noted that modeling of specific weight according to the Froude law requires that the ratio between prototype specific weight and model specific weight be unity. When specific weight differences are caused by temperature differences, this requirement will be fulfilled by modeling the same temperature in the model as would occur in the prototype, i.e., a one-to-one temperature scaling.

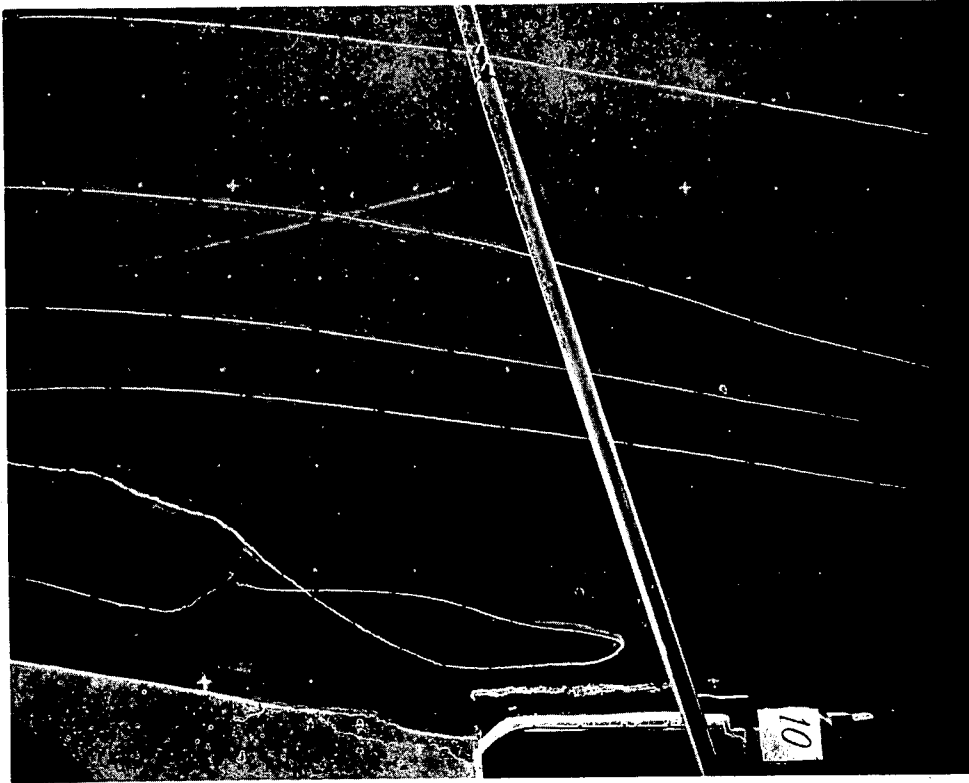

PHOTO NO. 9 VELOCITY MEASUREMENTS. CANDLE PATH LINES

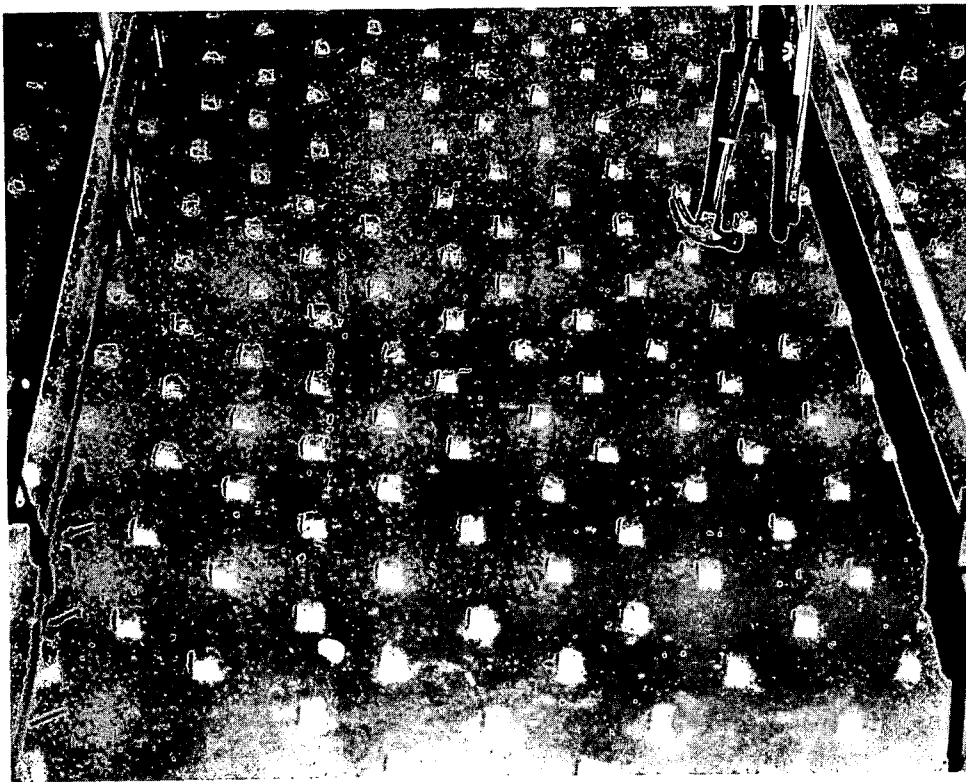

PHOTO NO. 10 ARTIFICIAL ROUGHNESS

RELATIONS BETWEEN PROTOTYPE AND MODEL PROPERTIES

	<u>INDIAN POINT II MODEL</u>	<u>PROTOTYPE</u>	
<u>GEOMETRIC</u>	Length	1 Foot	250 Feet
	Width	1 Foot	250 Feet
	Depth	1 Foot	60 Feet
	Volume	1 Foot ³	375,000 Feet ³
<u>KINEMATIC</u>	Time	1 Second	32.2 Seconds
	Velocity	1 FPS	7.74 FPS
	Flow Rate	1 CFS	116,000 CFS
<u>DYNAMIC</u>	Pressure	1 PSI	60 PSI
	Gravity Force	1 Pound	375,000 Pounds
<u>TEMPERATURE</u>	1°F	1°F	

The Kinematic-Dynamic-and Temperature Ratios are based on Froude Scaling i.e. Gravity and Inertia Forces are considered dominant forces.

TABLE II

Since the specific weight of water varies with temperature in a non-linear way the one-to-one density ratio can be modeled also when the model ambient temperature is different from the river ambient temperature. Figure 2 illustrates this. An ambient temperature for the river of 78F was assumed as a basis for the diagram. As an example, if the model ambient temperature is 60F the model temperature differential should be 20.5F in order to properly model a prototype differential of 15F.

The primary concern, thus, is in modeling the correct specific weight ratios and therefore when a "distorted" temperature of the warm effluent is used in the model the model effluent may be thought of merely as a tracer, having the true specific weight. This "tracer" has the advantage of being conveniently detected and also the hydrodynamic advantage of possessing the correct diffusion properties. When temperature differences in the model are in excess of those of the prototype a proper reduction must be made when test results are presented in terms of predicted prototype temperatures.

Specific weight differences in the prototype may also be due to variable salinity. The lower part of Hudson River is a typical estuary with salt water being forced upstream from the Atlantic Ocean due to the tidal action and partly due to the higher specific weight of the salt water which causes a "density flow" in the upstream direction. However at Indian Point density measurements presented in "Tides and Currents in the Hudson River" indicate that the specific gravity at Verplanck Point was 1.0021 as an average of 8 measurements taken during a survey in September, 1929 and that the maximum specific gravity difference was 0.004 with depth. This difference corresponds to a temperature difference of less

than 3F at an ambient temperature of 78F. More recent measurements of salinity have indicated a maximum salinity of approximately 5 parts per thousand (Dr. Gwyneth Howells) with no variation with depth. A salinity of 5 ppt corresponds to a specific gravity of 1.007. It should be noted in this connection that salinity varies with the time of the year, being a minimum at the time of maximum fresh water run-off and a maximum at the end of the summer or in connection with low fresh water flows.

In view of the uniform density and low absolute salinity at Indian Point it was felt that modeling of temperature induced specific weight differentials would yield an adequate representation of prototype conditions.

Also in view of the uniform density and low salinity it seems reasonable to assume that the dispersion properties in the vicinity of Indian Point are due mainly to turbulent diffusion and to the non-steady flow pattern associated with the tidal flow.

The turbulent diffusion is proportional to the kinematic eddy viscosity which in turn is a function of the Reynolds number of the flow. The Reynolds number ($Re = \frac{4Vym}{\nu}$) is very high (about 3×10^7) at ebb and flood strength and reduces, theoretically, to 0 at slack tides.

The non-steady flow behaviour is particularly marked in conjunction with slack tides. For instance, it was observed that flood occurs along the Indian Point shore a considerable period of time prior to flood at mid River. This indicates that a shear zone exists in this area which may account for a considerable increase in dispersion. Such large scale dispersion caused by non-steady flow, is mainly due to non-uniform river geometry.

From a model point of view, since the diffusion coefficient is a function of eddy viscosity it is important that model Reynolds numbers are large. This was accomplished by distorting the model. Further, in order to maintain a high turbulence level, artificial roughness was added to the model bottom. See Photo No. 10. The roughness magnitude was computed based on an assumed Manning n -value of 0.02 for the Hudson River. (No actual data of river roughness is available, therefore the chosen value was a conservative estimate based on Open Channel considerations.) The distortion factor, depth ratio/length ratio = 4.16, determines the equivalent roughness of the model. With the applied roughness the model maintained rough turbulent flow in major portions of the bed for most of the tide cycle period.

3.2 Velocity Distribution - Field Measurements

The velocity distribution in the model was measured using the technique described in 2.3 "Instrumentation". At the time when the tide machinery was designed and the model was put in operation the only available current data were from "Tides and Currents in Hudson River" by Paul Schureman, U. S. C. and G. S. Figure 3 shows the stage versus time and velocity versus time based on these data. Although it is indicated in the above publication that average conditions were attempted based on surveys carried out between 1854 and 1932 the ratio between flood strength and ebb strength seems to indicate a condition with a spring run-off of about 30,000 cfs.

Figure 3 shows comparisons between the stage and current data from the above source and model data based on measurements. It is seen that the midstream velocity magnitudes agree well with the prototype data. The apparent lag in time is due

to the arbitrarily chosen "0 time". $T = 0$ was defined as the time when the downstream discharge valve started opening, an operation which was well defined and easily recognizable. Some time ellapses in which the downstream momentum is counteracted by the inflow before slack tide can occur.

The stage curves, Figure 3, are referred to a datum so chosen that the curves become symmetrical. The average range at Indian Point is approximately 3 feet with high tide approximately 2 feet above MSL and low tide 1 foot below MSL. The model tide range was generally a few percent higher than that corresponding to the prototype range and the model stage produced a somewhat "fuller" curve than the prototype, as indicated in Figure 3. It is noted that in terms of flow pattern the range has insignificant effect.

Figure 4 shows a comparison between pathlines obtained by aerial photography in the field and pathlines photographically obtained from the model off Indian Point. The agreement was found acceptable for model operation.

Detailed comparison was made between flow patterns in the prototype and the model in certain areas. A specific feature of the tide that was found to have rather a significant effect on temperature distribution was the turn about of the flow along the east shore prior to slack at midstream. The field tests indicated, as shown on Figure 4, that floats along the east shore followed a velocity versus time curve approximately one hour prior to the curve for midstream velocities. The model results were in good agreement herewith.

Figure 4 also gives a comparison between midstream velocities measured at the field tests carried out August 14, 1968 and September 20, 1968 and the data obtained from "Tides and Currents in Hudson River." It is seen that for both the

field tests the velocity magnitudes were found to be considerably higher than indicated in "Tides and Currents". The tide stage of August 14 was recorded and was found to yield a range of 3.15 feet as compared to 2.9 feet for an average range.

This would explain some of the differences in velocity magnitudes. For the tide of September 20 only part of the stage curve was recorded. The recorded portion had

a considerably greater slope than the average stage curve indicating that also for this day the range was above normal.

As a conclusion the field tests seemed to indicate that the velocities in the Indian Point section of the Hudson River are generally higher than indicated by the midstream velocities given in "Tides and Currents in Hudson River." Since the flow rate of the model was based on the latter data the model would tend to yield conservative results with respect to cooling water dispersion.

3.3 Heat Transfer Conditions

An important factor in the heat balance both in the prototype and in the model is the heat transfer from the water surface. Since the model was sheltered by a building the solar radiation was largely reduced so that this contribution to the heat transfer may be neglected. The heat transfer then depends on the temperature difference between the water surface and the ambient air, the relative humidity and the wind speed. The latter may be taken as zero due to the building.

Heat transfer coefficients were measured two different ways as part of the test program. In one test the temperature distribution in a stratified, still body of water was measured over a period of time. The water was enclosed in a 25 foot wooden frame separating the test volume from the rest of the model. For this condition the

temperature reduction within the test volume was due to heat transfer to the air and conduction, essentially molecular diffusion, to the underlying, colder water. The latter part could be accounted for on basis of the temperature measurements.

These measurements produced quite consistent results indicating a heat transfer coefficient of $K = 6.0 \frac{\text{BTU}}{\text{ft}^2 \text{ hour } ^\circ\text{F}}$

The second method was based on operating the whole model with a constant heat input and determining the equilibrium condition at which the heat input was balanced by the heat given off from the water surface of the model and the sump. This method was considered as less accurate for the following reasons. The heat input included the power of the 20 HP pump. It was known from electrical measurements that the pump motor operated at approximately full load, therefore, the nominal motor power was converted to BTU/sec. Whether this amount of heat was actually received by the water could not be checked. Also the heat input from the model outfall structure would produce areas in the model with higher temperatures than the average water temperature and thus with a higher rate of heat transfer.

Three tests of this type were performed. (Reported in letters of October 23 and December 2, 1968 to Consolidated Edison) Test No. 1 was performed with a heat input corresponding to operation of units 1, 2 and 3 (4670 cfs, $\Delta T = 16\%$) and gave as a result $K = 10.1 \frac{\text{BTU}}{\text{ft}^2 \text{ hour } ^\circ\text{F}}$. In test No. 2 the heat input was equivalent to operating units 1 and 2 at 13.7F. This test indicated $K = 8.8 \frac{\text{BTU}}{\text{ft}^2 \text{ hour } ^\circ\text{F}}$. For Test No. 3 the pump with its 20 HP motor was the only source of heat input. This test indicated $K = 4.0 \frac{\text{BTU}}{\text{ft}^2 \text{ hour } ^\circ\text{F}}$. This result seems to indicate that the heat input estimated for the pump was on the high side.

The experimental determination of heat transfer coefficients mentioned is part of a continuing effort at Alden Research Laboratories to improve the knowledge in this area. Heat transfer coefficients have been measured in connection with several other cooling water studies, a Master's thesis with this subject was completed several years ago and further tests have been planned.

3.4 Temperature Conditions for the Model as a Whole

When the model and sump was filled with water and put in operation it may generally be assumed that the water temperature was at an equilibrium state determined by the surroundings. As soon as the pump was turned on and the cooling water effluent adjusted to its proper temperature the heating of the model water would take place. Since the heat loss with the above conditions would be zero initially, the rate of temperature rise would be directly proportional to the heat input. As an example it may be mentioned that the model temperature rise based on operation of units 1, 2 and 3 theoretically should be 1.4F per hour. A rate of rise of 1.3F per hour was measured in good agreement herewith.

The initial condition mentioned yields the maximum possible rate of temperature rise. The extreme condition in the opposite direction would be obtained at the point where the overall heat loss from the model and the sump would equal the heat input. Neither of these conditions would generally prevail during a test.

Several tide cycles, each of approximately 23 minutes duration, generally elapsed while instrumentation was adjusted and preparations were completed for the first test of the day. This would exclude the initial condition of maximum rate of temperature rise. On the other hand to reach the condition of equal heat input

and heat loss was impractical since this was a time consuming operation. The heat transfer test with 3 units required 12 hours continuous operation and steady state was then obtained due to an air temperature considerably lower than the ambient water temperature.

The effect of increasing model and sump water temperature would be to reduce the accuracy of ambient water temperature determination. The ambient water temperature was measured by two probes in the flow supplied to the model, i.e., two at the downstream end during the flood tide and two at the upstream end during the ebb tide. Therefore at a given time water at Indian Point would have been discharged into the model at a different ambient temperature than that measured by the ambient probes at that time. An estimate of this error may be established on the basis of the heat transfer tests and the residence time. If from the heat transfer test the rate of temperature rise is taken as 1.3F per hour and the residence time is taken as half a tide cycle or 12 minutes, the resulting error would be $\frac{1.3}{60} \times 12 = 0.26F$. This is in the order of the accuracy of the temperature determination and seems therefore to be without significance.

3.5 Significance of Model Length as Related to Heat Accumulation

The tidal flow is cyclic but due to the fresh water flow the flow versus time behaviour is not symmetric, the duration of flood flow is somewhat shorter than that of ebb flow. Therefore a water particle released at Indian Point at slack before flood will travel a certain distance upstream, turn back downstream at slack before ebb and in its downstream movement pass by Indian Point. The distance downstream from Indian Point where it again turns upstream at slack before flood is the net downstream

movement which varies mainly as a function of the rate of fresh water flow. The net downstream movement may be estimated at about 1100 feet at a minimum fresh water flow of 4000 cfs and 11,000 feet at a high spring flood dependent fresh water flow of 40,000 cfs.

A constant release of a conservative substance at Indian Point would produce the following, somewhat simplified, but yet pertinent, picture. Starting at slack before flood, accumulation would occur in an area outside the outfall. The "island" of substance-containing water would start moving upstream with the flood flow. The continuously released substance would immediately be carried with the flood flow in the upstream direction, occupying an area mainly determined by the flow pattern of the river flow. At slack before ebb the original "island" would be formed at Indian Point and at slack a new "island" would form at Indian Point. Thus three "islands" would be moving upstream during the second tide cycle, two of which were separated by the distance of the net downstream movement. At slack before ebb the third "island" would miss Indian Point by this distance. Theoretically after a number of tide cycles a "necklace" of "islands", chained together by substance containing water of varying concentration and with equidistance spacing equal to the net downstream movement would occur in the River. Longitudinal and lateral dispersion would have changed the initial boundaries and reduced the concentration tending to produce a more uniform distribution of the substance.

The ultimate condition indicated above would not develop in the Indian Point II Model because of its limited length. In fact an "island" produced at slack tide, both before flood and before ebb, would be discharged past the weirs of the model ends. The distance from Indian Point to the sections represented by the weirs was

approximately 9000 feet while the movement between slack tides is in the order of 20,000 to 30,000 feet.

Therefore the model results yield information about the effect of a continuous release of cooling water from Indian Point within the modeled area for one tide cycle. The effect of build up of heat over a period of time, corresponding to several tide cycles, was not modeled. The water leaving the model past the weirs was received by the sump where vigorous mixing was accomplished by the 20 HP supply pump. Therefore the sump temperature would rise with time, i.e., the model ambient temperature would increase over a series of model tide cycles. However, the ambient temperature was continuously measured at the inflow sections of the model and isotherms based on these temperature measurements.

In conclusion it should be mentioned that heated cooling water is not a conservative substance. The heat balance of the river is strongly dependent on heat dissipation to the atmosphere. The heat dissipation is determined by the climatic conditions defining a heat transfer coefficient and the surface temperature of the river. For given climatic conditions the heat dissipation would increase with increasing surface temperature and would therefore be maximum for areas affected by the above mentioned "islands".

4. UNDISTORTED SUB-MODEL 1:50 OF THE COOLING WATER OUTFALL STRUCTURE

4.1 Introduction

A number of open channel type outfall configurations were tested in the Indian Point II model. During the course of these studies it was found desirable to discharge the cooling water from submerged outfall openings in order to meet more rigorous temperature requirements for the Hudson River. Preliminary studies in the Indian Point II model, which has a distortion of 4.16, indicated that the testing of submerged outlets would yield local results not corresponding to equivalent prototype outlets. The reason was that a jet formed by an outlet, is a specific hydraulic phenomenon, which develops without regard to the model distortion. A free jet, issuing into an infinite ambient recipient, has an angle of divergence of about 11.3°. Therefore in the distorted model the spread of the jet would appear to occur at too low a rate. The cooling water jet would entrain excessive ambient water at the point where the river surface was reached and would therefore indicate a resulting temperature on the low side. Since the results thus would be on the optimistic side, rather than on the conservative side, it was decided to carry out the detailed investigation of the outfall configuration in an undistorted model. The aim of these tests was twofold: 1) To determine the geometry of the outfalls so as to meet specified requirements with respect to river surface temperatures; 2) To determine the boundary condition to be imposed on the distorted model so as to obtain correct results from this model outside the area directly affected by the outfalls.

Tests in the undistorted model were carried out in August of 1968 (Progress Report August 1968) in October 1968 (Progress Report October 1968) and in March of 1969 (Progress Report April 1969). A summary of these tests is presented herein. In order to evaluate the effectiveness of a particular outfall configuration an efficiency parameter is defined as the ratio between the highest surface temperature observed in the vicinity of the outfall and the temperature of the cooling water. Both these temperatures refer to the ambient temperature of the modeled river water.

4.2 The Model

It was decided to construct the undistorted outfall model utilizing the heat capacity of the boiler supplying the distorted model. Part of the sump area for the distorted model was found to be a convenient site for the undistorted model, providing river ambient water for the model without any extra effort in terms of piping, installing of pump capacity, etc. Based on the above conditions a model scale ratio of 1:50 was chosen. Photo No. 11 shows the model discharge channel with six 4-foot high openings as viewed from the river. The river bottom topography was modeled on the basis of the data used for the distorted model. The lateral slope of the river bottom outside the outfall is relatively gentle and constitutes an almost plane sloping surface within the nearest 300 to 400 feet off shore. Therefore the increased submergence of the outfalls could be modeled by increasing the depth of water in the model rather than by actually excavating to greater depth of the outfall. This saved considerable time in testing and also gave the advantage of more direct comparison of different amounts of submergence.

Part of the discharge channel and the sheet piling along the river shore, containing the outfall openings, was modeled in sheet metal to an elevation such that a water depth in the discharge channel of up to 32 feet could be modeled. A regulating gate was installed at the downstream end of the model to regulate the depth of water. A 4" warm water pipeline containing an orifice meter and valves for adjusting the temperature as well as the flow rate was installed.

The model was equipped with 22 thermocouples connected to one of the recorders of the distorted model, see Photo No. 12. These were placed with reference to a grid system for which N60 and the grant of water line were base lines. For detailed measurements a thermistor set with 12 probes was used, providing more flexibility than the more stationary thermocouples.

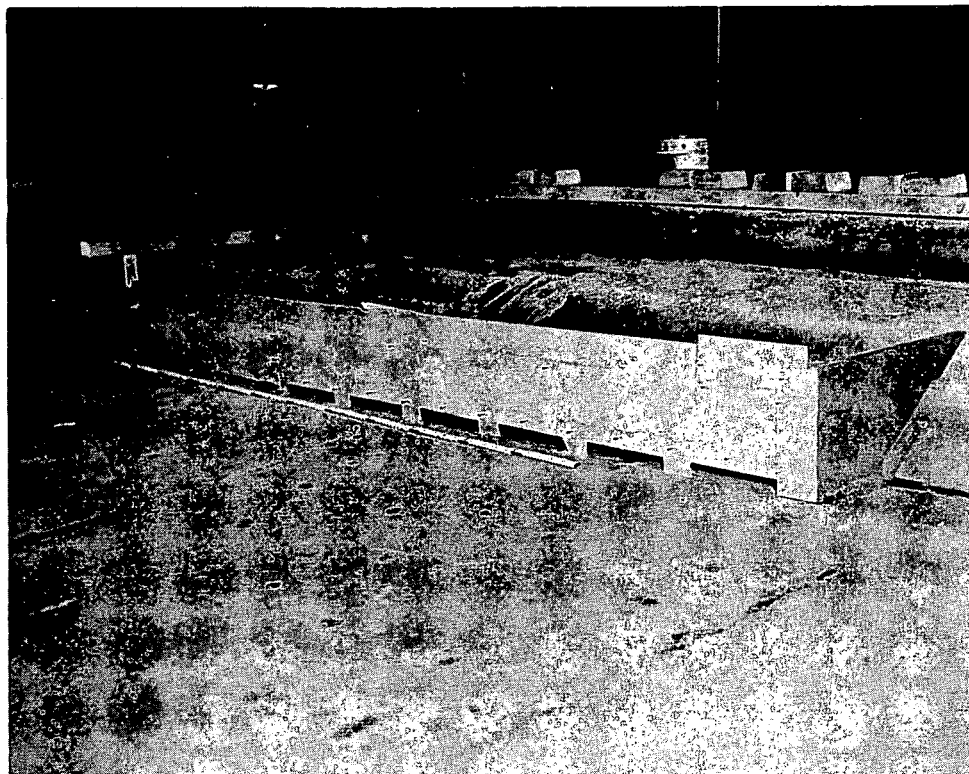

PHOTO NO. 11 UNDISTORTED MODEL. SIX 4 FOOT HIGH OPENINGS

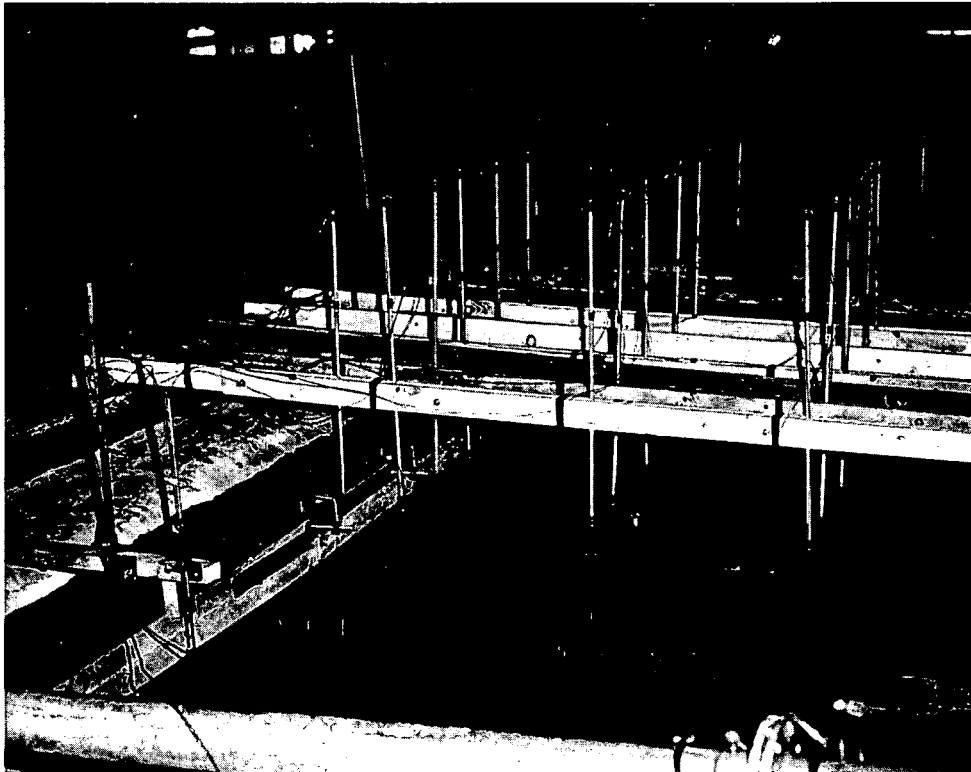

PHOTO NO. 12 UNDISTORTED MODEL IN OPERATION

4.3 Test Results

The outfall configurations tested and reported herein are summarized in the following Table III and detailed results are presented in Figures 5 - 14:

Test Data	Length of Outfall Structure	Depth of Channel Below MSL	Number of Openings	Dimensions of Openings	Water Level Difference Between Channel and River	Effluent Temperature ΔT_E Above River Ambient	Ratio of Max. Observed Surface Temp. ΔT_S to ΔT_E	Figure Number for Details
	feet	feet		feet	F	F		
March 1969	340	20	17	2.4 x 15	1.5	13.8	0.48	5
March 1969	240	20	12	4 x 15	1.5	14.0	0.50	6
Aug. 1969	240	20	6	4 x 30	1.5	17	0.53	7
March 1969	340	20	17	2.8 x 15	1.25	13.9	0.54	8
Oct. 1968	240	20	6	8 x 30	0.3	17	0.59	9
March 1969	240	20	12	6.5 x 15	0.5	13.7	0.61	10
Oct. 1968	240	20	6	7 x 30	0.4	17	0.67	11
March 1969	340	20	224	2.5 DIA.	0.6	12.9	0.67	12
Oct. 1968	240	25	6	7 x 30	0.4	17	0.70	13
Oct. 1968	240	30	6	7 x 30	0.4	17	0.65	14

TABLE III DATA OF TESTED OUTFALL CONFIGURATIONS

In general the tests results have been arranged as to decreasing efficiency. It is noted that the smaller the ratio between maximum observed river temperature and effluent temperature the more effective is the outfall structure in providing dilution.

The general trend indicated by the table values is that dilution primarily increased with discharge velocity. It is also seen that within the range tested the length of the outfall structure does not have a significant influence on the dilution. Submergence of the outfall openings does have an effect on dilution, increasing submergence improves the dilution, however, this effect is not as marked as that due to exit velocity.

It should be noted that the efficiency values shown for the tests of August and October, 1968 are not as accurate as those shown for the tests performed in March, 1969. For two reasons the latter are more accurate. The ambient temperature was more stable due to more uniform temperature of the water and the flow pattern of the water representing river flow was improved by better designed guide vanes in the upstream part of the model.

One of the tests seems to fall outside of the general efficiency pattern namely the test with six 8 by 30 foot openings, Figure 9. It is felt that the relatively favorable efficiency value indicated for this test is in error. A probable explanation is that the highest surface temperature escaped measurement due to the particular flow pattern produced by this outfall configuration.

The test with 224 circular openings, 2.5' diameter in two rows, spaced 3 feet center to center distance both horizontally and vertically, indicates a relatively low efficiency. Despite the higher exit velocity this design is equivalent to 6 openings 7 by 30 feet in terms of dilution.

The effective exit velocity is indicated by the water level difference between the outfall channel and the river. The exit velocity is approximately equal to $\sqrt{2gh}$ where h is the water level difference, g is the gravity constant. The exit velocity determined this way is higher than the nominal velocity computed as $\frac{Q}{A}$ where Q is the effluent flow rate and A is the total area of the outfall openings. The reason is that the flow is contracted by passing through the sharp cornered openings. A coefficient of contraction was computed for several of the tests and found to have a value of between 0.6 and 0.7. It was found that the coefficient increased slightly with the longer outfall structure presumably due to the relatively lower channel velocities. This is reflected in the fact that the height of the openings could be somewhat reduced without exceeding a water level difference of 1.5 feet between channel and river. The nominal area with the 240 foot long channel was 720 feet² while the nominal area with the 340 foot channel was 612 feet² for 1.5 feet water level difference. The 720 foot² opening area yields an opening height of 2.8 feet with the 340 foot long channel. A test with these conditions was performed, see Figure 8.

Tests were performed to determine the effect on water level difference of adjustable openings at the downstream end of the outfall channel. These tests were conducted with the outfall configuration consisting of a 340 foot long structure containing 17 openings 2.4 feet high and with 5 foot partitions between the openings. Figure 15 shows the results. It is seen that the "head loss" decreased rapidly when the last opening was extended up to the water surface, one free opening reduced the water level difference by 50%. A plot on semilogarithmic paper indicated that the gain in "head loss" varied exponentially with the number of free openings. It is seen from Figure 15 that the additional gain, when more than 3 openings were free,

was insignificant.

4.4 Conclusions of Sub-Model Tests

Model tests in an undistorted model of ratio 1:50 simulating a variety of outfall configurations indicated that an initial reduction of the effluent cooling water temperature of approximately 50% may be achieved in one of several ways:

- 1) a 340 foot long structure with 17 openings 2.4' x 15' reduced the maximum surface temperature to 48% of the effluent temperature
- 2) a 240 foot long structure, 12 openings 4' x 15'; reduction to 50%
- 3) a 240 foot long structure, 6 openings 4' x 30'; reduction to 53%
- 4) a 340 foot long structure, 17 openings 2.8' x 30'; reduction to 54%

While structures 1), 2) and 3) produced a water level difference between the channel and the river of 1.5 feet, structure 4) caused a difference of 1.25 feet.

It was found that the water level difference between channel and river may be reduced by 50% by extending the furthestmost downstream opening of structure 1) to the water surface. The gain with additional free openings decreased exponentially. Adjustable outfall openings would be used at times when the need for initial dilution is reduced.

It is interesting to note that the rather well developed theoretical approach to the dilution problem applied to the flow conditions of structure 1) indicates a temperature reduction to approximately 25% of the effluent temperature. The theoretical approach assumes an infinite depth above and below the outfall "slot" and

is therefore not applicable to the boundary conditions of this outfall. The model results indicating only about 50% reduction reflect the reduced entrainment of ambient water due to the boundary conditions.

5. TEST RESULTS, MAIN MODEL

5.1 General

When the testing of the undistorted model was completed and an outfall configuration was selected based on these tests, satisfying the temperature requirements prevailing at that time, an extensive series of tests were conducted in the main model. These tests were carried out between November 4 and December 6, 1968. The adopted outfall configuration consisted of six 7 foot high, 30 foot wide openings with 10 foot wide separations. The upstream opening was placed 500 feet downstream from the intake for Unit No. 3. The bottom of the openings was flush with the channel bottom at elevation -20 feet with reference to MSL.

The main model outfall structure was mounted with an adjustable gate. The gate position was determined by trial and error so as to produce the same temperature increase at a distance corresponding to 200 feet from the outfall as determined in the undistorted model. The model results presented in the following are, strictly speaking, applicable to this outfall configuration only. However the results of the undistorted model tests presented in Section 4 indicate that a number of outfall configurations yielded temperature patterns quite similar to those for the tested outfall. Therefore, with the aid of Section 4 the following tests results may be used to extend the application to other outfall structures.

It should be noted that an outfall configuration with higher "efficiency" than that of the tested configuration would yield generally lower temperature elevations. Therefore the following test results may be interpreted as conservative distributions, i.e., temperatures on the high side, for such an outfall.

The main model tests consisted of 79 recorded tide cycles, representing a series of different conditions. Excluding probe positions as a variable the prime variables were as indicated in the following table:

<u>TEST SERIES</u>	<u>NUMBER OF UNITS</u>	<u>AMBIENT RIVER TEMPERATURE</u>	<u>DISCHARGE TEMPERATURE</u>
310 - 325	1 + 2 + 3	48 - 53 F	17 - 19 F
501 - 531	"	41 - 49 F	17 - 19 F
532 - 551	"	42 - 54 F	33 - 35 F
600 - 611	1 + 2 + 3	40 F	26 - 28 F
410 - 418	1 + 2	45 - 55 F	16 - 18 F
420 - 421	1 + 2	49 F	32 F

TABLE IV. TESTS CONDUCTED AND APPROXIMATE CONDITIONS

Within the test series indicated in Table 4 the thermocouple positions were varied both horizontally and with respect to depth.

For each tide cycle 28 scans were recorded covering all 96 probes. One scan would produce data for plotting the isotherms within the modeled area of the river and the time for sampling the data was approximately 0.4 hours (prototype). In plotting the data the mid-point of the time interval was chosen to represent the "instant" of the isotherm pattern.

A great number of isotherm patterns were plotted for comparison and evaluation of the cooling water temperature effect. For presentation in this report were chosen eight "instants" in the tide cycle as representative for the development with

time of the cooling water pattern over a tide cycle.

The position of probes was varied both horizontally and with respect to depth. Comparison between data taken at two different sets of horizontal positions showed that one set was adequate for determining the isotherm pattern. It also showed that superposition of data from two positions required extensive treatment of the data to match the two sets. The reason was primarily that the isotherm location varied rapidly with time. Therefore the scanning of two tide cycles would have to be started at almost exactly the same time in the cycle to produce compatible data.

The depth of the thermocouples were varied between 0 (water surface) and the bottom, generally in steps of 6 feet from the surface down to 24 feet depth and in greater increments below 24 feet depth. 0 depth was by definition 1/4 inch (model) below the surface at low tide. In terms of prototype this meant at low tide 20" below the water surface or, at high tide 4 feet 8' below the water surface.

The isotherms presented in Figures 16 - 101 are all converted to a temperature rise of the cooling water of 16.4F with 3 units and 14.0F with operation of Units 1 and 2. The conversion was performed according to the description in 3.1 "Model Similitude Relations".

5.2 Test Results Reported

The isotherm patterns selected to represent the test results are presented on Figures 16 - 101. These Figures may be grouped according to the following Table 5.

<u>TEST NO.</u>	<u>UNITS</u>	<u>ΔT</u>	<u>T_{AMB} F</u>	<u>DEPTH</u>	<u>FIGURE NO.</u>
522	1+2+3	16.4	44	0	16 - 23
525	"	"	50	6	24 - 31
527	"	"	51	12	32 - 38
528A	"	"	46	18	39 - 46
529A	"	"	51	24	47 - 54
533	"	"	80	0	55 - 62
534	"	"	80	6	63 - 69
542	"	"	80	24	70 - 77
410	1+2	14.0	65	0	78 - 85
416	"	"	56	6	86 - 93
420	"	14.0	80	0	94 - 101

TABLE V. TEST NUMBER AND DATA RELATED TO FIGURE NUMBER

Each group of Figures represents a tide cycle with a given depth of the probes and 8 different times in the cycle. The general development of the isotherm patterns with time is quite independent of the temperature, the number of units operating and the depth. Thus a description is given below for only one test, i.e. one tide cycle.

5.3 Tests with Units Nos. 1 + 2 + 3

Test 522 represents surface isotherms for 3 units discharging 4670 cfs of cooling water with a temperature rise of 16.4F above an ambient river temperature of 44F.

Figure 16 shows the isotherms at $t = 1$ hour. At this time there was a slight upstream flow in the river and the cooling water accumulated during slack tide has started moving upstream. The accumulation of cooling water was accentuated by the upstream flow along the east shore starting in the order of one hour prior to slack at mid-river. The highest surface temperature increase was 8F.

Figure 17, $t = 2$ hours, shows the cooling water moving upstream. It is noted that the area of the maximum surface temperature has been reduced as compared to $t = 1$ hour.

Figure 18, $t = 3.7$ hours, indicates that the areas of representing 1F, 2F and 4F temperature rise have been greatly reduced and that the maximum surface temperature decreased from 8F to between 4F and 6F. The reason for the overall reduction of heated surface area is the higher river velocities with resulting increased transport capacity and more efficient mixing. The decrease of the maximum surface temperature is partly due to the down-river component of the effluent velocity, which, when the cooling water enters the upstream river flow, aggravates the mixing. It is seen that for the ebb part of the tide cycle the 8F maximum surface temperature was consistent.

Figure 19, $t = 4.6$ hours, shows some "swelling" of the heated areas indicating that the flood velocities had decreased. At this time slack along the east shore is due shortly as indicated by the position of the 4F isotherm.

Figure 20, $t = 6.2$ hours shows the cooling water accumulated during slack before ebb moving downstream. By comparison to Figure 16 it is seen that the accumulation was less extensive than at slack before flood. The maximum surface temperature again increased to 8F.

Figure 21, $t = 7.9$ hours, is near ebb strength. The cooling water now was carried downstream along the east shore. The 1F isotherm was carried past the tide gate.

Figure 22, $t = 9.7$ hours, subsequent to ebb strength, shows a reduction of the area encompassed by the 4F isotherm as compared to the conditions at 7.9 hours. This indicates the greater rate of mixing with higher river velocities.

Figure 23, $t = 11.4$ hours, is towards the end of the ebb tide. The affected area increased with the reduced flow velocities and the position of the 4F isotherms was shifted outwards from the shore indicating the turnabout of the flow near the east shore. This isotherm pattern transformed itself into that shown on Figure 16, thus completing a tide cycle.

The temperature conditions for test No. 522, an ambient river temperature of 44F, produced a minimum density differential between cooling water and river water. (Ambient temperatures below 40F would further reduce the density differential, however such conditions are extremely difficult to model and this was not attempted.) It is therefore interesting to compare the results of this test to those of test No. 533 where the ambient temperature was 80F. This represents the extreme case in terms of a high density differential. Figures 55 to 62 show that areas affected by the cooling water were generally greater and also show a tendency towards generally higher surface temperatures. Where in test No. 522 the prevalent surface

temperature was 1F, test No. 533 indicates occasionally a 2°F area.

These trends are due to the greater buoyancy of the cooling water in test No. 533 which tends to bring the sub-surface discharge to the surface. Accordingly, test No. 533 should indicate less effect of heat at the lower elevations. A comparison between tests No. 529A, Figures 47 - 54, and No. 542, Figures 70 - 77, both for 24 feet depth, the former with an ambient temperature of 51F, the latter of 80F, bears this out.

It is interesting to note that the potential energy with respect to the water surface of the cooling water at its exit, based on the density differential, is equivalent to the energy loss of the river water flowing a distance of more than 1 mile at 2 fps. Therefore an effect in terms of added spreading would be expected with the higher ambient temperature, i.e., the higher density differential.

Returning to the tests with an ambient temperature of about 50F it is noted that the areas bounded by isotherms of given magnitude decrease with depth in the river. At 24 feet depth the effect was insignificant and tests at 30 feet depth indicated generally no heat effect at all. Results from tests at 6, 12, 18 and 24 feet depth are shown on Figures 24 to 54. The general development with time follows closely the description given above for test No. 522.

5.4 Tests with Units 1 + 2

Three tests with discharge from units No. 1 and No. 2 are included. Results for test No. 410 are shown on Figures 78 - 85 indicating surface isotherms for 2670 cfs cooling water at 14F above an ambient river temperature of 65F. The behaviour of the isotherm pattern with time was similar to that for the three unit discharge. A comparison to test No. 522, three units, shows that the areas

affected and the temperature rise produced by the two unit operation was almost as extensive as that for three units. There are two reasons for this. The two unit flow was discharged through the same outfall structure as used with three units. Therefore the discharge or jet velocity with two units was about 43% less than with three units and accordingly the initial mixing was considerably reduced. Also the higher ambient temperature in test No. 410 would increase the spread of the cooling water.

Test No. 416 is shown on Figures 86 to 93. The isotherms are for 6 feet depth and an ambient temperature of 56F.

Test No. 420 was with two units operating and an ambient temperature of 80F. Comparison of the isotherms produced by this test with those from test No. 533, three units operating and 80F ambient temperature, again shows the effect of the reduced initial mixing with two units operating. Surface areas affected and temperature elevations were almost as extensive as for operation with three units.

5.5 Recirculation

The tendency towards recirculation of heated cooling water was determined from a number of tests. Figures 102 and 103 show the measured recirculation for units 1, 2 and 3 operating at a 17F temperature rise. Figure 102 is for an ambient river temperature of 50F while Figure 103 shows the recirculation with 79F ambient temperature. It is seen that the recirculation was but slightly dependent on ambient river temperature. The increase in intake temperature was marked at the beginning of the flood tide in connection with the build-up of cooling water in the vicinity of the plant as described in Section 5.3. It is seen that the upper part of the intakes receive somewhat warmer water than the lower parts. The effective recirculation did not amount to more than in the order of 1F and only for some hours

out of the 12.5 hour tide cycle.

Figure 104 shows the recirculation measured with units 1 and 2 operating. The recirculation was less than with 3 units and amounted to less than 1F for about 5 hours.

INDIAN POINT II MODEL

GENERAL ARRANGEMENT

MODEL RATIO

1:250

FROM POND

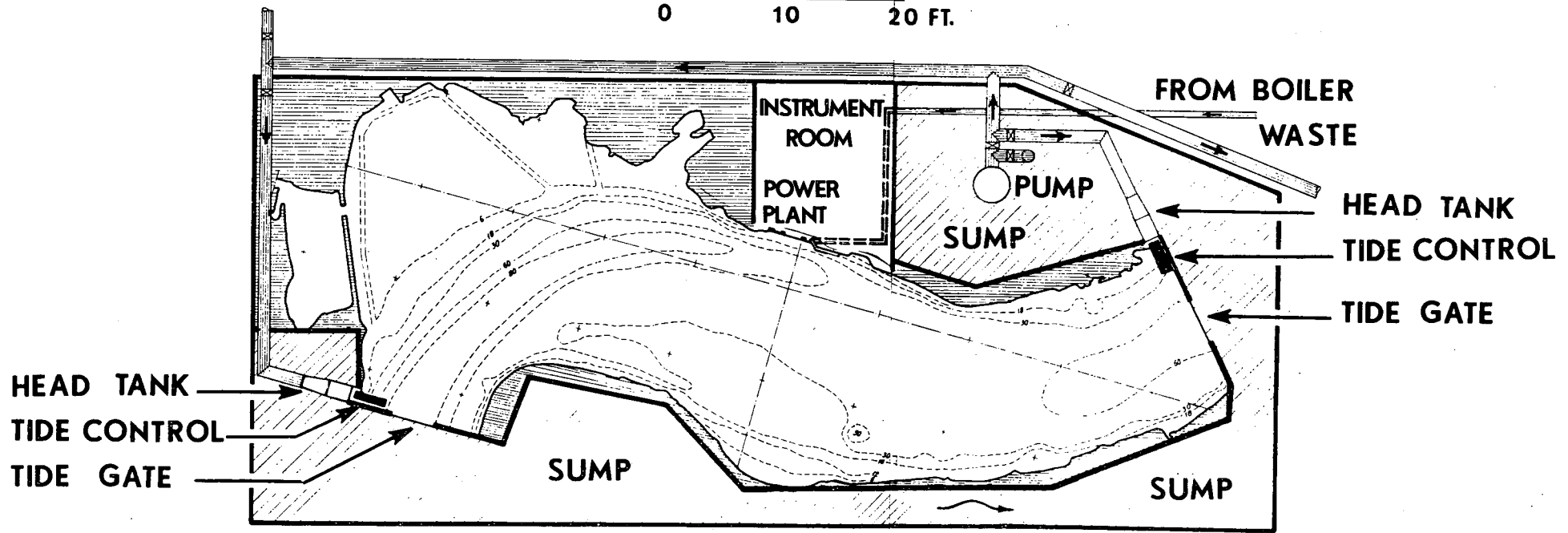
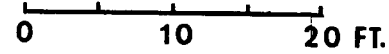

FIG. 2

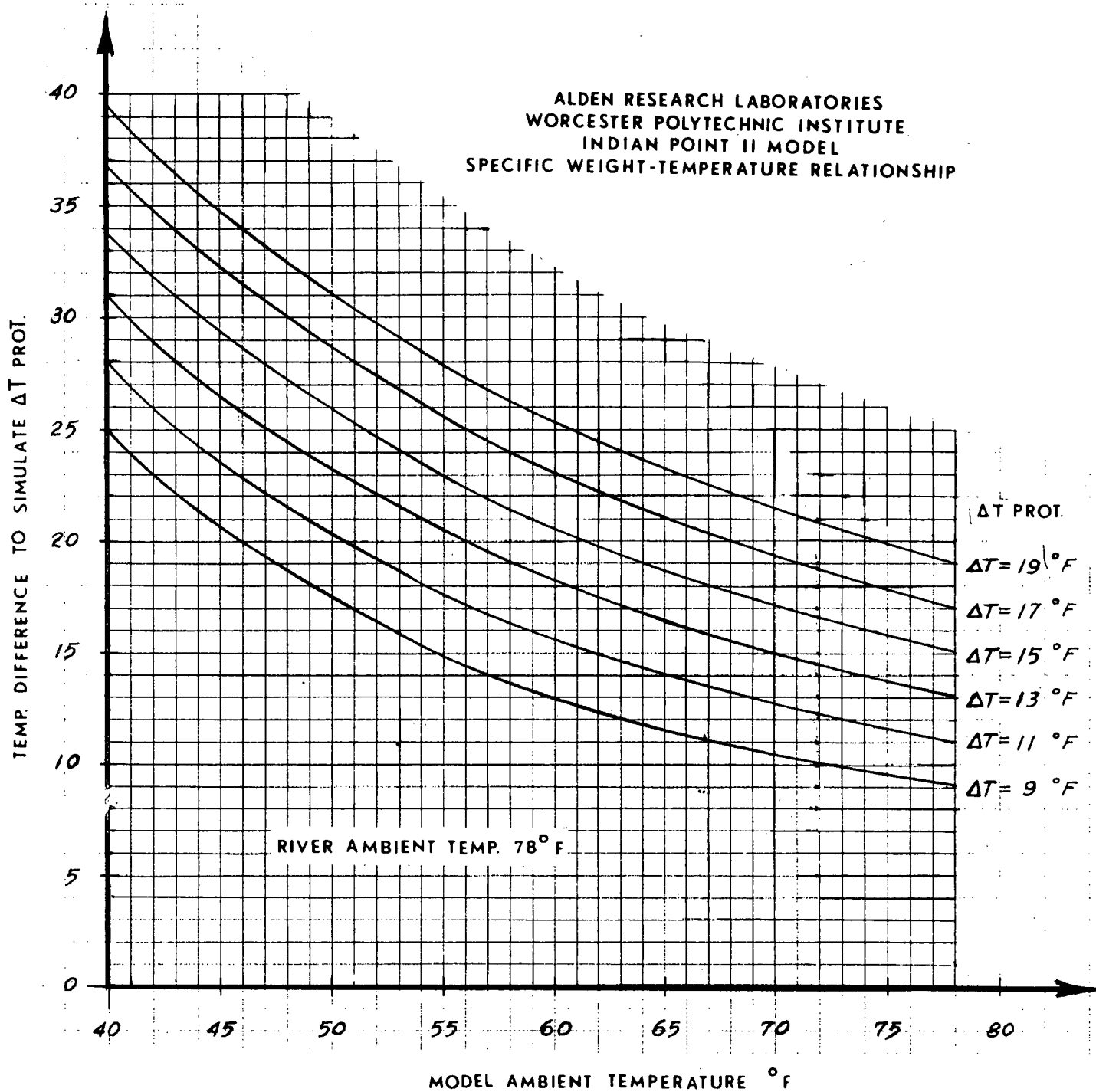
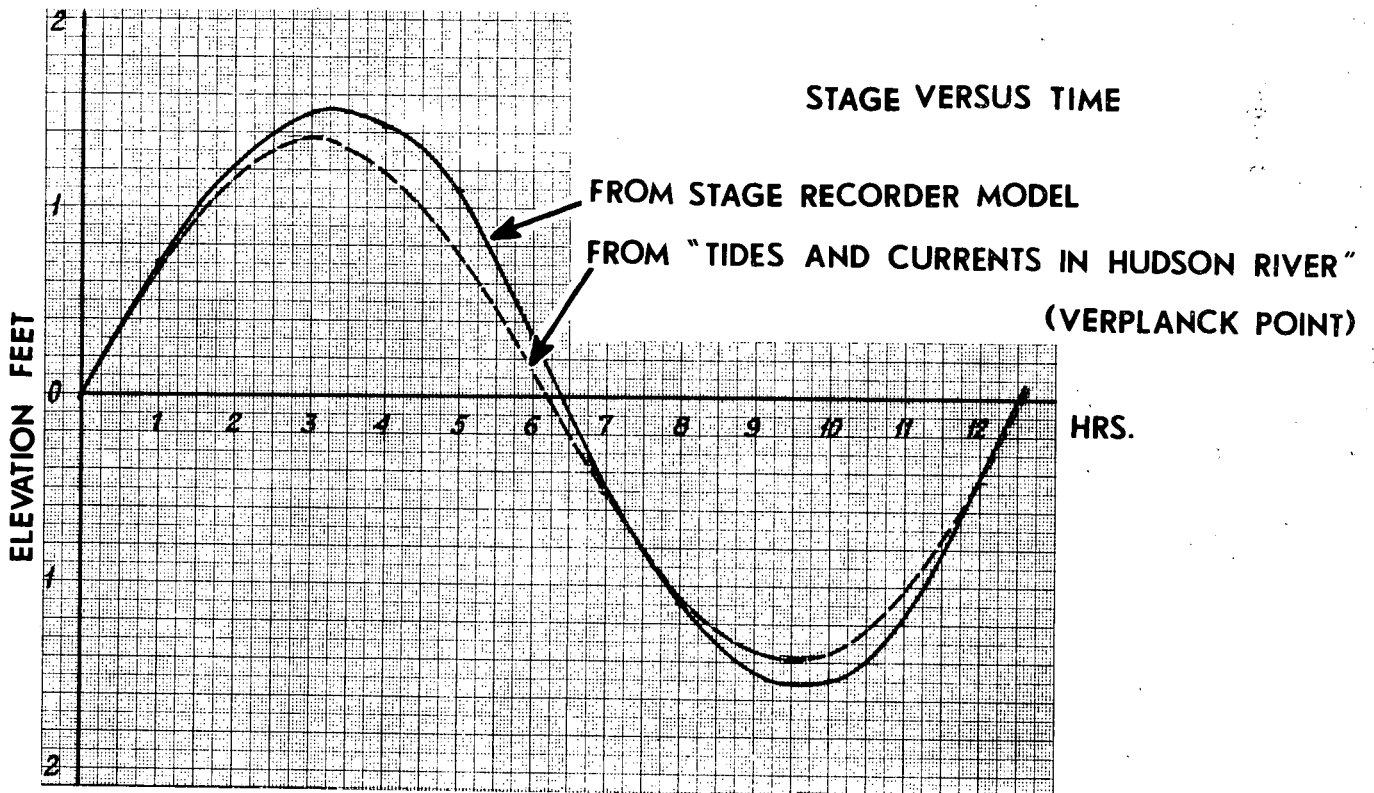
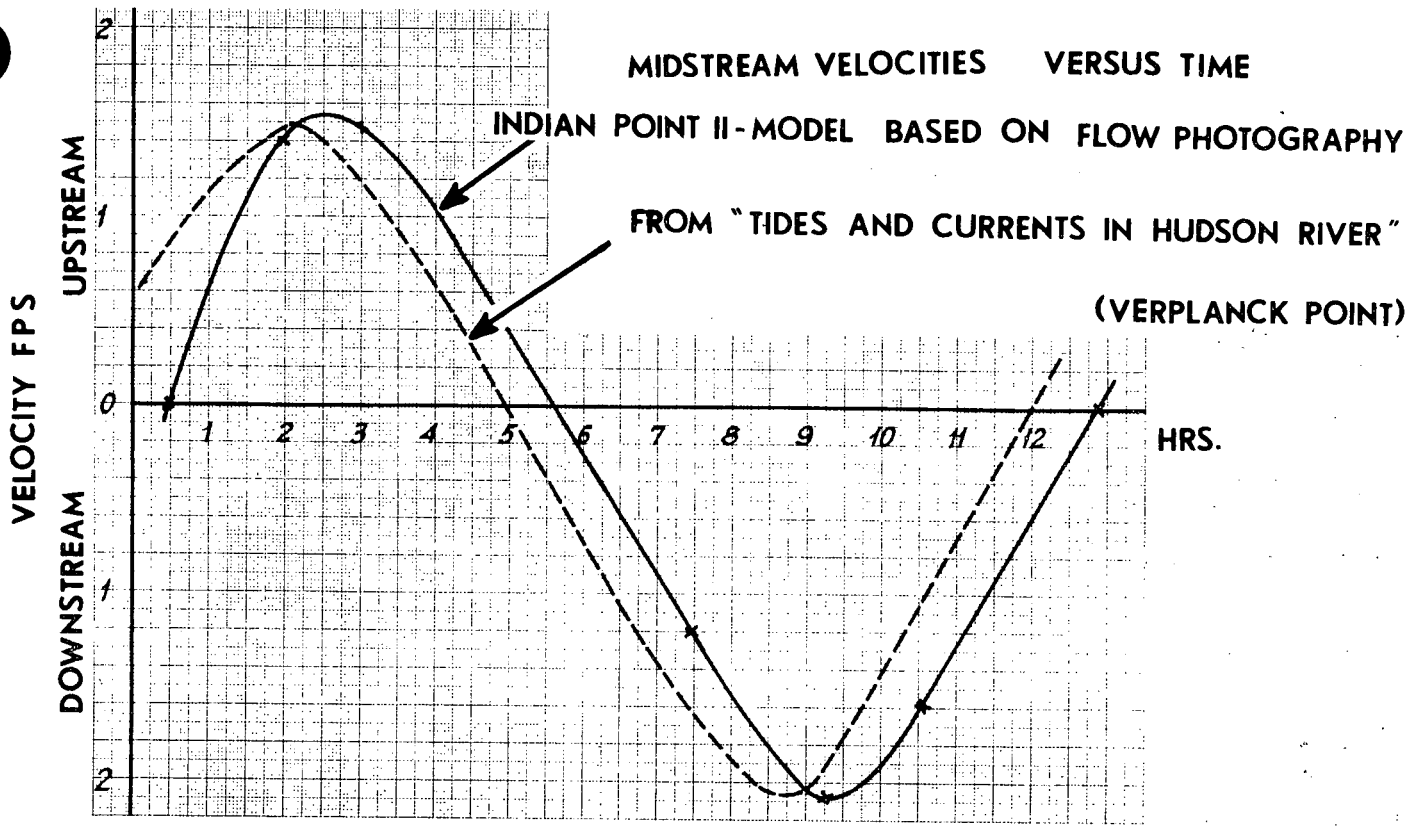

FIG. 3

COMPARISON MODEL TO PROTOTYPE



ALDEN RESEARCH LABORATORIES
WORCESTER POLYTECHNIC INSTITUTE
HYDRAULIC MODEL STUDIES
FOR
CONSOLIDATED EDISON COMPANY, N. Y.

FIG. 4

COMPARISON BETWEEN PATH LINES OFF INDIAN POINT

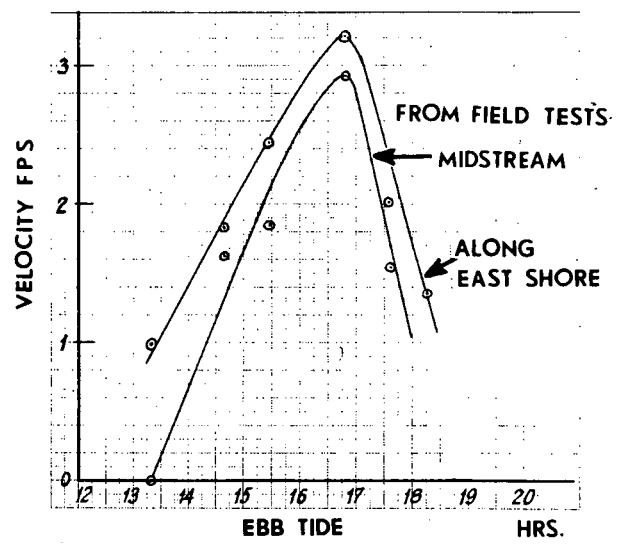
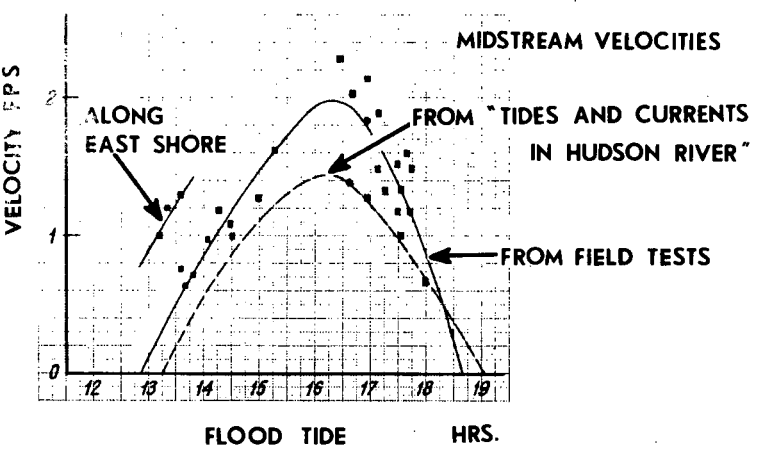
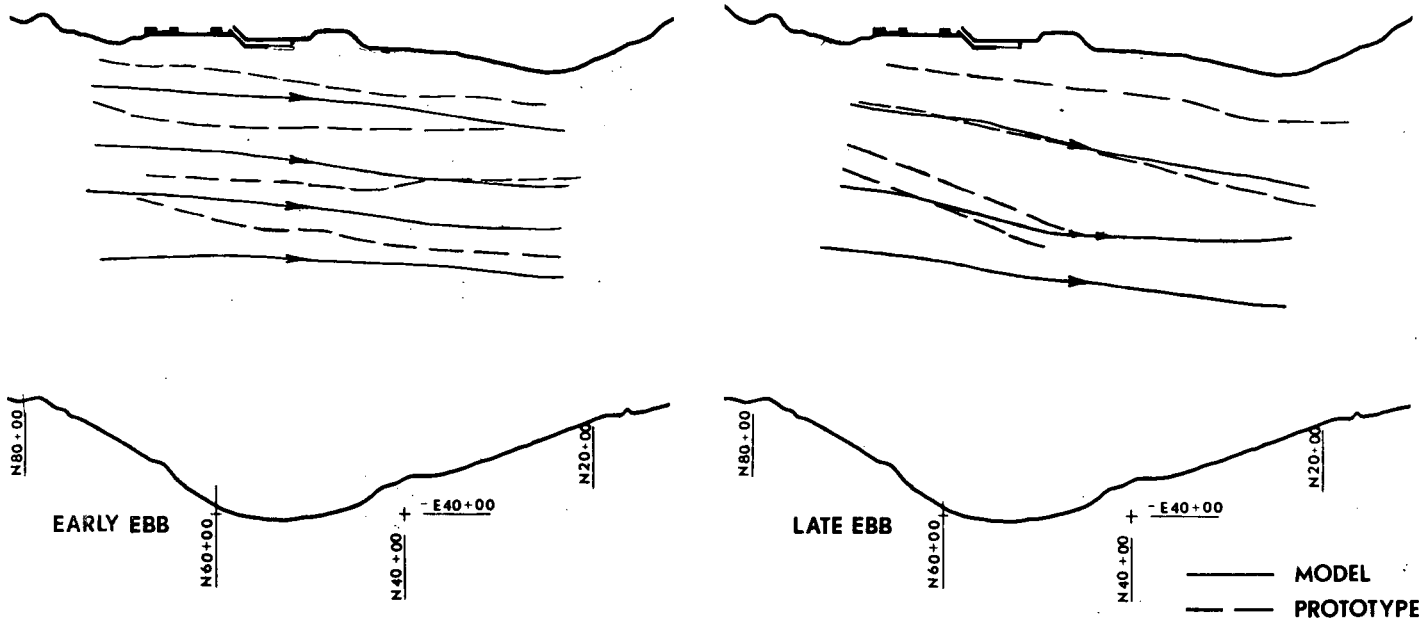

ALDEN RESEARCH LABORATORIES
 WORCESTER POLYTECHNIC INSTITUTE
 HYDRAULIC MODEL STUDIES
 FOR
 CONSOLIDATED EDISON COMPANY, N. Y.

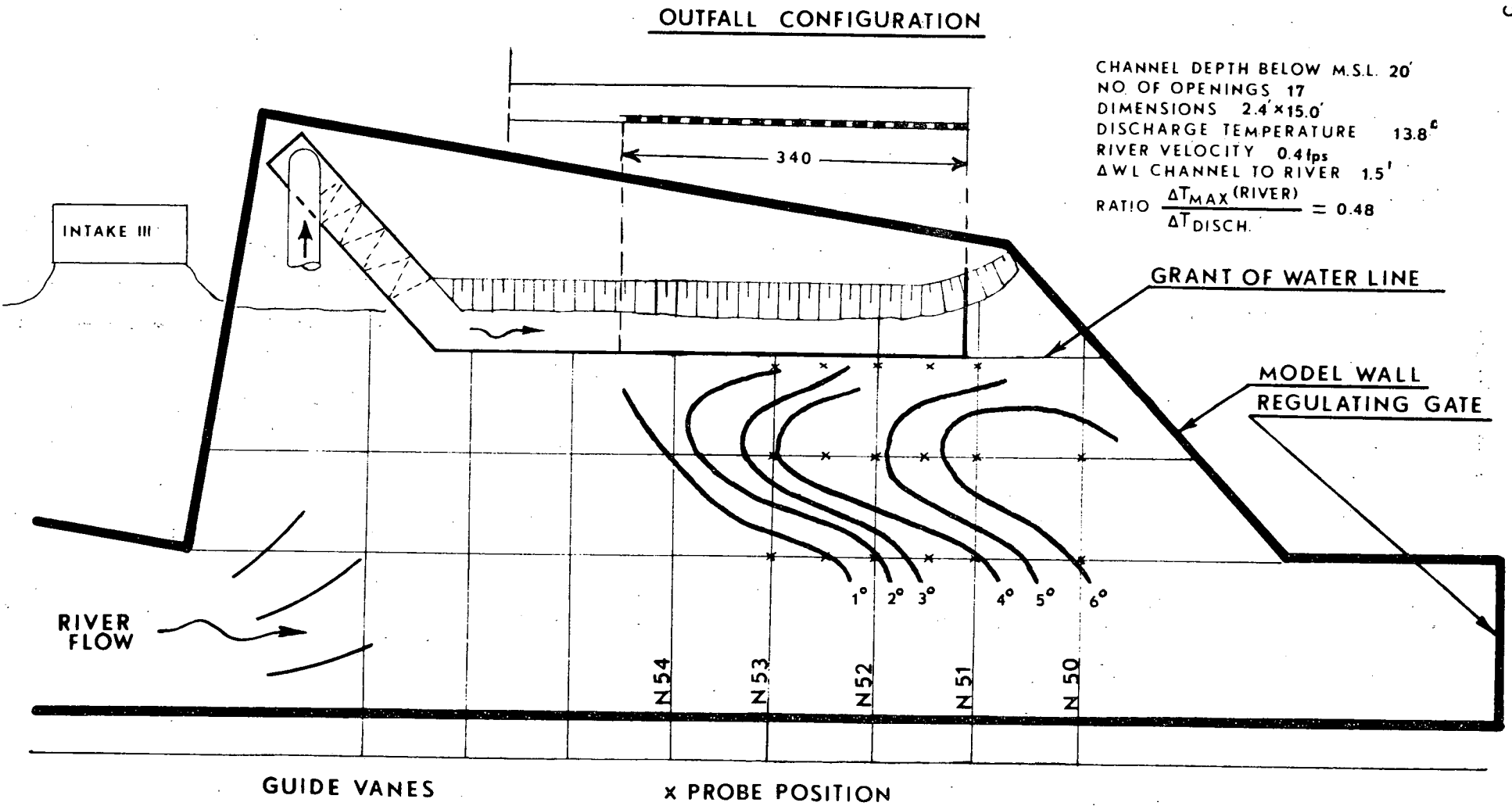

ALDEN RESEARCH LABORATORIES
 WORCESTER POLYTECHNIC INSTITUTE
 INDIAN POINT II SUB-MODEL
 MODEL SCALE 1:50 (UNDISTORTED)
 SURFACE ISOTHERMS
 TEST DATE MAR '69

OUTFALL CONFIGURATION

CHANNEL DEPTH BELOW M.S.L. 20'
 NO. OF OPENINGS 12
 DIMENSIONS 4' x 15'
 DISCHARGE TEMPERATURE +14°
 RIVER VELOCITY ≈ 0.4 fps
 ΔWL CHANNEL TO RIVER 1.5'
 RATIO $\frac{\Delta T_{MAX}(RIVER)}{\Delta T_{DISCH.}} = 0.50$

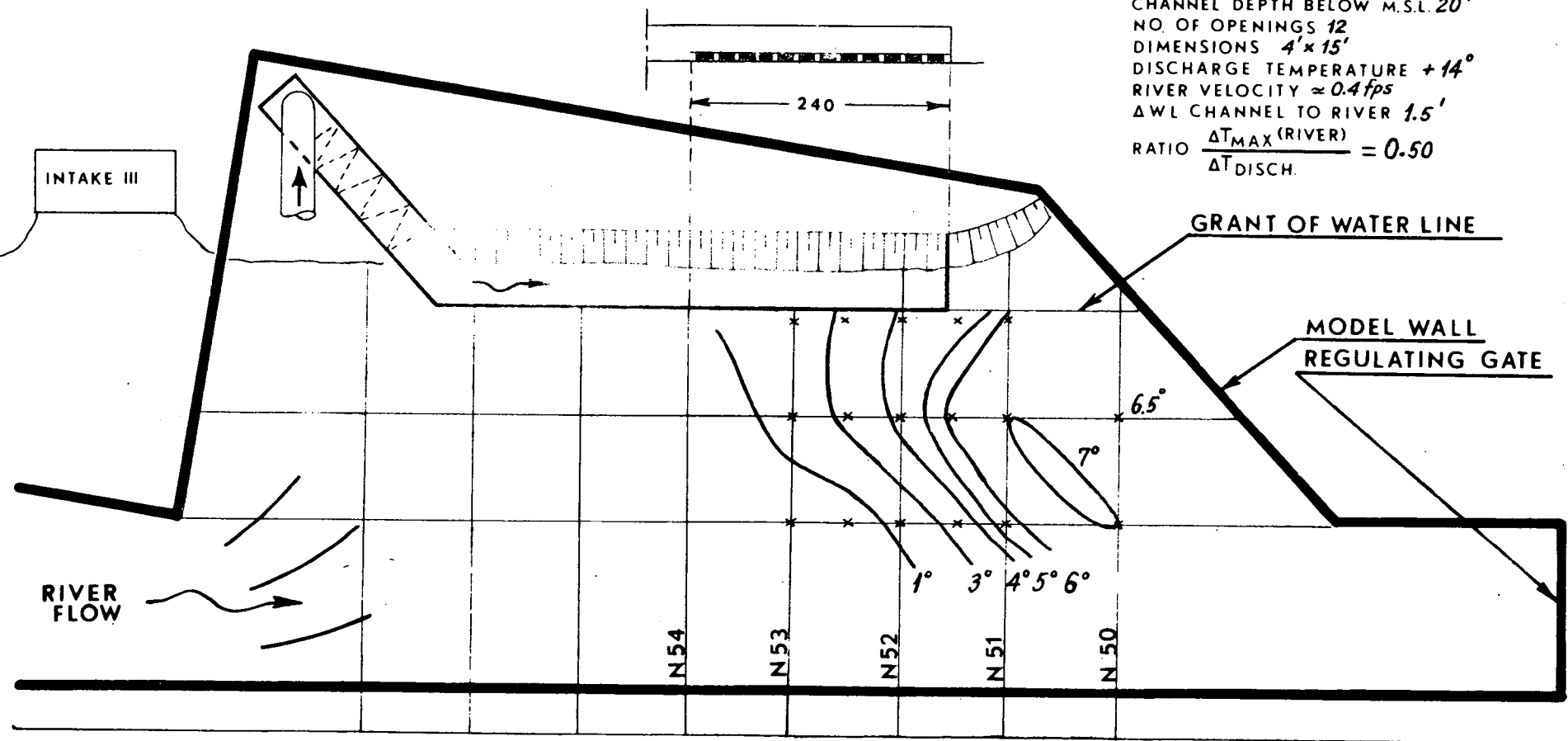

GUIDE VANES

x PROBE POSITION

ALDEN RESEARCH LABORATORIES
 WORCESTER POLYTECHNIC INSTITUTE
 INDIAN POINT II SUB-MODEL
 MODEL SCALE 1:50 (UNDISTORTED)
 SURFACE ISOTHERMS
 TEST DATE MAR '69

FIG. 6

OUTFALL CONFIGURATION

CHANNEL DEPTH BELOW M.S.L. 20'
 NO. OF OPENINGS 6
 DIMENSIONS 4x30'
 DISCHARGE TEMPERATURE 17°
 RIVER VELOCITY 0.4 fps
 ΔWL CHANNEL TO RIVER 1.5'
 RATIO $\frac{\Delta T_{MAX} (RIVER)}{\Delta T_{DISCH.}} = 0.53$

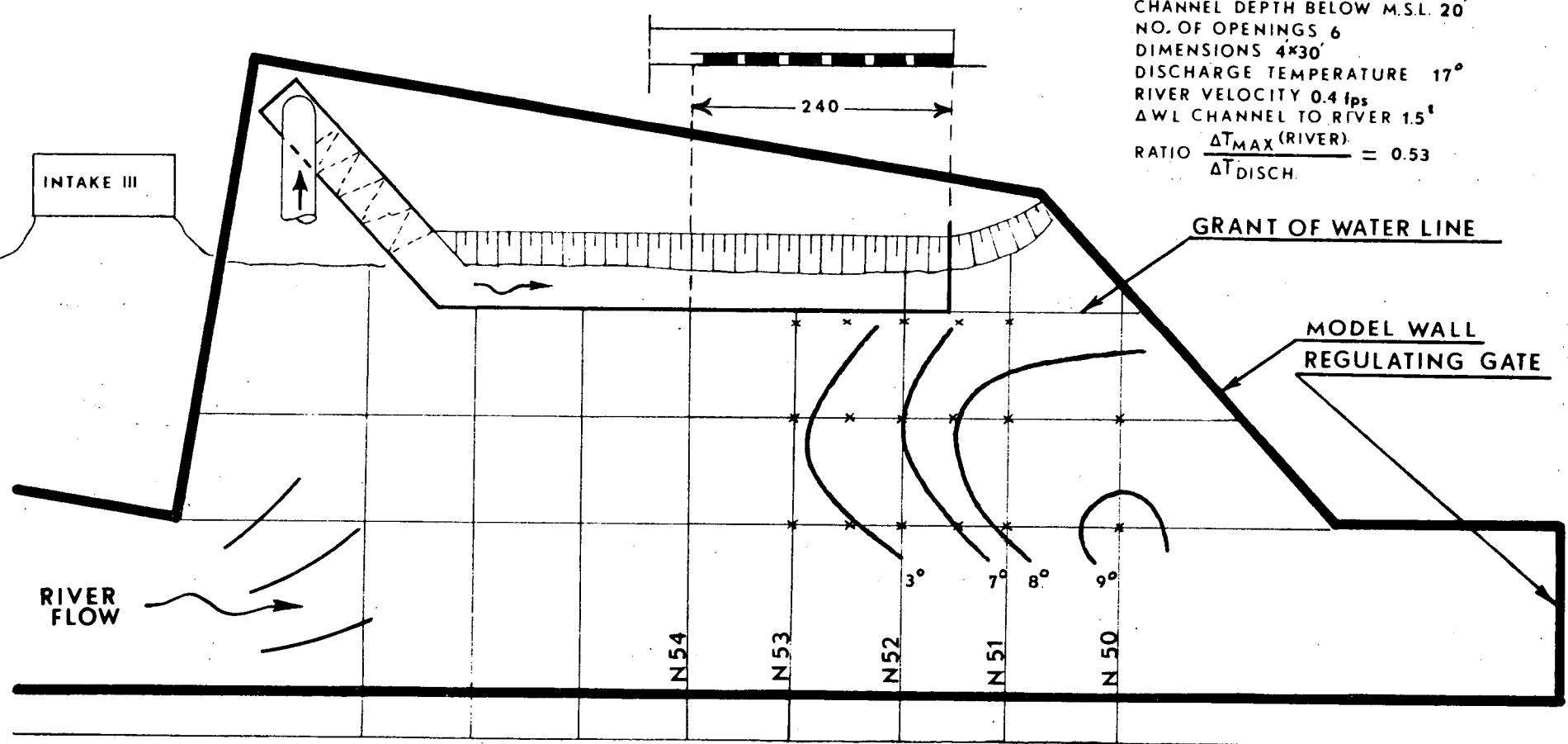

GUIDE VANES

x PROBE POSITION

ALDEN RESEARCH LABORATORIES
 WORCESTER POLYTECHNIC INSTITUTE
 INDIAN POINT II SUB-MODEL
 MODEL SCALE 1:50 (UNDISTORTED)
 SURFACE ISOTHERMS
 TEST DATE AUG. '68

OUTFALL CONFIGURATION

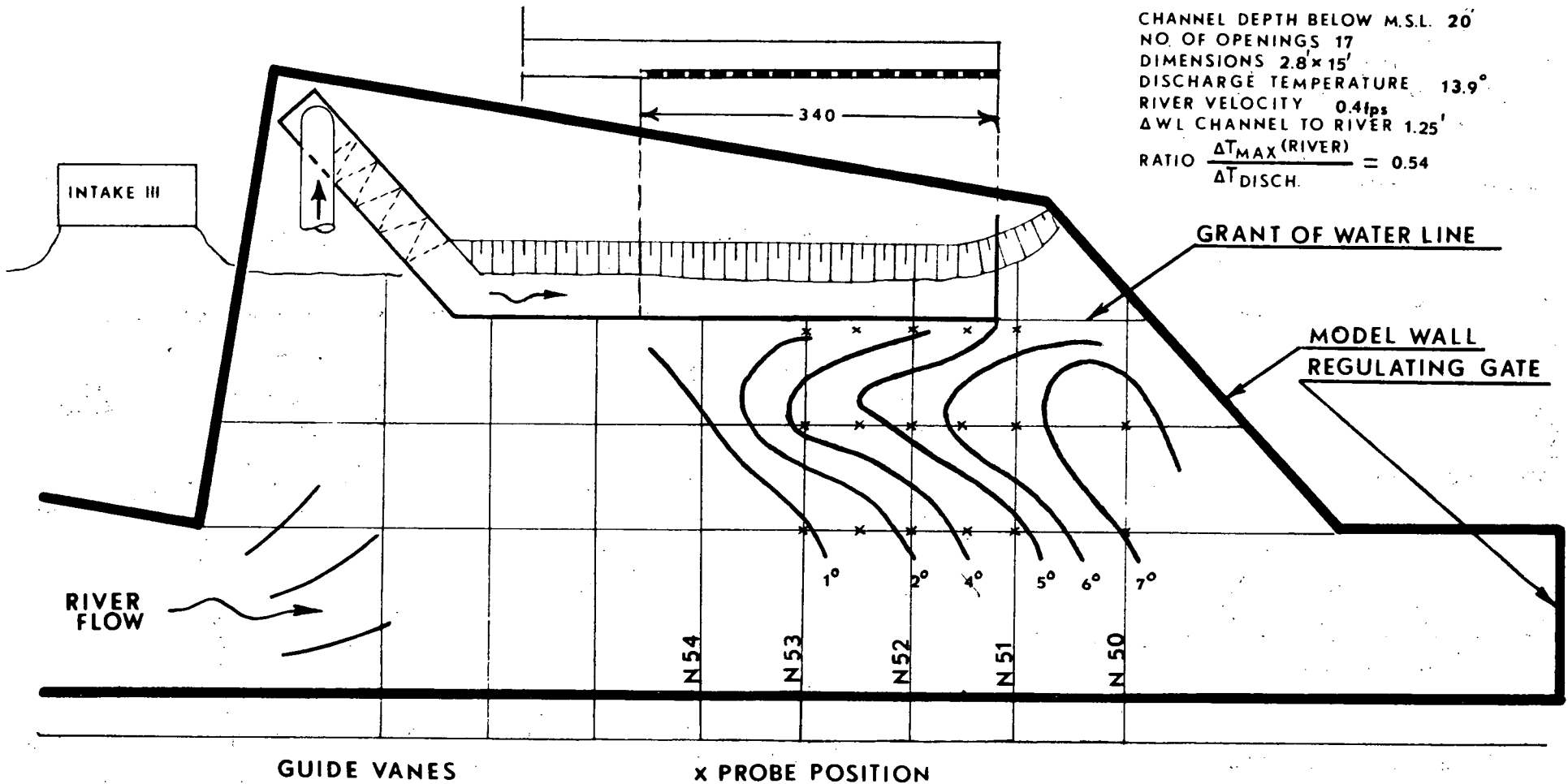

CHANNEL DEPTH BELOW M.S.L. 20'
 NO. OF OPENINGS 17
 DIMENSIONS 2.8 x 15'
 DISCHARGE TEMPERATURE 13.9°
 RIVER VELOCITY 0.4fps
 ΔWL CHANNEL TO RIVER 1.25'
 RATIO $\frac{\Delta T_{MAX}(RIVER)}{\Delta T_{DISCH.}} = 0.54$

GRANT OF WATER LINE

MODEL WALL REGULATING GATE

RIVER FLOW

GUIDE VANES

x PROBE POSITION

ALDEN RESEARCH LABORATORIES
 WORCESTER POLYTECHNIC INSTITUTE
 INDIAN POINT II SUB-MODEL
 MODEL SCALE 1:50 (UNDISTORTED)
 SURFACE ISOTHERMS
 TEST DATE MAR '69

FIG. 8

OUTFALL CONFIGURATION

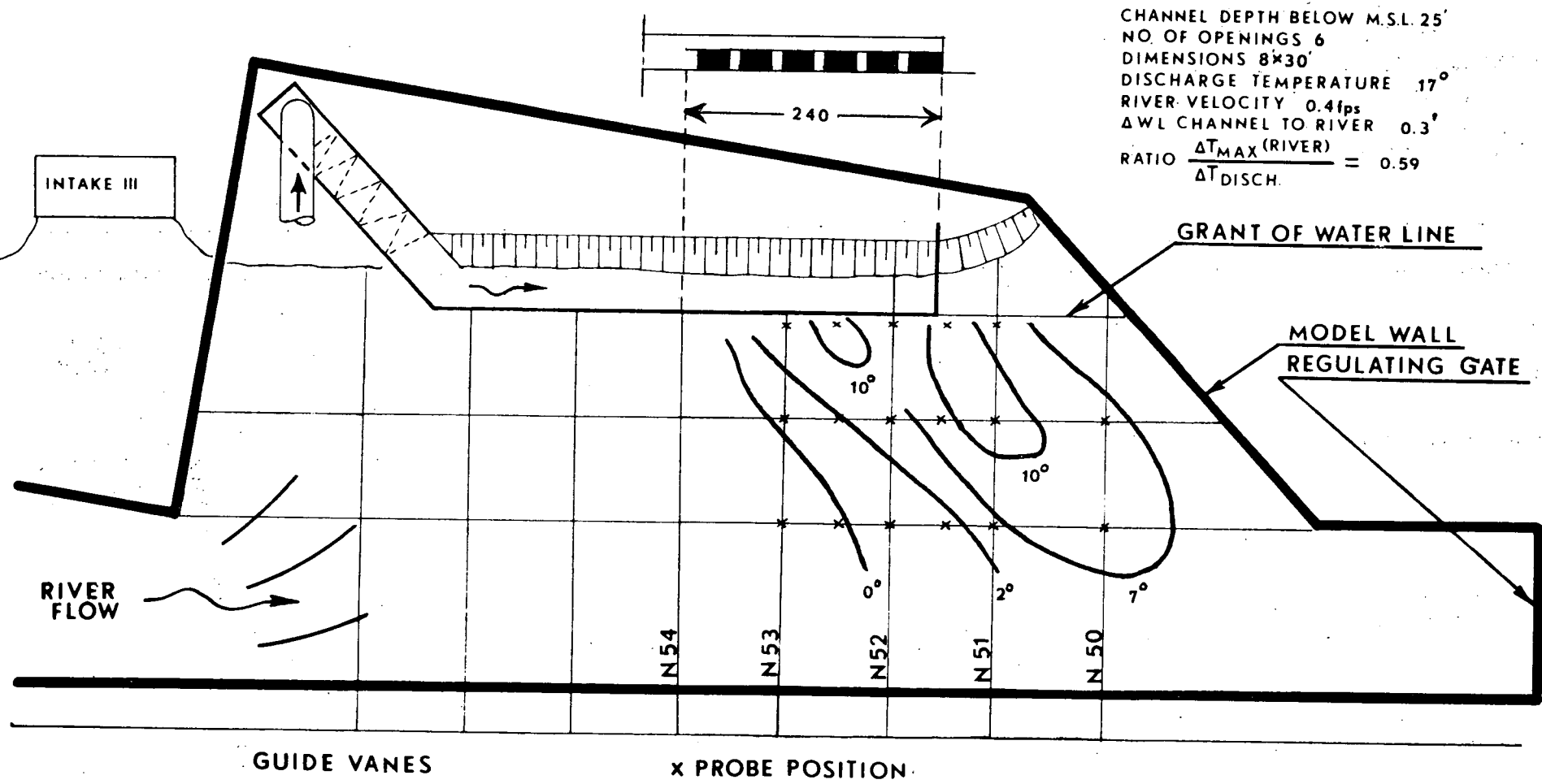

CHANNEL DEPTH BELOW M.S.L. 25'
 NO. OF OPENINGS 6
 DIMENSIONS 8x30'
 DISCHARGE TEMPERATURE 17°
 RIVER VELOCITY 0.4fps
 $\Delta W L$ CHANNEL TO RIVER 0.3'
 RATIO $\frac{\Delta T_{MAX}(RIVER)}{\Delta T_{DISCH.}} = 0.59$

ALDEN RESEARCH LABORATORIES
 WORCESTER POLYTECHNIC INSTITUTE
 INDIAN POINT II SUB-MODEL
 MODEL SCALE 1:50 (UNDISTORTED)
 SURFACE ISOTHERMS
 TEST DATE OCT. '68

OUTFALL CONFIGURATION

CHANNEL DEPTH BELOW M.S.L. 20'
 NO. OF OPENINGS 12
 DIMENSIONS 6.5'x15'
 DISCHARGE TEMPERATURE 14°
 RIVER VELOCITY 0.4fps
 ΔWL CHANNEL TO RIVER 0.5'
 RATIO $\frac{\Delta T_{MAX} (RIVER)}{\Delta T_{DISCH.}} = 0.61$

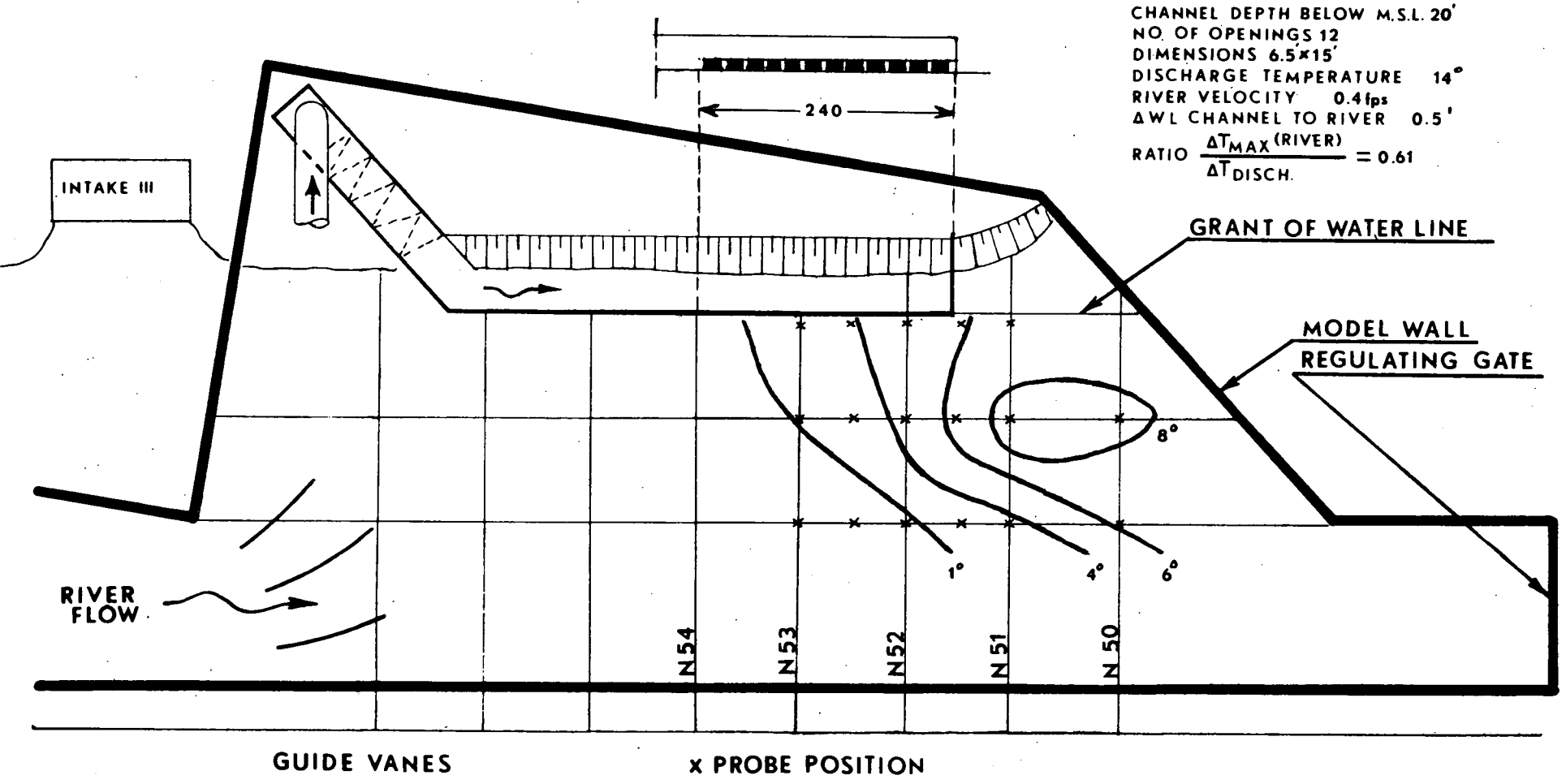

ALDEN RESEARCH LABORATORIES
 WORCESTER POLYTECHNIC INSTITUTE
 INDIAN POINT II SUB-MODEL
 MODEL SCALE 1:50 (UNDISTORTED)
 SURFACE ISOTHERMS
 TEST DATE MAR '69

FIG. 10

OUTFALL CONFIGURATION

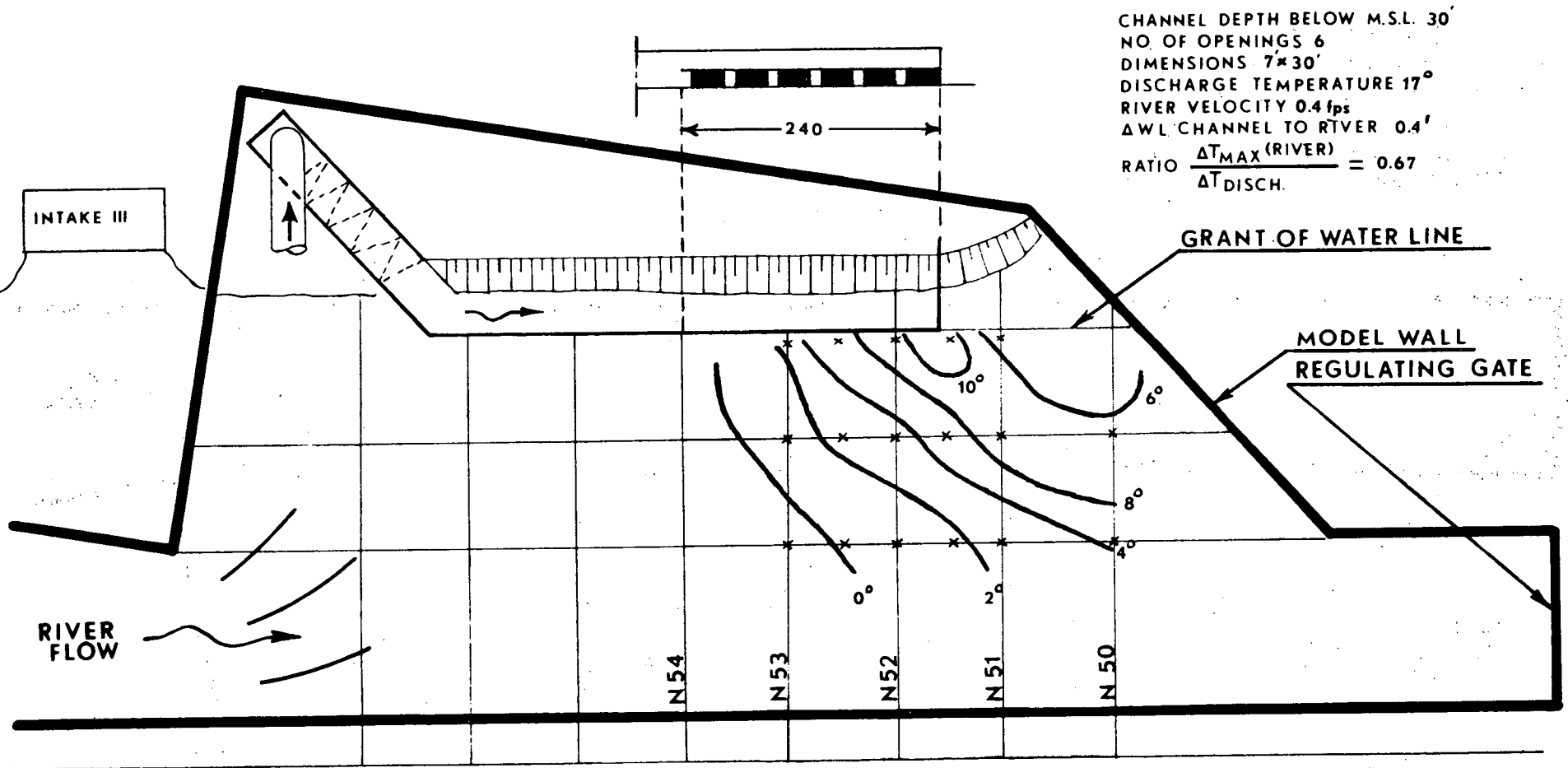

CHANNEL DEPTH BELOW M.S.L. 30'
 NO. OF OPENINGS 6
 DIMENSIONS 7x30'
 DISCHARGE TEMPERATURE 17°
 RIVER VELOCITY 0.4 fps
 ΔWL CHANNEL TO RTVER 0.4'
 RATIO $\frac{\Delta T_{MAX} (RIVER)}{\Delta T_{DISCH.}} = 0.67$

GUIDE VANES

x PROBE POSITION

ALDEN RESEARCH LABORATORIES
 WORCESTER POLYTECHNIC INSTITUTE
 INDIAN POINT II SUB-MODEL
 MODEL SCALE 1:50 (UNDISTORTED)
 SURFACE ISOOTHERMS
 TEST DATE OCT. '68

OUTFALL CONFIGURATION

CHANNEL DEPTH BELOW M.S.L. 20'
 NO. OF OPENINGS 224
 DIMENSIONS 2.5' DIA.
 DISCHARGE TEMPERATURE 12.9°
 RIVER VELOCITY 0.4 fps
 ΔWL CHANNEL TO RTVER 0.6'
 RATIO $\frac{\Delta T_{MAX}(RIVER)}{\Delta T_{DISCH.}} = 0.67$

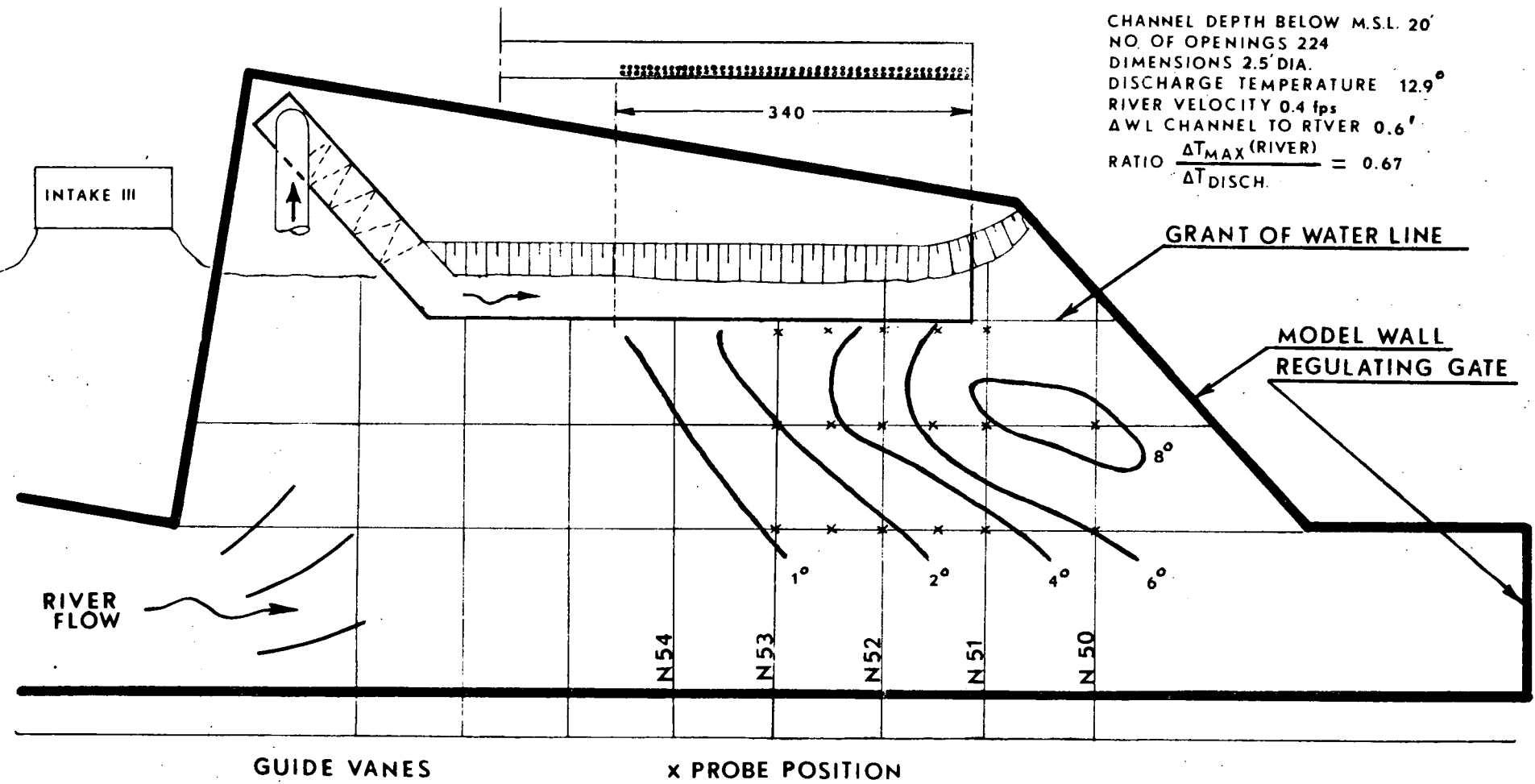

ALDEN RESEARCH LABORATORIES
 WORCESTER POLYTECHNIC INSTITUTE
 INDIAN POINT II SUB-MODEL
 MODEL SCALE 1:50 (UNDISTORTED)
 SURFACE ISOTHERMS
 TEST DATE MAR '69

FIG. 12

OUTFALL CONFIGURATION

CHANNEL DEPTH BELOW M.S.L. 25'
 NO. OF OPENINGS 6
 DIMENSIONS 7x30'
 DISCHARGE TEMPERATURE 17°
 RIVER VELOCITY 0.4 fps
 ΔWL CHANNEL TO RIVER 0.4'
 RATIO $\frac{\Delta T_{MAX}(RIVER)}{\Delta T_{DISCH.}} = 0.70$

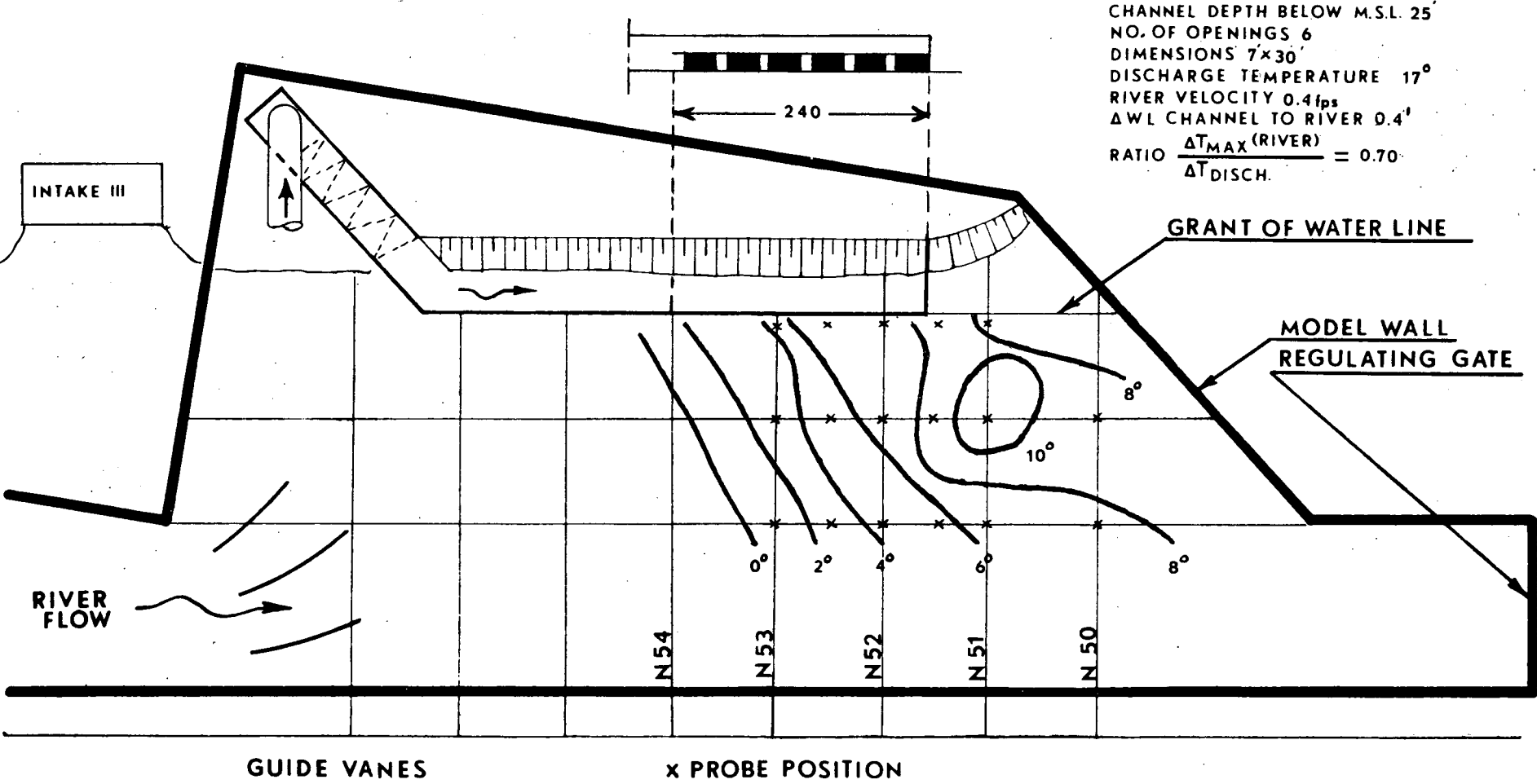

ALDEN RESEARCH LABORATORIES
 WORCESTER POLYTECHNIC INSTITUTE
 INDIAN POINT II SUB-MODEL
 MODEL SCALE 1:50 (UNDISTORTED)
 SURFACE ISOTHERMS
 TEST DATE OCT. '68

OUTFALL CONFIGURATION

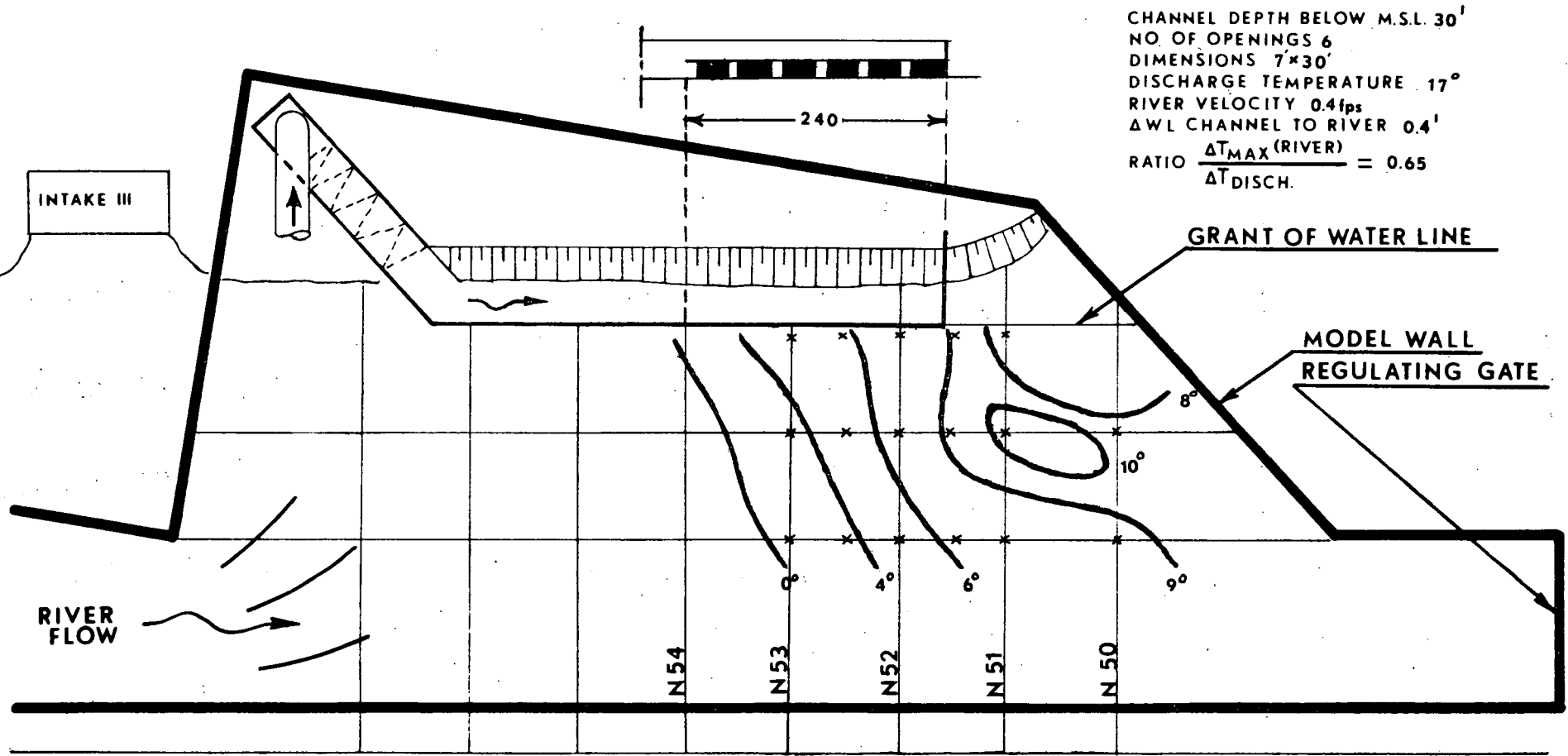

CHANNEL DEPTH BELOW M.S.L. 30'
 NO. OF OPENINGS 6
 DIMENSIONS 7'x30'
 DISCHARGE TEMPERATURE 17°
 RIVER VELOCITY 0.4fps
 ΔWL CHANNEL TO RIVER 0.4'
 RATIO $\frac{\Delta T_{MAX}(RIVER)}{\Delta T_{DISCH.}} = 0.65$

GUIDE VANES

x PROBE POSITION

ALDEN RESEARCH LABORATORIES
 WORCESTER POLYTECHNIC INSTITUTE
 INDIAN POINT II SUB-MODEL
 MODEL SCALE 1:50 (UNDISTORTED)
 SURFACE ISOTHERMS
 TEST DATE OCT. '68

FIG. 14

FIG. 15

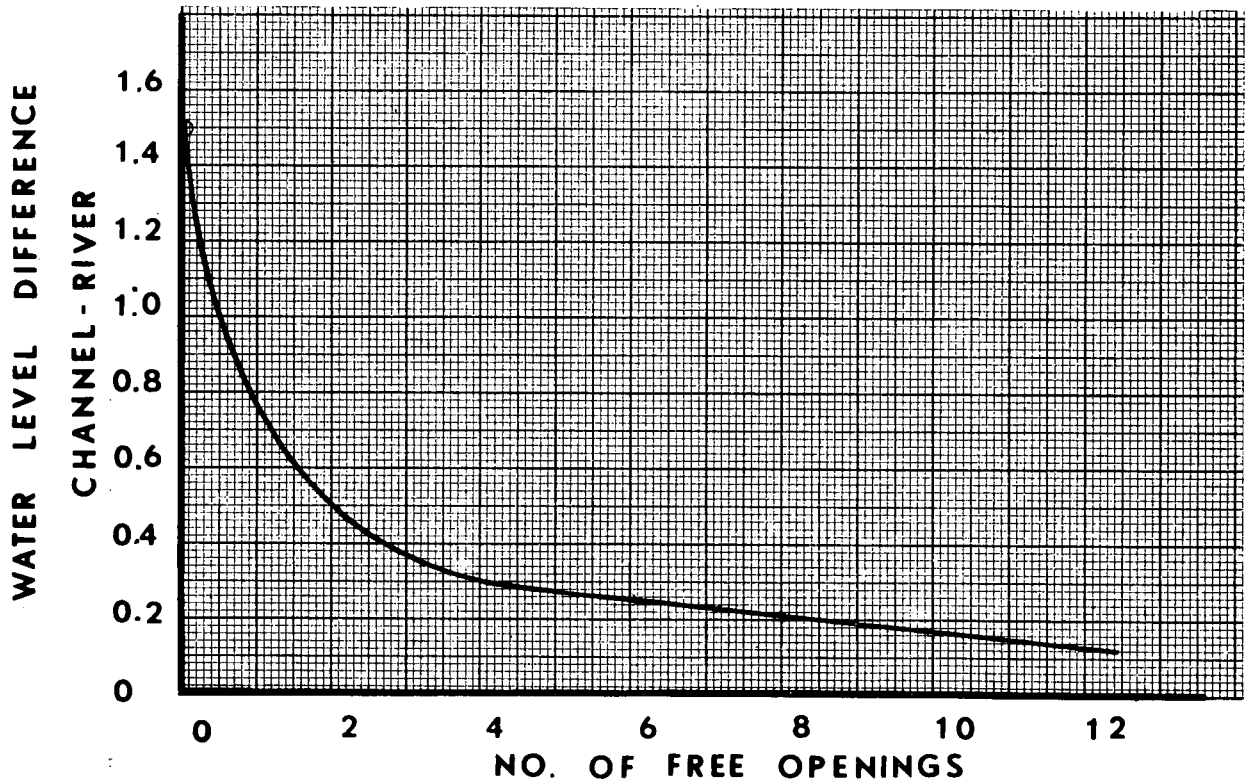
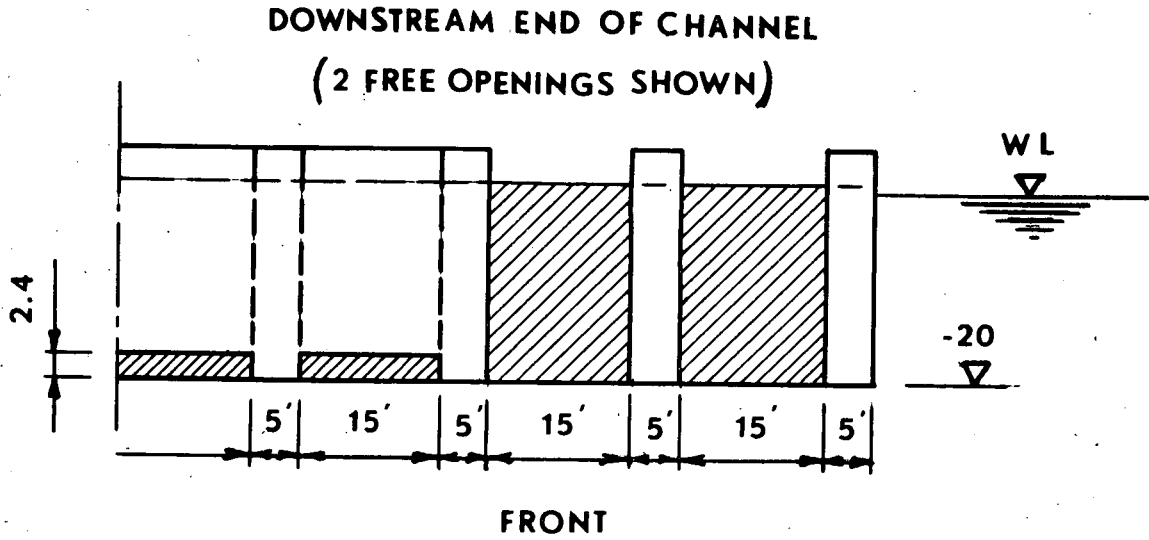

ALDEN RESEARCH LABORATORIES
WORCESTER POLYTECHNIC INSTITUTE
INDIAN POINT II SUB-MODEL

MODEL SCALE 1:50 (UNDISTORED)
WATER LEVEL DIFFERENCE CHANNEL - RIVER

INDIAN POINT II MODEL

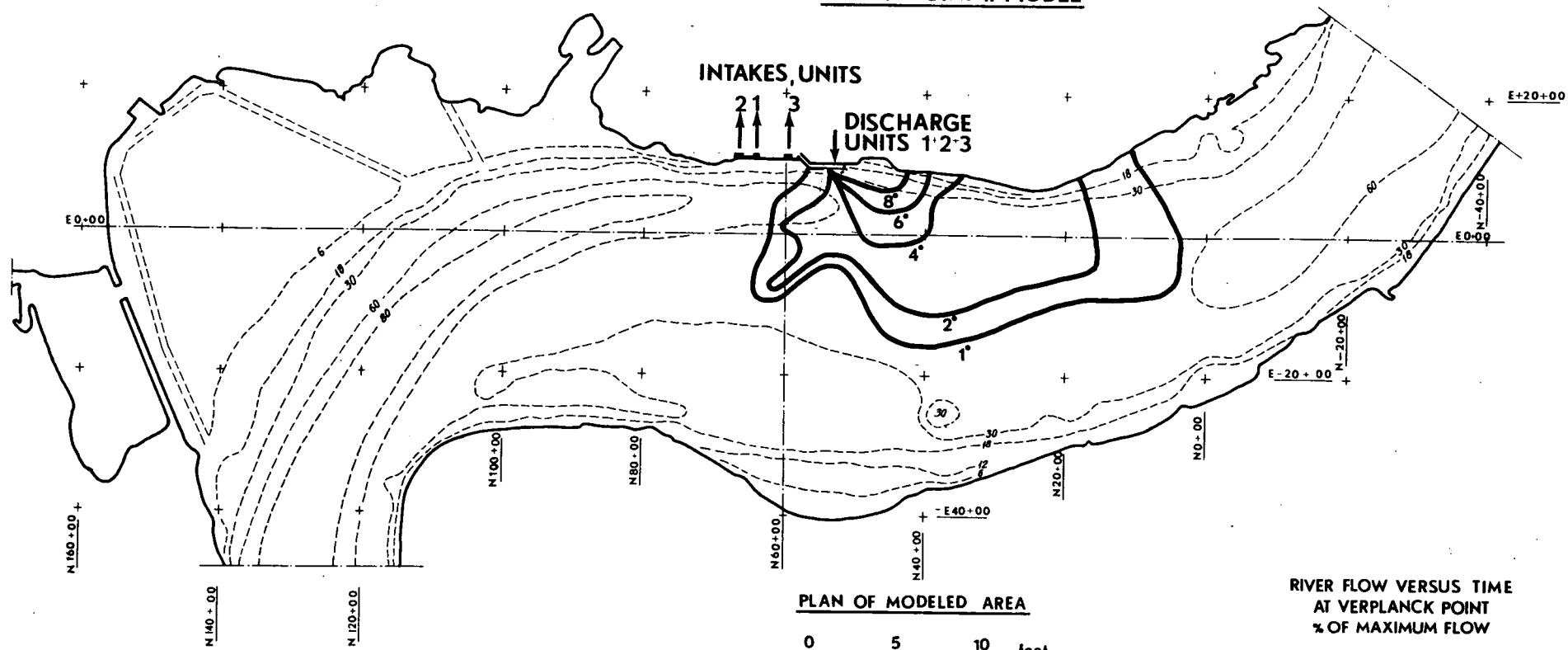

**RIVER FLOW VERSUS TIME
AT VERPLANCK POINT
% OF MAXIMUM FLOW**

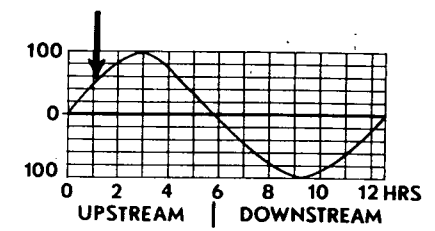

ARRANGEMENT OF OUTFALL STRUCTURE

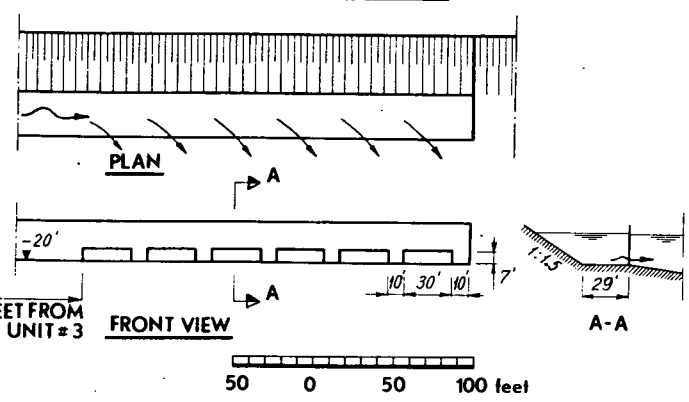

TEST CONDITIONS

TEST NUMBER AND DATE 522 ; 26 NOV , 1968
 UNITS OPERATING AND DISCHARGE 1,2,3 ; 4670 cfs
 DISCHARGE TEMPERATURE ABOVE AMBIENT RIVER 16.4 °F
 TIME IN TIDE CYCLE SEE DIAGRAM
 RIVER AMBIENT TEMPERATURE 44 °F
 AIR TEMPERATURE DRY BULB 46.4 °F
 AIR TEMPERATURE WET BULB 39.5 °F
 RELATIVE HUMIDITY 53 %
 DEPTH OF ISOTHERMS 0 feet
 ISOTHERMS ARE DEGREES ABOVE AMBIENT RIVER TEMPERATURE

ALDEN RESEARCH LABORATORIES
 WORCESTER POLYTECHNIC INSTITUTE
 HYDRAULIC MODEL STUDIES
 FOR
 CONSOLIDATED EDISON COMPANY, N. Y.

FIG. 16

INDIAN POINT II MODEL

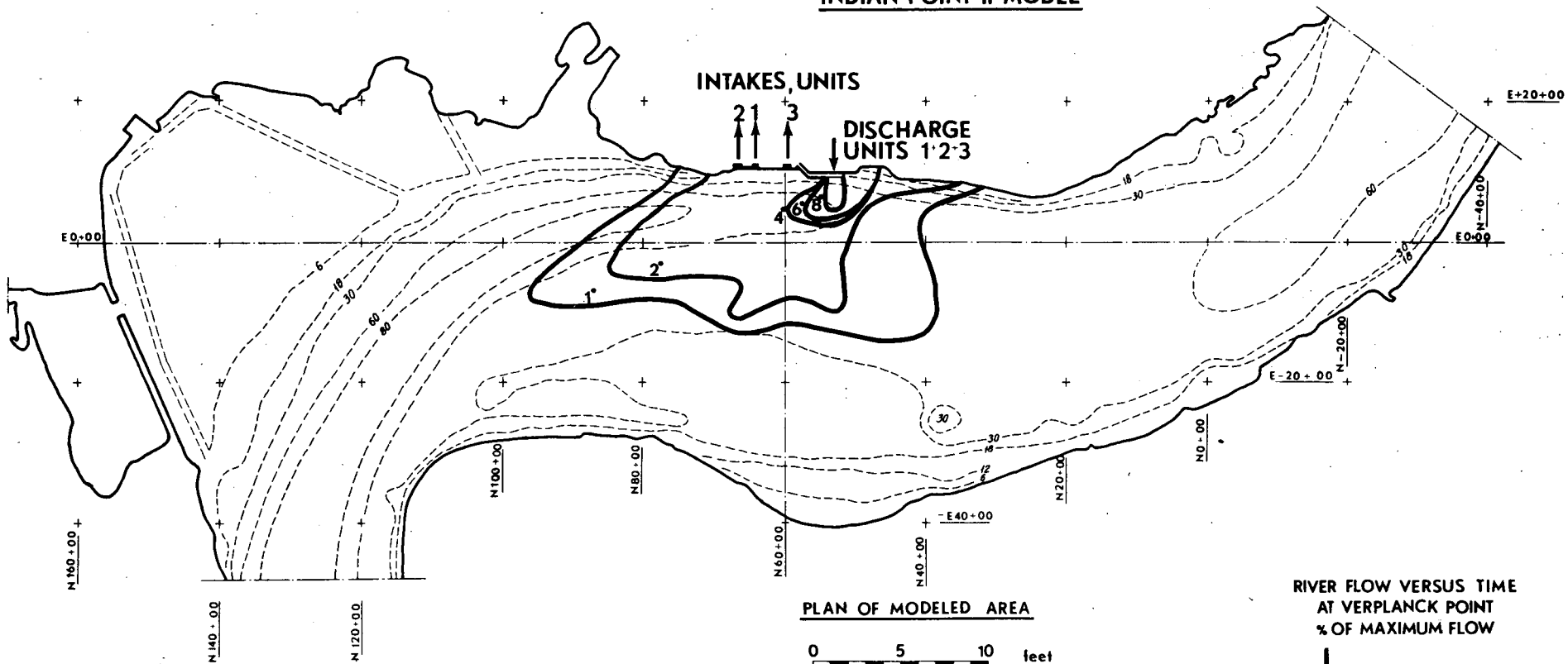

PLAN OF MODELED AREA

SCALES

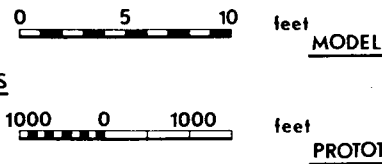

**RIVER FLOW VERSUS TIME AT VERPLANCK POINT
% OF MAXIMUM FLOW**

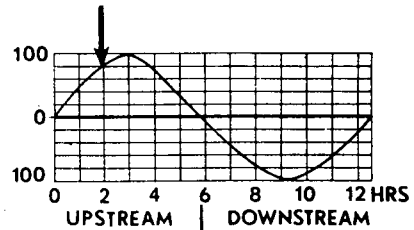

ARRANGEMENT OF OUTFALL STRUCTURE

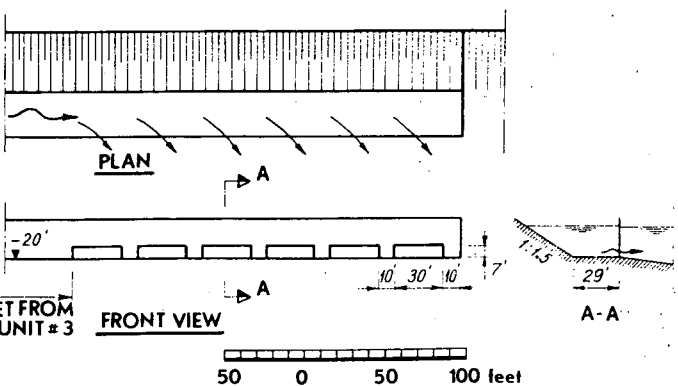

TEST CONDITIONS

TEST NUMBER AND DATE 522 ; 26, NOV , 1968
 UNITS OPERATING AND DISCHARGE 1,2,3 ; 4670 cfs
 DISCHARGE TEMPERATURE ABOVE AMBIENT RIVER 16.4 °F
 TIME IN TIDE CYCLE SEE DIAGRAM
 RIVER AMBIENT TEMPERATURE 44 °F
 AIR TEMPERATURE DRY BULB 46.4 °F
 AIR TEMPERATURE WET BULB 39.5 °F
 RELATIVE HUMIDITY 53 %
 DEPTH OF ISOTHERMS 0 feet
 ISOTHERMS ARE DEGREES ABOVE AMBIENT RIVER TEMPERATURE

ALDEN RESEARCH LABORATORIES
 WORCESTER POLYTECHNIC INSTITUTE
 HYDRAULIC MODEL STUDIES
 FOR
 CONSOLIDATED EDISON COMPANY, N. Y.

INDIAN POINT II MODEL

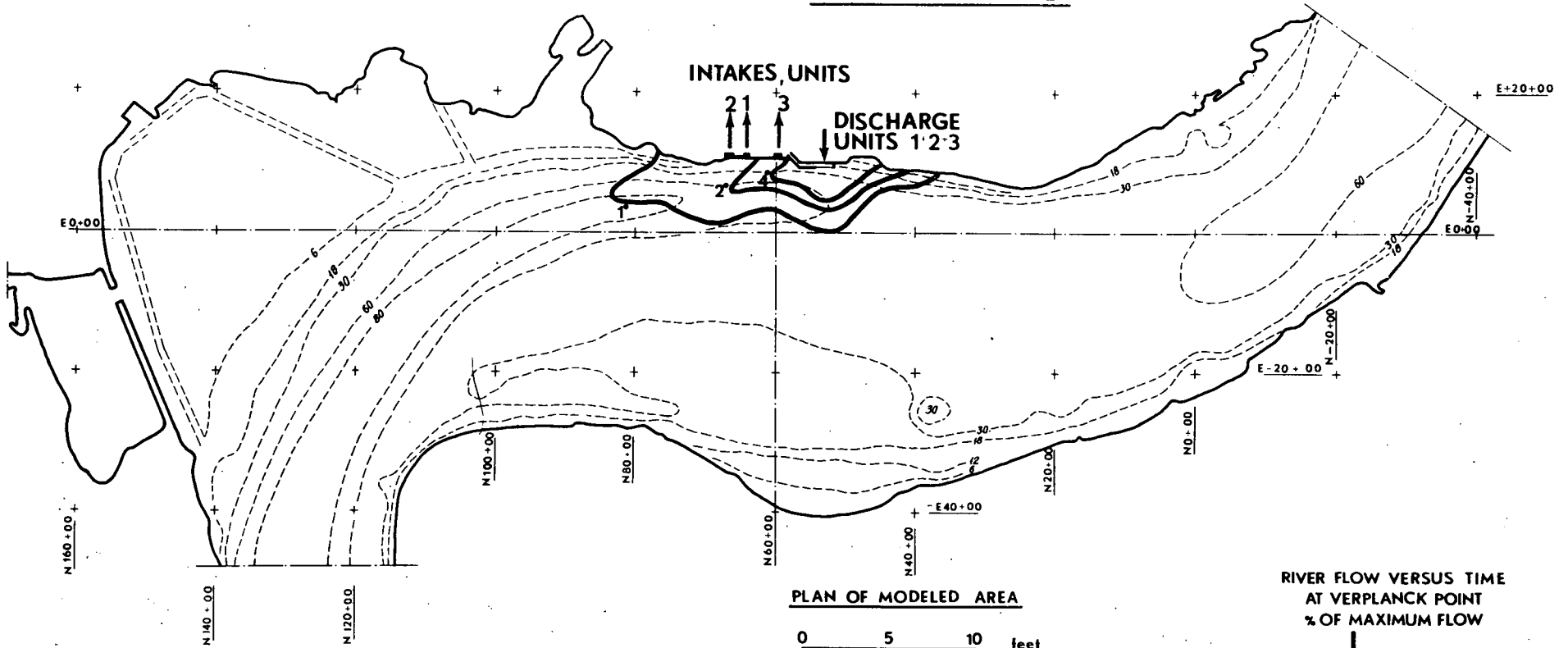

PLAN OF MODELED AREA



SCALES

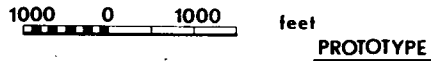

**RIVER FLOW VERSUS TIME AT VERPLANCK POINT
% OF MAXIMUM FLOW**

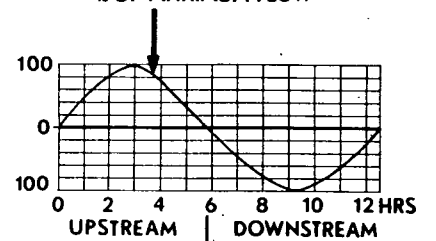

ARRANGEMENT OF OUTFALL STRUCTURE

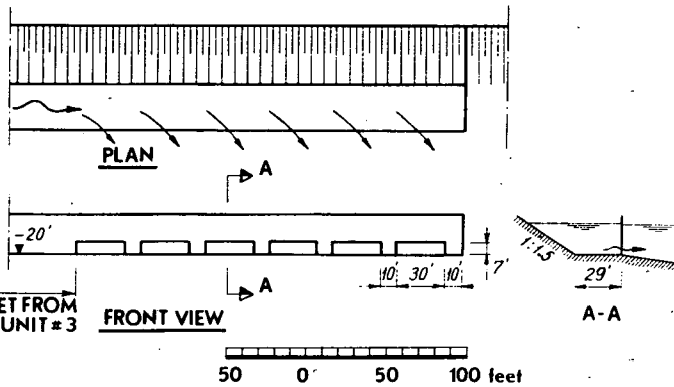

TEST CONDITIONS

TEST NUMBER AND DATE 522 ; 26, NOV ,1968
 UNITS OPERATING AND DISCHARGE 1,2,3 ; 4670 cfs
 DISCHARGE TEMPERATURE ABOVE AMBIENT RIVER 16.4 °F
 TIME IN TIDE CYCLE SEE DIAGRAM
 RIVER AMBIENT TEMPERATURE 44 °F
 AIR TEMPERATURE DRY BULB 46.4 °F
 AIR TEMPERATURE WET BULB 39.5 °F
 RELATIVE HUMIDITY 53 %
 DEPTH OF ISOTHERMS 0 feet
 ISOTHERMS ARE DEGREES ABOVE AMBIENT RIVER TEMPERATURE

ALDEN RESEARCH LABORATORIES
 WORCESTER POLYTECHNIC INSTITUTE
 HYDRAULIC MODEL STUDIES
 FOR
 CONSOLIDATED EDISON COMPANY, N. Y.

INDIAN POINT II MODEL

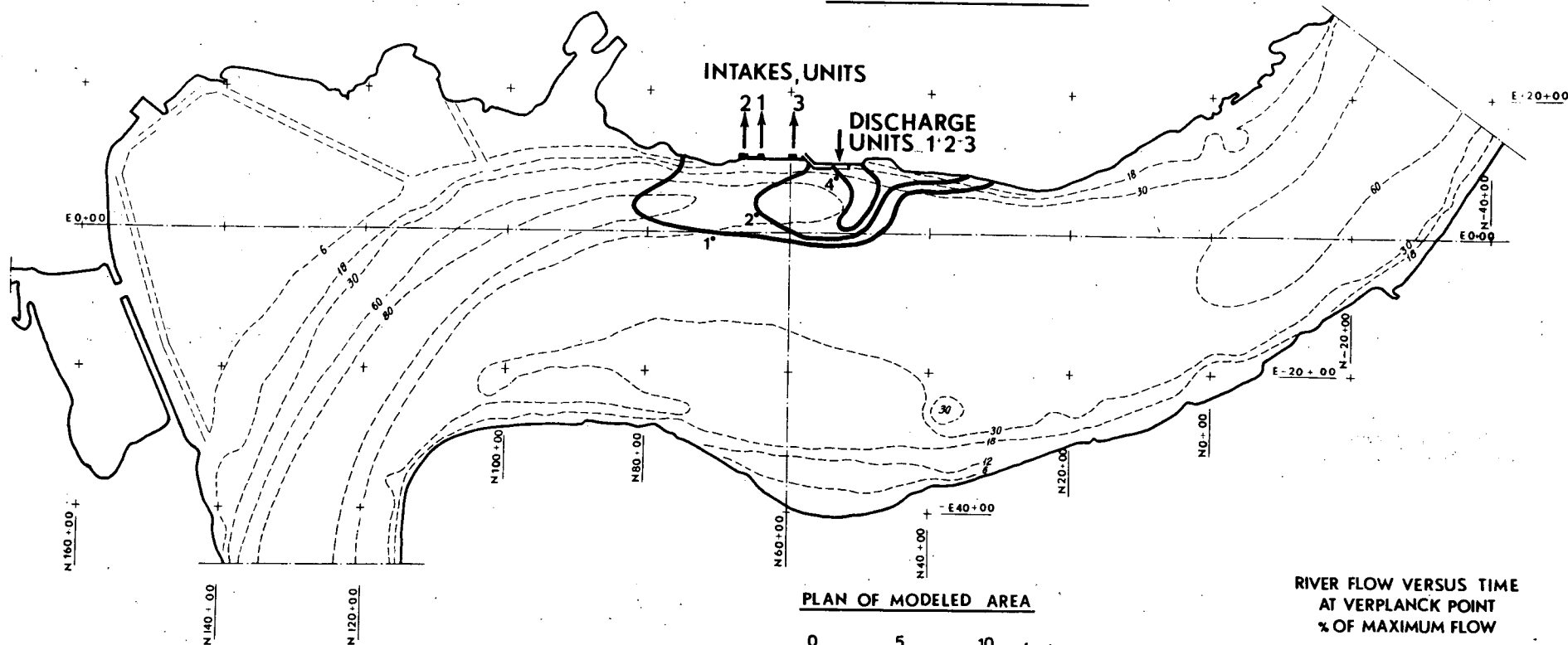

PLAN OF MODELED AREA

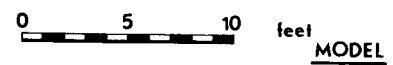

SCALES

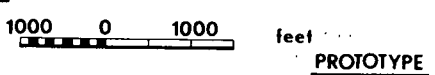

TEST CONDITIONS

TEST NUMBER AND DATE 522 ; 26 NOV, 1968
 UNITS OPERATING AND DISCHARGE 1,2,3 ; 4670 cfs
 DISCHARGE TEMPERATURE ABOVE AMBIENT RIVER 16.4°F
 TIME IN TIDE CYCLE SEE DIAGRAM
 RIVER AMBIENT TEMPERATURE 44 °F
 AIR TEMPERATURE DRY BULB 46.4°F
 AIR TEMPERATURE WET BULB 35.9°F
 RELATIVE HUMIDITY 53 %
 DEPTH OF ISOTHERMS 0 feet
 ISOTHERMS ARE DEGREES ABOVE AMBIENT RIVER TEMPERATURE

**RIVER FLOW VERSUS TIME AT VERPLANCK POINT
% OF MAXIMUM FLOW**

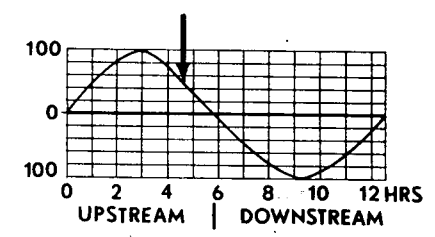

ARRANGEMENT OF OUTFALL STRUCTURE

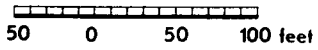
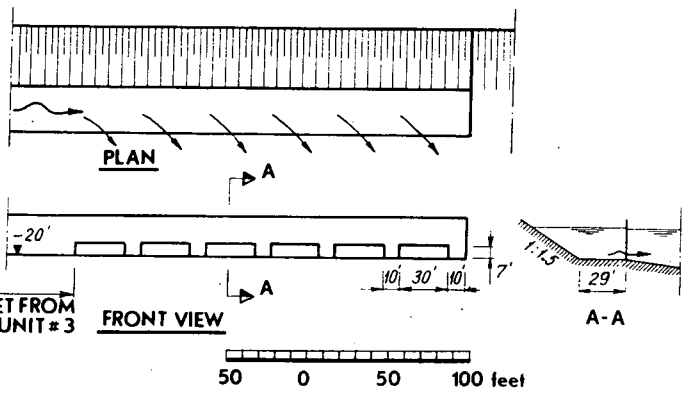

ALDEN RESEARCH LABORATORIES
 WORCESTER POLYTECHNIC INSTITUTE
 HYDRAULIC MODEL STUDIES
 FOR
 CONSOLIDATED EDISON COMPANY, N. Y.

INDIAN POINT II MODEL

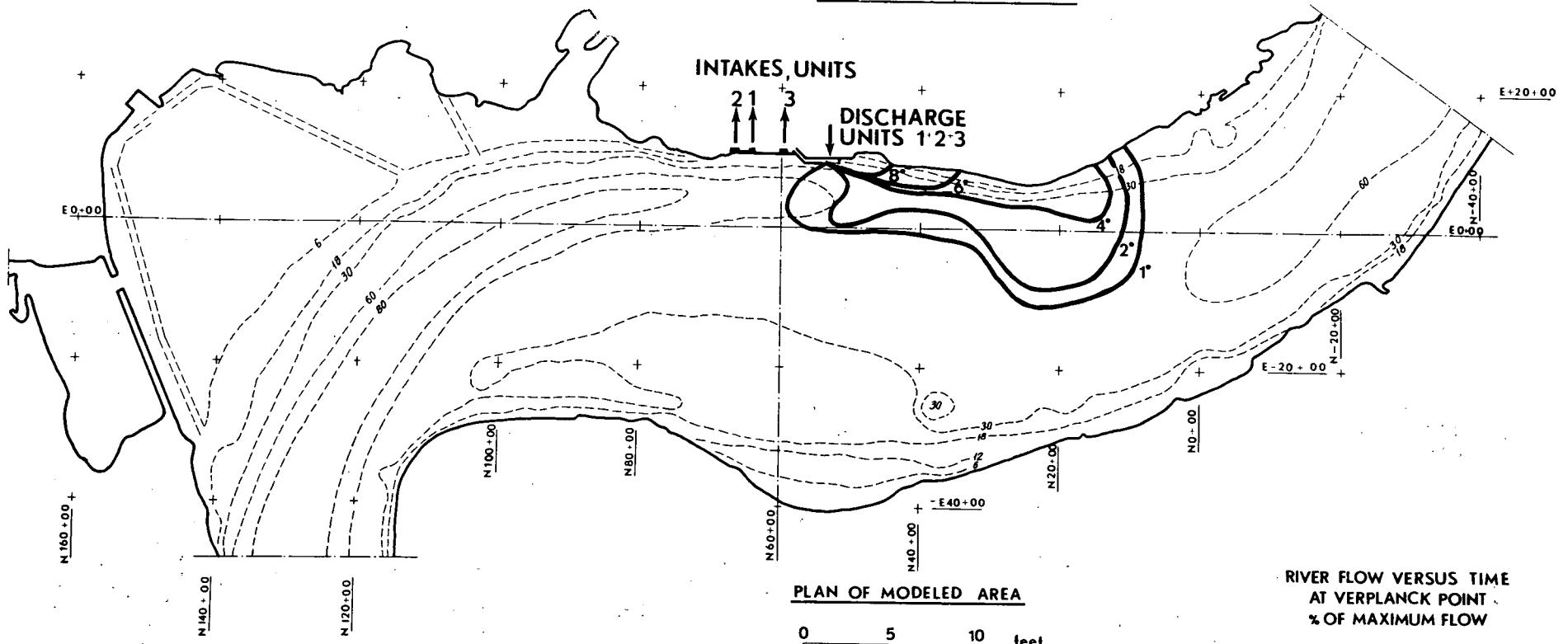

PLAN OF MODELED AREA

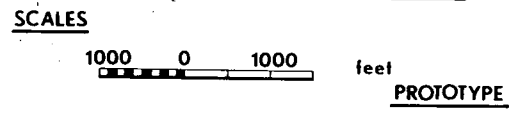

RIVER FLOW VERSUS TIME AT VERPLANCK POINT
% OF MAXIMUM FLOW

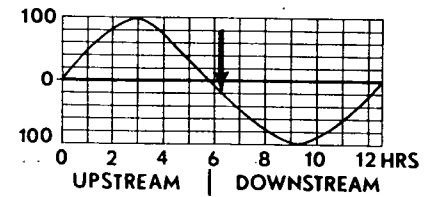

TEST CONDITIONS

TEST NUMBER AND DATE 522 ; 26 NOV ,1968
 UNITS OPERATING AND DISCHARGE 1,2,3 ; 4670 cfs
 DISCHARGE TEMPERATURE ABOVE AMBIENT RIVER 16.4 °F
 TIME IN TIDE CYCLE SEE DIAGRAM
 RIVER AMBIENT TEMPERATURE 44 °F
 AIR TEMPERATURE DRY BULB 46.4 °F
 AIR TEMPERATURE WET BULB 39.5 °F
 RELATIVE HUMIDITY 53 %
 DEPTH OF ISOTHERMS 0 feet
 ISOTHERMS ARE DEGREES ABOVE AMBIENT RIVER TEMPERATURE

ALDEN RESEARCH LABORATORIES
 WORCESTER POLYTECHNIC INSTITUTE
 HYDRAULIC MODEL STUDIES
 FOR
 CONSOLIDATED EDISON COMPANY, N. Y.

ARRANGEMENT OF OUTFALL STRUCTURE

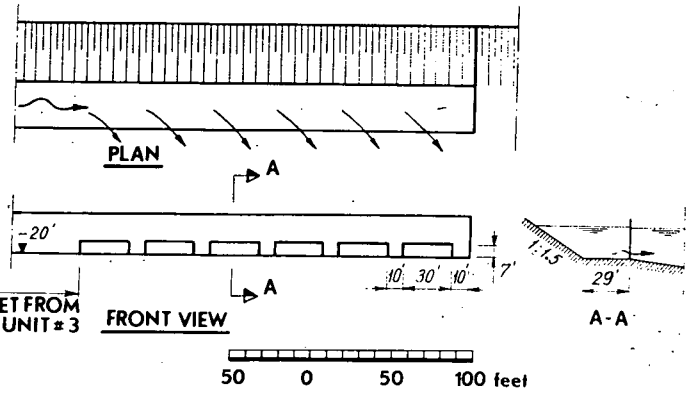

500 FEET FROM INTAKE UNIT #3

INDIAN POINT II MODEL

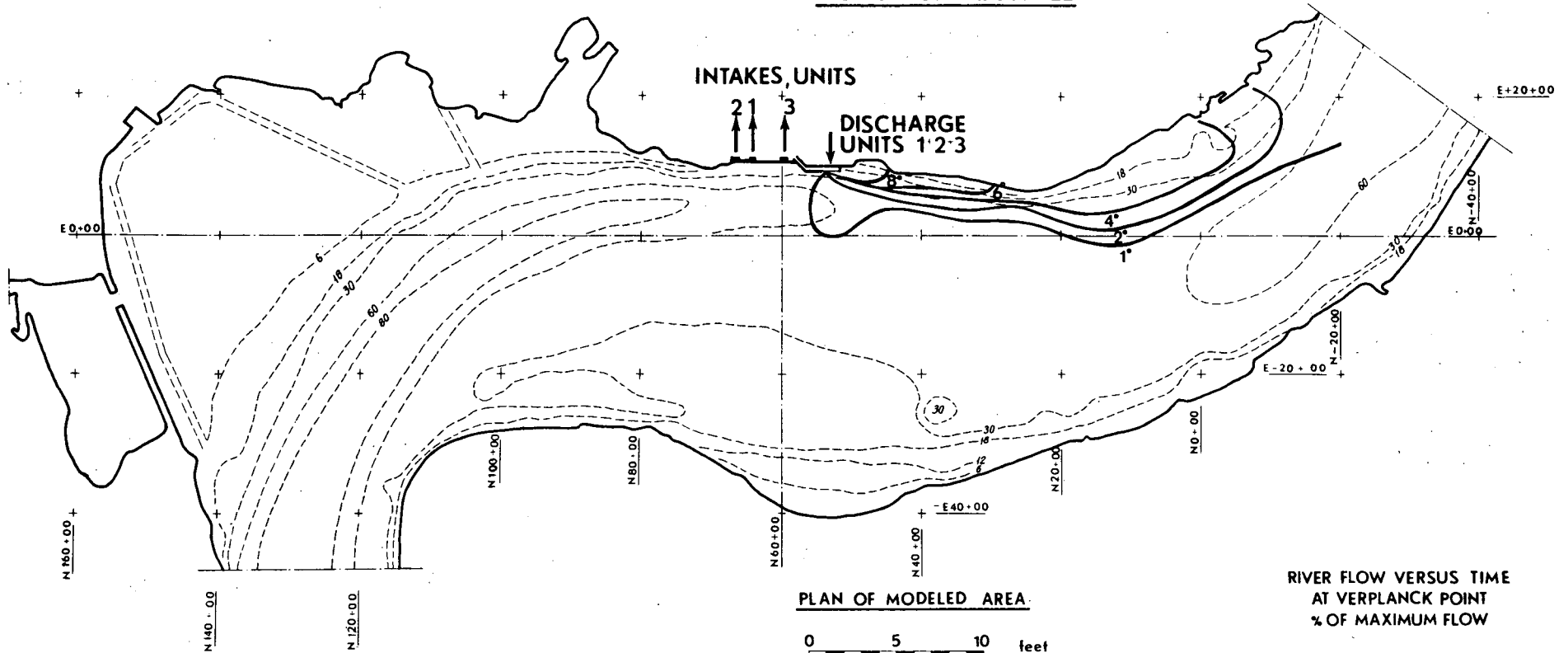

PLAN OF MODELED AREA



SCALES

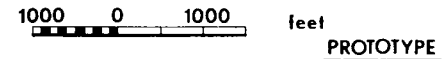

RIVER FLOW VERSUS TIME AT VERPLANCK POINT % OF MAXIMUM FLOW

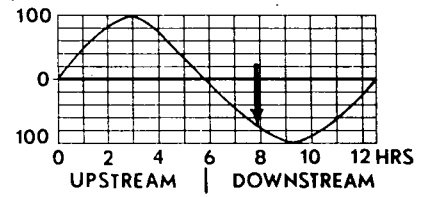

ARRANGEMENT OF OUTFALL STRUCTURE

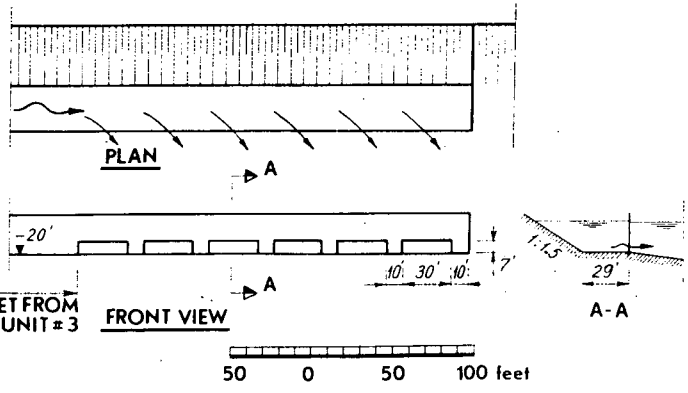

TEST CONDITIONS

TEST NUMBER AND DATE 522 ; 26 NOV , 1968
 UNITS OPERATING AND DISCHARGE 1,2,3 ; 4670 cfs
 DISCHARGE TEMPERATURE ABOVE AMBIENT RIVER 16.4°F
 TIME IN TIDE CYCLE SEE DIAGRAM.
 RIVER AMBIENT TEMPERATURE 44 °F
 AIR TEMPERATURE DRY BULB 46.4°F
 AIR TEMPERATURE WET BULB 39.5°F
 RELATIVE HUMIDITY 53 %
 DEPTH OF ISOTHERMS 0 feet
 ISOTHERMS ARE DEGREES ABOVE AMBIENT RIVER TEMPERATURE

ALDEN RESEARCH LABORATORIES
 WORCESTER POLYTECHNIC INSTITUTE
 HYDRAULIC MODEL STUDIES
 FOR
 CONSOLIDATED EDISON COMPANY, N. Y.

INDIAN POINT II MODEL

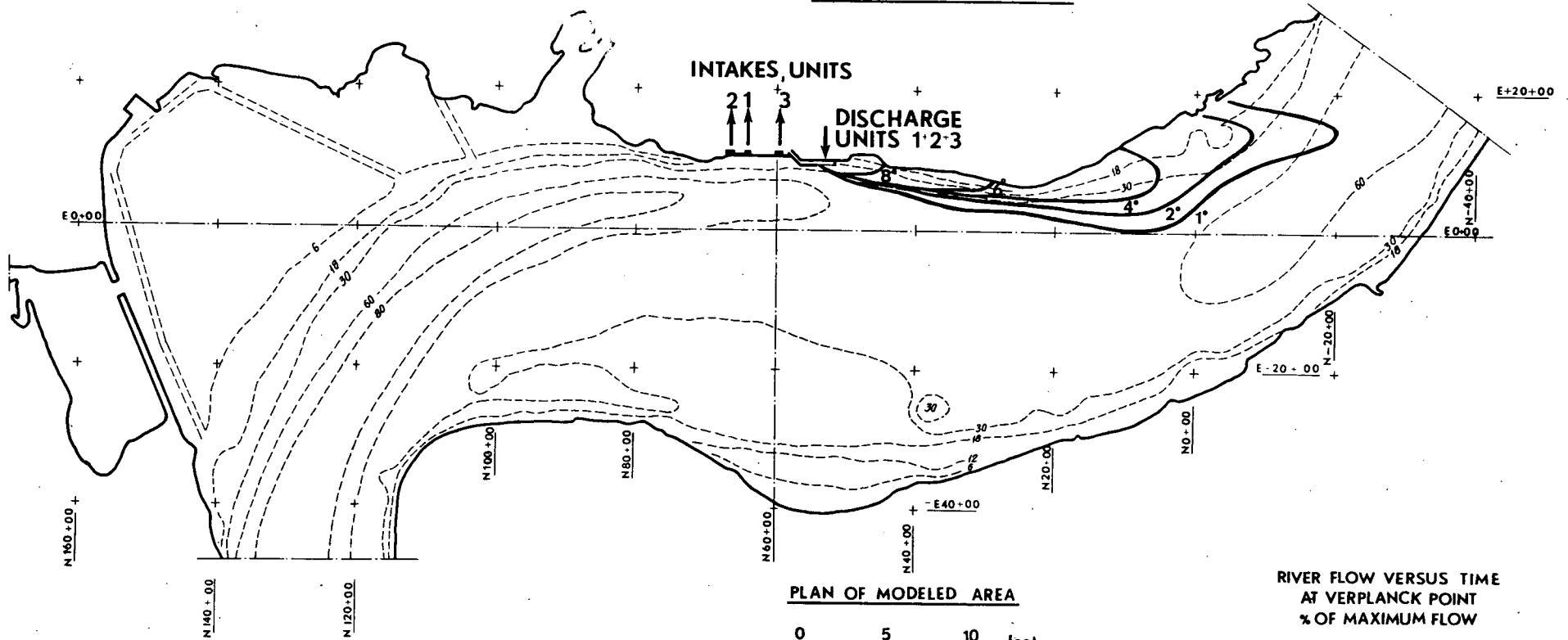

**RIVER FLOW VERSUS TIME
AT VERPLANCK POINT
% OF MAXIMUM FLOW**

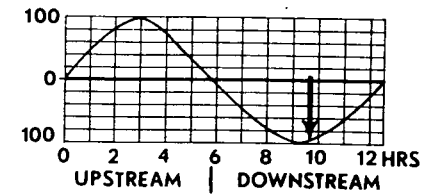

ARRANGEMENT OF OUTFALL STRUCTURE

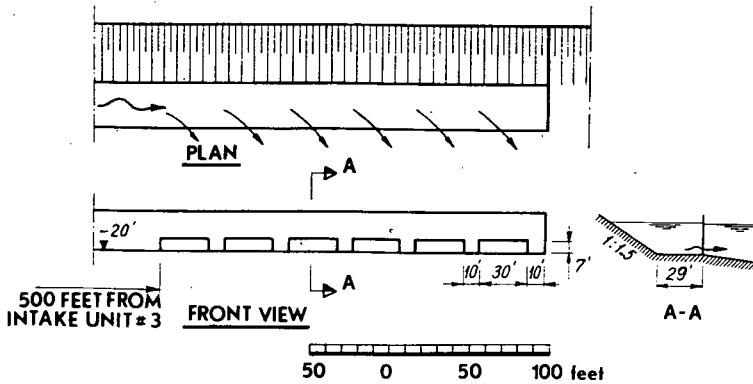

TEST CONDITIONS

TEST NUMBER AND DATE 522 ; 26 NOV , 1968
 UNITS OPERATING AND DISCHARGE 1,2,3 ; 4670 cfs
 DISCHARGE TEMPERATURE ABOVE AMBIENT RIVER 16.4 °F
 TIME IN TIDE CYCLE SEE DIAGRAM
 RIVER AMBIENT TEMPERATURE 44 °F
 AIR TEMPERATURE DRY BULB 46.4 °F
 AIR TEMPERATURE WET BULB 39.5 °F
 RELATIVE HUMIDITY 53%
 DEPTH OF ISOTHERMS 0 feet
 ISOTHERMS ARE DEGREES ABOVE AMBIENT RIVER TEMPERATURE

ALDEN RESEARCH LABORATORIES
 WORCESTER POLYTECHNIC INSTITUTE
 HYDRAULIC MODEL STUDIES
 FOR
 CONSOLIDATED EDISON COMPANY, N. Y.

INDIAN POINT II MODEL

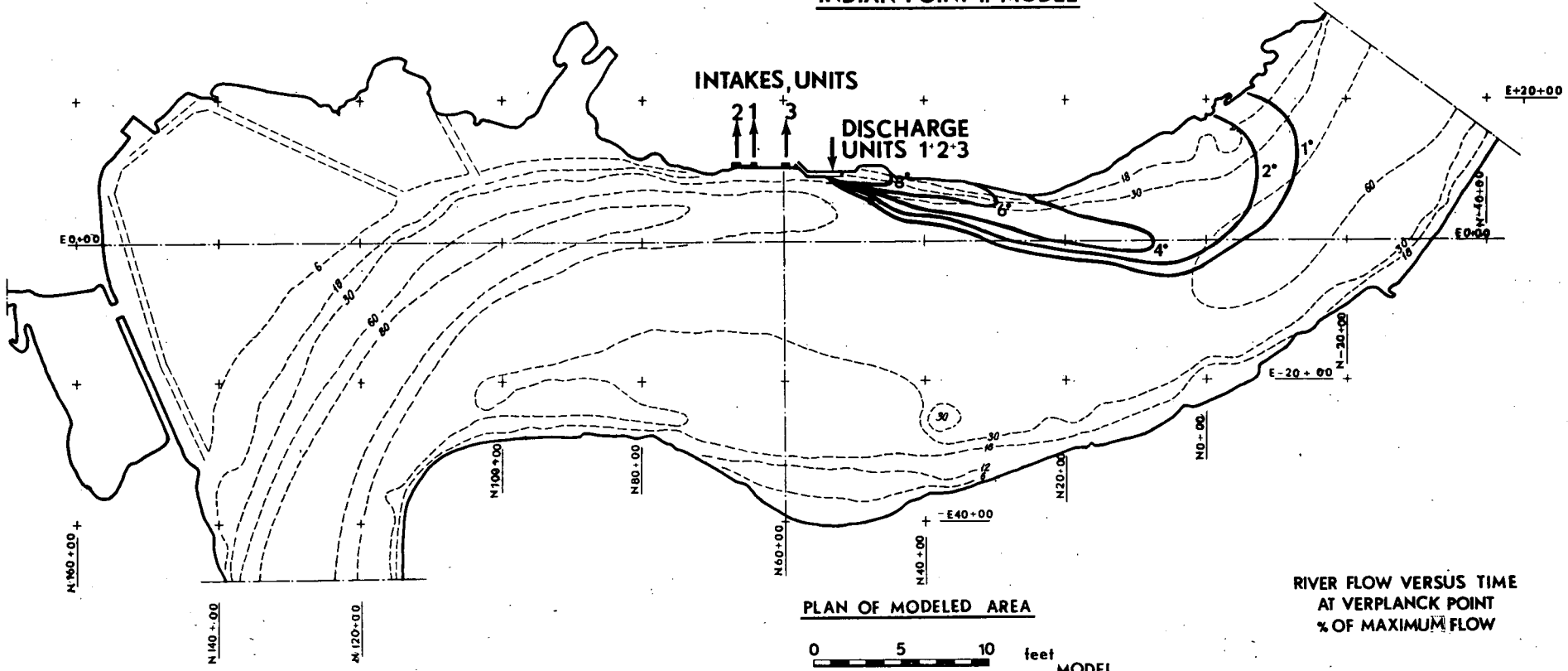

PLAN OF MODELED AREA

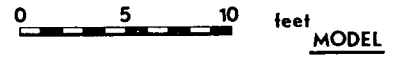

SCALES

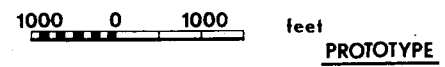

RIVER FLOW VERSUS TIME AT VERPLANCK POINT % OF MAXIMUM FLOW

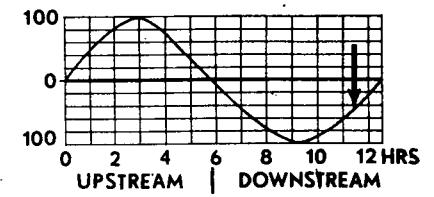

ARRANGEMENT OF OUTFALL STRUCTURE

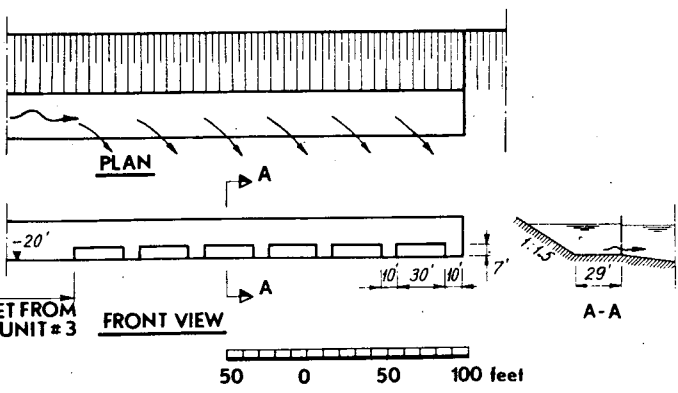

TEST CONDITIONS

TEST NUMBER AND DATE 522 ; 26 NOV , 1968
 UNITS OPERATING AND DISCHARGE 1,2,3 ; 4670 cfs
 DISCHARGE TEMPERATURE ABOVE AMBIENT RIVER 16.4°F
 TIME IN TIDE CYCLE SEE DIAGRAM
 RIVER AMBIENT TEMPERATURE 44°F
 AIR TEMPERATURE DRY BULB 46.4°F
 AIR TEMPERATURE WET BULB 39.5°F
 RELATIVE HUMIDITY 53%
 DEPTH OF ISOTHERMS 0 feet
 ISOTHERMS ARE DEGREES ABOVE AMBIENT RIVER TEMPERATURE

ALDEN RESEARCH LABORATORIES
 WORCESTER POLYTECHNIC INSTITUTE
 HYDRAULIC MODEL STUDIES
 FOR
 CONSOLIDATED EDISON COMPANY, N. Y.

INDIAN POINT II MODEL

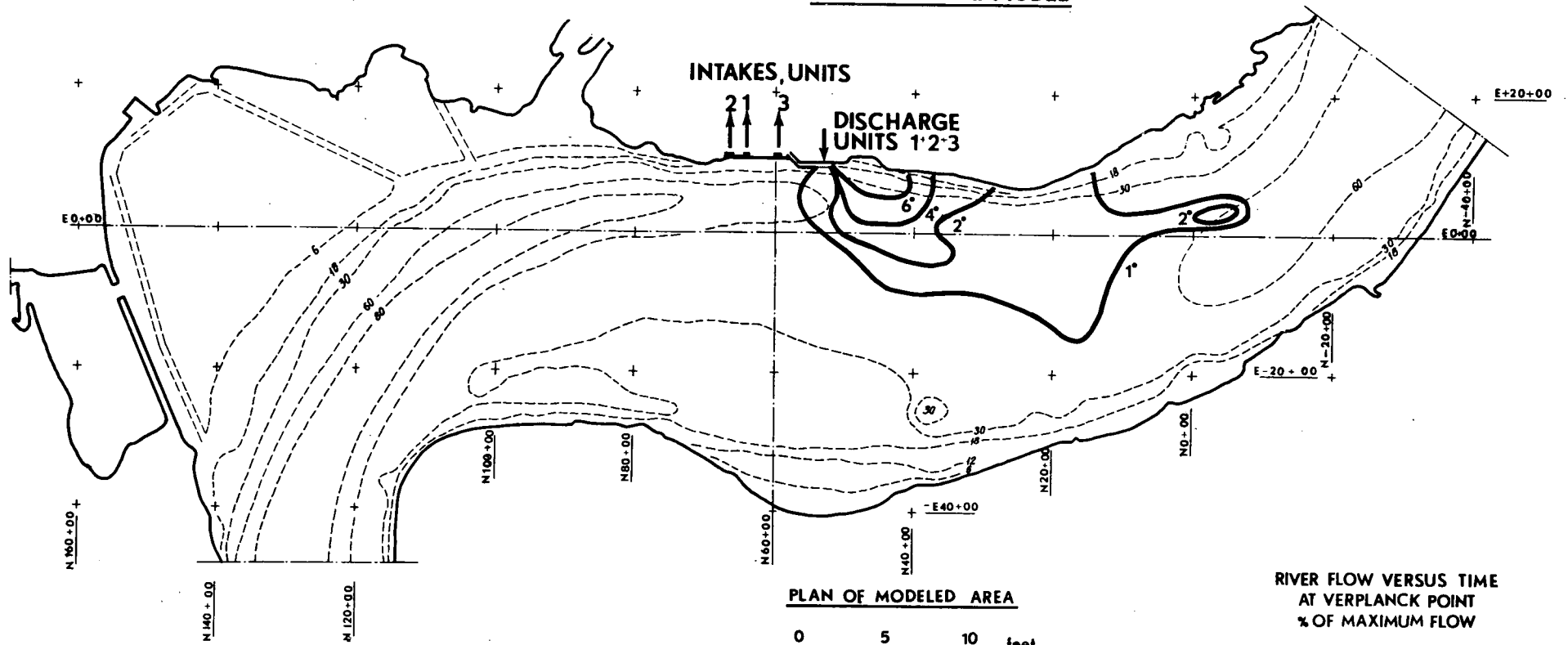

PLAN OF MODELED AREA

SCALES

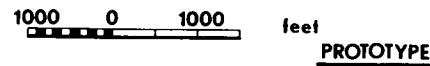

RIVER FLOW VERSUS TIME AT VERPLANCK POINT
% OF MAXIMUM FLOW

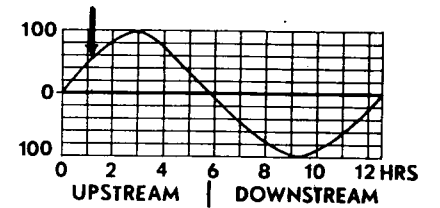

ARRANGEMENT OF OUTFALL STRUCTURE

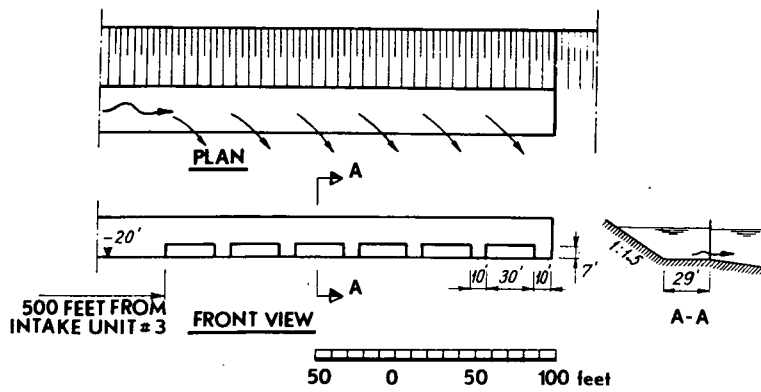

TEST CONDITIONS

TEST NUMBER AND DATE 525 ; NOV 27 , 1968
 UNITS OPERATING AND DISCHARGE 1,2,3 ; 4670 cfs
 DISCHARGE TEMPERATURE ABOVE AMBIENT RIVER 16.4°F
 TIME IN TIDE CYCLE SEE DIAGRAM
 RIVER AMBIENT TEMPERATURE 50 °F
 AIR TEMPERATURE DRY BULB 55 °F
 AIR TEMPERATURE WET BULB 49 °F
 RELATIVE HUMIDITY 62%
 DEPTH OF ISOTHERMS 6 feet
 ISOTHERMS ARE DEGREES ABOVE AMBIENT RIVER TEMPERATURE

ALDEN RESEARCH LABORATORIES
 WORCESTER POLYTECHNIC INSTITUTE
 HYDRAULIC MODEL STUDIES
 FOR
 CONSOLIDATED EDISON COMPANY, N. Y.

INDIAN POINT II MODEL

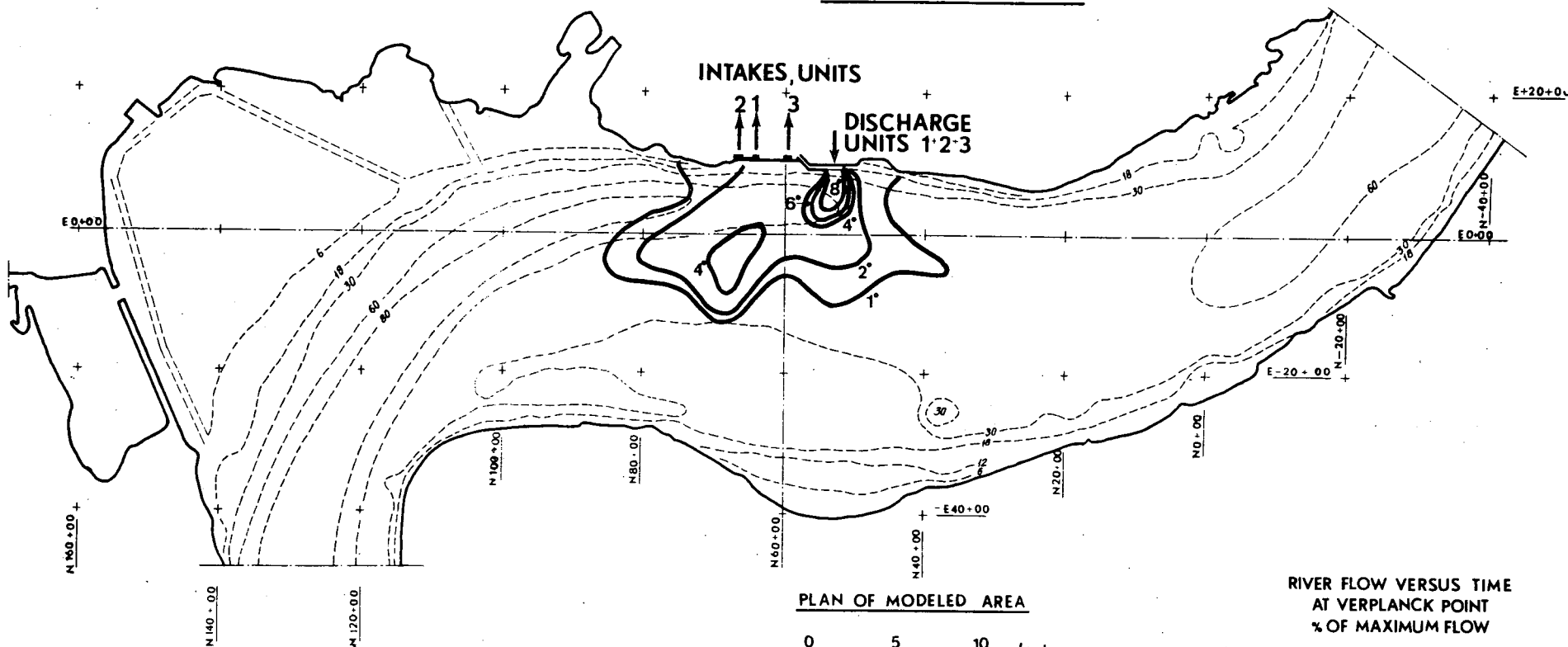

PLAN OF MODELED AREA



SCALES

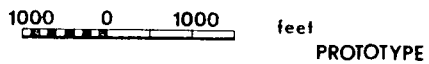

**RIVER FLOW VERSUS TIME
AT VERPLANCK POINT
% OF MAXIMUM FLOW**

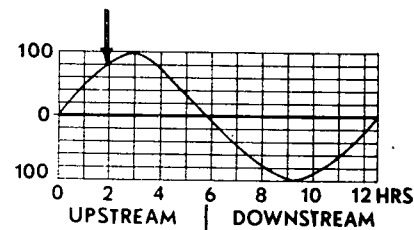

ARRANGEMENT OF OUTFALL STRUCTURE

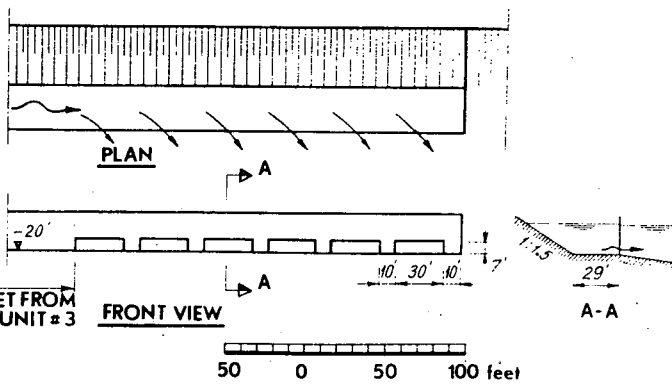

TEST CONDITIONS

TEST NUMBER AND DATE 525 ; NOV 27 , 1968
 UNITS OPERATING AND DISCHARGE 1,2,3 ; 4670 cfs
 DISCHARGE TEMPERATURE ABOVE AMBIENT RIVER 16.4°F
 TIME IN TIDE CYCLE SEE DIAGRAM
 RIVER AMBIENT TEMPERATURE 50 °F
 AIR TEMPERATURE DRY BULB 55 °F
 AIR TEMPERATURE WET BULB 49 °F
 RELATIVE HUMIDITY 62 %
 DEPTH OF ISOTHERMS 6 feet
 ISOTHERMS ARE DEGREES ABOVE AMBIENT RIVER TEMPERATURE

ALDEN RESEARCH LABORATORIES
 WORCESTER POLYTECHNIC INSTITUTE
 HYDRAULIC MODEL STUDIES
 FOR
 CONSOLIDATED EDISON COMPANY, N. Y.

INDIAN POINT II MODEL

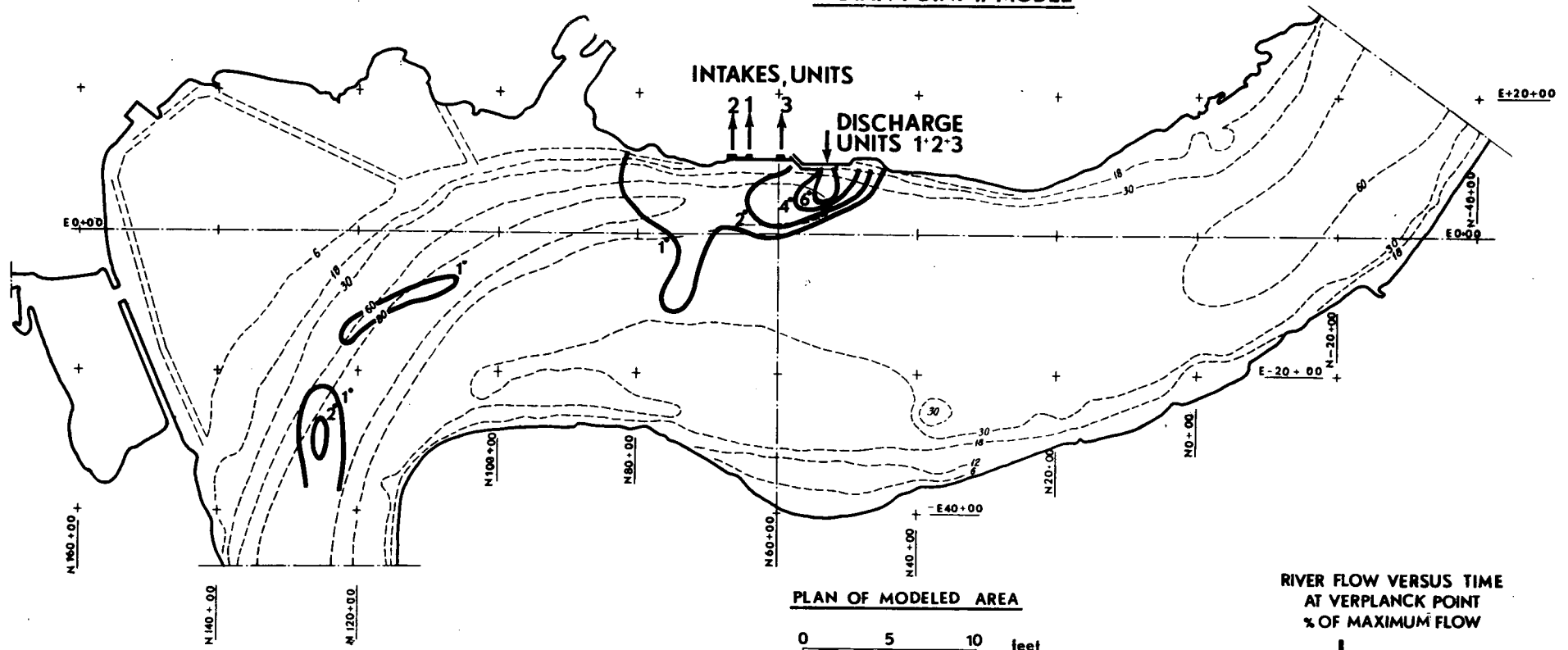

PLAN OF MODELED AREA



SCALES

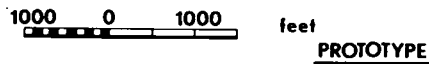

RIVER FLOW VERSUS TIME AT VERPLANCK POINT
% OF MAXIMUM FLOW

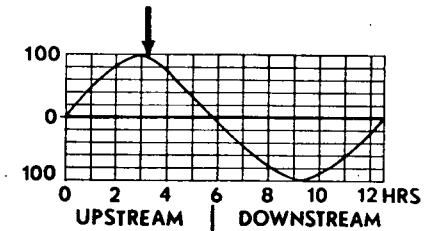

ARRANGEMENT OF OUTFALL STRUCTURE

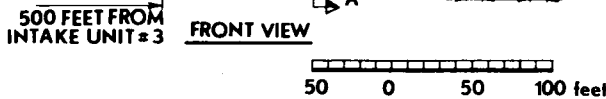
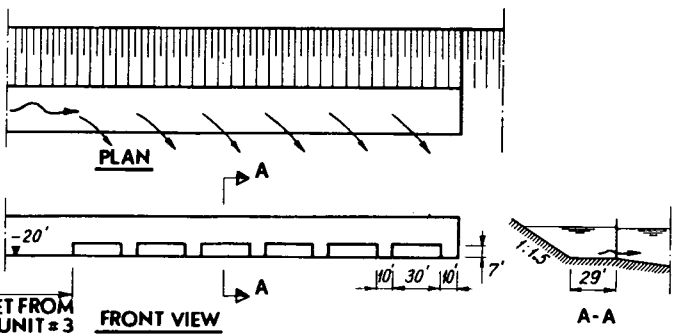

TEST CONDITIONS

TEST NUMBER AND DATE 525 ; NOV 27 , 1968
 UNITS OPERATING AND DISCHARGE 1,2,3 ; 4670 cfs
 DISCHARGE TEMPERATURE ABOVE AMBIENT RIVER 16.4 °F
 TIME IN TIDE CYCLE SEE DIAGRAM
 RIVER AMBIENT TEMPERATURE 50 °F
 AIR TEMPERATURE DRY BULB 55 °F
 AIR TEMPERATURE WET BULB 49 °F
 RELATIVE HUMIDITY 62 %
 DEPTH OF ISOTHERMS 6 feet
 ISOTHERMS ARE DEGREES ABOVE AMBIENT RIVER TEMPERATURE

ALDEN RESEARCH LABORATORIES
 WORCESTER POLYTECHNIC INSTITUTE
 HYDRAULIC MODEL STUDIES
 FOR
 CONSOLIDATED EDISON COMPANY, N. Y.

INDIAN POINT II MODEL

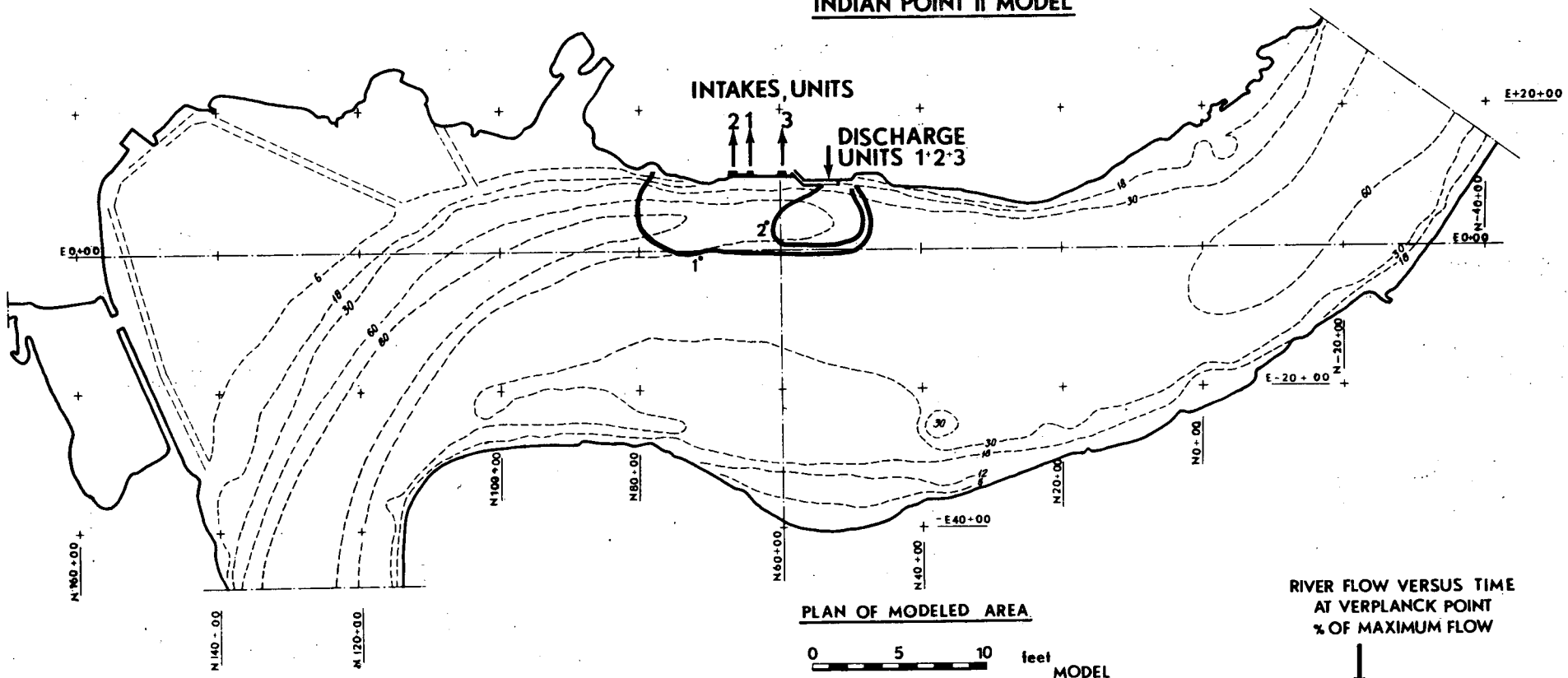

PLAN OF MODELED AREA



SCALES

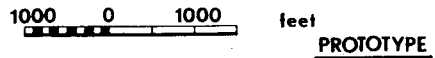

**RIVER FLOW VERSUS TIME AT VERPLANCK POINT
% OF MAXIMUM FLOW**

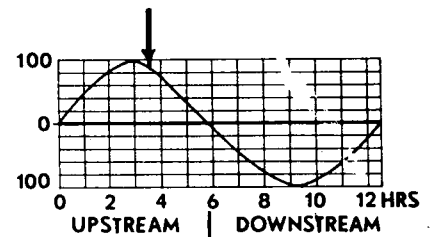

ARRANGEMENT OF OUTFALL STRUCTURE

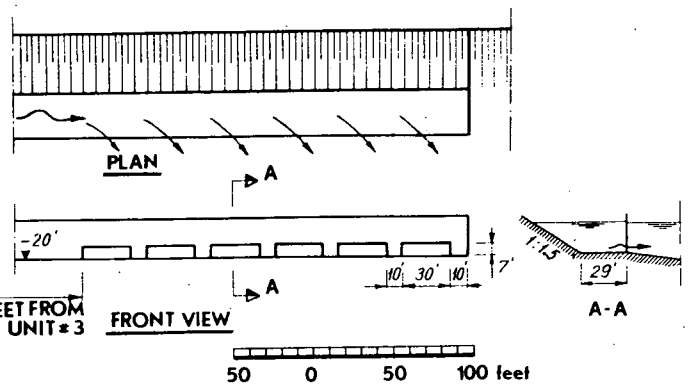

TEST CONDITIONS

TEST NUMBER AND DATE 525 ; NOV 27 ,1968
 UNITS OPERATING AND DISCHARGE 1,2,3; 4670 cfs
 DISCHARGE TEMPERATURE ABOVE AMBIENT RIVER 16.4°F
 TIME IN TIDE CYCLE SEE DIAGRAM
 RIVER AMBIENT TEMPERATURE 50 °F
 AIR TEMPERATURE DRY BULB 55 °F
 AIR TEMPERATURE WET BULB 49 °F
 RELATIVE HUMIDITY 62 %
 DEPTH OF ISOTHERMS 6 feet
 ISOTHERMS ARE DEGREES ABOVE AMBIENT RIVER TEMPERATURE

ALDEN RESEARCH LABORATORIES
 WORCESTER POLYTECHNIC INSTITUTE
 HYDRAULIC MODEL STUDIES
 FOR
 CONSOLIDATED EDISON COMPANY, N.Y.

INDIAN POINT II MODEL

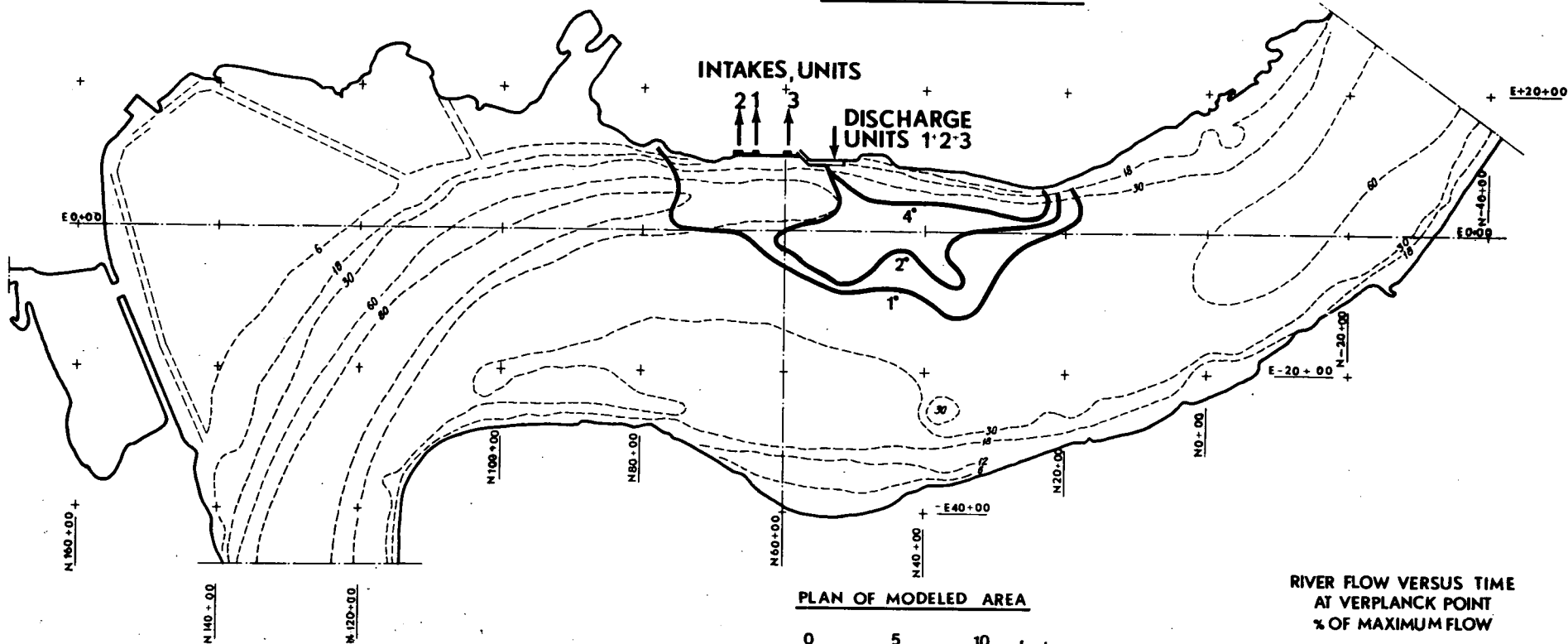

PLAN OF MODELED AREA

SCALES

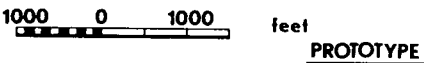

RIVER FLOW VERSUS TIME
AT VERPLANCK POINT
% OF MAXIMUM FLOW

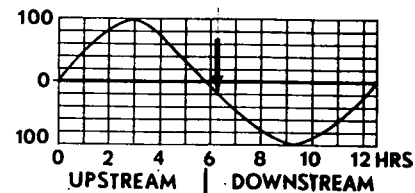

ARRANGEMENT OF OUTFALL STRUCTURE

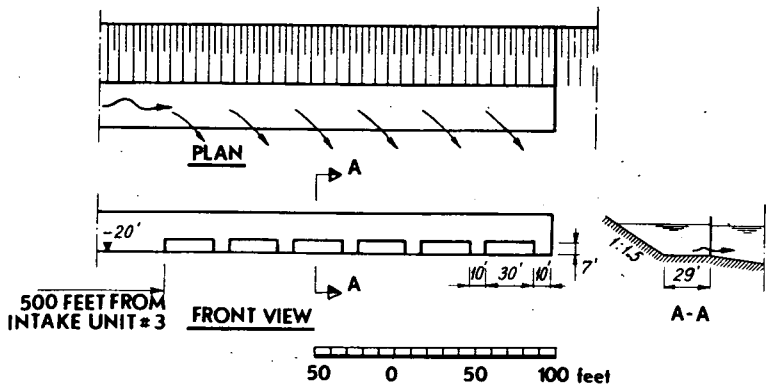

TEST CONDITIONS

TEST NUMBER AND DATE 525 ; NOV 27, 1968
 UNITS OPERATING AND DISCHARGE 1,2,3 ; 4670 cfs
 DISCHARGE TEMPERATURE ABOVE AMBIENT RIVER 16.4°F
 TIME IN TIDE CYCLE SEE DIAGRAM
 RIVER AMBIENT TEMPERATURE 50 °F
 AIR TEMPERATURE DRY BULB 55 °F
 AIR TEMPERATURE WET BULB 49 °F
 RELATIVE HUMIDITY 62 %
 DEPTH OF ISOTHERMS 6 feet
 ISOTHERMS ARE DEGREES ABOVE AMBIENT RIVER TEMPERATURE

ALDEN RESEARCH LABORATORIES
 WORCESTER POLYTECHNIC INSTITUTE
 HYDRAULIC MODEL STUDIES
 FOR
 CONSOLIDATED EDISON COMPANY, N. Y.

INDIAN POINT II MODEL

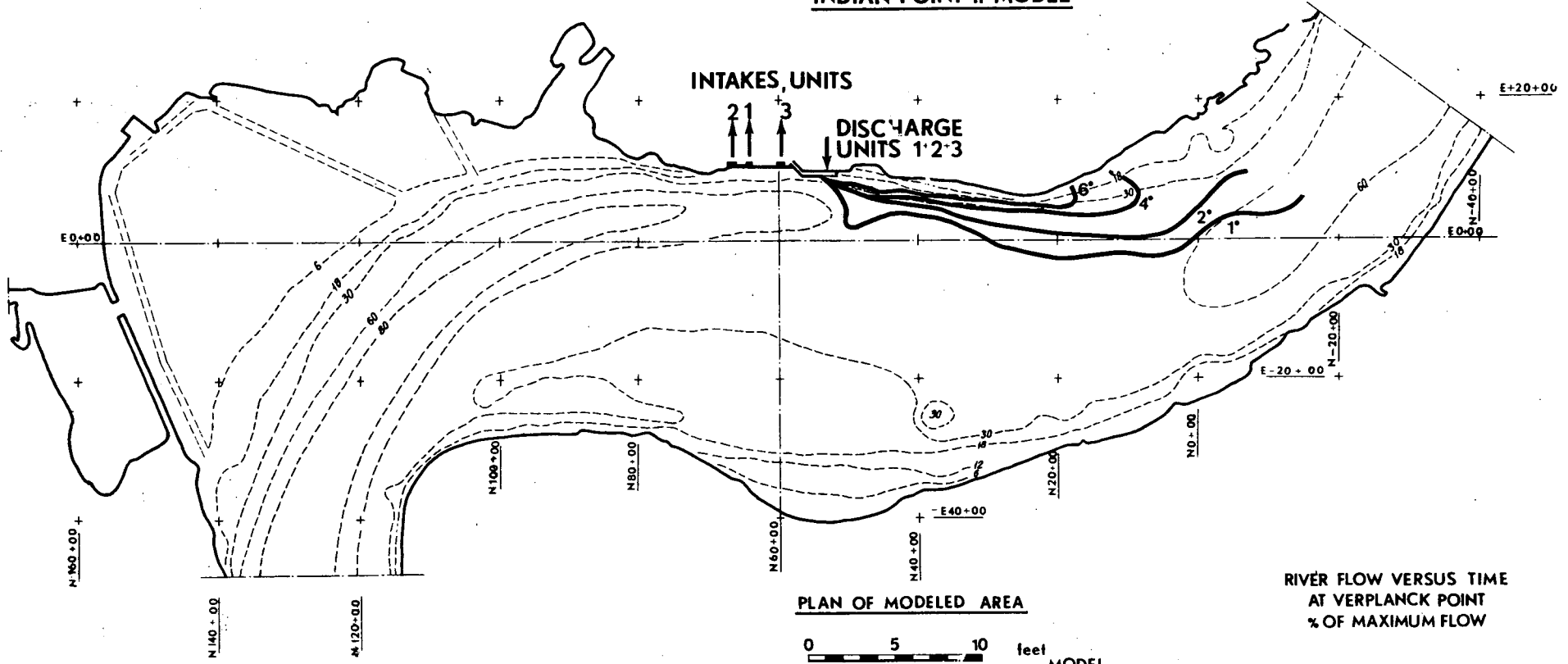

PLAN OF MODELED AREA



SCALES

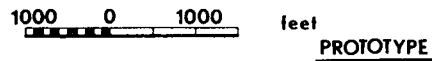

**RIVER FLOW VERSUS TIME AT VERPLANCK POINT
% OF MAXIMUM FLOW**

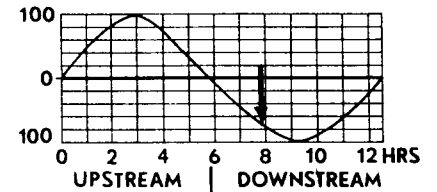

ARRANGEMENT OF OUTFALL STRUCTURE

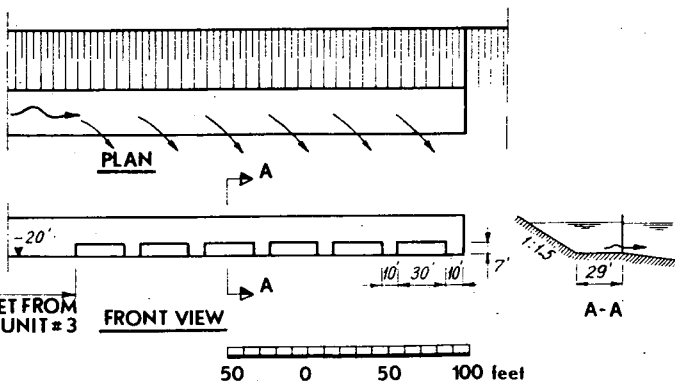

TEST CONDITIONS

TEST NUMBER AND DATE 525 ; NOV 27 ,1968
 UNITS OPERATING AND DISCHARGE 1,2,3 ; 4670 cfs
 DISCHARGE TEMPERATURE ABOVE AMBIENT RIVER 16.4 °F
 TIME IN TIDE CYCLE SEE DIAGRAM
 RIVER AMBIENT TEMPERATURE 50 °F
 AIR TEMPERATURE DRY BULB 55 °F
 AIR TEMPERATURE WET BULB 49 °F
 RELATIVE HUMIDITY 62 %
 DEPTH OF ISOTHERMS 6 feet
 ISOTHERMS ARE DEGREES ABOVE AMBIENT RIVER TEMPERATURE

ALDEN RESEARCH LABORATORIES
 WORCESTER POLYTECHNIC INSTITUTE
 HYDRAULIC MODEL STUDIES
 FOR
 CONSOLIDATED EDISON COMPANY, N. Y.

INDIAN POINT II MODEL

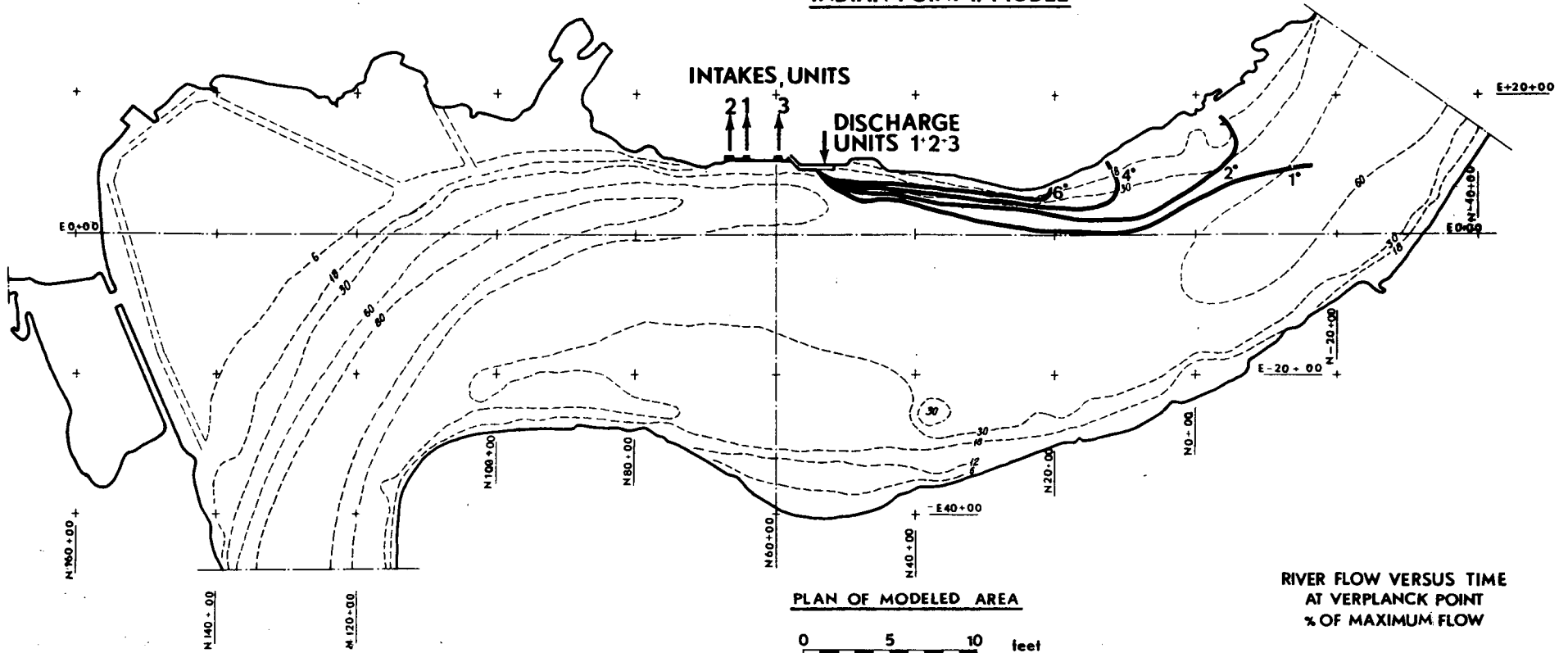

PLAN OF MODELED AREA



SCALES

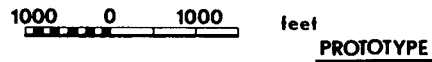

**RIVER FLOW VERSUS TIME AT VERPLANCK POINT
% OF MAXIMUM FLOW**

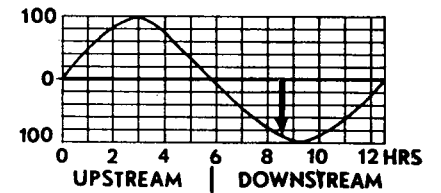

ARRANGEMENT OF OUTFALL STRUCTURE

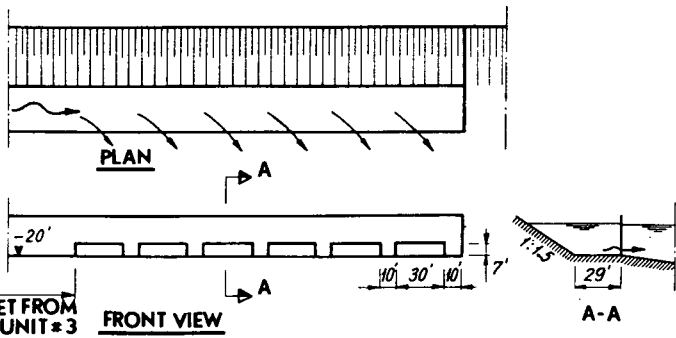

500 FEET FROM INTAKE UNIT #3

FRONT VIEW

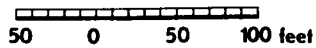

TEST CONDITIONS

TEST NUMBER AND DATE 525 ; NOV 27, 1968
 UNITS OPERATING AND DISCHARGE 1,2,3 ; 4670 cfs
 DISCHARGE TEMPERATURE ABOVE AMBIENT RIVER 16.4 °F
 TIME IN TIDE CYCLE SEE DIAGRAM
 RIVER AMBIENT TEMPERATURE 50 °F
 AIR TEMPERATURE DRY BULB 55 °F
 AIR TEMPERATURE WET BULB 49 °F
 RELATIVE HUMIDITY 62 %
 DEPTH OF ISOTHERMS 6 feet
 ISOTHERMS ARE DEGREES ABOVE AMBIENT RIVER TEMPERATURE

ALDEN RESEARCH LABORATORIES
 WORCESTER POLYTECHNIC INSTITUTE
 HYDRAULIC MODEL STUDIES
 FOR
 CONSOLIDATED EDISON COMPANY, N. Y.

INDIAN POINT II MODEL

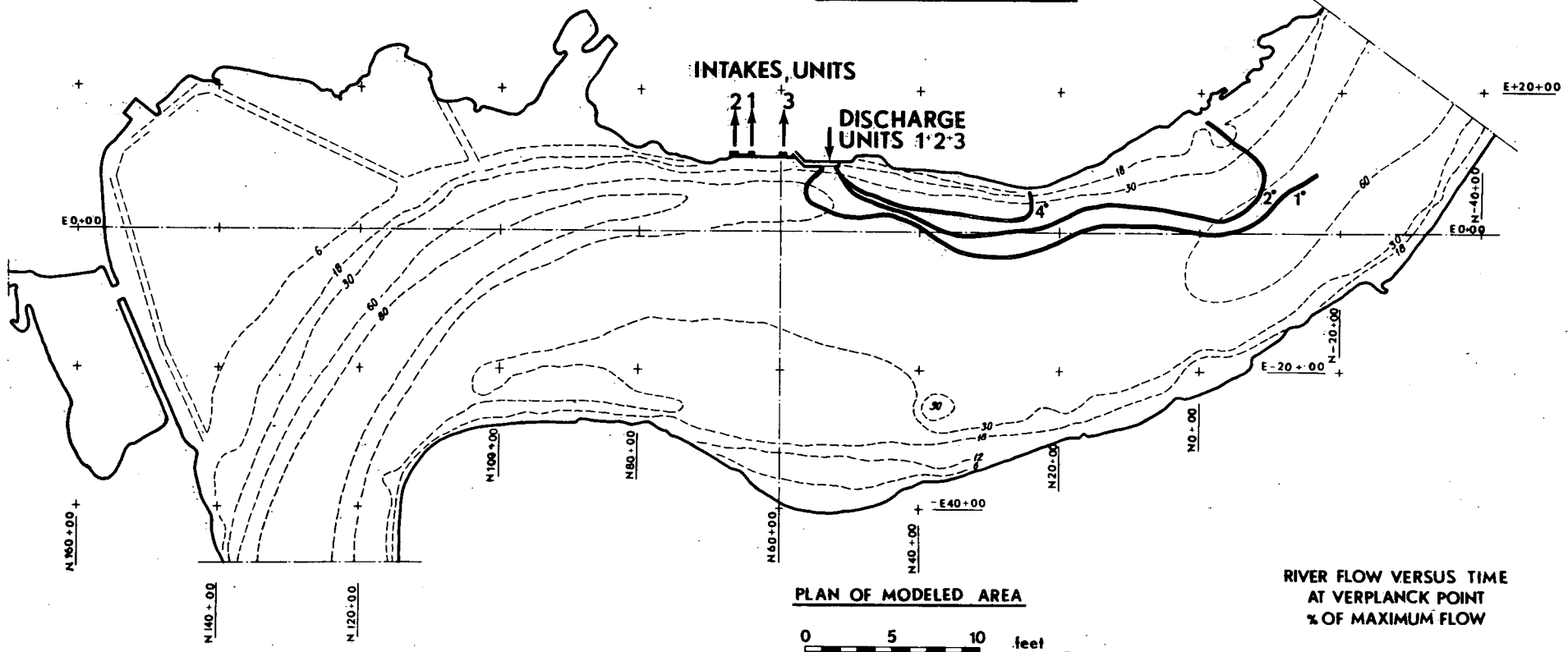

PLAN OF MODELED AREA

SCALES

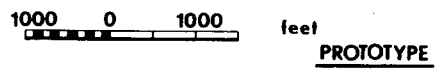

**RIVER FLOW VERSUS TIME AT VERPLANCK POINT
% OF MAXIMUM FLOW**

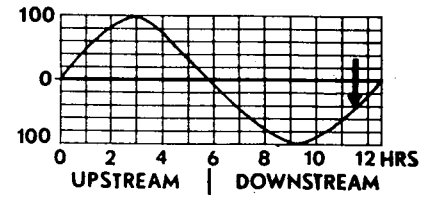

ARRANGEMENT OF OUTFALL STRUCTURE

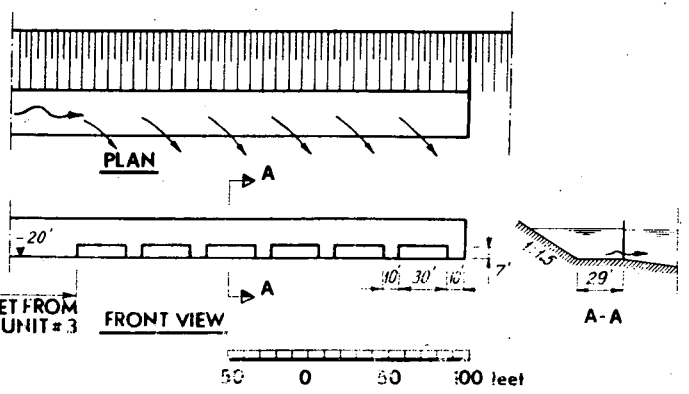

TEST CONDITIONS

TEST NUMBER AND DATE 525 ; NOV 27, 1968
 UNITS OPERATING AND DISCHARGE 1,2,3 ; 4670 cfs
 DISCHARGE TEMPERATURE ABOVE AMBIENT RIVER 16.4°F
 TIME IN TIDE CYCLE SEE DIAGRAM
 RIVER AMBIENT TEMPERATURE 50 °F
 AIR TEMPERATURE DRY BULB 55 °F
 AIR TEMPERATURE WET BULB 49 °F
 RELATIVE HUMIDITY 62 %
 DEPTH OF ISOTHERMS 6 feet
 ISOTHERMS ARE DEGREES ABOVE AMBIENT RIVER TEMPERATURE

ALDEN RESEARCH LABORATORIES
 WORCESTER POLYTECHNIC INSTITUTE
 HYDRAULIC MODEL STUDIES
 FOR
 CONSOLIDATED EDISON COMPANY, N. Y.

INDIAN POINT II MODEL

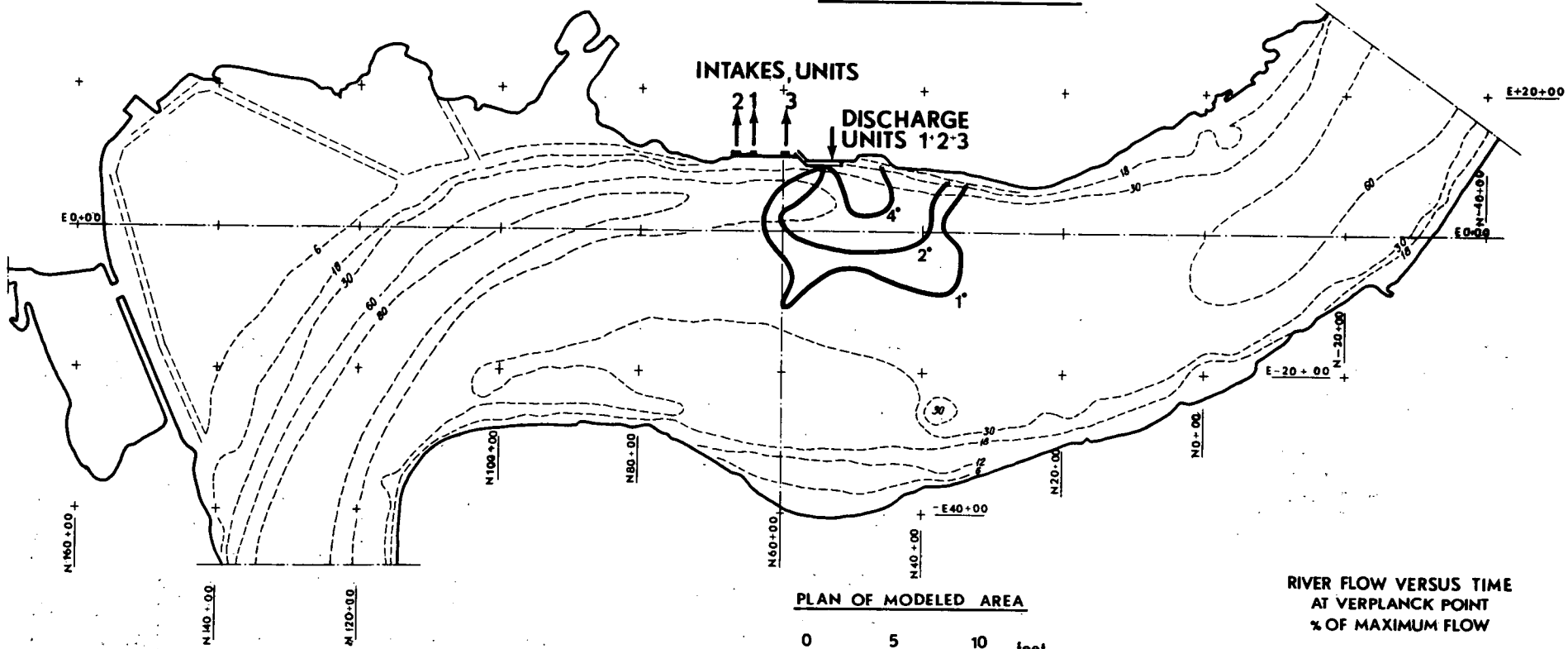

PLAN OF MODELED AREA



SCALES

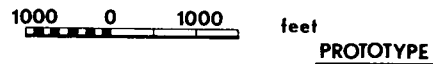

**RIVER FLOW VERSUS TIME AT VERPLANCK POINT
% OF MAXIMUM FLOW**

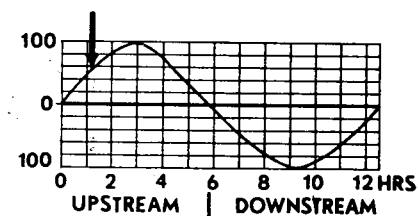

ARRANGEMENT OF OUTFALL STRUCTURE

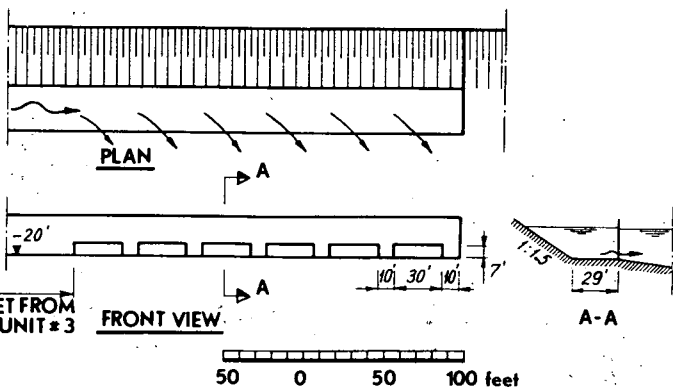

TEST CONDITIONS

TEST NUMBER AND DATE 527 ; NOV 27 ,1968
 UNITS OPERATING AND DISCHARGE 1,2,3 ; 4670 cfs
 DISCHARGE TEMPERATURE ABOVE AMBIENT RIVER 16.4°F
 TIME IN TIDE CYCLE SEE DIAGRAM
 RIVER AMBIENT TEMPERATURE 51 °F
 AIR TEMPERATURE DRY BULB 52.9°F
 AIR TEMPERATURE WET BULB 48.0°F
 RELATIVE HUMIDITY 70 %
 DEPTH OF ISOTHERMS 12 feet
 ISOTHERMS ARE DEGREES ABOVE AMBIENT RIVER TEMPERATURE

ALDEN RESEARCH LABORATORIES
 WORCESTER POLYTECHNIC INSTITUTE
 HYDRAULIC MODEL STUDIES
 FOR
 CONSOLIDATED EDISON COMPANY, N. Y.

INDIAN POINT II MODEL

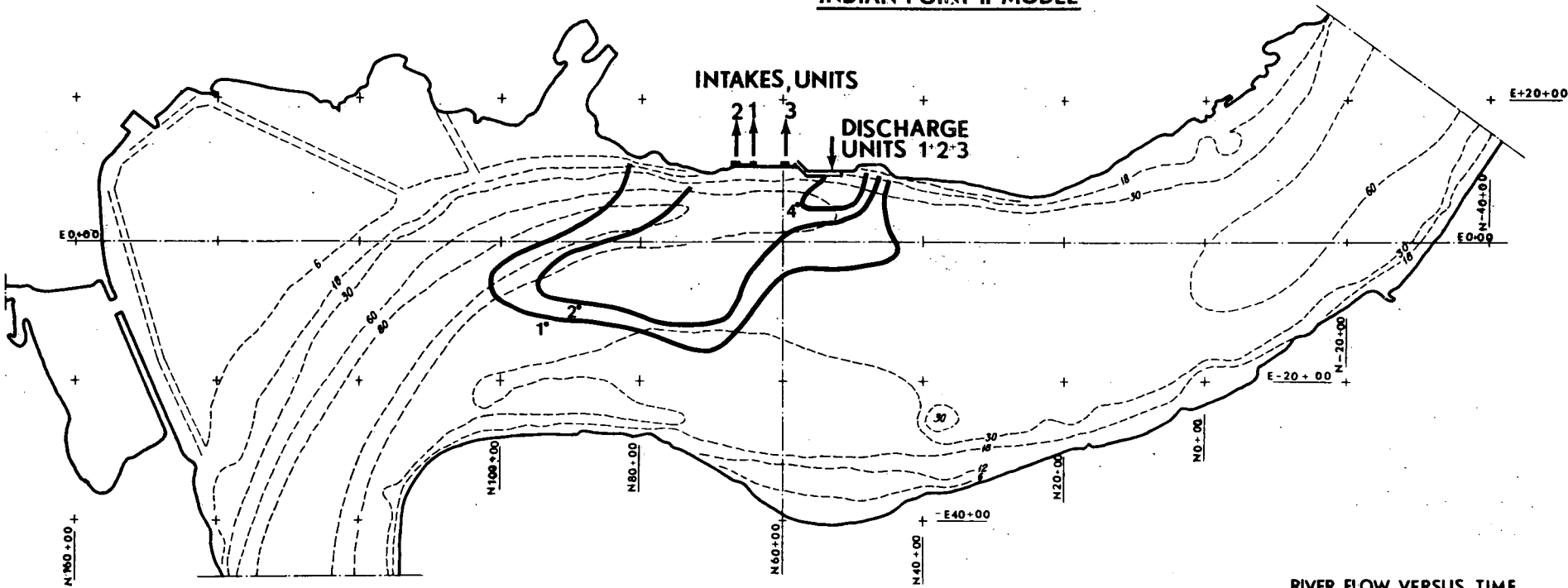

PLAN OF MODELED AREA



SCALES



**RIVER FLOW VERSUS TIME AT VERPLANCK POINT
% OF MAXIMUM FLOW**

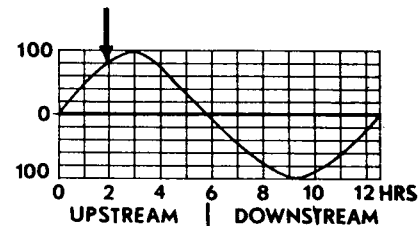

ARRANGEMENT OF OUTFALL STRUCTURE

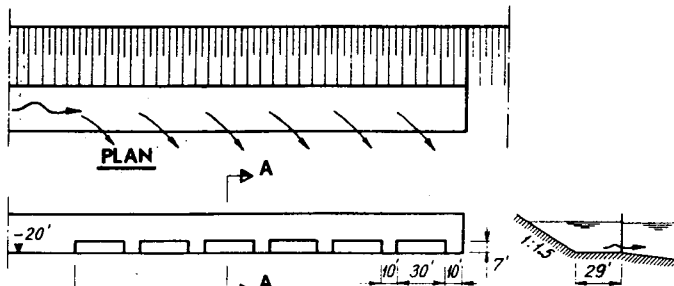

TEST CONDITIONS

TEST NUMBER AND DATE 527 ; NOV 27 ,1968.
 UNITS OPERATING AND DISCHARGE 1,2,3 ; 4670 cfs
 DISCHARGE TEMPERATURE ABOVE AMBIENT RIVER 16.4 °F
 TIME IN TIDE CYCLE SEE DIAGRAM
 RIVER AMBIENT TEMPERATURE 51 °F
 AIR TEMPERATURE DRY BULB 52.9 °F
 AIR TEMPERATURE WET BULB 48.0 °F
 RELATIVE HUMIDITY 70%
 DEPTH OF ISOTHERMS 12 feet
 ISOTHERMS ARE DEGREES ABOVE AMBIENT RIVER TEMPERATURE

ALDEN RESEARCH LABORATORIES
 WORCESTER POLYTECHNIC INSTITUTE
 HYDRAULIC MODEL STUDIES
 FOR
 CONSOLIDATED EDISON COMPANY, N. Y.

INDIAN POINT II MODEL

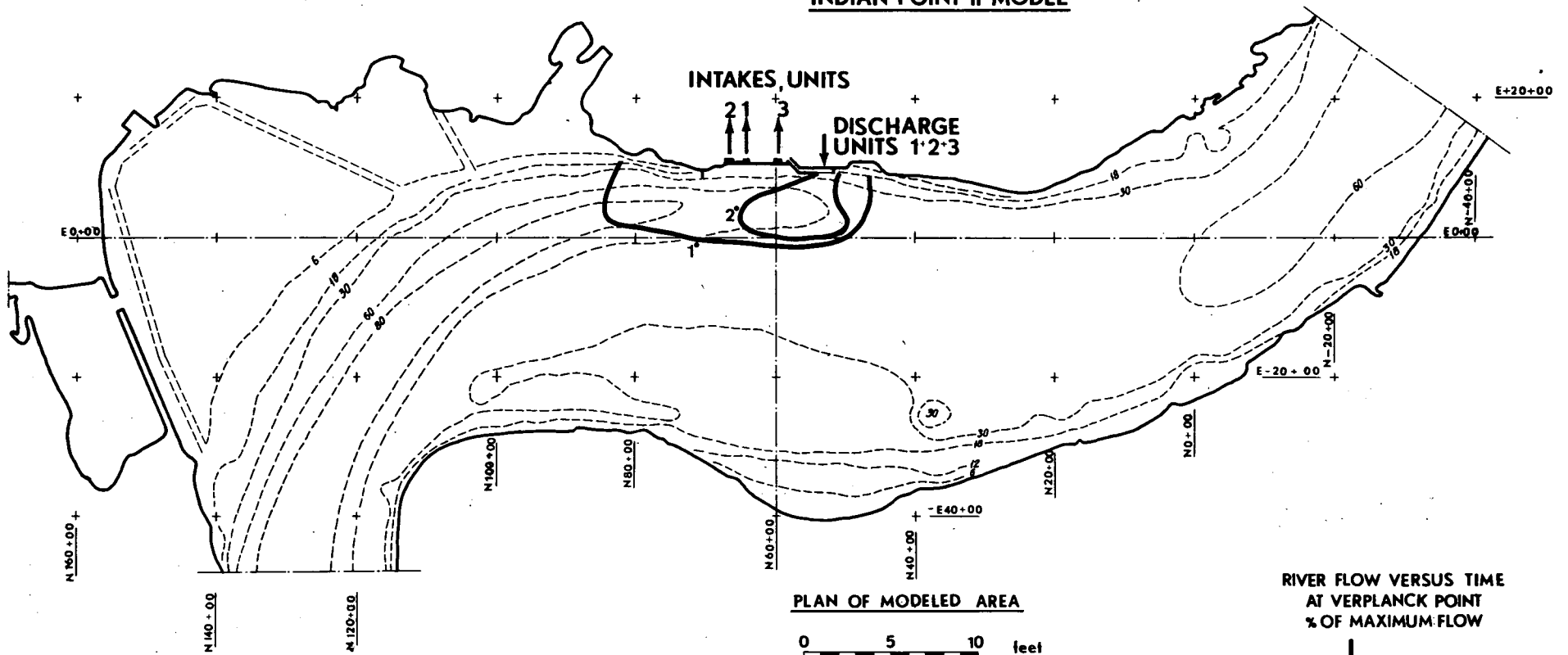

PLAN OF MODELED AREA

SCALES

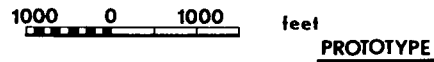
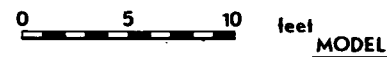

**RIVER FLOW VERSUS TIME AT VERPLANCK POINT
% OF MAXIMUM FLOW**

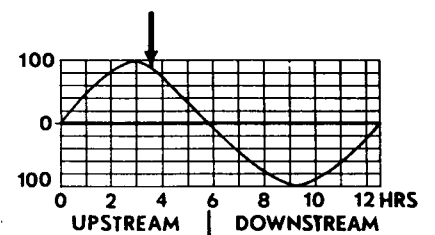

ARRANGEMENT OF OUTFALL STRUCTURE

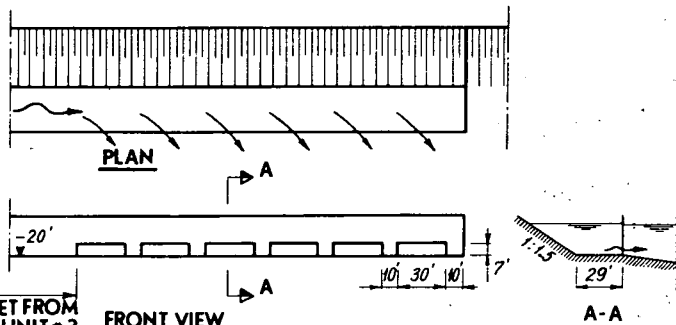

500 FEET FROM INTAKE UNIT #3

FRONT VIEW

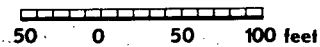

TEST CONDITIONS

TEST NUMBER AND DATE 527 ; NOV 27 , 1968
 UNITS OPERATING AND DISCHARGE 1,2,3 ; 4670 cfs
 DISCHARGE TEMPERATURE ABOVE AMBIENT RIVER 16.4°F
 TIME IN TIDE CYCLE SEE DIAGRAM
 RIVER AMBIENT TEMPERATURE 51.0°F
 AIR TEMPERATURE DRY BULB 52.9°F
 AIR TEMPERATURE WET BULB 48.0°F
 RELATIVE HUMIDITY 70 %
 DEPTH OF ISOTHERMS 12 feet
 ISOTHERMS ARE DEGREES ABOVE AMBIENT RIVER TEMPERATURE

ALDEN RESEARCH LABORATORIES
 WORCESTER POLYTECHNIC INSTITUTE
 HYDRAULIC MODEL STUDIES
 FOR
 CONSOLIDATED EDISON COMPANY, N. Y.

INDIAN POINT II MODEL

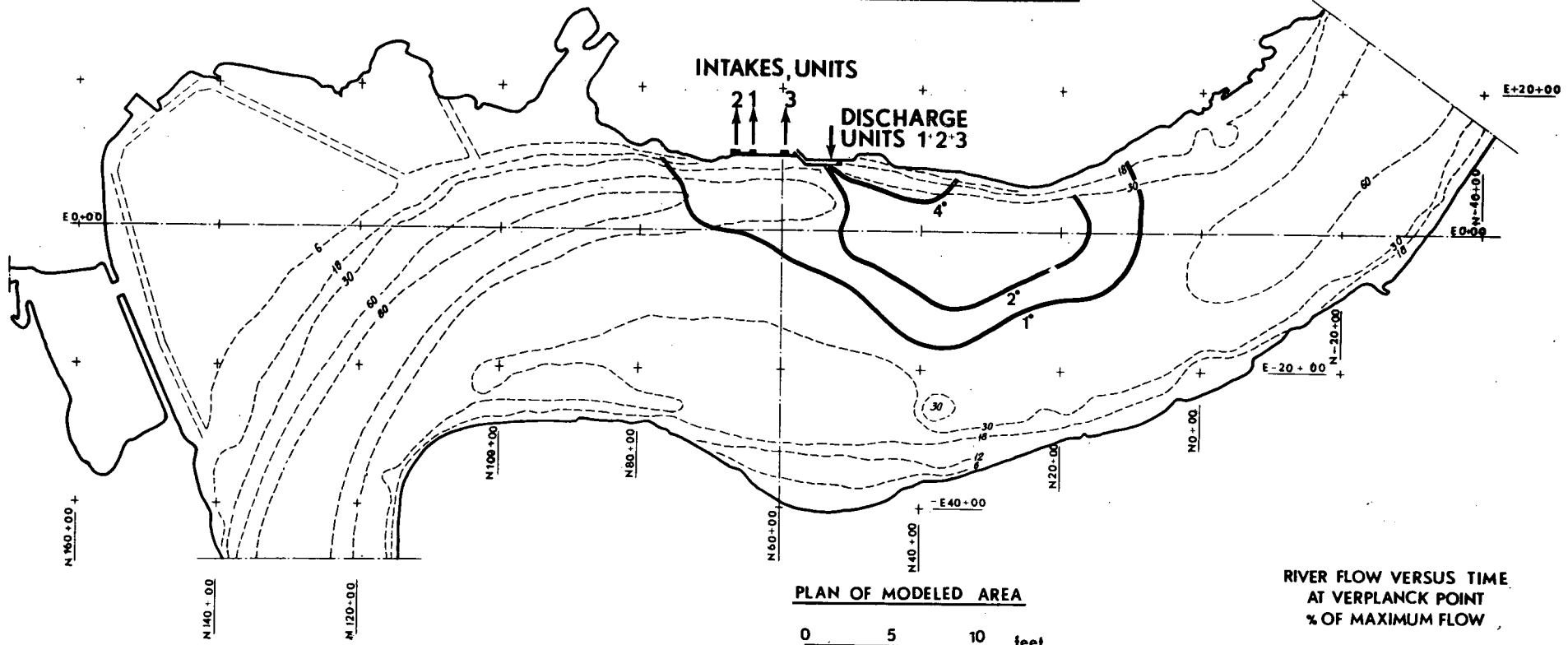

PLAN OF MODELED AREA



MODEL

SCALES

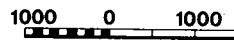

PROTOTYPE

**RIVER FLOW VERSUS TIME AT VERPLANCK POINT
% OF MAXIMUM FLOW**

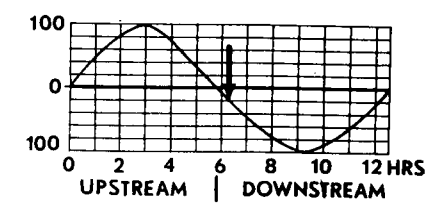

ARRANGEMENT OF OUTFALL STRUCTURE

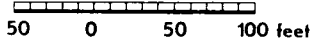
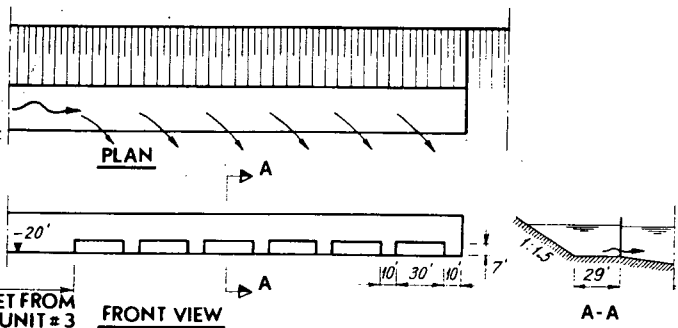

TEST CONDITIONS

TEST NUMBER AND DATE 527 ; NOV 27 ,1968
 UNITS OPERATING AND DISCHARGE 1,2,3; 4670 cfs
 DISCHARGE TEMPERATURE ABOVE AMBIENT RIVER 16.4°F
 TIME IN TIDE CYCLE SEE DIAGRAM
 RIVER AMBIENT TEMPERATURE 51 °F
 AIR TEMPERATURE DRY BULB 52.9°F
 AIR TEMPERATURE WET BULB 48.0°F
 RELATIVE HUMIDITY 70 %
 DEPTH OF ISOTHERMS 12 feet
 ISOTHERMS ARE DEGREES ABOVE AMBIENT RIVER TEMPERATURE

ALDEN RESEARCH LABORATORIES
 WORCESTER POLYTECHNIC INSTITUTE
 HYDRAULIC MODEL STUDIES
 FOR
 CONSOLIDATED EDISON COMPANY, N. Y.

INDIAN POINT II MODEL

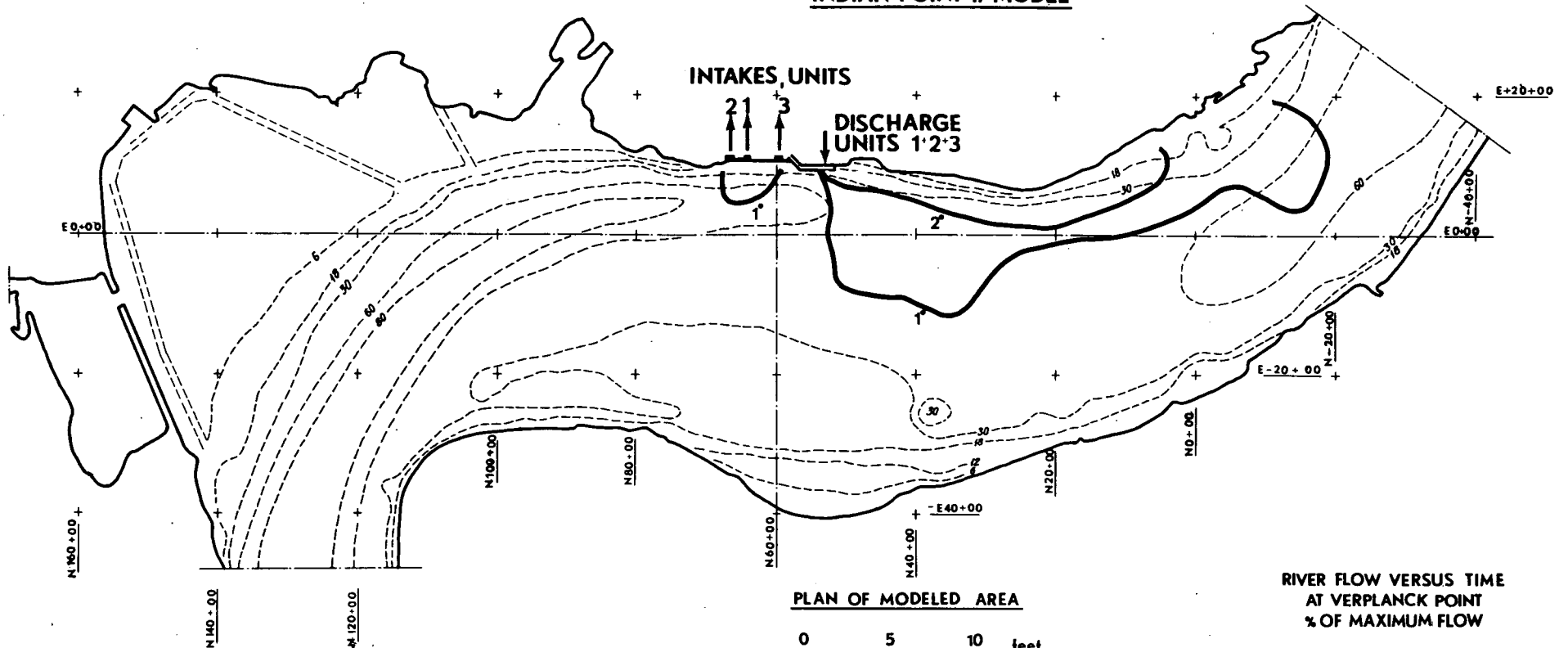

PLAN OF MODELED AREA



SCALES

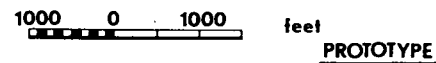

RIVER FLOW VERSUS TIME
AT VERPLANCK POINT
% OF MAXIMUM FLOW

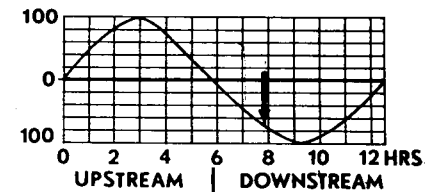

ARRANGEMENT OF OUTFALL STRUCTURE

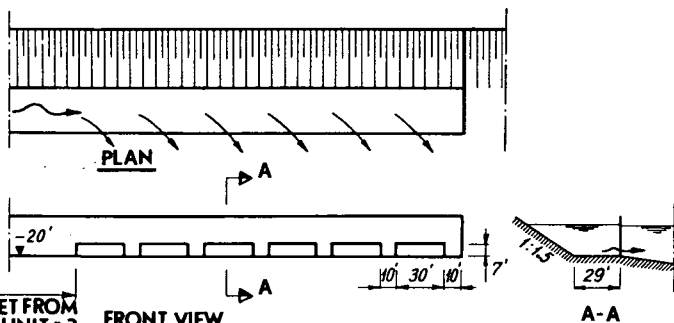

500 FEET FROM
INTAKE UNIT #3

FRONT VIEW

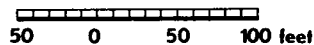

TEST CONDITIONS

TEST NUMBER AND DATE: 527 ; NOV 27, 1968
 UNITS OPERATING AND DISCHARGE: 1,2,3 ; 4670 cfs
 DISCHARGE TEMPERATURE ABOVE AMBIENT RIVER: 16.4°F
 TIME IN TIDE CYCLE: SEE DIAGRAM
 RIVER AMBIENT TEMPERATURE: 51.0°F
 AIR TEMPERATURE DRY BULB: 52.9°F
 AIR TEMPERATURE WET BULB: 48.0°F
 RELATIVE HUMIDITY: 70 %
 DEPTH OF ISOTHERMS: 12 feet
 ISOTHERMS ARE DEGREES ABOVE AMBIENT RIVER TEMPERATURE

ALDEN RESEARCH LABORATORIES
 WORCESTER POLYTECHNIC INSTITUTE
 HYDRAULIC MODEL STUDIES
 FOR
 CONSOLIDATED EDISON COMPANY, N.Y.

INDIAN POINT II MODEL

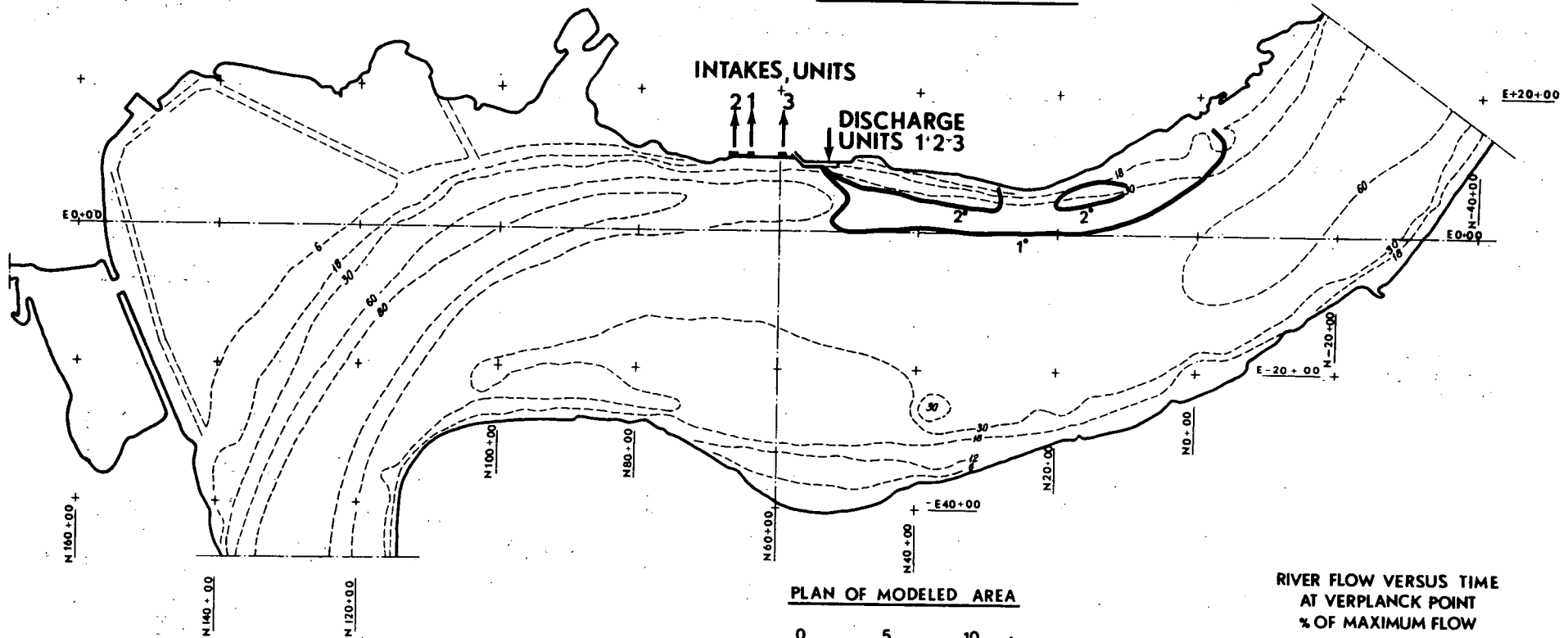

PLAN OF MODELED AREA



MODEL

SCALES

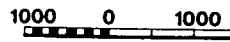

PROTOTYPE

RIVER FLOW VERSUS TIME AT VERPLANCK POINT % OF MAXIMUM FLOW

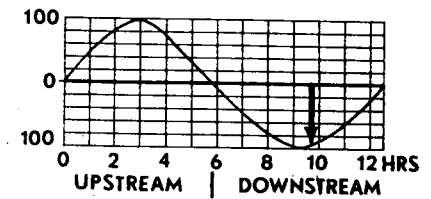

ARRANGEMENT OF OUTFALL STRUCTURE

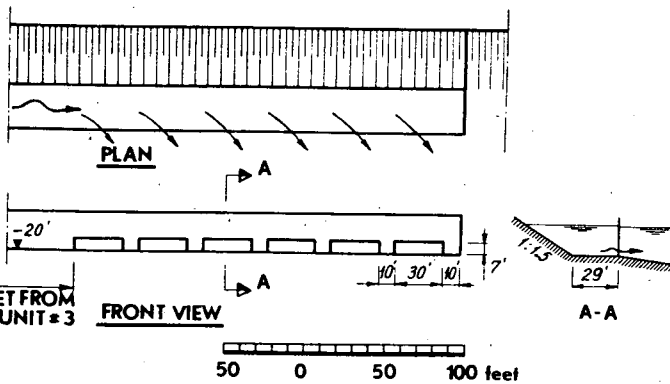

TEST CONDITIONS

TEST NUMBER AND DATE 527 NOV. 27, 1968
 UNITS OPERATING AND DISCHARGE 1,2,3; 4670 cfs
 DISCHARGE TEMPERATURE ABOVE AMBIENT RIVER 16.4°F
 TIME IN TIDE CYCLE SEE DIAGRAM
 RIVER AMBIENT TEMPERATURE 51.0°F
 AIR TEMPERATURE DRY BULB 52.9°F
 AIR TEMPERATURE WET BULB 48.0°F
 RELATIVE HUMIDITY 70 %
 DEPTH OF ISOTHERMS 12 feet
 ISOTHERMS ARE DEGREES ABOVE AMBIENT RIVER TEMPERATURE

ALDEN RESEARCH LABORATORIES
 WORCESTER POLYTECHNIC INSTITUTE
 HYDRAULIC MODEL STUDIES
 FOR
 CONSOLIDATED EDISON COMPANY, N. Y.

INDIAN POINT II MODEL

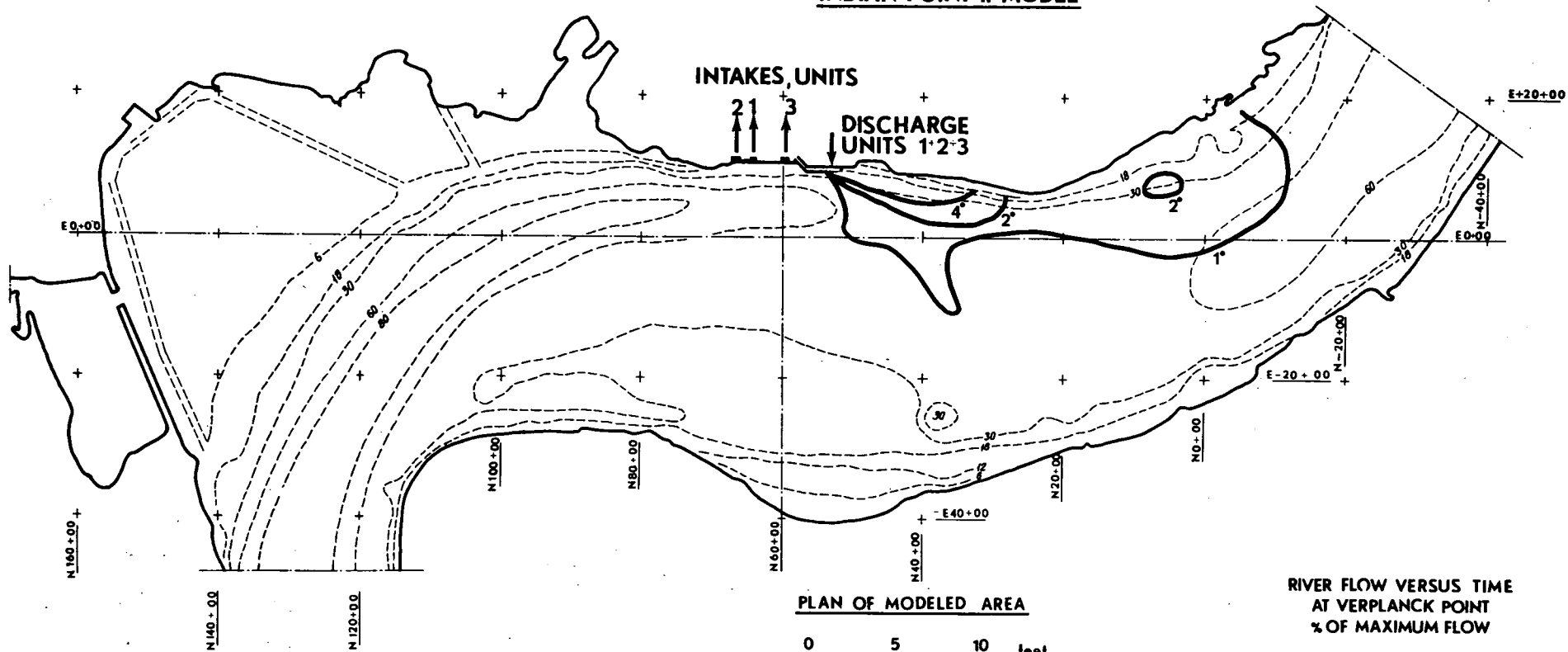

PLAN OF MODELED AREA



SCALES

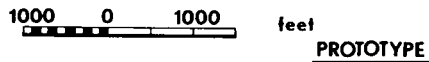

RIVER FLOW VERSUS TIME
AT VERPLANCK POINT
% OF MAXIMUM FLOW

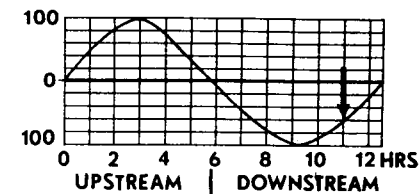

ARRANGEMENT OF OUTFALL STRUCTURE

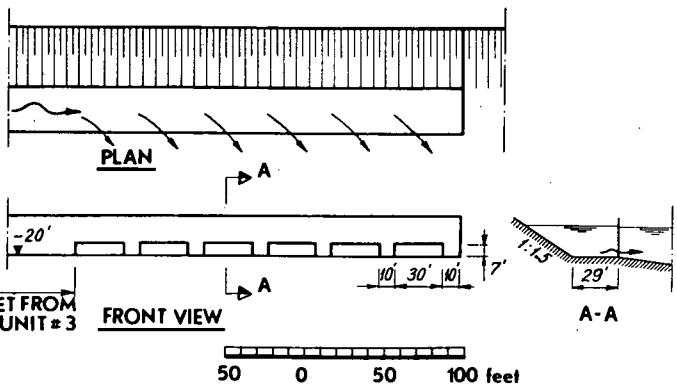

TEST CONDITIONS

TEST NUMBER AND DATE 527 ; NOV 27 , 1968
 UNITS OPERATING AND DISCHARGE 1,2,3 ; 4670 cfs
 DISCHARGE TEMPERATURE ABOVE AMBIENT RIVER 16.4°F
 TIME IN TIDE CYCLE SEE DIAGRAM
 RIVER AMBIENT TEMPERATURE 51 °F
 AIR TEMPERATURE DRY BULB 52.9 °F
 AIR TEMPERATURE WET BULB 48.0 °F
 RELATIVE HUMIDITY 70 %
 DEPTH OF ISOTHERMS 12 feet
 ISOTHERMS ARE DEGREES ABOVE AMBIENT RIVER TEMPERATURE

ALDEN RESEARCH LABORATORIES
 WORCESTER POLYTECHNIC INSTITUTE
 HYDRAULIC MODEL STUDIES
 FOR
 CONSOLIDATED EDISON COMPANY, N. Y.

INDIAN POINT II MODEL

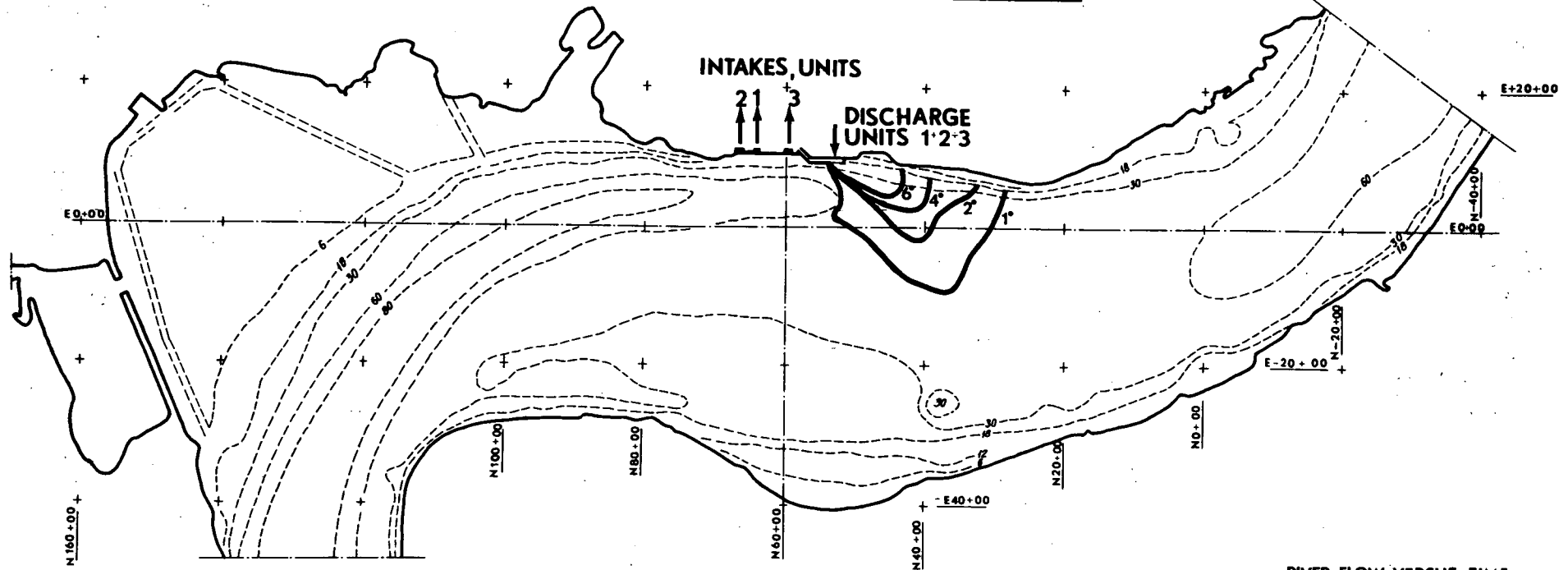

PLAN OF MODELED AREA

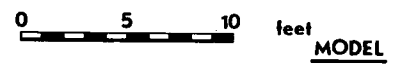

SCALES

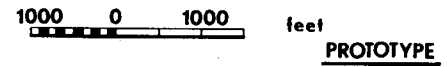

**RIVER FLOW VERSUS TIME AT VERPLANCK POINT
% OF MAXIMUM FLOW**

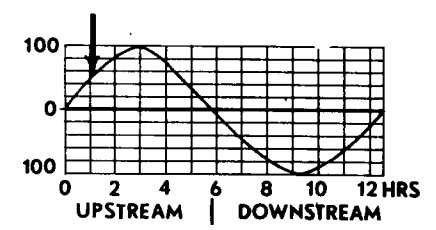

ARRANGEMENT OF OUTFALL STRUCTURE

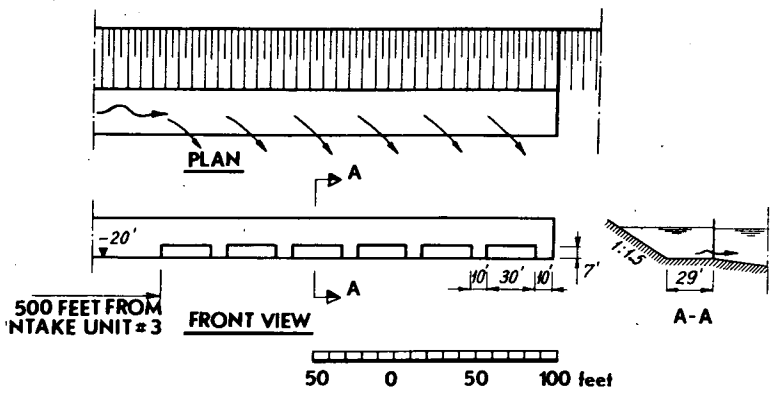

TEST CONDITIONS

TEST NUMBER AND DATE 528A ; NOV 29 , 1968
 UNITS OPERATING AND DISCHARGE 1,2,3 ; 4670 cfs
 DISCHARGE TEMPERATURE ABOVE AMBIENT RIVER 16.4°F
 TIME IN TIDE CYCLE SEE DIAGRAM
 RIVER AMBIENT TEMPERATURE 46 °F
 AIR TEMPERATURE DRY BULB 56.5°F
 AIR TEMPERATURE WET BULB 51.3°F
 RELATIVE HUMIDITY 72 %
 DEPTH OF ISOTHERMS 18 feet
 ISOTHERMS ARE DEGREES ABOVE AMBIENT RIVER TEMPERATURE

ALDEN RESEARCH LABORATORIES
 WORCESTER POLYTECHNIC INSTITUTE
 HYDRAULIC MODEL STUDIES
 FOR
 CONSOLIDATED EDISON COMPANY, N. Y.

INDIAN POINT II MODEL

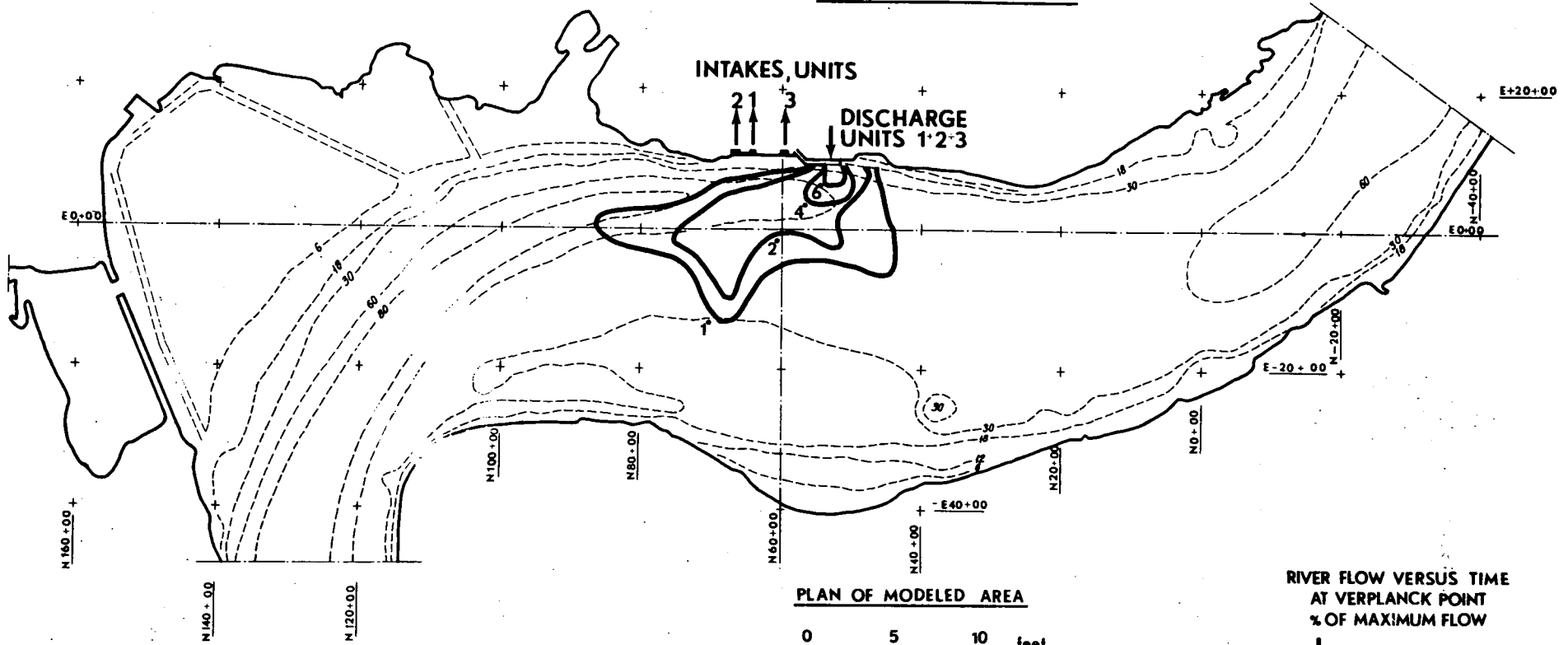

PLAN OF MODELED AREA



SCALES

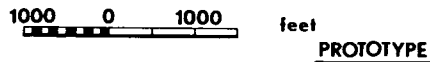

RIVER FLOW VERSUS TIME AT VERPLANCK POINT
% OF MAXIMUM FLOW

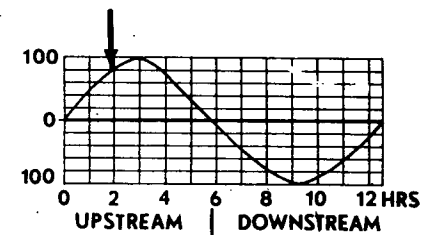

ARRANGEMENT OF OUTFALL STRUCTURE

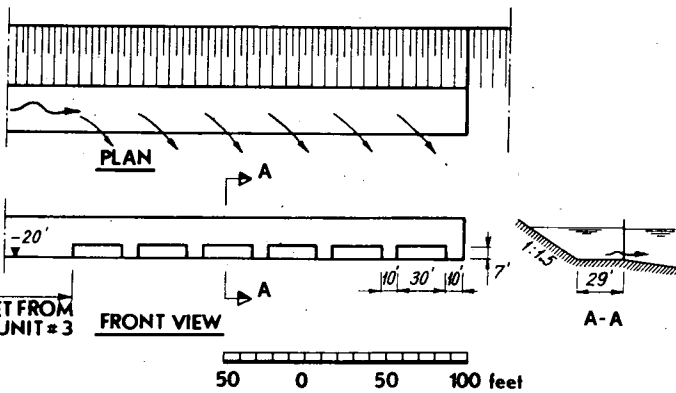

TEST CONDITIONS

TEST NUMBER AND DATE 528A ; NOV 29 , 1968
 UNITS OPERATING AND DISCHARGE 1,2,3 ; 670 cfs
 DISCHARGE TEMPERATURE ABOVE AMBIENT RIVER : 16.4°F
 TIME IN TIDE CYCLE SEE DIAGRAM
 RIVER AMBIENT TEMPERATURE 6 °F
 AIR TEMPERATURE DRY BULB 56.5°F
 AIR TEMPERATURE WET BULB 51.3°F
 RELATIVE HUMIDITY 72 %
 DEPTH OF ISOTHERMS 18 feet
 ISOTHERMS ARE DEGREES ABOVE AMBIENT RIVER TEMPERATURE

ALDEN RESEARCH LABORATORIES
 WORCESTER POLYTECHNIC INSTITUTE
 HYDRAULIC MODEL STUDIES
 FOR
 CONSOLIDATED EDISON COMPANY, N. Y.

INDIAN POINT II MODEL

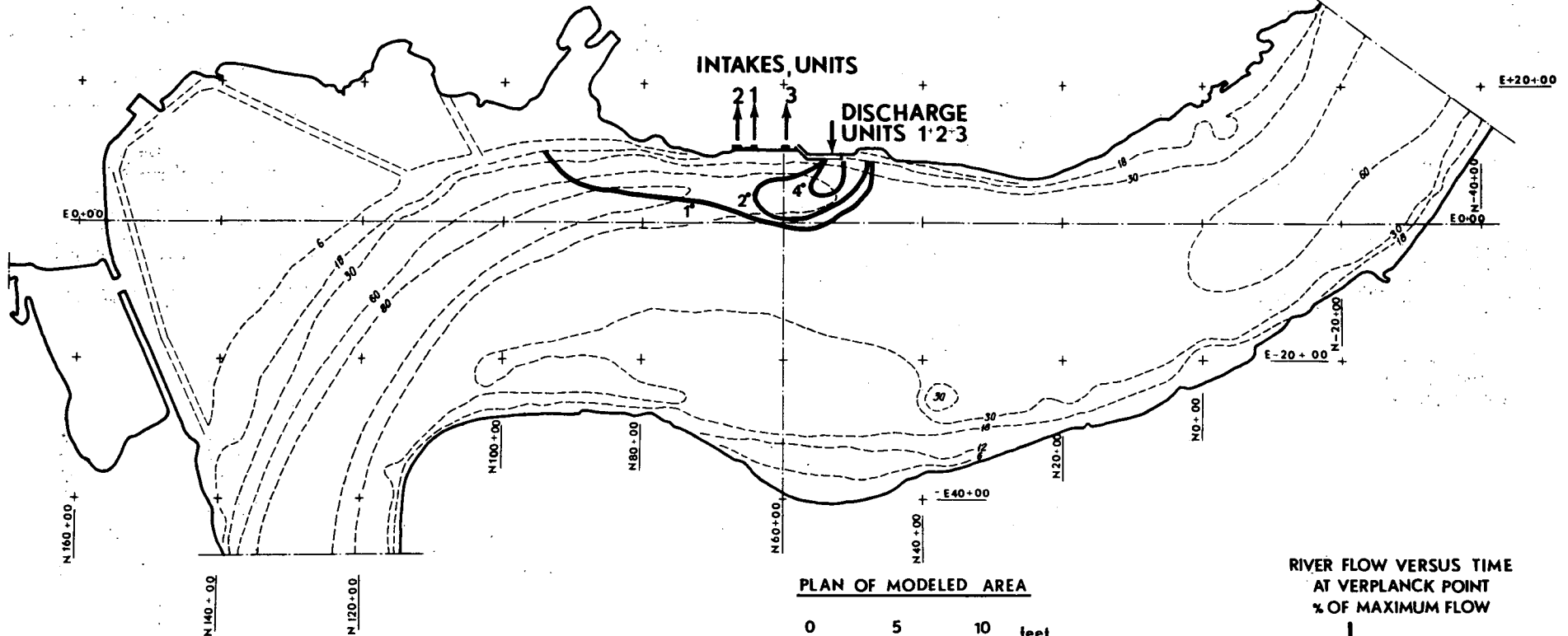

PLAN OF MODELED AREA



SCALES

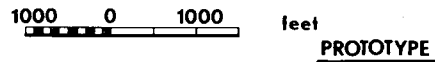

**RIVER FLOW VERSUS TIME AT VERPLANCK POINT
% OF MAXIMUM FLOW**

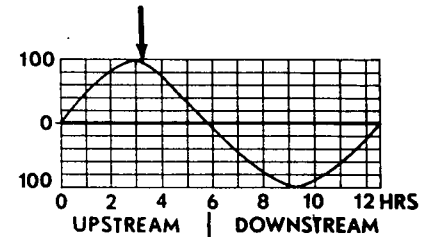

ARRANGEMENT OF OUTFALL STRUCTURE

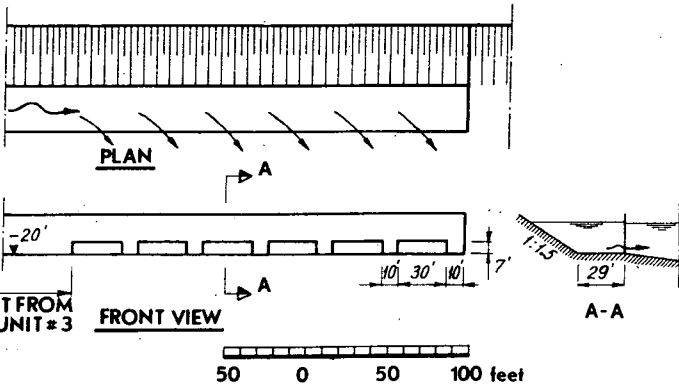

TEST CONDITIONS

TEST NUMBER AND DATE 528A ; NOV 29 ,1968
 UNITS OPERATING AND DISCHARGE 1,2,3 ; 4670 cfs
 DISCHARGE TEMPERATURE ABOVE AMBIENT RIVER 16.4°F
 TIME IN TIDE CYCLE SEE DIAGRAM
 RIVER AMBIENT TEMPERATURE 46 °F
 AIR TEMPERATURE DRY BULB 56.5°F
 AIR TEMPERATURE WET BULB 51.3°F
 RELATIVE HUMIDITY 72 %
 DEPTH OF ISOTHERMS 18 feet
 ISOTHERMS ARE DEGREES ABOVE AMBIENT RIVER TEMPERATURE

ALDEN RESEARCH LABORATORIES
 WORCESTER POLYTECHNIC INSTITUTE
 HYDRAULIC MODEL STUDIES
 FOR
 CONSOLIDATED EDISON COMPANY, N. Y.

INDIAN POINT II MODEL

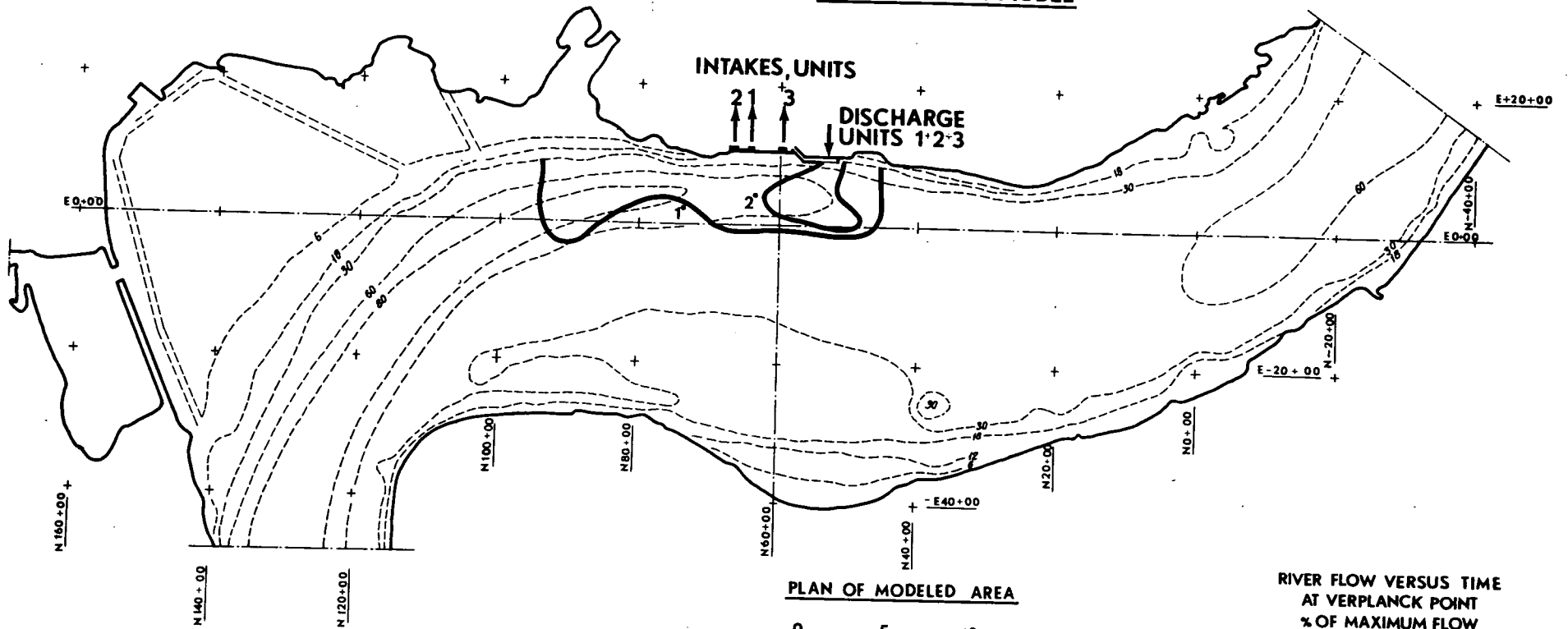

PLAN OF MODELED AREA

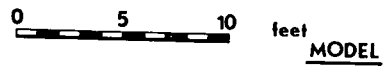

SCALES

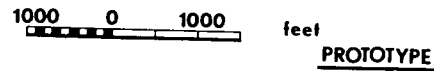

**RIVER FLOW VERSUS TIME AT VERPLANCK POINT
% OF MAXIMUM FLOW**

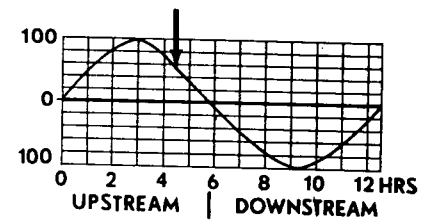

ARRANGEMENT OF OUTFALL STRUCTURE

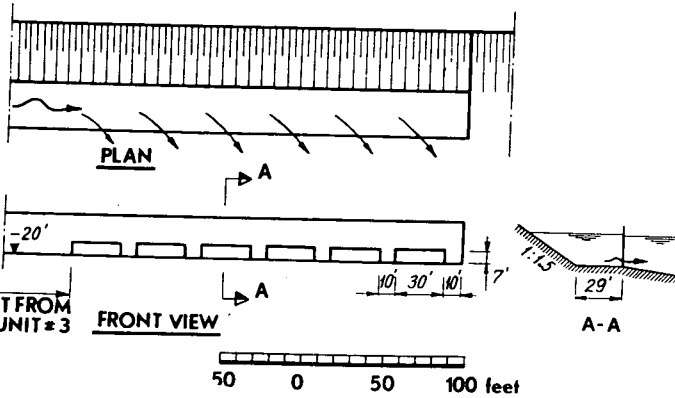

TEST CONDITIONS

TEST NUMBER AND DATE 528A ; NOV 29 , 1968
 UNITS OPERATING AND DISCHARGE 1,2,3 ; 4670 cfs
 DISCHARGE TEMPERATURE ABOVE AMBIENT RIVER 16.4°F
 TIME IN TIDE CYCLE SEE DIAGRAM
 RIVER AMBIENT TEMPERATURE 46 °F
 AIR TEMPERATURE DRY BULB 56.5 °F
 AIR TEMPERATURE WET BULB 51.3 °F
 RELATIVE HUMIDITY 72 %
 DEPTH OF ISOTHERMS 18 feet
 ISOTHERMS ARE DEGREES ABOVE AMBIENT RIVER TEMPERATURE

ALDEN RESEARCH LABORATORIES
 WORCESTER POLYTECHNIC INSTITUTE
 HYDRAULIC MODEL STUDIES
 FOR
 CONSOLIDATED EDISON COMPANY

FIG. 42

INDIAN POINT II MODEL

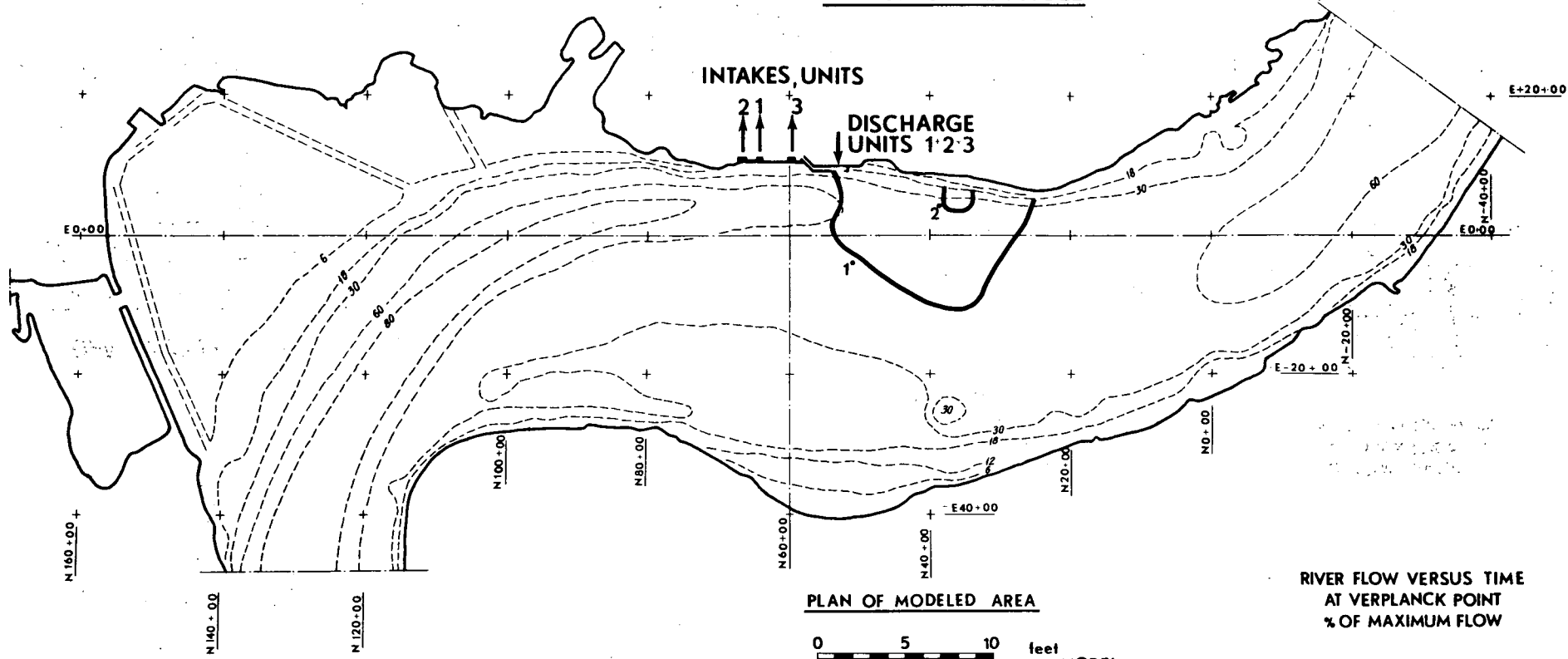

PLAN OF MODELED AREA



SCALES

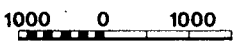

**RIVER FLOW VERSUS TIME AT VERPLANCK POINT
% OF MAXIMUM FLOW**

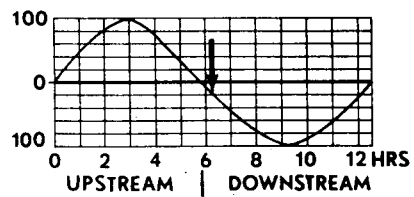

ARRANGEMENT OF OUTFALL STRUCTURE

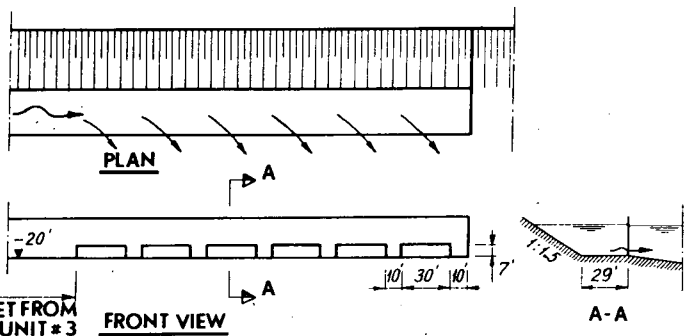

500 FEET FROM INTAKE UNIT #3

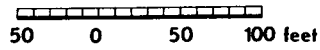

TEST CONDITIONS

TEST NUMBER AND DATE 528A ; NOV 29 ,1968
 UNITS OPERATING AND DISCHARGE 1,2,3 ; 4670 cfs
 DISCHARGE TEMPERATURE ABOVE AMBIENT RIVER 16.4°F
 TIME IN TIDE CYCLE SEE DIAGRAM
 RIVER AMBIENT TEMPERATURE 46 °F
 AIR TEMPERATURE DRY BULB 56.5°F
 AIR TEMPERATURE WET BULB 51.3°F
 RELATIVE HUMIDITY 72 %
 DEPTH OF ISOTHERMS 18 feet
 ISOTHERMS ARE DEGREES ABOVE AMBIENT RIVER TEMPERATURE

ALDEN RESEARCH LABORATORIES
 WORCESTER POLYTECHNIC INSTITUTE
 HYDRAULIC MODEL STUDIES
 FOR
 CONSOLIDATED EDISON COMPANY, N. Y.

INDIAN POINT II MODEL

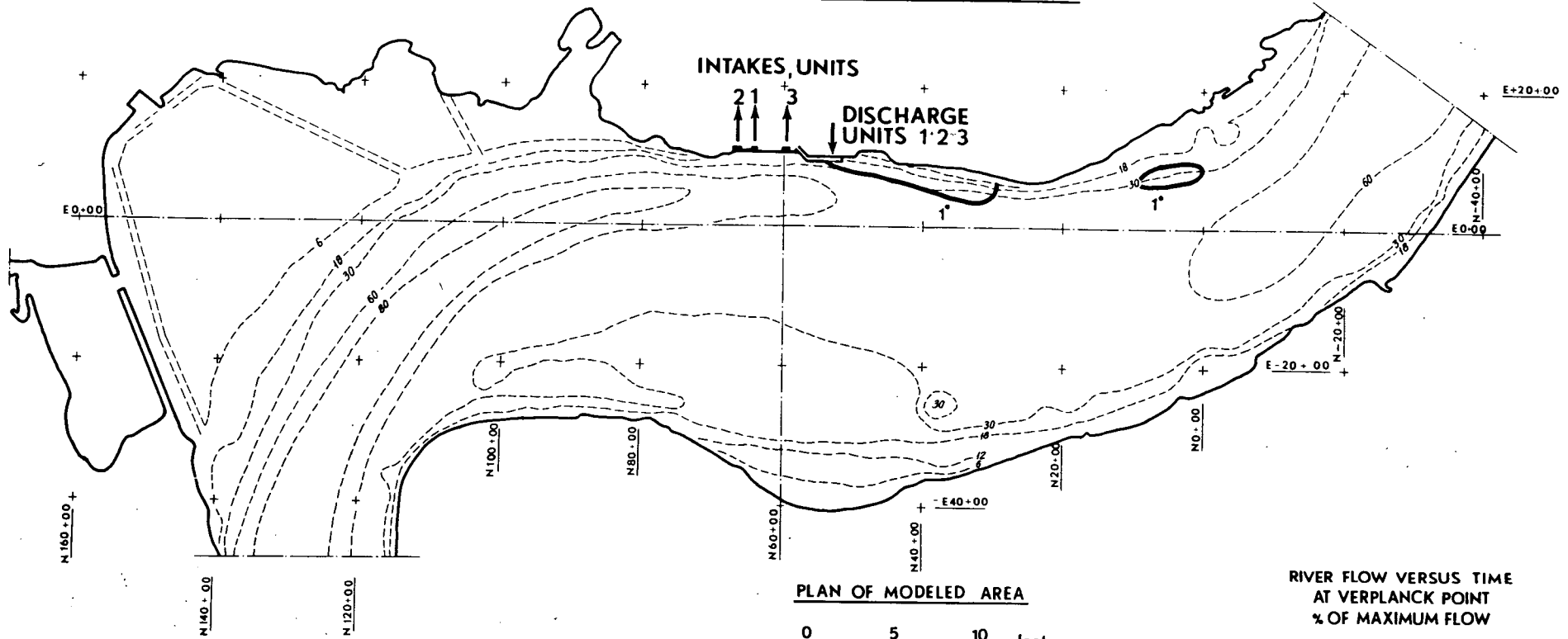

PLAN OF MODELED AREA



SCALES

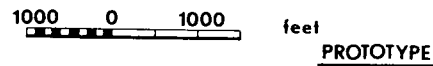

TEST CONDITIONS

TEST NUMBER AND DATE 528A ; NOV 29 , 1968
 UNITS OPERATING AND DISCHARGE 1,2,3 ; 4670 cfs
 DISCHARGE TEMPERATURE ABOVE AMBIENT RIVER 16.4°F
 TIME IN TIDE CYCLE SEE DIAGRAM
 RIVER AMBIENT TEMPERATURE 46 °F
 AIR TEMPERATURE DRY BULB 56.5°F
 AIR TEMPERATURE WET BULB 51.3°F
 RELATIVE HUMIDITY 72 %
 DEPTH OF ISOTHERMS 18 feet
 ISOTHERMS ARE DEGREES ABOVE AMBIENT RIVER TEMPERATURE

RIVER FLOW VERSUS TIME
 AT VERPLANCK POINT
 % OF MAXIMUM FLOW

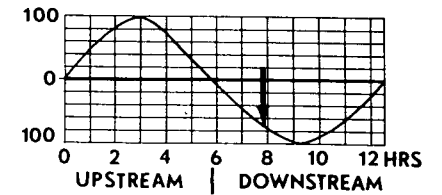

ARRANGEMENT OF OUTFALL STRUCTURE

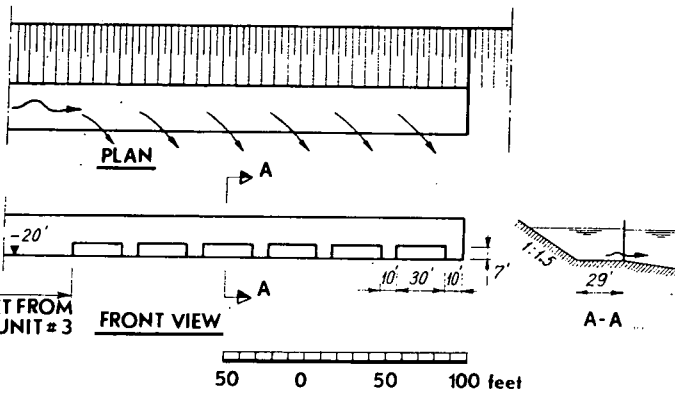

ALDEN RESEARCH LABORATORIES
 WORCESTER POLYTECHNIC INSTITUTE
 HYDRAULIC MODEL STUDIES
 FOR
 CONSOLIDATED EDISON COMPANY, N. Y.

INDIAN POINT II MODEL

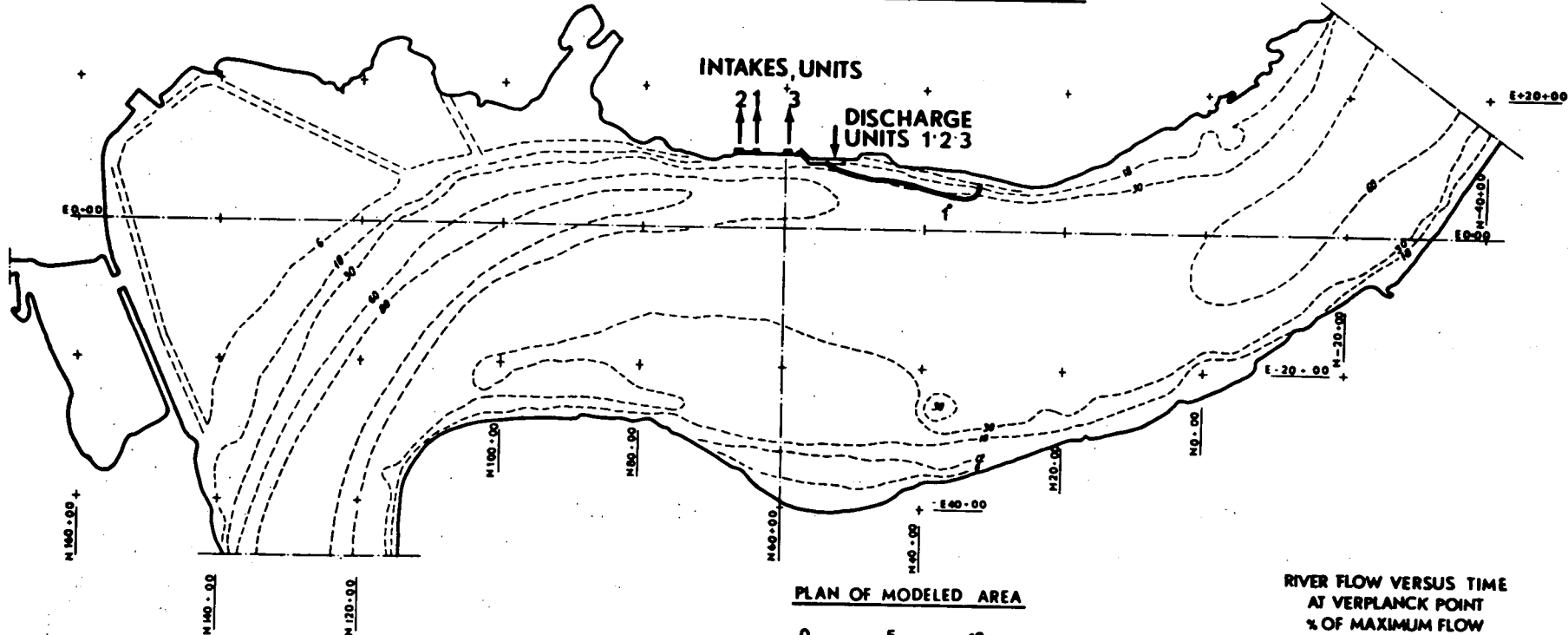

PLAN OF MODELED AREA

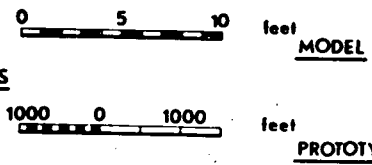

SCALES

RIVER FLOW VERSUS TIME AT VERPLANCK POINT % OF MAXIMUM FLOW

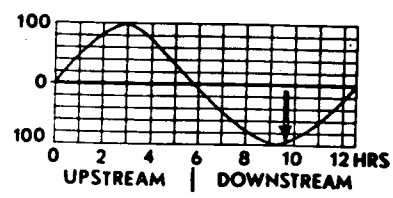

ARRANGEMENT OF OUTFALL STRUCTURE

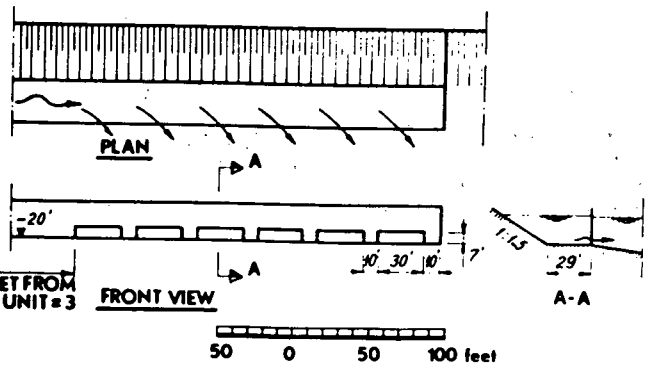

TEST CONDITIONS

TEST NUMBER AND DATE 528A ; NOV 29 , 1968
 UNITS OPERATING AND DISCHARGE 1,2,3 ; 4670 cfs
 DISCHARGE TEMPERATURE ABOVE AMBIENT RIVER 16.4°F
 TIME IN TIDE CYCLE SEE DIAGRAM
 RIVER AMBIENT TEMPERATURE 46 °F
 AIR TEMPERATURE DRY BULB 56.5°F
 AIR TEMPERATURE WET BULB 51.3°F
 RELATIVE HUMIDITY 72 %
 DEPTH OF ISOTHERMS 18 feet
 ISOTHERMS ARE DEGREES ABOVE AMBIENT RIVER TEMPERATURE

ALDEN RESEARCH LABORATORIES
 WORCESTER POLYTECHNIC INSTITUTE
 HYDRAULIC MODEL STUDIES
 FOR
 CONSOLIDATED EDISON COMPANY, N. Y.

INDIAN POINT II MODEL

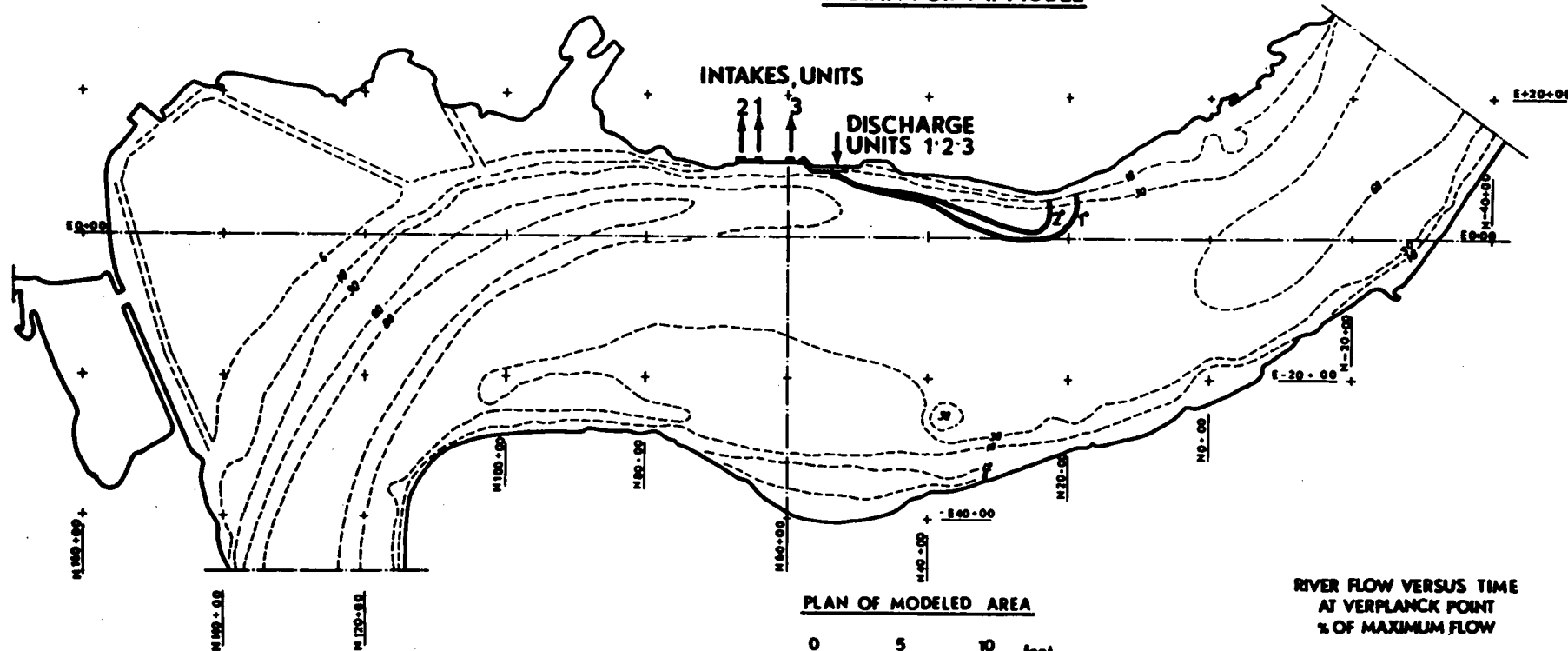

PLAN OF MODELED AREA

0 5 10 feet MODEL

SCALES
1000 0 1000 feet PROTOTYPE

RIVER FLOW VERSUS TIME AT VERPLANCK POINT
% OF MAXIMUM FLOW

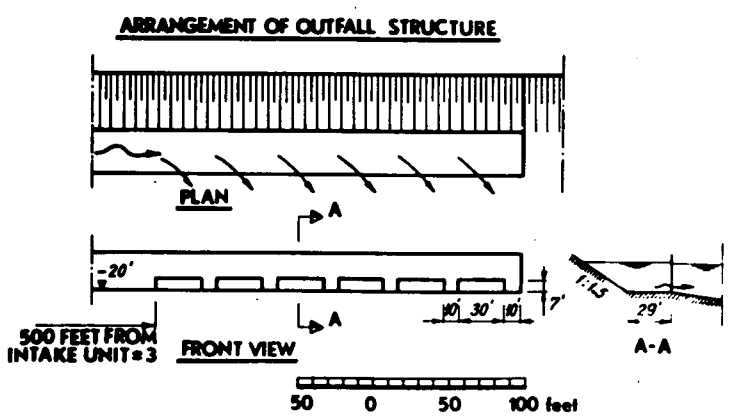
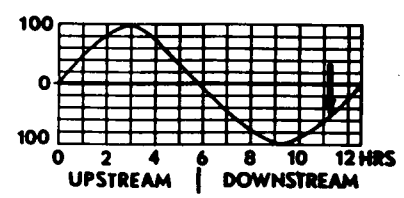

TEST CONDITIONS

TEST NUMBER AND DATE 528A ; NOV 29 , 1968
 UNITS OPERATING AND DISCHARGE 1,2,3 ; 4670 cfs
 DISCHARGE TEMPERATURE ABOVE AMBIENT RIVER 16.4°F
 TIME IN TIDE CYCLE SEE DIAGRAM
 RIVER AMBIENT TEMPERATURE 46 °F
 AIR TEMPERATURE DRY BULB 56.5°F
 AIR TEMPERATURE WET BULB 51.3°F
 RELATIVE HUMIDITY 72 %
 DEPTH OF ISOTHERMS 18 feet
 ISOTHERMS ARE DEGREES ABOVE AMBIENT RIVER TEMPERATURE

ALDEN RESEARCH LABORATORIES
 WORCESTER POLYTECHNIC INSTITUTE
 HYDRAULIC MODEL STUDIES
 FOR
 CONSOLIDATED EDISON COMPANY, N. Y.

INDIAN POINT II MODEL

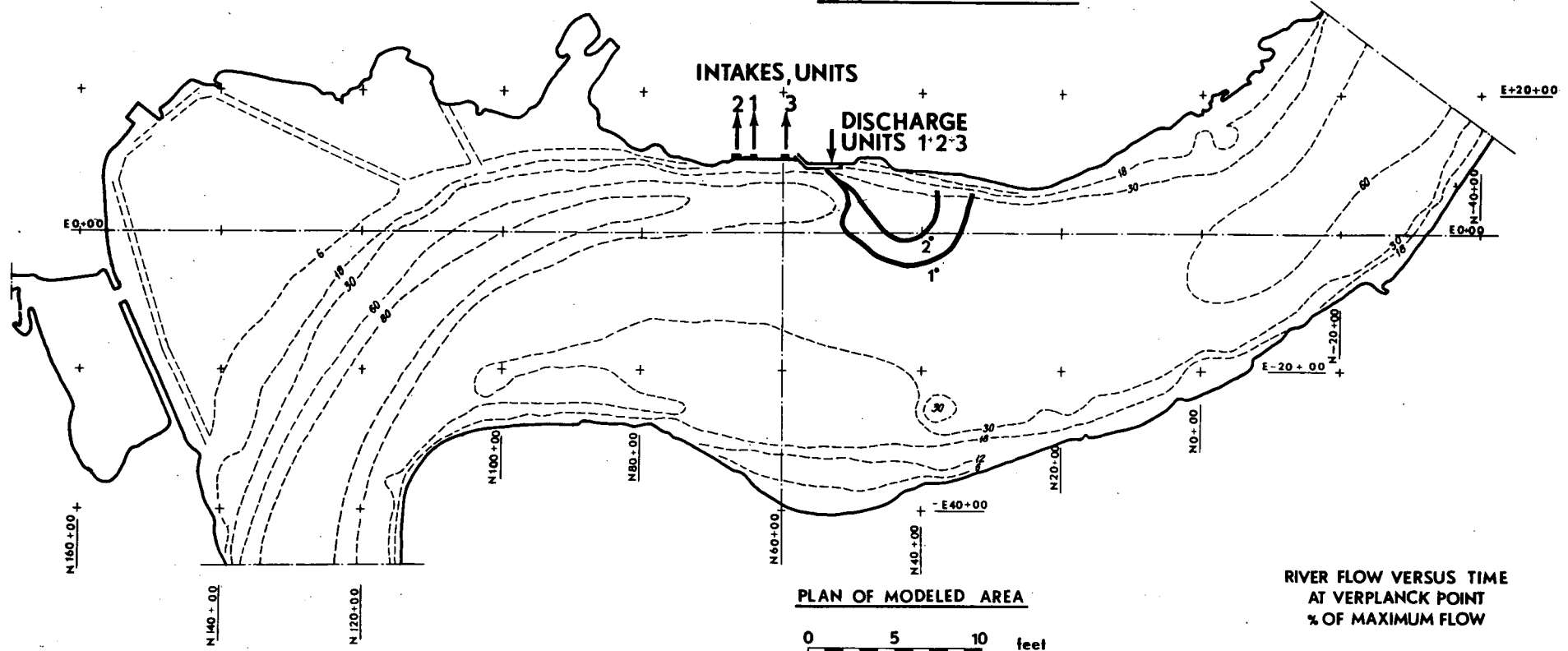

PLAN OF MODELED AREA



SCALES

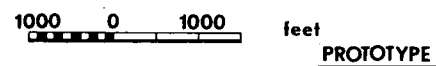

**RIVER FLOW VERSUS TIME AT VERPLANCK POINT
% OF MAXIMUM FLOW**

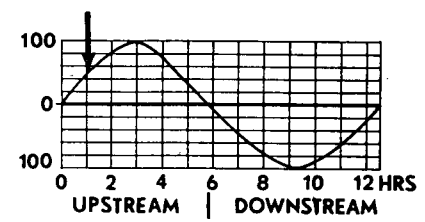

ARRANGEMENT OF OUTFALL STRUCTURE

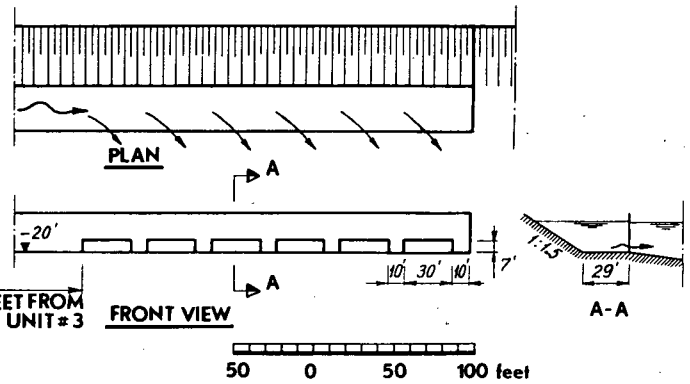

TEST CONDITIONS

TEST NUMBER AND DATE 529A ; NOV 29 ,1968
 UNITS OPERATING AND DISCHARGE 1,2,3 ; 4670 cfs
 DISCHARGE TEMPERATURE ABOVE AMBIENT RIVER 16.4°F
 TIME IN TIDE CYCLE SEE DIAGRAM
 RIVER AMBIENT TEMPERATURE 51.°F
 AIR TEMPERATURE DRY BULB 58.9°F
 AIR TEMPERATURE WET BULB 53.5°F
 RELATIVE HUMIDITY 72 %
 DEPTH OF ISOTHERMS 24 feet
 ISOTHERMS ARE DEGREES ABOVE AMBIENT RIVER TEMPERATURE

ALDEN RESEARCH LABORATORIES
 WORCESTER POLYTECHNIC INSTITUTE
 HYDRAULIC MODEL STUDIES
 FOR
 CONSOLIDATED EDISON COMPANY, N. Y.

INDIAN POINT II MODEL

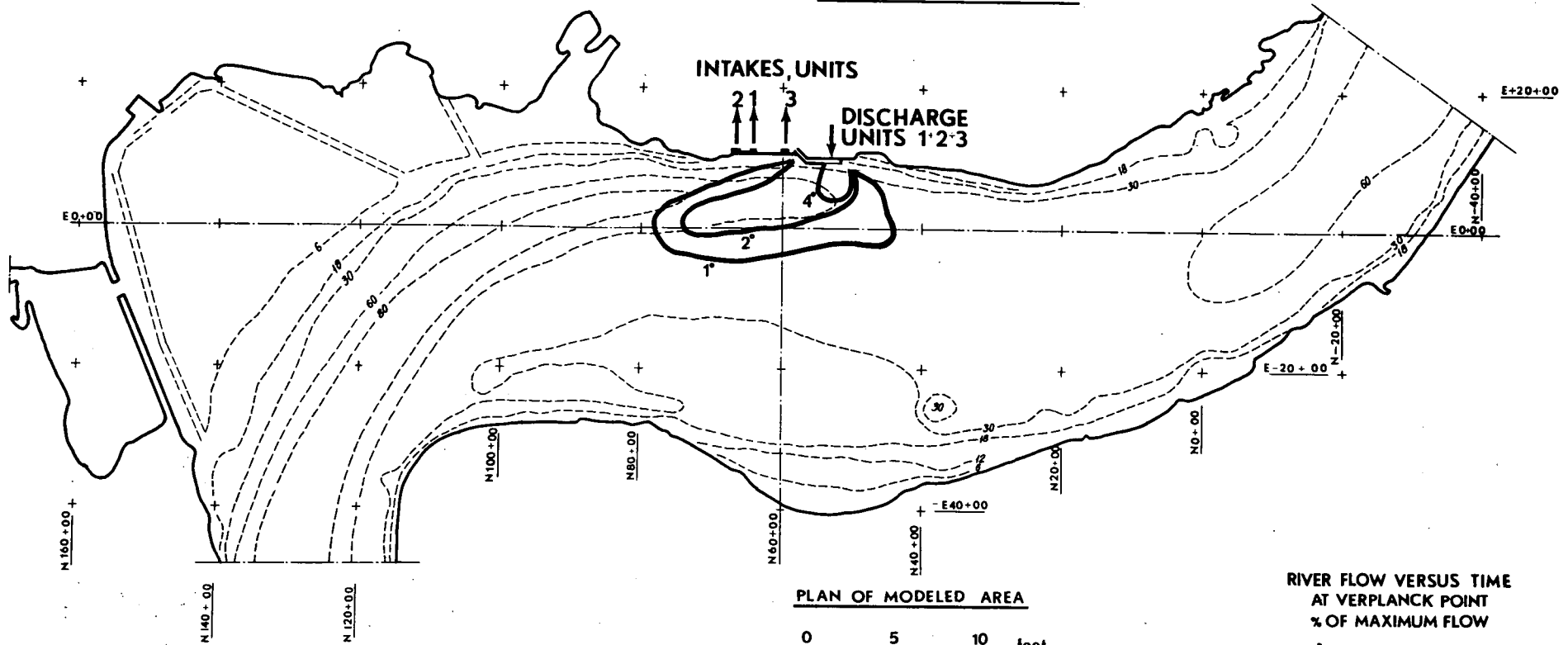

PLAN OF MODELED AREA

SCALES

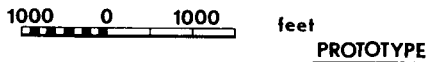

**RIVER FLOW VERSUS TIME AT VERPLANCK POINT
% OF MAXIMUM FLOW**

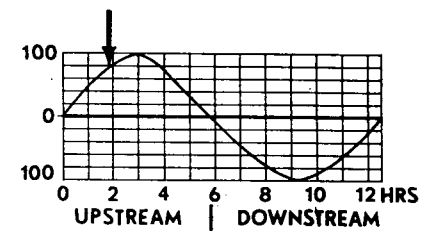

ARRANGEMENT OF OUTFALL STRUCTURE

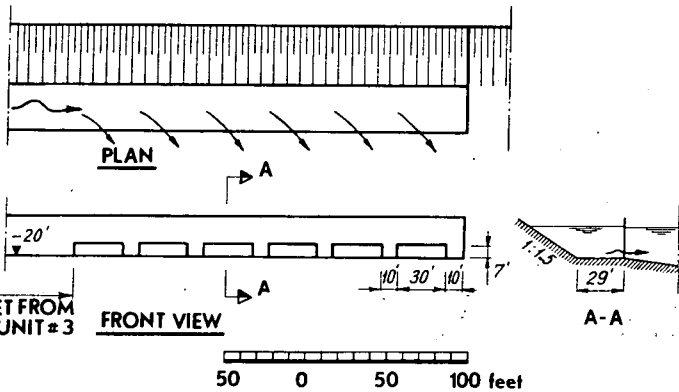

TEST CONDITIONS

TEST NUMBER AND DATE 529A ; NOV 29 , 1968
 UNITS OPERATING AND DISCHARGE 1,2,3 ; 4670 cfs
 DISCHARGE TEMPERATURE ABOVE AMBIENT RIVER 16.4°F
 TIME IN TIDE CYCLE SEE DIAGRAM
 RIVER AMBIENT TEMPERATURE 51 °F
 AIR TEMPERATURE DRY BULB 58.9°F
 AIR TEMPERATURE WET BULB 53.5°F
 RELATIVE HUMIDITY 72 %
 DEPTH OF ISOTHERMS 24 feet
 ISOTHERMS ARE DEGREES ABOVE AMBIENT RIVER TEMPERATURE

ALDEN RESEARCH LABORATORIES
 WORCESTER POLYTECHNIC INSTITUTE
 HYDRAULIC MODEL STUDIES
 FOR
 CONSOLIDATED EDISON COMPANY, N. Y.

INDIAN POINT II MODEL

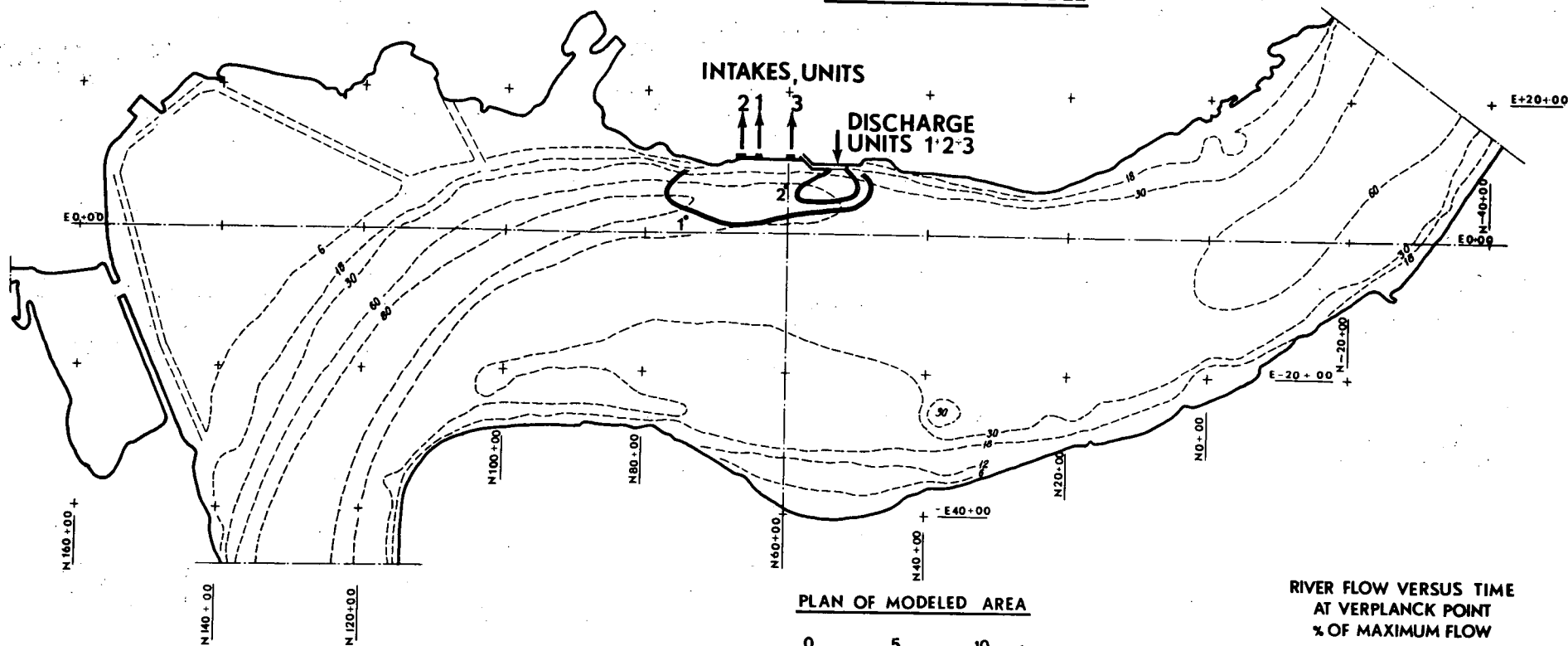

PLAN OF MODELED AREA

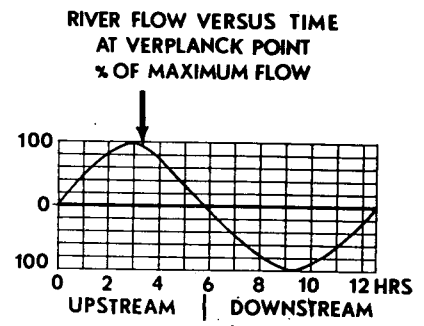
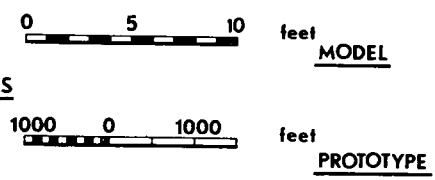

ARRANGEMENT OF OUTFALL STRUCTURE

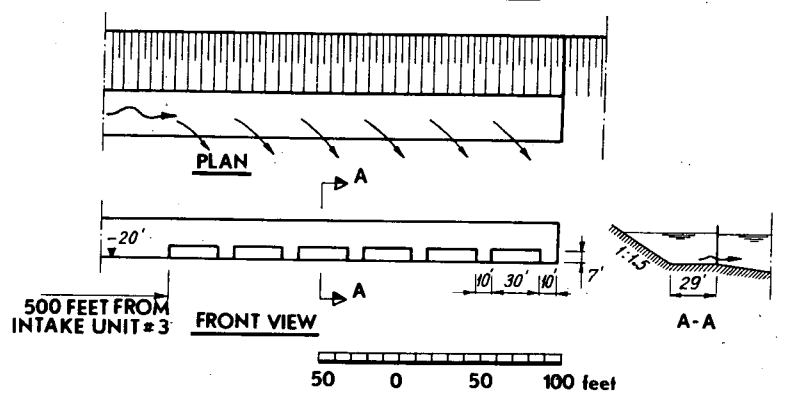

TEST CONDITIONS

TEST NUMBER AND DATE 529A ; NOV 29 , 1968
 UNITS OPERATING AND DISCHARGE 1,2,3 ; 4670 cfs
 DISCHARGE TEMPERATURE ABOVE AMBIENT RIVER 16.4°F
 TIME IN TIDE CYCLE SEE DIAGRAM
 RIVER AMBIENT TEMPERATURE 51.0°F
 AIR TEMPERATURE DRY BULB 58.9°F
 AIR TEMPERATURE WET BULB 53.5°F
 RELATIVE HUMIDITY 72 %
 DEPTH OF ISOTHERMS 24 feet
 ISOTHERMS ARE DEGREES ABOVE AMBIENT RIVER TEMPERATURE

ALDEN RESEARCH LABORATORIES
 WORCESTER POLYTECHNIC INSTITUTE
 HYDRAULIC MODEL STUDIES
 FOR
 CONSOLIDATED EDISON COMPANY, N. Y.

INDIAN POINT II MODEL

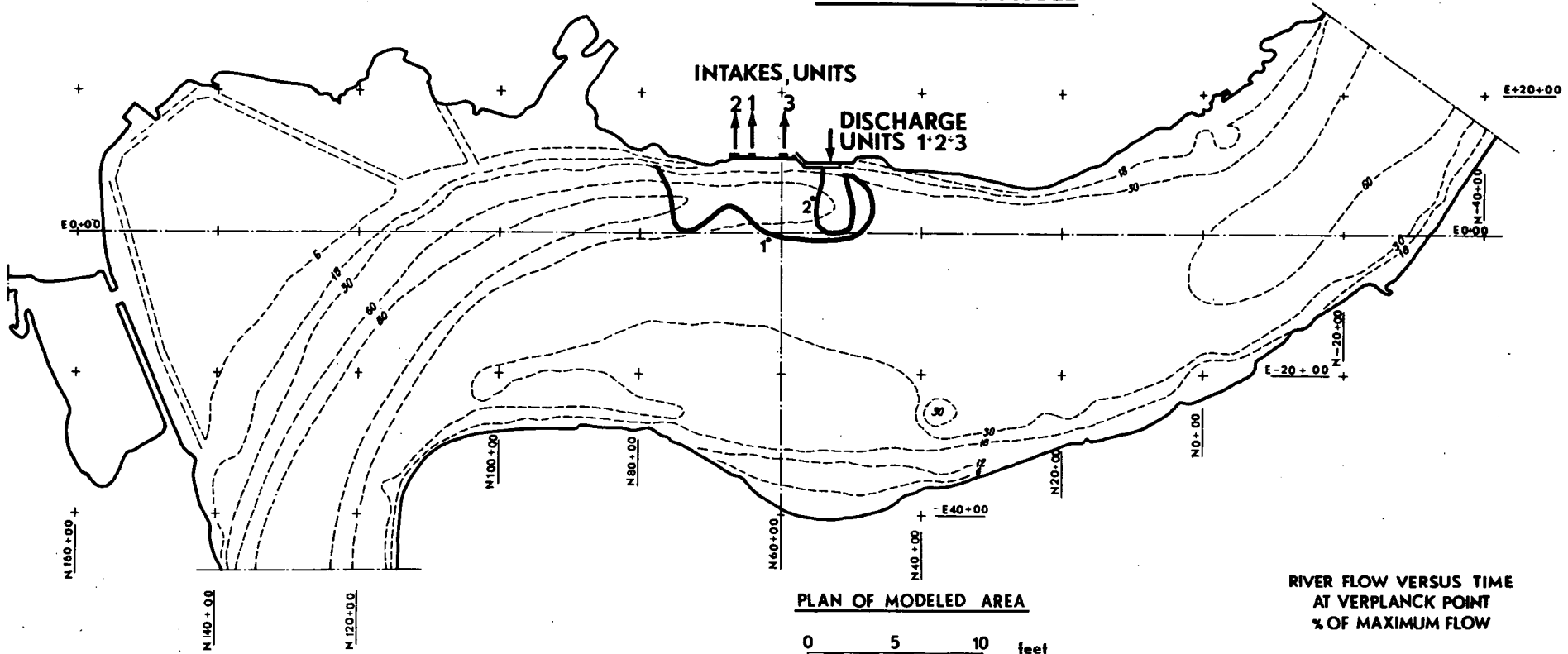

PLAN OF MODELED AREA

0 5 10 feet **MODEL**

SCALES

1000 0 1000 feet **PROTOTYPE**

**RIVER FLOW VERSUS TIME AT VERPLANCK POINT
% OF MAXIMUM FLOW**

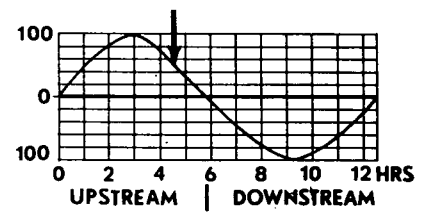

ARRANGEMENT OF OUTFALL STRUCTURE

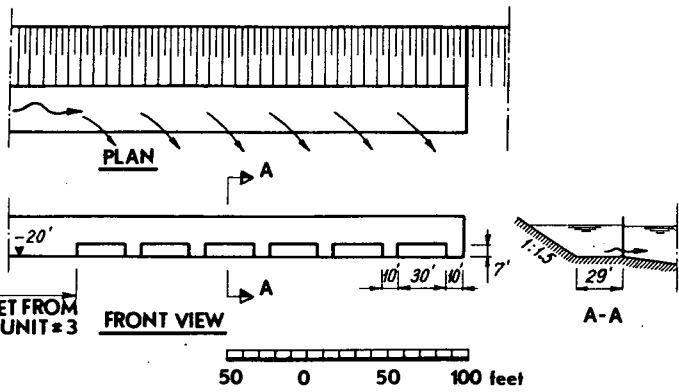

TEST CONDITIONS

TEST NUMBER AND DATE 529A ; NOV 29 ,1968
 UNITS OPERATING AND DISCHARGE 1,2,3 ; 4670 cfs
 DISCHARGE TEMPERATURE ABOVE AMBIENT RIVER 16.4°F
 TIME IN TIDE CYCLE SEE DIAGRAM
 RIVER AMBIENT TEMPERATURE 51.0°F
 AIR TEMPERATURE DRY BULB 58.9°F
 AIR TEMPERATURE WET BULB 53.5°F
 RELATIVE HUMIDITY 72 %
 DEPTH OF ISOTHERMS 24 feet
 ISOTHERMS ARE DEGREES ABOVE AMBIENT RIVER TEMPERATURE

ALDEN RESEARCH LABORATORIES
 WORCESTER POLYTECHNIC INSTITUTE
 HYDRAULIC MODEL STUDIES
 FOR
 CONSOLIDATED EDISON COMPANY, N. Y.

FIG. 50

INDIAN POINT II MODEL

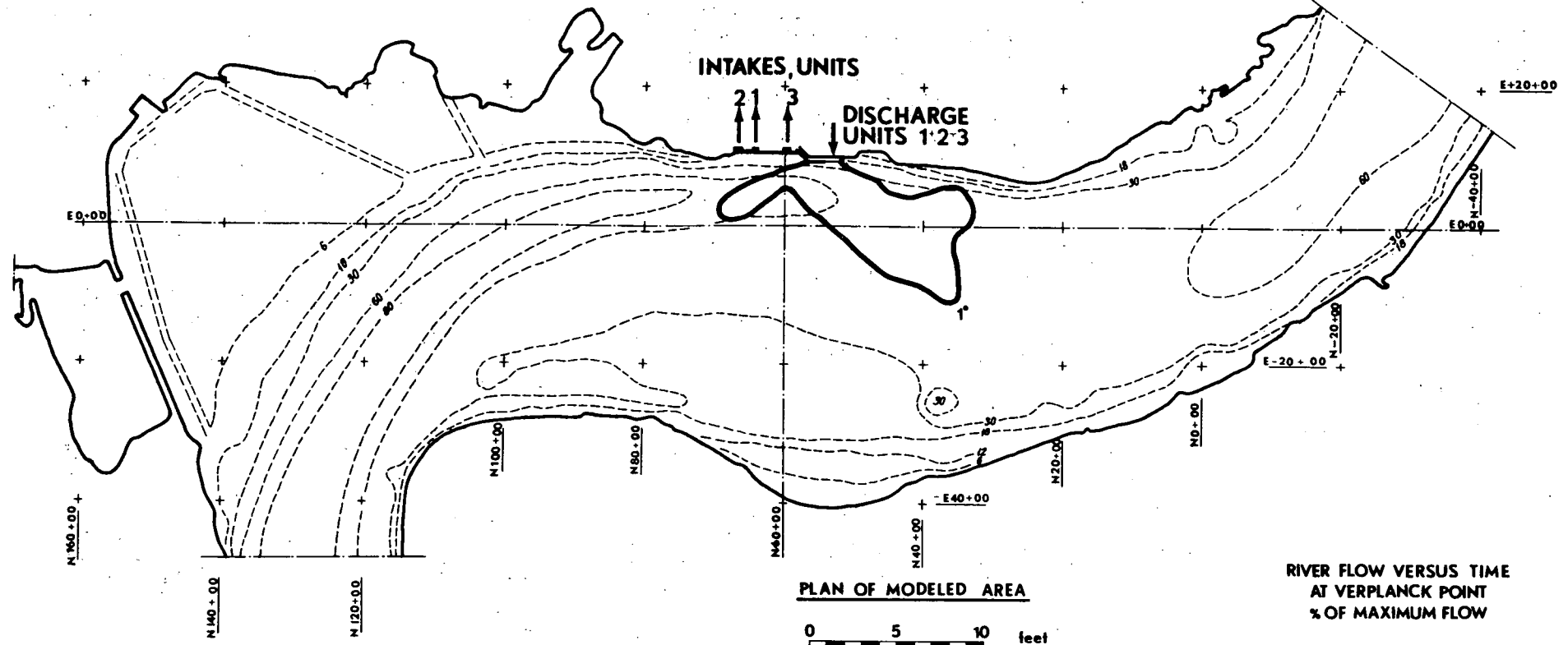

PLAN OF MODELED AREA

0 5 10 feet
MODEL

SCALES

1000 0 1000 feet
PROTOTYPE

**RIVER FLOW VERSUS TIME AT VERPLANCK POINT
% OF MAXIMUM FLOW**

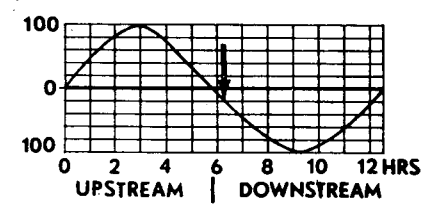

ARRANGEMENT OF OUTFALL STRUCTURE

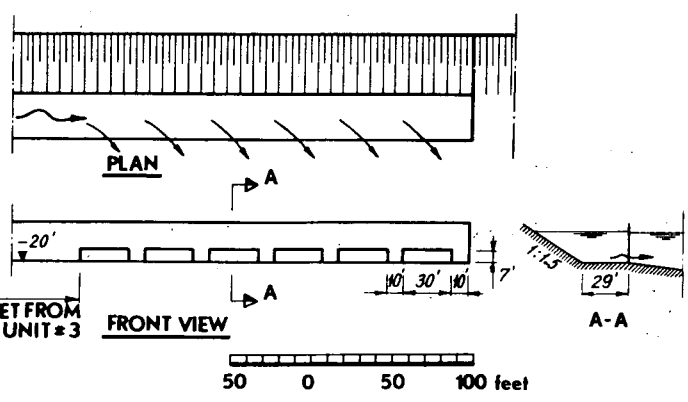

TEST CONDITIONS

TEST NUMBER AND DATE: 529A ; NOV 29, 1968
 UNITS OPERATING AND DISCHARGE: 1,2,3 ; 4670 cfs
 DISCHARGE TEMPERATURE ABOVE AMBIENT RIVER: 16.4°F
 TIME IN TIDE CYCLE: SEE DIAGRAM
 RIVER AMBIENT TEMPERATURE: 51 °F
 AIR TEMPERATURE DRY BULB: 58.9°F
 AIR TEMPERATURE WET BULB: 53.5°F
 RELATIVE HUMIDITY: 72 %
 DEPTH OF ISOTHERMS: 24 feet
 ISOTHERMS ARE DEGREES ABOVE AMBIENT RIVER TEMPERATURE

ALDEN RESEARCH LABORATORIES
 WORCESTER POLYTECHNIC INSTITUTE
 HYDRAULIC MODEL STUDIES
 FOR
 CONSOLIDATED EDISON COMPANY, N. Y.

INDIAN POINT II MODEL

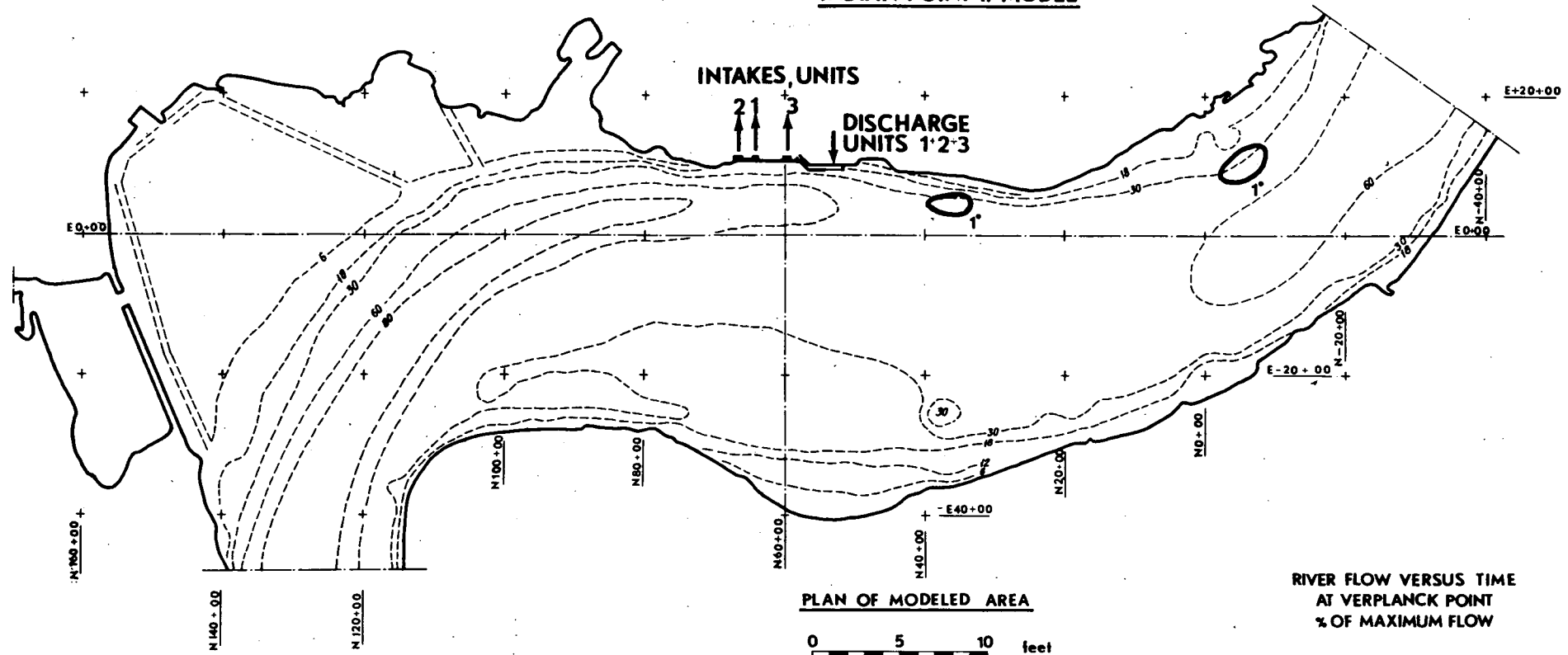

PLAN OF MODELED AREA

0 5 10 feet

MODEL

SCALES

1000 0 1000 feet

PROTOTYPE

RIVER FLOW VERSUS TIME AT VERPLANCK POINT
% OF MAXIMUM FLOW

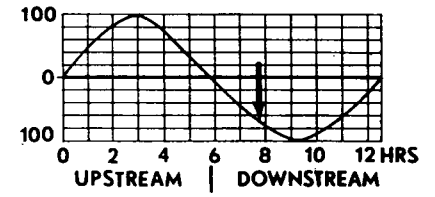

ARRANGEMENT OF OUTFALL STRUCTURE

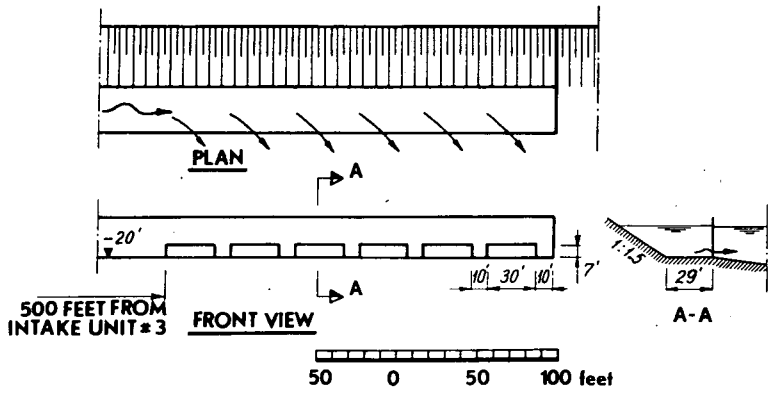

TEST CONDITIONS

TEST NUMBER AND DATE 529A ; NOV 29 , 1968
 UNITS OPERATING AND DISCHARGE 1,2,3 ; 4670 cfs
 DISCHARGE TEMPERATURE ABOVE AMBIENT RIVER 16.4°F
 TIME IN TIDE CYCLE SEE DIAGRAM
 RIVER AMBIENT TEMPERATURE 51 °F
 AIR TEMPERATURE DRY BULB 58.9°F
 AIR TEMPERATURE WET BULB 53.5°F
 RELATIVE HUMIDITY 72 %
 DEPTH OF ISOTHERMS 24 feet
 ISOTHERMS ARE DEGREES ABOVE AMBIENT RIVER TEMPERATURE

ALDEN RESEARCH LABORATORIES
 WORCESTER POLYTECHNIC INSTITUTE
 HYDRAULIC MODEL STUDIES
 FOR
 CONSOLIDATED EDISON COMPANY, N. Y.

INDIAN POINT II MODEL

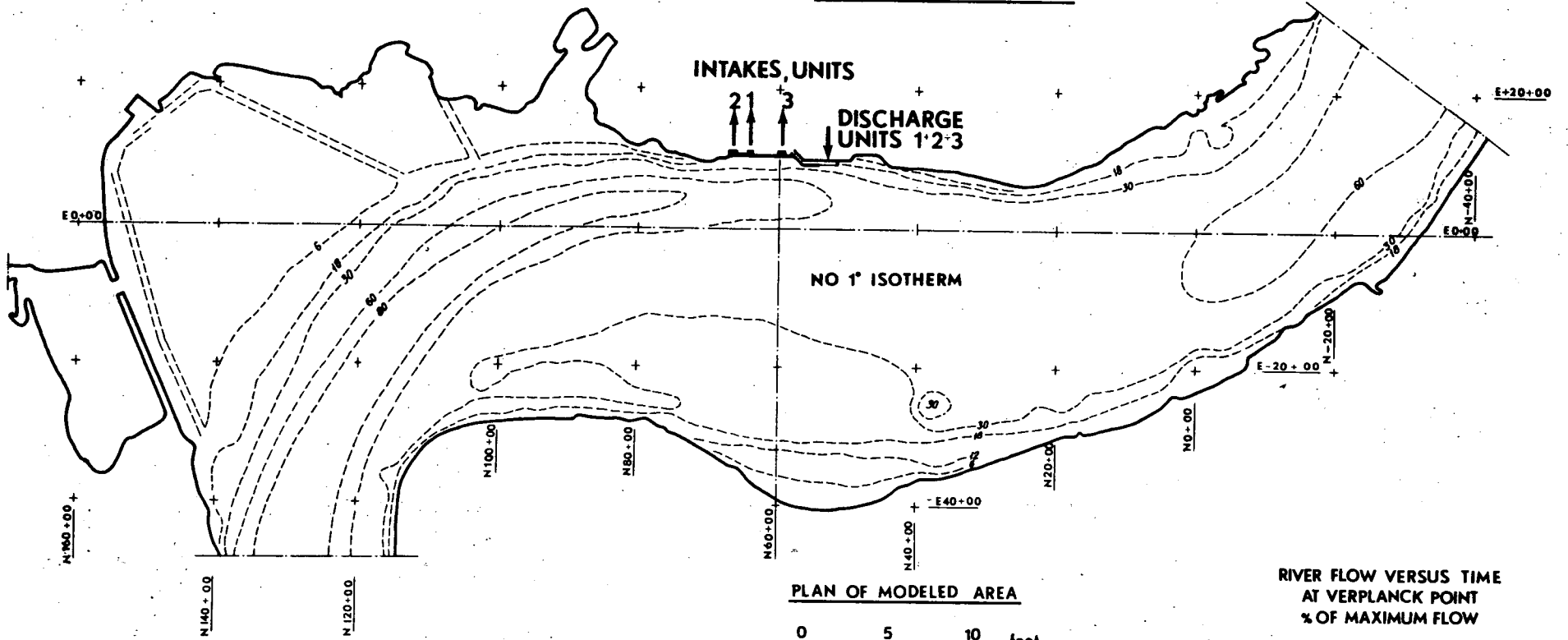

PLAN OF MODELED AREA



SCALES

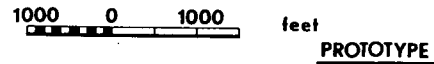

**RIVER FLOW VERSUS TIME AT VERPLANCK POINT
% OF MAXIMUM FLOW**

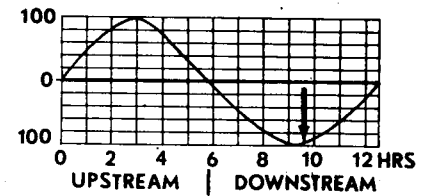

ARRANGEMENT OF OUTFALL STRUCTURE

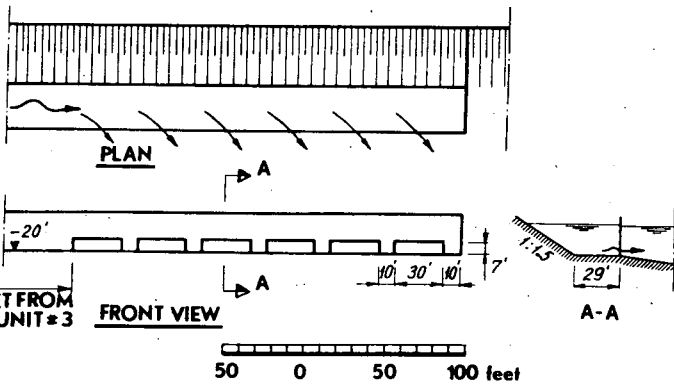

TEST CONDITIONS

TEST NUMBER AND DATE 529A ; NOV 29 , 1968
 UNITS OPERATING AND DISCHARGE 1,2,3 ; 4670 cfs
 DISCHARGE TEMPERATURE ABOVE AMBIENT RIVER 16.4°F
 TIME IN TIDE CYCLE SEE DIAGRAM
 RIVER AMBIENT TEMPERATURE 51 °F
 AIR TEMPERATURE DRY BULB 58.9°F
 AIR TEMPERATURE WET BULB 53.5°F
 RELATIVE HUMIDITY 72 %
 DEPTH OF ISOTHERMS 24 feet
 ISOTHERMS ARE DEGREES ABOVE AMBIENT RIVER TEMPERATURE

ALDEN RESEARCH LABORATORIES
 WORCESTER POLYTECHNIC INSTITUTE
 HYDRAULIC MODEL STUDIES
 FOR
 CONSOLIDATED EDISON COMPANY, N. Y.

INDIAN POINT II MODEL

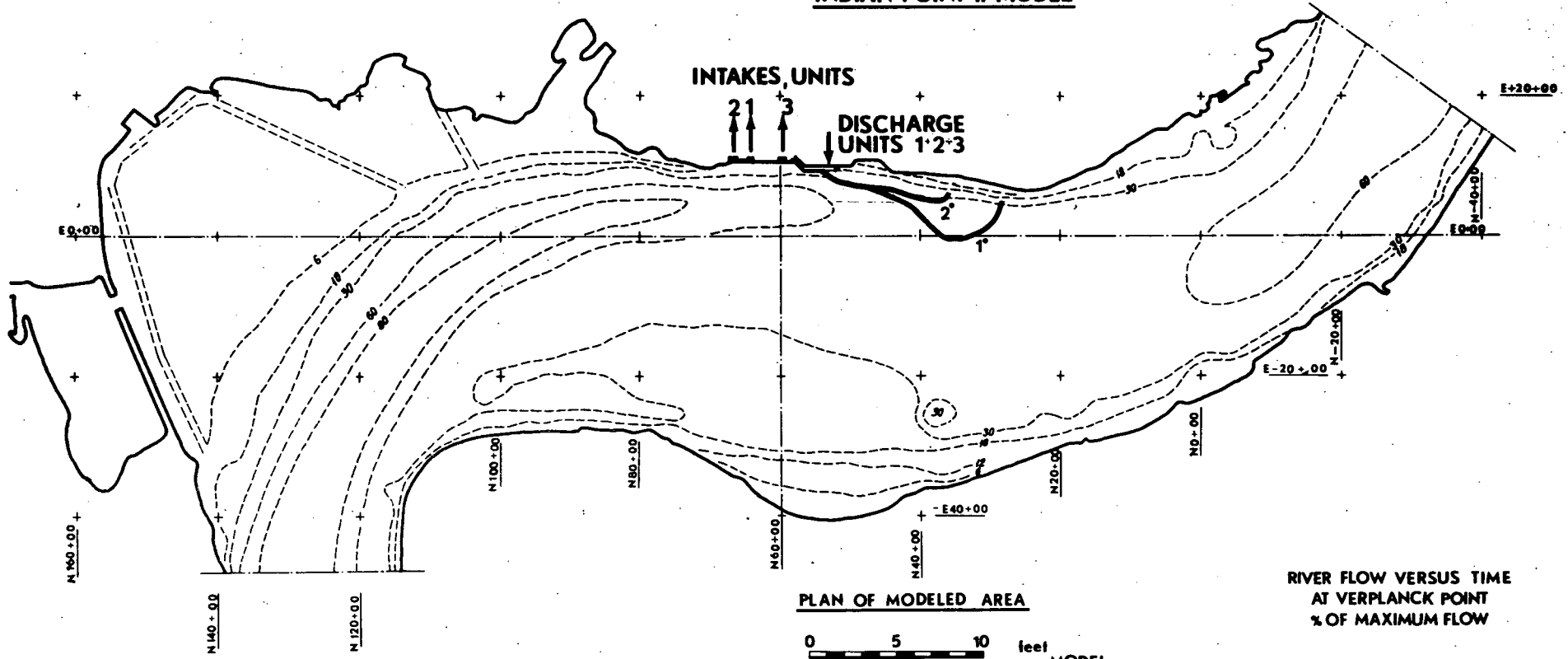

PLAN OF MODELED AREA



SCALES

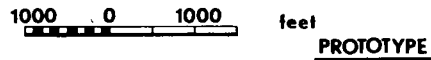

RIVER FLOW VERSUS TIME AT VERPLANCK POINT
% OF MAXIMUM FLOW

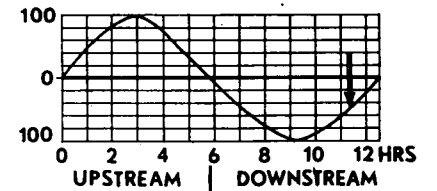

ARRANGEMENT OF OUTFALL STRUCTURE

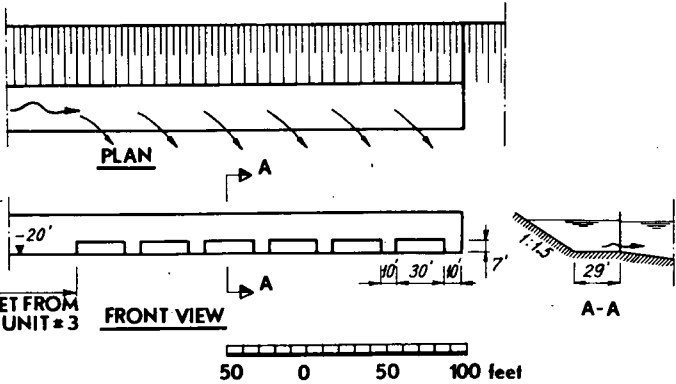

TEST CONDITIONS

TEST NUMBER AND DATE 529A ; NOV. 29, 1968
 UNITS OPERATING AND DISCHARGE 1,2,3 ; 4670 cfs
 DISCHARGE TEMPERATURE ABOVE AMBIENT RIVER 16.4°F.
 TIME IN TIDE CYCLE SEE DIAGRAM
 RIVER AMBIENT TEMPERATURE 51.0°F
 AIR TEMPERATURE DRY BULB 58.9°F.
 AIR TEMPERATURE WET BULB 53.3°F.
 RELATIVE HUMIDITY 72 %
 DEPTH OF ISOTHERMS 24 feet
 ISOTHERMS ARE DEGREES ABOVE AMBIENT RIVER TEMPERATURE

ALDEN RESEARCH LABORATORIES
 WORCESTER POLYTECHNIC INSTITUTE
 HYDRAULIC MODEL STUDIES
 FOR
 CONSOLIDATED EDISON COMPANY, N. Y.

INDIAN POINT II MODEL

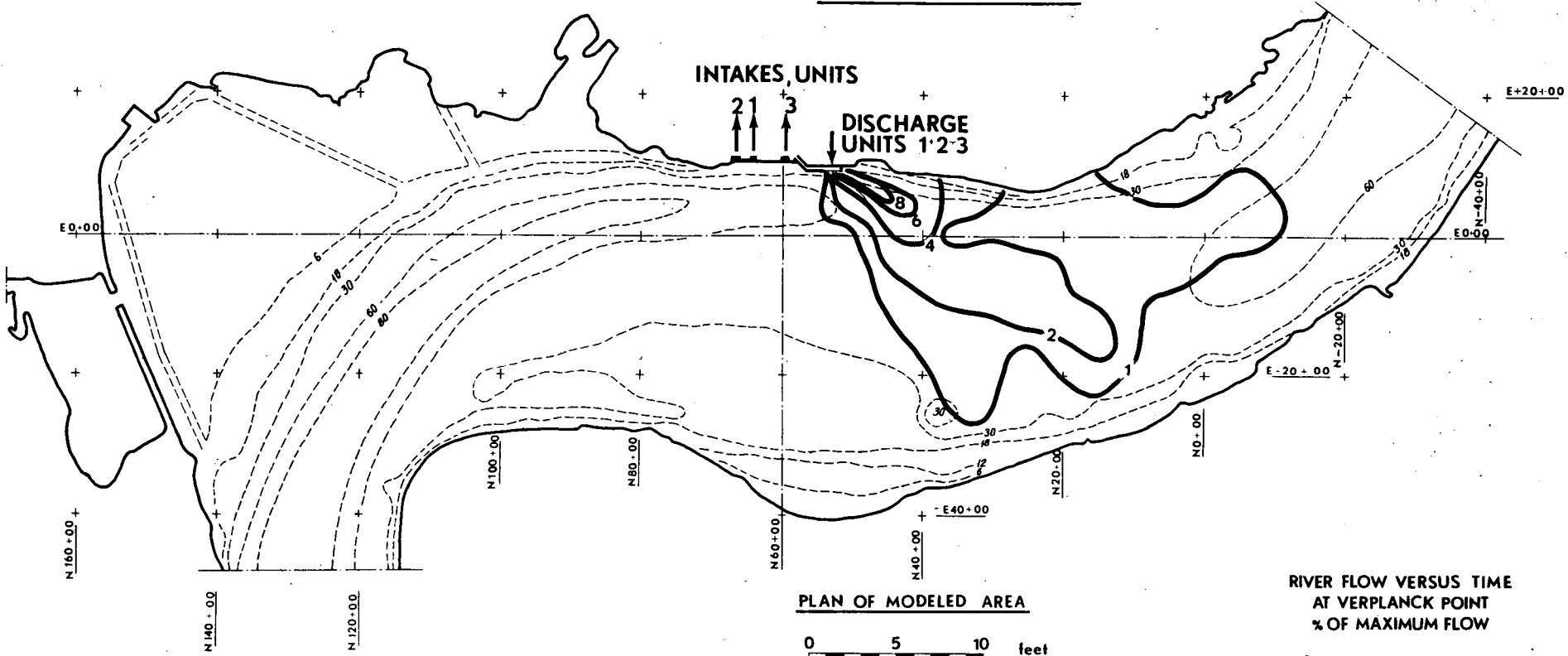

PLAN OF MODELED AREA

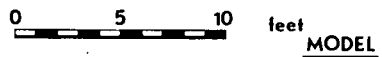

SCALES

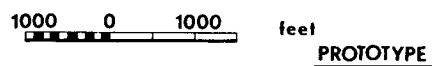

**RIVER FLOW VERSUS TIME AT VERPLANCK POINT
% OF MAXIMUM FLOW**

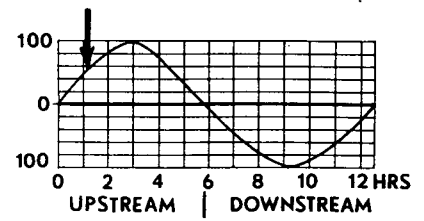

ARRANGEMENT OF OUTFALL STRUCTURE

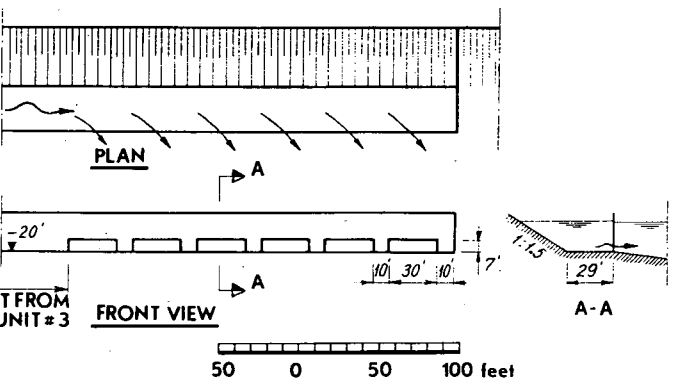

TEST CONDITIONS

TEST NUMBER AND DATE 533 ; NOV 30, 1968
 UNITS OPERATING AND DISCHARGE 3 ; 4670 cfs
 DISCHARGE TEMPERATURE ABOVE AMBIENT RIVER 16.4 °F
 TIME IN TIDE CYCLE SEE DIAGRAM
 RIVER AMBIENT TEMPERATURE 80 °F
 AIR TEMPERATURE DRY BULB 83.7 °F
 AIR TEMPERATURE WET BULB 78 °F
 RELATIVE HUMIDITY 77 %
 DEPTH OF ISOTHERMS 0 feet
 ISOTHERMS ARE DEGREES ABOVE AMBIENT RIVER TEMPERATURE

ALDEN RESEARCH LABORATORIES
 WORCESTER POLYTECHNIC INSTITUTE
 HYDRAULIC MODEL STUDIES
 FOR
 CONSOLIDATED EDISON COMPANY, N. Y.

INDIAN POINT II MODEL

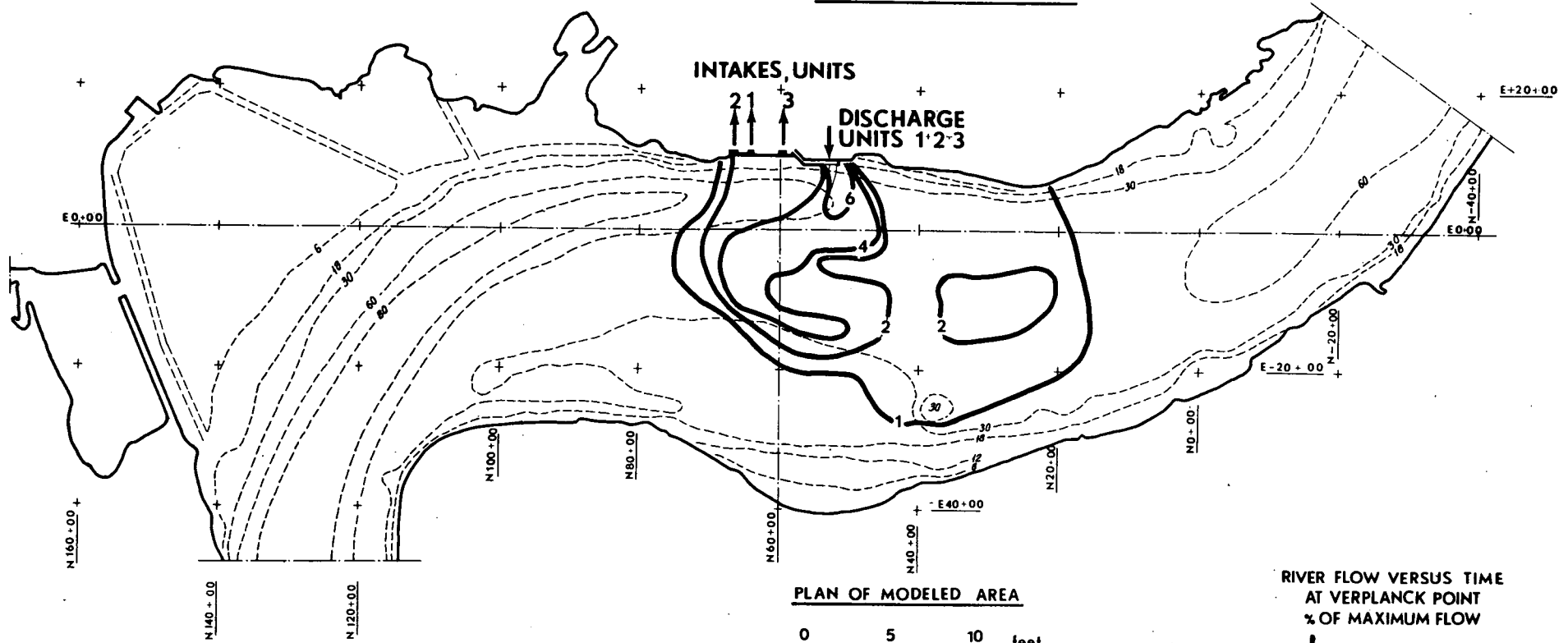

PLAN OF MODELED AREA

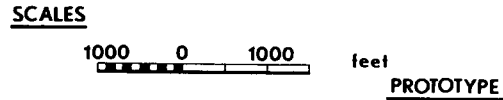

RIVER FLOW VERSUS TIME AT VERPLANCK POINT
% OF MAXIMUM FLOW

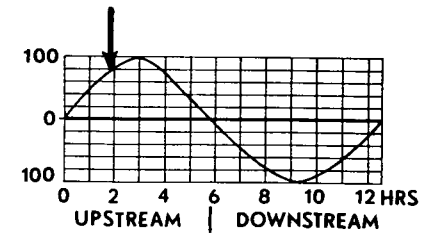

ARRANGEMENT OF OUTFALL STRUCTURE

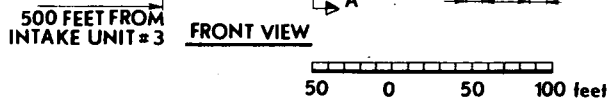
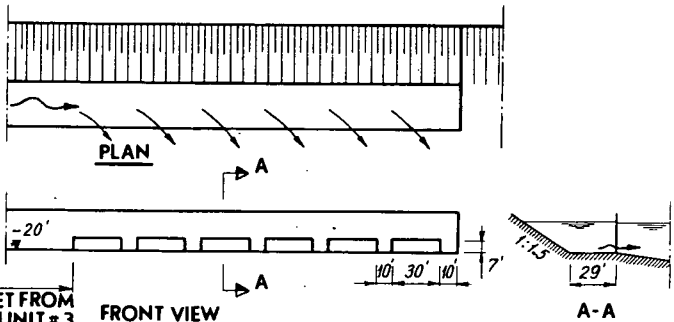

TEST CONDITIONS

TEST NUMBER AND DATE 533 ; NOV 30, 1968
 UNITS OPERATING AND DISCHARGE 3 ; 4670 cfs
 DISCHARGE TEMPERATURE ABOVE AMBIENT RIVER 16.4 °F
 TIME IN TIDE CYCLE SEE DIAGRAM
 RIVER AMBIENT TEMPERATURE 80 °F
 AIR TEMPERATURE DRY BULB 83.7 °F
 AIR TEMPERATURE WET BULB 78 °F
 RELATIVE HUMIDITY 77 %
 DEPTH OF ISOTHERMS 0 feet
 ISOTHERMS ARE DEGREES ABOVE AMBIENT RIVER TEMPERATURE.

ALDEN RESEARCH LABORATORIES
 WORCESTER POLYTECHNIC INSTITUTE
 HYDRAULIC MODEL STUDIES
 FOR
 CONSOLIDATED EDISON COMPANY, N. Y.

INDIAN POINT II MODEL

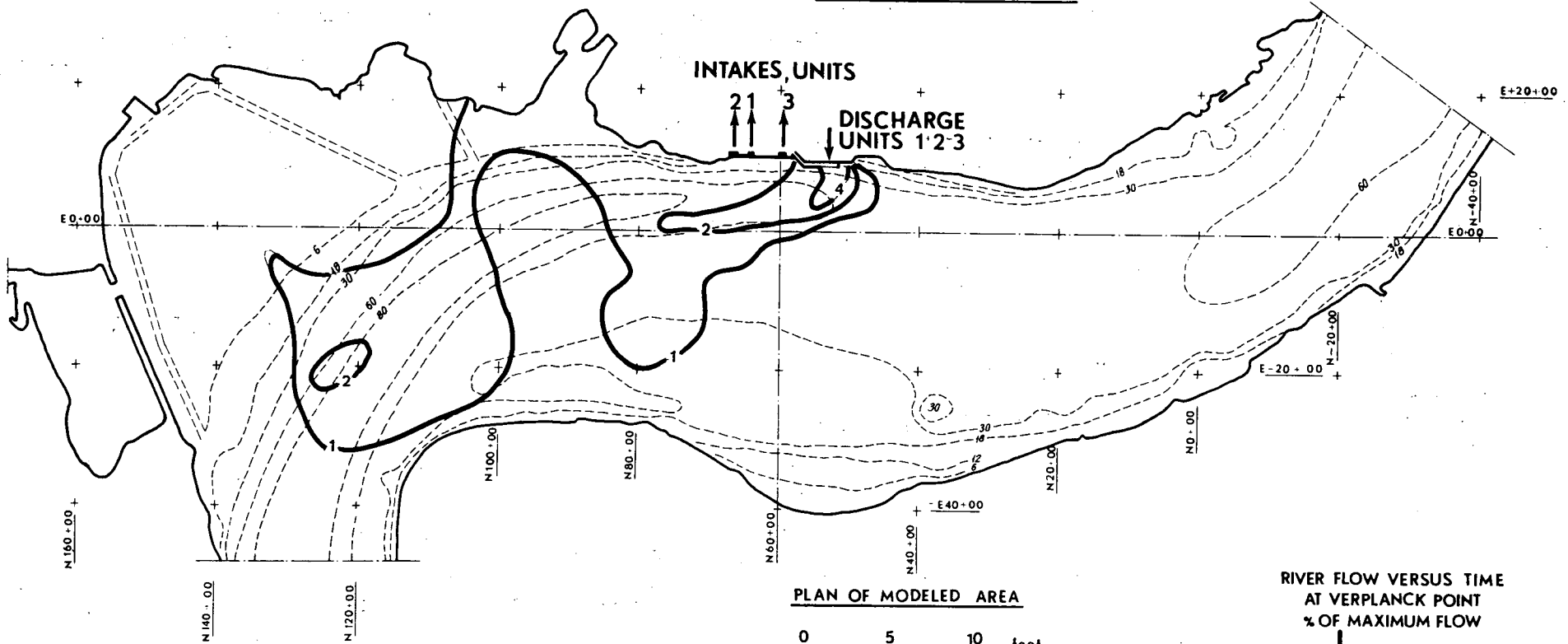

PLAN OF MODELED AREA

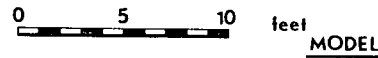

SCALES

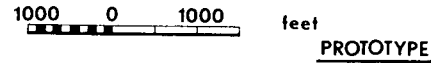

TEST CONDITIONS

TEST NUMBER AND DATE 533 ; NOV 30, 1968
 UNITS OPERATING AND DISCHARGE 3; 4670 cfs
 DISCHARGE TEMPERATURE ABOVE AMBIENT RIVER 16.4 °F
 TIME IN TIDE CYCLE SEE DIAGRAM
 RIVER AMBIENT TEMPERATURE 80 °F
 AIR TEMPERATURE DRY BULB 83.7 °F
 AIR TEMPERATURE WET BULB 78 °F
 RELATIVE HUMIDITY 77 %
 DEPTH OF ISOTHERMS 0 feet
 ISOTHERMS ARE DEGREES ABOVE AMBIENT RIVER TEMPERATURE

**RIVER FLOW VERSUS TIME AT VERPLANCK POINT
% OF MAXIMUM FLOW**

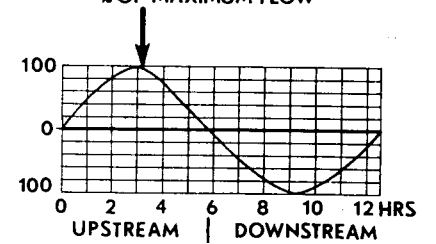

ARRANGEMENT OF OUTFALL STRUCTURE

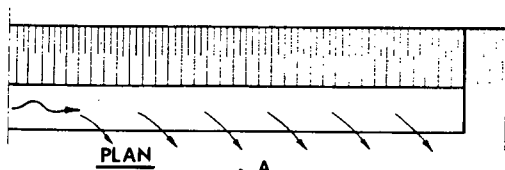

PLAN

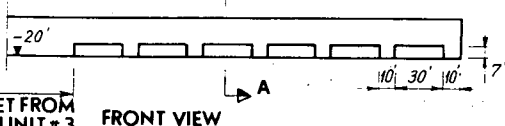

FRONT VIEW

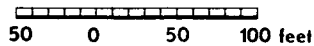

A-A

ALDEN RESEARCH LABORATORIES
 WORCESTER POLYTECHNIC INSTITUTE
 HYDRAULIC MODEL STUDIES
 FOR
 CONSOLIDATED EDISON COMPANY, N. Y.

500 FEET FROM INTAKE UNIT #3

INDIAN POINT II MODEL

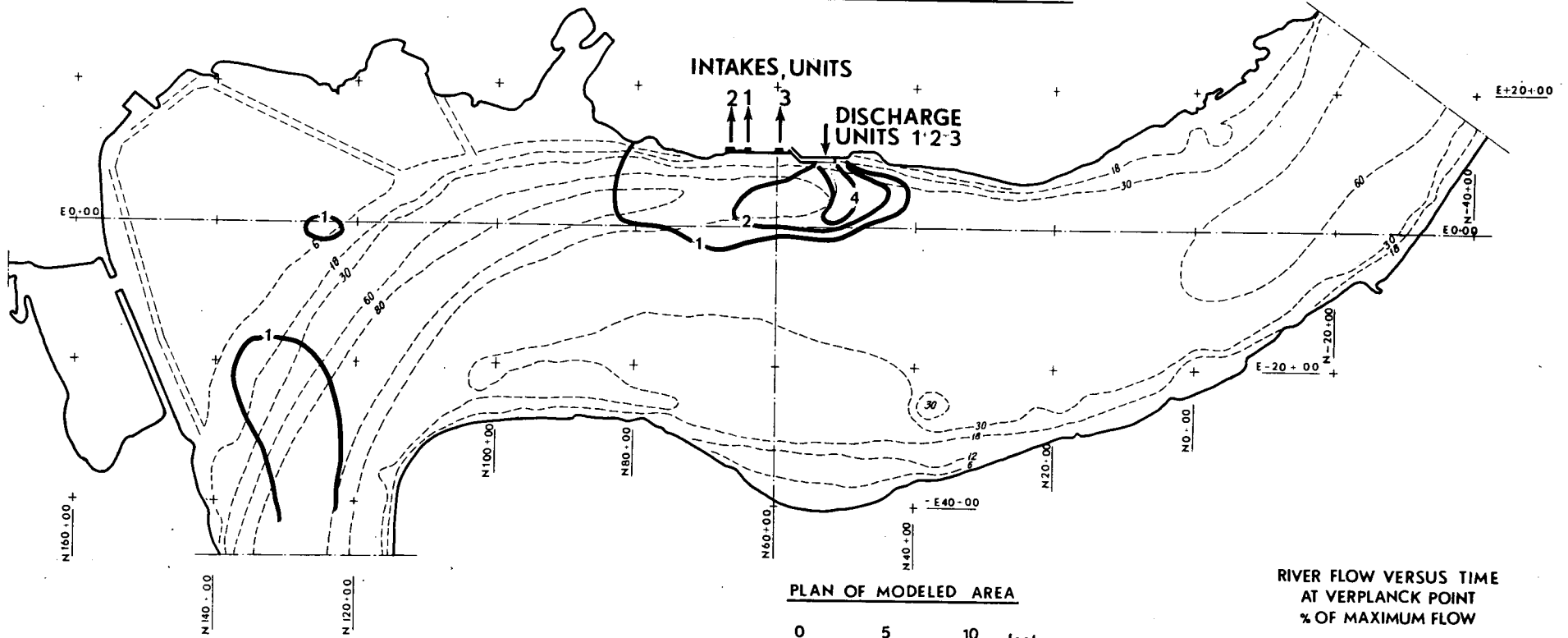

PLAN OF MODELED AREA

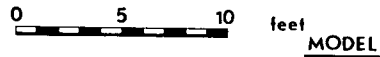

SCALES

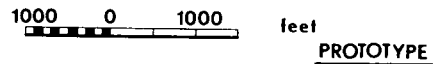

**RIVER FLOW VERSUS TIME AT VERPLANCK POINT
% OF MAXIMUM FLOW**

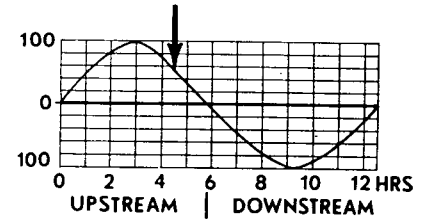

ARRANGEMENT OF OUTFALL STRUCTURE

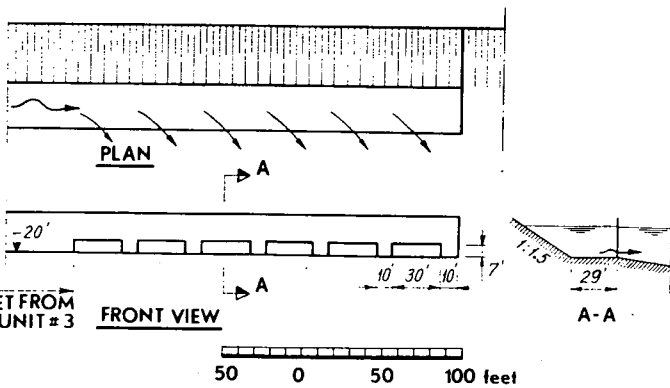

TEST CONDITIONS

TEST NUMBER AND DATE 533 ; NOV 30, 196870
 UNITS OPERATING AND DISCHARGE 3; 4670 cfs
 DISCHARGE TEMPERATURE ABOVE AMBIENT RIVER 16.4 °F
 TIME IN TIDE CYCLE SEE DIAGRAM
 RIVER AMBIENT TEMPERATURE 80 °F
 AIR TEMPERATURE DRY BULB 83.7 °F
 AIR TEMPERATURE WET BULB 78 °F
 RELATIVE HUMIDITY 77 %
 DEPTH OF ISOTHERMS 0 feet
 ISOTHERMS ARE DEGREES ABOVE AMBIENT RIVER TEMPERATURE

ALDEN RESEARCH LABORATORIES
 WORCESTER POLYTECHNIC INSTITUTE
 HYDRAULIC MODEL STUDIES
 FOR
 CONSOLIDATED EDISON COMPANY, N. Y.

INDIAN POINT II MODEL

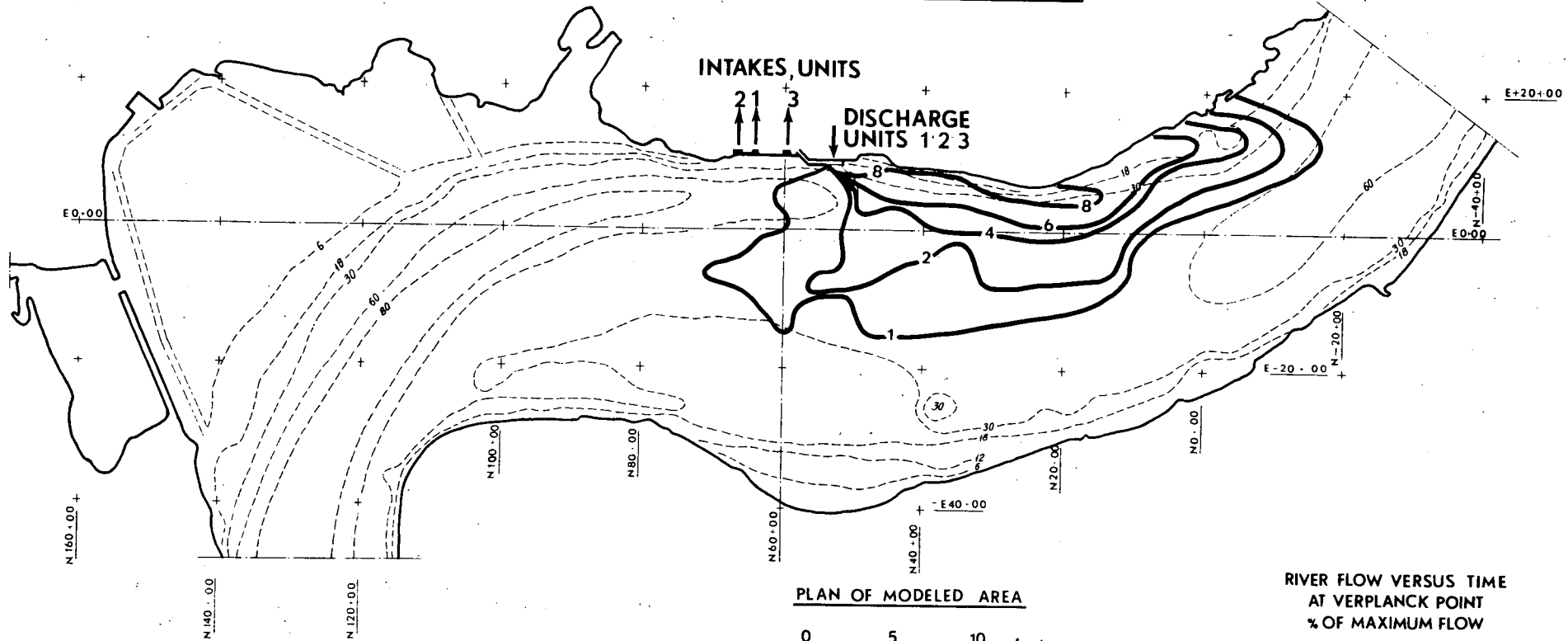

PLAN OF MODELED AREA



SCALES

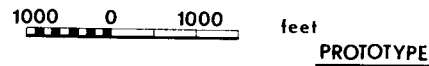

RIVER FLOW VERSUS TIME AT VERPLANCK POINT % OF MAXIMUM FLOW

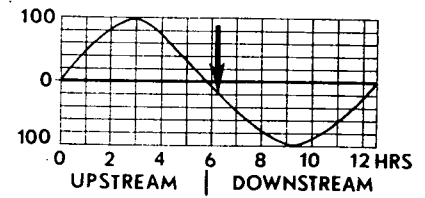

ARRANGEMENT OF OUTFALL STRUCTURE

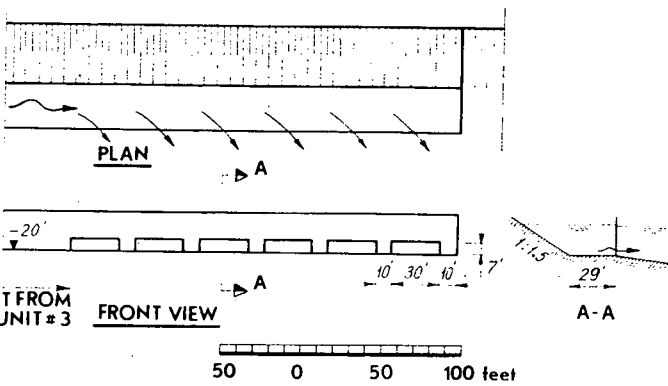

TEST CONDITIONS

TEST NUMBER AND DATE 533 ; NOV 30, 1968
 UNITS OPERATING AND DISCHARGE 3; 4670 cfs
 DISCHARGE TEMPERATURE ABOVE AMBIENT RIVER 16.4 °F
 TIME IN TIDE CYCLE SEE DIAGRAM
 RIVER AMBIENT TEMPERATURE 80 °F
 AIR TEMPERATURE DRY BULB 83.7 °F
 AIR TEMPERATURE WET BULB 78 °F
 RELATIVE HUMIDITY 77 %
 DEPTH OF ISOTHERMS 0 feet
 ISOTHERMS ARE DEGREES ABOVE AMBIENT RIVER TEMPERATURE

ALDEN RESEARCH LABORATORIES
 WORCESTER POLYTECHNIC INSTITUTE
 HYDRAULIC MODEL STUDIES
 FOR
 CONSOLIDATED EDISON COMPANY, N. Y.

INDIAN POINT II MODEL

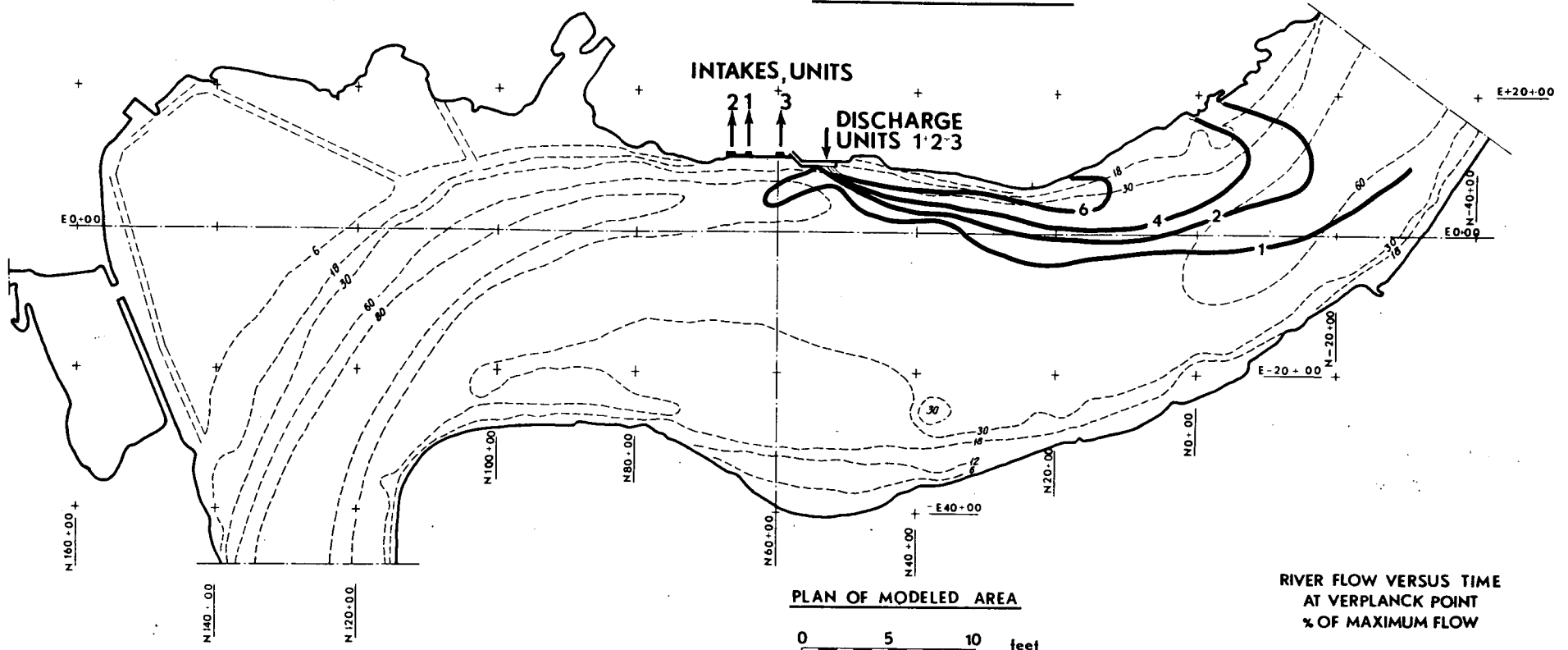

PLAN OF MODELED AREA

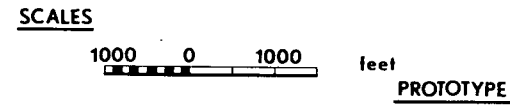

**RIVER FLOW VERSUS TIME AT VERPLANCK POINT
% OF MAXIMUM FLOW**

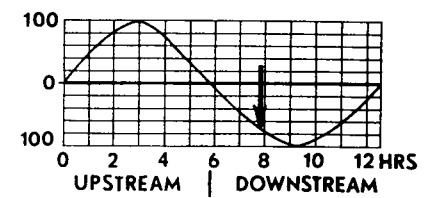

ARRANGEMENT OF OUTFALL STRUCTURE

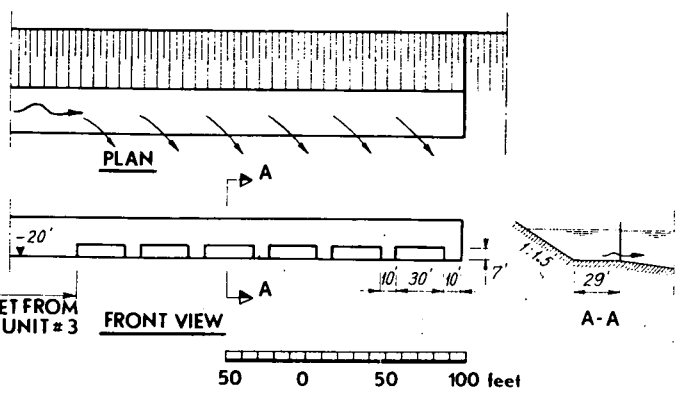

TEST CONDITIONS

TEST NUMBER AND DATE 533 ; NOV 30, 1968
 UNITS OPERATING AND DISCHARGE 3 ; 4670 cfs
 DISCHARGE TEMPERATURE ABOVE AMBIENT RIVER 16.4 °F
 TIME IN TIDE CYCLE SEE DIAGRAM
 RIVER AMBIENT TEMPERATURE 80 °F
 AIR TEMPERATURE DRY BULB 83.7 °F
 AIR TEMPERATURE WET BULB 78 °F
 RELATIVE HUMIDITY 77 %
 DEPTH OF ISOTHERMS 0 feet
 ISOTHERMS ARE DEGREES ABOVE AMBIENT RIVER TEMPERATURE

ALDEN RESEARCH LABORATORIES
 WORCESTER POLYTECHNIC INSTITUTE
 HYDRAULIC MODEL STUDIES
 FOR
 CONSOLIDATED EDISON COMPANY, N. Y.

FIG. 60

INDIAN POINT II MODEL

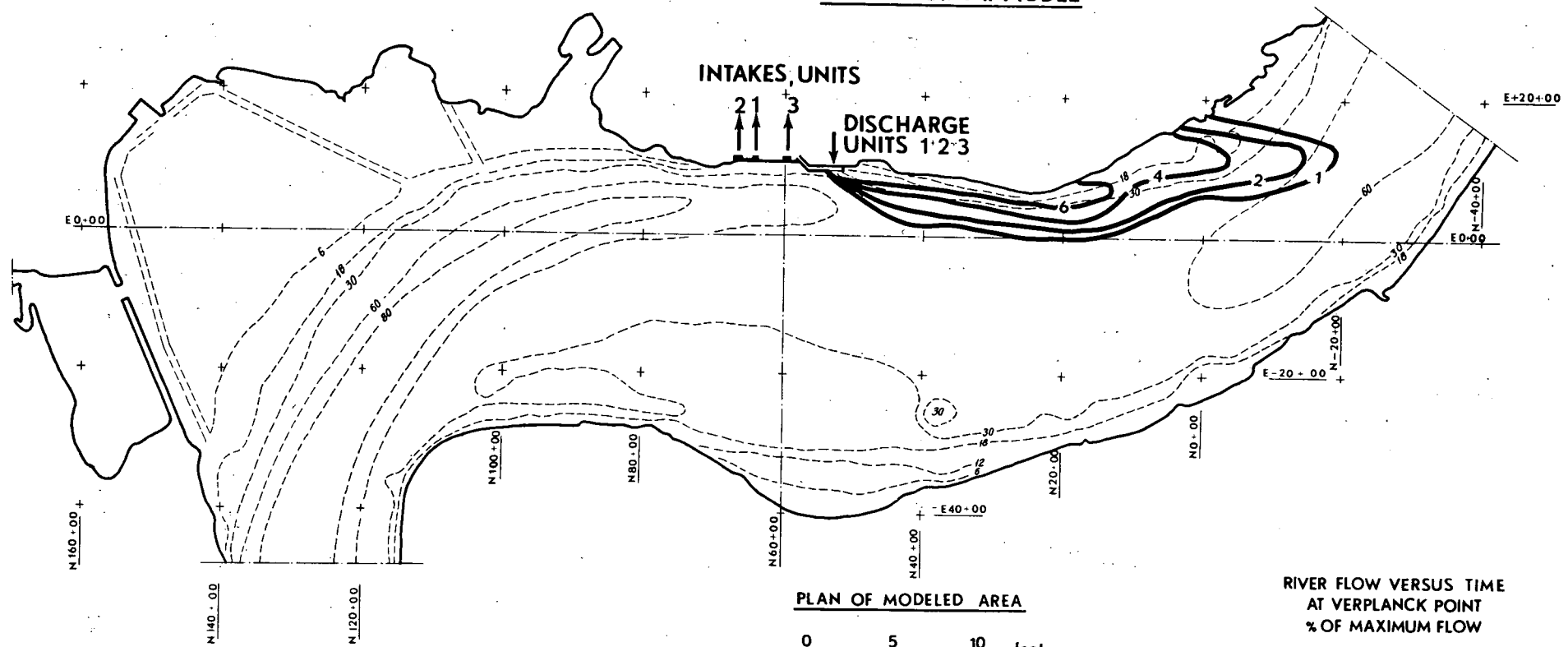

PLAN OF MODELED AREA

SCALES

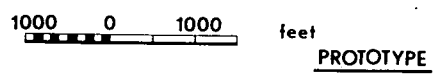

**RIVER FLOW VERSUS TIME AT VERPLANCK POINT
% OF MAXIMUM FLOW**

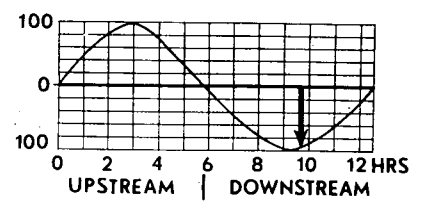

ARRANGEMENT OF OUTFALL STRUCTURE

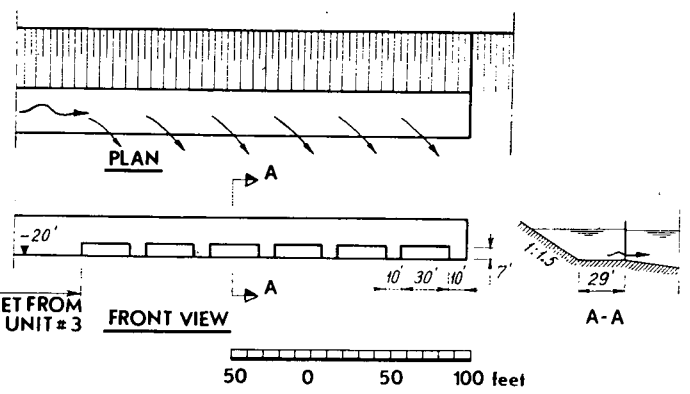

TEST CONDITIONS

TEST NUMBER AND DATE 533 ; NOV 30 ,1968
 UNITS OPERATING AND DISCHARGE 3 ; 4670 cfs
 DISCHARGE TEMPERATURE ABOVE AMBIENT RIVER 16.4 °F
 TIME IN TIDE CYCLE SEE DIAGRAM
 RIVER AMBIENT TEMPERATURE 80 °F
 AIR TEMPERATURE DRY BULB 83.7 °F
 AIR TEMPERATURE WET BULB 78 °F
 RELATIVE HUMIDITY 77 %
 DEPTH OF ISOTHERMS 0 feet
 ISOTHERMS ARE DEGREES ABOVE AMBIENT RIVER TEMPERATURE

ALDEN RESEARCH LABORATORIES
 WORCESTER POLYTECHNIC INSTITUTE
 HYDRAULIC MODEL STUDIES
 FOR
 CONSOLIDATED EDISON COMPANY, N. Y.

INDIAN POINT II MODEL

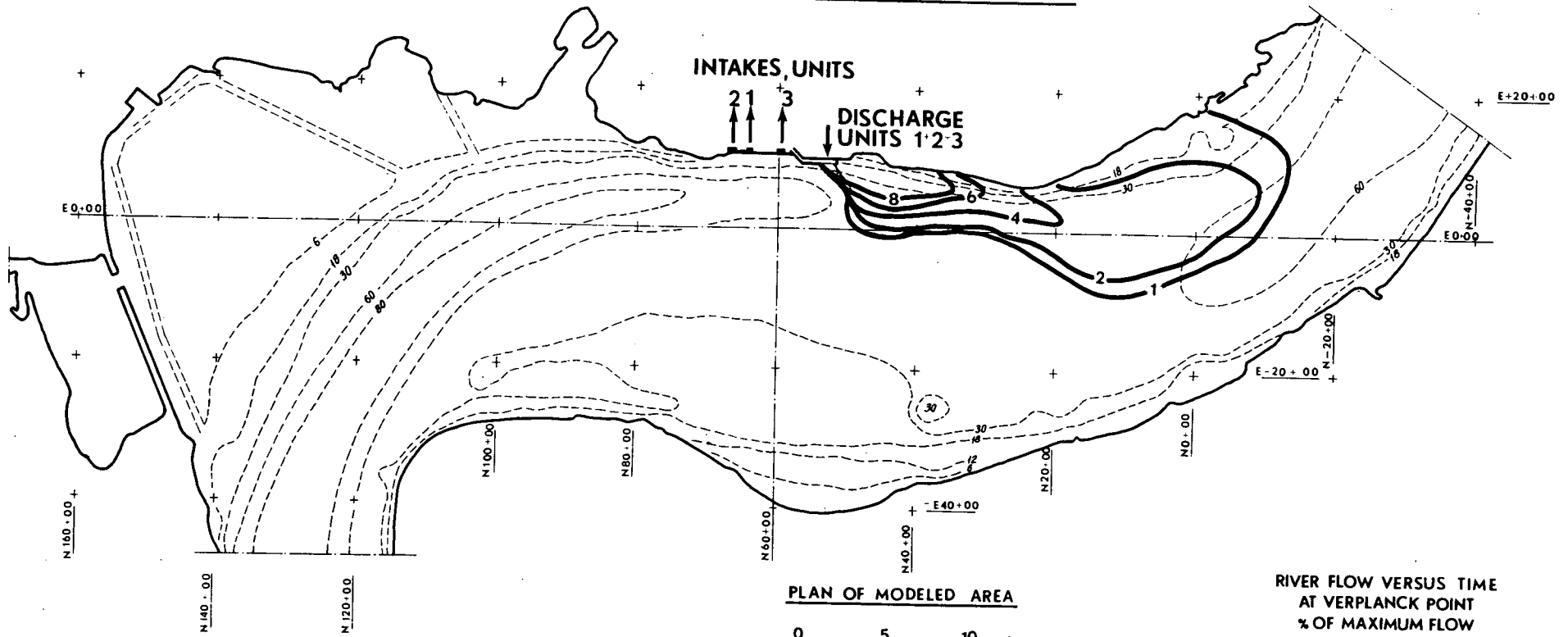

PLAN OF MODELED AREA



SCALES

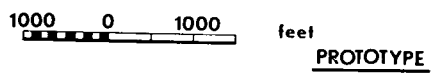

RIVER FLOW VERSUS TIME AT VERPLANCK POINT
% OF MAXIMUM FLOW

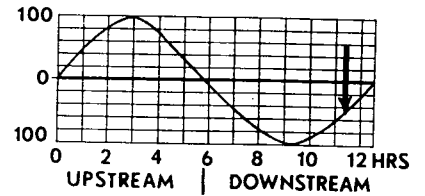

ARRANGEMENT OF OUTFALL STRUCTURE

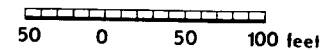
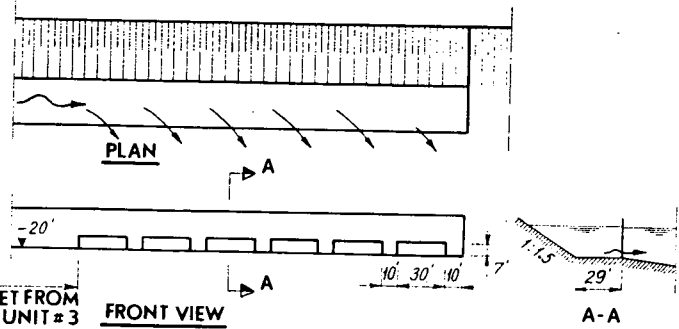

TEST CONDITIONS

TEST NUMBER AND DATE 533 ; NOV 30, 1968
 UNITS OPERATING AND DISCHARGE 3 ; 4670 cfs
 DISCHARGE TEMPERATURE ABOVE AMBIENT RIVER 16.4 °F
 TIME IN TIDE CYCLE SEE DIAGRAM
 RIVER AMBIENT TEMPERATURE 80 °F
 AIR TEMPERATURE DRY BULB 83.7 °F
 AIR TEMPERATURE WET BULB 78 °F
 RELATIVE HUMIDITY 77 %
 DEPTH OF ISOTHERMS 0 feet
 ISOTHERMS ARE DEGREES ABOVE AMBIENT RIVER TEMPERATURE

ALDEN RESEARCH LABORATORIES
 WORCESTER POLYTECHNIC INSTITUTE
 HYDRAULIC MODEL STUDIES
 FOR
 CONSOLIDATED EDISON COMPANY, N. Y.

INDIAN POINT II MODEL

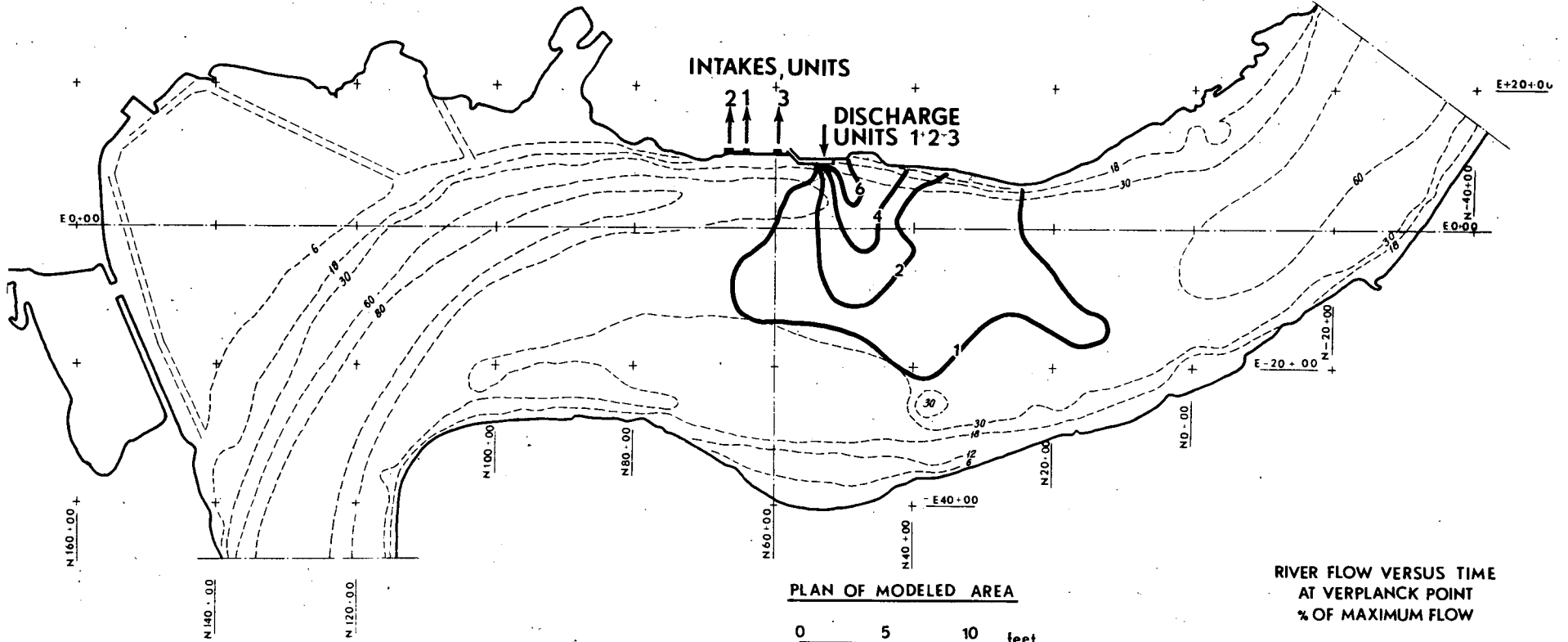

PLAN OF MODELED AREA

SCALES

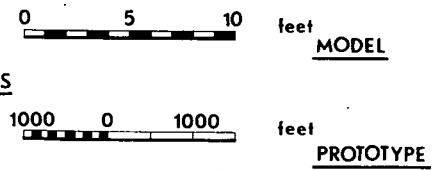

**RIVER FLOW VERSUS TIME AT VERPLANCK POINT
% OF MAXIMUM FLOW**

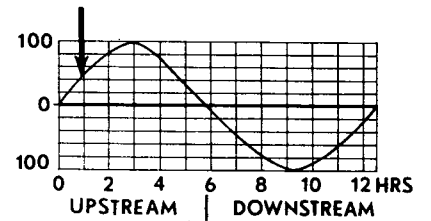

ARRANGEMENT OF OUTFALL STRUCTURE

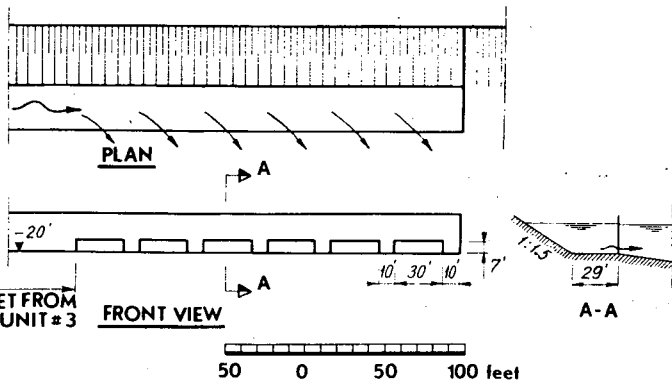

TEST CONDITIONS

TEST NUMBER AND DATE 534 ; DEC 2, 1968
 UNITS OPERATING AND DISCHARGE 3 ; 4670 cfs
 DISCHARGE TEMPERATURE ABOVE AMBIENT RIVER 16.4 °F
 TIME IN TIDE CYCLE SEE DIAGRAM
 RIVER AMBIENT TEMPERATURE 80.0 °F
 AIR TEMPERATURE DRY BULB 87.8 °F
 AIR TEMPERATURE WET BULB 84.0 °F
 RELATIVE HUMIDITY 84 %
 DEPTH OF ISOTHERMS 6feet
 ISOTHERMS ARE DEGREES ABOVE AMBIENT RIVER TEMPERATURE

ALDEN RESEARCH LABORATORIES
 WORCESTER POLYTECHNIC INSTITUTE
 HYDRAULIC MODEL STUDIES
 FOR
 CONSOLIDATED EDISON COMPANY, N. Y.

INDIAN POINT II MODEL

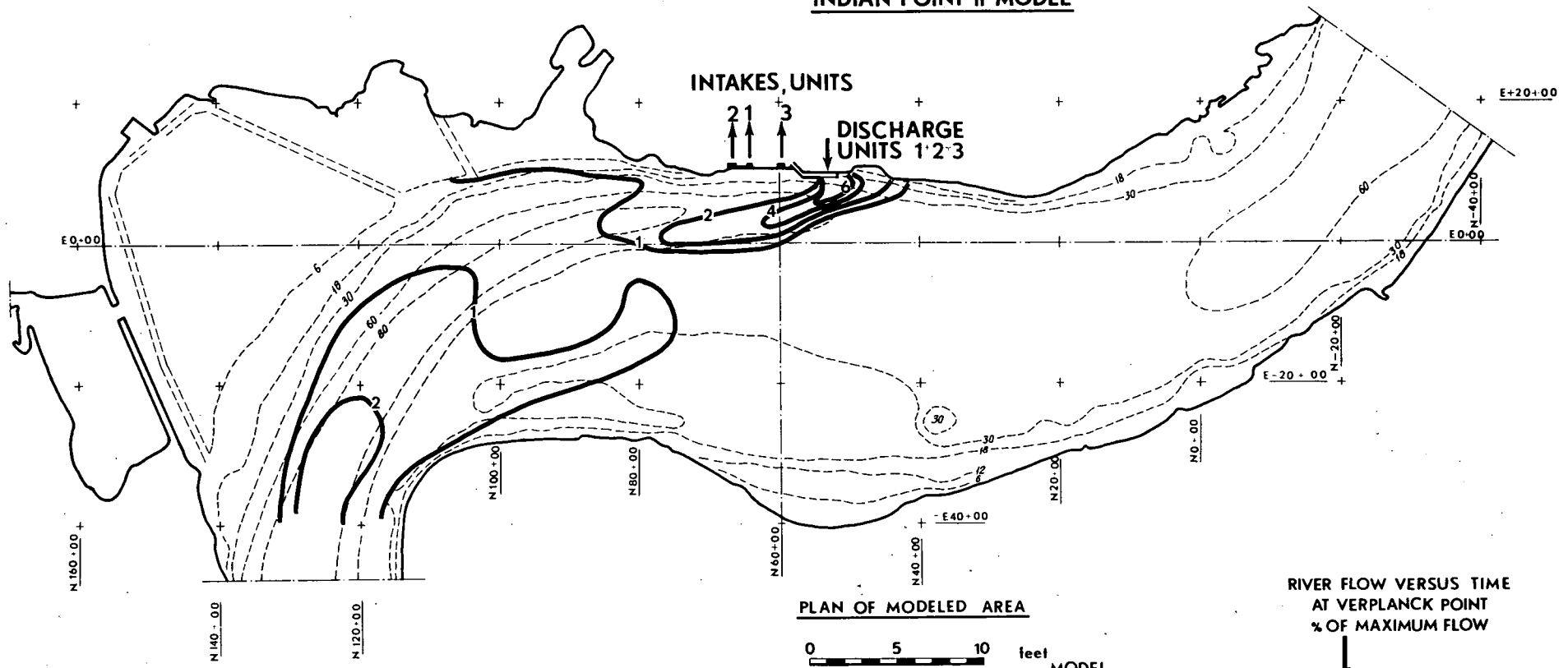

PLAN OF MODELED AREA

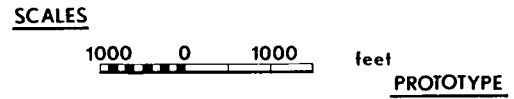
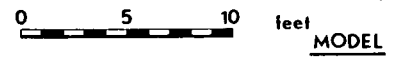

RIVER FLOW VERSUS TIME AT VERPLANCK POINT
% OF MAXIMUM FLOW

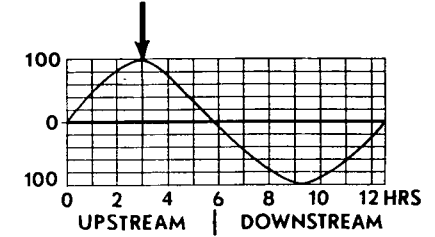

ARRANGEMENT OF OUTFALL STRUCTURE

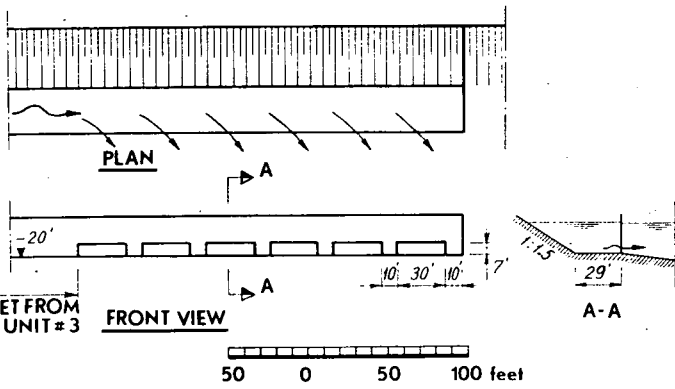

TEST CONDITIONS

TEST NUMBER AND DATE 534 ; DEC 2, 1968
 UNITS OPERATING AND DISCHARGE 3 ; 4670 cfs
 DISCHARGE TEMPERATURE ABOVE AMBIENT RIVER 16.4 °F
 TIME IN TIDE CYCLE SEE DIAGRAM
 RIVER AMBIENT TEMPERATURE 80.0 °F
 AIR TEMPERATURE DRY BULB 87.8 °F
 AIR TEMPERATURE WET BULB 84.0 °F
 RELATIVE HUMIDITY 84 %
 DEPTH OF ISOTHERMS 6 feet
 ISOTHERMS ARE DEGREES ABOVE AMBIENT RIVER TEMPERATURE

ALDEN RESEARCH LABORATORIES
 WORCESTER POLYTECHNIC INSTITUTE
 HYDRAULIC MODEL STUDIES
 FOR
 CONSOLIDATED EDISON COMPANY, N. Y.

INDIAN POINT II MODEL

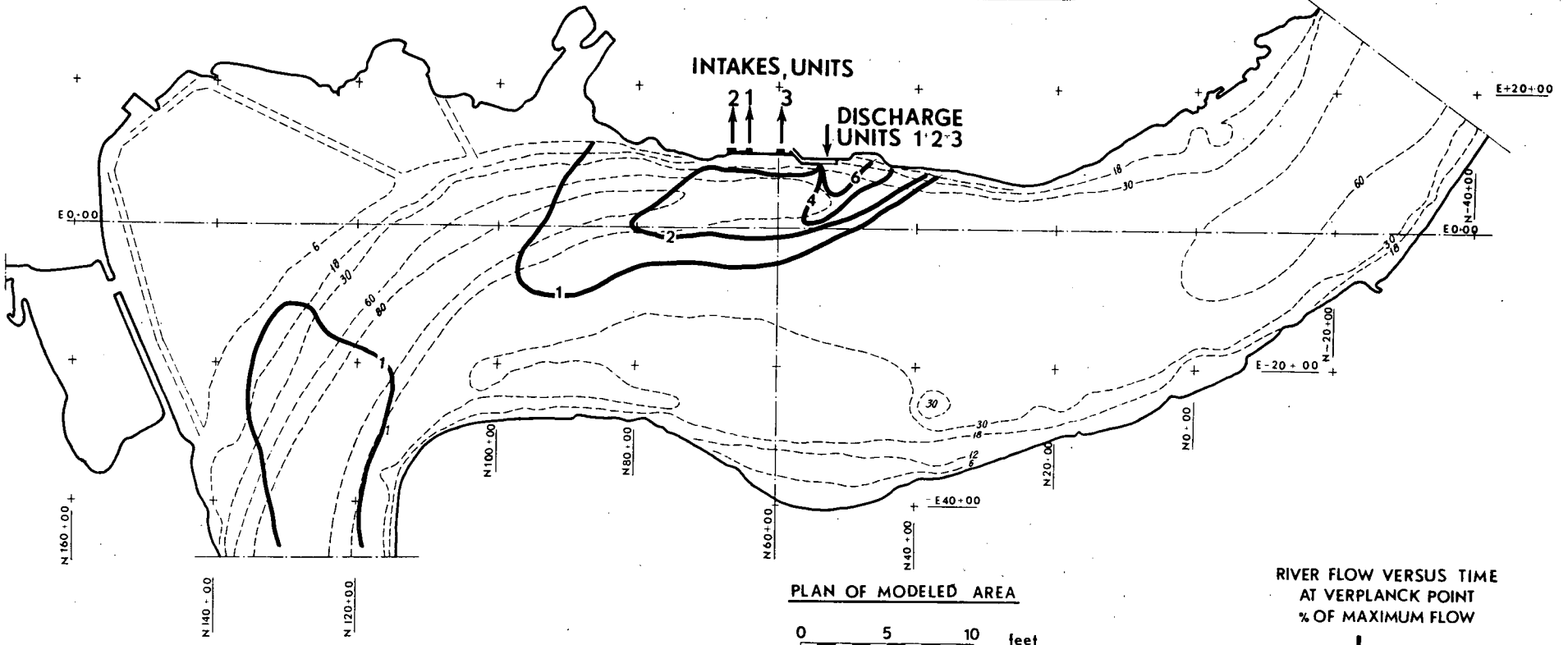

PLAN OF MODELED AREA



SCALES

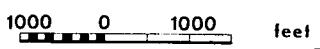

MODEL

PROTOTYPE

**RIVER FLOW VERSUS TIME AT VERPLANCK POINT
% OF MAXIMUM FLOW**

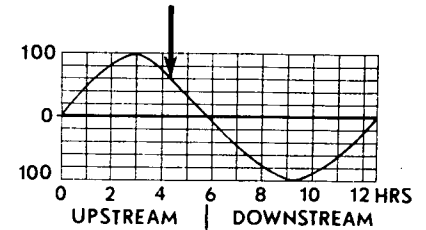

ARRANGEMENT OF OUTFALL STRUCTURE

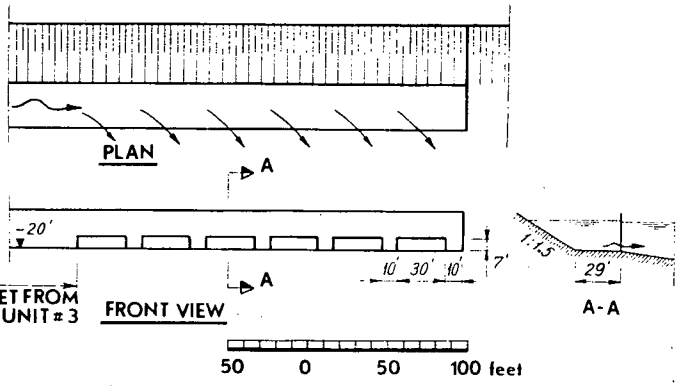

TEST CONDITIONS

TEST NUMBER AND DATE 534 DEC 2, 1968
 UNITS OPERATING AND DISCHARGE 3 : 4670 cfs
 DISCHARGE TEMPERATURE ABOVE AMBIENT RIVER 16.4 °F
 TIME IN TIDE CYCLE SEE DIAGRAM
 RIVER AMBIENT TEMPERATURE 80.0 °F
 AIR TEMPERATURE DRY BULB 87.8 °F
 AIR TEMPERATURE WET BULB 84.0 °F
 RELATIVE HUMIDITY 84 %
 DEPTH OF ISOTHERMS 6 feet
 ISOTHERMS ARE DEGREES ABOVE AMBIENT RIVER TEMPERATURE

ALDEN RESEARCH LABORATORIES
 WORCESTER POLYTECHNIC INSTITUTE
 HYDRAULIC MODEL STUDIES
 FOR
 CONSOLIDATED EDISON COMPANY, N. Y.

INDIAN POINT II MODEL

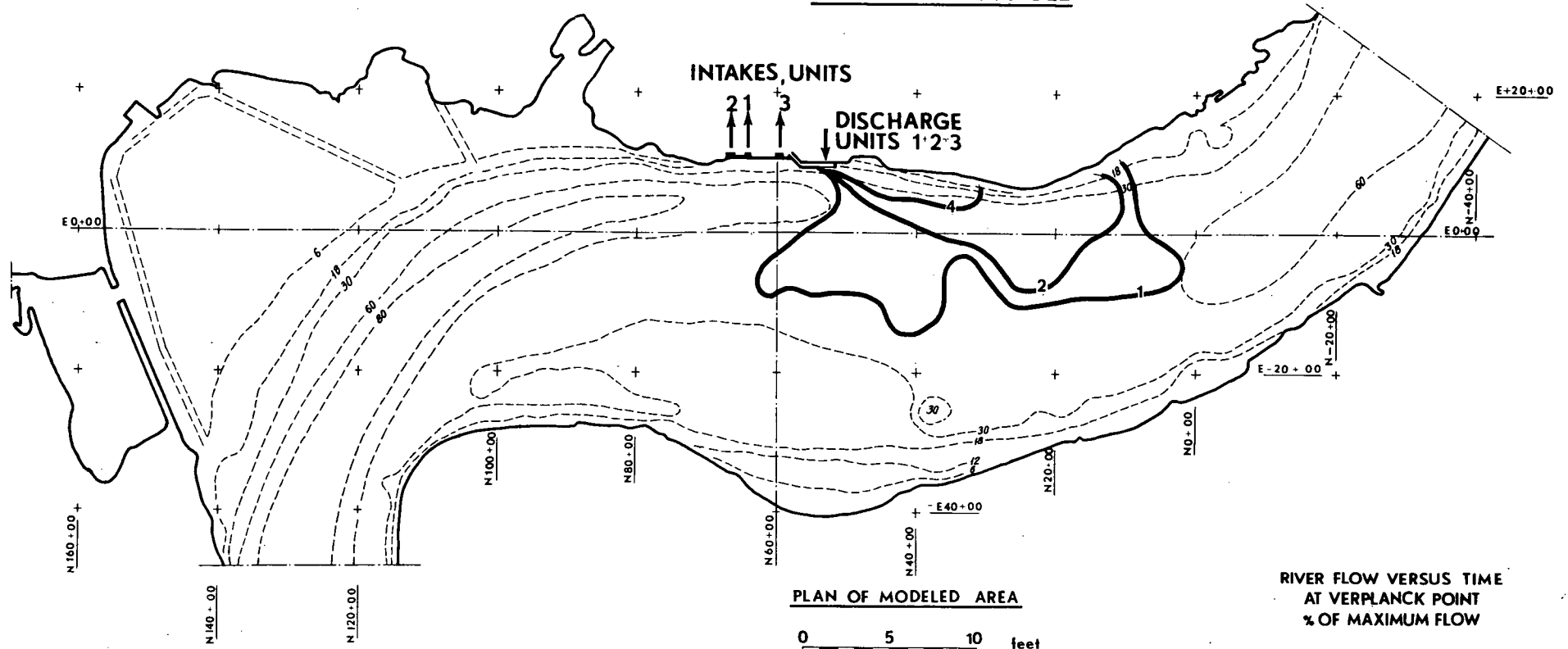

**RIVER FLOW VERSUS TIME
AT VERPLANCK POINT
% OF MAXIMUM FLOW**

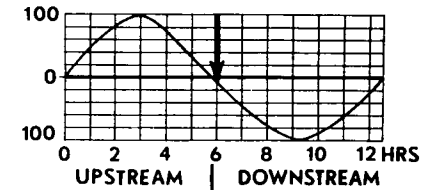

SCALES

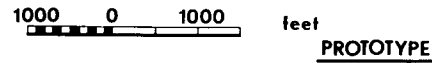

ARRANGEMENT OF OUTFALL STRUCTURE

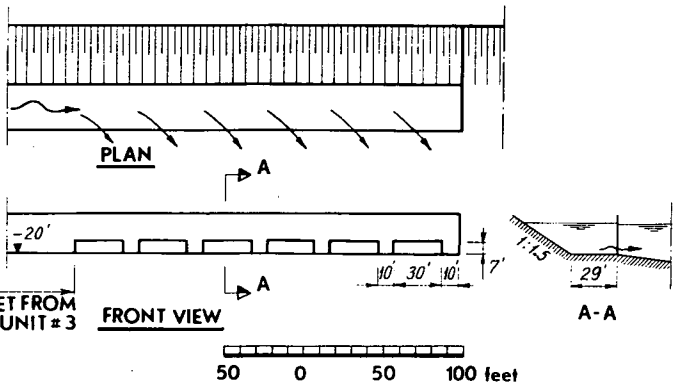

TEST CONDITIONS

TEST NUMBER AND DATE 534 ; DEC 2, 1968
 UNITS OPERATING AND DISCHARGE 3 ; 4670 cfs
 DISCHARGE TEMPERATURE ABOVE AMBIENT, RIVER 16.4 °F
 TIME IN TIDE CYCLE SEE DIAGRAM
 RIVER AMBIENT TEMPERATURE 80.0 °F
 AIR TEMPERATURE DRY BULB 87.8 °F
 AIR TEMPERATURE WET BULB 84.0 °F
 RELATIVE HUMIDITY 84 %
 DEPTH OF ISOTHERMS 6 feet
 ISOTHERMS ARE DEGREES ABOVE AMBIENT RIVER TEMPERATURE

ALDEN RESEARCH LABORATORIES
 WORCESTER POLYTECHNIC INSTITUTE
 HYDRAULIC MODEL STUDIES
 FOR
 CONSOLIDATED EDISON COMPANY, N. Y.

INDIAN POINT II MODEL

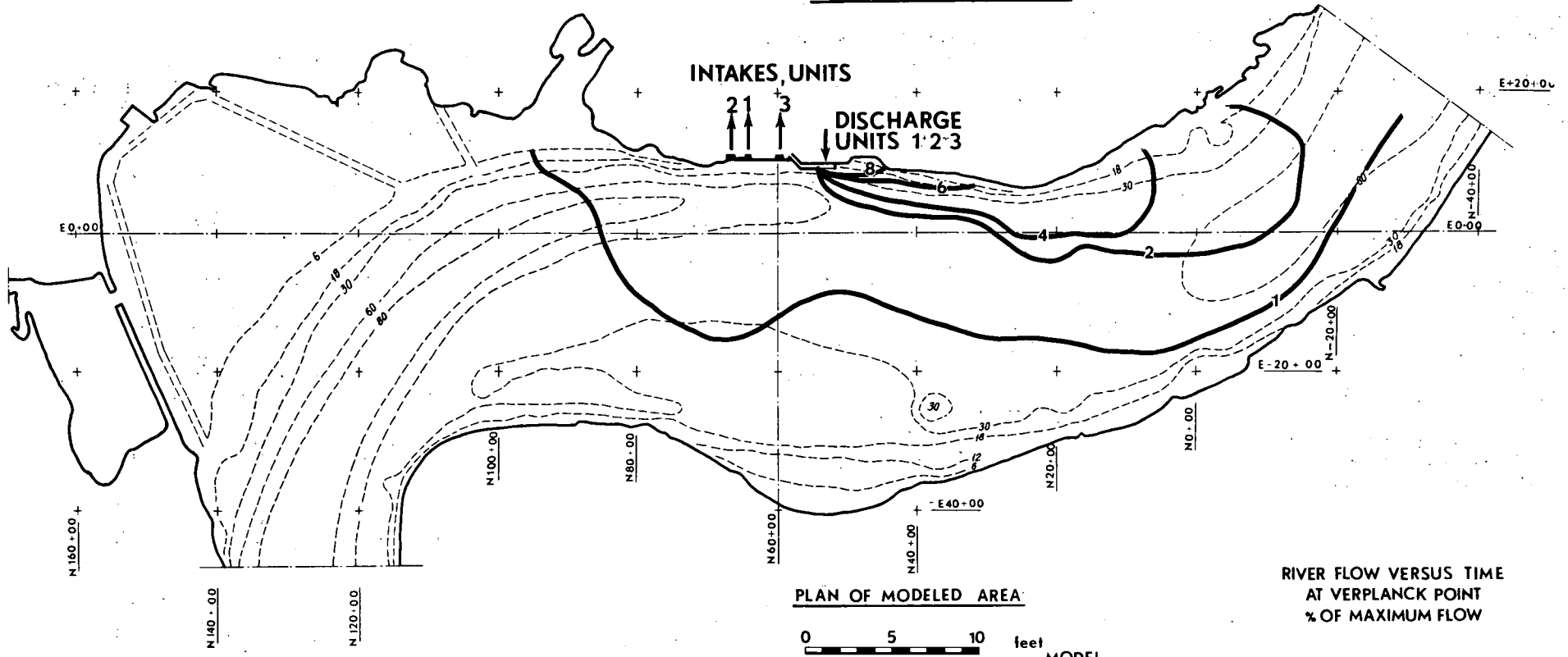

PLAN OF MODELED AREA



SCALES



MODEL

PROTOTYPE

**RIVER FLOW VERSUS TIME AT VERPLANCK POINT
% OF MAXIMUM FLOW**

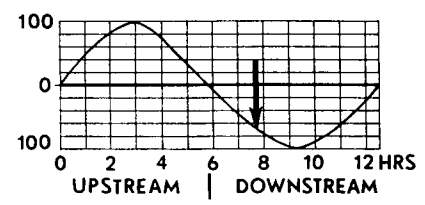

ARRANGEMENT OF OUTFALL STRUCTURE

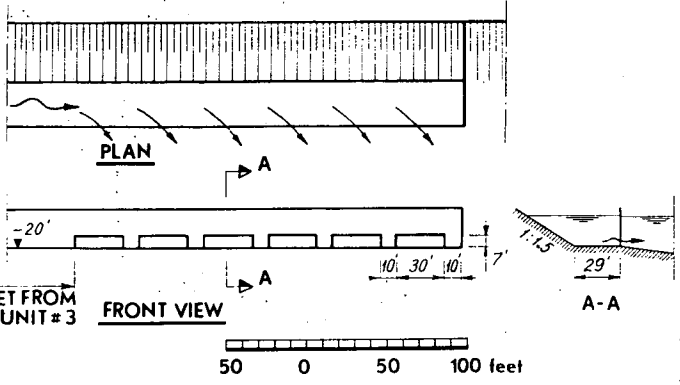

TEST CONDITIONS

TEST NUMBER AND DATE 534 ; DEC 2, 1968
 UNITS OPERATING AND DISCHARGE 3 ; 4670 cfs
 DISCHARGE TEMPERATURE ABOVE AMBIENT RIVER 16.4 °F
 TIME IN TIDE CYCLE SEE DIAGRAM
 RIVER AMBIENT TEMPERATURE 80.0 °F
 AIR TEMPERATURE DRY BULB 87.8 °F
 AIR TEMPERATURE WET BULB 84.0 °F
 RELATIVE HUMIDITY 84 %
 DEPTH OF ISOTHERMS 6 feet
 ISOTHERMS ARE DEGREES ABOVE AMBIENT RIVER TEMPERATURE

ALDEN RESEARCH LABORATORIES
 WORCESTER POLYTECHNIC INSTITUTE
 HYDRAULIC MODEL STUDIES
 FOR
 CONSOLIDATED EDISON COMPANY, N. Y.

INDIAN POINT II MODEL

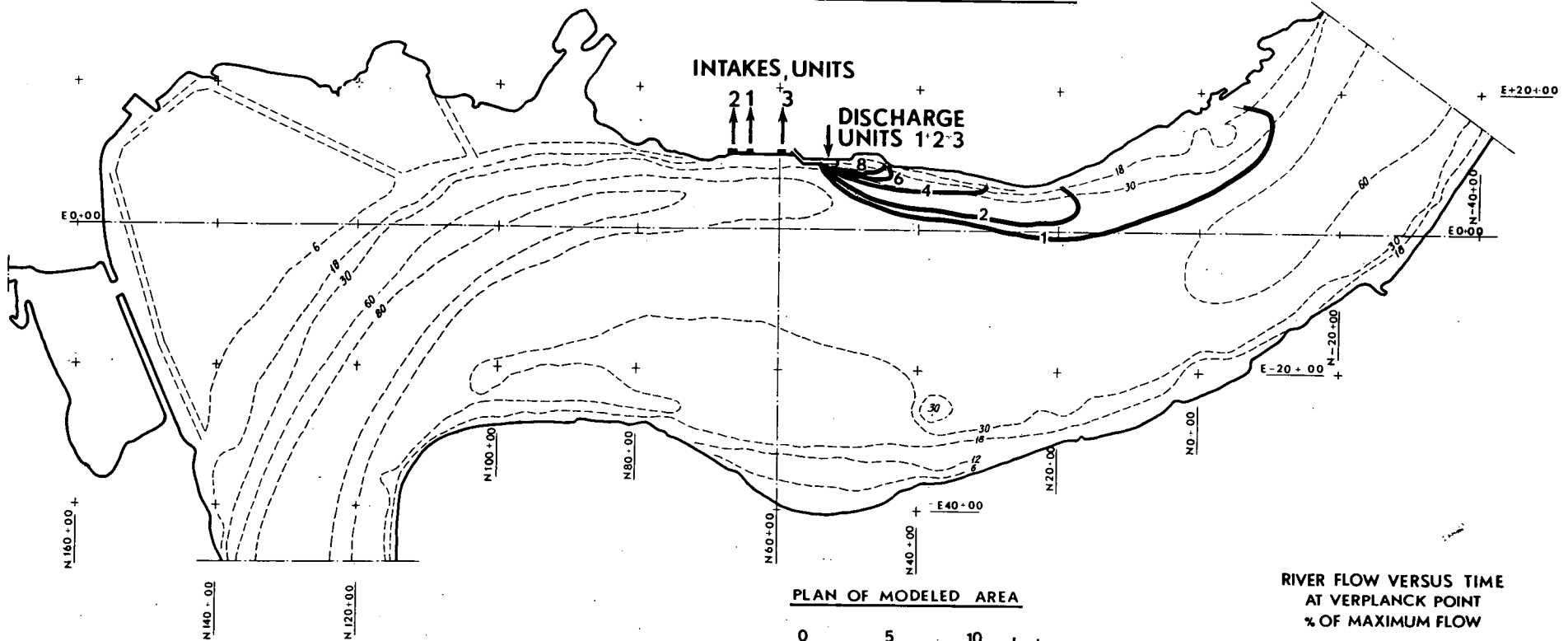

PLAN OF MODELED AREA



SCALES

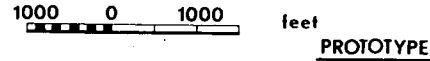

RIVER FLOW VERSUS TIME
AT VERPLANCK POINT
% OF MAXIMUM FLOW

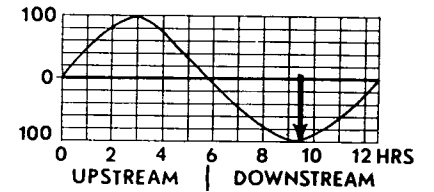

ARRANGEMENT OF OUTFALL STRUCTURE

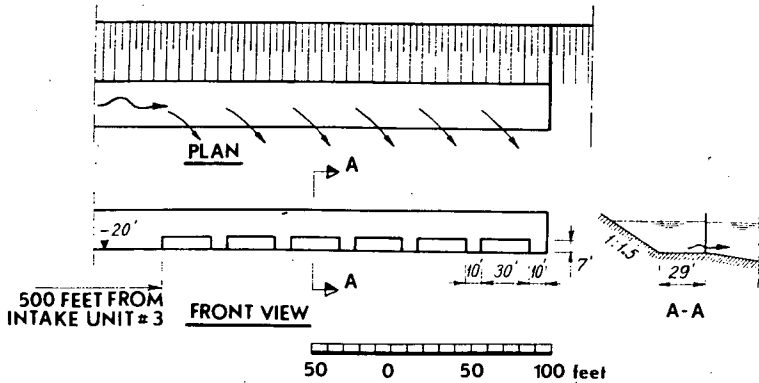

TEST CONDITIONS

TEST NUMBER AND DATE 534 ; DEC 2, 1968
 UNITS OPERATING AND DISCHARGE 3 ; 4670 cfs
 DISCHARGE TEMPERATURE ABOVE AMBIENT RIVER 16.4 °F
 TIME IN TIDE CYCLE SEE DIAGRAM
 RIVER AMBIENT TEMPERATURE 80.0 °F
 AIR TEMPERATURE DRY BULB 87.8 °F
 AIR TEMPERATURE WET BULB 84.0 °F
 RELATIVE HUMIDITY 84 %
 DEPTH OF ISOTHERMS 6 feet
 ISOTHERMS ARE DEGREES ABOVE AMBIENT RIVER TEMPERATURE

ALDEN RESEARCH LABORATORIES
 WORCESTER POLYTECHNIC INSTITUTE
 HYDRAULIC MODEL STUDIES
 FOR
 CONSOLIDATED EDISON COMPANY, N. Y.

INDIAN POINT II MODEL

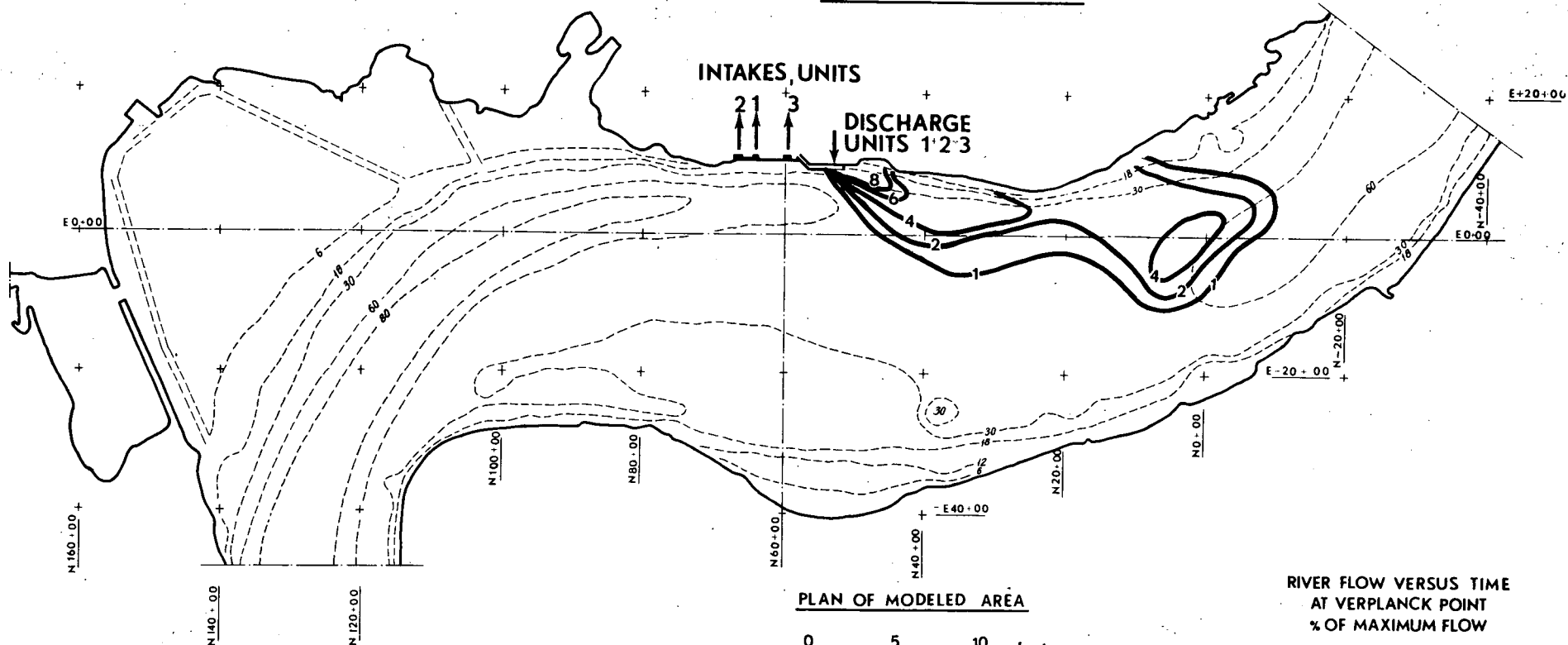

PLAN OF MODELED AREA

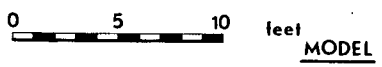

SCALES

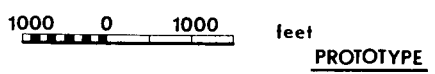

**RIVER FLOW VERSUS TIME AT VERPLANCK POINT
% OF MAXIMUM FLOW**

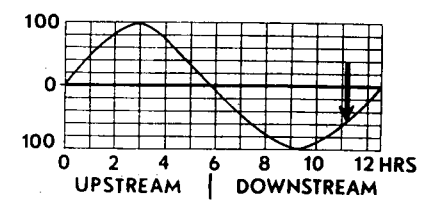

ARRANGEMENT OF OUTFALL STRUCTURE

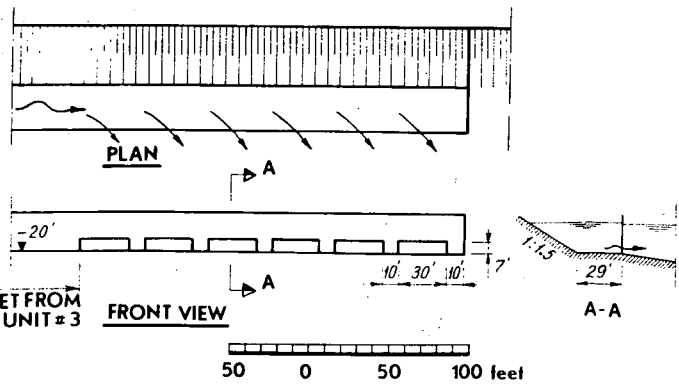

TEST CONDITIONS

TEST NUMBER AND DATE 534 ; DEC 2, 1968
 UNITS OPERATING AND DISCHARGE 3; 4670 cfs
 DISCHARGE TEMPERATURE ABOVE AMBIENT RIVER 16.4 °F
 TIME IN TIDE CYCLE SEE DIAGRAM
 RIVER AMBIENT TEMPERATURE 80.0 °F
 AIR TEMPERATURE DRY BULB 87.8 °F
 AIR TEMPERATURE WET BULB 84.0 °F
 RELATIVE HUMIDITY 84 %
 DEPTH OF ISOTHERMS 6 feet
 ISOTHERMS ARE DEGREES ABOVE AMBIENT RIVER TEMPERATURE

ALDEN RESEARCH LABORATORIES
 WORCESTER POLYTECHNIC INSTITUTE
 HYDRAULIC MODEL STUDIES
 FOR
 CONSOLIDATED EDISON COMPANY, N. Y.

INDIAN POINT II MODEL

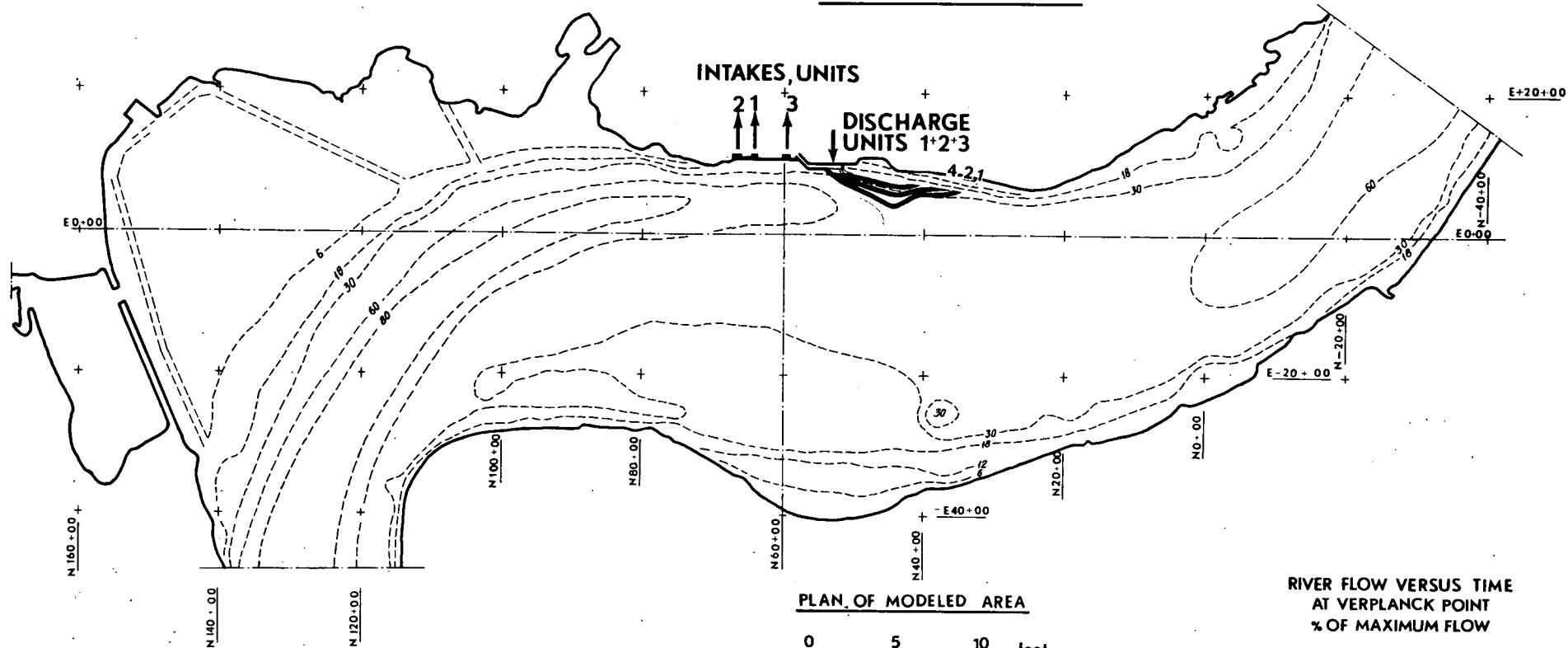

PLAN OF MODELED AREA



SCALES

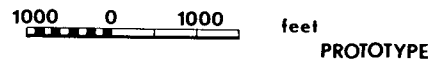

**RIVER FLOW VERSUS TIME
AT VERPLANCK POINT
% OF MAXIMUM FLOW**

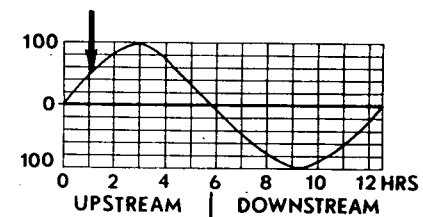

ARRANGEMENT OF OUTFALL STRUCTURE

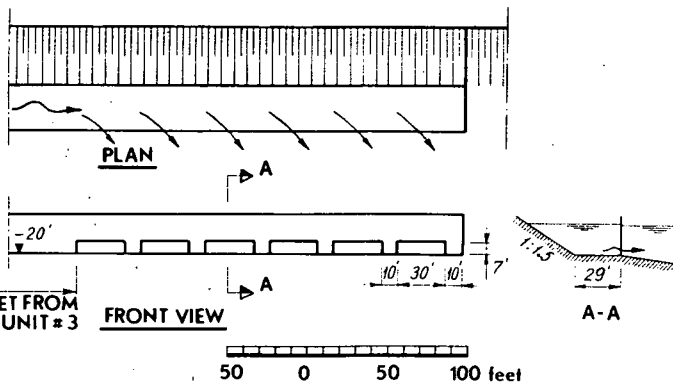

TEST CONDITIONS

TEST NUMBER AND DATE 542 ; DEC 3, 1968
 UNITS OPERATING AND DISCHARGE 3, 4, 670 cfs
 DISCHARGE TEMPERATURE ABOVE AMBIENT RIVER 16.4 °F
 TIME IN TIDE CYCLE SEE DIAGRAM
 RIVER AMBIENT TEMPERATURE 80 °F
 AIR TEMPERATURE DRY BULB 85 °F
 AIR TEMPERATURE WET BULB 77.6 °F
 RELATIVE HUMIDITY 72 %
 DEPTH OF ISOTHERMS 24 feet
 ISOTHERMS ARE DEGREES ABOVE AMBIENT RIVER TEMPERATURE

ALDEN RESEARCH LABORATORIES
 WORCESTER POLYTECHNIC INSTITUTE
 HYDRAULIC MODEL STUDIES
 FOR
 CONSOLIDATED EDISON COMPANY, N. Y.

INDIAN POINT II MODEL

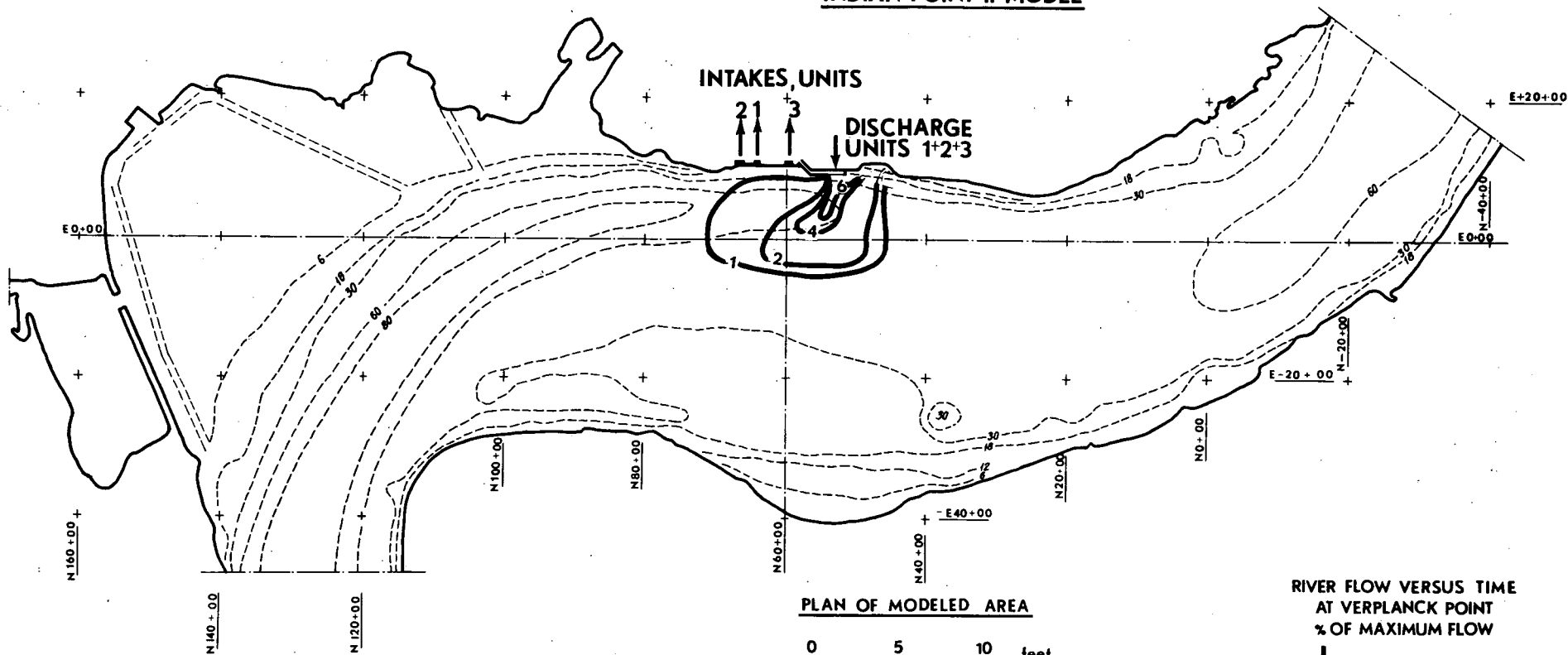

PLAN OF MODELED AREA

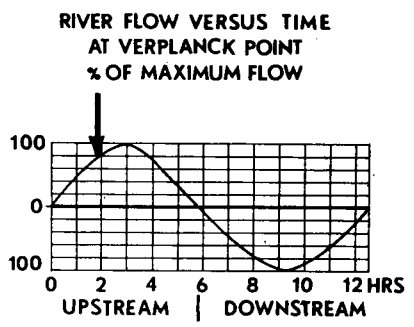
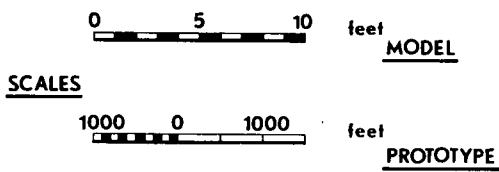

ARRANGEMENT OF OUTFALL STRUCTURE

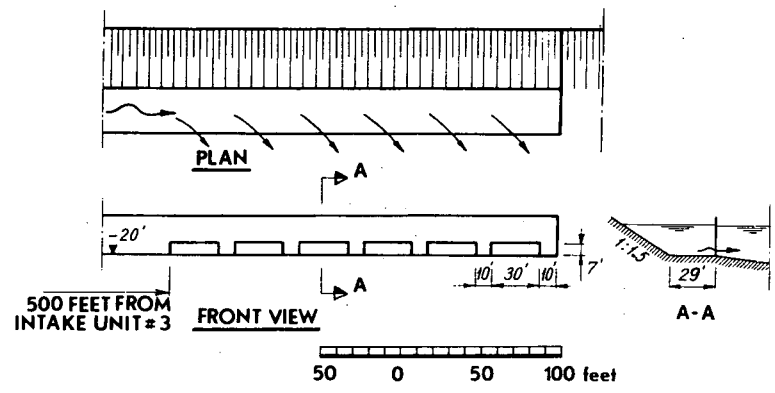

TEST CONDITIONS

TEST NUMBER AND DATE 542 ; DEC 3, 1968
 UNITS OPERATING AND DISCHARGE 3; 4670 cfs
 DISCHARGE TEMPERATURE ABOVE AMBIENT RIVER 16.4 °F
 TIME IN TIDE CYCLE SEE DIAGRAM
 RIVER AMBIENT TEMPERATURE 80 °F
 AIR TEMPERATURE DRY BULB 85 °F
 AIR TEMPERATURE WET BULB 77.6 °F
 RELATIVE HUMIDITY 72 %
 DEPTH OF ISOTHERMS 24 feet
 ISOTHERMS ARE DEGREES ABOVE AMBIENT RIVER TEMPERATURE

ALDEN RESEARCH LABORATORIES
 WORCESTER POLYTECHNIC INSTITUTE
 HYDRAULIC MODEL STUDIES
 FOR
 CONSOLIDATED EDISON COMPANY, N. Y.

INDIAN POINT II MODEL

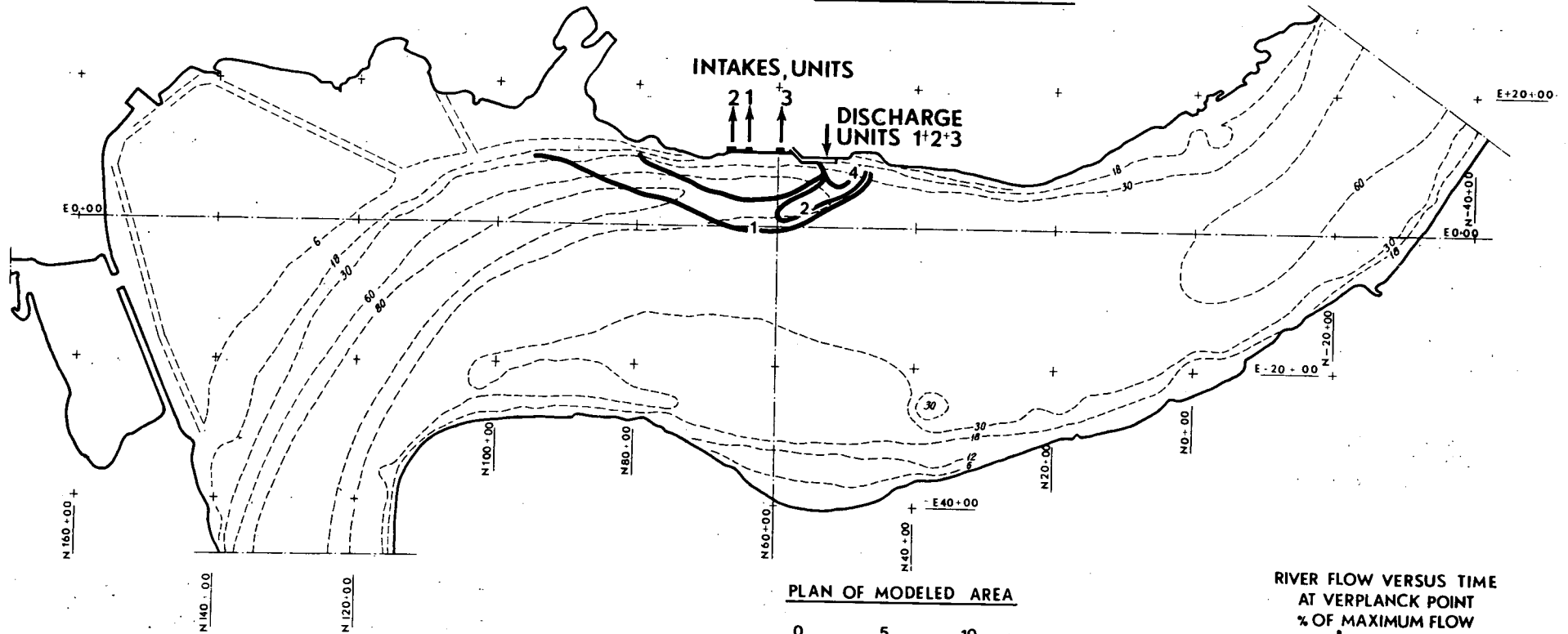

PLAN OF MODELED AREA

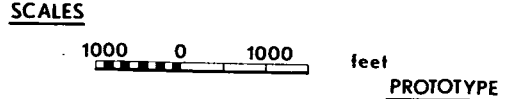
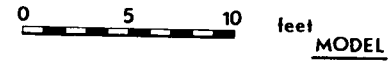

RIVER FLOW VERSUS TIME AT VERPLANCK POINT
% OF MAXIMUM FLOW

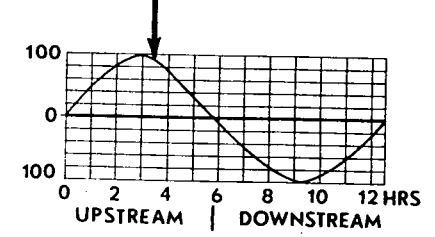

ARRANGEMENT OF OUTFALL STRUCTURE

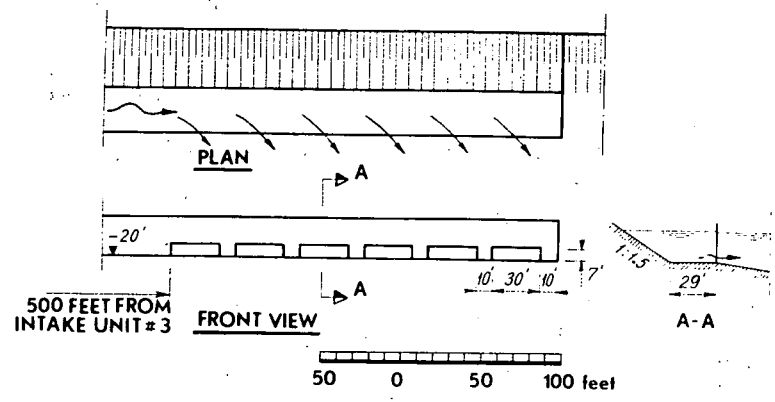

TEST CONDITIONS

TEST NUMBER AND DATE 542 ; DEC 3, 1968
 UNITS OPERATING AND DISCHARGE 3 ; 4670 cfs
 DISCHARGE TEMPERATURE ABOVE AMBIENT RIVER 16.4 °F
 TIME IN TIDE CYCLE SEE DIAGRAM
 RIVER AMBIENT TEMPERATURE 80 °F
 AIR TEMPERATURE DRY BULB 85 °F
 AIR TEMPERATURE WET BULB 77.6 °F
 RELATIVE HUMIDITY 72 %
 DEPTH OF ISOTHERMS 24 feet
 ISOTHERMS ARE DEGREES ABOVE AMBIENT RIVER TEMPERATURE

ALDEN RESEARCH LABORATORIES
 WORCESTER POLYTECHNIC INSTITUTE
 HYDRAULIC MODEL STUDIES
 FOR
 CONSOLIDATED EDISON COMPANY, N. Y.

INDIAN POINT II MODEL

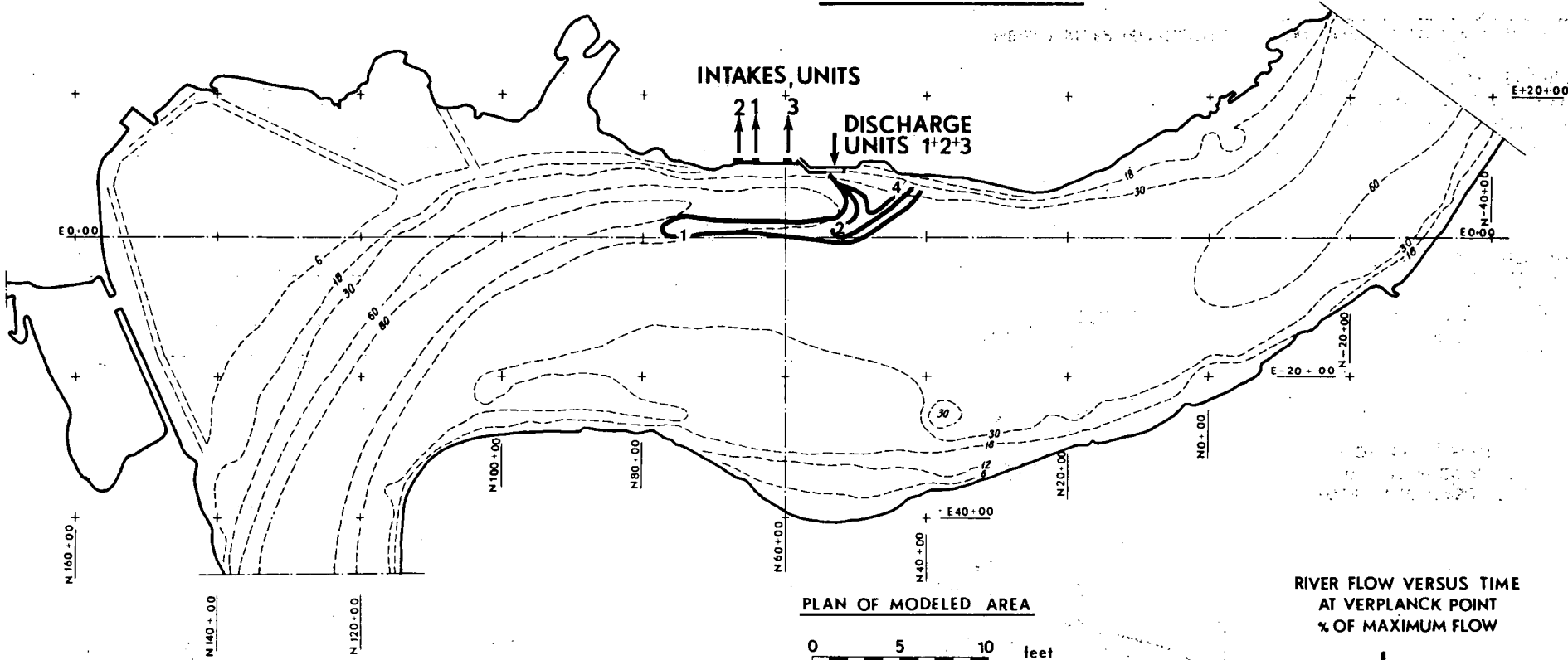

PLAN OF MODELED AREA

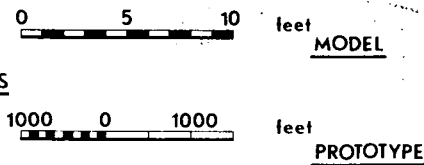

RIVER FLOW VERSUS TIME AT VERPLANCK POINT % OF MAXIMUM FLOW

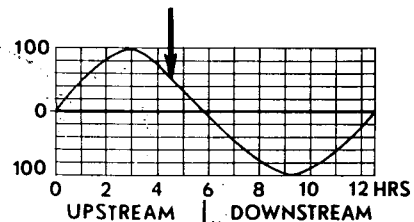

ARRANGEMENT OF OUTFALL STRUCTURE

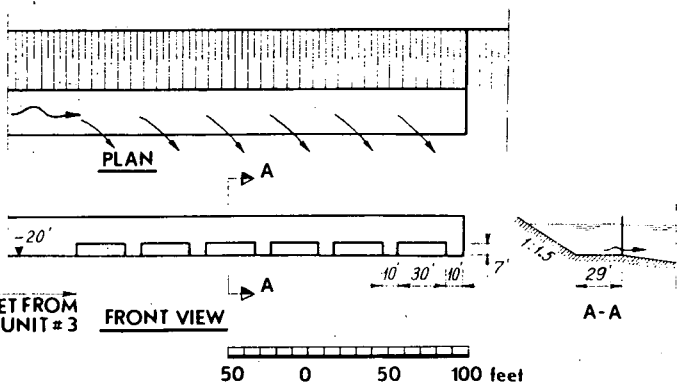

TEST CONDITIONS

TEST NUMBER AND DATE 542 DEC 3, 1968
 UNITS OPERATING AND DISCHARGE 3,4670 cfs
 DISCHARGE TEMPERATURE ABOVE AMBIENT RIVER 16.4 °F
 TIME IN TIDE CYCLE SEE DIAGRAM
 RIVER AMBIENT TEMPERATURE 80 °F
 AIR TEMPERATURE DRY BULB 85 °F
 AIR TEMPERATURE WET BULB 77.6 °F
 RELATIVE HUMIDITY 72 %
 DEPTH OF ISOTHERMS 24 feet
 ISOTHERMS ARE DEGREES ABOVE AMBIENT RIVER TEMPERATURE

ALDEN RESEARCH LABORATORIES
 WORCESTER POLYTECHNIC INSTITUTE
 HYDRAULIC MODEL STUDIES
 FOR
 CONSOLIDATED EDISON COMPANY, N. Y.

INDIAN POINT II MODEL

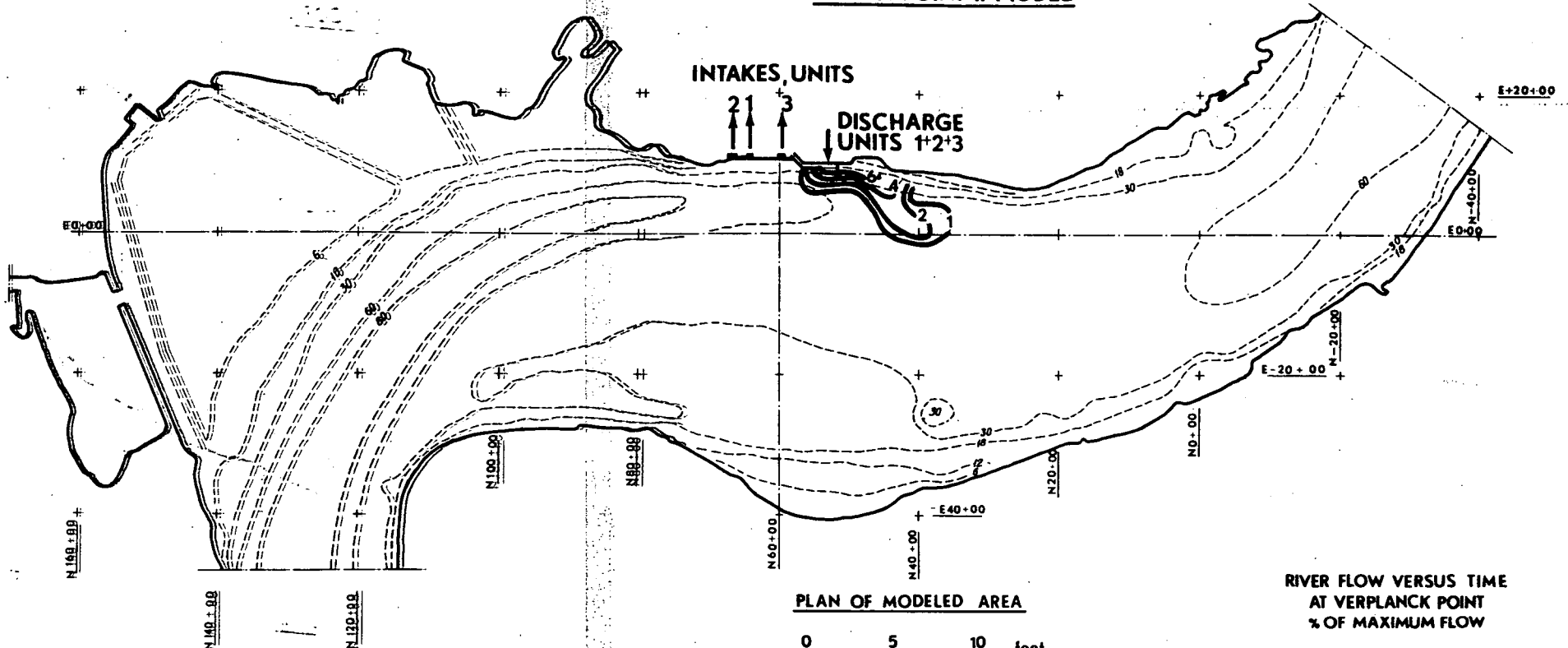

PLAN OF MODELED AREA



SCALES

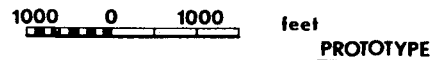

**RIVER FLOW VERSUS TIME
AT VERPLANCK POINT
% OF MAXIMUM FLOW**

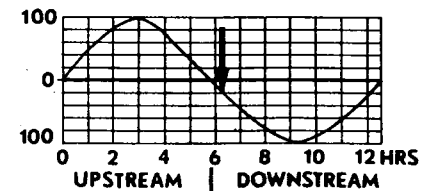

ARRANGEMENT OF OUTFALL STRUCTURE:

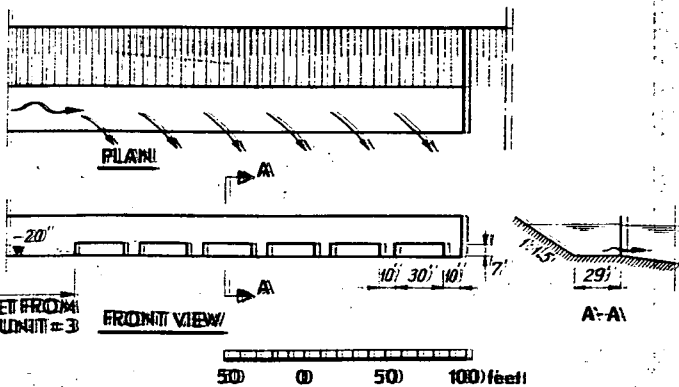

TEST CONDITIONS

TEST NUMBER AND DATE 542 ; DEC 3, 1968
 UNITS OPERATING AND DISCHARGE 3 ; 4670 cfs
 DISCHARGE TEMPERATURE ABOVE AMBIENT RIVER 16.4 °F
 TIME IN TIDE CYCLE SEE DIAGRAM
 RIVER AMBIENT TEMPERATURE 80 °F
 AIR TEMPERATURE DRY BULB 85 °F
 AIR TEMPERATURE WET BULB 77.6 °F
 RELATIVE HUMIDITY 72 %
 DEPTH OF ISOTHERMS 24 feet
 ISOTHERMS ARE DEGREES ABOVE AMBIENT RIVER TEMPERATURE

ALDEN RESEARCH LABORATORIES
 WORCESTER POLYTECHNIC INSTITUTE
 HYDRAULIC MODEL STUDIES
 FOR
 CONSOLIDATED EDISON COMPANY, N. Y.

FIG. 74

INDIAN POINT II MODEL

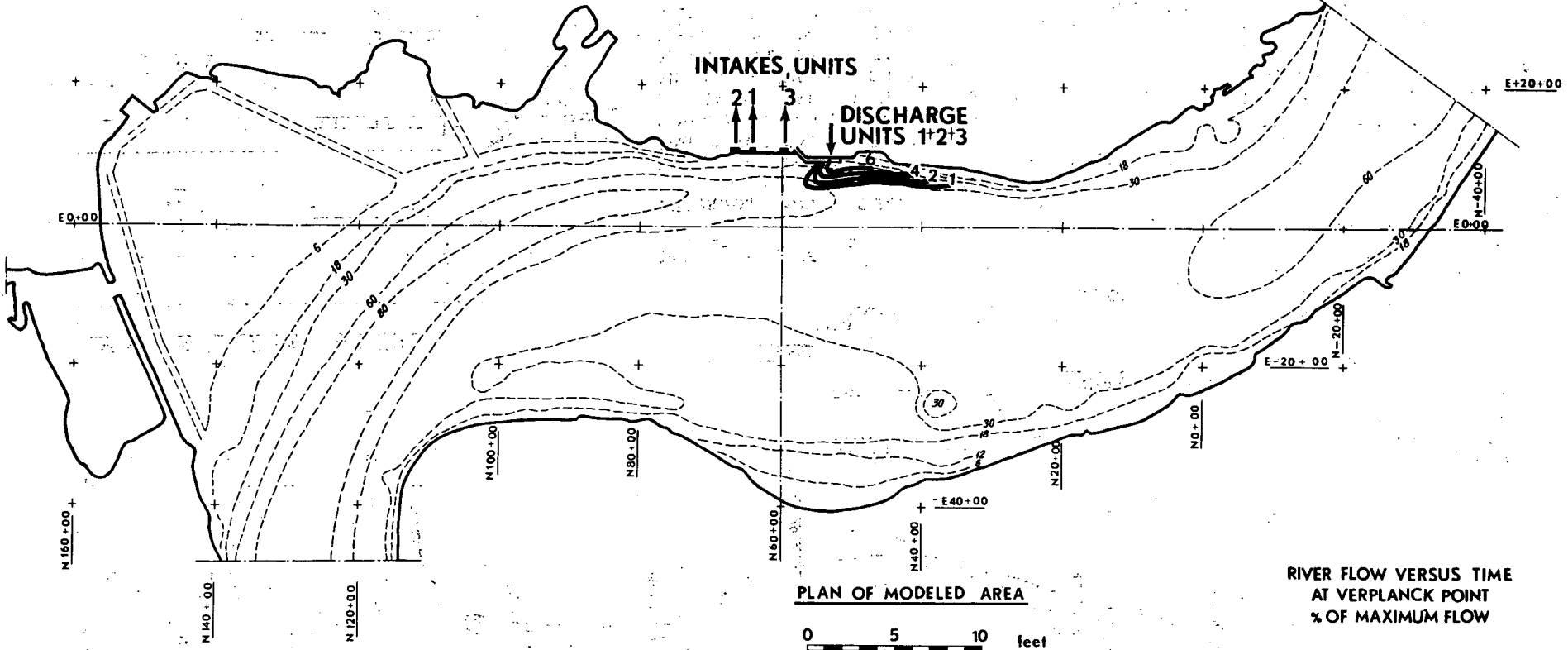

PLAN OF MODELED AREA

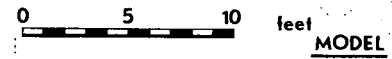

SCALES

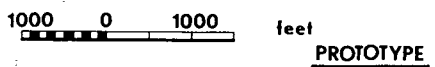

RIVER FLOW VERSUS TIME AT VERPLANCK POINT
% OF MAXIMUM FLOW

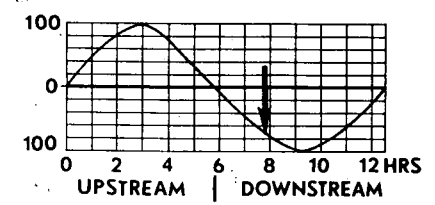

ARRANGEMENT OF OUTFALL STRUCTURE

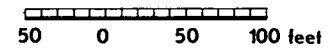
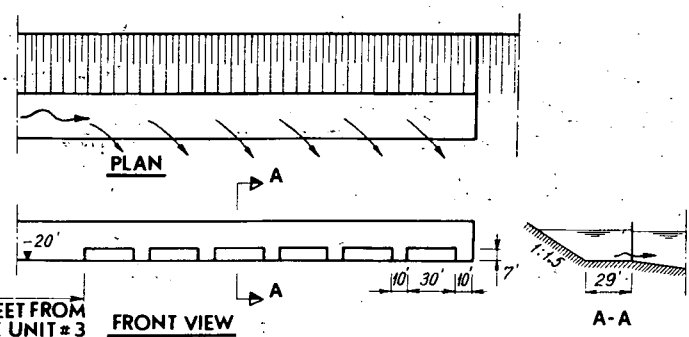

TEST CONDITIONS

TEST NUMBER AND DATE 542 ; DEC 3, 1968
 UNITS OPERATING AND DISCHARGE 3 ; 4670 cfs.
 DISCHARGE TEMPERATURE ABOVE AMBIENT RIVER 16.4 °F
 TIME IN TIDE CYCLE SEE DIAGRAM
 RIVER AMBIENT TEMPERATURE 80 °F
 AIR TEMPERATURE DRY BULB 85 °F
 AIR TEMPERATURE WET BULB 77.6 °F
 RELATIVE HUMIDITY 72 %
 DEPTH OF ISOTHERMS 24 feet
 ISOTHERMS ARE DEGREES ABOVE AMBIENT RIVER TEMPERATURE

ALDEN RESEARCH LABORATORIES
 WORCESTER POLYTECHNIC INSTITUTE
 HYDRAULIC MODEL STUDIES
 FOR
 CONSOLIDATED EDISON COMPANY, N. Y.

INDIAN POINT II MODEL

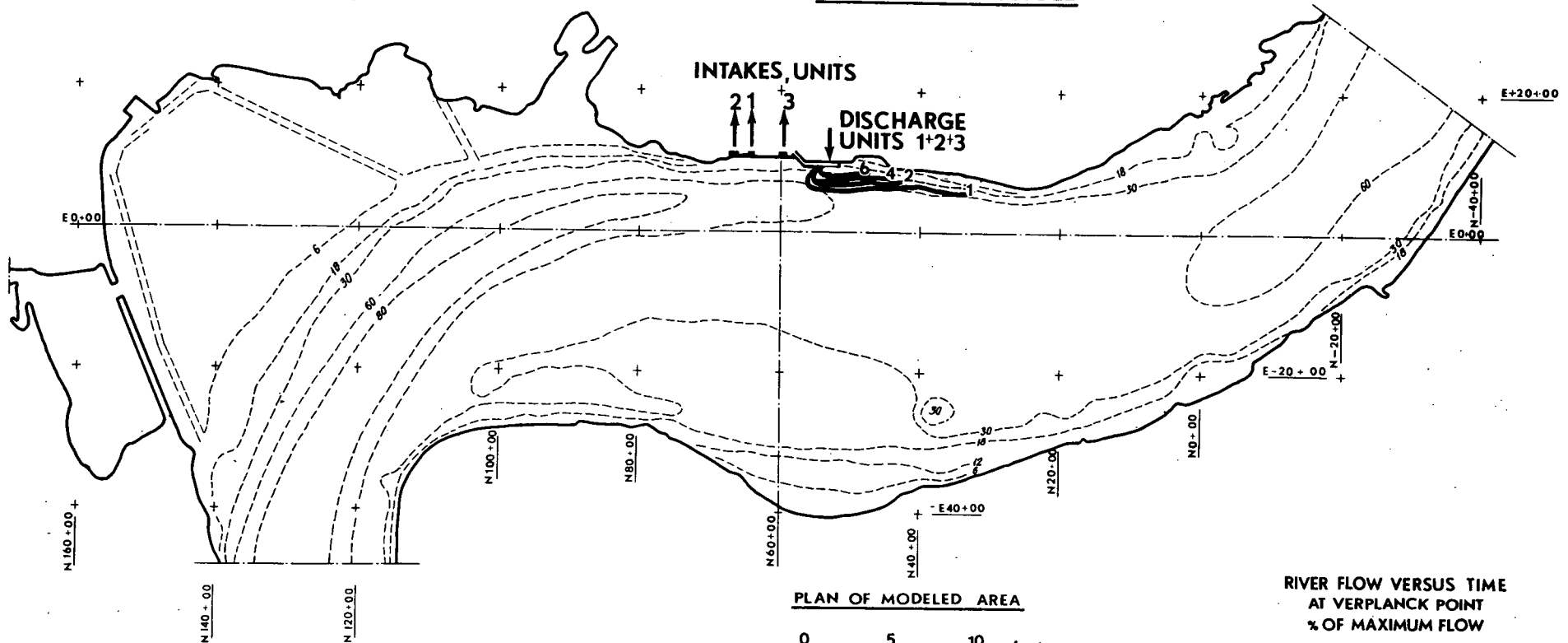

PLAN OF MODELED AREA



SCALES

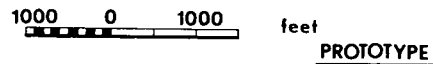

**RIVER FLOW VERSUS TIME
AT VERPLANCK POINT
% OF MAXIMUM FLOW**

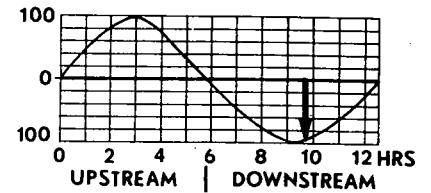

ARRANGEMENT OF OUTFALL STRUCTURE

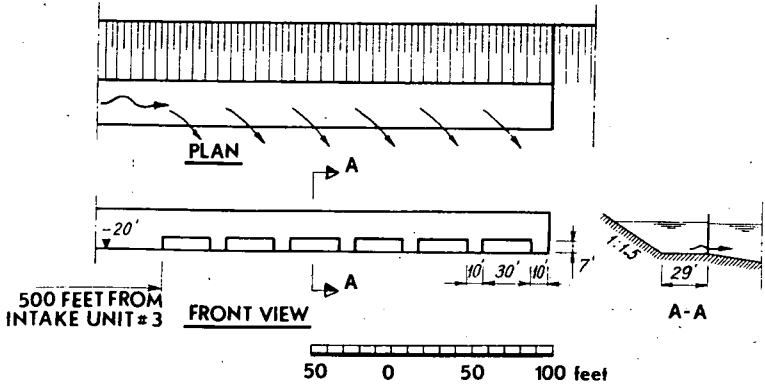

TEST CONDITIONS

TEST NUMBER AND DATE 542 ; DEC 3, 1968
 UNITS OPERATING AND DISCHARGE 3 ; 4670 cfs
 DISCHARGE TEMPERATURE ABOVE AMBIENT RIVER 16.4 °F
 TIME IN TIDE CYCLE SEE DIAGRAM
 RIVER AMBIENT TEMPERATURE 80 °F
 AIR TEMPERATURE DRY BULB 85 °F
 AIR TEMPERATURE WET BULB 77.6 °F
 RELATIVE HUMIDITY 72 %
 DEPTH OF ISOTHERMS 24 feet
 ISOTHERMS ARE DEGREES ABOVE AMBIENT RIVER TEMPERATURE

ALDEN RESEARCH LABORATORIES
 WORCESTER POLYTECHNIC INSTITUTE
 HYDRAULIC MODEL STUDIES
 FOR
 CONSOLIDATED EDISON COMPANY, N. Y.

FIG. 76

INDIAN POINT II MODEL

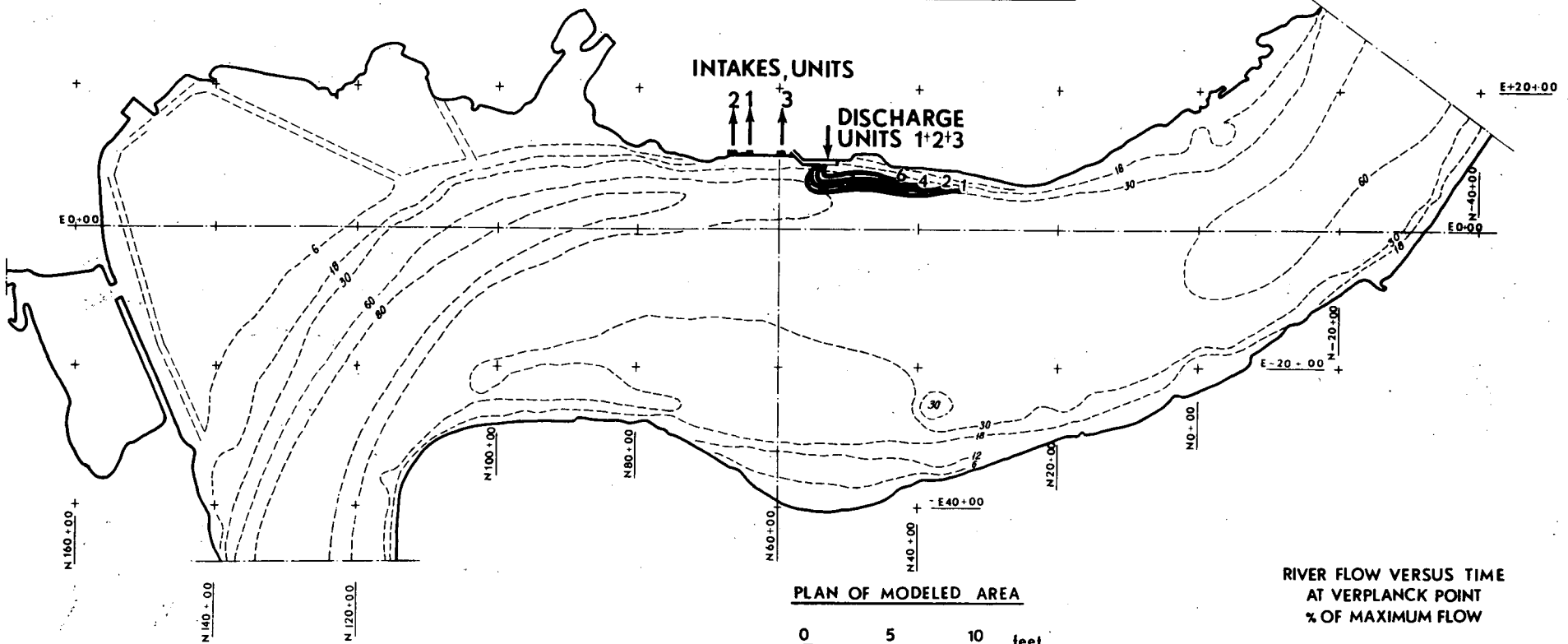

PLAN OF MODELED AREA

SCALES

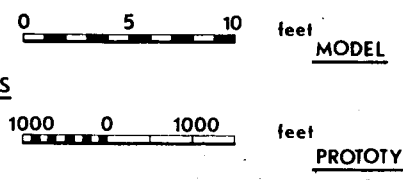

**RIVER FLOW VERSUS TIME AT VERPLANCK POINT
% OF MAXIMUM FLOW**

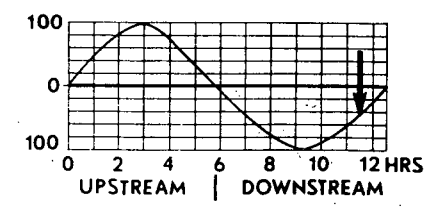

ARRANGEMENT OF OUTFALL STRUCTURE

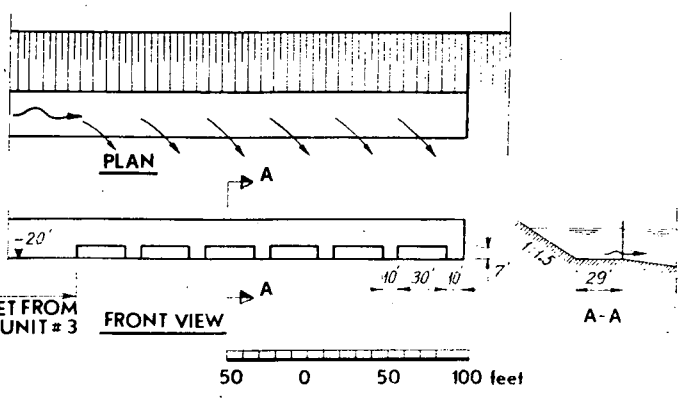

TEST CONDITIONS

TEST NUMBER AND DATE 542 ; DEC 3, 1968
 UNITS OPERATING AND DISCHARGE 3 ; 4670 cfs
 DISCHARGE TEMPERATURE ABOVE AMBIENT RIVER 16.4 °F
 TIME IN TIDE CYCLE SEE DIAGRAM
 RIVER AMBIENT TEMPERATURE 80 °F
 AIR TEMPERATURE DRY BULB 85 °F
 AIR TEMPERATURE WET BULB 77.6 °F
 RELATIVE HUMIDITY 72 %
 DEPTH OF ISOTHERMS 24 feet
 ISOTHERMS ARE DEGREES ABOVE AMBIENT RIVER TEMPERATURE

ALDEN RESEARCH LABORATORIES
 WORCESTER POLYTECHNIC INSTITUTE
 HYDRAULIC MODEL STUDIES
 FOR
 CONSOLIDATED EDISON COMPANY, N. Y.

INDIAN POINT II MODEL

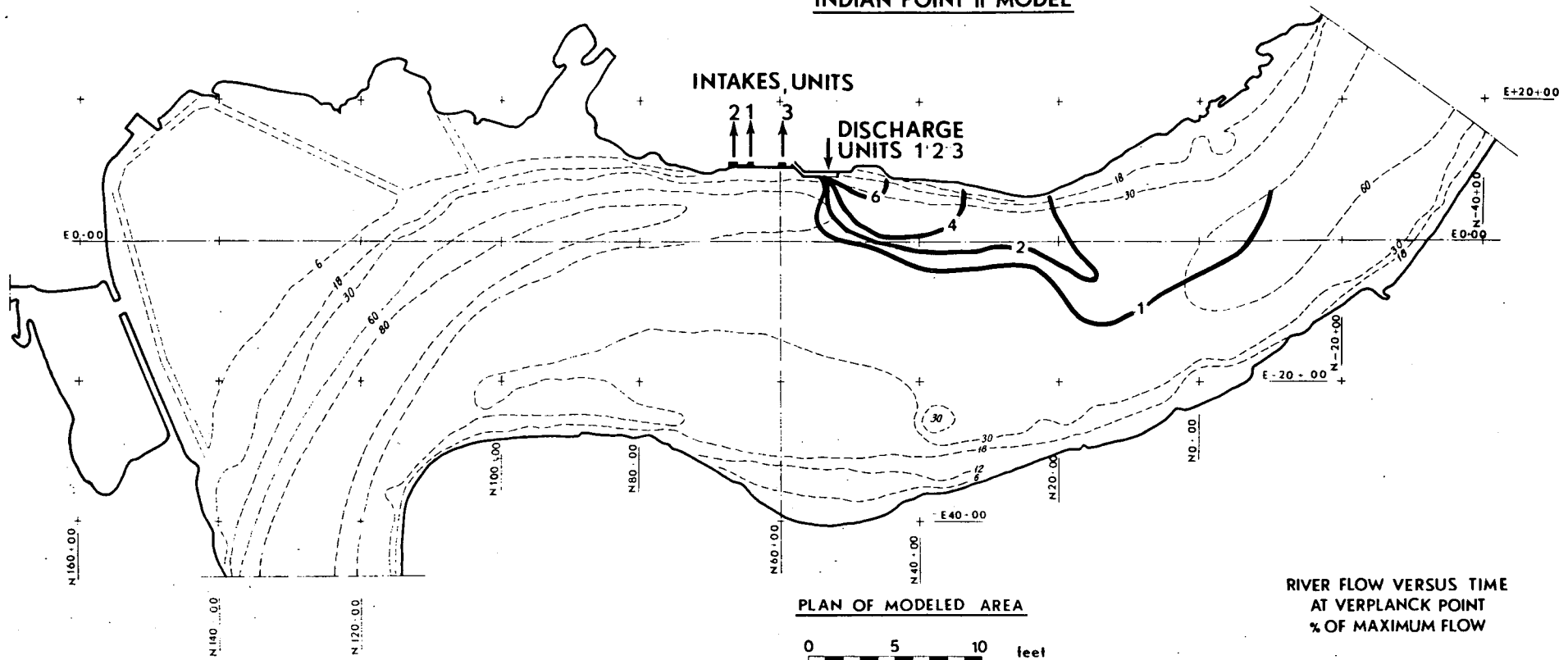

PLAN OF MODELED AREA



SCALES

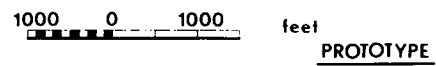

RIVER FLOW VERSUS TIME AT VERPLANCK POINT
% OF MAXIMUM FLOW

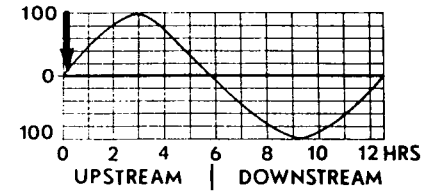

ARRANGEMENT OF OUTFALL STRUCTURE

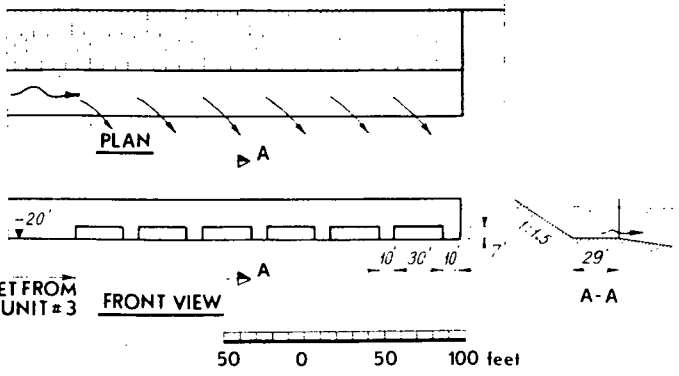

500 FEET FROM INTAKE UNIT #3

FRONT VIEW

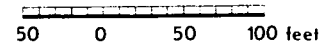

TEST CONDITIONS

TEST NUMBER AND DATE 410 ; NOV 6, 1968
 UNITS OPERATING AND DISCHARGE 2, 2670 cfs
 DISCHARGE TEMPERATURE ABOVE AMBIENT RIVER 14 °F
 TIME IN TIDE CYCLE SEE DIAGRAM
 RIVER AMBIENT TEMPERATURE 65 °F
 AIR TEMPERATURE DRY BULB 64 °F
 AIR TEMPERATURE WET BULB 60 °F
 RELATIVE HUMIDITY 80%
 DEPTH OF ISOTHERMS 0 feet
 ISOTHERMS ARE DEGREES ABOVE AMBIENT RIVER TEMPERATURE

ALDEN RESEARCH LABORATORIES
 WORCESTER POLYTECHNIC INSTITUTE
 HYDRAULIC MODEL STUDIES
 FOR
 CONSOLIDATED EDISON COMPANY, N. Y.

FIG. 78

INDIAN POINT II MODEL

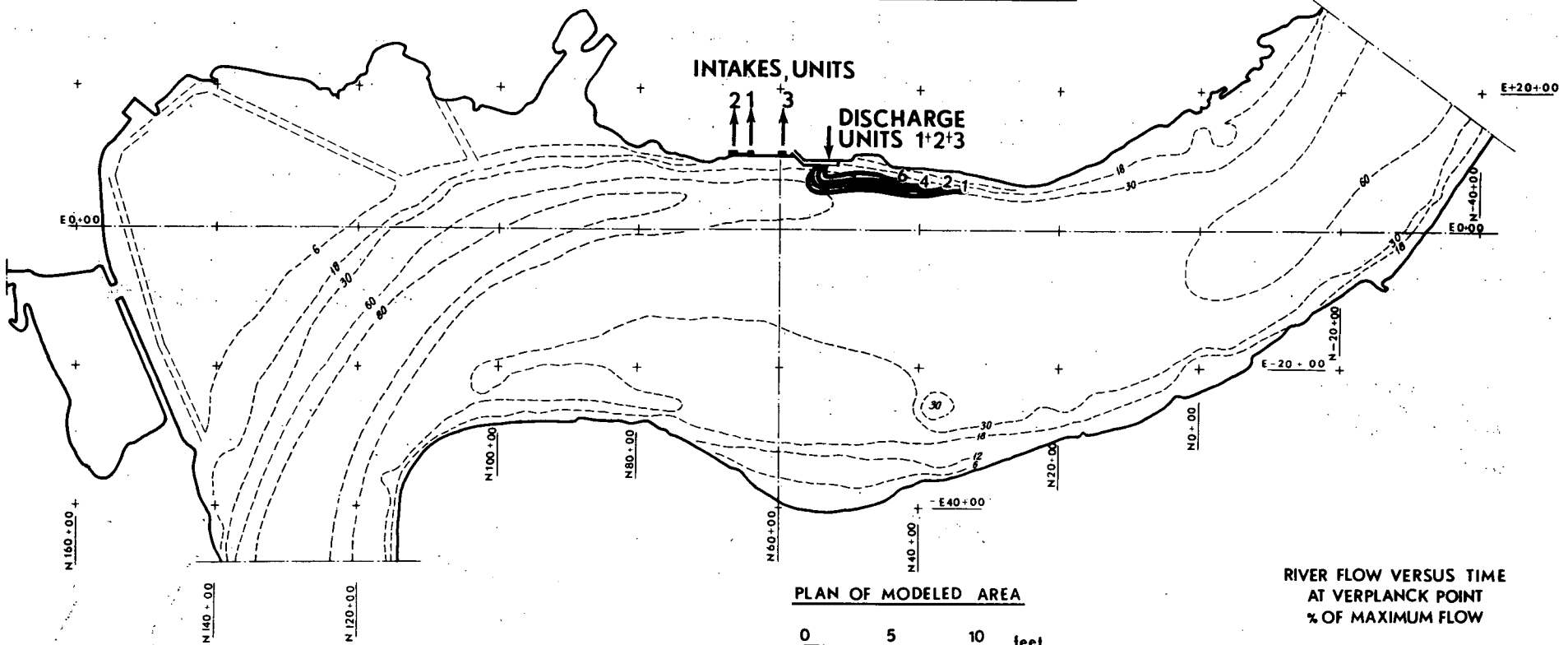

PLAN OF MODELED AREA

SCALES

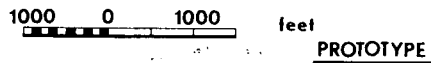
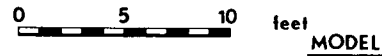

**RIVER FLOW VERSUS TIME AT VERPLANCK POINT
% OF MAXIMUM FLOW**

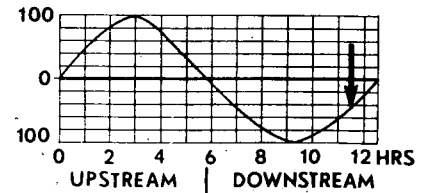

ARRANGEMENT OF OUTFALL STRUCTURE

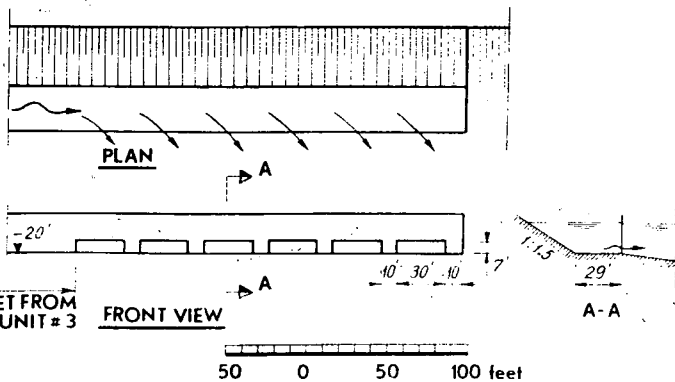

TEST CONDITIONS

TEST NUMBER AND DATE 542 ; DEC 3, 1968
 UNITS OPERATING AND DISCHARGE 3 ; 4670 cfs
 DISCHARGE TEMPERATURE ABOVE AMBIENT RIVER 16.4 °F
 TIME IN TIDE CYCLE SEE DIAGRAM
 RIVER AMBIENT TEMPERATURE 80 °F
 AIR TEMPERATURE DRY BULB 85 °F
 AIR TEMPERATURE WET BULB 77.6 °F
 RELATIVE HUMIDITY 72 %
 DEPTH OF ISOTHERMS 24 feet
 ISOTHERMS ARE DEGREES ABOVE AMBIENT RIVER TEMPERATURE

ALDEN RESEARCH LABORATORIES
 WORCESTER POLYTECHNIC INSTITUTE
 HYDRAULIC MODEL STUDIES
 FOR
 CONSOLIDATED EDISON COMPANY, N. Y.

INDIAN POINT II MODEL

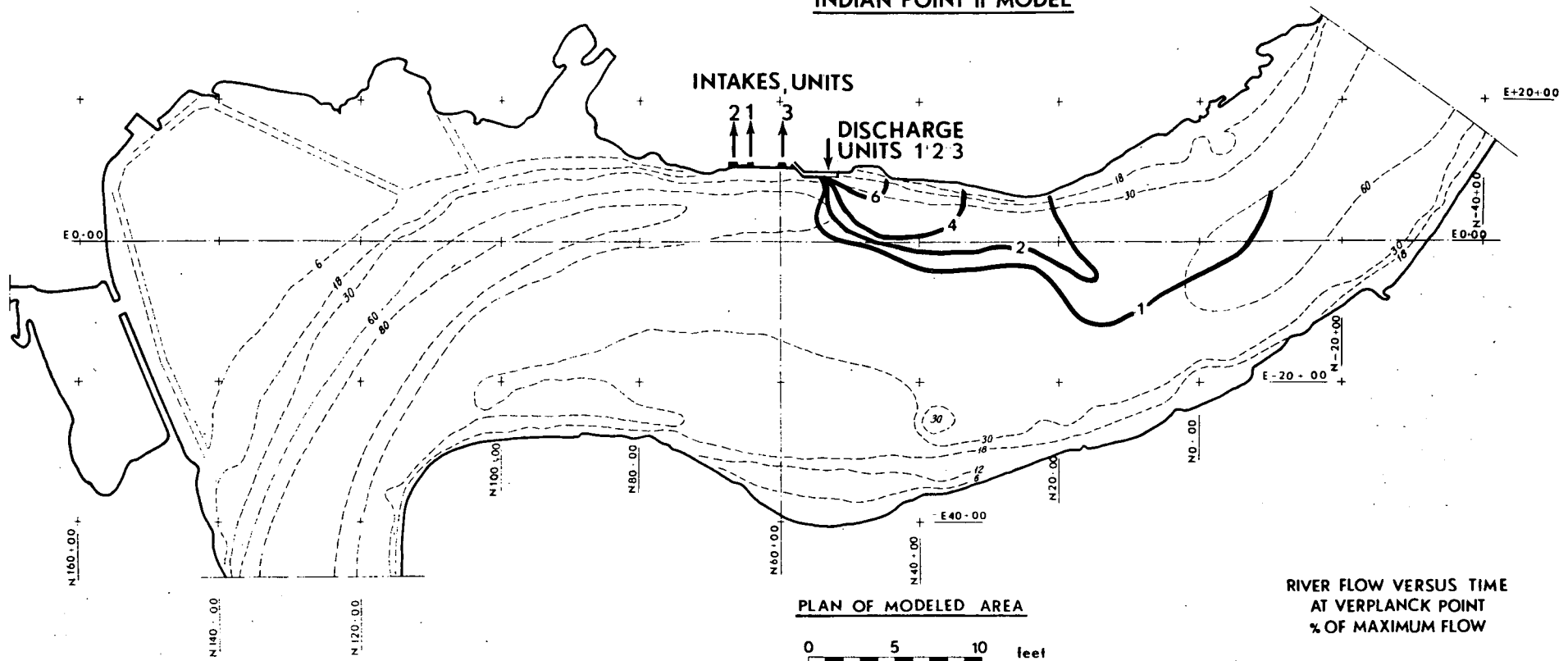

PLAN OF MODELED AREA

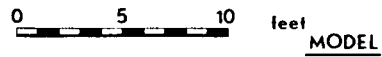

SCALES

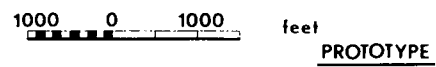

RIVER FLOW VERSUS TIME AT VERPLANCK POINT
% OF MAXIMUM FLOW

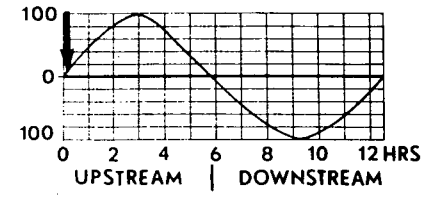

ARRANGEMENT OF OUTFALL STRUCTURE

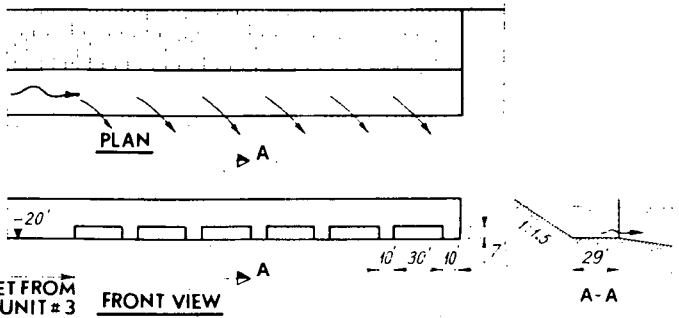

500 FEET FROM INTAKE UNIT #3

FRONT VIEW

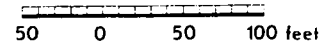

TEST CONDITIONS

TEST NUMBER AND DATE 410 ; NOV 6, 1968
 UNITS OPERATING AND DISCHARGE 2; 2670 cfs
 DISCHARGE TEMPERATURE ABOVE AMBIENT RIVER 14 °F
 TIME IN TIDE CYCLE SEE DIAGRAM
 RIVER AMBIENT TEMPERATURE 65 °F
 AIR TEMPERATURE DRY BULB 64 °F
 AIR TEMPERATURE WET BULB 60 °F
 RELATIVE HUMIDITY 80%
 DEPTH OF ISOTHERMS 0 feet
 ISOTHERMS ARE DEGREES ABOVE AMBIENT RIVER TEMPERATURE

ALDEN RESEARCH LABORATORIES
 WORCESTER POLYTECHNIC INSTITUTE
 HYDRAULIC MODEL STUDIES
 FOR
 CONSOLIDATED EDISON COMPANY, N. Y.

FIG. 78

INDIAN POINT II MODEL

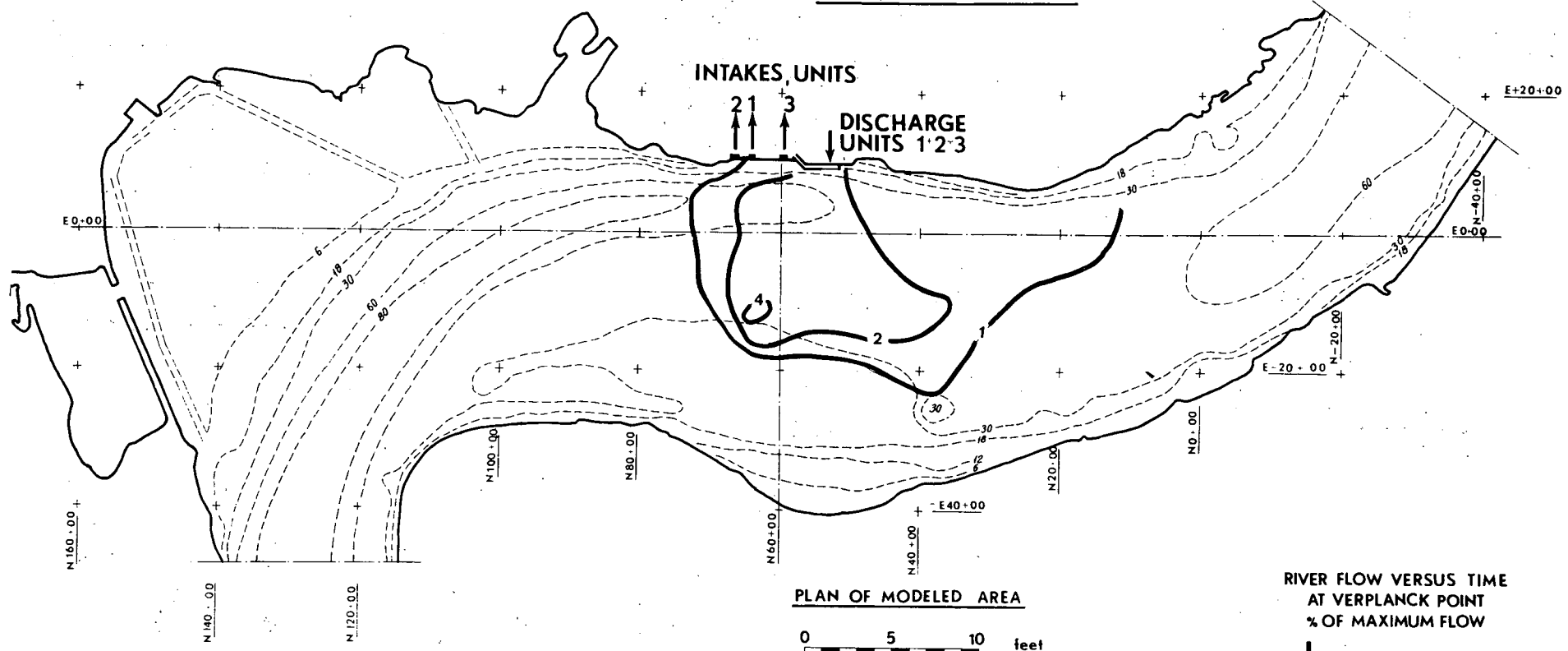

PLAN OF MODELED AREA

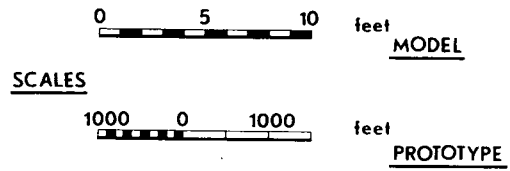

**RIVER FLOW VERSUS TIME AT VERPLANCK POINT
% OF MAXIMUM FLOW**

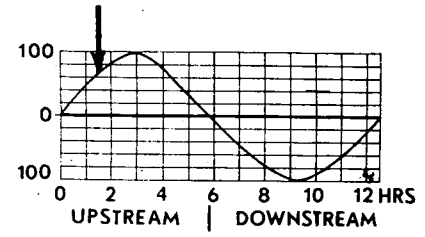

ARRANGEMENT OF OUTFALL STRUCTURE

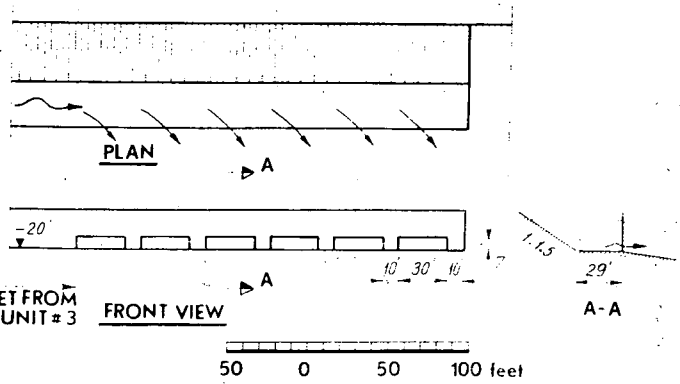

TEST CONDITIONS

TEST NUMBER AND DATE 410 ; NOV 8, 1968
 UNITS OPERATING AND DISCHARGE 2; 2670 cfs
 DISCHARGE TEMPERATURE ABOVE AMBIENT RIVER 14 °F
 TIME IN TIDE CYCLE SEE DIAGRAM
 RIVER AMBIENT TEMPERATURE 65 °F
 AIR TEMPERATURE DRY BULB 64 °F
 AIR TEMPERATURE WET BULB 60 °F
 RELATIVE HUMIDITY 80%
 DEPTH OF ISOTHERMS 0 feet
 ISOTHERMS ARE DEGREES ABOVE AMBIENT RIVER TEMPERATURE

ALDEN RESEARCH LABORATORIES
 WORCESTER POLYTECHNIC INSTITUTE
 HYDRAULIC MODEL STUDIES
 FOR
 CONSOLIDATED EDISON COMPANY, N. Y.

INDIAN POINT II MODEL

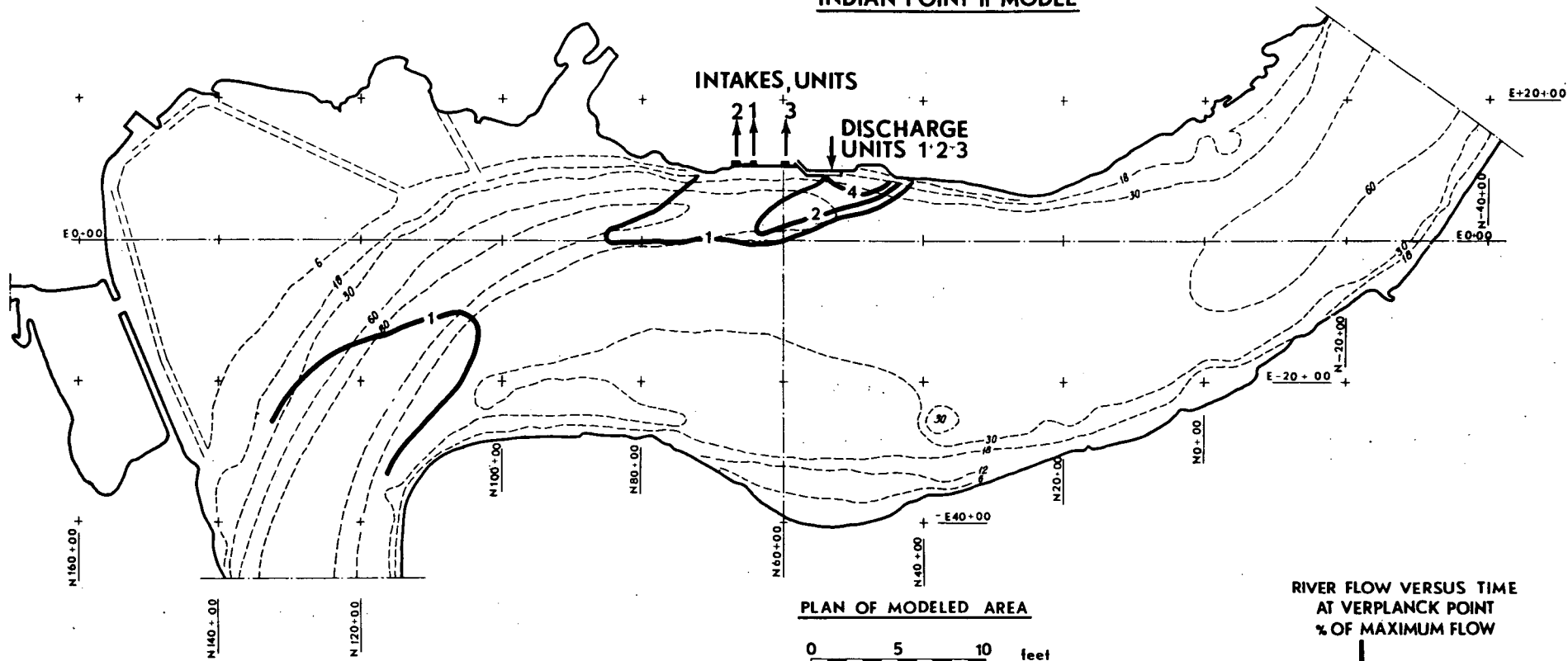

PLAN OF MODELED AREA



SCALES

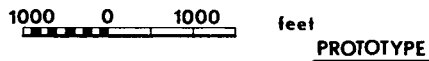

**RIVER FLOW VERSUS TIME AT VERPLANCK POINT
% OF MAXIMUM FLOW**

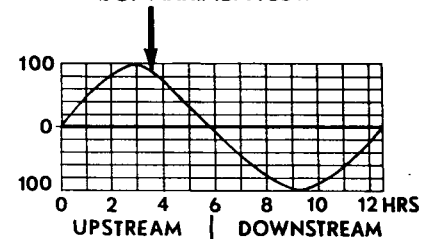

ARRANGEMENT OF OUTFALL STRUCTURE

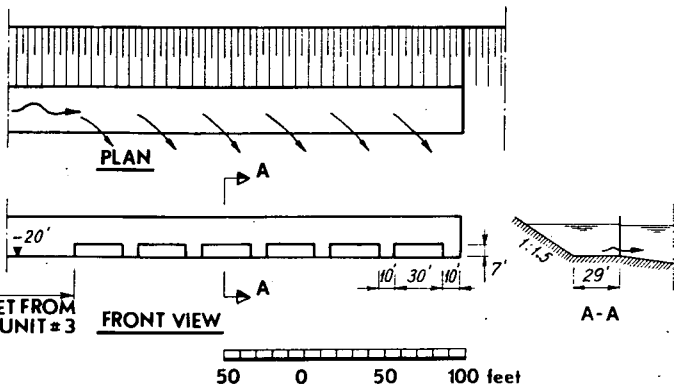

TEST CONDITIONS

TEST NUMBER AND DATE 410 ; NOV 8, 1968
 UNITS OPERATING AND DISCHARGE 2; 2670 cfs
 DISCHARGE TEMPERATURE ABOVE AMBIENT RIVER 14 °F
 TIME IN TIDE CYCLE SEE DIAGRAM
 RIVER AMBIENT TEMPERATURE 65 °F
 AIR TEMPERATURE DRY BULB 64 °F
 AIR TEMPERATURE WET BULB 60 °F
 RELATIVE HUMIDITY 80%
 DEPTH OF ISOTHERMS 0 feet
 ISOTHERMS ARE DEGREES ABOVE AMBIENT RIVER TEMPERATURE

ALDEN RESEARCH LABORATORIES
 WORCESTER POLYTECHNIC INSTITUTE
 HYDRAULIC MODEL STUDIES
 FOR
 CONSOLIDATED EDISON COMPANY, N.Y.

INDIAN POINT II MODEL

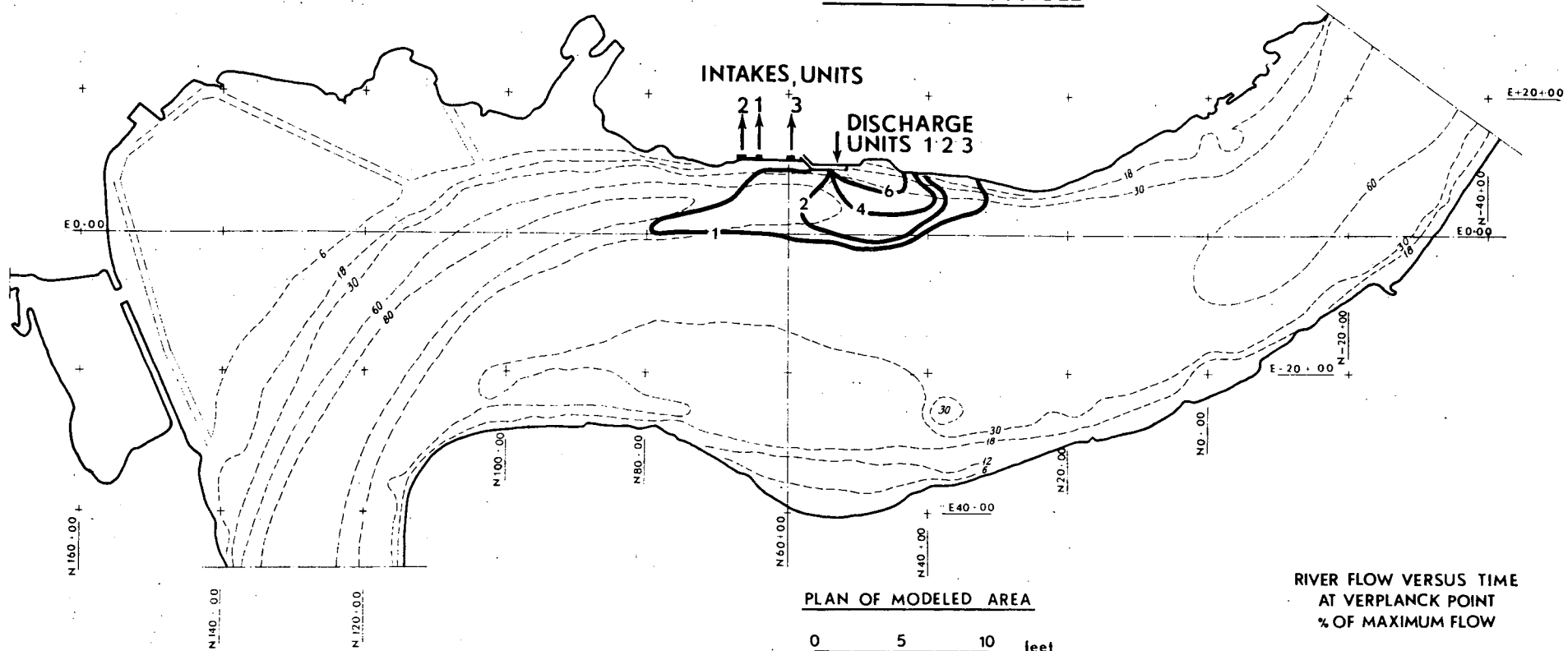

PLAN OF MODELED AREA

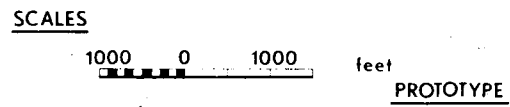
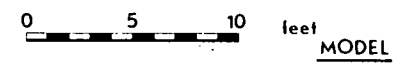

**RIVER FLOW VERSUS TIME AT VERPLANCK POINT
% OF MAXIMUM FLOW**

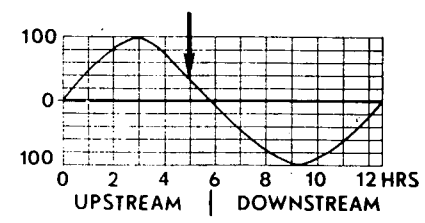

ARRANGEMENT OF OUTFALL STRUCTURE

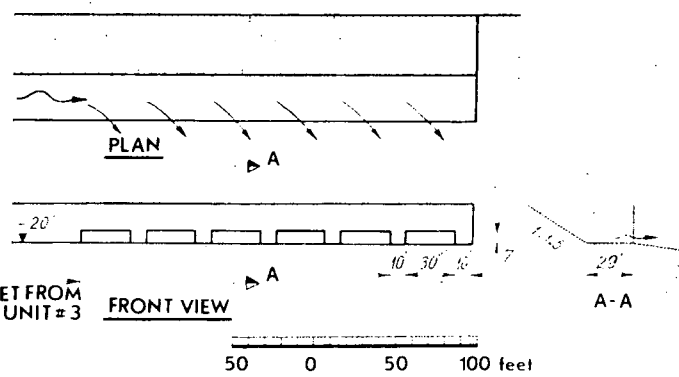

TEST CONDITIONS

TEST NUMBER AND DATE 410 ; NOV 8, 1968
 UNITS OPERATING AND DISCHARGE 2 ; 2670 cfs
 DISCHARGE TEMPERATURE ABOVE AMBIENT RIVER 14 °F
 TIME IN TIDE CYCLE-SEE DIAGRAM
 RIVER AMBIENT TEMPERATURE 65 °F
 AIR TEMPERATURE DRY BULB 64 °F
 AIR TEMPERATURE WET BULB 60 °F
 RELATIVE HUMIDITY 80%
 DEPTH OF ISOTHERMS 0 feet
 ISOTHERMS ARE DEGREES ABOVE AMBIENT RIVER TEMPERATURE

ALDEN RESEARCH LABORATORIES
 WORCESTER POLYTECHNIC INSTITUTE
 HYDRAULIC MODEL STUDIES
 FOR
 CONSOLIDATED EDISON COMPANY, N. Y.

INDIAN POINT II MODEL

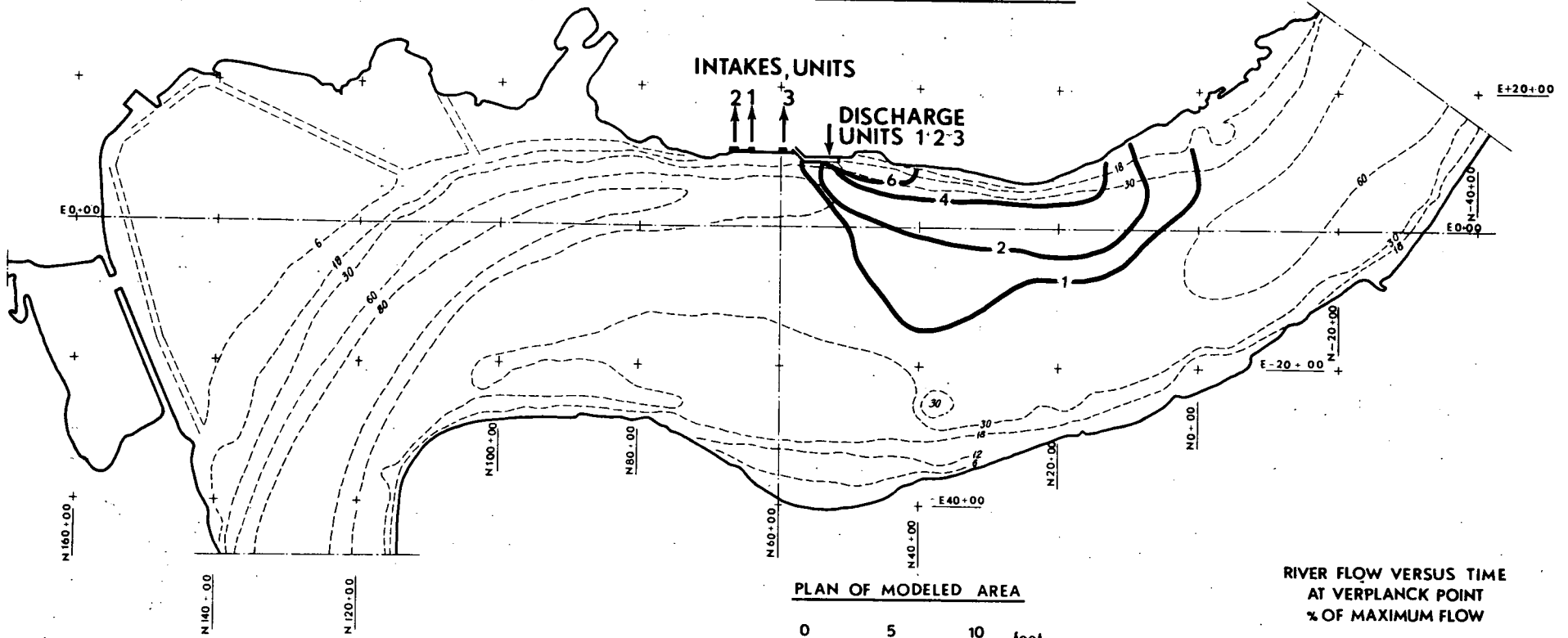

PLAN OF MODELED AREA



SCALES

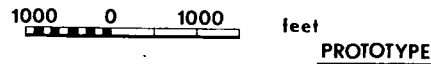

RIVER FLOW VERSUS TIME AT VERPLANCK POINT
% OF MAXIMUM FLOW

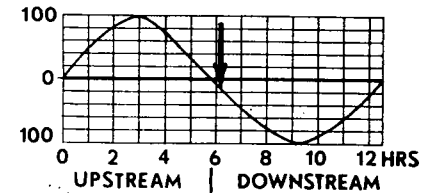

ARRANGEMENT OF OUTFALL STRUCTURE

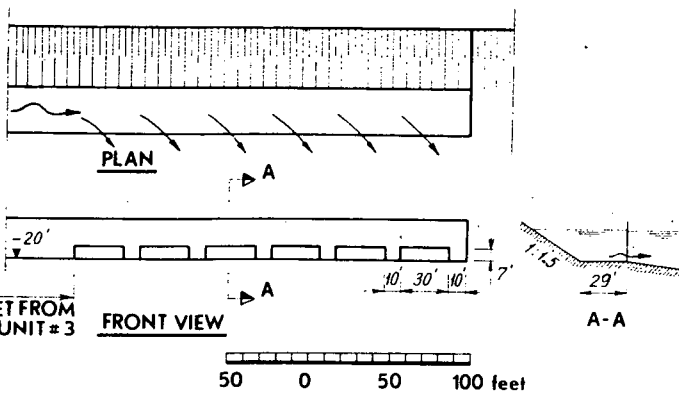

TEST CONDITIONS

TEST NUMBER AND DATE 410 ; NOV 8, 1968
 UNITS OPERATING AND DISCHARGE 2, 2670 cfs
 DISCHARGE TEMPERATURE ABOVE AMBIENT RIVER 14 °F
 TIME IN TIDE CYCLE SEE DIAGRAM
 RIVER AMBIENT TEMPERATURE 65 °F
 AIR TEMPERATURE DRY BULB 64 °F
 AIR TEMPERATURE WET BULB 60 °F
 RELATIVE HUMIDITY 80 %
 DEPTH OF ISOTHERMS 0 feet
 ISOTHERMS ARE DEGREES ABOVE AMBIENT RIVER TEMPERATURE

ALDEN RESEARCH LABORATORIES
 WORCESTER POLYTECHNIC INSTITUTE
 HYDRAULIC MODEL STUDIES
 FOR
 CONSOLIDATED EDISON COMPANY, N. Y.

INDIAN POINT II MODEL

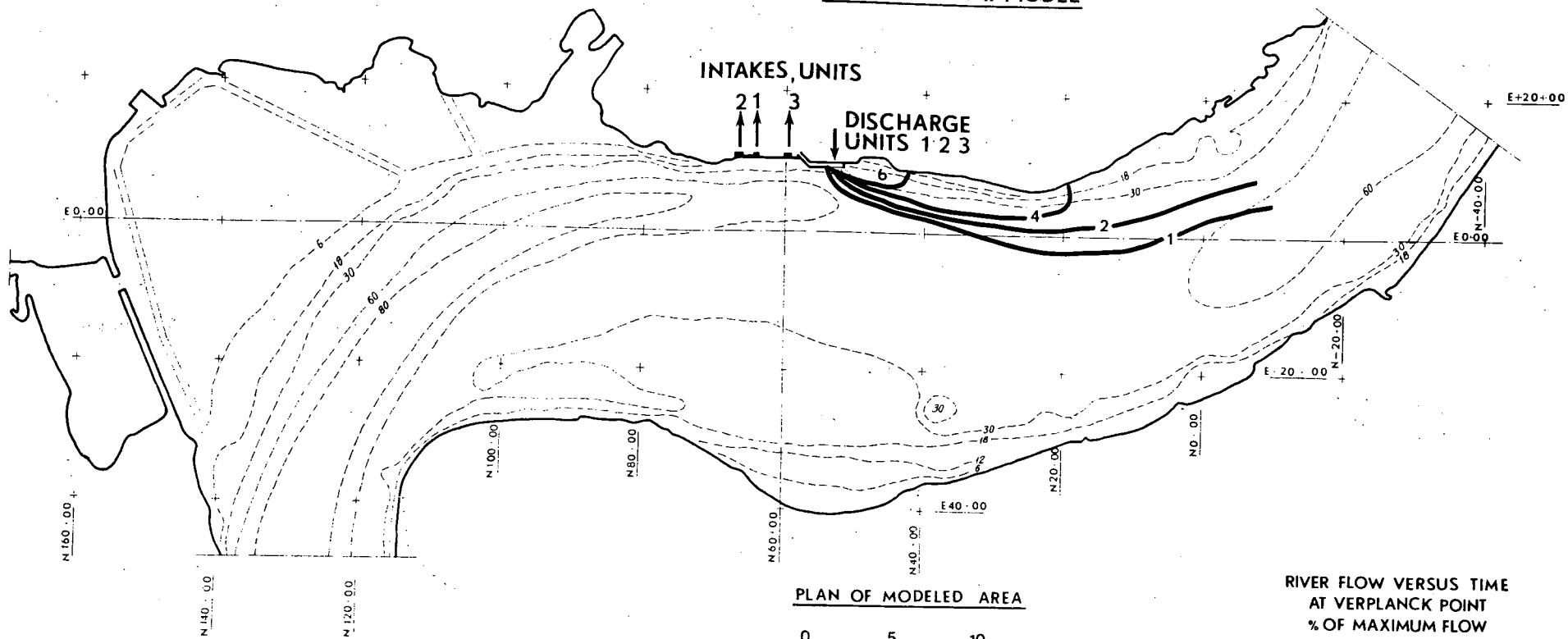

PLAN OF MODELED AREA



SCALES

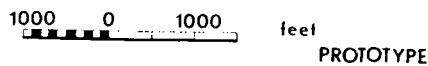

**RIVER FLOW VERSUS TIME AT VERPLANCK POINT
% OF MAXIMUM FLOW**

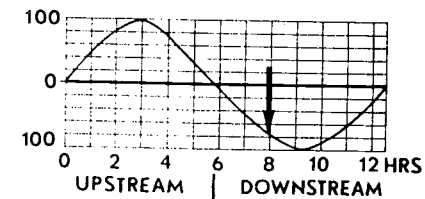

ARRANGEMENT OF OUTFALL STRUCTURE

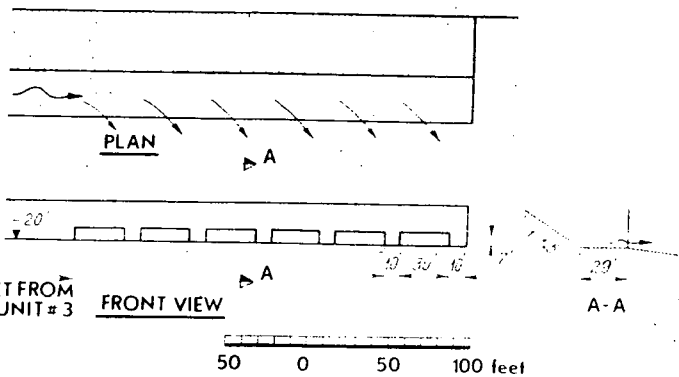

TEST CONDITIONS

TEST NUMBER AND DATE 410 ; NOV 8, 1968
 UNITS OPERATING AND DISCHARGE 2, 2670 cfs
 DISCHARGE TEMPERATURE ABOVE AMBIENT RIVER 14 °F
 TIME IN TIDE CYCLE SEE DIAGRAM
 RIVER AMBIENT TEMPERATURE 65 °F
 AIR TEMPERATURE DRY BULB 64 °F
 AIR TEMPERATURE WET BULB 60 °F
 RELATIVE HUMIDITY 80%
 DEPTH OF ISOTHERMS 0 feet
 ISOTHERMS ARE DEGREES ABOVE AMBIENT RIVER TEMPERATURE

ALDEN RESEARCH LABORATORIES
 WORCESTER POLYTECHNIC INSTITUTE
 HYDRAULIC MODEL STUDIES
 FOR
 CONSOLIDATED EDISON COMPANY, N. Y.

INDIAN POINT II MODEL

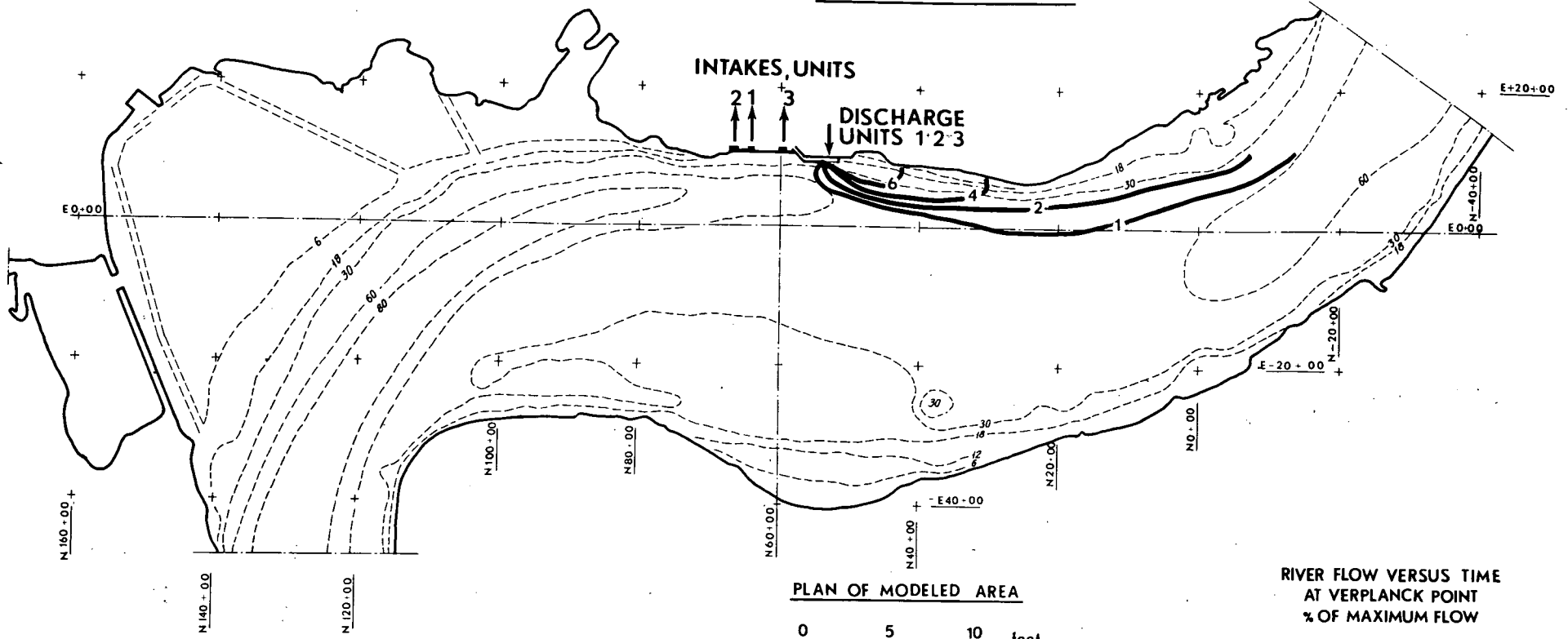

PLAN OF MODELED AREA

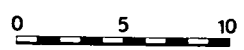

MODEL

SCALES

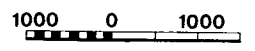

PROTOTYPE

RIVER FLOW VERSUS TIME AT VERPLANCK POINT
% OF MAXIMUM FLOW

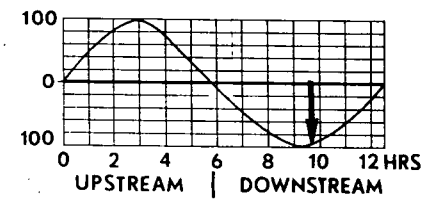

ARRANGEMENT OF OUTFALL STRUCTURE

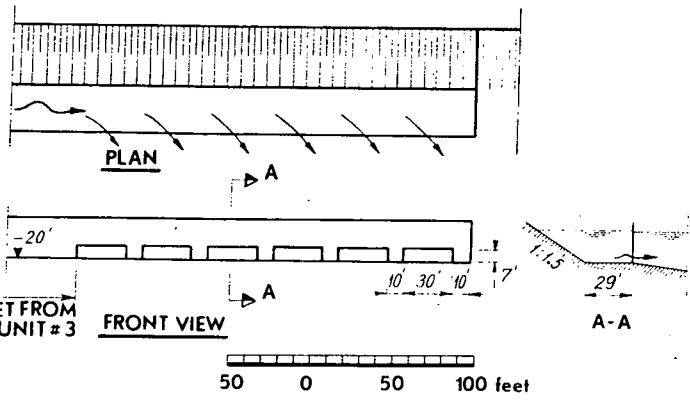

TEST CONDITIONS

TEST NUMBER AND DATE 410 ; NOV 8, 1968
 UNITS OPERATING AND DISCHARGE 2; 2670 cfs
 DISCHARGE TEMPERATURE ABOVE AMBIENT RIVER 14 °F
 TIME IN TIDE CYCLE SEE DIAGRAM
 RIVER AMBIENT TEMPERATURE 65 °F
 AIR TEMPERATURE DRY BULB 64 °F
 AIR TEMPERATURE WET BULB 60 °F
 RELATIVE HUMIDITY 80%
 DEPTH OF ISOTHERMS 0 feet
 ISOTHERMS ARE DEGREES ABOVE AMBIENT RIVER TEMPERATURE

ALDEN RESEARCH LABORATORIES
 WORCESTER POLYTECHNIC INSTITUTE
 HYDRAULIC MODEL STUDIES
 FOR
 CONSOLIDATED EDISON COMPANY, N. Y.

INDIAN POINT II MODEL

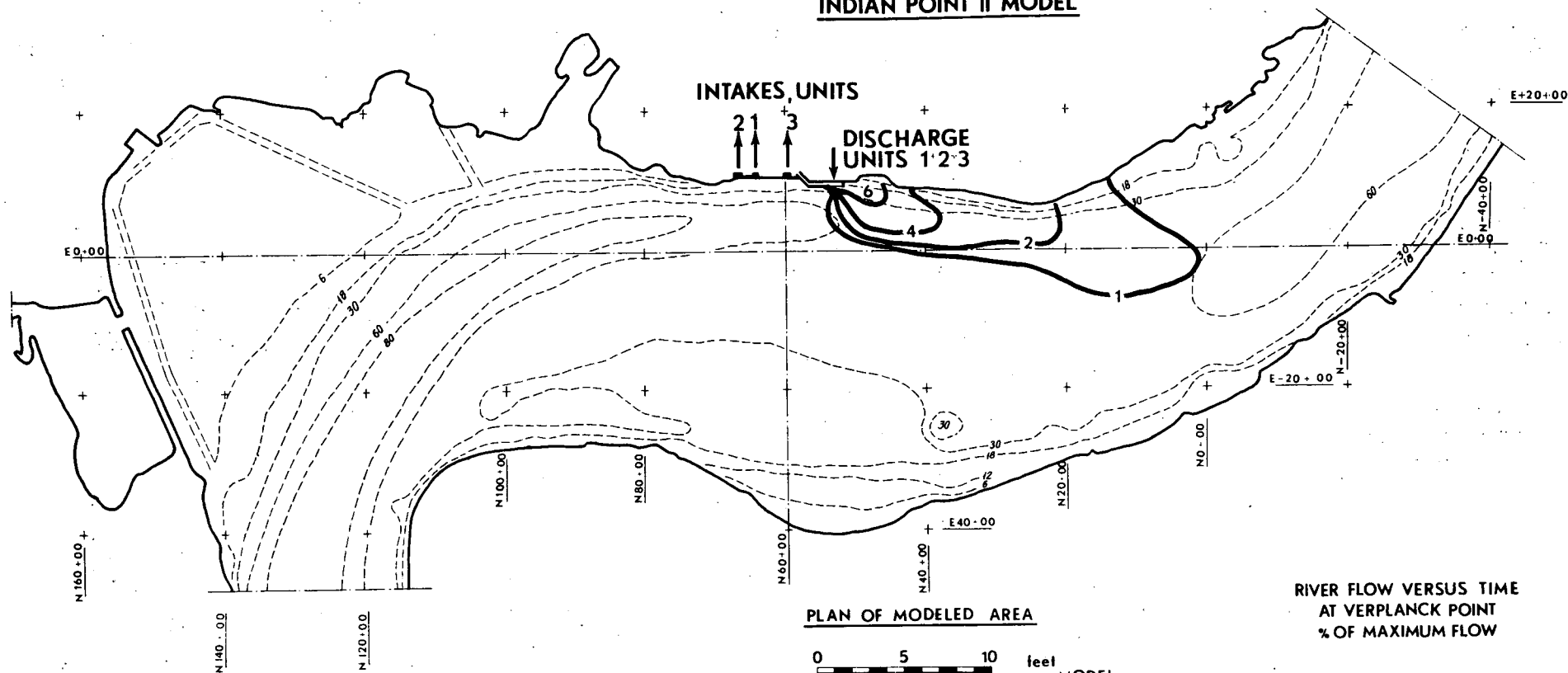

PLAN OF MODELED AREA



SCALES

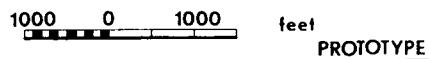

**RIVER FLOW VERSUS TIME
AT VERPLANCK POINT
% OF MAXIMUM FLOW**

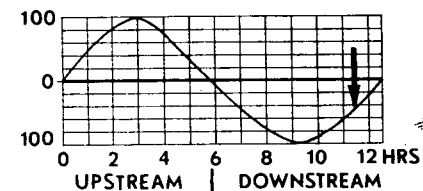

ARRANGEMENT OF OUTFALL STRUCTURE

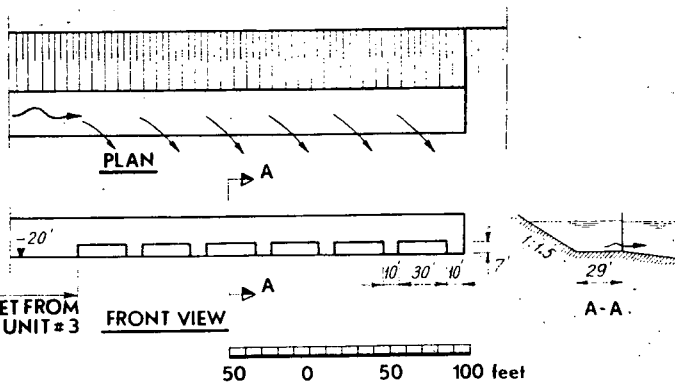

TEST CONDITIONS

TEST NUMBER AND DATE 410 ; NOV 8, 1968
 UNITS OPERATING AND DISCHARGE 2 ; 2670 cfs
 DISCHARGE TEMPERATURE ABOVE AMBIENT RIVER 14 °F
 TIME IN TIDE CYCLE SEE DIAGRAM
 RIVER AMBIENT TEMPERATURE 65 °F
 AIR TEMPERATURE DRY BULB 64 °F
 AIR TEMPERATURE WET BULB 60 °F
 RELATIVE HUMIDITY 80%
 DEPTH OF ISOTHERMS 0 feet
 ISOTHERMS ARE DEGREES ABOVE AMBIENT RIVER TEMPERATURE

ALDEN RESEARCH LABORATORIES
 WORCESTER POLYTECHNIC INSTITUTE
 HYDRAULIC MODEL STUDIES
 FOR
 CONSOLIDATED EDISON COMPANY, N. Y.

INDIAN POINT II MODEL

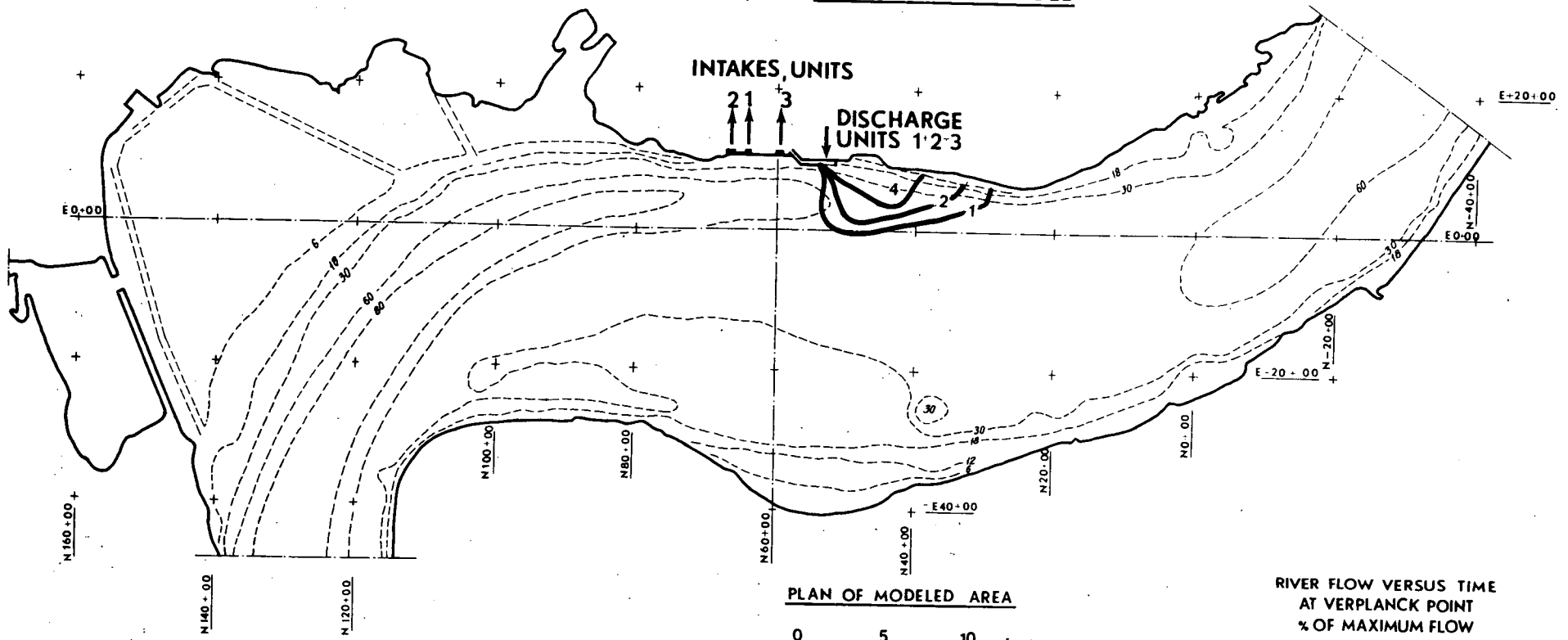

PLAN OF MODELED AREA

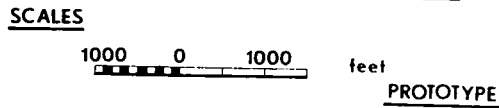

RIVER FLOW VERSUS TIME AT VERPLANCK POINT % OF MAXIMUM FLOW

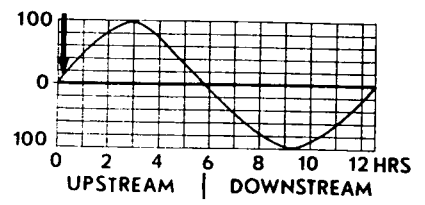

ARRANGEMENT OF OUTFALL STRUCTURE

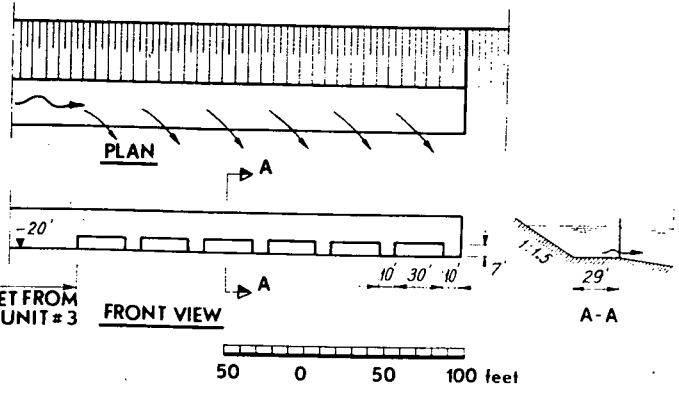

TEST CONDITIONS

TEST NUMBER AND DATE 416 ; NOV 9, 1968
 UNITS OPERATING AND DISCHARGE 2; 2670 cfs
 DISCHARGE TEMPERATURE ABOVE AMBIENT RIVER 14 °F
 TIME IN TIDE CYCLE SEE DIAGRAM
 RIVER AMBIENT TEMPERATURE 56 °F
 AIR TEMPERATURE DRY BULB 61 °F
 AIR TEMPERATURE WET BULB 57 °F
 RELATIVE HUMIDITY 78 %
 DEPTH OF ISOTHERMS 6 feet
 ISOTHERMS ARE DEGREES ABOVE AMBIENT RIVER TEMPERATURE

ALDEN RESEARCH LABORATORIES
 WORCESTER POLYTECHNIC INSTITUTE
 HYDRAULIC MODEL STUDIES
 FOR
 CONSOLIDATED EDISON COMPANY, N. Y.

INDIAN POINT II MODEL

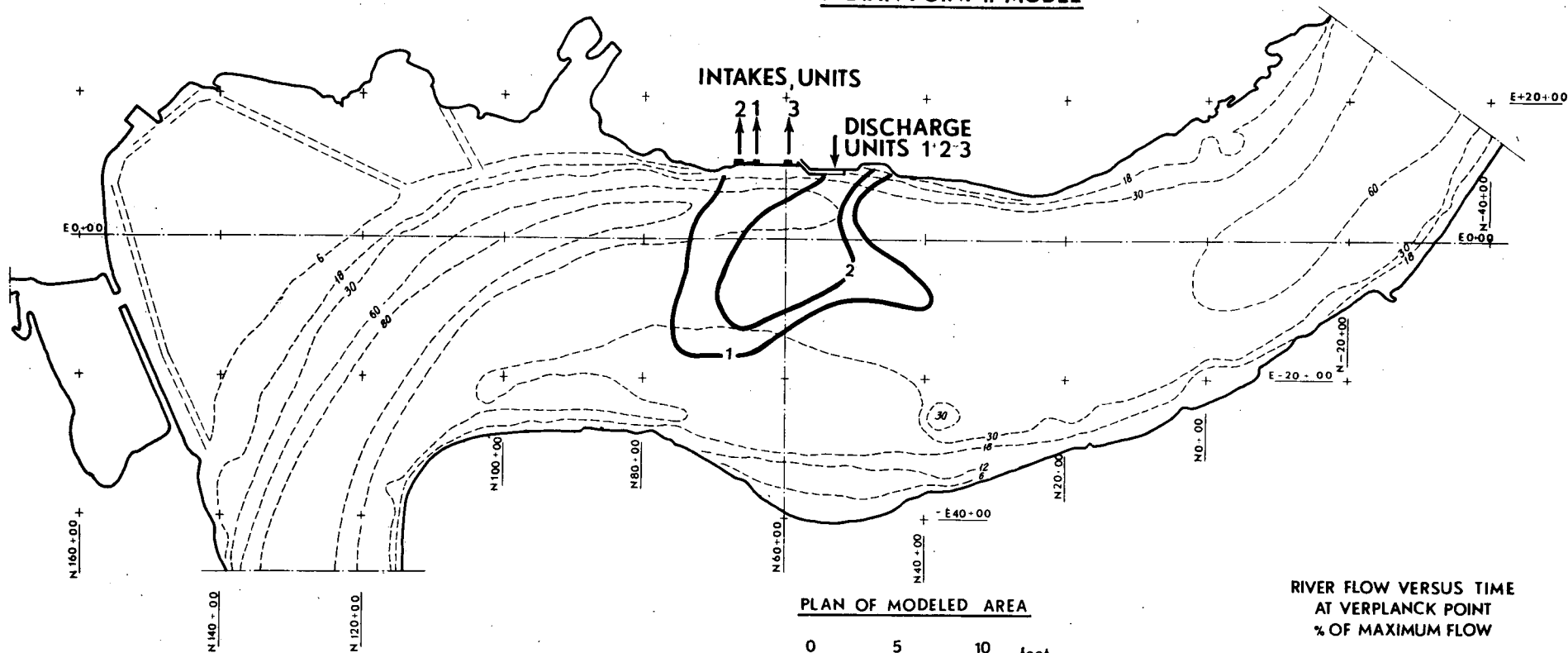

PLAN OF MODELED AREA

SCALES

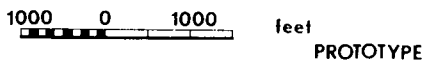

**RIVER FLOW VERSUS TIME AT VERPLANCK POINT
% OF MAXIMUM FLOW**

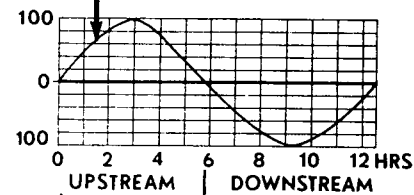

ARRANGEMENT OF OUTFALL STRUCTURE

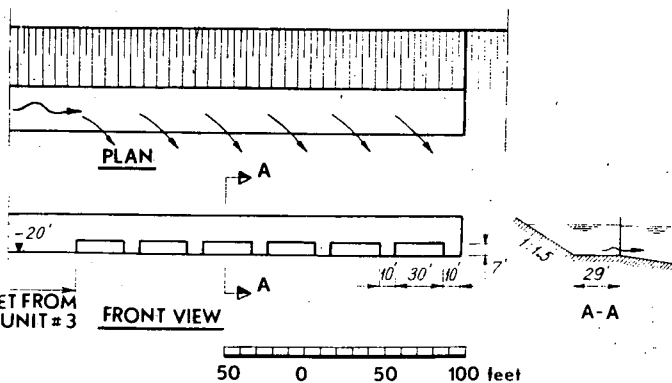

TEST CONDITIONS

TEST NUMBER AND DATE 416 ; NOV 9, 1968
 UNITS OPERATING AND DISCHARGE 2 ; 2670 cfs
 DISCHARGE TEMPERATURE ABOVE AMBIENT RIVER 14 °F
 TIME IN TIDE CYCLE SEE DIAGRAM
 RIVER AMBIENT TEMPERATURE 56 °F
 AIR TEMPERATURE DRY BULB 61 °F
 AIR TEMPERATURE WET BULB 57 °F
 RELATIVE HUMIDITY 78 %
 DEPTH OF ISOTHERMS 6 feet
 ISOTHERMS ARE DEGREES ABOVE AMBIENT RIVER TEMPERATURE

ALDEN RESEARCH LABORATORIES
 WORCESTER POLYTECHNIC INSTITUTE
 HYDRAULIC MODEL STUDIES
 FOR
 CONSOLIDATED EDISON COMPANY, N. Y.

INDIAN POINT II MODEL

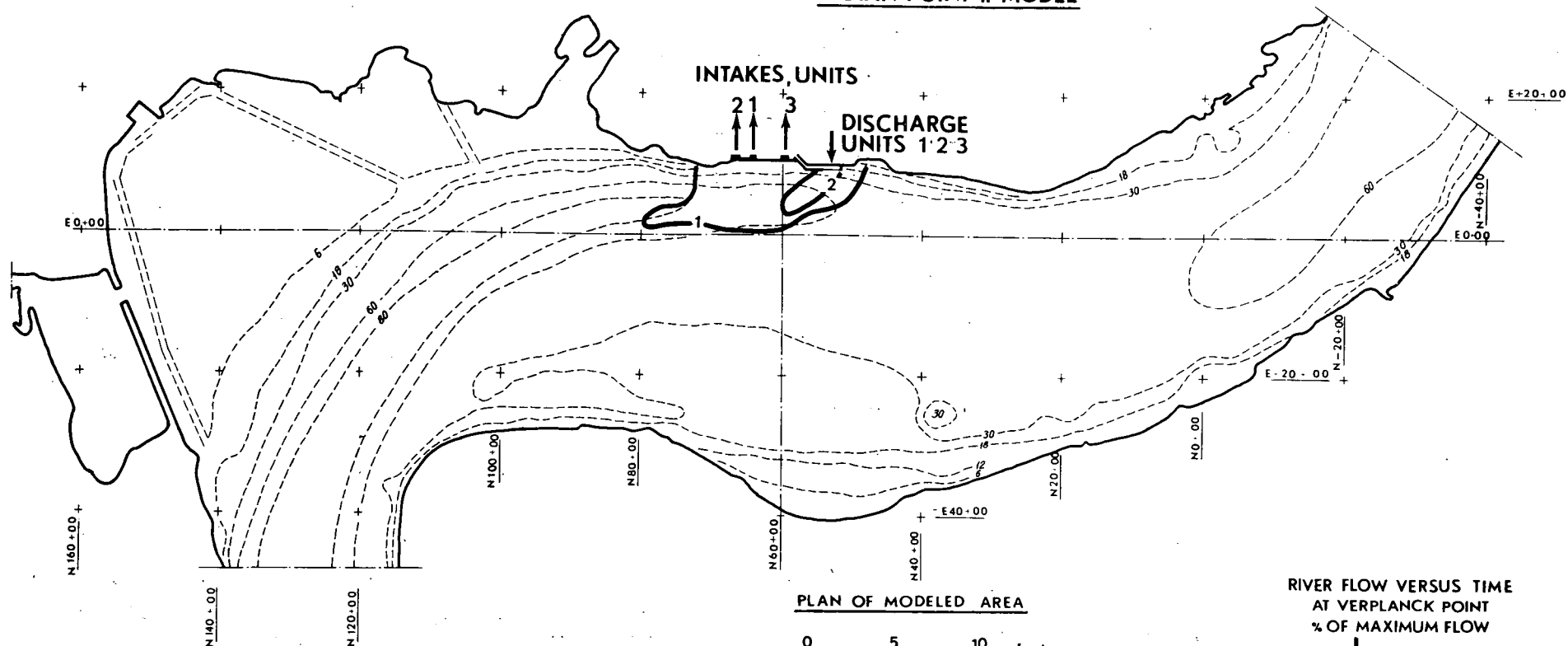

PLAN OF MODELED AREA



SCALES

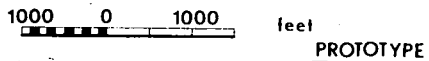

TEST CONDITIONS

TEST NUMBER AND DATE 416 ; NOV 9, 1968
 UNITS OPERATING AND DISCHARGE 2 ; 2670 cfs
 DISCHARGE TEMPERATURE ABOVE AMBIENT RIVER 14 °F
 TIME IN TIDE CYCLE SEE DIAGRAM
 RIVER AMBIENT TEMPERATURE 56 °F
 AIR TEMPERATURE DRY BULB 61 °F
 AIR TEMPERATURE WET BULB 57 °F
 RELATIVE HUMIDITY 78 %
 DEPTH OF ISOTHERMS 6 feet
 ISOTHERMS ARE DEGREES ABOVE AMBIENT RIVER TEMPERATURE

RIVER FLOW VERSUS TIME
 AT VERPLANCK POINT
 % OF MAXIMUM FLOW

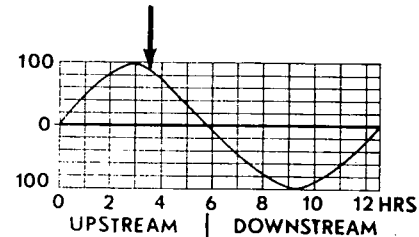

ARRANGEMENT OF OUTFALL STRUCTURE

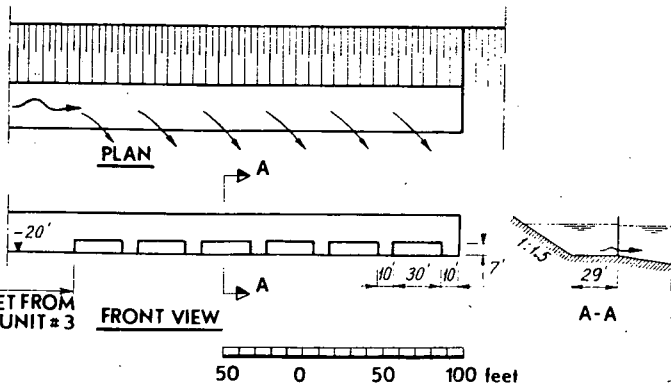

ALDEN RESEARCH LABORATORIES
 WORCESTER POLYTECHNIC INSTITUTE
 HYDRAULIC MODEL STUDIES
 FOR
 CONSOLIDATED EDISON COMPANY, N. Y.

INDIAN POINT II MODEL

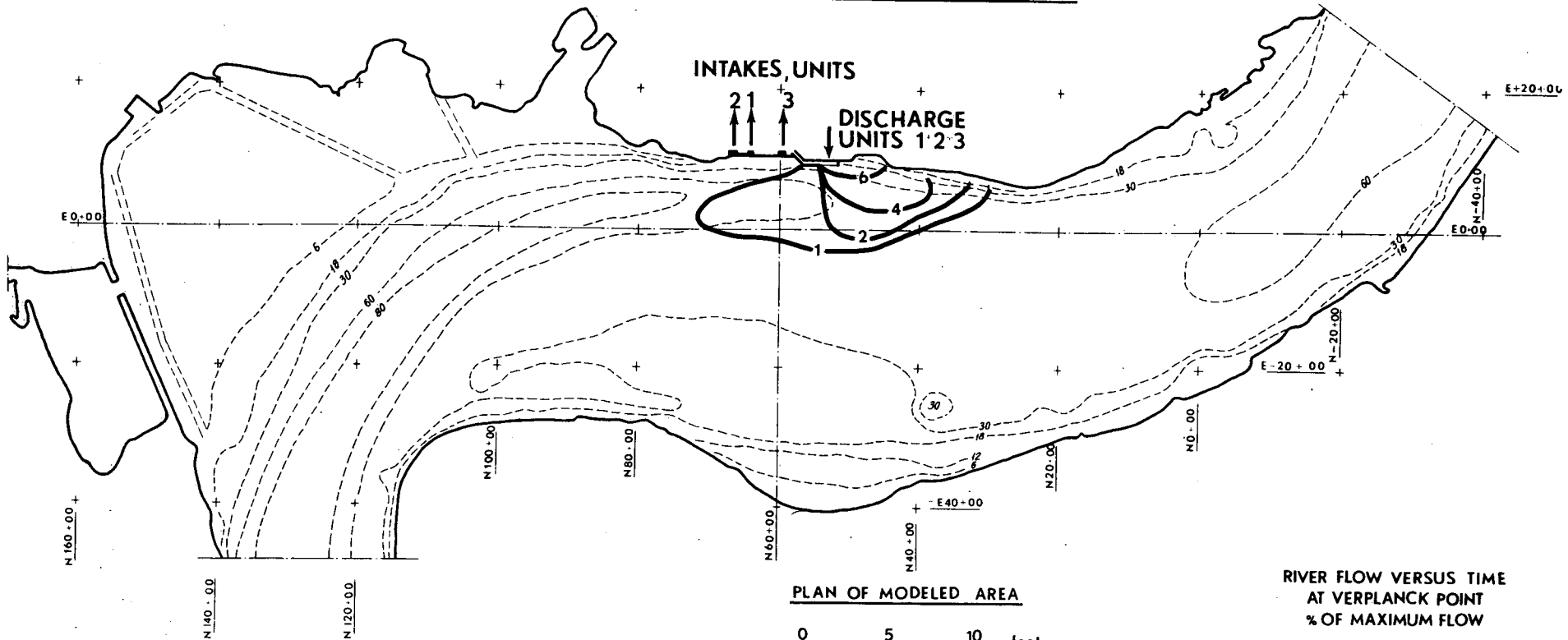

PLAN OF MODELED AREA



SCALES

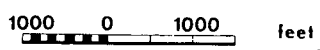

MODEL

PROTOTYPE

**RIVER FLOW VERSUS TIME AT VERPLANCK POINT
% OF MAXIMUM FLOW**

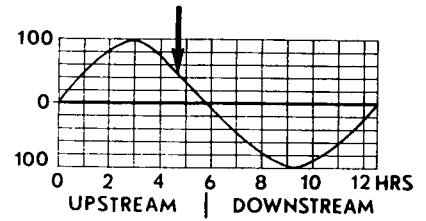

ARRANGEMENT OF OUTFALL STRUCTURE

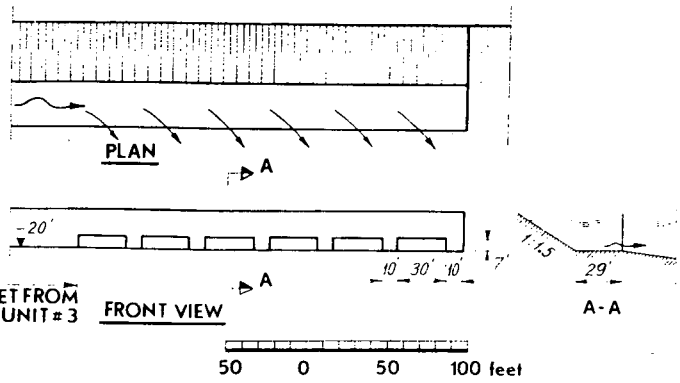

TEST CONDITIONS

TEST NUMBER AND DATE 416 ; NOV 9, 1968
 UNITS OPERATING AND DISCHARGE 2 ; 2670 cfs
 DISCHARGE TEMPERATURE ABOVE AMBIENT RIVER 14 °F
 TIME IN TIDE CYCLE SEE DIAGRAM
 RIVER AMBIENT TEMPERATURE 56 °F
 AIR TEMPERATURE DRY BULB 61 °F
 AIR TEMPERATURE WET BULB 57 °F
 RELATIVE HUMIDITY 78 %
 DEPTH OF ISOTHERMS 6 feet
 ISOTHERMS ARE DEGREES ABOVE AMBIENT RIVER TEMPERATURE

ALDEN RESEARCH LABORATORIES
 WORCESTER POLYTECHNIC INSTITUTE
 HYDRAULIC MODEL STUDIES
 FOR
 CONSOLIDATED EDISON COMPANY, N. Y.

INDIAN POINT II MODEL

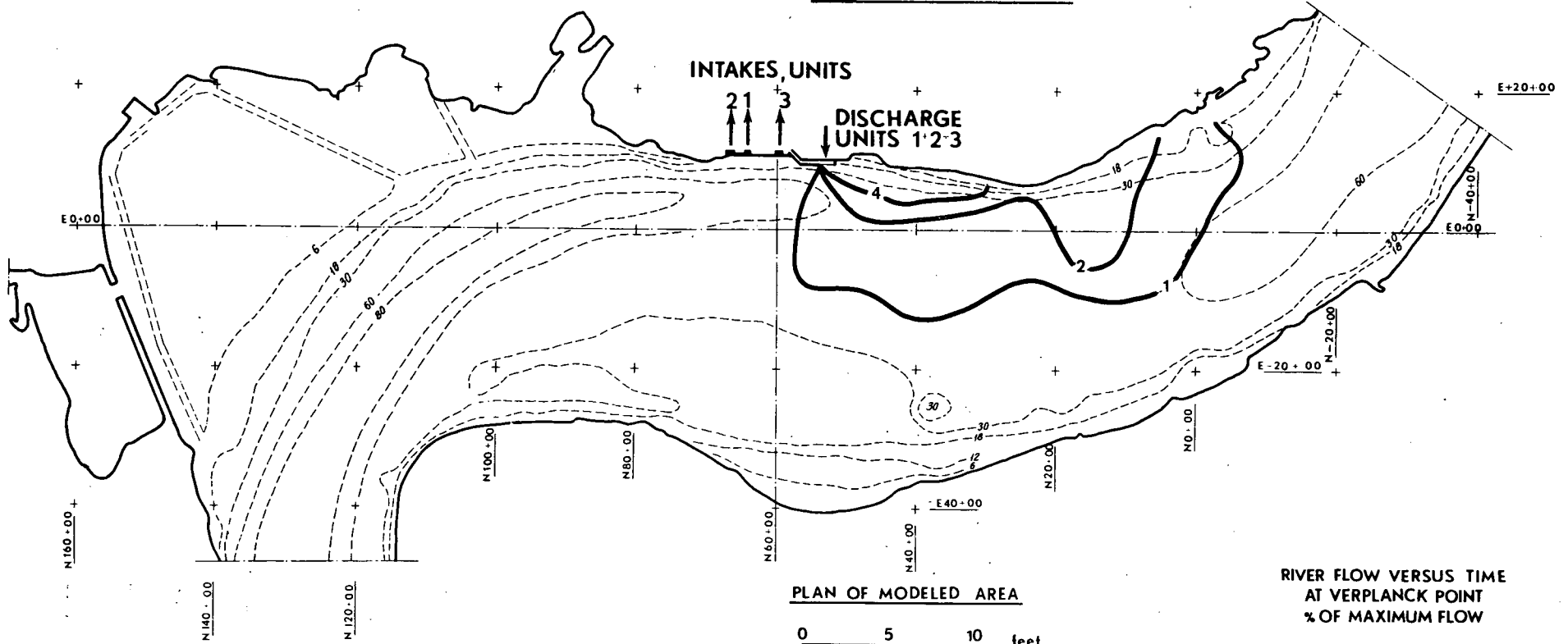

PLAN OF MODELED AREA



SCALES

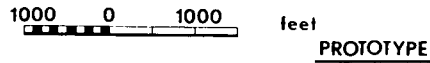

RIVER FLOW VERSUS TIME
AT VERPLANCK POINT
% OF MAXIMUM FLOW

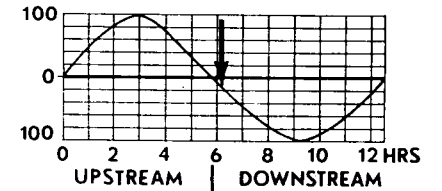

ARRANGEMENT OF OUTFALL STRUCTURE

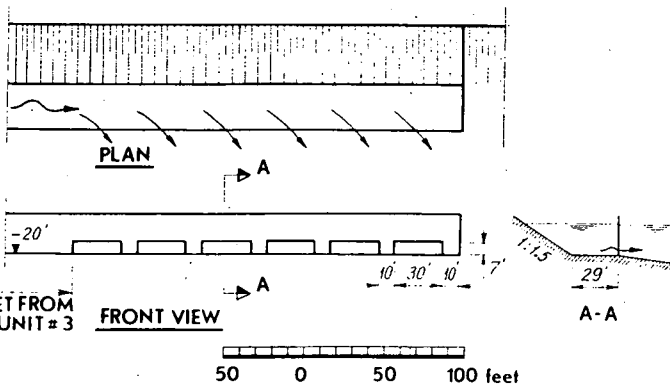

TEST CONDITIONS

TEST NUMBER AND DATE 416 ; NOV 9, 1968
 UNITS OPERATING AND DISCHARGE 2 ; 2670 cfs
 DISCHARGE TEMPERATURE ABOVE AMBIENT RIVER 14 °F
 TIME IN TIDE CYCLE SEE DIAGRAM
 RIVER AMBIENT TEMPERATURE 56 °F
 AIR TEMPERATURE DRY BULB 61 °F
 AIR TEMPERATURE WET BULB 57 °F
 RELATIVE HUMIDITY 78 %
 DEPTH OF ISOTHERMS 6 feet
 ISOTHERMS ARE DEGREES ABOVE AMBIENT RIVER TEMPERATURE

ALDEN RESEARCH LABORATORIES
 WORCESTER POLYTECHNIC INSTITUTE
 HYDRAULIC MODEL STUDIES
 FOR
 CONSOLIDATED EDISON COMPANY, N. Y.

INDIAN POINT II MODEL

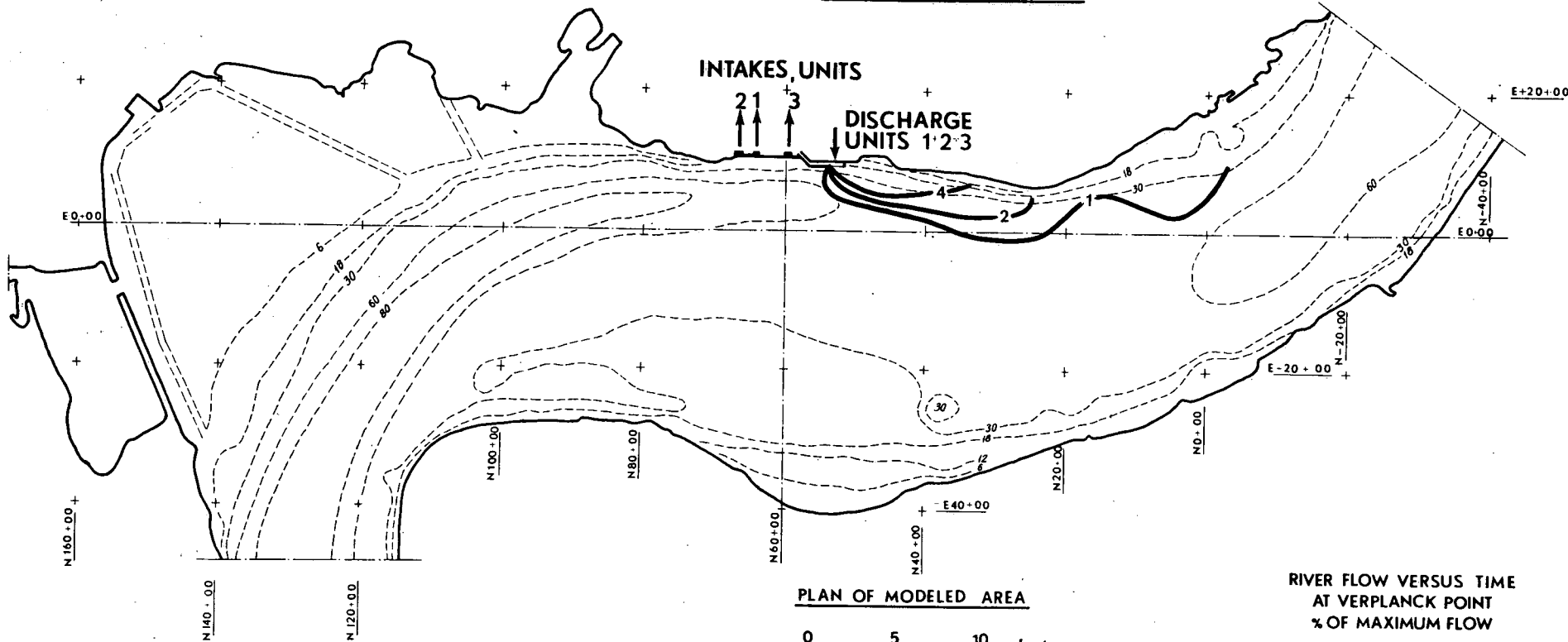

PLAN OF MODELED AREA



SCALES

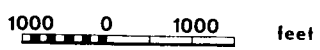

**RIVER FLOW VERSUS TIME AT VERPLANCK POINT
% OF MAXIMUM FLOW**

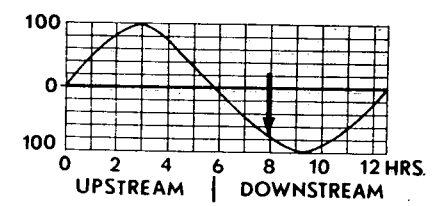

ARRANGEMENT OF OUTFALL STRUCTURE

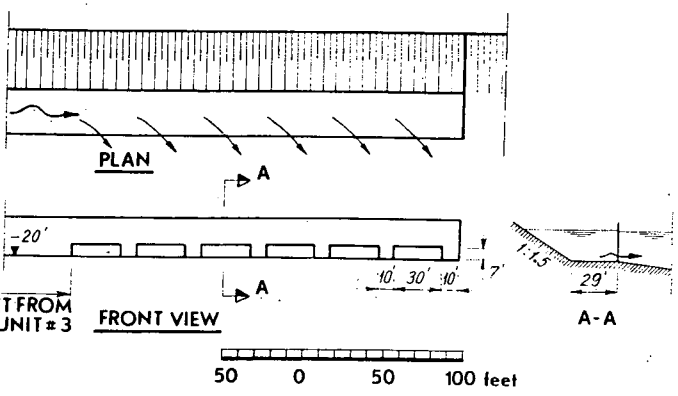

TEST CONDITIONS

TEST NUMBER AND DATE 416 ; NOV 9, 1968
 UNITS OPERATING AND DISCHARGE 2 ; 2670 cfs
 DISCHARGE TEMPERATURE ABOVE AMBIENT RIVER 14 °F
 TIME IN TIDE CYCLE SEE DIAGRAM
 RIVER AMBIENT TEMPERATURE 56 °F
 AIR TEMPERATURE DRY BULB 61 °F
 AIR TEMPERATURE WET BULB 57 °F
 RELATIVE HUMIDITY 78 %
 DEPTH OF ISOTHERMS 6 feet
 ISOTHERMS ARE DEGREES ABOVE AMBIENT RIVER TEMPERATURE

ALDEN RESEARCH LABORATORIES
 WORCESTER POLYTECHNIC INSTITUTE
 HYDRAULIC MODEL STUDIES
 FOR
 CONSOLIDATED EDISON COMPANY, N. Y.

INDIAN POINT II MODEL

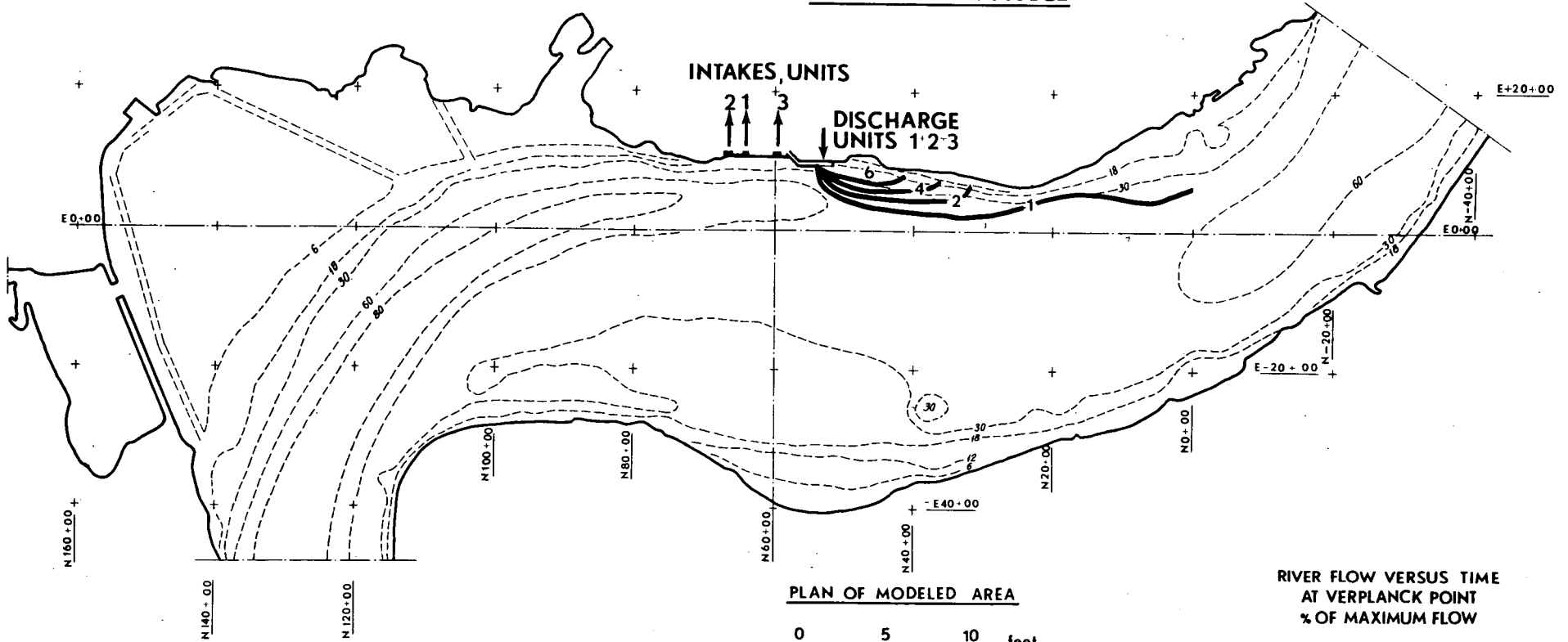

PLAN OF MODELED AREA



SCALES

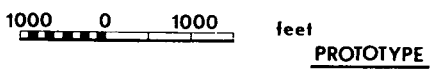

RIVER FLOW VERSUS TIME AT VERPLANCK POINT
% OF MAXIMUM FLOW

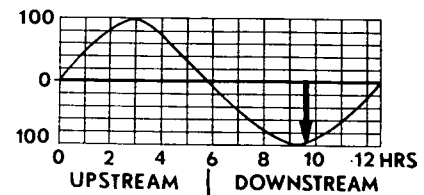

ARRANGEMENT OF OUTFALL STRUCTURE

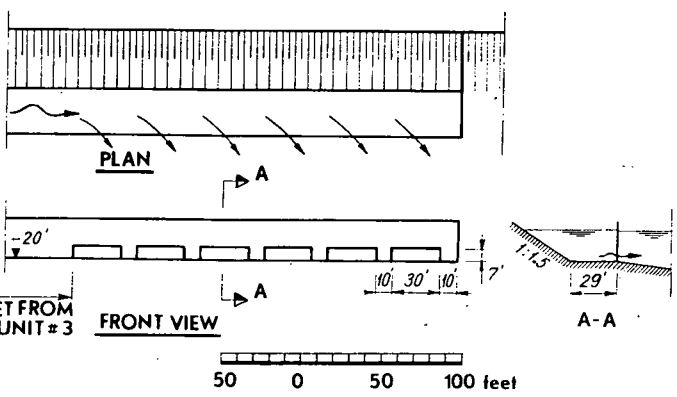

TEST CONDITIONS

TEST NUMBER AND DATE 416 ; NOV 9, 1968
 UNITS OPERATING AND DISCHARGE 2; 2670 cfs
 DISCHARGE TEMPERATURE ABOVE AMBIENT RIVER 14 °F
 TIME IN TIDE CYCLE SEE DIAGRAM
 RIVER AMBIENT TEMPERATURE 56 °F
 AIR TEMPERATURE DRY BULB 61 °F
 AIR TEMPERATURE WET BULB 57 °F
 RELATIVE HUMIDITY 78 %
 DEPTH OF ISOTHERMS 6 feet
 ISOTHERMS ARE DEGREES ABOVE AMBIENT RIVER TEMPERATURE

ALDEN RESEARCH LABORATORIES
 WORCESTER POLYTECHNIC INSTITUTE
 HYDRAULIC MODEL STUDIES
 FOR
 CONSOLIDATED EDISON COMPANY, N. Y.

INDIAN POINT II MODEL

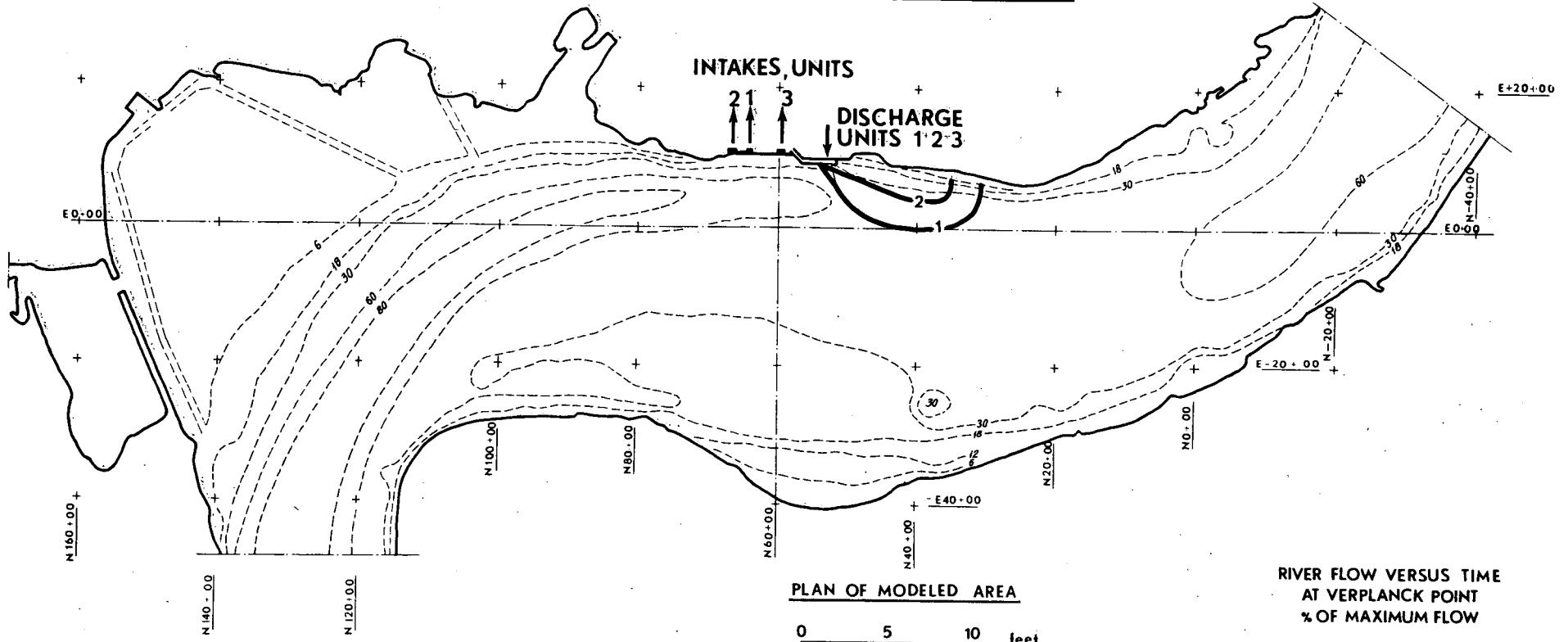

PLAN OF MODELED AREA



SCALES

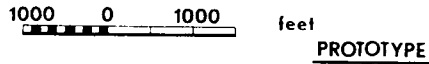

**RIVER FLOW VERSUS TIME AT VERPLANCK POINT
% OF MAXIMUM FLOW**

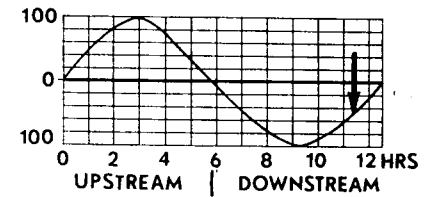

ARRANGEMENT OF OUTFALL STRUCTURE

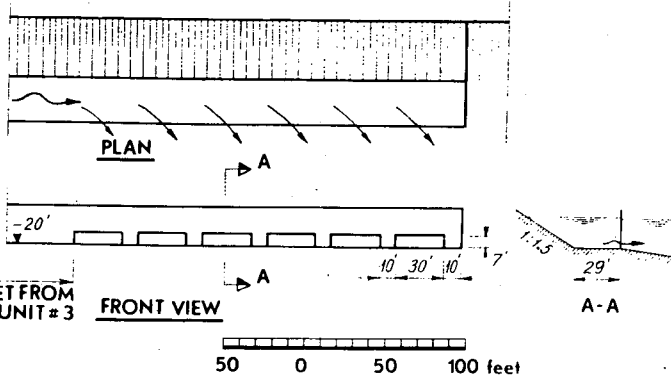

TEST CONDITIONS

TEST NUMBER AND DATE 416 ; NOV 9, 1968
 UNITS OPERATING AND DISCHARGE 2; 2670 cfs
 DISCHARGE TEMPERATURE ABOVE AMBIENT RIVER 14 °F
 TIME IN-TIDE CYCLE SEE DIAGRAM
 RIVER AMBIENT TEMPERATURE 56 °F
 AIR TEMPERATURE DRY BULB 61 °F
 AIR TEMPERATURE WET BULB 67 °F
 RELATIVE HUMIDITY 78%
 DEPTH OF ISOTHERMS 6 feet
 ISOTHERMS ARE DEGREES ABOVE AMBIENT RIVER TEMPERATURE

ALDEN RESEARCH LABORATORIES
 WORCESTER POLYTECHNIC INSTITUTE
 HYDRAULIC MODEL STUDIES
 FOR
 CONSOLIDATED EDISON COMPANY, N. Y.

INDIAN POINT II MODEL

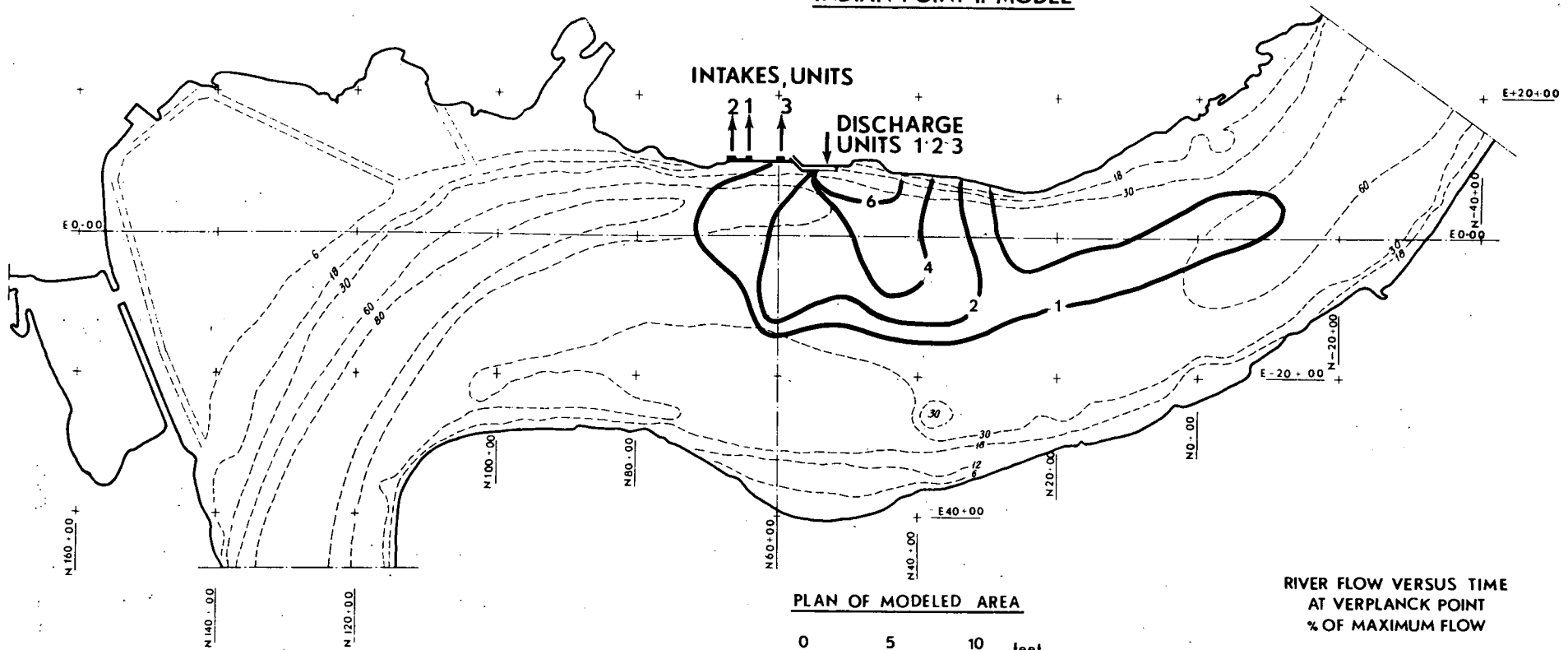

PLAN OF MODELED AREA

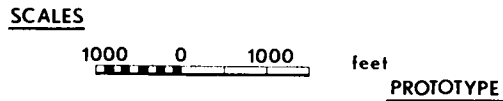

**RIVER FLOW VERSUS TIME AT VERPLANCK POINT
% OF MAXIMUM FLOW**

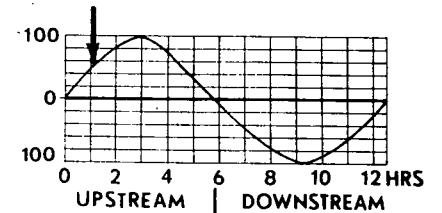

ARRANGEMENT OF OUTFALL STRUCTURE

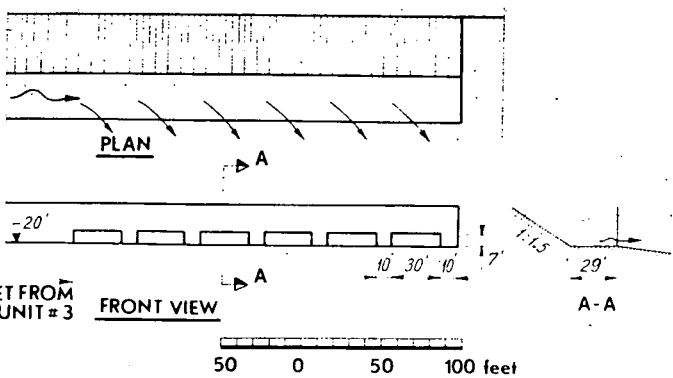

TEST CONDITIONS

TEST NUMBER AND DATE 420 ; DEC 6, 1968
 UNITS OPERATING AND DISCHARGE 2; 2670 cfs
 DISCHARGE TEMPERATURE ABOVE AMBIENT RIVER 14 °F
 TIME IN TIDE CYCLE SEE DIAGRAM
 RIVER AMBIENT TEMPERATURE 80 °F
 AIR TEMPERATURE DRY BULB 77.7 °F
 AIR TEMPERATURE WET BULB 71 °F
 RELATIVE HUMIDITY 73 %
 DEPTH OF ISOTHERMS 0 feet
 ISOTHERMS ARE DEGREES ABOVE AMBIENT RIVER TEMPERATURE

ALDEN RESEARCH LABORATORIES
 WORCESTER POLYTECHNIC INSTITUTE
 HYDRAULIC MODEL STUDIES
 FOR
 CONSOLIDATED EDISON COMPANY, N. Y.

INDIAN POINT II MODEL

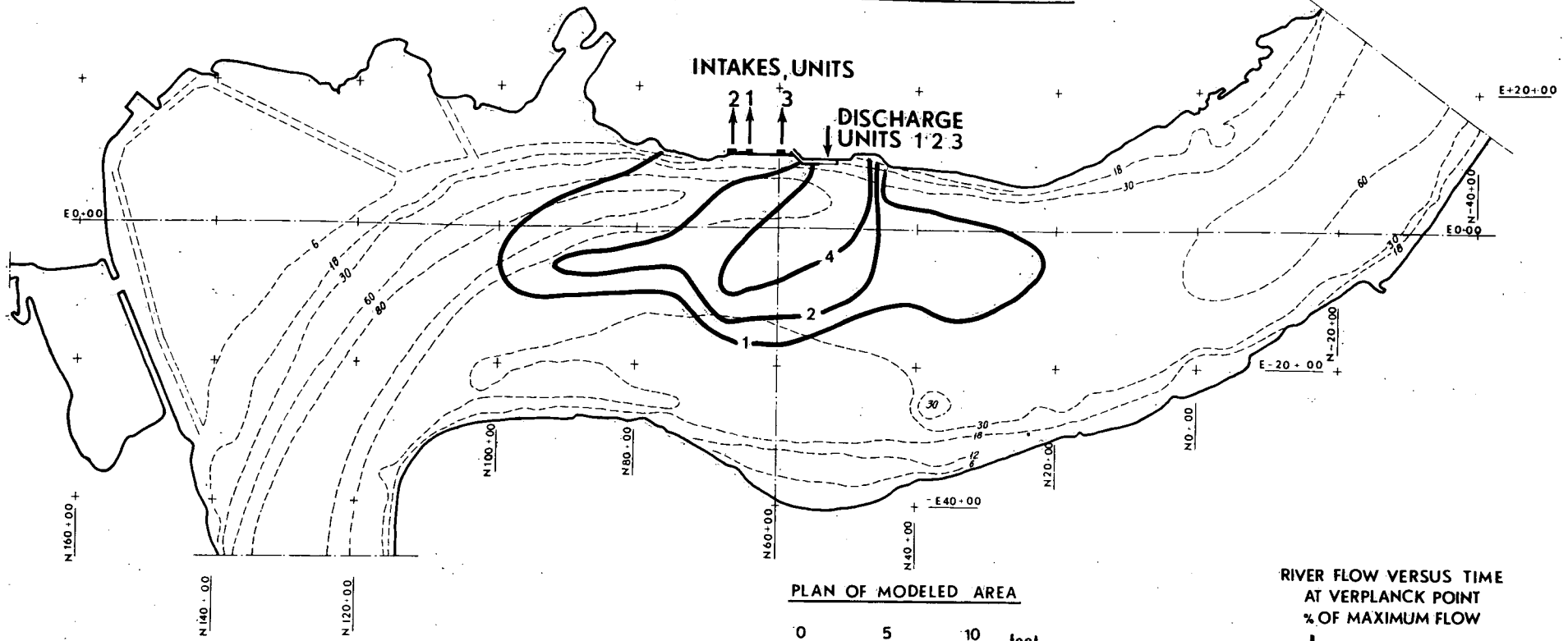

PLAN OF MODELED AREA

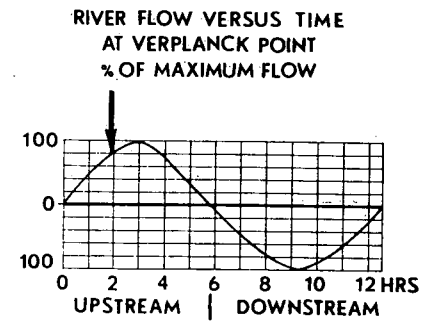
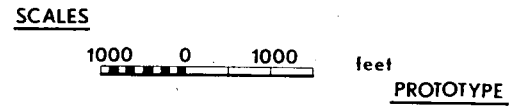

ARRANGEMENT OF OUTFALL STRUCTURE

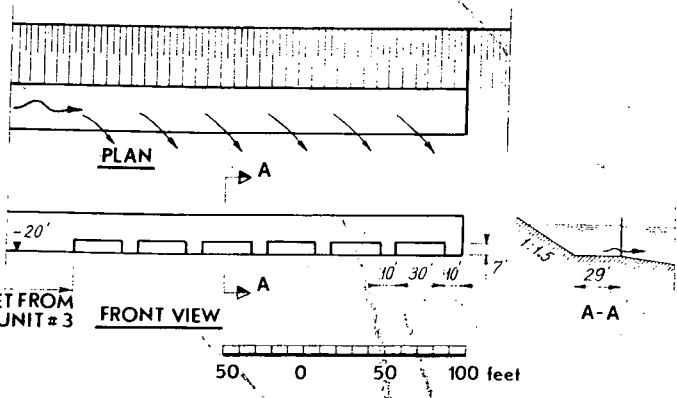

TEST CONDITIONS

TEST NUMBER AND DATE 420 ; DEC 6, 1968
 UNITS OPERATING AND DISCHARGE 2 ; 2670 cfs
 DISCHARGE TEMPERATURE ABOVE AMBIENT RIVER 14 °F
 TIME IN TIDE CYCLE SEE DIAGRAM
 RIVER AMBIENT TEMPERATURE 80 °F
 AIR TEMPERATURE DRY BULB 77.7 °F
 AIR TEMPERATURE WET BULB 71 °F
 RELATIVE HUMIDITY 73 %
 DEPTH OF ISOTHERMS 0 feet
 ISOTHERMS ARE DEGREES ABOVE AMBIENT RIVER TEMPERATURE

ALDEN RESEARCH LABORATORIES
 WORCESTER POLYTECHNIC INSTITUTE
 HYDRAULIC MODEL STUDIES
 FOR
 CONSOLIDATED EDISON COMPANY, N.Y.

INDIAN POINT II MODEL

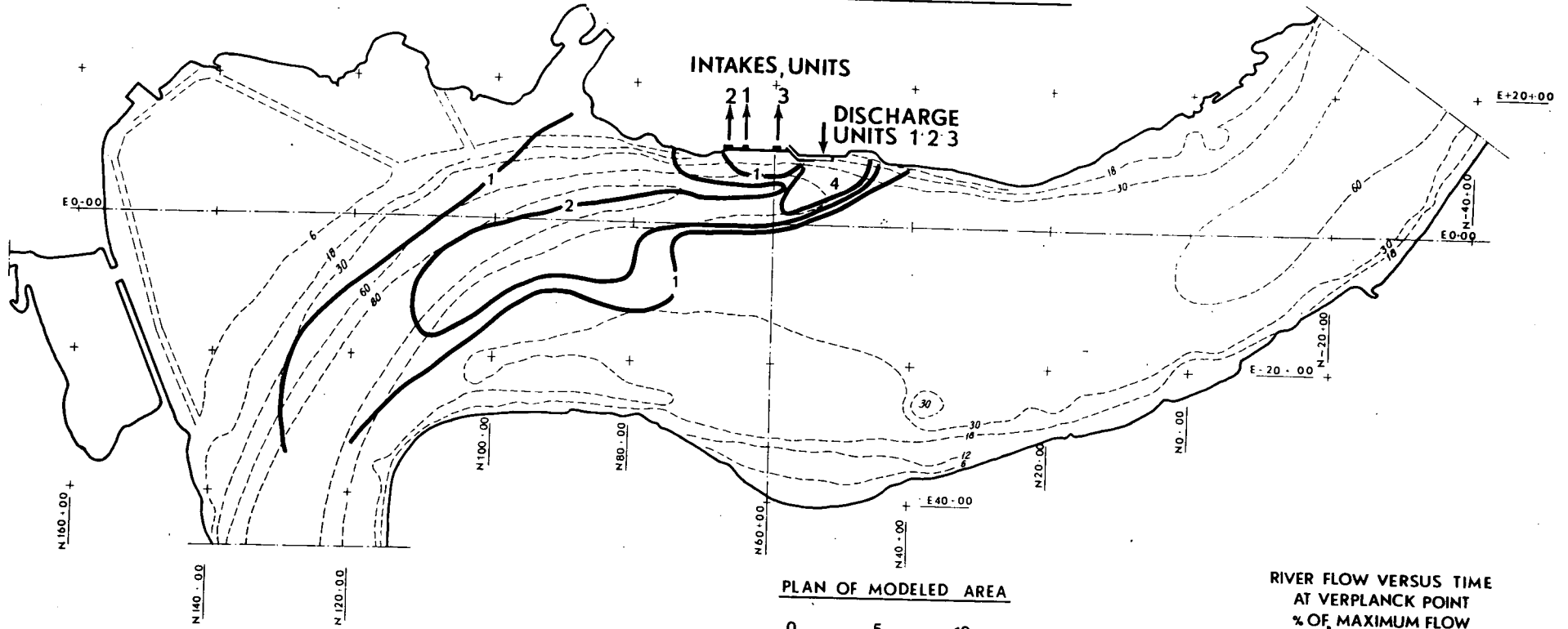

PLAN OF MODELED AREA

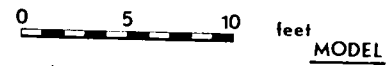

ARRANGEMENT OF OUTFALL STRUCTURE

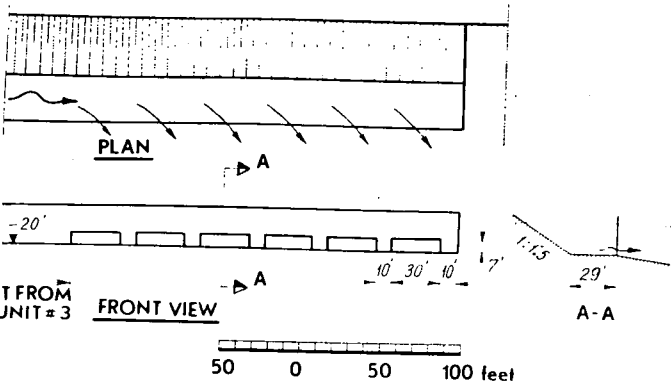

TEST CONDITIONS

TEST NUMBER AND DATE 420 ; DEC 6, 1968
 UNITS OPERATING AND DISCHARGE 2; 2670 cfs
 DISCHARGE TEMPERATURE ABOVE AMBIENT RIVER 14 °F
 TIME IN TIDE CYCLE SEE DIAGRAM
 RIVER AMBIENT TEMPERATURE 80 °F
 AIR TEMPERATURE DRY BULB 77.7 °F
 AIR TEMPERATURE WET BULB 71 °F
 RELATIVE HUMIDITY 73 %
 DEPTH OF ISOTHERMS 0 feet
 ISOTHERMS ARE DEGREES ABOVE AMBIENT RIVER TEMPERATURE

RIVER FLOW VERSUS TIME AT VERPLANCK POINT % OF MAXIMUM FLOW

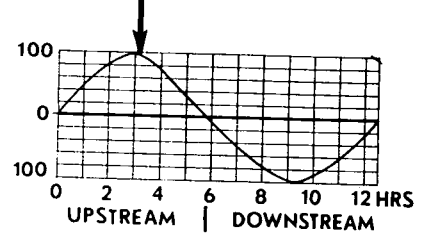

ALDEN RESEARCH LABORATORIES
 WORCESTER POLYTECHNIC INSTITUTE
 HYDRAULIC MODEL STUDIES
 FOR
 CONSOLIDATED EDISON COMPANY, N. Y.

INDIAN POINT II MODEL

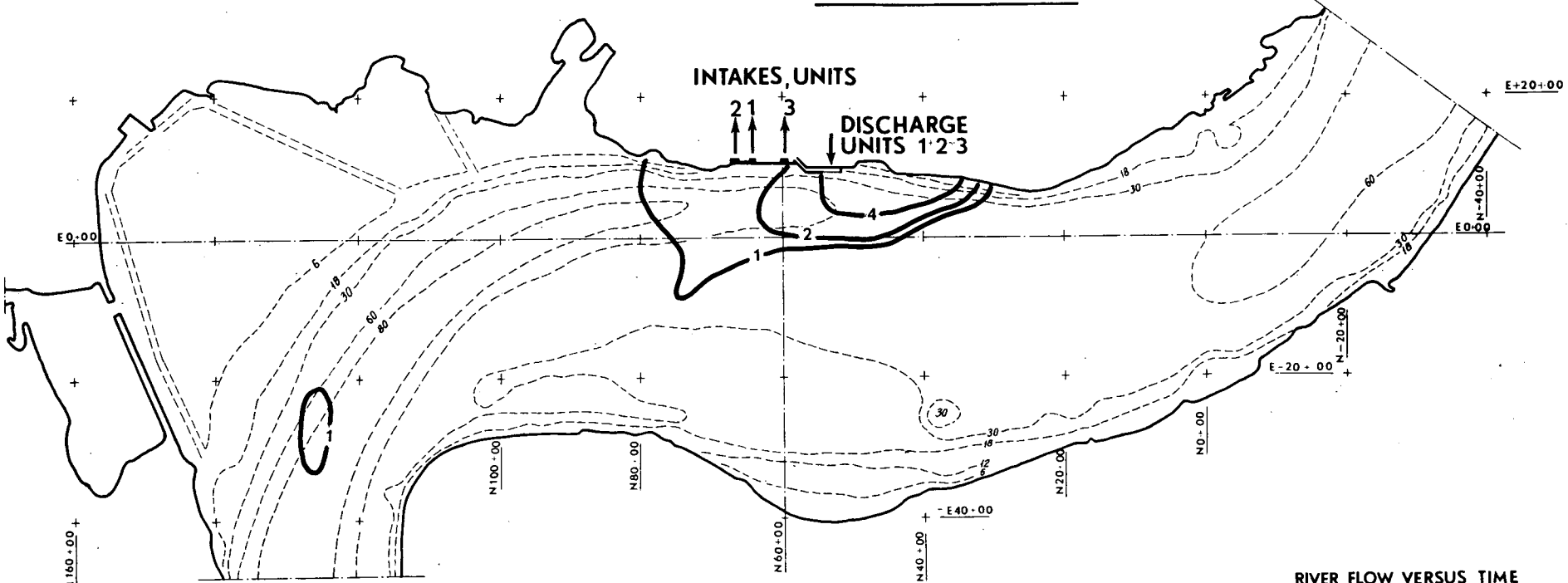

PLAN OF MODELED AREA

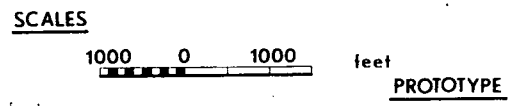

**RIVER FLOW VERSUS TIME AT VERPLANCK POINT
% OF MAXIMUM FLOW**

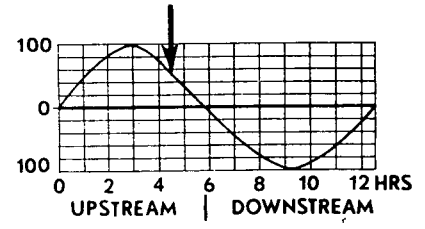

ARRANGEMENT OF OUTFALL STRUCTURE

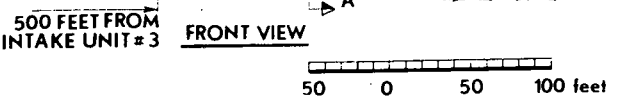
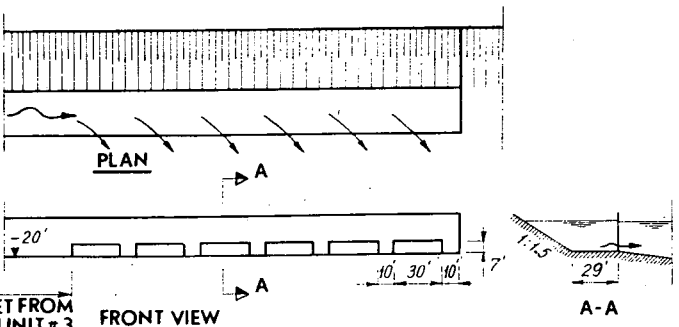

TEST CONDITIONS

TEST NUMBER AND DATE 420 ; DEC 6, 1968
 UNITS OPERATING AND DISCHARGE 2 ; 2670 cfs
 DISCHARGE TEMPERATURE ABOVE AMBIENT RIVER 14 °F
 TIME IN TIDE CYCLE SEE DIAGRAM
 RIVER AMBIENT TEMPERATURE 80 °F
 AIR TEMPERATURE DRY BULB 77.7 °F
 AIR TEMPERATURE WET BULB 71 °F
 RELATIVE HUMIDITY 73 %
 DEPTH OF ISOTHERMS 0 feet
 ISOTHERMS ARE DEGREES ABOVE AMBIENT RIVER TEMPERATURE

ALDEN RESEARCH LABORATORIES
 WORCESTER POLYTECHNIC INSTITUTE
 HYDRAULIC MODEL STUDIES
 FOR
 CONSOLIDATED EDISON COMPANY, N. Y.

INDIAN POINT II MODEL

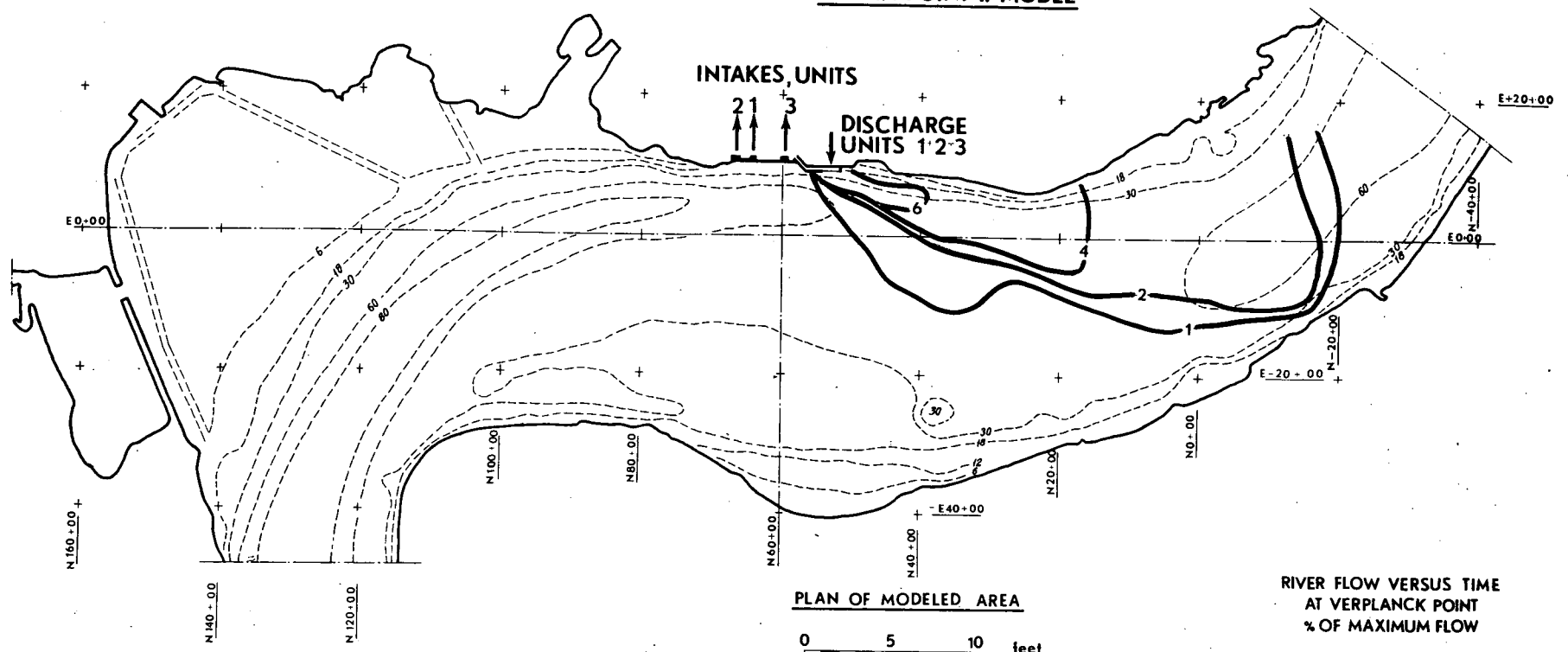

PLAN OF MODELED AREA



SCALES

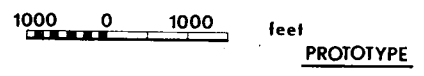

**RIVER FLOW VERSUS TIME AT VERPLANCK POINT
% OF MAXIMUM FLOW**

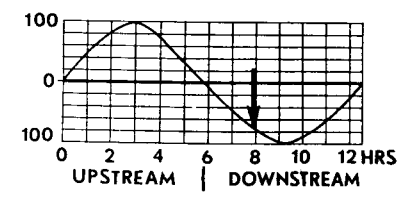

ARRANGEMENT OF OUTFALL STRUCTURE

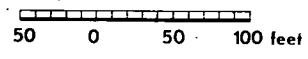
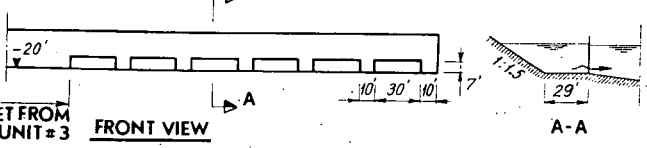
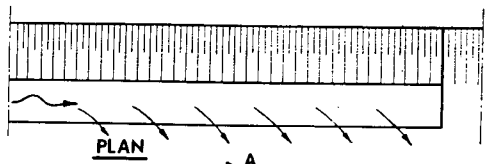

TEST CONDITIONS

TEST NUMBER AND DATE 420 ; DEC 6, 1968
 UNITS OPERATING AND DISCHARGE 2, 2670 cfs
 DISCHARGE TEMPERATURE ABOVE AMBIENT RIVER 14 °F
 TIME IN TIDE CYCLE SEE DIAGRAM
 RIVER AMBIENT TEMPERATURE 80 °F
 AIR TEMPERATURE DRY BULB 77.7 °F
 AIR TEMPERATURE WET BULB 71 °F
 RELATIVE HUMIDITY 73 %
 DEPTH OF ISOTHERMS 0 feet
 ISOTHERMS ARE DEGREES ABOVE AMBIENT RIVER TEMPERATURE

ALDEN RESEARCH LABORATORIES
 WORCESTER POLYTECHNIC INSTITUTE
 HYDRAULIC MODEL STUDIES
 FOR
 CONSOLIDATED EDISON COMPANY, N. Y.

INDIAN POINT II MODEL

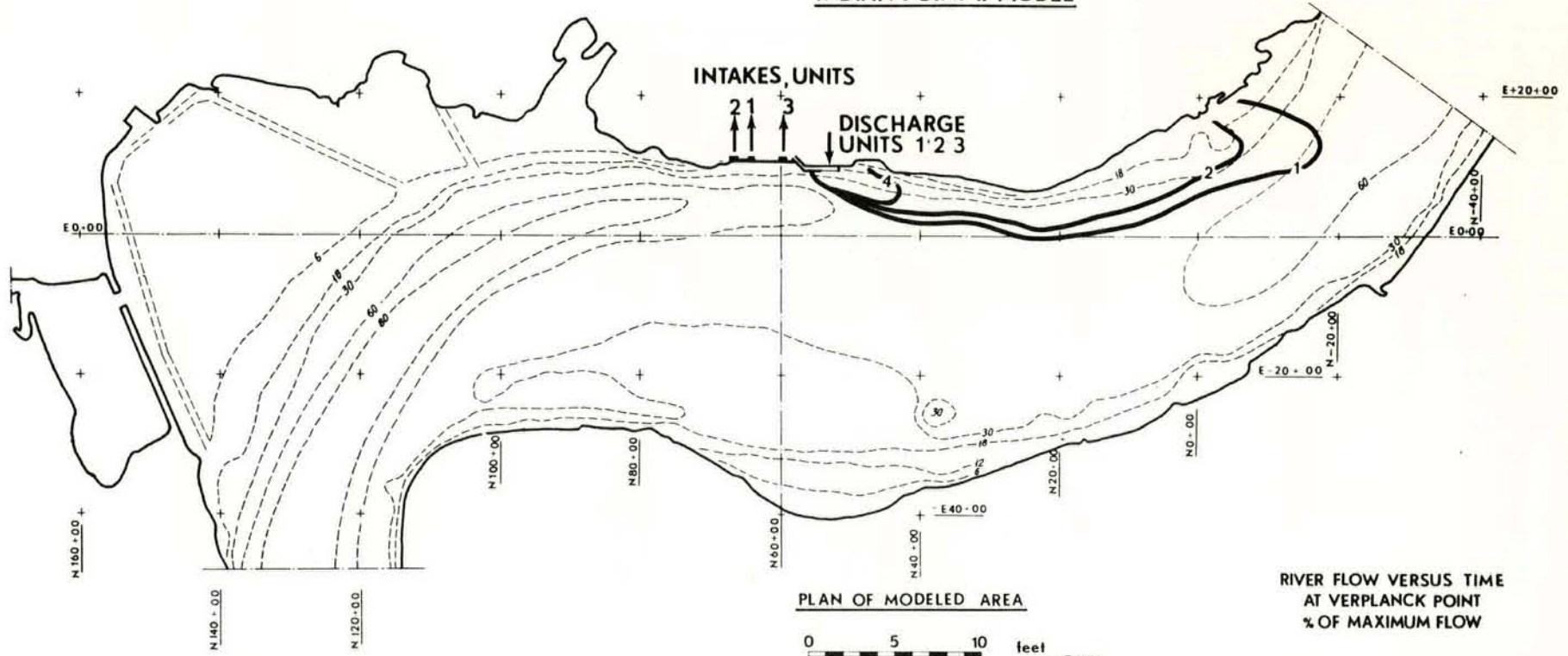

PLAN OF MODELED AREA

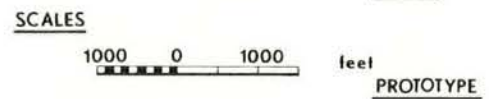

RIVER FLOW VERSUS TIME AT VERPLANCK POINT
% OF MAXIMUM FLOW

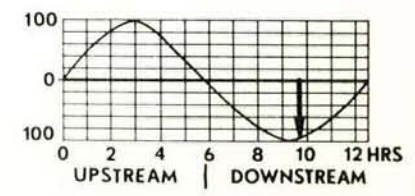

ARRANGEMENT OF OUTFALL STRUCTURE

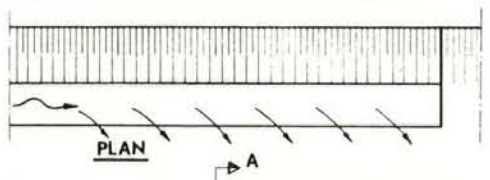

FRONT VIEW

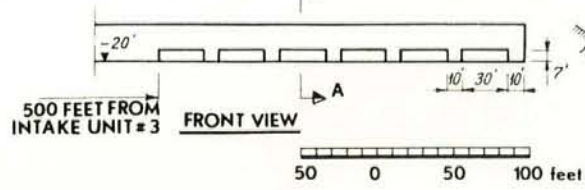

TEST CONDITIONS

TEST NUMBER AND DATE 420 ; DEC 6, 1968
 UNITS OPERATING AND DISCHARGE 2 ; 2670 cfs
 DISCHARGE TEMPERATURE ABOVE AMBIENT RIVER 14 °F
 TIME IN TIDE CYCLE SEE DIAGRAM
 RIVER AMBIENT TEMPERATURE 80 °F
 AIR TEMPERATURE DRY BULB 77.7 °F
 AIR TEMPERATURE WET BULB 71 °F
 RELATIVE HUMIDITY 73 %
 DEPTH OF ISOTHERMS 0 feet
 ISOTHERMS ARE DEGREES ABOVE AMBIENT RIVER TEMPERATURE

ALDEN RESEARCH LABORATORIES
 WORCESTER POLYTECHNIC INSTITUTE
 HYDRAULIC MODEL STUDIES
 FOR
 CONSOLIDATED EDISON COMPANY, N. Y.

FIG. 100

INDIAN POINT II MODEL

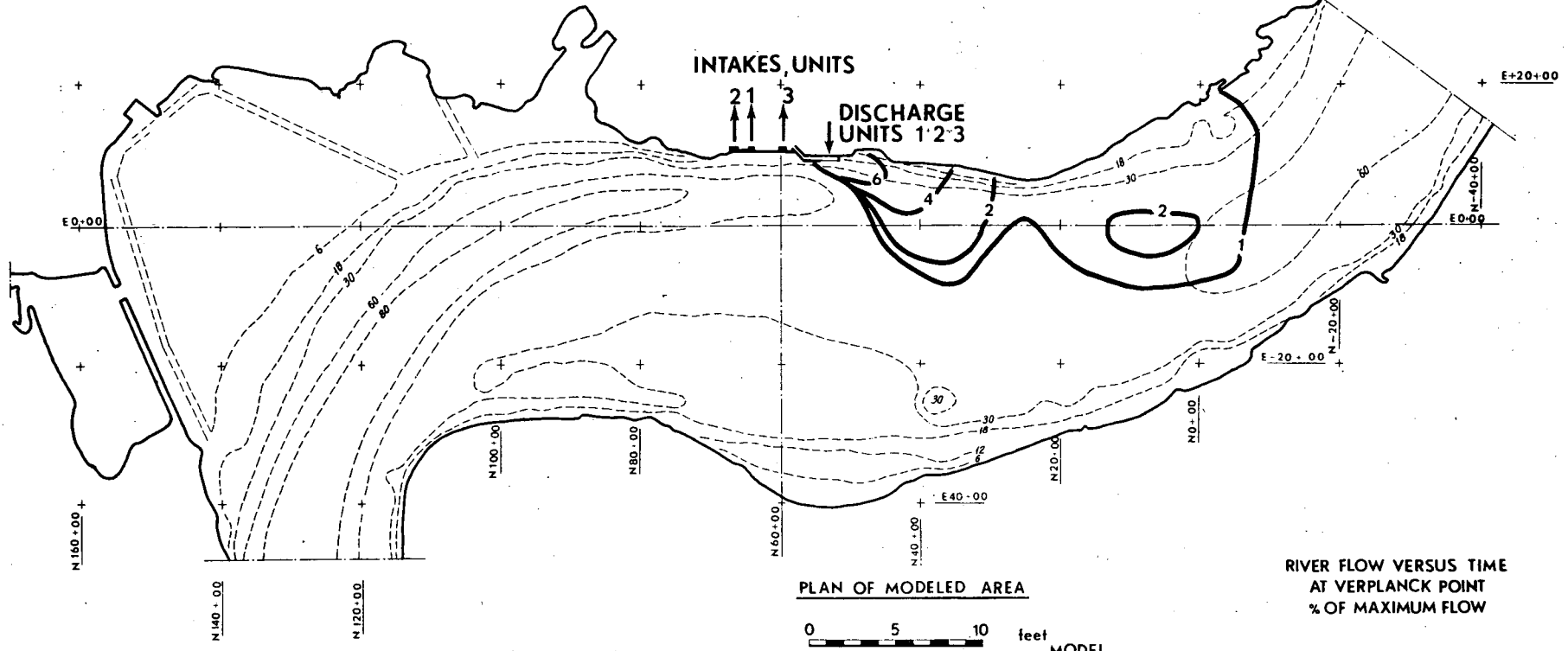

PLAN OF MODELED AREA



SCALES

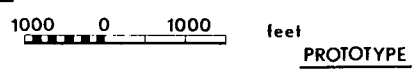

**RIVER FLOW VERSUS TIME AT VERPLANCK POINT
% OF MAXIMUM FLOW**

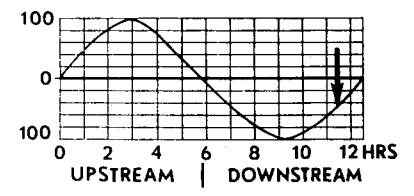

ARRANGEMENT OF OUTFALL STRUCTURE

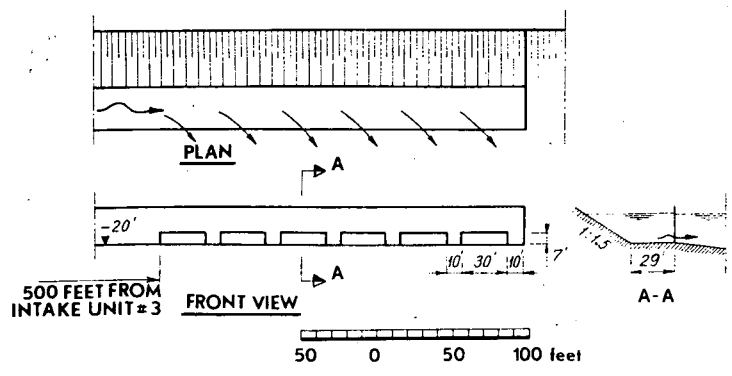

TEST CONDITIONS

TEST NUMBER AND DATE 420 ; DEC 6, 1968
 UNITS OPERATING AND DISCHARGE 2; 2670 cfs
 DISCHARGE TEMPERATURE ABOVE AMBIENT RIVER 14 °F
 TIME IN TIDE CYCLE SEE DIAGRAM
 RIVER AMBIENT TEMPERATURE 80 °F
 AIR TEMPERATURE DRY BULB 77.7 °F
 AIR TEMPERATURE WET BULB 71 °F
 RELATIVE HUMIDITY 73 %
 DEPTH OF ISOTHERMS 0 feet
 ISOTHERMS ARE DEGREES ABOVE AMBIENT RIVER TEMPERATURE

ALDEN RESEARCH LABORATORIES
 WORCESTER POLYTECHNIC INSTITUTE
 HYDRAULIC MODEL STUDIES
 FOR
 CONSOLIDATED EDISON COMPANY, N. Y.

INDIAN POINT MODEL #2
MEASURED RECIRCULATION
UNITS 1+2+3 4670 CFS $\Delta T=17^{\circ}\text{F}$
AMBIENT WATER TEMP. 50°F

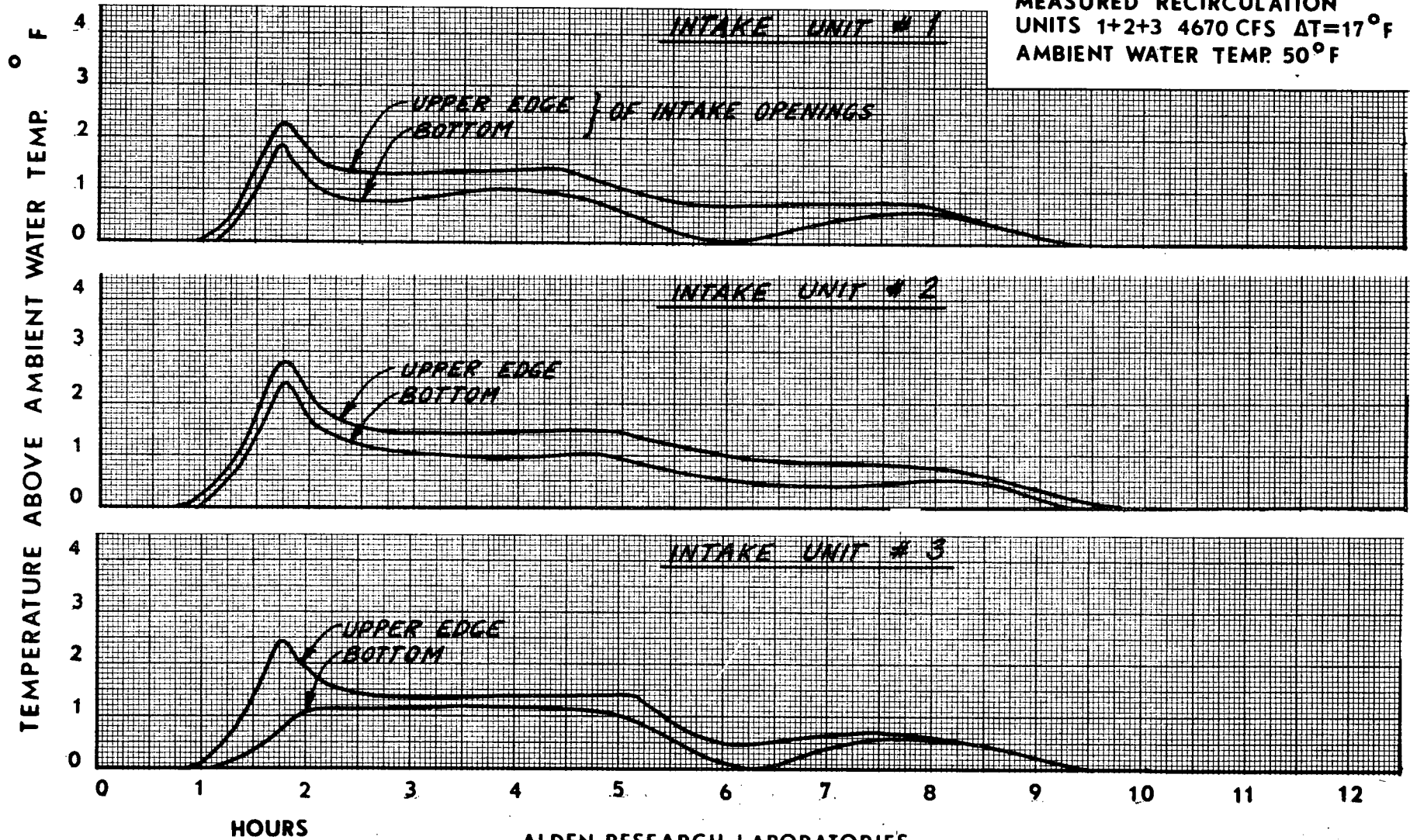

ALDEN RESEARCH LABORATORIES
WORCESTER POLYTECHNIC INSTITUTE
INDIAN POINT II MODEL

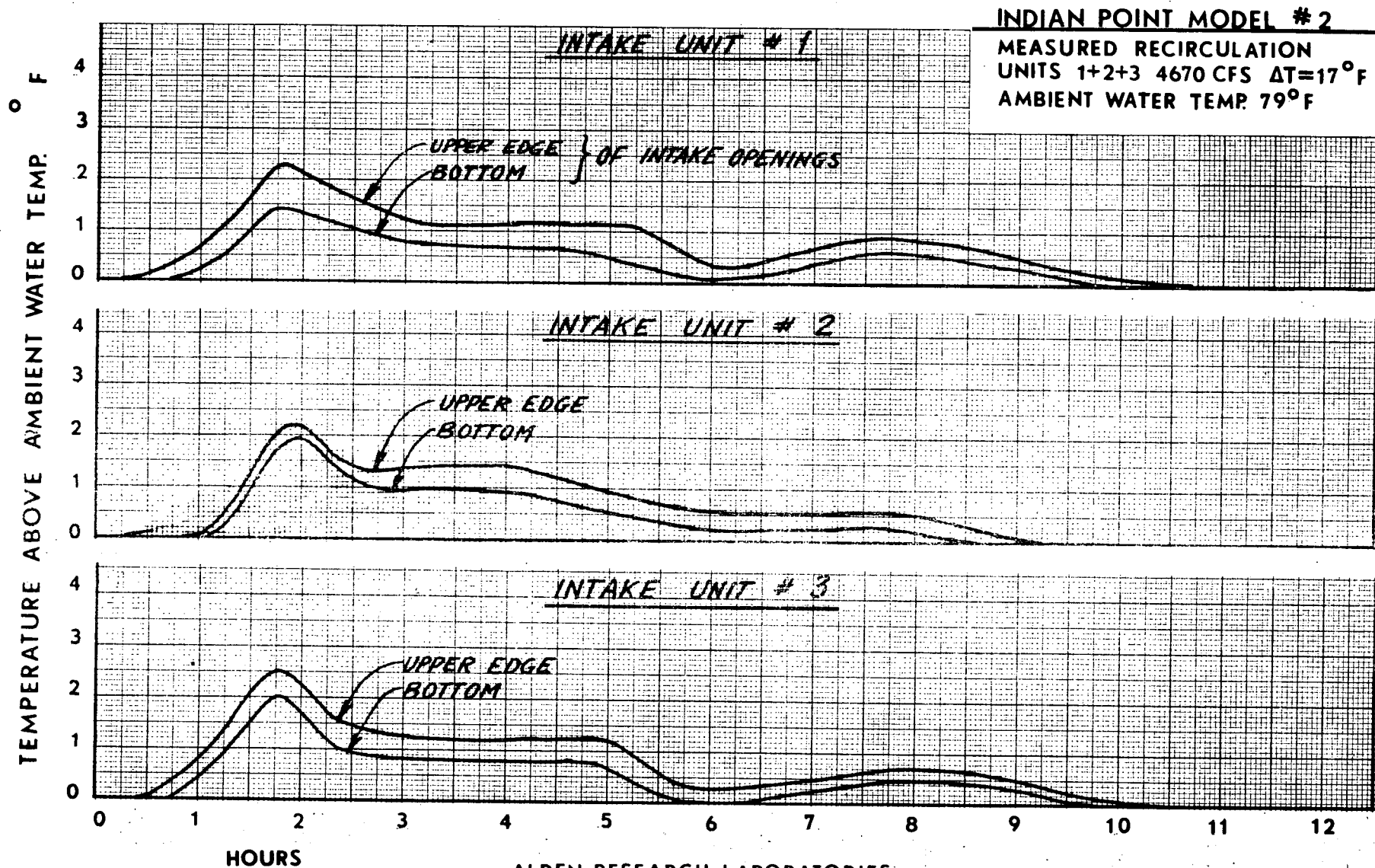

ALDEN RESEARCH LABORATORIES
 WORCESTER POLYTECHNIC INSTITUTE
 INDIAN POINT II MODEL

INDIAN POINT MODEL #2

MEASURED RECIRCULATION
UNITS 1+2 2670 CFS $\Delta T=16^{\circ}\text{F}$
AMBIENT WATER TEMP 50°F

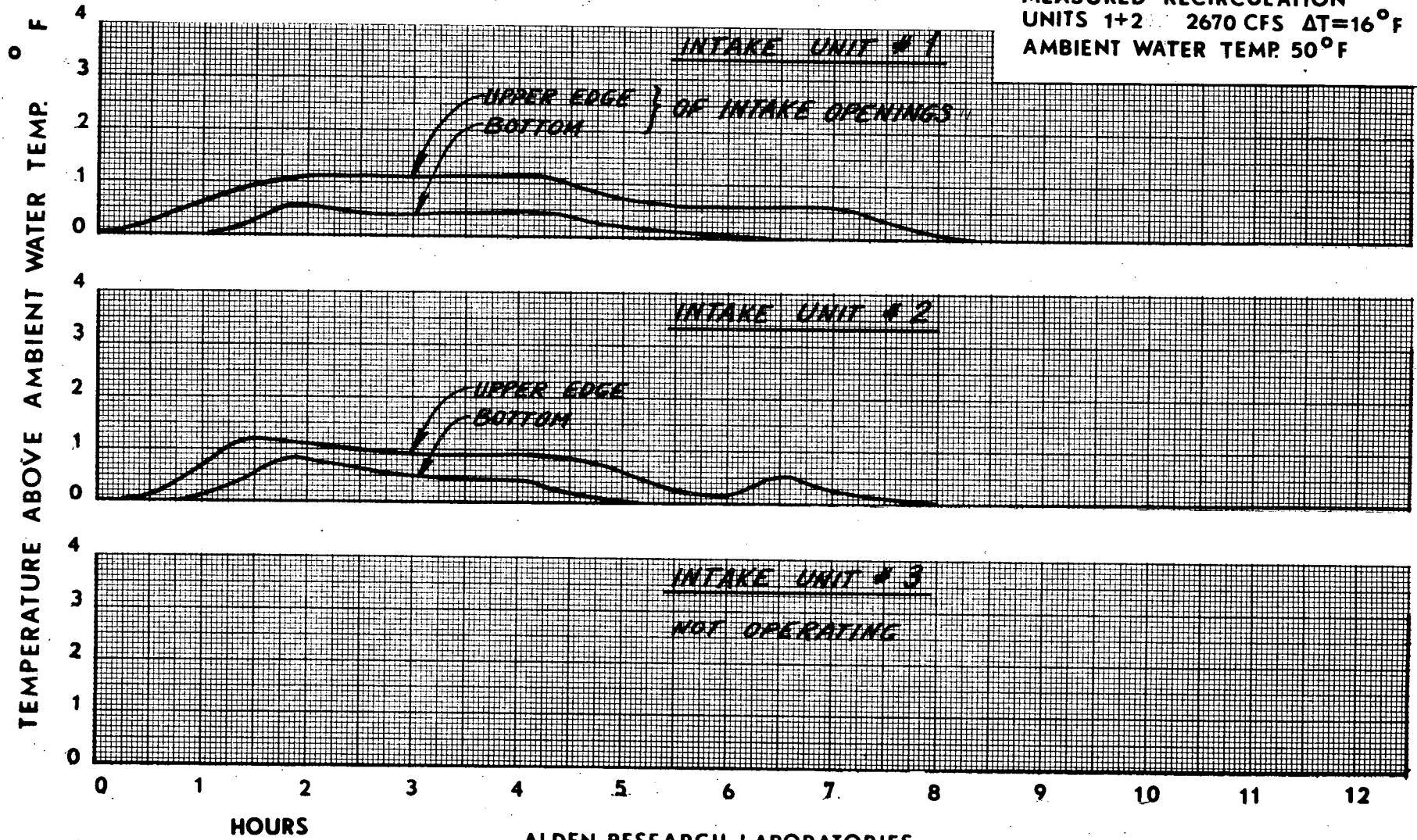

ALDEN RESEARCH LABORATORIES
WORCESTER POLYTECHNIC INSTITUTE
INDIAN POINT II MODEL