

NOTES

- THE PIPING DESIGNER SHALL PROVIDE INSTRUMENT ROOT VALVES AND INSTRUMENT PIPING IN CONFORMANCE WITH THE REQUIREMENTS OF THE PROCESS INSTRUMENT SPECIFICATION AT-3030.
- THE CRD SYSTEM HCU'S ARE ARRANGED IN FOUR SCRAM GROUPS LOCATED IN TWO MECHANICAL ZONES OF THE REACTOR BUILDING. EACH MECHANICAL ZONE CONTAINS TWO SCRAM GROUPS. EACH HCU SCRAM GROUP SERVES ONE QUADRANT OF THE REACTOR CORE.
- PROVIDE DRAIN VALVES AT ALL SYSTEM LOW POINTS.
- PROVIDE VENT VALVES AT ALL SYSTEM HIGH POINTS.
- EXCEPT AT POINTS OF CONNECTION WITH THE REACTOR VENDOR SUPPLIED EQUIPMENT OR PIPING, THE PIPING DESIGNER SHALL SIZE PIPES IN CONFORMANCE WITH THE SYSTEM DESIGN SPECIFICATION AND PROCESS DIAGRAM.
- THIS DOCUMENT PROVIDES A FUNCTIONAL DEFINITION OF THE REQUIRED SYSTEM LEVEL PROCESS MONITORING AND CONTROL INSTRUMENTATION. IT DOES NOT ADDRESS DETAILS OF THE METHODS BY WHICH SIGNALS FROM THESE COMPONENTS WILL BE PROCESSED. THIS PROCESSING MAY INVOLVE THE PLANT MULTIPLEXING SYSTEM (M23) OR MAY UTILIZE DEDICATED HARDWIRING.
- CRD NITROGEN AND AIR LINES SHALL BE OF A NON-CORRODING MATERIAL.
- MULTIPLE ORIFICES CONNECTED IN SERIES AS SHOWN IN PURCHASE PART DRAWING OF ORIFICE DOOR. THE PRESSURE DROP ACROSS EACH ORIFICE IS 173 MPa AT PUMP RUN-OUT CONDITION. SEE COMPONENT DEVICE LIST FOR THE QUANTITIES OF ORIFICES.
- PIPING QUALITY CLASS EXTENDS TO CONNECTIONS WITH HCU. HCU DIAGRAM IS SHOWN FOR INFORMATION ONLY. FOR QUALITY CLASS OF THE HCU, SEE GROUP CLASSIFICATION DIAGRAM, AT-1030.

- FLUSHING CONNECTIONS SHALL BE PROVIDED IN ACCORDANCE WITH THE SPECIFICATION FOR CLEANING OF PIPE AND EQUIPMENT, AT-4910. TEMPORARY STRAINER SCREENS SHALL BE PROVIDED ON THE SUCTION SIDE OF ALL PUMPS IN ACCORDANCE WITH THE SPECIFICATION FOR FIELD CLEANING AND CLEANLINESS OF NUCLEAR PLANT COMPONENTS, AT-3070.
- APPROPRIATE ELECTRICAL ISOLATION SHALL BE PROVIDED BETWEEN THE NON-ESSENTIAL ROD WITHDRAW BLOCK SIGNAL (PS-281) AND THE ESSENTIAL REACTOR TRIP SIGNAL (PT-011).
- PIPE SIZE SHALL BE SPECIFIED BY THE PIPING DESIGNER.
- A PORTABLE NITROGEN CHARGING SYSTEM SHALL BE PROVIDED TO MEET THE REQUIREMENTS OF THE HCU. IT SHALL BE DESIGNED AND CONSTRUCTED IN ACCORDANCE WITH GOOD INDUSTRY PRACTICE AND SHALL HAVE THE APPROPRIATE SAFETY DEVICES, GAGES AND VALVES. A PRESSURE RELIEF VALVE SHALL BE INSTALLED DOWNSTREAM OF THE CHARGING STATION PRESSURE REGULATOR WHICH SHALL PREVENT PRESSURIZATION ABOVE SYSTEM REQUIREMENTS.
- SOURCE OF CRD SYSTEM WATER SHALL BE NORMALLY FROM THE CONDENSATE FEEDWATER AND CONDENSATE AIR EXTRACTION SYSTEM (N2). CONDENSATE STORAGE TANK IS THE ALTERNATE SOURCE IF CONDENSATE TREATMENT SYSTEM IS NOT IN OPERATION. FOR DETAILED DESIGN REQUIREMENT FOR SOURCE AND QUALITY OF WATER SEE CONTROL ROD DRIVE SYSTEM DESIGN SPEC. CS-4230. THE CRD SYSTEM INTERFACE CONFIGURATION WITH THE CONDENSATE FEEDWATER AND CONDENSATE AIR EXTRACTION SYSTEM (CFE/AE) SHALL BE DETERMINED BY THE ACTUAL C/D/W/A/D DESIGN.
- PROVISION FOR CONTAMINATION ISOLATION TO BE IN ACCORDANCE WITH CURRENT LICENSING REQUIREMENTS.

- PRESSURE INDICATOR SHALL BE LOCATED ON A STRAIGHT PIPE SECTION TEN PIPE DIAMETERS FROM PUMP OUTLET.
- ALL REFERENCED DESIGNATORS ARE PREFIXED BY C12- UNLESS OTHERWISE INDICATED.
- FLANGED PUMPS TO BE USED.
- THESE VALVES MUST BE OPEN FOR RAPID HYDRAULIC ROD INSERTION (ISRAM).
- FOR SEISMIC CATEGORY OF INDIVIDUAL FWCRO COMPONENTS, SEE REFERENCE 12.
- SYSTEM DESIGN CONDITIONS:
 - A) DESIGN PRESSURE - SEE BOUNDARY SYMBOLS
 - B) DESIGN TEMPERATURE = 84 °C
 - C) PIPING MATERIAL - SEE TABLE 1
 - D) PIPING SCHEDULE NUMBER - SEE TABLE 1
 - E) DESIGN/QUALITY CLASS - SEE BOUNDARY SYMBOLS
 - F) SEISMIC CATEGORY - SEE BOUNDARY SYMBOLS
 - G) FLUID - SEE TABLE 1
- PIPING INTERFACES WITH THE CRD PUMP, INCLUDING SUCTION, DISCHARGE, VENT, DRAIN AND POSITIVE PRESSURE SEAL LINES SHALL BE SPECIFIED BY THE PUMP SUPPLIER. REDUCERS ON THE SUCTION AND DISCHARGE PIPING SHALL BE PROVIDED AS REQUIRED.
- PIPE SIZE SHALL BE SPECIFIED BY THE PUMP SUPPLIER.
- EACH SCRAM INSERT LINE SHALL BE ASSIGNED A SUFFIX NUMBER WHICH CORRESPONDS TO THE CORE LOCATION OF ITS ASSOCIATED FWCRO.
- THE PIPING DESIGNER SHALL DETERMINE THE LOCATION OF THE LINE SIZE REDUCTION FOR THE CONNECTION WITH THE FWCRO. PIPE 20A-CRD-027 SHALL BE DELETED IF THE REDUCER IS AT THE FWCRO FLANGE.
- FLOW SIGHT GLASS BOXES SHALL BE PROVIDED TO ALLOW VISUAL OBSERVATION OF LEAKAGE FROM INDIVIDUAL OR SMALL GROUPS OF FWCRO'S. THE SPECIFIC NUMBER AND CONFIGURATION OF SIGHT GLASS BOXES SHALL BE DETERMINED BY THE PIPING DESIGNER BASED ON THE DESIGN OF THE UNDERVESSEL ARRANGEMENT.

- THE FWCRO LEAK DETECTION INSTRUMENTATION AS SHOWN PROVIDES A FUNCTIONAL DEFINITION OF THE MINIMUM LEAK DETECTION MONITORING REQUIREMENTS. THE ACTUAL INSTRUMENTATION CONFIGURATION SHALL BE SPECIFIED BY THE DESIGNER BASED ON THE DETAILED FWCRO LEAK DETECTION SYSTEM ARRANGEMENT.
- THE PIPING DESIGNER SHALL DETERMINE THE SPECIFIC CONFIGURATION OF DRAIN PIPING TO DELIVER FWCRO LEAKAGE FLOW TO LCW.
- HCU ROOM CRD FRICTION TEST CONNECTIONS ARE USED IN CONJUNCTION WITH A PORTABLE TEST CART TO PROVIDE TEMPORARY HYDRAULIC CONNECTION TO THE HCU FOR CRD FRICTION TESTING.
- THE ACTUAL HCU HEADER CONFIGURATION SHALL BE DETERMINED BY THE HCU ROOM PIPING LAYOUT DESIGN.
- THE PIPING DESIGNER SHALL SPECIFY THE LOCATION OF MAINTENANCE VALVES, IF REQUIRED, FOR AIR VALVE AND AIR HEADER DUMP VALVE MAINTENANCE.
- THE PIPING DESIGNER SHALL DETERMINE THE NEED FOR LINE SIZE REDUCTIONS FOR THE AIR HEADER DUMP VALVES AND AIR VALVES. THE REDUCERS MAY BE DELETED IF NOT REQUIRED.
- THE VALVE POSITION INDICATING LIGHT SHALL BE LOCATED EITHER IN A LOCAL PANEL OR ON THE HCU.
- THE PENETRATION NUMBERS FOR THE SCRAM LINES X-810 (AT 0°) AND X-70 (AT 180°)
- THE INSTRUMENT AIR SUPPLY SHALL BE DESIGNED TO ASSURE CONTINUED AIR SUPPLY TO THE SCRAM AIR HEADER AND FLOW CONTROL VALVES (FCV) WITH ANY SINGLE PRESSURE CONTROL VALVE OUT OF SERVICE.
- PIPE WITH A DESIGN PRESSURE OF 2.82 MPa OR GREATER SHALL HAVE ITS MINIMUM WALL THICKNESS NO LESS THAN THAT OF A STANDARD WEIGHT PIPE, THICKER THAN STANDARD WEIGHT PIPE SHALL BE USED IF REQUIRED BY THE DESIGN PRESSURE OR OTHER REQUIREMENTS.
- VALVES WITH A DESIGN PRESSURE OF 2.82 MPa OR GREATER SHALL BE A MINIMUM OF CLASS 300, OR OF A HIGHER CLASS IF REQUIRED BY THE DESIGN PRESSURE.

REFERENCE DOCUMENTS	MPL NO.
1. REACTOR WATER CLEANUP SYS PAID	G31-1010
2. REACTOR RECIRCULATION SYS PAID	B31-1010
3. REACTOR BUILDING COOLING WATER SYS PAID	P21-1010
4. MAKEUP WATER SYS (CONDENSED) PAID	P13-1010
5. CONDENSATE FEEDWATER AND CONDENSATE AIR EXTRACTION SYS PAID	N21-1010
6. RECIRCULATION FLOW CONTROL SYS IBO	C81-1030
7. INSTRUMENT AIR SYS PAID	P52-1010
8. REACTOR PROTECTION SYS IBO	C71-1030
9. ROD CONTROL AND INFORMATION SYS IBO	C11-1030
10. ROD CONTROL AND INFORMATION SYS IED	C11-1040
11. NUCLEAR BOILER SYS PAID	B21-1010
12. PIPING AND INSTRUMENTATION DIAGRAM SYMBOLS	A10-3030

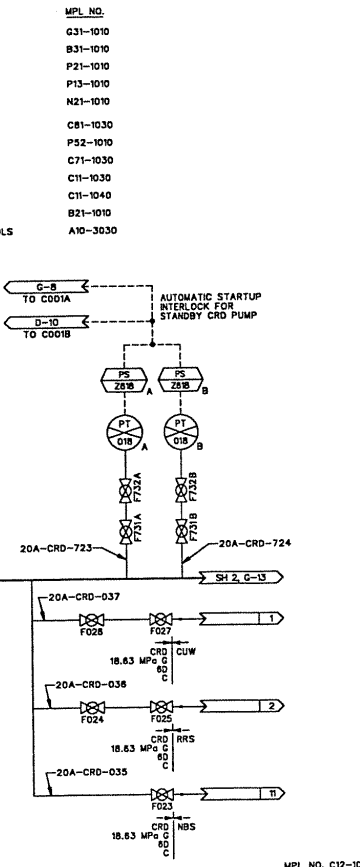

Figure 4.6-8 Control Rod Drive System P&ID (Sheet 1 of 3)

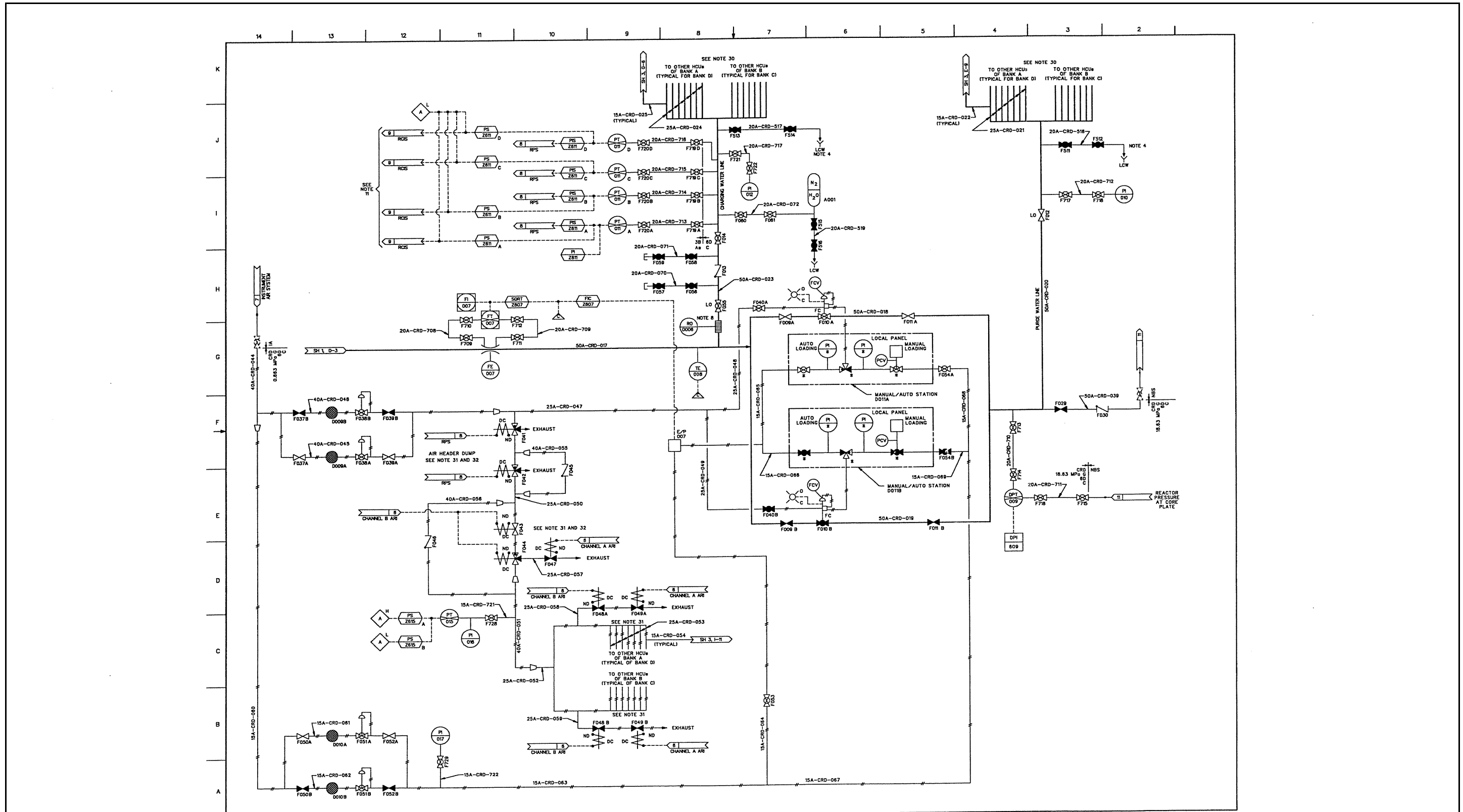

Figure 4.6-8 Control Rod Drive System P&ID (Sheet 2 of 3)

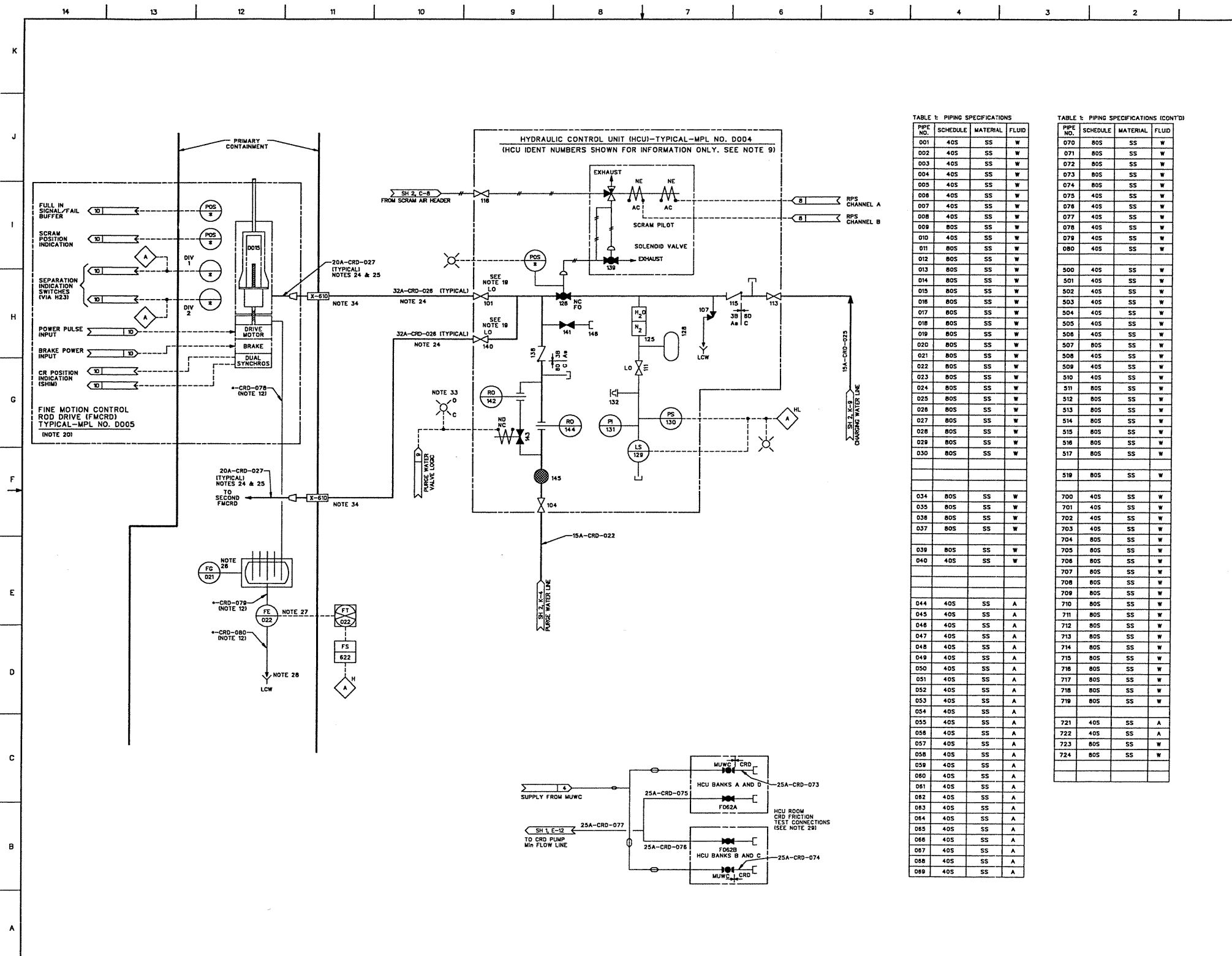

Figure 4.6-8 Control Rod Drive System P&ID (Sheet 3 of 3)

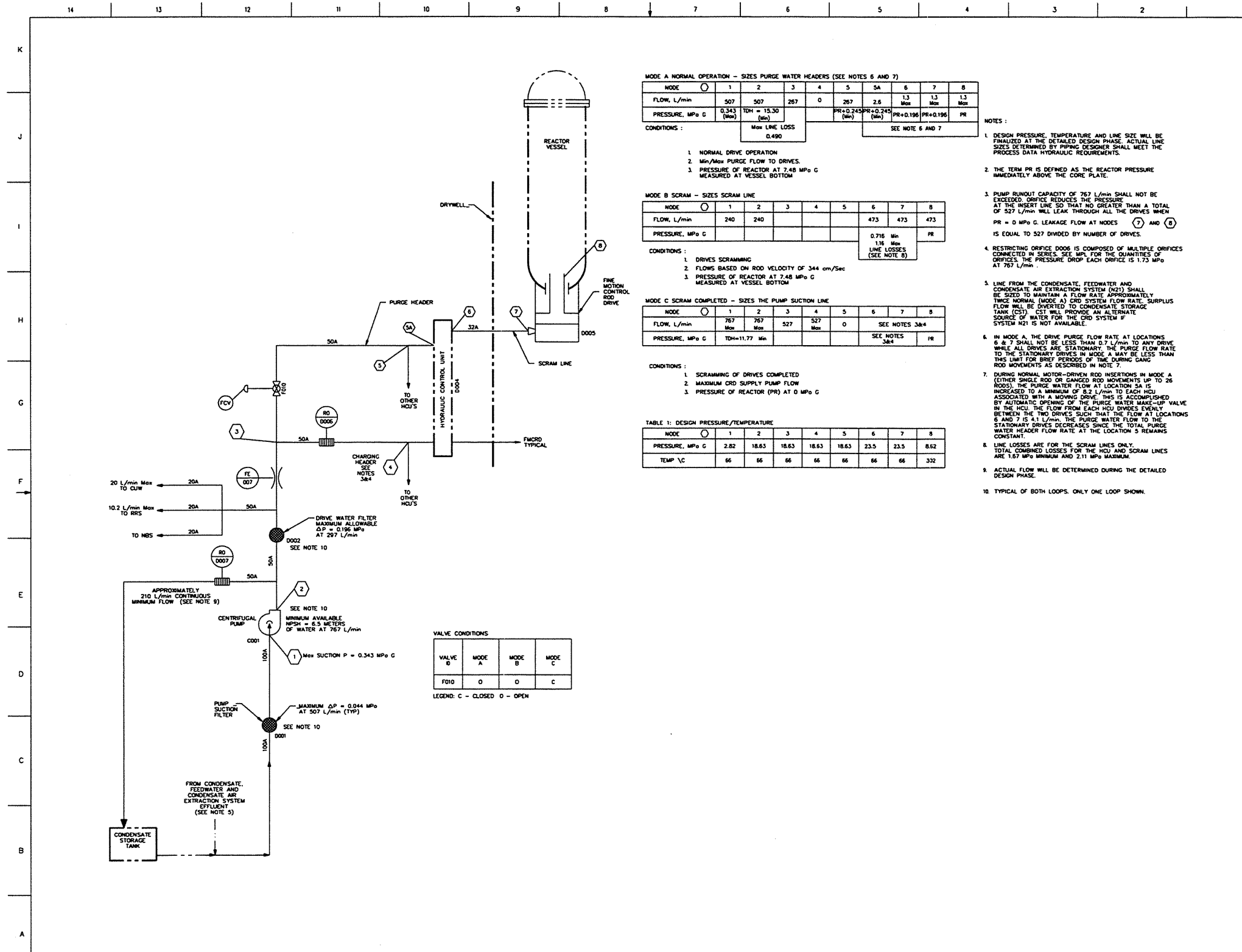

Figure 4.6-9 Control Rod Drive System PFD (Sheet 1 of 1)