

2.11 Station Auxiliary Systems

2.11.1 Makeup Water (Purified) System

Design Description

The Makeup Water (Purified) (MUWP) System is a distribution system with components located throughout the plant. The MUWP provides demineralized makeup water to the condensate storage tank, the surge tanks which are shared by the Reactor Building Cooling Water System and Heating, Ventilation, and Air Conditioning Emergency Cooling Water System and other plant systems.

The MUWP System consists of distribution piping and valves. Makeup water is supplied to the system by the Makeup Water Preparation System.

The MUWP System is classified as non-safety-related with the exception of the primary containment isolation function which is safety-related. The primary containment pipe penetration and isolation valves are classified as Seismic Category I and ASME Code Class 2.

The outboard containment isolation valve is a manual valve locked closed during standby, hot standby and power operation. The inboard containment isolation valve is a check valve (CV) that has an active safety-related function to close under system pressure, fluid flow, and temperature conditions.

Inspections, Tests, Analyses and Acceptance Criteria

Table 2.11.1 provides a definition of the inspections, tests, and/or analyses, together with associated acceptance criteria, which will be undertaken for the MUWP System.

Table 2.11.1 Makeup Water (Purified) System

Inspections, Tests, Analyses and Acceptance Criteria		
Design Commitment	Inspections, Tests, Analyses	Acceptance Criteria
1. The basic configuration of the safety-related portion of the MUWP System is as described in Section 2.11.1.	1. Inspections of the as-built safety-related portions of the MUWP System will be conducted.	1. The as-built safety-related portion of the MUWP System conforms with the basic configuration described in Section 2.11.1.
2. The CV designated in Section 2.11.1 as having an active safety-related function closes under system pressure, fluid flow, and temperature conditions.	2. Tests of the installed valve for closing will be conducted under system preoperational pressure, fluid flow, and temperature conditions.	2. The CV closes.

2.11.2 Makeup Water (Condensate) System

Design Description

The Makeup Water (Condensate) (MUWC) System is a distribution system with components located throughout the plant. Figure 2.11.2 shows the basic system configuration and scope.

Except for the level sensors and associated piping, the MUWC System is classified as non-safety-related.

The level sensors and associated piping are classified as Seismic Category I. Figure 2.11.2 shows the ASME Code class for the MUWC System piping and components.

The level instruments are located in the Reactor Building; the condensate storage tank (CST) and pump(s) are located outside the Reactor Building.

Each of the four MUWC System water level sensors is powered from the respective divisional Class 1E power supply. In the MUWC System, independence is provided between the Class 1E divisions, and also between the Class 1E divisions and non-Class 1E equipment.

The MUWC System has displays for CST water level in the main control room.

MUWC System components with display interfaces with the Remote Shutdown System (RSS) are shown on Figure 2.11.2.

Inspections, Tests, Analyses and Acceptance Criteria

Table 2.11.1 provides a definition of the inspections, tests, and/or analyses, together with associated acceptance criteria, which will be undertaken for the MUWC System.

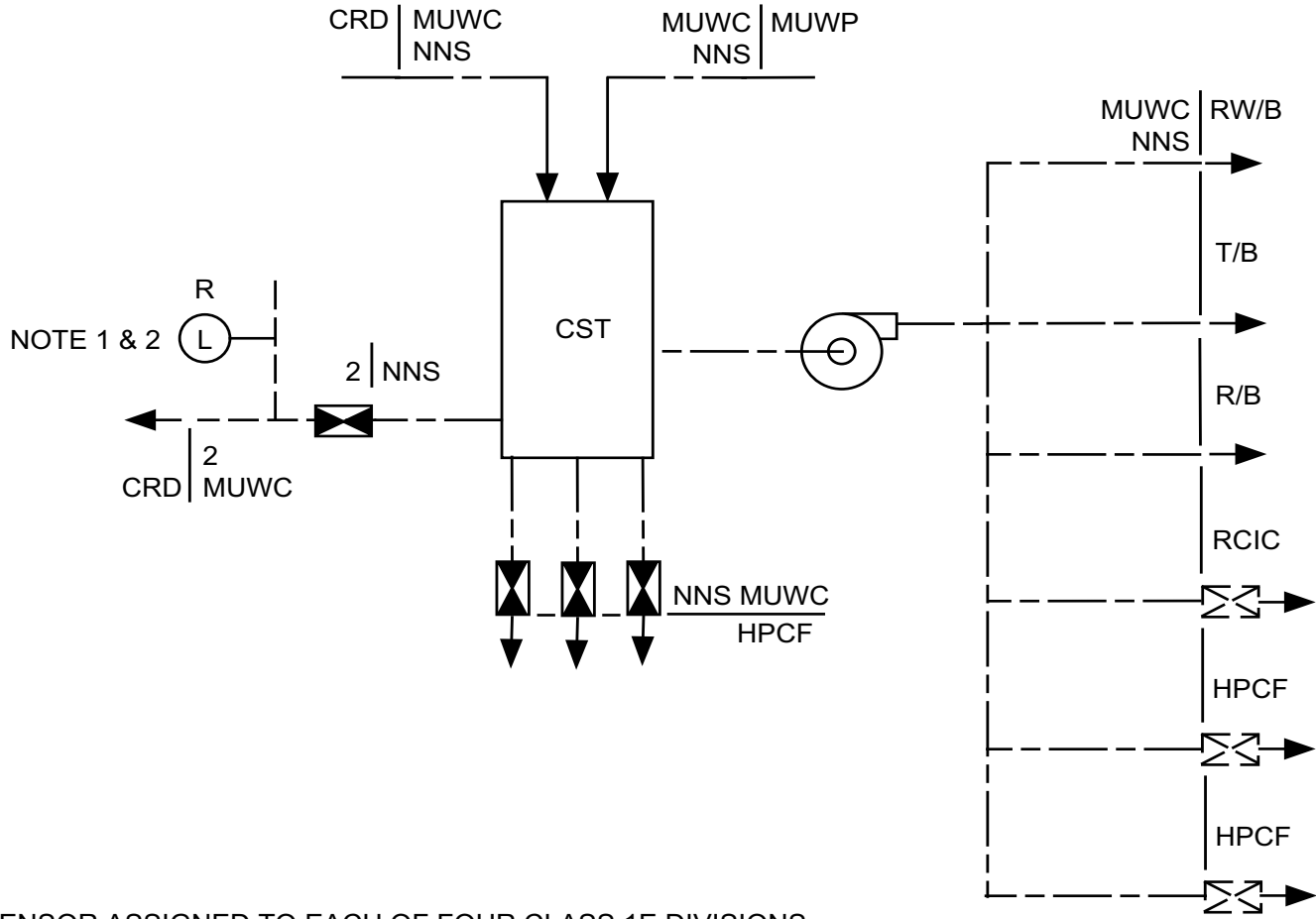

- NOTES:
 1. ONE SENSOR ASSIGNED TO EACH OF FOUR CLASS 1E DIVISIONS.
 2. RSS INTERFACE IS WITH DIVISION II LEVEL SENSOR ONLY.

Figure 2.11.2 Makeup Water (Condensate) System

Table 2.11.2 Makeup Water (Condensate) (MUWC) System

Inspections, Tests, Analyses and Acceptance Criteria		
Design Commitment	Inspections, Tests, Analyses	Acceptance Criteria
1. The basic configuration of the MUWC System is as shown on Figure 2.11.2.	1. Inspections of the as-built system will be conducted.	1. The as-built MUWC System conforms with the basic configuration on Figure 2.11.2.
2. The ASME Code components of the MUWC System retain their pressure boundary integrity under internal pressures that will be experienced during service.	2. A hydrostatic test will be conducted on those Code components of the MUWC System required to be hydrostatically tested by the ASME Code.	2. The results of the hydrostatic test of the ASME Code components of the MUWC System conform with the requirements in the ASME Code, Section III.
3. Each of the four MUWC System water level sensors is powered from the respective divisional Class 1E power supply. In the MUWC System, independence is provided between Class 1E divisions, and between Class 1E divisions and non-Class 1E equipment.	3. <ul style="list-style-type: none"> a. Tests will be performed on the MUWC System by providing a test signal in only one Class 1E division at a time. b. Inspections of the as-built Class 1E divisions in the MUWC System will be performed. 	3. <ul style="list-style-type: none"> a. The test signal exists only in the Class 1E division under test in the MUWC System. b. In the MUWC System, physical separation or electrical isolation exists between Class 1E divisions. Physical separation or electrical isolation exists between these Class 1E divisions and non-Class 1E equipment.
4. Main control room displays provided for the MUWC System are as defined in Section 2.11.2	4. Inspections will be performed on the main control room displays for the MUWC System.	4. Displays exist or can be retrieved in the main control room as defined in Section 2.11.2.
5. RSS displays provided for the MUWC System are as defined in Section 2.11.2.	5. Inspections will be performed on the RSS displays for the MUWC System.	5. Displays exist on the RSS as defined in Section 2.11.2.

2.11.3 Reactor Building Cooling Water System

Design Description

The Reactor Building Cooling Water (RCW) System distributes cooling water through three physically separated and electrically independent divisions. The system removes heat from plant auxiliaries and transfers it to the Ultimate Heat Sink (UHS) via the Reactor Service Water (RSW) System. The RCW System removes heat from emergency core cooling equipment, including the emergency diesel generators (DGs) during a safe reactor shutdown cooling function. RCW System configurations are shown in Figures 2.11.3a, 2.11.3b, and 2.11.3c. Figure 2.11.3d shows the RCW System control interfaces. All components cooled by the RCW System are parts of other systems and are not part of the RCW System. Each RCW division includes two pumps which circulate cooling water through the equipment cooled by the RCW System and through three heat exchangers which transfer the RCW heat to the UHS via the RSW System.

The RCW System performs a safe reactor shutdown cooling function following either a loss-of-coolant accident (LOCA) or a loss-of-preferred-power (LOPP) or both. Assuming a single active failure in any mechanical or electrical division or RCW support system, which disables any one of the three RCW divisions, the other two divisions perform safe reactor shutdown cooling.

Tables 2.11.3a, 2.11.3b, and 2.11.3c show which equipment receives RCW flow during various plant operating and emergency conditions. The tables also indicate how many heat exchangers are in service under each condition.

The RCW System is classified as safety-related except for those portions as shown on Figures 2.11.3a, 2.11.3b, and 2.11.3c as non-nuclear safety.

The RCW System responses to a LOCA signal are the following:

- (1) Starts any standby RCW pumps.
- (2) Opens any closed standby RCW heat exchanger outlet valves.
- (3) Opens all Residual Heat Removal (RHR) System heat exchanger cooling water outlet valves.
- (4) Closes all RCW containment isolation valves.
- (5) Closes valves to the following non-safety-related components (to Reactor Water Cleanup System (CUW) and reactor internal pump (RIP) MG sets).
- (6) Opens the RCW water temperature pneumatic control valves (located downstream of RCW heat exchangers) and closes the RCW heat exchanger bypass valves.

- (7) Overrides the RCW pump trip signal from low surge tank and low stand pipe level.

Safety-related valves separate the safety-related portions of the RCW System from the non-safety-related portions of the system. The separation valves to the non-safety-related RCW System are automatically or remote-manually operated, and their positions are indicated in the main control room.

Component design parameters are:

	Division A/B	Division C
Discharge flow rate (per pump)	$\geq 1420 \text{ m}^3/\text{h}$	$\geq 1237 \text{ m}^3/\text{h}$
Heat exchanger design basis heat removal capacities:(per heat exchanger)	$\geq 47.73 \text{ GJ/h}$	$\geq 44.38 \text{ GJ/h}$

These heat removal capabilities include a 20% margin above the minimum required for design basis accident conditions. Consequently, plant operation is acceptable with heat exchanger capacities greater than or equal to 80% of these values.

Figures 2.11.3a, 2.11.3b, and 2.11.3c show the ASME Code Class for the RCW System piping and components. The safety-related portions of the RCW divisions are classified as Seismic Category I. The piping to the fuel pool cooling (FPC) system heat exchangers and room coolers are classified as Seismic Category I.

The RCW pumps and heat exchangers are located in the lower floors of the Control Building. The equipment cooled by the RCW divisions are located in the Control Building, Reactor Building, Turbine Building, and Radwaste Building, (Figures 2.11.3a, 2.11.3b, and 2.11.3c).

Each of the three RCW divisions is powered from its respective Class 1E division as shown in Figures 2.11.3a, 2.11.3b, and 2.11.3c. In the RCW System, independence is provided between the Class 1E divisions and also between the Class 1E divisions and non-Class 1E equipment. The safety-related portion of each mechanical division of the RCW System (Divisions A, B, C) is physically separated from the safety-related portions of the other divisions.

The RCW System has the following displays and controls in the main control room:

- (1) Parameter displays for instruments shown on Figures 2.11.3a, 2.11.3b, and 2.11.3c.
- (2) Controls and status displays for the RCW active safety-related components shown on Figures 2.11.3a, 2.11.3b, and 2.11.3c.

The RCW System components with displays and control interfaces with the Remote Shutdown System (RSS) are identified in Figures 2.11.3a and 2.1.3b.

The safety-related electrical equipment shown on Figures 2.11.3a, 2.11.3b, and 2.11.3c, located in the Reactor Building, is qualified for a harsh environment.

The motor-operated valves (MOVs) shown on Figures 2.11.3a, 2.11.3b, and 2.11.3c have active safety-related functions to open, close, or both open and close, and perform these functions under differential pressure, fluid flow, and temperature conditions.

The check valves (CVs) shown on Figures 2.11.3a, 2.11.3b, and 2.11.3c have active safety-related functions to open, close, or both open and close under system pressure, fluid flow, and temperature conditions.

A separate surge tank of at least 16m³ is provided for each RCW division. Each surge tank is shared with the corresponding division of the HVAC Emergency Cooling Water (HECW) System. Makeup water is provided for the surge tank by the Makeup Water (Purified) (MUWP) System by an automatic or main control room signal. Low water level signals in the surge tanks do the following (in order of decreasing level):

- (1) Low—opens the MUWP makeup water valve.
- (2) Low-Low—closes the pneumatic and motor-operated valves which stop flow to the non-safety-related components.

The Suppression Pool Cleanup (SPCU) System provides a backup surge tank water supply.

The pneumatic-operated valves shown in Figures 2.11.3a, 2.11.3b, and 2.11.3c fail as follows in the event that either electric power to the valve-actuating solenoid is lost or pneumatic pressure to the valve is lost: RCW makeup valves from the MUWP fail open, RCW water temperature control valves fail open, RCW heat exchanger bypass valves fail closed, and the safety-related/non-safety-related separation valve fails closed.

Inspections, Tests, Analyses and Acceptance Criteria

Table 2.11.3d provides a definition of the inspections, tests, and/or analyses together with associated acceptance criteria, which will be undertaken for the RCW System.

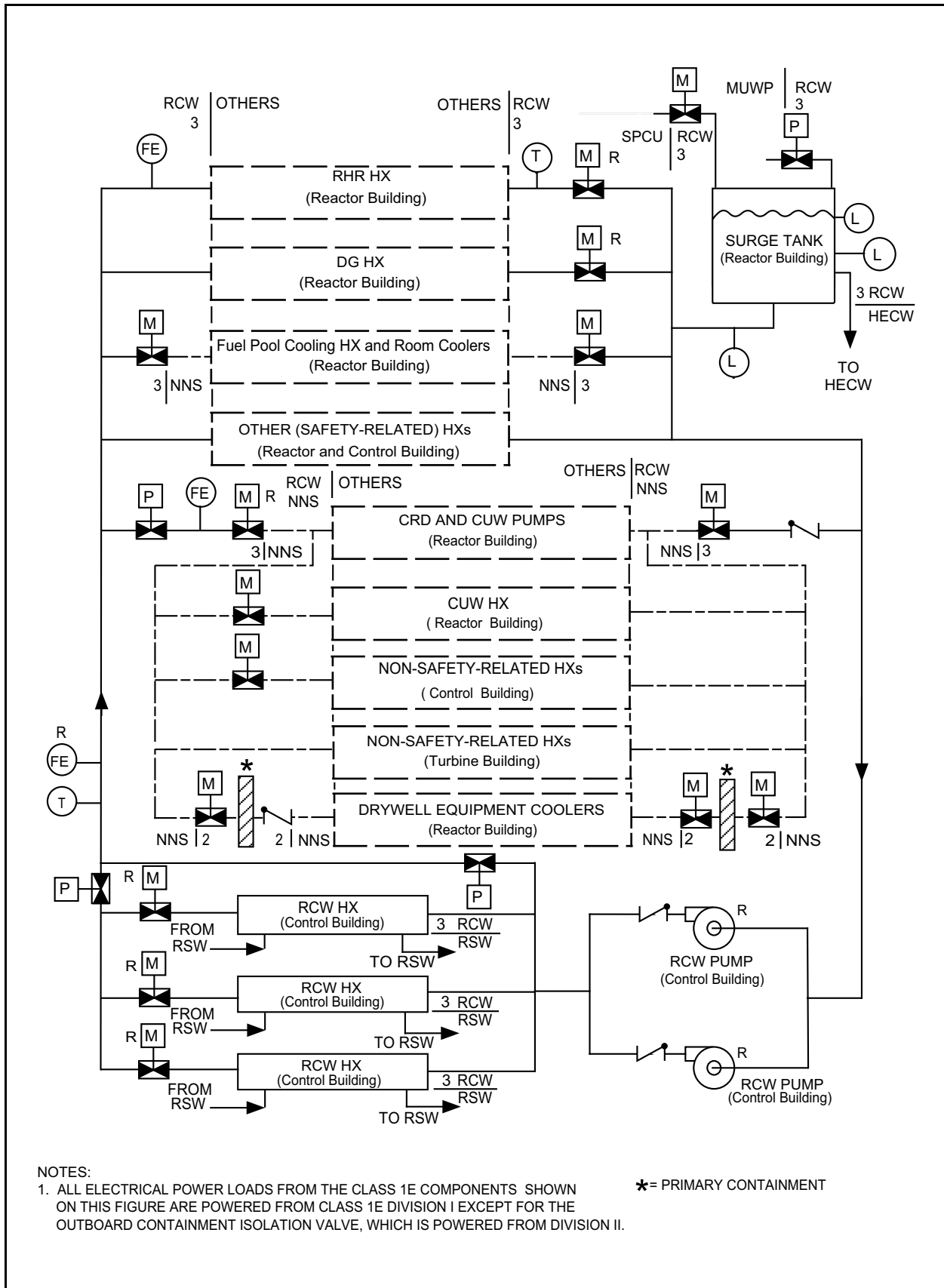

Figure 2.11.3a Reactor Building Cooling Water System (RCW-A)

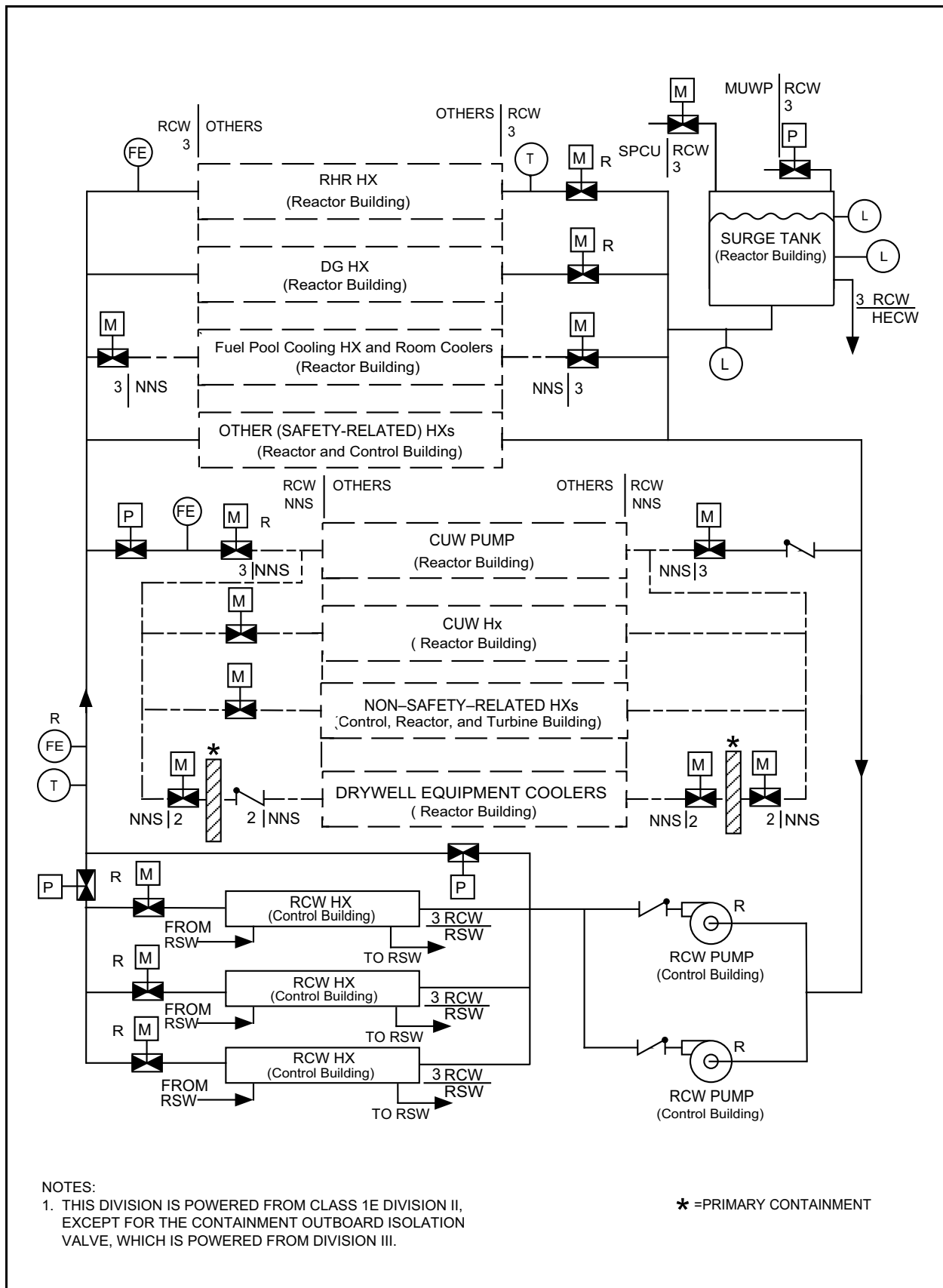

Figure 2.11.3b Reactor Building Cooling Water System (RCW-B)

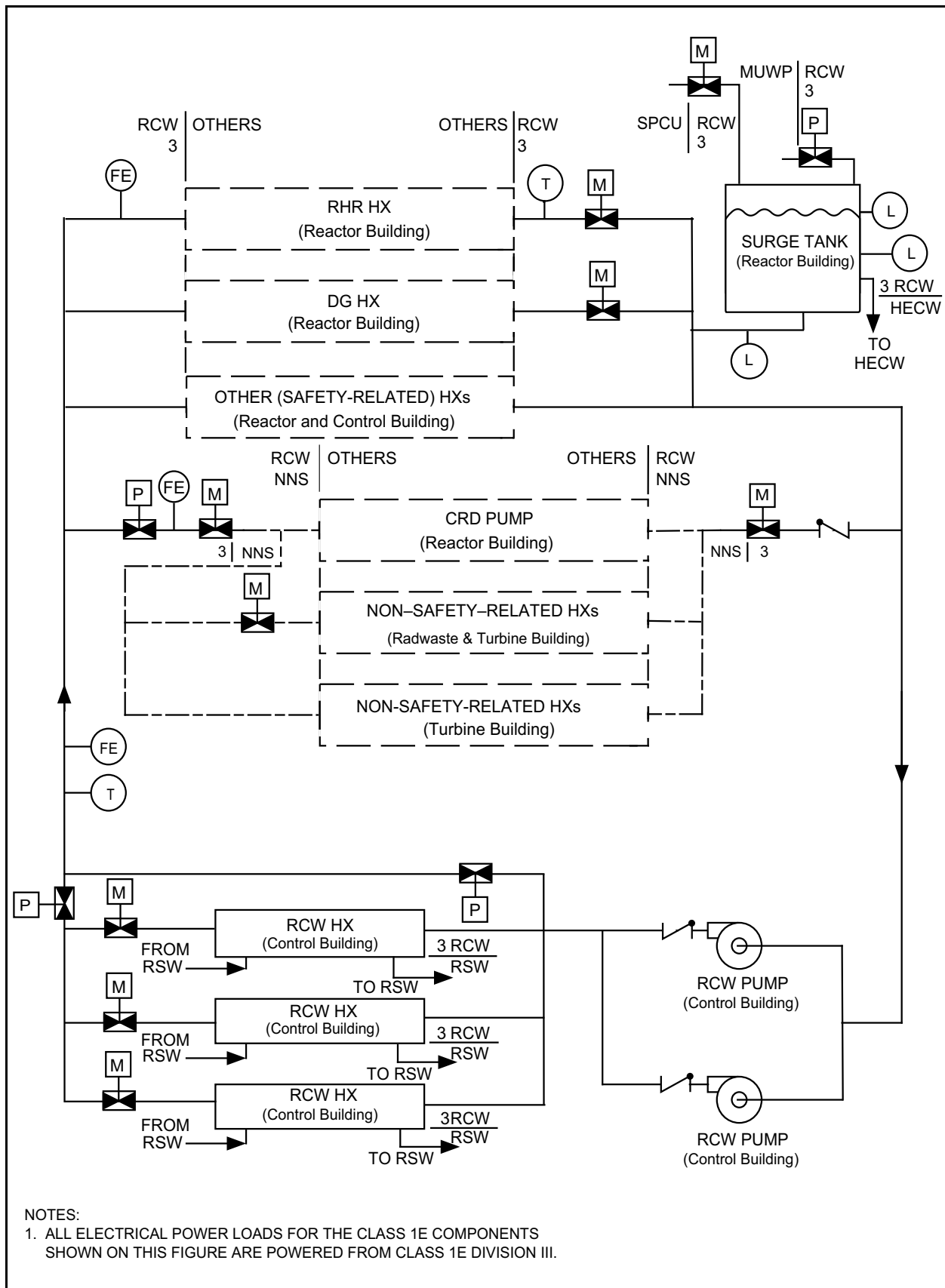
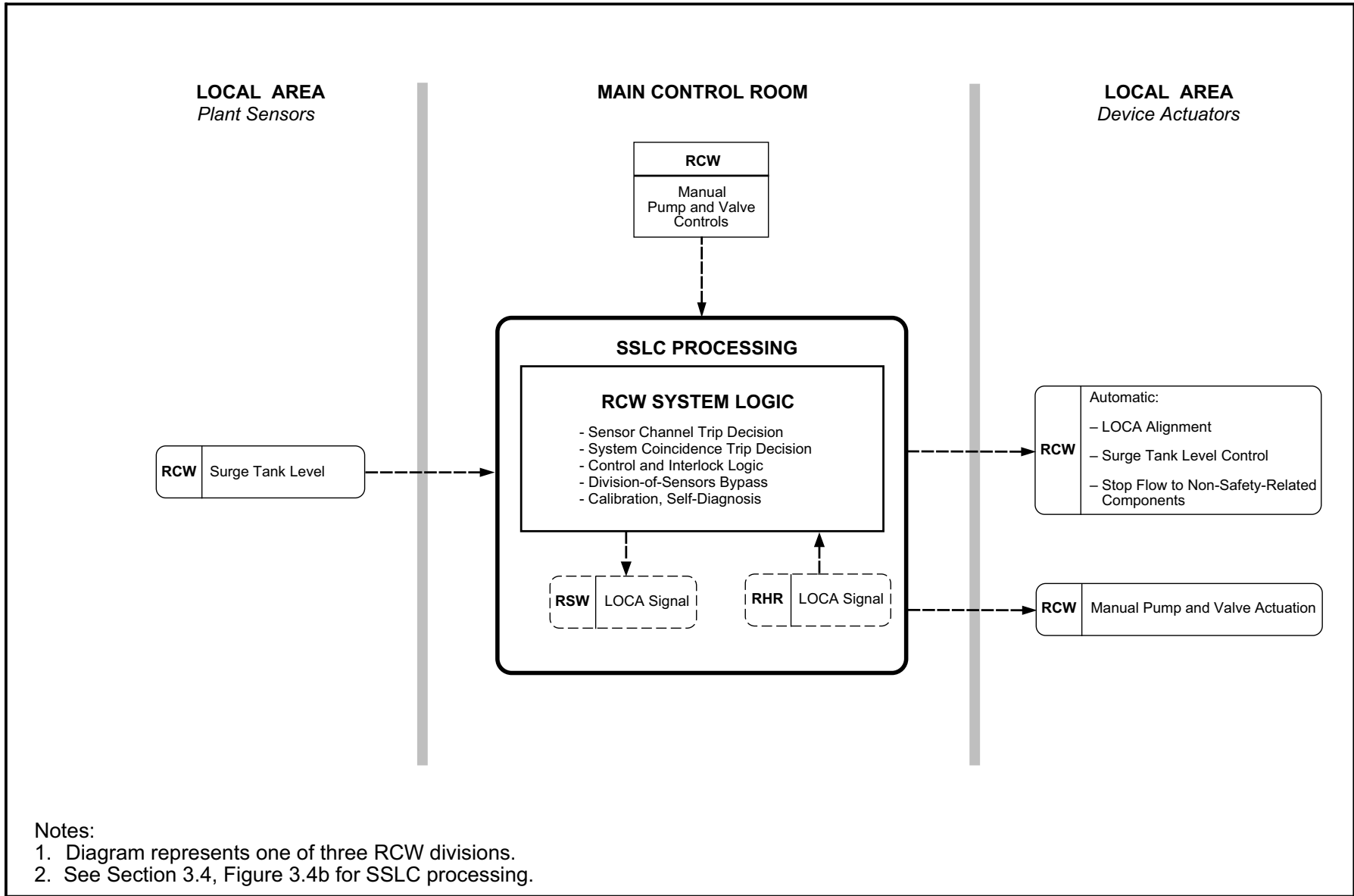

Figure 2.11.3c Reactor Building Cooling Water System (RCW-C)



Notes:

1. Diagram represents one of three RCW divisions.
2. See Section 3.4, Figure 3.4b for SSLC processing.

Figure 2.11.3d Reactor Building Cooling Water System Control Interface Diagram

**Table 2.11.3a Reactor Building Cooling Water Cooling Loads
Division A**

Operating Mode/Components *	Normal Operating Conditions	Shutdown	Hot Standby (loss of AC Power)	Emergency (LOCA)
RCW/RSW Heat Exchangers In Service	2	3	3	3
SAFETY-RELATED				
Emergency Diesel Generator A	†	†	‡	‡
RHR Heat Exchanger A	†	‡	‡	‡
Others (safety-related) ^f	‡	‡	‡	‡
NON-SAFETY-RELATED				
CUW Heat Exchanger	‡	‡	‡	†
FPC Heat Exchanger A ^{**}	‡	‡	‡	‡
Inside Drywell	‡	‡	‡	†
Others (non-safety-related)	‡	‡	‡	‡

* Some of these cooling loads are serviced by only one or two RCW divisions. These components may be reassigned to other RCW divisions if redundancy and divisional alignment of supported and supporting systems is maintained and the design basis cooling capacity of the RCW divisions is assured.

† Equipment does not receive RCW in this mode.

‡ Equipment receives RCW in this mode.

^f HECW refrigerators, room coolers (RHR, RCIC, CAMS), RHR motor bearing and seal coolers, and CAMS cooler.

^{**} Includes FPC room cooler.

**Table 2.11.3b Reactor Building Cooling Water Cooling Loads
Division B**

Operating Mode/Components *	Normal Operating Conditions	Shutdown	Hot Standby (loss of AC Power)	Emergency (LOCA)
RCW/RSW Heat Exchangers In Service	2	3	3	3
SAFETY-RELATED				
Emergency Diesel Generator B	†	†	‡	‡
RHR Heat Exchanger B	†	‡	‡	‡
Others (safety-related) ^f	‡	‡	‡	‡
NON-SAFETY-RELATED				
RWCU Heat Exchanger	‡	‡	‡	†
FPC Heat Exchanger B **	‡	‡	‡	‡
Inside Drywell	‡	‡	‡	†
Others (non-safety-related)	‡	‡	‡	‡

* Some of these cooling loads are serviced by only one or two RCW divisions. These components may be reassigned to other RCW divisions if redundancy and divisional alignment of supported and supporting systems is maintained and the design basis cooling capacity of the RCW divisions is assured.

† Equipment does not receive RCW in this mode.

‡ Equipment receives RCW in this mode.

^f HECW refrigerators, room coolers (RHR, HPCF, SGTS, CAMS), RHR and HPCF motor bearing and seal coolers, and CAMS cooler.

** Includes FPC room cooler.

**Table 2.11.3c Reactor Building Cooling Water Cooling Loads
Division C**

Operating Mode/Components*	Normal Operating Conditions	Shutdown	Hot Standby (loss of AC Power)	Emergency (LOCA)
RCW/RSW Heat Exchangers In Service	2	3	3	3
SAFETY-RELATED				
Emergency Diesel Generator C	†	†	‡	‡
RHR Heat Exchanger C	†	‡	‡	‡
Others (safety-related) ^f	‡	‡	‡	‡
NON-SAFETY-RELATED				
Others (Non-safety-related)	‡	‡	‡	‡

* Some of these cooling loads are serviced by only one or two RCW divisions. These components may be reassigned to other RCW divisions if redundancy and divisional alignment of supported and supporting systems is maintained and the design basis cooling capacity of the RCW divisions is assured.

† Equipment does not receive RCW in this mode.

‡ Equipment receives RCW in this mode.

^f HECW refrigerators; SGTS room coolers; room coolers, motor bearing coolers, and mechanical seal coolers for RHR and HPCF.

Table 2.11.3d Reactor Building Cooling Water (RCW) System

Inspections, Tests, Analyses and Acceptance Criteria		
Design Commitment	Inspections, Tests, Analyses	Acceptance Criteria
1. The basic configuration of the RCW System is as shown on Figures 2.11.3a, 2.11.3b and 2.11.3c.	1. Inspections of the as-built system will be conducted.	1. The as-built RCW System conforms with the basic configuration shown in Figures 2.11.3a, 2.11.3b and 2.11.3c.
2. The ASME Code components of the RCW System retain their pressure boundary integrity under internal pressures that will be experienced during service.	2. A hydrostatic test will be conducted on those Code components of the RCW System required to be hydrostatically tested by the ASME Code.	2. The results of the hydrostatic test of the ASME Code components of the RCW System conform with the requirements in the ASME Code, Section III.
3. The RCW System responses to a LOCA signal are as specified in Section 2.11.3.	3. Using simulated LOCA signals, tests will be performed for the RCW System.	3. Upon receipt of simulated LOCA signals, the responses of the RCW System are as specified in Section 2.11.3.
4. The RCW pump flow capacities and the RCW heat exchanger heat removal capacities are as specified in Section 2.11.3.	4. An analysis of the as-built RCW System will be performed. Tests will be performed of the flow capacities of the installed RCW pumps. Inspections and analyses will be performed to estimate the heat removal capacities of the RCW heat exchangers. Inspections and analyses will be performed to estimate the heat removal requirements of the as-built components which are cooled by the RCW System during LOCA conditions.	4. The estimated heat removal capacities of the as-built RCW System divisions exceed the estimated heat removal requirements of the components cooled by the RCW System divisions during LOCA conditions.
5. Each of the three RCW divisions is powered from its respective Class 1E division as shown in Figures 2.11.3a, 2.11.3b and 2.11.3c. In the RCW System, independence is provided between the Class 1E divisions and also between the Class 1E divisions and non-Class 1E equipment.	5. <ul style="list-style-type: none"> a. Tests will be performed on the RCW System by providing a test signal in only one Class 1E division at a time. b. Inspections of the as-installed Class 1E Divisions in the RCW System will be performed. 	5. <ul style="list-style-type: none"> a. The test signal exists only in the Class 1E division under test in the RCW System. b. Physical separation or electrical isolation exists between Class 1E divisions in the RCW System. Physical separation or electrical isolation exists between Class 1E divisions and non-Class 1E equipment.

Table 2.11.3d Reactor Building Cooling Water (RCW) System (Continued)

Inspections, Tests, Analyses and Acceptance Criteria		
Design Commitment	Inspections, Tests, Analyses	Acceptance Criteria
6. The safety-related portion of each mechanical division of the RCW System (Divisions A, B,C) is physically separated from the safety-related portions of the other divisions.	6. Inspections of the as-built RCW System will be performed.	6. The safety-related portions of each mechanical division of the RCW System is physically separated from the safety-related portions of the other mechanical divisions of the RCW System.
7. Main control room displays and controls provided for the RCW System are as defined in Section 2.11.3.	7. Inspections will be performed on the main control room displays and controls for the RCW System.	7. Displays and controls exist or can be retrieved in the main control room as defined in Section 2.11.3.
8. RSS displays and controls provided for the RCW system are as defined in Section 2.11.3.	8. Inspections will be performed on the RSS displays and controls for the RCW System.	8. Displays and controls exist on the RSS as defined in Section 2.11.3.
9. MOVs designated in Section 2.11.3 as having an active safety-related function will open, close, or both open and close under differential pressures, fluid flow, and temperature conditions.	9. Tests of installed valves for opening and closing, will be conducted under pre-operational differential pressure, fluid flow, and temperature conditions.	9. Upon receipt of the actuation signal, each MOV opens, closes, or both opens and closes, depending upon the valve's safety functions.
10. CVs, designated in Section 2.11.3 as having an active safety-related function, open, close, or both open and close under system pressure, fluid flow, and temperature conditions.	10. Tests of installed valves for opening, closing, or both opening and closing, will be conducted under system preoperational pressure, fluid flow, and temperature conditions.	10. Based on the direction of the differential pressure across the valve, each CV opens, closes, or both opens and closes, depending upon the valve's safety function.

Table 2.11.3d Reactor Building Cooling Water (RCW) System (Continued)

Inspections, Tests, Analyses and Acceptance Criteria		
Design Commitment	Inspections, Tests, Analyses	Acceptance Criteria
11. The pneumatic-operated valves shown in Figures 2.11.3a, 2.11.3b and 2.11.3c fail as follows in the event that either electric power to the valve actuating solenoid is lost or pneumatic pressure to the valve is lost: MUWP makeup valves fail open, RCW water temperature control valves fail open, RCW heat exchanger bypass valves fail closed, and the safety-related/non-safety-related separation valves fail closed.	11. Tests will be performed on the as-built valves by initiating loss of pneumatic pressure and power to the actuating solenoids.	11. The pneumatic actuated valves listed below fail as desired when either electric power to the valve actuating solenoid is lost or pneumatic pressure to the valve is lost: MUWP makeup water valves fail open, RCW water temperature control valves fail open, RCW heat exchanger bypass valves fail closed, and the safety-related/non-safety-related separation valves fail closed.
12. A surge tank with a capacity of greater than or equal to 16 m ³ is provided for each RCW division.	12. Inspection and a volume calculation using as-built dimensions will be performed.	12. The capacity of the surge tanks is greater than or equal to 16 m ³ .
13. A low surge tank water level signal opens the MUWP makeup valve and closes the pneumatic and motor-operated valves which stop flow to the non-safety-related components.	13. Tests will be performed on the as-built equipment.	13. The MUWP makeup valve opens and pneumatic and motor-operated valves which stop flow to the non-safety-related components close upon receipt of a low surge tank water level signal.

2.11.4 Turbine Building Cooling Water System

Design Description

The Turbine Building Cooling Water (TCW) System removes heat from the auxiliary equipment in the Turbine Building and rejects this heat to the Turbine Service Water (TSW) System. Figure 2.11.4 shows the basic system configuration and scope.

The TCW System is classified as a non-safety-related.

The TCW System is located inside the Turbine Building.

Inspections, Tests, Analyses and Acceptance Criteria

Table 2.11.4 provides a definition of the inspections, tests, and/or analyses, together with associated acceptance criteria, which will be undertaken for the TCW System.

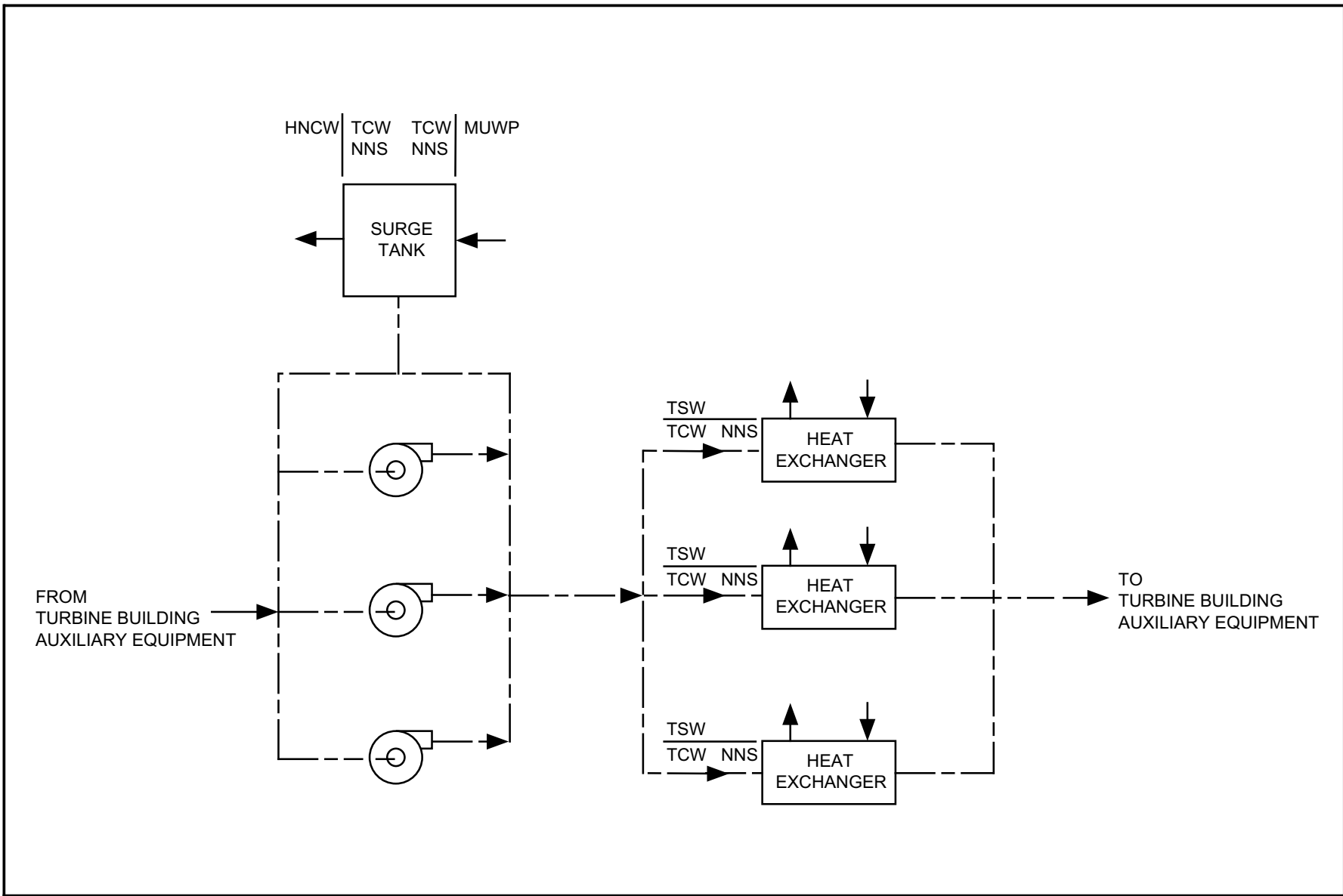

Figure 2.11.4 Turbine Building Cooling Water System

Table 2.11.4 Turbine Building Cooling Water System

Inspections, Tests, Analyses and Acceptance Criteria		
Design Commitment	Inspections, Tests, Analyses	Acceptance Criteria
1. The basic configuration for the TCW System is as shown on Figure 2.11.4.	1. Inspection of the as-built system will be conducted.	1. The as-built TCW System conforms with the basic configuration shown on Figure 2.11.4.

2.11.5 HVAC Normal Cooling Water System

Design Description

The Heating Ventilating and Air Conditioning (HVAC) Normal Cooling Water (HNCW) System delivers chilled water to the Drywell Cooling System and to non-safety-related fan coil units of building HVAC systems. Figure 2.11.5 shows the basic system configuration and scope.

The HNCW System is classified as non-safety-related with the exception of the primary containment isolation function.

The HNCW System pumps and refrigerators are located in the Turbine Building.

The primary containment penetrations and isolation valves are classified as Seismic Category I, and ASME Code Class 2.

The inboard containment isolation valves is powered from Class 1E Division II, and the outboard isolation valves are powered from Class 1E Division I. In the HNCW System, independence is provided is between Class 1E divisions, and also between the Class 1E divisions and non-Class 1E equipment.

The main control room has control and open/close status indication for the primary containment isolation valves.

The safety-related electrical equipment that provides primary containment isolation and is located in the primary containment and the Reactor Building is qualified for a harsh environment.

The primary containment isolation motor-operated valves (MOVs) shown on Figure 2.11.5 have active safety-related function to close and perform this function under differential pressure, fluid flow, and temperature conditions.

The check valve (CV) for containment isolation shown on Figure 2.11.5 has an active safety-related function to close under system pressure, fluid flow, and temperature conditions.

Inspections, Tests, Analyses and Acceptance Criteria

Table 2.11.5 provides a definition of the inspections, tests, and/or analyses, together with associated acceptance criteria, which will be undertaken for the HNCW System.

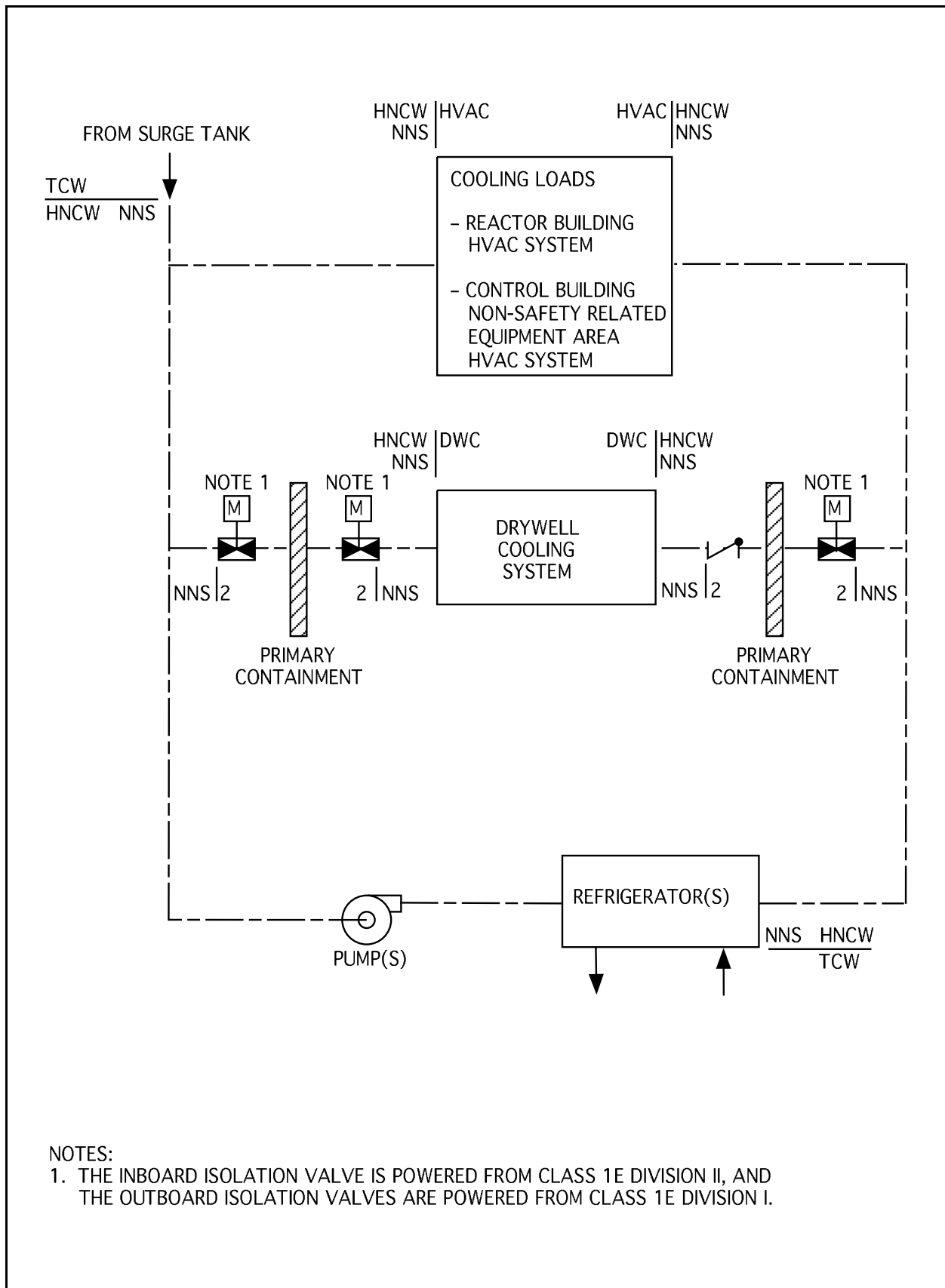

NOTES:

1. THE INBOARD ISOLATION VALVE IS POWERED FROM CLASS 1E DIVISION II, AND THE OUTBOARD ISOLATION VALVES ARE POWERED FROM CLASS 1E DIVISION I.

Figure 2.11.5 HVAC Normal Cooling Water System

Table 2.11.5 HVAC Normal Cooling Water (HNCW) System

Inspections, Tests, Analyses and Acceptance Criteria		
Design Commitment	Inspections, Tests, Analyses	Acceptance Criteria
1. The basic configuration of the HNCW System is as shown on Figure 2.11.5.	1. Inspections of the as-built system will be conducted.	1. The as-built HNCW System conforms with the basic configuration shown in Figure 2.11.5.
2. The ASME Code components of the HNCW retain their pressure boundary integrity under internal pressures that will be experienced during service.	2. A hydrostatic test will be conducted on those Code components of the HNCW System required to be hydrostatically tested by the ASME Code.	2. The results of the hydrostatic test of the ASME Code components of the HNCW System conform with the requirements in the ASME Code, Section III.
3. The inboard containment isolation valves is powered from Class 1E Division II, and the outboard isolation valves are powered from Class 1E Division I. In the HNCW System, independence is provided between Class 1E divisions, and between Class 1E divisions and non-Class 1E equipment.	3. <ul style="list-style-type: none"> a. Tests will be performed on the HNCW System by providing a test signal in only one Class 1E division at a time. b. Inspection of the as-installed Class 1E divisions in the HNCW System will be performed. 	3. <ul style="list-style-type: none"> a. The test signal exists only in the Class 1E division under test in the HNCW System. b. In the HNCW System, physical separation or electrical isolation exists between Class 1E divisions. Physical separation or electrical isolation exists between these Class 1E divisions and non-Class 1E equipment.
4. Main control room displays and controls provided for HNCW System are as defined in Section 2.11.5.	4. Inspections will be performed on the main control room displays and controls for the HNCW System.	4. Displays and controls exist or can be retrieved in main control room as defined in Section 2.11.5.
5. MOVs designated in Section 2.11.5 as having an active safety-related function, close under differential pressure, fluid flow, and temperature conditions.	5. Tests of installed valves for closing will be conducted under preoperational differential pressure, fluid flow, and temperature conditions.	5. Upon receipt of the actuating signal, each MOV closes.

Table 2.11.5 HVAC Normal Cooling Water (HNCW) System

Inspections, Tests, Analyses and Acceptance Criteria		
Design Commitment	Inspections, Tests, Analyses	Acceptance Criteria
6. The CV designated in Section 2.11.5 as having an active safety-related function closes under system pressure, fluid flow, and temperature conditions.	6. Tests of the installed valve for closing will be conducted under system preoperational pressure, fluid flow, and temperature conditions.	6. The CV closes.

2.11.6 HVAC Emergency Cooling Water System

Design Description

The Heating Ventilating and Air Conditioning (HVAC) Emergency Cooling Water (HECW) System delivers chilled water to the:

- (1) Control Room Habitability Area HVAC System.
- (2) Control Building Safety-Related Equipment Area HVAC System.
- (3) Reactor Building HVAC System (safety-related electrical equipment HVAC).

Figures 2.11.6a and 2.11.6b show the basic system configuration and scope.

The HECW System is classified as safety-related except for the chemical addition tank and associated piping and valves.

The HECW System is manually initiated.

Each HECW System refrigerator unit has a capacity of not less than 2.43 GJ/h. In Division A, the refrigerator unit on standby automatically starts if the other refrigerator unit is stopped. In Divisions B and C, any refrigerator unit on standby automatically starts if any of the other refrigerator units in Division B or C is stopped.

Safety-related portions of the HECW System are classified as Seismic Category I. Figures 2.11.6a and 2.11.6b show the ASME Code class for the HECW System piping and components.

The HECW System pumps and refrigerator units are located in the Control Building.

Each of the three HECW System divisions is powered from the respective Class 1E divisions as shown on Figures 2.11.6a and 2.11.6b. In the HECW System, independence is provided between Class 1E divisions, and also between Class 1E divisions and non-Class 1E equipment.

Except for the connections to the chemical addition tanks, each mechanical division of the HECW System (Divisions A, B, C) is physically separated from the other divisions.

The HECW System has the following main control room (MCR) displays and controls:

- (1) Control and status indications for the refrigerator units and pumps shown on Figure 2.11.6a and 2.11.6b.
- (2) Parameter displays for instruments shown on Figures 2.11.6a and 2.11.6b.

The check valves (CVs) shown on Figures 2.11.6a and 2.11.6b have active safety-related functions to open, close, or both open and close under system pressure, fluid flow, and temperature conditions.

The pneumatic-operated valves shown in Figures 2.11.6a and 2.11.6b fail as follows in the event that either electric power to the valve-actuating solenoid is lost or pneumatic pressure to the valve is lost: the differential pressure control valves fail closed, and the flow control valves to the cooling coils fail open.

Inspections, Tests, Analyses and Acceptance Criteria

Table 2.11.6 provides a definition of the inspections, tests, and/or analyses, together with associated acceptance criteria, which will be undertaken for the HECW System.

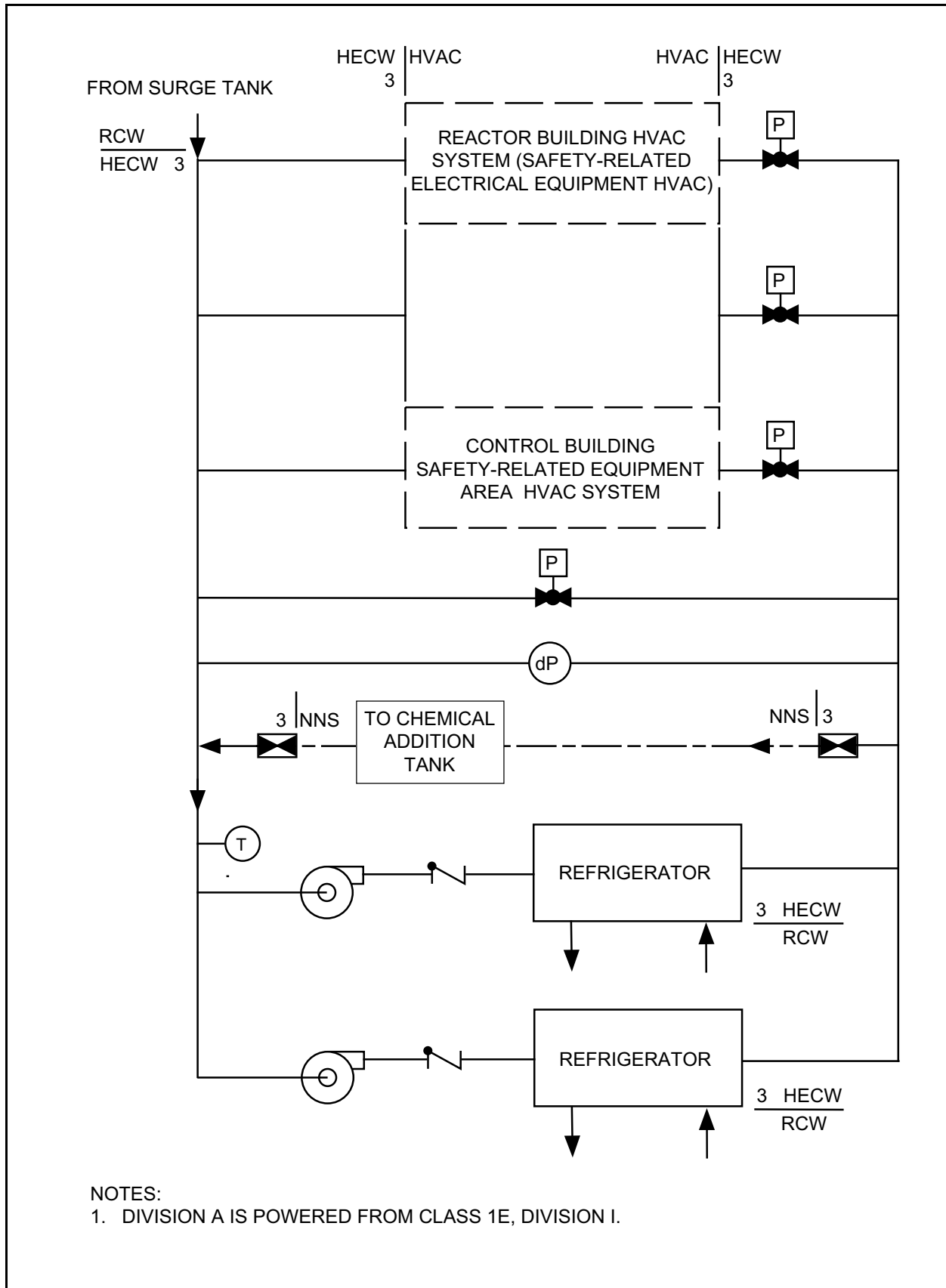

Figure 2.11.6a HVAC Emergency Cooling Water System (HECW-A)

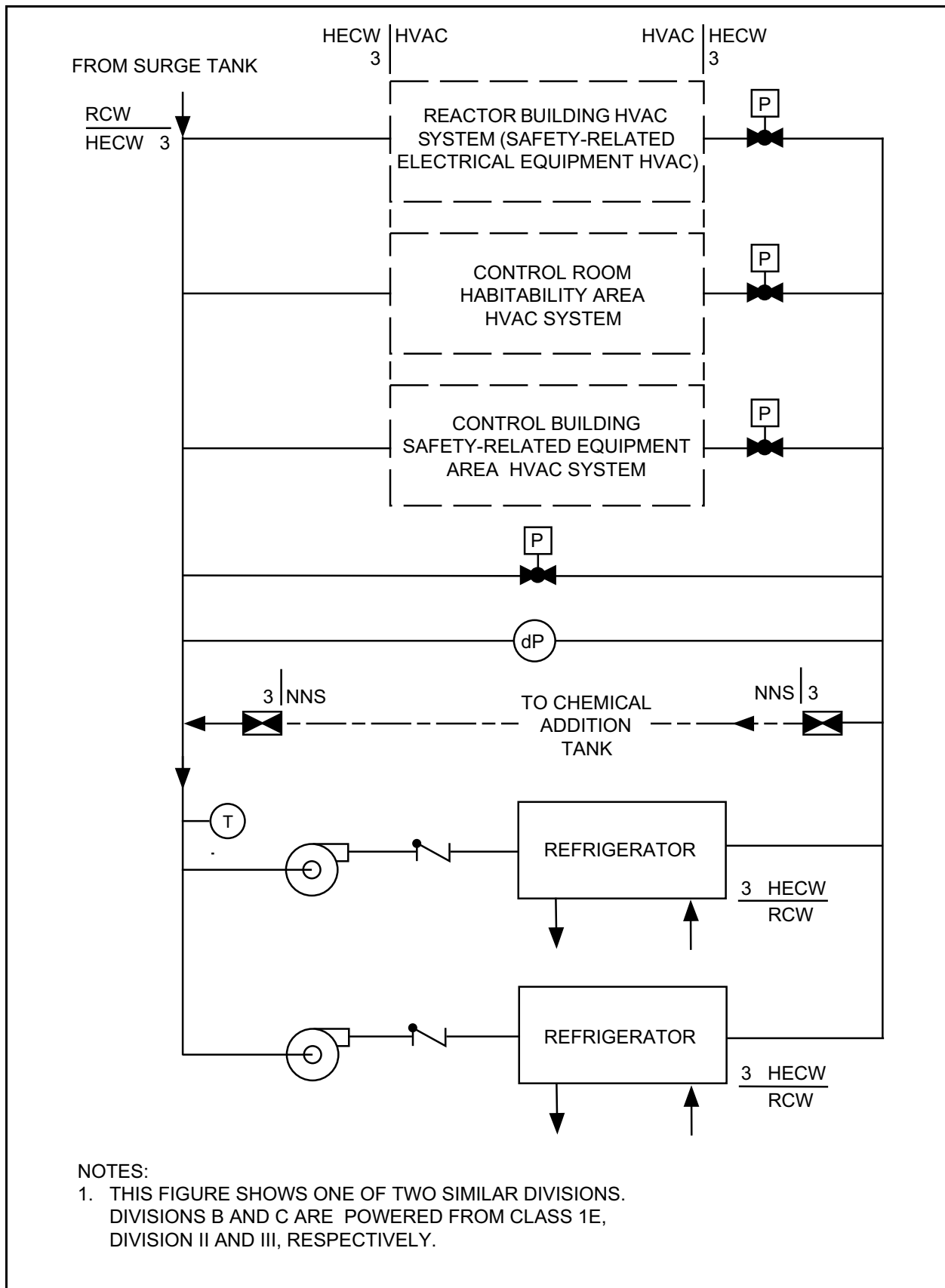

Figure 2.11.6b HVAC Emergency Cooling Water System (HECW-B and C)

Table 2.11.6 HVAC Emergency Cooling Water System

Inspections, Tests, Analyses and Acceptance Criteria		
Design Commitment	Inspections, Tests, Analyses	Acceptance Criteria
1. The basic configuration for the HECW System is shown on Figures 2.11.6a and 2.11.6b.	1. Visual inspections of the as-built system configuration will be conducted.	1. The as-built configuration of the HECW System is in accordance with Figures 2.11.6a and 2.11.6b.
2. The ASME Code components of the HECW System retain their integrity under internal pressures that will be experienced during service.	2. A hydrostatic test will be conducted on those Code components of the HECW System required to be hydrostatically tested by the ASME Code.	2. The results of the hydrostatic test of the ASME Code components of the HECW System conform with the requirements in the ASME Code, Section III.
3. Each HEWC System refrigerator unit has a capacity of not less than 2.43 GJ/h.	3. Type tests will be conducted on an as-built HECW System refrigerator units at a test facility.	3. Each HEWC System refrigerator unit has a capacity of not less than 2.43 GJ/h.
4. In Division A, the refrigerator unit on standby automatically starts if the other refrigerator unit is stopped. In Divisions B and C, any refrigerator unit on standby automatically starts if any of the other refrigerator units in Divisions B or C is stopped.	4. Tests will be conducted on each as-built HECW System refrigerator unit in Divisions A, B and C, using simulated signals indicating another refrigerator unit is stopped.	4. In Division A, the refrigerator unit on standby automatically starts upon receipt of a simulated signal indicating that the other refrigerator unit is stopped. In Divisions B and C, the refrigerator unit on standby automatically starts upon receipt of a simulated signal indicating that any of the other refrigerator units in Divisions B or C is stopped.
5. Each of the three HECW System divisions is powered from the respective Class 1E divisions as shown on Figures 2.11.6a and 2.11.6b. In the HECW System, independence is provided between Class 1E divisions, and between Class 1E divisions and non-Class 1E equipment.	5. <ul style="list-style-type: none"> a. Tests will be performed on the HECW System by providing a test signal in only one Class 1E division at a time. b. Inspections of the as-built Class 1E divisions in the HECW System will be performed. 	5. <ul style="list-style-type: none"> a. The test signal exists only in the Class 1E division under test in the HECW System. b. In the HECW System, physical separation or electrical isolation exists between Class 1E divisions. Physical separation or electrical isolation exists between these Class 1E divisions and non-Class 1E equipment.

Table 2.11.6 HVAC Emergency Cooling Water System (Continued)

Inspections, Tests, Analyses and Acceptance Criteria		
Design Commitment	Inspections, Tests, Analyses	Acceptance Criteria
6. Except for the connections to the chemical addition tank, each mechanical division of the HECW System (Divisions A, B, C) is physically separated from the other divisions.	6. Inspections of the as-built HECW System will be conducted.	6. Each mechanical division of the HECW System is physically separated from the other mechanical divisions of the HECW System by structural and/or fire barriers, with the exception connections to the chemical addition tank.
7. Main control room displays and controls provided for the HECW System are as defined in Section 2.11.6.	7. Inspections will be performed on the main control room displays and controls for the HECW System.	7. Displays and controls exist or can be retrieved in the main control room as defined in Section 2.11.6.
8. CVs designated in Section 2.11.6 as having an active safety-related function open, close, or both open and close under system pressure, fluid flow, and temperature conditions.	8. Tests of installed valves for opening, closing, or both opening and closing, will be conducted under system preoperational pressure, fluid flow, and temperature conditions.	8. Based on the direction of the differential pressure across the valve, each CV opens, closes, or both opens and closes, depending upon the valve's safety functions.
9. The pneumatic-operated valves shown in Figures 2.11.6a and 2.11.6b fail as follows in the event that either electric power to the valve actuating solenoid is lost or pneumatic pressure to the valve is lost: the differential pressure control valves fail closed, and the flow control valves to the cooling coils fail open.	9. Tests will be performed on the as-built valves by initiating loss of pneumatic pressure and power to the actuating solenoids.	9. The pneumatic actuated valves listed below fail as specified when either electric power to the valve actuating solenoid is lost or pneumatic pressure to the valve is lost: the differential pressure control valves fail closed, and the flow control valves to the cooling coils fail open.

2.11.7 Oxygen Injection System

No entry for this system.

2.11.8 This section not used.

2.11.9 Reactor Service Water System

Design Description

The Reactor Service Water (RSW) System removes heat from the Reactor Building Cooling Water (RCW) System and rejects this heat to the Ultimate Heat Sink (UHS). The portions of the RSW System that are in the Control Building are within the Certified Design. Those portions of the RSW System that are outside the Control Building are not in the Certified Design. Figure 2.11.9a shows the basic system configuration and scope within the Certified Design. Figure 2.11.9b shows the RSW System control interfaces.

The RSW System provides cooling water flow to either two or three of the RCW System heat exchangers in each division. On a loss-of-coolant accident and/or loss of preferred power (LOCA and/or LOPP) signal, any closed valves for standby heat exchangers are automatically opened and cooling flow is provided to all three heat exchangers in each division.

For each division of the RSW System, the heat exchanger inlet and outlet valves close upon receipt of a signal indicating Control Building flooding in that division.

The RSW System is classified as Seismic Category I and ASME Code Section III, Class 3 and consists of three separate safety-related divisions.

Each of the three RSW divisions is powered by its respective Class 1E division. In the RSW System, independence is provided between Class 1E divisions, and also between the Class 1E divisions and non-Class 1E equipment. Each mechanical division of the RCW system (Divisions A, B, C) is physically separated from the other divisions.

The RSW System has the following main control room (MCR) displays and controls: control and status displays for the valves shown on Figure 2.11.9a. The RSW System components with status displays and control interfaces with the Remote Shutdown System (RSS) are identified in Figure 2.11.9a.

The motor-operated valves (MOVs) shown on Figure 2.11.9a all have active safety-related functions to open and close under differential pressure and fluid flow conditions.

Interface Requirements

Part of the RSW System that are not within the Certified Design shall meet the following requirements:

- (1) Design features shall be provided to limit the maximum flood height to 5.0 meters in each RCW heat exchanger room.
- (2) The design shall have three divisions which are physically separated. For any structure(s) housing RSW System components, there shall be inter-divisional boundaries (including walls, floors, doors and penetrations) that have three-hour fire

rating. In addition, there shall be inter-divisional flood control features which preclude flooding from occurring in more than one division. Each division shall be powered by its respective Class 1E division. Each division shall be capable of removing the design heat capacity (as specified in Section 2.11.3) of the RCW heat exchangers in its division.

- (3) Upon receipt of a loss-of-coolant (LOCA) signal, components in standby mode shall start and/or align to the operating mode.
- (4) RSW System Divisions A and B shall have control interfaces with the Remote Shutdown System (RSS) as required to support RSW operation during RSS design basis conditions.
- (5) If required by the elevation relationships between the UHS and the RSW System components in the Control Building (C/B), the RSW System shall have antisiphon capability to prevent a C/B flood after an RSW System break and after the RSW System pumps have been stopped.
- (6) RSW System pumps in any division shall be tripped on receipt of a signal indicating flooding in that division of the C/B basement area.
- (7) Any tunnel structures used to route RSW System piping to the Control Building shall be classified as Seismic Category I. Tunnel flooding due to site flood conditions shall be precluded.

Inspections, Tests, Analyses and Acceptance Criteria

Table 2.11.9 provides a definition of the inspections, tests, and/or analyses, together with associated acceptance criteria, which will be undertaken for the portions of the RSW System within the Certified Design.

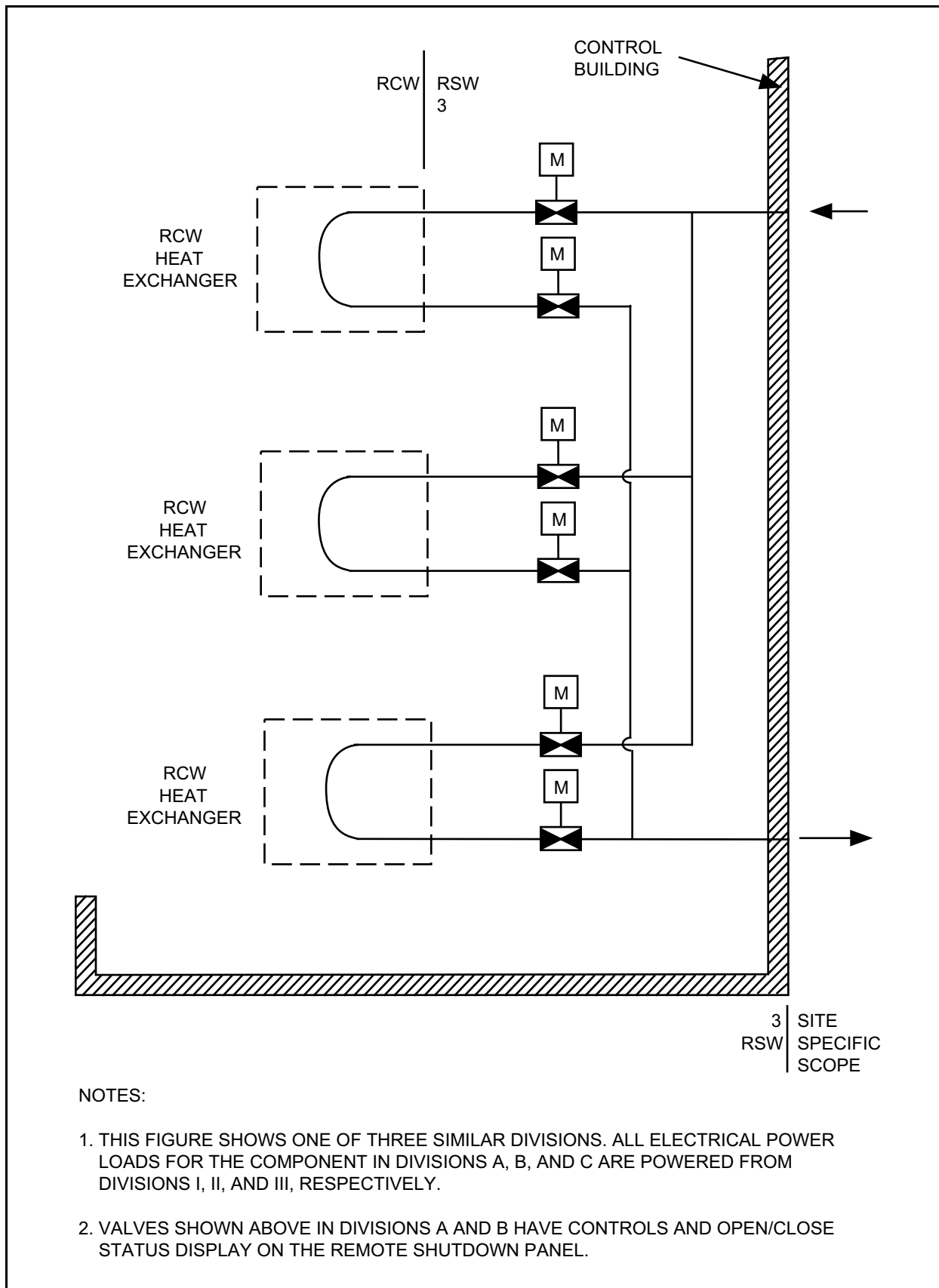
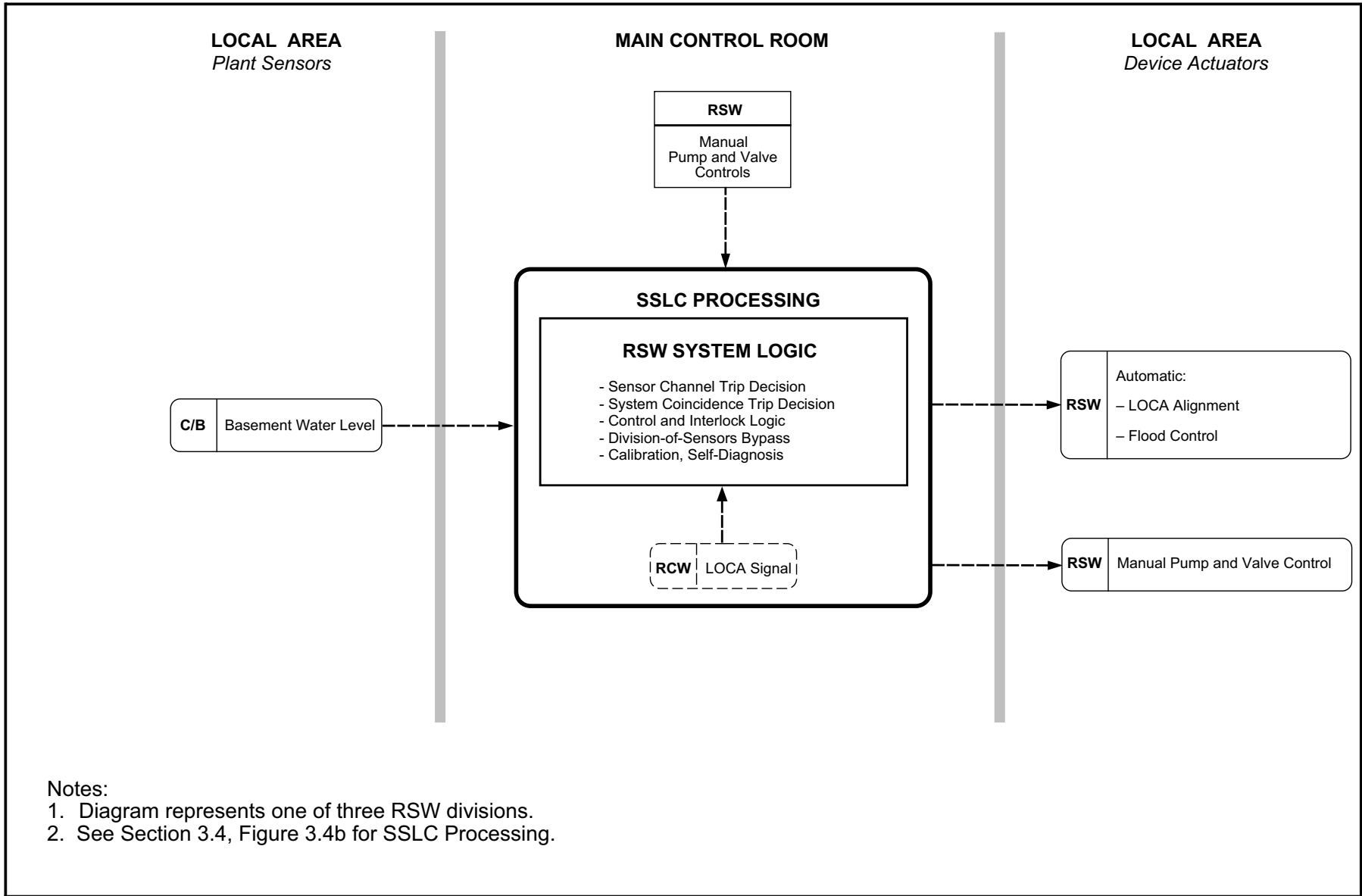

Figure 2.11.9a Reactor Service Water System



Notes:

1. Diagram represents one of three RSW divisions.
2. See Section 3.4, Figure 3.4b for SSLC Processing.

Figure 2.11.9b Reactor Service Water

Table 2.11.9 Reactor Service Water System

Inspections, Tests, Analyses and Acceptance Criteria		
Design Commitment	Inspections, Tests, Analyses	Acceptance Criteria
1. The basic configuration of the RSW System is as shown on Figure 2.11.9.	1. Inspections of the as-built system will be conducted.	1. The as-built RSW System conforms with the basic configuration shown in Figure 2.11.9.
2. The ASME Code components of the RSW System retain their pressure boundary integrity under internal pressures that will be experienced during service.	2. A hydrostatic test will be conducted on those Code components of the RSW System required to be hydrostatically tested by the ASME Code.	2. The results of the hydrostatic test of the ASME Code components of the RSW System conform with the requirements in the ASME Code, Section III.
3. On a LOCA and/or LOPP signal, any closed valves for standby heat exchangers are automatically opened.	3. Using simulated LOCA and/or LOPP signals, tests will be performed on standby heat exchanger inlet and outlet valves.	3. Upon receipt of simulated LOCA and/or LOPP signals, the standby heat exchanger inlet and outlet valves open.
4. For each division of RSW, the heat exchanger inlet and outlet valves close upon receipt of a signal indicating Control Building flooding in that division.	4. Using simulated signals, tests will be conducted on the heat exchanger inlet and outlet valves.	4. The heat exchanger inlet and outlet valves close upon receipt of a signal indicating Control Building flooding in that division.
5. Each of the three RSW divisions is powered by its respective Class 1E division. In the RSW System, independence is provided between Class 1E divisions, and between Class 1E divisions and non-Class 1E equipment.	5. <ul style="list-style-type: none"> a. Tests will be performed on the RSW System by providing a test signal in only one Class 1E division at a time. b. Inspections of the as-installed Class 1E divisions in the RSW System will be performed. 	5. <ul style="list-style-type: none"> a. The test signal exists only in the Class 1E Division under test in the RSW System. b. Physical separation or electrical isolation exists between Class 1E divisions in the RSW System. Physical separation or electrical isolation exists between Class 1E divisions and non-Class 1E equipment.
6. Each mechanical division of the RSW System (Divisions A, B, C) is physically separated.	6. Inspections of the as-built system will be performed.	6. Each mechanical division of the RSW System is physically separated from other mechanical divisions of the RSW System by structural and/or fire barriers.

Table 2.11.9 Reactor Service Water System (Continued)

Inspections, Tests, Analyses and Acceptance Criteria		
Design Commitment	Inspections, Tests, Analyses	Acceptance Criteria
7. MCR displays and controls provided for the RSW System are as defined in Section 2.11.9.	7. Inspections will be performed on the MCR displays and controls for the RSW System.	7. Displays and controls exist or can be retrieved in the MCR as defined in Section 2.11.9.
8. RSS displays and controls provided for the RSW System are as defined in Section 2.11.9.	8. Inspections will be performed on the RSS displays and controls for the RSW System.	8. Indications and controls exist on the RSS as defined in Section 2.11.9.
9. MOVs designated in Section 2.11.9 as having an active safety-related function open and close under differential pressure, fluid flow, and temperature conditions.	9. Tests of installed valves, for opening and closing will be conducted under preoperational differential pressure, fluid flow, and temperature conditions.	9. Upon receipt of the actuating signal, each MOV opens and closes, depending on the valve's safety function.

2.11.10 Turbine Service Water System

Design Description

The Turbine Service Water (TSW) System removes heat from the Turbine Building Cooling Water (TCW) System and rejects this heat to the power cycle heat sink which is part of the Circulating Water System. The portions of the TSW System that are in the Turbine Building are within the Certified Design. Those portions of the TSW System that are outside the Turbine Building are not in the Certified Design. Figure 2.11.10 shows the basic system configuration and scope of the portion within the Certified Design.

The TSW System is classified as non-safety-related.

Interface Requirements

The portions of the TSW System which are not part of the Certified Design shall meet the following requirement:

- None identified for this system.

Inspections, Tests, Analyses and Acceptance Criteria

Table 2.11.10 provides a definition of the inspections, tests, and/or analyses, together with associated acceptance criteria, which will be undertaken, for the portions of the TSW System within the Certified Design.

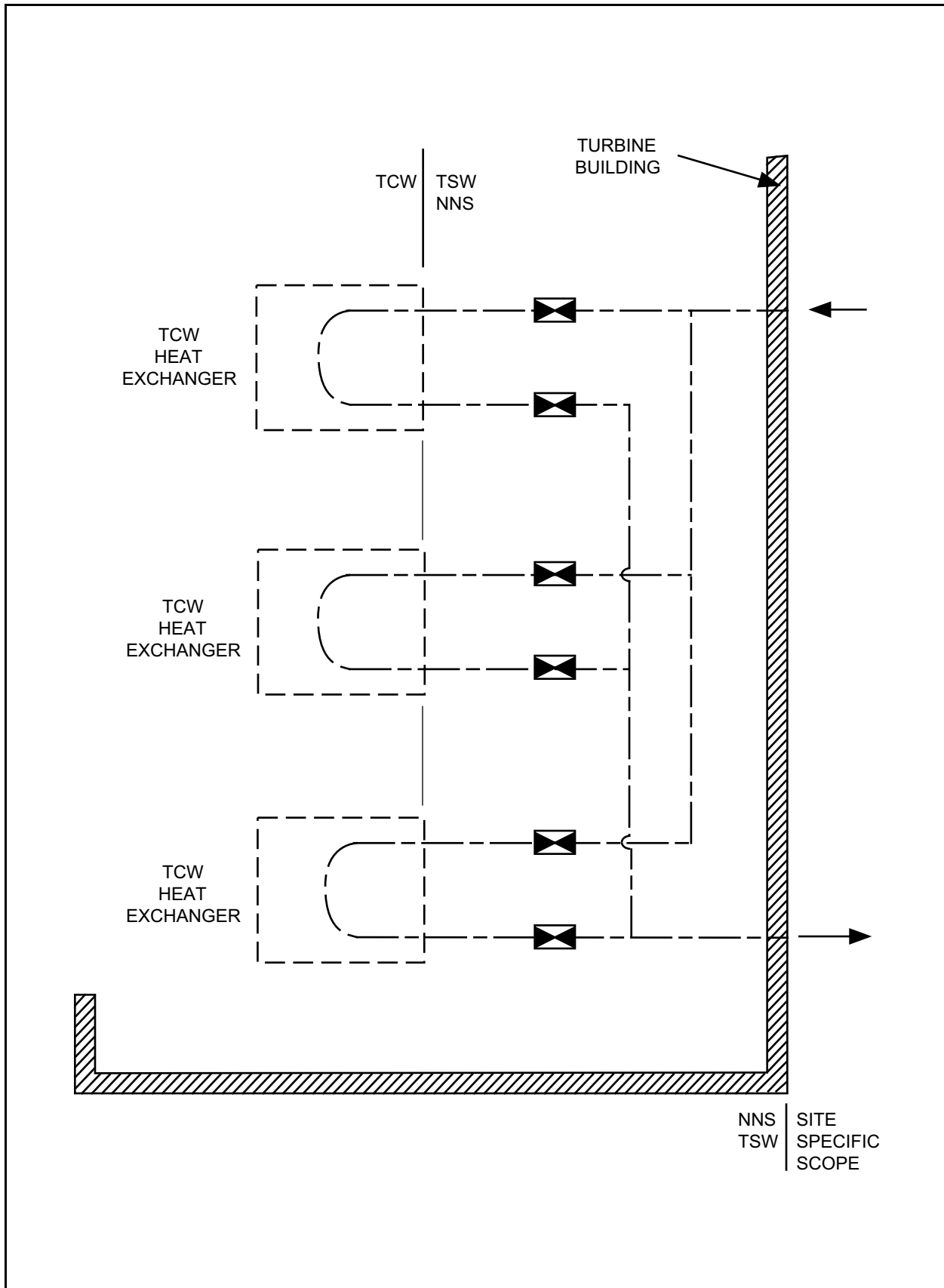

Figure 2.11.10 Turbine Service Water System

Table 2.11.10 Turbine Service Water System

Inspections, Tests, Analyses and Acceptance Criteria		
Design Commitment	Inspections, Tests, Analyses	Acceptance Criteria
1. The basic configuration of the TSW System is as shown on Figure 2.11.10.	1. Inspections of the as-built system will be conducted.	1. The as-built TSW System conforms with the basic configuration shown on Figure 2.11.10.

2.11.11 Station Service Air System

Design Description

The Station Service Air (SA) System consists of two air compressing trains, an air receiver tank, two trains of filters, piping, valves, controls and instrumentation. Figure 2.11.11 shows basic SA System configuration and scope.

The SA System provides compressed air for general plant use. The SA System also provides backup to the Instrument Air (IA) System in the event that IA System pressure is lost.

Except for the containment penetration and isolation valves, the SA System is classified as non-safety-related.

The containment penetration and isolation valves are classified as Seismic Category I. Figure 2.11.11 shows the ASME Code class for the SA System components.

The check valve (CV) for containment isolation shown on Figure 2.11.11 has an active safety-related function to close under system pressure, fluid flow, and temperature conditions.

Inspections, Tests, Analyses and Acceptance Criteria

Table 2.11.11 provides a definition of inspections, tests, and/or analyses, together with associated acceptance criteria, which will be undertaken for the SA System.

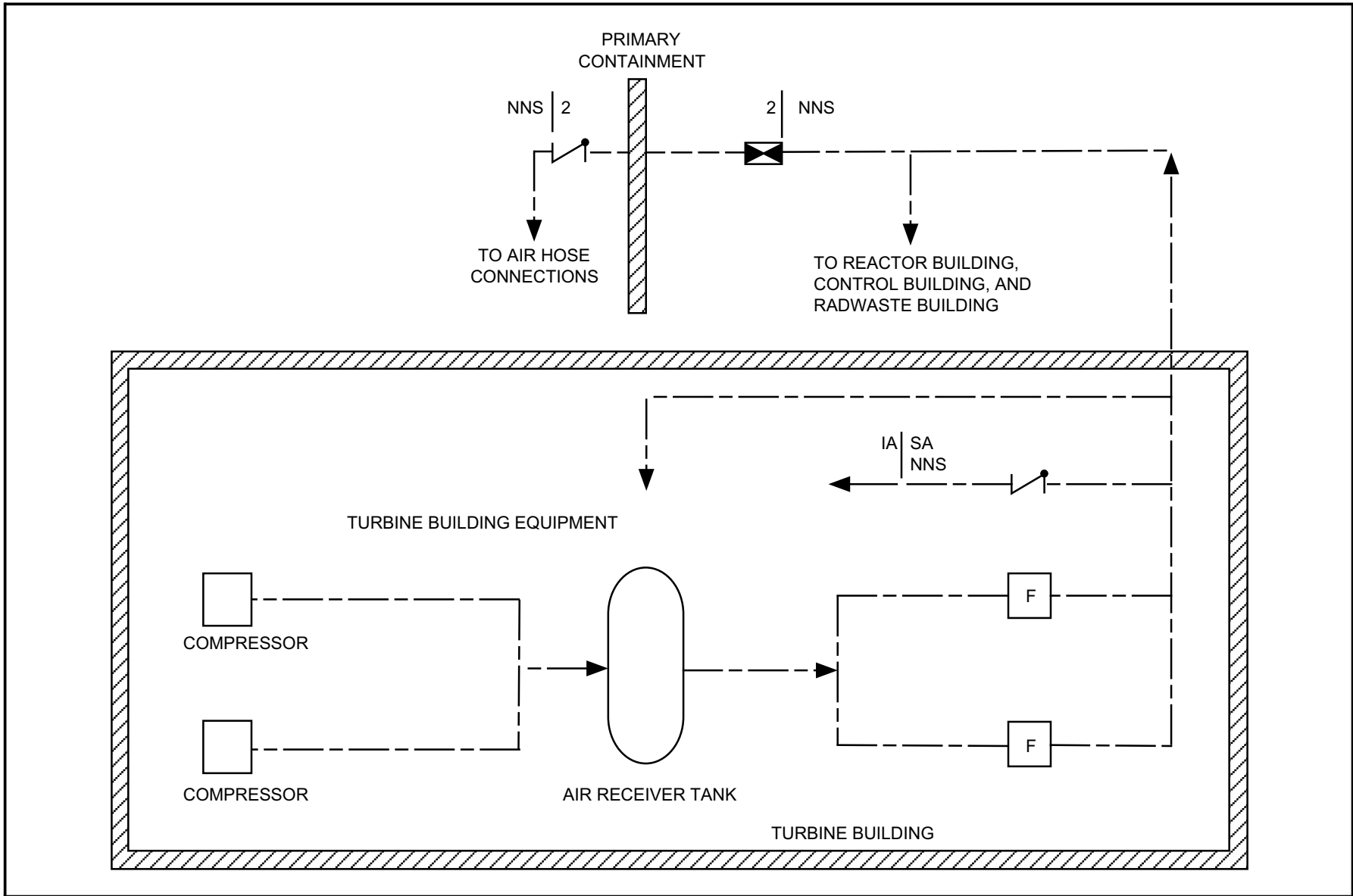

Figure 2.11.11 Station Service Air System

Table 2.11.11 Station Service Air System

Inspections, Tests, Analyses and Acceptance Criteria		
Design Commitment	Inspections, Tests, Analyses	Acceptance Criteria
1. The basic configuration of the SA System is as shown on Figure 2.11.11.	1. Inspections of the as-built system will be conducted.	1. The as-built SA System conforms with the basic configuration shown on Figure 2.11.11.
2. The ASME Code components of the SA System retain their pressure boundary integrity under internal pressures that will be experienced during service.	2. A pressure test will be conducted on those Code components of the SA System required to be pressure tested by the ASME Code.	2. The results of the pressure test of the ASME Code components of the SA System conform with the requirements in ASME Code Section III.
3. The CV designated in Section 2.11.11 as having an active safety-related function closes, under system pressure, fluid flow, and temperature conditions.	3. Tests of the installed valve for closing will be conducted under system preoperational pressure, fluid flow, and temperature conditions.	3. The CV closes.

2.11.12 Instrument Air System

Design Description

The Instrument Air (IA) System consists of two air compressing trains, an air receiver tank, two drying trains, piping, valves, controls and instrumentation. Figure 2.11.12 shows the basic IA System configuration and scope.

The IA System provides compressed air for pneumatic equipment, valves, controls and instrumentation outside the primary containment.

The IA System distribution piping penetrates the primary containment. During plant operation, this line is supplied with nitrogen by the High Pressure Nitrogen Gas Supply (HPIN) System. In the event that HPIN System pressure is lost, the IA System provides air backup by remote manual alignment of IA System.

Except for the containment penetration and isolation valves, the IA System is classified as non-safety-related.

The IA containment penetration and isolation valves are classified as Seismic Category I. Figure 2.11.12 shows the ASME Code class for the IA System piping and components.

The IA System containment isolation valve is powered from Class 1E Division I. In the IA System, independence is provided between the Class 1E division and non-Class 1E equipment.

The main control room has controls and open/close status indication for the containment isolation valve.

The safety-related electrical equipment that provides containment isolation and is located outside primary containment in the Reactor Building is qualified for a harsh environment.

The motor-operated valve (MOV) shown on Figure 2.11.12 has an active safety-related function to close and perform this function under differential pressure, fluid flow, and temperature conditions.

The check valve (CV) for containment isolation shown on Figure 2.11.12 has an active safety-related function to close under system pressure, fluid flow, and temperature conditions.

Inspections, Tests, Analyses and Acceptance Criteria

Table 2.11.12 provides a definition of inspections, tests, and/or analyses, together with associated acceptance criteria, which will be undertaken for the IA System.

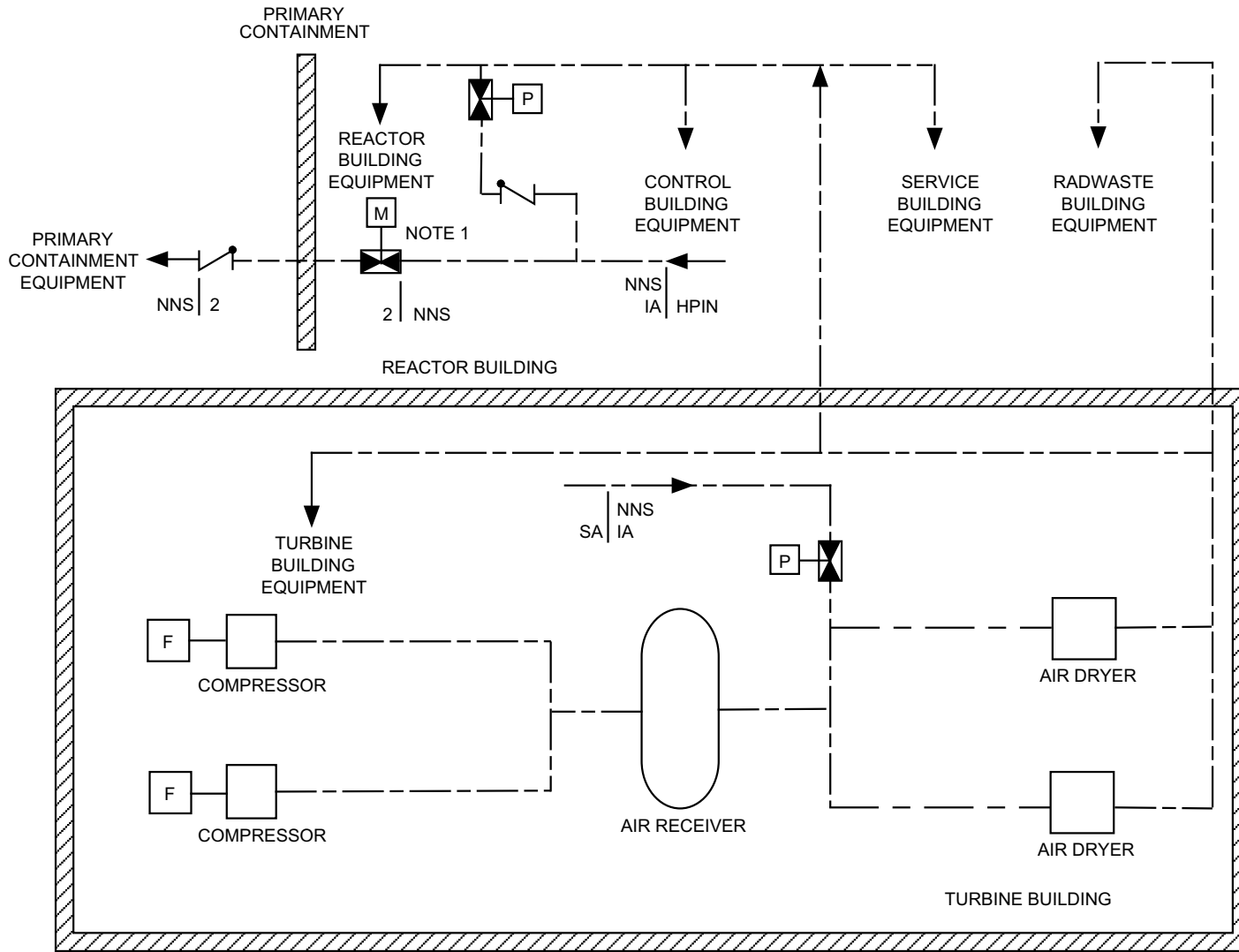

NOTES:
 1. CONTAINMENT ISOLATION VALVE IS POWERED FROM CLASS 1E DIVISION I.

Figure 2.11.12 Instrument Air System

Table 2.11.12 Instrument Air System

Inspections, Tests, Analyses and Acceptance Criteria		
Design Commitment	Inspections, Tests, Analyses	Acceptance Criteria
1. The basic configuration of the IA System is shown on Figure 2.11.12.	1. Inspections of the as-built IA System will be conducted.	1. The as-built IA System conforms with the basic configuration shown on Figure 2.11.12.
2. The ASME Code components of the IA System retain their pressure boundary integrity under internal pressures that will be experienced during service.	2. A pressure test will be conducted on those Code components of the IA System required to be pressure tested by the ASME Code.	2. The results of the pressure test of the ASME Code components of the IA System conform with the requirements in ASME Code Section III.
3. The IA System containment isolation valve is powered from Class 1E Division I. In the IA System, independence is provided between the Class 1E division and non-Class 1E equipment.	3. <ul style="list-style-type: none"> a. Tests will be performed on the IA System by providing a test signal in only one Class 1E division at a time. b. Inspection of the as-installed Class 1E division in the IA System will be performed. 	3. <ul style="list-style-type: none"> a. The test signal exists in the IA System only when the signal is applied to the division associated with the IA System. b. In the IA System, physical separation or electrical isolation exists between the Class 1E division and non-Class 1E equipment.
4. Main control room displays and controls provided for the IA System are as defined in Section 2.11.12.	4. Inspections will be performed on the main control room displays and controls for the IA System.	4. Displays and controls exist or can be retrieved in the main control room as defined in Section 2.11.12.
5. <ul style="list-style-type: none"> a. The MOV designated in Section 2.11.12 as having an active safety-related function closes under differential pressure, fluid flow, and temperature conditions. b. The CV designated in Section 2.11.12 as having an active safety-related function closes under system pressure, fluid flow, and temperature conditions. 	5. <ul style="list-style-type: none"> a. Tests of the installed valve for closing will be conducted under preoperational differential pressure, fluid flow, and temperature conditions. b. Tests of installed valve for closing will be conducted under system preoperational pressure, fluid flow, and temperature conditions. 	5. <ul style="list-style-type: none"> a. Upon receipt of the actuating signal the MOV closes. b. The CV closes.

2.11.13 High Pressure Nitrogen Gas Supply System

Design Description

The High Pressure Nitrogen Gas Supply (HPIN) System provides nitrogen to pneumatic equipment inside the primary containment. Figure 2.11.13 shows the basic HPIN System configuration and scope.

The HPIN System consists of:

- (1) Two divisional systems (Divisions A and B) which are supplied from bottled nitrogen supplies. These systems can supply nitrogen to the automatic depressurization system (ADS) accumulators on the safety/relief valves (SRVs).
- (2) A non-divisional system that is supplied from the Atmospheric Control (AC) System. This system can supply nitrogen to the non-ADS and ADS accumulators on the SRVs.

The two divisional systems and the containment penetrations and isolation valves on the non-divisional system are classified as safety-related.

During operation, all SRV accumulators are supplied from the non-divisional system. If the pressure sensor in either of the safety-related systems indicates low pressure, the valve between that system and the non-divisional system closes and the supply valve to the bottled nitrogen supply in that division opens. If the pressure sensor in the non-divisional system indicates a low pressure, the valves between the non-divisional and the divisional systems close.

The capacity of the bottled nitrogen supply in each HPIN division maintains the ADS valves in that division in an open condition for a period of at least seven days following a design basis accident.

The two divisional systems and the containment penetration and isolation valves in the non-divisional system are classified as Seismic Category I. Figure 2.11.13 shows the ASME Code class for the HPIN System piping and components.

Except for the isolation valves and distribution piping inside the primary containment, the HPIN System is located in the Reactor Building.

Each of the two HPIN divisions is powered from the respective Class 1E division as shown on Figure 2.11.13. In the HPIN System, independence is provided between the Class 1E divisions, and also between the Class 1E divisions and non-Class 1E equipment.

Outside the primary containment and except for the interconnection through the non-divisional system, each mechanical division (Divisions A and B) is physically separated from the other division.

The HPIN System has the following displays and controls in the main control room:

- (1) Parameter displays for the sensors shown on Figure 2.11.13.
- (2) Control and status indication for the active safety-related components shown on Figure 2.11.13.

The safety-related electrical equipment shown on Figure 2.11.13 located in the Reactor Building is qualified for a harsh environment.

The motor-operated valves (MOVs) shown on Figure 2.11.13 have active safety-related functions to open, close, or both open and close, and perform these functions under differential pressure, fluid flow, and temperature conditions.

The check valves (CVs) shown on Figure 2.11.13, have active safety-related functions to both open and close under system pressure, fluid flow, and temperature conditions.

Inspections, Tests, Analyses and Acceptance Criteria

Table 2.11.13 provides a definition of the inspections, tests, and/or analyses, together with associated acceptance criteria, which will be undertaken for the HPIN System.

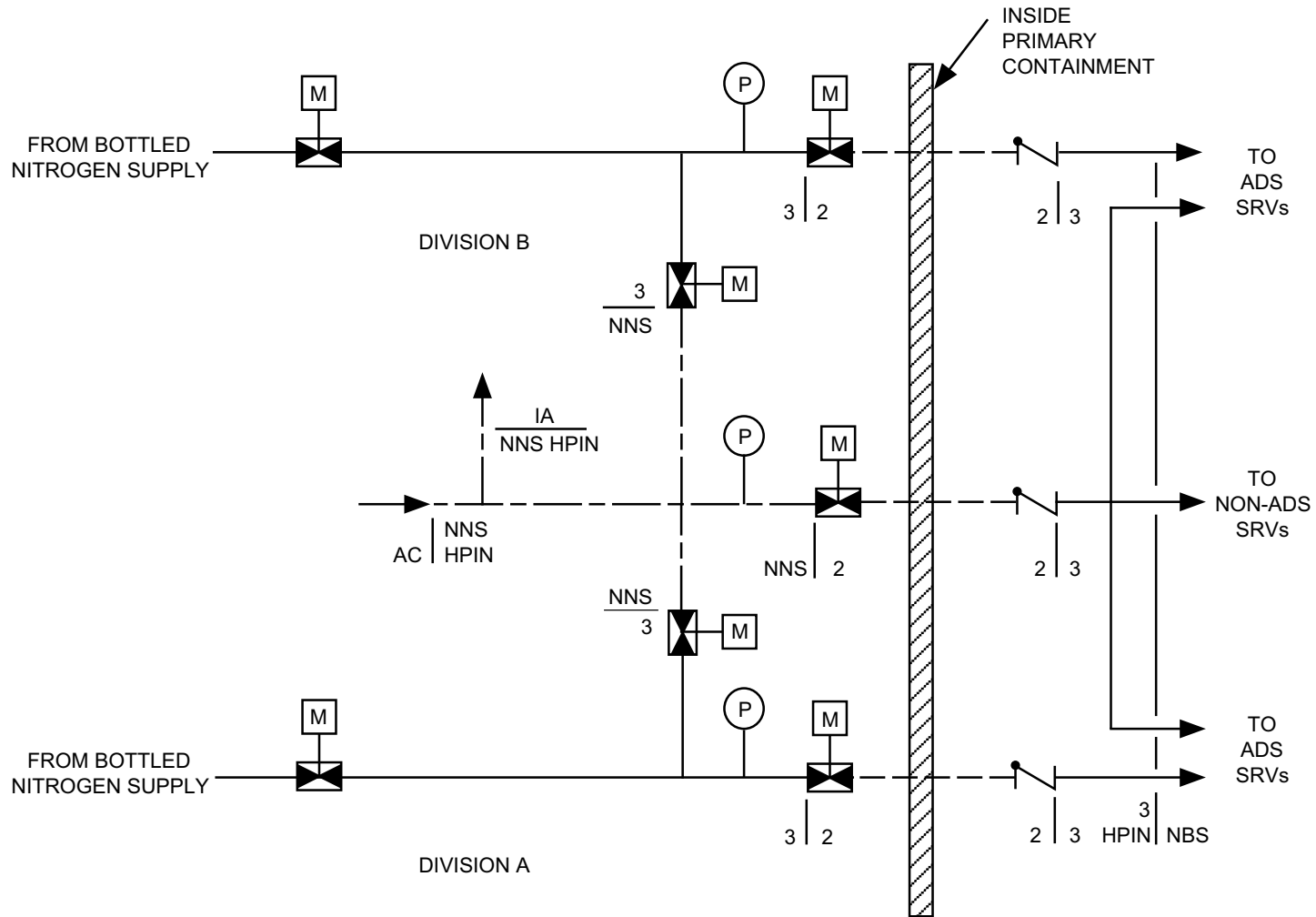

NOTES:

1. HPIN SYSTEM DIVISION-A IS POWERED FROM CLASS 1E DIVISION I, AND HPIN SYSTEM DIVISION-B IS POWERED FROM CLASS 1E DIVISION II. THE CONTAINMENT ISOLATION VALVE OF NON-DIVISIONAL PORTION OF THE HPIN SYSTEM IS POWERED FROM CLASS 1E DIVISION I.

Figure 2.11.13 High Pressure Nitrogen Gas Supply System

Table 2.11.13 High Pressure Nitrogen Gas Supply System

Inspections, Tests, Analyses and Acceptance Criteria		
Design Commitment	Inspections, Tests, Analyses	Acceptance Criteria
1. The basic configuration of the HPIN System is as shown on Figure 2.11.13.	1. Inspections of the as-built system will be conducted.	1. The as-built HPIN System conforms with the basic configuration shown on Figure 2.11.13.
2. The ASME Code components of the HPIN System retain their pressure boundary integrity under internal pressures that will be experienced during service.	2. A pressure test will be conducted on those Code components of the HPIN System required to be pressure tested by the ASME Code.	2. The results of the pressure test of the ASME Code components of the HPIN System conform with the requirements in ASME Code Section III.
3. If the pressure sensor in either of the safety-related systems indicates low pressure, the valve between that system and the non-divisional system closes and the supply valve to the bottled nitrogen supply in that division opens.	3. Tests will be conducted on each division of the as-built HPIN System using simulated pressure signals.	3. If the pressure sensor in either of the safety-related systems indicates low pressure, the valve between that system and the non-divisional system closes and the supply valve to the bottled nitrogen supply in that division opens.
4. If the pressure sensor in the non-divisional system indicates a low pressure, the valves between the non-divisional and the divisional systems close.	4. Tests will be conducted on the as-built HPIN System using simulated pressure signals.	4. If the pressure sensor in the non-divisional system indicates a low pressure, the valves between the non-divisional and the divisional systems close.
5. The capacity of the bottled nitrogen in each HPIN division maintains the ADS valves in that division in an open condition for a period of at least seven days following a design basis accident.	5. Analyses of the installed HPIN will be performed. The analyses will consider nitrogen leakage from the ADS actuators when maintaining the ADS valves open. Leakage from HPIN components when the system is in this mode will also be considered. The analyses will compare the total storage capacity in each division with the total leakage that occurs in a seven day period.	5. The capacity of the bottled nitrogen in each HPIN division maintains the ADS valves in that division in an open condition for a period of at least seven days following a design basis accident.

Table 2.11.13 High Pressure Nitrogen Gas Supply System (Continued)

Inspections, Tests, Analyses and Acceptance Criteria		
Design Commitment	Inspections, Tests, Analyses	Acceptance Criteria
6. Each of the two HPIN divisions is powered from the respective Class 1E division as shown on Figure 2.11.13. In the HPIN System, independence is provided between Class 1E divisions, and between Class 1E divisions and non-Class 1E equipment.	6. a. Tests will be performed in the HPIN System by providing a test signal in only one Class 1E division at a time. b. Inspections of the as-installed Class 1E divisions in the HPIN System will be performed.	6. a. The test signal exists only in the Class 1E division under test in the HPIN System. b. In the HPIN System, physical separation or electrical isolation exists between Class 1E divisions. Physical separation or electrical isolation exists between these Class 1E divisions and non-Class 1E equipment.
7. Outside the primary containment and except for the interconnection through the non-divisional system, each mechanical division (Divisions A and B) of the HPIN System is physically separated from the other division.	7. Inspections of the as-built HPIN System will be conducted.	7. Outside the primary containment and except for the interconnection through the non-divisional system, each mechanical division (Divisions A and B) of the HPIN System is physically separated from the other division by structural and/or fire barriers.
8. Main control room displays and controls provided for the HPIN System are as defined in Section 2.11.13.	8. Inspections will be performed on the main control room displays and controls for the HPIN System.	8. Displays and controls exist or can be retrieved in the main control room as defined in Section 2.11.13.
9. a. MOVs designated in Section 2.11.13 as having an active safety-related function open, close, or both open and close under differential pressure, fluid flow, and temperature conditions.	9. a. Tests of installed valves for opening, closing, or both opening and closing will be conducted under preoperational differential pressure, fluid flow, and temperature conditions.	9. a. Upon receipt of the actuating signal, each MOV opens, closes, or both opens and closes, depending upon the valve's safety functions.

Table 2.11.13 High Pressure Nitrogen Gas Supply System (Continued)

Inspections, Tests, Analyses and Acceptance Criteria		
Design Commitment	Inspections, Tests, Analyses	Acceptance Criteria
b. CVs designated in Section 2.11.13 as having an active safety-related function both open and close, under system pressure, fluid flow, and temperature conditions.	b. Tests of installed valves for both opening and closing, will be conducted under system pre-operational pressure, fluid flow, and temperature conditions.	b. Based on the direction of the differential pressure across the valve, each CV both opens and closes.

2.11.14 Heating Steam and Condensate Water Return System

No entry for this system.

2.11.15 House Boiler

No entry for this system.

2.11.16 Hot Water Heating System

No entry for this system.

2.11.17 Hydrogen Water Chemistry System

No entry for this system.

2.11.18 Zinc Injection System

No entry for this system.

2.11.19 Breathing Air System

No entry for this system.

2.11.20 Sampling System

Design Description

The Sampling (SAM) System obtains samples from systems throughout the plant. A part of the SAM System is a post-accident sampling system (PASS). The PASS takes post-accident gas samples from the primary containment and reactor coolant samples for analysis. The PASS collects samples during and after an accident and is shielded and remotely operated.

The PASS collects reactor coolant samples for measurement of boron and radionuclides (noble gases, iodines, cesiums and non-volatile isotopes).

The SAM System and PASS are classified as non-safety-related.

Inspections, Tests, Analyses and Acceptance Criteria

Table 2.11.20 provides a definition of the inspections, tests, and/or analyses, together with associated acceptance criteria, which will be undertaken for the SAM System.

Table 2.11.20 Sampling System

Inspections, Tests, Analyses and Acceptance Criteria		
Design Commitment	Inspections, Tests, Analyses	Acceptance Criteria
1. The basic configuration of the SAM System is as described in Section 2.11.20.	1. Inspections of the as-built system will be conducted.	1. The as-built SAM System conforms with the basic configuration described in Section 2.11.20.
2. The PASS collects samples of containment gases and reactor coolant.	2. A test of the as-built PASS will be conducted to obtain samples.	2. Containment gas and reactor coolant samples are collected by the PASS.

2.11.21 Freeze Protection System

No entry for this system.

2.11.22 Iron Injection System

No entry for this system.

2.11.23 Potable and Sanitary Water System

Design Description

The Potable and Sanitary Water (PSW) System provides water to the Reactor Building, Control Building, Turbine Building, Radwaste Building and Service Building and collects liquid sanitary wastes and entrained solids and conveys them to a sewage facility and then to a site discharge structure. Nonradioactive drain subsystems throughout the plant collect nonradioactive waste water and convey it to the site discharge structure. Water is supplied to the PSW System by the Makeup Water Preparation System.

Those parts of the PSW System that are within the Reactor Building, Control Building, Turbine Building, Radwaste Building and Service Building are within the Certified Design. Those parts of the PSW System that are outside these buildings are not within the scope of the Certified Design.

The PSW System is classified as non-safety-related.

The PSW System has no interconnections with radioactive systems having the potential for transferring radioactive materials into the PSW System.

Interface Requirements

The portions of the PSW System which are not part of the Certified Design shall meet the following requirement:

- None for this system.

Inspections, Tests, Analyses and Acceptance Criteria

Table 2.11.23 provides a definition of the inspections, tests, and/or analyses, together with associated acceptance criteria, which will be undertaken for the portions of the PSW System within the Certified Design.

Table 2.11.23 Potable and Sanitary Water System

Inspections, Tests, Analyses and Acceptance Criteria		
Design Commitment	Inspections, Tests, Analyses	Acceptance Criteria
1. The basic configuration for the PSW System is as described in Section 2.11.23.	1. Inspections of the as-built system will be conducted.	1. The as-built PSW System conforms with the basic configuration described in Section 2.11.23.
2. The PSW System has no interconnections with radioactive systems having the potential for transferring radioactive materials into the PSW System.	2. Tests will be conducted on the as-built nonradioactive drain system by pressurizing radioactive floor drains with water and observing the nonradioactive drains for evidence of leakage from the radioactive floor drains.	2. No water leakage from the radioactive drains in to the PSW System is observed.