

## PilgrimRenewal NPEmails

---

**From:** Lobo, Walter [wlobo@entergy.com]  
**Sent:** Thursday, October 21, 2010 5:06 PM  
**To:** Regner, Lisa  
**Cc:** Lynch, Joseph R  
**Subject:** 2010 Annual Update for Pilgrim License Renewal  
**Attachments:** 2.10.046 Annual Update for Pilgrim License Renewal.pdf

**Hearing Identifier:** PilgrimRenewalNonPublic\_EX  
**Email Number:** 351

**Mail Envelope Properties** (187F080CB3849B45B6AA5F580382F22708CE54FB)

**Subject:** 2010 Annual Update for Pilgrim License Renewal  
**Sent Date:** 10/21/2010 5:06:08 PM  
**Received Date:** 10/21/2010 5:06:15 PM  
**From:** Lobo, Walter

**Created By:** wlobo@entergy.com

**Recipients:**

"Lynch, Joseph R" <jlynch4@entergy.com>  
Tracking Status: None  
"Regner, Lisa" <Lisa.Regner@nrc.gov>  
Tracking Status: None

**Post Office:** VTYEXETSP001.etrsoth.corp.entergy.com

<b>Files</b>	<b>Size</b>	<b>Date &amp; Time</b>
MESSAGE	3	10/21/2010 5:06:15 PM
2.10.046 Annual Update for Pilgrim License Renewal.pdf		333672

**Options**

**Priority:** Standard  
**Return Notification:** No  
**Reply Requested:** No  
**Sensitivity:** Normal  
**Expiration Date:**  
**Recipients Received:**

October 21, 2010

U.S. Nuclear Regulatory Commission  
Attn: Document Control Desk  
Washington, DC 20555

**SUBJECT:** Entergy Nuclear Operations, Inc.  
Pilgrim Nuclear Power Station  
Docket 50-293  
License No. DPR-35

Pilgrim Nuclear Power Station License Renewal Application Annual Update Supplement (TAC MC9669)

- REFERENCES:**
1. Entergy Letter to U.S. NRC, License Renewal Application, dated January 25, 2006
  2. NRC Letter, "Summary of Telephone Conference Call Held on May 25, 2010, between the U.S. Nuclear Regulatory Commission and Entergy Nuclear Operations, Inc., Concerning the Annual Update Associated with the Pilgrim Nuclear Power Station License Renewal Application", dated October 15, 2010
  3. Entergy Letter, 2.09.074, to U.S. NRC, Pilgrim Power Station License Renewal Application Annual Update, dated December 28, 2009

**LETTER NUMBER:** 2.10.046

Dear Sir or Madam:

By Reference 1, Entergy Nuclear Operations, Inc. (Entergy) submitted the License Renewal Application (LRA) for Pilgrim Nuclear Power Station (PNPS).

Pursuant to 10 CFR 54.21(b), Entergy submitted the 2009 Pilgrim License Renewal Application (LRA) Annual Update by Entergy Letter 2.09.074, dated December 28, 2009 (Reference 3).

Upon review of the 2009 LRA Annual Update, the NRC staff had questions concerning the following issues:

- Metamic
- Emergency diesel generator air start system
- Recirculation pump cover thermal barrier

Entergy and NRC staff held several telephone conference calls, including Reference 2, concerning the above issues. Attachment 1 of this letter provides information clarifying each of the above issues.



Entergy is required by 10 CFR 54.21(b) to report changes to the current licensing basis (CLB) that materially affect the content of the PNPS LRA, including the Safety Analysis Report (SAR) supplement. In accordance with this requirement, Entergy has provided the requested supplement to the annual update.

This letter contains no commitments.

If you have any questions or require additional information, please contact Mr. Joseph R. Lynch, Licensing Manager, at (508) 830-8403.

I declare under penalty of perjury that the foregoing is true and correct.

Executed on the 21<sup>st</sup> of October, 2010

Sincerely,

A handwritten signature in cursive script that reads "Stephen J. Bethay". The signature is written in black ink and is positioned above the printed name.

Stephen J. Bethay

Attachment 1: Entergy Response to Additional Information Related Pilgrim License Renewal Changes (8 pages)

cc:

Ms. Lisa Regner  
Project Manager  
Office of Nuclear Reactor Regulation  
U.S. Nuclear Regulatory Commission  
Washington, DC 20555-0001

Susan L. Uttal, Esq.  
Office of the General Counsel  
U.S. Nuclear Regulatory Commission  
Mail Stop O-15 D21  
Washington, DC 20555-0001

Mr. Richard Guzman  
Office of Nuclear Reactor Regulation  
U.S. Nuclear Regulatory Commission  
Washington, DC 20555-0001

Sheila Slocum Hollis, Esq.  
Duane Morris LLP  
1667 K Street N.W., Suite 700  
Washington, DC 20006

Mr. Michael F. Weber, Director  
Office of Nuclear Material and Safeguards  
U.S. Nuclear Regulatory Commission  
Washington, DC 20555-00001

William Dean  
Regional Administrator  
US NRC Region 1  
475 Allendale Road  
King of Prussia, PA 19406

Mr. Matthew Brock, Esq.  
Commonwealth of Massachusetts  
Assistant Attorney General  
Environmental Protection Division  
One Ashburton Place  
Boston, MA 02108

Diane Curran, Esq.  
Harmon, Curran, and Eisenberg, L.L.P.  
1726 M Street N.W., Suite 600  
Washington, DC 20036

Mr. Robert Walker, Acting Director  
Massachusetts Department of Public Health  
Radiation Control Program  
Schrafft Center, Suite 1M2A  
529 Main Street  
Charlestown, MA 02129

Mr. John Giarrusso Jr.  
Nuclear Preparedness Manager,  
Mass. Emergency Management Agency  
400 Worcester Road  
Framingham, MA 01702

Mr. Eric J. Leeds, Director  
Office of Nuclear Reactor Regulation  
U.S. Nuclear Regulatory Commission  
Washington, DC 20555-00001  
NRC Resident Inspector  
Pilgrim Nuclear Power Station

Entergy Response to Additional Information Related to  
Pilgrim License Renewal Annual Update Changes

**Attachment 1**  
**To Entergy Letter No. 2.10.046**

(8 pages)

Entergy Response to Additional Information Related to  
Pilgrim License Renewal Annual Update Changes

**1. Metamic Issue:**

In the Pilgrim License Renewal Application annual update dated December 28, 2009 (Letter No. 2.09.074), it is stated that Metamic is now in use for the Spent Fuel Pool (SFP) racks. Metamic is relied upon for criticality protection.

The 2009 FSAR update recognizes changes to include the use of Metamic in the SFP. The cover letter states that "there were no new 10 CFR 50.59 evaluations during the period July 1, 2007 through June 30, 2009."

**Discussion:**

In the 50.59 screening analysis for Engineering Change (EC) # 4353-Spent Fuel Pool Capacity Expansion, Pilgrim evaluated whether Metamic can be used in the spent fuel pool racks. The key points are:

- Boral is no longer commercially available so a substitute equivalent, Metamic, was to be used.
- Reviewed TS 4.3 and found no changes necessary.
- Reviewed FSAR sections 10.3 and 10.4 and found that updates were required for sections 10.3.4.1, 10.3.6, and 10.3.8, Figures 10.3-4, 10.3-5, and 10.3-7.
- License Amendment dated June 22, 1994 approved Pilgrim to install additional racks into the SFP.
- Metamic and Boral are equivalent.
- Metamic has been approved for use as a neutron absorber by USNRC SER 2003 (ANO).
- Metamic was evaluated to ensure the critical parameters of the approved design are met:
  1. Same size and weight
  2. B-10 areal loading comparable
  3. No structural effects

NRC has identified that section 3.3.2.2.6 of NUREG-1801 regarding the potential loss of material and loss of neutron-absorption capability requires clarification to include different fuel rack materials. Pilgrim reviewed LR-ISG-2009-1 and determined the following:

- The SFP Boraflex material is managed under the criteria identified in section X1.M22 of the GALL.
- Metamic and Boral materials are managed under criteria of X1.M40 as recommended in LR-ISG- 2009-01.

A comparison of the GALL and ISG criteria for Pilgrim compliance follows.

Entergy Response to Additional Information Related to  
Pilgrim License Renewal Annual Update Changes

**X1.M22 (Boraflex)**

ISG Criteria	Pilgrim Compliance
<ul style="list-style-type: none"> <li>Frequency of Badger testing: <math>\leq</math> 5years</li> </ul>	Badger tests were performed in 2006 and are scheduled for 2011 based on 2006 results and Racklife Program.
<ul style="list-style-type: none"> <li>Blackness Test</li> </ul>	Performed in 1996 and 1998 and superseded by Badger Testing in 2006.
<ul style="list-style-type: none"> <li>Trend SFP Silica levels and evaluate using the Racklife Program; monthly, quarterly, or annually</li> </ul>	Silica levels are trended monthly and presently evaluated once per cycle using the Racklife Program. Program being revised for annual evaluation, before the period of extended operation.
<ul style="list-style-type: none"> <li>Measure Boron Areal Density using in-situ Badger Test</li> </ul>	Performed in-situ Badger test in 2006

**ISG-2009-01-X1.M40 (Material other than Boraflex)**

ISG Criteria	Pilgrim Compliance
<ul style="list-style-type: none"> <li>Monitor loss of material and degradation of neutron absorption capability via Badger Testing, or Coupon Program Surveillance</li> </ul>	Pilgrim uses Coupon Program Surveillance for its Boral and Metamic Rack material.
	Boral Coupons were retrieved and tested, based on the manufacturer's recommended surveillance schedule in 2006 and 2009. A Metamic SFP Rack and Coupon-Tree was installed in accordance with EC#4353 in 2009. Based on manufacturer and NRC guidelines, the first Metamic coupon is scheduled for retrieval and testing in 2011.

Pilgrim will manage the effects of aging of its SFP Racks in accordance with the clarification contained within LR-ISG-2009-01, Interim Staff guidance regarding the AMR of SFP materials. Boraflex material will be managed according to tenets of X1.M22 GALL. Boral and Metamic will be managed according to tenets of ISG-2009-01-X1.M40.

**2. Emergency Diesel Generator Air Start System Issue**

Pilgrim's LRA Drawing M219 showed a component identified as a "Motor Oil Fogger" in the piping from the Emergency Diesel Generator (EDG) air receiver tanks to one of the two sets of air start motors on the "A" EDG. The drawing showed "Motor Oil Foggers" in the piping on both sets of the air start motors for "B" EDG. The "Fogger Housing" described a unique component type whose integrity would be necessary to assure accomplishment of EDG intended function. PNPS License Renewal Annual Update Letter # 2.09.074 discussed the deletion of the "Fogger Housing" resulting in the following questions.

- How "Fogger Housing" is no longer required to support EDG intended function?
- How the pressure boundary function is being achieved?



## Entergy Response to Additional Information Related to Pilgrim License Renewal Annual Update Changes

### Summary:

- The new EDG air start motors do not require lubricated air, so the motor oil foggers with their “Fogger Housings” are no longer required.
- When the foggers were removed they were replaced with air piping components maintaining the pressure boundary.

### Discussion:

The Motor Oil Fogger and its housing are no longer needed to support the EDG intended function because the recently installed turbine type air motor does not require lubricated air. The original vane type motors utilize sliding vanes that rub against the motor housing walls and because of this internal friction vane type motors require oil foggers to provide constantly lubricated air.

The turbine type air motor uses blades to convert pneumatic power to mechanical power; the internal parts do not rub against the walls. The turbine type motor has permanently lubricated bearings and does not require an oil fogger as part of its air supply system.

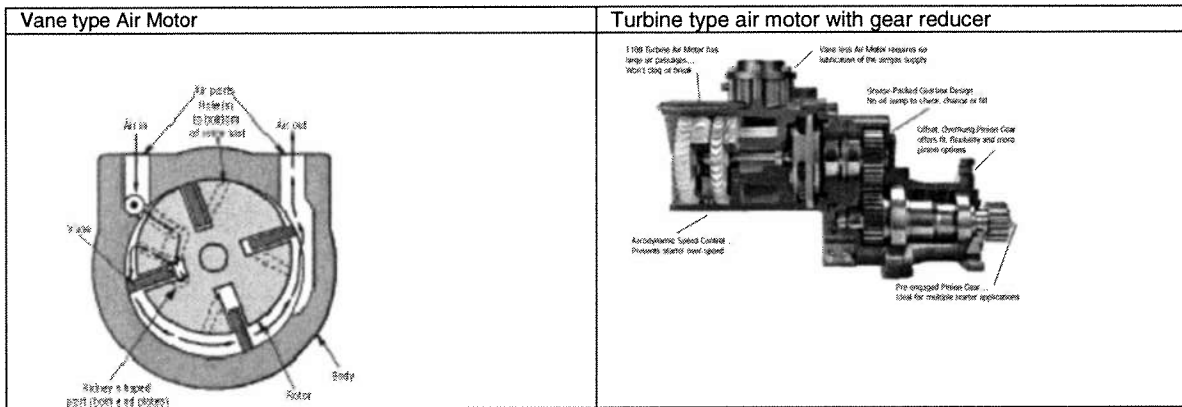

The vane type air start motors were replaced with turbine type air start motors using the Pilgrim Design Change Process (PDC 00-12, PDC 03-59, and EC0000012969); a PDC is a Plant Design Change, which is now called an EC, or an Engineering Change. The modifications were done over a period of years, during periods when the individual EDGs were out of service for extended PMs. This was intentionally scheduled to minimize the EDG System unavailability. This staged approach was the reason that LRA drawing M219 reflected “Fogger Housings” on some, but not all air lines to the air start motors.

The design changes installed the turbine type air motors on the EDGs, and removed the oil fogger, housing, and the inlet/outlet piping connections to the air starting system. The air pressure regulators, solenoid valves, and manual operating valves were replaced at the same time with higher air flow capacity units which maintain the pressure boundary. This reduced the differential pressure losses through the components, thereby providing increased oil pressure at the air motor. Post work tests were conducted to validate, and confirm that the air system performance met FSAR requirements. At this time, all vane type air motors have been replaced with turbine type air motors, and there are no “Motor oil Foggers” or “Fogger Housings” on the EDG air start systems.

Entergy Response to Additional Information Related to  
Pilgrim License Renewal Annual Update Changes

A safety screen was performed as part of the Process Applicability Determination (10CFR50.59 review process) for each PDC. It includes a basis that should allow the reviewer to reasonably reach same conclusion; that the air start system modification does not change the FSAR requirements in any way, and serves to improve the system reliability to achieve those requirements.

A comparison of the P&ID drawings M219 revisions demonstrates that the air system boundary was maintained and controlled as each set of vane type air motors were replaced with turbine type air motors. The following sections from P&ID drawing M219 shows the progression from a single turbine style air motor (and 3 vane type motors with oil foggers) as shown in the LRA drawing (Rev 19) , to the current configuration with 4 turbine style air motors (Rev 23), and no motor oil foggers.

Entergy Response to Additional Information Related to Pilgrim License Renewal Annual Update Changes

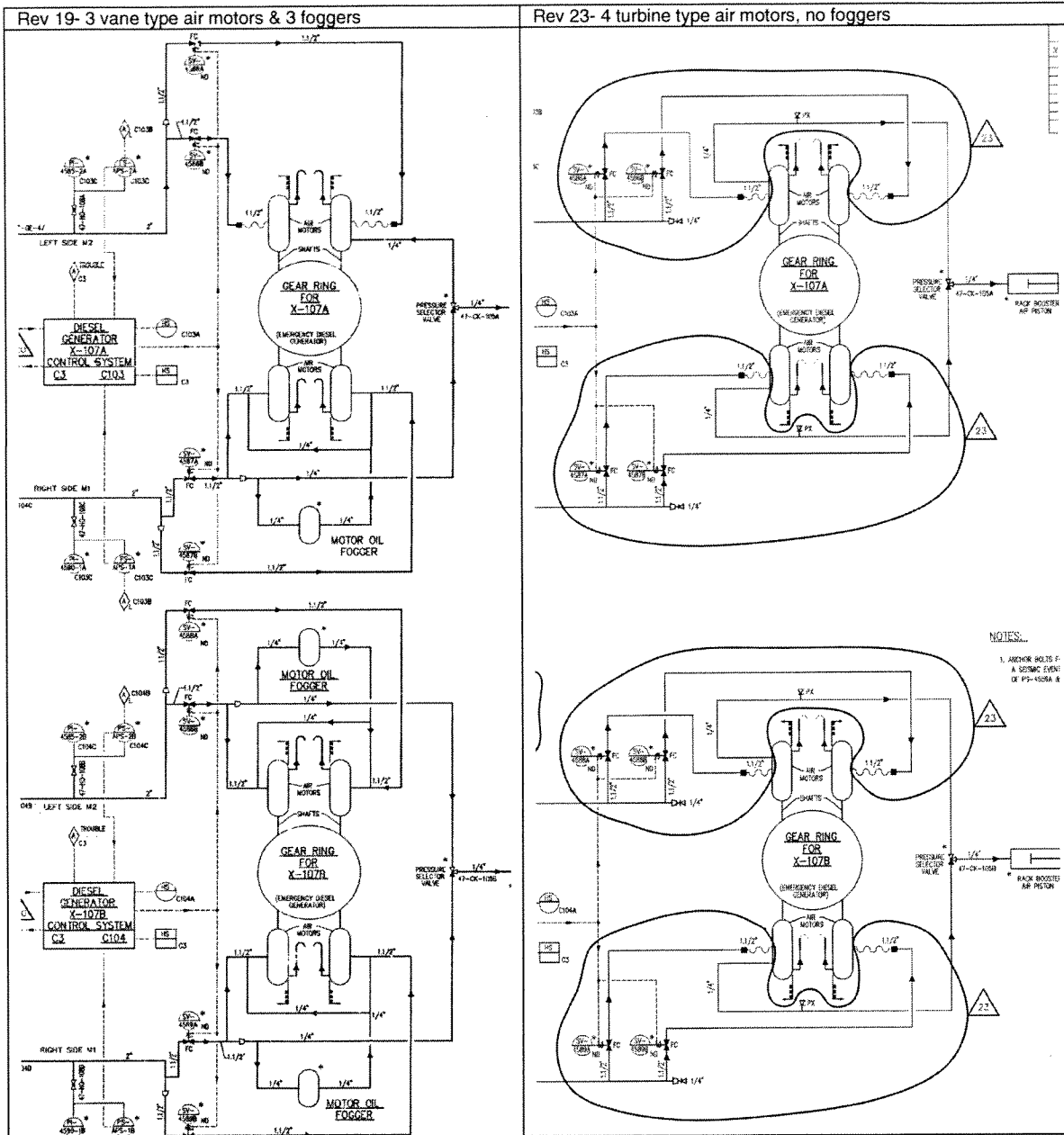

**3. Recirculation Pump Cover Thermal Barrier Issue**

PNPS License Renewal Annual Update Letter # 2.09.074 modified LRA Table 2.3.1-3 and removed the “pump cover thermal barrier (RR)” on page 2.3-11, without explaining the change.

Entergy Response to Additional Information Related to  
Pilgrim License Renewal Annual Update Changes

Summary:

Pilgrim replaced the Reactor Recirculation Pump internals and covers during Refueling Outage (RFO) 16 (April 2007), for P201-B; and RFO 17 (April 2009), for P201-A. The new Flowserve 4<sup>th</sup> generation pump internals and cover design change was implemented using ER#03118234. The design eliminated the "pump cover thermal barrier", which is a cooling water passage through the cover. The cooling water passage was a pressure boundary for RBCCW, and as part of the cover, a pressure boundary for reactor recirculation flow.

The new 4<sup>th</sup> generation Reactor Recirculation Pumps at Pilgrim no longer include a "pump cover thermal barrier", so this item was removed from Table 2.3.1-3 in the 2009 LRA Annual Update. The "Pump casing and cover" remain in the table, with the intended function of pressure boundary.

The modified table 2.3.1-3 from the 2009 update is shown below:

7. LRA Table 2.3.1-3, Reactor Coolant Pressure Boundary Components Subject to Aging Management Review, is revised as follows.

Page 2.3-11

Component Type	Intended Function
Pump cover thermal barrier (RR)	Pressure boundary

Discussion:

---

ER# 03118234

Nuclear Change Narrative

Page 10 of 24

---

3.0 Evaluation/Design Summary

- 3.1 Evaluation Resolution: This major rebuild/upgrade of the Reactor Recirculation Pumps (P-201A/B) includes only design changes that are for the purpose of upgrading the long-term reliability of the equipment by eliminating existing potential problems. The "Fourth Generation" pump design from the OEM (Flowserve, formerly Byron Jackson) was created primarily to eliminate concerns with thermal fatigue cracking of the pump shafts and covers that was noted industry-wide for this type of Reactor Recirculation or Reactor Coolant Pump.

The mechanical seal cooler has been completely reconfigured from the previous shell and tube type heat exchanger to a more robust tube-less cooler housing. The previous pump cover cooling has been completely eliminated resulting in only two connections of RBCCW cooling water to the pump versus the previous four connections. The mechanical connection of the impeller to the pump shaft has been replaced with an all-welded design. The pump cover gasket has been improved and the cover joint closure will be done with a stud-bolt and nut configuration versus the existing cap screws.

Entergy Response to Additional Information Related to  
Pilgrim License Renewal Annual Update Changes

Table 2.3.1-3 on page 2.3-11 of the LRA submittal is titled "Reactor Coolant Pressure boundary Components subject to Aging Management Review". The 11<sup>th</sup> and 12<sup>th</sup> items on the list are:

<u>Component Type</u>	<u>Intended Function</u>
Pump casing and cover (RR)	Pressure boundary
Pump cover thermal barrier (RR)	Pressure Boundary

The new 4<sup>th</sup> generation Reactor Recirculation Pumps at Pilgrim no longer include a "pump cover thermal barrier", so this item was removed from Table 2.3.1-3 during the 2009 LRA Annual Update. The "Pump casing and cover" remain on the list.