

**Lake, Louis**

---

**From:** Lake, Louis  
**Sent:** Thursday, December 10, 2009 8:25 AM  
**To:** Thomas, George  
**Subject:** FW: Emailing: PresconFieldInstallationManual.tif  
**Attachments:** PresconFieldInstallationManual.tif

For your info

-----Original Message-----

**From:** Lake, Louis  
**Sent:** Thursday, December 10, 2009 8:17 AM  
**To:** Masters, Anthony  
**Subject:** Emailing: PresconFieldInstallationManual.tif

Anthony;

Here is the tendon installation manual you requested in Question #2.

The message is ready to be sent with the following file or link attachments:

PresconFieldInstallationManual.tif

Note: To protect against computer viruses, e-mail programs may prevent sending or receiving certain types of file attachments. Check your e-mail security settings to determine how attachments are handled.

THE PRESCON CORPORATION  
FIELD INSTALLATION MANUAL

## GLOSSARY

Bearing Plate	Plate cast into concrete on which shims bear after elongating tendon to transfer prestress force to concrete.
Buttonheads	Cold-formed head on end of wires.
Buttress	Pilaster on the offset portion of structure where the horizontal tendons are stressed.
Casing Filler	Corrosion protection material which is pumped into sheathing after tendons are stressed.
Casing Filler Cap	Portion of the Filler Cap Assembly that covers the post-tensioning anchorage and retains gasket in position against bearing plate.
Cavitation	Air seeping into hydraulic system.
Clamping Jaws	Vise in heading machine that holds the wire while it is being headed.
"Do Not Exceed"	Maximum hydraulic gage pressure shown on the Stressing Data Table.
Elongation	The length a tendon stretches when tensioned.
Filler Cap	Cover used to hold corrosion protection material over the end of each tendon.
Gage	Instrument used on pumps to measure hydraulic pressures.

Heading Dies	End of heading ram which forms the buttonhead on end of wire.
Heading Machine	Machine used to form buttonheads on ends of wire.
Holst	Device for lifting loads.
Hydraulic Hose	Connector between pumps and hydraulic driven equipment.
Increment Shims	Thin shims for minute adjustments in stressing.
Jack Base	End of ram next to bearing plate.
Jog	Quick movement of switch to start and stop a motor.
Kellums Grips (Chinese Fingers)	Self-tightening, woven sock used to pull tendon into sheath.
Moyno Pump	Trade name of pump used to pump casing filler material into sheathing.
Power Unit	Electrically driven hydraulic pump which furnishes power to a piece of equipment.
PSI	Pounds per square inch.
Pull Rods	Connector from stressing washer thru ram which stresses a tendon.
Quick Coupler	Fittings (male and female) used on end of hydraulic hose to attach to hydraulic pump.
Ram	Hydraulic center hole jack used to stress a tendon.
Reddy Chek Gage	Pressure gage used to check machine pressures.
Reels or Baskets	Containers for casing filler feeder hose from pump to scaffold.

Reservoir Assembly

Hydraulic fluid container located on pump.

Scissor Jack

Tool used to move non-stressed and spread plate up the wires to the bearing plate.

Sheath

Tube used to form void in concrete.

Sheathing Filler Pump

Moyno pump.

Shims

Cut pieces of steel inserted between washer and bearing plate to maintain load put in the tendon.

Slings

Cables or straps used to handle material and equipment.

Stressing

Elongating or loading a tendon by using a ram.

Stud Bolts

Bolts screwed into bearing plates on which equipment is hung.

Tendon

A group of 1/4" high tensile strength wires threaded thru washers.

Tendon Location No.

The identity of a tendon location in the structure.

Tendon Puller

Winch on frame used to pull tendon thru sheathing.

Trumpet

Pipe welded to the backside of bearing plate that makes a diameter transition from bearing plate to sheath.

Uncoiling Tub

Machine used to uncoil or retract a tendon.

Viscosity

The thickness of a fluid.

Wise Grip

Lock-type pliers.

Washer

Part of end anchorage thru which the wires are threaded.

Washer Pusher

Machine used to slide washer back and forth on end of tendon.

Following are a Series of Details  
which will be referred back to as  
Figure Numbers in the write-up.  
Please familiarize yourself with them.

TENDON IN STRESSED POSITION

VERTICAL TRUMPET

TUNNEL CEILING

BEARING R

STRESSING R IN PLACE WITH TENDON IN STRESSED POSITION

TUNNEL FLOOR

FIG 2

VERTICAL TRUMPET

TUNNEL CEILING

BEARING R

TENDON EXTENDED TO RECEIVE STIFFENER R AND BUTTON HEADS

STIFFENER R WITH WIRE THREADED

APPROX 5'-0"

TUNNEL FLOOR

FIG 1



FIG. 3

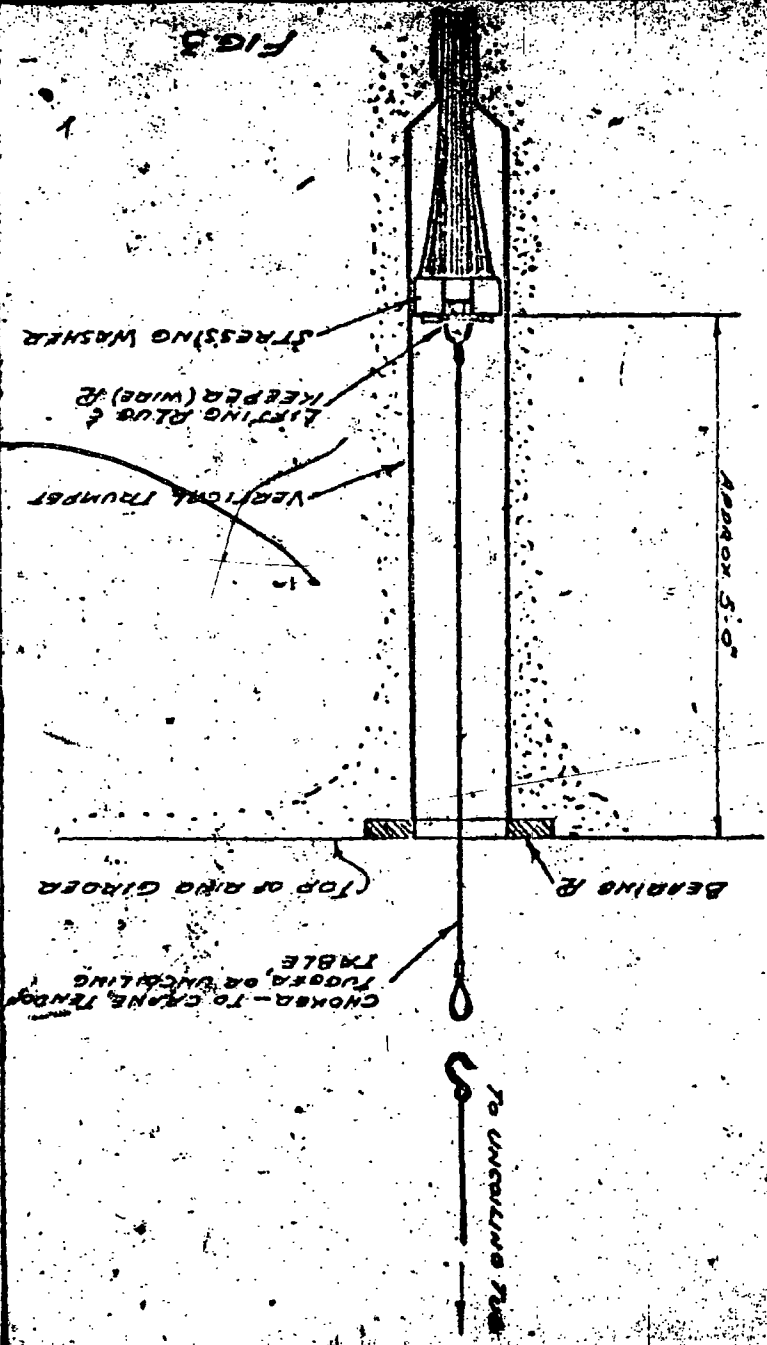
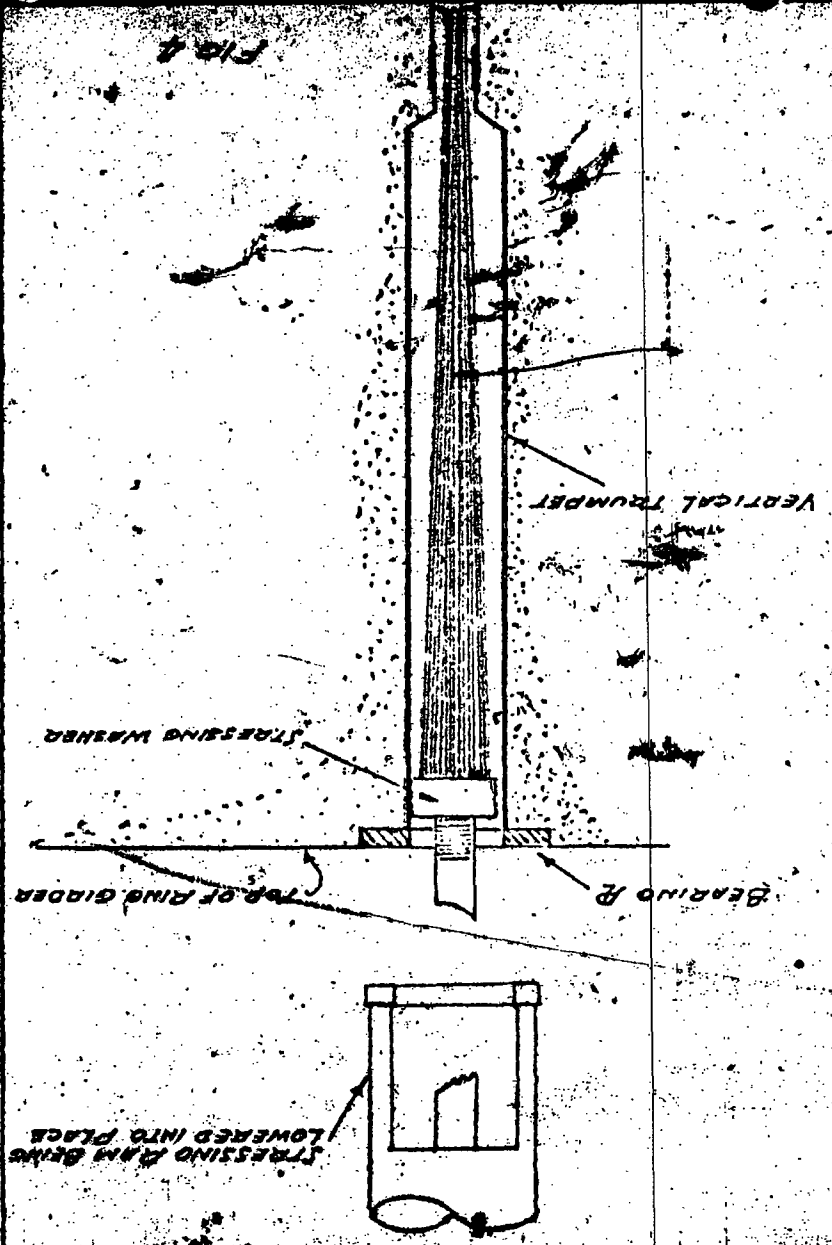
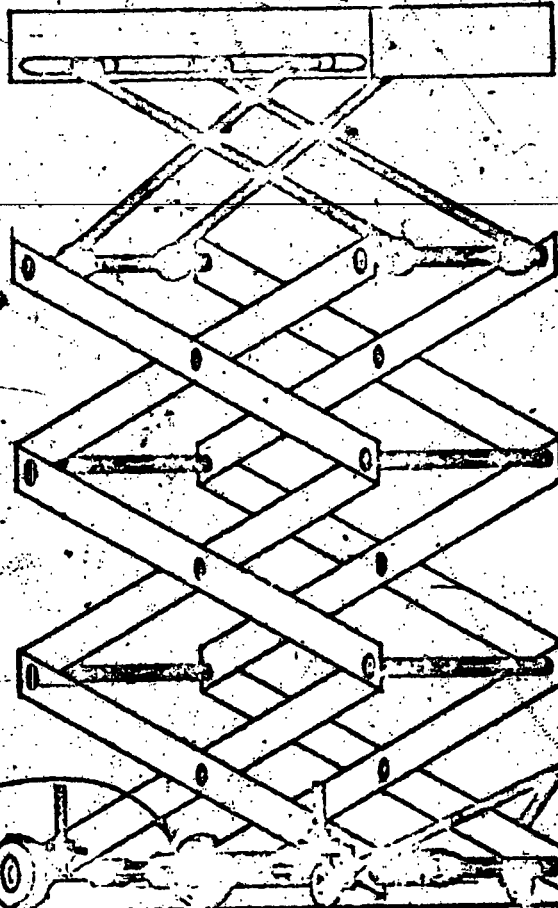

FIG. 4





CARRIAGE FOR DEAD END

MOBILE HANDLE

MOBILE WHEELS

VERT. MOTION (RAISING DEAD END INTO POSITION)

OUTSIDE WHEELS ARE FOR POCKET & TILT

**JACK DIMENSIONS:**

- 36" LONG
- 18" WIDE
- 20" HIGH IN RETRACTED POSITION
- 96" HIGH IN EXTENDED POSITION
- WEIGHT 250 POUNDS
- CAPACITY 1800 POUNDS MAXIMUM

Fig. 3-A

**THE FRESCON CORPORATION**

SUBJECT: SCISSOR JACK (FOR VERTICAL TENDING)

JOB NO. \_\_\_\_\_  
 FILE NO. \_\_\_\_\_  
 DATE 5-16-69  
 BY C.H. BOSWORTH  
 FORM NO. 241

SHEET NO. \_\_\_\_\_  
 OF \_\_\_\_\_

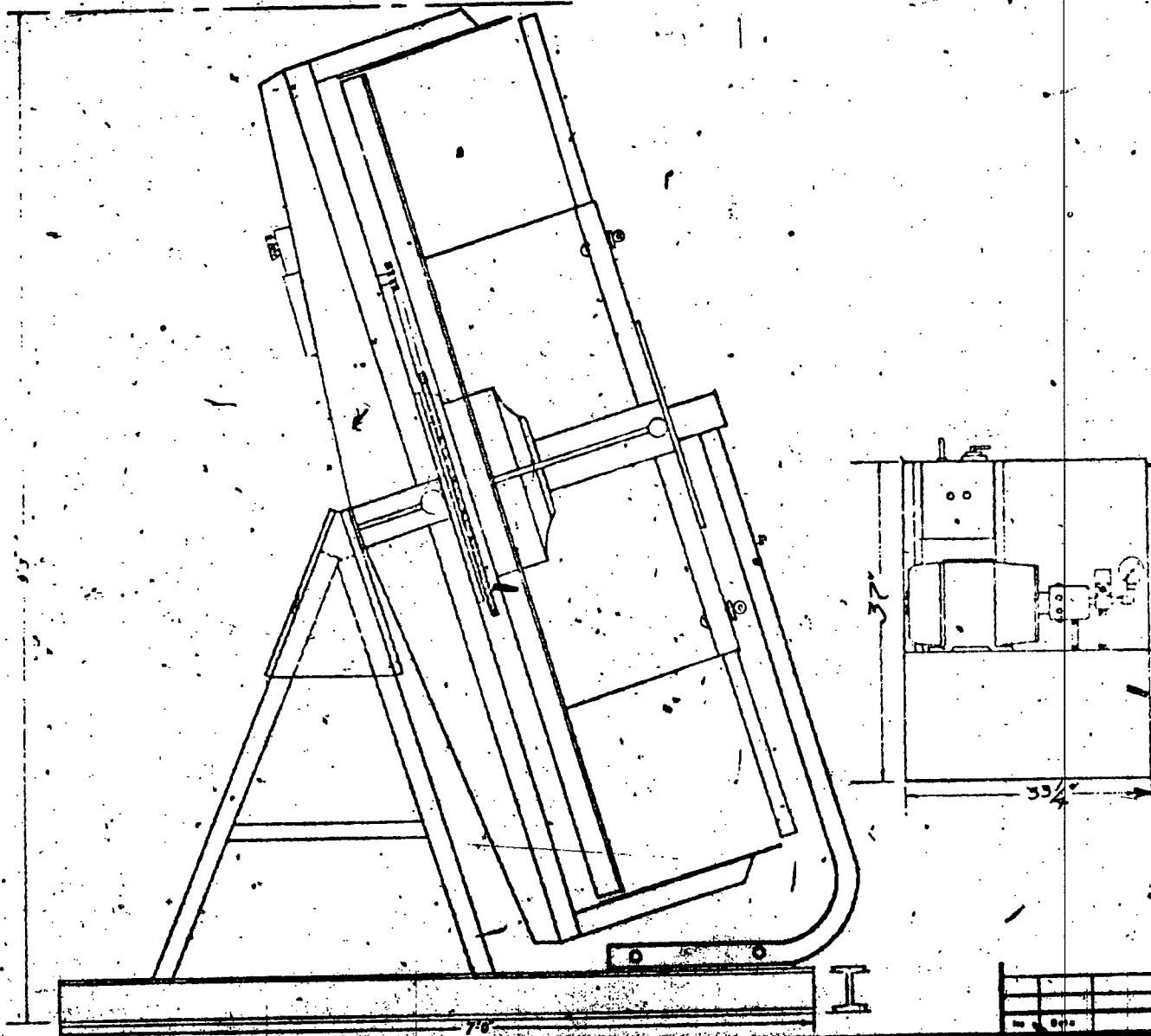

Fig. 5

**NOTE:**  
This drawing is property of THE PRESCON CORPORATION  
and may not be used in any manner or copied in whole or part  
without written permission from THE PRESCON CORPORATION



**The Prescon Corporation**  
P. O. Box 4000      1000 Central Ave.      Grand Rapids, Mich.

*Uncoiling Table*  
1500"      Pumping Unit 500"

Rev.	By	Checked	Sheet No.
1			21

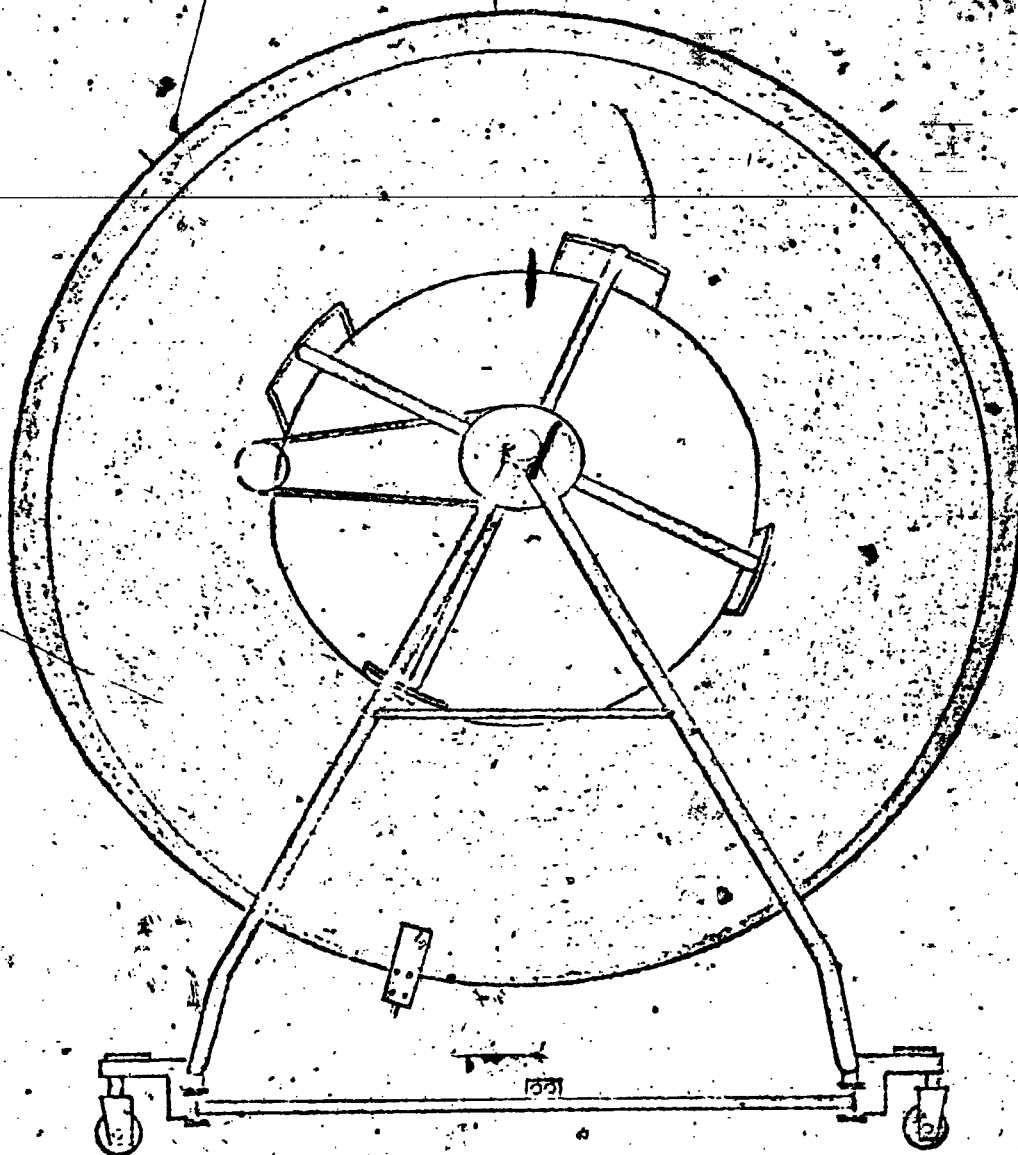

Fig- 5-A

*THE PRESCON CORPORATION*

SUBJECT

UNCOILING TABLE

JOB NO.

FILE NO.

DATE

BY

FORM NO. 241

SHEET NO.

OF

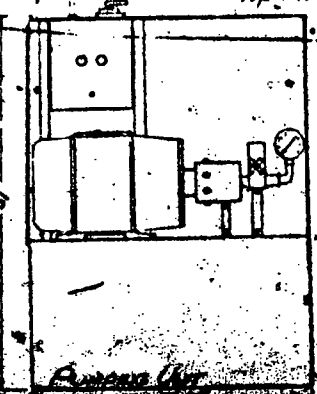
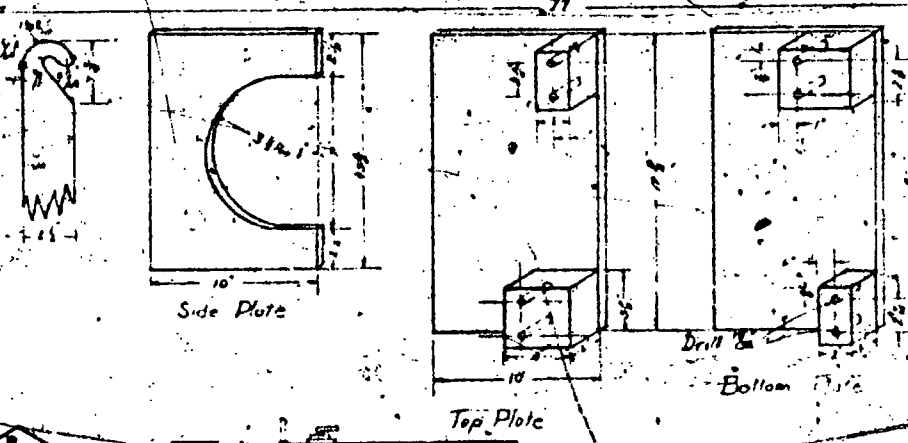
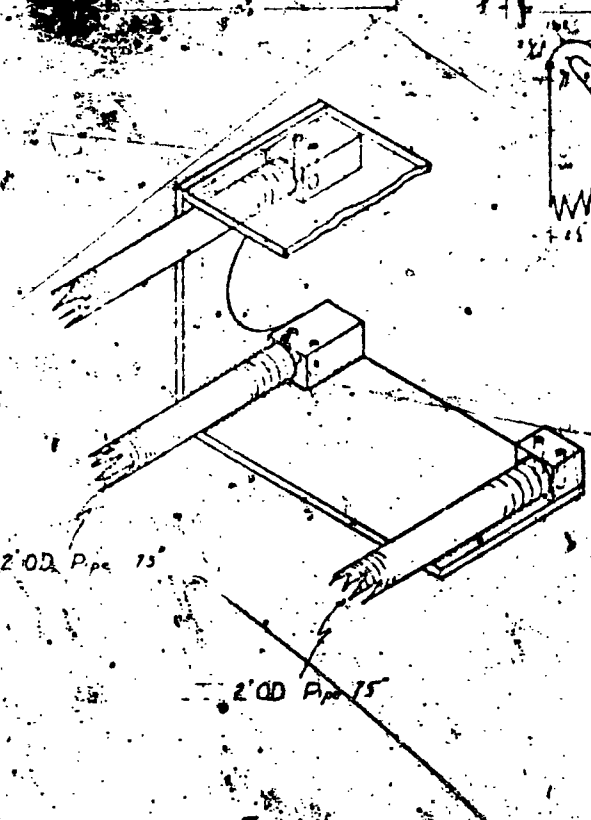
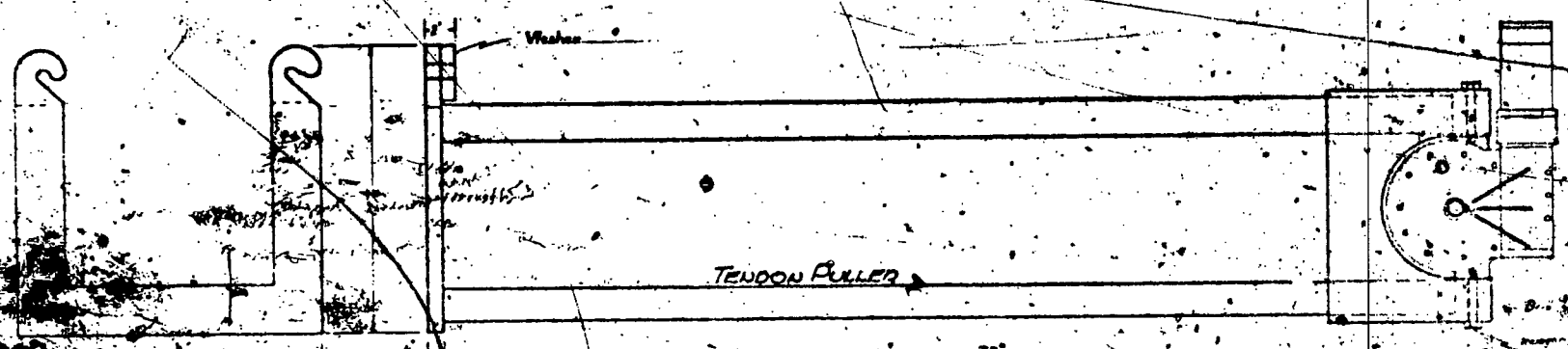

Note: Plates are made of 3/8\"/>

12 3/4 FT FLOOR AREA REQD.

Rev.	By	Check	Date
1			
2			
3			
4			
5			
6			
7			
8			
9			
10			

NOTICE  
This drawing is the property of THE PRESCON CORPORATION. It is not to be used in any manner or copied in whole or part without the permission of THE PRESCON CORPORATION.



**The Prescon Corporation**  
P.O. Box 1000  
4000 Central Expressway  
San Jose, California 95128

Tendon Puller & Ringing Unit  
110 110  
Rev. 11

E-2

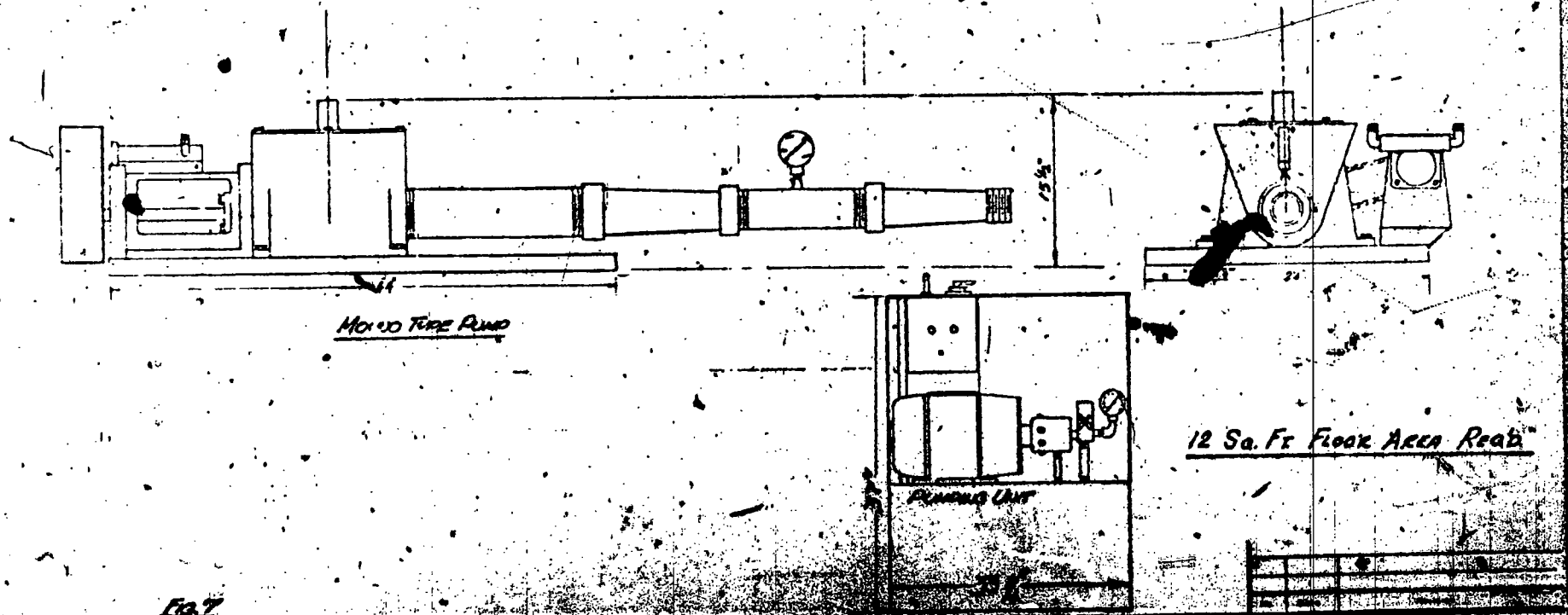

FIG. 2

NOTE:  
This drawing is the property of THE PATENT CORPORATION  
and may not be used in any manner or copied in whole or in part  
without special permission from THE PATENT CORPORATION.



The Patent Corporation  
1000 Broadway, New York, N.Y.

Engineering Dept. Planning Unit  
Patent No. 2,412,000

DATE	1/10/50
BY	J. H. [unclear]
CHECKED BY	[unclear]
APPROVED BY	[unclear]

FIG. 2

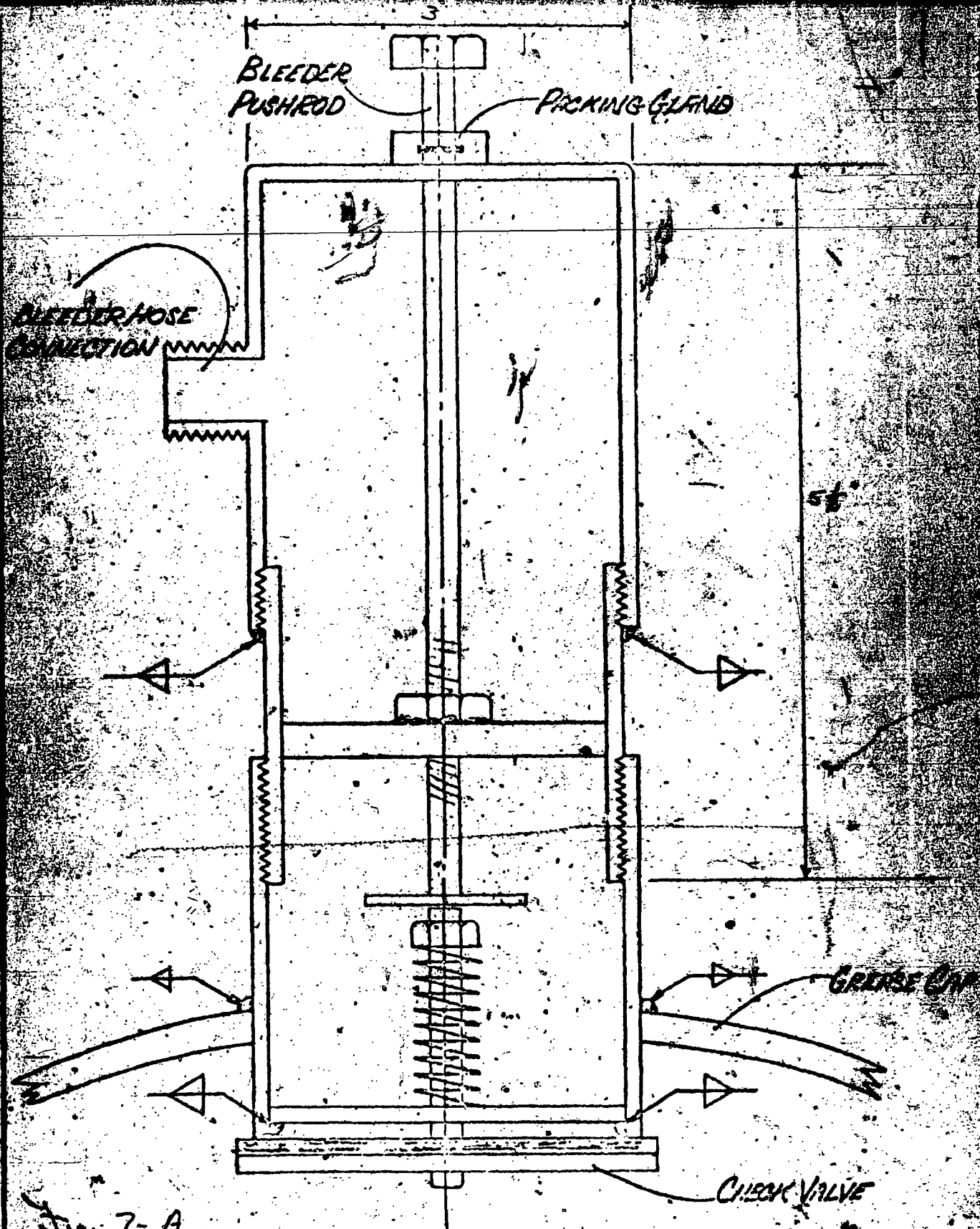

**THE PRISCON CORPORATION**  
 SUBJECT AIR BLEEDER ASSEMBLY (SHOWN  
 CONNECTED TO CHECK VALVE)

JOB NO. \_\_\_\_\_  
 FILE NO. \_\_\_\_\_  
 DATE \_\_\_\_\_  
 BY *P.A. Guertel*  
 FORM NO. 24

SHEET NO. \_\_\_\_\_  
 OF \_\_\_\_\_

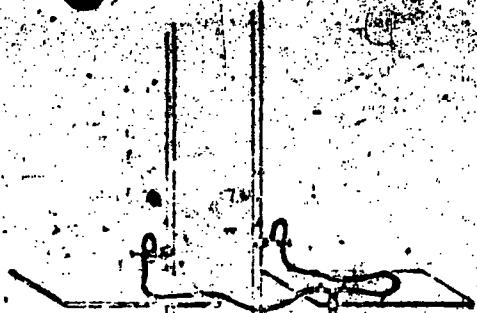

CASING FILLED METHODS

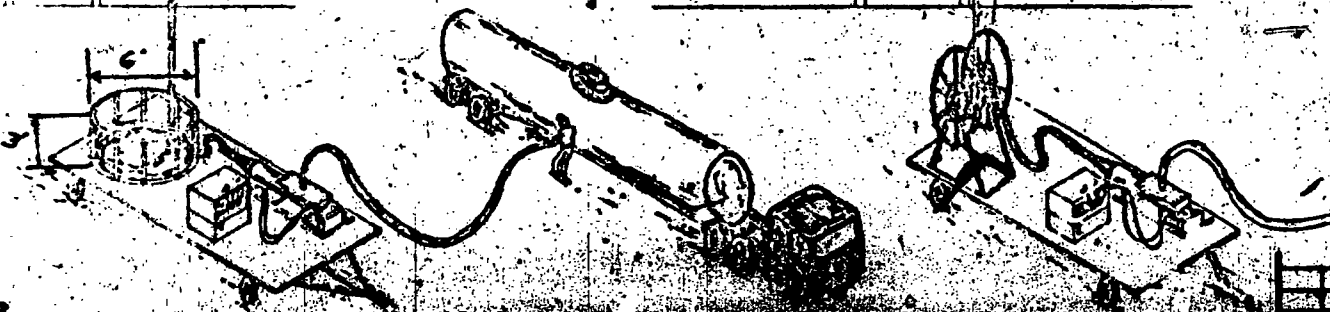

Fig. 8

NOTE: This device is the property of THE PERSEON COMPANY and may not be used in any manner or for any purpose without the express written permission of THE PERSEON COMPANY.



**THE PERSEON COMPANY**  
 1700 W. 10th St. - Tulsa, Oklahoma

DATE	
TIME	
BY	
NO.	



Fig. 9

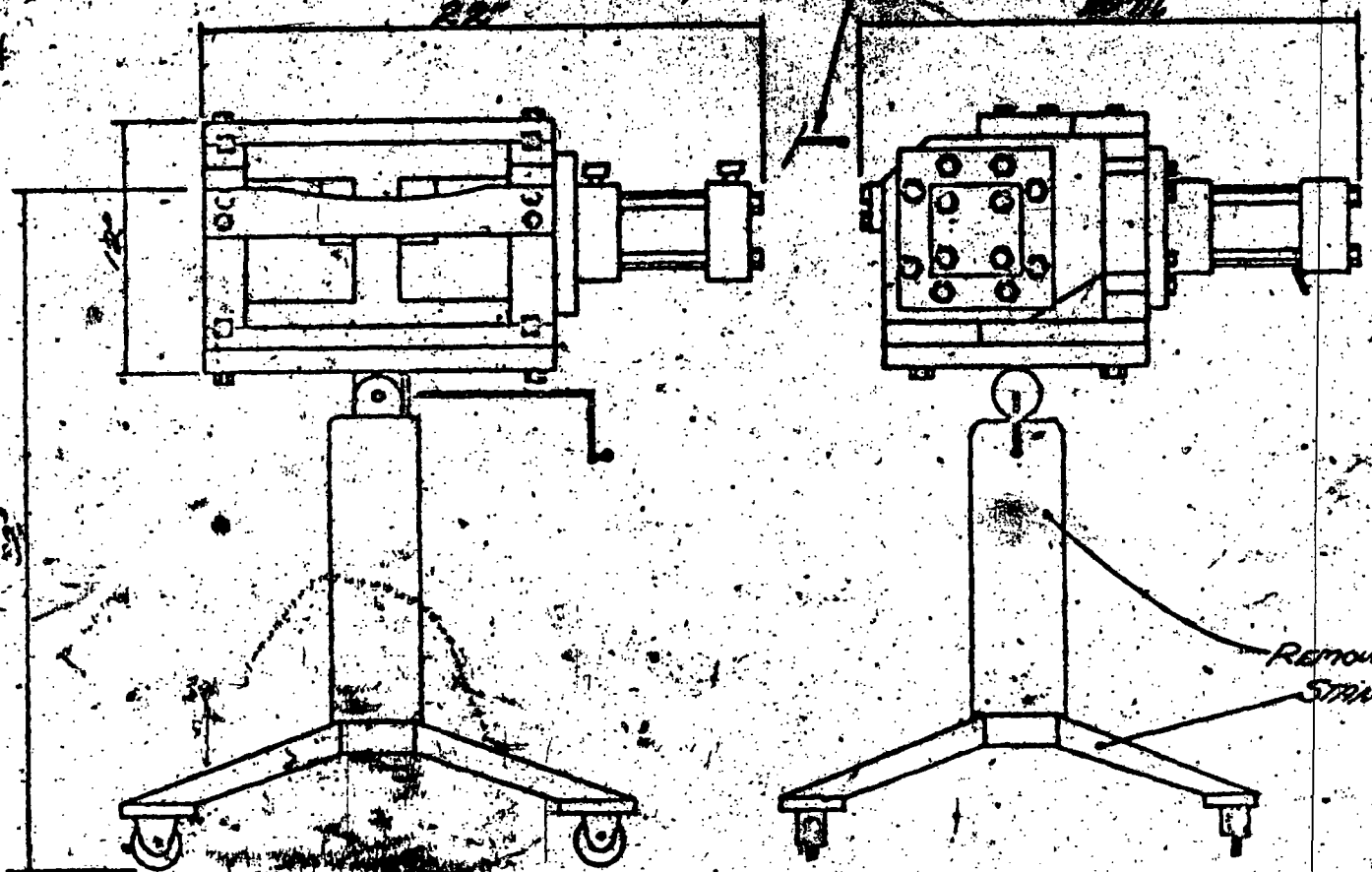

REMOVABLE FROM STAND

Herndon Machine  
Company

THE L. J. SCOTT CORPORATION  
Herndon, Massachusetts

JOB NO. \_\_\_\_\_  
 FILE NO. \_\_\_\_\_  
 DATE \_\_\_\_\_  
 BY: A. G. S. \_\_\_\_\_  
 FORM NO. 341

SHEET NO. \_\_\_\_\_

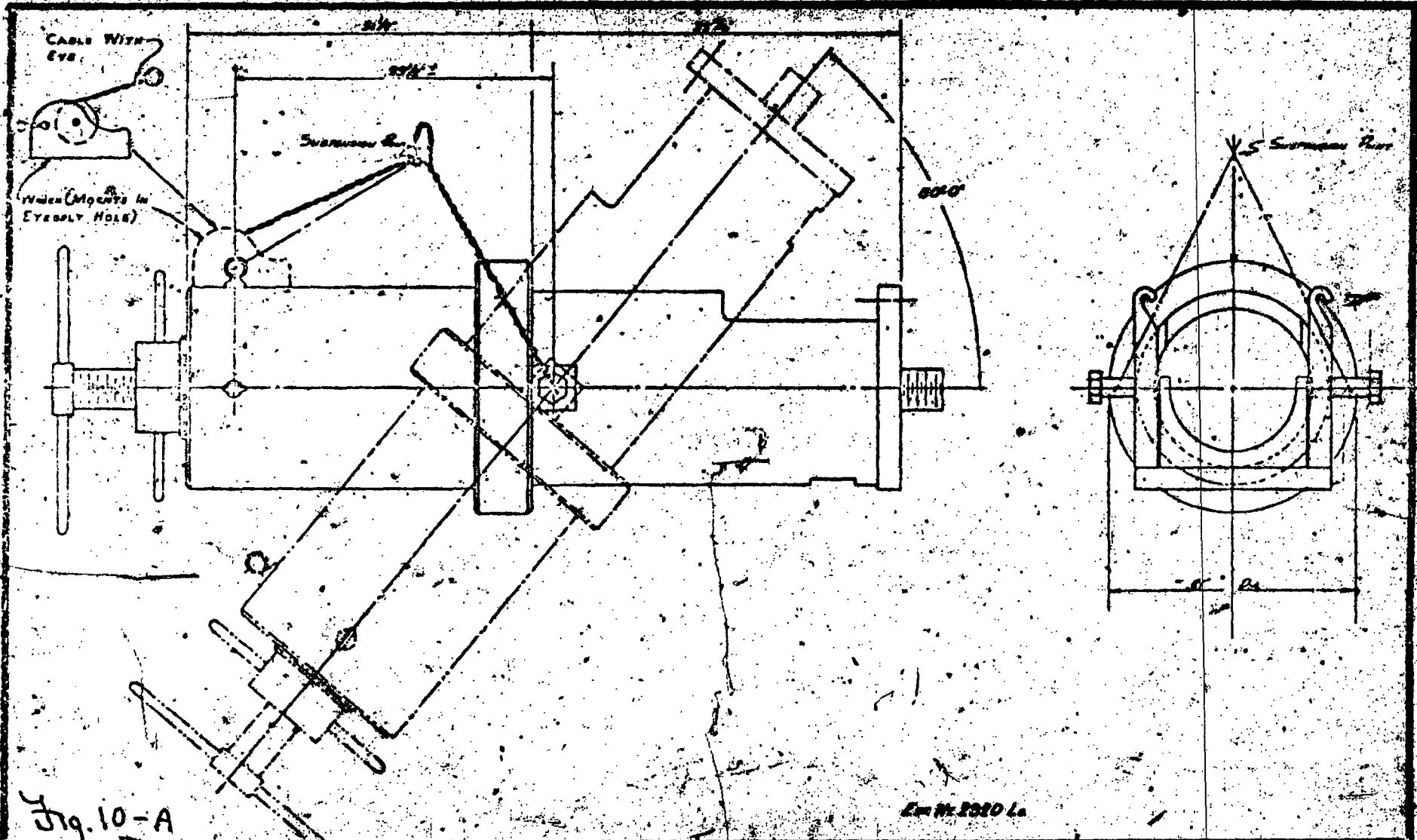

Fig. 10-A

Em No. 2020 L



**THE PRESCON CORPORATION**

DESIGNED BY	DATE	11-7-60
DRAWN BY	DATE	
CHECKED BY	DATE	

SECTION CC

SECTION BB

SECTION A

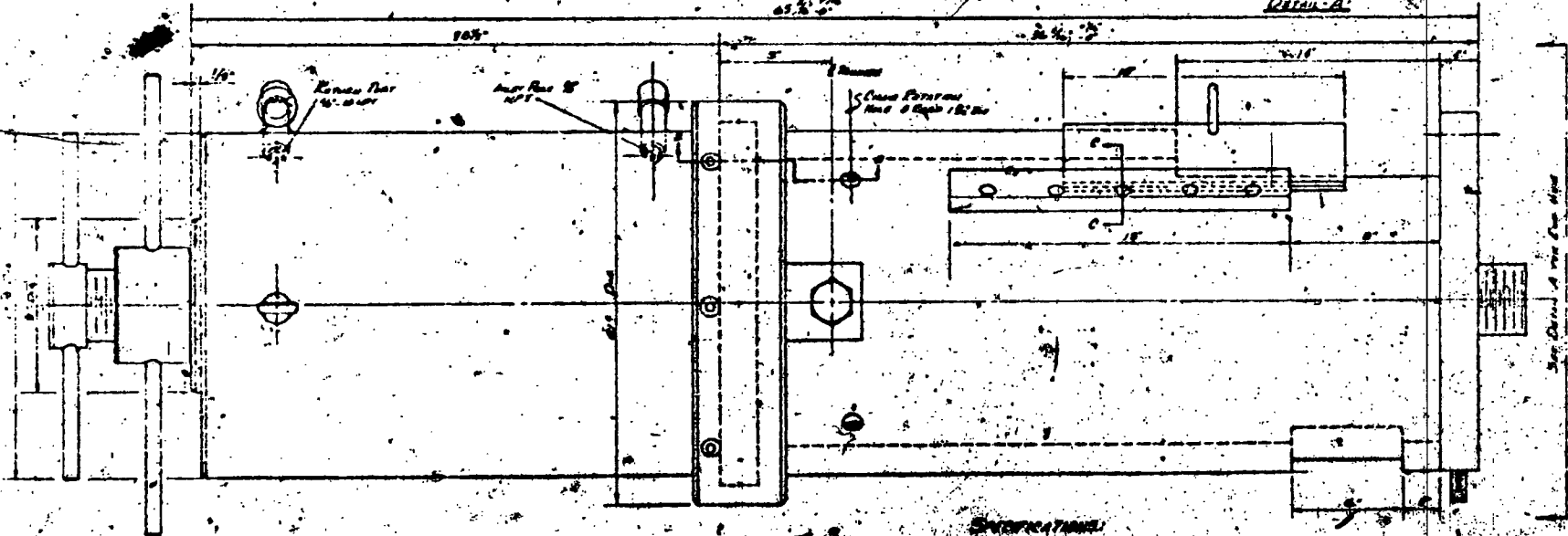

Fig. 10-B

**NOTIFICATIONS:**  
 1. This drawing is for the use of 4000 PSI  
 2. This drawing is for the use of 4000 PSI  
 3. This drawing is for the use of 4000 PSI  
 4. This drawing is for the use of 4000 PSI

THE PRESCON CORPORATION  
 500 JAY ROAD, CHICAGO, ILL.  
 U.S.A.



**THE PRESCON CORPORATION**  
 500 JAY ROAD, CHICAGO, ILL.  
 U.S.A.

500 JAY ROAD, CHICAGO, ILL.  
 U.S.A.

DATE	BY	CHKD.	APP'D.

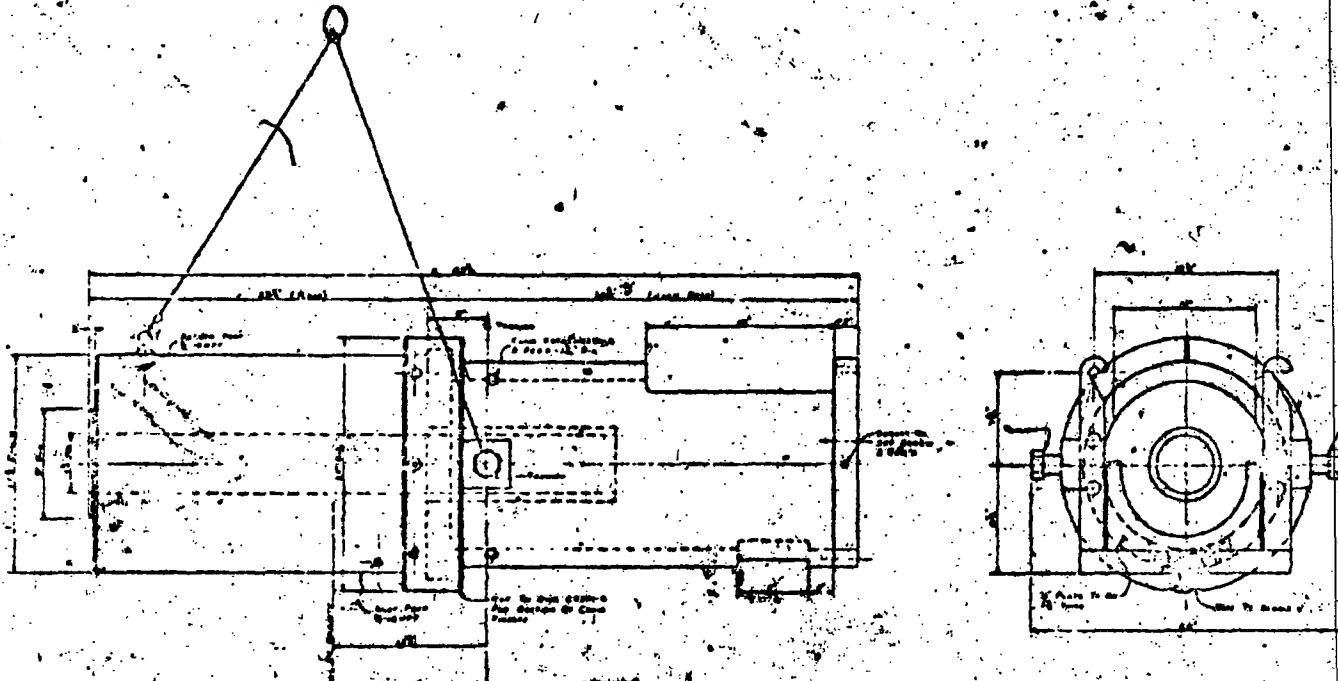

**NOTES:**  
 1. See drawing for details.  
 2. See drawing for details.  
 3. See drawing for details.  
 4. See drawing for details.  
 5. See drawing for details.

Fig. 10-c

<p>10-c</p>	<p>10-c</p>	<p>10-c</p>	<p>10-c</p>	<p>10-c</p>	<p>10-c</p>
-------------	-------------	-------------	-------------	-------------	-------------

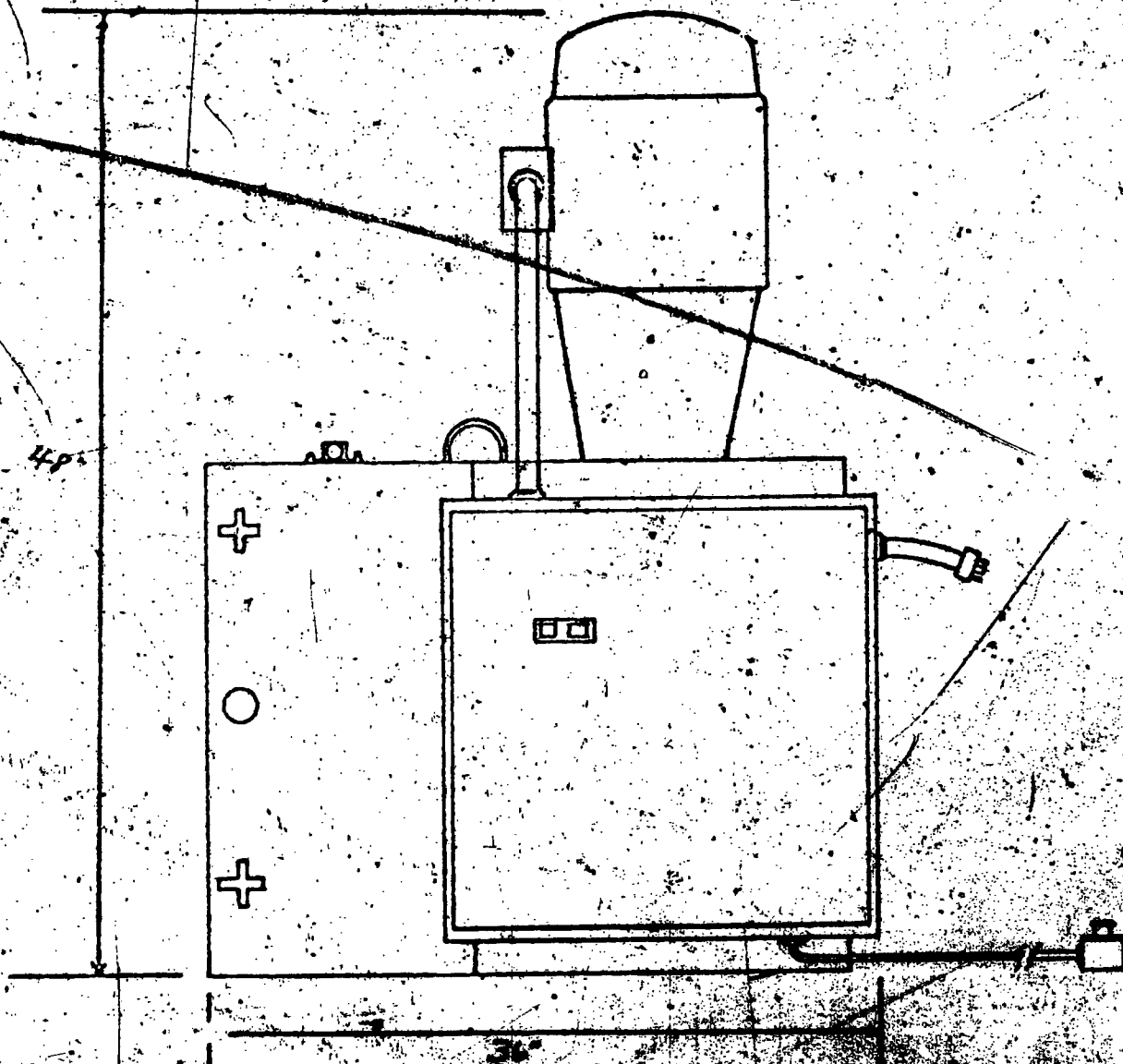

6.15 Sq. Ft. Floor Area Req'd.  
1500 LBS.

Flail

Copyright © 1964 by The Perseon Corporation  
All rights reserved. No part of this publication may be reproduced, stored in a retrieval system, or transmitted, in any form or by any means, electronic, mechanical, photocopying, recording, or by any information storage and retrieval system, without the prior written permission of The Perseon Corporation.



**The Perseon Corporation**  
2010 Avenue L, (10000)

2010 Avenue L, (10000)

REV	DATE	BY
1		

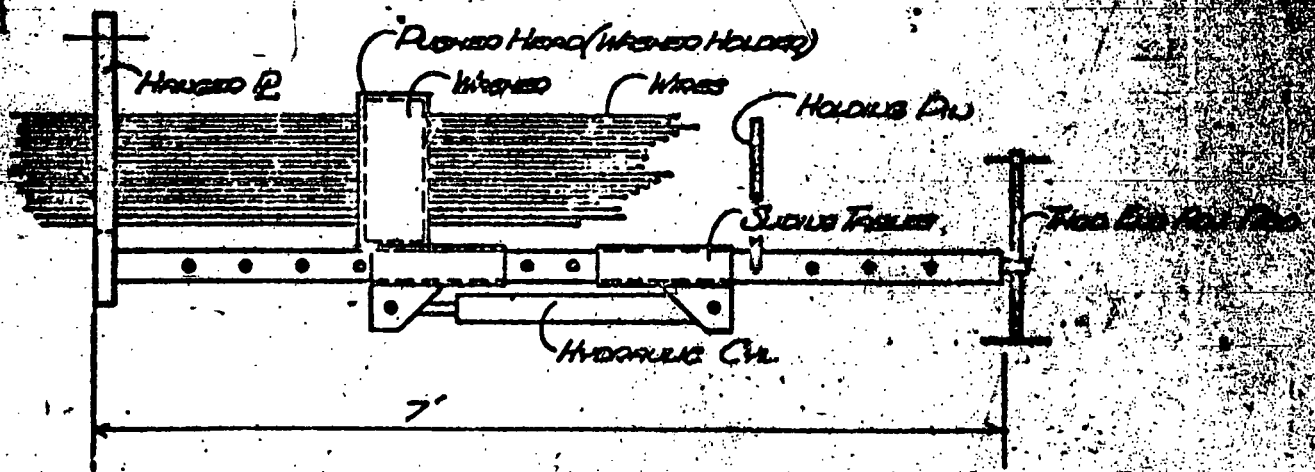
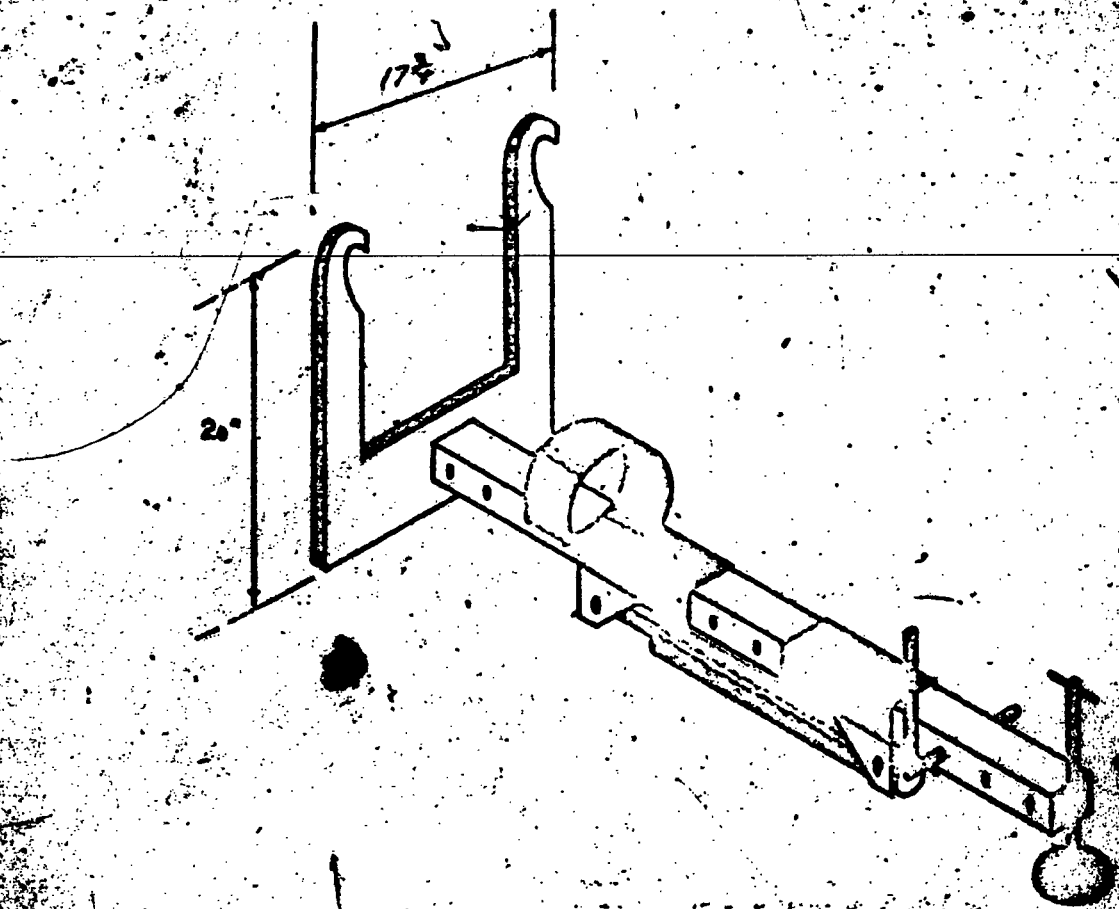

Fig. 12

**THE PRESCON CORPORATION**

SUBJECT PUSHED - PULLED FOR TENDON WASHER

JOB NO. \_\_\_\_\_  
 FILE NO. \_\_\_\_\_  
 DATE 3-15-49  
 BY C.H. Prescott  
 FORM NO. 241

SHEET NO. \_\_\_\_\_  
 OF \_\_\_\_\_

## SAFETY PRECAUTIONS

Prescon has built into the equipment the necessary safety measures to eliminate accidents. It is your responsibility as workmen to see that suggested precautions and safety measures are used at all times. For the safety of you and your fellow workmen, it is important not to cut corners and to employ good safety measures at all times.

A tendon is a group of high tensile wires which, when coiled, acts like a big spring. Due to their size, the tendons are difficult to coil into a small diameter; therefore, when it is in a coil, it tries to straighten out. The tendon arrives in a 7' diameter coil held by steel banding; when the bands are loosened, it will try to uncoil and will, unless it is confined to an area.

When the tendon has been placed into the uncoiling tub, be sure the four (4) pipe guards which keep the tendon from jumping out of the tub are securely in place before any of the bands are cut. Do not cut the small bands from around the tendon until the band is outside the tub.

The safety precautions should be followed closely while stressing. If a mistake is made, it could cause a failure of the tendon, concrete or equipment which could cost a man's life; therefore, observe safety precautions at all times.

When a tendon is being stressed, it will have nearly a million pounds of force behind it; therefore, be alert.

Obey the following precautions:

1. Be alert at all times.
2. There are two danger zones during stressing which should be avoided at all times while a tendon is being stressed to prevent

a casualty in case of an accident during the stressing operations:

- a. While stressing, do not stand behind the ram.  
If some failure occurs at any of the attachments to the tendon, the ram will move straight back for a few feet.
  - b. While stressing, do not stand within a 7' radius to the side of the ram. In case of a concrete failure behind the bearing plate, the ram may move violently in an arc direction.
3. Screw pull rod into washer so that a full thread engagement is assured.
  4. If any strange noise occurs in the equipment, Stop Immediately. Notify a Prescon Representative.
  5. If a crack occurs in the concrete, Immediately Stop. Call a Prescon Representative who in turn will notify the proper authority.
  6. Do not overstress - never let gage pressures go higher than the "Do Not Exceed" figure on the Stressing Data Table.
  7. Keep door closed on jackbase until you are ready to insert the shims.
  8. After stress pressures and elongation have been reached, open the Jackbase door and place both regular shims.
  9. Do not place only one shim without the other; either place both or none.
  10. Do not get your fingers between the washer and bearing plate. You could lose a finger if an accident occurs.
  11. If increment shims are needed, use a bar to move the regular



shims to make room for increment shims. All increment shims must be placed between regular shims and the bearing plate.

Make sure the same thickness increment shimming is used with each regular shim.

12. The rams are equipped with a safety valve in the event a hose or fitting breaks; if that occurs, the ram will hold pressure until the repair has been made.

13. Be sure of your communications before the pressure has been released on the shims. Many words sound alike when spoken; therefore, be sure of your instructions before you press buttons to operate a machine.

14. Keep in mind a machine has no brains. You, the workman, must furnish the brains to operate the equipment safely.

Let's not be a casualty!

**SUGGESTED PROCEDURES FOR  
POST-TENSIONING CONTAINMENT STRUCTURES**

**PLACING, STRESSING AND CURING**

**I. Preparation of Buttress Prior to Placing Tendons**

- A.** Clean and run tap in each 3/4" hole in bearing plate to remove cement and rust.
- B.** Remove any concrete which may be on face of bearing plate. Plate must be clean of cement.
- C.** If sandblasting is required for the bearing plate to be rust-free prior to closing the trumpet with the casing filler cap, then sandblasting should be done prior to placing the tendons. Plug trumpet to eliminate sand from going in sheathing.

**II. Tendon Delivery**

- A.** Schedules - Contractor will furnish written schedule listing four (4) week projected deliveries.
- B.** Transportation - Prescon will deliver tendons to the jobsite in trucks in accordance with contractor's schedule.
- C.** Unloading and/or Storage - Contractor will furnish equipment and personnel necessary for off-loading tendons from truck. All subsequent handling and storage will be by the Contractor.

**III. Tendon Placement**

- A.** The Contractor will furnish the following equipment and tools necessary for placing tendons:

A. Cont.

1. Hoisting Equipment
2. Scaffolds
3. Small hand tools in tool box on each scaffold consisting of:
  - a. Crescent wrenches (2)
  - b. Pliers (2)
  - c. Wrecking bars (2)
  - d. Screw drivers (2)
  - e. Vise grip (1)
  - f. Pocket size steel tape
4. Telephone head set (6 sets)
5. 220 or 440 volt, 3 phase, electricity with twist lock outlets (notify Vendor which voltage).
6. 110 volt electrical outlets for small hand tools, if needed.
7. 14 mil Permacel pipe tape - 3' per tendon.
8. 3/4 x 3" bolts (2 per tendon, but can be reused)
9. Slings for hoisting tendons
10. Vent valves or vent fittings
11. Band cutter
12. 2" strips of rubber used under Kellums Grips

B. Prescon will furnish the following equipment and tools necessary for placing tendons:

1. Uncelling tubs with power units (3)
2. Tendon puller with power units (3)
3. Heading Machines - field (7)

4. Rams with power units (7)
5. Kellums Grips (Chinese Fingers)
6. Washer pusher (6)
7. ~~Spare parts for all equipment repair~~

**C. Suggested Placing Procedures for Horizontal Tendons - step by step as follows:**

1. Prepare telephone communication hook-up between each end of tendon, A & B.
2. Tendon hook-up man on truck to unpackage tendon and attach slings.
3. Hoist tendon to scaffold or platform and place in uncoiling tub. (see Fig. 5)
4. Anchor washer to uncoiling tub with cable comb-a-long and tighten up all the slack in tendon washer.
5. Cut outside bands from around tendon.
6. End A mounts tendon puller (see Fig. 6) onto bearing plate with 3/4" stud bolts which contractor has screwed into 3/4" tapped holes provided in bearing plate.
7. End B pulls tendon puller cable thru sheath using an electrical tape
8. End B wraps 2" rubber tape thru and around wires to provide better grip for Kellums Grip.
9. Wrap protruding wire ends with 2" pipe tape.
10. End B attaches Kellums Grip securely to tendon over rubber tape.
11. Attach flexible pulling cable from puller to Kellums Grip eye at End B.

12. End B communicates with End A to start puller.
13. End B operates hydraulic controls of uncoiling tub while End A operates controls of puller. Continuous telephone communication should be maintained to insure coordination of tub and puller during uncoiling operation.
14. End B cuts steel bands on tendon as it goes into sheath.
15. End B pulls tendon until the end protrudes five feet (see Fig. 3) at End A while End B directs washer into trumpet (see Fig. 1).
16. If all tendons are placed before heading starts, move up to next tendon and repeat operation. If heading is done as tendons are placed, load heading machine on scaffold at End A.
17. Place washer into pusher guides.
18. Thread wires into washer at End A.
19. Place washer puller tool and engage motor to push washer back to bearing plate at End A.
20. Move heading machine into position at End A and head all wires (see Fig. 9).
21. Spray approved corrosion protection to end of wires and washer at End A.
22. Move washer back to end of wires by reversing motor of washer pusher at End A.
23. Insert stop into washer pusher to hold wires tight against buttonheads at End A.

24. Engage washer pusher power unit and it will push tendon back into trumpet.
25. Ends A & B check equalization of washers with respect to outside surface of bearing plates.
26. For temporary moisture protection, attach grease cap.
27. Move to next tendon and repeat operation.

Upon completion of all placing, lower uncoiling tub, pullers and heading machines to ground and store. Leave heading machine power unit on scaffold to be used for stressing.

If heading is not done until just before stressing, items 17 thru 27 will be done as a separate operation.

#### D. Suggested Placing Procedures for Vertical Tendons:

A vertical tendon must be handled differently than the horizontal tendons. The tendon is coiled, banded, and bagged as are the horizontal tendons. A short cable (20-foot long) must be coiled around the center of the tub and attached to the cable come-a-long which is a part of the uncoiling tub. All this rigging is necessary to be able to lower the tendon down into the trumpet for heading and lifting the tendon into stressing position after the spread plate has been placed on the bottom end of the tendon (see drawing, Fig. 1).

Step by step as follows:

1. Tendon hook-up man on truck to unpackage tendon and attach slings.

2. Hoist tendon and place in uncoiling tub.
3. Coil short cable that is attached to stressing washer around center of uncoiling tub and attach to cable come-a-long which is a part of the uncoiling tub.
4. Replace guard pipes in uncoiling tub.
5. Tighten up come-a-long until stressing washer is drawn up against the center part of the uncoiling tub.
6. Rotate tub until loose end of tendon is in position to feed out of tub.
7. Cut large bands from around tendon.
8. Rotate tub forward until tendon is extending out of tub approximately 4". Cover ends of wires with tape or a bullet to prevent wire ends from snagging sheathing as it is lowered.
9. Feed tendon into trumpet and permit washer to bottom out in the trumpet (see Fig. 1).
10. Disconnect short cable from cable come-a-long and leave attached to tendon (see Fig. 1).
11. Move to next tendon and repeat.

**E. Suggested Heading Procedures for Vertical Tendons**

All heading will be done in the tunnel. Tendons will be hanging from stressing washer and the loose end will be protruding from the lower trumpet approximately 4-1/2 feet. The spread bearing plate is approximately 14 x 14 x 2". A special scissor type jack equipped with a table to hold the bearing plate in position will be furnished by Prescon.

1. Mount bearing plate on scissor jack.
2. Thread wires into bearing plate.

3. Jack spread plate up into proper location against bearing plate and insert two (2) bolts to hold spread plate.
4. Move heading machine into proper position.
5. Head and check all wires.
6. Move to next tendon and repeat. Crew on top of the structure must lift tendon and locate to start stressing.
7. Move to next tendon and repeat.

**F. Suggested Stressing Procedures for Vertical Tendons**

1. Pick up stressing equipment in a vertical position with a crane (see Fig. 10).
2. Lower to bearing plate and secure with 3/4" stud bolts (see Fig. 2).
3. Turn pull rod until all the threads are made up.
4. Stress using same procedures as one stressing unit follows on the horizontal tendons.
5. Move to next tendon and repeat.

**G. Suggested Casing Filling Procedures for Vertical Tendons:**

Vertical tendons must be filled from the bottom.

1. Locate 2" holes in the tunnel.
2. Follow same procedures as for horizontal filling.

**IV. Tendon Stressing**

- A. Prescon will furnish the following Equipment and Tools necessary for Stressing Tendons.



1. 500-ton hydraulic rams with jack base and pull rods (see Fig. 10).
2. 20 horsepower hydraulic pump and gages (see Fig. 11).
3. Shims (including increments).
4. Filler Caps

B. The Contractor will furnish the following Equipment Tools necessary for Stressing Tendons.

1. Miscellaneous Tools, wrenches, slings
  - a. Crescent wrenches (2)
  - b. Pliers (2)
  - c. Wrecking bars (2)
  - d. Screw drivers (2)
  - e. Vise grip (1)
  - f. Steel tape.
2. Recommended Hydraulic Oils (red or blue color oil - no vegetable base oil)
  - a. Humble's Teresastic 43 or 52
  - b. Texaco's Regal A or B
  - c. Gulf's Harmony 44
  - d. Phillips' Mangus 215 or 315
  - e. Sinclair's Rubiline Light or Duro 200
3. Vent fittings - by Contractor

C. Prescon will furnish the following Technical Assistance for Stressing Tendons:

1. Additional technicians during stressing operation if required by specifications.
2. Procedure Manuals for each crew.

3. Two week's training program to qualify contractor's personnel for technical jobs.
- D. Prasco will furnish detailed Stressing Sequence and Stressing Data Table in accordance with specifications.
- E. Step by Step Stressing Procedures for Horizontal and Dome Tendons:
1. A & B establish telephone communications.
  2. Remove temporary filler caps.
  3. Each end attach overhead crane hook to stressing assembly.
  4. Hang ram (see Fig. 10) in place on 3/4" stud bolts attached to bearing plate at each end.
  5. Screw pull rod into washer at End A and End B. (Be sure a full thread engagement is achieved.)
  6. Attach hydraulic hose from pump (see Fig. 11) to ram (these fittings are free from dirt or other foreign matter.)
  7. Crew foreman gives orders to start stressing.
  8. Build gage pressures up at each end to 1,000 psi and verify elongation at each end.
  9. It is necessary for the pump operators to communicate the elongation each 1/4" and gage pressures each 1,000 psi. They do not have to stop the stressing operation but may just call these measurements off to each other. If one end is elongating faster than the other end, it must slow down and allow the other end to get even.
- Once a tendon pulls farther on one end than the other, it is

very difficult and time consuming to equalize the tendon. Most of the time the tendon has to be relieved and the operation has to be repeated.

11. When regular shims (1-3/4" thick) go into place, verify if gage pressures are in accordance with Stressing Data Table.
12. If shims go in place before required pressures are registered on gages, use increments until proper relationship between elongation and pressure is reached. Increment shims are always placed between 1-3/4" shims and bearing plates.
13. After shimming, release pressures by reversing the valve on the pump and pump the ram down the same as when tendon was being stressed. Stop pump when ram is fully retracted, then move to next tendon.

#### Casing Filler Operation

A. Prascon will furnish the following Equipment necessary for Pumping the Casing Filler:

1. Two (2) Moyno pumps (see Fig. 7).
2. Two (2) reels or baskets to house 200' of 2" hose (see Fig. 8).
3. Two (2) 200' x 2" hose with fittings.
4. Four (4) 25' x 2" or 1-1/2" hose.
5. Two (2) intake hose 25' x 2"?
6. Filler Caps.
7. Filler Plugs.

B. The Contractor will furnish the following Equipment and Materials necessary for pumping the Casing Filler:

1. Handling equipment to move pumps, filler, etc.
2. Storage tanks if desired.
3. All vents for sheathing.
4. Approved Casing Filler.

C. Casing Filling Procedures - step by step

1. Locate pump on ground or the trailer at center of buttress.
2. Hook-up intake hose from tank to pump.
3. The outlet hose has attached, with steel bands, a wire rope cable and a remote control 24 volt electric pump operating cable. The outlet hose is 2" in diameter and approximately 500' long, coiled in a basket, or rolled on a reel.

## EQUIPMENT DESCRIPTION

### UNCOILING TUB

Designed & Manufactured by  
The Prescon Corporation

An Uncoiling Tub (see Fig. 5) is a wheel approximately 8'0" in diameter that stands in a near vertical position. The tub is constructed so that the inside frame rotates to uncoil the tendon while the outside guard rail remains stationary. The tub is designed to allow the tendon to be fed straight down for vertical tendons, right or left for hoop tendons, or up for dome tendons.

The Uncoiling Tub is operated with a variable speed hydraulic motor, driven by a separate power unit. It has a forward and reverse valve which is operator controlled.

The hydraulic pump may be operated with either a 220 or 440 volt electric power.

Sketches, photos and maintenance information may be found on the following pages.

Empty weight - approximately 3,000#.

## MAINTENANCE INSTRUCTIONS

### UNCOILING TUB

The purpose of the Uncoiling Tub ( see Fig. 5) is to feed the tendon into the sheath. The uncoiling tub consists of a revolving tub that is powered by an electrically driven hydraulic motor.

Start-up and maintenance is as follows:

1. Be sure hydraulic hose connections are clean before hooking up power unit.
2. The fittings on gear box and tub rotating arm bearing should be greased every eight (8) hours of operation.
3. Check gear box lubricant every eight (8) hours of operation. If gear lubricant is needed for gear box, use EP-140 or equal as manufactured by Humble, Sinclair, Texaco, Gulf or Phillips.
4. Chain on drive should be snug but not too tight and should be checked daily. Keep chain lubricated with EP-140.

## MAINTENANCE INSTRUCTIONS

### POWER UNIT FOR TENDON PULLER AND UNCOILING TUB

Designed by:  
The Presson Corporation

Built by:  
Womack Machine & Supply Co.

The purpose of this power unit (see Fig. 6) is to supply power for the hydraulic motor on the tendon puller and uncoiling tub. The power unit consists of a 10 hp. electric motor, reservoir assembly, hydraulic pump, and controls.

Start-up and maintenance on this unit is as follows:

1. Shaft alignment between electric motor and hydraulic pump should be checked after pump arrives at jobsite and adjustments made if necessary. Shaft misalignment drastically reduces pump bearing life.
2. Reservoir should be filled with premium grade hydraulic fluid with a viscosity from 225 to 325 SSU at 100°F. Recommended hydraulic oils are as follows: Humble's Teresstic 43 or 52; Texaco's Regal A or B; Gulf's Harmony 44; Phillips' Mangus 215 or 315; Sinclair's Rubiline Light or Duro 200.
3. The fluid level should be maintained so it always shows full in the sight gage which is mounted on the reservoir assembly.
4. During operation, the temperature of oil should not exceed 150°F. Operating above 150°F. will damage the pump and break down the hydraulic fluid. Hydraulic fluid should be changed each 4,000 hours of operation.

5. The electric motor on the power unit is 220 or 440 volts, 3 phase. If unsure about electrical source, consult an electrician.
6. Jog the motor to check rotation. These motors are bi-directional and proper rotation as noted by arrow on hydraulic pump can be established by reversing any two power leads. Improper rotation of the pumps will cause cavitation which will damage pumps.
7. Check pressure with Reddy-Chek gage and adaptor and set relief valve to pressure designated by Prescon representative only. Pressure should be checked weekly.
8. At least once a year, or every 2,000 hours of operation, the oil tank should be drained, cleaned and filled with new oil.



## EQUIPMENT DESCRIPTION

### TENDON PULLER

Designed & Manufactured by  
The Prescon Corporation

A Tendon Puller (see Fig. 6) is a winch mounted on a frame which is approximately six feet (6') long. This equipment is designed to hang to bearing plates by 3/4" stud bolts.

The tendon puller is a hydraulic operated unit with an electrically driven hydraulic pump. It operates on 220 or 440 volts, 3 phase. It has a variable control valve which operates the winch in either direction, forward or reverse.

The winch has a 5/16" wire rope (175' long) attached.

Sketches, photos and maintenance information may be found on the following pages.

Approximate weight - 250#.

## MAINTENANCE INSTRUCTIONS

### TENDON PULLER

The purpose of the Tendon Puller is to pull the tendon through the sheathing and to slide the tendon in the sheathing for equalizing it for the stressing operation.

The tendon puller consists of a steel frame assembled with construction welds, and a winch that is driven by a hydraulic motor. The tendon puller has a base mounting that has two hooks that will fasten onto the two 3/4" studs that will be placed in the 3/4" holes in the bearing plate. These studs will also be used to support the stressing equipment.

The winch used in the tendon puller has a gear ratio of 36 to 1. This winch has a virtually indestructible cable drum fabricated from seamless steel tubing and stamped steel flanges. The drum may be free-spooled by means of a forged steel clutch.

Dependability is built into the winch. Its gear system consists of a steel worm mated with a bronze ring gear mounted on a forged steel spider, running on bronze bearings and on Timken thrust bearings. The shafting, worm gear, and run shafts are made of stressed-relieved, ground and polished stressproof steel. The winch has a pulling capacity of 8,000#. The pulling speed of the winch is 25 feet per 1,000 P.M. of input from the first layer of the cable on the drum.

The motor that powers the winch is a Char-Lynn type AS hydraulic motor. The hydraulic motor is operated at a pressure of 1400 psi. This motor is driven by a hydraulic pump. The pump of this unit will displace 12 GPM. With this pressure and displacement, the motor will run at a speed of 1155 RPM with a torque of 635 psi. Torque is normally given in feet - pounds.

The speed of the hydraulic motor is controlled by a manually operated variable control valve. This valve will allow the motor to be driven from 0 to 1155 RPM. The high starting torque and the ease at which the speed of the motor can be regulated makes a hydraulic motor an ideal source of power for this operation.

The winch has 175 feet of cable on its spool. This cable is 5/16-6 x 37 DD IWRC.

The tendon puller requires a minimum amount of maintenance.

1. There are two (2) Zirk grease fittings, one on each end of the spool bearing, that should be greased each day.
2. There is no need to check the gear lubricant in the gear box unless a leak is showing up on the outside. If a leak is visible, and if this leak is around a housing bolt, the bolt can be removed and the thread below the head of the bolt can be wrapped with teflon tape and replace the bolt. If any gear lubricant must be replaced, EP140 should be used.
3. There is no field maintenance necessary to be performed on the Char-Lynn hydraulic motor.
4. If hose fittings are broken down, it is good practice to wipe off the Pioneer Hydraulic Quick Coupler before making up the hose again. The greatest damage that can be done to a hydraulic system is to get foreign matter in the system.
5. Judgement must be used as to when cable must be replaced. Experience has shown that no two cables will wear alike.

## EQUIPMENT DESCRIPTION

### HEADING MACHINE

Designed & Manufactured by  
The Prescon Corporation

These machines (see Fig. 9) are hydraulically operated, designed to cold-form buttonheads on the ends of the wires. The machine is portable and can be adjusted to accept wire and form buttonheads at the various different orientations of the tendons.

The heading machine will actually be in two parts - the power unit, which will also be used for stressing, and the actual heading machine. The machine will be adapted so it can sit on a cart and be mobile or it can be hung from a hoist. In the stressing tunnel for the bottom vertical tendon anchors, the cart will have both a swivel base that will rotate  $360^{\circ}$  and the vertical base which will travel up to  $90^{\circ}$  in a vertical position. This will enable the operator to make either or both adjustments to make buttonheading more convenient.

The operator feeds one wire at a time into holding jaws while the heading die forms the head on the wire.

Approximate weight - 1,600#.

## MAINTENANCE INSTRUCTIONS

### HEADING MACHINE

The purpose of the heading machine (see Fig. 9) is to form spherical buttonheads on the ends of the prestress wire. The heading machine consists of a hydraulic pumping unit, clamping ram and heading ram.

Start-up and maintenance on this machine is as follows:

1. Check reservoir on power unit to be sure it is filled with hydraulic fluid. The type of oil should have a viscosity of 155 SSU at 100°F. For extreme cold weather operations, a lighter weight of oil should be used. Recommended hydraulic oils are: Humble's Teresstic 43 or 52; Texaco's Ragal A or B; Gulf's Harmony 44; Phillips' Mangus 215 or 315; Sinclair's Rubiline Light or Duro 200.
2. The electric motor for the unit is 220 or 440 volt, 3 phase. As a warning, be sure that correct heaters and starter coils are installed in the starter relay. If unsure about electrical source, consult an electrician.
3. When starting up the electric motor, be sure that it turns in the same direction as indicated on the hydraulic pump by an arrow. If it turns in the wrong direction, stop the motor immediately and change the position of any two lead wires in the plug or starter box.
4. Noise: pump "crackle" is due to lack of oil in the pump or air in the lines. Always keep the oil level at its proper height as indicated by a sight gage on the reservoir or it should be

within 2" to 3" from the top of the tank. Lack of oil also causes condensation and rust in the system.

5. The temperature of the oil should not exceed 150° F. during operation.
6. At least once a year, or every 2000 hours of operation, the oil tank should be drained, cleaned and filled with new oil.
7. Clamping jaws and heading ram should be checked for alignment in accordance with Quality Control Procedures. Short pieces of wire will be furnished by Prescon for this purpose.
8. Dies should be cleaned after each 90 wire tendon is headed. This can be done by using a pointed instrument such as an ice pick.
9. Grease fittings on clamping arms should be lightly greased after every 8 hours of operation.
10. Any adjustments to be made should be done by or at the direction of a Prescon man.
11. Heading dies may be expected to last 500 working hours.
12. Clamping jaws may be expected to last a year or more.
13. Prescon Field Supervisor will recommend and do any adjusting of the heading machine. He will check equipment daily.

## EQUIPMENT DESCRIPTION

### SHEATHING FILLER PUMP

Assembled by:  
The Prescon Corporation.

The Sheathing Filler Pump (see Fig. 7) is a Moyno pump equipped with an electrically driven, variable speed hydraulic motor. This driving motor can be controlled by remote control during the pumping of the casing filler.

The pump may be hooked directly to the sheathing filler source, be it storage tank, tank truck or 55 gallon drum. The pump will draw the filler directly from the sheathing filler source. The contractor may direct the method he chooses to feed the pump (see Fig. 8).

Prescon recommends receiving filler material in truck transport. Pumping directly from tank trucks or having a storage tank at the jobsite to store the material in is a much cleaner operation than drums and is more economical.

## MAINTENANCE INSTRUCTIONS

### SHEATHING FILLER PUMP

The purpose of this pump (see Fig. 7) is to pump sheathing filler into the sheathing after the tendon has been stressed. It consists of a Moyno type pump, capable of pumping 20 gallons per minute, and driven by a hydraulic motor. The power supply for the hydraulic motor will come from a pumping unit that displaces 12 GPM at 1400 psi.

Start up and maintenance is as follows:

1. Hose connections should be cleaned and one end connected to the hydraulic motor.
2. Attach one end of intake hose to pump and the other end to the storage tank or tank transport.
3. Start pump in a forward direction.
4. The pump will be equipped with a 24 volt remote control system so the man on the scaffold can operate the pump that is located on the ground if so desired.



## EQUIPMENT DESCRIPTION

### STRESSING EQUIPMENT

One unit of stressing equipment (see Fig. 9) consists of a 500-ton ram, jack base (which is bolted onto the ram), a pull rod, a nut, two (2) hydraulic hoses, and a hydraulic pump with 220-440 volts electric power.

The jack base is designed to rotate with ease by inserting a rod into one of the eight holes in the base and turning it. This will simplify the dome stressing operation which requires many orientations for the jack base. The pump is equipped with a valve assembly which has two (2) Pioneer quick couplers. One will have a gage which has been calibrated with the specific ram that it is used with.

The Prescon representative at the job site will have a master gage for each set of equipment, along with a spare gage that has been calibrated with the specific ram. The Prescon representative will test the accuracy of the gage being used daily by connecting the master gage to the second Pioneer quick coupler and stress a tendon with the master gage attached. If the gages differ more than 5%, the spare gage will be put on the machine and the inaccurate one will be returned to the plant for recalibration. The master gage should be handled and protected as a watch. Do not drop or abuse.

## MAINTENANCE INSTRUCTIONS

### STRESSING UNIT

The purpose of the stressing equipment (see Fig. 9) is to put a predetermined amount of stress on a tendon. The stressing equipment consists of a hydraulic pump unit, a 500 ton ram, jack base, pull rod, and a nut.

Start up and maintenance is as follows:

1. Voltage is 220 or 440, 3 phase. Be sure electrical supply is of the correct voltage and that the motors are properly phased.
2. Check oil level in reservoir. It should be in upper half of sight gage.
3. Couple hoses to ram as marked or per Prescon Personnel's instructions. Be sure that quick couplers are free of dust and other foreign material before attaching hoses to units. Also be sure that quick couplers are completely engaged.
4. Jog pump motor until you are satisfied that it is turning in the correct direction as indicated by the arrow on the pump.
5. With pump running, move four-way valve handle to the left and depress jog button. This will make the ram extend. Moving handle to the right will cause it to retract.
6. All trouble-shooting or adjusting of Prescon's equipment will be done by a Prescon representative or under his strict supervision. There should be no major maintenance required since the equipment is new. Also, we have tested the prototype in excess of 60,000 cycles without a maintenance problem.

February 22, 1972

Gilbert Associates, Inc.  
Post Office Box 1498  
Reading, Pennsylvania 19603

Attention: Mr. D. A. Skilton

Reference: Crystal River Unit 3-  
Containment Vessel  
Post Tension System

Dear Mr. Skilton:

This is to answer your letter of September 8, 1971, concerning revision number three (3) to our Quality Control Manual. Our comments, corrections and explanations are itemized as per your letter.

2. The hardness test number 41 has been added to this form. For parallelism of the faces compare check number 40, Sizing Check. As these washers are faced off in the lathe - not sawn from a bar - the parallelism needs not to be measured with a precision gauge. All our buttonhead test were done on washers with straight drill holes that were not countersunk. Therefore, countersinking does not apply. Since the washer is drilled from both sides, there is no burr to be removed. Since the washer is externally threaded, the thread check will assure the correct diameter dimension.

As to the frequency of checking of the wire holes we content that you get a 100% check as required by the specifications by requiring a 100% check by the operator and a 10% random check by the Quality Control Inspector.

3. See item 2

- 4. a. Refer to new page 2.2-33
- b. Correct
- c. Refer to comment number 2.

5. Page 2.2-45 has been changed to show a 100% check for splits. Any malformations or defects that are not detrimental to the diameter, eccentricity or crack criteria will not be considered cause for rejections.

6. Refer to page 2.3-10.

Continued

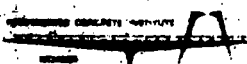

CONCEPT TOTAL SERVICE

9. Refer to page 2.3-24.
10. Has been corrected accordingly
14. Has been corrected accordingly
18. The only standards on this test is the new DIN (German Industrial Standards). As we cannot get any other parts for the hand tester, but standardized ones, we had to adjust the requirements accordingly.
25. Corrected accordingly
26. Refer to Item 2
30. Refer to Item 5
31. The template is built according to the principle shown on page 2.3-18, but it is constructed stronger and heavier than shown.
- A. Refer to Procedures for Wire Cutting
- B. The stud holes in the washers serve the only purpose to attach a keeper plate to the shop installed washer before coiling. As this is done in our plant, we can not see the need of plug gages for checking. There will not be a need for these holes on the site.

We resubmit hereby the following pages:

2.2-30	2.3-16
2.2-31	2.3-24
2.2-32	2.3-37
2.2-45	4.5-1
2.3-4	2.2-1
2.3-10	2.2-41

The following pages are considered approved:

2.2-20	4.4-2
2.3-6	4.4-3
2.3-8	4.4-4
2.3-19	2.2-4
2.3-20	2.2-18
2.3-21	2.2-36
2.3-25	2.2-46
2.3-29	2.2-47
2.3-48	2.2-48
3.3-1	2.2-49
4.4-1	2.2-50

Att: Mr. D. A. Skelton  
Ref: Crystal River Unit 3

Page Three  
February 22, 1972

In addition, we submit hereby the following revised pages for your approval:

2.2-32	2.3-30
2.2-33	2.3-31
2.2-38	2.3-32
2.2-46	2.4-9
2.2-47	3.5-1
2.2-48	3.6-1
2.2-49	3.8-1
2.2-50	4.6-1
2.3-12	5.1-1
2.3-19	5.2-3
	5.2-4

All pages submitted or resubmitted herewith, are marked for revision 4.

Yours very truly,

THE PRESCON CORPORATION

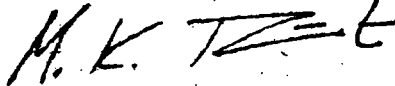

Mark K. Rust  
Project Engineer  
Eastern Division

MKR/ph

cc: Mr. Harry Koch  
Mr. E. R. Hottenstein  
Mr. W. S. O'Brian  
Mr. Jim Duren  
Ms. Tad Bickley