



Westinghouse Electric Company  
Nuclear Power Plants  
P.O. Box 355  
Pittsburgh, Pennsylvania 15230-0355  
USA

U.S. Nuclear Regulatory Commission  
ATTENTION: Document Control Desk  
Washington, D.C. 20555

Direct tel: 412-374-2035  
Direct fax: 724-940-8505  
e-mail: ziesinrf@westinghouse.com

Your ref: Docket Number 52-006  
Our ref: DCP\_NRC\_003015

September 29, 2010

**Subject: Supplementary Information on Proposed Changes for the AP1000 Design Control Document Rev. 18**

This letter is submitted in support of the AP1000 Design Certification Amendment Application (Docket No. 52-006). The information provided is generic and is expected to apply to all Combined License (COL) applicants referencing the AP1000 Design Certification and the AP1000 Design Certification Amendment Application.

Westinghouse provided preliminary information on changes which it proposed to include in Revision 18 of the AP1000 Design Control Document (DCD-18) in a January 20, 2010 letter (Reference 1). Supplementary information on some of those changes requested by the NRC was provided in a March 12, 2010 letter (Reference 2). Information was provided in an April 26, 2010 letter (Reference 3) for seven of the changes identified in the January 20, 2010 that were determined to meet one or more of the Interim Staff Guidance-11 (ISG-11) criteria for reporting to the NRC staff. The remaining 50 "elective" items in the January 20 letter are addressed in a letter dated May 21, 2010 (Reference 4). In a letter dated May 10, 2010 (Reference 5), information was provided for seven design changes that met one or more of the ISG-11 criteria and which supported the AP1000 Licensing Finalization schedule. In a letter dated May 25, 2010 (Reference 6), information was provided for two additional design changes that met one or more of the ISG-11 criteria and which supported the AP1000 Licensing Finalization schedule. In letters dated June 14, 2010 (Reference 7), June 18, 2010 (Reference 8), July 6, 2010 (Reference 9), July 8, 2010 (Reference 10), July 28, 2010 (Reference 11) July 29, 2010 (Reference 12), August 12, 2010, (Reference 13), and August 16 (Reference 14) information was provided for additional design changes. Supplementary information for Reference 11 was provided in References 15 and 19. Supplementary information for CN62 (initial information provided in Reference 5) was provided in Reference 16. Supplementary information for CN05 (initial information provided in Reference 3) was provided in Reference 17. Supplementary information for Reference 12 was provided in Reference 18.

This letter provides supplementary information on the design change (Change Number 74) which addresses improvements to the design for containment external pressure. Information on CN74 was initially provided in Reference 14. The supplementary information, which consists of responses to comments provided by the NRC at various times, is provided in Enclosures 1 - 3. For those responses which are still under review, the final response will be provided later. This is noted in the comment/response matrix. In those cases where resolution of the comment required changes to NRC Review Package pages, those revised report pages are provided in Enclosure 4. Enclosure 5 contains information on the Vacuum Relief System flow path which was requested by Enclosure 3 Comment 31.

DO63  
NRC

In those cases where resolution of the comment required changes to DCD pages, those revised DCD pages are provided in Enclosure 6.

As noted previously, the changes described in this and the referenced letters do not constitute all of the changes which Westinghouse proposes to include in DCD-18. Rather, the changes in this letter are in addition to those which Westinghouse either has submitted or will submit to the NRC as responses to Requests for Additional Information or Safety Evaluation Report Open Items.

Westinghouse will work with the NRC staff to disposition the changes described in this letter as expeditiously as possible. Questions related to the content of this letter should be directed to Westinghouse. Please send copies of such questions to the prospective COL applicants referencing the AP1000 Design Certification. A representative for each applicant is included on the cc: list of this letter.

Very truly yours,

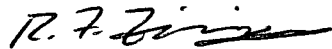

R. F. Ziesing  
Director, U.S. Licensing

References:

1. DCP\_NRC\_002744, Re-submittal of Proposed Changes for AP1000 Design Control Document Rev.18, January 20, 2010
2. DCP\_NRC\_002818, Supplementary Information to DCP\_NRC\_002744 – Re-Submittal of Proposed Changes for AP1000 Design Control Document Rev.18, March 12, 2010
3. DCP\_NRC\_002850, Final Information on Proposed Changes for the AP1000 Design Control Document Rev. 18, April 26, 2010
4. DCP\_NRC\_002874, Final Information on Proposed Changes for the AP1000 Design Control Document Rev. 18, May 21, 2010
5. DCP\_NRC\_002863, Information on Proposed Changes for the AP1000 Design Control Document Rev. 18, May 10, 2010
6. DCP\_NRC\_002879, Information on Proposed Changes for the AP1000 Design Control Document Rev. 18, May 25, 2010
7. DCP\_NRC\_002909, Information on Proposed Changes for the AP1000 Design Control Document Rev. 18, June 14, 2010
8. DCP\_NRC\_002918, Information on Proposed Changes for the AP1000 Design Control Document Rev. 18, June 18, 2010
9. DCP\_NRC\_002925, Information on Proposed Changes for the AP1000 Design Control Document Rev. 18, July 6, 2010
10. DCP\_NRC\_002932, Information on Proposed Changes for the AP1000 Design Control Document Rev. 18, July 8, 2010
11. DCP\_NRC\_002939, Information on Proposed Changes for the AP1000 Design Control Document Rev. 18, July 28, 2010
12. DCP\_NRC\_002940, Information on Proposed Changes for the AP1000 Design Control Document Rev. 18, July 29, 2010

13. DCP\_NRC\_002942, Information on Proposed Changes for the AP1000 Design Control Document Rev. 18, August 12, 2010
14. DCP\_NRC\_002941, Information on Proposed Changes for the AP1000 Design Control Document Rev. 18, August 16, 2010
15. DCP\_NRC\_003014, Supplementary Information on Proposed Changes for the AP1000 Design Control Document Rev. 18, September 3, 2010
16. DCP\_NRC\_003033, Supplementary Information on Proposed Changes for the AP1000 Design Control Document Rev. 18, September 9, 2010
17. DCP\_NRC\_003036, Supplementary Information on Proposed Changes for the AP1000 Design Control Document Rev. 18, September 16, 2010
18. DCP\_NRC\_003035, Supplementary Information on Proposed Changes for the AP1000 Design Control Document Rev. 18, September 22, 2010
19. DCP\_NRC\_003048, Supplementary Information on Proposed Changes for the AP1000 Design Control Document Rev. 18, September 29, 2010

## /Enclosures

1. Supplementary Information for CN74, AP1000 Containment Vessel External Pressure Analysis and Design Information for Change Number 74, Responses to 20 NRC Comments Plus 5 Additional Changes, Non-Proprietary
2. Supplementary Information for CN74, AP1000 Containment Vessel External Pressure Analysis and Design Information for Change Number 74, Responses to 4 Comments, Non-Proprietary
3. Supplementary Information for CN74, AP1000 Containment Vessel External Pressure Analysis and Design Information for Change Number 74, Responses to 47 Comments, Non-Proprietary
4. Supplementary Information for CN74, AP1000 Containment Vessel External Pressure Analysis and Design Information for Change Number 74, Revised Pages for NRC Review Package, Non-Proprietary
5. Supplementary Information for CN74, AP1000 Containment Vessel External Pressure Analysis and Design Information for Change Number 74, Vacuum Relief System Flow Path Description, Non-Proprietary
6. Supplementary Information for CN74, AP1000 Containment Vessel External Pressure Analysis and Design Information for Change Number 74, Revised DCD Pages, Non-Proprietary

cc: B. Anderson - U.S. NRC 6E  
 D. Jaffe - U.S. NRC 6E  
 E. McKenna - U.S. NRC 6E  
 T. Spink - TVA 6E  
 P. Hastings - Duke Energy 6E  
 R. Kitchen - Progress Energy 6E  
 A. Monroe - SCANA 6E  
 P. Jacobs - Florida Power & Light 6E  
 C. Pierce - Southern Company 6E  
 E. Schmiech - Westinghouse 6E  
 G. Zinke - NuStart/Entergy 6E  
 R. Grumbir - NuStart 6E  
 M. Melton - Westinghouse 6E

ENCLOSURE 1

Supplementary Information for CN74  
AP1000 Containment Vessel External Pressure Analysis and Design Information for Change Number 74  
Responses to 20 Comments Plus 5 Additional Changes  
Non-Proprietary

The table provides information on the changes to DCP\_NRC\_002941 identified by the NRC and information on changes to DCP\_NRC\_002941 that were identified independently.

WESTINGHOUSE NON-PROPRIETARY CLASS 3

Changes to DCP\_NRC\_002941 based on NRC comments.

	DCD Reference	NRC Comment	Westinghouse Response
1	Tier 2, Chapter 6 Section 6.2.3.5	Page 3/97 response description, item 1, should be added to AP1000, FSAR, Tier 2, 6.2.3.5, new 4 <sup>th</sup> paragraph, on page 40/97 – Please comment.	<b>Incorporated:</b> A new 4 <sup>th</sup> paragraph has been added to Tier 2, Section 6.2.3.5.
2	Tier 1, Chapter 2 Table 2.2.1-3	AP1000 FSAR, Tier 1, T2.2.1-3, should indicate VFS-PL-V800A, -V800B close in ≤30 seconds – Please comment.	<b>Incorporated:</b> Valves VFS-PL-V800A, -V800B added to Tier 1, T2.2.1-3 (Item 7) with closure time of ≤ 30 seconds.
3	Tier 2, Chapter 9 Section 9.4.7.2.1 Tier 2, Chapter 6 Section 6.2.3.2.1	As a follow-up to the 12 Aug 2010 telecon - proposed write-up for 9.4.7.2.1, 2 <sup>nd</sup> and 3 <sup>rd</sup> paragraphs should describe how the new 6" MOV closure times are consistent with the assumptions and criteria for the ECCS analysis (reflood backpressure) assumptions in the DCD Ch 15. In other words, the 12 sec. closure of the two 16" VFS valves bounds the 30 sec. closure of the two new 6" vacuum relief valves. This is to fully address the new vacuum relief design change compliance with SRP 6.2.4, CSB BTP 6-4.	<b>Incorporated:</b> Text added to paragraph 3 of DCD Section 9.4.7.2.1. Text added to paragraph 6 DCD Section 6.2.3.2.1 with a pointer to Section 9.4.7.
4	Tier 2, Chapter 9 Figure 9.4.7-1	NRC – In package sent, will WEC address how we Type C containment leak test the vacuum relief check valves?	<b>No Change Required:</b> Tier 2, Figure 9.4.7-1 (Sheet 1) of CN74 (DCP_NRC_002941) includes Note 11 indicating temporary spool pieces or blind flanges with test connections may be used for leakage testing.
5	Tier 2, Chapter 16 TS B3.6.10	TS Bases B 3.6.10 contain several bracketed numerical values, e.g., [-0.8] psig, [-1.47] psig. Are they meant to be COL information items?	<b>Response to be provided later.</b>
6	Tier 2, Chapter 16 TS B3.6.10 Tier 2, Chapter 6 Table 6.2.1.1-3	DCD Section 6.2 is listed as Reference 1 in TS Bases B 3.6.10. Information provided in the TS Bases such as "[-1.47] psig" cannot be found in DCD Section 6.2. Either the reference needs to be updated or the reference changed.	<b>Response to be provided later.</b>
7	Tier 2, Chapter 6 Table 6.2.1.1-9	Demonstrate that a numerical value used in the TS (e.g., [-0.8] psig) is more conservative than the assumed value in the safety analysis (i.e. takes into account component uncertainty, etc).	<b>Response to be provided later.</b>
8	Tier 2, Chapter 16 TS 3.6.10	Completion Time for TS 3.6.10 Required Action B.3.2 should be "once per 12 hours" - more frequent than SR 3.6.10.2.	<b>Response to be provided later.</b>
9	Tier 2, Chapter 16 TS 3.6.10	NRC – TS 3.6.10 Condition C – Do not indent "AND".	<b>Response to be provided later.</b>
10	Tier 2, Chapter 16 TS 3.6.10	NRC – In Bases 3.6.10, can WEC list Section 9.4.7 in References?	<b>Response to be provided later.</b>
11	Tier 2, Chapter 16 TS 3.6.10	NRC – In Applicability Section of Bases 3.6.10, first paragraph, second sentence. Add more information. Need information as to why assumption was conservative.	<b>Response to be provided later.</b>

WESTINGHOUSE NON-PROPRIETARY CLASS 3

	<b>DCD Reference</b>	<b>NRC Comment</b>	<b>Westinghouse Response</b>
12	Tier 2, Chapter 6 Figure 6.2.1.1-11	NRC – Figure 6.2.1.1-11 on vacuum relief, vertical axis should be “pressure” instead of “temperature”	Response to be provided later.
13	Tier 2, Chapter 16 TS 3.6.10	NRC staff requests the inclusion in TS 3.6.10 and the associated bases, a surveillance requirement (SR) to test the interlock feature between the Vacuum Relief Valves and the Containment Purge Discharge Isolation Valve (VFS-PL-V009) to ensure operability of the shared containment penetration is not affected by operation (surveillance testing included) of these Vacuum Relief Valves.	Response to be provided later.
14	Tier 2, Chapter 16 TS 3.3.2	TS 3.3.2, Actions CC.1, CC.2 and CC.3: The logical connectors “AND” should not be indented.	Response to be provided later.

WESTINGHOUSE NON-PROPRIETARY CLASS 3

	DCD Reference	NRC Comment	Westinghouse Response
15	Tier 2, Chapter 16 TS 3.3.2	TS Bases B 3.3.2, ACTIONS CC.1, CC.2, and CC.3: The discussion on Action CC.3 appears to indicate the plant operators will have 44 hours to open either an equipment hatch or both doors of an airlock, when the plant reaches Mode 5 or 6, to provide the required vacuum relief path, versus only 8 hours of the total 44 hours from the start of a plant controlled shutdown. Revise TS and Bases, as appropriate, to reflect a realistic time duration to establish an open flow path.	Response to be provided later.
16	Tier 2, Chapter 16 TS 3.6.4	TS Bases B 3.6.4, ASA, 3 <sup>rd</sup> paragraph: "1.7 psig" should be "1.7 psid" to be consistent with DCD 3.8.2.1.1.	Response to be provided later.
17	Tier 2, Chapter 16 TS 3.6.10	TS 3.6.10, Completion time for Action B.3.2: Similar text as provided for Action A.2.2 should be used.	Response to be provided later.
18	Tier 2, Chapter 16 TS 3.6.10	TS 3.6.10, Action B.3.3: "Restore vacuum relief flow path to OPERABLE status" should be "Restore temperature differential to OPERABLE range".	Response to be provided later.
19	Tier 2, Chapter 16 TS 3.6.10	TS Bases B 3.6.10, ACTIONS B.1, B.2, B.3.1, B.3.2, and B.3.3: Add "Once opened," at the beginning of 4 <sup>th</sup> paragraph. Also, revise 5 <sup>th</sup> paragraph to reflect restoring temperature versus relief flow path to operable status.	Response to be provided later.
20	Tier 2, Chapter 16 TS 3.6.10	TS Bases B 3.6.10, ACTIONS C.1, C.2, and C.3: Same comment as in Item 15 above.	Response to be provided later.

WESTINGHOUSE NON-PROPRIETARY CLASS 3

**Additional Changes to DCP\_NRC\_002941.**

	DCD Reference	Title	Reason for Change
			Tier 2
21	Appendix 1A	Conformance with Regulatory Guides -- RG 1.68, Initial Test Program for Water-Cooled Nuclear Power Plants, App. A.1.i	<b>Incorporated:</b> The change in-effect creates a vacuum breaker. Therefore, the first bullet under Clarification/Summary Description of Exceptions is deleted.
22	Chapter 16 SR 3.6.4.1	Containment Pressure Surveillance Requirement	<b>Response to be provided later.</b>
23	Chapter 16 SR 3.6.10.1	Vacuum Relief Valves Surveillance Requirement	<b>Response to be provided later.</b>
24	Chapter 16 B SR 3.6.10.1	Vacuum Relief Valves Bases Surveillance Requirements	<b>Response to be provided later.</b>
25	Chapter 16 B SR 3.6.10.2	Vacuum Relief Valves Bases Surveillance Requirements	<b>Response to be provided later.</b>



ENCLOSURE 2

Supplementary Information for CN74  
AP1000 Containment Vessel External Pressure Analysis and Design Information for Change Number 74  
Responses to 4 Comments  
Non-Proprietary

	DCD Reference	NRC Comment	Westinghouse Response
1	DCP_NRC_002941 Section 5	In the section of "Valve Modeling" in Containment Vessel External Pressure Analysis, it says that "a 20 second delay from setpoint being reached to valve actuation was assumed." However, the new functional diagram Figure 7.2-1 (sheet 19 of 21) does not appear to show this time delay for the Low-2 Containment Pressure variable. Please provide clarifications.	<b>Incorporated:</b> The 20 second time delay discussed is not an intentional time delay. This is the time assumed in the analysis to achieve full flow thru the MOV. The stoke time of the valve is 30 seconds. Full flow thru the valve occurs at 60% open (18 seconds). The time for processing the actuation signal through the Protection and Safety Monitoring System (PMS) is less than 1 second. However, 2 seconds was conservatively used in the analysis (consistent with the containment high pressure signal). Therefore the total time to achieve full flow through the MOV is assumed to be 20 seconds (18 seconds + 2 seconds). This is conservative for the analysis as no credit is taken for vacuum relief as the valve is opening.
2	Chapter 7 Section 7.7.1.11	In Table 7.2-5, WEC assigned Figure 7.2-1 (sheet 19 of 21) to the new functional diagram and revised the original Sheet 19 and 20 as Sheet 20 and 21, respectively. However, the corresponding changes do not appear to be in DCD Section 7.7.1.11 and CN #8.	<b>Incorporated:</b> The Subject of DCD Section 7.7.1.11 is the Diverse Actuation System (DAS). The logic to actuate the new containment vacuum relief function is performed in the PMS, not DAS. The new figure is being added after the existing Figure 7.2-1 (Sheet 18 of 20) because it is currently the last sheet related to the PMS. The current Sheets 19 and 20 of 20, which are related to the DAS, will become Sheets 20 and 21 of 21 as a consequence. This will be reflected in DCD Section 7.7.1.11.
3	Chapter 6 Table 6.2.3-1	The new Note 8 was created for Table 6.2.3-1, but was not referred to in the table.	<b>No Change Required:</b> Table 6.2.3-1 (Sheet 3 of 4) lists Note 8 in the "Signal" column of the VFS system.
4	Chapter 9 Section 9.4.7.1.1	The 1st and 2nd sentences in the new 2nd paragraph in DCD Section 9.4.7.1.1 could be deleted since they are covered in the 1st paragraph in the same DCD Section 9.4.7.1.1.	<b>Incorporated:</b> The new second paragraph in DCD Section 9.4.7.1.1 will be deleted in its entirety.

ENCLOSURE 3

Supplementary Information for CN74  
AP1000 Containment Vessel External Pressure Analysis and Design Information for Change Number 74  
Responses to 47 Comments  
Non-Proprietary

WESTINGHOUSE NON-PROPRIETARY CLASS 3

	DCD Reference	NRC Comment	Westinghouse Response
<b>Comments received via email dated Monday, August 23, 2010</b>			
1	Tier 2, Chapter 17 and 19	<p><b>Page 13</b></p> <p>During an audit at (W) headquarters, the staff confirmed that issues identified as Items 5b, 5c, and 5d in Table 3, "Proposed DCD Changes and Justification Table," have been adequately addressed. The staff cannot yet make the same determination with respect to Item 5a.</p>	<p><b>No change required:</b> Per the sensitivity assessment provided August 31<sup>st</sup> 2010 of the loss of containment isolation due to the vacuum relief DCP, it has been concluded that equipment added due to DCP-1958 is not risk significant therefore it should <u>not</u> be included into the scope of D-RAP or required diverse actuation from DAS.</p> <p>Equipment is included in the D-RAP program if equipment was identified as being risk significant (by RAW values or by inclusion by the expert panel). Since the PRA evaluation judged this DCP to not be risk significant it is judged that VFS-800A/B and VFS-803A/B should not be added to the D-RAP program.</p> <p>It is also felt that the equipment added due to DCP-1958 would not be judged to be risk significant for the following reasons.</p> <ul style="list-style-type: none"> <li>• The new motor operated vacuum relief valves (outside containment, VFS 800A/B) are closed at <u>all</u> times except 1) to relieve a postulated vacuum event and 2) for testing to verify their OPERABILITY.</li> <li>• The position of the valves is monitored and an alarm is provided to the control room operators at any time the valves are open.</li> <li>• There will be an automatic confirmatory interlock included that will close the valves at any time that the containment purge isolation valve inside containment (VFS-009) is open even though they should be closed anyway.</li> </ul> <p>The vacuum relief function that opens the MOVs is actuated through the PMS from the identical containment pressure channels (PCS-PT-005,6,7,8) that actuate containment isolation to close the valves. Therefore, if containment pressure is increasing (necessary before anything is going to be released from containment) it cannot also be low to cause the MOV's to open.</p>

WESTINGHOUSE NON-PROPRIETARY CLASS 3

	DCD Reference	NRC Comment	Westinghouse Response
2	Tier 2, Chapter 19 Table 19.55-1, 2	<p><b>Chapter 19:</b> The staff expects that VFS-800A/B and -803A/B, as seismic Category I valves, would appear in <b>Table 19.55-1</b> of <b>Section 19.55</b> of the DCD. Also, unless new basic events are added to <b>Table 19.55-2</b>, the absence of basic events involving these valves that are similar to those for failure of VFS-003 &amp; -004 (EQ-VFS-AOV-0304) and VFS-009 &amp; VFS-010 (EQ-VFS-AOV-0910) should be justified.</p>	<p><b>Incorporated:</b> The addition of four additional safety-related VFS valves (800A/B and 803A/B) as per DCP-1958 does not have any significant impact on the current AP1000 SMA. Because of the scope of the SMA analysis, cutsets are generated from the PRA based model to evaluate the overall HCLPF value of the plant. This is done by evaluating the HCLPF value for each cutset and then selecting the lower cutset HCLPF value as the overall plant HCLPF value. The HCLPF value for a selected cutset is defined as the higher HCLPF value among all the basic event contributing to the cutset. The AP1000 SMA model already includes a basic event for the VFS discharge valves (EQ-VFS-AOV-0910) and the four newly added valves are at an elevation consistent with the pre-existing valves (i.e., higher than elevation 100'), thus would not change the HCLPF value associated to the basic event. Because of the above, the four new valves are added in the SMA analysis by simply including them in the existing basic event EQ-VFS-AOV-0910). Table 19.55-2 is updated with the following description associated to BE EQ-VFS-AOV-0910: <i>"VFS Containment Air Exhaust Isolation Valves Fail (009, 010, 800A/B and 803A/B)"</i></p>
3	Tier 2, Chapter 19 Table 19.59-18	<p><b>Chapter 19:</b> In a letter (DCPNRC_002833) dated March 23, 2010, Westinghouse states that containment isolation valves were identified for control from DAS on the basis of the risk significance of each isolation valve. It is because of that risk significance that particular CIVs are within the scope of RAP—not because they are controlled from DAS. This clarification was appropriate, because the NRC staff had requested information in a way that implied a reversal of this cause and its effect.</p> <p>Now the same implication is made in the applicant's Item 5a of Table 3. (The staff concludes that <b>Item 39 in DCD Table 19.59-18</b> may be misleading and should be revised.)</p>	<p><b>Incorporated:</b> Equipment is included in the D-RAP program if equipment was identified as being risk significant (by RAW values or by inclusion by the expert panel). Equipment was identified as requiring DAS auction if the equipment was also identified as being risk significant. For this reason the PRA documentation commonly refers to the risk significant CIVs as ones that have DAS control as a means of describing the valves in the group, not as a means of describing how the valves were selected for D-RAP.</p> <p>A note will be added into Item 39 of Table 19.59-18 to clarify that CIVs were included into D-RAP if they were identified as being risk significant.</p>
4	Tier 2, Chapter 19 Table 19.59-18	<p><b>Chapter 19:</b> Other important insights related to the function of VFS may require an <b>additional entry in Table 19.59-18</b>.</p>	<p><b>Incorporated:</b> An insight (#86) will be added into Table 19.59-18 to identify that containment relief function is important for the integrity of the containment</p>

WESTINGHOUSE NON-PROPRIETARY CLASS 3

	DCD Reference	NRC Comment	Westinghouse Response
5	Tier 2, Chapter 17	<p><b>Chapter 17:</b>                      Since the determination that CIVs are to be within the scope of RAP is based on risk importance measures for both CDF and LRF (RAW <math>\geq 2</math> and F-V <math>\geq 0.005</math>) and <b>not</b> whether they are controlled from DAS, the staff will need to review the calculation of risk importance measures. Westinghouse has been asked to make the calculation available to the staff at Twinbrook.</p>	<p><b>No change required:</b> Currently all DCPs are reviewed by the PRA group to determine PRA impact. A PRA evaluation of the DCP is performed and PRA insights are provided to aid the AP1000 Change Control Board. Since DCPs are not incorporated into the PRA model at this time, RAW and FV values cannot be provided for VFS-800A/B and VFS-803A/B.</p> <p>Table 17.4-1 identifies that CIVs controlled by DAS were included into the D-RAP program based on RAW. This RAW value was for the basic event associated with the common cause failure of VFS-V009 &amp; VFS-V010 to close.</p> <p>It can be concluded from the sensitivity that we do not anticipate that importance measures for VFS-800A/B and VFS-803A/B in the updated operational mode will meet the criteria for being classified as risk-significant SSCs within the scope of D-RAP.</p>
6	Tier 2, Chapter 17	<p><b>Chapter 17:</b>                      If importance measures, SMA<sup>[1]</sup>, or expert panel determinations indicate that it is appropriate, additional revision(s) to Chapter 17 and Tier 1 Section 3.7 should be proposed.</p> <p>[1] Table 17.4-1: polar crane and pressurizer HCLPF values are also equal to the plant HCLPF value (0.50g), suggesting that they also belong in RAP.</p>	<p><b>No change required:</b> These components are already safety-related; therefore, adding them to D-RAP provided no additional assurance of reliability.</p>
7	Tier 2, Chapter 3 Table 3.9-16	<p><b>Page 18</b>  <b>Table 3.9-16:</b> Does inclusion in the AP1000 POV Program mean that VFS-800A/B will be pressure-tested in both directions? If not, testing in conjunction with scheduled ILRT should be considered. Unless failure to perform a pressure test from containment is justified, this assumption should be added to <b>Table 19.59-18</b>.</p>	<p><b>No change required:</b> No, as per the DCP, IST testing (APP J, LLRT) shall be conducted in one direction. Per GDC 56-8 Section 6.2, butterfly valves (as well as globe valves) may be tested in the reverse direction provided the results are conservative. Based on the installation of the valves, the test performed will be in the "non" preferred direction. This means that system pressure applied to the disc will tend to push it off its seat, i.e. conservative results.</p>

WESTINGHOUSE NON-PROPRIETARY CLASS 3

	DCD Reference	NRC Comment	Westinghouse Response
8	DCP_NRC_002941	<b>Table 3I.6-2:</b> It is not clear why position indication for VFS valves is not included in the list of potential high-frequency-sensitive safety-related components.	<b>Incorporated:</b> The VFS valves position indication are included in the list of potential high-frequency-sensitive safety-related components. They are listed as the Limit Switch consistent with other valves in the table. The table titled "Proposed DCD Changes and Justification Table" has been updated to reflect that the motor operators and limit switches for valves VFS-V800A/B have been added to the table as potential high frequency sensitive safety related components.
<b>Comments received via email dated Wednesday, August 25, 2010</b>			
9	Tier 2, Chapter 6	NRC staff will need to perform an audit of the WGOthic analyses, including the study that generated Figure 6.2.1.1-11. Please make these analyses available for audit.	<b>No change required:</b> Westinghouse Calc Note APP-SSAR-GSC-112 is available for NRC audit at our Rockville office.
10	Tier 2, Chapter 6	Please provide an equation for the chopped cosine temperature function. What is the basis for the 20°F temperature differential (25°F to 5°F) over 12 hours and why is it appropriate for use in this calculation?	<b>Response to be provided later.</b>
11	Tier 1, Chapter 2 Table 2.7.6-2	The design commitments in ITAAC 2.7.6-2 are containment isolation and vacuum relief. The associated ITA and AC reference Tier 1, Table 2.2.1-3 items 1 and 7, only appear to address containment isolation. Why are there no associated ITAAC for vacuum relief?	<b>Incorporated:</b> Vacuum relief valves VFS-PL-V800A, -V800B have been added to Tier 1, Table 2.7.6-2 (Item 2) with an open time $\leq$ 30 seconds.
12	Tier 2, Chapter 16 TS 3.6.4	Bases for TS 3.6.4 states that limiting negative pressure transient is loss of all AC power sources in extreme cold weather conditions. It also identifies 4 other transients that were evaluated, but these scenarios don't correspond to those identified in Section 5.0 of DCP 74. Please describe where these transients were evaluated. If referencing previous RAI responses or studies, explain how the results are applicable to current design.	<b>Response to be provided later.</b>

WESTINGHOUSE NON-PROPRIETARY CLASS 3

	DCD Reference	NRC Comment	Westinghouse Response
13	Tier 2, Chapter 16 TS 3.6.10	The Basis for Action A.2.1 in Tech Spec B3.6.10 states that opening VFS-PL-V009 and VFS-PL-V010 precludes the possibility of an excessive negative pressure inside containment since the containment is open to the outside. Please explain how air will be supplied through this line, which is designed to purge, should the containment develop a vacuum.	Response to be provided later.
14	Tier 2, Chapter 6 DCP_NRC_002941, Section 5.0	The sensitivity studies that defined the limiting case focused on max external pressure absent the operation of relief valves. Because the containment continues to depressurize for about an hour after the relief valves are open, how is it known that the most bounding case was selected? For example, demonstrate that once relief valves open, a LOAC at an external temperature of 25F produces the minimum internal pressure.	Response to be provided later.
15	Tier 2, Chapter 6 DCP_NRC_002941, Section 5.0	Because the analysis with internal temperature <80F did not model the vacuum relief valves, how does it demonstrate that it is not necessary to restrict inside to outside air temperature differential to <90F when T<80F.	Response to be provided later.
16	Tier 2, Chapter 16 TS 3.6.10	The Bases for Applicability of TS 3.6.10 states that the potential exists for negative containment pressure during Modes 1-4 and also during Modes 5-6 when both containment equipment hatches and airlocks are closed. The supporting analysis represents Mode 3, and used initial conditions from LCOs in TS 3.6.4 ( min containment pressure of -.2 psid) and TS 3.6.5 (max containment temperature of 120F), which are both applicable for Modes 1-4. Discuss how this analysis bounds Modes 5-6 which has no LCO for min containment pressure or max containment temperature.	Response to be provided later.



WESTINGHOUSE NON-PROPRIETARY CLASS 3

	DCD Reference	NRC Comment	Westinghouse Response
17	Tier 2, Chapter 6 DCP_NRC_002941, Section 5.0	<p>With respect to audit of APP-SSAR-GSC-112</p> <ul style="list-style-type: none"> <li>a) Please make Ref. 5, which contains heat rate calculations, and Ref. 7, which contains resistance calculations, available for audit.</li> <li>b) The sensitivity analyses in this calc note aren't consistent with those from Section 5.0 of the August 24, 2010 submittal. How will the differences be addressed in docketed correspondence?</li> <li>c) The base model is referenced to Case 8 of APP-SSAR-GSC-746. Is this the LOCA model, or were changes made to heat transfer coefficients or volumes to maximize heat loss?</li> <li>d) What heat conductors and/or volumes were initialized to the equilibrium temperature at the start of the transient run?</li> <li>e) Were any changes made to annulus heat transfer coefficients to address inexplicably high values identified in previous analysis?</li> <li>f) For the design basis model, the chopped cosine function essentially models a 2.5°F temperature decrease over the 4 hour transient. It was stated this adds conservatism to the analysis by accounting for day to night temperature variations, and that it is demonstrated to be a secondary effect. The staff does not find justification that either of these statements are true, so please describe why this is an appropriate assumption for a safety analysis.</li> </ul>	Response to be provided later.

WESTINGHOUSE NON-PROPRIETARY CLASS 3

	DCD Reference	NRC Comment	Westinghouse Response
18	Tier 2, Chapter 17	Westinghouse has used an expert panel process and performed calculations to support the determination that these valves <b>need not be added</b> to the RAP. The staff finds <b>no reason to disagree</b> . Whether the VFS valves in question belong within the scope RAP may depend upon risk importance calculations that are not yet available. Since they are already safety-related, the impact of adding them to the RAP at a later date will impose no additional design or construction requirements.	<b>No change required:</b> Verbal explanation accepted by NRC with no further action.
19	Tier 2, Chapter 17	The staff had requested a rationale for failing to add other SSCs (identified in the SMA) to the scope of RAP. Information that justifies their exclusion was provided in a proposed change to the DCD.	<b>No change required:</b> Verbal explanation accepted by NRC with no further action.
20	Tier 2, Chapter 19	The staff reviewed information at the Westinghouse office in Rockville, including "PRA Sensitivity of Impact on containment isolation available due to DCP-1958." The staff expects that the SMA will address " <b>all sequences leading to core damage or containment failure</b> " (words from SECY-93-087, emphasis added). This is not constrained by the probability of the sequence. Failure to open a path to relieve external pressure leads to containment failure. Failure to close/remain closed <i>is</i> containment failure. Please clarify the basis for failing to provide, in the SMA, HCLPF values for all VFS CIVs.	<b>No change required:</b> The response to comment 2 above addresses this issue.

WESTINGHOUSE NON-PROPRIETARY CLASS 3

	DCD Reference	NRC Comment	Westinghouse Response
<b>Comments received via email dated Thursday, September 2, 2010</b>			
21	DCP_NRC_002941 Section 6	Section 6.0, "Containment Isolation Consideration," in AP1000 Design Change Package (DCP) 74 states in the "Position" paragraph for 10 CFR Part 50, Appendix A, General Design Criterion 54, that testing AP1000 Vacuum Relief Power-Operated Butterfly Valves VFS-PL-V800A/B in the reverse direction of containment leakage is more conservative because the butterfly valves will be installed in the "non-preferred" direction. Clarify the statement in the DCP that the valves are installed in the non-preferred direction in that Figure 6-1 in AP1000 DCP 74 indicates that the valves will be positioned such that containment pressure will assist in sealing the valve closed against its seating surface. Further, specify the reference to the AP1000 Design Control Document (DCD) that requires the application of ANSI/ANS 56.8, "Containment System Leakage Testing Requirements," as indicated in AP1000 DCP 74.	<p><b>Incorporated:</b> Section 6.0 of the DCP_NRC_002941 (CN74) has been modified to clarify testing of the butterfly valves in the reverse direction of containment leakage.</p> <p>The text now reads: "The outboard butterfly valves will be tested using a temporary spool piece and test connections. The butterfly valves cannot be tested in the direction of containment leakage, however, it is more conservative to test the butterfly valves in the reverse direction of containment leakage, because the valves will be installed such that the containment pressure will assist in sealing the valve closed. This test method meets the requirements of ANSI 56.8, Section 6.2, Direction of Testing."</p>

WESTINGHOUSE NON-PROPRIETARY CLASS 3

	DCD Reference	NRC Comment	Westinghouse Response
22	DCP_NRC_002941 Section 9.1.1	Subsection 9.1.1, "Mechanical Design Requirements," in Section 9.1, "Outboard Motor Operated Valves VFS-V800A/B," of AP1000 DCP 74 specifies that AP1000 Vacuum Relief Power-Operated Butterfly Valves VFS-PL-V800A/B will be designed in accordance with the general requirements of Westinghouse valve specification APP-PV11-Z0-001. Specify in the DCP that qualification of these valves will be in accordance with ASME Standard QME-1-2007, "Qualification of Active Mechanical Equipment Used in Nuclear Power Plants," as accepted in Revision 3 to Regulatory Guide 1.100, "Seismic Qualification of Electric and Active Mechanical Equipment and Functional Qualification of Active Mechanical Equipment for Nuclear Power Plants," as planned to be specified in the next revision to the AP1000 DCD, such as indicated in the Westinghouse letter dated March 5, 2010, for power-operated valves within the scope of the AP1000 Inservice Testing (IST) Program.	<p><b>Incorporated:</b> Subsection 9.1.1 of DCP_NRC_002941 (CN74) has been revised to specify valves VFS-PL-V800A/B will be designed in accordance with DCD Tier 2 Section 3.9.</p> <p>The text now reads: "Valves VFS-800A/B are specified as ASME Class 2, 6" motor operated butterfly valves, with open and closed safety functions. They will be designed in accordance with DCD Tier 2 Section 3.9."</p>
23	DCP_NRC_002941 Section 9.1.1	Subsection 9.1.1 of AP1000 DCP 74 specifies a maximum stroke time of 30 seconds for opening and closing AP1000 Vacuum Relief Power-Operated Butterfly Valves VFS-PL-V800A/B. Specify in the DCP that the qualification process will verify (1) the design assumption that the valves will be capable of allowing full flow capacity within 20 seconds taking into consideration that the motor operator might not operate at constant speed during the valve opening stroke, and (2) each valve will have sufficient flow capacity to relieve vacuum conditions to avoid the containment external design pressure from being exceeded.	<p><b>Incorporated:</b> Subsection 9.1.1 of DCP_NRC_002941 (CN74) has been revised to include information regarding the flow capacity and time for full flow capacity for VFS-PL-V800A/B consistent with the assumptions of the safety analysis.</p> <p>The summary of mechanical design characteristics provided include:</p> <ul style="list-style-type: none"> <li>- Valve Material: Carbon Steel</li> <li>- Disk Style: Triple offset with bi-directional flow</li> <li>- Actuator: Motor Operated with locking gear sets to ensure actuator and shaft are held in position.</li> <li>- Close: Torque switch controlled.</li> <li>- Open: Limit with torque switch backup.</li> <li>- Leak-Tightness: FCI Class V</li> <li>- Capacity Coefficient: 868</li> <li>- Open/Close Stroke time of 30 seconds (max)</li> <li>- Full Flow Capacity in 18 seconds</li> </ul>

WESTINGHOUSE NON-PROPRIETARY CLASS 3

	DCD Reference	NRC Comment	Westinghouse Response
24	DCP_NRC_002941 Section 9.1.3	<p>Subsection 9.1.3, "Testing Requirements," of AP1000 DCP 74 specifies that AP1000 Vacuum Relief Power-Operated Butterfly Valves VFS-PL-V800A/B will be tested in accordance with ASME OM Code, Paragraph ISTC-3500 and Table ISTC-3500-1, "Inservice Test Requirements."</p> <p>Revise the AP1000 DCP 74 to specify that these motor-operated valves (MOVs) will be tested as described in AP1000 DCD Tier 2, Section 3.9.6, in accordance with 10 CFR 50.55a, including implementation of the ASME OM Code as incorporated by reference in the regulations and the supplemental requirements in 10 CFR 50.55a(b)(3)(ii) to ensure that the MOVs continue to be capable of performing their design-basis safety functions. Further, clarify the statement in this subsection that periodic verification of these MOVs will be based on the Joint Owners' Group (JOG) Periodic Verification report to specify that the periodic verification program will be in accordance with the description provided in AP1000 DCD Tier 2, Section 3.9.6, including the JOG Periodic Verification Program as accepted in the NRC safety evaluation dated September 25, 2006, and its supplement dated September 18, 2008. Also, the specification in the Westinghouse response to NRC staff question 2f on page 5 of the AP1000 DCP 74 that the valve and actuator components will be comprised of materials previously tested as part of the JOG program should be included in Subsection 9.1.3 of AP1000 DCP 74.</p>	<p><b>Incorporated:</b> Section 9.1.3. of DCP_NRC_002941 (CN74) has been revised to reference DCD Tier 2 Section 3.9.6.</p> <p>The revised text now reads: "The valves are considered Active and categorized as A in accordance with DCD Tier 2 Section 3.9.6."</p> <p>In addition, the information regarding the JOG Periodic Verification report has been removed.</p>

WESTINGHOUSE NON-PROPRIETARY CLASS 3

	DCD Reference	NRC Comment	Westinghouse Response
25	DCP_NRC_002941 Section 9.2.1 Tier 2 Table 3.9-16	<p>Subsection 9.2.1, "Mechanical Design Requirements," in Section 9.2, "Inboard Self Actuated Valves VFS-V803A/B," in AP1000 DCP 74 indicates the design requirements for AP1000 Vacuum Relief Containment Isolation Check Valves VFS-PL-V803A/B. ASME OM Code, Table ISTC-3500-1 states that if a check valve used for pressure relief is capacity certified, then it shall be classified as a pressure or vacuum relief valve. Therefore, AP1000 Vacuum Relief Containment Isolation Check Valves VFS-PL-V803A/B are within the scope of ASME BPV Code, Section III, Subsection NC-7000, "Overpressure Protection," as defined in Paragraph NC-7110 and require capacity certification as defined in Paragraph NC-7750. Specify in the DCP (1) VFS-PL-803A/B are vacuum relief valves that will be designed and qualified in accordance with ASME BPV Code, Section III, Subsection NC-7000; (2) the allowable tolerance for the 0.2 psi differential cracking pressure based on the design assumptions; and (3) the qualification process will demonstrate that each valve will have sufficient flow capacity to relieve vacuum conditions to avoid the containment external design pressure from being exceeded.</p>	<p><b>Incorporated:</b> Section 9.2.1 of DCP_NRC_002941 (CN74) and DCD Tier 2 Table 3.9-16 have been revised to reflect clarification of valves VFS-PL-V803A/B as vacuum relief valves. The differential cracking pressure tolerance and the full flow capacity of the check valves were added to Section 9.2.1.</p> <p>The Valve Type in table 3.9-16 has been changed from "Check" to "Relief." For consistency throughout the document, an editorial change has been made in this section to identify the IST Category as "AC" instead of "A."</p> <p>The text now states that the valves are tested in accordance with DCD Tier 2 Section 3.9.6 and Appendix I of the ASME OM Code. They are considered vacuum relief valves and will be designed in accordance with ASME BPV Code, Section III, Subsection NC-7000.</p> <p>Additionally, Note 39 in DCD Tier 2 Table 3.9-16 has been revised to remove reference to motor operated Valves VFS-PL-V800A/B.</p>

WESTINGHOUSE NON-PROPRIETARY CLASS 3

	DCD Reference	NRC Comment	Westinghouse Response
26	DCP_NRC_002941 Section 9.2.2	Subsection 9.2.2, "Testing Requirements," in Section 9.2 of AP1000 DCP 74 states that AP1000 Vacuum Relief Containment Isolation Check Valves VFS-PL-V803A/B are tested in accordance with ASME OM Code, Paragraph ISTC-3500 and Table ISTC-3500-1. In that these check valves provide a vacuum relief function with a design opening pressure, specify in the DCP that these valves will be tested in accordance with ASME OM Code, Appendix I, "Inservice Testing of Pressure Relief Devices in Light-Water Reactor Nuclear Power Plants," including testing to demonstrate that the design opening pressure requirement is satisfied. Further, the Westinghouse response to NRC staff questions 3d and 3e specifying bidirectional testing capability and Appendix I provisions with opening setpoint testing and closure testing should be specified in Subsection 9.2.2 of AP1000 DCP 74.	<p><b>Incorporated:</b> Subsection 9.2.2 of DCP_NRC_002941 (CN74) has been revised to include information about bidirectional testing of the vacuum relief containment isolation check valves.</p> <p>The following text has been added to Subsection 9.2.2:</p> <p>"Since the valves have a safety function in both the open and closed directions, they will be tested in both directions. The check valves will be exercised open using a mechanical exerciser in accordance with ISTC-5221(b)(1). The valve is designed with a mechanical exerciser to allow adjustment of the balancing device inherent to the valves. The valve is designed to begin to lift off the seat at 0.2 psid. This value will be used as the acceptance criteria.</p> <p>The valves will also be verified to close during the mechanical exercise test in accordance with ISTC-5221 (b)(3). The valves will be visually verified closed as well as leakage tested in accordance with the Appendix J program."</p>
27	DCD Chapter 3 Tier 2 Table 3.9-16	AP1000 DCP 74 should modify AP1000 DCD Tier 2, Table 3.9-16, "Valve Inservice Test Requirements," to classify AP1000 Vacuum Relief Containment Isolation Check Valves VFS-PL-803A/B as Category AC vacuum relief valves (not only check valves). This classification will require the valves to be inservice tested as vacuum relief valves per ASME OM Code, Paragraph ISTC-5230 or ISTC-5340, which specify the application of ASME OM Code, Appendix I. Table 3.9-16 also needs to add "Vacuum Relief" to the list of Safety Functions for AP1000 Vacuum Relief Containment Isolation Check Valves VFS-PL-803A/B, and add "Pressure relief in accordance with ASME OM Code, Appendix I" to the column for IST Type and Frequency for these valves.	<p><b>No change required:</b> This change is included in response to Comment #25 above.</p> <p>Per discussions with the NRC on 09/09/2010, "Vacuum Relief" has not been added to the Safety Functions since it is not included in Westinghouse's set list of Safety Functions for Table 3.9-16. In addition, the most recent revision of the package does include a third Inservice Testing Type and Frequency, "Vacuum Relief Test/2 Years." See RCS-PL-V010A/B as an example.</p>
28	DCP_NRC_002941	AP1000 DCP 74 should discuss the provisions for inspection and maintenance of the containment vacuum relief system following its actuation. For example, AP1000 Vacuum Relief Containment	<p><b>No change required:</b> The provisions for inspection and maintenance of the vacuum relief subsystem check valves are the same as those for any other active, safety-related, AP1000 valves listed in DCD Table 3.9-12, including other active check valves and pressure relief</p>

WESTINGHOUSE NON-PROPRIETARY CLASS 3

	DCD Reference	NRC Comment	Westinghouse Response
		<p>Isolation Check Valves VFS-PL-V803A/B will need to be visually inspected for potential damage that might have occurred to the check valve hinge pin or other internal parts as a result of flutter of the valve disc from flow through the check valve as the outside atmospheric pressure relieves the vacuum conditions within the AP1000 containment. The inspection and maintenance activity should confirm the operational readiness of the containment vacuum relief system and its individual components prior to further plant operation.</p>	<p>devices, and are not required immediately following system actuation and component operation.</p> <p>The vacuum relief valves, along with all active valves, are required to satisfy the various design, inspection, and testing requirements described for valve characteristics such as safety and seismic classification (DCD subsection 3.2), qualification (DCD subsection 3.11), in-service testing (DCD subsection 3.9.6), and other application-specific design and testing requirements (such as containment isolation leakage testing for valve seat leakage).</p> <p>These active valves are designed with sufficient durability over valve lifetime, as discussed later, such that they are not required nor intended to be inspected following individual valve actuation - either a single stroke actuation (such as following an in-service testing cycle), or following valve and safety-related subsystem actuation, such as sustained / extended component operation for a vacuum relief event.</p> <p>If a malfunction was identified with an active valve during testing or actuation of a safeguards function, then the valve would be subsequently investigated, evaluated, tested, inspected, and/or repaired as required. But in-service testing and inspection (including periodic diagnostic testing and documentation in component history) helps to provide reasonable assurance that components are functioning properly.</p> <p>DCD 3.9.6.2.2 specifically discusses check valve and pressure / vacuum relief device tests. The periodic testing and inspection for the vacuum relief valves that perform a vacuum relief function would include visual inspection, seat tightness, set pressure determination, and operational determination of balancing devices, etc., as specified in DCD 3.9.6.2.2 The test frequency specified for these Class 2 devices in the markup to DCD Table 3.9-16 for this vacuum relief function is a 2 year frequency, consistent with the in-service testing specified for other vacuum relief devices such as RCS-PL-V010A/B.</p> <p>The periodic testing and inspection results from the in-service testing are expected to be documented in material history and evaluation of trended results (such as valve stroke time changes or seat leakage</p>



WESTINGHOUSE NON-PROPRIETARY CLASS 3

	DCD Reference	NRC Comment	Westinghouse Response
			<p>values over time) can help to anticipate potential valve degradation effects that might potentially challenge operability prior to or beyond the next in-service testing cycle.</p> <p>The plant predictive maintenance program and its associated condition monitoring are intended to encompass these types of monitoring and predictive performance functions. This helps to identify these potential challenges to valve operation so that preventive maintenance can be updated as necessary to support continued valve operability over plant life. Therefore, corrective actions can be taken as required where potential challenges to valve operability are identified.</p> <p>From a design perspective, the valve design documents and specifications help to establish a valve operating lifetime, including characteristics such as valve operating cycles. These are documented in valve design specifications. For example, the required minimum number of specified valve operating open / close cycles for an active valve might be as many as 3000 or 6000 cycles, where it must be capable of performing its design basis functional operations throughout its working lifetime.</p> <p>The intent of the design specification criteria are to provide reasonable assurance that the valve performance in meeting these established design criteria, such as operating time and seat leak-tightness, will be satisfied during the working valve lifetime. A valve design vendor would be responsible for assuring that the valve can meet the specified design requirements.</p> <p>The in-service testing program and the associated test frequency as established as a reasonable periodicity to confirm operational readiness, i.e., valve safety functionality (open to safeguards position, close to safeguards position, confirm seat leak-tightness, etc.) on a basis that is prescribed, assuming that the valves are properly designed and valve qualification testing confirms that their design is acceptable.</p> <p>Therefore, the design requirements captured in the valve design specifications to the vendor help to provide confidence that any individual valve operational event will not challenge satisfactory valve</p>

WESTINGHOUSE NON-PROPRIETARY CLASS 3

	DCD Reference	NRC Comment	Westinghouse Response
			operation between in-service testing intervals, and that in-service testing and inspections confirm the continuing capability of the valve to perform its design basis safety function(s).
29	DCD Tier 1	AP1000 DCD Tier 1, Table 2.7.6-2 for the Containment Air Filtration System should be expanded to address ITAAC for the additional equipment included in AP1000 DCP 74 for the AP1000 vacuum relief system. For example, the ITAAC should address piping and component design in accordance with ASME BPV Code Section III; piping, components, and welds satisfying ASME BPV Code, Section III requirements for integrity; seismic design-basis capability; Class 1E environmental qualification; valve operating times; and MOV and check valve functional qualification. See, for example, AP1000 DCD Tier 1, Table 2.3.2-4 for the Chemical and Volume Control System.	<b>No change required:</b> The valves and piping have been added to Tier 1 Tables 2.2.1-1 and 2.2.1-2 respectively. That performs the same function as what is being requested without creating new Tables in Section 2.7.6 of Tier 1. The ASME Code Section III requirements will be addressed by ITAACs 2a, 2b, 3a, 3b, 4a, and 4b in Tier 1 Table 2.2.1-3. The Seismic qualification is handled in ITAACs 5.i, ii, and iii in Table 2.2.1-3. The Class 1E environmental qualification is handled with ITAACs 6.a.i and ii in Table 2.2.1-3. The MOV and check valve functional qualification is handled with ITAACs 11a.i, ii, iii, and iv in Table 2.2.1-3. The valve operating time is being handled with two separate entries in ITAAC tables. The closing times for those valves were added as a specific closing time to ITAAC 7.ii in ITAAC Table 2.2.1-3. We are also adding an opening time ITAAC test to Table 2.7.6-2. That will be new ITAAC 2.ii in Table 2.7.6-2.
30	DCP_NRC_002941 Section 9.3	Section 9.3, "Valve Design Specifications and Datasheets," in AP1000 DCP 74 indicates that the design specifications for AP1000 Vacuum Relief Power-Operated Butterfly Valves VFS-PL-V800A/B and AP1000 Vacuum Relief Containment Isolation Check Valves VFS-PL-V803A/B will be available for review at the WEC Rockville, MD office. Please notify the NRC staff when those documents are available at the WEC Rockville office.	<b>No change required:</b> The following valve design specifications and datasheets were made available for review in the WEC Rockville, MD office on Friday, September 3, 2010. <ul style="list-style-type: none"> <li>• APP-PV03-Z0-001, Rev. 4</li> <li>• APP-PV03-Z0D-192, Rev. 2</li> <li>• APP-PV11-Z0-001, Rev. 2</li> <li>• APP-PV11-Z0D-133, Rev. 2</li> </ul>
31	DCP_NRC_002941	Provide a description of the complete flow path for the AP1000 vacuum relief system to allow the NRC staff to review any piping or components that are not currently identified in AP1000 DCP 74 submitted on July 30, 2010.	<b>No change required:</b> Please see Enclosure 5 titled "Vacuum Relief System Flow Path Description" for a description of the Flow Path.

WESTINGHOUSE NON-PROPRIETARY CLASS 3

	DCD Reference	NRC Comment	Westinghouse Response
32	DCP_NRC_002941 All Sections	AP1000 DCP 74 should be reviewed for editorial changes. For example, the identification numbers for the AP1000 vacuum relief system valves are inconsistent, such as butterfly valves VFS-PL-V800A/B or VFS-V800A/B, and check valves VFS-PL-V803A/B or VFS-V803A/B. Also, the numbering of the two test frequency contributors in Subsection 9.1.3 should be corrected. Further, the table of NRC comments and responses at the beginning of AP1000 DCP 74 should be updated to reflect the response to additional staff questions.	<b>Incorporated:</b> Various editorial changes have been made. Valve identification tags have been made consistent and the two test frequency contributors in Subsection 9.1.3 have been deleted.  Since our approach is to provide revised report pages rather than updating the entire original report, this table will not be updated.
<b>Comments received via email dated Thursday, September 8, 2010</b>			
33	Tier 2, Chapter 7 Figure 7.2-1 Table 7.3-1	Confirm if the 2-out-of-4 voting logic shown in the new Figure 7.2-1 (Sheet 19 of 21) and also in Table 7.3-1 has the bypass capability.	<b>Incorporated:</b> The instrument channels related to containment vacuum relief have bypass capability just as those used for any other safety function performed by the PMS. Figure 7.2-1 (sheet 19 of 21) and Table 7.3-1 will be updated accordingly.
34	Tier 1, Chapter 2 Tables 2.5.2-3 & 4	Clarify if the newly added manual control in the PMS for the containment vacuum relief MOVs should be added to Tier 1 Table 2.5.2-4.	<b>Incorporated:</b> "Containment Vacuum Relief" will be added to Tier 1 Table 2.5.2-4. It will also be added to Tier 1 Table 2.5.2-3.
35	Tier 1, Chapter 2 Table 2.5.2-5 Tier 2, Chapter 18 Table 18.12.2-1	Clarify if the newly added manual control and status for the containment vacuum relief MOVs should be added to Tier 1 Table 2.5.2-5.	<b>Incorporated:</b> "Manual Containment Vacuum Relief" will be added to Tier 1 Table 2.5.2-5 as well as Tier 2 Table 18.12.2-1. The status of valves VFS-PL-800A/B is captured under the row of Table 2.5.2-5 titled "Remotely Operated Containment Isolation Valve Status" as the valves are containment isolation valves as well as Containment vacuum relief valves.
<b>Comments received via email dated Friday, September 17, 2010</b>			
36	Tier 2, Chapter 9 Section 9.4.7	The statement regarding compliance with Seismic Category II requirements was removed from the FSAR, Chapter 9.4.7. Please explain why this was done and explain how compliance with GDC 2 is ensured without this statement? The removed statement – <del>System equipment and ductwork whose failure could affect the operability of safety related systems or components are designed to seismic Category II requirements. The remaining portion of the system is nonseismic.</del>	<b>Response to be provided later.</b>

WESTINGHOUSE NON-PROPRIETARY CLASS 3

	DCD Reference	NRC Comment	Westinghouse Response
37	Tier 2, Chapter 6 DCP_NRC_002941, Section 5.0	<p><b>Regarding the “Sensitivity Studies to Address Staff’s Review of Containment External Pressure Analysis (APP-SSAR-GSC-112 Rev. 0)”:</b></p> <p>For Sensitivity 3, please explain why external temperature at time 0 is 18.57F rather than 25F. What external temperature was used to determine equilibrium conditions?</p>	Response to be provided later.
38	Tier 2, Chapter 6 DCP_NRC_002941, Section 5.0	<p><b>Regarding the “Sensitivity Studies to Address Staff’s Review of Containment External Pressure Analysis (APP-SSAR-GSC-112 Rev. 0)”:</b></p> <p>For Sensitivity 3, NRC meteorologists do not believe the max recorded temperature variation over a 24 hour period would be constant, or that a 6.4F temperature differential over 1 hour is conservative.</p>	Response to be provided later.
39	Tier 2, Chapter 6 DCP_NRC_002941, Section 5.0	<p><b>Regarding the “Sensitivity Studies to Address Staff’s Review of Containment External Pressure Analysis (APP-SSAR-GSC-112 Rev. 0)”:</b></p> <p>Staff would like to audit the calculation notes and associated WGOthic models supporting the sensitivity studies.</p>	Response to be provided later.
40	DCP_NRC_002941 Section 9.3	<p><b>Regarding the valve specifications referenced in CN 74:</b></p> <p>Specification APP-PV03-Z0-001 referenced in AP1000 DCP 74 for check valves VFS-PL-V803A/B to be used in the containment vacuum relief system does not address the vacuum relief function of those check valves.</p>	Response to be provided later.

WESTINGHOUSE NON-PROPRIETARY CLASS 3

	DCD Reference	NRC Comment	Westinghouse Response
41	DCP_NRC_002941 Section 9.3	<p><b>Regarding the valve specifications referenced in CN 74:</b></p> <p>Data Sheets APP-PV03-Z0D-192 and APP-PV211-Z0D-133 referenced in AP1000 DCP 74 do not apply to either VFS-PL-V800A/B or 803A/B to be used in the containment vacuum relief system.</p>	Response to be provided later.
42	DCP_NRC_002941 Section 9.3	<p><b>Regarding the valve specifications referenced in CN 74:</b></p> <p>Specification APP-PV11-Z0-001 states in Section 3.2.13.1 on page 27 that butterfly valves will be installed with the shaft in the horizontal direction unless otherwise specified. The basis for this orientation is not clear.</p>	Response to be provided later.
43	DCP_NRC_002941	<p>In the comment table (pdf file CN74 NRC 100914), item 13 includes a discussion of the ability of the vent path through VFS-PL-009 to accomplish the safety function to preclude an external pressure event. In response, this TS Action was removed from the TS. However, this flow path still appears to be credited as a vent path when VFS-PL-009 is open because there is an interlock disabling the vacuum relief system when VFS-PL-009 is open. Please explain why the safety function is always accomplished when VFS-PL-009 is open. Specifically, in the VFS system there are numerous valves or other potential blockages in the non-safety related flow path that could prevent internal and external pressure from equalizing through the system.</p>	Response to be provided later.

WESTINGHOUSE NON-PROPRIETARY CLASS 3

	DCD Reference	NRC Comment	Westinghouse Response
44	DCP_NRC_002941	<p>In a similar comment, please justify the following statement in the TS Bases:</p> <p>"If the 16-inch containment purge discharge isolation valves inside and outside containment, VFS-PL-V009 and VFS-PL-V010 are both open, then an excessive negative pressure inside containment cannot develop, since the containment is open to the outside."</p>	Response to be provided later.
45	DCP_NRC_002941	<p>The vacuum relief system is a single failure-proof system. Please explain how the design of interlock on the single valve (VFS-PL-009) on the single non-safety related flow path ensures the system is not vulnerable to a single active failure.</p>	Response to be provided later.
46	DCP_NRC_002941, Section 6.1	<p>Section 6.1 (WEC Response to BTP 6-4) states that "the following interlocks exist: V800A/B can't be opened unless V009 is closed. If open, V800A/B will close when V009 is opened". Please clarify where this interlock logic is implemented.</p>	Response to be provided later.
47	DCP_NRC_002941, Tech Spec Table 3.3.2-1	<p>The staff questioned the relevance of Item 30, Component Cooling Water System Containment Isolation Valve Closure, in Tech Spec Table 3.3.2-1, "Engineered Safeguards Actuation System Actuation System Instrumentation" in relation to CN74.</p>	Response to be provided later.

ENCLOSURE 4

Supplementary Information for CN74  
AP1000 Containment Vessel External Pressure Analysis and Design Information for Change Number 74  
Revised Pages for NRC Review Package  
Non-Proprietary

NRC Comments and WEC Resolutions to Prior NRC Package

	NRC Staff Comments	WEC Responses
1	<p><b>Draft AP1000 Design Change Package (DCP) 74 contains information specifying the logic for the control of the vacuum relief valves. The draft specifies containment low pressure signal takes priority over any containment isolation signals, such as containment pressure high or high radiation in containment, from closing containment isolation valves VES- PL-V800A and V800B following a containment low pressure signal. An explanation for how this meets the requirements of 10 CFR 50.34(f)(2)(xiv)(A) that that ensure that all non-essential systems are isolated automatically by the containment isolation system and the requirements of 10 CFR 50.34(f)(2)(xiv)(E) that automatic closing on a high radiation signal be provided for all systems that provide a path to the environment is required. In addition, see GDC 54 &amp; 56.</b></p>	<p>Valves VES- PL-V800A/B meet the 10CFR50.34(f)(2)(xiv)(A) and 10CFR50.34(f)(2)(xiv)(E) as follows.</p> <p>Valves VES- PL-V800A/B receive containment isolation and high radiation signals to automatically close the valve, and low containment pressure to automatically open the valve. The Open signal has priority over the Closed signal.</p> <p>The normally closed vacuum relief system motor operated valves (MOVs) are designed to open automatically when containment pressure reaches -0.8 psig and remain open to preclude exceeding the containment external design pressure (1.7 psid). While the vacuum relief system MOVs are open, the containment will be at a vacuum and flow will be into containment. Once the vacuum condition inside containment is reduced to near ambient pressure conditions (-0.2 psig), the Open signal is automatically cleared such that the vacuum relief system MOVs will then be allowed to close automatically in the event that a containment isolation signal or high radiation signal is present. In addition check valves VES- PL-V803A/B are self actuated check valves which will also be closed if a vacuum does not exist inside containment. The check valves will not be open until a 0.2 psid differential pressure exists. This is consistent with the vacuum relief system clear signal as well as the -0.2 psig containment pressure Technical Specification low alarm value.</p> <p>See Section 6.0 for details.</p>



WESTINGHOUSE NON-PROPRIETARY CLASS 3

2	<p><b>Draft DCP 74 for the planned containment vacuum relief system includes two normally closed motor-operated butterfly valves that will be powered by the 1E battery supply, and signaled to open on a specific containment vacuum pressure. The DCP should provide additional information to support the operational and sealing capability for these two motor-operated valves (MOVs). For example, the DCP should address the following:</b></p>	
2a	<p>Butterfly valve design that provides a leak-tight seal for its containment isolation function and also maintains full closed position with design-basis differential pressure from either flow direction until signaled to open.</p>	<p>Valves VFS- PL-V800A/B are 6" motor-operated valves designed to provide the following functions:</p> <p>Design/Functional Requirement: These valves will be designed to meet the general requirements of valve specification APP-PV11-Z0-001. The leak-tightness of the valves will be addressed by an air test in accordance with MSS-SP-61 and shall meet the 10 CFR 50 Appendix J leakage requirements.</p> <p>Valve features; Triple offset with bi-directional flow and leak tight sealing (FCI leak class V). Actuator example features; Locking gear sets shall be specified to ensure actuator and shaft are held in position.</p> <p>See attached design specification and representative data sheet contained in Sections 9.1.3 and 9.1.4.</p>
2b	<p>Functional design and qualification of these MOVs to satisfy their design-basis requirements for both containment isolation and vacuum relief functions.</p>	<p>These valves will conform to the general design and qualification requirements as specified in the PV11 valve specification APP-PV11-Z0-001. The system level design requirements for these valves will be defined in a VFS system level valve calculation. An example of system level requirements is shown in datasheet APP-PV11-Z0D-133. (Note this datasheet does not reflect the specific requirements of the vacuum relief check valves (V803A/B)).</p>
2c	<p>Operating control method using limit switch, torque switch, or a combination of these switches to provide assurance of valve sealing capability without overstroking the valve disk through the seat.</p>	<p>Close: Torque switch controlled.</p> <p>Open: Limit with torque switch backup.</p>

WESTINGHOUSE NON-PROPRIETARY CLASS 3

2d	<p>Power availability to operate these MOVs for the required number of cycles considering the valve, actuator, and motor sizes, stroke time, and torque requirements to operate under their design-basis conditions using the 1E battery supply over the time period which these valves might need to function with 1E power also supplied to other plant equipment.</p>	<p>Based upon VFS-PL-V800A and V800B being required to be stroked twice for their design basis operation, electrical design will consider these loads in the design calculations as follows. The valve(s) will be considered a RANDOM load within the methodology required in IEEE485 for each of the two operations and will therefore be added to the first and second worst one minute time steps of the battery profile. Electrical calculations, i.e. battery sizing and cable, take into consideration both starting current and stroke time rounded up to the whole minute(s) for all MOV operation(s). A computation has been performed in evaluation of this design change and demonstrates that the existing component rating requirements are adequate. This design change will be included in final design calculations for the IDS system.</p>
2e	<p>Description of plan to satisfy applicable ASME OM Code inservice testing (IST) provisions and 10 CFR Part 50, Appendix J leak-testing requirements.</p>	<p>Valves VFS- PL-V800A/B are 6" motor operated butterfly Class 2 valves with open and closed safety functions. The ASME OM Code was used to classify and categorize as well as specify the test requirements and frequencies described below. The valves are considered Active and categorized as A in accordance with ASME OM Code, ISTC-1300. The valves are tested in accordance with ISTC-3500 and Table ISTC-3500-1. The testing regime and frequencies are listed below:</p> <ul style="list-style-type: none"> <li>• Full Stroke Exercise - Refuel Shutdown</li> <li>• Remote Position Indication – 2 Years</li> <li>• Leakage Testing - In accordance with Appendix J frequency</li> <li>• Operability Test - In accordance with Power Operated Valve program</li> </ul>
2f	<p>Description of plan to satisfy 10 CFR 50.55a supplemental requirements for periodic verification of MOV design-basis capability, including application of Joint Owners Group (JOG) Program for MOV Periodic Verification with program scope to include this butterfly valve design and application.</p>	<p>Periodic Verification to be based on JOG Periodic Verification (PV) report, key contributors to periodic test frequency to be:</p> <ol style="list-style-type: none"> <li>1) Risk significance</li> <li>2) Function margin</li> </ol> <p>Risk significance to be established by WEC PRA (Refer to Section 8)          Functional margin to be based upon standard industry equations (EPRI), along with incorporating BWROG DC sizing methodology.</p> <p>Valve and actuator components to be comprised of materials previously tested as part of the JOG PV study.</p>

WESTINGHOUSE NON-PROPRIETARY CLASS 3

2g	Correction of valve size in draft DCP table 3.9-16.	Table 3.9-16 has been updated to reflect the correct valves sizes for VFS-PL-V800A/B and VFS-PL-V803A/B
2h	Containment isolation closing times compliance with CSB BTP 6-4 to support ch 15 analysis. (see NUREG-1793 chapter 6.2.4.13).	In the event of a LOCA with these valves open, the releases of radioactivity during the maximum time for valve closure (30 seconds) has been evaluated (APP-SSAR-GSC-113). The radiological consequences are bounded by those currently present in DCD 15.6.5.3.  See Section 6.0 for further details along with DCD markup provided in 9.4.7.2.1.
3	<b>Draft DCP 74 includes two parallel check valves in series with the butterfly valves in the planned containment vacuum relief system. The DCP needs to provide additional information to support the operational and sealing capability of these two check valves. For example, the DCP should address the following:</b>	
3a	Check valve design that provides a leak-tight seal for containment isolation function and will open at a preset containment vacuum pressure that supports the DCP analysis.	Valves VFS- PL-V803A/B are 6" swing check valves designed to provide the following functions:  1) Function: Containment Isolation  Design Requirement: These valves will be designed to meet the general requirements of valve specification APP-PV03-Z0-001. The leak-tightness of the valves will be addressed in the design by an air leakage tested in accordance with MSS-SP-61.  2) Function: Vacuum Relief  Design Requirement: These valves will be provided with a balanced, and adjustable, angled seat design. The nominal cracking pressure will be set in accordance with the vacuum relief system design requirements.  See attached design specification and representative data sheet contained in Sections 9.1.1 and 9.1.2
3b	Functional design and qualification of these check valves to satisfy their design-basis requirements for both containment isolation and vacuum relief functions.	These valves will conform to the general design and qualification requirements as specified in the PV03 valve specification APP-PV03-Z0-001. The system level design requirements for these valves will be defined in a VFS system level valve calculation. An example of system level requirements is shown in datasheet APP-PV03-Z0D-192. Note this datasheet does not reflect the specific requirements of these vacuum relief check valves (V803A/B).

WESTINGHOUSE NON-PROPRIETARY CLASS 3

3c	Installation orientation for check valve that supports design assumptions for operating differential pressure and sealing capability.	Per the PV03 valve specification APP-PV03-Z0-001, Section 3.2.13.2, check valves shall be installed with the checking element closing with gravity in the reverse flow direction. These valves will be installed in the horizontal direction in accordance with this design requirement.
3d	Capability for bidirectional testing of each check valve.	<p>Check valves VPS- PL-V803A/B have a safety function in both the open and closed positions. Since the valves are classified as vacuum relief check valves, the requirements of ISTC and Appendix I of the ASME OM Code will be applied.</p> <p><b>Bidirectional Testing Capability</b>  ASME OM Code, ISTC-5221 (a) requires the valves to have both an open and closed check valve test. Since the valves have a safety function in both the open and closed directions, ISTC-5221 (a) (1) applies.</p> <p><u>Open Test</u> – The check valves will be exercised open using a mechanical exerciser in accordance with ISTC-5221(b)(1) to verify the force required to open the valve is satisfied. The valve is designed with a mechanical exerciser to allow adjustment of the balancing device inherent to the valves. The valve is designed to begin to lift off the seat at 0.2 psid. This value will be used as the acceptance criteria.</p> <p><u>Closed Test</u> - The valves will be verified to close during the mechanical exercise test in accordance with ISTC-5221(b)(3). The valves will be visually verified closed as well as leakage tested in accordance with the Appendix J program.</p>
3e	Description of plan to satisfy applicable ASME OM Code IST provisions and 10 CFR Part 50, Appendix J leak-testing requirements, including appropriate provisions for vacuum relief devices in Appendix I to ASME OM Code.	<p>Valves VPS-PL-V803A/B are 6" swing check valves designed as Class 2 with open and closed safety functions. The ASME OM Code was used to classify, categorize as well as specify the test requirements and frequencies described below.</p> <p>The valves are considered Active and categorized as AC in accordance with ASME OM Code, ISTC-1300. The valves are tested in accordance with ISTC-3500 and Table ISTC-3500-1 as both check valves and vacuum relief devices. Appendix I of the ASME OM Code will be applied for vacuum relief devices. The testing regime and frequencies are listed below</p> <ul style="list-style-type: none"> <li>• Full Stroke Exercise - Refuel Shutdown</li> <li>• Leakage Testing - In accordance with Appendix J frequency</li> <li>• Vacuum Relief Test – 2 Years</li> </ul> <p>The full stroke exercise test of this valve will ensure that the open set point is met by using a mechanical exerciser. The close test is performed in conjunction with the leakage test and visual observation.</p>

WESTINGHOUSE NON-PROPRIETARY CLASS 3

3f	Correction of valve size in draft DCP table 3.9-16 & inclusion of set pressure (Ch 6).	<p>Table 3.9-16 has been updated to reflect the correct valves sizes for VFS-PL-V800A/B and VFS-PL-V803A/B.</p> <p>Refer to Section 5 (Page ) for set pressure details.</p>
4	A discussion/explanation concerning the validity of the minimum service metal analysis specified in Westinghouse Document APP-MV50-ZOC-039, as modified by Westinghouse letter dated July 9, 2010, is required. Explain why it is still valid (i.e., still bounding), and if it not valid, provide the new analysis.	Per NRC RAI - 381 3.8.1 CIB1-01 Revision 5, Westinghouse has agreed to revise APP-MV50-ZOC-039, and it is still applicable as the basis for the determination of the Containment Vessel lowest service metal temperature.
5	<b>Draft DCP 74 does not contain any changes to Chapter 17 or 19 despite:</b>	
5a	There was a single minimum cutset for this system to fail containment, there are now nine. This may impact the Chapter 17 and possibly Tier 1 Section 3.7.	Cutsets are not provided in DCD Ch. 17. The only applicability for D-RAP and containment purge valves is whether or not they are required to be manipulated by the DAS. See section 8.0 for description and calculation as to why DAS manipulation of the vacuum relief system is not required. For Tier 1 Section 3.7 the system reliability calculation is included in Section 8.0 and demonstrates adequate reliability to not be included in Section 3.7.
5b	Of the 8 cutsets for VFS failing, half of them increase the risk significance of the existing vent valves.	That is correct the values do increase slightly, but are within the same order of magnitude.
5c	There appear to be two CCFs (CCF of MOVs to open and CCF of check valves to open) that will prevent adequate venting when required (the other system failure mode).	Section 8.0 contains the calculation for assessing the risk of the multiple CCFs.
5d	Preliminary analysis may not have recognized that these failures can be latent.	Section 8.0 contains the calculation and addresses latent failures.

WESTINGHOUSE NON-PROPRIETARY CLASS 3

6	<b>A discussion of the following is required:</b>	
6a	Analysis assumptions, including a description of how the relief valves are modeled (#, set points, size, timing, etc), any sensitivity studies performed, and how initial conditions were calculated with justification for the most limiting case is required.	Section 5.0 of this report contains the requested information.
6b	How tech specs are tied to analysis assumptions.	<p>The containment external pressure analyses develop the acceptable range of operation for the internal to external temperature differential. The Tech Specs are established to ensure that operation of the AP1000 is within the ranges analyzed for maximum external pressure. For example, LCO 3.6.10 requires the internal containment to external containment temperature differential be <math>\leq 90</math> °F, and that if this cannot be achieved then containment temperature must be reduced <math>&lt; 80</math> °F.</p> <p>The containment transients were performed to develop the 90°F internal to external temperature differential operating band. The analyses show that with the application of the vacuum relief system that no postulated mechanistic pressure excursion can occur that would cause the containment external pressure to be greater than 1.7 psid while operating within the specified range.</p> <p>The <math>&lt; 80</math>°F criteria allows for plant operation at cold conditions where the 90 °F differential cannot be maintained. A run performed at -40 °F external temperature with a containment internal temperature of <math>\sim 85</math> °F was mitigated by the performance of the vacuum relief system.</p>
6c	Tech spec changes incorporating changes to the containment air-only cooling calculation and $< 6$ MWt decay heat requirement (ILO 9MWt).	Tech Spec changes provided as part of this draft change package are only related to the revised external pressure analysis and the addition of the vacuum relief system. Additional changes to the affected Tech Specs will be compiled and one complete, comprehensive set of Tech Spec changes will be provided in the final transmittal of the Change Notice in accordance with Westinghouse procedures.

## 1.0 BACKGROUND

DCD 6.2.1.1.4, External Pressure Analysis, describes the requirement for operator action to mitigate the consequences of an event causing a vacuum to be developed inside containment. Evaluations have been performed that indicate a pressure reduction will be realized inside containment following low ambient temperature (-40 °F) coincident with a loss of AC power. DCD 6.2.1.1.4 credits opening of the 16" vent and purge lines to mitigate the pressure reduction prior to reaching the containment shell design external pressure (2.9 psig).

The DCD states that the vent and purge valves are powered from the 1E batteries. The valve solenoids are powered by the 1E batteries however the valves are air operated valves such that loss of AC or pneumatic supply will cause the valves to close on spring force. Without AC power or pneumatic supply, the valves cannot be reopened.

## 2.0 PROPOSED CHANGES

The proposed change adds a Vacuum Relief System to the existing Containment Air Filtration System (VFS) vent line penetration as seen in Figure 1. The vent line was selected based on the ability to 1) provide enough flow area and 2) inherent to the containment venting system design the vent line will be under a slight negative pressure (vacuum system check valves will tend to close) and will not short cycle the normal containment air flow when the purge/vent system is in operation.

The proposed vacuum relief system consists of redundant vacuum relief devices inside and outside containment sized to prevent differential pressure between containment and the shield building from exceeding the design value of -1.7 psig.

Each relief flow path consists of a check valve (V803A/B) inside containment and motor operated butterfly valve (V800A/B) outside of containment. The redundant relief devices outside containment share a common inlet line with redundant outside air flow entry points. The outlet lines downstream of the outside containment relief devices are routed to a common header connected to the vent line penetration. The redundant relief devices inside containment share a common inlet line from the vent line penetration and have independent discharge lines into containment. Each relief device is designed to provide 100% of the required capacity to prevent a differential pressure across the containment vessel from exceeding the design value. Each relief flow path provides the required capacity, such that a single failure of any of the relief devices will not limit the required flow below what is required to mitigate a containment vacuum relief event.

The butterfly valves are designed with motor operators that are powered from separate 1E DC battery sources. They are designed to close within 30 seconds of receipt of either an automatic containment isolation signal, or a manual isolation signal. The opening time is not significant when evaluating the performance of the vacuum relief system, but is inherent to the actuator sizing of the valve. Each valve is qualified to provide 100% of the required capacity to mitigate the most bounding containment transient that requires vacuum relief.

The check valves are balanced to remain closed during normal operations, including containment vessel venting, to prevent inadvertent opening or chatter. Each valve is designed to provide 100% of the required capacity at the vacuum relief set pressure -0.8 psig., The balanced design of the valve will cause the self actuated check valves to close when containment is at a slight negative pressure (on the order of 0.2 psid), which ensures the containment becomes isolated prior to containment pressurization.

**3.0 PROPOSED DCD CHANGES AND JUSTIFICATION TABLE**

This section provides a detailed description of each DCD change required to implement this proposed design change. The actual DCD markups required to implement this proposed change are provided in Section 4.0.

DCD	Title	Reason for Change
<b>Tier 1</b>		
Table 2.2.1-1	Containment System	Valves VFS-PL-V800A/B and VFS-PL-V803A/B have been added to the Containment System equipment table. The valves are indicated with active functions to Transfer Closed and Transfer Open.
Figure 2.2.1-1	Containment System	The proposed vacuum relief system has been added to the Containment System figure on the vent line penetration (Penetration #32).
Table 2.2.1-2	Containment System Piping	Line numbers L800, L801A/B, L803, L804, and L805A/B have been added to the Containment System safety related line number list.
Text 2.7.6	Containment Air Filtration System	The proposed Vacuum Relief System safety function was added to the Containment Air Filtration System Safety Function description.
Table 2.7.6-2	Inspections, Tests, Analyses, and Associated Criteria (ITAAC) Table for the VFS	The proposed Vacuum Relief System safety function was added to the Containment Air Filtration System ITAAC Table description.
<b>Tier 2</b>		
Table 3.2-3	AP1000 Classification of Mechanical and Fluid Systems, Components, and Equipment	Valves VFS-PL-V800A/B and VFS-PL-V803A/B have been added to the table as Class B, Seismic Category I, and ASME Section III Class 2 Construction Code.
Table 3.7.3-1	Seismic Category I Equipment Outside Containment by Room Number	The VFS vacuum relief motor operated valves (VFS-PL-V800A/B) are Seismic Category I and will be located outside containment in the VAS Equipment Room (Room # 12651). Removed VFS containment isolation valves from Room #12452.



3.0 PROPOSED DCD CHANGES AND JUSTIFICATION TABLE (CONTINUED)

Text 3.8.2.1.1	General	The CV Design External Pressure is defined as 1.7 psid based upon the actuation point of the containment vacuum relief system.
Text 3.8.2.4.1.1	Axisymmetric Shell Analyses	Transient analysis no longer determines the design external pressure of the CV; therefore this section is revised to remove references to analysis that defined external pressure.
Table 3.8.2-1	Load Combinations and Service Limits for Containment Vessel	The CV load combinations table is updated based upon the new single design external pressure.
Table 3.9-12	List of ASME Class 1, 2, and 3 Active Valves	Valves VFS-PL-V800A/B and VFS-PL-V803A/B have been added to the Active Valve List since they have an active ESF function.
Table 3.9-16	Valve In-service Test Requirements	Valves VFS-PL-V800A/B and VFS-PL-V803A/B have been added to the Inservice Testing requirements Table. Valves VFS-PL-V800A/B are categorized as A, with Active Safety Missions. Valves V800A/B will be full stroke exercised during refueling shutdowns only, remote position indication tested, and receive a leakage rate test. In addition, Valves V800A/B will be included in the AP1000 POV Program and will be tested accordingly. Valves VFS-PL-V803A/B are categorized as AC with Active Safety Missions. Valves V803A/B will be full stroke exercised and receive a leakage rate test. In addition, these valves are categorized as vacuum relief valves and will receive a vacuum relief test in accordance with Appendix I of the ASME OM Code. All of the requirements of the ASME OM Code have been addressed.
Table 3.11-1	Environmentally Qualified Electrical and Mechanical Equipment	Valves VFS-PL-V800A/B and their respective motors and limit switches have been added to the table with the ESF/PAMS functions and required Operating Times. Valves VFS-PL-V803A/B have been added to the table with and ESF Function and required Operating Times.
Table 3I.6-2	List of Potential High Frequency Sensitive AP1000 Safety-Related Electrical and Electro-Mechanical Equipment	The motor operators for valves VFS-PL-V800A/B have been added to the table as potential high frequency sensitive safety related components.  and limit switches

## 3.0 PROPOSED DCD CHANGES AND JUSTIFICATION TABLE (CONTINUED)

Table 3I.6-3	List of AP1000 Safety-Related Electrical and Mechanical Equipment Not High Frequency Sensitive	Valves VFS-PL-V800A/B and VFS-PL-V803A/B have been added to the table as not potential high frequency sensitive safety related components.
Text 6.2.1.1.4	External Pressure Analysis	This text defines the containment pressure transient that forms the basis for sizing the vacuum relief system. Previously, this text had been incorrect as it credited IE batteries to open the containment ventilation purge isolation valves to mitigate a low containment pressure event. The text has been changed to reflect the revised analysis inputs, assumptions and containment pressure transient response. Using the results of this analysis, the vacuum relief system was sized to ensure that containment external pressure does not exceed the containment vessel design limit.
Table 6.2.1.1-9	External Pressure Analysis	The new external pressure analysis figure was revised as well. New Table 6.2.1.1-9 was added to list key parameters and assumptions used in the transient analysis.
Figure 6.2.1.1-11	External Pressure Analysis	Figure 6.2.1.1-11 has been revised to reflect the new containment pressure transient analysis.
Table 6.2.3-1	Containment Mechanical Penetrations and Isolation Valves	Since the proposed vacuum relief system valves are included as part of the containment air filtration vent line, valves VFS-PL-V800A/B and VFS-PL-V803A/B have been added to the table with the following actuation signals: Closes on Containment Isolation, High Radiation, and Opens on Low-2 Containment Pressure. Notes 8 and 9 were added to the Table. Note 8 addresses the Low-2 containment pressure to open the valve. Note 9 addresses testing of valves V800A/B in the reverse direction. Added stroke time of 30 seconds for valves VFS-PL-V800A/B.
Text 6.2.3.5	Instrumentation and Control Application	Statement addressing the priority logic of the containment vacuum relief signal was added.

WESTINGHOUSE NON-PROPRIETARY CLASS 3

3.0 PROPOSED DCD CHANGES AND JUSTIFICATION TABLE (CONTINUED)

Text 9.4.7.2.1	Containment Air Filtration System General Description	A general description of the proposed vacuum relief system has been added to the Containment Air Filtration System General Description. Included is a statement addressing the impact of a radiological release through the 6" vacuum relief valves.
Text 9.4.7.2.2	Containment Air Filtration System Component Description	A description of the valve types and locations for the proposed vacuum relief system. Motor operated butterfly valves outside containment and self actuated swing check valves inside containment have been added to the Containment Air Filtration System Safety Evaluation.
Text 9.4.7.2.3	Containment Air Filtration System Abnormal Plant Operation	A description of the vacuum relief valve operation during abnormal plant operation is provided.
Text 9.4.7.3	Containment Air Filtration System Safety Evaluation	A description of the proposed vacuum relief system piping and valves has been added to the Containment Air Filtration System Safety Evaluation to describe the independent/redundant vacuum relief lines. A statement was also added describing that the independent and redundant lines share a common containment penetration.
Figure 9.4.7-1	Containment Air Filtration System Piping and Instrumentation Diagram	This DCD figure has been revised to include the proposed vacuum relief system.
Table 9A-2	Safe Shutdown Components	The motor operated valves (VFS- PL-V800A/B) included in the proposed vacuum relief system are located in Fire Area/Fire Zone 1200 AF 01. Valve VFS- PL-V800A is powered from Division A and valve VFS- PL-V800B is powered from Division C.
Tech Spec 3.3.2	ESFAS Actuation Instrumentation	The addition of a vacuum relief subsystem provides design basis protection during a containment overcooling condition to protect the containment vessel integrity. Therefore, a TS is required to identify the OPERABILITY requirements for the accident mitigation functions for this subsystem. Since this system is automatically actuated, TS 3.3.2 requires identifying the actuation signals and their set points.

## 6.1 WEC RESPONSE TO BRANCH TECHNICAL POSITION 6-4

### WEC Position for AP1000 Vacuum Relief Power Operated Valves: VFS- PL-V800A/B Stroke Time and Control Logic

#### Normal Vent/Purge Operation

The VFS is designed such that the 16" purge isolation valves (V003/4) and vent isolation valves (V009/10) may be open during normal operation to filter the containment atmosphere and adjust containment pressure and temperature. It is anticipated that the system will be in operation (valves VFS-V003/4/9/10) open for approximately 20 hours per week. The VFS isolation valves are fast closure air operated valves designed to close with 10 seconds upon receipt of a Containment Isolation or High Radiation signal. This function prevents the release of radioactivity to the environment and meets the requirements of Branch Technical Position 6-4 for greater than 8" vent and purge lines.

#### Vacuum Relief Power Operated Valve Design

Valves VFS- PL-V800A/B are the outboard vacuum relief power operated isolation valves. The valves are specified as ASME Section III Class 2, 6" butterfly valves with motor operators. The valve actuator is designed to close the valve upon receipt of a closure signal within 30 seconds. This meets the containment isolation requirements for closure as specified in ANSI 56.2, Section 4.4.4.

#### Valve Functional Requirements

Open – The subject valves are normally closed and must open to provide a flow path of air from the outside atmosphere to containment in the event of vacuum conditions inside containment. This function provides protection of the containment vessel during the bounding event: a loss of power event coincident with cold weather conditions, as well as normal expected transients. The valves open automatically upon receipt of a Low-2 containment pressure signal.

Closed – The valves must remain closed to isolate the containment atmosphere from the outside environment. They provide redundant isolation because the power operated valves are placed in series with check valves. This function preserves containment integrity and precludes the release of radioactivity to the environment. The valves receive both confirmatory Containment Isolation and High-1 Containment Radiation signals to close.

#### Control/Logic

These valves receive the following actuation signals:

Open – V800A/B open on the following signals

### WESTINGHOUSE NON-PROPRIETARY CLASS 3

- Low-2 Containment Pressure
- Manual Vacuum Relief System Actuation

Close – V800A/B close on the following signals

- Automatic Containment Isolation
- High-1 Containment Radiation Signal
- Manual Containment Isolation
- Manual Containment Cooling

Valves VFS- PL-V800A/B are normally maintained closed during all modes of operation with position indication and alarms in the main control room to indicate when they are open.

To preclude the alignment of purge line isolation valves (V009 and V010) being opened at the same time as the vacuum relief valves (V800A/B), the following interlocks exist:

- V800A/B can not be opened unless V009 is closed.
- If open, V800A/B will close when V009 is opened.

This interlock feature eliminates the need for fast closure of these valves and ensures containment integrity at all times.

### Valve Operation

During an event of a vacuum condition inside containment valves V800A/B receive an open command based on a Containment Low-2 Pressure signal.

Valves V800A/B have priority logic such that the “Open-on-Low-2 Containment Pressure” Signal has priority and is generated at a containment pressure of -0.8 psig. The valves open automatically upon receipt of this Low-2 containment pressure signal. Once the containment pressure increases above -0.2 psid, the Containment Low-2 Pressure signal is no longer present. The valve remains in the open position until one of the following occurs:

- Containment Isolation
- High-1 Containment Radiation
- Manual Actuation
- Manual Containment Cooling

This functionality ensures that any event requiring vacuum relief inside containment can be mitigated to protect the containment vessel. In an event resulting in a LOCA, containment isolation is also assured.

**Summary**

The 30 second stroke time is acceptable for the vacuum relief power operated isolation valves (VFS-PL-V800A/B) for the following reasons:

- In the event of a LOCA with these valves open, the releases of radioactivity during the maximum time for closure (30 seconds) of these valves has been analyzed (APP-SSAR-GSC-113). The radiological consequences are bounded by those currently present in DCD 15.6.5.3.
- For the calculation of the minimum backpressure for a LOCA, the mass loss through the 6" vacuum relief system with a 30 second valve closure time was evaluated to ensure that the current methodology of modeling the 16" purge line performance remains limiting. The mass loss through the 16" purge line with a valve closure time of 12 seconds is greater than the mass loss through the 6" vacuum relief line with a valve closure time of 30 seconds (APP-VFS-M3C-224).
- The vacuum relief power operated valves (V800A/B) are maintained closed during all modes of operation and are not relied upon for vent/purge operation. An alarm exists in the main control room to indicate when either V800A or V800B is open.
- An interlock exists to prevent opening of the vacuum relief power operated valves (V800A/B) if the vent valve (V009) inside containment is open.
- Tech Spec 3.6.10 requires action to be taken should the vacuum relief system be declared inoperable in Modes 1-4.
- Should failure of V009 to close occur simultaneously with a LOCA, the outboard valves (V010, V800A/B) in the flow path will perform their safety related close functions. Valve V010 will close in 10 seconds. Valves V800A/B will already be in their closed position.
- Should failure of V010 to close occur simultaneously with a LOCA, the inboard valves (V009, V803A/B) in the flow path will perform their safety related close functions. Valve V009 will close in 10 seconds. Valves V803A/B will already be in their closed position.

## 9.0 VALVE DETAILED DESIGN

Based on ASME Section III requirements for containment vacuum relief systems and ANSI 56.8 requirements for containment isolation, the outboard valves must be power operated (i.e. air, electric, or electro-hydraulic) with independent power sources. The inboard valves are required to be self actuated (i.e., simple check valve).

### 9.1 Outboard Motor Operated Valves VFS-PL-V800A/B:

#### 9.1.1 Mechanical Design Requirements

Valves VFS-800A/B are specified as ASME Class 2, 6" motor operated butterfly valves, with open and closed safety functions. They will be designed in accordance with DCD Tier 2 Section 3.9. A summary of mechanical design characteristics is provided below:

- Valve Material: Carbon Steel
- Disk Style: Triple offset with bi-directional flow
- Actuator: Motor Operated with locking gear sets to ensure actuator and shaft are held in position.
- Close: Torque switch controlled.
- Open: Limit with torque switch backup.
- Leak-Tightness: FCI Class V
- Capacity Coefficient: 868
- ~~Open/Close Stroke time of 30 seconds (max)~~
- Full Flow Capacity in 18 seconds

#### 9.1.2 Valve Electrical Requirements:

Based upon VFS-PL-V800A and V800B being required to be stroked twice for their design basis operation, electrical design will consider these loads in the design calculations as follows: The valve(s) will be considered a RANDOM load within the methodology required in IEEE485 for each of the two operations and will therefore be added to the first and second worst one minute time steps of the battery profile.

Electrical calculations, i.e. battery sizing and cable, take into consideration both starting current and stroke time rounded up to the whole minute(s) for all MOV operation(s). A computation has been performed in evaluation of this design change and demonstrates that the existing component rating requirements are adequate. This design change will be included in final design calculations for the IDS system.

#### 9.1.3 Testing Requirements

The ASME OM Code was used to classify and categorize as well as specify the test requirements and frequencies described below:

The valves are considered Active and categorized as A in accordance with DCD Tier 2 Section 3.9.6. The testing regime and frequencies are listed below:

- Full Stroke Exercise - Refuel Shutdown
- Remote Position Indication – 2 Years
- Leakage Testing - In accordance with Appendix J frequency
- Operability Test – In accordance with Power Operated Valve program

~~Periodic verification will be based on JOG Periodic Verification (PV) report. The key contributors to periodic test frequency will be:~~

- ~~3) Risk significance (established by WEC PRA)~~
- ~~4) Function margin (based upon standard industry equations (EPRI), along with incorporating BWROG-DC sizing methodology)~~

## **9.2 Inboard Self Actuated Valves VFS-PL-V803A/B:**

### **9.2.1 Mechanical Design Requirements**

Valves VFS-803A/B are specified as ASME Class 2, 6" swing check valves, with open and closed safety functions. They will be designed in accordance with the general requirements of Westinghouse valve specification APP-PV03-Z0-001. A summary of mechanical design characteristics is provided below:

- Valve Material: Carbon steel with soft seats
- Disk Style: Balanced
- 0.2 psi differential nominal cracking pressure
- Leak-Tightness: Per MSS-SP-61

Valves shall be installed in the horizontal direction, such that the checking element will close with gravity in the reverse flow direction.

### **9.2.2 Testing Requirements**

The ASME OM Code was used to classify and categorize as well as specify the test requirements and frequencies described below:

The valves are considered Active and categorized as AC in accordance with ASME OM Code, ISTC-1300. The valves are tested in accordance with DCD Tier 2 Section 3.9.6 and Appendix I of the ASME OM Code. The valves are also considered vacuum relief valves and will be designed in accordance with ASME BPV Code, Section III, Subsection NC-7000. The testing regime and frequencies are listed below:

- Full Stroke Exercise - Refuel Shutdown
- Leakage Testing - In accordance with Appendix J frequency
- Vacuum Relief Test – Refuel Shutdown

Since the valves have a safety function in both the open and closed directions, they will be tested in both directions. The check valves will be exercised open using a mechanical exerciser in accordance with ISTC-5221(b)(1). The valve is designed with a mechanical exerciser to allow adjustment of the balancing device inherent to the valves. The valve is designed to begin to lift off the seat at 0.2 psid. This value will be used as the acceptance criteria.

The valves will also be verified to close during the mechanical exercise test in accordance with ISTC-5221 (b)(3). The valves will be visually verified closed as well as leakage tested in accordance with the Appendix J program.



ENCLOSURE 5

Supplementary Information for CN74  
AP1000 Containment Vessel External Pressure Analysis and Design Information for Change Number 74  
Vacuum Relief System Flow Path Description  
Non-Proprietary

### Vacuum Relief System Flow Path Description

Upon activation of the vacuum relief system, outside air enters through two, open-ended, gooseneck fittings located on the roof of the Auxiliary Building above the VAS Fan Room 12553. The air then travels through a 6" pipeline (L800) before splitting into two 6" pipeline paths (L801A and L801B). Each path contains a single, 6" motor-operated butterfly valve (V800A or V800B). The airflow then recombines into a single 6" pipeline (L803) before entering a 16" pipe via a branch, tee fitting. The 16" pipe then expands into a 24" pipe and then expands again into a 36" pipe before penetrating containment at VFS Containment Penetration C02. Immediately after the penetration there is a very short run of a 36" pipeline (L204) that reduces to 16" (L203). From the 16" (L203) pipeline there is a branch tee that the airflow travels through into a 6" pipeline (L804). Once again the airflow splits into two streams on its way to one of two 6" check valves (V803A or V803B) located in 6" pipelines (L805A or L805B). Once the air passes through either one of the check valves (V803A or V803B) is released to the containment atmosphere.

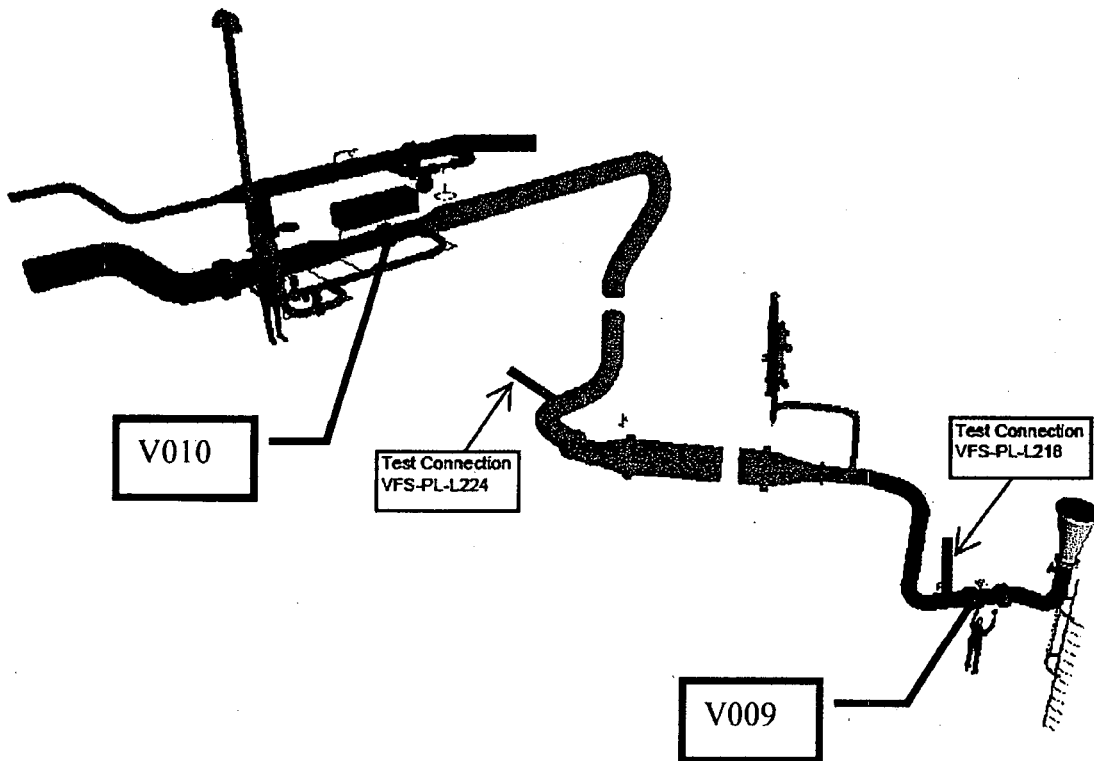

WESTINGHOUSE NON-PROPRIETARY CLASS 3

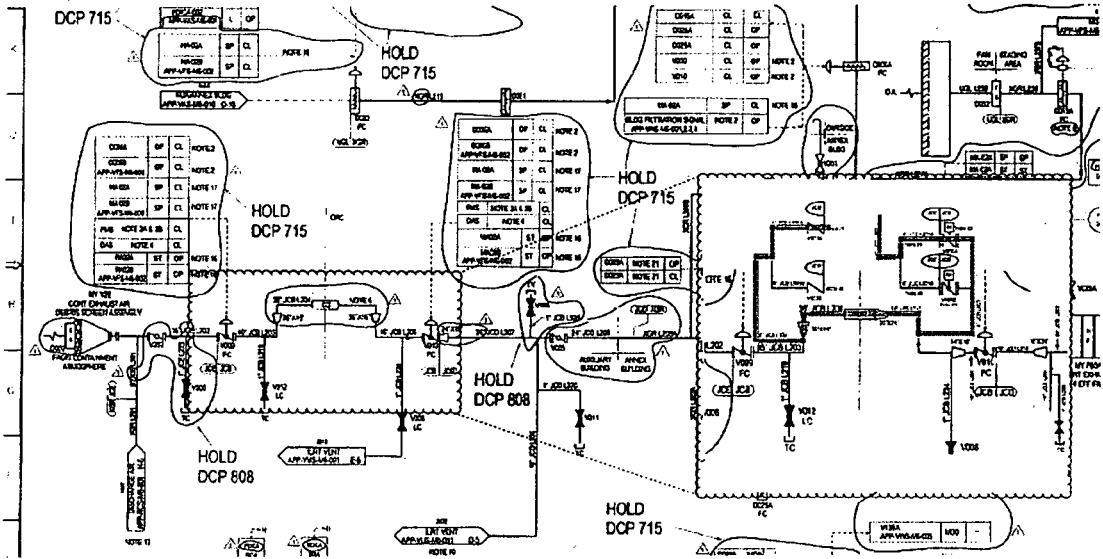

ENCLOSURE 6

Supplementary Information for CN74  
AP1000 Containment Vessel External Pressure Analysis and Design Information for Change Number 74  
Revised DCD Pages  
Non-Proprietary

Table 2.2.1-3 (cont.) Inspections, Tests, Analyses, and Acceptance Criteria		
Design Commitment	Inspections, Tests, Analyses	Acceptance Criteria
7. The CNS provides the safety-related function of containment isolation for containment boundary integrity and provides a barrier against the release of fission products to the atmosphere.	<p>i) A containment integrated leak rate test will be performed.</p> <p>ii) Testing will be performed to demonstrate that remotely operated containment isolation valves close within the required response times.</p>	<p>i) The leakage rate from containment for the integrated leak rate test is less than <math>L_a</math>.</p> <p>ii) The containment purge isolation valves (VFS-PL-V003, -V004, -V009, and -V010) close within 20 seconds, <u>containment vacuum relief isolation valves</u> (VFS-PL-V800A and -V800B) close within 30 seconds, SGS valves SGS-PL-V040A/B and SGS-PL-V057A/B are covered in Tier 1 Material, subsection 2.2.4, Table 2.2.4-4 (item 11.b.ii) and all other containment isolation valves close within 60 seconds upon receipt of an actuation signal.</p>
8. Containment electrical penetration assemblies are protected against currents that are greater than the continuous ratings.	An analysis for the as-built containment electrical penetration assemblies will be performed to demonstrate (1) that the maximum current of the circuits does not exceed the continuous rating of the containment electrical penetration assembly, or (2) that the circuits have redundant protection devices in series and that the redundant current protection devices are coordinated with the containment electrical penetration assembly's rated short circuit thermal capacity data and prevent current from exceeding the continuous current rating of the containment electrical penetration assembly.	Analysis exists for the as-built containment electrical penetration assemblies and concludes that the penetrations are protected against currents which are greater than their continuous ratings.
9. Safety-related displays identified in Table 2.2.1-1 can be retrieved in the MCR.	Inspection will be performed for retrievability of the safety-related displays in the MCR.	Safety-related displays identified in Table 2.2.1-1 can be retrieved in the MCR.
10.a) Controls exist in the MCR to cause those remotely operated valves identified in Table 2.2.1-1 to perform active functions.	Stroke testing will be performed on remotely operated valves identified in Table 2.2.1-1 using the controls in the MCR.	Controls in the MCR operate to cause remotely operated valves identified in Table 2.2.1-1 to perform active safety functions.

Table 2.5.2-3  
PMS Automatically Actuated Engineered Safety Features

Safeguards Actuation  
Containment Isolation  
Automatic Depressurization System (ADS) Actuation  
Main Feedwater Isolation  
Reactor Coolant Pump Trip  
CMT Injection  
Turbine Trip (Isolated signal to non-safety equipment)  
Steam Line Isolation  
Steam Generator Relief Isolation  
Steam Generator Blowdown Isolation  
Passive Containment Cooling Actuation  
Startup Feedwater Isolation  
Passive Residual Heat Removal (PRHR) Heat Exchanger Alignment  
Block of Boron Dilution  
Chemical and Volume Control System (CVS) Makeup Line Isolation  
Steam Dump Block (Isolated signal to non-safety equipment)  
MCR Isolation and Air Supply Initiation  
Auxiliary Spray and Letdown Purification Line Isolation  
Containment Air Filtration System Isolation  
Normal Residual Heat Removal Isolation  
Refueling Cavity Isolation  
In-Containment Refueling Water Storage Tank (IRWST) Injection  
IRWST Containment Recirculation  
CVS Letdown Isolation  
Pressurizer Heater Block (Isolated signal to non-safety equipment)  
Containment Vacuum Relief

**Table 2.5.2-4  
PMS Manually Actuated Functions**

Reactor Trip  
Safeguards Actuation  
Containment Isolation  
Depressurization System Stages 1, 2, and 3 Actuation  
Depressurization System Stage 4 Actuation  
Feedwater Isolation  
Core Makeup Tank Injection Actuation  
Steam Line Isolation  
Passive Containment Cooling Actuation  
Passive Residual Heat Removal Heat Exchanger Alignment  
IRWST Injection  
Containment Recirculation Actuation  
Control Room Isolation and Air Supply Initiation  
Steam Generator Relief Isolation  
Chemical and Volume Control System Isolation  
Normal Residual Heat Removal System Isolation  
Containment Vacuum Relief

Table 2.5.2-5 (cont.) Minimum Inventory of Displays, Alerts, and Fixed Position Controls in the MCR			
Description	Control	Display	Alert <sup>(1)</sup>
Passive Containment Cooling System (PCS) Storage Tank Water Level	-	Yes	No
PCS Cooling Flow	-	Yes	No
IRWST to Normal Residual Heat Removal System (RNS) Suction Valve Status <sup>(2)</sup>	-	Yes	Yes
Remotely Operated Containment Isolation Valve Status <sup>(2)</sup>	-	Yes	No
Containment Area High-range Radiation Level	-	Yes	Yes
Containment Pressure (Extended Range)	-	Yes	No
CMT Level	-	Yes	No
Manual Reactor Trip (also initiates turbine trip)	Yes	-	-
Manual Safeguards Actuation	Yes	-	-
Manual CMT Actuation	Yes	-	-
Manual MCR Emergency Habitability System Actuation	Yes	-	-
Manual ADS Stages 1, 2, and 3 Actuation	Yes	-	-
Manual ADS Stage 4 Actuation	Yes	-	-
Manual PRHR Actuation	Yes	-	-
Manual Containment Cooling Actuation	Yes	-	-
Manual IRWST Injection Actuation	Yes	-	-
Manual Containment Recirculation Actuation	Yes	-	-
Manual Containment Isolation	Yes	-	-
Manual Main Steam Line Isolation	Yes	-	-
Manual Feedwater Isolation	Yes	-	-
Manual Containment Hydrogen Igniter (Non-safety-related)	Yes	-	-
Manual Containment Vacuum Relief	Yes	-	-

Note: Dash (-) indicates not applicable.

2. These instruments are not required after 24 hours.



Table 2.7.6-2		
Design Commitment	Inspections, Tests, Analyses	Acceptance Criteria
1. The functional arrangement of the VFS is as described in the Design Description of this Section 2.7.6.	Inspection of the as-built system will be performed.	The as-built VFS conforms with the functional arrangement described in the Design Description of this Section 2.7.6.
2. The VFS provides the safety-related functions of preserving containment integrity by isolation of the VFS lines penetrating containment and providing vacuum relief for the containment vessel.	<p>i) See Tier 1 Material, Table 2.2.1-3, items 1 and 7.</p> <p>ii) <u>Testing will be performed to demonstrate that remotely operated containment vacuum relief isolation valves open within the required response time.</u></p>	<p>i) See Tier 1 Material, Table 2.2.1-3, items 1 and 7.</p> <p>ii) <u>The containment vacuum relief isolation valves (VFS-PL-V800A and VFS-PL-V800B) open within 30 seconds.</u></p>
3. The VFS provides the intermittent flow of outdoor air to purge the containment atmosphere during normal plant operation, and continuous flow during hot or cold plant shutdown conditions.	<p>i) Testing will be performed to confirm that containment supply AHU fan A when operated with containment exhaust fan A provides a flow of outdoor air.</p> <p>ii) Testing will be performed to confirm that containment supply AHU fan B when operated with containment exhaust fan B provides a flow of outdoor air.</p> <p>iii) Inspection will be conducted of the containment purge discharge line (VFS-L204) penetrating the containment.</p>	<p>i) The flow rate measured at each fan is greater than or equal to 3,600 scfm.</p> <p>ii) The flow rate measured at each fan is greater than or equal to 3,600 scfm.</p> <p>iii) The <u>nominal</u> line size is <math>\geq 36</math> in.</p>
4. Controls exist in the MCR to cause the components identified in Table 2.7.6-1 to perform the listed function.	Testing will be performed on the components in Table 2.7.6-1 using controls in the MCR.	Controls in the MCR operate to cause the components listed in Table 2.7.6-1 to perform the listed functions.
5. Displays of the parameters identified in Table 2.7.6-1 can be retrieved in the MCR.	Inspection will be performed for retrievability of the parameters in the MCR.	The displays identified in Table 2.7.6-1 can be retrieved in the MCR.

1. Introduction and General Description of Plant

AP1000 Design Control Document

Criteria Section	Referenced Criteria	AP1000 Position	Clarification/Summary Description of Exceptions
	App. A.1.f	Conforms	
	App. A.1.g	Conforms	
	App. A.1.h	Conforms	The characteristics of the AP1000 passive safety systems allow the support systems such as the cooling water systems, the heating, ventilating, and air conditioning and the ac power sources to be non-safety-related and simplified. The capability of these systems is established by testing. Cold water interlocks are not a design feature of the AP1000.
	App. A.1.i	Conforms	<p>The AP1000 has no secondary containment. Therefore, this guideline applies only to primary containment. The following systems or functions are not design features of the AP1000 and are therefore not tested:</p> <ul style="list-style-type: none"> <li>• Containment supplementary leak collection</li> <li>• Standby gas treatment</li> <li>• Secondary containment system</li> <li>• Containment annulus and cleanup</li> <li>• Bypass leakage tests on pressure suppression</li> <li>• Ice condenser systems</li> <li>• Containment penetration cooling</li> </ul>
	App. A.1.j	Conforms	Recirculation flow control, traversing incore probes, automatic dispatching control systems and hotwell level control are not design features of the AP1000.
	App. A.1.k	Conforms	
	App. A.1.l	Conforms	Condenser off gas systems are not a design feature of the AP1000.
	App. A.1.m	Conforms	
	App. A.1.n	Conforms	Seal water, boron recovery, shield cooling, refueling water storage tank heating, and equipment for establishing and maintaining subatmospheric pressures are not design features of the AP1000.
	App. A.1.o	Conforms	
	App. A.2	Conforms	As applicable for pressurized water reactor.
	App. A.3	Conforms	As applicable for pressurized water reactor.
	App. A.4	Conforms	As applicable for pressurized water reactor.

~~• Containment~~

~~and containment annulus vacuum breaker]~~

Table 3.9-16 (Sheet 24 of 26)

VALVE INSERVICE TEST REQUIREMENTS

Valve Tag Number	Description <sup>(1)</sup>	Valve/Actuator Type	Safety-Related Missions	Safety Functions <sup>(2)</sup>	ASME Class/IST Category	Inservice Testing Type and Frequency	IST Notes
VES-PL-V045	Eductor Flow Path Isolation Valve	Manual	Maintain Open Transfer Close	Active	Class 3 Category B	Exercise Full Stroke/2 Years	31
VES-PL-V046	Eductor Bypass Isolation Valve	Manual	Maintain Close Transfer Open	Active	Class 3 Category B	Exercise Full Stroke/2 Years	31
VFS-PL-V003	Containment Purge Inlet Containment Isolation Valve	Remote AO Butterfly	Maintain Close Transfer Close	Active-to-Failed Containment Isolation Safety Seat Leakage Remote Position	Class 2 Category A	Remote Position Indication, Exercise/2 Years Containment Isolation Leak Test Exercise Full Stroke/Quarterly Failsafe Test/Quarterly Operability Test	27, 31
VFS-PL-V004	Containment Purge Inlet Containment Isolation Valve	Remote AO Butterfly	Maintain Close Transfer Close	Active-to-Failed Containment Isolation Safety Seat Leakage Remote Position	Class 2 Category A	Remote Position Indication, Exercise/2 Years Containment Isolation Leak Test Exercise Full Stroke/Quarterly Failsafe Test/Quarterly Operability Test	27, 31
VFS-PL-V008	Containment Isolation Test Connection	Manual	Maintain Close	Containment Isolation Safety Seat Leakage	Category A	Containment Isolation Leak Test	27
VFS-PL-V009	Containment Purge Discharge Containment Isolation Valve	Remote AO Butterfly	Maintain Close Transfer Close	Active-to-Failed Containment Isolation Safety Seat Leakage Remote Position	Class 2 Category A	Remote Position Indication, Exercise/2 Years Containment Isolation Leak Test Exercise Full Stroke/Quarterly Failsafe Test/Quarterly Operability Test	27, 31
VFS-PL-V010	Containment Purge Discharge Containment Isolation Valve	Remote AO Butterfly	Maintain Close Transfer Close	Active-to-Failed Containment Isolation Safety Seat Leakage Remote Position	Class 2 Category A	Remote Position Indication, Exercise/2 Years Containment Isolation Leak Test Exercise Full Stroke/Quarterly Failsafe Test/Quarterly Operability Test	27, 31
VFS-PL-V800A	Vacuum Relief Containment Isolation A - ORC	Remote MO Butterfly	Maintain Close Transfer Close Maintain Open Transfer Open	Active Containment Isolation Safety Seat Leakage Remote Position	Class 2 Category A	Remote Position Indication, Exercise/2 Years Containment Isolation Leak Test Exercise Full Stroke/Refueling Shutdown Operability Test	27, 31
VFS-PL-V800B	Vacuum Relief Containment Isolation B - ORC	Remote MO Butterfly	Maintain Close Transfer Close Maintain Open Transfer Open	Active Containment Isolation Safety Seat Leakage Remote Position	Class 2 Category A	Remote Position Indication, Exercise/2 Years Containment Isolation Leak Test Exercise Full Stroke/Refueling Shutdown Operability Test	27, 31
VFS-PL-V803A	Vacuum Relief Containment Isolation Check Valve A - ORC	Relief	Maintain Close Transfer Close Transfer Open	Active Containment Isolation Safety Seat Leakage	Class 2 Category AC	Containment Isolation Leak Test Exercise Full Stroke/Refueling Shutdown Vacuum Relief Test 2 Years	39

Table 3.9-16 (Sheet 243 of 256)

VALVE INSERVICE TEST REQUIREMENTS

Valve Tag Number	Description <sup>(1)</sup>	Valve/Actuator Type	Safety-Related Missions	Safety Functions <sup>(2)</sup>	ASME Class/ IST Category	Inservice Testing Type and Frequency	IST Notes
VVS-PL-V803B	Vacuum Relief/Containment Isolation Check Valve B - IRC	Relief	Maintain Close Transfer Close Transfer Open	Active Containment Isolation Safety Seat Leakage	Class 2 Category AC	Containment Isolation Leak Test Exercise Full Stroke/Refueling Shutdown Vacuum Relief Test/2 Years	39
VWS-PL-V058	Fan Coolers Supply Containment Isolation	Remote AO Butterfly	Maintain Close Transfer Close	Active-to-Failed Containment Isolation Safety Seat Leakage Remote Position	Class 2 Category A	Remote Position Indication, Exercise/2 Years Containment Isolation Leak Test Exercise Full Stroke/Quarterly Fail-safe Test/Quarterly Operability Test	27, 28, 31
VWS-PL-V062	Fan Coolers Supply Containment Isolation	Check	Maintain Close Transfer Close	Active Containment Isolation Safety Seat Leakage	Class 2 Category AC	Containment Isolation Leak Test Check Exercise/Quarterly	27, 28
VWS-PL-V080	Fan Coolers Return Containment Isolation Thermal Relief Valve	Relief	Maintain Close Transfer Close Transfer Open	Active Containment Leakage Safety Seat Leakage	AC	Containment Isolation Leak Test/2 Years	27
VWS-PL-V082	Fan Coolers Return Containment Isolation	Remote AO Butterfly	Maintain Close Transfer Close	Active-to-Failed Containment Isolation Safety Seat Leakage Remote Position	Class 2 Category A	Remote Position Indication, Exercise/2 Years Containment Isolation Leak Test Exercise Full Stroke/Quarterly Fail-safe Test/Quarterly Operability Test	27, 28, 31
VWS-PL-V086	Fan Coolers Return Containment Isolation	Remote AO Butterfly	Maintain Close Transfer Close	Active-to-Failed Containment Isolation Safety Seat Leakage Remote Position	Class 2 Category A	Remote Position Indication, Exercise/2 Years Containment Isolation Leak Test Exercise Full Stroke/Quarterly Fail-safe Test/Quarterly Operability Test	27, 28, 31
WLS-PL-V055	Sump Discharge Containment Isolation IRC	Remote AO Plug	Maintain Close Transfer Close	Active-to-Failed Containment Isolation Safety Seat Leakage Remote Position	Class 2 Category A	Remote Position Indication, Exercise/2 Years Containment Isolation Leak Test Exercise Full Stroke/Quarterly Operation Fail-safe Test/Quarterly Operation Operability Test	27, 31
WLS-PL-V057	Sump Discharge Containment Isolation ORC	Remote AO PLUG	Maintain Close Transfer Close	Active-to-Failed Containment Isolation Safety Seat Leakage Remote Position	Class 2 Category A	Remote Position Indication, Exercise/2 Years Containment Isolation Leak Test Exercise Full Stroke/Quarterly Operation Fail-safe Test/Quarterly Operation Operability Test	27, 31
WLS-PL-V058	Sump Containment Isolation Thermal Relief Valve	Relief	Maintain Close Transfer Close Transfer Open	Active Containment Isolation Safety Seat Leakage	AC	Containment Isolation Leak Test/2 Years	27

38. The exercise stroke test for the VES pressure regulating valves will consist of a pressure drop test across the valve using the downstream test connection. This method ensures adequate testing of the valves.

(b) This note applies to the vacuum relief system check valves (VFS-V803A/B). It is not practical to exercise the check valves during normal power operation or during cold shutdown since the valves are located inside containment and require temporary test equipment for exercising. The inboard check valves will be full stroke exercised during refueling outages when the containment boundary is not required and containment entry is possible.

The actuation signal that occurs directly as a result of the event initiating containment isolation is designated in Table 6.2.3-1. If a change in valve position is required at any time following primary actuation, a secondary actuation signal is generated which places the valve in an alternative position. The closure times for automatic containment isolation valves are provided in Table 6.2.3-1.

The containment air filtration system is used to purge the containment atmosphere of airborne radioactivity during normal plant operation, ~~as described in subsection 9.4.7.~~ The containment vacuum relief system is a safety grade system, used to mitigate a containment external pressure scenario, and is part of the containment air filtration system. The containment air filtration system is designed in accordance with Branch Technical Position CSB 6-4. The purge component of the air filtration system uses 16-inch supply and exhaust lines and containment isolation valves. The vacuum relief component of the air filtration system uses 6-inch supply lines and containment isolation valves. These valves close automatically on a containment isolation signal. The entire containment air filtration system is described in subsection 9.4.7.

Section 3.6 describes dynamic effects of pipe rupture. Section 3.5 discusses missile protection, and Section 3.8 discusses the design of Category I structures including any structure used as a protective device. Lines associated with those penetrations that are considered closed systems inside the containment are protected from the effects of a pipe rupture and missiles. The actuators for power-operated isolation valves inside the containment are either located above the maximum containment water level or in a normally nonflooded area. The actuators are designed for flooded operation or are not required to function following containment isolation and designed and qualified not to spuriously open in a flooded condition.

Other defined bases for containment isolation are provided in SRP Section 6.2.4.

#### 6.2.3.2.2 Component Description

Codes and standards applicable to the piping and valves associated with containment isolation are those for Class B components, as discussed in Section 3.2. Containment penetrations are classified as Quality Group B and Seismic Category I.

Section 3.11 provides the normal, abnormal, and post-loss-of-coolant accident environment that is used to qualify the operability of power-operated isolation valves located inside the containment.

The containment penetrations which are part of the main steam system and the feedwater system are designed to meet the stress requirements of NRC Branch Technical Position MEB 3-1, and the classification and inspection requirements of NRC Branch Technical Position ASB 3-1, as described in Section 3.6. Section 3.8 discusses the interface between the piping system and the steel containment.

As discussed in subsection 6.2.3.5, the instrumentation and control system provides the signals which determine when containment isolation is required. Containment penetrations are either normally closed prior to the isolation signal or the valves automatically close upon receipt of the appropriate engineered safety features actuation signal.

resetting the original actuation signal. Resetting of the actuation signal does not cause any valve to change position. The design does not allow ganged reopening of the containment isolation valves. Reopening of the isolation valves is performed on a valve-by-valve basis, or on a line-by-line basis. Safeguards actuation signals take precedence over manual overrides of other isolation signals. For example, a containment isolation signal causes isolation valve closure even though the high containment radiation signal is being overridden by the operator. Containment isolation valves with power operators are provided with open/closed indication, which is displayed in the main control room. The valve mechanism also provides a local mechanical indication of valve position.

Vacuum relief containment isolation valves VFS-V800A/B receive containment isolation and high radiation signals to automatically close the valve, and low containment pressure to automatically open the valve. The Open signal has priority over the Close signal. The normally closed vacuum relief system motor-operated valves (MOVs) are designed to open automatically when containment pressure reaches -0.8 psig and remain open to preclude exceeding the containment external design pressure (1.7 psid). While the vacuum relief system MOVs are open, the containment will be at a vacuum and flow will be into containment. Once the vacuum condition inside the containment is reduced to near ambient pressure conditions (-0.2 psig), the Open signal is automatically cleared so that the vacuum relief system MOVs will then be allowed to close automatically in the event that a containment isolation signal or high radiation signal is present. In addition, check valves VFS-V803A/B are self-actuated check valves, which will also be closed if a vacuum does not exist inside the containment. The check valves will not be open until a 0.2 psid differential pressure exists. This is consistent with the vacuum relief system clear signal as well as the -0.2 psig containment pressure Technical Specification low alarm value.

Power supplies and control functions necessary for containment isolation are Class 1E, as described in Chapters 7 and 8.

#### 6.2.4 Containment Hydrogen Control System

The containment hydrogen control system is provided to limit the hydrogen concentration in the containment so that containment integrity is not endangered.

Following a severe accident, it is assumed that 100 percent of the fuel cladding reacts with water. Although hydrogen production due to radiolysis and corrosion occurs, the cladding reaction with water dominates the production of hydrogen for this case. The hydrogen generation from the zirconium-steam reaction could be sufficiently rapid that it may not be possible to prevent the hydrogen concentration in the containment from exceeding the lower flammability limit. The function of the containment hydrogen control system for this case is to promote hydrogen burning soon after the lower flammability limit is reached in the containment. Initiation of hydrogen burning at the lower level of hydrogen flammability prevents accidental hydrogen burn initiation at high hydrogen concentration levels and thus provides confidence that containment integrity can be maintained during hydrogen burns and that safety-related equipment can continue to operate during and after the burns.

The containment hydrogen control system serves the following functions:

- Hydrogen concentration monitoring

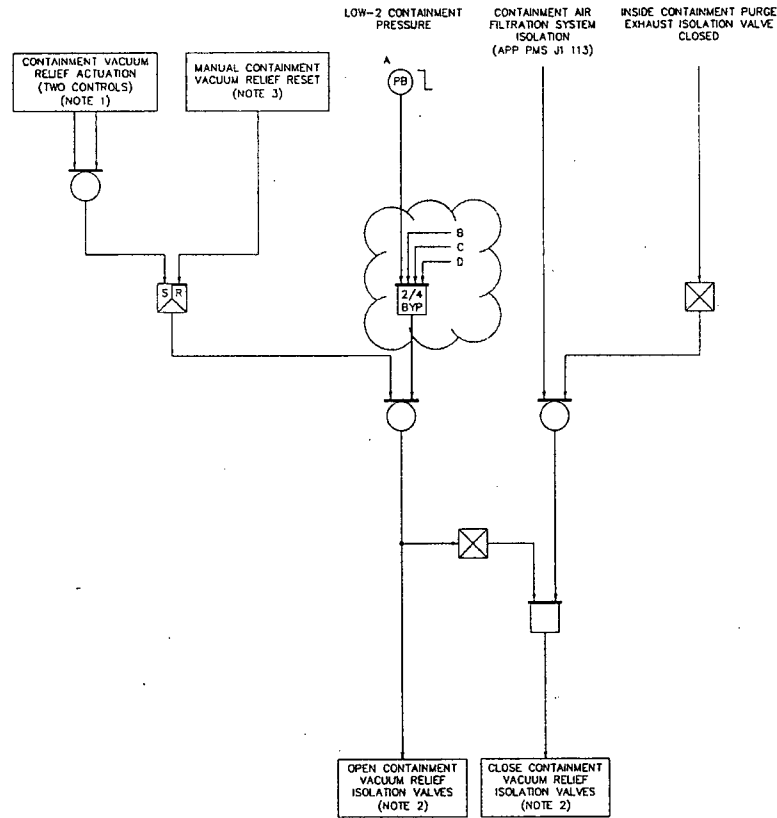

NOTES:

1. TWO MOMENTARY CONTROLS. OPERATING EITHER CONTROL WILL ACTUATE ALL APPLICABLE DIVISIONS.
2. COMPONENTS ARE ALL INDIVIDUALLY SEALED IN (LATCHED), SO THAT LOSS OF THE ACTUATION SIGNAL WILL NOT CAUSE THESE COMPONENTS TO RETURN TO THE CONDITION HELD PRIOR TO THE ADVENT OF THE ACTUATION SIGNAL.
3. SEPARATE MOMENTARY CONTROLS, ONE FOR EACH APPLICABLE DIVISION.

Figure 7.2-1 (Sheet 19 of 21)

Functional Diagram  
Containment Vacuum Relief Protection



Table 7.3-1 (Sheet 9 of 9)			
ENGINEERED SAFETY FEATURES ACTUATION SIGNALS			
Actuation Signal	No. of Divisions/ Controls	Actuation Logic	Permissives and Interlocks
Low IRWST level (Low-3 setpoint)	4	2/4-BYP <sup>1</sup>	None
b. Manual initiation	4 controls	2/4 controls <sup>3</sup>	None
<b>24. Chemical and Volume Control System Letdown Isolation</b> (Figure 7.2-1, Sheet 16)			
a. Low-1 hot leg level	1 per loop	1/2	Manual block permitted above P-12 Automatically unblocked below P-12
<b>25. Pressurizer Heater Trip</b> (Figure 7.2-1, Sheets 6 and 12)			
a. Core makeup tank injection	(See items 6a through 6e)		
b. High-3 pressurizer level	4	2/4-BYP <sup>1</sup>	Manual block permitted below P-19 Automatically unblocked above P-19
<b>26. Steam Generator Relief Isolation</b> (Figure 7.2-1, Sheet 9)			
a. Manual initiation	2 controls	1/2 controls	None
b. Low lead-lag compensated steam line pressure <sup>4</sup>	4/steam line	2/4-BYP <sup>1</sup> in either steam line	Manual block permitted below P-11 Automatically unblocked above P-11
<b>27. Close Component Cooling System Containment Isolation Valves</b> (Figure 7.2-1, Sheet 5)			
a. High reactor coolant pump bearing water temperature	4/pump	2/4-BYP <sup>1</sup> in affected pump	None
<b>28. Containment Vacuum Relief</b> (Figure 7.2-1, Sheet 19)			
a. Low-2 containment pressure	4	2/4-BYP <sup>1</sup>	None
b. Manual initiation	2 controls	1/2 controls	None

**Notes:**

- 2/4-BYP indicates bypass logic. The logic is 2 out of 4 with no bypasses and 2 out of 3 with one bypass.
- Any two channels from either tank not in same division.
- Two associated controls must be actuated simultaneously.
- Also, closes power-operated relief block valve of respective steam generator.
- The two-out-of-four logic is based on undervoltage to the battery chargers for divisions A or C coincident with an undervoltage to the battery chargers for divisions B or D.
- Any two channels from either loop not in same division.
- Any two channels from either line not in same division.
- This function does not meet the 10 CFR 50.36(c)(2)(ii) criteria and is not included in the Technical Specifications.

reducing the probability of a severe accident which potentially results from the unlikely coincidence of postulated transients and postulated common mode failure in the protection and control systems.

The protection and safety monitoring system is designed to prevent common mode failures. However, in the low probability case where a common mode failure does occur, the diverse actuation system provides diverse protection. The specific functions performed by the diverse actuation system are selected based on the PRA evaluation. The diverse actuation system functional requirements are based on an assessment of the protection system instrumentation common mode failure probabilities combined with the event probability.

The functional logic for the diverse actuation system is shown in Figure 7.2-1, sheets 1920 and 201.

The DAS is developed using a planned design process, which provides for specific design documentation during the following life cycle stages:

- Design Requirements Phase
- System Definition Phase

These life cycle stages are completed by developing a number of specific design documents. The following documents are developed to address the Design Requirements and System Definition Phases:

- WCAP-17184-P, "AP1000™ Diverse Actuation System Planning and Functional Design Summary Technical Report," including Appendix A, "DAS Setpoint Methodology Description," and Appendix B, "PRA Performance Requirements Associated with DAS Manual Actuation."

The DAS Technical Report identifies the DAS architecture and associated licensing basis at the functional design level. The overall DAS detailed design is not identified in the report. Select design details are identified only for the purpose of architectural completeness or licensing compliance. The content of this report is to cover SRP 7.8. Appendix A of the Technical Report describes the DAS setpoint methodology and provides a representative basis for DAS nominal trip setpoints. Appendix B addresses operator actions taken through DAS that are modeled in the "AP1000 Probabilistic Risk Assessment" (PRA). These manual actions are not required to mitigate design basis accidents but instead are modeled in the PRA to provide insights into sequences that involve multiple failures. This appendix lists the operator actions used in the PRA for manual DAS actions from the control room DAS actuation panel.

- WCAP-15775, "AP1000 Instrumentation and Control Defense-in-Depth and Diversity Report"

Diversity is a principle in instrumentation of sensing different variables, using different technology, using different logic or algorithms, or using different actuation means to provide different ways of responding to postulated plant conditions. NUREG/CR-6303 segregates the types of diversity into six different areas: human, design, software,

#### 9.4.6.4 Tests and Inspections

The containment recirculation cooling system is designed to permit periodic inspection of system components. Each component is inspected prior to installation. Components of the system are accessible for periodic inspection. A system air balance test and adjustment to design conditions is conducted in the course of the plant preoperational test program. Instruments are calibrated during testing. Automatic controls are tested for actuation at the proper setpoints. Alarm functions are checked for operability.

The system airflows are balanced in accordance with SMACNA HVAC Systems - Testing, Adjusting and Balancing (Reference 19).

#### 9.4.6.5 Instrumentation Application

The containment recirculation cooling system is controlled by the plant control system. Process indication and alarm signals are locally accessible through the plant control system. Refer to subsection 7.1.1 for a description of the plant control system.

Temperature controllers are provided in the ring headers of the corresponding containment recirculation fan coil unit which provide an input signal to modulate the central chilled water system supply valves to the cooling coils. The containment volumetric average high and low temperature are monitored and alarmed when the temperature is out of the normal operating range. The ambient temperature in a specific equipment compartment or areas of the containment are monitored and alarmed.

The discharge flowrate from each containment recirculation fan unit is monitored and low flow condition is alarmed to alert the operator for a manual start of the spare fan unit. Flow to the reactor cavity is also monitored and low flow condition is alarmed.

#### 9.4.7 Containment Air Filtration System

The containment air filtration system (VFS) serves the containment, the fuel handling area and the other radiologically controlled areas of the auxiliary and annex buildings, except for the hot machine shop and health physics areas which are served by a separate ventilation system.

##### 9.4.7.1 Design Basis

##### 9.4.7.1.1 Safety Design Basis

The containment air filtration system serves no safety-related function, other than provides the safety-related functions of containment isolation and containment vacuum relief, and therefore has no nuclear safety design basis except for containment isolation. System equipment and ductwork whose failure could affect the operability of safety-related systems or components are designed to seismic Category II requirements. The remaining portion of the system is non-seismic. See subsection 6.2.3 for a description of the containment isolation system. System equipment and ductwork whose failure could affect the operability of safety-related systems or components are designed to seismic Category II requirements. The remaining portion of the system is nonseismic. The containment isolation function is described in subsection 6.2.3. The

containment vacuum relief function automatically adjusts the internal containment pressure as it approaches the analyzed design parameters described in subsection 6.2.1.1.4. This adjustment in the pressure across the containment shell preserves the structural integrity of the shell by maintaining the differential pressure within the allowable limits as defined by the structural analysis described in subsection 3.8.2. The vacuum relief function is actuated on the Low-2 containment pressure signal and manually.

#### 9.4.7.1.2 Power Generation Design Basis

##### Containment Area

The containment air filtration system provides the following functions:

- Provides intermittent flow of outdoor air to purge the containment atmosphere of airborne radioactivity during normal plant operation, and continuous flow during hot or cold plant shutdown conditions to provide an acceptable airborne radioactivity level prior to personnel access
- Provides intermittent venting of air into and out of the containment to maintain the containment pressure within its design pressure range during normal plant operation
- Directs the exhaust air from the containment atmosphere to the plant vent for monitoring, and provides filtration to limit the release of airborne radioactivity at the site boundary within acceptable levels
- Monitors gaseous, particulate and iodine concentration levels discharged to the environment through the plant vent

The system conditions and filters outside air supplied to the containment for compatibility with personnel access during maintenance and refueling operations. Based on the maximum and minimum outside air normal temperature conditions shown in Chapter 2, Table 2-1, the system supplies air between 50 and 70°F. The air is distributed and conditioned within the containment by the containment recirculation system (subsection 9.4.6).

##### Radiologically Controlled Areas Outside Containment

The containment air filtration system provides filtration of exhaust air from the fuel handling area, auxiliary, or annex buildings to maintain these areas at a slightly negative pressure with respect to the adjacent areas when the radiologically controlled area ventilation system detects high airborne radioactivity or high pressure differential. Refer to subsection 9.4.3 for a description of the radiologically controlled area ventilation system.

#### 9.4.7.2 System Description

The containment air filtration system is shown in Figure 9.4.7-1.

registers, exhaust fans, filtration units, automatic controls and accessories. The supply air handling units are located in the south air handling equipment room of the annex building at elevation 158'-0". The supply air handling units are connected to a common air intake plenum, located at the south end of the fan room. The common air intake plenum #3 is located at the extreme south end of the annex building between elevation 158'-0" and about 180'-0". This plenum supplies air for the radiologically control area ventilation system, and the containment air filtration system. The intake is not protected from tornado missiles. The containment air filtration system supply air handling units discharge the supply air towards the east containment recirculation cooling system (VCS) recirculation unit to distribute the purge air within the containment. Refer to subsection 9.4.6 for a description of the containment recirculation cooling system.

The exhaust air filtration units are located within the radiologically controlled area of the annex building at elevation 135'-3" and 146'-3". The filtration units are connected to a ducted system with isolation dampers to provide HEPA filtration and charcoal adsorption of exhaust air from the containment, fuel handling area, auxiliary and annex buildings. A gaseous radiation monitor is located downstream of the exhaust air filtration units in the common ductwork to provide an alarm if abnormal gaseous releases are detected. The plant vent exhaust flow is monitored for gaseous, particulate and iodine releases to the environment. During containment purge, the exhaust air filtration units satisfy 10 CFR 50 Appendix I guidelines (Reference 20) for offsite releases and meets 10 CFR 20 (Reference 21) allowable effluent concentration limits when combined with gaseous releases from other sources. During conditions of abnormal airborne radioactivity in the fuel handling area, auxiliary and/or annex buildings, the filtration units provide filtered exhaust to minimize unfiltered offsite releases.

The size of the containment air filtration system supply and exhaust air lines that penetrate the containment pressure boundary is 36 inches in diameter. Each penetration includes an inboard and outboard branch connection with 16 inch diameter containment isolation valves that are opened when the containment air filtration system is connected to the containment. The ends of the 36 inch containment penetrations are capped for possible future addition of a high volume purge system. In the event of a loss-of-coolant accident (LOCA) while the containment air filtration system is aligned to containment, there will not be a significant release of radioactivity during closure of the 16 inch diameter supply and exhaust valves. The maximum time for valve closure (see Table 6.2.3-1) is consistent with the analysis assumptions for radiological consequences (see Table 15.6.5-2). The closure time is also consistent with the basis (compliance with 10 CFR Part 50.34100) for Branch Technical Position CSB 6-4 to Standard Review Plan 6.2.4 (Reference 23) or described in Subsection 6.2.1.5.

The exhaust air containment penetration also includes a containment vessel vacuum relief function to protect the containment from reaching the containment shell design external design pressure. In the event of a LOCA, while these 6-inch motor-operated vacuum relief valves are open, the releases of radioactivity during the maximum time for closure of these valves (see Table 6.2.3-1) have been evaluated. The radiological consequences are bounded by those currently presented in subsection 15.6.5.3. The maximum time for closure of the vacuum relief valves was also evaluated to determine the impact for the calculation of the LOCA minimum backpressure. The methodology depicted in subsection 6.2.1.5 bounds the minimum backpressure calculation.

Table 18.12.2-1 (Sheet 2 of 2)

**MINIMUM INVENTORY OF  
FIXED POSITION CONTROLS, DISPLAYS, AND ALERTS**

Description	Control	Display	Alert <sup>(2)</sup>
Manual reactor trip (Also initiates turbine trip Figure 7.2-1, sheet 19.)	x		
Manual safeguards actuation	x		
Manual CMT actuation	x		
Manual main control room emergency habitability system actuation <sup>(4)</sup>	x		
Manual ADS actuation (1-3 and 4)	x		
Manual PRHR actuation	x		
Manual containment cooling actuation	x		
Manual IRWST injection actuation	x		
Manual containment recirculation actuation	x		
Manual containment isolation	x		
Manual main steam line isolation	x		
Manual feedwater isolation	x		
Manual containment hydrogen igniter (nonsafety-related)	x		
Manual containment vacuum relief	x		

**Notes:**

1. Although this parameter does not satisfy any of the selection criteria of subsection 18.12.2, its importance to manual actuation of ADS justifies its placement on this list.
2. These parameters are used to generate visual alerts that identify challenges to the critical safety functions. For the main control room, the visual alerts are embedded in the safety-related displays as visual signals. For the remote shutdown workstation, the visual alerts are embedded in the nonsafety-related displays as visual signals.
3. These instruments are not required after 24 hours. (Subsection 7.5.4 includes more information on the class 1E valve position indication signals, specified as part of the post-accident monitoring instrumentation.)
4. This manual actuation capability is not needed at the remote shutdown workstation.

Table 19.55-2 (Sheet 5 of 5)

**BASIC EVENTS HCLPF VALUES**

<u>Basic Events ID</u>	<u>Basic Events Description</u>	<u>HCLPF (g)</u>	<u>Source</u>
<u>EQ-SHBLD-ROOF</u>	<u>Shield Building Roof Fails</u>	<u>0.71</u>	
<u>EQ-SHBLD-WALL</u>	<u>Shield Building Wall Fails</u>	<u>0.71</u>	<u>Same as roof</u>
<u>EQ-SLB</u>	<u>Failure of Feed and Steam Pipes on Secondary Side</u>	<u>0.81</u>	
<u>EQ-TRSF SWITCH</u>	<u>Transfer Switches Fail</u>	<u>0.5</u>	<u>Limiting value among those provided for electrical equipment</u>
<u>EQ-VFS-AOV-0304</u>	<u>Containment Air Filtration System Containment Air Supply Isolation Valves Air-Operated Valves 03 and 04 Fail</u>	<u>0.81</u>	<u>In rooms 12452/11400, above elevation 100'</u>
<u>EQ-VFS-AOV-0910</u>	<u>Containment Air Filtration System Containment Air Exhaust Isolation Valves Fail (009, 010, 800A/B, and 803A/B)</u>	<u>0.81</u>	<u>In rooms 12452/11400, above elevation 100'</u>
<u>EQ-WLS-AOV-5557</u>	<u>Liquid Radwaste System Containment Sump Isolation Valves Air-Operated Valves 55 and 57 Fail</u>	<u>0.81</u>	<u>In rooms 11300/12244, above elevation 100'</u>

Table 19.59-18 (Sheet 17 of 25)	
<b>AP1000 PRA-BASED INSIGHTS</b>	
<b>Insight</b>	<b>Disposition</b>
34. Depressurizing the RCS and maintaining a water level covering the SG tubes on the secondary side can mitigate fission product releases from a steam generator tube rupture accident. Severe accident management guidance is developed and implemented using the suggested framework provided in APP-GW-GL-027.	19.59.10
35. Loss of ac power does not contribute significantly to the core damage frequency. - Nonsafety-related containment spray does not need to be ac independent.	19.59
36. AP1000 has a nonsafety-related containment spray system.  Containment spray is not credited in the PRA. Failure of the nonsafety-related containment spray does not prevent the plant achieving the safety goals.  Severe accident management guidance for operation of the nonsafety-related containment spray system is developed and implemented using the suggested framework provided in APP-GW-GL-027.	6.5.2  19.59  19.59.10
37. Passive containment can withstand severe accidents without PCS water cooling the containment shell. Air cooling alone is sufficient to maintain containment pressure below failure pressure with high probability.	19.40
38. Operation of ADS stage 4 provides a vent path for the severe accident hydrogen to the steam generator compartments, bypassing the IRWST, and mitigating the conditions required to produce a diffusion flame near the containment wall.	19.41
39. Containment isolation valves controlled by DAS are important in limiting offsite releases following core melt accidents. <del>The containment isolation valves are included in the D-RAP.</del> These valves are identified as being risk-significant SSCs and are included in the D-RAP.  Operability of DAS for selected containment isolation actuations is addressed by short-term availability controls.	17.4  16.3
40. Reflooding the reactor pressure vessel through the break can have a significant effect on a severe accident by quenching core debris, achieving a controlled stable state, and producing hydrogen.	19.38 & 19.41
41. The type of concrete used in the basemat is not important.  The reactor cavity design incorporates features that extend the time to basemat melt-through in the event of RPV failure. The cavity design includes:  - A minimum floor area of 48 m <sup>2</sup> available for spreading of the molten core debris  - A minimum thickness of concrete above the embedded containment liner of 0.85 m	Appendix 19B  Appendix 19B



Table 19.59-18 (Sheet 25 of 25)

**AP1000 PRA-BASED INSIGHTS**

Insight	Disposition
<p>83. The passive cooling system louvers and screens cover 29 large vertical openings located all around the containment, each 9 feet high by 12 feet long, into an enclosed volume where the air inlet ducts are located. The screens are designed to help prevent foreign objects or debris from entering the air flow path. In the event of a snow or ice storm, some fraction of these air inlets can become blocked with snow or ice. The results of analysis, made available to the staff during the design certification of the AP1000, show that a considerable fraction of the inlet area can be blocked without a significant effect on the peak containment pressure for design basis events.</p> <p>Louvers are arranged within the air inlets to minimize the entrance of debris into the inlets. These louvers are fixed and, therefore, will not block the air flow path.</p> <p>The chimney outlet is designed to produce the necessary air flow in the event of an accident. The outlet contains two heavy grates to guard against missiles, and it is fully screened to prevent foreign objects from entering the containment annulus. The presence of a positive air flow during normal operation helps prevent ice and snow from entering the chimney.</p> <p>There is a surveillance requirement (SR 3.6.6.5) to verify every 24 months that the air flow path is unobstructed.</p>	<p>6.2.2.2.4</p> <p>3.6.6</p>
<p>84. The AP1000 is protected against external floods up to the 100-foot level, which corresponds to the ground level at each plant. From this point, the ground is graded so that water naturally flows away from the plant structures.</p>	
<p>85. The plant is designed such that the 100-foot level is slightly above grade and the level of anticipated external flooding. Below grade is protected against flooding by a water barrier consisting of waterstops and a waterproofing system. Seismic Category I SSCs below grade are designed to withstand hydrostatic pressures.</p> <p>The seismic Category I SSCs below grade are protected against external flooding by a water barrier consisting of waterstops and a waterproofing system.</p>	<p>3.4.1.1.1</p>
<p>86. <u>The vacuum relief system is important for the integrity of the containment during an event where a vacuum is developed inside containment. The vacuum relief system consists of redundant relief devices, and its function is to prevent differential pressure between the inside and outside of the containment from exceeding the design value.</u></p>	