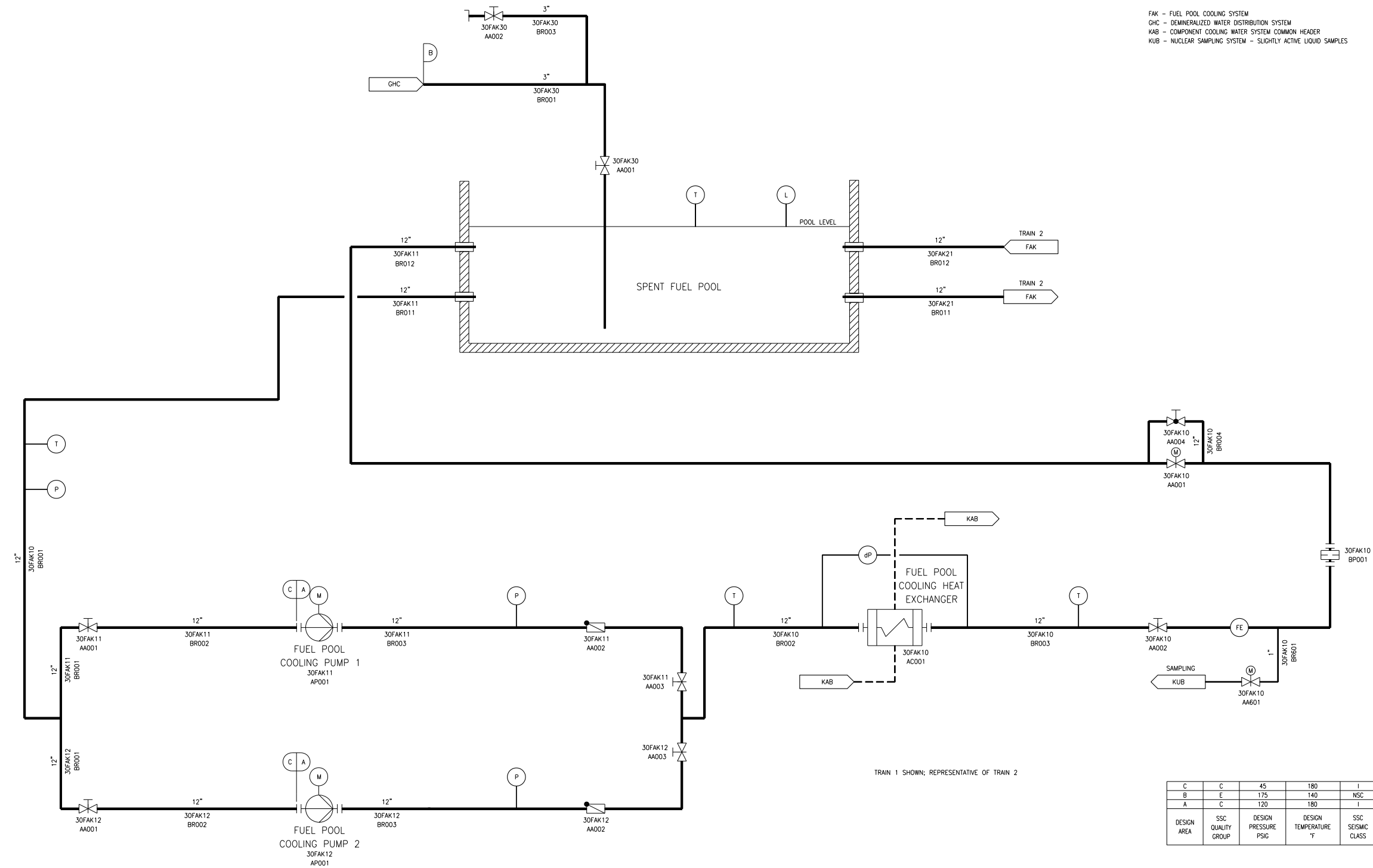
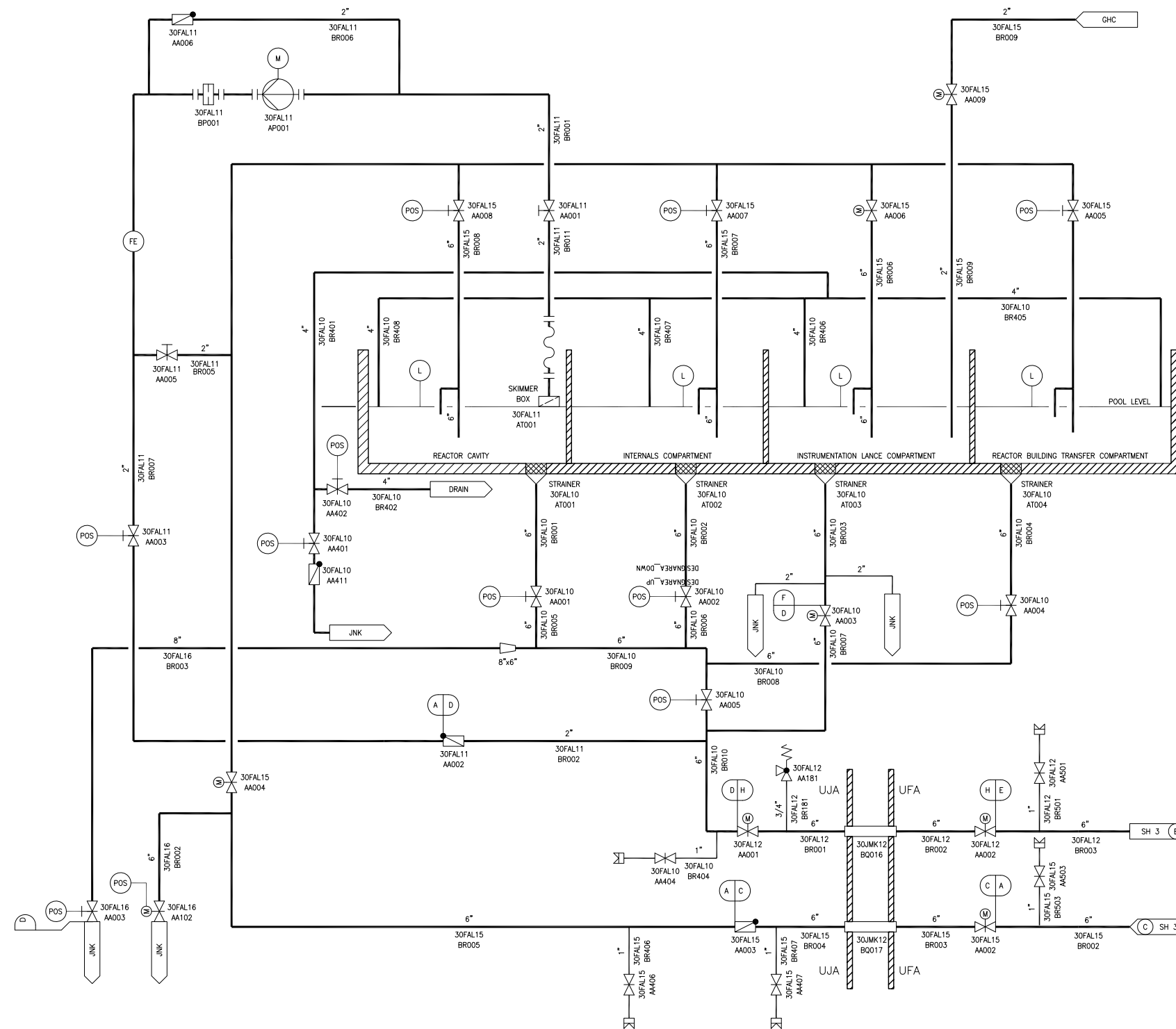

Figure 9.1.3-1—Fuel Pool Cooling System



FAK01T2

Figure 9.1.3-2—Fuel Pool Purification System
Sheet 1 of 5



FAL - FUEL POOL PURIFICATION SYSTEM
 GHC - DEMINERALIZED WATER DISTRIBUTION SYSTEM
 JNK - IN-CONTAINMENT REFUELING WATER STORAGE TANK SYSTEM
 UFA - FUEL BUILDING
 UJA - REACTOR BUILDING

D	C	175	140	I
F	D	62	338	II
H	B	90	338	I
E	D	110	140	NSC
C	B	175	338	I
A	D	175	140	NSC
DESIGN AREA	SSC QUALITY GROUP	DESIGN PRESSURE PSIG	DESIGN TEMPERATURE °F	SSC SEISMIC CLASS

REV 002
FAL0112

Figure 9.1.3-2—Fuel Pool Purification System
Sheet 2 of 5

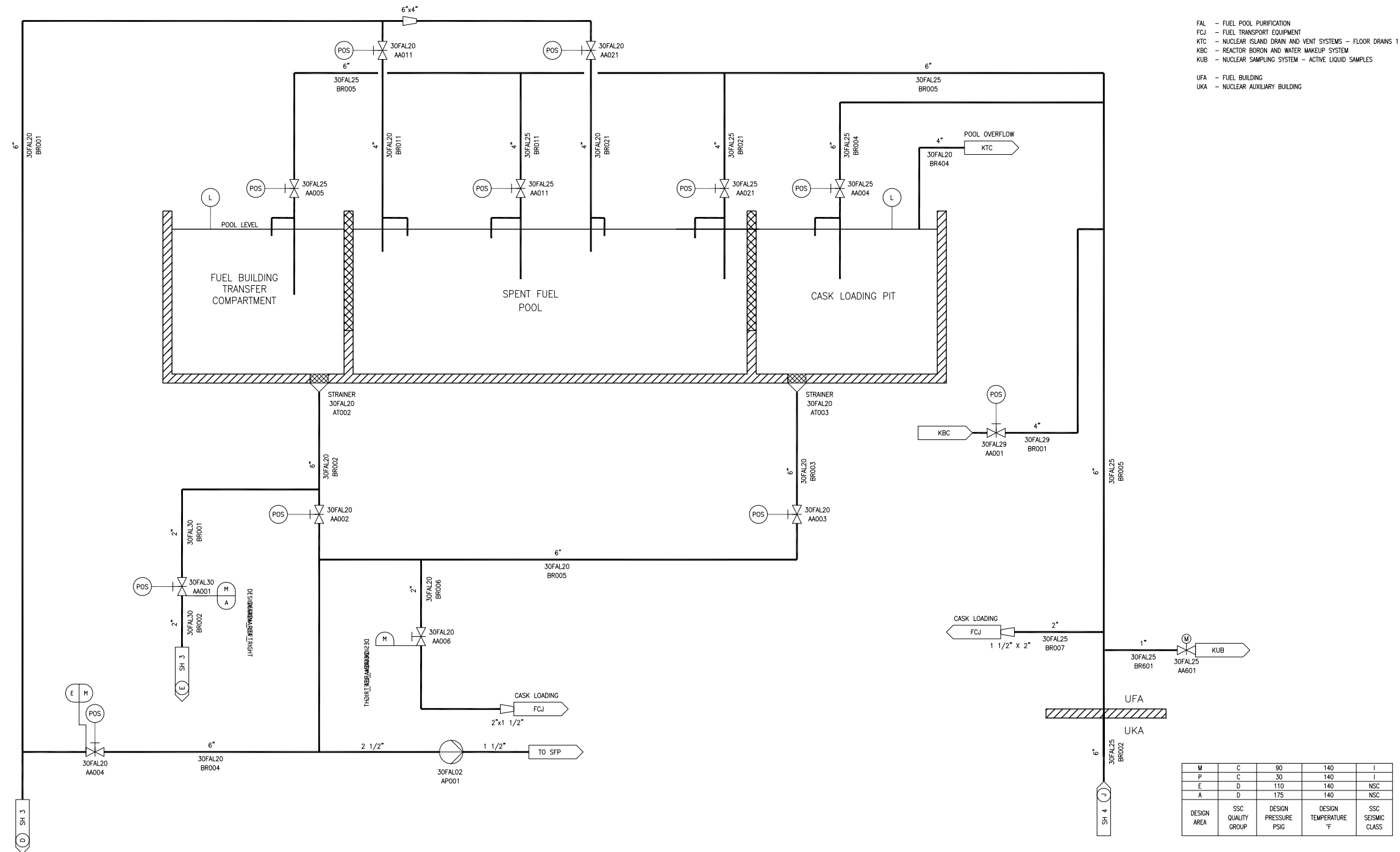

REV 002
FAL02T2

Figure 9.1.3-2—Fuel Pool Purification System
Sheet 3 of 5

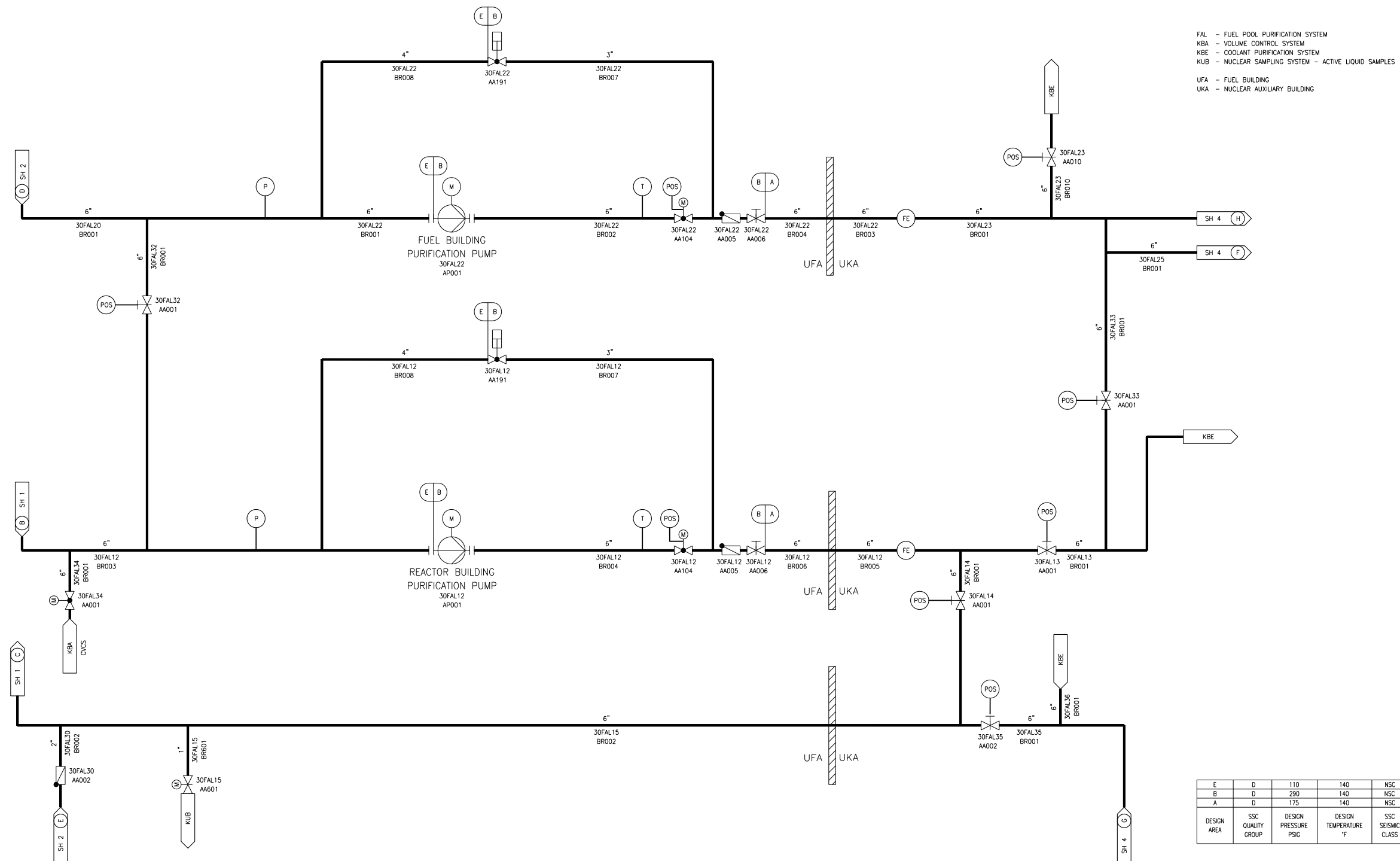

FAL03T2

Figure 9.1.3-2—Fuel Pool Purification System
Sheet 4 of 5

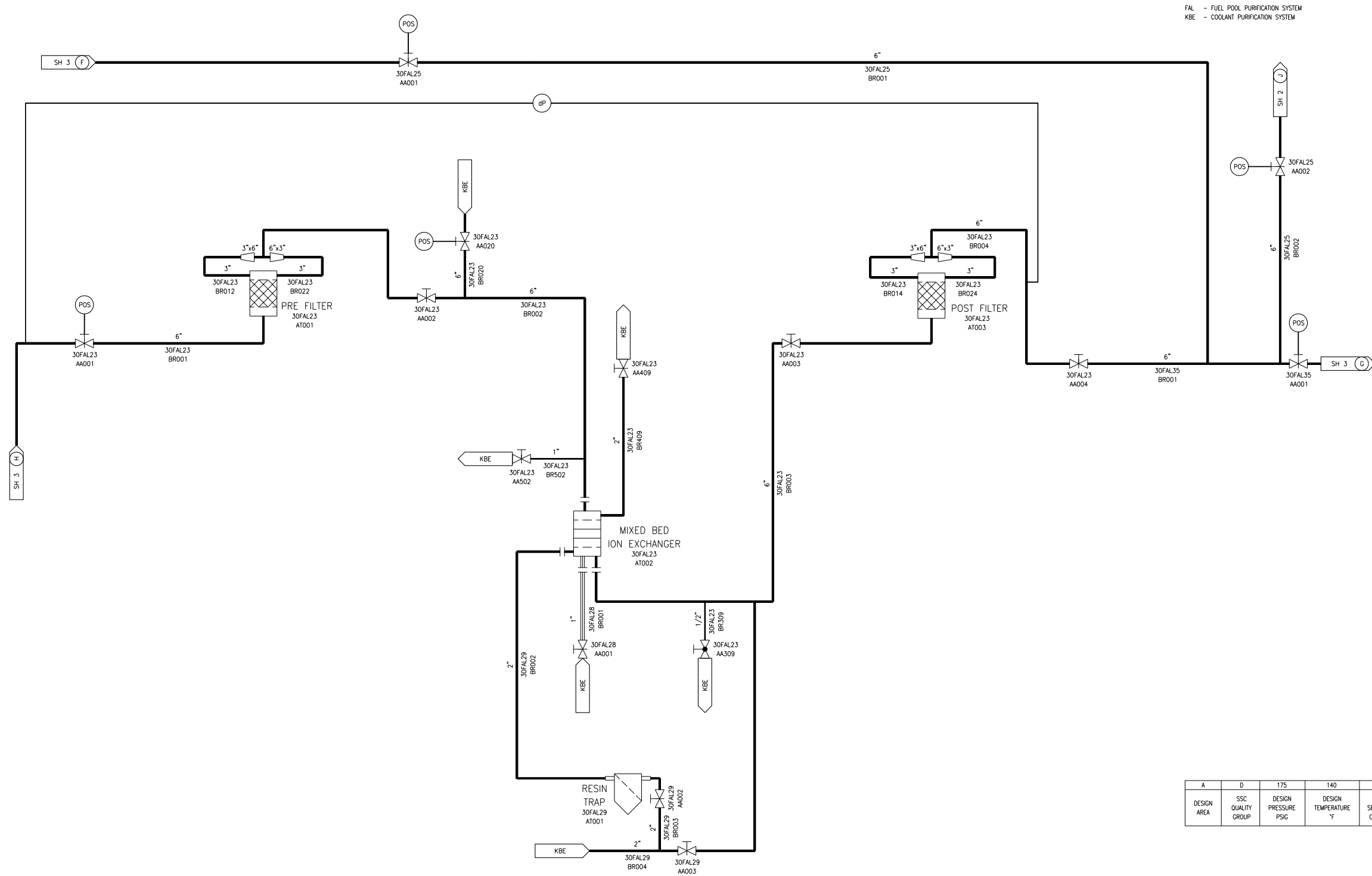

FAL - FUEL POOL PURIFICATION SYSTEM
KBE - COOLANT PURIFICATION SYSTEM

A	D	175	140	NSC
DESIGN AREA	SSC QUALITY GROUP	DESIGN PRESSURE PSIG	DESIGN TEMPERATURE °F	SSC SEISMIC CLASS

FAL04T2

Figure 9.1.3-2—Fuel Pool Purification System
Sheet 5 of 5

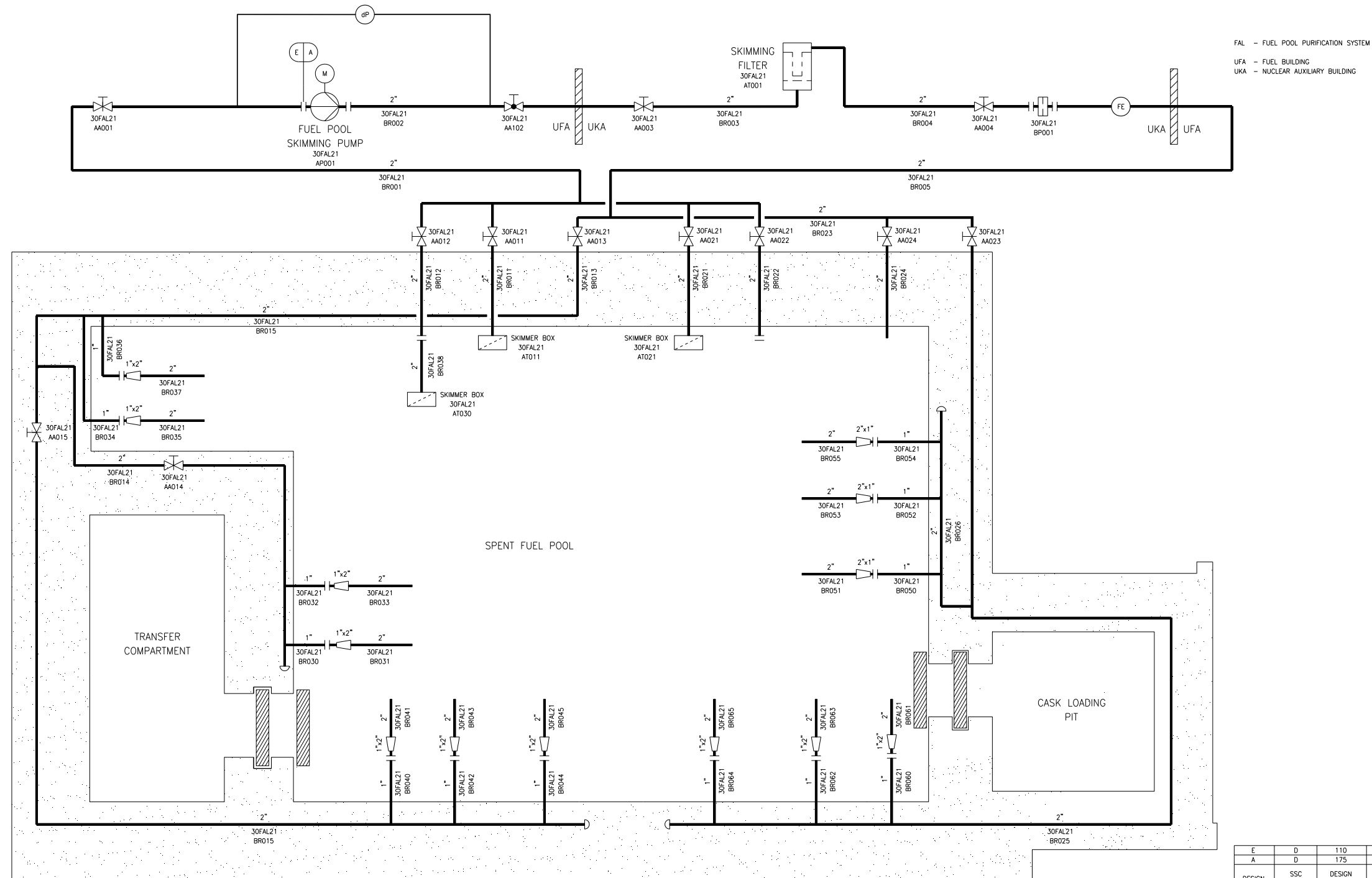

FAL - FUEL POOL PURIFICATION SYSTEM
UFA - FUEL BUILDING
UKA - NUCLEAR AUXILIARY BUILDING

E	D	110	140	NSC
A	D	175	140	NSC
DESIGN AREA	SSC QUALITY GROUP	DESIGN PRESSURE PSIG	DESIGN TEMPERATURE °F	SSC SEISMIC CLASS

FAL05T2