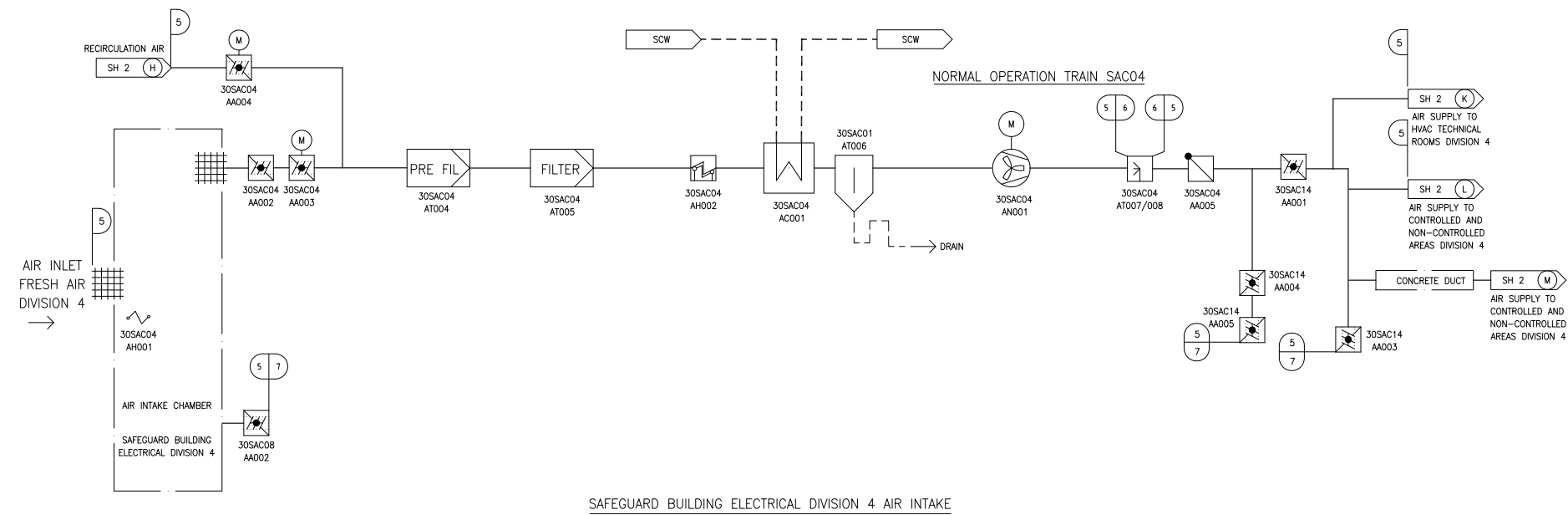
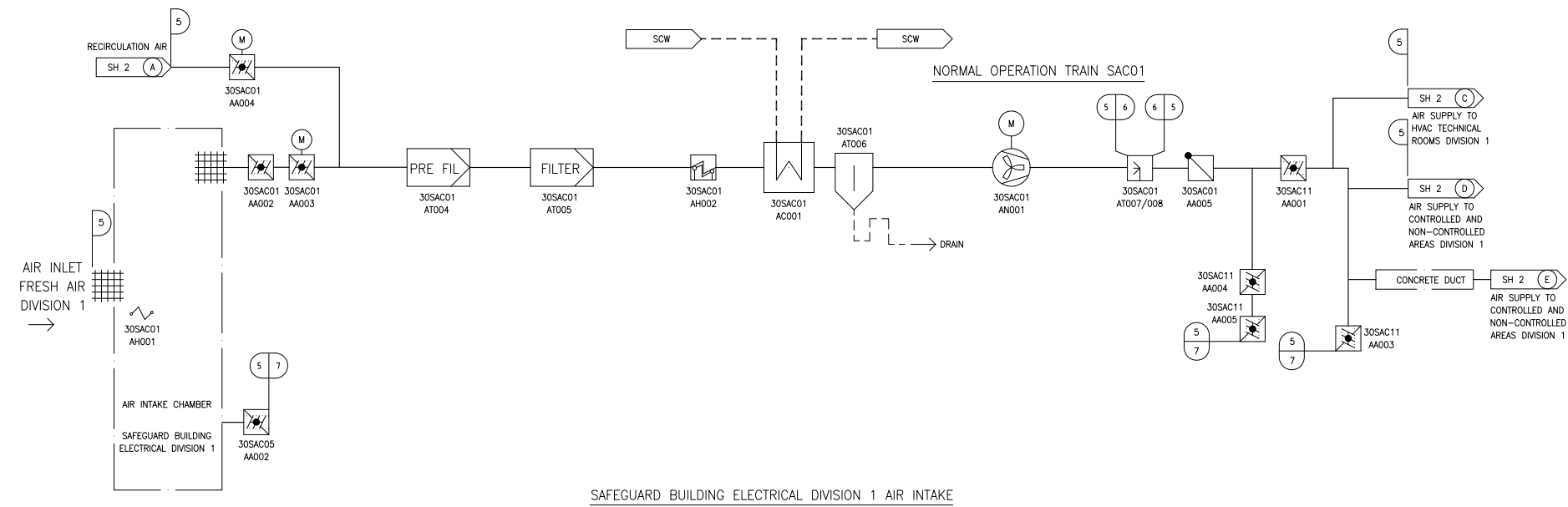

Figure 2.6.7-1—Electrical Division of Safeguard Building Ventilation System Division 1 and Division 4 Air Intake Functional Arrangement



7	AG-1	N/A
6	AG-1	II NS-AQ
5	AG-1	I
DESIGN AREA	ASME	SSC SEISMIC CLASS

REV 002  
SAC01T1

Figure 2.6.7-2—Electrical Division of Safeguard Building Ventilation System Division 1 and Division 4 Air Supply and Exhaust Functional Arrangement

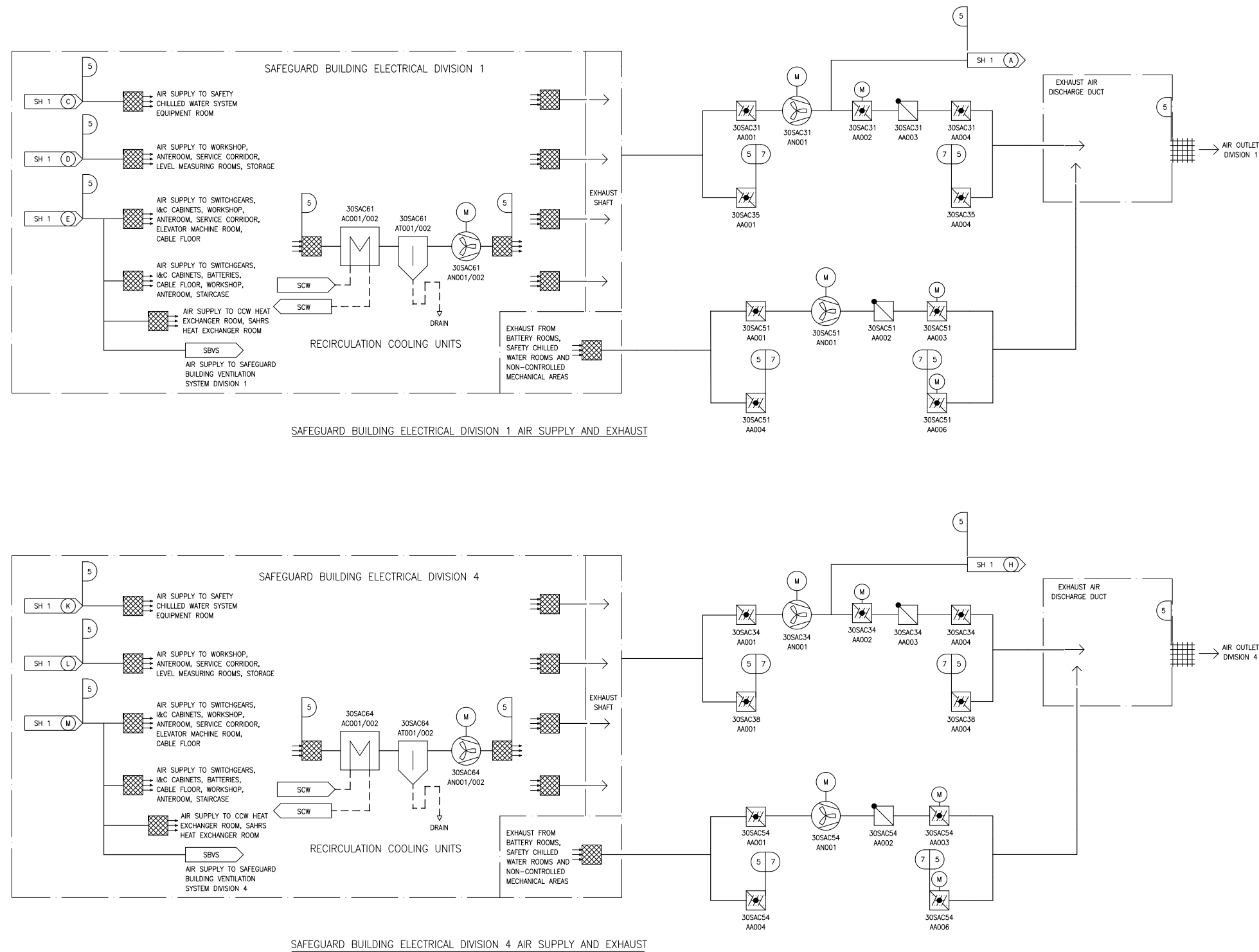

7	AG-1	N/A
5	AG-1	I
DESIGN AREA	ASME	SSC SEISMIC CLASS

REV 002  
SAC02T1

Figure 2.6.7-3—Electrical Division of Safeguard Building Ventilation System Division 2 and Division 3 Air Intake Functional Arrangement

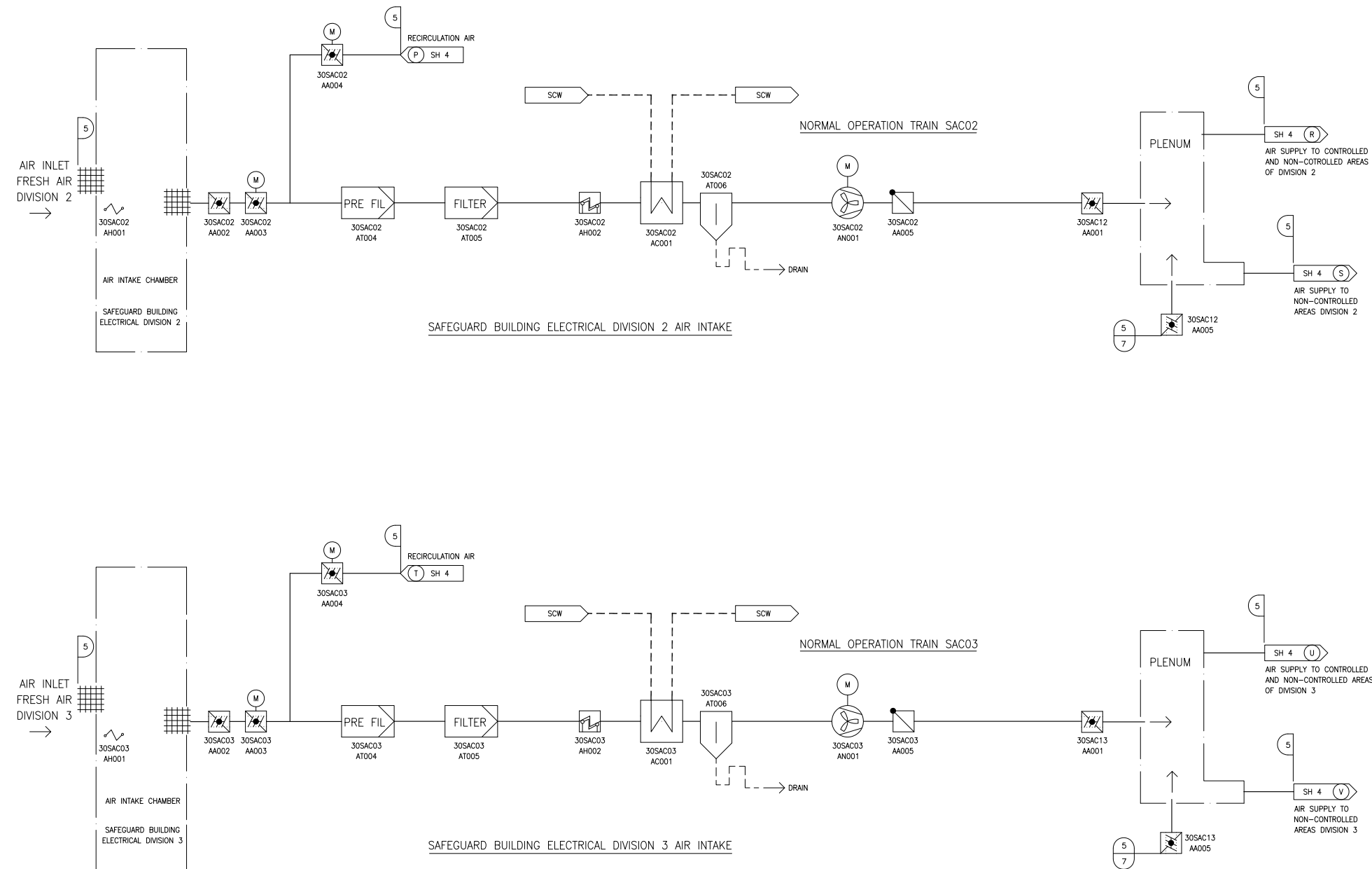

7	AG-1	N/A
5	AG-1	I
DESIGN AREA	ASME	SSC SEISMIC CLASS

REV 002  
SAC03T1

Figure 2.6.7-4—Electrical Division of Safeguard Building Ventilation System Division 2 and Division 3 Air Supply and Exhaust Functional Arrangement

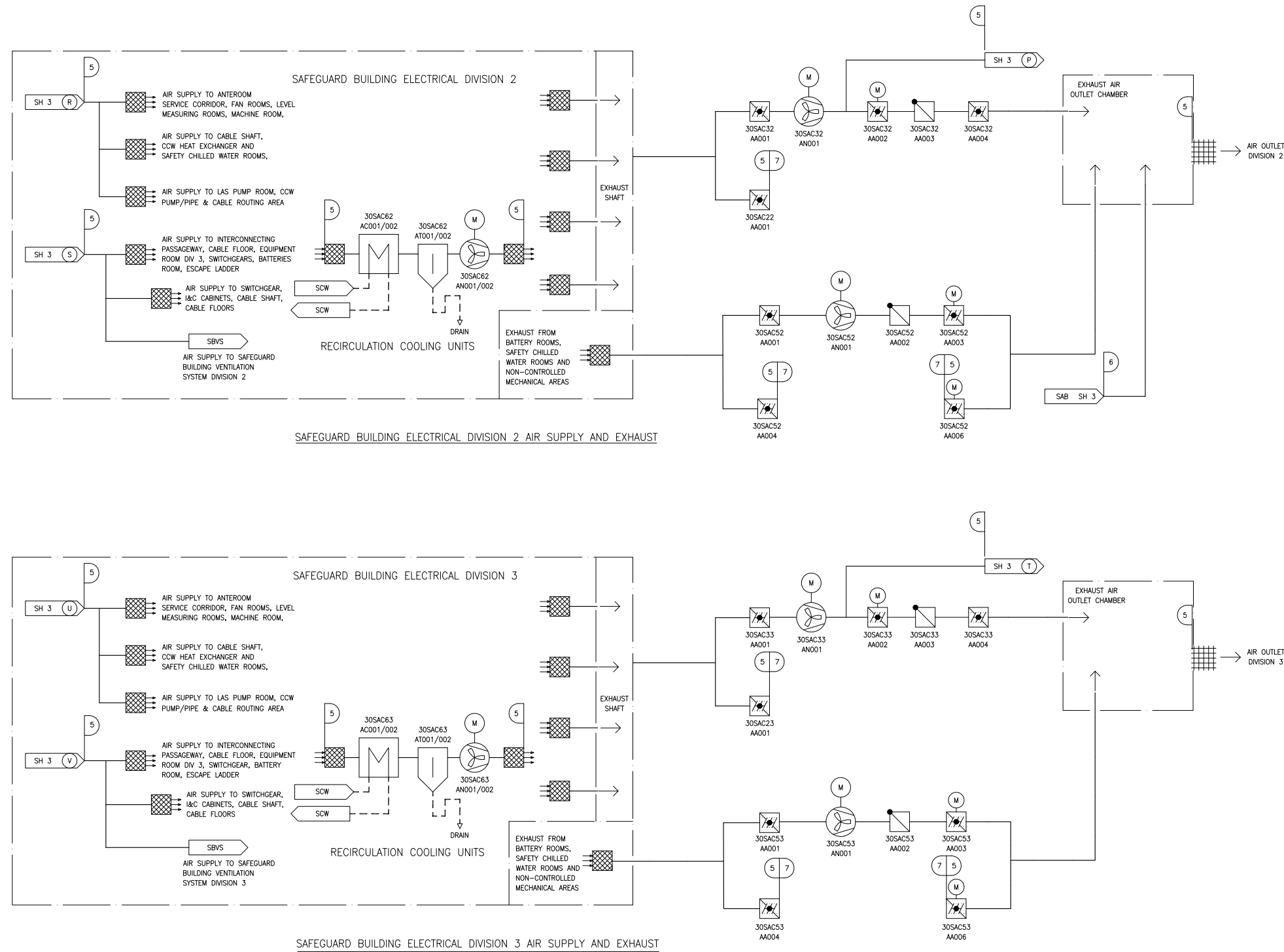

7	AG-1	N/A
6	AG-1	II
5	AG-1	I
DESIGN AREA	ASME	SSC SEISMIC CLASS

REV 002  
SAC04T1