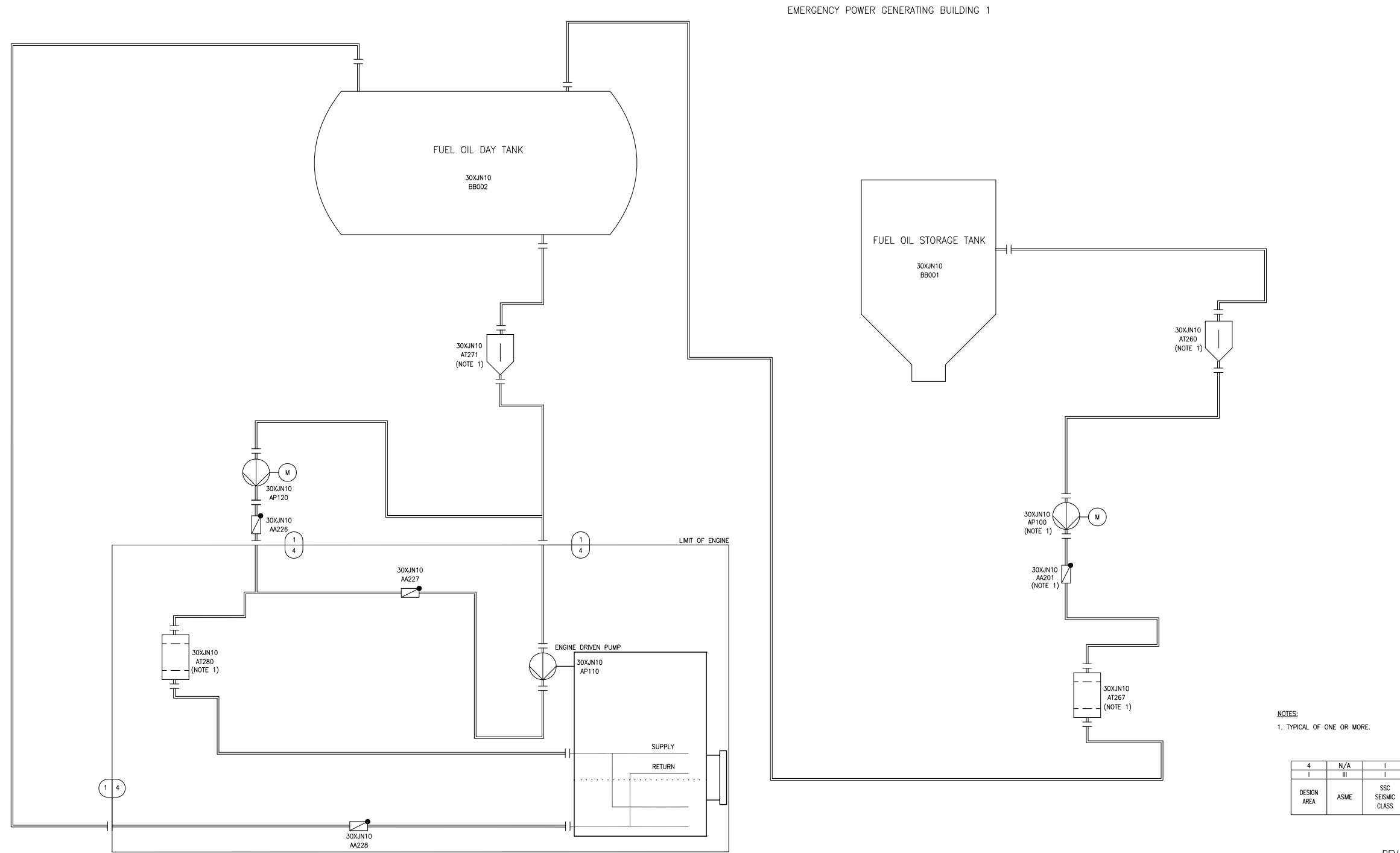

Figure 2.5.4-1—Emergency Diesel Generator Fuel Oil Storage and Transfer System Functional Arrangement
Sheet 1 of 4



REV 001
XJN01T1

Figure 2.5.4-1—Emergency Diesel Generator Fuel Oil Storage and Transfer System Functional Arrangement
Sheet 2 of 4

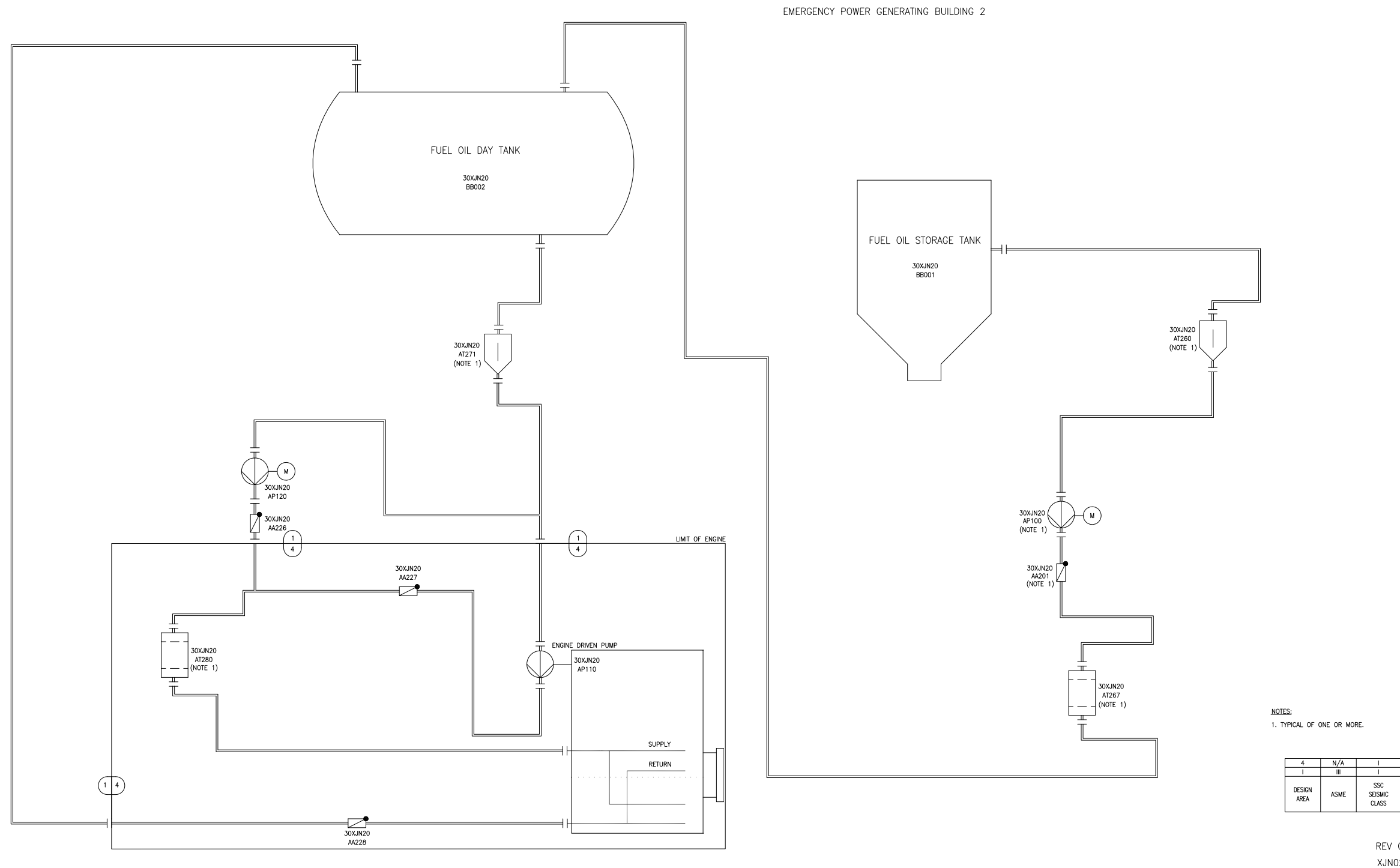
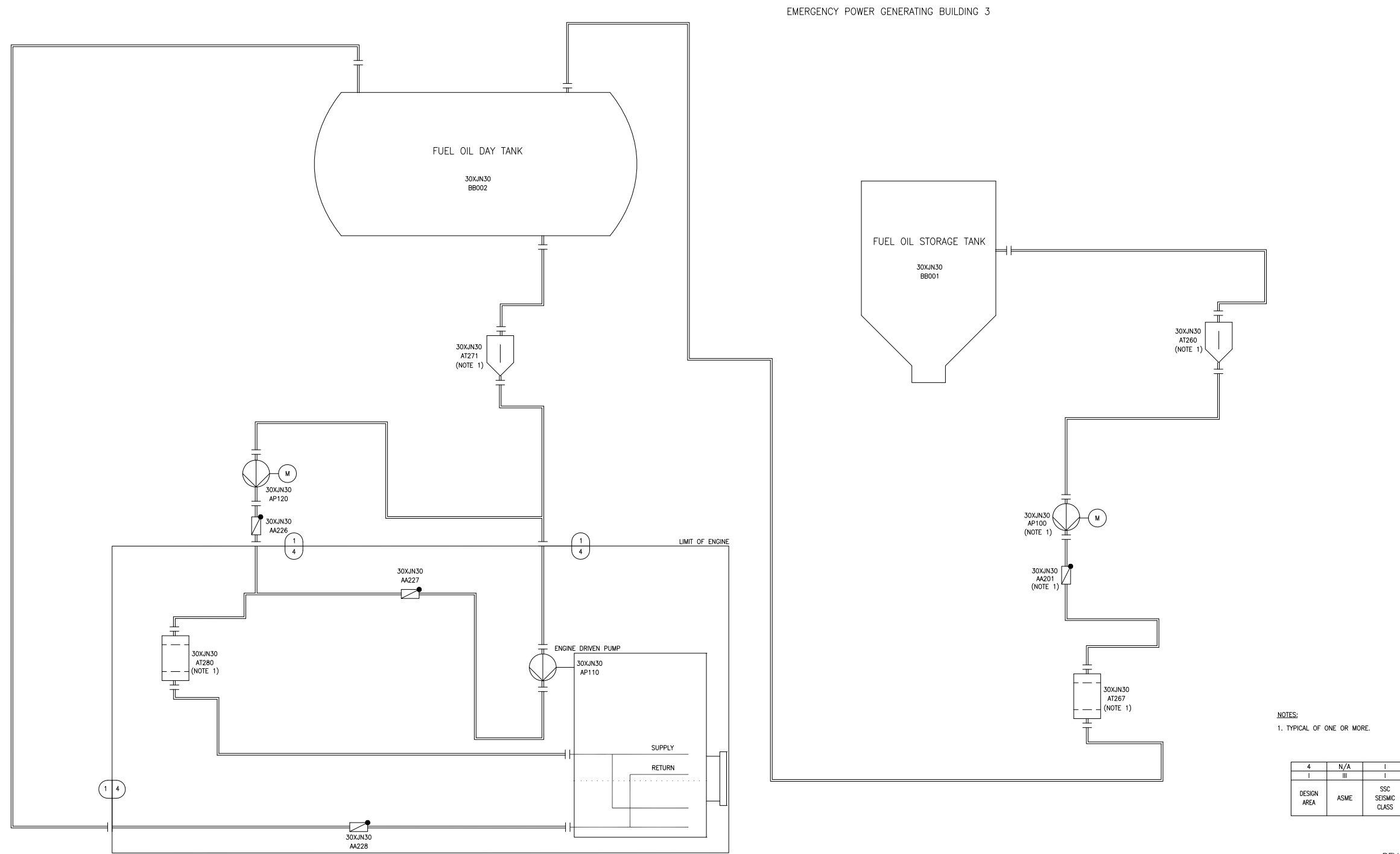

Figure 2.5.4-1—Emergency Diesel Generator Fuel Oil Storage and Transfer System Functional Arrangement
Sheet 3 of 4



REV 001
XJN03T1

Figure 2.5.4-1—Emergency Diesel Generator Fuel Oil Storage and Transfer System Functional Arrangement
Sheet 4 of 4

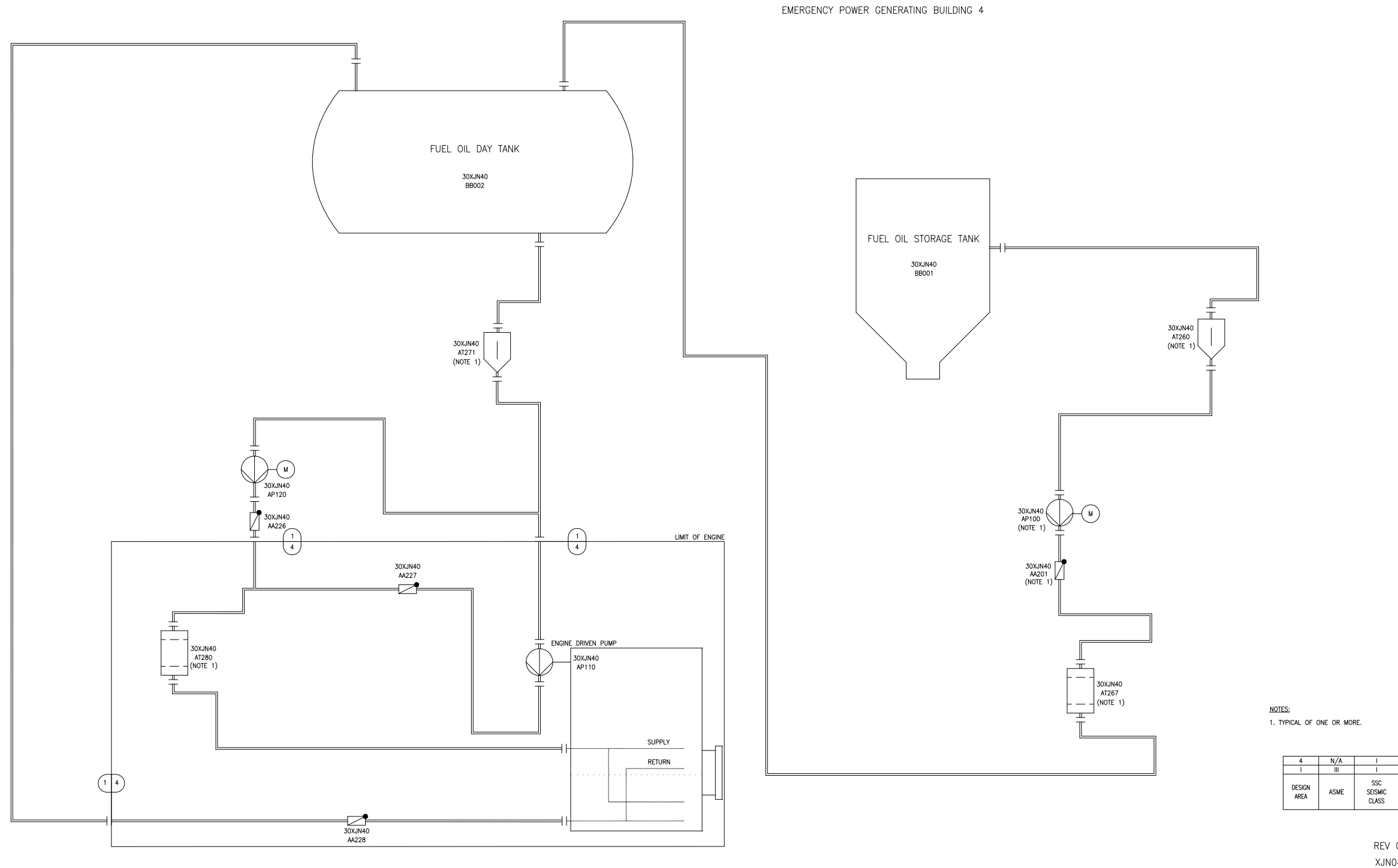
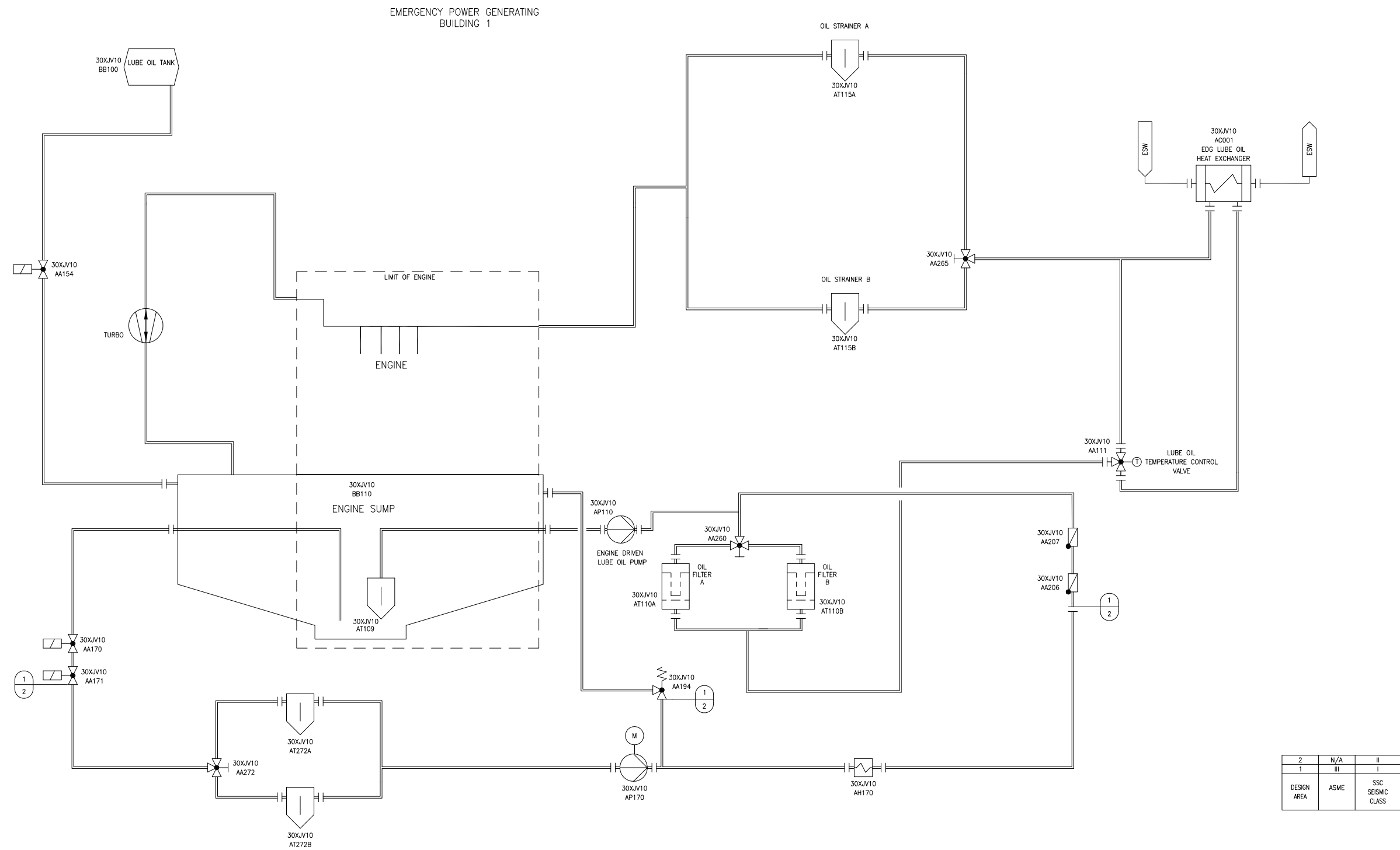

Figure 2.5.4-2—Emergency Diesel Generator Lubricating Oil System Functional Arrangement
Sheet 1 of 4



2	N/A	II
1	III	I
DESIGN AREA	ASME	SSC SEISMIC CLASS

XJV01T1

Figure 2.5.4-2—Emergency Diesel Generator Lubricating Oil System Functional Arrangement
Sheet 2 of 4

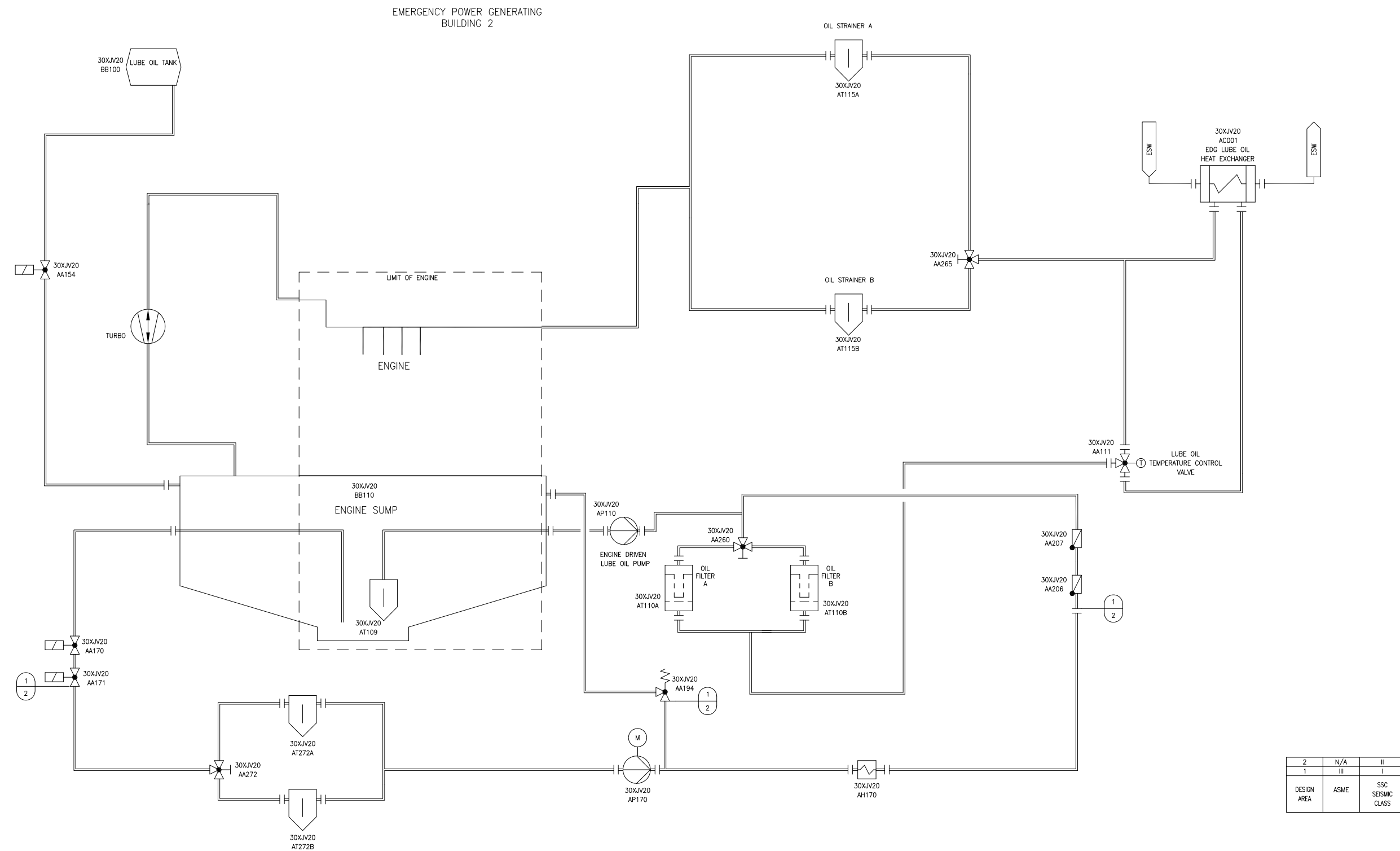

XJV02T1

Figure 2.5.4-2—Emergency Diesel Generator Lubricating Oil System Functional Arrangement
Sheet 3 of 4

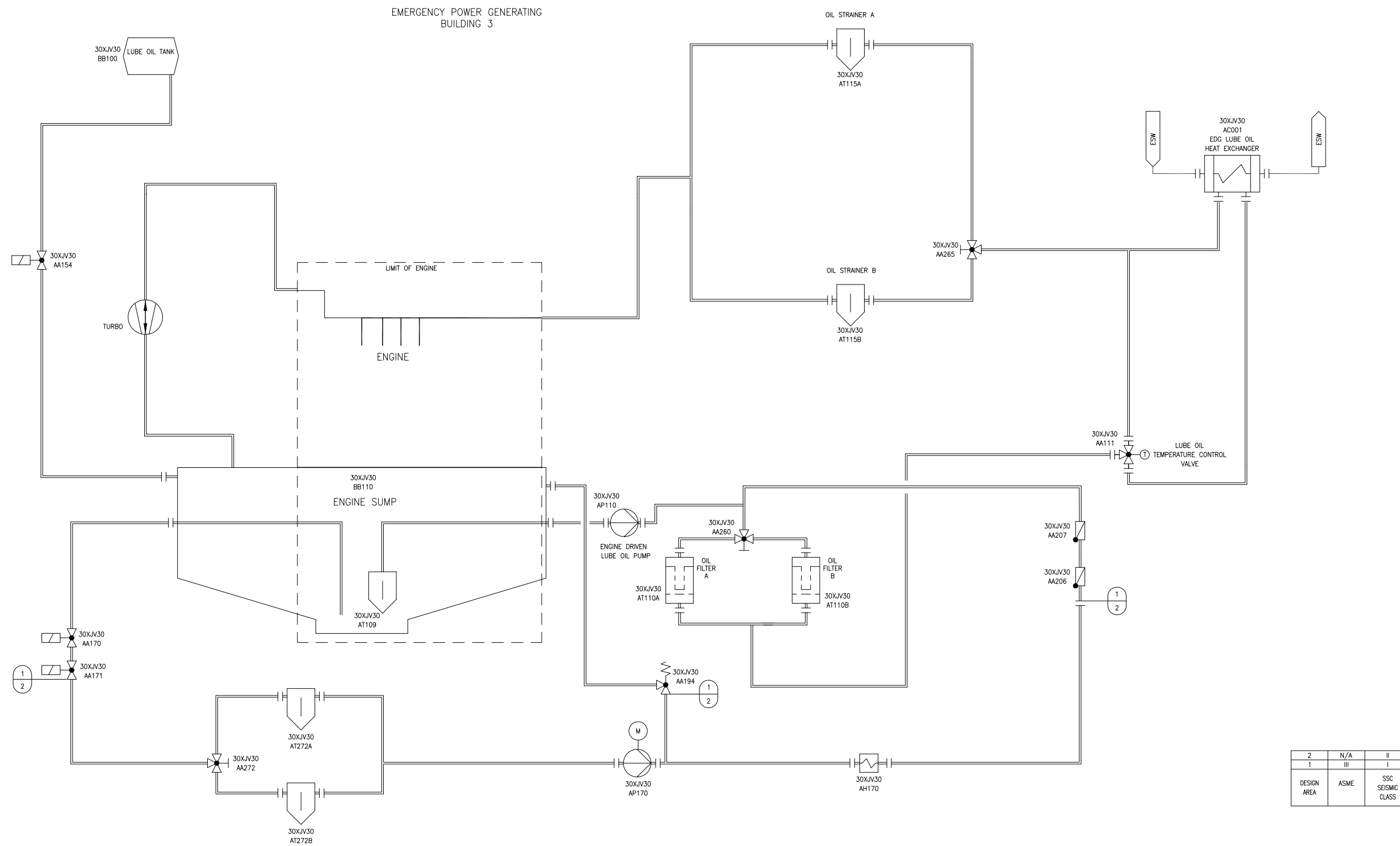

2	N/A	II
1	III	I
DESIGN AREA	ASME	SSC SEISMIC CLASS

XJV03T1

Figure 2.5.4-2—Emergency Diesel Generator Lubricating Oil System Functional Arrangement
Sheet 4 of 4

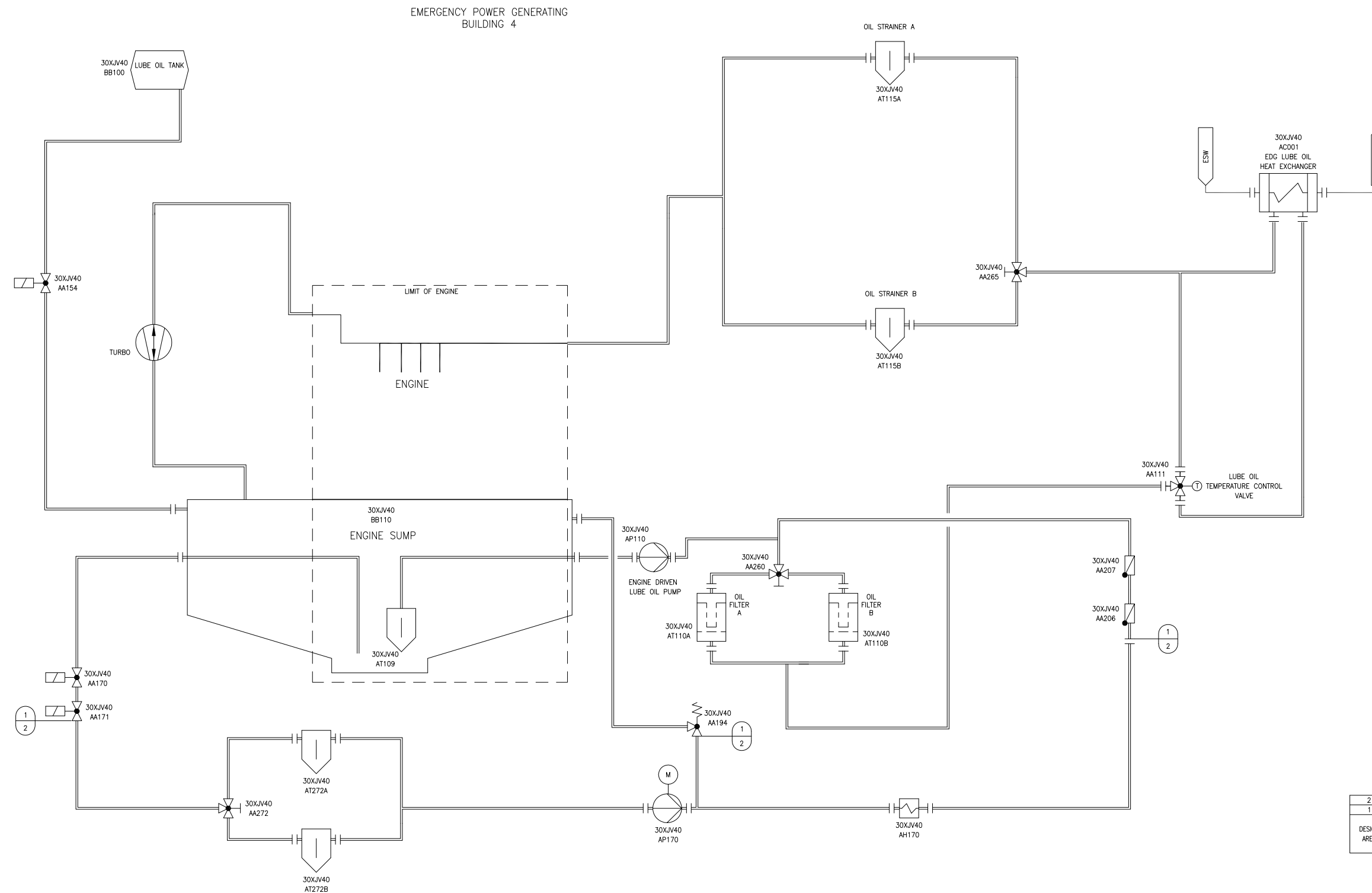
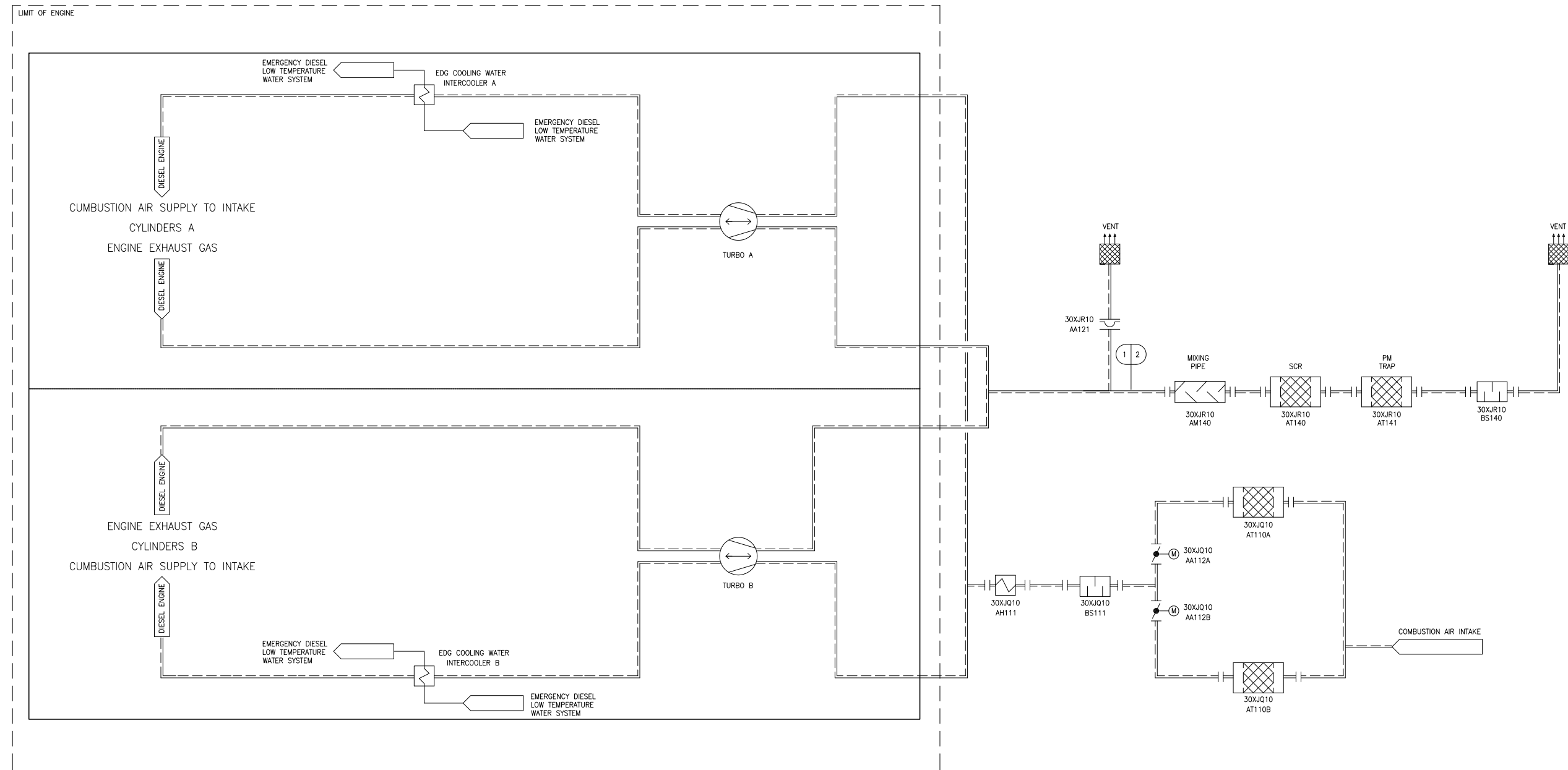

Figure 2.5.4-3—Emergency Diesel Generator Air Intake and Exhaust System Functional Arrangement
Sheet 1 of 4

EMERGENCY POWER GENERATING BUILDING 1



2	N/A	I I
1	III	I
DESIGN AREA	ASME	SSC SEISMIC CLASS

XJQ01T1

Figure 2.5.4-3—Emergency Diesel Generator Air Intake and Exhaust System Functional Arrangement
Sheet 2 of 4

EMERGENCY POWER GENERATING BUILDING 2

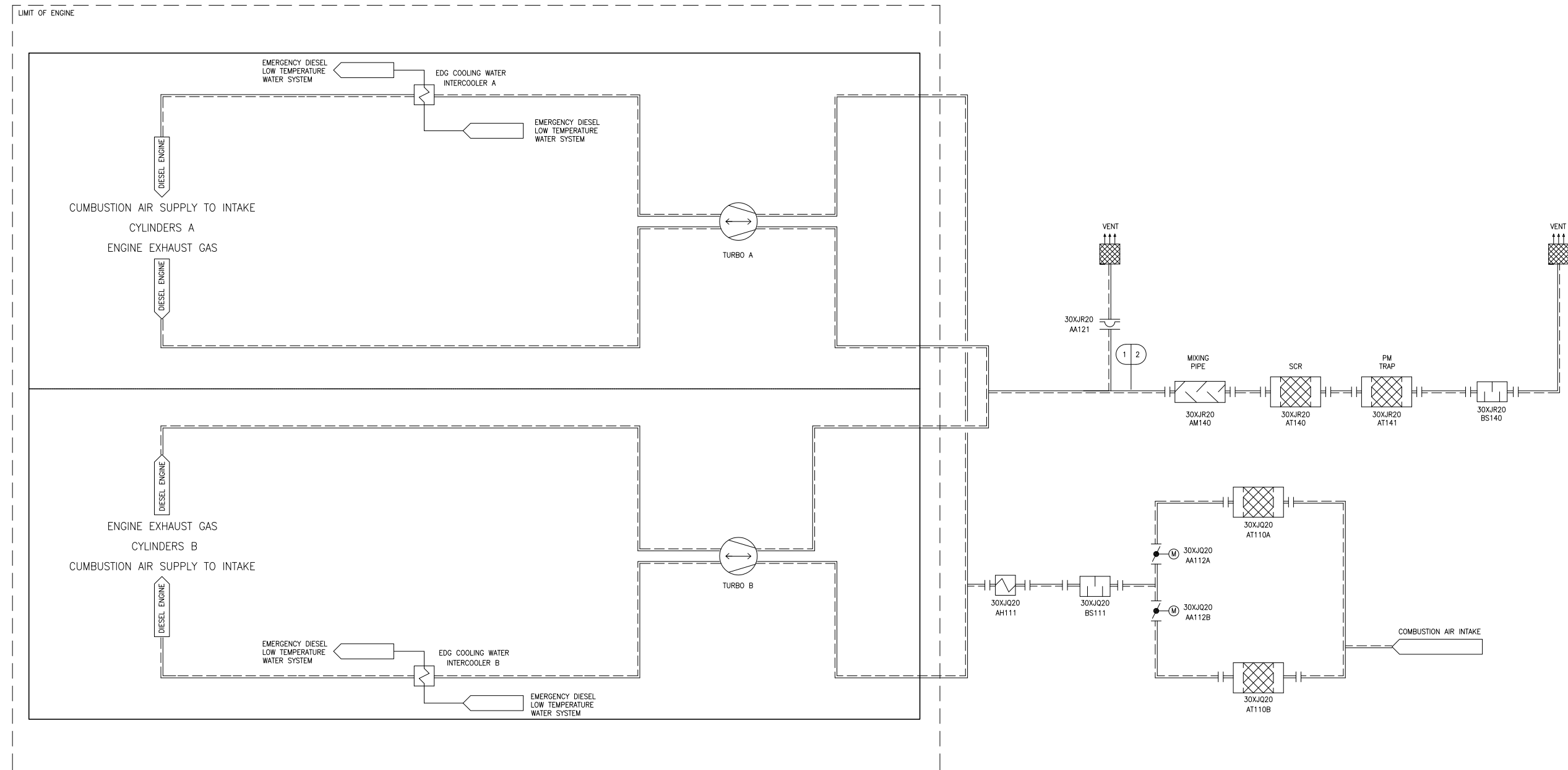

2	N/A	1 1
1	III	I
DESIGN AREA	ASME	SSC SEISMIC CLASS

XJQ02T1

Figure 2.5.4-3—Emergency Diesel Generator Air Intake and Exhaust System Functional Arrangement
Sheet 3 of 4

EMERGENCY POWER GENERATING BUILDING 3

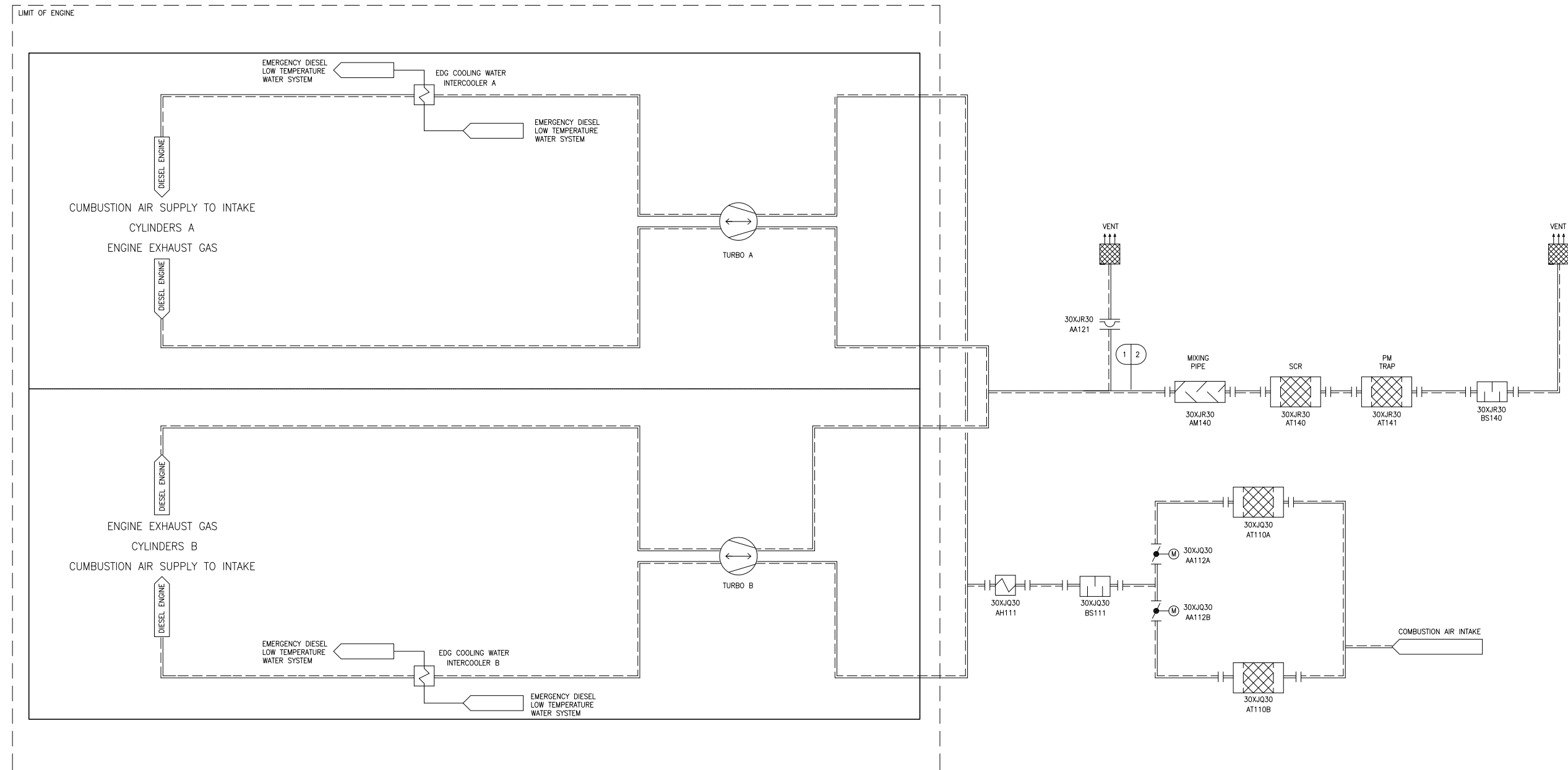

2	N/A	1 1
1	III	I
DESIGN AREA	ASME	SSC SEISMIC CLASS

XJQ03T1

Figure 2.5.4-3—Emergency Diesel Generator Air Intake and Exhaust System Functional Arrangement
Sheet 4 of 4

EMERGENCY POWER GENERATING BUILDING 4

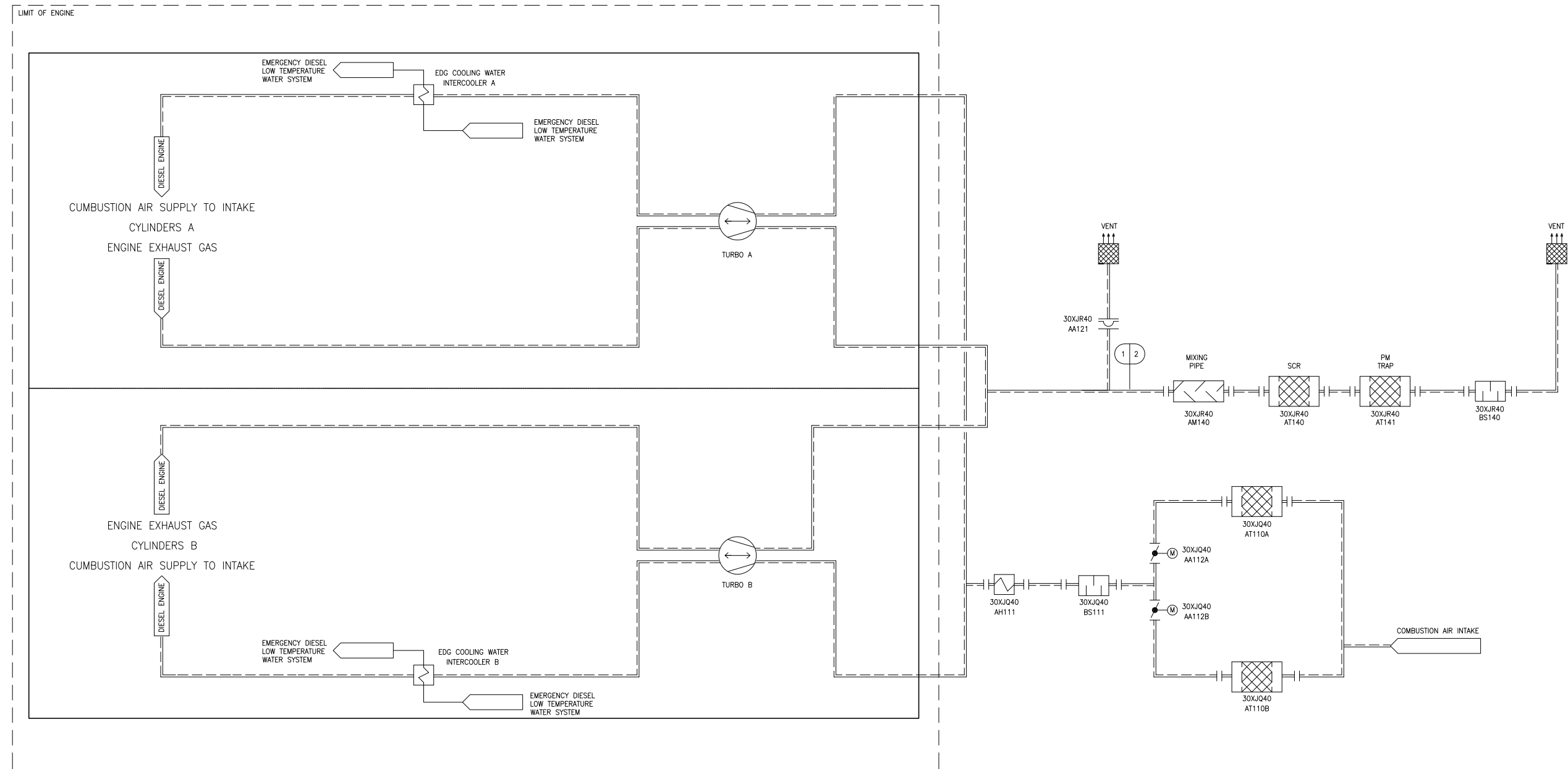

2	N/A	I I
1	III	I
DESIGN AREA	ASME	SSC SEISMIC CLASS

XJQ04T1

Figure 2.5.4-4—Emergency Diesel Generator Cooling Water System Functional Arrangement
Sheet 1 of 8

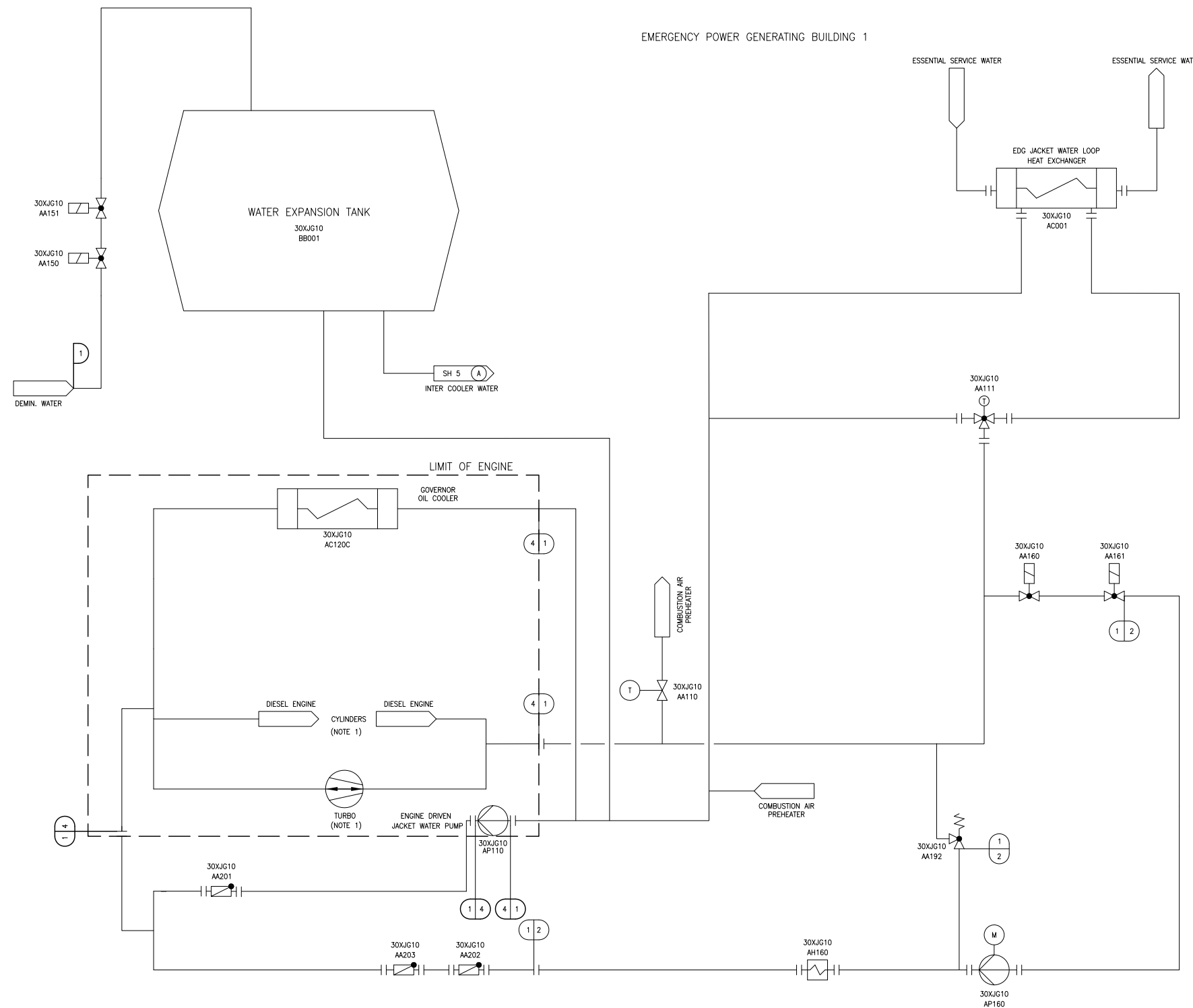

NOTES:
1. TYPICAL OF ONE OR MORE.

4	N/A	I
2	N/A	II
1	III	I
DESIGN AREA	ASME	SSC SEISMIC CLASS

XJG01T1

Figure 2.5.4-4—Emergency Diesel Generator Cooling Water System Functional Arrangement
Sheet 2 of 8

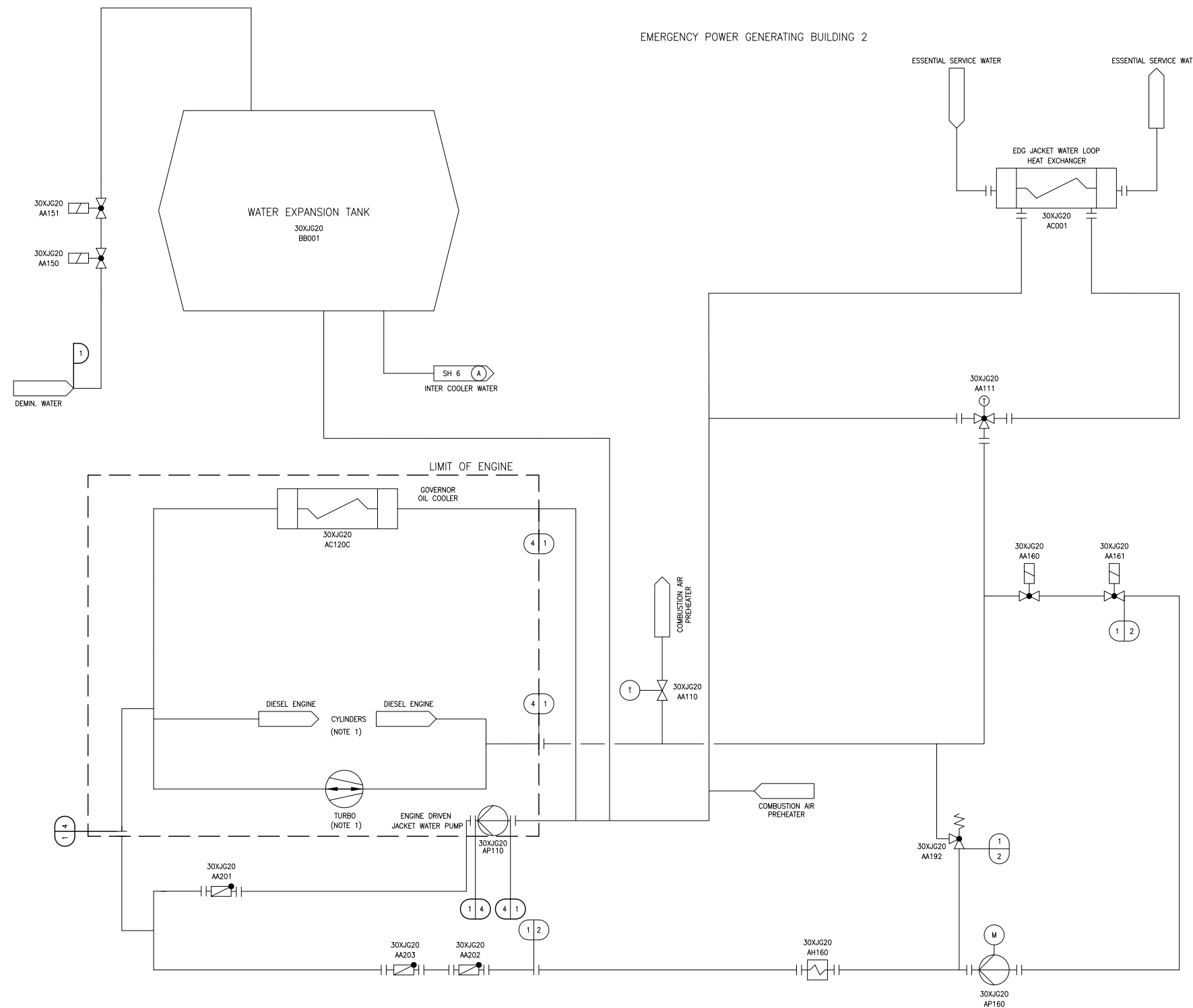

NOTES:
1. TYPICAL OF ONE OR MORE.

4	N/A	I
2	N/A	II
1	III	I
DESIGN AREA	ASME	SSC SEISMIC CLASS

XJG02T1

Figure 2.5.4-4—Emergency Diesel Generator Cooling Water System Functional Arrangement
Sheet 3 of 8

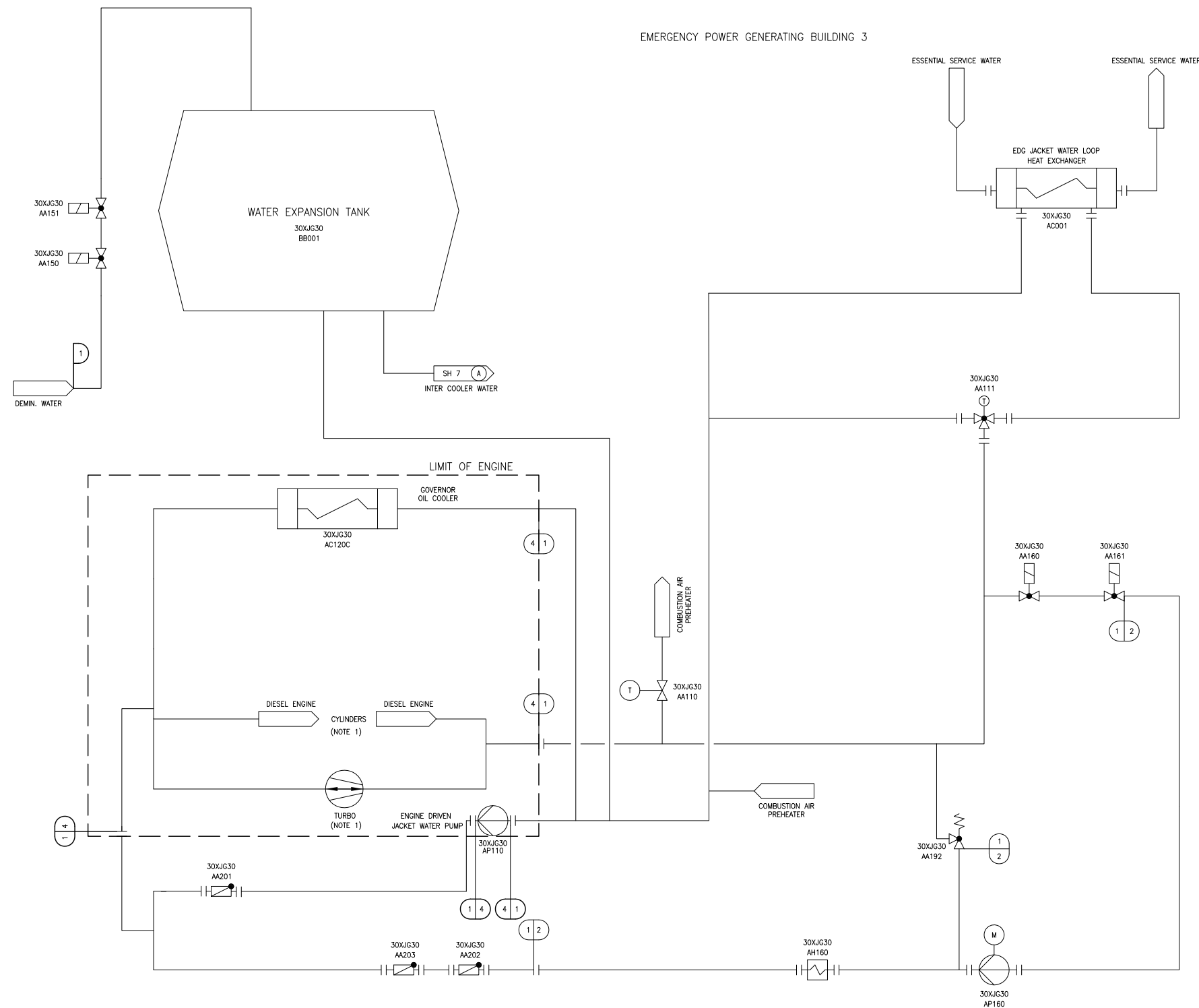

NOTES:
1. TYPICAL OF ONE OR MORE.

4	N/A	I
2	N/A	II
1	III	I
DESIGN AREA	ASME	SSC SEISMIC CLASS

XJG03T1

Figure 2.5.4-4—Emergency Diesel Generator Cooling Water System Functional Arrangement
Sheet 4 of 8

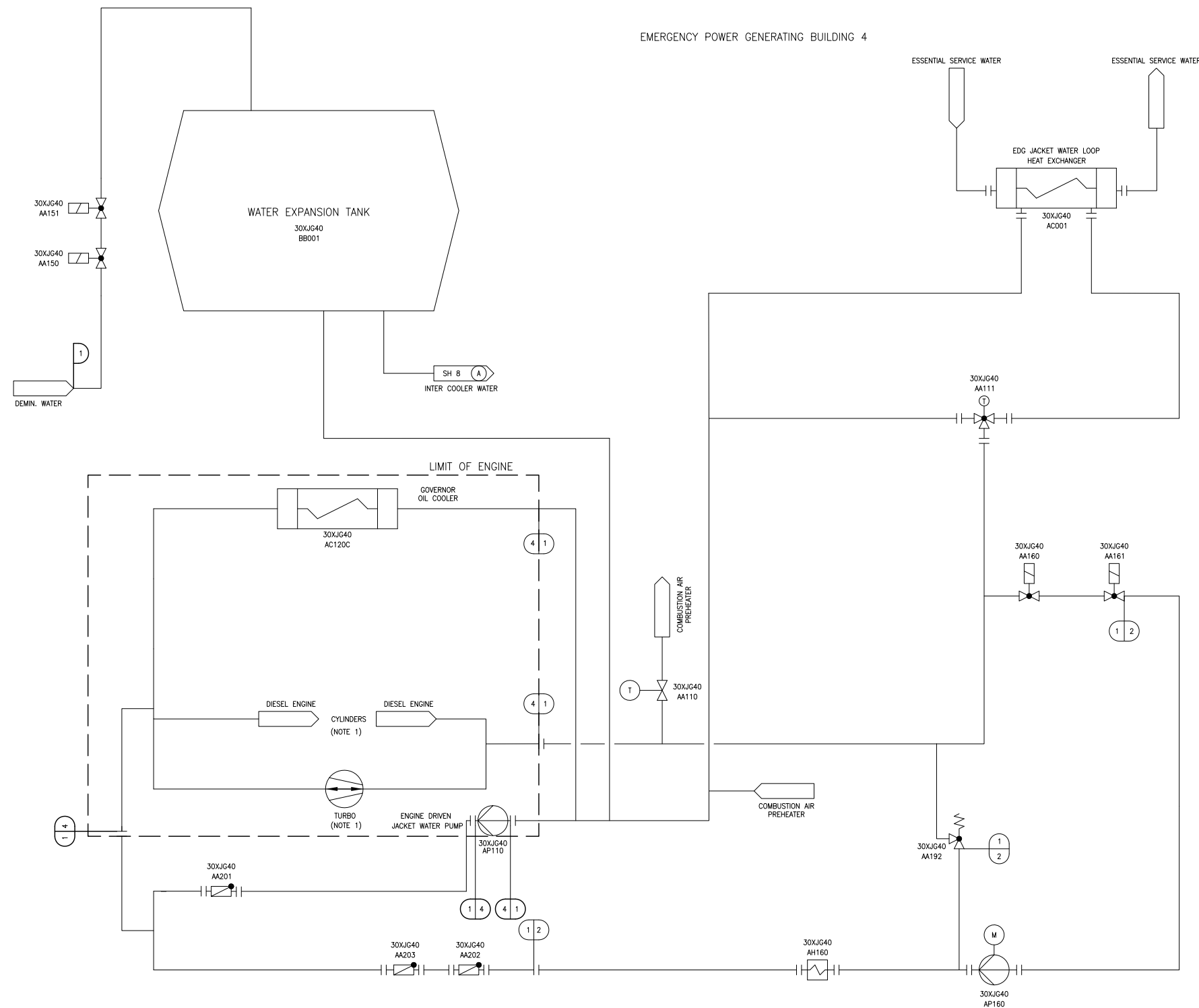

NOTES:
1. TYPICAL OF ONE OR MORE.

4	N/A	I
2	N/A	II
1	III	I
DESIGN AREA	ASME	SSC SEISMIC CLASS

XJG04T1

Figure 2.5.4-4—Emergency Diesel Generator Cooling Water System Functional Arrangement
Sheet 5 of 8

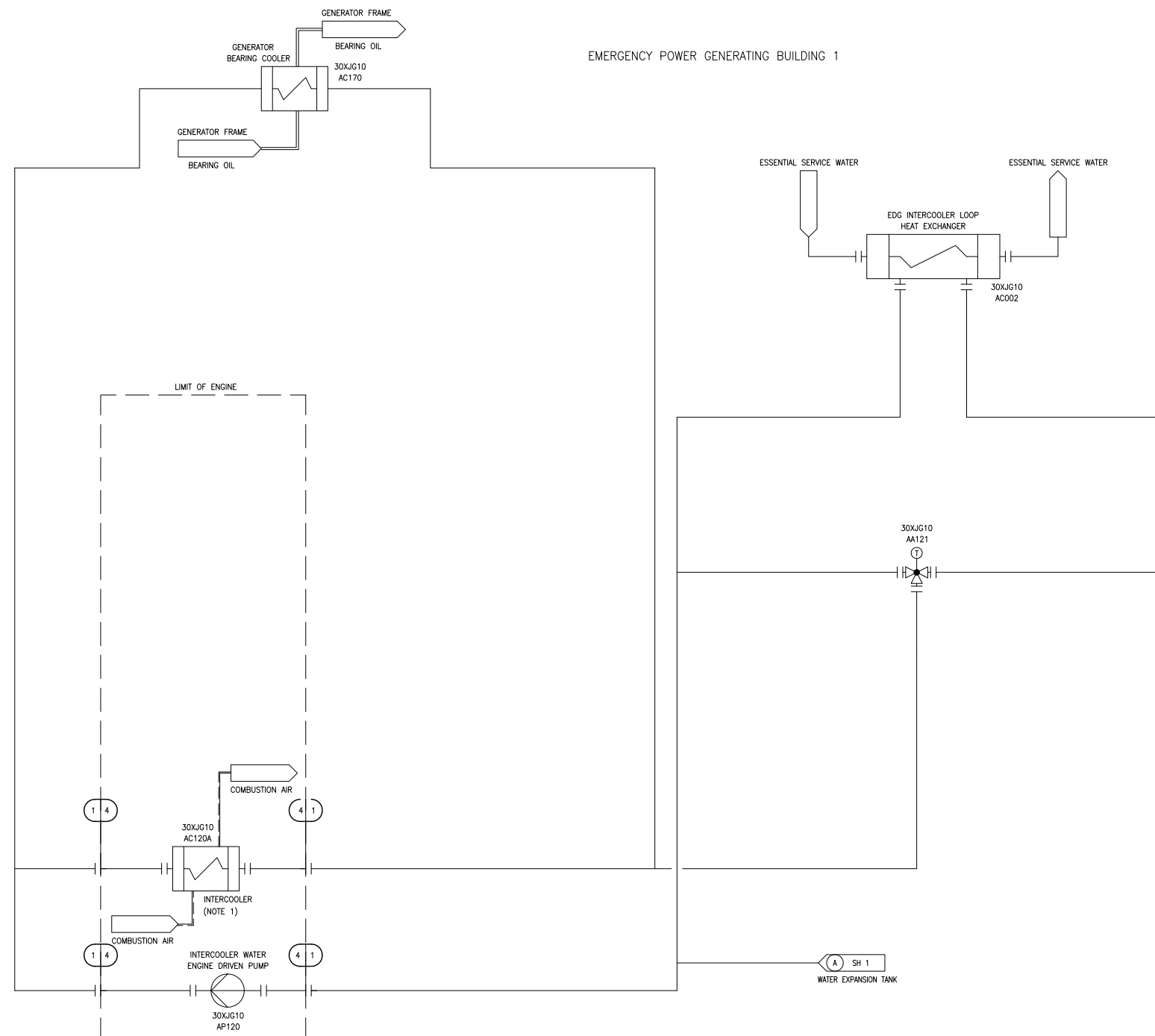

NOTES:
1. TYPICAL OF ONE OR MORE.

4	N/A	I
1	III	I
DESIGN AREA	ASME	SSC SEISMIC CLASS

XJG05T1

Figure 2.5.4-4—Emergency Diesel Generator Cooling Water System Functional Arrangement
Sheet 6 of 8

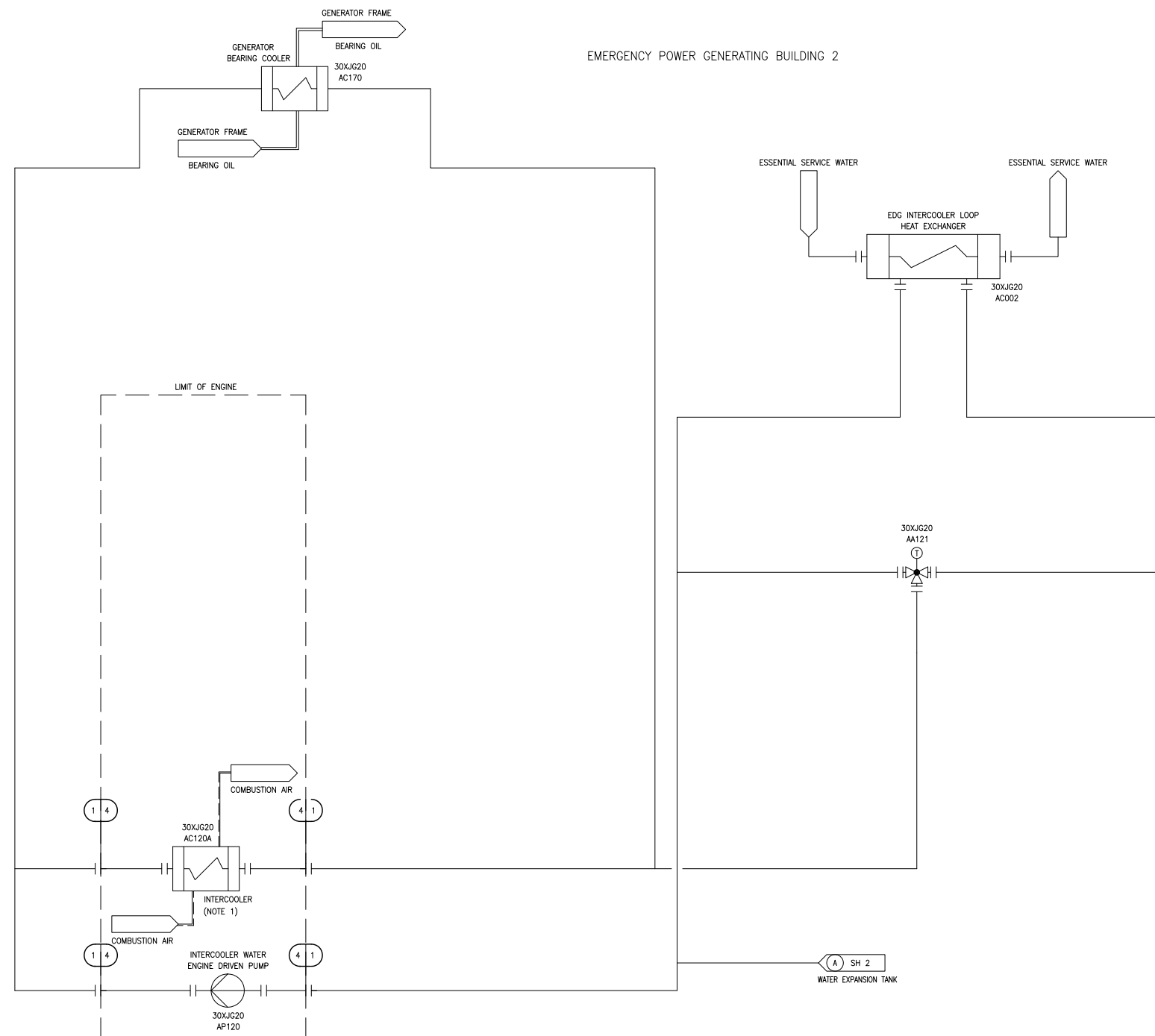

NOTES:
1. TYPICAL OF ONE OR MORE.

4	N/A	I
1	III	I
DESIGN AREA	ASME	SSC SEISMIC CLASS

XJG06T1

Figure 2.5.4-4—Emergency Diesel Generator Cooling Water System Functional Arrangement
Sheet 7 of 8

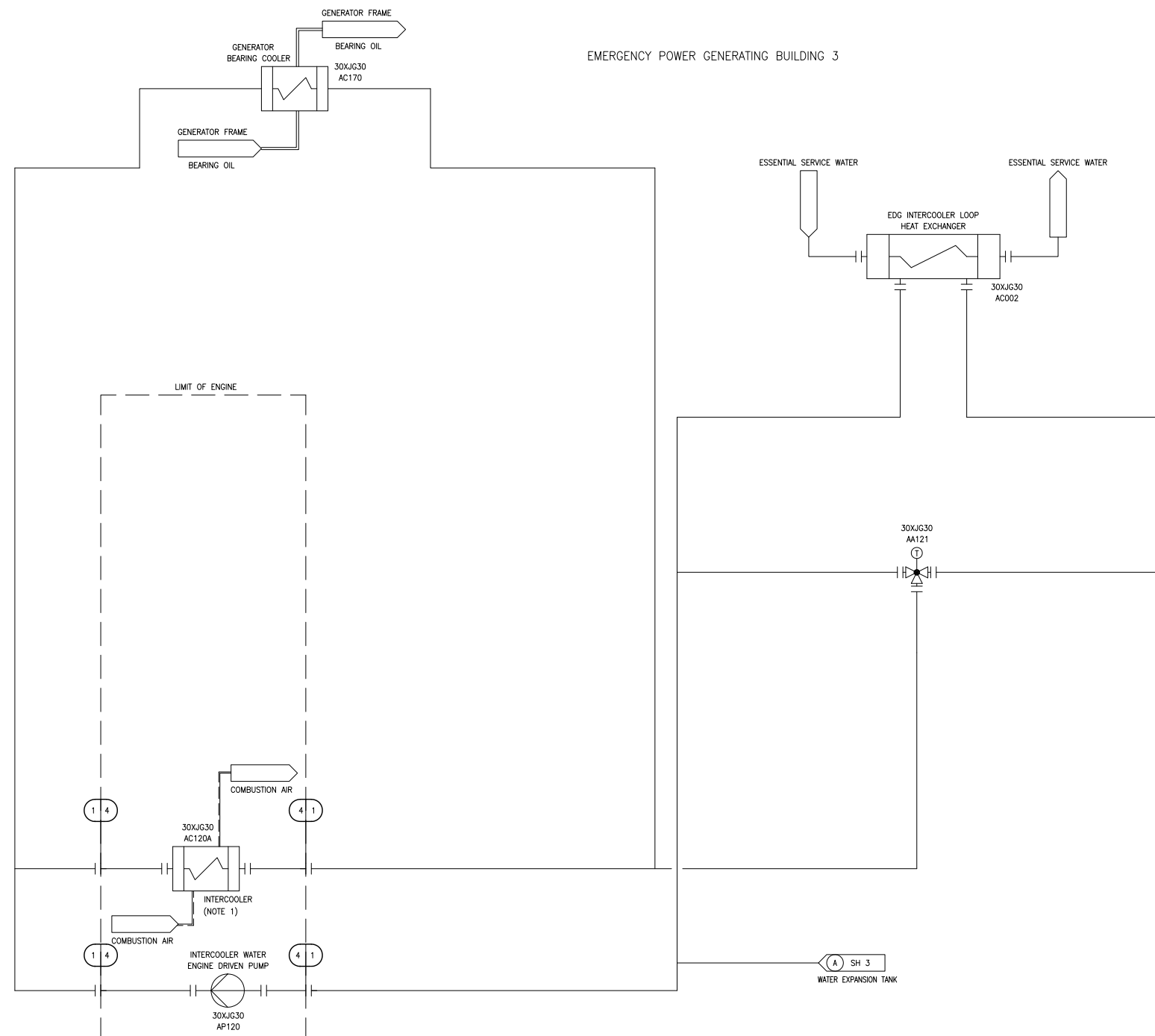

NOTES:
1. TYPICAL OF ONE OR MORE.

4	N/A	I
1	III	I
DESIGN AREA	ASME	SSC SEISMIC CLASS

XJG07T1

Figure 2.5.4-4—Emergency Diesel Generator Cooling Water System Functional Arrangement
Sheet 8 of 8

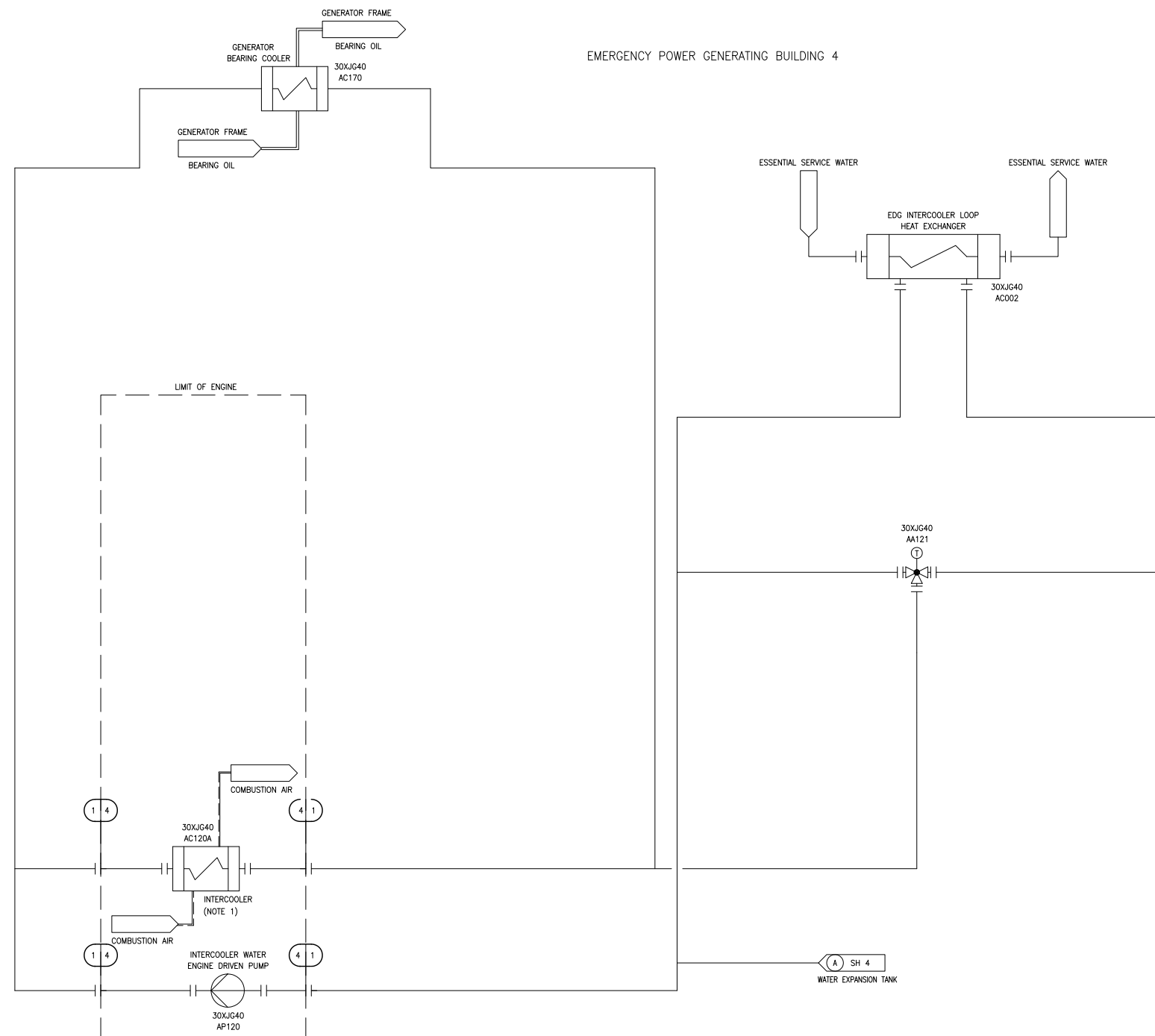

NOTES:
1. TYPICAL OF ONE OR MORE.

4	N/A	I
1	III	I
DESIGN AREA	ASME	SSC SEISMIC CLASS

XJG08T1

Figure 2.5.4-5—Emergency Diesel Generator Starting Air System Functional Arrangement
Sheet 1 of 4

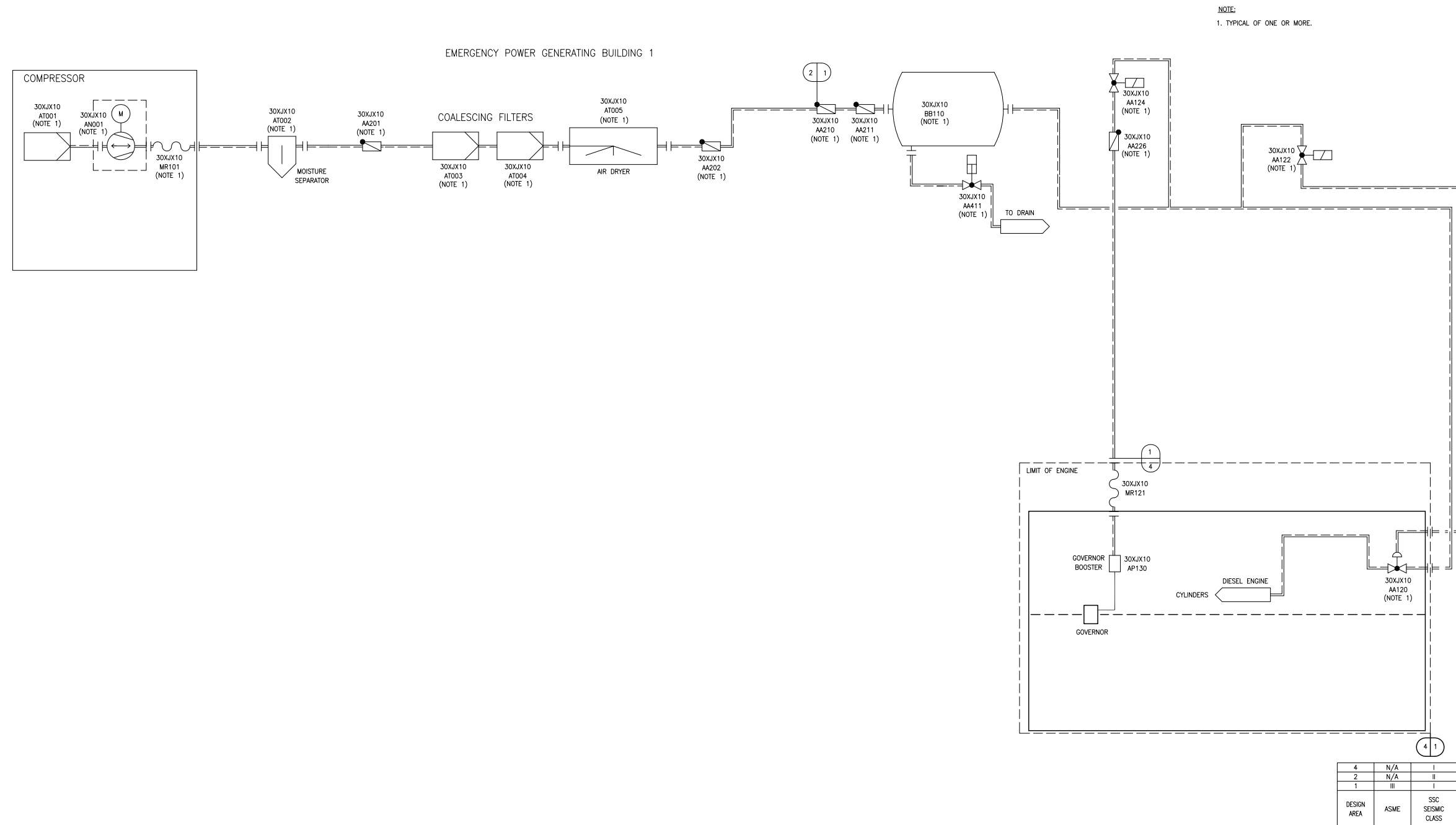

XJX01T1

Figure 2.5.4-5—Emergency Diesel Generator Starting Air System Functional Arrangement
Sheet 2 of 4

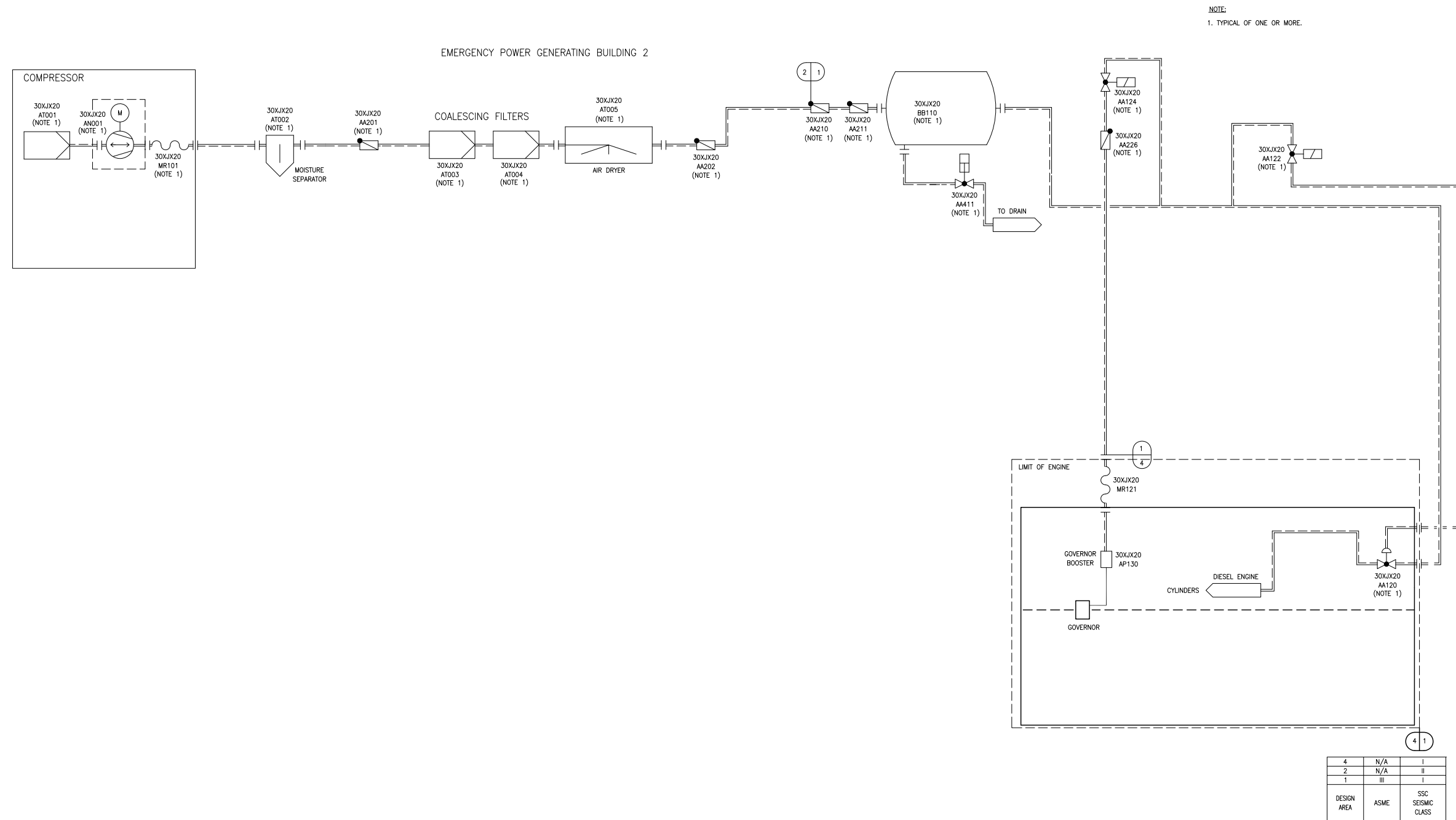

XJX02T1

Figure 2.5.4-5—Emergency Diesel Generator Starting Air System Functional Arrangement
Sheet 3 of 4

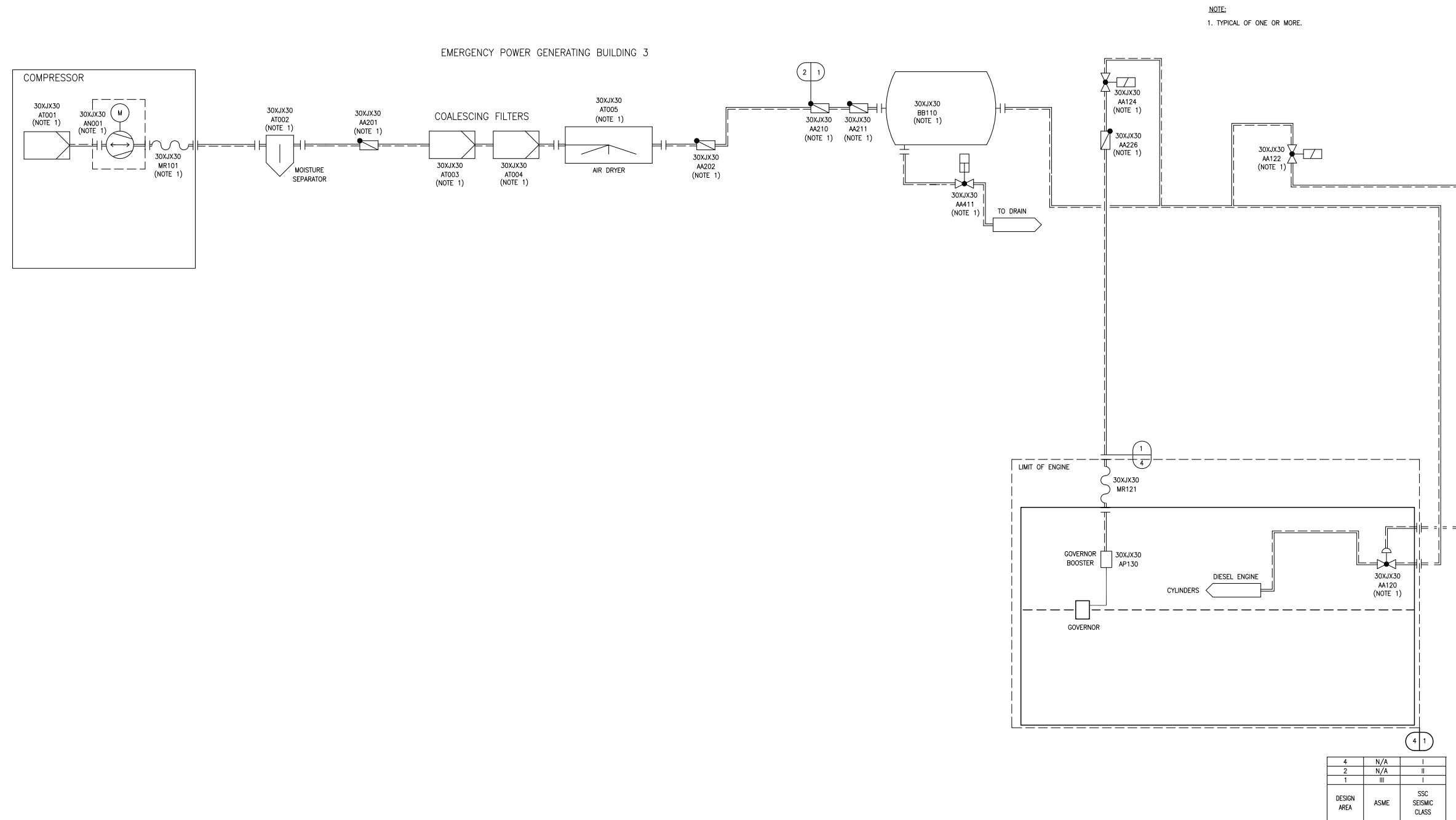

XJX03T1

Figure 2.5.4-5—Emergency Diesel Generator Starting Air System Functional Arrangement
Sheet 4 of 4

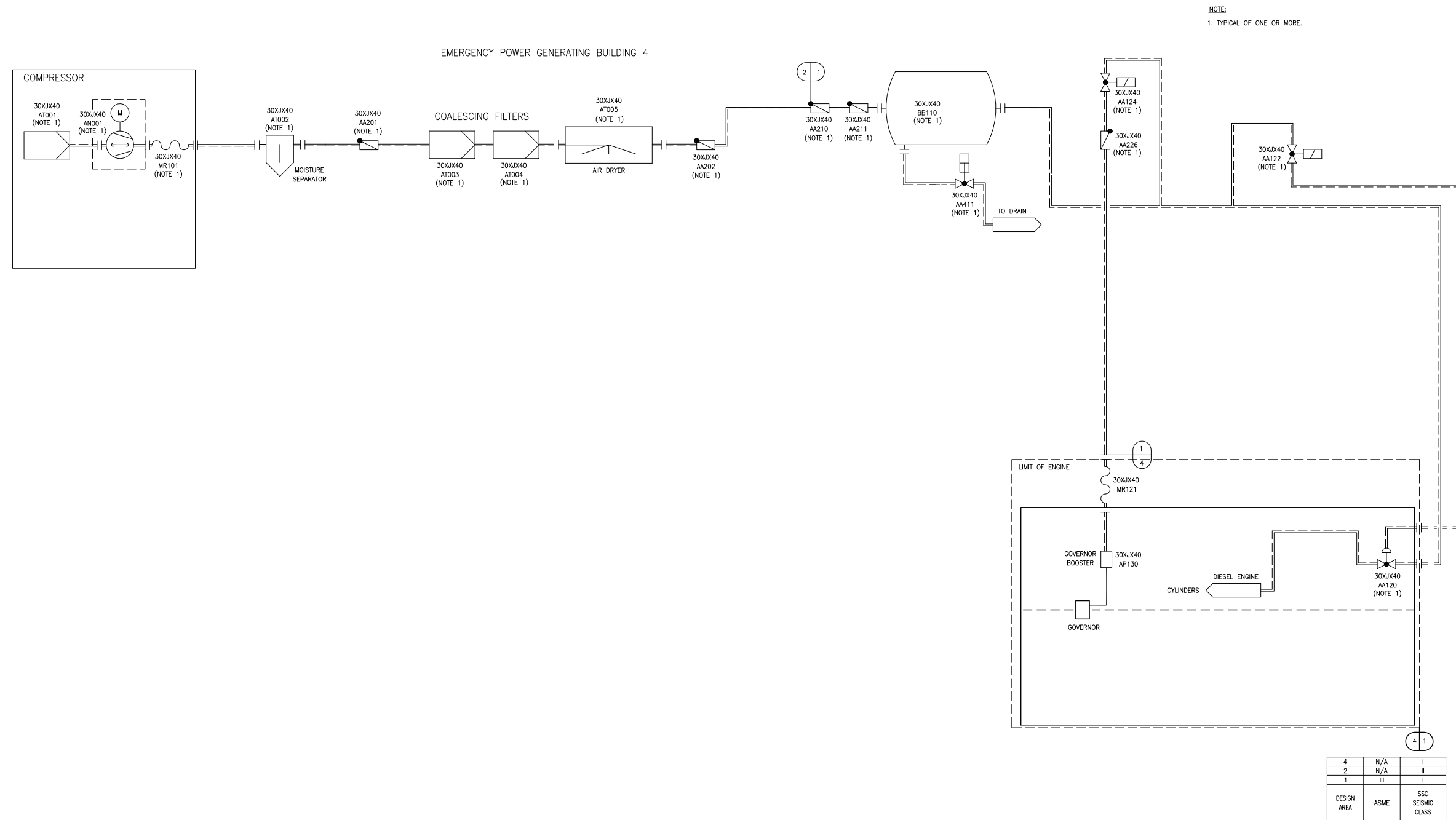

XJX04T1