

030-38350



August 17, 2010

Division of Industrial and Medical Nuclear Safety
Office of Nuclear Materials Safety and Safeguards
U.S. Nuclear Regulatory Commission
Washington, DC 20555-0001

Dear Sir/Madam,

Halco Lighting Technologies is applying for a license authorizing the distribution of lamps containing krypton-85 (Kr-85) glass tubes to persons exempt from licensing pursuant to 10 CFR 30.15(a)(8), or equivalent provisions of the regulations of any Agreement State. Halco has also submitted an application for a possession license with the State of Georgia Department of Natural Resources.

Please feel free to contact me at 770-242-3609 extension 308 if you have any questions about this request.

Sincerely,

David Nelkin
Director, Product Development

Cc: Robert Lewis, Director

Office of Federal & State Materials and Environmental Management Programs
Division of Materials Safety and State Agreements
U.S. Nuclear Regulatory Commission
11545 Rockville Pike T8E24
Rockville, MD 20852

P.O. Box 2834 Norcross, GA 30091-2834 • www.halcolighting.com
770.242.3612 • 800.677.3334 • FAX: 800.880.0822



573373

030-38350

NRC FORM 313 (3-2009) U.S. NUCLEAR REGULATORY COMMISSION
10 CFR 30, 32, 33, 34, 35, 36, 39, and 40

APPROVED BY OMB: NO. 3150-0120 EXPIRES: 3/31/2012

APPLICATION FOR MATERIALS LICENSE

Estimated burden per response to comply with this mandatory collection request: 4.3 hours. Submittal of the application is necessary to determine that the applicant is qualified and that adequate procedures exist to protect the public health and safety. Send comments regarding burden estimate to the Records and FOIA/Privacy Services Branch (T-5 F53), U.S. Nuclear Regulatory Commission, Washington, DC 20555-0001, or by internet e-mail to infocollects.resource@nrc.gov, and to the Desk Officer, Office of Information and Regulatory Affairs, NEOB-10202, (3150-0120), Office of Management and Budget, Washington, DC 20503. If a means used to impose an information collection does not display a currently valid OMB control number, the NRC may not conduct or sponsor, and a person is not required to respond to, the information collection.

INSTRUCTIONS: SEE THE APPROPRIATE LICENSE APPLICATION GUIDE FOR DETAILED INSTRUCTIONS FOR COMPLETING APPLICATION. SEND TWO COPIES OF THE ENTIRE COMPLETED APPLICATION TO THE NRC OFFICE SPECIFIED BELOW.

APPLICATION FOR DISTRIBUTION OF EXEMPT PRODUCTS FILE APPLICATIONS WITH:

OFFICE OF FEDERAL & STATE MATERIALS AND ENVIRONMENTAL MANAGEMENT PROGRAMS
DIVISION OF MATERIALS SAFETY AND STATE AGREEMENTS
U.S. NUCLEAR REGULATORY COMMISSION
WASHINGTON, DC 20555-0001

ALL OTHER PERSONS FILE APPLICATIONS AS FOLLOWS:

IF YOU ARE LOCATED IN:

ALABAMA, CONNECTICUT, DELAWARE, DISTRICT OF COLUMBIA, FLORIDA, GEORGIA, KENTUCKY, MAINE, MARYLAND, MASSACHUSETTS, NEW HAMPSHIRE, NEW JERSEY, NEW YORK, NORTH CAROLINA, PENNSYLVANIA, PUERTO RICO, RHODE ISLAND, SOUTH CAROLINA, TENNESSEE, VERMONT, VIRGINIA, VIRGIN ISLANDS, OR WEST VIRGINIA, SEND APPLICATIONS TO:

LICENSING ASSISTANCE TEAM
DIVISION OF NUCLEAR MATERIALS SAFETY
U.S. NUCLEAR REGULATORY COMMISSION, REGION I
475 ALLENDALE ROAD
KING OF PRUSSIA, PA 19406-1415

IF YOU ARE LOCATED IN:

ILLINOIS, INDIANA, IOWA, MICHIGAN, MINNESOTA, MISSOURI, OHIO, OR WISCONSIN, SEND APPLICATIONS TO:

MATERIALS LICENSING BRANCH
U.S. NUCLEAR REGULATORY COMMISSION, REGION III
2443 WARRENVILLE ROAD, SUITE 210
LISLE, IL 60532-4352

ALASKA, ARIZONA, ARKANSAS, CALIFORNIA, COLORADO, HAWAII, IDAHO, KANSAS, LOUISIANA, MISSISSIPPI, MONTANA, NEBRASKA, NEVADA, NEW MEXICO, NORTH DAKOTA, OKLAHOMA, OREGON, PACIFIC TRUST TERRITORIES, SOUTH DAKOTA, TEXAS, UTAH, WASHINGTON, OR WYOMING, SEND APPLICATIONS TO:

NUCLEAR MATERIALS LICENSING BRANCH
U.S. NUCLEAR REGULATORY COMMISSION, REGION IV
612 E. LAMAR BOULEVARD, SUITE 400
ARLINGTON, TX 76011-4125

PERSONS LOCATED IN AGREEMENT STATES SEND APPLICATIONS TO THE U.S. NUCLEAR REGULATORY COMMISSION ONLY IF THEY WISH TO POSSESS AND USE LICENSED MATERIAL IN STATES SUBJECT TO U.S. NUCLEAR REGULATORY COMMISSION JURISDICTIONS.

1. THIS IS AN APPLICATION FOR (Check appropriate item)

A. NEW LICENSE

B. AMENDMENT TO LICENSE NUMBER _____

C. RENEWAL OF LICENSE NUMBER _____

2. NAME AND MAILING ADDRESS OF APPLICANT (Include ZIP code)

Halco Lighting Technologies
2940 Pacific Drive
Norcross, GA 30071

3. ADDRESS WHERE LICENSED MATERIAL WILL BE USED OR POSSESSED

2940 Pacific Drive
Norcross, GA 30071

4. NAME OF PERSON TO BE CONTACTED ABOUT THIS APPLICATION

David Nelkin

TELEPHONE NUMBER

(770) 242-3609

SUBMIT ITEMS 5 THROUGH 11 ON 8-1/2 X 11" PAPER. THE TYPE AND SCOPE OF INFORMATION TO BE PROVIDED IS DESCRIBED IN THE LICENSE APPLICATION GUIDE.

5. RADIOACTIVE MATERIAL
a. Element and mass number; b. chemical and/or physical form; and c. maximum amount which will be possessed at any one time.

6. PURPOSE(S) FOR WHICH LICENSED MATERIAL WILL BE USED.

7. INDIVIDUAL(S) RESPONSIBLE FOR RADIATION SAFETY PROGRAM AND THEIR TRAINING EXPERIENCE.

8. TRAINING FOR INDIVIDUALS WORKING IN OR FREQUENTING RESTRICTED AREAS.

9. FACILITIES AND EQUIPMENT.

10. RADIATION SAFETY PROGRAM.

11. WASTE MANAGEMENT.

12. LICENSE FEES (See 10 CFR 170 and Section 170.31)

FEE CATEGORY	3I	AMOUNT ENCLOSED	\$ 9,700.00
--------------	-----------	-----------------	--------------------

13. CERTIFICATION. (Must be completed by applicant) THE APPLICANT UNDERSTANDS THAT ALL STATEMENTS AND REPRESENTATIONS MADE IN THIS APPLICATION ARE BINDING UPON THE APPLICANT.

THE APPLICANT AND ANY OFFICIAL EXECUTING THIS CERTIFICATION ON BEHALF OF THE APPLICANT, NAMED IN ITEM 2, CERTIFY THAT THIS APPLICATION IS PREPARED IN CONFORMITY WITH TITLE 10, CODE OF FEDERAL REGULATIONS, PARTS 30, 32, 33, 34, 35, 36, 39, AND 40, AND THAT ALL INFORMATION CONTAINED HEREIN IS TRUE AND CORRECT TO THE BEST OF THEIR KNOWLEDGE AND BELIEF.

WARNING: 18 U.S.C. SECTION 1001 ACT OF JUNE 25, 1948 62 STAT. 749 MAKES IT A CRIMINAL OFFENSE TO MAKE A WILLFULLY FALSE STATEMENT OR REPRESENTATION TO ANY DEPARTMENT OR AGENCY OF THE UNITED STATES AS TO ANY MATTER WITHIN ITS JURISDICTION.

CERTIFYING OFFICER - TYPED/PRINTED NAME AND TITLE: **Kim Cook Chief Operating Officer** SIGNATURE: *Kim Cook* DATE: **08/16/10**

FOR NRC USE ONLY

TYPE OF FEE	FEE LOG	FEE CATEGORY	AMOUNT RECEIVED	CHECK NUMBER	COMMENTS
			\$		
APPROVED BY				DATE	

573373

Halco wishes authorization under 10 CFR 32.14 to distribute lamps containing Kr-85 arc tubes. The following supporting information is provided as a supplement to NRC Form 313. This information has been provided as specified in NUREG-1556, Vol. 8, "Program Specific Guidance About Exempt Distribution Licenses" and 10 CFR 32.14.

Item 5. Radioactive Material

- a. Element and Mass Number Krypton-85
- b. Chemical and/or Physical Form gas (diluted in Argon)
- c. Maximum activity in each source ≤120 nanocuries per glass tube; 10 mCi total

Item 6. The distribution of lamps containing gaseous krypton glass tubes to persons exempt from licensing pursuant to Section 30.15, 10 CFR 30, or equivalent provisions of the regulations of any Agreement State.

Krypton-85 is an inert gas with low retention in the body when inhaled. The solubility of krypton gas has been found equal to 59.4 cm³/kg. Skin absorption of Kr-85 gas is insignificant (NUREG/CR-0215). Leak testing of the tubes is not required.

Halco expects to have no more than 10 mCi of Kr-85 in lamps on site at any one time.

Items 7-11 of the license application do not need to be completed per NUREG 1556, Vol. 8. Additional information concerning the manufacturing process and other radiation safety related items is provided below.

Halco has applied for a possession license by the State of Georgia. A copy will be forwarded to NRC in support of this application upon receipt.

Records of transfers shall be maintained as required by 10 CFR 32.25. Records shall include a description or identification of the type of each product transferred, for each radionuclide in each type of product, the total quantity of the radionuclide, and the number of units of each type of product transferred during the reporting period. We shall maintain the record of each transfer for a period of one year after the event is included in a summary report to the Commission.

Halco shall file the summary report by mail with the Director, Office of Nuclear Material Safety and Safeguards, U.S. Nuclear Regulatory Commission, Washington, DC 20555-0001,

The summary reports shall be filed within 30 days of the following:

- 1) five years after filing the preceding report; or
- 2) filing an application for renewal of the license under §30.37; or
- 3) notification to the Commission under §30.34(f) of our decision to permanently discontinue activities authorized under the license issued under §32.14.

The report will indicate that no transfers of byproduct material have been made during the reporting period should that be the case.

Halco shall inspect the lamps to assure that they are the proper models specified above and have been labeled as described in this application. Lamps that are not properly labeled will be relabeled in Halco's facility. Lamps that are the wrong model will be returned to the manufacturer and lamps that are damaged will be disposed of via recycling with a licensed recycle facility.

The lamps shall be offered for transportation in accordance with applicable Department of Transportation (DOT) and NRC regulations.

Design and Construction

Overview

Metal Halide light sources consist of a quartz or ceramic (Polycrystalline Alumina) arctube containing the radioactive material and an outer envelope of glass with one or two bases for electrical and mechanical contact with the luminaries. Lamp bases are generally made of ceramic material and/or metal with insulating material and withstand high temperatures.

The arctube is designed to maintain over a prolonged lifetime a vacuum tight noble gas environment for the electric arc, to preserve the filling during operation and to resist high temperatures as well as high temperature gradients. The pressure in the arctube under normal conditions is typically a few hundred of mbar below atmospheric pressure. The arctube thickness will range from 1mm to 1.5mm depending on the lamp wattage.

The Kr-85 and other gases are sealed in the arctube, which is then sealed into the outer envelope. The primary function of the outer envelope is to protect and maintain an inert atmosphere for the arctube and its mechanical and electrical supportive metal/glass components. The arctube is supported in this environment in different ways depending on the construction types shown below. Very small arctubes are supported by the lead wires, while larger arctubes and protected arctubes require additional support structures to ensure their proper protection and location. In instances of a protected lamp designed for open fixture use, the arctube will be surrounded by an additional quartz shroud.

Halco lamps have life expectancies ranging from 3,000 – 20,000 hours.

The various types of lamps are pictured below, with key components identified.

Manufacturing Process

The manufacturing process is shown in the following map.

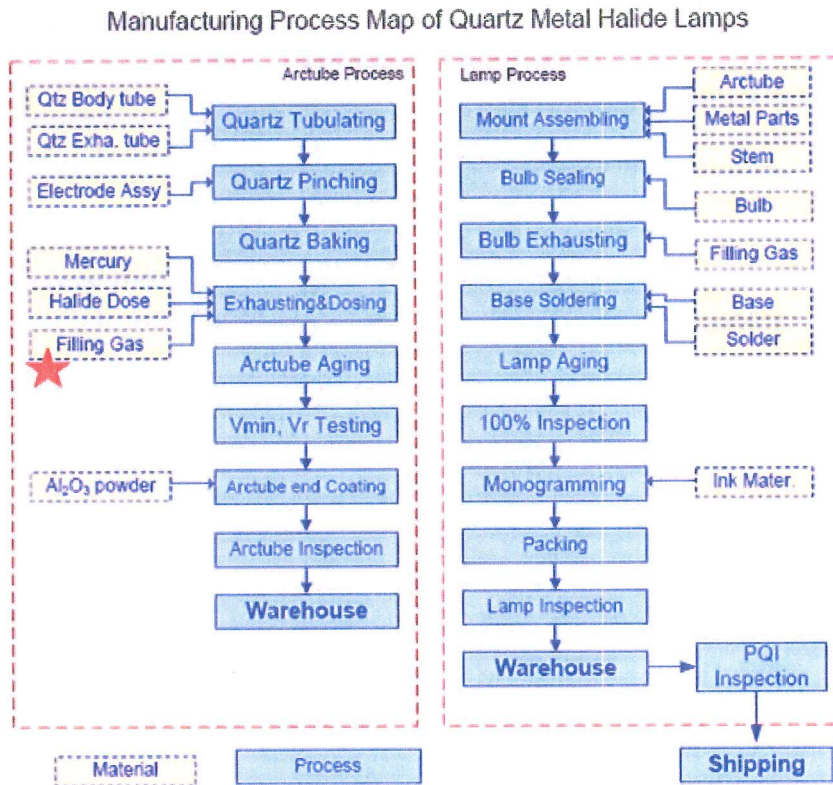

Halco proposes to distribute seven basic constructions of lamps containing Kr-85 arctubes, which are described in the following pages. Details of the most common lamp shapes used for each construction have been provided.

1 175W Medium Base and Below for Enclosed Fixtures

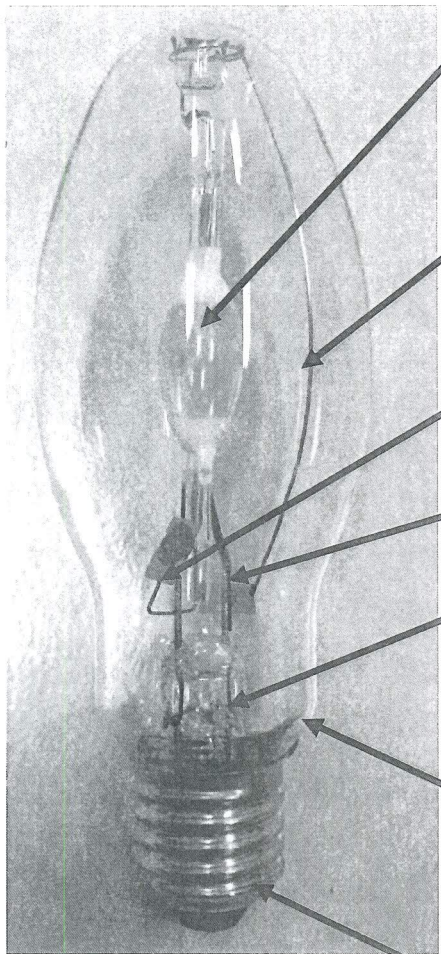

- Arctube:**
 - made of quartz or PCA material
 - emits light
 - contains Kr-85
- Frame:**
 - made of Ni wire
 - supports arctube
 - electrical connection via stem wire
- Getter:**
 - made of Zr-Al alloy
 - reduces impurity gases inside of lamp bulb
- Bi-metal switch:**
 - made of Ni material
 - contributes for lamp starting
- Stem:**
 - made of hard glass and metals
 - electrical connection to arctube
 - provides seal with envelope
- Envelope:**
 - made of hard glass material
 - protects arctube and metal parts from atmosphere
 - depending on lamp type, some envelopes are gas filled, some are vacuumed.
- Base:**
 - made of Ni coated copper and dark glass
 - electrical connection with lamp holder

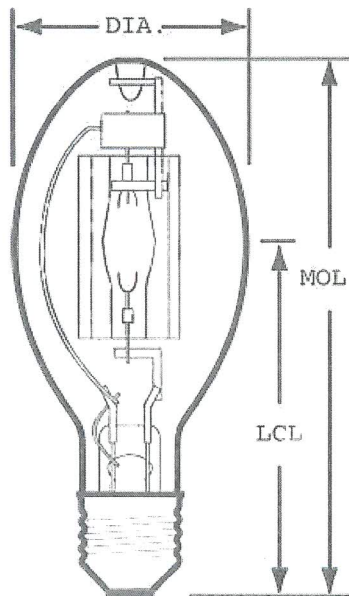

ED17	
M.O.L	5.45"
DIA.	2.125"

2 175W Medium Base and Below for Open Fixtures

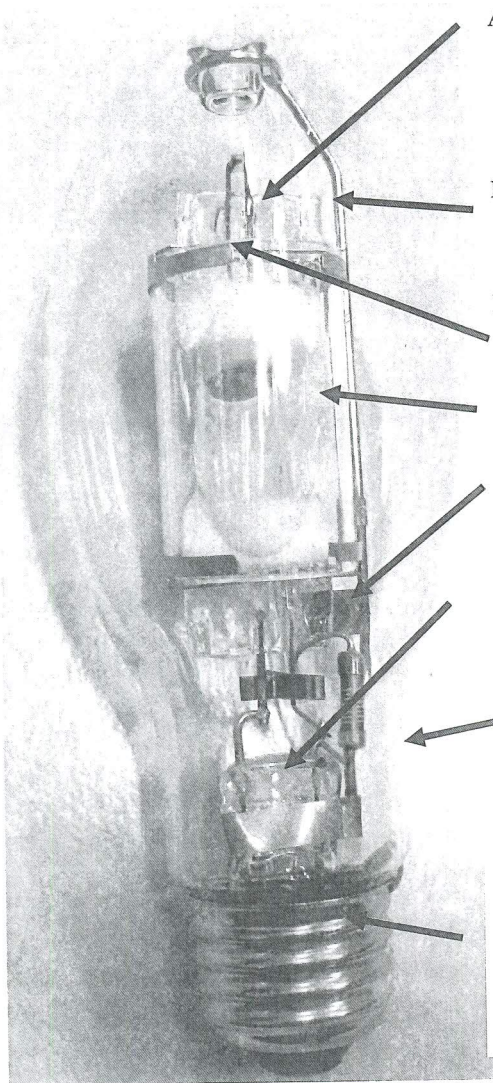

- Arctube:
 - made of quartz or PCA material
 - emits light
 - contains Kr-85
- Frame:
 - made of stainless steel wire
 - supports arctube
- Fly wire:
 - made of Ni wire
 - electrical connection via stem wire
- Quartz Shroud:
 - protects arctube for open fixture use
- Getter:
 - made of Zr-Al alloy
 - reduces impurity gases inside of lamp bulb
- Stem:
 - made of hard glass and metals
 - electrical connection to arctube
 - provides seal with envelope
- Envelope
 - made of hard glass material
 - protects arctube and metal parts from atmosphere
 - depending on lamp type, some envelopes are gas filled, some are vacuumed.
- Base:
 - made of Ni coated copper and metal
 - electrical connection with lamp holder

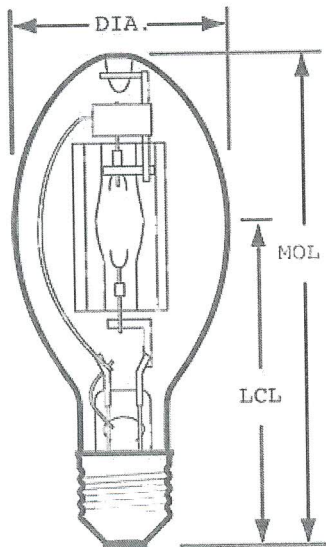

ED17	
M.O.L	5.45"
DIA.	2.125"

3 175W Mogul Base and Above for Enclosed Fixtures

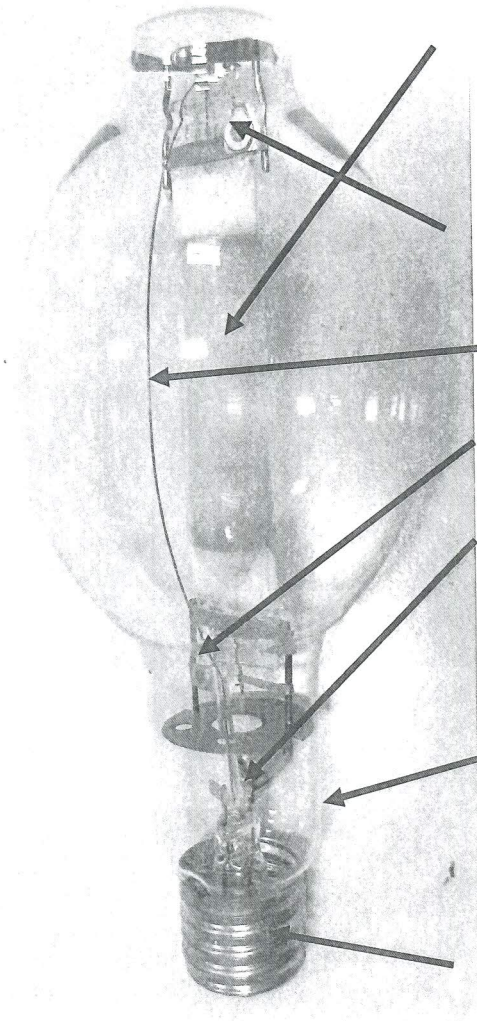

- Arctube:**
 - made of quartz or PCA material
 - emits light
 - contains Kr-85
- Frame:**
 - made of stainless steel wire
 - supports arctube
- Fly wire:**
 - made of Ni wire
 - electrical connection via stem wire
- Getter:**
 - made of Zr-Al alloy
 - reduces impurity gases inside of lamp bulb
- Stem:**
 - made of hard glass and metals
 - electrical connection to arctube
 - provides seal with envelope
- Envelope**
 - made of hard glass material
 - protects arctube and metal parts from atmosphere
 - depending on lamp type, some envelopes are gas filled, some are vacuumed.
- Base:**
 - made of Ni coated copper and metal
 - electrical connection with lamp holder

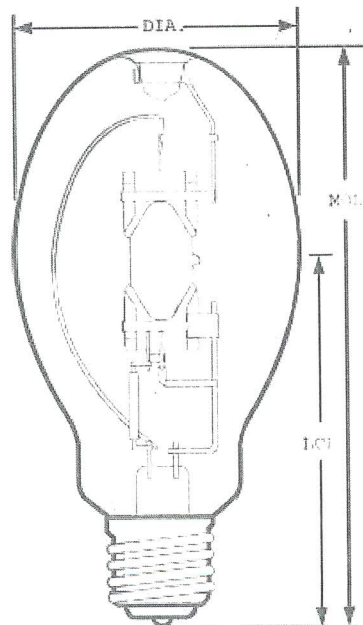

ED28	
M.O.L	8.25"
DIA.	3.5"

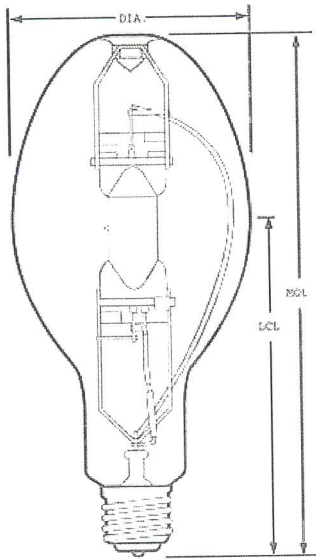

ED37	
M.O.L	11.50"
DIA.	4.625"

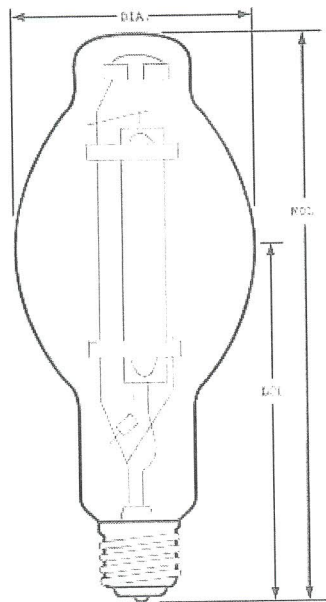

BT37	
M.O.L	11.50"
DIA.	4.625"

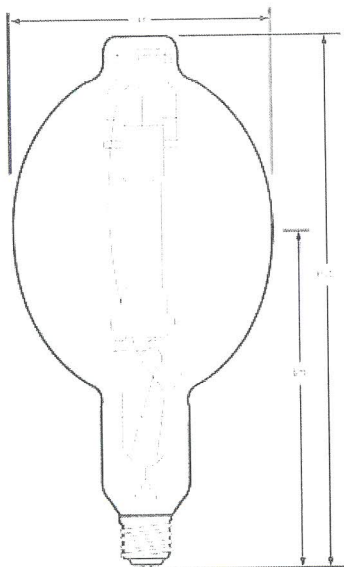

BT56	
M.O.L	15.40"
DIA.	7.00"

4 175W Mogul Base and Above for Open Fixtures

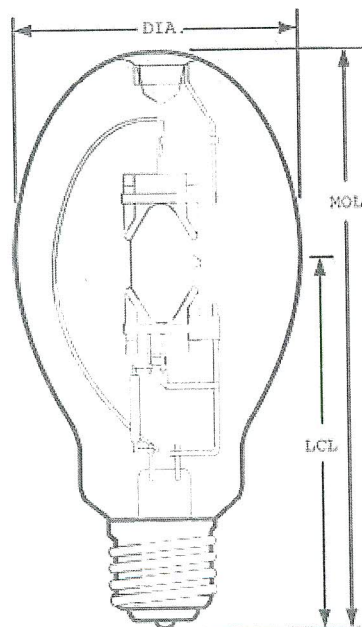
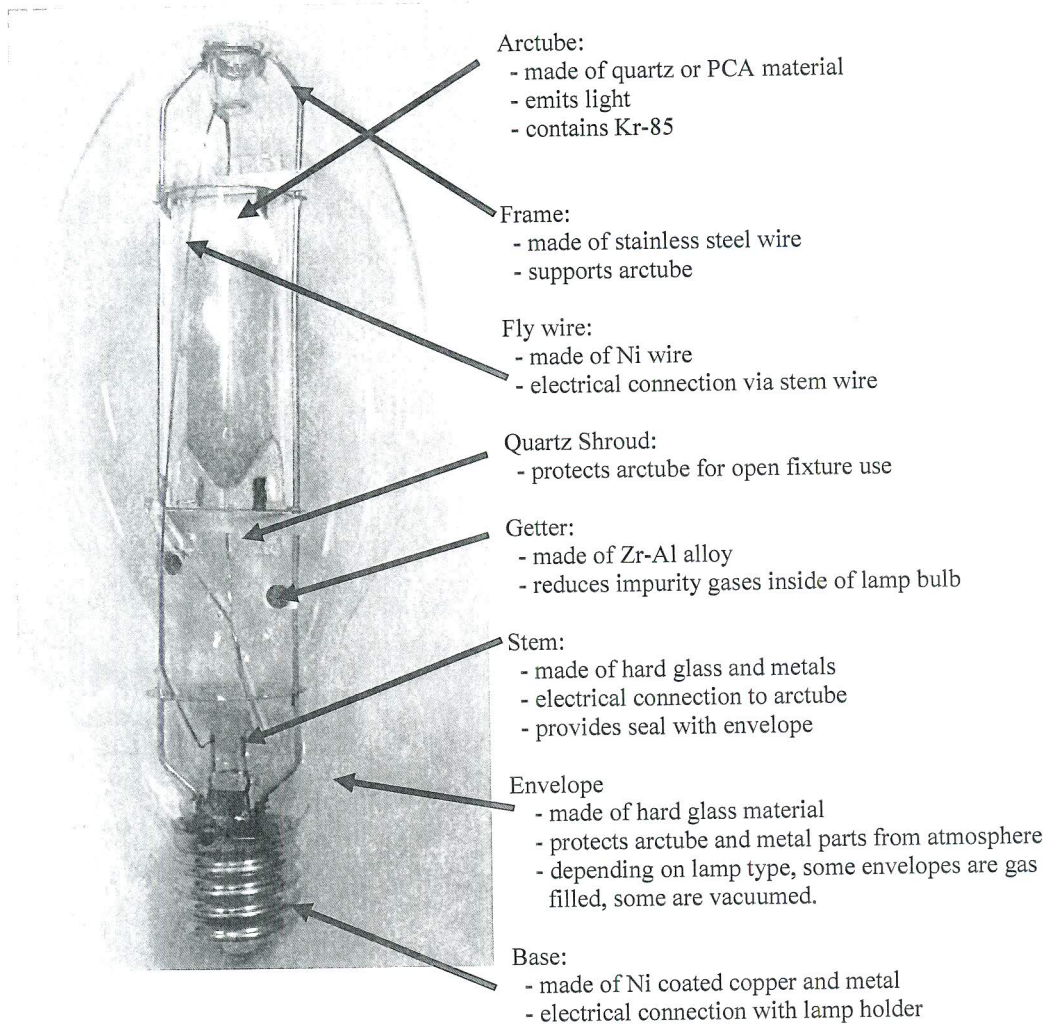

ED28	
M.O.L	8.25"
DIA.	3.5"

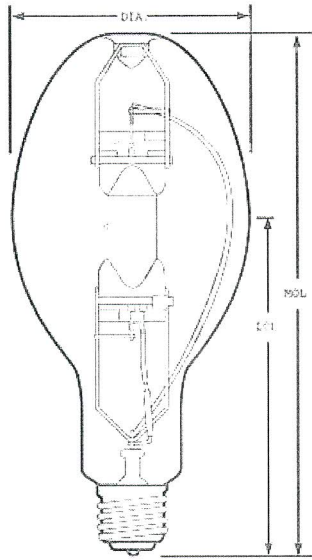

ED37	
M.O.L	11.50"
DIA.	4.625"

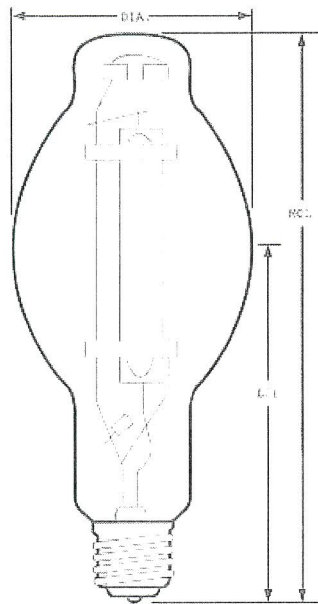

BT37	
M.O.L	11.50"
DIA.	4.625"

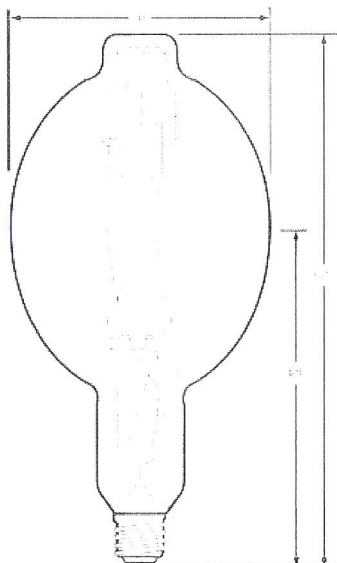

BT56	
M.O.L	15.40"
DIA.	7.00"

5 Tubular Type (Single Ended)

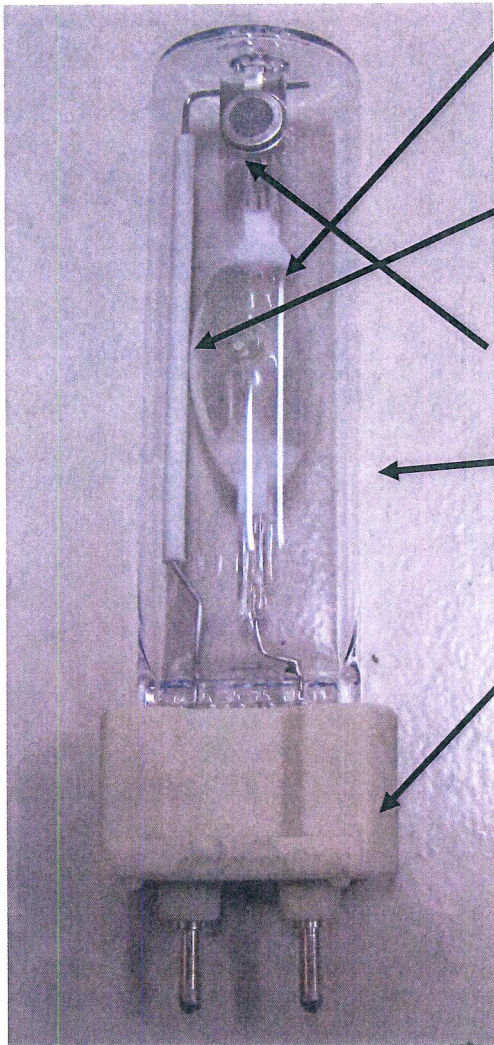

- Arctube:
 - made of quartz or PCA material
 - emits light
 - contains Kr-85
- Frame:
 - made of stainless steel wire
 - supports arctube
- Getter:
 - made of Zr-Al alloy
 - reduces impurity gases inside of lamp bulb
- Envelope
 - made of UVC quartz
 - protects arctube and metal parts from atmosphere
 - depending on lamp type, some envelopes are gas filled, some are vacuumed.
- Base:
 - made of ceramic material
 - electrical connection with lamp holder

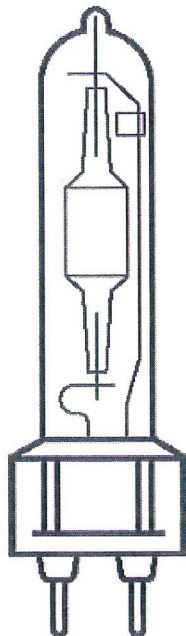

T6 (G12)	
M.O.L	3.94"
WIDTH	1.19"
T7 (G12)	
M.O.L	4.30"
WIDTH	1.19"

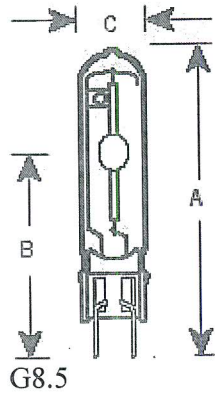

T4.5 (G8.5)	
M.O.L	3.15"
DIA.	0.563"

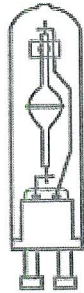

T4 (GU6.5)	
M.O.L	2.21"
DIA.	0.50"

Additional variations for the pictured construction (G.12 base type) exist in the forms of G8.5 base, GU6.5 base and other similar base type lamps which use the same arctube manufacturing processes, as well as support structures and sealing points, providing the same protections, with the variation being the method of connection with the luminaire.

6 Tubular Type (Double Ended)



Arctube:
 - made of quartz or PCA material
 - emits light
 - contains Kr-85

Frame:
 - made of stainless steel wire
 - supports arctube

Getter:
 - made of Zr-Al alloy
 - reduces impurity gases inside of lamp bulb

Bulb:
 - made of UVC quartz
 - protects arctube and metal parts from atmosphere
 - depending on lamp type, some envelopes are gas filled, some are vacuumed.

Base:
 - made of ceramic material
 - electrical connection with lamp holder

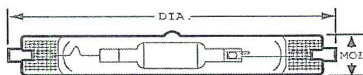

T6 (DE)	
M.O.L	4.69"
DIA.	0.75"

T7 (DE)	
M.O.L	5.43"
DIA.	0.875"

T8 (DE)	
M.O.L	6.42"
DIA.	1.00"

7 Reflector Type

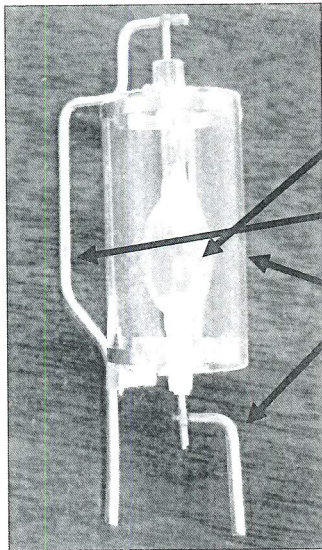

Arctube:

- made of quartz material
- emits light
- contains Kr-85.

Frame:

- made of Stainless steel
- supports arctube
- electrical connection of arctube with stem wire

Quartz Shield:

- made of Quartz Material
- protects arctube for open fixture use

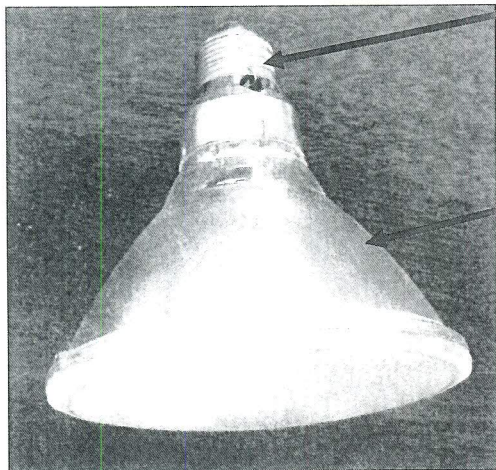

Base:

- made of Ni coated copper and dark glass
- electrical connects with lamp holder
- solder fixed with lamp bulb

Lamp outer bulb:

- made of hard glass material
- seals arctube and metal parts from air atmosphere
- Gas filled

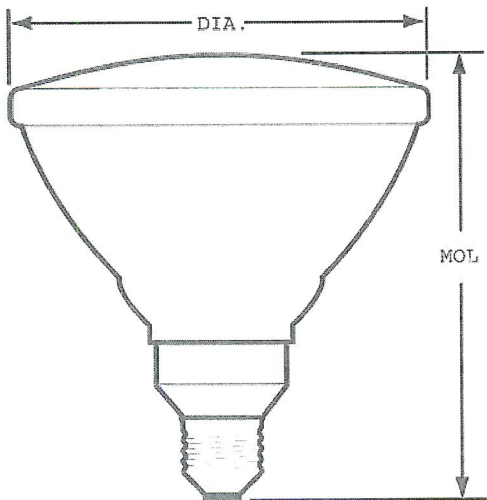

PAR38	
M.O.L	5.43"
DIA.	4.75"

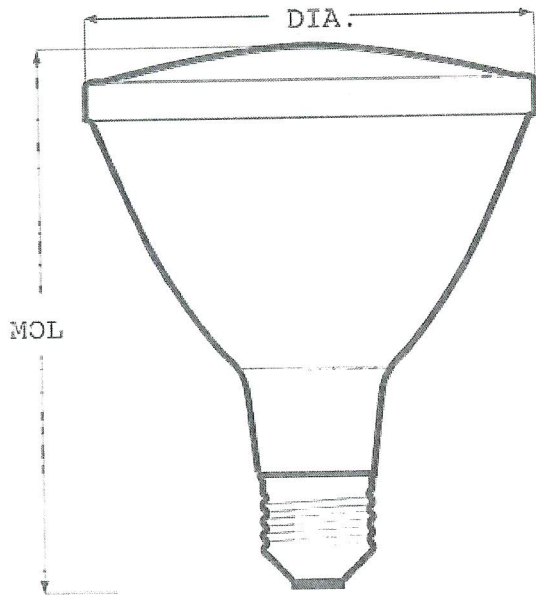

PAR30L	
M.O.L	4.80"
DIA.	3.75"

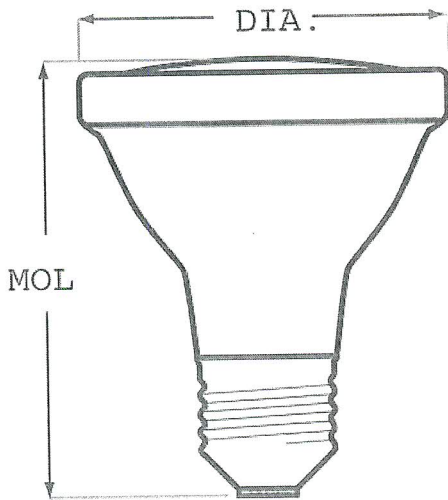

PAR20	
M.O.L	3.74"
DIA.	2.50"

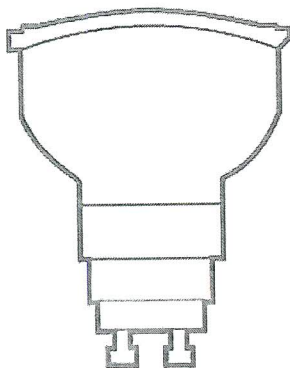

MR16 (GX10)	
M.O.L	2.56"
DIA.	2.00"

Additional variations for this same construction exist in the forms of PAR20, PAR30L, MR16 and related lamp shapes, which use the same arctube manufacturing processes, as well as support structures and sealing points, providing the same protections, but have different bases and lamp dimensions.

Manufacturing – Introduction of Kr-85 Into The Arctube

Krypton-85 gas is introduced into the arctube together with Ar gas during the arctube exhausting and dosing process after the arctube is vacuum pumped to a certain vacuum level. The arctube is sealed after the required gas pressure is filled and thus the Kr-85 is permanently sealed in the arctube (Fig.1). The Kr-85 fill gas pressure is controlled through presetting the required pressure on the fill gas pressure gage, which is capable of illustrating the pressure digitally, so that the fill gas pressure can be controlled and audited easily (Fig.2). The pressure gage is calibrated on a monthly basis. A strict quality control and quality assurance procedure ensures the proper amount of gas is applied; the gas pressure is checked by the operator during manufacturing, additionally the measurement is checked and recorded every two hours by process auditor according to MCP (Manufacturing Control Process). Based on the manufacturing status and production schedule, the fill gas pressure in the arctube will be tested periodically (weekly or biweekly).

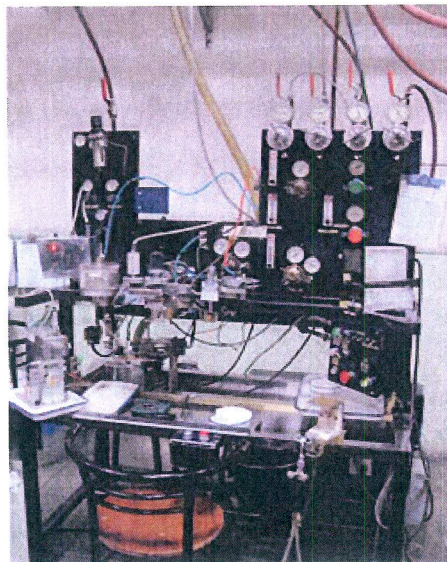

Fig.1 Arctube Exhausting bench

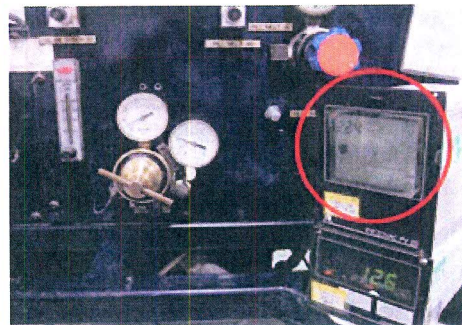

Fig.2 Pressure gauge

The Kr-85 gas bottle is embedded in a 3cm thick lead tank and placed into a control cabinet which is sealed after the installation. The control cabinet (shown in Fig. 3) is pump ventilated from the top to the air. Normally, the green light on the alarm is illuminated, indicating that the system is working properly. A red alarm light typically means there may be a leak in the system. When this occurs, the system will immediately shut down and seal off automatically. Per the standards of the Zhejiang Environmental Protection Bureau, the leaked Kr-85 will be ventilated out to the external environment per the ventilation pipe, and thus will not be accessible to the room air.

The Kr-85 content in each individual arctube is measured via a calculation derived from fill gas pressure. The fill gas pressure is strictly controlled via measurement of every arctube during manufacturing. Additionally, as noted above, the quality control auditor records the measurement

every 2 hours. The measurement equipment is calibrated on a monthly basis and production samples are tested to ensure accurate fill gas pressure on a weekly or bi-weekly basis.

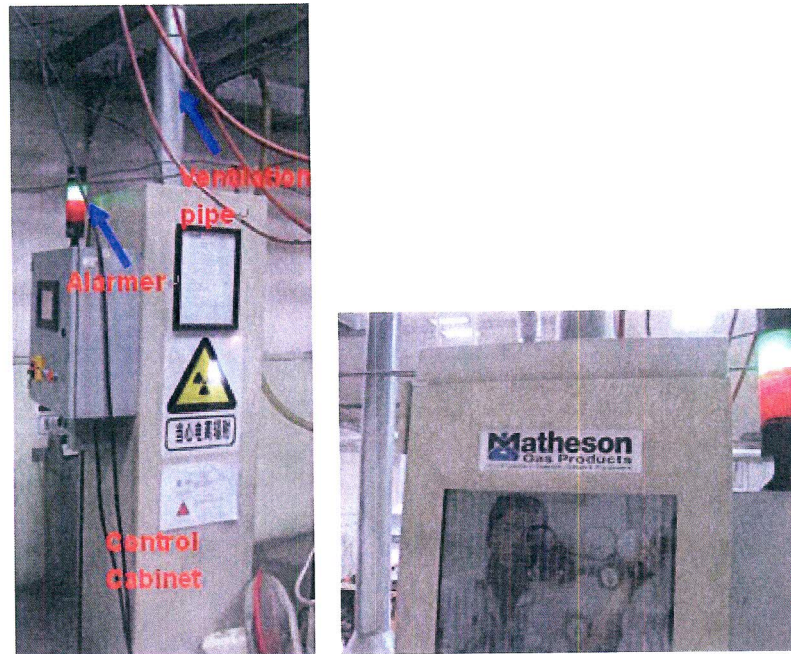

Fig. 3 Kr-85 gas operation system

Only trained and qualified personnel are permitted to operate and perform maintenance of the Kr-85 gas system. Strict operation procedures, a caution notice and warnings are also implemented to ensure safety (Fig.4).



Fig. 4

Lamp testing

After the arctube is sealed with Kr-85 and other relevant materials, the arctube is aged for 12 minutes prior to the arctube voltage check and arctube leak check. If the arctube is not sealed properly, leakage

will be measured as evidenced by detection of extremely low arctube voltage or failure to strike an arc. All arctubes that pass the initial arctube testing will be allowed to cool down and will then be re-aged for 5 minutes for an additional performance check before sending for finished lamp production. These dual checks ensure that no arctubes that permit the escape of the tube gas will be moved forward in the process and incorporated into a finished lamp.

After the arctube is incorporated into the envelope and the base has been attached, the lamp will be aged for 15 minutes followed by lamp voltage check and lamp leak check. Again, if the lamp contains an arctube that is not sealed properly or is leaking, it is easily detected due to extremely low lamp voltage or failure to light. Additionally, if the outer envelope is not sealed properly, the metal components inside of the lamp bulb will become oxidized. All lamps that pass the initial testing will be stored for at least 24 hours and will be re-aged for 10 minutes for additional lamp quality checking. The same detection methods as the first lamp check are used to determine possible leakage and other issues. Failed lamps will be removed from the production batch.

After the finished lamps are aged twice, the lamps will be 100% inspected for appearance, lamp seal quality, support structure, metal parts cleanness and other visual and physical inspections to ensure quality control.

Following lamp inspection, at least 5 lamps will undergo photometry checking for lamp voltage, CCT, lamp color, and starting performance. If all lamps pass, then the lamp batch will be accepted. If one lamp fails, 10 additional pieces are tested to ensure the batch is acceptable. If 2 lamps fail or any of the 10 additional lamps that are tested fail, then the batch is returned to quality control.

Once all finished lamps have passed all required testing, they are marked with an etch on both the envelope and the base; they are then packaged. All packaging has been tested and approved for prevention of support structure failure and/or arc tube rupture from a drop of 3 meters. A photograph of lamp packaging is provided on the following page.

Dose Rate

NRC regulations found in 10 CFR 30.15 limit the amount of Kr-85 per arctube to 30 μCi . Furthermore, levels of radiation from each tube must not exceed 1 millirad per hour at 1 centimeter from any surface. Given a gamma constant for Kr-85 of approximately 0.04 $\text{R}\cdot\text{cm}^2/\text{hr}\cdot\text{mCi}$, the dose rate at 1 centimeter from a Halco arctube will be no more than 0.005 mrad per hour at 1 centimeter.

Labels

All Halco lamps will be labeled with the following: "This lamp contains an arc tube with a filling gas containing no more than 120 nCi of Kr-85 and is distributed by Halco Lighting Technologies, Norcross, Georgia, 30071." Note the quantity of Kr-85 identified on the label will be adjusted to accurately identify the quantity used in the lamp (as some arctubes contain less than 120 nCi).

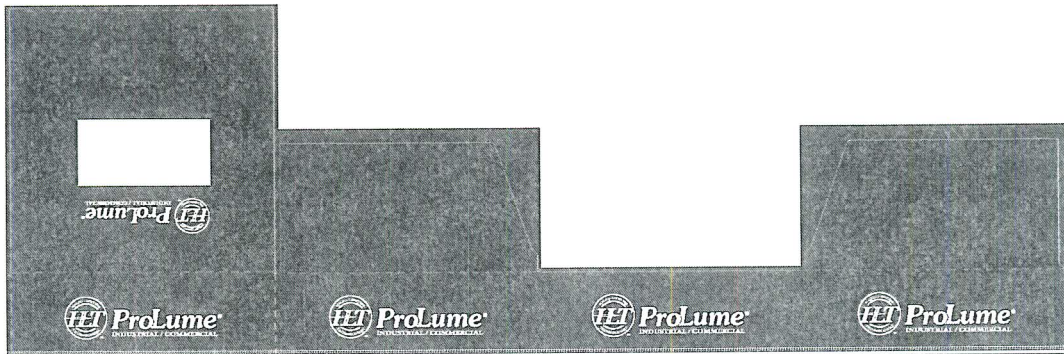

**Metal Halide Lamps
for use in
enclosed fixtures.**

DISPOSAL:
Lamp contains a small amount of mercury – dispose of in accordance with local regulations. Large quantities of lamps must be disposed of in accordance with the rules of the local authority.

WARNING:
This lamp can get extremely hot. Burn and eye irritation from direct view, ultraviolet radiation of outer envelope of the lamp is broken or punctured and the hot bulb can become an irritant. Do not use where people will remain. For more information see enclosed literature. Shocking or other safety precautions are used. Check types of lamps that will accept only metal-halide when the entire envelope is broken or punctured and is commercially available. This Lamp complies with IESNA minimum performance standards 21 CRI Output 1, 140lm/watt.

**LAMP CONTAINS MERCURY
Manage in Accord with
Disposal Laws**
See www.hampresycle.org



**Metal Halide Lamps
for use in
enclosed fixtures.**

WARNING!
Risk of electric shock.
• Turn power off before opening any enclosure or removal.
• Do not use where it is not specified as suitable for installation within an enclosed fixture.
• Risk of fire.
• Keep combustible materials away from lamps.
• Use in fixtures rated for this purpose. A damaged lamp inside an enclosure which may cause arcing or fire.
• Turn power off if glass bulb is broken. Fragments are a hazard to lamp.
• Unpackaged lamp requires may cause injury. Fix in properly designed.
• Do not touch fused surfaces.
• Do not use where it is not specified as suitable for use in enclosed fixtures.
• Use in enclosed fixture rated for this product.
• Do not use where it is not specified as suitable for use in enclosed fixtures.
• Use only approved rated ballast.
• Operate lamp only as specified on label.
• Turn lamp off at least once for 15 minutes per week.
• Do not clean lamp with a cloth.
• Do not use beyond rated life.
• Do not use lamp until fully installed.



METAL HALIDE METAL HALIDE METAL HALIDE METAL HALIDE

