

NOTES:  
 1. FOR SYMBOLS AND GENERAL NOTES SEE 1-47W611-70-1.  
 2. SWITCH LOCATED ON 480V MOV BOARD.  
 3. 1-HS-70-89B HAS BEEN REMOVED TO PREVENT A CONDITION ADVERSELY AFFECTING THE SAFETY FUNCTION OF THE ASSOCIATED VALVE DURING AN ACCIDENT. ASSOCIATED XS 1-XS-70-89A NO LONGER NEEDED.

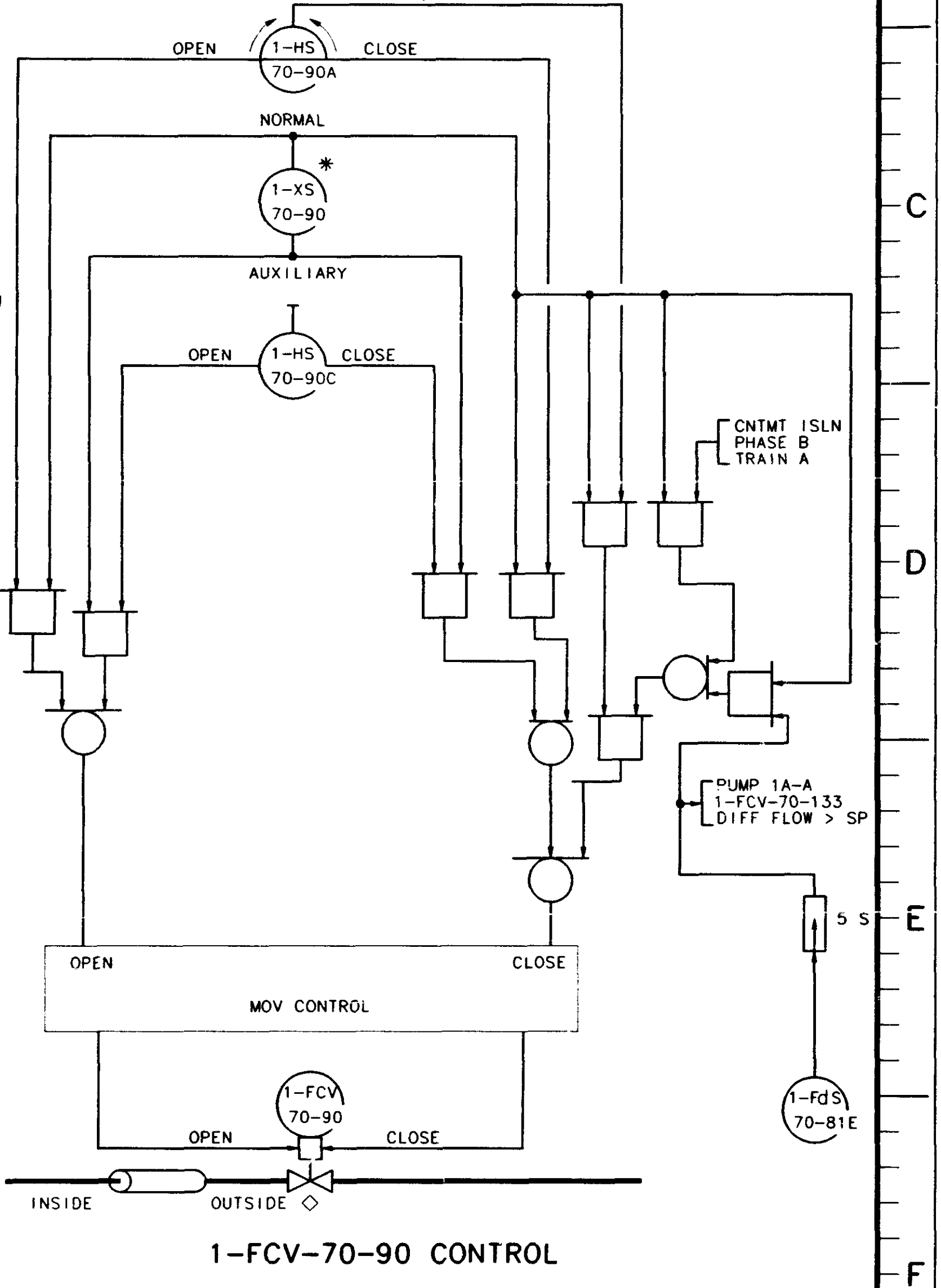

SYS 70

4	NR	3-6-95	MAF	PDH	JAT	NR	NR	NR	NR	NR
INCORPORATED SYS 70 BOUNDARIES.										
REV NO.	CHANGE REF	DATE	DFT	CHKR	DSGN	RVWR	APPD	APPD	APPD	ISSD
SCALE: NTS										EXCEPT AS NOTED
PROJECT FACILITY POWERHOUSE UNIT 1										
TITLE <b>ELECTRICAL LOGIC DIAGRAM COMPONENT COOLING SYSTEM</b>										
1	WATTS BAR NUCLEAR PLANT TENNESSEE VALLEY AUTHORITY									Q
DESIGN			INITIAL ISSUE			ENGINEERING APPROVAL				
DRAFTER C.N. CLABOUGH			CHECKER FRANK LAYFIELD			RO ISSUE PER			1 GARY BARNARD	
DESIGNER GARY BARNARD			REVIEWER R.L. FORESTER			EAI 3.10 & RIMS T28 '92 0121 805			2 C.A. ATKINS	
DATE 2-7-92			85 E			1-47W611-70-3			R4	

FSAR FIG.9.2-25

ISSUED BY: W.L. ELLIOTT/CWW  
 PRINT SIZE: 11x17  
 BR OR PROJ: AB CE EE ME NE FE SE TE BL BF WB SQ